

Scanned from the collections of
The Library of Congress



Packard Campus
for Audio Visual Conservation
www.loc.gov/avconservation

Motion Picture and Television Reading Room
www.loc.gov/rr/mopic

Recorded Sound Reference Center
www.loc.gov/rr/record

The TALKING MACHINE WORLD

For the
makers &
sellers of
talking
machines

Published Each Month by Edward Lyman Bill, Inc., at 373 Fourth Ave., New York, January 15, 1921

*The instrument by which
the value of all musical
instruments is measured*

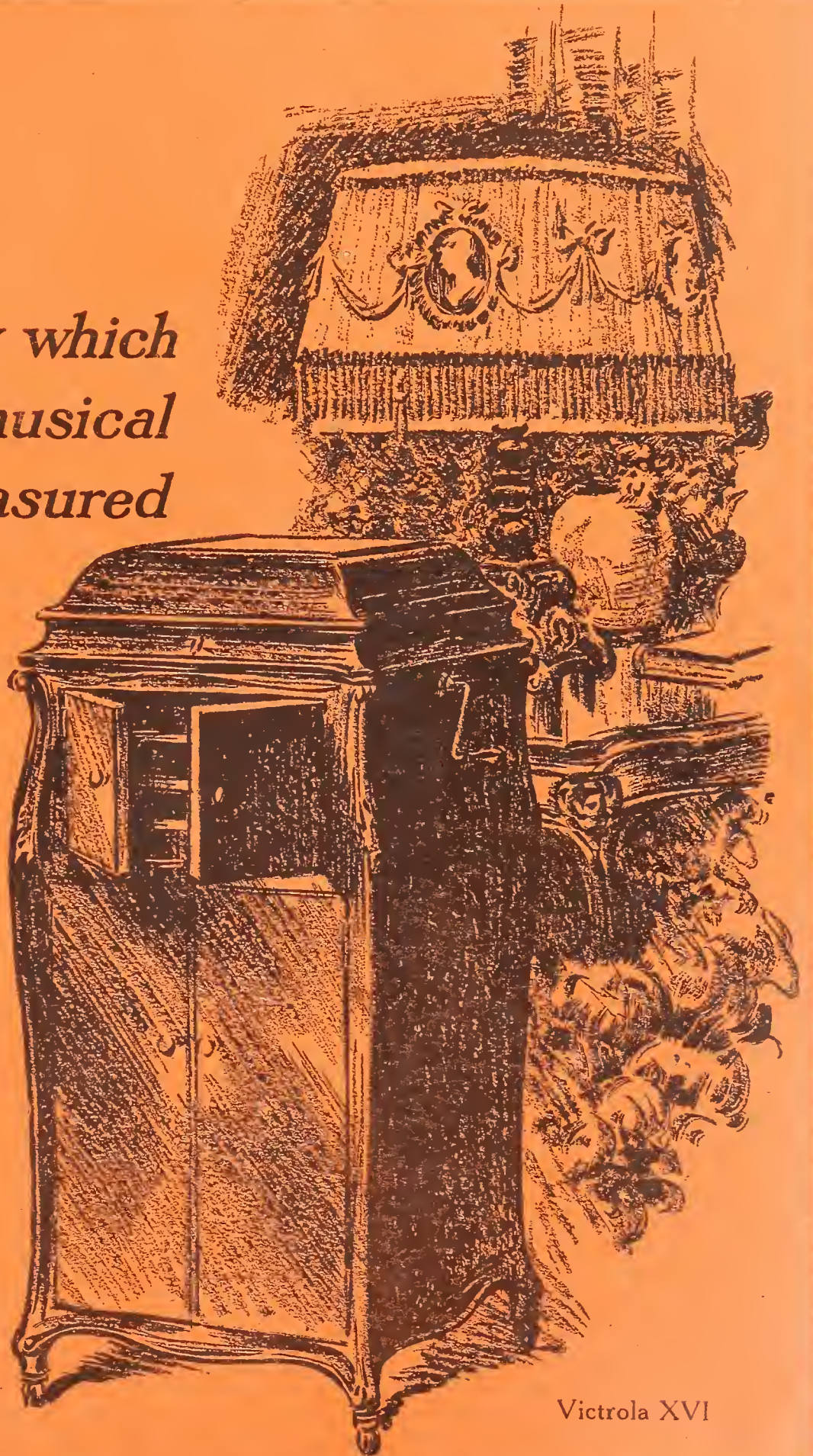

This trademark and the trademarked word "Victrola" identify all our products. Look under the lid! Look on the label!

VICTOR TALKING MACHINE CO.
Camden, N. J.

Victrola XVI

THE INSTRUMENT OF QUALITY
Sonora
CLEAR AS A BELL



Consider these facts!

Easiest to sell, bringing cash for sales, being in tremendous demand and keeping dealers' bank balances at the highest levels, the Sonora is the phonograph for YOU to handle.

Sonora has never been offered on the "dollar down" principle. Quality has been made the incentive at all times.

The Sonora line is wonderfully complete, including 32 superb instruments—7 upright, 24 period and 1 Portable. There is a Sonora to suit every purse, prices ranging from \$75 to \$1800.

Sonora dealers know that not only is the Sonora a money-maker now, but that it builds an enduring business for them.

The Sonora is licensed and operates under BASIC PATENTS of the phonograph industry, which insure you against troublesome patent litigation.

To MAKE, USE or SELL an infringing patent constitutes a violation of the patent law.

Write today regarding a Sonora agency.

With our new factories in operation we can now care for new dealers.

Sonora Phonograph Company, Inc.

George E. Brightson, *President*

NEW YORK: 279 BROADWAY

Canadian Distributors: I. Montagnes & Co., Toronto

The Highest Class Talking Machine in the World

The Talking Machine World

Vol. 17. No. 1

New York, January 15, 1921

Price Twenty-five Cents

SHOULD CONCENTRATE ON SELLING

Skilled Salesman's Time Should Not Be Taken Up With Minor Details—The More He Knows the More He's Worth to His Employer

The importance of giving the closest attention to the intelligent handling of record sales is pointed out very pertinently in the recent bulletin issued by the Putnam-Page Co., Victor distributor of Peoria, Ill., as follows:

"The employer who has little tasks to give his record selling people other than the work of selling records is using expert help for work that lesser paid people could accomplish. This refers to the work of mailing and stock taking and bookkeeping in other parts of the store.

"No salesperson in a Victor shop need ever be idle and time spent in studying records in stock and to come is of far more value as an eventual money getter than that utilized for minor tasks about a store. Have it a rule to plan each day in the record department and plan that day to include between-time study of records along previously discussed lines. Knowledge is power and power of mind makes sales.

"The more an employe knows of the employer's business the more that employe is worth. And this benefits both parties concerned.

"Record salespeople should have, and should exact, a proper amount of time to study their record offerings. But of all things use your day to profitable advantage. Do something toward selling other than to just wait on customers. There are many avenues—the telephone, the card index showing when the customer bought last, etc. Above all take a retrospect of the day—look backward and decide honestly for yourself if you have accomplished anything."

NOW'S THE TIME FOR COURAGE, CONFIDENCE AND ACTION

Every Brain and Hand in the Talking Machine Industry Should Utilize Every Atom of Energy, Every Constructive Thought, Every Helpful Suggestion to Develop Business During 1921

The opening of the New Year is usually associated with resolutions. In this connection there is no resolution more worthy of consideration by the talking machine and business man generally than that of resolving to cease grumbling and complaining, and to go out after business and to capture it. The Nation has not gone bankrupt overnight, although some of the rumor-mongers would have us believe so. There is business to be had in goodly volume by those who are sane and courageous—those who have faith in the United States and its future.

A great many of our business men have cut a sorry spectacle for the past six weeks; they have lost their accustomed poise and grit, and have joined with the weak-kneed crowd in a panic of pessimism that is only paralleled by the gloomy outlook pictured on the entrance of America into the world war. The prophets of disaster at that time were all mistaken in their conclusions as to the business future, and the prophets of disaster to-day will be likewise fooled regarding the development of business during 1921. It is time for faith, courage, confidence and—action.

Along this line we recently came across a very vital message to business America in the Chicago Evening Post which is well worth reproducing because of its timeliness. It reads as follows:

"This is the time for every brain and hand to utilize every atom of energy, every constructive thought, every helpful suggestion that will furnish more power to the business motor.

"This is the time when the generals of business must take off their coats, roll up their sleeves, spit on their hands and re-vim every department, inside and out. One hundred per cent management must register 110 per cent and more.

"This is the time when raw material men

RUSSELL HUNTING, JR., IN JAPAN

Now Is Chief Recorder for the Nipponophone Co., Ltd., in the City of Yokohama

Russell E. Hunting, Jr., is now head of the recording department for the Nipponophone Co., Ltd., of Yokohama, Japan. The Japanese music, on account of its many peculiarities, has been rather difficult to record in the past, but Mr. Hunting has mastered the subject and is now busily engaged in turning out records for his company. The Nipponophone Co., Ltd., has been established in Japan for ten years and is the pioneer firm in the talking machine industry in that country. Mr. Hunting's father is the chief recorder for the Pathé Frères Phonograph Co. in this country.

OPENS THIRD STORE IN KENOSHA

Mayer Drug Co. Handles the Puritan Phonograph With Great Success in That City

The Mayer Drug Co., of Kenosha, Wis., recently opened its third store in that progressive city, the new establishment at West Market and Main streets being in charge of Harry Mayer. The Mayer Drug Co. represents one of the few drug concerns that have given really earnest thought to their talking machine department and have won genuine success thereby. The company handles the Puritan line of machines and records in all its stores and makes a special feature of window displays.

Too often a dealer prepares his advertising copy and puts in all the essentials except the big one, the invitation to buy.

MOST DEALERS FAVOR INTEREST

Canvass by Stewart Talking Machine Co. Proves Majority Favor Charging of Interest—Strong Demand for New Road Signs Now Prevails

INDIANAPOLIS, IND., December 31.—The Stewart Talking Machine Co., Victor wholesaler of this city, reports that a canvass of its dealers shows an overwhelming majority in favor of the charging of interest on deferred payments. In fact, of the first 102 dealers who answered, ninety-two were in favor of the establishment of an interest rate, and only seven opposed to such a charge. The majority of the dealers favored an interest rate of 6 per cent, while some suggested 7 per cent, and others higher rates up to 10 per cent. The Stewart Co. has made a strong effort to bring about the charging of interest, not alone for the purpose of giving the dealer a fair return on the money that he is actually loaning the customer by making an instalment sale, but also to give the dealer some argument to present to the customer as to why it is desirable to pay cash.

The Stewart Co. reports that there is a lively demand from dealers for the special Victrola road signs, announced recently in The Talking Machine World, and it is probable that when the roads are open for heavy traffic in the Spring, it will not be possible to travel for many miles from Indianapolis in any direction without being confronted with a number of these signs.

WIRELESS MUSIC FOR LEAGUE

Concert at Chelmsford Entertains Audience 700 Miles Away at Geneva—Amplifying of Music Accomplished by Stentorphone

A news dispatch from London says that record music transmitted by wireless from Chelmsford was heard in every part of the hall of the League of Nations at Geneva, about 700 miles distant, in the course of new wireless telephone trials. The result was obtained by attaching a magnifying trumpet called a "stentorphone" to a telephone receiver.

In a subsequent statement Marconi's announced that when the stentorphone experiments are completed politicians will be able to deliver speeches simultaneously to several audiences in different parts of the world through the wireless telephone transmitters installed in their own homes. By the same means vocalists can give world-wide concerts.

GREAT HONOR FOR MME. D'ALVAREZ

Noted Contralto and Vocalion Artist First Woman to Sing in Westminster Abbey

Marguerite D'Alvarez, the noted Peruvian contralto, who, incidentally, records exclusively for the Vocalion, returned from a visit to England recently where she had the distinguished honor of being the first woman ever to sing in Westminster Abbey. Mme. D'Alvarez sang in the Abbey at the request of the Dean in aid of the Reconstruction Fund, and declared that the crowd was the largest which this famous edifice contained since the last coronation.

FIRE DESTROYS SHERMAN STORE

The headquarters of S. A. Sherman, Victor dealer, 2138 Third avenue, New York City, was visited by a serious fire on Saturday morning, December 18, which resulted in a complete loss. Mr. Sherman has been doing business at the above address for the past fifteen years and had on hand a large stock of Victor talking machines and records for the holidays. The loss is estimated at \$25,000, which was partly covered by insurance.

Eight Practical Ideas That Have Helped to Make Talking Machine Sales :: :: By Lyne S. Metcalfe

No. 1

Rouses Interest With Evening Musicales

An Indianapolis dealer sent invitations broadcast to people in his district announcing a "musicale" in his store. The following letter form was adopted:

"Dear Madam:—As one who appreciates good music, I request that you attend a free musicale to be held in our store next Wednesday evening, at 8 o'clock. We have just received a new supply of records and will render them on our newest and most improved machine, a phonograph startling in its perfect rendition of vocal and instrumental works; and we trust that you may be among those present. Just a 'get together' on the part of our people who like the best in music. We hope you may be present. Very truly yours, (Signed) _____."

This invitation was sent out on a special superfine letterhead. Out of 700 invitations, 230 responded. Special arrangements were made to subordinate all commercial or business atmosphere in the store and the finest machine obtainable was utilized for the playing of the records. The first musicale was a success; three others have been held since, with intervals of two weeks in between and the attendance is constantly growing. It is not a part of the plan to make sales at the time, but to find out those people in the district who like music and whose trade is worth while. It was only by eliminating all trace of "advertising" that the Indianapolis dealer got results. However, three sales were traced to interest aroused by the first musicale and four to that aroused by the second.

In addition it brought people into the store and record sales have shown a decided increase ever since the first affair. As a business winner, the making of an event out of a demonstration brought in the bacon.

No. 2

A Window Display That Got Results

"The talking machine is the only universal instrument—it brings into your parlor every instrument ever invented."

A yellow streamer, reading as above, was stretched across a dealer's show window in Seattle recently. In the window, resting on a velvet-draped platform, was a fine model of this dealer's leader. Arranged around it, in a semi-circle, were various musical instruments, includ-

ing the brass orchestral instruments as well as the violin, guitar, mandolin, harp, 'cello, etc., borrowed from a downtown dealer. From each instrument ran a blue ribbon to the talking machine. The price of each instrument was given on individual placards, while a large placard, well forward in the window, gave the total value of the instruments, excluding the talking machine.

The total was \$3,200. "And you could not play them all if you had them in your home," it was stated. "Yet, this talking machine will give you music created by every one or each of these instruments and it costs only \$200. And anybody can play it."

This sales argument was snappy and to the point. It attracted attention and brought sales. This dealer took advantage of the varying public taste concerning musical instruments.

He appealed to the likes and dislikes of every person who passed his door. He had a striking argument—the universal ability of the talking machine.

No. 3

Issues Manual for Care of Machines

A Chicago dealer last Spring issued a small manual, which he distributed among his customers, on the care of machines. It was not only explained that certain things must be done in order to preserve the tone and appearance of the talking machine, but also instructions in case of shipment or when using the machine at Summer resorts and under abnormal conditions. Requests for extra copies of the book gave him some good advertising, even among people whom he had never sold.

No. 4

Shows Personal Pictures of Stars

A St. Louis dealer secured a series of intimate views of the famous singers, orchestra leaders, etc., who furnish music for the records and had them greatly enlarged. He shows one star at a time, the pictures being mounted on an easel well forward in the window. A placard explains. Some of the features of this pictorial series were:

"Madam Schumann-Heink bathing one of her grandchildren.

"A good housekeeper, a mother, a grandmother and a nurse as well as a singer.

"You can hear her sing if you will step inside."

Another read:

"Caruso owns 480 suits of clothes and keeps two

valets busy looking after them. He also has enough walking sticks to supply one for each man in a regiment.

"Come in now and hear Caruso sing. No obligation."

And still another:

"Madam Homer sings her children to sleep every night. When she sings for operagoers she gets a thousand dollars a night.

"You can hear her sing for nothing—just step inside."

Introducing the human interest element in the famous record makers attracted widespread attention. Phonograph fans are just as much interested and curious regarding the private lives of the musical stars as movie fans are about the much-advertised and pictured movie stars.

No. 5

Increases Record Sales by Calls

A great many people, in Winter, hesitate to go out for records, and others, through sickness or business, neglect to look over the new selections though they would do so if they had time. An Omaha dealer takes his sales list and periodically phones talking machine owners asking permission to bring a dozen newly arrived selections up for demonstration. He "covers" as many as six and eight homes in the course of an evening and many sales result. He gets acquainted with his people in this way and they appreciate the pleasure of hearing the records and the service he thus renders them. In several cases he has managed to interest people in new machines to replace the old ones they have in use. He gets an opportunity to examine every machine in his district, personally, and this information is of great value to him.

No. 6

Utilizes Movies to Get Prospects

A Baltimore talking machine dealer has found movies of value in developing buyers for machines. A local film company produced a 100-foot picture, by trick photography, which brought a big laugh in local theatres and focused the attention of the people on his store. The picture revealed the antics of a dog who hears "his master's voice" in the machine and who tries to jump into it. Great care was taken to get funny expressions on the dog's face. At the end there appeared a picture of the dealer's store and a "close up" view of his leader.

No. 7

Dealer Offers to Catalog Records

Talking machine owners seldom take the care

(Continued on page 6)

Reasons Why NYACCO Albums Are the BEST

[In Six Chapters]

CHAPTER VI

The SIXTH consideration in the making of the NYACCO album shows the album all completed. The pockets, made two in one, reinforced into the solid wooden back by the staples, lie perfectly flat, which gives the first attraction when the album is opened.

Watch our final issue showing all our six chapters combined into one



Executive Office
23-25 Lispenard St.
New York, N. Y.

New York Album & Card Co.

Chicago Factory
415-17 S. Jefferson St.
Chicago, Ill.

Ask Your Jobber for Genuine NYACCO Albums---Accept no substitute.
Distributors throughout U. S.---Write Us for Name & Address of Jobber nearest you.

Victor Supremacy

The supremacy of the Victrola marks it as the greatest of all musical instruments.

And with Victrolas in such splendid variety, possibilities are unlimited for every Victor retailer.

"Victrola" is the Registered Trade-mark of the Victor Talking Machine Company designating the products of this Company only.

Warning: The use of the word **Victrola** upon or in the promotion or sale of any other Talking Machine or Phonograph products is misleading and illegal.

Important Notice. Victor Records and Victor Machines are scientifically co-ordinated and synchronized in the processes of manufacture, and should be used together to secure a perfect reproduction.

Victor Wholesalers

Albany, N. Y.....Gately-Haire Co., Inc.
 Atlanta, Ga.Elyea Talking Machine Co.
 Phillips & Crew Piano Co.
 Baltimore, Md.Cohen & Hughes.
 E. F. Droop & Sons Co.
 H. R. Eisenbrandt Sons, Inc.
 Birmingham, Ala...Talking Machine Co.
 Boston, Mass.Oliver Ditson Co.
 The Eastern Talking Machine Co.
 The M. Steinert & Sons Co.
 Brooklyn, N. Y....American Talking Mach. Co.
 G. T. Williams Co., Inc.
 Buffalo, N. Y.....W. D. & C. N. Andrews.
 Buffalo Talking Machine Co., Inc.
 Burlington, Vt....American Phonograph Co.
 Butte, Mont.Orton Bros.
 Chicago, Ill.Lyon & Healy.
 The Rudolph Wurlitzer Co.
 Chicago Talking Machine Co.
 Cincinnati, O.Ohio Talking Machine Co.
 The Rudolph Wurlitzer Co.
 Cleveland, O.The Cleveland Talking Machine Co.
 The Eclipse Musical Co.
 Columbus, O.The Perry B. Whitsit Co.
 Dallas, Tex.Sanger Bros.
 Denver, Colo.The Knight-Campbell Music Co.
 Des Moines, Ia....Mickel Bros. Co.
 Detroit, Mich.Grinnell Bros.
 Elmira, N. Y.....Elmira Arms Co.
 El Paso, Tex.....W. G. Walz Co.
 Honolulu, T. H....Bergstrom Music Co., Ltd.
 Houston, Tex.The Talking Machine Co. of Texas.
 Indianapolis, Ind...Stewart Talking Machine Co.
 Jacksonville, Fla...Florida Talking Machine Co.
 Kansas City, Mo...J. W. Jenkins Sons Music Co.
 The Schmelzer Co.
 Los Angeles, Cal...Sherman, Clay & Co.
 Memphis, Tenn. ...O. K. Houck Piano Co.

Milwaukee, Wis. ..Badger Talking Machine Co.
 Minneapolis, Minn..Beckwith, O'Neill Co.
 Mobile, Ala.....Wm. H. Reynolds
 Newark, N. J.....Collings & Co.
 New Haven, Conn..The Horton-Gallo-Creamer Co.
 New Orleans, La...Philip Werlein, Ltd.
 New York, N. Y....Blackman Talking Mach. Co.
 Emanuel Blout.
 C. Bruno & Son, Inc.
 Charles H. Ditson & Co.
 Knickerbocker Talking Machine Co., Inc.
 Musical Instrument Sales Co.
 New York Talking Mach. Co.
 Ornes, Inc.
 Silas E. Pearsall Co.
 Omaha, Nebr.Ross P. Curtice Co.
 Mickel Bros. Co.
 Peoria, Ill.Putnam-Page Co., Inc.
 Philadelphia, Pa...Louis Buehn Co., Inc.
 C. J. Hepp & Son.
 The George D. Ornstein Co.
 Penn Phonograph Co., Inc.
 The Talking Machine Co.
 H. A. Weymann & Son, Inc.
 Pittsburgh, Pa. ...W. F. Frederick Piano Co.
 C. C. Mellor Co., Ltd.
 Standard Talking Mach. Co.
 Portland, Me.Cressey & Allen, Inc.
 Portland, Ore.Sherman, Clay & Co.
 Richmond, Va.The Corley Co., Inc.
 Rochester, N. Y....E. J. Chapman.
 Salt Lake City, U..The John Elliott Clark Co.
 San Francisco, Cal.Sherman, Clay & Co.
 Seattle, Wash.Sherman, Clay & Co.
 Spokane, Wash. ...Sherman, Clay & Co.
 St. Louis, Mo.Koeber-Brenner Music Co.
 St. Paul, Minn....W. J. Dyer & Bro.
 Syracuse, N. Y....W. D. Andrews Co.
 Toledo, O.The Toledo Talking Machine Co.
 Washington, D. C..Cohen & Hughes.
 E. F. Droop & Sons Co.
 Rogers & Fischer.



Victrola VI, \$35
Mahogany or oak



Victrola IX, \$75
Mahogany or oak



Victrola XI, \$150
Mahogany, oak or walnut

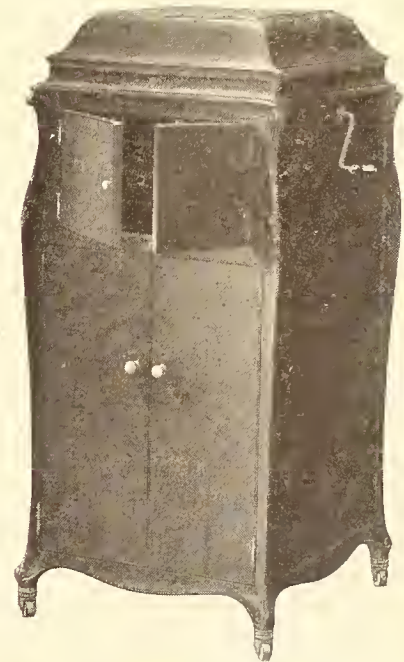

Victrola XVI, \$275
Victrola XVI, electric, \$337.50
Mahogany or oak

Victor Talking Machine Co.

Camden, N. J., U. S. A.



IMPORTANT TO THE TALKING MACHINE TRADE



SELECTING THEIR FAVORITES

NATIONAL PUBLISHING CO., 239 S. American St., PHILADELPHIA, PA.
CHICAGO OFFICE: 508 South Dearborn Street

Lower Prices for Record Albums

Yes, due to lower costs, we are making substantial reductions in prices.

We solicit your orders and correspondence.

OUR ALBUMS ARE MADE TO CONTAIN VICTOR, COLUMBIA, EDISON, PATHÉ, VOCALION AND ALL OTHER DISC RECORDS

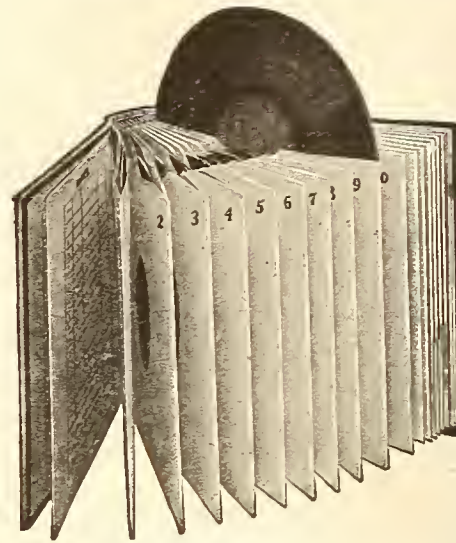

THE PERFECT PLAN

EIGHT IDEAS THAT HAVE WON SALES

(Continued from page 4)

of their records that they should. This is a well-known fact. A Pittsburgh dealer has capitalized this idea by offering to give every owner a start in keeping his catalog in order. He employs a sales girl who also is expert at record handling and stocking. Upon a call from a customer, she takes three grades of albums and quickly installs the system for the customer. The sale of the album is a part of the transaction. Very often six and even twelve books are sold to owners who have large collections. The service is appreciated by customers who always find the records misplaced when most wanted. A form letter launched this service scheme, announcing its value to the owner, also giving the prices of the books. The profit on the sale pays for the girl's time, since she does it all in the forenoons when business is slack.

No. 8

"Even a Monkey Can Play Our Machines"

To demonstrate the ease with which the modern talking machine may be operated, a Tampa, Fla., dealer secured an intelligent monkey and taught him how to wind a machine and start the record going. When Joko's education was complete he was placed in the show window and permitted to give the crowd a treat. At a given moment, when the last notes died out, the Simian promptly began all over again. A liberal reward of peanuts, at intervals, kept the monk busy. Also, he seemed to enjoy the music. He put a few records out of business, but at that the advertising secured was cheap.

C. M. DALLY WITH REMINGTON CORP.

Talking Machine Man Well Known in Metropolitan Territory to Represent the Remington Phonograph Co.—Popular and Capable

Everett H. Holmes, sales manager of the Remington Phonograph Corp., New York City, has announced the appointment of Chas. M. Dally as general wholesale representative of the above company for the Metropolitan district. Mr. Dally is well experienced in the talking machine field, having been connected in the past with both the Columbia and Pathé organizations. He also enjoys a large circle of friends in the Metropolitan field to which he has devoted much of his time.

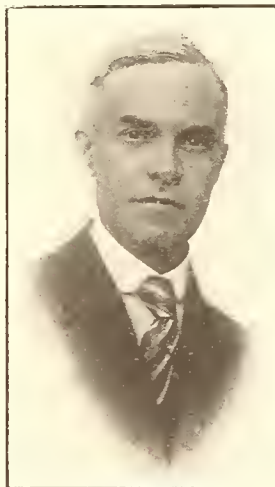

C. M. Dally

The name Remington is not new to Mr. Dally as some time previous to his work in the talking machine field he traveled in the Far East in the interests of the Remington rifle. He is enthusiastic over the Remington phonograph line.

D. J. Meggenburg has opened a new talking machine store in Manchester, Ia., and has secured a good stock of Brunswick machines

BRUNSWICK SHOP IN TERRELL, TEX.

Branch of Dallas Concern Opens Doors With Appropriate Musical Ceremonies

TERRELL, TEX., January 3.—The Brunswick Shop of Terrell held its formal opening last month and on the opening day there were held concerts both in the afternoon and evening. In addition to the record numbers given, the program was supplemented by the Louisiana Five Jazz Orchestra. Little Miss Cyrene Bell, of Dallas, gave a classic dance, impromptu.

The Brunswick Shop of this city is a new branch of the Bungalow House, 1818 Main street, Dallas. A. W. Macon, of the Bungalow House, Dallas, and W. H. Humphries, of the wholesale department, were present, and assisted J. E. Macon, local manager, in the opening.

Refreshments of sandwiches, cake and coffee were served to over 500 visitors.

The opening was decidedly one of the most novel and unique events ever held in Terrell.

ITS GENDER DEFINED

Tommy was always a troublesome boy and at grammar he was always at his worst.

"What gender is 'phonograph'?" asked teacher one day.

"Feminine gender," promptly replied Tommy. "No, no; it's neuter!" returned teacher sharply.

"Well, it ought to be feminine," was Tommy's unblushing reply; "'cause it repeats everything it hears!"

Peerless Metal Back Album



Write for particulars about this indestructible album.

PROSPERITY AND EXPANSION

On February 1st Peerless will be completely established in its new home—right on Broadway.

In these larger and roomier quarters our output will be substantially increased, which means an improved service to you. The new location is most convenient for visiting buyers and affords us the best possible shipping facilities to all points of the world.

All members of the phonograph industry are cordially invited to inspect our new plant and view the developments that Peerless has made in album manufacture.

PHIL RAVIS, President

PEERLESS ALBUM COMPANY
636 and 638 BROADWAY :: NEW YORK CITY

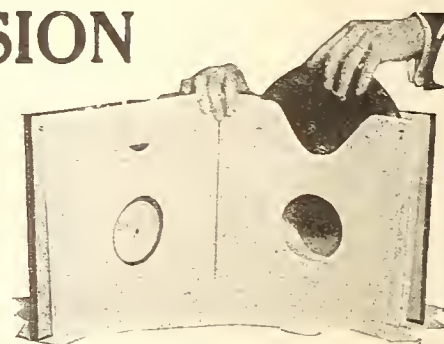

PEERLESS BIG TEN

Write for particulars about this new and exclusive album, offered in sets.

Chicago Office:
57 E. JACKSON BLVD.

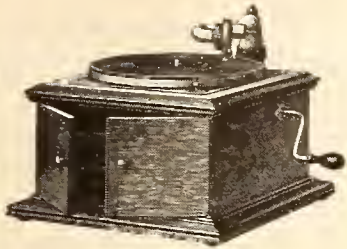

Victrola IV, \$25
Oak



Victrola VI, \$35
Mahogany or oak



Victrola VIII, \$50
Oak



Victrola IX, \$75
Mahogany or oak



Victrola X \$125
Mahogany, oak or walnut



Victrola XI, \$150
Mahogany, oak or walnut



Victor Supremacy

Supreme as a musical instrument, the Victrola naturally stands supreme as a business proposition.

The success of Victor retailers follows Victor supremacy as a matter of course.

"Victrola" is the Registered Trade-mark of the Victor Talking Machine Company designating the products of this Company only.

Warning: The use of the word **Victrola** upon or in the promotion or sale of any other Talking Machine or Phonograph products is misleading and illegal.

Important Notice. Victor Records and Victor Machines are scientifically co-ordinated and synchronized in the processes of manufacture, and should be used together to secure a perfect reproduction.

Victor Talking Machine Co.

Camden, N. J., U. S. A.



Victrola XIV, \$225
Mahogany, oak or walnut

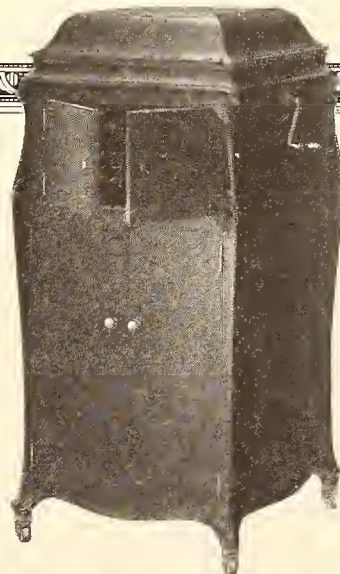

Victrola XVI, \$275
Victrola XVI, electric, \$337.50
Mahogany or oak

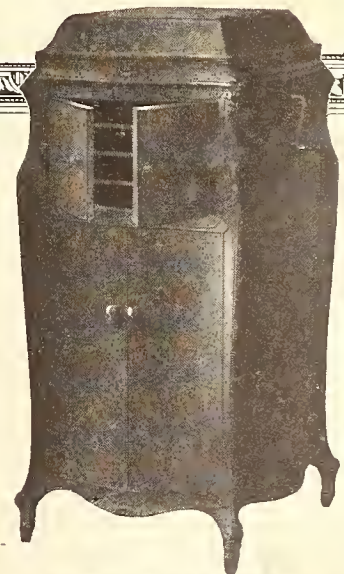

Victrola XVII, \$350
Victrola XVII, electric, \$415
Mahogany or oak

The TALKING MACHINE WORLD

For the makers & sellers of talking machines

PUBLISHED BY EDWARD LYMAN BILL, Inc.

President and Treasurer, C. L. Bill, 373 Fourth Ave., New York; Vice-President, J. B. Spillane, 373 Fourth Ave., New York; Second Vice-President, Raymond Bill, 373 Fourth Ave., New York; Assistant Treasurer, Wm. A. Low.

J. B. SPILLANE, Editor

RAY BILL, B. B. WILSON, BRAID WHITE, Associate Editors
L. E. BOWERS, Circulation Manager

Trade Representatives: A. F. CARTER, WILSON D. BUSH, C. CHACE, EDWARD LYMAN BILL, V. D. WALSH, E. B. MUNCH, CHAS. A. LEONARD, SCOTT KINGWILL, A. J. NICKLIN

Western Division: Republic Building, 209 So. State Street, Chicago, Ill. Telephone, Wabash 5774.

Boston: JOHN H. WILSON, 324 Washington Street

London, Eng., Office: 2 Gresham Buildings, Basinghall St. W. LIONEL STURDY, Mgr.

The Talking Machine World has regular correspondents located in all of the principal cities throughout America.

Published the 15th of every month at 373 Fourth Ave., New York.

SUBSCRIPTION (including postage): United States, Mexico, \$2.00 per year; Canada, \$3.00; all other countries, \$4.00. Single copies, 25 cents.

ADVERTISEMENTS: \$5.50 per inch, single column, per insertion. On quarterly or yearly contracts a special discount is allowed. Advertising pages, \$150.00.

REMITTANCES should be made payable to Edward Lyman Bill, Inc., by check or Post Office Money Order.

NOTICE TO ADVERTISERS—Advertising copy should reach this office before the first of each month. By following this rule clients will greatly facilitate work at the publication headquarters.

Long Distance Telephones—Numbers 5982-5983 Madison Sq.
Cable Address: "Elbill," New York.

NEW YORK, JANUARY 15, 1921

STARTING A NEW PAGE IN TRADE HISTORY

ACCORDING to leaders in the nation's business and those in close touch with the economic situation throughout the country it appears as though the crisis in the apparent wave of depression, or business suspension, has been passed and that during the next month, or at least in March, there should be a noticeable improvement in business conditions generally.

Readjustment all along the line was inevitable, and the public had evidently come to a realization of the fact, but the rapidity of the decline in business has been startling. It is declared that, with improved conditions in the agricultural domain, the situation will change materially for the better, and any measure of prosperity for the farmers will make itself felt immediately in every industry.

The logical advice offered by those in the best position to advise is that there should be a stop put to calamity howling and that, instead of wasting time complaining and worrying over the situation, the business men of the country should buckle down to business and by increased effort offset any possible depressing effects.

Such institutions as the Federal Reserve Board express themselves as ever so much more satisfied with the situation to-day than a year ago. Twelve months ago, members of the Board say, they didn't know when the drop would come or how hard the fall would be. Now the bottom has been reached and it is much easier to deal with an upward curve than a downward glide.

It may appear hard for dealers in certain sections to appear bright and cheerful when a falling off of business is in evidence, but it is certain that merely sitting tight and lamenting the change in the situation will not avail, whereas increased efforts will inevitably meet with some measure of success.

There is no reason in the world why the majority of talking machine dealers, and through them the manufacturers of the products they handle, cannot build up a substantial business total for the new year. It will mean conscientious effort, plenty of hard work, the expenditure of some real money for a trade development program, and a willingness to give the sort of service that will please the customer and make him a purchaser.

Regardless of how the general business situation may develop the talking machine dealer must become resigned to the fact that the easy times of the sellers' market are past—that instead of allocating a limited supply of machines and records to a hungry populace he must dig up business and cater to it just as do merchants in other

lines. In the long run it may be a good thing for some of the dealers and for the trade generally to be faced with a condition that requires the exercise of constructive salesmanship.

The leading manufacturers have for years preached the doctrine of better selling. When there was really little to sell it was pointed out that preparations should be made to meet a sellers' market. The manufacturers, and it is fair to say a good proportion of the dealers, realized that the situation must change some time. Those who heeded the warning are selling goods to-day, while those who didn't listen have some real problems to face.

THE UNION OF MUSIC AND EDUCATION

THE importance of music as a great civilizing force in the Nation is universally conceded, but it is sometimes overlooked that the talking machine is playing a tremendously vital part in this connection. Not only is it taking the very best in instrumental and vocal music into the homes of the poor as well as the rich, but it has assumed an important position in the educational system of the United States.

The most progressive educators throughout the country have recognized the great value of the talking machine in the school, not alone as a disseminator of musical knowledge, but as a refining influence that cannot fail to affect favorably students, no matter in what grade they are studying. The educational departments of our leading talking machine companies have been deluged with letters of a most commendatory nature from State superintendents of public instruction in which they concede that no other influence has been more potent for good than the use of the talking machine, combined with the very systematic form of educational service outlined for the schools.

It is inevitable that the increased appreciation of music, which must result from the use of the talking machine in the school, will indirectly stimulate a love for the best in music in the home, and from the home it is bound to radiate throughout the entire Nation.

The very successful work which is now being achieved through the campaign carried on by the National Bureau for the Better Advancement of Music is, needless to say, helpful to the talking machine industry. Its work is along progressive lines and means a broad encouragement in cultivating the art of music in every form throughout the Nation. This, of course, means much for the music industry as a whole, because the wider cultivation of music must result in a greater demand for musical instruments of all kinds, hence talking machine men should become active supporters of this movement. It should win their enthusiastic support, not only because it may help them in their individual business, but because music is a priceless asset to the community. It inculcates that art atmosphere—that refinement that leads the people from sordid tastes and desires to a new world of usefulness and pleasure.

DEVELOPMENT OF THE ART OF RECORDING

REPORTS from Paris to the effect that Ignace J. Paderewski, the famous pianist, will be able to play no more in public, again bring to mind the fact that the development of the art of music recording and reproduction through the medium of the talking machine and its records, and in this case also through the medium of the player-piano and music roll, has made it possible for music lovers to have in their libraries perfect reproductions of the art of this pianist. There comes first, of course, the living artist, but next there comes the reproduction of that artist's own interpretations of musical works, for it is this personal interpretation that is the real essence of the artist's standing and importance.

The work of the great musical artists of other generations is now entirely lost, except perhaps in the memories of the aged, but the work of the great artists of this generation is for the most part perpetuated through the medium of their recordings on records and rolls. Aside from the historical interest in such records, they doubtless will afford an invaluable aid to music students of the future in determining what advancement has been made in the art, and how the work of the masters of former years compares with the work of contemporary artists.

It would seem proper and right that some definite effort be made to gather together, under State, or preferably national, auspices, the recordings of these artists, if only for their truly historical value. The industry itself should be the first to advocate, and where possible facilitate, the carrying on of work of this kind. It will probably

be a work unselfish and without profit, but a move that will prove of undeniable benefit to musicians and historians of the future.

Already certain records by well-known artists of the day, having been cut out of the catalogs by the manufacturers in favor of new titles, are being sought by collectors, and several such records command a substantial premium. The records to be preserved should be selected before they are cut out of the catalogs and become scarce.

THE UNWISDOM OF BARGAIN ADVERTISING

BARGAIN advertising soon becomes a habit, not alone with the advertiser, but with that portion of the public which reads his announcements. This is a fact that should be remembered by the talking machine dealer who is inclined to be extravagant in the presentation of special values to the public through newspaper announcements. When a house once establishes its reputation for cutting prices, the road back to normal, correct business methods becomes a long and tortuous one. Having once educated the public to look for special inducements, whether real or imaginary, the dealer soon finds that it is almost impossible for him to do business on a straight dollar-value-for-a-dollar basis. There are some houses in the talking machine trade right now which will find it mighty hard to do business except on the special sale plan, and that's not a healthy condition. When talking machines must be disposed of according to Baxter street methods there is likely to be something wrong either with the product or with the selling plan.

FIGHTING DISCRIMINATORY TAXES

THERE are already indications that the music industry is in for another fight during the coming year to prevent, if possible, the levying of discriminatory taxes on musical instruments and accessories under the revision of the War Revenue Act. The Secretary of the Treasury in his recent report very frankly urges that the excise tax on talking machines, pianos, etc., be increased from five per cent to ten per cent in order to bring in increased revenue estimated at \$13,000,000 from that source. Various other committees, official and unofficial, as well as individuals, have taken it upon themselves to ask that the tax burden on musical instruments be increased in order to move part of the load from other interests.

There are the usual effective arguments, of course, that music instead of being a luxury is a prime necessity of modern civilization and has been so proven; that it is distinctly educational and a builder of harmony and morale. An equally strong argument is that the music industry cannot afford to stand higher taxes—cannot absorb them—and under existing conditions cannot pass them along to the public.

The Music Industries Chamber of Commerce has already started an active campaign to fight out the tax question in Washington, and it might be well for the various talking machine interests, whether or not they are affiliated with the Chamber, to co-operate

with that body and lend their support in making any protest general and representative of every branch of the music industry.

A TIME FOR REASON, NOT EXAGGERATION

IT is unfortunate that the majority of the daily papers in commenting upon changes in industrial conditions, and particularly upon the so-called wave of depression, have been inclined to exaggerate the situation somewhat in an effort, perhaps, to please their readers. This fact has been brought home to the talking machine trade most emphatically through the medium of recently published reports regarding the trend of business in our own industry. Some of the newspapers took special occasion to advise the public under startling headings that the talking machine business is in bad shape, that factories here and there were shutting down and throwing some thousands of workers out of employment. It is true that some factories have shut down and other factories have curtailed their output temporarily, but nothing like on the scale intimated in daily press reports.

There is no question but that this inclination to exaggerate depression in certain industries has a bad effect not alone upon the public but upon those engaged in the retailing of specified products,—particularly those who are not in close touch with the actual manufacturing situation. It would be well for retailers to acquaint themselves with the actual facts in order that they may deliver the proper message to their local public in some form or another. The reports should not be allowed to spread without some attempt being made to contradict them. Otherwise the psychological effect, if not the material effect, is going to be bad.

THE INCREASING EFFICIENCY OF LABOR

SOME interesting reports regarding the increasing efficiency of labor are now in evidence, which would indicate that the workers are commencing to realize that co-operation with their employers rather than antagonism is the most satisfactory plan in the end. For the past couple of years the vicious idea prevailed among a certain type in labor circles that the less a man accomplished for his employer the more employment he was giving his fellow workmen. This brought about a state of mind where fewer hours, more holidays and higher wages seemed to be the principal ambition of a great many employes.

The change now in evidence may be attributed largely to the increased number of men looking for work and to the weeding out being made by employers, which is resulting not only in an improved morale among the workers, but in increased productive power. In the talking machine industry, at least, labor is one of the important items in the increased cost of production, and if prices ever come down it must be by reason of the increased efforts of the worker to deliver a greater value through a larger production than has been to his credit for the past couple of years.

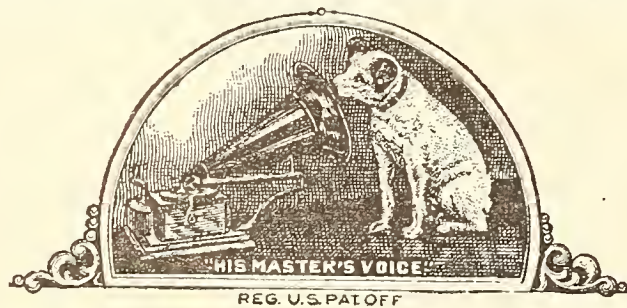

BUSINESS AS USUAL

Fire could never destroy Ormes service or the trademark of the great line we distribute.

Therefore Ormes service **continues**—at temporary quarters on the 4th floor, 103 East 125th Street, cor. Park Avenue.

Telephone Harlem 7302 as usual

ORMES, Inc.

103 E. 125th St. *Wholesale Exclusively* **NEW YORK**

Real Sales People Now Necessary in the Success of Talking Machine Business :: By Courtenay Harrison

If there is one business on earth where the type of salesman or woman on the job counts more than in another, it is in the talking machine business. People do not become "temperamental" as a rule when buying pancake flour, tooth paste or woolen socks, nor do they act as if the decision they make might make or break their entire lives—and use up the salesman's time accordingly. But when buying a talking machine it's altogether a different matter. The most practical business man or the most settled matron in town is liable, under stress of settling definitely the question of whether or not to buy the Jonesrola, to become as temperamental as Janovsky, the violinist. They are more apt than not—even though they come in and ask to see a certain type of machine which indicates having made up their minds beforehand—to stand in awe about saying the final "yes" to the salesman's "Shall I send this one up?" And it's a cinch that except in an unusual case this "yes" is not going to be forthcoming until the salesman has exhibited a good deal of real salesmanship as well as tact and patience.

This brings us, then, back to the main road again. Better-than-average salespeople are needed in the retail talking machine store. This need not frighten anyone either. A good many people who sell other things beside talking machines and records and who call themselves salesmen are not that at all. They are just order takers. But a talking machine and record salesman or woman, to accomplish worth-while results, must be a real sales person in all that the word implies. It is mighty easy to get disgusted with a "temperamental" customer, who has made and unmade decisions at five-minute intervals, as to what

model and design she is going to buy, or whether or not she will buy at all—just now. Yes, it is mighty easy to get disgusted or lose patience; and the same holds good for selling records. About the first thing that a good talking machine and record salesman learns is that patience is indeed a virtue that pays cash returns. The going may be hard, with your demonstration, and attempts to close with some extra-crabby cus-

Who Are the Most Satisfactory All-Round Sales Persons for a Talking Machine Store—Men or Women?

tommer, but as Briggs would say when, just as you feel you are going to crack under the strain, willy-nilly, she suddenly says: "Well, you can send up this \$300 console model, I reckon." Oh Boy! ain't it a grand and glorious feeling?

I have been asked more than once by talking machine dealers who know that I have made investigations in talking machine stores all over the country to state which I thought the most satisfactory all-round sales persons for a retail talking machine store—men or women? I have always given the "stock" answer that it all

depended on the type of person as to the best all-round results that could be secured.

However, as my place of residence does not have to appear at the head of this article, I am going to make the frank statement here that the most successful talking machine department I have ever seen, for a city its size, is run by a woman and she has nothing but women sales people. An interesting thing about this department is that it is on the fourth floor of a furniture store, and in the mid-West city in which it is located there are a great many exclusive talking machine shops on the ground floor right in this neighborhood. Yet this competition does not prevent this fourth-floor talking machine shop from doing an enormous business—a business recognized by the wholesale firms which supply it with goods to be larger than that done by many of the ground-floor shops in the neighborhood.

To tell the story of this department's success, it is only necessary to use one word—salesmanship. The young woman in charge and her three capable assistants know how to give their customers a service that will bring them back, even four stories up.

Are these super sales people, you might ask? They are not. They are young women, untrained when they entered the business, in most instances. That's one reason why they have made such a success of their work. But let the woman in charge of the department tell the story herself:

"Recognizing that upon the ability to sell successfully—and this is meant in the broadest sense—rested the success or failure of this department I determined when I took charge of the work to, at least, give my customers something in sales-



A WALNUT TALKING MACHINE CABINET

The finest phonograph is appropriately encased in

AMERICAN WALNUT

"The Cabinet-wood Superlative."

Superb and refined beauty—rich shading which even improves with age—wonderful reliability as a cabinet-wood—all these together put AMERICAN WALNUT in the very front rank of woods

For Phonograph Cabinets

More and more purchasers every day are giving to AMERICAN WALNUT their very first (and very insistent) preference. It pays to supply what is demanded.

We illustrate herewith an AMERICAN WALNUT TALKING MACHINE CABINET of elegant design. Could you imagine a more beautifully figured veneer than that which it exhibits?

Valuable data for makers or data for dealers and the "Brochure de Luxe" for your salesmen. Address the producers of American Walnut lumber, the

AMERICAN WALNUT MANUFACTURERS' ASSOCIATION
Room 1022 616 So. Michigan Boulevard Chicago.

manship that they would not get from the average sales person. I knew by shopping experiences of my own that more often than not the beautiful ads about a store's 'wonderful service' were the brain-children of the ad man, and had no foundation in fact; I had had plenty of experience with the 'sorry we haven't got it, is that all, well, good-by' type of record sales person, and I determined early in the game to do something, anything that would convince the customer that here at last was a store that had a personal interest in him and his wishes.

"In the past four years, since I took charge here, I have had a great deal of experience hiring girls. I think, by the way, that the average woman makes a better salesman in this line than men do. She has woman's intuition, you know, has more tact and patience than the average man, and you know it just naturally isn't as easy for a man to say 'no' to a woman.

"But these qualities, more or less natural, as you might say, to an intelligent woman, do not make a successful talking machine sales person. I train all of our girls before they get actively at work. That brings up another point. Frankly, I would rather have a green but willing school-girl who was anxious to learn and enthusiastic about starting out selling than an 'experienced' girl who had been trained along certain lines and thought she knew about all there was to know about the game. It is too much trouble to 'unlearn' the last-named young woman, and teach her our way. Another thing, I will never under any consideration hire a girl who has had experience solely in some big store where customers were 'fed' to the department with little trouble and where only a popular and exclusive line that 'sells itself' was carried. Such a girl, despite her experience, is probably not a sales person at all, but an order taker instead.

"Whenever I take on a new girl, I let her use her first ten days 'loafing' around the department, familiarizing herself with the stock, and the location of all items, studying the record catalogs and learning the names of the artists and the sort of work they perform. I have known stores where

the girls did not know whether Marion Harris was a vaudeville star or a grand opera singer. Another thing that many young women in the selling game do not realize is that for an admirer of some certain artist to hear that artist's name horribly butchered in pronouncing is almost as galling as to have her own name mispronounced. In things like this we aim to outshine the average store. That is the way in which we render a super-service that brings customers back.

"I personally believe in letting the girls develop their own personalities and 'swing' customers this way. Many of the largest and most successful businesses in America are successful mainly because of their personnel and yet many retail store owners are jealous of sales people having friends who ask for them. It is true if this sales person should leave she might take a few customers along with her, but the percentage would be too small to do any great injury. And the benefits of letting sales people build up their own list of customers far offset any possible harm that might be done.

"I even go so far as to give each of the girls a filing cabinet in which to keep their customers listed, and while these files are naturally open to

my inspection, the girls take a personal pride in following up their prospects with literature furnished by the manufacturers, by our own advertising department and with telephone calls when they have records they think a certain customer would like to hear.

"I know it is old stuff, as the saying goes, but I impress upon every girl to never under any consideration allow anyone to wear out her patience or make her mad, as even the person who, with apparent perverseness, uses up a lot of time without buying, crabbing the while perhaps, cannot help but admire the continued evenness of disposition and unfailing courtesy of the sales woman. The customer, indeed, is always right in this shop.

"They say of our store that we have the sweetest-tempered sales people in town. Crabby customers gave us that name and it has been a big ad for us. Even the crabs come back again, just to see if they can 'get us going,' but they buy, as a rule, on the second trip. Sales people who know what selling means in its broadest sense will make a talking machine department different from the general run, and put it 'over the top' financially, and that is the sole reason for our success 'four flights up'."

COLUMBIA MEN MEET IN ASHLAND

Dealers and Company Officials Discuss Plans for Trade Betterment in Coming Year—C. E. Hall Succeeds C. E. Kramer as Manager

HUNTINGTON, W. VA., January 3.—Columbia dealers and officials of the Columbia Graphophone Co. met early last month at the Ventura Hotel and discussed plans for the improvement of the Columbia trade in the territory. Addresses were delivered by C. E. Kramer, the retiring district manager, and by C. E. Hall, the incoming district manager; by Larry Neighbor, manager of the record department; J. H. Kruse, credit manager, and R. H. Woodford, manager of the Cincinnati district.

They told dealers assembled from Huntington, Ashland, Ironton and adjacent communities

of additional Columbia factories, of the general policy and sales outlook, and incidentally congratulated the Huntington dealers on initiative, especially in the matter of co-operation with the national advertising. M. F. Field, of Ashland, discussed the co-operative spirit manifest there now. Those present, in addition to the above-named officials, were:

P. H. Katz, of the Chapman Furniture Co.; Joseph Horton, of the Samuel Horton Co.; U. O. Banion, of W. T. Oppenheimer, Huntington; A. F. Hibbard, W. H. Farrell, Opal Pyles, of Huntington; Gertrude Price, Agnes Daugherty, M. F. Field, R. S. Goldcamp, Mrs. R. S. Goldcamp, Anna Mary Hanichen, Isabel L. Nourot, Alex Josselson, U. O. Banion, Mattie Gray, C. D. Alexander, Goldie Borden, of Ashland; Lou D. Smith, Charles Ward, of Ironton; A. L. Folan, of Charleston.



Let him help you

There is a better way to keep the store records you need

In your city there is a representative of The National Cash Register Company. He is a student of business systems. He has been trained to be of service to merchants—to help them solve their problems.

Let him show you how you can get the store records you need without

working overtime on day books, pass books, ledgers, and memorandums. He will show you the easiest way to get these records.

You need them once a year for your Income Tax report. You need the same figures every day to control your business.

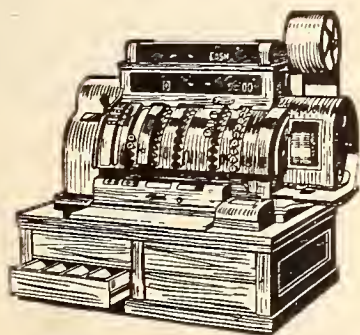

We make cash registers for every line of business. Priced \$75 and up.

NATIONAL CASH REGISTER CO.
DAYTON, OHIO.

Paste This In Your Hat



YOU are building up a steady income with every single sale of Columbia Grafonolas or Columbia Records if you follow up the sale and supply the purchaser with proper service. Columbia Grafonolas and Records are essentially "service goods"—points of contact for future sales. You're losing money on every sale if you fail to follow it up.

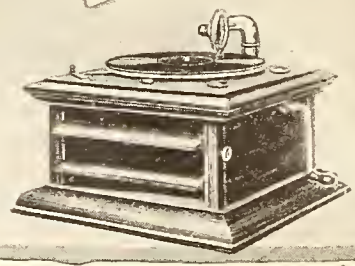
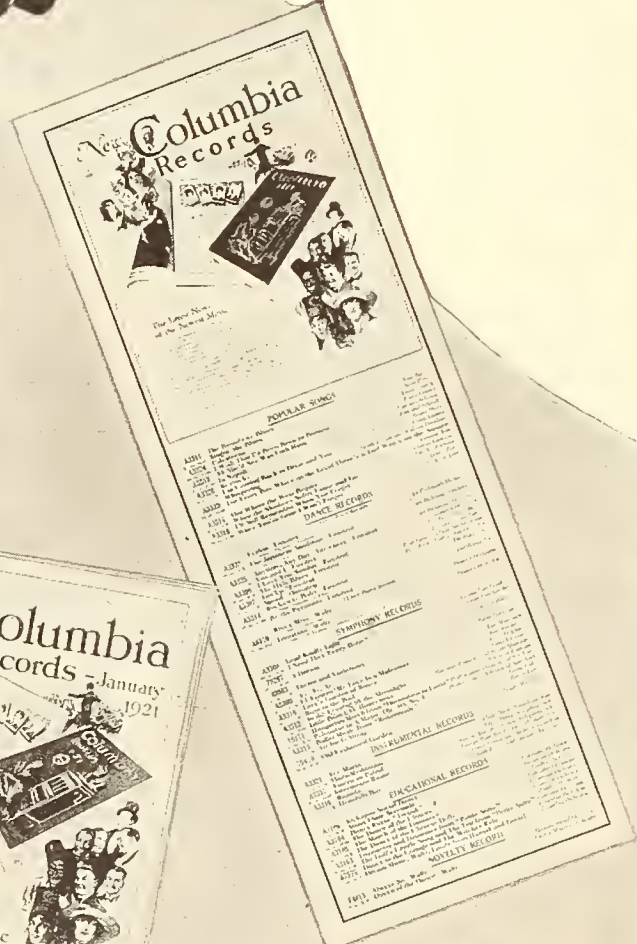
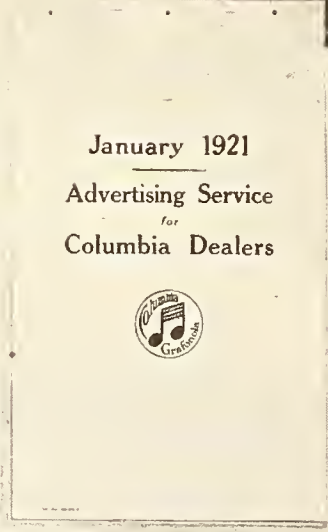

Columbia

And Keep It Pasted



HERE are a few of many ways to supply constant service where it counts the most:

Use the invaluable self-service fixtures. They will increase your sales by serving your customers faster than you can serve them yourself. That's service!

Send the Columbia Monthly Record Supplements to your whole mailing list every month. Aren't the Lodges in your town giving dances? Cash in on the winter dance craze. Let all the boys and girls know about all the latest dances. That's service!

Make a note on your mailing list of every customer's taste in records—dance records, love songs, violin solos, band, opera, comic, or whatever it is—and offer your customers all the new records of the type you know they prefer. That's service—the way to make steady customers!

The Columbia Monthly Record Hangers are *news* to every record fan, just as much as the Monthly Record Supplements. Put them up the moment you get them. Display

them where they're sure to be seen. That's service!

The Monthly Advertising Service for Columbia Dealers Portfolio carries many mighty convincing advertisements for you to run in your local papers. Use these consistently, and you will find that your returns will be sure and big. Keep your product before the people. That's service!

Have your repair man always take with him at least a dozen of the latest records. Then, after he has made the repairs, he can play some of these latest records for your customers on their own instruments right in their own homes. That's service! Sales? Just try it!

The first thing any normal human being notices in a new land is the flag of the land of his birth, wherever it is displayed. Are there many foreign born in your town? Then show in your window the beautiful Columbia decalcomania sign carrying the flags of two score nations. That's service! See how it will attract purchasers of Columbia foreign records.

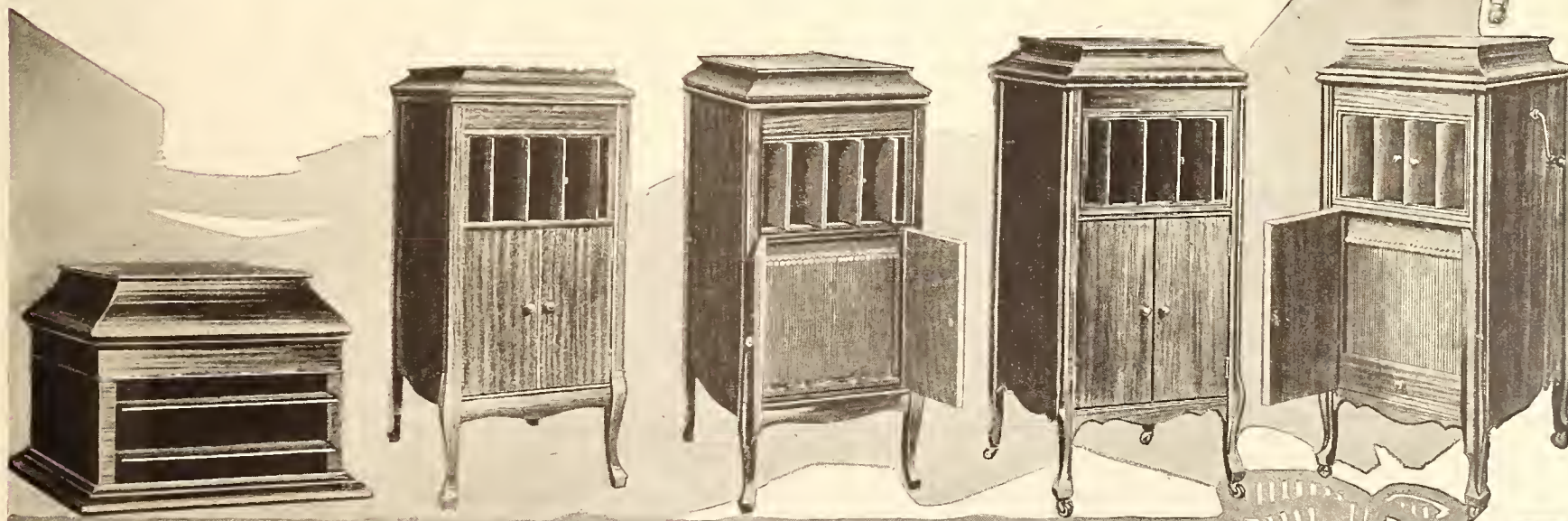

Sales Department

COLUMBIA GRAPHOPHONE COMPANY, New York

Grafonola and Records



When you, Mr. Distributor, sell your dealer a sealed package of needles—you put your stamp of approval on the package, as to the full number of needles, their quality and uniform lengths.

When you, Mr. Dealer, pass a sealed package of needles over your counter to your customers, you guarantee the accuracy of count, uniform length, points and hardness of the needles.

HERE IS THE VITAL FACT: *the Brilliantone Steel Needle Co. guarantees all packages of BRILLIANTONE NEEDLES and all needles packed by them to contain 100 needles of Uniform Length, Uniform Points and Uniform Hardness to the package.*

Remember—An inferior or imperfect needle will cause customer dissatisfaction—no matter how perfect the machine and record.

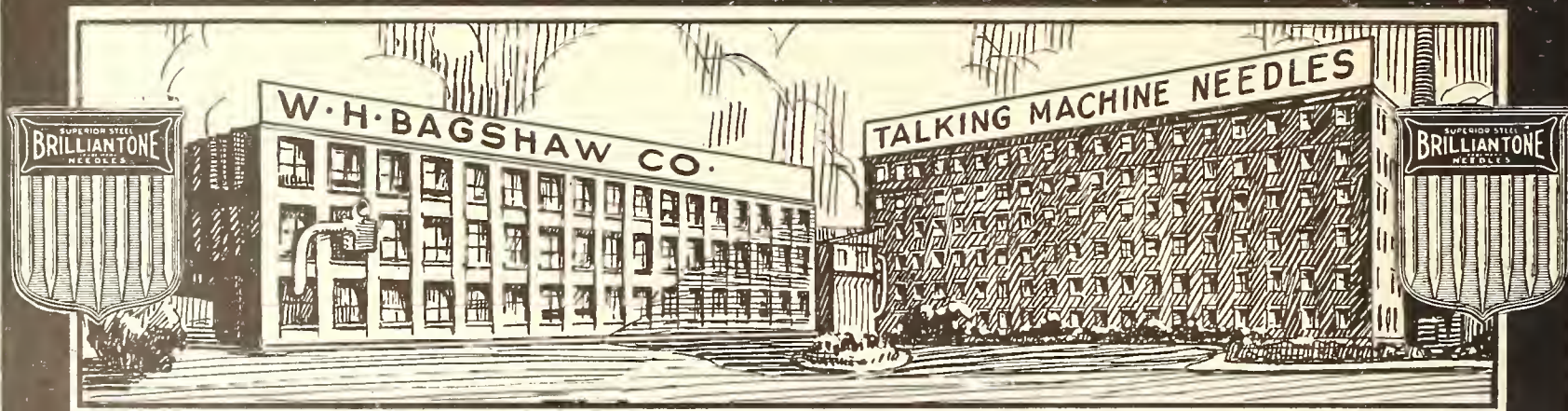

BRILLIANTONE

STEEL NEEDLE CO. of America, Incorporated

Selling Agents for

W. H. BAGSHAW & CO. Factory, Lowell, Mass.

AT 34th STREET **347 FIFTH AVENUE,** SUITE 1003
NEW YORK

Canadian Distributors: The Musical Mdse. Sales Co., 79 Wellington St. W., Toronto
Foreign Export: Chipman Ltd., 8-10 Bridge St., New York City

How to Get Best Sales Results by Using the Right Kind of Business Letters :: By R. R. Ricketts, Jr.

Good letters are business getters. Are you using this means to additional sales? Many dealers say: "What good are letters?—See the prospect!" By all means, see the prospect, but remember—a letter rushes in—not where salesmen fear to tread—but where "treading" is prohibited.

A letter has these advantages: A prospect will read a letter when he is "too busy" to see a salesman. He can "dismiss" a letter—he is not so sure about the salesman. He is more "off guard" when reading a letter because he has not that feeling, often experienced in the presence of a salesman, that an attempt is being made to "force" him to buy. The majority of people are too curious to throw aside a letter without reading it. They will begin it, at least, and, if it is interesting they will continue to read, whether they are specially interested in talking machines or not, in the same way that you read an advertisement of some article you know nothing about and are not particularly concerned with: the headlines are inviting and before you realize it, you have read it. It has some quality, snap perhaps, that compels your attention.

Letters are an aid to sales that you, no doubt, have not considered possibilities. For example, are you getting your share of restaurant sales? Of moving picture theatre sales? The former are using the talking machine more than the latter, but "movie" houses are using them, from the smaller ones to at least two that I know of seating 3,000. Such a sale means a better than ordinary advertisement for your machine and should, if followed up by a notice in the theatre program, or otherwise, result in sales.

Many restaurant owners, if confronted by a salesman, without preamble of any kind, will not consider purchasing a machine, whereas, after having read a letter in which various arguments, relative to why a machine would be of advantage to him, are presented, his reception of the salesman will probably not be such a cold one. A letter that is deferential in tone, snappy and brief, acts as a much better introduction than a card! It also tends to do away with any conscious or unconscious antagonistic attitude that many present to a salesman.

A wonderful salesman once said that he always made it a point, after he had gotten a prospect in, by letter or otherwise, to write him, putting down

the proposition in black and white, giving him a description of its good points and prices. He said there was a psychology about the "personal touch" and the tangible something the prospect could refer to that a letter provided. This is undoubtedly true.

Now as to the writing of the letter. Of course it depends on who is the writer and to whom the letter is to be sent. Let us say it is to be written not by a firm, but by one of their salesmen, and is to reach the average business man. Start your letter with a bang! For example: "Are you interested in good music? If so, I am confident that you would be interested in hearing the Best phonograph. The Best reproduces the voice

A Prospect Will Read a Letter When He Is Too Busy to Receive a Salesman—Snappy Letter Compels Notice

naturally. You may not have liked the talking machines you have heard." If he has liked them, so much the better. If not, your mention of the fact is equivalent to saying, "I appreciate your position in disliking talking machines, but," etc.) And a prospect always likes to know his position is appreciated! To finish the sentence, "but, if you enjoy music that is music, I am sure you would delight in hearing the Best, and that the short time spent in the hearing would result in many hours of real pleasure." You may say, "the writer" in place of "I" if you wish, although some authorities regard it as an affectation.

Make your letter brief, interesting, courteous and sincere. Don't say your machine is the greatest the world has ever known. Maybe it is, but don't say it in so sensational a manner. It will impress the very credulous but it won't help, in fact it will hinder, you with the not so credu-

lous. Try to make your prospect feel that he may come in and hear the machine and not be "pushed" to buy. Say, perhaps, "We urge you to hear the machine; the purchasing is in your hands entirely. Any attempt to force a sale is, of course, poor business, and it is our desire that you feel free to come in at any time and as often as you like. I should very much appreciate a reply." You may wish to lay more stress on something other than tone—the cabinet, say. It goes without saying that you must be prepared to back up your statements. Here we have something like this:

"Mr. R. L. Prospect, City.

"Dear Sir: Are you interested in good music? If so, I am confident you would be interested in hearing the Best phonograph. This instrument reproduces the voice naturally. You may not have liked the phonographs you have heard, but, if you enjoy music that is music, I am sure you would delight in hearing the Best, and that the short time spent in the hearing would result in many hours of real pleasure. A catalog of the Best is inclosed but I should like to state a few pertinent facts in this letter that might be of interest."

(In this paragraph you may list the special advantages of your machine, what improvements it originated, why its tone is the finest, etc.)

"It is a pleasure to demonstrate the Best, not only to a prospective customer, but to anyone interested in music. We urge you to hear the machine; the purchasing is in your hands entirely. Any attempt to force a sale is, of course, poor business, and it is our desire that you feel free to come in at any time and as often as you like. I should very much appreciate a reply.

"Very truly yours."

Try it on your neighbor!

INSTALL DEMONSTRATION ROOMS

WORCESTER, MASS., January 3.—The Widener's Grafonola Shop of this city is equipping its new warerooms with an elaborate installation of demonstration rooms and record-filing equipment. The work is being done by a local Worcester concern, C. L. Goodwin & Co., which specializes in store equipment and has made installations in a number of other New England talking machine warerooms.



SUPREME



THE ECLIPSE MUSICAL CO.

Victor Wholesaler

Cleveland, Ohio



Frank Crumit sings "I'm a Lonesome Little Rain Drop", the big song hit of the *Greenwich Village Follies of 1920*, and that melodious love song "Margie." Thousands of people have been waiting for this record. **A-3332.**

Columbia Graphophone Co.
NEW YORK

SUGGESTIONS OF VALUE ON THE GRANTING OF CREDITS

Timely Advice on This Important Subject, Particularly Applicable to the Talking Machine Trade, Offered by J. H. Tregoe, Secretary-Treasurer of National Association of Credit Men

An appreciation of economic laws and organization has been neglected in our country for the reason that in times of depression or strain there is a breaking down of some principles and a commission of mistakes which react unfavorably and unnecessarily on the credit structure. We have lacked backbone in the face of serious problems. We have done things which never would have been considered in sane periods, and we wonder when this temperament will be rectified and the American business man stand for the very highest and the most constructive ideals when the currents are not moving in his direction.

The seller's market through which we have passed produced interesting situations and, though the opportunities for driving hard bargains and escaping hard contracts were frequently availed of, yet such a market enabled us to correct some weaknesses in credit granting. Terms were abbreviated, a very necessary feature whenever the country is passing through an unusual period, and it has become customary to use credit as capital. The seller's market also permits the opportunity of restraining trade abuses and they have become legion in the credit commerce of our nation. Coincident with the coming in of the deflation period, a period of deep anxiety which requires skilful treatment, the market reverted once again into the hands of the buyers. Conditions were reversed with the slowing down of business and with the consuming public on a strike. Nothing depresses merchants more than a lack of orders, a slowing down of the plant with the attendant unemployment. In order to keep the wheels moving, in order to produce business, the temptation is very strong not only to cut prices, but to sell terms. Herein is one of the gravest dangers in any trade, especially

so in the music trade. Previously long terms had been allowed the purchaser. Financing purchases of this type requires extensive capital and credit. The turnover is not sufficient and profits can alone be made by overstrain. A return to this situation must be avoided, no

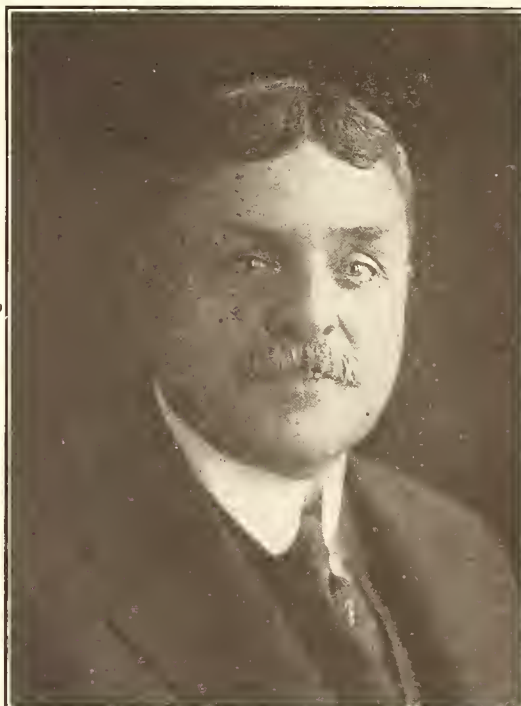

© Underwood & Underwood
J. H. Tregoe

matter how strong the temptation is to sell. Credits must be kept liquid whilst the nation is passing through its recuperative period, and every enterprise not observing this principle and using too much of the nation's available credit is merely retarding the recuperative process and holding us back from a complete restoration.

We cannot emphasize too strongly, therefore, the confinement of competition to values alone. Terms mustn't be sold. Should business move slowly, should the very bottom appear to have dropped out of things, character must stand the strain and hold fast to manly practices. Watching the various trends and currents in this crisis of the nation's industrial affairs, the earnest appeal to hold fast should be heeded. Getting adrift, returning to old conditions, selling terms and doing the unwise and uneconomic thing would be very unfortunate for merchants and the nation.

We are not in the least overplaying in this brief message the seriousness of matters. We are not endeavoring to throw the least fear into the heart of anyone. We cannot discount the real seriousness of our present crisis, and yet, with fundamental conditions absolutely sound, we must merely pass through a recuperative period, and good sense dictates the giving of every assistance we can to the patient. A good grip on ourselves and every looseness cast to the winds will build an American spirit of which we may be very proud.

VISITS GRESHAM MEMORIAL

Rosa Ponselle, Columbia Star, Visits Memorial Erected to First American Killed in the War

While in Evansville, Ind., Rosa Ponselle, the famous grand opera star and Columbia artist, visited the James Bethel Gresham Memorial Home. This is a unique bungalow which was erected by workmen giving their time free and for which furnishings were contributed by firms and organizations of the city. Money was also donated in the form of an endowment fund, and the whole was given to the mother of James Bethel Gresham, who was the first American soldier to be killed in the war after the United States declared war. Miss Ponselle had a very nice visit with Mrs. Gresham. The latter was greatly pleased with the honor paid her.

Quality

Distinction

The "VICSONIA" Reproducer

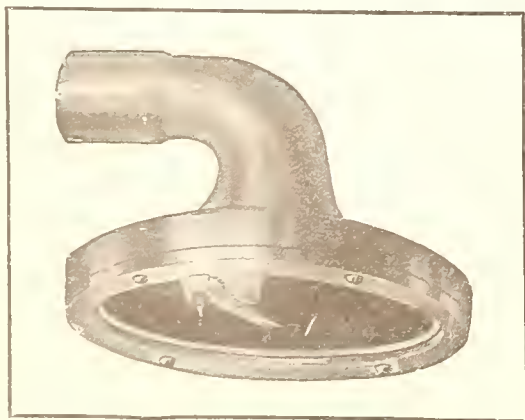

Recognized for its Perfect interpretation of Edison Disc Records on Victrolas and Grafonolas.

Fitted with permanent jewel point. No loose parts.

Note: The Vicsonia is made of **Bronze**, sand casted and machined to measurement. Finished in heavy Nickel or Gold plate. Flexible stylus.

Meet the demand—Serve your customers

Sample Model "A" or "B" Vicsonia will be sent on receipt of \$4.50. Retail price \$7.50.

Note: Model "B" Vicsonia plays both **Edison** and **Pathe** records

VICSONIA MFG. CO., Inc.

313 E. 134th STREET

NEW YORK, N. Y.

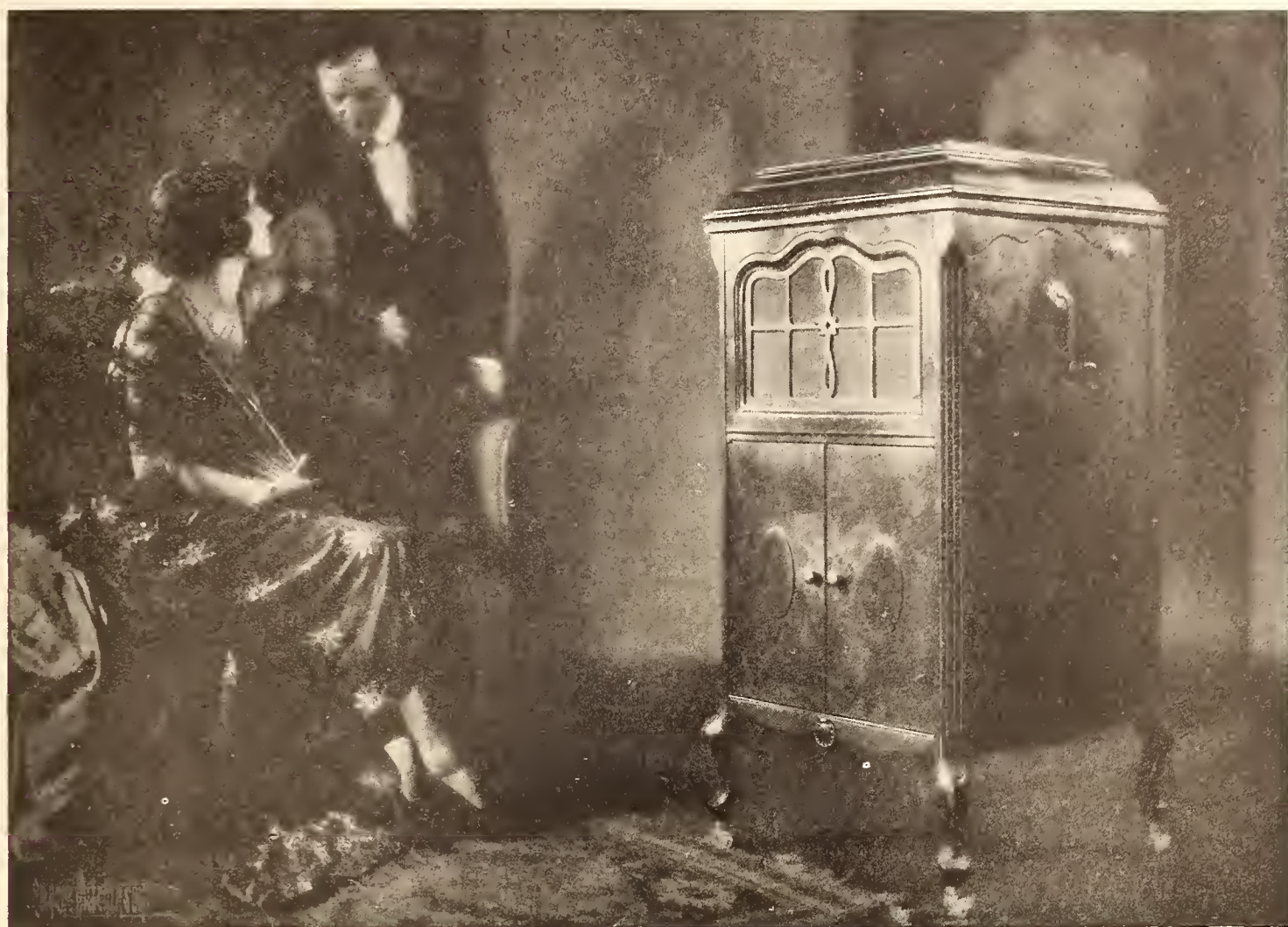

Widdicomb Queen Anne Art Model

Dealers Have Endorsed the Widdicomb

Recently we have had occasion to demonstrate the Widdicomb to a number of America's foremost phonograph dealers.

These men, dealers who are successful merchandisers, say that the Widdicomb Amplifying Tone Chamber marks a new epoch in phonograph history.

Now for the first time, it is possible to play all makes of records on the Widdicomb without the slightest vibration or metallic harshness.

At the same time the Widdicomb Amplifying Tone Chamber does full justice to the lower as well as to the higher musical notes. When playing an orchestral record the deeper, richer tones are given equal prominence.

This supremacy of tone in the Widdicomb is the final result of construction based on scientific laws. It is

not a gift of chance but a feature for which Widdicomb experts worked many months and expended thousands of dollars to perfect. The exclusive Tone Chamber in the Widdicomb is made of a patented composition that positively eliminates vibration.

The sound waves as they pass through it are extended and expanded so that you get full tonal value without "blasting." In other words, it simply reproduces more truly.

The dealer who has the Widdicomb franchise feels confident that he sells a phonograph of the highest quality; unequaled in tone; distinctive in appearance, and richer in special features than any other phonograph on the market.

For your own information let us give you the 1921 details.

The Widdicomb Furniture Company
Grand Rapids, Michigan Fine Furniture Designers Since 1865

Widdicomb
PHONOGRAPH
The Aristocrat of Phonographs

HOW TO CREATE ADVERTISEMENTS THAT BRING RESULTS

Roy Durstine, Prominent Authority on Advertising, Lays Down the Precepts Which Must Be Followed in the Creation of Good Advertising in Interesting Book on This Subject

Advertisers in every line are endeavoring these days to get away from the beaten path and make copy that has pulling power and originality. The days of the stereotyped advertisement is passed, according to advertising experts, and the dawn of a better day is already well above the horizon. An advertisement that complies with all the requirements laid down by the average old-time advertising manual and is just as good for one thing as another is really not good for anything at all. Roy Durstine, a recognized authority on advertising, has just written a book on making advertisements and making them pay, and he declares that the uselessness of this adjustable advertisement is "all the fault of the outrageous person who first boiled down advertising to this formula: First, focus the attention. Second, interest the reader. Third, create a desire. Fourth, show that you satisfy that desire. Fifth, stimulate action." No art can be boiled down to a formula. If it could be, then that art would be too easy to be worth while. Mr. Durstine is merciless to the advertising men who have not progressed beyond the application of formulas. He tells us that this kind of advertising man becomes "a merchandising expert," who exerts pressure on "prospects" and whose customers are always "clients."

Mr. Durstine lays down many precepts for good advertising among which the following may be cited as worthy of study by every business man who has before him the problem of adequately presenting his goods to the public through the medium of advertising.

"Every business, no matter how young and how old, has a personality. To catch the spirit of that personality and to reflect it in words and type and picture is the job of every advertisement.

"There is an old saying in advertising—that nothing can be said about a twenty-five-cent cigar which has not already been said about a five-cent cigar. If you descend to superlatives in selling a product of real quality you find that the maker of inferior merchandise has been there first. So the strongest way you can convey an impression of supreme merit is by inference—by atmosphere. The man whose merchandise falls in the class below yours may

employ many of the devices of design which you also use, but he doesn't dare give as little information.

"There ought to be something about an advertisement as contagious as the measles. Without sincerity an advertisement is no more contagious than a sprained ankle.

"To sell something of doubtful merit is dishonest. Such a fundamental error in merchandising as to sell an inferior article by jumping up sales through advertising is like inflating a punctured tire. What you say may be sound enough, but the sales volume won't stick because there is a leak in quality.

"It is not sufficient that they (advertisements) make people talk. The German people have made a great many people talk about them in the past five years, but it has not advanced their position in the esteem of the world.

"It is difficult to think of any business which cannot be advertised. No, that's an exaggeration. * * * Burglars shouldn't. That's one business that is peculiar."

"To sum up," says Brander Matthews in a review of this book in the New York Times, "Mr. Durstine's book is what Horace Greeley called 'mighty interesting reading.' It takes us outsiders behind the scenes. It helps us to understand how it is that we would not be surprised if we were to read that Phoebe Snow had married Sunny Jim, moved to Spotless Town, adopted a couple of Campbell Kids and was letting the Golddust Twins do her work."

A RECORD STOCK IS ALIVE

Putnam-Page Bulletin Points Out Value of Good Stock and Good Selling

"Your record stock is alive, aglow, the liveliest salable thing in any store. It is constantly changing—more alive, more aglow every day, every hour," says the Putnam-Page Co., Victor distributors, in one of its recent bulletins. "And we can reflect that stock when we meet our trade. Of course, we have new and splendid things coming in right along. Tell your friends and come again real soon. You will find something new every hour." That's the spirit in which to meet your customers—it wins.

MUSIC FINDS PLACE IN SUBWAY

Ticket Seller Brings His Talking Machine to Work With Him and Latest Songs Delight the Hurrying Commuters on Way to Work

A correspondent informs us that music has at last invaded the dark reaches of the Interborough subway and now the hurrying crowds at the Brooklyn Museum station are entertained as they push their nickels across the grimy glass above the "How Many?" sign by the strains of the latest music coming from the talking machine within the ticket seller's booth. Evidently there is one ticket seller who has an imagination that has not been stifled by the roar of the subway trains. He has reasoned that if his instrument entertains him at home it will also do its pleasant work while at his daily task. And so he put his idea into execution at once. He greets his patrons with a smile and receives a smile in return. Everyone is happy.

PUBLIC HAS BIG BUYING POWER

Roger W. Babson, Statistics Expert, Gives Ten "Bull" Trade Factors in Address Before Advertisers' Club in Recent Meeting

Roger W. Babson, business statistician, told the Advertisers' Club last week what he believed were the ten "bull" factors in business to-day. He said that of the many factors foretelling business prosperity the following were the most important:

That the great mass of people still have the Government bonds which they purchased during the war and until these bonds are sold there remains great purchasing power.

That billions of dollars previously spent for liquors are now used to buy comforts and merchandise.

That the national banking system is more flexible than it was during any other period of financial stress.

That national advertising has come to stay, to be a steadying force in business.

That the war caused much standardization resulting in production efficiency.

That foreign trade impetus will continue for many years from the war impetus because of our new merchant marine.

Seasonable fluctuations in manufacturing and selling are being eliminated.

Reduction in taxation, especially business and profit taxation, may be expected.

Recent election showed people are conservative and will back a business Government.

The war made America the richest country.

The apparent inconsistency of the present depression with the indications above, Mr. Babson said, was due to the fact that depression follows the extravagance, dishonesty and inefficiency which always end a period of prosperity such as this country has passed through.

MANY NEW USES FOR MAGNAVOX

Most Illuminating Volume Just Issued by the Magnavox Co.—Shows Trade Use of Instrument and Its General Popularity

The many uses of the Magnavox for magnifying sound are found in easily accessible form in a new and most interesting booklet just issued by the Magnavox Co., of Oakland, Cal. The application of the Magnavox to the talking machine and its use in amplifying music are shown in detail as well as its uses for public gatherings where speakers are desirous of making their words audible and impressive to large audiences.

OPENS STORE IN MANCHESTER, IA.

J. G. Lewis, of Manchester, Ia., has moved into the building in that city formerly occupied by the Farmers & Merchants State Savings Bank, and has installed a stock of talking machines and other musical instruments.



HENRY BURR



ALBERT CAMPBELL



JOHN MEYERS

EIGHT FAMOUS VICTOR ARTISTS

In Concert and Entertainment

Personal Appearance of

Eight Popular Victor Favorites on One Program

A live attraction for live dealers and jobbers

Bookings now for season 1921-1922
A few available dates for Spring, 1921
Sample program and particulars upon request

P. W. SIMON, Manager
1604 Broadway New York City



FRANK CROXTON



MONROE SILVER



BILLY MURRAY



FRED VAN EPS



FRANK BANTA

Famous Ensembles including
Campbell & Burr - Sterling Trio - Peerless Quartet



Why everyone is talking about Brunswick Records

They have been a great sensation.

Everywhere you go you find dealers and phonograph owners commenting on the way Brunswick Records have captured the public.

Music lovers everywhere recognize their superiority in the most emphatic way possible — by constantly demanding more and still more Brunswick Records.

Such an unqualified endorsement has placed the stamp of approval on these artistic companions of the already successful phonograph.

There are many things that enter

The buyers of records can now shop in the Brunswick Catalog, and find music to their liking, no matter what their individual preferences may be. They will always find something new, something timely, something fascinating and different.

Note "The Spiral Stop—on Brunswick Records"

into the production of a fine record. It would be too long a story to tell.

But we can say that, coming into the record business at this time, we felt that we had to make a record which would be not only as good as, but much better than any record already on the market.

The New Year finds the Brunswick Catalog well rounded out. A noteworthy balance in every department has been attained. Each month of the coming year will see this good foundation strengthened and built up by carefully selected releases.

THE BRUNSWICK-BALKE-COLLENDER COMPANY

General Offices: 623-633 South Wabash Avenue, Chicago

Branch Houses in Principal Cities of United States,
Mexico and Canada

New England Distributors:

Kraft, Bates & Spencer, Inc., 1263 Boylston Street,
Boston, Mass.

Canadian Distributors:

Musical Merchandise Sales Co.,
79 Wellington St., West,
Toronto



Brunswick

PHONOGRAPHS AND RECORDS

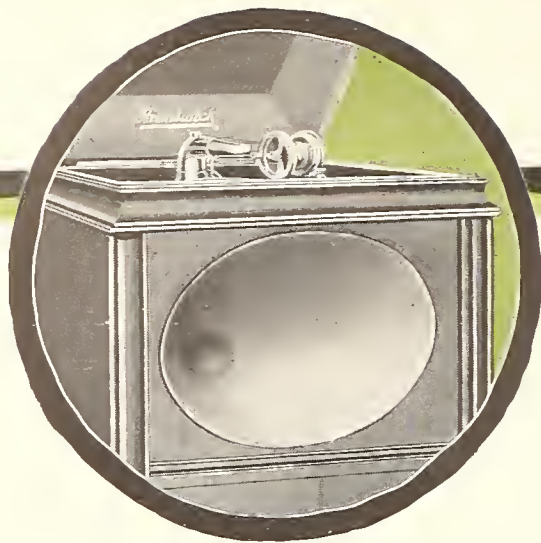

The Brunswick Oval Tone Amplifier, built entirely of wood

58 per cent increase in 1920

These figures mark the remarkable advance of Brunswick Phonograph and Record sales over 1919.

And this in the face of the many adverse manufacturing and merchandising conditions of the year just closed.

The New Year finds Brunswick more solidly established than ever.

Six phonograph factories, two record pressing plants, and forty branch houses in principal cities, put every Brunswick dealer, no matter where he may be located, in close and intimate touch with the makers

of the Brunswick Phonograph and Brunswick Records.

The Brunswick-Balke-Collender Company takes this opportunity to express its sincere appreciation of the constructive co-operation it has received from all Brunswick dealers. It realizes, with due acknowledgment, that its growth and development has been made possible through the loyalty and activity of its Phonograph and Record dealers, and it is the purpose of this company to be still more deserving of this spirit and support.

THE BRUNSWICK-BALKE-COLLENDER COMPANY

General Offices: 623-633 South Wabash Avenue, Chicago

Branch Houses in Principal Cities of United States,
Mexico and Canada

New England Distributors:
Kraft, Bates & Spencer, Inc., 1263 Boylston Street,
Boston, Mass.

Canadian Distributors:
Musical Merchandise Sales Co.,
79 Wellington St., West,
Toronto

Brunswick
PHONOGRAPHS AND RECORDS

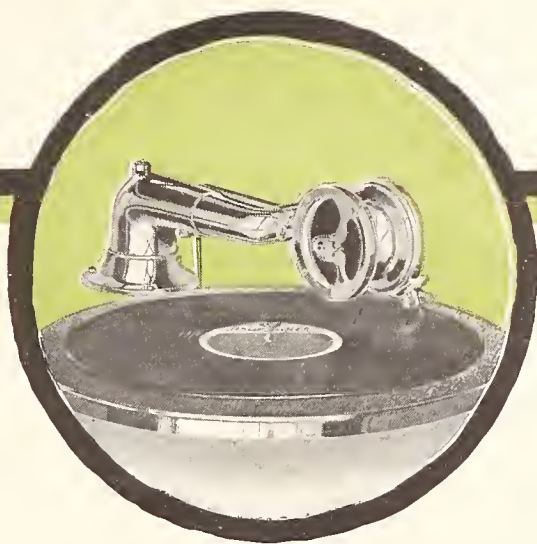

The Brunswick Ultona, playing a Brunswick Record

What Brunswick offers the dealer

The record of achievement mentioned on the opposite page may be easily verified by you. Brunswick offers you facts, instead of a glowing prospectus of things to be accomplished, of a demand to be created.

You will find The Brunswick and Brunswick Records in leading stores everywhere—in stores which are very slow to put their names behind a product until its merits have been proved beyond a doubt.

As a business man you realize the

advantage of doing business direct with the manufacturer, without any intermediate parties whose interests may possibly conflict with yours, or who may be interested in other phonographs.

Brunswick makes The Brunswick from top to bottom. Brunswick controls every step of phonograph and record making from start to finish.

There is no dependence upon outsiders. The Brunswick is not an assembled phonograph.

THE BRUNSWICK-BALKE-COLLENDER COMPANY

General Offices: 623-633 South Wabash Avenue, Chicago

Branch Houses in Principal Cities of United States,
Mexico and Canada

New England Distributors:
Kraft, Bates & Spencer, Inc., 1263 Boylston Street,
Boston, Mass.

Canadian Distributors:
Musical Merchandise Sales Co.,
79 Wellington St., West,
Toronto

Brunswick

PHONOGRAPHS AND RECORDS



Elias Breeskin *Master Violinist*

An exclusive Brunswick artist

Some press comments on his 1920 Australian tour of 40 concerts

Sydney, Australia, Daily News, August 18th, 1920.

Mr. Elias Breeskin, violinist, in the recital given in the Town Hall last night, had ample scope for the display of his talent. He is undoubtedly a fine artist, sympathetic in his treatment of cantabile, and sure in his technic in double-stopping and rapid passages. His harmonies are a delight to hear.

Sydney, Australia, Daily Telegraph, August 18th, 1920.

It was the first opportunity of hearing Mr. Elias Breeskin, the Russian violinist, to advantage apart from the orchestra. He confirmed the impression that he is equipped with an extremely finished technic, combined with an unflinching certainty of intonation and a strikingly well-developed sense of beauty of tone.

The Daily Mail, Brisbane, Australia, June 26th, 1920.

Mr. Elias Breeskin established himself the

favorite. He certainly held the audience enthralled and roused it to a pitch of feeling seldom experienced in Brisbane. The serene perfection of his technic, a spontaneity of expression, his strong personality, and the grace and beauty of his style were factors which combined to stamp him as a finished performer. Melody poured forth from his violin in tones of rare freshness—tones which only the greatest artists can create.

Standard, Brisbane, Australia, 1920.

But the more one hears the more one is tempted to give place of place to the violinist, Mr. Elias Breeskin, on account of his absolute mastery of a glorious instrument that is so seldom really mastered. Blessed with personality, he seems to fairly revel in the most difficult compositions, always displaying marvelous technic and a genuine sympathy that is evidenced in perfect expression and delightful purity of tone.

THE BRUNSWICK-BALKE-COLLENDER COMPANY

General Offices: 623-633 South Wabash Avenue, Chicago

Branch Houses in Principal Cities of United States,
Mexico and Canada

New England Distributors:

Kraft, Bates & Spencer, Inc., 1263 Boylston Street,
Boston, Mass.

Canadian Distributors:

Musical Merchandise Sales Co.,
79 Wellington St., West,
Toronto

Brunswick

PHONOGRAPHS AND RECORDS

NEW TAX LEGISLATION AND THE MUSIC TRADE

Pertinent Comments Upon the New Year's Tax Problems in Washington Offered by George W. Pound, General Counsel of the Music Industries Chamber of Commerce

There is no question but that the matter of tax legislation will prove of tremendous importance to the music industry, and American industries at large, for that matter, during 1921, for the determined effort of various trade interests to have wartime taxation lightened materially or eliminated altogether is being met with an equally earnest effort on the part of certain Governmental and private interests to make war taxation burdens more or less permanent, and particularly to continue to discriminate against certain industries—the music industry, for instance—in placing upon them the burden of excise taxes. More than one suggestion has been made that the excise taxes on musical instruments be doubled.

In speaking of the legal questions that will face the industry during the year just opened George W. Pound, general counsel of the Music Industries Chamber of Commerce, said to The World:

"Above all other permanent trade problems is always the menace of tax legislation. Twice have we met that issue and triumphed. Now for the third time we are confronted with an agitation for a further tax upon music and certain other industries.

"I, personally, do not believe that a general tax bill will be enacted at this session. It is the last and short session of the Sixty-sixth Congress. It expires by limitation March 4. And the Administration from President and Secretary of the Treasury down the line are wholly opposed to any bill which will repeal or lessen excise or other taxes. The Republican majority is not sufficient to carry a measure over such opposition. But the problems involved will be thoroughly discussed and probably worked out during this short session, and hence be ready for introduction and passage early in the Special Session, which the country confidently expects to be called by President Harding immediately after March 4 next.

"And, again, the tax question in all its aspects, particularly as to the amount of revenue required, and therefore the demand for manufacturing taxes, will be materially affected by tariff and similar considerations. Senator Curtis (Kansas) and many Senate and House leaders favor a moderately high protective tariff, one that will raise a billion dollars of revenue. Many Southern members are secretly and some openly in favor of a protective tariff. I believe there is no question but that the Sixty-seventh Congress, probably in the Summer of 1921, will pass a protective bill, not an extreme measure, but higher than the present act, and giving proper protection to American industry. We should have a bill which will protect us from the constant menace of pauper labor in Europe from after-war dumping. It is no concern of ours as to what Europe thinks of such a proposal. We must look to our own interests. Europe is surely sadly stricken, but I look for a full recovery, and much sooner than generally expected. Witness the phenomenal recovery from a state of similar exhaustion in 1871 by France.

"In my opinion, upon musical instruments the new bill should give a protection of 45 per centum.

"At the present moment it is impossible to forecast final action upon the tax matter. The excess profits feature seems doomed. And let us trust our excise taxes, also. The proposed tariff bill will help us on this greatly. Sentiment as to a general sales tax is very sharply divided. It has objectionable features, surely, but appeals strongly in its simplicity and general application.

"Watchful waiting for a few weeks is our manifest line of endeavor."

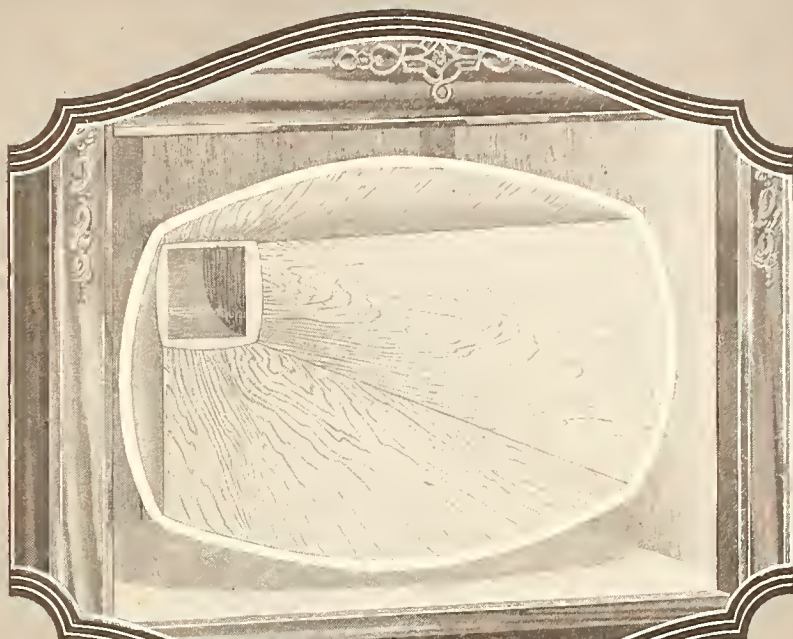

HARPONOLA

Look at the PROFIT

You can make more money with the HARPONOLA than with many other makes because our distribution plan permits us to give you a bigger territory on a non-competitive basis.

We give you better terms—which mean: LONGER PROFITS.

And the machine, itself, fully meets all comparison tests in tone, in appearance and in mechanical reliability.

It will certainly pay you to have the HARPONOLA PROPOSITION.

A good profit in every machine. Repeat sales built by our special proposition on OKEH records. Write for details.

THE HARPONOLA CO.
101 MERCELINA PARK
CELINA, OHIO
EDMUND BRANDTS, President

The
PHONOGRAPH
with the
GOLDEN
VOICE

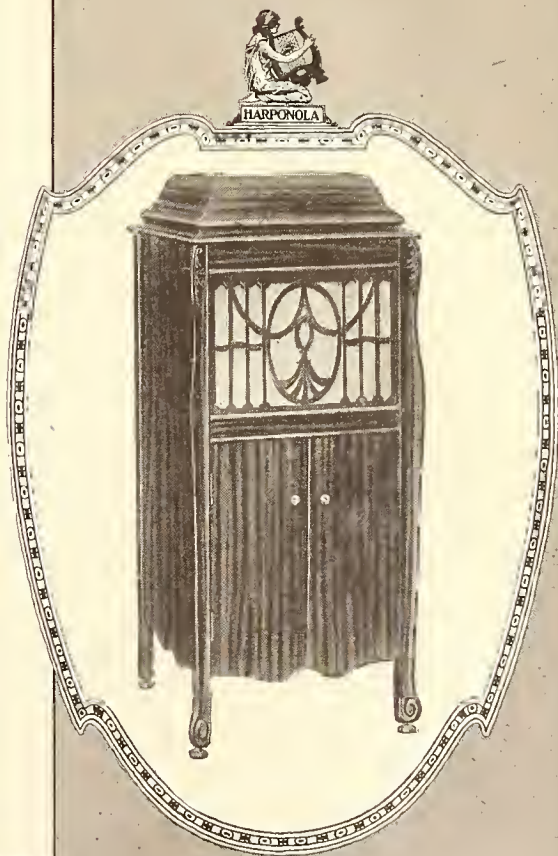

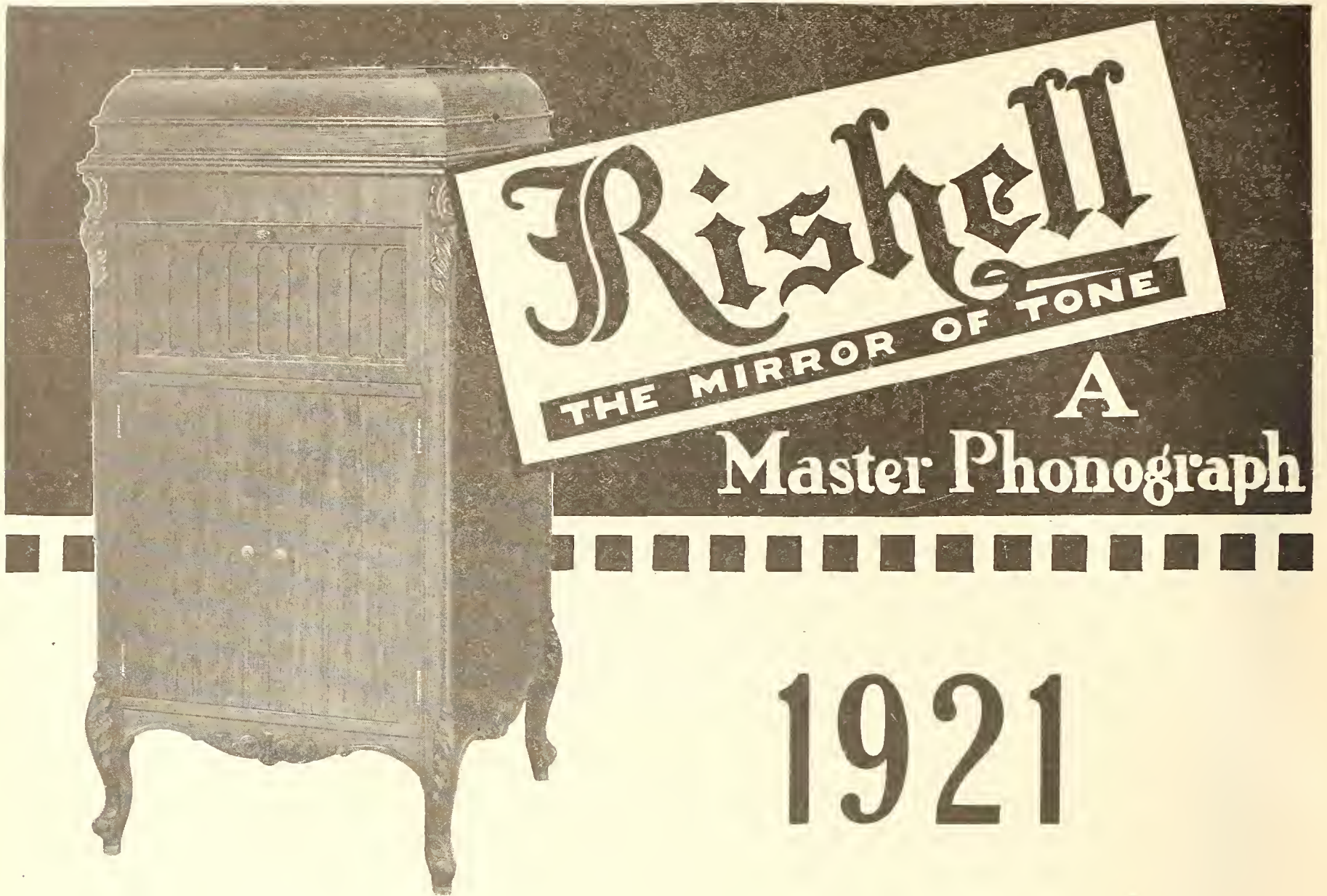

Rishell
THE MIRROR OF TONE
A
Master Phonograph

1921

The new year will usher in the hardest competition the talking machine business has ever known.

Weak "machines" will be weaker than ever before; some strong "machines" will need the keenest kind of salesmanship to keep in line.

Rishell has so many great selling points that it will make a market anywhere, and keep any market it makes. 55 years' business success assures the *stability* of this business, and a constant *forward* movement in production and sales. Write TODAY for terms to jobbers and dealers.

RISHELL PHONOGRAPH CO.

WILLIAMSPORT, PA.

New York Distributor: GRAND TALKING MACHINE CO.
268-270 Flatbush Avenue Extension, BROOKLYN, N. Y.

Various Methods of Increasing Sales Service Efficiency Described :: :: By William Bliss Stoddard

The Swank Hardware Co., Johnstown, Pa., has established a commendable record for efficient service in connection with its talking machine department and has seen it grow in six years from a small floor space and no demonstration booths to a department six times the size, with twelve booths for demonstrating. The company attributes the greater part of its success to the efficient salesmanship of its sales force. Said the manager recently:

"It is not unusual for this department to handle from 250 to 300 customers a day. A good saleswoman who is familiar with stock can wait on two or three customers at the same time, as the patrons usually prefer to go to a booth to play the record themselves. We sell only the standard lines—merchandise that we can stand back of with our own as well as the manufacturer's guarantee. We endeavor to give courteous, efficient and intelligent service, and make it a special point to have the salesgirls, as well as all others connected with the department, thoroughly familiarize themselves with all the records and machines, so that they can answer any questions regarding them, whether it be concerning the mechanism of the machine or the singers and songs of the records. We take advantage of every opportunity to further the education of our salespeople. We have them attend concerts of all the prominent artists who visit our city, and at present one of our salesgirls is taking a two weeks' course of intensive training in record and machine selling conducted by one of the talking machine manufacturers.

The firm maintains a modern service and repair shop in charge of a first-class mechanic who understands repairing motors, tone arms, sound boxes, etc. "This repair shop is practically self-sustaining," said the manager, "as the charges on repair jobs other than our own pay the salary of the mechanic. We find it pays us to give prompt and satisfactory service on any machine we sell that develops trouble. It insures more satisfied customers and brings them in for more records."

His recipe for a successful talking machine department was summed up in a few words: "Get the best line you can secure—the exclusive agency, if possible—and give someone charge of this department who is really interested and will put the necessary 'pep' and 'effort' back of it to bring out all the good points of the machines and records and thus increase the sales."

Preventing "Outs" on Phonograph Records

One of the greatest difficulties that confront the dealer handling a large stock of records is the proper stocking with standard records, so as not to be obliged to inform the prospective purchaser that the record he desires is not in stock at present. A firm in one of the growing cities of the great Southwest has found an excellent way to overcome this. As soon as a shipment of records is received the saleswoman takes one record from each selection and pastes a piece of red paper in the upper right-hand corner of the open end of the jacket. The record stands on edge in the rack with the printing on the jacket toward the left, which brings the red paster at the top. This label is marked with the number, price, date of receipt and quantity. If it is a staple number the saleswoman knows about how fast it will sell. She accordingly sets aside a certain number as reserve stock. These go to the right of the record whose jacket bears the red label. The stock to sell from goes to the left of this labeled record. When a salesperson comes to the record with the red seal she knows it is time to order new stock and a memo of this is given the buyer, thus preventing the disappointing of customers.

Records Over the Telephone

The Lion Store, Toledo, Ohio, has adopted a

plan for increasing the sale of records which has been in vogue for some time by several Western merchants. This is the announcement of "Hear Victor Records Over Your Own Telephone." The arrangements which preceded the appearance of the advertisements consisted of the installation of a special private telephone in one of the store's record booths and a special transmitter attachment which intensified the sound emitted from the sound chamber of the Victrola. The arrangement enabled one to sit in his own home and hear the newest records played. During the cold and dreary season this telephone line was especially profitable, as scores kept indoors by the bad weather wanted new music to entertain them and, while they would not buck the storm to go to the store, when they found they could get a line on the newest music over the 'phone they were quick to take advantage of it. Orders are taken over the 'phone, likewise, for any records it is desired to have sent out, and these are either charged or delivered c. o. d. With the record supplements sent out each month is enclosed a sticker bearing the number of the private concert telephone of the store, with the request that this be pasted in the telephone book. The telephone business is growing constantly and the store has a list of people who have requested that they be called each time the new records are received.

Music Firms Feature the Joy of Music

Co-operative advertising is becoming more popular all the time and now a sextette of the leading music houses of New Orleans have combined to get "the joy of music" before the public. Just prior to the holidays they took an entire page in the local papers and adorned it

with a classic picture of Pan and a group of Grecian dancing nymphs. This cut was captioned in heavy black letters, "Music Brings Joy," and the signature contained the following well-known names: L. Grunewald Co., Ltd., Philip Werlein, Ltd., Dwyer Piano Co., Collins Piano Co., D. H. Holmes Co., Ltd., and Dugan Piano Co. The balance of the ad was devoted to what the great minds thought of music:

"The Greeks developed civilization to a point never equaled in some respects. They knew how to get the rich joy out of living and to distinguish real pleasure from temporary gratification. Plato and Aristotle proclaimed the same message as Euripides—that music is the well-spring of cheerfulness. Great men down through the ages have expressed the same thought. Shakespeare, Milton, Darwin, Beecher, Lincoln, Schwab and Roosevelt all give us the same message.

"Are you profiting from the mass of evidence? Are you filling your own home with soothing music? Do not delay! Buy a phonograph and have a hymn, an opera, a stirring march or a simple ballad always available."

NEW QUARTERS IN COLUMBUS, IND.

COLUMBUS, IND., December 31.—The Hoover-Rowlands Furniture Co. have installed an elaborate talking machine department in their store at Sixth and Washington streets, having secured the agency for the Brunswick phonograph.

The manufacturer who is feeling the pulse of the public through the retail trade is able to establish a policy that brings business.

1921 Victor Business Forecast

☞ It is due to the foresight and wisdom of the wonderfully efficient organization of the Victor Talking Machine Company that every Victor Retailer can look forward to the year Nineteen Twenty-one as reaching another point in advanced sales for the Victor products.

☞ Perfection in manufacturing, backed by the most wonderful advertising, with a constant, gradual increased production, has made the Victor business grow larger every year. Victor Retailers have every confidence in Victor products because they know these facts.

☞ Thanks to you, Victor Retailers, for putting your energy and your money into improved Victor establishments. We know the year Nineteen Twenty-one will show just as much increase in sales over Nineteen Twenty as Nineteen Twenty did over Nineteen Nineteen.

☞ Do not be affected by conditions which are affecting other industries. Put your shoulder to the wheel! Your Victor business is *bound* to increase.

Knickerbocker Talking Machine Co.
ABRAM DAVEGA, Vice-Pres.

KNICKERBOCKER TALKING MACHINE CO.

Metropolitan Victor Wholesalers

138 West 124th Street

New York

Gennett

RECORDS

"The difference is in the tone"



For a Happy New Year and new record delights, hear the new
GENNETT RECORDS

- | | |
|-------------------------------------------------------------------------------------------------------------------------------------------------------------------------------------------------|------------------------------------------------------------------------------------------------------------------------------------------------------------------------------------------------------------|
| 4650—Deenah (Tango Fox Trot). Raderman's Orchestra.
Fair One (Fox Trot). Cordes' Orchestra . . . \$.85 | 4649—Broadway Rose. Sam Ash, Tenor—Orchestra Acc.
Rose of My Heart. Ernest Davis, Tenor—Orch. Acc. \$.85 |
| 9096—My Home Town is a One Horse Town. The "Har-
monizers." Vocal Quartette—Orchestra Accompaniment.
Palesteena. Billy Jones, Tenor, with Orch. Acc. . . \$1.00 | 2508—One Day Nearer Home. Ethel Toms and John Perry.
Contralto and Tenor Duet—Orchestra Accompaniment.
The Ninety and Nine. Robert Carr, Baritone—Orchestra
Accompaniment . . . \$1.25 |
| 9090—It's Nice to Get Up in the Morning. (Lauder).
The Portobello Lassie. Hector Gordon. Scotch Comedian
—Orchestra Accompaniment . . . \$1.00 | 2509—Grande-Overture "1812"—Part I. (Tschaikowsky).
Grande-Overture "1812"—Part II. (Tschaikowsky).
His Majesty's Scots Guards Band. . . \$1.25 |
| 9092—What Will You Do With Jesus? Ethel Toms and Robert
Carr. Contralto and Baritone Duet—Orchestra Acc.
Hold Thou My Hand. Robert Carr, Baritone—Orchestra
Accompaniment . . . \$1.00 | 2510—Selections From Faust—Part I. (Gounod).
Selections From Faust—Part II. (Gounod).
His Majesty's Scots Guards Band . . . \$1.25 |
| 4648—The Hula Blues (Fox Trot).
Annie My Own (Novelty Fox Trot). Raderman's Or-
chestra . . . \$.85 | 4647—Feather Your Nest (Fox Trot). Joseph Knecht's Wal-
dorf-Astoria Dance Orchestra.
I Love the Land of Old Black Joe Medley (One-Step).
Intro; My Little Bimbo. Yerkes' Jazzarimba Orch. \$.85 |

Hear these, and other new Gennetts on the January list, at any Starr dealer

THE STARR PIANO COMPANY, Richmond, Indiana

NEW YORK - CHICAGO - LOS ANGELES - BIRMINGHAM - DETROIT - CINCINNATI
 CLEVELAND - INDIANAPOLIS - JACKSONVILLE - LONDON, CANADA

Thousands of people in your territory are taking piano lessons. Every one of them ought to hear the great Josef Hofmann play Chopin's "Fantaisie Impromptu" and Liszt's "The Rustling of the Woods". A-6174

Columbia Graphophone Co.
NEW YORK



BRINGS SUIT OVER THE USE OF THE NAME "EMERSON"

Emerson Piano Co. Seeks to Have Emerson Phonograph Co. Restrained From Using Name "Emerson" on Phonographs—Defendant Files Answer and Makes General Denial

The Emerson Piano Co., as a corporation under the laws of Illinois, and with its principal place of business in Boston, Mass., recently filed a bill of complaint in the United States District Court, Southern District of New York, against the Emerson Phonograph Co., Inc., a New York corporation, asking that the court restrain the latter concern from further use of the name "Emerson" in connection with the manufacture and sale of musical instruments, particularly phonographs and records, and also to order an accounting of profits and the payment of damages.

In its complaint the Emerson Piano Co. declares that that company and its predecessors have since 1849 been engaged in the manufacture and sale of musical instruments, particularly pianos, under the trade-mark "Emerson," and have spent large sums in advertising that name. The complaint recites the history of the Emerson Piano Co.'s business up to the present time and sets forth that the company has not been confined to the manufacture of one type of musical instrument, but has made an instrument of the player-piano type bearing the name "Emerson-Angelus," and on or about December 1, 1919, extended its business to include the manufacture of phonographs bearing the trade name "Emerson."

The complaint goes on to say: "For the purpose of informing the public of the plaintiff's rights in the premises and in order that the plaintiff's rights might be made clear and certain the plaintiff has caused the said trade-mark to be registered according to the statutes of the United States, to wit, Certificate No. 53,383, registered the 5th day of June, 1906. * * *

"And the plaintiff has more recently, to wit, on or about December 6, 1919, made application to the United States Patent Office for the registration of its lawful trade-mark, 'Emerson,' for musical instruments, as applied specifically to sound-reproducing instruments or phonographs. And the plaintiff further says that during the latter part of July, 1920, it learned for the first time that an opposition to its said application had been entered by this defendant in the United States Patent Office, in which, without shadow of right or basis in law, the defendant herein opposed the granting of the plaintiff's said application, that plaintiff has duly answered in said opposition proceeding, and said proceeding is pending in the United States Patent Office."

The complaint goes on to declare that because of the reputation and quality of the plaintiff's goods, all musical instruments stamped or marked with the plaintiff's trade-mark, "Emerson," have been, and are, highly esteemed by dealers and purchasers and are selected and purchased at high prices in preference to other goods. It declares that the plaintiff's ownership of the trade-mark "Emerson" as applied to

musical instruments is of great value and profit, approximately many thousands of dollars. It is further averred that "the trade-mark 'Emerson' has been universally known and recognized as indicating that goods bearing such trade-mark were the product of the plaintiff, and said trade-mark has become, and is, valuable property right of the plaintiff and a protection to purchasers of musical instruments made by the plaintiff, and that the word 'Emerson' has become, and is, the exclusive property of the plaintiff as applied to musical instruments, and that the plaintiff is entitled to the sole and exclusive use and benefit thereof, and that the plaintiff is entitled to recover for damages, or profits, which have resulted, or accrued, from the infringement of the plaintiff's rights hereinafter set forth."

The plaintiff declares that notice in writing of its trade-mark rights in the word "Emerson" was given to the defendant on or about February 19, 1920.

In its reply to the bill of complaint, the Emerson Phonograph Co., Inc., enters a general denial, declaring that this corporation was organized and has been conducted under the leadership of Victor H. Emerson, "a nationally known and recognized genius and figure in the phonograph industry," and that since the date of the

company's organization in 1915, it has been extensively engaged in manufacturing and selling phonographs and records, and has spent large sums in advertising the trade-mark Emerson under which its goods have been uninterruptedly sold up to the present time in interstate commerce throughout the United States and foreign countries. The answer also declares that "Emerson records and Emerson phonographs are known from one end of this country to the other, and constitute in the public mind throughout the United States one of the leading branches of this industry. * * * * The word 'Emerson' in the phonograph industry is today recognized and known as indicating as the source and origin of phonograph goods the Emerson Phonograph Co. and no one else."

The defendants call attention to the fact that the right of the Emerson Phonograph Co. to manufacture its phonograph records in spite of the apparent monopoly of the Jones patent was upheld by the court in 1916.

In filing its answer the defendant company, in turn, "prays that the Emerson Piano Co. may be enjoined and may be ordered to account" and also that damages be assessed.

NYTROLA IS NAME OF NEW MACHINE

A new talking machine known as the Nytrola is being manufactured by the T. & H. Specialty Co., of Charleston, W. Va. The capacity of the present plant is said to be twenty machines a day.

Profits Depend On Sales

A very definite policy of the C. C. Mellor Company is to lend every assistance within reason for stimulating their customers' sales of Victrolas and Victor records. :: :: :: ::

C. C. Mellor Company

1152 Penn Avenue,

Pittsburgh, Pa.

\$5.⁰⁰ for Every New Use Suggested
for the

Magnavox

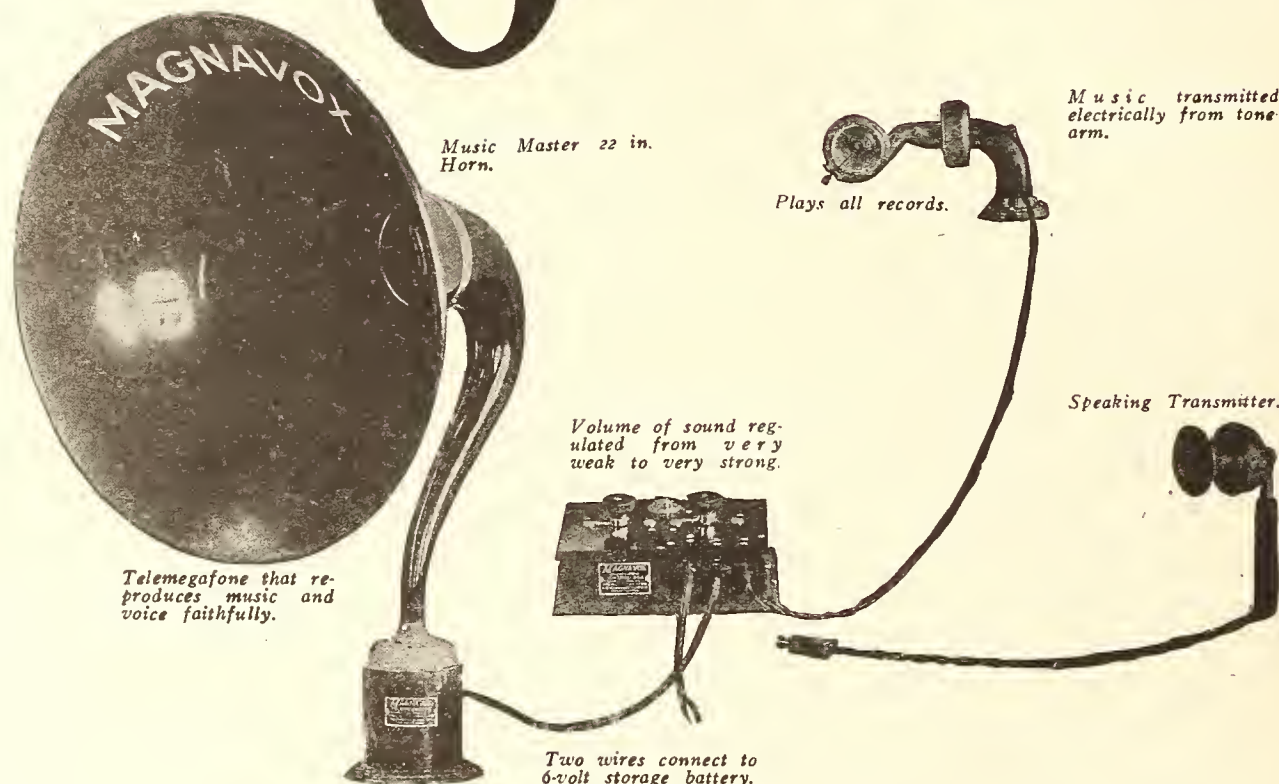

Telemegafone that reproduces music and voice faithfully.

Music Master 22 in. Horn.

Plays all records.

Music transmitted electrically from tone arm.

Volume of sound regulated from very weak to very strong.

Speaking Transmitter.

Two wires connect to 6-volt storage battery.

YOU know what the Magnavox does—so magnifies the voice or sounds from a phonograph record or any other source that every word or note can be heard by a vast audience whether in an auditorium or outdoors. Or the sound can be modified at will to a mere whisper.

We're finding new uses for this instrument every day, but we want a lot more.

You may know some new ones. Tell us and win \$5.00 for each one.

Herewith are listed a few suggestions, to serve as illustrations. Each person to register a use, as yet not known to us, will receive \$5.00.

There's big profit selling this instrument and the field for its use seems unlimited.

Send for Bulletin 22520 which tells all about the Magnavox.

A few uses suggested for the Magnavox:

- For Concerts and Entertainments
- For Lectures and Public Speakers
- For Playgrounds
- On Shipboard
- On Recreation Piers
- To take place of Band or Orchestra
- For Dances
- For Church Entertainments
- For Social Gatherings
- Calling between Departments
- For Shop Keepers to attract attention to their Stores
- To demonstrate Records
- For Beaches
- For Skating Rinks
- For Fairs and Exhibitions
- For Train and Open Air Announcements
- Y. M. C. A.'s and Y. W. C. A.'s
- For Schools
- As a Megaphone
- For Contractors directing work on Buildings

J. O. MORRIS CO., Inc.

Distributors for New York and New England

1270 Broadway, New York City

SIMPLICITY IN WINDOW DISPLAY

Concentration on a Single Subject, a Machine or Record, Brings Most Successful Results—An Illustration Worth Noting

A practical demonstration of the fact that the proper display of a single instrument is generally more effective than a windowful of goods arranged haphazard, and calculated to confuse the observer, is found in the following story from the last issue of *The Puritan*, the house organ of the United Phonographs Corp., Sheboygan, Wis., under the caption, "An Accidental Success":

It is a temptation when dressing a show window to put in more goods than the public can "measure up" without coming to a halt and making a deliberate inspection.

Most window dressers advocate concentration on one or two objects, rather than a diffusion of attention on many. This does not hold true of dress goods and apparel windows because women always take time to inspect everything of this kind displayed.

A phonograph, being a relatively small article, takes up so little room that the dealer is tempted to put in several, either of the same make, or a variety of makes. This is the general practice, but a variation is often effective.

A merchant in Cleveland was changing his window trim, and after removing all the goods he was called away, and only had time to put one *Puritan* in the space before closing time. A few *Puritan* records were placed against the base, together with a neat gray card, lettered in white, "The World's Greatest Entertainer." No other goods were shown.

On approaching the store next morning, the dealer was surprised to see an unusual number of well-dressed people inspecting the display. Three people entered when he opened the door, and throughout the morning there were many others attracted. We don't know whether sales were made then, but there was no doubt that the solitary *Puritan* and the simple eye-catching card had made an impression. "This was an accidental stunt," said the proprietor. "If I had had time I was going to put in a windowful, and it must be there is something in this 'concentrated attraction' idea after all."

There is an idea here set forth that is well worth emulation.

BRILLIANTONE CO.'S SOUVENIR

Among the most attractive remembrances presented by talking machine houses to their customers this season is that of the Brilliantone Steel Needle Co. of New York City. Prior to the Christmas holidays there was sent from the Brilliantone headquarters an exceedingly attractive desk set, consisting of a letter opener and scissors with gold-finished handle and sheathed in a leather case with a brass tip. This useful and artistic memento will serve perpetually as a reminder of the good will of the Brilliantone Steel Needle Co. and Byron R. Forster and Harry W. Acton, who direct its destinies, throughout the New Year.

Your Problem Is Ours

Good Profits (to you)

— Good Service (to your customers)

Answer: TONAR RECORD BRUSHES

(Trade Mark)



Have we solved the above problem correctly?

Write to-day for prices and sample and see for yourself

PARKS & PARKS, Inc.

TROY, N. Y.

New York Office, C. E. Peabody & Co., 186 Greenwich St.

Southern Representatives: I. W. Becker & Co., 226½ Peachtree St., Atlanta, Ga.

WOMEN SUCCEED IN MUSIC STORES

Bring Best Results in Selling Music, Says Prominent Woman Writer—Talking Machine Demonstration Needs Feminine Touch

"Service has always been Mrs. Brewster's theory of success," says a writer in *The Independent Woman*, describing the career of a brilliant talking machine saleswoman.

"And she believes that the maximum of service can only be obtained from a sales force that is intelligent. The question does not revolve about the relative ability of man or woman when it comes to the selling end of the game; it is whether the proposition they sell has a feminine or masculine appeal.

"I do not like men on the sales force of a talking machine shop, but it is not because I do not think men cannot sell as well as women," Mrs. Brewster said. "In the first place such a job is apt to attract only the man or boy who is lazy. It is a position that requires the feminine touch, and the man who gets into such a job is apt in time to become effeminate.

"Of course, such individual cases as the man working his way through a musical course, or passionately interested in music for the music's sake, are not to be considered. The average boy, however, prefers ragtime to good music, and he follows his taste when demonstrating to the public, and when the public leaves before he is half through his demonstration he nonchalantly lights a cigarette and forgets about the lost sale."

CLOSE EMERSON CANADIAN BRANCH

Brockville, Ont., Investors Will Have Money Invested Returned to Them According to Statement Issued by the Local Board of Trade

BROCKVILLE, ONT., January 3.—On account of difficulties which have beset the parent concern in the United States the establishment in Brockville of a Canadian branch of the Emerson Phonograph Co. has been abandoned. Brockville people have subscribed considerable stock in the project, which will be returned to them as a result of representations made by the Board of Trade, which had endorsed the proposition. The Standard Securities Corp. was acting as selling agent. The capitalization of the company was \$500,000 and exclusive rights had been granted to the Emerson Canadian Co., Ltd. It was the purpose of the company to manufacture Emerson records and, ultimately, produce phonographs.

URGES ETHICS IN BUSINESS

Commissioner Murdock Places Inviolability of Contract First

Business men of the nation are giving to the whole world a service beyond price, Victor Murdock, chairman of the Federal Trade Commission, said in an address in Cleveland, O., recently.

"The modern business man trades wares, quality and service, for money and good-will," he said. "Service thrives through an exercise of those factors which have built up our civilization. First and foremost among those factors is inviolability of contract. We must keep our word. A verbal pledge should remain a bond.

"The man who misrepresents in trade, in labels, in advertisement or in sale has no place in this situation, for a single unfair competitor, sometimes a single unfair act, will disorder a whole line of industry. The man who cripples a competitor by unfair methods is blocking the path of progress, not blazing it."

CHAUTAUQUA PHONO. CO. FORMED

The Chautauqua Phonograph Co. has been incorporated under the laws of Delaware to manufacture talking machines. The capital of the corporation is \$1,000,000 and the incorporators are C. B. Bishop, H. H. Ochletree and A. A. Bishop, Wilmington.

AUTOMATIC STOPS

The simplest and most efficient Automatic Stop on the market. They give excellent service, are easily installed and are absolutely guaranteed.

Send 50 cents for Sample Stop

Kirkman Engineering Corporation
484-490 Broome St., New York

How Best to Protect Musical Instrument Designs by Means of Patents :: :: By Waldon Fawcett

In a special article in The Music Trade Review recently Waldon Fawcett, of Washington, called particular attention to the inclination of various concerns to secure what are known as "design patents" on their products in order to prevent competitors from copying various popular models of musical instruments at the expense of the originators.

In discussing this important question Mr. Fawcett says in part:

"That the music industries are but just awakening to the importance of protecting distinctive cases, cabinets, benches, etc., against intentional or unintentional imitation or duplication is attested by the number of firms in the trade that have lately taken out, at one swoop, as it were, patents covering their entire range of models. As an illustration—one among many—we find a Chicago manufacturer of phonographs taking out, only a few weeks ago, a battery of patents covering the ornamental designs of this firm's respective sound-reproducing cabinets—period models as well as new contributions to the category of 'uprights.' Many firms in the trade, not content with isolating their ensemble designs, have taken out patents on grilles, tone control devices and other details.

"As the patenting of the designs of musical instrument cases becomes more general in the industry we may expect that such evidence of originality of conception will be more extensively played up as a 'talking point.' The term 'patented' has long been a word to conjure with in the music trades, as in other commercial and industrial fields, but heretofore music tradesmen, in invoking the prestige of patents, have usually had reference to mechanical patents.

When you stop to realize it, though, the design patent comes closer to the elements of salesmanship than its mechanical counterpart. Upon the latter may depend something of the service that an instrument will give its owner; yea, and something of its tone, perhaps, but design patents give the measure of the appearance of an instrument and every purveyor of musical wares knows that 'appearances count.'

"Some skeptics in music trade circles have re-

Originality of Design Conception Will Be More Extensively Played Up as a "Talking Point" in the Future

mained lukewarm in the face of the new trend to design patenting because of a cynical theory that 'any old thing' can be made the subject of a design patent. In all fairness, this suspicion that there is no insistence upon 'inspiration' as the prerequisite of a design patent is not justified. To be sure, design patents cover features of musical instruments that are ornamental rather than utilitarian, but in order to win one of Uncle Sam's testimonials to orig-

inality there must be a new appearance created by inventive process and serving the purpose of embellishment. The umpires at Washington even undertake to draw a distinction between novelty and invention and it has on more than one occasion been held that minor differences or departures in the outline of a musical instrument case, such as might suggest themselves to any resourceful workman, could not be accepted as a basis for design patents.

"One of the limitations of the design patent system is that which denies protection to fresh productions that are essentially nothing more than adaptations of old designs, long known in the art of the industry. Mere changes in size, color or material will not support a claim for a design patent, nor will a regrouping or rearrangement of devices and ornamental forms long known in the music industries unless, mayhap, the adapter has so completely disguised and rejuvenated his mediums of adornment that the effect produced is that of a new entrant.

"Judging from correspondence that has come to Washington from quarters within the trade, some musical instrument manufacturers and marketers have refrained from taking out design patents under the impression that the monopoly thus conferred can apply only to the ornamentation upon an article of manufacture rather than to the article of manufacture itself, as that article is manufactured and produced. It is unjust to thus narrowly appraise the scope of design patent protection. There are precedents aplenty to prove that design patents may be taken out on articles which have a useful mechanical function, provided such articles also

NEW YEAR'S GREETINGS

There's Real Joy and Happiness in Every Package of

DE LUXE NEEDLES

What better New Year's Wish, therefore, could we suggest than that every Warehouse, Store and Home could share with our long list of satisfied customers the entire satisfaction and everlasting Happiness in the use of DE LUXE NEEDLES exclusively throughout the New Year 1921?

DON'T FORGET THESE FACTS

1. Perfect Reproduction of Tone
2. No Scratchy Surface Noise
3. Plays 100-200 Records



Full Tone



Medium Tone

DUO TONE COMPANY, Inc.

Sole Manufacturers of De Luxe Needles

ANSONIA, CONN.

Three for 30 cents

Liberal Discounts

Oké Records

BLUES! BLUES!



MAMIE

SMITH

AND HER JAZZ HOUNDS

- | | | | | |
|--------|---|--------------------------------|-----------|---------------------------------|
| 4228 | } | MEM'RIES OF YOU, MAMMY | - | Mamie Smith and Her Jazz Hounds |
| 10 in. | | IF YOU DON'T WANT ME BLUES | - | Mamie Smith and Her Jazz Hounds |
| \$1.00 | | | | |
| 4194 | } | THE ROAD IS ROCKY | - - | Mamie Smith and Her Jazz Hounds |
| 10 in. | | FARE THEE HONEY BLUES | - | Mamie Smith and Her Jazz Hounds |
| \$1.00 | | | | |
| 4169 | } | CRAZY BLUES | - - - - | Mamie Smith and Her Jazz Hounds |
| 10 in. | | IT'S RIGHT HERE FOR YOU | - | Mamie Smith and Her Jazz Hounds |
| \$1.00 | | | | |
| 4113 | } | THAT THING CALLED LOVE | - - - - - | Mamie Smith |
| 10 in. | | YOU CAN'T KEEP A GOOD MAN DOWN | - - - | Mamie Smith |
| \$1.00 | | | | |

GENERAL PHONOGRAPH CORPORATION

OTTO HEINEMAN, *President*

25 West 45th Street New York City, N. Y.

Factories: Newark, N. J. Elyria, Ohio Putnam, Conn. Springfield, Mass. Kitchener, Ont.
Branch Offices: Chicago, Ill. Toronto, Can. London, Eng.





make a pleasing impression on the eye. The Commissioner of Patents, in the same spirit, ruled not long since that a design patent should not be refused simply because a device has moving parts.

"The attitude of the Federal courts in recent years, both as affecting musical instruments and other articles of commerce that are in somewhat the same relative position, is that protection may be invoked via a design patent for a new and original shape given to an article of manufacture quite as readily as for an ornamentation placed on the article and that the 'appearance' of an article is none the less patentable because a mechanical function is involved.

"Some disappointment has been occasioned now and then to music industry interests by the fact that the protection of design patents cannot be invoked for what is known as the 'internal structure' of an article, as, for illustration, a hidden part of a piano or player. Inasmuch, though, as the whole basis of a design patent is the 'appearance' of the article—the effect on the mind through the eye—it is but logical that no feature of interior construction should be accorded the shelter of a design patent. There have even been instances in which design patents have been denied for articles 'for obscure use,' evidently on the premise that it is too much to expect that an article that is covered up or used in an obscure manner should possess any high degree of artistic excellence. However, all such cases are considered individually and just as in other directions a border line case is often disposed of in a manner that spreads the blanket of a design patent over features that, at casual glance, might not seem susceptible of such entrenchment.

"In view of the fact that in the music trades the differences between patented designs are apt to be matters of detail it is highly important that in the most recent pronouncement on the subject of designs by a Federal court of appeals the principle was laid down that when it comes to ascertaining what is objectionable 'identity of appearance' it is to be borne in mind that the persons liable to be deceived are not experts, but ordinary observers giving such attention to the matter as purchasers usually give. 'If the effect produced upon the eye is the same,' the court puts it, infringement is established. Broadly speaking, the tendency seems to be to afford more rather than less protection than formerly under a design patent."

Tell your prospect why he should buy. Don't ask why he doesn't.

MISS MORRISEY MARRIES

Prominent Edison Star Becomes Bride of Roy J. Keith, Also Well Known in the Trade

Marie Morrisey, the popular contralto and widely-known Edison artist, was married on December 21 to Roy J. Keith, formerly vice-president of the New York and Chicago Talking Machine Co. Mr. Keith is now vice-president of the Curtis Candy Manufacturing Co., of Chi-



Miss Marie Morrisey

cago. Miss Morrisey is one of the most popular of Edison artists, both with Edison phonograph owners and Edison dealers, and it is felt that they all join in the hearty congratulations and best wishes here extended. She was the first Edison artist to take up regular tone-test recital work and go on tour, and she has just completed a six weeks' tour through the Middle West. The couple will spend their honeymoon in Honolulu and California, and on their return will make Chicago their home. Miss Morrisey will not abandon the concert field.

TALKER TO ANSWER TELEPHONE

When you are expecting a friend to call you on the phone and you are unexpectedly called away, you may leave a message for him on a record, according to the story of a new device perfected by E. L. Grauel, one of the engineers of the Automatic Telephone Co., and explained by him at a recent meeting of the members of the Chamber of Commerce in Philadelphia.

Now is the time to consider results in terms of what it costs to produce them.



BLANDIN

BLANDIN owners are ever increasing. When you compare Blandin reproduction, you will understand why no other phonograph will entirely satisfy you.

Racine Phonograph Co., Inc. RACINE, WISCONSIN.



FINGER NAIL REPRODUCES SOUND

Some owners of talking machines have discovered that the finger nail possesses the properties for reproducing music from the record grooves. It has been found that if the finger nail is sharpened slightly so that it will fit into the grooves of the record a faint reproduction will be heard as soon as the record revolves. Although the volume of sound is very small, the reproduction is very clear and the words of a song may be distinguished with ease. Strange to say, if a needle is held between the fingers no sound is heard. This story is being extravagantly "played up" in the daily papers.

Stopping advertising in order to save money is like letting the bearings of your automobile run dry to save oil.

REYNOLDS - MOBILE ALABAMA - VICTOR DISTRIBUTOR - SERVING VICTOR DEALERS IN ALABAMA MISSISSIPPI FLORIDA - Includes image of a Victrola and the 'His Master's Voice' logo.

The
SERENADO
TRADE MARK
SERENADO MFG. CO.

CEDAR RAPIDS, IOWA

ORGANIZATIONS ARE BUILT ON SERVICE

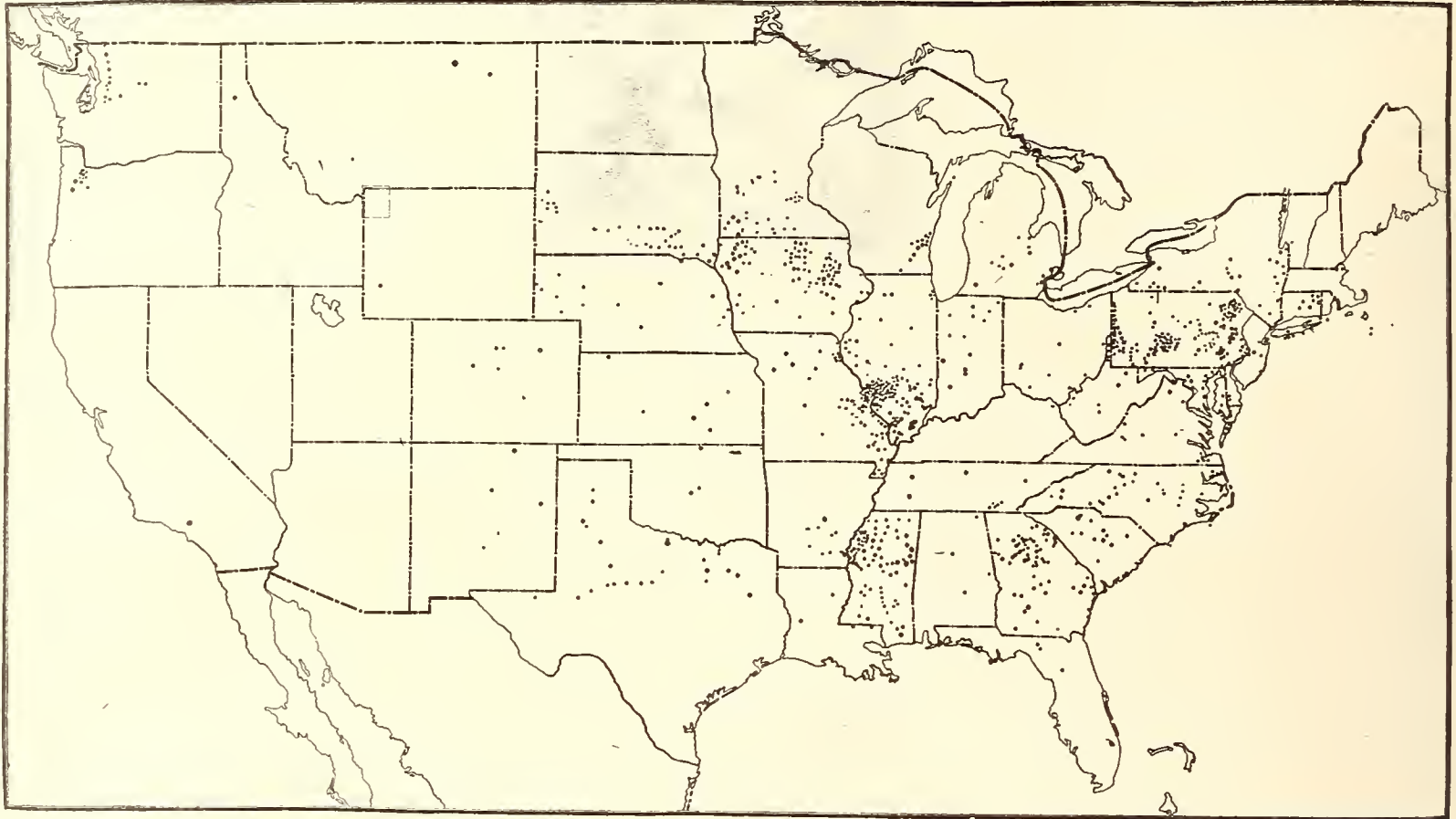

THE PROOF OF SERVICE IS AN ORGANIZATION

There is a dealer under contract for the sale of The Serenado at each point shown on the map.

Some of those dealers are large, some of them are operating in a small way but each and every one of them contracted with us because The Serenado was recognized as standard and of high quality and our effective co-operation and the low prices made possible by our merchandising methods were desired.

They are continuing with us for the same reasons.

As states are opened the better class of dealers are taking on the line—isn't that a guarantee of service rendered?

SERENADO MFG. CO.
 CEDAR RAPIDS, IOWA

All the World's Artists play and sing their best
 for the Audience of **The Serenado**

BRINGING MUSICAL APPRECIATION TO THE PUBLIC SCHOOLS

Interesting Details Showing How Fourteen Schools in Cicero, Ill., Are Utilizing the Grafonola as a Factor in Augmenting Musical Knowledge—A Story of Real Progress

Cicero, Ill., a city of over 45,000, the largest city in Cook County except Chicago, with a school enrolment of 7,000, has recently demonstrated a great appreciation of the place music deserves in its public schools and of the ability of the Columbia Grafonola, in particular, to bring to the scholars in Cicero the message of music. The School Board could not provide the

for this fine piece of work goes primarily to the children of these schools, but some of it must be shared with Miss Genevieve Quealy, Chicago representative of the educational department of the Columbia Graphophone Co., and some to E. Blimke, of the Chicago sales force, and to Justin Bros., the Columbia dealer in Cicero. The schools in Cicero which are now equip-

memory and athletic contests, with public-spirited citizens offering money prizes wherewith to purchase an instrument. The more schools are thrown on their own resources to provide means for the purchase of talking machines the sooner School Boards will wake up to their obligation to provide all schools with this needed equipment.

BRUNSWICK STORE IN HOLLYWOOD

Reed & Dady have opened a new Brunswick store in Hollywood, Cal., located at 6611 Holly-

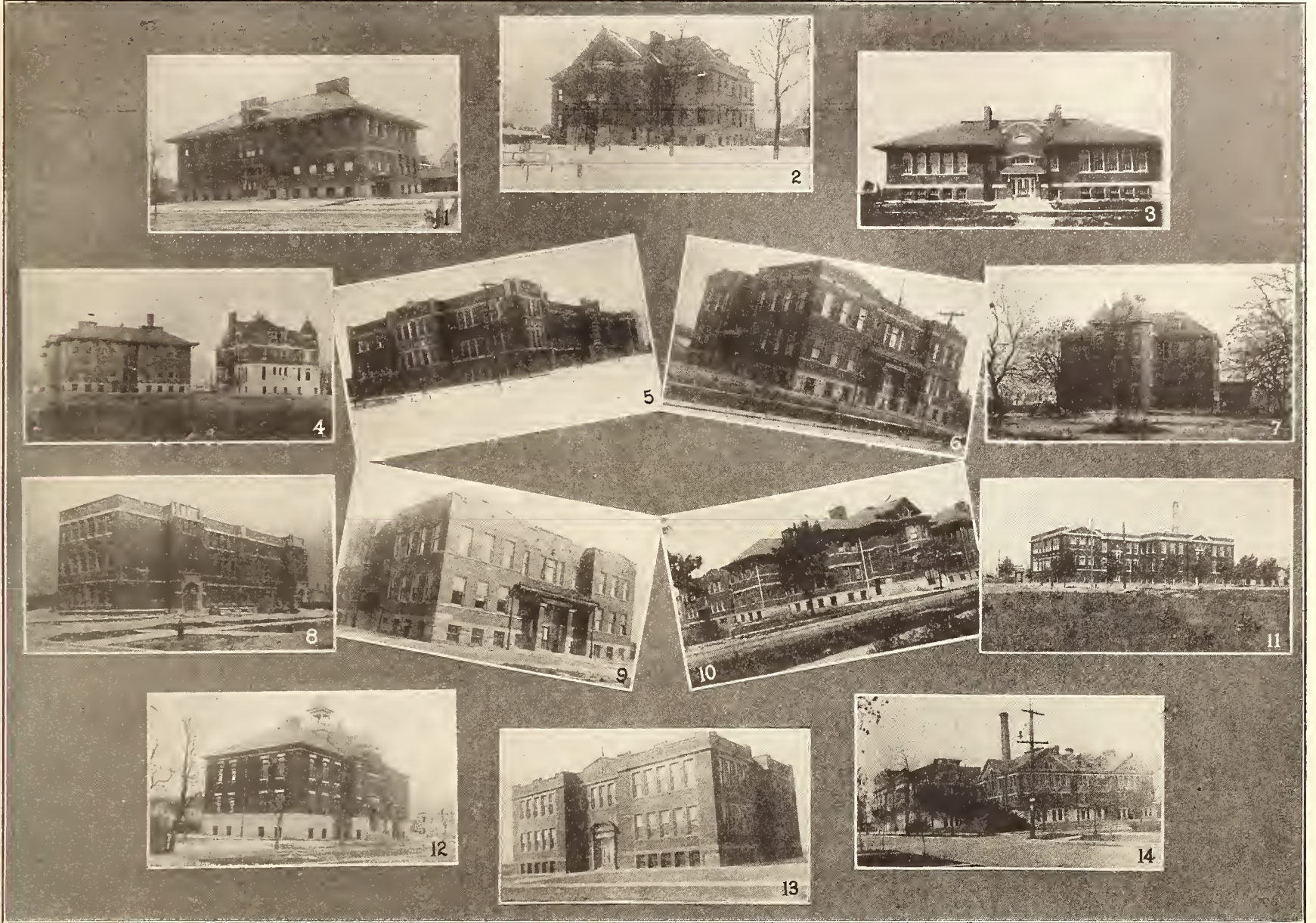

Fourteen Schools of Cicero, Ill., Where Columbia Grafonolas Have Been Installed Through the Efforts of Pupils

funds at the time, therefore the scholars took matters in their own hands and raised the money. Each school formed its own unit, entered into a campaign to collect old papers and newspapers and with the proceeds of the sales from these bought their Grafonolas.

Not a school heretofore had an instrument. Now each of the fourteen schools in Cicero has a Columbia Grafonola, bought and paid for outright by the pupils of each school. Credit

ped with Grafonolas are as follows: Woodbine, Morton Park, Drexel, Goodwin Clyde, Cicero, Sherlock, McKinley, Woodrow Wilson, Roosevelt, John Paul Jones, Burnham, Hawthorne, Columbus and J. H. Sterling Morton High School.

There are other ways that may be suggested to the schools for raising funds with which to purchase talking machines, such as cake and candy sales, suppers and fairs, essay, music

wood boulevard. All models of the Brunswick are shown in the attractive display rooms, which are finished in royal blue and ivory.

O. S. Grove has opened a new talking machine store at 517 Thirteenth street, Oakland, Cal., where the Aeolian-Vocalion line will be featured under the management of H. Murphy, formerly manager of the City of Paris phonograph department.



Superior Service

7 High-class Models

IN FOUR FINISHES POPULAR PRICED \$105 to \$350

BIG INDUCEMENTS to a LIVE DEALER—PLAYS ALL DISC RECORDS. Machines in Transit, same day ORDER RECEIVED

Write for Agency

Eastern Penna., New Jersey, Delaware and Maryland

Ask about the TONOFONE NEEDLE, the wonder of the age. Large profits and constant demand.

VITANOLA DISTRIBUTORS CO.

1025 ARCH STREET

PHILADELPHIA, PA.

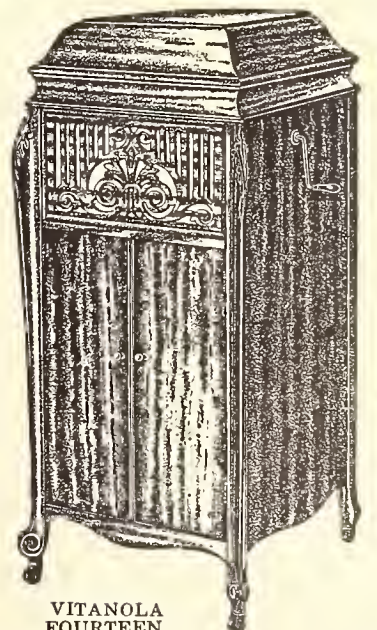

VITANOLA FOURTEEN

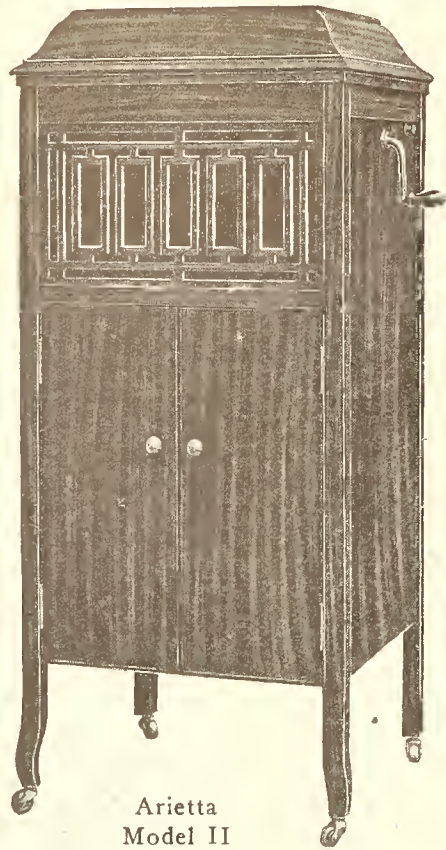

Arietta Model II

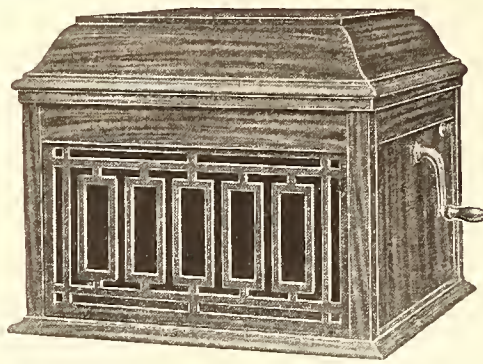

Arietta—Model I



Arietta Model III

Immediate Delivery!

NO HEAVY INVESTMENT in machines to protect yourself—no loss of sales during the busy season because of shortages. You can order as many ARIETTAS as you need now and get IMMEDIATE DELIVERY on future orders, as you need them. In other words—

The Machines You Want, When You Want Them!

And ARIETTA Prices Are RIGHT!

ARIETTA HAS EVERYTHING your most exacting customer can ask for—sweetness of tone, beauty of design, quality of materials and workmanship—and the prices are right!

That's the reason ARIETTA is putting new life in dormant phonograph departments—it represents the kind of value people are demanding nowadays—and it nets you a satisfying profit.

At least, investigate the ARIETTA proposition. Fill in and mail the coupon and get our exclusive agency offer by return mail. Do it NOW!



Arietta Model IV

Emerson Records

We are wholesale distributors. Write for list of latest releases. Quick service!

Rountree Corporation

Manufacturers
Richmond, Va.

ROUNTREE CORP., Richmond, Va.
Gentlemen: Kindly send me details about the ARIETTA PHONOGRAPH and your agency proposition, without obligating me.
Name
Address
Post Office
W-1-21

THE CHOOSING OF SALESMEN

Some Excellent Suggestions on That Subject Are Offered by Hugh Chalmers

Hugh Chalmers, one of the most-noted business men in America—so because of his master ability both as salesman and sales manager—considers the following points most valuable in hiring salesmen:

Has the salesman letters of recommendation? If so, he probably is a man who needs them. Is the salesman one who can be fired as easily as he can be hired? That is, is he a brother, cousin, uncle, father or son of a present employe or officer of the firm? Can he give a surety company bond? If not, chances are something is wrong with the man. Can he give his last employer as well as previous employers as reference? Has he made a study of the science of salesmanship? Did he work as a boy, or was he brought up in idleness until of age? Did he learn to overcome obstacles in youth or tackle the problems of the world as a full-grown man? Are his habits good? By that is not meant is he 100 per cent good, but is he a decent sort of fellow? Does he over-indulge in things he should not? Would he impress you favorably if he were trying to sell you something instead of applying for a job? Has he saved money? If not, why not? Can he get to the point quickly or does he take a circuitous route? Can he answer objections quickly? Try him out. Ask him to give three reasons why he thinks he can sell your goods and test his ability to think quickly and give logical answers. Is he quick-tempered? A quick-tempered man weakens himself in the eyes of others when he loses his temper. Is his voice pleasing or rasping? Has he respect for the opinions of others? Do his voice and his manner impress you as carrying conviction when he makes a point? Has he enthusiasm in his nature? Does he respect the opinions of others? Is he positive in his statements? Can he listen as well as talk? Does he know when to stop talking? Is he

easily discouraged when told he can't have the job?

The reasons why these questions are asked are obvious. A firm is known by its representatives and should carefully select men who reflect nothing but credit on the house which they are representing.

THE COLUMBIA IN CENTRAL EUROPE

Interesting Account of a Grafonola That Has Seen Service in Y. M. C. A. Work

W. P. Viles, Y. M. C. A. secretary, at Leitmeritz, Czecho-Slovakia, who during the war



Bohemian Children Listening to the Grafonola

won a Croix de Guerre, sent the picture herewith reproduced to the Columbia Graphophone Co. The scene shows Bohemian children surrounding a Columbia Grafonola in the Y. M. C. A. at the Leitmeritz garrison. In writing about it Mr. Viles said: "I have carried this machine through the Siberian campaign during 1918-1919 and here this year without a failure to play at every winding. This is a fact which is worthy of mention."

MEETING OF TALKING MACHINE MEN

Local Association of Retailers Fixes Date for Annual Entertainment and Discusses Numerous Matters of Trade Interest

At the monthly meeting of the Talking Machine Men, Inc., held at the Hotel Pennsylvania recently, it was announced that April 10 was the date selected for the annual dinner and entertainment of the Association, the probabilities being that the affair will be held at the Hotel Pennsylvania, as has been the case during the past two years.

The Sunday closing question also came up for discussion during the meeting and the matter was placed in the hands of a grievance committee for definite action.

The question of record exchanges among members was also considered and E. G. Brown, secretary of the Association, and Irwin Kurtz were appointed a committee to visit Philadelphia and make a study of the very successful system of record exchange that has been put in practice by the Philadelphia Association. Information as to the methods of the exchange will be placed

before the Association.

NEW BOSTON INCORPORATION

The Independent Talking Machine Co. of New England, with main offices in Boston, has incorporated with a capital of \$100,000. The incorporators are Philip E. Sage and Samuel Albert, of Cambridge, and Ella C. McLoughlin, of Brookline.

A DEBUT IN AMERICA

But well known all over the world

ODEON and FONOTIPIA

RECORDS

make their first bow to the American Trade

**AMERICAN and COMPLETE INTERNATIONAL REPERTOIRES
RECORDED IN THE COUNTRIES OF ORIGIN**

ONLY THE VERY BEST SELECTED FROM OUR VAST REPERTOIRES

ENGLISH—FRENCH—ITALIAN—SPANISH—GERMAN—
DUTCH—SCANDINAVIAN—RUSSIAN—POLISH—BOHEMIAN—
SERBIAN—HUNGARIAN—TURKISH—ARABIC—CHINESE—
GRECIAN—HEBREW—YIDDISH—SLOVENISH—
ROUMANIAN—SYRIAN

THE ARTISTIC RECORDINGS COMPRISE SELECTIONS BY THE MOST FAMOUS ARTISTS

SINGLE SPRING MOTORS

Distributors Will Appreciate Our Proposition

POPULAR PRICED TABLE PHONOGRAPHS

American Odeon Corporation

100 WEST 21ST STREET
NEW YORK



Granby Phonographs Are Selling Today In Spite of the So-Called Depression

FIFTEEN to twenty sales daily in towns of from 10,000 to 60,000 population prove Granby's contention that business is what you make it.

And so strong is our faith in this contention that we are going to prove it to every dealer who is not so steeped in pessimism that he is blind to opportunity.

**WE WILL SELL HIS CONSIGNMENT OF GRANBY
PHONOGRAPHS AND FINANCE THE DEAL FOR HIM**

What is the use of grumbling and growling over business conditions? Wake up and make business conditions what you want them to be.

Write or wire us today for details.

GRANBY PHONOGRAPH CORPORATION
N O R F O L K - V I R G I N I A
.. Factory · Newport News..

The two big song hits of the *Ziegfeld Follies of 1920* are "I've Got the Blues for My Kentucky Home" and "Marimba." Van and Schenck make a doubly popular record by singing one of these songs on each side. Order big. A-3336

Columbia Graphophone Co.
NEW YORK



REPAIRS

TALKING MACHINE TROUBLES AND HOW TO REMEDY THEM

Conducted by Andrew H. Dodin

Adjustments That Make Sales

After the rush of holiday buying is over a great help to future sales will be found in having your salesman call on a number of those customers to whom you have sold machines within the past few years, with the idea of looking over their machines to see if they are in correct playing condition. There are a great many little minor adjustments that can be made which would not only be appreciated by the machine owner, but would also help greatly in selling more records.

Probably the greatest fault found with the average machine is in the speed adjustment. The machine is almost always found to run either too fast or too slow. The record, recorded at seventy-eight revolutions per minute, must be reproduced at that speed to insure proper time for dancing, or proper pitch for the voice or instrument. On all machines, no matter of what make, will be found some method of changing the speed of the motor. Look to this point first and make the adjustment, counting the speed of the turntable by placing a small piece of white paper between a record and the turntable felt, start the motor running, and then counting seventy-eight revolutions of the paper to the minute.

Once the speed is adjusted correctly it is an easy matter to play over a record to see if the sound box is in proper adjustment. If it should squeak or make a buzzing sound take a small jeweler's screwdriver and try tightening up the needle arm adjustment screws, and then see if the wax placed at the junction of the needle arm and mica diaphragm is not cracked or off entirely. If it is simply cracked hold the flame of a match near enough to it to melt the wax so that it will run together evenly, or if off entirely put on some new wax.

The motor board can be taken out of the machine so that the motor can be oiled at the proper places and vaseline put on the governor and turntable spindle spirals. If the condition of the motor is such that it must be sent to your repair shop the matter, of course, can be taken up at once with the owner. After a thorough inspection and adjustment the customer is assured that the machine is again in first-class condition and this can be depended upon to awaken new interest in its owner to the point of purchasing some of the latest records (have latest catalogs handy) merely as an appreciation of the foresight of the dealer who has taken enough interest in him to see that he was getting the best results possible from the machine.

The wise manager knows the channels of distribution as a pilot knows the rocks and the harbors

NOVEL IDEA IN EDISON ADVERTISING

In the Edison national advertising for February, advance proofs of which have just been sent to Edison dealers, the public is invited to join with Thomas A. Edison in an experiment, the purpose of which is to ascertain and classify the effects of music on the minds and moods of mankind.

Its readers will be invited to analyze their own mental reactions to music either in their homes or at an Edison dealer's store, the only necessary appointments being an Edison phonograph, a number of Edison Re-Creations and a specially prepared chart upon which the various mood changes may be recorded.

William J. Burns, head of the Wm. J. Burns International Detective Agency, the first man to fill out the "Mood Change Chart," will be shown in the advertising analyzing his own mental reactions, as well as a photographic reproduction of the chart filled out by him and showing the results of his analysis.

NEW VICTOR SALES HELPS

Several Very Valuable Aids for the Retail Victor Dealer Just Off the Press

The Victor Talking Machine Co. has just issued a splendid budget of sales helps which emphasize its desire to help the dealer to achieve greater results in a business way. This literature includes the regular January supplement as well as supplements for the same month in the following languages: Bohemian, Greek, Hebrew (Yiddish), Hungarian, Italian, Lithuanian, Mexican, Norwegian, Polish, Portuguese, Roumanian, Russian and Swedish, as well as proofs of ready-made advertisements.

ADVERTISING RESPONSIBILITY

What you advertise you "say to the world"—responsibility is correspondingly great and the consequences are in proportion.—From a bulletin of the Dallas Music Industries' Association.

"LIBROLA"

A Library Table PHONOGRAPH

Dealers can complete their line with this high-class instrument which appeals to the best clientele.

Progressive dealers everywhere are developing a prestige building, profitable business with the "Librola." Write for prices and open territory.

Immediate Deliveries



No. 250T. Patent applied for. Price \$125 Net
48" long, 28" wide, 31" high. Finished all around
Oak, Mahogany or Walnut
All flat surfaces veneered, all others solid Mahogany or Walnut

We are ready to make immediate deliveries. Send in your orders today.

SEABURG MANUFACTURING COMPANY
JAMESTOWN, NEW YORK

\$13,624,121 IN TAXES FROM TRADE

Government Report Shows Great Income From Music Industry as a Result of Excise Taxes —500 Per Cent Gain Over Preceding Year

WASHINGTON, D. C., January 5.—According to the annual report of the Commissioner of Internal Revenue for the year ending June 30, which has just been issued, the music industries paid in excise taxes on pianos, player-pianos, talking machines, records, music rolls, etc., a total of \$13,624,121.46 on the basis of five per cent of the manufacturer's selling price. The tax represents payment on a total business during the year of \$272,482,429.20.

The figures in the latest report represent an increase of about 500 per cent over the revenue realized from the industry during the preceding year, when the total was only \$2,283,245.99, the tax being at the rate of only three per cent and then only on specified products.

It is believed that the figures given in the report should offer an additional and convincing

argument in favor of the maintenance of the excise tax rate at the present standard instead of doubling it, as suggested by the Secretary of the Treasury. It is pointed out that increasing the tax to ten per cent would serve to cut down business and would not double the revenue as hoped, while on the other hand the music industry in proportion to its volume of business has done more than its share in financing the country, especially when it is considered that in addition to the excise taxes there must also be paid the usual excess profit taxes and other levies.

PIRAMIDA PHONO. CO. ORGANIZED

The Piramida Phonograph Co., Brooklyn, N. Y., has been incorporated with a capital of \$20,000. The incorporators are G. B. Glover, N. Galpern and H. L. Williamson, 619 Eastern Parkway.

Generosity is best shown in a candid estimation of other men's virtues and good qualities.

LOPEZ SIGNS WITH COLUMBIA CO.

Famous Vaudeville Jazz Orchestra to Make Records for the Columbia Co. Exclusively

Vincent Lopez, the well-known pianist, and his jazz orchestra, known as "Lopez and His Harmony Kings," recently signed a two-year con-



Vincent Lopez

tract to record exclusively for the Columbia Graphophone Co. His musicians played seventy weeks on the Keith circuit with Pat Rooney in his "Rings of Smoke" and are said to be the highest-paid band in vaudeville. During that time they played eight weeks at the Palace Theatre, New York. They will shortly open in Pat Rooney's new show, "Oh, Pat!"

A BOOK FOR ADVERTISERS

Crain's Market Data Book and Directory of Class, Trade and Technical Papers, is just about ready for delivery. It lists all of the business publications of the United States and Canada, giving circulation, rates, size of type page, closing dates, in addition to a market analysis of each trade, profession and industry. It is published by G. D. Crain, Jr., 417 South Dearborn street, Chicago.

FEDERAL ELECTRIC SIGN



"The Sign they Never Forget"

Cuts the Cost of Getting New Customers

Every possible new customer who goes to a competitor represents so much profit loss—profit on the first sale as well as on all future sales.

If your place of business is lost in darkness, customers will continue to trade with your competitors.

Brighten up your store front—erect a Federal Electric Sign. It carries your message 24 hours a day and attracts business from a distance in each direction including cross streets. It cuts the cost of getting new customers. Made of porcelain enameled steel, it cannot rot, rust or fade. Never needs refinishing. Costs only a few cents for electricity—no other expense. Tear off and mail coupon for full information, price and free sketch of Porcelain Enameled Sign for your business—no obligation.

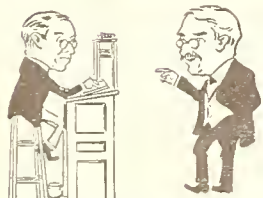

"Credit the Sign for that Last Sale, Joe"

Tear off and Mail Coupon Now

FEDERAL ELECTRIC COMPANY

Representing Federal Sign System (Electric), 8700 South State Street, Chicago, Ill.

Please send me full information, price and free sketch of a Porcelain-enameled Steel Sign for my business. Explain your 9-months-to-pay Plan.

Name City State Street and No. Business Store Frontage No. of Floors..... T.M.W. 1

Why Break Records? Just File Them!

That is if you have the wonderful Record filing system which is a feature of

The Marvelous MAGNOLA



Watching the Music Come Out

This is only one feature of many that will command your interest and attention. Let us send you handsome illustrated catalog and information as to our plans for helping you to make money with MAGNOLA.

MAGNOLA TALKING MACHINE COMPANY

OTTO SCHULZ, President

General Offices 711 MILWAUKEE AVENUE CHICAGO Southern Wholesale Branch 1830 CANDLER BLDG. ATLANTA, GA.



"Working" The Victor Talking Sign

We are tied up with them!

CHICAGO
Talking Machine Co.
112 N. Michigan Av.

Victor Wholesale



Overtime!"

Machine Factory

significant-isnt it?

Are You tied up with us?

is Exclusively

NEW YORK
Talking Machine Co.
119 West 40th St.



THE Binger
CO.
N.Y.

BEAUTIFUL PATHE FLOAT IN PARADE

Elaborate Phonograph Display Carries Off the Honors in Stirring California Pageant

ANAHEIM, CAL., January 3.—The anniversary of Armistice Day in this city was celebrated with an elaborate pageant and parade and among the varied and beautiful features none attracted more favorable attention than the float of Roland B. Ingram, the progressive Pathé dealer of Anaheim.

As will be seen by the photograph herewith given, the float was an extensive affair, being thirty-eight feet in length, and it was the largest one in a parade two miles in length. The float was drawn by a runabout car artistically decorated with streamers and bunting, and at the helm was perched a magnificent Red Rooster, representing the famous Pathé trade-mark, two charming little girls, surrounded by Old Glory, standing in the rear.

But the float proper was really the piece de resistance of the parade. On the expansive platform was arranged one of the magnificent twenty-four-sheet posters done in colors, with an ensemble group of the celebrated Pathé artists and stars of the opera, concert and theatre stage. A handsome period model stood in the rear center and the sides and arches of the float were festooned with garlands, flags, flowers, pictures and other decorations, the whole artistic conception being very well carried out.



Pathé Float That Won the Honors

is located its newly constructed two-story warehouse. According to E. F. Parr, assistant to the president, the change is expected to bring members of the executive staff in closer relation with the wholesale business of the organization. Mr. Parr also declared that during the year 1921 he expected to make a good record for sales.

The man who has sold goods is the man who can tell whether the advertising copy is able to do the same.

ATLANTA JOBBER IN NEW QUARTERS

Wholesale Offices of Edison Phonographs, Inc., Now in New Two-story Building

Phonographs, Inc., Edison jobber in Atlanta, Ga., has transferred its wholesale offices from 182 Peachtree street, at which address its retail establishment is located, to 41 Cone street, where

TO HANDLE VOCALION EXCLUSIVELY

Aeolian Co. Announces That Sale of Columbia Machines and Records Will Be Discontinued

The manager of the wholesale department of the Aeolian Co. announced this week that that company had decided to discontinue the handling of Columbia Grafonolos and records, not only in its New York warerooms, but also in its metropolitan and wholesale branches. The reason given for the change was that "the great popularity of the Aeolian-Vocalion and Vocalion records made it difficult to sell instruments or records not manufactured by the company itself."

SUGGESTION ON DEMONSTRATING

One of the best demonstrations is somewhat along these lines, says The Puritan. Take a good instrumental record reproducing the various instruments. Tell the prospect to listen for some particularly interesting part of the record, telling him in advance that when the record is completed you will explain just how the instrument achieves such perfect reproduction. After the record is played begin the sales talk on the reproducer, the tone chamber, the tone arm, the sound box, the motor, etc. Then, if necessary, play a vocal record to demonstrate vocal reproductions and one or two ensemble or solo recordings. With this plan, demonstrations will last half as long and produce specific results with a more certain and speedier close with lessened overhead expense.

NEW BROOKLYN INCORPORATION

The Messig Orchestrion Corp., Brooklyn, N. Y., has been incorporated to manufacture musical instruments. The capital of the new company is \$25,000 and the incorporators are L. J. Harris, J. O. Fowler and G. Messig, 506 Gravesend avenue.

GARFORD "BABY" PHONOGRAPHS

A Popular Line of Toy Phonographs

Nothing More-Nothing Less

The "BABY" Model RETAILS AT \$6

MODEL X RETAILS AT \$12



CLOSED

A Splendid Dealer Proposition Is Available

GENERAL PHONOGRAPH MFG. CO., Elyria, Ohio

CARDINAL RECORDS

RELEASE No. 1

January 1, 1921

POPULAR SONG HITS		POPULAR DANCE HITS	
Cat. No.		Cat. No.	
2001	"Palesteena"—Comedy Song, Sung by Fred Whitehouse	2007	"Japanese Sandman"—Fox-trot, Played by Raderman's Dance Orchestra
	"She Gives Them All the Ha! Ha!"—Comedy Song, Sung by Fred Whitehouse, Assisted by Lew Brown		"Whispering"—Fox-trot, Played by Raderman's Dance Orchestra
2002	"Broadway Rose"—Tenor Solo, Sung by Charles Hart	2008	"Grieving for You"—Fox-trot, Played by Ben Selvin's Dance Orchestra
	"I've Got the Blues for My Old Kentucky Home" —Ballad Sung by Helen Bell Rush		"Feather Your Nest"—Fox-trot, Played by Ben Selvin's Dance Orchestra
2003	"My Home Town Is a One-Horse Town"— Comedy Quartet Sung by the Harmonizers	2009	"Caresses"—Fox-trot, Played by Greene's Novelty Orchestra
	"Don't Take Away Those Blues"—Tenor Solo, Sung by Ernest Hare		"Hop, Skip and Jump"—Fox-trot, Played by Greene's Novelty Orchestra
2004	"Down the Trail to Home, Sweet Home"—Duet, Sung by Hart and Shaw	STANDARD NUMBERS	
	"I'd Love to Fall Asleep and Wake Up in My Mammy's Arms"—Tenor Solo, Sung by Charles Hart	2010	"Souvenir"—Violin Solo.. Played by Vera Barstow "Berceuse"—Violin Solo.... Played by Vera Barstow
2005	"Margie"—Harmony Trio, Sung by the Crescent Trio	2011	"Sunny South"—Medley, Played by Cardinal Concert Band
	"Old Pal, Why Don't You Answer Me"— Baritone Solo..... Sung by Elliot Shaw		"Blue Danube"—Waltz, Played by Cardinal Concert Band
SACRED NUMBER		2012	"Aloha Oe"—Instrumental Duet, Played by Ferera and Franchini
2006	"Onward, Christian Soldiers"—Sacred Hymn, Sung by Gotham Quartet		"Honolulu Waltz"—Instrumental Duet, Played by Ferera and Franchini

FIRST RELEASE A HUGE SUCCESS

Are You One of the Lucky Dealers?

IF not—WHY not?

CARDINAL

RECORDS

PHONOGRAPHS

Are Smooth
Well Recorded
Popular Standards
Latest Hits
Best Artists

Best Finish
Krasberg Motor
Automatic Stop
Automatic Cover Support
Tone Expansion Tongues

Jobbers and Dealers—Write for details of exclusive franchise

CARDINAL PHONOGRAPH CO.

Sales Office: 106 East 19th Street, New York

Factories: Newark, O.—Zanesville, O.—Pt. Pleasant, N. J.

Why the Subject of Profit Protection Is of Keen Interest to the Talking Machine Dealer

E. G. Brown, of Bayonne, N. J., secretary of the Talking Machine Men, Inc., recently received from Thomas M. Pletcher, president of the Q R S Co., Chicago, an interesting letter emphasizing the wisdom of price maintenance in fairness to the dealer and the public. The letter read in part:

"When a man mentions the two words, 'price maintenance,' the majority of his listeners begin to think about something else. They have heard the two words so often that the phrase has almost lost its meaning. So I have long since stopped using it, but I never will stop talking upon the subject of profit protection.

"A dealer can justly say, 'What business can it be of any outsider if I choose to cut my prices and sacrifice my profits, the money comes out of my own pocket; if there is any suffering to be done I am the one who pays the piper.' True enough, but you've only told half of the story and the weakest half at that.

"Every merchant is a part of the economic business structure of the country. To exist and contribute his part to the welfare of the retail structure his business must progress and prosper. Most certainly the bankrupt and the barely existing, never really prosperous merchants are not doing anything to help either themselves or the trade in which they are engaged. So, the first step to being a really sound merchant is profit protection—price maintenance—whatever you choose to call it. The asking of excessive profits is a menace, but it is so rare that we need hardly even discuss it.

"In every branch of retail trade there is an accepted margin of gross profit necessary for the payment of overhead and earning of a net at the end of the year. In some lines, such as groceries, it is small; in others, such as music lines, it is by comparison larger, but in each and every trade the accepted margin is the result of years of evolution—finding of cost of doing business, credit risks, investments, locations, rents, etc., necessary to the carrying on of any business, whether it be in the music trade or any other line.

"And the fairness of these margins is conclusively proven by the fact that capital invested in relation to sales comes within a few

per cent of yielding the same earnings in various retail lines no matter how widely divergent their character, all of which leads right to the subject of price maintenance, or profit protection, by selling at the established retail figure, the figure which pays your overhead and really nets an earning after the sale is made.

"A good many retailers ask why the manufacturers should be interested in the resale price of the article. They say as long as the manufacturer gets his wholesale figure and his bills are paid what does he care about the resale price? Our attitude on this subject is that our interest in retail prices is based upon our absolute knowledge that our prosperity is so closely interwoven with that of our dealers that the two are inseparable.

"We set a resale price on our goods that is fair—fair to the consumer—yielding a fair and satisfactory margin to the man who sells them—a safe margin. The retailer who cuts below the resale price we suggest is first of all doing himself an injury—he is doing business on a margin which is unsafe. He does his competitor an injury if that competitor is weak enough to meet his too low price—and he does the industry an injustice by disturbing the economic safety factor of proper profit margin. This holds true of every retail line in the world, from foodstuffs to farm machinery, and everything in between.

"The man who cuts prices usually consoles himself with the thought that while he may not make any money on the reduced articles his profits on other lines will make it up. This has been proven a fallacy, for in order to bring up his average general profits he would be obliged to charge more than a fair price for the other articles.

"The weak salesman invariably resorts to price cutting as a medium of securing business. And yet price cutting as a business bringer is an absolute failure. I make that statement unqualifiedly. Why? Well, how do you personally judge the value of things you buy of which you possess no technical knowledge? Such as wearing apparel, etc.? By the price, of course. And that's the way the customer judges merchandise you sell. He is not an expert, his only recourse is judgment by price,

and consequently he regards the higher-priced goods as better than those marked at a considerably lower figure.

"You may say that if two merchants side by side are selling the same trade-mark articles, one at full price, the other at a cut price, this statement will not maintain. But it does. When a consumer sees two articles in two windows bearing the same trade-mark, at two different prices, his reaction is that the cut-price goods must be seconds or inferior in quality; in other words, there must be a hidden reason for the cut.

"And he is always safe in dealing with the full-price merchant, because that man's price maintenance policy enables him to stand back of his goods and gladly render the kind of service that your cut-price merchant cannot afford to give.

"Price cutting used to be a terrible evil in the ready-mixed paint business; retailers everywhere cut their profits into nothing, using paint presumably as a leader, depending on price attractions to attract other trade to their stores. An acquaintance of mine who is interested in the industry made an exhaustive investigation of the entire situation, and his records showed that in towns where there were three merchants cutting and one merchant protecting his profits by price maintenance the full-price dealer was doing more business than any of his competitors. This situation existed not in one town, but practically every city investigated.

"I am so radical on this subject that I do not hesitate to state frankly that I hope the time will come when Congress will see its way clear to pass a law compelling a manufacturer to set a fair retail price on his merchandise, printed right on the goods, and enforce adherence thereto on the part of everyone concerned.

"The ultimate purchaser is absolutely protected by a price suggested by the manufacturer. Why? Simply because the manufacturer knows he must fix a fair price to insure his sales in competitive markets. He realizes that he must have volume. If his price is too high it will restrict his sales; therefore, the buying public is as fully protected as the retailer who sells the goods."



DITSON SERVICE

Has back of it years of successful experience and an understanding of dealer problems that will make the road smoother during the coming months.

VICTOR EXCLUSIVELY

Chas. H. Ditson & Co.
NEW YORK

Oliver Ditson Co.
BOSTON

The continued growing demand for the Sonora proves that the public wants the **BEST—and the best at the same price is always easy selling**

IT isn't MAGIC that creates the demand for Sonoras: it's MERIT! Buyers look at the Sonora and see its superb appearance. They listen to the Sonora and hear its magnificent tone. They examine the Sonora and observe its important exclusive features. Then they buy the Sonora because critical comparison shows that Sonora is unequalled.

THE Sonora line is extraordinarily complete, including 24 marvelous period models and 7 charming upright styles. Sonora's quality is internationally famous.



You want to handle the phonograph the public wants. The price of Sonoras ranges from \$75 to \$1800 and each Sonora at its price represents matchless value.

Sonora—English Renaissance-Edgemoor

The path to big sales and to large cash sales is through the wonderful

THE INSTRUMENT OF QUALITY
Sonora
 CLEAR AS A BELL



WITH Sonora's new factories completed and working to capacity we may be able to add your name to the list of successful Sonora dealers providing you make early application. *The best at the same price sells the quickest.*

Sonora has numerous patents of its own and is licensed and operates under BASIC PATENTS of the phonograph industry, which insures you against troublesome patent litigation. To MAKE, USE or SELL an infringing patent constitutes a violation of the patent law.

American Hardware & Equipment Co.,

Charlotte, N. C.
North Carolina and South Carolina.

Gibson-Snow Co.,

Syracuse, N. Y.
State of New York with the exception of towns on Hudson River below Poughkeepsie and excepting Greater New York.

W. B. Glynn Distributing Co.,

Saxtons River, Vt.
States of Maine, New Hampshire, Vermont and part of Massachusetts.

Griffith Piano Co.,

605 Broad St., Newark, N. J.
State of New Jersey.

Hessig-Ellis Drug Co.,

Memphis, Tenn.
Arkansas, Louisiana, Tennessee, Mississippi.

Kiefer-Stewart Co.,

Indianapolis, Ind.
Entire State of Indiana.

Lee-Coit-Andreesen Hardware Co.,

Omaha, Nebr.
State of Nebraska.

The Magnavox Co.,

616 Mission Street, San Francisco, Cal.
Washington, California, Oregon, Arizona, Nevada, Hawaiian Islands, Northern Idaho.

C. L. Marshall Co., Inc.,

82 Griswold St., Detroit, Mich.
409 Superior St., Cleveland, O.
Michigan and Ohio.

Minneapolis Drug Co.,

Minneapolis, Minn.
States of Montana, North Dakota, South Dakota, Minnesota.

I. Montagnes & Co.,

Ryrie Bldg., Toronto, Canada.
Canada.

Moore-Bird & Co.,

1751 California St., Denver, Colo.
States of Colorado, New Mexico and Wyoming east of Rock Springs.

M S & E,

221 Columbus Ave., Boston, Mass.
Connecticut, Rhode Island and Eastern Massachusetts.

Robinson-Pettet Co., Inc.,

522 West Main St., Louisville, Ky.
State of Kentucky.

Schroeder Piano Co.

820 Liberty Ave., Pittsburgh, Pa.
Western Pennsylvania and West Virginia.

C. D. Smith Drug Co.,

St. Joseph, Mo.
Missouri; Northern and Eastern part of Kansas and five counties of N. E. Oklahoma.

Sonora Distributing Co. of Texas,

Dallas, Texas.
Western part of Texas.

Sonora Phonograph Co., Inc.

279 Broadway, New York.
Distributors for Greater New York and towns on Hudson River below Poughkeepsie.

Southern Drug Co.,

Houston, Texas.
Southeastern part of Texas.

Southern Sonora Co.,

310-314 Marietta St., Atlanta, Ga.
Alabama, Georgia and Florida.

Southwestern Drug Co.,

Wichita, Kans.
Southern part of Kansas, Oklahoma (except 5 N. E. counties), and Texas Panhandle.

Strevell - Paterson Hardware Co.,

Salt Lake City, Utah.
Utah, Western Wyoming and Southern Idaho.

C. J. Van Houten & Zoon,

Marquette Bldg., Chicago, Ill.
Illinois and Iowa.

Yahr & Lange Drug Co.,

Milwaukee, Wis.
Wisconsin, Upper Michigan.



The Highest Class Talking Machine in the World

EDISON DISC JOBBERS TO CONVENE IN MONTREAL

Association to Hold Annual Convention in That City on February 10th and 11th

Preliminary announcement has been made to the effect that the annual convention of the Edison Disc Jobbers' Association will be held in Montreal on February 10 and 11. It is understood that the Edison Laboratories will be represented as usual.

This will be the first time in the history of the Edison jobbers' organization that their annual convention will be held outside of New York City, all former conventions having been held at the once famous Knickerbocker Hotel, which was closed permanently several months ago. Just where the next convention will be held in Montreal has not yet been disclosed.

SERVICE ON TRIAL IN JANUARY

Dealers Must Live Up to Expectations of Their Customers During the New Year

"The service given by every dealer will be up for trial before a brand-new jury during January," says the Victor Talking Machine Co. in its monthly letter to the trade. "All of the new customers you served during the holiday season will take it as a matter of course that you will be able to supply the new monthly records. Try to acquaint every one of your new customers with the first-of-the-month idea and the direct relation between the new supplement and the Victor catalog.

"It will pay you to make the most of the sales helps by co-ordinating your advertising activities. Advertising is just as important to your success in January as in December; more so, in fact, as the results will be governed largely by your persistency in keeping your name before the people of your community."

MOHR NOW WITH COLUMBIA

Carl H. Mohr, formerly advertising manager of the Standard Electric and Elevator Co., is now associated with the Columbia Graphophone Co., at Baltimore, Md.

OFFER PERIOD MODEL SERVICE

Dealers May Use Special Rooms of Collings & Co. to Demonstrate Period Designs to Prospects—Expects Plan to Aid Sales

Collings & Co., the well-known Victor distributors of Newark, N. J., have just forwarded to the trade in their territory a letter covering their "Period Model Service." Dealers are cordially invited to inspect the new "Period Model Room," where the various types of period models are shown in appropriate surroundings.

This move was made by the organization to free dealers from the handicap of not having such an exhibition room. Dealers having prospects for period models who have not decided on the particular design are invited to use the Collings & Co. quarters for both demonstration and sales purposes. Appointments for this purpose are made in advance and the particular settings are arranged to suit the occasion.

Collings & Co. believe that this arrangement will greatly increase the dealer's sales in period models, or at least will facilitate them. The shipments of the instruments following the purchase can be made direct from the warerooms of Collings & Co., but billed, of course, by the dealer in his usual manner.

OPENS STORE IN ALLENTOWN

J. H. Johnson to Handle Remington Phonograph in That Territory

ALLENTOWN, PA., January 4.—J. H. Johnson, one of the foremost violinists in this vicinity, has opened an up-to-date music store at 518 North Seventh street and carries a complete line of musical instruments and all accessories. He is the exclusive agent in this district for the Remington phonograph. Mr. Johnson is well known as an instructor of the violin, having studied extensively with the foremost teachers in New York and Philadelphia. In addition to his duties connected with his new enterprise he will continue with his professional work as before.

Washington Irving has said that a sharp tongue is the only tool that grows keener with constant use.

MICA DIAPHRAGMS

Absolutely Guaranteed Perfect
We get the best India Mica directly.
We supply the largest Phonograph Manufacturers.
Ask for our quotations and samples before placing your order.

American Mica Works
47 West St. New York

NEW BRIDGEPORT BRUNSWICK STORE

General Music House Finds Enlargement Imperative and Makes Improvements

BRIDGEPORT, CONN., January 3.—What was once a drug store on the corner of Broad street and Fairfield avenue is now the home of the Brunswick phonograph for this city. This is the second improvement that Mr. Gilman, the proprietor, has made on his store in the last two years.

Mr. Gilman was first located on Main street and his small quarters soon became cramped and he was compelled to seek a larger store. He then located at 235 Fairfield avenue about four years ago and had ample space in a room 25 by 100 feet. The following year it was necessary to occupy the upper floor, but business increasing forced him to consider a larger quarters and addition in his force. When the drug store was vacated he cut through into the store on the corner and turned it into a beautiful musical parlor.

The music store now occupying 229-235 Fairfield avenue is devoted entirely to musical merchandise. One can buy anything from an accordion to a \$1,500 phonograph. They are exclusive agents for the Brunswick phonograph and records. Mr. Gilman started his career as a violin and mandolin teacher, also handling accessories.

The Southern Illinois Music Co., are also Edison dealers in Christopher, Ill., where they report business far ahead of that of last year.

Puritan

Distributors for the Puritan Phonograph in Western Pennsylvania, So. W. New York, Western Maryland, Virginia and West Virginia

Special— Player Rolls 4 for \$1.00

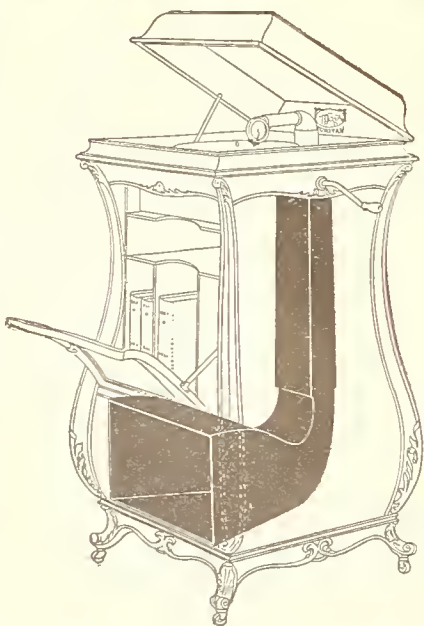

Melodee and Universal Player Rolls. Late popular dance numbers, songs, waltzes, etc.—also standard favorites and Hymns while they last—\$25.00 per 100. Order now—we will make you a good selection.

NEEDLES

BRILLIANTONE WALL KANE TONOFONE VIOLAPHONE VALLORBES VELVETONE
Record Brushes—Repeater-stops—Record Albums

Reed Efficiency Furniture Demonstrating Rooms Counters Racks
Our Specialty—Write for catalog

UNIVERSAL DISPLAY FIXTURES FOR YOUR EVERY NEED—50% OFF LIST

THE REED COMPANY INC.

5748-50 Ellsworth Avenue

:::

:::

:::

Pittsburgh, Pa.

Eight beautiful models, ready for immediate shipment.

Each unit manufactured in Puritan's own factory and every part is guaranteed.

The Puritan Phonograph (the phonograph which literally speaks for itself). There is richness and purity in the reproduction—quite different from other instruments—that invariably pleases the listener. The most critical music lovers declare that such smoothness, clearness and volume of tone has never been produced by ordinary phonograph. (Write us for catalog and dealership.)

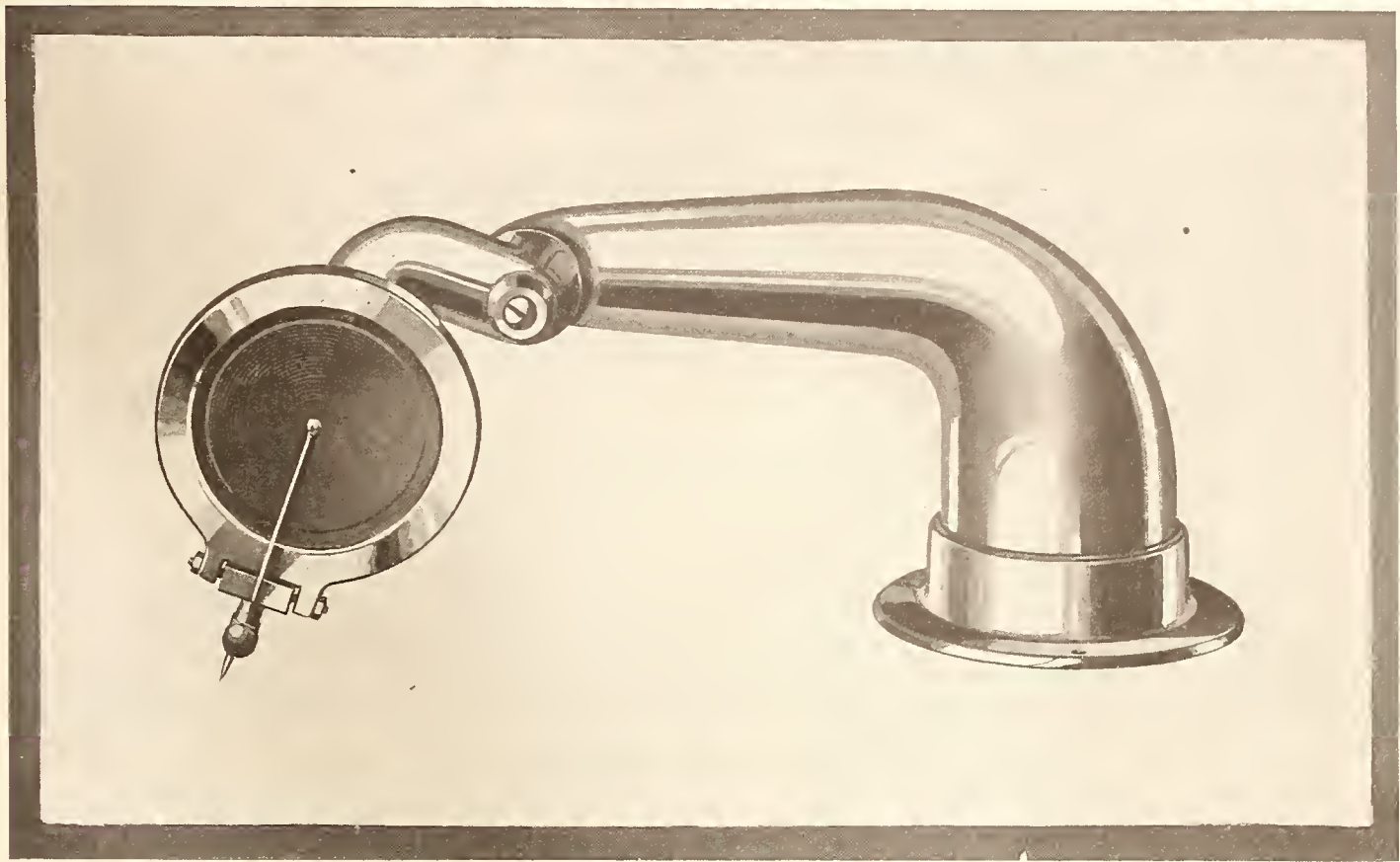

Blood Tone Arm and Reproducer 8½ inch length

Renowned the country over for its simplicity of design and operation, its mellow, natural and life-like reproduction, it has been generally accepted as standard equipment for high-grade phonographs.

EDISON

Universal Attachments

VICTOR

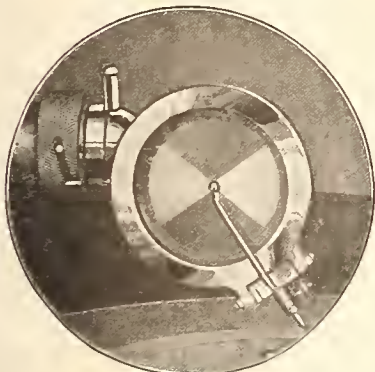

Fig. A

Every owner of an Edison phonograph is a prospect for this attachment. Plays Victor records with that superior, mellow quality of tone so characteristic of the "Blood."

Victor Position

Fig. A shows Blood Reproducer in position for playing Victor and other lateral cut records.



Fig. B

Hill and dale records are reproduced correctly by the "Blood" method. A demonstration will convince you of its superior playing qualities.

Edison Position

Fig. B shows Blood Reproducer in position for playing Edison and other hill and dale records.

W
R
I
T
E
Today
for
S
A
M
P
L
E
S

Victrola owners can now enjoy the wonderful creations of SERGEI RACHMANINOFF, the celebrated Russian pianist, so artistically reproduced in Edison records.

Edison Position

Fig. C shows Blood Reproducer in position for playing Edison and other hill and dale records.

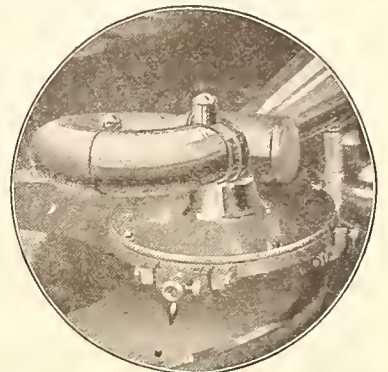

Fig. C

Equipped with the "Blood" mute and Nomika diaphragm, every note and every word is reproduced in all its original clearness and beauty.

Victor Position

Fig. D shows Blood Reproducer in position for playing Victor and other lateral cut records.

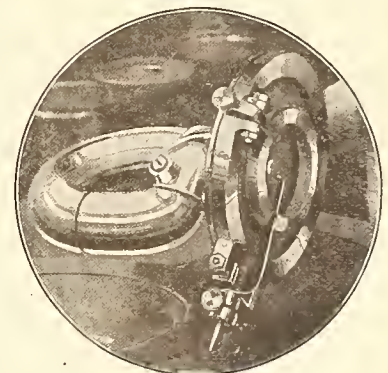

Fig. D

START THE NEW YEAR RIGHT

Every piece of apparatus that leaves our factory is covered by the "BLOOD" guarantee—SATISFACTION OR MONEY REFUNDED. Let's get acquainted now.

Jewel Phonoparts Company

670 W. Washington Blvd.

Chicago

The New
BLOOD
AUTOMATIC STOP
is now ready

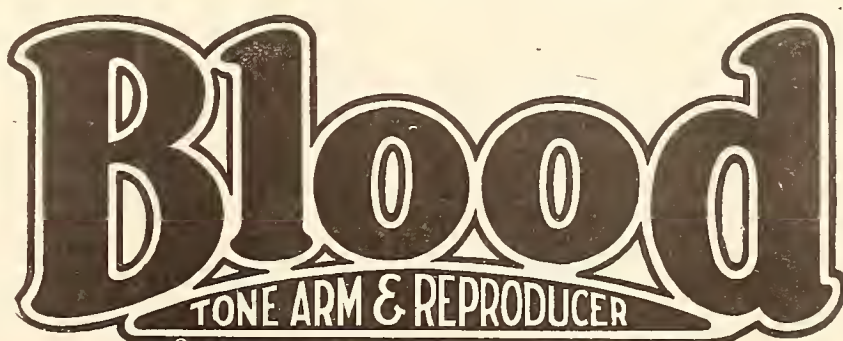

Immediate Deliveries on
Tone Arms, Uni-
versal Attachments,
Automatic Stops



Kerekjarto Week

From January 29 to February 6

will repay you in dollars and cents. Kerekjarto is the great new Hungarian violinist, who counts his European followers by the hundreds of thousands. He has just made his first Columbia Records. Watch for them. Columbia 79456 and 49900.

Columbia Graphophone Co.
NEW YORK

ANSONIA DEALER GIVES CONCERT

A. H. Yudkin Presents Edison Artists in Tone-test Recital—Announces Opening of New Store in Charge of Miss Anna Kanaly

ANSONIA, CONN., January 4.—For the past several years A. H. Yudkin, local distributor for the Edison, has been treating the public once each season to a musical entertainment of a high order. Recently Gould armory was filled to more than its seating capacity when the Alderman presented Miss Betsy Lane Shepherd, soprano, and Miss Madeline MacGuigan, violinist, assisted by Igor Sokoloff, 'cellist; Rienzi Thomas, pianist, and the Edison diamond disc phonograph. More than 700 residents of the associated communities listened to a splendid program.

The several numbers were rendered delightfully and the audience was more than satisfied with its evening's entertainment. Each number was applauded and the program was of a generous length.

The Re-creation of Miss Shepherd's voice was one of the hits of the evening. Rendering "Comin' Through the Rye," she ceased singing when the lights were turned out and the Edison phonograph on the stage with her took up the song in her own voice and carried it through, while the audience once again was shown the possibilities of the Edison.

It was announced that Mr. Yudkin would open his new Edison salesroom at Elizabeth and Third

streets in the building purchased by him a few months ago. The entrance will be on Third street. The exterior appearance of the block has been changed by the installation of three large plate-glass windows on the Third street side, and the interior has been thoroughly renovated and made into a salesroom, which will be managed by Miss Anna Kanaly, who has been in Mr. Yudkin's employ in the Main street store.

TAKE ON THE BUXKIN LINE

The Cabinet & Accessories Co. has added the well-known Buxkin line of moving covers to the list of talking machine accessories distributed by this institution. Otto Goldsmith, president of the company, reports a good demand for these covers and that they are giving entire satisfaction wherever sold. The World is in receipt of an attractive but yet entirely useful greeting presented by the Cabinet & Accessories Co. during the Christmas season. It consists of a leather folder containing legal document sized envelopes for Liberty Bonds, life, fire, health and accident insurance policies, contracts, deeds, notes, mortgages and wills.

CLEMENS RESIGNS FROM CHENEY

J. R. Clemens has resigned as advertising manager of the Cheney Talking Machine Co., of Chicago, to join the advertising department of the Federal Electric Co., of the same city. Mr. Clemens' successor has not yet been named.

ADVERTISING STIMULATES DEMAND

An Interesting Disquisition on the Subject of "Who Pays for the Advertising?" Which Is of Timely Interest These Days, When Publicity Is One of the Greatest Essentials

In a recent issue of "The Puritan," which is issued by the United Phonographs Corp., in the interests of the Puritan phonograph, there appears the following timely comment on that oft-repeated question, "Who Pays for the Advertising?":

"The more you turn this question over in your mind, the more difficult seems the answer. Very often a man will change his opinion about it half a dozen times in a week—if he thinks that much about it.

"If you ask the man who pays the advertising bill, he will tell you 'I do.' But, does he?"

"If he didn't advertise his product, the public demand for it would be less, for advertising certainly stimulates demand. Smaller demand would mean fewer and smaller dealer's orders; therefore there would be less sales and less profit. Smaller orders from dealers would also mean restricted production, and this would of course increase manufacturing costs per article, because a manufacturer can produce a thousand identical articles relatively cheaper than he could produce one. In other words, the manufacturer makes more money with advertising than without it. So how can he be said to pay for the advertising?"

"Lots of people say in an offhand way, 'Oh, the consumer pays for the advertising. But, inasmuch as advertising enabled the manufacturer to produce in quantities big enough to lower manufacturing costs, the consumer is actually benefited by lower prices. It is perfectly clear then that the consumer does not pay for the manufacturer's advertising.

"We have closed two sides of the triangle; let's see about the third. Does the retailer pay for the advertising? Evidently not, because advertising increases his turnover, and therefore his profits.

"Then, who does pay for the advertising, We cannot tell, unless it is the competitor who pays for the other man's advertising in the business he loses by not advertising at all.

"The foregoing ought to act as a stimulant to those dealers who have not been accustomed to steady and consistent advertising.

"You will need cuts. We have them for the asking. Also, display features of various kinds to back up the work you do in the newspapers.

"There can be no steady, consistent growth of a business without steady, persistent advertising. The size of the advertisement is of less importance than the frequency with which it appears. Nor is it size so much as eye-catching features, like a good illustration and good typography, that causes the public to think of your store. No matter what size store you keep, there should be someone in it whose job it is to take care of the advertising, and get results for the money spent."

Phonograph Dealers—

People who cannot afford to buy Phonographs are buying Violins, Guitars, Banjos, Ukuleles, etc.

Why Wait

and let this business go by your shop?

Extend your line to include

DURRO VIOLINS, BOWS, STRINGS, Etc.

LESTER & SALANTI ACCORDEONS

ABBOTT BAND INSTRUMENTS

DUSS BAND HARMONICAS

S. S. STEWART BANJOS, GUITARS, UKULELES

OUR POPULAR LINES OF ACCESSORIES

They will not add to your overhead expense.

They are quick sellers and yield liberal profits.

They make fine displays and draw repeating customers.

Write today for complete catalog and assortments
for Phonograph Dealers



DURRO
Choice of Artists
Throughout the World

BUEGELEISEN & JACOBSON

5-7-9 UNION SQUARE

NEW YORK



DIRECT FACTORY PRICE—JUST MENTION THE QUANTITY

**MOTORS
TONE ARMS
REPRODUCERS**

CASTINGS { **TURNTABLES
MOTOR FRAMES
TONE ARMS
HORNS and THROATS**
Grey Iron
and Brass for

**Stylus Bars
Screw Machine Parts
Talking Machine Hardware**

Direct Quantity Importations On

{ **JEWEL and STEEL (Bulk or Packed)
PHONOGRAPH NEEDLES
GENUINE RUBY BENGAL MICA**

*EASTERN REPRESENTATIVE
CHERINGTON MFG. CO.
IRONCLAD MOTORS*

D. R. DOCTOROW

*Vanderbilt Ave. Bldg.
51 East 42nd St., New York
Tel. Vanderbilt 5462*

OPENS NEW YORK SALES QUARTERS

Cardinal Phonograph Co. Invites Dealers to Visit New Office at 106 E. Nineteenth Street—Cardinal Record Releases for January—New Castle Model Popular—The Trade Outlook

The Cardinal Phonograph Co. has placed the first Cardinal record release, consisting of twelve discs, in the hands of the dealers during December. The second release of ten records is ready for delivery January 15. Records will be released twice a month hereafter. The large number of sample orders received from the dealers throughout the country indicates that there is plenty of room for a new record of good quality.

The new sales headquarters, at 106 East Nineteenth street, New York, were thrown open on Monday, December 27, and all business with the Cardinal Phonograph Co. will be transacted at that address. An invitation is extended dealers to make that address their headquarters while in New York City and have their mail addressed to them there. This office is in charge of Robert Clifford and is equipped to give service to the dealers. A large stock of phonographs and records will be carried, assuring prompt delivery.

Wm. S. Lucas, who has been covering the Middle West territory, will be in New York to assist Mr. Clifford in interesting metropolitan dealers. Albert Freedman, who is well known through his connection with the Emerson Phonograph Co., will also be a city representative.

The new Castle model No. 35, which was placed on the market in December, met with instant response from the dealers, and it is expected that it will prove a big seller.

The Cardinal Phonograph Co. has again increased its output of phonographs to keep up with the demand.

The number of advance orders received for records from dealers who have promised to put in a full line of phonographs with the records is a prediction of a substantial increase in business for the future.

The prospects for the year just opened look very favorable and the company is planning an advertising campaign that will greatly assist the dealer in the disposing of Cardinal products.

SETTING THE READER RIGHT

Through an error, the instrument pictured on the first page of the insert of the Sonora Phonograph Co., Inc.'s advertisement in the December World was entitled The English Renaissance, de Luxe—Edgemoor. This should have been Italian Renaissance, de Luxe—Milano, the correct legend being given on page 3 of the insert above mentioned.

THE VALUE OF ATMOSPHERE

If it can be said that your store has "atmosphere" then it is a sign that what you are doing is being appreciated. Atmosphere is of paramount importance in a music store and the public response to the right atmosphere is quick.

COTTON FLOCKS

.. FOR ..

Record Manufacturing

**THE PECKHAM MFG. CO., 238 South Street
NEWARK, N. J.**

AN ORIGINAL LETTERHEAD

Ogden Sectional Cabinet Co. Uses Four-page Letterhead for Correspondence

LYNCHBURG, VA., January 2.—The Ogden Sectional Cabinet Co., Inc., of this city, is making use of a four-page letterhead for its correspondence. The first page is blank for correspondence use. The inside spread carries a detailed descrip-

tion of both the Ogden system for the dealer and the You-Nit cabinets for table type machines. On the last page is a comprehensive order blank for the convenience of the dealer in sending in his requirements.

SHELL-O-PHONE CO. IN BANKRUPTCY

E. Buell was recently appointed receiver for the Shell-O-Phone Talking Machine Co., Chicago, by Judge Carpenter, of the U. S. District Court. A petition in bankruptcy was filed on December 15, the day before the appointment of the receiver, by the Oakville Co., Oakville, Conn.; Modern Method Platers Co., Milwaukee, Wis., and the Wisconsin Die Casting Co., also of that city. The liabilities listed totaled \$6,132.56. No assets were given.

OPENS STORE IN BRIDGEPORT

The E. K. Music Shop has recently opened a new store in Bridgeport, Conn., at 927 East Main street. Talking machines, records, accessories and sheet music are carried.

**INDIVIDUALITY IN YOUR PRODUCT
WILL MEAN MORE SALES FOR YOU!**

Competition in talking machines is growing more strenuous each day. It is not a question of price any longer but of quality—higher quality and better tone. Maintain the claims of quality and tone reproduction in your product—make it be individual.

**Equip Your Phonographs With the New
EMPIRE UNIVERSAL TONE ARM and REPRODUCER**

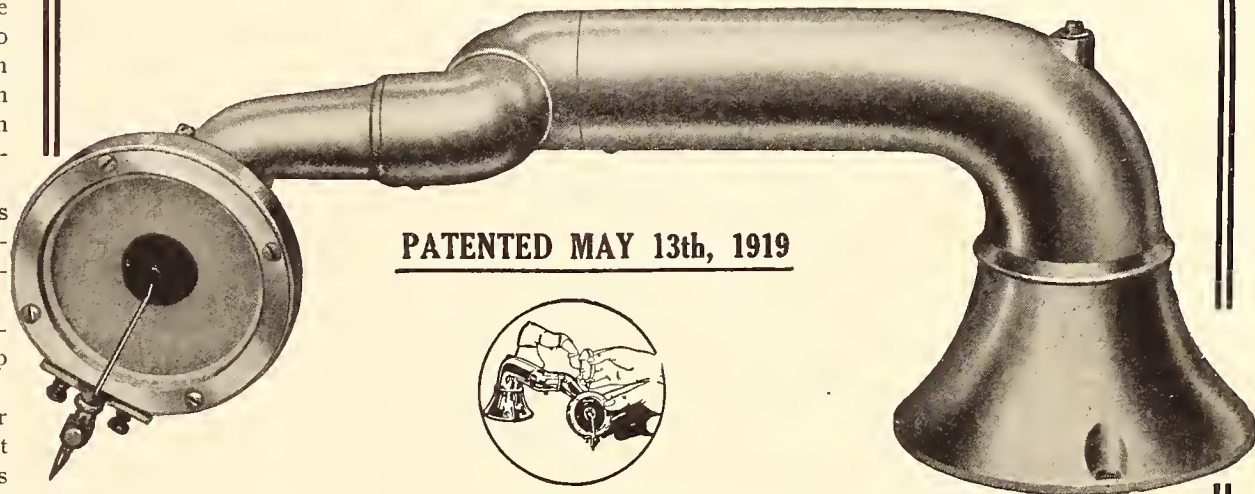

PATENTED MAY 13th, 1919

We are prepared to submit to reliable manufacturers samples of our tone arms and reproducers in order to enable them to determine the merit of our product. Our prices are low and the quality of our product is second to none. Write or wire us for samples and quotations and give us an outline of your 1921 requirements.

We Also Manufacture Attachments for Edison Phonographs



No. 1
Plays
only lateral
cut records.
Retail
at \$5.00

No. 2
Plays all
records.
Retail
at \$7.50

THE EMPIRE PHONO PARTS CO.

1362 EAST 3rd STREET

CLEVELAND, OHIO

Branch Office: 33 Auditorium Bldg., Chicago, Ill.

MAGNAVOX Music and Voice Telemegafones

The Magnavox Telemegafone is one of the most important inventions of the Magnavox Company. It reproduces music and voice with the electro-dynamic principle of the telephone.

MAGNAVOX REPRODUCES MUSIC AND VOICE

MAGNAVOX TELEMEGAFONE

Magnavox to 'Bawl Out' Bond Slackers

Will Urge Buying of Victory Loan

Magnavox Will Transmit Voice of Airman a Mile Up to Use Invention in Aid of Subscriptions.

Magnavox Carries Voice of Visitor Distinctly

Magnavox Carries Voice of Visitor Distinctly

Magnavox Carries Voice of Visitor Distinctly

Magnavox Carries Voice of Visitor Distinctly

Magnavox Carries Voice of Visitor Distinctly

Magnavox Carries Voice of Visitor Distinctly

Magnavox Carries Voice of Visitor Distinctly

Magnavox Carries Voice of Visitor Distinctly

Magnavox Carries Voice of Visitor Distinctly

Magnavox Carries Voice of Visitor Distinctly

Magnavox Carries Voice of Visitor Distinctly

Magnavox Carries Voice of Visitor Distinctly

Magnavox Carries Voice of Visitor Distinctly

Magnavox Carries Voice of Visitor Distinctly

the fulfillment of three great Prophecies

"We represent small sounds as great and deep, likewise great sounds extenuate and sharp. . . . We have certain helps, which set to the ear do further the hearing greatly. We also have divers strange and artificial echoes reflecting the voice many times, and as it were tossing it; and some that give back the voice louder than it came, some shriller, and some deeper."
—SIR FRANCIS BACON in *The New Atlantis*, published 300 years ago.

Edward Bellamy published, in 1888, a famous novel entitled "Looking Backward." In this novel he described a remarkable contrivance by means of which the world of the period A. D. 2000 would hear music, the human voice, or other sound magnified to any desired volume.

MAGNAVOX appeared 83 years before Bellamy's prediction and 283 years before H.G.Well's prophesy.

"Graham's attention was immediately arrested by a violent, loud hoot, followed by a vast leathery voice: 'The master is sleeping.' 'He is in excellent health'....Graham stopped at the first sentence.... This was the General Intelligence Machine.... For a space it seemed to be gathering breath...He paused. He addressed himself to the unseen multitudes (by means of it)."

—H. G. WELLS, in *When the Sleeper Wakes*, Published in 1899 and prophesying the world of A. D. 2200.

MAGNAVOX Phonograph Projected Beyond Tent City by Invention of Peter L. Jensen, Delegate to National Electrical Association Convention; Meeting Adjourns.

Magnavox Music and Voice Telemegafone. Wales, Vice-President of the National Electrical Association, and many public speakers have used it successfully.

MAGNAVOX DEMONSTRATION ENTERTAINS HOTEL GUESTS

THE MAGNAVOX COMPANY, Oakland, California

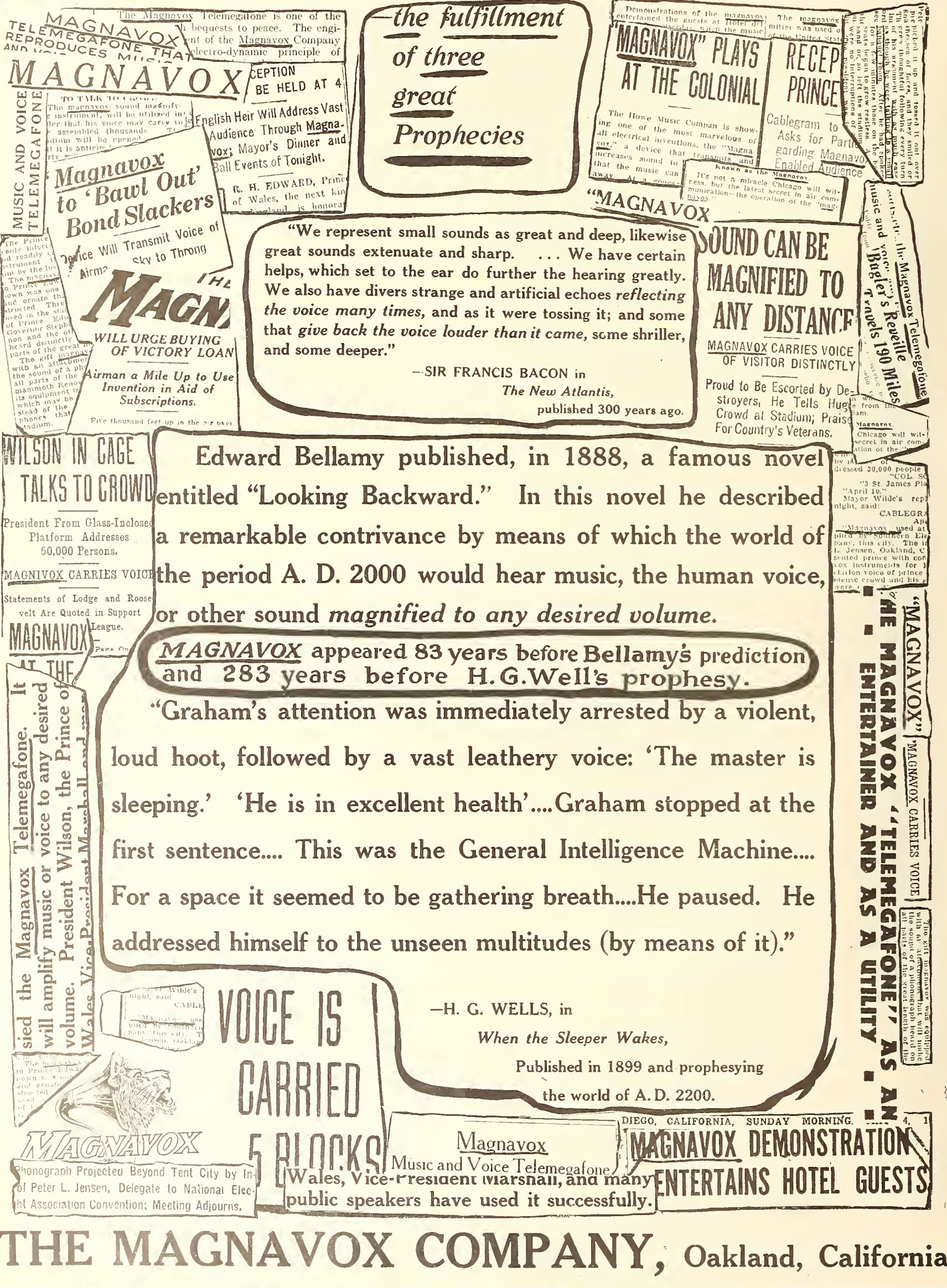

POT LEADED OR PAINTED WHITE

Some Worth-while Comments on Business Methods From the "Voice of the Victor"

There has been much said and written in the talking machine and other trades regarding the tendency of certain merchants to resort to unsound, if not questionable, business methods in an effort to stimulate sales. In commenting on this situation there appeared recently in "The Voice of the Victor" the following editorial captioned "Pot Leaded or Painted White" which is worthy of careful consideration. The editorial reads:

"Does anybody deliberately choose to do business on a wrong basis?

"The obvious negative answer then prompts the question, why is it that wrong tendencies in competitive sales work often originate and gain considerable impetus before the error is realized and correction made difficult?

"The usual answer—Competition—is not sound in logic but deceives even those who utter it.

"Competition is a fine thing—that is, it can be! It can be a fine, invigorating influence that leaves the hands clean and the eyes clear—or it can be a mean, furtive nickel-snatching nightmare.

"The kind of competition you have in your town or in your neighborhood will be the kind that you, yourself, help to bring about. You can compete for sales or compete for repossessions. The competition will be as keen in the one case as in the other—the difference will be in the profits.

"Some years ago eight enthusiastic young men built eight sailboats, all exactly alike, so that they might indulge in what is known as "one design" yacht racing. It's the best kind of sport because the results are up to the relative skill of the individual. They were fine, seaworthy, little boats, all painted white, and there was no need of handicaps because they were all on the same footing.

"Then one man—a bit greedier than the rest—gave his boat a coat of pot lead and won the next race easily.

"Pot lead, being a slick and slippery article, reduces what sailor men know as the "hull friction." The boat slides through the water a little better than when paint is used. And so, since there was no rule against pot leading, there was nothing for it but to pot lead all the boats because the other seven men naturally weren't willing to give one man so obvious an advantage. So, by the time the next race was sailed all the boats were again on an equal footing—with this difference:

"Pot lead makes a boat faster, but it also makes her dirtier. Every time you touch it you get smeared with black.

"After a few races the eight enthusiastic young men were most extraordinarily sick of their bargain. True enough, they were all on the same footing, but they were dirty, whereas in the first place they also had been all on the same footing—and clean.

"The pot lead was taken off—but it took much more time and effort to get back to their decent and clean competitive basis than it had to befoul the fine, clean, little craft they had started out with—and the point is that, painted or pot leaded, clean or dirty, they had been on the same competitive basis in each case.

"What's the use?

"You think you'll get a little more business (save the mark!) if you advertise a dollar down and a dollar a month. All right! How long is it before John Jones across the way advertises a dollar down and fifty cents a month?

"Then it's your move, isn't it?

"And the 'Business' you get by this method—is it really any good to you? Do you think bookkeepers and collectors work for nothing? Or that banks lend money for the fun of the thing?

"Competition? Competition is the life of trade, so they say, but there's one sure thing, and

that is that if your competition is for the purpose of making money you'd better compete for business that's really worth something."

A MESSAGE TO INSPIRE CONFIDENCE

Edison Phonograph, Ltd., San Francisco, Offers Dealers Some Convincing Figures Regarding the Country's Prosperity, Its Development and Its Future Possibilities

SAN FRANCISCO, CAL., December 28.—Addison N. Clark, manager of the sales promotion department of Edison Phonographs, Ltd., is of the opinion that if retail merchants in musical lines will lift their eyes beyond the immediate commercial horizon at this time of price deflation in most lines of merchandise they will see much to encourage them. Following out this idea Edison Phonographs, Ltd., sent out to their dealers all along the Pacific Coast a Christmas greeting of an unusual sort. Not only was there offered a message of optimism, but there was presented for the consideration of the dealer a table of carefully compiled figures showing the manner in which the nation had progressed during the past twenty years in social, financial, industrial and agricultural lines, how the cotton production and consumption had grown and how transportation had developed.

The figures show that the United States had produced and was producing the bulk of the world's supply of many products and more than a fair percentage of other essentials. The figures were of the sort to inspire confidence and were supported by the slogan: "Then slip your Edison car into high, step on the gas and make 1921 the greatest business year in your career."

SPECIALIZES ON THE BRUNSWICK

The Phonograph Shop has been opened in Canon City, Col., by W. E. Gillaspay and C. E. Callison. The Shop is featuring Brunswick phonographs and records exclusively. A large stock has been secured.

\$250,000 REAL ESTATE DEAL

A. H. Curry, President of Texas-Oklahoma Phonograph Co., Handles Important Transaction in Dallas, Tex.—To Erect Building

DALLAS, TEX., December 30.—For a consideration of \$250,000 A. H. Curry, president of the Texas-Oklahoma Phonograph Co., local Edison jobber, sold to-day to Henry I. Bromberg and associates property, 50x200 feet, on the north side of Elm street, between Akard and Ervay streets.

As a part of the consideration Mr. Curry purchases from Mr. Bromberg 121x152 feet at the northwest corner of Lamar street and McKinney avenue and 100x50 feet at the southwest corner of Jackson and Market streets. These properties were taken at a price said to be about \$105,000.

The sale of this Elm street property furnishes an illuminating instance of the rising values of Dallas real estate. Six months ago for that property Mr. Curry paid \$175,000. His intention then was to house the Texas-Oklahoma Phonograph Co. at that location. Further consideration of that proposition, however, made such a move seem inadvisable. The property was then leased for ten years for a consideration of \$240,000.

On one of the properties acquired through the disposal of the Elm street location a four-story building will be erected and occupied by the Texas-Oklahoma Phonograph Co. In every respect this location is ideal for a jobbing establishment.

TO FEATURE VICTOR LINE

On December 20 the G. M. McKelvey Co., talking machine dealers of Cleveland, O., discontinued other lines of instruments and records and arranged to feature the Victor line exclusively, under the title McKelvey's Victrola Department. The present manager, R. O. Danforth, will remain in charge.

We Are Prepared

to consider

Additional Contracts for 1921

Fifteen years' experience in the manufacture of highest grade

Talking Machine Cabinets

Large modern factory, thoroughly equipped with latest up-to-date machinery especially designed for this work.

Highest Financial and Business Standing

We have a most wonderful proposition for export business

Write today for particulars

The Wabash Cabinet Company

Wabash, Ind., U. S. A.

TEN COMMANDMENTS OF SALESMANSHIP

Some Vital Factors to Success Very Tersely but Comprehensively Covered in the Ten Commandments of Salesmanship Compiled by Paul E. Weiss, of Knight-Campbell Co.

Many points which salesmen are vitally interested in for their own good are contained in concise form in the following ten commandments of salesmanship which have been compiled by Paul E. Weiss, of the Knight-Campbell Music Co. of Denver:

1. Be Agreeable. Other things being equal, I go to the store where the salesforce try to please me. I buy of the man who acts as though he likes me. Exert yourself to make a pleasing impression on me, please. I appreciate it. Hence, dress well. Untidy clothes mean you don't care what I think of your appearance. But don't dress too well. That gives you an air of showing off. Dress just right. If you don't know how, find out. Cultivate a pleasing voice. Learn to converse entertainingly. Cut out all mannerisms. Give me the impression of a gentleman; honest, square, anxious to please and at all times good-natured.

2. Know Your Goods. Don't let there be any question I can ask you relative to the manufacture, history, distribution, or uses of what you have to sell that you cannot answer. If you are selling talking machines, know all about all the kinds, and all the points about them. Put in your spare time making yourself an encyclopedia of information about your goods.

3. Don't Argue. Go with me in your talk, not against me. Lead, don't oppose. Don't show we where I am wrong. Dodge a square issue, and show me wherein you are right. Suggest. Don't antagonize. Argument, as a rule, results in irritation, not conviction.

4. Make Things Plain. Don't use any words I don't understand. You can explain the most complicated matter to a washerwoman if you know your subject perfectly and practice using simple language. Don't air your technical knowledge and try to impress me. I want to be flattered, not awed.

5. Tell the Truth. Don't lie, or exaggerate, or mislead, or conceal. Let me feel that you are sincere, and mean every word you say, and that every statement you make is of par value. If you represent goods that need lying about, directly or indirectly, quit. There are plenty

EDISON CONCERTS BY RADIOPHONE FOR DETROIT HOMES

DETROIT, MICH., January 5.—Radio concerts and dances, with selections furnished by the Edison phonograph, have become quite the vogue in the homes of a number of well-to-do residents and members of the Detroit Radio Association in this city. Nightly, in the offices of the Association, located in the heart of the city, some form of entertainment takes place, providing diversion simultaneously in a number of homes, of which some actually are located between four and five miles away.

The apparatus is similar to that of the wireless telephone, the music being sent broadcast by simply starting the transmitter and focusing the sound waves from the phonograph on the microphone, an electrical instrument for making audible even the most feeble sounds. The various sounds are then simply carried up to the antennae and from there through space to the receiving stations, each of which is equipped with an amplifier in order to make the sounds audible throughout the room.

Miss Mabel Norton Ayres, noted concert soprano, who has been associated with the Edison Shop, Chicago, for some time, recently gave the first of a series of weekly concerts over the radiophone, also singing several numbers in duet with Edison Re-Creations of Marie Rap-

old and Anna Case. The concert was unusually successful, both voices, despite their long journey through the air, remaining clear and distinct. Charles Mitchell Mixer, also of the Chicago

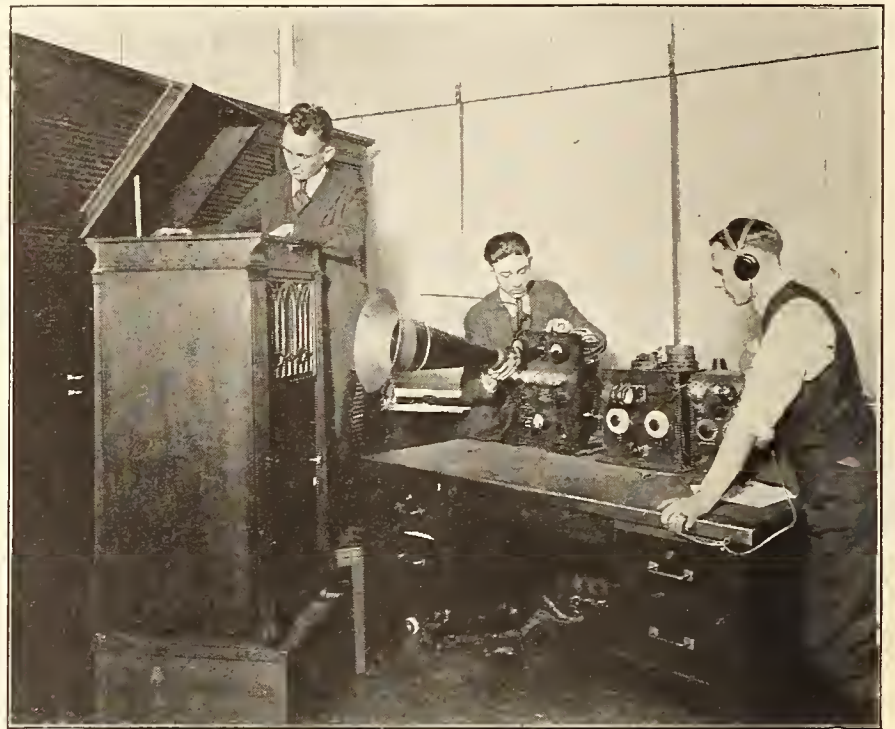

Sending Apparatus Used for Wireless Concerts

Edison Shop, contributed several numbers on the violin, playing in unison with Re-Creations of the same selections on the Edison phonograph, and was applauded by a number of different audiences in different parts of the city, all at the same time.

Radio dances also have taken a permanent place among the popular pastimes of Detroit's younger set and have become a regular thing in the homes of those fortunate enough to have had the necessary receiving apparatus installed.

of articles that are straight and all right. Sell them.

6. Be Dependable. Even in small things create the impression that whatever you promise is as much to be depended upon as your signed note. If you make an appointment at 3 p. m. Tuesday, be there at 2:45. If you promise me a bench or scarf or roll of music, see that I get it. I don't want to be put to the trouble of asking for it.

7. Remember Names and Faces. If you have not the natural gift for this, acquire it. Get a little book and set down every day the names of those you have met, with their characteristics. Practice this until you become expert. No man likes to be forgotten or to have you ask his name.

8. Don't Be Egotistical. Eliminate the pronoun "I" as much as possible from your vocabulary. Talk about me, not yourself; I'm the one you want to win.

9. Think Success. Success begins in the mind. Why think fifty cents when it is just as easy to think fifty dollars? Tell success stories, not incidents of failure or hard luck. Radiate prosperity. Feel prosperous. It's catching. Keep your chin up.

10. Be Human. The reason that you are hired to sell goods is that you are a human being. Otherwise your employer would have sent a catalog. So be a human being, likable, engaging, full of human electricity. For I patronize, as a rule, the salesman I like.

MAY PETERSON ON LONG TOUR

May Peterson, the prominent soprano and Vocalion artist, will leave about the middle of January on a three-months' concert tour extending to the Pacific Coast, during which Miss Peterson will take occasion to call upon Vocalion distributors and dealers in the various cities visited.

A USEFUL HOLIDAY GIFT

M. Steinert & Sons Co., Victor distributors, Boston, Mass., have sent to their many friends in the trade a most attractive Christmas reminder in the shape of a metallic thermometer, which is dial-shaped and in brass, and will prove an attractive ornament for the desk top as well. The famous Victor trade-mark occupies a fitting place on the dial.

THERE ARE CHEAPER NEEDLES THAN

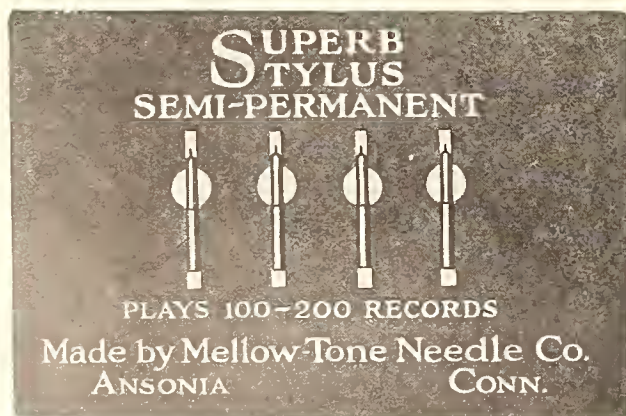

Plays all
Records

Saves all
Records

BUT NONE THAT ARE LESS EXPENSIVE

4 needles on card like above 25c

Made in LOUD, MEDIUM and SOFT Tones

SEND FOR SAMPLES, DISCOUNTS AND SALES HELPS

Mellowtone Needle Co., Inc. Sole Manufacturers Ansonia, Conn.

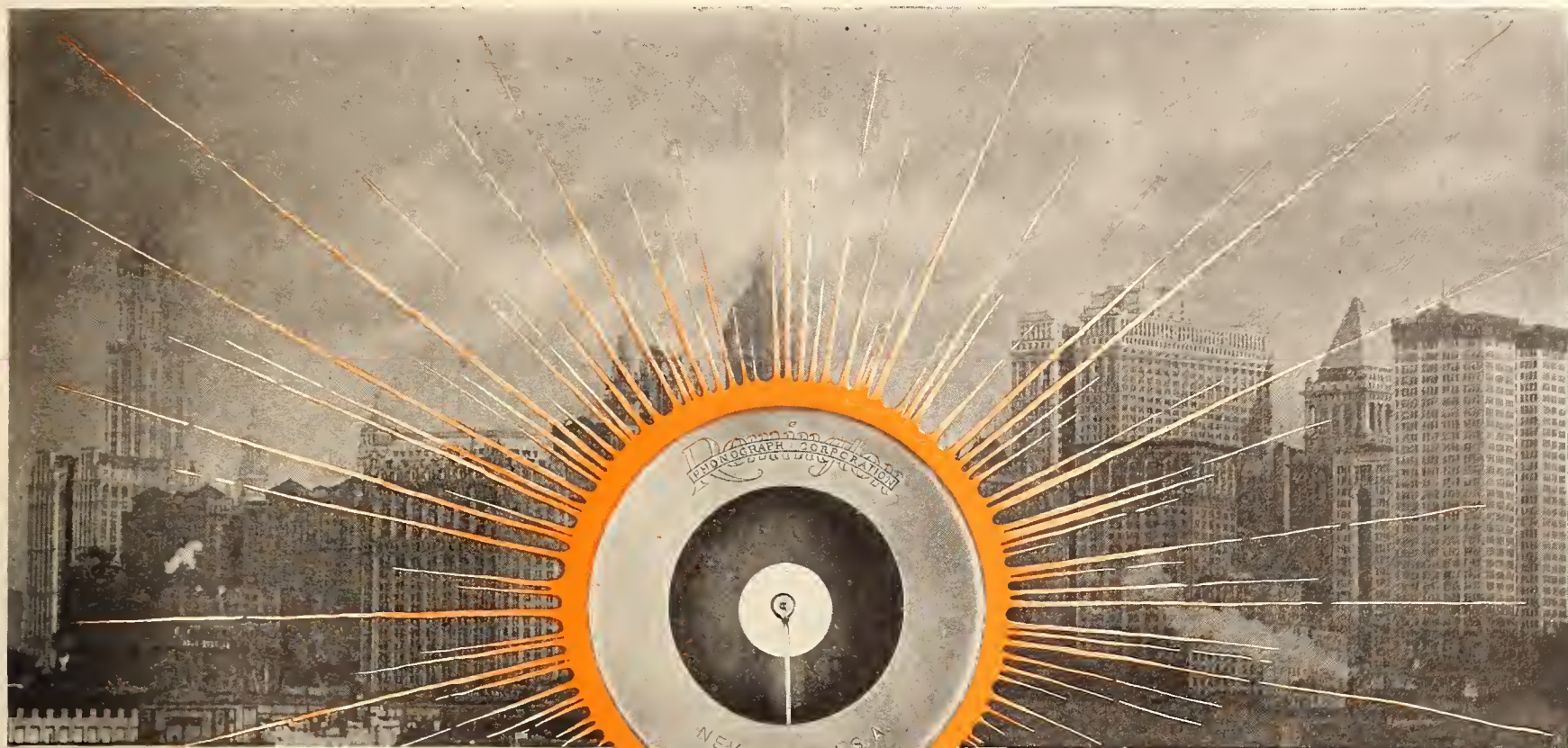

The Dawn of a New Business Era

The ways of yesterday are passed. Making and selling Phonographs means from now a business wherein only the strong can succeed.

We started to make Phonographs when the market was already getting round shouldered trying to carry the burden of overproduction. We hardly need tell you

the load of "too many phonographs" has already doubled up some manufacturers and dealers. Yet in face of this very condition we went ahead and made the

Remington Phonograph

GOOD AS THE NAME

because we have, and know by every test, something more than simply a phonograph, as the term is generally applied. We have the highest developed, farthest advanced, sound-reproducing instrument ever offered to the trade and public. The Remington Reproducer, the heart of the Remington Phonograph, is built on two accepted scientific principles: 3 point contact and elastical mounting.

By use of these two principles we obtain the free vibrating diaphragm, thereby reproducing the most delicate tones of voice or instrument as well as the fullest tones of the trained operatic artist, without the least hint that the tones are other than those produced by the artist himself. And what is true of the voice is true of all instruments, including the piano.

Suppose you put our claims to the test, by making us prove to your sense of hearing that the Remington Phonograph is purer in tone-reproducing qualities than your preconceived ideas permitted you to believe.

We are particularly interested in hearing from dealers who are steeling themselves for the strenuous competition that exists in normal times.

Remington
PHONOGRAPH CORPORATION
Remington

Philo E. Remington
President

Everett H. Holmes
Sales Manager

James S. Holmes
Vice-President

1662-64-66 Broadway, New York, U. S. A.

Artistic Media for Concentrating the Public Mind on High Class Record Sales



Liberty

Appreciating the fact that first impressions count, talking machine dealers in all sections of this great country have vied with each other in the artistic equipment of their wareroom interiors with remarkably artistic results. But before the casual passer-by "obeys that impulse" to enter the ware-

room of the talking machine retailer his attention must be gained and his interest aroused. But, of course, the generation of this interest and attention should be aroused in a dignified yet forceful manner. While the startling stunt may gain attention, it is doubtful whether it will gain it in a favorable or permanent manner. One of the best definitions of good advertising is "that which is said or done to create

through the costumed life-like figures of famous characters from the operas which have been produced by the Penn Phonograph Co., Victor dis-

window display. With the introduction of the grand opera characters by the Penn Phonograph Co., the talking machine dealer is enabled to



Don Jose



Gilda



Canio



Tosca



Duke of Mantua

tributors of Philadelphia, with the endorsement of the Victor Co. The subject of window figures has been given the most careful attention by progressive merchants in all lines. The old-

dress his windows in a manner comparable with the displays of the biggest department stores and at a cost far less.

The talking machine dealer who has the Victor franchise is enabled to offer the public the recordings of the most famous stars of the Metropolitan Grand Opera Co. and these figures enable him to capitalize the distinction which he enjoys by featuring in his window a life-like characterization of the various parts sung on the Red Seal records. These figures allow the dealer a wide latitude in the dressing of his window. For instance, with a set of the twelve different models an excellent ensemble of the leading characters in the realm of grand opera may be displayed. Or, through the featuring of one distinct model in the center of the window, selling activities may be centered upon the sale of one particular Red Seal record.



Amneris



Rhadames



Marguerite



Mephistopheles



Carmen



Scarpia

a favorable impression." The dealer is dependent upon his windows to create interest in the minds of the many who pass his warerooms and to create that interest favorably.

A material aid in the dressing of windows has been made available to the Victor retailer

time familiar headless figures are fast disappearing in the department stores of the country and in their place is appearing the entirely life-like figures for display purposes. In the large department stores located in the various leading cities, vast sums are spent for these figures in

The entire set consists of six male figures and six female figures and the grand opera parts portrayed by these figures are as follows: Canio, Carmen, Don Jose, Marguerite, Mephistopheles, Tosca, Scarpia, Amneris, Rhadames, Gilda and Duke of Mantua. These figures are sculptured with the most exceeding care and the facial expressions are strikingly life-like. They are delicately tinted in flesh color. In the costuming of these figures no detail has been forgotten. The various costumes have been designed by a prominent Philadelphia operatic costumer and the work has been executed in his studio in the Quaker City.

An idea of the exact portrayal of the parts these figures represent may be found in the fact that the costumes have been made in rich silks, satins, velvets, lace and similar fine material and that real human hair is used for the wigs.

It is said that these figures constitute one of the greatest methods for the featuring of Red Seal records that have ever been offered to the Victor dealer and their popularity may be gauged by the continuously growing list of Victor dealers ordering these figures from their distributors. Their use is not alone limited to the window, but they are equally attractive for interior display. The set consists of twelve models, but through the purchase of only two female and one male model the entire twelve characters are available, if displayed one at a time, as the costumes are interchangeable as are the heads and arms.

The Cabinet & Accessories Co., Inc.

145 East 34th Street, New York City

OTTO GOLDSMITH, President

Bubble Books

Record Albums, Record Envelopes, Stock Envelopes, Supplement Envelopes, Motrolas, Attachments, Phonograph Lights, Oils and Polishes, Motors and Tone Arms.



Cirolas

Converto Cabinets, Music Roll Cabinets, Sectional Cabinets, Needles, Record Cleaners, Moving Covers, Name Plates, Stewart Phonographs, Badger Cabinets for Victrolas.

The C & A Special

This cabinet for the Victrola IX, with molding, hinged so machine can easily slide in, casters, lock and key, shelves interior, nickel plated trimmings, in all finishes, top, 18 1/4" x 21 7/8", height, 33" and 34".

WRITE FOR CATALOGUE

The ALL FROM ONE SOURCE HOUSE Will Supply You With Everything For Your Fall Trade.

TELLS VALUE OF TALKING MACHINE

Reasons Why Music Should Be in Every Home Outlined in Daily Paper—Talking Machine Music "Perfect," Declares Writer, Who Adds His Testimony to Much on Record

Enjoyment is not all there is in the possession of a good talking machine, although the enjoyment feature will pay the possessor very well, indeed, for the investment, the Charleston, W. Va., Mail informs its readers. The educational features of the talking machine is one of its principal recommendations. Get a good talking machine and a lot of good records and you can do more to teach your children to sing, play and love good music than you can by any other means. The music that comes from the talking machine is perfect music. Whether it is grand opera or "jazz" it is the best that can be produced. Go into a home where there is a talking machine and learn how the children of this home appreciate music. Even the four-and-five-year-old kiddies learn to sing classical selections with marvelous accuracy of words and precision of tone.

Boys and girls who are studying music are wonderfully helped in their work by hearing the perfect selections that it is possible to hear on the machine, and such boys and girls who are not provided with this assistance are at a distinct disadvantage. For instance, a boy who is a violin student should hear a selection by one of the masters repeatedly every day. This same applies to the student of piano and voice.

As a means of inducing the kind of sociability the parents want their children to enjoy and discouraging the other kind the music machine is well worth while. Let the children dance at home and confine their dancing to the proper dances and they will not be wanting to go to the public "jazz" palaces. Rather they will want to stay at home and dance or visit their neighbors' homes, where they can dance to the music of the reproducing machines and the more this sort of thing is encouraged the more nights the young folks will spend at home or in neighboring

friend's home. Young folks will dance. This is an age of dancing. The thing to do is to induce young people to dance properly amid proper surroundings. If there is dance music at home the young folks will dance at home. If there isn't any music in the home they will seek out the public places where there is music, and some of these places may not be just the sort of places you would like to have your children frequent.

Doctors will tell you there isn't anything better in connection with a meal than music. To have music with your meals at home is a very simple matter when the home is equipped with a talking machine.

There are many more uses besides these that you can put your talking machine to, but these that are mentioned plus the enjoyment that a family gets out of the machine should make them indispensable.

HEINEMAN CELEBRATES BIRTHDAY

President of General Phonograph Corp. Show-ered With Good Wishes on Anniversary

Monday, December 20, was the birthday of Otto Heineman, president of the General Phonograph Corp., New York City. The employes and many friends of Mr. Heineman in the trade took advantage of the opportunity to congratulate him on having passed another year of his very successful career.

All day long messages and people flowed into his private offices to extend their congratulations. There were many gifts, which included a wonderful floral tribute from the employes of the General Phonograph Corp. It was a day during which the bars of official capacity were completely dropped and a spirit of social comradeship prevailed.

HISTORICAL AND TECHNICAL

The first real talking machine, in which no improvement has ever been made, was made out of a rib.—Howard (Kansas) Courant.

NEW YORK'S SECOND MUSIC WEEK

Otto H. Kahn Heads Committee That Will Look After Details of Second Annual Music Celebration in Metropolis, May 1-7, Inclusive

Announcement was made this week by the National Bureau for the Advancement of Music that Otto H. Kahn, of Kuhn, Loeb & Co., has accepted the honorary chairmanship of the committee which will conduct New York's second annual Music Week, May 1-7, 1921.

At a meeting last week in the offices of the Bureau, Berthold Neuer, of William Knabe & Co., was chosen as chairman of the committee, and C. M. Tremaine, director of the National Bureau for the Advancement of Music, was elected secretary.

At this meeting it was unanimously voted to set the next Music Week for the first week in May as being better from a weather point of view for both outdoor and indoor observances than an earlier or a later date.

In response to an invitation sent to him to act as honorary chairman, Mr. Kahn wrote: "I am pleased to accept the position of honorary chairman of the committee for New York's Music Week of 1921. I wish you every success in this auspicious and public-spirited movement."

Mr. Kahn took a keen interest in the work of the 1920 Music Week Committee, of which he was honorary chairman. That he is no less interested in the work of the 1921 committee is indicated by the fact that he has suggested several persons as members who, he believes, would add to the strength of the committee, thus aiding in its success.

The personnel of the 1921 Music Week Committee will be announced later. Careful consideration is being given to the selection of every member to insure the best results from the committee as a whole.

Don't wind your machine like a hurdy-gurdy. Treat it with the respect it deserves. One good turn deserves another, even if it is a talking machine.



Oplex Electric Signs Will Build Your Sales

THE striking advantage of Flexlume Oplex Electric Signs is that they are day signs as well as night signs—raised snow-white glass letters on a dark background. The lamps are enclosed and so arranged that all the light is thrown through the openings which form the letters. At night each character stands out of the darkness a solid letter of light.

Other advantages are lowest upkeep cost, greatest reading distance, most artistic designs and the fact that any trade-mark can be reproduced in Oplex characters.

Let us send you a sketch showing an Oplex Sign to meet the particular needs of your store.

Flexlume Sign Company

1436-38 Niagara St.

Buffalo, N. Y.

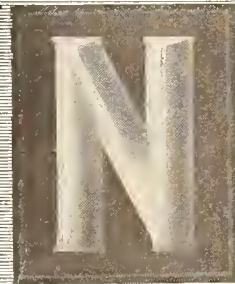

H.K. Lorentzen

Manufacturer of
Exclusive Cabinet Hardware and Accessories
 60 Grand Street
 New York City

TO DEFEND MUSIC INDUSTRY AGAINST UNFAIR TAXATION

Definite Plans Being Made by the Music Industries Chamber of Commerce to Have the Interests of the Trade Protected So Far as Revision of the Present Federal Taxes Is Concerned

At a meeting of the Advisory Committee to the Legal Bureau of the Music Industries Chamber of Commerce recently definite plans were decided upon for presenting the case of the music industry at Washington with respect to proposed tax revision.

Arrangements have been made for proper representation at Washington pending the recovery of the Chamber's counsel, Mr. Pound, who, it is hoped, will return to his work within two or three weeks. Mr. Smith, the general manager, will also be in Washington every week or ten days at least, and every effort will be made to have representative members of the industry there to appear before Congressional committees at the proper time. The committee also made plans to obtain the necessary data and statistics to show that a continuance of the 5 per cent excise tax, in face of the expected business conditions and the necessary installment nature of the industry, will inevitably result in curtailed business and consequent loss of revenue to the Government. In this connection it is interesting to note that Canada has had to abolish similar excise taxes to prevent stoppage of industry. The Canadian situation will be used freely in arguments of the industry before Congress.

The Chamber has issued the following statement concerning the tax situation at Washington:

The Ways and Means Committee is now holding hearings on the tax question. These hearings will not be continued after the holidays, and from that time until the end of the session the entire attention of the committee will be given over to the tariff. These first hearings are evidently very preliminary in their nature.

At present the committee is interested not in the effect of taxation on individual industries or details of tax plans, but rather in general policies or plans of raising the necessary revenue.

The general idea at Washington seems to be to spend this session in passing the various appropriation bills to determine the minimum amount absolutely required to be raised by taxation so that the next session can be devoted to the method of raising the necessary sum.

The report of the Secretary of the Treasury concerning the amount of money to be raised and methods for raising it was apparently not well received by the committee. However, the ideas of the committee members have evidently become more favorable to the report in general now that the real financial situation of the Government and the difficulty of raising the necessary revenue becomes apparent. The report of the Secretary of the Treasury was compiled practically entirely, it is understood, by Professor T. S. Adams, the tax expert of the Treasury Department. It is, therefore, important to note that Chairman Fordney said that when the Ways and Means Committee finally frames its bill Professor Adams will be asked to co-operate constantly in its preparation.

No great discussion or special thought has yet been given to the general sales tax plan. This plan seems to be almost universally favored in Washington, but nearly everyone appears to fear that when it is discussed as an actual plan of taxation there may be so many arguments against it that it will not stand a show of becoming law. It is too early to find such opinion on the sales tax.

There is every indication that Congress expects a very difficult task in raising the necessary taxes, and for this reason is going to be very insistent for facts to support any argument showing why any industry should not be taxed especially by any method proposed. It is, therefore, advisable for the Chamber to gather all necessary facts and figures about the industry in order that our arguments against discriminatory taxation may be based on such facts and

figures. Furthermore, inasmuch as tax legislation will not become important work of the Ways and Means Committee until the next session, the Chamber has the next few weeks to prepare its data and arguments and still have time to take these up with individual members of the committee prior to the next session.

EDISON PORTFOLIO IN POCKET SIZE

Volume Containing Edison Sales Propositions Reproduced in Miniature for Dealers' Use

Widespread interest throughout the entire Edison trade has resulted from the announcement, just made by the Edison Laboratories,

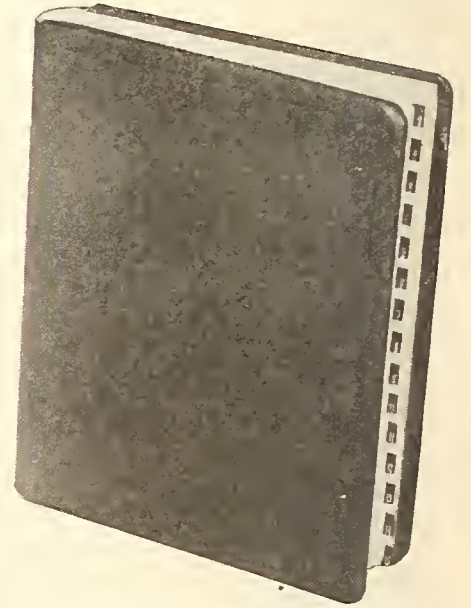

The Miniature Edison Portfolio

that a new miniature portfolio, reproduced photographically from the now famous portfolio issued in the early part of last year, has just been published and is ready for distribution.

Advertising experts and leading merchants throughout the country have hailed the fourteen points of the Edison sales propositions, contained in the portfolio, as "the greatest step in salesmanship taken in recent years."

RECEIVERS FOR A. T. EMERSON, INC.

Appointment by Judge Knox Closely Follows Same Action in Case of Emerson Phonograph Co., Inc.—Assets \$400,000, Liabilities \$300,000

Closely following the appointment of receivers for the Emerson Phonograph Co., Inc., it was announced that Judge Knox has appointed Maurice P. Davidson and Walter J. Ennison receivers for A. T. Emerson, Inc., in a suit brought by Sheip & Vandegrift, Inc., a creditor, for \$5,000 and upward. A. T. Emerson, Inc., has been in business since March 16, 1920. The assets are said to be close to \$400,000 and the liabilities approximately \$300,000. The financial difficulties of the Emerson Phonograph Co., Inc., it is said, brought about the failure of the defendant company, which it owes more than \$150,000, according to the statement made.

HAVE YOU EVER BEEN THERE?

"Don't you enjoy listening to your new phonograph?"

"I would but for one thing."

"What's that?"

"My wife and the lady next door, who always comes in every time we start it up, carry on such a loud conversation while it is playing that I have never heard a record on it yet above that din."—Florida Times-Union.

IF

PRICE

were the only consideration, we'd be entitled to your business anyway; but we also have

QUALITY and what is of SERVICE

equal importance



No. 1265 Cup

This applies not only to Needle Cups, but to Lid Supports, Lid Hinges, Automatic Stops, and practically everything your cabinets will need.

WEBER-KNAPP CO.

Jamestown, N. Y.

Okeh Records

FEBRUARY RELEASE

4148 { I'M WAITING FOR SHIPS THAT NEVER
10-in. COME IN (Baritone with Orch.) . . . Elliott Shaw
\$1.00 { I'M ON MY WAY (Vocal Quartet with Orch.)
Shannon Four

4215 { OLD PAL, WHY DON'T YOU ANSWER ME?
10-in. (Tenor with Orch.) Sam Ash
\$1.00 { I'M IN HEAVEN WHEN I'M IN MY MOTHER'S
ARMS (Tenor with Orch.) Lewis James

4221 { WHAT CHA GONNA DO WHEN THERE
10-in. AIN'T NO JAZZ (Singing Comedienne with
\$1.00 Rega Orch.) Aileen Stanley
LOOK WHAT YOU'VE DONE WITH YOUR
DOG-GONE DANGEROUS EYES (Singing
Comedienne with Rega Orch.) . . . Aileen Stanley

4222 { ALL SHE'D SAY WAS "UMH HUM" (Tenor
10-in. Duet with Orch.) Billy Jones-Ed. Smalle
\$1.00 { PALESTEENA (Tenor with Orch.) Billy Jones

4223 { BEAUTIFUL ANNABELL LEE (Tenor-Baritone
10-in. Duet with Orch.) Hart-Shaw
\$1.00 { THERE'S A VACANT CHAIR AT HOME,
SWEET HOME (Tenor-Baritone Duet with
Orch.) James-Shaw

4224 { I WANT TO KNOW WHERE TOSTI WENT
10-in. (When He said "Good-Bye") (From "Broad-
\$1.00 way Brevities of 1920") (Baritone with
Orch.) Ernest Hare
MY HOME TOWN IS A ONE-HORSE TOWN
(Tenor Duet with Orch.) . . . Billy Jones-Ed. Smalle

4225 { ON HILO BAY (Hawaiian Guitar Duet)
10-in. Ferera-Franchini
\$1.00 { ON THE BEACH AT WAIKIKI (Hawaiian
Guitar Duet) Ferera-Franchini

4210 { DARLING (Intro. "Come to the Moon") (Med-
10-in. ley Fox-trot) . . . Harry Raderman's Jazz Orchestra
\$1.00 { JUST SNAP YOUR FINGERS AT CARE (From
"Greenwich Village Follies of 1920") (Fox-
trot) Lanin's Roseland Orchestra

4211 { MARGIE (Fox-trot) Rega Dance Orchestra
10-in. CORAL SEA (Fox-trot)
\$1.00 Rudy Wiedoeft's Palace Trio

4212 { GRIEVING FOR YOU (Fox-trot)
10-in. Lanin's Roseland Orchestra
\$1.00 { SWEET CUBAN LOVE (Fox-trot)
Harry Raderman's Jazz Orchestra

4213 { I'M A LONESOME LITTLE RAIN DROP (From
10-in. "Greenwich Village Follies of 1920") (Fox-
\$1.00 trot) Joseph Samuels' Jazz Band
I'LL BUY THE BLARNEY CASTLE (One-step)
Green Brothers' Novelty Band

4214 { I WANT TO GO TO THE LAND WHERE THE
10-in. SWEET DADDIES GROW (Intro. "All the
\$1.00 Boys Love Mary") (One-step)
Rudy Wiedoeft's Palace Trio

PEACOCK WALK (Fox-trot)
Harry Raderman's Jazz Orchestra

4216 { WHY DID YOU LEAVE ME? (Fox-trot)
10-in. Joseph Knecht's Waldorf Astoria Dance Orch.
\$1.00 TOREADORA (Fox-trot)
Harry Raderman's Jazz Orchestra

4217 { IF A WISH COULD MAKE IT SO (Intro.
10-in. "We've Got Something") (From Musical Play,
\$1.00 "Tickle Me") (Fox-trot)
Joseph Knecht's Waldorf Astoria Dance Orch.

THE WEDDING BLUES (From Musical
Comedy, "Pitter Patter") (Fox-trot)
Lanin's Roseland Orchestra

4218 { HOP, SKIP AND JUMP (Fox-trot) (With Inci-
10-in. dental Saxophone by Nathan Glantz)
\$1.00 Rega Dance Orchestra

4219 { FOR EVERY BOY WHO'S ON THE LEVEL
10-in. (Intro. "Good-Bye, When I Say Good-Bye to
\$1.00 You") (One-step)
Harry Raderman's Jazz Orchestra

4219 { IN MY SWEET LITTLE ALICE BLUE GOWN
10-in. (Intro. Chorus of "To Be Worthy") (Waltz)
\$1.00 (From Musical Comedy, "Irene")
Joseph Knecht's Waldorf Astoria Dance Orch.

PRETTY MISS VIRGINIA (Waltz)
The All American Five

4220 { ZOWIE (Fox-trot) Joseph Samuels' Jazz Band
10-in. AMORITA (Fox-trot)
\$1.00 Green Brothers' Novelty Band

4227 { SLEEPY HOLLOW (Where I First Met You)
10-in. (Waltz) Okeh Marimba Band
\$1.00 THE HULA BLUES (Fox-trot)
Okeh Marimba Band

4226 { COLONEL BOGEY MARCH Conway's Band
10-in. BATTLESHIP CONNECTICUT MARCH
\$1.00 Conway's Band

GENERAL PHONOGRAPH CORPORATION

OTTO HEINEMAN, *President*

25 West 45th Street

New York City, N. Y.

Factories: Newark, N. J. Elyria, Ohio Putnam, Conn. Springfield, Mass. Kitchener, Ont.

Branch Offices: Chicago, Ill Toronto, Can. London, Eng



SEES IMPROVEMENT IN THE CREDIT SITUATION IN 1921

Jas. S. Alexander, President of the National Bank of Commerce, Says Progressive Improvements Now Operative Should Result in Better Money Conditions During the New Year

Better money conditions in 1921 should result from the progressive improvements now operative in certain adverse factors of the country's bank credit situation, according to a statement made by James S. Alexander, president of the National Bank of Commerce. He expresses the opinion that banking may expect to serve the needs of legitimate business with a lesser degree of credit strain than during the past year. The chief cause of betterment, he says, was a reduction in the volume of war paper and frozen and speculative commercial credits in bank resources, impairing their liquidity.

"Business men are justified in feeling confident that the money situation in the United States in 1921 will be a very different matter from what it has been during 1920," Mr. Alexander's statement says. "Certain specific factors are clearly recognizable as the chief adverse forces affecting bank credit during the past year, and there is every reason for believing they will not be so powerfully operative in the year to come."

To illustrate improvement of unfavorable factors in the situation, Mr. Alexander cites figures of 800 banking institutions, reporting weekly to the Federal Reserve Board, with resources estimated at about 40 per cent of the resources of all banks. From January to mid-October, he points out, these banks showed a decrease of \$500,000,000 in the amount of United States securities owned by them and of \$380,000,000 in loans secured by Government securities, which for all banks would indicate a reduction in war paper holdings of about two billion dollars. There also was a drop of \$200,000,000 in loans secured by stocks and bonds, this item representing in considerable part speculative operations. At the same time loans chiefly for manufacturing, commercial and agricultural purposes showed an increase of \$1,510,000,000.

"These figures indicate that while there has been marked contraction in the non-liquid and speculative elements of bank credits, there has been a continued expansion in the accommodation extended to meet business needs," the statement says. "This explains why, although to mid-October contraction was not operative in the total volume of credit, better conditions were in sight in the banking situation. It was because there had been this marked improvement in the quality of credit.

"A contraction in commercial credits set in during October. In this month the reduction of the non-liquid elements also maintained a rapid pace. Thus two elements of betterment were operative, improved liquidity and contraction of the total.

"If the foregoing facts and deductions are of value, it is not because of the light they throw on past events, but because of the promise they hold for the future. They carry the conviction that credit conditions should be more satisfactory during 1921 than they have been during 1920. These figures justify business men in expecting our credit resources to function more efficiently in the future than they have in the immediate past to facilitate their business operations, because the four great causes of impaired credit in 1920 should not exert the same influence in the year that lies ahead.

"We may assume that war paper, in passing from the hands of the banks, will rest permanently in the hands of the ultimate investor, where it belongs, and that it will not again seriously impair the liquidity of commercial bank resources. We may also hope that we shall not in 1921 see a national transportation breakdown which added a large portion to the impairment of credit. Again, we may expect that there will not be the same violent price changes and that, therefore, commercial credit will not be employed for purposes of commodity speculation to the same extent. Finally,

we may expect that prices and the production of goods will be co-ordinated more closely to normal public demands and the emergency should not arise to carry such large unliquidated stocks over a period of stagnation.

"With these factors absent or reduced in degree it should be possible for business men to find ample means for financing their operations and to make their calculations with the definite assurance that the cost of credit will not be prohibitive, while the supply may be relied upon to meet all legitimate demands.

"The situation is yet far from normal. The continued lack of public buying has made it impossible for many commodities and for many lines of merchandise to become reasonably liquidated, and the process cannot be completed until buying once more becomes active and production is again demanded. But the banks have stood by business, and business may feel confident that it is within the power and the inclination of the banks to continue to co-operate."

"TALKER" POPULAR FOR DANCING

Teachers of Dancing Find Talking Machine More Satisfactory Than Orchestra

There is an increasing demand for talking machines among teachers of dancing throughout the country and it is now universally conceded that the talking machine provides better music for dancing than any orchestra. Moreover, the cost of operation is much smaller, while the musical repertoire is always the latest and best, thanks to the up-to-dateness of the record manufacturers.

REMINGTON NEW YEAR'S GREETING

A very cheery and optimistic greeting has recently been received by The World and the rapidly increasing clientele of the Remington Phonograph Corp., of New York City. Following the wish to its friends for "A Merry Christmas and a Happy New Year," the Remington says: "The officers of this corporation are very firmly convinced that the year 1921 will be evidenced by peace, plenty and prosperity and express the hope that you may enjoy fully the good things in store for us all."

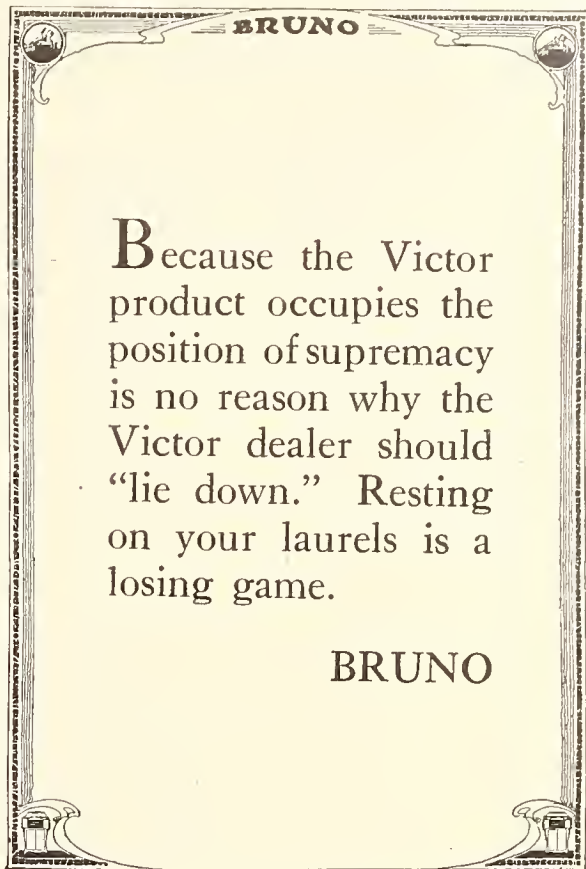

BRUNO

Because the Victor product occupies the position of supremacy is no reason why the Victor dealer should "lie down." Resting on your laurels is a losing game.

BRUNO

VICTOR READY REFERENCE LABELS

New Issue Offers Several Improved Features of Interest to Dealers Handling Records

Shortly after the first of the year the Victor Co. expects to ship the revised issue of ready reference labels which can be used with all styles of stock envelopes and stock cards. They have, however, several new features. One of the most important benefits claimed for the ready reference label service is the complete cross index which it offers for all records in the domestic section of the catalog. In the new issue the cross index has been brought up to date and includes all records now listed. Another feature is a brief sales talk which is provided for each record.

A special list accompanies the Red Seal section of the catalog, suggesting records which may be of interest to a purchaser who has shown preference for a certain kind of selection. The new labels also show when the selection was first announced and gives the telegraphic code word to identify each record, thus providing an excellent means for educating the sales person.

Quicken Dealer Turnover

Purchasing Agents co-operate with their own Sales Departments by supplying accessories and fittings of distinctive designing. Dealers in turn find ready sales for Phonographs and Furniture so equipped.

PHONOGRAPH ACCESSORIES

For Immediate Delivery—Needle Cups and Double Spring Motors, capable of playing three 12-inch records. Also—Lid Supports, Automatic Stops, Tone Rods, Knobs, Escutcheons, Sockets, etc.

FURNITURE TRIMMINGS

A complete offering in all the Period and Commercial Furniture Lines.

REFRIGERATOR HARDWARE

All sized Locks and Hinges

Samples and complete information on request

Grand Rapids Brass Company
Grand Rapids, Michigan New York: 7 E. 42nd. St.

Edison Message No. 8

The fall of merchandise prices to the normal price level represented by Edison Phonographs brings chaos to many businesses.

Prices of most merchandise were inflated during and after the war, but the prices of Edison Phonographs, since 1914, advanced only 15%, including War Tax, thereby stabilizing the Edison Phonograph business.

“Edison Stood the Gaff”

THOMAS A. EDISON, Inc.
ORANGE, N. J.

Every dealer knows the popularity of Lucy Gates' Columbia Records. The "Doll Song" from the *Tales of Hoffmann* and "A Geisha's Life" are both popular selections. Order a lot of this record for steady sales. A-3326

Columbia Graphophone Co.
NEW YORK



TALKING MACHINE EXPORTS GROW

Exports, Including Records, for Ten Months Ending October, 1920, Total \$6,377,974

WASHINGTON, D. C., January 4.—In the summary of exports and imports of the United States for the month of October, 1920 (the latest period for which it has been compiled), which has just been issued, the following figures on talking machines and records are presented.

The dutiable imports of talking machines and parts during October, 1920, amounted in value to \$77,614, as compared with \$60,489 worth which were imported during the same month of 1919. The ten months' total ending October, 1920, showed importations valued at \$751,587, as compared with \$445,922 worth of talking machines and parts during the same period of 1919.

Talking machines to the number of 9,839, valued at \$481,471, were exported in October, 1920, as compared with 7,113 talking machines, valued at \$262,954, sent abroad in the same period of 1919. The ten months' total showed that we exported 69,784 talking machines, valued at \$3,297,305, as against 52,336 talking machines, valued at \$1,817,399, in 1919, and 54,675 talking machines, valued at \$1,627,243, in 1918.

The total exports of records and supplies for October, 1920, were valued at \$243,973, as compared with \$292,054 in October, 1919. For the ten months ending October, 1920, records and accessories were exported valued at \$3,080,669; in 1919, \$2,822,653, and in 1918, \$1,842,752.

UNUSUAL COMMENT ON TONE-TEST

An interesting commentary on a recent Edison Tone-Test recital, given in South Boston, Va., in which Miss Grace Hofheimer, the popular pianist, took part, was received by the Edison Laboratories in a letter from the Edison dealer at that place and read as follows:

"The janitor of the high school was present the night of the Tone-Test recital, but it so happened that no one explained to him the purpose of the concert, or what was to take place. The next morning, when we went to remove the instrument from the auditorium, he came up with the remark that Miss Hofheimer was a wonderful woman: 'She must have electricity in her fingers,' he said.

"'Why,' we asked.
"'Because,' he replied, 'she would raise her hands off them keys and the piano kept playing.'

"Now wasn't that a delicate compliment?"

TO CONCENTRATE ON WHOLESALE

The Artophone Corp., of St. Louis, has announced that after January 1 it will confine itself to wholesale business exclusively. It, therefore, retires from the retail talking machine and record field in the Saintly City.

TIPS FROM THE SUCCESS MARKET

Worth-while Advice Given by Writer in Steger Employees' Magazine

Under the heading, "Tips From the Success Market," Harry I. Shumway has a very interesting article in a recent issue of the Steger Employees' Magazine, published regularly by the Steger & Sons Piano Mfg. Co., manufacturers of the Steger phonograph. The article gives some very illuminating sidelights on business in general and defines some common terms as follows:

"*Perspiration, Unlimited.* Here is a gilt-edge stock that will pay you dividends from a hundred to a million per cent. There isn't the least chance of a loss. Stockholders in this company report gains beyond their widest hopes. Rumors that this company has merged with the *Coat & Vestoff Company* are not denied. There are melons being cut every day. So many, in fact, that space forbids mentioning them.

"*Stick-to-it Industrial Corporation.* A good stock of permanent value. Satisfactory dividends are regularly paid. There have been adverse reports, at times, concerning this stock, and an expert was employed to investigate. It turned out that those who had not realized dividends were investors also in *Pig-headed Associates*. The two look something alike at first sight but are really entirely different.

"*Smile and Boost Company, Inc.* One fine stock, says the expert, and one that will be in greater

demand than ever. Always has paid good dividends and always will. There is no limit to what it can earn. If you have never taken a flier in this worth-while stock, better get aboard. You'll enjoy possessing it aside from its intrinsic possibilities.

"*Take It Easy Mine.* Not recommended. So far this company has never paid a dividend and nothing on the horizon indicates that it ever will."

FAMOUS VICTOR ARTIST TO WED

Mme. Amelita Galli-Curci, grand opera star and famous Victor artist, will be married to Homer Samuels, her accompanist, in St. Paul or Minneapolis, on January 16. Mme. Galli-Curci, in announcing her approaching marriage, said she was very happy. Although the famous prima donna has applied for American citizenship and will complete her naturalization papers before her marriage, yet inasmuch as Mr. Samuels is an American her marriage to him makes her one.

BUILDING UP A GOOD BUSINESS

John H. Bieling, for many years a member of the American and Haydn quartets, and who, as announced in *The World* some months ago, has opened a new Victor store at Hempstead, is building up a very nice business in that section of Long Island, and is active in the musical life of the community.

YAZOO RIVER RED GUM

Specials for prompt shipment:

- 2 cars 1 1/4" 1st and 2nd Plain Red Gum.
- 1 car 1 1/2" 1st and 2nd Plain Red Gum.
- 5 cars 2" 1st and 2nd Plain Red Gum.
- 8 cars 2" 1st and 2nd Qrtd. Red Gum.
- 8 cars 2 1/2" Common and Btr. Qrtd. Red Gum.
- 4 cars 3" Common and Btr. Qrtd. Red Gum.
- 8 cars 1 1/4" No. 1 Common Plain Red Gum.
- 10 cars 2" No. 1 Common Plain Red Gum.
- 2 cars 2" No. 1 Common Qrtd. Red Gum.
- 10 cars 2" No. 1 Common Qrtd. Red Gum.
- 3 cars 3" No. 1 Common and Btr. Plain Red Gum.
- 5 cars 1 1/4" 1st and 2nd Sap Gum.
- 5 cars 1 1/2" 1st and 2nd Sap Gum.
- 10 cars 2" 1st and 2nd Sap Gum.
- 2 cars 3" 1st and 2nd Sap Gum.
- 5 cars 1 1/4" No. 1 Common Sap Gum.
- 5 cars 1 1/2" No. 1 Common Sap Gum.
- 10 cars 2" No. 1 Common Sap Gum.
- 2 cars 3" No. 1 Common Sap Gum.
- 5 cars 1 1/2" No. 1 Common and Btr. Qrtd. White Oak.
- 5 cars 3" No. 1 Common and Btr. Qrtd. White Oak.
- 5 cars 4" No. 1 Common and Btr. Qrtd. White Oak.
- 10 cars 1" No. 1 Common and Btr. Qrtd. Red Oak.
- 6 cars 1 1/2" No. 1 Common and Btr. Qrtd. Red Oak.

Our Red Gum is of soft texture and rich dark color. Specially manufactured and seasoned.

Send us your inquiries for all kinds of cabinet woods.

THOMAS & PROETZ LUMBER CO.

3400 Hall St., St. Louis, Mo.

A Lyric Agency Is a Money-Maker

To those dealers appreciating a quality record---prompt deliveries---first releases and a favorable sales arrangement, we can offer a money-making opportunity.

LYRIC RECORDS are backed by a national and local advertising campaign, thus creating a demand in territory where dealers can "cash in" on the demands.

Ours is a permanent and constantly growing organization and dealers here have an opportunity of obtaining an agency with a steadily increasing value.

Co-operate and Grow

A Lyric Jobber Is Ready to Serve You



Send at once for latest bulletin and offer to dealers

LYRAPHONE CO. OF AMERICA 117 Mechanic St.,
NEWARK, N. J.

AN ENVIABLE SALES RECORD

Granby Dealers in Norfolk Sell \$67,000 Worth of Machines in Three Weeks' Time

NORFOLK, VA., January 2.—An illustration of what can be done by any merchant who will get up and hustle is given by E. C. Howard, director of sales of the Granby Phonograph Corp., of this city. Mr. Howard gives us as a specific instance the experience of Philip Levy & Co., Granby dealers of Norfolk, from December 1 to December 24 of 1920. In that period Levy & Co. sold 421 Granby phonographs, totaling \$67,000. The population of Norfolk is only about 135,000. These sales were built up with no other help than intensive selling, backed up by constant newspaper advertising. The largest spread of the newspaper campaign did not exceed one-half page and the usual size of copy was one-eighth page. This large volume of sales was also made with the competition of possibly twelve or more other dealers carrying other lines. Mr. Howard states, and this instance proves, that a certain part of the inaction in the talking machine trade is psychological rather than actual. Mr. Howard said, in closing the report of this incident: "Of course, we all know conditions are below normal and the dealers in Norfolk who depend so largely on tobacco and cotton are in no better shape than anyone else, but, given the proper attention, there is plenty of business for at least one live concern in every town if he will only go get it."

Those in the trade who have met E. C. Howard realize that he is a man who practices what he preaches, as may be seen from the steady and healthy growth of Granby sales under his direction.

DEALER CREATES HUMAN INTEREST

McKelvey Co. Uses Special Stories to Push Sales of Special Records

The McKelvey Co., Victor dealer of Youngstown, O., makes a practice of creating a human interest background to a particular record of which it wishes to boom the sale. The following illustrates the idea in detail as it was used by this company to make a background for sentimental records:

"Sentiment! What a word it is! The destiny of a nation, the course of a human life, the action of all mankind are swayed by it.

"Many laugh at sentiment and pretend they have none. Believe them not! Somewhere in the secret chambers of thought is a remembrance of old loves, the tender touch of a vanished hand; buried deep in an ancient trunk or bureau is a packet of letters, a diary inscribed in youthful days, or perhaps a faded shawl that once covered the frail shoulders of a beloved mother.

"The best-loved songs of all time have been songs of sentiment. Other songs may come, have their day, and disappear. But the song that voices a true sentiment, spoken from a full heart, remains.

"Such a song arises only too seldom from the world's turmoil, but when its rare melody at last is heard it stirs the hearts of millions. Such a song is a power for good, a creator of joy unmeasured, a flawless diamond gleaming among earth's dusty pebbles."

HOLDS PARTY FOR THE CHILDREN

Jackson Columbia Dealer Entertains 2,500 Boys and Girls in Novel Fairyland Fete—Good Example of Community Work by Retail Dealer

Stern's Music Shop, of Jackson, Mich., recently held a very effective children's party during the local fair week. While the fair was in progress the manager of the Grafonola department of this house arranged a "Fairyland," which was attended by about 2,500 children. Circulars and tickets were distributed throughout the city and country roundabout, advertising was inserted in the newspapers and school teachers were visited, all with a view to getting the children of Jackson into the store.

For their reception, the entire store floor was cleared of practically all furniture and made into one large playground; trees were brought in from the woods and set up; beautiful singing birds in small cages were placed among the branches; hundreds of Japanese lanterns were hung around the store, each illuminated with a small electric bulb; the display windows were filled with toys and the glass panes were covered with cut-outs of lions, bears and other animals, and the demonstration booths were fitted up to correspond. A number of students were dressed up as fairies and they danced and sang from the balcony above the demonstration booths to the tune of a Grafonola. Souvenirs were given to each child as he left.

It was a wonderful example of how a large number of children can be successfully entertained by a retail merchant and, of course, experience has shown that it pays to win the good will of the children in your community.

The manager of this store has the following to say about the appeal to youth: "Children like the things that they can understand and that suit them. A beautiful shop, with great, brilliantly lighted windows and massive furnishings, awes a young child into silence and shyness, even though he may be impressed with its beauty; but the moment he sees a little chair and a small table, on which is a child's book, his shyness vanishes and he feels comfortable and at home. He becomes interested at once in everything in that corner, for he feels that he has found a place in which things for children are displayed. The spell is cast and henceforth this spot becomes his 'stamping ground'."

USES STRIKING COLUMBIA DISPLAYS

Minneapolis House Has Policy of Arranging Novel Displays in Demonstration Booths

The Grafonola department of the Hurley-Moren-Frank Co., Minneapolis, has made quite a success of its policy of fixing up the record demonstration booths with striking displays. One booth recently was decorated with flags and other patriotic insignia to feature the "American Legion March." Another was fitted up with a Japanese model, a fan, Japanese lanterns and several pieces of Japanese bric-a-brac, to feature "The Japanese Sandman."

ADVERTISES IN JEWISH PRESS

The Revere Phonograph Co., of Revere, Mass., has found it profitable to advertise Jewish selections in the Jewish newspapers. It has built up quite an additional record clientele in this way.

Why YOU need them

They're well advertised.

They're in demand.

They bring you a good profit and more cash on each sale.

There is nothing "just as good."



Semi-Permanent Phonograph

NEEDLES

give complete satisfaction. They play many times, do away with the inconvenience of frequent needle changing and increase the records' life.

These needles bring regular customers to your store. Send your order in today.

25c per package of 5 40c in Canada

Sonora Phonograph Company, Inc.

GEORGE E. BRIGHTSON, President
New York, 279 Broadway

Canadian Distributors: I. Montagnes & Co.
Toronto

CAUTION! Beware of similarly constructed needles of inferior quality.



**Superior Workmanship
Superior Finish
Superior Service**



Trade Mark
"SUPERCASE"
Mark
DIE CASTINGS

THE SUPERIOR DIE CASTING CO.

411 FRANKFORT AVE.

CLEVELAND, OHIO

THE SUCCESSFUL PROMOTION OF RECORD SALES BY MAIL

Three Letters That Have Been Used With Excellent Results by Victor Dealers in Ohio—The Advantage of Making a Direct Appeal to the Prospective Customer

The Eclipse Musical Co., Victor wholesaler of Cleveland, O., recently selected three letters, reproduced below, as being especially good examples of what some of its dealers were doing in the way of mail sales promotion. They are worthy of study, because they contain a very large measure of human interest and selling appeal:

November 13, 1920.

Miss Dorothy Moore, Columbus, O.

Dear Miss Moore:—Knowing of your interest in vocalization or a well-trained voice, and fully appreciating the difficulty encountered in the training, it affords us much pleasure to offer the Oscar Saenger course for your consideration.

We sing a great deal by imitation; then, of course, the artist's own interpretation means much. We believe you could follow no better leaders in colorature work than Galli Curci, Garrison, or Tetrizzini. They all sing "Charmant Oiseau" from "Perle de Bresil," each perhaps differently, yet from each you can get a splendid thought that you may apply to your own work.

All the necessary technique and exercise for the development of perfect vocalization are provided and explained in the Oscar Saenger Record Course, just as they are in Mr. Saenger's own school. Mr. Saenger is, and has been, the teacher of such artists as Althouse, Garrison, Jacoby, Rapold, Baker, Scotti and Hempel.

We know it to be a wonderful advantage to be able to possess these lessons.

In our music room we have all of the Victor Artists' records, and would be glad to have you come and hear them any time at your convenience.

We desire to give you such service as will enable you to enjoy and appreciate this much-prized course. Very truly yours,

THE MOREHOUSE-MARTENS CO.

November 13, 1920.

Miss Margaret Mary Anderson, Columbus, O.

Dear Little Miss Anderson:—Do you like bedtime stories? And if so, have you ever heard this story of the big dog and the kitty cats? Well, even if you have, I shall tell it to you again.

"Once upon a time there was a big grey mother cat who had a little grey kitten. The mother cat lay on the warm,

sunny porch, and said 'meow,' meaning 'come here,' and the little grey kitten cuddled close to her mother's warm, soft fur, and said 'Purrurr.'"

"Suddenly, around the corner of the porch came a big—black—dog, who said, 'Bow wow,' and ooh-h-h! what happened to that dog?" . . . and the balance of this story is the very interesting part.

Due to the fact we have many little girls to write (you see we are very busy), we cannot send you stories complete, or very often; but if your mamma would come to our store and buy you a record of the many stories, you would enjoy every one because they are told on the record just as I began to tell it here.

If your mamma wishes, she can bring you to our Music Rooms any time to hear the lovely songs and stories for little boys and girls.

We hope to see you real soon, and have you hear these little stories of "Tom Thumb," and "Chicken Little," and many others. Your very good friend,

THE MOREHOUSE-MARTENS CO.

GALLI-CURCI SAID:

"The Victrola has been my greatest teacher"

With this statement in mind, we wish to tell you of the real value the Victrola and Victor Red Seal Records can be to the Music Teacher and Student.

By listening to the records of the Red Seal Artists you can benefit by their masterful rendition of many of the world's famous compositions.

You can study Opera with Caruso, Melba, Farrar, or Scotti; Oratorio with Evan Williams, Louise Homer, Witherspoon; Concert Songs with McCormack, Alma Gluck, de Gogorza, Galli Curci or Mabel Garrison; you can study Violin with Heifetz, Kreisler, Elman, Maud Powell or Zimhalist; Violoncello with Hans Kindler; Piano with Paderewski, Cortot or Rachmaninoff.

You can repeat their records as often as desired and by playing over the part you are particularly interested in become thoroughly familiar with the artists' vocalization and interpretation.

We extend an invitation to the Music Teachers, Musicians and Students of Pittsburgh to come to our Victrola Department and make use of our large library of Victor Records. We will gladly play any of them for you at any time. Yours very truly,

THE ROSENBAUM CO.,
Victrola Department.

MACY-VICTOR DAMAGE SUIT OPENS

As The World goes to press, word is received that the suit of R. H. Macy & Co. against the Victor Talking Machine Co., Camden, N. J., and various Victor wholesalers as co-defendants, asking triple damages for alleged violations of the Sherman Law, has been set down for trial on January 11 in the United States District Court for the Southern District of New York.

AMERICAN ODEON CORP. SETTLED

The American Odeon Corp. is now well settled in its new home at 100 West Twenty-first street, New York. This concern reports an active business and a very bright outlook for the future. On account of being located in the heart of the wholesale district it receives a good many calls from the trade.

"What a splendid physique that fellow has!"

"Yes, but think of the exercise he gets. He's a traveling salesman and has to undress every night in a Pullman berth."

FAULTLESS

PIVOT BEARING

CASTERS

Casters that roll easily across the floor—and smoothly. No clatter—no unsteadiness.

Simple construction—no complicated parts to get out of order; nothing to retard easy movement. Strong—plenty of metal in required places to resist strains.

Silent—neat appearing—a real necessity to YOUR talking machine, these FAULTLESS CASTERS.



Full Size—C-65

Made with leather, fibre, felt, steel and lignum vitae wheels. A word from you puts all our caster experience at your service and brings you a copy of Faultless Catalog "G".

FAULTLESS CASTER COMPANY

EVANSVILLE, INDIANA

"Move the FAULTLESS Way"

Eastern Sales Office:

Geo. Mittleman, 200 Fifth Avenue, N. Y.

Stewart

Talking Machine Company

JOBBERS
for the
Victor
Talking
Machine
Company



Indianapolis

Now-12 Tonofone Needles for 25c!



DEALERS—Here Is a Bigger Profit for You!

Tonofone
The Phonograph Needle
With the Flexible Point

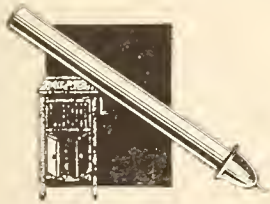

Send Coupon for
Sample Needles FREE

Dealers and others who have not tested Tonofone Flexible Point Needles recently, are invited to send coupon below for FREE samples to test at our expense. Prove for yourself that Tonofone Needles are musically, mechanically and scientifically correct.

R. C. WADE COMPANY
110 S. Wabash Avenue, Chicago, Ill.

Gentlemen:—Please send FREE Samples of Tonofone Needles for us to test at your expense.

Name.....
City.....
State..... Street.....

Here is the most attractive price and profit proposition you were ever offered on Tonofone or any other phonograph needle.

To introduce our new, bigger value, bigger profit package, which gives your customers 12 Tonofone needles for 25c, we are offering you a price of \$14.00 a carton of 100 packages—or \$7.50 a half carton of 50 packages.

The \$14.00 carton retails for \$25.00 giving you a profit of \$11.00 a carton, or 11c a package. This is 44% on your selling price and 79% on your investment. You will recognize this as a very exceptional profit.

Why not fill out the coupon below and order direct from this advertisement? You will need a big stock of Tonofone Needles at this after-holiday season, when phonographs are most largely used. It is the best time to introduce this new 25c package, which gives your customers so much more for their money, and you a bigger profit.

The Tonofone Flexible Point is one of the greatest inventions in phonograph needle history. Scientific new methods have now brought it to a very high degree of perfection. Each needle plays 20 to 50 records—any disc record on any phonograph—one needle for all tones.

The Tonofone flexible point is of correct and uniform size—not tapered. Being flexible it brings out clearer tones and gives more accurate reproduction. Being softer than any record, it minimizes surface noises and prolongs the life of records. Now sold by over 3000 leading talking machine dealers everywhere.

Please order direct from this advertisement, using coupon below. The needles will be shipped on our positive guarantee. Terms: Cash with order, less 2% or 30 days net on approved references or established credit rating.

R. C. WADE CO.
110 So. Wabash Avenue Chicago, Illinois

Tonofone

The Phonograph Needle With the Flexible Point

R. C. WADE CO., 110 S. Wabash Ave., Chicago, Ill.

Gentlemen: Please enter our order for Tonofone Needles as follows, which may be shipped through one of your wholesale distributors.

.....Cartons, 100 packages, at \$14.00.....
.....Half Carton, 50 packages, at \$7.50.....

Firm Name.....
City.....
State..... Street.....
Above is purchased subject to your positive guarantee

Window Dressing One of the Fundamental Arts of Retail Merchandising

By C. J. Potter
Before Advertising Clubs' Convention

When our ancestors back in the early ages hung their goods up on pegs and placed their rude pottery on shelves in front of their caves they acted in response to the same idea which prompts the modern merchant to spend many thousands of dollars a year in placing his goods in windows that are attractively decorated and cunningly designed to draw the attention of the public. Display advertising was the first advertising, far antedating written advertising. When the tailor in the early sixteenth century took a suit of clothes and hung them up in his shop window he found that passersby stopped to look at his wares. That is our first record of window display.

The progress which has been made in the art of window display during the past quarter of a century is truly remarkable, but shows what can be done when science and brain power are concentrated on one thing. To-day window dressing is an art and is considered one of the most potent factors in retail merchandising. Over 15,000 men are following this profession, many of them devoting their entire time to planning the displays which are to be seen in store windows in every city in the country.

The talking machine industry is one that is vitally concerned with the window display. Both manufacturers and dealers have learned the wisdom of utilizing windows for the display of their merchandise. Manufacturers have prepared special material which the dealer may use in his store windows to advertise the manufacturer's product. This material has been planned with care and is designed to accomplish one thing, to increase the dealer's sales. It has

been estimated that from 30 to 50 per cent of sales are made from window displays. Some dealers have valued their windows at \$200,000 a year!

Window displays come in for much attention on the part of every live talking machine dealer who has a wealth of material offered him in

*Some Merchants Say
Thirty to Fifty Per-
cent of Their Sales
Can Be Attributed
To Window Displays*

order that he may make the best of his opportunities. Manufacturers have taken occasion to complain at various times over the apparent lack of interest on the part of their dealers in the material sent out to them. In this connection it is interesting to note the opinion of C. J. Potter in an address before the convention of the Associated Advertising Clubs at Indianapolis in June. Mr. Potter said:

"In the past year I have read a great many articles written by advertising men, sales managers and others on dealer helps. Some of them

insisted that the dealer was a no account, lazy boor, who didn't appreciate the wonderful things he was being furnished to help him get rich. Some good suggestions were offered by these writers, but I fear that the men who plan the big campaigns are not well informed on the subject of window display. They probably realize to some extent the potent selling force of a window, but they forget that window advertising is a highly specialized profession and instead of calling in a practical display man they put an advertising writer or an artist on the job to design the displays for a campaign. The result—not used by the dealer. Why? Not practical.

"Take the case of many of the large stores. You would be surprised at the amount of cut-outs, dummy cartoons and lithographed cards which are sent to these stores and are in turn sent to the waste paper baler. And, gentlemen, do not blame the merchant, for the stuff was not in keeping with the rest of the store. It was designed by a man who knew nothing of the character of display material which was being used by these big establishments, therefore a waste of effort and money.

"There is no excuse for any man who is handling an advertising campaign not to give his client a complete service. I firmly believe that no advertising campaign which has for its purpose the selling of merchandise through retail stores is complete without window display helps and show cards, so that the force of the campaign can be crystallized in the merchant's window.

"In creating window display helps for manu-

The HOWE



*Tone — RICH
CLEAR • MELLOW
it does not Blast*

BALL BEARING
No obstruction
in the base

C.W. Howe & Company
21 East Van Buren St. Chicago-Ill.

PAUL WHITEMAN'S Big Fox Trot Hit
"I NEVER KNEW"
(I COULD LOVE ANYBODY LIKE I'M LOVING YOU)
 Published by LEO. FEIST Inc., FEIST BLDG New York

YOU CAN'T GO WRONG WITH ANY FEIST SONG

facturers who wish to co-operate with the larger stores, who, after all, are the real merchandisers of this country, it is well to remember that these stores are big institutions and are well organized and departmentized and, in many instances, spend more money for advertising than do a lot of the national advertisers.

"You can readily see how very important it is to have the display men design the displays for manufacturers and if more display men were called into the advertising conference there would be thousands of dollars saved each year.

"The display man knows how to make the displays an integral part of the advertising, because he will put the same selling arguments about the article that are embodied in the copy. The display will have the same appeal because he understands how to combine color, art and design so that they will express the same thought as featured in the national publications and local newspapers.

"A questionnaire sent out by Mr. Potter previous to the convention addressed to a number of display men, asking them the amount of display material received each year from manufacturers, how much of it was available and suitable for their purposes, what kind of material they found practical and what kind the most impractical?

"In analyzing these questionnaires when they were returned," said Mr. Potter, "it was evident that the manufacturer has little knowledge of the needs of the larger stores in the way of display material, for quite a large percentage of material that is sent out is not acceptable, as a great many of the show cards are too large. Some of the cutouts, especially those that are lithographed, are in the wrong colors.

"The material which seems to be the most acceptable are cutouts of photographic enlargements and small counter signs, the latter with the easel backs. Mechanical and moving displays of the manufacturer's product were voted 'no good at all,' as they detracted from the merchandise.

"It is, therefore, obvious that cutouts illustrating the use of the merchandise if made properly are the most acceptable and the type liked best are photographic enlargements or reproductions of hand paintings."

So far the discussion has had to do principally with the larger stores. Many of the talking machine stores in this country fall under a second class, which is made up of smaller stores where a regular display man, as such, is not retained all the time. It is this type of dealer that the manufacturer can most help by furnishing practical display material and display ideas. Such material must be very different in size and form from that furnished to the larger stores, because of the different requirements.

It has been suggested that the manufacturer, before preparing a set of display material, secure the services of an experienced display man and send him to visit the various stores to decide just what material would be of most value to all concerned. Once the decision has been

made then the different display sets are to be constructed carefully and sent out to the dealer. Careful instructions should accompany each display. The idea behind the instruction is not to try to make a display man out of the dealer, but to show him how he can use his display in a way to get the desired results.

When the displays are sent out they should be so timed as to tie up with the magazine and newspaper advertising of the manufacturer. Jobbers should have supplies of these displays in ample time so that they might distribute them to the dealers on time. With the display material on hand in all parts of the country it is easy for the dealer to get his set and have it set up in his window when the national advertisements appear. In the talking machine field this has been done to a large extent under recently improved methods and it is to this that the industry owes a measure of its success. But the rules laid down cannot cover all circumstances, as Mr. Potter pointed out in his conclusion as follows:

"Every manufacturer has his own problems, because the thing that will register for one manufacturer will not register for another. Therefore, it is absolutely necessary to design window trims for each specific line, but before designing be sure and find out from the retailer if they are the things that he wants and if you will do this you will find that the retail merchant will work with the manufacturer hand in hand to create greater sales for his product."

EDISON PLAYS PRINTED

Playlets Originally Presented During Caravan Tours Now Ready in Printed Form

The Edison Laboratories have just had printed a modest pamphlet containing the five plays shown at the 1920 Edison Caravan Convention, in New York, Chicago and San Francisco, which is in response to repeated demands from the trade. A copy is being sent every Edison dealer.

Although the 1920 Edison Caravan Convention is regarded by many as something past and gone, interest in it still seems extraordinarily alive, and especially keen have been the attention and curiosity aroused by the five one-act business plays, written by William Maxwell for the convention sessions.

One of the greatest tributes paid to William Maxwell, and to the products of his pen, up to the present time, is contained in an article written by Arthur McClure for a recent issue of Printers' Ink, called "Bringing the Stage Into the Sales Convention." After dwelling at length upon the plays themselves, Mr. McClure says:

"As a playwright, the vice-president of the Edison Co. is in a class by himself. He wrote five plays so that not more than three actors would be needed in each one, and so that the same three performers, two men and one woman, could handle the fifteen parts. Managers of stock companies, take notice! This is efficiency."

VELVET COVERED TURNTABLES

ADD TO THE QUALITY OF MACHINES



A.W.B.

Boulevard
VELVETS

THE BEST TALKING MACHINES ARE EQUIPPED WITH

A. W. B. BOULEVARD VELVETS

GRAND PRIZE—GOLD MEDAL, ST. LOUIS EXHIBITION

WRITE FOR SAMPLES AND PRICES

A. WIMPFHEIMER & BRO., Inc.
 450-460 Fourth Avenue, New York

ESTABLISHED 1845

Clearartone

PHONOGRAPH

SPEAKS FOR ITSELF

MICA DIAPHRAGMS

We are now cutting our own Mica Diaphragms and can take orders in any quantity. We can furnish you first quality clear Ruby India Mica. Sizes $1\frac{23}{32}$ " to $2\frac{9}{16}$ ". Also occasionally some second quality.

SUNDRY DEPARTMENT

MOTORS

No. 01—Single-spring, 10-inch turntable, plays 1 10-inch record, \$2.75.

Swiss F. V. B. — Double-spring, \$6.85.

No. 2—Double-spring, 10-inch turntable, plays 3 10-inch records, \$5.50; with 12-inch turntable, \$5.75.

No. 9—Double-spring, 12-inch turntable, plays 3 10-inch records; cast-iron frame, \$7.85.

No. 11—Double-spring, 12-inch turntable, plays 7 10-inch records; cast-iron frame, bevel gear wind, \$9.75.

STONE ARMS AND REPRODUCERS

Play All Records

No. 1—\$1.95 per set.
No. 4—\$4.50 per set.

No. 6—\$4.25 per set.
No. 7—\$3.75 per set.
No. 9—\$2.95 per set.

MAIN SPRINGS

No. 00— $\frac{5}{8}$ in., 9 ft., 29c.
No. 01— $\frac{7}{8}$ in., 7 ft., 29c.
No. 02— $\frac{3}{4}$ in., 7 ft., 29c.
No. 1— $\frac{3}{4}$ in., 9 ft., 39c.
No. 1A— $\frac{3}{4}$ in., 10 ft., 49c.
No. 2— $1\frac{1}{8}$ in., 10 ft., 39c.
No. 3— $\frac{7}{8}$ in., 11 ft., 43c.
No. 4—1 in., 10 ft., 43c.
No. 5—1 in., 11 ft., heavy, 49c.
No. 6— $1\frac{1}{4}$ in., 11 ft., 69c.
No. 7—1 in., 15 ft., 59c.

We also carry other size main springs to fit Victor, Columbia and all other motors.

RECORDS—10-inch Columbia double disc records, 36c each; 12-inch, 65c each.

Special prices on springs in quantity.

GOVERNOR SPRINGS—To fit VICTOR, COLUMBIA and all other motors. Special prices on large quantities to Motor Manufacturers.

We also manufacture special machine parts, such as worm gears, stampings, or any screw machine parts for motor; reproducer and part manufacturers.

Special quotations given to quantity buyers in Canada and other export points.

Write for our 84-page catalog, the only one of its kind in America, illustrating 33 different styles of talking machines and over 500 different phonographic parts.



No. 135—Price \$135

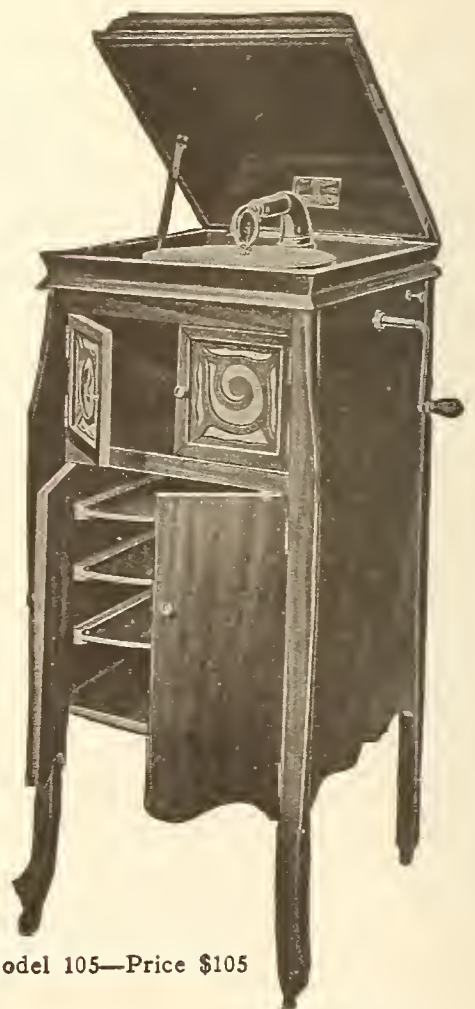

Model 105—Price \$105

SAPPHIRE, DIAMOND AND STEEL NEEDLES

STEEL NEEDLES

10,000 Lots.....39c per M
100,000 Lots.....35c per M
1,000,000 Lots.....30c per M
5,000,000 Lots.....29c per M

SAPPHIRE BALLS

	Each
Dozen Lots	11c
Hundred Lots	9c
Thousand Lots	8c
5-Thousand Lots	7c

SAPPHIRE POINTS

	Each
Dozen Lots	12c
Hundred Lots	10c
Thousand Lots	9c
5-Thousand Lots	8c

GENUINE DIAMONDS

	Each
Dozen Lots	\$1.00
Hundred Lots90
Thousand Lots75



Model 175—Price \$175

The CLEARARTONE has become very popular because of its quality, splendid value and the advertising sales campaign that now stands back of it. DEALERS! Watch us grow—write for our agency and grow with us. Keep our 84-page catalog of phonographs and all accessories handy—Sent free on request.

LUCKY 13 PHONOGRAPH COMPANY

503 East 19th Street

310-312-314 Avenue A

New York, N. Y.

TROY MUSIC HOUSE HAS BIG YEAR

Increase of 150 Per Cent Over Last Year Reported—Special Window Display Used in Troy, Albany and Schenectady Stores

TROY, N. Y., January 3.—Cluett & Sons, the enterprising piano merchants of this city, have closed a very big year in their talking machine department, which has been under the capable



Cluett & Sons' Aeolian-Vocalion window management of Amos E. Russell. The increase over last year's sales is estimated over 150 per cent. This is certainly a showing of which all concerned can feel proud. This company arranged a very attractive Christmas and New Year window, which was used in the Cluett stores in this city as well as Albany and Schenectady. The illustration herewith gives but a very meager idea of its attractiveness.

RIDGEWAY'S NEW COLUMBIA STORE

Ross Drug Co. Establishes Attractive Music Section, Featuring Columbia Line

RIDGEWAY, PA., January 4.—The Ross Drug Co.'s musical department is a very attractive addition to the big storerooms. A large section of the rear alongside the prescription department has been partitioned off, and with the big window makes a very comfortable, light, roomy room for the display of their line of Columbia Gramophones, records and musical merchandise. The acoustic properties, too, are particularly appropriate. The Columbia Gramofona is here shown in the various styles and designs and different woods.

The Ross Drug Co. has arranged for weekly shipments as fast as they are released, and customers may order special records in these shipments. The general public is invited to visit the department.

BIG SONORA HOLIDAY ADVERTISING

Sonora dealers located in metropolitan New York reported considerable results in sales through the advertising which was inserted around the holidays by the Sonora Co. in the New York Times, Journal, World, Sun and Globe. In these ads the new standard period models were featured.

A note from Edith Helena, who is singing in vaudeville down South, states that she saw a young negro in front of her hotel in Tampa, Fla., and asked him how he spent his time.

"Oh, Ah jest sets an' thinks," he replied, "an' when Ah ain't thinkin' Ah jest sets."

PLAN NEW NATIONAL ASSOCIATION

Music Trades Association of Southern California Moves to Form National Organization of Talking Machine and Phonograph Dealers

LOS ANGELES, CAL., December 31.—J. W. Boothe, general manager of the music department of Barker Bros., introduced a resolution at the last general meeting of the Music Trades Association of Southern California which had for its object the formation of a National Talking Machine and Phonograph Dealers' Association, and the secretary was accordingly instructed to write a letter to the various associations with this purpose in mind.

The following letter has been sent over the signature of A. G. Farquharson, the secretary:

"A resolution was adopted at our last meeting which has for its aim the foundation of a National Association of Retail Talking Machine and Phonograph Dealers, and the secretary was accordingly instructed to write to all of the retail talking machine, phonograph and music trades associations throughout the United States and ask them for their support and co-operation towards the formation of such an association—the object being the advancement, betterment and protection of the industry.

"It was suggested that delegates from the various associations should attend the Chicago Convention of Piano Merchants, which is to be held during the Spring of 1921.

"Enclosed you will find a copy of our constitution and by-laws, together with a list of some of the resolutions adopted during the past few months. These are for your information. Copies of some of your motions and resolutions would be highly appreciated by us."

ACTIVITY WITH BROOKS MFG. CO.

SAGINAW, MICH., January 3.—Despite the slowing up of trade in many industries the Brooks Mfg. Co., widely known through its creation of the Brooks Automatic repeating phonograph, is enjoying a very excellent volume of business and looks forward in a most optimistic way to increasing business during 1921. Dealers who have handled this product are very enthusiastic about its selling and musical qualities, as it contains a number of exclusive features which enables it to make a wide appeal.

Have you noticed that the most successful dealer the recent holiday season was the dealer who worked the hardest for trade?

NYOIL
FOR YOUR PHONOGRAPH

Made in Our Watch Oil DEPARTMENT

which for half a century has made 80% of all the watch, clock and chronometer oil used in America.

The Best Oil For Any Talking Machine

In refining, Nyoil is given the same care as our famous watch oil receives. All gums and impurities are removed, leaving it

Colorless, Odorless and Stainless.

Housekeepers say they would not be without Nyoil because it is best for phonographs and sewing machines—for polishing furniture and woodwork and is odorless and will not stain. It is free from acid and will not gum, chill or become rancid. Sportsmen find it best for guns because it prevents rust.

NYOIL is put up in 1-oz., 3/4-oz. and 8-oz. Bottles and in Quart and Gallon Cans.
For Sale by all Talking Machine Supplies Dealers
WILLIAM F. NYE, New Bedford, Mass., U.S.A.

FALK OPENS NEW VICTOR STORE

Wisconsin Dealer Has Exclusive Victor Agency for Live Business Center

STOUGHTON, Wis., January 4.—O. N. Falk & Son have converted the rear suite of offices on the second floor of the Rexall store into demonstration rooms for Victrolas, for which they are the exclusive agents in this city. These rooms are now stocked with a large line of Victrolas in the different woods and in a wide variety of sizes and styles. In the near future it is the intention of O. N. Falk & Son to erect an inside staircase to this demonstration suite, and in time it is expected that the firm's steadily growing business in Victrolas and Victor records will be transferred to the second floor.

E. J. PRUIN BRANCHES OUT

E. J. Pruin, of Zeeland, Mich., has built up a very successful talking machine business in addition to handling pianos and other musical instruments. Branches have been opened recently in Holland and Grand Rapids, with the Edison as the leading instrument.

Putnam-Page Company

VICTOR DISTRIBUTORS

¶ Central Illinois and its environs are rich in Victor opportunities, and to the dealer who has vision and merchandising courage we offer an exceptional service.

¶ That service is based on the dealer's proximity to our distributing headquarters and his desire to make his business representative of the product we distribute.

PUTNAM-PAGE COMPANY

PEORIA, ILLINOIS

ACME-DIE

- CASTINGS -

ALUMINUM-ZINC-TIN & LEAD ALL PYS

AcmeDie-Casting Corp.

Boston Rochester Brooklyn N.Y. Detroit Chicago



EXTRA!
Bert Williams has discovered that "Eve Cost Adam Just One Bone"! Hear it and you'll laugh so hard that the coupling will come true—"You'll Never Need a Doctor No More." But you'll need extra clerks to handle the rush of customers when you put this record on sale. A-3339

**Columbia Graphophone Co.
 NEW YORK**

SONORA MEN TO GO ON TOUR

L. C. Lincoln Will Cover Pennsylvania and J. W. Desbecker New York

L. C. Lincoln, advertising manager of Sonora Phonograph Co., plans to make a trip through parts of Pennsylvania in the early part of January. He will visit Sonora dealers in this territory and discuss with them the problems of advertising and retail merchandising for 1921.

J. W. Desbecker, of the Sonora advertising department, will also make a trip through New York State, and his purpose will be identical with that of Mr. Lincoln.

OPEN NEW BRUNSWICK SHOP

HOLLYWOOD, CAL., January 3.—Reed & Dady have opened their new exclusive Brunswick shop, 6611 Hollywood boulevard, one of the finest shops on the Pacific Coast.

All models of cabinet and period designs are on display in the new Brunswick shop, which has three record rooms in addition to the beautiful display space.

FIFTY LINES OF ACTIVITY

Music Industries Chamber of Commerce Is Working Along Half a Hundred Lines Connected With the Music Industry

There has just been issued by the Music Industries Chamber of Commerce an imposing list of fifty lines of activity in which the various divisions of the Chamber are at present earnestly engaged. With most of these activities the majority of the trade members are already quite familiar, for they have come in direct contact with them in one way or another, but the list calls to attention considerable special work with which the trade is not quite so familiar at the present time.

Particular interest attaches to the work of the National Bureau for the Advancement of Music, twenty-three of the principal activities of this important department of the Chamber being listed, including the weekly service for the music pages throughout the country, community chorus work, the campaign for the appointment of music commissions, the advertising campaigns, the co-operative work with other organizations, preparation of special literature, etc., etc.

The work of the Legal Bureau is outlined in a briefer list, with special emphasis laid upon the activities of that Bureau and representatives in Washington, in connection with many important legislative matters that are constantly coming up and which are calculated to affect music trade interests.

Interesting information is offered regarding the activities of the Export Bureau, which is now in active operation and is accomplishing results. The work of the Better Business Bureau, and of the Trade Service Bureau now in process of development, also receives attention and there are listed half a score of unclassified activities of the Chamber that are in themselves of distinct importance and are calculated to keep the trade together and to develop propaganda that will prove helpful in interesting members of other trades, Government officials and the public generally in music and the things that go to make music. Of these unclassified activities perhaps the most interesting from a trade point of view is the interest exhibited by the Chamber and its various Bureaus in the organization of various State and local associations and in the development of those bodies.

INSPECT RECORD EXCHANGE SYSTEM

New York Men Go to Philadelphia to Observe Workings of New Exchange System

E. G. Brown, secretary of the Talking Machine Men, Inc., the organization composed of leading talking machine dealers of New York, New Jersey and Connecticut, and Irwin Kurtz, of that Association, made a trip early this month to Philadelphia to observe the workings of the record exchange system recently inaugurated by the Philadelphia Talking Machine Men's Association.

REMINGTON FACTORY FOR TRENTON

Site Along Pennsylvania Railroad Tracks Purchased by New York Company for New Plant

TRENTON, N. J., January 3.—Local real estate circles in this city report the recent sale of a large tract of land comprising about fifteen acres advantageously situated along the line of the Pennsylvania railroad and close by the Trenton Fair Grounds. The purchaser of this large tract is the Remington Phonograph Co., of New York City, and it is expected that plans will shortly be filed for the erection of a large and modern factory for the manufacture of Remington phonographs. The selection of Trenton for the new Remington factory is said to be due principally to the advantages which the site offers in the way of transportation facilities and labor conditions. A frontage of 575 feet along the Pennsylvania railroad will provide excellent shipping facilities to distant points. The production of Remington phonographs is now accomplished in two factories, one in Brooklyn and one in Jersey City and the executive offices of the company are located at 1662 Broadway, New York City.

A VERY HELPFUL HOUSE ORGAN

The Puritan Full of Material That Is of Practical Value to Any Retailer

One of the brightest of the various house organs that come to the desk of the editor of The World is The Puritan, a snappy little monthly publication devoted to the interests of the Puritan phonograph and issued by the United Phonographs Corp., Sheboygan, Wis. The editor of The Puritan has the faculty for collecting merchandising and advertising ideas of genuine value to the dealer and presenting them in a manner that is understandable and practical. The Puritan dealer who gives the proper attention to this publication cannot help but gather from it ideas that, if properly applied, will mean more business.

ANNOUNCING ASSOCIATED No. 70 UNIVERSAL TONE ARM

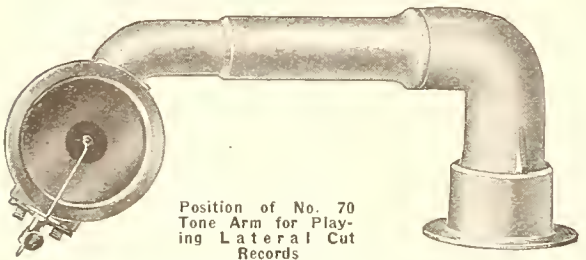

Position of No. 70 Tone Arm for Playing Lateral Cut Records

Quality Construction Unusually Good Tone No Blasting
 For use in Phonographs retailing up to \$100.

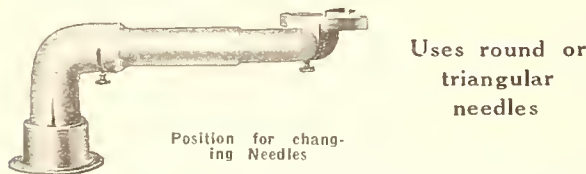

Position for Changing Needles

Uses round or triangular needles

The price is right for low-priced machines and the quality is there for high-quality instruments.



Position for Playing Hill and Dale Records

Price for sample—\$2.00. Quantity price on application.

Associated Phonograph Supply Co.
 Dept. 70 Cincinnati, Ohio

ROTTEN STONE

We are the only miners and manufacturers in this country of Rotten Stone for use in Phonograph Record making. Our product is now in use by practically every record manufacturer in this country. We are also headquarters for all other minerals for record making and everything we handle is made especially for this purpose and absolutely guaranteed. Expert advice given upon any formula.

KEYSTONE MINERALS CO.
 41 Union Square, New York City

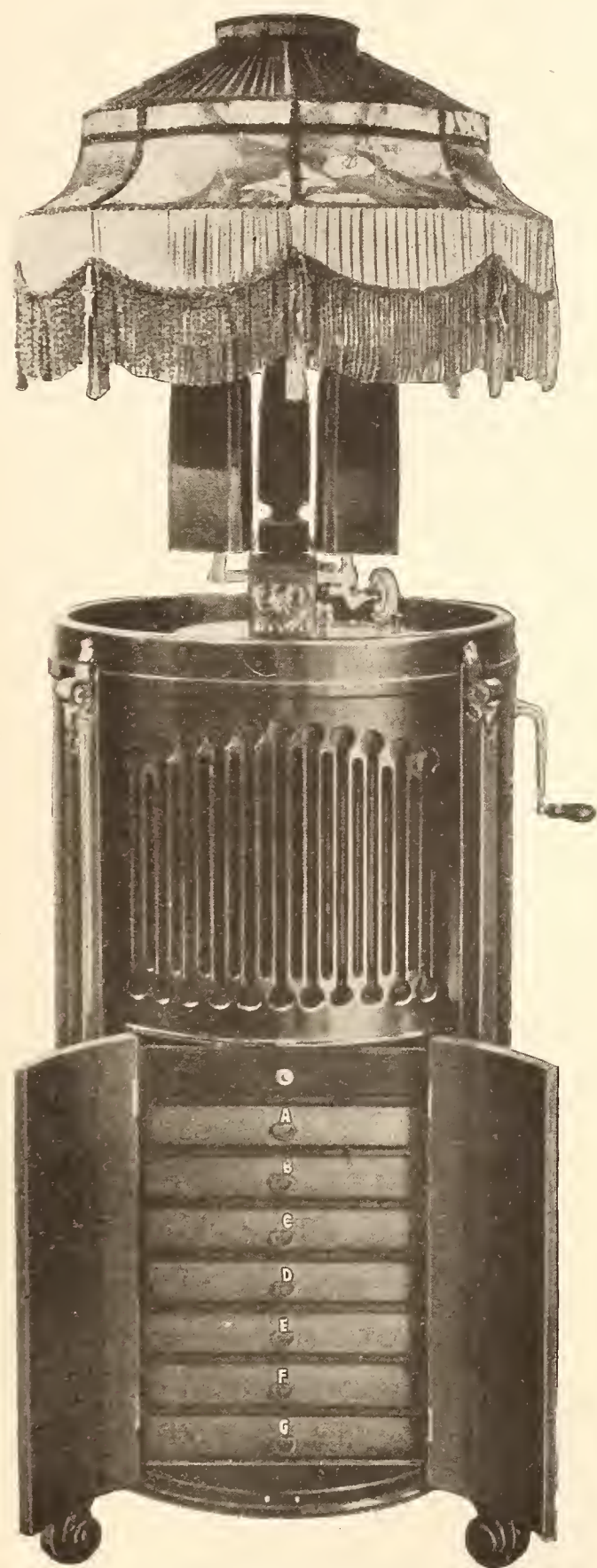

*A Circular Instrument
Luxurious In Finish
Lamp Detachable*

Eye and Ear Appeal

*Combined They
Make Easy the
Selling of the*

Modernola

THE tone of this different instrument measures up to the musically educated. Modernola tone is accurate---rich----full----even.

Then it has an added appeal---its unique and indescribably beautiful appearance. An individualized instrument of circular design, surmounted by silken lamp, it is a real creator of atmosphere in any home setting.

The Modernola enhances music values. It cheers. It sentimentalizes.

Increased production permits an extension of territory. Jobbers and dealers are invited to write for information.

THE MODERNOLA COMPANY

JOHNSTOWN, PA.

Eastern Distributors:

Eastern Phonograph Corporation, 100 West 21st Street, New York

BRUNSWICK IN WILKES-BARRE, PA.

Large Department Store, for Years Opposed to Talking Machines, Takes Brunswick Agency

WILKES-BARRE, PA., January 5.—"Mac Williams," one of the largest department stores in the East, has secured the agency for the Brunswick. Although this company has always declined to handle talking machines it was only after careful thought and thorough inspection of the various makes on the market that it decided on the Brunswick.

The Brunswick department, which is fully equipped with sales and record demonstrating booths, all of which are mahogany, is one of the finest in this section. An experienced man is in charge.

They are thorough believers in advertising and immediately commenced running full-page ads announcing the addition of the Brunswick, which ads are bringing more than satisfactory results.

MAX SMITH A REMINGTON DEALER

Brooklyn Man Expects Great Things of New Agency in Brooklyn

Among recent dealers who have taken on the Remington line of phonographs is Max Smith, of 798 Franklin avenue, Brooklyn, N. Y. Mr. Smith is enthusiastic over the Remington proposition and plans to give it energetic representation in his locality. This new Remington dealer was appointed by John Streiff, distributor of Remington phonographs in Brooklyn and the entire length of Long Island. Mr. Streiff expects shortly to announce several new appointments of local agencies to be established. Mr. Streiff also conducts retail warerooms for the Remington line at Flatbush avenue, Brooklyn. He reports that the Remington line is popular in the "city of churches and borough of homes" and that sales have been very satisfactory.

ORMES IN TEMPORARY QUARTERS

Victor Distributor, Undaunted by Fire Loss, Finds New Location and Resumes Business—Now Serves Dealers From 103 E. 125th Street

The ability to promptly recover from misfortune and to push ahead as though nothing had happened is a true test of the stamina of either man or organization. This test was proved in the recent fire at Ormes, Inc.

On the day that last month's issue of The World went to press fire destroyed the warerooms of Ormes, Inc., Victor distributors, at 26 East 125th street, New York City. Scarcely had the flames died out when Clarence L. Price, head of the Ormes organization, set about securing new quarters to carry on the business. The fire occurred on Friday evening and by Monday morning the organization had found new quarters two blocks distant, at 103 East 125th street, on the northeast corner of Park avenue. The new quarters are located on the fourth floor of the large business structure at that address and have every facility for the successful carrying on of Ormes service to the Victor retailer. An excellent emergency stock of Victor merchandise was secured and with hardly the loss of a business day the business of Ormes, Inc., progressed as usual—even to the same telephone number, Harlem 7302, which number has so often proved a lifeline to the Ormes-Victor retailer in the past. Mr. Price was able to secure an immediate transfer of his former telephone line to his new location.

NEW BROOKLYN CORPORATION

The Sterling Art Co., Inc., Brooklyn, New York, has received a charter from the Secretary of State, to deal in talking machines, musical instruments, etc. The capital, \$25,000. Directors are Archibald M. Llano, 91 East Eighteenth street; William A. Price and Ruth Price, 189 East Eighteenth street, Brooklyn.

VIRGINIA REA APPEARS IN OMAHA

Brunswick Artist Entertains Lions' Club With Pleasing Recital of Songs

OMAHA, NEB., January 4.—The Brunswick-Balke-Collender Co., through the district phonograph manager, R. S. Pribyl, recently had the pleasure of presenting Miss Virginia Rea to the Lions' Club, a business men's organization of this city.

Miss Rea sang a very beautiful Spanish song, which was received by this club with a great ovation. Her repertoire was magnificent and was highly complimented and encored by everyone present, and the Brunswick concern was congratulated on being fortunate in having so charming an artist sing exclusively for it. Her complimentary song was greatly appreciated and it was the unanimous desire of everyone present that Miss Rea appear again in concert in Omaha in the very near future.

FISHING AND BUSINESS ARE ALIKE

The angler will tell you his sport is the greatest man has discovered beneath the sun, and if you are an angler you will agree with him.

In the first place it gets you up early (as any worth-while business should), then it requires a fine patience (which most business does) and a skill in feeling the nibble and making the landing which will do justice to the keenest minded salesman "angling" for a prospect.

Unless you have some of the fisherman in your makeup you have missed some very essential attributes of the perfect salesman.

Cultivate patience in talking to your dealers and exercise wisdom and judgment in "landing" them.

And, by the way, do not forget that "getting up early," when the worms are fresh and there is a long day before you to reach the best "holes" which are always farther up stream than the ordinary fellow goes!—Columbia Peptimist.

THE NEW MODEL E
GARFORD PHONOGRAPH

The Greatest Value on the Market
IMMEDIATE DELIVERIES IN ANY QUANTITY

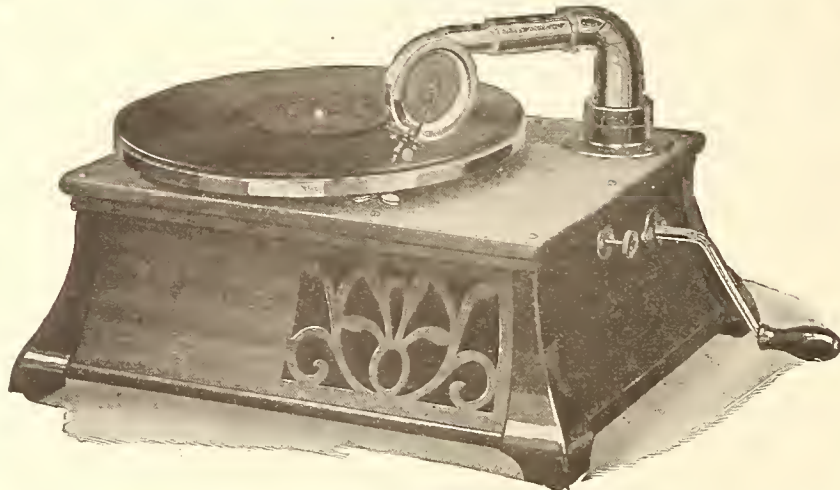

New Model "E" Garford Phonograph
Plays All Makes of Records Superior Tone Quality
Write for Proposition

The General Phonograph Mfg. Co.
ELYRIA, OHIO

Doehler Die-Castings

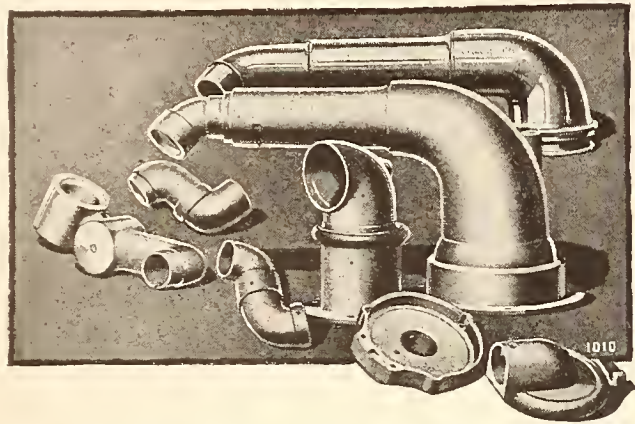

Doehler Die-Casts in White Metal and produces Finished Brass Castings by its patented "DO-DI" Process.

Truly typify the best product of the die-casting art.

For Doehler talent, both engineering and manufacturing, developed the die-casting art to its present high standard.

And builded three large modern manufacturing plants at Brooklyn, Toledo and Chicago in order to better and more quickly serve the exacting requirements of its customers—America's most discriminating manufacturers.

*DOEHLER is truly
Die-Casting Headquarters*

THE WORLD'S LARGEST MANUFACTURERS OF DIE CASTINGS
DOEHLER DIE-CASTING CO.
HEAD OFFICE AND EASTERN PLANT: BROOKLYN, N.Y. CENTRAL PLANT: TOLEDO, OHIO WESTERN PLANT: CHICAGO, ILL.
SALES OFFICES IN ALL PRINCIPAL CITIES

COLUMBIA DISPLAY AT COUNTY FAIR

Pittsburgh Dealer Furnishes Columbia Banners to Exhibitors and Makes a Big Hit

Carl Botefuhr, Columbia dealer in Pittsburgh, Kan., recently secured some worth-while publicity for his line at the Pittsburg County Fair



Using Columbia Banners to Advantage

by furnishing Columbia banners to various exhibitors. These banners were placed around the booths in the manner indicated by the accompanying picture. They served not only to call attention to the Columbia trade-mark, but also as a sunshade. Many of the exhibitors said they were going to use these improvised sunshades as part of their future equipment in moving from county to county, following the various county fairs.

MAN WHO WORKS WILL WIN IN 1921

Sales Campaign to Get Music Into the Homes of Employes With Aid of Employers

A. L. Maresh, head of the Maresh Piano Co., Cleveland, O., made a very important suggestion some time since, when he pointed out to the heads of a number of manufacturing institutions that instead of distributing cash bonuses at the end of the year they could give talking machines instead. In this connection a large number of No. XI Victrolas were distributed to good purpose.

The point is that this suggestion might be followed up with advantage not only around the holiday, but throughout every month of the year. Employers generally realize the great value of music not only in the factory, but also in the home, and there would be no opposition to dealers getting in touch with employes of large plants whereby every worker may be enabled to get music in his home at a reasonable expenditure of cash. These are times when every possible means of stimulating trade must be considered and the dealers should see to it that the workshop, as well as every school and home, should contain a talking machine and a library of records.

It is not difficult to prepare a sales campaign

along this line and it is the man who is going to originate new sales plans and who is prepared to execute them that is going to make the best business record during the new year which has just opened up. In 1921 it is the man who works who will win.

NEW COLUMBIA BLACKBOARD SIGN

The Columbia Graphophone Co. has prepared a bulletin board, which is in reality a blackboard sign, on which any particular record can be featured. The selections can be changed as often as desired. These can be ordered by Columbia dealers through their branch distributors.



SAPPHIRES IMPORTED

BALLS	POINTS
20 c. each	20 c. each
16 c. in dozen lots	18 c. in dozen lots
13 c. in hundred lots	15 c. in hundred lots
12 c. in thousand lots	13½ c. in thousand lots

942 MARKET STREET
SAN FRANCISCO, CAL.



PHONOGRAPH CASES Reinforced 3-ply Veneer

The Standard Case for Talking Machines and Records

Let us figure on your requirements.

MADE BY
PLYWOOD CORPORATION, Goldsboro, N. C.
Mills in Va., N. C. and S. C.

LORAIN HOUSE NOW VICTOR DEALER

Reidy-Reichlin-Scanlan Co. Celebrates Event
With Elaborate Ceremonies

The Reidy-Reichlin-Scanlan Co., of Lorain, O., started handling the Victor line recently, at which time they held a very pretentious and successful opening. A large newspaper campaign preceded the opening and a special parade was held, which included trucks loaded with Victrolas and Victor records, and one truck containing the Lorain City Band.

A feature of the opening consisted of songs by talented artists. The Fisher Cross Jazz Orchestra of Cleveland provided dance music throughout most of the day. A special Ferris wheel window was prepared for the delight of the children. During the afternoon the Women's Civic Association of Lorain visited the store in a body. A number of out-of-town people were present, including representatives of the Eclipse Musical Co. and Victor Talking Machine Co.

TELLS OF TONOFONE POPULARITY

E. H. Wade Calls Upon the Trade in New York
—Tonofone Needle Output Increases

A recent visitor to the city was Edward H. Wade, manager of sales of the R. C. Wade Co., makers of the Tonofone talking machine needle, 110 South Wabash avenue, Chicago. Mr. Wade had an interesting story to tell of the expansion of this business and the growth of interest in the Tonofone needle, thanks to its special merits of satisfying the particular needs of those most critical in the matter of tone reproduction in connection with the talking machine.

The Tonofone is now being placed with leading dealers from the Pacific to the Atlantic, and from Canada to the Gulf, and it is expected that the New Year just opened will show the greatest output of Tonofone needles in the history of this company.

Do You Throw Money Away?

It is not a popular pastime—but still it is unconsciously done by many who just don't know that *Repair Parts* can be bought for less

**RENE MADE SPRINGS AND PARTS LAST LONGER
COST LESS**

RENE MFG. CO.

Montvale, N. J.

NEW HOME FOR PEERLESS ALBUM CO.

Large Quarters Leased at 636 Broadway, New York—Additional Equipment to Be Installed and Shipping Facilities Improved

The Peerless Album Co., formerly of 49 Bleecker street, New York, has leased new premises at 636-638 Broadway, where several hundred feet of additional floor space will be available for the installation of new equipment to provide for increased production. The extra space will also permit of improved shipping facilities.

The new location, between Howard and Grand streets, is easily accessible to practically all the principal lines of transportation, which should appeal particularly to visiting buyers, who will find the new quarters very convenient.

Phil Ravis, president of the company, has been carrying on negotiations for some time past with a view to securing new quarters. The Peerless Album Co. has one of the most efficient record album plants in the country and in future the albums will be manufactured in their entirety in the new quarters, which will be occupied about February 1. Some time ago the company announced a new album offering some new, exclusive, patented features, manufactured in sets. The trade has received this new prod-

uct with favor and it promises to become the leader of the company's line.

HANDSOME UNICO VICTORY CLOCK

Novel Holiday Greeting Sent Out by Unit Construction Co., of Philadelphia

A very unique holiday souvenir has been sent by Rayburn Clark Smith, president of the Unit Construction Co., to his friends in the trade. The gift is a Unico Victory clock, which is a Unico aeroplane propeller, in the center of which the clock has been neatly set.

The Unit Construction Co. during the war made many aeroplane propellers, including the ones used on the first aeroplane to make the transatlantic flight. The Unico Victory clocks are made from the type of propeller used to generate current for the radio equipment on some of Uncle Sam's battleplanes. It is a very unique souvenir of the world war, as well as of the holidays.

QUITE A RECORD TO HAVE

"My brother Georgie swallowed a dime, and we sent for the minister."

"Why the minister?"

"Oh, he can get money out of anybody, dad says."

BELL HOOD *Semi-Permanent Needle*

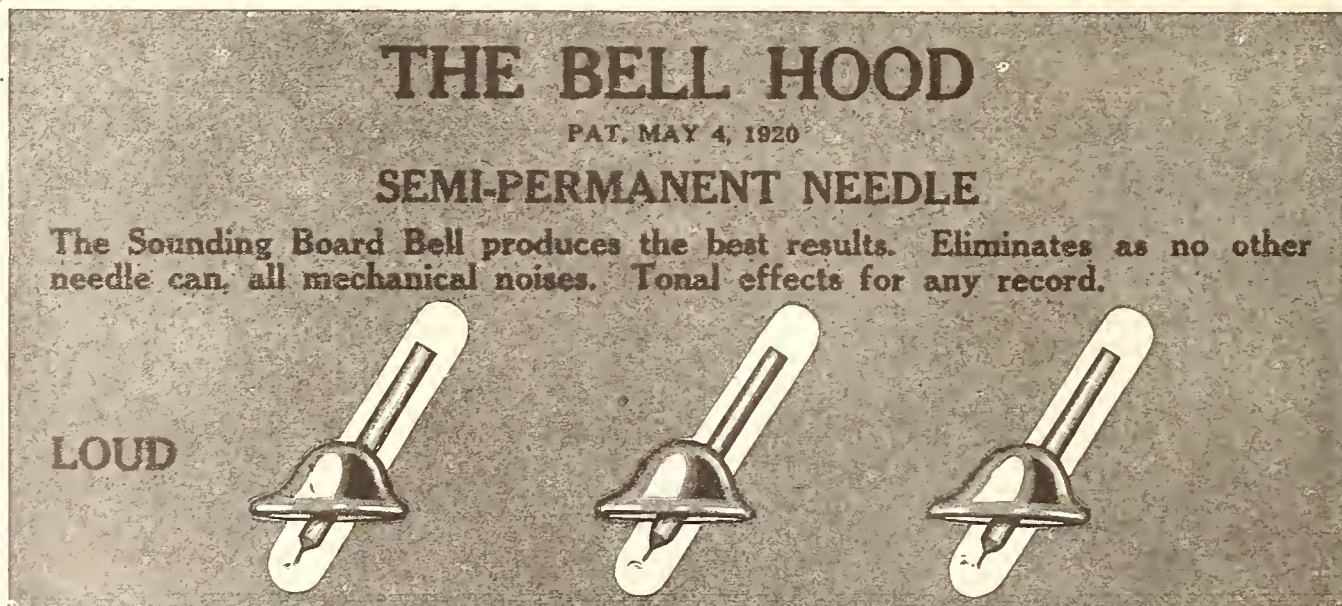

Made by the Bell Hood Needle Co., New Haven, Conn., U. S. A.

IMPROVES YOUR PHONOGRAPH 100 PER CENT "The Bell Does It"

Purifies the tone, reduces the scratching and mechanical sounds to a minimum.

SEMI-PERMANENT POINT—Loud—Medium—Soft

A profitable needle for dealers to sell. More than 2000 Dealers are now selling them with splendid success. Order from the nearest branch.

THE BELL HOOD NEEDLE CO.

183 Church St., New Haven, Conn.

3901 Sheridan Road
Chicago, Ill.

PETERMAN SALES CO.
Oneonta, Alabama

A. M. BRINKLE
33 So. 16th St., Philadelphia, Pa.

807 The Arcade, Cleveland

89 10th St., South
Minneapolis

Distributors for all states west of
Mississippi River and Wisconsin

Oké

will import for you records from the repertoires of
BEKA and FAVORITE and others

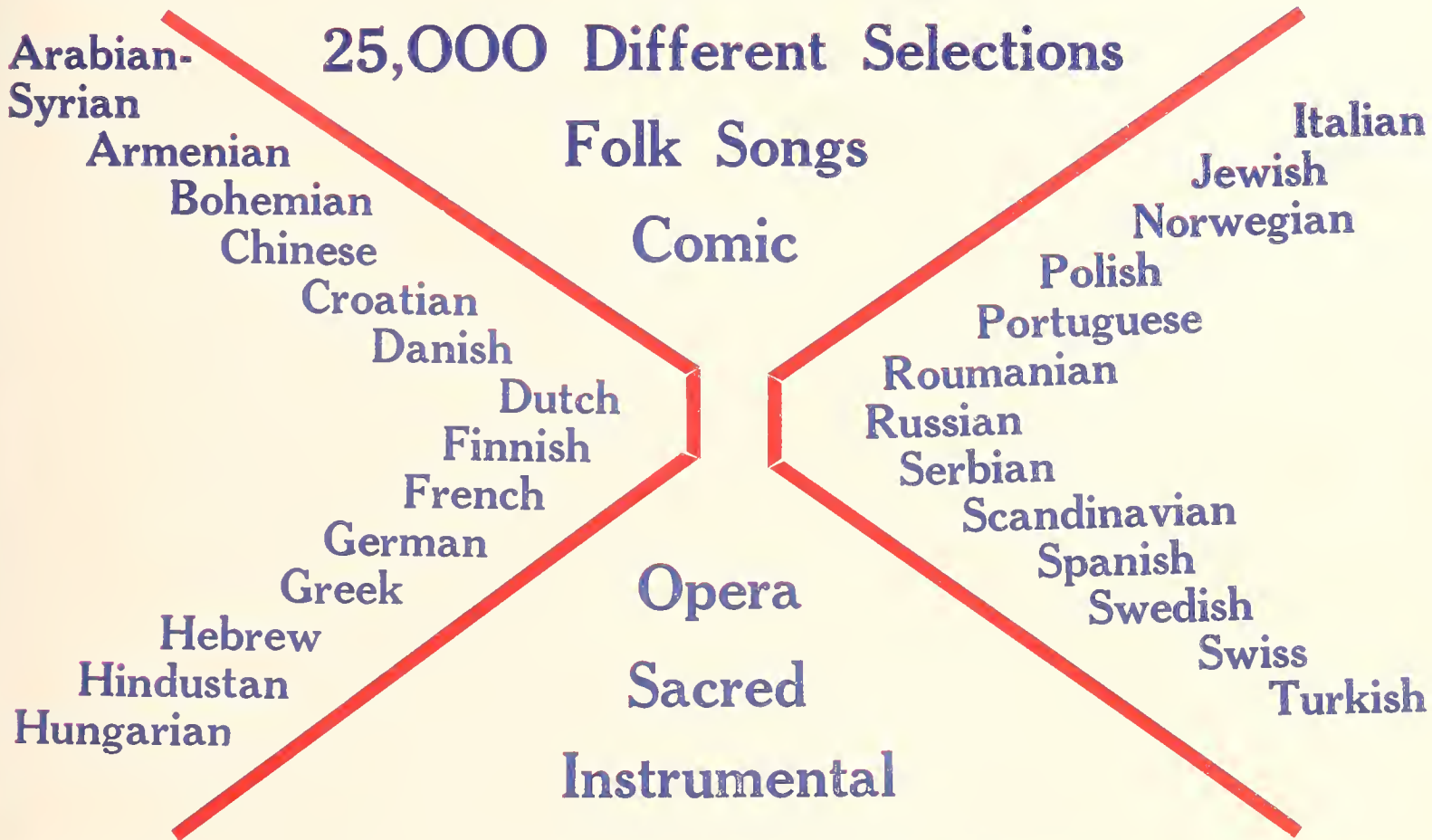

ALL RECORDS ARE RECORDED IN NATIVE COUNTRIES

A large number of foreign matrices in

German, Hungarian, Italian, Jewish and Polish
have arrived, and a substantial list of records in these languages with
the Oké label will be released shortly.

GENERAL PHONOGRAPH CORPORATION

OTTO HEINEMAN, *President*

25 West 45th Street, New York City, N. Y.

Factories: Newark, N. J. Elyria, Ohio Putnam, Conn. Springfield, Mass. Kitchener, Ont.

Branch Offices: Chicago, Ill. Toronto, Can. London, Eng.





CABLE ADDRESS REG'D
"FILASSE-PHILA."

THE MARK OF

LONG DISTANCE 'PHONE
BARING 535

ANY { Size
Quantity
Quality

SERVICE AND
Phonographically Speaking



SATISFACTION

They Talk For Themselves

Quotation }
Delivery } RIGHT
Product }

IMICO INDIA RUBY MICA DIAPHRAGMS

INTERNATIONAL MICA COMPANY PHILADELPHIA, PA. U. S. A.

INTERNATIONAL MICA CO., 106-110 W. Lake St., Chicago, Illinois

FACTORY AND SALES DEPT.,
37TH AND BRANDYWINE STS.,
WEST PHILA., PA.

FEDERAL PHONO SUPPLY CO.
3009 JENKINS ARCADE
PITTSBURGH, PA.

LAKESIDE SUPPLY CO.
416 SOUTH DEARBORN ST.
CHICAGO, ILLINOIS

MOORE & WHITESIDE
MONTREAL, CANADA

WALTER S. GRAY
SAN FRANCISCO, CAL.

STEINOLA COMPANY
Kansas City, Mo.

"IMICO" and "SERVICE" are SYNONYMOUS

OKLAHOMA DEALER'S VERY STRIKING WINDOW DISPLAY



Ferguson Bros., retail merchants of Muskogee, Okla., recently featured Columbia Gramophones and Columbia records through an attractive window display. A paneling was built in the back of the window, which was finished in a rich, creamy white. Display cards which featured records by particular artists were tastefully arranged. The picture shows the effect produced.

The success here achieved points the way whereby other dealers can utilize their show windows to good purpose.

NEW UDELL BLUE BOOK

Handsome Volume Devoted to Descriptions and Illustrations of Udell Cabinets Just Issued

The new Udell Blue Book, just off the press, is a very beautiful example of artistic printing and editing. It is a wonderfully made up catalog of the line of music roll and talking machine record cabinets manufactured by the Udell Works of Indianapolis.

The cover, printed in a bronze blue ink on Blue Castilian Cover, shows a marked resemblance to the finer varieties of Spanish leather and is one of the newest and best examples of the binder's art. The body text is printed with blue tint border on each page. The illustrations are printed in dull black ink on Dejonge's White Art Mat. The effect is soft, and the cuts have a photographic appearance.

The introduction is devoted to a statement of Udell policy, the principal feature of which is that "Udell Dependable Cabinets are built around the proposition that they must 'measure up' with the piano, the player-piano or the talking machine that they are used with." This subject is admirably handled.

In the new Udell Blue Book there are over forty-seven photographic illustrations of music roll cabinets and over twenty-six of talking machine record cabinets, with a number of full-page sketches showing Udell cabinets in home environments.

EVERSHARP PENCILS AS XMAS GIFTS

Officials of the C. C. Mellor Co., Victor wholesaler of Pittsburgh, gave their friends in the trade a very handsome holiday souvenir in the form of a gold Eversharp pencil, engraved with the name of the person to whom it was given. Accompanying this gift was a very handsome engraved Christmas card featuring a period Victrola.

DEMAND FOR TURNTABLE VELVETS

Official of Importing House Believes Talking Machine Industry Must Stick to Quality

Harold Wimpfheimer, one of the heads of A. Wimpfheimer & Bro., 450 Fourth avenue, New York City, manufacturers and importers of velvets, velveteens and plushes particularly adapted for the equipment of turntables of talking machines, recently stated that despite the unsettled business condition the demands for the season of 1921 for his firm's product, "Boulevard Velvets," have shown an increase over the early orders of 1920.

In accounting for this situation he says, "There is no doubt that the talking machine industry is going through a period of reconstruction. It seems to be the unanimous opinion in the trade that the future of the industry lies mainly in the manufacture of quality machines that can meet the competition of the coming months. It becomes necessary therefore for manufacturers to equip their machines with features that will add quality to their instruments."

A. Wimpfheimer & Bro. carry several selections of velvets, velveteens and plushes which they find particularly good material for turntables. "Boulevard Velvets" received the Grand Prize and Gold Medal at the St. Louis Exposition.

If that fabled golden fleece existed to-day it would be worth its weight in wool.

COLUMBIA CONVENTION POSTPONED

Branch Managers Will Defer Meeting Until New Offices Are Ready

The 1921 Convention of Columbia Branch Managers, which was scheduled for the early part of January, has been postponed. At the time the January date was set the lease which puts the Columbia executive offices in the Gotham National Bank Building, Columbus Circle, New York City, had not been closed. In view of this lease having been closed, it was decided to defer the convention until the new executive quarters are ready to receive the branch managers. An inspection of the new executive home will be a feature of the 1921 convention.

"MAGNET" DECALCOMANIE NAMEPLATES

FOR TALKING MACHINE CABINETS ETC.

DORAN CO.
44 HURON ST.
DETROIT, MICH.

SOLD BY
HURTEAU, WILLIAMS & CO.
MONTREAL — OTTAWA

FROM
THE PHONOGRAPH CO.
1240 HURON ROAD (Street level)
PHILADELPHIA - PHILADELPHIA
CLEVELAND

Pamphlets with fac-simile illustrations and prices mailed on request.

SMITH-SCHIFFLIN CO.
149 Church Street New York City

Kunkel Piano Co.
BALTIMORE

SOLD BY
WALTER D. MOSES & CO.
Oldest Music House in VA and N.C.
103 E. BROAD STREET
RICHMOND, VA.

SOLD BY
J. E. STRATFORD
AUGUSTA, GA.

PATHE DISTRIBUTORS

ARMSTRONG FURNITURE CO.
59 N. Main St., MEMPHIS, TENN.

BRISTOL & BARBER
3 East 14th St., NEW YORK

BUFFALO WHOLESALE HARDWARE CO., 317 Washington St., BUFFALO, N. Y.

BURNHAM, STOEPER & CO.
19 E. Larned St., DETROIT, MICH.

CHURCHILL DRUG CO.,
BURLINGTON, IA.

CHURCHILL DRUG CO.
CEDAR RAPIDS, IA.

CHURCHILL DRUG CO.
PEORIA, ILL.

COMMONWEALTH PHONOGRAPH CO.
19-21 Lyman St., SPRINGFIELD, MASS.

EASTERN PHONOGRAPH CO.
100 West 21st St., NEW YORK

THE FISCHER COMPANY
943 Chestnut Ave., CLEVELAND, O.

THE FISCHER COMPANY
44-46 Vine St., CINCINNATI, O.

FULLER-MORRISON CO.
540 W. Randolph St., CHICAGO, ILL.

JOHN A. FUTCH CO.
35 Auburn Ave., ATLANTA, GA.

GRAY & DUDLEY CO.
NASHVILLE, TENN.

HALLET & DAVIS PIANO CO.
146 Boylston St., BOSTON, MASS.

HARBOUR-LONGMIRE PHONOGRAPH CO. 1001 Elm St., DALLAS, TEXAS

HARBOUR-LONGMIRE PHONOGRAPH CO.
311 W. Main St.,
OKLAHOMA CITY, OKLA.

INTERSTATE PHONOGRAPH CO.
1026 Chestnut St., PHILADELPHIA, PA.

INTERSTATE PHONOGRAPH CO.
1018 Wabash Ave., CHICAGO, ILL.

W. W. KIMBALL CO.
Jackson & Wabash Aves., CHICAGO, ILL.

F. P. MAY HARDWARE CO.
469 C St., WASHINGTON, D. C.

MOONEY, MUELLER & WARD CO.
101 S. Meridian St., INDIANAPOLIS, IND.

MORLEY MURPHY HARDWARE CO.
GREEN BAY, WIS.

PATHE CITY SALES
10 Grand Ave., BROOKLYN, N. Y.

PITTSBURGH TALKING MACHINE CO.
963 Liberty Ave., PITTSBURGH, PA.

RICE-STIX DRY GOODS CO.
ST. LOUIS, MO.

RICE-STIX DRY GOODS CO.
NEW ORLEANS, LA.

ROCHESTER PHONOGRAPH CO., Inc.
44 Clinton Ave., North, ROCHESTER, N. Y.

SALT LAKE HARDWARE CO.
SALT LAKE CITY, UTAH

M. SELLER & CO.
Fifth and Pine Sts., PORTLAND, ORE.

M. SELLER & CO.
SPOKANE, WASHINGTON

G. SOMMERS & CO.
Park Square, ST. PAUL, MINN.

WM. VOLKER & CO.
DENVER, COLORADO

WM. VOLKER & CO.
HOUSTON, TEXAS

WM. VOLKER & CO.
Main, 2d and 3d Sts., KANSAS CITY, MO.

WEAVER PIANO COMPANY
YORK, PA.

WESTERN PHONOGRAPH CO.
820 S. Broadway, LOS ANGELES, CAL.

WESTERN PHONOGRAPH CO.
985 Market St., SAN FRANCISCO, CAL.

WRIGHT & WILHELMY CO.
Tenth and Jackson Sts., OMAHA, NEB.

PATHE FRÈRES PHONOGRAPH CO.
10-56 GRAND AVENUE
BROOKLYN, N. Y.



THE PHONOGRAPH YOU
NEVER WIND

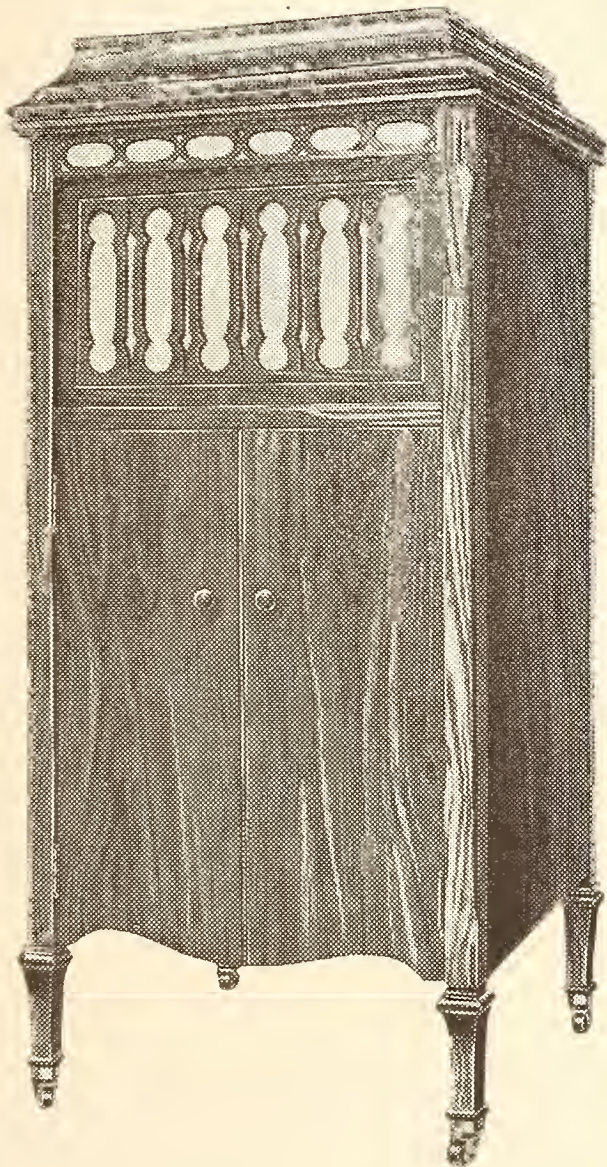

**ELECTRIC
 SUPREME**

Costs no more
 than the ordinary

PHONOGRAPH

For use with alternating current

**IS NOISELESS
 HAS NO GEARING
 ONLY ONE MOVING PART**

**PLAYS ALL RECORDS
 ALWAYS READY TO PLAY
 ALWAYS PLAYS AT CORRECT SPEED
 NO NEEDLES TO CHANGE—NO WINDING**

*If you are NOT a Pathé Dealer better telegraph
 at once to nearest distributor*

PATHÉ FRÈRES PHONOGRAPH CO.
 10-56 GRAND AVENUE
 BROOKLYN, N. Y.



Marion Harris vamps 'em all in "I'm a Jazz Vampire." That explains her advice in the coupling: "Never Let No One Man Worry Your Mind." You'll sell all you order. A-3328

**Columbia Graphophone Co.
NEW YORK**

REVIEW OF GENERAL TRADE CONDITIONS IN NORTHWEST

Dealers Handling the Better Types of Machines Close a Very Excellent Year—Competition Is Somewhat Keen Among Concerns Handling Lower-priced Machines—News of the Month

ST. PAUL and MINNEAPOLIS, MINN., January 3.—Unquestionably the Northwestern talking machine folks could be much worse off than they are. The results of their planning and striving during the closing months of 1920 have not come up to their expectations, but the net outcome does not look so badly after all. Some of the retail dealers now realize that they were too optimistic last Spring and ordered more heavily than the recent developments warranted. These are now overstocked, and with the competition of the large flock of mushroom concerns, which are slashing prices regardless of the consequences, they may have some difficulty in unloading stock along legitimate lines. Wherever possible, dealers in this position have attempted to cancel orders and even decline shipments and this turn has greatly embarrassed the jobbers and distributing agencies.

"We had a rather brisk talking machine trade throughout the Northwest just before Christmas, due to the stimulation of the holiday spirit, but now that the effect of the stimulant has vanished we can only await developments," said Sewell A. Andrews, of the Minneapolis Drug Co., distributor of the Sonora phonographs. "The retail dealers are now taking their losses in their turn and the experience is not pleasing them at all. How long the process of readjustment is to continue we are unable to say, but undoubtedly every one wants the operation completed speedily so that the country again may be restored to normal business health."

W. J. Dyer & Bro. had a wonderful talking machine trade in December, according to George A. Mairs. He concedes that the present situation is somewhat mixed, but protests against the pessimistic talk going on, not only in the newspapers and other publications, but man between man. "There is too much talk and too

little hustle," he asserted with his usual vigor.

All the employees of W. J. Dyer & Bro., about one hundred in number, were the guests of the house at a nice dinner party at the St. Paul Athletic Club Tuesday, January 4, 1921. W. J. Dean, founder and head for fifty years, presided with courtesy and genial dignity.

Information from the headquarters of the Edison phonographs in the Northwest is to the effect that there are no regrets. Some of the local dealers, particularly in certain rural sections, have not done as well as they had expected, but many other dealers turned in repeat orders. It is not likely that suspension of operations in the East will affect the Northwestern

VALUABLE BOOK ON EXPORTING

Jas. H. Collins in "Straight Business in South America" Gives Some Practical Information on Exact Business Conditions There

A new volume which should prove of distinct value to those engaged in the export field and those interested in the development of export markets is "Straight Business in South America," written by James H. Collins, the well-known special investigator on business subjects for the Saturday Evening Post, the Philadelphia Public Ledger, and other publications. Mr. Collins presents clearly and forcefully the various situations that the exporter must meet, and must expect to meet in handling South American business, and it is therefore a most timely and useful volume.

One of the essentials to success, declares Mr. Collins, is for the exporter to possess business imagination; to believe in the possibilities of foreign business, and to be prepared to go into the field on a permanent basis, instead of re-

situation in any particular for a short time, at any rate.

"We took our inventory on January 1 and found 234 Victor records and a half-dozen Victrola sixes," said Eugene F. O'Neill, of the Beckwith-O'Neill Co. "We should have at least 500,000 records and a houseful of Victrolas in order to supply our trade friends. But we had twelve complete turnovers in 1920, and while we have made desperate efforts to accumulate a real jobber's stock we have failed. The Victor Co. has been sending us much more than ever before, but we are still away behind in orders."

"We have put on additional salesmen to inaugurate the year 1921, and that tells just where we stand in relation to the future," said John E. Gerlick, representing the Stone Piano Co. in Twin City territory. "The Vocalions have been firmly established in the Northwest and we view the future with absolute confidence."

garding it as a passing venture. He tells of the sort of countries that go to make up South America; the general character of their peoples as it affects the business man; the question of banking and shipping; the making of investments; the problems of distributing, retailing and advertising, and something of the business customs and forms that must be observed if the American is to gain the confidence and the real respect of the South American business man.

Mr. Collins states that continental business methods must be followed and gives reasons. He outlines the elements of European competition, the advisability of buying, as well as selling, and offers an abundant fund of other general information that is of the sort that can be easily assimilated. His book is one that should prove of distinct value to the exporter and the members of his staff, regardless of the length of time the exporter has been engaged in South American business. The book is published by D. Appleton & Co., New York, and is listed at \$2.50.

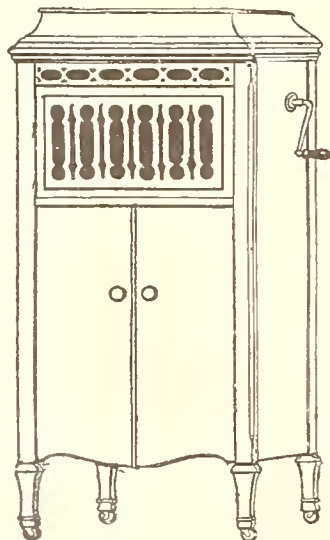

SOUTHERN DISTRIBUTORS

Pathé PHONOGRAPHS
and RECORDS



GRAY & DUDLEY CO.

Write Today for Agency Proposition

NASHVILLE

TENNESSEE

VICTOR READY REFERENCE LABELS

New Issue Offers Several Improved Features of Interest to Dealers Handling Records

Shortly after the first of the year the Victor Co. expected to ship the revised issue of ready reference labels which can be used with all styles of stock envelopes and stock cards. They have, however, several new features. One of the most important benefits claimed for the ready reference label service is the complete cross index which it offers for all records in the domestic section of the catalog. In the new issue the cross index has been brought up to date and includes all records now listed.

A special list accompanies the Red Seal section of the catalog, suggesting records which may be of interest to a purchaser who has shown preference for a certain kind of selection. The new labels also show when the selection was first announced and give the telegraphic code word to identify each record, thus providing an excellent means for educating the sales person.

NEW LANCASTER BRUNSWICK SHOP

A. E. Pitt Has Handsome Establishment With Large Display Windows and Signs

A Brunswick shop has been opened in Lancaster, Pa., by A. Emerson Pitt, a former Brunswick dealer of Oxford, Pa. This shop has a frontage of 42 feet, 32 of which is bulk windows, making the finest display in that vicinity. He has also placed in front of the shop large electric signs bearing the Brunswick trade-mark.

Although the Brunswick has not been formerly represented in Lancaster, Mr. Pitt, who is thoroughly familiar with the product, is very enthusiastic and is having particular success in the sales of high-priced models.

He has just completed rebuilding the body of a Dodge car, in the rear of which is a facsimile of a large Brunswick phonograph, which will be used in delivering to customers.

NEW JERSEY SONORA WHOLESALE

Griffith Piano Co. Given Territory of Whole of New Jersey

The Griffith Piano Co., Newark, N. J., which has hitherto acted as a Sonora wholesaler for part of New Jersey, will cover the entire State as a Sonora distributor, effective January 1, 1921. This company has made a big success with the Sonora line to date, and looks forward to a bigger year for 1921.

GOODS MUST BE PROPERLY MARKED

Indian Regulations Regarding the Marking of Imported Goods Should Be Conformed to Strictly in Order to Avoid Delay

Lack of care in marking merchandise shipped to India by American manufacturers frequently causes the importers of the goods to suffer loss and needless delay, writes Consul L. G. Barre Dawson, who is stationed at Madras. According to Mr. Dawson this would be avoided if the goods were marked in this country to conform to the requirements of the Indian merchandise marks law.

The principal requirements of this law are that all goods imported into India shall have marked on them or their containers the name of the country of origin in letters fully as large as any of those contained in the trade-mark or description of the goods.

During the last year, Mr. Dawson reports, a number of shipments of American merchandise have either been passed with a warning by the Indian customs authorities or on the payment of suitable penalties. Where possible, the goods were passed after qualification of false trade descriptions.

The Arnold Music Co., Jacksonville, Fla., had a very artistic display of Victor machines at the recent Florida State Fair. Manager Arnold entertained some big crowds.

THE COLUMBIA CALENDAR

Artistic Holiday Souvenir Issued by Columbia Graphophone Co.

The Columbia Graphophone Co. issued an exceedingly attractive holiday souvenir this year, in the form of a 1921 calendar. A reproduction of an oil painting of an elderly couple sitting before the fire near a Grafonola is the main feature of the cover. Under this appears the music score of the first line of "Be it ever so humble, there is no place like home." The music extends just far enough to cover this one world-famous line. There is a page for each month of the year, and on each month red and green backgrounds indicate the dates of the month on which new Columbia records are released, and in each month the release of foreign records is distinguished from the other releases.

There is also a reproduction in colors of a beautiful painting for each month, which pictures Columbia artists in action, ranging from wonderful operatic scenes to jazz settings. These calendars are being sent out by Columbia dealers in a special envelope as a holiday present to their present and prospective customers.

AND THE CHECK CAME BACK

An Obliging Music Dealer Loses Twenty-one Dollars by Good Nature

PERU, IND., January 4.—Pleasant Bell, manager of the Bell Music House, is anxious to learn the whereabouts of a Herman Miller, who at one time gave promise of being one of Bell's best customers. Miller bought a talking machine and paid a deposit of \$10, saying he would return later in the day after he had received his pay check and would pay \$40 more to make up the required first instalment. He did return with a check for \$71.20, but said the banks were closed and he had not been able to cash the check. Bell, therefore, cashed the check and gave Miller \$31.20. The check came back, but Miller didn't.

File Your Records so you can find them and it's easy to sell them.

This System pays for itself by increasing Sales through better service and Automatic ordering of "Sold-Out" Records

OGDEN'S PATENTED RECORD FILING CABINETS AND VISIBLE TAB INDEXES ARE GUARANTEED

MODEL No. 2150 D.D.
2 UNITS ILLUSTRATED

93 inches

40 inches

48 inches

15 inches

2150 THIN RECORDS IN EACH UNIT. STOCK FINISHES:
4300 RECORDS IN 2 UNITS. WHITE/IVORY & PEARL GRAY
2150 EDISONS IN 2 UNITS. MAHOGANY & OAK

OGDEN SECTIONAL CABINET CO., INC., LYNCHBURG, VA.

LOCKING ROLL TOP PREVENTS DUST AND THEFT. ALSO SUPPLIED WITH SPANISH LEATHER CURTAIN.

350 10" OR 10 1/2" RECORDS ON EACH SHELF. FILED IN SALES SYSTEM COVERS AND WITH INDEX GUIDES.

350 10" OR 10 1/2" RECORDS ON THIS SHELF, ALSO 3 SHELVES ABOVE.

SOFT FLAT SUPPORTING SPRINGS PREVENTS WARPING (PATENTED). HOLDS 350 10" OR 12" RECORDS.

10" AND 12" RECORDS FILED ON SAME SHELF, HELD FLUSH AT THE FRONT BY PATENTED ADJUSTERS.

Immediate Shipments

on all models in standard finishes. Light and Golden Oak, Red and Brown Mahogany, Enamels, White, Old Ivory and French Grey.

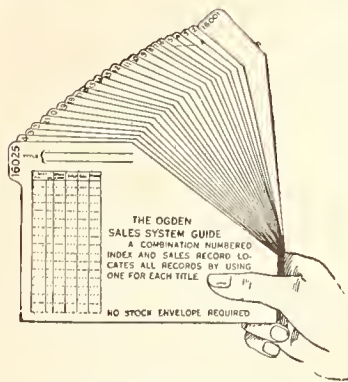

Visible Tab Paperoid Index

The Tab extends in front of the record with numbers always visible. Used the same as a stock envelope, one for each title, leaving all records in their envelopes. Is used to re-order by and keeps "Sold-out" numbers continually before you.

Shows quick and slow sellers. The best and simplest "Sales and Ordering" index ever devised and rapidly replacing the stock cover because of its many advantages. Fits any filing system, shelving or racks. Printed both sides for right or left hand flat or upright filing.

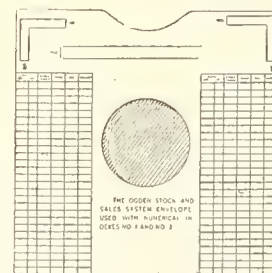

SALES SYSTEM ENVELOPES

keep track of what you sell and what you need—an automatic inventory, showing profitable and slow sellers. Arranged for upright or flat filing and will fit any system.

Sectional Models Fit Any Size Stock and Help You Grow.



THE OGDEN SALES SYSTEM IS EQUIVALENT TO AN EXTRA CLERK AND INCREASES SALES

Mr. Jobber— Line Up With a "Live" Line

"Some choice territory still available"

Prima-Donna

"The Instrument Inspired"



"Bungalow"



"Stratford"



"Blackstone"

--The
Entering
Wedge

To
Phonograph
Sales



"Astoria"



"Majestic"



"Parlor Grand"

Write for Our Unusual Money-making Proposition

Let us show you how Prima-Donnas, as compared to other high-grade phonographs, are sold at a price that offers the biggest money-making proposition on the market. How we co-operate with the jobber by supplying him with selling helps such as jobbers' letters and broadsides to interest the dealer, beautiful five-color catalogs, dealers' four-color store folders, six-color store hangers, newspaper ad electros, moving picture slides, etc.

We sell exclusively through our jobbers, all inquiries from dealers, due to our extensive advertising, are referred to our jobber in that territory.

Unexcelled Tone and Craftsmanship

Prima-Donna Phonographs, due to their especially designed and scientifically constructed all wood amplifier, develop a wonderful richness and clearness of tone that is unsurpassed. They will play any and all records correctly, with a fidelity to the recorded music that instantly appeals to the music lover and connoisseur.

You must admit the designs of the Prima-Donna are beautiful. As for construction and finish we ask the opportunity to prove Prima-Donna superiority. All cabinets are solidly constructed, the panels, which are 5-ply, either genuine mahogany or quartered oak, are inserted in a continuous frame that makes the cabinet absolutely wear-proof.

PRICES FROM \$85 to \$225—LIBERAL DISCOUNTS

Unreservedly GUARANTEED for One Year

MR. RETAILER We Have a Jobber in Your Territory
Who Can Supply You Overnight With
These Big Phonograph Values :: ::

GENERAL SALES CORPORATION

1520 BUFFUM STREET

MILWAUKEE, WIS.

OWNING AND OPERATING
GENERAL MFG. CORP. RECORDERON PHONOGRAPH CO.
MFRS. OF PHONOGRAPHS
HEANEY-SCHWAB BILLIARD MFG. CO., Makers of Fine Billiard and Pool Tables Since 1882

Featuring the MUSICAL POSSIBILITIES of the TALKING MACHINE

[Editor's Note:—This is the third of a new series of articles by William Braid White, devoted to the various interesting opportunities which prevail in the domain of education for the retailer of talking machines. The subject is one of great interest and we commend these articles to the consideration of all who are devoting attention to the featuring and developing of the musical possibilities of the talking machine.]

THE WONDER OF SCHOOL WORK

The retail man, in whatever capacity he works, who takes the time to read these articles, will have realized ere this that my object has all along been to awaken thought and to stimulate the wise action which arises only from wise thinking. The talking machine business is not a fly-by-night business. It has long ago achieved that respectable condition which is signified by large capital investment and elaborate statistical showings. It no longer occupies a small or poor position. It therefore requires to be considered by all who are engaged in it from the viewpoint of its true position.

That is why the educational side of the talking machine is so supremely important. If sound reproduction machines are really important to the world, if they actually fill a needed place in that world, if they have a legitimate position amongst the many implements of musical art, then obviously it is of the utmost importance to the talking machine industry that talking machines should have an appropriate place amongst the implements—the machinery of the country's educational system.

Music or Machinery?

Of course, if the talking machine is not a legitimate instrument for the reproduction of music, that is a different matter. No merchant, however, and rightly, would agree to so outrageous a statement, if it were made: yet many merchants act as if it were true and as if the last thing which ought to be connected with the talking machine business is the idea of music. Actually, of course, it is the idea of music which, above all other ideas, ought to be cultivated in the exploitation of talking machines. That is why the educational position of the talking machine is of such transcendent importance to the talking machine industry. For if one thing is more certain than another it is that the musical and cultural value of the talking machine has yet to be completely established. The connoisseurs know it, and the trade, in a sort of way, knows it; but the mass of the

buying public does not yet know it. That, once more, is why the educational position of the talking machine is so essential to the prosperity of the trade.

How many merchants are studying this question closely? Not, one imagines, very many. The matter of placing the talking machine in the schools of every community is not a matter to be settled offhand. It has taken the best brains and effort of some of the wisest individuals in the industry, during several years, to place the talking machine in even some of the schools. And when once it has been placed the problem of retaining it in its place is found to be still more engrossing. It may be well to glance at a few of the points to which the school authorities naturally look when they are considering the use of the talking machine as an aid in primary and secondary education.

How the Schools Look at It

The subject is, of course, enormously wide and deep, for in truth there is scarcely an aspect of educational method which would not be more definitely focused by the use of music in some form. A very few of the possibilities and some of the broader elements in the large subject-matter can alone be touched on here.

What is the principal use of music from the educational standpoint? Undoubtedly its principal use is as a harmonizer of thought, a unifier of effort, a stimulus to mental processes of every sort. The elementary fact, known to everyone, that music helps the efforts of armies in the field, nerves men to more intense output of energy and cheers those whose work would otherwise be intolerably monotonous, has its reflection in the entire scope of educational effort. When children learn, as a pleasant and natural activity, to sing together, to dance together and to listen to a certain amount of good music every day, those children cannot help being brighter, less fatigued, more cheerful and happier generally than any equal number of children who have not this advantage. This fact is by now well known to educational authorities, and it is therefore usually not very difficult to get these officials to see the great advantages which the talking machine possesses, as accompanist, as soloist and as orchestra.

How It Is Done

At this point, however, there enters another

matter, also of essential importance. It is absolutely essential that the music shall be carefully and skilfully selected. Here comes in the special educational departments of some of the great talking machine companies, which annually spend large sums in research, in making special records of educational music of all sorts, going into details not even thought of by the ordinary dealer. To read carefully the literature put out for the benefit of their dealers by these companies is an education in itself along these lines. We find that special courses of instruction in folk songs, in folk dances, in the history of music, in American music, in the instruments of the orchestra, in part-singing, in literally dozens of branches and subjects, are put at the disposal of the school children and their teachers. Not only this, but there are special school machines and even special courses of instruction for rural music supervisors and county superintendents who may wish to instruct rural school teachers in the use of the talking machine for educational purposes in remote country school-houses.

The variety and richness of the courses offered, the wonderful care taken to put the true meaning and scope of the talking machine as an element in education, and, in short, the extraordinary efficiency of the entire work, can hardly fail to astonish and fascinate the least interested merchant or salesman, or to give that person a more exalted and juster idea of what the talking machine really is and how wonderful a thing it has come to be.

The Merchant's Position

Of course, the merchant who is considering the various points which have been set forth here will not fail to note that the selling of talking machines to schools is only a very small part of the introduction and maintenance of the talking machine as a necessary engine of education. He will at once see that it is one thing to sell a machine and quite another thing to keep it in use. He will see, in short, that his principal work will very likely be to induce among the educational authorities of his community a beginning interest, which afterwards is to be worked up and made into something really useful by the extraordinarily efficient departments of the great manufacturers which are

(Continued on page 74)



HERE IT IS

The

FLETCHER UNIVERSAL
TONE ARM and REPRODUCER

Gives Proper Playing Weights for all Records. No Adjustment Screws or Springs.

SAMPLES \$8.00

Specify 8½" or 9½" arm

FLETCHER-WICKES CO., 6 East Lake Street, Chicago, Illinois

THE GEORGE McLAGAN FURNITURE CO., STRATFORD, ONTARIO, EXCLUSIVE CANADIAN AGENTS

THE WONDER OF SCHOOL WORK

(Continued from page 73)

organized and kept in motion for that one purpose. For this is not a matter to be treated with contempt. It is not a matter to be monkeyed with.

Biggest Weapon of the Merchant

On the other hand, the use of the talking machine in the schools is the biggest weapon the merchant has to wield, if only he will realize this fact. It should be his delight to help along this good cause in every conceivable way, regarding all his work as so much effective and result-bringing advertising. If he is wise and will co-operate wholeheartedly with those who are experts in school work, he will see that he is doing the best thing he can possibly do to make his own business bigger and better, and to place himself in a sure position as a center of musical influence and the resort of the music-buying public of his community.

Here, perhaps, the merchant will find his best and most practical relation to the educational aspects of the talking machine. In any case, whatever be the part he actively takes, he ought to find the utmost pleasure and interest in studying the truly wonderful possibilities of the talking machine in the schools. The educational work now actually prepared and being done far surpasses the knowledge of most of the men in the trade. It ought to be better known. If it were the talking machine would be more respected, better liked and treated with an enthusiasm which it deserves, but does not always get.

A PITTSBURGH INCORPORATION

The Salvee Reproducer Co., Pittsburgh, Pa., has been incorporated to do business in talking machines. The capital of the new company is \$50,000 and the incorporators are F. Centrobi, Grafton; L. Salvi and A. Segreto, Ingram.

BRUNSWICK ARTIST SINGS ON COAST

Theo. Karle Appears in Los Angeles and Is Entertained at Brunswick Music Shop

LOS ANGELES, CAL., January 3.—The Los Angeles branch of the Brunswick-Balke-Collender Co. reports that Theo. Karle appeared in concert recently before a very large and receptive audience. The recital was a splendid success and is indicative of the kind of performance that Mr. Karle is always capable of. After the recital Mr. Karle, Mr. Klein and Mr. Voorhies, of the Brunswick Co., were entertained at luncheon in the Brunswick Music Shop by Mr. and Mrs. Moore. Many interesting facts pertaining to the recording of records were made clear by Mr. Karle, who spoke very enthusiastically over his association with Brunswick records.

TRAVELING EXPENSES DEDUCTIBLE

May Be Exempted From Income Tax by Ruling of Internal Revenue Department

WASHINGTON, D. C., January 4.—Internal Revenue Commissioner Williams announced lately a new ruling by which commercial travelers and business men traveling for business purposes are allowed to deduct from income tax returns reasonable and necessary traveling expenses, including railroad fares, meals and lodging, in an amount not in excess of ordinary similar expenditures at home.

If an individual receives a salary without compensation for traveling expenses his traveling expenses in excess of similar expenditure at home are deductible. If he receives a salary and traveling expenses, such as a per diem, any excess is held to be additional income. Payment for a sample room is held to be a business expense. All traveling expenses in detail are required to be taken into account in making returns.

SHOULD OBSERVE INVOICE RULES

American Chamber of Commerce in Brazil Calls Attention to Penalties Suffered by Importers for Carelessness of American Shippers

The Music Industries Chamber of Commerce has received from the American Chamber of Commerce at Sao Paulo, Brazil, a communication calling attention to the difficulties experienced by the failure of American shippers to comply fully with the regulations regarding Brazilian consular invoices. The Sao Paulo Chamber calls attention to the fines which result from the use of abbreviations and the necessity of giving the complete information called for each separate column of the Brazilian invoice form, and says:

"Consignors of merchandise are failing to write out the country of origin of the goods and the country where the goods were purchased in full in each of the columns provided for the purpose on the consular invoice and are abbreviating along the top of each column the name of the country of origin, 'United States of America' or 'Estados Unidos da America,' to 'U. S. A.' or 'E. U. da A.,' placing these initials across the two columns in question.

"This abbreviation is necessary for convenience sake, but the consignees in Brazilian ports, on dispatching their goods, are fined because of such abbreviations.

"We might also call your attention to the fact that the custom house officials discharging the goods receive 50 per cent of the fines levied on consignees taking their wares from the custom house, which fact encourages fines for the slightest deviation from the Brazilian consular invoice regulations."

A very successful Edison tone-test, with Glen Ellison as the featured artist, was given recently in Chagrin Falls, O., under the auspices of Brewster & Stroud. The affair attracted an enormous crowd.



Equip your store NOW for

Bigger Record Sales in 1921

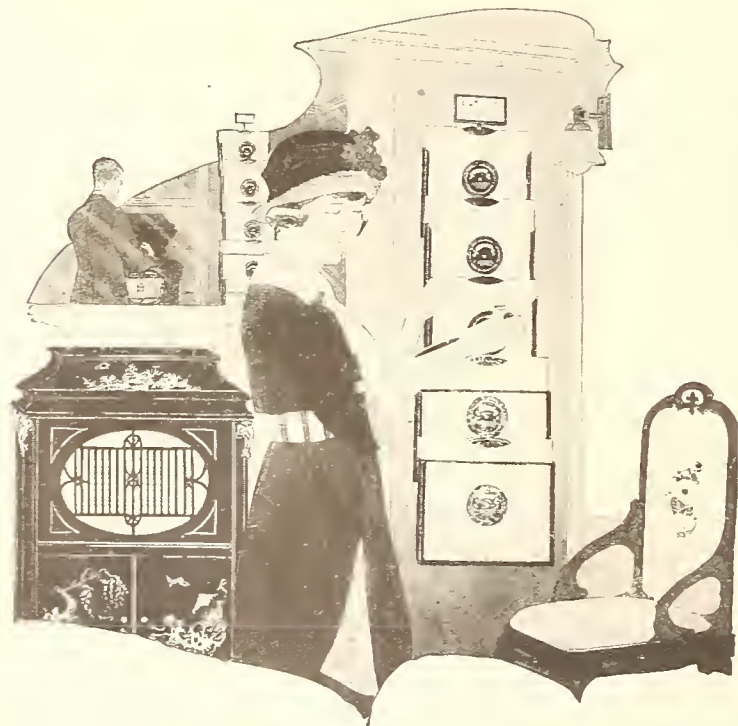

SELF-SERVICE MULTIPLEX No. 501
Described in NEW CATALOG

Every fixture in the MULTIPLEX line is a Sales Help, built to fill a need and a place in your business.

ST. LOUIS
MULTIPLEX
Record-Selling
FIXTURES

will increase your record sales in 1921. Write for New Catalog describing all MULTIPLEX Fixtures, including the Self-service MULTIPLEX shown at left.

Multiplex Display Fixture Co.

General Offices: 919 Tenth Street, St. Louis



MR. MAXWELL LOOKS FOR EARLY REVIVAL OF BUSINESS

Interesting Discussion of Conditions in Reference to Closing Down of Edison Phonograph Departments—Great Demand for Re-Creations—Why 1921 Will Be a Good Year

A number of newspapers in the East announced immediately after Christmas that the phonograph works of Thos. A. Edison, Inc., in Orange, N. J., had closed down indefinitely. When asked for a confirmation of the general reports William Maxwell, vice-president of Thomas A. Edison, Inc., took occasion to confirm the fact that the phonograph plant had been closed as completely as possible and gave some interesting reasons for that action. He said:

"I regret that I cannot confirm the report that our phonograph works are wholly closed down. However, we have closed down as completely as possible. It is perhaps rather unusual for a manufacturer to regret that he cannot entirely discontinue manufacturing operations, but our case is somewhat exceptional. In fact, I doubt if there is any other manufacturer, in any line, who has precisely the same problem that we have. At a time when prices are being reduced in numerous lines of merchandise we are at our wits' end to avoid increasing the prices of our phonographs, and should Congress decide to increase the excise tax on phonographs I doubt if we can avoid advancing our prices.

"The slump in general business came as no surprise to us. In fact, we had been preparing for it ever since the Summer of 1919. That is the reason why we made only nominal advances in our prices. As a consequence of these merely nominal advances we have been operating on a narrow margin of profit, which made it exceedingly desirable to maintain an even production through every month of the year. Thanks to the co-operation of our dealers and jobbers, we have been able to do this very successfully. However, some time ago it became apparent that a temporary curtailment of our phonograph manufacturing operations would probably be necessary. In preference to hobbling along on one leg we decided to use both legs until we had accumulated a moderate-sized and well-balanced inventory, and then shut down for a short time. We have been working in co-operation with our cabinet manufacturers and a temporary shut-down will enable some of them to make needed rearrangements and readjustments.

"Unfortunately our inventory of phonographs is not quite so large on some models as we had anticipated, but we trust there will be no prolonged shortage of these models.

"We are at present in communication with our jobbers, for the purpose of ascertaining their probable requirements during 1921, and the manufacture of phonographs will be resumed just as soon as the jobbers are able to give us their commitments for 1921.

"While it is theoretically true that the fixed expense which accumulates during a shut-down is an element of cost and that accordingly a curtailed manufacturing operation is open to no greater objection than a complete shut-down, it has been my experience that it is better to charge off the fixed expense that accrues during a shut-down and make a fresh start when you are in a position to establish the proper kind of a manufacturing operation.

"It should, of course, be understood that we have not curtailed our manufacture of Re-Creations. On the contrary, we are increasing it as rapidly as possible. It will, no doubt, be of interest to the trade to learn that we are installing a special department in the manufacturing laboratories for the speedy production of timely selections. We expect this department to be in operation about February 15. Some of the apparatus has already been installed and the installation will proceed as rapidly as possible.

"The reports from our dealers on Christmas business, particularly in the cities and larger towns, are materially better than we had anticipated and as we look for a rather rapid revival of general business our principal apprehension at the present time is that our jobbers may not be able to make adequate anticipations of their requirements.

"It is natural for business men who have gone through previous periods of business depression to base their opinions on past experience and therefore many look for a gradual, rather than a rapid, recovery. In this situation past experience is not an altogether infallible guide, as we have a new kind of financial system, which, in view of the rather acute deflation of credit that has occurred, may contribute considerable resilience to the recovery of business. There is at present every indication that there will soon be a shortage of many kinds of merchandise and there may very soon be quite a scramble among buyers and a different attitude on the part of the buying public. In certain lines of industry it seems to me that the situation has been handled just about as badly as possible and all branches of industry must, in some measure, pay the penalty. On the other hand, we shall all be benefited when the deadlock ends.

"A year ago I was considerably worried about the future, but I have no apprehensions at present, as it seems to me very plain that 1921 is going to be a good year for every legitimate enterprise."

MUSICAL INSTRUMENTS FOR SCHOOL

Supervisor of Evansville, Ind., Says Public Funds Should Be Used for Their Purchase

EVANSVILLE, IND., January 4.—Miss Ada Bicking, supervisor of music in the public schools, advocates the investment of public funds in musical instruments for the schools. She says that in view of a recent investment of \$25,000 in machinery in the Central High School it would be no more than fair to set aside money to equip the music department.

The 1920 Christmas season has proved good for New York City Sonora dealers. On Friday, December 17, one Sonora dealer reported as the largest day in the history of his business. The sales on this date included two Sonora Period models of over \$1,500 each.



Fletcher Alltones Needle

Patent Pending

A new semi-permanent needle that actually plays **ALL TONES—LOUD, MEDIUM AND SOFT—** and the gradations between, perfectly. Made of special steel that does not injure the record as do harder substances.

To give long life to the record and to get the best possible results while playing, recommend **FLETCHER ALLTONES NEEDLES** to your customers.—They will appreciate it.

Stocking this one needle meets every demand at a saving in space and capital.

Retail price per card of four needles 25c

Boxes of 100 cards, to dealers \$15

Valuable selling helps free

Jobbers—Write for Territory and Proposition

FLETCHER ALLTONES NEEDLE CO., INC.

205 Travis Street

San Antonio, Texas

New York Jobber

ANDREW H. DODIN, Inc.

28 Sixth Avenue

New York

ADVERTISING HELPS SAN FRANCISCO HOLIDAY TRADE

Fact That Business Was Close to Normal Credited to Good Publicity—Popular-priced Period Styles Suggested—Eight Per Cent Interest on Instalments—Trade Happenings

SAN FRANCISCO, CAL., January 4.—The music dealers of San Francisco, as well as many merchants in other lines, gave newspaper advertising a vital test during the holidays this year. Fearing a Christmas slump by reason of the very poor showing made the first week of December, the dealers began rushing to the newspapers with extra ad copy. The papers were almost swamped with display ads of all classes. The people responded and the last two weeks before Christmas the business toned up to a point somewhere near normal. Rainy weather undoubtedly prevented a vast amount of buying, and the general spirit of retrenchment of course had its effect. On the whole, as far as can be ascertained at this time, the holiday business in San Francisco was good, though not up to expectations. To compare this holiday season with that of a year ago would be unfair, as last year was one of extraordinary opportunities. There is every reason to believe that the post-holiday business this season will be most encouraging.

Attractive Window Displays

The Christmas decorations of the music stores this season show a great advance in good taste in that there are but few prominent show window displays of the regulation gaudy character. Flowers are used in greater profusion than ever before in connection with the red berries and greenery. Simplicity of arrangement and richness of tone have been striven for by the leading dealers.

Wants Cheaper Period Models

The period styles in talking machines have attracted the most flattering attention in San Francisco and many have been sold, but unless these models are materially reduced in price they will never be a really vital factor in the trade, so one well-known dealer in San Francisco is bold enough to predict. Says this man, who does not wish his name used: "People rave over the periods, but when we tell them the price they wilt immediately. I believe good period models could be manufactured very much cheaper than those we now have and I can see no valid reason for not trying. I would say that a design somewhat simpler than those now mostly to be seen, and smaller, would prove a winner if it could be retailed at a moderate price. A period design which is not too pronounced, one that would harmonize a little more consistently with the other furnishings of the house, would no doubt be a winner if the price is right. Most of the old models are not artistic and they do not appeal to people of the best taste. The influence of the period styles is good and I hope it will speedily be reflected in the popular-priced machines."

To Charge Eight Per Cent Interest

At the last meeting of the Talking Machine

Dealers' Association of San Francisco Bay Counties the members agreed to adopt the policy of charging eight per cent interest on all deferred payments. Even the department stores have agreed to the plan. The meeting was addressed by Manner Chipman, the well-known sales expert, and about sixty-five members attended.

Edgar I. Jessen, formerly with the Aeolian office in San Francisco, is making preparations to engage in business on his own hook.

Managers Change Jobs

Mr. Storms, who has been manager of the O. S. Grove store in Oakland, is now the manager of the City of Paris talking machine department in San Francisco, and Harry Murphy, formerly in this position, has accepted the post of manager for the Grove company. A fair exchange of jobs is no robbery.

Plenty of Victor Stock

Billy Morton, manager of the retail talking machine department of Sherman, Clay & Co., San Francisco, found no reason to complain about holiday business. Plenty of Victor stock was on hand to take care of the Christmas demand, and he says the sale of Victor merchandise was very satisfactory indeed. The record business was especially heavy.

Otto May, factory representative of the Victor Co., has just been on a tour of southern California. He expects to make his headquarters in San Francisco.

Brings in Optimistic Report

R. E. Kane, of the Sherman, Clay & Co. traveling force, is in San Francisco for the holidays. He has interviewed the trade in northern California pretty thoroughly in the last few weeks and he says business conditions, as reflected by the demand for Victor goods, are nothing to worry about. He found none of the dealers complaining of financial embarrassment. He says the exclusive shops are all reporting good business.

Becomes Manager in San Mateo

Ernst Bachelor, formerly of the wholesale department of Sherman, Clay & Co., has accepted the position of manager of the Levy Bros. exclusive Victor store of San Mateo. Mr. Levy is a Class A sales promoter and his friends in San Francisco feel assured that he will prove a live business getter down the Peninsula.

Used Extra Salesmen

Manager Corcoran, of the Wiley B. Allen talking machine department in San Francisco, took on a few extra salesmen to help out during the holidays. He finds the marketing situation improving, but says that there is plenty of room for more efficient salesmanship and that "easy" sales are not as common as formerly.

E. P. Tucker, manager of the Los Angeles store of the Wiley B. Allen Co., paid a flying visit to

Well Rated Dealers
Can Discount Their

PHONOGRAPH INSTALLMENT CONTRACTS

WITH US

Thereby Turning Their Accounts
INTO WORKING CAPITAL

Mercantile Finance Company
COMMERCIAL PAPER
COLLATERAL LOANS

459-465 Montgomery St.
San Francisco, Cal.

headquarters in San Francisco just before Christmas.

Delays on New Columbia Home

Owing to delays in completing the new building, the Columbia Graphophone Co. San Francisco branch will not be settled in the new quarters on Bryant and Rincon streets until early in January. Mr. Wilcox will attend the sales managers' convention of the Columbia Co. in New York in January.

Collins and Harlan in Tone Tests

Byron G. Harlan and Arthur Collins, the well-known tenor-baritone comedy duo vocalists whose Edison re-creations have won so much popularity of late, will make a tour of the Pacific Coast the coming Spring, during which the trade will have the opportunity of hearing a splendid series of tone-test recitals. The singers will be accompanied on the trip by William Reed, the versatile flutist and saxophonist.

James L. Loder, Pacific Coast sales manager of the Sonora Co., has placed Chas. H. Carder in charge of the business in the Northwest. Mr. Carder's headquarters are at Room 219, McDermott Building, Seattle. He is a strong man who has been in the phonograph business for years.

F. J. Allgeo, formerly of the Sonora retail sales force, has been transferred to the wholesale traveling force and will cover territory from Bakersfield to the Oregon line.

SONORA SIGN IN RED BOOK PICTURE

A full-page illustration, accompanying a story by Mrs. Wilson Woodrow in the November Red Book, shows a night scene on upper Times Square, New York City. In this picture the Sonora electric sign, which has played so prominent a part in making Broadway a great White Way, is clearly visible, and is the only actual advertising apparent in the picture.

The Master Talking Machine Co., Inc., of Cattaraugus, have certified to a voluntary dissolution at Albany, N. Y.

FOUNDED 1835



Distributors

ARMSTRONG'S

There are numerous reasons why Pathé Dealers are satisfied.
Write today for full information.

ARMSTRONG FURNITURE CO.
59 and 61 North Main Street
Memphis, Tenn.



STEGER

The finest reproducing phonograph in the world

CLEAR, resonant, life-like is the voice of the artist or instrument, as reproduced with fidelity by the truly artistic Steger. To listen to this wonderful phonograph is to enjoy all the thrill and pleasure of hearing the living voice. The beautiful Steger brings to the home all of the world's best music and plays it with a vivacity and realism that no other phonograph can surpass.

Its many exclusive features, the patented adjustable Steger tone-arm, the scientifically-designed sound amplifying chamber of even-grained spruce and the get-at-able record file are eloquent reasons for the Steger's recognition as the finest of reproducing phonographs.

The Steger Phonograph is as beautiful in finish and design as it is charming in its tone-reproducing qualities. There is a variety of artistic styles at a wide range of attractive prices.

Progressive phonograph merchants have found that Steger representation brings prestige and profits.

A complete plan of dealer merchandising co-operation adds immeasurably to the value of the Steger agency.

Desirable territory open. Write for the Steger proposition today.

PHONOGRAPH DIVISION
STEGER & SONS PIANO MFG. COMPANY

Steger Building, Chicago, Ill.



Model 506 \$295.00



Model 505 \$220.00



Model 502 \$145.00



Model 504 \$200.00

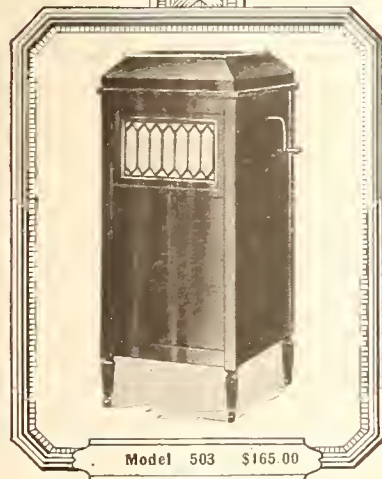

Model 503 \$165.00



Model 501 \$115.00

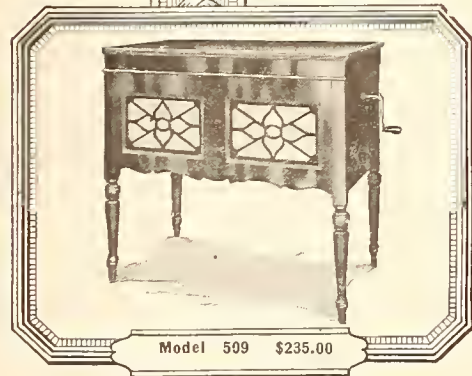

Model 509 \$235.00

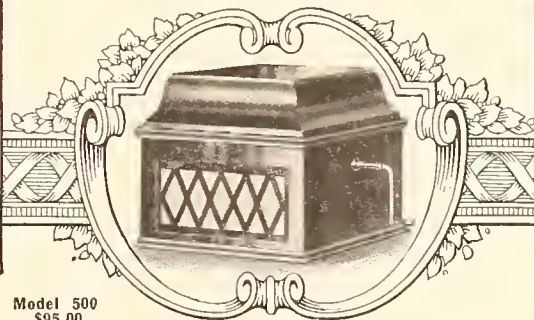

Model 500 \$95.00

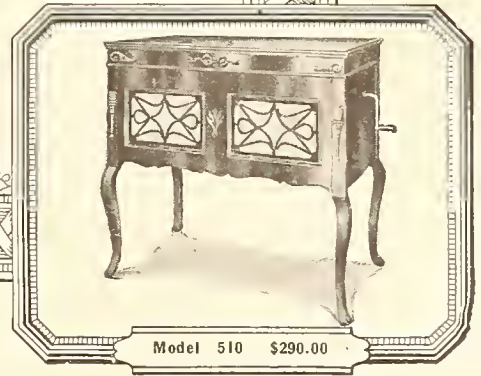

Model 510 \$290.00

THE NEW FOX TROT HIT
by the writers
of "BUBBLES"
"LONESOME"
ETC.

"Feather Your Nest"

Featured by Vaudevilles
most prominent Headliners

Published by
LEO FEIST Inc.
FEIST BLD'G NEW YORK

You can't go wrong
with any Feist Song



ST. LOUIS TALKING MACHINE MEN CLOSE A GOOD YEAR

While Business Was Uneven, Vigorous Rejuvenation in Closing Weeks of Year Helped to Hold Up the Year's Average—Demand Most Marked for High-Priced Machines—Events of Month

ST. LOUIS, Mo., January 4.—Take it all the way through and 1920 was pretty good to the St. Louis talking machine men. It is true that business slumped in the Fall, when the buyers' strike got around to the talking machines, but there was a vigorous rejuvenation in the last two weeks before Christmas, saving the holiday trade and helping to hold up the year's average. The demand throughout the year was for the higher-priced machines, dealers reporting that the price level was considerably higher than last year. The same was true of the Christmas business. On volume of business the year appears to have been better than 1919. Dealers, of course, had the advantage of sufficient stocks, which they did not have in 1919. The Christmas business in most cases did not compare so favorably with that of the previous Christmas. The record sales were consistently good throughout the year, being little affected by the Fall slump in machine sales. The Christmas sales of records were heavy and as usual there was a brisk sale right after Christmas. Dealers, both wholesale and retail, say candidly that they expect business to be slow for the next two or three months, because of the general feeling of uncertainty, but after that they expect it to gradually improve, and, as the year advances, increasingly approximate the normal.

The talking machine bias of the public was so obvious as Christmas drew near that most of the piano dealers who also handle talking machines concentrated their advertising and selling energies on the talking machines. Advertising was not nearly so heavy of either as it was the year before, but the talking machines got most of it. The simple fact was that it was easy to sell talking machines and

hard to sell pianos, so the stores followed the line of least resistance.

The Columbia Graphophone Co.'s St. Louis branch made a good showing last year, according to Manager E. M. Morgan. Mr. Morgan was at the helm only part of the year and had to expend considerable of his energy on reorganization work, but made a good showing in spite of that and with his new organization in working shape he expects to do a great deal better the coming year.

F. C. Schuyler, in charge of the Foreign Record Department of the Columbia Co., is here for two or three weeks, working the territory out of St. Louis in the interest of the German records, which are again being put out by the Columbia people.

S. R. Lemberg, of the Columbia Co., after making a trade survey in St. Louis, has returned to New York.

R. O. Pierce, of the Columbia sales organization, spent the holidays in Chicago. L. D. Bauer, whose headquarters are in Little Rock, Ark., spent the holidays with St. Louis relatives.

Miss Julia Phelan, who had been connected for five years with the Silverstone Music Co. wholesale department, was recently struck by an automobile as she was leaving a street car near her home and killed.

The Macky Furniture Co., which handles the Columbia line, is selling its entire stock preliminary to going out of business.

The 1920 wholesale business of the Silverstone Music Co. was 65 per cent greater than the 1919 business, according to Myron Goldberg, vice-president and general manager of the company. And the retail business also showed a decided increase, he says. The Chip-

pendale \$295 model was the best seller, and there were quite a number of sales of period models at \$500 and up. The Silverstone experienced the late Fall slump, along with all the others, but the Christmas business came strong.

The retail store of the Silverstone Music Co. has been rechristened the Edison Shop. Mark Silverstone, president of the company, offered a prize of \$100 to the retail salesman who made the greatest percentage of cash sales in December, and \$50 to the salesman making the second best record. The first prize was won by William Miller, who collected 33 per cent cash on his sales. Ralph Connor was second with 28 per cent cash. Miller's total sales were \$8,500 and Connor's were \$5,800. The cash collected by all the Edison Shop salesmen averaged 25 per cent.

J. E. Maunder, manager of the Stix, Baer & Fuller talking machine department, says the Christmas business of his department was comfortably ahead of the previous Christmas business, with the sales mostly \$150 and up, averaging \$175. He had plenty of Styles 10 and 11 in Victrolas for the Christmas trade, but was short of Styles 14, 16 and 17. He had a good stock of all styles of Sonoras, which were ordered ten months in advance. He says the sales of records after Christmas were not as good as usual.

Manager J. F. Ditzell, of the Famous & Barr Co. music salon, has been reaping the reward of a Brunswick advertising campaign, which began November 1. The two quarter pages a week which he has been running in the newspapers have been so strongly approved by the Brunswick people that they have been sending copies out to the trade. The result of the advertising has been that the talking machine sales pulled away ahead of the previous year. The sales of Victrolas ran greatly ahead of last year.

An effort is to be made by the Music Mer-

PHONOGRAPH RECORD LABELS



That will meet the requirements of the manufacturer of Records. Our experience along this line assures you of the best of results, quality as well as artistic in design. We make record labels for some of the largest record manufacturers.

If we are not making any of the following Specialties for you we would be pleased to quote you as our experience enables us to give you the desired results.

KEYSTONE PRINTED-SPECIALTIES COMPANY

321-327 Pear Street
SCRANTON, PA.

Our Specialties—
Phonograph Record
Labels
Gummed Stickers of
large quantities
Trading Stamps, etc.

chants' Association of St. Louis to get together on talking machine terms. At the last meeting a committee was appointed, composed of Mark Silverstone, Silverstone Music Co.; W. R. Jackson, Brunswick-Balke-Collender Co.; W. P. Chrisler, Aeolian Co., and E. C. Rauth, Koerber-Brenner Music Co., to fix up and submit to the next meeting a uniform schedule.

Victor dealers in St. Louis have not lacked for material for advertising during December, for an unusually large number of Victor artists have appeared during this period. Florence Hinkle gave the first of a series of after-dinner concerts planned for members of the Missouri Athletic Association, and Merle Alcock the second on December 5. The latter gave a very pleasing concert at the Odeon on December 17. Emilio DeGogorza proved one of the most popular artists appearing with the St. Louis Symphony when he sang with that body on December 10 and 11. The Kieselhorst Piano Co. took the occasion of Efreim Zimbalist's visit with the St. Louis Symphony to use a full page of the program to inform the audience of his Victor records. The Flonzaley Quartet had a very appreciative audience on December 14 when they gave their usual finished performance for the fifth consecutive season in St. Louis.

There are appearing in the windows of the Victor dealers of St. Louis attractive cards announcing the appearance in the city of Victor artists. Photographs of the artists are used, together with the announcement of time and place. These are being placed by the Koerber-Brenner Co.

One of the finest Victor departments in St. Louis is being completed by the Wurlitzer Co. The use of walnut throughout gives it a particularly dignified appearance.

That the Victrola concerts given by the Spengel Furniture Co. of Highland, Ill., are becoming more popular each time was evidenced by the capacity crowd present at the concert given in December. The firm gave out its 1921 calendars of beautiful design as souvenirs at this concert.

The T. E. Clark Music Co. of Cape Girardeau, Mo., is working in the rural and village schools of that vicinity to stimulate interest in the Music Memory Contest instituted by the State Teachers' College of that place. Letters and personal visits are showing results. Many schools are accepting the Dunlap plan of securing Victrolas and records where the school

boards have not found it possible to add these to the school equipment.

The Koerber-Brenner Co. displayed for December in its service show window the Binger Christmas display put out by the Reinicke-Ellis Co.

HOLIDAY GREETINGS RECEIVED

The World Acknowledges the Many Expressions of Good Will and New Year Greetings Sent by Prominent Members of the Trade

The World takes pleasure in acknowledging at this time the receipt of the many holiday and New Year greetings from its friends in the trade. Among those from whom cards were received are: Victor Talking Machine Co.; Knickerbocker Talking Machine Co.; C. Bruno & Son, Inc., New York; C. C. Harvey Co., Boston; Arthur A. Trostler, Kansas City; Stewart Talking Machine Co., Indianapolis; Blackman Talking Machine Co., New York; Buegeleisen & Jacobson, New York; Jones Motrola, Inc.; Philadelphia; George Seiffert, Eastern Phonograph Corp., New York; Serenado Mfg. Co., Cedar Rapids, Ia.; Southern Sonora Co., Atlanta, Ga.; Cardinal Phonograph Co.; Empire Phono Parts Co., Chicago.

W. D. & C. N. Andrews, Buffalo; Brooks Mfg. Co., Saginaw; A. J. Crafts Piano Co., Richmond, Va.; Wellington Smith; the Biddle Agency, Philadelphia; Remington Phonograph Corp., New York; E. G. Brown, Bayonne, N. J.; New England Talking Machine Co., Boston; Modernola Co., Johnstown, Pa.; Marcel Wheat; Mr. and Mrs. Billy Murray; Louis E. Rosenfield, Emerson Phonograph Co.; Joseph Menchen, Vacuum Record Lifter Co., New York; Mr. and Mrs. Arthur Geissler, New York Talking Machine Co.; Mr. and Mrs. C. N. Andrews, Buffalo; Mickel Bros., Des Moines; Francis X. Boucher, E. F. Droop & Sons Co., Washington, D. C.; Cabinet & Accessories Co., Inc., New York; J. J. Davin, Reinicke-Ellis Co., New York; Eclipse Musical Co., Cleveland; Leonard D. Crone, Binger Co., New York; C. C. Mellor Co., Pittsburgh, Pa.; M. Steinert & Sons, Boston; Ross P. Curtice Co., Omaha, Neb., and others referred to elsewhere.

40% OF FARMERS POSSESS TALKERS

Player-Piano Owners Average 13.16 Per Cent and Piano Owners 44 Per Cent, According to Facts Gathered by Farm Paper

Howard's Dairyman, a leading authority on dairy farming, made an investigation to secure statistics from its subscribers. The percentages they have tabulated are as follows, and came in reply to the question:—

Do you think that musical instruments could be advertised and sold successfully to farm people through farm papers?

Of the total number of replies received, 82 per cent said "Yes."

Distribution of musical instruments—of those replying to the questionnaire—indicates that musical instrument owners are divided as follows:

- 3.20% Cornet.
- 5.08% Saxophone.
- 39.97% Talking machine.
- 20.30% Violin.
- 6.39% Horns.
- 6.20% Other brass instruments.
- 44.00% Piano.
- 13.16% Player-piano.

The question was also asked—Are you planning to buy any of these?—and 28.74 per cent said "Yes."

The instruments in which the readers are most interested are: 37.84 per cent piano, 35.14 per cent talking machine, 9.91 per cent player.

The Thompson Piano Co., 90 Elm street, New Haven, Conn., during December sold seven Aeolian-Vocalion art models as well as a good output of regular styles.



Delivery Envelopes

*Art Series
New Designs*

NEW LIST OF RECORDS

Every 60 Days

Very Good Victor Records

We Will Be Pleased to Play Any of Them for You

1497-10	Swiss Little Bells	Victrola	1.00
1498-10	Monterville Road	Victrola	1.00
1499-10	Land Where the Road is Long	Victrola	1.00
1500-10	One Night in the Old Days	Victrola	1.00
1501-10	Music of the Sea	Victrola	1.00
1502-10	The Tumble Down Stair	Victrola	1.00
1503-10	The Music of Love	Victrola	1.00
1504-10	My Heart is in the Hand	Victrola	1.00
1505-10	Swiss Little Bells	Victrola	1.00
1506-10	Swiss Little Bells	Victrola	1.00
1507-10	Swiss Little Bells	Victrola	1.00
1508-10	Swiss Little Bells	Victrola	1.00
1509-10	Swiss Little Bells	Victrola	1.00
1510-10	Swiss Little Bells	Victrola	1.00

Very attractive proposition to Jobbers

Write for trial shipment

CLEMENT BEECROFT
5546 North 5th Street
PHILADELPHIA

GODOWSKY VISITS GOTHENBURG

Dealer in Town of 1800 Secures Noted Artist for Concert Appearance

The Omaha branch of the Brunswick-Balke-Collender Co. writes: "We are very proud to state that we have a little town in our territory called Gothenburg, that ranks right along with the larger cities. Our dealers there, Erb Bros., presented Leopold Godowsky in concert on December 28, and in the papers gave Godowsky's itinerary as follows: Chicago, Des Moines, Omaha, Gothenburg, Denver, San Francisco and Los Angeles. This surely puts Gothenburg right up with the headliners."

The town of Gothenburg has a population of only 1800. This should be mighty convincing evidence that one Brunswick dealer is alive to his possibilities and realizes one of the best means of capitalizing on his Brunswick records by having the artist appear in person before his customers and prospective customers.

What More Can You Ask

All the features that go to make a talking machine Profitably Salable you will find as regular equipment of Magnola: "Built by Tone Specialists."

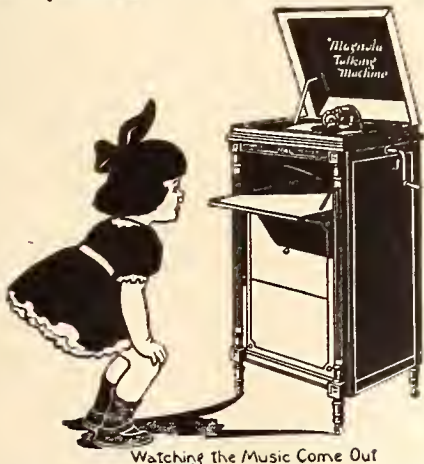

Watching the Music Come Out

Complete description of all these features is to be found in our handsome illustrated catalog, which we should like to send you. May we? Ask us to tell you our plans for your benefit!

MAGNOLA TALKING MACHINE COMPANY
OTTO SCHULZ, President
General Offices: 711 MILWAUKEE AVENUE CHICAGO
Southern Wholesale Branch: 1830 CANDLER BLDG. ATLANTA, GA.

CHARM



Photograph of N. Y. Sonora Phonograph Co. showroom reproduced by courtesy

THE Talking Machine Cabinet that sets firmly upon the floor, that is not, so to speak, upon stilts, is more sightly and a handsomer piece of furniture—therefore more desirable to your customers.

This is the reason why so many Talking Machine manufacturers are today equipping their models with **Domes of Silence**.

They realize that these slides permit of the Cabinet setting closer to the floor, thus giving an added charm to its appearance as well as saving strain upon the legs and saving floors and rugs.

HENRY W. PEABODY & COMPANY

Domes of Silence Division

17 STATE STREET

NEW YORK

SPECIFY DOMES of SILENCE

RESUMPTION OF INDUSTRIAL ACTIVITY IN BUFFALO

Reopening of Local Plants Expected to Mean Substantial Spring Business for Talking Machine Dealers—Columbia Co. Seeking New Location—Next Meeting of Local Association

BUFFALO, N. Y., January 5.—Although almost every other business was complaining of a slackness in the Christmas trade, it was a different story with the talking machine men here. All of them reported a brisk holiday season, with all the business that they could handle. With the signs all pointing to a general betterment of conditions the outlook is still more rosy. A great many of the establishments that have been laying off their employes are planning resumption of work after the first of the year.

The general depression did not hit Buffalo as hard a blow as it did some of the other cities where there is not so great a diversity of manufacture. In this city, where there is a very large variety of industries, many of the men who were laid off in certain of the plants found work in the others. A number of big new industries plan to open here, employing thousands of men. Among them is the new Dunlop tire plant, the first unit of which is now practically finished. At this unit alone 5,000 persons are to be employed.

The Buffalo branch of the Columbia Graphophone Co., although its present quarters here are large, has outgrown them and is now seeking a location where it can get more space to handle the increasing volume of its business. If a new location can be found the company plans to make a rearrangement some time after the first of the year, according to G. W. Peace, the assistant branch manager. The present offices occupy the second and third floors of the building at 737 Main street.

W. T. Duffy has been transferred from the Dealer Service department to the merchandise department of the Columbia Co. here.

Mrs. Fred Mann, wife of the Boston manager of the Columbia Co., was a recent caller at the offices of the Buffalo branch.

G. W. Peace, assistant branch manager of the Columbia Co., who has been severely ill with pneumonia, is now able to be back on the job once more.

W. Lawton the branch manager of the company, is making a trip through some of the towns in his district.

Robert Hollinshead, formerly head of the Buffalo district of the Brunswick Co., has become associated with the Q R S Music Roll Co. here. Charles Markham, who has been with the company for some time, will take charge of the Brunswick Buffalo district.

A handsome store which will handle Brunswick phonographs and records exclusively has been opened in the Main-Utica section by Wehrle & Beach, who also have a store at Williamsville. It will be known as the Music Shoppe.

Another agency which has just been established by the Brunswick branch is at the Music Shoppe at Olean. This store, which is located at 113 North Union street, is operated by Houghton & Rungie.

The next meeting of the Buffalo Talking Machine Dealers' Association will be held January 12, when matters of general interest will be discussed. C. E. Siegesmund, president of the association, will be chairman of the meeting.

The music trades group of the Buffalo Chamber of Commerce will hold a meeting January 25. General discussion will take up the meeting.

C. N. Andrews, Victor dealer in this city, was a recent visitor at the Victor Co.'s plant at Camden.

George W. Pound, secretary of the Music Industries Chamber of Commerce, is ill at the Lenox here. Physicians say it will be two or three weeks before he will be able to take up his work once more.

Some fine period models of Victrolas, which were on display in the windows of the Wurlitzer store, narrowly escaped injury when a gale which hit the city just before Christmas broke two of the windows. Fortunately, how-

ever, none of the machines was hit by the shattered glass.

There is an especially big demand for records now, according to dealers. "Whispering" is having an especially big run, and the dealers predict that it will exceed that of "Dardanella."

HELPING PARAMOUNT RECORD SALES

The Paramount Co. Issuing Attractive Display Features for Dealers' Use

PORT WASHINGTON, WIS., January 3.—The Paramount Co., manufacturer of the Paramount phonographs and records reports that during the month of December the company moved more records from the factory than during any previous month in its history. The Paramount Co. has been paying particular attention to its Dealer Service department and has supplied to the retail trade many attractive displays that have aided in sales building.

The latest of these sales helps was a snappy poster for window display, printed in black and yellow on white and featuring the fox-trot "Margie." A jazz band in full action is shown at the top of the poster.

CALENDAR FROM "PEARSALL KID"

A companion gift to the memorandum pad and holder issued by the Silas E. Pearsall Co., Victor wholesaler, New York, last year was given this Christmas to its many friends in the trade in the shape of a perpetual desk calendar in lacquered brass. The calendar is perpetual and is finished in the same handsome style as the token of last year.

Great expectations and small preparations usually go hand in hand.

J. A. FRYE WITH KNIGHT-CAMPBELL

Former Member of Victor Co. Traveling Department Becomes Sales Manager of Victor Wholesale Organization of the Knight-Campbell Music Co., in Denver, Colo.

DENVER, COLO., January 3.—The Knight-Campbell Music Co. has just announced the appointment of J. A. Frye, formerly connected for a long time with the traveling department of the Victor Talking Machine Co., as sales manager of



J. A. Frye

the company's Victor wholesale organization. The new move is considered a most important one, as Mr. Frye is well known in the trade and has a fund of experience in the Victor business that should prove of material value to the Victor dealers with whom he comes in contact through his new connection.

The Knight-Campbell Music Co. wholesales Victor goods in Colorado, New Mexico, Wyoming, western Kansas and Nebraska, and has built up an organization and a distributing plant that are up to the minute in every particular. The company maintains an elaborate dealers' service which carries up-to-date and modern business methods to the very doorstep of the dealer, as it were.

Ward's Khaki Moving Covers



Grade "D" Cover with No. 3 Straps.

THE C. E. WARD CO.

(Well-Known Lodge Regalia House)

101 William St., New London, Ohio

Also Manufacturers of Rubberized Covers and Dust Covers for the Wareroom

Distributors

- BRISTOL & BARBER, INC.
111 E. 14th St., New York City
- YAHR & LANGE DRUG CO.
207-215 E. Water St., Milwaukee, Wis.
- COHEN & HUGHES, INC.
Washington, D. C.
- BECKWITH-O'NEILL CO.
Minneapolis, Minn.
- STREVELL-PATERSON HARDWARE CO.
Salt Lake City, Utah
- C. L. MARSHALL CO., INC.
Beckman Bldg., Cleveland, O.
Butler Bldg., Detroit, Mich.
- THE REED CO.
237 Fifth Avenue, Pittsburgh, Pa.
- C. J. VAN HOUTON & ZOOM
140 S. Dearborn St., Chicago, Ill.
- SONORA DISTRIBUTING CO. OF TEXAS
Dallas, Texas
- KNIGHT-CAMPBELL MUSIC CO.
1608 Wynkoop St., Denver, Colo.
- CHAS. H. YATES
311 Laughlin Bldg., Los Angeles, Cal.
- W. D. & C. N. ANDREWS
Buffalo, N. Y.
- SACHS & CO.
425 So. Wabash Ave., Chicago
- SHERMAN, CLAY & CO.
741 Mission St., San Francisco, Cal.
- JOHN A. FUTCH CO.
35 Auburn Ave., Atlanta, Georgia
1500 South Boulevard, Charlotte, N. C.
630 Washington St., Jacksonville, Fla.
- ORTON BROTHERS MUSIC HOUSE
Butte, Mont.
- GRAY & DUDLEY CO., Nashville, Tenn.
- ASSOCIATED FURNITURE MFRS.
St. Louis, Mo.
- W. J. DYER & BRO., St. Paul, Minn.
- AMERICAN PHONOGRAPH CO.
Burlington, Vt.
- JOSEPH BARNETT & CO., Cedar Rapids, Ia.

USE BRAINS, SAYS T. A. EDISON

People Fail to Develop Thinking Powers Because They Fail to Use Them, He Declares—Explains Popularity of Phonograph

"It is because they do not use their thinking powers that so many people have never developed a creditable mentality," according to Thomas A. Edison, in an interview appearing in the January American Magazine, entitled, "Why Do So Many Men Never Amount to Anything?"

"The brain that isn't used rusts," he says, "and the brain that is used responds. The brain is exactly like any other part of the body; it can be strengthened by proper exercise, by proper use. Put your arm in a sling and keep it there for a considerable length of time, and, when you take it out, you find that you can't use it. In the same way, the brain that isn't used suffers atrophy."

When asked which of his inventions he liked best, Mr. Edison replied: "I like the phonograph best. Doubtless that is because I love music. And then it has brought so much joy into millions of homes all over the country, and, indeed, all over the world. Music is so helpful to the human mind that it is naturally a source of satisfaction to me that I have helped in some way to make the very finest music available to millions who could not afford to pay the price and take the time necessary to hear the greatest artists sing and play."

"Many inventions are suitable for the people at large because of their carelessness. Before a thing can be marketed to the masses, it must be made practically fool-proof. Its operation must be made extremely simple. That is the one reason, I think, why the phonograph has been so universally adopted. Even a child can operate it."

"Another reason," he added, "is that people are far more willing to pay for being amused than for anything else."

\$100,000,000 CORPORATION TO FINANCE EXPORT TRADE

New Organization Formed Under the Provisions of the Edge Law at Meeting Held in Chicago Last Month—Expected to Be Ready to Operate Early in New Year

CHICAGO, ILL., January 3.—With the object of financing long-term foreign loans to build up the export trade of the United States the Foreign Trade Financing Corp. was launched here last month and a committee of thirty was named to perfect the organization immediately. John McHugh, vice-president of the Mechanics and Metals National Bank of New York, was named to head the committee and has consented to serve as permanent chairman of the board of directors.

Following addresses by leading American bankers, industrial and agricultural heads a committee on plan and scope presented its conclusions to the conference, which was called by the American Bankers' Association. The committee named a permanent organization committee of thirty prominent business men, recommended organization of a corporation capitalized at \$100,000,000, with a potential capacity of \$1,000,000,000, and asked for an immediate \$100,000 subscription to underwrite the corporation's organization activities.

The report of the committee was unanimously adopted, and following adjournment of the conference the permanent committee went into session for its preliminary work. It is planned to perfect organization and have the corporation in operation by January 1, 1921.

The plea for an underwriting subscription was answered immediately and the total amount of \$100,000 raised within ten minutes.

The conference unanimously adopted a report of the committee on plan and scope. The corporation directors are to be chosen as representative of commerce, finance, agriculture and industry, with due regard to geographical representation.

The committee named to supervise the formation of the corporation includes John Mc-

Hugh, Herbert Hoover, Paul Warburg, Charles H. Sabin, Fred I. Kent, A. T. Bedford, George E. Smith, Louis E. Pierson, John S. Drum, James B. Forgan, Thomas E. Wilson, Arthur Reynolds, Alexander Legg, Joseph de Frees, F. O. Watts, J. R. Howard, J. B. Culberson, Levi L. Rue, Philip Stockton, Oscar Wells, Julius H. Earnes, Herbert Myrick, John S. Lawrence, E. M. Herr, Roy D. Chapin, John J. Raskob, Charles A. Hinsch, Peter W. Goebel, Thomas B. McAdams and John Sherwin.

"This meeting marks the opening of a new day," said William C. Redfield, former Secretary of Commerce, after the conference. "I hope that the time will come when every industry will look back on this occasion as the time when things began."

Willis H. Booth, of the Guaranty Trust Co. of New York, characterized the decision as "the thing most necessary for the re-establishment of confidence both in Europe and the United States, to keep business going sanely and labor properly employed."

"It is a unique financial corporation," he went on, "inasmuch as it is the largest banking business ever organized and has been started in the open without financial profit to its originators and broadly participated in by leaders in banking, industry and agriculture alike. It should have the immediate effect of restoring better feeling in this country by showing the way for release of congested surpluses, both of farm products and manufactured goods."

HANDLING THE VICTROLA

H. Fraiberg & Sons, 5605 Fleet avenue, Cleveland, O., recently opened a new talking machine department in which the Victrola is being featured.

The Brooks Automatic Repeating Phonograph

is justly termed The Wonder Instrument. It has all the good

DEALERS

There are some communities where the BROOKS is not represented effectively as yet. Write us at once regarding your territory. We are planning a sales campaign of wide scope this year and large distributors and dealers will find the acquisition of the BROOKS line a big factor for business volume during 1921.



Model
145

THE REPEATING DEVICE

The Brooks Automatic Repeating and Stop Device is an exclusive Brooks feature. It gives this phonograph a broader scope than any other make and requires no attention beyond setting the needle and turning a little knob. It is to the phonograph what the self starter was to the automobile.



Model
165

qualities of other high grade makes, but is completely put in a class by itself by virtue of the inbuilt Repeating Device, which enables the operator to play any make of record, any desired number of times.

Shown are three Brooks models of different sizes, all beautifully carved and finished. Each style is identically equipped with the repeating and stop device.



Model
250

Brooks
The
Wonder
Instruments

**Automatic Repeating
Phonographs**

BROOKS MANUFACTURING COMPANY, SAGINAW, MICH.

The SPHINX MOTOR

Promotes Confidence and Sales

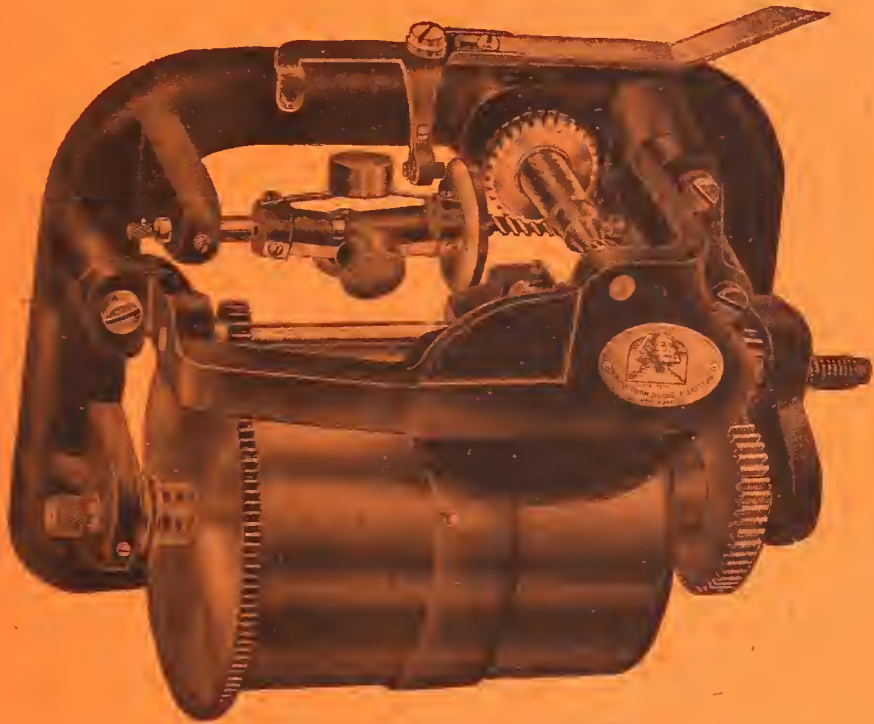

THERE is no part of the phonograph more vital to its successful operation and assured reputation than the motor. When the motor possesses the demonstrated merits of the Sphinx, it becomes a valuable sales feature that inspires confidence, stimulates buying and makes for rapid turnover.

The Sphinx Motor is the one motor designed in accordance with accepted engineering principles. Its practical selling advantages are definitely recognized by the trade.

To make the Sphinx Motor the basic sales feature of your 1921 sales campaign is to insure ready acceptance on the part of the ultimate user.

*The Standard by which all
Phonograph Motors are
judged and valued*



Reg. U. S. Pat. Off.

**SPHINX
GRAMOPHONE MOTORS, Inc.**

512 FIFTH AVENUE
NEW YORK

**Just off the press--
Send for your copy today**

THIS interestingly written, instructive pamphlet, prepared by our engineering department, will enlighten you on the most important facts about the generation and transmission of spring power in phonograph motors.

Extra copies will be cheerfully sent to you for distribution among the members of your selling organization.

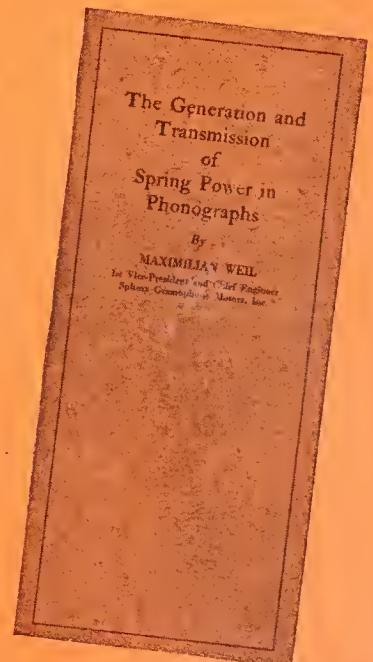



ARTISTS' FIGURES DRAW TRADE

Showing of Miniature Figures Representing Noted Victor Artists Attracts Attention and Business to Retail Store in Philadelphia

PHILADELPHIA, PA., January 3.—One of Philadelphia's largest and most successful Victor dealers is B. B. Todd, whose warerooms are located at 1623 Chestnut street, on the great shopping thoroughfare. Mr. Todd is a strong believer in the advertising advantages of his windows on this busy street and gives much personal attention to their attractive dressing. He recently



Todd's Artistic Grand Opera Window

purchased a complete set of the operatic figures made by the Penn Phonograph Co., Victor distributors, also of this city, which have been used for window display purposes to excellent advantage.

In writing to the Penn Phonograph Co. of the success he attained through the use of those figures he stated in part: "We did not think for a moment that they would turn out to be such a big attraction. Having recently opened this store we found that it required something to attract the attention of the passers-by and this just seemed to fill the bill. In fact, people would stop their automobiles and get out to look at the figures. We also received quite a number of telephone calls from people who

passed by in the street cars congratulating us on the beautiful window display. I was a little discouraged some time ago at the amount of record business we had been getting, but as soon as we placed these opera figures in the window our cash record business almost doubled. So you can see that this was just the window attraction we required in order to make the passers-by realize that there was a new Victor store in this vicinity. We believe that the purchase of these figures is an investment worth while for the Victor retailer."

T. W. Barnhill, president of the Penn Phonograph Co., stated that other dealers had found these figures particularly attractive for the interior of their demonstration booths as well and that these figures on display during the demonstration of records had had a favorable result in the increased sale of Red Seal records.

SALES HELPS FOR SONORA DEALERS

Wealth of Excellent Publicity Issued by the Sonora Phonograph Co. for the Month

The dealer sales helps released by the Sonora Phonograph Co., Inc., as an aid to sales for Sonora dealers, include this month some new movie slides, some new display cards to use in the windows and street cars, 24 sheet posters for use outdoors, wooden road signs, special crystal glass sign, human figure cut-outs, several screens including one featuring the Adam period model, cover of the new Sonora song and copies of the song itself with dealer's name imprinted thereon, needle display card, a fourteen reason poster, needle display case, a binder for The Sonora Bell, the house organ; a glass Sonora bell, a glass trade-mark sign, a special decalomania suitable to be mounted on either glass or wood or an automobile body, brass sign proclaiming the Sonora as "the highest class talking machine in the world," an art glass sign for use in demonstration booths, two electric light signs and other signs of various types.

PHILIP WERLEIN, LTD., IN NEW HOME

Prominent Victor Wholesaler Occupies New Building at 517-521 Bienville Street

NEW ORLEANS, LA., January 4.—Philip Werlein, Ltd., of this city, progressive Victor wholesaler, has recently moved into a new building at 517-519-521 Bienville street. The general plan of the building has been so arranged as to take care of every detail of the large wholesale Victor business which this company carries on. It is planned to have a very attractive reception room for visiting dealers, testing booths for demonstrating Victrolas and records, and especially modern and fine will be the service room designed to take care of every form of dealers' help that this company and the Victor Co. have available for the use of dealers all through the South. This new move of the Werlein Co. admirably exemplifies the wonderful growth of its Victor business and the desire to expand its organization to be able to take care of its dealers efficiently. Nineteen-twenty-one promises to be one of the largest years the Werlein Co. have so far enjoyed, and this fine new building is suitably equipped to take care of their ever-increasing business.

A. L. JEWETT WITH STARR CO.

Former Piano Man Now Engaged in Selling Starr Phonographs and Gennett Records

BOSTON, MASS., January 4.—A. L. Jewett, well known to the music trade in New England and in other sections of the country through his connection with the piano manufacturing business and at one time as president of the National Piano Co., is now associated with the Starr Piano Co., Richmond, Ind., traveling in the interests of Starr phonographs and Gennett records. Mr. Jewett's wide acquaintanceship among music dealers is standing him in good stead.



"A Manophone in Every Home"

What Tonal Quality Means

The strongest factor in the sale of a phonograph is Tonal Quality—resonance—vibration—volume!

This means that the instrument must be perfectly proportioned, evenly balanced and properly equipped with a noiseless, smooth-running motor. These essentials are requisite to the successful reproduction of music.

The Manophone

Master workmen fashion and finish every Manophone—men who have grown gray in the service of musical instrument manufacture. These men feel a sense of personal pride in the production of correctly made instruments.

That is why the Manophone possesses a distinctiveness which can only be described as Quality.

Manophone Dealers Wanted Everywhere

is the ideal instrument for the home. It actually reproduces,—not merely plays with disquieting rattles and scratches. Plays all disc records clearly and accurately with incomparable tonal quality and volume.

Every Manophone Dealer knows the advantages of these features. They play an important part in the development of phonograph sales.

If you are looking for greater profit possibilities in 1921 write at once for our Manophone Dealer's Business Building Plan.



The Manophone Corporation

Adrian

::

::

::

Michigan

1920 BUSINESS SHOWS UP WELL FOR CLEVELAND TRADE

Many Retailers Surprised to Find the High Average—New Establishment Planned—To Reward Good Salesmanship—Talking Machines for Bonuses—Some Business-building Practices

CLEVELAND, O., January 5.—Predictions of a bigger year for the talking machine business in this section, based upon the fact that 1920 has exceeded even the remarkable achievements of 1919, are offered by leaders in the industry here following a careful survey of conditions among retailers and jobbers alike.

It was the belief of some retailers that they did not do the good business in 1920 that they expected until their figures were gone over, according to Ed B. Lyons, sales manager of the Eclipse Musical Co., Victor jobbers. It has been proved, however, that the reverse is true, and that although there were many inquiries for machines from consumers during 1919 that could not be met for lack of machines, at least of certain models, during 1920 there was a better opportunity to close real business because there was more merchandise to do the business with.

Planning New Establishments

It is admitted that, to equal or exceed the 1920 showing, harder work and real salesmanship will be necessary during the coming year. But that this does not dismay the live handler of talking machine merchandise is apparent from the fact that there are numerous individuals and groups seeking to open new establishments in the immediate Cleveland district.

Equally good results have been proved with other interests besides the Victor, including the Pathé, represented by the Fischer Co.; the Edison Phonograph Co.; the Columbia, for which J. L. Du Breuil is manager here, and others. Another healthy condition is the announcement by many firms that their staffs will be retained intact and that salaries will not be reduced.

To Reward Best Salesmanship

Among the interesting movements planned for the new year will be the campaign to ascertain the best Victor merchandise seller in the Cleveland and northern Ohio territory by the Cleveland Talking Machine Co. The incentive will be a trip, with all expenses paid, to New York, Philadelphia and the Victor factory at Camden, where a course will be taken in Red Seal salesmanship by the leaders in the race. The awards will go, one to the best seller in Cleveland, the other to the best in the outside territory. The work of the individuals during January will be taken as the basis for the campaign, which will run through February. It is expected that every retail establishment will have representatives in the campaign and that at least 500 young women will seek the high honor.

Children's Record Hanger a Hit

Meanwhile the hanger for children's records, issued by the Cleveland Talking Machine Co., is bringing the results expected of it. Considerable human interest, emanating from the small folk who come to dealers' stores, is developed. In one establishment a small child insisted that

a certain violin record simply had to be bought, though his elders wanted only dance records. Another recognized an air he had been learning at school and, like a well-known advertisement, wasn't happy till he got it. The result is, dealers assert, that many children's records that have been in stock for months are moving, as well as the newer and more popular pieces for the little people.

For Music Memory Contest

Industrial establishments, motion picture houses, and civic and women's organizations in Lorain will co-operate in a music memory contest to be conducted in that city under direction of Music Supervisor Wright.

Demonstrate Before Teachers

Series of lectures and demonstrations of Victor merchandise and its uses in school work were held by Miss Grazella Puliver, educational director the Cleveland Talking Machine Co., and Mrs. Beaver, of the P. B. Whitsit Co., during the conclave of the Ohio State Teachers' Association at Columbus.

Columbia Branch Managers' Meeting

Prior to leaving for New York to attend the convention of district managers of the Columbia Graphophone Co. J. L. Du Breuil, manager of the Cleveland district, held a branch managers' meeting at Hotel Winton here, attended by representatives from all parts of the territory. Plans for the new year were tentatively adopted and will be acted upon following developments at the national gathering of Columbia in New York City.

Open New Department in Newark, O.

Among new establishments to start the new year will be that of the John J. Carroll Co., Newark, O., one of the highest-class department stores in this section of the country. An entire floor will be used for the presentation and sale of Victor machines and records. A dozen or more booths will be used for demonstration purposes. An informal opening was held, at which 5,000 persons were present. Jack Evans, well known in the talking machine industry in the central part of the State, and noted for progressive achievement, will be in charge of the new department. A formal opening early in the Spring is planned, at which several unique features will be introduced to the trade.

A New Store in Dover, O.

Another new establishment is planned by W. A. Winkler, at Dover, O., in which novel arrangement of booths and presentation of records will be offered. While the department was in process of completion Mr. Winkler did not wait for business to come in, but went after it with the astonishing result that seven machines were sold in one day.

What will be practically an entirely new store for Victor merchandise is planned by the H. B. Kurtz Co., Conneaut, O. This firm had a fire

ILSLEY'S GRAPHITE PHONO SPRING LUBRICANT

Ilseley's Lubricant makes the Motor make good
Is prepared in the proper consistency, will not run out, dry up, or become sticky or rancid. Remains in its original form indefinitely.
Put up in 1, 5, 10, 25 and 50-pound cans for dealers.
This lubricant is also put up in 4-ounce cans to retail at 25 cents each under the trade name of

EUREKA NOISELESS TALKING MACHINE LUBRICANT

Write for special proposition to jobbers.

ILSLEY-DOUBLEDAY & CO., 229-231 Front St., New York

some time back, but is now prepared to present Victor goods in a modern, high-class establishment. Several attractive features in the interest of patrons are planned by the management.

A New De Forest Store

William De Forest, of the M. V. De Forest establishments, has become manager of the recently acquired Niles, O., store of that firm and is completing arrangements to put this new account on a par with the already famous De Forest stores at Sharon and Greenville, Pa., and Warren, O.

A Handy Souvenir

The Cleveland Talking Machine Co. is distributing as a New Year's present, in fact an all-year-round, useful gift, a bound volume of supplements for the entire year of 1920. These supplements, being in handy form, are expected to be a considerable aid to dealers in stimulating record sales.

Talking Machines for Bonuses

January is the month of bonuses for employees in industrial plants in the Cleveland district. The policy of previous years will be carried out by numerous concerns in the territory. But instead of giving the winners of bonuses mere money they will give workers talking machines. At least this is the plan now being worked out by A. L. Maresh, of the Maresh Piano Co., and eagerly accepted by plant owners and managers, according to Mr. Maresh. It is Mr. Maresh's plan to sell talking machines of the better sort of Victor models to the factory heads and have them distribute them among employees. It is expected that at least one hundred machines can be sold in this manner. The plan will not only save money for those distributing bonuses, Mr. Maresh has learned, but will serve to exercise greater contentment in the home that music is recognized as making.

Hans Kindler Meets Local Dealers

Following its program for bringing the artist and those who sell the artist's records closer together, the Cleveland Talking Machine Co. was host to Hans Kindler, noted cellist, in the Cleveland Co.'s reception room. The meeting, like all of these gatherings, was well attended by representatives from local retail establishments.

Ted Lewis and Band Entertain

That the presence of artists before the people who know them only from records is a tremendous boost for machine and record sales is the firm conviction of G. E. Lennox, manager.

(Continued on page 86)

Victor Dealers of the Rocky Mountain Region

Put Your Selling Problem Up To Us

Our expert staff of Victor merchandising specialists are at your command at all times—each offering you a real service in helping you to solve your retail problems.



Our five floors devoted exclusively to Victor goods, and to the needs of Victor dealers, are admirably equipped to offer a genuine service.

We Back the Dealer Who Backs the Victor

Knight-Campbell Music Co., 1608 Wynkoop Street, Denver, Colo.



And now — the SHOW DOWN

There is one thing that all talking machine people seem to have agreed upon, in the past couple of years.

It has been common talk that four—or, possibly, five—companies would receive the great bulk of the Phonograph business of the future.

Since 1914 the Phonograph business has been “exploited”, just as almost every other American industry.

Aladdin-like incidents are familiar to every one of us.

But Time, the Tomb-builder and Stabilizer, is fast restoring order.

And, after all is said and done, we always find that most everybody knows enough to “get in out of the rain”.

The Aeolian Company has always been the first musical instrument house of the world. It has never been anything else. It has had no side lines.

The scientifically constructed VOCALION and its realistic Red Records are in an assured position. The prestige of genuine merit and conservative merchandising makes them amply capable to receive the greater portion of the patronage of the critical.

THE AEOLIAN COMPANY
Aeolian Hall, New York

Chicago San Francisco St. Louis Cincinnati Boston London Paris
529 So. Wabash Ave. 455 Mission Street 1004 Olive St. 25 W. Fourth St. 190 Boylston St. 135 New Bond St. 32 Ave. De L'Opera

GOOD CLEVELAND TRADE IN 1920
(Continued from page 84)

ager of the Columbia Grafonola department of Brown Bros., following a concert at which Ted Lewis and his Jazz Band played before 1,000 persons that packed the lower floor of the Brown store. The event was arranged by J. L. Du Breuil, district manager of the Columbia, and H. S. Schultz, sales manager, and H. C. Cooley, assistant manager in this territory. Ted autographed records and these went like the proverbial hot cakes.

Santa Claus Brings Business

One of the biggest successes locally emanating from the holiday activities is attributed to the Randolph House of Good Music in having Santa Claus and his assistant, in person, advertising the house and delivering talking machines during the Christmas season. The innovation has been so good as a business getter that C. H. Randolph, head of the house and originator of the idea, is already figuring on using it on different occasions through the year. Santa Claus and his assistants were recruited from the work rooms of the house and garbed in true Santa Claus style. Between times of delivering merchandise to purchasers they were out on the street with the company's truck, equipped with a sound magnifying device attached to a talking machine, distributing literature and having a good time with the people generally. The move was supplemented by liberal advertising in daily newspapers, with pictures showing the Santas in action.

Novel Demonstrating Plan

The latest method of putting music into the home, even if people do not live there as yet, has been adopted by the Henry Leopold Furniture Co. Making arrangement with the Lovett Co., real estate dealer, the Leopolds have equipped completely a six-room house in the West End of Cleveland, installing therein a Victrola. The idea was originated by Henry Leopold, advertising manager. The completely furnished house, for sale without or with the furniture, was advertised and the first day 500 persons called to inspect the property, according to Lovett officials. Increased sales traced directly to the furniture display have followed, according to Gilbert Leopold, and it is expected that marked improvement in talking machine



SOSS

INVISIBLE HINGES



Soss Invisible Hinges

are essential to preserve the beauty of design, particularly when it is desired to disguise the talking machine cabinet. In many of the better cabinets of today Soss Hinges are used. They are mechanically accurate and can be installed quickly and easily.

Write for Catalogue T.

SOSS MANUFACTURING COMPANY
Grand Avenue and Bergen Street, Brooklyn, N. Y.



sales will follow as the plan becomes better known to home hunters. It is the purpose of the Leopold Co. to install talking machines and complete furnishings in a score of local homes.

The Kennedy-Green Co., Okeh record jobber in northern Ohio, announces the appointment of Tom O'Connor, well-known Cleveland business man, who will cover territory outside of Cleveland.

Unico President Entertains

Reyburn Clark Smith, president, and A. C. (Gus) Mayer, genial district manager, of the Unit Construction Co., were recent visitors in the Cleveland district, surveying the activities of different firms in the industry as a basis for the 1921 campaign of their company. While here Mr. Smith was host at a dinner to mark the departure to Los Angeles of Milton Ganger, formerly with Cleveland talking machine firms and more recently of the Smith Music Co., Ashland, O. Members of the party included C. K. Bennett, general manager; Ed B. Lyons, sales manager; Earle Poling, traveling representative, and Mrs. I. M. Howard, record department manager, the Eclipse Musical Co.

"Columbia Week" Successful

Continuance of the campaign inaugurated largely for the benefit of dealers for the holiday period is contemplated by Cleveland district officials of the Columbia Graphophone Co. The plan, in effect several weeks, has been productive of extraordinary business for all dealers who have taken part. Several different phases have been combined by Columbia leaders here to make a harmonious whole for the event. Window decorations, signs, circular advertising of newspaper-page size, newspaper advertising and other material have been prepared at headquarters here and sent to retailers. The event is known as "Columbia Week." Arrangements have been made with grocery stores and other retail places where many people gather daily, to install machines and sets of records and have the machines play constantly. A neat sign states the machine is from a certain dealer.

Young women, supplied with quantities of records, call at the homes of the people, asking to play these records on the machine owned by the householder. They sell no records, but advise of the event being held at the dealer's store. Machine owners go to the store and buy new records. In homes where there are no machines a note is made, a machine is sent out on trial for a period and usually is purchased within a few days after the initial trial. The campaign has been conducted under personal direc-

tion of J. L. Du Breuil, district manager; H. C. Cooley, assistant manager, and H. C. Schultz, sales manager.

Muehlhauser Co. Plans

An enlarged talking machine department, with several unique features for patrons, is included in the plans of the Muehlhauser Bros. Piano Co., which moves to its new location at Euclid avenue and East Twenty-first street February 1. The new location will provide a total space of 8,000 square feet, twice as much as this progressive house started with three years ago, when it entered the music field here. Although the Muehlhauser firm is new as a firm, it is old in its personnel, as the members—Adolph Muehlhauser, president; Otto C., vice-president and general manager, and Fred, treasurer, have spent a lifetime in the trade.

ATTENDING FURNITURE EXPOSITION

H. C. Naill, of the Geo. A. Long Cabinet Co., has left for Grand Rapids, Mich., where he is attending the Furniture Exposition being held in that city from the first to the twenty-second of January. Mr. Naill is going in the interests of the Geo. A. Long Cabinet Co. to promote the Long line of specialties which are being exhibited.

Eastern Sales & Export Office
WILLIAMSPORT, PA., U. S. A.

Eastern Sales Agents for

Universal Stamping & Mfg. Co.
Master Motors

H. G. Saal Co.
Famous Saal Motors

Sterling Devices Co.
Guaranteed Tone Arms

Villinger Mfg. Co.
Phonograph Hardware

Electric Motors
100 Per Cent. Efficient

Eastern Sales & Export Office
Williamsport, Pa., U. S. A.

MAIN-SPRINGS
For any Phonograph Motor
Best Tempered Steel

1 in. x 10 ft. for	Columbia.....	Each	\$0.50
1 in. x 13 ft. for	Victor.....	Each	0.50
1 1/4 in. x 13 ft. for	Victor.....	Each	0.75
1 in. x 12 ft. for	Heineman.....	Each	0.60
7/8 in. x 10 ft. for	Col. Pathé-Heineman	Each	0.50
1 3/8 in. x 16 ft. for	Heineman	Each	1.20
1 x 16 ft. for	Saal or Silvertone....	Each	0.90
1 in. x 10 ft. for	Saal or Silvertone..	Each	0.60
1 in. x 16 ft. for	Sonora or Brunswick	Each	0.90
3/4 in. x 10 ft. for	all small type machines	Each	0.45
1 1/2 in. full size for	Edison Disc.....	Each	2.10

SAPPHIRES—Genuine

Pathé very best loud tone genuine, each 15c; 100 lots, \$11.50.
Edison very best loud tone, 15c each or \$12.00 in 100 lots.

MOTORS

Special price on Krasberg motors.
Order right from this ad.
Send for price list of other repair parts.

The Val's Accessory House
1000-1002 Pine St. St. Louis, Mo.



The Fibre Needle Builds Enthusiasm

It makes constant purchasers of talking machine records.

It creates increasing appreciation of the more standard types of music and directly affects the sale of operatic records.

It places the talking machine upon a higher plane as a home entertainer

And therefore

Helps you to sell more and better machines.

Push the Fibre Needle

B & H FIBRE MFG. CO.

33-35 W. Kinzie Street, Chicago, Ill.

INTENSIVE SALES PROMOTION IN MILWAUKEE

This Policy to Be Pursued Throughout Trade This Spring—Enormous Holiday Record Business—Leading Jobbers and Dealers Optimistic Regarding Outlook—News of Month

MILWAUKEE, Wis., January 10.—In the realization of the fact that the "acid test" for the talking machine business has come, the trade in Milwaukee is engaged in the most intensive sales promotion campaign that has ever been put forth. Holiday business received an injection of this sort during the latter part of November and throughout December, with the result that what ordinarily might have been a rather restricted volume of business assumed proportions that were very satisfactory.

Most of the retail stores entered the new year with a larger carry-over of stock than a year ago. The inventories, however, are not regarded as excessive, for in most instances they are no larger than customary at this time. Nevertheless the amount of merchandise on hand is sufficient to awaken all to the need of applying the most substantial salesmanship principles that have ever been required if business between now and the Easter holiday season is to be sustained at the desired point.

Holiday business in records unquestionably was the largest in history, and the shelves of all dealers were so bare on January 1 that it might truly be said that record stocks were "shot to pieces." Dealers are gradually accumulating new stocks. The demand since the holidays has kept up wonderfully well and the local trade looks for a continuance of good record business for a long time to come.

One thing which dealers feared might result from the unusual conditions prevailing in business generally, namely, that some stores might undertake extreme measures to move stocks, came about only to a small extent. However, some apprehension still is expressed that some efforts will be made to stimulate business by offering instruments at greatly reduced prices. It is figured that as the new year moves on, trade will not be exceptionally brisk for a few weeks, while some members of the trade will deem it necessary to convert merchandise into cash and try to accomplish this by playing the popular melody of the day, "cut prices," the favorite device of merchants in many other lines for the last five or six months.

In the main, however, the local trade does not believe in that kind of merchandising. This is especially true of dealers who belong to the Milwaukee Association of Music Industries and through such membership do not countenance unethical business methods. It is felt that while post-holiday business, as usual, will not be especially active, it will not be necessary to break down the standards of the music business to liquidate stocks, regardless of the pressure.

The Better Business Bureau of the Milwaukee

Personal Service

G. F. RUEZ
Pres. and Treas.

H. A. GOLDSMITH
Secretary

S. W. GOLDSMITH
*Vice-Pres. and
General Mgr.*

The members of our company are always available and will gladly see you personally or write you at any time we can possibly serve you.

Get acquainted with the Badger brand of personal service.

Badger Talking Machine Company

Exclusive Victor Distributor

135 SECOND STREET

MILWAUKEE, WIS.

Association of Commerce, with the co-operation of the Music Industries Chamber of Commerce Bureau, nipped in the bud a number of attempts made by several Milwaukee dealers to "put over" some campaigns that smacked of bad ethics. Oscar H. Morris, director of the Milwaukee Bureau, is keeping an eagle eye on the advertising of all business men to prevent a turmoil of bad publicity, for which present conditions are likely to open the way.

Talking machine dealers are very much encouraged by the fact that numerous large industries in this city, which have been running at greatly reduced capacity, or been entirely idle for several weeks or longer, are now resuming normal operations, re-employing thousands of men whose earning power has been sharply reduced. It is a fact, however, that idleness was probably less in Milwaukee than in other large cities, due to the fact that the industry of this city is the most diversified of any big community, as a consequence of which men released from certain plants were readily absorbed by others.

According to Harry A. Goldsmith, secretary of the Badger Talking Machine Co., Victor jobber, 135 Second street, 1921 is bound to be a big year because an early return of industrial and commercial activity is bound to create another era of prosperity. The public is too well sold on music, he says, to stop buying musical instruments. The market is far from being saturated. At the same time business in records is certain to be heavy because of the enormous number of instruments now in homes and factories which require constant new purchases.

Thomas I. Kidd, manager of the Brunswick-Balke-Collender Co., 275-279 West Water street, is one of the real optimists in regard to the future of the talking machine industry. Sales of the Brunswick in 1920 in Mr. Kidd's territory were far and away the largest in the history of the house, and his dealers are continuing to place very satisfactory orders, both for instruments and records.

"We have not the least complaint to make about Sonora business," said Fred E. Yahr, president of the Yahr & Lange Drug Co., 207-215 East Water street, distributor of the Sonora in Wisconsin and Upper Michigan. "Naturally, trade is not so active now as it was in the last two to three months, which is to be expected

after the holidays are over, but business is picking up nicely and we feel that we are going to have the best year we have ever known."

Charles J. Orth, distributor of the Puritan in Wisconsin and northern Michigan, expresses satisfaction over conditions and is mapping out campaigns for the rest of the Winter and the coming Spring which are laid on much broader lines than ever before. Easter coming considerably earlier this year than usual, Mr. Orth believes, will be a material factor in stimulating music business of all kinds, and especially the talking machine and record line.

The Phonograph Co. of Milwaukee, 49 to 51 Oneida street, Edison distributor, has recently increased its capital stock from \$100,000 to \$150,000 to accommodate the expansion of its business and provide for further enlargement.

Miss Helen Gunnis, for several years at the head of the talking machine department of the C. W. Fischer Furniture Co., 211-215 Second street, Milwaukee, has joined the staff of the Edmund Gram Music House, 414-416 Milwaukee street, which features the Aeolian-Vocalion and the Cheney. Miss Gunnis had wide experience in retailing the Cheney during the time the franchise was held by the Fischer Company. She is widely known in the trade, and has done considerable recording for the Aeolian-Vocalion and Columbia records.

Raimund Wurlitzer, son of Howard Wurlitzer, president of the Rudolph Wurlitzer Co., Cincinnati, was married December 30 to Miss Pauline Theckla Pabst, daughter of Frederick Pabst, of Milwaukee. Mrs. Wurlitzer's grandfather was the founder of the great Pabst brewery.

Page & Zimmermann, Ladysmith, Wis., retail jewelers and Pathé dealers, have separated the two lines and installed a complete music store in the Page building. The new store is one of the handsomest in northern Wisconsin and has been especially well stocked with instruments and records.

The H. C. Bendler Co., Sheboygan, Wis., Brunswick dealer, has opened a branch store at Sheboygan Falls, a thriving community about seven miles west of Sheboygan. The store is temporarily quartered in the Frank A. Stroub pharmacy.

Clemens Reinders, a leading furniture dealer of Kewaskum, Wis., has opened a talking machine department which features the Edison.

THE TOLEDO TALKING MACHINE CO.

TOLEDO, OHIO

WHOLESALE



EXCLUSIVELY

THE SCOTFORD TONEARM AND SUPERIOR REPRODUCER

Manufactured under the Patents of Louis K. Scotford

Some New Finishes and Reduced Prices for 1921

Before making your Tonearm and Reproducer contract for 1921, it will be to your interest to try out the Scotford inventions. Samples of the several combinations illustrated below will be submitted on approval to responsible rated firms. New concerns not rated may try out any or all of the models on depositing the list prices, and we agree to refund the full amount on return of the samples—or will adjust the price at quantity rate if a quantity is later ordered

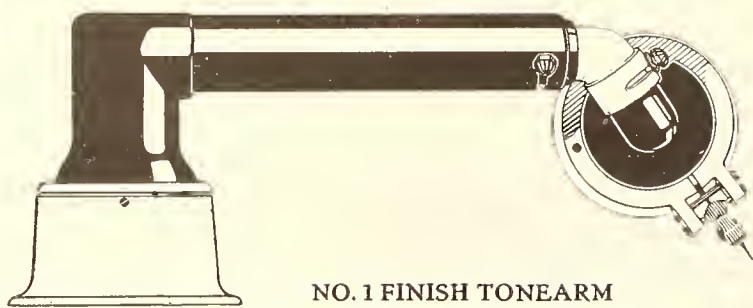

NO. 1 FINISH TONEARM
Plated Base, Black Main Elbow and Tube, Plated Connection with No. 1 or No. 2 Finish Reproducer

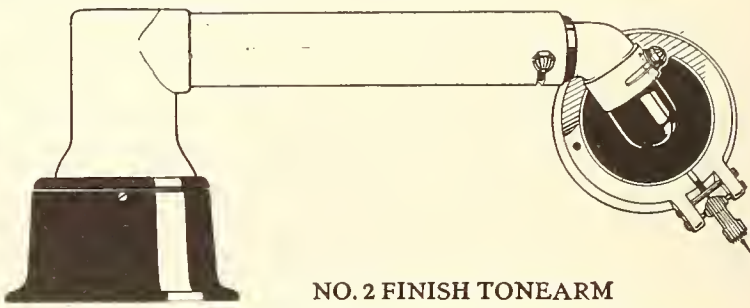

NO. 2 FINISH TONEARM
Black Base, Plated Main Elbow and Tube, Plated Connection with No. 1 or No. 2 Finish Reproducer

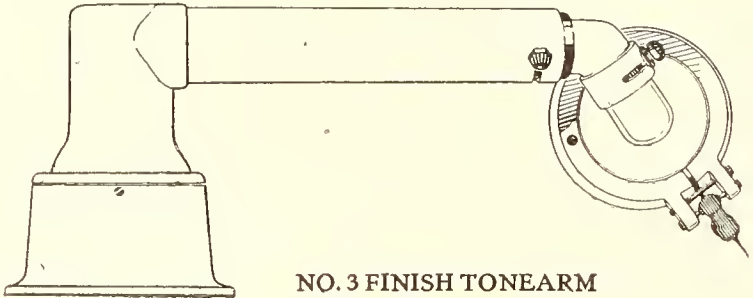

NO. 3 FINISH TONEARM
with No. 3 Finish Reproducer
All Parts Plated



NO. 1 FINISH REPRODUCER
Black Face Ring and Back
Plated Frame

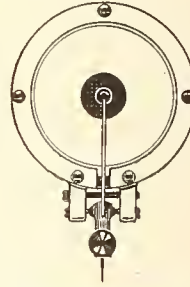

NO. 2 FINISH REPRODUCER
Plated Face Ring and Frame
Black Back
NO. 3 FINISH
All Parts Plated

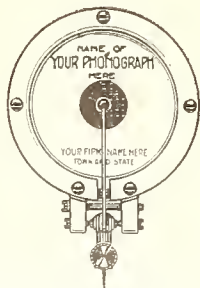

MICA DIAPHRAGM
Your Nameplate

No extra charge for Reproducer with individual nameplate when the necessary Decalcomania Transfers are furnished by customer. Such Transfers require four to eight weeks to manufacture

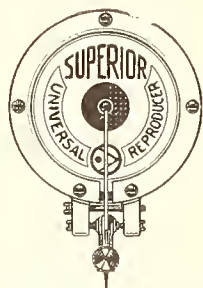

MICA DIAPHRAGM
"Superior" Nameplate

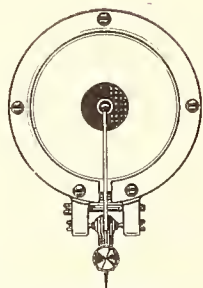

MICA DIAPHRAGM
Plain Gilt Plate

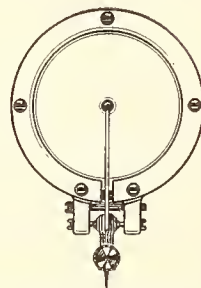

MICOMPO DIAPHRAGM
Plain Gilt Plate
"Superior" Nameplate
or Your Nameplate

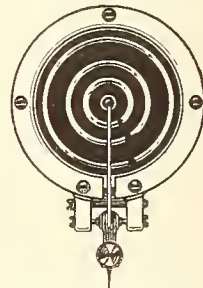

BLACK DIAPHRAGM
Plain Black
Gilded
or Your Nameplate

List Prices, including Parcel Postage

	PLATINOID or NICKEL PLATE	POLISHED ROMAN GOLD PLATE	Prices stated are for the Reproducer with First Quality Clear India Mica Diaphragm. For MicoMpo or Black Diaphragm deduct 50 cents
No. 1 FINISH Tonearm and Reproducer . . .	\$7.00—Reproducer only \$4.00	\$ 9.00—Reproducer only \$5.00	
No. 2 FINISH Tonearm and Reproducer . . .	\$7.75—Reproducer only \$4.50	\$10.00—Reproducer only \$5.50	
No. 3 FINISH Tonearm and Reproducer . . .	\$8.50—Reproducer only \$5.00	\$11.00—Reproducer only \$6.00	

PLATINOID is a new electro-plate finish which looks like Silver but costs no more than Nickel. Unlike Silver or Nickel, it is non-tarnishable

Quantity Prices are Much Lower than List Prices above

BARNHART BROTHERS & SPINDLER
Monroe and Throop Streets - CHICAGO

On the Columbia Novelty Record this month the Royal Serbian Tambouritza Orchestra plays two waltzes—"Spring Flowers" and "Quiet Night." How those novelty records do sell! E-4624.

**Columbia Graphophone Co.
NEW YORK**



INDIANAPOLIS CONTINUES TO BE A BUSY TRADE CENTER

W. J. Baker in Charge of Brunswick Business—Hopkins Purchases Edison Shop—Kipp Entertains Forces—Stewart Data on Deferred Payments and Interest—New Columbia Manager

INDIANAPOLIS, IND., January 5.—W. J. Baker, of Chicago, for the last three years traveling auditor of the Brunswick-Balke-Collender Co., has been placed in charge of the Indianapolis branch of that company to succeed Manager Frank Buttweiler, who has been placed in charge of the Cleveland branch. Mr. Baker has been with the company eleven years, serving in various capacities at Grand Rapids, Mich.; Toledo, Detroit and Chicago.

Associated with Mr. Baker in the Indianapolis branch is A. G. Burr, sales manager. Mr. Burr is widely known in Indiana and Illinois and has been with the Indianapolis branch since last June. He speaks most enthusiastically of the year's business in Brunswick machines, which, he says, has been much larger than the business of the previous year. The number of Brunswick dealers in Indiana, he says, has doubled within the last few months and the prospects are that the number will be again doubled in the next year. He is planning now a larger and more elaborate demonstration room and will soon enlarge the record stockroom which was constructed a few months ago with the expectation of its being ample in size for several months yet to come.

C. A. Grossart, manager of the Brunswick Shop, says that he did a remarkably good holiday business, particularly in records. He says he turned over his record stock many times during the month of December and was hard pressed to serve all the buyers.

Among the Victor dealers of the State who exhibited much activity in an advertising way during the holiday season was O. L. Foster, of Lafayette, whose quarter-page newspaper advertisement afforded an example of excellent copy containing a personal appeal that was exceptionally good. Following a general argument on the supremacy of the Victrola this dealer inserted in typewriter type, signed with a

fac-simile of his own signature, the following message:

"For more than ten years I have sold Victrolas in Lafayette. During this time I have been offered the agency for each of the other makes of instruments. If there were any instrument that could qualify in the same class as the Victrola I would have welcomed it long ago, as I have never yet been able to secure enough Victrolas to supply the ever-increasing demand."

George E. Stewart and E. T. Huller, as a vigilance committee representing the Stewart Talking Machine Co., corrected some misleading advertising used by an Indianapolis furniture store and an Indianapolis drug store. The committee, with the support of a representative of the Indianapolis Better Business Bureau, induced the furniture dealer to surrender the Victrola sign with which he had been advertising two phonographs of another make and induced the druggist to change a window sign to read "Phonograph needles" instead of "Victor needles."

Purchases Edison Shop

The Hopkins Music Co., headed by W. O. Hopkins, has purchased the Edison Shop from the Kipp Phonograph Co. Mr. Hopkins will continue to be the manager of the store.

Mr. Hopkins says the record sales during the holiday season were far ahead of the sales in previous years. The capacity of his record department, he says, was taxed to the limit in caring for the trade. The average price of machines sold during the last weeks of the year was higher than last year, according to Mr. Hopkins.

William S. Cooke, manager of the Indianapolis Talking Machine Co., says that on the day before Christmas he did the largest record business in the history of the store. One of the features of Mr. Cooke's holiday offerings was a

"nursery" machine which he personally evolved by the artistic application of a paint brush to the \$75 type of Victrola. What Mr. Cooke did was to make the machine white with blue trimming and fanciful pictures of Mother Goose characters well known and well beloved of children.

Kipp Phonograph Co. Entertains

On December 27 the Kipp Phonograph Co. entertained the men of its sales and shipping force at the annual stag party that is a regular event of the company's holiday celebration. A feature of the party was the initiation of new members. The ceremony was conducted under the direction of Walter E. Kipp, president, acting as "High Priest of Ceremonies," and H. G. Anderson, general sales manager, acting as "High Guard and Guide." A banquet was served in the packing room with all the style of which one of the well-known caterers of the city was capable.

A dinner and entertainment for the benefit of the women members of the force was given on December 29. This comprised a banquet and dance at the Athenaeum, following a theatre party at the Murat Theatre to witness "The Charm School." The men of the sales force, with their wives, were guests at this affair, as were the women of the sales and office force.

Miss Minnie Springer, manager of the Victrola department of the Taylor Carpet Co., says that her Christmas business was by far the best in the history of the store. She says she is inclined to credit this largely to the fact that during December the department was advertised on twenty-one large billboards in Indianapolis. These billboards had been used by the seven Victrola dealers of the city for one year ending November 30, after which time the Taylor Carpet Co. contracted for them for an indefinite period.

Dealers Favor Interest Charges

The Stewart Talking Machine Co. has been conducting a field investigation on the question of charging interest on deferred payments. The investigation was conducted by letter and personal calls among the representative dealers in its territory and it showed that ninety-two out of 102 dealers favor the establishment of an interest rate. The questions asked of the dealers were as follows:

Would you like to see all Victor dealers charge interest on deferred payment contracts?

Do you charge interest on sales of this nature? What rate? How long have you used this system?

If you are using this system at the present time please explain in brief your ideas concerning it and what effect it has on your sales.

If you are not in favor of charging interest on deferred payment contracts state briefly your main objections.

Ninety-two dealers answered "yes" to the first question. Seven dealers answered "no." Three dealers expressed indifference on the question, two of them saying they sold for cash only.

Of the ninety-two who favored adopting the
(Continued on page 92)

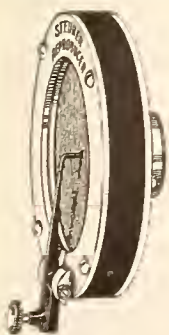

You have probably tried many reproducers hoping to find one which will overcome and eliminate thin, metallic, sharp tones. The STEURER REPRODUCER will satisfy you that we have succeeded in producing roundness of tone, volume, detail and a quality of tone entirely free from nasal or metallic characteristics.

We guarantee satisfaction.
Samples to the trade, \$7.00 each.
Fully covered by patents.

Steurer Reproducer Company, Inc.

158 West 21st Street

New York City

INDIANAPOLIS A BUSY TRADE POINT

(Continued from page 91)

plan of charging interest, fifty-five favored the interest rate of 6 per cent, seven favored 7 per cent, five favored 8 per cent, one favored 10 per cent and three said they did charge interest of some sort, but did not say how much. Twenty-one dealers were uncertain as to what the amount of interest should be.

Of the seven dealers opposing an interest charge one gave as his reason that interest is hard to compute and so causes trouble in book-keeping. He said, also, that such a charge would be contrary to the policy of his house, whether in the sale of Victrolas or other merchandising. Another opponent of interest charging declared that in department stores the Victrola leaseholders make better payments than do those on open account.

F. L. Scott, Jr., New Columbia Manager

F. L. Scott, Jr., for the last year manager of the dictaphone department of the Dallas, Tex., branch of the Columbia Graphophone Co., has been made manager of the Indianapolis branch of the company, to succeed B. L. Brown, who resigned to enter the real estate business in Indianapolis. Mr. Scott has been with the Columbia Co. since 1908, except for a period of three years, when he was an officer in the regular army. He located at Dallas after his discharge from the army. Prior to his army service he was connected with the St. Louis branch.

Mr. Scott reports the business in his territory during the holidays was nearly equal to the business of the corresponding period last year. Some of the dealers, he says, did a better business. He attributes the success of the season largely to an intensive house-to-house sales campaign carried on during December in sixteen Indiana towns and five Kentucky towns.

J. M. Bayliss, of the New York executive office of the Columbia Co., has been in Indianapolis to make final plans for the interior layout of the new standardized Columbia branch to be located in the six-story concrete building erected for the Capital Paper Co., at 225-229 West South

Stewart
Talking Machine Company

JOBBERS
for the
Victor
Talking
Machine
Company

Indianapolis

street. It is planned to make the new branch one of the most modern phonograph distributing plants in the United States.

New Home for Capital Paper Co.

The Capital Paper Co., distributor of the Kimball phonographs, will move into its new building about January 15. C. F. Kahn, manager, says the phonograph business, which they have carried three months, will be made a full department, with E. H. Jarrard as manager. Mr. Jarrard was formerly manager of the Amberola department of the Kipp Phonograph Co. The new building will provide a display room with 700 square feet of floor space. The company has Indiana and part of Illinois for distribution of the Kimball machine and also of the Grey Gull records. It supplies fifty-two dealers in Indiana.

Among the new dealers in Indiana to become

agents for the Pathé phonograph during the last month are J. M. Harney & Son, of Union City, and James W. Dauthitt, of Bedford. C. O. Mueller, manager of the Pathé department of the Mooney-Mueller-Ward Co., reports the holiday business in his territory to have been very satisfactory.

Reports from the distributors and dealers generally in the Indianapolis territory indicate practically a normal business in the leading makes of phonographs, while the popular makes of records sold ahead of the holiday season last year. It is conceded that while buyers held back from buying costly products they bought freely of the less costly, a fact made apparent by reports of unprecedented parcel-post business, both outgoing and incoming, through the Indianapolis post office. Although the holiday business was chiefly in small goods and merchandise, yet phonographs sold showed a higher average price than last year.

SLUMP IN DEMAND FOR SHELLAC

Reports From Calcutta Are to Effect That Stocks Are Piling Up and Prices Falling

According to reports from Calcutta, India, there is being experienced a steady decline in the demand for shellac, with the result that heavy stocks are being accumulated by the dealers in that section with a resultant drop in prices. In calling attention to the situation the Journal of Commerce, New York, declares that the slowing down in demand for phonograph records is responsible for the situation in the shellac market, and gives the talking machine industry credit for consuming 85 per cent of the total output of shellac.

Inasmuch as any slump in talking machine business has affected machine sales particularly, and the record output in most cases has been little, if any, in excess of demand, it seems as though the newspaper was wrongly informed regarding the facts of the situation. However, the news that shellac is coming down in price is in itself encouraging.

Wholesale Exclusively

THE continuous demand for the Victrola is proving that "all is not gold that glitters." So concentrate your efforts where the results will be greatest.

Pearsall Service is an aid to better business.

10 EAST 39th ST. NEW YORK CITY

SILAS E. PEARSALL COMPANY

DISTRIBUTORS

TRUST IN EXPERIENCE



ABSOLUTE control of every situation comes from knowledge of the **FACTS**—not from guesswork or theory.

WHEN YOU SIGN UP for the **TALKING MACHINE WORLD SERVICE** exclusively in your city you secure the best that money can buy in the way of service from highly trained retail music experts.

THE COST? NOTHING—when you notice the results obtained for the money invested.

WE WILL GLADLY forward complete information regarding the **TALKING MACHINE WORLD SERVICE** upon receipt of the attached coupon.

Talking Machine World Service,
373 Fourth Avenue, New York City.

If other dealers in big cities as well as small towns are getting results and making a big profit on the Talking Machine World Service, I'd like to know all about it. Without obligation, send me sample copies of ads, form letters, ideas, etc. Tell me what it will cost per month for exclusive use in my territory.

The population of my city is.....
I handle these machines.....
My firm name is.....
By
My address

K.-1-15-21.

Mail the above coupon today.

TALKING MACHINE WORLD SERVICE
373 FOURTH AVENUE
NEW YORK CITY

LARGE TOTAL SALES RECORD FOR YEAR IN LOS ANGELES

Review of Business Conditions—Victor Period Designs Grow in Favor—Brunswick Activity—Garbett Delivers Interesting Lectures to Victor Dealers Under Auspices of Sherman, Clay & Co.

LOS ANGELES, CAL., January 4.—Considering that the business for the month of December, 1919, was phenomenal, that for the last month of 1920 was extremely satisfactory, for the volume of the sales exceeded that of the former by a large margin in the aggregate. Many firms showed a large increase over the corresponding month of the previous year, while others claimed that they at least equaled last year's figures for the month, but none admitted a falling off. Total sales for the year 1920 far exceed those for 1919. There is a general feeling of optimism for 1921.

Sells First Period Model for Cash

H. H. Fish, of the Southern California Music Co., enjoys the distinction of selling the first of the Victor Victrolas of period design. These models, which have been looked forward to for a really long time, reached Los Angeles just

in time for holiday business and have been much admired for their superb workmanship and excellent tone. Mr. Fish sold a Louis XVI Electric for \$1,265 cash.

War Hero in Santa Barbara

After a splendid war record in France, William de Vitalis returned to New York suffering from the effects of poison gas. He was advised by physicians to take up his residence on the Pacific Coast, and located in Santa Barbara, where he was given charge of the Vocalion department of Bolton & Jones. Mr. de Vitalis was formerly at Aeolian Hall, New York.

Blue Bird Manager Returns

After an extended six-weeks' trip in the East, M. F. Fybush, general manager of the Blue Bird Talking Machine Co., has returned to Los Angeles. In discussing the readjustment period which had been reached in the phonograph busi-

ness, as in other lines, Mr. Fybush expressed the opinion that the public would demand 100 per cent merit in the goods that they purchased and that the manufacturer who concentrated along these lines was bound to survive and win out.

Barker Bros. Have Busy Days

During at least two weeks previous to Christmas Day the thirty-two record demonstration booths and salesrooms in the phonograph department of Barker Bros. were taxed to their limit, and there were times when customers were obliged to await their turn to listen to records in comfort. General Manager Booth reports that the sales for December far exceeded those for the corresponding period of last year.

New Vice-president at Richardson's

Wid Gunning, editor of "Wid's Daily," the publication which is known far and wide as the "Dun and Bradstreet" of Filmdom, has secured an interest in Richardson's, Inc., and was recently elected as one of the vice-presidents of the company. Mr. Gunning was well known formerly in talking machine circles and was at one time a member of the traveling sales force of the Victor Talking Machine Co.

Opens Special Repair Shop

A much-needed repair shop has been opened by F. L. Cook in the Bumiller Building. Mr. Cook is well known among the trade as a very competent expert repairman and "trouble shooter," and his shop will be much appreciated by dealers whose own repair departments are extra busy or who are without such help.

Pathé Rooster Holds Sway

The phonograph department of Goodan-Jenkins Furniture Co. is devoted exclusively to the sale of Pathé phonographs and records. W. C. MacDonald, manager of the department, is a very enthusiastic devotee of Pathé products and believes that the public is realizing more and more the points of excellence of the Actuelle and of Pathé records.

Wiley B. Allen Co. Specializes

Manager Tucker and his able department manager, Mr. Jackson, seem determined to leave no stone unturned towards making their record department second to none. Accordingly the services of Mrs. Greenwood have been engaged as a combination efficiency, educational and originality expert. Mrs. Greenwood comes well equipped through the experience which she gained on the educational staff of the Victor Talking Machine Co., and this, combined with a charming personality and a wonderful and untiring capacity for hard work, cannot fail to produce results.

Barnes Boosts Brunswicks

Some very excellent publicity is being given the Brunswick phonograph and records by the Barnes Music Co. George H. Barnes, president of the concern, has a strong grudge against himself; instead of being head of a very successful music house he should be devoting all his time to advertising. It is too bad but cannot be helped, although doubtless there are many who would trade jobs, and anyhow, George lets off steam by writing the copy for the Barnes Music Co., and it is very good and, what is most important of all, it produces results.

Sherman, Clay & Co.'s Dealer Service

A series of lectures have been recently given to Victor dealers by A. F. Garbett, special representative for Sherman, Clay & Co., Victor distributors. Mr. Garbett was formerly with the Victor Talking Machine Co. and edited both the Victor monthly supplement and the Voice of the Victor. His knowledge of music is very extensive and he seems to have mastered the art of record salesmanship. His lectures filled his hearers with renewed enthusiasm and gave entirely new and original ideas both from a psychological point of view and a musical sense. Reports have already been made of direct results obtained by his pupils at these few lectures.

Harry Clubb, who was very well known in Los Angeles in former days and was for years in charge of the talking machine department of the Wiley B. Allen Co., was a visitor here for a few days recently. He was heartily welcomed.

TALKING MACHINE WORLD

YOU HAVE AGAIN DEMONSTRATED YOUR WONDERFUL "PULLING" POWER BY SELLING "YOU-NIT" CABINETS ALL OVER THE U. S. A. AND CUBA IN 60 DAYS.

OGDEN

AT LAST A CABINET

(For all Table Type MACHINES)

Which becomes a "Unit" with the Machine. Fits so the open space or Dust Trap is closed. All You-Nit cabinets are in harmony with the construction of the machine they are made for.



Model A-E
Fitted to Edison Chaset
Files 55 Edison Records
Price \$19.50
Rough and Natural Finish



Edison Model
PATD & PATS. PENDG



Model B-E
Fitted to Edison Chaset
Files 112 Edison Records
Rough and Natural Finish
Price \$24.00

BETTER CABINETS, LOWER PRICE, MORE PROFIT
 A Model for Every Table Type.
 Edison Disc and Amberolas. Victrola VIII & IXA, Grafonola C & D, Pathé 3 & 6.

Write for list of jobbers carrying this stock and prices of all models.

Prepare now to supply the increasing demand for lower priced outfits.
 We can ship you now.

OGDEN CABINET CO.

Lynchburg, Va.

ANOTHER SONORA ACHIEVEMENT

Announcing the introduction of the
ETUDE MODEL \$100—list



Dimensions:
42³/₄" high
17¹/₂" wide
17¹/₂" deep

SONORA feels absolutely confident that this is the greatest phonograph value offered today and this is in line with Sonora's long established policy of giving the greatest value consistent with highest quality at all times.

The Etude model embodies all the features of construction that have made the Sonora famous and in every way is representative of the Sonora product.

While this model is already in production and deliveries are being made from the factory now, the demand for it will immediately be so great that it is suggested that orders be placed early.

SONORA PHONOGRAPH COMPANY, INC.

George E. Brightson, *President*
NEW YORK CITY 279 BROADWAY

Canadian Distributors: I. Montagnes & Co., Toronto

THE INSTRUMENT OF QUALITY
Sonora
CLEAR AS A BELL



THE HIGHEST CLASS TALKING MACHINE IN THE WORLD



Unico Department, Burley & Beisinger, Buffalo, N. Y.

Give a Thought to Sales-Efficiency

Now that the holiday rush is over, sit down a minute and let us analyze the sales-efficiency situation at your store.

It is true, isn't it, that people purchase articles from one store in preference to buying the same things at another. There is always a reason.

People will buy where they get the most service for their money over and above the fixed price of the article purchased. This service takes many forms, but always narrows down to sales-efficiency. Are your customers getting the utmost in sales-efficiency from you?

Unico Equipment will enable you to render sales-efficiency in the highest degree.

Unico Decorative Treatment will attract the customer—Unico Demonstrating Rooms will offer your customer proper environment—Unico Racks and Counters will add to the general attractiveness, they will put your stock in order and enable you to produce efficient service to your customer.

We want you to write, telling us your requirements. Of course, this will not incur any obligations on your part.

Our ability to make immediate shipments followed by immediate installation service makes Unico Equipment doubly desirable to you.

Unico Construction is patented.

Unico Designs are patented.

UNIT CONSTRUCTION COMPANY

NEW YORK
299 Madison Ave.
Corner 41st St.

Rayburn Clark Smith, President
58th Street and Grays Avenue
PHILADELPHIA

CHICAGO
Willoughby
Building

DETROIT DEALERS WELL PLEASED WITH TRADE SHOWING

December Closed a Year Uneven but of Good Volume as a Whole—To Fight for Larger Trade in 1921—Jewett Activity Abounds—Talking Machine Records in Great Demand—Other News

DETROIT, MICH., January 4.—Another year has gone and once again dealers are busy taking inventory and figuring up their reports for the year. While we haven't had any dealers give us actual figures, we do know this—December business with most dealers was off about 10 per cent as compared with the same month in 1919, while the year, as a whole, was better. On the other hand, we know of dealers who did a bigger business this year than last. But even a slight decline in the gross business for the month is taken as an increase because dealers say that unemployment in Detroit during December this year was the greatest in ten years and naturally it could hardly be expected that sales would be normal. However, they did not fall down 50 per cent, as was expected. Dealers are all smiling these days and are very much pleased over the December showing, as well as of the entire year just passed.

Now another year has come and dealers are already planning for a good business. Maybe it will not be as good as 1920, but nevertheless dealers are going to strive hard for business, realizing that with conditions gradually back to normal it also means keener competition and a harder fight for new business. They will not wait until the national advertising of the big concerns brings people to their stores—instead, they will go out after new business.

New fields form an important subject with dealers and they should carefully analyze this matter. It is surprising, the number of places where talking machines can be used to good advantage. We already have them in restaurants, confectionery stores, schools, churches, shoe-shining places and factories, but only in a partial list of these places. Why not in more of them? It means that dealers will and must employ outside salesmen to go after this new class of business. It's a subject and a matter that dealers

pay too little attention to, owing to the fact that most of their sales come so easy—from people who come into the stores and are already sold because of the national advertising.

One of the big talking machine record hits right now is "Margie." The writer was in a certain store where the hit was advertised. No less than a dozen people asked for the record, but the store was entirely out. Did these people wait? Positively not. They went around the corner and kept going until they found some store that had it for sale. This is another point that needs attention. Dealers should judge the hits and order accordingly; and jobbers should also prepare for big orders, as well as reorders, and be prepared to supply dealers almost at a moment's notice. If the druggist is out of some article he phones the wholesaler, and the same day he is taken care of. Why not such prompt service in the talking machine industry?

J. L. Grinnell, president of Grinnell Bros., has left for Sea Breeze, Fla., where he has a winter home. C. A. Grinnell, vice-president of the company, leaves for the same place the last week in January. Both will remain there the entire winter.

Grinnell Bros. will hold their annual convention of branch managers the last week in the month. Talking machine topics will comprise a good share of the program.

Up in Grand Rapids quite a number of prominent officials of phonograph companies are attending the semi-annual furniture exposition, which is a good field for new business. Dealers from all parts of the world gather there in January, and it is an opportune time to secure new representatives. Most of the companies have permanent display rooms there and their entire line is on exhibition.

A. A. Fair, sales manager for the Jewett Phonograph Co., 1730 Penobscot Building, De-

troit, and factory at Allegan, Mich., announces that the demand has already started for the Jewett phonograph and orders are coming in daily as well as applications from dealers and jobbers for franchises. Jobbers have already been appointed in Iowa, California and London, England, and new ones will be added just as fast as the company can get around to it. "We are determined to make the Jewett one of the most popular phonographs," said Mr. Fair. "We will specialize in period designs at popular prices, although we also will make a line of uprights. But we are not going to bother with the real cheaply priced product, neither do we want the thousand-dollar model which dealers sell only once in a while. The public demands good merchandise at popular prices and that's what we are going after." Mr. Fair got his start in the music business with Grinnell Bros., where he was general utility man. Then one day he was made a flattering offer from Sam Lind, former manager of the Columbia wholesale branch, which he accepted. Mr. Fair for some time traveled the State calling on the dealers; then he went with the Acolian-Vocalion Co. whose line he sold for more than a year. A few weeks ago he accepted the sales management of the Jewett Phonograph Co.

The new owners of the shops formerly conducted here under the style of the Wallace Brown Co. are gradually doing away with this name and calling them "Brunswick Shops." Although the holidays are over the Brunswick Shops have not let up on their advertising, and it is their plan to keep at it constantly during the coming year.

PAUL BAERWALD RETURNS

Paul Baerwald, Eastern sales manager of General Phonograph Corp. recently returned from Asheville, N. C., where he spent two weeks' vacation with his wife and daughter. When seen by The World this week he was feeling fit in every way and optimistic regarding the business future.

Jewett Phonograph Agencies Are Now Being Assigned

Those who avail themselves of the opportunity of securing a Jewett agency franchise at this time will, in so doing, assure themselves an enviable future in the field of phonograph agencies.

The Jewett line marks an innovation in phonograph merchandising, in that it includes a complete line of console models representing the finest type of cabinetry yet designed to sell at popular prices.

We invite correspondence from reliable distributors and dealers.

Jewett Phonograph Company
1730 Penobscot Building
Detroit, Mich.

The new Jewett Phonograph is the latest manufacturing achievement of the Jewett Brothers, builders of the well-known Paige automobile—"The Most Beautiful Car in America."



"Queen Anne" Console Model

Length—40 inches
Height—36 inches
Depth—24 inches
List Price—\$225

JEWETT PHONOGRAPH COMPANY,
1730 Penobscot Bldg., Detroit, Mich.

Please send me details regarding your agency proposition in this locality.

Name

Address

MCCARTHY AND TIERNEY'S NEW ONE
"WHY DON'T YOU"
 THE BIG MELODY HIT FROM "AFGAR"
 SUNG BY
ALICE DELYSIA
 PUBLISHED BY
LEO FEIST INC.
 FEIST BLDG. NEW YORK

"You can't go wrong with any Feist Song"



HIGHLY IMPORTANT TO TALK PRICES, NOT TERMS, TO-DAY

C. S. Hammond, Manager of the Music Salons of Fred. Loeser & Co., Brooklyn, Gives Sound Advice Based on Successful Experience in the Music Trade Field

"You have asked for a story on phonograph salesmanship. If I felt that I could add anything to the already complete literature on this subject I would gladly do so.

"As I see it, however, there are certain more important matters which we, as phonograph merchants and salesmen, must observe at this time. By doing this we will have a part in the building of a solid structure which will be better able to withstand the storms of business depression or financial stringency than if we were altogether interested in selling as many phonographs as the market could possibly absorb, regardless of the manner in which they were sold.

"Let us assume that during the present year all merchants recognize the wisdom of handling and selling only certain well-known and established makes of instruments, thus insuring their business future against the come-backs of dissatisfied customers. We are safe in making that assumption because the day of the nondescript phonograph is past. With that fact as a starting point in our reasoning it must be evident to any thinking merchant that these instruments should be merchandised in a high-class, dignified manner.

"Already we are beginning to see entirely too much of the 'one dollar down and one dollar per week' variety of phonograph advertising. I would like to have someone tell me just what advantage any one phonograph merchant thinks he has when perhaps a dozen other of his weak-spined brethren are indulging in this same kind of advertising, as far as the securing of immediate sales is concerned. It doesn't take a smart merchant or a literary genius to write an ad which chiefly features low prices and low terms.

"This fact, of course, might be the reason why the newspapers are carrying so much of this kind of advertising at present.

"Aside from the fact that the selling and advertising of phonographs on this basis is bad business from an economic standpoint, is it not also true that such advertising has a tendency to cause the public at large to have less respect for our business?

"We should have more human interest advertising, featuring the joy and educational advantages that a phonograph will bring into the home, and the salesmen who maintain the point of contact with the customer should sell these instruments on that basis. They should be able

to talk about the quality of the instrument. They should have a reasonable fund of musical information and be able to interest the customer more in the musical possibilities of the instru-



C. S. Hammond

ment than in the low terms on which it could be purchased.

"All phonograph merchants should feel sincerely thankful to the Sonora Co. for the influence it has exerted in discouraging 'easy-terms' advertising.

"Manufacturers, merchants and salesmen should study their business problems this coming year as they have never done before. There is good business to be had by those who will go after it in a high-grade, constructive manner."
 —Sonora Bell.

VICTOR NUMERICAL RECORD LIST

The Victor Talking Machine Co. has just issued to the trade the 1921 Numerical List of Victor Records, a truly imposing volume, including all records announced prior to the January, 1921, supplement. The list takes its usual form with space left for the pasting in of the new numerical supplements as issued during the current year. Intelligent use of the volume will do much to simplify the handling of the record problem for the dealer.

The Colver Brothers Music Co., Holyoke, Col., has opened a branch store at Haxtun, Col., under the management of L. F. Allan.

Phonograph and Record Manufacturers

Ahead of you is a year of supreme "selling". The dealer will need every selling assistance you can give him.

But he will appreciate and use only that material which does actually help him sell machines and records.

Einson Litho Inc. have for years designed and lithographed Window Displays, Interior and Counter Displays for the largest concerns in the talking machine industry.

Put your 1921 dealer display problem up to experienced specialists.

EINSON LITHO INCORPORATED

Executive Offices
and Art Studios
71 W. 23rd St., N. Y.

Factory & Plant
327 East 29th St.
New York, N. Y.

1921

The Year of Quality Phonographs

—
Use Our 1921 Meisselbach
Motor of Quality

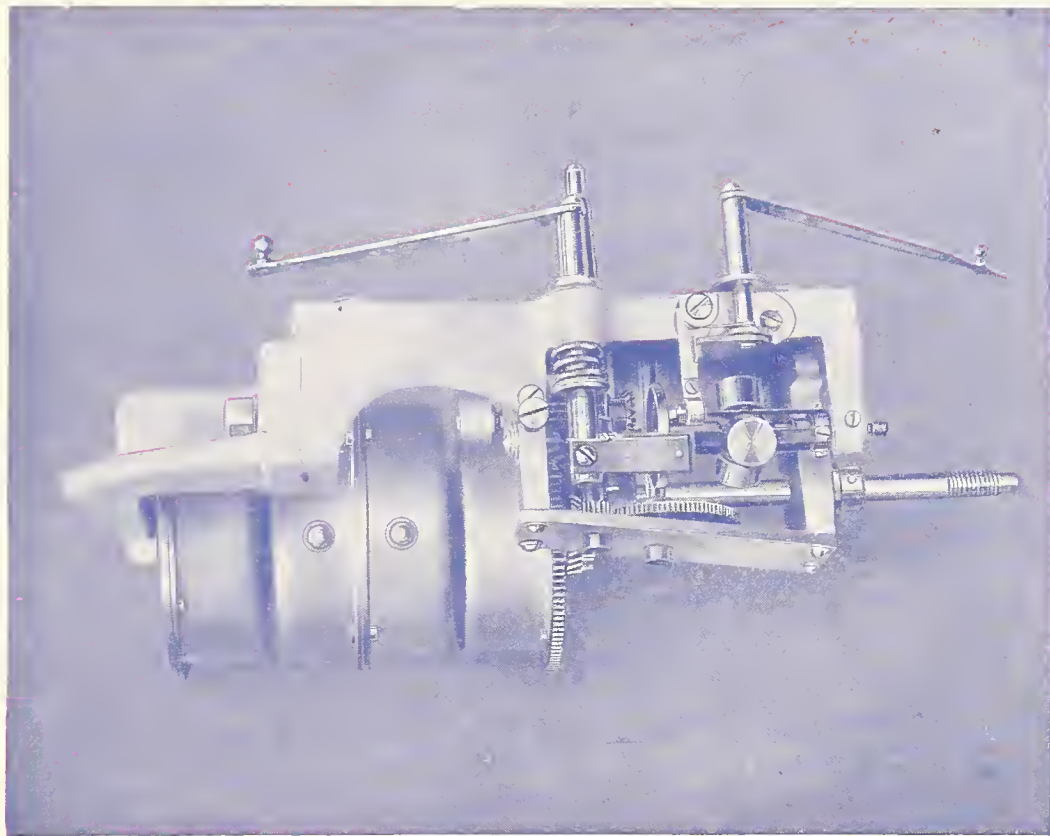

19-A

You Will Have Only Satisfied Customers

GENERAL PHONOGRAPH CORPORATION

OTTO HEINEMAN, *President*

25 West 45th Street New York City, N. Y.

Factories: Newark, N. J. Elyria, Ohio Putnam, Conn. Springfield, Mass. Kitchener, Ont.

Branch Offices: Chicago, Ill. Toronto, Can. London, Eng.



The Trade in **BOSTON** and **NEW ENGLAND**
 JOHN H. WILSON, Manager
 324 WASHINGTON ST., BOSTON, MASS.

BOSTON, MASS., January 5.—The old year did not end exactly in a blaze of glory, for the holiday business was not what dealers or jobbers would have liked, but the most interesting thing is that the conditions have not left any bad scars on the face of local business and there is the greatest hopefulness that the new year, as it develops, week by week, will steadily gather impetus toward a more normal condition. The local credit men hold that good times are near and by way of bolstering up their position the credit defense committee of the Boston Credit Men's Association has sent out a communication which reads as follows:

"Good times are just ahead. We believe a heavy domestic buying demand will come just as soon as the new reduced level of prices becomes stabilized.

"To hasten the coming of good times business men should, at this inventory season, reprice their stocks on hand at replacement value, eliminating all damaged lines, even if such action results in reduction of capital assets.

"Face the situation courageously and by so doing get ready for the immense buying demand that has been held back by war prices.

"The Boston Credit Men's Association, a co-operative organization of over 1,000 credit grantors, with membership drawn from manufacturers, wholesale houses and banks, will be glad to confer with any merchant who is temporarily affected by the deflation, with a view to helping him out of his difficulties, so that his business may be saved and continued.

"There is no cause for any business man to be discouraged. Conditions confronting us at this time are no different from those that have in the past been met and successfully overcome.

"By avoidance of drastic or hasty action, by proper respect for the rights of others, by closer co-operation and with full and complete confidence in each other, all will work out satisfactorily.

"Present conditions may be made the groundwork for greater prosperity by determination to build business upon saner, safer and stronger foundations. Let us all get together."

Geo. W. Hopkins to Speak

George W. Hopkins, general sales manager

**Best Wishes
for
Nineteen Twenty One**

And may the service we give you
in this New Year be helpful
toward making it prosperous and

VICTOR-IOUS

**Steinert
Service
Serves**



**Use
Tungs-tone
Styli**

M. STEINERT & SONS CO.
 VICTOR WHOLESALERS
 35 Arch Street :: :: :: :: :: :: Boston

for the Columbia, is scheduled to be a speaker at the Boston City Club on Thursday, January 13, when he will take for his topic "Business To-day; What Are You Going to Do About It?"

Kenneth E. Reed an Optimist

Kenneth E. Reed, wholesale manager of the M. Steinert & Sons Co., is one of the especially hopeful spirits in the trade and he is looking for a resumption of healthy business soon after the new year. He claims that as this section was one of the first to feel the effects of poor business it will be the first to get over it; in other words, the first to come under the spell of a renewal of business activity. He says, further, that the Steinert house, despite general

conditions, had a good year, that there has been a splendid spirit of co-operation among all those with whom the Steinert concern does business and that there is every reason to look for rapidly improved conditions, provided everyone does his part.

Sentenced on Theft Charge

In the municipal court Judge Duff sentenced Herbert L. Royer, of the Royer Talking Machine Co., and Charles Lowell to six months in the House of Correction at Deer Island, following a trial in which the conspiracy was bared to steal talking machines, which resulted in the victimizing of several stores as well as dealers. Both Royer and Lowell appealed and were held in \$2,000 for the superior court. Edward J. McDonough, who gave the court much valuable evidence, had his case placed on probation.

According to one of the stories told, McDonough had been a much-wanted person around the Boston stores, assuming a new name, so it is alleged, for each store he entered, and he confessed to former District Attorney Webber, who appeared in behalf of the victimized talking machine dealers, that he had bought machines ranging in price from \$75 to \$275 from dealers on the leased plan, paying an initial payment of from \$5 to \$10. As "W. J. Quinlan" or "Finnerty" or some other name he would sign leases and have the machines sent to different addresses. He would wait at each address until the machine was delivered and then have it removed to the talking machine store in Lowell, from where it would be reshipped to Royer at the latter's place of business.

One of the officers attached to City Hall avenue police station was able to locate nine machines which had been stolen and had them returned to their owners. It is hoped in the local trade that the present disposition of this case will put a stop to a situation that had become highly annoying to dealers in Greater Boston.

Suffers Damage From Smoke

The quarters of the New England Talking Machine Co. in Beach street were somewhat damaged by smoke during a fire a few nights ago, which broke out on the third floor of the

(Continued on page 101)

1921

A year full of
great opportunities
for the
Victor Retailer

✻

**Eastern Talking Machine
Co.**

85 Essex Street
Boston, Mass.

**EASTERN
SERVICE**

"NEW ENGLAND SERVICE
FOR NEW ENGLAND DEALERS"



Established 1870

Oldest and Largest
Manufacturers of
Talking Machine
NEEDLES
in the World



“Fifty Years of Needle Making.”

“If a Talking Machine Needle could be made better, Bagshaw would make it.”

W. H. BAGSHAW CO.

INCORPORATED 1917

LOWELL, MASS.

W. H. BAGSHAW
COMPANY
LOWELL, MASS.

building in the part occupied by a tobacco concern. The fire started at a time when the neighboring theatres were letting out and there was great excitement as the apparatus filled the streets.

Talking Machine Men in Association

The newly-elected advisory committee of the New England Music Trade Association is made up of two divisions, the talking machine and the piano. Those composing the former include R. V. Davis, of the F. C. Henderson Co.; Harry Spencer, of Spencer's Music Shop, but better identified as with the Brunswick; Kenneth E. Reed, of M. Steinert & Sons Co. (Victor); Arthur C. Erisman, of the Grafonola Co. of New England (Columbia); R. O. Ainslie, of the Hallet & Davis Co., handling the Pathé; L. H. Ripley, of the Pardee-Ellenberger Co., handling the Edison; Walter Gillis, of 359 Boylston street, handling the Victor; W. E. Titus, head of the talking machine department of the Jordan Marsh Co., and Fred Gardner, of Lawrence. On the executive board is E. M. Wheatley, of the Vocalion Co., and Harry Spencer is also on the membership committee.

Some Attractive Holiday Souvenirs

Several useful and artistic gifts were given out at the holiday season to their friends by local concerns. The Eastern Talking Machine Co., for instance, gave away a beautiful gold-plated Eversharp pencil, which will long be a pleasant reminder of the group of hustling business men who compose this active organization. In addition, a handsomely engraved Christmas and New Year's greeting went out, this, of course, in far larger numbers.

The M. Steinert & Sons Co. remembered their friends with a brass desk thermometer, which is a fit companion to the desk pads sent out a year ago. With each thermometer went a card of kindly greeting. The Hallet & Davis Co. was represented by a bronze paper cutter of the most serviceable description. In the handle is embossed the seal of the house, which serves

HORTON-GALLO-CREAMER CO

NEW HAVENCONNECTICUT

VICTOR SERVICE SPECIALISTS

THE New Year is before us. We can largely make it what we will. Let us help you make it a banner year.

for permanent identification. From the C. C. Harvey Co. came an artistically engraved card carrying the compliments of the season.

Vocalion in Theatre Lobby

In the lobby of the Colonial Theatre, one of Boston's leading playhouses, during the first of the month Manager Wheatley, of the local Vocalion headquarters, had placed a Vocalion on display and its special purpose was to play

the records of John Charles Thomas, who is starting at this theatre in "Apple Blossoms." Mr. Thomas is a Vocalion artist and his records, according to Manager Wheatley, have been in great demand in this territory, the sale receiving added impetus as a result of the novel method of demonstration in the theatre lobby. At the same time a large photograph of Mr. Thomas and members of the company in "Apple Blossoms," taken on the stage of the Colonial, was featured in the windows of the Vocalion store in Boylston street.

Mr. Wheatley reports an excellent Christmas trade and the new year found him looking forward to a large broadening of the Vocalion business in this territory. He has recently opened up a number of new accounts in various cities in New England.

President Frederick Silliman, of the Pardee-Ellenberger Co., Edison distributor, reports that this company is starting the new year with a lighter stock than was the case a year ago, following a satisfactory Christmas business. He says that the recent closing of the talking machine department of the Edison works will not, so far as he can foresee, have any effect in the local territory.

Successful Columbia Drive

Manager Fred E. Mann, of the Columbia, says that the two months' drive was most successful and arrangements are being made to keep it up for a while longer. The drive developed a great many excellent prospects which will be closed up as soon as business conditions again become normal. He says that in his territory the year's business taken as a whole was good.

Steinert Christmas Parties

While two separate Christmas parties were
(Continued on page 102)



CRESSEY & ALLEN

CO-OPERATION

Wherever co-operation can be extended toward helping the New England Victor dealer to greater success the firm of Cressey & Allen is at all times ready to lend the experience of their veteran organization.

PORTLAND MAINE

LONG
TRADE MARK

MUSIC CABINETS

See Display Ad in This Issue

Peerless Record Album

See Display Ad in This Issue

SPECIAL

I am prepared to ship all orders on either line promptly.
Send your orders for both these lines to
L. W. HOUGH, 20 Sudbury St., Boston, Mass.
New England Representative

THE TRADE IN BOSTON AND NEW ENGLAND—(Continued from page 101)

under way at the Boylston street establishment of the M. Steinert & Sons Co. on the Thursday before the great holiday there was still another at the Arch street Victor headquarters of the Steinert house and this was some party, as might be expected if Kenneth Reed had anything to do with it. Assisting Mr. Reed in the arrangements was Miss Alice Downing, head of the accounting department, and there was almost everything to make the evening a pleasant one. A big, illuminated tree was set up on the third floor, from which there were numerous joke gifts taken, and there was a "gift dance" which proved awfully good fun. For other entertainment there was "Shady," the faithful elevator man, who, with a dusky partner, gave some skits which they often do under the name of "The Kandy Kids." There were fully forty to enjoy the evening, which ended with dancing and refreshments.

Columbia Associates Celebrate

Another enjoyable party held that same night was at the Columbia headquarters, at 1000 Washington street, where eighty of the Columbia Associates had a merry time. The arrangements were in the hands of W. R. Fleming, head bookkeeper, and Miss Anna M. Walsh, head of the statistical department. There was a Christmas grab and the program enlisted the services of considerable home talent. There were contralto solos by Miss Ellen Gardner, an English girl, who has lately joined the Columbia organization; Joseph Cohen, who gave some imitations of Charlie Chaplin; Joseph Eagan, in recitations, and a comedy skit by Messrs. Reznich, Berman and Spector; James Grogan also did a clog dance. There were refreshments and dancing. The wives of some of the head officials were among the invited guests.

Moir Closes Boston Store

C. C. Moir, the Cambridge talking machine dealer, who for more than a year has operated a Boston store at 181 Tremont street, where the L'Artiste was featured, closed this place the

first of the month and all the goods were removed to the Cambridge store. H. C. Shea, who was in charge of the office, associated himself with the Rosen Talking Machine Co., at 11 School street, beginning January 1.

Robert Steinert's Christmas Trip

Robert Steinert, of the Arch street Victor headquarters of the Steinert Co., spent the Christmas holidays with friends in New York, Philadelphia and Washington. Between his social duties he found time to go to Camden and make an inspection of the Victor plant.

Sharmat in the South

Samuel W. Sharmat, head of S. W. Sharmat & Son, is in the South, making his headquarters at Miami, Fla., where he plans to spend several weeks.

Doing Well With the Regina

The Musical Sales Corp., which is now handling the Regina, has been very successful thus far in placing this talking machine in a number of high-class establishments throughout New England. There have been many overtures from dealers who are anxious to handle this proposition and Leon Sharmat, who is the head of the corporation, is well pleased at the 1921 prospects for the Regina.

A New Corporation

The Independent Talking Machine Co. of New England is one of the new concerns to be incorporated under the laws of Massachusetts. Its capital is placed at \$100,000 and the incorporators are Philip E. Sage and Samuel Albert, of Cambridge, and Ella C. McLoughlin, of Brookline.

Ainslie to Visit Syracuse

R. O. Ainslie, manager of the Pathé, is planning to be in Syracuse, N. Y., January 10 for the banquet which A. B. Ogden is to give to F. C. Howard and the entire staff of the F. C. Howard Piano Co., and there will also be present several dealers from nearby places. While away Mr. Ainslie also will visit other places in New York State. This Pathé manager reports

**Your Guarantee
Mr. Dealer
LANSING KHAKI
COVERS**

*For All
Phonographs*

Unqualified Endorsement
of Biggest Manufacturers
and Dealers



Slip
and Rubber
Covers
for
Phonographs

Slip
and Rubber
Covers
for
Pianos

*All Good
Distributors*



**Eliot and Warrenton Sts.
BOSTON, 11, MASS.**

PERFECTION BALL-BEARING TONE ARMS

PERFECTION FLEXI-TONE REPRODUCERS

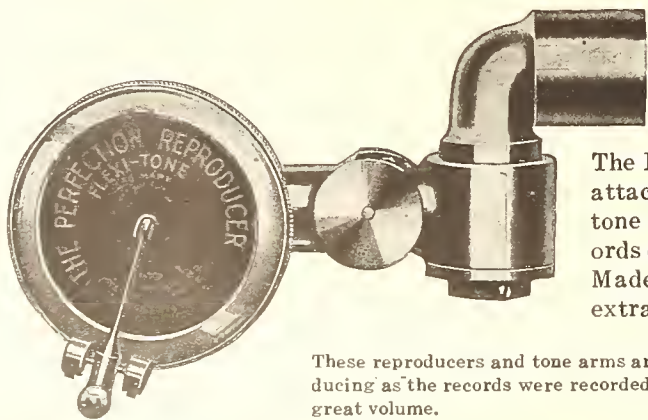

**Manufacturers—
Jobbers—
Dealers—**

The Perfection Flexitone reproducer No. 7 attached to the Perfection ball-bearing tone arm No. 4 plays all lateral cut records on all types of Edison Disc Machines. Made in nickel and 24 carat gold finish, extra fine quality disc.

These reproducers and tone arms are the very finest made, mechanically—reproducing as the records were recorded in the recording room—clarity of sound with great volume.

WRITE FOR DESCRIPTIVE CATALOG AND PRICES

Manufactured by

**New England Talking Machine Co.
16-18 BEACH STREET BOSTON, 11, MASS.**

DISTRIBUTORS:

CALIFORNIA
San Francisco—Walter S. Gray Co.
COLORADO
Denver—Denver Dry Goods Co.
GEORGIA
Atlanta—Phonographs, Inc.
IOWA
Des Moines—Harger & Blish
MASSACHUSETTS
Boston—Pardee-Ellenberger Co.

MISSOURI
St. Louis—Silverstone Music Co.

NEBRASKA
Omaha—Shultz Bros.

NEW YORK
Albany—American Phonograph Co.
New York—The Phonograph Corp. of Manhattan

OHIO
Cleveland—The Phonograph Co.

PENNSYLVANIA
Pittsburgh—Buehn Phono. Co.
Philadelphia—Girard Phono. Co.

UTAH
Ogden—Proudfit Sporting Goods Co.

VIRGINIA
Richmond—C. B. Haynes Co., Inc.

**Factory Representative—Louis A. Schwarz
1265 BROADWAY, NEW YORK, N. Y.**

Christmas business as having been quite good, both in wholesale and retail ends, this being largely due to the special selling offers which the Pathé made during the season. Mr. Ainslie, on the whole, is quite optimistic over the outlook for 1921.

A Fine Holiday Window

One of the prettiest windows during the holiday season was that of Frank S. Horning, at 22 Boylston street, where a beautifully illuminated and decorated tree attracted considerable attention. Tastefully done up were groups of records scattered about the window, a quick reminder of what ought to prove desirable Christmas gifts. Mr. Horning had a good trade, especially during the evenings.

Herbert Shoemaker's Enjoyable Vacation

Herbert Shoemaker, of the Eastern Co., has returned from Philadelphia and Camden, where he has been spending his Christmas vacation, much of the time being spent with his family. The Eastern Co.'s Christmas business made a

THE TRADE IN BOSTON AND NEW ENGLAND—(Continued from page 102)

good showing and the whole establishment is keen on a big improvement during January.

Looks for Big January Business

Joseph Burke, of the Musical Supply & Equipment Co., spent a part of the holidays at Atlantic City, whither he went with Mrs. Burke for a vacation following a busy season. He returns to his work much benefited by the change. He reports some excellent prospects in the Sonora line and he is looking for a good January business. Mr. Burke is taking a short trip into Connecticut in a few days.

PLANNING NEW STORE CHAIN

United Phonograph Stores, Inc., Chartered Under Delaware Laws at \$1,000,000 to Deal in Talking Machines at Retail

BOSTON, MASS., January 4.—The United Phonograph Stores, Inc., incorporated in Delaware for \$1,000,000, for the present has its offices in this city at 185 Devonshire street, though the fiscal department is in New York. It is the purpose of this concern to operate a chain of talking machine stores, and already Richard M. Nelson, first vice-president of the company, and remembered as lately with the Beacon Phonograph Co., reports that five stores in New England have linked up with the concern. In fact, it is New England which will first be combined in this consolidation of retail stores.

The officers of the company are: President, John A. Easton; first vice-president, Richard M. Nelson; second vice-president, Arthur L. Logan, who also has been connected with the Beacon in the capacity of secretary; secretary and assistant treasurer, Adolph O. Moss; treasurer, Samson D. Whittimore. The board of directors consists of these five and Charles Gomprecht, of New York, former treasurer of the Times Square Auto Supply Co. and former chain store organizer of the Keystone Tire & Rubber Co.

BEACON AFFAIRS BEING ADJUSTED

Walter J. Barris, Hardwood Dealer, Is Assignee and Hopes to Settle Claims Outside of Court —Book Assets Said to Be \$58,000

BOSTON, MASS., December 30.—At a meeting of some thirty of the creditors of the Beacon Phonograph Co., held at the factory in Somerville, Walter J. Barris, of the Barris-Fralick Co., dealer in hardwoods in Charlestown, and the third largest creditor of the Beacon, was selected to be assignee, and it was the consensus of opinion that it would be far more advantageous to all concerned to close out the business as soon as possible and settle up its affairs between themselves rather than proceed through the bankruptcy courts, which, it is claimed, would involve extra and unnecessary expense.

In all there are 114 creditors. The two largest are reported to be the Old Colony Trust Co., which, it is understood, loaned money to the Beacon to the extent of \$21,000, and the Palmer Parker Co., lumber dealer, whose claim is for \$4,000. That of the Barris-Fralick Co. is for \$3,000. Some of the smallest creditors have claims running from \$5 to \$10.

It is claimed that the Beacon represents an investment of some \$65,000; that the book assets stand at \$58,000, but may eventually represent quite a shrinkage; and the accounts receivable are placed at \$30,000, but these, too, may suffer a shrinkage, as it is understood many machines already out are being returned. As there are many machines at the factory in process of construction it is the belief of the assignee, concurred in by the creditors present at the meeting, that these should be finished and disposed of and thus turned into cash.

It is the hope of those creditors attending the meeting that all having claims against the Beacon Co. will assent to the suggested plan

of liquidating the business and not pressing their claims through the bankruptcy court.

"Buy Now" Move Is Making Strides

The "Buy Now" circular, brought out by the Cleveland Chamber of Commerce and sent throughout the country by national trade organizations, has met with success and is being adopted by Chambers of Commerce in other cities.

The declaration, prepared by the Manufacturers' and Wholesale Merchants' Board, the Retail Merchants' Board and the Industrial Development Committee, urges all to buy conservatively, cautiously, but to buy at the present time.

It declares that the disinclination of merchants to buy has brought the business of the country to a standstill and points out that failure to purchase now will bring about a buying wave later, which will result in a shortage in merchandise and an advance in prices.

REPRESENTS THE MAGNAVOX

TERRE HAUTE, IND., January 4.—John Jensen, owner of the Brunswick Shop, 527 Wabash avenue, has become the local agent for the Magnavox Telemegafone. He has been entertaining the citizens of Terre Haute.

THAU TO ATTEND VICTOR SCHOOL

George Thau, assistant secretary of the Blackman Talking Machine Co., Victor wholesaler of New York, will attend the next session of the Victor Salesmanship School, which will be held in Camden the latter part of this month.

KRAFT-BATES AND SPENCER INC.
NEW ENGLAND DISTRIBUTORS



Every Brunswick Sold Sells Others

A REAL customer is not one who buys a thing once, but one who would buy it again, if he had to do it over.

All Brunswick buyers belong to this class. Brunswick owners become enthusiastic about The Brunswick. They take delight in explaining its various features, particularly the Ultona.

Naturally they take pride in having something new, exclusive and different from the rest.

The Brunswick has created an army of recommenders who work unconsciously to make more sales. And they really feel that they are doing others a favor in praising it. Thus Brunswick satisfies the real test of worth—the product stays sold.

KRAFT-BATES & SPENCER, Inc., 156 Boylston Street, BOSTON, MASS.
NEW ENGLAND DISTRIBUTORS

TONOFONE, VICTROLENE, MOTROLAS, RECORD FLASHER
Steel Needles Jewel Points Albums Record Brushes Khaki Covers

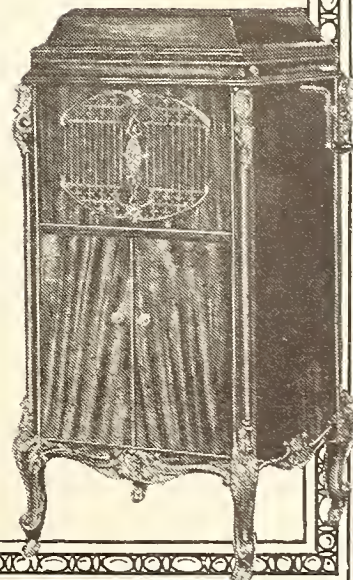

All Grey Gull Records 85c. Retail

Not merely a few, but the ENTIRE LINE---

A regular STAMPEDE to get them at this price. Write nearest distributor. See List below.

Our output has been doubled, then tripled. And now we are doubling it again to fill the orders.

Price COUNTS nowadays, as Grey Gull Dealers can testify. A dollar for records is too high---it's a War Price. 85 cents is Normal---and the Public BUYS. Try it and see.

Grey Gull Records are recorded and manufactured complete in one plant by a conservative, strongly financed concern. They are not tied to any phonograph. Send in a trial order to nearest distributor.

Dance Hits

- MARGIE—Fox-trot, Selvin's Novelty Orchestra } L-1036
10-in.
- BIDDY—Fox-trot.....All Star Trio } 85c
- FEATHER YOUR NEST—Fox-trotBanjopators } L-1037
I'D LOVE TO FALL ASLEEP } 10-in.
AND WAKE UP IN MY } 85c
MAMMY'S ARMS—Fox-trot, }
Banjopators }
- WHISPERING—Fox-trot, } L-1031
Joseph Samuels' Music Masters } 10-in.
- KISMET—Fox-trot, } 85c
Joseph Samuels' Music Masters }
- GRIEVING FOR YOU—Fox-trot, } L-1038
Banjopators } 10-in.
- BEAUTIFUL ANNABEL LEE— } 85c
Fox-trotBanjopators }
- JAPANESE SANDMAN—Fox-trot, } L-1032
Joseph Samuels' Music Masters } 10-in.
- LOUISIANA—Waltz, } 85c
Grey Gull Dance Orchestra }
- DOLLY, I LOVE YOU—Fox-trot, } L-1030
All Star Trio } 10-in.
- DANCE-O-MANIA—Fox-trot, } 85c
Gilt Edge Four }
- WHOSE BABY ARE YOU—Fox-trotAll Star Trio } L-1029
LAST PART OF EVERY PARTY } 10-in.
(from "Irene"), introducing Castle } 85c
of DreamsAll Star Trio }
- CARESSES—Fox-trot ..Banjopators } L-1034
I'VE GOT THE BLUES FOR MY } 10-in.
OLD KENTUCKY HOME—Fox-trotBanjopators } 85c

Song Hits

- BROADWAY ROSE, } L-2043
Sung by Charles Harrison } 10-in.
- BLUE DIAMONDS, } 85c
Sung by Henry Burr }
- FEATHER YOUR NEST, } L-2044
Sung by Charles Harrison } 10-in.
- WHEN HE GAVE ME YOU } 85c
(Mother of Mine), }
Sung by Henry Burr }
- AVALON....Sung by Ernest Hare } L-2040
LIKE WE USED TO BE. Sung by } 10-in.
Charles Hart and Louise Terrell } 85c
- TRIPOLI, Sung by Charles Hart and } L-2034
Louise Terrell } 10-in.
- HIAWATHA'S MELODY OF } 85c
LOVE, Sung by Charles Hart and }
Louise Terrell }
- MY LITTLE BIMBO DOWN ON } L-2015
THE BAMBOO ISLE, } 10-in.
Sung by Billy Jones } 85c.
- TIDDLE-DEE WINKS, }
Sung by Billy Murray }
- THE MOON SHINES ON THE } L-2030
MOONSHINE, } 10-in.
- JINGA-BULA-JING-JING, } 85c
Sung by Billy Jones }
- LET THE REST OF THE WORLD } L-2017
GO BY.....Sung by Henry Burr } 10-in.
- WOND'RING..Sung by Charles Hart } 85c
- I'LL BE WITH YOU IN APPLE } L-2020
BLOSSOM TIME, } 10-in.
Sung by Henry Burr } 85c.
- LITTLE TOWN IN THE OULD }
COUNTY DOWN, }
Sung by Henry Burr }

Distributors

- American Phonograph Co.
17 N. Ionia Ave.,
Grand Rapids, Mich.
- Associated Furniture Manufacturers
1209 Washington Ave.,
St. Louis, Mo.
- Joseph Barnett & Co.
218 Fourth Ave., East,
Cedar Rapids, Iowa
- Capital Paper Company
South St.,
Indianapolis, Ind.
- Cole & Dunas Music Co.
54 W. Lake Street,
Chicago, Ill.
- Excelsior Music Co.
Cape Girardeau, Mo.
- Fuller Phonograph Co.
101 N. Water Street,
Wichita, Kansas
- Grey Gull Records, Inc.
295 Huntington Ave.,
Boston, Mass.
- National Phonograph Co.
518 Penn Avenue,
Pittsburg, Pa.
- Scott Register Co.
New Bern, N. C.
- Seidel Music Publishing Co.
Indianapolis, Ind.
- T. & H. Specialty Co.
Charleston, W. Va.
- United Music Stores
619 Cherry Street,
Philadelphia, Pa.



INCORPORATED

295 HUNTINGTON AVENUE, BOSTON, MASS.

C. R. ELY WITH REMINGTON CORP.

Joins That Organization as Western Sales Manager—Has Had Wide Experience

Everett H. Holmes, sales manager of the Remington Phonograph Corp., has announced the appointment of Clifford R. Ely as Western sales manager of the company. Mr. Ely is one of the best-known members of the wholesale traveling fraternity, and will visit the talking machine trade throughout the West. For many years he was a member of the Columbia Co. traveling staff and numbers among his friends



C. R. Ely

dealers from coast to coast.

As the Western sales manager of the Remington Phonograph Corp., Mr. Ely's long and successful acquaintance with the industry will be utilized to excellent advantage, as he is in a position to render Remington dealers efficient service and co-operation.

A NEW STORE IN KOKOMO

KOKOMO, IND., January 4.—W. S. Barringer, for several years head of the purchasing department of the Stewart Talking Machine Co. at Indianapolis, has opened a Victor shop at 304 North Main street. The name of the shop is "Barringer's." It is equipped with four large booths and record shelves with a capacity of 10,000 records.

OPENS STORE IN CANON CITY, COL.

The Brunswick-Balke-Collender Co., through its Denver branch, has established a new Brunswick phonograph store in Canon City, Col., with W. E. Gillespy and C. E. Callison in charge.

TO RECORD WABASH COLLEGE SONGS

Receipts Form Sale of Records to be Turned Into College Endowment Fund

CRAWFORDSVILLE, IND., January 4.—Songs of Wabash College are to have national circulation through the medium of the phonograph. The records will be sold without profit to the writers of lyrics and music, all financial returns going to the endowment fund of old Wabash. It is now sought to increase the endowment fund by \$2,000,000.

Wabash is a Presbyterian college founded in 1832. The institution has always given much encouragement to music, especially during the last twenty years. A song now as much a part of the college as the campus is "Old Wabash," written in 1899 by two young men now held in hearty esteem by the alumni. At that time Carroll Ragan, at present an official of a New York financial house, and Edwin Meade Robinson, of the Cleveland Plain Dealer and nationally known as a poet, were college chums at Wabash. Ragan composed the music and Robinson wrote the words of the song that was used for the first time at the inauguration of Dr. William P. Kane as president of the college.

This song, as well as Wabash's "War Song" and "Alma Mater," is to be sent forth to cheer the hearts of alumni and friends through the universally popular phonograph, according to the plans of those who have set themselves to the task of giving the school an endowment that will increase the educational scope of the school until 500 young men can be accommodated through additional facilities.

THAT PHANTOM CHURCH CHOIR

CHAMPAIGN, ILL., January 5.—The mystery of an invisible choir which has stirred the congregation of a Paxton (Ill.) Lutheran Church was solved to-day when it became known that Clarence Lundeen, a sixteen-year-old student, had

BRUNO

Can dealers in other lines honestly figure their stock one hundred per cent on the dollar? You can, Mr. Victor Dealer.

BRUNO

been experimenting with a wireless telephone.

Lundeen connected a phonograph with a wireless sending-set in his workshop, then he transmitted the music produced to a large horn connected with an amplifier which was concealed in a tree just outside the church.

The church was in direct line with the sound from the horn, and for this reason the music seemed directly above the congregation. For several days the "phantom music" had been the talk of the town.

The Del Signo Song Shop Co., consisting of R. H. and Vernon Kellogg and L. D. Cole, has opened a new music and talking machine store at Third and Spurgeon streets, Santa Ana, Cal.

FIBRE—Nothing is so beautiful, so comfortable, so practical, so economical—FIBRE

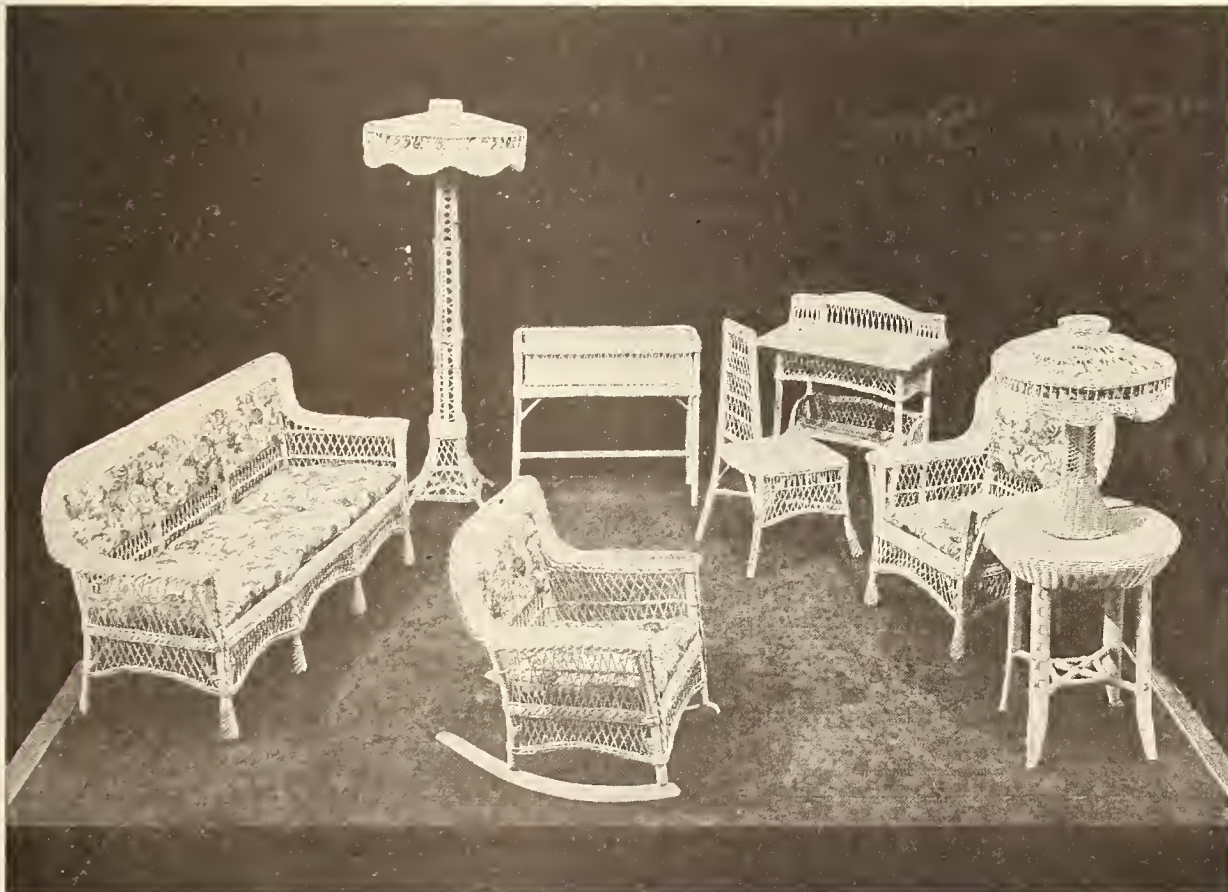

A Suggestion for Your Reception Room—ENTIRE SUITE for \$210.00
Several Hundred Pieces to Choose From

Your wholesaler will help you fit up your establishment with this up-to-date furniture. If he doesn't, write us. These Shattucks are the thing for you, and we'll prove it. Ask for our suggestion for your booth.

THE SHATTUCK FIBRE FURNITURE COMPANY

Makers of the line of Masterpieces

10615 BROADWAY

::

::

CLEVELAND, OHIO

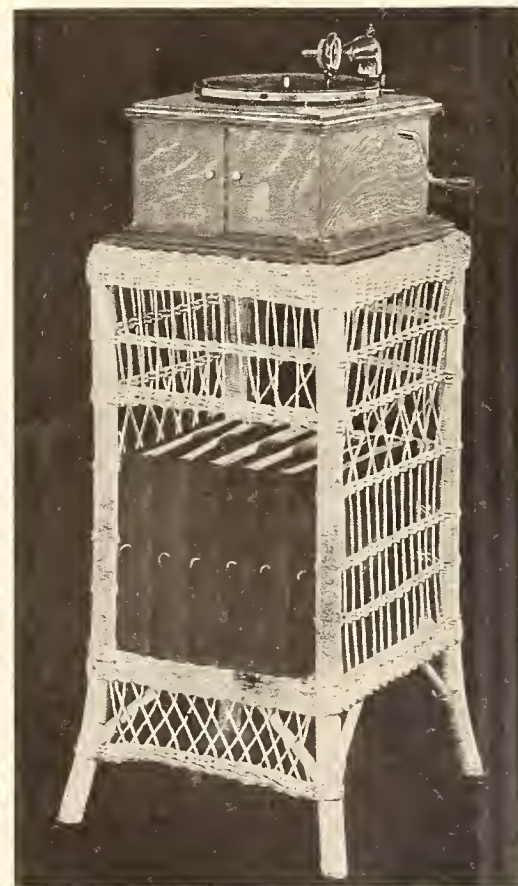

SHATTUCK FIBRE STAND FOR VICTROLA IV

Finished in Oak or Mahogany, \$12.00

For Victrola VI, \$13.00. For Victrola IX, \$15.00

These hand-woven fibre stands afford a pleasing and practical element in house furnishing. Style, too, favors this stand, as the demand for hand-woven furniture is increasing very rapidly. Being wire reinforced, these stands are practically indestructible. The many uses to which this stand can be put after the small machine is traded is another advantage. Ask your distributor.

Edison Message No. 88

We point with pride to the record that, while most manufacturers were boosting their prices, on the slightest pretext, to 100 per cent and more in many instances, Thos. A. Edison permitted the price of Edison phonographs to advance only 15 per cent, including War Tax, since 1914.

“Edison Stood the Gaff”

THOMAS A. EDISON, Inc.

ORANGE, N. J.

“Darling” and “Missy,” the two latest fox-trots played by Art Hickman’s Orchestra, will keep the crowd dancing into your store as long as you have one of these records left. A-3334

**Columbia Graphophone Co.
NEW YORK**



WANT UNDISTRIBUTED EARNINGS TAX

Committee on Federal Taxation of National Association of Credit Men Makes Important Recommendations Regarding New Tax Plans

Setting forth that the adoption of their plan would result in equalization of distribution of taxes on earnings, the Committee on Federal Taxation of the National Association of Credit Men have issued a book entitled “The Undistributed Earnings Tax—A Plan to Tax the Current Year’s Earnings of Corporations Not Distributed.” The proposed new tax, it is explained in the text, was designed to replace the excess profits tax. Copies have been sent to members of Congress and thousands of business men throughout the country.

The prime recommendations contained in the committee’s book are:

1. Elimination of the excess profits tax.
2. Elimination of the corporation income tax.
3. Dividends from current earnings to be subject to the normal tax in the hands of the individual.
4. Substitution of a corporation undistributed earnings tax at graduated rates.
5. Dividends which are paid from earnings of prior years on which the corporation has paid the undistributed earnings tax not to be considered as income to the individual shareholder. Dividends may not be paid from surplus until earnings of current year have first been used for that purpose.

6. Adjustment of rates of taxation on personal incomes, both normal and surtax, to meet the requirements of the budget from income taxes.

The committee argues that the changes recommended would make not only for a more equal distribution, but would make taxation of this class more simple and equitable. The plan, it says, involves simply an extension of the income tax principle and therefore does not involve necessity to set up new tax machinery. It is further contended that the changes outlined will remove the penalty that rests on small shareholders in corporations and encourage investment on the part of larger groups, thereby contributing to the financial and economic stability of the country.

NEW DESIGN ON SONORA SIGN

The latest design to be used in the Sonora electric sign, on the corner of 42nd street and Fifth avenue, New York, features one of the new period models, viz., a Gothic Jr. Notre Dame, in a room overlooking a wintry landscape. A basket of bright-hued flowers produces a color effect which adds materially to the general attractiveness.

The Jackson Phonograph Co., formerly located in Loveland, Col., has moved its business to new quarters at 39th and Walnut streets, Denver, Col. C. I. Jackson is manager of the company.

NEW VICTROLA 80 IS ANNOUNCED

Latest Model, of Floor Type, Is to Be Listed at \$100 Retail—Welcome Christmas Surprise for Victor Wholesalers and Dealers

The Victor wholesalers and dealers throughout the country had a Christmas surprise in the form of an announcement by the Victor Talking Machine Co. of a new Victrola, No. 80, a full cabineted instrument of attractive design embodying all the recognized Victrola features and listed at \$100 retail.

There have been, of course, rumors about the trade of the coming appearance of the new



New Victrola 80

Victrola, but the announcement of a new instrument just at this time is held to be most welcome. Victrola 80 is 38½ inches high, 18¾ inches wide, and 20¾ inches deep. It is equipped with all the recognized Victrola features, including a double spring file drive motor of the latest model, an automatic brake and speed regulator, and an automatic speed indicator. All exposed metal parts are nickel plated.

The new Victrola will be manufactured in the usual variety of finishes, but at the outset will be available only in mahogany, English brown and American walnut. Arrangements have been made to ship available quantities of the new model to distant Western points first, and to follow the usual West to East shipping schedule.

The man who serves only himself is slave to a greedy master.

SEND FOR ILLUSTRATED PRICE LIST AND FREE SAMPLE
“GLOBE” TRANSFER NAME PLATES
DEALERS EVERYWHERE APPLY THEM ON PHONOGRAPHS, PIANOS, ETC.
GLOBE DECALCOMANIE CO.
263 SUSSEX ST., NEWARK, N. J.

The KENT MASTER ADAPTER



plays ALL RECORDS at their best on the EDISON DISC PHONOGRAPH



Write for particulars concerning this, the best known and largest seller of its kind in the market. Attractive prices and terms will be quoted you.

WE specialize in attachments for Edison and Victor machines; also soundboxes, diamond, sapphire and steel needles. Drawn brass tone arms made to order. Tube and pipe bends of all kinds successfully executed.

F. C. KENT CO. :: Specialty Manufacturers
IRVINGTON, N. J.

whose phonograph accessories “win their way by their play”



We are able to offer to the Phonograph Industry a complete phonograph line, including machine and records.

The Aeolian-Vocalion

There are only six such lines in the country, and of the six we believe the Aeolian-Vocalion to be the one most profitable for the dealer, because:

- 1st, It is a quality line from start to finish.
- 2nd, The merchandise is backed by the whole strength of the Aeolian Company (the foremost manufacturers of musical instruments in the world).
- 3rd, A distributor, ourselves, who has proven not only his ability but his willingness to serve the industry and to help it in every possible way.
- 4th, Our sales policy—Give each dealer room to expand and develop his Aeolian-Vocalion business, and where he creates a demand let him enjoy the fruits of his labor; help the dealer get more business instead of establishing new dealers who encroach on territory developed by the old one.
- 5th, Our job—To Sell Aeolian-Vocalion goods *for* the dealer, rather than *to* the dealer.

PHILADELPHIA SHOWCASE CO

127 North 13th Street
PHILADELPHIA

2002 Jenkins Arcade
PITTSBURGH

"YOUR PHONE IS YOUR STOCK SHEET."

The Trade in PHILADELPHIA and LOCALITY

PHILADELPHIA, PA., January 3.—The prophecy of 1920 has not been fulfilled so far as the holiday trade is concerned. During almost the entire year the trade has been skeptical and has been looking for a slump in business. And especially was there uneasiness felt last Summer that by Fall and this Winter business was going to be in a depressed state and many dealers looked for a very dull holiday business.

The result has been just the opposite. The holiday business this year was extremely good. With most firms it equaled that of last year, and, in fact, the entire year of 1920 was a record breaker. The Victor Co. has recovered itself nicely and has made a most liberal distribution of both machines and records to jobbers in this city, as well as throughout the country.

The talking machine dealers in every line are starting the new year with renewed energy and should make a resolution to not let pessimism take hold of them in any way. The manufacturers have left the firms well stocked to enter the new year, in spite of passing through an active holiday trade.

The dealers spent the week between Christmas and New Year in getting their stocks into good shape. The stores never looked so attractive during the holidays and to a great extent this has been due to the Penn Phonograph Co. and its Victor operatic figures. These figures were used for decorative purposes by almost all the Victor dealers in this city and by certain of them the entire line was shown, including the John Wanamaker store, which had both a Market street and a Chestnut street window display of them; by B. B. Todd, who used a full set to decorate his Chestnut street window; by H. A.

Weymann & Son, who had a complete set on display, and various other firms who had partial displays. The Penn Victor dogs were also used by many of the firms.

The stores are looking attractive at present. The exterior decoration of the entire Piano Row, painted in a pink-gray effect, all the woodwork being done in green bronze, is about completed and the Row now looks most attractive.

To Distribute Vocalion Line

The most important change that has to be noted with the first of the year is the relinquishing of the wholesale representation of the Sonora phonographs by the Philadelphia Show Case Co., which in their stead has taken the representation here of the Aeolian Co.'s product—the Vocalion machine and the Vocalion records. With this machine the company will have about double its present Sonora territory, and its distribution has been placed in charge of J. H. Burkart, formerly of the firm of Blake & Burkart. Mr. Burkart has had considerable experience in the business and for some time has been connected with the Philadelphia Show Case Co.

Getting Emerson Goods

The Emerson Philadelphia Co. reports that it is in excellent shape and is getting goods right along and in large quantities from the Emerson factories, so that the recent financial reverses that came to that company did not seem to feaze the Emerson dealers in this territory. Manager Harry Fox, the head of the Emerson Philadelphia Co., says that he is quite delighted with the way the dealers in the Emerson have stuck to him.

During December Mr. Fox has had his new

establishment at 810 Arch street fully renovated. He has ample space now and believes he is going to do a very big business. He has had the second floor nicely arranged in offices, with elegant furnishings, and has built for himself an attractive private office.

Good Season for the Pathé

The Pathé Co. reports that it had a remarkably good holiday business and much greater in volume than it had expected, although it was prepared and was able to take good care of all orders that came in. Its December business compared more than favorably with that done last year, which can be confirmed by all the dealers who handle the Pathé here.

The Pathé Co. had its store most attractively decorated for the holidays, the work having been done in a most artistic way by S. Glover Flood, a son of Mr. Flood, who is looking after the Pathé jobbers here. Mr. Flood, Jr., has been associated with Walter L. Eckhardt ever since the latter began handling the Pathé in this territory and is acting as a salesman in the South Jersey and Pennsylvania territory of the firm. Among the recent visitors to the Pathé offices were M. Kowitz, of Easton, Pa., and O. K. Fink, of Pottstown.

T. P. Ratcliff a Visitor

T. P. Ratcliff, of the Aeolian Co., in charge of the record department of that firm, visited Philadelphia between the Christmas and New Year holidays.

Gimbel Bros. are still continuing their drive on talking machines. They gave an attractive concert at their store on New Year's Day, in

(Continued on page 110)

Mr. Dealer

A NEW YEAR different in conditions and methods has begun. The fulfillment of promised factory production, combined with able distribution and strong retail methods, will make this

A Prosperous Victor Year

This Organization Is Ready

Are You?

The Louis Buehn Company
OF PHILADELPHIA

THE TRADE IN PHILADELPHIA AND LOCALITY—(Continued from page 109)

which a number of artists at present appearing in Philadelphia took part.

Why Blake & Burkart Are Pleased

Herbert Blake, the head of the firm of Blake & Burkart, is highly elated over his holiday business. It was much better than he had anticipated and it was the biggest holiday business his firm has thus far enjoyed. In fact, the entire year of 1920 was very good for this firm. The firm released the lease they had on the store, which they operated as a branch, at 204 South Eleventh street, and where the Columbia was handled exclusively. Instead they have leased a part of the building and the basement, which they will use to store stock and do repair work.

The Columbia Holiday Business

The Columbia Co. had a very satisfactory holiday business and did considerably better than it had anticipated; probably not quite as good as last year, but it must be remembered that the firm had a wonderful holiday business in 1919, being one of the few distributors in this territory who were able to keep their dealers well supplied with both machines and records.

Among the recent visitors to the Columbia offices here were Robert Porter, field manager of the Columbia; H. H. Brown, of West Chester; B. Freeman, of Chester; J. H. Bartlett, of Wilmington; A. Giacobbi, of Hammonton, N. J.; S. P. Speigel, of Woodbury, N. J.; A. J. Eberhard, of Camden; Mr. Thompson, of Thompson & Swartley, Souderton, Pa.; A. Wolson, of Chester; W. E. Mingin, of Medford, N. J.; Mr. Anderson, of the Columbia Grafonola Shop, of Wilmington, Del.; T. W. Dubois, of Paulsboro, N. J.; N. L. Kaplin, of Burlington, N. J., and H. C. Jarvis, of Millville, N. J.

The Columbia Co. this week will have all its salesmen together, both in and out of town, for a conference to lay plans for the promotion of the work in the new year.

The Artistic Buehn Building

The Louis Buehn Co. has completed all the improvements in its local headquarters which could not be made earlier on account of the leases of certain tenants. All through the department hardwood floors have been placed, as well as a new stairway leading to the Victor period model room, which is the front room on the second floor. Handsome rugs that conform to the general decorations have been laid and all the offices have been finished in mahogany.

The period model room is particularly handsome and it has not yet been finished, for the reason that the designers wish to wait until they

get all the models in place before they supply the furniture. The Buehn Co. has only about a half-dozen of these models on hand up to this time, but it expects to have a complete line before the month is out. When finished this room will be solely for the display of these models for the benefit of the retailers who will not have the opportunity to carry a full line of them, but who can call at the Buehn establishment with their customers and let them see them in the artistic environment that Mr. Buehn has provided. Any visitors to Philadelphia within the next six months would do well to pay a visit to the Buehn establishment, if they want to see one of the handsomest talking machine stores they have ever seen.

E. V. Martin's New Quarters

The E. V. Martin firm will in a few days close its store at 224 South Fifty-second street, having taken a new corner store at the southwest corner of Fifty-second and Irving streets, where they will have a much better opportunity to display their handsome stock. Mr. Winders, who is manager of the store, states that in their former home, being in the middle of the block, they had poor opportunities to make a window display, in comparison with several of their near neighbors, but in their new home they will have both attractive windows on Fifty-second street and also on Irving street.

Victrola Display at Estey Hall

The Estey Co., of this city, is devoting the entire floor space at "Estey Hall" to a display of Victrolas. Sound-proof rooms, artistically arranged, have been installed to accommodate the increasing number of patrons of this institution. This floor is entirely given over to machines and the showing is an impressive one. The record department remains on the first floor.

A Compliment From an Authority

The display of Penn operatic figures in the windows of B. B. Todd, on Chestnut street, had universal appeal, but its particular advertising value was noted and appreciated by an advertising expert in no way connected with the talking machine trade. Mr. Todd was recently in receipt of a letter of appreciation from William Neville, assistant advertising manager of the Philadelphia Record. Mr. Neville's expert opinion of this display is summed up in one quoted sentence from his letter to Mr. Todd, "I do not think in all my experience I have ever had the pleasure of gazing upon a window which carried as much real attractiveness as your window does."

DECALCOMANIA

Name Plates for Talking
Machines, Pianos, etc.

High Class Workmanship

Write us for further information

National Decalcomania Co.
220-230 N. 60th St., Philadelphia, Pa.

THE WINDOW AS A SALES MAKER

Excellent Work Achieved by the Talking Machine Co., Philadelphia, for the Jones Motrola

PHILADELPHIA, PA., January 3.—The Talking Machine Co., Victor dealers of this city, has featured the Jones Motrola in a particularly attractive window display in several of its seven retail stores



How Jones Motrola Was Featured

in this city. In the window shown herewith the entire space has been given over to a display of Motrolas and features the five-dollar monthly payment plan which it is using and offering in selling the Motrola. The drive on the five-dollar monthly payment plan for the Motrola lasted an entire month. The results are reported to have been remarkably successful.

FINDS THE TRADE OPTIMISTIC

Rayburn Clark Smith Brings Back Excellent Report From Recent Business Trip

PHILADELPHIA, PA., January 3.—Rayburn Clark Smith, president of the Unit Construction Co., of this city, recently completed a tour of twelve of the principal cities of this country in the interest of Unico equipment. On this trip Mr. Smith interviewed over 100 dealers and some seventeen jobbers. In almost every instance Mr. Smith found the dealer or jobber to be enthusiastic over the coming year in spite of the fact that business had temporarily quieted somewhat. Mr. Smith furthermore found that the expressions of optimism were being backed up by energetic plans that were being laid by these same jobbers and dealers for the advancement of their businesses during the coming year.

Turning from general trade conditions, Mr. Smith touched upon the 1921 outlook for the large organization of which he is chief executive. Mr. Smith said: "Whereas the first few months of the coming year may not quite equal our exceptional record of last year, I am confident that business during the balance of the year will be exceptionally good and we are laying our plans accordingly."



WEYMANN 1108 CHESTNUT ST. PHILADELPHIA, PA.
ESTABLISHED 1864

Victor
Wholesale
Distributors

Victor Supreme

The Victor dealer who devotes his entire energy to the advancement of Victor merchandise in his Talking Machine Department will find that in turn his entire business will be greatly benefited.

At Your Service

H. A. WEYMANN & SON, Inc.
1108 Chestnut Street Philadelphia, Pa.

Q. R. S.
PLAYER
ROLLS

WEYMANN
KEYSTONE STATE
STRING
INSTRUMENTS

Keystone Die-Casting Co.
Norristown, Pa.

ALFRED C. RANTSCH
Pres. and Gen. Sales Mgr.

E. J. W. RAGSDALE
Treas. and Gen. Mgr.

IMPORTANT ANNOUNCEMENT

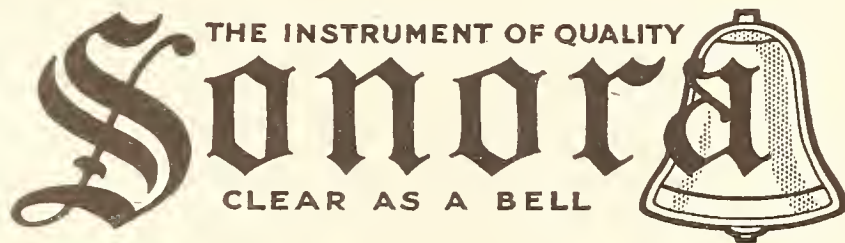

takes pleasure in announcing the appointment of

THE SONORA COMPANY OF PHILADELPHIA

OF 1214 ARCH STREET, PHILADELPHIA, PA.

as distributor in the following territory:

EASTERN PENNSYLVANIA, MARYLAND, DELAWARE,
DISTRICT OF COLUMBIA AND VIRGINIA

Mr. E. S. White, Vice-President of the new company, formerly in charge of sales of Sonora in this territory, will direct the sales in the new organization.

* * * * *

Also the

SCHROEDER PIANO COMPANY

OF 820 LIBERTY STREET, PITTSBURGH, PA.

as distributor for Sonoras in

WESTERN PENNSYLVANIA AND WEST VIRGINIA

THE TRADE IN PHILADELPHIA AND LOCALITY—(Continued from page 110)

THE SONORA CO. OF PHILADELPHIA

New Concern of That Name Chartered Under Laws of Delaware to Act as Distributor of the Sonora Line in Eastern Pennsylvania

PHILADELPHIA, PA., January 5.—The Sonora Co. of Philadelphia has just been incorporated under the laws of Delaware, with capital stock of \$500,000, for the purpose of manufacturing and dealing in talking machines, the incorporators being given as T. L. Croteau, M. A. Bruce and S. E. Dill, all of Wilmington. This new concern has been formed for the purpose of taking up the wholesaling of Sonora phonographs throughout eastern Pennsylvania, Maryland, Delaware, District of Columbia and Virginia.

The new company will make its headquarters in Philadelphia at 1214 Arch street. Elmer S. White, formerly in charge of sales of Sonora in this territory, will be the active sales head of the new organization. He has already made a fine record in the distributing field. The Sonora

Co. of Philadelphia entered active business on January 1, 1921. Mr. White, by the way, was connected with the distribution here of the Sonora almost from the time it came to Philadelphia and is also a proprietor of a talking machine store at 4844 North Broad street. Mr. White is a Sonora enthusiast and will most certainly do an excellent business with this excellent machine. All the dealers who now handle the Sonora here are highly enthusiastic over its popularity, so that his work is going to be more or less easy. F. H. Owens, who has long been associated with the Philadelphia Show Case Co., has resigned to accept the position as assistant to Mr. White.

LIT BROS. FEATURE BRUNSWICK

PHILADELPHIA, PA., January 4.—Lit Brothers, one of the largest department stores in Philadelphia, recently secured the agency for the Brunswick phonograph. Their phonograph department, one of the largest in this part of the country, is fully

equipped to handle this valuable addition, and the success they are meeting with is beyond their expectations.

BECOMES STEGER DISTRIBUTOR

E. V. Martin Secures the Steger Phonograph Representation for State of Pennsylvania

PHILADELPHIA, PA., January 3.—E. V. Martin, of 1025 Arch street, has been appointed distributor of the Steger line of phonographs for the State of Pennsylvania and surrounding territory. This concern has a well-established whole sale organization and is well experienced in the distribution of talking machines in this section of the country. In conjunction with the Steger phonograph the Gennett record will also be distributed as well as the Tonofone needle.

H. C. Russell has opened a new talking machine store in Fillmore, Cal., where he features the Brunswick phonograph.

Why Is the Penn-Victor Dog a Success?

FIRST—Because the Penn-Victor Dog advertises the Victor Talking Machine and Victor Records, the best talking machine and records on the market.

SECOND—Because the Penn-Victor Dog is recognized as the dog in the trade-mark "His Master's Voice." Everybody admires the dog and wants it if it can be had.

THIRD—Because the Penn-Victor Dog establishes a personal relation between the dealer who gives it away, his name being cast in the pedestal, and the person receiving it.

FOURTH—Because dealers in all parts of the United States, England, Canada, Bermuda, Australia, Hawaii, Brazil, Argentina and Central America have used the Penn-Victor Dog and many have written us telling of its successful use as an advertising feature.

FIFTH—Because the Penn-Victor Dog affords the dealer the opportunity to make a complete survey of his territory through the use of the questionnaire as shown in the illustration, a dog being given to those persons filling out the questionnaire.



Questionnaire

VICTROLA DEPARTMENT

R. L. FOORD FURNITURE CO., Wilmington, Delaware

Do you own a Talking Machine (yes or no).....
What Make
Is it in good playing condition (yes or no).....
Have you ever thought of exchanging it for a newer or larger model (yes or no).....
Do you receive the Victor Record Supplement each month (yes or no).....
Have you ever thought of buying a Victrola (yes or no).....
Name
Address
City

The questionnaire shows you who has a Victrola; who has not a Victrola; who has the desire for a Victrola; who has a machine of another make and wishes to exchange it in part payment for a Victrola; whose name is not on your mailing list for the monthly supplement, but wants it there.

- Atlanta, Ga.....Elyea Talking Machine Co.
Baltimore, Md.....Cohen & Hughes
Boston, Mass.....Oliver Ditson Co.
Birmingham, Ala.....Talking Machine Co.
Buffalo, N. Y.....Buffalo Talking Machine Co.
Chicago, Ill.....Chicago Talking Machine Co.
Cleveland, Ohio.....Cleveland Talking Machine Co.
Denver, Colo.....The Knight-Campbell Music Co.
El Paso, Tex.....W. G. Walz Co.
Honolulu, T. H.....Bergstrom Music Co., Ltd.

- Indianapolis, Ind.....Stewart Talking Machine Co.
Jacksonville, Fla.....Florida Talking Machine Co.
Memphis, Tenn.....Houck Piano Co.
Kansas City, Mo.....J. W. Jenkins Music Co.
Milwaukee, Wis.....Badger Talking Machine Co.
Minneapolis, Minn.....Beckwith-O'Neill Co.
Mobile, Ala.....Wm. H. Reynolds.
New Haven, Conn.....The Horton-Gallo-Creamer Co.
Newark, N. J.....Collings & Co.
New Orleans, La.....Phillip Werlein, Ltd.
New York City.....Emanuel Blout, C. Bruno & Son, Knickerbocker Talking Machine Co. New York Talking Machine Co. Ormes, Inc. Silas E. Pearsall Co. Louis A. Schwarz, Inc.

- Omaha, Neb.....Mickel Bros.
Philadelphia, Pa.....H. A. Weymann & Son.
Pittsburgh, Pa.....W. F. Frederick Piano Co.
Portland, Me.....Cressey & Allen, Inc.
Rochester, N. Y.....E. J. Chapman.
St. Louis, Mo.....Koerber-Brenner Co.
Toledo, Ohio.....The Toledo Talking Machine Co.
Washington, O. C.....Cohen & Hughes, E. F. Droop & Sons Co. Robt. C. Rogers Co.

Dealers not served by any of these distributors will be sold direct by us or we will charge through your preferred distributor if so requested.

PENN PHONOGRAPH COMPANY, Inc. 913 ARCH ST., PHILADELPHIA, PA.

Victor Distributors Wholesale Only

THE TRADE IN PHILADELPHIA AND LOCALITY—(Continued from page 111)

PHILADELPHIA SHOW CASE CO. VOCALION DISTRIBUTORS

Became Wholesale Representatives for That Line in Pennsylvania, Delaware, Southern New Jersey and Other Districts on January 1—Hold Sales Convention in New York

PHILADELPHIA, PA., January 4.—On January first the Philadelphia Show Case Co., at 127 North 13th street, this city, became official distributors for the Aeolian-Vocalion and Vocalion records for the State of Pennsylvania, Southern New Jersey and Delaware exclusively, as well as covering some territory in surrounding States.

This new deal represents one of considerable

tributing agency for the Vocalion and Vocalion records the sales staff of the company attended a convention at Aeolian Hall, New York, in order to become thoroughly familiar with the product. The convention opened on Tuesday, December 28, with an informal sales meeting in the morning at which Vocalion sales policies were explained. This was followed by a trip



Those in Attendance at Sales Conference of Philadelphia Show Case Co.

magnitude, for the Philadelphia Show Case Co. has made elaborate arrangements to handle the Vocalion line in a big way and to cover intensively the large territory committed to its keeping. In taking up the new line the company has relinquished distributing rights of the Sonora in this territory.

In addition to the preparations made in this city to not only feature the Vocalion energetically, but to provide for stocking and shipping facilities, the company recently perfected the arrangements of its Pittsburgh quarters in the Jenkins Arcade.

The Philadelphia Show Case Co. has for some months past been acting as distributor for the Melodee music rolls, and will continue and, in fact, develop its music roll business.

Just prior to officially taking over the dis-

tribution of inspection through the hall, and a special pipe organ recital.

After luncheon at the Republican Club the conventioners met in the artists' room at the hall and listened to addresses by F. L. Young and A. C. Berg, of Boston, who talked on retail sales, and H. G. Stoehr, who talked on motor construction. After dinner at the Claridge the party were guests of the Aeolian Co. at the performance of "Mecca" at the Century Theatre.

Wednesday was Melodee day, and the salesmen enjoyed a live sales talk by Geo. H. Bliss, general manager of Melodee Music Co., and other officials. After luncheon a visit was made to the recording studio, where Ernest Hare and Colin O'Moore made records for the edification of the visitors. Later in the afternoon T. P.

MAIN SPRINGS

Send for Price List

EVERYBODY'S TALKING MACH. CO.

Authorized Distributors

Heineman & Meisselbach Motors

38 N. 8th Street, Philadelphia

Ratcliff gave a record analysis with the aid of the Phonodeik.

Those who attended the New York convention included Graham French, president of the Philadelphia Show Case Co.; J. H. Burkhart, who has been put in charge of Vocalion sales; James Pentz, manager of the Pittsburgh quarters; J. J. Reilly, Douglas Langford, Thomas Ross, Robert Piersol, John Russell, M. S. Jones, Edward Wharton and Albert Rousel.

PITTSBURGH SONORA DISTRIBUTOR

PITTSBURGH, PA., January 4.—The Schroeder Piano Co., of this city, is the new Sonora distributor for Western Pennsylvania and West Virginia. The new appointment became effective January 1. This concern has been prominent as one of America's leading retailers in the music industry.

A PRACTICAL HOLIDAY SOUVENIR

One of the distinctly practical and attractive souvenirs of the holiday season was the gold-plated key chain, equipped with a numbered identification disk, sent out to its many friends in the trade by the Standard Talking Machine Co., Victor wholesalers in Pittsburgh. The identification disk is finished on one side to represent a Red Seal record, while on the reverse side is the trade-mark of the Standard Co., a key number, and instructions to return the keys to the Standard Co. in the event that they were lost.

Geake & Barber have organized the New Mexico Phonograph Co. in Albuquerque, N. M., and are featuring the Sonora.

"Nameplates With a Personality"

For Manufacturers and Dealers of Talking Machines, Phonographs, Musical Instruments, etc.

E. V. YEUELL CO., Malden, Mass.

When You'll Think of Nameplates You'll Think of Yeuell.

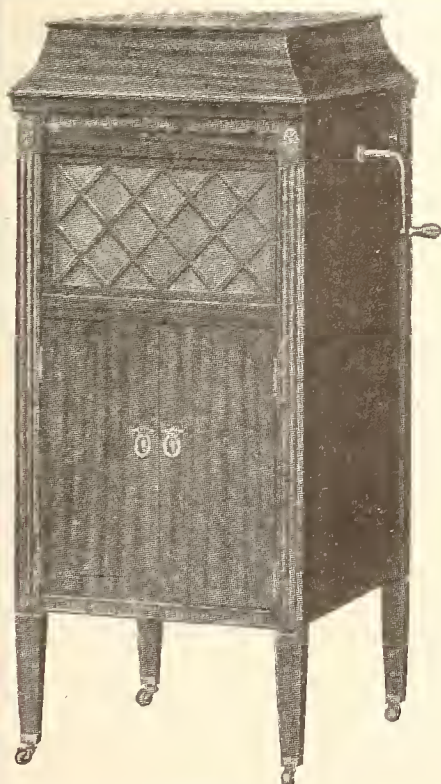

MODEL C

Lyrician
MARVELOUS TONE QUALITY

PLAYS ALL RECORDS

Six Beautiful Models

We offer attractive proposition to

DEALERS and DISTRIBUTORS

We can make immediate shipment for the holiday trade.

Distributors Wanted in Several States

AMERICAN TALKING MACHINE CO., Inc.

GENERAL OFFICES AND FACTORY

BLOOMSBURG, :: PENNA.

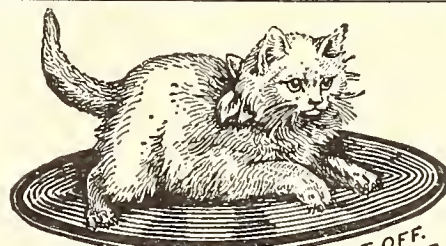

NEVER SCRATCHES

WE ARE DISTRIBUTORS FOR

LYRIC LATERAL RECORDS

Dealers Supplied on Short Notice
Supplying you with Bulletins, Hangers, Cut-outs and Advertising Matter is one feature of

LYRIC SERVICE

HOW THE NEW YEAR IS VIEWED!

Sonora Wholesalers in Various Sections View the Future With Distinct Optimism

Sonora Phonograph Co., New York City, recently published in its house organ, "The Sonora Bell," a digest of opinions on 1921, as forwarded to the Sonora executive offices by Sonora distributors located in all parts of the country.

The W. B. Glynn Distributing Co., Saxton's River, Vt., anticipates a slight slump during the readjustment period, but for the year a healthy growth and solid development.

The Gibson-Snow Co., Inc., Syracuse, N. Y., feels that business for 1921 will not fall behind, but that it will in fact exceed the business done in 1920.

M. S. & E., of Boston, report 1920 as the biggest in volume by far of any year, and that, while it is true the business in a few of the cities and towns in their territory slumped toward the end of the year, expectations have been far exceeded. They attribute a large part of the Sonora success to the tremendous advertising campaign of the Sonora Co., and say that, after conference with many bankers and manufacturers of New England, they feel extremely optimistic regarding 1921.

Yahr & Lange Drug Co., Milwaukee, believes that business will continue good, and in fact be greater this year than last. So far no slump has been reported in the territory covered by this company.

The Southern Sonora Co., Atlanta, writes that conditions in the South appear to be really worse than they are. They say that Georgia is the worst of any of the Southern States, but that the year of 1920, as a whole, has been quite profitable for most of the dealers below the Mason and Dixon line. They do not believe the talking machine business in general will be as large in 1921 as in some former years, but that there will be larger business for those dealers

handling standard lines of recognized value. The depression caused by the fall in price of cotton they expect to ease up the latter part of February or the beginning of March.

Moore-Bird & Co., Denver, write: "1921 will be prosperous, nothing wild, nor something for nothing, but good business for those who sell good merchandise in a high-class way."

Robinson-Pettit, Inc., Louisville, report a good year just finished. They place their confidence with respect to the future on the fact that the financial condition of the country is fundamentally sound.

PHONOGRAPHS IMPROVE WHISTLING

After Machines Were Installed in Indiana School Boys Whistle Better Class of Music and, Moreover, Show Regard for Tune

Good whistling by the small boy can be promoted by the use of the phonograph in the public schools, according to a story in the Indianapolis News. The uplift of whistling took place in an Indiana town. The News gives the following account of what happened:

"Whistling carpenters and others who work out of doors are common enough. Whistling indoors is regarded as a crime by many fellow-workers who have nervous temperaments and find neighborly whistling a distraction. Not long ago the supervisor of music in the public schools of an Indiana city undertook to raise the standard of public whistling and contended that he had been successful in his effort.

"He found in walking about the town where he lived that boys of various ages were prone to whistle. Some of them whistled off key, while others maintained the tune readily enough, yet their selections appalled the music teacher. He placed talking machines in the school buildings and began teaching the youngsters something about good music. He found that all they needed was an opportunity to hear something worth while.

Your Opportunity to Buy at the Right Price

We manufacture 3 and 5-ply panel stock in all thicknesses and woods. Also 3-ply shelf stock for Talking Machine Cases.

Ask for quotations on our Talking Machine Crating Boxes. They are built of solid woods.

THE BRANDTS FURN. CO.
CELINA, OHIO

"Some time later he made a whistling survey and reported that boys who formerly whistled ragtime were then giving their attention to standard overtures. Many would welcome such results elsewhere."

RECOMPENSE

If I have with a single song
Made glad one heart,
To steal a moment in the day
From pain apart;
Then I have gained a golden gain
Sans soil or stain,
And all the worthless life of me
Not lived in vain—N. Y. Sun.

INCREASE CAPITAL STOCK

The Ebers Brothers Music Co., Fresno, Cal., has increased its capital stock from \$25,000 to \$100,000 in order to provide for future expansion.

Mr. Victor Dealer

ONE of the greatest evils which cuts into your sales is the fact that the public is not fully educated to realize that a Victrola is the name of a product of the Victor Talking Machine Company and not a general name for talking machines. Nothing will increase your sales to a greater extent; nothing will raise the Victrola to an even higher reputation than by educating the public to realize that there is only one genuine Victrola. Convey this thought in all your advertisements, in all your sales talks, and in all your form letters.

With over six thousand loyal dealers and possibly twenty-five thousand sales people instilling this one idea into the minds of millions of people each year, the public will become educated to what the word "Victrola" stands for, and your own sales will be materially increased.

W. D. & C. N. ANDREWS
BUFFALO, N. Y.



AL JOLSON says:
Oh, What a Fox-Trot is —
"GRIEVING FOR YOU"

You can't go wrong with any *Feist* song

Published by LEO FEIST Inc., Feist Bldg, New York

LOOKS FOR A REVIVAL OF BUSINESS

Grand Talking Machine Co. Expands Its Lines —B. Abrams' Quick Rise in the Trade

The Grand Talking Machine Co., 270 Flatbush avenue extension, Brooklyn, N. Y., which was recently appointed distributor for Rishell phonographs, is also the manufacturer of the Dulciphone talking machine needles, as well as distributor for Q R S music rolls and accessories.



B. Abrams

At the head of this progressive concern is B. Abrams, who twelve years ago was an apprentice in the factory of the Behning Piano Co., New York, and whose ambition at that time was to become a piano technician. However, after obtaining an elementary knowledge of piano manufacturing,

traveled throughout the country and gained wide experience in the many channels of distributing musical instruments and merchandise.

In 1915, realizing the great possibilities in the talking machine field, Mr. Abrams established a small office in Brooklyn and opened up a jobbing business which grew so fast that shortly after he moved into larger quarters on Adams street. In May, 1920, he leased 8,000 feet of floor space in the present Flatbush avenue location.

In commenting on the prospects for business during 1921 Mr. Abrams said: "I look for a revival of a normal business in the early Spring. The short-sighted policy of many dealers in holding their stock requirements to a minimum and refusing to buy beyond their current needs will reflect to the advantage of the manufacturer in the Spring. Dealers will just be clamoring for merchandise and will be placing orders for great quantities of instruments and accessories for future deliveries. Business will loom up large again following the temporary slump attending the reconstruction period, which now shows signs of disappearing rapidly."

NEW SOTHERN & MARLOWE RECORDS

First Records by Noted Shakespearean Artists Appear in Victor February Supplement

The interesting feature of the Victor record supplement for February is without question the listing of the first records by E. H. Sothorn and Julia Marlowe, the famous exponents of Shakespearean drama, whose recordings for the Victor were reported in *The World* recently. For their first records Sothorn and Marlowe have selected the immortal balcony scene from "Romeo and Juliet," and have succeeded in presenting their art through the medium of the disc in a manner that presages serious attention in the future to the more general recording of the recognized standard dramatic works.

REMOVAL AND EXPANSION IN BOSTON

BOSTON, MASS., January 5.—To-day the wholesale department of the Brunswick controlled by Harry Spencer got finally moved from its old location at 156 Boylston street to 1265 Boylston street, some distance out in the Back Bay section. In the new quarters an entire floor and basement will be used for Brunswick wholesaling.

Meanwhile the F. C. Henderson Co. comes into full possession of 156 Boylston street; that is, whereas the company has been operating the retail department on the ground floor for several weeks past it will now have the large basement and the mezzanine floor which in the old Kraft, Bates & Spencer days was utilized for pianos.

The Barnes Music Co., Brunswick phonograph dealers in Los Angeles, Cal., carried some especially attractive advertising in connection with the appearance of Pavloska and Breeskin, Brunswick artists, in a recital in that city.

HENRY STADLMAIR, SR., RETIRES

Effective December 31, 1920, Henry Stadlmair, Sr., resigned as president and general manager of C. Bruno & Son, Inc., New York City, Victor distributors and musical merchandise wholesalers. The officers of the company now are H. Hohner, president; William J. Haussler, treasurer and general manager, and J. Harris, secretary.

BRUNSWICK IN THE SCHOOL

George T. Baker & Co., Brunswick phonograph dealers in Bemidji, Minn., recently placed a Brunswick in the Sixth State Normal School, located in that city.



The Home of the Grand Talking Machine Co. an opportunity to travel was presented to him and in the capacity of salesman Mr. Abrams

New! New! APEX Fibre Needle Cutter

Cuts with the grain to the point.
 Makes the use of fibre needles as cheap as steel.
 No variation in angle or size of cut.
 Does not crush the shell.

Small Size—Simple Construction
 For sale through jobbers and dealers.

Retail Price \$1.50

Manufactured by

W. H. WADE 14 N. Michigan Avenue CHICAGO

New! New!

Patented Nov. 2, 1920

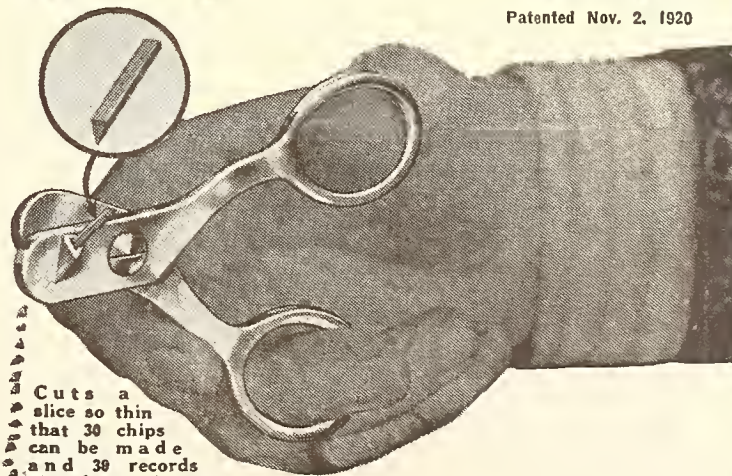

Cuts a slice so thin that 30 chips can be made and 30 records played with one fibre needle.

This

is Yours Mr. Victor Dealer
-and 25 other equally attractive
WINDOW DISPLAYS

—at a cost that is *trivial*, compared with the added profits and prestige you are certain to receive through their use.

They are all YOURS—if you are a subscriber to the Binger Company VICTOR Sales Promotion Service. This effective and reasonably-priced plan is created and produced by The Binger Company, for Victor dealers exclusively; and distributed to the trade through its sales agents, The Reincke-Ellis Company.

The service provides each dealer with a complete set of permanent patented fittings, any or all of which may be used with a single display. These fittings are constructed of seasoned wood, and may be had in any finish to harmonize with the equipment of your store or show window.

At regular intervals during the year, you receive 26 complete, up-to-the-minute, dollar-drawing window displays, with architectural floor-plan for each trim, adapting it to the shape and size of your show windows. Each display beautifully lithographed in many colors, is made up in sections on heavy cardboard stock, and arranged for quick insertion into the fittings. The whole scheme has been so clearly worked out, that any person can install the complete display within a very few minutes. Included with each layout, for the convenience of the dealer, is a miniature display, all set up showing just how the "big show" will look when completed.

*This exceptional service, Mr. Victor Dealer
—every bit of it designed exclusively for YOU
costs but one dollar a day!*

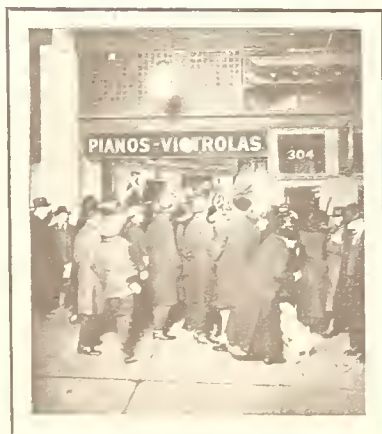

ATTRACTS CHRISTMAS CROWDS

Flashlight photo of crowd in front of Christmas VICTOR window of E. Lein's Piano Co., 304 West 42nd St., N. Y. C.
Display supplied by The Binger Co. Victor Sales Promotion Service.

C. BRUNO & SON INC.
VICTOR DISTRIBUTORS
351-353 4th Ave. New York



Let your windows "back up" the organization that stands back of your store and your service. This is the fourth window of the first series of displays being supplied to Victor dealers by the Binger Company Victor Sales Promotion Service. It features the Victor factory in life-like cut-out set pieces, beautifully lithographed in colors. Each building stands out separately and distinct against the Camden skyline. The actual trim is over 4 feet in height, by about 8 feet wide, and makes a most impressive window.

YES, Mr. Victor Dealer, to have just one of these displays made up for *you alone* would cost several hundred dollars!

That would represent art work only—not allowing one cent for the "brains" back of the idea.

Whereas: these displays represent weeks of "planning" by the Binger Company display experts working in close touch with men prominent in the Victor Industry—before the "idea" is even put on paper.

No wonder that those dealers who have viewed these displays in their entirety express surprise at the extremely low cost. It is made possible only through the participation of hundreds of other dealers, co-operating with the Binger Company VICTOR Sales Promotion Service.

Besides the window displays, you receive 26 "peppy" sales-talks for your sales force; 26 newsy, convincing newspaper advertisements; 26 valuable suggestions for direct-mail advertising; and an abundance of miscellaneous data that will help your business to become a bigger and better one.

Any Victor distributor in the United States is in a position to secure the Binger Company VICTOR Sales Promotion Service for you—and will be glad to serve you although he does not make a penny of profit as a result of its sale. His only reward is the knowledge that your use of this service will make you a more successful Victor dealer.

The band wagon is rolling, Mr. Victor Dealer—and there is room for YOU. When are you going to get aboard?

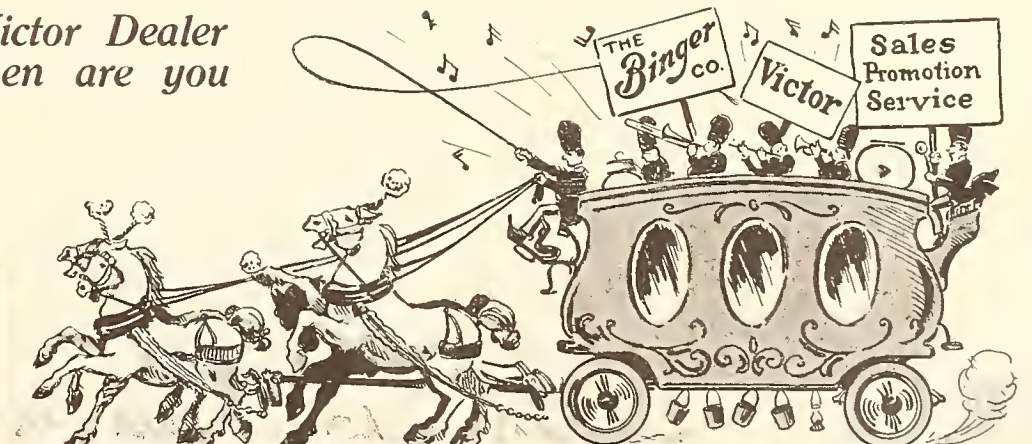

C. BRUNO & SON INC.
VICTOR DISTRIBUTORS
351-353 4th Ave. New York

When business competition is keenest, the dealer having the most complete selling equipment has every advantage. If you are not prepared with the best, we have it for you and can make prompt delivery and installation.

Plans and estimates promptly submitted.

VANVEEN & COMPANY INC.

12 YEARS OF STUDY AND EXPERIENCE IN
BUILDING AND PLANNING MUSIC STORES

· HEARING ROOMS · RECORD RACKS · COUNTERS ·

EXECUTIVE OFFICE
47-49 WEST 34th STREET
NEW YORK CITY

SALES OFFICE
1711 CHESTNUT STREET
PHILADELPHIA

WANT A LOWER TARIFF ON MICA

Asserted That Even Present Duty of 25 Per Cent Offers Distinct Advantage to European Manufacturers of Mica Products Generally

Various members of the talking machine trade, particularly manufacturers of sound boxes, have taken a keen interest in the efforts being made by certain interests to have the duty on mica increased under the new tariff law. At the present time imported mica carries a duty of 25 per cent, and it is held by talking machine men that inasmuch as this duty gives a distinct advantage to European manufacturers

of sound boxes, the tariff should be reduced instead of increased. Hearings on the duty to be fixed on mica were scheduled to be held before the Ways and Means Committee beginning on January 11.

In discussing the situation, J. F. Frazee, of the Phonograph Appliance Co., said: "The question of a proper tariff on mica should attract the attention of all manufacturers of talking machines, for the subject is one in which they have a very vital interest which may not be apparent on the surface.

"At the present time imported mica carries a duty of 25 per cent, which gives the foreign manufacturer of mica products generally a very decided advantage over the American manufacturer.

"The cost of the mica diaphragm, as compared with the cost of the entire machine in which it is used, is almost negligible. In spite of the very great increase in cost of imported mica the cost of diaphragms to consumers has not increased in proportion. This is due to the fact that other manufactured mica products have borne the increased cost of manufacturing diaphragms, and unless the American manufacturer fabricates other lines of mica used in the electrical and scientific trades he would not be able to make diaphragms at all, unless he could charge from two to three times the amount at which diaphragms are now selling.

"It is in this aspect of the case that the talking machine industry generally should be interested. If the duty on raw mica is increased as the American miners are asking Congress to increase it, the manufacturers of electrical and scientific specialties will find a very large proportion of their business going to manufacturers abroad, and it is doubtful if the American industry can survive as a whole.

"Imported mica is essential to the industry generally, and it is absolutely necessary to the talking machine industry, and unless the American manufacturer can continue his general mica business profitably consumers of diaphragms

will in all probability have to look elsewhere.

"This means that diaphragms will have to be imported at a very heavy duty, and we are assured by many who have undertaken to use imported diaphragms that the foreign product is not at all satisfactory. It cannot be depended upon for uniform thickness, for good workmanship, or for proper handling in shipment. Deliveries are necessarily uncertain, and manufacturers who depend upon imported diaphragms are obliged to order in very large quantities without any guarantee as to the product or any possibility of replacing defective goods, or returning them for credit. If they are not in position to do this they are at the mercy of importing jobbers.

"While the diaphragm alone, considered merely from the viewpoint of its cost, is an extremely small item, there can be no question that the pre-eminence of the American talking machine in the markets of the world has depended as much upon the perfection of the diaphragms generally used in their construction as upon any other one element.

"Should this advantage be lost to the American manufacturer by reason of increased tariff on the raw material, it will be a serious handicap which may require years to overcome, and in maintaining the quality of the American talking machine, he must inevitably suffer, while the expense of obtaining diaphragms and the trouble attendant upon dealing with foreign countries will occasion innumerable delays and unnecessary loss.

"We believe that the talking machine industry generally should take this matter up seriously with Congressmen and should make it plain to their representatives that the whole industry will suffer if a higher tariff is levied upon the importation of raw mica. At the same time we believe that it would be to the advantage of the industry generally if their Congressmen were urged to place raw block mica on the free list, or at least to reduce the high tariff which now prevails."

When you say, Mr. Victor Dealer, that the Victor Tungs-Tone Stylus is the most efficient talking machine needle the world has ever known, you have told the unqualified truth—and truth will always prevail.

BRUNO

HAPPENINGS IN THE DOMINION OF CANADA

HERO EMPLOYEES OF BERLINER GRAMOPHONE CO. HONORED

Tablets Unveiled at Company's Plant Near Montreal—Victrola Concert by Radio—Great Advertising Campaign by Dealers—How Customers Are Interested in Records—New Company Appears

MONTREAL, CAN., January 6.—A tablet to the memory of two employes of the Berliner Gramophone Co. who died, and fifteen others who fought, in the great war, was unveiled at the company's plant, St. Henry, by Lieut. Col. Alexander McMillan, D. S. O. A large crowd of relatives of the men whose names are inscribed on the brass tablet were present, as were also members of the company. Harold Chilvers, manager of the company, introduced Col. McMillan, who made a short and appropriate address. He was later presented with a gold match-box by H. S. Berliner, vice-president of the company, who was present. The tablet was unveiled whilst several men in uniform saluted and a bugler sounded the "Last Post."

The following names are engraved on the tablet: Wm. Walker, D. S. O.; D. H. Boyd, A. H. Cooper, Emile Girard, B. Smith, P. Newman, Donald Robinson, H. A. Foster, J. A. Muir, Jas. Davis, J. J. Ryan, H. E. Dewar, Croix de Guerre; H. Laird, Archer Gibbs, H. E. Walker, J. McDonnell, D. Hogan.

An arrangement has been concluded between the Berliner Gramophone Co., Ltd., and the Marconi Wireless Telegraph Co., of Canada, whereby the wireless students in and around Montreal will have the advantage of a musical program every Tuesday evening. The text of the announcement reads:

"By arrangement with the Marconi Wireless Telegraph Co., of Canada, a 'His Master's Voice' Victrola concert, featuring the latest and most popular selections, will be given to-night and on every Tuesday from 8 to 9 p. m. for the benefit of wireless students. Those who own 'amplifiers' can arrange an entertainment for their friends both novel and interesting.

"There are many radio receiving stations in and around Montreal that can receive wireless telephone communications. Look for one in your neighborhood. Find out who your friends are that may have one.

"Stations within a radius of two hundred miles of Montreal should be able to enjoy these wireless telephone concerts, as every record will be heard as clearly and distinctly as though it were playing on your own Victrola in your own home. Captains and officers of ships in port are invited to enjoy this entertainment aboard their vessels. Operators tune to 1,200 meters."

T. M. Briggs, a Montreal man, has been allowed two claims on a disc record folio, to which has been assigned patent number 205,012 by Ottawa.

A common occurrence during the holiday season was the number of full pages used by the various phonograph dealers and manufacturers in the local dailies. As a matter of fact, the writer does not know of any year where so much publicity has been given the different makes in newspaper advertising space and it certainly was no fault of theirs if the public failed to respond to their appeals to investigate the various makes on the market.

The repeal of the luxury tax of 10 per cent came almost at the last minute, too late to be of any material assistance or to be felt in increased sales. Some of the dealers made known the fact of a reduction in large-sized copy. On the whole, the trade was satisfied with the volume of business transacted, which measured up well with last year's holiday trade total.

A talking machine dealer who caters largely to a select class of customers told your correspondent recently that he makes a practice of sending out with each monthly record supplement a mailing card upon which the customer

can indicate the records he would like to hear in his own home by appointment. He said that he found this system not only appealed to the busy man and woman for legitimate reasons, but likewise made a strong impression upon the class who like to be catered to and feel that by having the salesman come to their homes

they are showing just a little bit of "class." When the salesman is of the right sort he makes this desire to show "class" bring dividends that are worth while.

At Waterville, Quebec, a new company, the Waterville Vencer & Panel Co., Ltd., have acquired a factory formerly owned by George Gale & Sons. This plant has a floor space of 150,000 square feet and is being remodeled to suit the requirements of the purchasers. The company expects to be ready for operation about March 1, 1921, with a force of 150 hands.

OPENING OF ADAMS STORE IN TORONTO A BIG SUCCESS

Columbia Grafonolas and Records Handled at This Establishment—Recent Sonora Visitors—Ted Lewis and His Celebrated Band Score—Brilliantone Needles Popular—Other News

TORONTO, ONT., January 4.—A full page announcement in the Toronto evening papers recently heralded the formal opening of the new Adams furniture store, 211-219 Yonge street. The event is of interest to the trade in that Adams are well-known Columbia dealers. Not only were Grafonola recitals held and Columbia records demonstrated, but several new period models were on exhibit. These had been sent direct from the New York Fifth avenue store and were neatly displayed on the ground floor of the building.

The 48th Highlanders' Band discoursed music on afternoons and evenings. Joe Carr, a noted tenor, sang and Ted Lewis and his splendid aggregation of Jazz Kings were also present. This organization makes records exclusively for Columbia, and had been playing in the Greenwich Village Follies at the Royal Alexandra Theatre during the week. The honor fell to Adams to present them during their Toronto visit.

A recent visitor to the office of I. Montagnes & Co., sole Canadian Sonora distributors, was L. C. Lincoln, manager of the Sonora Phonograph Co.'s advertising department. Mr. Lincoln's mission was mainly to arrange for extensive Sonora billboard advertising throughout Canada. Already ten big billboard signs have been provided for in Toronto at important intersections. E. Van Gelder, of I. Montagnes & Co., has returned to headquarters from a visit to Sonora dealers in the Western provinces. He reports a successful trip and a growing interest in the West in the Sonora.

To Sonora dealers throughout Canada has gone out a recent trade letter, signed by George E. Brighton, president of the Sonora Phonograph Co., Inc., New York, showing why Sonora prices will not be reduced.

Toronto Columbia dealers took advantage of the recent visit to the Royal Alexandra Theatre of Ted Lewis and his celebrated Jazz Band by making this fact the basis of some of their advertising. More than one Columbia dealer told The World correspondent that a noticeable increase in Ted Lewis' Jazz Band record sales had been observed as a result of the prominence this organization had received during its week's engagement at the theatre.

The Brilliantone Steel Needle Co. has many

plans for putting up its brands of steel needles in attractive cans that help the dealer to sell them quickly.

The retail store of the National Piano Co., Ltd., Yonge street, has added the Sonora to its talking machine department.

Dominion House Furnishing Co., Ottawa, is making a big drive on the "Columbia Dollar Club," whereby on payment of this sum membership is enrolled and a Columbia machine delivered. The membership is limited to 100.

MOTOR CONSTRUCTION KNOWLEDGE

C. J. Pott, Manager of General Phonograph Corp., Canadian Branch, in Interview With The World Says Knowledge of Motor Structure Necessary but Need Not Be Thrust Upon the Customer—Pointers of Interest

In conversation with C. J. Pott, manager of the General Phonograph Corp. of Canada, Ltd., the question came up of a selling incident cited in The World recently. The case that was mentioned was that of a salesman who lost a good sale because he could not give any intelligent answer to the prospective customer's question regarding certain details of the construction of the motor.

"How far should a salesman go in talking motor equipment to a prospect?" The World correspondent asked Mr. Pott.

"Well, I would say, as a rule, it is not necessary to go into details about the mechanism of the motor," replied Mr. Pott. "Of course, there is no hard and fast rule. The more the salesman knows about motors the better. The surer he is about the quality of the motor in the machine he is trying to sell, the more confidence and enthusiasm he has, and, therefore, the better salesman he is.

"But I would keep that knowledge in reserve. If it is needed the salesman has it. It seems to me the average buyer does not know much about the hundred and one things that enter into the building of a high-grade motor. He knows little and perhaps cares less. If I were a floor salesman I think I would say to the man examining a certain instrument, 'The motor

(Continued on page 120)

Talking Machine Supplies and Repair Parts

SPRINGS, SOUND BOX PARTS, NEEDLES

THE RENÉ MANUFACTURING CO.
MONTVALE, NEW JERSEY

NEWS FROM DOMINION OF CANADA
(Continued from page 119)

in this model is a ———, which is recognized the world over as a particularly high-grade product. It has stood the most critical tests for an easy-running, noiseless, strongly built, efficient motor that we put our name and reputation behind it in the assurance that it will give you perfect satisfaction. It is a trade-marked article which the manufacturer stands behind and it has such a reputation in the trade that we stand behind it too.

"In the average case selling talk like that wins the customer's confidence, I believe, quite as much as any attempt to go into a too detailed description of the motor."

"I suppose a salesman would be safe in applying that description to any of the new improved types of the Meisselbach or OkeH motors, if the machine he was selling were equipped with that brand," your correspondent ventured, incidentally.

"Well, now," Mr. Pott chuckled, as he packed some Prince Albert in his favorite pipe, "if you put that in the form of a statement I certainly won't deny it."

GOOD NEEDLES FOR DEMONSTRATION

L. J. Unger, Brilliantone Traveler, Believes Demonstration Is Critical Time in Making Sale—Needles Must Meet All Requirements

No needles are too good for record demonstrations. It should be a rule that the buyer of a new machine gets a package of the best possible needles with his purchase. These two statements were strongly emphasized by L. J. Unger, who recently visited Canadian points representing the Brilliantone Steel Needle Co., Inc., New York. Although naturally interested in the success of the talking machine and record business as a whole, Mr. Unger is a needle specialist, and he takes every opportunity of impressing the

importance of the needle in securing a good reproduction of the tone that has already been put into the records.

"Sometimes I come across a salesman who feels he is exercising a wise economy in using cheap needles for demonstrating in the store," he said in the course of a chat with The World correspondent. "If there is one time that the best is none too good it is when demonstrating for people who by their coming into the store have shown an interest and are then in a mood to criticize and make comparisons. The only way to have your goods show up to the best possible advantage is to use the best needles you can get.

"Another thing, when a dealer is delivering a new instrument to a customer it is wise to put in a package of the very best needles. If the needles sent should be inferior ones the customer might easily be disappointed with his purchase when he plays it in his own home. For this and other reasons I would say start him off right."

MAKES MUSIC ON THE SIDEWALK

Canadian Dealer Opens Store and Draws Big Crowds by Placing Instrument in Street Before His Door—Booms Sale of Records

WELLAND, ONT., January 5.—J. O. Glass, a talking machine dealer of this city, introduced the advent of his store here in quite a novel way and he intended that every person passing his way should know that a new music store had arrived. Selecting a machine from his stock Mr. Glass placed it right on the sidewalk and putting on the loud pedal he introduced "music in the street." "Avalon" and other new records were played, drawing people from around different corners to see "what was doing." Mr. Glass had not provided seats for his audience, but had he known such a large crowd would arrive he undoubtedly might have arranged for a grand stand. Of course, that evening many wished

those records he had played and the clerks had to get busy in a hurry.

The store, which is a branch store of J. W. Glass, of St. Catherines, has been placed under the able management of J. O. Glass, a son. There are four modern and comfortable demonstrating rooms, where Victor talking machines and pianos are on display.

Mr. Glass is a live wire, and although he has only just established here, yet he has made a host of friends and customers. He has started in right—he is advertising—which points always to success in business.

L. K. LINCOLN BACK FROM TRIP

L. K. Lincoln, advertising manager of the Sonora Phonograph Co., New York, returned to the city this week from a short trip through eastern Pennsylvania, during which he called on Sonora dealers. He found that all those he called upon had experienced a good holiday business and were facing the future confident of the prosperity it holds for them.

THEATRE CHOOSES THE BRUNSWICK

When the feature photoplay "Humoresque" was shown in the Grand Theatre, Los Angeles, the Brunswick was selected to play the violin solo "Humoresque" as an introduction, because of its excellence.

Mattson Music Co., of that city, supplied the instrument and took advantage of the occasion by advertising in the newspapers.

MAKES SONORA TALK OVER 'PHONE

SENOIA, GA., January 5.—The proprietor of Hollberg's Pharmacy, of this city, recently wrote to the Sonora Co. as follows: "Wish to say that I had the pleasure of demonstrating the Sonora to a lady over the telephone yesterday afternoon, and making the sale all O. K. for the Minuet Model. This goes to show that the Sonora makes the strongest kind of appeal."

MERCHANDISING VALUE

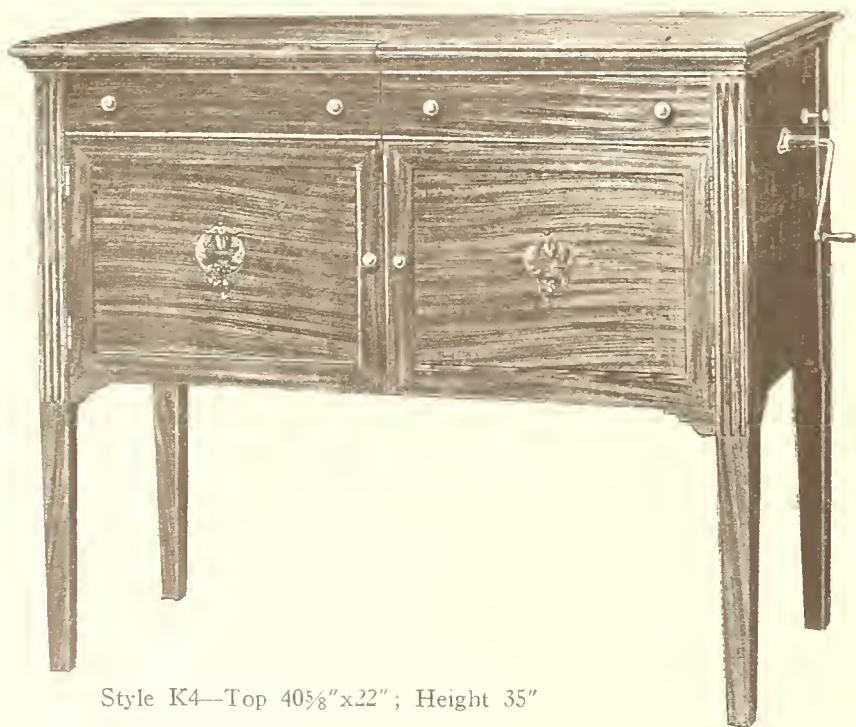

Style K4—Top 40 5/8"x22"; Height 35"



Style K5—Top 41"x22 1/2"; Height 35"

\$150

Retail Price

\$160

LAUZON QUALITY

The foresighted merchant with a hand on the pulse of public demand will immediately perceive the opportuneness of the above popular priced consoles.

Lauzon quality assures honest value and the price is a 1921 proposition calculated to build sales throughout the year.

MICHIGAN PHONOGRAPH CO.

Phonograph Division, Lauzon Furniture Co.
Office, National City Bank Bldg. Factory, Monroe avenue and 6th street
GRAND RAPIDS, MICH.



MEETING 1921 CONDITIONS

By J. NEWCOMB BLACKMAN

The outlook for business in 1921 is disappointing and discouraging to many, but opens the way for greater opportunity and prosperity for Manufacturers, Wholesalers, Retailers and Employes who are prepared to meet 1921 conditions.

General business is again realizing the fact that inflation must be followed by deflation, and that those who best survive these extreme conditions are what might be termed "conservatives" on the average.

VICTOR SUPREMACY was never more apparent than to-day.

The law of average over a period of time produces the result by which all are judged.

Contrast the condition of VICTOR business during the past few months and forecast the opportunities for 1921, as against the majority of competing lines, and you will appreciate that the VICTOR policy is intended to insure permanent success.

1921 will be a "show-down year"—a period of "the survival of the fittest."

The VICTOR wholesaler will find it necessary to invest more capital to adequately meet the needs of the VICTOR dealer. He should be able and willing to build up a stock of Victrolas and Records as increased production makes it possible. His financial condition should enable him to give ample credit to dealers whose business transactions are conservative.

The "survival of the fittest" among VICTOR dealers will continue to prove the wisdom of concentration and specialization. High-class representation ought to be encouraged and rewarded.

The dealer who expects support will give it. He will choose his line or source of supply on a permanent investment basis.

The coming year will be a year of "reaping" according to our "sowing." A year of reaction, but also a year of reward. In some cases, a time to introduce new resolutions and new policies.

The BLACKMAN TALKING MACHINE CO. is prepared to meet 1921 conditions and will welcome an opportunity to help its VICTOR dealers do so.



Blackman

TALKING MACHINE CO.

81 READE ST. NEAR CHURCH ST. NEW YORK
VICTOR DISTRIBUTORS EXCLUSIVELY WHOLESALE



How to Make 1921 a Happy New Year

In Spite of Everything!

They say that things are pretty bad—
 They couldn't be much worse
 But that's no reason, after all,
 Why YOU should hire a hearse.
 They say the world is going to
 The Bowwows pretty soon;
 But there'll be time enough, no doubt,
 For many a merry tune.
 The price of eggs may aviate—
 With every other ration;
 But you can thank your lucky stars—
 You still have Syncopation.

No matter what you have to hand
 Your landlord on the First;
 No matter if it's quite impossi-
 BILL to quench a thirst—
 We still make catchy dance hits that
 Intoxicate the feet—
 A lot of new ones every month—
 That simply can't be beat.
 So cease to mourn your tragic fate—
 The world is not so bad.
 Those tantalizing Emersons
 Will keep you feeling glad.

January, the biggest month for record business, is here:
Every Month Is Big With the EMERSON Dealer

Emerson Records

of the VERY LATEST Songs and Dances

First!

Cast Your Eye Over These!

SELECTION	SHIPMENTS MADE
10295 Margie. Fox-trot.....Plantation Dance Orchestra	December 9th
10279 Darling. Fox-trot.....Green Brothers' Novelty Band	November 16th
10294 Just Snap Your Fingers at Care. Medley Fox-trot Waldorf-Astoria Dance Orchestra	November 27th
10293 June, I Love No One But You. Fox-trot, Orlando's Society Orchestra	November 27th
10242 Whispering (Dance). Fox-trot.....Van Eps Specialty Four	September 13th
10300 Whispering (Vocal). Tenor Solo.....Sam Ash	December 11th
10301 Margie (Vocal). Tenor Solo.....Eddie Cantor	December 11th
10292 Palesteena. Novelty Song.....Eddie Cantor	November 23rd
10302 Broadway Rose. Tenor Solo.....Irving Kaufman	December 11th
10296 Broadway Blues. "Blues" Character Song.....Sissle & Blake	December 3rd
10282 Feather Your Nest. Medley Fox-trot.....Vernon Trio	November 17th
10304 Caresses. Fox-trot.....Lanin's Roseland Orchestra	December 17th
10303 Grieving for You. Fox-trot.....Jos. Samuels' Music Masters	December 11th

The Ideal Phonograph and Record Combination

EMERSON RECORDS—THE EMERSON PHONOGRAPH

The Phonograph with the Emerson Music Master Horn

Play Emerson Records with Emerson Needles, a Quality Product



EMERSON PHONOGRAPH CO., Inc.

206 Fifth Avenue, New York

315 South Wabash Avenue, Chicago



INDUSTRIAL ACTIVITY ENCOURAGES PITTSBURGH TRADE

Little Business Slump Noted During Holiday Season—Period Models Very Popular—What the Various Managers Report—New Sonora Distributors—Vocalion Shop Expands

PITTSBURGH, PA., January 3.—Talking machine dealers here are facing the new year with confidence and a feeling of optimism. The year just ended, on the whole, was considered by the various dealers as very satisfactory, as sales of talking machines and records were heavy, especially the last two months of 1920. Period models were in urgent demand during the holiday season and some of the dealers were taxed to the utmost to get their orders filled.

With the iron and steel mills in the Pittsburgh district assured of steady operation on orders that will necessitate the mills running for the next eight to ten months this condition is bound to have a healthy action on the various other business interests of the Steel City. There is no pessimism found among the talking machine fraternity here. All are eager and expectant for the new business that awaits them during the coming twelve months.

S. H. Nichols, manager of the Pittsburgh offices of the Columbia Graphophone Co., said: "We have just closed a year that was most satisfactory from a business standpoint from all angles and I am highly pleased with the results that we have achieved here. As to the future, I can only say that I feel convinced that it will be a great Columbia year. Our dealers have been given excellent service and they, in turn, have been able to serve their patrons to an eminently satisfactory degree. I believe that with normal conditions obtaining we will enjoy a most prosperous year in 1921 for the Columbia line. At least, we will try to be prepared for it."

Albert A. Buehn, treasurer of the Buehn Phonograph Co., Edison distributors, in referring to the prospects for the coming year, said to The Talking Machine World representative: "I believe that 1921 will be just as good as, if not better than, 1920. There is a great deal of business to be had, in fact, in sight, but the live dealer must go after it. There is a tendency on the part of the public to hold back, awaiting a revision downward in prices, but we in the Edison line of business are fully aware of the fact that this will not take place. We must, therefore, inform the public in an intelligent manner of the true situation. The reconstruction work that is necessary here and abroad is such as to insure prosperous times, and while there may be just a short period for readjustment I feel that business in the coming year will be better than ever, if we make it so by going after it in a determined and wise manner." Mr. Buehn stated that December sales showed a marked increase over the same period a year ago. Among the recent callers at the Buehn Co. offices were the following Edison dealers: H. H. Findt, Steubenville, O.; J. O. Clawson, Bellevernon, Pa.; S. G. Patterson, Beaver Falls, Pa.; C. B. Smith, Phillipi, W. Va.; H. L. Rosenburg, South Fork, Pa.; J. R. Klingensmith, Greensburg, Pa.; S. R. Pollock, Indiana, Pa.; C. H. Hutson, New Bethlehem, Pa.; W. A. Steadman, Butler, Pa.; John Phillips, Brownsville, Pa.; C. A. Wessler, Monongahela, Pa.; Glenn F. Miller, Ellwood City, Pa., and M. S. Nimmo, Nanticoke, Pa.

Thieves broke into a schoolhouse near Uniontown, Pa., and stole a new Victrola that had been purchased before the holidays by the school children. There is no clue to the thieves.

For the purpose of entertaining patrons the Dormont Pastry Shop, which has just been opened in West Liberty avenue, Dormont, a suburb of Pittsburgh, has installed a New Edison phonograph and a number of Edison records. The phonograph is placed in the tea room and is a pleasing part of the new stand, which is conducted by Mr. and Mrs. Fred Henze.

"As far as 1921 is concerned, I believe that it will be a banner year for the sale of Pathé goods," said H. J. Brennan, manager of the Pittsburgh Talking Machine Co., Pathé distributors. Continuing, Mr. Brennan said: "I see nothing that would indicate a depression in

business. From the reports that I have received from my roadmen, as well as some of the prominent Pathé dealers, I am led to agree with them that earnest endeavor will solve many of the sales problems that will face us the coming year. The year that is now gone was a very satisfactory one from a business standpoint. We did an excellent business and feel proud of our accomplishments. I realize that the field is ripe for the Pathé dealer who uses energy and tact in his salesrooms. We will do all in our power to give the best of service to the Pathé fraternity the next year in our territory."

John Hahn has been appointed manager of the record department of the Columbia Graphophone Co., taking the place of the late David Wise, Jr. He plans an aggressive campaign.

Robert Porter, field manager of the Columbia Graphophone Co., with headquarters in New York, was a caller at the Columbia offices here.

J. A. Scanlan, Jr., sales manager of the phonograph division of the Brunswick-Balke-Collender Co. (Pittsburgh offices), is looking for a marked increase in sales of Brunswick phonographs and records during 1921 over the previous year. Mr. Scanlan stated that the year just closed was a very satisfactory one for his department and he emphasized the fact that Brunswick dealers were given 100 per cent service. Among the new Brunswick dealers are the following: J. H. Bair & Son, Oakland Brunswick Phonograph Shop and Home Furniture Co., Pittsburgh; D. E. Beegle, New Kensington, Pa.; C. N. Johnson, Martinsburg, Pa.; Charles H. Hutson, New Bethlehem, Pa.; Kail & Cebula, Latrobe, Pa.; J. McLain, Rossiter, Pa.; W. D. Noble, Martins Ferry, O.; S. R. Pollock, Indiana, Pa.; M. A. Ritchie, Beaver Falls, Pa.

(Continued on page 125)

The CHENEY



A Superior Phonograph—and it Sells at an Average Price

The Cheney is acknowledged to be a superior musical instrument. Through its own musical merit its reputation has spread and sales have climbed.

In addition, Cheney cabinets are made by the finest cabinet makers in the country. Both in its period designs and in expert cabinet work it appeals to that class of your trade which appreciates good furniture.

The sales opportunity for you lies in the fact that The Cheney gives you a phonograph of highest calibre to offer to your best customers at average, standard prices.

Regular Models—\$125 to \$385
Art Models—\$325 to \$625

CHENEY TALKING MACHINE COMPANY
Chicago and New York



Sheraton

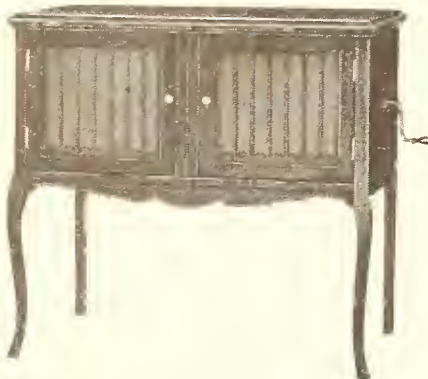

Colonial



Louis XV



Chippendale



Hepplewhite

QUALITY
HANOVER, PA., U.S.A.

Announcing the Addition of Five New Cabinets to the Line

Period models are much in vogue at this time. We have met the situation by designing the five period models shown.

Victor dealers will be interested in them as they are intended to be used with the popular Victrola VI.

The combination makes a perfect outfit that can be sold at a price that will have a strong appeal.

LONG CABINETS

Represent the last word in cabinet perfection and are sold with our absolute guarantee as to quality and satisfaction.

Write for copy of catalogue.

The Geo. A. Long
Cabinet Company
HANOVER, PA.

ACTIVITY IN PITTSBURGH TRADE
(Continued from page 123)

Martsof Furniture Co., Ambridge, Pa., and E. S. Tyler, Point Marion, Pa.

Jules Tarlow, manager of the Kaufmann & Baer Co. talking machine department, is most enthusiastic over the Christmas holiday sales and stated to The World representative that the volume of business handled far exceeded that of the same period a year back. Mr. Tarlow also stated that he was looking forward to an exceptionally brisk Spring season in the four lines of talking machines he handled in his department—the Victrola, Columbia, Grafonola, Aeolian-Vocalion and others. During the recent visit to the Nixon Theatre of Ray Miller, the "Melody King," and his black and white boys Mr. Tarlow arranged for Miller and his company to give an entertainment in the Kaufmann & Baer auditorium. The entertainments were given a most enthusiastic reception by a large audience. They sang and played their latest hits, "Rose of Spain," "Can You Tell?" "Avalon," "Just Like a Gypsy," etc. Miller and his singers also gave a similar entertainment during their stay here at the Sonora-Melodee Shop, where another large crowd was entertained.

The Vocalion Shop, one of the most attractive talking machine shops in Pittsburgh, has been taken over by the Philadelphia Show Case Co., which utilizes the first floor of the spacious quarters in the Jenkins Arcade as the retail department where the Vocalion Melodee player rolls, Okeh records, Bubble Books, Vocalion records and the Magnavox are on sale. The retail department is handsomely equipped and there is a fine display of the Vocalion as well as the other merchandise handled. The retail shop is under the management of E. C. Doel. The wholesale department is located on the mezzanine floor and is under the direction of J. A. Pentz, who is well and favorably known to the talking machine fraternity. Mr. Pentz stated that the prospects for business in the immediate future were exceedingly bright, especially in view of the fact that from now on Vocalion dealers will be able to secure more prompt and efficient service than ever before. Wayne D. Montgomery, who for a long time was connected with the Pittsburgh office of the Columbia Graphophone Co., will cover the Pittsburgh district for the Vocalion interests. John Russell is the roadman for southern Pennsylvania. The territory under the direction of Mr. Pentz covers the entire State of Pennsylvania and parts of New York, Ohio, West Virginia, Maryland and Virginia.

The Sonora phonograph distributing agency in the future will be located in the building of the Schroeder Piano Co., 820 Liberty avenue, Pittsburgh, with H. Milton Miller in charge.

T. T. Evans, manager of the wholesale Victrola department of the C. C. Mellor Co., is most optimistic relative to the prospects for Victor business in his territory the coming year and is preparing to handle an increased volume of trade.

R. R. Myers, Victor representative in the Pittsburgh district, is elated over the outlook for new business in 1921 and is convinced that there will be some record-breaking sales of Victor merchandise. He said that the Victor Co. was prepared to furnish all possible aid and service to the Victor dealers. Mr. Myers spent some time in the West Virginia territory and found Victor dealers there well pleased with business indications.

Miss Lillian A. Wood, manager of the Victor educational department of the C. C. Mellor Co., returned from Harrisburg, where she attended a meeting of the State Educational Association. A portion of the time was given over to a music section and there was much said in favor of the use of talking machines in the public schools.

P. W. Simon, the well-known Victor dealer of Uniontown, Pa., was a visitor to Pittsburgh. His local manager, Mr. Gebhard, also was a caller at the Mellor wholesale Victor department, with Mrs. Gebhard and their daughter.

E. B. Heyser, general manager of the W. F.

Frederick Piano Co., Victor distributor, said he was convinced that there would be a marked increase in sales of Victor machines and Victor records the next few months. He based his opinion on the very excellent industrial outlook in western Pennsylvania.

E. G. Hays & Co. have added the Modernola to their talking machine department. They also handle the Brunswick line.

FOREIGN RECORD TRADE GROWS

Emerson Phonograph Co. Tells of Increasing Interest in Foreign Record Catalogs

Louis D. Rosenfield, director of the foreign record department of the Emerson Phonograph Co., reports a growing demand for the four foreign record catalogs issued by his company; namely, the Polish, German, Hebrew-Jewish and Italian catalogs.

He says the company will continue to issue new records monthly for each one of these four catalogs and bearing out this policy, the first of this month, twelve new records were announced for the Jewish catalog and eleven for the Italian.

Mr. Rosenfield attributes the success of the Emerson foreign record business to the fact that all the numbers included in it are strictly native selections. He believes that foreign records succeed only insofar as they give exactly what the foreign population want, namely, their own native songs and their own native instrumental pieces.

PAVLOSKA SELECTS A BRUNSWICK

Reed & Dady, of the Hollywood Brunswick Shop, Los Angeles, Cal., report a call from Madam Irene Pavloska, Chicago Grand Opera star and Brunswick artist, to their salon, where she selected a model 117 Brunswick phonograph for her Hollywood home.

Ben Reynolds & Co., music dealers of Washington, Pa., have enlarged their talking machine department in which they feature the Victor line.

SELLING AGENTS FOR NEW MACHINE

M. M. Roemer Sales Corp., New York, to Handle the Oxford Phonograph Throughout the Country

The M. M. Roemer Sales Corp., of New York, was recently appointed sole United States selling agents for the "Oxford" phonograph, a new machine made in exclusive cabinet designs by the Mundler Corp., of New York. Although only placed upon the market a short time ago this phonograph has already made a very favorable impression.

The Oxford is the creation of S. Mundler, head of the Mundler Corp., who has had many years' experience in the industry, being formerly connected with talking machine manufacturing interests in London, England. In the past he has also been closely related to the industry on the continent, and his decision to place the Oxford before the trade and public was decided upon after a thorough study of what he felt was the present need.

The Oxford is manufactured in one size, but in a number of designs and is also manufactured upon special order to meet the requirements of period rooms, etc. The Mundler Corp. operates a large cabinet factory at 318 East Seventy-fifth street, New York City.

EXPECTS STRONG RECORD MARKET

E. D. Colen, secretary of the Emerson Phonograph Co., New York, stated to a representative of The World that the holiday business, as reported by Emerson dealers, was excellent in view of present conditions, and that the outlook is very encouraging. He looks forward to a very strong market for records in general, and Emerson records in particular, for a good many months to come.

The Merrill Music Co., Merrill, Wis., Cheney dealer, suffered a severe loss by fire early in December, but before the holidays was quartered in the Lincoln Hotel building.



Business men today are pragmatic. Their test for every idea is, "Will it work?"

That is the test we relish for our endeavor.

For that test brings out fully the genuine, practical, "workable" value of the man-to-man co-operative effort behind our Service.

Elyea Talking Machine Co.
Atlanta, Georgia

Exclusively Victor *Strictly Wholesale*



Kerekjarto (pronounced Kerek-yahrto) is the name of the new Hungarian violinist, who jammed the aisles of Carnegie Hall, New York, with his first two American concerts. His first Columbia Records are Sarasate's "Zapateado" and "Romanza Andaluza." Every real music lover will want them. Columbia 79456 and 49900.

**Columbia Graphophone Co.
NEW YORK**

THE COBROLA MAKES ITS BOW

New Portable Phonograph Introduced to Trade by Cobro Mfg. Co.

PHILADELPHIA, PA., January 3.—The new year has ushered in a new trade product—the Cobrola portable phonograph. This new machine is made by the Cobro Mfg. Co., whose executive offices are located in the Bulletin Building, this city. The factories of the company are at Vineland, N. J., and Hartford, Conn. The firm has been established for some years and has built up a reputation in the manufacturing of metal products and wire specialties and both factories are equipped with automatic machinery of the highest type.

This instrument is produced in a very attractive cabinet which is covered with genuine cowhide leather in black or, mahogany brown, embossed. The interior is upholstered in high-grade velvet and plush, harmonizing with the color of the leather. Its equipment includes a double spring motor, the Cobrola reproducer, record holder and leather handle. All metal parts are nickel plated.

One of the strong features in the sale of the Cobrola is the two years' guarantee against any imperfections due to defective material or improper workmanship. Upon the sale of each machine the dealer is required to return to the Cobro Mfg. Co. a card giving the name of the purchaser and other necessary information. Thus, an extensive list of all Cobrola owners will be at the command of the company. Circulars in both English and Spanish have been prepared and attractive window display cards for the dealers' use will also shortly be ready.

The personnel of the Cobro organization is as follows: D. S. Cohen, president; L. M. Sanders, vice-president, and G. E. Matteson, treasurer. Mr. Matteson was formerly president of the Commercial Guarantee Co., of this city. The company was incorporated under the laws of the State of New Jersey for \$150,000 and is a closed corporation.

Frank A. Hayes and Claude Phillip have organized the Music Box, Inc., in Beverly, Mass., and have opened a store in the Ware Theatre Building for the handling of Columbia Grafonolas and records, together with a general line of musical goods.

DEVICE TO PREVENT OVERWINDING

Jersey City Concern Places on Market New Device to Accomplish That Purpose

The Phonograph Specialties Mfg. Co., 67 Fleet street, Jersey City, N. J., has just placed on the market a new device which, it is claimed, makes it impossible to overwind talking machine motors. This device is attached to the motor shaft, following which the winding crank is inserted into its usual position. It is most simple in construction and occupies very little space and can be easily attached in a few minutes. After the device is made part of the motor itself the usual winding of the motor and its functions are carried out without any instructions being necessary. When the motor is sufficiently wound the winding crank automatically ceases to wind and becomes neutral. Not only does the attachment protect the spring from being overwound, but relieves strains upon the various parts of the motor caused by such action.

While the company at present is only manufacturing this device for one make of machine its construction with change in the size of the grooves for attaching the winding crank will make it applicable to all makes of motors and the manufacturer will shortly announce deliveries for other talking machines.

THE "BUNGALOW HOUSE" IN DALLAS

New Exclusive Brunswick Shop of Unique Character Opened in That City

DALLAS, TEX., January 3.—A new Brunswick Phonograph Shop has been opened at 1818 Main street, under the alluring title of the "Bungalow House." The new store has been fitted up in distinctly bungalow fashion, attractively designed and furnished, with every convenience provided for the customer. The interior of the bungalow contains a living room with its fireplace and draperies, a reception hall, library, dining-room and even kitchen, and in each room is a Brunswick phonograph of suitable type. The second floor contains Brunswick Hall, and a rest room for women. The hall itself will be used for recitals and will also be made available for meetings of women's clubs, etc.

The proprietors of the new shop are W. O.

Rosser and W. A. Macon, both from Chicago. The staff includes Floyd Johnson, A. H. Zall and C. L. Warrick. Mrs. J. K. Byers is in charge of the record library.

OKEH RECORDS IN DEMAND

Okeh Records Increasing Continually in Output and in Sales for January

Announcement was made last week by John Cromelin, general sales manager of the General Phonograph Corp., New York, that the daily shipments of Okeh records now being made are several hundred per cent larger than the daily shipments being made a year ago at this time. Mr. Cromelin anticipates that before the end of 1921 the daily shipments of Okeh records will increase at least 100 per cent over the present output.

NEWS OF EMERSON TRAVELERS

H. E. Morrison, sales manager of the Emerson Phonograph Co., New York, left the first of the month for an extended trip through the West. He will be gone in all about three months and was accompanied by Robert MacMacken, special field representative of the Emerson Co. The latter, in all probability, will locate permanently on the Western Coast. Mr. Morrison will hold general conferences with the Emerson distributors located in the western part of the country.

Chas. F. Usher, special field representative, is making his headquarters with the Ohio Emerson Co., recently appointed Emerson distributor located at Columbus, O. He will co-operate in the promotion and educational work.

Owen J. Logan, special field representative, will make his headquarters with the Roundtree Corp., Emerson distributor at Richmond, Va., with a similar purpose in view.

Harry J. O'Connor, of the Emerson Chicago office, is at present located with the Emerson distributor at Indianapolis.

Paul Zerrahn, special field representative, is now located with the Emerson Products Co., the distributor at Syracuse.

Morton Lucas, special field representative of the foreign record division of the Emerson Co., will also make his headquarters pro tem. with the Emerson Products Co., at Syracuse, and will cover upper New York, with a view to promoting the sales of the Emerson Polish, German, Italian and Jewish records.

BERNAT ACTING SALES MANAGER

While H. E. Morrison, sales manager of the Emerson Phonograph Co., is in the West on a three months' trip, J. I. Bernat, advertising manager, is acting as sales manager in addition to directing the publicity of the company. He knows the ropes.

W. H. Lester, Brunswick dealer in St. Petersburg, Fla., recently installed a \$125 model Brunswick phonograph in the new Knights of Columbus Hall, in that city.

H. J. SMITH LABORATORIES

Jewel Manufacturer

EXECUTIVE OFFICES,
FINISHING and
RECORDING
LABORATORY JEWELS

Plant No. 1
833 Broad Street
Tel. 2896 Market
NEWARK, N. J.

SAWING
GRINDING
ROUGHING
ROLLING and
EXPERIMENTAL
LABORATORY

Plant No. 2
54½ Franklin St.
NEWARK, N. J.

MANUFACTURER OF

Phonograph Diamond and Sapphire Reproducing Points—Recording Laboratory Jewels—Rough Diamond—Diamond Powder—Experimental Work. Jewels manufactured for all talking machine records. Consulting Specialist on all experiments relating to any new recording grooves. Recording problems satisfactorily worked out.

NO CUT IN VICTOR PRICES IN PROSPECT

Ralph L. Freeman, Director of Distribution of Victor Co., in Replying to Inquiry of A. D. Geissler Explains Position of That Company

Some very interesting and illuminating correspondence has recently ensued on the subject of prices for Victor records and Victrolas between A. D. Geissler, president of the New York Talking Machine Co., Victor wholesaler of New York City, and Ralph L. Freeman, director of distribution, Victor Talking Machine Co., Camden.

Mr. Geissler originally wrote to the Victor Co. that rumors were persistent among certain Victor dealers to the effect that a reduction in the prices of both machines and records was imminent, and asking if there was any reason for believing these rumors would prove true.

Mr. Freeman's letter in response very clearly sets forth the price situation in so far as it affects Victor products, and makes it evident that no reduction in the price of either Victor records or Victrolas is likely at this time. Mr. Freeman's letter follows verbatim:

"December 31, 1920.

"New York Talking Machine Co.,
New York, N. Y.

"Gentlemen:—Responding to your letter of December 30, we desire to say that there is absolutely no foundation in fact for any rumors to the effect that the Victor Co. is contemplating reductions in its prices for its products, either instruments or records.

"We have not made any general statement on this subject for the reason that it appeared to be impossible to adequately cover in a condensed statement the many features which have enabled the Victor Co. to offset the great difference between its increase in cost of production and the relatively small increase in its prices.

"On June 29 last, at Atlantic City, our president stated that during the war period the Victor Co. had handled an increase in cost of labor and material of at least 166 per cent, with only about 34 per cent increase in its prices. Since that date we have made no increases in our prices, but the last figures available, those for the three months ended September 30, 1920, show still further increases in cost of production, due to the fact that we are now using materials purchased at higher prices than those heretofore effective with us.

"One factor that has been most effective in stabilizing this company's prices during the last five years has been the strong financial position which had been developed for the very purpose of taking care of some such emergency, and which has enabled the company to purchase its requirements of materials at better prices than were generally quoted. A considerable portion of the difference between increase of production costs and increase of prices has been taken out of our profits, but the most important factor in the whole situation has been the ingenuity of our organization in devising improved equipment whereby manufacturing costs could be reduced without deterioration in quality.



REGINA

Apply for Prices and Territory for this most Attractive Proposition to

Musical Sales Corp.
5 BROMFIELD ST.
BOSTON, MASS.

MODEL 901

Turn your Table-Type Phonograph Sales into Bigger Profits.

IF you do not see how you can make sales and money by handling Udell record cabinets, write us and let us tell you what other dealers are doing.



No. 1402

Write today for the Udell Blue Book and other information

The UDELL WORKS

Indianapolis—1250 West 28th St.

"The policy of the Victor Co. has always been to do a large business on a moderate percentage of profit. Circumstances of the last few years have reduced our margin of profit to the point where it cannot be considered satisfactory or adequate for the maintenance of our organization. We believe that further advances in prices may be avoided, but certainly there can be no consideration of any downward revision in our prices until actual reductions in cost have been accomplished sufficient to allow the Victor Co. a safer margin of profit. Predictions against the future are always hazardous and we would not care to assume the responsibility of issuing any guarantees or doing more than give you a frank statement of the situation as it now appears to us. We cannot see any possibility of developments which would enable us to reduce our prices in the near future. Very truly yours,

"VICTOR TALKING MACHINE CO.,
"Ralph L. Freeman, Director of Distribution."

E. R. JOHNSON GIVES \$100,000

A contribution of \$100,000 to the European Relief Council from Eldridge R. Johnson, president of the Victor Talking Machine Co., for the carrying on of relief work among several million needy children in Central and Southeastern Europe, was announced this week by Herbert Hoover, who has been charged with the task of raising \$33,000,000 for relief work.

TAKES CHARGE AS MANAGER

MEMPHIS, TENN., January 4.—Saul Bluestein has recently been made manager of the Sonora Music Rooms, of this city. This is the talking machine department operated by the Fortune-Ward Co. Mr. Bluestein was formerly in charge of the talking machine department of J. Goldsmith & Son Co., of this city. Mrs. Dorothy Drigg and Miss Northrup Penland will be associated with him.

PLAN NEW NATIONAL ASSOCIATION

Music Trades Association of Southern California Moves to Form National Organization of Talking Machine and Phonograph Dealers

LOS ANGELES, CAL., January 3.—J. W. Boothe, general manager of the music department of Barker Bros., introduced a resolution at the last general meeting of the Music Trades Association of Southern California which had for its object the formation of a National Talking Machine and Phonograph Dealers' Association, and the secretary was accordingly instructed to write a letter to the various associations with this purpose in mind.

The following letter has been sent over the signature of A. G. Farquharson, the secretary:

"A resolution was adopted at our last meeting which has for its aim the foundation of a National Association of Retail Talking Machine and Phonograph Dealers, and the secretary was accordingly instructed to write to all of the retail talking machine, phonograph and music trades associations throughout the United States and ask them for their support and co-operation towards the formation of such an association—the object being the advancement, betterment and protection of the industry.

"It was suggested that delegates from the various associations should attend the Chicago Convention of Piano Merchants, which is to be held during the Spring of 1921.

"Enclosed you will find a copy of our constitution and by-laws, together with a list of some of the resolutions adopted during the past few months. These are for your information. Copies of some of your motions and resolutions would be highly appreciated by us."

J. P. MIDDLETON A VISITOR

John P. Middleton, exclusive Columbia dealer at Pittsfield, Mass., was a visitor this week to the Columbia executive offices. He said he had enjoyed a very fine holiday business.

THE MID-WEST

WESTERN DIVISION OF THE WORLD, CHICAGO, JANUARY 8, 1921.

So we are at the beginning of another year. Yes, and a year which looks very much as if it were going to develop into a very interesting and possibly even exciting stretch of twelve months. The truth is, we are getting to the bottom of our present low curve so rapidly that we are likely to outrun our own courage and to hold back our own recovery through the illogical though not unnatural process of losing heart when half way through. In point of fact, we are reaching bottom with truly wonderful rapidity. All through the realm of industry, whether in or out of the music industries, the process of liquidation and readjustment is in full swing and is continuing at a staggeringly rapid rate. And why should it not? This is no time for sluggish methods. What we want to do is to liquidate, to get out of the mess as quickly as we can, so as to reach bottom and start upward again. And, fortunately, all signs seem to show that we are doing this very thing. In fact, signs are not wanting that in some lines and in connection with some important corporations the bottom point has been reached and the upturn has begun. Stock market values in certain critical industrials are recovering and dividends are being passed much less frequently than seemed likely a month ago. The Spring is still three months away and prophecy is proverbially dangerous. Yet a prophecy we are willing to make. It is that before the violets are showing through the new grass of Spring there will have begun, and be well under way, such a restoration of industrial activity as will surprise even the most enthusiastic of us. Meanwhile let us hasten the process of readjustment, each of us by every means in his power. Let wholesalers and retailers together realize that what is needed is not necessarily specific reductions of figures by specific percentages as adjustment on a fair basis of existing figures to current levels of supplies and labor. We want readjustment—not reduction, deflation—not loss. And we can have them.

THE Western Division of The Talking Machine World, looking at the facts presented to their observation from all sections of the industry

as it centers here, has come to the very definite conclusion that the only proper attitude for us all is an attitude of very reasonable confidence. We do not like the word "optimism," for that word is really neither felicitous nor accurate. It comes to mean a belief in some conclusion a little better than is warranted by the facts of any case. One has come, unfortunately for the significance of the term, to think of an optimist as a person who invariably and futilely cries out that everything is lovely when, in truth, everything is just the other way around. Of course, optimism, like pessimism, represents a purely mental quality. "The world," "society," "industry," "business," are not abstractions existing in a sort of way all by themselves. They are different names given at different times to the whole assemblage of living men and women looked at from different standpoints, or functioning in different ways. What all the men and women in the world think is what, in actual fact, is thought by the "business world," by "society," or by what we often and very inaccurately call "the world." We are the world ourselves, and as we think in our hearts so is the world. Therefore, when conditions are bad it is because the world—that is, you and I and the rest of us—is feeling blue, or is reaping, in its own guilty conscience, the harvest of its sowing of tares in the shape of extravagance, recklessness and dishonesty. We reap what we sow. Wherefore neither optimism nor pessimism, in the ordinary sense of those words, should have any meaning for the man who thinks straight. For such a man will clearly see that the one great need is to keep one's head and to think out one's problems without allowing oneself to be led out of the straight path by the malignant hypnotism of the crowd. Crowds are always foolish, and crowd action is always foolish action. The man who thinks wins. And that man, wherever you find him, will tell you that there is every reason for rational confidence on the part of every man who has not made an absolute mess of his business affairs during the past year.

We make no bones about stating our belief that the coming year will be a year of strenuous success for those who fight. Our Chicago

Marguerite
Sets an
Example

Tribune, which, though it is unhappily mistaken in supposing itself to be the world's greatest newspaper, is nevertheless a journal which enjoys much influence, is telling each day that 1921 is to be a big year for fighters. Well, we in this newspaper office like fighters and don't mind saying so. We don't think that the fighting needs to be so terribly strenuous. We look for no scenes of carnage; we anticipate neither shrieks of the wounded in the distance nor cries off stage, but we do think that what would have been considered six years ago to be the natural job—going out and digging up the business—will have to become natural once more. The human animal is a lazy beast. Whether he admits it or not the fact remains that he just naturally hates work and takes to periods of rest like a bear to its Winter quarters. Now we are just at the end of one of these lovely periods of hibernal dreaming and resting. The sun of good, hard work is shining and we have to come out of our caves and start hustling. That is all that hurts us. Some of our elegant salesmen ought to take example from the writer's lady friend Marguerite. Marguerite is a turtle, of the soft-shell, snapping variety, which has imparted a touch of romance to the writer's happy home for several years. Normally, each year Marguerite sleeps from about December 15 to April 1. This year, however, she is still awake at this writing and refuses to hibernate. Neither nice warm sand nor any other temptation is strong enough to persuade her to lay herself down for the customary period of repose for the brief twenty-four hundred hours or so, during which she has been accustomed to forget the cares of life. Marguerite, in a word, declines to hibernate. Marguerite sets a good example.

WHILST we are talking about it, let us remind ourselves that the sellers' market has completely and irrevocably passed, but that it is not necessary to assume, in consequence, that we are in the

On
Taking
Off Weight

least worse off for that. One of the facts usually overlooked during any readjustment period is that we habitually become inefficient in proportion as business comes more easily to us. The fact is that the stress of competition in the industries where sharp competition normally rages, or that of service in the industries or occupations where quality is the most important item (as, of course, it ought to be in all) furnishes the necessary and in fact indispensable spur, without which the pace of self-improvement and of administrative and productive efficiency must constantly lag. In a condition of society where the demand is for better quality and where the buyer can pick and choose, there is the constant spur to greater and greater efforts on the part of all producers and distributors towards efficient methods. When, however, business is very prosperous, when the buyers are more numerous than the goods to be bought, when the demand is on the part of the buyer for some thing, rather than on the part of the seller for some buyer, then efficiency declines, invariably and inevitably. If there were not these periodical downturns, with their readjustments of method, of thought and of action, efficiency would disappear from the face of the earth and men would find themselves dying, industrially and socially, through a process of dry rot. We need these reminders, and their invariable effect is to tighten up the braces of the industrial and commercial machine, to force efficient methods and, in short, to prepare us for another period of easy times.

NOR should we forget that this, as some say, trying, period has taught us one plain and simple truth. It has taught us that the talking

We Are
Finding
Ourselves

machine has found its place permanently in the affections of the people. No one can doubt this who has seen how the talking machine industry, young, to a large extent untried, and to a still larger extent over-enthusiastic, has come through the present test. The talking machine, in a word, has proved itself, and has shown that it is to be

POINT OF VIEW

reckoned with in future as one of the completely necessary elements in the musical culture of the nation, as of the world in general. But we should remember at the same time that there are talking machines and talking machines. The public taste, in coming around to the belief that the talking machine is a desirable article of possession for purposes of entertainment, amusement and culture, is also coming around to the belief that there is a difference between one talking machine and another. In consequence, public taste will soon begin to fix upon the machines which experience demonstrates are the least troublesome and the most satisfactory. Reputations spread fast, and they depend finally upon character. The day for quality and service has come, and the manufacturer of machines or accessories who is not convinced on this point will be well advised to convince himself as rapidly as possible: for otherwise he is likely to find himself unpleasantly surprised one of these days. The great need of the moment is high quality combined with service. If dealers now shy at a new machine or even at one not so new, be assured that the principal reason for their feeling is a doubt as to the permanence and reliability of the article. This doubt, whether the article will stand up or whether service on repairs, etc., can be had, is a doubt which is present as often in the mind of the ultimate consumer as of the retail merchant. Which is another way of saying that quality is more important this year than it ever was before.

WE ran across a new one the other day. A certain firm, which shall be nameless, is going out after business in a really exciting sort of way, and among other stunts is working the residential districts by means of outside salesmen (vulgarly called door-bell ringers) very carefully: in fact is combing with a fine-tooth comb. One of the door-bell boys reported, when he came in at the end of a recent strenuous day, that he had run across one apartment house containing eleven families, on all of which he duly called. Five of the eleven had talking machines. Of the remaining six, one would not have a talking machine on any consideration. Five, on the contrary, were quite willing to envisage a talk-machine in the living room, but had been holding off for various reasons. When our bright young friend got into full working order he brought all five down to the point where they wanted to talk prices and terms: and why do you suppose they had been holding off? Well, because they were bitten by the prevailing belief that prices in all lines must come down and so were simply waiting until there were more evident signs of the process coming into tangible existence before going downtown. When, however, a salesman appeared from downtown out in their neck of the woods and began to work hard for business, these families, separately and independently, but as it happened identically, concluded that there must be real bargains at any store whose management was working so hard to get business. Which, of course, is simply another way of saying that there are more ways of killing a cat than by drowning it in cream. Comprenny?

WHICH reminds us that we have been hearing from many sources all sorts of queer stories concerning devious methods of selling talking machines, now being practiced, apparently with success, by various persons who have no real stake in the trade. One thing leads to another. Commercial salaries have not been rising like the wages of mechanics, and many queer shifts are made to boost up family incomes by such men. Only the other day we were surprised to learn of a veteran clerk who has been selling from his home talking machines of fair quality at a moderate price, in small quantities and on a basis not far from cash. This man, of course, and others like him deserve our sympathy. But the fact remains that they are securing business which the regular trade ought to have and to which it alone is entitled. On the other hand, of course, all this sort of fantastic business proves two things very clearly. It proves, for one thing, that business is to be had by those

who will go after it. And it also proves that if the methods to which we have accustomed ourselves are not producing results, other methods must be devised. If it be true, as the evidence just now adduced seems to show, that canvassers who go from door to door with nothing but a catalog and a line of conversation can sell talking machines on a healthy basis, then it is also true that the talking machine is a desired article and that the people have the wherewithal to buy it. The only remedy, in the face of facts like these, is for the legitimate dealers to go and do likewise. In a word, the legitimate trade must be willing to go out and look for the business which is being obtained by persons who, having no trade tradition to hold them back, are using whatever means appeal to them as being most likely to secure immediate results. House-to-house canvassing, classified want advertising in the daily papers and sometimes—one is inclined to think—a slight looseness in statement concerning the reason for selling from the home are doing the work of selling successfully. Is there not a hint here for the rest of us?

OUR revered contemporary, The Music Trade Review, which, in case our readers do not know it, we now state to be a weekly devoted to the piano trade (as Artemus Ward used to say: "N. B. This is wrote sarcastick") has been enjoying itself lately with grave discussions concerning what we personally feel compelled to call the nuisance of overjazzed music. Here is a point where the record men have it all over their colleagues of the music-roll. One can never sufficiently admire the talent, the ability and the courage which led the pioneers, particularly, let us say straightforwardly, the Victor Talking Machine Co., to stand up for the best in music year after year. It would be simply impossible to overestimate the value of that contribution to the development of American civilization. This is not yet a wholly civilized people. Good music is yet to be developed in a national sense; and here the talking machine industry may rightly be congratulated. For the talking machine has introduced to more people in the United States and elsewhere the message of good music than has any other single agency. Now music appreciation is solely and simply a matter of familiarity. One gets to understand and appreciate by getting to know, by personal contact, by the close touch of hand to hand. So with music. The talking machine has taught thousands, nay, tens of thousands, something about the meaning of music which all the jazz-ieties in the world can neither take away from them nor make them regret. We have that much to be thankful for at any rate.

ONE imagines that any manufacturer in this or any other industry would give a rather cold reception to the enthusiast who should enter the sanctum with a "perpetual motion" machine. In fact, the world does not regard the notion of perpetual motion with any particular sympathy. But one is led to the belief that the talking machine trade is about as near to that ideal as it could well be. Let us elucidate. We have now repeating devices which start the record going again as soon as it has been played through. That is a good start towards perpetual motion. Then, lest the spring of the motor run down, we have machines for keeping it wound up. And so the music needs not come to an end through lack of co-operation from the motor. Or, for that matter we have electric motors which will keep on running so long as the customer pays the bill for the current. And, lastly, there are permanent or semi-permanent needles which do not need to be changed till any number of records up to fifty have been played. If a keen-minded merchant were looking for a really exciting bit of publicity, via the window display for instance, he could scarcely do better than give a "perpetual motion" exhibition. It surely would draw the crowds. Here is an idea absolutely free, gratis and for nothing. Who will be the first retailer to carry it out?

More Ways Than One!

Dropping Our Hammer, We Seize the—!

An Idea Worth Considering

The Elusive "Gyp"

Have You Heard the New MANDEL Records?

There is a treat in store for you. The MANDEL Record is the newest lateral cut record out. We consider the MANDEL Record the last word in quality. The quality of the music as well as the record itself is second to none.

MANDEL Records are recorded for this Company. The masters from which MANDEL Records are pressed are our own property. We have engaged the very best talent obtainable for the recording of our records. The names of the artists are well known in the amusement field.

The first release consists of sixteen records—thirty-two selections—including the very latest dance music and instrumental music as well as standard vocal and instrumental and operatic selections. This first list has been selected with great care, having in mind their commercial value.

Our plan is to release ten numbers monthly. All new records released will be selected with a view to their salability, for it is our intention to build up a catalog only of good selling numbers.

Attached is an order blank for the entire assortment of sixteen records. We would suggest that you sign and mail this order blank to us at once.

Popular Dance Records

- 4001 { AVALON—Fox-trot,
10 in. { Raderman's Novelty Dance Orchestra
\$1.00 { DARLING—Fox-trot.... Ben Selvin's Dance Orchestra
- 4002 { THE JAPANESE SANDMAN—Fox-trot,
10 in. { Raderman's Orchestra
\$1.00 { FEATHER YOUR NEST—Fox-trot,
Selvin's Syncopating Melodists
- 4003 { WHISPERING—Fox-trot Raderman's Orchestra
10 in. { GRIEVING FOR YOU—Fox-trot.... Selvin's Orchestra
\$1.00 {
- 4009 { THE LOVE NEST (From the musical comedy, "Mary")
10 in. { Green Bros.' Novelty Orchestra
\$1.00 { ALABAMA MOON—Fox-trot Green's Orchestra

Hawaiian Selections

- 4004 { ALOHA OE—Hawaiian Guitars... Ferera and Franchini
10 in. { HONOLULU MARCH—One-step
\$1.00 { Hawaiian Guitars—Ferera and Franchini

Standard Selections

INSTRUMENTAL

- 4013 { WASHINGTON POST MARCH... Mandel Military Band
10 in. { NATIONAL EMBLEM MARCH,
\$1.00 { Mandel Military Band
- 4014 { AMERICAN PATROL—March... Mandel Military Band
10 in. { SUNNY SOUTH—March..... Mandel Military Band
\$1.00 {
- 4015 { POET AND PEASANT OVERTURE—Part 1
10 in. { Mandel Concert Band
\$1.00 { POET AND PEASANT OVERTURE—Part 2
Mandel Concert Band

Popular Vocal Records

- 4005 { BROADWAY BLUES—Contralto Solo,
10 in. { Aileen Stanley, with Orchestra
\$1.00 { DON'T TAKE AWAY THOSE BLUES—Baritone Solo
Ernest Hare—Orchestra Accomp.
- 4006 { TIRED OF ME—BALLAD—Tenor Solo
10 in. { Chas. Hart and Orchestra
\$1.00 { DOWN THE TRAIL TO HOME, SWEET HOME—
—Duet—Tenor and Baritone. Elliot Shaw and Chas. Hart
- 4007 { WHEN I LOOKED IN YOUR WONDERFUL EYES
10 in. { —Tenor Solo..... Chas. Hart, with Orch. Accomp.
\$1.00 { I'D LOVE TO FALL ASLEEP AND WAKE UP IN
MY MAMMY'S ARMS—Soprano, with Orchestra
Helen Bell Rush
- 4008 { MY LITTLE BIMBO DOWN ON THE BAMBOO
10 in. { ISLE—Baritone, with Orchestra..... Ernest Hare
\$1.00 { PALESTEENA—Comedy Selection, Orchestra Accomp.
Fred Whitehouse

Standard Vocal Numbers

- 4010 { A DREAM—Tenor Solo with Orchestra.... James Price
10 in. { ABSENT—Tenor Solo, Orchestra Accompaniment
\$1.00 { James Price
- 4011 { GOOD BYE (Tosti)—Soprano with Orchestra. Ida Wells
10 in. { SING ME TO SLEEP—Soprano Solo, Orchestra Ac-
\$1.00 { comp. Ida Wells
- 4012 { MIMI—(From the opera La Boheme)
10 in. { Sung by Mme. Fonariova
\$1.00 { VISI D'ARTE—(From the opera Tosca)
Sung by Mme. Fonariova

Violin Selections

- 4016 { SOUVENIR Played by Vera Barstow
10 in. { BERCEUSE Played by Vera Barstow
\$1.00 {

CUT THIS ORDER BLANK—MAIL IT TO-DAY—FIRST RELEASE MANDEL RECORDS

MANDEL MANUFACTURING CO.

1455 W. Congress Street, Chicago, Ill.

Ship as soon as possible by Parcel Post Express your assortment of 16 first release Mandel Records, at your regular trade discount.

Signed _____

From our **CHICAGO** HEADQUARTERS
 REPUBLIC BLDG., 209 SOUTH STATE ST TELEPHONE WABASH 5774

EDWARD VAN HARLINGEN

WILLIAM BRAID WHITE

EUGENE F. CAREY

ARTHUR E. NEALY

A. SNYDER

CHICAGO, ILL., January 5.—The holiday season just passed has surprised everyone in point of sales. In the city of Chicago, at least, talking machines were pushed, through advertising campaigns, house-to-house canvass and in every other way imaginable. Judging by the newspaper advertisements just before Christmas one might imagine the public was on a talking machine purchasing spree. There were special offers galore, special terms, and even reduced prices. Full-page advertisements carried the news to the public in startling headlines. All of the various makes, even the best known, were offered with exceedingly small down payments; most, in fact, being delivered after the purchase of a few records on the so-much-per-week plan.

So much for the holiday advertisements. The result was a very large sale of instruments throughout the city, which has had the good effect of clearing things up somewhat. It can probably be said that the holiday sales of talking machines in Chicago were far better than the average of the rest of the country. As a matter of fact, manufacturers of pianos and other musical instruments complain that talking machines were pushed to the exclusion of piano sales.

Intensive selling seems to be the order for the coming year. House-to-house canvassing on the part of the dealer and better dealer service on the part of the manufacturer will have a more important place in the new order of things. It is the belief of those best qualified to gauge business conditions and make predictions that the honest value will find a market in 1921. Whether the instrument be of the popular-price type, or of the expensive period console design, if the price is right and the integrity of the goods themselves assured, the aggressive dealer will be able to show a satisfactory balance a year hence. Probably a number of concerns will retire from business. These retirements may be caused by financial difficulties or from lack of merit in the product itself. In either case the result will be to strengthen the lines that remain.

Retail stocks are undoubtedly very much lower than before the holidays. Conservatism has been the watchword of the dealer during the past six months. He has been content to

run along on very much lower stocks than before. Visiting dealers have been few for some time past, wherefore many can be expected after the first of the year. There is an unprecedented list of furniture dealers scheduled for the market opening both here and in Grand Rapids, which is an excellent sign.

The wholesale business is destined to enjoy a steady increase commencing with the first of the year. Of course, this does not mean much because it has been practically at a standstill for a month or so. Predictions for the opening of a better retail trade vary from February 1 to April.

Handsome Sonora Display

At 669 N. Michigan avenue, where the autos of "Gold-Coasters" pursue their lordly way to and from Sheridan road, C. J. Van Houten & Zoon have installed one of the most handsome and artistic small window displays in the country. The window has been prepared solely as an advertising project to benefit Sonora dealers in Chicago and is in the front of a building used for a dancing academy. No machines are being sold from this place, although the proprietors of the dancing academy undertake to refer inquiring purchasers to C. J. Van Houten & Zoon.

The window display cost the above Sonora jobbers fifteen hundred dollars and is equipped as follows: On display are the Sonora Gothic De Luxe Normandy model in antique walnut, the retail price of which is \$1,500; a Louis XV De Luxe Du Barry at \$1,250, and a Jacobean Robespierre in antique walnut at \$1,300. The woodwork is done in old ivory enamel, the draperies in English mohair casement cloth with a pleated valance two feet deep across the entire top of the window. Blue and tan half-tassels hang from the valance. An antique Chinese chair and marbleized console table, two carved wood candlesticks and a Glendale carpet complete the interior. On the outside an illuminated sign flashes the Sonora trade-mark night and day to the passing automobiles.

Is Business Bad?

Not according to gentlemen of the type of Wm. R. Gross, of Mattoon, Ill. Mr. Gross works for the M. J. Ritter Drug Store of this city. He is a decided talking machine enthusiast and, bad times or good, believes these instru-

ments can be sold if the proper effort is put forth. A short time ago he asked his manager to be freed from the duties in the store in order to go out and canvass the neighborhood for talking machine prospects. The photograph shows fifteen hundred dollars' worth of Victrolas disposed of in one day by Mr. Gross. The phonographs were lined up outside the



One Day's Sales of Victrolas

store as shown, for the purpose of advertising, and as a result this young gentleman obtained fifteen more prospects.

When it is remembered that the feat was accomplished during a period when talking machines were not selling with remarkable rapidity, we are inclined to give Mr. Gross all the more credit.

Makes Will on Record

Earl H. Reynolds, Chicagoan, has set a fashion in recording of wills. We use the word recording literally. After dictating his wishes into the instrument, two attorneys followed by dictating their names as the spoken signatures of witnesses. James E. Callahan, one of the attorneys, says "the voice is mightier than the pen." The judge before whom a phonographic will is offered for probate can tell whether the testator was strong or weak from the tone of his voice as reproduced by the sound. He can also judge whether the testator was of sound and reasoning mind from the fluency or lack of fluency evidenced by the record.

A Children's Hour

The Celeste Music Co., of Pekin, Ill., has worked out an original and effective plan for interesting the children of its clientele. On Friday and Saturday mornings of each week throughout the Summer months the children of this town are entertained at the above store. A

(Continued on page 133)

**When in the market for Fibre Needle Cutters
 Always get our prices
 Do not be put off with any other cutter
 Efficiency is our first object**

& we want your valued orders

**Will we hear from you soon?
 Allow us to quote you on a quantity
 Do not wait until the other fellow outsells you
 Enter your order at once. (Today.)**

WADE & WADE

3807 LAKE PARK AVE.

CHICAGO, ILL.

An Example

Of the Dealers' Helps prepared by Lyon & Healy



A set of four envelope enclosures of the highest class in design and text. Insert one in every statement or letter you mail to a customer. They are drawn by a high-priced artist, printed in colors, and carry effective sales talks. There is a space for imprinting your name and address.

Lyon & Healy Dealers' Helps Increase Your Sales

All of the Lyon & Healy services are well tested and tried. We use them for our own retail trade—one of the largest in the country.

They are sold exclusively to the MOST PROGRESSIVE VICTOR DEALER in each city. If you are that man, write for a complete list of our services, full information and samples.

LYON & HEALY

Victrola Distributors

CHICAGO

FROM OUR CHICAGO HEADQUARTERS—(Continued from page 131)

story hour with educational records, both musical and spoken, is the attraction. Mrs. Julia A. Catron, a member of the firm, and a person who has had several years' experience in both State and local musical club work, arranges the programs. These are made as educational as possible without sacrificing the interest of the audiences. The benefit to the firm of these pleasant hours given the children accrues in the latter's support of the Celeste Music Co.

Foils Bandit

C. H. Smith, of the Smith Piano Co., on Wabash avenue, recently had an exciting experience with an automobile thief who attempted to steal his auto as it was standing in front of the store. Mr. Smith observed the bandit just as he was starting up and gave chase. The man was caught before he had even got as far as Jackson Boulevard, and turned over to the police.

Fire on "Row"

At 6:30 o'clock Monday morning, December 27, the Chicago fire department was called out to extinguish a fire in the basement of the Adam Schaaf establishment on Piano Row. The blaze was of little consequence and was immediately brought under control. An overheated furnace caused by a sudden change in the weather was responsible. The merchant from whom we obtained this information solemnly asserts that he was on the job looking for customers at this early hour of the morning, and so personally viewed the events.

Fights Excise Tax

The Chicago Piano Club, which numbers among its membership many talking machine men, has instituted propaganda to combat the proposed excise tax legislation under contemplation in Washington. At a recent regular weekly meeting Otto Schulz, president of the National Piano Manufacturers' Association, and manufacturer of Magnola talking machines, spoke regarding the proposed legislation, which, if it goes into

effect, will put an excise tax of ten instead of five per cent on musical instruments. He urged whole-hearted effort on the part of the trade in opposition to this increase in tax, pointing out its unfair and demoralizing effect upon the industry. After considerable discussion it was moved and carried that a special committee be appointed to collect such data as the members of the club might find valuable in sending to their representatives at Washington.

With Play-All Phonograph Co.

W. G. Laing has been appointed as sales manager of the Play-All Phonograph Co., located at 328 River street, this city. Mr. Laing has had previous connection with the talking machine industry, but during the past two years has been active in the automobile field. Joseph R. Bean, formerly with the Consolidated Talking Machine Co., of this city, has also rejoined the Play-All organization.

Granby Executive Here

H. H. Shoemaker, sales manager of the Granby Phonograph Corp., paid a short visit to Chicago during the latter part of December for the purpose of conferring with his Chicago representative, R. J. Waters. Mr. Shoemaker was decidedly optimistic in his 1921 expectations, but does not anticipate a big opening up of retail business for a couple of months yet. "I am convinced that the phonograph of quality, representing dollar for dollar value, is destined to sell in ever-increasing volume," he said. "We are going ahead on the assumption that 1921 will show a good business. We were receiving orders, particularly from the South, right up until the end of the year."

Music Teachers Meet Here

The trade will note with interest that the Music Teachers' National Association held its 42nd Annual Convention in Chicago on December 30. The association has not held a meeting in this city since 1888. It was a three-day affair, starting on Wednesday, December 29 and end-

ing Friday, the 31st. The Hotel La Salle was the center of activities, and the program included some very interesting speakers on highly interesting subjects. Music, of course, is playing a more important part in the curriculum of schools every year. The talking machine, particularly, has its place in the grammar school, and the doings of the educators should be of interest to the trade.

Petitioned in Bankruptcy

E. Buell has been appointed receiver in bankruptcy for the Shell-O-Phone Talking Machine Co. of Chicago. A petition in bankruptcy was filed on December 15 by the Oakville Co. of Oakville, Conn.; Modern Method Platers Co. of Milwaukee, Wis., and the Wisconsin Die Casting Co., also of Milwaukee. The liabilities listed totaled \$6,132.56. There were no assets given.

Van and Schenck Entertain

Van and Schenck, famous entertainers of the "Ziegfield Follies of 1920," amused members of the Chicago Piano Club at their noonday luncheon on Monday, January 3. The Columbia Co.'s Chicago staff, together with Harry L. Schoenwald, are the gentlemen responsible for bringing this attraction to the Piano Club.

Manufacture Excelsior Pads

The H. W. Selle Co., of this city, has built up quite considerable business in the talking machine field in connection with the manufacture of excelsior pads for packing. The company has been in the business of manufacturing these pads since 1907, but it was only recently that its talking machine business has grown to its present proportions. After spending some years and a large sum of money in experimenting, the H. W. Selle Co. has perfected a machine which rapidly and effectively turns out this article so much needed for the shipping of talking machines.

Cheney Christmas Advertisements

The Cheney Talking Machine Co. carried an
(Continued on page 135)

Your Account With Us

Lateral
Cut

Okeh

Lateral
Cut

Records

Will Be an Insurance Policy Against

EMPTY RECORD SHELVES
LOSS OF CUSTOMERS

LOSS OF PROFITS

Record Dealers Reach the Acme of Wisdom

WHEN THEY STOCK UP WITH POPULAR HITS ON

OKEH RECORDS

No Waiting for Delayed Shipments When You Order From Us

MAGNOLA TALKING MACHINE COMPANY

711 Milwaukee Avenue
OTTO SCHULZ, President
CHICAGO, ILL.

Phonograph Motors

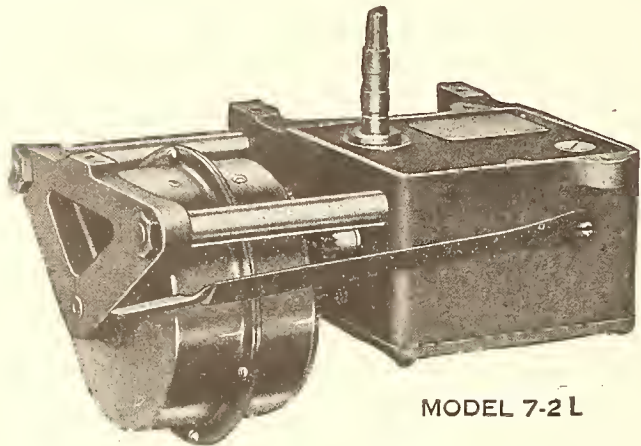

MODEL 7-2 L

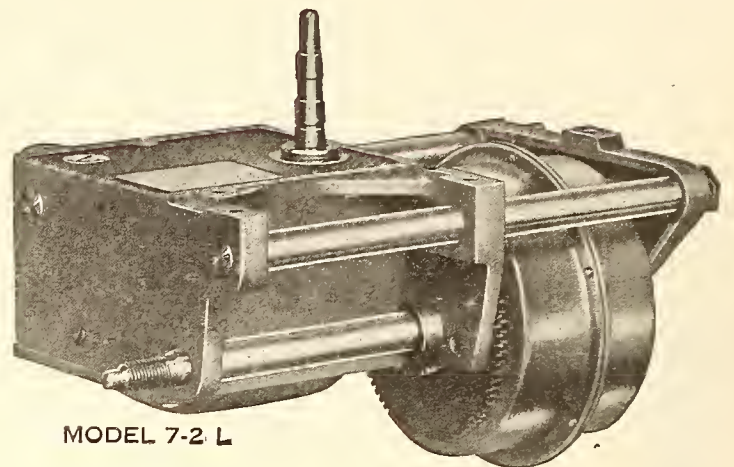

MODEL 7-2 L

Silent—Self-Lubricating—Enclosed No Tuning is Necessary

Think of what this means to you. Think of the time and money you have spent in past years, are spending now, tuning and adjusting noisy motors. Think of the business and money you have lost and realize that now it is unnecessary for you to do any tuning if these ENCLOSED MOTORS are used.

If you have to correct a motor when it reaches you, someone will have to correct it after it leaves you. If it didn't stand shipping shock once, it won't stand it again.

The basis of all motor trouble is faulty design. Even perfect workmanship will not offset it. Our Engineers knew by experience the weaknesses of the open type motor, and overcame them in the design of this ENCLOSED MOTOR.

All delicate parts are housed in a rigid rectangular casting. This keeps out dust and dirt, and makes it possible to use a capillary oiling system which is automatic. The enclosed casting protects the mechanism in handling, besides being so rigid that motors can be shipped any distance without getting

out of adjustment. It insures your finished instruments reaching your jobbers, dealers, and customers in good condition. And although the driving mechanism is in the cabinet, out of sight, mechanical excellence does help make sales to the customer. The smooth, easy winding, the absolute uniformity of speed and the utter absence of noise or vibration are eloquent of quality—finesse.

Excepting only springs, castings, felts, etc., we make every part of this motor in our own factory, where we can and do control its accuracy. We are in real quantity production, and making as we do just one thing—PHONOGRAPH MOTORS—enables us to make better motors. This is a highly specialized business—it takes concentration, experience, capital, and fine equipment—We have all of them.

We are now supplying many of the large Talking Machine manufacturers with these motors, and their motor troubles are over. If you want to see the end of **YOUR** motor difficulties, we will show you.

Supplied in 2, 3 and 4 Spring Models
Felt and Velour Table Coverings, Nickel and Gold Finish
Write us for full information, details of design, models, prices, etc.

UNITED MANUFACTURING & DISTRIBUTING Co.

LAKE SHORE DRIVE AND OHIO ST. CHICAGO, ILL.

FROM OUR CHICAGO HEADQUARTERS

(Continued from page 133)

effective Christmas advertising campaign featuring its various models. Chicago newspapers have contained full-page announcements of these artistic instruments illustrated in the usual Cheney style. Cheney dealers throughout the country were supplied with cuts and copy for a series of Christmas advertisements similar to those used in Chicago.

New Rockford Store

A. G. Ogren, of the A. G. Ogren Music Co., Rockford, Ill., was a visitor to Chicago during the latter part of December and told of his new store in Rockford. The formal opening for this was held on the 11th of the month, with special music provided to entertain customers. The feature of the entertainment was a number of selections by a harp-violin-cello trio.

"The holidays have shown quite a satisfactory trade with us," said Mr. Ogren, "and we expect our new store to adequately take care of an increased business in 1921." The A. G. Ogren Music Co. handles the Victor line.

More Repeater-Stops

R. P. Hartenstein, manager of the Repeater-Stop Co., reports a satisfactory sale of Repeater-Stops during the holiday season. "There is an increasing demand for the refinements with which to equip talking machines, and we look forward to a highly successful year in point of Repeater-Stops," he said.

Speed in Deliveries

The photograph shows one of the Lyon & Healy high-speed motor trucks. This truck has a capacity of nine pianos or forty Victrolas, and recently made a record by traveling 210 miles from Chicago to an Indiana town and return in

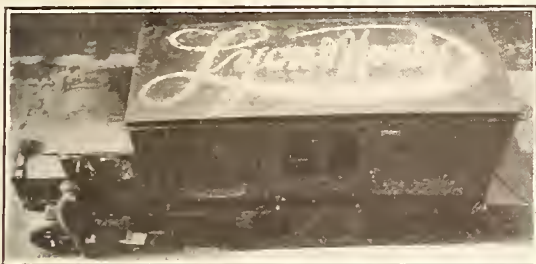

How Lyon & Healy Deliveries Are Made

fourteen hours, or at a rate of about twenty-one miles per hour. The truck contains a Packard motor, equipped with a special body designed by Lyon & Healy's traffic department. The truck is fitted with special pneumatic tires ten inches in thickness and forty-four inches in diameter. The proud chauffeur claims that his "limousine" rides like a Pullman car.

Columbia Doings

A Christmas party for everyone connected with the Chicago office of the Columbia Graphophone Co., with their wives, sweethearts and friends, was given Monday evening, December 27, in the Stevens Building. The feature of the evening was the arrangement of the program, and the announcements, for which G. MacNichol was entirely guilty. D. W. Donahue, who, by the way, has recently come with the Columbia,



Repair Parts

For All and Every Motor That Was Ever Manufactured



We can supply any part. The largest and most complete assortment of repair parts—in the United States—on hand, for old, obsolete and present-day motors. If your order cannot be filled from stock, we will make it up special.

Special prices on main springs, governor springs, micras, repair parts, motors, tone arms, steel needles, etc., in quantity lots.

Expert repairing on all makes of phonographs and motors.

INCORPORATED UNDER THE LAWS OF ILLINOIS

Consolidated Talking Machine Co.

SUCCESSORS TO
Standard Talking Machine Co.
United Talking Machine Co.
Harmony Talking Machine Co.
O'Neill-James Co.
Aretino Co.

Manufacturers of
High Grade Talking Machines, Disc Records,
Talking Machine Supplies, Etc.



TRADE MARK
"CONSOLA"
CABLE ADDRESS
"CONSOLA"

227-229 W. Washington St., Chicago, Ill.

furnished a good deal of the humor for the party. "Dinny" can tell you more jokes and ask more funny questions than the entire organization can answer.

A grand march, led by Manager J. McKenna, was very impressive—can you imagine grand marching to syncopated music of the "Stars and Stripes Forever," Mendelssohn's Wedding March and Chopin's Funeral March? An imitation of Frisco was given by A. J. Bell, who is indeed a great dancer, and everyone agrees that some day "Bell" will stand out in the lights of the Palace Theatre. More power to him.

Miss "Nubs" Allan and "Lucky" Wilber entertained with the latest songs of the Feist Co., including "Feather Your Nest," "Grieving for You" and "I'm a Little Nobody That Nobody Loves."

As a surprise feature, J. Kapp was asked to revive "Look What My Boy Got in France." The sales talk was given and then Kapp sang it. The third anniversary of this song is coming shortly—watch for it. Mr. Smith was responsible for the arrangement of the entire party, securing the accommodations and appointing the committees. This was the first party the Columbia branch ever had. Judging from the result—the happy looks of all who were there—it was a tremendous success.

Convert Concert Hall

The concert hall of the Lyon & Healy store was used during the holiday season as a talking machine salon. The regular machine demonstration space on the first floor had been found in-

adequate to take care of the holiday rush. Looking in upon L. C. Wiswell and his energetic associates during the weeks before or after Christmas one would hardly gain the impression that business was dull. The Lyon & Healy record department on the second floor was taxed to the limit during the holidays, and it is to be regretted that some of the calamity howlers in the trade could not have been taken on a little sight-seeing tour through the department.

Aeolian Campaign a Success

The holiday advertising campaign in the interests of Aeolian-Vocalion in Chicago was a decided success. According to H. B. Levy, mid-Western representative, the sales total in this city during 1920 was brought up to exceed that of the year previous, largely through the special efforts of holiday campaigns. The Vocalion business of Mandel Bros. was increased twenty per cent, which is quite remarkable when it is considered that the year previous was also a good one for this house.

The holiday offer consisted of a Christmas Club, which enabled prospective purchasers to place the machine in their homes upon the purchase of a few records. There were generous clauses in the contracts given the purchasers, providing protection in case the machines were destroyed by fire, etc. There was also a life insurance clause giving the purchasers a clear bill of sale in case the latter died before the machine was paid for.

(Continued on page 137)

TRANSFER NAME-PLATES

We make the Transfer Name-Plates and Trade-Marks for the largest talking machine manufacturers in this country and for dealers in every state.

YOUR NAME, Mr. Dealer, on every machine brings the owner back to you or records and his friends to you for a machine.

Samples, Suggestions and Sketches Furnished Free

THE MEYERCORD COMPANY, CHICAGO

Largest Manufacturers of

DECALCOMANIA

Transfer Name-Plates

UNIVERSAL MASTER MOTOR No. 20

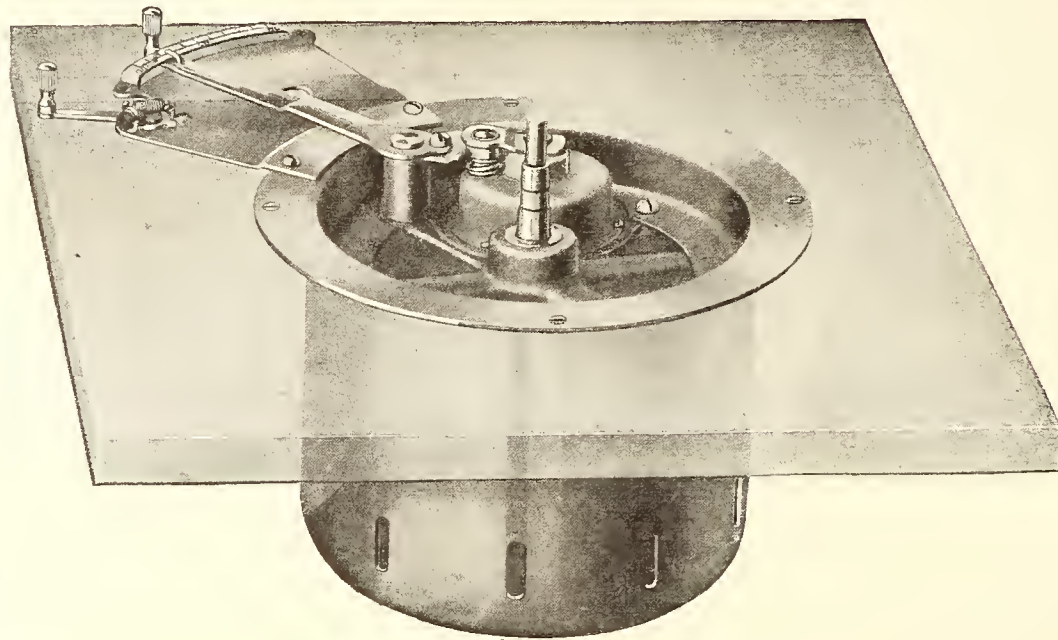

Three Essentials for Your Success in 1921

Your success as a manufacturer of or dealer in phonographs will depend upon three things: Your selling plans and methods, the mechanical excellence of your product and the amount of energy and enthusiasm which you put into your work.

Features that sell the UNIVERSAL MASTER MOTOR No. 20

Silent operation.

Sealed in dust-proof (fool-proof) case.

Perfect lubrication and accessible oiling system.

No heavy hanging parts to become damaged or thrown out of adjustment in shipping.

No noisy ratchet winding mechanism.

Gear shafts short and heavy—do not spring when under load.

Governor sets vertically—the correct position for centrifugal governor.

The Drum assembled with spring is always a complete unit.

Easily and quickly installed.

As for your selling methods that is a matter entirely within your own hands. Our place, as far as your success is concerned, lies in our ability to supply you with a phonograph motor which has radically new and novel features, making it unique and interesting from the standpoint of the buyer and with a record of past achievement which makes it a safe and sure proposition for the manufacturer and dealer.

As for the enthusiasm necessary for you to make a success of 1921, that is entirely up to you. We know, however, that if you have not yet been fortunate enough to see the performance of the Universal Enclosed Master Motor you will become enthusiastic over it the moment you see it in operation. We say see advisedly, for silent operation is an accomplished fact with this motor.

Marshall Field, the greatest merchandising genius of our times, is credited with this bit of philosophy—"Buy in cold blood; sell with enthusiasm." We invite you to buy the Universal Enclosed Master Motor in cold blood—with critical eye and ear—for we know that once you become acquainted with it you will sell it with enthusiasm.

Write for Samples.

Universal Stamping & Mfg. Co.

1917-1925 S. Western Ave., Chicago

FROM OUR CHICAGO HEADQUARTERS—(Continued from page 135)

The same sort of a campaign was carried on in Milwaukee by the Edmund Gram Piano Co., agents for the Vocalion in the Cream City. By the night before Christmas they had exceeded their Vocalion sales of the previous year.

"We do not expect a phenomenal increase in 1921," says Mr. Levy, "but look for a good healthy continuance of Vocalion sales throughout the mid-West. The Vocalion is a quality instrument and it is my belief that quality will sell at an increasingly greater premium in the coming year. We hear a lot about the towns where men are being laid off by the thousands, but less publicity is given to the towns and industries where men are being taken back."

Death of Harrison H. Michael

Harrison H. Michael, traveling representative for the Chicago Talking Machine Co. through Michigan, Illinois and Indiana, died at his home in this city on January 1. Mr. Michael, who was formerly with the Victor Co., had a large following of friends throughout the country who will learn with great regret of his death.

Closed Great Tonofone Year

The R. C. Wade Co., manufacturer of the Tonofone needles, closed in 1920 one of the best years in the history of its business. The demand for Tonofone needles has been steadily growing throughout the country and dealers everywhere report that users of Tonofone needles are highly pleased with the tone results possible from the records through the medium of this needle. Progressive sales plans for 1921 are now under way and it is certain that the Tonofone will be a tremendous factor in the industry during the progress of the year so recently opened.

Stewart Phonograph in Chicago

A. C. Moreland, sales manager of the Stewart Phonograph Corp. of Buffalo, was a visitor to Chicago this month. He came for the purpose of aiding in the establishment of a Chicago office, which is to be in charge of Lester B. Suf-

fens. The location of the office has not yet been decided upon, but extensive plans are being made for aggressive representation of the Stewart line in Chicago. Mr. Moreland reports a rapidly improving outlook for the Stewart machine and is very jubilant over certain new improvements in the Stewart product, which will make it more successful than ever. Mr. Sufens will be remembered as having been formerly with the Pathé department of the W. W. Kimball Co.

Chicago Furniture Show

Exhibitors at the Chicago Furniture Market are saying that the furniture show which opened Monday of last week is drawing as many visitors as any show in the past and from present indications it seems that there will be a record-breaking attendance. The big buildings on Michigan and Wabash avenues which house the exhibits of nearly five hundred manufacturers of furniture and allied lines officially threw open their doors for the regular mid-Winter buying season on Monday morning. The showing made, which can only be mentioned in a general way, includes not only the standard furniture designs, but an increased number of talking machine exhibits. At present there are only a few of the well-known houses, such as Mandel, Vitanola, the Joseph Knittel Co., of Peoria; the Eagle Wood Turning Co., who have their demonstration booths open. But it is said by the managers of the building that before the end of the week quite a number of talking machine manufacturers will have arrived with their exhibits. It is also believed that the combined talking machine exhibits of both the Grand Rapids show and the Chicago show will be much larger than ever before.

Petition for Adjudication

A petition for adjudication has been filed in the Chicago Federal Court against the Genoa Piano Co., which manufactures pianos and talking machines in Genoa, Ill. The affair is a

EXCELSIOR PADS

The most satisfactory packing material for packing phonographs for shipment. Used to advantage by the largest manufacturers. Send for prices and samples.

H. W. SELLE & COMPANY

Manufacturers

1000-1016 N. Halsted St., Chicago, Ill.

minor one both from a business and financial standpoint.

Good Progress in Vitanola Affairs

The affairs of the Vitanola Talking Machine Co. are rapidly approaching a very satisfactory condition. An interesting development is the report that the equity receivership appointed some time ago is soon to be discharged upon order of the court and the affairs of the company turned over to its officials. A statement outlining a plan which it is believed points the way to a satisfactory development of the financial affairs of this corporation has been issued by Referee Wheelock, who has been in charge of the company since the equity proceedings in the United States District Court.

A feature of the plan is the proposed sale of the recently completed plant of the Vitanola Co. at Cicero and the application of the cash proceeds therefrom to the immediate needs of the business. It is planned to operate the former factory of the Vitanola Co. in this city for manufacturing purposes as soon as the sale of the Cicero plant has been approved by the receiver.

An agreement covering the methods under which the company is to operate has been drawn

(Continued on page 138)

ORDER FROM WADE

HAVE THE HITS WHEN THEY ARE HITS

"12th Street Rag" "MARGIE" "FEATHER YOUR NEST"

OKeh
Records

Cover a line complete—
Instrumental Classics
Vocal Classics
and all the big

HITS



OKeh
Records

Will stimulate your business—Secure this wonderful line in your locality.

Do this today.

Mail in the

COUPON

Wade Talking Machine Co.
WHOLESALE DISTRIBUTORS.

12-20 N. MICHIGAN AVE.
CHICAGO, ILL.

Wade Talking Machine Co., 12 to 20 N. Michigan Ave., Chicago, Ill.

Please send us your Dealer's Proposition on *OKeh* Records
Machines

(Insert lines carried)

Records

(Insert lines carried)

Name

Address

(Write name and address plainly)

FROM OUR CHICAGO HEADQUARTERS—(Continued from page 137)

up between the Vitanola Co. and its creditors' committee under the supervision of Receiver Wheelock. This committee is composed of men of long experience and a practical knowledge of the talking machine industry.

It may be said that the members of the Vitanola Co. have had the confidence and support of both the receiver and the creditors' committee and they have all worked together harmoniously to the end of putting this business on its feet so that it may be again a factor in the industry.

Solar's Unique Outfit

Solar's Music Shop, Columbia dealer in this city, recently budded forth with a very striking automobile truck, as may be seen from the pic-



Some Stunt in Selling Grafonolas

ture herewith. The body of the automobile is painted a bright yellow and the large reproduction of the Grafonola is finished to imitate red mahogany, which makes quite a brilliant contrast.

This unique outfit was designed and built by Frank Solar, proprietor of Solar's Music Shop. During the Summer he placed a D-2 Grafonola inside of the big model and gave concerts to crowds in front of moving picture theatres and other places. The smaller instrument, of course, was entirely concealed.

He is now working on a plan so that he can drive down the principal streets of Chicago and, with the use of a Magnavox, provide music of considerable volume for the pedestrians as he passes by. To this end he is working on a plan to suspend the working parts of a Grafonola inside the big imitation Grafonola in such a manner that the bumping along the street will not affect the playing ability of the instrument.

Piano Club Grows

More and more talking machine men are signing up as members of the Chicago Piano Club. A concerted effort is being made to interest the talking machine men of the city in the club and its purposes. President M. J. Kennedy believes that the organization has a real excuse for being in the co-operation that it can give its members and through its participation in local musical affairs. The membership list has mounted steadily since the present officers outlined their ambitious campaign a few months ago.

The regular Monday noon meetings at the Illinois Athletic Club have increased in interest and attendance until now one is sure of seeing a large number of members of the local trade at the above meeting place every week.

At the meeting on the third of January the Club was entertained by Van and Schenck, of the Ziegfeld "Follies." The two comedians sang and danced to one of the largest Monday noon meetings on record, the total attendance numbering sixty-six.

New Sacred Records Released

The Rodeheaver Co., 440 South Dearborn street, is out with the announcement of the first release of "Rainbow Sacred Phonograph Records." These consist of selections by famous evangelistic speakers and singers. As the company says in the announcement, "This may be the day of 'jazz,' but there is a large and ever-increasing element which is seeking gospel phonograph music. An energetic, country-wide advertising campaign throughout the churches and through the medium of religious papers and newspapers has been organized."

The selections will include male and female quartets and chorus selections, gospel hymns and anthems and selections from evangelistic talks and sermons.

The recording laboratories are situated at Winona Lake, Ind., which has long been famous as a center of evangelistic effort. The company has also an Eastern branch at 814 Walnut street, Philadelphia.

With Music Center

Elbert Hagerstrom has become a member of the sales staff of the Chicago Music Center, located in the Leiter Building, at State and Van Buren streets. The Chicago Music Center operates a large phonograph department and features Columbia Grafonolas and records.

Great Demand for Fibre Needles

With the enormous demand for records, which manufacturers seem unable to satisfy, there is necessarily a consequent demand for needles, and this is being felt to good purpose at the headquarters of the B & H Fibre Mfg. Co. At no time in the history of this well-known manufacturing institution did such a demand exist

Sterling

All that the name implies

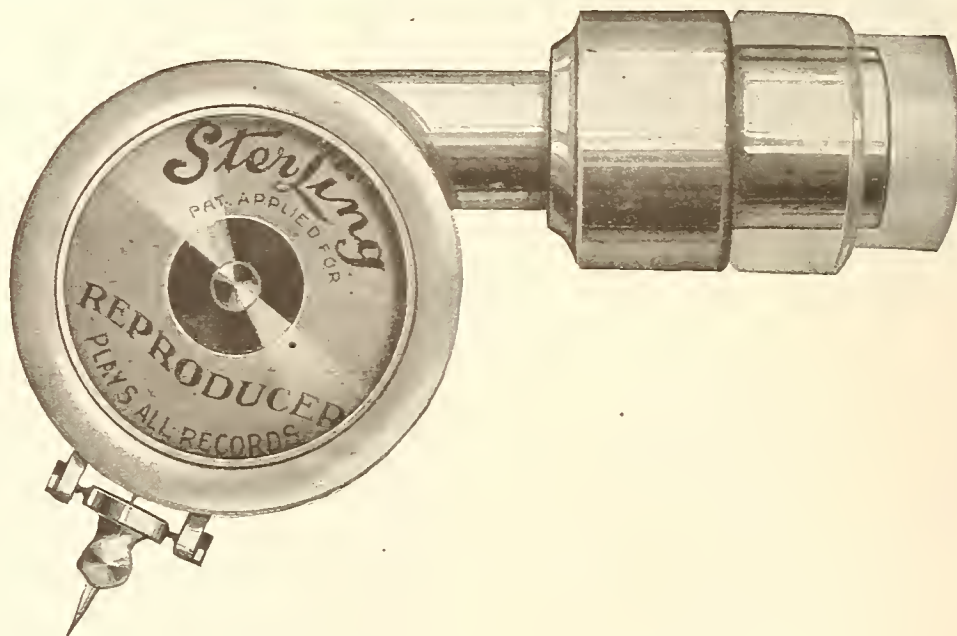

It is made for the purpose of giving perfect rendition of both Hill and Dale and Lateral Cut Records. What does a Satisfied Customer Mean to You?

STERLING DEVICES COMPANY

534 LAKE SHORE DRIVE

CHICAGO, ILLINOIS

FROM OUR CHICAGO HEADQUARTERS—(Continued from page 138)

for fibre needles, and this is indicative of the increasing sales of records throughout the country. Although the B & H Fibre Mfg. Co. has increased its output during the last year, it is planning for a still further output of fibre needles during 1921.

Elected to Steger Board

Charles E. Byrne, advertising manager of Steger & Sons Piano Mfg. Co., has been elected secretary and treasurer of this concern. Mr. Byrne also takes his place as a member of the board of directors. C. G. Steger, president, in



Charles E. Byrne

commenting on the matter, said that Mr. Byrne has been connected with the company for ten years, starting as advertising manager, and had always been an exceptionally hard worker. Faithful service, sheer ability and unusual capacity have now brought him deserved promotion.

He has made a thorough study of the music industry and is a member of the Chicago bar. Mr. Byrne formerly was a newspaper man and is known to the newspaper fraternity as a writer of magazine articles. He is an ex-president of the Loyola University Alumni Association, a member of the City Club, the Indiana Society and various other social organizations.

Mr. Byrne's promotion to the post of secretary-treasurer comes as a well-merited reward for his splendid ability and loyal service.

Prepare Plans for Busy Year

The Universal Stamping & Mfg. Co., of this city, have prepared plans for a very busy year, and are now working on a number of orders for motors for manufacturers, which indicates that there is plenty of confidence in the industry among manufacturers of repute who realize that the talking machine is a staple musical instrument that is going to be in steady demand in 1921 not only in America but throughout the world.

Look for Increased Volume of Business

The Brunswick-Balke-Collender Co., well-known manufacturer of Brunswick phonographs and records, looks forward to a vastly increased volume of business during 1921. In discussing



Loud—Extra Loud
Medium
50 Needles, 15 Cents

MAIN OFFICE
1867 Milwaukee Avenue

Order From This Ad.
Nupoint Ass't
100 Pkgs. Assorted
Dealer's Price \$7.00
Retail Value \$15.00
FREE!!
Display Stand and
Sample Packages
With Each Order

PHONOGRAPH SURGERY
LET US CO-OPERATE WITH YOU

We Operate the Largest and Most Up-to-date Equipped
Phonograph Repair Shop in the West

Have You a Phonograph Repair Agency?

Send for our Catalog and Particulars. It Tells You What We Can Do for You

The Co-Operative Manufacturing Company

ALL PHONES, HUMBOLDT 3345
CHICAGO

SALES OFFICE & SHOWROOM
637 Milwaukee Avenue

Jobbers in
Phonograph
Motors
Tone Arms
Records
Hardware
Needles and
Repair Parts
All Makes

the outlook Percy L. Deutsch, secretary-treasurer of the company, said: "We are very glad at this time to say that while the retail business is not as good as we anticipated and the dealers are somewhat disappointed, still we look for a vastly increased volume in Brunswick phonograph business for 1921. There are many reasons for this opinion, but it is based primarily upon the fact that hundreds of dealers throughout the country have stated their intention of taking on the Brunswick phonograph and records as early in the year 1921 as they can unload their present stock of other makes of machines.

"Of course, the product itself is appreciated by the trade and this, together with the enormous amount of advertising we have put behind it, has made it one of the most stable lines on the market to-day. It might be interesting to know, also, that our volume of sales for 1920 will be practically double that of 1919."

Proposed Victor Dealers' Association

The permanent organization of the proposed Victor Dealers' Association will be consummated within a week or so when the committee headed by R. B. Corcoran will meet for the purpose of drafting a constitution. No definite date has been set for this meeting. It is expected that in the latter part of the month the dealers of this territory will be called upon to formally decide whether or not a permanent organization will be formed. The general sentiment is in favor of forming an organization because of its great possibility for good.

Schaff Bros.' Effective Window Display

The Schaff Bros. Co., of Huntington, Ind., has been featuring some very attractive windows during the past few weeks, which have created much favorable comment from those who have had the privilege of inspecting them. The left window was devoted to a special Christmas display

in which Santa Claus and his reindeer were the most thrilling characters in the famous old story that interested the children of Huntington as it always has the children of other centuries.

The window on the right side of the Schaff door was occupied by the Binger Window Service, which is illustrated herewith, and which showed up exceptionally well despite the fact that the window is comparatively small. The entire display reflects the greatest possible credit



One of Schaff Bros. Co. Windows

on the executives of this store for effectiveness and artistic completeness.

Naturally, Schaff Bros. Co.'s retail store enjoyed a most excellent business, a large part of the credit for which is due to these window displays.

Visiting Trade in Wisconsin

S. Aminoff, of the sales force of the local headquarters of the Emerson Phonograph Co., is on a business trip to Wisconsin. He expects to make more than three hundred calls during his present trip. During his previous trip, which he closed just before Christmas, he established fifteen new agencies.

VARNISH DRYROOMS

MODERN PHONOGRAPH
CABINET INSTALLATION

MAKE EVERY DAY
A PERFECT DRYING DAY

DRYING SYSTEMS, INC. 11-17 So. Desplaines St. CHICAGO.

**Edison Diamond
Amberolas--Plus Service**

You know the quality of Edison instruments. Until you have placed a trial order with us, you are unfamiliar with SERVICE.

A TRIAL CONVINCES

Our Service Covers the Country

William H. Lyons
Formerly Jas. I. Lyons
17 W. Lake St. Chicago

FROM OUR CHICAGO HEADQUARTERS—(Continued from page 139)

LAKESIDE "F & L" AUTOMATIC STOP

100% EFFICIENT

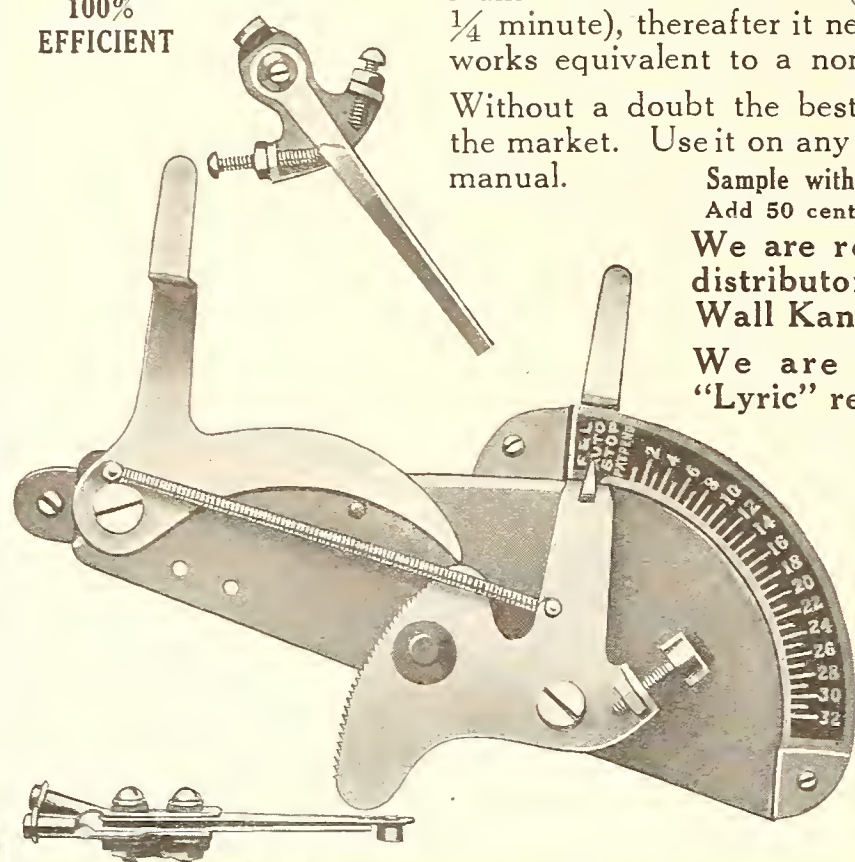

Number each record once (which takes only a 1/4 minute), thereafter it needs no setting, and works equivalent to a non-set stop.

Without a doubt the best automatic stop on the market. Use it on any machine, electric or manual.

Sample with full instructions \$1.75
Add 50 cents for electric machine.

We are recently appointed distributors of the famous Wall Kane Needles.

We are distributors of "Lyric" records. It will pay you to try them.

Let us supply your needs on all accessories. Prompt shipments.

LAKESIDE SUPPLY CO.

416 So. Dearborn Street
CHICAGO, ILL.

Tel. Harrison 3840

PACIFIC COAST BRANCH
WILLIAMS BLDG.
SAN FRANCISCO, CAL.

HOW A CHICAGO RETAILER BUILT UP A GREAT BUSINESS

The Story of Edward Greenstone, Proprietor of the Greenstone Furniture Co., Emphasizes the Opportunities for the Man Who Aspires—Tells How He Has Built Up His Business

CHICAGO, ILL., January 6.—From immigrant to clerk in department store, and thence to the ownership of one of the foremost retail furniture and talking machine businesses in Chicago, runs the story of Edward Greenstone, proprietor of

in a little frame building store at Milwaukee and Western avenues nine years ago. The phrase appears in street-car cards, in circulars, in newspaper advertising and in every sort of publicity put out by his concern. He has en-

lishment. Salesmen are given the most rigid instructions never to misrepresent goods in any way, and whatever is said for an article by a salesman is always backed up by the concern after the article is sold. They endeavor to please the customer and avoid friction in every case. For this reason the giving out of records on approval is eliminated. To this end, also, Mr. Greenstone has surrounded himself with a high-class force of salespeople.

"A poor salesman is the most costly item in the world to the owner of a retail business," he says. "I would rather have one good, tactful salesman than half a dozen inferior ones. The kind of a man that can send a prospect away possessed of an agreeable impression of the store and the people in it, whether or not that prospect eventually purchases, is the kind of a man we want. To my mind this is one of the greatest essentials of salesmanship; and not the mere securing of a name on the dotted line. The salesman of this kind builds up that mouth-to-mouth advertising which rolls up larger and larger volumes of business as the years go on."

Mr. Greenstone is a firm believer in the advantages of the corner store. All of his establishments are located on busy corners where trade naturally gravitates. He contemplates the opening of additional stores in Chicago in the near future and asserts that all of these will be on prominent corner locations.

House-to-house advertising of the proper sort is used by this concern extensively. Mr. Greenstone requires that every bit of literature going out over his name be of uniformly high quality. "The matter of securing the proper kind of help for the distribution of circulars is also important," he remarked. "We pay six dollars per thousand for the distribution of circulars, where we could pay two dollars and fifty cents. We do this because we wish to be assured of proper delivery. We want the men to go up and rap on the door, hand out the circular and thus secure the attention of the householder."

The Greenstone Talking Machine Co. charges six per cent interest on all instalment sales. It does this in competition with other stores which do not, and succeeds in getting a larger volume of trade. Ten or twelve sales per store per year are lost, it is approximated, in this way, which is not enough to make up for the loss of money if the machines were not sold at interest.

Mr. Greenstone has stores in Chicago located as follows: an exclusive Columbia store at Milwaukee avenue north and Robey; a Columbia and Victor store at Milwaukee and Armitage, and the main store, located at 1315 Milwaukee avenue. The first named was established only several months ago and is one of the finest talking machine establishments outside of the loop.



THE PRESENT GREAT EMPORIUM CONDUCTED BY THE EDWARD GREENSTONE CO.

the Edward Greenstone Furniture Co. and of two exclusive talking machine stores. The story of Mr. Greenstone's success, according to his own statement, is told in two words: the "square deal"—which has furnished the keystone to his system of merchandising and advertising during a period of nine years' business activity. His success offers an eloquent testimonial to the correctness of the policy that has as its watchword unswerving honesty, just as does that of Marshall Field and his great institution.

"Square Deal" has been featured by Mr. Greenstone since the inception of his business

deavored to stamp it upon the public's mind indelibly as an integral part of all Greenstone transactions, so that the inhabitants of that part of the city from which he draws his trade will instinctively think of his store when they think of purchasing furniture and talking machines.

Not only has he advertised in every way possible the "Square Deal" policy, but he has not made the mistake of failing to carry out his advertised policies in his actual business transactions. The policy that "the customer is always right" rules in Mr. Greenstone's estab-

Magnifies Sound 50 Times
ACME SOUND AMPLIFIER

Enables the repairman to locate the precise point of origin of unnecessary noise in the motor without loss of time or useless disorganization of the mechanism which results from guessing or the sense of hearing alone.

MAKES EVERY MOVING PART IMMEDIATELY ACCESSIBLE

"Guesswork Won't Do"

The ACME allows a test with the drag of the needle throughout the length of the record.

ACME

The Acme Speed Indicator

- is precision made.
- clears the tone arm.
- locates motor troubles.
- registers 78 and 80 revolutions.

"The repairman's stethoscope."

Made by
Acme Engineering & Mfg. Co.
355 Union Park Court CHICAGO

FROM OUR CHICAGO HEADQUARTERS—(Continued from page 140)

DOING GOOD EDUCATIONAL WORK

Miss Elsa Stein, of the Lyon & Healy Educational Department, Delivering Many Addresses Before Educators, Women's Clubs, Etc.

CHICAGO, ILL., January 4.—Among those who are working hard and systematically and getting results in a campaign for placing Victrolas in the schools is Miss Elsa Stein, of the educational department of Lyon & Healy, the prominent Victor wholesalers. Miss Stein has kept in close touch with educators, with women's clubs and other organizations whose influence is calculated to help the cause and has made frequent addresses before such bodies.

Miss Stein has prepared an elaborate talk on

"The Victrola in the School" suitable for practically every occasion, in the course of which she treats from various angles the musical requirements of the child and explains just how those requirements are met by special Victor records. The talk is made more interesting by the demonstration of the records themselves. She explains the possibility of utilizing folk songs and how through the Victrola even a small child is given an understanding of the works of the great composers. That Miss Stein's work is effective is indicated by the excellent results that it brings.

The Addison Pellegrom-Golsom Housefurnishing Co. has opened a new talking machine department in its attractive store in Grand Rapids, Mich.

PERFECTS NEW ELECTRIC MOTOR

L. P. Valiquet, Well-known Inventor, Announces Improved Type of Electric Drive

CHICAGO, ILL., January 3.—L. P. Valiquet, who is known throughout the industry as an inventor and who has been connected with the trade since 1898, when he had much to do with the development of the Zon-O-Phone, the first instrument equipped with a worm screw governor, has recently perfected a new type of electric motor for talking machines. The distinctive feature of the new motor is a double governor control operated by the usual disc indicator on the motor board, which practically

(Continued on page 142)

FOR THE EDISON

The Oro-Tone
QUALITY FIRST

FOR THE VICTOR

AND NOW FOR THE COLUMBIA
JUST SAY "Send Samples on Approval"

No. 1-E Oro-Tone Edison Attachment

For Playing All Records on the Edison

Reproducers Fitted With Special Oro-Tone Diaphragms

Attached in a second. Needle retains perfect center in playing either hill and dale or lateral cut records. NOTE—Operates the same as the regular Edison reproducer with the raising and lowering lever. TONE QUALITY—Full, rich and glowing, with great carrying power and absence of metallic shrillness and surface noises.

Retail Price, Nickel Plated, \$8.50. Highest Grade Gold Plate, \$12.50



Illustrating the No. 1-E Oro-Tone attached to the Edison

No. LS-V Oro-Tone Victor Attachment

For Playing All Records on the Victor

Reproducers Fitted With Special Oro-Tone Diaphragms

Attached in one second. Needle retains perfect center in playing either lateral or hill and dale cut records. TONE QUALITY—Deep, rich and mellow, with great volume, eliminating thin metallic tones and surface or needle noises on the records.

Retail Price, Nickel Plated, \$6.50. Highest Grade Gold Plate, \$9.50

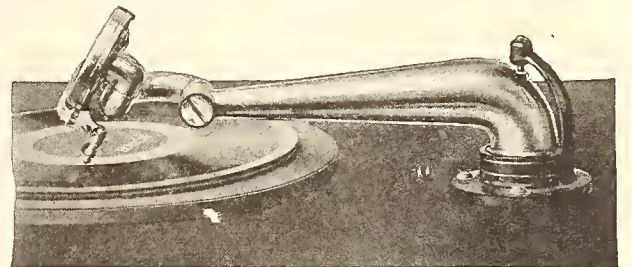

Illustrating the LS-V Oro-Tone attached to the Victor

The Impossible Has Been Accomplished

No. I-C Oro-Tone Columbia Attachment

For Playing All Records on the Columbia

Reproducers Fitted With Special Oro-Tone Diaphragms

Attached in one second. Needle retains perfect center in playing either hill and dale or lateral cut records. TONE QUALITY—Rich and musical with splendid volume and definition. Surface or needle noises practically eliminated.

Retail Price, Nickel Plated, \$6.50. Highest Grade Gold Plate, \$9.50

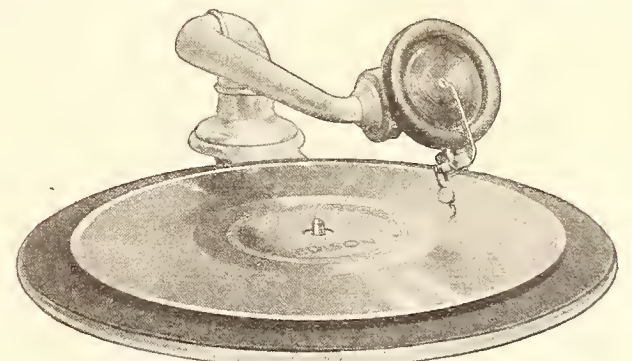

Illustrating the No. I-C Oro-Tone attached to the Columbia

SEND FOR—Copy of 'Oro-Tone'

The O

ribes the complete

FROM OUR CHICAGO HEADQUARTERS—(Continued from page 141)

eliminates any variation of turntable speed due to fluctuations of the electric current. This problem of a constant turntable speed has been one of the worries in electric motor development.

In the course of his career in the trade Mr. Valiquet has been associated with the engineering department of a number of the leading companies, and has designed and built several types of spring motors now in regular use. The greatest work was the development of the Krasco enclosed motor for which he holds the patent rights.

THE MANDEL RECORD NOW ON THE MARKET

Further Evidence of the Growing Strength of the Mandel Organization—Something of the Men Behind This Enterprising House

CHICAGO, ILL., January 4.—The Mandel Mfg. Co. is one of the concerns in the talking machine trade which face the future full of faith and confidence, due to the fact that the company has long been prepared to meet any situation that may develop in the field. The reorganization of the company was effected last Summer, following which the concern sought out all weaknesses, improved the product, and prepared in



Joseph F. Grossman

every way possible to meet conditions in a sane, solid manner and in keeping with a definite policy.

The new Mandel organization is headed by men whose past experience fits them to pilot a business-ship through a rough sea. At its head is Joseph F. Grossman, president, who brings to the organization a vast experience gained through sixteen years of legal experience in Chicago, where he has been closely allied with many large business organizations. During the last administration of ex-Mayor Carter H. Harrison Mr. Grossman was assistant corporation counsel. His legal training has given him keen analytical powers, which he brings to his new office as president of this company. He gave up his legal practice to assume his new duties.

Maurice B. Silverman is a figure well known in talking machine circles. He was sales manager of the original Mandel organization and can boast of having built up one of the strongest

WHERE CAN THE REPEATER-STOP BE SECURED?

DEALERS! Start the new year right and put in a stock of Repeater-Stops, the fastest seller on the market.

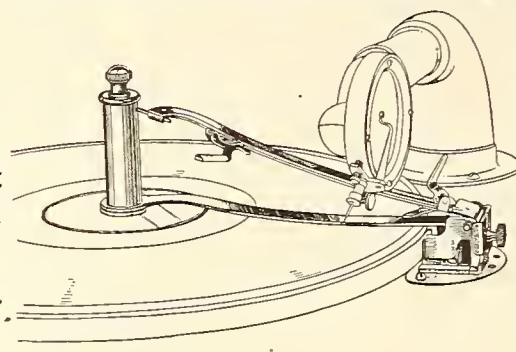

The following is a partial list of our distributors:

- Atlanta, Ga. Southern Sonora Company, Southern Paramount Co., Elyea Company
Baltimore, Md. A. Burdwise, H. R. Eisenbrandt Sons, Inc.
Birmingham, Ala. Talking Machine Company
Brooklyn, N. Y. G. T. Williams Co., Inc.
Buffalo, N. Y. W. D. & C. N. Andrews, Buffalo Talking Machine Co., Inc.
Chicago, Ill. Chicago Talking Machine Co., Lakeside Supply Company
Cleveland, Ohio. Cleveland Talking Machine Company
Denver, Colo. Knight-Campbell Music Company
Detroit, Mich. Grinnell Bros.
El Paso, Tex. F. G. Billings Piano Co.
 Fargo, N. Dak. Stone Piano Co.
Houston, Tex. Southern Drug Co., Talking Machine Company of Texas
Indianapolis, Ind. Stewart Talking Machine Company
Jacksonville, Fla. John A. Futch Company, Florida Talking Machine Company
Kansas City, Mo. Wm. Volker & Co., Richards Conover Hdw. Co.
Los Angeles, Cal. Western Jobbing & Trading Company
Memphis, Tenn. Hessig Ellis Drug Co., O. K. Houck Piano Co.
Milwaukee, Wis. A. G. Kunde, Godfrey & Sons
Minneapolis, Minn. Beckwith O'Neill Company
Mobile, Ala. W. H. Reynolds
New Orleans, La. Philip Werlein, Ltd.
New York, N. Y. Cabinet & Accessories Co., Fulton Talking Machine Co., Knickerbocker Talking Machine Co., Bristol & Barber
Omaha, Nebr. A. Hospe Company, Schmoller & Mueller Piano Co.
Philadelphia, Pa. Penn Phonograph Co., Inc., Heath & Gorham
Pittsburgh, Pa. C. C. Mellor Co., Ltd., The Reed Company
Red Lodge, Mont. Ball Music Company
Rochester, N. Y. E. J. Chapman
San Francisco, Cal. Walter S. Gray Co.
Salt Lake City, Utah. Consolidated Music Co., Salt Lake Hardware Co., John Elliott Clark Co.
St. Paul, Minn. W. J. Dyer & Bro.
Syracuse, N. Y. Gihson Snow Company
Tampa, Fla. Tampa Hardware Company
Toledo, Ohio. Toledo Talking Machine Co.
Toronto, Canada. The Music Supply Company, His Master's Voice Co.
Washington, D. C. Rogers & Fischer
Wichita, Kans. Eberhardt Hayes Company

REPEATER-STOP CO., 115 So. Dearborn St., Chicago, Ill.

phonograph sales staffs in the business. His experience concerning matters in the phonograph industry dates back to 1915. He has come in personal contact with phonograph manufacturers, dealers and jobbers, and has studied the point of view of each. When the reorganization of the Mandel Mfg. Co. took place he was made its vice-president as well as sales manager.

John H. Hupp was also associated with the original Mandel organization as credit manager, and was retained by the new organization and

position where he will build up his credit and his business.

It has been the policy of this company to train and retain its organization and to discourage frequent changes, either in its factory or in



M. B. Silverman

made its secretary. Mr. Hupp has had a varied experience in matters relating to credits and was also a salesman. His knowledge of sales has given him an insight into the inner recesses of the merchants' business, and he is intensely human in the manner in which he handles his accounts. His theory is not to curtail extensions of credit, but rather to put the dealer in a



J. H. Hupp

its selling division. The factory personnel consists of men who have been allied with this organization since its inception. Raymond T. Bell, superintendent of works, is an engineer of vast training and experience, particularly in the phonograph field. He served in several important capacities for one of the largest phonograph manufacturers in the world and brought to the Mandel Mfg. Co. his years of experience.

After several months of preparation the Mandel record is now a reality. The first release, consisting of thirty-two selections, was distributed in January. Mandel records are all cut, and it is the intention of the company to add at least twenty selections to its program monthly. When the first announcement made to Mandel dealers the influx of orders indicated that this was just what dealers were waiting for.

It is every indication that, backed by good service and co-operation, the Mandel Mfg. Co. will retain for itself a definite position in the industry.

Advertisement for 'HANDY' REVOLVING CASE CLAMP. Includes image of the device and text: 'All Steel and Iron', 'Will absolutely square cases and will not wear out.', 'Labor Saving and Indestructible', 'Gives Speed and Accuracy', 'HANDY MFG. CO. CHI'

WE ILLUSTRATE THE "HANDY" REVOLVING CASE CLAMP WE ALSO MAKE IT STATIONARY

FROM OUR CHICAGO HEADQUARTERS—(Continued from page 142)

A TIME FOR AGGRESSIVE SALESMANSHIP, SAYS HOPKINS

Sales Manager of the Columbia Graphophone Co. Makes Straight-from-the-shoulder Talk on the Curative for Business Ills—Cutting Down Sales and Advertising Means Slower Trade

CHICAGO, ILL., January 7.—Some straight-from-the-shoulder remarks that are timely and pertinent were uttered by George W. Hopkins, sales manager of the Columbia Graphophone Co., at a recent gathering of a number of prominent business executives covering many lines of industry in this city. He emphasized the fact that now is the time for real salesmanship, which can demonstrate itself for the first time in many years, and declared that with the greatest crops ever harvested in the history of the Nation, with business on a sound, fundamental basis, there is nothing wrong excepting the mental attitude of those who refuse to act at a time which calls for real intelligent and direct action.

After pointing out the value of an interchange

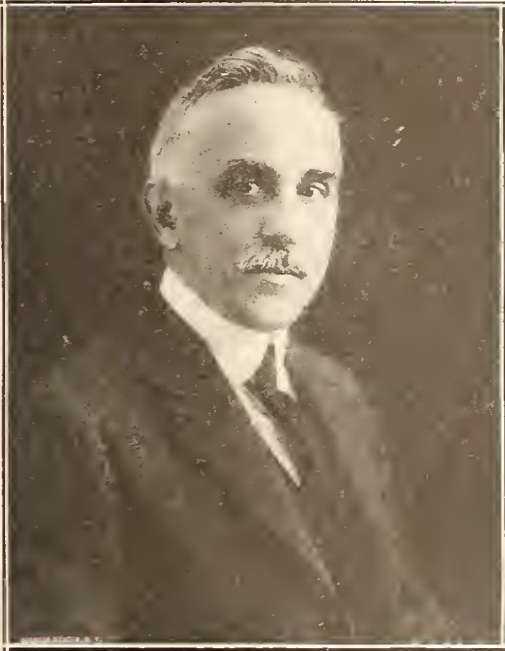

George W. Hopkins

of ideas, Mr. Hopkins said: "The trouble with a lot of us sales managers is that we like to sit in our office at a big mahogany desk, and when a salesman has something to tell us that he has gleaned from his own experiences we shut him up with 'I know better,' instead of letting him talk and get his story off his chest.

"You can't pour enthusiasm into a salesman when he is full of bile, or something else that needs to get out of his system; so don't forget that you are not only his business 'doc,' but his business 'daddy' as well, and that he is perfectly right that he should come to you with his story.

"How much do you really know about picking salesmen? I believe that 75 per cent of the failures of salesmen are chargeable directly to the men who hired them. I blame myself three-fourths of the time when a man whom I have selected falls down on our proposition, for the reason that I have either hired the wrong man or I have failed to sell him our sales plan so that he can put it over.

One Alibi Gone by the Board

"For years practically every institution has been face to face with a condition which furnished a constant and unanswerable alibi for the sales force whenever we attempted to check up the work. It was a bunch of orders in front of us which we were unable to fill. In consequence, a lot of firms made the mistake of allowing their sales organizations to run down. In some cases they laid off almost all of their men, retaining only a few.

"My sales training was originally in the biscuit game. From biscuits I went into chewing gum, and from chewing gum to music. When I got into the music game I had before me practically all of the copy that my firm as well as its competitors had used for seventeen years back. An analysis of this copy showed that 85 per cent of these advertisements were featuring classical music. Still, it was a well-known fact

that popular music outsold classical music ten to one, according to everyone whom I asked about the subject.

"I immediately made the major point of Columbia advertising popular music, and in a short time we jumped to the front. Our increase in sales this year is more than 100 per cent. We are literally selling tons of music. I mean exactly what I say. We go to a dealer's store and tell him that we want him to sell a ton of records, all of one popular song, and that we expect him to sell them within a week, without a nickel's worth of advertising help from us.

Not Done by Cutting Prices

"But it isn't done by price cutting. We don't believe in price cutting. Columbia phonographs will continue to be sold at the same prices as heretofore. Price cutting is a lazy man's method

of inducing business, and does not build for permanency or profit.

"We have kept every one of our salesmen, and when the period of hesitation arrived, about the first of May, we had our entire sales force trained and ready to meet the situation. The training we had given to our salesmen during the time that we were oversold consisted of nothing more or less than making retail salesmen of them, by sending them into the retail furniture and music houses and having them put on local campaigns, selling phonographs to Mrs. Householder.

"A lot of dealers at first resented the idea that we should tell them how to run their phonograph departments; the trouble being that these dealers, the same as our salesmen and the same as we sales managers, had become inflated and had decided that the wonderful business which they had enjoyed during the past few years was due to their own personal management and brains.

(Continued on page 144)

B. B. BLOOD



WISHES to announce to the trade that both Mr. O. J. Kloer and Mr. B. B. Blood have withdrawn from the Jewel Phonoparts Co. and will immediately begin the manufacture of all new Blood products---among which is a non-infringing tone arm that will be ready about February 15th.

They also wish to take this opportunity of thanking the trade in general for its patronage, and they will strive to merit a continuation of the good-will which they have enjoyed.

Blood & Kloer

460 West Erie St.

CHICAGO, ILL.

A Better Fibre Needle Cutter for Less Money

The ALTO

Retail Price **\$1.00**

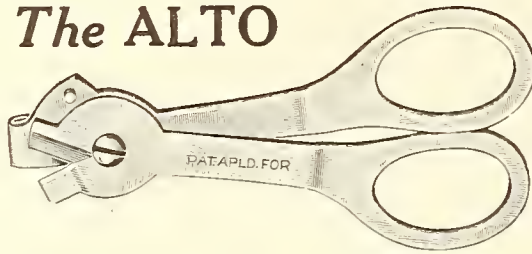

Send for a Sample and Convince Yourself

Territory open for distributors

ALTO MFG. CO.

3801 Rokeby Street, Chicago, Illinois

FROM OUR CHICAGO HEADQUARTERS—(Continued from page 143)

Dealers Became Very Independent

"The big business which retailers enjoyed during the era of liberal spending entirely changed a lot of our dealers. Before the war they were live wires, hustlers. They went outside of their store after business. They made it a point to meet desirable customers outside and

to solicit their trade. As business improved they withdrew into the store and met only such customers as came into their place of business. With still bigger sales they left the floor of their salesrooms and hid themselves away in a little cight by eight office with a frosted glass door and the word 'Private' printed in letters six inches high.

"But last May, when this hesitation period began, the buyer opened his door and began to take an interest in things again. Then the salesman whom we had trained through retail work was able to explain how to sell a ton of records in one week, by means of a plan that was different, and that actually put over the sales.

"We have recently sold these records by the ton in Chicago, New York, Detroit and practically every other large city. It is now being done throughout the United States—one dealer selling a ton of records in a week—where they never dreamed of selling even one-tenth of a ton of music in a week.

Direct to the Public

"The plan was simply to take the music to the public. Five-ton trucks were engaged. They were trimmed exactly as big windows would be trimmed in the music store. They were driven through the streets and popular music was dispensed, together with printed matter which carried the bold statement that the local music house would sell one ton of certain records within a week. The thing went over, and went over big.

"Salesmanship is coming into its own again. The time is here right now when the concern which fails to build up a strong force of personal salesmen will be left far behind. Within the next five years real sales ability will be so highly prized that salesmen will be able to pick their own boss. Will they pick you? Are you keeping your organization and your selling plans up so that you can sell them to the salesman who is really worth while?

Here's an Optimistic Note

"Recently I talked to an economist. I asked him to show me a period of general depression in business occurring the same year when agriculture afforded a wonderful crop. After looking over the statistics for a hundred years the economist was forced to admit that no such

parallel was to be found. Never before have we had such crops. Never before have consumers had more money to spend, and any time the consumer has money I am going to lie awake nights studying how to get it.

"It is true that the public is expecting reduced prices. People are not going to be quite so reckless in spending their money and I am glad of it, for it is doubly hard to keep up a sales force when sales are to be made without any effort, and when buying is done without care. The past few years have been trying to the real salesman. It took all the pep out of him to be hobbled because demand was far ahead of production. But those days have passed.

"Are you going to help your salesmen by proving to them that there is nothing wrong with business except as it may exist in their minds or in the mind of the dealer? Are you going to prepare them so that they are equal to the occasion? There are only two things necessary to sell your product so as to bridge the present period of hesitation. The first is quality. No business that is worth while can carry on or carry through unless the basis of your selling talk, advertising copy and all that you do is quality. The other thing is service. Don't overlook the fact that the humblest employe in your factory can hinder or help your reputation for either service or quality.

Scores Attitude of Daily Newspapers

"I don't think the newspapers have given business a square deal. With one hand they take money for space advertising copy that invites the public to come in and buy, and with the other they write the most damnable, pessimistic lot of junk that you ever read. The result is that Mrs. Consumer merely postpones her buying, frequently with the false hope that she is going to get her needs filled at much lower prices.

"What we need is safe and sane optimism. Once more I repeat: 'There is nothing the matter with this country; there is nothing the matter with business, excepting mentally. The dealer is mentally sick. A sick man can't prescribe for himself. Your sales force will be sick unless you have provided insurance for them while they were well. The firm which has shown

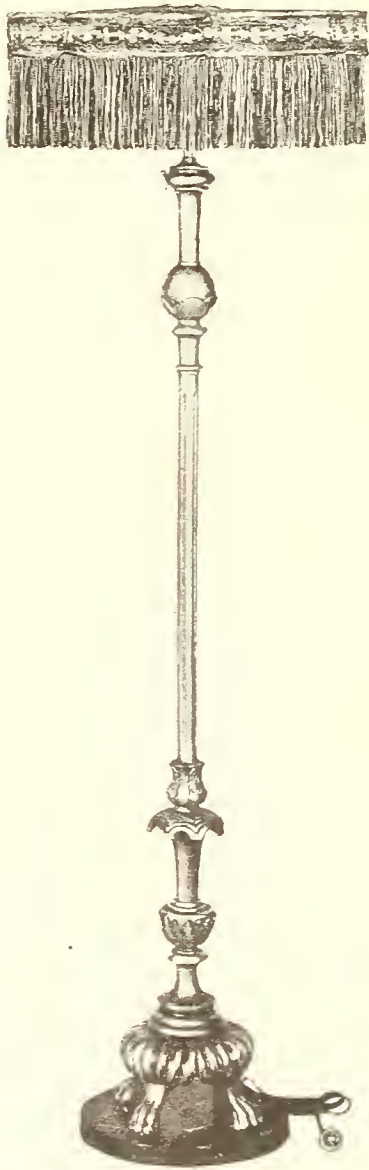

Lamps Will Light the Way to More Profits for You

OUR NEW CREATIONS—will bring you more business.

OUR HIGH STANDARD QUALITY—will make satisfied customers.

OUR LOW PRICE—will make larger profits for you.

Write or wire now for our new catalog No. 3

EAGLE WOOD TURNING CO.

507 W. MONROE ST.

CHICAGO - - - ILL.

THE FERRO AUTOMATIC STOP is the best, most accurate automatic stop on the market.

Its operation is positive. There is no guesswork about its stopping the motor at the right moment, all the time.

It is a combination automatic stop and hand brake—will work properly either way.

Order a sample NOW

FERRO PHONOGRAPH PARTS CO. 1455 W. Congress St., Chicago, Ill.

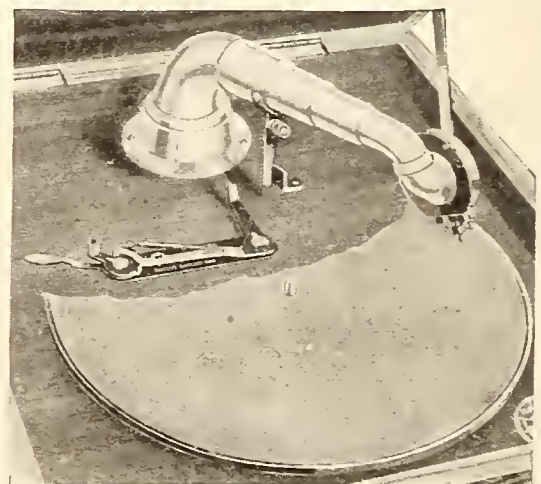

foresight by keeping up its sales organization can be compared to the man who took out his life insurance while he was well. The firm which has failed to do so will find that it is a hard job to get life insurance when you are sick.

If you have allowed your sales organization to become weakened go back to your office and begin to-day. Make a careful analysis of the conditions out in the field. You will find that there is absolutely nothing wrong. Don't try to judge by what your competitors are doing. Go out in the field and analyze the possibilities that your line has, remembering that agricultural prosperity was never greater than to-day and that this is the real basis for big business."

CANTON TRADE SHOWS UP WELL

Despite Bad Situation in Automotive Field, Talking Machine Sales Are Strong

CANTON, O., January 8.—The holiday season was a fairly active one with the retail music dealers of Canton. A survey of the trade by a representative of The World revealed that in some instances business was even better than last year. E. H. Woomer, manager of the Canton Phonograph Co., in discussing Christmas business, said: "While our pre-Christmas sales were below last year's, those between Christmas and New Year's boosted the total until the 1919 sales were passed by a good margin. It appears many who received money for Christmas invested it in talking machines or records."

The George C. Wille Co., Market avenue N, reports the biggest record sales in the history of the store the day previous to Christmas, when sales aggregating better than \$1,000 were reported. This store also disposed of its share of talking machines.

S. B. Van Fossen, manager of the A. B. Smith Piano Co.'s store here, declared business at the store was much heavier than last year in the face of the industrial depression which has prevailed here since early Fall.

The Alford & Fryar Piano Co., Klein & Hefelman and the D. W. Lerch Co. all report phonograph sales satisfactory during the holidays. Records sold well at all stores, as did player-piano rolls. These concerns view the outlook most optimistically.

Merchants are optimistic as to the future and despite the slump in the automotive industry, which affects most every plant in the Canton district, a steady business is expected after the middle of this month.

C. W. SHUMWAY'S NEW POST

C. W. Shumway, formerly northern California manager for the Western Jobbing & Trading Co., has resigned from that concern and has opened an exclusive Sonora shop at 721 Macdonald avenue, Richmond, Cal., in one of the best sections of the city.

A. D. GEISSLER ON THE OUTLOOK

President of New York Talking Machine Co. Expresses Confidence on What 1921 Holds for the Talking Machine Trade of This Country

Arthur D. Geissler, president of the New York Talking Machine Co., Victor wholesaler of New York, and also of the Chicago Talking Machine Co., Victor wholesaler of Chicago, in a statement made public the early part of the month expresses great confidence in what 1921 holds for the Victor trade. He said in part:

"To a great, great many in the talking machine business this has been a 'blue' Christmas. Because the Yuletide of 1920 did not bear with it the same prosperity and opulence of 1919 the contrast has been made to seem more bitter to the great majority of talking machine manufacturers.

"The one outstanding exception, not only in the talking machine industry but practically in the entire industrial world, has been the Victor Talking Machine Co.

"The dealers and jobbers who in the past have put their whole reliance on the judgment of the Victor Talking Machine Co. and its directors in the conduct of their business are to-day reaping that complete satisfaction of mind which must come from knowing that 1921 holds for them at least an era of safe and sane merchandising.

"To-day in the talking machine field there are many men and concerns that are doing one of two things mentally, either writhing with remorse after an excess of expansion or ignoring the validity of great outstanding facts and conditions.

"Our business in the last four or five years has come too easily. Next year will give us all an opportunity to test the strength of our organization. Personally, I welcome the prospect of being able to go out and fight for business not only in our own field, but unexplored and undeveloped territories."

FORWARD STRIDES OF LAUZON

The Michigan Phonograph Co., of Grand Rapids, Mich., is quite optimistic about general business, and particularly about the increasing popularity of the Lauzon phonograph. The company closed a very satisfactory year in 1920 and broadened out its business not only at home but abroad. The capacity of the plant has been increased, and a number of new period styles of exceeding attractiveness added to the line. President George M. Cook, in a recent talk, stated that a number of plans were under way for a further development of this business during the year, particularly in the way of new styles that will win the attention of the public.

The Lansing Sales Co., of Boston, has announced the appointment of R. Lipp, who recently arrived from Chicago, to succeed P. M. Perasky, who has resigned.

"The Music Without the Blur!"

This ideal of talking machine manufacture is attained more nearly than by any other, in the construction of the

MARVELOUS MAGNOLA
"Built by Tone Specialists"

"Magnola's Tone Deflector eliminates the scratch"

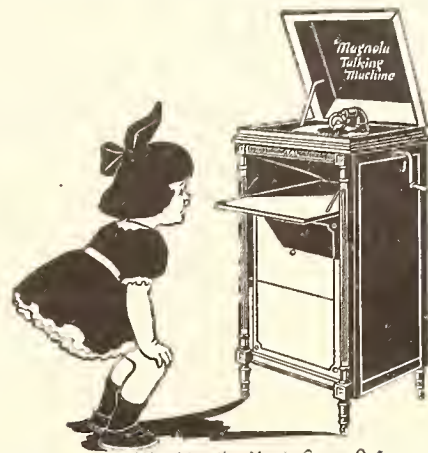

Watching the Music Come Out

We want to show you how to make money with MAGNOLA; and how MAGNOLA is the best buy on the Talking Machine Market to-day.

Send us your name and let us send you some real Talker Tips.

MAGNOLA TALKING MACHINE COMPANY

OTTO SCHULZ, President

General Offices 711 MILWAUKEE AVENUE CHICAGO
Southern Wholesale Branch 1530 CANDLER BLDG. ATLANTA, GA.

CONSOLIDATION IN CANTON, O.

E. H. Woomer Phonograph Co. Merged With the Geo. C. Wille Music Co., That City

CANTON, O., January 10.—One of the most important deals in local music trade circles was the announcement this week of the merging of the E. H. Woomer Phonograph Co. with the George C. Wille Music Co. Although owned by George C. Wille, the store of the Woomer Phonograph Co., Cleveland avenue SW., will continue to operate by its former policy and E. H. Woomer will continue as manager. The Woomer store handles the Brunswick phonograph and the same make of records, while the Wille store has been established here for about seven years and is one of the best-known retail music houses in the city.

MAKING "TALKERS" IN BUTTE

M. H. Merrian and R. T. Newland, who conduct a music shop at 342 South Main street, Butte, Mont., are now manufacturing a talking machine in that city which they hope to introduce to the trade at large in due course. This instrument was recently displayed by the Butte Chamber of Commerce at its offices and attracted a great deal of attention.

Phono Truck

Not only an Artistic Delivery Truck Body, but a Sensational Advertisement as well. A Great Combination that will save you many dollars in Advertising and Pay for itself.

We can imitate any talking machine on the market and fit it to your Auto Body.

It Weathers the Weather and brings you trade.

Write for particulars.

ARTISTIC CABINET & WOODWORKING CO.

1415 Custer St. (Near Clybourn and Southport Sts.) Phone Diversey 1823 CHICAGO, ILL.

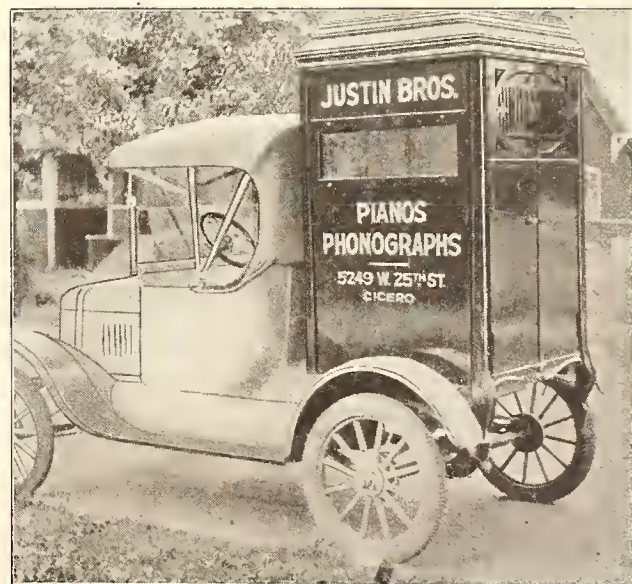



Columbia Dealers' comments on Columbia Self-Service Fixture No. 8:

"It has more than paid for itself in 60 days."
 "Especially essential to us on busy days."
 "We had to fill the fixture up three different times, which means that between 350 and 400 records were sold."

Columbia Graphophone Co.
 NEW YORK

FINE NEW SHOP IN LOS ANGELES

Reed & Dady Open Elaborate Quarters on Hollywood Boulevard Devoted Exclusively to the Display and Sale of Brunswick Products

LOS ANGELES, CAL., January 3.—Reed & Dady recently opened a most elaborate exclusive Brunswick phonograph shop at 6611 Hollywood boulevard, this city, after the premises had been in the hands of expert cabinet men, carpenters and decorators for several weeks.

The main showrooms and salesrooms are on the main store floor, which has been arranged to represent the interior of a typical California bungalow, with the front set off by casement windows fitted with small panes of glass. A hallway runs through the center of the bungalow, and the whole is topped by a tile roof. The sales and demonstration rooms on each side of the hall are attractively decorated and furnished and designed to permit the customer to enjoy privacy when purchasing. The carpets and hangings are all in delft blue.

This house deals exclusively in the Brunswick products and is showing these new musical products in various attractive styles and designs. There are period models, Colonials, models De Luxe and other kinds shown in various finishes. The firm also carries all releases of the Brunswick records and its record department has been so designed that there will be no warping of records kept in stock.

The proprietors of the new company are: G. J. Reed, Ronald A. Reed and H. E. Dady, and the staff includes Harry James Beardsley, well known in Hollywood musical circles.

INCORPORATED

The Piramida Phonograph Co., of Brooklyn, was recently incorporated at Albany, N. Y., with a capital stock of \$20,000 by G. B. Glover, N. Galpern and H. L. Williamson, 69 Eastern Parkway, Brooklyn.

It is better to wear an old coat than to borrow a new one.

MONTGOMERY BACK IN PITTSBURGH

Returns to Talking Machine Field in That City as Wholesale Representative for the Philadelphia Show Case Co.

PITTSBURGH, PA., January 8.—Wayne D. Montgomery, well known in this section of the country through his connection with the local branch of the Columbia Graphophone Co. as wholesale representative, has again returned to Pittsburgh as wholesale representative for the Philadelphia Show Case Co., which has become jobber for the Aeolian-Vocalion, Vocalion records and Melodee music rolls in Pennsylvania.

Mr. Montgomery was largely instrumental in bringing about the formation of the Pittsburgh Talking Machine Dealers' Association, and left the trade here to go into the service. He served abroad with the flying corps, and upon his return entered the industrial truck business.

WITH THE EMERSON ARTISTS

Several Leading Lights Appearing in Musical Productions and in Vaudeville

Walter Scanlan, the Irish tenor, is having a successful tour in his new play, "Hearts of Erin." Newspapers in cities where he has appeared have made very favorable comments and have compared him with the world's most celebrated Irish tenors.

Eddie Cantor continues to be a big success with the Shubert production, "Midnight Rounders." He has just finished four weeks in Philadelphia, two weeks in Baltimore with this production, and is now with it in Boston for an indefinite period.

Irving and Jack Kaufman are being headlined in the Keith circuit and have been honored by being brought back to New York territory eight times within the last three months.

Arthur Fields is being headlined in the Loew circuit, a unique feature of his tour consisting of a film showing him making records in the recording studios of the Emerson Co. This film is exhibited in every house prior to and during his appearance.

DOING BIG OKEH RECORD TRADE

TOLEDO, O., January 10.—The Summit-Cherry market, of this city, now harbors, under the management of R. H. Richards, a double booth devoted to talking machines and records. The Master-tone line of machines is handled and the Okeh line of records. The Okeh record business has already grown to be a large and active enterprise. Demand for Mamie Smith numbers has been particularly large and Mr. Richards has expressed himself on numerous occasions as being very enthusiastic about the line and well pleased with his merchandising policy of bringing music to the attention of housewives when they are doing their marketing.

When Wisdom is not at home, Silence must stand guard.

At Your Service

for
1921

and
Thereafter

**The William Phillips
 Phono Parts Corp.**

Manufacturers of

TONE ARMS

and

SOUND BOXES

of proved merits

Write us for prices and other particulars

145 West 45th Street

New York

COUNTRY'S BUSINESS NOW FACES SHOW-DOWN PERIOD

A Clear Analyzation of Business Conditions During the War Period and a Forecast of 1921 and What Is Promised for the Business Man, Offered by J. Newcomb Blackman

Generally speaking, it is true that history repeats itself. The repetition may be in different form, but the fact that there is no certainty as to the time, manner or result of its repetition often causes a disregard of the fact and a lack of preparation for the inevitable.

This country was not prepared for war and in keeping with the foregoing statement disregarded what might be termed the handwriting on the wall. We relied, as usual, on the fact that we were an undefeated nation apparently capable of meeting any emergency and willing to assume the cost of victory.

Permanently profitable business is transacted with due regard for the laws of economics, while modern war is conducted with an utter disregard of economy.

The immediate need was for men and war material. Cost was disregarded almost entirely.

Demand for several years has so exceeded supply that the outbidding process left the cost of labor and material at the termination of the war extremely inflated. Corresponding deflation must follow.

We are now experiencing the show-down period. Never was there a better time, however, to analyze and capitalize our experiences.

Discussing the talking machine business, and particularly the Victor, what does a review of the last few years reveal? The Victor Co. was the first to offer its services to the Government. Acceptance required an immediate and increasing curtailment of regular production.

Had the war continued no doubt the Government would have realized the unfairness of allowing the patriotism of men and concerns to be selfishly capitalized by others. Many grasped the opportunity to enter the manufacturing field.

In my judgment, the greater part of 1921 will see everybody resuming their natural places in the business world and the "reaping" will be largely according to our "sowing." Is this not what we face in meeting the show-down period of 1921?

There will be more failures among manufacturers and the trade in general. The extreme curtailment of the purchasing public, following a recklessness of expenditure, has resulted in discriminating buyers.

As merchants we must be willing to do less business and make less money for a short time if by that process we can quickly return to normal.

Refusal to reduce prices of commodities or to

accept a lower wage, in some cases, only results in the shutting down of factories, the unemployment of thousands and an added determination on the part of the buying public to extremely curtail purchases.

The business man or the employe who meets the inevitable a little ahead of the other fellow will hold his business or his job. The temporary sacrifice will be extremely small compared to the permanent benefit.

I am not advocating reduced prices or extreme methods except where absolutely neces-



J. Newcomb Blackman

sary. Naturally, the merchandise which has had very little advance can have little or no reduction at the moment. Neither should the employe who has been faithful, and in many cases at the sacrifice of a larger salary, be expected to suffer a reduction, but should be rewarded now by having his position and the salary insured.

There is no general rule that can be applied except that the deflation should be in proportion to the inflation in every case.

Concluding, the show-down period in the talking machine business indicates a "survival of the fittest"—fewer manufacturers, wholesalers and retailers.

We will return to quality and workers will succeed shirkers.

The talking machine business for 1921 will be both promising and profitable to many, but not to all, and those who are preparing to meet 1921 conditions ought to be extremely optimistic, for I am firmly convinced they will be amply rewarded.

NEW "MUSIC SHOP" IN NEW ORLEANS

L. Grunewald Co. Formally Opens First Branch Store on South Rampart Street

NEW ORLEANS, LA., January 10.—The "Music Shop," the South Rampart street branch of the L. Grunewald Co., held a formal opening recently and began the actual business of selling "everything in the musical line." The store is at 600 South Rampart street.

The branch is managed by Louis A. Guenard, who was connected with the piano department of Grunewald's for the last five years. A number of floral offerings were made by friends and employes of the store. The Music Shop forms one of the brightest spots in that section of the city. Its interior is white throughout and as it is situated on a corner there is plenty of light. A complete line of talking machines, pianos and musical instruments is handled by the shop and shortly a sheet music department is to be added.

EXPANSION WITH U-SAV-YOUR CO.

Distributors Well Pleased With the Dressing—Local Post Office Feels Business Growth

WARREN, MASS., January 7.—The U-Sav-Your Mfg. Co., manufacturer of U-Sav-Your dressing for the Victrola, reports the enlargement of its distributing organization by the addition of several well-known jobbers.

Collings & Co., Victor distributor of Newark, N. J., is making a drive this month on the sale of U-Sav-Your with very satisfactory results. This company reports that the dealers it has sold this dressing to have found the dressing entirely satisfactory and have reordered in a substantial manner.

As a result of the popularity of U-Sav-Your dressing, the post office at Warren, Mass., has been raised from third class to second class as the U-Sav-Your Mfg. Co. is doing business not only all over the United States of America but with a number of foreign countries as well.

BEHYMER SELECTS THE BRUNSWICK

It is announced that L. E. Behymer, impresario, known throughout the South and West for his successful handling of the Pacific Coast concert tours of the world's greatest artists, has chosen a style 120 Brunswick phonograph for his studio.

The Greater New York Talking Machine Co., Manhattan, has been incorporated with capital stock of \$10,000 by I. Ehrlich, M. M. Alpert and L. Levin.

Piknik Prospects in Your Community

Sell Every School a Piknik and Open Up the Largest Field of Prospects

The Piknik is perfectly adapted to every requirement of the school room, where for the greater part of the year it is daily before the pupil, the real buying factor in the home.

The name suggestion, "PIKNIK," not only stamps itself indelibly on the pupil's mind but conjures up pictures the lure of which creates the purchase desire. Supplement this with the beautiful tone and other appealing features of the Piknik and you have a combination that draws business.

Every Y. M. C. A. summer school or camp, fraternal organization, dancing school, business school, etc., will give the Piknik its stamp of approval.

It is the highest class portable phonograph. It is built to win friends and repeat business.

Write for Particulars

PIKNIK PORTABLE PHONOGRAPH, Inc.

Lakewood, New Jersey

Motor and Spring Safety Device

(PATENTS APPLIED FOR)

IMPOSSIBLE TO OVERWIND THE MOTOR

When sufficiently wound, the handle automatically ceases to wind. Thus, any child can wind the talking machine with safety.

A Simple Fool-Proof Device —Fills a Long-Felt Want—

Can be attached by anyone in a few minutes.

NOW READY FOR VICTOR MACHINES

Territory Open to Jobbers and Dealers

PHONOGRAPH SPECIALTIES MFG. CO.

67-69 Fleet St.

Jersey City, N. J.

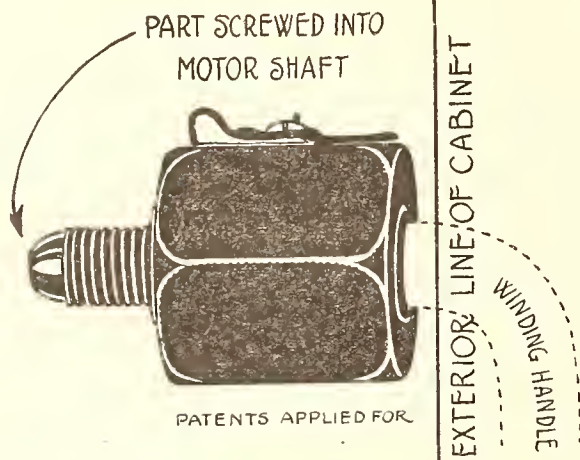

RETAIL PRICE \$3.75

LIBERAL DISCOUNTS TO THE TRADE

FOR AMERICAN MUSIC FESTIVAL

C. N. Andrews a Member of Advisory Board of National American Music Festival to Be Held in Buffalo During First Week of October

BUFFALO, N. Y., January 3.—Curtis N. Andrews, of the house of W. D. and C. N. Andrews, Victor wholesalers, is one of a group of prominent men of Buffalo who have been appointed members of the advisory board of the National American Music Festival, which is to be held here during the week of October 3-8, 1921.



C. N. Andrews

For many years past this music festival has been held in Lockport, N. Y., and has become one of the recognized important musical events in the East. The festival, however, has outgrown Lockport, and through the efforts of prominent musicians and music lovers of Buffalo a plan was formulated to underwrite the festival and bring it to this city. The advisory board and others have pledged \$25,000 annually to insure the presentation of the festival here.

The festival is designed to feature the American-born artist and composer, as well as the American language, and during the festival contests among musicians and composers will be held, with suitable awards to stimulate interest.

CONTRIBUTED A UNIQUE FLOAT

NOBLESVILLE, IND., January 3.—Clarke, Brock & Co., Sonora dealers of this city, recently contributed a unique float to the local industrial



Artistic Float with Magnavox

parade. The Sonora on the rear of the float was equipped with a Magnavox, so that those watching the parade were favored with some attractive music.

George Clay Cox, of Rochester, N. Y., whose manufacturing interests in the talking machine industry have been extensive and varied, was recently called to Virginia, Ill., on account of the death of his sister in that city.

TRADE NEWS FROM NEW ORLEANS

Business Uneven, but Retail Sales Are Fair—Columbia Activity—Diamond Disc Reports Progress—To Attend Jobbers' Meeting—News of Month Worthy of Record

NEW ORLEANS, LA., January 5.—No two persons in the talking machine business in New Orleans have the same thing to say about business conditions and since the correspondent does not audit their books just how business really is remains a secret. One man says: "Business got worse and worse and now it's 'worse'." Another says: "We're doing the biggest business ever." "I don't know," reports another, and so it goes.

The writer's own private idea, publicly expressed, is that the wholesale business isn't so much, but that the retail sales are good, due probably to the large crowds on the streets, attracted to the retail section by price-slashing sales on cloths and clothing being held by various stores in that business.

The Columbia branch, managed by A. B. Creal, assisted by H. P. Wise, reports that the house-to-house canvass was very successful. The Times-Picayune, the morning paper, gave a party to a number of its friends on the evening of December 29 and Mr. Wise furnished the music for dancing and other activities with a Grafonola.

The Diamond Disc Shop, the retail department of the Diamond Music Co., which handles the Edison in this territory as jobbers, reports the best business in its history. Wholesale salesmen started out January 2 and 3 determined to be optimistic and try to imbue others with the same feeling. L. T. Donnelly, manager of the Diamond Music Co., declares that there is business to be had and hard work and advertising will get it.

"People must eat and be clothed and the South certainly has the cotton for clothing, so there is and will be money to be spent. Our 1920 business showed a good lead over 1919. We expect a third more business in 1921."

Mr. Donnelly is going to the jobbers' meeting in Montreal February 10. He says things may be a little slow for the first three months, but he expects his company to more than make up for the slowness in the following nine months.

GEO. MEYER OPENS REPAIR SHOP

George Meyer, for a number of years connected with J. J. Cavanaugh, well-known exclusive Victor dealer of Brooklyn, N. Y., has gone into the talking machine repair business on his own account with headquarters at 137 Lawrence street, Brooklyn.

L. F. Geissler, formerly general manager of the Victor Talking Machine Co., plans to depart soon for Florida, where he and Mrs. Geissler will spend the greater part of the Winter season.

SONORA CHANGES IN ATLANTA

ATLANTA, GA., January 5.—R. V. Emmert, who formerly covered Georgia for the Southern Sonora Co., Sonora distributor located in this city, has recently resigned and left for the Pacific Coast. Wm. A. Rawson, secretary of the company, will henceforth handle the southern half of the State, and Ernest Milburn, a talking machine man of some five years' experience, will cover the northern part of Georgia. Chas. J. Rey will take care of the city of Atlanta. Van B. Smith will continue to cover Florida, and Seymour Herzfeld will handle Alabama as usual.

ON A VISIT TO CHICAGO

A. D. Geissler, president of New York Talking Machine Co., New York, and Chicago Talking Machine Co., Chicago, left the early part of the month for Chicago. He was accompanied by Mrs. Geissler. He plans to make his home in the Windy City for the next few months, centering his business activities on the affairs of the Chicago Talking Machine Co. and engaging in a series of conferences with his associates there, D. A. Creed, W. C. Griffith and G. P. Ellis.

A charter of incorporation has been granted to the International Mica Corp. at Albany, N. Y., for the purpose of operating mica-bearing properties. The authorized capital of the company is \$50,000 and the incorporators are G. A. Smith, F. J. Saxton and P. A. Hauser, of 45 West 34th street, New York City.

BRUNO

Selling a man a Victor is like rolling off a log. It's easy. Selling him a carload of records, that's easy too, but it means a bit more of your time, and it's worth it.

BRUNO

A Message From the Fred. Gretsch Mfg. Co. For 1921

**Telling why it is essential for the music dealer
to make a good connection for the coming year.**

Under the exceptional conditions of the past years, the Gretsch standard of quality and true production of instruments has been maintained.

The Gretsch organization has been fortunate in meeting the heavy demands of its many dealers. With the prospects of improvement of conditions during the coming year, Gretsch Service will be more efficient than ever before.

The Gretsch instrument is tried and true. As you know that we manufacture a large variety of musical merchandise, we can offer you the best prices.

If you are not handling our merchandise ask us for full particulars.

Do not fail to send for our price list.

A FEW OF OUR SPECIALTIES:

- | | |
|---------------------------|-------------------------|
| La Tosca Violin Strings | Koholas & Co. Ukulele |
| 20th Century Violin Cases | The Banjo Ukulele |
| 20th Century Drums | Rex Flat Back Mandolins |
| 20th Century Bells | Rex Banjo Mandolins |
| 20th Century Music Stands | Rex Guitars |
| Eagle Brand Pitch Pipes | Rex Violins |
| Rex Banjos | Gretsch Cornets |
| Cello Banjos | Gretsch Saxophones |
| Rex Strings | Gretsch Bugles |

and

THE VIOLAPHONE TALKING MACHINE

With the Violin Tone

THE FRED. GRETSCH MFG. CO.

MUSICAL INSTRUMENT MAKERS
Since 1883

54-82 BROADWAY

BROOKLYN, N. Y.

ARTo RECORDS



The ARTo girl with dainty dangling feet, silken-clad ankles, youthful and neat. Smilingly sits and sings and swings. While to her ARTo Roll and Record clings.

Into the Home—

ARTo Music Rolls bring **JOY**
 ARTo Phonograph Records bring **AMUSEMENT**
 ARTo Profit-Sharing Certificates bring **PROSPERITY**

\$1.00 ARTo 10 Inch Phonograph Records \$1.00
 THE LATEST SONG AND DANCE HITS
 for FEBRUARY, 1921

- 9040 { My Mammy. Baritone Solo.....Ernest Hare
 Bright Eyes. Tenor Solo.....Arthur Hall
- 9039 { Oh Gee! Say Gee! You Ought to See My Gee Gee.
 Tenor Solo.....Billy Jones
 Rosie, Make It Rosy for Me. Tenor Solo.....Billy Jones
- 9038 { I Never Knew I Could Love Anybody Like I'm Lov-
 ing You. Fox-trot. Chorus Sung by Bob Miller,
 Society Symphonic Orchestra
- { Why Don't You? From "Afgar." Introducing:
 "Feather Your Nest." Medley Fox-trot,
 Selvin's Novelty Orchestra
- 9037 { You Oughta See My Baby. Fox-trot. Choruses Sung
 by Jack Landauer.....ARTo Dance Orchestra
 Just Snap Your Fingers at Care. From "Greenwich
 Village Pollies of 1920." Introducing: "Love
 Flower." Medley Fox-trot,
 Selvin's Novelty Orchestra
- 9036 { Beautiful Faces Need Beautiful Clothes. Intro-
 ducing: "Rock-a-Bye, Lullaby, Mammy." Med-
 ley Fox-trot.....Ernie Cutting's Melodists
 Rose. Fox-trot.....Ernie Cutting's Melodists
- 9041 { Left All Alone Again Blues. From "The Night
 Boat." Fox-trot.....Joseph Samuel's Dance Orchestra
 Bo-La-Bo. Egyptian Fox-trot,
 Raderman's Dance Orchestra

Ask for the Complete Catalog of ARTo Records

THE ARTo CO.

ARTo Word Rolls \$1.00
 VOCo Word Rolls 85c.

- 1320 April Showers Bring May Flowers. Fox-trot.
- 1327 Becky From Babylon. Fox-trot.
- 1319 Bright Eyes. Fox-trot.
- 1332 Congo Nights. Fox-trot.
- 1334 Down By the O-H-I-O. O-My-O. One-step.
- 1323 Give Me a Million Beautiful Girls, But Give Me Them
 One at a Time. One-step.
- 1329 Good-Bye. From "Lady Billy." Fox-trot.
- 1321 In the Heart of Dear Old Italy. Waltz Song.
- 1328 Just a Week From To-day. Fox-trot.
- 1326 Love Bird. Fox-trot.
- 1330 Look for the Silver Lining. From "Sally." Fox-trot.
- 1324 My Mammy. Fox-trot.
- 1331 Nightingale. Fox-trot.
- 1318 Oh Gee! Say Gee! You Ought to See My Gee Gee
 From the Fiji Isle. Fox-trot.
- 1316 Rose I Call Sweetheart. The. Ballad.
- 1315 Rosie, Make It Rosy for Me. Fox-trot.
- 1322 Somebody Like You. Fox-trot.
- 1333 Strut. Miss Lizzie. Fox-trot.
- 1317 You Oughta See My Baby. Fox-trot.
- 1325 Yokohama Lullaby. Fox-trot.

STANDARD MUSIC ROLL CO.

Factories: Orange, N. J.

New York Office: 1604 Broadway

VICTOR CO. SECURES INJUNCTIONS

Preliminary Injunction Granted by Federal Court in Chicago Against Columbia Phonograph Cabinet Co. and Harmonola Talking Machine Co. for Alleged Patent Infringement

CHICAGO, ILL., January 11.—Judge Fitzhenry, in the United States District Court here, has granted a preliminary injunction in favor of the Victor Talking Machine Co. and against the Columbia Phonograph Cabinet Co., Axel Nordlund, Royal Nordlund, et al.

The Victor Co. brought action on the charge of infringement by the defendants of patents No. 814786, claims one and forty-two, No. 814848, claims seven, nine, ten and eleven, and English patent No. 947227, claims twenty-nine and thirty-seven.

The court granted a preliminary injunction on claims two and forty-two, upon the plaintiff giving bond of \$5,000 to secure the defendants under the provisions of the Clayton Act. The defendants were granted leave at any time for good cause, upon three days' notice, to move to advance the trial of the main case. The attorneys for the Victor Co. were Brown, Boettcher, & Dienner, and William H. Kenyon. The defense was represented by Wilkerson, Huxley, Byron & Knight.

The same court also granted a preliminary injunction in favor of the Victor Co. against the Harmonola Talking Machine Co., Sidney Schroyer & Co., et al., on the same patent claims, and under the same conditions, i. e., that plaintiffs give bond of \$5,000, and that defendants be granted leave to move to advance the trial of the main case.

SPECIAL DELIVERY RULING

Receipts Will No Longer Be Required by Mail Carriers

Special delivery mail will be delivered in future without requiring receipts and will be left in the regular mail receptacles when personal delivery cannot be accomplished, according to an announcement yesterday by Postmaster Thomas G. Patten, which explains that this service is changed in accordance with amended postal regulations.

It points out that special delivery is intended to expedite the mail and that the registry system is provided to insure safety. Mail containing currency or articles of value should be registered and postal money orders should be used to make remittances instead of coin or currency.

COOPERSTOWN VOCALION CONCERT

COOPERSTOWN, N. Y., January 3.—On the 14th and 15th of December Bundy & Cruttenden gave a very splendid invitation concert at their store in this city. In spite of the inclement weather the concert was very well attended and a great deal of enthusiasm expressed over the splendid reproduction of various artists' renditions. All of the numbers were played on the Aeolian-Vocalion, though various types and makes of records were used to demonstrate the versatility of the Vocalion, as well as splendidly demonstrating the use of the Graduola. A feature of the concert was a luncheon served with the compliments of the Aeolian Co., the food and service being obtained from the American Legion Restaurant, of Cooperstown. During intermission in both concerts a little discourse was given by Jerome B. Sabath, traveling representative of the Aeolian Co., on the mechanical and laboratory work of making records.

COLUMBIA LINE IN ROCHESTER

The Palace Columbia Shop, of Rochester, N. Y., has secured the agency for the full Columbia line of Grafonolas and records formerly held in that city by Arthur W. Oster. Mr. Davis, the proprietor of this establishment, proposes to establish a chain of retail stores covering adjacent cities. D. A. Little is manager of this new Columbia store.

THE NEXT WALTZ
 HIT
 WILL BE

KISS A MISS

THE NEXT BIG SONG
 HIT
 WILL BE

OHIO
 O MY O

PUBLISHED BY THE
 HOUSE THAT PUT OVER

"MISSOURI"
 "HINDUSTAN"
 "SWEET AND LOW"
 "NAUGHTY WALTZ"



The House of
 The Western Sun

FORSTER
 MUSIC PUBLISHER INC.
 235 SOUTH WABASH AVE
 CHICAGO

GLEANINGS *from the* WORLD *of* MUSIC

GATHERING TO DECIDE UPON BEST MUSIC FOR THE MOVIES

Association of Musical and Motion Picture Managers to Convene in New York to Consider the Question of Suitable Music to Go With Films in Moving Picture Theatres

The Association of Musical and Motion Picture Managers will convene in New York over a three-day period, commencing January 24, for the proposed purpose of "securing the best in music and applying it nationally throughout the United States in conjunction with picture theatres and with a further object of inaugurating a booking office for the purpose of supplying artists with engagements in many theatres of the country, thus protecting the mutual interests of those concerned."

Other objects of the organization will be for the purpose of "defining the value of music as a national institution in its application to pictures and bringing it up to a higher standard." The headquarters will be at the Hotel Astor and the meetings are scheduled to take place in both the Capitol and Rialto theatres on alternate days of the week.

The organization is sponsored by Charles D. Isaacson, editor of the music department of the New York Globe, who has long been a pioneer in progressive musical activities.

According to Mr. Isaacson, much interest has been manifested in the movement and a response has been received from over one hundred representative exhibitors of the country who have signified their intention of attending. These interested parties include the heads of the largest chain theatres extending from coast to coast.

Prominent figures in American music are to attend the gatherings and these will include Henry Hadley, the composer; Artur Bodanzky, of the Metropolitan Opera House, and Paul Eisler, his assistant. Others who are scheduled to take an active part in the discussions are Carl Joseph Brail, Hugo Reisenfeld and S. L. Rothapfel.

E. C. Mills, chairman of the board of directors of the Music Publishers' Protective Association, has been invited to address the gatherings and has accepted.

While this move will no doubt tend towards the general elevation of musical taste, and can be looked upon with gratification by all those interested in such progress, there is some dissenting opinion in the popular publishing field regarding this particular movement. While this opinion is not directly antagonistic, there seems to be a feeling that the channels now open for publicity to popular songs through the medium of motion picture houses will, to a large extent, be closed to popular works. The popular publishers, of course, cannot look with pleasure upon the elimination of any field that gives

popularity to their numbers. They admit that few of their issues are of a permanent character, and thus must be capitalized in a comparatively short space of time. All of this, of course, must be interesting to the talking machine dealer who really gets his quick turnovers, as far as records are concerned, from the sale of popular songs and dance music.

The publishers themselves have been instrumental in late months in assisting and encouraging booking offices whose purpose was to furnish singers for motion picture houses. Their interest, however, did not extend to the dictation of what should be sung by those whom

they booked; rather it was a case of letting the exhibitor select the type of singer who would please his public. So far this move has been a success, and the publishers have looked forward to extending such work. At no time have they, the publishers, endeavored to program the strictly novelty songs in motion picture houses, at least not through any organization, and in instrumental form where orchestrations are used novelties are arranged for through a particular department of each publisher. All angles of the situation are to be thrashed out at the coming meetings, and it does not appear that the new organization in question is endeavoring to arrange the musical programs from a central source. After all, it will be the local exhibitor and his audience who will judge the merits, or rather the popularity, of the plans to be put into being after the convention.

A QUINTET WHO SUCCESSFULLY PURVEY "JAZZ" MUSIC

Original Dixieland Jazz Band, Now Making Victor Records, Has Had Interesting and Lively Career Both in This Country and Abroad

The announcement that the original Dixieland Jazz Band is making records for the Victor Talking Machine Co. recalls the uninterruptedly successful and notable career of this lively and

introduce this form of cacophony to our European brethren. So impressed was Albert De Courville, manager of the London Hippodrome, that he booked them as a special feature in the



Original Dixieland Jazz Band

wide-awake organization. To them is due in large measure the extraordinary popularity that "jazz" has achieved, not only in America, but in Europe as well, where it was the first to

"Joybells" show there, and here the "Dixielanders" played for four solid months. They created a furore also at the exclusive club of

(Continued on page 153)

The Crooning Moonlight Song Hit

Alabama Moon

Vocal Duet by
Olive Kline and Elsie Baker
VICTOR RECORD
 No 45203



To
ALL DEALERS
of
RECORDS and
WORD ROLLS

Biggest selling Record
 and Roll successes.
 The most played num-
 bers in the country.
 Every dealer should
 get in quick.

“CARESSES”

The sensational society fox-trot of America

“PALESTEENA”

The tremendous big musical comedy fox-trot song hit

“I'M A LONESOME LITTLE RAINDROP”

Fox-trot—the sensational hit of the Greenwich Village Follies

“SWEET LITTLE STRANGER”

The sensational fox-trot hit of “Jim Jam Jems”

“OH MY GOODNESS”

The tremendous fox-trot hit

“BY THE PYRAMIDS”

Ever-popular fox-trot song

ALL FROM THE GREAT MUSIC HOUSE *of*
SHAPIRO BERNSTEIN & CO.
INC.
 BROADWAY AT 47th St. . NEW YORK

It's sweeping the Country!
HONOLULU EYES
 The most beautiful Waltz Melody
 in years Published by LEO FEIST INC
 FEIST BLDG.
 NEW YORK

"You can't go wrong with any Feist Song"

SUCCESSFUL PURVEYORS OF JAZZ
 (Continued from page 151)

the "400," known as Martens, to which royalty and aristocracy repaired to refresh their bored and jaded nerves. Their success was so marked that the club was renamed the Dixie Club in their honor. For a year and a half after this the organization played at another famous London night club, the exclusive Rector's, of that city, and this year found them once more back in New York. A tour of the Keith houses in New York and elsewhere immediately followed, and then came the present exclusive contract for their appearance at the "Folies Bergere," New York's famous resort, for which the ordinary attractions of the Great White Way carry no message. Prior to their departure abroad early in 1919 the Original Dixieland Jazz Band had made a number of talking machine records, including the popular "Livery Stable Blues," "Bluein' the Blues," "Tiger Rag" and others. Their new Victor recordings are sure of a big demand.

The Dixieland Jazz Band is composed of the following: D. J. LaRocca, cornet; Eddie Edwards, trombone; Larry Shields, clarinet; Anthony Acarbaro, drums, and J. Russell Robinson, pianist.

OPENS STORE IN FORDHAM

The Excel-Q-Phone Talking Machine Co. has recently opened a new talking machine shop at 12 East Fordham road, New York. This new shop will carry a line of Lawson phonographs and Gennett records, also the Lawson piano. A repair department is to be installed which will take care of all kinds of repair work under the supervision of an expert mechanic. R. W. Mangam, the proprietor, will have active charge.

HANDLING POPULAR MUSIC EASILY

Introduction of "Self-service" Rack Simplifies the Problem for Those Dealers Who Hesitate at the Cost of a Sheet Music Department

From time to time it has been suggested in various quarters that some plan be devised for supplying with talking machine records printed slips bearing the lyrics of the song featured on the record. As a matter of fact, one or two manufacturers and dealers tried out the plan only to discover that by so doing they violated the Copyright Law in that song lyrics are protected under that law. It has been demonstrated, however, that there is a more or less substantial demand for printed words of the sheet music of songs offered in record form.

Quite a number of talking machine dealers have installed stocks of sheet music to meet this apparent demand from record buyers, but there are other dealers who hesitated to take this step because they felt that it meant the tying up of capital in sheet music that would prove popular for only a limited period. Some retailers have compromised by stocking only standard and operatic sheet music, which is salable to a greater or less degree year in and year out.

During the past year there has been devised a method whereby dealers can carry popular works in limited quantities and on a basis that requires little or no salesmanship. Under this plan a rack is provided to hold about fifty different selections with all the title pages plainly in view. The rack is about six feet long, twelve inches wide and sets close against the wall, thereby occupying little floor space. With the titles showing the customer in most cases makes his own selection, which puts the system on a "self-service" basis.

While it is true that most popular numbers prove active sellers for only a comparatively short period the dealer need not stock up on them heavily, for there are a number of music jobbers who can place in his hands additional copies of the more salable numbers overnight as they are needed.

Since the elimination of the ten-cent store as a factor in the distribution of popular music, the dealer carrying popular prints need not fear greatly the competition of the old days and in addition the retail prices allow a sufficient margin of profit to justify any dealer in placing such goods in stock. If any talking machine dealer feels the need of additional revenue this field and its plan is worthy of investigation.

MUSICIAN AND SALESMAN

Sales Director of the Fred Gretsch Mfg. Co. Is an Accomplished Musician

A. Preveti, in charge of sales promotion work for the Fred Gretsch Mfg. Co., musical instrument manufacturer, Brooklyn, is a musician of rare ability as well as an able sales director. Mr. Preveti is a capable performer on no less than ten different instruments and is in great demand for band and orchestra work in Brooklyn, New York and the metropolitan district. He is busy every night with engagements. His wide knowledge of instruments and the art of playing them stands him in good stead in his work with the Gretsch organization. He cannot be accused of not practicing what he preaches, for all his professional work is done with Rex and Twentieth Century instruments, the well-known brands of the Fred Gretsch Mfg. Co.

Landau's new store at Wilkes-Barre, Pa., is making a beautiful display of Victors.

CONGO NIGHTS
 SENSATIONAL FOX-TROT
 WORDS BY RUBEY COWAN MUSIC BY VIOLINSKY
 MOSCONI BROS.
 PUBLISHED BY MACK STARK & COWAN MUSIC PUB. INC. 234 W. 46ST. N.Y.
 in Raymond Hitchcock's HITELY KOO 1920

Universal Self-Service Record Displayors

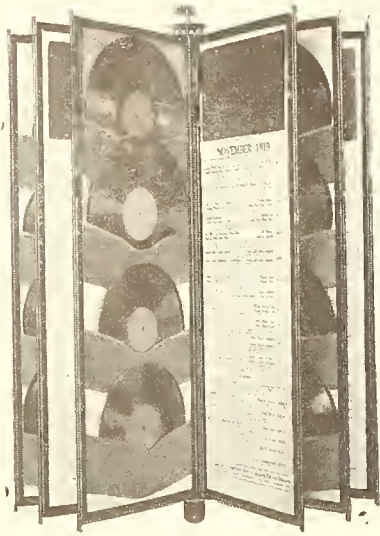

No. 560

THE SILENT SALESMAN

"Every dealer has records in stock that he would like to move. Place a dozen or more of the number on a table or rack in the front of your store where customers can look them over and select one or more to be played.

A slow-moving record may have more music value than those records around which popular demand is centered.

Remember that the Victor Company passed on the desirability of the record before it was pressed for sale.

Give your customers a chance to sell records to themselves.

This plan is not experimental. Stores that have tried it record good results."

(The above is a copy of an advertisement of the New York and Chicago Talking Machine Companies appearing in an issue of The Talking Machine World.)

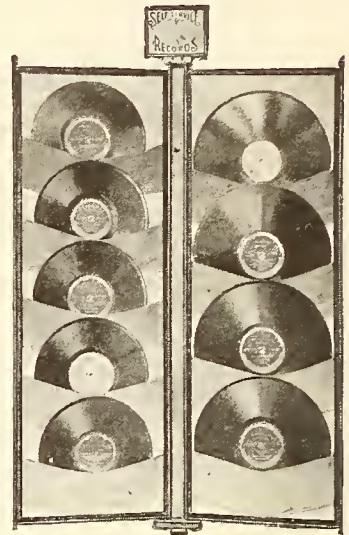

No. 550

Now is the time to increase your sales and cut out your overhead.

Make every bit of your store, booth or window space produce more business.

Universal Displayors are effective salesmen---they earn their cost in a week, but keep on earning profits for years.



No. 567

Our line now contains more than fifty different models. Displayors made of all steel and guaranteed for ten years, finished in two coats of ebony enamel, double baked, that will harmonize with the most beautiful decorative scheme.

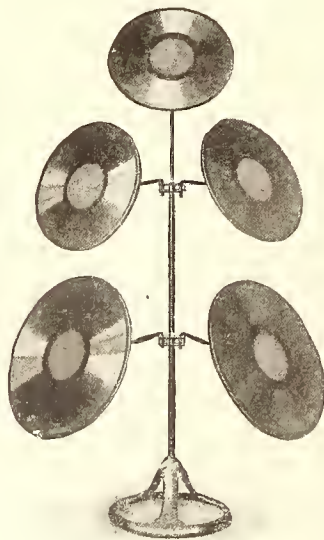

No. 501

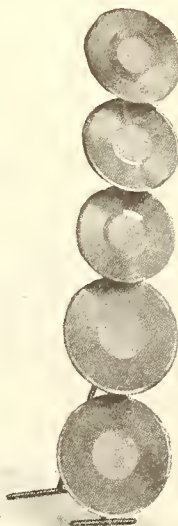

No. 553

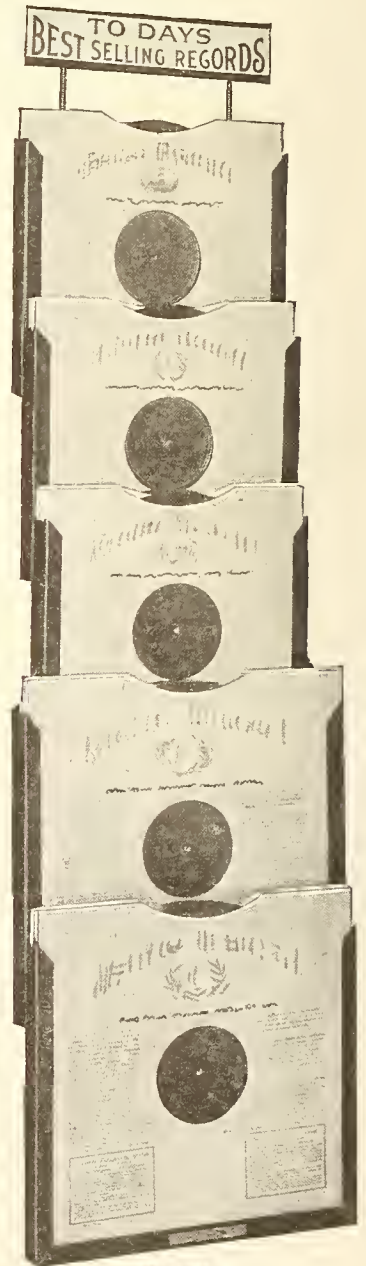

No. 565

Universal Fixture Corporation 133 WEST 23rd STREET
NEW YORK, N. Y.

Universal Displayors Increase Business and Reduce Selling Cost



No. 563

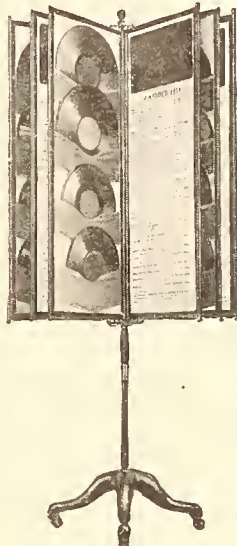

No. 561

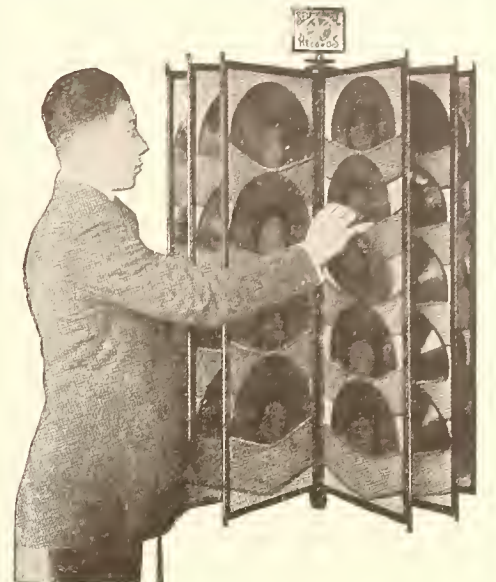

No. 528

Practically All Distributors Throughout the United States Handle Our Line
 Ask your jobber to send you a catalogue. He knows if you install Universal Displayors your record business will increase.
 The day of "allotment" has passed. The problem now is to sell records and dispose of slow-moving numbers.



No. 559



No. 568



No. 502

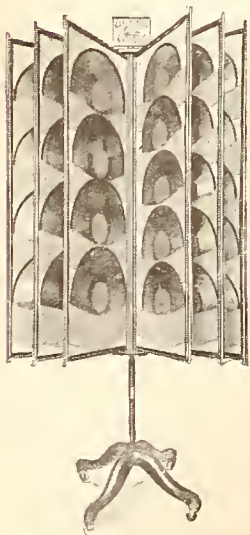

No. 551

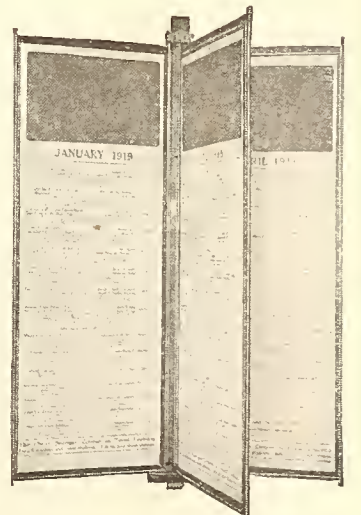

No. 558

Universal Fixture Corporation 133 WEST 23rd STREET
 NEW YORK, N. Y.

TALKER EXHIBITS AT GRAND RAPIDS FURNITURE MARKET

Feature of the January Market Was the Firmness in Prices of Talking Machines, Which Were Much in Evidence—Some Concerns Which Were Represented at This Great Display

GRAND RAPIDS, MICH., January 7.—The first few days of the furniture market indicate that the register of out-of-town merchants will be great. However, in spite of this the general opinion is that buying will be light. Most of the merchants are here for the purpose of finding out whether or not prices are being reduced. In furniture lines their expectations are being met, with cuts as high as 33 per cent being frequently evident, but there have been practically no reductions in talking machines, for which reason the buying of these instruments is naturally slow.

This very fact—the stability of talking machine prices—is, however, one of the most gratifying features of the present market from a talking machine man's standpoint. It is having the effect of increasing the confidence of dealers for the reason that it goes to show talking machine prices have not been high and will remain stable in the midst of general furniture reductions.

The talking machine exhibits are not as numerous this year as in years past, and certain of the furniture concerns that have been manufacturing cabinets or complete machines are gradually withdrawing from the field. Nevertheless, the older, better-known names continue as prominent as ever. One of the new developments is that of a combination talking machine and davenport, called the "Davenola," manufactured by the Andy Mouw Co., of Grand Rapids. As a davenport this piece of furniture admirably conceals the reproducing apparatus and as a talking machine its tone is excellent. The turntable, motor, tone arm and amplifier are located under one arm of the davenport, while a compartment for records is under the other. The Davenola is exhibited on the first floor of the Klingman Building.

On the sixth floor of the same building is

located the Starr Piano Co.'s exhibit. This is in charge of District Manager W. H. Huttie and A. L. Jewett, traveling representative.

Kesner & Jerlaw are exhibiting on the fourth floor of the Klingman Building. Their complete line of Sonata instruments is shown, together with a new model of combination library table and talking machine. This last has proven exceedingly popular with furniture buyers and during the coming year Kesner & Jerlaw plan to feature it conspicuously. This firm also plans to bring out a number of other new models, but await more opportune conditions. Both M. L. Kesner and N. Jerlaw were on hand to greet visiting dealers.

The Delpheon Talking Machine Co. exhibited on the fourth floor of the Keeler Building, with Harry P. Crouch in charge. The fibre amplifying chamber and the special Delpheon automatic stop were features that attracted the attention of visiting merchants.

The Cheney Talking Machine Co. exhibited at its factory headquarters at 423 Monroe avenue, with W. A. McMahon receiving visitors. Prof. Forrest Cheney was also on hand to meet his friends in the trade. The complete Cheney line of uprights, art consoles and special art models was on display with the numerous patented features of this line calling forth much favorable comment from dealers.

The Widdicomb talking machines were exhibited in the factory at Fifth and Dewey streets, with J. G. Griswold and M. A. Guest greeting visiting merchants. The complete Widdicomb line of both uprights and consoles was shown. The usual Widdicomb luncheons, famous for their gustatory excellence, attracted the customary noonday gatherings. Automobiles bearing the name Widdicomb were at the Hotel Pantlind to transport dealers to and from the plant.

The Michigan Phonograph Co. exhibited at its store on Campau square and caused somewhat of a furor among buyers of talking machines by its showing of two new console models to retail for \$150 and \$160. In addition to the regular line of machines there were also exhibited a universal master model enclosed motor and a Saal special open motor, as well as a complete line of tone arms, reproducers and attachments made by the Sterling Devices Co., of Chicago. Geo. M. Cook, assisted by H. W. Knoblauch, was in charge.

Charles W. Kalder exhibited at his salesroom on Fountain and Division streets a complete line of Elite machines, phonograph motors and accessories. Mr. Kalder has obtained the jobbing rights in his territory for the L'Artiste line of instruments, which was also exhibited.

The Grand Rapids Brass Co. exhibited in its offices on Scribner street. A complete display of phonograph hardware was shown visiting dealers.

COURT ASSESSES HEAVY FINE

Chas. E. Garvin and Garvin-Brown Co. Fined \$22,150.20 on Charge of Violating Injunction, Brought by Victor Talking Machine Co.

CHICAGO, ILL., January 8.—Judge Fitzhenry, in the United States District Court here, has handed down a decision in an action brought by the Victor Talking Machine Co., Camden, N. J., against Garret W. Woodward, Charles E. Garvin, doing business under the trade name and style of Garvin Furniture Co., et al., for violation of an injunction issued in March, 1918, fining Garvin and the Garvin-Brown Co. the sum of \$22,150.20, of which sum \$20,150.20 is to be paid to the plaintiff, and all unpaid taxable costs of suit assessed at the date of the entry of the order and which may hereafter accrue. August Hurt, one of the defendants, was fined \$500, and the case against Josephine Garvin, another defendant, was dismissed. The court's decision followed a report of the Master in Chancery.

**OKeh
Records**

Be a Satisfied Dealer

Sell

**OKeh
Records**

OKeh Records

The records are famous and so are we!

Tie up with us, the livest record distributor. Let us help double your sales profits.

We can take you over the top to success.

Our driving power to prosperity is enforced by hearty co-operation, quick shipments and a stock large enough to fill all orders.

Don't forget **OKeh Records** and Kennedy-Green! The two names are the cornerstone of your success.

All communications are welcome. Write today!

KENNEDY-GREEN

1865 Prospect Ave., Cleveland, Ohio

Columbia Dealers' comments on Columbia Self-Service Fixture No. 8:
"Has earned its cost several times over."
"As essential to every Columbia dealer as his demonstration hearing room."
"People just naturally cannot help operating it."
"Sold records that we had in stock."

Columbia Graphophone Co.
NEW YORK



P. J. BURNS' NEW POST

Edison Sales Manager Joins Metropolitan Forces as Sales Promotion Manager

P. J. Burns, until recently sales manager of the Amberola Department at the Edison Laboratories, has resigned that position to become sales promotion manager for The Phonograph Corporation of Manhattan, Edison jobbers for New York City and the metropolitan district.

Mr. Burns has been associated with the Edison Laboratories in various capacities for more than



P. J. Burns

a decade and brings to his new position a wealth of experience gained through close application to his numerous responsibilities during that time. Back in 1907, several years before the advent of the New Edison disc, he joined the Edison organization to become an office boy and junior clerk. Promotion followed rapidly, and in August, 1919, after having devoted several years to various phases of sales promotion work at the Orange laboratories, he went on the road to act as territorial supervisor in the Dominion of Canada. The Amberola Department, of which he was in charge during the past ten months, has shown remarkable results under his careful guidance.

Asked for a statement, Mr. Burns remarked: "There is no doubt about the possibilities of the New Edison in the metropolitan district. The immense population of this district is in touch with the best in art and music and it is merely a matter of time and education before the recreation of music is fully recognized. I am glad that my new duties will provide the opportunity to co-operate with the local dealers in serving the music-loving public of New York City and its environs."

B. R. Stacy and C. E. Pool, of Marshfield, Ore., have arranged to open a new piano and talking machine store in the Lauridsen Block, Port Angeles, Wash.

PRESCOTT TELLS OF THE TRADE SITUATION IN GERMANY

Prominent Talking Machine Expert Returns From Visit to Germany and Holland—Great Activity in "Talker" Trade in Germany—Interesting Review of the Situation

F. M. Prescott, whose interesting contribution in last month's World on the existing trade situation in Germany attracted such general attention, returned recently to his home in Riverdale, N. J., after a short but very strenuous time visiting important personages and centers in Germany and Holland.

In a chat with The World, Mr. Prescott remarked that the leading industries in Germany, and particularly the talking machine trade, are enjoying a very large measure of prosperity, and the contrast between the conditions there and the slowing up of trade in America was noticeably evident on his return from abroad.

"Despite the tremendous taxation the Germans seem determined," said Mr. Prescott, "not only to 'do business,' but to get their share of the world's trade, and they are working to that end in a very vigorous way. The money situation, owing to the general use of paper currency, seems to enable the manufacturers to expand, to employ ample labor, pay good wages, and better still, pay good dividends.

"Of course there is a lot of misery among the very, very poor, but in the main conditions in Germany as far as prices and living are concerned, are considerably better than in New York—in fact, a comparison would hardly be fair, because everything is tremendously low-priced, judging from present money exchange standards.

"The talking machine industry of Germany is largely concentrated in Berlin and since the war there has been a steady 'getting together' of manufacturers with the result that there are fewer companies but a greatly increased output of talking machines and particularly of records. A great many of the record companies in Berlin have their eyes upon the American market, and it is not improbable that German records will figure in our domestic trade at an early date.

"The compulsory eight-hour day now existent in every line of industry, as against the ten-hour day, is not popular with manufacturers, neither is the law giving a council of workmen in the factory virtually the management of the plant. In other words, the employes are a factor as important as the employer or capitalist in pro-

duction. Of course this is part of the Socialist regime which employers would like to have eliminated, but which will remain unless there is a change of government."

Mr. Prescott is one of the old-time talking machine men of this country, who has also played a part internationally because he was one of the founders of the Odeon record in Germany—in fact, there are few men so widely known in the record field as this globe trotter, who, although somewhat retired from really active work, still keeps in close touch with affairs in the industry.

ENLARGE SONORA TERRITORY

Southern Sonora Co., Atlanta, to Cover North and South Carolina as Well as Present Territory of Alabama, Georgia and Florida

ATLANTA, GA., January 8.—The Southern Sonora Co., which has been distributing the Sonora line through Alabama, Georgia and Florida with great success, has now arranged to act as Sonora distributor in the States of North and South Carolina also, according to announcement made by E. N. Upshaw, president of the company.

James M. Brown will represent the company in South Carolina, and W. W. Stanley will cover North Carolina. Mr. Stanley has had much experience traveling for a talking machine line.

The Southern Sonora Co. also distributes Emerson records through the States of Alabama, Georgia and Florida, but this distributing contract does not take in North and South Carolina.

According to Mr. Upshaw, conditions throughout the South give promise of improvement during the Spring months. Dealers in the larger towns reported a very good holiday business, but dealers in the smaller communities experienced no unusual demand.

The Brownie Music House, Port Angeles, Wash., handling pianos and talking machines, has been remodeled in a very attractive manner. The offices have been moved to a balcony in order to provide more wareroom space.

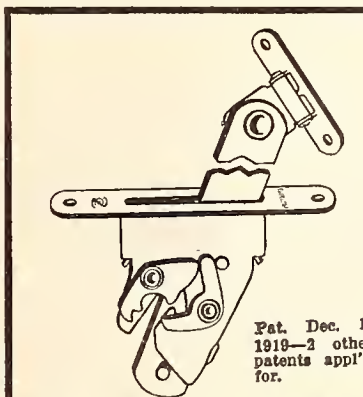

The New Automatic Cover Support

Noiseless in Operation
 Foolproof in Construction
 Made With Both Bent and Flexible Hinges
 Heavily Nickel Plated or Specially Finished to Order

Send \$1 for 3 samples—one of each model
 WRITE FOR CATALOGUE

A. F. Zega Mfg. Co.

Main Office:
 810 Broad Street
 Room 601
 NEWARK, N. J.



Factory:
 77-81 Mill Street
 BLOOMFIELD, N. J.

NEW OFFICERS OF CIROLA CORP.

At a recent election of officers Max Gordon was elected president of the Cirola Phonograph Corp. of New York City, succeeding L. Dresner. Otto Gressing was appointed general sales manager. Through the acquisition of the manufacturing facilities of the Birdsong Co., of Newark, N. J., manufacturers of tone arms and accessories, the production of Cirolas has been materially increased. The Newark plant will be operated in addition to the Cirola factory in Philadelphia.

VOCALION ARTISTS TO TOUR

Rosa Raisa and Giacoma Rimini, exclusive Vocalion artists and members of the Chicago Opera Co., started on a tour on January 11 that will include Chicago, Boston and Cincinnati.

EXCELLENT PROSPECTS IN CANADA

E. C. Scythes, manager of the Aeolian Co. branch in Toronto, Can., has been spending several days at Aeolian Hall, New York. He reports that general business conditions in Canada are much improved, that the panicky season is over, and that he expects to have a very successful year with the Vocalion.

BRANCH MANAGERS IN NEW YORK

H. B. Levy, manager of the wholesale Vocalion department of the Aeolian Co. branch in Chicago, and E. M. Wheatley, manager of the Vocalion Co., Boston, were among the recent visitors to Aeolian Hall, New York.

The dealer who works hardest will get the best results in 1921.

J. C. RAY IN GOOD HEALTH

Former Assistant to H. L. Willson Now Located in Los Angeles

J. C. Ray, for many years a right-hand man to H. L. Willson, general manager of the Columbia Co., is enjoying much better health. He left New York some time ago for Los Angeles, where he has been getting along splendidly. He recently took over considerable territory for the Columbia branch at Los Angeles.

INCORPORATED

Among recent incorporations under the laws of the State of New York is the William Phillips Phono Parts Corp., with a capital of \$50,000. The incorporators are S. Abrams, H. Stern and W. Phillips, 41 Bennett street, New York City.

The Motrola way is the only way to wind your phonograph

The following jobbers are distributing this remarkable electric device:

VICTOR DISTRIBUTORS

- Cohen & Hughes, Washington, D. C.
Florida Talking Machine Co., Jacksonville, Fla.
Lyon & Healy, Chicago, Ill.
Cohen & Hughes, Baltimore, Md.
E. F. Droop & Sons Co., Baltimore, Md.
Eastern Talking Machine Co., Boston, Mass.
Beckwith O'Neill Co., Minneapolis, Minn.
J. W. Jenkins' Sons Music Co., Kansas City, Mo.
Schmelzer Arms Co., Kansas City, Mo.
W. D. & C. N. Andrews, Buffalo, N. Y.
Perry B. Whitsit Co., Columbus, Ohio.
Penn Phonograph Co., Philadelphia, Pa.
Badger Talking Machine Co., Milwaukee, Wis.
Stewart Talking Machine Co., Indianapolis, Ind.
Reynolds Music House, Mobile, Ala.
Talking Machine Co., Birmingham, Ala.
H. A. Weymann & Son, Philadelphia, Pa.
Geo. D. Ornstein Co., Philadelphia, Pa.
Rudolph Wurlitzer Co., Chicago, Ill.
W. J. Dyer & Bro., St. Paul, Minn.
Clark & Jones Piano Co., Birmingham, Ala.
Knight-Campbell Music Co., Denver, Colo.
Horton-Gallo Creamer Co., New Haven, Conn.
E. F. Droop & Sons Co., Washington, D. C.
Rudolph Wurlitzer Co., Cincinnati, Ohio.
Collings & Co., Newark, N. J.
Buffalo Talking Machine Co., Buffalo, N. Y.
W. D. Andrews Co., Syracuse, N. Y.
Toledo Talking Machine Co., Toledo, Ohio.
W. F. Frederick Piano Co., Pittsburgh, Pa.
J. Samuels & Bros., Providence, R. I.
O. K. Houck Piano Co., Memphis, Tenn.
W. G. Walz Co., El Paso, Texas.
C. C. Moller & Co., Pittsburgh, Pa.
Elyea Talking Machine Co., Atlanta, Ga.
Philip Werlein, Inc., New Orleans, La.
Cressey & Allen, Portland, Me.
H. Eisenbrandt & Son, Baltimore, Md.
Gately-Haire Co., Inc., Albany, N. Y.
Elmira Arms Co., Elmira, N. Y.
Charles H. Ditson Co., New York, N. Y.
Musical Instrument Sales Co., New York, N. Y.
Standard Talking Machine Co., Pittsburgh, Pa.
Badger Talking Machine Shop, Milwaukee, Wis.
EDISON DISTRIBUTORS
Denver Dry Goods Co., Denver, Colo.
Pardee Ellenberger Co., New Haven, Conn.
Phonographs, Inc., Atlanta, Ga.
Diamond Music Co., New Orleans, La.
Pardee Ellenberger Co., Boston, Mass.
Harger & Blish, Des Moines, Iowa.
American Phonograph Co., Gloversville, N.Y.
Phonograph Co., Milwaukee, Wis.
American Phonograph Co., Albany, N. Y.
Phonograph Corporation, Chicago, Ill.
Lawrence H. Lucker, Minneapolis, Minn.

- Silvertone Music Co., St. Louis, Mo.
Phonograph Co., Cincinnati, Ohio.
Phonograph Co., Cleveland, Ohio.
Girard Phonograph Co., Philadelphia, Pa.
Buehn Phonograph Co., Pittsburgh, Pa.
Proudfit Sporting Goods Co., Ogden, Utah.
Kipp Phonograph Co., Indianapolis, Ind.
American Phonograph Co., Gloversville, N. Y.
W. A. Meyers, Williamsport, Pa.
C. B. Haynes Co., Inc., Richmond, Va.

PATHE DISTRIBUTORS

- John A. Futch Co., Jacksonville, Fla.
Fuller Morrison Co., Chicago, Ill.
Hallet & Davis Piano Co., Chicago, Ill.
W. W. Kimball Co., Chicago, Ill.
National Piano Co., Baltimore, Md.
Wm. Volker Co., Kansas City, Mo.
Wright & Wilhelmy Co., Omaha, Nebr.
Pathé Freres Phonograph Co., New York City.
Fischer Co., Cleveland, Ohio.
Pittsburgh Pathéphone Co., Pittsburgh, Pa.
Buffalo Wholesale Hardware Co., Buffalo, N. Y.
Harbour Longmire Phonograph Co., Oklahoma City, Okla.
Salt Lake Hardware Co., Salt Lake City, Utah.
R. B. Broyles Furniture Co., Birmingham, Ala.
Western Phonograph Co., San Francisco, Cal.
Interstate Phonograph Co., Philadelphia, Pa.
Gray & Dudley Hardware Co., Nashville, Tenn.
G. Sommers & Co., St. Paul, Minn.
Pathéphone Shop, Rochester, N. Y.
F. P. May Hardware Co., Washington, D. C.
Western Phonograph Co., Los Angeles, Cal.
Wm. Volker & Co., Denver, Col.
John A. Futch Co., Atlanta, Ga.
Bristol & Barber, New York, N. Y.
Rochester Phonograph Co., Rochester, N. Y.
John A. Futch Co., Charlotte, N. C.
Wm. Volker & Co., Houston, Texas.

STARR PIANO COMPANY—All Branches and Distributors

BRUNSWICK DISTRIBUTORS

- Kraft, Bates & Spencer, Inc., Boston, Mass.
Butler Bros., Chicago, Ill.
Brunswick-Balke-Collender Co., Seattle, Wash.
Brunswick-Balke-Collender Co., Los Angeles, Cal.

SONORA DISTRIBUTORS

- Western Jobbing & Trading Co., Los Angeles, Cal.
Minneapolis Drug Co., Minneapolis, Minn.
Smith, Kline & French Co., Philadelphia, Pa.

- Yahr & Lange Drug Co., Milwaukee, Wis.
Hessig Ellis Drug Co., Memphis, Tenn.
Strevell-Paterson Hardware Co., Salt Lake City, Utah.
Southern Sonora Co., Atlanta, Ga.
Southern Drug Co., Houston, Texas.
C. J. Van Houten & Zoon, Chicago, Ill.
Alexander Drug Co., Oklahoma City, Okla.
Sonora Distributing Co., Dallas, Texas.
Philadelphia Show Case Co., Philadelphia, Pa.

MISCELLANEOUS

- A. C. Becker Co., Chicago, Ill.
Empire Talking Machine Co., Chicago, Ill.
F. C. Henderson Co., Boston, Mass.
National Phonograph Co., Pittsburgh, Pa.
Hoeffler Piano Co., Milwaukee, Wis.
American Phonograph Co., Burlington, Va.
E. R. Godfrey & Sons Co., Milwaukee, Wis.
Gilbert Bros. Mfg. Co., Wichita, Kansas.
Associated Furniture Manufacturers, St. Louis, Mo.
Wiley B. Allen Co., San Francisco, Cal., and branches.
Cabinet & Accessories Co., New York City.
Plaza Music Co., New York City.
Emerald Co., Birmingham, Ala.
O. J. De Moll & Co., Washington, D. C.
Wade Talking Machine Co., Chicago, Ill.
Wilson-Broadway Music Co., Chicago, Ill.
New Orleans Furniture Co., New Orleans, La.
Sanford, Chamberlain & Albers Co., Knoxville, Tenn.
Commonwealth Edison Co., Chicago, Ill.
Cheney Talking Machine Co., Chicago, Ill.
A. G. Kunde Music Co., Milwaukee, Wis.
H. T. Gratz, Louisville, Ky.
Adora Phonograph Co., Detroit, Mich.
Federal Talking Machine Co., Pittsburgh, Pa.
Electric Supply Co., Memphis, Tenn.
Waltham Piano Co., Milwaukee, Wis.
Tiffany Phonograph Sales Co., Cleveland, O.
Grand Talking Machine Co., Brooklyn, N. Y.
Electric Appliance Co., San Francisco, Cal.
Universal Phonograph & Supply Co., New York, N. Y.
Lansing Sales Co., Boston, Mass.
New England Supply & Equip. Co., Boston, Mass.
Esco Music & Accessories Co., Brooklyn, N. Y.
Walters & Barry Corp., Buffalo, N. Y.
Sterling Roll & Record Co., Cincinnati, Ohio.
Northwest Phonograph Jobbers, Inc., Spokane, Wash.
Scott Weighing Machine Co., Topeka, Kansas.

BROOKS MFG. CO., Saginaw, Mich.

BRUNSWICK-BALKE-COLLENDER CO. Branches Everywhere

COLUMBIA WHOLESALERS Everywhere

CANADIAN DISTRIBUTOR—His Master's Voice, Ltd., Toronto, Canada

29 W. 35th St. JONES-MOTROLA, Inc., New York

DETROIT—LOS ANGELES—KANSAS CITY, MO.

Jobbers—Write us—We have a wonderful proposition to offer you

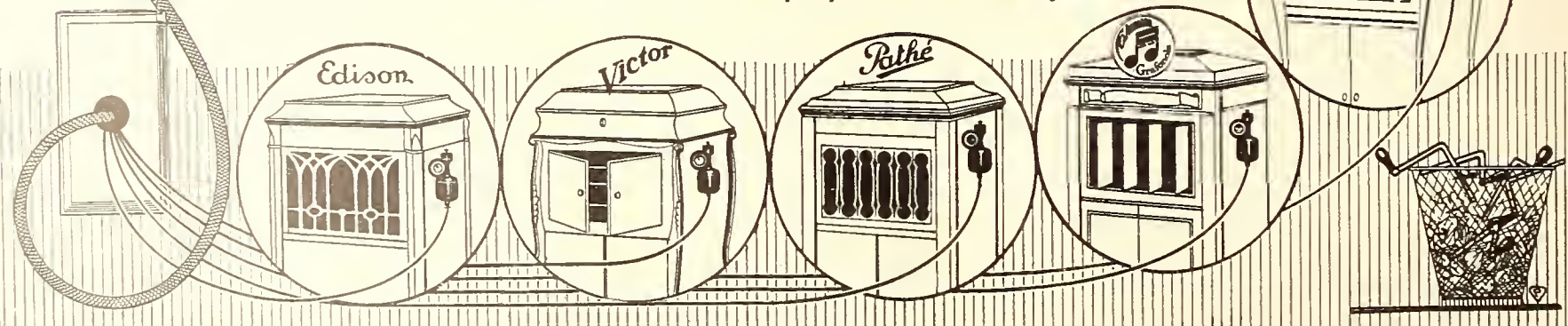

THE TALKING MACHINE WORLD SERVICE

Robert Gordon's Page -

A DEPARTMENT DEVOTED TO PROMOTING RETAIL SALES



Be "Up and Doing" Instead of "Down and Out"

FEBRUARY is almost upon us! The shortest month in the year, yet the greatest month for birthdays of American patriots. As I look back over what I studied about Georgie and Abe, I can only remember one characteristic which both possessed in common to a great degree, and that one characteristic—their untiring desire to work and to be of service.

Work and service, mixed together for about half a man's lifetime, is the best formula in the world for success. Washington and Lincoln and thousands of others whose names do not appear in history have proven that this is true.

Reports now in on 1920 holiday business show that merchants who went after business aggressively made a good showing, and that those whose policy was passive did not fare very well. Don't be passive! Push for sales! Confidence and courage are needed!

* * *

A TRAVELING representative of one of the large talking machine companies stopped in at our office the other day and told us the following interesting story: Recently, while visiting a city in Ohio, it was necessary for him to call on a certain talking machine dealer on whom he had not previously called. On mounting a street-car he asked the conductor if he happened to know where Smith's store was. The reply was "Get off at Henry street, and it's just 300 steps." When the car stopped and he got off, he inquired again from a passerby. This man pointed in the direction off the main street and said, "Just 300 steps up there."

Of course the eternal question mark presented itself as to why both parties said "300 steps." On visiting the store, the representative learned that the proprietor, realizing that he was off the main street, had taken this slogan: "Just 300 steps off Main street." The result was that although the store was not visible from the main thoroughfare, practically everyone had become acquainted with it. The prosperous business which the establishment was enjoying was proof of the pie.

The moral of the little story is that after all it is a wise plan to advertise where you are, and to put your store on the "main street mind" of the buyers, regardless whether it is on the principal thoroughfare or not.

* * *

THE street vender who cries his wares to the public as he moves along has after all a pretty good sales idea behind his proposition, in that he gets about and brings his merchandise to the attention of a greater number of people than if he remained in one place.

Several companies have had the same sales idea, when they have put the following plan into their business: Equipping several of their salesmen with small handbags which contain the month's releases of records, they sent these men to call on their list of clients who had slowed up in the buying of records. On going to the prospective customer's home they offered to demonstrate the records. The idea was most successful. Not only did they sell a large number of records, but they also managed to secure a large amount of work for the repair department. To-day these same companies send their men out on regular schedules of appointments to the homes of these people, where they play over the releases and sell a considerable number before they leave.

* * *

SOME people believe that when sales begin to drop off on one of the articles which they are selling, they should devote all their sales efforts towards pushing that product, so as to keep up the sales. On the other hand, there is such a thing as following the line of least resistance—the line which takes the least sales effort to make the bell on the cash register ring.

Recently, the public has slowed up in buying high-priced articles. The buying of anything which involves a very considerable investment has been postponed until prices drop. Yet, on the other hand, the public continues to buy liberally where the investment is small. Therefore, at this time—push your record sales, build up your repair department, feature your accessories. In other words, push those things which do not mean a heavy investment to the public. By pushing these ends of your business, you will get cash sales which are advantageous at this time.

UNDER present business conditions it is highly important to get people to visit your store. In every line of business we find establishments inducing the public, by one means or another, to make such visits. Department stores are running sales to attract the public. Other establishments are giving free exhibitions of imported merchandise and art, or are offering some special inducement, which will bring the people to their store. The talking machine dealer should also attract the public to his establishment.

Concerts are probably one of the best means of attracting the public to your store. If you use this plan do not fail to give the concerts proper publicity, through advertising, through cards in your window and through direct mail contact with your prospects. Bringing people into your store not only affords an opportunity to secure the names of new prospects, but it keeps the people—young and old—in your city thinking about talking machines, records and musical instruments of all kinds.

* * *

IT may not be out of place at this time to say a word on advertising. Too many people today are cutting down their expenses at the wrong end. If your business has slowed up, under no conditions cut down on your advertising. After all, advertising is a tonic for your business. It is the medicine with which to rejuvenate sales. It is the voice of your firm to the public. The less the tendency of the people to visit your store, the more you should advertise in order to visit them and induce them to visit your establishment.

However, see to it that your advertisements are tuned to meet current conditions. Be sure that coupon ads are plentiful. They are opportune, because you will need *new, live names* to work on. Make reprints of these advertisements and mail them to your general prospect list by first or third class mail. The idea of this is to secure new fresh names that are live prospects at this time. Do not feature cut prices. Our survey of the last ninety days indicates that the wisest course lies in featuring quality and terms. Advertising cut prices in most cases only serves to postpone buying. It makes your customers feel bigger sales are coming. However, be sure that you do not feature small payments and long-time sales. Credit isn't going to be easy to secure, in fact hasn't been for some time. But if you advertise unusually liberal terms you will get that kind of business—for the words of the prophet, "As ye sow, so shall ye reap," are still true.

This is no time to sit around and say, "Business is dull." Business is just as bright and big as you make it.

* * *

FEBRUARY offers a good chance to sell some extra records. There is nothing better than a record as a Valentine gift. During the two or three weeks prior to St. Valentine's Day we suggest that in every letter or circular you send out there be a small printed circular enclosed, bringing attention to the public of this fact. With nothing more than a slip on which is printed "A Record makes an ideal Valentine," you will call public attention to the value and adaptability of a record as a Valentine. We would also suggest that your window be decorated, prior to St. Valentine's Day, in such a way as to appropriately carry out the Valentine theme.

If you push this idea this year it will increase your sales and also educate the American people to the idea, so that in following years Valentine's Day will mean heavy record sales for you. This idea may also be profitably applied to music rolls.

* * *

EVERYTHING comes to him who waits" is an old saying—but the dealer who waits for customers is going to have plenty of time to twiddle his thumbs. To-day it is a case of getting out after the customer, instead of waiting for the customer to come in. Increase your outside sales force; enlarge your prospect list, either through the telephone book, directories, or pushing door-bells. The successful merchant to-day realizes that his store is only the center of his business, and that the arms of it must extend throughout the whole city. "Opportunity knocks but once." Therefore, knock on the doors of your townspeople and get the opportunity instead of waiting until the opportunity gets you.

EDITOR'S NOTE—Mr. Gordon, who writes this monthly page, is also director of "The Talking Machine World Service." Mr. Gordon will publish on this page any good ideas submitted by you for the benefit of the trade, and also answer any questions you ask him concerning merchandising problems. Use this department as much as you like. It is intended to serve you.

VICTOR CO. SECURES INJUNCTION AGAINST WANAMAKER

In Decision Recently Issued U. S. District Court Holds That Victor Patents Have Been Infringed by John Wanamaker and Issues Order for an Injunction and an Accounting

Judge Augustus N. Hand in the United States District Court for the Southern District of New York, on December 4, handed down a decision granting an injunction and accounting in the action brought by the Victor Talking Machine Co. against John Wanamaker, New York, on the charge of infringing Patents Nos. 814,786 and 814,848. In issuing the injunction the court upheld four of the five claims made under the two patents.

Inasmuch as the case has been of considerable interest to the trade at large, the decision of the court is published herewith in full:

This is a suit for infringement of Letters Patent Nos. 814,786 and 814,848. The application for each patent was filed February 12, 1903, and the patents were each issued on March 13, 1906. The claims at issue are 42, 2 and 36 of Patent No. 814,786, and 7 and 11 of Patent No. 814,848. These claims are as follows:

Of No. 814,786:

"42. A talking machine, comprising a tapering sound-

conveyor, means for attaching sound reproducing means to the small end thereof and horn coupling and supporting means with which the other end of said conveyor is movably connected.

"2. In a talking machine, an amplifying horn proper, a record support, a tapering sound tube movable independently of the amplifying horn proper and supported to move in a given plane parallel with said record-support, a sound box mounted upon and communicating with the small end of said tube and movable independently thereof toward and away from the record-support, said horn and tube communicating and supporting means at the communicating portion of said horn and tube.

"36. In a talking machine, a record support, a hollow sound-conducting arm movable in a given plane parallel with said support, and a sound box mounted upon, communicating with and movable independently of said arm, toward and away from the record-support, said sound box being movable upwardly and to the other side of its point of support, whereby it may be supported in an inoperative position by contact with said arm or a portion thereof."

Of No. 814,848:

"7. An amplifying horn, comprising a continuously tapering tube having a joint to allow a movement of one end of said horn in relation to the other, said horn being supported at said joint.

"11. An amplifying horn, comprising a tapering, curved tube, said tube being pivoted on a substantially vertical axis to allow a horizontal movement of the smaller end of said tube, the curved portion of said horn connecting sections thereof lying in substantially parallel planes, said axis passing through or adjacent said curved portion."

I shall first allude to the question of infringement. It was held by Warrington, J., in the case of Gramophone Co., Ltd., vs. Ruhl, heard in the English Chancery Division, that a tone arm which was not substantially tapering did not come within the claims of the British patent that seem to have been identical with those under consideration. But it is stated that the tone arm of the defendant in that case, while smaller in the area where it joined the sound box than it was where it joined the upper part of the horn, attained the difference by a sudden enlargement. A diagram of that tone arm is shown in the opinion of the Court of Appeals, which likewise held there was no infringement.

Judge Sessions, in the case of Victor Talking Machine Co. vs. Cheney Talking Machine Co., decided August 5, 1920, held that the tone arm of the defendant in that case was tapering and did infringe claim 42 of Patent No. 814,786, but that the horn as a whole did not, infringe claims 7 or 11 of Patent No. 814,848, because it was neither continuously tapering nor had it a tapering curved tube. He said: "That portion of the tube lying between the tone arm and the orchestral sections, which is approximately of the same length as the tone arm itself, is of constant and slightly less diameter than the larger end of the tone arm."

Evidently the variation from a continuous taper was far greater than in the horn and tone arm of the defendant in suit, and the tube of the Cheney machine may be regarded not as curved, but with rectangular joints.

The British Court of Appeals, in passing on this very question in the case of Gramophone & Typewriter, Ltd., vs. Ullmann, held that unsubstantial variations in continuous tapering would not avoid infringement and Judge Learned Hand reached the same conclusion in his opinion filed January 14, 1913, in the case of Victor Talking Machine Co. vs. Hoschke.

None of the cases have held that so small a deviation from a continuous taper as the four to five inches of tone arm next the sound box, and the three and one-quarter inches farther along the tube of defendant's horn, is a sufficient variance to avoid the claims in suit. I find a clear infringement and regard the only real question as that of validity.

The records before Judge Learned Hand in the Lindstrom and Hoschke cases and before Judge Sessions in the recent Cheney case were practically the same as that now presented except for the Winne alleged prior use, the Miller patent and the Columbia taper tone arm. There is, however, the significant further addition to the present record consisting of the testimony of complainant's own expert to the effect that the ordinary hearer could not distinguish between the sounds from a tapered tone arm and those from one with parallel sides. Undoubtedly the complainant's expert, Mr. Hunter, insisted that careful experiments would show a superiority of tone in a machine having a tapering tone arm. The evidence of the practical abandonment of the first Johnson machine having a tone arm with parallel walls and the immediate success in the trade of the later form of instrument with a tapering arm is a tribute to the utility of the talking machine described in the patents in suit. This argument from commercial success has been enough to satisfy Judge Learned Hand, Judge Sessions and at least one and perhaps two English Courts of Appeal that a tapering tone arm in combination with the other elements present in the claims under consideration was sufficiently novel and useful to be patentable. I doubt the conclusion of Justice Warrington in the case of Gramophone Co. vs. Ruhl, supra, to the effect that an improvement in tone which can only be detected by trained experts does not involve an advantage to the public which justifies a patent. In the first place, even if no class but well-trained musicians could detect the advantage, I can see no reason for saying that it is not useful. Furthermore, I think it possible that even the average man may have a real preference for sounds which he has not training or concentration consciously to compare with those less pleasing. The

FOR "PART" FOLKS

You people who make phonograph accessories, needles, filing devices, etc.—let us tell you of our facilities for turning out a thousand or a hundred thousand show cards, posters or window displays.

Details and photographs gladly sent upon request.

USOSKIN LITHO, Inc.
230 WEST 17th ST., NEW YORK CITY

unanimous opinion of so many judges, as well as the commercial success of the tapering tone arm as soon as it was put on the market, and the apparent abandonment of the non-tapering tone arm, are most persuasive. The point is a close one, but I am of the opinion that the results achieved by the Johnson device in suit should outweigh the evidence of some experts that a tapering tone arm affords no advantage, and even the admission of Mr. Hunter that the superiority of its tone cannot readily be detected. I find no reference in the patents which seem to have been before the courts in former litigations which literally meets the combination described in the patents in suit and agree with the judges who have heretofore passed on the question that the patent is valid so far as the art is concerned that they appear to have had before them in the prior litigations.

There remains the consideration of the new prior art. I think the construction of slot machines by Abner Tisdell prior to any date of invention claimed by Johnson is established by a number of witnesses who impressed me as credible. I do not understand it to be disputed that Abner Tisdell came to No. 1013½ Gates avenue, Brooklyn, about March, 1900. There seems to be no doubt that Tisdell constructed a twelve-record machine with a tapering tone arm during that year, or the early part of the next, but these events happened about twenty years ago; work was done on the machines covering a period of a number of years and Winne, for whom they were made by Abner Tisdell, testified that the latter, in 1900, was at 1013½ Gates avenue, "doing work for me building parts of slot machines, experimental work." (Record page 376). In 1915 Winne testified as follows about the first twelve-record machine:

"* * * We saw certain things were faulty. I could not state exactly how long we worked on these improvements, but I would say it was at least two, if not three, years after this first machine was constructed that we continued the building of these machines." (Record pp. 414, 415.)

Winne then added that it would be pretty hard to tell then what things they found faulty and that they worked on improvements at least two, if not three, years after the first machine was made. (Record page 414.) Another place, Winne said the defects were "just the coin mechanism." (Record page 380.)

Lather, who worked on the machines both at the Gates avenue and Myrtle avenue shops of Abner Tisdell, testified, in 1915, that the first twelve-record machine was a sort of experiment and was not a success for the purpose

CABINETS

Highest Grade
Moderate Prices
Immediate Deliveries

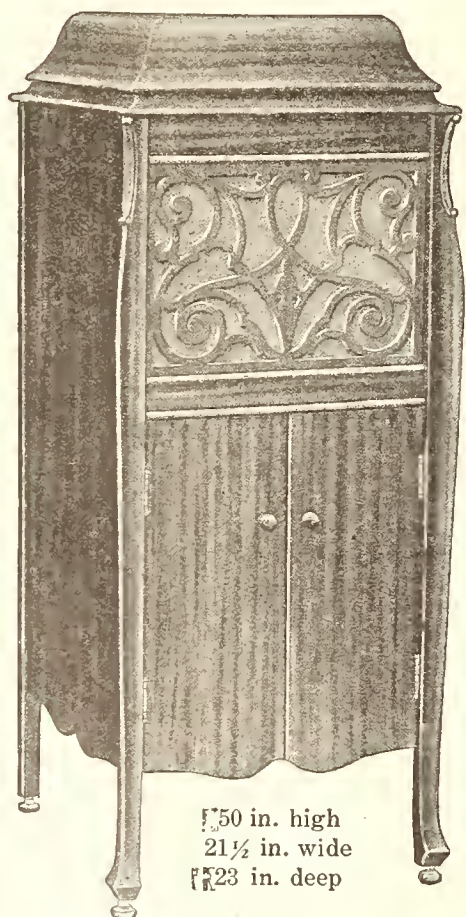

750 in. high
21½ in. wide
23 in. deep

One of Our Popular Models

We can fill promptly orders for Genuine Mahogany, Quartered Oak and American Walnut Cabinets.

We use only five-ply selected wood. Eight models in the line. The finest cabinets at moderate prices.

Send us your specifications today.

The Celina Specialty Co.
CELINA, OHIO

BRUNO

The Victor is not only the nation's talking machine, but it is the "World's Musical Instrument."

BRUNO

Phonograph Horns or Amplifiers

Cast metal base in three different designs, round and rectangular, for metal or wood extensions. Scientifically constructed to give best tone. Musical critics have pronounced our tone unsurpassed by any machine on the market.

Shaped Phonograph Cabinet Legs, Any Quantity, At Reasonable Prices

Buy Your Cabinets Knocked Down

We can supply five different sizes and designs.

Write today for full description and prices, stating quantity wanted.

INDIANA PHONOGRAPH SUPPLY CO.
321 Baldwin Block,
Indianapolis, Ind.

of an automatic slot machine (Record page 431), and added that it was four or five years later that the other machines were constructed. He also said that the twelve-record machine was a secret before it was completed. (Record page 433.)

I think such evidence as this from a man who was helping Abner Tisdell develop the slot machines shows a failure to comply with the well-established rule that a prior use must be established by clear testimony and beyond a reasonable doubt. I think the witnesses were reputable and truthful, but lack of clear documentary evidence or physical exhibits showing date of reduction to practice leaves the question whether the Tisdell conception was reduced to successful practice or was in public use before the date of Johnson's application problematical. As the proof stands, the trials can only be regarded as experimental prior to an even later date.

The tapering tone arm, which appears in the Miller reissue patent, cannot be regarded as anticipating that feature of the Johnson patent. The matters in interference did not relate to a tapering tone arm. The affidavits of Miller furnish the only evidence of the date of his conception, and his sketch dated December 2, 1900, showing a talking machine with a tapering arm, does not establish that date by documentary evidence, for Miller does not state when the date was placed on the sketch. Moreover, the language of his specification nowhere describes or claims such an element as a tapering tone arm, but only shows a diagram of such an arm. There is no reason to suppose that this feature was a part of Miller's conception. I do not regard claim 37 of the Miller reissued patent No. 12963 as calling for a tapering tone arm. It is applicable to an amplifier having a tone arm, either with parallel sides, as shown in Figure 4, or with tapering sides as shown in Figure 1, and makes no claim to any special shape.

As for the Columbia defense, the date is too late. I think it clear that Johnson's conception was at least prior to the Summer of 1902, and that dies were made and successful devices constructed embodying his invention during that Summer of the character of Exhibit 18. The Columbia device appears to have originated in Hinkley's sketch in October. This was rapidly followed by reduction to practice, but of a later date than Johnson, who proceeded steadily from the early Summer of 1902 until he put his talking machine on the market in the Spring of 1903 and filed the applications for his patents on February 12, 1903.

On the whole case I hold all the claims in issue valid and infringed except claim 36 of Patent No. 814,786. That is not limited to a tapering tone arm. I regard it, therefore, as showing no invention over the Elfering or Johnson and Denison prior patents. The only modifications of claim 36 in suit are obvious equivalents. *Victor vs. Edison*, 229 Fed. 999; *American Graphophone Co. vs. Gimbel*, 240 Fed. 971.

The complainant is entitled to an interlocutory decree adjudging all the claims in issue, except 36, supra, valid and infringed, and providing for an injunction and an accounting. The suit as to claim 36 should be dismissed.

(Signed) AUGUSTUS N. HAND,
 District Court.

January 4th, 1921.

Kenyon & Kenyon were attorneys for the Victor Co., and Dunn, Goodlett, Massie & Scott for the defendants.

FAMOUS SINGERS RECORDS

Famous Singers Records, Manhattan, with a capital of \$50,000, was incorporated at Albany, N. Y., last week by J. M. Ranko, M. W. Rappaport, F. A. Lappen, 135 West 116th street.

WANTED—Salesmen for splendid side line, all over the country. Pocket sample. Ten to twenty dollars daily easily made. Demonstration requires few minutes only. Write Puritone, Room 1408, 347 Fifth avenue, New York City.

DRIVES CAR INTO STORE

Philadelphia Autoist Brings Up in Show Window of Victor Record Store

PHILADELPHIA, Pa., January 7.—An automobile driven by Joseph B. Cox clipped off part of the glass of the Victor Record Store at 52d and Chestnut streets today, and came to a stop in the doorway.

Cox was driving east on Chestnut street and Sacks, a policeman, alleges he lost control of the machine as he approached 52d street. The car first took the sidewalk at the northwest corner of 52d and Chestnut streets, then got back on the pavement and swerved to the northeast corner, where it crashed into the window. Curiously enough, the entire window was not broken, but the car just smashed a hole in the side of the pane big enough to permit it to go through.

The Music Box, Inc., of Beverly, Mass., has been incorporated to deal in phonographs.

FILE PETITION IN BANKRUPTCY

Creditors Take Action Against Independent Talking Machine Co., of Manhattan

A petition in bankruptcy was filed on January 6 against the Independent Talking Machine Co., of Manhattan, Inc., manufacturers of phonographs and supplies at 12 East Forty-second street, New York, by the Mica & Micanite Supply Corp., the Martini-Kuhn Corp. and the Sandler Paper Box Co. It is reported that the liabilities of the concern are about \$250,000, with assets of about \$50,000.

On January 7 Judge Hand, in the United States District Court, appointed Arthur Y. Dalziel receiver for the company, under bond of \$10,000.

Schwartz, Kramer & Jelling, Brooklyn, N. Y., have been incorporated with a capital stock of \$10,000 to deal in phonographs. The incorporators are W. J. Jelling, M. Kramer and J. R. Schwartz.

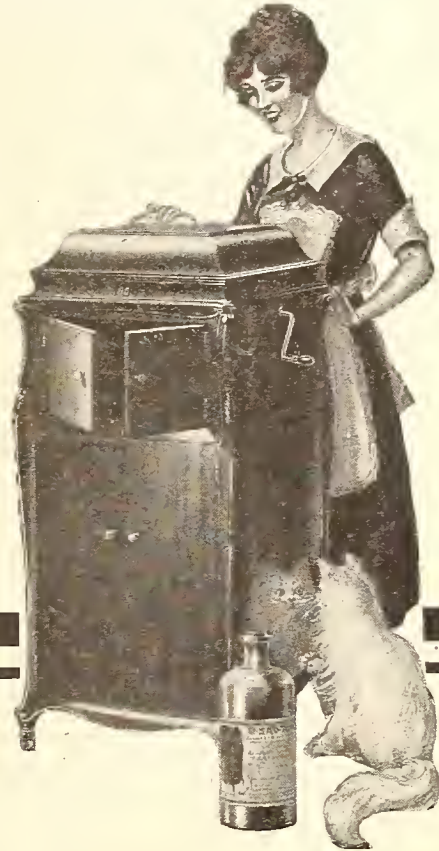

U-SAV-YOUR
 (Reg. U. S. Pat. Off.)
Confidence

YOU must have perfect confidence in the article you sell or you "fool yourself" and you lose customers.

Collings & Company, New Jersey Victor Distributors, are selling thousands of dollars' worth of our wonderful cleanser and dressing. They believe as we do—There is nothing better on the market.

Blank & Company sell a "polish" they make because one of their men in the workshop "got up" a mixture, and now wonder why they are not receiving a repeat business.

Blank No. 2 has a "lot" of — polish and when that is gone then they will put in U-sav-your.

Blank No. 3 are interested only in their own polish.

We want your confidence. Try "U-sav-your"—test it to your heart's content—then, if you find it is the best you ever saw—stock it—but first sell *yourself* a bottle, and you will point with pride to your U-sav-your business, having confidence in your goods and yourself.

U-sav-your feeds the wood, gives it life—wondrous, beautiful life.

Purchase from your Victor Distributor, or write direct to us. Discount very attractive. Repeat business guaranteed.

U-SAV-YOUR MFG. COMPANY
 33 Perkins Avenue Warren, Mass.



Delivery Service

Beginning with the New Year, adequate stock of Stephenson Precision-Made Motors, Tone-Arms and Sound Boxes will be carried in Newark, Toronto and Chicago, and will be sold F. O. B. these points.

This step is in line with the Stephenson policy—to back the Stephenson Precision-Made Motor with every possible service.

STEPHENSON
DIVISION
DE CAMP & SLOAN INC.
One West Thirty-fourth Street
New York City

**TO ARGUE VICTOR-STARR
SUIT ON FEBRUARY 5TH**

Actual Arguments in the Case to Be Heard in the U. S. District Court on That Date Following Taking of Testimony Last Month

The important suit brought by the Victor Talking Machine Co., Camden, N. J., against the Starr Piano Co., Richmond, Ind., charging infringement of the Johnson patents covering the making of lateral cut talking machine records, will come up for argument before Judge Learned Hand in the U. S. District Court, New York, on February 5.

Testimony in the case was taken during the last two weeks in December, this feature consuming something like eight days. The interest of the trade at large in the suit was evidenced by the number of talking machine men who were regular attendants at the court during the taking of the testimony. Numerous technical experts were called by both sides.

Kenyon & Kenyon appeared as counsel for the Victor Co., while Kerr, Paige, Cooper & Hayward appeared in like capacity for the defendant.

HOLMES TO JOIN SHULTZ BROS.

Former Territorial Supervisor for Edison Laboratories to Become Connected with Edison Jobbers in Omaha, on February First

Announcement has just been made that H. R. Holmes, formerly territorial supervisor for the Edison Laboratories and recently engaged in



H. R. Holmes

sales promotion work for the Edison organization, will soon become field representative for Shultz Bros., Edison jobbers in Omaha, Neb. He will probably take up his duties on February 1.

Mr. Holmes has been connected with the Edison Laboratories in various capacities for a number of years and is splendidly equipped to assume the various responsibilities which will go with his new position. It is a policy at the Edison Laboratories to introduce men of the live-wire type into the sales department, where they absorb all the Edison policies and gain familiarity with every phase of the Edison business before they are appointed to the various supervisorships.

The American Home Recorder, Inc., 220 Market street, Newark, N. J., manufacturer of a home recorder, was recently placed in the hands of a receiver. Arthur T. Vanderbilt, a well-known Newark lawyer, was appointed by the court to take charge of the affairs of the company.

WANTED—Salesmen for splendid side line, all over the country. Pocket sample. Ten to twenty dollars easily made daily. Demonstration requires few minutes only. Write Puritone, Room 1408, 347 Fifth avenue, New York City.

WHY ENCOURAGE PESSIMISM?

Some Timely Words From A. J. Kendrick Which Are Worthy of Consideration

A. J. Kendrick, sales manager for the Brunswick-Balke-Collender Co.'s phonograph department, has mailed out to the trade a common-sense little announcement regarding prices, which reads:

"What is the matter with the Associated Press and the newspapers? Why do they print scarehead announcements about price reductions, factories closing, and exaggerated reports of people thrown out of employment?"

"You may remember that when the cotton spinning mills of the East closed their doors the newspaper columns were filled with double-headed announcements about overstocks and prices coming down. Contrast those announcements with the little five-line press report printed to-day, of five of these mills resuming

business at Greenwood, S. C., and form your own conclusions. The report is as follows: 'The five cotton mills in Greenwood County are now operating full time, after having curtailed production for several weeks. With one exception the plants have day and night shifts.'

"The space given to this is exactly one-half inch. Another example: 'According to a custom which has prevailed with us for many years, all of our factories shut down wholly or in part on December 1 for inventory-taking purposes. This is the usual custom in all furniture factories.'

"The Associated Press gave this incident several inches of broadcast publicity. We consider it reasonably good free advertising, but what is the idea? Can you solve the riddle?"

"All of our factories will resume immediately after the first of the year, as 1921 will, in our opinion, be a record-breaker in all of our various lines. Our sales during the first eleven months of 1920 show an increase of 42 per cent. December showed a still further improvement."



Operaphone

JANUARY, 1921

POPULAR VOCAL

21193	{ Kentucky (Little-Fier). Baritone, Orch. accomp.....Ernest Hare
1.00	{ I've Got the Blues for My Kentucky Home (Gaskill). Male Quartet, Orch. accomp.....The Harmonizers
21194	{ The St. Louis Blues (Handy). Tenor, Orch. accomp.....Al. Bernard
1.00	{ Midnight Moon (Hare-Schafer-Bernard). Baritone, Orch. accomp.....Ernest Hare
21195	{ Broadway Rose (West-Fried-Spencer). Baritone, Orch. accomp.....Elliott Shaw
.85	{ Beautiful Annabell Lee (Bryan-Mehlinger-Meyer). Tenor and Baritone, Orch. accomp.....Lewis James and Elliott Shaw
21196	{ Sighing (Cool-Bridges). Male Trio, Orch accomp.....Orpheus Trio
.85	{ I Want to Go to the Land Where the Sweet Daddies Grow (Moran-Von Tilzer). Soprano, Orch. accomp.....Marjie Oow

DANCE

31170	{ Palesteen (Conrad-Robinson). Fox-trot.....Joe Johnson's Novelty Dance Orch.
.85	{ I'm a Lonesome Little Raindrop (Hanley). Fox-trot, Joe Johnson's Novelty Dance Orch.
31171	{ Feather Your Nest (Kendis-Brockman). Fox-trot.....Regal Novelty Dance Orch.
1.00	{ You're Just Like a Rose (Hubbell). Fox-trot.....Eddie Kuhn and His Orch.
31172	{ Margie (Conrad-Robinson). Fox-trot. Intro: "Singing the Blues." (Orch.)
1.00	{ Caresses (Monaco). Fox-trot. (Orch.).....Tennessee Ticklers
31173	{ Darling (Schonberg). Fox-trot.....Harvey's Xylophone Band
1.00	{ Show Me How (Creamer-Layton). Fox-trot.....Broadway Dance Orch.

HAWAIIAN

61114	{ Naughty Waltz (Levy). Waltz.....Hawaiian Singing Guitars
.85	{ Sweet Luana (Burt-Zamecnik).....Hawaiian Singing Guitars

INSTRUMENTAL

51146	{ Alice, Where Art Thou? (Ascher). Violin, Flute and Piano.....Mendelssohn Trio
1.00	{ Canzonetta (Op. 6) (A. d'Ambrosio). Violin Solo.....Irving Weiss

RECORDS

OPERAPHONE CO. INC., LONG ISLAND CITY, N. Y.

Edison Amberola Message No. 13

Mr. Phonograph Dealer:

With a line of instruments that sells at very moderate prices, and yet satisfies the musical desires of the most fastidious, the 5,100 merchants who handle the New Edison Diamond Amberola are well fortified to meet the new conditions of the New Year.

THOMAS A. EDISON, Inc.
AMBEROLA DEPARTMENT
ORANGE, N. J.

THE VISION

Devoted to the Interest of the Educational Work Being Conducted by the Talking Machine Dealers and Jobbers

The Victor Talking Machine Co., educational department, announces in its February supplement the first of a series of recordings of the principal scenes from the dramas of Shakespeare by E. H. Sothorn and Julia Marlowe, the recognized masters of interpretative Shakespeare roles. The numbers announced are 12-inch Red Seal recordings of The Balcony Scene, "Romeo and Juliet," Parts I and II.

* * * *

The use of the Magnavox in schools has been attracting considerable attention. Millburn (N. J.) High School has a Victrola placed in the principal's office connected to several magnifying electric horns in various parts of the building. In marching, the music begins simultaneously in all parts of the building for the passing of periods or dismissal. This does away with the necessity for the formerly omnipresent school bell.

* * * *

An interesting use of the Victrola is found in the Fox Hills (N. Y.) Base Hospital, where many Victor artists have appeared to cheer the boys during the past season. The wounded men hear the artist, then, by donation from some benefactor, the records are procured so they first "hear the artist, then hear their Victor records."

* * * *

Caroline Hobson, educational director of Stewart Talking Machine Co., Indianapolis, Ind., reports splendid results in school work throughout the whole State.

* * * *

May Cloud, educational director of Putnam-Page Co., Peoria, Ill., central Illinois Victor jobber, is enthusiastic over the prospect of again receiving Princess Watahwaso, interpreter of original Indian melodies, on her Western tour.

* * * *

"Listening Lessons for Little Children," the attractive \$1 children's book with annotated records and a complete primary teaching course for the Victrola for mothers or teachers, has gone into its third edition.

* * * *

The Columbia Graphophone Co. educational department has been represented at many State teachers' meetings this year.

* * * *

Lillian Wood, educational director for the C. C. Mellor Co., Pittsburgh, Pa., Victor jobber, attended the Pennsylvania State Teachers' Convention during the holidays. A feature of the program was the speech on "Music and Education," by Dr. J. C. Finnegan, State superintendent of schools. Dr. Hollis Dann, Cornell Univer-

sity School of Music, is now State supervisor of music for Pennsylvania.

* * * *

Dealers are always hitting upon new schemes to interest people in the educational uses of their factory's product. Window displays of schoolrooms, with blackboards, benches and other furniture borrowed from local furniture houses, are now beginning to make their appearance. In every case the window fails unless a school instrument with record on turntable and soundbox down is evident in the central portion of the picture.

* * * *

The Columbia Co. has prepared a special booklet to foster a love of the best music in school and home. Knowing that the proper way to begin is with the children, the company has contributed toward their education a set of eight records, comprising thirty-two selections of the world's best music so fitted to their needs that this love for music is created and made permanent.

The pamphlet embodies the actual work of teaching in the Horace Mann School, Teachers' College, Columbia University, and has the hearty endorsement of Professor Patty S. Hill, director of kindergarten and primary departments, under whose personal direction these records were made. Their value lies in the fact that well-known compositions of great artists have been remade for the child mind and need, preserving at the same time the charm, quality and integrity of the original music.

* * * *

Sally Hamlin, the youthful recitationist, who has made some of the most delightful Victor recordings of James Whitcomb Riley and Eugene Field poems, is now giving a course of entertainments every night in the school year in New York City schools. Part of her program is devoted to John Alden Carpenter's pianologues and part to poetry. In the latter she uses a M-XXV Victrola and orchestral records to provide synchronized musical accompaniment.

* * * *

Not to be outdone by the East, the Far West has taken hold of educational work with great gusto. Sherman-Clay Co. (San Francisco, Cal.) has a strong, live educational staff.

* * * *

L. W. Inman, educational director for Sanger Bros., Victor jobbers, Dallas, Tex., has done remarkably good work in the State, bringing the lesson of the advantages of school business before hundreds of schools and dealers this year.

* * * *

A beautiful poster, listing attractive school records, is the product of the Cleveland Talking Machine Co. (Cleveland, Ohio), Victor jobber. Miss Grazella Pulliver, educational director, is doing splendid work in this field.

* * * *

Helen Colley, educational director Emanuel Blout (Victor jobber), New York, has announced a series of New York City school con-

CRYSTAL EDGE MICA DIAPHRAGMS

The Standard of Quality

PHONOGRAPH APPLIANCE CO.
174 Wooster St., New York

certs by the popular Victor artist, Princess Watahwaso. The management of the Princess is under direction of Franklin G. Dunham, Ditson Building, 10 East Thirty-fourth street, New York City.

MME. HEMPEL HEARD IN RECITAL

Capacity Audience at Carnegie Hall Shows Great Enthusiasm Over Soprano's Work

Frieda Hempel, soprano of the Metropolitan Opera Co., and noted Edison artist, sang at Carnegie Hall, New York, on January 5 before a capacity audience who evinced great enthusi-



Frieda Hempel

asm. The affair was advertised as Mme. Hempel's only New York recital this season, although she has appeared in company with other artists. Robert Gayler, who is also connected with the Edison organization, presided at the organ during Mme. Hempel's recital.

FILE SCHEDULES IN BANKRUPTCY

Supreme Phono Parts Co., Inc., at 145 West Forty-fifth street and 145 Lafayette street, New York, has filed schedules in bankruptcy, with liabilities of \$36,886 and assets of \$12,076, main items of which are stock, \$7,000; accounts, \$5,972; machinery, \$500, and deposits in banks, \$298.

MASTER WAX

BUSINESS BLANKS

The Wax and Novelty Company

67-69 Paris Street, Newark, N. J.

Will continue the business hitherto carried on by me at 16 West 39th Street, New York. All work will be done under my personal supervision.

I will be able also to work out special problems in connection with record making for anyone needing experienced advice or assistance.

F. W. MATTHEWS

NEW MELODY SUCCESS BY THE
WRITER OF "HIAWATHA" "MICKEY PEGGY" ETC

"Rose of My Heart"

The Big Song Hit from
Ziegfeld's Midnight Frolic
as sung by John Steel

Published by
Leo Feist Inc.
Feist Bldg. New York

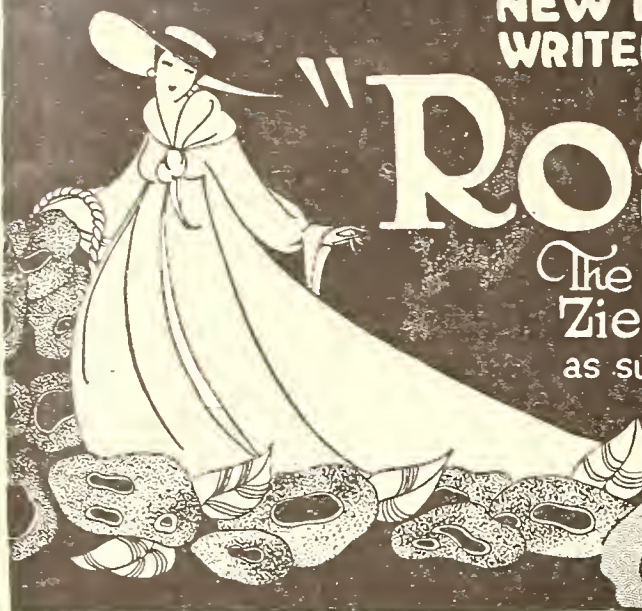

"You can't go wrong
with any Feist Song"

GLANTZ AND HIS LAUGHING SAX

Saxophone Specialist Became Popular Over Night Through His Work on "Dardanella" Record—Has Won Great Popularity Since

There is apparently one sure way for a musician to become popular with the public, and that is through the medium of phonograph records, for in many respects the recording art demands distinctiveness and originality to a



Glantz Back From Canadian Campaign

great degree. In this connection the career of Nathan "Laughing" Glantz is interesting, for his saxophone specialties have been heard through the medium of several makes of records, and it is not exaggerating to any degree to say he is one of the best-known saxophone artists to-day.

Mr. Glantz obtained his recognition among record buyers through his playing of the saxophone in the Okeh record of "Dardanella," and both "Dardanella" and Mr. Glantz are said to have become popular over night in record form, the Okeh being the first record of "Dardanella" on the market.

Glantz did the laughing sax on this record with the Rega Orchestra, which is famous for its original interpretation and clever recording tricks. Through "Dardanella" and other records, Glantz and his laughing saxophone became famous with thousands of record users.

Recently Glantz went to Canada to record for the Berliner Gramophone Co., and the accompanying picture shows Glantz returning to the United States after a hard day's work in Canada loaded with Canadian exchange, sufficient apparently to crowd his saxophone out of the case.

Mr. Glantz is now playing for practically all the record companies and with different orchestra combinations. His latest hit is "Hindoo

Hop," an Okeh record of a number written by Sol. P. Levy, composer of "The Naughty Waltz."

The Okeh records made by Glantz, in company with the Rega Orchestra, include "Rose," "Nightingale," "A la Patee," "Margie," "Humming" and "Caresses."

NEW COLUMBIA CO. PRESIDENT

Van Horn Ely Succeeds Francis S. Whitten as Head of That Company—Latter Becomes Chairman of Board of Directors of Company

Van Horn Ely, who has been a director and member of the executive committee of the Columbia Graphophone Co. for several years past, was elected president of this institution at a meeting of the directors held January 5. He succeeds Francis S. Whitten, who was elected chairman of the board of directors of the Columbia Graphophone Co.

TONOFONE JOBBERS IN NEW YORK

Cabinet & Accessories Co. and Robt. Clifford to Push Well-known Tonofone Needles

The Cabinet & Accessories Co., 145 East 34th street, New York, and Robert Clifford, who is manager of the Cardinal Phonograph Co.'s New York branch, 106 E. 19th street, have been appointed jobbers for the Tonofone needles made by the R. C. Wade Co., Chicago. These two well-known concerns intend to pursue a vigorous campaign to the end that the Tonofone needle and its merits are brought to the attention of a large constituency in the metropolis and throughout the East. These deals were consummated by E. H. Wade, manager of sales, who is at present visiting the trade in New York. Reports from Chicago are to the effect that business with the R. C. Wade Co. is of remarkable volume these days.

M O D E R N O L A

The instrument unique

M O D E R N O L A

A home delight to Ear and Eye

M O D E R N O L A

Beauty—Tone—Utility

M O D E R N O L A

Satisfaction for dealer and customer

Send your orders now:

Apply immediately for agency

Exclusive Eastern Distributors

EASTERN PHONOGRAPH CORPORATION

GEO. SEIFFERT
PRESIDENT

Office and Showrooms:

101 West 20th Street
100 West 21st Street

Corner Sixth Avenue, New York

Telephone Chelsea 2044

FRANK J. COUPE HONORED

Sales Manager of Sonora Co. Elected Vice-president at Annual Meeting This Week—Present Officers of Company Re-elected

At the annual meeting of the board of directors of Sonora Phonograph Co., Inc., New York City, held the second week in January, all of the present officers in this prominent institution were re-elected. They are as follows:



Frank J. Coupe

George E. Brightson, president; L. C. Hasell, vice-president; John Herzog, second vice-president; Joseph Wolff, treasurer; E. H. Jennings, secretary and assistant treasurer; A. C. Valeur, assistant treasurer.

A new addition was made to the official board in the person of Frank J. Coupe, sales manager of the company, who was elected to the office of vice-president.

FEATURING THE MANDEL LINE

The Standard Woodenware Co., of Los Angeles, Cal., has obtained the exclusive distributing agency for the Mandel phonograph in California, Arizona and Nevada. An intensive campaign has been started to distribute this popular instrument. This company will also handle the Mandel records which have been just introduced to the trade.



FULTON (Model 35)

Mahogany, 16x16x10 in., double spring motor, universal tone arm. Back casting and metal horn. Discount according to quantities.

True-tone, Cleartone, Brilliantone and Puretone Needles in metal boxes or packages at 50 cents per M. Discount in large quantities. Truetone Needles come 200 to a metal box.

Double and triple spring Motors, Tone-arm, Auto Stops, Repeater Stops, etc. Phono parts and accessories, as Motors, Tone-arms, Sound Boxes, Cabinets and Cabinet hardware. Repair parts for all makes.

Distributors of the Arto Music Rolls and Arto Phonograph Records.

Cash with order

FULTON TALKING MACHINE CO.
253-255 Third Ave., New York City
Between 20th and 21st Streets

TRADE SITUATION IN CINCINNATI

Baldwin Business Shows Immense Gain—Otto Grau Improves—Anderson Doing Good Work With Wurlitzer Co.—Columbia News

CINCINNATI, O., January 10.—Talking machines were among the most popular of the holiday purchases in Cincinnati last month and without exception all dealers reported satisfactory sales.

Manager Sherman B. McLaughlin, of the Baldwin Co., who only recently added a talking machine department, reported that the entire stock of both records and machines had been sold out. The special finishes seem to be popular with customers this year and took the lead over mahogany. All sales were made on either the cash basis or 10 per cent and the balance in one year, which insures an exceptionally high-class trade. The Baldwin Co.'s window for the holidays was unique and made quite a hit. It showed a large, comfortable living room with a big old-fashioned mantel and stocking hung beside the fireplace. There were big comfortable chairs and other furnishings that made such a room attractive. In one corner there was a talking machine and beside it a life-sized Santa Claus holding a record. There was no advertising matter to detract from the scene, but the window brought the trade.

The Otto Grau Co. has made some improvements in its talking machine department. New enclosed record racks have been installed and the front of the store has been given over to this line. This move has greatly increased the trade in records. The sale of talking machines for the holidays last month showed an increase of over 30 per cent over the 1919 sales, according to Vice-President F. J. Volz.

S. T. Sigman, manager of the talking machine department of the Wurlitzer Co., Victor distributors, has started a drive on accessories and plans to make this the big feature for the present. The sales department of the Wurlitzer Co. has been greatly strengthened by the addition to its staff of C. R. Anderson, formerly with the Indianapolis Talking Machine Co., who came to the Wurlitzer Co. late last year as city sales manager. Mr. Anderson will be remembered by the trade as the man who invented the ampliphone used to hear records over the telephone.

The Columbia Graphophone Co. has just completed a model shop in its office which is designed to show dealers how their stores should be arranged to make them attractive to customers and increase sales. There are hearing rooms, record racks, counters, show windows and electric signs, in fact, everything that can be used to make an attractive salesroom. This feature is expected to prove of great value to dealers in enabling them to see some of the faults in their methods of displaying and selling.

S. A. SHERMAN REBUILDING

New York Dealer Whose Store Was Destroyed by Fire Plans Bigger and Better One

S. A. Sherman, whose establishment at 2138 Third avenue, near 116th street, New York, was destroyed by fire, as reported elsewhere in this issue, is now rebuilding his entire establishment, which he owns, and intends to have one of the most attractive stores handling Victor talking machines and records in the city. Mr. Sherman is most appreciative of the many courtesies shown him by the members of the trade.

WE Will Buy for Cash
Job Lots of Machines,
Records, Motors, Tone
Arms, Parts, and Every-
thing in the Talking Ma-
chine Line.

Keen Talking Machine Supply Co.
49 N. 10th ST., PHILADELPHIA, PA.

VICTOR RECORDS BY LA SCALA ORCHESTRA

Victor Co. Announces That Famous Orchestra Under Baton of Toscanini Will Make Victor Records—Now Touring the United States

The La Scala Orchestra of Milan, Italy, under the baton of Maestro Arturo Toscanini, one of the world's greatest conductors in the symphony and operatic field, arrived in this country during the past month and is now on tour. During the appearance of this famous organization in New York it scored the highest praise from our leading critics, not alone on account of the superb, masterful leadership of Toscanini, but the band itself is one which ranks with the great musical organizations of the world.

In connection with the arrival of the La Scala Orchestra the announcement has just been officially made by the Victor Talking Machine Co. that the La Scala Orchestra, under the baton of Toscanini, will make records for the Victor Co. during its present visit to America. This announcement will undoubtedly arouse the liveliest interest among dealers and also users of Victor records throughout the country, for everyone recognizes that Toscanini and his band will be introduced in a fittingly artistic manner through the medium of these records.

There are few figures in the musical world capable of exciting more interest than this great Italian conductor whose triumphs have been pretty well divided between Europe and America. During the World War he was honored for valor for his wonderfully inspiring work in directing military music and concerts for the Italian army, and his work was recognized not only by the Italian Government, but aroused tremendous popularity among the men. In New York, of course, Toscanini's great work as conductor of the Metropolitan Opera Orchestra before he left for the war has made him a great favorite.

The records of the La Scala Orchestra will have a tremendous interest for everybody who loves music and its traditions, for the La Scala Theatre is the traditional home of the great Italian opera, and here it is that many of the world's most famous artists made their debut.

JAMES F. BOWERS RETIRES

President of Lyon & Healy Gives Up Active Work—A Notable Figure in the Industry

CHICAGO, ILL., January 12.—James F. Bowers, who recently celebrated his fiftieth year of service with Lyon & Healy, this week retired from the presidency of this institution. Mr. Bowers has long been identified with the music industry in all its ramifications, having served as president of the New York Piano Manufacturers' Association and also as president of the National Association of Talking Machine Jobbers.

With the retirement from active service of Mr. Bowers will go the best of wishes of an army of friends throughout the industry for his welfare and happiness.

A. C. Ireton, general manager of Edison Phonographs, Ltd., San Francisco, is sending out a letter on business conditions which abounds in facts that should lead the dealer to a sane, courageous course on business advancement.

Everlasting Decorative Flowers and Plants, Vines and Garlands

My illustrated catalogue in colors No. 35, free for the asking; write for it today.

Frank Netschert
61 Barclay St., New York

JERSEY DEALERS HEAR J. G. PAINE

Large Attendance at Luncheon Given by Victor Dealers of New Jersey January 11

The Victor dealers of New Jersey held a luncheon at the Robert Treat Hotel, Newark, N. J., at noon on Tuesday of this week. As special guest of the occasion, John G. Paine of the legal department of the Victor Talking Machine Co. attended.

The educational department of the Victor Talking Machine Co. contributed as an entertainment feature the services of Princess Watahwaso, mezzo-soprano, who has made a series of records of Indian songs, dances and folk-lore, who was accompanied at the piano by Mrs. R. E. Williams. Her program was roundly applauded.

The leading address was made by John G. Paine, who said in part: "I bring you the congratulations of the Board of Directors of the Victor Talking Machine Co.—a message from headquarters." Following which Mr. Paine told the dealers of a series of plans making for future progress of the Victor Co. He told of the increased production which would be received through the enlargements of the present factories in both talking machine and record plants. Speaking of the present business situation he called the gathering's attention to the revival of business which can be visualized by the smoke outpouring from factory chimneys in plants which in a recent period were shut down.

He further stated that while it was true that the Victor Talking Machine Co. hardly needed a revival of business in order to sell its product—as a matter of fact the plants are running at full capacity—the company feels that the time has arrived when it can consider further expansion on a large scale. He spoke of the lure during the past two years to cheapen the product in order to increase production, but to which the Victor organization did not succumb. The high ideals of the company as to quality were adhered to throughout that period and new developments of the company would be along the same high standard lines—quality.

Among those who attended were: Franklin G. Dunham, of the educational department of the Victor Talking Machine Co.; Robert C. Hopkins, Victor representative for northern New Jersey; J. A. Bliesenick, of Hahne & Co., Newark, N. J.; G. S. Welch, W. S. Beebe, Harrison, N. J.; O. M. McCollum, Rahway, N. J.; Thomas K. Henderson, of Munger & Long, Camden, N. J.; Clark M. Price, Jersey Music Co., Bloomfield, N. J.; H. N. Truesdell, Irvington, N. J.; Daniel F. Egan, of E. S. Applegate & Co., Trenton, N. J.; R. H. Veale, James McGarry, H. A. Glasser, G. A. Barlow's Sons Co., Trenton, N. J.; T. B. Roche, of Collings & Co., Newark, N. J.; C. J. Collins, Mathushek & Sons Piano Co., Jersey City, N. J.; Eli Zion, of the Union Talking Machine Co., Elizabeth, N. J.; George F. Porepp, White Star Music Co., Jersey City, N. J.; S. Wolfson, of Bayonne, N. J.; Leo Schlein, Jersey City Talking Machine Co., Jersey City, N. J.; A. Galuchie, Jersey City, N. J.; J. L. Spillane, Collings & Co., Newark, N. J.; Charles J. Honsberger, Armstrong Piano Co., Newark, N. J.; C. L. Johnston, Blackman Talking Machine Co., New York; Irwin Moser, Camden, N. J.; L. W. Collings, of Collings & Co., Newark, N. J.; Beall McCandless and E. P. Perkins, of the Elizabeth Talking Machine Co., Elizabeth, N. J.; Fred G. Loeffler, Union Hill, N. J.; Louis Frey, Carlstadt, N. J.; Robert Brunner, Acme Music Co., Rutherford, N. J.; Albert Leon, Perth Amboy, N. J.; A. Landay, Paterson, N. J.; E. Bainbridge, Paterson, N. J.; Geo. L. Hirtzel, Jr., Elizabeth, N. J.; L. L. Spencer, Pearsall & Co., New York; Frederic Barlow, of G. A. Barlow's Son Co., Trenton, N. J.; Joseph W. Schwetz, Knickerbocker Talking Machine Co., New York; B. H. Roth, West New York, N. J.; J. J. Davin, Reinicke-Ellis Co., New York; Otto Goldsmith, Cabinet & Accessories Co., New York; J. Donlan, Ridgewood Talking Machine Co., Ridgewood, N. J.; N. Alexander, Long Branch, N. J.

THE FEBRUARY AMBEROLA DISPLAY

Unusually Attractive Window Treatment Prepared for Use of Amberola Dealers

The Edison Amberola window display for February is unusually attractive and should make a strong appeal to Edison Amberola dealers, as well as to the public, with a consequent good effect upon sales. The display emphasizes

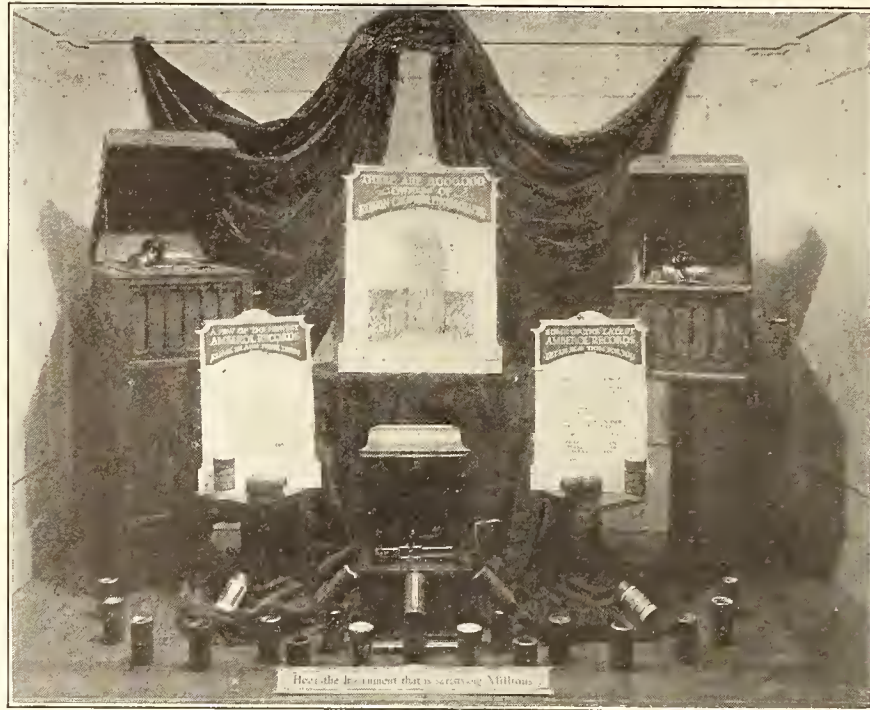

Window Combines Attractiveness With Practicality particularly the fact that several million homes work and are building up a good prospect list.



Hoffay Phonographs Resurrectone Reproducers Airtight Tone-Arms Famous the World Over. HOFFAY PHONOGRAPH CO. 59 4th Ave. New York City

in the United States are at present equipped with Amberolas, and at the bottom of the window display is a strip reading appropriately: "Hear the Instrument That Is Satisfying Millions." In the display the three large units are handsomely lithographed in colors to represent triumphal arches, the centerpiece showing the Edison cylinder phonograph with its background of multitudes, while the two side cards enumerate some of the Amberol records for February.

The H. S. Barney Co., 217 State street, Schenectady, N. Y., are scoring great success in their efforts to bring to the children of that city a greater appreciation of music. They are giving an hour each day to this good

MAIN SPRINGS

Guaranteed to be made of the highest grade carbon steel procurable. Prices quoted are possible only because of our immense purchasing and distributing powers.

	Lots of					
	1 each	6 each	12 each	25 each	50 each	100 each
No. 28 3/4"x.022x9 feet, for Carola, Triton, Melophone, etc., pear shape hole.....	\$.40	\$.38	\$.37	\$.35	\$.33	\$.31
No. 29 3/4"x.022x10 feet, for small Columbia, Universal, Heineman, Harmony, Vanophone, Pathé, pear shape45	.43	.42	.40	.38	.35
No. 30 7/8"x.022x10 feet, for Blick, Wonder, Premier, Meisselbach, Nos. 9 and 10, square hole.....	.50	.47	.46	.44	.42	.40
No. 31 1"x.025x9 feet, for Swiss motors, small Columbia, Stewart, pear shape hole.....	.60	.54	.52	.50	.48	.45
No. 32 1"x.020x13 feet, for small Victor, pear shape hole60	.54	.52	.50	.48	.45
No. 33 1"x.025x12 feet, for Pathé, Heineman, Mandel, Aeolian, Meisselbach, Vitanola, pear shape hole75	.70	.67	.60	.55	.50
No. 34 1"x.025x14 feet, for Sonora, Saal, Thomas, Silvertone, oblong hole80	.75	.70	.65	.60	.55
No. 35 1"x.028x10 feet, for all styles Columbia machines, pear shape60	.54	.52	.50	.48	.45
No. 36 1"x.025x9 feet, for Meisselbach, No. 12, Thomas, oblong hole60	.54	.52	.50	.48	.45
No. 37 1"x.025x16 feet, for Meisselbach, Saal, Thomas, Silvertone, Modernola, Rishell, Widdicomb, Sonora, oblong hole90	.85	.83	.80	.75	.70
No. 38 1"x.025x16 feet, for Vitanola, pear shape....	.90	.85	.83	.80	.75	.70
No. 39 1"x.028x11 feet, for Edison Standard, pear shape65	.59	.57	.53	.50	.47
No. 40 1 3/16"x.028x16 feet, for Heineman, Pathé, Rex, pear shape95	.90	.88	.85	.80	.75
No. 41 1 1/2"x.027x25 feet, for Edison Diamond Disc, pear shape hole	2.00	1.80	1.70	1.65	1.55	1.50

(If the above are desired in assorted sizes, the quantity price will be allowed.)

Write for our latest catalogue, now on the press, containing hundreds of needed repair parts. Ask for catalogue W.

EVERYBODY'S TALKING MACHINE CO.
38 North Eighth Street PHILADELPHIA, PA.

Exclusive Distributors for the General Phonograph Corporation

A MOST EFFECTIVE MEANS FOR DISPLAYING LITERATURE



How the Brunswick Circular Holder Operates

The Brunswick-Balke-Collender Co., 623-633 South Wabash avenue, Chicago, Ill., is now introducing the new Brunswick phonograph circular holder which, as illustrated, contains eleven pockets for circulars or other literature — three sets of circulars on each side, two on each end and one set on top. The entire top of the holder swings on a pivot, the base being of wood. The exposed parts of the holder are made in correct representation of mahogany, with the lettering printed in gold. The total height is 11½ inches, while the height of the panels holding the circulars is 3¾ inches. The holder, which is 11¼ inches long and 9⅝ inches over all, is a great convenience to visiting customers, and will undoubtedly have a great vogue with dealers. It is sold at a very reasonable price to the trade.

C. V. Bissell, manager of the local store of the Starr Piano Co., reports that the business during the past season has been extremely good and that he is making every preparation for a greater trade during the coming year.

H. E. Meyer, of the H. E. Meyer Music Co., which until recently occupied salesrooms in the Altman Building, moved to the old location of the wholesale department of the Columbia Graphophone Co. at 1017 McGee street, following the removal of the Columbia wholesale organization to larger quarters in the new wholesale district of the city. Mr. Meyer has also added the Emerson line.

Down in the southern part of Missouri quail hunting has been extremely good, as the representative for The World can justly testify after a month's hunting trip in the foothills and hills of the Ozarks. But quail is not the only sport that would bring good results in that section of the country, for there reside thousands of inhabitants that are good prospects for talking machines, pianos and other musical instruments that are un hunted and on whom there is no closed season. However, the dealers in the larger towns in the southern part of the State seem to look upon these prospects as either undesirable or else they have enjoyed such a tremendous business without going outside their own establishments to get it that they have not thought of them at all.

And right here is where the mail-order house gets in its work that encourages more than one talking machine and piano dealer to resort to real cuss-words. The expedition took the writer to several inland towns of from ten to 1,000 inhabitants. These are towns where a musical instrument has to be transported from the railway station by either team and wagon or motor truck distances of from three to thirty miles. "Too far!" is perhaps the cry that the lazy dealer might put forth, but not so with some organizations, for here we find the old reed organ in all its sanctified glory and never a talking machine with even a worn-out record to raise a cry of protest.

Occasionally we found a piano, but that was so rare that it was indeed remarkable. It was in a village thirteen miles from a railroad that boasted some sixty inhabitants, a town of music-loving human beings, such as exist in Rome, Egypt, Hawaii or the United States, but this instrument was one of the cheap variety of the mail-order house that saw its best day the day it was shipped, and not a talking machine in the entire community, less than one hundred and fifty miles from Kansas City and less than fifty miles from the metropolis of the Southwest, Missouri, Springfield, which boasts several talking machine establishments.

The season of 1921 will find more than one talking machine establishment making plans for the broadening of its business, to acquire a greater selling radius, and the very best advice, as we can see it, is to look upon your own streets and within your own county and, perhaps, you will find it.

KANSAS CITY DEALERS MAKE GOOD START IN NEW YEAR

Active Post Holiday Business—Wunderlich and Other Dealers Tell of Conditions—Some Removals—World Representative Discovers Section Where Sales of "Talkers" May Be Made

KANSAS CITY, Mo., January 8.—The talking machine business during the month of January has started with a rush in this city and locality. With the immense holiday demand satisfied there seems to have been a large percentage of the business carried over into the new year. One of the most prominent dealers declared that it was his belief that this situation was the result of the expectancy of the public for lower prices at the first of the year. The prices did not drop as they expected, but the promises of talking machines for Christmas presents had to be kept; hence the result has been a very greatly increased business for the month of January, a usually dull one in the trade here.

Harry Wunderlich, of the Wunderlich Music Co., in comparing the business of 1920 with that of 1919, said: "Now that the year 1920 has passed the books can be made to show an exact and just comparison. All the propaganda to encourage early buying during the 1920 holiday season brought only small results, due to the fact that the public generally labored under the impression that prices of all goods would decrease. The holiday season was one mad rush of delayed shopping everywhere, and the talk-

ing machine establishments suffered as all other business houses did in having the trade that should have been extended over a three-week period crowded into three or four days. The business of 1920 equaled that of 1919 regardless of the conditions that existed in the trade, and most houses showed an increase over that of the 1919 season. The thought now is for the coming year, and after carefully analyzing the conditions as they now appear it is safe to say that the year will bring the greatest success to the talking machine dealers that the industry has ever enjoyed."

E. S. Hall, of the Hall Music Co., was forced to move again; this time from 1002 Grand avenue to the Arlington Building on Tenth street because of the expiration of lease.

The Smith, Barnes & Strohber Piano Co.'s branch here has been endeavoring to interest parents in musical merchandise for children, with unprecedented success. One method of increasing the attention of the elders through the children and the building of a huge prospect list prior to the holiday trade was the offering of prizes for the best prospect list of names submitted by children.

THE PHONOSTOP—The Stop That Stops Them All

Victor, Columbia, Pathé, Edison, even the Lyric. Try all other stops if you wish to, but eventually come to us for the PHONOSTOP, the first and the most efficient; therefore the best. You can set it "in the dark as well as the light." The children operate it perfectly.

Order early—
we will ship
promptly

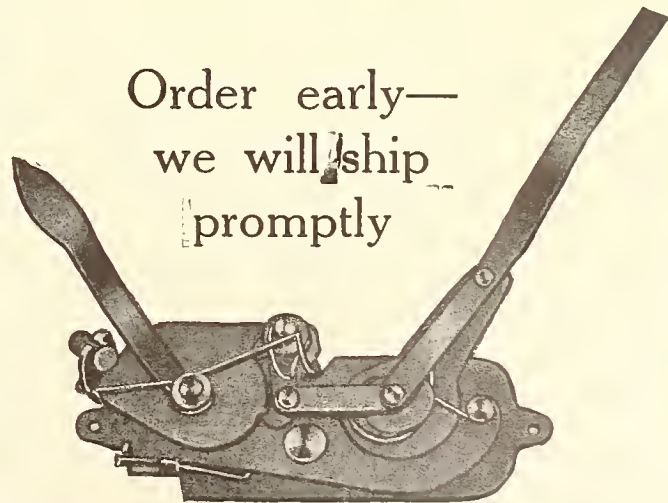

Made Right Acts Right Stays Right

THE PHONOMOTOR CO. - 121 WEST AVENUE ROCHESTER, N. Y.

WESTERN REPRESENTATIVES: CHICAGO

Harry Engel, McClurg Building, and Jewel Phonoparts Co., 630 W. Washington Street

Pathé

REG. U.S. PAT. OFF.



EASTERN PHONOGRAPH CORPORATION

GEO. SEIFFERT, Pres.

WHOLESALE DISTRIBUTORS

OFFICES AND SHOWROOMS
101 West Twentieth St. 100 West Twenty-first St.
Cor. Sixth Avenue NEW YORK
Telephone: Chelsea 2044

Pathé

REG. U.S. PAT. OFF.



THOMAS VOCALION RECORDS GROW IN POPULARITY

The Aeolian Co. reports that the Vocalion records of John Charles Thomas, the light opera star, are in great demand in every city where

eral times over, and a stand with a liberal supply of his records was installed in the lobby of the theatre so that patrons might make their



John Chas. Thomas and Apple Blossom Chorus

he is appearing in one of the leading roles in "Apple Blossoms," the successful operetta. In Philadelphia, when "Apple Blossoms" was showing, the dealers sold out of Thomas records sev-

record purchases when homeward bound.

"Apple Blossoms" is now playing in Boston, where it has been installed for a long run. In that city the Vocalion has been placed in the lobby of the theatre where it plays Thomas records before and after the performance and during the intermission. The result has been a heavy record demand.

Allen C. Robinson has purchased the controlling interest in the Bergstrom Music Co., Honolulu, H. I., Victor wholesaler, and has succeeded W. D. Adams as president.

WANTED—Salesmen for splendid side line, all over the country. Pocket sample. Ten to twenty dollars easily made daily. Demonstration requires few minutes only. Write Puritone, Room 1408, 347 Fifth avenue, New York City.

REPAIRS

24 Hour Service

Largest and best equipped shop in New York

We call for and deliver in New York

Outside of New York, Send by Express or Parcel Post

W. BAHR

336 East 87th Street New York

Tel. Lenox 7156

MEETING PROBLEMS SQUARELY

E. O. Rockwood, Columbia Credit Manager, Finds Business Men Ready to Work Together to Further Best Interests of the Trade

E. O. Rockwood, general credit manager of Columbia Graphophone Co., who recently returned from a Western trip, remarked to The World:

"My trip covered the sections of the country where the company's business comes in closest contact with those who produce from the soil and who at this time are the cause of a tremendous amount of frozen credit by their failure to move the last crop that they produced. The result of holding back the crops for higher prices is observable in many directions and its effect is generally well understood. The effect is probably temporary. The credit situation is essentially sound, as there are assets in view to liquidate outstanding credits.

"The situation, however, has given occasion for another demonstration of the red-blooded way in which the agricultural and banking interests of the country look a situation in the face and refuse to be either discouraged or depressed. I consider it a wonderful demonstration of the courage, strength and sagacity of our farming and financial interests and a factor of tremendous constructive importance that the farmers and bankers are getting together for conference, for mutual understanding by each of the other's position, requirements and outlook, and seeking by conference to arrive at a practical policy that will relieve present conditions to the greatest advantage of all concerned and with protection to those most likely to be hurt.

"The extent and effect of these conferences are very great and will be felt in a short time. The 'state of mind' most to be desired having been effected results are bound to follow quickly. The spirit is permeating to the most remote communities. A conspicuous example of this 'get-together' effort may be seen in the recent movement to form a hundred-million-dollar corporation to foster exports."

STATEMENT OF THE OWNERSHIP, MANAGEMENT, CIRCULATION, ETC., REQUIRED BY THE ACT OF CONGRESS OF AUGUST 24, 1912, OF THE TALKING MACHINE WORLD, published monthly at New York, N. Y., October 1, 1920.

State of New York } ss.
County of New York }

Before me, a Notary Public in and for the State and county aforesaid, personally appeared J. B. Spillane, who, having been duly sworn according to law, deposes and says that he is the Editor of The Talking Machine World and that the following is, to the best of his knowledge and belief, a true statement of the ownership, management (and if a daily paper, the circulation), etc., of the aforesaid publication for the date shown in the above caption, required by the Act of August 24, 1912, embodied in section 443, Postal Laws and Regulations, printed on the reverse of this form, to wit:

1. That the names and addresses of the publisher, editor, managing editor and business managers are: Publisher, Edward Lyman Bill, Inc., 373 Fourth Ave., New York City; Editor, J. B. Spillane, 373 Fourth Ave., New York City; Managing Editor, J. B. Spillane, 373 Fourth Ave., New York City; Business Manager, none.

2. That the owners are: (Give names and addresses of individual owners, or, if a corporation, give its name and the names and addresses of stockholders owning or holding 1 per cent or more of the total amount of stock.) Edward Lyman Bill, Inc., 373 Fourth Ave., N. Y. City; Caroline L. Bill, New Rochelle, N. Y.; J. B. Spillane, 373 Fourth Ave., N. Y. C.; J. Raymond Bill, 373 Fourth Ave., N. Y. City; B. B. Wilson, 373 Fourth Ave., N. Y. City; Carleton Chace, 373 Fourth Ave., N. Y. City; E. P. Van Harlingen, 209 So. State St., Chicago, Ill.

3. That the known stockholders, mortgagees, and other holders owning or holding 1 per cent or more of total amount of bonds, mortgages, or other securities are: (If there are none, so state.) None.

4. That the two paragraphs next above, giving the names of the owners, stockholders, and security holders, if any, contain not only the list of stockholders and security holders as they appear upon the books of the company but also, in cases where the stockholder or security holder appears upon the books of the company as trustee or in any other fiduciary relation, the name of the person or corporation for whom such trustee is acting, is given; also that the said two paragraphs contain statements embracing affiant's full knowledge and belief as to the circumstances and conditions under which stockholders and security holders who do not appear upon the books of the company as trustees, hold stock and securities in a capacity other than that of a bona fide owner; and this affiant has no reason to believe that any other person, association, or corporation has any interest direct or indirect in the said stock, bonds, or other securities than as so stated by him.

5. That the average number of copies of each issue of this publication sold or distributed, through the mails or otherwise, to paid subscribers during the six months preceding the date shown above is ——. (This information is required from daily publications only.)

(Signed) J. B. SPILLANE.

Sworn to and subscribed before me this 1st day of October, 1920.

(Seal) Eugene R. Falck, Notary Public No. 6, N. Y. Co. (My commission expires March 30, 1922.)

THE TALKING MACHINE RECORD IS AN IDEAL VALENTINE

The Columbia Graphophone Co., New York, is conducting a very extensive campaign to educate the American public to the fact that talking machine records in general, and Columbia records

lithograph record envelope has been issued, the pictorial side of which is illustrated herewith. On the flap, on the reverse side of the envelope, appears the following appropriate poem:



To My Valentine
 I would that I could sing to you,
 As knights of old were wont to do,
 But ah! my song, how-e'er sincere,
 Would scarce bring pleasure to your ear,
 And so I know you'll pardon, friend,
 If I this worthier minstrel send.

This envelope makes an extremely attractive and altogether seasonable container for Valentine records. A further part of this campaign lies in the fact that the Columbia national advertising in the magazines and newspapers will be devoted to the Valentine theme in February. This means that millions of people will have the idea of sending records for Valentines brought to their attention. The Dealer Service Department of the Columbia Co. has also prepared two extremely attractive window displays, featuring the same

THE MAINTENANCE OF QUALITY

This Will Be the Mainstay of the Dealer During 1921, Says Jerome Harris, of C. Bruno & Son, Inc.—Building Up Business Prestige

That maintenance of quality will reap its reward during the coming year is the opinion of Jerome Harris, secretary of C. Bruno & Son, Inc., Victor wholesalers, New York City.

"The closing months of 1920 demonstrated beyond the question of a doubt that the buying public had confidence in the trade-marked article of merchandise," said Mr. Harris. "It is only a matter of sound business logic that a firm which has spent a vast fortune in the building up of its business prestige, and which prestige is represented by its trade-mark, would allow nothing to happen that would destroy confidence in that trade-mark. Throughout the coming year the demand for all merchandise, and in mentioning merchandise I am particularly thinking of talking machines and records, will undoubtedly continue on a sound and healthy basis—in other words, reach a normal basis. The purchaser will be insistent upon merchandise of proven merit and value. I know of no better guide in the selection of merchandise than a trade-mark that has stood for quality. The dealer who sells such merchandise has his business built on a rock foundation and can feel absolutely secure in devoting his efforts and resources to its distribution. We can, therefore, safely predict an excellent year for the Victor retailer."

GREAT CROWD AT OPENING

Over 1,300 people attended the recent opening of the "Arthora," 37 Atlantic street, Stamford, Conn., a new Victor shop owned by Otto and Albert Ruckgraber. In connection with the opening there was a concert, the principal artists being the Biltmore Hawaiian Sextet.

Columbia Eight-color Lithograph Record Envelope in particular, make ideal Valentines. In support of this campaign a very handsome eight-color idea, which is certain to appeal to a large army of progressive dealers.

The Mutual TONE ARMS & SOUND BOXES

"TRY THEM AND BE CONVINCED" ANNOUNCEMENT

The Mutual Phono Parts Mfg. Co.

Successors to the Mutual Talking Machine Co.

Announce the continuance of the business formerly conducted by the Mutual Talking Machine Co., with offices and factory located at

**149-151 Lafayette Street
New York**

We want to call particular attention at this time to our new tone arm (No. 3) and our No. 5 sound box, which have been adopted by some of the most prominent manufacturers. Also the complete former line improved.

Ask for prices and samples

IMPORTANT NOTICE

TO THE

AMERICAN TRADE

The Sterno Manufacturing Company
 19 CITY ROAD LONDON, E. C. ENGLAND

Manufacturers of the world known COMPACTOPHONE—the most complete portable gramophone extant—beg to announce the conclusion of arrangements for the EXCLUSIVE SELLING RIGHTS IN THE UNITED STATES OF THE

High Grade Motors Manufactured By **Mermod Freres** St. Croix Switzerland

WONDERFUL MECHANISM

These motors represent the acme of workmanship and quality. Each part is made to the finest gauge limits and assembled to run with the precision of a watch—silent and true. Messrs. Mermod Freres is an old established Swiss manufacturer. Back of their motors are years of hard practical experience. The experimental stage was left behind a decade or more ago. Reliability and quality are therefore assured.

DIFFERENT MODELS

Mermod Freres motors comprise several types—single and double spring worm and pinion-gear drive, the very latest and scientific method of construction.

CONSULT US

Before placing your orders elsewhere consult us as to prices and terms of trading. We are out for quick shipments and prompt delivery direct from the factory to the buyer.

SPECIAL TERMS TO JOBBERS

Within the near future it is proposed to establish
A CENTRAL DISTRIBUTING DEPOT IN NEW YORK
 Meanwhile trade inquiries should be directed to

THE STERNO MANUFACTURING CO.
 19 CITY ROAD LONDON, E. C., ENGLAND

CONFIDENCE AND OPTIMISM UPPERMOST IN BALTIMORE

Wonderful Record Business Being Done—Leading Jobbers and Dealers Are Determined to Make 1921 as Good a Business Year as the Year Just Closed—News of the Trade

BALTIMORE, January 7.—Confidence and optimism form the atmosphere that pervades the talking machine business in this territory. Jobbers and dealers all forecast a year of big business. This confidence is not confined to any one line, but men handling the various makes of machines in this territory all echo the same view.

With all of the cry of hard times and tight money there was a marked increase in cash business done in December. A canvass of the trade shows that the time payment business done was of a very safe nature in the vast majority of cases.

A wonderful record business was done by all of the dealers. The Columbia and Victor dealers were well supplied with records, although there was not quite sufficient to handle the business of the latter lines. The Vocalion and the Brunswick, as well as the Emerson records all showed fine business.

"It was a fine season for business," declared William S. Parks, manager of the Columbia for this territory, "and the year's close, despite the business depression that lasted for several months, was ahead of the previous year. Through our house-to-house campaign we have managed to cut our stock in our dealers' hands down to a very small amount. In fact, the stock on hand in the hands of the dealers at this time is smaller than for a long period. This means that the future holds a big business for us and the year 1921 will surely be a banner one. It may not start off this month or next month with a tremendous stride of buying, but before the Summer gets well under way the business is bound to be here." Mr. Parks has recently made a tour of his territory and found conditions good. Mr. Parks visited the Eastern shore of Maryland and was particularly impressed with the three stores of the Eastern Shore Music Co. in Cambridge, Salisbury and Crisfield. This

chain is part of the system being established by the company of which W. T. Sibbett, formerly of the road sales staff of the Columbia, is the head.

W. C. Roberts, manager of E. F. Droop & Sons Co., says: "Business went ahead well in 1920 over the previous year and had it been possible to obtain the goods there is no telling how good the business would have been. Machines and records are coming along well and the demand for the Victor lines is still strong. I am looking forward to 1921 being a great year with a large increase in business, providing, of course, we are able to obtain the product. I think we will."

A. J. Boden, of Sanders & Stayman, Vocalion representatives, said business showed very fine and the year of 1921 is going to be a banner one.

Elmer J. Walz, manager of the wholesale Victor department of Cohen & Hughes, was well pleased with the way business came to a close for the year. "While product came along better toward the end of the month and all of the dealers received an equal share," declared Mr. Walz, "there is plenty of opportunity to sell machines and especially records, if we can continue to get them. This is going to be a great year. The trade is on its toes and working out plans of business building and we are all set for big business and we are going to do it."

Eddie Rosenstein, of the Clark Musical Sales Co., Emerson distributors, said business with them was exceptionally good and he is looking forward to a continuance of the business during the coming year, when he expects to see big production in records and machines.

C. D. Messenger, whose Victrola business is located in North Baltimore, in what is known as the residential section, says business with

him showed 125 per cent increase. This is the way he described business keeping up: "New Year morning I came down into the store to look around and had determined that we would not open for business because it was our wedding anniversary. While in the store someone looking in saw me and knocked hard and long and finally not being able to get out without sneaking out and probably making an old customer angry I opened the door. In a little while my wife had to come in and help, and it was four o'clock before we managed to close up, and I did \$270 worth of record business. I am going to enlarge my business and generally improve my store this year."

Rayburn Clark Smith, president, and G. A. Lyons, district representative of the Unit Construction Co., were visitors to Baltimore during the month. Both men expressed the view that this is going to be a great year for the talking machine business.

A CAMPAIGN OF CONFIDENCE

Artistic Supplements Emphasizing the Great Activity of the Victor Plant Attract Attention

The New York Talking Machine Co. and Chicago Talking Machine Co., Victor wholesalers in New York and Chicago respectively, have recently been conducting a very far-reaching and intensive campaign emphasizing the fact that the Victor factory is working overtime. Tens of thousands of colored supplements have been issued by direct mail and through the trade press, picturing the Victor factory at night with the lights burning, in evidence of the fact that intensive production is going on at the Victor plant at this time, when so many factories in this and other industries are shutting down for more or less definite periods and working on a part time basis. The working overtime idea is nicely presented in such a way as to bring out the value of the dealers linking up with these two prominent wholesaling institutions of the Victor industry.

THE VICTOR TALKING MACHINE COMPANY

Has acquired control of

THE GRAMOPHONE COMPANY, Ltd.

of Great Britain

We believe The Gramophone Company will be a tremendous success, and have procured a limited amount of Gramophone Company Limited Ordinary Stock, which we offer subject to prior sale or change in price at \$7 per share

Write for further information

BOENNING, GARRISON & CO.

BANKERS & BROKERS

MEMBERS PHILADELPHIA STOCK EXCHANGE

904-9 Stock Exchange Building

Philadelphia, Pa.

WORLD'S CLASSIFIED ADVERTISING

Any member of the trade may forward to this office a "Situation" advertisement intended for this Department to occupy a space of four lines, agate measure, and it will be inserted free. Replies will also be forwarded without cost. Additional space will be at the rate of 25c. per line. If bold faced type is desired the cost of same will be 25c. per line. Rates for all other classes of advertising on application.

FACTORY MANAGER—Young married man, with three years' experience as assistant to phonograph factory manager, thorough knowledge of production, motor installation, upfitting, cabinet work, time system and cost of reduction, also experienced as salesman, wants position along these lines where ability and earnest effort will be rewarded. Box "885," care The Talking Machine World, 373 Fourth Ave., New York City.

WANTED—Thoroughly experienced manager and superintendent for phonograph cabinet factory. Location New York State. Address with full particulars, past experience, reference, etc. Confidential. Box "882," care The Talking Machine World, 373 Fourth Ave., New York City.

POSITION WANTED—Successful repairman, managing the service department of four chain stores for large well-known firm, wishes to communicate with a firm who can offer a position requiring skill, energy and salesmanship. Is expert on any standard machine and can sustain a sales force. Would prefer wholesale firm. Am familiar with dealers' service problems and can give pleasing service. Accustomed to training repairmen quickly and thoroughly. Reliable references. Box "884," care The Talking Machine World, 373 Fourth Ave., New York City.

WANTED—A No. 1 salesman who know the trade meaning of the word salesmanship and who have been waiting for an opportunity to demonstrate it can find a position where the return for their efforts will be commensurate with their ability. The right men will be given an opportunity to earn from \$10,000 to \$20,000 per year. Box "887," care The Talking Machine World, 373 Fourth Ave., New York City.

WANTED—A real sales manager for a talking machine, a man who has had a high, successful experience in this field. A high-grade, big-caliber man. None other need apply. Address for appointment Box "889," care The Talking Machine World, 373 Fourth Ave., New York City.

WANTED—We have an opportunity for several high-class men to establish themselves in a permanent connection with us. We are promoting a new and original sales campaign in New York and vicinity, and we desire the services of several high-class men to call on dealers with this new sales proposition. We are one of the leading established manufacturers of talking machines and records, nationally advertised and recognized as a leading line by the better class of dealers. High-class men of experience preferred, but will consider college men or men who have made good in their respective spheres. Address Box "891," care The Talking Machine World, 373 Fourth Ave., New York City.

WANTED—Furniture and phonograph salesmen to handle our line on commission basis. American Talking Machine Co., Inc., Bloomsburg, Pa.

POSITION WANTED—Recording expert with broad technical experience wishes situation. Can organize and manage recording and plating laboratory. Address Box "893," care of The Talking Machine World, 373 Fourth avenue, New York City.

WANTED—Salesmen for splendid side line, all over the country. Pocket sample. Ten to twenty dollars daily easily made. Demonstration requires few minutes only. Write Puritone, Room 1408, 347 Fifth avenue, New York City.

POSITION WANTED—Expert with portable recording set will do lateral recording for the trade. New York or elsewhere. Terms on application. Address Box "894," care The Talking Machine World, 373 Fourth Ave., New York City.

FOR SALE

An exclusive Columbia Grafonola store, in city of twenty-five thousand in Connecticut. This store is beautifully equipped with six paneled hearing rooms, record racks and show case to match; fine location and doing good business. Will sell at inventory, about \$10,000.00. The stock new and clean. This is an exceptional opportunity; good reason for selling. Box "888," care of The Talking Machine World, 373 Fourth avenue, New York City.

For Sale—Elegant, Clean, New Stock

Business opportunity worth while
Piano and general musical merchandise. Business located in Wichita, Kansas. Present owner wishes to retire from active selling end of business and will contract with the purchaser of this establishment to carry all instalment paper on very attractive basis. Will require about \$18,000 to \$20,000 to handle deal. Might consider selling half interest to thoroughly reliable experienced piano man. Have good lease and elegant location. Fully equipped in every respect. Doing good business. Address Mr. Wyotte Alvin, 1444 Park place, Wichita, Kansas.

VICTOR AGENCY FOR SALE

For \$5,000. Merchandise extra. Reply to Box "892," care of The Talking Machine World, 373 Fourth avenue, New York City.

FOR SALE

Victrolas, Victor Red Seal Records, Victor and Columbia Records. Anything required in the phonograph line at reduced prices. Mandell & Co., 88 Rivington street, New York City.

FOR SALE

Complete shop for manufacturing phonograph diamond points, with my newly invented automatic polishing machine for 12 pieces at a time. Address Helfer, Box 286, Oyster Bay, N. Y.

FOR SALE

A good, live music store in a live town of seven thousand people. No competition. The store will invoice for four thousand five hundred dollars. Investigate. Longmont Music Co., Longmont, Cal.

WANT TO BUY

Phonograph and music roll stores in Eastern section from Maine to Georgia. Give full particulars. Box "881," care of The Talking Machine World, 373 Fourth avenue, New York City.

YOUNG MAN with eight years' experience wishes to connect with some reliable concern as either salesman or manager. Box "886," c/o The Talking Machine World, 373 Fourth Ave., New York City.

POSITION WANTED—Wholesale piano and phonograph salesman of several years' experience will be open for position after January 15, 1921. For the past three years I have been traveling for one of the largest standard makes of phonographs in the country. First-class references on request. Address J. H. Keller, 745 Jefferson Ave., Scranton, Pa.

POSITION WANTED as manager retail phonograph department or store. Prefer East Atlantic States. Larger Northern or Southern cities. Fully experienced and competent to handle any place offered. Best of references. Experience all makes. Address E. E. T., 85 East Fifth St., Atlanta, Ga.

POSITION WANTED—A manufacturer of high-grade phonograph cabinet of exclusive design and features desires to join forces with a manufacturer of high-grade phonograph motors. Box "890," c/o The Talking Machine World, 373 Fourth Ave., New York City.

Monthly Price List of Main Springs

2 in. x .022 x 16 ft., Meisselbach No. 18..	Each	\$1.50
1½ in. x .027 x 21 ft., for Edison Disc....	Each	1.50
1¼ in. x .022 x 17 ft., reg. Victor.....	Each	0.75
1¼ in. x .022 x 17 ft., Victor new style....	Each	0.75
1 3/16 in. x .025 x 16 ft., Heineman No. 44....	0.90	
1 in. x .025 x 12 ft., Heineman No. 33 & 77....	0.50	
1 in. x .028 x 10 ft., for Columbia.....	Each	0.50
1 in. x .020 x 13 ft., Victor	Each	0.50
1 in. x .020 x 13 ft., Victor new style....	Each	0.50
¾ in. x .023 x 10 ft.....	Each	0.38
¾ in. x .023 x 10 ft., oval hole	Each	0.35
¾ in. x .022 x 8 ft., for Swiss motor....	Each	0.30
¾ in. x .025 x 11 ft., for Edison	Each	0.30

MICA DIAPHRAGMS

1 23/32 in. Victor Ex. Box, first grade.	Each	0.15
1 7/8 in., new Victor No. 2, very best....	Each	0.18
1 31/32 in., for Sonora.....	Each	0.20
2 3/16 in., for Columbia No. 6.....	Each	0.25
2 9/16 in., for Pathé or Brunswick....	Each	0.45

SAPPHIRES AND STEEL NEEDLES

Pathé, very best loud tone, genuine....	Each	0.15
Pathé, soft tone	Each	0.18
Edison, very best, medium tone.....	Each	0.18
Edison, very best, loud tone.....	Each	0.15
Edison, genuine diamond.....	Each	1.90
Steel needles, all tones.....	Per 1,000	0.50

ATTACHMENTS

in Gold or Nickel-plated		
Kent attachments for Victor arm.....	Each	0.25
Kent attachments for Edison with C box	Each	2.50
Kent attachments without box for Edison	Each	1.60
Victor, Universal old style.....	Each	1.15

MOTORS

No. 1 Single Spring with 10-inch turntable	2.75
No. 2 Double Spring with 12-inch turntable	6.00
No. 3 Double Spring with 12-inch turntable	9.00

STONE ARMS

No. K with sound box.....	Each	\$3.25
No. E with sound box, very loud.....	Each	6.00
No. M with sound box, very loud.....	Each	4.90

SOUND BOXES

No. B 1 Bliss Sound Box, fit Victor....	Each	\$1.75
No. B Balance, fit Victor.....	Each	0.75
No. C Balance, fit Victor.....	Each	1.00
No. F Favorite, fit Victor.....	Each	1.90
No. F Favorite, fit Columbia.....	Each	1.90
No. P Favorite, fit Victor.....	Each	2.00
No. G Glory, fit Victor.....	Each	3.25

CABINET HARDWARE

Automatic, nickel-plated lid support..	Each	0.30
Highly nickel-plated needle cups....	Per 100	1.50
Covers for cups	Per 100	0.75
Highly gold-plated	Per 100	7.00
Cover gold-plated	Per 100	5.00
Piano Hinges, 15½-in. long, nickel-plated.	Each	0.25

REPAIR PARTS

Columbia driving shaft, No. 11778.....	Each	0.50
Columbia bevel pinion, No. 12333.....	Each	0.90
Columbia bevel pinion, latest style....	Each	0.90
Columbia bevel pinion, No. 3189.....	Each	0.35
Columbia worm gear No. 6409.....	Each	0.30
Columbia Stylus bar.....	Each	0.50
Columbia driving gear ratchet No. 2152	Each	0.20
Columbia cranks	Each	0.45
Columbia governor weights.....	Each	0.10
Columbia governor shaft, No. 3004....	Each	0.40
Columbia governor bearing, No. 11923..	Each	0.25
Columbia governor springs.....	Per 100	1.00
Columbia governor screws.....	Per 100	1.00
Columbia barrel screws, No. 2621..	Per 100	1.00
Columbia so'dbox thumb screws....	Per 100	1.50
Victor cranks, short or long.....	Each	0.45
Victor Stylus bar (needle arm).....	Each	0.35
Victor governor springs	Per 100	1.00
Victor governor screws	Per 100	1.00
Victor governor balls, new style.....	Each	0.10
Turntable felts, 10 in., round.....	Each	0.15
Turntable felts, 12 in., round.....	Each	0.20
Motor bottom gear for Triton motor..	Each	0.20

Terms, Net Cash—Mail Remittance With Order

FAVORITE MFG. CO.
1506 DeKalb Ave., Brooklyn, N. Y.

TALKING MACHINE WORLD CLASSIFIED ADVERTISING— (Continued from page 174)

YOU CAN MAKE MORE MONEY

By making your own polish to sell or use. Simple and inexpensive, yielding 100% profit. Used and endorsed for years by leading manufacturers and dealers. Can be guaranteed in every way. Formulae and instructions never before sold at any price, sent on receipt of \$2.00. Money refunded if not satisfactory. Music Trades Service Bureau, 433 Briar place, Chicago, Ill.

WANTED

Victor or Columbia store in or near New York City. Quick buyer and cash waiting. Address Mermelstein, 506 West 137th St., New York City.

FOR SALE

1,100 etched aluminum name plates of registered trade-mark "Centrola." Price for trade-mark and above plate, \$200. Address John Huthwaite, 28 Rockaway avenue, Brooklyn, N. Y.

FOR SALE OR ROYALTY

The latest and best improvement in phonograph cases. A combination in a cabinet in which the doors open and disappear into the cabinet when the lid is lifted to insert the record without touching the doors. No knobs or hardware on outside of case. Would give exclusive right to the proper party. Can try it out beforehand as to selling qualities, but must act at once. Address C. B. Landis, 1718 Park Ave., Philadelphia, Pa.

What Have You to Sell in Records?

Will clean up your stock. Write at once. Buy any make disc or cylinder records. Pay cash. Give full details. Job in records, albums, steel and sapphire needles always on hand. The Benjamin Weil Co., 20 South Second street, Philadelphia, Pa.

FOR SALE

Quantity of high-grade fourteen-inch record albums, new and in perfect condition. Also quantity of 10 in., 12 in. and 14 in. Pathé record envelopes on which is printed the Pathé trade-mark and advertising. Will entertain any reasonable offer. Box "883," care of The Talking Machine World, 373 Fourth avenue, New York City.

MUSIC STORE

For sale, on account of pressure of other business, we will sell our beautiful, well appointed store at inventory, about \$10,000. Located in west Pennsylvania. We handle high-class standard lines; no near competition; the only exclusive music store in this section. A little gold mine for some one. With this store goes a beautiful furnished apartment. Write or wire Box "876," care The Talking Machine World, 373 Fourth Ave., New York City.

RECORDS PRESSED

With or without your stock.

STOCK ROLLED or BLANKED or BOTH

Brooklyn, N. Y. Plant now prepared to accept additional contracts, large or small. Densite Products Mfg. Co., 311-313-315 Ellery St., Brooklyn, N. Y.

CABINETS

Complete or in the white. Beautiful designs in all sizes. Oak, Mahogany or Walnut for immediate delivery. Send for circular. EVERETT HUNTER MFG. CO., McHenry, Ill.

THIS IS YOUR OPPORTUNITY

Exclusive Edison (Disc and Cylinder) and Brunswick phonograph business for sale. Also carry line of small musical goods, sewing machines and supplies. A big opportunity for a live wire. Business in A-1 condition now and making money. Good reason for selling. If interested write or call and see me; will be pleased to answer inquiries. Address, No. 955 Grove St., Meadville, Pa.

An advertisement in this Classified Section of The World reaches the largest number of talking machine trade readers in the world.

WITH THE TRADE IN PORTLAND

General Business Keeps Up in Good Shape—Appearances of Artists Help Record Sales—Some Recent Changes in the Trade

PORTLAND, ORE., January 6.—Taking everything into consideration the year 1920 wound up in good shape in the talking machine trade in this section of the country, and there is every indication that the business will remain active for a long time to come.

Big business is being done at Hyatt's. The advertisements of this firm have caused considerable attention and have had an excellent effect upon its trade. C. A. Alphonse, general manager, says the concerts given by the various artists who have appeared in this city this season have materially increased the sales of high-class records of all makes. Hackett, Amato, Scotti and other big artists have called attention by their recitals to their records, and the sales show the appreciation of the public. The Victor shortage is still felt, but the Hyatt Talking Machine Co. has always had one of the best supplies of records of all kinds in the city, so the record department is kept very busy. The company has quite a novel and interesting method of attracting custom on Saturday. Right outside of the store entrance is a Toledo scale and the first five persons getting weighed on that day who weigh a certain determined weight have the privilege of entering the store and selecting a record.

Mr. Hyatt has sold some handsome Brunswick period models and also some very fine Edisons. The Elks staged a big entertainment for needy children at Christmas and it is reported

that Santa Claus bore a very close resemblance to C. A. Alphonse.

Charles Hackett, tenor, who appeared in concert at the Heilig Theatre, made a big hit, and the Columbia records of the big tenor are in great demand.

Four handsome \$295 Edison machines, Chipendale model, were among the sales made by M. C. Collins, manager of the talking machine department of Reed, French & Co. Shipments of new Edison and Victor records have been received and the record department is showing signs of a very active and successful trade. Miss Meighen, in charge of the record department, says they are congratulating themselves over the announcement of the Edison people that they will have all the new hits out each month, as the call for the latest dance music, songs, and so forth, is a big one.

Miss Acevia Bennett is keeping up her reputation as a first-class saleswoman. She is now with the McCormick Music Co. A big business in Columbias as well as in Victors has been done by the house. One of Miss Bennett's sales last Saturday was a \$275 Victor. Mr. McCormick reports a good demand for Columbia Grafonolas, of which they have a fine stock on hand.

Since the Perry Music Co. and the Pacific Phonograph & Record Exchange Co. have combined forces, business has been quite active at the store on upper Washington street. The talking machine business is better than it has been for some time. Cremonas are selling very well. This machine is well advertised and is growing in popular favor. The Stradivara and New Comfort are also carried by the Perry Co.

E. W. Moody, in charge of the Pacific Coast Phonograph Co., is well satisfied with the progress the business has made since moving into its new location. They have been fortunate in securing a number of needed records.

The referee in bankruptcy announces that the first dividend in the matter of the World Phonograph Co., bankrupt, will be declared January 20.

M. W. Brand, who has been engaged in the retail music business in Sheboygan, Wis., for over thirty years, selling pianos, talking machines, etc., has closed his store and will conduct his business from his home, 1946 North 6th street.

VOLIVA BANS JAZZ RECORDS

CHICAGO, ILL., January 10.—By an edict promulgated to-day by Wilbur Glenn Voliva, overseer and virtual ruler of Zion City, Ill., all phonograph discs which record music of the variety known as "jazz" are to be summarily confiscated and destroyed by fire as unholy and disagreeably noisy. Next!

MUTUAL CO. SCHEDULES

Mutual Talking Machine Co., Inc., New York, at 145 West Forty-fifth street and 151 Lafayette street, has filed schedules in bankruptcy, with liabilities of \$27,558 and assets of \$14,266, main items of which are stock, \$7,500; accounts, \$4,255, and Liberty bonds, \$1,550.

"Does It Play All Records?"

Certainly MAGNOLA does; and without any extra attachments, too. This is only one feature, albeit a most important one, in the thoroughly up-to-date equipment of the MARVELOUS MAGNOLA.

MAGNOLA "Built by Tone Specialists"



Watching the Music Come Out

May we send you our handsome illustrated catalog chock full of information concerning the wonderful construction system of Magnola and the beauties of its musical results, its artistic appearance and its moderate price?

Send your name and let us tell you more!

MAGNOLA TALKING MACHINE COMPANY

OTTO SCHULZ, President

General Offices 711 MILWAUKEE AVENUE CHICAGO
Southern Wholesale Branch 1530 CANDLER BLDG. ATLANTA, GA.

NEEDLES

WE MANUFACTURE

Diamond needles for Edison

Sapphire needles for Edison

Sapphire needles for Pathe

in stock ready for delivery

MERMOD & CO., 874 Broadway, N. Y.



EUROPEAN HEADQUARTERS

2 GRESHAM BLDG., BASINGHALL ST., E.C. LONDON

W. LIONEL STURDY, MANAGER

Survey of 1920 Business Results Proves Disappointing to Members of Gramophone Co.—Various Conditions That Served to Interfere With Trade Progress—Planning Co-operation in Publicity—Some Interesting Developments in Association Progress—Columbia Co. Plans Orchestral Program—Sinkler Darby Honored by Gramophone Co. Associates—New Vocalion Record Factory Starts Operating—Exhibition of Foreign Products—What the Latest Record Lists Have to Offer

The old year has passed out, leaving behind the thought with most of us that it has been altogether disappointing in a commercial way. If the opening months of 1920, with their high promise of good trade, had been maintained the year would have closed very differently than actually was the case. We were all looking forward to a continuance of those prosperous sales conditions prevalent during the war period and had every good reason to expect a bumper year. But it was not to be. Certain classes of trade collapsed very suddenly, this condition being particularly applicable to the gramophone industry. From February onwards sales slackened to a degree hitherto foreign to our industry. Throughout the Summer months it became really serious, and at last the truth had to be faced, that the public were not buying. Expensive publicity was maintained by at least the leading record concerns with little result upon sales. September and October were unusually flat from the viewpoint of trade and it was not until well into November that things began to move in the right direction. Even then trade was much below

par, though sales increasingly improved throughout the month of December, only reaching something like normal during the Christmas rush week. Altogether 1920 has been a very lean year and to it the British gramophone trade says good-bye without regret.

There is much to explain the parlous state of industry of the past year in the way of labor strikes, high cost of general commodities, and that feeling of unrest, universal in its action and effect, all of which culminate in disturbance of trade and much unemployment. These are causes far more likely to adversely affect the gramophone industry than most others, and particularly so when the retail section falls into a 1920 channel of pessimism. We must all realize that a special effort will be necessary to the maintenance of trade this year, because a bunch of last year's troubles may—very probably will—remain with us for yet a considerable time. Business development will require more than ever an intelligent handling if we are to make a satisfactory showing. Much depends on the dealer, upon whose local enterprise and energy rests to a great extent the progress of the gramophone industry in the New Year. The manufacturers and factors may be relied upon to keep things on the move, but however much they advertise and circularize and systematize, I shall always pin my faith to the belief that the real foundation of progressiveness in trade rests upon the men who are in direct touch with the public. That is why I urge distributors to avail themselves of every reasonable opportunity of linking up their efforts locally with the national efforts of the manufacturers.

In this connection I happened upon some interesting data the other day when chatting with the publicity director of a well-known firm. For some time he has been working upon an educational plan among dealers with the object of convincing them of the value to be derived by linking up with the firm's publicity in provincial centres. Complete stereos of stock advertisements (pierced for the dealer's name and address) were offered free for use, it was suggested, in local journals. As a result of persistent effort over 500 dealers are now using this publicity idea with excellent and sales-increasing results. Local dealers in each town take space under, over, or adjacent to the company's national advertisement in the local paper. All this is practical sales work that is cumulative in its effect, and all to the permanent good of the talking machine industry. It is more of this kind of co-operation among manufacturers and their dealers that I hope will be a strong feature of 1921 trade. It is essential.

The Christmas trade rush meant a high-speed effort among the staffs of the wholesale houses. At it night and day one factor told me, and with truth, if the state of his warehouse was any criterion. As in this case, so everywhere I went were to be seen crowds of dealers' messengers clamoring for fulfilment of averagely good-sized record orders and machines. For the transport of machines all sorts of vehicles were under requisition, from the motor lorry to the humble cycle-carrier. A good week was the verdict of all the factors.

In records there appeared to be a persistent call for instrumental and particularly Christmasy descriptive and dance numbers. Current vocal hits,



"His Master's Voice"

Copyright

This intensely human picture stands for all that is best in music

—it is the "His Master's Voice" trade-mark, and it brings to you, no matter where you are, the very best music of every kind, sung and played by the world's greatest artists—the greatest singers, pianists, violinists, orchestras and bands—all enshrined in the unequalled "His Master's Voice" records

'His Master's Voice'

—the trade-mark that is recognized throughout the world as the

HALL-MARK OF QUALITY

DENMARK: Skandinavisk Grammophon-Aktielselskab, Frihavnens, Copenhagen.

FRANCE: Cie. Française du Gramophone, 115 Boulevard Richard Lenoir, Place de la République, Paris.

SPAIN: Compañía del Gramófono, 56-58 Balmes, Barcelona.

SWEDEN: Skandinaviska Grammophon-Aktiebolaget, Drottning Gatan No. 47, Stockholm.

RUSSIA: The Gramophone Co., Ltd., 45, Nevsky Prospect, Petrograd (Petersburg); No. 1 Solyanka, Solyanoi Dvor, Moscow; 9, Golovinsky Prospect, Tiflis; Nowy-Swiat 30, Warsaw; 11 Michailovskaya Ulitsa, Baku.

INDIA: The Gramophone Co., Ltd., 139, Balhaghatta Road, Calcutta; 7, Bell Lane, Fort, Bombay.

Great Britain:

The Gramophone Company, Ltd.

HAYES - MIDDLESEX - ENGLAND

AUSTRALIA: S. Hoffnung & Co., Ltd., Sole Concessionaries of The Gramophone Company, Limited, 163, Pitt Street, Sydney.

NEW ZEALAND: Gramophontum, Ltd., 118-120 Victoria Street, Wellington.

SOUTH AFRICA: Darter & Sons, Post Box 174, Capetown; Mackay Bros., Post Box 251, Johannesburg; Mackay Bros. & McMahan, Post Box 419, Durban; Ivan H. Haarbuerger, Post Box 105, Bloemfontein; Franz Moeller, Post Box 108, East London; B. J. Ewins & Co., Post Box 86, Queens-town; Handel House, Kimberley; Laurence & Cope, Post Box 132, Buluwayo; The Argus Co., Salisbury.

EAST AFRICA: Bayley & Co., Lourenço Marques.

HOLLAND: American Import Co., 22a, Amsterd Veerkade, The Hague.

ITALY: A. Bossi & Co., Via Orefici 2, Milan.

EGYPT (Also for the Sudan, Greece and the Ottoman Empire): K. Fr. Vogel, Post Box 414, Alexandria.

The **VULCAN MAIN SPRINGS**

J. STEAD & CO LTD

SEND *to-day* for **SAMPLES & PRICES** **SHEFFIELD**

MANOR WORKS

BRITISH MADE

MANUFACTURED BY J. Stead & Co Ltd Sheffield.

carols and such-like were, of course, in big demand. Many dealers around town were featuring albums of records as Christmas presents. These contained sets of records covering complete operas, and in some cases albums were put up containing a dozen mixed records of vocal, orchestral and band selections, or to customers' choice—a very good idea which found favor.

Based upon the disappointments of last year's trade most of us are sanguine enough to believe in the probability of an improvement in 1921. To that end let us all heartily subscribe by action rather than word.

Latest Association News

From C. E. Timms, the secretary of the above association, comes the following report:

"The regular monthly meetings of the general committee of the association have been fully attended, and in addition other special meetings have recently been necessary to deal with matters of urgency and great interest to the trades represented.

"The following houses have recently applied for, and been elected to, membership: Keith Prowse & Co., Ltd., Standard Manufacturing Co. (Acton), Ltd., The Limit Engineering Co., Spring Motors, Ltd., Alfred Graham & Co., Gramostyles, Ltd.

"The association's representatives elected to serve on the Federation of British Music Industries comprise: H. J. Cullum, M. B. E.; Herbt. W. Dawkins, A. J. Mason, W. Manson, Frank Samuel, Louis Sterling, C. E. Timms, secretary.

FROM OUR LONDON HEADQUARTERS—(Continued from page 176)

"The monthly publication of statistics of imports and exports is proving one of the most valuable of the association's activities, and this feature has been adopted by kindred societies.

"On the question of railway rates and conditions earnest endeavors have been and are being made direct with the railway authorities and in collaboration with the federation to secure a modification of the present unsatisfactory state of affairs, particularly in regard to the conveyance of gramophone records by passenger train. Representations on the subject have also been made to the Ministry of Transport, and in the event of no concession being granted members, many of whom have already furnished valuable information on the subject, will be asked to supply details necessary to prepare a case for presentation to the railway rates advisory committee. The immediate concession desired is that gramophone records be conveyed by passenger train at company's risk, or, alternatively, that if conveyed as at present by passenger train at owner's risk they be accepted at the owner's risk rate instead of, as now, at the company's risk rate.

"The interests of the trade in regard to the proposed British Empire Exhibition in 1923 are being cared for, and representations on the question of the guarantee fund from the industry, in accordance with the general scheme, have been made to the federation.

"All manufacturing houses in membership have

recently had an opportunity of expressing their views, to be conveyed to the proper authority, on the question of fair conditions for imports into this country.

"In the recently published report to the Board of Trade by the Merchandise Marks Committee, the evidence furnished by this association receives considerable prominence, and the recommendations made are extraordinarily good. This matter is now being dealt with on behalf of the whole music industry by the federation, which will make any requisite further representations on this important subject.

"A mission to Germany to inquire into and report as to trade conditions, etc., there will shortly be dispatched under the auspices of the federation, and these gentlemen have been furnished with full particulars regarding the information required by the gramophone and small goods (musical instrument) industry. The information, when obtained, will be conveyed to members through the usual channels."

The Columbia Orchestral Program

For the 1920-21 season the Columbia Co. has secured the exclusive recording services of such famous conductors and orchestras as Sir Henry J. Wood and the New Queen's Hall Orchestra, Alick Maclean and the New Queen's Hall Light Orchestra, Sir Thomas Beecham and the Beecham Symphony Orchestra, Albert Coates and the London Symphony Orchestra, Hamilton Harty and the Hallé Orchestra. The cream of orchestral talent allied to gramophonic art—an irresistible combination! And on the revue and musical comedy side Columbia seems to have "claimed" a very exclusive association—the company that delivers the goods with a vengeance!

An Associate of Emile Berliner

A complimentary luncheon and presentation was recently made to Sinkler Darby upon the occasion of the relinquishment of his position as one of the recording "angels" of the Gramophone Co., Ltd., after no less than twenty-one years' service. Many friends and colleagues were present. Mr. Darby's connection with the talking machine industry dates back to 1895, when he became associated with Emile Berliner, who at that period was successfully grappling with the problem of disc reproduction and manufacture. At this excellent school Mr. Darby gained wide knowledge and experience and in 1899 he was retained by the newly-born Gramophone & Type-writer Co. During an unbroken twenty-one years' association with the "His Master's Voice" he counts to his credit the recording of the voices and playings of many of the great artists whose glorious art has during this period passed into the realms of commerce in the shape of records. Mr. Darby proposes to re-enter business life after a period of complete rest.

Special Propaganda by "His Master's Voice"

At this time of the year many of the British gramophone companies develop along special lines in their sales appeal to the general Christ-

(Continued on page 178)

"PERFECT POINTS"

BRITAIN'S BEST Gramophone Needle
(Guaranteed made from High Carbon Steel)

IS MADE BY

W. R. STEEL, of REDDITCH,
Head Office and Works—QUEEN ST.

Scientifically pointed, Hardened and Tempered on the latest up-to-date machinery and plant by skilled craftsmen only.

RESULT:
A FIRST QUALITY NEEDLE far ahead of anything of pre-war quality

INQUIRIES SOLICITED
Special Quotations for Quantities

Manufacturer of all Kinds of Sewing Needles

FROM OUR LONDON HEADQUARTERS—(Continued from page 177)

mas present-buying public. Additional and widespread publicity efforts are the order of the day. This is particularly applicable to the "His Master's Voice" Co. Among special advertising propaganda was a \$6,000 front page advertisement in London's most widely circulated journal, devoted to "A Christmas Message to Every Music Lover." That message told of the boundless joy of gramophone music this Christmas-tide. Many of the "His Master's Voice" models were illustrated, with price and description, while pictures of dancing couples and romping children, of course, in company with Nipper, visualized the value of musical entertainment. A really pleasing and most telling advertisement.

Another useful effort by this company was the production of appropriately designed advertisement stereos for their dealers' local use. These are supplied free and quite a goodly number were used.

In addition to the usual batch of monthly issues the "His Master's Voice" made ample provision in the way of dance records, a special list having been provided. There are also records of the chief items from the musical comedy "A Night Out."

Gramophone Retail Dealers' Association

A recent committee meeting of the above association considered various designs of a badge for issue in the form of a transfer to be used by members on their windows and in other suitable ways. By a majority choice a design resembling a record with the title of the association around the edge was adopted. It is thought that where the design is displayed the buying public will place their confidence. Members will also be supplied with a framed certificate to hang in their showrooms.

The committee will now sit regularly on the first Tuesday each month at 233 Regent street, London, for the purpose of dealing promptly with matters requiring consideration as affecting members of the association.

A general meeting is called for January 26 to approve rules and discuss among other things the ethics of and questions relating to the hire purchase system of trading. In particular it is desired to reach common agreement as to scale of deposits and deferred payments.

The foregoing indicates a real progressive spirit which augurs well for the future success of the retail association movement. Unity is strength. The combined support of at least 1,000 dealers will make for the exercise of an influence to the solid good of every section of the gramophone industry. Get together, dealers, and join up!

Electric Gramophone Motors

In the provision of electrically driven mechanism for gramophones we are unquestionably far behind the U. S. A. Until quite recently nothing of the kind was known here. It is satisfactory to record, however, the almost simultaneous introduction of two such motors, one made by Electric Gramophone Motors, Ltd., of which more

will be heard later on, and one by W. H. Reynolds (1915), Ltd. The latter is called a "Motophon" and is said to be the result of no less than ten years' continuous research and experiment. Direct or alternating current on any voltage will suit the Motophon. It has a direct drive and is minus gears, running perfectly silent. For this useful invention Messrs. Reynolds have secured the sole selling rights throughout the world. An electric motor has been much sought after on this side and Reynolds' introduction is already the talk of the trade. Dealers have accorded it a warm welcome, and it is not too much an anticipation that sales will quickly reach substantial proportions. It may be remarked that under test the Motophon ran for 500 hours consecutively, using up current equalling only that of a 20-watt lamp.

Aeolian New Record Factory at Work

As previously reported, the activities of the Aeolian Co., Ltd., have for some time past been concentrated upon the production of a new record called the Vocalion. The first impressions from the factory are now in the hands of the trade. By all reports the new disc has found immediate favor by reason of its musical qualities. My own observations confirm the belief that the Vocalion will quickly acquire a firm place among records of standing, for, apart from tonal merit, there is an evident determination on the manufacturing side to produce a perfect record in all respects. The material used makes for an absence of grittiness and consequent lessening of surface scratch, and the good finish of the record is another feature that will appeal. A very artistically designed label is used.

Adequate preparation has enabled the company to come out with something like 170 records, which, as a preliminary canter, is decidedly good. And of the titles every known class of music seems to have been catered to in quite a nice variety. There are records of operas, musical comedies, revues, foxtrots, dance numbers, sacred, standard ballads, representing a very careful choice of selections that may be regarded as permanent favorites.

Another feature of interest is the goodly number of high-class artists and musical organizations who have signed on for "Vocalion" recording. I notice such names as Albert Sammons (violin), Archibald Joyce's Dance Orchestra, Band of H. M. 1st Life Guards, Lenghi-Cellini, Lionel Tertis, George Baker, Madie Scott, Frank St. Leger, Destourael, to mention only a few. These are sufficient to show that the Vocalion people have planned their productions on a high plane of artistic merit.

The records are in size ten inches and twelve inches, single and double-sided, prices varying from 4s. 6d. to 8s. retail. In conclusion a measure of praise is due to the designer of the company's publicity literature, which, throughout, is conceived upon a very artistic, not to say expensive, level. Large spaces have been taken in the chief London and provincial newspapers, maga-

zines, etc., to advertise the Vocalion productions—records and machines.

Exhibition of Foreign Products

A great exhibition of foreign goods may now be inspected in London. It comprises no less than 100,000 samples of articles made abroad, and a library of some 13,000 foreign catalogs. This great commercial exhibition has been organized by the Overseas Trade Department of the Board of Trade, the object being to show by practical demonstration what British manufacturers have to meet in the way of competition. On the plea that what others can do British labor and capital can also do, the exhibition will serve to enlighten our manufacturers and help them to a study and emulation of foreign effort. Samples may be borrowed, and every practical assistance is officially afforded that British firms may regain and develop their pre-war standing in the markets of the world. It is regarded as a most beneficent scheme.

More Prize Band Zonophone Records

The St. Hilda Colliery Grand Championship Band has made further records for the British Zonophone Co., Ltd. Typical examples of fine recording are the two new records just announced. No. 2073 carries two particularly attractive musical items—"Chimes of Joy" and "Kilties' Kourtsip"—intermezzo, one-step. No. 2074 is also in big demand—"Dinah's Holiday" and "Pat's in America." Other notable band contributions to this list are 2075, "Whirligig," selection 1 and 2, a big London success, and "Kentucky," fox-trot, with which is coupled "City of Laughter," waltz, introducing excerpts from some recent musical items. These two discs will stand out as brilliant examples of the work of the Black Diamond Band.

Another instrumental that is likely to prove a ready seller at this period is No. 2077, "God Gave Me Wonderful Dreams" and "Tulip Time," both prettily rendered by the Royal Cremona Orchestra. There are a number of good vocals itemized, and a special call will doubtless be made for No. T2078, "One Little Hour" and "Milissa," sung by the popular lyric tenor, Sydney Coltham.

In addition to the foregoing the British Zonophone Co. features titles appropriate to the festive season in goodly and choice variety.

Trade News in Brief

It is announced that the next music trade convention will be held at the Thanet town of Ramsgate. Accommodation has been booked at the Granville Hotel for the convention period of May 24 to 30 inclusive.

The government is taking a keen and practical part in the development of British trade overseas. At the instance of the Department of Overseas Trade a handbook has been published dealing succinctly with the splendid organization and valuable official service at the disposal of British firms desirous of wooing the markets of the world. It is really a most helpful guide to the propagation of overseas trade.

At the Kingsway Hall is exhibited a concert gramophone bearing the terribly unnatural name of the "Naturafone."

AUSTRALIA.

Herbert G. Polyblank,
SYDNEY,
N.S.W.

BELGIUM.

P. Carton,
Rue Karel Ooms, 11,
ANVERS.

ITALY.

G. Menaboni,
Via S. Sebastiano 2,
LIVORNO.

SPAIN.

Ernesto Verdu,
ALICANTE.

ENGLAND.

A. Waite & Co., Ltd.,
15-17 Figtree Lane,
SHEFFIELD.

Songster
Talking
Machine
Needles

Manufactured by J. STEAD & CO. LTD.
MANOR WORKS, SHEFFIELD ENGLAND.



LATEST PATENTS RELATING TO TALKING MACHINES AND RECORDS

WASHINGTON, D. C., January 8.—Indicator for Phonograph Reproducers. Joseph Wolff, assignor to the Sonora Phonograph Co., New York. Patent No. 1,350,763.

This invention relates to indicators for positioning the reproducers of talking machines. The objects are to provide visual means whereby the reproducing stylus may be placed in the proper position in the record groove, whereby the operator will not be compelled to watch the point of the stylus when starting the machine.

Further objects are to provide an indicator which will not interfere with the operation of the machine, and which, when not in use, will be practically concealed from view; to provide means to indicate the point in the record groove corresponding to the stylus position on said record groove, and also the provision of means of the character described, simple in construction, inexpensive to manufacture and so designed

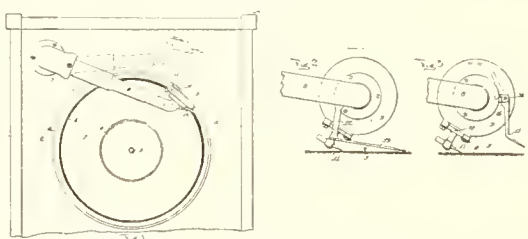

and constructed that it may be readily and easily attached to disc talking machines now in general use.

Figure 1 is a plan view of a talking machine with the cover removed and with the invention applied. Fig. 2 is a rear elevation of a sound box with the invention affixed to the tone arm, and Fig. 3 is a similar view of a modification.

Talking Machine. George H. Isley, Worcester, Mass. Patent No. 1,355,081.

The present invention relates to talking machines, and more particularly to such machines which are adapted to play continuously, by the use of a multiplicity of records, the latter being brought progressively by mechanical means into position for playing by the tone-producing mechanism of the machine. The invention of the present application resides in certain improvements and refinements upon a machine of similar type which is shown and described in prior co-pending application Serial No. 108,342, filed July 10, 1916,

Figure 1 is a plan view of a machine embodying the present invention, certain parts being broken away to disclose more fully the construction; Fig. 2 is a transverse sectional view thereof partly on the line 2—2 of Fig. 1, disclosing interiorly the operating mechanism of the machine;

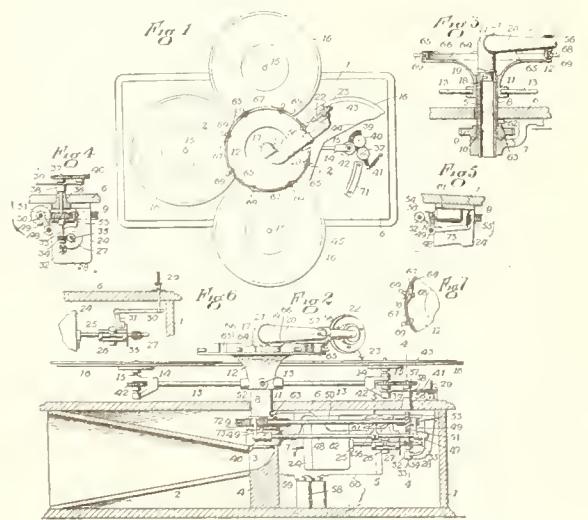
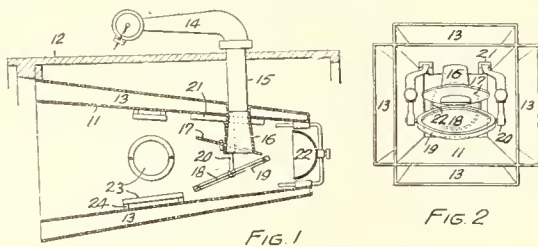

Fig. 3 is a central sectional view of the tone arm support and associated parts; Fig. 4 is a section on the line 4—4 of Fig. 2; Fig. 5 is a section on the line 5—5, Fig. 2; Fig. 6 is a fragmentary detail view showing the governing mechanism of

the machine, and Fig. 7 is a fragmentary detail view showing a modified cam construction.

Controlling Means for Gramophones. Charles A. Fisk, Arrotsford, Quebec, Canada. Patent No. 1,354,961.

This invention relates to improvements in means for controlling or regulating the tone and volume of sound produced by gramophones, and the object of the invention is to provide a simple, inexpensive, durable and easily adjusted means



by which the sound produced by a gramophone may be regulated as to tone and volume.

The device consists briefly of a horn which may be built into the casing of a gramophone or otherwise suitably located, having separate sounding boxes surrounding it. The tone arm of the gramophone leads into the horn and is provided with an adjustable diaphragm. Various sound regulating means may be mounted in the horn.

Figure 1 is a vertical, longitudinal, sectional view of the device; Fig. 2 is a front elevation.

Talking Machine Apparatus. Albert J. Swing and Albert S. King, Cincinnati, O. Patent No. 1,355,711.

This invention relates to improvements in talking machines. One of its objects is to provide an improved combination of sound transmitting mechanism to preserve and transmit all of the sound reproduced by the diaphragm. Another object is to provide in combination with a transmitting diaphragm a horn or megaphone the inner end of which from a point close to the diaphragm is subdivided into a plurality of separate tubular compartments, and which merge into a common compartment at different points between the inner and outer ends of the horn. Another object is to provide an improved horn.

Figure 1 is a diagram partly in section through a talking machine apparatus embodying the improvements; Fig. 2 is an enlarged sectional view of the diaphragm casing and tone arm detached; Fig. 3 is a cross sectional diagram

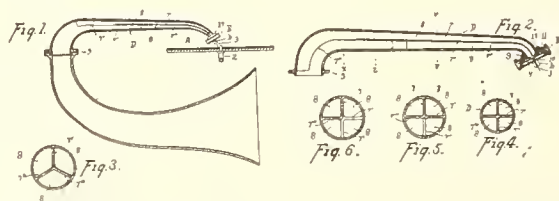

through a modified form of tone arm divided into three compartments; Fig. 4 is a section on line v—v of Fig. 2; Fig. 5 is a section on line z—z of Fig. 2; Fig. 6 is a section on line x—x of Fig. 2.

Apparatus for Recording and Reproducing Sound. Richard S. Arthur, New York. Patent No. 1,355,523.

This invention relates more especially to the transmission of motion to the record, in sound recording and reproducing machines, so as to cause the same to travel beneath the stylus of the sound box, and the objects of the invention are to prevent the transmission of vibrations and tremors to the record from the driving apparatus, and thus improve the quality of the sound. It will be understood that in many sound recording and reproducing machines, and particularly the less expensive ones, there is considerable irregularity in the movement produced by the motor, which is transmitted to the record, if the connection is a rigid one, and

detrimentally affects the sound reproduction. The objects of the invention are to remedy this and to provide a resilient or yielding connection between the motor and the record which shall turn it with sufficient positiveness and at the same time absorb any slight irregularities, such as vibrations or tremors, and give the record a perfectly smooth and uniform motion; to do this simply and inexpensively, and to obtain other advantages and results as may be brought out in the following description.

Figure 1 is an elevation of a cylinder machine of ordinary and well-known construction illus-

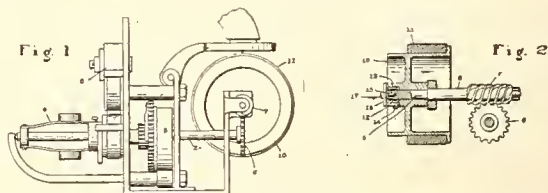

trating the application of the invention thereto; Fig. 2 is a section through the cylinder and record thereon.

Reproducer for Talking Machines. John W. Kaufmann, Baltimore, Md. Patent No. 1,354,197.

This invention is an improvement in reproducers, and has for its object to provide a new and improved connection between the needle and the diaphragm controlling lever, which will eliminate the usual rigidity between these parts and which will intensify the movement of the needle during its transmission to the diaphragm of the talking machine.

In the drawings: Figure 1 is a perspective view of the improved reproducer; Fig. 2 is a similar view of the holding bracket for the transmission member; Fig. 3 is a similar view of the diaphragm controlling lever; Fig. 4 is a perspec-

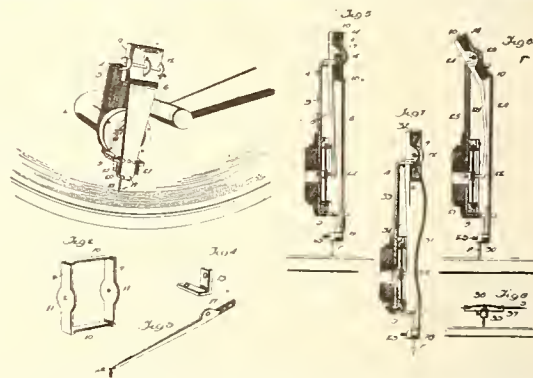

tive view of one of the connecting brackets; Fig. 5 is a longitudinal section; Figs. 6 and 7 are views similar to Fig. 5, showing modified constructions; Fig. 8 is a side view showing a modified form of needle holder.

Combined Table Light, Fan and Phonograph. Peter R. Gonsky, Detroit, Mich., assignor to the Endlessgraph Mfg. Co., New Jersey. Patent No. 1,359,053.

This invention has for an object to provide a construction in a stand and mechanism whereby the appliance may be used as a gramophone, fan and reading light combined, adapted to be set upon any suitable horizontal surface, and utilized for its various functions in an efficient manner, without interference of one with another.

It is an important object to give a construction of this character in which the shaft for the rotating table of the gramophone may be employed to rotate and drive the fan, and an additional interposed

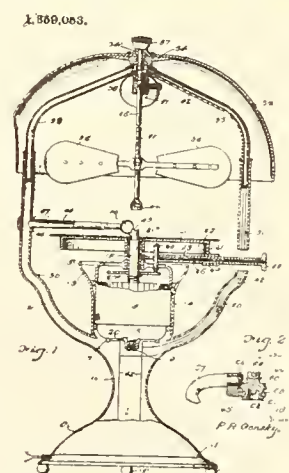

LATEST PATENTS RELATING TO TALKING MACHINES AND RECORDS—(Continued from page 180)

flexible shaft connection employed, without interfering with the proper use of the appliance for the rapid emplacement and removal of the record disc. A further aim is to give novel improvements in the structural details and elements of an appliance of this character, whereby its manufacture will be facilitated, its use made efficient, and its action also. A further important aim is to utilize a lamp-motor base as a sound amplifier. Another important aim is to give a novel means for raising and lowering a fan connection from engagement with the gramophone main shaft.

According to the drawings Figure 1 is an elevational view of one embodiment of the invention. Fig. 2 is a detail of a flexible shaft connection.

Sound Box Attachment. Wm. H. Fraser, New York. Patent No. 1,358,719.

One of the objects of the invention is to provide the sound-box of a sound reproducing machine with a simple and efficient mechanism, in the form of an attachment, to modify the sound.

Another object of the invention is to so construct the sound-modifier that it can be conveniently mounted upon sound-boxes and the sound-modifying member brought, at will, into operative or inoperative position.

A further object of the invention is to so construct the attachment that it serves at the same time as a protecting means for the diaphragm of the sound-box.

Figure 1 represents a portion of a talking machine, provided with a sound-box constructed in accordance with the present invention; Fig. 2 is a front elevation of the improved sound-box;

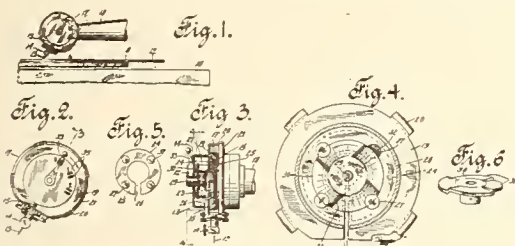

Fig. 3 is a section taken on line 3—3 of Fig. 2; Fig. 4 is a section taken on line 4—4 of Fig. 3, on a larger scale; Fig. 5 is a front elevation of the sound-modifying element of the attachment; and Fig. 6 is a perspective view of a mechanism in engagement with the sound-modifying element.

Phonograph. Wm. P. Dalrymple, Chicago, Ill. Patent No. 1,358,709.

This invention relates to improvements in phonographs, and among the objects of the invention are to provide a light, portable, simple and efficient mechanism which may be made in compact form so as to occupy a small space; it being contemplated that the device may be made small enough in size to be carried in the pocket.

In general terms the device comprises a housing or case, preferably oval in form, with all of the operative mechanism arranged within it, and the running parts mounted in a frame adapted to slide endwise within the housing or case; whereby the rotative disc which carries the sound record travels in a straight line from one end of the casing to the other to carry a fixed stylus in a spiral line over the surface of the sound record.

Figure 1 is a top plan view showing the complete instrument. Fig. 2 is a view of the instrument in side elevation with a small portion of the side wall of the casing broken away to disclose the parts within. Fig. 3 is a horizontal section on the line 3—3 of Fig. 4 looking downward.

Fig. 4 is a vertical longitudinal section on the line 4—4 of Fig. 3. Fig. 5 is a horizontal section on the irregular line 5—5 of Fig. 4 looking downward. Fig. 6 is a horizontal section on the line 6—6 of Fig. 4 looking downward. Fig. 7 is a

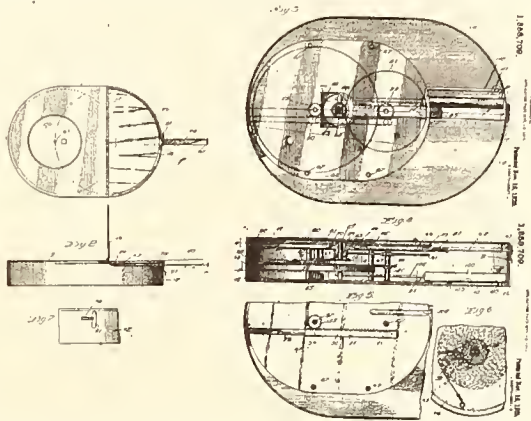

fragmentary view in end elevation showing a portion of the casing with the winding stem or bar extending through it. Fig. 8 is a fragmentary view in axial section through the cylinder of a dash pot comprising a part of the device. Fig. 9 is a top plan view showing a modified form of the

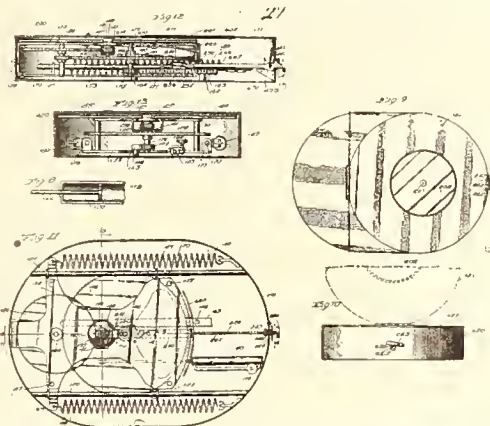

device. Fig. 10 is a vertical section on the line 10—10 of Fig. 9. Fig. 11 is a view showing the modified form of the device in a horizontal section taken immediately below the cover of the housing. Fig. 12 is a longitudinal vertical section on the line 12—12 of Fig. 11. Fig. 13 is a transverse vertical section taken on the line 13—13 of Fig. 11.

Sound Amplifier. John E. Christensen, Chicago, Ill. Patent No. 1,358,706.

This invention relates to sound amplifiers or horns employed in connection with phonographs and other sound reproducing machines, and its object is to provide a horn of novel and improved construction and design whereby the sounds are

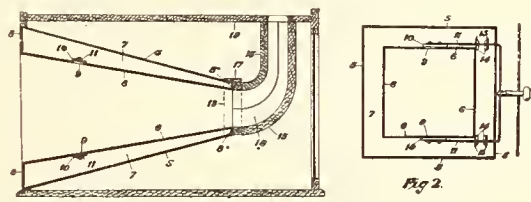

rendered soft and mellow, and all harsh noises are eliminated or reduced to a minimum.

In the drawing Figure 1 is a longitudinal section of the horn, and Fig. 2 is a cross-section thereof.

Stylus Holder for Talking Machines. Frederick E. Joss, Brooklyn, N. Y., assignor to the Lektophone Corp., Delaware, Md. Patent No. 1,359,995.

This invention relates to talking machines, and in particular to machines of the Hopkins type, in which the vibrations of the stylus, during its travel along a phonic line, are transmitted to a conical diaphragm of large area, freely supported in unconfined air, in a manner to move the entire conical portion of the diaphragm bodily.

According to the present invention the former universal mounting of the stylus holder is sim-

plified, and at the same time improved, by utilizing a stylus holder which, instead of being made in two parts, as before, consists of a single part only which is mounted in the supporting bar and connected with the transmission rod in such a manner that it can adapt itself with equal facility to both types of vibrations. In this way, the actual cost of construction is decreased, while any danger of the stylus-carrying part of the holder working loose upon the base of the holder is avoided, so that a more effective construction is provided than the one formerly utilized.

Figure 1 is a side elevation of the improved stylus holder, applied to a supporting bar, the latter appearing in dotted lines; Fig. 2 is a front view, but the bar is shown herein in full lines; Fig. 3 is a perspective view of the holder; Figs. 4 and 5 are horizontal and vertical sectional views

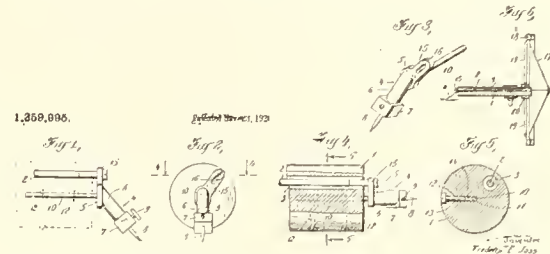

taken, respectively, on line 4—4 of Fig. 2 and 5—5 of Fig. 4, looking in the direction of the arrows; and Fig. 6 is a fragmental vertical sectional view on a reduced scale, showing the diaphragm mounted on the supporting bar and connected to the transmission rod.

Phonograph Cabinet. Nils Herman Cedarquist, Alhambra, Cal. Patent No. 1,359,791.

Phonograph cabinets of the so-called "cabinet type" are commonly constructed with a box divided into two compartments. The upper one is open at the top and disposed therein is a phonograph motor mechanism. The lower compartment has a horn or amplifier built in, and is connected to the reproducer or sound box by a tone arm. It is common practice to build up the amplifier of wood or metal. Wood amplifiers have certain disadvantages due to the inherent quality of such material in absorbing vibration. Metal, on the other hand, has natural periods of vibration which accentuate certain tones and destroy the natural quality of the sound. It is the primary object of the invention to provide an amplifier which does not absorb or accentuate vibration. Another object of this invention is to provide an amplifier of the character described

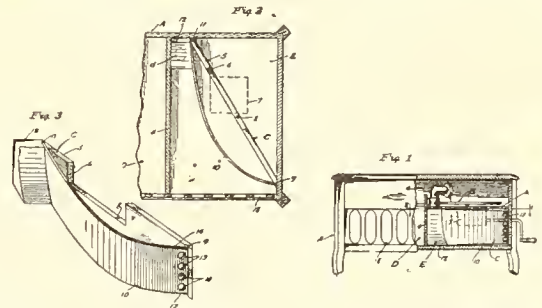

with a wall which serves to direct air vibration and acts as a sounding board, whereby the amplifier may be built of wood. A further object of this invention is to provide a wall of the character described which has its greatest amplitude of vibration adjacent the mouth of the horn.

Figure 1 is a front elevation of a phonograph cabinet with a portion in section showing the amplifier; Fig. 2 is an enlarged section taken on the line 2—2 of Fig. 1 showing the amplifier; Fig. 3 a perspective view of the sounding board.

LESLEY'S PATCHING VARNISH

dries in 10 seconds, flows without showing the lap. With it damaged varnish can be repaired invisibly and permanently. Complete Repair Outfit, \$3.50; 1 quart, \$1.90; 1 pint, \$1.00.

LESLEY'S CHEMICAL CO., MFR.
10 So. New Jersey Street, Indianapolis, Ind.

DISTRIBUTORS:

- MOONEY-MUELLER-WARD CO., Indianapolis, Ind.
- BALDWIN-MILLER CO., Indianapolis, Ind.
- SONORA DISTRIBUTING CO., Dallas, Texas
- LANSING SALES CO., Boston 11, Mass.

REPAIRS

All Makes of Talking Machines
Repaired Promptly and Efficiently

ANDREW H. DODIN

28 Sixth Avenue New York

TELEPHONE, SPRING 1194

PATENTS

Hand Books on Patents, Trade Marks, etc., sent free. Our 74 years of experience, efficient service, and fair dealing, assure fullest value and protection to the applicant. The Scientific American should be read by all inventors.
MUNN & CO., 617 Woolworth Bldg., N. Y.
Tower Bldg., Chicago. 625 F St., Washington, D.C.
Hobart Bldg., 582 Market St., San Francisco, Cal.

Advance RECORD BULLETINS for February, 1921

VICTOR TALKING MACHINE CO.

- POPULAR SONGS
18712 Oh Gee! Say Gee! You Ought to See My Gee
My Home Town Is a One-Horse Town,
18710 Broadway Rose,
18705 When You're Gone I Won't Forget,
18709 I'm a Lonesome Little Raindrop,
35704 Just Snap Your Fingers at Care,
18716 My Isle of Golden Dreams,
18715 If You Could Care,
18714 Tip Top,
18713 12th Street Rag,
45214 Deep in Your Eyes,
87321 A Dream,
74659 The Fountain,
64903 Passepied,
87322 Si j'etais Jardinier,
64920 Come, Ye Disconsolate,
64917 Sicilienne and Rigaudon,
64924 Love Nest,
64925 'Tis an Irish Girl I Love and She's Just Like You,
74661 Eighth Symphony,
64921 Spinning Song,
FIRST RECORDS BY SOTHERN AND MARLOWE,
74662 Romeo and Juliet,
74663 Romeo and Juliet,
64923 O Primavera

COLUMBIA GRAPHOPHONE CO.

- SYMPHONY RECORDS
79456 Zapateado,
49900 Romanza Andaluza,
A3326 Tales of Hoffmann,
A6172 Scheherazade,
A6173 Carnevale Di Venezia,
49820 Nocturne in E Flat,
49766 Lucia Di Lammermoor,
A3331 Anchors Aweigh,
A3339 Eve Cost Adam Just One Bone,
A3338 At the Circus,
A3336 I've Got the Blues for My Kentucky Home,
A3330 You're Just Like a Rose,
A3335 Nightingale,
A3337 Just Snap Your Fingers at Care

- Oh, My Goodness!—Fox-trot,
A6175 Beautiful Annabel Lee—Waltz,
Pussy Willow Waltzes—Waltz,
E4624 Spring Flowers—Waltz,
A3328 I'm a Jazz Vampire,
A3332 Margie,
A3333 Broadway Rose,
A3329 Tired of Me,
A3334 Darling,
A3327 Silver Threads Among the Gold,
Love's Old Sweet Song

AEOLIAN CO.

- OPERATIC SELECTIONS (IN ITALIAN)
52001—La Traviata—Ah Fors e Lui,
52002 Otello—Credo,
30115 Vesperi Siciliani—Bolero,
STANDARD SELECTIONS
24012 Le Cygne,
24012 Salut d'Amour,
HAWAIIAN SELECTIONS
A-14129 Aloha Oe,
Hula Hula,
POPULAR SELECTIONS
A-14130 Rockabye Lullaby,
The Old-Fashioned Garden,
A14131 I've Got the Blues for My Old Kentucky Home,
A-14132 Palesteena,
Margie,
A-14133 Beautiful Annabel Lee,
A-14134 Sweet Mama,
A-14135 Home Again Blues,
DANCE SELECTIONS
A-14136 Dolly,
A-14137 Margie,
A-14138 Caresses,
A-14139 Nightingale,
A-14136 Dolly,
A-14137 Margie,
A-14138 Caresses,
A-14139 Nightingale

EDISON RE-CREATIONS

- 82201 Di' se fedele,
82202 Barcarolle,
82203 Chanson Bachique,
82204 Hush, Little Baby,
80579 Over the Waves,
80580 Broken Melody,
80581 What a Friend We Have in Jesus

- 50411 Daddy and the Boy,
Little Boy and His Mother at the Circus,
50691 Silver Star,
50692 Connaught Man,
50693 Wedding of the Rose,
50694 Four Jacks March,
Ring and the Rose

EDISON AMBEROL RECORDS

- ROYAL PURPLE RECORDS
29068 Lass o' Mine,
29069 Long, Long Ago,
REGULAR LIST
4166 Feather Your Nest,
4167 Four Jacks March,
4168 There's a Vacant Chair at Home,
4169 Dinnie Donohue,
4170 Love's a Magic Spell,
4171 Whispering,
4172 Change Your Name,
4173 Observing Visitor March,
4174 Japanese Sandman,
4175 Aloha Oe,
4176 Our Little Love Affair,
4177 Mother Machree,
4178 Whispering,
4179 Sunrise and You,
4180 Napoli,
4181 Broadway Blues,
4182 Avalon,
4183 My Home Town Is a One-Horse Town,
4184 Old Pal,
FRENCH RECORDS
27194 Ce n'est pas vrai,
27195 La Chanson De Martha,
FINNISH RECORDS
11711 O Hellas barn,
11712 Savolaisen laulu

PATHE FRERES PHONOGRAPH CO.

- "POP" SUPPLEMENT NO. 41
POPULAR VOCAL
22479 Little Crumbs of Happiness,
22480 My Budding Rose,
22481 Mandalay,
22482 Rose,
22483 Now I Lay Me Down to Sleep,
22484 That Talla-Hassee Lassie,
20480 Lonely Blues,
22473 My Land of Memory,
20481 Won't You Come Along?,
22485 Brazil,
22486 Hula Blues,
Just Snap Your Fingers at Care

ADVANCE RECORD BULLETINS FOR FEBRUARY—(Continued from page 182)

- 22487 I Love to Fox-trot (From "Honey Girl") (Von Tilzer)—Fox-trot, Waldorf-Astoria Dance Orchestra (Joseph Knecht, Director)..... 10
- Granada (McKiernan-Spencer)—Fox-trot, Green Brothers' Novelty Band..... 10
- 40215 Rosie (Make It Rosy for Me) (Clarke-Merkur)—Fox-trot..... Joseph Samuels' Music Masters..... 12
- No Wonder I'm Blue (Ahlert)—One-step, Joseph Samuels' Music Masters..... 12
- REGULAR PATHE FEBRUARY LIST
- OPERATIC AND OTHER VOCAL RECORDS
- 54061 I Pagliacci (Leoncavallo) "Prologue"—Basso, in Italian..... Adamo Didur..... 12
- 54062 Welcome Love (O ben tornato, Amore) (Roxas)—Soprano, in Italian..... Claudia Muzio..... 12
- 54063 My Old Kentucky Home (Foster)—Soprano, Yvonne Gall..... 12
- 25048 La Jolie Fille de Perth (Bizet) "When the Flame of Love"—Baritone..... Percy Hemus..... 10
- On the Road to Mandalay (Kipling-Speaks)—Baritone..... Percy Hemus..... 10
- STANDARD SONGS SUNG IN ENGLISH
- 22459 Bedouin Love Song (Pinsuti)—Basso, Wilfred Glenn..... 10
- Dreams (Porteous-Strelzki)—Basso, Wilfred Glenn..... 10
- 22460 My Hero (from "Chocolate Soldier") (Stange-Straus)—Soprano..... Lora Hoffman..... 10
- Cherie (Come to Me) (Alexander-Edwards)—Soprano..... Lora Hoffman..... 10
- 25049 I'll Sing Thee Songs of Araby (Wills-Clay)—Baritone..... Wells Clary..... 10
- Invictus (Henley-Huhn)—Baritone..... Wells Clary..... 10
- GOSPEL HYMNS SUNG AS QUARTETS
- 22461 Almost Persuaded and All Hail the Power (Coronation)—Organ accomp., Lyric Male Quartet..... 10
- Whiter Than Snow and Only a Step to Jesus—Organ accomp..... Cathedral Quartet..... 10
- 27034 Two Hungarian Dances (Brahms) as danced by Lada..... Nahan Franko and Orchestra..... 10
- Two Indian Dances, No. 1 "Deer Dance," No. 2 "War Dance" (Skilton), as danced by Lada, Nahan Franko and Orchestra..... 10
- 27033 Blue Danube (Strauss) as danced by Lada, Nahan Franko and Orchestra..... 10
- Sweet, Sweet Lady (Stanton-Spross), as danced by Lada, (Lewis James, Tenor), Nahan Franko and Orchestra..... 10
- NEW INSTRUMENTAL RECORDS
- 20477 Sweet and Low (Barnby)—Cornets and trombones, Jules Levy, Jr.'s, Brass Quartet..... 10
- When You and I Were Young, Maggie (Butterfield)—Cornets and trombones, Jules Levy, Jr.'s, Brass Quartet..... 10
- 59087 Prelude in G Minor, Op. 23 (Rachmaninoff)—Piano solo..... Joseph Lhevinne..... 12
- Trepak, Op. 72 (Tschaikowsky)—Piano solo, Joseph Lhevinne..... 12

GENNETT LATERAL RECORDS

- 4651 Change Your Name, Malinda Lee (Bernard)—Tenor and baritone duet. Orch. accomp. Al Bernard-Ernest Hare
- See Old Man Moon Smile (Bernard)—Tenor and baritone duet. Orch. accomp. Al Bernard-Ernest Hare
- 9098 The Bullfighters March (Kotann) His Majesty's Irish Guards Band
- Spear-mint March. 1st Infantry Regiment Band of Belgium
- 9099 Thousand Kisses Waltz (Joyce) The Blue Bohemian Orchestra
- Forever Waltz (Waldeufel) The Blue Bohemian Orchestra
- 9100 I'll Sing Thee Songs of Araby (Clay)—Tenor. Orch. accomp..... Wilfred Clayton
- Take a Pair of Sparkling Eyes (Sullivan)—Tenor. Orch. accomp..... Wilfred Clayton
- 2511 La Donna e Mobile (Woman Is Fickle) (Verdi)—Tenor from Rigoletto. Italian. Signor Angelo Roselli
- Vesti la Guibba (On With the Play) (Leoncavallo). Tenor from Pagliacci. Italian. Signor Angelo Roselli
- 2512 Peace, Perfect Peace—Quartet: Tenor, soprano, contralto, bass. Fred Whitehouse, assisted by Lew Brown
- Come Unto Me—Quartet: Tenor, soprano, contralto, bass. Charles Hart
- 2513 The Sinner and the Song—Quartet: Tenor, so-

- prano, contralto, bass. Battle Hymn of the Republic (Howe)—Quartet: Tenor, soprano, contralto, bass.
- 4655 Broadway Rose Medley (Fried-Spencer)—Fox-trot. Intro.: Gingham Girl. Joe Coleman's President Orchestra
- Caresses Medley, (Monaco)—Fox-trot. Intro.: Kentucky..... Joe Coleman's President Orchestra
- 4656 Margie (Conrad-Robinson)—Baritone. Orch. Ernest Hare
- All She'd Say Was Um-hum (Zany-MacEmery-Van-Schenck)—Baritone. Orch. accomp. Ernest Hare
- 4657 Grieving For You Medley (Gibson-Ribond-Gold)—Fox-trot. Intro.: Mammy's Apron Strings. Green Bros.' Novelty Band
- Darling (Schonberg)—Fox-trot. Green Bros.' Novelty Band
- 4658 Margie (Conrad-Robinson)—Fox-trot. Intro.: June..... Vernon Trio
- Nightingale (Coburn-Rose)—Fox-trot. Intro.: Drifting Along..... Vernon Trio
- 9102 Beautiful Annabell Lee (Mehlinger-Meyers)—Tenor-baritone duet..... Mason-Ring
- Don't You Remember the Time? (Williams)—Tenor-baritone duet. Orch. accomp..... Mason-Ring
- 9105 Carry Me Back to Old Virginny—Vocal trio. Orch. accomp..... Knickerbocker Trio
- Darling Nellie Gray—Vocal trio. Orch. accomp. Knickerbocker Trio
- 4654 Onward, Christian Soldiers—Baritone. Orch. Royal Dadmun
- The Holy City (Adams)—Baritone. Orch. Royal Dadmun
- 9103 William Tell Overture (Rossini)—Part I "At Dawn"..... His Majesty's Scots Guards Band
- William Tell Overture (Rossini)—Part II "The Storm"..... His Majesty's Scots Guards Band
- 9104 William Tell Overture (Rossini)—Part III "The Calm"..... His Majesty's Scots Guards Band
- William Tell Overture (Rossini)—Part IV "Finale"..... His Majesty's Scots Guards Band
- 4652 Feather Your Nest (Kendis-Brockman-Johnson)—Tenor. Orch. accomp..... Billy De Rex
- Nobody to Love (Kahn-Mehlinger-Meyers)—Tenor. Orch. accomp..... Billy Jones

PARAMOUNT RECORDS

- INSTRUMENTAL
- 50038 American Aviation March... Creator and His Band
- Stars and Stripes March... Creator and His Band
- 33073 Oh, That We Two Were Maying—Violin, 'cello and piano..... Hackel-Berge Trio
- The Old Refrain—Violin, 'cello and piano, Hackel-Berge Trio
- DANCE SELECTIONS
- 20037 Margie—Fox-trot..... Frisco Syncopaters
- Twelfth Street Rag—Fox-trot..... Palace Trio
- 20039 Rose—Fox-trot..... Palace Trio
- Old Pal, Why Don't You Answer Me?—Waltz, Frisco Syncopaters
- 20041 Hula Blues—Fox-trot..... Vernon Trio
- Beautiful Faces—Medley fox-trot; intro. Rock-a-bye Lullaby Mammy..... Frisco Syncopaters
- VOCAL SELECTIONS
- 33074 Roll On, Silver Moon—Yodel song, with orch. accomp..... Frank Camplain
- Sleep, Baby, Sleep—Yodel song, with orch. accomp. Frank Camplain
- 33075 The Low-Back'd Car—Tenor solo, orch. accomp., John Burke
- Molly Brannigan—Tenor solo, orch. accomp., John Burke
- 20040 My Home Town Is a One-Horse Town—Soprano solo, orch. accomp..... Aileen Stanley
- Broadway Rose—Tenor solo, orch. accomp., Charles Harrison

CARDINAL PHONOGRAPH CO.

- FIRST RELEASE
- 2001 Palestine—Comedy Song. Orch. accomp., Fred Whitehouse
- She Gives Them All the Ha! Ha!—Comedy Song. Orch. accomp. Fred Whitehouse, assisted by Lew Brown
- 2002 Broadway Rose—Tenor solo. Orch. accomp., Charles Hart
- I've Got the Blues for My Old Kentucky Home—Ballad. Orch. accomp..... Helen Bell Rush

- 2003 My Home Town Is a One-Horse Town—Comedy quartet. Orch. accomp..... The Harmonizers
- Don't Take Away Those Blues—Tenor solo. Orch. accomp..... Ernest Hare
- 2004 Down the Trail to Home, Sweet Home—Duet. Orch. accomp..... Hart-Shaw
- I'd Love to Fall Asleep and Wake Up in My Mammy's Arms—Tenor solo. Orch. accomp., Charles Hart
- 2005 Margie—Harmony Trio. Orch. accomp., The Crescent Trio
- Old Pal, Why Don't You Answer Me?—Baritone solo. Orch. accomp..... Elliot Shaw
- 2006 Onward, Christian Soldiers—Sacred hymn. Orch. accomp..... Gotham Quartet
- Nearer, My God, to Thee—Sacred hymn. Orch. Accomp..... Gotham Quartet
- 2007 Japanese Sandman—Fox-trot, Raderman's Dance Orchestra
- Whispering—Fox-trot... Raderman's Dance Orchestra
- 2008 Grieving for You—Fox-trot, Ben Selvin's Dance Orchestra
- Feather Your Nest—Fox-trot, Ben Selvin's Dance Orchestra
- 2009 Caresses—Fox-trot..... Greene's Novelty Orchestra
- Hop, Skip and Jump—Fox-trot, Greene's Novelty Orchestra
- 2010 Souvenir—Violin solo. Piano accomp., Vera Barstow
- Berceuse—Violin solo. Piano accomp., Vera Barstow
- 2011 Sunny South—Medley..... Cardinal Concert Band
- Blue Danube—Waltz..... Cardinal Concert Band
- 2012 Aloha Oe—Instrumental duet..... Ferera-Franchini
- Honolulu Waltz—Instrumental duet..... Ferera-Franchini

EMERSON PHONOGRAPH CO.

- DANCE HITS
- 10295 Feather Your Nest (Kendis-Brockman-Johnson)—Fox-trot..... Plantation Dance Orchestra
- Margie (Conrad-Robinson)—Fox-trot, Plantation Dance Orchestra
- 10303 Grieving For You (Gibson-Ribaud-Gold)—Fox-trot..... Joseph Samuels' Music Masters
- Just We Two (Walter Scanlan)—Waltz, Green Bros.' Novelty Band
- 10304 Caresses (James V. Monaco)—Fox-trot, Lanin's Roseland Orchestra
- Nightingale (Vincent Rose)—Fox-trot, Lanin's Roseland Orchestra
- 10293 June, I Love No One But You (Hickman-Black)—Fox-trot..... Orlando's Society Orchestra
- Some One Cares (Geo. J. Bennett)—Fox-trot, Orlando's Society Orchestra
- 10294 Just Snap Your Fingers at Care—Medley. Intro.: "Love Flowers" (Louis Silvers)—Fox-trot, Joseph Knecht's Waldorf-Astoria Dance Orchestra
- Bring Back My Love Dreams (Jacques Grandie)—Fox-trot..... Sherbo's Mont Martre Orchestra
- 10298 Rose of My Heart (Neil Moret)—Fox-trot, Joseph Samuels' Music Masters
- My Little Bimbo Down on the Bamboo Isle—Medley. Intro.: "I Love the Land of Old Black Joe" and "I Wish That I'd Been Born in Borneo" (Grant Clarke-Walter Donaldson)—One-step..... Plantation Dance Orchestra
- 10305 Show Me How (Creamer-Layton)—Fox-trot, Selvin's Novelty Orchestra
- Sweet Cuban Love (Perry-Coots)—Fox-trot, Sanford's Famous Dance Orchestra
- 10306 Bidly (J. S. Zamecnik)—One-step, Merry Melody Men
- Zula Boola (Motzan-Gillen)—Fox-trot, Plantation Dance Orchestra
- 10307 Midnight (Sherwood-Banta-Vandersloot)—Fox-trot..... Merry Melody Men
- Hop, Skip and Jump (Hal Dyson)—Fox-trot, Saxe Holtsworth Harmony Hounds
- 10308 In the Dusk (Frank H. Grey)—Fox-trot, Sherbo's Mont Martre Orchestra
- Korinthia (J. C. Knight)—One-step, Joseph Knecht's Waldorf-Astoria Dance Orchestra
- 10309 I Want to Be Somebody's Baby (Smalley-Greer)—Fox-trot..... Palace Trio (Wiedoeft-Perry-Akst)
- That Cat Step (Breau-Henderson)—New novelty dance..... Sanford's Famous Dance Orchestra
- SONG HITS
- 10301 Margie (Davis-Robinson-Conrad)—Novelty song. Orch. accomp..... Eddie Cantor
- I Wish That I'd Been Born in Borneo (Clarke-Donaldson)—Comedy song. Orch. accomp. Eddie Cantor

(Continued on page 184)



THIS SALESMAN

WILL DISPLAY SUGGEST REMIND SELL FOR YOU

Dulciphone Needles

"The Highest Quality Needle in America"

MADE SCIENTIFICALLY OF THE HIGHEST GRADE CARBON STEEL. GUARANTEED TO PLAY THE LONGEST RECORD WITHOUT VARIATION AND WITH PUREST REPRODUCTION

DEALERS' PRICE 6 1/2c Per Package | Your Initial Order for 100 Packages Free Brings the Handsome Display Case

Jobbers and Sales Agents write for our proposition to you

GRAND TALKING MACHINE CO., Inc.

268-270 Flatbush Ave. Extension Brooklyn, N. Y.

YOUR ORDER BLANK—ACT NOW

Gentlemen: Enclosed find Check Money Order for \$6.50 for my order of 100 packages of Dulciphone Needles. (Case FREE with order of 100 packages or more.) Name Address City

Manufacturers of

Dulciphone Phonographs Dulciphone Needles

Distributors of

QRS Player Rolls Rishell Phonographs

ADVANCE RECORD BULLETINS FOR FEBRUARY—(Continued from page 183)

- 10292 Palestena (Conrad-Robinson). Comedy Song, Orch. accomp.Eddie Cantor
She Gives Them All the Ha! Ha! Ha! (Brown-Von Tilzer). Comedy Song, Orch. accomp.,
Eddie Cantor
- 10302 Broadway Rose (West-Fried-Spencer). Tenor solo, Orch. accomp.Irving Kaufman
Look! What You've Done With Your Dog-Gone Dangerous Eyes (Kalmar-Ruby). Character song, Orch. accomp.Arthur Fields
- 10299 On Sweetheart Shore, from musical production, "Hearts of Erin" (Scanlan-Bergh). Tenor solo, Orch. accomp.Walter Scanlan
Nora, from musical production, "Hearts of Erin" (Walter Scanlan). Tenor solo, Orch. accomp.,
Walter Scanlan
- 10300 Whispering (Halvin-John Schonberger). Tenor solo, Orch. accomp.Sam Ash
Hold Me (Art Hickman-Ben Black). Tenor solo, Orch. accomp.Irving Kaufman
- 10296 Broadway Blues (Swanstrom-Morgan). "Blues" character song, piano accomp.Sissle-Blake
The Saint Louis Blues (W. C. Handy). "Blues" character song, Orch. accomp.Al. Bernard
- 10297 Old Pal, Why Don't You Answer Me? (Lewis-Young-Jerome). Tenor solo, Orch. accomp.,
Eugene Spencer
Like We Used to Be (Robinson-Kortlander). Tenor and baritone duet, Orch. accomp.,
Charles Hart-Elliott Shaw
- 10310 Oh Gee! Say Gee! You Ought to See My Gee Gee from the Fiji Isle (Brown-Von Tilzer). Novelty song, Orch. accomp.Arthur Fields
All She'd Say Was Umh-Hum (Zany-Emery-Van-Schenck). Comedy song, Orch. accomp.,
Irving and Jack Kaufman
- 10311 When You're Gone I Won't Forget (Reid-De-Rose). Male quartet, Orch. accomp. Shannon Four
As We Live and Love We Learn (Robinson-Kortlander). Tenor solo, Orch. accomp.,
Irving Kaufman

STANDARD AND OPERATIC SELECTIONS

- 10312 Safe in the Arms of Jesus (Doane-Crosby). Tenor and baritone duet, Orch. accomp.,
John Young and Fred Wheeler
Softly Now the Light of Day (Gottschalk). Tenor and baritone duet, Orch. accomp.,
John Young and Fred Wheeler
- 10313 Honolulu March. Hawaiian guitars,
Ferera and Franchini
Isle of Paradise (Pflorito-Earl). Hawaiian guitars and xylophone.Hawaiian Trio
(Ferera-Franchini-Green)
- 10314 Largo (Handel). Violin solo, saxophone obbligato, piano accomp.Maximilian Rose
Minuet in G (Beethoven). Violin solo, piano accomp.Maximilian Rose
- 10230 Evocation, from "Robert Le Diable" (Meyerbeer). Bass solo in French, Orch. accomp.,
Enzo Bozano
Lakme, On Doux Regard Se Voile, from "Lakme" (Leo Delibes). Bass solo in French, Orch. accomp.Enzo Bozano

LYRIC RECORDS

DANCE RECORDS

- 4237 Why Don't You (from "Afgar")—Fox-trot, Selvin's Novelty Orchestra
Marimba—Fox-trot. Waldorf-Astoria Dance Orchestra
- 4238 I Never Knew—Fox-trot. Selvin's Novelty Orchestra
Now and Then—Fox-trot. Selvin's Novelty Orchestra
- 4239 Hop, Skip and Jump—Fox-trot, Green Bros. Novelty Orchestra
Alabama Moon—Waltz,
Green Bros. Novelty Orchestra
- 4240 My Mammy—Fox-trot. Selvin's Novelty Orchestra
Rose—Fox-trot. Rudy Wiedoeft's Palace Trio
- 4241 Honey Dew—Fox-trot,
Jos. Knecht's Waldorf-Astoria Dance Orchestra
Lotus Flower—Waltz,
Jos. Knecht's Waldorf-Astoria Dance Orchestra

- 4242 Bright Eyes—Fox-trot,
Harry Raderman's Jazz Orchestra
Show Me How—Fox-trot,
Rudy Wiedoeft's Palace Trio

POPULAR SONG HITS

- 5232 Old Pal, Why Don't You Answer Me (Baritone, Orch. accomp.),
Ernest Hare with Saxophone Solo by Rudy Wiedoeft
It's All Over Now (Soprano)....Helen Bell Rush
- 5233 My Home Town Is a One Horse Town (Male Quartet, Orch. accomp.)....The Harmonizers
She Gives Them All the Ha, Ha, Ha (Tenor, with Orch.),
Fred Whitehouse, assisted by Lew Brown
- 5234 Blue JeansCharles Harrison
Country Kerry Mary.....Charles Harrison
- 5235 Get Up!Ernest Hare
Oh! Gee! Say! Gee!.....Fred Whitehouse

STANDARD SONGS AND HYMNS

- 6215 Come Where My Love Lies Dreaming (Tenor solo with String Orchestra)....Reed Miller
Auld Lang Syne.....Stellar Quartet
- 5904 Onward, Christian Soldiers (Male Quartet, with Orchestra)....Lyric Male Quartet
Nearer, My God, to Thee (Male Quartet, with Orchestra)Lyric Male Quartet

POPULAR INSTRUMENTALS

- 4705 Isle of Paradise.....Ferera and Franchini
Wailana WaltzFerera and Franchini
- 4807 Light Cavalry Overture.....Lyric Military Band
On to Victory (Philip Egner).....Lyric Military Band

OKEH RECORDS

- 4148 I'm Waiting for Ships That Never Come In. Baritone, orch. accomp.Elliott Shaw
I'm on My Way. Vocal quartette, orch. accomp.,
Shannon Four
- 4215 Old Pal Why Don't You Answer Me? Tenor, orch. accomp.Sam Ash
I'm in Heaven When I'm in My Mother's Arms. Tenor, orch. accomp.Lewis James
- 4221 What Cha Gonna Do When There Ain't No Jazz. Singing comedienne with Rega, Orch.,
Aileen Stanley
Look What You've Done With Your Dog-gone Dangerous Eyes. Singing comedienne with Rega, Orch.Aileen Stanley
- 4222 All She'd Say Was "Umh Hum." Tenor, orch. accomp.Billy Jones-Ed. Smalle
Palestena. Tenor, orch. accomp.Billy Jones
- 4223 Beautiful Annabell Lee. Tenor-baritone, orch. accomp.Hart-Shaw.
There's a Vacant Chair at Home Sweet Home. Tenor-baritone duet with orch.James-Shaw
- 4224 I Want to Know Where Tosti Went (When He Said "Good-Bye") (From "Broadway Brevities of 1920"). Baritone with orch.Ernest Hare
My Home Town Is a One Horse Town. Tenor duet with orch.Billy Jones-Ed. Smalle

HAWAIIAN SELECTIONS

- 4225 On Hilo Bay. Hawaiian guitar duet,
Ferera-Franchini
On the Beach at Waikiki. Hawaiian guitar duetFerera-Franchini

DANCE AND INSTRUMENTAL

- 4210 Darling (Intro. "Come to the Moon"). Medley, fox-trot.Harry Raderman's Jazz Orchestra
Just Snap Your Fingers at Care (From "Greenwich Village Follies of 1920"). Fox-trot,
Lanin's Roseland Orchestra
- 4211 Margie. Fox-trotRega Dance Orchestra
Coral Sea. Fox-trot.Rudy Wiedoeft's Palace Trio
- 4212 Grieving for You. Fox-trot,
Lanin's Roseland Orchestra
Sweet Cuban Love. Fox-trot,
Harry Raderman's Jazz Orchestra

- 4213 I'm a Lonesome Little Rain Drop (From "Greenwich Village Follies of 1920"). Fox-trot.Joseph Samuels' Jazz Band
I'll Buy the Blarney Castle. One-step,
Green Brothers' Novelty Band
- 4214 I Want to Go to the Land Where the Sweet Daddies Grow (Intro. "All the Boys Love Mary"). One-step.Rudy Wiedoeft's Palace Trio
Peacock Walk. Fox-trot,
Harry Raderman's Jazz Orchestra
- 4216 Why Did You Leave Me? Fox-trot,
Joseph Knecht's Waldorf-Astoria Dance Orchestra
Toreadora. Fox-trot. Harry Raderman's Jazz Orchestra
- 4217 If a Wish Could Make It So (Intro. "We've Got Something") (From Musical Play, "Tickle Me"). Fox-trot,
Joseph Knecht's Waldorf-Astoria Dance Orchestra
The Wedding Blues" (From Musical Comedy, "Pitter Patter"). Fox-trot,
Lanin's Roseland Orchestra
- 4218 Hop, Skip and Jump (with incidental saxophone by Nathan Glantz). Fox-trot,
Rega Dance Orchestra
For Every Boy Who's on the Level (Intro. "Good-bye, When I Say Good-bye to You"). One-step.Harry Raderman's Jazz Orchestra
- 4219 In My Sweet Little Alice Blue Gown. (Intro. Chorus of "To Be Worthy") (From Musical Comedy, "Irene"). Waltz,
Joseph Knecht's Waldorf-Astoria Dance Orchestra
Pretty Miss Virginia. Waltz. The All-American Five
- 4220 Zowie. Fox-trot.Joseph Samuels' Jazz Band
Amorita. Fox-trot.Green Brothers' Novelty Band
- 4227 Sleepy Hollow (Where I First Met You). WaltzOkeh Marimba Band
The Hula Blues. Fox-trot.Okeh Marimba Band
- 4226 Colonel Bogey March.Conway's Band
Battleship Connecticut March.Conway's Band

ARTO RECORDS

DANCE RECORDS

- 9036 Beautiful Faces Need Beautiful Clothes. Intro.: "Rock-a-bye Lullaby Mammy." Medley Fox-trotErnie Cutting's Melodists
Rose. Fox-trot.Ernie Cutting's Melodists
- 9037 You Oughta See My Baby. Fox-trot. Chorus: sung by Jack Landauer.ARTo Dance Orchestra
Just Snap Your Finger at Care, From "Greenwich Village Follies of 1920." Intro.: "Love Flower." Medley Fox-trot,
Selvin's Novelty Orchestra
- 9038 I Never Knew I Could Love Anybody Like I'm Loving You. Fox-trot. Chorus sung by Bob MillerSociety Symphonic Orchestra
Why Don't You? From "Afgar." Intro.: "Feather Your Nest." Medley Fox-trot,
Selvin's Novelty Orchestra
- 9041 Left All Alone Again Blues. From "The Night Boat." Fox-trot,
Joseph Samuel's Dance Orchestra
Bo-La-Bo. Egyptian Fox-trot,
Raderman's Dance Orchestra
- 9042 Whose Baby Are You? From "The Night Boat." One-stepBilly Murray's Melody Men
Dardanella. Fox-trot.Rudy Wiedoeft's Trio

VOCAL RECORDS

- 9039 Ob Gee! Say Gee! You Ought to See My Gee GeeBilly Jones
Rosie, Make It Rosy for Me.Billy Jones
- 9040 My MammyErnest Hare
Bright EyesArthur Hall
- 9043 Matrimonial Difficulties. Darkey comedy conversationBilly Golden-Billy Hughes
I Want a Jazzy Kiss.Arthur Collins-Byron Harlan
Down Barcelona Way.Arthur Collins-Byron Harlan
Shades of Night.Sterling Trio
- 3053 Tell Me, Pretty Maiden. From "Florodora." ARTo Light Opera Singers
In the Shade of the Sheltering Palm. From "Florodora"Elliot Shaw

You Ought to Know

In case you are contemplating expanding the sphere of your business to include departments devoted to Pianos, Player-Pianos, Musical Merchandise or Sheet Music, that you'll find news and comments about them all in



ESTABLISHED 1876

The oldest and leading music trade weekly, which covers every branch of the industry

It Contains

Instructive and educational articles. Hints on salesmanship and advertising. Editorials that are timely and authoritative. Facts about the new things in the trade. Trade happenings in all parts of the United States

"Review the Music Trade With Us"

Send your \$2 now for a full year's subscription to

THE MUSIC TRADE REVIEW
373 FOURTH AVENUE
NEW YORK

Some Leading Jobbers of Talking Machines in America



TEST IT. 
 OUR VICTOR
Record Service
 has a reputation for efficiency.
 Suppose you try it.
E. F. DROOP & SONS CO.
 1300 G. STREET, WASHINGTON, D. C.
 231 N. HOWARD STREET, BALTIMORE, MD.

William Volker & Co., Kansas City, Mo.; Houston Tex., and Denver, Col.

DISTRIBUTORS
 Complete Pathephone and Pathe Record Stocks.
 The best proposition for the progressive dealer.

Sherman, Clay & Co.

 San Francisco, Los Angeles, Portland, Seattle, Spokane
 PACIFIC COAST DISTRIBUTORS OF
 VICTOR PRODUCTS

The PERRY B. WHITSIT CO.
 Distributors of
Victrolas and Victor Records
 COLUMBUS, OHIO



Where Dealers May Secure
COLUMBIA
 Product

Ready, Full Stocks, and Prompt Deliveries
 from Convenient Shipping Centers
 all over the United States.

Distributors

Atlanta, Ga., Columbia Graphophone Co., 63 N. Pryor St.
 Baltimore, Md., Columbia Graphophone Co., 16 South Howard St.
 Boston, Columbia Graphophone Co., 1000 Washington St.
 Buffalo, N. Y., Columbia Graphophone Co., 737 Main St.
 Burlingame, Cal., Columbia Graphophone Co., 1130 Balboa Ave.
 Chicago, Ill., Columbia Graphophone Co., 325 W. Jackson Blvd.
 Cincinnati, O., Columbia Graphophone Co., 317-321 East 8th Street.
 Cleveland, O., Columbia Graphophone Co., 1812 East 30th St.
 Dallas, Tex., Columbia Graphophone Co., 316 North Preston St.
 Denver, Colo., Columbia Stores Co., 1608 Glen-arm Ave.
 Detroit, Mich., Columbia Graphophone Co., 115 State St.
 Indianapolis, Ind., Columbia Graphophone Co., 209 W. Washington St.
 Kansas City, Mo., Columbia Graphophone Co., 2006 Wyandotte St.
 Los Angeles, Cal., Columbia Graphophone Co., 809 S. Los Angeles St.
 Minneapolis, Minn., Columbia Graphophone Co., 18 N. 3rd St.
 New Haven, Conn., Columbia Graphophone Co., 206 Meadow St.
 New Orleans, La., Columbia Graphophone Co., 517-525 Canal St.
 New York City, Columbia Graphophone Co., 121 West 20th St.
 Omaha, Neb., Columbia Graphophone Co., Elgth and Jackson Sts.
 Philadelphia, Pa., Columbia Graphophone Co., 40 N. 6th St.
 Pittsburgh, Columbia Graphophone Co., 632-640 Duquesne Way.
 Salt Lake City, Utah, Columbia Stores Co., 221 South West Temple.
 Seattle, Wash., Columbia Graphophone Co., 911 Western Ave.
 Spokane, Wash., Columbia Stores Co., 161 South Post St.
 St. Louis, Mo., Columbia Graphophone Co., 1127 Pine St.
 Tampa, Fla., Tampa Hardware Co.

Headquarters for Canada:
 Columbia Graphophone Co., 54-56 Wellington St., West, Toronto, Ont.

Executive Office
COLUMBIA GRAPHOPHONE CO.
 Woolworth Building New York

W. J. DYER & BRO.
 DYER B'LD'G, ST. PAUL, MINN.
 NORTHWESTERN DISTRIBUTORS
 OF THE
VICTOR
 Machines, Records and Supplies
 Shipped Promptly to all
 Points in the Northwest

Mickel Bros. Co.
 Omaha, Nebraska
 Des Moines, Iowa
Victor Distributors

Wholesale Exclusively
EASTERN TALKING MACHINE CO.
 85 Essex Street, Boston
VICTOR DISTRIBUTORS

Every talking machine jobber in this country should be represented in this department, no matter what kind he handles or where he is located. The cost is slight and the advantage is great.

ARTICLES OF INTEREST IN THIS ISSUE OF THE WORLD

Ready Reference for Salesmen, Dealers and Department Heads

Time for Courage, Confidence and Action..	3	The Selection of Salesmen.....	31
Intelligent Handling of Record Sales.....	3	The Importance of Profit Protection to the Dealer	37
Eight Practical Ideas That Help to Make Sales	4	How Advertising Stimulates Demand.....	42
A New Page in Trade History.....	8	Ten Commandments of Salesmanship.....	46
The Union of Music and Education.....	8	Concentrating the Public Mind on High-Class Record Sales	48
A Time for Reason, Not Exaggeration...	9	The Value of the Talking Machine.....	49
The Unwisdom of Bargain Advertising....	9	To Defend Industry Against Unfair Taxation	50
Real Sales People Now Necessary in the Success of the Talking Machine Business.10-11		The Successful Promotion of Record Sales by Mail	56
How to Get the Best Results From Business Letters	15	Window Dressing One of the Fundamental Arts of Retail Merchandising.....	58-59
Suggestions of Value on the Granting of Credits	16	Musical Possibilities of the Talking Machine	73
How to Create Advertisements That Bring Results	18	Business Conditions Reviewed.....	75
The Big Buying Power of the Public.....	18	Importance of Prices, Not Terms, To-day..	98
New Tax Legislation and the Music Trade..	19	Why a Lower Tariff on Mica.....	118
Methods of Increasing Sales Service Efficiency Described	21	Conditions in Mid-West Reviewed.....	128-129
Value of Simplicity in Window Display....	25	A Time for Aggressive Salesmanship...143-144	
Success of Women in Music Stores.....	25	Country's Business Now Faces Showdown Period	147
How Best to Protect Musical Instrument Designs by Patents.....	26	A Question of Suitable Music for Films... 151	
Bringing Musical Appreciation to the Public Schools	29	Robert Gordon's Page Devoted to Retail Selling	159

A C B Z A C D F H K L N P Q S U V X Y B D F G I J L N P Q S U V X Y Z C E F H J K W O P R T A C E M O N
 G E F Y
 H J K W
 M O N
 P Q R
 S R P O M K V H F E C V B C E F H J K W O P R T U N Y L B D E G I J M J O Q S T V M Y V B D
INDEX TO ADVERTISERS

A		H		R	
Acme Die Casting Corp.	61	Handy Mfg. Co.	142	Phonograph Appliance Co.	165
Acme Engineering & Mfg. Co.	140	Harponola Co.	19	Phonograph Specialties Mfg. Co.	148
Aeolian Co., New York	85	Hessig-Ellis Drug Co.	39	Phonomotor Co., The	169
Alto Mfg. Co.	144	Hillman & Son Phonograph Co.	39	Piknik Portable Phonograph, Inc.	147
American Mica Works	40	Hoffay Phono. Co.	168	Plywood Corp.	65
American Odeon Corp.	31	Horton-Gallo-Creamer Co.	101	Putnam-Page Co.	61
American Talking Machine Co., Inc. (Bloomsburg)	113	Hough, J. E., Ltd.	179	S	
American Walnut Mfrs. Ass'n.	10	Hough, L. W.	101	Schroeder Piano Co.	111
Andrews, W. D. & C. N.	114	Howe & Co., C. W.	58	Seaburg Mfg. Co.	33
Armstrong Furn. Co.	76	I		Selle & Co., H. W.	137
Artistic Cabinet & Woodworking Co.	145	Ilsley, Doubleday & Co.	84	Serenado Mfg. Co.	28
Arto Co., The	150	Indiana Phono. & Supply Co.	161	Shapiro, Bernstein Co.	152
Associated Phonograph Supply Co.	62	International Mica Co.	67	Shattuck Fibre Furn. Co.	105
B		J		Sherman, Clay & Co.	185
B & H Fibre Co.	87	Jewel Phonoparts Co.	41	Smith Drug Co., C. D.	39
Badger Talking Machine Co.	88	Jewett Phono. Co.	97	Smith, Kline & French Co.	39
Bagshaw Co., W. H.	100	Jones-Motrola, Inc.	158	Smith Laboratories, H. J.	126
Bahr, W.	170	K		Smith-Schiffin Co.	67
Barnhardt Bros. & Spindler	90	Keen Talk. Mach. Supply Co.	167	Sonora Co. of Philadelphia	111
Beecroft, Clement	79	Kennedy-Green Co.	156	Sonora Distr. Co. of Texas	39
Bell Hood Needle Co.	66	Kent Co., F. C.	107	Sonora Phonograph Co., Inc.	95
Blackman Talking Machine Co.	121	Keystone Die Casting Co.	110	Inside Front Cover, 38, 39, 55, 95	
Blood & Kloer	143	Keystone Minerals Co.	62	Soss Mfg. Co.	86
Boenning, Garrison & Co.	173	Keystone Printed Specialties Co.	78	Southern Drug Co.	39
Brandts Furn. Co.	114	Kiefer-Stewart Co.	39	Southern Sonora Co.	39
Brilliantone Steel Needle Co.	14	Kirkman Engineering Corp.	25	Southwestern Drug Co.	39
Brooks Mfg. Co., The	82	Knickerbocker T. M. Co.	21	Sphinx Gramophone Motors	82
Bruno & Son, Inc.	51, 105, 116, 117, 118, 148, 160	Knight-Campbell Music Co.	84	Standard Music Roll Co.	150
Brunswick-Balke-Collender Co.	18	Kraft, Bates & Spencer, Inc.	103	Standard Talking Machine Co.	185
Buegeleisen & Jacobson	42	L		Starek & Cowan	153
Buehn Co., Louis	109	Lakeside Supply Co., Inc.	140	Starr Piano Co.	22
C		Lansing Co.	102	Stead & Co., J.	177, 178
Cabinet & Accessories Co.	48	Lee-Coit-Andresen Hdwe. Co.	39	Steel, W. R.	177
Cardinal Phono. Co.	36	Lesley's	181	Steger & Sons Piano Mfg. Co.	77
Celina Spec. Co.	160	Long Cabinet Co., Geo.	124	Steinert & Sons Co., M.	99
Cheney Talking Machine Co.	123	Lorentzen, H. K.	50	Stephenson, Inc.	162
Chicago Talking Machine Co.	34	Lucky 13 Phonograph Co.	60	Sterling Devices Co., The	138
Classified Want Ads	174, 175	Lundstrom Mfg. Co., C. J.	89	Sterno Manufacturing Co.	172
Columbia Graphophone Co.	12, 13, 16, 23, 33, 42, 53, 62, 70, 91, 107, 126, 146, 157	Lyon & Healy	132	Steuer Reproducer Co., Inc.	91
Consolidated Talking Machine Co.	135	Lyons, W. H.	139	Stewart T. M. Co.	56, 92
Co-operative Mfg. Co., The	139	Lyrphone Co. of America	54	Strevell-Patterson Hardware Co.	39
Cressey & Allen	101	M		Superior Die Casting Co.	55
D		Magnavox Co.	44	T	
Ditson Co., Oliver	37	Magnola Talking Machine Co.	34, 79, 133, 145, 175	Talking Machine World Dealer Service	93
Doctorow, D. R.	43	Mandel Mfg. Co.	130	Thomas & Proetz Lumber Co.	53
Dodin, Andrew H.	181	Manophone Corp., The	83	Toledo Talking Machine Co.	88
Doehler Die-Casting Co.	65	Marshall Co., Inc., C. L.	39	U	
Droop & Sons Co., E. F.	185	Matthews, F. W.	165	Udell Works	127
Drying Systems, Inc.	139	Mellor's	23	Unit Construction Co.	96
Duo-Tone Co.	26	Mellowtone Needle Co.	46	United Mfrs. & Dist. Co.	134
Dyer & Co., W. J.	185	Mercantile Finance Co.	76	Universal Fixture Corp.	154, 155
E		Mermod & Co.	175	Universal Stamping & Mfg. Co.	136
Eagle Wood Turning Co.	144	Meyercrood Co.	135	U-Sav-Your Mfg. Co.	161
Eastern Phono. Corp.	166, 170	Michigan Phono. Co.	120	Usoskin Litho	160
Eastern Sales & Export Office	86	Mickel Bros. Co.	185	V	
Eastern Talking Machine Co.	99, 185	Minneapolis Drug Co.	39	Val Accessory House	86
Eclipse Musical Co.	15	Modernola Co.	63	Van Houten, C. J., & Zoon	39
Edison, Inc., Thos.	Back Cover, 52, 106, 164	Montagnes, I., & Co.	39	Van Veen & Co.	118
Eight Famous Victor Artists	18	Morris Co., J. O.	24	Viconia Mfg. Co., Inc.	16
Einson Litho, Inc.	98	M. S. & E.	39	Victor Talking Machine Co.	Front Cover, 5, 7
Elyea T. M. Co.	125	Multiplex Display Fixture Co.	74	Vitanola Distributors Co.	29
Emerson Phonograph Co.	122	Munn & Co.	181	Volker & Co.	185
Empire Phono. Parts Co.	43	Musical Sales Corp.	127	W	
Everybody's Talking Machine Co.	113, 168	Music Trade Review	184	Wabash Cabinet Co., The	45
F		Mutual Phono. Parts Mfg. Co.	171	Wade Co., R. C.	57
Faultless Caster Co.	56	N		Wade & Wade	131
Favorite Mfg. Co.	174	National Cash Register Co.	11	Wade Talking Machine Co.	137
Federal Electric Co.	34	National Decalcomania Co.	110	Wade, W. H.	115
Feist, Leo	59, 78, 98, 115, 153, 166	National Publishing Co.	6	Walshall Music Co.	39
Ferro Phono. Parts Co.	144	Netschert, Frank	167	Ward Co., C. E.	81
Fletcher All Tones Needle Co.	75	New England Talking Machine Co.	102	Wax & Novelty Co., The	165
Fletcher-Wickes Co.	73	New York Album & Card Co.	4	Weber-Knapp Co.	50
Flexlume Sign Co.	49	New York Talking Machine Co.	34	Weymann & Son, H. A.	110
Forster Music Publisher, Inc.	150	Nye, William F.	61	Whitsit Co., Perry B.	185
Fox Pub. Co., Sam.	151	O		Widdicomb Furniture Co.	17
Fulton Talking Machine Co.	167	Ogden Sectional Cabinet Co., Inc.	71, 94	Wimpfheimer & Bro., A.	59
G		Ohio Sales Co.	39	Y	
General Phonograph Corp.	Inserts following pages 26, 50, 66, 98	Operaphone Co., Inc.	163	Yahr & Lange Drug Co.	39
General Phonograph Mfg. Co.	35, 64	Ormes, Inc.	9	Yeuell Co., E. V.	113
General Sales Corp.	72	Oro-Tone Co.	141	Z	
Gibson-Snow Co.	39	P		Zega Mfg. Co., A. F., The	157
Globe Decalcomanie Co.	107	Paramount Talking Machine Co.	Inside Back Cover		
Glynn, W. B., Distributing Co.	39	Parks & Parks	25		
Gramophone Co., Ltd.	176	Pathé Frères Phonograph Co.	68, 69		
Granby Phono. Corp.	32	Peabody & Co., Henry W.	80		
Grand Rapids Brass Co.	51	Pearsall Co., Silas E.	92		
Grand Talking Machine Co.	183	Peckham Mfg. Co.	43		
Gray Co., Walter S.	65	Peerless Album Co.	6		
Gray & Dudley Co.	70	Penn Phonograph Co.	112		
Gretsch Mfg. Co., Fred.	149	Philadelphia Show Case Co.	108		
Grey Gull Records	104	Phillips, Wm., Phono. Parts Co.	146		
Griffith Piano Co.	39				



Console CI
Queen Anne Design

Looking Ahead

Now that the Christmas rush is over and you have more time to plan and think, why not outline a definite policy—a store campaign of action—for 1921?

Talk prosperity. Make your store look cheerful. Go after business with renewed energy and decide to make your store a center of business activity.

First of all, of course, you must believe in the merchandise you handle. Then you can put enthusiasm behind it.

Paramount dealers are able to do this. They know the "merit of their wares." They know the Paramount line is a substantial business building line, supported by close, whole-hearted co-operation from the Paramount organization.

Let us tell you in a more detailed way about the Paramount line and our plan of dealer co-operation for 1921. Write us, or the jobber in your territory, today.

Paramount Records for February

THE PARAMOUNT CO.,
PORT WASHINGTON, WIS.

- | | | |
|-------|-----------------------------------------------------------------------|----------------------|
| 50038 | { AMERICAN AVIATION MARCH | Creator and His Band |
| | { STARS AND STRIPES MARCH | Creator and His Band |
| 33073 | { OH THAT WE TWO WERE MAYING—Violin, Cello and Piano.. | Hackel-Berge Trio |
| | { THE OLD REFRAIN..... | Hackel-Berge Trio |
| 20037 | { MARGIE—Fox-trot | Frisko Syncopaters |
| | { TWELFTH STREET RAG—Fox-trot..... | Palace Trio |
| 20039 | { ROSE—Fox-trot | Palace Trio |
| | { OLD PAL, WHY DON'T YOU ANSWER ME?—Waltz..... | Frisko Syncopaters |
| 20041 | { HULA BLUES—Fox-trot | Vernon Trio |
| | { BEAUTIFUL FACES—Medley Fox-trot (Intro.: Rock-a-bye Lullaby Mammy), | Frisko Syncopaters |
| 33074 | { ROLL ON, SILVER MOON—Yodle Song, with Orch. Accomp.... | Frank Camplain |
| | { SLEEP, BABY, SLEEP—Yodle Song, with Orch. Accomp..... | Frank Camplain |
| 33075 | { THE LOW BACK'D CAR—Tenor Solo, Orch. Accomp..... | John Burke |
| | { MOLLY BRANNIGAN—Tenor Solo, Orch. Accomp..... | John Burke |
| 20040 | { MY HOME TOWN IS A ONE HORSE TOWN—Soprano Solo, Orch. Accomp., | Aileen Stanley |
| | { BROADWAY ROSE—Tenor Solo, Orch. Accomp..... | Chas. Harrison |



Style XXX

DISTRIBUTORS:

SHIPLEY-MASSINGHAM CO.,
Pittsburgh, Pa.,
For Western Penn. and West Virginia

JOERNS BRDS. MFG. CO.,
St. Paul, Minn.,
For Minn., So. Dak., No. Dak.,
East Montana

E. R. GODFREY & SONS CO.,
Milwaukee, Wis.,
For Iowa, Illinois, Michigan, Indiana
and Wisconsin

PETER-NEAT-RICHARDSON CO.,
Louisville, Ky.,
For Kentucky

BREWER & COMPANY,
Boston, Mass.,
For New England States

A. J. HARWI HDWE. CO.,
Atchison, Kans.,
For Kansas

OKLAHOMA PHONOGRAPH CO.,
Oklahoma City, Okla.,
For Oklahoma

PARAMOUNT DISTRIBUTORS, INC.,
Seattle, Wash.,
For Wash., No. Dregon, No. Idaho
and West Montana

RICHMOND HARWARE CO.,
Richmond, Va.,
For Virginia

WITTE HARDWARE CO.,
St. Louis, Mo.,
For Missouri

P. C. DOERR CO.,
New Orleans, La.,
For Mississippi and Louisiana

SOUTHERN PARAMOUNT CO.,
Atlanta, Ga.,
For Georgia, No. Carolina, So. Carolina
and Florida

PEOEN IRDN & STEEL CO.,
Houston, Texas,
For Texas

BRANDON & TURNER,
Little Rock, Ark.,
For Arkansas

H. O. TAYLDR CO.,
Buffalo, N. Y.,
For West New York

PARAMOUNT SALES CO.,
Denver, Colo.,
For Colorado, Wyoming, New Mexico,
Utah, Arizona, Eastern Nevada, South-
ern Idaho, Southern Montana

Paramount Phonographs *and* Records

Should the Government
increase the Excise Tax
on phonographs, we shall
be forced to *increase*
our prices.

THOMAS A. EDISON, Inc.

ORANGE, NEW JERSEY

**JOBBER OF THE NEW EDISON, EDISON RE-CREATIONS, THE NEW EDISON DIAMOND AMBEROLA
AND BLUE AMBEROL RECORDS**

CALIFORNIA
Los Angeles—Edison Phonographs,
Ltd.
San Francisco—Edison Phonographs,
Ltd.

COLORADO
Denver—Denver Dry Goods Co.

CONNECTICUT
New Haven—Pardee-Ellenberger
Co., Inc.

GEORGIA
Atlanta—Phonographs, Inc.

ILLINOIS
Chicago—The Phonograph Co.
Wm. H. Lyons (Amberola only).

INDIANA
Indianapolis—Kipp Phonograph Co.

IOWA
Des Moines—Harger & Blish.
Sioux City—Harger & Blish.

LOUISIANA
New Orleans—Diamond Music Co.,
Inc.

MASSACHUSETTS
Boston—Pardee-Ellenberger Co.
Iver Johnson Sporting Goods
Co. (Amberola only).

MICHIGAN
Detroit—Phonograph Co. of
Detroit

MINNESOTA
Minneapolis—Laurence H.
Lucker

MISSOURI
Kansas City—The Phonograph Co.
of Kansas City.
St. Louis—Silverstone Music
Co.

MONTANA
Helena—Montana Phonograph
Co.

NEBRASKA
Omaha—Shultz Bros.

NEW YORK
Albany—American Phonograph
Co.
New York—The Phonograph
Corp. of Manhattan.
Syracuse—Frank E. Bolway & Son,
Inc. W. D. Andrews Co.
(Amberola only).

OHIO
Cincinnati—The Phonograph Co.
Cleveland—The Phonograph Co.

OREGON
Portland—Edison Phonographs,
Ltd.

PENNSYLVANIA
Philadelphia—Girard Phono-
graph Co.
Pittsburgh—Buehn Phonograph
Co.
Williamsport—W. A. Myers.

RHODE ISLAND
Providence—J. A. Foster Co.
(Amberola only).

TEXAS
Dallas—Texas-Oklahoma Phono-
graph Co.

UTAH
Ogden—Prondfit Sporting Goods
Co.

VIRGINIA
Richmond—The C. B. Haynes
Co., Inc.

WISCONSIN
Milwaukee—The Phonograph Co.
of Milwaukee.

CANADA
Montreal—R. S. Williams &
Sons Co., Ltd.
St. John—W. H. Thorne & Co.,
Ltd.
Toronto—R. S. Williams & Sons
Co., Ltd.
Vancouver—Kent Piano Co., Ltd.
Winnipeg—R. S. Williams & Sons
Co., Ltd.
Babson Bros. (Amberola only).
Calgary—R. S. Williams & Sons
Co., Ltd.

The TALKING MACHINE WORLD

For the
makers &
sellers of
talking
machines

Published Each Month by Edward Lyman Bill, Inc., at 373 Fourth Ave., New York, February 15, 1921



The best-known trade-mark in the world
designating the products of the Victor Talking Machine Co.

Supreme in Tone and Design

DEALERS who handle the Sonora today know why it has such a hold on the public. Sonora is extensively and forcefully advertised, but this isn't the real secret of its success. What then is? *Clear, obvious, undeniable superiority!* Sonora has always been first to introduce important improvements.

The Sonora is unique in having won the highest score for tone at a great international exposition against all competitors. It was the first phonograph to play ALL MAKES of disc records without extra attachments and *doesn't limit the owner to the products of one maker.*

Sonora has more important features than any other phonograph. Some of these are:

Extra-long-running, powerful, silent *motor.*

Tone control at the sound source, the correct place.



Minuet

Sonora was the first phonograph to have an *all wood* sound amplifier.

Magnificent *design* and cabinetry.

Effective, simple *automatic stop.*

Convenient *envelope filing system.*

Motor meter which tells how many more records can be played without rewinding.

ALL BRASS tone arm to secure the finest tone, instead of a cheap zinc-lead-tin casting.

Cabinet panels of *wood 3/4" thick* instead of 3/8" like many other makes.

Remember — Sonora is licensed and operates under BASIC PATENTS of the phonograph industry and Sonora dealers are not troubled by patent litigation.

For particulars regarding an agency write today.

SONORA PHONOGRAPH COMPANY, INC.

George E. Brightson, *President*

NEW YORK : 279 BROADWAY

Canadian Distributors: I. Montagnes & Co., Toronto

The Highest Class Talking Machine in the World

THE INSTRUMENT OF QUALITY

Sonora

CLEAR AS A BELL



The Talking Machine World

Vol. 17. No. 2

New York, February 15, 1921

Price Twenty-five Cents

C. N. ANDREWS NOW SOLE OWNER OF BUFFALO BUSINESS

Buys Interest of His Brother in This Well-known Victor Distributing Institution—Plans Better Service for Talking Machine Trade of Northern New York Where Possible

BUFFALO, N. Y., February 4.—On February 1 Curtis N. Andrews, of W. D. & C. N. Andrews, announced to the trade that he had bought over the business from the senior partner, W. D. Andrews, and also announced that the firm would be known in future as Curtis N. Andrews. Although a change in the name has taken place, Curtis N. Andrews assures the trade generally that the same co-operation and service will be extended as formerly, only in a greatly increased way.



C. N. Andrews

The firm of Curtis N. Andrews had its birth under the name of W. D. Andrews, in 1906, when it was located at Seneca and Wells streets. W. D. Andrews, who before that time had established the corporation of W. D. Andrews Co. in Syracuse, saw the great possibility of a Victor wholesale enterprise in Buffalo. C. N. Andrews became connected with the firm at the time of its inception in Buffalo.

In 1909 the firm moved to 632 Main street,

where it occupied much larger space and was doing both a retail and wholesale business. A few years after moving to this location the firm was changed to W. D. & C. N. Andrews, C. N. Andrews becoming a partner.

The continued growth of the jobbing business necessitated the enlargement and rearrangement of its quarters, and in March, 1919, it was necessary to discontinue the retail business in order to devote every effort to wholesaling so as to give dealers the best type of service.

On July 1, 1919, the organization again moved, this time locating at Pearl and Court streets, which is in the very heart of the city. In this new building, which the firm owns, they at present occupy three entire floors, devoted exclusively to Victor wholesaling.

With the firm coming under the ownership of Curtis N. Andrews, there is no question but that better service than ever will be rendered to the Victor dealer, where this is possible. Having been born in upper New York State, and having lived there all his life, Mr. Andrews thoroughly understands the buying psychology of the people of the upper New York region. He has devoted practically his entire business career to Victor merchandising and there is no question but that Mr. Andrews is extremely well fitted to meet conditions.

TALKING MACHINE EXPORTS GROW

Exports, Including Records, for Eleven Months Ending November, 1920, Total \$7,153,487

WASHINGTON, D. C., February 6.—In the summary of exports and imports of the United States for the month of November, 1920 (the latest period for which it has been compiled), which has just been issued, the following figures on talking machines and records are presented:

The dutiable imports of talking machines and parts during November, 1920, amounted in value to \$63,882, as compared with \$44,488 worth which were imported during the same month of 1919. The eleven months' total ending November, 1920, showed importations valued at \$815,469, as compared with \$490,410 worth of talking machines and parts during the same period of 1919.

Talking machines to the number of 9,796, valued at \$397,426, were exported in November, 1920, as compared with 6,535 talking machines, valued at \$343,896, sent abroad in the same period of 1919. The eleven months' total showed that we exported 79,530 talking machines, valued at \$3,694,731, as against 58,871 talking machines, valued at \$2,161,295, in 1919, and 59,604 talking machines, valued at \$1,772,716, in 1918.

The total exports of records and supplies for November, 1920, were valued at \$378,087, as compared with \$488,445 in November, 1919. For the eleven months ending November, 1920, records and accessories were exported valued at \$3,458,756; in 1919, \$3,311,098, and in 1918, \$2,104,778.

ASK RECEIVER FOR ATLANTA HOUSE

Petition Filed Against Southern States Phonograph Co. by Several Creditors

ATLANTA, GA., February 4.—An involuntary bankruptcy suit, accompanied by a petition for the appointment of a receiver, was last month filed in the bankruptcy division of the United States Court, in this city, against the Southern States Phonograph Co., Inc., a company organized in Atlanta several months ago for the purpose of manufacturing and distributing phonographs and records.

The suit was filed through Attorney William A. Fuller, counsel for the petitioning creditors, the principal one being Rhett, O'Beirne & Lockridge, an insurance partnership, with claims of \$1,165.91 against the corporation, which has offices in the Arcade Building and a large factory and warehouse on Marietta street. Judge Samuel H. Sibley set the hearing for a receiver.

Few of the golden opportunities we hear about would stand the acid test.

MUSIC WHILE YOU WAIT

Early Morning Travelers To and From the Railroads Hear Caruso for a Nickel

Early morning workers who cross the Bay to the Jersey side have music while they wait in the terminals for trains to take them to the outlying factory towns and cities. Many of them have some time to spare and the result is music.

At the Central Railroad of New Jersey terminal there are two big automatic phonographs. Their records consist of everything from jazz to opera by musical comedy singers and famous artists. For a nickel the early workers listen to Caruso while waiting for the 7:15. A railroad attache says that every morning there is a concert, and sometimes opposition ones, for the workers always come with enough nickels to keep the machines working until the trains depart.

The Tiphany Phonetic Corp., New York, has been incorporated with capital stock of \$4,000,000, to engage in the manufacture of phonographs. The incorporators are J. R. Jentes, W. W. Staub and C. B. Bash.

TO OPEN NEW STORE IN BROOKLYN

Schwartz, Kramer & Jelling, Inc., to Open "The Brunswick Temple of Music" at Kings Highway on or About March First

Schwartz, Kramer & Jelling, Inc., represent the latest addition to the piano and talking machine houses of Brooklyn, N. Y., having just leased a large store at Kings Highway and Coney Island avenue, that city. The new concern has adopted for its store title "The Brunswick Temple of Music," but although the Brunswick phonographs will be featured very strongly, pianos and musical merchandise generally will also be handled.

The new store, which will be opened on March 1, is now being equipped and decorated. A number of soundproof booths are being installed and the general decorative design is in the Greek-Gothic style.

Milton Kramer, vice-president and general manager of the company, is well known in the local trade, having been connected with the wholesale and retail talking machine business for a number of years.

The Industry Is Facing a Period of Genuine Development

AMERICAN industries as a whole have just been going through a most strenuous period, and although at no time has the situation suggested a panic, there developed conditions nevertheless that shook the stability of more than one line of business. Apparently the talking machine trade has been one of those to come through the period of uncertainty with comparatively few scars, despite the talk of pending catastrophes which only a short time ago was heard frequently.

Considering the point to which the industry has developed during the past few years, and the conditions under which it developed, there has been shown a stability that is indeed gratifying. Not that there have been no failures, but these failures have been comparatively few and, with one or two exceptions, of a character to arouse little apprehension. In some quarters there has been a tendency among some of the weaker members of the trade to fold their business tents, as it were, and silently steal away, but this thinning out and a clearing up of unsound institutions will unquestionably

work to the betterment of the trade when things finally adjust themselves.

That the talking machine trade, both in the manufacturing and retail ends, has not lost its allurements for those seeking business opportunities is indicated by the number of new concerns which have announced their intention of invading one or another branch of the field. In the most places the announced capital is of sufficient size to indicate that the "shoe string" era has passed, and that these coming trade factors are working on the idea of permanence.

Having proven its stability, it would seem that the talking machine trade has before it a period of genuine development along lines that will insure the maintenance of that stability. The oft-repeated claims that the industry is still in its infancy may be considered by now somewhat exaggerated, but the man who cannot see before the trade most attractive opportunities for development is certainly lacking in vision.

Ideas for Increasing Interest in the Sales of Talking Machine Records :: :: By Frank H. Williams

Everyone who owns a talking machine is, or should be, interested in hearing the new records as they come to the dealer's store and in learning what are the favorite records of other owners of talking machines.

But the fact remains that only a comparatively small percentage of people owning talking machines make a practice of going to the dealer's store regularly every month and listening to a demonstration of the new records. It is also true that there isn't the interest there should be in knowing what are the biggest sellers among the new and old records and just what records make the biggest hit with local folks.

It would seem as though in these facts there lay a splendid opportunity for the furniture store which deals in "talkers" and records or the straight talking machine dealer to stir up a lot of interest in records which will focus a lot of attention on the store and boost the store's record sales appreciably.

Aside from personal invitations and record recitals there are a number of inexpensive and easy ways in which a store might stir up such interest and increase its sales. For instance, the store might inaugurate a school stunt along these lines:

The dealer might take an instrument around to one or two schools which didn't own talking machines and might play some of the best-known old-time songs for these schools at the regular daily assembly. This in itself would be a good stunt, as it would make the children talk about the entertainment and thereby implant in their homes the germ of a desire to own machines. The dealer would be also demonstrating to the schools the immense advantages of owning machines.

If all the schools in the city already own machines then the dealer might simply take the records to some one or two of the most prominent schools and play them on the school machines at the assembly periods. Then, while the selections were being rendered, the demonstrator would gauge the amount of applause each selection received. In this way it would be found which of the selections were most popular with the schools. After finding out which of the records were the most popular the store might make a window display of all the records

used in the demonstration and then give point to the display by the use of a placard reading like this:

"What Is YOUR Favorite Old-time Song?"

"Look at the records in this window. We played them at the Jefferson and Bloomingdale schools this week. And the records which got the greatest applause from the children were:

"Home, Sweet Home,' and 'My Old Kentucky Home.'

"Rather a surprising selection, isn't it? Are these two YOUR favorite selections? Which two of the records shown in this window are YOUR favorites?"

"Come in and let us play these records for

*The Dealer Who Will
Win in Record Sales
Is He Who Employs
Distinctly Original
Exploitative Methods*

you and also any other records you'd like to hear. Tell us what records you like, so that we can tell the rest of the local public what this city's favorite old-time songs are."

Such a stunt would be sure to attract a lot of attention and would also make a lot of people want to register their selections with the store. And if the store offered to give free five records to the persons naming the record which received the greatest number of votes then the interest in the affair would be quite largely increased.

Suppose, again, that the dealer interviewed some of the leading citizens of the town and secured from them expressions as to what old-time and modern songs and musical selections they prefer. And suppose that he placed in the show windows of his store the various records named by these citizens and attached to each

record a card bearing the name, address and business occupation of the man or woman naming that particular record as his or her favorite. And suppose that point is given to this exhibit by a placard placed in the middle of the window reading about like this:

"What are YOUR favorite talking machine records?"

"Here are some of the records favored by leading local citizens.

"Are these records also YOUR favorites? Or do you prefer some entirely different songs and musical selections?"

"Come in and tell us what records you like and then let us play for you the selections shown in this window. You'll be very much interested in hearing the music that especially appeals to the leading bankers, leading club women of the city and others."

Wouldn't a stunt of this kind stir up a lot of interest and make the store very extensively talked about. And wouldn't such word-of-mouth advertising be a mighty good thing for the store and tend to boost its business? And wouldn't the bringing of many new people into the store also tend to popularize the establishment and to increase its new business?"

People are always interested in stunts of this kind. They are so intimate and personal and so strictly home-town stuff that it is only natural for folks to have their attention attracted to them and to then talk about them extensively.

Furthermore, a stunt of this character is the very sort of thing that would make a splendid "feature" story for a newspaper and it is quite likely that some one of the local newspapers would be glad to seize on the idea and play it up in a special feature article.

Here's still another way in which the alert dealer might stir up additional interest in new and old-time records:

Suppose that the store from month to month told about the records of which it had sold the greatest quantity during the previous month. Such information might be given in two sections—one section telling about the best-selling old-time records and the other telling about the best-selling new records. Six best sellers in each section might be given and some of the reasons why folks purchased these records

(Continued on page 6)

NYACCO Albums At Pre-War Prices



Sacrificing entire stock at less than to-day's market prices.
F. O. B. New York or Chicago.

Executive Office
23-25 Lispenard St.
New York, N. Y.

New York Album & Card Co.

Chicago Factory
415-17 S. Jefferson St.
Chicago, Ill.

FEATURES why NYACCO ALBUMS are the BEST as already proven by their great demand

1. Solid wood back re-inforced with cloth hinges which holds back firmly to the cover.
2. Two-in-one pockets secure each envelope from coming apart.
3. Each side edge metal piece reinforced by steel nails into the solid wood back together with staples that secure the pockets are made all-in-one.
4. Pockets can easily be removed by lifting staples from their places, new leaves can be inserted and the staples placed into position again by pressure of the thumb.
5. Specialize in making a ten-inch pocket into a twelve-inch cover, giving cabinet uniform appearance when equipped with ten and twelve-inch albums.
6. The pockets lie perfectly flat when the book is opened.

Ask Your Jobber for Genuine NYACCO Albums---Accept no substitute.
Distributors throughout U. S.---Write Us for Name & Address of Jobber nearest you.

Victor supremacy is self-evident

It is the supremacy of achievement---
of great things actually accomplished.
And it brings success to Victor
retailers everywhere.

"Victrola" is the Registered Trade-mark of the Victor Talking Machine Company designating the products of this Company only.

Warning: The use of the word **Victrola** upon or in the promotion or sale of any other Talking Machine or Phonograph products is misleading and illegal.

Important Notice. Victor Records and Victor Machines are scientifically co-ordinated and synchronized in the processes of manufacture, and should be used together to secure a perfect reproduction.

Victor Wholesalers

Albany, N. Y.....Gately-Haire Co., Inc.
Atlanta, Ga.Elyea Talking Machine Co.
Phillips & Crew Piano Co.
Baltimore, Md.Cohen & Hughes.
E. F. Droop & Sons Co.
H. R. Eisenbrandt Sons, Inc.
Birmingham, Ala...Talking Machine Co.
Boston, Mass.Oliver Ditson Co.
The Eastern Talking Machine Co.
The M. Steinert & Sons Co.
Brooklyn, N. Y....American Talking Mach. Co.
G. T. Williams Co., Inc.
Buffalo, N. Y.....W. D. & C. N. Andrews.
Buffalo Talking Machine Co., Inc.
Burlington, Vt....American Phonograph Co.
Butte, Mont.Orton Bros.
Chicago, Ill.Lyon & Healy.
The Rudolph Wurlitzer Co.
Chicago Talking Machine Co.
Cincinnati, O.Ohio Talking Machine Co.
The Rudolph Wurlitzer Co.
Cleveland, O.The Cleveland Talking Machine Co.
The Eclipse Musical Co.
Columbus, O.The Perry B. Whitsit Co.
Dallas, Tex.Sanger Bros.
Denver, Colo.The Knight-Campbell Music Co.
Des Moines, Ia....Mickel Bros. Co.
Detroit, Mich.Grinnell Bros.
Elmira, N. Y.....Elmira Arms Co.
El Paso, Tex.....W. G. Walz Co.
Honolulu, T. H....Bergstrom Music Co., Ltd.
Houston, Tex.The Talking Machine Co. of Texas.
Indianapolis, Ind...Stewart Talking Machine Co.
Jacksonville, Fla...Florida Talking Machine Co.
Kansas City, Mo...J. W. Jenkins Sons Music Co.
The Schmelzer Co.
Los Angeles, Cal...Sherman, Clay & Co.
Memphis, Tenn. ...O. K. Houck Piano Co.

Milwaukee, Wis. ...Badger Talking Machine Co.
Minneapolis, Minn..Beckwith, O'Neill Co.
Mobile, Ala.Wm. H. Reynolds.
Newark, N. J.....Collings & Co.
New Haven, Conn..The Horton-Gallo-Creamer Co.
New Orleans, La...Philip Werlein, Ltd.
New York, N. Y....Blackman Talking Mach. Co.
Emanuel Blout.
C. Bruno & Son, Inc.
Charles H. Ditson & Co.
Knickerbocker Talking Machine Co., Inc.
Musical Instrument Sales Co.
New York Talking Mach. Co.
Ormes, Inc.
Silas E. Pearsall Co.
Omaha, Nebr.Ross P. Curtice Co.
Mickel Bros. Co.
Peoria, Ill.Putnam-Page Co., Inc.
Philadelphia, Pa...Louis Buehn Co., Inc.
C. J. Heppe & Son.
The George D. Ornstein Co.
Penn Phonograph Co., Inc.
The Talking Machine Co.
H. A. Weymann & Son, Inc.
Pittsburgh, Pa. ...W. F. Frederick Piano Co.
C. C. Mellor Co., Ltd.
Standard Talking Mach. Co.
Portland, Me.Cressey & Allen, Inc.
Portland, Ore.Sherman, Clay & Co.
Richmond, Va.The Corley Co., Inc.
Rochester, N. Y....E. J. Chapman.
Salt Lake City, U..The John Elliott Clark Co.
San Francisco, Cal.Sherman, Clay & Co.
Seattle, Wash.Sherman, Clay & Co.
Spokane, Wash. ...Sherman, Clay & Co.
St. Louis, Mo.Koerher-Brenner Music Co.
St. Paul, Minn....W. J. Dyer & Bro.
Syracuse, N. Y.....W. D. Andrews Co.
Toledo, O.The Toledo Talking Machine Co.
Washington, D. C..Cohen & Hughes.
E. F. Droop & Sons Co.
Rogers & Fischer.

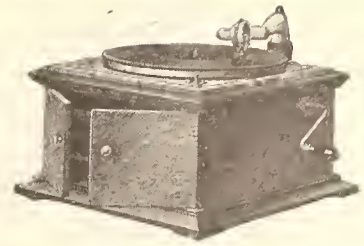

Victrola VI, \$35
Mahogany or oak



Victrola IX, \$75
Mahogany or oak



Victrola XI, \$150
Mahogany, oak or walnut



Victrola XVI, \$275
Victrola XVI, electric, \$337.50
Mahogany or oak

Victor Talking Machine Co.
Camden, N. J., U. S. A.



IMPORTANT TO THE TALKING MACHINE TRADE



SELECTING THEIR FAVORITES

NATIONAL PUBLISHING CO., 239 S. American St., PHILADELPHIA, PA.
CHICAGO OFFICE: 508 South Dearborn Street

Lower Prices for Record Albums

Yes, due to lower costs, we are making substantial reductions in prices.

We solicit your orders and correspondence.

OUR ALBUMS ARE MADE TO CONTAIN VICTOR, COLUMBIA, EDISON, PATHÉ, VOCALION AND ALL OTHER DISC RECORDS

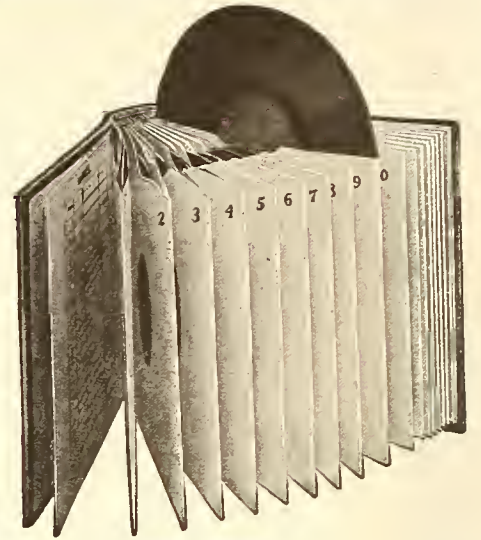

THE PERFECT PLAN

INCREASING INTEREST IN RECORDS

(Continued from page 4)

might be added. For instance, in the new records section it might be stated that some of the reasons given by purchasers for securing these particular records were as follows:

"I'm buying this record because it is a peach of a one-step."

"It seems to me that everybody's buying this record nowadays and I want to be on the band wagon."

"I'm simply crazy about this record."

"I think this is the catchiest tune I've ever heard."

And some of the reasons assigned for purchasing the old-time records might be summarized as follows:

"This always was one of my favorite selections and now that we have a talking machine I want to play it often."

"I heard this melody when I was a boy and I've always desired to be situated so that I can hear it frequently."

INCORPORATED

The Sterling Art Co., of Brooklyn, was incorporated at Albany recently with a capital of \$25,000 for the purpose of dealing in phonographs. Those interested are Archiland M. Llano and Wm. A. and Ruth Price, 189 East Eighteenth street, Brooklyn, N. Y.

A man's wealth depends not so much on what he has as on what he could do without.

INCREASE CAPITAL TO \$10,000,000

Heywood Bros. & Wakefield Co. Expand Capital to Conformity With Increasing Business

Heywood Bros. & Wakefield Co., manufacturers of talking machines and furniture, have certified with the authorities of the State of New Jersey to an increase in capital stock from \$7,000,000 to \$10,000,000, divided into 100,000 shares at \$100 each, 60,000 common and 40,000 preferred stock.

GETTING EYES ON THE BULLETINS

Interesting Suggestion to Attract Attention of People Who Pay Instalments on Purchases

A large majority of the talking machines bought by women are sold on instalments, says Buy at Home News, and it is usually a woman who brings down her account book and pays the monthly instalments. For that reason at either side of the cashier's window there is a bulletin of the new records for the month. The customers' eyes fall on these while their receipts are being made out, with the result that additional sales are made.

The Kingsbury Music Co., of Denver, Col., has been appointed Victor dealer. This business is owned by Miss Marion Kingsbury, who at one time was a member of the Metropolitan Opera Co., and who intends to conduct a very artistic establishment devoted to music and its exploitation.

NEW VICTOR STORE IN CLEVELAND

Nela Park Music Shoppe Opens Attractive Establishment in East End of City Which Is Controlled by A. Finesilver

CLEVELAND, O., February 5.—A very important addition to the retail Victor stores in this city is that just opened by the Nela Park Music Shoppe, which is controlled by A. Finesilver, who was formerly with the Hippodrome orchestra. The new establishment is located in the East End and is adjacent to some of the largest manufacturing establishments in the city, notably the National Lamp Works of the General Electric Co., as well as several high-class resident suburban communities. Edward B. Lyon, sales manager of the Eclipse Musical Co., Victor wholesaler, co-operated with Mr. Finesilver in the arrangements for the opening as well as the general details of the interior construction.

IN THE MARKET FOR MACHINES

Augusto Marin, manufacturers' agent and merchandise broker, located and operating in Aguadilla, Porto Rico, W. I., writes The Talking Machine World as follows: "I am in the market for some talking machines. Please ask American manufacturers to send catalog, prices and discount to me direct." Mr. Marin's address is P. O. Box 125.

James Pawley, talking machine dealer of Pleasantville, N. J., has secured larger quarters in the Red Men's Hall Building in that town.

Peerless Metal Back Album



Write for particulars about this indestructible album.

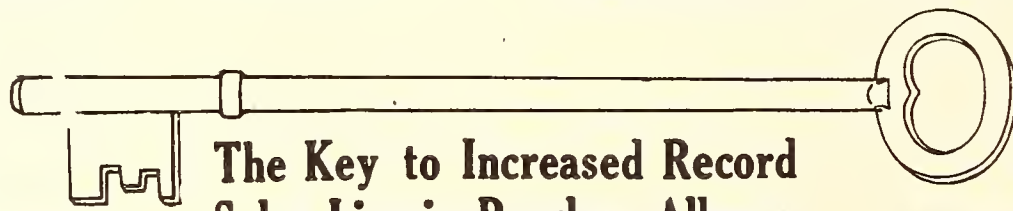

The Key to Increased Record Sales Lies in Peerless Albums

Let us show you how to increase your record business through the application of Peerless Albums and our sales suggestions.

Now that we are thoroughly established in our new home, right on Broadway, we wish to extend a standing invitation to the trade to call upon us when in town.

Our new plant and equipment marks a development which furthers our slogan of "Peerless quality and service."

PHIL RAVIS, President

PEERLESS ALBUM COMPANY
636 and 638 BROADWAY :: NEW YORK CITY

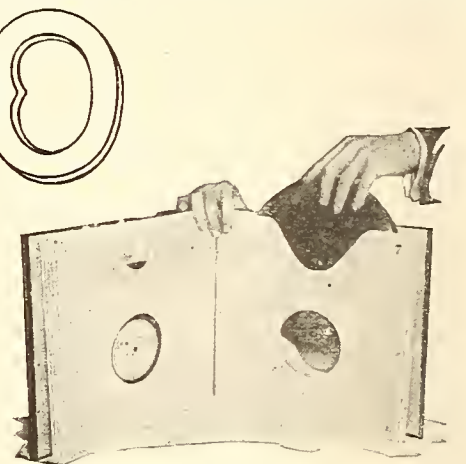

PEERLESS BIG TEN

Write for particulars about this new and exclusive album, offered in sets.

Chicago Office:
57 E. JACKSON BLVD.

once the carrying out of a program that should bring definite results in a comparatively short time. After all, the dealers in everything musical, whether pianos, talking machines or ukuleles, are working in a sense to a common end, and are joined together by a certain bond of sympathy, and when there comes time for action the work of a united industry is naturally more effective than the independent efforts of several disjointed sections. This is a point worth thinking about.

As a matter of fact, the name "National Association of Music Merchants" was adopted to supersede the previous title of "The National Association of Piano Merchants" with a definite idea in mind of bringing into the association talking machine men, inasmuch as the majority of the piano retailers handle talking machines, and a discussion of talking machine problems would therefore find a fitting place in the association councils.

Just at the present time the National Association of Music Merchants is officially recognized as the retail division of the Music Industries Chamber of Commerce, with which a number of the leading talking machine manufacturers, as well as the leading talking machine jobbers, are officially affiliated. It might be that to make unnecessary the formation of a new talking machine dealers' organization certain changes in the existing association might be desirable in order to meet certain specific requirements of talking machine men. That is a matter that could easily be decided.

Meanwhile, the question is for the retailers to get together in some way or another for the purpose of protecting their interests in various directions, in the matter of Federal tax legislation, for instance, and for improving general trade conditions when such improvement seems possible. If only the spirit of camaraderie is developed among the members of the trade any association fulfils a definite and useful purpose.

CURBING ACTIVITIES OF "GYP" DEALERS

THE retail talking machine trade, in the larger cities particularly, has suffered more or less from the operations of "gyp" dealers for several years past, and despite the efforts that have been made to curb the activities of these "private house" or "storage" specialists they have continued to flourish to an annoying degree in one form or another. The enforcement of local ordinances and State laws has served to discourage the practice of using the names of standard machines to market inferior products, but false statements regarding values have still persisted.

The recent decision of the Federal Trade Commission against a group of Chicago operators working under the names of various storage companies, in which the defendants were found guilty of unfair methods of competition in interstate commerce and were ordered to discontinue their methods, should serve to discourage "gyp" dealers in other sections to a large extent. The defendants claimed that they were selling "\$250-size" phonographs which were

in storage, and of which there were only a limited number, at the "special price" of \$69.50. The Commission found that the special price quoted was the usual resale price of the instruments and that they were not in storage but were manufactured by the defendants, and that the quantity was not limited. The other advertised statements were, so far as is known, correct.

The prosecution of the Chicago people resulted from a complaint filed by the Better Business Bureau of the Music Industries Chamber of Commerce, which has on several occasions put a stop to questionable methods of talking machine advertising and selling, either through moral suasion or by the bringing of legal action. Its work in this connection is worthy of the highest praise.

SOME DEVELOPMENTS OF INTEREST

ACCORDING to authoritative reports from the great furniture market in Grand Rapids the competition in the matter of talking machine production offered by furniture manufacturers seems to have reached its peak. During the past few years furniture factories have been handling an increased volume of talking machine business, either as marketers of complete machines or as suppliers of cabinets for those who themselves market machines.

In some cases the manufacture of furniture was discontinued entirely in order that entire plants might be given over to talking machine cabinet production, and even with these great facilities cabinets for a time were difficult to obtain. It now seems that a number of furniture manufacturers have sensed a change in conditions and decided to go in again for furniture, with cabinet production largely eliminated, and the manufacture of completed instruments continued as a subsidiary enterprise.

This change in front has not come suddenly, but was heralded close to a year ago and efforts of certain manufacturers to tie up furniture plants on big cabinet contracts met with little or no success. The reason assigned for the change by some furniture men is that the newer talking machine companies who felt that their success would be permanent have either increased their own cabinet-producing facilities or have equipped their own cabinet-making plants, which meant that the furniture man was left high and dry when existing contracts ran out. To have held on to the cabinet business indefinitely would have meant that the furniture men must go back into furniture production suddenly and be called upon to re-establish their furniture markets under strong competition.

There are, of course, a number of furniture manufacturers who will continue marketing complete machines of their own production that have been manufactured along correct lines and have won a substantial reputation and a market for themselves. These are the men who had vision and faith in the talking machine industry, and who, moreover, possessed the good judgment to use their own names on the products turned out by their factories. The development is an interesting one and provides food for thought.

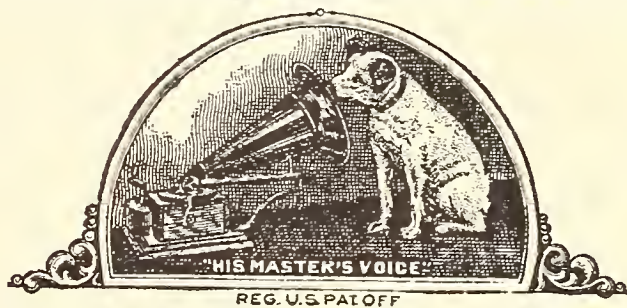

"HITCH YOUR WAGON TO A STAR"

is a maxim that has been handed down from generation to generation. The exclusive Victor retailer well appreciates the value of this saying.

As the year progresses we believe that the exclusive Victor retailer will reap what he has sown in energetically featuring Victor merchandise exclusively.

Ormes service will assist their dealers in every way possible consistent with good merchandising

ORMES, Inc.

103 E. 125th St. Wholesale Exclusively NEW YORK

Why People Buy by Mail, With Suggestions for Meeting Mail Order Competition :: D. G. Baird

By
D. G. Baird

The people of this country are addicted to the mail order habit. If any one doubts this statement let him consider the fact that one mail order house alone sold more than a quarter of a billion dollars' worth of goods last year. In other words, this one company did a business equal to a \$2.50 sale to every man, woman and child in the United States last year.

And this is just one mail order house—the largest one in the country, it is true, but there are many mail order houses in America. And they are all doing business. Yes, they are doing business and they are doing it in my town and in your town, Mr. Dealer.

The merchants in a small town in Kansas got together some time ago and determined to find out just how much money was leaving their town that ought to be kept there. They went to the post office, the express office and to the banks and made inquiries. And they got some astounding figures! They couldn't get the names of those individuals who were patronizing the out-of-town stores, of course, but they could get facts on the volume of business being done in their town by their absentee competitor.

One of the leading bankers of the town stated his position on the subject when he said to the committee that had called to interview him: "Gentlemen, I had rather have the amount of money sent through this one bank for goods bought out of town than to have the receipts of any one of your stores."

Why Do They Do It?

These are not pleasant facts to the honest dealer who is trying to give honest service and to earn an honest living. But, as the old saying has it, "Facts are facts and figures are figures,"

and there is no reason to deny either. Neither does it do any good to bewail the facts or to get mad and "cuss" the mail order houses or the ones who patronize them. It behooves us, rather, to study the situation and try to learn whether or not there is any cure for the affliction.

Why do our fellow citizens buy by mail instead of buying from us?

A little thought will furnish several reasons.

*A Mail Order House
Has No Method That
Cannot Be Duplicated
and Improved Upon by
the Local Dealer*

In the first place, these houses sell through their catalogs in which they have pictured and described their goods. These catalogs are sent out through the mails into the homes of the people and the people study them. Every member of the family turns through the catalog time and again, looking and looking, with an especially long look each time at some coveted article. The result is a very natural one—the looker becomes a buyer.

The ones who prepare the mail order catalogs are specialists in their fields and they turn out a product that fully meets the four fundamentals of advertising. The big book of itself catches the attention, aided, perhaps, by some curiosity to know just what it has to offer. Desire is aroused by looking at the displays and conviction is borne in upon the looker by the splendid descriptions and expositions given of the goods. The prospect is moved to action by the fact that he desires the goods and believes that he can get them cheaper from the mail order house.

A dealer in washing machines, writing in a trade periodical, tells of his experience in dealing with a citizen of his town who was known to be a confirmed patron of the mail order house. The dealer, on hearing that this gentleman was in the market for a washing machine, decided to go after the business.

He invited the customer to come to his store and look over his stock. The latter came and was shown the local merchant's washing machine and was told of its many excellent features. "At least," says the dealer, "I told him *all I knew* about it." (The italics are his, too.)

"Then," continues the dealer, "he started in by asking a few questions about the washer and in half an hour he had told me more about washing machines than I had ever heard or dreamed of. Finally I asked him where he had learned the washing machine business. He hadn't learned it, he said, but he knew all about 'em—from their most inward and basic principle to the outside finish—from reading mail order catalogs."

Yes, the mail order house advertises. And it doesn't stop with advertising through the me-

STATEMENT

OKeh Records have proven themselves!

QUESTION - Has your service been as good as the record?

SUGGESTION - Try KENNEDY-GREEN service in connection with

OKeh Records
DEAN NEEDLES, etc.

ANOTHER SUGGESTION - Write

KENNEDY-GREEN COMPANY

1865 Prospect Avenue

Cleveland, Ohio

AND SEE WHAT HAPPENS

dium of its catalog. In every Sunday paper in my town appears a full-page advertisement of talking machines and another of an encyclopaedia. We are not concerned about the latter, but we are about talking machines.

The fact that the mail order house advertises is not, of course, anything new or startling, but the point is this: The mail order house lets the people know that it has the goods. And how often it happens that the local dealer does not let the people know that he has the goods!

The representative of a publishing house that does some business by mail tells this story. His house had advertised a book on business management and in reply several department store executives throughout the country ordered the book by mail. In each case the store was a customer of the publisher's and carried in stock the book which the executives ordered.

From the same towns where department store officials had ordered this book came other orders in sufficient numbers to have amply justified the expense of advertising the book in the local papers. So this publicity got the business not only of the people in the communities who should have bought from their dealers, but of the dealers themselves!

Now if the head of a department store will not take the trouble to learn whether or not his own store carries in stock a book he wants, but goes ahead and orders it direct, how can we expect the customers to come looking through our dusty rows of records to learn whether we have what they want when it is so easy to order it by mail?

Still another reason why so many people buy by mail is the fact that all goods are marked in plain figures. They don't have to ask the price on one or several articles. They don't have to ask why one article is higher than another—they are told in the text. They are not hurried in making their choice. They can take their time and think things over—talk the matter over with other members of the family maybe—then make up their minds as to whether they shall buy.

And when they do buy they feel sure that they are getting the goods much cheaper than they could buy them from their dealers. This, after all, is the greatest reason why people buy by mail. Oh, yes, no doubt they are mistaken—but do they know that they are mistaken?

And, finally, when they send their orders off they know that if they are not satisfied they can get their money back without question. True, they may experience some annoyance and inconvenience in obtaining refunds, but they feel sure that it will be all right.

Wherein They Are Mistaken

The people who buy by mail are, of course, mistaken in many of their beliefs concerning mail order goods and service. They frequently do not consider the fact that prices are f. o. b. the factory and that freight and drayage are pretty high these days. Nor do they seem to understand that the mail order houses are enabled to make the prices they offer only because they buy in large quantities and employ cheap labor in their factories. In other words, the mail order house is able to sell cheaper because it buys in a big way, crowds the manufacturer on prices and then does business with a minimum overhead.

Again, the people feel sure that if they are dissatisfied with the goods they may return them and their money will be cheerfully refunded. This may be true, but as a matter of fact refunds are invariably made in the form of an order for merchandise of equal value. Then if the customer sends this back and asks for a postal money order they will probably send him an express money order or a cashier's check; or if he asks for one of these they will very likely send him a postal money order. Considerable annoyance is frequently experienced in this way.

Then, too, many a customer has ordered goods from a mail order house and has had to wait so long for them that he didn't need them when at last they did arrive.

Meeting Competition

These are true facts. But do the people know that they are true facts? And if they don't know this why don't they know it?

We don't like to "knock" any one's business, but here is a situation that demands action of some kind. The local dealer is certainly entitled to the business and has right on his side from every standpoint. Couldn't we then compare prices a little and point out a few cases in which we excel the mail order house?

One dealer who handles electric lamps and fixtures in a Western city was selling a certain lamp that cost him \$2.75 for \$5 and putting it up in the customer's home when he was surprised to learn that a mail order house was selling the same lamp for \$6.95 and the customer paid the express and had to install it himself.

This is a daily occurrence in every town in the country. The mail order house handles some standard goods, as a rule, and it usually charges as much or more for such goods as the dealer charges. Why not get a catalog and make some comparisons?

The methods adopted by the mail order houses get the business, but they have no methods that dealers cannot duplicate and improve upon.

Take the matter of creating desire, for example. The mail order house depends upon its attractive pictures and descriptions to arouse desire. But the dealer has the privilege of displaying the actual goods in his show windows and of picturing them in his advertisements.

The catalogs give good descriptions and construction talks on goods, but how much better the dealer can do this in personal conversation with the prospect! The dealer must, to be sure, know his goods. If he does not know his goods he will find himself in the predicament of the dealer who tried to sell a washer to one who knew more about the machine than he. This is the dealer's business; he should know his goods.

The local dealer can guarantee satisfaction or money back and can live up to his guarantee without inconveniencing his patrons in the way the mail order houses do.

The dealer has the advantage in every respect. Let him make the most of this advantage and the receipts of his out-of-town competitor will not be so large this year.

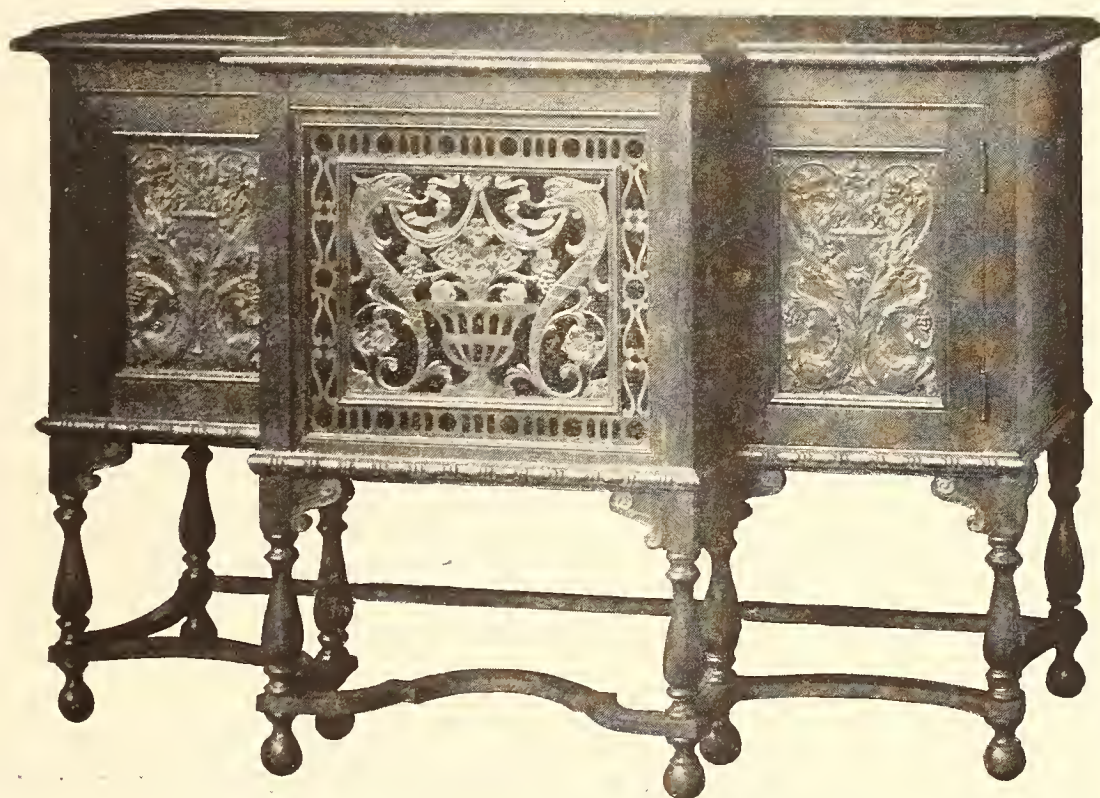

AN AMERICAN WALNUT PHONOGRAPH CABINET



For Phonograph Cabinets

Walnut is surely as desirable as it has proved to be for the finest of other forms of furniture for four hundred years and longer. Beauty, remarkable working qualities and its hold on the public demand put AMERICAN WALNUT in the forefront for the finer musical instrument cases.

Write for data for makers or data for dealers and the "Brochure de Luxe" for your salesmen.

AMERICAN WALNUT MANUFACTURERS' ASSOCIATION, Room 1022, 616 South Michigan Boulevard, Chicago, Illinois

Here's Your Chance

Big March 59c Sale

To keep the Columbia Record Catalog within a reasonable size, we *must* retire certain records. Many of these are still popular enough to sell quickly at a popular price. Here's your chance. Never in the history of the music business have Columbia dealers been able to sell such good records at so low a price with a big advertising campaign to help them.

Limited Supply

Within a few days you will receive our Retired Record List, which will give you the full list of records to be sold at 59 cents. If you need more of these 130 numbers, you can get them from our Branches at 59 cents, less your regular discount. We have discontinued the manufacture of these records, so the supply is limited.

Recent Releases

The majority of these records have been released within the last eighteen months. You'll find on the list selections by such artists as Al Jolson, Art Hickman's Orchestra, Van and Schenck, Harry Fox, Guido Deiro, the Paul Biese Trio, Ted Lewis' Jazz Band, Henry Burr, Campbell and Burr, the Peerless Quartette, Sterling Trio, etc.



COLUMBIA GRAPHOPHONE COMPANY
NEW YORK

Columbia

How the Show Window, "Your Silent Salesman," Can Help Develop Prosperity :: By Ellis Hansen

During the readjustment now taking place in almost all lines of business, progressive dealers in the music trade have no doubt given much thought to the task of improving and stimulating their business.

The splendid article by Bruce Barton in Printers' Ink (reprinted in The World this month) showing how salesmen can make prosperity, brought to my mind another kind of salesman that is just as important a factor for good or bad for the retail store as the traveling salesman described by Mr. Barton is to the jobber. This is the silent salesman—your show window.

While some of the leading music stores

The makers of talking machines, records and player rolls are doing much to dispel such antiquated views and awaken the dealers' interest in making timely and interesting displays. To this end many have various kinds of window services, consisting of monthly lithographed show cards, hangers and display units that are sold to dealers at cost or sometimes

A sloppy, disorderly display, placed there perhaps by an indifferent office boy without the least regard for order, symmetry or artistic



Black and white dance record display designed by Ellis Hansen. Silhouettes cut out of black velvet, mounted on white silk panels. Background: pearl gray plush curtains. recognize the window as the most important part of the establishment and pay proper attention to their displays, there are still entirely too many dealers who only make a half-hearted

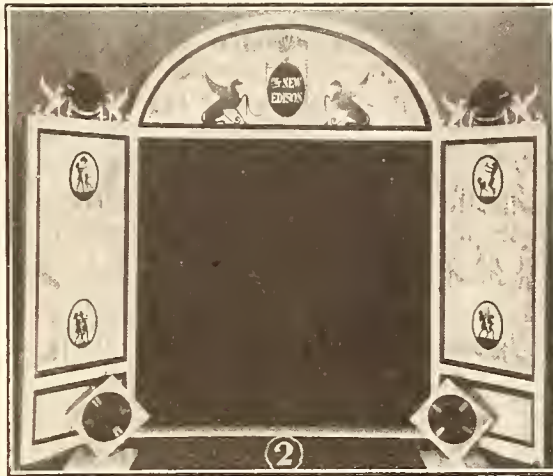

Display screen designed by Ellis Hansen for Adam period instruments. Color scheme: ivory, Nile green and black. Notice characteristic Adam ornaments.

given away. These could be of great service and very helpful to the dealer who would follow the directions given, using common sense and taste in the arrangement.

Manufacturers' Window Helps

Unfortunately the size and shape of windows differ so much that almost every dealer has a problem of his

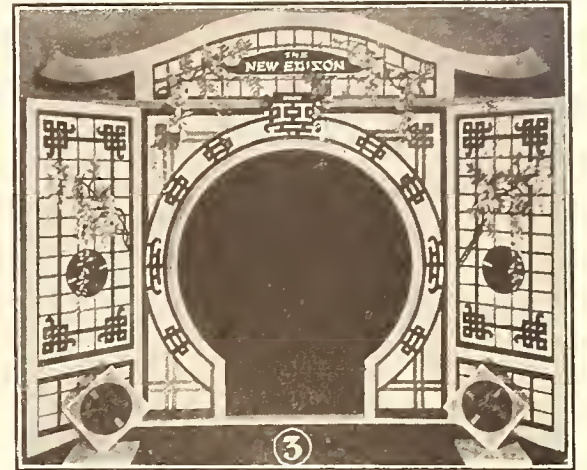

A bit of old Japan, designed by Ellis Hansen. Color scheme: canary yellow with light green trellis. Japanese fretwork japanned black. Artificial wistaria branches over trellis with long sprays of delicate tinted pink flowers. Background: dark green plush.

conception, is a poor greeting and does not spell welcome for the music lover with money to spend for your merchandise. All these rather pertinent remarks lead up to the plan I like to suggest to dealers who believe in their "silent salesman" and would like to have really fine and attractive window displays.

Almost every drygoods or hardware store that can boast of as few as half dozen people have their regular display man who strives to



Christmas display designed by Ellis Hansen. Corner window treatment showing two lines of instruments. Floor and all ornamentations are snow covered. Size of window 16x20 feet. Special stress is laid upon instruments to make capital on the "gift idea," eleven instruments being shown. Notice the effective use of floor lamps.

effort, if any at all, and look upon the show window as a mere concession to business—a disagreeable necessary evil that not only adds to the light bill, but makes the merchandise used for display shabby and dusty.

own. Professional jealousy makes it difficult for Brown to use the same display as Blank, his competitor, is using in the next block down the same street—and some dealers misuse these displays in a way that is positively depressing.

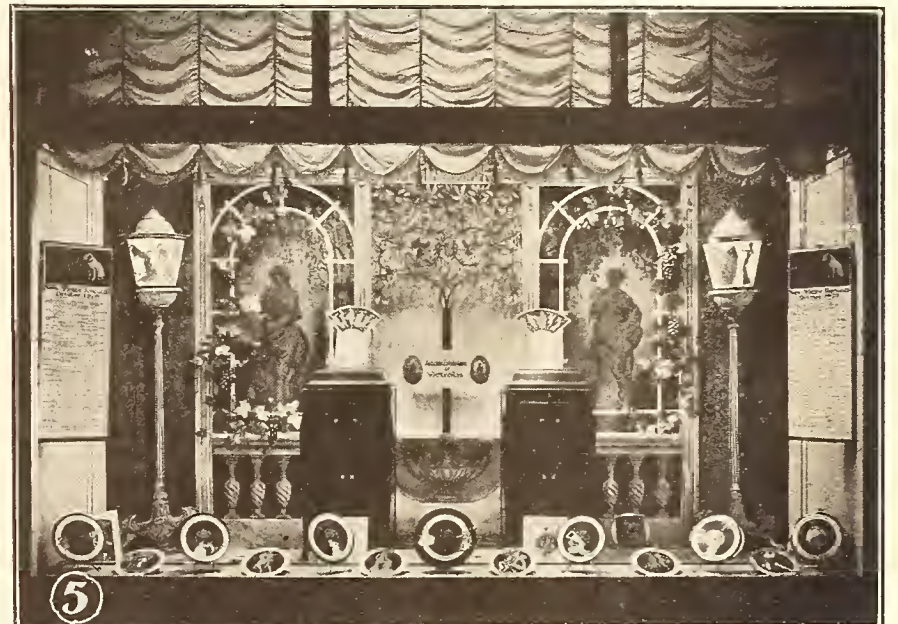

Fall opening display designed by Ellis Hansen, featuring records from Morris Gest's production of "Aphrodite"—the greatest feature of this extravaganza was the Russian Ballet arranged by Michel Fokine, said to be the creator of the Russian Ballet. For this reason a number of famous ballet records were shown in connection with Bakst costume color plates from Ballet Russe. The dance pictures on the floor lamps are color reproductions from the Aphrodite Ballet. The Fall panels showing Faun and Nymph were imitation tapestries. The center decoration was a "cut-out" of a conventionalized peach tree on marble background. Bunches of artificial grapes and grape leaves on the white trellis added to the Fall atmosphere. It created considerable attention.

present hardware and drygoods in most pleasing and artistic displays.

Get a Display Man From Your Own Force

With new records and player rolls every month the modern music store is fully as much in need of a window trimmer to spend at least part of his time to make the windows attractive. Dealers who read these lines will perhaps say: "Granting that all this is true, how are we going to get a trimmer even if we felt like spending a little money on display material? How could we afford to pay a salary for changing our windows a few times each month?" My answer would be—Don't get a professional trimmer that perhaps would not know the first thing about music or the line of instruments you have for sale. Select one of your own people to spend part of his

(Continued on page 16)



PHONOGRAPH CASES

Reinforced 3-ply Veneer

The Standard Case for Talking Machines and Records

Let us figure on your requirements

MADE BY
PLYWOOD CORPORATION, Goldsboro, N. C.
Mills in Va., N. C. and S. C.



“Look! What You’ve Done With Your Dog-Gone Dangerous Eyes,” sings Benny Davis. And the logical coupling also sung by this new exclusive Columbia artist is “Love, Honor and O-Baby.” Will they sell? Oh! Baby! A-3348.

**Columbia Graphophone Co.
NEW YORK**

SHOW WINDOWS MAKE PROSPERITY

(Continued from page 15)

time on display work and get someone who has an inclination for this very interesting and fascinating work—one who is observing, enthusiastic and painstaking. Allow him a reasonable expense account as you do for any other department and encourage him as you would any other employe starting out on a new venture and the expenditure will soon justify itself.

The Mission of the Show Window

The display should create a musical atmosphere and appeal to the love of music that exists in nearly every one. It should be based on a certain idea and tell a single story easily recognized. There must be something in the window to attract attention and arouse curiosity. Finally the display must deliver a message that induces the prospective customer to enter the store. That, after all, is the true mission of the show window, and when that is accomplished the rest is up to the sales people. This may sound rather difficult until you begin to study the great library of music in all its varieties contained in the general record and player roll catalogs. Among the more than two hundred different music displays designed and made by me in the last twenty years, of which I have photographs, every one has been built around a certain idea that has dominated the display and “put over” the story strong enough to be recognized almost at a glance.

The Months of the Year in Window Displays

The different seasons should be strongly reflected. In the last months of the year special stress should be laid upon instruments to make capital of the “gift idea.” At that time window shoppers are on the lookout for suitable Christmas gifts and few other articles meet these requirements better than musical instruments. January should be devoted to record and roll displays to supply the thousands of new instrument owners. February for a Valentine display. March is the month for the great variety of Irish selections dear to the hearts of the many sons and daughters that hail from the Green Isle and make these United States their home. The latter part of March and the beginning of April is Easter week. (This year March 27). May for Spring display. June

with its roses is the month of the bride. July for its glorious Fourth. August for vacation window. The golden fruits and beautiful flowers of September should be reflected in a glorious Fall display. Hallowe’en for October. Thanksgiving for November, and the great climax should be reached not later than December 10 in a wonderful Christmas window. Other ideas that lend themselves for display purposes, and which can be used almost any time during the year, are children’s music, grand opera, dance music and the hundred and one ideas the observing display man can gather from the record catalog.

The period models now on the market open up new vistas and opportunities for the resourceful trimmer. Adam and Gothic interiors, and a bit of old Japan help wonderfully well to set off the high-class instruments made in these styles and when properly carried out add “class” and distinction to the stores that install them.

The “Why” of Backgrounds

There should be a radical change in your windows every five or six weeks. It is not enough to change the show cards—the entire background and color scheme must be changed, as only a decided change will attract attention. This can only be accomplished with special backgrounds and is one reason for their popularity. Many music houses have no background at all in their windows, with the result that if the awning is pulled down during the summertime to protect the instruments, the pianos and phonographs almost merge into the dark depths of the store as seen from the outside. If the dark-colored instruments were set off with a light contrasting background this complete waste of window space during the greater part of the day would be avoided.

How to Get Ideas for Backgrounds

The display man should send in his subscriptions for the Merchant Record and Show Window, 5707 West Lake street, Chicago, Ill., the best publication on window displays. Through the advertising pages in this journal he can get in touch with the leading manufacturers and dealers of display material who will be glad to mail their catalogs chockful of suggestions that may prove of great value. This journal contains every month some of the best examples of the window trimmers’ art and a front page in colors. With the many ex-

amples and helpful hints it should not be hard for the display man to select such ideas for backgrounds and settings to suit his particular store.

Nothing New Under the Sun

It is not necessary to make strictly original backgrounds. Few experienced trimmers can hope to emerge with absolutely new ideas, far less the beginner. A thoughtful adoption presented in a new and interesting form is far better than a poor original. Lowell says: “Though old the thought and oft expressed, ’tis his at last who says it best.”

Put Play Into Your Display Work

In conclusion I should like to make a few remarks to the coming display man. Watch every fine window in your city and try to learn something from it. Give deep thought to all details, don’t leave anything to chance. If you have any special show cards made, use as few words as possible that they may be read hastily. Never “knock” or even mention any competing line of instruments. Try to inject your individuality, which is a charm in itself. Balance your displays. This does not mean that the various instruments should be handled with geometrical precision, but if one large instrument is placed at one side of the window there should be some decorative feature on the other side to balance it, for instance, a vase of flowers on a pedestal.

Don’t be afraid to handle a saw, a hammer or a paint brush even if it is a new experience to you. Any fool can have things made for him if he has the money to pay for it. To do something useful all by yourself, something you were not trained to do, is to give yourself a new sense of mastership, which more than anything will help you over new obstacles and make you believe in yourself. I often think that the Yankee characteristic “Jack of all trades” accounts to a great degree for the mastership of the American window-trimmer who counts more than 15,000 in his profession and is acclaimed and recognized to be the most skillful in the world. A good piece of window work represents to me real happiness and pride of creation which is often far more precious than pride of possession. And when the job is finished and the display is a success, where is there any sweeter music than a few words of praise from the “boss” and the official stamp of approval from the office boy that it is “swell”? All the hard work in forgotten in the joyful determination to make a still greater effort to make the next one a “whale” of a window that will make people sit up and take notice. And you can do it. GO TO IT.

VALUE OF CO-OPERATIVE EFFORT

Men who strive to build themselves up by tearing down the work of their fellows generally succeed in undermining their own foundations and falling into the common ruin. The secret of success is co-operative effort and giving to every one credit for that which is his due.

H. J. SMITH LABORATORIES

Jewel Manufacturer

EXECUTIVE OFFICES,
FINISHING and
RECORDING
LABORATORY JEWELS

Plant No. 1
833 Broad Street
Tel. 2896 Market
NEWARK, N. J.

SAWING
GRINDING
ROUGHING
ROLLING and
EXPERIMENTAL
LABORATORY

Plant No. 2
54½ Franklin St.
NEWARK, N. J.

MANUFACTURER OF

Phonograph Diamond and Sapphire Reproducing Points—Recording Laboratory Jewels—Rough Diamond—Diamond Powder—Experimental Work. Jewels manufactured for all talking machine records. Consulting Specialist on all experiments relating to any new recording grooves. Recording problems satisfactorily worked out.

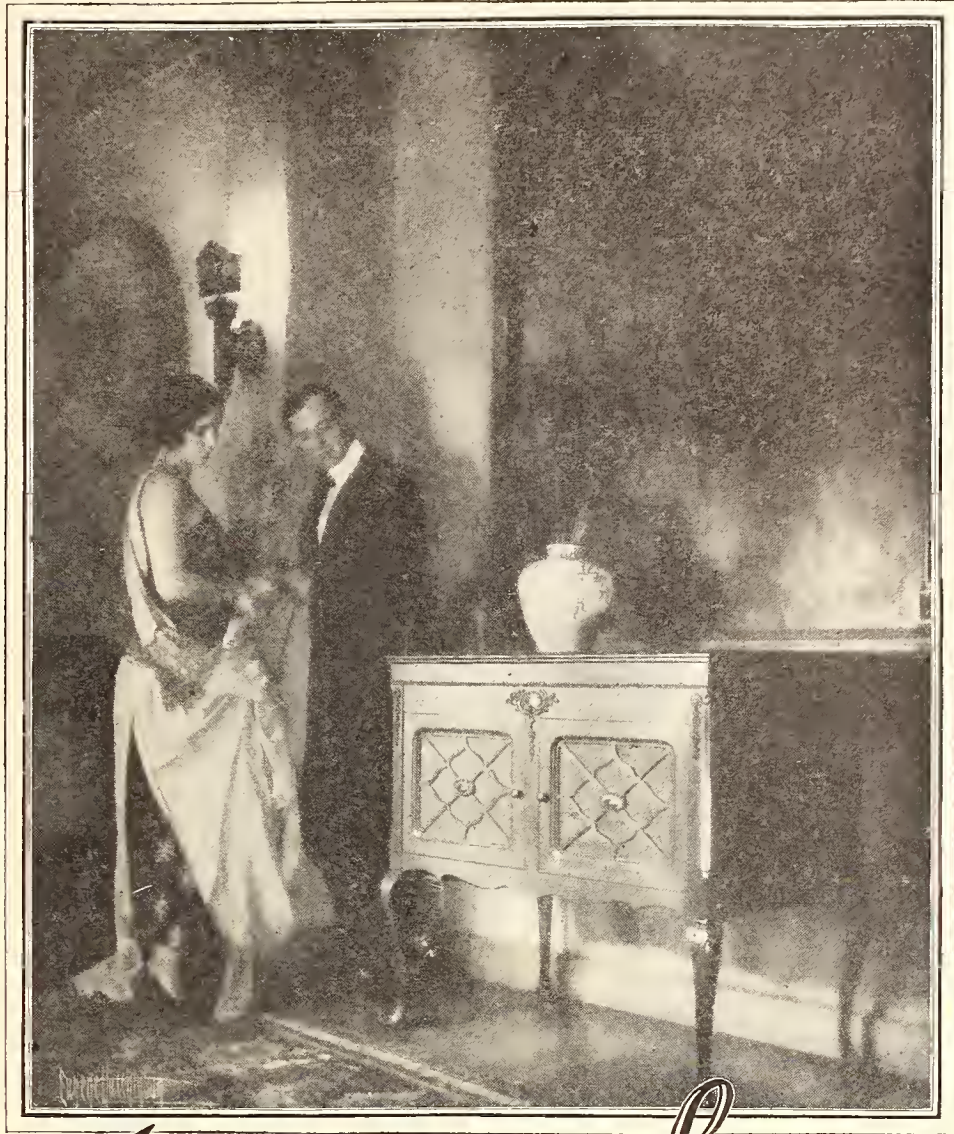

Widdicomb

PHONOGRAPH

The Aristocrat of Phonographs

DEALERS tell us that the Widdicomb appeals to all and everyone alike. Primarily, this is due to two main facts:

First: In the Widdicomb Phonograph the Amplifying Tone Chamber does full justice to the lower as well as to the higher musical tones. When playing an orchestral record on the Widdicomb, the deeper, richer tones are given equal prominence. And because the Amplifying Tone Chamber is vibrationless there is no suggestion of metallic harshness.

Second: The simple grace of all Widdicomb cabinet work depicts the fine art of true period interpretation. In this character of workmanship, where genuine knowledge of art and decoration is essential, the fame of Widdicomb cabinetmakers is known broadcast. Yet so subtle is the adaptation that the Widdicomb is at home in any furniture setting.

Write for latest catalog showing the many styles of Widdicomb Art Phonographs.

The Widdicomb Furniture Co.

Grand Rapids

Michigan

Fine Furniture Designers Since 1865

FAMOUS ARTISTS RECORD SHAKESPEARE FOR POSTERITY

First of a Series of Recordings of Julia Marlowe and E. H. Sothern, Two of the World's Foremost Interpreters of Shakespeare, Announced by Victor Educational Department

Great interest has been aroused in both talking machine and educational circles by the announcement in this month's Victor record supplement of the first of a series of records by Julia Marlowe and E. H. Sothern, the world's greatest Shakespearian actors. Lovers of Shakespeare, students of the drama seeking unquestionable standards of interpretation, and teachers and students in the public schools of America have long hoped that the talking machine might extend its already great service to mankind by offering selections from the spoken drama recorded by masters of the art.

President Johnson, of the Victor Co., in an interview granted the magazine System, which was reprinted in the December World, expressed his views on the importance of the talking machine in education, saying that he believed that when it is fully developed the talking machine will play as important a part in education as did the printing press. He expressed his confidence that the talking machine record would greatly enlarge its bounds into reproducing plays, short stories and even novels, and that the masterpieces of Shakespeare would soon be recited on records by expert elocutionists. This latter prophecy has now come true, and the educational department of the Victor Co. is taking honest pride in the truly excellent results that have been obtained.

True to its traditions of securing the best artists in the field of music, the Victor Co. has not fallen short of its high standard in securing interpreters of the spoken drama. Julia Marlowe and E. H. Sothern stand without peers on the English-speaking stage as exponents of the works of Shakespeare. These two eminent artists need no introduction to the American public. Both Miss Marlowe and Mr. Sothern, singly and as co-stars, have behind them long and splendid records of brilliant stage successes. Their last joint tour during the season 1919-1920 was a triumph from coast to coast.

It will be of interest to readers of The World to note the ever-growing interest that so many of the world's really great people are taking in the service of the talking machine to mankind. Miss Marlowe and Mr. Sothern, not playing this season, have journeyed all the way from England solely to make these Victor records.

They realize that it is only through Victor recording (and the elaborate equipment that the Victor Co. has already firmly established for serving the schools) that they may fittingly bequeath their matchless art to the youth of America and all coming generations. They have spent many years of arduous study in the field



Julia Marlowe and E. H. Sothern
As Viola and Malvolio in "Twelfth Night"

of the classic drama, and it is with a feeling of real joy that they now know that the artistic fruits of their labor are not to be lost, but preserved as a lasting heritage to posterity.

The first records chosen to announce the series of recordings comprise the immortal balcony scene from "Romeo and Juliet." Other well-known scenes, both duos and monologues from various Shakespearian dramas, are to make their appearance in due course.

INCORPORATED

The Venetian Phonograph Co., Scranton, Pa., has been chartered with capital stock of \$25,000 to engage in the retailing of phonographs. The incorporators are Dominico Ciccotti, Ernesto Alfano and Frank Skettino.

A LIVE COLUMBIA DISTRIBUTOR

Tampa Hardware Co. Celebrates Twenty-first Anniversary With Twenty-page Supplement to the Tampa Daily Times of Recent Date

The Tampa Hardware Co., of Tampa, Fla., has won national celebrity for its progressiveness, and a further proof of its just claim to this title is to be found in the issuance of a twenty-page supplement to the Tampa Daily Times of January 8, devoted entirely to the twenty-first anniversary of the founding of this institution.

Twenty pages devoted to one single subject as a section of a daily paper is something unique. It was inspired by W. C. Thomas, the guiding genius of the Tampa Hardware Co., and one of the big farseeing business men of Florida.

The real purpose back of the stunt was not so much to tell of the rapid growth and wonderful success of the Tampa Hardware Co., but to recall to the business men of Florida the economic soundness of the State at a time when optimism can be capitalized. Incidentally the retailer was offered helpful suggestions intended to aid him in making legitimate profits at a time when the market is no longer soaring.

Mr. Thomas remarked: "When the section was first proposed to some of the biggest manufacturers in America they came back with letters praising the idea enthusiastically—many of them thinking so well of it that they authorized advertisements of their own to appear in the special section. In fact, the demand for space caused an early readjustment of the original plan to publish a six or eight page section, the final capitulations demanding a twenty-page section."

The Tampa Hardware Co. has long been a Columbia distributor, and has a strong organization for the exploitation of the Grafonola and Columbia records, under the able direction of J. A. Bryan, Jr., throughout a large territory. This company handles everything in the line of hardware and agricultural implements in addition to the Columbia line.

TO CONCENTRATE ON WHOLESALE

Frank E. Bolway & Son to Retire From Retail Business in Syracuse and Rochester

SYRACUSE, N. Y., February 2.—Frank E. Bolway & Son, Inc., wholesale phonograph piano and sporting goods dealers, who have operated a retail store here and one in Rochester and have been connected with other retail enterprises, have announced that the firm will retire at once from the retail business. The increase in their wholesale business and the desire to avoid friction with retailers buying from their jobbing departments were given as the principal reasons for the change. The Bolway sales organization extends into more than one-third of the United States.

A new site on South Clinton street has been obtained and will be opened about February 1. The present site in South Salina street, which is under lease, will be rented.

In the new building a salesmen's conference room will be arranged on the first floor, and the second given over to general offices of the company. The remainder of the building will be used as a warehouse.

USE OF "TALKER" IN THE SCHOOL

TRENTON, N. J., February 4.—At the recent meeting of the Mercer County Teachers' Club, held at the Court House, this city, Prof. J. M. Dorey gave a talk and demonstration on "The Use of the Talking Machine in the School." It was listened to with the greatest interest, and was followed by a discussion which demonstrated that the talking machine is proving to be a factor of importance in the development of musical taste and appreciation.

Some men are like small ants—always in a hurry, and about what the Lord only knows.



HENRY BURR



ALBERT CAMPBELL



JOHN MEYERS

EIGHT FAMOUS VICTOR ARTISTS

In Concert and Entertainment
Personal Appearance of
Eight Popular Victor Favorites on One Program
A live attraction for live dealers and jobbers

Bookings now for season 1921-1922
A few available dates for Spring, 1921
Sample program and particulars upon request

P. W. SIMON, Manager
1604 Broadway New York City



FRANK CROXTON



MONROE SILVER



BILLY MURRAY



FRED VAN EPS



FRANK BANTA

Famous Ensembles including
Campbell & Burr - Sterling Trio - Peerless Quartet

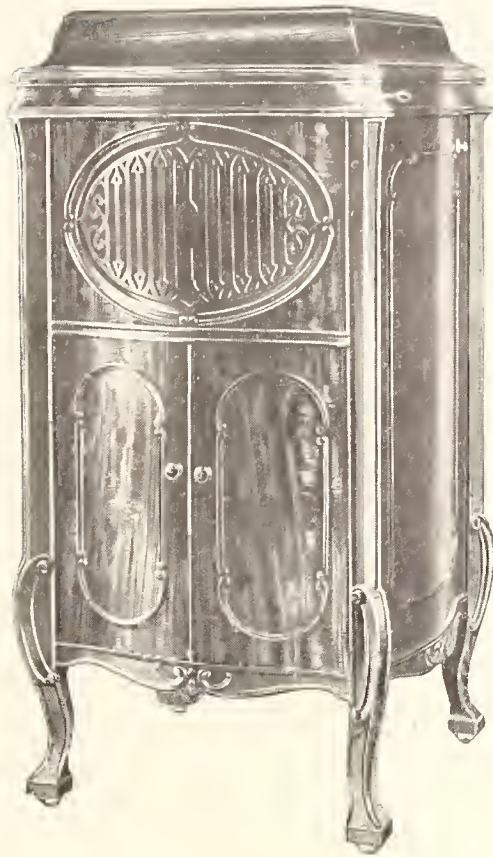

Dealer Representation

48% increase since June 1, 1920

These figures represent the new dealers gained by Brunswick in unrepresented districts in a seven months' period.

The same phenomenal growth and expansion is shown in all divisions of the business.

The increase in total sales on phonographs and records, for instance, was more than 58% over 1920.

The increase in Brunswick record production was 144% in a six months' period.

Brunswick dealers everywhere are enthusiastic about The Brunswick and Brunswick Records.

So, too, are the people who bought them. In hundreds of thousands of American homes are Brunswicks which could not possibly be replaced.

Brunswick offers the phonograph dealer not a plan or prospectus, but actual facts and figures and the experiences of dealers who have made money selling Brunswicks.

Seven great factories and two record pressing plants are working to supply the demand for 1921. Forty branch houses, located in principal cities, give the Brunswick dealer prompt and efficient service, no matter where he may be.

Brunswick national advertising, constant and dominating, creates customers for the Brunswick dealer, supplemented by the intensive local work of a Dealers' Service Department.

All combining to make the Brunswick franchise the most valuable today.

THE BRUNSWICK-BALKE-COLLENDER COMPANY

General Offices: 623-633 South Wabash Avenue, Chicago

Branch Houses in Principal Cities of United States, Mexico and Canada

New England Distributors:
Kraft, Bates & Spencer, Inc.,
1265 Boylston St., Boston, Mass.

Canadian Distributors:
Musical Merchandise Sales Co.,
79 Wellington St., West, Toronto.

Brunswick
PHONOGRAPHS AND RECORDS



Leopold Godowsky, Master Pianist

Exclusive Brunswick Artist

The splendid records which this great genius has made for Brunswick are a revelation of what Brunswick has accomplished in reproducing the piano, the most difficult of all instruments to record. The brilliance and power of this wizard of the keys are so faithfully interpreted, with such a vivid embodiment of his art, that his warmest admirers are astonished at the fidelity of the reproduction.

His Record "Rustle of Spring" is a marked example of what Brunswick Studios have done in piano recording.

Mr. Godowsky's early appearances, as scheduled to date, are as follows:

Feb.	1.....	San Francisco, Cal.
	7.....	San Diego, Cal.
	14.....	Denver, Colo.
	15.....	Longmont, Colo.
	24.....	Detroit, Mich.
March	1.....	New York, N. Y.
	2.....	New York, N. Y.
	4.....(With Max Rosen)	Philadelphia, Pa.
	6.....	Cleveland, O.
	11.....	Joplin, Mo.
	16.....(With Max Rosen)	New Orleans, La.
April	1.....	Eureka, Cal.
July	15.....	Ithaca, N. Y.

THE BRUNSWICK-BALKE-COLLENDER COMPANY

General Offices: 623-633 South Wabash Avenue, Chicago

Branch Houses in Principal Cities of United States, Mexico and Canada

New England Distributors:
Kraft, Bates & Spencer, Inc.,
1265 Boylston St., Boston, Mass.

Canadian Distributors:
Musical Merchandise Sales Co.,
79 Wellington St., West, Toronto.



The Gotham

Brunswick
PHONOGRAPHS AND RECORDS

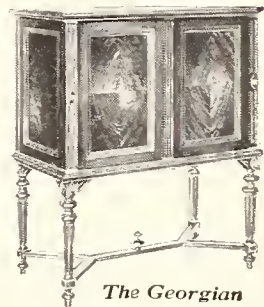

The Georgian

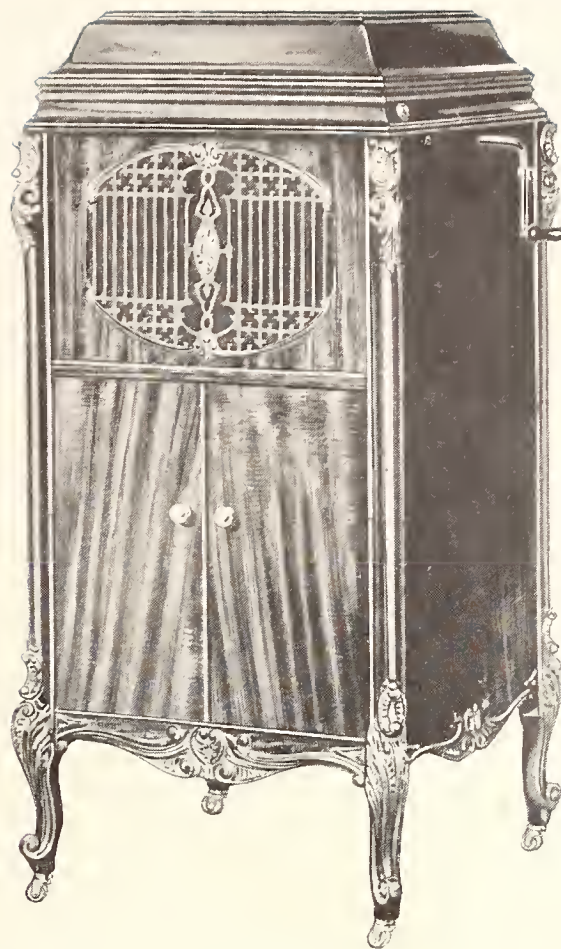

March Release of Brunswick Records

A well-balanced selection from the popular and romantic fields, some of them hits of the hour, some of them staples for which there is always a demand.

The next best thing for your customers—if they haven't a Brunswick—is Brunswick Records on the phonograph they have.

Any phonograph can play Brunswick Records

- | | | | | |
|------------------|---|----------------------------------------------------------------------------|-----------|----------------------------------------|
| 10026
10-inch | { | Thank God for a Garden (Del Riego) (Tenor) | | Mario Chamlee |
| 30003
12-inch | { | Ave Maria (Schubert-Wilhelmj) (Violin Solo—Pianoforte by Frederic Persson) | | Max Rosen |
| 13015
10-inch | { | Smilin' Through (Penn) (Baritone) | | Richard Bonelli |
| | { | Mother o' Mine (Kipling-Tours) (Baritone) | | Richard Bonelli |
| 5039
10-inch | { | Christ Arose (Lowry) Easter Hymn | | Collegiate Choir |
| | { | Come, Thou Almighty King (Wesley-Giardini) | | Collegiate Choir |
| 30004
12-inch | { | Marche Militaire (Schubert-Tausig) (Pianoforte Solo—Concert Paraphrase) | | Leopold Godowsky |
| 2068
10-inch | { | I Want To Be The Leader of The Band (Yellen-Gumble) | | Amphion Male Quartet |
| | { | My Mammy (Lewis-Young-Donaldson) | | Amphion Male Quartet |
| 2062
10-inch | { | Beale Street Blues (Handy) | | Al Bernard and Carl Fenton's Orchestra |
| | { | St. Louis Blues (Handy) | | Al Bernard and Carl Fenton's Orchestra |
| 25002
12-inch | { | Rigoletto (Verdi) Quartet | | Vessella's Italian Band |
| | { | Carmen (Bizet) Selection | | Vessella's Italian Band |
| 2066
10-inch | { | Kiss-A-Miss (Baron) Waltz | | Carl Fenton's Orchestra |
| | { | Singin' The Blues (Robinson-Conrad) Fox Trot | | Bennie Krueger's Orchestra |
| 2065
10-inch | { | Hula Blues (Noble) Fox Trot | | Green Bros.' Novelty Band |
| | { | Hop, Skip and Jump (Dyson) Fox Trot | | Rudy Wiedoeft's Californians |
| 2067
10-inch | { | Rosie (Merkur) Fox Trot | | Carl Fenton's Orchestra |
| | { | Caresses (Monaco) Fox Trot | | Green Bros.' Novelty Band |

THE BRUNSWICK-BALKE-COLLENDER COMPANY

General Offices: 623-633 South Wabash Avenue, Chicago

Branch Houses in Principal Cities of United States, Mexico and Canada

New England Distributors:
Kraft, Bates & Spencer, Inc.,
1265 Boylston St., Boston, Mass.

Canadian Distributors:
Musical Merchandise Sales Co.,
79 Wellington St., West, Toronto.



The Oxford

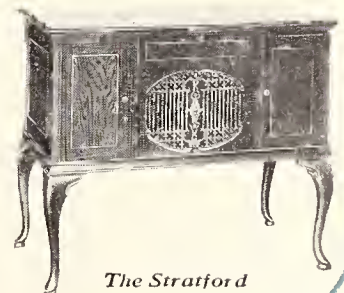

The Stratford

Brunswick
PHONOGRAPHS AND RECORDS

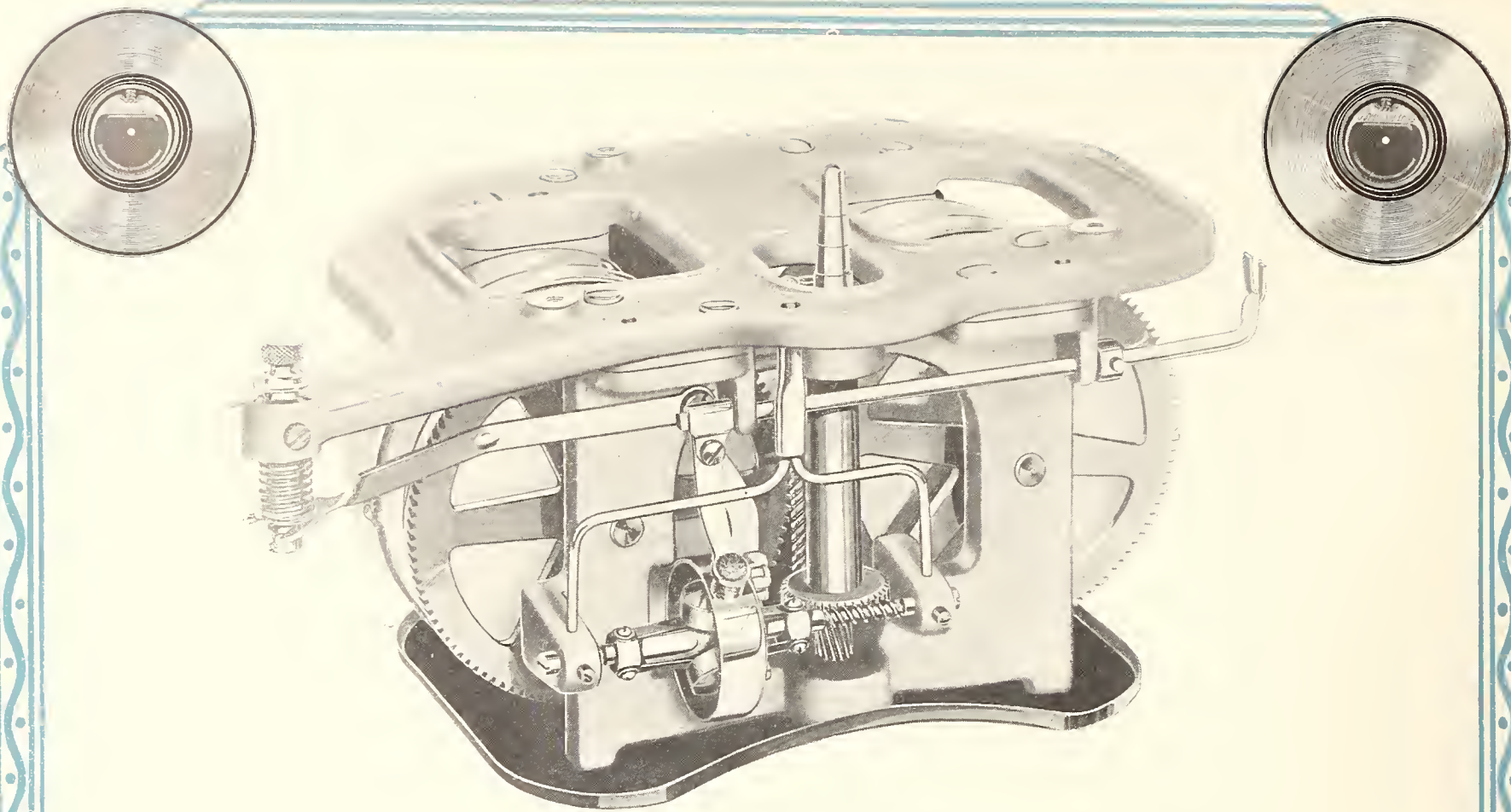

The Brunswick Motor (4-Spring)

Noiseless Vibrationless Unvarying
Accurate as a Watch

To insure a perfect reproduction a phonograph must rotate the record at an absolutely uniform rate of speed, for the slightest variation in speed will change the pitch and spoil the music.

Such a motor is a part of the exclusive Brunswick Method of Reproduction — the most exactly built and carefully fitted spring motor possible to make. It is worm-wound and winds easily while playing. It is worm-driven, to promote accuracy. Built on the vertical spring principle to eliminate vibration.

One of the other good features is the fact that the automatic stop works directly on the governor, instead of clutching the turntable, greatly reducing strain on the mechanism and making for longer life.

This motor can be obtained *only* on The Brunswick. It is made complete by Brunswick, in Brunswick factories, just as every separate part of the Brunswick Phonograph is made. The Brunswick-Balke-Collender Company is one of the few, if not the only, phonograph manufacturer in the whole world making a phonograph in its entirety.

Brunswick places no reliance upon outsiders at any stage of phonograph or record making. Brunswick operates its own timber lands in northern Michigan, is cutting its own veneer logs, slicing its own veneer, and manufacturing its own panels.

A plant is even being completed for manufacturing veneered shooks for shipping phonographs.

Every department of Brunswick business is 100% Brunswick.

THE BRUNSWICK-BALKE-COLLENDER COMPANY

General Offices: 623-633 South Wabash Avenue, Chicago

Branch Houses in Principal Cities of United States, Mexico and Canada

New England Distributors:
Kraft, Bates & Spencer, Inc.,
1265 Boylston St., Boston, Mass.

Canadian Distributors:
Musical Merchandise Sales Co.,
79 Wellington St., West, Toronto.

Brunswick
PHONOGRAPHS AND RECORDS

MAKER OF RECORDS IMMORTALIZED

The Art of Caruso and the Importance of His Talking Machine Records Emphasized in Interesting Editorial in the Brooklyn Eagle

The following tribute to the value and importance of the talking machine in the sphere of music to-day is taken from the Brooklyn Eagle of recent date. It emphasizes afresh that the talking machine has won a unique place in the domain of art—a position which has been recognized by the editors of our leading publications:

"A while ago Caruso was stricken with pleurisy and people began to wonder whether or not the famous voice had sounded its last beautiful note of song. Accident or death befalling great artists always arouses a sense of loss, for after all there are few artists in the world at any one time, and we do not feel that we can spare any of the art and beauty with which they surround us.

"When a painter dies his hand is forever stilled, but his pictures live, and with care, generation upon future generation can enjoy them and learn from them. It is so also with a great architect and his work, and a poet or an inventor. But until recently when a master of song died his song died with him, his voice was forever stilled and the people that came after had only the tradition that remained to help them feel the greatness of the voice that was gone. Jenny Lind, who was called the Swedish Nightingale, had a marvelous voice, but it is gone now, and lives only in the memory of those who heard her sing. So it was until recent years with all great singers and musicians—their work, their art was only for their own generation and it faded out with their lives.

"But the invention of the phonograph has changed this. Now the finest achievements of the singer, the most delicate interpretations of the pianist, the violinist and every other musical artist, are indelibly engraved on the talking machine record and can be renewed again and again.

"Caruso's voice will never die, for we have it with us for all time and the people of many years hence will enjoy it, too. The talking machine, you see, is more than a thing of pleasure—that is an end in itself—but its greatest value lies in the fact that it has enabled us to catch and hold forever the beauty of a song before it dies away on the air."

TAKES ON THE VOCALION LINE

The W. T. Crane Piano Co., Syracuse, N. Y., which recently became representative for the Aeolian Co. line of pianos and Pianolas in that territory, has just added the Vocalion and Vocalion records to its line.

If an employer asks a salesman to make a special effort on a certain line of goods, the salesman should never come back to the house explaining his inability to succeed. He should have sold the goods.

Your Opportunity to Buy at the Right Price

We manufacture 3 and 5-ply panel stock in all thicknesses and woods. Also 3-ply shelf stock for Talking Machine Cases.

Ask for quotations on our Talking Machine Crating Boxes. They are built of solid woods.

THE BRANDTS FURN. CO.
CELINA, OHIO

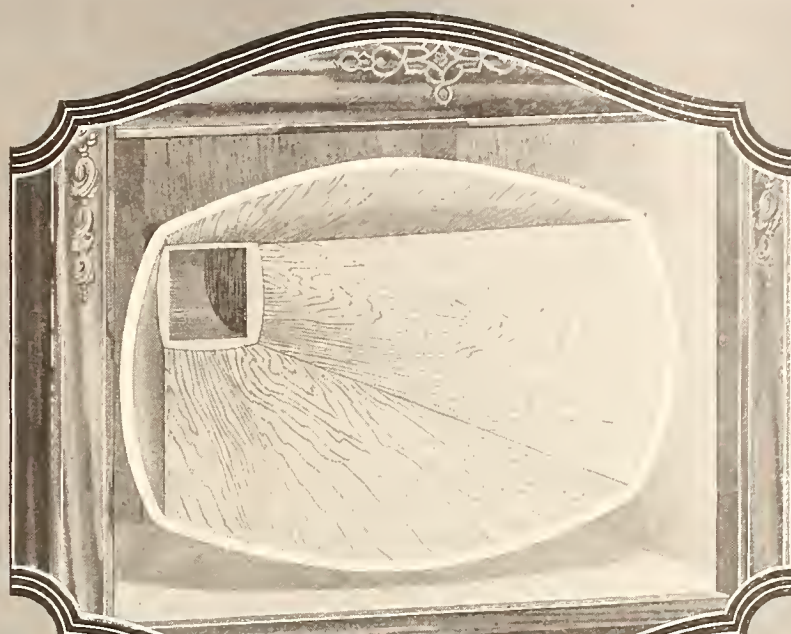

HARPONOLA

WHY Harponola Dealers STICK

Harponola Dealers have first of all a splendid instrument that can be handled at a good profit.

But, fine as that is, the vital reason that Harponola Dealers stick with us is this:

WE ARE SQUARE WITH OUR DEALERS. We back them up and make good on every claim and promise we make.

A limited amount of jobbing territory now open. Get our combination proposition on Harponolas and Okeh Records

THE HARPONOLA CO.
101 MERCELINA PARK
CELINA, OHIO
EDMUND BRANDTS, President

The PHONOGRAPH
with the
GOLDEN VOICE

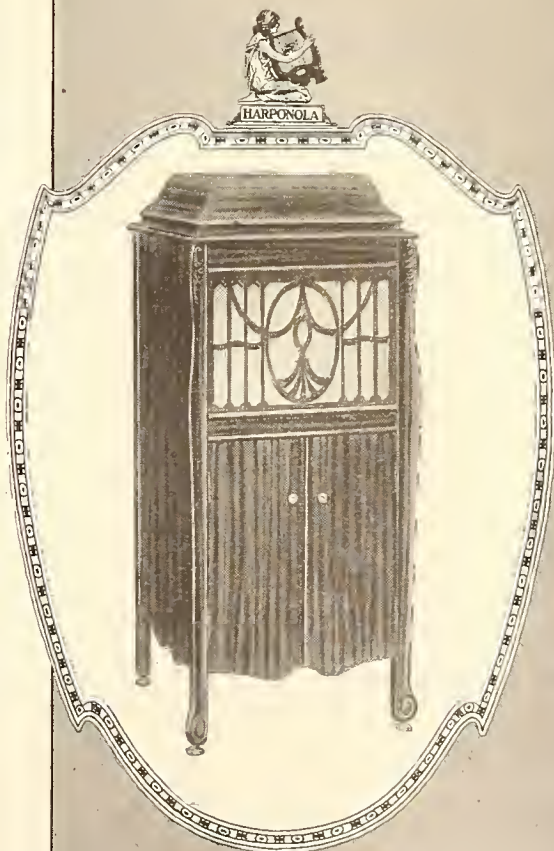



Rishell
THE MIRROR OF TONE
A
Master Phonograph

Consistency

1921 is proving to be the greatest Rishell year, especially because of the unfaltering pace, during the past 55 years, of the great company producing it. **The momentum of uninterrupted success is back of Rishell.** It is going forward at a pace that only great capital, great equipment, great prestige, can give to a great product. Rishell Phonographs make their market and keep it growing. Wire today for particulars of our liberal jobber contract.

RISHELL PHONOGRAPH CO.

WILLIAMSPORT, PA.

New York Distributor: GRAND TALKING MACHINE CO.
268-270 Flatbush Avenue Extension, BROOKLYN

Why Talking Machine Trade Should Support Movement to Encourage "Buying Now"

Members of the talking machine industry, either individually, through local organizations, or through the Music Industries Chamber of Commerce, would do well, in considering the present attitude of the public toward buying and ways and means for changing that attitude, to take heed of the movement that has developed among manufacturers and merchants and even bankers in various sections of the country to promote the "Buy Now" idea.

High prices alone are not responsible for the slackening off in buying, for there has been too much talk of thrift, of buying only necessities, of hoarding money, and of preparing to meet the days of famine, as it were. Bankers particularly seem to have taken a special delight in preaching to the worker of the coming of hard times, and the necessity of rigid economy on the one hand, while preaching optimism to certain other elements of our citizenry on the other.

There has been too much talk of thrift—so much so that the term thrift has apparently been accepted as meaning miserliness. The public has been told to buy only the necessities of life, and with every manufacturer and merchant apparently endeavoring by propaganda to bring his own particular product into that category there has resulted a confusion that has moved the average man to cease practically all his buying and not waste time endeavoring to differentiate between necessities and luxuries.

The business men of the country have come to the conclusion that the time for watchful waiting is past and that a strong nationwide propaganda to "Buy Now" is necessary to overcome the effects of the constant preaching of economy and thrift. In several of the cities of the country the "Buy Now" movement has made strong headway, and has received the support of Chambers of Commerce and business men's organizations.

In New York recently there was formed a National Prosperity Bureau by a number of prominent manufacturers, merchants and bankers representing commercial interests from all over the country. The Bureau is to carry on a campaign along the lines used for promoting Liberty loans, using newspaper and billboard advertising and working directly on the public through local organizations.

The arguments put forth by the Bureau and by the "Buy Now" organizations that have been formed in various cities are that prices have reached rock bottom, that the public can buy most articles right now cheaper than ever before, or cheaper than they will ever be able to buy them in the future, and that unless there is a general wave of buying, sensible, perhaps conservative, but nevertheless steady, there will be a severe permanent blow struck to the prosperity of the Nation. Attention is called to the fact that many factories have shut down, throwing thousands of men out of employment, and that by not buying, and, therefore, failing to create a demand for the products of these factories, the individual is simply aiding in bringing about a condition of depression that must ultimately affect him and his interests directly.

It may be a while before the public can be induced to buy on a normal basis, but there is no question but that they have the ability to buy. Savings bank deposits have never increased so tremendously as during the past couple of years, and with the average of wages very little below wartime standards the question of the financial status of the ordinary individual does not enter.

Any general movement to encourage buying, and to bring the Nation back to sensible spending, must, of necessity, have some effect in

stimulating the sale of musical instruments of various sorts. It is, therefore, the wise thing for the music industry to be represented in the campaign so that the effects will be as direct as possible. It is much easier to persuade a man to resume buying as a practice than it is to preach thrift and then endeavor to persuade him

to put part of his money, saved by denying himself, into one or two particular products.

It is, of course, too soon to determine just what effect the "Buy Now" campaign will have in stimulating retail sales and consequently wholesale manufacturing, but it is a move in the right direction—one that should be encouraged.

COMPLETES A MODEL DEPARTMENT

Moser Furniture Co. Prepares for a Large Columbia Business in 1921

KNOXVILLE, TENN., February 2.—The Moser Furniture Co., Columbia dealer of this city, has recently completed a model talking machine department. There are two beautiful hearing rooms, divided by record rack and counter, all of which are finished in ivory. The fittings are luxuriant and the seating arrangements unusually comfortable. The Moser Furniture Co. is a comparatively new Columbia representative, and is starting off with a campaign of extensive proportions. This includes newspaper advertising, unique window displays, special truck service and a host of merchandising ideas, many of which were secured through the Dealer Service department of the Columbia Co. The manager of this department reports a gratifying business and expressed enthusiasm over the house-to-house canvass campaign which is now in process.

The Harris-Douglas Furniture Co., of Boulder, Col., has opened a talking machine department in which it is featuring the Victrola with great success.

MUSIC AFFORDS RECREATION

Secretary of R. C. Wade Co. Says Music Is Needed to Relieve Strain of Modern Life

Dorchester Mapes, secretary and treasurer of the R. C. Wade Co., Chicago, which concerns manufactures the well-known "Tonofone" needles, makes some interesting comments on the talking machine business in general, and the needle business in particular, in a recent letter to The World. It reads in part:

"We want to go on record on a question that is vital to you and the rest of us—the phonograph industry is not a non-essential. We have been harping on this particular subject for some time. Always, and especially in times like these, we Americans are working under high pressure and must have relief and diversion or we go to pieces. Some of us go to pieces anyway. I want to ask you how better and at such very small cost can people get needed rest and recreation than through music, and especially the phonograph in particular?"

"We, in the needle business, are in an enviable position, because, even if no more records or machines were sold for months to come, people would still use the ones they have, and they must have needles."



FAITH and PROFITS

YOU must make a profit to live. You must have faith in the goods you sell. You must have the best for your customers or—no sales—and likewise no profits. U-sav-your gives you *all*, as it is the highest class cleanser and dressing on the market. "Make no mistake about this."

Schmelzer Company, Kansas City, Mo., say: "We are more than pleased with U-sav-your."

The Horton-Gallo-Creamer Co., New Haven, Conn., say: "We have tested it ourselves and find it very satisfactory."

Collings & Company, Newark, N. J., say: "U-sav-your brings us new customers and lots of repeat business."

If we paid a thousand dollars for more space we could fill it with "words of praise."

A great inventor was not satisfied with the candle light, so he produced the electric light. U-sav-your is to the "polish" trade what the electric light is to the candle.

If you want satisfied customers, If you want to keep faith, If you want a profit,

THEN SELL U-SAV-YOUR.

Sun and air dry the wood, don't they? A "polish" will not *feed* the wood and "put in" what the elements take out—but—U-SAV-YOUR *will*.

Write for liberal terms. Repeat sales guaranteed.

U-SAV-YOUR MFG. COMPANY

33 PERKINS AVENUE

WARREN, MASS.

"A new Gennett!"



The **ELUSIVE CHARM**

—the magnetic personality of the artists' original rendition of music, is the distinctive alluring appeal in **Gennett Records.**

Hear new **Gennett** No. 4656 re-animate the rich colorful baritone of Ernest Hare singing the song-hit "Margie," and on the other side the same artist delights with "All She'd Say was Umh-Hum."

Your dealer will gladly give you a hearing

Gennett Records

Manufactured by

The Starr Piano Company

Richmond, Indiana

New York—Chicago—Los Angeles—Birmingham—
Detroit—Cincinnati—Cleveland—Indianapolis—
Boston—Jacksonville—London, Canada

Have you ordered a set of actual Studio Photographs of Exclusive Columbia Favorites, framed, with artist's name and a short selling talk printed on the mat beneath each picture? They make all your customers' favorites still more familiar and enable you to tie up to their local appearances.

Columbia Graphophone Co.
NEW YORK



AUSTRALIAN EXCHANGE RULING HURTS EXPORT TRADE

Under Recent Court Ruling All Duties Are Assessed on the Commercial Value of Exchange Rather Than Upon the Mintage Value—Decision Works Hardships on Importers of American Goods

In a letter just received by The World from F. Owen French, Sydney, Australia, representative for the Jesse French & Sons Piano Co. and other lines in Australia and New Zealand, Mr. French states that the position of exchange is steadily becoming more serious, and has been a great obstacle in the handling of import trade. The latest blow has been an order of the court obligating customs authorities to assess duty on the commercial value of exchange and not, as previously, on the mintage value. This means that instead of duty being assessed on the invoice value at \$4.86 to the pound sterling it will be assessed on the ruling

rate of exchange at the date of the invoice, which rate may be \$3.40. As the duty is approximately forty per cent, the ruling works a great hardship on the importer of American goods.

On the other hand, when goods are imported from countries where the exchange rate is in favor of Australia, the Australian importer benefits to that extent. The basing of the duty upon the exchange rate is proving a strong factor toward discouraging American export business, and an effort is being made to have the court's decision in the test case either changed entirely or at least adjusted, to provide relief.

KLEIN-HEFFELMAN CO.'S NEW HOME

New Seven-story Building Being Erected by Music Concern in Canton, O., Will Be Ready for Occupancy on or About March 1

CANTON, O., February 2.—Towering seven stories over Canton's downtown business district, the new Klein-Heffelman building, at Fifth street and Market avenue N, will be ready for occupancy March 1, according to store officials. When completed the building will house the company's three big stores, one of which is its music store, long established just across the street from the new building site. Approximately \$450,000 has been expended on the building, which is to be one of the finest and most complete department stores in eastern Ohio. In the new building this company will enlarge in all its music departments and will have one whole floor devoted to the display and sales rooms for its piano, phonograph and musical merchandise trade.

RHODES BROS.' NEW SALESROOM

Prominent Department Store in Tacoma Adds New Salesroom for Victor Display

TACOMA, WASH., February 2.—Rhodes Brothers, of this city, have recently added a very attractive new salesroom to their talking machine



Rhodes Bros.' New Showroom

department, which is located on the sixth floor of this large department store. The Victor line is handled and a goodly display of the various styles is shown in this room, which is a combination rest, sales and display room. The talking machine department has a very competent sales staff and does an excellent volume of business. Although there has been some slowing up in business since the holidays there is now a steady improvement in sales which is bound to continue, as the year gets older. All connected with the Rhodes Bros. establishment expect to close a large volume of business in 1921.

NEW TRUCK FOR LANDAY BROS.

Landay Bros., the prominent talking machine and piano dealers, New York, have just added a new truck to their large fleet of motor vehicles. The new truck is equipped with a van body, and designed for use in delivering both Victrolas and pianos.

Entertaining a customer by a business talk apparently foreign to your own line, yet edging up close to your proposition and creating interest and desire, is an art in which few men excel. It pays to give it cultivation.

SUCCESSFUL SELLING ESSENTIALS

There is nothing mysterious about salesmanship. Thousands of successful salesmen have never studied psychology or the kindred sciences. To be able to sell is to be human. Successful selling is made up of a number of little things—a smile, a word of cheer, a tone of voice, a right word at the right time.

The Brush Furniture Co., of Brush, Col., which has recently been appointed Victor dealer, reports an excellent business in the territory in which it operates.

COLUMBIA BRANCH IN TORONTO

The Columbia Graphophone Co. has recently opened up its first branch house in Canada serving the retail trade direct. This establishment is located at 204 St. Catherine street, Montreal, with Hector Garand as manager.

Don't look for trouble unless you can handle it when you find it.

We Figure This Way:

The more we assist our dealers in promoting the sales of Victrolas and Victor records, the faster their business will grow. And, naturally, good business for our dealers results in good business for us.

Wouldn't you value an affiliation with a wholesaler who realizes that his success depends on your success?

C. C. Mellor Company
1152 Penn Avenue, Pittsburgh, Pa.



PRESIDENT-ELECT W. G. HARDING
Used Magnavox Equipment During His Campaign



TELEMEGAFONES

—
 If there is no distributor near you write for our new Bulletin MV-14
 —

It gives complete information of the many uses of Magnavox Music and Voice Telemegafones

Both the new President and his political opponents recognized the enormous advantages of Magnavox apparatus and by means of it talked to many crowds of from 40,000 to 100,000 people.

MAGNAVOX
 MUSIC AND VOICE

TELEMEGAFONES TYPE MV-1

increase the volume of the voice or any phonograph many times. * * * * * Magnavox Special Telemegafone equipment will still further increase the volume of the voice to enormous strength for public speaking to vast assemblages of people. * * * * *

THE MAGNAVOX CO. :: Oakland, Calif.

TRADING "TALKERS" FOR FURS

Captain Krupp Tells Interesting Story of His Visit to Northern Lands and of the Popularity of the Talking Machine Among Natives

To those people residing in Siberia, particularly those centers visited occasionally by ship-masters who take seasonable loads of merchandise from the United States, the talking machine is one of the most effective instruments for closing profitable "trades" of rare furs. Captain Krupp in a recent article in one of the Sunday papers tells of his visit to Cape Nome, Unalakleet and Yukon River to exchange merchandise for furs with the Eskimos. From there he pushed into Siberia and Kamchatka and to Hokkaido, the island home of the hairy Ainu, the aboriginal Japanese, where he made new friends beyond the outposts of civilization in the neighboring Asia.

Telling of his visit to one of these fur centers Captain Krupp remarked after his luggage carrier had untied several bundles:

"I passed to the wife and daughter of the house a bundle of flashy bead necklaces and started the talking machine. While the head of the house was looking inside the talking machine for the singer, who happened this time to be Billy Golden, singing 'Turkey in the Straw,' the Indian asked how much money I wanted for the music box. I replied that I did not sell talking machines or beads for money, but I would trade them for furs.

"How many furs you catch him in trade?" the Indian asked.

"I don't know," I replied. 'Bring them out and I will look them over.'

"Whereupon the entire family began to lug in marten, sable, ermine and squirrel furs. I made several lots and traded a talking machine for one lot, a mackinaw coat for another lot, a 10-pound bucket of candy for another and three strings of beads and a calico dress for another. Before leaving I presented to the man some cheap baubles which took their fancy and our negotiations were at an end, every one being fully satisfied that a satisfactory and profitable deal had been closed."

ROEHR CO. DEPARTMENT REMODELED

Topeka Concern Makes Improvements in Order to Handle Growing Business

TOPEKA, KAN., February 1.—The W. F. Roehr Music Co., of this city, has just completed remodeling its talking machine department, which comprises a series of eight rooms on the first floor divided by one large record stockroom, with necessary equipment. This store, the oldest Victor representative in the State, has enjoyed many years of successful talking machine merchandising throughout the State of Kansas. Aside from its Victor activities it has also introduced Brunswick phonographs and records in a large way in Kansas.

The Nostrand Phonograph Co., of Brooklyn, N. Y., has announced its dissolution.

Your Problem Is Ours

Good Profits (to you)

+ Good Service (to your customers)

Answer: TONAR RECORD BRUSHES

(Trade Mark)



Have we solved the above problem correctly?

Write to-day for prices and sample and see for yourself

PARKS & PARKS, Inc.

TROY, N. Y.

New York Office, C. E. Peabody & Co., 186 Greenwich St.

Southern Representatives: I. W. Becker & Co., 226 1/2 Peachtree St., Atlanta, Ga.

SECURED VICTROLA ON BAD CHECK

Long Island News Co. Loses Victrola XVII to Swindler—Trade Asked to Be on Lookout

The Long Island News Co. reports that a man representing himself as Edward Nostrand, a resident of Flushing, L. I., called at the store of the News Co. last month and purchased a Victrola XVII, Serial No. 8437, in English brown finish, for which he gave a check. The check was later returned marked "N. G.," and investigation proved that in the house where the machine had been delivered the man had held a room only two days. The machine was traced to a tea and coffee store in New York, and there all trace was lost.

The man is described as being about five feet five inches tall, smooth shaven, florid complexion, and representing himself as a civil engineer. Dealers and repairmen are asked to be on the lookout for the machine, Serial No. 8437, and to notify the manager of the Flushing store of the Long Island News Co. at 45 Main street.

DEVELOPING IDEAS

The right kind of man material will grab an idea and make it bigger. The wrong kind will use that one idea and then sit down and wait for you to hand them another. The right kind of man will learn something new from every experience. And he will develop incidents into laws of action.

FAMOUS FRENCH CABINET

Original From Which Edison Machine Was Copied Shown on Postcard Photograph

Below is a postcard photograph just received of the celebrated cabinet dating from the reign of Louis XII, belonging to the French Govern-

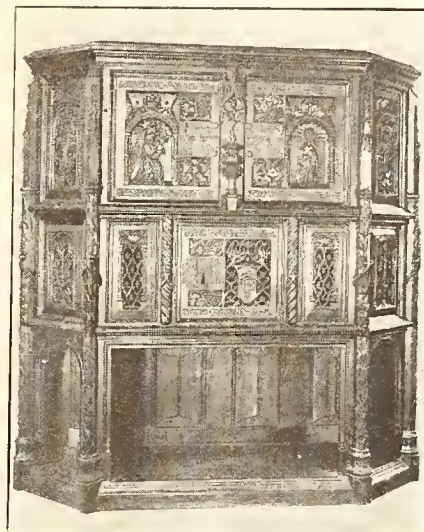

41. Musée de CLUNY — Dressoir, art français, commencement du XVII^e siècle. C. B.

Historic Edison Cabinet

ment, and now to be seen in the Hotel De Cluny, Paris. The Edison French Gothic phonograph, shown in the Edison catalog at \$5,500 and one time featured in the Edison national advertising, is an exact replica of this cabinet, said to be the finest piece of Gothic furniture in the world. One of these is now in the home of Thomas A. Edison.

SOJOURNS IN SOUTHERN CALIFORNIA

H. L. Hale, of the Hale Music Co., Marshfield, Ore., was a visitor at the offices of the Walter S. Gray Co. in San Francisco January 14 on his way to southern California and Arizona, where he will spend the Winter. Mr. Hale is a veteran of the big war, was wounded in the Argonne and put in the rest of his time as a soldier in the hospital. He spent several hours in San Francisco fighting the battle over again with some members of the Walter S. Gray Co. forces who were also there.

A salesman who decides at first sight that certain goods will not sell is assuming that his judgment is better than the judgment of all his customers.



AUTOMATIC STOPS

The simplest and most efficient Automatic Stop on the market. They give excellent service, are easily installed and are absolutely guaranteed.

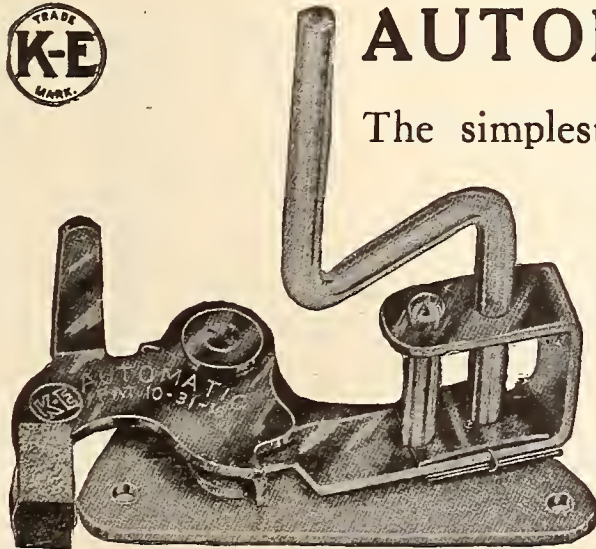

Send 50 cents for Sample Stop

Kirkman Engineering Corporation
484-490 Broome St., New York

The Important Part Salesmen Can Play in Bringing About Better Conditions By Bruce Barton

As a writer on business subjects Bruce Barton has set forth a number of business truths through the medium of type, but never was truth presented more forcefully or at a more appropriate time than in his booklet issued recently, "As Prophets, Are Your Salesmen a Loss?" The booklet represents a reprint of an article under that title by Mr. Barton which appeared recently in *Printers' Ink*.

It will be well for every manufacturer, wholesaler and retailer in the music industry, and for that matter in every other industry, to read and ponder over the following paragraphs. Seldom has a situation and a way to meet it been presented so clearly and forcefully.

The Apostle of Gloom

Into a country store a salesman enters, drops his bags on the floor and leaning confidentially across the counter asks:

"Well, how's business with you?" The tone of his voice indicates little expectation of an encouraging reply.

"Rotten," responds the merchant, fitting his answer perfectly to the other's mood.

"Same story everywhere," exclaims the salesman. "I just blew in from Lebanon on number forty-six. You know Ed Kidder over there; he says the last two weeks are the worst he's ever known in twenty years of business."

"Ain't been quite as bad as that here," says the merchant, struggling to retain a shred of hope.

"Well, things get worse before they get better, you can take my word for that. I'll tell you the labor situation in this country is all wrong. Those fellows have just simply forgotten how to work, if they ever knew how in

the first place. They've got to be taught a good, stiff lesson. Am I right?"

The merchant nods, turning toward a customer who had entered with the intention of spending some money. The customer restrains his impulse, however, and joins the audience instead.

"Another thing, it's going to take ten years to get the railroads into shape if it takes a day," the visitor continues authoritatively. "Why,

Salesmen Should All Preach Constructive Optimism Instead of Scattering Tales of Hard Luck and Gloom

before the war we used to ship from our factory to Kansas City in nine days; lately we've had stuff on the road for five and six weeks. Five and six weeks, can you beat that?"

By this time the audience has grown to quite a group, more intending customers having been veered from their course.

"Of course I'm an optimist, y' understand. My wife says that if I fell out of a ten-story window I'd bounce right up again; that's the

kind of a fellow I am. But when I left New York things were pretty gloomy. We'll see breadlines before this Winter is over, I'm telling you; and soup kitchens and everything. . . . Well, I suppose there's no use showing you anything to-day?"

"Not to-day," responds the merchant decisively.

"Well, so long."

The customers drift out, clutching their money a little tighter; the merchant in his solitude sits and broods upon his troubles. The salesman hurries on from store to store, and by evening time ten merchants and fifty citizens are filled with a deeper foreboding. They have met a man from New York who has told them direful things. It is time to be careful. Let every man keep a firm hold upon his purse and warn his wife to buy nothing.

In twenty days that salesman may visit twenty little towns, and who shall measure the power for good or ill that lies in his well-meaning but often thoughtless talk?

To give the impression that this man is in any way typical of the great army of American salesmen would be to do an immense injustice to as fine a body of men as were ever gathered together in business. There are unworthy members of that army, to be sure, as there are unworthy representatives of every profession; but the vast majority of salesmen are loyal, capable and intelligent in an unusual degree. The point I want to emphasize is merely this: that no other body of men have it so largely in their power to promote sound or unsound economic thinking in the United States as American salesmen, and I wonder whether this

COMMON SENSE

In Facing the Problems and Formulating Your Plans for the Year's Business, Common Sense Should Dictate That the Product Which Stands Foremost of Its Kind Obviously Stands Foremost as the Best Business Proposition.

DE LUXE NEEDLES

Have Stood the Gaff and Are as Always the Same Old Dependable Standby

Samples, Discounts and Full Particulars Upon Request

DUO-TONE COMPANY, INCORPORATED

Sole Manufacturers of De Luxe Needles
ANSONIA, CONN.

Don't Forget These Facts

- 1. Perfect Reproduction of Tone
- 2. No Scratchy Surface Noise
- 3. Plays 100-200 Records



Full Tone



Medium Tone

Three for 30 cents



IN THE HANDY CAN

NYOIL

FOR YOUR PHONOGRAPH

Made in Our Watch Oil DEPARTMENT

which for half a century has made 80% of all the watch, clock and chronometer oil used in America.

The Best Oil For Any Talking Machine

In refining, Nyoil is given the same care as our famous watch oil receives. All gums and impurities are removed, leaving it

Colorless, Odorless and Stainless.

Housekeepers say they would not be without Nyoil because it is best for phonographs and sewing machines—for polishing furniture and woodwork and is odorless and will not stain. It is free from acid and will not gum, chill or become rancid. Sportsmen find it best for guns because it prevents rust.

NYOIL is put up in 1-oz., 3¼-oz. and 8-oz. Bottles and in Quart and Gallon Cans.

For Sale by all Talking Machine Supplies Dealers
WILLIAM F. NYE, New Bedford, Mass., U.S.A.

fact has been sufficiently recognized by the salesmen themselves and the sales managers who direct them.

How many manufacturers recognize it, and take pains to provide their representatives with current economic information of interest to stimulate wholesome thinking on the part of the men they meet? How many have ever stopped to ask themselves these questions: "Haven't I a responsibility to the communities that support me beyond merely filling their stores with my product? When my men travel in and out of those towns what do they carry with them and leave behind them in addition to my goods?" . . .

What are salesmen of America carrying these days in addition to their sample cases? And what should they be carrying and leaving behind them at every call?

Tell Everybody They Must Work

Three things at least, it seems to me.

First of all, every man who travels ought to be doing his share to spread abroad the gospel of hard work as our only sure path to salvation. In every town to-day are men who are waiting in idleness for business to "pick up again," and indulging meantime in conversation that adds to their own depression and that of other men. It would put us a long way forward if every such man would to-morrow morning find some way to go to work. The kind of work makes little difference; the important thing is that he should be busy instead of idle, should have his mind turned away from his troubles and, by his example, stimulate other men to activity. If customers refuse to be lured to his counter let him wash the front windows or paint the front door. Let him put his boy Joe, or his daughter Nellie, in charge for a while and go dig in his garden or patch up the back steps, as his wife has been

ROTTEN STONE

We are the only miners and manufacturers in this country of Rotten Stone for use in Phonograph Record making. Our product is now in use by practically every record manufacturer in this country. We are also headquarters for all other minerals for record making and everything we handle is made especially for this purpose and absolutely guaranteed. Expert advice given upon any formula.

KEYSTONE MINERALS CO.

41 Union Square, New York City

urging him to do for the past four or five years. Let him somewhere, somehow, do something; for gloom and foreboding are frightfully contagious, and idleness is the parent germ of both. . . .

With that needed gospel, every salesman ought to carry also a generous measure of tolerance in days of stress and change like these. We're all born intolerant; we are naturally suspicious of anyone who thinks differently from ourselves. Some of us overcome that inherited tendency as we grow older; some of us are merely hardened and confirmed in its bad effects. The pages of history are stained with the record of men's cruelty to one another because of an unwillingness to entertain the new idea, and the heresy of one generation becomes the commonplace orthodoxy of the next.

Intolerance is dangerous enough in any age, but peculiarly so in a period when everything is changing so rapidly as now. The man in business who says, "We have always done things this way, and so we always will," is likely to wake up and find that the course of the river of Business has shifted overnight and left him high and dry. And the man who says "It was good enough for my father and it is good enough for me" ought to have a commission appointed to look into his mental condition.

Most of us would be a lot more comfortable if the world would quietly go back to the settled conditions of 1913, but it never will. And while we do not want to lose anything that was good in the older order we ought to be very careful that the chariot of progress does not come along and run us down, because we are standing in the middle of the road and facing the wrong way. New truth comes into the world wearing such strange clothes and covered with so many false whiskers that one has to be constantly on the lookout. I never see a crowd of queer-looking folks professing some crazy idea without remembering how queer-looking the crowd must have been that followed Jesus of Nazareth. I never see all the respectable people of a city on one side of a question without remembering that all the respectable people of Athens were on the same side of the question when Socrates was put to death. But the crowd was wrong, and the one was right.

Backing a Sure Bet

Our nerves are ragged from the war. We spend an awful lot of time in picking on each other, and denouncing each other, and calling for a return to the good old days which are gone—and weren't so awfully good at that. And what we need most of all is a willingness to believe in the general goodness of our fellow-men, coupled with a reasonable readiness to try the new thing before we condemn it because it is new. . . .

You meet men to-day who talk as if the race were going barefoot from this time forward, and there would never be any more market for shoes; they talk as if we were all going to walk forever, and there would never be any more call for automobiles. And by that foolish, useless conversation they impede the coming of the day whose coming they most earnestly desire. But men of the Morgan and Rothschild type waste no time in any such futile conversation. They go steadily forward betting on the future, knowing that there is only one way that the curve of business can point in the long run, and that is up, because the United States is marching on. . . .

Hundreds of thousands of men travel in and out of the towns of America; some of them, Mr. Manufacturer, travel for you. They ought to be apostles of sound thinking and vigorous courage. The towns ought to be better towns, and the business men in them better business men, because your representatives have called. You have it in your power to make every man, in a sense, a prophet of the gospel of hard work, of broader tolerance, and of unflinching faith.

Many salesmen already are improving their opportunity in a magnificent degree. I could name certain organizations whose men are furnished with a daily supply of wholesome, interesting information, out of which to make conversation with their customers, and so to pro-



BLANDIN

IT is indeed gratifying that music lovers should so promptly assign the Blandin Phonograph the leadership in musical re-production. You are cordially invited to come in and hear a piano, violin or voice record re-produced on the Blandin.

Racine Phonograph Co., Inc.
RACINE, WISCONSIN.



note the wider diffusion of sound economic thought. Such men render a service that is far beyond the mere distribution of goods and, coming to the end of their path, have the satisfaction of knowing that many communities are better because they have passed that way.

And I have known other salesmen who left behind them nothing better than a fund of discolored stories and an occasional new word of slang. Men of that sort are unworthy of the high calling of salesmen. They are mere recorders of orders when they might be apostles of sound thinking. As prophets they are just a dead loss.

The Mignon DeLuxe Records and Phonograph Co., New York, has been incorporated with capital stock of \$150,000 by J. A. Voskamp, I. A. Lyons and L. B. Burgas.

HITS—FIRST AND BEST ON Actuelle RECORDS

(Needle Cut Records by Favorite Pathé Artists. All Size 10)

- | | | |
|--------|---|-----------------------------------------------------------------|
| 022492 | { | VELMA—Saxophone Solo.....Rudy Wiedoeft |
| \$1.00 | | MARRIAGE BELLS—Van Eps-Banta Trio
Banjo, Saxophone and Piano |
| 022493 | { | WITH THE COMING OF TO-MORROW
Robert Bruce, Tenor |
| \$1.00 | | DEAREST ONE
Lewis James and Elliott Shaw, Tenor and Baritone |
| 022494 | { | BONNIE LASSIE.....Charles Hart, Tenor |
| \$1.00 | | MELLO CELLO—Dance Rhythm....Elliott Shaw, Baritone |
| 022495 | { | THE ARABIAN YOGI MAN.....Crescent Trio |
| \$1.00 | | MY MAMMY.....Carlton Williams, Tenor |
| 020484 | { | CRAZY BLUES—Dance Rhythm.....Noble Sissle, Tenor |
| 85c. | | GREAT CAMP MEETIN' DAY....Noble Sissle, Tenor |
| 022497 | { | STRUT, MISS LIZZIE.....Ernest Hare, Baritone |
| \$1.00 | | HOME AGAIN BLUES—Dance Rhythm
Ernest Hare, Baritone |

LATEST DANCE HITS

- | | | |
|--------|---|-----------------------------------------------------------------------------------------------------|
| 022498 | { | HUMMING—Fox-trot.....Joe Gibson and His Orchestra |
| \$1.00 | | I NEVER KNEW (I Could Love Anybody Like I'm
Loving You)—Fox-trot....Joe Gibson and His Orchestra |
| 022499 | { | O-HI-O (O-My-O)—One-step
Bennie Krueger and His Orchestra |
| \$1.00 | | LEARNING—Fox-trot....Bennie Krueger and His Orchestra |
| 020485 | { | LOVE BIRD—Fox-trot.....Casino Dance Orchestra |
| 85c. | | THE LEGEND—From "Lady Billy"—Waltz
Casino Dance Orchestra |
| 020486 | { | BRIGHT EYES—Fox-trot.....Casino Dance Orchestra |
| 85c. | | LOOK FOR THE SILVER LINING—From "Sally"
(Fox-trot).....Casino Dance Orchestra |
| 022502 | { | I NEVER REALIZED—Fox-trot.Piedmont Dance Orchestra |
| \$1.00 | | I LOST MY HEART TO YOU—Fox-trot
Piedmont Dance Orchestra |
| 022501 | { | MAKE BELIEVE—Fox-trot..Nicholas Orlando's Orchestra |
| \$1.00 | | TWO SWEET LIPS.....Nicholas Orlando's Orchestra |

Pathé Frères Phonograph Co. Brooklyn, N. Y.

HITS—FIRST AND BEST ON



LATEST DANCE HITS

- 22498 { HUMMING—Fox-trot
Joe Gibson and His Orchestra
Size 10 { I NEVER KNEW (I Could Love
\$1.00 { Anybody Like I'm Loving You)
Fox-trot. Joe Gibson and His Orchestra
- 22499 { O-HI-O (O-My!-O!)—One-step
Bennie Krueger and His Orchestra
Size 10 { LEARNING—Fox-trot
\$1.00 { Bennie Krueger and His Orchestra
- 20485 { LOVE BIRD—Fox-trot
Casino Dance Orchestra
Size 10 { THE LEGEND, from "Lady Billy"
85c. { —Waltz ... Casino Dance Orchestra
- 20486 { BRIGHT EYES—Fox-trot
Casino Dance Orchestra
Size 10 { LOOK FOR THE SILVER
85c. { LINING, from "Sally"—Fox-trot
Casino Dance Orchestra
- 20487 { PERSIA—Fox-trot
Eddie Kuhn and His Orchestra
Size 10 { NOW AND THEN—Fox-trot
85c. { Duane Sawyer and His Novelty Orchestra
- 22501 { MAKE BELIEVE—Fox-trot
Nicholas Orlando's Orchestra
Size 10 { TWO SWEET LIPS—Fox-trot
\$1.00 { Nicholas Orlando's Orchestra
- 22502 { I NEVER REALIZED—Fox-trot
Piedmont Dance Orchestra
Size 10 { I LOST MY HEART TO YOU
\$1.00 { —Fox-trot
Piedmont Dance Orchestra

POPULAR VOCAL HITS

- 22493 { WITH THE COMING OF TO-
MORROW... Robert Bruce, Tenor
Size 10 { DEAREST ONE
\$1.00 { Lewis James and Elliott Shaw
Tenor and Baritone Duet
- 22494 { BONNIE LASSIE
Charles Hart, Tenor
Size 10 { MELLO CELLO
\$1.00 { Dance Rhythm, Elliott Shaw, Baritone
- 22495 { THE ARABIAN YOGI MAN
Crescent Trio
Size 10 { MY MAMMY
\$1.00 { Carlton Williams, Tenor
- 22496 { TIMBUCTOO... Billy Jones, Tenor
Size 10 { SOMETHING
\$1.00 { The Harmonizers (Male Quartet)
- 20484 { CRAZY BLUES
Dance Rhythm, Noble Sissle, Tenor
Size 10 { GREAT CAMP MEETIN' DAY
85c. { Noble Sissle, Tenor
- 22497 { STRUT MISS LIZZIE
Ernest Hare, Baritone
Size 10 { HOME AGAIN BLUES
\$1.00 { Dance Rhythm. Ernest Hare, Baritone

Pathé Frères Phonograph Co.

Brooklyn, N. Y.

BUBBLE BOOKS

Tie Up Your Sales of Bubble Books with a Bubble Book Party

THIS very interesting Mother Goose novelty can be given by schools, clubs, societies, etc., as a social entertainment very easily. It makes a big hit with the children because they can all take part in it as Mother Goose characters.

There's nothing like a Bubble Book Party to stir up the sales of Bubble Books.

When you are in New York, during February or early in March, come to the Bubble Theatre in the Bush Terminal Sales Building, 130 West 42nd Street, and see for yourself just how attractive such a party is. Matinee at 4.15 P. M. daily.

Bubble Book Sales Service

130 West 42nd Street

NEW YORK CITY

Twenty-five child actors under expert direction take part in it. You are cordially invited any day that suits your pleasure.

The Bubble Books are year-round sellers because their appeal is universal. Big national advertising and genuine selling helps, intelligently and heartily gone into, create business for you.



Nora Bayes Week—from February 26th to March 5th—will make this wonderful popular star known to the comparatively few people in this country who don't know her already. You have a dozen records by her, twenty-four selections, all hits. Her latest is A-3347.

**Columbia Graphophone Co.
NEW YORK**



WHERE GREAT ARTISTS WILL MEET

Columbia Graphophone Co. to Establish "Green Room" in One of the Three Top Floors Set Aside for Their Recording Laboratories in the Gotham Building, Columbus Circle

In olden days, when theatres were few and far between, all the eminent artists of the theatrical stage used to gather in the famous "Green Rooms" of the old-time English theatres. Now that New York has more than half a hundred theatres, many concert halls and vaudeville houses and two great opera houses open every season, such a concentration of talent would seem impossible.

But it can and will be brought about, to a great extent, because of the fact that so many of stageland's present-day favorites and of the great musicians of the past three years are making records for the Columbia Graphophone Co. This company recently signed a million-dollar lease for the eight top stories of the new twenty-four-story Gotham National Bank Building at Broadway and Fifty-ninth street, and is making elaborate preparations for the reception of these artists.

The three top floors have been set aside for the Columbia recording laboratories and in addition to these recording rooms with especially prepared acoustic properties, where music in all languages will be recorded by specialists, there will be a department given over to the reception of musicians in an atmosphere that tends to develop their art.

Here such great opera stars as Rosa Ponselle, Charles Hackett, Riccardo Stracciari, Jeanne Gordon, Hipolito Lazaro, Jose Mardones, Margaret Romaine, Leon Rothier, Mary Garden, Maria Barrientos, Florence Macbeth and Cyrena Van Gordon will meet and mingle with such leading instrumental artists as Eddy Brown, Pablo Casals, Percy Grainger, Josef Hofmann, Sascha Jacobsen, Toscha Seidel, Eugen Ysaye and Duci di Kerekjarto.

Such lively popular artists as Al Jolson, Nora Bayes, Frank Crumit, Marion Harris, Guido Deiro, Van and Schenck, Bert Williams and Harry C. Browne will foregather with such dance orchestras and organizations as Art Hickman's Orchestra, The Happy Six, Sherbo's Orchestra, Sweatman's Jazz Band, Ted Lewis' Jazz Band and the Paul Biese Trio.

Some of the concert and symphony orchestra artists who will be admitted to this musical center are Lucy Gates, Louis Graveure, Hulda Lashanska, Barbara Maurel, George Meader, Alice Nielsen, Oscar Seagle Grace Wagner, Carmela Ponselle and the members of the Chicago, Cincinnati, Columbia and French Symphony Orchestras, the Philharmonic Orchestra of New York and the Gino Marinuzzi Symphony Orchestra.

The statement of a Columbia official that atmosphere to artists is almost like the air they breathe and the right atmosphere brings out musicians' God-given talent conveys a hint of the splendors to be expected in this modern

"Green Room." Its very location in the immediate neighborhood of the Metropolitan Opera House, Carnegie Hall, the theatres and vaudeville houses, brings it into a musical and artistic atmosphere.

GETTING CLOSE TO THE DEALER

Do you realize that—The jobber's salesman is largely responsible for the success of his customers? He can help his customers by suggestions and advice. If he is informed on conditions his customers soon find it out and turn to him for counsel. He should be in position to counsel with them wisely. It means much for the progress of a business.

A salesman should, first and foremost, be loyal to the house that employs him, and so long as he continues to accept its money in payment for services he is in duty bound to refrain from any action or word that will prove detrimental to his employer.

NEW POST FOR H. D. BERKLEY

H. D. Berkley, who for many years has been connected with several Victor organizations, both wholesale and retail, and who more recently was assistant general manager of the Enterprise Music Supply Co., has been appointed manager of the Victrola department of Bloomingdale Bros., Inc., New York City.

INCORPORATED TO MAKE RECORDS

New Comfort Records has been incorporated with capital stock of \$75,000 under the laws of Delaware to engage in the manufacture of phonograph records. The incorporators are C. T. Cohee, C. B. Outten and R. E. McCloskey, of Wilmington.

The Home Recorder, Inc., 222 Market street, Newark, N. J., has been incorporated with capital stock of \$400,000, to manufacture musical instruments.



Business men today are pragmatic. Their test for every idea is, "Will it work?"

That is the test we relish.

For that test brings out fully the genuine, "workable" value of the man-to-man co-operative effort behind our Service.

Elyea Talking Machine Co.
Atlanta, Georgia

Exclusively Victor *Strictly Wholesale*

An Interesting Fact—With a Moral

FROM December 1st to December 24th there were sold from the store of Phillip Levy & Company, Norfolk, Va., a city of 135,000 population---

**421 Granby Phonographs
Totalling Over \$67,000.00**

The Granby was sold in actual competition with a dozen dealers handling all makes, which speaks pretty well for Granby.

Local newspaper advertisements—not big space, but advertisements featured regularly and persistently—were valuable aids in making these sales.

The Moral

There is plenty of business in your territory if you handle the right phonograph line, and will only go after it intelligently.

Conditions in Norfolk, at present, are no better nor worse than in any other city.

If you want to know the details of the selling campaign that produced these results, get in touch with us immediately.

GRANBY PHONOGRAPH CORPORATION
N O R F O L K - V I R G I N I A
.. Factory .. Newport News ..

Various Methods of Increasing Talking Machine Sales Interestingly Described

By W. Bliss Stoddard

St. Patrick's Day, which will soon be with us, is one that naturally lends itself to mirth and music, as the Irish are a light-hearted musical race, and it is natural that a music dealer should seize upon it as a means of pushing his talking machines and records, especially the latter. Preparations should now be made for window or other displays of records of Irish music, instrumental and vocal, and in this connection it is interesting to set forth the very excellent display made last year by the Thearle Music Co. of San Diego, Cal., who played up "St. Patrick's Day" in a very attractive manner. Its window heralding the date caused everybody to smile and stare. The large window was floored with fluted grass green crepe paper, and the tall floor lamp had a wide spreading shade of the same color and material. Basking in the green glow of this lamp—the effect was enhanced by having green bulbs instead of the customary translucent ones—was a four-foot Victor dog, wearing a huge bow of green ribbon, and a green stovepipe hat a yard high. At either end of the room were late model Victrola cabinets, and down in front, set in wire racks, were a half dozen records, to each of which was pasted a big green shamrock on which was printed in black the name of the selections—"Where the River Shannon Flows," "The Wearing o' the Green," "That Tumble-down Shack in Athlone," and many standard Irish melodies.

A week before the seventeenth of March they sent out broadcast green cards on which were gold harps, while printed on the cards were: "Celebrate St. Patrick's Day with mirth

and music." "Get your old Irish melodies or new popular ballads from the Thearle Music Co." About the same time, too, they sent out special invitations to their regular customers, and inserted a general invitation in the papers to an hour of music. This was given in their music hall on the Saturday afternoon before St. Patrick's Day, thus giving the audience a chance to hear many of the new and old



Thearle Co.'s St. Patrick's Day Window

favorites, and lay in some special records for entertainment on the seventeenth. All of the selections were Irish, and different groups were given on the leading phonographs, with a final group of songs rendered by a local tenor. The manager of the music department was in charge of the concert, and prefaced each selection with a short talk on the composer, the history of the song and any little stories of human interest connected with the music.

While arranged to push the sale of Irish

records there were many others sold that afternoon, as the guests, both before and after the concert, were invited into the demonstration rooms, and heard a number of the new records ranging from comic to classic.

A Lure in Securing Prospects

It will soon be marble time and the fondness of the youngsters for the little spheres is well known. Accordingly, any merchant who wishes to secure a good list of talking machine prospects could do no better than follow the plan used very effectively last season by Kremer Bros., Fond du Lac, Wis. They laid in great quantities of marbles and then inserted a number of small ads in the local papers. Three of these were used, each on a different page, the sporting page, the comic section and the front pages being selected—as the ones which would attract most attention from the boys. The first of these ads was adorned with a picture of a freckle-faced lad shouting:

HEY, SKINNAY! C'MON OVER!
50,000 Marbles FREE!
Let's go to KREMER BROS., 36 N. Main St., next Saturday, between the hours of 8:00 A.M. and 5:00 P.M., where we can get a bag of 25 marbles absolutely free if we bring along the coupon below properly filled out.
KREMER BROS.

The second ad showed a group of boys playing marbles, and was captioned:

Knuckles Down! No Hunching!
50,000 MARBLES ABSOLUTELY FREE!
Every boy and girl in Fond du Lac can get a big bag of 25 marbles, all colors, absolutely free by bringing the coupon of this ad properly filled out to our store on Saturday, April 10, between the hours of 8:00 A.M. and 5:00 P.M.
KREMER BROS.

(Continued on page 34)

Reaching Discriminating Buyers

In a bulletin announcing the new Victrola No. 80, the Victor Co. describes this model as one that will appeal strongly to the most discriminating buyers. We agree with the Victor Co. in this belief, and know that the price of an even \$100 is psychologically right.



We have arranged a special plan to help Victor dealers introduce the Victrola No. 80 in a manner calculated to produce big sales results. May we co-operate with you?

Collings & Company

Victor Distributors throughout Northern New Jersey and Northeastern Pennsylvania

PLUM BUILDING

Clinton and Beaver Sts. Newark, N. J.

Note: Use U-Sav-Your dressing and preserve the beautiful original factory finish on your cabinets.

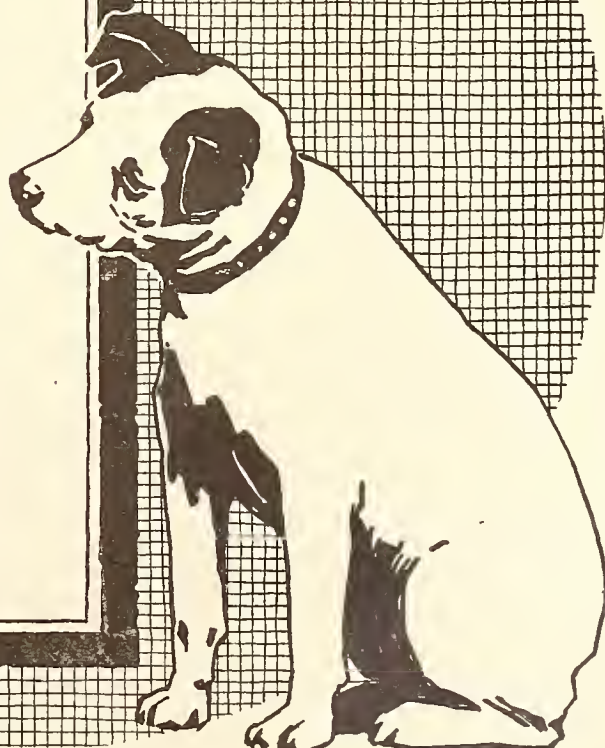

VARIED WAYS OF INCREASING SALES

(Continued from page 33)

The third ad showed no cut, but played up the "marble" idea:

MARBLES! 50,000! MARBLES!! FREE! FREE!

For the boys and girls of Fond du Lac

The balance of the ad was similar to the others. At the bottom of each ad was a coupon, which was to be cut out, filled out, and brought to the store. This coupon stated the name and address of the parents of the lad, and whether or not they owned a talking machine. In addition to the addresses of those who already possessed talking machines the firm secured a list of 500 prospects who did not own one. The names of all who owned machines were turned over to the record department for circularization on the monthly new records, while the other list was sent to the factory who manufactured the machine they handled, and the factory sent each of them literature on the subject. A factory representative also gave daily demonstrations of the machine, and during this one month the talking

machine department showed the healthiest growth in its history.

Music for the Winter Evenings

"As the days begin to lengthen, the cold begins to strengthen," and there are long Winter evenings when few care to stir from the house. This is the time when the phonograph is especially appreciated for its varied entertainment qualities. In order to bring this effectively to mind the Maison & Blanche, New Orleans, La., arranged a striking window display. Their window, which was a very large one, had glass extending entirely to the floor, and this was covered with cotton wadding to represent snow. The entire window pane was covered with little patches of cotton—each attached by a drop of glue—so that the effect to the passerby was that of a raging snowstorm. On an artificial snow mound was placed a Grafonola, while a mound at the other side held a Victrola. In the rear was a cardboard house, with doors and windows of waxed paper, with a strong light behind them. A card down front suggested: "Music in the home will help to make merry the long Winter evenings."

TO MAKE EXTENDED CONCERT TOUR

Mamie Smith and Her Jazz Hounds, Widely Known Through Her Okeh Records, Has Arranged to Make a Coast-to-Coast Tour—It Promises to Be a Big Success

Mamie Smith and her Jazz Hounds are answering the unanimous demand for personal appearances by going on concert tour. Under the management of the Standard Amusement Co., with offices at Suite 502, Vanderbilt Avenue Building, New York, a coast-to-coast tour is being scheduled.

The company is to be known as "Mamie Smith and Her Jazz Hounds Revue." There will be added features to the original Jazz Hounds, as Mamie Smith will carry a varied company of well-known entertainers. They will give a full evening's performance. The popularity Mamie and her Jazz Hounds have won on Okeh records has assured her managers of record-breaking audiences. The engagements she has already filled in a number of Eastern and Southern cities were played to capacity-filled houses.

The program which will be offered on tour will consist of recent selections released on Okeh records made by this organization as well as other late Broadway jazz and Blues hits. The attraction will be booked only in large auditoriums where there is sufficient seating capacity to accommodate the crowds.

IN FINANCIAL TROUBLE

The Stratford Phonograph Co., of Ashland, O., was adjudicated a bankrupt on January 12, and the first meeting of the creditors was held in Ashland on January 27. At this meeting the creditors proved their claims, appointed a trustee, examined the bankrupt, and transacted such other business as came before the meeting.

VALUE OF ENTHUSIASM

Enthusiasm is not excitement; it is earnestness. Not frenzy, but fervor. Not arrogant braggadocio of your goods, but ardent belief in your goods. Enthusiasm is lasting, not temporary. It carries the dealer with you, not away from you. It makes him sell your goods as well as buy your goods.

The biggest interest man has to pay on a loan is on borrowed trouble.

FEDERAL ELECTRIC SIGN



Make Your Store Front Produce More Business

When you have an energetic salesman in the form of a glittering electric sign in front of your store, you sell not just the person who happens to look in your windows—but the hundreds of people who pass within a block or two in each direction.

That is where a Federal Electric Sign proves such a big business getter—its cheerful invitation is irresistible. A Federal Electric Sign pays for itself many times over for many years to come—made of porcelain enameled steel, cannot rust, rot or decay—will last indefinitely. As a progressive merchant, you should not overlook this opportunity to gain a step on competition. Send coupon today for full information and sketch showing how your sign will look. No obligation.

Tear Off and Mail Coupon Now

FEDERAL ELECTRIC COMPANY

Representing Federal Sign System (Electric) : 8700 South State St., Chicago, Ill.

Please send me full information, price and free sketch of a Porcelain-enameled Steel Sign for my business. Explain your 9-months-to-pay Plan

Name.....City.....State.....

Street and No.....Business.....

Store Frontage.....No. of Floors.....



9 Months to Pay!

The first payment brings you your sign—you have nine months to make the final payments.

Why Break Records? Just File Them!

That is if you have the wonderful Record filing system which is a feature of

The Marvelous MAGNOLA

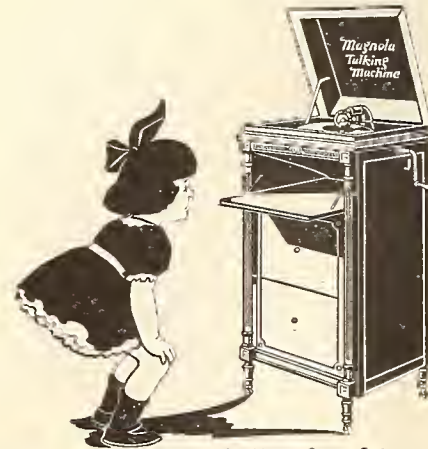

Watching the Music Come Out

This is only one feature of many that will command your interest and attention. Let us send you handsome illustrated catalog and information as to our plans for helping you to make money with MAGNOLA.

MAGNOLA TALKING MACHINE COMPANY

OTTO SCHULZ, President

General Offices 711 MILWAUKEE AVENUE CHICAGO Southern Wholesale Branch 1530 CANDLER BLDG. ATLANTA, GA.

Announcing THE DANCE NEEDLE



TO THE TRADE:

A new needle known as the DANCE NEEDLE has been invented for the purpose of doing full justice to the tonal volume of dance music.

The DANCE NEEDLE is the only one of its kind in the market, and this name alone will make it an ideal selling proposition.

The DANCE NEEDLE is a decided novelty that can be featured as a direct attraction to the consumer. Every buyer of dance music is a prospect for substantial sales of the DANCE NEEDLE. Approximately 75% of all records sold are dance records, and this means that 75% of all needles sold will eventually be the DANCE NEEDLE.

There is no other needle manufactured that has such a unique and direct appeal to the consumer.

Manufactured by

GENERAL PHONOGRAPH CORPORATION

OTTO HEINEMAN, *President*

25 West 45th Street

New York City, N. Y.

Factories: Newark, N. J. Elyria, Ohio Putnam, Conn. Springfield, Mass. Kitchener, Ont.

Branch Offices: Chicago, Ill. Toronto, Can. London, Eng.

GIVE THE PUBLIC GOOD MUSIC

Says Albert Spalding, Who Berates Musicians for Carelessly Selected Music Programs—Says a Day of Reckoning Is Coming

American audiences are making artists lazy. That is the opinion expressed by Albert Spalding, famous violinist and Edison artist, who declares that a day of reckoning is coming in the music world when artists will regret the careless habits into which commercialism has led them.

"In the fulfilment of the great trust which rests in great musicians, there are certain essentials," said Mr. Spalding in a recent interview. The most important, it appears to me, is the presentation of great works finely performed."

Mr. Spalding claims that in their desire to please easily satisfied audiences even the most noted musicians are getting the habit of singing indifferent works that are familiar, in order to gain the ready applause that brings recalls, consequent success and, also, consequent box office receipts.

"Public taste in art, like water, runs down hill," said the violinist. "If unchecked it will end its course in a muddy and chaotic stream. I know of no cure for it unless artists and managers co-operate and by mental stimulation of each other's efforts in the right direction institute a system of good plumbing for the art of music. If you want water pure and uncontaminated, you don't pump for it at its lowest levels. It is best when obtained as near as possible to its source. It is the same with music. And its effect on the public is the same. Drinking contaminated water is known to be poisonous to the body. Listening to bad music is no less poisonous to the mind. I have no intention or desire to preach a pessimistic sermon. I refuse to admit, or believe, that the public is more than a passive contributor to it. Public opinion is not an affirmative quality. It concurs or acquiesces in leadership."

REMINGTON ELECTRIC SIGN THAT ATTRACTS ATTENTION



The Remington Phonograph Corp. is featuring the Remington name and product in a striking manner on the Great White Way through a large electric sign erected upon the roof of the Remington Building, at 1662 to 1666 Broadway, New York City. The Remington executive and wholesale offices occupy the second floor of this building. This sign has already taken its place as a part of the lighting of the Great White Way and is becoming a familiar sight to the thousands of theatregoers as they promenade on this famous thoroughfare. The accompanying illustration gives a good idea of the size of this new sign.

SHOWS USES OF RECORD FLASHER

Standard Accessory Corp. Prepares New Booklet on Advantages of Its Product

MILWAUKEE, Wis., February 4.—The Standard Accessory Corp., 355-357 East Water street, this city, is sending to the trade a very attractive folder showing very clearly how the record flasher which it manufactures is used on talking machines; also inside the player-piano to

light up the music roll. It brings out very clearly the merit of the flasher, describing the different ways in which it can be used. The folder also shows a half-size tungsten battery which can be used in connection with the flasher when electricity is not available. Special note is made in this attractive folder of the fact that the record flasher finds a very ready market among the farmers, over 51 per cent of whom, statistics show, own a talking machine or a player-piano.

GARFORD "BABY" PHONOGRAPHS

A Popular Line of Toy Phonographs

Nothing More-Nothing Less

The "BABY" Model RETAILS AT \$6

MODEL X RETAILS AT \$12



A Splendid Dealer Proposition Is Available.

CLOSED

GENERAL PHONOGRAPH MFG. CO., Elyria, Ohio

Edison Message No. 90

It will be many years before the general level of commodity prices is as low as the present prices of Edison Phonographs.

Edison Phonographs increased in price less than 15%, including War Tax, since 1914.

“Edison Stood the Gaff”

THOMAS A. EDISON, Inc.
ORANGE, N. J.

MEADER SCORES IN McKEESPORT

Columbia Artist Arouses Great Enthusiasm in Recent Concerts in McKeesport

McKEESPORT, PA., February 1.—George Meader, the celebrated American tenor and exclusive Columbia artist, made a sensational showing during



George Meader

his appearance in this city recently. Mr. Meader is known throughout the United States as the boy soprano, with phenomenal gifts, and has endeared himself to the hearts of New York music lovers by singing in St. George's and other metropolitan churches. He has sung in Europe with the leading orchestras, and is one of the few boy sopranos who has realized the promise of his early youth and retained the sweetness and purity of voice which so charmed his early hearers. In the McKeesport concert there was a quality in Mr. Meader's voice that seemed to strike a responsive chord in the hearts of his audience.

In order to give the high-school students an opportunity to hear this opera star, F. C. Wampler, of F. C. Wampler & Sons, Inc., local manager, made a special price to them, with the result that a record-breaking audience thronged the hall. Mr. Wampler states that the concert was a tremendous success in every way.

SELLS FACTORY TO WATERMAN CO.

General Phonograph Corp. to Concentrate Motor and Tone Arm Business in Elyria, O.—To Continue Record Making in Newark

The factory on Thomas street, Newark, which the General Phonograph Corp., New York, has owned for some time past, has recently been sold to the L. E. Waterman Co., makers of fountain pens.

In referring to this transaction, Otto Heine-man, president of the General Phono. Corp., informed The World that the sale was made because in the future all of the motor and tone arm business of the company will be concentrated in the factories at Elyria, Ohio. The plan of concentrating all of this end of the business in one city will make for greater efficiency in manufacturing.

Okeh records will continue to be manufactured the same as heretofore, in the Newark plant, and for this purpose a large portion of the factory to which the Waterman Co. now holds title has been leased. The Okeh record business continues to grow in a substantial manner.

THE VALUE OF REPUTATION

Everybody likes to do business with a gentleman—a man who is clean, both outside and inside; who neither looks up to the rich nor down on the poor; who can lose without squealing and win without bragging; who is considerate of women and old people; who is too brave to lie, too generous to cheat and who takes his share of the world and lets others have theirs.

INSTITUTES "NO PURCHASE HOUR"

Fordham Store Sets Aside Special Time to Serve Needs of Patrons—No Goods Sold During This Time—Pres. Mangam Outlines Plan

A rather unusual and highly commendable idea has been developed by R. W. Mangam, president and general manager of the Excel-O-Phone Talking Machine Co., 12 East Fordham road, New York. In order to give his patrons the advantages of real store service he conceived the idea of having once a week a "No Purchase Hour" which should be given over entirely to the wishes of customers of the store. In discussing the workings of this plan, Mr. Mangam said:

"Positively no merchandise will be sold at our Fordham road store between the hours of 8 and 9 o'clock on Friday evening of each week, unless by special need or request. This hour shall be devoted to 'Service.'

"We want every person in this section at that time to step in and get acquainted. We believe that the talking machine is a mighty important

bit of furniture in the home, entitled to proper attention by both the owner and by us. Possibly there is some question regarding your instrument that puzzles you; you note with alarm a tone variation, a grind, a lack of clarity, or some other discrepancy regarding which you may desire to be enlightened.

"Or, possibly, there has come to your attention some device or attachment for your instrument that offers an improvement—a labor-saving device, such as an automatic stop, wind, repeater, etc. We will be glad to demonstrate and explain these articles. Then, again, maybe you are contemplating the purchase of a talking machine, but have hesitated to inquire of us, due to a belief that there might appear to be an obligation to purchase. We don't want you to feel that way. We will cheerfully demonstrate our instruments, explain their many points of superiority, and justify to you our belief in their quality, without obligation.

"Drop in. Tell us what we can do for you. We are at your service. It is the keynote of this enterprise, and our motto is: The customer is always right."

THE COLOR VALUE OF MUSIC

Cyril Scott, the English Composer, Speaks Interestingly of the Occult in Music

Cyril Scott, the English composer, who is in the United States lecturing on "The Occult in Music," says that "brilliant, flashing colors in startling and attractive forms are seen by the trained clairvoyant when beautiful music is played.

"I know at least one initiate in England," said Mr. Scott, "who knows nothing whatever about music, yet he enjoys music immensely because of the flashing, living colors and the wonderful beauty of forms that he sees with his clairvoyant vision.

"The theosophists say that musical forms and colors are sensed by the pineal gland. The colors are produced simultaneously and yet they do

not interfere one with another, but are vividly distinct and gorgeous. The modern French music of Ravel and Debussy is particularly rich in nature-spirit effects.

"The spiritual value of the music can be determined by the purity and beauty of the colors. Scriabine, in the latter part of his life, made music a definite vehicle for spiritual expression and his compositions glow so richly with color and form that clairvoyant adepts take the most exquisite delight in his music.

"The masters, or initiates, use music for their purposes, inspiring musicians and thus bringing spiritual influences directly to bear on the world."

A salesman may not know it all, but neither does the customer. The more a salesman knows about his goods the better he can sell them.



**THE
VICTOR
RECORD**

A series of

ACHIEVEMENTS

Series 2



Producing the Victrola type of instrument was a forward step in the industry taken by the Victor Company, the importance of which can hardly be overestimated. In this form the talking machine immediately stepped forward as a beautiful element in the furnishing of a home—a charming piece of furniture; and all unpractical and unsightly features connected with sound reproducing were eliminated.

With the development of this style went forward also the development in richness of tone, giving an instrument covering all music unapproachable for quality and service.

Scarcely anything in the pioneering work of the Victor Talking Machine Company has had more wide-reaching influence than the creating of this Victrola Style.

KNICKERBOCKER TALKING MACHINE CO.

ABRAM DAVEGA, Vice-Pres.

Metropolitan Victor Wholesalers

138 West 124th Street

New York

The public's pride of possession makes Sonora the most popular phonograph

DON'T think that because you may have difficulty in selling some make of phonograph that phonographs as a class are being neglected by the public.

People buy more carefully now. They compare. They examine. They judge. Then they buy and they buy quality.

This is a real Sonora market, because the more severe the tests, the more brilliantly does Sonora distinguish itself.

Sonora means a wonderfully complete line for one thing. A customer can choose from 24 period styles, 7 uprights and 1 Portable model---and all these are standard stock models and not made-to-order specials.

Prices are from \$75 to \$1800.

SONORA business is keeping up to a high mark because the magnificent Sonora tone makes sales. And the superb Sonora cabinets (a joy to the connoisseur of fine furniture) make sales. And the many exclusive and vital features for which Sonora is famous make sales.

It is risky to handle a phonograph the manufacture of which may be discontinued at any time.

It's another thing to sell Sonoras, world famous for their superiority, and licensed and operating under BASIC PATENTS of the phonograph industry which guarantee that Sonora's future is secure.

It's easy to sell when you offer



THE ELITE

The Highest Class Talking Machine in the World

THE INSTRUMENT OF QUALITY

Sonora

CLEAR AS A BELL



Write today regarding a Sonora agency to the distributor covering your territory

GIBSON-SNOW CO.,

Syracuse, N. Y.

State of New York with the exception of towns on Hudson River below Poughkeepsie and excepting Greater New York.

W. B. GLYNN DISTRIBUTING CO.,

Saxtons River, Vt.

States of Maine, New Hampshire, Vermont and part of Massachusetts.

GRIFFITH PIANO CO.,

605 Broad St., Newark, N. J.

State of New Jersey.

HESSIG-ELLIS DRUG CO.,

Memphis, Tenn.

Arkansas, Louisiana, Tennessee, Mississippi.

KIEFER-STEWART CO.,

Indianapolis, Ind.

Entire State of Indiana.

LEE-COIT-ANDREESEN HARDWARE CO.,

Omaha, Nebraska

State of Nebraska.

THE MAGNAVOX CO.,

616 Mission St., San Francisco, Cal.

Washington, California, Oregon, Arizona, Nevada, Hawaiian Islands, Northern Idaho.

C. L. MARSHALL CO., INC.,

82 Griswold St., Detroit, Mich.

409 Superior St., Cleveland, O.

Michigan and Ohio.

MINNEAPOLIS DRUG CO.,

Minneapolis, Minn.

States of Montana, North Dakota, South Dakota, Minnesota.

I. MONTAGNES & CO.,

Ryrie Bldg., Toronto, Can.

Canada.

MOORE-BIRD & CO.,

1751 California St., Denver, Colo.

States of Colorado, New Mexico and Wyoming east of Rock Springs.

M S & E,

221 Columbus Ave., Boston, Mass.

Connecticut, Rhode Island and Eastern Massachusetts.

ROBINSON-PETTET CO., INC.,

522 West Main St., Louisville, Ky.

State of Kentucky.

C. D. SMITH DRUG CO.

St. Joseph, Mo.

Missouri, Northern and Eastern part of Kansas and five counties of Northeastern Oklahoma.

SONORA PHONOGRAPH CO. OF PITTSBURGH,

820 Liberty Ave., Pittsburgh, Pa.

Western Pennsylvania and West Virginia.

SONORA CO. OF PHILA., INC.,

1214 Arch St., Philadelphia, Pa.

Eastern Pennsylvania, Maryland, Delaware, District of Columbia and Virginia.

SONORA DISTRIBUTING CO. OF TEXAS,

Dallas, Texas.

Western part of Texas.

SONORA PHONOGRAPH CO., INC.,

279 Broadway, New York.

Distributors for Greater New York and towns on Hudson River below Poughkeepsie.

SOUTHERN DRUG CO.,

Houston, Texas.

Southeastern part of Texas.

SOUTHERN SONORA CO.,

310-314 Marietta St., Atlanta, Ga.

Alabama, Georgia, Florida and North and South Carolina.

SOUTHWESTERN DRUG CO.,

Wichita, Kansas.

Southern part of Kansas, Oklahoma (except five N. E. counties), and Texas Panhandle.

STREVELL-PATERSON HARDWARE CO.,

Salt Lake City, Utah.

Utah, Western Wyoming and Southern Idaho.

C. J. VAN HOUTEN & ZOON,

Marquette Bldg., Chicago, Ill.

Illinois and Iowa.

YAHR & LANGE DRUG CO.,

Milwaukee, Wis.

Wisconsin, Upper Michigan.

Each Sonora at its price
represents the maximum of value

IMPORTANT CHANGES IN REGULATIONS REGARDING PAYMENT OF WAR EXCISE TAXES JUST ANNOUNCED

Treasury Department Announces Several Important Changes in Manner of Reckoning Excise Taxes Which Are of General Interest—Rulings on Certain Types of Musical Instruments

WASHINGTON, D. C., February 5.—Extensive changes in regulations 47 of the Internal Revenue Bureau covering payment of excise taxes on automobiles, musical instruments and other articles by manufacturers were announced by the Treasury Department recently.

Article 3 has been clarified to make it plain that when a manufacturer of a taxable article quotes a unit price which includes selling price and a direct statement of the portion of the total that applies as tax the tax can be reckoned on the selling price as stated and not on the total price given. Other changes follow:

Article 4—Discounts and expenses. The ruling in regulations 47 permitting an adjustment of the tax in the case of an adjustment in price on goods sold over a period of time on a quantity rebate has been extended to permit an adjustment in the tax in the case of an adjustment in price under an agreement made at the time of the sale to make such adjustment in case of a decline in the market.

Article 7—Who is a manufacturer? This article has been modified to provide that while a manufacturer is generally a person who (1), actually makes a taxable article, or (2) by changes in the form of an article produces a taxable article, or (3) by the combination of two or more articles produces a taxable article, under certain circumstances such a person is not a manufacturer for the purpose of the tax; but that if a dealer or jobber owns a patent, trademark, formula or recipe for a taxable article and contracts with another person or firm for the manufacture thereof, the contract specifying that the article can be manufactured only for such dealer or jobber and that it will be sold by such dealer or jobber as the manufacturer, the dealer or jobber is held to be the manufacturer for the purpose of the tax.

Article 15 has been made to read:

"A concern which does not manufacture for sale separately any part or accessory, but is engaged in doing strictly a repair business and makes only occasionally a part which may be needed for an immediate repair job performed by it, is not considered a manufacturer and is not required to pay any tax in respect to parts so manufactured and used.

"A person, partnership or corporation engaged in the business of building over automobile tops or bodies for installation on new or old chassis is not considered to be doing strictly a repair business, even though all such tops or bodies are manufactured as needed for an immediate job, but is held to be a manufacturer of automobile parts or accessories and subject to tax as such."

Article 17—Musical instruments. This article has been amplified to provide that so-called "toy talking machines, pianos, music boxes, etc., are taxable only if capable of use as practical musical instruments, and also to provide that orchestrions, mechanical violin players, etc., with a standard or modified piano player action incorporated therein, are subject to tax only on that portion of the price charged which represents the selling price of such action."

Article 34, on manufacturers who are also retailers, and Articles 42 and 43, covering export sales, have also been amended.

Article 41, credits and refunds, has been amplified to define in detail the difference between an "overpayment or overcollection," as distinguished from an "illegal or erroneous" payment or collection. The law permits a taxpayer to take credit for an overpayment or overcollection, whereas an illegal or erroneous payment or collection must be recovered through a claim for refund.

GRAFONOLA IN PROMINENT THEATRE

LOS ANGELES, CAL., January 25.—J. Van Grove, Columbia dealer of this city, recently made a sale of a K-2 walnut Columbia Grafonola to Sid Grauman, who is using it on the stage of his million-dollar theatre. This is one of the largest moving picture establishments in this section of the country and is one of a chain of which Mr. Grauman is proprietor.

F. E. WATKINS IN THE SOUTH

F. E. Watkins, of Watkins Bros., Inc., Hartford, Conn., is now on an extended visit to Pinehurst, N. C., where he will take part in the annual trap-shooting meet. Directly after the tournament Mr. Watkins will leave for Arcadia, Fla., where he will spend the rest of the Winter hunting.

GOOD YEAR FOR LYRIC RECORDS

The American Talking Machine Co., Bloomsburg, Pa., is showing a very optimistic spirit in business conditions generally. B. W. Jury, general manager, reports a very fine business on Lyraphone and Lyric records and prophesies that 1921 will prove a banner year for everybody in the talking machine industry who works hard to make it so.

INCORPORATED IN MASSACHUSETTS

The Music Box Co., Inc., Beverly, Mass., has been incorporated, with \$10,000 capital, to deal in phonographs, pianos and musical instruments generally. The incorporators and officers are Frank A. Hayes, C. H. Phillips and W. D. Phillips.

If a salesman is capable of determining beforehand the question whether goods will sell or not he is wasting his time on the road. He is worth \$10,000 a year to any house in business, and they will not ask him to work more than half an hour a day, either.



You Can Sell Musical Instruments With Oplex Signs

FLEXLUME Oplex Electric Signs are the kind with the *raised* snow-white glass letters on a dark background. This makes them excellent day signs as well as night signs. The night effect is solid letters of light standing out of the darkness.

Oplex Signs are selling musical instruments. Let us send you a sketch showing an Oplex Sign for your store.

FLEXLUME SIGN COMPANY
36 Kail Street Buffalo, N. Y.







LINCOLN
February 12

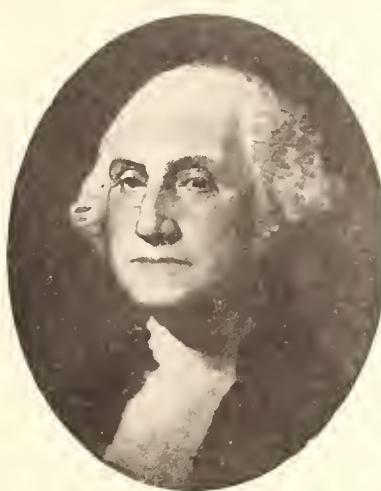

WASHINGTON
February 22

THE BIRTHDAYS OF TWO ILLUSTRIOUS AMERICANS

The country which can produce such stalwart and inspiring characters as Abraham Lincoln and George Washington, whose birthdays we honor this month, is the country to not only place your entire faith in, but your capital, meaning brains, ability and money, as well.

The business trials of to-day are nothing compared to the national trials the father and savior of America went through. And America to-day is greater and more powerful because these men have lived.

The faith in America was what prompted us to enter the phonograph field when there already were "too many manufacturers".

Also our faith in America told us to go ahead because in the

Remington Phonograph

We knew we had a sound reproducing machine that represented the greatest advance ever made in instruments of this character.

Our faith in America instilled the belief that there is always room at the top and that is the place we are headed for.

The impetus behind us is the Remington Phonograph with the Remington Reproducer, built on entirely new principles, our policy to give a dollar's worth in exchange for the other man's dollar, and the knowledge that we are here to serve and not to be served.



1662-64-66 BROADWAY
New York, U. S. A.

PHILO E. REMINGTON, President
JAMES S. HOLMES, Vice-President
EVERETT H. HOLMES, Sales Manager



The dealers who are not as yet familiar with the Remington Phonograph and our selling and agency proposition are invited to make inquiries.





Marion Harris sings "Yankee" and "Grieving for You." You'll have lots of difficulty deciding which side of this record is the best seller. But you'll sell so many that you won't care. A-3353.

Columbia Graphophone Co.
NEW YORK

ELECTRIC SIGNS AS AN AID TO BUSINESS

Written for The World by EINAR GRAFF

Most business men are agreed that the low ebb of the nation's buying has been passed, and that from now on we will witness a constant, steady increase in business. The United States Department of Labor officials report that national unemployment is decreasing. Many factories which were closed have resumed their activity. Advertising agencies find many calls for their assistance from business men who believe that the year 1921 will reward those who fight for business.

It was universally agreed some time ago that the "order-taking" days were over, and that to obtain business now it is necessary to go back to the old methods of real selling, as in the days before the war.

The war demonstrated the value of advertising. One of the very effective means used in all countries in fighting the war was publicity. Heads of many old conservative concerns who formerly scorned advertising are now knocking at the doors of advertising agencies. They appreciate that if they are to get their share of this year's business they must fight for it.

The retailer must do his share. The average retailer, because of the nature of his business, cannot use the advertising means of wholesalers, but he has a very effective means of publicity at his disposal, namely, the electric sign. Regardless of where he is located—on a dark side street or a brilliantly lighted business avenue—the electric sign has a value to him

worth many times its cost. It is no exaggeration to say that the retailer who does not take advantage of the advertising power of the elec-



A Sign That Attracts the Public
tronic sign is annually permitting many dollars in potential profits to go to waste.

By means of an electric sign, a retailer may advertise at less cost to a larger number of potential customers than by any other medium. The sign is located outside of his place of business, and is seen by all who pass directly

by it or within a distance of two or three blocks—persons who frequent the neighborhood of his store, and therefore logical customers.

The electric sign is valuable to the retailer in other ways. It identifies the location of his store in the minds of the public. It gives his store an attractive, bright, prosperous and stable air, which increases its drawing power and instills confidence in the potential customers.

An electric sign not only advertises the store after nightfall. It has an equal advertising value during the day. As an example, consider the porcelain enameled steel blue and white signs which are familiar on the streets of most of our cities, probably because retailers have found them to be the most practical. They withstand weather. They do not fade and need never be painted. When they become soiled they may be washed with soap and water, and look like new. They last indefinitely.

This year will reward business men who fight for business. The intelligently aggressive merchant will prosper—he will take advantage of every opportunity before him, such as placing in front of his store an electric sign, and the utilization of other modern equipment that will advertise his progressiveness, as well as interest the buying public.

IN PROCESS OF REORGANIZATION

The Superior Court of Hartford County last month appointed a receiver for the Bristol Furniture Co., Bristol, Conn., which also handles talking machines. This action was taken for the purpose of reorganization and not because of insolvency.



DEFEND



THE ECLIPSE MUSICAL CO.

Victor Wholesaler

Cleveland, Ohio

DIRECT FACTORY PRICE—JUST MENTION THE QUANTITY

**MOTORS
TONE ARMS
REPRODUCERS**

CASTINGS
Grey Iron
and Brass for

**TURNTABLES
MOTOR FRAMES
TONE ARMS
HORNS and THROATS**

**Stylus Bars
Screw Machine Parts
Talking Machine Hardware**

Direct Quantity Importations On

**JEWEL and STEEL (Bulk or Packed)
PHONOGRAPH NEEDLES
GENUINE RUBY BENGAL MICA**

*EASTERN REPRESENTATIVE
CHERINGTON MFG. CO.
IRONCLAD MOTORS*

D. R. DOCTOROW

*Vanderbilt Ave. Bldg.
51 East 42nd St., New York
Tel. Vanderbilt 5462*

TALKING MACHINE MEN MEET

Monthly Gathering of Local Talking Machine Dealers' Association Held at Hotel Pennsylvania—Plans for Annual Banquet Now Being Made—Alfred L. Smith Makes Address

At the monthly meeting of the Talking Machine Men, Inc., held at the Hotel Pennsylvania on Wednesday afternoon, January 19, it was decided, following the presentation of the report by the entertainment committee, of which J. J. Davin is chairman, to hold the annual banquet and election of the Association at the Hotel Pennsylvania on the evening of March 29.

The committee, of which E. G. Brown, secretary of the Association, was a member, which visited and conferred with the Philadelphia Talking Machine Dealers' Association for the purpose of obtaining information as to ways and means for exchanging surplus record stock between dealers then reported. It was decided to acquaint every member of the organization with the plans proposed and a decision for the adoption of this system will be voted upon at the February meeting of the body.

The Victor Luncheon Club, composed of a number of Victor dealers who are also members of Talking Machine Men, Inc., reported that their organization had sent a bouquet of flowers to Enrico Caruso, who has been ill, with a letter expressing hopes for his speedy recovery. They received a telegram of thanks in response. The Talking Machine Men, Inc., then voted unanimously to appropriate a sum for a like purpose.

J. J. Davin, Chester Abelowitz and Cass Riddle were appointed a committee to confer with the producers of the show "Erminie," now playing at a local theatre, for the purpose of obtaining a block of seats for a theatre party to be given in the near future.

A letter was read from the Los Angeles Music Trades' Association, in which it was proposed to form a national association of local talking machine bodies for the advancement, betterment and protection of the industry.

Alfred L. Smith, general manager of the Music Industries Chamber of Commerce, then addressed the gathering on the proposed increase of taxes on musical instruments. He suggested a limited sales tax on all sales of goods, wares and merchandise from the raw material to the finished article as the principal method of raising the revenue necessary to make possible the elimination of the excess profits tax, the higher surtaxes and the manufacturers' excise taxes which, it is generally conceded, are seriously retarding business.

Mr. Smith spoke to the members on invitation of E. G. Brown, secretary, who is also State commissioner for New Jersey of the National Association of Music Merchants. He called attention to the weakness of the tax programs of the Treasury Department and of the National Industrial Conference Board, which includes an increase in excise taxes, and declared that musical instruments are not subject to an excise tax. This fact, he said, will be proved by informa-

COTTON FLOCKS

.. FOR ..

Record Manufacturing

**THE PECKHAM MFG. CO., 238 South Street
NEWARK, N. J.**

STRANGE "DOINGS" WITH CRYSTALS

Interesting experiments with Rochelle salts at the International Communications Conference are reported in Science and Invention.

The first surprise was a demonstration with Rochelle salt crystals. "When it comes to gymnastics," explained the engineer in charge, "no one has anything on the Rochelle salt crystals." And every one agreed.

It was shown that when these crystals are twisted or pressed an electric current flows from them—is squeezed from them, as the engineer puts it. And conversely, when a current flows into them they wiggle and wobble in a most capricious fashion. There was a phonograph with the ordinary reproducer replaced by a salt crystal. From this crystal wires were led to another crystal placed in a phonographic horn, and when the phonograph was turned on the first crystal wiggled, producing currents which made the second crystal wiggle so violently that rich music poured from the horn.

How to open a safe without knowing the combination or wrecking it was also demonstrated.

tion which the Chamber is now gathering for presentation at Washington at the proper time.

A nominating committee was then appointed, composed of the following: William Berdy, J. Schick, Arthur Herrman, A. B. Schouler and M. Goransky.

C. H. Kolling, of the Phonograph Specialties Co., of Jersey City, N. J., addressed the gathering on the merits of his personal invention, a non-overwinding motor spring safety device.

**INDIVIDUALITY IN YOUR PRODUCT
WILL MEAN MORE SALES FOR YOU!**

Competition in talking machines is growing more strenuous each day. It is not a question of price any longer but of quality—higher quality and better tone. Maintain the claims of quality and tone reproduction in your product—make it be individual.

**Equip Your Phonographs With the New
EMPIRE UNIVERSAL TONE ARM and REPRODUCER**

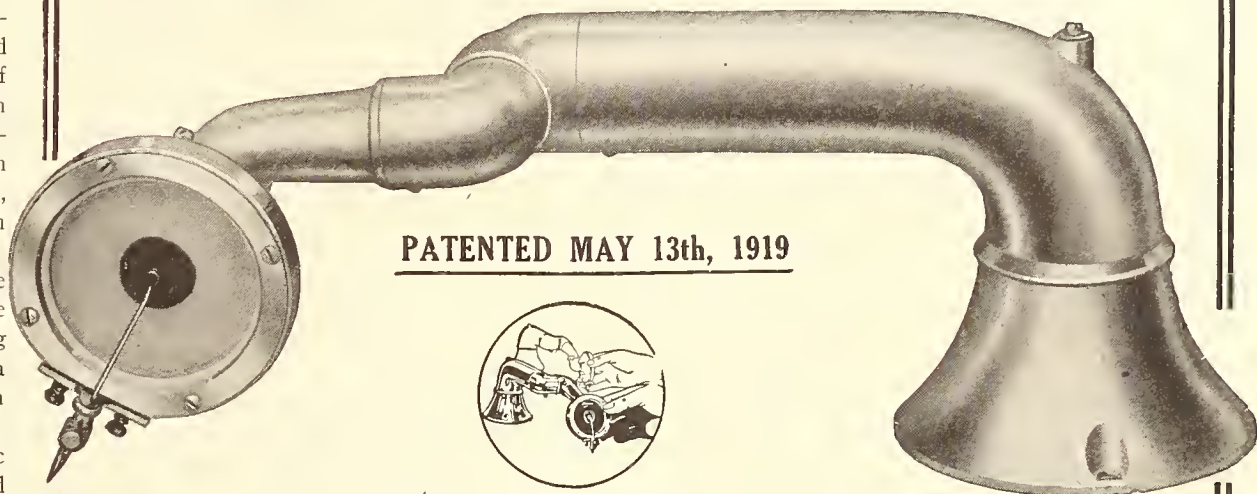

PATENTED MAY 13th, 1919

We are prepared to submit to reliable manufacturers samples of our tone arms and reproducers in order to enable them to determine the merit of our product. Our prices are low and the quality of our product is second to none. Write or wire us for samples and quotations and give us an outline of your 1921 requirements.

We Also Manufacture Attachments for Edison Phonographs



**No. 1
Plays
only lateral
cut records.
Retail
at \$5.00**

**No. 2
Plays all
records.
Retail
at \$7.50**

THE EMPIRE PHONO PARTS CO.

1362 EAST 3rd STREET

CLEVELAND, OHIO

Branch Office: 33 Auditorium Bldg., Chicago, Ill.

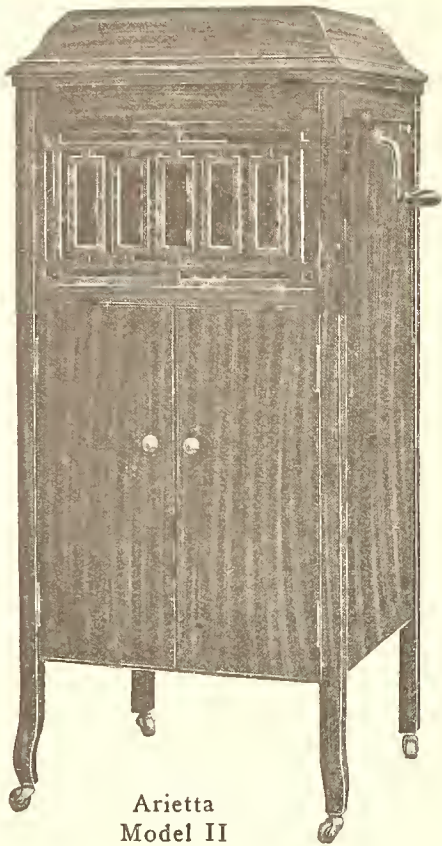

Arietta Model II

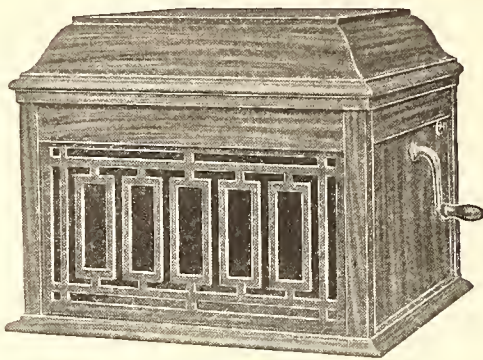

Arietta—Model I

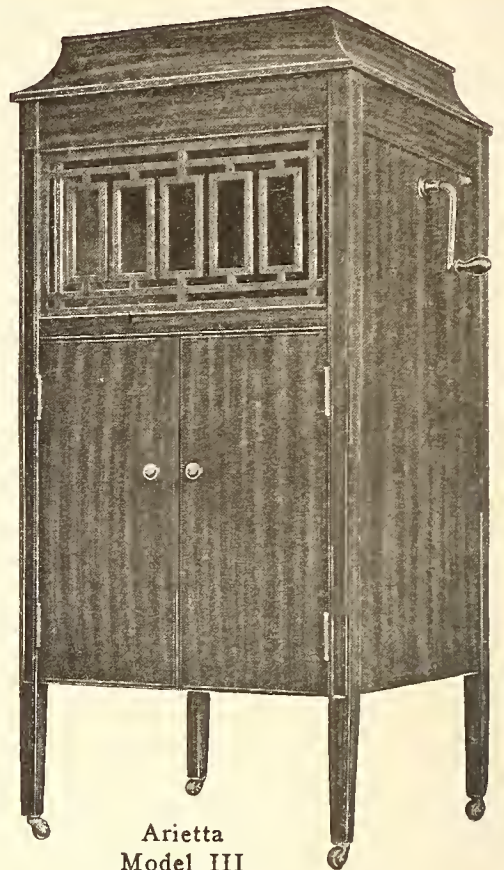

Arietta Model III



Tone, Quality, Beauty, Price ARIETTA Has It All!

FIRST of all, the Phonograph you sell must have TONE. ARIETTA has it---wonderfully clear and true to life. And ARIETTA plays ALL Records with the same fidelity.

But PRICE---today, more than ever---is a mighty important factor. ARIETTA prices are RIGHT!

That's the big reason why ARIETTA is putting new life in dormant phonograph departments—it represents the kind of value people are demanding nowadays—and it nets you a satisfying profit.

At least investigate the ARIETTA proposition. Fill in and mail the coupon and get our exclusive agency offer by return mail. Do it NOW!

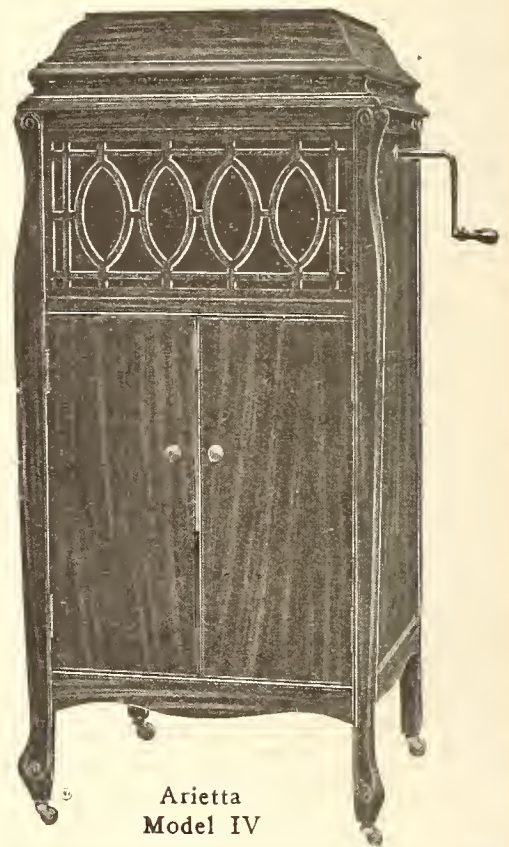

Arietta Model IV

**Emerson
Records**

We are wholesale distributors. Write for list of latest releases. Quick service!

ROUNTREE CORP., Richmond, Va.
 Gentlemen: Kindly send me details about the ARIETTA PHONOGRAPH and your agency proposition, without obligating me.
 Name
 Address
 Post Office
 W-221

Rountree Corporation

Manufacturers
Richmond, Va.

THE NEW COLUMBIA CO. PRESIDENT

Van Horn Ely a Man of Wide Experience in Business Management of Large Institutions

Van Horn Ely, who was recently elected president of the Columbia Graphophone Co., New York, is a man of wide experience in the business management of large institutions. In



Van Horn Ely

addition to being president of the Columbia Co. he is president of the American Railways Co. of Philadelphia, which concern operates twenty electric light, power and trolley companies throughout the country.

He has maintained a close contact with the talking machine industry through his close affiliation with Francis S. Whitten, the former president of the Columbia Co., who is now chairman of the board of directors.

L. K. LINCOLN VISITS PITTSBURGH

Advertising Manager of Sonora Phonograph Co. Found Trade in That Section in a Generally Satisfactory Condition During Visit There

L. K. Lincoln, advertising manager of Sonora Phonograph Co., Inc., New York, recently returned from a trip during which he visited practically all the retailers in Pittsburgh and environs.

In chatting with *The World*, Mr. Lincoln stated that he found the retail merchants, in every case, imbued with a thoroughly optimistic spirit regarding the opportunity for increased business in the very near future. He called on dealers representing practically every make of instrument and found that the machine business has been holding up quite well since the holiday season, though it does not run as well proportionately as the record business.

Mr. Lincoln spent a considerable portion of his time with the new Sonora distributors, the Schroeder Piano Co. of Pittsburgh, which concern is promoting the Sonora line in a most vigorous manner throughout that section of the country.

JERSEY COMPANY GETS CHARTER

The Ware Campbell Co., Hammonton, N. J., has received a charter to manufacture talking machines. The capital of the new corporation is \$50,000 and the incorporators are Charles M. Ware, Albert Campbell and Ernest D. Ware, Millville, N. J.

APPOINTED SONNENBERG MANAGER

W. H. Tyler has been appointed manager of the Victrola department of the Sonnenberg Piano Co., in New Haven, Conn. He was formerly connected with the Landay Bros.' stores in New York

Intelligent conversation on general topics sometimes accomplishes greater results than more direct efforts to secure business.

PATHE ARTISTS IN CONCERT FIELD

Popular Record Stars Appear in Many Recitals—Extensive Tours Planned Which Cover All Parts of the United States

Pathé artists are exceedingly active in the concert field and are swinging across the entire continent on their concert tours. Thus, dealers in every section of the country are able to stimulate sales of their Pathé records through the local appearance of these popular artists. The enterprising dealer with a sense of news can always build up much publicity from the appearance of a popular artist in his city. The theatre and concert managers are usually always glad to give posters to dealers for their windows, and newspaper publicity co-ordinated with a window display and the records of the artists usually results in noticeably increased record sales.

Madame Matzenauer, contralto and celebrated opera star, has been booked for recitals in the most important musical centers in the country, from the first of the year straight through till Spring.

Paul Althouse, celebrated tenor singer and Pathé artist, is now engaged in an extensive Western tour covering the most prominent cities on the Pacific Coast.

Patricola, the versatile Pathé star, and Jacques Thibaud, eminent violinist and Pathé artist, are covering the various sections of the country, and the Tollefsen trio of violin, piano and 'cello, whose recordings on Pathé records are familiar, have completed an extensive Southern tour. The Sunday evening concerts at the Waldorf-Astoria Hotel, New York City, have proved very popular in musical circles of the metropolis and many noted Pathé stars have charmed the gatherings at this noted hostelry on Sunday evenings.

The February Pathé record supplement includes the release of numbers by Joseph Lhevinne, master pianist, who is now an exclusive Pathé artist.

An entire page in the January 5 issue of Pathé News is devoted to Pathé and Actuelle records.

MARKMAN TO COVER THE SOUTH

Well-known Traveling Man to Represent Remington Phonograph Corp. in Southern Territory—Has Large Acquaintanceship in Trade

The Remington Phonograph Corp., New York City, has announced the appointment of M. B. Markman as the Southern wholesale representa-



M. B. Markman

tive for the Remington line. Mr. Markman was for some years connected with the sales department of Becker Bros., piano manufacturers, and more recently represented a prominent line of phonographs in the Southern territory. Mr. Markman's large acquaintanceship in the Southern territory, combined with his enthusiasm regarding the Remington products, will be a combination that is destined to result in greatly increased sales for the Remington line in this territory.

We Are Prepared
to consider
Additional Contracts for 1921

Fifteen years' experience in the
manufacture of highest grade

Talking Machine Cabinets

Large modern factory, thoroughly equipped
with latest up-to-date machinery especially de-
signed for this work.

**Highest Financial and Business
Standing**

We have a most wonderful proposition for export business

Write today for particulars

The Wabash Cabinet Company
Wabash, Ind., U. S. A.

REAL READJUSTMENT MUST BEGIN WITH THE FARMER

No Sound Price Reduction or Adjustment Is Possible so Long as the Farming Element Continues Its Present Boycott of the Public and Industry, Says J. Harry Shale

J. Harry Shale, vice-president of the Bankers' Commercial Security Co., New York, whose wide business and financial interests make his opinions on business conditions of genuine value, holds to the viewpoint that there cannot be any downward adjustment of prices, or any marked decrease in the high cost of living, until the farming element in many sections of the country comes to a realization that the war is over and that wartime prices for farm products cannot continue. In a recent interview Mr. Shale said:

"No sound price reduction or adjustment is possible in this country so long as the farming element continues its present boycott of the public and of industries in an effort to realize exorbitant prices for farm products. So long as the farmers are able to hold such products as cotton and wheat for higher prices on a speculative basis there can be no general adjustment of living or production costs in any part of the country. The attitude of the farmer is a fundamental problem to be considered in any such adjustment. Agriculturists fail to realize that, with other countries getting their affairs into better shape, they are facing competition in the marketing of wheat, cotton, grain and other products, and are taking a chance on a sudden deflation that will undoubtedly cause more loss to them than they would suffer by taking a fair profit now on their present crops.

"In this scheme of readjusting the country's living and production status, certain losses must be taken right along the line, and if the various factors face the situation honestly the individual losses will prove more or less immaterial. If the farmer will start the ball rolling the industries will certainly follow. At the present time, with the South and West crying about the low prices being offered for grain and cotton, the fact is generally known that the people of those sections have more real money right now than ever before in their history. On top of this we find agriculturists with money in the bank asking credit from banks in order to carry their crops over to a time when they can force a better market. The solution of this problem is for the banks to insist upon the farmers financing their own

speculative operations, and refusing to extend loans for such purposes. This attitude on the part of many of the country's banks has already been made evident, and we may rightly expect to see some beneficial results very shortly.

"So-called price reductions at the present time are almost without exception fictitious and based on unsound principles. The remedy lies not in going from the top down, but in starting at the bottom and reconstructing and readjusting from the fundamentals. An honest shaving of prices cannot take place until there is a



J. Harry Shale

lessening of production costs, and these costs will be cut only when they are granted relief from underneath. In other words, it centers upon the agriculturist to realize the situation and take appropriate, and what may become necessary, action towards bearing his burden in the carrying out of the readjustment program.

"The only likelihood of a chance of price reduction from any other cause lies in the adjustment of the tax situation, and the cutting down or elimination of excess profit taxes, with

a view to eliminating the pyramiding of taxes that has been the natural result. If there is any improvement made in the tax situation it will mean that both manufacturers and merchants will be compelled to take a temporary loss covering products actually in stock, or in process of completion, and accept a certain shrinkage in assets, and the outcome will be a chance to make a slight shaving in prices generally.

Have Reached Bottom of Business Depression

"Personally, I believe we have reached the bottom of the business depression, and that we are about to return to a safe and sane basis. Every day now will see a number of changes for the better in the general business situation.

"The merchants who have held off buying stock to carry them over the next few months in anticipation of a general break in prices will find in the late Spring that they will have lost, rather than gained, by the delay, for prices will be much the same as they are now and dealers will have difficulty in getting goods promptly enough to serve their purposes. The manufacturer cannot be expected to do all the gambling, and he is not going to make up reserve stocks of instruments for the last-minute accommodation of dealers unless he has bona-fide orders on hand.

Short Terms Protection Against Deflation

"Those retailers who, in the face of the facts that are presented by manufacturers, insist upon believing that the period of deflation will be an extended one should at least arrange to protect their interests in the event of any such deflation in prices, by insisting upon short terms and, most important of all, substantial first payments, sufficiently large to cover any possible price reduction. Those who are fond of making comparisons with the automobile trade can realize what would have happened had machines been sold on the basis of a couple of hundred dollars down, and a month later the list price been reduced \$600 or \$700. Under such conditions it would pay the buyer to give up his car and sacrifice his first payment for the sake of realizing the benefit of a full price cut in the purchase of a new car. It is, of course, out of the question for such a condition to exist in the music trade, but to insist upon the buyer securing a substantial equity in the instrument at the outset will afford the dealer protection against the unexpected.

"It might be well as a last thought to again refer to the farming situation, and to advise retailers who are catering to the rural trade to watch their credits carefully."

HE IS A TALKING MACHINE DOCTOR

Syracuse Man Diagnoses and Cures Ills to Which These Instruments Are Heir

"When your talking machine gets out of order or has any symptoms of deterioration take it to a talking machine hospital. That's what you would do if you were registering illness. The talking machine is such a large contributor to your pleasurable diversions that you cannot allow its disorders to progress beyond recovery."

This is the way W. M. Goff, 119 West Onondaga street, Syracuse, N. Y., tells the public that he is an expert in repairing talking machines. He is with the Howard Piano Co., of that city.

NEW CORPORATION IN OLEAN, N. Y.

The Houghton & Rungle Music Co., Olean, N. Y., has been incorporated under the laws of New York State to do business in talking machines and other musical instruments. The capital is \$10,000 and the incorporators are J. V. and L. A. Houghton and H. P. Rungle.

THE VALUE OF ADVERTISING

The money spent on advertising, if spent sensibly, skillfully and ably, is economical. If you have good advertising and push the sale of the article you save overhead costs, says Sir Eric Geddes.

THE
CABINET & ACCESSORIES
COMPANY

145 E. 34th STREET ··· NEW YORK

THE CIROLA

Your Ears
Will Buy It!



Price Now, \$35.00
Special Introductory Discount to Dealers
Write or Phone
for Representative to call

IN THE HEART OF NEW YORK

GET ALL YOUR ACCESSORIES FROM ONE SOURCE

Lundstrom Converto Cabinets
Record Albums
Record Delivery Envelopes
Motrolas
Record-Lites
Fibre Needle Cutters
Tonofone Needles
Phonograph Cabinets
Table Cabinets, All Kinds
Talking Machine Toys
Brilliantone Needles
Fletcher Needles
Red, White & Blue Needles
Polishes and Oils
Eject-O-File Cabinets
Repeaters and Rotometers
Wall-Kane Needles
Record Cleaners
Dust and Moving Covers
Standard Phonographs
Motor Spring Safety Device
All from One Source

OTTO GOLDSMITH
President

Reduced Prices

Lundstrom **CONVERTO**

PATENTED DEC. 11, 1917

Talking Machine Cabinets

VICTOR DEALERS handling Lundstrom Converto Cabinets will be interested in knowing that in keeping with the times we have recently reduced our prices on all Standard Design Converto Cabinets; at the same time improving the construction by adding casters and ferrules to all of these models heretofore without same.

We are also offering wholesalers direct shipment from factory to their customers, which considerably reduces the cost of handling. These important changes will enable Converto Dealers to continue to meet competition of the low price cabinet machines by offering a GENUINE VICTROLA with cabinet type advantages at a lower price than usually charged for machines with reputation yet to be established.



THE C. J. LUNDSTROM MFG. CO.
LITTLE FALLS, N. Y.

Lundstrom "Converto" Cabinets are broadly covered by patents. Infringements will be promptly prosecuted.

CONVERTO WHOLESALE DISTRIBUTORS

- | | |
|---------------------|-----------------------------------|
| Albany, N. Y. | Gately-Haire Co., Inc. |
| Atlanta, Ga. | Elvea Talking Machine Co. |
| | Phillips & Crew Piano Co. |
| Baltimore, Md. | Cohen & Hughes, Inc. |
| | E. F. Droop & Sons Co. |
| Birmingham, Ala. | Talking Machine Co. |
| Buffalo, N. Y. | W. D. & C. N. Andrews |
| Burlington, Vt. | American Phonograph Co. |
| Chicago, Ill. | Lyon & Healy |
| Cincinnati, Ohio | Rudolph Wurlitzer Co. |
| Cleveland, Ohio | Cleveland Talking Machine Co. |
| Columbus, Ohio | The Perry B. Whitsit Co. |
| Dallas, Texas | Sanger Bros. |
| Denver, Colo. | The Knight-Campbell Music Co. |
| Des Moines, Ia. | Mickel Bros. Co. |
| Elmira, N. Y. | Elmira Arms Co. |
| El Paso, Tex. | W. G. Walz Co. |
| Houston, Texas | The Talk. Mach. Co. of Texas |
| Indianapolis, Ind. | Stewart Talking Machine Co. |
| Jacksonville, Fla. | Florida Talking Machine Co. |
| Kansas City, Mo. | J. W. Jenkins' Sons Music Co. |
| | Schmelzer Co. |
| Memphis, Tenn. | O. K. Houck Piano Co. |
| Mobile, Ala. | Wm. H. Reynolds |
| Newark, N. J. | Collings & Co. |
| New Orleans, La. | Philip Werlein, Ltd. |
| New York City | Emanuel Blout |
| | Cabinet & Accessories Co., Inc. |
| | Knickerbocker Talking Machine Co. |
| Omaha, Nebr. | Mickel Bros. Co. |
| | Ross P. Curtice Co. |
| Peoria, Ill. | Putnam-Page Co. |
| Philadelphia, Pa. | C. J. Hepp & Son |
| | Penn Phonograph Co. |
| | H. A. Weymann & Son, Inc. |
| Pittsburgh, Pa. | Standard Talking Machine Co. |
| Portland, Me. | Cressey & Allen, Inc. |
| Richmond, Va. | The Corley Co., Inc. |
| St. Paul, Minn. | W. J. Dyer & Bro. |
| San Francisco, Cal. | Walter S. Gray Co. |
| Syracuse, N. Y. | W. D. Andrews Co. |
| Toledo, Ohio | Toledo Talking Machine Co. |
| Washington, D. C. | Cohen & Hughes, Inc. |
| | E. F. Droop & Sons Co. |

TALKING MACHINE TRADE NOW FACES SHOW-DOWN PERIOD

A Very Interesting Analysis of Business Conditions Which Prevailed During the War Period and a Forecast Regarding What Is Promised the Business Man During 1921

By J. NEWCOMB BLACKMAN, President, Blackman Talking Machine Co., New York

EDITOR'S NOTE:—Through an error on the part of our printers, who mislaid part of the copy of Mr. Blackman's article in the January issue of *The World*, we are reprinting this interesting contribution in its correct and proper form this month.

Generally speaking, it is true that history repeats itself. The repetition may be in different form, but the fact that there is no certainty as to the time, manner or result of its repetition often causes a disregard of the fact and a lack of preparation for the inevitable.

This country was not prepared for war and in keeping with the foregoing statement disregarded what might be termed the handwriting on the wall. We relied, as usual, on the fact that we were an undefeated nation apparently capable of meeting any emergency and willing to assume the cost of victory.

Permanently profitable business is transacted with due regard for the laws of economics, while modern war is conducted with an utter disregard of economy.

The immediate need was for men and war material. Cost was disregarded almost entirely.

Demand for several years has so exceeded supply that the outbidding process left the cost of labor and material at the termination of the war extremely inflated. Corresponding deflation must follow.

We are now experiencing the show-down period. Never was there a better time, however, to analyze and capitalize our experiences.

Discussing the talking machine business, and particularly the Victor, what does a review of the last few years reveal? The Victor Co. was the first to offer its services to the Government. Acceptance required an immediate and increasing curtailment of regular production.

Had the war continued no doubt the Government would have realized the unfairness of

allowing the patriotism of men and concerns to be selfishly capitalized by others. Many grasped the opportunity to enter the manufacturing field.

In my judgment, the greater part of 1921 will see everybody resuming their natural places in the business world and the "reaping" will be largely according to our "sowing." Is this not



J. Newcomb Blackman

what we face in meeting the show-down period of 1921?

There will be more failures among manufacturers and the trade in general. The extreme curtailment of the purchasing public, following a recklessness of expenditure, has resulted in discriminating buyers.

With plenty of talking machines and records to select from, what will be the result? In 1921 the problem will not be one of production but of distribution.

The leading manufacturers—and they are really very few when properly classed—will be the ones financially able to meet new conditions. I believe that the wholesaler and dealer who have earned for themselves creditable reputations over a period of many years will get all the support needed.

It will be not only a selling proposition, but also a financial one. In other words, speaking as a distributor, I believe we must resume our true mission.

We must carry stock as production makes it possible, so that we will have on hand, to meet the needs of the dealer, a stock of instruments and records somewhat in keeping with pre-war times.

The banks are curtailing and forcing the liquidation of credits. It will be highly important for dealers to have goods that will stand the test and have proved their permanent value from every standpoint.

When the liquidation process makes it necessary to sacrifice merchandise, the effect is the same as with any security held as collateral against loans. The value of the security is depressed; more margin is called for; or liquidation, regardless of the result, must follow.

A tightening of credits on the part of the banks has opened a larger field for financing companies who have been making loans against instalment leases. They, however, are not going to see the collateral value of such leases depressed through cut-price sales, over-production, or by failures of the manufacturers, without protecting their interests.

I may be prejudiced because my company handles the product of but one manufacturer, but, as they say, "be that as it may," the fact remains that Victor supremacy was never so apparent as to-day. Victor demand was never so clearly demonstrated as permanent. Victor product is still in demand beyond supply.

An ideal condition in merchandising would be always to have enough goods to fill the de-

Interesting Facts For Progressive Dealers

No matter what you may have THOUGHT about phonographs, you can't appreciate the full significance of Tonal Qualities until you have heard

The Manophone



Dealers Wanted Everywhere

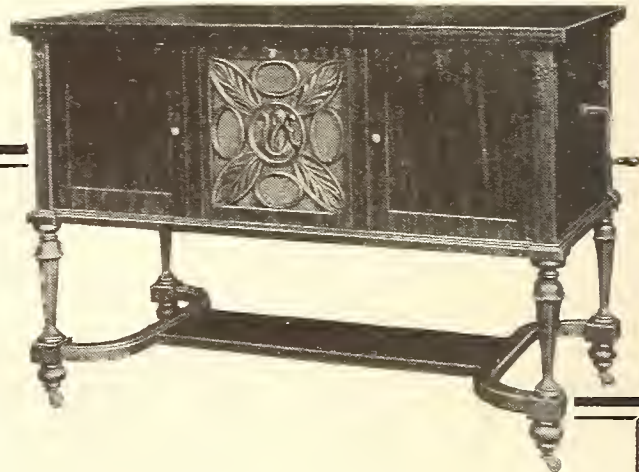

"A Manophone in
Every Home"

And the distinctiveness of this quality in the MANOPHONE is no mere accident.

The men who make the MANOPHONE have back of them 68 years' experience in the manufacture of musical instruments—a fact which means much in the realization of proper musical tones through resonance and vibration.

MANOPHONE Dealers have many points of superiority to help them in the sale of these instruments.

The story of the MANOPHONE is deeply interesting and fascinating; the quality of the instrument is unusually attractive and compelling. Such features spell profit to Dealers.

Have you had our Dealer Business Building Plan unfolded to you? If not, write us—TODAY.

The Manophone Corporation
Adrian, Michigan

**CRYSTAL EDGE
MICA
DIAPHRAGMS**
The Standard of Quality
PHONOGRAPH APPLIANCE CO.
174 Wooster St., New York

mand on a profitable basis, without over-production.

It is to be deplored that the demand for Victor goods has been so greatly in excess of the supply. The evils of over-production, however, have done and will do more damage to the general talking machine industry than an oversold product such as the Victor.

It is a good time, I believe, for the best business men and employes to assume their position as leaders. We should not be pessimistic. On the other hand, we have every reason to be optimistic. Following a temporary business depression I can see no reason why we should not enter an era of great business prosperity for at least five years.

As merchants we must be willing to do less business and make less money for a short time if by that process we can quickly return to normal.

Refusal to reduce prices of commodities or to accept a lower wage, in some cases, only results in the shutting down of factories, the unemployment of thousands and an added determination on the part of the buying public to extremely curtail purchases.

The business man or the employe who meets the inevitable a little ahead of the other fellow will hold his business or his job. The temporary sacrifice will be extremely small compared to the permanent benefit.

I am not advocating reduced prices or extreme methods except where absolutely necessary. Naturally, the merchandise which has had very little advance can have little or no reduction at the moment. Neither should the employe who has been faithful, and in many cases at the sacrifice of a larger salary, be expected to suffer a reduction, but should be rewarded now by having his position and the salary insured.

There is no general rule that can be applied except that the deflation should be in proportion to the inflation in every case.

Concluding, the show-down period in the talking machine business indicates a "survival of the fittest"—fewer manufacturers, wholesalers and retailers.

We will return to quality and workers will succeed shirkers.

The talking machine business for 1921 will be both promising and profitable to many, but not to all, and those who are preparing to meet 1921 conditions ought to be extremely optimistic, for I am firmly convinced they will be amply rewarded.

IT'S NOT ALWAYS EASY

- To apologize,
 - To begin over,
 - To take advice,
 - To admit error,
 - To be unselfish,
 - To be charitable,
 - To face a sneer,
 - To be considerate,
 - To keep on plugging away,
 - To wear a smile—
- BUT IT ALWAYS PAYS.**

It is not the one who can hold out, but the one who can hold in that usually wins a hard argument.

PATHE LAYS PLANS FOR BIG YEAR

New Electric Motor Announced to Trade With the New Year—President Widmann Tells a Golf Story With a Moral for the Trade

The change in general market conditions is being energetically met by the sales organization of the Pathé Frères Phonograph Co., of Brooklyn, N. Y. Realizing the return to intensive selling conditions, this organization has already laid plans for an extensive sales campaign for 1921. Several of these plans have already been successfully inaugurated, and more will follow shortly.

The executive offices fairly hum with activity and the officials of the company, when interviewed, all concurred in optimistic predictions for the year ahead. E. A. Widmann, president, relates a story that admirably portrays the current conditions in the trade. Mr. Widmann, who is a golf enthusiast, was recently approached on the links by a fellow club member who said: "Your game is a little off to-day." "No," Mr.

Widmann modestly replied, "when I make a particularly good score I am a little off my regular playing, for it is away from normal." Mr. Widmann aptly applies this story to the talking machine trade in that during the entirely unprecedented rush of orders during wartime the trade was actually "off" its usual conditions, but that in 1921 the trade will find and keep its normal status, which promises to be satisfactory to all.

The Pathé Frères Phonograph Co. started the new year well with the presentation to the trade of the new Pathé alternating electric current motors. These new electric motors, although before the trade only a short space of time, have already proved very popular, and a regular and steady demand has been developed for them. The first issue of Pathé News of the new year devoted the entire first page to a detailed description of this new motor.

The capital stock of the La Belle Talking Machine Co., New York, has been increased from \$15,000 to \$50,000.



ODEON

RECORDS

from EVERY LAND

Know them by their "TEMPLE of MUSIC"
Trade Mark



AMERICAN and COMPLETE INTERNATIONAL REPERTOIRES
RECORDED IN THE COUNTRIES OF ORIGIN

English—French—Italian—Spanish—German—Dutch—Hungarian—
Turkish—Arabian—Chinese—Greek—Scandinavian—Russian—Polish—
Bohemian—Serbian—Hebrew—Yiddish—Slovenish—Roumanian—Syrian

FONOTIPIA RECORDS



by world-famous OPERATIC and CONCERT STARS

DISTRIBUTORS will realize the value of
a connection with us

American Odeon Corporation

100 WEST 21st ST. NEW YORK





H.K. Lorentzen

Manufacturer of
Exclusive Cabinet Hardware and Accessories
 60 Grand Street
 New York City

RED ROOSTER WINS BLUE RIBBON

Famous Pathé Trade-mark Finds Place of Honor at Omaha Poultry Show

OMAHA, NEB., February 5.—Among the novel features of the annual poultry show, held recently in this city, none attracted more lively attention than the exhibit of the stately Pathé Red Rooster who occupied a place among the blue ribbon winners and who was admired by the hosts of visitors. The exhibit was arranged by the Pathé Sales Co. in conjunction with the Wright & Wilhelmy Co., Pathé distributors, both of this city. The lordly rooster was placed on a turntable in a large cage in a way that made it continually revolve, all of the mechanism being beneath the cage, out of sight. Although the rooster was not a live bird but a large rooster statue revolving on a turntable, the secretary of the show decided that in accordance with their rules the big rooster, statue or not, was to be judged along with the rest of the Rhode Island Red entrants. The Pathé rooster was awarded a blue ribbon as being the most perfect specimen of his particular kind, age and weight on exhibition.

DIAPHRAGM CONCERN INCORPORATES

A recent incorporation is that of the Reacoustic Diaphragm Co., manufacturer of diaphragms for talking machines and telephones. The incorporators are A. E. Thomas and C. and A. J. Kegan, 231 East Fiftieth street. The new company is capitalized at \$10,000.

Duke's Music House, Peru, Ind., is going out of business, according to advices received.

PSYCHOLOGY IN EDISON DISPLAY

Window Display for February Based on Thos. A. Edison's Chart for Analyzing Moods

The Edison window display for February is destined to make people sit up and take notice. It appeals directly to a universal trait of human nature—curiosity.

Few people can resist the temptation to have their palm read, or their fortune told. The Edi-

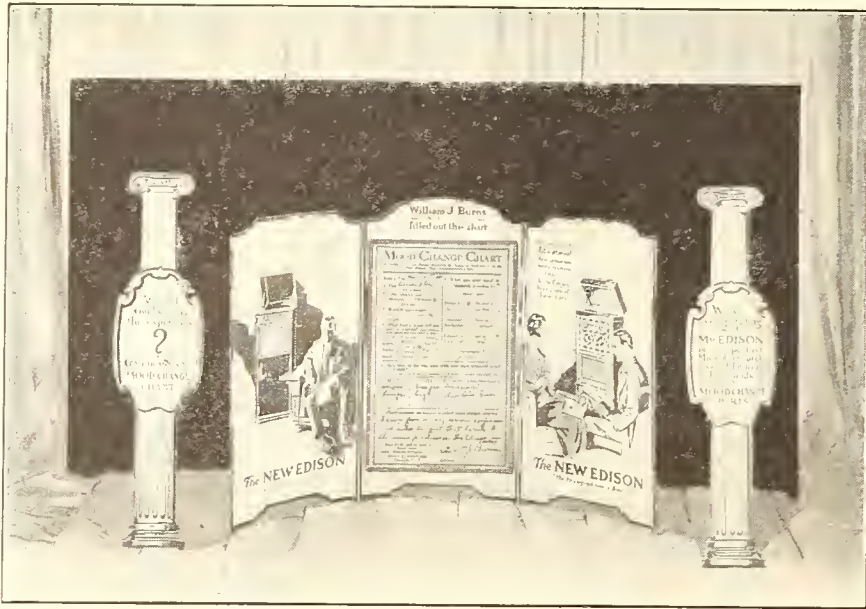

Edison Window Display for February

son Mood Change Chart, upon which both the February Edison national advertising and window display are based, appeals to the same instinct—only the Edison Mood Change Chart is not bunk.

It is an established fact that all people are creatures of moods and that music powerfully affects these moods. As is announced in the February advertising and window display, Thomas A. Edison is conducting a nation-wide research for the purpose of investigating the effects of music on our various moods.

It will be noticed in the photograph that no Edison phonographs and no Edison Re-Creations are displayed in the window. In fact, there is nothing in the window but the display

strikingly brought into relief by a black screen. The purpose of this is to remove all selling ideas that might detract from the purpose of the display and to arouse curiosity and induce inquiries concerning the Mood Change Chart.

BACHARACH HAS A BRIGHT PLAN

Member of Ways and Means Committee Would Provide General Sales Tax While Continuing Excise Taxes on Musical Instruments

WASHINGTON, D. C., January 29.—Members of the music trade might do well to watch for activities of Representative Bacharach, of New Jersey, who, as a member of the Ways and Means Committee, has submitted a plan for a general sales tax of one per cent to be levied on final gross sales. In addition to the general sales tax, however, Mr. Bacharach would continue excise taxes on automobiles, musical instruments, jewelry, etc., while eliminating from the excise tax list candy, wearing apparel, perfumery, etc. Should the plan be considered seriously it would mean that the music trade would have to meet a general sales tax while continuing to pay excise taxes, and thus be subjected to strong discrimination. This is not a fair or square proposition.

THE POWER OF A SONG

We are the music-makers
 And we are the dreamers of dreams,
 Wandering by lone sea-breakers
 And sitting by desolate streams—
 World-losers and world-forsakers
 On whom the pale moon gleams;
 Yet we are the movers and shakers
 Of the world forever it seems.

With wonderful fearless ditties
 We build up the world's great cities,
 And out of a fabulous story
 We fashion an empire's glory;
 One man with a dream at pleasure
 Shall go forth to conquer a crown;
 And three with a song's new measure
 Can trample a kingdom down.

—A. O'SHAUGHNESSY.



DITSON SERVICE

Has back of it years of successful experience and an understanding of dealer problems that will make the road smoother during the coming months.

VICTOR EXCLUSIVELY

Chas. H. Ditson & Co.
 NEW YORK

Oliver Ditson Co.
 BOSTON

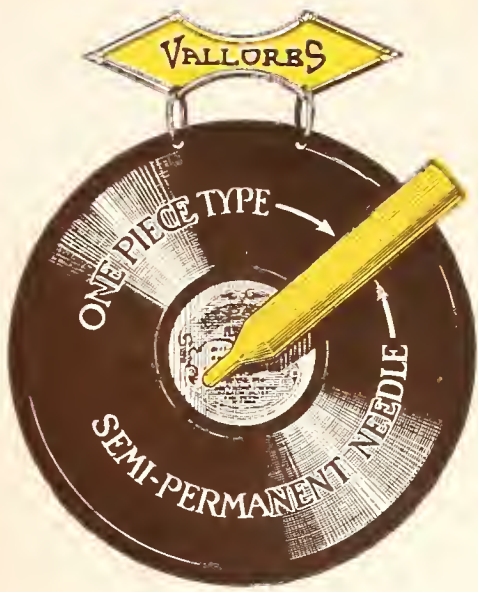

JOBBERS AND RETAILERS —FOREWORD—

Phonograph needle business knows no depression. Quite the contrary. The million or more new phonographs that were sold during the past few years are only now beginning to create an enormous demand for needles.

Aggressive jobbers and dealers know that, if anything, these phonographs will be played more and more. Back it up with a determination to cut a big swath in your overhead expenses by your needle profits.

The big demand for auto tires developed as an aftermath to the sale of autos. Similarly, we are only now on the crest of the largest demand for needles.

The needle to pin your faith to, for big profits, is the ultimate needle, i. e., the Semi-Permanent, which in turn finds its highest development in

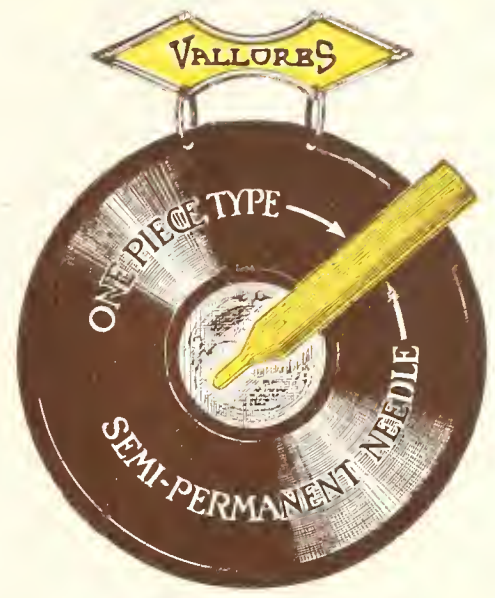

VALLORES ONE PIECE TYPE SEMI-PERMANENT PHONOGRAPH NEEDLE

FOR IT IS THE

"BEST TONE FOR THE HOME"

The Vallorbs One-Piece Type Semi-Permanent Needle is the product of a company closely affiliated with the phonograph industry for 15 years, during which time it has been called on to make master recording jewels for recording laboratories, besides regular commercial products, and for the benefit of new dealers in the phonograph field, who perhaps do not have mature technical knowledge that only comes with years of contact. You cannot judge or appreciate the tonal qualities of Vallorbs Needles until you and your friends try them in the home with a representative home stock of records, under home environment, for conditions are different in the store, where the acoustics are different and where only brand new records are played that exert far greater wearing influence upon all kinds and types of needles. Vallorbs Needles for long-wearing and beautiful quality are superior and constructed particularly for "the best tone for the home."

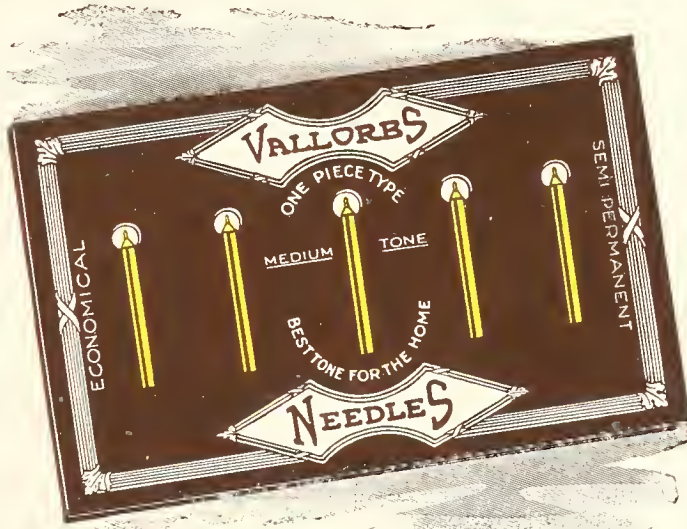

Vallorbs one-piece type semi-permanent needles are supplied in three volumes—loud, medium, soft—in boxes of 100 cards. The most handsome needle display box yet devised. Everybody is attracted to it.

The largest and most attractive show window and counter advertising cards, that certainly pull the inquiries from all who see them.

At 25 cents per card of five needles they are most ready sellers, and your profit is greater.

Vallorbs needles are "persona grata" to all dealers and advertise no competing make of record or phonograph.

RETAILERS

Order a box of 100 cards assorted tone volumes—loud, medium, soft—with a handsome display card for your window. Place box on full display in your store and the cash register will ring a tingling jazz melody.

JOBBERS

Don't wait until you hear others say "Business is 'picking up.'" Pick it up yourself. Write Vallorbs for their irresistible proposition from which the "kick" is removed, for it is strictly law-abiding. "Everything to gain and nothing to lose."

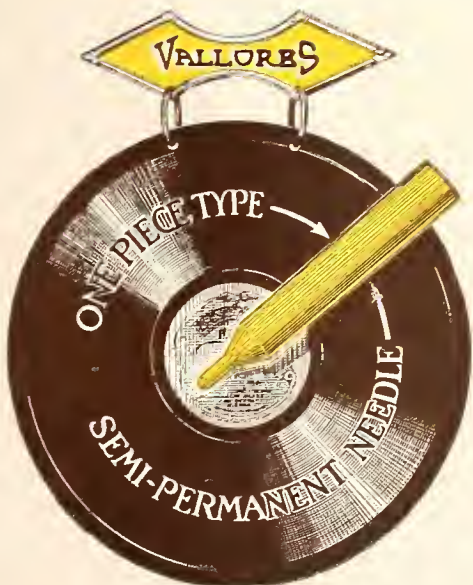

LANCASTER, PA., U. S. A.

DIAMOND POINTS FOR EDISON RECORDS
SAPPHIRE BALL JEWELS FOR PATHE RECORDS

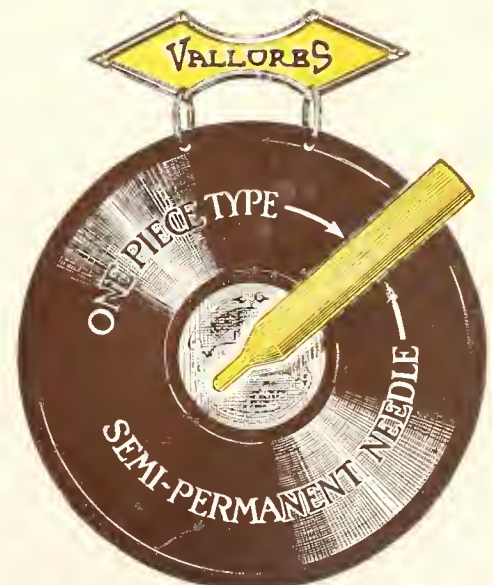

In Rosa Ponselle's rendering of "Maria, Mari!" (Marie, Ah, Marie!) you have a pure Neapolitan melody sung by a marvelous princess of song. This record will be selling steadily more than a score of years from now. Columbia 49870.

Columbia Graphophone Co.
NEW YORK



EXCELLENT WINDOW DISPLAY IDEA

Edison Shop, Dallas, Tex., Arranges Two Special Windows at Holiday Time That Combine Originality and Attractiveness

The Edison Shop, Dallas, Tex., of which C. H. Mansfield is president and manager, featured a window display at Christmas time that



Night Scene Showing Cottage on Christmas Eve was artistic and attention-compelling. As a matter of fact, it was really two displays in one, for one window of the store was arranged as a sort of sequel to the other. The pictures,

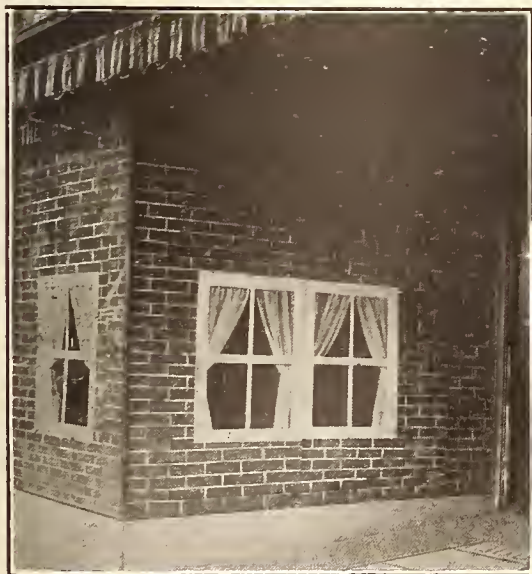

Another Display, Showing Cottage at Close Range

unfortunately, were received too late for the January issue, but are presented herewith.

The first window, an exterior scene, showed a little cottage on Christmas eve, with Santa Claus landing in front of it in his airplane and about to deliver a Chippendale model Edison. The father can be seen standing on the porch holding the door open for Santa, while mother is inside decorating the Christmas tree. A "property" moon cast a beautiful glow over the window, and a number of stars helped in the illumination.

The second window was arranged to represent the exterior of the cottage, with real windows, through which the interior of a cozy

living room was revealed, with the Christmas tree in place, and the New Edison underneath just after Santa had left it. Both windows attracted large crowds throughout the holidays, and the idea is one that might be adopted with profit not only for some other holiday season, but perhaps at other times during the year.

RECEIVER FOR TALKING BOOK CORP.

Creditors File Petition Against New York Record Book Manufacturing Concern

On January 26 a petition in bankruptcy was filed against the Talking Book Corp., New York, manufacturer of talking machine records and appliances at 1 West Thirty-fourth street. On January 27 Judge Hand appointed Jacob Scholes and Thomas H. Matters, Jr., receivers in \$1,000 bond. It was said at that time that the liabilities exceeded \$75,000 and that the assets might exceed \$5,000.

RECORD FACTORY IN DENMARK

The first factory for the manufacture of talking machine records was established recently in Drammen, Denmark. The factory is equipped throughout with the latest American machinery. The product will be for home consumption with possible export to the neighboring countries.

A salesman should not feel alarmed when he learns that competitors are ahead of him on his route. There are just as many behind him.

IMPORTANT APPOINTMENTS MADE

A. C. Mayer Becomes General Sales Manager of the Unit Construction Co.—A. W. Deas, Jr., Eastern Sales Manager, with J. N. Hallinan as Assistant—Efficiency Bench Makes Debut

PHILADELPHIA, PA., January 27.—Several new appointments have been made in the sales organization of the Unit Construction Co., of this city, manufacturer of Unico demonstrating rooms, record racks and counters. A. C. Mayer has been appointed general sales manager of the company. Arthur W. Deas, Jr., has been appointed Eastern sales manager of the Unit Construction Co., with headquarters at 299 Madison avenue, New York City. The territory under the direction of Mr. Deas will be New York State, east of Buffalo, and New England. Mr. Deas has already started intensive work in the development of the territory and recently covered New England as far as Portland, Me. J. Neil Hallinan has been appointed assistant to Mr. Deas with the title of Assistant Eastern Sales Manager, and will make his headquarters in the same office with Mr. Deas.

The announcement of a new Unico product is made at this time. The Efficiency Bench which has just been presented to the trade by the Unit Construction Co. is a repair bench. It is the result of much careful study and, as its name implies, it is said to be one of the most efficient benches for the repair man that have yet been produced. Plans are under way to push this product during the year.

YAZOO RIVER RED GUM

Specials for prompt shipment:

- 2 cars 1 1/4" 1st and 2nd Plain Red Gum.
- 1 car 1 1/2" 1st and 2nd Plain Red Gum.
- 5 cars 2" 1st and 2nd Plain Red Gum.
- 8 cars 2" 1st and 2nd Qrtd. Red Gum.
- 8 cars 2 1/2" Common and Btr. Qrtd. Red Gum.
- 4 cars 3" Common and Btr. Qrtd. Red Gum.
- 8 cars 1 1/4" No. 1 Common Plain Red Gum.
- 10 cars 2" No. 1 Common Plain Red Gum.
- 2 cars 2" No. 1 Common Qrtd. Red Gum.
- 10 cars 2" No. 1 Common Qrtd. Red Gum.
- 3 cars 3" No. 1 Common and Btr. Plain Red Gum.
- 5 cars 1 1/4" 1st and 2nd Sap Gum.
- 5 cars 1 1/2" 1st and 2nd Sap Gum.
- 10 cars 2" 1st and 2nd Sap Gum.
- 2 cars 3" 1st and 2nd Sap Gum.
- 5 cars 1 1/4" No. 1 Common Sap Gum.
- 5 cars 1 1/2" No. 1 Common Sap Gum.
- 10 cars 2" No. 1 Common Sap Gum.
- 2 cars 3" No. 1 Common Sap Gum.
- 5 cars 1 1/2" No. 1 Common and Btr. Qrtd. White Oak.
- 5 cars 3" No. 1 Common and Btr. Qrtd. White Oak.
- 5 cars 4" No. 1 Common and Btr. Qrtd. White Oak.
- 10 cars 1" No. 1 Common and Btr. Qrtd. Red Oak.
- 6 cars 1 1/2" No. 1 Common and Btr. Qrtd. Red Oak.

Our Red Gum is of soft texture and rich dark color. Specially manufactured and seasoned.

Send us your inquiries for all kinds of cabinet woods.

THOMAS & PROETZ LUMBER CO.

3400 Hall St., St. Louis, Mo.

Mr. Jobber— Line Up With a "Live" Line

"Some choice territory still available"

Prima-Donna

"The Instrument Inspired"

--The
Entering
Wedge

To
Phonograph
Sales



"Bungalow"



"Stratford"



"Blackstone"



"Astoria"



"Majestic"



"Parlor Grand"

Write for Our Unusual Money-making Proposition

Let us show you how Prima-Donnas, as compared to other high-grade phonographs, are sold at a price that offers the biggest money-making proposition on the market. How we co-operate with the jobber by supplying him with selling helps such as jobbers' letters and broadsides to interest the dealer, beautiful five-color catalogs, dealers' four-color store folders, six-color store hangers, newspaper ad electros, moving picture slides, etc.

We sell exclusively through our jobbers, all inquiries from dealers, due to our extensive advertising, are referred to our jobber in that territory.

Unexcelled Tone and Craftsmanship

Prima-Donna Phonographs, due to their especially designed and scientifically constructed all wood amplifier, develop a wonderful richness and clearness of tone that is unsurpassed. They will play any and all records correctly, with a fidelity to the recorded music that instantly appeals to the music lover and connoisseur.

You must admit the designs of the Prima-Donna are beautiful. As for construction and finish we ask the opportunity to prove Prima-Donna superiority. All cabinets are solidly constructed, the panels, which are 5-ply, either genuine mahogany or quartered oak, are inserted in a continuous frame that makes the cabinet absolutely wear-proof.

PRICES FROM \$85 to \$225—LIBERAL DISCOUNTS

Unreservedly GUARANTEED for One Year

MR. RETAILER We Have a Jobber in Your Territory
Who Can Supply You Overnight With
These Big Phonograph Values :: ::

GENERAL SALES CORPORATION

1520 BUFFUM STREET

MILWAUKEE, WIS.

OWNING AND OPERATING
GENERAL MFG. CORP. RECORDEON PHONOGRAPH CO
MFRS. OF PHONOGRAPHS
HEANEY-SCHWAB BILLIARD MFG. CO Makers of Fine Billiard and Pool Tables Since 1882

TOSCANINI AND LA SCALA ORCHESTRA SCORE TRIUMPH

Noted Musical Organization Under Great Conductor Received Enthusiastically in New York—Makes Records for Victor Co.—Now on Extended Concert Tour of the Country

The announcement made in *The World* last Fall to the effect that the great La Scala Orchestra, under the baton of Arturo Toscanini, would, upon its arrival in the United States for



Arturo Toscanini

a concert tour of the country, make a number of records for the Victor Talking Machine Co., has been followed by the appearance of the orchestra here and the actual making of the first of the records.

The status of Toscanini and the La Scala Orchestra in musical circles is fully proven by the enthusiasm that evidenced itself when the or-



The La Scala Orchestra Now Touring the United States

chestra gave its several concerts at the Metropolitan Opera House and Carnegie Hall in New York. The Metropolitan and Toscanini are far from being strangers, inasmuch as that conductor spent some important years as the musical leader of the Metropolitan Opera Co. As a matter of fact, it was the breaking out of the war which caused him to give up his work here to go back to Italy, where he was assigned to direct the military music and concerts for the soldiers, in which work he won high honors.

With the La Scala Orchestra now recording for the Victor, the Victor Co. has added to its permanent record library the works of one of the greatest musical organizations of the world. The La Scala Opera House is known as the traditional home of Italian opera, and probably saw the opening performances of more masterpieces than any other structure in the world. For more than 140 years it has held a dominant place in opera, and it is therefore but natural that the permanent orchestra of such an institution should be an organization of unusual calibre.

The first Victor recordings of the La Scala Orchestra are formally announced in the March list and will be eagerly awaited by the trade and the public. As a matter of fact, the La Scala Orchestra is now on an extended tour of the country, having completed a series of concerts in New York, and through the medium of this tour and the personal touch brought about thereby with the music lovers of the country at large there should be, and unquestionably will be, created an exceptional demand for the records of the organization.

It is understood that Victor dealers in cities to be visited by Toscanini and the La Scala Orchestra will put forth special efforts to see that the appearance of the orchestra receives due recognition and particularly that the public is made acquainted with the fact that La Scala records will soon be available for their libraries. For the information of the trade in general, who are naturally anxious to keep in touch with the La Scala organization, we append herewith the itinerary of the orchestra from the time it left New York on January 31 until its return to the metropolis on March 6. It will be noted that few of the principal cities in the East and Middle West have been overlooked in the itinerary, which in full is as follows: February 1, Rochester; 2 and 3, Cleveland; 4, Detroit; 6, Indianapolis; 7, Louisville; 8, Cincinnati; 9, Columbus; 10, St. Louis; 11, Springfield; 12, Milwaukee; 13, Chicago; 15, Grand Rapids; 18, Davenport; 19, Des Moines; 20, Kansas City; 22, Tulsa; 23, Wichita; 24, Topeka; 25, Omaha; 27, Chicago; March 1, Pittsburgh; 2, Philadelphia; 3, Washington; 5, Scranton; 6, New York (Hippodrome). The orchestra is making the tour under the management of Loudon Charlton, the prominent New York impresario.

BUFFALO DEALER FILES PETITION

BUFFALO, N. Y., February 5.—A voluntary petition in bankruptcy has been filed in the United States Court here by William Turner, Inc., dealer in talking machines, records and musical merchandise. In the petition filed by Wesley C.

Pettit, vice-president of the corporation, the liabilities were given as \$8,967.53 and the assets as \$7,275.20.

BRUNO

Depending upon your memory, Mr. Victor Dealer, is a risky proposition. Eliminate all hazard by using the indispensable Victor Record Order Stock Book—a Wonder Book at trivial cost.

BRUNO

GRAND RAPIDS STORES IMPROVE

Dealers Adding Booths and Making Preparations for Big 1921 Trade

GRAND RAPIDS, MICH., February 5.—The Friedman-Springs Co., owner of a large department store here, has installed a talking machine department on the fourth floor, with four individual booths for the record department. Pathé machines and Pathé records are handled exclusively. The Winegar Furniture Co., handling Victor talking machines and records exclusively, plans to build two new booths in February. Nine booths are now used for demonstration.

"We handle the Victor exclusively and a comparison of sales shows that we did a better business in Victrolas in 1920 than we did in 1919. And sales since January 1, 1921, have compared very favorably with the same period of a year ago," says W. M. Winegar, manager.

The Young & Chaffee Furniture Co., of this city, completed the building of eight new booths in January, giving them a total of thirty booths in the record department, which is said to be the largest record department in Michigan. This firm handles the Victor exclusively.

Ready Dealer Sales

Purchasing Agents can better co-operate with their own Sales Departments by supplying accessories and fittings of distinctive designing. Dealers in turn appreciate the advantages in handling Furniture so equipped.

PHONOGRAPH ACCESSORIES

For Immediate Delivery—Needle Cups and Double Spring Motors, capable of playing three 12-inch records. Also—Lid Supports, Automatic Stops, Tone Rods, Knobs, Escutcheons, Sockets, etc.

FURNITURE TRIMMINGS

A complete offering in all the Period and Commercial Furniture Lines.

REFRIGERATOR HARDWARE

All sized Locks and Hinges

Samples and complete information on request

Grand Rapids Brass Company
Grand Rapids, Michigan New York: 7 E. 42nd. St.

Not Written For You— But Send For a Copy

THERE are a good many reasons why you should read this book, even though you personally are not supposed to be the "ultimate consumer" of its pages.

Scores of our dealers have written us highly appreciative letters regarding it. One of them summed up the general opinion of all when he said: "Aside from its being the most interesting, convincing, and beautiful bit of consumer literature I've ever seen, the reading of it has been of direct benefit to me. I've read between the lines and gained some real pointers on phonograph merchandising."

The book was written for dealer distribution to prospective purchasers of



The Phonograph Instrumentized

A SIDE from the fact that the book is everything the above-mentioned dealer says it is, it will give you a bird's-eye view of the Dalion merchandising plan—and it will show you the exclusive sales features of the instrument—it will give you a general idea of how whole-heartedly we co-operate with our dealers to make their phonograph department the most profitable part of their business.

Send for it—TODAY. The book is worth having on its own account, and the postage stamp that carries your inquiry may turn out to be the best investment you ever made.

Milwaukee Talking Machine Mfg. Co. Milwaukee

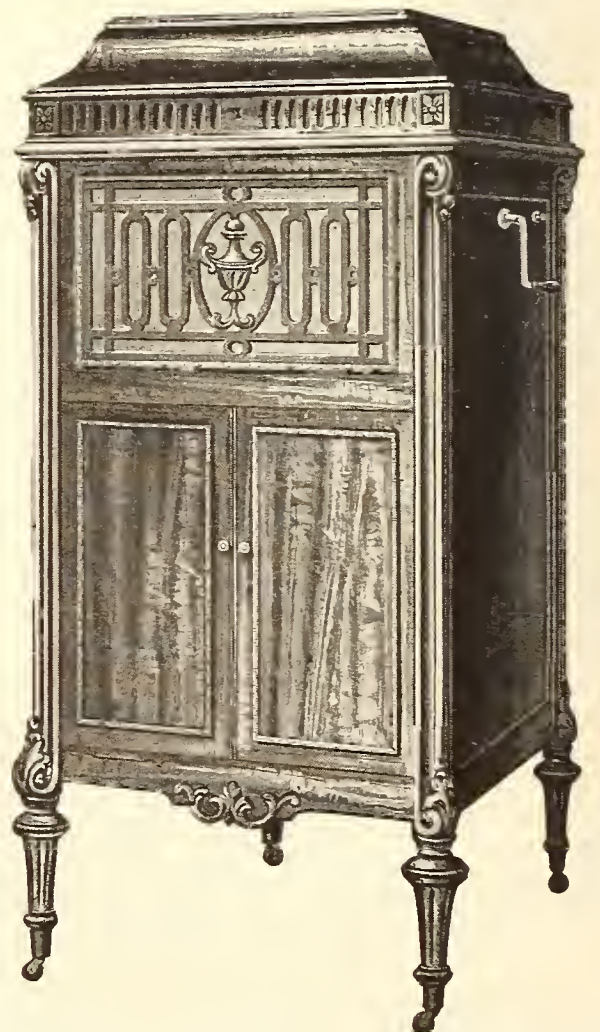

FEATURES VICTOR OPERA FIGURES

Kansas City House Finds Drawing Power of These Display Features to be Great

KANSAS CITY, Mo., February 4.—The J. W. Jenkins' Sons Music Co., of this city, has been using to very good effect the small figures of famous grand opera characters recently put out by the Victor Co. These small figures make an attractive window display feature and are always interesting to the music-loving public. The Penn Phonograph Co., of Philadelphia, distributor of these figures, furnished the local house with the miniatures used in the displays.

The Jenkins Co., by the way, has found these window displays very effective in moving goods, and its experience bears out the words recently published in the Voice of the Victor, which said:

"The figures attract crowds. That has been demonstrated. Crowds mean curiosity. Curiosity means that people want to know what things are all about. When they find out, if the things are good, they want to possess them. And the pride of possession is a human characteristic that never will change so long as humanity exists.

"The idea of these figures is to move little-known as well as well-known opera records. It is one of the misfortunes of popular taste that some of the very finest records do not sell as well as those better known. People stick to two or three favorite numbers from each opera because they know them. But if they become familiar with others they will buy and enjoy them."

INCORPORATED IN BROOKLYN

The Mutual Phono Parts Corp., New York, has been incorporated at Albany with a capital of \$15,000. The incorporators are H. Segal, H. Stahl and N. Garfinkel, 319 Lincoln place, Brooklyn.

CUBA NOW IMPORTS MANY TALKERS

Smaller Types of American Instruments Growing in Popularity With Islanders—Canada Takes Second Place and Australia Is Third

Cuba is coming to the front as an importer of American talking machines. A glance at the latest report of the Department of Commerce (November, 1920) shows that out of a total of 9,796 talking machines exported by the United States during that month, Cuba took 3,600, or more than one-third. The country importing the next highest number was Canada, which took 2,723 instruments. Australia followed in third place with a score of 484.

The value of the exports of talking machines to Cuba in that month was \$96,805, to Canada \$133,009, and to Australia \$31,776. An examination of the values of these instruments shows that the average cost of each instrument exported to these countries went in inverse proportion to the number of instruments. The average value of each machine sent to Cuba was \$27; to Canada, \$50, and to Australia, \$65. To all appearances the higher-priced instruments were imported by Australia, and Canada and Cuba preferred smaller talking machines.

LEWIS STERLING VISITS NEW YORK

Official of London Columbia Branch Crosses Ocean for Brief Visit

Lewis Sterling, managing director of Columbia Graphophone Co., Ltd., of London, made one of his periodical visits to the Columbia executive offices in New York last month. He was accompanied on his trip from England by Mrs. Sterling.

Many of the qualities that make a man a good salesman are born in him. It is possible for him to learn a few things, nevertheless.

PAINTS ADS ON AUTO WHEELS

Sanders & Stayman, Connellsville, Pa., Use Ford Wheels to Good Advantage

What is the use of having nice disc wheels on a Ford runabout if you don't put them to practical use? That was the thought that struck the manager of the Sanders & Stayman store in Connellsville, Pa., with the result shown in the accompanying photograph. Whenever and wherever the runabout stops the names Vocalion records and Aeolian-Vocalion are presented strongly to the gaze of those who stop to look, and the idea of the lettered wheels, being new in Connellsville, never fails to attract a full measure of interest. Sanders & Stayman attribute several sales to these revolving advertisers.

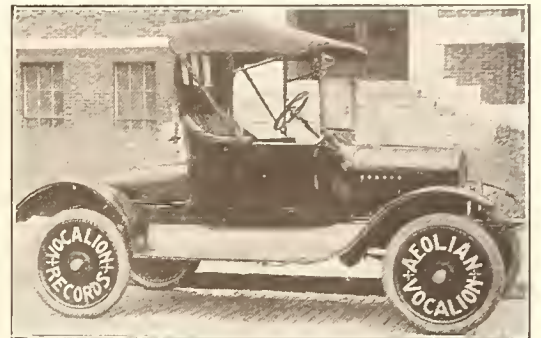

Note the Novel Advertising on the Wheels. Vocalion records and Aeolian-Vocalion are presented strongly to the gaze of those who stop to look, and the idea of the lettered wheels, being new in Connellsville, never fails to attract a full measure of interest. Sanders & Stayman attribute several sales to these revolving advertisers.

A VERY SIGNIFICANT FACT

"Eighty-four per cent of the business failures of 1920 were firms which did not advertise." This figure is the outcome of a country-wide investigation made by one of the greatest financial agencies in the country.

A good salesman can get as good a price for his goods as anyone, and better prices than a poor salesman can. A man who has to cut prices to get an order does not understand selling.

W.D. & C.N. ANDREWS
BUFFALO, N.Y.

extending the same service & satisfaction

will be known in the future as

CURTIS N. ANDREWS
BUFFALO, N.Y.

Victor
HIS MASTER'S VOICE

Victor Wholesale

PETER G. SPITZ JOINS PARAMOUNT

Well-known Talking Machine Man to Be Factory Representative for Wisconsin Territory—Has Many Plans for Coming Year

PORT WASHINGTON, Wis., February 4.—Peter G. Spitz, who has been long acquainted with the talking machine and record trade and has established a host of friends in western Iowa and Nebraska, has been appointed factory representative by the Paramount Co. for this territory.

Mr. Spitz has had extensive experience, is well versed in all the details of the business



Peter G. Spitz

and is in a position to give valuable information and assistance to his dealers.

Now with the Paramount staff, Mr. Spitz was connected with the selling force of the Victor Co. for a number of years. He has also handled the Edison, Columbia and Brunswick lines and has just recently severed his relationship with the Carpenter Paper Co., of Omaha, Neb., for whom he was traveling as a special representative selling Emerson phonographs and records.

Mr. Spitz is very enthusiastic about the talking machine industry and feels sure that a good volume of business will be secured in 1921 with the Paramount line.

FRAUDULENT SALES PRACTICES STOPPED BY COMMISSION

On Information Submitted by Better Business Bureau of Music Industries Chamber of Commerce the Federal Trade Commission Issues Restraining Order Against P. Tyrrell Ward

Another mail order phonograph dealer whose advertising appeared in newspapers throughout the country has been ordered to stop certain practices by the Federal Trade Commission.

Following is the form of the advertising complained of: "\$69.50 takes beautiful \$250 size mahogany cabinet grand phonograph, one diamond and one sapphire jewel point, everlasting needles, 200 regular steel needles and records. Absolutely new. Will ship C. O. D. on approval. Act quick. Household Storage Co., Wilmette, Ill."

(1) The Federal Trade Commission, acting upon information submitted by the Better Business Bureau of the Music Industries Chamber of Commerce, found that the respondent, in competition with other persons, firms and corporations engaged in the sale of phonographs throughout the various States and Territories of the United States and the District of Columbia, sold phonographs to purchasers, directly, by means of advertising matter, catalogs, correspondence, and such other ways peculiar to what is known commonly as the mail-order business.

(2) That the advertising matter used by respondent in the course of his business contained certain false and misleading statements, among which were the following, viz.:

(a) That respondent was regularly engaged in the storage and warehouse business and by reason of conducting such business came into possession of a single phonograph or single lots of phonographs which had never been removed from the cases in which such phonographs were crated when they left the factory.

(b) That such phonographs were of a value vastly in excess of the price at which respondent offered them for sale to purchasers and prospective purchasers; that such offers of sale were limited to a single phonograph or to a lot of single phonographs that would not again be made.

(3) That respondent in the period from November, 1918, to and until the month of March, 1920, during which period he was engaged in the sale of phonographs in the manner hereinbefore described, was not engaged in the storage or warehouse business, but was regularly engaged in the business of selling phonographs of a grade and quality which were manufactured to sell at resale and were customarily sold at resale by respondent in the regular course of his business at less than one-third of the resale

price (\$250) at which such phonographs were listed in the advertising matter of respondent; that the phonographs dealt in by the respondent in the period hereinbefore mentioned were not stored and the number of phonographs offered for sale by respondent's advertisements were not limited as advertised, but were taken from respondent's regular stock, to replenish which the respondent had made arrangements with the manufacturer.

(4) That the trade name, "Household Storage Co.," was used by the respondent for the purpose of deceiving purchasers and the public generally into believing that the respondent was conducting a business principally of storing household goods and incidentally selling phonographs.

The practices of said respondent, under the conditions and circumstances described in the foregoing findings, are unfair methods of competition in interstate commerce and constitute a violation of the Act of Congress, approved September 26, 1914, entitled "An Act to Create a Federal Trade Commission, to define its powers and duties, and for other purposes."

Following the findings of the Commission the following decision was rendered:

It is now ordered that the respondent, P. Tyrrell Ward, and his agents and employes do cease and desist from using in the sale in interstate commerce of phonographs the trade name of Household Storage Co. or any other trade name which might have a tendency to lead the public into the belief that the business conducted by the said P. Tyrrell Ward is that of storing household goods.

And it is further ordered that the said P. Tyrrell Ward shall, within sixty days after the service of a copy of this order upon him, file with the Commission a report in writing, stating in detail the manner in which this order had been complied with and conformed to.

The Dulciphone Shop, Brooklyn, N. Y., has been incorporated with capital stock of \$25,000. The three incorporators are L. Levy, E. L. Rockmore and F. X. Goette.

A salesman should have a good memory for names and faces, or do as the German army officer who, berating his subordinate for forgetfulness, said: "If you are such a d—d fool as to forget everything, why don't you put it down on paper as I do?"

HERE IT IS
The
**FLETCHER UNIVERSAL
TONE ARM and REPRODUCER**

Gives Proper Playing Weights for all Records. No Adjustment Screws or Springs.
SAMPLES \$8.00 Specify 8½" or 9½" arm

FLETCHER-WICKES CO., 6 East Lake Street, Chicago, Illinois
THE GEORGE McLAGAN FURNITURE CO., STRATFORD, ONTARIO, EXCLUSIVE CANADIAN AGENTS

FREE - To Dealers Who Do Not Sell Tonofone Needles

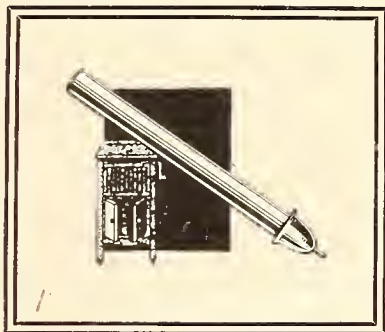

SEND Coupon for Sample Package of Needles NOW!

New "12 for 25c" Package a Big Success!

To introduce our new, bigger value, bigger profit package, which gives your customers 12 Tonofone needles for 25c, we are offering you, for a limited time, a price of \$14.00 a carton of 100 packages—or \$7.50 a half carton of 50 packages.

The \$14.00 carton retails for \$25.00, giving you a profit of \$11.00 a carton, or 11c a package. This is 44% on your selling price and 79% on your investment. You will recognize this as a very exceptional profit.

Please order direct from this advertisement, using coupon below. The needles will be shipped on our positive guarantee. Terms: Cash with order, less 2%, or 30 days net on approved references or established credit rating.

ORDER BLANK

R. C. WADE CO.
110 So. Wabash Ave., Chicago, Ill.

Gentlemen:—Please enter our order for Tonofone Needles as follows, which may be shipped through one of your wholesale distributors.

.....Cartons, 100 packages, at \$14.00.....
.....Half Carton, 50 packages, at \$7.50.....

Firm Name.....

Street.....

City..... State.....

Above is purchased subject to your positive Guarantee.

If you are not yet selling Tonofone Phonograph Needles, mail us the coupon below, so we can send a package FREE for you to try at our expense. When they come test them on all kinds of records. Note how wonderfully they play popular songs and instrumental records as well as grand opera records. How they reproduce them as never before.

Over 3,000 dealers know the Tonofone Flexible Point has standardized a new degree of needle perfection. Each needle plays 20 to 50 records—any disc record on any phonograph—one needle for all tones.

The Tonofone Flexible Point is of

correct and uniform size—not tapered. Being flexible it brings out clearer tones and gives more accurate reproduction. Being softer than any record, it minimizes surface noise and prolongs the life of records.

If you already know Tonofone quality, send the order coupon at left for carton of the new, easy-selling, bigger value, bigger profit package—which gives your customers 12 needles for 25c. Note the special introductory prices to dealers.

Mail one of the coupons at once.

R. C. WADE CO.

110 So. Wabash Ave., Chicago, Ill.

Tonofone

The Phonograph Needle With the Flexible Point

R. C. WADE CO., 110 So. Wabash Ave., Chicago, Ill.

Gentlemen:—Please send FREE sample package of Tonofone Needles for us to test at your expense.

Firm Name.....

Street.....

City..... State.....

TAX EXPERTS FAVOR SALES TAX

Sales Taxes vs. Excise Taxes Form Topic of Discussion at Third Tax Conference of National Industrial Conference Board at Hotel Astor—Alfred L. Smith Represents Music Industries

The idea of a sales tax particularly in a limited form to apply to all sales of commodities, as a substitute for excise taxes, was given a big impetus at the Third Tax Conference of the National Industrial Conference Board held at the Hotel Astor, New York. That most of the tax experts gathered to discuss the tax question were becoming favorably inclined to some sort of a sales tax was evident in spite of the fact that the revised report of the conference board's tax committee still recommended increases and an extension of excise taxes. The Music Industries Chamber of Commerce was represented at the conference by its general manager, Alfred L. Smith.

The report of the tax committee, which was the subject of discussion, embraced a great variety of tax recommendations adopted after exhaustive investigation relative to abolition of excess profits tax, surtaxes, increases in corporation income taxes and a number of remedial changes in the law having little effect on revenue; but practically all of the discussion, during both days of the session, centered on the question of sales versus excise taxes.

The proponents of the sales tax brought out conclusively the fact that excise taxes are sales taxes in every sense of the word and must have practically any disadvantages which can be properly said to exist with sales taxes. The question, therefore, resolved itself into that of whether or not it is better to raise revenue by sales taxes at high rates upon a few selected industries rather than by a very small tax upon all sales.

Early in the conference the discussions were concerned chiefly with the question of a general sales or turnover tax as a substitute for all taxation on business versus the recommendation of

the board's tax committee, but as the session progressed there were indications that advocates of the general sales or turnover tax would agree with the advocates of a limited sales tax upon the general principles that a tax on the sale of all commodities should be the chief method of raising revenue to offset the elimination of excess profits taxes, certain surtaxes and excise taxes.

SOUTHERN VICTOR DEALERS MEET

Hold Two-day Convention in Memphis and Are Guests of O. K. Houck Piano Co.—Twelve States Represented and 100 Delegates Present

MEMPHIS, TENN., February 3.—Memphis was host on January 20 to about 100 music men, members of the Southern Victor Dealers' Association, representing twelve Southern States, in convention at Hotel Chisca. Atlanta, Birmingham, New Orleans, Nashville and other cities sent delegates.

The afternoon session was featured by a talk on scientific selling by F. A. DeLano, of the Victor School of Salesmanship. Delegates were guests of the O. K. Houck Piano Co. at an 8 o'clock banquet. A special program of music and entertainment had been planned to make the event memorable to all those who attended.

The second day was given over to business sessions and an automobile tour of Memphis parks and points of interest. Officials of the association who had charge of the convention plans were B. B. Burton, president; R. G. Brice, vice-president; W. E. Cumming, treasurer, and R. P. McDavid, secretary.

INCORPORATED

The Opera Disc Co., New York, has been incorporated with capital stock of \$10,000 to manufacture and sell sound reproducers. The incorporators are C. G. Galston, M. Hesslein and C. Rose.

ILSLEY'S GRAPHITE PHONO SPRING LUBRICANT

Ilsey's Lubricant makes the Motor make good
Is prepared in the proper consistency, will not run out, dry up, or become sticky or rancid. Remains in its original form indefinitely.
Put up in 1, 5, 10, 25 and 50-pound cans for dealers.
This lubricant is also put up in 4-ounce cans to retail at 25 cents each under the trade name of

EUREKA NOISELESS TALKING MACHINE LUBRICANT

Write for special proposition to jobbers.
ILSLEY-DOUBLEDAY & CO., 229-231 Front St., New York

INTRODUCES THE CERTIFIED NEEDLE

Reflexo Products Corp. Announces Gilt-edge Certified Needle—Its Construction Described

And now comes the certified needle. The Reflexo Products Corp., New York City, which introduced the Reflexo needle to the trade over a year ago, has announced the advent of the gilt-edge certified talking machine needle. This new needle has a Brilliantone base, thus guaranteeing its uniformity of length and quality and has a gilt plating which is guaranteed never to tarnish. Each needle will play ten records. Simultaneously with the announcement of this new needle the Reflexo Products Corp. has evolved the slogan: "You've Bought the Rest, Now Buy the Best." Every box in which these needles are shipped will provide the dealer with an excellent counter display to bring these needles forcefully and attractively to the attention of his customers.

HAS GOOD RECORD FILING SYSTEM

Brooklyn Dealer Uses 3,000 Individual Compartments for Records—Claims Saving of Time to Salesman as One of Many Advantages

The Arthora Talking Machine Co., Brooklyn, N. Y., now has in operation a filing system for records which, according to Manager Ruchgaber, has many advantages. The records are located in 3,000 individual compartments. Each compartment is labeled with the number of the record and only a small number of the same record is kept in the file at one time. One record is in a master envelope, which is turned around when the record is out of stock. Although this system of filing requires more frequent replenishing of records in the individual compartments, it, however, enables the salesman to locate desired numbers with greater speed and accuracy and enables the dealer to keep constant track of his stock.

Judgment has been filed against Meyer S. Greenberg (United Phonograph Co.) in New York County Court by I. Flatow for \$139.81. The United Phonograph Co. conducted its business in a store on the Bowery, New York City.

PERIOD MODELS
Louis XVI Model—also Queen Anne Period
Now Ready for Delivery

To
Retail
at
\$150.00

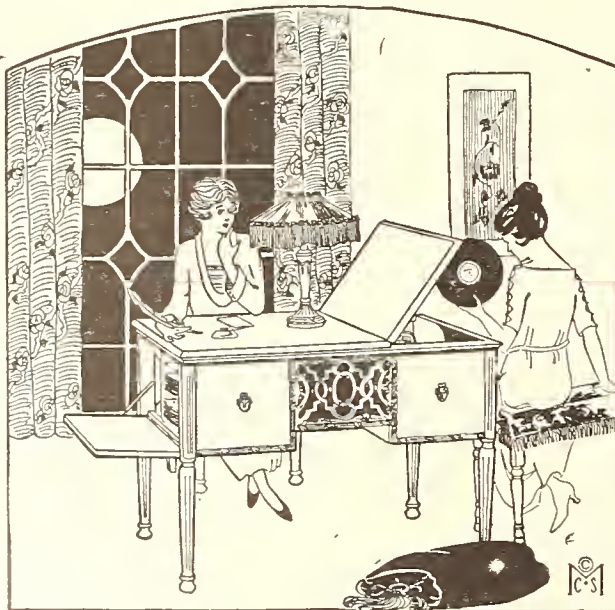

Write
for
Dealers'
Discounts

No. 175. Pat. applied for. 42" long, 26" wide, 31" high.
Finished on all sides—golden oak, mahogany or walnut

Complete Your Line with These High Class Models

This high class instrument will enable you to meet any competition, because of its beauty, clarity of tone and utility.

You are missing Dollar profits if you do not write for information—Today.

SEABURG MANUFACTURING COMPANY
JAMESTOWN, NEW YORK

Stewart
Talking Machine Company

JOBBERS
for the
Victor
Talking
Machine
Company

Indianapolis

PAUL WHITEMAN'S Big Fox Trot Hit
"I NEVER KNEW"
(I COULD LOVE ANYBODY LIKE I'M LOVING YOU)
 Published by LEO. FEIST Inc., FEIST BLDG New York

YOU CAN'T GO WRONG WITH ANY FEIST SONG

TREMAINE GIVES MOTION PICTURE MEN FACTS ON MUSIC

At Conference of Motion Picture and Musical Interests in New York Last Month C. M. Tremaine Declares That More Money Was Spent for Music Than for All Higher Education

In an address before the First National Conference of Motion Picture and Musical Interests at the Hotel Astor, New York, on January 25, C. M. Tremaine, director of the National Bureau for the Advancement of Music, astonished a large audience by declaring that more money is spent in this country for musical instruction than for all other higher education combined. He spoke to the movie men from the dollars and cents point of view and declared that it was to their interest to introduce music in their theatres.

"I do not wish to bother you with statistics," Mr. Tremaine said, "but it may surprise many of you to know that the people of the United States are spending more money on musical instruction than on all other higher education combined. According to the United States Census Bureau the following sums were spent for higher education in 1913:

Public high schools	\$64,199,952
Private high schools	13,949,195
Other private and public schools of similar standing	13,198,033
Colleges and universities	89,535,110
Normal schools	14,956,105
	\$195,838,395

"The amount spent for musical education of all kinds is given as \$220,000,000. This figure is not taken from the census, but is taken from a speech of an ex-president of the National Music Supervisors' Association in a Rochester convention, and I am uncertain as to the year to which it referred."

Mr. Tremaine told of the increased amount of space devoted to music by the press of the country, the greater attention given to it in the schools and the remarkable spread of the Music Week idea. Speaking of music in its relation to interests of the moving picture industry in this country, he said:

"Music is an attraction. Of this there is no doubt. It even attracts people who are unconscious of the pleasure music gives them. A few of the progressive men in the motion picture world have been quick to realize this fact and have made music more and more a feature of their appeal to the public. The proof of my argument is conclusively demonstrated by the fact that the men in the motion picture world who have done this are the conspicuous successes.

"The time surely is coming when all should utilize music for their like benefit. They should do this for the increased profit which will accrue to them, but the time is also coming when they will need to do so to maintain their relative position. Take two houses showing equally good films. The one which has the more attractive music program will steadily increase its patronage at the expense of the other. Part

of the audience will come specifically to hear the music. Many others will come without being conscious of the reason, but will find themselves gravitating there because they enjoy going without knowing why. To get the full benefit of this you should exploit your musical achievements in your advertising. Build up an individuality about your house, both by the distinctiveness of your musical program and by the prominence of this feature in your public announcements. Identify yourself conspicuously with the Music Memory Contests and the Music Weeks. Help them and be helped by them.

"Personally I wish to see the motion picture houses improve their musical offerings because I believe they will be one of the chief factors in making America a musical nation. It is the only agency which brings music to many people who would not otherwise go to hear music. But in your own interest I urge every manager here not to leave without learning something which will aid him to utilize music to make his house more attractive to his local public."

Don't put your good nature in the same class with the fire escape—to be used only in an emergency.

SHEPARD CO. HAS NEW DEPARTMENT

Providence Victor House Now Has Fine Salon With All Modern Improvements

PROVIDENCE, R. I., February 4.—What is declared to be one of the handsomest talking machine departments in this section of the country has just been completed by the Shepard Company, which handles the Victor line. The new department is 135 feet in length, thirty-five feet wide, and has a complement of twenty demonstration booths of mahogany and glass. A large record library offers a wide selection of Victor records and the sales force, under the direction of Manager John D. Elliot, has been trained to give the best of service to patrons. A special children's corner is a feature which appeals to the little folks. The Shepard Co. is now an exclusive Victor dealer.

G. W. HOPKINS VISITS BRANCHES

Columbia General Sales Manager Finds Conditions Among Dealers Good

George W. Hopkins, general sales manager of Columbia Graphophone Co., New York, has just completed a trip, during which he visited the Columbia branches in New Haven, Boston, Pittsburgh, Philadelphia and Chicago. The reports made and facts presented by the different branch managers indicate a steady picking up in both the machine and record demand.

VELVET COVERED TURNTABLES

ADD TO THE QUALITY OF MACHINES

A.W.B. *Boulevard* VELVETS

THE BEST TALKING MACHINES ARE EQUIPPED WITH

A. W. B. BOULEVARD VELVETS

GRAND PRIZE—GOLD MEDAL, ST. LOUIS EXHIBITION

WRITE FOR SAMPLES AND PRICES

A. WIMPFHEIMER & BRO., Inc.
 450-460 Fourth Avenue, New York

ESTABLISHED 1845

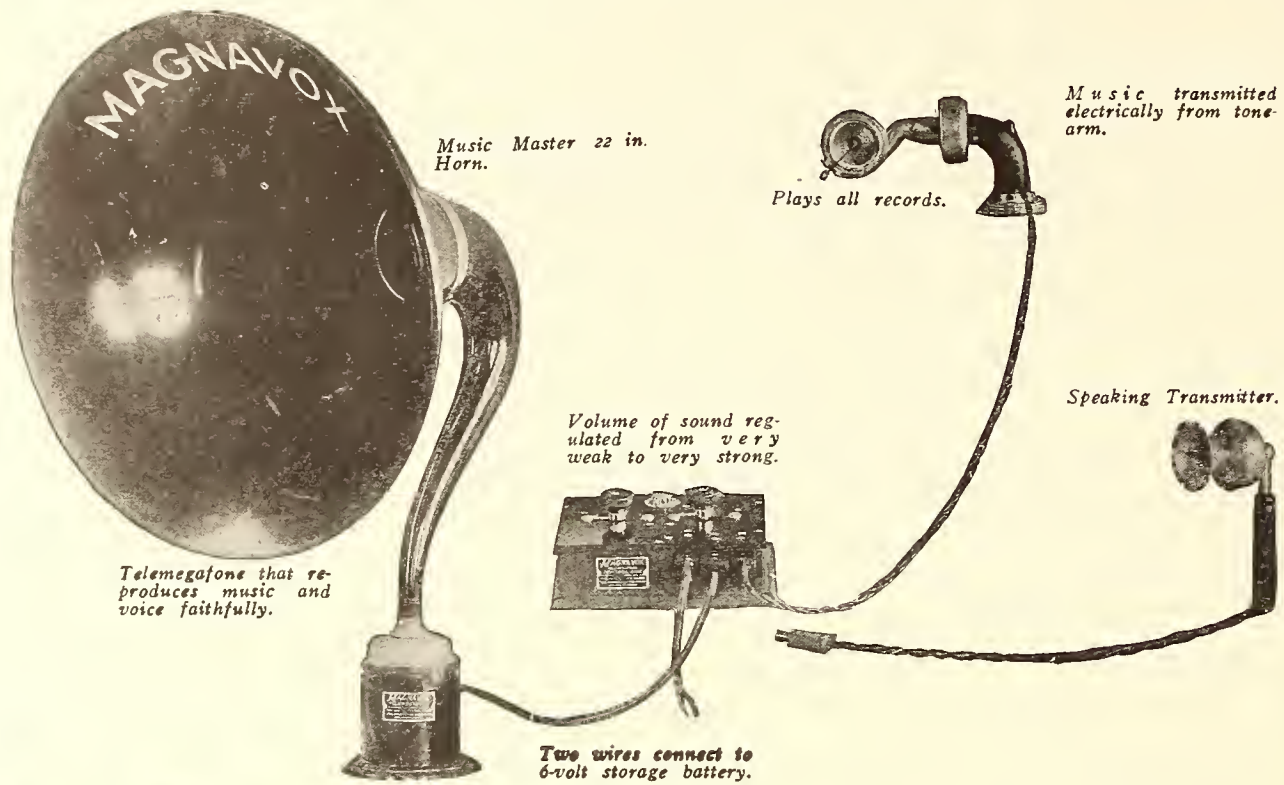

Magnavox

The Magnavox Multiplies Phonograph Sales

Because it raises the usefulness of phonographs to a degree never before attained.

CONSIDER it a moment. With a Magnavox attachment a phonograph can be heard in the farthest corner of a vast hall distinctly and clearly. At a big dance you can have band music without the expense of a band. At the theatre you can have orchestra music without an orchestra.

For school, summer camp, community center and playground the Magnavox is in great demand. It can be attached to a phonograph

easily and quickly, and the volume of sound regulated to the exact degree desired—extremely loud or a mere whisper.

The Magnavox is operated by a small storage battery so that it can be used in the wilderness, where there is no electric current, just as easily as in the city.

The Magnavox will increase your sales and add a handsome profit.

Full particulars on request

J. O. MORRIS CO., Inc.

Distributors for New York and New England

1270 Broadway, New York City

EXPANDING TRADE IN ATLANTA

Trade Conditions Show Improvement—New Store for Phillips & Crew—Okeh Record of "Crazy Blues" a Big Hit—Myers-Miller Increase Sales Force—Dealers Optimistic

ATLANTA, GA., February 6.—There has been considerable activity in the talking machine and record business locally since the first of the year, and several of the older firms are planning entering into the business on a much larger scale. Specifications and plans are being made by at least two of the more important dealers for new stores to be occupied as soon as they can be made ready. The trade generally seems to be in a healthy condition, and while many, in fact, most, dealers have rather full stocks on hand, they do not seem to be worried by the fact and are pushing advertising and sales plans for all they are worth.

The Phillips & Crew Piano Co., Victor dealer, has taken a modern store on Peachtree street, the main fashionable shopping and residential center of the city, and will begin extensive alterations shortly in order to make this the most modern, fully appointed Victor retail salesroom in the South. It is understood from Harvey Phillips, firm member, that the plans for the new store contemplate a complete installation of booths adequate to care for the constantly expanding business, and that there will be a concert hall in connection with the store sufficiently large to seat three to four hundred as an audience.

The Wilson Music Co., Inc. (The Delphoon Shop), Columbia dealer, is enjoying a most satisfactory business. President Wilson has just returned from New York, where he visited the Columbia Co.'s general offices, and found them in a most optimistic mood. His trip covered also Philadelphia, Richmond, Va., and other cities north of here.

The Edison Shop states through Mr. Bingham, manager of the retail store, that they have had a nice business of late and that a continuation of same is expected.

Mr. Bingham has recently enjoyed a trip of two weeks to Florida.

The Myers-Miller Furniture Co., Columbia dealer, has added to its sales force in the past few weeks and has benefited by this strengthening of the personnel. The record business has continued to grow nicely.

Theodore Steinway, of Steinway & Sons, New York, was a recent visitor to the city.

Miss Lila Gordon, in charge of the Myers-Miller Furniture Co.'s Columbia department, recently married Paige Lewis, of this city.

It would not be fitting to close this letter without some mention of the marvelous sales of the record "Crazy Blues," issued by Okeh and recorded by Mamie Smith, of Atlanta, a lady of the colored persuasion. To say that the Atlanta colored population has gone "crazy" about this record would be putting it mildly. Your correspondent has never in many years' experience known a hit to "go over" so big.

A salesman of intelligence will understand that he has something to learn, and will be a good listener. He will be ready to accept suggestions from all sources, and profit by them wherever he may.

NEEDLES

WE MANUFACTURE

Diamond needles for Edison
Sapphire needles for Edison
Sapphire needles for Pathe

in stock ready for delivery

MERMOD & CO., 874 Broadway, N. Y.

CLAUDE BUCKPITT BUYS BUILDING

Piano and Talking Machine Dealer of Elmira, N. Y., Will in Future Be Housed in His Own Business Property in That City

ELMIRA, N. Y., January 29.—Claude Buckpitt, dealer in pianos and talking machines, of 113 North Main street, practically has completed details whereby he acquires title from Adam Mander to the Mander or Lyceum Block at 156 and 158 Lake street, the first floors of which are occupied by W. H. Miller and James Falsey, respectively. It is expected that the deal will be completed within a day or so and Mr. Buckpitt will take possession at once. The price to be paid is approximately \$40,000.

Mr. Buckpitt will remove his business from Main street to the store occupied by Mr. Miller, using the second and third floors as well. Later he also may occupy the other store.

Mr. Buckpitt plans extensive improvements to the property. He will tear out the north

wall of the Lyceum Theatre entrance on Lake street and construct a handsome show window. Later he will install a passenger and freight elevator, and it is likely that new fronts will be added to both stores.

Mr. Buckpitt came to Elmira in 1907 from Schenectady, where he conducted a music store. He maintained a store in the Merchants' National Bank Building for two years, removing to the Snyder Building in 1909. His rapidly increasing business now necessitates a further expansion.

STANDARD CO. OFFERS SALES HELPS

The Standard Talking Machine Co., Victor wholesaler of Pittsburgh, Pa., in the interests of promoting for its dealers the sales of Victor goods, has sent out a folder containing constructive ideas and sales helps, which also serves as a source of information concerning the various business supplies and sales promotion material offered by the company.

GET IN ON THE PROFITS

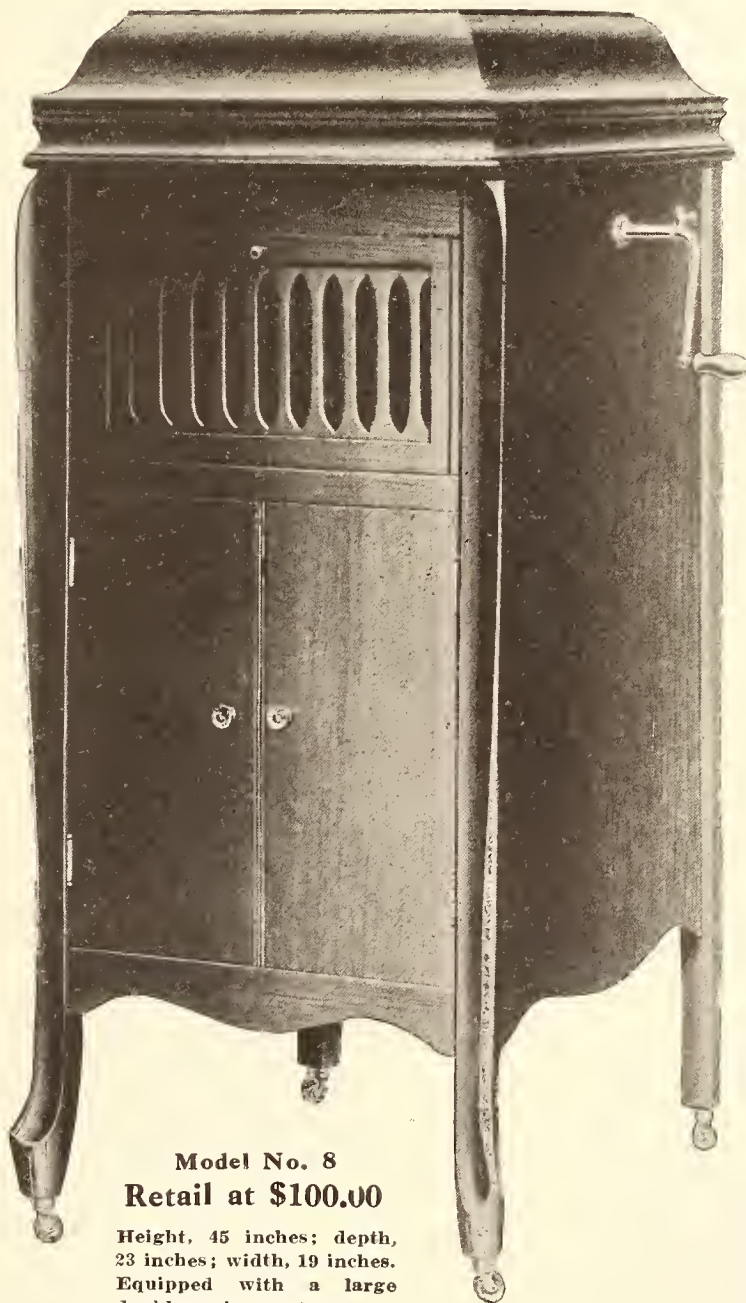

Model No. 8
Retail at \$100.00

Height, 45 inches; depth, 23 inches; width, 19 inches. Equipped with a large double-spring motor.

Here is a sales creator that will bring profits into your store.

This quality machine, designed to sell, attracts immediate attention.

Now is the time to place the fast-selling Charmaphone line on your floors.

We have a dealer's proposition which will pay you to investigate.

Write for our Price List and dealers' arrangement.

CHARMAPHONE COMPANY

39 West 32nd St., N. Y. City

Factory: Pulaski, N. Y.



Hulda Lashanska with Eddy Brown accompanying her in that tender song of sentiment "Happy Days"—this is a record that only Columbia could give you! This is a record that will never grow old! Columbia 79213.

**Columbia Graphophone Co.
NEW YORK**

A TRIBUTE TO SALESMANSHIP

Reporter of Fort Wayne Paper Awards Prize for Politeness to Miss Bentz After a Visit to a Number of Stores in That Thriving City

FORT WAYNE, IND., February 1.—After making the rounds of the music stores of this city the politeness-seeking reporter of a Fort Wayne newspaper awarded the paper's prize for politeness to Miss Beatrice Bentz, clerk in the music department of the Wolf & Dessauer store.

"The most accommodating set of folks yet met," was the verdict of the reporter after he had spent hours in music stores sitting through programs of music especially put on for his benefit. Record after record was brought out, he says in his report of the search, with never a hint of impatience, and it was only after the most difficult sort of a test that Miss Bentz was declared the winner.

The reporter wrote that it was with a feeling of satisfaction that in his search through the music stores he found that Fort Wayne music lovers were turning to other selections than the extreme popular variety. Records of the classics, opera selections and numbers by leading artists were in most cases, he said, displayed as prominently in the stores as the jazz type of music.

Writes the reporter concerning the prize-winner:

"Miss Bentz first attracted the attention of the sleuth when she was seen to be especially gracious in searching for a record desired by a customer. Replies to questions and suggestions were given with a pleasant emphasis invariably being accompanied with an agreeable smile.

"While listening to several records, the reporter closely observed the work of the clerks. Although the special demonstration booths were all in use, Miss Bentz would have been 'pleased to put on any record on one of the machines in the outer room,' but the reporter decided to wait for a booth. The incident which brought the money to Miss Bentz occurred after the re-

porter had been observing her exceedingly courteous treatment of customers for some time when a man came in and handed the young lady a long list of records which he wanted. Although it was decidedly a hard nut to crack, Miss Bentz took the list with a smile and proceeded to fill the order, displaying a cheerful disposition despite the fact that it was an unusually busy hour and that her immediate task was frequently interrupted by customers desiring to know if this or that record was kept in stock. A pleasant reply was the rule in each case and the smile was always in evidence.

"Finding that a number of the records wanted were not in stock, the clerk expressed sincere regret and gave the customer suggestions and directions leading to the purchase of the missing numbers in other stores."

TONOFONE JOBBERS IN NEW YORK

E. H. Wade, manager of sales for the Tonofone needle made by the R. C. Wade Co., of Chicago, Ill., has appointed Maurice Richmond, Inc., Broadway and 47th street, New York City, and the Eastern Phonograph Corp., 100 West 21st street, New York, distributors to represent the Tonofone needle in New York and surrounding territory. These two jobbers are in addition to Robert Clifford and Cabinet and Accessories Co., which were appointed a few weeks ago, in accordance with the policy of the R. C. Wade Co. to push vigorously the sales of their needles through the East.

E. H. Wade, who recently visited the trade in New York, states that the demand for these needles in all parts of the country is very gratifying and that 1921 promises to be a banner year for the company.

The Howard Stowers Co., Bronx, has been incorporated with a capital of \$25,000, to do a business in all kinds of musical instruments. The incorporators are B. Bamonte, M. Petrane and N. F. Babino.

HANGS ON TO THE PHONOGRAPH

Judge's Remarks Indicate That Repossessions of Talking Machines Are Uncommon

A Brooklyn judge remarked to one of Sonora's officials: "I've been going over some repossession notices and I observe that there are very few phonograph items among them. It seems that when goods are bought on the instalment plan the purchaser is not particularly averse to having the instalment man come and take this furniture back, if it is a table, chair, sofa or other article of household use. But when it comes to the phonograph it is a different story and even though the other articles go back to the concerns which sold them, somehow, somewhere, the purchaser manages to scrape up the amount necessary to pay up the instalments and the phonograph hangs on though everything else disappears.

"It is for this reason that phonograph paper is held in high esteem and instalment dealers can raise money on it without great difficulty."

HE OWNED FOUR TALKING MACHINES

Negro Farmer of Georgia Kept Young Folks at Home by Providing Them With Music

The fallen price of cotton seems to have had its effect on the music business in the South if we may believe the story of a pawnbroker of Macon, Ga., who tells of a negro farmer who sought to pawn four talking machines, all instruments of high grade. The negro declared that he felt the pinch of hard times and would redeem the loan as soon as he found a market for his cotton crop. When asked why he had bought four talking machines the negro said that he had purchased one instrument for one of his girls and later found that the only way to keep his other children at home was to provide each of them with a talking machine of their own.

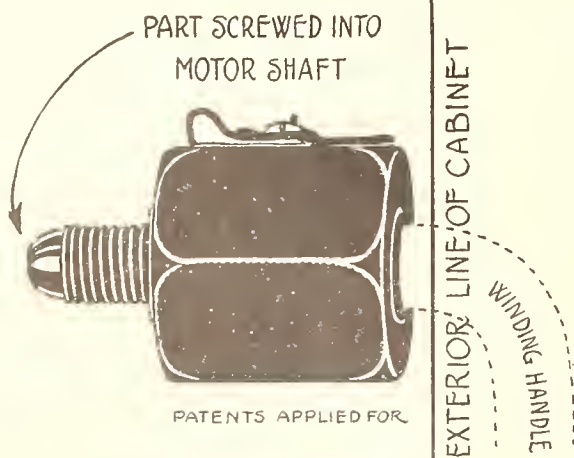

RETAIL PRICE \$3.75

Samples sent post paid on receipt of \$2.25
LIBERAL DISCOUNTS TO THE TRADE

Motor and Spring Safety Device

(PATENTS APPLIED FOR)

IMPOSSIBLE TO OVERWIND THE MOTOR

When sufficiently wound, the handle automatically ceases to wind. Thus, any child can wind the talking machine with safety.

A Simple Fool-Proof Device —Fills a Long-Felt Want—

Can be attached by anyone in a few minutes.

NOW READY FOR VICTOR MACHINES

Territory Open to Jobbers and Dealers

PHONOGRAPH SPECIALTIES MFG. CO.
67-69 Fleet St. Jersey City, N. J.

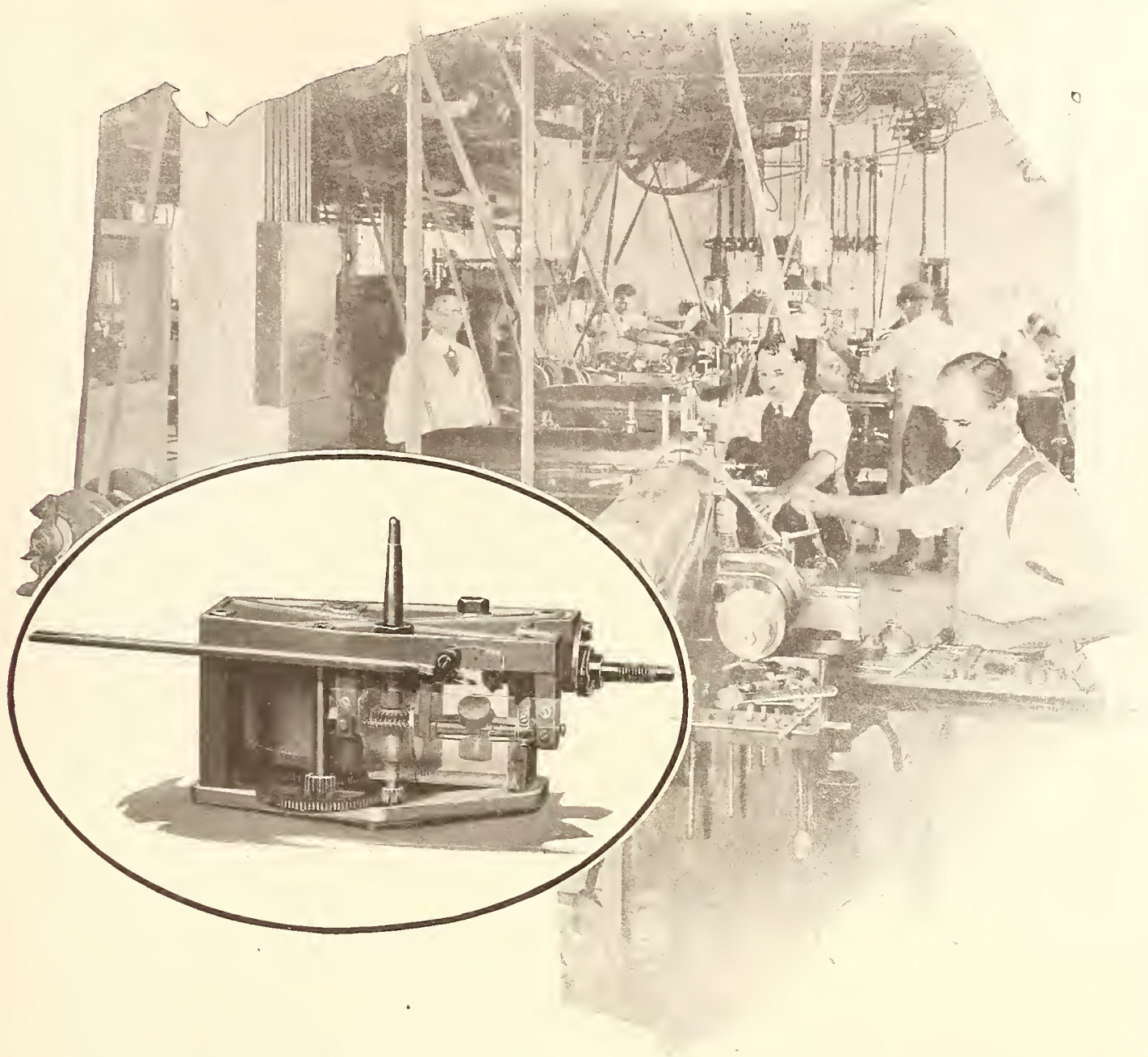

The Cheney Motor Is the Heart of the Instrument

Only by following these motors through our factory can you realize the care and precision with which they are made. The real test comes, however, in their use. Day after day, year after year, Cheney Motors deliver perfect service.

The **CHENEY**

In these times when the buying public is more critical than ever, we look toward the future with supreme confidence. This confidence is inspired by knowing that our devotion to the highest manufacturing standards, coupled with the exclusive and basic principles of Cheney construction found in no other phonograph, will always insure to Cheney dealers the finest in reproducing instruments.

THE CHENEY TALKING MACHINE CO.
New York Chicago



*The Cheney costs no more than other phonographs.
Sells for \$125 to \$385.*

CLEVELAND TRADE PREPARES FOR ASSOCIATION REUNION

Meeting and Banquet Take Place Late in February—Reorganization of Brunswick District Branch—New Establishments Opened Up—Record Artists to Appear in Concert—Other News

CLEVELAND, O., February 2.—The annual banquet of the Talking Machine Dealers' Association of Northern Ohio will be the biggest event of its kind ever held in this section of the country. This is the opinion of officials and entertainment committee, following announcement of

kept secret until the night of the entertainment.

Officers of the organization for the coming year are: President, Grant Smith, Euclid Music Co.; vice-presidents, R. Svehla, Svehla's Music House, and B. Ptak, Ptak's Music House; secretary, Ed B. Lyons, Eclipse Musical Co.; treasurer, W. E. Shay, Elyria.

Opening of Spence Music Co.

City officials and persons prominent in the social life of Zanesville attended the opening there of the Spence Music Co., of which E. O. Callender is manager. Twelve booths and equipments and decorations in keeping with the size of the store have been installed. An orchestra and local talent rendered musical numbers and several thousand persons were present. The opening was aided by George H. Deacon, traveling representative of the Cleveland Talking Machine Co.

Talking machine interests here planning events in which artists who make records would appear have had their plans set back by the burning of Gray's Armory, popular hall for these gatherings. City officials promise speeding up on the construction of Public Hall, however, and it is expected the latter will be ready for first use early in August.

Important Brunswick Changes

Developments of this territory by the Brunswick-Balke-Collender Co. is seen in the reorganization of the Cleveland district branch and the naming of new heads of departments here. F. S. Buttweiler comes from the Indianapolis branch as branch manager here. P. H. McCulloch, formerly at Chicago, becomes phonograph division manager. Both have had long experience in their respective divisions. Mr. Buttweiler has been with the company forty-two years and managed eight different branches. He

is treasurer of the company's Merit Club, attained in sales competition. Mr. McCulloch is not only well versed in Brunswick activities, but is considered an authority on talking machine business developments.

Colonial Music Shoppe Opens

Among the first of new retail establishments to open this year is the Colonial Music Shoppe, in the extreme eastern end of town. A. Finesilver, recently in other business and formerly with the Hippodrome Theatre orchestra, is head



F. S. Buttweiler

tentative plans in connection with the annual meeting of the organization held January 26. The festivities will be under the capable direction of Louis Meier, L. Meier & Sons; C. C. Lipstreu and Ford Young, the Lakewood Music Co. The gathering will take place late in February and several novel features are on the program, all of which will be held in reserve and



P. H. McCulloch

of the enterprise. The new store is located in a growing suburban district and is close to many industrial establishments, including the National Lamp Works of the General Electric Co. Ed B. Lyons, sales manager, the Eclipse Musical Co., Victor jobber, assisted Mr. Finesilver in establishing the new business. A record for equipment installation was made by the Unit Con-

THE NEW MODEL E.
GARFORD PHONOGRAPH
 The Greatest Value on the Market
 IMMEDIATE DELIVERIES IN ANY QUANTITY



New Model "E" Garford Phonograph
 Plays All Makes of Records Superior Tone Quality
Write for Proposition
The General Phonograph Mfg. Co.
 ELYRIA, OHIO

The Name

DOEHLER

has become synonymous
with **DIE-CASTING**

to America's most discriminating manufacturers

A preference earned by the quality of its goods, its knowledge of the business and the service rendered by its three big Die-Casting Plants at Brooklyn, Toledo and Chicago.

If you are thinking of die-castings to cut the cost of manufacture, to eliminate complication or to speed production,

Die-Casting Headquarters can help you.

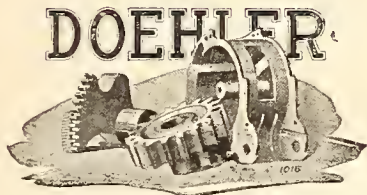

White Metal and Aluminum Die Castings — "Do-Di" Finished Brass Castings—Doehler Babbitt Lined Bronze Back Bearings — "Do-Lite" Babbitt Lined Aluminum Back Bearings.

THE WORLD'S LARGEST MANUFACTURERS OF DIE CASTINGS
DOEHLER DIE-CASTING CO.
EAST OFFICE AND EASTERN PLANT: BROOKLYN, N.Y. CENTRAL PLANT: TOLEDO, OHIO. WESTERN PLANT: CHICAGO, ILL.
SALES OFFICES IN ALL PRINCIPAL CITIES

struction Co., which had booths and other accessories in place in less than a week from the time the order was sent from this city.

Celebrates Columbia Week

Columbia week was to be celebrated by the Cleveland Columbia Graphophone Co. officials and dealers. About February 1 exclusive Columbia artists were to appear in concert here, including Josef Hofmann, Happy Six, Hulda Lashanska, Ed Brown and Kerekjarto.

To Install Victrolas in the Schools

The Cleveland Talking Machine Co. has endorsed the plan of the Magazine and School Co-operative Association, which calls for the installing of Victor machines in all schools in the country. The move has been approved by former Governor Cox, of Ohio, and President-elect Harding. Irwin Dunlap is head of the Association. It is planned to create much uplift work through the use of talking machines in schools.

A Great Achievement

After several years' effort it remains for the Yahrling & Rayner Co., Warren, O., to accomplish the hitherto impossible, the recognition of music in the news columns of daily newspapers the same as other activities are recognized as news. This has been attained without any special event being put on at the store. The result is a one-column story telling about musicians, their music and how music is an aid to more satisfactory living, with mention of the development of music through the talking machine.

Cortot Scores in Recital

Among artists to be seen and heard at close range by members of the trade here has been Alfred Cortot, French pianist, noted alike in concert and records. He was invited to address the salesmanship classes conducted under direction of Miss Grazella Puliver, educational director of the Cleveland Talking Machine Co.

Some Edison News

New dress for an old method of attracting consumer interest to new and large machines is being used by Harry Tucker, the Phono-

graph Co., Edison distributor. Lists of owners of small models have been prepared with the prices paid for the machines. These owners have been approached with judiciously worded and illustrated pamphlets, pointing out in each individual case the opportunity to use their small machines as a partial down-payment on new and larger models. The exact amount that is allowed on each machine is mentioned. Immediate response and several sales followed the announcement in the first few days of the plan.

A series of unusual tone-test concerts by Cleveland Edison dealers was being planned for early in February. Through the co-operation of Phonograph Co. officials, artists were to be brought here, the plan calling for a large tone-test for every day during the week, each at a different dealer's store. Among artists who were planning to come here was Glenn Ellison.

Levy Acquires Phillips Store

A. R. Levy, for eight years identified with the talking machine industry here, has acquired the Joe Phillips store in East Seventy-ninth street and will conduct it as his own business.

Kennedy-Green Co. Expansion

Development of foreign record business on a large scale is being planned by the Kennedy-Green Co., Okeh record jobber in northern Ohio. Through co-operation with the General Phonograph Corp. the best compositions of Europe will be procured and developed under American manufacturing skill. The listing calls for seventeen foreign languages and the initial distribution will include Polish, Italian and German records, the others being added as fast as they can be produced.

Famous Record Artists in Concert

Concerts by record-making artists are getting to be the correct thing in music here. In November came the Eight Famous Victor Artists and early in February will come Marion Harris and the Columbia Saxophone Sextet and Yerkes' Novelty Orchestra, representative of Columbia music. This group was to appear at Gray's Armory, under the sponsorship of Columbia

dealers, including N. Speilman, B. Salzman, M. Chiaken, M. Bernstein and A. Sognick. All Columbia dealers have been co-operating in the sale of tickets. A similar event is planned by Harry Webber, Akron dealer.

Another similar event was being planned by the Brunswick-Balke-Collender Co., co-operating with George S. Dales, Akron dealer in Brunswicks, for the appearance there of Theodore Karle, exclusive Brunswick artist, who was to appear at a hall there and later hold a reception at the Dales establishment. Autographed records were to be distributed. Personal assistance in the event was to be given by P. H. McCulloch, phonograph division sales manager, and Jack Kennedy, of the Cleveland staff.

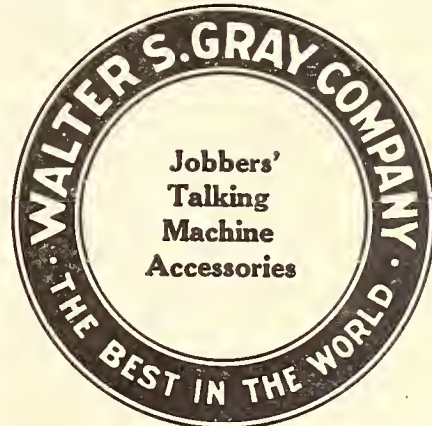

SAPPHIRES IMPORTED

BALLS	POINTS
20 c. each	20 c. each
16 c. in dozen lots	18 c. in dozen lots
13 c. in hundred lots	15 c. in hundred lots
12 c. in thousand lots	13½ c. in thousand lots

942 MARKET STREET
SAN FRANCISCO, CAL.

EFFICIENT MERCHANDISING HELPS

Members of Sales Staff of Bruno Attend Victor Salesmanship School—Harris Tells of Service Values—Mr. Landau a Recent Visitor

Edward G. Evans and Joseph C. Schlick, of the sales staff of C. Bruno & Son, Inc., Victor wholesalers, New York City, attended the Victor Salesmanship School at Camden, N. J., during the month of January. Both Mr. Evans and Mr. Schlick were enthusiastic in their praise of the value of this course. Jerome Harris, secretary of the company, is energetically promoting the Bruno policy of service to the dealer, and in this respect is enthusiastically recommending that the dealer take advantage of every facility offered by the Victor organization in efficiently merchandising the great line which they carry. Mr. Harris specifically calls attention to the ready reference labels and stock record book. Both these systems Mr. Harris classes as providing unequalled help in the modern efficient merchandising of Victor products.

Among recent visitors to Bruno headquarters was H. Landau, of Wilkes-Barre, Pa. Mr. Landau's Victor business in this city has progressed remarkably, due to his intense enthusiasm over the Victor line and his energetic salesmanship. Mr. Landau has conducted a number of drives with exceptional success on "Last Opportunity Records," cut-out records in the Victor list.

USING PROPER JUDGMENT

A salesman who receives a sample of goods from his house, and upon first view determines that it "won't sell," and places his judgment flatly against that of his house without exerting his best efforts on a trial, is giving exhibition of a deplorable lack of common sense, and offering an insult to the intelligence of his employer.

W. A. Winkler, Dover, O., has taken on the Victor line of talking machines and records.

Do You Throw Money Away?

It is not a popular pastime—but still it is unconsciously done by many who just don't know that *Repair Parts* can be bought for less

**RENE MADE SPRINGS AND PARTS LAST LONGER
COST LESS**

RENE MFG. CO.

Montvale, N. J.

CATALOG OF MUSICAL MERCHANDISE

Buegeleisen & Jacobson have demonstrated their enterprise in the musical merchandise field through the prompt publishing during the early part of the year of their 1921 catalog of musical merchandise. This catalog is said to be the first catalog printed containing the new scale of prices. Although the prices listed therein are the latest, the policy of the house of Buegeleisen & Jacobson to correct prices to the date of invoice assures the purchaser of the advantage of any possible further reduction.

The new catalog consists of forty pages and lists instruments from all parts of the world and contains the merchandise of old and established standing, such as Durro violins, Duss band instruments, Lester accordeons and Stewart banjos.

SEQUOIA LINE APPEARS ON COAST

New Instrument Is Manufactured by Southern California Hardwood & Mfg. Co.

LOS ANGELES, CAL., February 1.—The Southern California Hardwood & Mfg. Co., which has been making the Hawthorn phonograph for some time, has announced a new line of instru-

ments to be known as the Sequoia phonographs. A record-filing device will also be manufactured. A. C. Einstein, formerly with the Manophone Corp. and also the Hobart M. Cable Co., has been appointed general manager of the Sequoia division.

"STICK TO FACTS"

When you start to advertise,
Stick to facts!
Good business isn't built on lies—
Stick to facts!
No matter what you have to sell!
The truth is good enough to tell!
Boost your goods and boost them well,
But stick to facts!

When tempted to exaggerate,
Stick to facts!
Tell the truth, don't overstate—
Stick to facts!
If the truth is not enough,
Something's wrong about your stuff,
Anyway, don't try to bluff—
Stick to facts!

Makers, merchants, middlemen,
Stick to facts!
Pick your points with pungent pen,
Stick to facts!
Tho others make their figures lie,
Boasting of their values high,
Causing trade to pass you by,
You stick to facts!

BELL HOOD *Semi-Permanent Needle*

THE NEEDLE WITH TONE QUALITY

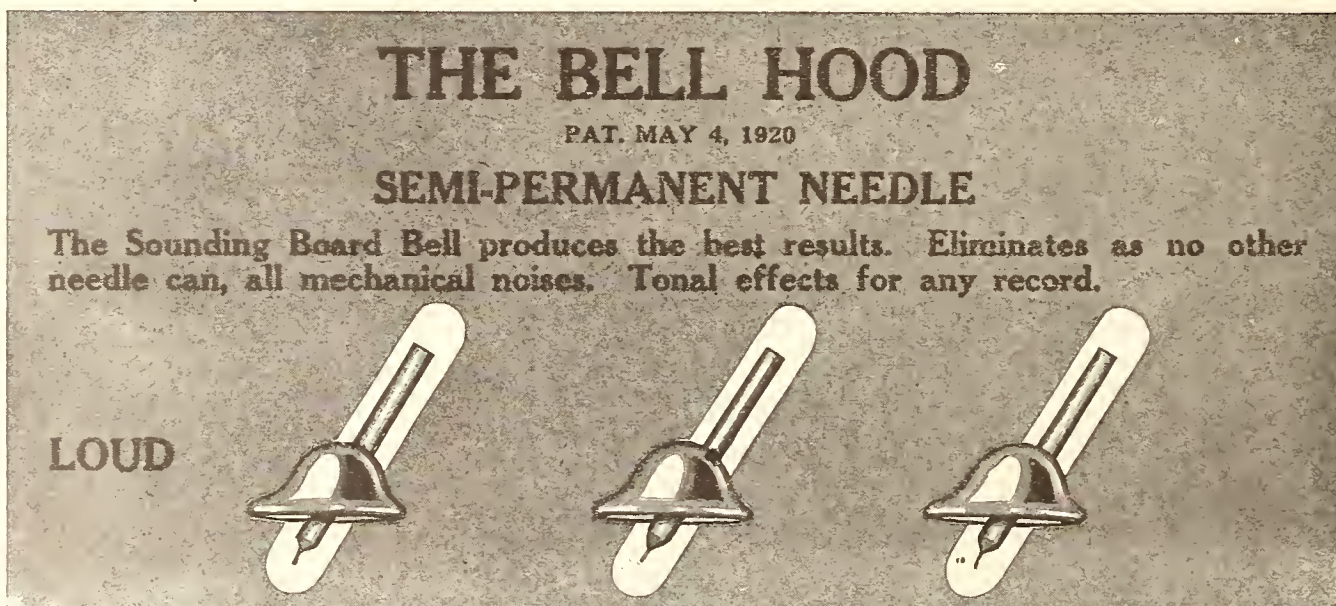

Made by the Bell Hood Needle Co., New Haven, Conn., U. S. A.

IMPROVES YOUR PHONOGRAPH 100 PER CENT
"The Bell Does It"

Purifies the tone, reduces the scratching and mechanical sounds to a minimum.

SEMI-PERMANENT POINT—Loud—Medium—Soft

A profitable needle for dealers to sell. More than 2000 Dealers are now selling them with splendid success. Order from the nearest branch.

THE BELL HOOD NEEDLE CO.

183 Church St., New Haven, Conn.

3901 Sheridan Road
Chicago, Ill.

PETERMAN SALES CO.
Oneonta, Alabama

A. M. BRINKLE
33 So. 16th St., Philadelphia, Pa.

807 The Arcade, Cleveland

89 10th St., South
Minneapolis

Distributors for all states west of
Mississippi River and Wisconsin

Announcing

JOHN McCORMACK

ON

OKeh Records

We have great pleasure in announcing that we have secured the right to market wonderful recordings of the voice of

JOHN McCORMACK

*The World-famous Irish tenor
The greatest tenor on the concert stage*

These recordings were made in London for the International Talking Machine Company, and we have secured at great expense a license to offer them to the American public.

These records are McCormack himself. No more need be said.

Ready about February 20th

- 50001 } I HEAR YOU CALLING ME (Marshall), Orchestra Accompaniment
12 in. }
\$1.50 }
- 50005 } CELESTE AIDA, (From "Aida") (Verdi), Orchestra Accompaniment
12 in. }
\$1.50 }



GENERAL PHONOGRAPH CORPORATION

OTTO HEINEMAN, *President*

25 West 45th Street

New York City, N. Y.



CABLE ADDRESS REG'D
"FILASSE—PHILA."

THE MARK OF

LONG DISTANCE 'PHONE
BARING 535

ANY { Size
Quantity
Quality

SERVICE AND
Phonographically Speaking



SATISFACTION

They Talk For Themselves

Quotation }
Delivery }
Product } RIGHT

IMICO INDIA RUBY MICA DIAPHRAGMS

INTERNATIONAL MICA COMPANY PHILADELPHIA, PA.
U. S. A.

INTERNATIONAL MICA CO., 106-110 W. Lake St., Chicago, Illinois

FACTORY AND SALES DEPT.,
37TH AND BRANDYWINE STS.,
WEST PHILA., PA.

FEDERAL PHONO SUPPLY CO.
3009 JENKINS ARCADE
PITTSBURGH, PA.

LAKESIDE SUPPLY CO.
416 SOUTH DEARBORN ST.
CHICAGO, ILLINOIS

MOORE & WHITESIDE
MONTREAL, CANADA

WALTER S. GRAY
SAN FRANCISCO, CAL.

STEINOLA COMPANY
Kansas City, Mo.

Write for "IMICO" representation in your territory—domestic or foreign. Special facilities for Export Business.

"IMICO" and "SERVICE" are SYNONYMOUS

OUTSIDE SALESMEN GETTING RESULTS IN LOS ANGELES

Talking Machine Houses Going After Business and Getting It—Educational Plans Discussed—Magnavox on Tour of the World—Local Association Holds Meeting

LOS ANGELES, CAL., February 1.—Talking machine business for the first month of the year has been fair. Record sales would have been considerably larger, of course, if stocks had been more complete—there is still a considerable shortage among the old standard numbers, and many of the late hits are soon sold out, while records of the most famous artists have been unobtainable for months. The engagement of crews of outside salesmen has been inaugurated by a few firms, which serves as a reminder of old times when house-to-house canvassing was in vogue. With the increase of stocks of machines urged by jobbers and manufacturers on the dealer there is no doubt that greater efforts will be made toward sales than ever before during the present year, and many persons who have no thought of owning a talking machine at the present time of writing will find themselves proud possessors of reproducing instruments before the passing of many moons has taken place.

Educational Representative Entertained

A dinner which was attended by sixty-five persons was given at Christopher's on January 18. Mrs. Greenwood, manager of the record department of the Wiley B. Allen Co., presided, and the guest of the evening was Miss Cross, special representative of the educational department of the Victor Talking Machine Co. A majority of the record salesmen and saleswomen from the various Victor record departments in Los Angeles were present, as well as managers and the heads of departments. After a sumptuous repast Mrs. Greenwood made a neat speech and introduced Miss Cross, who, she said, would relate some of the methods which were employed in educating children along musical lines through the Victrola. Miss Cross then gave a most interesting demonstration with charts and a school Victrola, which had been provided for the occasion. Then, after the tables and chairs had been placed on one side instruction was given in folk dancing, and Miss Cross soon had the satisfaction of seeing the entire company engaged in a rousing Danish folk dance. Everybody declared the evening a most delightful and instructive one and all were unanimous in their praise of the charm and skill shown by their fair guest.

Magnavox to Go Around the World

A trip around the world which will occupy two years commenced last week when the twenty-eight-foot boat Wisdom 2 left the port

of Los Angeles for the South Seas. The Marquesas, Fiji and Samoa Islands will first be visited, and subsequently the Antipodes, Sumatra and Borneo, and thence to China and India. The voyage is undertaken for scientific research work and included in the equipment are motion picture machines and a Sonora phonograph equipped with a Magnavox. The Sonora with the Magnavox is in charge of G. A. McNeil, who was formerly a member of the sales force of the music department of Barker Bros. The effect of grand opera, sacred music and jazz on the natives of the various countries should add considerably to the interest and results of the expedition.

Sherman, Clay Manager Visits San Francisco

Charles Ruggles, Los Angeles branch manager of Sherman, Clay & Co., Victor distributors, left last week for a visit to San Francisco. Mr. Ruggles anticipates a wonderful year in business and looks forward to an increased supply of records and the elimination of the back orders for hundreds of thousands of records which he has placed with the factory during the last few months.

Music Trades Association Meets

The monthly meeting of the Music Trades Association of Southern California was held on January 12 at Ye Bull Pen Inn. There was a large attendance present. E. A. Geissler, president, occupied the chair.

Spends Night on Ocean in Hydroplane

Newton Hancock, of the Hancock Music Co., had an unpleasant experience recently which might have ended still more seriously. He was invited to attend a ball at San Diego, together with three other musicians, in order that they might dispense sweet music to the dancers. It

was arranged that they should be taken down the coast over the sea in a Navy hydroplane. Unfortunately the machine developed engine trouble and they were obliged to descend two thousand feet to the ocean. This proved a difficult task because it was dark, but it was accomplished safely. However, in spite of search parties in the shape of submarine chasers being sent out, they were not found until 6 o'clock next morning and were compelled to spend the night baling a leaky boat—seasick, cold and hungry.

Blue Bird Company Speeds Up

Increased production of Blue Bird phonographs, including some new period models, is taking place at the factory. General Manager Fybush recently appointed D. G. Sunderland as superintendent of sales, and aggressive sales plans have been inaugurated and it is anticipated that still further additions to the plant will be necessary.

A LOWELL STORE THAT IS BUSY

LOWELL, MASS., February 1.—The Lowell Commission House, located at 374 Middlesex street, which carries the Emerson line and that of the General Phonograph Corp., has been having a good business and apparently this is one of those houses that refuses to be "downed" by alleged business conditions. The manager of the talking machine department of this large establishment, which as a larger proposition carries a fine line of rare antiques, has been taking on a large stock of goods in anticipation of better days, which condition is warranted by present sales, which are growing fast.

BUYS THE TRIPLETT STORE

The Triplett Phonograph Store, Osgood, Ind., has been purchased by Dr. Freeman, who is perfecting plans for its enlargement and improvement.

"MAGNET" DECALCOMANIE NAMEPLATES

FOR TALKING MACHINE CABINETS ETC.

Pamphlets with fac-simile illustrations and prices mailed on request.

SMITH-SCHIFFLIN CO.
149 Church Street New York City

G. W. HOPKINS SAYS DEPRESSION IS DUE TO PESSIMISM

General Sales Manager of Columbia Co., in a Vigorous Talk on "Business To-day" Before the City Club of Boston, Gives Some Selling Advice Which Is Both Timely and Needful

In an address made by Geo. W. Hopkins, general sales manager of the Columbia Graphophone Co., at the City Club of Boston late last month he very pertinently pointed out that the period of "business hesitation" should be charged up to those "bankers and newspapers who, beginning last May, spread broadcast that pessimistic drool—'Don't buy; prices are coming down'." He bearded one of these bankers and forced him to admit that "never in one hundred years has the country suffered a panic when such crops have been gathered as those of 1920."

Mr. Hopkins' subject was "Business To-day—What Are You Going to Do About It?"—and his sallies of wit and forceful arguments aroused much applause. As readers of *The World* know, Mr. Hopkins is a one hundred per cent believer in newspapers and in advertising, but he remarked when "such pessimistic drool" appeared in columns parallel to the advertising the latter availed little.

Draws Golf Analogy

He declared present conditions artificial, when pessimism prevails without reason, and likened the situation to the "water hazard" on a golf links, when three players in a foursome draw old balls or "floaters" out of their pockets, preparing for a failure, but the fourth, with confidence, tees an absolutely new ball, and drives over, the only winner.

"Grit gets" is his motto, and his cure for prevailing pessimism is the breaking of precedents and the doing of the unusual.

Dodging orders has become a habit, he asserted, because for three years the factories have not been able to catch up. "The pitiful thing about the retailer," he said, "is that as he has gradually withdrawn he has come to think himself grown to be a great man; but he hasn't grown; he has only swelled, and then last May the bubble was pricked." The Italian fruit vendor Mr. Hopkins pronounces a natural salesman, for when you ask: "How much are half a dozen bananas?" he promptly puts them in a bag and, holding them out, says: "Twenty-five cents."

The speaker stressed the value of "phrenology, graphology, psychology and mental analysis" in determining the potential value of a salesman and confided to his auditors that he does not pick a man with strong home ties, "for when Friday night comes he'll want to be traveling towards his family, with a resultant loss of forty-eight hours to the firm." The automobile salesman should be advised not to demonstrate a higher speed than twenty miles an hour to a man with high cheek bones, "for they indicate caution strongly developed."

Picking Stenographers

There was a burst of laughter when Mr. Hopkins exclaimed: "Lots of stenographers are picked for form," but when it died away he

explained: "I don't mean what you think I mean. There's a mark right here in the forehead that tells whether the girl will get her pothooks all mixed up." As for graphology, he alleged that "fifty words of handwriting will enable you to read even whether the writer likes music." He added that "there are ninety-two points on every man's face to tell character," but advised that questioning be also resorted to, since he admitted that sometimes some of the points contradict others.

Illustrating his recommendations for the resort to unusual methods he declared that "Dodge Bros. began to beat the bushes in May and were the only automobile concern that came through to December 15 with increased sales." He also told of increasing sales of Columbia records in one Lawrence store 400 per cent by introducing a dancing couple in the windows with the sign: "Come in and learn the new dances to music of the Columbia Grafonola."

Window Display Work

He found a grocer selling crackers at nine cents a pound and remonstrated. ("This was before the war.") The grocer explained that it was a window display to attract trade and challenged Mr. Hopkins to do better. The next week Mr. Hopkins put the same article in the window with a sign—eleven cents—and sold four times as many. "The public believed that it was a cut of four cents—something back from the one coin piece."

In conclusion he warned against "paper profits," and the looming up of volume, a possible 100 per cent profit, pointing out that the really successful man is the one who turns over his goods six times a year, even though he gets only 40 per cent. One of his final aphorisms was: "Selling is like the measles. It is catching; but a lot of salesmen don't expose themselves."

At the dinner in Mr. Hopkins' honor John H. Fahey presided, and F. Warren Kimball paid tribute to Mr. Hopkins' success while in the employ of the Chase & Sanborn Co. and in the Y. M. C. A. evening law school. Likewise Nelson B. Todd, secretary of the class of '08, William F. Rogers and George W. Coleman complimented the guest of honor as one of the leading advertising men in the country.

JOIN REFLEXO CO. FORCES

Julius and Nestor Roos to Devote Entire Time to Selling of Reflexo Products

The Reflexo Products Co., New York City, producers of the Reflexo polish for talking machines and the Reflexo needle, have added to their sales organization through the appointment of Julius and Nestor Roos. Both of the Messrs. Roos are well known in talking machine circles as men who do things.

COAST FURNITURE MEN ORGANIZE

Talking Machine Interests Represented at Recent Convention Held in Tacoma, Wash.

Furniture interests on the Pacific Coast have organized in order to better the conditions of their trade. Recently the Furniture Manufacturers' and Jobbers' Association met in Tacoma, Wash., and agreed upon advertising and selling campaigns designed to bring the industry to the front. Among the directors of the Association is W. H. Beharrell, of the Heywood Bros. & Wakefield Co., makers of the Heywood-Wakefield phonograph. The Stradivara Phonograph Co. was represented at the meeting by W. S. Klein. It was decided to organize the trade into units for each city and Mr. Beharrell was chosen vice-president of the Portland group.

PERIOD MODELS SELL QUICKLY

Fifth Avenue Sonora Salons Close Phenomenal Business—Many Patrons Purchase Several Instruments at One Time

An interesting report was received recently from Mrs. Edmund J. Brewster, manager of the Fifth avenue salons of the Sonora Phonograph Co., who gave the Sonora sales division an accurate idea of the unlimited sales possibilities afforded the Sonora dealer in New York territory. In this report Mrs. Brewster stated that one customer, a New York City broker, purchased the following Sonoras: one \$775 Sonora as a present for his wife and one \$425 Colonial model for his Summer home, and as gifts for friends, one \$1800 Sonora for a city home, one \$975 Sonora for a country house and four Sonoras, ranging in price from \$215 to \$250 each, making a total of eight Sonoras for this one customer.

A music lover residing in Brooklyn purchased three Sonoras at one time, selecting an Italian Renaissance model, and two Nocturnes for his nieces. A New York business man purchased three Sonoras, selecting a Hepplewhite-Pembroke for his own use, and two Nocturnes as gifts for the members of his family.

The New Year started well at the Fifth avenue salons, one customer, on January 3, taking only a half hour to select two Sheraton De Luxe models, one for himself and the other as a gift for his mother. On January 4 two Queen Anne standards were sold to a visitor.

Practically all of these sales were cash transactions, and Mrs. Brewster well deserved the congratulations which she received from Geo. E. Brightson, president of the Sonora Phonograph Co., and the members of the executive and sales organization.

There is nothing in the world that will shut off instructions from the house so quickly as an abundance of orders sold at the right price.

THE TOLEDO TALKING MACHINE CO.

TOLEDO, OHIO

WHOLESALE



EXCLUSIVELY

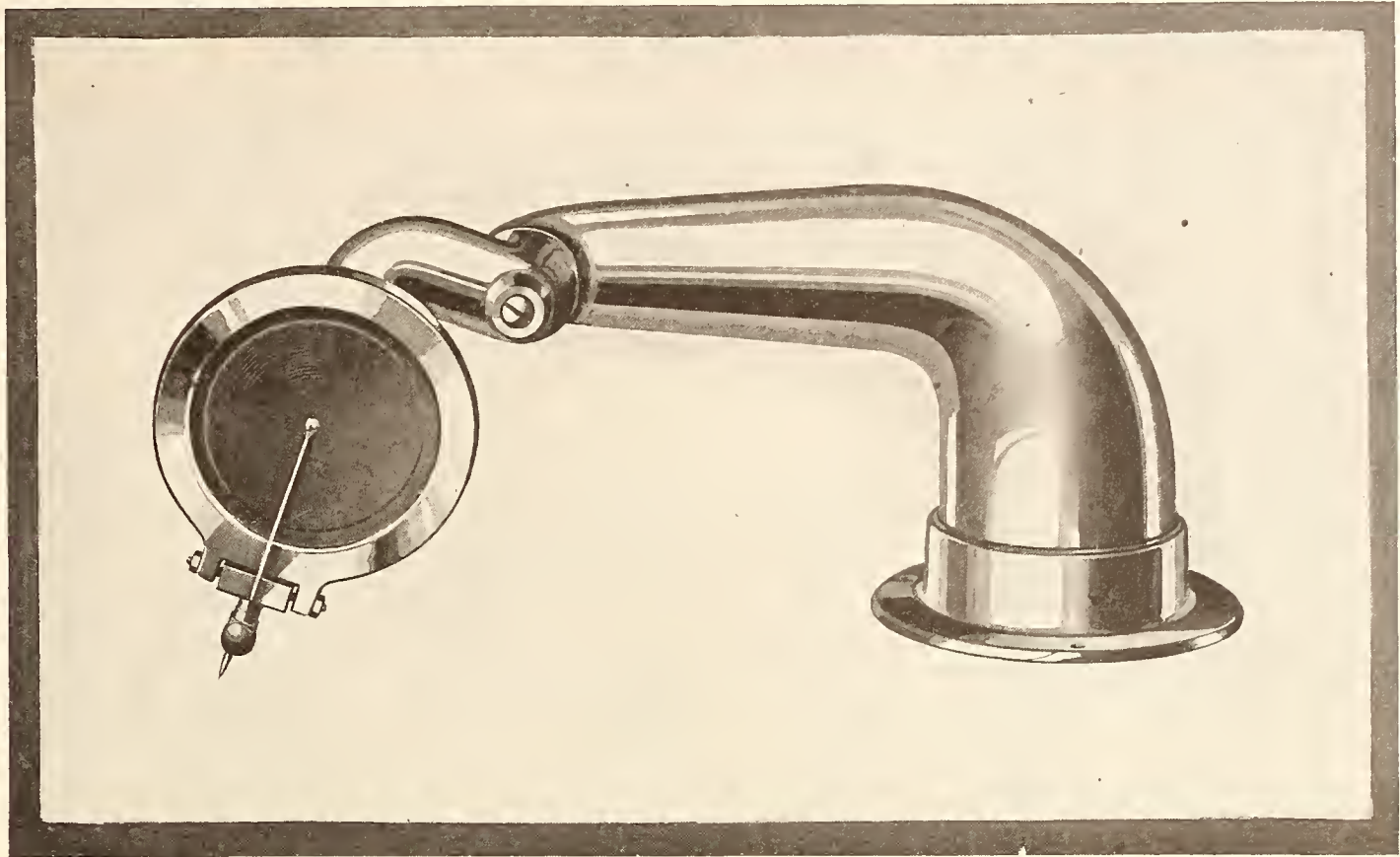

The Jewel Tone Arm and Reproducer 8½ inch length
 We have changed the name and improved the product.

EDISON

Universal Attachments

VICTOR

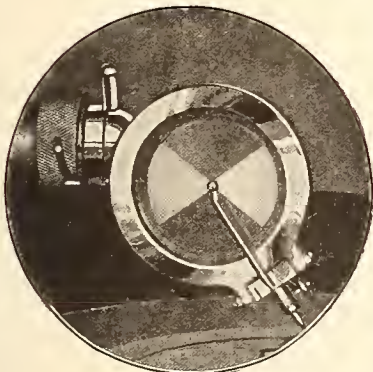

Fig. A

Every owner of an Edison phonograph is a prospect for this attachment. Plays Victor records with that superior, mellow quality of tone so characteristic of the "Jewel."

Victor Position

Fig. A shows Jewel Reproducer in position for playing Victor and other lateral cut records.



Fig. B

Hill and dale records are reproduced correctly by the "Jewel" method. A demonstration will convince you of its superior playing qualities.

Edison Position

Fig. B shows Jewel Reproducer in position for playing Edison and other hill and dale records.

W
R
I
T
E
Today
for
S
A
M
P
L
E
S

Victrola owners can now enjoy the wonderful creations of SERGEI RACHMANINOFF, the celebrated Russian pianist, so artistically reproduced in Edison records.

Edison Position

Fig. C shows Jewel Reproducer in position for playing Edison and other hill and dale records.

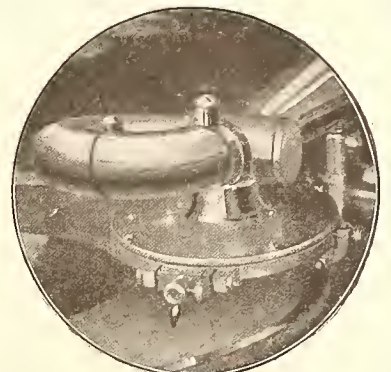

Fig. C

Equipped with the "Jewel" mute and Nomika diaphragm, every note and every word is reproduced in all its original clearness and beauty.

Victor Position

Fig. D shows Jewel Reproducer in position for playing Victor and other lateral cut records.

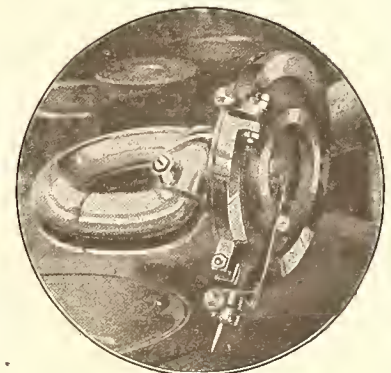

Fig. D

Send for a sample of our new Non Taper Tone Arm

Every piece of apparatus that leaves our factory is covered by the "JEWEL" guarantee—**SATISFACTION OR MONEY REFUNDED.** Let's get acquainted now.

Jewel Phonoparts Company
 670 W. Washington Blvd. Chicago

The New
JEWEL
AUTOMATIC STOP
 is now ready



Immediate Deliveries on
 Tone Arms, Uni-
 versal Attachments,
 Automatic Stops



Frank Crumit gives her "60 days" when he proposes to "Rosie." You'll reorder in much less time than that unless you double your initial order. "My Gee Gee (From the Fiji Isle)," a tenor solo by Tod Weinhold, is the coupling. A-3346.

Columbia Graphophone Co.
NEW YORK

INDIANAPOLIS A BUSY TALKING MACHINE NEWS CENTER

Hendricks Succeeds Rosner as Manager of Pearson's—Stewart Pointers to Dealers—Artists' Visits Help Record Sales—Leading Jobbers and Dealers Tell of Trade Betterment—Other News

INDIANAPOLIS, IND., February 5.—T. W. Hendricks, former manager of the Boice Voice Shop at Kansas City, Mo., has succeeded M. C. Rosner as manager of the talking machine department of the Pearson Piano Co. Mr. Rosner has entered the trucking and storage business. Prior to his connection with the Boice Voice Shop Mr. Hendricks was for several years assistant manager of the wholesale and retail departments of the J. W. Jenkins' Sons Music Co., of Kansas City. He is reorganizing the Pearson Co.'s talking machine department with a view of making more prominent the service features. He is adopting a distinctive form of advertising that drives home the idea of Pearson service.

Miss Frances Coyl, formerly of Wideners' Grafonola Shops, has been employed as a saleswoman in the talking machine department of the Baldwin Piano Co. C. P. Herdman, manager of the department, says the outlook for business is much brighter than it has been for many weeks and that the number of inquiries and prospective purchasers increases each week. He has added two women canvassers and two salesmen to his outside force with satisfactory results.

W. G. Wilson, of Wideners' Grafonola Shops, reports the business of the last half of the month to be much better, with every indication of an early revival of normal conditions. He has added Dell Masters to his sales force.

"Our January business has been much better than we anticipated, both in instruments and Re-creations," says H. G. Anderson, general sales manager of the Kipp Phonograph Co., Edison distributors. "Some sections of our territory report excellent business, while in other sections business still is slow. These conditions,

we believe, depend a good deal on the activity of the various dealers."

Among the Indiana Edison dealers who visited the Kipp Co.'s plant during the month were: G. W. Guthrie, Princeton; Mr. Kelleher, of the Thompson Drug Co., Danville; Mr. Osbon, of the Osbon Dry Goods Co., Noblesville; William M. Moore, of the William M. Moore Co., Brazil; Mr. Rupert, of the New Home Furniture Co., Linton, and Mr. Calvin, of Sadie Calvin & Sons, Nashville.

As throwing an interesting sidelight on the general business conditions, Edgar Eskew, of the Pathé Shop, reports that during the second week in January sales were fewer than in any other week in the history of the shop, while at the same time collections were the best. The last two weeks of the month, Mr. Eskew reports, showed a marked improvement over the business of the last few months, and he anticipates an early return to normal.

"The Pathé Actuelle steel needle record is meeting with more and more favor in this territory," says C. O. Mueller, manager of the wholesale Pathé department of the Mooney-Mueller-Ward Co. "We have passed the experimental stage now and this record is very hard to beat."

Mr. Mueller says he is receiving better reports from central and northern Kentucky, which is in the tobacco belt. He says the reports show that the tobacco is being sold after a long fight between the tobacco raisers and the tobacco companies. The consequence of this, according to Mr. Mueller, is a decided improvement in the talking machine business, which for some time has been very dead in that territory.

With the Pathé prices guaranteed up to July 1 the dealers throughout the Indiana territory

are doing better business, says Mr. Mueller. He reports that the Lamb-Zink Furniture Co., of New Albany, Ind., has just taken on a larger Pathé contract and is going after the phonograph business in a big way.

Charles Herring, Brunswick dealer of Elwood, Ind., has arranged through the Indianapolis branch of the Brunswick-Balke-Collender Co. to have the Isham Jones Orchestra play for a dance at the Elks Club in Elwood February 10. Herring, of course, is letting the people of his town and county know that the Isham Jones Orchestra plays exclusively for Brunswick records.

Jensen Bros., of Terre Haute, carload buyers of Brunswick phonographs, entertained at dinner W. J. Baker, manager; A. G. Burr, sales manager, and W. E. Pierce, all of the Brunswick Indianapolis branch, and their wives. After the dinner the company was entertained with vaudeville and dancing in the concert room of the Brunswick Shop. Mr. Burr reports the C. W. Damm Music Co., of Brazil, Ind., as a new distributor of the Brunswick phonograph and records.

The Brunswick dealers of Fort Wayne are planning to book the Isham Jones Orchestra for a dance some time in February.

W. O. Hopkins, of the Edison Shop, made a "tie-up" of newspaper advertising and window display with a Rachmaninoff concert at the Murat Theatre that brought immediate results in the way of numerous requests from prospects who wished to hear the Edison Rachmaninoff Re-creations. Mr. Hopkins featured the affair in half-page newspaper advertisements.

Under the direction of Miss Caroline Hobson, head of the educational department of the Stewart Talking Machine Co., plans are being made for educational classes to be held February 22, 23 and 24. The classes are conducted as preparatory for the larger sessions at the Victor factory.

C. C. Supplee, Victor field representative, has

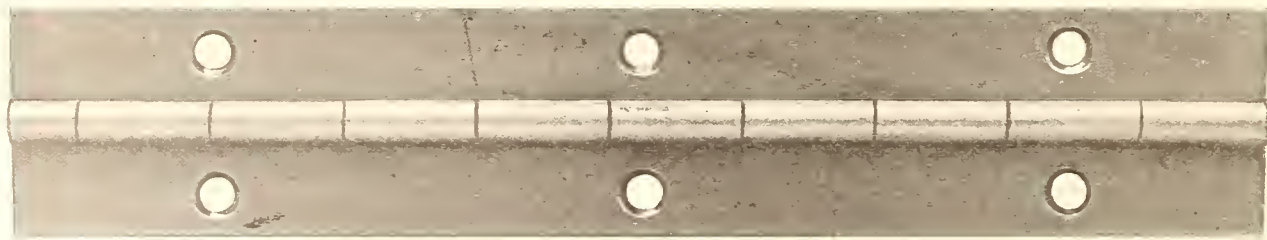

WE DO NOT MAKE MOTORS

But we can supply you any other Phonograph Hardware or Fittings

Let Us Make Your

HINGES
LID SUPPORTS
NEEDLE CUPS

KNOBS
TONE RODS
DOMES OF SILENCE

AUTOMATIC STOPS
DOOR CATCHES
NEEDLE RESTS

WEBER-KNAPP CO.

Jamestown, N. Y.

Stewart
Talking Machine Company

JOBBER
for the
Victor
Talking
Machine
Company



Indianapolis

returned to the Indianapolis territory and is actively engaged in helping dealers to prepare for a big year. One of the suggestions which he is carrying to the dealers is that arrangements be made for improved finances.

George E. Stewart, of the Stewart Talking Machine Co., has returned from a trip to the Victor factory.

The house organ of the Stewart Co. prints the following comparison and comment on the Victor advertising done in Indianapolis newspapers during December:

"Hoping to reap the benefit of the talking machine harvest which falls to the hand of the good reapers every December, dozens of pre-

viously inactive talking machine advertisers leaped into the columns of the Indianapolis newspapers just previous to the last holidays.

"Figures show that 84,000 agate lines of newspaper advertising were used by all makes in competition with Victor in this locality.

"The total lineage used by the Victor Co. and its dealers in the Indianapolis papers was 42,000. The closest approach to this figure by any group representing a single line of musical instruments totaled 22,000 lines. The next mark was 12,950 lines, set by a group which, at the present time, is practically out of the newspapers altogether.

"In some months the Victor dealers of Indianapolis have used 60 per cent of the advertising space devoted to phonographs and talking machines in the Indianapolis papers.

"The fact that they used last December only 33 1/3 per cent indicates purely that other makes outdid themselves in strenuous efforts to increase business."

The Vigilance Committee of the Stewart Co. had occasion recently to stop the use of Victrola electrotypes in advertising of stencil instruments by dealers in Connersville, Brownstown and For, Ind. The dealers were warned they were making a serious mistake in using any of the exclusive advertising assets of Victor dealers to promote the sale of other machines.

The Victor dealers of Indianapolis have largely increased their record sales by recent visits to the city of Tetraxini, Galli-Curci and Rachmaninoff. They are prepared to take advantage of a coming concert by Toscanini and his La Scala Orchestra, of Milan. Dealers in other cities are laying plans to take advantage of open dates for the Eight Famous Victor Artists who appeared in Indianapolis last Fall. All Indianapolis Victor dealers report a marked increase in record sales following these concerts.

GIMBEL BROS.' BRUNSWICK DISPLAY

Large Show Window of New York Department Store Devoted to Interests of Brunswick

Good publicity was recently given the Brunswick phonograph by Gimbel Bros., New York, in a specially designed window display, as shown in the accompanying picture. The window was situated on a corner and consequently offered unusual opportunities for attractive display.

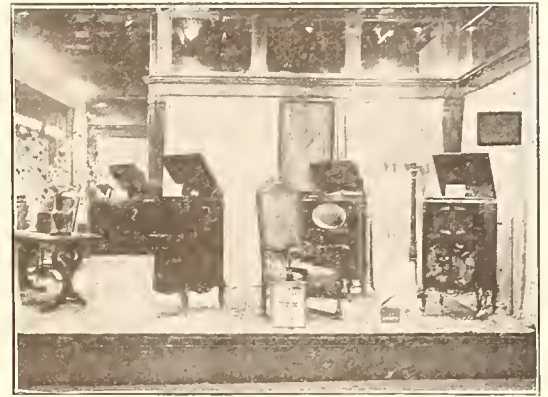

A Recent Brunswick Display at Gimbel's Models of the Brunswick were placed in this window, one instrument having the grill removed to show the tone amplifier, which is a special feature of the Brunswick. In each case the lid of the instrument was raised in order to show the different positions of the Ultona reproducer in playing all makes of records without extra attachment.

As Gimbel Bros.' store is placed in the heart of New York's shopping center and is constantly surrounded by great crowds, the Brunswick received some very valuable publicity.

There are more traveling men than there are salesmen. Moral: A traveling man should aspire to become a real salesman.

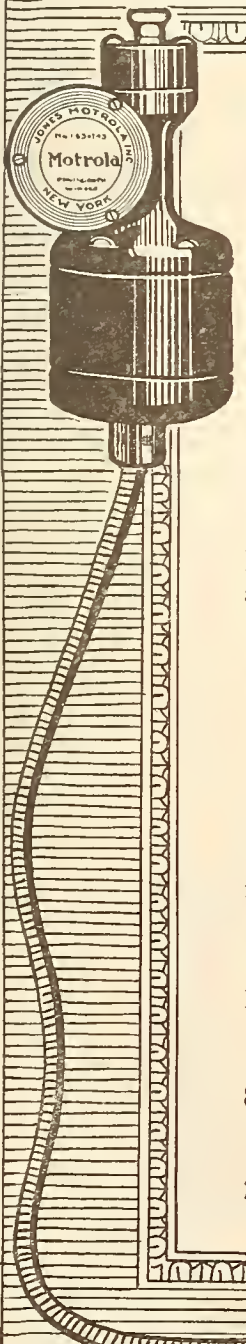

Brunswick

and the Motrola

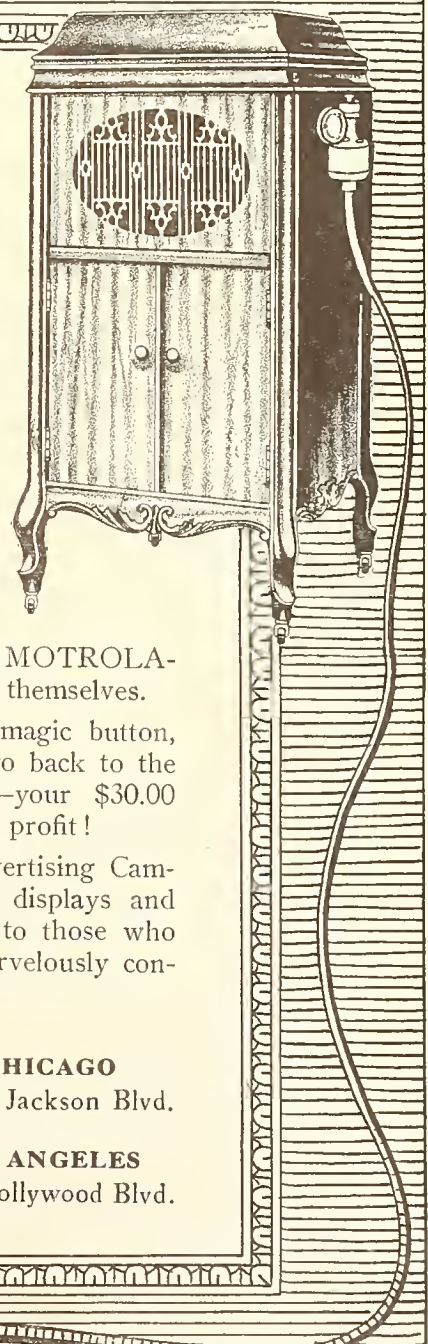

Since the Brunswicke-Balke-Collender Co., have unreservedly indorsed the MOTROLA, all Brunswick distributors carry a complete stock of these electric self-winding instruments, hence can give your orders immediate delivery.

The Columbia Graphophone Co., The Starr Piano Co., and other prominent phonograph manufacturers have also heartily indorsed the MOTROLA and placed it with their distributors, because it is equally adaptable to all makes of machines, and can be simply and easily attached.

Insure the lives of your demonstration phonographs by electrically winding them to the proper tension instead of having them jarred and possibly overwound. Then when your customers drop in to try the latest record they will get MOTROLA-WISE by actually operating it themselves.

Once they have touched the magic button, they will never be satisfied to go back to the hand-cranking process of old—your \$30.00 sale is made, and at a handsome profit!

Tie up with the National Advertising Campaign by MOTROLA window displays and store demonstrations;—show it to those who are daily reading about this marvelously convenient self-winder.

<p>DETROIT 83 E. Woodbridge St.</p>	<p>JONES-MOTROLA, Inc. 29 West 35th Street, New York, N. Y.</p>	<p>CHICAGO 57 E. Jackson Blvd.</p>
<p>ATLANTA 226 1/2 Peachtree St.</p>	<p>KANSAS CITY, MO. 1104 Walnut St.</p>	<p>LOS ANGELES 6019 Hollywood Blvd.</p>

DEATH OF CHARLES J. ORTH

Passing of Prominent Talking Machine Jobber and Music Merchant of Milwaukee Greatly Regretted—Widely Recognized as Composer

MILWAUKEE, Wis., February 5.—Charles J. Orth, distributor of the Puritan phonograph and Puritan records in the Wisconsin and Upper Michi-



Charles J. Orth

gan territory, and one of the best-known musicians and music merchants of the Northwest, died Tuesday, February 1, after an illness of several months with organic trouble. His death was a great shock, for after a siege of severe illness immediately after the holidays he was reported to be improving rapidly and expecting to return to his desk within a short time.

Mr. Orth was born in Milwaukee fifty-four years ago and made this city his lifetime home. As a youth he came into prominence as a musician and as a composer, which, about twenty-five years ago, led to his entering the music trade as a business. He continued his musical activities and produced a number of notable compositions. "In a Clock Store," a descriptive piece, has gone into thousands of American homes on the Columbia record. Other noted compositions are "Draper Hall March" and "Romance," a symphonic poem which was placed on the program of the famous Boston Symphony Orchestra.

After devoting about twenty years to the retail piano and talking machine business Mr.

Orth, five years ago, entered the jobbing field as well, becoming distributor of the Sonora. About two years later he was appointed exclusive distributor of the Puritan line in the State and Upper Peninsula. He continued in the retail business, the headquarters being at 504 Grand avenue, Milwaukee.

Mr. Orth was prominent in Masonic circles, having been a member of Kilbourn Lodge, Calumet Chapter, Ivanhoe Commandery and Wisconsin Consistory, 32d degree Scottish Rite, as well as Tripoli Temple of the Mystic Shrine. He also was a life member of Garfield Lodge, Knights of Pythias. Funeral services were conducted February 4 under the auspices of Kilbourn Masonic Lodge.

V. W. MOODY VISITS NEW YORK

Popular Victor Wholesaler Calls Upon Victor Trade—Makes Interesting Comments Anent Business Outlook in His Territory

V. W. Moody, general sales manager of the Buffalo Talking Machine Co., Buffalo, N. Y., Victor wholesaler, was a visitor to New York last week calling upon his many friends in the trade. While here Mr. Moody visited the editorial offices of The World and gave an interesting account of general conditions in Buffalo territory and his observations anent the retail situation as a whole were illuminating.

In a chat with The World Mr. Moody commented upon the fact that Victor dealers everywhere are preparing energetic and aggressive Spring campaigns, which will undoubtedly produce excellent results. Included in these campaigns are practically every form of high-grade and effective publicity, and the jobbers are co-operating with the dealers in every possible way.

Mr. Moody emphasized the fact that those dealers who are going after business along efficient lines are reporting very satisfactory sales totals. Here and there a dealer complained that January business was not up to his expectations,

but upon inquiry Mr. Moody learned that this particular dealer had not instituted any definite sales campaign after the close of the holiday season, but had depended upon the momentum of Fall and holiday trade to carry him through the Winter and Spring months. Needless to say, he was disappointed with the sales figures, but this mistaken sales idea is rapidly disappearing and practically in every instance Mr. Moody was furnished with data by the dealer which indicated that Victor representation this year will reflect in every detail the fame and prestige of Victor product.

Commenting upon the situation in his own territory Mr. Moody stated that there exists a feeling of optimism and confidence which is most gratifying. Victor dealers are utilizing every means at their command to increase their sales totals, and with the hearty co-operation of the Victor factory and the Victor jobbers the results for the first six weeks of the new year have been pleasing and satisfying.

S. Rinaldo, proprietor of the Rinaldo Grafnola Shop, Meriden, Conn., who has been looking for a suitable location in order to expand his business, has announced that he expects to be installed in a new building before the end of the month.

File Your Records so you can find them and it's easy to sell them.

This System pays for itself by increasing Sales through better service and Automatic ordering of "Sold-Out" Records

OGDEN'S PATENTED RECORD FILING CABINETS AND VISIBLE TAB INDEXES ARE GUARANTEED

MODEL No. 2150 D.D.
2 UNITS ILLUSTRATED

LOCKING ROLL TOP PREVENTS DUST AND THEFT, ALSO SUPPLIED WITH SPANISH LEATHER CURTAIN

350 10" or 10 1/2" RECORDS ON EACH SHELF FILED IN SALES SYSTEM COVERS AND WITH INDEX GUIDES

350 10" or 10 1/2" RECORDS ON THIS SHELF, ALSO 3 SHELVES ABOVE.

SOFT FLAT SUPPORTING SPRINGS PREVENTS WARPING (PATENTED), HOLDS 350 10" OR 12" RECORDS.

10" AND 12" RECORDS FILED ON SAME SHELF, HELD FLUSH AT THE FRONT BY PATENTED ADJUSTERS

93 INCHES

48 INCHES

48 INCHES

15 INCHES

2150 THIN RECORDS IN EACH UNIT. STOCK FINISHES: 4300 RECORDS IN 2 UNITS. WHITE IVORY & PEARL GRAY MAHOGANY & OAK

OGDEN SECTIONAL CABINET CO., INC., LYNCHBURG, VA.

Immediate Shipments

on all models in standard finishes. Light and Golden Oak, Red and Brown Mahogany, Enamels, White, Old Ivory and French Grey.

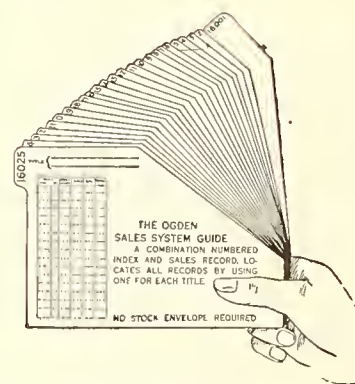

Visible Tab Paperoid Index

The Tab extends in front of the record with numbers always visible. Used the same as a stock envelope, one for each title, leaving all records in their envelopes. Is used to re-order by and keeps "Sold-out" numbers continually before you. Shows quick and slow sellers. The best and simplest "Sales and Ordering" index ever devised and rapidly replacing the stock cover because of its many advantages. Fits any filing system, shelving or racks. Printed both sides for right or left hand flat or upright filing.

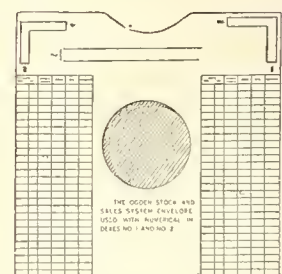

SALES SYSTEM ENVELOPES keep track of what you sell and what you need—an automatic inventory, showing profitable and slow sellers. Arranged for upright or flat filing and will fit any system.

Sectional Models Fit Any Size Stock and Help You Grow.



THE OGDEN SALES SYSTEM IS EQUIVALENT TO AN EXTRA CLERK AND INCREASES SALES

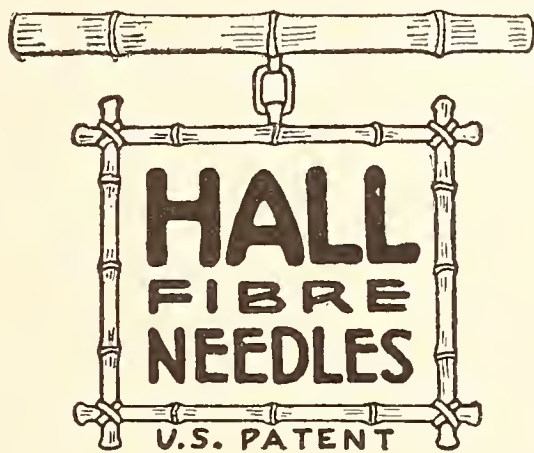

Announcement

The Hall Manufacturing Co.

Succeeds the

B & H Fibre Manufacturing Co.

The product hereafter
will be known as the

HALL FIBRE NEEDLE

In order to better identify the needle which has won so great popularity in the homes of talking machine owners throughout the country, and for the protection of our dealers, jobbers and ourselves against inferior substitutes, the B & H Fibre Mfg. Co. have decided to make the above change in name.

Office and Factory - 33-35 W. Kinzie St., Chicago

Is Your Sales Service Taken for Granted or Do You Know It's Right? :: :: By Frank M. Knowles

"Nope, we ain't got that record." "Nope, I don't know when we'll get any." "Nope, I ain't able to tell where you can find one."

Tell the average talking machine dealer that one of his snappy sales women had given those three answers in sequence to three direct questions from a prospective customer, and had then turned her back and walked away to resume an interrupted conversation with a fellow employe, and the dealer would more than likely question one's veracity. It might have happened in a competitor's store, he'd admit, but in his own store, never.

And the case is not an exceptional one, more's the pity, for a tour of an even dozen retail talking machine establishments made by the writer in search of a mere eight records brought forth the fact that really efficient retail sales organizations—that is, efficient in every detail, regardless of whether or not the boss happens to be about—are surprisingly few.

Would it seem possible that a customer with money in pocket could remain standing for an average of five minutes in each of three talking machine stores before any inquiry was made regarding his desires? Yet that happened in three out of twelve stores, twenty-five per cent, to be exact. In the first store—a really beautiful place—it was about luncheon time and the establishment was apparently in entire charge of a young woman. When the writer entered she was at the telephone. He waited quietly on the theory that business was being transacted, but soon learned from hearing snatches of the conversation that it was merely a social visit over the wire. Did the young woman acknowledge his presence by a smile or nod of the head to indicate politely

that she would be with him in a minute or so? She did not. She simply glanced at him casually once or twice and went right on talking to "Mabul." The exit of the prospective customer was accomplished without interruption, and the telephoning kept right on.

On another day two or three sales people in a store were busy when the writer entered, but a young fellow, apparently a bookkeeper, sat

Sometimes There Is a Wide Difference Between the Sort of Service Planned and the Sort That Is Rendered

figuring at a desk. The writer stood and stood and then stood some more, first on one foot and then on the other. He made his nervousness quite evident. The bookkeeper glanced up but said nothing. Two salesmen could be seen in booths talking to customers, but neither one had even a smile to spare. Here, too, the prospective customer walked out without interference. Admitting that the bookkeeper knew nothing of selling, and that the salesmen themselves were busy, it would have been a simple

matter for the former to have explained the situation and asked the customer to be seated for a moment until a salesman should be free. Or it would have been equally easy for one of the salesmen to have excused himself from the booth long enough to explain the circumstances to the customer and make him feel that his business was wanted even though there were no facilities at the moment for taking care of it. In either case, had the customer been forced to leave without being served, he would have held no ill feelings. Being simply neglected he went out feeling sore.

In the third instance two men and a girl, all apparently salespeople, were in a booth enjoying the reading of what was apparently a letter or circular of some sort. The laughter was hearty and continuous. When the door slammed after the writer's entrance all three looked up, gave him a glance, and then went on enjoying themselves. The prospective customer stood there for about a minute, although it seemed longer, and then decided to move along. As he opened the door one of the salesmen came hurriedly out of the booth with a loud "Hey," but the customer felt that he would do better making hay out where the sun was shining. This was the most flagrant neglect of a customer that came to the writer's attention, and was so flagrant as to be little short of criminal.

It is a generally recognized fact that giving the customer what he wants is not salesmanship—it is simply filling an order. The selling comes with the presentation and sale of records for which the customer has not asked, but are of sufficient interest to him to warrant their purchase. One of the elementals of talking

MERCHANDISING VALUE

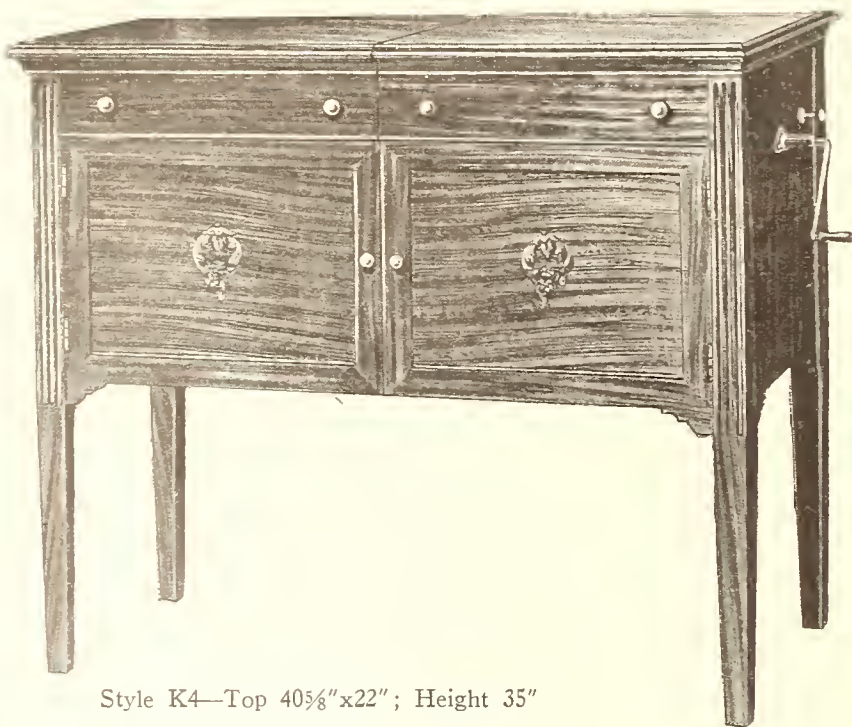

Style K4—Top 40 $\frac{5}{8}$ "x22"; Height 35"



Style K5—Top 41"x22 $\frac{1}{2}$ "; Height 35"

\$150

Retail Price

\$160

LAUZON QUALITY

The foresighted merchant with a hand on the pulse of public demand will immediately perceive the opportuneness of the above popular priced consoles.

Lauzon quality assures honest value and the price is a 1921 proposition calculated to build sales throughout the year.

MICHIGAN PHONOGRAPH CO.

Phonograph Division, Lauzon Furniture Co.
Office, National City Bank Bldg. Factory, Monroe avenue and 6th street
GRAND RAPIDS, MICH.

**MICA
DIAPHRAGMS**

Absolutely Guaranteed Perfect
We get the best India Mica directly.
We supply the largest Phonograph Manufacturers.
Ask for our quotations and samples before placing your order.

American Mica Works
47 West St. New York

machine salesmanship would seem to be to call the customer's attention to the new current releases, if not to the standard, or popular, numbers in the regular catalog. If he asks for a violin solo, the logical thing would seem to be to call his attention to other violin solos, to new numbers by stringed quartets, etc. In the face of all this, in four of twelve stores, although the customer received more or less prompt attention and was privileged to read and study the advertising on the walls and in the booths, he was permitted to leave after purchasing one record, and after answering in the negative the simple question, "Anything else to-day?"

The fact that the writer finally came home with twelve instead of eight records proves that he was in a receptive mood and might have listened to a suggestion that he hear one or two worth-while records demonstrated for his benefit.

In another of the twelve stores the attention received from the salesman was so strong as to be little less than embarrassing. He used every trick in the trade, and then some more. He talked records, records, and records, from the time the customer passed inside the door, and so anxious was he to build up a sale that he hardly took time to demonstrate records which he recommended and with which the customer was not familiar. The customer asked for one particular record on his list. He came out with his head swimming and with the requested record and three more unrequested records under his arm, and on leaving him at the door with an urgent plea that he at least listen to "Margie," the salesman acted as though in purchasing only four records the customer had really wasted his time and was altogether rather unappreciative of the salesman's interest. That particular man was a salesman, but in his enthusiasm he had developed the fault of crowding his customer too much. When the writer wants to buy some more records he is going to a store where there are real salesmen, but where he will not be rushed off his feet. The sensation isn't pleasant.

In the four remaining stores the service might be described as fully up to the standard. In two cases this was due probably to the fact that the proprietor himself did the serving and naturally took a personal interest in cultivating the customer's friendship with a view to getting his permanent trade. In two other stores, and they were not big main street establishments, either, the sales people, one salesman and one saleswoman, to be exact, managed to send the writer out with an extra record or two and a general feeling of satisfaction. The young lady, who apparently was in direct charge of the record selling, was busy when the writer entered, but stole a moment from her first customer to offer the writer the latest supplement and some special literature and asked him to be seated for just a moment until she was free. She was so pleasant about it that one seemed almost under obligation to stick around until he could receive the desired attention.

This particular young woman, as well as the young man in the next store, knew records; not only those they handled, but competing makes, which made possible comparisons of recordings that were calculated to be strongly in favor of the records at hand. The writer is addicted to string music and to choruses, and when he made that fact evident in his request for two or

three records they were offered him by both sales people, not jazzy fox-trots, crashing band selections or saxophone sobs, but music of the sort he favored. It made the selection of some extra records a simple and pleasant matter and the feeling upon leaving the store was that the salesman had really conferred a favor by calling attention to recordings that might otherwise have remained unknown.

It is to be taken for granted that every talking machine retailer wants his people to give the sort of service that will build up business and win appreciation and that he tries earnestly to develop his organization to that end. When he is in sight it is most likely that the sales people "snap to it," as it were, and endeavor to work along proper lines. The test of the service, however, is the sort that is rendered when the boss is out of sight and out of hearing. If a dealer in another character could come back into his store as a customer at a time when he is supposed to be absent he probably would find some things to surprise him. It is not always the fault of the salesman. The dealer in his

talks and in his training has gone at them from the angle of the employer and has not had a chance to test out that knowledge from the angle of the customer. Spying, of course, is to be condemned because it upsets morale and breeds discontent, but the adoption of some friendly method that will provide a guide to the salesman's methods from the customer's angle should prove helpful to both dealer and salesman.

As a matter of fact, one large concern in the West has engaged a capable woman whose duty is to circulate through its own and other stores for the purpose of observing ways and means for improving the general merchandising and selling tactics of the organization. This plan is worthy of emulation.

VOCALION AGENT IN SALAMANCA

A. L. Niles, talking machine dealer of Salamanca, N. Y., has recently been appointed an authorized representative for the Aeolian-Vocalion line of phonographs and records.

**Fletcher
Alltones
Needle**

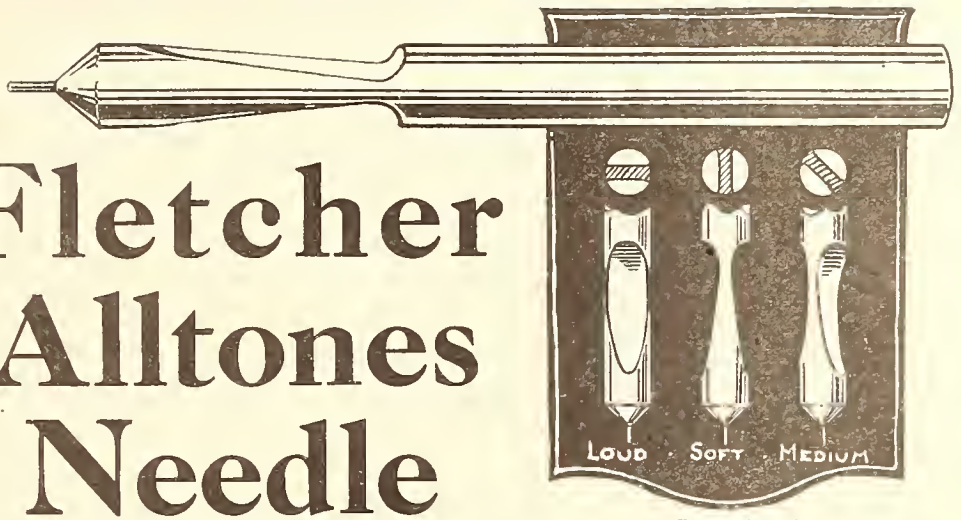

Patent Pending

A new semi-permanent needle that actually plays ALL TONES—LOUD, MEDIUM AND SOFT—and the gradations between, perfectly. Made of special steel that does not injure the record as do harder substances.

To give long life to the record and to get the best possible results while playing, recommend FLETCHER ALLTONES NEEDLES to your customers.—They will appreciate it.

Stocking this one needle meets every demand at a saving in space and capital.

Retail price per card of four needles 25c

Boxes of 100 cards, to dealers \$15

Valuable selling helps free

Jobbers—Write for Territory and Proposition

**FLETCHER ALLTONES
NEEDLE CO., INC.**

205 Travis Street

San Antonio, Texas

New York Jobber

ANDREW H. DODIN, Inc.

28 Sixth Avenue

New York

BETTER TONE IS EVIDENT IN THE CALIFORNIA TRADE

Anti-Crab Society Organized to Combat the Pessimists—Columbia Co. Branch Settled in New Quarters—Some Recent Trade Visitors—Talking Machine Dealers Plan Fancy Dress Ball

SAN FRANCISCO, CAL., February 1.—The San Francisco trade is pretty well satisfied with January business, which was somewhat better than was expected. Some concerns report more sales this month than the same month a year ago, but, taking the business as a whole, perhaps there is a slight falling off. A decidedly better tone is evident and the leading purveyors of musical merchandise are confident that the year will turn out all right. Panic talk is at a discount and membership in the Anti-Crab Society is increasing by leaps and bounds. Billy Morton, manager of the retail talking machine department of Sherman, Clay & Co., is president of the new organization and he has been empowered to appoint an anti-gloom committee whose business it will be to investigate all cases of commercial pessimism coming up before the society. Believing in the potency of a cheerful philosophy in the conduct of business, the society will seek to banish all unwholesome whimpering from the ranks of the San Francisco talking machine fraternity. Real grievances will be accorded serious consideration, but imaginary ones will be ruthlessly laughed out of court.

Savings Bank Deposits Increase

The California banks report a great increase in savings deposits for this month. There is more money of this kind on hand than ever before, hence it does not seem reasonable to suppose that the lovers of music will not continue to patronize the shops with the usual readiness when prices and goods are satisfactory. The hold-off attitude is not so strong as it was. The percentage of non-employment in California is much lower than in the East and there is good cause to expect a big revival in building the coming Spring. The housing problem is acute in some sections of the State and new homes must be provided for the people. Population is increasing here at a greater ratio than at any time since before the war.

Columbia Co. Is Now in New Quarters

The San Francisco branch of the Columbia Graphophone Co. has at last got moved into the new building on Bryant, near Second street. The new quarters are not completed as yet, and the place is rather upset, but business is going on as usual. The offices on the second floor are exposed to a flood of sunlight and are most pleasant in their appointments. The model shop, for the benefit of the Columbia patrons, is located on the same floor as the offices and is indeed a truly model shop. Meetings of an educational character will be held periodically in the shop and the dealers will be invited to attend. The company will also launch a new house-to-house canvass campaign very soon in order to co-operate with the dealers in stimulating business. Mr. Wilcox, the manager, is gratified with the present business out-

look and is naturally pleased with the new building, which offers so many modern advantages in the matter of handling business. The new violin records of Kerekjarto, which have just arrived on the Coast, have made a wonderful impression on those who have been privileged to hear them and it is a foregone conclusion that they will make a wide appeal out this way to music-lovers. The recent song recital of Louis Graveure, the famous baritone, stimulated not a little the demand for his exclusive Columbia records.

A. S. Garbett Visits Fresno

A. S. Garbett, formerly editor of Etude and the Victor Monthly Supplement, was a recent visitor at the Fresno store of Sherman, Clay & Co., and while there he gave several talks on salesmanship for the benefit of the store force.

Remick Shop Uses Magnavox

Ben Adkins, manager of the Remick Song Shop on Market street, has adopted the Magnavox as an auxiliary in his publicity department. The latest Remick song hits are transmitted to the passing public through the strenuous medium of the Magnavox, and everybody is minded to "stop, look, listen." The instrument carries a melody above the noise of the street.

Coast Likes Policy of Victor Co.

O. N. Rothlin, in charge of the San Francisco record division of the wholesale Victor department of Sherman, Clay & Co., says the Coast business is good, and better than Eastern business. Records are arriving a little better and he hopes to have sufficient stock to accommodate all the trade in the near future. The policy of the Victor Co. to back up popular record hits will mean much to the Coast trade. Three of the most popular hits on the Coast are: "Whispering," "Feather Your Nest" and "Coral Sea." The last named is by King Zaney and Herb Brown, both residents of and popular in California.

Brunswick Gains Growth Fast

The San Francisco office of the Brunswick-Balke-Collender Co. reports fine progress with the Brunswick records on the Pacific Coast. The demand is growing fast and steadily in all parts of the Coast territory. The stock of Brunswick machines in San Francisco is ample for the requirements of the trade at the present time, and during the holidays there was no shortage except on a few numbers. Clark Wise, accompanied by Mrs. Wise, will leave next week for a ten-day trip to Los Angeles and vicinity on business and pleasure.

Big Time Promised at Fancy Dress Ball

The talking machine dealers of San Francisco are planning for their annual fancy dress ball, to be held soon, and it is the ambition of the association to put over something this year which will make a big smoke. The trade

Well Rated Dealers
Can Discount Their

PHONOGRAPH INSTALLMENT CONTRACTS

WITH US

Thereby Turning Their Accounts
INTO WORKING CAPITAL

Mercantile Finance Company
COMMERCIAL PAPER
COLLATERAL LOANS

459-465 Montgomery St.
San Francisco, Cal.

is getting so blasé that it takes a sensation to get them together socially these days. Billy Morton has his brains working on the project.

Batkin Finds January Normal

A. A. Batkin, of Byron Mauzy, says January business is normal and that the people are showing a keen though discriminating interest in the best of offerings. Buying is careful, but there is plenty of buying. Rollin V. Astra, office manager for Byron Mauzy, is receiving the congratulations of the trade upon the advent in his home of an eight-pound baby daughter.

ORDERS SONORA IN UNIQUE WAY

Customer of Drug Store Includes Order for
Nocturne Model in His Drug List—An Un-
usual Method of Purchasing a Phonograph

A search for orders recently took A. C. Marugg, of the sales staff of the Minneapolis Drug Co., Minneapolis, Minn., Sonora distributor, into the store of F. J. Warner, at Marietta, Minn. Business was pretty brisk and the owner of the drug store and both of his clerks were busy serving customers. Mr. Warner was attending to the requirements of a customer of ordinary appearance, probably a prosperous farmer. The visitor had a piece of rough wrapping paper, from which he was reading with slight difficulty, the notes having evidently been made hastily with a soft pencil stub. "One can Mennen's talcum powder," he read from the list, and Mr. Warner immediately brought it down from the shelves. "Calox tooth powder," the customer continued, reading from his notes, "a large chamois, one Sonora Nocturne model, and let me see some hair brushes."

The proprietor helped the customer load the Sonora into his car without showing any unusual symptoms, but Mr. Marugg hurried to the telegraph office to advise his house that the dealers in his territory were "selling Sonoras like packages of chewing-gum."

FOUNDED 1835



Distributors

ARMSTRONG'S

There are numerous reasons why Pathé Dealers are satisfied.
Write today for full information.

ARMSTRONG FURNITURE CO.

59 and 61 North Main Street

Memphis, Tenn.



STEGER

The finest reproducing phonograph in the world

CLEAR, resonant, life-like is the voice of the artist or instrument, as reproduced with fidelity by the truly artistic Steger. To listen to this wonderful phonograph is to enjoy all the thrill and pleasure of hearing the living voice. The beautiful Steger brings to the home all of the world's best music and plays it with a vivacity and realism that no other phonograph can surpass.

Its many exclusive features, the patented adjustable Steger tone-arm, the scientifically-designed sound amplifying chamber of even-grained spruce and the get-at-able record file are eloquent reasons for the Steger's recognition as the finest of reproducing phonographs.

The Steger Phonograph is as beautiful in finish and design as it is charming in its tone-reproducing qualities. There is a variety of artistic styles at a wide range of attractive prices.

Progressive phonograph merchants have found that Steger representation brings prestige and profits.

A complete plan of dealer merchandising co-operation adds immeasurably to the value of the Steger agency.

Desirable territory open. Write for the Steger proposition today.

**PHONOGRAPH DIVISION
STEGER & SONS PIANO MFG. COMPANY**

Steger Building, Chicago, Ill.



Model 506 \$295.00



Model 505 \$220.00



Model 502 \$145.00



Model 504 \$200.00



Model 503 \$165.00



Model 501 \$115.00



Model 509 \$235.00



Model 500 \$95.00



Model 510 \$290.00

MCCARTHY AND TIERNEY'S NEW ONE

"WHY DON'T YOU"

THE BIG MELODY HIT FROM "AFGAR"

SUNG BY ALICE DELYSIA

PUBLISHED BY LEO FEIST Inc. FEIST BLDG. NEW YORK

"You can't go wrong with any Feist Song"



GREAT DEMAND FOR RECORDS IN MILWAUKEE TERRITORY

Wholesale and Retail Trade Expanding—Dealers and Jobbers Optimistic Anent Outlook—Death of C. J. Orth Regretted—Sales Promotion and New Ideas of Merchandising Prominent—Other News

MILWAUKEE, Wis., February 11.—A demand for talking machine records that overshadows anything ever experienced in the local trade is the most conspicuous feature of current business conditions. The sales of instruments are satisfactory, but, as usual at this time of the year, the demand is of a scattered nature and dealers are obliged to go further into the highways and byways than at any other season to seek out willing prospects. While stocks of instruments are generally reported to be ample to meet current requirements, record merchandise is still below par, and it is a constant battle for dealers to keep an adequate stock on hand, especially of the popular numbers. This situation, however, is slowly being relieved.

The wholesale trade has received a great deal of encouragement, especially in the last two or three weeks, from the improvement in orders from the retail trade. For a number of weeks immediately following the holidays retail requisitions were of rather small volume and confined mainly to "high spot" selections to fill in or round out stocks. Ordinarily the post-holiday time is one of considerable buying to overcome stock depletion through holiday shopping, but conditions unfavorable to broad consumer buying in November and December made this less necessary than customary. Still, in respect to some styles, new buying by retailers was of a relatively high order.

"Business is growing better every day," is the cheerful report of Sam W. Goldsmith, vice-president of the Badger Talking Machine Co., Victor jobber. "Our retail trade likewise is very hopeful, and it looks as if the Easter season this year will be quite important from a talking machine standpoint. The holiday comes much earlier than normally, so that we already are

beginning to get some effect of buying in anticipation of a good demand at that time. As far as records are concerned we have never had a more wonderful business than that which we are enjoying right now. We simply can't keep abreast of the demand."

The trade was inexpressibly shocked to learn of the death, on February 1, of Charles J. Orth, one of the best-known men in the Wisconsin music trade, who has been especially prominent as the distributor of Puritan phonographs and Puritan records in the Wisconsin and Upper Michigan territory. Mr. Orth had been in poor health for more than two months, but his condition was improving steadily and his passing, therefore, came as a sudden blow to a vast host of friends. A biography of Mr. Orth will be found on another page of this issue.

Brunswick instrument and record business in the first six weeks of the new year has surpassed that of the same period of 1920 by a comfortable margin, which is especially gratifying in view of the fact that, earlier, the hope had been to reach last year's volume. "That we should go ahead of 1920 was beyond our expectations, still we feel it augurs well for healthy increases during the rest of the year," said T. I. Kidd, manager of the Milwaukee branch of the Brunswick-Balke-Collender Co., 275-279 West Water street. "We feel sure this will be the best Brunswick year in the northwestern territory that we have ever known."

The Phonograph Co. of Milwaukee, 49-51 Oneida street, is getting excellent results from its special sales campaign in Wisconsin as a follow-up of vigorous promotion during the holiday season.

The Yahr & Lange Drug Co., 207-215 East Water street, distributor of the Sonora in Wis-

consin and Northern Michigan, is reaping the benefit of an elaborate advertising campaign carried on during all of 1920 and being continued in even a broader way this year. Besides extensive newspaper and magazine advertising the Yahr company is using billboards to good advantage. This publicity is regarded as some of the finest and most striking billboard advertising that has ever been done in this part of the country. The dignity and elegance of the boards are especially appealing and the cause of much favorable comment to supplement praise of the instrument.

According to H. M. Hahn, sales manager of the Paramount phonograph department of E. R. Godfrey & Sons Co., 293 Milwaukee street, this Made-in-Wisconsin instrument and Paramount records as well are establishing some new records. The company handles five Central States and also wholesale talking machine store equipment, accessories and supplies.

The Columbia branch continues to exert a notable sales promotion effort, the feature of which is the close co-operation given its dealers in the Milwaukee and Wisconsin territory. As a rule the large display advertisements give the full list of dealers, which is highly appreciated by them and is resulting in an identification of dealers with a pioneer and popular instrument and records which is building up a most advantageous position for the line. Columbia record business, as reported by representative downtown dealers, is bigger and better than it has ever been before.

A striking piece of Columbia publicity was done recently during the two-weeks' engagement of the "Greenwich Village Follies" at the Davidson Theatre. One afternoon Ted Lewis and his famous jazz band appeared at Waldheim's, 210-214 West Water street, and gave a program before nearly 2,000 people—all that could be crowded into the big store. More than 500 had to be turned away.

The Kesselman-O'Driscoll Co., 517-519 Grand

PHONOGRAPH RECORD LABELS



That will meet the requirements of the manufacturer of Records. Our experience along this line assures you of the best of results, quality as well as artistic in design. We make record labels for some of the largest record manufacturers.

If we are not making any of the following Specialties for you we would be pleased to quote you as our experience enables us to give you the desired results.

KEYSTONE PRINTED-SPECIALTIES COMPANY

321-327 Pear Street
SCRANTON, PA.

—O—

Our Specialties—
Phonograph Record Labels
Gummed Stickers of large quantities
Trading Stamps, etc.

—O—

avenue, originally established as a small Victor retailer on the northwest side, and now one of the largest general music stores in the Middle West, has recently effected further notable extension of its organization. The talking machine division, featuring the Victor and the Edison, continues under the management of L. J. Monroe, with A. J. Althaus as assistant. This division also handles all record, player roll and small goods sales.

The R. H. Zinke Music Co., 425 Milwaukee street, one of the leading East Side Victor dealers in Milwaukee, has experienced a splendid growth in the first nine months of its existence. The business was established on May 1, 1920, and under the efficient administration of Richard H. Zinke, a veteran Victor man, has become one of the best-known stores in Milwaukee. The Victor record department is particularly a feature and has built up a large clientele.

Miss Julia Wolff, manager of the talking machine and record department of the Edmund Gram Music-House, 414-416 Milwaukee street, has been introducing some new ideas in merchandising the Aeolian-Vocalion and the Cheney. Miss Wolff is a firm believer in keeping in constant touch with present customers and with prospects as well. This not only has made the Gram house as widely known as a talking machine house as it has been known for years as the home of the Steinway, but built up a very large volume of record business for the Aeolian line, particularly among the more discriminating.

The Milwaukee Better Business Bureau, conducted as part of the activities of the Association of Commerce, has accomplished splendid work in checking what threatened for a short time to lead to a flood of unethical advertising, in as well as out of the music trade. The latest report of complaints and results of handling them mentions the case of a pharmacy house which advertised: "We have the largest stock of phonographs in the county." The same house was accused of violating an agreement in cutting the price of a certain phonograph by giving away a number of records with each instrument. "When appealed to the company agreed to discontinue such tactics and to cooperate with the Better Business Bureau," is the conclusion given in the report of the case.

Oscar H. Morris, secretary and manager of the Bureau, is also serving his first term as a member of the State Senate from the fifth district, comprising the highest-class residence district in Milwaukee.

Clarence C. Warner, 428 Eleventh avenue, vice-president of the Milwaukee Association of Music Industries, recently was featured in a special article in one of the local newspapers as a veteran Victor dealer who has been in this line for twenty years.

The Fred Leithold Music Co., 325 Main street, La Crosse, Wis., has recently completed important improvements and enlargements of its store, which make it one of the most expansive as well as attractive in any part of the State. Fred Leithold, president and manager, is a vice-president of the Wisconsin Association of Music Industries and an enthusiastic member of the National Association. A feature of the rebuilt store is the talking machine department, which represents the Victor exclusively. Eight booths have been installed and the record library has been enlarged to accommodate 15,000 to 16,000 numbers.

To Sell a Victrola as an ordinary talking machine is to belittle its great value.

To display any other talking machine alongside of the Victor divides the customer's interest and your selling argument too, lessening your chances of selling either machine.

We can help you sell the Victor.

Write us

BUFFALO TALKING MACHINE CO.

Wholesale Victrola Distributors
BUFFALO, N. Y.

CANADIAN MUSICAL IMPORT DATA

Complete Figures as Published by Dominion Bureau of Statistics for November Last

OTTAWA, ONT., February 5.—During the month of October, 1920—the last month for which figures are available—Canada imported musical instruments and parts to a total value of \$365,698, of

which \$232,394 is credited to talking machines and records. This latter figure, while considerably lower than that for October, 1919 (which was \$370,908, to be exact) is \$68,799 greater than the import figure for September, 1920. To translate these figures, which have been compiled by the Dominion Bureau of Statistics from records supplied by the Department of Customs, into words, it is equivalent to saying that Canada imported more talking machines and parts in October, 1920, than in September, 1920, and yet, as compared with the imports of October, 1919, there has been a considerable falling off. The import figures are as follows:

	Talking Machines and Finished Parts Thereof					
	Sept. 1920	Oct. 1920	Oct. 1919	6 Mos. Ending Oct. 1919	Ending Oct. 1920	
United Kingdom ..	\$1,334	1,116	1,131	2,995	10,431	
United States	\$138,193	208,753	329,134	1,286,005	1,066,477	
Japan	\$234	1,116	1,336	
Switzerland	\$116	593	5,049	14,634	6,269	
Other Countries	\$165	20	377	
Total	\$140,042	210,462	335,314	1,304,770	1,084,890	
	Records (Disc and Cylinder)					
	Sept. 1920	Oct. 1920	Oct. 1919	6 Mos. Ending Oct. 1919	Ending Oct. 1920	
United Kingdom ..	\$272	40	126	899	1,528	
United States	\$23,281	21,892	35,468	222,704	152,399	
Japan	\$.....	110	1,301	
Other Countries	\$.....	489	
Total	\$23,553	21,932	35,594	223,713	155,717	

Personal Service

G. F. RUEZ
Pres. and Treas.

H. A. GOLDSMITH
Secretary

S. W. GOLDSMITH
Vice-Pres. and
General Mgr.

The members of our company are always available and will gladly see you personally or write you at any time we can possibly serve you.

Get acquainted with the Badger brand of personal service.

Badger Talking Machine Company

Exclusive Victor Distributor

135 SECOND STREET MILWAUKEE, WIS.



New Unico Establishment—O. K. Houck Piano Co., Memphis, Tenn.

CONSTRUCTIVE SALESMANSHIP THE BATTLE CRY FOR 1921

This is a selling year. Never, in our history, has there been greater need for Sales Effort. Potential Selling Efficiency is the keynote of the Unico System.

Unico Equipment is the surest guarantor of retail sales known to the Talking Machine Industry—1700 successful dealers attest this fact.

Unico Equipment is a permanent asset and not subject to the usual depreciation of ordinary store equipment. There are many instances of resale of Unico Equipment after several years' use, at prices higher than the original cost.

Unico Service covers every angle of your Merchandising problem, from efficient department layout to accomplished sales, and is available to every Talking Machine Dealer, no matter where located.

Unico Service operates with marvelous rapidity. Speed—Yes, but not at the expense of quality, efficiency and permanent value.

The Battle is to the Strong—and the Quick. Make your Selling Equipment 100 per cent Strong and do it Quickly.

Wire, write or phone today to our nearest office.

Your problem will receive immediate expert attention.

Unico Demonstrating Rooms, Counters, Record Racks and Decorations are available in twelve designs and standard finish for immediate shipment.

*Unico Construction
is patented.*



*Unico Designs
are patented.*

UNIT CONSTRUCTION COMPANY

NEW YORK
299 Madison Ave.
Corner 41st St.

Rayburn Clark Smith, President
58th Street and Grays Avenue
PHILADELPHIA

CHICAGO
Willoughby
Building

SOPRANO SCORES SUCCESS

Miss Cyrena Van Gordon, Exclusive Columbia Artiste, Receives Ovation in Role of "Brunhilde"—Newspapers Give Enthusiastic Praise

Miss Cyrena Van Gordon, exclusive Columbia artist and prominent dramatic soprano, attained phenomenal success in the role of "Brunhilde" in the production of one of Wagner's famous operas given recently by the Chicago Opera Co. in Chicago. The performance given by this renowned dramatic soprano was the subject of general praise by all the Chicago newspapers, and Columbia dealers took advantage of her success to feature her records prominently in their advertising.

In the Chicago Herald-Examiner Miss Van Gordon's superb rendition of this difficult role was accorded enthusiastic praise, the musical



Miss Cyrena Van Gordon

critic of the paper stating in part as follows: "A wonderful performance! A great triumph for a young American artist; a victory for opera in English! This was the consensus of opinion after the 'Valkyrie' last evening. It was one of the most brilliant successes of the season, an occasion marked by breathless attention on the part of the huge audience, which filled the Auditorium to its utmost capacity and then broke loose after every act to express in no uncertain terms of approval how it was affected by this splendid achievement.

"Miss Van Gordon met the test easily and triumphantly. She was dramatically powerful and vocally superb. Even her English was all one could ask, and the picture she made as the maid in shining armor, with her silver shield and scarlet cloak, will not soon be forgotten, especially when she came on the stage leading her milk-white steed.

BRUNO

Victor Ready Reference Labels make slow-moving records speedy sellers. Just put them into your record rack, Mr. Victor Dealer, and watch the record racket.

BRUNO

"By what she accomplished last evening, Miss Van Gordon takes her place among the foremost singers of the day. She is fulfilling the late Maestro Campanini's prediction: 'You will one day be one of the greatest dramatic sopranos of the age'."

DINNER TO F. C. HOWARD

Head of Company of That Name and Members of Staff Guests at Testimonial Dinner

SYRACUSE, N. Y., January 31.—The testimonial dinner to F. C. Howard, head of the F. C. Howard Piano Co., and members of his staff, by A. D. Ogden, the company's road man handling the Howard account, was a great success in every particular. The guests included Mrs. Howard, wife of the proprietor; Mrs. Ogden, R. O. Ainslie, assistant treasurer of the Hallet & Davis Co., who devotes his attention to the Pathé line, and who came over from Boston for the occasion; E. B. Dryden, traveling representative of the Pathé; E. C. Adams, the Pathé dealer at Cato, N. Y., who started in October and who has built up a most creditable business; William Goff, of the Howard staff, and Mrs. Goff; Miss Louise Howard, Mr. and Mrs. Howard's daughter, and J. H. Persee, S. J. Seckner, E. N. LaRose, Florence Souders and Morris Souders, all members of Mr. Howard's staff.

Mr. Ogden was toastmaster, and there were interesting talks by Mr. Howard, Mr. Dryden, Mr. Adams and Mr. Ainslie. The latter, in recognition of the excellent upbuilding of the Pathé business in this territory, presented Mr. Ogden with a Pathé Actuelle, the gift coming from the Hallet & Davis Co.

W. S. GRAY CO. ANNUAL MEETING

John L. McNab, Prominent Attorney, Now One of Directors of San Francisco House

SAN FRANCISCO, CAL., January 27.—The stockholders of the Walter S. Gray Co. held their first annual meeting at the offices of the company, 942 Market street, January 25, at which time the first dividend checks were distributed, the corporation having been in existence just one year. The president submitted a statement of condition and report on business for the year and stated that, while he was fairly well satisfied with the volume of business and profits for 1920, he was of the belief that 1921 would see both largely increased.

Only one change was made in the Board of Directors and Mr. Gray, the president, believes he has greatly strengthened the board by the addition of John L. McNab, a prominent attorney of San Francisco, as he is a man of large affairs and very well and favorably known throughout the Pacific Coast. The new Board of Directors consists of Walter S. Gray, John L. McNab, Robert G. Gray, G. Victor Strain and A. M. Gray.

The officers elected are: Walter S. Gray, president; Robert G. Gray, vice-president; M. F. Olson, secretary, and A. M. Gray, treasurer.

BUY MINNEAPOLIS DRY GOODS CO.

W. C. Whitney and W. S. MacGregor Now in Complete Control of Large Concern

MINNEAPOLIS, MINN., February 5.—W. C. Whitney and W. S. MacGregor, who have for some time managed the affairs of the Minneapolis Dry Goods Co., have purchased the company and will change the name to the Whitney-MacGregor Co. The new owners have announced that there will be no change in the established merchandising policies of the company. Plans for bigger business, however, are under way and improvements to the store arrangement and equipment are now being carried out.

The man who can do things, and do them right without being continually instructed, is the man who is appreciated in business.



25c+25c+25c., etc. means good profits!

EVERY sale of Sonora needles rings up at least a quarter in the cash register. And it is the easiest thing imaginable to sell these needles. Just call your customers' attention to them!



Semi-Permanent

NEEDLES

deserve to be placed in the best position on your counters. They give unequalled satisfaction in service and bring buyers back to your store again and again for more.

Because of their superior quality these needles are preferred by the public.

Send in your order today if your stock is incomplete.

Loud — Medium — Soft

25c. per card of 5 (40c. in Canada)

Sonora Phonograph Company, Inc.

GEORGE E. BRIGHTSON, President
279 Broadway NEW YORK

Canadian Distributors
I. Montagnes & Co.
Toronto

CAUTION! Beware of similarly constructed needles of inferior quality.

BUFFALO SEEKS LAW AGAINST MISLEADING ADVERTISING

Chamber of Commerce Back of This Movement—W. D. Andrews Purchases—Wallace New Columbia Dealer—V. W. Moody on Trip—Rice Store Destroyed by Fire—News of Month

BUFFALO, N. Y., February 2.—Legislation which would make it an actionable offense for a concern dealing in musical instruments to publish misleading advertising, which gives the customer an enlarged impression of what he is getting for his money, is now being sought by the music trades group of the Buffalo Chamber of Commerce. The group is now working on a campaign for such a law, and is seeking to enlist the aid of the whole Chamber.

This comes as the result of certain advertisements of talking machines which have come to the notice of the group. Samples of the advertisements were displayed at a recent meeting of the music men, and after giving them careful consideration it was decided that some of them were misleading and deceptive. In these alleged deceptive ads, it was held, the customer was given the impression that he was getting more equipment at the price named than was really the case. And so the music trades group is now working for a law which will make misleading advertising a punishable offense.

Announcement that he had purchased the interest of W. D. Andrews, his senior partner, was made February 2 by Curtis N. Andrews, of the firm of W. D. & C. N. Andrews, the prominent Victor wholesalers. W. D. Andrews will look after interests which he has in Syracuse. This matter is referred to elsewhere.

A serious fire in the business section of the city occurred on January 17, originating in the talking machine store of Herman Rice. The building burned to the ground and several adjoining buildings were destroyed before the fire was gotten under control.

V. W. Moody, of the Buffalo Talking Machine Co., finds that dealers throughout his territory are maintaining a good level of sales and he expects them to increase steadily. Mr.

Moody recently made a trip to New York and called on his friends in the trade there.

Much interest in the new foreign language Okeh records is reported by the Iroquois Sales Corp. This city has a large Polish population which should purchase many of the records in their own language.

Charles Hoffman, Sonora and Brunswick dealer, had a narrow escape from serious injury recently. He was driving his auto in Delaware avenue and swerved sharply to avoid hitting another car. His car brought up against the curb, smashing two wheels. But outside of a shaking up, Mr. Hoffman was uninjured.

A number of dealers in this district were callers at the Columbia Buffalo branch office. Among them were Frederick Jeness, of Jeness Bros., Lockport; H. S. Miller, of Avon, and Robert Mann, of Warsaw.

E. L. Wallace is the new Columbia representative in Rochester. He takes the place of D. A. Little, who has taken charge of the Palace Music Shop there. Through Mr. Little, Marion Harris and the Columbia Saxophone Sextet will appear at Rochester February 11, playing at a concert and for a dance there. The artists will also come to Buffalo and Niagara Falls. Arrangements are being made for a concert in this city.

W. P. Duffy, merchandise supervisor at the Columbia branch office here, and formerly in the dealers' service department at the Philadelphia office, became a benedict last month. The bride was Miss Martha Hurlock, of Philadelphia.

N. A. Taber, manager of the local Pathé office, reports that business is going very well with him. Many sales are being made by Pathé dealers and a number of new agencies established. Among the new Pathé dealers are

Robert E. Schwalb, of 285 Genesee street, and Gerald Arndt, of Town Line.

Charles Markham, local manager for the Brunswick phonograph, has just returned from a trip through his territory, and reports that he finds business is good. Among the cities visited by Mr. Markham in the course of his trip were Syracuse and Utica.

ODD SITUATION IN NEW ZEALAND

Country Has Plenty of Money but Needs Credit—Condition Arises Because of Hold-up in Gold Exportation—Bonds for Imports

American exporters to New Zealand are advised by Consul-General Winslow, at Auckland, to meet in a generous way the economic situation which has developed there. He explains that there are plenty of good, conservative, reliable business houses to whom, it would seem, a reasonable amount of credit can be safely extended, and with profit. It is suggested, in view of the prohibition on the exportation of gold, that American business houses take in payment, or as security for payment of imports, bonds and Government debentures.

Money is plentiful in the dominion, the banks really holding more than can be put to good use, but there is difficulty in establishing credits in London and New York, because gold cannot be exported. The trade balance has steadily gone against the country since the beginning of 1920, and toward the end of the year the banks announced that they would discourage the importation of non-essentials, such as motor cars, high-priced millinery, jewelry, confectionery, etc., and would not finance such importations unless exceptionally good reasons existed for them at the time. Though this policy was exceedingly embarrassing for both bankers and importers, its adoption seemed essential, in view of the necessity of allaying possible panic as a result of the most trying period experienced in the dominion since the beginning of the war.



Model
145

The Brooks Automatic Repeating Phonograph

is justly termed The Wonder Instrument. It has all the good

DEALERS
There are some communities where the BROOKS is not represented effectively as yet. Write us at once regarding your territory. We are planning a sales campaign of wide scope this year and large distributors and dealers will find the acquisition of the BROOKS line a big factor for business volume during 1921.

THE REPEATING DEVICE

The Brooks Automatic Repeating and Stop Device is an exclusive Brooks feature. It gives this phonograph a broader scope than any other make and requires no attention beyond setting the needle and turning a little knob. It is to the phonograph what the self starter was to the automobile.



Model
165

qualities of other high grade makes, but is completely put in a class by itself by virtue of the inbuilt Repeating Device, which enables the operator to play any make of record, any desired number of times.

Shown are three Brooks models of different sizes, all beautifully carved and finished. Each style is identically equipped with the repeating and stop device.



Model
250

Brooks
The
Wonder
Instruments

Automatic Repeating
Phonographs

BROOKS MANUFACTURING COMPANY, SAGINAW, MICH.

The SPHINX MOTOR

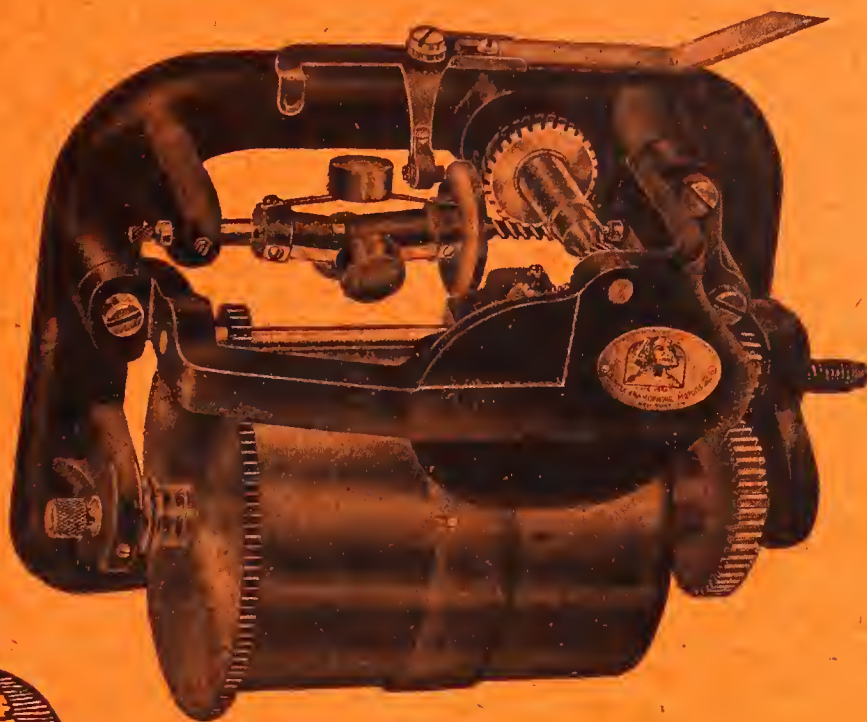

Reg. U. S. Pat. Off.

*The Standard By
Which All Phono-
graph Motors
Are Judged and
Valued.*

QUALITY plays an important role today in successfully marketing a phonograph—whether building up a clientele for a new product, or extending distribution on one well established. The first requisite quality feature of any good instrument is its motor.

THE Sphinx Motor possesses advantages that can instantly be appreciated on sight and demonstration. It concentrates on quality. It instills confidence, tears down sales resistance and makes the entire phonograph more quickly salable—by offering an effective sales “approach.”

BACKED by the resources and reputation of an organization responsible for many institutional developments in the phonograph field, the Sphinx Motor should receive a prominent place in your phonograph sales efforts for the ensuing year.

SPHINX GRAMOPHONE MOTORS, Inc.
512 FIFTH AVENUE, NEW YORK

Concentrates on Quality

Repossessions

are now stacking high in warerooms. What are you going to do with those YOU have? **KNOCK OFF \$50.00 to \$100.00?**

Don't Do It!

Buy a few dollars' worth of **LESLEY'S PATCHING VARNISH** and other needed finisher's supplies and make them look better than new at an average cost of \$3.50 each: **THEN MAKE THE PROFIT YOU SHOULD HAVE.**

LESLEY'S FINISHER'S SUPPLIES are the best possible and are sold on a **MONEY BACK GUARANTEE.** Write a letter today and tell us how much trouble you have and we will tell you how little it will cost you for the stuff to **FIX 'EM UP.**

Lesley's Chemical Co.

10 S. New Jersey St.
Indianapolis, Ind.

WALTER SCANLAN SCORES A HIT

Popular Irish Tenor Attains Success in "Hearts of Erin"—Emerson Records in Active Demand

The Emerson Phonograph Co., New York, has received interesting reports from Pittsburgh in connection with the appearance of Walter Scanlan, the popular Irish tenor, in the musical comedy "Hearts of Erin." Mr. Scanlan has scored a phenomenal success in this musical



Walter Scanlan

play, and according to the present schedule "Hearts of Erin" will probably open in New York during April. Emerson dealers in Pittsburgh have taken advantage of Mr. Scanlan's appearance in their city to feature his records to excellent advantage. The Emerson records of the two hits in this show, "Nora" and "On Sweetheart Shore," have met with an active demand, particularly as these records reflect in every detail Mr. Scanlan's superb voice.

BYRON DAVEGA FORSTER ARRIVES

Almost simultaneously with the advent of the new year arrived Byron Davega Forster. B. R. Forster, president of the Brilliantone Steel Needle Co., is the proud father and is enthusiastically telling his many friends in the trade of the Brilliantone of the youngster's cries. Mrs. B. R. Forster, it will be remembered, is the daughter of I. Davega and sister of Abram Davega, president and vice-president, respectively, of the Knickerbocker Talking Machine Co. B. D. Forster is the first male arrival in the Forster family and has two older sisters.

Dave Roth, proprietor of Roth's Music Store, 186 South High street, Columbus, O., has taken on the Okeh line of records. He is also adding six demonstration booths for the hearing of these records.

NEW BUILDING FOR LANDAU'S

Victor Dealers of Wilkes-Barre, Pa., Purchase \$130,000 Property to House Business

WILKES-BARRE, PA., February 3.—Landau's, Victor retailers of this city and Hazleton, Pa., have recently purchased the large Hurwitz Building at 34 South Main street. This deal is said to be one of the most important real estate transactions in this city of recent years, the consideration being quoted at \$130,000. After extensive alterations and improvements have been made, Landau's will take possession of the building and will have one of the largest and best equipped music houses in this section of the State.

The new building runs 225 feet deep and has three floors with large display windows facing on Main street. In the rear of the building is an alley which will provide excellent facilities for the expeditious receiving and shipping of merchandise. It is planned to have thirty demonstration rooms installed in the Victor department, which will place this department among the largest in the Keystone State. With the acquisition of the new building it is planned to open a piano department. Five well-known makes will be carried. Ample space will also be devoted to player roll and sheet music departments.

Landau's is one of the oldest music houses in the city. Under the able direction of Hyman Landau and Harry Michlosky, the affairs of this firm have met with continued success and the business has grown to the point where the foregoing change has been made an absolute necessity. The new location is but a half block distant from the present location at 70 South Main street, which this firm has occupied for years.

COLUMBIA STORE IN BATTLE CREEK

P. E. McMurphy last month opened a Columbia Shop in Battle Creek, Mich., at 60 East Main street. The store equipment includes five demonstration booths and a large record rack and record counter.

MAIN SPRINGS

Guaranteed to be made of the highest grade carbon steel procurable. Prices quoted are possible only because of our immense purchasing and distributing powers.

(No Shipment Made Less Than Six Springs)

	Lots of				
	6	12	25	50	100
	each each each each each				
No. 24 1/2"x.018x8 feet, for small toy motors, pear shape hole	.20	.18	.17	.16	.15
No. 25 5/8"x.020x8 feet, for Sonora, Swiss, Pathé, pear shape hole	.22	.20	.19	.18	.17
No. 26 5/8"x.020x11 feet, for Edison Gem, loop end	.30	.28	.27	.26	.25
No. 28 3/4"x.022x9 feet, for Carola, Triton, Melophone, etc., pear shape hole	.38	.37	.35	.33	.31
No. 29 3/4"x.022x10 feet, for small Columbia, Universal, Heineman, Harmony, Vanophone, Pathé, pear shape	.43	.42	.40	.38	.35
No. 30 7/8"x.022x10 feet, for Blick, Wonder, Premier, Meisselbach, Nos. 9 and 10, square hole	.47	.46	.44	.42	.40
No. 31 1"x.025x9 feet, for Swiss motors, small Columbia, Stewart, pear shape hole	.54	.52	.50	.48	.45
No. 32 1"x.020x13 feet, for small Victor, pear shape hole	.54	.52	.50	.48	.45
No. 33 1"x.025x12 feet, for Pathé, Heineman, Mandel, Aeolian, Meisselbach, Vitanola, pear shape hole	.70	.67	.60	.55	.50
No. 34 1"x.025x14 feet, for Sonora, Saal, Thomas, Silver-tone, oblong hole	.75	.70	.65	.60	.55
No. 35 1"x.028x10 feet, for all styles Columbia machines, pear shape	.54	.52	.50	.48	.45
No. 36 1"x.025x9 feet, for Meisselbach, No. 12, Thomas, oblong hole	.54	.52	.50	.48	.45
No. 37 1"x.025x16 feet, for Meisselbach, Saal, Thomas, Silver-tone, Modernola, Rishell, Widdicomb, Sonora, Stephenson, oblong hole	.85	.83	.80	.75	.70
No. 38 1"x.025x16 feet, for Vitanola, pear shape	.85	.83	.80	.75	.70
No. 39 1"x.028x11 feet, for Edison Standard, pear shape	.59	.57	.53	.50	.47
No. 40 1 3/16"x.028x16 feet, for Heineman, Pathé, Rex, pear shape	.90	.88	.85	.80	.75
No. 41 1 1/2"x.027x25 feet, for Edison Diamond Disc, pear shape hole	1.80	1.70	1.65	1.55	1.50

(If the above are desired in assorted sizes, the quantity price will be allowed.)

TERMS: 2% 10 days or 30 days net, to houses with satisfactory commercial rating. To others, 3% discount, cash with order. Please enclose Parcel-post charges, if wanted that way.

Write for our latest catalogue, now on the press, containing hundreds of needed repair parts. Ask for catalogue W.

EVERYBODY'S TALKING MACHINE CO.

38 North Eighth Street PHILADELPHIA, PA.

Exclusive Distributors for the General Phonograph Corporation

BELIEVES IN HIGH-GRADE BUSINESS CANTON TRADE SHOWS BETTERMENT

S. B. McLaughlin, Manager of Baldwin Piano Co. Department, Tells Why That Class of Trade Is the Best for the Dealer

CINCINNATI, O., February 3.—Sherman B. McLaughlin, manager of the talking machine department of the Baldwin Piano Co., is a firm believer in going after high-grade business on a high-grade basis, and in an interview with The World says he is heartily in sympathy with the stand taken by C. S. Hammond, manager of the talking machine department of Loeser & Co., Brooklyn, N. Y., in his interesting article which appeared in The Talking Machine World January.

"If talking machine dealers as a whole would see the ethics of good business by interesting the customer in the quality and musical advantages of the instrument instead of advertising the fact that one could purchase the instrument on ridiculous terms, the instrument itself would mean more to the purchaser, business placed on a higher scale, and dealers would become more able to withstand financial storms," said Mr. McLaughlin.

"A salesman has a stronger line of sales argument by showing the superior quality and advantages of the machine on sales than by treating the customers as if they were non-music lovers and simply desired to buy any machine providing the terms were the lowest and the payments easiest.

"The average Victrola prospect is too much educated to-day along the lines of talking machines to believe that ridiculous 'dollar down and dollar a week' terms must be used in order to sell an instrument so high in the public opinion as the Victrola, and dealers who resort to these tactics not only cheapen their place of business, but degrade the instrument which they offer for sale, in the mind of the customer.

"We represent ourselves as high-grade dealers in every respect, which right is certainly ours, for we carry on our business in a high-grade way and handle a high-grade instrument. Our term sales are based on the ten to twelve-month plan, not over. Our sales force is educated along the lines of a good substantial down payment.

We have no difficulty in securing these terms, as our patrons visit us to purchase an article of quality and therefore expect to pay for that which they receive. Terms are seldom discussed until after the sale is made on the merits of the machine."

The Derwin Music Co., New York, has been granted a charter at Albany. The capital of the new corporation is \$10,000 and the incorporators are: V. T. Folmer, L. and J. J. Derwin, 203 West 103d street.

Resumption of Big Industrial Plants Has Beneficial Effect on Business—Klein-Heffelman Co. to Move Into New Building—Other News

CANTON, O., February 3.—With partial resumption of two of Canton's largest steel plants music dealers declare there has been a slight improvement in business. The majority of the dealers report a good January, especially the Alford & Fryar Co. Sales of this company for the month of January were in excess of the December business, according to A. M. Alford. W. H. Woomer, proprietor of the Canton Phonograph Co., told The World representative that business with his concern during the month of January was better than past months and that indications were that February would be still better. S. B. Van Fossen, new manager of the J. W. Brown Piano Co., says there is a noticeable improvement in business at this store and that he believes, with more plants resuming, that business for Spring will be nearer normal than for a year.

All downtown stores, including the Klein-Heffelman Co., George Wille and the Alford & Fryar Co., declare record sales the past month better than the average. The engagement of "Irene," the popular musical show, here helped music dealers and stimulated record sales, according to W. H. Woomer.

Preparations are being made by the Klein-Heffelman Co. to vacate its present quarters for the new and spacious \$450,000 building, just across the street. It is hoped that this will be ready for occupancy early next month. Special attention is to be given the musical department, according to E. J. Heffelman, president of the company.

Music dealers at Alliance report much improvement in sales of talking machines and musical goods generally. Many of the factories, which have been idle for several weeks, are resuming and dealers anticipate a business revival in the Spring. It is understood that the Alford & Fryar Co. will establish a branch in that city in the Spring.

The Ideal Co. at Massillon, which is to move into the newly completed \$1,000,000 Snyder-Hess building, will maintain a music department in its big department store, according to Charles Wagoner, of the firm. The Ideal Co. will occupy, besides the basement, five of the eight floors.

The D. W. Lerch Music Co., of Canton, recently opened an attractive new store on Main street in Massillon.

REMODELING WORCESTER STORE

The Steeres Music Store, Worcester, Mass., which handles Sterling and Mathushek pianos, Sterling players, Columbia Grafonolas, Melodee rolls, etc., is now being remodeled, and when the operation is completed the store will be one of the most attractive in the city.

What More Can You Ask

All the features that go to make a talking machine *Profitably Salable* you will find as regular equipment of *Magnola*: "Built by Tone Specialists."

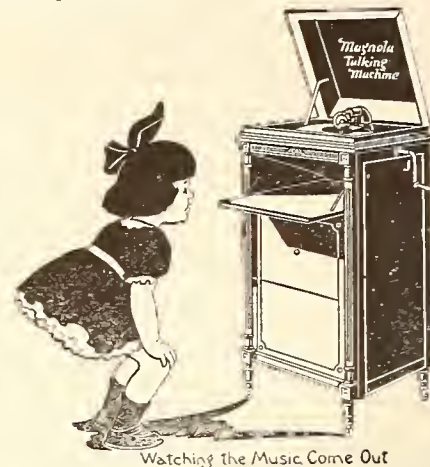

Watching the Music Come Out

Complete description of all these features is to be found in our *handsome illustrated catalog*, which we should like to send you. May we? Ask us to tell you our plans for your benefit!

MAGNOLA TALKING MACHINE COMPANY

OTTO SCHULZ, President

General Offices 711 MILWAUKEE AVENUE CHICAGO
Southern Wholesale Branch 1530 CANDLER BLDG. ATLANTA, GA.

MELODEE ROLL WINDOW DISPLAYS

First of Attractive Series of Window Cards to Be Shown in February

The new monthly window display service to stimulate interest in, and sales of, Melodee music rolls is now in operation, and the Melodee Music Co. has already distributed the first of the displays which will be seen in dealers' windows in February. Two cards are included in the first showing, one featuring "Mother's Songs," played by Florence Beebe and Cliff Hess, and the other four popular numbers, including "Bright Eyes," "Down by the Ohio," "My Mammy" and "Rosie." The signs are most attractive in design, and are of the sort calculated to attract attention.

IMPROVED PACKING FOR BENCHES

Boston, Mass., February 5.—The Lansing Sales Co., of this city, has inaugurated a progressive innovation in the shipping of piano benches which, in the future, are to be shipped in veneer packing cases similar to those used for Victrolas. This will be a marked improvement over the former crates. A. J. Cullen, president of the company, expects to leave in the very near future for a trip covering New York, Philadelphia and the Middle West.

THE PHONOSTOP

In its fifth year. Best and most popular. Set in one second. Better than any Non-Set stop yet invented. Perfect *Service* and *Satisfaction*. Made in Gold and Nickel Plate. *Universal*.

Give us your trade—we will hold it by **MERIT**

THE PHONOMOTOR CO. - 121 WEST AVENUE ROCHESTER, N. Y.

WESTERN REPRESENTATIVES: CHICAGO

Harry Engel, McClurg Building, and Jewel Phonoparts Co., 630 W. Washington Street

Order early—
we will ship
promptly

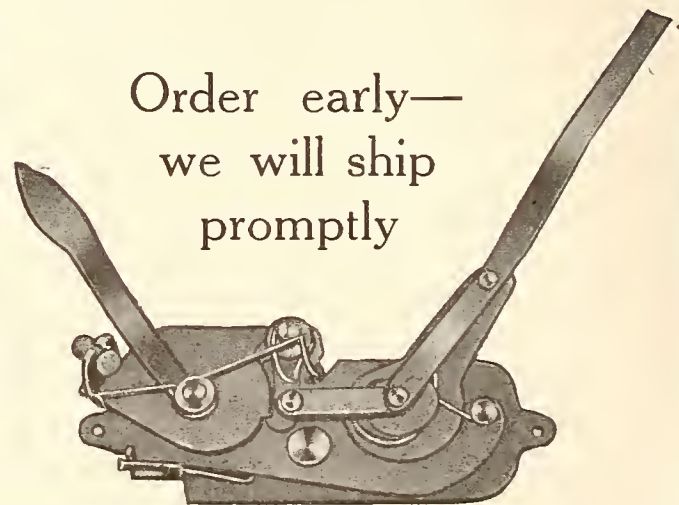



INVESTMENT vs. SPECULATION

Do you know the difference between Investment and Speculation? Have you had any experience in the stock market in the last few years? If so, you ought to know the difference. If not, ask a few friends who have had experience.

You will find Investment much safer and more profitable in the end than Speculation.

Victor Talking Machine Co.'s products represent the highest class type of Investment for Victor dealers who require safety of principal combined with dependable income.

Ask your banker or your broker what tests are applied to determine whether a security is an Investment or a Speculation. Apply these tests to the Victor Talking Machine Co. and its products.

You may only need to review your own experience or that of dealers who have speculated with other lines.

If you must be assured of the best supply and service as a Victor Dealer then you should choose as your Victor Distributor one to whom you can apply the same Investment tests.

The greatly increased supply of Victor Victrolas and records will enable dealers to be more discriminating.

As Victor Distributors we strive to reflect Victor Supremacy.

Avoid Speculation, Mr. Victor Dealer, if you value the good-will of your trade.

The Victor line, in combination with Blackman as your source of supply, will prove to be a most profitable Investment for Victor Dealers.

J. NEWCOMB BLACKMAN.



Blackman
TALKING MACHINE CO.
81 READE ST. NEAR CHURCH ST. NEW YORK
VICTOR DISTRIBUTORS EXCLUSIVELY WHOLESALE



SOUTHERN VOCALION DISTRIBUTORS

Company of That Name Organized in Birmingham, Ala., With W. H. Shire as President, to Distribute Vocalion Machines and Records, as Well as the Melodee Music Rolls

The Aeolian Co. announced last week that it had appointed the Southern Vocalion Distributors, Inc., as distributors of Vocalion machines in the Southern territory. The new company will be headed by William H. Shire as president



Wm. H. Shire

and general manager. Mr. Shire is well known in the phonograph industry, as he had charge of the Emerson phonograph distribution in this territory for over three years, as well as covering the territory west of the Mississippi. The company has opened offices at 226 North Twentieth street, Birmingham, Ala., but has plans to open headquarters at Atlanta just as soon as a suitable location can be obtained.

Mr. Shire's life work has been the distribution of merchandise, and with the full knowl-

edge that he has of the needs of the dealers he is making plans for service to Vocalion agents that is going to solve many problems that face phonograph dealers. A very important one is giving them a quick turnover on their stock. He is leaving Birmingham in the near future for a trip through the Southern territory so he may come in personal contact with the problems of each dealer.

Southern Vocalion distributors will also distribute Melodee rolls and a large stock order has already been placed and stock is en route to the Birmingham office.

MODERNOLA CO. IN NEW PLANT

New Factory Building in Johnstown, Pa., Occupied Without Halt in Production

JOHNSTOWN, PA., February 5.—The Modernola Co., of this city, has now taken possession of its new factory, the transfer to the new plant being accomplished with practically no hindrance to production. The new Modernola factory has three times the capacity of the former plant and is built according to the best approved plans and is equipped with the most modern machinery. George Seiffert, president of the Eastern Phonograph Co., Modernola distributor for the East, was in Johnstown during the early part of the month and was enthusiastic over the facilities of the new factory.

RECEIVER FOR ACKOLET MFG. CO.

VINCENNES, IND., January 31.—On the petition of Lucius R. Henley the Knox circuit court has appointed John A. Schild receiver for the Ackolet Manufacturing Co., 1810 North Second avenue. The company manufactures specialties, principal among which is an automatic stop.

The petitioner is a stockholder and says that the company's liabilities are about \$20,000 in excess of its assets. He says he is the endorser on notes of the company to the extent of \$10,000.

SUPREME No. 5 SOUND BOX

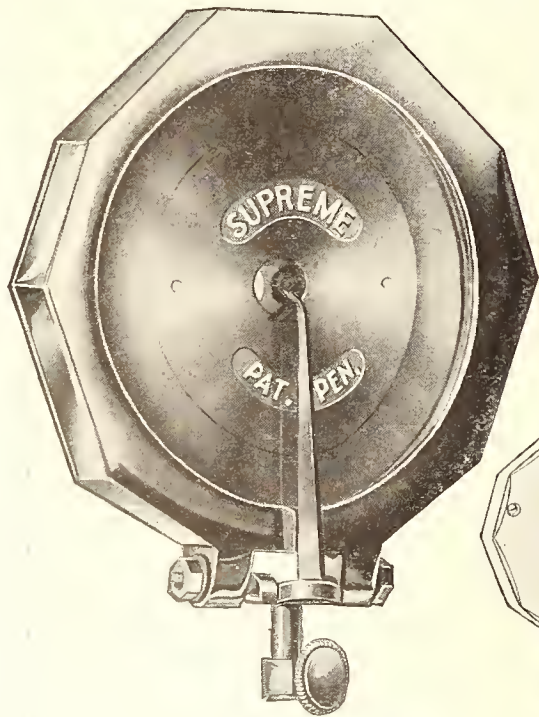

An extra word in regard to this box. It represents the latest development in the art. Tone is both loud and mellow. Although new, it is taking well and making friends fast.

Although the quality of its tone is the strongest talking point it possesses, yet its shape and design is different. Octagonal in design, cone shaped back, heavily plated, it is a thing of beauty.

In the cone shaped back is the resonator, upon which the calculations have been made to a scientific nicety. The secret of the tone of this box

lies here, and is designed to give that deep, rich tone that so many strive for.

*Send for a sample and listen to it once. It hits you right away.
Sample, Nickel \$5.00, Gold \$7.00*

Tone arms for every talking machine at revised prices

The William Phillips Phono Parts Corp.
145 WEST 45th ST. NEW YORK

BRUNO

Having proven to be one of the greatest educational factors the world has ever known, the Victor Talking Machine is destined to be a necessary requisite in every school and home. Consider, Mr. Victor Dealer, what this means to you.

BRUNO

PLAN STRONG DRIVE ON NEEDLES

Brilliantone Steel Needle Co. to Carry on Intensive Campaign During Current Year

An intensive sales campaign is being conducted under the direction of Byron R. Forster, president of the Brilliantone Steel Needle Co., New York, and H. W. Acton, secretary of the company. Despite the fact that both Brilliantone steel needles and Reflexo needles, of the Reflexo Products Co., Inc., have already attained a tremendous sales volume, it is planned to make a special drive during 1921 that will eclipse all former campaigns.

The Brilliantone Steel Needle Co. is the sales agent for the old established firm of W. H. Bagshaw Co., of Lowell, Mass. The product of this company has been well known to the trade for many years through its uniform high quality. In describing their plans for the coming year, B. R. Forster, president of the Brilliantone Steel Needle Co., stated in part: "The Bagshaw Co. for more than fifty years has centered its activities upon the production of needles and is the greatest single producer of steel needles in the world. C. H. Bagshaw and his associates have decided to center their activities entirely upon the manufacturing of talking machine needles. The Brilliantone Steel Needle Co. is sales agent and our prices are exactly the same as the factory prices. No commission or brokerage is added.

"The Brilliantone Steel Needle Co. has achieved exceptional success and with the announced increase of manufacturing facilities at the Bagshaw factory at Lowell, combined with the intensive campaign to be carried on, it is expected that even greater heights will be attained in the year that is to come."

WILL ENTER RED SEAL SCHOOL

PORTLAND, ME., February 7.—Miss Gertrude Longley, of F. E. Tainter & Co., Lewiston, Me., well-known Victor dealers, will be a member of the Red Seal school at the factory of the Victor Talking Machine Co., Camden, N. J., starting the course on February 14. Miss Longley is well known in the New England Victor trade and is most enthusiastic regarding the value of the Red Seal course.

NEW YORK RETAILER IN TROUBLE

A petition in bankruptcy has been filed against Sam Zitterer, trading as Lenox Phonograph Shop, at 113 West 116th street, by Samuel Spiro, a creditor. Judge Hand has appointed John L. Lyttle receiver in \$1,000 bond. Liabilities are said to be about \$10,000.

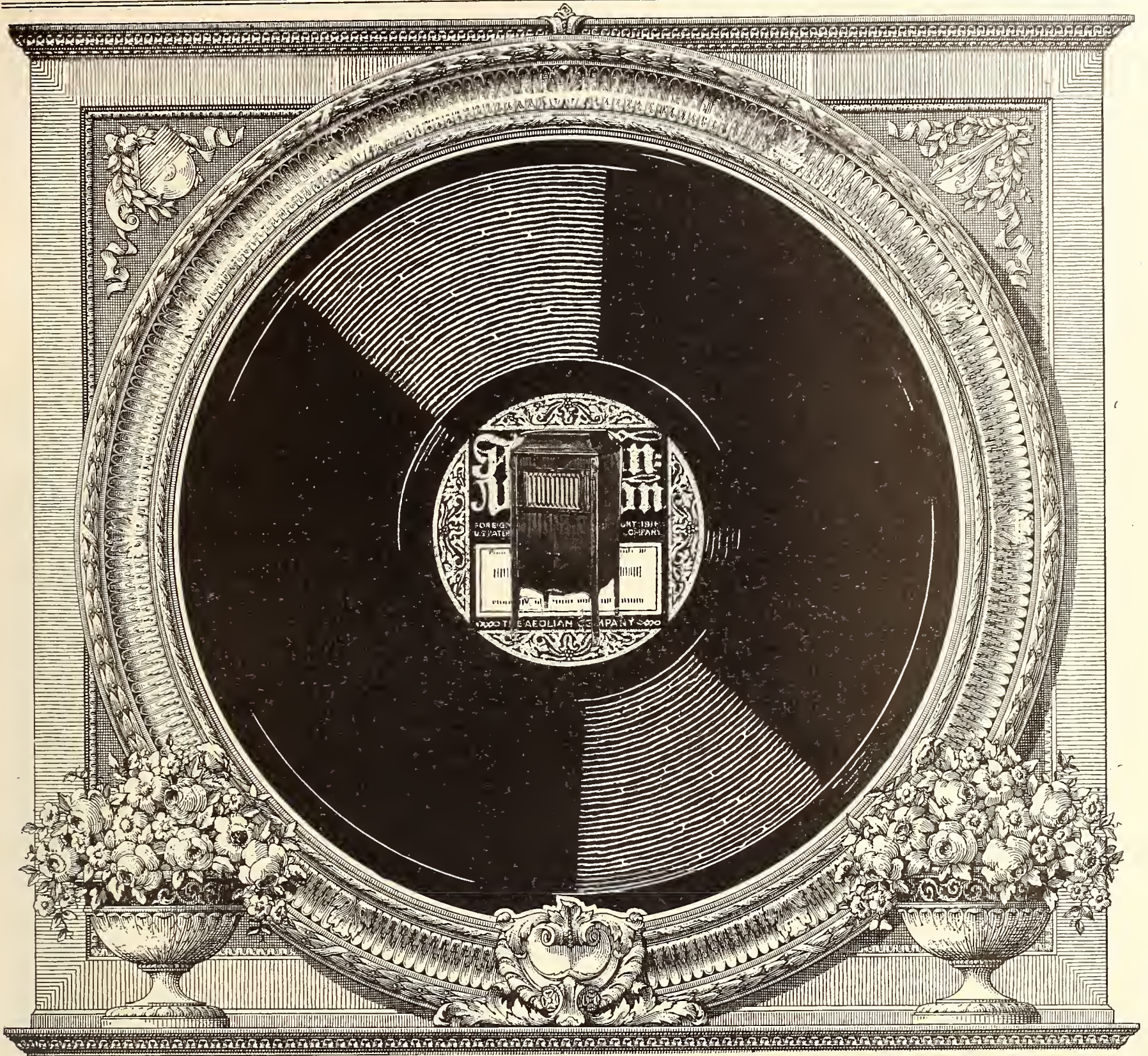

The Phonograph Situation Today

THE phonograph business is today approaching the normal—is steady into a sound and permanent industry.

Like the bicycle of many years ago and the automobile of later days, it has passed through its period of hectic and unnatural stimulation.

The maelstrom concerns, brought into existence by the inability of established manufacturers to supply an abnormal demand, are passing. The present year will see their end. Phonograph dealers have already seen the handwriting on the wall.

They are also beginning to feel the "sales resistance" of a more careful public—the public that is being gradually educated—not alone from the performance of unknown phono-

graphs, but also from their comparative value after a year or so of use.

Now is the time for shrewd phonograph dealers to found their business upon the rock of genuine merit. Tie up to a line which is already established, one which is selling because of inherent qualities, which enables it to overcome all competition—one whose musical and artistic qualifications are above all criticism.

The Aeolian Company is the largest manufacturer of musical instruments in the world. The Vocalion is more than a phonograph—it is a supreme musical instrument, and the Vocalion (red) records have achieved the highest place of honor with the music-loving public.

THE AEOLIAN COMPANY
Aeolian Hall **New York**

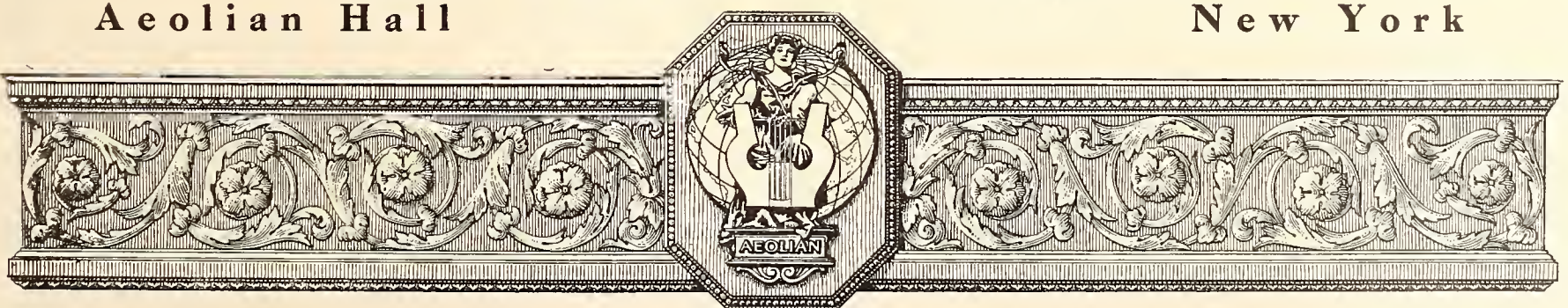

ACTIVE "TRADE DOINGS" IN THE PITTSBURGH TERRITORY

Urge Enactment of New Law—Talking Machine Men Meet—New Brunswick Representatives—Edison Dealers to Assemble—Business Steadily Bettering—Drake Tells How Business Can Be Had

PITTSBURGH, PA., February 7.—Talking machine dealers of Pittsburgh and vicinity are keenly interested in the proposed law for the protection of the trade that will be presented to the Pennsylvania Legislature for enactment at the present session. The attention of the talking machine and music dealers' fraternity here was called to the proposed law by Charles L. Hamilton, of the S. Hamilton Co., Victor and Columbia Grafonola dealer, who is an active member of the Talking Machine Dealers' Association of Pittsburgh and a former president of the organization.

Ask Dealers to Interest Themselves

Mr. Hamilton had letters sent to all of the trade and others interested in talking machines, in which he urged that the members of the Legislature from Pittsburgh and vicinity be petitioned to see that the bill is enacted into a law. In part his letter reads as follows:

"How many pianos have you lost because your customers failed to pay rent for their houses and the landlords seized and sold your pianos to satisfy rent claims? The answer to that question should be 'None,' for there is a law in Pennsylvania which gives you adequate protection if you do as directed.

"How many talking machines have you lost for the same reason? The answers to that will vary because there is now no law protecting our talking machines against seizure and sale by landlords to satisfy rent claims.

"George W. Pound, the energetic and capable general counsel for the Music Industries Chamber of Commerce, has been instrumental in having introduced in the State Legislature 'An Amendment to the Laws of Pennsylvania,' which, if passed, will make it possible for each and every one of us to put our talking machines out on monthly payments without having the constantly pressing fear and possibility of the landlords seizing and selling them to satisfy their rental claims. This amendment is thus worded:

"An act to exempt talking machines, phonographs and musical instruments of every description, leased or conditionally sold to, or hired by, any person or persons residing in or having a place of business in this Commonwealth, from levy or sale on execution or distress for rent."

In closing the letter Mr. Hamilton makes the

following timely and pertinent admonition:

"We merchants in talking machines, phonographs and musical instruments of every description are alive to the importance of such protection as this act will afford, but the State legislators are not. It is up to us to impress upon them the importance of making this suggestion a law of the State.

"Do not forget that the landlords of the State and some of the real estate agents are going to be busy against this amendment, as some of them rest easy when they know they have a talking machine belonging to you or to me in the house of one of their tenants, for, if the tenant does not pay up, the talking machine will pay all or a large part of the back rent."

It is expected that when the bill is reported in committee a delegation of talking machine dealers and other musical merchandise dealers will visit the State Capitol at Harrisburg in favor of the proposed amendment.

Talking Machine Dealers' Association Meets

The January meeting of the Talking Machine Dealers' Association of Pittsburgh was held at the Hotel Chatham, Tuesday evening, January 25. The usual dinner preceded the business meeting. The latter part of the time devoted to the assembly was marked by a full and free interchange of opinion as to the outlook of the talking machine trade in this section. There was a marked feeling of optimism reflected in the various statements made by representative talking machine dealers from different parts of the city and county. Among the speakers were: F. C. Wampler, of McKeesport; Clark Wright, of East Pittsburgh; French Nestor, of the Standard Talking Machine Co.; George H. Rewbridge, manager of the wholesale Victrola department of the W. F. Frederick Piano Co.; A. R. Meyer, of the Joseph Horne Co. talking machine department, and the well-known president, John H. Phillips, of the Northside Victor dealer. The sentiment of those who spoke was very strongly in favor of maintaining an optimistic view of the future of the trade. As far as business in the Pittsburgh district is concerned, it was emphasized that energy and ambition plus common sense and good salesmanship would bring the desired results to the talking machine dealers.

In the matter of the Association affiliating with other Allied Music Trade organizations,

a committee of three was named, consisting of Messrs. Nestor, chairman; Wright and Leo Half, of Homestead, to investigate the matter and make a report to the association at a future meeting.

President Phillips named the following as an executive committee or board of directors: C. L. Hamilton, Messrs. Rewbridge, Wright and Half, J. C. Roush, William Wampler, Thomas T. Evans, N. Spear and John Henk. The officers are also members of the directorate.

Edison Dealers to Meet in Pittsburgh

The Buehn Phonograph Co., Edison distributor, has made an advance announcement of the convention of Edison dealers in the Pittsburgh zone, on February 23 and 24, at the Fort Pitt Hotel. Among the speakers will be William Maxwell, vice-president of Thomas A. Edison, Inc. There will also be a number of helpful papers read by various Edison dealers, followed by discussions. The two days of profitable conferring will be wound up by an elaborate dinner and dance. All of the dealers have been urged to bring their wives and employes with them. A. A. Buehn, treasurer of the company, stated to The World representative that the convention will be one of the largest and most important ever held under the auspices of the Buehn organization.

Miss Lillian A. Wood a Busy Woman

Miss Lillian A. Wood, manager of the Victor educational department of the C. C. Mellor Co., will spend two weeks during this month at the Victor School of Salesmanship, at Camden, N. J. Miss Wood has been a very busy person the past few weeks promoting the educational work by appearing before various teachers' institutes in western Pennsylvania demonstrating the practicability of a Victrola in the school-room. In addition to this Miss Wood gave a series of "selling" talks to groups of saleswomen in talking machine shops. On her way to Camden Miss Wood will stop at Harrisburg to attend the State School Directors' Convention. In her very admirable work Miss Wood has the capable and efficient assistance of Miss H. H. Taudte, of the Mellor Victor staff.

F. J. Drake Says "Business Can Be Had"

Fred J. Drake, manager of the C. C. Mellor Co.'s retail Victor department, is positive that there will be ample business in his department due to his system of promoting sales with the aid of his staff of salespersons. Mr. Drake is inclined to view the talking machine situation with satisfaction and believes that the business can be secured by "going after it."

Elated Over Sonora Outlook

H. Milton Miller, manager of the Sonora Co., distributor of the Sonora phonograph in this territory, is elated over the outlook for business and feels that sales this Spring will show a marked increase over the same period a year back. He has two men on the road whose reports, he asserts, are highly gratifying from a sales standpoint.

Represents the Modernola Co.

J. A. Endres, formerly with the Brunswick sales organization, is now the Pittsburgh representative of the Modernola Co., of Johnstown, Pa. He has offices and show rooms in the Fort Pitt Hotel.

Returns From Extended Trip

H. J. Brennan, manager of the Pittsburgh Talking Machine Co., Pathé distributor, returned from a trip to the Pathé dealers in western Pennsylvania, eastern Ohio and West Virginia. Mr. Brennan stated that the outlook for increased Pathé business was very encouraging in the Pittsburgh territory.

New Brunswick Representatives

J. A. Scanlan, sales manager of the phonograph division of the Brunswick-Balke-Collender Co., stated to The World representative that the advance sales for Spring delivery of Brunswick phonographs and Brunswick records were most pleasing. He believes that Brunswick dealers have taken his suggestions and are "pushing" the line with gratifying results. Among the new Brunswick dealers in Mr. Scanlan's territory are: W. S. Morrison, Somerset.

(Continued on page 90)

READJUSTED PRICES

SPRINGS

No. 200—5/8-inch x 8 ft.	\$.27
No. 201—3/4-inch x 7 ft.29
No. 202—7/8-inch x 10 ft., Meisselbach..	.35
No. 203—3/4-inch x 9 ft.35
No. 204—1-inch x 10 ft., Col. all styles	.50
No. 205—1-inch x 9 ft., Meiss No. 2..	.45
No. 206—1-inch x 12 ft., Pathé, Heineman, Meisselbach55
No. 207—1-inch x 13 ft., Small Victor	.55
No. 208—1 1/4-inch, New Victor85
No. 209—1-3/16-in. x 16 ft., Heineman & Pathé90
No. 210—1 1/2-inch x 11 ft., Edison Diamond Disc	1.50

OTHER SIZES UPON REQUEST

SAPPHIRES

GENUINE EDISON TYPE SAPPHIRE POINT NEEDLES				
In lots of.....	12	25	100	500
	11c	10 1/2c	9 1/2c	8 1/2c
GENUINE PATHE TYPE SAPPHIRE POINT NEEDLES				
In lots of.....	12	25	100	500
	10c	9 1/2c	9c	8 1/2c
GENUINE EDISON TYPE DIAMOND POINT NEEDLES				
In lots of.....	12	25	100	500
	1.50	1.40	1.25	1.15

We also handle a complete line of

MOTORS, TONE ARMS, REPRODUCERS, Etc.

SPECIAL QUANTITY PRICES. WRITE TODAY

THE ARGUS PHONOGRAPH SUPPLY CO.

30 EAST 23d ST., Tel. 1749 Gramercy NEW YORK CITY



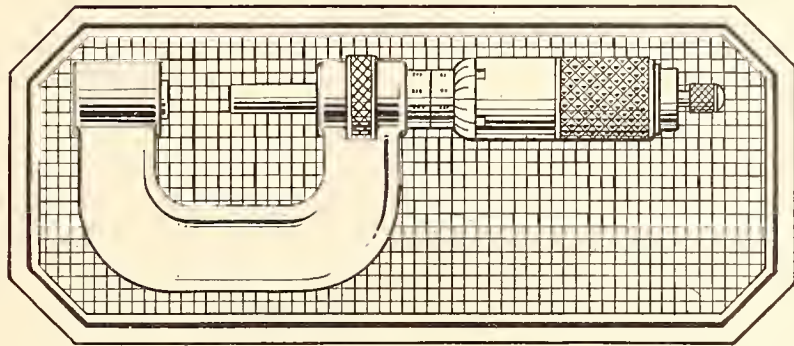

Precision

*T*his word, Precision, was not connected carelessly with the Stephenson Phonograph Motor, nor was it chosen as are many trade names, simply as a distinguishing mark. But, rather, it grew with the product, naturally, slowly, even as character develops in a man.

And Precision . . . Exactness . . . Accuracy . . . these mean much in any mechanical appliance -- less wear, quiet running, longer life. And these in turn mean greater service and greater satisfaction.

The Stephenson Precision-Made Motor through service rendered and satisfaction given has earned this word, Precision, even as character must be earned. And always will it be guarded carefully—always will the Stephenson Motor be a Precision-Made Motor.

STEPHENSON
DIVISION
 DE CAMP & SLOAN INC.
 One Hundred and Seventy Pennington Street
 Newark, New Jersey



DOINGS IN THE PITTSBURGH TRADE

(Continued from page 88)

Pa.; S. A. Phillips Music Co., Morgantown, West Va.; Seneca Mercantile Co., Chambersville, Pa.; L. B. Vaughan, Columbiana, O.; M. P. Wagner, Brownsville, Pa.; M. P. Ritchie, Verona, Pa.; J. C. Wishart & Son, Washington, O.; Martin & Schiller, 822 Wood street, Wilkesburg, Pa., and L. C. Millheim, Butler, Pa.

W. C. Hamilton Honored

At the request of Alfred L. Smith, general manager of the Music Industries Chamber of Commerce, W. C. Hamilton, president of the S. Hamilton Co., and also president of the Piano Merchants' Association of Pittsburgh, named a legislative committee, Mr. Smith having requested Mr. Hamilton to be the chairman. His associates are as follows: W. C. Dierks, of the C. C. Mellor Co.; E. B. Heyser, of the W. F. Frederick Co., both Victor distributors; E. G. Hays, of E. G. Hays & Co., Brunswick and Modernola dealers, and Theodore Hoffmann, of the J. M. Hoffmann Co., Brunswick dealer.

January Business Flattering

"Our January business was most flattering and we are positive that February will make as good, if not a better showing in the sale of Columbia Grafonolas and Columbia records," said S. H. Nichols, the well-known manager of the Pittsburgh office of the Columbia Graphophone Co. Mr. Nichols is very optimistic relative to Columbia business this Spring and is of the opinion that with the coming of April there will have been reached a readjustment in business circles that will permit of unlimited business opportunities.

A recent visitor to the Pittsburgh offices was George W. Hopkins, the well-known live wire general sales manager of the Columbia organization, with headquarters in New York. He presided at a salesman's conference while here.

Paramount Grows in Popularity

H. W. Cross, manager of the talking machine department of the Shipley-Massingham Co., Paramount phonograph distributor, stated that the sales of Paramount phonographs and Paramount records for January were much greater than had been anticipated. A four-day service for records has been inaugurated between the factory in Port Washington, Wis., and Pittsburgh. Mr. Cross is confident that the Paramount line will be a winner in 1921 in his territory.

J. C. Roush in Florida

J. C. Roush, the well-known president of the Standard Talking Machine Co., Victor distributor, with his family, is spending the Winter season at Palm Beach, Fla.

Reports an Increasing Demand

J. A. Pentz, manager of the Pittsburgh office of the Philadelphia Show Case Co., Aeolian-Vocalion distributor, reported a very brisk season in January and stated that orders were coming in with marked regularity from the three roadmen that the Pittsburgh office has in

THE FINEST OF
CORE STOCKS

For Phonographs and Record Cabinets

Are supplied by the

GERMAIN BROS. CO.

Makers of the Famous
"Germain Piano Backs"

SAGINAW

MICHIGAN

the field. "The outlook for the sale of the Vocalion and the Aeolian-Vocalion records in this section is very bright," said Mr. Pentz. The Vocalion-Mel-O-Dee Shop, where the retail end of the trade is handled, is also doing a very satisfactory business according to Manager Doel. Sales of Aeolian-Vocalion records and the Bubble Books have been a feature.

MONTHLY KNICKERBOCKER RECITAL

Abram Davega Discusses Value of Various Accessories—March Victor Records Played

The Knickerbocker Talking Machine Co., Victor wholesaler, held a monthly recital of advance records on Wednesday morning, February 2, in the auditorium of Knickerbocker headquarters, New York City. In spite of the inclement weather a representative number of Knickerbocker Victor dealers were present. The entire advance list of March Victor records was played. The stage was attractively set with the new period model Victrola which also served to demonstrate the new records. In the forefront of the stage were two of the new copper electric signs produced by the advertising department of the Victor Co. and which were later verbally called to the attention of the visiting dealers. These signs are equipped with changeable slides and a permanent display of the Victor trade-mark. At the present time four changes of slides are available.

During the course of the recital Abram Davega, vice-president of the company, followed his usual custom of giving helpful ideas to the assembled dealers. Besides calling attention to the new copper Victor signs, Mr. Davega spoke enthusiastically on the Victor record stock book. Mr. Davega urged the use of this book by the dealer and outlined its many advantages. In concluding his address, Mr. Davega reviewed present business conditions and prophesied that the retailer who used every facility offered him and energetically stimulated his sales would find 1921 a very profitable year. J. J. Davin, of the Reincke-Ellis Co., was present and had set up two advance displays that the Binger Co. will shortly produce, in the model windows adjoining the Knickerbocker auditorium. One display realistically depicted the interior of the Metropolitan Opera House and the other was a patriotic display covering Lincoln's and Washington's birthdays.

Following the recital, all repaired to the Hotel Theresa, where the Knickerbocker Talking Machine Co. again played host to the dealers in the serving of a sumptuous luncheon. The Reincke-Ellis Co. distributed, through the Knickerbocker Talking Machine Co., an attractive novelty to all present, consisting of a pocket mirror, the reverse side of which simulated a Victor record. The appropriate title of this record was, "Her Bright Smile Haunts Me Still."

MASTER WAX

BUSINESS BLANKS

The Wax and Novelty Company

67-69 Paris Street, Newark, N. J.

Will continue the business hitherto carried on by me at 16 West 39th Street, New York. All work will be done under my personal supervision.

I will be able also to work out special problems in connection with record making for anyone needing experienced advice or assistance.

F. W. MATTHEWS

Kerekjarto's playing of Sarasate's "Jota de Pablo" is the most phenomenal violin record ever made. It will have steady sales for years. Columbia 49903.

**Columbia Graphophone Co.
NEW YORK**



SUIT AGAINST PULLMAN COMPANY

Failure to Deliver \$300,000 Worth of Edison Period Cabinets Starts Action

On February 2 the Edison Phonograph Works brought suit against the Pullman Co. in the Federal District Court, at Chicago, Ill., to recover \$300,000 damages, for the Pullman Co.'s failure to deliver a large quantity of Chippendale and Inlaid Sheraton cabinets, which it had contracted to deliver within a specified time.

NEW REMINGTON CORP. TREASURER

Harry F. Sieber, Well-Known Banker, Elected to That Office—Everett H. Holmes, Secretary

At a recent meeting of the directors of the Remington Phonograph Corp., Harry F. Sieber, late president of the Parkway Trust Co., Philadelphia, Pa., and at present president of the United States Acceptance Corp., was elected treasurer of the corporation. Everett H. Holmes was elected to fill the office of secretary.

SITUATION IN THE NORTHWEST

C. R. Stone, of the Stone Piano Co., Minneapolis and Fargo, Tells of Manner in Which the Wheat Crisis Has Affected Trade

C. R. Stone, of the Stone Piano Co., Minneapolis, Minn., and Fargo, N. D., was a visitor to Aeolian Hall this week and brought with him an interesting report regarding the general business situation in the Northwest, and particularly in the wheat belt.

Business is practically at a standstill in that section, declared Mr. Stone, owing to the fact that the wheat growers are refusing to release their crops except at high prices. This means that the farmer's credit has been utilized to the limit, and he has no free money either to invest in new goods, or to meet payments upon goods already bought in anticipation of the income from the last harvest. The situation is beginning to adjust itself slowly, however, but unless these prices advance materially there is little hope for any rapid improvement.

Meanwhile, the music men in the Northwest are going after business with renewed vigor, finding customers among those who are not directly affected by the tying up of wheat.

MARKET NEW MODEL SOUND BOX

The Mutual Phono Parts Mfg. Corp., New York City, which was recently formed to take over the assets and production of the former Mutual Talking Machine Co., has recently placed on the market a new sound box known as No. 5. The men identified with this new company are Herman Segal, president, and N. Garfinkel, secretary and treasurer. Mr. Segal has had eighteen years' experience in the talking machine industry and will devote his particular attention to the production activities of the new company.

GRANBY MANAGER IN NEW YORK

E. C. Howard Brings Encouraging Report From Norfolk Headquarters

E. C. Howard, general sales manager of the Granby Phonograph Corp., was among the recent visitors to the metropolis and stayed in New York for a week looking after Granby interests. A number of new dealers have been appointed in Greater New York who are featuring the Granby phonograph with much enthusiasm. Mr. Howard reports that the distribution of the Granby phonograph throughout the entire country has progressed at a rapid pace and that a steady volume of reorders is being received at the headquarters in Norfolk.

Mr. Howard is devoting his time both night and day to the Granby proposition and has brought Mrs. Howard and his young daughter to Norfolk, Va., where they are making their residence.

JOINS CRESSEY & ALLEN STAFF

E. P. Johnston Now Connected With Prominent Victor Wholesaler—Well Known in Trade

E. P. Johnston, who has had extensive experience in the talking machine business, has recently joined the traveling staff of Cressey & Allen, Victor distributors, Portland, Me. Mr. Johnston has a host of friends in the trade who wish him success in his new post, and his thorough knowledge of the industry will enable him to co-operate efficiently with the dealers.

C. R. Cressey, of the firm of Cressey & Allen, and C. B. Snow, manager of the company's wholesale Victor department, have just returned from a visit to the Victor factory at Camden, N. J., imbued with renewed optimism and enthusiasm for the coming year. En route to Portland, Me., they spent a few days in New York, visiting their many friends in the talking machine trade.

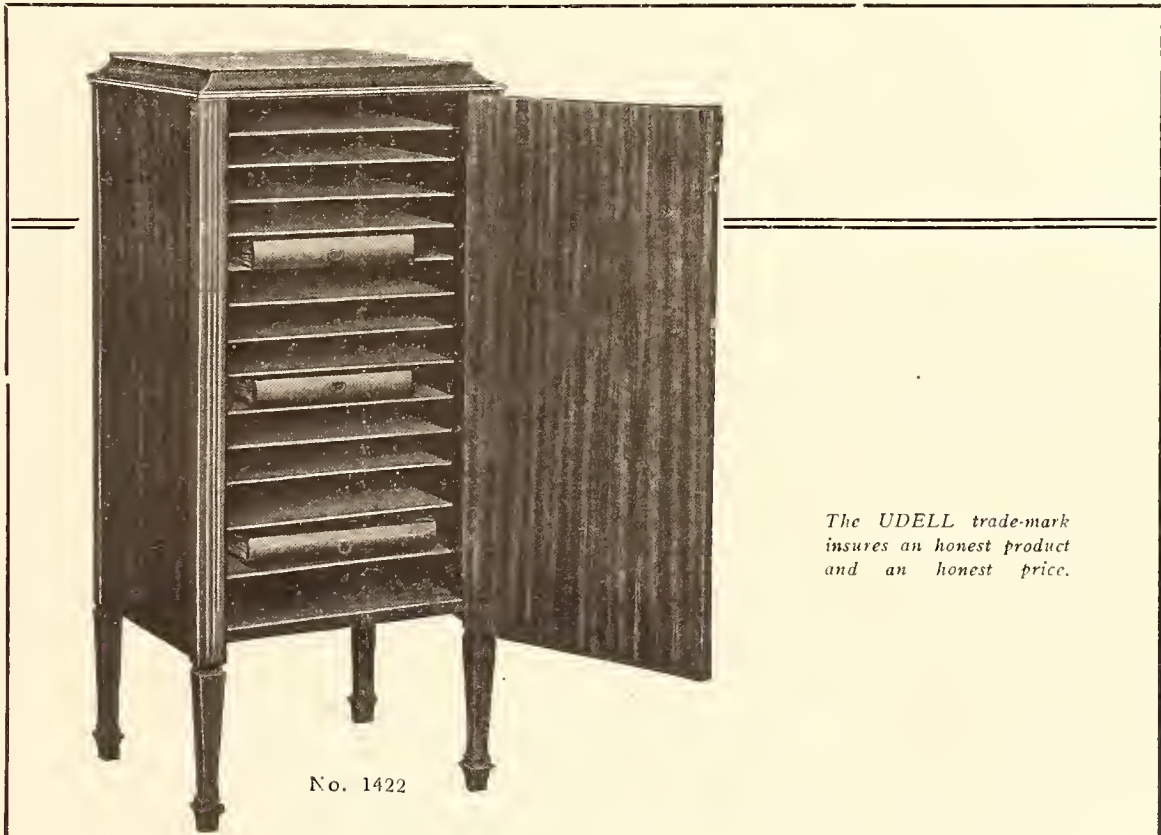

The UDELL trade-mark insures an honest product and an honest price.

Auxiliary Cabinet

YOU doubtless have many customers who have bought floor types of Talking Machines but they have an overflow of records that they do not know what to do with. We accordingly have made pattern No. 1422 to fill this demand. The design is such that it will harmonize in any surroundings. It can be used with any floor type Talking Machine to splendid advantage. Write today for our new Blue Book of Record Cabinets.

The UDELL WORKS
Indianapolis—1250 West 28th St.

REPAIRS

TALKING MACHINE TROUBLES AND
HOW TO REMEDY THEM

Conducted by Andrew H. Dodin

FACTS THAT SAVE TIME AND MONEY

The repairman should be very careful in his handling of machines in the homes of the customers. Very often the complaint will be over some trifling matter—such as a brake leather squeaking, automatic stop not working or speed adjusting screw not going down far enough. Rather than go ahead and take the motor apart to find the trouble, always make it a point to first ask the customer what the complaint is, and then be guided accordingly. You will find, in the course of a month, that this one little question will save you hours of work. Another point—don't be too quick to tell the customer what the actual trouble is—that this part is broken or that this part is worn out, or you will give the impression that the machine is not a good one, and consequently will soon wear out. This idea often leads the customer to demand an exchange of motors, and once you do that, whenever anything happens to the machine they look to you to make another exchange rather than repair the old motor.

The dealer will find it a good plan, and a great saver of time for his repairman, if, at the time he makes a machine sale, he calls the attention of the purchaser to the following:

1. That a machine must be oiled at stated times.
2. If used to any great extent, make a point of going over the governor spring screws and tightening them up about once every six months; also the motor board screws and nuts.
3. Take out the winding key, oil the threads on the winding shaft and also oil the winding key where it rubs against the escutcheon plate.
4. Put vaseline on the spiral cuts of the turntable spindle and governor spindle.
5. See that brake leather is properly held in place, and that turntable does not hit or rub against any part of the motor board attachments.

These little hints, if given, and followed by the machine owner, will save him trouble and expense and will certainly conserve for other purposes the time of the repairman.

SOSS INVISIBLE HINGES

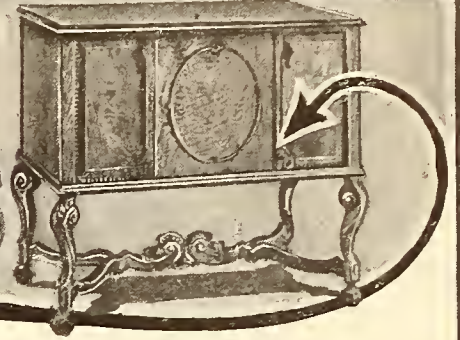

Soss Invisible Hinges

preserve beauty. The fine cabinet work which is required in many instances to preserve the disguise of talking machine cabinets requires that hinges be as inconspicuous as possible. Soss Hinges are invisible.

Write for Catalogue T.

SOSS MANUFACTURING COMPANY
Grand Avenue and Bergen Street, Brooklyn, N. Y.

EIGHT VICTOR ARTISTS ON TOUR

Covering Leading Cities in the West and South
During February and March

The Eight Famous Victor Artists are continuing their tour of the United States, meeting with success at every turn. Despite the so-called slump in attendance at theatres generally, the "Eight Famous" seem to be enjoying even better success at this time.

Their tour in February will be through Arkansas, Louisiana and Texas, covering the following points on these particular dates: February 16, Texarkana, Ark.; 17, Shreveport, La.; 18, Beaumont, Tex.; 19, Port Arthur, Tex.; 21, Houston, Tex.; 22, Austin, Tex.; 23, Waco, Tex.; 24, Brownwood, Tex.; 25, San Angelo, Tex.; 26, Abilene, Tex.; 28, Fort Worth, Tex. March 1, Wichita Falls, Tex.; 2, Dallas, Tex.; 3, McAlester, Okla.; 4, Muskogee, Okla. These data will aid in dealers' co-operation.

SONORA MOTION PICTURE SLIDES

The advertising department of the Sonora Phonograph Co. has prepared two attractive motion picture slides which are now being fur-

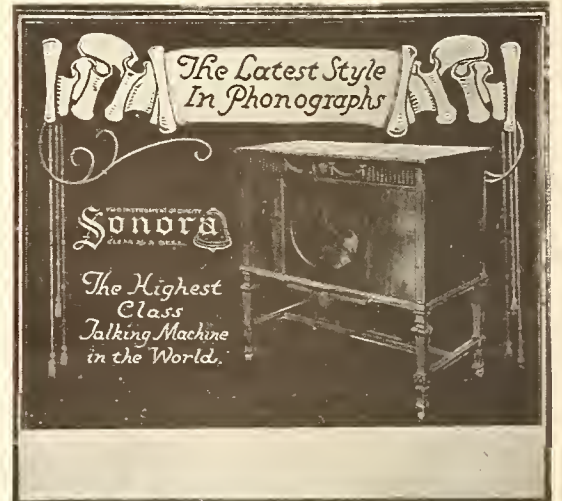

One of the Sonora Slides for Dealers

nished to Sonora dealers. This method of publicity is being used generally by Sonora representatives throughout the country, and the advertising department at the executive offices



Another One of the Series

has received many letters of commendation regarding the distinctiveness and artistic design of these slides. Dealers should avail themselves of this means of bringing their house to the attention of the people of their town.

Next month ends the Winter. Then will come Spring and with Spring comes a busy season. Are you ready for it?

"Thrift," "Prosperity" and Einson Lithography

IT is more than a coincidence that "Einson" Service and "Einson" Lithography should be playing an important part in the two great public-spirited campaigns now under way—the National Thrift Drive and the National Prosperity Campaign.

For "Thrift" the Einson Organization was called upon to lithograph the posters used in the campaign. Execution was the test, and Einson performance won.

For "Prosperity" the Einson Organization was commissioned to create, design and lithograph all the units in the campaign—from outdoor posters, window displays to poster stamps. Vision, ideas, originality and execution were the tests, and again the Einson Organization proved itself in actual performance.

The same initiative, fertility of ideas, clearness of vision and quality of lithograph production are at the service of national advertisers who want to help their dealers sell more merchandise.

EINSON LITHO INCORPORATED

Executive Offices and Art Studios
71 West 23rd Street, New York, N. Y.

Factory and Plant
327 East 29th Street, New York, N. Y.

We Will Do for You What We Have Done for Others

"I consider your Service and your policy the finest thing I have ever run into in all the years I have been in business. I consider the Service you give worth many, many times its cost, and would not give it up for anything. We find that our phonograph and piano business has grown to nearly three times what it was last year, since using your Service.

"We desire to say right now that the sympathetic penetration of your Service into our individual needs has brought a sustaining element of originality and power of inestimable value to our organization, especially at this time of expansion. We received a great many favorable comments on our advertising. It sure brings the best customers into our store.

"Hats off to the Talking Machine World Service that makes the cash register work overtime!"

ABSOLUTE control of every situation comes from knowledge of the **FACTS**—not from guesswork or theory.

WHEN YOU SIGN UP for the **TALKING MACHINE WORLD SERVICE** exclusively in your city, you secure the best that money can buy in the way of **SERVICE** from highly trained retail music experts.

THE COST? NOTHING—when you notice the results obtained for the money invested.

WE WILL GLADLY forward complete information regarding the **TALKING MACHINE WORLD SERVICE** upon receipt of the attached coupon.

Talking Machine World Service,
373 Fourth Avenue, New York City.

If other dealers in big cities as well as small towns are getting results and making a big profit on the Talking Machine World Service, I'd like to know all about it. Without obligation, send me sample copies of ads, form letters, ideas, etc. Tell me what it will cost per month for exclusive use in my territory.

The population of my city is.....
I handle these machines.....
My firm name is.....
By
My address

K. 2-15-21.

Mail the above coupon today.

TALKING MACHINE WORLD SERVICE
373 FOURTH AVENUE
NEW YORK CITY

NOVEL FIRE OR BURGLAR ALARM

New York Fireman Perfects Device Utilizing Talking Machine and Telephone

Some time ago The World told of an invention patented by William J. Lush, a New York City fireman, which provided for a means of giving an automatic alarm over the telephone. The idea embodied seemed a practicable one and the device promised early completion. Mr. Lush has now placed his finished contrivance on exhibition in Grand Central Palace.

The alarm system may be applied to both burglary and fire. A telephone instrument is placed before a small talking machine, which is connected with wiring throughout a building. For fire alarm small devices very highly sensitive to heat are distributed. Upon any increase of temperature, such as might be caused by a fire, a current is transmitted to the alarm box. This releases the weight. The falling weight lifts the receiver of the telephone. Simultaneously the talking machine is set going, and repeats again and again into the telephone mouthpiece:

"A fire has broken out (in such and such a place)."

The Central operator relays the call on to the fire station.

For burglary, any disturbance to wiring such as might be caused by a robber, or a cashier's pressing a button with his foot, starts the machinery. Instead of the fire alarm record a burglar alarm record has been placed on the instrument. The telephone operator is told:

"A robbery is occurring (at such and such a place)."

An ordinary telephone instrument suffices for the device. It may be used for conventional purposes and placed in the alarm box when desired.

The opening of the new Columbia branch in Baltimore has been set for April 1, according to a recent announcement.

HANDSOME VEST-POCKET CATALOG

Sonora Period Models Illustrated in New Catalog—Hand-colored Illustrations are Unique and Attractive—Convenient Little Volume

A leather-bound, vest-pocket size catalog of Sonora period models has just been issued by the advertising division of the Sonora Phonograph Co. This catalog, which is unique in many respects, will be a welcome addition to the



Vest-pocket Edition of the Sonora Catalog

library of high-class publicity matter introduced by this progressive advertising department.

A full page is devoted to illustrating each model in the Sonora period line and every illustration is hand-colored. This miniature catalog reflects dignity and quality in every detail, and Sonora dealers and jobbers who have visited advertising headquarters in New York are most enthusiastic in praising this new book.

On the reverse side of the illustration there is given a brief description of the model that is illustrated, as, for example, the Louis XV-DuBarry is described as follows: "Walnut and

mahogany; width, fifty-three inches; height, thirty-eight inches; depth, twenty-three inches; antique gold trimmings; carved wooden tone arm; motor meter; capacity of 100 records."

Among the instruments presented in this handsome catalog are the following Sonora period models: Jacobean, Jr.-Lancaster; Sheraton-Kenilworth; Heppelwhite, Jr.-Pembroke; Louis XVI-Royale; Louis XVI-Richelieu; English Renaissance-Edgemoor; Colonial-Mt. Vernon; Chippendale-Windermere; Queen Anne-

Queensboro; Jacobean-Robespierre; Gothic-Normandy; Gothic, Jr.-Notre Dame; Heppelwhite-Traymore; Adam-Hartford; William and Mary-Raleigh; Italian Renaissance-Milano; Heppelwhite-Canterbury; Louis XV-Lorraine; Heppelwhite, Jr.-Islington; Adam-Westminster; Italian Renaissance, Jr.-Luzerne; Duncan Phyfe-Fulton; Italian Renaissance-Verona.

RAISING THE LID WINDS MOTOR

Unknown Efficiency Fan Offers Suggestion to Do Away With Bother of Winding Spring

A musical efficiency expert has suggested something new for inventors to puzzle over. In order to do away with the usual winding of the motor after every few selections have been played, he suggests some sort of device which will rewind the motor by the simple action of raising and lowering the lid. The motion of raising the lid to insert a record will wind the motor half way and the closing of the lid will complete the job. In this way he claims that it is entirely possible to wind the motor to a tension sufficient to play one record. Why all this "efficiency"? If he really wants to save himself trouble, why not get an electric motor? He wouldn't even have to lower the lid then! That ought to appeal to him!

WILL MARKET AUTOMATIC STOP

The Sterling Devices Co., Chicago, Ill., will soon announce a new non-set automatic stop adapted to all makes of talking machines, and preparations for an intensive advertising campaign are now under way. The unique feature of the Sterling non-set automatic stop is the fact that it forms an integral part of the tone arm and is not a part of the motor, thereby giving it a universal application. The executives of the company are enthusiastic regarding this new addition to their line, and full details will be offered to the trade at an early date.

Fred Wenzel was recently elected treasurer of the Sterling Devices Co., assuming his new duties several weeks ago.

PEERLESS ALBUM CO. MOVES

The Peerless Album Co. moved early this month to its new home, 636-638 Broadway, New York. As announced in the January number of The World the new quarters are centrally located and visiting buyers will find the new address a most convenient one.

To Phonograph Engineers

Today the average citizen, not alone the technical expert, knows that the Reproducer makes or mars the phonograph. Practice, not theory, has long demonstrated that the reproducer is *the fundamental* which governs the musical value of the instrument.

Quality in the Reproducer is the *foundation* on which quality performance *must* be based.

Combined with scientific amplifier construction

The Newton Reproducer

stands unrivalled; the high light of achievement in sound reproduction and a worthy foundation for the phonograph par excellence.

Sample for inspection and test forwarded promptly

(Standard hub 11/16" opening)

Price—G. P. \$5.00—N. P. \$4.00

W. L. NEWTON & CO., INC.

SCRIBNER BUILDING
397 FIFTH AVENUE, NEW YORK CITY

BRUNO

DIG!!

COMMERCIALY, Mr. Victor Dealer, you enjoy a distinct and enviable position, one that will be maintained only just so long as you keep your "shoulder to the wheel." Keeping your shoulder to the wheel means that you have a definite objective, without which you are maneuvering poorly, and are destined to defeat. Having a set purpose, you, as a conscientious and worthy Victor Dealer, have an unobstructed and direct road to still greater success.

Put into practical use Victor "equipment," such as Ready Reference Labels, Stock Record Books, Electrical Signs, Advertising Copy, Window Displays, Operatic Figures and other Victor Business Builders; utilize the helps that assure a prosperous future, and which must eventually be in the scheme of all successful Victor Dealers.

It has been "easy picking" for the Victor Dealer during the last six years, a veritable joy-ride, so to speak—and now, well—let's get down to real work.

Thousands of talking machines of questionable quality and dubious origin are now being urged upon the public—a public that has not been educated as you have been—and it now becomes your moral duty to impress upon the people in your community the reasons for VICTOR SUPREMACY.



Determination, courage, originality and resourcefulness are elements that will decide whether you are to be or not to be successful in a big way.

All we have said in the foregoing is expressed or implied in just one little word, a word of but three letters, "DIG." Let this be your pass word.

C. BRUNO & SON, Inc.

351-353 Fourth Avenue

New York

Victor Distributors to the Dealer Only

J. J. REILLY MADE SALES MANAGER

Advanced to Important Post in Melodee Roll Department of Vocalion Co. of Pennsylvania

PHILADELPHIA, Pa., February 5.—John J. Reilly has been made sales manager of the Melodee roll department of the Vocalion Co. of Pennsylvania, located in this city, formerly the Philadelphia Show Case Co., wholesale distributor of



John J. Reilly

the Vocalion instruments, Red records and Melodee music rolls.

"Jack" Reilly, as he is familiarly known to the trade, has been closely associated with both the music roll and phonograph industries for many years and, being thoroughly familiar with every phase of music roll merchandising and conversant with all the details of this industry, is particularly well qualified to fill his new post.

He started his music roll experience at Lyon & Healy's, Chicago, and shortly after was placed in charge of the music roll department of the George P. Bent Co., Chicago, and was also placed in charge of the Victor department of that company when it was opened. Next he went with Grinnell Bros., in Detroit, and then with John Wanamaker, in Philadelphia, as music roll department manager.

The wholesale field offering opportunities for wider activities, Mr. Reilly joined the traveling staff of the Universal Music Co., and for the past two and one-half years has represented this company, and later on the Melodee Co., in all the large cities in the Eastern territory, also visiting the Vocalion phonograph dealers.

NEWS OF EMERSON TRAVELERS

Sales Manager Morrison Now on Pacific Coast Co-operating With Jobbers

H. E. Morrison, sales manager of the Emerson Phonograph Co., is now on the Pacific Coast, and during the past ten days has spent considerable time in Seattle and Spokane. At the latter city Mr. Morrison co-operated with the Northwest Phonograph Jobbers, Inc., Emerson jobbers, in connection with their sales plans for the coming year.

C. F. Usher, field representative for the company, has been calling on the trade in Ohio, working in conjunction with the Emerson Ohio Co., Cleveland, O., in the development of 1921 business. His reports indicate that dealers in this territory are preparing for an active Emerson trade.

Morton Lucas, field representative of the company, is now in Chicago, co-operating with the sales staff of the Emerson branch in that city in stimulating the demand for foreign language records.

Owen Logan, field representative, is working with the sales staff of the Emerson Products Co., Syracuse, N. Y., Emerson jobbers, and the outlook in this territory is very gratifying.

EDMUND BRANDTS TO EUROPE

Prominent Manufacturer to Make Extensive European Trip and Desires to Be of Assistance to Those Desiring European Connections—Widely Acquainted in Foreign Lands

CELINA, O., February 3.—Edmund Brandts, who is well known in the talking machine trade and furniture circles as sales manager and partner in the Mersman Bros., Brandts Co., of this city, plans to embark on an extended European tour the latter part of April. His itinerary includes a large portion of the European continent.

Mr. Brandts came to this country from Gladbach, Germany, about seventeen years ago and is identified with several very successful manufacturing enterprises in this city. While Mr. Brandts was first prompted to make this trip because of his European family ties and his inability to visit the land of his nativity during the war, he plans to combine business with pleasure by taking care of special trade assignments on the other side for a number of American manufacturers. Mr. Brandts is well acquainted with many influential business and professional men in France, Germany, Holland, Belgium, Spain and Italy and plans to use this acquaintanceship in forming advantageous European connections.

ENTERS THE FIELD AS WHOLESALER

The Argus Phonograph & Supply Co., New York, has recently been formed to wholesale talking machine specialties, and it will particularly concentrate on the sale of main springs for motors and sapphires and diamonds for reproducers. The company will be incorporated very shortly with Charles Alweis as president and Alfred Sondheim as secretary and treasurer. Both of these men are well-known in the talking machine trade, and the new company has already established a number of excellent accounts in the industry.

THE VICTOR TALKING MACHINE COMPANY

Has acquired control of

THE GRAMOPHONE COMPANY, Ltd.

of Great Britain

We believe The Gramophone Company will be a tremendous success, and have procured a limited amount of Gramophone Company Limited Ordinary Stock, which we offer subject to prior sale or change in price at \$7.50 per share

Write for further information

BOENNING, GARRISON & CO.

BANKERS & BROKERS

MEMBERS PHILADELPHIA STOCK EXCHANGE

904-9 Stock Exchange Building

Philadelphia, Pa.

Featuring the MUSICAL POSSIBILITIES of the TALKING MACHINE

[Editor's Note:—This is the fourth of a new series of articles by William Braid White, devoted to the various interesting opportunities which prevail in the domain of education for the retailer of talking machines. The subject is one of great interest and we commend these articles to the consideration of all who are devoting attention to the featuring and developing of the musical possibilities of the talking machine.]

LET'S GET BACK TO MUSIC

Dealers in all parts of the country are finding it necessary to devise new and more effective methods of selling. Nobody claims that the people of the United States are short of cash, or that they have lost the interest they were showing a year ago in music and musical instruments. Dealers who understand the truth about the situation know that the present reluctance is relative. It looks very big when compared with the crazy extravagance of a year ago; but it is not at all big compared with the sort of coyness that had to be overcome five years ago. In other words, salesmen have lost their keenness after a period of two years of sellers' market; and now they are finding it hard to get back the old "pep."

But some things have changed meanwhile. For one thing, since 1914 the number of dealers who sell talking machines has enormously increased. Hundreds of piano merchants have taken on talking machines, and they above all are the persons who are just now complaining that sales are slow. The regular talking machine specialists on the other hand, although they are not occupied merely in trying to allot an insufficient stock of machines among a crowd of eager would-be purchasers, nevertheless are selling machines. The truth of course is that the latter have learned by experience

that there is only one sure way to get retail talking machine business, irrespective of other conditions. That way is to dig out the prospect and then demonstrate until the desire for music has been aroused.

Arouse Desire

When, in fact, this desire for music has been definitely aroused there will be little or no serious difficulty in making sales on reasonable terms and at the right prices.

It is just at this point that these remarks begin to square with the general purpose of these articles. If we do not feature the musical possibilities of the talking machine we shall not be able to arouse a desire for music. If we do not arouse a desire for music then we shall have nothing to fall back on but prices and terms. Now, at a time like the present, the worst possible argument is prices and terms. For those who are likely to be good risks are the very persons who will now be willing to wait "till prices come down," as they put it. They will wait because they are careful in money matters; and so long as the only language in which they are allowed to think of the proposed talking machine are money terms they will do the very natural thing and wait. Who can blame them?

On the other hand, those who will bite eagerly now at easy terms are likely to be those who will buy anything if only it is to be had "on time." Just at the present moment business of this kind is not desirable.

Now, therefore, the wise merchant will work as never before to interest his prospects in music, in the musical side and the musical possibilities of the talking machine.

Work of this kind must begin, of course, with the canvasser who first digs up the prospect, and must be simultaneously developed in newspaper advertising. That which is vital just now is to surround the idea of the talking machine with the atmosphere of musical entertainment. There is nothing so important as this, and unless it is persistently carried out the merchant may wonder in vain what is the matter with business. In fact, he will never find out.

The Most Interesting Thing

Now, what is the most interesting thing which can be said about the talking machine, from the musical standpoint? The answer should scarcely be needed at all, but one notices that merchants have been getting out of the habit of thinking of music lately and have manifested a deplorable tendency to think only in terms of furniture and instalments. Therefore let every one remember now that the most interesting statement you can make about the talking machine is that it comprises all musical instruments and all music, that it is "all music" brought to the purchaser's home and fireside, that it is all that you can ask for in a musical way, and that it has the power to satisfy every musical desire, from the desire for a dance to the desire for the classics of violin literature.

That is the most interesting thing one can say and some snappy presentation of the statement should stand somewhere in every newspaper advertisement and be repeated in every canvasser's talk as well as in the closing talk in the store.

"Music All the Time"

If I were writing newspaper copy for the re-
(Continued on page 98)

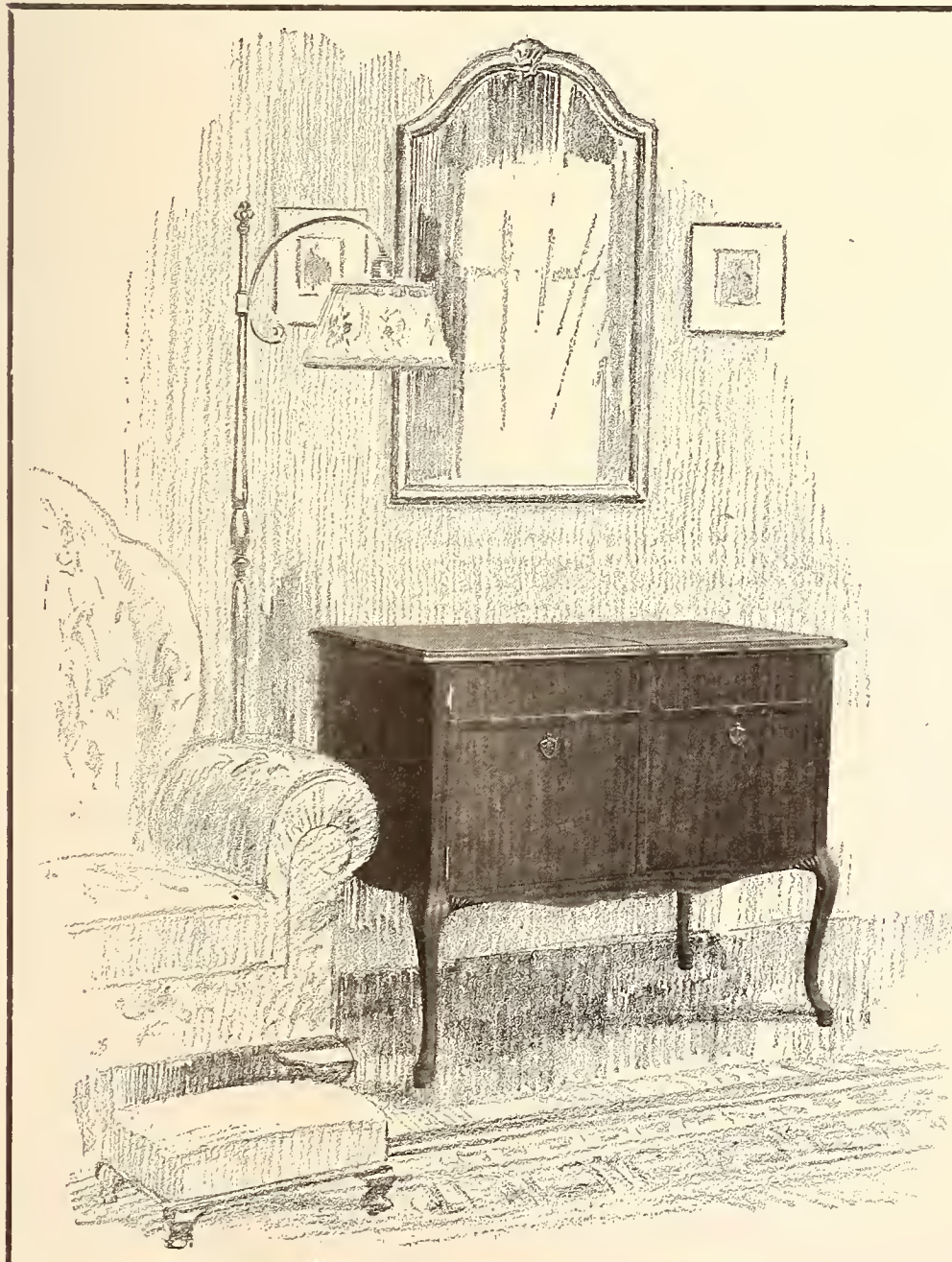

This Exquisite Queen Anne Console

is one of the models in the Jewett line of popular-priced consoles. It is a musical instrument of acknowledged superiority in tone, design and cabinet work.

The fact that this model retails for practically one-third less than other consoles of the same high grade gives a clear conception of the possibilities in store for those who become dealers or distributors of the Jewett line of popular-priced quality phonographs.

Details of agency proposition furnished on request.

JEWETT

PHONOGRAPHS

JEWETT PHONOGRAPH COMPANY,
1730 Penobscot Bldg., Detroit, Mich.

Please send me details regarding your agency proposition in this locality

Name

Address



It's sweeping the Country!

HONOLULU EYES

The most beautiful Waltz Melody
in years

Published by LEO FEIST INC
FEIST BLDG.
NEW YORK

"You can't go wrong with any Feist Song."

FEATURING THE MUSICAL POSSIBILITIES OF THE "TALKER"
(Continued from page 98)

tail talking machine trade just now, I should talk music all the time. That does not mean classical music, or operatic music, or vocal music, or dance music, or jazz music, exclusively or specially. It means just music in general. And I should talk the universality of the talking machine and the universal appeal of music till, figuratively, the cows came home. Then I should take very good care that the canvassers talked everything or anything else save prices and terms. I should make them, in fact, talk music all the time, pointing out to every one that, indeed, a good talking machine is neither very expensive nor hard to buy; but not claiming for a moment that a good talking machine can in any circumstances be a "bargain," in the ordinary sense of that abused term.

Letting Them Listen

And I should go further. I should insist that the sales talk in the store be a musical talk and a musical demonstration. I should insist that from the moment the prospect and his family arrived in the store their time should be kept occupied with music, music, music, chosen at their command in the beginning, but gradually worked over so as to concentrate their attention upon the tone and the general musical beauty of the talking machine. I should insist further that such a variety of music, after the

original choices had been played, should be placed before the prospect, so as to ensure that the wonderful possibilities of entertainment and fun residing in the great catalogs of records should be at least dimly sensed, to the end that not only a desire for a machine, but a lasting desire for new records, as often as possible, should be implanted.

The Universal Love

It is the unanimous opinion of all who have to do with the teaching of music in the schools or with community music in any form that the love for music is by all odds the nearest to being universal of any passion not utterly animal. At the present time, those who are merchandising the means for satisfying this love are making the mistake of their lives in not uniting upon a general preaching of the gospel of music in their advertising and in their selling. Prices and terms are necessary enough, of course, but they do not belong in the forefront of the argument. And in fact they belong very much in the background just now.

"Getting Them In"

It will be said that the main difficulty now is to get the people into the store. That may be true, but it is also true that the people will come wherever there is an attraction. During the present peculiar period through which we

are rapidly and most successfully passing some of our largest retailers of talking machines have kept themselves busy without any let-down by the expedient of running some continuous attraction of a musical sort calculated to keep the people on the alert and to "bring them in." The great house of Lyon & Healy in Chicago has been running daily concerts for a long time past in its recital hall, with splendid results. Men and women drop in, hear the talking machine under the most perfect conditions, find that they are not solicited or bothered, go away, think about it, wonder if the possession of such a machine could be managed in some way, and then, ten to one, the lady of the home is visited by a clever young outside salesman from the same great house. The result can be foreseen, can it not?

There are plenty of variants to be worked out by the wise and active salesmanager or merchant. There are some general thoughts calculated to impress upon all concerned the great text "If you want to sell just now sell that the value of which cannot be estimated in dollars, but which is more and more desired in proportion as it is made more and more familiar: sell music, and nothing else!"

TAKES ON NEW LINES

The Cabinet & Accessories Co., New York City, has added to the large list of accessories which this firm carries the Tonofone needle, manufactured by the R. C. Wade Co., of Chicago. Otto Goldsmith, president of the company, has experienced a decided demand in the territory which he covers for a semi-permanent needle of high quality and has already found that the Tonofone needle is meeting with much success among the dealers he supplies.

The Cabinet & Accessories Co. has also been appointed exclusive metropolitan distributor for the Cirola phonograph. Mr. Goldsmith plans to feature this portable phonograph extensively in the months to come. The exclusive territory extends within a radius of twenty-five miles in each direction from the Grand Central Station.

STRATFORD PHONO. CO. AFFAIRS

In the matter of the Stratford Phonograph Co., bankrupt, the trustee has filed a petition for authority to sell the present property of the bankrupt located at Ashland, O., at public auction, and this petition was scheduled to come up for hearing before the Referee in Bankruptcy on February 14, and it is announced that if not then otherwise ordered this sale will be ordered and held on February 19, 1921, as advertised.

Miss Ruth Howard, who was until recently manager of the phonograph department at Byron Mauzy, of Oakland, Cal., has been given charge of the record department of Long's Music House, Pasadena.

MR. RETAILER:

Do you know that one card of



Plays all Records

Saves all Records

PLAYS 100-200 RECORDS

Made by Mellow-Tone Needle Co.
ANSONIA CONN.

will play 500 to 800 RECORDS

Think what it means to be able to tell a customer that.

Retails 25c. per card.

LOUD MEDIUM SOFT

SEND FOR SAMPLES AND DISCOUNTS

Mellowtone Needle Co., Inc. Sole Manufacturers Ansonia, Conn.

Oké Records

MARCH RELEASE

4228 { MEM'RIES OF YOU MAMMY (Popular Blues)
10-in. (Vocal) . . . Mamie Smith and Her Jazz Hounds
\$1.00 { IF YOU DON'T WANT ME BLUES (Popular
Blues) (Vocal)
Mamie Smith and Her Jazz Hounds

4229 { BROADWAY ROSE (Tenor with Orch.)
10-in. Billy Jones
85c. { LITTLE CRUMBS OF HAPPINESS (Tenor with
Orch.) Lewis James

4243 { ONE, TWO, THREE, FOUR (Vocal Trio with
10-in. Hawaiian Guitars) Crescent Trio
85c. { MAUI ALOHA (Hawaiian Guitar Duet)
Ferera-Franchini

4244 { COUNTY KERRY MARY (Tenor and Quartet
10-in. with Orch.) Sam Ash & Shannon Four
85c. { BONNIE LASSIE (Tenor and Quartet with Orch.)
Charles Hart & Shannon Four

4245 { LIKE WE USED TO BE (Baritone with Orch.)
10-in. Elliott Shaw
85c. { THERE IS ONE GIRL (Will She Ever Be Mine)
(From the Musical Play, "Hearts of Erin")
(Tenor and Quartet with Orch.)
Sam Ash & Shannon Four

4246 { ONE SWEET DAY (Tenor with Orch.)
10-in. Lewis James
85c. { IN THE HEART OF DEAR OLD ITALY (Vocal
with Orch.) Crescent Trio

4247 { PICKANINNY ROSE (Baritone with Orch.)
10-in. Ernest Hare
85c. { LINDY (Vocal with Orch.) Shannon Four

4248 { ANNIE LAURIE (Scotch Ballad) . . . Shannon Four
10-in. { CARRY ME BACK TO OLD VIRGINNY (Vocal
85c. with Orch.) The Three Virginians

4249 { TURKEY IN THE STRAW (Comic Vocal)
10-in. (Baritone with Orch.) Billy Golden
85c. { RABBIT HASH (Monologue) Billy Golden

4230 { JUNE (I Love No One But You) (Fox-trot)
10-in. Joseph Knecht's Waldorf Astoria Dance Orch.
85c. { DROP ME A LINE (Intro. "My Husband's
Dearest Friend") (From Musical Play,
"Honeydew") Orlando's Orchestra

4231 { CARESSES (Fox-trot) . Lanin's Roseland Orchestra
10-in.
85c. { HINDOO HOP (Fox-trot) . . Rega Dance Orchestra

4232 { PALESTEENA (Fox-trot)
10-in. Green Brothers' Novelty Band
85c. { HONOLULU EYES (Waltz)
Green Brothers' Novelty Band

4233 { NO WONDER I'M BLUE (Fox-trot)
10-in. Joseph Samuels' Jazz Band
85c. { SOMEBODY'S EYES (Fox-trot)
Harry Raderman's Jazz Orchestra

4234 { HUMMING (Fox-trot) Rega Dance Orchestra
10-in.
85c. { ROSIE (Make It Rosy for Me) (Fox-trot)
All Star Trio

4235 { ROSE (Fox-trot) Rega Dance Orchestra
10-in.
85c. { BEAUTIFUL FACES (From "Broadway Brevi-
ties") (Fox-trot) Vernon Trio

4236 { SHOW ME HOW (Fox-trot) Vernon Trio
10-in.
85c. { SWEET LOVE (Fox-trot) Orlando's Orchestra

4237 { NOW AND THEN (Fox-trot)
10-in. Harry Raderman's Jazz Orchestra
85c. { DOLLY, I LOVE YOU (Fox-trot)
Harry Raderman's Jazz Orchestra

4238 { LOTUS FLOWER (Waltz)
10-in. Joseph Knecht's Waldorf Astoria Dance Orch.
85c. { MIDNIGHT (Fox-trot) Orlando's Orchestra

4239 { NIGHTINGALE (Fox-trot) . Rega Dance Orchestra
10-in.
85c. { ALGIERS (Fox-trot) Rega Dance Orchestra

4240 { YOU'RE JUST LIKE A ROSE (Introducing,
10-in. "Hello Imagination") (From Hippodrome
85c. Show, "Good Times") (One-step) (Accor-
dion) Perry
85c. { IT ISN'T WHAT SHE DOES THAT MAKES
ME LOVE HER (Introducing, "I Told You
So") (Fox-trot) (Accordion) Perry

4241 { EL CAPITAN (March) Conway's Band
10-in.
85c. { THE NEW COLONIAL MARCH . . Conway's Band

GENERAL PHONOGRAPH CORPORATION

OTTO HEINEMAN, *President*

25 West 45th Street New York City, N. Y.

Factories: Newark, N. J. Elyria, Ohio Putnam, Conn. Springfield, Mass. Kitchener, Ont.

Branch Offices: Chicago, Ill. Toronto, Can. London, Eng.





The Trade in BOSTON and NEW ENGLAND

JOHN H. WILSON, Manager
324 WASHINGTON ST., BOSTON, MASS.

Boston, Mass., February 5.—Not a few local talking machine houses report business as having been spotty during the past month. Five days of a week, for instance, would be quiet, then there would be a spurt on Saturday, only to have the quiet regime return on the following Monday. Most places report the record business as very good, but the buying of machines has not been especially conspicuous. The feeling is pretty general, however, that the current month will show an improvement in conditions and that from now on there will be an appreciable advance, for it is conceded by the leaders in the talking machine business that the corner has been turned and that everything is on the upward move to better times.

Optimistic Over the Outlook

Manager Fred E. Mann, of the Columbia Co., became quite cheery the other day when The World correspondent dropped in and listened to him read extracts from a recent issue of a Wall street magazine in which the Columbia was put in a very favorable light. Taking his cue from some of the optimistic statements wherein the 1920 business was reported to have shown such a big increase over the previous twelve months, Mr. Mann proceeded to express himself very confidently anent the business that is ahead for the company, in part basing his remarks upon his own near-at-hand experience right here in his own field. He said that after a dullness following the first of the new year, there being a natural stagnation every January, things began to pick up, and all the dealers were looking forward to an era of good business on which the larger dealers in particular already have made a start. With the facilities that the company has to turn out the goods he believed the time was not far off when the entire output of the factory would be speedily taken as fast as put out.

New Pathé Representation

The Pathé department of Hallet & Davis has begun the new year under most auspicious conditions. Stephen A. Colahan, who has been for eight months manager of the retail department of the Pathé, is now more closely associated with Wholesale Manager R. O. Ainslie, and will

Optimism, Confidence and Steinert Service

Overcome and surmount any and all
obstacles or difficulties and help make

LOYAL



DEALERS

VICTOR-IOUS

M. STEINERT & SONS CO.
VICTOR WHOLESALERS

35 Arch Street :: :: :: :: Boston
STEINERT SERVICE SERVES

devote most of his time to traveling through the New England field. Toward the latter part of January he and Mr. Ainslie spent several days looking over the Providence and Pawtucket, R. I., territory. Some new concerns with which the Pathé has lately signed up are Doyle & Mitchell, Amesbury; Henry Baker, Hyannis; Raphael Seney, Plainfield, Conn., and J. & M. Company, Pawtucket, R. I.

A Visitor From Nova Scotia

Colonel E. C. Phinney, of the firm of N. H. Phinney, Ltd., of Halifax, Nova Scotia, was a recent caller on Manager Mann of the Columbia. Col. Phinney had been in New York and spent

several days in the laboratories of the company. His house is the largest Columbia jobber in the Province, and it operates eight stores. Mr. Mann speaks of Colonel Phinney as a real live wire.

Two other callers at the Columbia headquarters here have been H. S. Root, of the H. S. Root Co., of Newport, Vt., where he is an exclusive Columbia dealer; and J. P. Middleton, who also conducts an exclusively Columbia shop at Pittsfield.

Toward the latter part of January the local headquarters of the Columbia had with it two of the company's auditors from New York, here to pay their regular semi-annual visits—W. G. Westenfeld and H. L. Brewster.

Leaves the Hub for Mineola

H. L. Pratt, who has been with the executive office sales department of the Columbia Co. in New York, has finally got his family moved over to the metropolis, having found a home at Mineola, Long Island. The family home has been in Newton Centre, which is a suburb bordering on Boston.

New Puritan Agents

Manager Ellsworth, local manager for the Puritan, made by the United Phonograph Corp., says that he finds business decidedly picking up. He has lately taken on several new dealers in New England, among them Ordway & Dalton, at White River Junction, Vt.; the Farrar Furniture Co., at Bangor, Me., and the Cornell Music Store, at Middleton.

New Store in Roxbury Section

A new shop just opened in the Roxbury district to be devoted exclusively to the Puritan is the Harmony Shop, 2413 Washington street. The store has a good frontage, is 110 feet deep, and is in charge of J. H. Duffy, an enterprising young man.

To Represent the O. K. Records

A. J. Delaurie, formerly with the Emerson Co. and well known around Boston, has associated himself with the E. B. Shiddell Co., jobbers for the Okeh records, and will devote his time to the Massachusetts territory. Mr. Townsend, who has been handling the Greater Boston territory for some time, is meeting with

(Continued on page 101)

EASTERN SERVICE

"NEW ENGLAND SERVICE
FOR NEW ENGLAND DEALERS"



TODAY'S successful Victor dealer is careful, determined and persistent. He believes that satisfactory service helps progress. He knows that Eastern Service specializes for his best interests by using every power to maintain and improve his profits.

Eastern Talking Machine Co.
85 Essex Street
Boston, Mass.

W·H·BAGSHAW·COMPANY·



The Triumph of the Talking Machine Needle Industry

SINCE the founding of the company in 1870 Bagshaw has taken a most active and prominent part in the upbuilding of the Talking Machine Needle industry.

The progress of the company from the beginning has been markedly influenced by the firm belief of every member of the institution in its plans, purposes and products. Harmony of effort, intelligent work, confidence in the company and in one another—these influences have combined to build Bagshaw to its present great proportions.

The rounding out of its first half century finds the organization full of youth and determination, alive to the promises of the future and strengthened by the good will and good faith of customers whose patronage has been earned and held through merit.

W. H. BAGSHAW CO.
LOWELL, MASS.

Oldest and Largest Makers of Talking Machine Needles in the World

Established 1870

Incorporated 1917

Selling Agents

Brilliantone Steel Needle Co. of America
347 Fifth Avenue New York City

THE TRADE IN BOSTON AND NEW ENGLAND—(Continued from page 99)

marked success. Mr. Shiddell reports an unusually prosperous season and adds that he is well pleased at the way the New Year has started. His quarters, at 142 Berkeley street, are getting big supplies of records, but they are taken by the trade almost as fast as received, he says.

F. C. Howard a Visitor

F. C. Howard, the talking machine dealer of Syracuse, N. Y., who was honored by a big testimonial dinner the early part of January, was a welcome visitor to Boston later in the month, coming here with R. O. Ainslie, the wholesale manager of the Pathé, who was one of the guests at the Syracuse banquet. Mr. Howard was pleasantly entertained while in Boston.

West End Phonograph Co. Opens New Store

The West End Phonograph Co., located in Leverett street, has opened a new store in Causeway street, opposite the North station. It will be devoted exclusively to the Victor product. At the Leverett street store only the Columbia line will be carried.

Unit Construction Men Visitors

Three of the Unit Construction Co. staff visited the Boston trade during January. First came Rayburn Clark Smith, the president, who was accompanied by Gus Mayer, the sales manager, and they remained in town several days. The following week Arthur W. Deas, Jr., the company's Eastern manager at the New York office, came to Boston and he got the same cordial handshake that is always accorded popular members of the trade. Mr. Deas, on leaving Boston, went on to Portland, Me., for a visit among the trade.

Plan to Visit Bermuda

President Charles H. Farnsworth, of the Eastern Talking Machine Co., is planning a trip to Bermuda, and if he can make the proper arrangements, he will start in a short time.

Prepare for Concert of Eight Victor Artists

Kenneth Reed, wholesale manager of the Steinert's Victor headquarters, will soon be busy on the plans for the Spring tour in New England of the Eight Famous Victor artists. These concerts will be limited to six or less and will take place the first week in April. Those places where arrangements have already been definitely made are: Worcester, Lawrence, Providence, R. I., and Bangor, Me. The latter part of January Manager Reed made a trip into the Western Massachusetts territory and New York; and later he took a trip over to the Camden factory.

Vocalion Artist Attracts Big Crowd

John Charles Thomas, the baritone of "Apple Blossoms," lately given at the Colonial Theatre, and who is one of the artists featured by the Vocalion, gave a largely attended concert in Jordan Hall on the afternoon of January 20, and his voice was described by one daily newspaper as having fluency, richness and warmth and "one of the most beautiful baritones heard here in years." Such praise should make for great popularity with his Vocalion records.

John Maguire Broadens His Scope

John Maguire, who has been a valued employe of the Eastern Talking Machine Co. for a number of years, is no longer inside the establishment. Instead he is now on the road, having taken the place of Edward J. Dunham, who resigned lately. Mr. Maguire's territory is in eastern Massachusetts, and he is making good in

HORTON-GALLO-CREAMER CO

NEW HAVEN  **CONNECTICUT**

VICTOR SERVICE SPECIALISTS

THE Year 1921 is before us. We can largely make it what we will. Let us help you make it a banner year.

every way, thanks to a pleasing personality, an intimate knowledge of the business and a convincing way of presenting his Victor line.

Sympathy for Herbert F. La Roe

The local trade learns with regret of the bereavement which has come to Herbert F. La Roe, of La Roe's Music Store, at Woonsocket, R. I., in the loss of his wife, who died about the middle of January.

Hammond Buys a Puritan

A recent purchaser of a Puritan talking machine from the warerooms at 429 Boylston street was John Hays Hammond, Jr., the famous inventor, whose royalties on inventions controlled by the United States Government brings him a small fortune annually. Mr. Hammond had examined the mechanics of the Puritan but a short time when he pronounced the system on

which this talking machine was built as nearly perfect. The features that made their special appeal were the long wooden horn and the resonant sound board, a combination that he believed was capable of giving the purest tone. The horn, too, had points of superiority in his estimation.

Wilbur W. Longfellow's Plans

Wilbur W. Longfellow, who came back to Boston several months ago to become manager of the Barite Company in Boylston street, is no longer connected with that house, and it may be that he will go into some other line of business.

Visiting the Trade in the West

Mr. Cullen, of the Lansing Sales Co., is in the West on a business trip. He has been in
(Continued on page 102)

LONG
TRADE MARK

MUSIC CABINETS
See Display Ad in This Issue

Peerless Record Album
See Display Ad in This Issue

SPECIAL

I am prepared to ship all orders on either line promptly.

Send your orders for both these lines to
L. W. HOUGH, 20 Sudbury St., Boston, Mass.
New England Representative

Dealers' Cooperation

Dealers' problems are quickly solved by the house of Cressey & Allen

Our earnest desire to promote dealer sales is well known throughout New England. From every corner Victor dealers come to confer, for experience has proven that we DO help materially. It is this cooperation that is building our prestige and standing with New England Victor dealers.

CRESSEY & ALLEN
PORTLAND, MAINE



THE TRADE IN BOSTON AND NEW ENGLAND— (Continued from page 101)

Chicago and, according to his original itinerary, he was to have gone as far as Kansas City. During his absence the business is being efficiently cared for by R. G. Lipp, a new acquisition to the company, who came East a few weeks ago from Chicago, where he was president of the All-in-One Corporation. Mr. Lipp says business through January was very good.

Burke in Optimistic Mood

Joe Burke was over in New York a while ago attending a directors' meeting of the Mu-

dow in the Boylston street warerooms of the M. Steinert & Sons Co. It was one of the most attractive windows on this thoroughfare, in fact, it was one of the most artistic creations seen anywhere in the city during the holidays. Scattered about in the foreground were the beautiful operatic figures which are recognized as the output of the Penn Phonograph Co., of Philadelphia. Stopping to enjoy the window, in one corner of which was a tall and beautifully decorated and illuminated tree, one saw that the



An Artistic Steinert Window, Showing Use of Grand Opera Figures

sical Supply & Equipment Co. Since then President Morris, of the company, has been here in town. Manager Burke reports the Sonora and Magnavox business has shown a marked improvement during January, and the latter is finding especial favor among the managers of halls.

A Beautiful Steinert Window

The accompanying picture was taken during the Christmas holidays and shows the large win-

whole idea was to feature the Red Seal Victor records which, through this clever display, enjoyed an enormous sale through the medium of the Steinert house.

R. G. Clarke With Cluett

Raymond G. Clarke, who was one of Manager Wheatley's staff at the Vocalion headquarters, is now located at Albany, N. Y., where he has associated himself with Cluett & Co., which house handles the Vocalion.

MAKES FULL RESTITUTION

BOSTON, MASS., February 6.—In the cases of Herbert L. Royer and Charles Lowell, who were sentenced in the municipal court several weeks ago to six months each in the House of Correction, full restitution has been made. Lowell pleaded guilty to Henry P. Fielding, the assistant district attorney, when the cases came up in the superior court, and the latter recommended probation.

Royer pleaded nolo contendere and Assistant District Attorney Fielding recommended his case be placed on file. The full restitution made included the paying by Royer and Lowell of the costs of the trial and the return of the machines which had been taken. The original charge included seven counts for receiving stolen goods.

The story of the cases against these two men was told in last month's issue of The World. Having taken an appeal from the lower court's finding of guilty Royer and Lowell were out on \$2,000 bail awaiting disposition in the upper court.

MANY COMPLIMENTARY OPINIONS

WARREN, MASS., February 1.—B. D. Perkins, manager of the U-Sav-Your Mfg. Co., manufacturers of U-Sav-Your dressing for Victrolas, has received many highly complimentary reports from distributors of U-Sav-Your polish. The Horton-Gallo-Creamer Co., of New Haven, Conn., has had exceptional results in the distribution of this line and states that repeat orders are coming in very satisfactorily. The Schmelzer Co., of Kansas City, Mo., made an equally encouraging report and both these firms expect that by the Spring a large business will be developed with this line. Collings & Co., Newark, N. J., were among the first distributors

KRAFT-BATES AND SPENCER INC.

NEW ENGLAND DISTRIBUTORS

Brunswick

PHONOGRAPHS AND RECORDS

Could You Become a Brunswick Dealer?

JUST as Brunswick factory, materials and methods must conform to absolutely rigid standards, so, too, Brunswick dealers must prove their desirability. They must show that they appreciate the fact that The Brunswick is a high-class specialty, and that they will always present it to the public as such.

There is no mystery about the astounding success of The Brunswick—built up in four years' time against keen competition. The Brunswick Method of Reproduction has several basic improvements which no other phonograph has or ever can have. The Brunswick Ultona, for instance, is the only reproducer ever invented which actually plays all makes of records just exactly as they should be played, and without using attachments.

The Brunswick offers the most profitable phonograph franchise obtainable, not only because of the excellence of The Brunswick itself from the buyer's viewpoint, but also because of the faster turnover for the dealer.

For The Brunswick has not been and will not be cheapened by cut-price and easy-term devices which tie up the dealer's money in long-time payments.

KRAFT-BATES & SPENCER, Inc., 1265 Boylston Street, BOSTON, MASS.
NEW ENGLAND DISTRIBUTORS

Steel Needles

Albums

Record Brushes

Khaki Covers

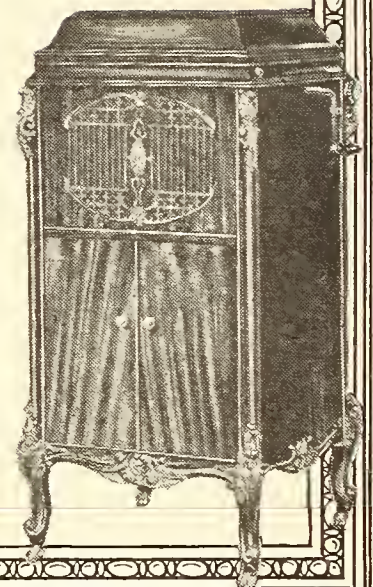

THE TRADE IN BOSTON AND NEW ENGLAND—(Continued from page 102)

of the U-Sav-Your cleanser and dressing and have therefore already developed very satisfactory business with this product. During the month of January every dealer in New Jersey was called upon in reference to the U-Sav-Your polish. The result of this canvass is reported entirely satisfactory.

NEW MUSIC SHOP OPENED IN BOSTON

Copley Square Music Shop, on Huntington Ave., to Handle Columbia Exclusively

BOSTON, MASS., February 1.—The accompanying picture shows the interior of the Copley Square Music Shop, located at 40 Huntington avenue, this city. The interior is finished in French



Interior View of New Music Shop

gray and between the windows down one side are French plate mirrors. It is an exclusively Columbia shop and from the first it has handled a large amount of goods, its machines and records constantly finding a ready sale. E. A. Carr is the president of the company operating the store and E. B. Sewall is the treasurer. Mrs. A. W. Graves is in charge of the sales work. Mr. Carr is a newcomer in the talking machine field, having heretofore been identified with other lines of business. In his home city of Gloucester he is associated intimately with its musical life and is the leader of the local orchestra.

URGES MEMORY CONTESTS

Mrs. Oberndorfer Points Out Advantages of Music Memory Contests in Address Recently Delivered at Meeting in Boston

BOSTON, MASS., February 4.—That music memory contests should be started in every community of America by women's clubs was one of the declarations made at a meeting in the Museum of Fine Arts a few days ago by Mrs. Anne Faulkner Oberndorfer, of Chicago. Mrs. Oberndorfer is chairman of the music department of the General Federation of Women's Clubs, and wife of Max Oberndorfer, member of the Chicago Symphony Orchestra, and through her efforts the school children of that city hear the best compositions through the frequent visits of players to the classrooms. In the course of her talk Mrs. Oberndorfer said:

"Briefly, the plan is to enlist the support of the clubs, board of education, superintendent of schools, supervisor of music, newspapers and music dealers. A list of fifty good instrumental compositions is made. These selections should be available on records, player-piano rolls, and in simple piano sheet music, which the children can play themselves. Newspapers should be asked to publish the lists, and possibly a short analysis of each number. At the end of six weeks, or two months, these fifty good compositions will be known by every child and in every home in your community. Then the contest should be held, with preliminary contests in each school. Eight or ten of the compositions should be played, without programs, the children writing down the name of the composition, composer, and possibly when and where he lived, and the meaning of the selection. The twenty-five best papers should constitute the school team, and then the final contest of teams should be held in a big hall, under the auspices of the community musical interests.

**Your Guarantee
Mr. Dealer
LANSING KHAKI
COVERS**

*For All
Phonographs*

**Unqualified Endorsement
of Biggest Manufacturers
and Dealers**



*All Good
Distributors*



**Eliot and Warrenton Sts.
BOSTON, 11, MASS.**

"Americans have had the wrong attitude regarding music for so many years that it is difficult for us to grasp quickly the full realization of its power. As a nation we have treated music as a thing apart from, instead of a part of, our daily life. The General Federation has pledged its support to all good American music. What are we to do about it? First, we must familiarize ourselves with the music that is being used in our homes, clubs, schools, churches, Sunday schools, theatres, moving picture houses, and the music that is being advertised in our shops, magazines and newspapers. We shall be surprised; we may even be horrified with what we find, but it is time we knew."

"Nameplates With a Personality"
For Manufacturers and Dealers of Talking Machines,
Phonographs, Musical Instruments, etc.
E. V. YUELL CO., Malden, Mass.
*When You'll Think of Nameplates
You'll Think of Yeuell.*

**The "Perfection" Universal Ball-Bearing Tone Arm
No. 6 With New Pur-i-tone Reproducer (attached)**

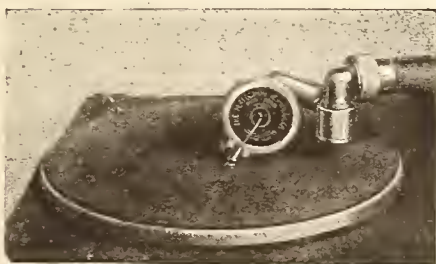

Set in position for playing "lateral" cut records

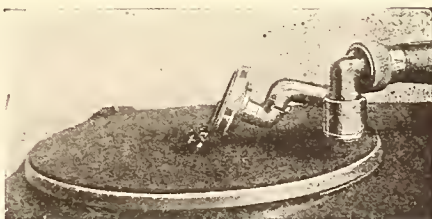

Set in position for playing "hill and dale" records with diaphragm facing front of machine

The "Perfection" Universal Ball-Bearing Tone Arm No. 6 with New Pur-i-tone Reproducer attached plays Victor, Columbia and all other makes of disc records on all types of Edison Disc Machines, producing with clarity and volume of tone excelled by no other attachment. This attachment is manufactured in Gold, Nickel and Oxidized finish (William & Mary) with the best of India Mica Discs.

WRITE FOR DESCRIPTIVE CATALOG AND PRICES

Manufactured by

**New England Talking Machine Co.
16-18 BEACH STREET BOSTON, 11, MASS.**

DISTRIBUTORS:

CALIFORNIA
San Francisco—Walter S. Gray Co.
COLORADO
Denver—Denver Dry Goods Co.
GEORGIA
Atlanta—Phonographs, Inc.
IOWA
Des Moines—Harger & Blish
MASSACHUSETTS
Boston—Pardee-Ellenberger Co.

MISSOURI
St. Louis—Silverstone Music Co.

NEBRASKA
Omaha—Shultz Bros.

NEW YORK
Albany—American Phonograph Co.
New York—The Phonograph Corp. of Manhattan

OHIO
Cleveland—The Phonograph Co.

PENNSYLVANIA
Pittsburgh—Buehn Phono. Co.
Philadelphia—Girard Phono. Co.

UTAH
Ogden—Proudfit Sporting Goods Co.

VIRGINIA
Richmond—C. B. Haynes Co., Inc.

**Factory Representative—Louis A. Schwarz
1265 BROADWAY, NEW YORK, N. Y.**

Bright Eyes, Rosie, Margie, Palesteena, Feather Your Nest, Rose, Why Don't You, Grieving For You, Broadway Rose, Oh Gee! Say Gee!, and all the other latest dance and song hits ready for immediate delivery on

Grey Gull Records at 85c. Retail

Price COUNTS nowadays, as Grey Gull Dealers can testify. A dollar for records is too high---it's a War Price. 85 cents is Normal---and the Public BUYS. Try it and see.

Grey Gull Records are recorded and manufactured complete in one plant by a conservative, strongly financed concern. They are not tied to any phonograph. Send in a trial order to nearest distributor.

Distributors

American Phonograph Co.
17 N. Ionia Ave.,
Grand Rapids, Mich.

Associated Furniture Manufacturers
1209 Washington Ave.,
St. Louis, Mo.

Joseph Barnett & Co.
218 Fourth Ave., East,
Cedar Rapids, Iowa

Capital Paper Company
South St.,
Indianapolis, Ind.

Cole & Dunas Music Co.
54 W. Lake Street,
Chicago, Ill.

Excelsior Music Co.
Cape Girardeau, Mo.

Fuller Phonograph Co.
101 N. Water Street,
Wichita, Kansas

Grey Gull Records, Inc.
295 Huntington Ave.,
Boston, Mass.

National Phonograph Co.
518 Penn Avenue,
Pittsburg, Pa.

Scott Weighing Machine Co.
Topeka, Kan.

Seidel Music Publishing Co.
Indianapolis, Ind.

Smith & Phillips Music Co.
409 Washington St.,
E. Liverpool, Ohio

T. & H. Specialty Mfg. Co.
Charleston, W. Va.

United Music Stores
619 Cherry Street,
Philadelphia, Pa.

Dance Hits

BRIGHT EYES—Fox-trot.....Bennie Krueger's Orchestra } L-1045
10-in.
TOODLES—Fox-trot.....Joseph Samuels' Music Masters } 85c.

FEATHER YOUR NEST—Fox-trot.....Banjopators } L-1037
I'O LOVE TO FALL ASLEEP AND WAKE UP IN } 10-in.
MY MAMMY'S ARMS.....Banjopators } 85c.

MARGIE—Fox-trot.....Selvin's Novelty Orchestra } L-1036
10-in.
BIODY—Fox-trot.....All Star Trio } 85c.

GRIEVING FOR YOU—Fox-trot.....Banjopators } L-1038
10-in.
BEAUTIFUL ANNABEL LEE—Waltz.....Banjopators } 85c.

ROSIE—Fox-trot.....Sung for Dancing by Ernest Hare } L-1039
10-in.
OH GEE! SAY GEE!—Fox-trot, } 85c.
Sung for Dancing by Ernest Hare

YOU OUGHTA SEE MY BABY—Fox-trot, } L-1042
Banjopators, with vocal chorus by Ernest Hare } 10-in.
WHY DON'T YOU?—Fox-trot, } 85c.
Banjopators, with vocal chorus by Ernest Hare

PALESTEENA—Fox-trot, } L-1040
Banjopators, with vocal chorus by Ernest Hare } 10-in.
MY HOME TOWN IS A ONE-HORSE TOWN—Fox-trot, } 85c.
Banjopators, with vocal chorus by Ernest Hare

WHISPERING—Fox-trot.....Joseph Samuels' Music Masters } L-1031
10-in.
KISMET—Fox-trot.....Joseph Samuels' Music Masters } 85c.

ROSE—Fox-trot, } L-1041
Banjopators, with vocal chorus by Ernest Hare } 10-in.
LOOK WHAT YOU'VE OONE WITH YOUR OOG-GONE } 85c.
DANGEROUS EYES—Fox-trot, }
Banjopators, with vocal chorus by Ernest Hare

I NEVER KNEW—Fox-trot, } L-1044
Banjopators, with vocal chorus by Ernest Hare } 10-in.
JUST LIKE A ROSE—Fox-trot.....Gilt Edge Four } 85c.

AVALON—Fox-trot.....Starita Saxophone Sextette } L-1027
10-in.
CUBAN MOON—One-step...Krueger's Melody Syncopators } 85c.

JAPANESE SANDMAN—Fox-trot, } L-1032
Joseph Samuels' Music Masters } 10-in.
LOUISIANA—Waltz.....Paragon Dance Orchestra } 85c.

Song Hits

BROADWAY ROSE.....Sung by Charles Harrison } L-2043
10-in.
BLUE DIAMONOS.....Sung by Henry Burr } 85c.

TRIPOLI.....Sung by Charles Hart and Louise Terrell } L-2034
10-in.
HIAWATHA'S MELODY OF LOVE } 85c.
Sung by Charles Hart and Louise Terrell

FEATHER YOUR NEST.....Sung by Charles Harrison } L-2044
10-in.
WHEN HE GAVE ME YOU (Mother of Mine), } 85c.
Sung by Henry Burr

MY LITTLE BIMBO, OOWN ON THE BAMBOO ISLE, } L-2015
10-in.
TIIOOLE-DEE WINKS.....Sung by Billy Murray } 85c.

LET THE REST OF THE WORLD GO BY, } L-2017
10-in.
Sung by Henry Burr } 85c.
WONO'RING.....Sung by Charles Hart

I'LL BE WITH YOU IN APPLE BLOSSOM TIME, } L-2020
10-in.
Sung by Henry Burr } 85c.
LITTLE TOWN IN THE OULO COUNTY OOWN, }
Sung by Henry Burr

AVALON.....Sung by Ernest Hare } L-2040
10-in.
LIKE WE USED TO BE, } 85c.
Sung by Charles Hart and Louise Terrell

JUST LIKE A GYPSY.....Sung by Ernest Hare } L-2042
10-in.
DON'T TAKE AWAY THOSE BLUES, } 85c.
Sung by Ernest Hare

I'O LOVE TO FALL ASLEEP AND WAKE UP IN } L-2029
10-in.
MY MAMMY'S ARMS.....Sung by Billy Jones } 10-in.
DOWN IN CHINATOWN, } 85c.
Sung by Billy Jones and the Harmonizer Quartet

OLD PAL (Why Don't You Answer Me?), } L-2036
10-in.
Sung by Charles Hart } 85c.
PRETTY KITTY KELLY.....Sung by Charles Hart

CHILI BEAN.....Sung by Billy Murray } L-2018
10-in.
MARIELLA.....Sung by Patricola } 85c.

OOWN THE TRAIL TO HOME, SWEET HOME, } L-2025
10-in.
Sung by Charles Hart } 10-in.
WHEN I LOOK IN YOUR WONDERFUL EYES, } 85c.
Sung by Henry Burr



INCORPORATED

295 HUNTINGTON AVENUE, BOSTON, MASS.

BRUNO

Like a new broom, Victor Ready Reference Labels sweep clean. Cobwebs never form where these little trojans are. Let them work for you, too, Mr. Victor Dealer.

BRUNO

UNIQUE RETAIL ESTABLISHMENT

Sonora Dealer Purchases Church as Retail Headquarters—Unusual Means for Display

In these days of "blue laws" it is interesting to learn that someone is actively engaged in an opposite direction. In the city of Franklin,



Novel Retail Sonora Headquarters

N. H., it was decided that one of the churches was not needed, and an enterprising Sonora dealer, H. E. Rainville, purchased the church and turned it into a retail home for the Sonora.

This home for the display of the Sonora product is not only unique but has possibilities for display which are thoroughly unusual. On the opening day Mr. Rainville gave a concert, and no less than a thousand people from Franklin and the vicinity called to inspect this Sonora retail establishment.

Mr. Rainville, who is one of Franklin's best-

No. 35217--Basket filled with flowers each 75c., per dozen \$7.50.

My Spring Catalogue No. 35 with illustrations in colors of Everlasting Decorative Flowers, Plants, Vines, Shrubbery, etc., free for the asking; write for it to-day.

FRANK NETSCHERT
61 BARCLAY ST. NEW YORK, N. Y.

known business men, came to this country from Canada in 1890, and three years later began work for C. C. Paige, continuing with Mr. Paige for sixteen years. Eight years ago Mr. Rainville bought out Mr. Paige, and the business under his management has grown to be one of the leading concerns of its kind in this territory.

ANNOUNCE COLUMBIA RECORD SALE

Selected List of Retired Columbia Records to Be Offered to Public at Fifty-nine Cents Each in Order to Reduce Size of Catalog

The Columbia Graphophone Co. announced this week that, effective March 1, Columbia dealers may offer their trade a list of 130 records (260 selections) which will retail at fifty-nine cents.

In making this important announcement the company stated as follows: "To keep the Columbia record catalog within a reasonable size we must retire certain records. Many of these are still popular enough to sell quickly at a popular price. Within a few days you will receive our retired record list which will give you the full list of records to be sold at fifty-nine cents. If you need more of these 130 numbers you can get them from Columbia branches at fifty-nine cents, less your regular discount. We have discontinued the manufacture of these records, so the supply is limited.

"The majority of these records have been released within the last eighteen months. You will find on the list selections by such artists as Al Jolson, Art Hickman's Orchestra, Van and Schenck, Harry Fox, Guido Deiro, the Paul Biese Trio, Ted Lewis' Jazz Band, Henry Burr, Campbell and Burr, the Peerless Quartet, Sterling Trio, etc.

"We are going to advertise this sale in all parts of the country in the daily papers. The publicity value of this sale to your store will depend upon the degree of energy and enthusiasm with which you back it up. We will supply you with advertisements that will pull if you want to advertise it on your own account."

The 130 records on the retired record list included in this fifty-nine-cent sale are all ten-inch double-disc Columbia records, and these records will be eliminated from all future editions of the Columbia record catalog, and will not be pressed at the Columbia record plant in the future. The sale applies only to these 130 records, each one of which will carry a suitable label advising the public that the record is on the special retired list, retailing at fifty-nine cents.

PROSPECTS BRIGHT IN CHICAGO

H. B. Levy, Aeolian Co. Manager, Brings Encouraging Report From the West

H. B. Levy, manager of the Chicago branch of the Aeolian Co., who was at headquarters at Acolian Hall, New York, last month, had the following to say regarding the business situation in the West:

"Retail Vocalion business in Chicago over and since the holidays was very satisfactory. The Christmas Club carried on by Mandel Brothers, who retail the Vocalion in Chicago, pulled tremendous results, and although the advertising was on our two cheaper instruments, the average sale actually brought in by this advertising was very much in excess of the retail prices on the instruments featured.

"Possibly the most interesting development of our Chicago business is the merchandising of the new Red Record. These recordings are going through in such excellent shape and the product itself is of such distinctiveness that 1921 will undoubtedly be a great year so far as the sale of these records is concerned, not only in Chicago, but in the entire territory surrounding. This fact, coupled with the increased production program, enhances our agency terms tremendously. This is reflected by the many inquiries we are receiving, not only in Chicago, but elsewhere from our national advertising in the Saturday Evening Post, etc."

ESTABLISH FACTORY IN SHANGHAI

The Franco-Chinese Co., Ltd., has opened a factory in Shanghai to manufacture talking machines and records.

FORM NEW MOTOR CORPORATION

The Haidel Spring Motor Mfg. Corp. was recently incorporated in Delaware with an authorized capital of \$1,000,000. The incorporators are: C. T. Cohee, C. B. Outen and S. L. Mackey of Wilmington.

NOW WITH BALDWIN PIANO CO.

W. H. Youse and E. P. McDonald have resigned from the Period Cabinet Sales Co., at New Albany, and are now associated with the Baldwin Piano Co., in Louisville, Ky.

To be a good listener is sometimes as important with the salesman as to be a good talker. If possible, he should be both.



The No. 106 Shattuck Fibre Stand after its owner had traded the No. 6 Victrola

Has Your Distributor Approached You on These Beautiful Victrola Stands?

The demand for Fibre furniture is growing very rapidly. That is only one of the many reasons why the Shattuck hand-woven Fibre Stand sells.

Finished in Oak or Mahogany, or special finishes to match any settings, nothing is more beautiful, more practical, more economical.

Everybody likes these "Shattucks" and everyone can afford to have one. They'll sell your small machines.

The Shattuck Fibre Furniture Company
Makers of Quality Furniture
CLEVELAND :: OHIO

Ask your distributor how we furnish your booths and reception room

SELLING TALKING MACHINES

WHAT are your customers' requirements in a Talking Machine?

First, that it reproduce well. Second, that it adds to the Home picture.

With the first we have nothing to do, but with the second a lot.

The higher you raise the body of a Talking Machine Cabinet from the floor the less it fits into the picture and yet you must have legs to the Cabinet and you must apply something to make it easy to move.

Slides—Domes of Silence—are the only contrivances upon the market that do not unduly raise the Cabinet and yet help make it easy to move the machine from place to place, save strain upon the legs—save floors—save rugs.

This is the reason so many Cabinets from the high price period models down are today equipped with Domes of Silence.

**HENRY W. PEABODY
& CO.**

Domes of Silence Division

17 State Street

New York

Specify DOMES OF SILENCE



Riccardo Stracciari sings "La Paloma" with its imperishable charm just as they sing it in Madrid and all over South America. Stock up! Columbia 49758.

**Columbia Graphophone Co.
NEW YORK**



JONES ORCHESTRA IN NEW YORK

Celebrated Brunswick Record Makers Appear at Ziegfeld "Midnight Frolic" in Special Three-day Engagement on February 1, 2 and 3

On February 1, 2 and 3 the special feature at the Ziegfeld "Midnight Frolic" on the Amsterdam Roof in New York was the celebrated



The Isham Jones Orchestra

Isham Jones Orchestra of Chicago, which has won wide popularity through the dance records which it has made exclusively for the Brunswick records manufactured by the Brunswick-Balke-Collender Co. During the three nights' engagement the crowds on the roof were treated to a real musical dance festival.

Prior to the opening night and during the three days of the engagement the newspapers carried advertisements telling of the event and

announcing the fact that this orchestra recorded exclusively for the Brunswick-Balke-Collender Co., and the selections which were heard at the "Midnight Frolic" could be had on Brunswick records from any Brunswick dealer. The appearance of these artists in New York afforded good publicity for the dance records.

COLUMBIA RECORD PRICES REDUCED

Records by Non-exclusive Artists Reduced From One Dollar to Eighty-five Cents

Columbia dealers were advised this week by Geo. W. Hopkins, general sales manager of the Columbia Graphophone Co., that, effective February 1, all records by non-exclusive Columbia artists in the ten-inch double-disc blue label A series, ten-inch double-disc green label E series and ten-inch double disc C series will retail at eighty-five cents, instead of the former price of one dollar. Records by exclusive Columbia artists, consisting of the theatrical favorites, dance orchestras, etc., will continue to be sold at one dollar.

In his letter to the trade Mr. Hopkins stated that the records listed at this reduced price would be advertised generally, and that every form of co-operation would be offered to the dealers to enable them to take advantage of this important announcement. Attached to Mr. Hopkins' letter was a list of the Columbia non-exclusive artists whose records will hereafter retail at eighty-five cents.

PAUL BIESE JOINS COLUMBIA CO.

Prominent Orchestra Director of Chicago Takes Similar Post With the Columbia

G. C. Jell, general manager of the Columbia recording laboratory, announced this week that Paul Biese, director of the orchestra at the Pantheon Theatre, Chicago, Ill., and one of the best-known exponents of modern dance and popular music, will become associated with the



Paul Biese

Columbia Graphophone Co. on May 1 as an orchestra conductor.

Mr. Biese has won countrywide renown as one of the leading musical conductors in the popular field, and the Columbia records made by the Paul Biese Trio and the Paul Biese College Inn Orchestra have been enthusiastically received by Columbia dealers and the public.

Robert Hood Bowers, formerly one of the orchestra conductors at the Columbia record laboratory, resigned on February 1.

40 SONORA DEALERS IN KENTUCKY

The Robinson-Pettet Co., distributor of the Sonora in the State of Kentucky, recently carried an ad in the Louisville papers calling attention to the increased growth of Sonora demand in that State and pointed out that forty dealers are now handling the Sonora in Kentucky.

NO ILL EFFECTS FROM FIRE

The retail establishment of J. S. Case, located in Logan, Ohio, which was recently damaged by fire, is now in good shape again inasmuch as all the talking machine and record stock was removed in time so that the stock was but slightly disfigured.

The KENT MASTER ADAPTER



plays ALL RECORDS at their best on the EDISON DISC PHONOGRAPH



Write for particulars concerning this, the best known and largest seller of its kind in the market. Attractive prices and terms will be quoted you.

WE specialize in attachments for Edison and Victor machines; also soundboxes, diamond, sapphire and steel needles. Drawn brass tone arms made to order. Tube and pipe bends of all kinds successfully executed.

F. C. KENT CO. :: Specialty Manufacturers IRVINGTON, N. J.

whose phonograph accessories "win their way by their play"

SEND FOR ILLUSTRATED PRICE LIST AND FREE SAMPLE
"GLOBE" TRANSFER NAME PLATES
DEALERS EVERYWHERE APPLY THEM ON PHONOGRAPHS, PIANOS, ETC.
GLOBE DECALCOMANIE CO.
263 SUSSEX ST., NEWARK, N. J.

Sheraton⁷,

Colonial



Louis XV



Chippendale



Hepplewhite



The Console

This type of talking machine cannot be bought today except at a very high price—a price beyond the means of many people who want that type machine.

We have solved the problem by designing the five period models shown. These designs faithfully represent the periods. The cabinet work and finish are up to the usual LONG QUALITY standard.

These five "CONSOLES" are intended to be used in connection with the popular Victrola VI, producing a combination outfit that *looks like* a complete unit costing \$250.00, but which you can sell at a very moderate price—a price within the reach of all.

Orders received for them indicate that these cabinets have caught the popular fancy, and they are bound to be big sellers.

Place your orders NOW.

Write for copy of catalogue.

**The Geo. A. Long
Cabinet Company**
HANOVER, PA.

The Trade in PHILADELPHIA and LOCALITY

PHILADELPHIA, PA., February 8.—The talking machine business in Philadelphia during the month of January was very much better than was anticipated. For some reason unaccounted for the dealers had gotten it into their heads the month was going to be a bad one, so there was nothing else to do but let "nature take its course." They acted in a sort of attitude "Ye who enter here leave all hope behind," and seemed almost determined to make it a bad month in order that they should not have to undergo the humiliation of being mistaken if it should turn out to be a good month. Fortunately it turned out to be a good month, and it got better every day from the start. It was a much better January than the same month in 1920 and the dealers are entering the second month of the year with a firm hold on things, which looks most encouraging for the future. All the stores are very well stocked with goods and even the Victor jobbers are beginning to be able to get sufficient machines and records, something they have not been able to do for at least five years.

Dealers Hear Victor Officials Speak

All that remains to be done now is for the dealers to "go to it" and keep a level head. The jobbers have been getting busy in this regard and have been calling their dealers together and arranging special talks for them by men who are keenly alive to the situation and who will be able to give them some strong points on selling, especially under present conditions. One of these firms is the Louis Buehn Co., which held meetings on February 3 and February 7 which were attended by dealers throughout this territory. Prominent members of the Victor Co.

spoke. The story of these meetings, speakers, etc., is referred to in a special article in another section of the paper.

Columbia Co. Also Holds Meetings

The Columbia Graphophone Co. has also been having profitable meetings of its sales force and dealers throughout the territory. The first of these meetings was held on January 19 at the Bellevue Stratford and was attended by a complete representation from the sales department of the Philadelphia branch, which was addressed by George W. Hopkins, the general sales manager from the New York office. He went over the details of the policy of the company for 1921, the goal to be reached and the plan of action to be followed.

New Columbia Band Accompaniment Records

Another interesting meeting was held at the Columbia offices on the Tuesday following, January 25, which was addressed by W. A. Willson, the head of the educational department of the Columbia. It was held in the Model Shop at Sixth and Filbert streets. Among other things, and the most important, and which really brought him to Philadelphia, was the representation to the sales force of the new Columbia band accompaniment records for singing patriotic, sacred and old familiar songs in homes, schools and clubs. This new system, in which a uniform key will be used, will be brought out in ten records, each presenting four songs, which will be ready for distribution in March. The Columbia Co. believes that in this system it has struck an idea that is going to be very popular. As Mr. Willson explained, by adjusting the Grafonola to make the records sound softer or louder the accompaniment will

serve for a small group or a large assemblage. With the possession of these records a piano, an accompanist or a leader will no longer be necessary. All that is necessary is to possess the records and immediately there is available a well modulated accompaniment played by skilled musicians personally supervised by an authority on home, school and community singing, Peter W. Dykema, who has made the records in a uniform key.

Some Visitors at Columbia Offices

Manager Cummin, of the Columbia, has just returned home from a trip during which he visited the firm's dealers in Wilkes-Barre, Scranton, York and Lancaster. Among the recent visitors to the Columbia were: H. A. Yerkes, assistant general manager of the Columbia Co., accompanied by Joseph Baylis.

Territorial Dealers' Meetings Planned

Very shortly there will be held at the Philadelphia office what they call territory dealers' meetings, the object of which is to enlighten all the dealers on the company's plans for 1921. Dealers from the different territories will attend. These meetings in the past have been very well attended and have been very helpful to the dealers. M. J. Shaden, who has been added to the Columbia sales force, replacing W. S. Schreiner, has started to cover his territory in the western part of Pennsylvania.

Buehn Shows Victor Period Designs

The Louis Buehn Co. has finally succeeded in getting at least a sample of the Period Model Victors and have them now arranged to good advantage in the room it has given over to this purpose in its remodeled building. They

(Continued on page 110)

We Are Prepared

To aid **Our Dealers** in making this their biggest year in **Victor Merchandising**.

Increased **Victor Production** will call for more intelligent and concentrated application in sales methods. Constructive counsel will be given, when desired, on **Business Problems**.

We place at your command careful, fair and dependable methods of distribution. Also the use of our **Victor Period Model Salon**.

The Louis Buehn Company
OF PHILADELPHIA

THE REGINA "NATURE'S TONE" PHONOGRAPH

Distributed in Eastern Penna.—Delaware—Maryland and Southern New Jersey by

Send your inquiries direct for terms, territory and selling helps.

THE DUTTON CORPORATION
1025 ARCH STREET
PHILADELPHIA, PA.

We get back of every dealer and co-operate—not unload our stock on him.

One visit to our showrooms or a little correspondence with our campaign manager will soon prove "THE REGINA" fears no competition if you "let it speak for itself."



Models from
\$32.50 to \$350.00

THE TRADE IN PHILADELPHIA AND LOCALITY—(Continued from page 109)

present a very attractive appearance with the handsome new furnishings which have been added to the room. There are eight different period models in all, the last one to be received being the Louis XVI.

Change in Talking Machine Co. Branch

The Talking Machine Co.'s West Philadelphia branch, which has been located at Fifty-second and Chestnut streets for a number of years, is about to be removed to the second door from the corner, 103 South Fifty-second street in a new building just completed.

Aeolian Line for Philadelphia Show Case Co.

Several important changes were made by the Philadelphia Show Case Co. in January. It has given up the representation here of the Sonora and the Okeh records, and in their place has taken on the full Vocalion line of the Aeolian Co., both machines and records. Mr. Burkart, formerly of the firm of Blake & Burkart, has been given charge of the department. The Sonora Co., of Philadelphia, has been appointed distributor for the Sonora, as well as for the Okeh records, and has opened an establishment at 1214 Arch street on the sixth floor.

The Philadelphia Show Case Co. has made considerable change in its department, having moved the salesrooms and offices to the second floor and fitted up the third floor of the establishment as a showroom for the Aeolian-Vocalion machines and records. These are dis-

played in an attractive way and there is a piano in the room, so that the firm's customers can come in and make themselves at home, demonstrating anything the firm carries in the talking machine line and the Melodee music rolls.

Publish Interesting House Organ

The United Music Stores, of this city, are publishing an interesting house organ entitled "United Music Trades." This publication has already reached its third issue and has made for itself an important place among the dealers who secure their merchandise from the United Music Stores. Besides carrying a collection of news briefs of the dealers of the Quaker City and adjacent territory, space is devoted to a summary of the latest sheet music numbers which they job together with an itemized list of the releases of the Pianostyle and ConnORIZED rolls. This company also distributes Brilliantone and Reflexo needles, Kleernote player pumps, Satin-O polish, record albums, record covers and Grey Gull records.

Talking Machine Men Hear Address

At the dinner of the sales department of Stern & Co., dealers in talking machines and furniture at 712 Market street, which was held at the Bellevue-Stratford late last month, Edwin O. Lewis delivered an interesting address.

Robinson to Travel in Interest of Vocalion

James Robinson, formerly a traveling man for the Girard Phonograph Co., has become a trav-

eling representative of the Philadelphia Show Case Co. and will cover for that firm the States of South Jersey, Delaware and Maryland in the interests of the Vocalion line and the Melodee music rolls. Mr. Robinson has long been connected with the industry. A recent visitor to the Philadelphia company's offices was C. H. Tracey, of the Aeolian Co., New York.

Select Best-dressed Windows

The Emerson Philadelphia Co., distributor of Emerson records and phonographs, recently



Hopkins' Attractive Window

held a contest among dealers for the best-dressed window. The contest was held with the purpose of stimulating popular sales and providing increased incentive for attractive windows during the holiday season. The dealers photographed their windows and a great many photographs were submitted. The selection of the best photograph was very difficult due to the general attractiveness of all photographs submitted. In fact, it was impossible to select one best and the honor of first place was therefore divided between two, the Hopkins Piano & Phonograph Co., of Chester, Pa., and the Blue Bird Music Shop, of 6020 Lansdowne avenue, Philadelphia, Pa. We present an illustration of the first-named, but we may say that the Blue Bird window was also admirably arranged and of such merit that the judges had to divide honors for first place.

C. E. Gabriel Returns to the Fold

Charles E. Gabriel, after an absence of twelve
(Continued on page 112)



WEYMANN 1108 CHESTNUT ST.
ESTABLISHED 1864 PHILADELPHIA, PA.

Victor
Wholesale
Distributors

Victor Supreme

The Victor dealer who devotes his entire energy to the advancement of Victor merchandise in his Talking Machine Department will find that in turn his entire business will be greatly benefited.

At Your Service

H. A. WEYMANN & SON, Inc.
1108 Chestnut Street Philadelphia, Pa.

Q.R.S.
PLAYER
ROLLS

WEYMANN
KEYSTONE STATE
STRING
INSTRUMENTS

Keystone Die-Casting Co.
Norristown, Pa.

ALFRED C. RANTSCH
Pres. and Gen. Sales Mgr.

E. J. W. RAGSDALE
Treas. and Gen. Mgr.

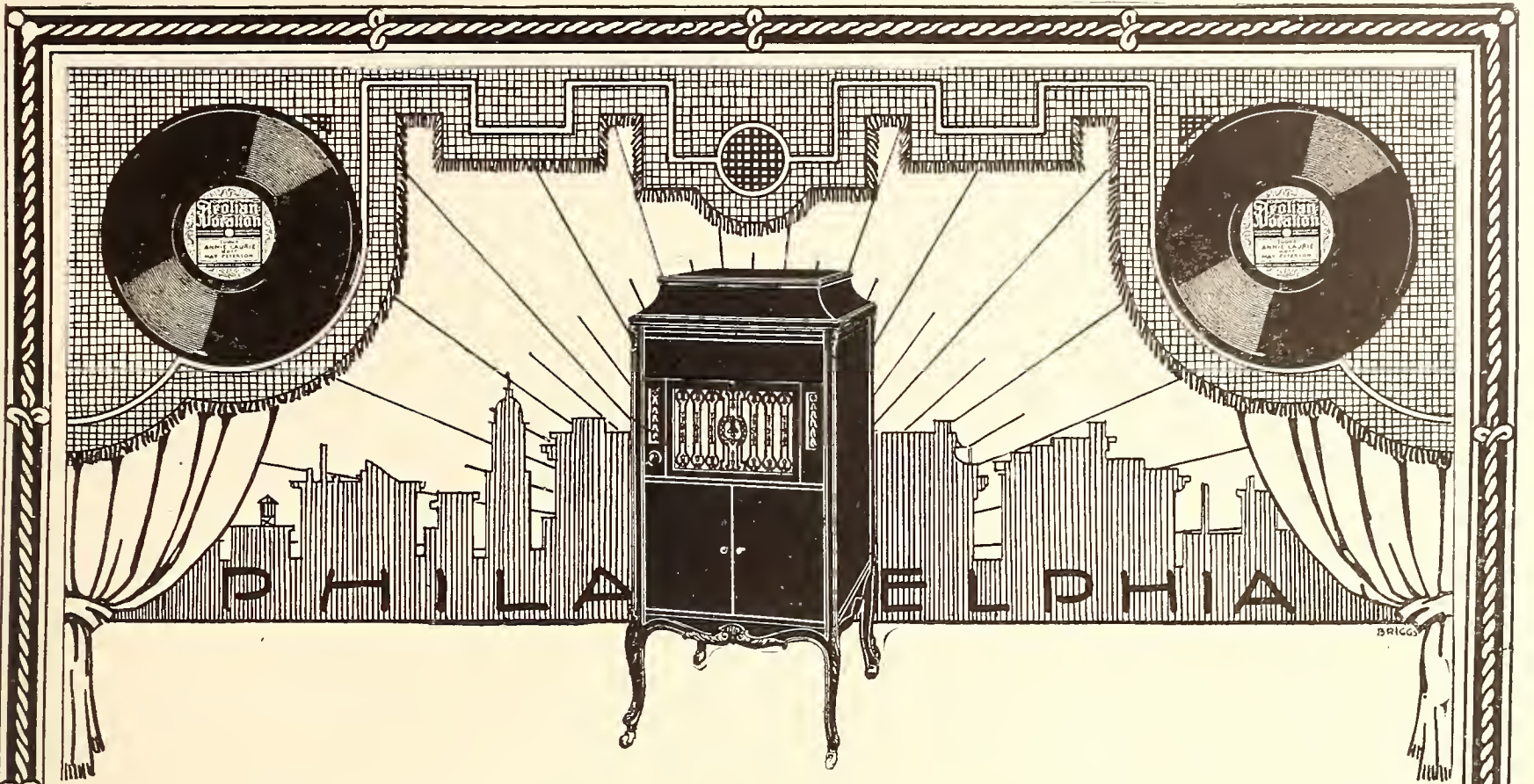

What sort of phonograph line do you, Mr. Dealer, want to sell?
 We believe the following are prime requisites:

VOCALION

Made by THE AEOLIAN COMPANY

- 1st, A quality line.
- 2nd, A complete line—both machines and records.
- 3rd, A line backed by a strong house—One that has proven it is in the phonograph business to stay.
- 4th, A line on which you can get service: That is, get goods when you want them and not have the goods crammed down your throat when you don't want them.
- 5th, A line on which you are protected; on which you know you will not have to divide the business with innumerable competitors handling the same line.
- 6th, A line where no attempt is made to coerce you into following the dictatorial policy of the distributor or manufacturer.

The Vocalion Line, made by the Aeolian Company, fulfills each and every one of these conditions. We believe the Vocalion Line, made by the Aeolian Company, to be so much the best line for the retailer that we gave up an established business of well over a Million Dollars a Year to become an Aeolian-Vocalion distributor.

PHILADELPHIA SHOWCASE CO

127 North 13th Street
 PHILADELPHIA

2002 Jenkins Arcade
 PITTSBURGH

"YOUR PHONE IS YOUR STOCK SHEET."

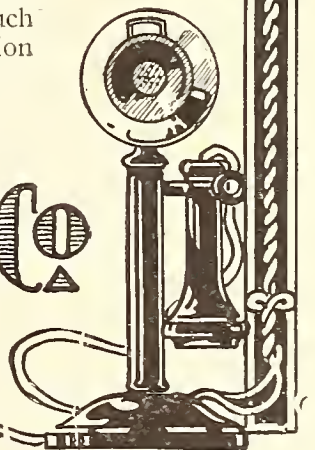
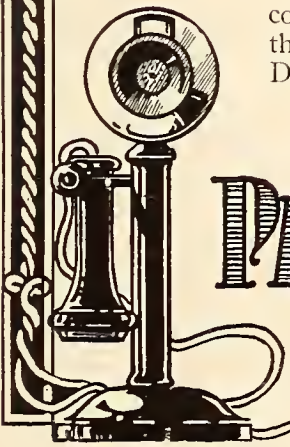

THE TRADE IN PHILADELPHIA AND LOCALITY—(Continued from page 112)

and another that winds the center of the spring. Both of these are important accessories to a talking machine shop and have been selling in large numbers. Philip Grabuski, of the Everybody's sales force, has just returned from a trip down in New Jersey, bringing with him some very substantial orders, and after remaining at home a few days he started on a trip to the South, covering every section as far down as Florida. Paul Baerwald, the general manager of the General Phonograph Corp., was a visitor to the office of Everybody's this week.

Consolidate Two Buildings

The United Music Store Co., located for some months at 619 Cherry street, has purchased the building adjoining, 617 Cherry street, and as soon as the leases of the tenants expire will convert the two buildings into one. The first floor of the present establishment is occupied by the offices and an extensive sheet music department. The second floor is the Pianostyle floor, where there is carried a line of more than 15,000 music rolls and large quantities of needles and pumps. The third floor is devoted to the Connorized roll department, where there is a stock of upwards of 50,000 rolls. The fourth floor is entirely given over to the foreign music rolls. The stock is said to be the largest carried by any one in this city consisting of about 30,000 picked numbers.

A. J. Heath Believes in Spirit of Optimism

A. J. Heath & Co. report that they had a very good Okeh record business in January and especially on the Mamie Smith records, for which they received very large orders. Their January business, like their December business, was 50 per cent better than any previous month. Mr. Heath says: "There seems to be a little optimism in the trade at the present time and even if business generally is not very much better I feel that as long as the dealers are showing a little optimism we do not need to wait long before things will reach a normal and satisfactory state." W. C. Fuhri, general sales manager of the General Phonograph Corp., was a visitor in Philadelphia the past week.

RECENT VICTOR LITERATURE

The Victor Co. has just sent out to its dealers a goodly budget of sales literature which, in the hands of enterprising dealers, should be productive of excellent results in a business way. In addition to the regular Victor record supplements there are attractive supplements in the following languages: Bohemian, Finnish, Greek, Hebrew (Yiddish), Hungarian, Italian, Mexican, Norwegian, Slovak, Swedish and Turkish.

SEEK CHANGE IN PENNSYLVANIA LAW

Efforts Being Made to Have Amended the Law Permitting of Seizure of Talking Machines in Cases of Execution Sales for Rent

An effort is to be made at the present session of the Pennsylvania State Legislature in Harrisburg to have amended the law which at present permits of the seizing of pianos, talking machines and other musical instruments for rent. The amendment, which reads as follows, has been introduced through the efforts of the Music Industries Chamber of Commerce:

"An act to exempt talking machines, phonographs and musical instruments of every description leased or conditionally sold to or hired by any person or persons residing in or having a place of business in this Commonwealth, from levy or sale on execution or distress for rent.

"Section 1. Be it enacted, etc., that all talking machines, phonographs and musical instruments of every description leased, conditionally sold to or hired by any person or persons residing in or having a place of business in this Commonwealth under a lease or contract of sale reserving title in the owner, lessor or vendor until paid for, shall be exempt from levy and sale on execution or distress for rent due by such person or persons so leasing or conditionally purchasing or hiring any such talking machines, phonographs and musical instruments of every description, in addition to any articles or money now exempt by law, so long as the title thereto remains in the owner, lessor or vendor; provided, that the owner, lessor or vendor of such talking machines, phonographs and musical instruments of every description, or his or their agent or agents or the person or persons so leasing or conditionally purchasing or hiring the same shall give notice to the landlord or his agent that the said talking machines, phonographs and musical instruments of every description are leased, conditionally sold or hired."

Dealers throughout Pennsylvania are urged to support the measure by writing to their State senators and assemblymen in its favor. "In my judgment every help should be given to have the bill passed," said George W. Pound, general counsel for the Chamber. "The present law is a discrimination against the talking machine and against music, and the moral effect is bad. Every music merchant should write to his legislative representatives in favor of the act."

Now, altogether, for a Spring drive for retail trade!

MAIN SPRINGS

Send for Price List

EVERYBODY'S TALKING MACH. CO.

Authorized Distributors

Heineman & Meisselbach Motors

38 N. 8th Street, Philadelphia

HUVER HEADS PHILA. ASSOCIATION

Officers of Victor Dealers' Association Chosen at Annual Meeting Last Month

PHILADELPHIA, PA., February 4.—The annual meeting of the Philadelphia Victor Dealers' Association was held on January 13 at the Bellevue-Stratford Hotel at 12.30, and the following officers were unanimously elected to serve for the year 1921: G. W. Huver, president; W. G. Linton, vice-president; H. Royer Smith, secretary, and A. C. Weymann, treasurer.

J. Ralph Wilson, the retiring president, declined a renomination for this office in a brief speech stating that while he felt that he did not wish to take the responsibility of the leadership of the association for another year, he wanted the new officers and members to feel that he was vitally interested in the success of the association and that he was anxious and willing when called upon to render any service at any time and in any way possible.

G. W. Whitney, general manager of C. J. Heppe & Son, in a very fitting speech, called the members' attention to the splendid work that Mr. Wilson had done in organizing and bringing the association to its prosperous condition at the present time.

The new president appointed the following executive committee to serve for the year 1921: G. W. Whitney, of E. J. Heppe & Son; J. R. Wilson, of J. R. Wilson Co.; Herman Cole; Manager McCarthy, of Gimbel Brothers, and General Manager Ellis, of the Talking Machine Co.

LOUISVILLE SONORA SHOP BUSY

The Sonora Shop, of Louisville, Ky., is now occupying permanent and attractive quarters at 650 South Fourth street. M. D. May, who is the proprietor of this shop, reports an increasing demand for the Sonora. A number of new booths have recently been installed, making five in all which this shop operates. All stores report increasingly good business.

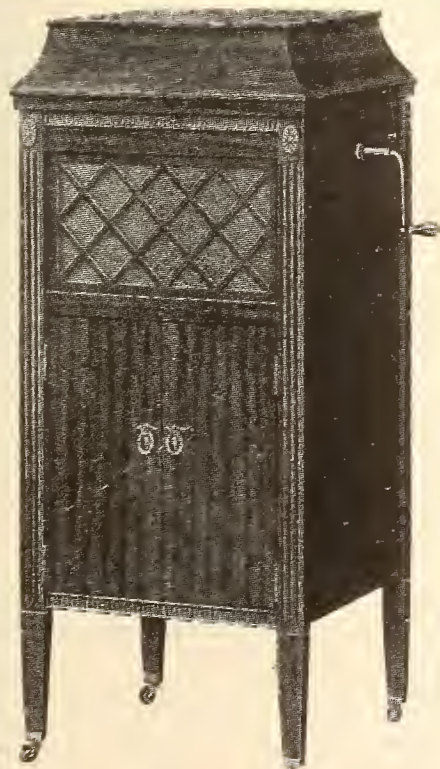

MODEL C

Lyrolian
MARVELOUS TONE QUALITY

PLAYS ALL RECORDS
Six Beautiful Models

We offer attractive proposition to
DEALERS and DISTRIBUTORS

We can make immediate shipment on all models.

Distributors Wanted in Several States

AMERICAN TALKING MACHINE CO., Inc.

GENERAL OFFICES AND FACTORY

BLOOMSBURG, :: PENNA.



WE ARE DISTRIBUTORS FOR
LYRIC LATERAL RECORDS

Dealers Supplied on Short Notice
Supplying you with Bulletins, Hangers, Cut-outs and Advertising Matter is one feature of

LYRIC SERVICE

TO RECORD ON PACIFIC COAST

E. N. Burns, of Columbia Co., Leaves for San Francisco in Order to Secure Some Additional Records by Art Hickman's Orchestra

E. N. Burns, vice-president of the Columbia Graphophone Co., who is devoting practically all of his time to the recording division, left for the Pacific Coast on Sunday with a recording equipment for the purpose of making an additional series of Art Hickman's Orchestra records. This famous exclusive Columbia artist and his orchestra are now playing at the St. Francis Hotel, in San Francisco, where they are steadily increasing their tremendous popularity and prestige.

It is possible that Mr. Burns will also make a series of records by Ted Lewis and his band, as this well-known orchestra and exclusive Columbia artist are at present also sojourning on the Pacific Coast.

CO-OPERATING WITH DEALERS

Griffith Piano Co., Newark, N. J., Sonora Jobber, Rendering Efficient Service to Dealers—Enthusiastic Regarding Period Model Business

The Griffith Piano Co., Newark, N. J., Sonora jobber, which has been notably successful in developing sales in its territory, has devoted particular attention to stimulating the demand

REYNOLDS
 - MOBILE ALABAMA -
VICTOR DISTRIBUTOR
 HIS MASTER'S VOICE
VICTOR VICTROLAS
VICTOR RECORDS
SERVING VICTOR DEALERS
 IN
'ALABAMA'
'MISSISSIPPI'
'FLORIDA'

quickly, and that their sales possibilities are unlimited. In our Newark store we placed a Sonora Chippendale in our window and sold two in a few hours. In fact, in one day we sold six period models because passers-by admired the models in our window display.

"Our experience has absolutely 'sold' us on period models, and we look forward to a very big year in this type of Sonoras. About sixty per cent of our total advertising will be devoted to featuring period models. The instruments will be featured extensively in all of our sales plans, and our dealers will be given every opportunity to take advantage of our experience and our organization in the development of period model business."

OPTIMISTIC OVER OUTLOOK

A recent visitor to New York was W. F. Hitchcock, president of the Phonomotor Co., Rochester, N. Y. He was accompanied by his son, and called upon the leading members of the trade in this city in the interest of the electric talking machine motor and automatic stop which his firm manufactures. Regarding trade conditions Mr. Hitchcock was optimistic and reported a steady improvement not only in his territory, which he recently visited, but also throughout the Canadian trade, which he had previously toured in order to learn of conditions there.

AKRON HAS WIRELESS CONCERTS

Young Radio Enthusiast Entertains Nearby Operators Twice Daily With Song Hits

AKRON, O., February 5.—Sending music by wireless is the latest accomplishment of Donald A. Hoffman, 50 S. Balch street, this city. Daily, between the hours of 3 and 4 and 6 and 7, the notes of the latest records are sent out on air waves and are picked up by the wireless operators within a radius of forty miles. With an ordinary receiving outfit the musical waves can be picked up, Hoffman says. The concerts have been sent out every day this week.

"With the attachment of certain coils to magnify the sound at the receiving end and the addition of a horn similar to that on an ordinary talking machine, the wireless concerts can be received in any part of the city with the same volume of sound as when records are played on the machine," Hoffman says. "There would be no more difference in the sound from the horn at the receiving end than if the horn was part of an ordinary talking machine."

According to Hoffman the sound is picked up at South Akron station so strong with the ordinary wireless head receivers that it can be heard all over the room. When the wireless receiver is placed to the transmitter of a telephone the playing music can be plainly heard in the receiver at the other end of the line.



Busy Home of Griffith Piano Co.

for Sonora period models. Its efforts have met with a hearty response from the dealers, and the Griffith sales organization is co-operating to excellent advantage with Sonora representatives in handling this business.

Commenting recently upon the possibilities for 1921 Sonora period model business, one of the executives of the Griffith Piano Co. said: "Dealers who stocked Sonora period models as an experiment have found that they sell

Quality

Distinction

The "VICSONIA" Reproducer

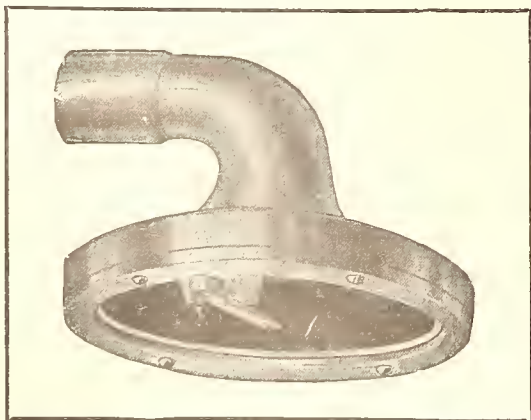

Recognized for its Perfect interpretation of Edison Disc Records on Victrolas and Grafonolas.

Fitted with permanent jewel point. No loose parts.

Note: The Vicsonia is made of **Bronze**, sand casted and machined to measurement. Finished in heavy Nickel or Gold plate. Flexible stylus.

Meet the demand—Serve your customers

Sample Model "A" or "B" Vicsonia will be sent on receipt of \$4.50. Retail price \$7.50.

Note: Model "B" Vicsonia plays both **Edison** and **Pathe** records

VICSONIA MFG. CO., Inc.

313 E. 134th STREET

NEW YORK, N. Y.



AL JOLSON says;
Oh, What a Fox-Trot is —

"GRIEVING FOR YOU"

You can't go wrong with any *Feist* song

Published by LEO FEIST Inc., Feist Bldg, New York

BUYING PUBLIC IN TWIN CITIES AGAIN IN THE MARKET

Trade Somewhat Slow, but Optimism Prevails as to a Good Volume of Trade Later in Year—Jobbers and Dealers Tell of Conditions and All Plan Vigorous Campaign for Trade

MINNEAPOLIS and ST. PAUL, MINN., February 3. —Although the trade situation in the Twin Cities and tributary territory appears to be somewhat easier, it cannot truthfully be said that conditions have settled down to a normal basis. Retail merchants think that the general public is much better disposed and better tempered than it has been for some months past and is not tugging so hard on the purse strings as it was. They may be right, but if so there is hardly any noticeable improvement in the results obtained by the music merchants unless among those dealing mainly in talking machines.

Local dealers who loaded up rather heavily last Fall in expectation of a great holiday trade are still carrying larger stocks than they like to have at this season of the year. Quite a number of dealers escaped this predicament by canceling orders that had not been shipped. Between the dealers who are unable to settle for their orders and those who sent in cancellations the lot of the distributing houses hardly is an enviable one.

And still one will find no gloom in the music marts of Minneapolis and St. Paul. There is an air of optimism and confidence in the future that is very gratifying to all. The Winter always is slow in the great Northwest and, after all, it is not believed that the net returns for the early months of 1921 will fall below the general average for a comparative period. In fact, some houses will show a better figure than the average, though hardly comparable to 1920.

"We have no complaint whatever as to the state of our business affairs," said Jay H. Wheeler, head of the Pathé department of G. Sommers & Co. "We realize that business conditions have been somewhat disturbed through

various causes, but we dislike to harp on such things. It may be that we could handle more orders and yet we frankly say we find the results generally satisfactory, in view of the troubled affairs in the commercial world."

Matters are moving quite nicely with W. J. Dyer & Bro., Victor distributors. Why, George A. Mairs, head of the department, even has the temerity to complain that he can't get enough goods. It should be explained that he has had some difficulty in obtaining certain models which are in demand. Of late the shipments of Victor goods have been quite satisfactory.

Laurence A. Lucker, distributor of the Edison machines and records, states that he reviews the past year with entire satisfaction. Business success, he figures, should not be measured by weekly or monthly results, but by the year, and the year 1920, taken as a whole, was a joy and a pride. There is no reason to doubt that 1921 will be other than an excellent year when once normalcy has been attained, which probably will be by early Spring.

The Stone Piano Co. has been conducting a systematic and well-arranged advertising campaign for the Aeolian-Vocalions and this instrument now is regarded in the Twin Cities as one of the standard machines of the day.

FORT WAYNE HOUSE TAKES LEASE

FORT WAYNE, IND., January 31.—The Ulrey Music Shop, 1520 South Calhoun street, has taken a long-time lease on the two floors just above the Windsor jewelry store, 1204 South Calhoun street. Mr. Ulrey says an upstairs location with cheaper rent will enable him to give better values. He will carry all makes of records.

ROBT. H. BOWERS WITH AEOLIAN

Noted Musical Authority Becomes Musical Director of Vocalion Recording Studios

Robert Hood Bowers, noted musical authority and composer of operettas and other works, has joined the staff of the Aeolian Co. as musical director of the Vocalion recording studios. Mr.



Robert Hood Bowers

Bowers is well qualified for the new post inasmuch as he has for several years past been connected with another prominent talking machine company in a similar capacity and with great success. He has already taken up his new duties at the Vocalion studios in New York and it is expected that the results of his efforts will soon make themselves apparent.

Mr. Bowers' experience as a composer and as a director has given him a thorough insight into musical values, a knowledge of the sort of music that appeals most to the public and the proper manner of producing or reproducing it through the medium of the talking machine record.

New! APEX Fibre Needle Cutter

Cuts with the grain to the point.
Makes the use of fibre needles as cheap as steel.
No variation in angle or size of cut.
Does not crush the shell.

Small Size—Simple Construction
For sale through jobbers and dealers.

Retail Price \$1.50

Manufactured by

W. H. WADE 14 N. Michigan Avenue
CHICAGO

New!

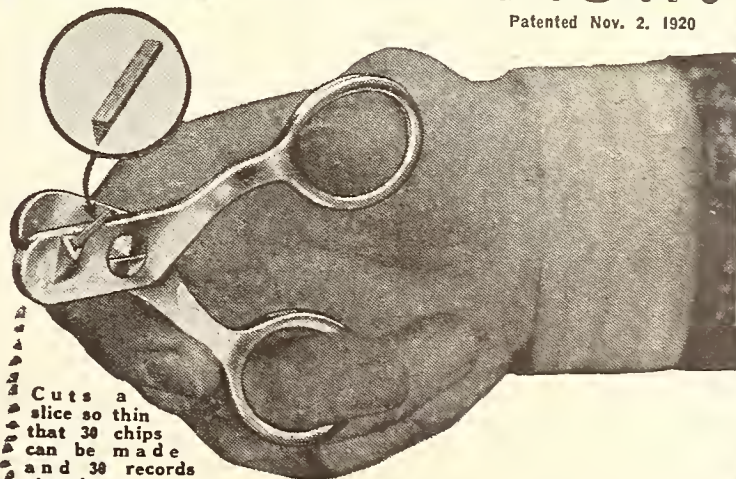

New!

Patented Nov. 2, 1920

Cuts a slice so thin that 30 chips can be made and 30 records played with one fibre needle.

THE SCOTFORD TONEARM AND SUPERIOR REPRODUCER

Manufactured under the Patents of LOUIS K. SCOTFORD

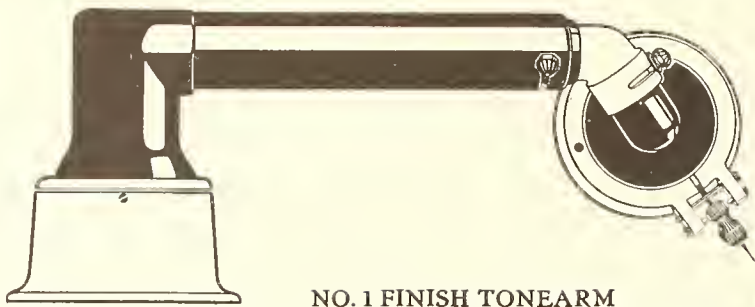

NO. 1 FINISH TONEARM
Plated Base, Black Main Elbow and Tube, Plated Connection with No. 1 or No. 2 Finish Reproducer

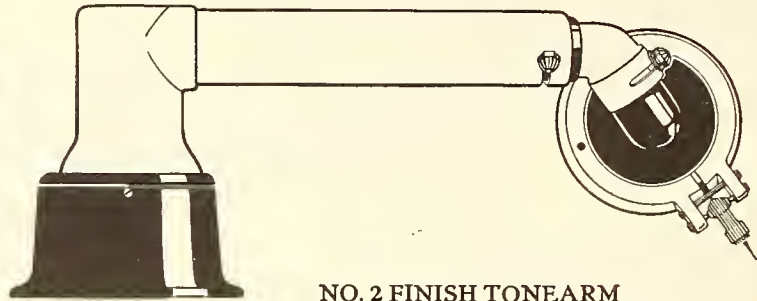

NO. 2 FINISH TONEARM
Black Base, Plated Main Elbow and Tube, Plated Connection with No. 1 or No. 2 Finish Reproducer

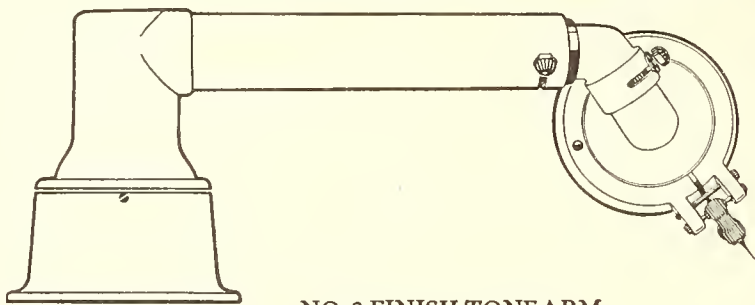

NO. 3 FINISH TONEARM
with No. 3 Finish Reproducer
All Parts Plated



NO. 1 FINISH REPRODUCER
Black Face Ring and Back
Plated Frame

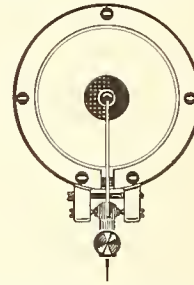

NO. 2 FINISH REPRODUCER
Plated Face Ring and Frame
Black Back

No. 1 Finish is recommended as most practical, most durable, best looking and lowest priced

NO. 3 FINISH REPRODUCER
All Parts Plated

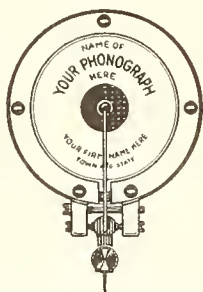

MICA DIAPHRAGM
Your Nameplate

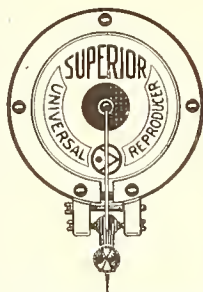

MICA DIAPHRAGM
"Superior" Nameplate

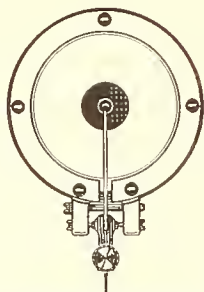

MICA DIAPHRAGM
Plain Gilt Plate

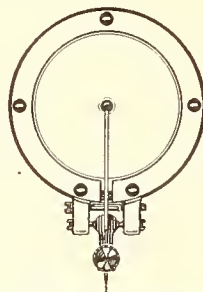

MICOMPO DIAPHRAGM
Plain Gilt Plate
"Superior" Nameplate
or Your Nameplate

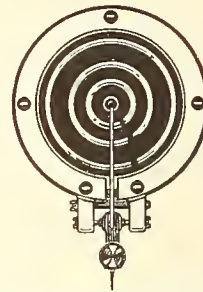

BLACK DIAPHRAGM
Plain Black
Gilded
or Your Nameplate

Customer to furnish the necessary Decalcomania Transfers when ordered with individual Nameplate

Order should Specify (1) Style Number of Finish, (2) Kind of Plating, (3) Kind of Diaphragm and (4) whether "Superior" Nameplate or Plain

No. 1 Finish is recommended as a pleasing combination of japanned and plated parts which is very practical and durable. In this style, the most handled parts of the Tonearm and Reproducer are given several coats of black rubber japan baked on at high temperature. The effect is a rich gloss which retains its lustre and will outwear any kind of electroplating. The contrast of the black parts with the plated parts of Platinoid, Nickel or Gold is very effective. The black face ring of the reproducer in this finish is not recommended in connection with the Black Composition Diaphragm nor with a name plate design in which the background is black. But it is highly attractive with the Black Diaphragm Gilded or with a name plate design of gold background. For the Black Diaphragm or black name plate, No. 2 finish Reproducer is recommended, which may be used with No. 1 or No. 2 Tonearm

Platinoid is a new electro-plate which will not tarnish. It looks like Platinum or Silver but costs no more than Nickel

Prices on 100 or Larger Quantities will be Quoted on Application

QUANTITY PRICES

Effective January 1, 1921

SCOTFORD TONEARM and SUPERIOR REPRODUCER Combined	STYLE 1 FINISH		STYLE 2 FINISH		STYLE 3 FINISH	
	PLATINOID OR NICKEL	POLISHED ROMAN GOLD	PLATINOID OR NICKEL	POLISHED ROMAN GOLD	PLATINOID OR NICKEL	POLISHED ROMAN GOLD
24 and less than 100, per set.....	5.25	6.90	5.50	7.45	5.75	8.10
6 and less than 24, per set.....	5.45	7.20	5.70	7.75	5.95	8.40
2 and less than 6, per set.....	5.65	7.50	5.90	8.05	6.15	8.70
Sample delivered prepaid.....	7.00	9.00	7.75	10.00	8.50	11.00

Deduct 50 cents from price of sample and 30 cents each from quantity prices 2 or more for the Reproducer with Micompo or Black Composition Diaphragm

Length 8 1/2 inches from center of tonearm base to needle point. Inside diameter of base 2 inches. Diameter of base flange 3 1/8 inches. Height from bottom of flange to top of main elbow 3 3/8 inches. Special Low Base can be furnished for cabinets having shallow lids. The Low Base is 5/16 inch lower than the standard base, making the height from bottom of flange to top of main elbow 3 1/8 inches

EXTRA CHARGE FOR SPECIAL LENGTH

The Tonearm is regularly made with 5-inch tube, and combined with the Superior Reproducer, the measurement is 8 1/2 inches from center of the base opening to needle point. Must be mounted so that the needle centers on the turntable spindle, otherwise the needle cannot center the groove when playing. Special lengths to order at these prices:

500 and over delivered at one time, each....	No extra charge
250 and less than 500 delivered at one time, each....	\$0.05
100 and less than 250 delivered at one time, each....	.10
24 and less than 100 delivered at one time, each....	.15
6 and less than 24 delivered at one time, each....	.20
2 and less than 6 delivered at one time, each....	.50
Sample.....	1.00

NOTE—Special lengths are not carried in stock, but require extra time to manufacture. We recommend that where possible the standard 8 1/2 inch length be adopted. This affords the ideal weight, 5 ounces to 5 1/4 ounces at the needle point, and the correct radius for playing 14 inch, 12 inch and smaller records

SAMPLES ON APPROVAL TO RESPONSIBLE RATED FIRMS

BARNHART BROTHERS & SPINDLER

Monroe and Throop Streets CHICAGO

PATENTED
January 13, 1920

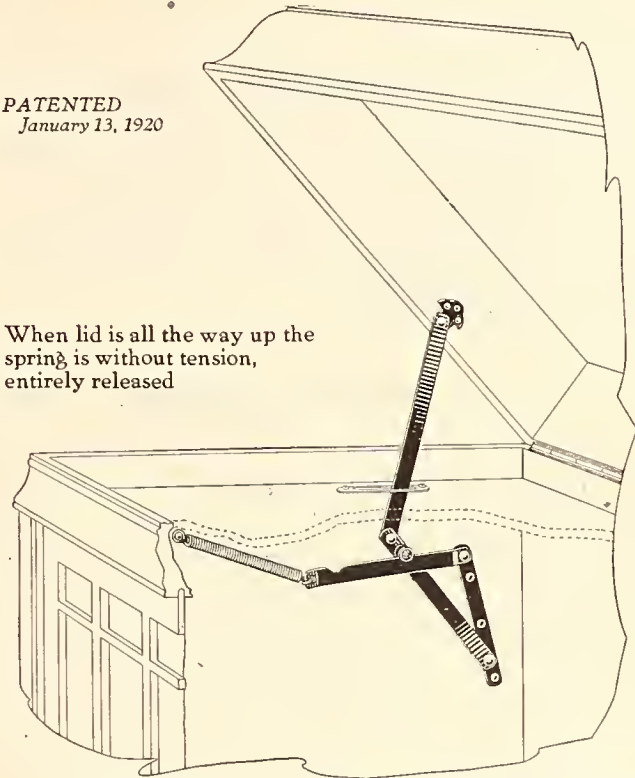

When lid is all the way up the spring is without tension, entirely released

The SUPERIOR LID SUPPORT

The Spring Balance that Does Not Warp the Lid

A mere touch of the finger lifts or closes the lid, which stops at any point desired. The simplest support made. Easiest to install. Positive and noiseless in operation

The material used in the manufacture of this support is the best cold rolled steel, and takes a high finish. The plating is of fine quality. Black Rubber Japan is recommended as a durable and economical finish suited to any style of cabinet finish

When lid is closed the steel roller fits into the notch of track-arm, preventing spring from exerting any pull on the lid while down

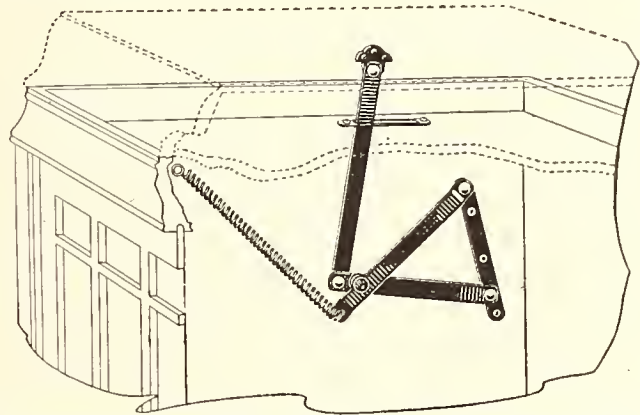

QUANTITY PRICES	BLACK RUBBER JAPAN		PLATINOID OR NICKEL		POLISHED ROMAN GOLD	
	With Escutcheon	Without Escutcheon	With Escutcheon	Without Escutcheon	With Escutcheon	Without Escutcheon
500 and over, each.....	\$0.40	\$0.35	\$0.45	\$0.40	\$0.85	\$0.70
250 and less than 500, each...	.45	.40	.50	.45	.90	.75
100 and less than 250, each...	.50	.45	.55	.50	.95	.80
24 and less than 100, each...	.55	.50	.60	.55	1.00	.85
6 and less than 24, each...	.60	.55	.65	.60	1.05	.90
2 and less than 6, each...	.65	.60	.70	.65	1.10	.95
Sample delivered prepaid.....	.75	.75	.75	.75	1.25	1.25

Coil Spring is of the required strength for operating the average lid. For extra heavy lids a DOUBLE STRENGTH SPRING can be furnished at an extra charge of 10 cents each. The Lid Support as regularly supplied fits the left side of cabinet, but on special order can be made for the right side at no extra charge. Eight Screws are furnished for each Support with Escutcheon, six Screws for each Support without Escutcheon

The SUPERIOR UNIVERSAL REPRODUCER

Connections are provided for applying the Superior Reproducer to several standard machines, thus equipping these machines for playing all makes of records. Jobbers and Dealers in phonographs and records may with this line make it easier to sell their machines, and greatly extend the demand for records. Owners of old machines, when supplied with this new and improved means of playing, renew interest, and again become buyers of records



VERTICAL

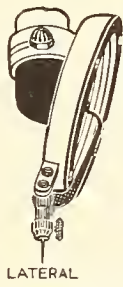

LATERAL

In turning the Reproducer from one position to the other the needle remains on the same center at the same angle

Connections shown are for applying the Reproducer to different machines named

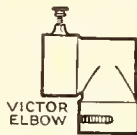

VICTOR ELBOW



GOOSENECK FOR VICTOR

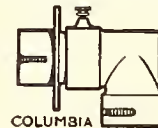

COLUMBIA



PATHE



EDISON

QUANTITY PRICES on Application

ORDER BY NUMBER	RETAIL PRICE
Superior Reproducer with 21-VE Victor Elbow.....	\$6.50
*Superior Reproducer with 21-VGN Gooseneck for O. S. Victor.....	8.00
Superior Reproducer with 21-CC Columbia Connection.....	7.00
Superior Reproducer with 21-P Connection for O. S. Pathe.....	7.00
Superior Reproducer with 21-E Connection for Edison.....	7.50

Nickel and Japan	Gold and Japan
\$6.50	\$8.50
8.00	10.75
7.00	9.50
7.00	9.50
7.50	10.00

*For the older type Victor having the small tonearm manufactured prior to 1918, the 21-VGN Gooseneck Connection is preferred, for the reason it takes the place of the regular Victor Gooseneck into the tonearm. The 21-VE Elbow is correct for newer Victors having the enlarged tonearm; it may be used for older type small tonearms, but the volume of tone is not quite full, as the elevated position of the Victor Gooseneck with the Superior causes partial closing of the opening from gooseneck into the tonearm

The SCOTFORD MODEL I REPRODUCER

This is the original Scotford Reproducer, designed to equip Victor and Columbia machines for playing vertical cut (hill-and-dale) records. It plays only vertical cut records, such as Edison and Pathe, but plays them at their best.

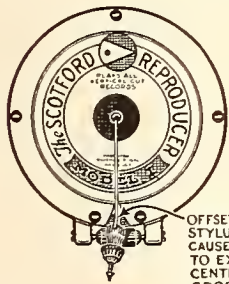

OFFSET OF STYLUS BAR CAUSES NEEDLE TO EXACTLY CENTER THE GROOVE

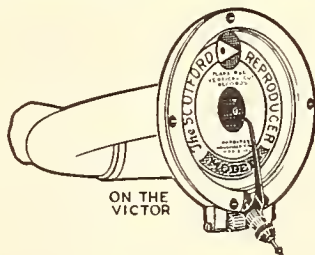

ON THE VICTOR

The Reproducer is made to fit the Victor exactly; with the connection shown below, it may be attached to the Columbia

CONNECTION FOR COLUMBIA

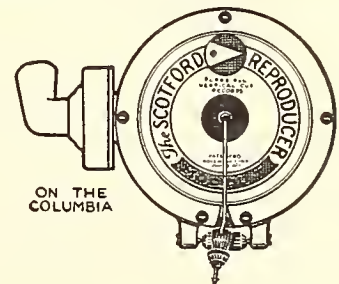
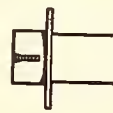

ON THE COLUMBIA

QUANTITY PRICES on Application

ORDER BY NUMBER	RETAIL PRICE
Scotford Model I Reproducer 1-V for Victor.....	\$6.00
Scotford Model I Reproducer with 1-C Connection for Columbia.....	6.75

Nickel and Japan	Gold and Japan
\$6.00	\$7.50
6.75	8.75

Many owners of Victor and Columbia machines prefer to use their regular reproducers for playing Victor and Columbia records. For all these, the Scotford Model I Reproducer affords the ideal means of playing records of the vertical cut. It takes but a moment to remove the regular reproducer and attach the Scotford. Fits the Victor exactly, and with the connection shown, it may be readily attached to the Columbia tonearm. This Reproducer has a large Diaphragm, and is the finest obtainable for playing Edison, Pathe and records of similar cut on the Victor and on the Columbia

Samples sent Prepaid at the Retail List Price

BARNHART BROTHERS & SPINDLER

Monroe and Throop Streets CHICAGO



Sell your customers who ask for waltzes "Baby Dreams" and "I'll Be With You In Apple Blossom Time," played by Prince's Orchestra, and they'll be back the following morning for more. A-6177.

Columbia Graphophone Co.
NEW YORK

REAWAKENING OF TRADE IN THE ST. LOUIS TERRITORY

Higher Priced Machines Have Call—Collections in Excellent Shape—Ennis and Castleman Welcomed—Jackson Tells of Brunswick Activities—How Co-operation Helps—News of Month

St. Louis, Mo., February 7.—The talking machine business in St. Louis is still slumbering, but retailers and distributors think that they can discern stirrings which portend a reawakening. The most sanguine do not expect the awakening to be boisterous, but they believe that with the coming of Spring the awakening will be followed by a fairly active movement. In a retail way there appears to be a tendency to drop down from the highest priced machines to what might be called the second rank, machines that retail for \$150 to \$250. The only explanation suggested is that it is an expression of the general conservatism which prevails. On the other hand there is practically no demand for the cheaper machines. Most of the dealers in St. Louis and the St. Louis jobbing territory carried pretty full stocks over the holidays and they have been exerting them-

selves since to work this stock off in the expectation of reduced factory prices or the putting out of new models at lower prices. During this operation, naturally, they have not been buying. Reports are that they have been fairly successful and that they will shortly be in a position to begin buying. The overstocked condition after the holidays, it seems, was not so much in standard makes as in the other makes, but the effect is the same as if the dealers had been overloaded with standard machines, so far as their capacity for buying is concerned.

One encouraging fact is the improvement in collections. Distributors say that, whereas a short time ago dealers had to confess themselves unable to make any payments at all, now there are few who are failing to make substantial payments. A better feeling is reported among the dealers than prevailed shortly after the

holidays. The realization is general that they all have to get back to a selling basis.

The sales of records have been but little affected by the general business stagnation. All retailers say that the demand for new releases is as keen as it ever was and that there is a steady call for the old favorites.

Conditions Show Betterment

The monthly report of William McC. Martin, Federal Reserve agent for the Eighth District, notes a decrease of general business pessimism and some improvement in conditions throughout the district. This explanation is given:

"This reverse psychology is based on the opening up of scattered buying, not particularly noteworthy in volume, but of a character indicating that stocks of merchandise have reached a point where they must be replenished and that a good part of the war inflation has been absorbed by the leveling of prices. In lines where the readjustment has made greatest progress, buying is heaviest. The public is in need of goods and is more disposed to fill its requirements than was the case during the closing months of last year. In a number of important lines there seems to be a greater degree of stability, deflation having gone sufficiently far to restore confidence in future values. This has resulted in the placing of some fair orders by retail merchants, and wholesalers have also begun to build up their stocks. Most of the buying, however, is for immediate delivery, there being relatively little done in the way of future commitment. Ultra caution is still the dominating feature among distributors of merchandise, and ultimate consumers have relaxed their recent regime of economy only to the extent of taking what they are obliged to have, or what they may require at very evidently reduced prices.

"Generally the holiday trade was moderately satisfactory only. Great quantities of goods were moved, however, and the opening of the new year found stocks in much better shape than was thought possible two months ago."

Welcome for Mr. Castleman

St. Louis Victor dealers have been making the acquaintance of the factory representative recently appointed to the Missouri territory, Mr. Castleman. Missouri has been without a representative for the past six months and welcomes Mr. Castleman, as well as Morris de C. Freeman, who has returned to the western Illinois territory. Mr. R. J. Coleman, of the educational department of the Victor Co., was also a St. Louis visitor recently, and is working in the schools of southwest Missouri at present.

F. E. Ennis Takes Charge

F. E. Ennis, formerly manager of the phonograph department of the Bloomingdale Store in New York, arrived in St. Louis late in January and took charge of the phonograph department of the Stix, Baer & Fuller Co., succeeding John Maunder, who had been temporarily in charge, following the departure of W. J. Medairy, who resigned to take charge of a department at Atlanta, Ga. Mr. Ennis has taken hold with energy, assisted by Mr. Maunder, who

QUALITY and SERVICE

Both are synonymous with us

Built on 18 years' experience of scientific experiment and accomplishments in the manufacture of high-grade phonograph parts.

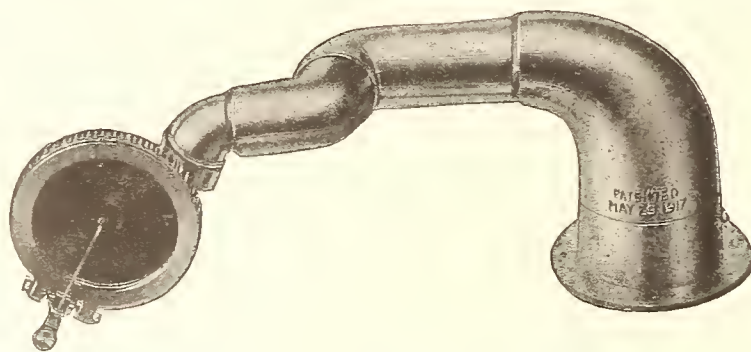

The New Mutual No. 3 Tone Arm

and the New Mutual No. 5 Sound Box, have proved a wonderful success. Write for sample.

Ask for our new revised price list and full particulars

The Mutual
TONE ARMS & SOUND BOXES

PHONO PARTS CORP.

149-151 Lafayette St.

New York City

will remain with the department, and is working out plans for giving the department new impetus.

Mr. Medairy has given up his Atlanta connection on account of ill health, and has returned to St. Louis. He is reported to be rather seriously ill at his home.

Re-elected President

Joseph B. Hellrung, assistant manager of the Hellrung & Grimm Housefurnishing Co., has been re-elected president of the Retail Furniture Dealers' Association.

Changes Name of Company

J. H. Kirkland has purchased the piano and talking machine business of the Horras Piano Co., on Twelfth street, and has changed the name to the Kirkland Piano Co. The Brunswick talking machine is handled.

Brunswick Sales Stimulated

Manager Jackson, of the Brunswick-Balke-Collender Co., says the increase in the sales of Brunswick records is very gratifying and that the movement of machines is improving. "The tendency," he said, "is for dealers who bought up makeshifts during the period of shortage to clean them out and the standard lines are handicapped by that liquidation. They all realize that they have got to get back to the selling basis. The potential market has not changed. The demand is best for the \$250 Brunswick. It has a wider field than the more expensive models and its sales are steadily increasing."

Theodore Karle, tenor, made his first appearance in St. Louis early in February since he became a Brunswick artist, and the sale of his Brunswick records was greatly stimulated.

A. J. Kendrick, sales manager of the phonograph department of the Brunswick-Balke-Collender Co., was in St. Louis in the early part of the month on his way to Chicago.

Miss Rosebrugh Makes Address

Miss Blanche Rosebrugh, of the Victor educational department of Scruggs-Vandervoort & Barney, was invited recently to speak before the Eighth District Federation of Music Clubs of Missouri on the subject of the influence of me-

chanical reproducing instruments on music in the schools. Dr. J. W. Withers, superintendent of St. Louis schools, preceded this with an address on the effect of music appreciation study in our schools.

Edison Demand "Remarkably Good"

Mark Silverstone, president of the Silverstone Music Co., says the Edison retail trade is remarkably good and the wholesale business is improving. Dealers, he says, have to a great extent cleared out the stocks that they carried over the holidays and will soon be buying normally. Mr. Silverstone will go to Montreal to attend the Edison jobbers' convention and expects also to visit the Edison laboratories.

To Open St. Louis Branch

The Smith Drug Co., St. Joseph, Mo., jobber for Missouri for the Sonora phonograph, is arranging to open a St. Louis branch in the Arcade Building. It has not been announced who will be in charge of it.

To Attend Convention in Montreal

C. P. Curry, treasurer of the Texas-Oklahoma Phonograph Co., Dallas, Tex., passed through St. Louis on his way to the Edison jobbers' convention at Montreal.

A. F. Odell, an Edison dealer of Quincy, Ill., accompanied by his wife, has gone on a pleasure trip to San Antonio and Los Angeles.

Value of Co-operation

That Fritz Kreisler is a favorite with St. Louis concertgoers was proved again when the S. R. O. sign was in evidence days before his recent concert in this city. The same thing happened last Spring at his fourth appearance during the season. Three exclusive Victor dealers used the medium of the program with full-page reminders of his Victor records, and Victor stores over the city kept the public informed as to where his records might be heard.

Columbia News Brieflets

Manager Edwin M. Morgan, of the Columbia Phonograph Co., has returned from a business trip to Memphis, Tenn., and Little Rock, Ark.

A. W. Roos, assistant manager of the Columbia Phonograph Co., reports that collections

have improved greatly and all but a few of the dealers are making substantial payments and are in a fair way toward cleaning up.

O. F. Benz, record sales manager of the Columbia Phonograph Co., was in St. Louis early in February in the interest of the new records. From St. Louis he went to Texas.

Artophone Activities

The Artophone Co. has added two console models to its line of Artophones. Manager Salmon, of the Okeh record jobbing department, in announcing a reduction in prices on February 1 from \$1 to 85 cents on all except Mamie Smith records, said that the January business was greater than that of December and that in the past three months over 300 accounts have been opened through the South. The entire South is covered from the St. Louis jobbing center. The company has decided not to move from its present location on Olive street.

The Aeolian Co. has discontinued handling the Columbia machines and records at its St. Louis store.

The Thoman Phonograph Co. has been incorporated by the Secretary of State of Missouri, with a capital stock of \$80,000.

NEW SOLOTONE CO. ORGANIZED

With Authorized Capital of \$100,000—Take Over Present Solotone Business

PHILADELPHIA, PA., February 1.—Announcement appeared in the financial section of the Philadelphia Public Ledger of the taking over of the Solotone Mfg. Co., maker of Solotone phonographs, by the Solotone Phonograph Co. The new company has an authorized capital of \$100,000 preferred stock and \$100,000 common stock and has recently issued a prospectus covering its future plans and offering both preferred and common stock to the general public.

A. E. Landon, Canadian branch manager of Columbia Graphophone Co., was recently a visitor to the executive offices, New York City.

85c NEW CARDINAL RECORDS 85c
NOW READY FOR DELIVERY

6—NEW CARDINAL RECORDS—6
ALL HITS

<p>The Phonograph With The Tongue</p>	<p>No. 2015</p>	<p>COUNTY KERRY MARY <i>Orch. Accomp. sung by Chas. Harrison</i> IT'S ALL OVER NOW <i>Orch. Accomp. sung by Helen Bell Rush</i></p>	<p>No. 2016</p>	<p>MY MAMMY <i>Fox Trot, Vocal Chor.</i> WHY DON'T YOU <i>Fox Trot</i></p>	<p>Played by Ben Selvin's Dance Orch.</p>	<p>The Record That Talks</p>
	<p>No. 2013</p>	<p>OH GEE, SAY GEE, YOU OUGHT TO SEE MY GEE GEE FROM THE FIJI ISLE <i>Orch. Acc. sung by Fred Whitehouse</i> GET UP <i>Orch. Accomp. sung by Ernest Hare</i></p>	<p>No. 2017</p>	<p>I NEVER KNEW <i>Fox Trot</i> NOW AND THEN <i>Fox Trot</i></p>	<p>Played by Ben Selvin's Dance Orch.</p>	
	<p>No. 2014</p>	<p>ROSE <i>Fox Trot</i> SHOW ME HOW <i>Fox Trot</i></p>	<p>Played by Rudy Wiedoeft's Palace Trio</p>	<p>No. 2018</p>	<p>HONEY DEW <i>Fox Trot</i> LOTUS FLOWER <i>Waltz</i></p>	

Jobbers and Dealers—Write for Information

CARDINAL PHONOGRAPH CO.

106 EAST 19th ST., NEW YORK CITY

FACTORIES — NEWARK, OHIO — ZANESVILLE, OHIO — PT. PLEASANT, N. J.

Edison Amberola Message No. 14

Mr. Phonograph Dealer:

Has it ever occurred to you that you do not have to create a demand for the New Edison Diamond Amberola? Hundreds of satisfied Amberola owners in your vicinity are doing that for you. Amberol Record sales to these owners alone make the line a profitable one. The Instruments and Records are in the class of merchandise now demanded by the public because—the price and quality are right.

THOMAS A. EDISON, Inc.

AMBEROLA DEPARTMENT

ORANGE, N. J.

HAPPENINGS IN THE DOMINION OF CANADA

VICTOR RADIO CONCERTS NOW THE VOGUE IN MONTREAL

Berliner Gramophone Co. Staff Hear Musical Program at Home of H. S. Berliner—Leslie Co. Expansion—Pequegnat With McLagan Corp.—Muzio and the Edison Score—Other News

MONTREAL, QUE., February 5.—On a recent evening several members of the Berliner Gramophone Co., Ltd., staff met at the home of H. S. Berliner to hear a musical program by wireless telephone. At the Marconi station just below the Bonaventure depot a Victrola was placed beside the transmitting apparatus. "His Master's Voice" records by Kreisler, Lauder, Billy Murray, Lewis James, Coleman's, Raderman's and Henri's orchestras were played and this music was heard clearly and easily, not only by the group in Mr. Berliner's home, but it is estimated by at least one hundred and fifty other persons or groups who had Marconi receiving equipment at points as far distant as Ottawa, Father Point, etc. In addition to the music Mr. Berliner's guests heard the "Cassandra" talking from out in the ocean, another ship off the coast of Nova Scotia, the Navy Yards at Brooklyn, N. Y., and Washington sending messages.

It is almost uncanny to think of sitting in one's own home and by means of a simple little piece of framework on the table actually hearing music and conversations miles and miles away. The receiving equipment, installed for the occasion in Mr. Berliner's house, was about one-third the number of amplifications required to talk across the Atlantic. That means with an apparatus of three times the strength the party gathered there could have heard the same music and messages transmitted at London or Paris. It is understood that the Marconi Co. will give similar weekly demonstrations each Tuesday throughout the Winter.

The J. H. Leslie Co., Ltd., has taken over the musical instrument business so successfully operated for some time past by J. H. Leslie, in Liverpool, N. S. Mr. Leslie is president of the new organization. It is believed that the new company will become a powerful factor in music merchandising circles in Nova Scotia. A branch has already been opened in Bridgewater, under the direct management of Vice-President Denome, and branches will be opened at other points just as soon as the necessary arrangements can be made. "His Master's Voice" products are handled exclusively by the J. H. Leslie Co. in all stores.

Sinkler Darby, of London, Eng., whose post office address has been the leading centers of Europe during the past twenty-one years, has returned to this side of the Atlantic. Mr. Darby, who is one of the pioneers in the science of sound reproduction, is now in Montreal. He is filling an engagement with the recording laboratories of the Berliner Gramophone Co., Ltd.

George S. Pequegnat, so well known in Montreal music trade circles, where for several years he has conducted the Phonograph Shop on St. Catherine street, is going out of the retail business to join the selling organization of the McLagan Phonograph Corp., Ltd., of Stratford. He will have charge of the Eastern territory including the Maritime Provinces, and will continue to reside in Montreal.

The incorporation of the Fromson Co. of Canada, Ltd., is announced with a capital stock of \$100,000, the chief place of business to be in Montreal. This company is the maker of the "Fromsona" phonograph.

The Chamberland Trio and the Moretti Trio are two new Montreal organizations whose first recordings will shortly appear on "His Master's Voice" records. They have achieved notable effects with violin, flute and celesta, also with clarinet, 'cello and celesta.

"His Master's Voice," Limited, Halifax, N. S., branch, held its second staff dance recently. The arrangements were under the direction of J. McKay Tait. About thirty couples were present. A buffet supper was served, which was presided over by Miss Edna Doyle and Miss Bent.

New companies recently registered include Canadian Phonograph Distributors.

W. D. Stevenson, of London, Ont., vice-president of the Starr Co. of Canada, Limited, Canadian distributors of Starr phonographs and Gennett records, recently passed through Montreal en route to his firm's headquarters at London, from a visit

MARKED BETTERMENT EVIDENT IN BUSINESS IN TORONTO

B. A. Trestrail Joins Musical Merchandise Sales Co.—Dorian Heads Company to Handle Phonola Output in Elmira—Columbia Co. Removal—Exhibitors at Furniture Exhibition—Magnavox Scores

TORONTO, ONT., February 6.—Wm. B. Puckett and Fred A. Trestrail, proprietors of the Musical Merchandise Sales Co., Canadian distributors for Brunswick phonographs, Q R S player rolls, Brilliantone needles, etc., have just announced that the interest formerly owned by the late John E. White in their company has been purchased by Burdick A. Trestrail, brother of Fred, who joined forces with them at the close of their fiscal year, January 31, 1921. "Bert" Trestrail, as he has always been known to the trade, will be remembered as the former advertising manager, then piano manager, and finally manager of sales and promotion for the R. S. Williams & Sons Co., Limited, since 1912, which position he held when he went overseas. Returning in 1919, he organized his own sales company known as the Mutual Sales Service. Mr. Trestrail, while with the Williams firm, was very actively associated with the introduction, development and promotion of the New Edison. His re-entering the music trade exclusively will be welcomed by his many friends throughout Canada and Brunswick and Q R S dealers especially welcome the assistance and energy he will put forth to increase their sales.

A new company is being organized to handle the output of the Phonola Co.'s factory at Elmira. In charge of this new organization, the Phonola Sales Co. of Canada, is Otis C. Dorian, well known to the Canadian trade and who was formerly general manager of the Pathé Frères Phonograph Co. Application has been made for a charter for the new company. George H. Honsberger, who was on the selling staff of Pathé Frères, has also joined the Phonola firm.

The executive offices of the Canadian branch of the Columbia Graphophone Co. have been moved from 54-56 Wellington street West, Toronto, to the Hugh C. MacLean, Limited, Building, 345-347 Adelaide street West, and the staff is now comfortably settled at the latter address. This change was occasioned by the removal of the Columbia record-pressing plant from the Wellington street building, to the big plant acquired from the Canadian Aeroplanes, Limited, in the early Fall of 1919. The change will consolidate the Columbia manufacturing departments, give the record-pressing department four

times its former floor space and double the facilities for the staff at the head offices for Canada. A. E. Landon, the Columbia Canadian manager, and his associates occupy the second floor of the MacLean Building. In the center of the floor is a large Grafonola showroom. A large reception room with bay windows is most attractively furnished. There is also a suite of offices occupied by the Dictaphone branch, both sales and service departments.

R. W. Burgess, well known to the Canadian trade, has joined the traveling staff of I. Montagnes & Co., Canadian distributors of the Sonora and will cover the territory from Kingston to the Eastern coast. His headquarters will be in Montreal.

H. A. Stevenson has opened a song shop at 269½ Princess street, Kingston, Ont., carrying Brunswick phonographs and records.

V. B. Hodges, of the Musical Merchandise Sales Co.'s selling staff, and who has been featuring the Brunswick line in Manitoba and Saskatchewan for the past three or four months, has come East and is now traveling from the home office in Toronto.

The Toronto Furniture Exhibition held in the John Key Building, 36-38 King street, West, from January 10 to 22 was well attended, and the exhibition was pronounced a big success. One of the most interesting sections of the exhibition was that devoted to talking machine displays by the Imperial Phonograph Corp., Division of the National Table Co., Ltd., Owen Sound; Gold Medal Furniture Mfg. Co., Ltd., Toronto and Uxbridge; Phonola Co. of Canada, Ltd., Elmira, and Musical Merchandise Sales Co., Toronto, Canadian distributors of Brunswick phonographs and records and Le Page phonographs, made by the Le Page Communion Cup Co., 2382 Dundas street, West, Toronto.

C. W. Lindsay, Ltd., Ottawa branch, made good use of a Magnavox at its big store recently. A horn was fitted to a second-story window and Ottawa's main thoroughfare was gay with all kinds of musical selections.

C. J. Pott, Canadian manager of the General Phonograph Corp., has returned to Toronto after spending a few days in New York, and is most optimistic as to business conditions for 1921.

Talking Machine Supplies and Repair Parts

SPRINGS, SOUND BOX PARTS, NEEDLES

THE RENÉ MANUFACTURING CO.
MONTVALE, NEW JERSEY

EMERSON DANCE "HITS"



"HITS"

Toe-teasing dance hits of the "encore" kind.
Song hits of the "hum-along" type

Hits orchestrated and recorded with an attention to detail and "atmosphere" which place them in a class apart. Hits which an Emerson dealer can always count upon having FIRST, before his competitor is even aware that they are hits.

Here are some of the latest:

SONG

- 10327—You Oughta See My Baby. Comedy Song
EDDIE CANTOR
Give Me a Million Beautiful Girls. Character Song
Irving Kaufman
- 10324—My Mammy. Novelty Song.....*Arthur Fields*
O-HI-O. Novelty Song.....*Irving Kaufman*
- 10326—Crazy Blues. "Blues" Character Song. *Sissle & Blake*
Melinda Lee. Comedy Song.....*Bernard & Hare*
- 10329—Bright Eyes. Tenor Solo.....*Irving Kaufman*
My Home Town Is a One-Horse Town.
Comedy Song.....*Irving & Jack Kaufman*
- 10316—Feather Your Nest. Baritone Solo.....*Arthur Fields*
Grieving For You. Baritone Solo.....*Arthur Fields*
- 10325—There Is One Girl, Will She Ever Be Mine?
Tenor Solo.....*Walter Scalan*
Killarney. Tenor Solo.....*Walter Scalan*
- 10320—I'm Saving Up My Dough for Rae and Me.
Novelty Song.....*Arthur Fields*
He Always Goes Farther Than Father.
Comedy Song.....*Fred Hillebrand*

DANCE

- 10317—Rosie, Make It Rosy for Me. Fox-trot
Plantation Dance Orchestra
Kentucky Blues. Fox-trot.....*Merry Melody Men*
- 10328—Home Again Blues. Fox-trot Toddle
Plantation Dance Orchestra
Palesteena. Fox-trot.....*Plantation Dance Orchestra*
- 10315—Broadway Blues. Fox-trot.....*Merry Melody Men*
Now and Then. Fox-trot.....*Selvin's Novelty Orchestra*
- 10295—Margie. Fox-trot.....*Plantation Dance Orchestra*
Feather Your Nest. Fox-trot
Plantation Dance Orchestra
- 10330—I Never Knew. Fox-trot..*Orlando's Society Orchestra*
Honolulu Eyes. Waltz.....*Orlando's Society Orchestra*
- 10321—No Wonder I'm Blue. Fox-trot
Lanin's Roseland Orchestra
Humming. Fox-trot.....*Lanin's Roseland Orchestra*
- 10318—Honeydew Medley. Fox-trot
Joseph Knecht's Waldorf-Astoria Dance Orchestra
Pitter Patter. Medley. Waltz
Joseph Knecht's Waldorf-Astoria Dance Orchestra
- 10319—Rose. Fox-trot.....*Sherbo's Mont Martre Orchestra*
Old Fashioned Garden. One-step
Joseph Knecht's Waldorf-Astoria Dance Orchestra
- 10322—Kiss-A-Miss. Waltz.....*Selvin's Novelty Orchestra*
I Told You So. Medley. Fox-trot
Joseph Samuels' Music Masters
- 10323—My Wild Flower. Fox-trot..*Lakesonian Brass Sextette*
Ouija. One-Step.....*Lakesonian Brass Sextette*

Play Emerson Records on the
Emerson Phonograph
The Phonograph with the
Emerson Music Master Horn

Emerson Phonograph Company, Inc.

NEW YORK
206 Fifth Avenue

CHICAGO
315 South Wabash Avenue

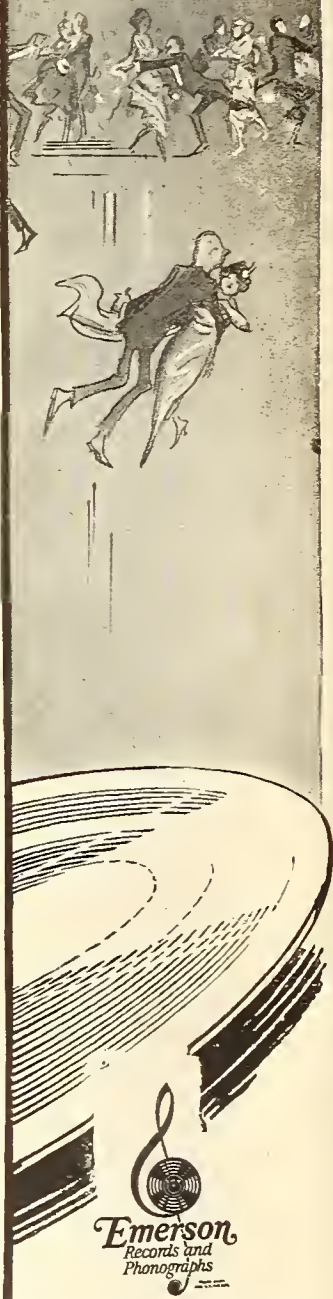

Hear also, Emerson Records in Polish, Italian, Jewish and German.

Emerson records play wonderfully on all phonographs. But of course they are at their very best on the Emerson—the phonograph with the concealed Emerson Music Master Horn, made of rounded solid spruce, of all woods the most resonant and sound amplifying. Ten Emerson models in all, priced from \$80 to \$1,000.

Emerson Needles are of Supreme Quality

Emerson Records

TESTIMONY IN TONE-ARM CASES

Taking of Testimony in Actions Brought by Victor Co. Against Brunswick-Balke-Collender Co. and General Phonograph Corp.—Arguments to Be Heard on March 7

GRAND RAPIDS, MICH., February 5.—The presenting of testimony in the action brought by the Victor Talking Machine Co., Camden, N. J., against the Brunswick-Balke-Collender Co., Chicago, for alleged infringement of the Johnson Tone-Arm Patents Nos. 814,786 and 814,848, consumed all of last week in the U. S. District Court for the Northern District of Michigan, with Judge Sessions presiding. The taking of testimony started on Monday, January 24, and ended on Saturday afternoon.

Arguments on the case will be heard before Judge Sessions on March 7, and briefs will be filed by opposing counsel late in February.

At the same time, and in the same court, testimony was taken in the action brought by the Victor Co. against the General Phonograph Corp. for alleged violation of the same Johnson patents. Arguments on this case will also be heard on March 7 before Judge Sessions and briefs will be filed about a week before that date.

APPROPRIATE MUSIC AT FUNERAL

Talking Machine Used to Furnish Sacred Music at Funeral Services in Macon

MACON, Mo., February 4.—A talking machine was used to furnish the music at the funeral of Mrs. Mary Stiles at the home of her daughter, Mrs. A. B. Thompson, in Clarence. The services were conducted by the Rev. Ward M. Baker, pastor of the M. E. Church, South. The selections played by the talking machine were: "The Mother's Prayer," "Rock of Ages" and "Jesus, Lover of My Soul." This was the first time a talking machine has been used on such an occasion in this part of the country.

USING VICTOR REFERENCE LABELS

Increasing Number of Dealers Realizing the Value of These Record Selling Helps

An increasing number of Victor dealers are adopting with success the use of Victor Ready Reference Labels for records, and are particularly enthusiastic over the revised issue of labels prepared for the current year, which embodies several new features.

One of the features that is considered of particular value is the system of cross indexing whereby it is possible at a glance to note other records of the same selections as recorded by different individuals or organizations, which not only saves times, but in cases where the desired record is out of stock, or does not measure up to the customer's requirements, saves the sale because the selection in another form is available immediately.

Other features of the Ready Reference Labels include the phonetic spelling of the title, especially valuable in handling records of foreign selections or by foreign artists; the English equivalent of foreign titles; reference to the monthly record supplement in which the original description of the record appeared, which saves time in searching; classification of the record according to the nature of the selection, which makes easy the bringing out of other records in keeping with the customer's taste; and the catalog numbers of several other records of similar appeal. With all this information instantly available, the efficiency of even the best informed salesman is greatly increased. For the new salesman the labels offer an inexhaustible mine of record information of the sort that makes sales.

NEW DEALERS IN PENNSYLVANIA

P. G. Scallsmith, of Gettysburg, Pa., and C. G. Martin, 641 Main street, Darby, Pa., have recently been added to the ranks of talking machine dealers handling the Victor line.

CLAUDE BUCKPITT BUYS BUILDING

Piano and Talking Machine Dealer of Elmira, N. Y., Will in Future Be Housed in His Own Business Property in That City

ELMIRA, N. Y., February 5.—Claude Buckpitt, dealer in pianos and talking machines, of 113 North Main street, practically has completed details whereby he acquires title from Adam Mander to the Mander or Lyceum Block at 156 and 158 Lake street, the first floors of which are occupied by W. H. Miller and James Falsey, respectively. It is expected that the deal will be completed within a day or so and Mr. Buckpitt will take possession at once. The price to be paid is approximately \$40,000.

Mr. Buckpitt will remove his business from Main street to the store occupied by Mr. Miller, using the second and third floors as well. Later he also may occupy the other store.

Mr. Buckpitt plans extensive improvements to the property. He will tear out the north wall of the Lyceum Theatre entrance on Lake street and construct a handsome show window. Later he will install a passenger and freight elevator, and it is likely that new fronts will be added to both stores.

Mr. Buckpitt came to Elmira in 1907 from Schenectady, where he conducted a music store. He maintained a store in the Merchants' National Bank Building for two years, removing to the Snyder Building in 1909. His rapidly increasing business now necessitates a further expansion.

NEW QUARTERS IN MONTICELLO

The Ackerman Music Shop has just opened handsome new quarters on Main street, Monticello, Ind. The new store comprises two stories and a balcony, all used for the display and sale of musical instruments, and a number of sound-proof booths have been installed. Mr. Ackerman has conducted a music business in Monticello for a number of years.



PAT. APPL'D FOR.

Our Latest Success
The L. S. Compound Rocker Action
ORO-TONE
The highest grade Reproducer made

SEND FOR SAMPLE

ORO-TONE FEATURES
Extension A telescopes into large elbow B, giving a length adjustment from 7¼ to 9½ inches. Adjustment screw C engages an indexed channel in extension A, assuring perfect alignment. Slightly releasing locking thumb screw E permits height adjustment of large elbow in base ring D. Releasing locking screw E entirely permits tone arm to be removed from base ring D for packing separately before shipping if desired.

Ask for illustrated and descriptive catalog which will acquaint you with the excellent features incorporated in Oro-Tone Tone Arms and Reproducers, which make the Oro-Tone the most scientific and highest grade combination offered.

L-S STANDARD

The Oro-Tone Co. QUALITY FIRST

1000 to 1010 GEORGE ST. CHICAGO, ILLINOIS

MELODEE

The World's Finest Music Roll

**Produces Musical Effects Possible
With No Other Roll**

MELODEE WHOLESALERS

FOUR DISTINCT SUPERIOR QUALITIES

- M. STEINERT & SONS
35 Arch St. - - - - - Boston, Mass.
- MELODEE MUSIC CO., INC.
29 West 42nd St. - - - - - New York
- PHILADELPHIA SHOWCASE CO.
123 N. 13th St. - - - - - Philadelphia, Pa.
- PHILADELPHIA SHOWCASE CO.
1001 Jenkins Arcade - - - - - Pittsburgh, Pa.
- CHAS. M. STIEFF, INC.
315 North Howard St. - - - - - Baltimore, Md.
- O. J. DE MOLL
12th and G Sts., N.W. - - - - - Washington, D. C.
- SOUTHERN VOCALION DISTRIBUTORS, INC.
226 N. 20th St. - - - - - Birmingham, Ala.
- GRINNELL BROS.
First and State Sts. - - - - - Detroit, Mich.
- LYON & HEALY
Wabash Ave. and Jackson Blvd. - - - - - Chicago, Ill.
- MELODEE MUSIC CO.
529 So. Wabash Ave. - - - - - Chicago, Ill.
- STONE PIANO CO.
826 Nicollet Ave. - - - - - Minneapolis, Minn.
- J. W. JENKINS' SONS MUSIC CO.
1013 Walnut St. - - - - - Kansas City, Mo.
- W. J. DYER & BRO.
21 W. 5th St. - - - - - St. Paul, Minn.
- MELODEE MUSIC CO.
455 Mission St. - - - - - San Francisco, Cal.

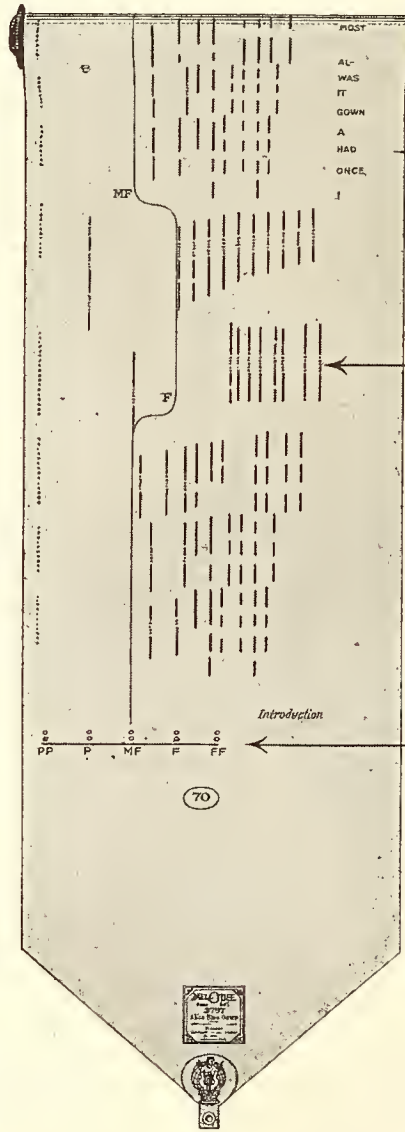

← **UNBREAKABLE
STEEL SPOOL ENDS**

← **WORDS PRINTED
NOT STENCILED**

← **NOTES BRIDGED
WILL NOT DISCORD**

← **LOUD and SOFT
EXPRESSION LINE**

*Melodee is not only out first with the Hits but has the finest
Catalogue of Standard, Classical, Opera and Sacred Selections
No Roll Department complete without Melodee*

Melodee Music Co., Inc.

New York

Chicago

San Francisco

LOUIS BUEHN ENTERTAINS DEALERS

Louis Buehn Co. Entertains Great Assemblage of Dealers Who Hear Addresses by Prominent Victor Officials—Notable Event

PHILADELPHIA, PA., February 8.—In two meetings held this month, one on Thursday, February 3, and the other on Monday, February 7, the Louis Buehn Co. has had almost every firm with which it does business represented. These gatherings were addressed by prominent men from the Victor factory who were able to give the dealers a great amount of advice first hand.

The first meeting, on February 3, was attended by eighty-five Victor dealers from this city and immediate vicinity with whom the Buehn



Louis Buehn

firm does business. The meeting was held in the new Victor Period Model Salon, beginning at 3 p. m. Mr. Buehn made the address of welcome to the guests, and then introduced the speakers, who were John G. Paine, of the Victor Co., whose subject was, "Selling Victor Goods Is More Than Merchandising"; John S. MacDonald, salesmanager of the Victor factory, who made an address on "The Present Situation"; Ernest John, advertising manager of the Victor Co., who spoke on advertising, and John J. Davin, of the Reincke-Ellis Co., of New York City.

The meeting was over at 5.30, when the speakers and guests were taken to the Arcadia, where a supper was served, after which the entire body was conveyed in automobiles to the Metropolitan Opera House to attend, as the guests of the Buehn firm, the concert given by the eminent baritone, Titta Ruffo.

The meeting was highly illuminating, and there was shown a spirit of enthusiasm by those present which will no doubt be carried into their business in the near future. At the meeting on the 10th the same program was carried out, the guests numbering about fifty dealers from towns in the outlying districts, reaching as far as Al-

toona. This meeting was also held in the Period room and was followed by a supper at the Arcadia, and in the evening the guests were taken to the Shubert Theatre to witness a performance of "Kissing Time." The following day they were taken on a tour of inspection of the Victor factory. The Victor Co. was heartily in sympathy with these meetings, and assisted in every way.

OKEH RECORD PRICES REDUCED

All Popular Recordings, Except Those by Mamie Smith, Now Eighty-five Cents

The General Phonograph Corp. sent out an important announcement to the trade recently to the effect that beginning February 1 all popular Okeh records will be listed at 85 cents instead of \$1, with the exception of records made by Mamie Smith, which will continue to be listed at \$1.

This announcement was accorded a popular reception by Okeh dealers generally, especially as the Okeh record division of the General Phonograph Corp. is planning to give enhanced service and co-operation to the dealers in merchandising this well-known record line.

THEO. FLETCHER GOING TO TEXAS

President of Fletcher Alltones Needle Co. to Visit Headquarters in San Antonio

Theo. Fletcher, of the Fletcher Alltones Needle Co., who has been spending some time in New York in connection with the marketing of that product, left recently for his home in San Antonio, Tex., where are also located the main offices of the company. While in Texas Mr. Fletcher will give considerable time to perfecting a new type of talking machine, of which he is the inventor, designed to play records that run for from ten to twenty minutes or more, the records being recorded by a special process, also of Mr. Fletcher's invention. Before returning to New York Mr. Fletcher plans to spend several weeks in Chicago superintending the building of model machines.

He stated to The World that there was a steady increase in the demand for Alltones needles from dealers in the metropolitan district, where Andrew H. Dodin, Inc., is the local jobber, and elsewhere about the country. Advertisements in The Talking Machine World have even brought inquiries from several foreign countries. At the recent Marine Exposition in New York, where there was a demonstration of the practicability of transmitting music by wireless, Alltones needles were used to secure the desired results.

At the present time the special display cards bearing the Fletcher Alltones needles, which were issued some time ago by the company, are to be seen in the show windows of many talking machine stores, and the attention they attract has resulted in a fair run of sales, according to the dealers.

Phonograph Dealers—

**Read this
and profit by it**



calculator to uphold trade standards with disc

THE GENERAL MUSIC STORE

THE advocates of the general music store in which there may be purchased anything of a musical nature from a jew's-harp to a grand piano, and they are steadily increasing in number, have apparently had their contentions strongly upheld in the volume of holiday business done in the small goods departments of music stores all over the country.

There have come to The Review many reports to the effect that, although the piano business, and in some cases even the talking machine business, was hardly up to normal, the demand for small musical instruments, violins, banjos, ukuleles, etc., surpassed all previous records. It is hard to give any real reason why this should be so unless it is the result of increased attention given to the featuring of such instruments, and a more general appreciation of their usefulness.

Summing it up, it seems as though the musical merchandise department, properly conducted, has reached a point where it represents a real asset to the store—a point where it has an intrinsic, rather than a merely potential, value, from the cold business point of view.

THE PROSPERITY THAT LIES AHEAD

Editorial from Jan. 8th edition of the MUSIC TRADE REVIEW.

**Carry Everything
in MUSICAL MERCHANDISE**

- Durro Violins, Bows, Strings
- Duss Band Harmonicas
- Lester & Salanti Accordions
- Abbott Band Instruments
- S. S. Stewart Banjos, Guitars
- Mandolins & Ukuleles
- High Grade Accessories

They mean

**NO ADDITIONAL EXPENSE
QUICK SELLERS, LIBERAL
PROFITS
FINE WINDOW DISPLAYS
REPEATING CUSTOMERS**

Write for Our 1921 Catalog
Fully Illustrated

Special Assortments for Phonograph
Dealers



Buegeleisen & Jacobson
5-7-9 Union Square
New York

EDISON STORE IN GLOVERSVILLE

GLOVERSVILLE, N. Y., February 5.—Van Duesen and Clarence J. Stoner have taken over the store at 5 North Main street, which has been operated for some time, an outgrowth of the Griffin store, by John C. Beal and Floyd W. Becker, who have been in charge of the Edison department. The main business of the new concern will be to deal in draperies, but the Edison department will be continued and will be pushed actively.

FREE RECITALS ATTRACT MANY

A good illustration of the popularity of record music with the general public is found in the fact that at a recent free Victrola concert held in the recital room of the Grinnell Bros. store in Detroit many persons were turned away because the room was already more than full.

The Language Phone Method, New York, has filed notice of dissolution.

**Operaphone
RECORDS**

All the Latest Hits
Popular Songs and Dances

Operaphone Co., Inc.
Long Island City N. Y.



Art Hickman's Orchestra accompanying Nora Bayes! The most popular orchestra in America accompanying the most popular comedienne in the country in "I Could Have Had You (But I Let You Get By)." Coupled with "Love Nights" by Nora Bayes. No wise Columbia dealer will let this chance get by. A-3347.

**Columbia Graphophone Co.
NEW YORK**

TRADE VOLUME EXCEEDS EXPECTATIONS IN CINCINNATI

Enormous Record Demand With Machine Sales Growing—Edison Jobbers to Attend Convention in Montreal—Increase of Publicity—Ohio Talking Machine Co. and Columbia Co. Report Progress

CINCINNATI, O., February 3.—Considering the fact that January is always supposed to be a very dull month and also the general inactivity in nearly all lines of business the talking machine business in Cincinnati held up remarkably well last month and in some cases far exceeded the expectations of the most optimistic. While there was a very fair demand for machines the demand for records was exceptionally good and, many houses say, far in excess of the December business. This is explained by the fact that many people who bought machines during the holiday season are now buying additional records. The fact that business has held up so well during the month has made dealers optimistic and they are confidently looking forward to a very satisfactory year's business. Many of the out-of-town dealers from Kentucky, Indiana, West Virginia and Ohio were in the city during the month and, basing their views on reports by these men, the local jobbers feel they are justified in predicting a prosperous year for the trade.

R. W. Mock, who formerly was city salesman for the Columbia Co., has become city sales manager for the Sterling Roll & Record Co., and is planning to make a record showing for the Sterling company's goods this year. Manager Dawson is highly elated over prospects.

Alfred Ray, of the Ray Music Shop, of Hamilton, was down from that city the last of the month to make purchases for a new shop that he is opening up at Middletown. This is a good field, and Mr. Ray expects to do a big business with talking machines and records there. He has just returned from a trip to Portsmouth and he states there are goodly signs around these various Ohio towns of business picking up.

P. H. Oelman, manager of The Phonograph Co. (Edison), left the first of February for New York, where he discussed requirements for the coming year, and from there he went on to Montreal to attend the Edison Jobbers' Convention. He was joined at Montreal by R. T. Carrol, sales manager of the company, who expects to bring back some very interesting news for the dealers. Mr. Carrol states there is a great deal of interest being shown in the local territory in the Mood Change chart which is being introduced to the dealers by William Maxwell, vice-president of Thomas A. Edison, Inc. Mr. Maxwell has written dealers at considerable length concerning this feature, and all indications point to his securing the heartiest co-operation in assisting Mr. Edison in his research work as to the effect of music on the human emotions. Very satisfactory results are ob-

tained by following up this feature by dealers, he says.

Mr. Carrol has just been over some of the Kentucky territory, and he declares the tobacco situation there is not nearly as bad as the papers would lead one to believe. This is very important to the talking machine business, for tobacco is the big crop in many of the sections and the sales of machines and records depend largely on the outcome of this crop. Edward Burkhardt, in charge of the Covington and Newport stores, takes the same view and expects to do a big business on the Kentucky side during the year. E. A. Searles, the Edison dealer of Huntington, W. Va., was down during the month and declared conditions in that State were improving steadily, and he expects an unusually good year. He predicts that the demand from his territory will exceed that of last year.

Through the co-operation of L. Oberdorfer, Edison dealer of Paris, Ky., two Chippendale were used to aid the Bourbon County drive for the Herbert Hoover Relief Fund, held in that city last month. Mr. and Mrs. A. E. Simpson are locating a new store at Piqua, Ohio, where they will handle the Edison. They formerly had an Edison branch at Hillsboro, O., but are embarking on their new venture on a larger scale than heretofore. The Edison dealers are advertising extensively following the Edison plan of interlocking advertising using the newspapers and the direct mail advertising, believing now is an excellent time to build up a prestige that will lead to much future business.

The Ohio Talking Machine Co. reports business in records exceptionally good, but states it is unable to get enough records to supply the big demand. The sale of machines has been very fair for this time of year. West Virginia was declared to be the best field at present. Kentucky and Indiana are handicapped by the tobacco and agriculture situation, but these conditions are expected to eventually right themselves and business to pick up. Among the dealers in during the month were Searles, of Huntington; Hogge, of Clarksburg, W. Va., and Murphy, of Maysville, Ky.

E. M. Shute, assistant manager of the Columbia Graphophone Co., is looking forward to a very big demand for records as a result of an announcement made February 1 to the effect that all 10-inch double-sided records, either A, B or C series, of non-exclusive artists, were reduced from a dollar to 85 cents. This, he states, will do much to stimulate business.

Mr. Shute takes a very optimistic view of the business outlook. He expects the Columbia to have an excellent year. The local branch has a complete stock of all types and finishes of machines and is able to meet the big demand for records. Manager R. H. Woodford left the last of the month for a business trip East. Among the dealers in during the month were: W. L. Hall, of Pineville, Ky.; C. S. Sampson, Huntington, W. Va.; C. S. Boyer, Lancaster; Dr. Freeman, of Osgood, Ind.; the Hasson brothers, of Lawrenceburg, Ind.; S. R. Follis,

Ward's Khaki Moving Covers



Grade "D" Cover with

No. 3 Straps

THE C. E. WARD CO.

(Well-Known Lodge Regalia House)
101 William Street New London, Ohio
Also Manufacturers of Rubberized Covers
and Oust Covers for the Wareroom

Distributors

- BRISTOL & BARBER, INC.
111 E. 14th St., New York City
- YAHR & LANGE DRUG CO.
207-215 E. Water St., Milwaukee, Wis.
- COHEN & HUGHES, INC.
Washington, D. C.
- BECKWITH-O'NEILL CO.
Minneapolis, Minn.
- STREVELL-PATERSON HARWARE CO.
Salt Lake City, Utah
- C. L. MARSHALL CO., INC.
Beckman Bldg., Cleveland, O.
Butler Bldg., Detroit, Mich.
- THE REEO CO.
237 Fifth Avenue, Pittsburgh, Pa.
- C. J. VAN HOUTON & ZOON
140 S. Dearborn St., Chicago, Ill.
- SONORA DISTRIBUTING CO. OF TEXAS
Dallas, Texas
- KNIGHT-CAMPBELL MUSIC CO.
1608 Wynkoop St., Denver, Colo.
- CHAS. H. YATES
311 Laughlin Bldg., Los Angeles, Cal.
- W. O. & C. N. ANOREWS
Buffalo, N. Y.
- SACHS & CO.
425 So. Wabash Ave., Chicago
- SHERMAN, CLAY & CO.
741 Mission St., San Francisco, Cal.
- JOHN A. FUTCH CO.
35 Auburn Ave., Atlanta, Georgia
1500 South Boulevard, Charlotte, N. C.
630 Washington St., Jacksonville, Fla.
- ORTON BROTHERS MUSIC HOUSE
Butte, Mont.
- GRAY & OULEY CO., Nashville, Tenn.
- ASSOCIATED FURNITURE MFRS.
St. Louis, Mo.
- W. J. DYER & BRO., St. Paul, Minn.
- AMERICAN PHONOGRAPH CO.
Burlington, Vt.
- JOSEPH BARNETT & CO., Cedar Rapids, Ia.

G. W. Hunter, J. J. Bochenek, of Dayton, O.; Alfred Ray, of Hamilton; Frank Horning, of Brookville, Ind.; Henthorne, of Columbus, and L. M. Kusworn, of Dayton.

C. M. Robinson, of the Robinola Co., reports a very fair month, and says business for January was ahead of the business done in January of last year. He figures that by the middle of March there will be a general picking up in the talking machine business. The outlook for the year is encouraging, he thinks.

Otto Grau Co. and the Baldwin Co. report a very fair business in the talking machine departments of their houses during the month.

The Crystola Co. is optimistic over trade. The manager reports business as very good the first part of the month, but rather quiet at present. Reports from all dealers, he says, show they are looking for a big spurt in the business to start about the last of March. Many of them say people are holding off in expectation of a drop in price. Mr. Swing does not believe there is much chance of prices on talking machines dropping, however, for he points out that the advance in the price of musical instruments was not great and he can see little prospect of any large reductions being made. The dropping off of sales among dealers who sell largely to farmers is explained by the fact that the country banks, which used to consider farmers' paper very desirable, have notified dealers they no longer will accept notes of any kind, which works a hardship on both the farmer and the dealer. Mr. Swing makes the assertion that he honestly believes that if the banks would loosen up and do their part in extending needed credit to farmers business would boom within twenty-four hours.

HAS DESIGNS ON THE PREACHER

Jazz Enthusiast Writes General Phonograph Corp. Asking for Mamie Smith Records That Will Make the Preacher Forget His Dignity

The advertising department of the General Phonograph Corp., New York, received recently an interesting letter from a Mamie Smith enthusiast in North Carolina. Evidently this admirer of the Mamie Smith records has studied jazz music more carefully than the English language, but the letter in itself is an indication of the popularity that Mamie Smith Okeh records have attained in all sections of the country. In fact, this letter is only one of many of similar tenor that the General Phonograph Corp. has received during the past few months. It reads:

"I rite you to please send me one of your latest catalog of latest popular songs and musical comedy hits popular dacing numbers I got the Crazy Blues all ready and if you have any other latest Blues sung by Mamie Smith and her jazz hounds send along 2 or 3 C. O. D. with the catalog I want something that will allmost make a preacher come down out of the pulpit and go to dancing and hang his head and cry I want all you send to be Blues."

MASTERS - MOTHERS - STAMPERS

Good records come from good stampers.

Stampers can be no better than Masters and Mothers.

Our specialty is electro-deposition of metals. Our advanced knowledge along these lines brings to the Art something that has long been needed.

We will take your waxes and by improved methods of deposition will produce perfect masters, mothers and stampers.

Our equipment and capacity are such that we can give you prompt service. Write us today for particulars.

COPPER PROCESS COMPANY

19 West 44th Street

Tel. Vanderbilt 4626

NEW YORK CITY

The Mamie Smith Okeh library is being steadily augmented by new records made by this popular artist, and the phenomenal success of these records is reflected in the enthusiastic reports of Okeh jobbers and dealers throughout the country who state that the demand for Mamie Smith recordings has far exceeded all expectations.

RECORDING ARTISTS IN CONCERT

Laura Littlefield, Victor Artist, and Alice McDowell, Ampico Artist, Appear Before Enthusiastic Audience in East Liverpool, O.

EAST LIVERPOOL, O., January 31.—An appreciative audience heard Laura Littlefield, Victor artist, and Alice McDowell, pianist, at the Ceramic Theatre Friday night, January 21. The concert was staged under the auspices of the Victor department of the Lewis Bros. Music Co. Miss Littlefield, a soprano, pleased the audience with a number of solo numbers, while Miss McDowell thrilled her listeners with her performance at the piano. Miss Littlefield records songs for the Victor Co., while Miss McDowell makes Ampico piano records.

FIRE DAMAGES STOCK

The stock of the C. A. Brawn Music Co., in Bangor, Me., was badly damaged by fire and water in a blaze which destroyed an adjoining building recently.

NEW MELODEE ROLL DISTRIBUTOR

Southern Vocalion Distributors, Inc., Birmingham, Ala., Also Act as Wholesale Representatives for Melodee Rolls in That State

The Melodee Music Co., Inc., New York, announces that the Southern Vocalion Distributors, Inc., recently organized in Birmingham, Ala., have been appointed Southern distributors for Melodee rolls. Oscar Willard Ray, general sales manager of the Melodee Music Co., is particularly gratified over the new connection, in that it will take care of the growing demand for Melodee rolls in that section of the country and will provide for the prompt filling of orders from local stock.

The shipment of the stock order for the Southern Vocalion Distributors, Inc., has aircady gone forward and Wm. H. Shire, the president and general manager of the company, looks for a very large immediate business on the numbers in the very attractive Blue catalog which the Melodee Music Co. has just issued. He reports that the rolls played by Eubie Blake, the famous "Blues" player, are meeting with great demand in the territory that he has already covered. A special shipment is being rushed on "Boll Weevil Blues," played by Eubie Blake. Mr. Shire also plans to feature the standard and sacred catalog, which is picked from the best-selling numbers of the large and complete Melodee catalog.

SUPERIORITY OF CELINA BUILT CABINETS

has steadily increased the number of our customer friends.

The Console Model Chippendale

—only one model of four new designs—will add still more to the prestige of our line, for it will create more business for you.

The Celina Specialty Co.

CELINA, OHIO



THE MID-WEST

WESTERN DIVISION OF THE WORLD, CHICAGO, ILL., FEB. 8, 1921. WELL, the great day has come! It has also, as it were, gone. The groundhog, in a word, has emerged on time. He has crawled from

**Emergeth
the
Groundhog!**

his hole. He has looked around, all around. He has seen a shadow. He has supposed it to be his shadow. And he has acted accordingly. But in fact the groundhog, for once in his career, has been wrong. What he saw was not his shadow, though it certainly looked like it. It was the last fading shadow of the DARK BLUE HAZE! And what is the Dark Blue Haze? The D. B. H., dear friends, is the fog which has enveloped the world with indigoesque gloom since last the swallows ceased to fly. That same Dark Blue Haze, glory be, is nevertheless rapidly dissipating its dark blue self and is hieing away to wherever the home of dissipated clouds may be. Business is no longer on the down grade. For which again many thanks. In short, after all the difficulties and troubles of the past few months, the fact remains as clear as it well can be that everything is on the mend. The talking machine business has done wonderfully well, and has held up in a manner which its most enthusiastic admirers could hardly have expected. It all goes to show that we very seldom realize the strength of a position until we find ourselves compelled to defend it against odds which seem to be overwhelming. Then we become desperate, spit on our hands and hop to it in record time. We immediately find that we have been looking at all the unfavorable elements in the situation, and eliminating all the others. And that is why what the groundhog really saw was not his shadow, but the last disappearing shade of the DARK BLUE HAZE!

WHILE we are speaking about groundhogs, weather and business, we might as well remind the gentle reader that moving day is only

**The Merry
Month of
Moving**

two and a half months away. When moving day approaches, even though there be housing shortages and all that sort of thing, flats (beg pardon, "apartments") and bungalows change hands with considerable frequency. Now, a good many of those who move do a certain amount of shopping beforehand in the way of new furniture, and all that sort of thing. The gentlemen who sell talking machines will forgive us if we say that their musical instruments may, for the moment and purely as a matter of argument, be included for present purposes with furniture. Then, if that be so, it is plain that the "furniture" business of the great cities ought to be very much alive on or about the period between April 5 and May 1. Whereby, unless we miss our guess, the talking machine trade ought to perk up and get busy along about the same date. Why not? Why should not the talking machine merchant get busy and begin talking actively about how nice it would be to have a nice new talking machine in that nice new home when Mr. and Mrs. move next May 1? This is a stunt that the furniture men never neglect. They always realize that the moving householders will look with less and less favor on their old stuff in comparison with the nice newly directed rooms of the new place as the day of actual moving approaches: and they never fail to take advantage of the fact. Talking machine men, please don't overlook this, even if it be old stuff.

EVERYBODY tells us that record business is remarkably good, both in wholesale and in retail. This is pleasant news, but it was to have

**On
With the
Dance!**

been expected. Dance records are leading in all editions, and this, too, is in accord with anticipation. The fact is, of course, that the people of this country are just as much dance-mad as ever they were. And why not? One may object to some of the noises that are called music and one may equally well object to some of the dances which some misguided young folks seem to like. But to object to the fact that the nation is dance-crazy would be nonsense. For one thing, the talking machine is the home promoter of dancing, par excellence, and the more talking machines there are in the homes the fewer excuses there will be for rushing out every night to dance

in a public place. Incidentally, the talking machine men might capitalize this suggestion in their advertising. Does any one forget how for several years the famous house of Brunswick has capitalized the suggestion of home in their successful billiard table advertising? Now, this same house is in the talking machine business, too, and its advertising department certainly has not forgotten the home suggestion. Not much! Well, what they have not forgotten the talking machine merchant anywhere need not forget. The talking machine is the universal instrument. No matter what be the intellectual level of the individual, that individual can be touched somewhere by the lure of music and is consequently fair game for the seller of talking machines. For the talking machine alone supplies every want in music. Dancing is one of the branches of music. Dancing is the music of the body, and needs the music of tone to frame it and set it to work. The dance craze of the nation is therefore a very real part of the talking machine business and the craze for dance records is one of the healthiest signs we have seen for a long time in respect of our industry. For the line of musical progress is straight. From the lower to the higher it goes unvaryingly. If the purchaser of records starts on dance music, he or she will end on the highest priced and most artistic numbers. It always works the same way. Wherefore, we have every reason to rejoice, for when dance records are selling like hot cakes the infection will surely spread to the other branches of the record trade in a very short time.

FROM all we hear, likewise, supplies and equipment of all kinds are selling very well indeed. The remark applies to automatic stops,

**Accessories
Continue in
Demand**

repeaters, record lights, record-cleaners, spring-motor winders, permanent and semi-permanent needles, and, in fact, every sort of accessory to the talking machine. This industry of ours is getting to look like the motor car business. Accessory equipment is more and more considered indispensable as the talking machine takes a more and more surely established place in the affections of the people. Nor should anyone overlook the fact that whenever the sale of these accessories is on the increase then the general trade is also certainly in a favorable condition. For when the people begin to take enough interest in their talking machines to buy all sorts of accessory improvements to them they are taking an interest which cannot be brushed aside as trivial. The talking machine, plainly, is beginning to settle itself firmly in the affections of the people. It is becoming a staple, just as the motor car has become a staple. Twenty years ago it was very much a question whether the motor car would ever amount to anything. Thirteen years ago another wise, intelligent man told the writer that the flying machine was against the laws of Nature and of God; yet within that very year the Wright Brothers had done the trick. The talking machine twenty years from now will be—what? Wherefore let us not forget that we are only at the beginning and that this activity in the accessory field is one of our growing pains.

A VERY good salesman—not of talking machines but of pianos—said to the writer this very day, "About six months ago the gang up

**Finding
the Lost
Art**

and down Wabash avenue" (which for the benefit of those readers who are not fortunate enough to reside in Chicago we shall say is a principal street and the Piano Row of our metropolitan burg.—Ed.) "made up their minds that it was going to be a bad year for business. They won. But about one-tenth of the number, including myself, made up our minds that it was going to be a good year. And we won, too. We have been doing business right along every day, but doing it only by hard, stiff work, by going out after prospects and digging them up, and then by selling. The truth is," continued our friend, who was in a meditative mood, "that salesmanship had been a lost art during the war days. It was not necessary to do any real selling when the people were falling over themselves to buy any sort of a thing that looked like a piano or, for that matter, a talking machine. Now to-day two things are plain. One is that under

POINT OF VIEW

cover of this abnormal state of affairs a great deal of trash was palmed off on the unwary as good stuff. Another is that, the public being thus rendered suspicious, the goods which are offered to-day must be better than they need have been a few years ago. This again means that still better salesmanship is needed. But after all it is not necessarily any better salesmanship than was needed to sell any kind of piano or talking machine, say, in 1913. The trouble with us is that we have had an easy time for so long that we cannot bring ourselves to realize that work is the order of the day. Work! Why, some salesmen have no grievance at all, save that they have to get out and dig once more! Laziness, that's all is the matter with most of us."

SPEAKING of accessories, as we were just now, and the demand for them, Mr. Hartenstein, of the Repeaterstop Co., told us the other day

Brains at Work

that January was the best month his company had had so far in its career. Now this is mainly interesting as a statement in connection with the rapidly growing interest in what may be called "accessory equipment" of all kinds. In a previous paragraph we noted that when the people take a large interest in accessories it means that they are clearly sold on the general idea behind all these: in this case on the general idea of talking machine. But there is another side to the question. There is what we may call the trade or professional side. The rapid growth in the number and variety of accessories furnishes proof that a great many persons are actively engaged in thinking out improvements to the talking machine. And this is of itself a very important matter also. For it shows in another and most notable manner how the talking machine has taken hold of the national imagination and how much interest is being focused on it. The talking machine, in reality, is one of the most fascinating and significant productions of the age and the possibility of perfecting it to the limit in every direction has taken a strong hold on the thoughts of men and women everywhere. It not only has not reached a condition of stagnation, it actually has not yet reached one of equilibrium. That is one of the most hopeful signs about it. Indeed, if business had actually come to a complete stop we should still feel obliged to rejoice from the mere fact that so much that is valuable and practical is being thought out merely in matters of accessory improvement. This is a viewpoint often overlooked.

READERS of the various feature articles which appear in this magazine each month are aware that under the general title, "Featuring the Musical Possibilities of the Talking Machine,"

A Great Company's Great Work

a great deal has been said about the educational side of the talking machine and about the work which is being done by different manufacturers to promote this work. It would be as unfair as it would be untrue to pretend that the vastly greater part of this educational work has not originated from the Victor Talking Machine Co. It was at Camden that the systematic introduction of the talking machine in the schools was first considered seriously and undertaken as part of a general policy. The literature which has issued from the company's offices since that momentous day on all phases of the educational work has been very voluminous and extraordinarily interesting. It has covered every possible phase of the case. It comprises in itself a complete course in musical appreciation written by experts of the first order, and with its records and machines constitutes a remarkable achievement in the co-ordination of educational method with educational ideal. Very few merchants, we cannot help saying, truly realize the quite stupendous nature of the Victor Co.'s work in these respects. It is beyond the ordinary mercantile experience and must be thoroughly inspected by actual visual contact before it can be appreciated. To anybody who is at all skeptical we recommend the most careful intensive study of the Victor Co.'s educational literature, which is as voluminous as it is fascinatingly and interestingly written.

WHICH allows us further to observe that the men who sell the talking machine are usually the last to recognize its real greatness. It

Our Infant Art

is all very well to be a good salesman, but it is even more necessary to be a good prophet, if one wants to realize completely the future possibilities—nay, the future certainties—of the talking machine. To-day most of us are so much interested in thinking of how we can sell Mrs. Jones or Mr. Smith that we lose sight of what it is we are selling. We cannot see the town for the houses, the forest for the trees. Look, for instance, at the records. The art of recording Sound is in its infancy. No one knows, or is likely for many years to know, what the near future may bring forth in this respect. One thing is certain, of course, and that is that we are to-day only at the beginning of a road that will take us very far. It is almost quite certain that the next few years will see the development of vast improvements in the materials of which records are made and also in the application of the record and reproducer to wider fields. The phono-letter sent by mail and telling its story in the very tones of the sender's voice is yet to come. But this is prophecy and we have no special desire to go prophesying away like a red-faced Nixon, as Sam Weller said. We out here in the mid-West, indeed, have this against the record end of the business, namely, that the recording laboratories stay so persistently on the Atlantic Coast. Pressing plants are beginning to appear in our territory, but the secret rooms where the great singers and instrumentalists bring their art to have it perpetuated by the magical etching of the sound-groove remain painfully aloof from us.

SPEAKING of records, by the way, the Western Division of The World received the other day a very interesting letter from John

Slovakia Is on the Map

Danko, who makes phonographs and sells them, with records of various makes, out on Milwaukee avenue in the Irving Park district of Chicago. This gentleman tells us that he has many calls for records in the Slovak language, but that the supply of these and of other records in Slavonic dialects is not by any means satisfactory to him. He says that these records have various defects. They are, to quote his own words, "either not sung or played by our people, or they have too many mistakes in music and in grammar; and above all, there are not enough new records, but too much of the same thing over and over again." Mr. Danko wonders why this should be so and wonders further whether there is any way of remedying the defects he alleges. Of course, it is not possible for us to speak with any authority on the subject, for we are not experts in the Slavonic languages, but it can readily be understood that the task of providing adequate lists of suitable numbers in dialects which are not of the first importance must be considerable. The Slovaks are the inhabitants of the eastern end of what is now the Czecho-Slovak Republic, and are an agricultural people, less urban than the highly developed Czechs of Bohemia. The Slovak language is not so important as Czech, Polish or Russian; and probably that accounts for the condition to which Mr. Danko refers, so far as it may be found, upon investigation, actually to exist. We make no doubt that Mr. Danko is sincere and he may very likely be right. The point of immediate interest to our readers is that Chicago is only one of many communities which have a large, useful, civically desirable and prosperous population who have come from parts of Central and Eastern Europe which are hardly known even by name to the average native citizen. These peoples are music-lovers to the last one, and are buyers of talking machines and records in generous quantities. A little more attention might well be given to their wants. Merchants who would take the trouble to investigate the foreign record field would soon find their trouble rewarded. The valuable articles on this subject by Mr. Sebok in recent issues of this magazine put the issue quite clearly. More attention to genuine music-love like this and less competition in a field already highly competitive, for the patronage of the jazz-fiends, would be a good thing all the way round.



The
TUNGSTONE
STYLUS —
exclusively **VICTOR**

NEW YORK
 Talking Machine Co.
 119 West 40th St.

CHICAGO
 Talking Machine Co.
 12 N. Michigan Av.

Victor Wholesalers Exclusively

From our CHICAGO HEADQUARTERS

REPUBLIC BLDG., 209 SOUTH STATE ST TELEPHONE WABASH 5774

EDWARD VAN HARLINGEN

WILLIAM BRAID WHITE

EUGENE F. CAREY

ARTHUR E. NEALY

A. SNYDER

CHICAGO, ILL., February 5.—One encouraging phase of the recent period through which the wholesale trade is passing is found in the information now being given out by the supply and accessory houses to the effect that buying of both supplies and of accessories is actually improving. These industries, like other branches of the trade, have been more or less at a standstill for the past few weeks, and the present recovery seems to point the way to a gradual building up throughout the entire trade. The manufacturers of talking machines have been moving very slowly, conserving their resources and at the same time getting rid of what material they had on hand. They have done this to protect both themselves and their dealers by waiting until a reduction in supply prices should come along. These reductions have come, although they have not been as great as was anticipated.

One thing distinctly noticeable is that the manufacturers are giving more for the money than has ever been the case before. In doing this they are upholding their old prices to some extent. Instead of turning out machines of the same quality as heretofore, they are turning out instruments embodying better workmanship throughout as well as a finer quality of woods, finishes, etc. Another thing noticeable is a tendency on the part of the manufacturer to install more equipment. In brief, it is evidently the desire to make the talking machine not only a better product musically, but to make it more attractive architecturally—a fitting product for the home.

Retail Trade Benefits by Canvassing

In the retail end of the game there has also been a pick-up, especially in the outlying districts. This has been due entirely to efforts of the dealers to build up their canvassing forces. Numerous prospects who are holding back waiting for reductions. From the reports they have been bringing back it appears that the owners of talking machines number about four-tenths of the urban population in the local district. If these reports stand up under analysis, the immediate conclusion will be that the field to be covered in the future is a mighty big one and that there is still room for more sales than here-

tofore. Seemingly all that remains to be done is to get busy and canvass the trade thoroughly.

Another thing that is pleasing the retailers is that accessories, such as albums, repeating devices, etc., are moving in good order. This would seem to indicate that the record business is going big and that the sales of dance music are increasing. As a matter of fact, the foregoing statements are true. Dance music is leading the field in the record business and in all makes of records.

Credit Conditions Show Improvement

We are told by the various credit departments that collections are very good, all things considered, and they are not having as much trouble along this line as might be expected. While it is true that the manufacturing industries have laid off great numbers of men, this has been only temporary, the purpose being, of course, to rehire at lower wages. Certainly full forces are not yet working again, but they are gradually coming back to normal, and it is expected throughout the industrial centers that the month of April will see everything going along at a good clip.

At this season, in years gone by, one of the big bugbears not only of this industry but others as well was the freight situation. It was next to impossible to get freight shipments through because of the vast amount of freight being moved throughout the country. Now that the manufacturing in all lines has asserted itself the railroads seem to be in condition to do some fast work, and this is being taken advantage of by manufacturers of talking machines. It is true that the orders they are sending out are not large ones, but the number of small ones they are taking care of is keeping them fairly busy.

Lakeside Active

The Lakeside Supply Co. held its annual sales conference in Chicago last week, and the entire sales force, consisting of eleven road men and several local salesmen, had a wonderful time at a banquet given by the company in one of the local hotels. The banquet followed an interesting day which was given over to sales talks and a visit through their wood-working plant. The Lakeside Supply Co., by the way, is putting out a good line of electrically operated phono-

graphs, which are known as the "Electrophone," as well as the "Chorister," a spring machine. Each line includes several models. This company recently took over the Chicago agency for the Lyric lateral-cut records and at present it is carrying a very large stock of these records, which are being distributed rapidly among the Chicago trade.

Records for Advertising

About a year or so ago the Chicago office of the Talking Machine World made a suggestion to the trade that it would be a good idea for those having recording plants to look up the possibility of using records for advertising purposes. We pointed out how many companies made a practice of large quantities of literature each month and how the recipients of this mail threw large quantities of it away without even taking the trouble to open it. We suggested that the recording men should point out that if an advertising sales talk were recorded on a record and sent to the people, those owning talking machines, of course, more attention would be paid to what the advertiser had to say and greater advertising benefits would result. It seems that this proposition was actually taken up in a small way, but nothing definite ever came of it. The matter was brought to our attention again this week by inquiries sent in from two electric companies asking where information could be obtained regarding the manufacturing of "sales talk" records. We believe there is a very big field to be covered in this sort of work and that hardly a concern in the country now sending out large quantities of mail each month which would not listen to this proposition.

To Introduce New Reproducer

Barnhardt Bros. & Spindler have brought out a new reproducer which they expect to introduce to the trade in about three months. This reproducer was invented by Gregg K. Mills, an engineer connected with the Chicago Telephone Co. The working models have already been completed and it is expected that the dies will be finished in a short time. One of the many features claimed for this new sound box is perfect insulation. The material will be a new alloy devised by their casting department. The new metal is known as "Tenso." Tenso, by the way,

(Continued on page 133)

When in the market for Fibre Needle Cutters
Always get our prices
Do not be put off with any other cutter
Efficiency is our first object

& we want your valued orders

Will we hear from you soon?
Allow us to quote you on a quantity
Do not wait until the other fellow outsells you
Enter your order at once. (Today.)

WADE & WADE

3807 LAKE PARK AVE.

CHICAGO, ILL.

The Second

Example of the Dealers' Helps prepared by Lyon & Healy



A six-page Art Folder, issued each month, which serves both as an envelope for the monthly supplement and a very distinctive advertisement as well. It is handsomely lithographed in several colors. The best records of the current month are featured and one page is devoted to a strong sales letter. Your name and address are imprinted. This folder will boost your record business.

Lyon & Healy Dealers' Helps Increase Your Sales

All of the Lyon & Healy services are well tested and tried. We use them for our own retail trade—one of the largest in the country.

They are sold exclusively to the most progressive Victor dealer in each city. If you are that man, write for full information, samples, and a complete list of our helps.

LYON & HEALY

Victrola Distributors

CHICAGO

FROM OUR CHICAGO HEADQUARTERS—(Continued from page 131)

is an alloy that is much lighter and has greater tensile strength than brass and is from three to four times stronger than white metal. The use of this new alloy will permit the various parts of reproducers and tone arms to be much thicker and will lessen the probability of threaded parts pulling out.

The casting department of this company has also brought out a new finish, which is known as "platinoid plate." This is an electro-plate finish which closely resembles silver, but, unlike silver, will not tarnish. The cost of finishing with platinoid is practically the same as that of nickeling. The platinoid is an exclusive feature with Barnhardt Bros. & Spindler and will be controlled by them exclusively. Another new finish on which they claim exclusive rights is a rubberized japan which is said to be more durable than old japan finishes and to have more of a rubber consistency, which eliminates any possibility of cracking or chipping. A combination of the japan with the platinoid offers many new possibilities for artistic designs in both tone arms and reproducers.

Pleased Over Okeh Record Popularity

H. S. Schiele, vice-president and treasurer of the Artophone Corp., St. Louis, paid the Chicago office of The World a visit while here on a buying trip a few days ago. Mr. Schiele was enthusiastic over the way the Okeh records were going in St. Louis and said that they expect to make a clean-up before very long. Since his company took on the jobbing agency for Okehs in St. Louis many new dealers have taken on this line of records and the Okeh family is steadily growing. Mr. Schiele stated that the general opinion in St. Louis is that business will be back to normal by March 1 at the latest. There is an increased demand for console machines and it is believed by many dealers that this type of instrument will lead the field in 1921.

New Store Opened

A. J. Bell, who for the past several years was connected with the record sales department of

the local branch of the Columbia Co., has become manager of the Imperial Talking Machine Co., an exclusive Columbia store, at 2308 West Madison street, Chicago. Mr. Bell succeeds Harry Passavay, who has retired from the talking machine business because of other interests. Mr. Bell was very popular with the Columbia dealers and since he has taken up these new connections many of his old dealer friends have called on him and wished him success.

When Will Times Be Good?

The R. C. Wade Co., maker of the Tonofone needle, through Dorchester Mapes, secretary and treasurer of the company, has sent out to the trade, under date of January 25, the following letter upon conditions which is interesting and timely:

"Francis H. Sisson, vice-president of the Guaranty Trust Company, of New York, at the annual banquet of the National Automobile Chamber of Commerce last Tuesday night, said: 'When will a stable basis for business be re-established?' In other words, when will times be good?"

"This same thought is discussed nowadays wherever bankers or business men get together—it is the question of the hour, and the answer is easy. Business will be good when we make it good, and every business man must do his part. Confidence, courage and hard work is what is required of us all.

"Mr. Sisson also said: 'The business conditions of this nation are fundamentally sound.' The buying power of the American people was never greater than to-day, but never before were people as keen about getting full value for their money.

"We are doing our part. We honestly believe we are giving the biggest needle value ever offered and we are carrying on an intensive campaign of co-operation with our wholesale distributors to make every retail dealer in the country know this. To finance this campaign we are anticipating our profits months

ahead and doing it without a whimper.

"In keeping with this policy we offered you an extra 5 per cent on our new, bigger value, bigger profit, 12 for 25c. package—to apply on all orders placed during the month of January. Don't throw away this 5 per cent—we offered it in all sincerity and want you to take full advantage of it.

"The business is there and those who go after it hard and give good value will get it. The handwriting is on the wall and easy to read. Don't ignore it. Orders dated and mailed not later than February 1 will be subject to the extra 5 per cent. Why not order now—to-day—on the basis of our letter of January 3?"

Exhibit Fernogrand at Stratford Hotel

O. R. Bowman and J. M. Dick, sales managers for the Fernogrand Co., are exhibiting their baby grand talking machine at the Stratford Hotel this month. The baby grand is manufactured in Cincinnati by E. H. McConnell, president of the concern. The Fernogrand Co. was reorganized and reincorporated on January 1 with a capitalization of \$175,000. The instrument is made in strictly period designs, intended to match the furniture in any household. It is equipped with the Ellis reproducer, the manufacturing rights of which are controlled by the Fernogrand Co. Piano men and talking machine men of Chicago have shown great interest in the Stratford exhibit. Messrs. Bowman and Dick have had their hands full receiving visitors and predict an excellent sale of the line in this territory.

Advertise for Business

The following sentiments, which appeared in Advertising and Selling of December 18 as coming from C. G. Steger, president of the Steger & Sons Piano Co., manufacturers of the Steger phonograph, should meet with support from manufacturers and foresighted merchants:

"It is the duty of manufacturers and merchants to redouble their efforts in sales-produce-

(Continued on page 135)

Your Account With Us

**Lateral
Cut**

**Okeh
Records**

**Lateral
Cut**

**Will Be an Insurance Policy Against
EMPTY RECORD SHELVES LOSS OF CUSTOMERS
LOSS OF PROFITS**

**Record Dealers Reach the Acme of Wisdom
WHEN THEY STOCK UP WITH POPULAR HITS ON**



No Waiting for Delayed Shipments When You Order From Us

MAGNOLA TALKING MACHINE COMPANY

711 Milwaukee Avenue

OTTO SCHULZ, President

CHICAGO, ILL.

The FONOLIER

FOR ANY

Talking Machine or Phonograph

The Only Portable Phonograph Light

Has Already Met With the Enthusiastic Approval of the Chicago Trade

Place a Fonolier near the turntable and by turning the button it will illuminate the

RECORD
and
REPRODUCER

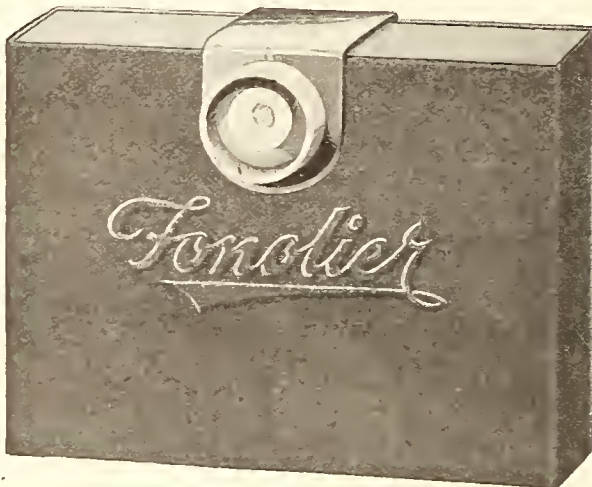

No screws or tacks to mar the woodwork.

“KEEP A FONOLIER
ON YOUR
PHONOGRAPH”

PAT. PEND.

RETAIL
PRICE
COMPLETE

\$2.00

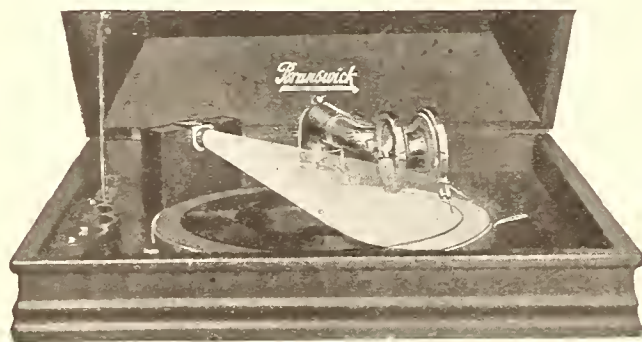

SIMPLE, EFFICIENT, ATTRACTIVE AND A SELF SELLER

Regular Trade Discount. Six (6) Fonoliers Are Packed to a Carton for the Dealer

Order a Carton From Your Wholesale Distributor

OR WRITE US GIVING HIS NAME

EXTRA BATTERIES RETAIL .75 EACH

We Sell Through Wholesale Distributors Only

Batteries Guaranteed Against Shelf Depreciation for Six Months

Manufactured by Fonolier Division

STUART PRODUCTS CORPORATION, 663 West Washington Street, Chicago, Illinois

SOLE SALES AGENT

W. A. CARTER

57 East Jackson Boulevard

Chicago, Illinois

NOTE—Send All Inquiries to W. A. Carter

FROM OUR CHICAGO HEADQUARTERS
(Continued from page 133)

tion by means of intensified consumer advertising during this period of readjustment. It has been said that the public likes to go from one extreme to another, but it would be dangerous for leaders of industry to do likewise.

"Well-planned advertising is conservative and continuous. Some business men believe in 'splurging' when conditions are highly prosperous and in stopping all advertising when times become rather critical. Publicity that is constructive and consistently maintained throughout good times and bad is certain to prove most profitable in the long run.

"When the buying demand of the public slows up, it is imperative that the manufacturer and merchant should put on the accelerator in going after sales by making use of intensified consumer advertising. The Steger institution intends to drive all the harder, from the standpoint of advertising and salesmanship, in campaigning for sales of Steger pianos, player-pianos and phonographs."

Good Emerson Display

The photograph shows the display of E. J. Hallett & Son, of Pontiac, Mich. The sign featuring Emerson records is eight feet long and



Hallett Store Features Emerson

four feet high, the field being painted in a brilliant red with white letters. The sign rests on a platform covered with bright green crepe paper forming a decided contrast to the red sign. Along the ledge of the window, arranged so that from the street it has the appearance of running along the top of the sign, is a board also covered with green paper on which are hung records at regular intervals.

Piano Club Gives Prizes

Pursuing its policy of doing its utmost to advance the cause of music, both trade and professional, in Chicago and the mid-West, the Chicago Piano Club, which is made up of piano and talking machine men of the city, has decided to give four prizes of \$50 each to the National Federation of Music Clubs for distribution in their fourth biennial national contest for young professional musicians. These contests, which are sponsored by the above organization, have succeeded in creating a nation-wide interest because of their work in developing the talent of professional musicians. The Piano Club is to be congratulated upon the altruistic spirit with which it has engaged in this work.

The purpose of the contests is to recognize

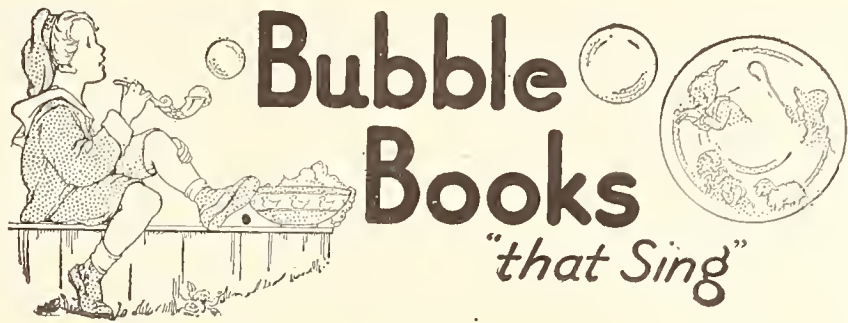

ANNOUNCING

A NEW BUBBLE BOOK RELEASE

**BUBBLE BOOK No. 13 and
NEW REVISED PRICE LIST**

List Price	- - - - -	\$1.25 ea.
Less than Gross Lots	- - - - -	83c ea.
In Gross Lots	- - - - -	79c ea.
Three Gross Lots	- - - - -	75c ea.

Order Your Quota Early—Write Today.

Consolidated Talking Machine Company
227-229 W. Washington Street Chicago, Illinois

the superior ability of American music teachers by bringing their artist-pupils into prominence, and to encourage and inspire music students to greater efforts in artistic achievement. Incidentally, it will give opportunity and publicity to the most talented young musicians of America, and perhaps be the means of launching them on a professional career. This knowledge will be of value to dealers throughout the country, inasmuch as they may be able to serve their clients by telling the latter about the contests. Mrs. Louis Yeager, 300 Forest avenue, Oak Park, is chairman of the national contest and can be communicated with by interested parties.

Columbia Salesman School

Over at the Chicago office of the Columbia Co. they have a large demonstration booth fitted up so as to represent a dealer's store. The room is very large, and where its front wall used to be they have set up some plateglass windows and a doorway, so that it looks exactly like the front of a regular talking machine store. This "store" is used for very many purposes, but perhaps the most important purpose for which it is used is the "dealers' salesmanship school," which holds sessions every Wednesday morning. This school is presided over by our old friend, "Professor" Kapp, of the "See What My Boy Got in France" fame. In order to become a regular professor, it was necessary for Kapp to don a pair of horn-rimmed spectacles, of the Harold Lloyd type, and purchase a regu-

lar teacher's ruler. Now as to the dealers, they are divided up into four sections, North Side, West Side, South Side and Loop, and they alternate every Wednesday for their lesson. When the dealers get together, Kapp enthrones himself behind a mahogany desk and the lessons begin. He begins by explaining minutely to the students just what the Columbia Co. is doing that particular week in the way of sales helps, such as literature, advertising propoganda, etc. Every piece of literature is gone over very carefully and explained and criticized by both Mr. Kapp and the class.

When the school began its first course, about a month ago, it was questioned whether the dealers would take to it, but after the first day of school the news spread around among the Columbia dealers and when the second class met it seemed that every dealer of that particular section was not only on hand, but had brought his' relatives with him.

Big New Loop Store

Jerome H. Remick Co., music publishers, will open a ground floor store at Jackson boulevard and State street next May in which they will handle sheet music, talking machine records, player rolls and small musical merchandise. The store now occupied by the Johnston Candy Co. has been rented for a ten-year period at a sum of \$225,000.

When it is realized that this will be the only first floor music establishment in the Loop on
(Continued on page 136)

TRANSFER NAME-PLATES

We make the Transfer Name-Plates and Trade-Marks for the largest talking machine manufacturers in this country and for dealers in every state.

YOUR NAME, Mr. Dealer, on every machine brings the owner back to you or records and his friends to you for a machine.

Samples, Suggestions and Sketches Furnished Free

THE MEYERCORD COMPANY, CHICAGO

Largest Manufacturers of **DECALCOMANIA** Transfer Name-Plates

FROM OUR CHICAGO HEADQUARTERS—(Continued from page 135)

State street the magnitude of the venture will be appreciated. When an old established concern like Jerome H. Remick takes a ten-year lease on State street for the purpose of selling music, it demonstrates the fact that the best known prophets of musicdom are ready to stake their cash on an optimistic belief in the future of music in this country.

Chicken vs. Worms

Once in a while in the midst of all his worries the tired business man gets a little literature which makes such a hit with him that he pastes it up over his desk where everyone may read it, and then he heaves a sigh of relief and agrees with himself that this little old world is not such a bad place to live in after all. At this time particularly, when everything is topsyturvy, letters of this kind are the best stimulant a business man can get. The latter is too much inclined to worry over the "falling off" in business, and to forget entirely that there ever was such a thing as business or that it still exists. However, we know of one man in Chicago who believes in the future and who is doing his darndest to spread sunshine to all of the manufacturers in the trade by means of clever little letters. That man is our old friend, Walter Magill, who handles the sales of the Universal Stamping & Mfg. Co. and a great part of the sales for H. G. Saal Co. His most recent letter is as follows. Read it and see if you don't agree that it is hitting the nail on the head:

"Would a Hen Stop Scratching If the Worms Got Scarce?"

"That little question seems to say more in a few words than anything we have heard. The answer, of course, is 'No.' The hen would keep right on scratching. Being very regular in her hours, she would probably continue to get up and retire with the sun. But we can readily believe that the aforementioned hen would utilize less time for dusting herself in the sand and would put in more productive minutes and hours on the main job of 'scratching for worms.'

"After a rain a hen has an easy time. Worms are numerous—there are a lot of them on top of the ground. It's 'easy picking.'

"That's the way business has been for the last three years. Now it is a little more like the problem the hen has when in the midst of a long dry spell—worms are scarcer and deeper down. Business is about the same. We are getting back to the 'good old days.'

"However, the hen hasn't stopped scratching and she isn't going to. She must have worms—you have got to have business. It's there, maybe not quite so plentiful, maybe a little deeper down—but it is there.

"Just let's keep in front of us that pertinent question, 'Would a Hen Stop Scratching If the Worms Got Scarce?'

"Then, let's emulate the hen."

Cathedral Co. Moves

At a meeting of the stockholders of the Cathedral Phonograph Co., which was held at the Fontenelle Hotel, Omaha, Nebr., on Wednesday, January 26, it was decided that the affairs of that company should be placed in the hands of a creditors' and stockholders' committee. It was proposed to continue the business for the benefit and protection of all concerned, and also for the purpose of submitting to all creditors a proposition whereby all obligations would be extended for a period of from six months to two years. The officers of the company now are Axel Akers, president; J. S. Gullborg, vice-president; Harry Hildreth, Jr., treasurer, and E. F. Bader, secretary. It was also decided that the company should move its executive offices from Omaha, Nebr., to Chicago. This plan was carried out, and the general offices of the Cathedral Phonograph Co. are now located at Room 1402, Consumers' Bldg.

The company proposes to pay one hundred cents on the dollar in the following manner: 15 per cent payable in six, nine, twelve, fifteen, eighteen and twenty-one months beginning February 1, 1921, and the balance of 10 per

EXCELSIOR PADS

The most satisfactory packing material for packing phonographs for shipment. Used to advantage by the largest manufacturers. Send for prices and samples.

H. W. SELLE & COMPANY
Manufacturers

1000-1016 N. Halsted St., Chicago, Ill.

cent exactly twenty-four months from that date. The factory of this company is located at Marion, O., and is fully equipped with the latest facilities for the manufacture of phonographs. Likewise, its buildings are of the same type.

The following men were selected at the creditors' and stockholders' meeting to effect the plan of settlement as above outlined. J. S. Gullborg, A. A. Monson, Harry Hildreth, Jr., A. Akers, R. Z. Morrison, E. F. Bader, G. O. Mayer, J. R. Roberts and C. E. Corey. It is understood that no preferences will be allowed and everyone will be accorded the same treatment. It has also been proposed that creditors' claims of less than \$50 be paid within ninety days from date and that all others join in the plan of settlement above outlined. If the creditors adopt the plan an agreement will be drafted whereby all property and assets of the Cathedral Co. will be transferred to the committee of creditors and stockholders to carry out the plan and all creditors will be asked to execute the agreement.

The financial statement of this company as of December 31, 1920, claims total assets of \$697,321.60 and shows total liabilities of \$845,215.29, leaving a deficit or loss of \$147,893.69.

Enter the Fonolier

One of the latest entrants into the talking

THE BIGGEST HIT OF THE YEAR!

PLACE THIS STAND ON YOUR COUNTER

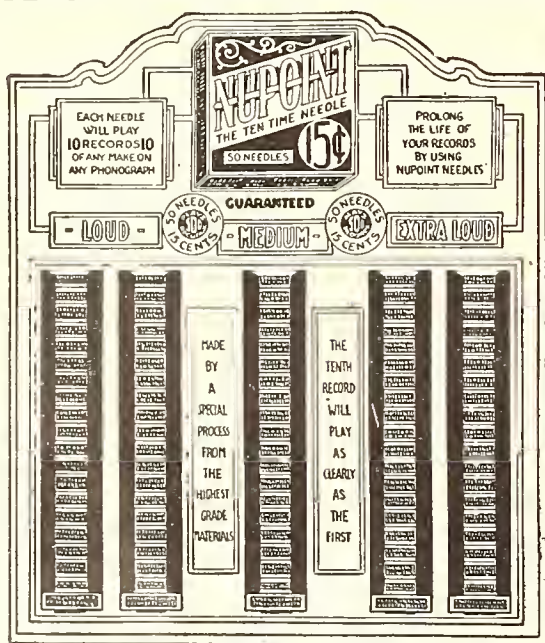

NUPOINT THE TEN TIME NEEDLE



Loud
Medium
Extra Loud

Carton
100 Pkgs.

NUPOINT THE TEN TIME NEEDLE

BIGGER PROFIT FOR DEALER
BIGGER VALUE FOR CUSTOMER

Live dealers, on the alert for new profit possibilities, can cash in on NUPPOINTS. They offer the biggest needle profits in the trade, to the dealer—and the greatest needle value in America, to the customer. Order your supply NOW.

NUPPOINTS are made of specially tempered steel. Three coatings of a secret chemical solution, on the point, then a patented, permanent GOLD FINISH, guarantee every NUPPOINT to play TEN records—the tenth one as clear and distinct as the first. This chemical treatment also minimizes the scraping—preserves the records—and purifies the tone.

MONEY-BACK GUARANTEE

NUPPOINT needles are sold with the maker's contract—a guarantee that stands squarely behind dealer and customer alike—MONEY BACK IF NOT SATISFIED WITH THE QUALITY OR VALUE.

24-Hour
Delivery



NUPOINT NEEDLES SELL AND SATISFY
FREE—DISPLAY STAND

A beautiful display stand holding 100 packages is given free with all introductory orders.

50 Needles to package
Each Needle plays 10 records
100 packages to carton

Dealer's Price
\$7.00
per Carton

Dealer's Profit \$8.00

Retail Value
\$15.00

JOBBERS—WRITE FOR SAMPLES AND ATTRACTIVE PROPOSITION!

NUPOINT MANUFACTURING CO.

128 No. Wells St., Chicago, Ill.

FROM OUR CHICAGO HEADQUARTERS—(Continued from page 136)

machine field is the Stuart Products Corp., whose headquarters are located at 663 West Washington street. The Stuart people have come out with a new battery lamp, to be used on talking machines. Selling arrangements have been made for the talking machine trade, and W. A. Carter, whose office is located at 57 East Jackson boulevard, has been appointed general sales representative. Mr. Carter is well known to the trade, and for a long time has been representing the Jones Motrola, as well as the Peerless Album Co. The Stuart Corp., manufacturer of Fonolier, anticipates that because of its compactness and neatness it will be used not only on the talking machine, but in "parlor, bedroom and cellar" as well. Fonolier is put up in a small imitation leather case, measuring 4"x3"x1 1/4" and the electric light bulb is counter-sunk into the side of the case.

This permits its use on the talking machine without attaching it. All that is necessary for the owner to do is to press a little button

on the back and the light illuminates the record or whatever else is necessary. By reason of its having no attachments it can be readily used in any part of the house that the owner may desire.

Out for Jobbers

The Nupoint Mfg. Co., of this city, has lately developed its business to such an extent that it is now able to take on more jobbers and for this purpose it has launched an extensive campaign. This company manufactures a talking machine needle which it has christened the "Nupoint." It claims for the Nupoint needle that "it is made of an especially high-grade tempered steel, having three coatings of a secret chemical solution, which guarantees ability to play ten records without changing the needle, and that it is covered with a patented permanent gold finish, which minimizes the scraping and scratching and purifies the tone of the record." The sales of this needle are being looked after by M. Cole, who has established his headquarters at 128 North Wells street. Mr. Cole says

that with each original order the company is offering a highly colored display stand as well as a quantity of sample packages.

In New Headquarters

The Chicago Musical Sales Co., wholesale distributor of talking machines and accessories, announces this month that it has moved to larger quarters and is now located at 56 East Randolph street, where it is in position to give immediate service to the trade. The manager of this company is our old friend, J. A. Tidmarsh, who was at one time connected with the Chicago branch of Hallet & Davis, Pathé division. Besides small portable talking machines this company features accessories such as needles, record brushes, albums, needle cutters, etc. According to Manager Tidmarsh it looks as though the dealers all over town were making a clean-up on the accessory end of the game. And this is just as true of conditions out of town.

Timely Brunswick Letter

A. J. Kendrick, general sales manager for (Continued on page 138)

FOR THE
EDISON

The Oro-Tone
QUALITY FIRST

FOR THE
VICTOR

AND NOW FOR  THE COLUMBIA
JUST SAY "Send Samples on Approval"

No. I-E Oro-Tone Edison Attachment

For Playing All Records on the Edison

Reproducers Fitted With Special Oro-Tone Diaphragms

Attached in a second. Needle retains perfect center in playing either hill and dale or lateral cut records. NOTE—Operates the same as the regular Edison reproducer with the raising and lowering lever. TONE QUALITY—Full, rich and glowing, with great carrying power and absence of metallic shrillness and surface noises.

Retail Price, Nickel Plated, \$7.50. Highest Grade Gold Plate, \$10.50



Illustrating the No. I-E Oro-Tone attached to the Edison

No. LS-V Oro-Tone Victor Attachment

For Playing All Records on the Victor

Reproducers Fitted With Special Oro-Tone Diaphragms

Attached in one second. Needle retains perfect center in playing either lateral or hill and dale cut records. TONE QUALITY—Deep, rich and mellow, with great volume, eliminating thin metallic tones and surface or needle noises on the records.

Retail Price, Nickel Plated, \$6.50. Highest Grade Gold Plate, \$9.50



Illustrating the LS-V Oro-Tone attached to the Victor

 The Impossible Has Been Accomplished

No. I-C Oro-Tone Columbia Attachment

For Playing All Records on the Columbia

Reproducers Fitted With Special Oro-Tone Diaphragms

Attached in one second. Needle retains perfect center in playing either hill and dale or lateral cut records. TONE QUALITY—Rich and musical with splendid volume and definition. Surface or needle noises practically eliminated.

Retail Price, Nickel Plated, \$6.50. Highest Grade Gold Plate, \$9.50

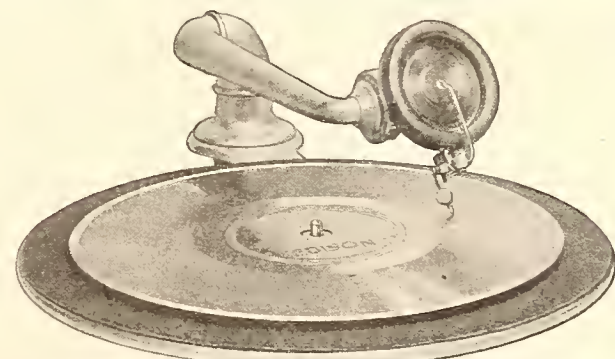

Illustrating the No. I-C Oro-Tone attached to the Columbia

SEND FOR—Copy of "The Oro-Tone," which illustrates and describes the complete Oro-Tone line.

The Oro-Tone Co.
QUALITY FIRST

1000 TO 1010 GEORGE STREET
CHICAGO, ILLINOIS

FROM OUR CHICAGO HEADQUARTERS—(Continued from page 137)

the Phonograph division of the Brunswick-Balke-Collender Co., recently sent out a letter to the Brunswick trade which was of a very encouraging nature. Instead of commenting on this letter, we are presenting it herewith, as we believe that the meat contained therein will be of value to many dealers. It reads:

"The steadiness of the Brunswick dealer throughout the period of readjustment, from which the country is now emerging, has been an impressive demonstration of

"(1) The confidence of the dealers in the fundamental soundness of the country.

"(2) The dealers' knowledge that the Brunswick line and its pricing are right.

"(3) The dealers' faith in The Brunswick-Balke-Collender Co., and its policies, founded long ago, now the best assurance that the affairs of the company and of those associated with it will always be protected by a well-founded, deliberate action.

"We take this means of again assuring you that your confidence and faith in this company are not reposed in vain.

"We repeat the statement, unadorned, that Brunswick prices will NOT be changed. As the gradual lowering of the cost of material and labor permits, the value of the product will be enhanced by betterments and added features. There will be no sharp transition, and, consequently, Brunswick inventories will not depreciate.

"Some, in the past, have been inclined to doubt the policy of standardized values. The correctness of the standard value is now proven beyond the question of doubt. The dissenters have paid heavily—some with their business lives. Those who stood fast are now prepared to enter into the opportunity of a better day."

Replogle Visits

One of the recent visitors to the Chicago trade was G. L. Replogle, vice-president and general manager of the Aladdin Phonograph Co., Kansas City, Mo. He is on his way back

to Kansas City after paying a visit to the Aladdin plant at Eau Claire, Wis. In a talk with a representative of The World, he stated that the company's headquarters are now located at 2305 to 2307 Penn street, Kansas City, and a space of 18,000 square feet is occupied. This company was incorporated some time ago for \$50,000, and the amount is fully paid in. "It looks to me," said Mr. Replogle, "as though business is going to be exceptionally good this Spring, and I am sure there is a tremendous amount of business to be had in the way of selling talking machines. All that is necessary is to point out to the dealer the good old ways of going after and show him that it isn't necessary to sit down and wait for new selling methods to develop."

Hear "Louisiana Five"

Antonio Lada and his syncopation artists entertained members of the Chicago Piano Club at their regular weekly meeting Monday, January 24, at the Illinois Athletic Club. The boys received much applause from the piano men, a couple of whom were guilty of swaying their shoulders à la shimmy during the performance. The Louisiana Five are Columbia artists and well known to lovers of dance music throughout the country.

Lyon & Healy Dealer Helps

The advertising department of Lyon & Healy has been very busily engaged recently in bringing out new ideas that will help increase sales for the dealers. Before these helps are offered to the dealer they are given a thorough try-out and test in the retail department of Lyon & Healy's big store on Wabash avenue. This department, by the way, is one of the largest in the country and should serve as a barometer for trade conditions. The service that it is getting out is for the exclusive use of Victor dealers and each month these dealers receive samples of the helps gotten out by the advertising department. The latest helps recently tested out, which, by the way, have proved very

successful, are the six-page art folders which will be issued each month. These folders are very artistic and colorful, and serve both as an envelope for the dealers' regular monthly supplements and as a distinctive advertisement. The drawings are all lithographed in several colors and the best records for the current month are featured. One of these pages is devoted exclusively to a strong sales letter, and a space is left for the imprint of the dealer's name.

West Sider Moves

The Schultz Piano Co., located at Madison and Ogden streets, has erected a new store at Oakley boulevard and Madison street. This is a structure forty-four by one hundred and twenty feet in the midst of one of the busiest business sections of the outlying districts. The Schultz Piano Co. plans to move into its new quarters around the first of the month.

What E. H. Gary Thinks of Music

It is most interesting to know that the movement for music in industry receives the increasing approval of big business. Here's what E. H. Gary writes in a letter to the Chicago Piano & Organ Association:

"I believe that music conservatively and consistently applied to industry should be a material benefit to both the workers and the employers. If 'music hath charms to soothe the savage breast,' it certainly will have a good influence upon people as intelligent and well informed as the employes generally of this country."

Tone Shop Bankrupt

The Tone Shop, formerly located in the North American building, and before that in the Republic building, was declared bankrupt by an order in Judge Carpenter's court last month. The petition was filed against Walter A. Pushee, trading as Walter A. Pushee & Co., and the Tone Shop, by the Phonograph Manufacturers Credit Bureau, of which Alfred S. Bruno is president. To the latter gentleman goes the

(Continued on page 140)

Sterling

STONE ARMS REPRODUCERS and ATTACHMENTS

High Class Workmanship
Beautiful Finish
(Nickel or Gold)
Simple, Practical Design
are features of
Sterling Guaranteed Products

Send for Bulletin No. 9

STERLING DEVICES CO.

534 Lake Shore Drive
CHICAGO

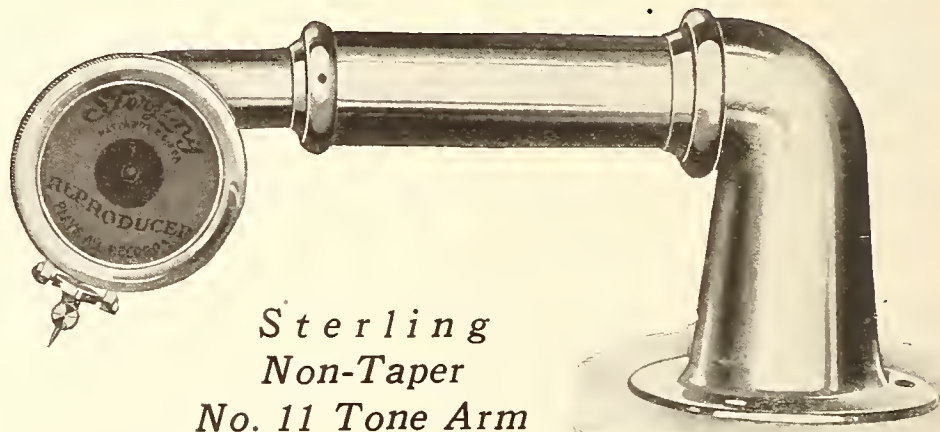

*Sterling
Non-Taper
No. 11 Tone Arm*

Sterling Reproducers Play All Records

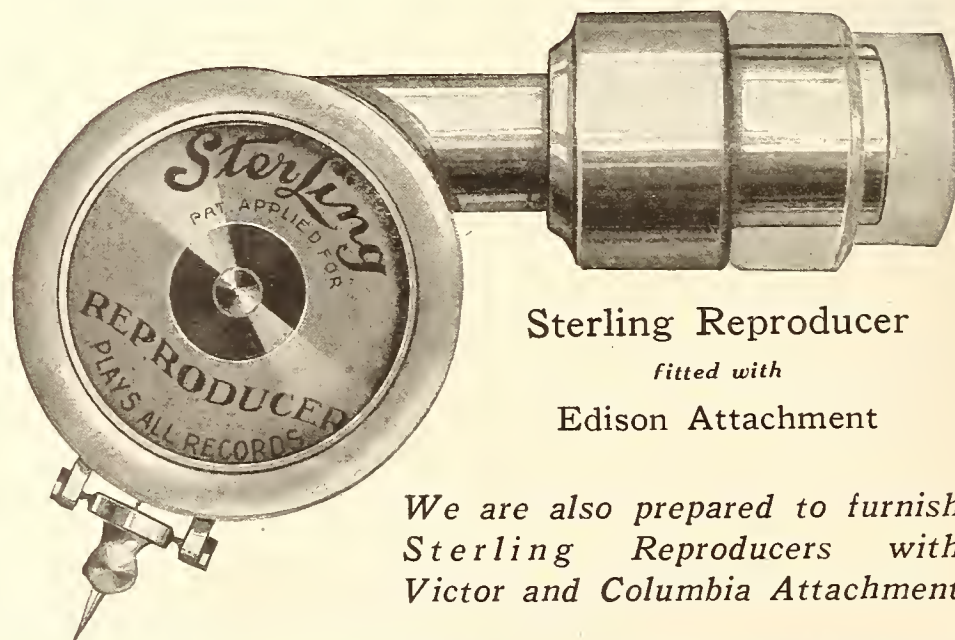

*Sterling Reproducer
fitted with
Edison Attachment*

*We are also prepared to furnish
Sterling Reproducers with
Victor and Columbia Attachment*



Now
85c.

No Better Record Made!

Grey Gull records are made in a large, amply financed factory—under one roof—of the best materials obtainable, and by the best artists available. The Grey Gull executives have been making records for years. They comprise America's most successful record experts. Grey Gull records are 10 inch, lateral cut records and are guaranteed to play at least 100 times. They have a silk smooth surface and brilliant volume. There can be no better records made at any price.

**No Agency Strings—
Order When and What You Want**

Every hit appears on Grey Gull records first. "Margie," "Broadway Rose," "Beautiful Annabelle Lee," and every other hit of the day are yours without agency strings. There is no red tape. You are not obligated to sell any particular phonograph or assume any binding contracts. Order when and what you want. On-time deliveries are guaranteed.

**The 85c Price
Will Increase Your Sales**

Grey Gull records at 85c. offer the biggest record values in America. The price insures two sales at 85c. to each buyer, instead of one sale at \$1.00. You can afford to stock 85c. records, because you know the price is rock-bottom. It takes away the nervous feeling that you have when you stock records retailing at \$1.00 or more.

One of the Special Bargains Listed in Our New Bulletin

Here is an example of the record-breaking values now offered in our March, 1921, bulletin. This book shows a complete line of phonographs, musical instruments, supplies and accessories at rock bottom prices.

Write for your copy today

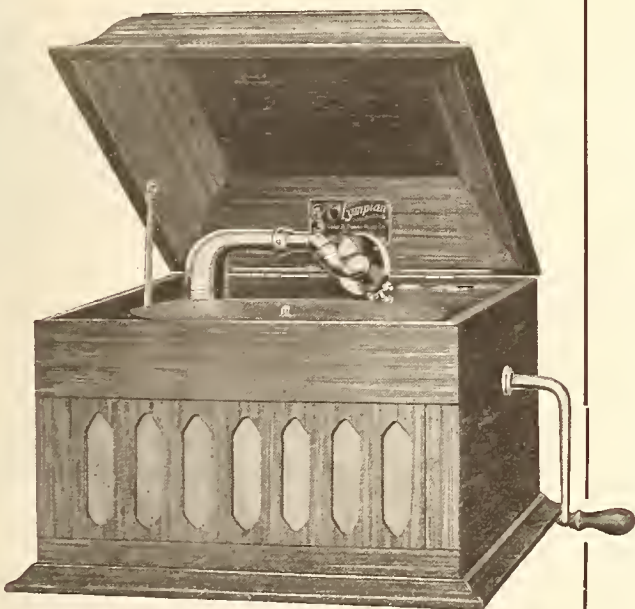

Olympian Model 60 The Big Trade Winner

Model 60 is just another example of Olympian guaranteed quality at a special low price. At \$50.00 to \$60.00 you can offer more real value than can be had in another instrument and you will still make more than 100 per cent. Act quick, as we are offering but a limited stock at these special prices.

Order from this Ad

Plays as loud and clear as the large cabinet phonographs. Has an all-wood tone-chamber, universal tone-arm, cast-iron frame, double spring Heineman motor. Plays all makes of records.

Size 13 inches high, 19½ inches deep, 17 inches wide. Finished in genuine mahogany. Limit of 6 of Model No. 60 to any one dealer.

No. 60-AJ

Wholesale Price, each \$24.50

**20
Best
Sellers**



**40%
Discount
to Dealers**

- | | | | |
|-----------------------------------------------------------------------------------------------------------------------------------------------------------|--------|-----------------------------------------------------------------------------------------------------------------------------------------------------------------------------------------------------------|--------|
| 1. Rosie—Fox-trot, Sung for Dancing by Ernest Hare } 10-in.
Oh Gee! Say Gee! } 85c.
Sung for Dancing by Ernest Hare | L-1039 | 11. Sweet Mamma—Fox-trot, Krueger's Melody Syncopaters } L-1025
Just Like a Gypsy—Fox-trot, } 10-in.
Grey Gull Dance Orchestra } 85c. | L-1025 |
| 2. Palestena—Fox-trot Banjopaters } L-1040
My Home Town Is a One-horse Town— } 10-in.
Fox-trot Banjopaters } 85c. | L-1040 | 12. Avalon Sung by Ernest Hare } L-2040
Like We Used to Be, } 10-in.
Sung by Charles Hart and Louis Terrell } 85c. | L-2040 |
| 3. Grieving for You—Fox-trot Banjopaters } L-1038
Beautiful Annabelle Lee—Waltz. Banjopaters } 10-in.
} 85c. | L-1038 | 13. Whose Baby Are You?—Fox-trot, All-Star Trio } L-1029
Medley Fox-trot from "Irene," } 10-in.
All-Star Trio } 85c. | L-1029 |
| 4. Margie—Fox-trot. Selvin's Novelty Orchestra } L-1036
Biddy—Fox-trot. All Star Trio } 10-in.
} 85c. | L-1036 | 14. Old Pat (Why Don't You Answer Me?), } L-2036
Sung by Charles Hart } 10-in.
Pretty Kitty Kelly. Sung by Charles Hart } 85c. | L-2036 |
| 5. Feather Your Nest—Fox-trot. . . Banjopaters } L-1037
I'd Love to Fall Asleep and Wake Up in } 10-in.
My Mammy's Arms. Banjopaters } 85c. | L-1037 | 15. Tripoli, } L-2034
Sung by Charles Hart and Louis Terrell } 10-in.
Hiawatha's Melody of Love, } 85c.
Sung by Charles Hart and Louis Terrell | L-2034 |
| 6. Whispering—Fox-trot, Joseph Samuels' Music Masters } L-1031
Kismet—Fox-trot, Joseph Samuels' Music Masters } 10-in.
} 85c. | L-1031 | 16. Let the Rest of the World Go By, } L-2017
Sung by Henry Burr } 10-in.
Wond'ring Sung by Charles Hart } 85c. | L-2017 |
| 7. Japanese Sandman—Fox-trot, Joseph Samuels' Music Masters } L-1032
Louisiana Waltz. Grey Gull Dance Orchestra } 10-in.
} 85c. | L-1032 | 17. When You and I Were Young, Maggie, } L-2021
Sung by Charles Hart } 10-in.
A Perfect Day. Sung by Henry Burr } 85c. | L-2021 |
| 8. I've Got the Blues for My Old Kentucky } L-1034
Home—Fox-trot Banjopaters } 10-in.
Caresses—Fox-trot Banjopaters } 85c. | L-1034 | 18. The Rosary. Sung by Henry Burr } L-2026
I Hear You Calling Me, } 10-in.
Sung by Charles Hart } 85c. | L-2026 |
| 9. Dolly, I Love You—Fox-trot. All Star Trio } L-1030
Dance-O-Mania—Fox-trot. Gilt Edge Four } 10-in.
} 85c. | L-1030 | 19. My Isle of Golden Dreams—Waltz, Starita Saxophone Sextette } L-1011
Lucille—Fox-trot. Starita Saxophone Sextette } 10-in.
} 85c. | L-1011 |
| 10. Broadway Rose. Sung by Charles Harrison } L-2043
Blue Diamonds. Sung by Henry Burr } 10-in.
} 85c. | L-2043 | 20. The Country Doctor and the Rube Patient } L-7005
—Character Dialogue by Steve Porter and } 10-in.
Billy Jones } 85c.
Swapping Horses—Character Dialogue by }
Steve Porter and Billy Jones | L-7005 |

An Order for These Hits Will Convince You

In all, Grey Gull records offer you a quality product—hits when you want them—service without red-tape—the lowest price in America. Place an initial order for these twenty best sellers, or for any selections that you desire. Convince yourself.

Order Today at Our Risk

If you are not satisfied with Grey Gull records, return them at our expense. That guarantee protects you and your customer alike.

Cole & Dunas Music Co.

Wholesale Headquarters for Phonographs, Musical Instruments
and Supplies

50 to 56 West Lake St.

Chicago

LAKESIDE PHONOGRAPH PRODUCTS



THE
ELECTRO-PHONE
ELECTRICALLY
DRIVEN
PHONOGRAPH



MOTORS-TONE ARMS
ALL PHONOGRAPH
EQUIPMENT
WALL KANE
NEEDLES
ACCESSORIES

DISTRIBUTORS

LYRIC RECORDS

HITS FIRST

PROMPT SERVICE

BEST SELECTIONS

LAKESIDE SUPPLY CO.

412-16 SO. DEARBORN ST.

CHICAGO, ILL.

PHONE HARRISON 3840

part of the motor. This, they claim, gives it an universal application. The Sterling people report that there was a slight pick-up in business towards the latter part of January and that from present indications the trade is awakening. At a recent election of officers of this company Fred Wenzel was elected treasurer.

Tell of Business Expansion

The Jewel Phonoparts Co. has shown a phenomenal growth since its organization two years ago and its sound boxes, equipped with a Nomika diaphragm and Jewel mute, have had an exceedingly favorable reception by talking machine manufacturers. The business in the past year has grown to a point where the sales receipts amount to \$200,000. This company has an authorized capital of \$100,000, \$60,000 of which has been paid in, all except \$2,500, in cash.

Plans are being worked on at present for the enlargement of the mechanical department and the company expects, within a short time, to bring out many new articles which fill a long-felt want in the trade. One of these new features is the non-taper Jewel tone arm. The various phonograph accessories to be placed by the company will hereafter be known as "Jewel" instead of "Blood."

The men most strongly interested financially in the company are men of large business experience able to stand behind the company in any financial way needed. These men are also taking an active part in the business thereof and giving it the benefit of their past business experience in other lines. The sales for the Jewel Phonoparts Co. are now being handled by A. B. Cornell, who is known to every manufacturer of talking machines in the business, as well as to a great number of retail dealers. It is announced that "O. J. Kloer and B. B. Blood, who were formerly connected with said company, are no longer interested in same or in its employ in any way."

Black and White Melody Boys Entert'n

The W. W. Kimball Co., Pathé distributor of this city, capitalized the appearance at a local theatre of Ray Miller's Black and White Melody

FROM OUR CHICAGO HEADQUARTERS—(Continued from page 138)

bulk of the credit for bringing about a settlement in the Tone Shop's affairs. The petitioner alleged that Pushee, in his store on West Madison street, had sold fixtures to his brother for \$100 which in reality were worth much more than this amount. He is also said to have secured goods on consignment with the understanding that he would turn over collections to the consignee, but failed in doing this. He is also said to have borrowed money from various

discount companies, turning over leases as collateral security.

New Automatic Stop

The Sterling Devices Co., 536 Lake Shore Drive, is preparing to place on the market a new non-set automatic stop, which it has perfected, and is said to be adaptable to all makes of talking machines. One of the unique features of this new Sterling stop is that it forms an integral part of the tone arm proper and is not a



Okéh Records



Unexcelled by comparison

We can supply the most popular hits and give prompt service. Write for details of our "Dealer Proposition"

Wade Talking Machine Co
WHOLESALE DISTRIBUTORS.

12-20 N. MICHIGAN AVE., CHICAGO, ILL.

FROM OUR CHICAGO HEADQUARTERS—(Continued from page 140)

Boys whose delightful and catchy renditions on Pathé records are popular throughout the entire country. During their recent engagement at the Illinois Theatre, these musical monarchs of jazzland proved the big feature in the show of striking hits and, following the regular performance at the theatre, the Miller Melody Boys gave popular recitals at the W. W. Kimball Co.'s music store, where they entertained the patrons

Payment of First Dividend

On January 20 a meeting of creditors of the World Phonograph Co. was held before Sidney Eastman, referee in bankruptcy, and at that time payment of the first dividend to creditors whose claims have been proved and allowed was considered. A report was also submitted asking for \$740 for final receivership fees and \$1,000 for receiver's attorneys.

Lyon & Healy Elect Officers

The annual meeting and election of officers of Lyon & Healy, manufacturers and dealers, was held on February 1 and resulted in the election of Marquette Healy, president; Columbus Healy, vice-president; C. R. Fuller, secretary and treasurer, and J. F. Bowers, chairman of the Board of Directors.

Mandel Co. Stockholders' Meeting

The following notice was sent out early in the month by John H. Hupp, secretary of the Mandel Mfg. Co., Chicago, Ill.: "Notice is hereby given that pursuant to the by-laws of Mandel Manufacturing Co., the regular annual meeting of the stockholders of this company will be held at its office, 1455 West Congress street, in the City of Chicago, County of Cook, State of Illinois, on Tuesday, February 15, 1921, at the hour of 2 o'clock p. m., for the purpose of electing directors for the ensuing year, and for the transaction of such other business as may properly come before the meeting."

GREY GULL RECORDS IN THE WEST

Cole & Dunas Music Co. Take on Western Sales for Grey Gull Records—George Bradford Associated With Concern

CHICAGO, ILL., February 5.—Cole & Dunas Music Co., jobbers of talking machines, supplies and accessories, have acquired the Western agency



Window Display of Grey Gull Records for distribution of Grey Gull records. A complete line of these records will be carried in stock at their warerooms and offices located at 54 West Lake street.

George Bradford, formerly with the Q R S Music Co., the Imperial Player Roll Co., and the Starr Piano Co., has associated himself with Cole & Dunas and will devote most of his time to pushing the sale of Grey Gull records. A number of dealers have already been established in Chicago, and a number of window displays have been prepared featuring the line. One of these is shown in the accompanying photograph. It is in a store located at 617 South State street and shows the window display cards furnished by the Grey Gull advertising department to dealers, also smaller posters listing the monthly releases and featuring the Grey Gull retail price of 85 cents.

TALKING MACHINE BUSINESS CAN BE HAD—GO GET IT!

The Industry Needs a Stimulating Dose of Salesmanship—Dealers Have Neglected Canvassing and Prospect Lists—Proof of This Demonstrated by a Canvass Made by The World

"Let the dead past bury its dead." The business slump is passing. It is not a time for mourning and discussing the past or the reasons or causes for the recent business slump—it is the time to be up and doing—to create business and to work along sales lines that will mark new achievements.

Manufacturers and dealers everywhere have, with a few exceptions, plenty of goods on hand, but instead of getting out and selling, which, by the way, seems to have become a lost art, many of them are sitting by the wayside bemoaning their fate, with the result that sooner or later we will hear of some of them going out of business. This is inevitable. What this industry needs at the present time is a good stimulating dose of salesmanship. No one need sit down and worry his head off thinking up new ideas

that will increase sales. Everyone has the necessary material under his thumb, and it is merely a question of application. What the manufacturer needs to do is to send his salesman out on the road with instructions not to cut prices or offer ridiculous propositions in an effort to get business, but to teach the retailer he calls on to make use of the material he has on hand. This material is his prospect list and should be fully utilized.

It is a well-known fact that for the past couple of years every dealer in this country has neglected his prospect lists and his canvassing. The reason he did it was because they were not then necessary, and the reason he is continuing to neglect them is because he imagines that at the present time the buying public is broke.

(Continued on page 142)

The
**New Blood Non-Infringing
Tonearm and Reproducer**

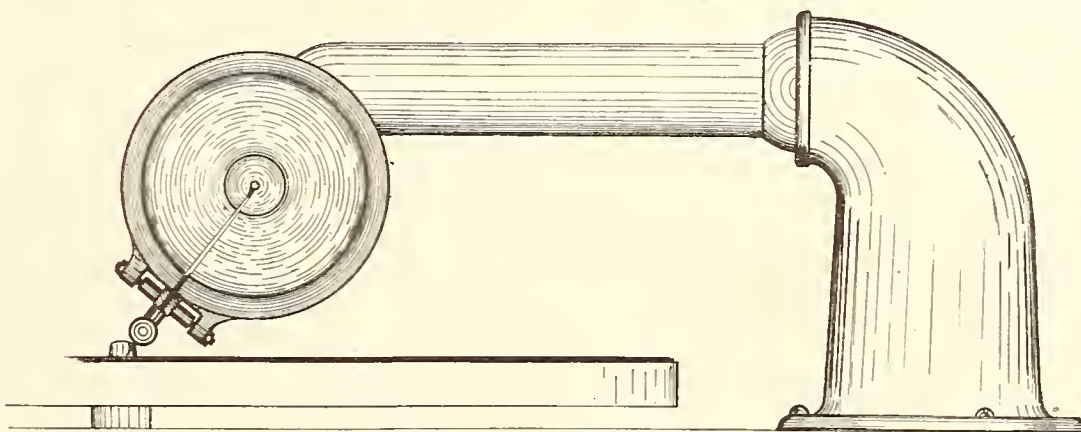

Nothing more need be said of this arm, only that it possesses the same high qualities that have always characterized BLOOD equipment.

*Standard length (8½") Proper weight
Universal playing and NO Springs*

Order the NEW BLOOD and be safe in every sense of the word.

We will be in production this month to furnish you the right kind of goods at the right price.

Exclusively manufactured by

Blood & Kloer

404 WEST ERIE STREET

CHICAGO, ILL.

FROM OUR CHICAGO HEADQUARTERS—(Continued from page 141)

In this he is sadly mistaken; and if he feels that he wants to prove to himself that the people still have plenty of money, all he must do is to get a line on some bond or stock salesman and take note of the way the latter is raking in the shekels. When people are broke they never buy anything, but sometimes they get their heads together and go looking for bargains which they create themselves by holding off purchases.

Several weeks ago we put the proposition of canvassing up to a few wide-awake dealers in Chicago, who, by the way, were of the opinion at that time that business had gone on the blink, and the result was that these dealers are to-day moving practically as much goods as they ever did. Recently a representative of this paper canvassed a building that contained ten families. After canvassing these families he brought back the following information: Four of these families had talking machines, one of them did not even care to consider a talking machine; but the others were in the market for machines and, in fact, anxious to get them. When asked why they didn't come out to buy an instrument, their come-back in a sense was unanimous: "If we go downtown to buy a talking machine we shall get one at the regular price and no inducements, whereas if we wait until we are approached by a canvasser we can take it for granted that we shall get something way below the regular price, plus a good inducement. Our reasons for believing this are that whenever the dealer sends around a canvasser, he needs business. If he had the business a canvasser would be unnecessary. Therefore, we anxiously await the arrival of a canvasser."

This tip was given several dealers around town, who, by the way, thought at first no such situation existed. They tried the proposition out with one or two canvassers and have since that time been gradually adding to their force. To our way of thinking, if canvassing is the necessary stimulant for one locality, it surely ought to work in others; and our suggestion to the trade in general is to dig up the old prospect lists and start the canvassing forces to working and moving goods. To the manufacturer we would add, "Re-educate your dealers along these lines and teach them salesmanship of the old 'Go Get It' type."

RICH TUNGSTEN ORE IN ARGENTINA

Trade Commissioner George S. Brady has forwarded a sample of tungsten ore from the Providence of Catamarca, Argentina. The bureau of mines has made analysis of this ore which shows that it contains 64.46 per cent wolfram, 10.95 per cent silica plus insoluble matter, and considerable calcium carbonate. In other words, the material is about 80 per cent scheelite, 11 per cent silica, etc., and 9 per cent soluble matter, mostly calcite. The name of the owner is not given by Mr. Brady, but if any American companies are interested the Latin-American Division of the Bureau of Foreign and Domestic Commerce can obtain a report upon the matter.

The "Ten Commandments of Salesmanship" which appeared on page 46 of last month's World were, we understand, written originally by Dr. Frank Crane.

WHERE CAN THE REPEATER-STOP BE SECURED?

DEALERS! Start the new year right and put in a stock of Repeater-Stops, the fastest seller on the market.

The following is a partial list of our distributors:

Atlanta, Ga.....	Southern Sonora Company Southern Paramount Co. Elyea Company	Milwaukee, Wis.....	A. G. Kunde Godfrey & Sons
Baltimore, Md.....	A. Burdwise H. R. Eisenbrandt Sons, Inc.	Minneapolis, Minn...	Beckwith O'Neill Company
Birmingham, Ala....	Talking Machine Company	Mobile, Ala.....	W. H. Reynolds
Brooklyn, N. Y.....	G. T. Williams Co., Inc.	New Orleans, La....	Philip Werlein, Ltd.
Buffalo, N. Y.....	W. D. & C. N. Andrews Buffalo Talking Machine Co., Inc.	New York, N. Y....	Cabinet & Accessories Co. Fulton Talking Machine Co. Knickerbocker Talking Machine Co. Bristol & Barber
Chicago, Ill.....	Chicago Talking Machine Co. Lakeside Supply Company	Omaha, Nebr.....	A. Hospe Company Schmoeller & Mueller Piano Co.
Cleveland, Ohio.....	Cleveland Talking Machine Company	Philadelphia, Pa....	Penn Phonograph Co., Inc. Heath & Gorham
Denver, Colo.....	Knight-Campbell Music Company	Pittsburgh, Pa.....	C. C. Mellor Co., Ltd. The Reed Company
Detroit, Mich.....	Grinnell Bros.	Red Lodge, Mont...	Ball Music Company
El Paso, Tex.....	F. G. Billings Piano Co.	Rochester, N. Y.....	E. J. Chapman
Fargo, N. Dak.....	Stone Piano Co.	San Francisco, Cal..	Walter S. Gray Co.
Houston, Tex.....	Southern Drug Co. Talking Machine Company of Texas	Salt Lake City, Utah	Consolidated Music Co. Salt Lake Hardware Co. John Elliott Clark Co.
Indianapolis, Ind....	Stewart Talking Machine Company	St. Paul, Minn.....	W. J. Dyer & Bro.
Jacksonville, Fla....	John A. Futch Company Florida Talking Machine Company	Syracuse, N. Y.....	Gibson Snow Company
Kansas City, Mo....	Wm. Volker & Co. Richards Conover Hdw. Co.	Tampa, Fla.....	Tampa Hardware Company
Los Angeles, Cal....	Western Jobbing & Trading Company	Toledo, Ohio.....	Toledo Talking Machine Co.
Memphis, Tenn.....	Hessig Ellis Drug Co. O. K. Houck Piano Co.	Toronto, Canada....	The Music Supply Company His Master's Voice Co.
		Washington, D. C...	Rogers & Fischer
		Wichita, Kans.....	Eberhardt Hayes Company

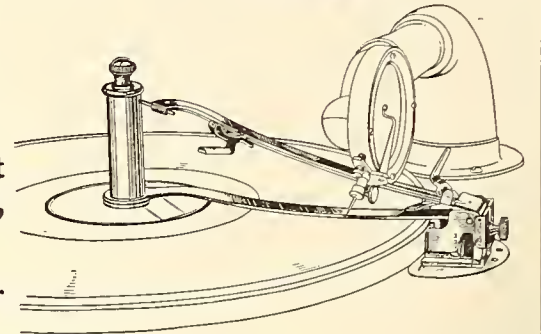

REPEATER-STOP CO., 115 So. Dearborn St., Chicago, Ill.

WHY WE MUST ALL NOW GET TO WORK—THIS MEANS YOU!

Walter Magill, Sales Manager, the H. G. Saal Co., Discusses Best Means of Adjusting Ourselves to Present Conditions—Correct Salesmanship and Work Are Secrets of Success

If we could read what is perplexing the minds of business men to-day, we would probably find them all battling with the same question, "How can I survive present business conditions?" And while there might be much difference of opinion among them as to the best methods of adjusting themselves to present circumstances, there would be found a remarkable unanimity as to the slogan of the hour. All would agree—and agree heartily—that the wisdom of the ages as applied to the present needs is summed up in one word—*work!*

Salesmanship up to a few months ago had become a lost art; the high-grade salesman had become a pacifier and a diplomat. It was not a question of price, but of delivery, and the salesman could pass the buck to the plant.

But now it is different. Intensive buying has given way to intensive selling. The salesman of former days must "come back." His past record will not help him. Younger men imbued with native pep will pass him by unless he looks to his laurels. He will have to inventory his selling qualifications, and if he is wise he will set about to rehabilitate his salesmanship and learn the art over again if that be necessary.

The man who cannot adjust himself to the needs of the present cannot take an effective part in the readjustment going on about him.

Employers are appraising their selling forces, for self-preservation compels them to do it. The man who can produce results is the man of the hour, and the field was never clearer

for the man of ability. Have you read the story of Mr. Hastings? We believe it is worth repeating.

Mr. Hastings, a real estate salesman, learned that a large Eastern manufacturing company had decided to open an extensive plant in Indianapolis. He boarded the next train for the company's headquarters in Camden, N. J., won a hearing from the firm's president, put before him the advantages of certain property at Hammond, Ind., and eventually closed the deal for \$300,000 to the satisfaction of the buyer, the seller, the city of Hammond, himself and his firm.

Needless to say, the present general business depression has not depressed Mr. Hastings.

Such efforts overcome the handicaps of temporary business depression. When enough of these handicaps are overcome the depression ceases to exist.

That is a task which now confronts the business man. Mr. Hastings set an example of overcoming handicaps by individual effort, which proves it can be done. If it can be done by one man in one line of business, why cannot it be done by another man in another line of business—in our line of business? Individual effort is needed. It will bring not only individual reward, but a betterment of conditions throughout the nation.

And the great fact that we ought to think about and talk about to-day is the greatness and the soundness of our country. When a country like ours concentrates on one thing, what is the result? We have but to remember the great war and the part we played in it. We made many mistakes, but the fact remains that there was only one result to look for with such concentration of effort. Instead of fighting, we must now all get to work, and if every one of us does his share with the same undivided spirit that ruled us two and three years ago, there is no question about the outcome. Resourceful, tireless brains and sturdy, ambitious brawn will drive forward and bring about a condition in this country that will cause the writers of history to gasp in astonishment as they make this record: "This was the

(Continued on page 144)

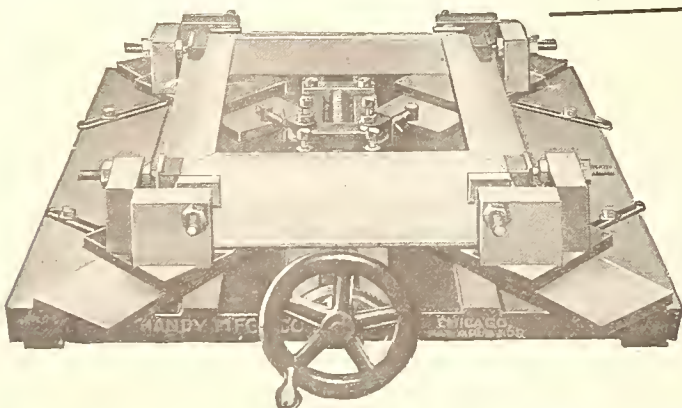

WE ILLUSTRATE THE

"Handy" Dome Clamp

Quick action for clamping domes and frames on Talking Machine Cabinets

Write for Catalogue of clamping machines for Cases and for all purposes.

VENEER PRESSES AND CLAMPS

HANDY MFG. CO.

27 E. Madison St., Chicago, Ill.

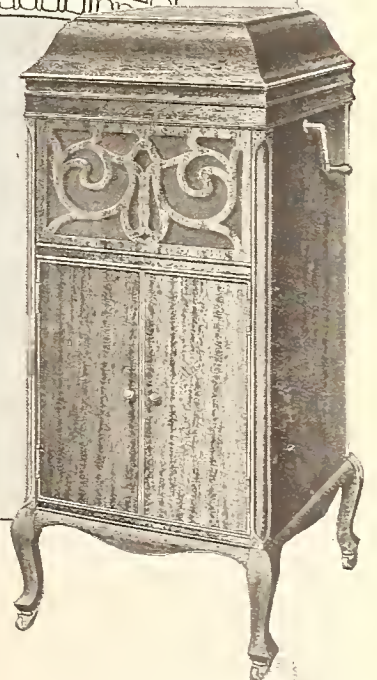
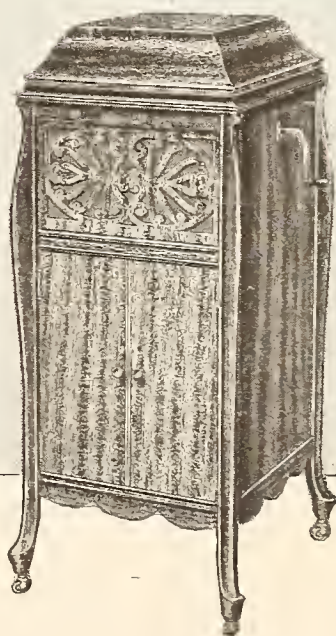
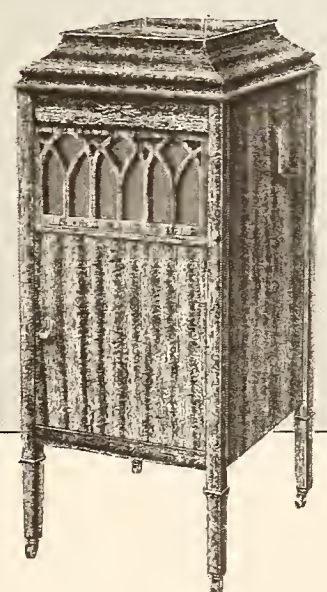
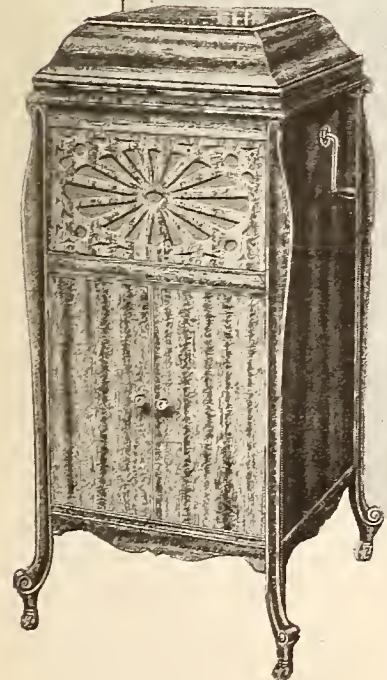
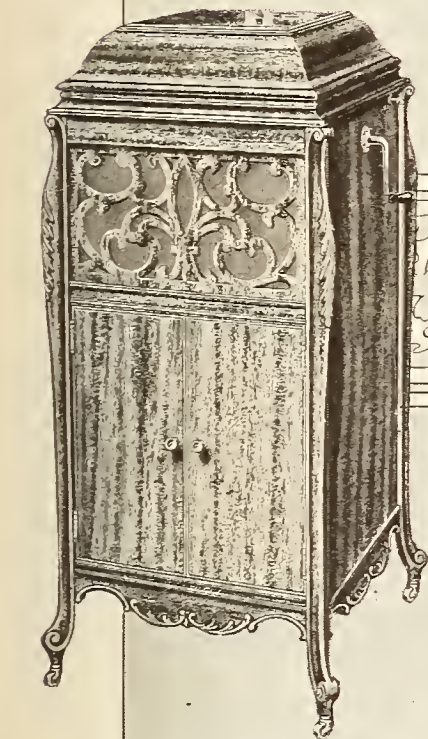

A Dealer's Proposition of Unusual Merit

We have developed a plan to stimulate dealers' sales—a plan that may solve YOUR selling and financial problems.

The plan is a liberal one, enabling aggressive dealers to build their phonograph business to an unlimited degree.

The large resources of the MANDEL MANUFACTURING COMPANY will be used to advertise and finance dealers in MANDEL Phonographs and Records.

We consider this the greatest opportunity ever offered to dealers. It comes just in time to solve the selling problems that every dealer is facing to-day.

Mandel Phonographs and Mandel Records

Good products, coupled with a good selling plan, assure success. MANDEL Phonographs are built to give lasting satisfaction to every purchaser. We consider the MANDEL line one of Quality throughout,—second to none in musical performance, mechanical equipment and appearance. It is a commercially successful line because of the moderate price of each model. Five distinctive models, ranging in retail price from \$110.00 to \$200.00, give MANDEL dealers a line that has no competition. Place the MANDEL beside any other phonograph for a test in musical quality. Compare its mechanical equipment; the finish and appearance of the cabinet; then compare it in price—your verdict will be for the MANDEL. The MANDEL is not merely assembled, but built by us from start to finish. Our guarantee extends to the ultimate owner.

MANDEL records are just out. This new lateral-cut record embodies volume and sweetness of tone that are remarkable. MANDEL records will be favorably received and will help dealers sell more MANDEL Phonographs.

Write to-day for complete details of our co-operative financing and advertising proposition

Mandel Manufacturing Company

1455 W. Congress Street

Chicago, Ill.

FROM OUR CHICAGO HEADQUARTERS—(Continued from page 142)



Order From This Ad.
Nipont Ass't
100 Pkgs. Assorted
Dealer's Price \$7.00
Retail Value \$15.00
FREE!!
Display Stand and
Sample Packages
With Each Order

Loud—Extra Loud
Medium
50 Needles, 15 Cents

MAIN OFFICE
1867 Milwaukee Avenue

PHONOGRAPH SURGERY

LET US CO-OPERATE WITH YOU

We Operate the Largest and Most Up-to-date Equipped
Phonograph Repair Shop in the West

Have You a Phonograph Repair Agency?

Send for our Catalog and Particulars. It Tells You What We Can Do for You

The Co-Operative Manufacturing Company

ALL PHONES, HUMBOLDT 3345 CHICAGO SALES OFFICE & SHOWROOM
637 Milwaukee Avenue

Jobbers in
Phonograph
Motors
Tone Arms
Records
Hardware
Needles and
Repair Parts
All Makes

age of WORK in America. After the war the fighters became workers. The lost art of selling was revived and brought to a high state of perfection. The motto of the time was WORK."

And the historian would be correct, and in the dawn of the new business day which has just begun let us make new resolves, carry them out to the letter and meanwhile let us work!

LYON & HEALY ADOPT PENSION PLAN

Great Chicago House Announces Liberal Pension and Sick Benefit for Their Employees

CHICAGO, ILL., February 7.—After months of study the board of directors of Lyon & Healy have worked out a comprehensive plan to reward their employes in case of illness or retirement, according to the following schedule:

"With a view to providing a certain protection for older members of this organization, and in recognition of lengthy and valuable service, the board of directors have adopted the following pension plan, effective as of February 1, 1921:

"A—An employe shall be entitled to retirement and to a pension when he shall have reached the age of sixty and shall have completed twenty years' continuous service with the company.

"B—Such retirement may be effected at the request of the employe or by action of the board of directors.

"C—Any employe of any age who shall have completed twenty years' service, and shall, through sickness or accident, be incapacitated for further service, shall also be entitled to retirement and pension. The question of incapacity is to be determined by a committee composed of the president, the secretary and the company physician.

"D—The pension shall be one-half of the average salary for the three years previous to retirement, except that it shall not be more than \$150.00 or less than \$60.00 per month.

"E—Should death occur to an employe at any time after five years' service, a death benefit of \$250.00 will be paid to the estate of the deceased.

"F—The company reserves the right to alter the amount of the above benefits at any time.

"The board of directors have also been considering for some time the adoption of a definite policy covering the remuneration to be paid in case of illness of such employes as receive no extra compensation for overtime work.

"The advantages of such a policy should be twofold; first, to make sure that under given conditions all shall receive the same fair treatment; second, to make known to employes just what protection and assistance they can rightly expect in case of illness.

"Commencing February 1, 1921, salaries during continuous illness will be paid under the following schedule:

Length of Service at start of absence	Full Salary Paid	Half Salary Paid
3 mo. to 1 yr.	4th to 15th day,	16th to 27th day,
1 yr. to 2 yrs.	1st to 3d week, incl.	4th to 9th week, incl.
2 yrs. to 5 yrs.	1st to 6th week, incl.	7th to 10th week, incl.

"After five years of service each case is to be considered on its individual merits.

"All employes desiring to benefit by the above must be willing, during their illness, to be examined by a physician selected by the management, and at the management's expense.

"All cases of enforced absence, whether through sickness or other cause, should be reported the first day to the department manager.

"More than two hours' unexcused absence will cause the loss of the three bonus half days during the following month.

"This plan, upon one week's notice, is subject to modification at any time."

VARNISH DRYROOMS



MADE FOR RECORD GRAPH
LABORER'S INSTALLATION

MAKE EVERY DAY
A PERFECT DRYING DAY

DRYING SYSTEMS, INC. 11-17 So. DESPLAINES ST. CHICAGO.

WALNUT MANUFACTURERS MEET

American Walnut Manufacturers' Association Holds Annual Meeting in Chicago and Discusses Conditions in Veneer Field

CHICAGO, ILL., February 5.—On January 20 and 21 twenty members of the American Walnut Manufacturers' Association met in Chicago to hold the annual meeting, elect officers and discuss ways and means for further popularizing walnut veneers for use in furniture and musical instrument manufacture. The association has been carrying on a national publicity campaign in the interest of its products, and reports for the year show that the results have been most satisfactory. The efforts of the association to make it known that there is plenty of walnut available have not only greatly increased the demand for this wood for furniture uses, but have led to its extensive use for interior woodwork in a large number of the finer hotels, office buildings, clubs, churches and public buildings.

Reports from the Furniture Shows at Grand Rapids and Chicago indicate largely increased use of American walnut in all the better grades of dining-room, bed-room and living-room furniture. A canvass of the mills, however, shows that most of them are shut down or only running long enough to cut up the logs on hand. Buying of logs has entirely ceased and most of the country logs have been brought in and sawed. Stocks of walnut lumber are reported to be approximately normal, but logs are far below normal, many of the mills having cut out. Since it takes from six to eight months' time to increase the flow of logs to operate mills at full capacity, a strong demand for walnut in the Spring will find lumber stocks developing shortages that cannot be overcome for six months or more. The association announces that it is planning to

(Continued on page 145)

Magnifies Sound 50 Times
ACME SOUND AMPLIFIER

Enables the repairman to locate the precise point of origin of unnecessary noise in the motor without loss of time or useless disorganization of the mechanism which results from guessing or the sense of hearing alone.
MAKES EVERY MOVING PART IMMEDIATELY ACCESSIBLE

"Guesswork Won't Do"

The ACME allows a test with the drag of the needle throughout the length of the record.

A
C
M
E



**The
Acme Speed Indicator**

- is precision made.
- clears the tone arm.
- locates motor troubles.
- registers 78 and 80 revolutions.

"The repairman's stethoscope."
Made by

Acme Engineering & Mfg. Co.
355 Union Park Court CHICAGO

Edison Diamond Amberolas--Plus Service

You know the quality of Edison instruments. Until you have placed a trial order with us, you are unfamiliar with SERVICE.

A TRIAL CONVINCES

Our Service Covers the Country

William H. Lyons

Formerly Jas. I. Lyons
17 W. Lake St. Chicago



FROM OUR CHICAGO HEADQUARTERS—(Continued from page 144)

extend its service features on American walnut to the general public whether they may be interested in walnut for furniture or for interior woodwork.

The officers elected at the annual meeting were as follows: President, L. C. Moschel,

Langton Lumber Company, Pekin, Illinois; vice-president, V. L. Clark, Des Moines Saw Mill Company, Des Moines, Iowa; treasurer, H. B. Sale, Hoffman Brothers Company, Fort Wayne, Indiana; secretary-manager, George N. Lamb, Chicago, Illinois.

phonographs of standard makes of great value, at abnormal and unusual reductions from full standard resale prices. These advertisements did not disclose that the advertiser was engaged in the business of selling phonographs or was selling phonographs for the manufacturers, but conveyed the impression that the advertiser was a householder and was offering for sale a phonograph which had been used by such householder only a short time; (b) Advertisements in which the respondents, Waverly Brown and John T. Conley, used the following trade names, Illinois Storage Co., Chicago Storage Co. and Chicago Storage Sales Co., which newspaper advertisements, together with the catalogs and letters used by said respondents, contained certain false and misleading statements as follows:

FEDERAL TRADE COMMISSION STOPS "GYP" DEALING

Government Authorities Proceed Against Chicago Concern on Complaint of Better Business Bureau, and Issue Order Restraining It From Continuing Questionable Selling Practices

In response to complaints from a number of talking machine dealers, particularly in the Middle West, the Better Business Bureau of the Music Industries Chamber of Commerce some time ago began to gather data regarding the publication of classified advertising in various newspapers offering "\$250-size" phonographs for \$69.50 and thereabouts, giving the addresses of "storage" companies and individuals at private addresses in Chicago and thereabouts.

As a result of the information gained by the Better Business Bureau through its investigations complaint was made before the Federal Trade Commission against Waverly Brown, Mrs. Waverly Brown and John T. Conley, trading as the Illinois Storage Co., Chicago Storage Co., Chicago Storage Sales Co. and the Tyrolia Talking Machine Co. At a hearing on the case held at Washington recently before Huston Thompson, chairman, and Nelson B. Gaskill, J. Garland Pollard and Victor Murdock, Federal Trade Commissioners, the following findings were reported:

and in selling the same in commerce among the several States and Territories of the United States and the District of Columbia in competition with other persons, firms and corporations similarly engaged.

The said respondents in the sale of the phonographs made by them used the following trade names, to wit: Illinois Storage Co., Chicago Storage Co. and Chicago Storage Sales Co. The phonographs made by the said respondents were manufactured by them under the trade name of the Tyrolia Talking Machine Co. Mrs. Waverly Brown, one of the respondents, assisted Waverly Brown and John T. Conley, respondents, in the sale of the phonographs manufactured by the said Waverly Brown and John T. Conley, respondents.

2. The phonographs sold by the respondents, Waverly Brown and John T. Conley, were advertised for sale by means of newspaper advertisements, catalogs, correspondence and such other ways peculiar to what is known commonly as the mail order business. The newspaper advertising done by the respondents was of the following two classes, viz.: (a) Advertisements in the classified advertising columns of newspapers, circulating in Illinois and Wisconsin, in which the names of the advertisers were given as Mrs. Waverly Brown or Waverly Brown, which advertisements offered for sale slightly used

1. That the phonographs so advertised had been stored for safekeeping with one or another of the storage concerns intended to be indicated by the title used, and that such phonographs were offered for sale for the purpose of reimbursing such storage concern for unpaid storage charges.

2. That said respondents were regularly engaged in the storage and warehouse business, and by reason of conducting such business came into possession of a single phonograph, or single lots of phonographs, which had never been removed from the cases in which they were crated when they left the factory and were being offered for sale by said respondents for the purpose of reimbursing them for unpaid storage charges.

3. The phonographs advertised for sale by respondents, Waverly Brown and John T. Conley, which advertisements were in the name of Waverly Brown and Mrs. Waverly Brown, were new and unused phonographs and the supply was limited only by the capacity of Waverly Brown and John T. Conley, respondents, to re-

(Continued on page 146)

The **HOWE**

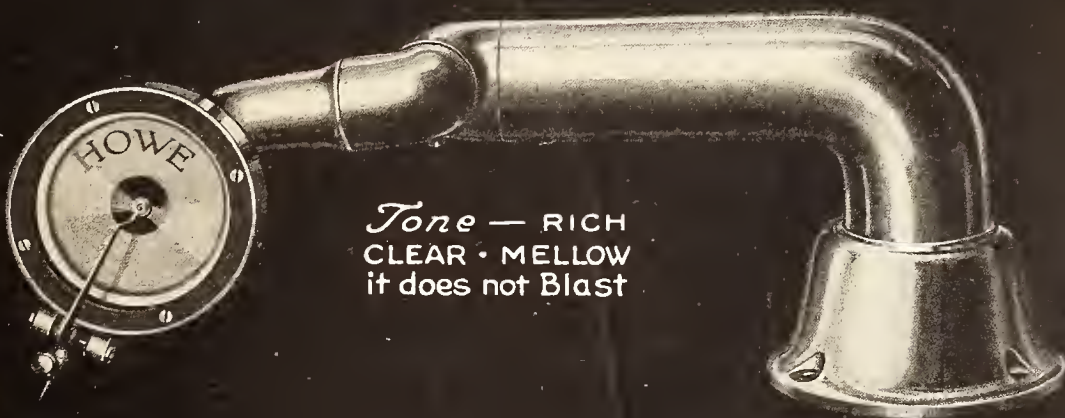

Tone — RICH
CLEAR · MELLOW
it does not Blast



BALL BEARING
No obstruction
in the base

C.W. Howe & Company
21 East Van Buren St. Chicago Ill.

THE \$1.00 CUTTER—HERE IT IS

Retail Price **\$1.00**

A better Fibre Needle Cutter for less money

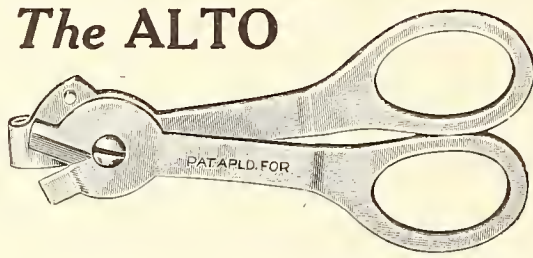

Send for a Sample and Convince Yourself

ALTO MFG. CO.

3801 Rokeby Street, Chicago, Illinois

FROM OUR CHICAGO HEADQUARTERS—(Continued from page 145)

plenish through manufacture such needs as the said Waverly Brown, respondent, and Mrs. Waverly Brown, respondent, might have through answers to such advertisements.

Respondents Were Manufacturers

4. That the respondents, Waverly Brown and John T. Conley, from March, 1919, to and until the month of August, 1919, during which period they were engaged in the manufacture and sale of phonographs in the manner herein described, were not engaged in the storage and warehouse business, but were regularly engaged in the business of manufacturing and selling phonographs of a grade and quality which were manufactured to sell at resale and were customarily sold by respondents in the regular course of their business at less than one-third of the resale price (\$250) at which such phonographs were listed in the advertising matter of respondents; that the phonographs dealt in by such respondents in the period hereinbefore mentioned were not stored, and the number of phonographs offered for sale by such respondents' advertisements were not limited, as advertised, but were taken from respondents' regular stock, which respondents were replenishing from time to time.

5. That each and every one of the trade names, Illinois Storage Co., Chicago Storage Co. and Chicago Storage Sales Co., was used by the respondents, Waverly Brown and John T. Conley, for the purpose and with the effect of deceiving purchasers and prospective purchasers in the public generally into believing that such respondents were conducting the business of storing household goods and for the purpose and with the effect of accomplishing the

deception intended by the use of the false and misleading statements mentioned in subdivision (b) of paragraph 2 hereof.

6. That such respondents, Waverly Brown and John T. Conley, used the name of Mrs. Waverly Brown, respondent, with her consent, and used the name of Waverly Brown in advertisements offering phonographs for sale for the purpose and with the effect of deceiving the purchasers and prospective purchasers and the public generally into believing that such purchasers and prospective purchasers were being offered a phonograph of standard make at a certain resale price, to wit, \$250, which said phonograph had been slightly used, when in truth and in fact the respondents intended, by the use of such advertisements, to dispose of the new phonographs manufactured by them under the name of the Tyrolia Talking Machine Co.

Conclusion

The practices of the respondent under the conditions and circumstances described in the foregoing findings are unfair methods of competition in interstate commerce and constitute a violation of the Act of Congress, approved September 26, 1914, entitled "An Act to Create a Federal Trade Commission, to define its powers and duties and for other purposes."

The findings bore the signature of Huston Thompson, chairman.

Upon reporting its findings in the case the Commission issued the following restraining order which, it is believed, will prove effective in putting a stop to the practices complained of and in discouraging others from adopting similar methods:

"This proceeding having been heard by the Federal Trade Commission upon the complaint of the Commission, the testimony and evidence, and the Commission having made its findings as to the facts with the conclusion that the respondents have violated the provisions of Section 5 of an Act of Congress, approved September 26, 1914, entitled 'An Act to Create a Federal Trade Commission, to define its powers and duties, and for other purposes;'

The Restraining Order

"It is now ordered that the respondents, Waverly Brown, Mrs. Waverly Brown and John

T. Conley, do cease and desist from selling in interstate commerce, new and unused phonographs, manufactured by them or any of them, or dealt in by them or by any of them as a business, by means of advertising matter, circulated throughout the States and Territories of the United States, having a tendency to mislead the public into believing that slightly used phonographs of standard make of highest values are being offered for sale by private owners at abnormal and unusual reductions from full standard resale prices, when in truth and in fact said phonographs are new and unused and are manufactured by Waverly Brown and John T. Conley, respondents, to sell to purchasers and users thereof and are sold by such respondents to purchasers and users thereof for less than one-third of the stamped resale price at which they are listed in the catalogs of said respondents.

"It is further ordered that the respondents, Waverly Brown and John T. Conley, do cease and desist from using in their advertising matter, circulated throughout the States and Territories of the United States, and in the sale in interstate commerce of phonographs, any of the following trade names, to wit: Illinois Storage Company, Chicago Storage Company, Chicago Storage Sales Company, or any other trade name which might have a tendency to lead the public into believing that the business conducted by the said Waverly Brown and John T. Conley is that of storing household goods.

"It is further ordered that the said Waverly Brown, Mrs. Waverly Brown and John T. Conley shall within sixty days after the service of a copy of this order upon them file with the Commission a report in writing stating in detail the manner in which this order has been complied with and conformed to.

"By order of the Commission,

"(Signed) J. P. YODER, Secretary."

The complaint before the Federal Trade Commission was filed only after the Bureau had endeavored through friendly protests to have the defendants change their methods. The result of the case is to be regarded as a distinct victory for the Bureau in its fight against what are considered unfair trade methods.

"Does It Play All Records?"

Certainly **MAGNOLA** does; and without any extra attachments, too. This is only one feature, albeit a most important one, in the thoroughly up-to-date equipment of the **MARVELOUS MAGNOLA**.

MAGNOLA "Built by Tone Specialists"

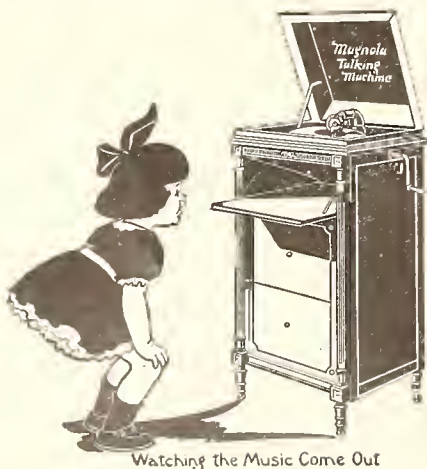

Watching the Music Come Out

May we send you our handsome illustrated catalog chock full of information concerning the wonderful construction system of **Magnola** and the beauties of its musical results, its artistic appearance and its moderate price?

Send your name and let us tell you more!

MAGNOLA TALKING MACHINE COMPANY

OTTO SCHULZ, President

General Offices 711 MILWAUKEE AVENUE CHICAGO
Southern Wholesale Branch 1530 CANDLER BLDG. ATLANTA, GA.

THE FERRO AUTOMATIC STOP is the best, most accurate automatic stop on the market.

Its operation is positive. There is no guesswork about its stopping the motor at the right moment, all the time.

It is a combination automatic stop and hand brake—will work properly either way.

Order a sample NOW

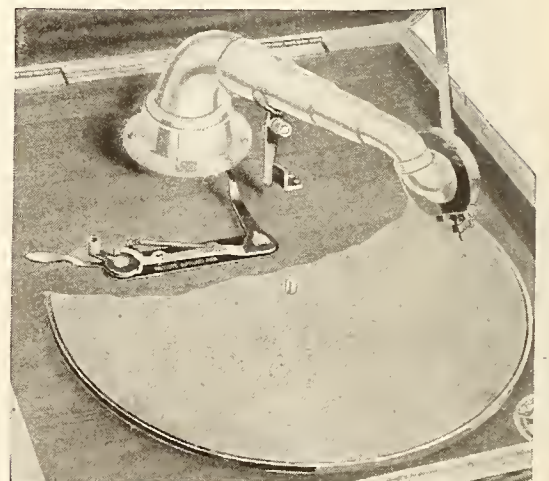

FERRO PHONOGRAPH PARTS CO. 1455 W. Congress St., Chicago, Ill.

There is a certain satisfaction and pride in the possession of the best, aside from its intrinsic value. The difference between Van Veen equipment and the common-place product is narrow when measured in dollars, but is broad in painstaking effort and ultimate result; it is the best and within your reach.

Plans and estimates promptly submitted.

VANVEEN & COMPANY INC.

12 YEARS OF STUDY AND EXPERIENCE IN
BUILDING AND PLANNING MUSIC STORES

HEARING ROOMS · RECORD RACKS · COUNTERS ·

EXECUTIVE OFFICE
47-49 WEST 34th STREET
NEW YORK CITY

SALES OFFICE
1711 CHESTNUT STREET
PHILADELPHIA

ENTERPRISE OF CLEVELAND DEALERS

Unite in Preparing for Appearance of Chicago Grand Opera Co. There in March—Lively Interest Shown in Sales Race—Shepherd's Educational Work—Other News of Interest

CLEVELAND, O., February 7.—Talking machine jobbers and dealers here have assisted in underwriting the appearance in Cleveland, March 14-17, of the Chicago Grand Opera Co. In order to bring the event to this city promoters had to guarantee \$64,000. When the situation was presented to the Cleveland Talking Machine Co., Victor jobber, the plan was approved, and this firm, with the Wolfe Music Co., the Euclid Music Co., the May Co. talking machine department, the Buescher Co. and M. V. De Forest, Sharon, Pa., all dealers, also agreed to help finance the move. Considerable advantage is seen by the trade in the appearance here of the company, which will be heard at the Hippodrome Theatre, because Edward Johnson, Galli-Curci and Ruffo, Victor artists, are among those to be seen in person as well as heard. Daily newspaper advertising will supplement the activities of dealers in the pushing of record sales during the event.

Keenest interest in the sales race, with two trips to the Victor factory, lasting two weeks, and with all expenses paid, is manifested by

**WE Will Buy for Cash
Job Lots of Machines,
Records, Motors, Tone
Arms, Parts, and Every-
thing in the Talking Ma-
chine Line.**

Keen Talking Machine Supply Co.
49 N. 10th ST., PHILADELPHIA, PA.

sales people in stores in and out of Cleveland. The event is being conducted by the Cleveland Talking Machine Co. The sales aggregate of the individuals in the race for January has been taken as the basis for the real work during February. The person in Cleveland who makes the highest percentage gain during this month over January's showing will be declared the winner for the city, and the same applies to the individual making the like showing outside the city. The event is being conducted by Miss Grazella Puliver, publicity manager of the Cleveland. Many girls in the campaign are eager to make the trip, as they have never been away from home, but the plan also has the effect of not only increasing sales for the dealers, but adds to the development of the individual sales worker as well. Sales to be considered are in records, needles, books and other merchandise other than machines.

As part of the educational work for the people who follow the higher musical events, Arthur Shepherd, assistant conductor, Cleveland Symphony Orchestra, lectured at Canton February 5, using Victor machines, records and orchestral charts to explain the merits and qualities of the music to the people who were to attend the concert by the orchestra on February 6.

First-hand impression of the Isham-Jones Orchestra, exclusive dance record maker for the Brunswick-Balke-Collender Co., was to be had by the people of Lima, in connection with a big public invitation dinner dance held under the auspices of the Maus Piano Co. at Elks' Hall, in that city.

Extension of Brunswick operations into the southern part of the State is planned by A. B. Williams, of Massillon, and G. M. Earle, of New Philadelphia, both Brunswick dealers. Mr. Williams' interests at Massillon have been taken over by O. W. Bammerlin. Mr. Williams and Mr. Earle will open an exclusive Brunswick establishment at Springfield and will continue to operate the Earle establishment at New Philadelphia.

EDISON STILL A STUDENT AT 74

In the Book Review section of the New York Herald, in the issue of Sunday, February 6, the life of Thomas A. Edison and some of his remarkable habits were the subject of an article by Thomas Commerford Martin, illustrated by intimate sketches by Karl Illava. Mr. Martin pointed out that while the "Grand Old Man" is now at the seventy-fourth milestone he is a constant student and works in a library which is filled with books recording the achievements of others.

EUROPEAN TRADE

I am to make an extended business trip in Europe, leaving in April. Will visit all important countries, with the possible exception of Russia and the Balkan States.

Because of my business connection, sales and manufacturing experience, I am competent to handle any special trade assignments that American manufacturers might desire.

Your advantage would consist in a considerable saving in expense over sending a man across, or in the closer understanding of the requirements that could be given me, in comparison with delegating the work to a foreign representative.

I will be pleased to enter into preliminary correspondence at once with manufacturers who have or desire foreign trade.



I am in position to build up a permanent connection or sales organization for you, if desired.

Address

**EDMUND
BRANDTS**

Celina, Ohio

Sec'y & Treas.

**The Mersman Bros.
Brandts Company**

Photo inserted to identify me with business acquaintances who may more readily "place me" thereby.

WORK OF THE EDUCATIONAL DEPARTMENT

A Section of The World Devoted to the Admirable Work Being Carried on by the Various Educational Departments Conducted by Manufacturers, Jobbers and Dealers

L. W. Inman, educational director, of Sanger Bros., Dallas, Texas, has devised an ingenious plan for country-wide drives among the dealers of Texas and Oklahoma. A series of form-letters with definite campaign plans are sent to all dealers conducting educational work. Results are proving beyond Mr. Inman's most sanguine expectations.

* * *

New York City teachers are being prepared to teach the subject of music appreciation in the schools by a course being conducted Tuesdays and Thursdays at 4 p. m., Washington Irving High School, by Edith M. Rhetts, educational staff, Victor Talking Machine Co. Over 1,100 teachers have enrolled for the course which lasts six weeks, ending in March. These lectures are under the supervision of F. G. Dunham, national representative, Victor educational department, and are being given with the full support and approval of George H. Gartlan, Director of Music, New York City public schools.

* * *

The Cleveland Talking Machine Co., Cleveland, O., Miss Grazella Puliver, educational director, is constantly making things move in its territory. Miss Pulliver's scheme of the hanger of educational numbers most in demand has proven so popular as to solicit response from the far-corners of San Francisco and Portland, Me.

* * *

Peter W. Dykema, professor of music at the University of Wisconsin, has compiled a special collection of music, which has recently been issued by the Educational Department of the Columbia Graphophone Co. of New York and which is regarded as an entirely new species of band accompaniment recordings.

The new records are especially designed for use in homes, schools, clubs, churches, hotels and wherever people dance or engage in group or community singing. The great impetus for community singing which followed as an aftermath of the war is largely responsible for this new type of record. During the war there were song leaders in every military camp, in shipyards and munition works, arsenals, etc., and it was found that community singing could accomplish a great deal in so far as increasing morale and effort was concerned. Since the war community singing has been utilized to a very large degree by industrial organizations, by churches, by civic bodies, by schools, by clubs and by many other types of organization, to accomplish the same results, viz., increased working effort or increased morale and esprit de corps.

The new Columbia collection is a set of band

accompaniment records for singing patriotic, sacred and old familiar songs, which means that they fit in with all the classes of organizations mentioned above. They aim, in practice, to take the place of the song leader, and in preparing this collection every endeavor has been made to capitalize the knowledge and experience accumulated by song leaders during the war.

Professor Dykema compiled the collection and personally supervised the making of all the records. He is recognized as one of the foremost song leaders in America and as a pioneer in the movement for greater participation by all the people in the producing of music. During the war he left his post with the university to become an army song leader and director of music in Washington for the War Camp Community Service.

These new records differ from the ordinary run of dance and vocal pieces in that they are recordings of a special sort of accompaniment, are keyed for the particular purpose for which they are to be utilized, and contain the right rhythm and accelerations which crowd singing demands. Each record has a short introduction which leads up to the singing.

The full list of songs is included in a collection entitled "Twice 55 Community Songs," published by C. C. Birchard & Co. The band accompaniment recordings have four selections on each record. There are ten records in all, and their keys, tempo and arrangement are the same as those adopted by the Committee of the Music Supervisors' National Conference. The selections include patriotic numbers, songs of the home, songs of love and friendship, harmony or part songs, songs of humor and hymns.

* * *

Vassar College, Poughkeepsie, N. Y., has just purchased for its new Song Appreciation Course a complete working library of songs of Victor Red Seal artists.

* * *

The R. Wurlitzer Co., Cincinnati, O., has published a very inexpensive but compelling booklet, "The Victrola in the Nursery," featuring the M-IV and VI Victrolas, with educational records for little children. This booklet is an envelope "stuffer" to the supplement mailing list, and has already resulted in the sale of many instruments. Combined with the new book, "Music Appropriate for Little Children" (Victor Talking Machine Co.), the installation of such nursery equipment insures a love for music in the hearts of the little tots.

* * *

The Reincke-Ellis Co., New York and Chicago, sole distributor for the Binger dealers' window service, has devised as its August 29th

release the most complete school-room display yet conceived. A M-XXV Victrola is featured with blackboard, desks, etc.

* * *

The Schmelzer Co., Kansas City, Mo., has been making fast progress in its educational department under the direction of David Walsh, formerly of the educational staff of the Victor Co. One of the treats planned by the Schmelzer Co. for dealers this year is the coming of Princess Watahwaso, Indian mezzo-soprano, in school concerts for April.

* * *

Collings & Co., Victor jobbers, Newark, N. J., made a record in the sale of Victor XXVs in a recent campaign conducted under the direction of the Metropolitan District representation of the Victor educational department.

* * *

Miss Lillian Wood, educational director, Mellor's, Pittsburgh, Pa., has been doing splendid work in institutes of teachers held in nearby counties.

* * *

Columbia Graphophone Co.'s educational department will remove in the near future to the Gotham National Bank Building, Columbus Circle, New York City.

* * *

Louis Mohler, author of "Music Moods" and formerly a teacher in the New York City school system, is now a member of the educational staff, Columbia Graphophone Co.

* * *

The singing of Muratore in the Chicago Opera Co. season, New York City, has developed an extraordinary demand for his Pathé records.

MOVES OFFICES TO BOSTON

Atlas Sales Corp. Now Located at 10 High Street, That City

The Atlas Sales Corp., whose executive offices were formerly located in Richford, Vt., has announced its removal to 10 High street, Boston.

This company specializes in packing cases for talking machine manufacturers and is sales agent for the Nelson & Hall Co., Richford Mfg. Co., Blair Veneer Products Co. and the Veneer Products Co.

FANCY DRESS BALL FOR APRIL 2

San Francisco Talking Machine Dealers Set That Date for Big Celebration

SAN FRANCISCO, CAL., February 5.—"Billy" Morton, manager of the Sherman, Clay & Co. talking machine department, has been selected by the talking machine dealers of San Francisco to make arrangements for a fancy dress and mask ball at the St. Francis Hotel, April 2. Complete harmony now prevails among the local dealers and methods and policies of advertising are slated for discussion at the next meeting of the association.

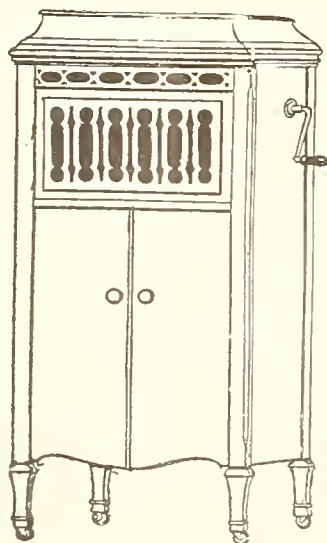

SOUTHERN DISTRIBUTORS

Pathé PHONOGRAPHS and RECORDS



GRAY & DUDLEY CO.

Write Today for Agency Proposition

NASHVILLE

TENNESSEE



Don't make your phonograph and record customers go elsewhere for their other musical requirements.

It means extra exertion on the part of the customer and loss of profit for you.

Open up a musical instrument department. It will be a source of extra profits and make your warerooms headquarters for *everything* musical.

In selecting a line of musical merchandise there are two important things to consider.

FIRST—The quality and reputation of the line.

SECOND—The experience of the house you deal with and the service that they can offer you.

The House of Gretsch is known from coast to coast. The line is complete. We can serve you with the best in every instrument made and our success has been built upon the service and co-operation we have always extended to our dealers.

Write us for our advice and general information regarding the installation of a money-making musical merchandise department.

We have special assortments running from \$500 to \$1,000 and up. Each assortment will give you a complete line of musical merchandise.

THE FRED. GRETSCH MFG. CO.

MUSICAL INSTRUMENT MAKERS

Since 1883

54-82 BROADWAY

BROOKLYN, N. Y.

NICE NEWS**SPECIAL BULLETIN**

THE COMING WALTZ HIT OF THE COUNTRY

ROMANCE

THE NEW MELODY FOX-TROT

SWEET LAVENDER

- ☞ For these numbers we have just contracted for daily newspaper advertising in 125 *principal* cities.
- ☞ The follow-up will cover *every* section of the country.
- ☞ The professional and orchestral work will be characterized by that thoroughness and stick-to-it-iveness that has given B. D. NICE its wonderful reputation.

☞ We made this number one of the biggest Oriental sellers. A standard selection.

TENTS OF ARABS

ALL LEE DAVID NUMBERS

☞ The most persistent hit ever released. Steadily increasing in popularity and demand.

WOND'RING

Make Immediate Inquiry

B. D. NICE & CO., Inc., Music Publishers

1544 Broadway

New York City

GLEANINGS *from the* WORLD *of* MUSIC

“MELODY SONG” SEEMS TO HAVE CAUGHT PUBLIC FAVOR

So-called Successor of Jazz Is Making Excellent Progress With the Trade and Public—Standard and Quality of Songs Show Steady Improvement

Popular songs, as recognized by the majority of those in the trade, run in cycles. At least, so say the song writers and publishers. We have our one-steps, fox-trots, jazz, Hawaiian and other such works, all of which have their spells of popularity. Some of them have periods of revival, but in every season there is a type of number that appears to stand out prominently.

Following the war we had jazz and more jazz, until we were surfeited with jazz, so much so that there were even organizations which took up the cudgels to eliminate it altogether, but, like all other kinds of songs that have won their popularity, they must have their day, and all the propaganda to destroy them had little or no effect.

Now, however, it would appear that jazz has really passed into oblivion. All indications have pointed in that direction for some months, and there has arisen to take its place the “melody song,” and, after all, there is only one method of eliminating any type of number, and that is to produce a successor.

With the “melody song” we have a distinctive style of song which appears to please the most fastidious music lover, a work whose popularity does not quickly wane, but, once acknowledged, is with us for a period of several months. This was never true of “jazzy” numbers, whose popu-

larity was short-lived, and with the entry of this new type the dealer in sheet music, records and player rolls can stock goods with a better knowledge of their salability.

That the “melody song” is an improvement over the compositions that have won great popularity during the past two seasons is something that cannot be very well disputed. In fact, all sides acknowledge its power to win adherents.

The song writer, too, feels better about this new situation inasmuch as, once his work attains a measure of success, he is assured of a sale and, of course, royalties, for a period of several months, whereas in writing the jazz sort of work, or even any ordinary novelty, he had no such assurance.

From a business standpoint all interests connected with songs are in a much better position to-day than in some seasons past, and the average music lover, too, is better pleased.

The “melody song” will be with us for some time, and now that everyone recognizes such numbers as an improvement over songs that had great popularity in late seasons, it is a prevalent hope that there will be no return of jazz and there are some indications that we are to even have further improvements in coming songs in a quality way.

“AVALON” CASE HEARD IN COURT

Judge Hand, in U. S. Court, on Complaint Brought by Ricordi & Co., Issues Temporary Injunction Against Jerome H. Remick & Co.

The United States District Court room in the Federal Building, New York, where Judge Augustus N. Hand presides, took on the appearance of a lively music store recently during the trial of the action brought by G. Ricordi & Co. against Jerome H. Remick & Co., to restrain the latter from continuing the publishing and sale of the song “Avalon,” claiming that the music of the popular song is the same as that of the aria in the opera “La Tosca,” for which Ricordi & Co. hold the copyright. In order to enable the court to judge the similarity of the music a piano, a violin, a trumpet and a talking machine were called upon to play in turn the popular song and grand opera aria.

After hearing both sides of the case Judge Hand granted a temporary injunction against Remick & Co., with the proviso that Ricordi & Co. furnish a bond of \$25,000 as a guarantee that

the litigation would be carried through. He also agreed to suspend the temporary injunction against Remick & Co. provided that company put up a bond of a similar amount to cover possible damages should the suit be decided against them.

PADEREWSKI COMING TO AMERICA

Famous Artist and Former Premier of Poland Resigns as Member of Peace Delegation

According to a press dispatch from Morges, Switzerland, under date of January 29, former Premier Paderewski of Poland announced that he had resigned as a member of the Polish peace delegation, but declared the report of his resignation as Polish delegate to the League of Nations was incorrect. Paderewski said he wished to be relieved of part of his work because of his indifferent health. His coming trip to America, he said, would be of a private nature and purely for rest, and he expected to return to Switzerland in September to resume his functions as representative of the Polish



An Immediate Coast to Coast Sensation

Played, Sung and Featured Everywhere

Published by

Sam Fox Pub. Co. Cleveland and New York

nation to the League of Nations organization.

Speaking of reports that he might resume his public appearances on the concert stage, the famous pianist declared he would never play in concert again, although he had received many excellent offers from America. His American trip would be undertaken about the end of February, he said, and he would first visit California, where he has many friends.

PIONEERS HONOR EDISON

Celebration of Seventy-fourth Birthday of Great Inventor Was Held at His Home

The Edison Pioneers, an organization of associates of Thomas A. Edison between 1870 and 1885, made great preparations to observe the seventy-fourth anniversary of the birth of Mr. Edison, which occurred on February 11. The Pioneers held their annual meeting in Mr. Edison's home, Llewellyn Park, West Orange, N. J., and a dinner was served, at which Mrs. Edison was hostess.

The Most Original Novelty Lyric and Melody of Many Seasons
YOU'LL SAY SO WHEN YOU HEAR IT:

SCANDINAVIA

(SING DOSE SONG AND MAKE DOSE MUSIC)

By RAY PERKINS

Be Sure to have a good supply of Records, Player Rolls and Sheet Music on hand.
STARK & COWAN, Music Publishers, Inc., 234 W. 46th St., N.Y. C.

To
ALL DEALERS
of
RECORDS and
WORD ROLLS

Biggest selling Record and Roll successes. The most played numbers in the country. Every dealer should get in quick.

“CARESSES”

The sensational society fox-trot of America

“PALESTEENA”

The tremendous big musical comedy fox-trot song hit

“LOVE, HONOR and O-BABY”

The prevailing comedy song

“LOVE BIRD”

An overnight fox-trot success—and an acknowledged hit

“ROYAL GARDEN BLUES”

Chicago's big “Blue” hit

“YOKOHAMA LULLABY”

Breezy Jap-a-nee-zee fox-trot novelty

ALL FROM THE GREAT MUSIC HOUSE *of*
SHAPIRO BERNSTEIN & CO.
INC.
 BROADWAY AT 47th St. . NEW YORK

STOCKING POPULAR SHEET MUSIC

Plan by Which the Hits Can Be Handled Without Big Outlay of Capital

In this department of the January issue a plan was outlined of a system of stocking the active sellers in popular music without carrying large quantities of goods. The method suggested was one so often found in song shops where a self-service rack, carrying from twenty to sixty numbers and occupying little wall space, is invariably used. By this method it was shown that dealers could carry "fast sellers" without either involving themselves in heavy investments or in adding to the details of their business. The method being so simple, the stock being so easily watched and kept, the numbers selected being those that are current record hits, there is little or no business judgment involved.

Supplementing the suggestion in the article mentioned, we are herewith reproducing a "revolving hexagonal floor roller music displayer," manufactured by the Universal Fixture Corp., whose offices are located at 135 West Twenty-third street, New York City. Here, also, is a method of carrying the popular hits and, if desired, other works, without requiring large quan-



Universal Fixture for Displaying

titles of stock. The fixture has a height of six feet, a base diameter of twenty-two inches, has forty-eight pockets, eight to a side, and will hold a total of 720 sheets of music, or fifteen in each pocket.

A rack of this kind, for those who wish to supply the wants of their trade in sheet music, proves an attractive piece of store furniture and at the same time does much to create sales.

To the talking machine dealer who wishes to try out such a plan the best method of arranging for stock would be through a central jobbing organization. In that manner he would be able to obtain the hits of twenty or thirty publishers from one source and in limited quantities.

While it is the custom, under the rules of the Music Publishers' Protective Association, to discourage the return of goods, any jobber would be willing to assist in the selection of active sellers in a manner that would eliminate any necessity for returns. In New York City there are two such distributors, the Crown Music Co.

(Continued on page 154)

*You hear them
Everywhere!*

**"SIREN
OF A
SOUTHERN
SEA"**

A GREAT FOX-TROT SONG
BY THE WRITER OF
"HINDUSTAN"

**"LEARNING
SOPHIE TUCKER'S
VERY OWN**

They don't write 'em any better

*The House of
The Western Sun*

FORSTER
MUSIC PUBLISHER, INC.
235 SOUTH WABASH AVE.
CHICAGO

ARTo RECORDS



The ARTo girl with dainty dangling feet, Silken-clad ankles, youthful and neat. Smilingly sits and sings and swings. While to her ARTo Roll and Record clings.

85c. ARTo 10 Inch Records 85c.
THE LATEST DANCE AND SONG HITS

FOR MARCH, 1921

- 9047 { Mazie. Fox-trot. Choruses Sung by Arthur Hall, Selvin's Novelty Orchestra
- 9047 { Love Bird. Fox-trot. ARTo Dance Orchestra
- 9047 { Make Believe. Fox-trot. Choruses Sung by Arthur Hall, Moulin Rouge Orchestra
- 9048 { I Lost My Heart to You. Fox-trot, Selvin's Novelty Orchestra
- 9046 { Home Again Blues. Fox-trot. Merry Melody Men
- 9046 { Look for the Silver Lining. Introducing: "Whip-Poor-Will" from "Sally." Medley fox-trot, Merry Melody Men
- 9050 { Over the Hill. Baritone Solo. Ernest Hare
- 9050 { Answer, Saying That You Love Me. Tenor Solo, Billy Jones
- 9049 { The Rose I Call Sweetheart. Tenor Solo, Charles Harrison
- 9049 { I Used to Love You, But It's All Over Now. Tenor Solo, Arthur Hall
- 3054 { Danny Deever. Baritone Solo. Herbert Palmer
- 3054 { Oh, Dry Those Tears. Tenor Solo. Walter Barnhy
- 3055 { A Dream. Tenor Solo. Walter Barnhy
- 3055 { Sing Me to Sleep. Soprano Solo. Nevada Vanderveer
- 3056 { Nearer, My God, to Thee. Male Voices, Shannon Four
- 3056 { Onward, Christian Soldiers. Male Voices, Shannon Four
- NEGRO SONG AND DANCE RECORD
- 9045 { The Jazz Me Blues. Vocal Blues. Accom. by Harris' Blues and Jazz Seven. Lucille Hegamin
- 9045 { Everybody's Blues. Fox-trot. Choruses Sung by Lucille Hegamin. Harris' Blues and Jazz Seven
- 3057 { Baltimore Centennial March. ARTo Military Band
- 3057 { Second Regiment Connecticut March, ARTo Military Band
- 3015 { Humoresque. Violin Solo. E. B. Thiele
- 3015 { Traumerei. Violin Solo. E. B. Thiele

Ask for the complete Catalog of ARTo Records

ARTo Word Rolls \$1.00
VOCo Word Rolls 85c.

FOR MARCH, 1921

- 1346 Answer, Saying That You Love Me. Fox-trot.
- 1354 Dearest One. Waltz Song.
- 1343 Do You Ever Think of Me? Fox-trot.
- 1355 Dolly, I Love You. Fox-trot.
- 1356 Dreamy Hawaii. Waltz Song.
- 1352 Everybody Knows. Waltz Song.
- 1345 Happiness, I Find My Happiness. Dear, With You. Fox-trot.
- 1341 Home Again Blues. Fox-trot.
- 1337 Humming. Fox-trot.
- 1350 Little Tin Soldier, or the Little Rag Doll. The. Fox-trot.
- 1344 Love in Lilac Time. Waltz Song.
- 1340 Make Believe. Fox-trot.
- 1342 Mazie. Fox-trot.
- 1351 My Mother's Evening Prayer. Waltz Song.
- 1349 No Wonder I'm Blue. Fox-trot.
- 1333 Over the Hill. Ballad.
- 1348 Two Sweet Lips. Fox-trot.
- 1339 Underneath Hawaiian Skies. Fox-trot.
- 1336 When the Autumn Leaves Begin to Fall. Waltz Song.
- 1335 Would You? I'll Say You Would. Fox-trot.
- 1347 Wyming. Waltz Song.
- 1353 Yan-Kee. Fox-trot.

The above songs without words can be had in the ARTo POPULAR Rolls, which retail at 70c.

THE ARTo Co.
STANDARD MUSIC ROLL CO.
Factories, Orange, N. J.
New York Offices, 1604 Broadway

OUR PRINCIPAL JOBBERS ARE:

- CROWN MUSIC CO., New York City.
- PLAZA MUSIC CO., New York City.
- FULTON TALKING MACHINE CO., New York City.
- GRIMLER SALES CO., New York City.
- ARTo RECORD SALES CO., Brooklyn, N. Y.
- WILLIAM H. FERRIS CO., INC., Brooklyn, N. Y.
- THE MORRIS MUSIC PUBLISHING CO., Philadelphia, Pa.
- CONSOLIDATED TALKING MACHINE CO., Chicago, Ill.

EUGENE and WILLIE HOWARD'S TERRIFIC HIT in THE PASSING SHOW of 1921

UNDERNEATH HAWAIIAN SKIES

The most beautiful Fox-Trot Melody
in years

Published by LEO FEIST INC
FEIST BLDG.
NEW YORK

"You can't go wrong
with any Feist Song."

STOCKING POPULAR SHEET MUSIC

(Continued from page 153)

and the Plaza Music Co. In Chicago there are also two, the McKinley Music Co. and F. J. A. Forster. In Kansas City, the J. W. Jenkins' Sons Music Co., and in San Francisco, Sherman, Clay & Co., make it possible to have accessible business arrangements with sheet music jobbers from central locations.

PAY DESERVED TRIBUTE

Newspaper Article Discusses Phenomenal Success Attained by Mrs. I. V. Brewster—Capable Manager of Sonora Fifth Avenue Salons Is Well Known in Trade

In one of last Sunday's newspapers there appeared a two-page symposium giving a series of brief articles relative to the important positions held by women in the business world. These articles included practically every phase of commercial life and one of the most interesting in the series gave an account of the phenomenal rise of Mrs. I. V. Brewster, manager of the handsome Sonora Fifth Avenue salons at 660 Fifth Avenue, New York.

This article, which constituted a well-deserved tribute to Mrs. Brewster's exceptional sales ability, read as follows:

"Four years ago Mrs. I. V. Brewster took a position with a talking machine company as a sales clerk at \$12 a week. Last year her income reached the \$10,000 mark and this year she expects a considerably larger amount. Personality and service account for her achievement.

"In addition to the importance she attaches to a pleasing personality Mrs. Brewster stresses the idea of service not only by giving it herself, but by instilling the thought in her sales force, for she is now the manager, with a very unusual personnel, selected primarily because of individual intelligence and culture. She picks girls of good home training for her staff.

"That any success worth having is based on service Mrs. Brewster firmly believes. She also is of the opinion that the maximum of service can only be attained by a sales force thoroughly imbued with this fundamental principle.

"In measuring up a woman's financial success in the business world it is quite necessary to take into account the why and the how of it. Not many men are handing out salaries in five figures to executives unless they are worth it, and when it is known that Mrs. Brewster had sales amounting to \$300,000 on the books at the close of 1920 it can readily be seen there is no discrepancy between her munificent salary and her value to her company."

The Baltimore headquarters of the Columbia Co. is now the proud possessor of a handsome clock which was won by that organization in the sales contest conducted last year.

JAZZ ARTIST FOR ARTO RECORDS

Lucille Hagamin to Make Arto Records Exclusively—Price Reduced to Eighty-five Cents

The Arto Co., Inc., Orange, N. J., manufacturer of Arto records, has just closed negotiations with Lucille Hagamin, the well-known colored singer and exponent of modern jazz, to sing exclusively for Arto records. Miss Hagamin will be accompanied by the "Harris' Blues



Miss Hagamin, Harris Blues and Jazz Seven

and Jazz Seven." In the March list of Arto records there are two numbers both of which are renditions by this artist. They are "The Jazz-Me Blues" and "Everybody's Blues." The Arto Co. has issued a special hanger for the trade in which are featured these two new offerings and an advertising campaign is under way.

The Arto Co. has also announced that, commencing February 1, Arto double-faced records have been reduced to eighty-five cents retail.

ADDS TO ACCESSORY LIST

L. A. Schwarz Now Handles Valances, Victrolene Polish and Other Specialties

L. A. Schwarz, New York, manufacturers' representative, recently completed a trip through New England in the interests of the various well-known accessories on his list. He has recently added several new lines, among them being Kichler valances, Victrolene polish and the Portable Phonograph Light. This list has grown to such proportions that he is now representing fifty different accessory manufacturers.

The valances, for the windows of talking machine stores, are made by L. A. Kichler, of Cleveland, and have been placed on display at the office of Mr. Schwarz in New York City. These valances prove a forward step in the treatment of the dealer's window and enable him to secure, at a reasonable cost, valances featuring the line of talking machines which he may carry. These valances come in various widths and are being prepared for all makes of machines.

They will also be made on special order. Mr. Schwarz has lately broadened his activities to include player-piano accessories, among them being Lansing benches and Kleernote player pumps. Mr. Schwarz left the early part of the week for an extended trip through the South and West. He planned to take in the principal centers of business during the course of his trip and expects to make a good showing for his newly added specialties.

\$10,000 A YEAR—

Not One Penny Investment

SELLING THE

The Only
Life-Time-
Guaranteed-
Phonograph

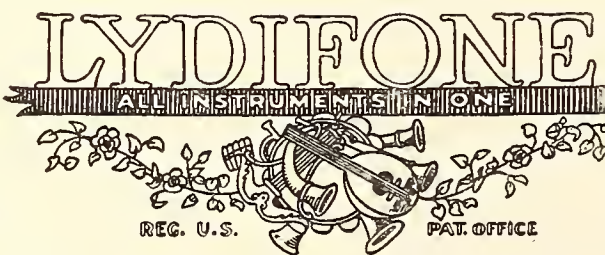

No Collecting
No Repairing
No Delivery
No Risk

Write for Particulars

LYDIFONE CO.—DEUTSCH BROS., Sole Distributors
2265 THIRD AVENUE, NEW YORK

THE SILENT SALESMAN

Increase your sales and cut out your overhead

Make every bit of your store produce business

The day of "allotment" has passed. The problem now is to sell records and dispose of slow-moving numbers. Dealers who find they have on hand a slow-moving stock of records will find UNIVERSAL DISPLAYORS the means of boosting sales of all numbers of this kind. Every title is visible at a glance. Records can be removed and replaced in an instant.

UNIVERSAL DISPLAYORS SUBSTITUTE SIGHT FOR SEARCH.

Secure your displayors at once. Your jobber handles them.



No. 567



No. 513

BETTER HAVE SOME OF THESE SALESMEN WORKING FOR YOU

We manufacture over fifty different models for the display of records, music rolls and sheet music. Send for our complete catalogue. Your jobber who handles our line will be more than pleased to send you a copy.



No. 563



No. 566



No. 568

Universal Fixture Corporation

**133 WEST 23rd STREET
NEW YORK, N. Y.**

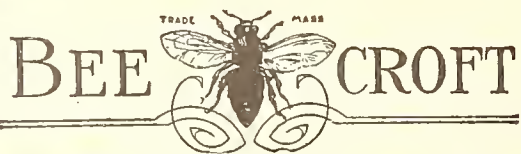

Delivery Envelopes

Art Series
New Designs

NEW LIST OF RECORDS

Every 60 Days

A Selected List of Victor Records



We Will Gladly Play Any of THESE for You

- 5088) Wonderful America March (Loney) New York Melrose Band
- 5089) Wonderful America March (Loney) New York Melrose Band
- 5090) Wonderful America March (Loney) New York Melrose Band
- 5091) Wonderful America March (Loney) New York Melrose Band
- 5092) Wonderful America March (Loney) New York Melrose Band
- 5093) Wonderful America March (Loney) New York Melrose Band
- 5094) Wonderful America March (Loney) New York Melrose Band
- 5095) Wonderful America March (Loney) New York Melrose Band
- 5096) Wonderful America March (Loney) New York Melrose Band
- 5097) Wonderful America March (Loney) New York Melrose Band
- 5098) Wonderful America March (Loney) New York Melrose Band
- 5099) Wonderful America March (Loney) New York Melrose Band
- 5100) Wonderful America March (Loney) New York Melrose Band
- 5101) Wonderful America March (Loney) New York Melrose Band
- 5102) Wonderful America March (Loney) New York Melrose Band
- 5103) Wonderful America March (Loney) New York Melrose Band
- 5104) Wonderful America March (Loney) New York Melrose Band
- 5105) Wonderful America March (Loney) New York Melrose Band
- 5106) Wonderful America March (Loney) New York Melrose Band
- 5107) Wonderful America March (Loney) New York Melrose Band
- 5108) Wonderful America March (Loney) New York Melrose Band
- 5109) Wonderful America March (Loney) New York Melrose Band
- 5110) Wonderful America March (Loney) New York Melrose Band
- 5111) Wonderful America March (Loney) New York Melrose Band
- 5112) Wonderful America March (Loney) New York Melrose Band
- 5113) Wonderful America March (Loney) New York Melrose Band
- 5114) Wonderful America March (Loney) New York Melrose Band
- 5115) Wonderful America March (Loney) New York Melrose Band
- 5116) Wonderful America March (Loney) New York Melrose Band
- 5117) Wonderful America March (Loney) New York Melrose Band
- 5118) Wonderful America March (Loney) New York Melrose Band
- 5119) Wonderful America March (Loney) New York Melrose Band
- 5120) Wonderful America March (Loney) New York Melrose Band



Very attractive proposition to Jobbers

Write for trial shipment

CLEMENT BEECROFT
5546 North 5th Street
PHILADELPHIA

G. A. VALENTINE'S INVENTION

Introduces the Valens Talking Machine, Containing New Principles of Reproducing Sound

The Valens Co. has recently been formed in Yonkers, N. Y., for the purpose of manufacturing a talking machine bearing that name. G. A. Valentine is president; Phillip Loff, vice-president; R. E. Belknap, secretary and treasurer, and William D. Mitchell, factory superintendent. This machine is a combination of wood and metal with resonators and embodies entirely new principles of reproducing sound. The company has established a fully equipped factory in Yonkers, where this machine is to be manufactured. G. A. Valentine is the inventor of this new instrument and states that it is the result of many years of research and study.

R. R. Karch, assistant secretary of Thos. A. Edison, Inc., was a recent visitor to the R. S. Williams & Sons Co., Ltd., Toronto headquarters.

TRADE HAPPENINGS IN PORTLAND

Remick Expansion—Recent Aeolian Visitors—Fred Graves With Reed, French Co.—New Sonora Agencies—Compliment Stradivara

PORTLAND, ORE., February 5.—Jerome H. Remick, president and owner of the nationally known music-publishing house and Columbia dealer, spent several days in Portland recently. "I can truthfully say that Portland is one of the best music cities in the country," said Mr. Remick, following a conference with Taylor C. White, manager of the Portland Remick Song Shop. "Some of the songs which became the rage in the East first 'took' in Portland before they became really popular east of Chicago." Because of the growth of the Portland branch, plans for the enlargement of the local store are now under way.

Mr. White announced that the enlargement and alterations contemplated were for the purpose of taking care of increased talking-machine business. It is contemplated cutting a large stairway to the basement of the building, where three demonstration rooms, twelve feet by twelve feet, will be installed. The plan is not only to get more room to care for the business, but to place the demonstration rooms away from the piano, which is used to demonstrate the sheet music. These rooms will be handsomely furnished and will be equipped with special lighting facilities and with the most modern method of ventilation. The alterations will be completed by the first of March, it is expected.

Mr. White has secured the services of Miss May Rice, whom he has placed in charge of the talking machine department and states that she is more than coming up to expectations as a manager and saleswoman.

John H. Matney, who for several years had charge of the Reed, French talking machine department, has accepted a position in the same capacity with the Edwards Furniture Co.

En route from the East to attend the national convention at San Francisco, 150 members of the American Wood Preservers' Association, the National Tie Producers' Association and the Mountain States Lumber Dealers' Association stopped off in Portland for a couple of days to visit the various lumber and forest products industries of Portland and vicinity. Through F. N. Clark, of the Stradivara Phonograph Co., a machine built by the Portland concern was placed in the observation car and furnished music for the men and their wives on their trip from here to San Francisco.

D. C. Peyton, in charge of the talking machine department of the Meier & Frank Co., reports business in good shape both in machines and records. M. M. Hull, Western representative of the Aeolian Co., of San Francisco, and Leo Shatney, his traveling representative for the Pacific Northwest, called on Mr. Peyton this week.

Frank M. Case, manager of the Portland Wiley B. Allen branch, has just returned from a business trip through eastern Oregon and Washington.

Fred W. Graves, formerly president and general manager of the Graves Music Co., has affiliated with the Reed, French Piano Co., and will have a hand in the general management of this store. Mr. Graves is well known among the music people of Portland and has been in the business in this city for the last twenty years and was the first wholesale and retail jobber and dealer in the Edison in Portland.

Mr. Carder, Pacific Northwest representative for the Sonora talking machine, was a visitor at the Lipman, Wolfe & Co.'s store this week. Direct agencies are being established by Mr. Carder throughout the Northwest and he is meeting with decided success everywhere. Lipman & Wolfe are the exclusive west side distributors of this machine in Portland, while Jack Chisholm will be direct representative of the Sonora on the east side of the river. A. Stayney, proprietor of the Laurelhurst Pharmacy, will also handle the Sonora machine.

ARGUMENTS IN VICTOR-STARR CASE

Action Heard in U. S. District Court in New York on February 5

Arguments in the suit brought by the Victor Talking Machine Co., Camden, N. J., against the Starr Piano Co., of Richmond, Ind., for alleged infringement of the Johnson patents covering lateral-cut records were heard by Judge Learned Hand in the United States District Court in the Woolworth Building on Saturday, February 5. Testimony in the case was taken during and following the holiday season and attracted wide attention. The courtroom was also crowded by talking machine men to hear the arguments. The court took the matter under advisement immediately and it is expected that a decision will be handed down at an early date. The case is regarded as one of the most important now before the courts.

The argument for the plaintiff was presented by Richard Eyre, of Kenyon & Kenyon, and for the defendant by D. W. Cooper, of Kerr, Paige, Cooper & Hayward.

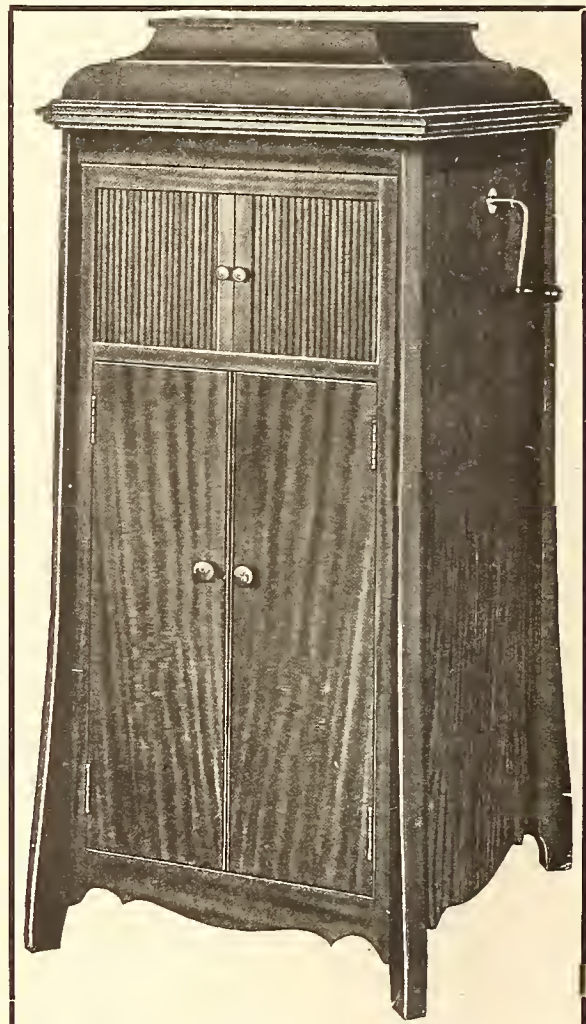

Deterling Talking Machines Create Sales

BECAUSE of their distinctive features

ATTRACTIVE DESIGNS—will hold the eye.

CABINETS—Built to stay built—they will not fall apart.

SLIDING DOORS—Unique and attractive—will modify the tone volume—without muffing.

FILING SYSTEM—A quality point—very effective and easy to demonstrate.

DETERLING MERITS and Motors keep them sold.

Send for Our Story

DETERLING MFG. CO.

TIPTON

INDIANA

Jeanne Gordon, contralto star of the New York Metropolitan Opera Company, sings that weird, dramatic song, "Re Dell' Abisso" (King of the Shades), from *Un Ballo in Maschera*, in a manner to thrill you to the core. Columbia 49747.

**Columbia Graphophone Co.
NEW YORK**



JOINS W. H. REYNALDS' STAFF

M. H. Wheat Now Associated With Prominent Victor Jobber—Thoroughly Familiar With Retail Merchandising and Methods

MOBILE, ALA., February 9.—M. H. Wheat, who has become associated with the wholesale division of W. H. Reynalds, Victor jobber in this city, is attaining signal success in his new post, and Victor retailers in this territory are taking advantage of Mr. Wheat's many years of experience in the industry.

When he first joined the talking machine trade Mr. Wheat occupied the post of South-



M. H. Wheat

eastern distributing representative for the Paramount Talking Machine Co., resigning this position to join the organization of the Atlanta branch of the Brunswick-Balke-Collender Co. Mr. Wheat is thoroughly familiar with the problems confronting Victor retailers in this section of the country, and his association with one of the largest Victor jobbers in the South insures his continued success.

INTRODUCES ELECTRIC MODEL

TIPTON, IND., February 8.—The Deterling Mfg Co., of this city, manufacturer of the Deterling talking machine, has increased its capital and according to present plans will expand its manufacturing facilities considerably. Two new models will be added to the line, together with a new electric model. The company has arranged for the use of a distinctive type of electric motor, which has only one movable part, and Deterling dealers have already placed orders for the new electric model, which will be on the market within the next six weeks.

A NEW YORK INCORPORATION

The Pace Phonograph Corp. has just been incorporated at Albany, N. Y., with a capital stock of \$100,000. The incorporators are Arthur W. Britton, Samuel B. Howard and Robert K. Thistle, of New York.

DETROIT DEALERS LOOK FOR GOOD BUSINESS IN 1921

Spirit of Optimism Prevails—Grinnell Branch Managers Hold Convention—Why Jewett Phonograph Co. Is Pleased With Outlook—Victrola Shortage Still Prevails—Phillips With Jewett

DETROIT, MICH., February 7.—The viewpoint of leaders in the talking machine industry in this city is that if they don't get big business the first six months they are sure to get it the last half of the year. Experience of the past has proven that each year shows up well over the preceding year, and while January was a comparatively dull month indications are that the months to come will be a great deal better. Anyway, they argue—should it take another few months to recover from the present depression people will want to spend and buy when they do get money, and talking machines will be among the first articles to get patronage. It is a positive fact that the talking machine industry is suffering less from the depression than almost any other industry. While the dealers are not doing their usual business for this time of the year we don't hear anybody report that he is losing money—dealers are not sacrificing their product and taking a loss as you will find in other retail lines. So really, after all, the talking machine dealer can congratulate himself that his business is holding up as well as it does.

Grinnell Bros. at their eighteenth annual convention of branch managers held the week of January 25 gave considerable time to a discussion of ways and means of increasing their business in records. The various dealers participating in the discussion gave many novel methods which they have used to good advantage. Reports of the dealers on their business for 1920 showed that the talking machine business in every instance was more than satisfactory. Some dealers reported that while their small goods and piano departments may have suffered, the talking machine business more than held its own and that record business was unusually good during the year. Grinnell Bros. not only handle the Victor line in all of their twenty-six branch stores, but they also are Michigan jobbers. The convention was a big success not only from a business, but from a social standpoint. The big events were the annual banquet and the annual for Sea Breeze, Fla., to remain all Winter.

At the annual stockholders' meeting of Grinnell Bros. directors were re-elected as follows: I. L. Grinnell, C. A. Grinnell, A. A. Grinnell, E. W. Grinnell and S. E. Clark. C. A. Grinnell, vice-president of the company, left January 31 for Sea Breeze, Fla., where he will remain the balance of the Winter.

A. A. Fair, sales manager of the Jewett Phonograph Co., with offices in the Penobscot Building and factory at Allegan, Mich., is very enthusiastic about the coming year and says that, judging from the way dealers are selling the new product and re-ordering, the total sales the first year are sure to exceed expectations. The company is completing its plans for a big production this year and is appointing new dealers as fast as its special representatives can get around to it.

George D. Phillips is now special representative in Michigan for the Jewett Phonograph Co. He was formerly with the Aeolian-Vocalion Co. in Michigan. He has a large following in Michigan and has expressed himself as being exceedingly enthusiastic over the Jewett models he has already seen.

A. A. Grinnell, treasurer of Grinnell Bros., having complete supervision over the talking machine end of the company's business, both wholesale and retail, states that there is still a shortage on some of the larger Victrola sizes and on some records. "Business is none too good just now, but we are hoping to make up for it later in the year," he said to The World correspondent.

Dealers all over the State do not look for any noticeable resumption in business before another sixty or, maybe, ninety days. The motor car factories are now adding a few men, but they are far from their normal employment basis. Manufacturers do not look for big orders to be placed until after all the motor car shows are over, and then it will take some time again to get into quantity production.

Paul Hayden, connected with the Columbia Graphophone Co.'s advertising department for the past eight years, resigned from this position the first of the month and will devote his time to his many musical and literary activities. Mr. Hayden will direct the publicity campaign for Kerejarto, well-known violinist, who recently became an exclusive Columbia artist.

BRUNO

To be in the front of the procession, every merchant must advertise. Advertising, Mr. Victor Dealer, puts a stimulus to your business that means big round dollars in the bank for you.

BRUNO

MULTIPLEX SELF-SERVICE FIXTURES

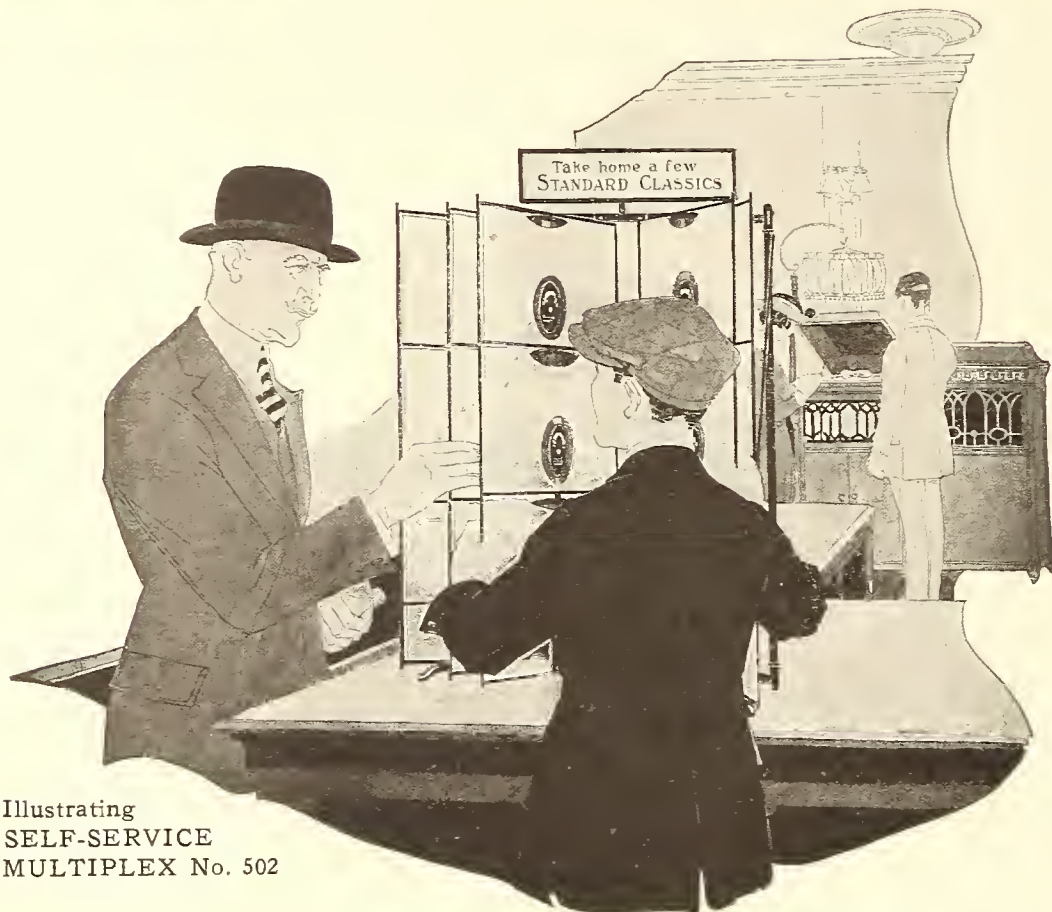

Illustrating
SELF-SERVICE
MULTIPLEX No. 502

**These MULTIPLEX Fixtures
will double your Record Sales**

Each MULTIPLEX is a sales-producer—each one is built to fit a place and fill a need in your store. They will rapidly increase your record business and soon pay for themselves in more sales and larger sales.

Order Through Your Jobber

Multiplex Display Fixture Co.

General Offices: 920 N. Tenth St.
ST. LOUIS



SELF-SERVICE
MULTIPLEX
No. 500



Be sure to
get genuine
MULTIPLEX SELF-SERVICE
MULTIPLEX No. 503

Write for NEW CATALOG

COLUMBIA NEWS AT NEW HAVEN

Manager Haring Gives Interesting Business Report—Bert Williams Featured in Columbia Advertising in Conjunction With His Stage Appearance—Mrs. Drysdale Makes Address

NEW HAVEN, CONN., February 7.—H. B. Haring, manager of the local branch of the Columbia Graphophone Co., held a sales meeting a few days ago and during the course of the meeting gave a gratifying report of the business closed by the branch for the month of January. According to Mr. Haring's report, business has started up very well for the new year, quite a number of desirable accounts having been opened in the month of January to handle the Columbia line exclusively.

Bert Williams, exclusive Columbia artist, appeared in this city recently in "Broadway Brevities" and all local Columbia dealers "tied up" to his appearance in their newspaper advertising. A few days ago this popular artist gave a song recital in the warerooms of Edw. Wittstein's Music Shop, exclusive Columbia dealer. Bert Williams, accompanied by F. C. Collins, of the local wholesale staff, visited all Columbia dealers and also spent quite some time at the local branch.

Columbia dealers in this territory have organized the Columbia Dealers' Association and interesting meetings are held every Tuesday morning.

Mrs. Drysdale, of the educational department at the Columbia executive offices in New York, visited this branch recently and also addressed a meeting of the Connecticut Teachers' Federation at New Haven.

MAKES OPTIMISTIC COMMENT

In a recent issue of Advertising & Selling, a well-known advertising magazine, there appeared a symposium giving the views of well-known advertising managers as to their plans for 1921.

One of the interesting articles in this symposium was written by L. C. Lincoln, advertising manager of the Sonora Phonograph Co., Inc., who stated as follows: "The growth of our business has been phenomenal and our advertising appropriation has naturally grown in proportion with the sales. Our 1920 campaign cost twice as much as in 1919 and our appropriation for 1921 will be limited only by the buying power of the country. We do not expect it in any case to be less than the 1920 appropriation.

"Based on the viewpoint of manufacturers of various lines, the outlook for 1921 is not so good as was anticipated several months ago, but a recent visit among several of our retail dealers outside of New York City has disclosed the fact that they are very optimistic and are not at all apprehensive of the future.

"Since they are the ones that have their fingers continually on the public pulse, it would seem that the outlook is anything but bad."

ISSUES NEW CATALOG OF PARTS

Everybody's Talking Machine Co., 38 North Eighth street, Philadelphia, Pa., has just issued a new catalog in which prices on its motors, tone-arms, sound boxes and other talking machine accessories are given space. There are over a hundred illustrations of the various products handled by this firm, accompanied by elaborate descriptive material. Copies are now being forwarded to the trade, and the company feels the new price quotations particularly and the other up-to-date material will be a source of reference and information for manufacturers throughout the country.

OCCUPY NEW QUARTERS IN TORONTO

The Columbia Graphophone Co. has recently moved to new and more attractive quarters at 347 Adelaide street, West, Toronto, Can.



THE TALKING MACHINE WORLD SERVICE

Robert Gordon's Page -

A DEPARTMENT DEVOTED TO PROMOTING RETAIL SALES



Get Back to the Business of Selling

THAT we are face to face with new conditions to-day seems to be the idea that is prevalent in the minds of the retail talking machine merchants. As a matter of fact, we are *not* face to face with new conditions. We are merely reentering a period when talking machines must be *sold*, and when dealers must devote their energies to making progress through those channels which will serve to stimulate sales. As a progressive merchandiser I advise that you employ the fundamental principles of business success in order to stimulate your sales. These are not new—they are those fostered and pushed back in the days when the horn machine was the prevalent type. With due acknowledgment to The Talking Machine World I quote extracts from the editorial of Issue No. 1, Vol. I, of that periodical, published on January 15, 1905:

"Intelligent exploitation is the keynote of success with the progressive talking machine dealer.

. . . Your window should be made attractive, as the outside appearance of your store is a great factor to prospective customers. . . Great care should be exercised in handling your customers when entering your establishment. Don't let them get into the hands of a \$10.00 a week clerk.

. . . Make your customer feel at home, and handle him so that he may have your confidence. Give him what he wants. . . Many dealers in business to-day are too close with themselves, and as the old saying goes: 'If you hold a twenty-five-cent piece before your eyes, you could not see a fifty-cent piece in the back of it.' The talking machine must be treated separately and departmentalized. . . The dealers who have fitted up attractive rooms for the exhibition and sale of talking machines are the ones who score a tremendous business success. . . There is no reason why you should not gain publicity by giving fine entertainments, to which can be invited the best class of people. . . Advertising is another big feature in intelligent exploitation. Newspaper and also direct mail solicitation of your prospective customers should be established, so that you may keep in touch with them and be on hand at the psychological moment when they will buy. The larger manufacturers have kept the talking machine before the public, through the columns of the leading magazine and through the columns of the leading magazines, and 'printers' ink.' But dealers should do their part locally, as the manufacturer cannot be expected to do it all."

These are short extracts from the editorial pages of The Talking Machine World in 1905. They were timely then and they are just as timely now. Those avenues which brought patrons to your stores in the old days still remain the leading avenues to-day.

Make your store your headquarters. Build up and extend your sales organization throughout your city. Advertise—and keep your name and your merchandise before the public's eye continually. Use coupon ads in order to get new names. Give concerts to bring the public into your shop so you get other new names. Keep intelligent salespeople at the disposition of your customers at all times. See that your show-windows are always neatly and attractively arranged. Follow these tips and your sales will keep up in a satisfactory manner.

* * *

I AM positive whereof I speak because it has been my privilege to see reliable reports of the business which has been done by retail talking machine merchants in practically every section of the country through the last 120 days. The past four months, you will concede, embrace a time when the so-called buyer's strike took deepest effect, and when complaints about bad business were most rampant on the part of manufacturers and retail dealers. These

reports show that in a great many instances retail dealers encountered a severe falling off in their sales volume. These same reports show that a very fair number of retail merchants experienced no slump, but, on the contrary, throughout this period continued their business on a very profitable basis and one which involved a volume commensurate with that done in the earlier months of 1920.

You may ask why this discrepancy exists between the reports of certain merchants and those of others. The answer is very clear. In the cases where a material slump of lengthy duration was experienced those merchants, without exception, failed to utilize, in an aggressive manner, the various agencies for promoting retail sales, such as impressive window displays, newspaper advertising that appeals, canvassing representatives, salesmen in the store that know their business fully and can sell with understanding, influential direct mail effort and merchandising ideas which produce new names and bring new people into the store or in contact with the representatives of the store.

On the other hand, those merchants who had used all these vital agencies in the promotion of retail sales continued, without a single exception, to secure a satisfactory business.

* * *

HAVING mentioned the matter of advertising it is not out of place at this time to go more thoroughly into this subject. As Sophocles so well put it: "A short saying often carries much wisdom," and as Shakespeare put into the mouth of one of his characters in Richard III: "'Tis better to be brief than tedious." The average talking machine merchant usually has the fault of trying to crowd too much into a small space. An advertisement with brevity of copy will attract the eye much quicker than an advertisement crowded to the margin with descriptions, illustrations and other material. There are very few of us who read from one end of an advertisement to the other. Yet, there are hardly any of us who do not glance at practically all of the advertisements in the daily newspapers. When writing your advertisements put yourself in the position of the reader—look through the newspaper and see what attracts your eye. Arrange your own advertising copy after this plan. Illustrations will liven up an advertisement to a large extent. However, one must be careful in the selection of these illustrations. A poor illustration is worse than none. If, by chance, you are located in a city where you have competition from another dealer of your own line, "Service" should be featured in all of your advertisements.

In this way you will not only sell the public on the advantages of the make of machine which you handle, but will also educate the people to the fact that your store is the logical place to buy this merchandise.

* * *

DUE to the fact that the American public has been extremely susceptible to modern dance music many dealers are losing the true broad vision conceived in the invention of the talking machine. They are merely looking at the talking machine as an ideal source of amusement. This is only one of the great services which the talking machine renders. Its importance as an educator and as a stimulator toward appreciation of good music must not be forgotten. There are many people in your community who are not susceptible to the modern dance music—they are, however, lovers of high-class music. Therefore, bring to the attention of the people of your community the value of the talking machine as the purveyor of high-class music. As an educator of music the talking machine cannot be surpassed. The great number of records manufactured forms a library rich in material for the fundamental study of music. Not only can the talking machine be used for teaching "Young America," but it can also serve as materially in training the voices of the older people. Do not let the public labor for a moment under the illusion that the talking machine produces inferior music. The fact that the great opera stars of America will record three or four times before finally considering their own singing sufficiently good to release is proof of the fact that only quality rendition of high-class music is procurable on the talking machine.

EDITOR'S NOTE—Mr. Gordon, who writes this monthly page, is also director of "The Talking Machine World Service." Mr. Gordon will publish on this page any good ideas submitted by you for the benefit of the trade, and also answer any questions you ask him concerning merchandising problems. Use this department as much as you like. It is intended to serve you.

TO HANDLE HOMOCHORD RECORDS

A. G. Kunde, of Milwaukee, Acquires Jobbing Rights for United States of Records Made by the Homophone Co., of Berlin

MILWAUKEE, Wis., February 7.—A. G. Kunde, for the past ten years exclusive Columbia jobber in Milwaukee, has relinquished the jobbing agency and will also dispose of the retail business he has conducted for many years at his attractive store on Grand avenue. The reason for this move is that Mr. Kunde has acquired the sole rights for the United States of the Homochord records, made by the Homophone Co., of Berlin, which has the reputation of being the largest of European record manufacturers. Their record catalog embraces song and speech in thirty-three different languages. Mr. Kunde has already large shipments of the Homochord records on the way and the small sample stock he has on hand has excited the keenest interest of dealers who specialize in foreign records. He will lease in a few days new quarters which

CABINETS AT A PRICE

4 SIZES

Genuine Mahogany,
American Walnut and
Golden Quartered Oak



Height 49 inches
Width 21 "
Depth 22½ "

Write us today

No order too small or too large

Let us submit you our price that is right, and can make prompt shipments

Player-Tone Talking
Machine Co.

967 Liberty Avenue
Pittsburgh, Pa.

will be of ample dimensions and sufficient to carry a large stock for American distribution.

Mr. Kunde made a pleasure trip to Europe last Summer and though he had no business intent at the time naturally dropped into talking machine stores. He soon heard many favorable things said of the Homochord line and finally decided to go to Berlin and investigate it, with the result above stated.

NEW VOCALION DAMBOIS RECORDS

Noted 'Cellist Adds Two Contrasting Numbers to the Vocalion Record Catalog

The Vocalion record bulletin for March contains two more 'cello records by Maurice Dambois. This talented artist is equally as skillful as a pianist as he is a 'cellist. He has recorded in his last records "Love's Old Sweet Song" and one of Ernest Ball's recent numbers, "Let the Rest of the World Roll By." His swan song, "Le Cygne," by Saint-Saens, which appeared in February, has proved so popular that the majority of dealers have had to reorder on this number; in fact, all the selections of Dambois are meeting with a very favorable reception from buyers of high-class records.

VICTOR DEALERS OPTIMISTIC

Visitors to New York Talking Machine Co.'s Office Give Gratifying Reports of Business in Many Sections—News of Month

During the past fortnight quite a number of out-of-town Victor dealers visited the headquarters of the New York Talking Machine Co., New York, Victor wholesalers. All of these dealers were optimistic to a marked degree in discussing business conditions in their respective localities, emphasizing the fact that their sales for January compared very favorably with January, 1920, and that there was an undercurrent of confidence throughout their trade which indicated a healthy Spring business.

Among these callers were Hyman Landau, Wilkes-Barre, Pa.; S. D. Stoehr, Scranton, Pa.; A. C. Huff, Bethlehem, Pa., and Wilson Clinton, New Haven, Conn.

D. A. Creed, vice-president of the New York Talking Machine Co. and the Chicago Talking Machine Co., arrived in New York a few days ago to spend several weeks at the executive offices of the New York Talking Machine Co.

M. Williams, city representative of the Chicago Talking Machine Co., was a caller at the offices of the New York Talking Machine Co. en route to Chicago after attending the Red Seal course at the Victor factory in Camden, N. J.

PLANNING A REORGANIZATION

The Supertone Talking Machine Co. will, according to the present plans of interested creditors, undergo a reorganization. It is also understood that an effort will be made to acquire the assets of the Triangle Phono Parts Co. and combine the two organizations for the purpose of greater efficiency and the carrying out of several new ideas that have been proposed for the further development of the company.

W. J. STEVENS WITH PATHE

Now Connected with the Traveling Staff of This Prominent Organization

W. J. Stevens, formerly manager of the Emerson Record Sales Co. and prior to that connected with the city sales department of the Pathé Frères Phonograph Co., has returned to



W. J. Stevens

the Pathé organization and is now connected with its traveling staff. Mr. Stevens has had many years' experience in the talking machine trade and has studied intensely the needs of the dealer. His former connection with the Pathé organization and his thorough knowledge of and enthusiasm over Pathé products have enabled him to take up his new duties with much success.

INTRODUCE "DANCE" NEEDLE

General Phonograph Corp. Adds New Needle to Line—Specially Adapted for Dance Music

The General Phonograph Corp. has just placed on the market a new needle which will be known as the "Dance" needle, and, as the name implies, this needle is manufactured especially for use on dance records. The needle embodies certain distinctive features which make it particularly adaptable for reproducing dance records, and as this type of record represents approximately seventy-five per cent of the total record sales, the needle division of the General Phonograph Corp. is preparing an extensive campaign to feature this new product.

Paul L. Baerwald, of the Eastern sales division, is concentrating a considerable part of his activities on developing the demand for the "Dance" needle, and the results to date have been very gratifying. The package itself is distinctive and the individuality of the name allows the dealer to feature the new needle to advantage.

INCORPORATED IN LINTON, IND.

The Columbia Music Store, Linton, Ind., has recently been incorporated with a capital of \$25,000. The directors are E. G. Patterson, H. D. Gilbreath and M. W. Gilbreath.

HERE AT LAST—A Phonograph of Supreme Quality

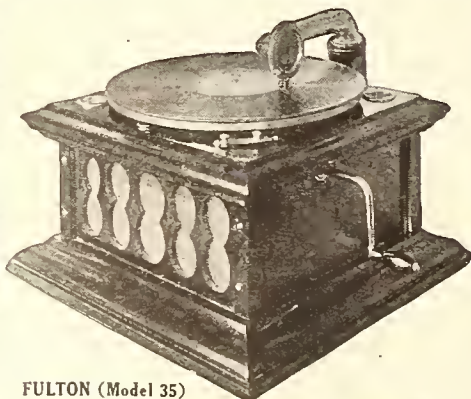

FULTON (Model 35)

Mahogany, 16x16x10 in., double spring motor, universal tone arm. Back casting and metal horn.

Price for Sample NOW \$15.75

Write for discounts in quantity lots.

We are also Wholesale Dealers and Jobbers of—
Phonographs, Records, Cabinets, Motors, Tone Arms,
Needles and Accessories, Repair parts for all makes.

Distributors of the Arto Phonograph Records and Arto Music Rolls. Write for details.

Cash with order

FULTON TALKING MACHINE CO.

253-255 Third Avenue New York City
Between 20th and 21st Streets



BEAUTY



**THE
INSTRUMENT
UNIQUE**

UNIQUE

SOME BELIEVE IN MAKING A SUCCESS BY COPYING OTHERS WHO HAVE BEEN SUCCESSFUL ¶ SOME REALIZE THAT THE COPY MUST ALWAYS BE LESS SUCCESSFUL THAN THE ORIGINAL ¶ THE LARGE MAJORITY OF INTELLIGENT BUYERS PURCHASE THE THING THAT HAS ITS OWN CHARACTER AND STANDS ON ITS OWN FEET—THE MORE READILY WHEN IT OFFERS REAL BEAUTY AND UTILITY ¶ MODERNOLA OFFERS BOTH AND IN ADDITION A TONE OF EXCEPTIONAL TRUTH AND RICHNESS

THE
MODERNOLA COMPANY
JOHNSTOWN, PA.
Eastern Distributors.
EASTERN PHONOGRAPH CORPORATION
100 WEST 21st STREET, NEW YORK



TONE

UTILITY



ANNOUNCES NEW SALES PLANS

Columbia Foreign Language Department Will Introduce Important Plans—R. F. Bolton Familiar With Dealers' Problems

During the past few months the foreign language record division of the Columbia Graphophone Co. has completed important plans whereby Columbia dealers will receive enhanced service and co-operation from this important division of the business. R. F. Bolton, sales manager of the department and one of the veterans of

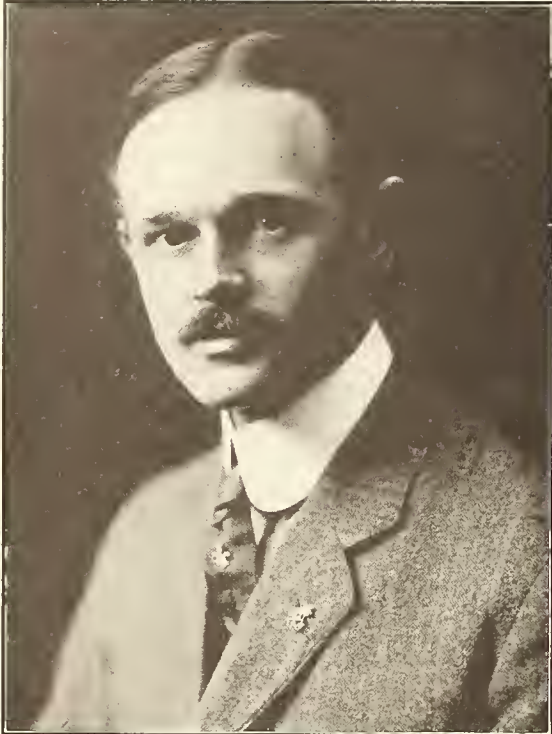

R. F. Bolton

the talking machine industry, is thoroughly familiar with the problems confronting the dealer in the development of foreign language record trade, and he and his associates have left nothing undone to solve these problems efficiently and practically.

A plan was recently introduced in the Columbia foreign language record department whereby one particular man is responsible for a language or a group of languages. The languages have been divided into approximately five groups, and each man has been assigned to the group of languages with which he is familiar. This plan has proven a signal success, as it places the responsibility for the different languages in the

hands of experienced and competent men who know every detail of the languages to which they have been assigned.

The Columbia foreign language record department recently revived the German list and is building it up along lines that will appeal to German record buyers. The list will be composed of the best-known German folk songs, concert numbers, sacred selections and a representative group of standard music.

Mr. Bolton announced recently that arrangements were completed whereby Scio's Hungarian Gypsy Orchestra will make Columbia records exclusively. The first records of this orchestra will be ready very shortly, and the popularity of this orchestra among the Hungarian populace insures the success of these records.

PURCHASE ASSETS FROM RECEIVER

Phonograph Recording Laboratories to Operate Business of American Recording Laboratories

The assets of the American Recording Laboratories, which recently went into the hands of a receiver, have been purchased by a newly organized company which will operate at the old address, 49 West Forty-fifth street, New York, under the firm name of the Phonograph Recording Laboratories. Hartwell W. Webb, who is well known in recording circles and who has been associated with several record companies in official capacity, will direct the affairs of the new company.

ARTISTIC CHENEY WINDOW DISPLAY

That it is possible to put life, character and originality into a window display of talking machines is proven by the accompanying reproduction of the show window of Dives, Pomeroy & Stewart, of Harrisburg, Pa., in which Cheney phonographs are featured to excellent advantage. The display attracted wide attention and the department manager declares that a substantial number of sales resulted directly therefrom.

It would not be convenient for the average talking machine dealer to secure and keep on

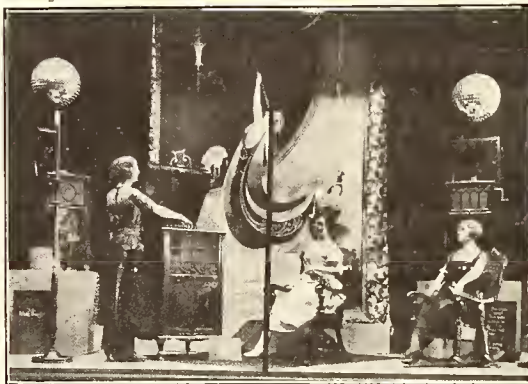

Dives, Pomeroy & Stewart's Display

hand wax figures of full size to lend attractiveness to his displays, but the use of such figures is an easy matter for department stores, and even the small dealer can either rent or borrow one or two figures to individualize his window.

LYDIFONE SALES PLAN A SUCCESS

The Lydifone Co., of which Deutsch Bros. are sole distributors at 2265 Third avenue, New York, has recently established many agencies for the Lydifone and, according to D. A. Newman, of the company, offers a most attractive proposition to the dealer. This sales plan is meeting with pleasing success, more than fifty dealers handling the line.

Deutsch Bros. operate three large stores in New York and are among the city's large merchandisers of furniture, pianos and phonographs. For more than eight years they have featured the Lydifone.

General Manager Nolder, of the Starr Piano Co., Los Angeles, Cal., reports exceptionally good sales for January after a bumper December business. F. C. Valentine, manager of the talking machine department, was formerly with the Hauschildt Music Co., of San Francisco.



Hoffay Phonographs
Resurrectone Reproducers
Airtight Tone-Arms
Famous the World Over.
HOFFAY PHONOGRAPH CO.
59 4th Ave. New York City

BRUNSWICK IN GREEN BAY, WIS.

Local Dealer Uses Artistic Window Displays to Increase Sales of Machines and Records

The Stiller Photo Supply Co., Green Bay, Wis., is an active Brunswick dealer and is finding a ready sale for both Brunswick machines and records in its territory. The accompanying



photograph shows a Brunswick display in the window of the store. Since taking on the Brunswick agency the Stiller Co. has found the talking machine end of its business a very profitable one and is making plans to expand this department in the near future.

LARGE RECORD SHIPMENTS

I. Lesser, of the Western Jobbing & Trading Co., Los Angeles, Cal., reports large shipments of Emerson records have been received in which are included the popular numbers, "Do You Ever Think of Me" and "Bright Eyes." Mr. Lesser recently returned from a trip to San Francisco in company with H. E. Morrison, assistant sales manager, and Robert MacKin, special representative of the Emerson Phonograph Co.

ASSOCIATED No. 70 UNIVERSAL TONE ARM

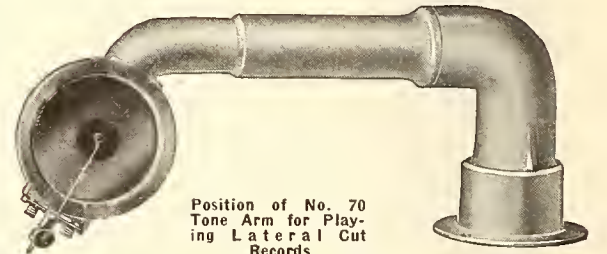

Position of No. 70 Tone Arm for Playing Lateral Cut Records

Quality Construction
Unusually Good Tone **No Blasting**
For use in Phonographs retailing up to \$100.
Price for sample—\$2.00.
Quantity price on application.

Associated Phonograph Supply Co.
Dept. 71 Cincinnati, Ohio

LATEST POPULAR HITS

ARTO Phonograph Records
Now 85c

ARTO Word Rolls
Now \$1.00

Roll Numbers	Record Numbers
1324—My Mammy	} 9040
1319—Bright Eyes	
1318—O, Gee, Say, Gee.....	} 9039
1295—Rosie, Make It Rosy for Me	
1317—You Ought to See My Baby	} 9037
1295—Just Snap Your Fingers....	
1292—Margie	} 9030
1224—Honolulu Eyes.....	
1279—Broadway Rose.....	} 9026
1271—Feather Your Nest.....	
1240—Whispering	} 9019
1209—In Old Manila.....	

Samples sent upon request at regular 40% dealers' discount.

Write for details.

Cash with order.

DISTRIBUTORS
FULTON TALKING MACHINE CO.
253-255 Third Ave., New York City
Between 20th and 21st Streets

MAKES TIMELY BUSINESS ANALYSIS

Mr. Heany, of General Sales Corp., Says That Dealers Who Are Hustling Are Making Good Sales—Optimistic Over Outlook

MILWAUKEE, Wis., February 7.—The General Sales Corp., of 1520 Buffum street, this city, is quite an important institution. Owning and operating as it does the General Manufacturing Corp. and the Recordeon Phonograph Co., both large productive institutions in this city, and also the Heaney-Schaad Billiard Mfg. Co., which, in another large factory, make fine billiard and pool tables, is truly some achievement since 1882. Mr. Heaney, in a chat with The World, stated that they are not at all displeased with the present outlook.

"Of course, we have passed through a period, like other manufacturers, of temporary quiescence, but from every news channel, and we have control of many, comes indications of a revived activity in the near future. There has been a large amount of retail business done, but this has not registered directly at the desks of manufacturers, simply because the dealers had such large stocks. We know, however, despite the comparative smallness of orders, that these stocks are being very rapidly depleted. Dealers, especially in the country, are doing a very fair business, perhaps not as large as during the period of wild prosperity, but at the same time a good, steady business. Especially is this true of men who have kept themselves and their employes hustling on the sales end.

"There is a general feeling that business will open up in a very notable way about March 1. We are ready to take up some slack in our present jobbing alignment by way of making arrangements with a very few good jobbers."

The General Sales Co. issues one of the handsomest catalogs which the writer remembers to have come before his notice in the many years of his experience in this trade. In a distinctly non-hot air, but very dignified manner, it sets forth the merits and the selling points of

the company's talking machines. It is very artistic, with a most attractive cover and a very delectable typographic and artistic makeup throughout.

EXHIBITING AT TOY FAIR

General Phonograph Mfg. Co. Exhibits Garford Phonographs at Toy Fair in New York—Homer Stephens in Charge of Display

The General Phonograph Mfg. Co., Elyria, O., manufacturer of Garford phonographs, has a very interesting exhibit at the Toy Fair which opened February 7 at the Hotel Imperial, New York, and which will continue until March 12. Homer Stephens is in charge of this exhibit and the dealers are evincing keen interest in the company's line of phonographs.

Among the models exhibited are the well-known "Baby" types retailing at \$6 and \$12, which have attained tremendous success throughout the country. Mr. Stephens is also introducing two new models retailing at \$25 and \$35, and these instruments are attracting the attention of all visitors. The well-known model "E" Garford phonograph continues to be a prime favorite with the trade and Mr. Stephens has received large orders from visitors to the fair.

PREPARES AN ATTRACTIVE FOLDER

The Fred Gretsch Mfg. Co., Brooklyn, N. Y., has prepared an attractive folder on banjos for the trade. This folder, entitled "Better Banjos for Better Banjo Players," attractively sets forth the merits of the Rex line of banjos, tenor banjos and banjo mandolins of this company. Three styles are described—the Professional, the Artist and the Presentation styles. All three styles are of the highest grade and have a distinct appeal to those who appreciate the better make of banjos. A. Prevet, of this company, is now working upon a new price list which will be shortly ready for the trade.

THE ELECTRIC TONE-A-PHONE

New Product, Marketed by Vitalis Himmer, Amplifies and Transmits Record Music by Electricity—An Interesting Development

Vitalis Himmer, who for many years manufactured the well-known "Audion" line of tone arms and reproducers, but who during the past year has been experimenting on electrical devices for tone transmission, has just announced the completion of such a product and is marketing it under the trade name, the "Electric-Tone-A-Phone," which reproduces, amplifies and transmits by electricity the tones from talking machine records.

In announcing his new product as ready for the market Mr. Himmer says: "There is no doubt that the electrical methods will find many uses in developing additional phonographic amplification. It is a well-known fact that phonograph music is being sent out by wireless in various parts of the country and for the amusement of sailors and officers aboard ships, and it is quite certain that within a very short time the electric transmission of music on a more elaborate scale will be the feature of many homes."

Mr. Himmer has a wireless station upon which he receives wireless communications and the electrical devices which he is manufacturing are being developed for the production of wireless music so amplified that it can be distinctly heard over reasonably large areas. Mr. Himmer's devices have aroused much interest.

NEW DISTRIBUTORS APPOINTED

PHILADELPHIA, PA., February 8.—The Penn Phonograph Co., Inc., of this city, producers of the well-known Penn-Victor miniature dogs, announce the appointment of three additional well-known distributors for this trade-mark novelty—the American Talking Machine Co., the G. T. Williams Co., of Brooklyn, N. Y., and Chas. H. Ditson & Co., New York City.

To Serve You Best

is the definite, unswerving aim of

GRINNELL SERVICE

The great and constantly growing prestige and popularity of Victor products makes this the line through which the merchant wins highest standing for his establishment in his community and achieves greatest business success. Through it he best serves his buying public.

He builds for permanency and ever greater business.

We Can Be a Real Aid to You in Your Victrola and Record Business.

With a half-century of merchandising experience we've a full appreciation of what service really means.

It is on the basis of this knowledge that we ask the opportunity of serving you.

We know that the ability to supply the Victrolas and Records wanted is essential.

That accuracy in filling orders is absolutely necessary.

That there must be no delay in shipment.

That all we can do to serve your interests serves our own. WE ASK THE PRIVILEGE OF DEMONSTRATING HOW PERFECTLY WE CAN CARE FOR YOUR VICTROLA AND RECORD NEEDS.

Grinnell Bros

Wholesale Distributors of Victrolas and Records

FIRST AND STATE STREETS

DETROIT

Edison Message No. 91

We shall be compelled to advance Edison phonograph prices if the Excise Tax on phonographs is increased.

THOMAS A. EDISON, Inc.

ORANGE, NEW JERSEY

CONVENTION OF EDISON JOBBERS OPENS IN MONTREAL

Two-day Conference Started on February 10 With a Large Attendance—Preliminary Conference Held at Edison Laboratories at Orange—Some of Those Who Were There

MONTREAL, CANADA, February 11.—Instead of New York City, as heretofore, the scene for the Edison Jobbers' Convention of 1921 is in Montreal, where, at the Windsor Hotel, a two-day business session opened yesterday, February 10, and continuing to-day, will wind up with a banquet and dance to-night—an event in social and musical circles.

As a preliminary to this event there was held a two-day conference by the Edison Jobbers' Committee of Standards of Forms and Practices at the Edison Laboratories, in Orange, N. J., on February 4 and 5, whereat the committee, the chairman of which is A. H. Curry, discussed with Mr. Maxwell and other officials of the company the famous fourteen sales propositions. New and valuable ideas resulted from their exchange of ideas. Besides Chairman Curry, of the Texas-Oklahoma Phonograph Co., Dallas, Tex., the committee of standards comprises Albert E. Buehn, Buehn Phonograph Co., Pittsburgh, Pa.; P. H. Oelman, the Phonograph Co., Cincinnati, O.; M. M. Blackman, the Phonograph Co., of Kansas City, Mo.; Frank E. Bol-

way, Frank E. Bolway & Son, Inc., Syracuse, N. Y.

For the trip to this city a special car was engaged. Those aboard it representing the Edison Laboratories were: Mr. and Mrs. T. J. Leonard, Mr. and Mrs. J. A. Shearman, Mr. and Mrs. W. H. Miller, Mr. and Mrs. E. H. Philips, Mr. and Mrs. Wm. Maxwell, Mr. and Mrs. S. B. Mambert, Messrs. J. B. Gregg, D. E. Wheeler, D. P. Babcock, A. L. Walsh, Delos Holden, C. S. Gardner, R. R. Karch and E. Trautwein. Others of the party were: E. C. Boykin, Phonograph Corp. of Manhattan, New York City; W. E. Kipp, Kipp Phonograph Co., Indianapolis, Ind.; W. F. Taylor, Texas-Oklahoma Phonograph Co., Dallas, Tex.; C. B. Haynes and E. Bowman, the C. B. Haynes Co., Inc., Richmond, Va.; J. Unger, of Laurence H. Lucker, Minneapolis, Minn.; H. H. Blish, Jr., Harger & Blish, Des Moines, Ia.; L. T. Donnelly, Diamond Music Co., Inc., New Orleans, La., and John Lee Mahin, of the Federal Advertising Agency, New York City. The party received a hearty welcome from their Canadian confreres.

nection that whenever an enactment requires an expenditure the cost of it must fall upon the tax-paying public and were we to undertake everything that is suggested by legislators, Federal and State, the country would go bankrupt. Economy must be emphasized in legislation. Freak measures must be avoided. We must not depart from the traditions of Government nor feel that an act may prove a curative for every public ill."

CARUSO ON ROAD TO RECOVERY

Noted Tenor to Go to Atlantic City Soon and Will Later Sail for Italy

Enrico Caruso, the famous Victor artist, is now convalescing rapidly and satisfactorily from his recent attack of pleurisy. While it is true that at one time his condition was extremely critical, still, despite the report which appeared in many newspapers, he did not have a hemorrhage in his throat. The accident which was reported as a hemorrhage was due entirely to the pleurisy from which he was at that time already suffering.

At the present time he is still in New York and is making very rapid progress on account of his tremendous natural vigor. He plans to leave with his family for Atlantic City the latter part of February, and after a sojourn there will sail in the early Summer for Italy. He plans to spend the Summer at his home in that country. There is, in the opinion of those best qualified to know the facts, no reason to doubt that he will soon be singing in opera with the same masterly vigor that previously characterized his art.

PROMOTION FOR F. W. SCHWOEBEL

JACKSONVILLE, FLA., February 9.—The Florida Talking Machine Co., Victor wholesalers of this city, have found it necessary, as a result of business demands, to expand the business materially. F. W. Schwoebel, formerly with the Victor traveling department, who has been with the company for the past year, has been appointed sales manager and will have complete charge of the sales department.

Columbia dealers from various centers in Indiana held a gathering at the Hotel Anthony, in Ft. Wayne, on February 8. John McKenna and J. Kapps attended from Chicago, and the affair was under the management of F. S. Binger, the Indiana representative.

SMITH ADDRESSES EDISON JOBBERS

General Manager of Music Industries Chamber of Commerce at Montreal Convention

Alfred L. Smith, general manager of the Music Industries Chamber of Commerce, upon his return to New York on Thursday, after having appeared before the Ways and Means Committee in Washington to urge higher tariffs on musical instruments and parts, left for Montreal, Canada, to speak before the convention of the Edison Diamond Disc Jobbers' Association, his address being confined chiefly to a report of what the Chamber is doing in connection with the Federal tax situation.

CREDIT MEN OPPOSE FREAK LAWS

What Is Needed Just Now Is Economy in the Matter of Legislation, Says J. H. Tregoe

Stating that there are too many laws in this country, J. H. Tregoe, executive secretary of the National Association of Credit Men, in his February letter to the members of that organization, declares that the time has come to emphasize the need of economy in legislation.

"The country has grown ripe for legislation of the freak type," writes Mr. Tregoe. "Without disparaging the entrance of women into governmental affairs and endowing her with the right of suffrage, yet this experiment, of tremendous significance to the nation, may develop legislative ideas which will really submerge the true purposes of the Government into mere sentiment. Wherever it is within the powers of man to accomplish something its accomplishment should be left to him and his effort not supplemented by legislation enactors. The laws shouldn't be used for the attainment of objects beyond the reasonable powers of man. We have had bills introduced for the curing of all kinds of ailments, for all manner of welfare projects and we should remember in this con-

COMPLETE FILES OF WORLD DESIRED

An advertiser is anxious to secure complete files of The Talking Machine World for a number of years past. Readers having such files and are willing to dispose of them are requested to communicate with this office.

Amelita Galli-Curci, the famous soprano and Victor artist, has signed a contract to sing for the Metropolitan Opera Co. next season in New York.

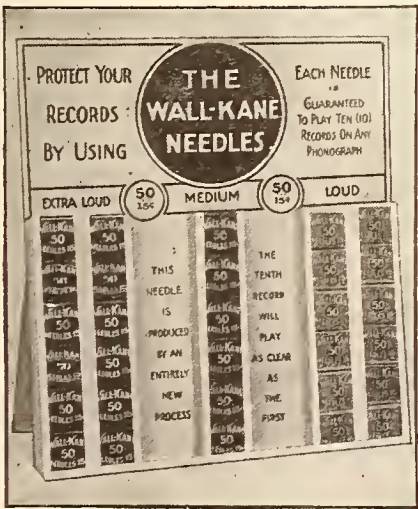

This handsome metal enamel display stand holds 60 packages, 2 doz. extra loud, 1 doz. medium, and 2 doz. loud; each package containing 50 WALL-KANE NEEDLES, retailing for 15c. Price of Stand to dealers, \$4.60; \$4.90 Far West. Single packages, 7 1/2c; 8c in the Far West.

WALL-KANE NEEDLES

One of the important reasons why you should sell Wall-Kane Needles is:

They have made good. On the market for many years and the demand for them is greater than ever before.

Attractive display containers, each holding 100 packages of a tone of WALL-KANE Needles, cost the dealer \$7.50; \$8 in the Far West

Some Jobbing Territory Still Open



PROGRESSIVE PHONOGRAPHIC SUPPLY CO.

145 WEST 45th STREET
NEW YORK CITY



DYNAMIC FORCE OF JAZZ MUSIC NOW BEING RECOGNIZED!

R. L. Goldberg, the Clever Cartoonist of the Evening Mail, Conceives a Brilliant Idea Which May Interest Talking Machine Men Who at Times Face the Problem of Flat Tires and No Pump

Marvelous what the inventive mind can do when it applies itself to a problem. Peruse the following process through the maze of its wanderings and if at the end you know what it is all about you will immediately trot your talking

and a spark sets off the Roman candle, which shoots a fiery star skyward. But you have carefully fastened a string across the path of this fiery star and this string is struck and broken by the burning ball. The breaking of the string

ment begins to play some wicked jazz. This dynamic music—which is not yet prohibited by law and will never be as soon as motorists like yourself have found out its real value as a tire pumper—so moves the spirit of the jazz-bird that he dances madly up and down on the bellows you have provided. The bellows is connected to the tire valve. Now as the jazz-bird dances the air is forced into your tire, and there you are. You are now ready to proceed

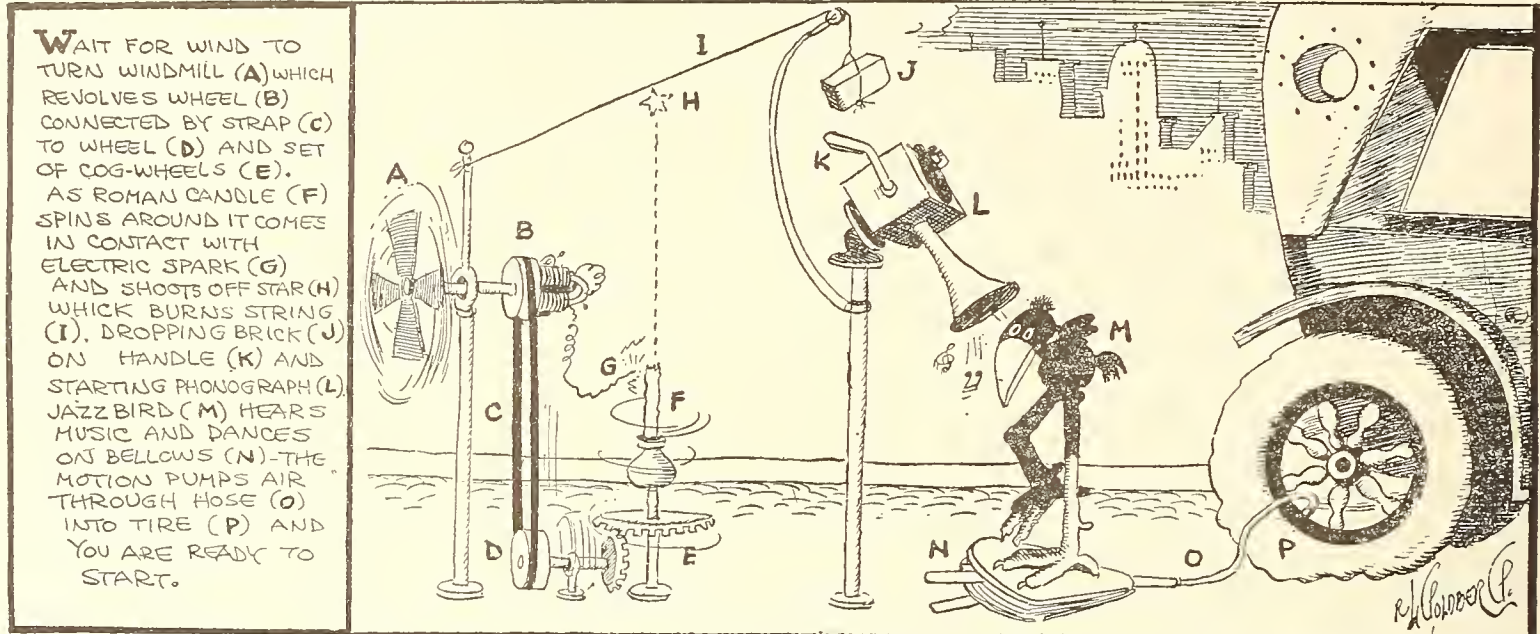

WAIT FOR WIND TO TURN WINDMILL (A) WHICH REVOLVES WHEEL (B) CONNECTED BY STRAP (C) TO WHEEL (D) AND SET OF COG-WHEELS (E). AS ROMAN CANDLE (F) SPINS AROUND IT COMES IN CONTACT WITH ELECTRIC SPARK (G) AND SHOOTS OFF STAR (H) WHICH BURNS STRING (I), DROPPING BRICK (J) ON HANDLE (K) AND STARTING PHONOGRAPH (L). JAZZ BIRD (M) HEARS MUSIC AND DANCES ON BELLOWS (N)—THE MOTION PUMPS AIR THROUGH HOSE (O) INTO TIRE (P) AND YOU ARE READY TO START.

How the Problem of the Flat Tire and the Tired Business Man Is Solved Without Aid of Einstein's Theory

machine out in the garage and try it out. Picture yourself stranded on some lovely but garageless country road with a flat tire and no pump. Enough to take out of life the little joy the law still allows. If it had not been for the talking machine you would never have overcome such an obstacle as that! But Fate has smiled upon you and with your portable instrument in the side pocket you can set about righting all your troubles.

First study the picture carefully and save your laughs for the last chapter after the curtain falls. Here you are on the road with a flat tire—all you need to start with is a windmill. The wind which whistles inside your coat collar will turn this wheel rapidly. At the end of the shaft on which the wheel is mounted place a generator and connect it with a set of cog-wheels to a turntable in the center of which is a Roman candle. From the end of the generator runs a wire attached to the fuse of the candle. As the wind blows and turns the wheel current is generated

releases the weight on the end, a common brick will do, and this weight falls upon the starting lever of the talking machine which you have thoughtfully brought along.

Here is where music gets in its dirty work. When the starting lever is released the instru-

upon your way. What could be sweeter? And the master mind, by the way, which evolved this epoch-making invention, was our old friend R. L. Goldberg, cartoonist of the Evening Mail. He wins the—supply the latest wheeze for yourself.

MAKING PROFITABLE USE OF DEALER SERVICE MATERIAL

Letter Recently Sent Out for the Purpose of Stimulating Dealers to a More Frequent Use of Window Display Material Is Worthy of the Consideration of Those Interested

Manufacturers and wholesalers in the talking machine industry are spending enormous amounts of money on dealer service material, no small part of which has been devoted to window displays. Very frequently the retail merchants have not been prone to make the maximum use of this material, which means a considerable total loss in money, not only to the house preparing the material, but also to the dealer through loss of sales.

A letter which was recently used by a wholesale grocer to stimulate his dealers in using the window material supplied to them a short time ago was worked over by a talking machine man so as to make it adaptable to the use of the talking machine industry:

"Dear Customer of Ours:

"Several days ago the proprietor of a retail music store in the eastern part of the State wrote us a very enthusiastic letter about his sales of (—) talking machines.

"This merchant, it seems, did not know that a good market for operatic selections existed in his vicinity until he received a few pieces of our advertising material which aimed to increase sales for this class of record. He put up the signs and counter cards we sent him and dressed his window with the special background we recommended. Judging from his letter, he was more than surprised by the market he had tapped by simply putting on display these signs which will whet anybody's musical appetite.

"It occurred to us that you would like to feature operatic records for a few days, so we are sending you some of this same advertising.

"If you don't find time to get it up before our Mr. Blake sees you again ask him to give you a few suggestions. He has a knack of fixing up a window that you won't find many to have. He will be glad to put this advertising on operatic records to work. Sincerely yours,

"Better Business Company."

GRADUATES ARE ENTHUSIASTIC

CAMDEN, N. J., February 9.—Another large class has just graduated from the School of Salesmanship conducted by the Victor Talking Machine Co. Now that we are in an era when intelligent selling effort is required on the part of retail merchants the function performed by this school is especially opportune, and it is interesting to note that the members of the Victor trade attending include representatives from the most distant points, on the Western coast. A substantial attendance has been secured from every section of the country and the enthusiasm of the graduates is very great. Many proprietors of retail establishments are among those graduated from the last session.

PUSHING VICTOR PRODUCTION

CAMDEN, N. J., February 9.—The factory of the Victor Talking Machine Co., this city, continues active production on a normal basis. While

most of the other factories in the talking machine industry are operating on a part-time basis, or practically shut down, the shortage for Victor merchandise continues to exist, and production is being vigorously pushed forward to meet current demands.

RECORD COUNTERS WELL ARRANGED

HACKENSACK, N. J., February 9.—The Bergen Talking Machine Co., Victor dealer of this city, has arranged its record counter in an especially attractive manner. In the center of the counter proper is a large Victor dog, with several miniature dogs in front of him. On each side of the dog is a basket of fresh flowers. On the top of the record rack there are four large spherical electric lights of white glass. There is one word lettered on each of these, and reading from left to right they run: "We Aim to Please." Hanging on the wall back of these are three large sepia prints of celebrated Victor artists.

The Mutual No. 6

Knife Edge, Spring Suspension Reproducer

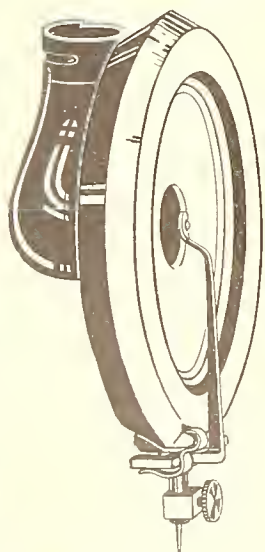

No Screws
or
Adjustment

No Blasts
Adjusts Itself

All Sound Box troubles are eliminated in this new patented, scientifically built Reproducer

Send for samples and particulars

Mutual Phono Parts Mfg. Co.
149-151 Lafayette St. New York, N. Y.



PHONOGRAPH MUSIC, OVER A WIRE

Reproduced, Amplified, Transmitted Electrically

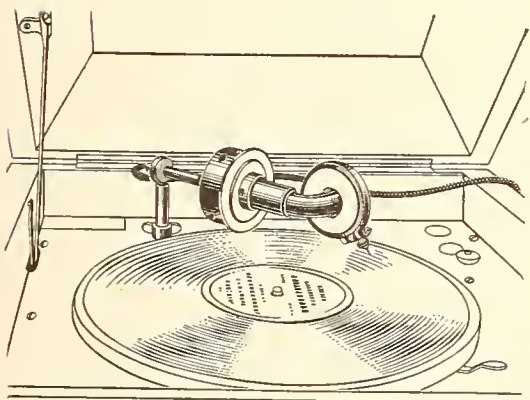

Showing Electric Arm Attached to Commercial Phonograph

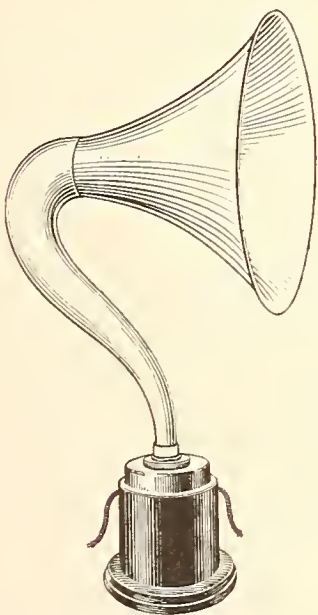

Big, Round, full tone.

Electric arm attaches to any phonograph without tools (see cut).

Playing Unit, with 12-inch all aluminum horn, may be located at distant point, or with straight, upright horn, concealed in beautiful Lamp or Electric light fixture (see top cut).

Needle surface noise inaudible.

Volume control from a whisper to full power of Band.

Quality of Tone superb, rich, sounds like the real thing, can not be compared with commercial phonographs.

Operates on small storage battery.

Can be heard a mile away in the open, quiet country at full power.

Reproduces all there is on the record.

Wonderful for Homes, Churches, Schools, Clubs, Restaurants, Dance Halls, Gardens, Tennis Court, Sea Shore, Summer Resorts, Porches, etc.

New possibilities for the Phonograph.

Manufacturers adopt it for your cabinets.

Live dealers secure exclusive territorial agencies.

Will sell to only one dealer in a town.

Fully guaranteed—Retail price only \$150.

In Hand-Carved finest quality polychrome lamp \$220

VITALIS HIMMER JR. 203-205 Sixth Ave., New York

TO-DAY

You Must Sell "QUALITY" and "SERVICE"

Your customer demands it. Price is a secondary consideration. When you are ordering your table instrument requirements remember there is nothing quite so good as the Piknik.

Made Portable in 30 seconds

Built to win friends and repeat business. Spend two cents and get acquainted.

It will pay you to handle the best.

The Piknik is the best portable phonograph on the market.

THE PIKNIK PORTABLE PHONOGRAPH, Inc.

Lakewood, New Jersey

EDISON KEEN AND ACTIVE AT 74

Famous Figure in World of Science Celebrates Birthday in Usual Way—Tells of World Problems to Solve—Flooded With Messages

The event of Thomas A. Edison's seventy-fourth birthday on February 11 was widely commented upon by the press all over the country. Breaking his usual custom of silence, he gave a lengthy interview to the public and showed that,

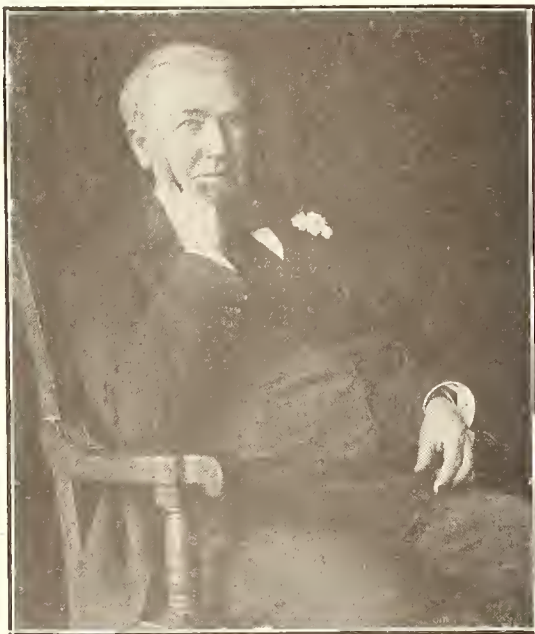

Thos. A. Edison

both in mind and body, he is still more active than many a younger man. His interest in the affairs of the world is keen and his judgment sure. He believes in a tax on all sales and declares that business men should be allowed to work out their own salvation without government interference. On his birthday Mr. Edison was the recipient of thousands of messages of congratulation and good-will from men and women in every walk of life, especially from the famous artists whose musical genius has been made permanent through the New Edison and the Recreations.

EMERSON RECORDS NOW 85 CENTS

The Emerson Phonograph Co. announced on Monday, February 14, that, effective immediately, all Emerson records will be listed at eighty-five cents with the exception of records made by Eddie Cantor, famous musical comedy star and exclusive Emerson artist, which will continue to retail at \$1.00. Included in the eighty-five-cent library will be all of the exclusive Emerson artists with the exception of Eddie Cantor.

IMPROVING CONDITIONS IN SOUTH

R. L. Freeman and J. S. Macdonald Make Extended Trip and Give Interesting and Encouraging Views of the Business Situation

Ralph L. Freeman, director of distribution of the Victor Talking Machine Co., Camden, N. J., and J. S. Macdonald, sales manager of the same company, recently returned from an extended trip through the Southern section of the country, including such important centers as Richmond, Jacksonville, Atlanta, Birmingham, Mobile, New Orleans, Houston, Dallas, Memphis and Cincinnati.

In a chat with The World they reported that although the market for the various crops and livestock produced in the region they covered had fallen off very much in price, the fundamental conditions are satisfactory. Most of the business men in this part of the country have prospered to a large extent during the last three or four years, and it is not compulsory that they move their present crops, etc., on an immediate basis.

The potential and actual market for Victrolas they found to be excellent. The holiday business was good even in those centers where general business depression existed in the largest degree, and despite the lull in the sale of crops the sale of Victrolas and Victor records has kept up very well since the first of the year.

VAN HORN ELY AT PALM BEACH

Van Horn Ely, president of the Columbia Graphophone Co., is spending a few weeks at Palm Beach, Fla. H. L. Willson, vice-president and general manager of the Columbia Graphophone Co., returned recently to New York after an important trip through the West, where he visited the various Columbia factories.

Charles Gorsch, Margaretville, N. Y., has taken the agency for the Remington.

CRYSTOLA CO. PLANS EXTENSION

R. C. Swing Assumes Entire Managership of Company, Succeeding W. R. Thomas

CINCINNATI, O., February 10.—Plans for the reorganization and extension of the Crystola Co., of this city, are now under way. R. C. Swing, treasurer and general manager of the company, has assumed entire managership of the company following the resignation of W. R. Thomas, in December.

"Business is fine with us," said Mr. Swing. "We did better in January than in November or December. Our dealers and the public are gradually learning the genuine merits of our non-vibrating glass amplifier and also the easily demonstrated advantages of our diaphragm, which is of special composition and of graduated thickness." An active selling campaign on behalf of the Crystola agents is assured by Mr. Swing, beginning in the course of the next two or three months.

TO JOB WALL-KANE NEEDLES

Appointment of Distributors in New York, Chicago and Syracuse Announced

The distribution of Wall-Kane needles has been augmented through the appointment of three progressive distributing houses by the Progressive Phonographic Supply Co., manufacturers of this product. The three new distributors are the Maurice Richmond Music Co., New York City; H. Engel, Chicago, Ill., and B. Cohen, Syracuse, N. Y. The affairs of the Progressive Phonographic Supply Co. are progressing in a very satisfactory manner. Due to the illness of D. Tauber, general manager of the company, N. Cohen, president and treasurer of the Progressive Phonographic Supply Co., is actively taking hold of the directing of the affairs of the company from the executive offices, New York City.

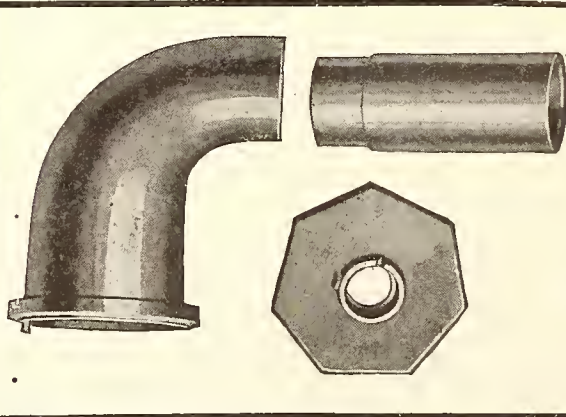

The Superior Die Casting Co.
Cleveland, O.

PROGRESS OF THE TRIAL OF THE MACY-VICTOR CASE

Action Which Began Before Judge Mack and Jury in the United States District Court, New York, on January 17 Enters Fifth Week, With Plaintiff's Side Still Unfinished—Some Interesting Testimony Offered—It Is Now Estimated That the Trial Will Last Another Month

For the past month the interest of the trade has been centered in the proceedings of the United States District Court for the Southern District of New York, where the action brought by R. H. Macy & Co., the New York department store, against the Victor Talking Machine Co., Camden, N. J., and a number of Victor wholesalers located in and about New York, in an effort to secure \$570,000 triple damages for alleged violation of the Sherman Act, has been on trial before Judge Mack and a jury.

The suit is regarded as the most important ever brought in the trade from many angles and both sides in the litigation had prepared for a long and bitter fight. The trial was started before Judge Mack on January 17 and as *The World* goes to press the presentation of arguments and testimony by the plaintiff has just about been finished. With the defense still to be heard it is believed that at least three weeks will be required to bring the case to a conclusion.

Edmond E. Wise, of Wise & Seligsberg, appeared for Macy & Co., with George W. Schurman, of Hughes, Rounds, Schurman & Dwight, appearing for the Victor Co., and Gilbert H. Montague for the several jobbers.

Plaintiff's Attorney Opens Case

The case was opened by Mr. Wise, who, in behalf of the plaintiff, made the claim that the right of the Victor Co. to fix resale prices was not recognized, and cited the decision of the Supreme Court in the Sanatogen case in support of his argument. He also called attention to the fact that the U. S. Supreme Court had sustained the demurrer filed by Macy & Co. through an action brought by the Victor Co. in 1914 seeking to restrain Macy & Co. from cut-

ting prices on Victor goods. In presenting his case Mr. Wise paid tribute to the effectiveness of the tremendous advertising campaign carried on by the Victor Co., which had resulted, he said, in "Victor" or "Victrola" being accepted as a generic term for all talking machines by a goodly proportion of the public. In support of the plaintiff's case much was made of the fact that Macy & Co. had been unable to purchase Victor goods direct from the Victor Co. or the various jobbers included in the action since about 1913, and had suffered a material loss in potential profits as a result.

Opening Argument for Defense

Mr. Schurman, for the Victor Co., declared that his clients had, in every instance, complied with the law and that the present action grew out of the alleged violation by Macy & Co. of a contract they had entered into with the Victor Co. He called attention to the fact that the earlier contracts between the Victor Co. jobbers and dealers had been passed upon favorably by the United States courts up to and including the Circuit Court of Appeals and that it was not until after Macy had proceeded with the alleged violation of the Victor contract that the United States Supreme Court had declared that instrument ineffective. In short, it was maintained by the defense that at the time the dispute arose with Macy & Co. the Victor contract had been upheld by all the courts before which it had been taken. It is also claimed by the defense that Macy & Co. had sought to secure jobbers' discounts upon purchases and had been refused by the Victor Co. as a matter of trade policy.

The Cause of the Jobbers

Mr. Montague, for the defendant jobbers, denied the existence of any conspiracy among his clients in refusing to supply Macy & Co. with goods, declaring that at the time the plaintiff had attempted to secure goods from the jobbers and, in fact, practically up to date, there was, and has been, a distinct shortage of Victor products; that with limited supplies wholesalers naturally preferred to do business with friendly interests and that the right of a merchant to refuse to sell for cause, or for no cause, has been upheld at least twice by the Supreme Court during the past couple of years. Mr. Montague also emphasized the fact that at the time the various contracts were in force they had been upheld as legal by the courts and that even since the adverse decision of the United States Supreme Court on that question the sound economic principles back of a system of price maintenance had been supported by many important authorities and interests and that legislation to permit of the establishment of standard prices had been, and was, before Congress.

Herbert N. Straus the First Witness

Herbert N. Straus, of R. H. Macy & Co., was the first witness called by the plaintiff, who remained on the stand for practically two days answering direct questions and replying to cross-examination by counsel on both sides relative to the relationship between Macy & Co. and the Victor Co. from 1908 to 1913, when the disagreement started, and then to date. Mr. Straus told chiefly of happenings since 1913, when Macy & Co. refused to sign a new dealers' contract with the Victor Co. jobbers. He outlined the efforts that had been made to reach an understanding, and particularly the efforts that had been made, largely under his personal direction, to secure Victor goods directly from jobbers, or indirectly through other channels.

The testimony of Mr. Straus was at times distinctly interesting and illuminating and the character of the questions and answers resulted in frequent clashes between opposing counsel.

The next witness was C. H. Williams, described as a buyer for the Macy store, whose

special duty, it appeared, was to secure Victor merchandise wherever possible and who devoted an average of half his time to that work. Williams declared that he had called personally upon various jobbers in New York and other cities in the East, particularly after the Supreme Court had sustained the Macy demurrer to the Victor Co.'s complaint in 1917. His testimony regarding alleged conversations between himself and the various jobbers and their representatives seemed particularly interesting to the defendants, several of whom he named in person. It appeared that much work and trouble was involved in getting the desired goods.

Later on Percy Straus, a brother of Herbert N. Straus, and also a member of the Macy firm, was called to the witness stand and added some testimony to that given by his brother. Herbert N. Straus was recalled to the stand for re-cross-examination a week or so after his first direct testimony in order to verify the statement that Macy & Co. upheld prices on the toilet preparations of Colgate & Co. and spent an unpleasant few minutes with the Victor Co.'s attorney as a result.

Another witness for the plaintiff was Julian Florian, who in 1914 was manager of what was then the wholesale Victor department of I. Davega, Jr., Inc., and who brought to light some alleged dealings he had with Macy after the company had ceased to be a licensed Victor dealer.

Florian testified in the course of his direct examination to the existence of a special arrangement he had made with Macy & Co. running from May 4, 1914, to the Fall of that year, whereby various Victor goods were purchased by the plaintiff at regular retail prices and that subsequently a cash refund was made, such refund being placed in sealed envelopes and carried personally by Florian to Mr. Straus. The deal, it was brought out, followed the introduction of Florian to the Macy storeroom where he was shown a considerable stock of Victor goods and informed that they had been obtained from other sources. Florian admitted that he had been discharged from the Davega employ in December, 1914.

The attorney for the defense secured the admission from Florian that he was "sore" at Mr. Davega and also at the Victor Co., and had sued I. Davega, Jr., Inc., for the loss of his position, finally settling the case out of court.

An Interesting Witness

A particularly interesting witness for the plaintiff was Harry E. Oliver, who shed some interesting light upon the methods adopted by the Macy house for securing Victor goods after May, 1914. Oliver stated that he went to various recognized sources of supply in an effort

(Continued on page 170)

CABINETS

MODERATE PRICES
IMMEDIATE DELIVERY



Cut shows our
new 48"
E Model

Send for circular of our line

Everett Hunter Mfg. Co.
McHENRY, ILL.

**WALL-KANE
PHONOGRAPH
NEEDLES**

*Brilliantone
Steel Needles
Tonofone
Flexible Needles*

*Send for complete
price list to*

MORRIS RICHMOND
1552 Broadway
NEW YORK

DISTRIBUTORS

PROGRESS OF VICTOR-MACY TRIAL

(Continued from page 169)

to secure Victor goods, and had taken from the classified telephone directory a list of dealers in talking machines and called on a number of them, citing names, addresses and, in some cases, dates. He stated that he had a fund of money belonging to Macy & Co. standing under his own name in a bank and had drawn on that fund to pay for Victor machines and records which were billed to him personally and delivered to his office at 215 Fourth avenue. The goods were in turn billed to Macy & Co. by Oliver. The witness testified to some of his experiences in traveling to various cities and towns seeking Victor merchandise, and in the course of a lengthy cross-examination gave other information that was interesting, and in some cases important.

The testimony also included the presenting of depositions from Edward Briggs, secretary and treasurer of the Oliver Ditson Co., Boston, and H. A. Winkelman, manager of the wholesale Victor talking machine department of that company.

Russell C. Downs, who stated that he was employed by the New York Talking Machine Co. as stock clerk from December, 1913, to the Spring of 1916, was also called as a witness and gave some testimony of value. He stated, for instance, that Victor records had been marked for identification and that he could tell the name of the dealer from such markings. The defense was interested particularly in Downs' admission that a special premium was paid upon sales of the Ru-Stella machine offered by Macy & Co. as their own product.

Benj. Switky, who for some years operated as a Victor jobber, was one of the witnesses called by the plaintiff and told of the efforts made by the Victor Co. representatives to trace back goods that had been purchased by Macy & Co., and something of his relations with the company while acting as one of its wholesale representatives.

Two days were devoted to the direct examination and cross-examination of Mr. Switky in order to bring out various points in his relationship as a distributor with the Victor Co. and its representatives, and with the members of the retail trade.

Former Dealers Called

Another witness for the plaintiff was Ellen Byrne DeWitt, formerly a licensed Victor dealer, who answered the questions put to her in a manner that frequently aroused merriment in the courtroom. Max A. Fischer, also a former Victor dealer, who apparently had many business dealings with Macy & Co., was likewise called to the stand and testified at length.

Marie B. Kaplan, another erstwhile Victor dealer, also spent some hours in the witness chair, her testimony being followed by that of her attorney, D. W. Steele, who recited the results of several alleged visits to Camden.

The plaintiff also called to the stand a number of past and present employes of Macy & Co., who were connected with, or had knowledge in some way of, the methods adopted by the Macy concern for securing supplies of Victor goods after they had been cut off the dealers' list. Among these were Rita A. Smith, a former stenographer; Barbara Sowa, Mrs. Wil-

liam Gilroy, Michael Peyser and Philip Ochsenhaut. The testimony of these witnesses was devoted chiefly to identifying sales slips and receipts and detailing the means by which purchases of Victor goods were financed and checked and the goods handled.

Court Adjourned Until February 14

The court was adjourned on the afternoon of February 9, to resume on February 14. Up to the time of adjournment nearly 1,800 typewritten pages of testimony had been placed on file. It is expected that the plaintiff will wind up its case during the coming week, when the defense will take the stand and present its side. It is not improbable that the trial will last at least another month.

MUSIC TEACHER ADDS TESTIMONY

Value of Talking Machine in Public School Musical Instruction Outlined by Russell S. Gilbert in Letter to New York Newspaper

The value of the talking machine in teaching music in the public schools is forcefully explained by Russell S. Gilbert in a recent letter to The Sun, New York. As Mr. Gilbert is a teacher of music his testimony should bear weight as coming from one who has had actual experience. His letter follows:

"To the Editor of The Sun.

"Sir: I have taught music in New York for eight years and have had pupils from both the private and public schools. Both are well drilled in the technique of music, but lacking the music itself.

"Owing to the size of the classes the teachers are forced to teach by rule only. The result is that the children can recite rules in music as they recite rules in grammar. They apply the grammar because they are speaking every day. They do not connect the rules of music with music itself unless they are taking private instruction in music and can apply the rules.

"The children are taught to find out what key the piece is written in by a series of arithmetic, counting from the last sharp or flat. The rule is correct if the piece is in major, but gives the wrong answer if it is a minor key. What good are such rules? The mere writing of chords on the blackboards does not instruct the

THE VECTOR COMPANY
Electrical and Mechanical Engineers
Experts on designs, plant equipment and production.
Estimates furnished for complete equipment of recording laboratories and manufacturing plants.
Phonographs, Electric Motor Drives, Components and Records.
Correspondence Invited
THE VECTOR COMPANY
 225 Fifth Ave., New York Tel. Madison Sq. 9305

children any because they cannot hear them and they would fail to recognize one of them if it were played. I know, for I have tested dozens of them.

"Let the technique of music be left to the private teacher and let the schools devote the time to actual singing and hearing of the best music, the history of music and musicians, etc. The work of spreading the knowledge of the best music by means of the talking machine, as done in the schools here, is producing splendid results."

ADD MATRIMONIAL LITERATURE

Minister Suggests Records of Love-Making in Speech Giving Advice on Marriage

In an address before a meeting of the ministers of Toledo, O., one of the clergymen of that city took occasion to remark in the course of his address on marriage and the kind of a wife to choose, that the husband should never cease to court his wife. He also declared that it would be a good idea for every girl to secure a record of the endearing words spoken by the ardent lover during the period of courtship. Then, a few years later, she could show him what he used to be and remind him of his better days by playing the record on the family talking machine.

As for logic of the good divine's words, life is too short to argue. But, it might be whispered, our Toledo friend may, if he doesn't look out, start something. Has anyone any views on the matter? Don't keep them secret, if you have.

HOW AN ENTERPRISING DEALER USES EXTRA WALL SPACE



Clever Mural Sign Used by the Scanlan Co., St. Joseph, Mo.

The advertising department of the Columbia Graphophone Co. received recently an interesting photograph from the Scanlan Hardware Co., South street, St. Joseph, Mo., Columbia dealer, showing how this enterprising merchant is using the extra wall space in his establishment. The artistic sign which is presented in the accompanying illustration was painted by George Hoffman, one of the clerks at the Scanlan store, and this unique publicity was commented upon favorably by visitors to these warerooms.

ACME-DIE

- CASTINGS -

ALUMINUM-ZINC-TIN & LEAD ALL TYPES

Acme Die-Casting Corp.

Boston Rochester Brooklyn N.Y. Detroit Chicago

Pat. Dec. 1.
1919-2 other
patents appl'd
for.

The New Automatic Cover Support

Noiseless in Operation
 Foolproof in Construction
 Made With Both Bent and Flexible Hinges
 Heavily Nickel Plated or Specially Finished to Order
 Send \$1 for 3 samples—one of each model
 WRITE FOR CATALOGUE

A. F. Zega Mfg. Co.

Main Office:
810 Broad Street
Room 601
NEWARK, N. J.

Factory:
77-81 Mill Street
BLOOMFIELD, N. J.

Victor Dealers of the Rocky Mountain Region

Put Your Selling Problem Up To Us

Our expert staff of Victor merchandising specialists are at your command at all times—each offering you a real service in helping you to solve your retail problems.



Our five floors devoted exclusively to Victor goods, and to the needs of Victor dealers, are admirably equipped to offer a genuine service.

We Back the Dealer Who Backs the Victor

Knight-Campbell Music Co., 1608 Wynkoop Street, Denver, Colo.

TO DISTRIBUTE WALL-KANE NEEDLES

Maurice Richmond, Inc., New York, Organized for That Purpose

Maurice Richmond, head of the Maurice Richmond Music Pub. Co., Inc., and for over twenty-three years general manager of the Enterprise Music Supply Co., has organized a company for



Maurice Richmond and F. H. Burt

the purpose of taking over the distribution of the well-known "Wall-Kane" steel needles. The company will operate under the firm name of Maurice Richmond, Inc.

Associated with Mr. Richmond, who will act as general manager of the concern, is F. H. Burt. Mr. Burt has been in the music business in various capacities for a period of years and more recently has given particular attention to the needle business and its market. Under his direction the new organization will endeavor to place before the trade, monthly, a series of ideas for the promotion of sales.

In speaking of his new acquisition Mr. Richmond said: "I believe the needle business is still in its infancy. The market is constantly growing and as our product is a well-advertised one, requiring little sales effort, we feel we have acquired a substantial proposition."

At present the executive offices of the firm are at 1552 Broadway, but about March 15 it will move into its new home at 1658 Broadway, near Fifty-first street, New York City.

PLYMOUTH PHONOGRAPH CO. ELECTS

PLYMOUTH, Wis., February 5.—The Plymouth Phonograph Co. held its annual meeting on February 1 and re-elected its board of directors as follows: H. W. Bolens, J. B. Thierry, J. H. Wheeler, W. H. Thommen and Frank L. McIntyre. The directors met subsequently and re-elected Mr. Thommen president and Mr. McIntyre secretary-treasurer.

HOLD BUBBLE BOOK PARTIES

Bubble Book Sales Service Introduces Novel Publicity Idea—Parties Attended by Dealers

The Bubble Book Sales Service, New York, distributor of Bubble Books, has instituted an unusual campaign featuring these books. Incidental to the Toy Fair, which opened last week in New York, and which will continue until March 12, this company is giving a series of Bubble Book parties in the auditorium of the Bush Terminal Building, 130 West Forty-second street, New York, where the company has its executive offices.

The parties, which are given daily, were inaugurated on February 7 and have proven very successful. A talking machine is used to play the Bubble Book nursery rhymes, while twenty-five child actors pantomime the story on the stage in conjunction with the reproduction of the record.

According to present plans the Bubble Book Sales Service will co-operate with talking machine dealers throughout the country in giving similar Bubble Book parties. To date more than forty of these Bubble Book parties have been arranged in the leading trade centers and the dealers are enthusiastic regarding the results obtained from this unique publicity idea. These parties have not only resulted in substantial sales of Bubble Books, but have served to interest the children and their parents in the musical value of the talking machine.

Invitations were sent to talking machine dealers everywhere by the Bubble Book Sales Service to attend the unique series of parties now being given in the auditorium of the Bush Terminal Building, and many successful dealers have advised the company that they will attend.

Paul Zerrahn, formerly field representative of the Emerson Phonograph Co., New York, resigned from this position the first of February.



KICHLER VALANCES

especially designed for the windows of the Talking Machine Dealer. We can reproduce and embroider any trade-mark and any type of lettering.

KICHLER VALANCES will improve the appearance and increase the sales value of your show windows. Write us for our descriptive literature.

THE L. A. KICHLER CO.

717 Lakeside Ave. N. W.

(Dept. W)

CLEVELAND

Eastern Representative—Louis A. Schwarz, 1265 Broadway, New York City

IMPORTANT NOTICE

TO THE

AMERICAN TRADE

The Sterno Manufacturing Company
 19 CITY ROAD LONDON, E. C. ENGLAND

Manufacturers of the world known COMPACTOPHONE—the most complete portable gramophone extant—beg to announce the conclusion of arrangements for the EXCLUSIVE SELLING RIGHTS IN THE UNITED STATES OF THE

High Grade Motors Manufactured By **Mermod Freres** St. Croix Switzerland

WONDERFUL MECHANISM

These motors represent the acme of workmanship and quality. Each part is made to the finest gauge limits and assembled to run with the precision of a watch—silent and true. Messrs. Mermod Freres is an old established Swiss manufacturer. Back of their motors are years of hard practical experience. The experimental stage was left behind a decade or more ago. Reliability and quality are therefore assured.

DIFFERENT MODELS

Mermod Freres motors comprise several types—single and double spring worm and pinion-gear drive, the very latest and scientific method of construction.

CONSULT US

Before placing your orders elsewhere consult us as to prices and terms of trading. We are out for quick shipments and prompt delivery direct from the factory to the buyer.

SPECIAL TERMS TO JOBBERS

Within the near future it is proposed to establish
A CENTRAL DISTRIBUTING DEPOT IN NEW YORK
 Meanwhile trade inquiries should be directed to

THE STERNO MANUFACTURING CO.
 19 CITY ROAD LONDON, E. C., ENGLAND

NEW BRUNSWICK FLANGE SIGN

Brunswick-Balke-Collender Co. Introduces Sign for Dealers Which Can Be Attached to the Side of a Building—Artistically Prepared

The advertising department of the Brunswick-Balke-Collender Co., after many requests from dealers, has brought out a new flange-sign which can be fastened against the side of a building. The sign is lithographed in baked-on colors. The sign is of twenty-four gauge steel and one end is turned at right angles, so



Convenient Sign for Dealers

that it can be fastened to a building. The printed matter, in turn, is covered with a weather-resisting varnish and this gives the sign a very high gloss finish. The accompanying photograph will give an idea how the sign will look, but it must be seen in order to be fully appreciated.

A BRIEF COURSE IN MUSIC

The Victor Talking Machine Co., Camden, N. J., is planning to publish in its house organ, "The Voice of the Victor," a series of articles dealing with the structure of music. Taken altogether, these will constitute a brief course in music. They are especially designed to enable salesmen who have no technical knowledge of music to acquire a general understanding thereof, which will help in selling many unfamiliar records. These articles will supplement the Victor salesmanship course given in Camden.

CONGRATULATIONS FOR S. H. JACOBS

Samuel H. Jacobs, advertising manager of the Remington Phonograph Corp., New York City, is receiving the congratulations of his many friends in the trade on the birth of a son on January 31. Mr. Jacobs states that the new arrival resembles the Remington phonograph in the respect that he has both tone and quality, as well as endurance.

STONE CO. HOLDS RAILROAD DANCE

Employees of Vocalion Distributor in Fargo, N. D., Enjoyed a New and Original Form of Terpsichorean Entertainment Recently

FARGO, N. D., February 8.—The employees of the Stone Piano Co., distributor of Aeolian-Vocalions and records, as well as Melodee music rolls, in this city, held a "railroad dance" recently, a novelty that proved very popular with the members of the staff. The order of dance was made out like a railroad time-table, with the dances at fifteen-minute intervals, named according to the cities and towns in which the Stone Co. has established dealers.

The dancers traveled as far West as Billings, Mont., over the Aeolian Line, with A. G. Stanton as "general manager" and George H. Dower as "passenger agent." The party left Stone's Auditorium at 9 p. m. to the accompaniment of a one-step, which took them as far as Casselton, which is just about one step from Fargo. Other stops, each of them Vocalion strongholds, included Valley City, Jimtown, Steele, Bismarck, Mandan, Dickinson, Beach, Glendive, Miles City. The party arrived at Billings at 12 o'clock, promptly on time. Music was furnished by Bill Becker's Track Walkers, and the following Stone employes served in the capacity mentioned: Gene Howell, conductor; Bill Becker, engineer; Bill Shaw, brakeman; Anne Hagen, newsboy; Wes. Smillie, auditor; Maggie Lien, dining car conductor; Edward Stalheim, road master, and Bert Schumacher, ticket agent.

The Stone Piano Co. reports that it did a better phonograph business during January, 1921, than it did in January of either 1919 or 1920. This firm is the North Dakota distributor for the Aeolian-Vocalion phonograph, as well as the Vocalion records.

MICKEL MUSIC CO. OPENS

The Mickel Music Co., of Marshalltown, Ia., opened its exclusive Victor store on February 3. It is located in the heart of the business section, has six exceptionally large booths finished in ivory and blue and the whole store is carpeted with light blue Wilton carpet. Mickel's efficiency expert, Miss Jardine, officiated and little celluloid Victor dogs were given away as souvenirs. The manager of the new store is Warren Stevens.

TO CONVENE IN CHICAGO

An educational convention will be held in Chicago, the third week in March, under the auspices of the Victor Talking Machine Co. According to present plans the affair will be attended by a very large number, representing every section of the country, and the program itself will be of a most instructive and constructive sort.

The Pease Music Store, Tuckahoe, N. Y., is now located in the Plaza Theatre Building. W. J. Snow is manager. The Pathé line is handled.

It's a Difficult Thing

to trim a window with real records.

Tin records also present difficulties, as they cannot be pinned up.

The best way out is to use THE USOSKIN IMITATION RECORD, made of a special card-board stock and looking so like an original record that even the Victor Dog himself gets puzzled as to which is which.

Your jobber will gladly supply you. Ask him for details and prices.

USOSKIN LITHO, Inc.
230 WEST 17th ST., NEW YORK CITY

NEW VAN VEEN INSTALLATIONS

Model Shop and Wholesale Display at Ditson's—New Equipment at Bloomingdale's

Van Veen & Co., Inc., manufacturers of Van Veen hearing rooms, record racks and counters, have installed a model shop and wholesale display department in the headquarters of Chas. H. Ditson & Co., on Thirty-fourth street, New York City. This company has also lately completed a large and handsome talking machine department in Bloomingdale Bros.' New York store. This installation consists of twenty demonstration rooms and occupies a large portion of the third floor of this big store. Leon Tobias, of the Van Veen sales staff, is at present out of town on an extensive trip. Van Veen & Co., Inc., state that Mr. Tobias is sending in a great number of inquiries and is laying out a large number of installations for the dealers. In the majority of the cases these are for dealers who have long planned improvements in their warerooms and have held off the actual work awaiting the signs of an improvement in general business conditions. Many of these dealers feel that business is decidedly on the upward trend and have made plans to have work on installations commenced within the next two or three weeks.

NEW VICTOR STORE IN CRESTON, IA.

McGregor Bros. & Coens, of Creston, Ia., have opened their music department. The department occupies a space fifteen feet by thirty-six feet in the front of the store, with five French booths finished in gray, and the whole department is covered with gray carpet to match. The booths and lobby are equipped with wicker and overstuffed furniture, which adds greatly to the appearance.

John McCormack, the celebrated Victor artist, is due to sail for home on April 19 on the "Aquitania." He will finish up his grand opera engagement at Monte Carlo shortly.



You have probably tried many reproducers hoping to find one which will overcome and eliminate thin, metallic, sharp tones. The STEURER REPRODUCER will satisfy you that we have succeeded in producing roundness of tone, volume, detail and a quality of tone entirely free from nasal or metallic characteristics.

We guarantee satisfaction.
Samples to the trade, \$7.00 each.
Fully covered by patents.

Steurer Reproducer Company, Inc.
158 West 21st Street
New York City

MAIN-SPRINGS

**For any Phonograph Motor
Best Tempered Steel**

1 in. x 10 ft. for Columbia.....	Each	\$0.50
1 in. x 13 ft. for Victor.....	Each	0.50
1 1/4 in. x 18 ft. for Victor.....	Each	0.75
1 in. x 12 ft. for Heineman.....	Each	0.60
7/8 in. x 10 ft. for Col. Pathé-Heineman	Each	0.50
1 1/8 in. x 16 ft. for Heineman	Each	1.20
1 x 16 ft. for Saal or Silvertone....	Each	0.90
1 in. x 10 ft. for Saal or Silvertone..	Each	0.60
1 in. x 16 ft. for Sonora or Brunswick	Each	0.90
3/4 in. x 10 ft. for all small type machines	Each	0.45
1 1/2 in. full size for Edison Disc.....	Each	2.10

SAPPHIRES—Genuine

Pathé very best loud tone genuine, each 15c; 100 lots, \$11.50.
Edison very best loud tone, 15c each or \$12.00 in 100 lots.

MOTORS

Special price on Krasberg motors.
Order right from this ad.
Send for price list of other repair parts.

The Val's Accessory House
1000-1002 Pine St. St. Louis, Mo.

THE AEOLIAN SYMPHONY ORCHESTRA

Among the Vocalion records announced by the Aeolian Co. to be released in March are the first records of the Aeolian Symphony Orchestra. These records are destined to meet with a popular reception. The March numbers include "Ballet Egyptien" and "Praeludium."

VICTOR CO. HONORS WASHINGTON

The advertising department of the Victor Talking Machine Co., Camden, has recently designed a very effective window display for the use of Victor dealers around Washington's birthday. In the center, on a flag-draped mount, is a bust of Washington; at the right, a floor model Victrola; at the left, with a sprig of a cherry tree placed over it, is a card which reads, "Truth—The Victrola Reproduces the Music of the World's Greatest Artists Truthfully." On either side of the bust two records are mounted about four inches from the floor, with the face of the record toward the street. On the top of each is pasted a colored cardboard hatchet.

SONORA PUBLICITY ON LONDON BUS

The Sonora phonograph is advertised to excellent advantage in London, and travelers



How the Sonora Phonograph Is Advertised on the London Bus

around this famous metropolis cannot fail to be favorably impressed with this publicity. Not only does this advertising appear on billboards

APPOINT NEW OKEH JOBBERS

Sonora Phonograph Co. of Philadelphia New Okeh Jobber—Well Equipped to Serve Dealers

W. C. Fuhri, general sales manager of the Okeh record division of the General Phonograph Corp., New York, announced this week that the Sonora Co. of Philadelphia had been appointed distributor for Okeh records in that territory. This company, which was recently formed to distribute Sonora products, has already attained signal success, and the dealers in Philadelphia territory will receive maximum co-operation from the company's sales staff in handling Okeh records.

The Philadelphia Show Case Co., Philadelphia, is no longer a jobber of Okeh records.

NEW BORI RECORDS SOON

Lucrezia Bori is soon to return to the active world of Victor recording artists. Several years ago an operation was performed on her throat which was not immediately successful. She has since, however, recovered entirely and recently made her return debut in "La Boheme" at the Metropolitan Opera House, New York City. Her return to opera is generally felt to be one of the most important events of the current opera season. In the very near future she will make some new Victor records, which will be released probably in the early Fall.

EDISON ARTISTS GIVE CONCERTS

No less than three Edison tone tests were given by Glen Ellison, well-known Edison artist, under the auspices of the Fitzgerald Music Co., Los Angeles, Cal., during the month of January. Zar Hagey, manager of the Edison department, reports excellent results in business from these demonstrations. On Wednesday, February 2, another Edison tone test was arranged for by the Fitzgerald Music Co., in which the inimitable Collins and Harlan appeared.

F. D. HALL TO VISIT JAPAN

CHICAGO, ILL., February 10.—F. D. Hall, of the Hall Mfg. Co., and inventor of the well-known fibre needle bearing his name, leaves for Japan March 10 to close contracts for personally selected bamboo and attend to other matters.

in strategic positions, but Sonora "ads" are seen everywhere on the top of the big buses.

The accompanying illustration shows how prominently the word Sonora stands out on the

HE STANDS BEHIND HIS PRODUCT

B. D. Perkins, Chief Executive of U-Sav-Your Mfg. Co., Has Built Up Quite a Business

WARREN, MASS., February 4.—Back of every successful enterprise is usually the personality of some one man who is devoting his every interest to it. It becomes his hobby. Such is the case with U-Sav-Your dressing, back of which is B. D. Perkins, chief executive of the U-Sav-Your Mfg. Co. The Perkins family is well known in this section of the Commonwealth and



B. D. Perkins

the various industries with which they have been identified have prospered due to their enterprise and fair business dealings. In the case of U-Sav-Your cleanser Mr. Perkins experimented for many years and when it met the most exacting requirements as a perfect polish he placed it on the market. His faith in the merits of U-Sav-Your is clearly visualized in the guarantee of the company, which is watermarked into every letterhead—"If our dressing is not the very best polish and cleanser you ever have used we will refund your money." In speaking to a representative of The World, Mr. Perkins stated that although he stands ready to back up this guarantee he has never yet been given the opportunity. Mr. Perkins reports that the sale of this cleanser has grown in increasing proportions since the first day it was presented to the talking machine trade.

AN EFFECTIVE VICTROLA WINDOW

NEW HAVEN, CONN., February 9.—The Loomis Temple of Music, of this city, recently ran a very effective Victrola window display. Five floor models were placed across the window, fairly well back from the front. Between these and the street a collection of seven handsomely mounted portraits of Victor artists was placed. Ribbons ran from these to the sound chamber of the Victrola located in the center of the window. On the panels, at the back of the window, several large portraits of other famous Victor artists appeared.

IMPORTANT LETTER TO TRADE

The Phonomotor Co., Rochester, N. Y., manufacturer of the Phonostop, has advised the trade that it is in no way connected with a company bearing a similar name located in Brooklyn, N. Y. The name "Phonomotor" has been registered in the United States Patent Office and the Phonomotor Co., which is owned by W. F. Hitchcock, has attained signal success in the sale of its products to the talking machine trade.

George Feldman has purchased the Columbia grafonola agency and music store formerly conducted by Otto P. Osmers, at 7604 Fifth avenue, Brooklyn, N. Y., which will be continued under the name of "The Music Lovers' Shop."

WORLD'S CLASSIFIED ADVERTISING

Any member of the trade may forward to this office a "Situation" advertisement intended for this Department to occupy a space of four lines, agate measure, and it will be inserted free. Replies will also be forwarded without cost. Additional space will be at the rate of 25c. per line. If bold faced type is desired the cost of same will be 25c. per line. Rates for all other classes of advertising on application.

SALESMAN WANTED to handle popular-priced talking machines on commission basis as a side line. See our advertisement in this issue. The Charmaphone Co., 39 West 32nd St., New York City.

WANTED—Position as sales manager for large well-known concern manufacturing or distributing phonographs or phonograph products. I have been sales manager of one jobbing concern doing a million-dollar business a year and because of illness gave up position. I am 31 years old, American, with six years' phonograph experience. Only offers of high-grade positions with assured future will be considered. "Box 901," care The Talking Machine World, 373 Fourth Ave., New York City.

WANTED—Experienced phonograph and cabinet salesman. One who has had experience and has trade established. Will pay good salary and commission to live wide-awake man. State full particulars in first letter. Address "Box 902," care The Talking Machine World, 373 Fourth Ave., New York City.

POSITION WANTED—Young man of excellent manufacturing and executive experience and ability, with A-1 record, wishes to connect with some phonograph concern. Now assistant superintendent of phonograph plant. Desires change for permanent connection. "Box 905," care The Talking Machine World, 373 Fourth Ave., New York City.

POSITION WANTED—Sales manager and executive, now employed, desires to make change; 15 years' experience in United States, Canada and Europe with two of the largest phonograph companies. Successful record in selling, advertising, factory supervision, sales organization and the handling of men. "Box 907," care The Talking Machine World, 373 Fourth Ave., New York City.

HAVE opening for salesmen calling on musical trade, either part time or full time. "Box 906," care The Talking Machine World, 373 Fourth Ave., New York City.

WANTED—Young man, good average education, with aptitude for figures and knowledge of the retail Victor record business, to work in wholesale record ordering department of a large Victor jobber. Good prospects. In answering give age, references and salary expected. "Box 909," care The Talking Machine World, 373 Fourth Ave., New York City.

POSITION WANTED—Retail talking machine and record salesman, now employed, having had four years' experience, desires to make change. Address "Box 895," care The Talking Machine World, 373 Fourth Ave., New York City.

DEPARTMENT MANAGER WANTED—Good opening for man of ability and talking machine experience. Must be competent to undertake entire management of Victrola department in large city store and increase volume of sales. Address, stating qualifications, "Box 896," care The Talking Machine World, 373 Fourth Ave., New York City.

VICTROLA SALESMAN WANTED—One of experience and proven ability, who can direct the work of other salespeople, place record orders and, above all, stimulate sales. Good proposition in medium-sized city for right man. Address, stating qualifications, "Box 897," care The Talking Machine World, 373 Fourth Ave., New York City.

WANTED—Specialty men and accessory houses to handle our line of record envelopes and pockets with the talking machine trade. Some very desirable territory still open. We are the largest producers of this line to-day and have most attractive prices and prompt delivery. Address J. L. Gillespie Co., 237 Fifth Ave., Pittsburgh, Pa.

WANTED—Sales representative, located permanently in either Baltimore or Washington, to handle a real quick moving line of phonograph records in the State of Maryland and the District of Columbia. To the man with real selling ability and experience an opportunity is offered to make real money and a big future. Write us at once, giving full particulars and an appointment will be made promptly. Newton-Elting, Inc., Trenton, N. J.

OPPORTUNITY FOR EXTRA COMMISSION. Men now selling phonographs or benches will find it entirely profitable to sell our popular line of pianos and players. Fine as side line. Address Opportunity, "Box 848," care The Talking Machine World, 373 Fourth Ave., New York City.

WANTED—Furniture and phonograph salesmen to handle our line on commission basis. American Talking Machine Co., Inc., Bloomsburg, Pa.

SALESMEN WANTED—If you have had at least four years' retail experience in the talking machine and piano business we can use you. The positions we have open are for the type of men who know how to present a high-class proposition in a strictly high-class manner. We do not want amateurs. You will have to travel. Drawing account against commission will be allowed you after you have proved to us that you are the man capable of presenting our proposition. This position is good for \$5,000 the first year, provided you lend us your entire time. The concern for which you will work has been in business over 40 years and enjoys an unquestioned reputation throughout the music industry. Please outline to us your qualifications for fulfilling this position in first letter. Address your reply to "Box 898," care The Talking Machine World, 373 Fourth Ave., New York City.

WANTED—Position as manager of phonograph department or store in Western Pennsylvania. Can furnish best references; eleven years' experience as manager and salesman. Address H. C. Hornberger, 720 Clara Ave., St. Louis, Mo.

YOUNG MAN with eight years' experience wishes to connect with some reliable concern as either salesman or manager. Box "886," c/o The Talking Machine World, 373 Fourth Ave., New York City.

For Sale—Elegant, Clean, New Stock

Business opportunity worth while
Pianos and general musical merchandise. Business located in Wichita, Kansas. Present owner wishes to retire from active selling end of business and will contract with the purchaser of this establishment to carry all instalment paper on very attractive basis. Will require about \$18,000 to \$20,000 to handle deal. Might consider selling half interest to thoroughly reliable experienced piano man. Have good lease and elegant location. Fully equipped in every respect. Doing good business. Address Mr. Wyotte Alvin, 1444 Park place, Wichita, Kansas.

RECORDS FOR SALE

1,500 standard lateral cut records, not over five of a number and no war numbers. Will sell from 200 to 300 at 37½ cents each net. 500 or over at 35 cents each net. Cash. Player-Tone Talking Machine Co., 967 Liberty Ave., Pittsburgh, Pa.

FOR SALE

Mr. Piano Merchant. Are you looking for a new location? A music store in town of five thousand, located in the wealthiest territory in the State of Wisconsin. Practically without competition and doing a fine business in pianos, phonographs and small goods. This store is in a cash territory. The building is strictly modern with fine show windows and the best location in town. Present owner has the agency for several standard makes of pianos, phonographs and records. Small goods will pay all overhead expenses and show a profit. Rent reasonable. If interested, write G. W. G., care The Talking Machine World, 373 Fourth Ave., New York City.

RECORDING

Established New York laboratory prepared to take on limited amount of outside recording. Full particulars on application. Write Box "899," care of The Talking Machine World, 373 Fourth Ave., New York City.

EXCEPTIONAL OFFER

Several hundred new Emerson records and other accessories at a bargain. Everett Hunter Mfg. Co., McHenry, Ill.

CABINETS

Beautiful new design in mahogany, oak and walnut. Send for circular. Everett Hunter Mfg. Co., McHenry, Ill.

FOR SALE

2,500 German imported Odeon records, 11 in. and 12 in. All opera selections, sung by famous artists. Will sell the lot or in parts; a few million of the Truetone and Puritone needles, in metal boxes or packages, at a very low price. Box "903," care The Talking Machine World, 373 Fourth Ave., New York City.

CABINET FACTORY

Factory will make estimates on specially designed or standard talking machine cabinets. Plant equipped to render exceptional service. Price right. Write at once for estimates. Box "901," care The Talking Machine World, 373 Fourth Ave., New York City.

FOR SALE

400 Edison cylinder, two-minute records. Will offer all or a part at a very low price. All in good condition. M. Johnson Co., Valley, Neb.

FOR SALE

\$6,000 buys an established phonograph business. Complete stock of Columbia phonographs and records, also leather goods, kodaks and novelties. For further information apply 130 Washington St., Hoboken, N. J.

WANTED

To purchase talking machine store that has a Victor contract. Address "Box 908," care THE TALKING MACHINE WORLD, 373 Fourth Ave., New York City.

WANTED

We will pay cash for new or used Victrolas styles 4 and 6. Write full particulars with lowest prices. Woodard & Wells, 538 So. Dearborn St., Chicago, Ill.

FOR SALE

Victrolas, Victor Red Seal Records, Victor and Columbia Records. Bargains always on hand. Anything required in the phonograph line at reduced prices. Mandell & Co., 88 Rivington St., New York City.

STORE FOR SALE

Established and well-paying accessory business, handling motors, tone arms and supplies, wholesale and retail, also repair work, for sale on account of other interests. Short hours and very handsome returns on investment. Location, Philadelphia. Cash required, about \$3,500. Present owner will help manage if necessary. Address Box "900," care of The Talking Machine World, 373 Fourth Ave., New York City.

On account of large contracts, I can offer for prompt delivery, high-grade best quality

STEEL NEEDLES

at the following prices, subject to change without notice:

- 10 thousand lots.....40c. per thousand
- 100 thousand lots.....35c. per thousand
- 500 thousand lots.....31c. per thousand
- 1 million lots.....30c. per thousand
- 5 million lots.....27c. per thousand

Packages of 100 needles each, samples on application.

RICHARD EULER
Albion St. and L. I. R. R. ELMHURST, L. I.
Telephone Newton 2401

FOR SALE

Complete Stock Columbia Records. Closing out our Columbia records. Complete stock, in A-1 perfect condition. New envelopes. Contains good stock popular and dance numbers. All new; no cut-outs. Will sell 20 per cent below cost. Tri-State Talking Machine Co., El Paso, Tex.

Quality and Prices

Main Springs (best quality)

- No. 5, 1 in. by 10 ft. for Columbia.....\$4.50 per dozen
 - No. 9, 1 in. by 16 ft. for Victor Oval hole..... .68 each
 - No. 3, 3/4 in. by 10 ft. oval.....2.60 per dozen
 - No. 14, 1 1/4 ins. by 10 ft. oval.....4.50 per dozen
- Prices for other sizes on request.

Motors

- Swiss F. V. B. No. 4 Double Springs; plays four 10-inch records with one winding; 12-inch turntable; top regulator; noiseless running; strong and durable, with all accessories, complete at.....\$4.90
- Worth \$10. Price for sample..... 5.25
- No. 3 "Black Diamond," special spring, plays three 10-inch records, 12-inch turntable, top regulator, complete.....\$3.50

Tone Arms with Reproducers

- No. 1, Universal, good tone, nicked.....\$2.25
- No. 4, Universal, loud and clear, nicked; suitable for good cabinets, complete..... 4.50

Governor Springs

For Victor; High Grade Steel.....\$1.00 per 100

Needles

MAGIC TONE spear shaped, two tones in one. Can produce a very loud tone.....\$0.50 per 1,000
100 in package; 200 in metal box.....\$1.50 per dozen boxes

We Also Have in Stock

- Micas, assorted sizes, per dozen..... \$0.75
- Reproducers only, fit Victor; fine and clear sounding, each..... 1.25
- Stoppers, underneath table, per dozen..... 1.00
- Felts, 10 inches, per dozen..... .85
- Felts, 12 inches; fine green wool, per dozen..... 3.00
- Needle cups, per 100..... 2.00
- Needle cup covers, per 100..... 1.00
- Turntables, assorted, 12 inches; per dozen..... 4.00
- Handles with knobs, assorted, per dozen..... 1.75
- Needle holding screws, assorted, per dozen..... .25
- Needle rests; large size, per dozen..... .60

Repair Parts for All Makes of Machines

Can we send our 1921 price list of accessories? We manufacture a line of Low-priced table and floor phonographs.

The "Wollman Silvertone"

Send for illustrations.

Our model 85, 46 1/2 inches high by 18 inches by 18 inches; Mahogany finish, double motor, loud and clear, complete at..... \$35.00

We guarantee our goods to be just as represented. In addition to the low prices, at which all the merchandise is sold, we offer a special discount of THREE per cent when remittance or deposit for C. O. D. shipments accompanies an order.

Wollman Talking Machine Mfg. Co.

"Reliable Merchants for 25 Years"

560-562 Grand St. Brooklyn, N. Y.

NAME OF COMPANY CHANGED

B & H Fibre Mfg. Co., of Chicago, Will Hereafter Be Known as the Hall Mfg. Co.—Name of Inventor to Be Allied to Product

CHICAGO, ILL., February 9.—Announcement is made this month by the B & H Fibre Mfg. Co. that at a recent meeting of the officers of that company it was decided to change the firm name and that this company will henceforth be known as the Hall Mfg. Co. This was decided upon with a view in mind of standardizing the name of Hall, so that in the future when the name Hall would be mentioned fibre needles would immediately be thought of.

This company is one of the oldest concerns in the West connected with the talking machine industry. Many years ago, when it first came into being, it got its name, B & H, from the partnership then existing between Messrs. Barry and Hall, who founded the business. The fibre needle was originated by Frederick D. Hall, who had in mind something that would tend to bring out all the qualities in a high-class record, but at the same time eliminate surface noise entirely. When he began experimenting Mr. Hall at first used an ordinary toothpick and by means of this, he says, the possibilities offered by a needle made of some material other than metal which would bring out the fine qualities of a record and at the same time modulate the volume and reduce scratching became apparent. Later he hit on the idea of using bamboo fibre, but one of the early difficulties that arose was due to the fact that when it was used on a record with a lot of volume, such as, for example, the "Sextet From Lucia," the terrific vibration would shatter the needle.

Mr. Hall then set out to develop a needle that would withstand the strain imposed upon it by such a record and within a short time he hit upon the idea of running the bamboo fibres through a series of chemical processes which would cause the fibre to hold up. In putting the needle through this chemical process it was discovered that when in use the needle not only held up under any strain, but that it also oiled the surface of the record and this in turn helped in the preservation of the record. From that day to this the sales of the Hall fibre needle have been steadily growing and in all the time it has been on the market it has made friends. It has never been the claim of this company that the Hall fibre needle was adaptable to all kinds of music. They have always maintained that where lots of volume was wanted in a record, such as one used for dancing purposes, the fibre needle is not the ideal, but they have maintained that where ordinary volume is wanted, plus quality of music and minus surface noise, as, for example, in the rendition of high-priced or classical music, nothing can give better satisfaction.

The business has grown to such proportions of late that its magnitude was becoming a great burden for Frederick D. Hall, the inventor, and he soon saw that it was necessary to take new blood into the company. This plan has just been recently carried out and a new board of directors elected, with L. C. Wiswell as president. Mr. Hall will continue to dictate the policies of the company and has been elected chairman of the board of directors. The other officers of the company are taking an interest in the Hall Mfg. Co. as a purely personal matter and their other business connections in the trade will have no bearing upon their official duties in the Hall Mfg. Co. The general manager of the Hall Mfg. Co. is, as before, H. J. Fiddelke.

The Hall Mfg. Co., basing its opinion upon the phenomenal growth of the business in the past two years, has come to the conclusion

SALES REPRESENTATIVE

We would like to represent several well-known firms in the East manufacturing talking machine motors and accessories Alsop Engineering Co., 200 West 72nd St., New York City.

that there is bigger business ahead than ever before. With this end in view Mr. Hall has decided to secure a larger amount of raw material. In order to secure the desired quality of material to uphold the standard of the Hall fibre needle some one with a knowledge of requirements must make a personal selection of the raw materials. Mr. Hall will, therefore, set sail for Japan on March 10 and visit the bamboo markets of the Far East to place orders for future deliveries.

EFFECTIVE EMERSON PUBLICITY

Attractive Advertising Now Appearing in Newspapers—Featuring Latest Releases

The Emerson Phonograph Co. has resumed its effective advertising campaign in some of the leading cities throughout the country, using good-sized space in several important trade centers where Emerson distributors are located.



The campaign is meeting with pleasing success and the distributors and dealers are enthusiastic over the results received from this publicity.

This copy features some of the hits on the current Emerson releases and there is a distinctive and unique character to the text which gives the Emerson advertising individuality. In a recent advertisement, in which the accompanying illustration is used, the following Emerson artists were featured: Eddie Cantor, Irving Kaufman, Arthur Fields, Plantation Dance Orchestra and the Merry Melody Men.

NOW WITH OPPENHEIMER-ALSOP CO.

The Baldauf-Rosenblatt Co., of Oskaloosa, Ia., has consolidated with two other stores in its town and in the future will be known as the Oppenheimer-Alsop Co. Plans are being prepared for a five-booth department. H. Graves is manager of the department.

"The Music Without the Blur!"

This ideal of talking machine manufacture is attained more nearly than by any other, in the construction of the

MARVELOUS MAGNOLA
"Built by Tone Specialists"

"Magnola's Tone Deflector eliminates the scratch"



Watching the Music Come Out

We want to show you how to make money with MAGNOLA; and how MAGNOLA is the best buy on the Talking Machine Market to-day.

Send us your name and let us send you some real Talker Tips.

MAGNOLA TALKING MACHINE COMPANY

OTTO SCHULZ, President

General Office Southern Wholesale Branch
711 MILWAUKEE AVENUE 1530 CANDLER BLDG.
CHICAGO ATLANTA, GA.



EUROPEAN HEADQUARTERS

2 GRESHAM BLDG., BASINGHALL ST., E.C. LONDON



W. LIONEL STURDY, MANAGER

Need for Special Efforts to Develop Trade—Public in Non-Buying Mood—British Industries Fair May Be Assimilated—Gramophone Association to Meet and Dine—Sonora Models Attract—News From Far East—Winner Products to Be Exhibited—The Algraphone Talking Machine Makes Its Debut—Lower Record Rates on Railways Refused—New Zonophone Records—Complete Records of Opera "The Pirates of Penzance" Introduced—Interesting Budget of News of the Month

LONDON, E. C., February 3.—In these days, when the elements of business progress are overclouded and set back by causes more or less beyond control, there's need in the thought that manufacturing and wholesale traders at least realize the urgent necessity of making special effort to enliven sales. The school of publicites tells us that the best, indeed the only, tonic is advertising along certain approved lines. Very true, up to a point. But undoubtedly supplemental assistance is needed to encourage purchases of musical instruments. This is so far recognized that many British musical houses have arranged so-called "sales," meaning that by wholesale price reduction they hope to awaken the public from the lethargy into which it has fallen.

This preamble brings one to the fact that 'twere useless to deny U. K. trade conditions are somewhat unhealthy. In many piano and other factories short time only is being worked and in the gramophone industry many hundreds of workpeople find themselves with nothing to do. There is much distress in labor circles and not

a little anxiety among employers who, I am glad to say, are doing everything possible to mitigate hardship.

In general industrial circles the position is exceedingly bad. Apart from hundreds of thousands on short-time work, about 1,000,000 people have registered at the labor exchanges as being unemployed. Its bad effect on industry, and the musical instrument trade in particular, is too obvious to mention.

One other aspect of the situation cannot, however, be overlooked. It is that the public is undoubtedly withholding its money pending a general reduction of prices. This expectation is fully justified by a pretty big move in that direction already. "Sales" are the order of the day. There have been one or two in the gramophone trade and many price reductions were made during the Autumn. Further reductions may be in sight, but I do not think the trade can bank upon anything very material in this way, though as I write information reaches me of a reduction to 2 shillings 6 pence in the price of Coliseum records.

The record trade, comparatively, is in better shape than the instrument side, notwithstanding that many dealers are offering some rare bargains in machines.

Trade is likely to receive a nice flip by the opening of the British Industries Fair, February 21 to March 4, at the White City, London. In the musical instrument section there are about fifty exhibitors, fairly representative of every side of the industry. Some firms could not be accommodated with space, they having ignored the advice to make early application. The Board

of Trade has worked splendidly towards making known the business attractions of the exhibition and continuous press publicity throughout the Empire will result in a really big attendance of buyers from all parts. The value of the fair may be gauged by the fact that at least one gramophone manufacturer is still busy following up prospects and executing orders placed by trade visitors to last year's exhibition.

The Gramophone Association

In a twelve-page news letter—an occasional private communication to members of the Association—the recent work of this really active trade organization is chronicled.

The subjects dealt with comprise statistics of imports, exports and re-exports, general trade information, railway rates and conditions, the British Empire Exhibition proposed to be held in London in 1923, trade conditions in Germany, detailed particulars re trade openings abroad, etc., etc. The work of the Federation of B. M. I. on behalf of the gramophone and small goods trade is also duly emphasized. Full and official information on the intricate customs procedure to secure drawback on re-exports has been carefully collated and placed at the disposal of members.

The annual dinner will be held at Frascati's Restaurant, Oxford street, on Wednesday, February 23. This date has been arranged to coincide with the period of the British Industries Fair to give all Provincial members an opportunity of attending.

Gramophone Trade in the Emerald Isle

Advertisements of gramophone wares figure
(Continued on page 178)



"His Master's Voice"

Copyright

This intensely human picture stands for all that is best in music

—it is the "His Master's Voice" trade-mark, and it brings to you, no matter where you are, the very best music of every kind, sung and played by the world's greatest artists—the greatest singers, pianists, violinists, orchestras and bands—all enshrined in the unequalled "His Master's Voice" records

'His Master's Voice'

—the trade-mark that is recognized throughout the world as the

HALL-MARK OF QUALITY

DENMARK: Skandinavisk Grammophon-Aktieselskab, Frihavn, Copenhagen.

FRANCE: Cie. Française du Gramophone, 115 Boulevard Richard Lenoir, Place de la République, Paris.

SPAIN: Compañía del Gramófono, 56-58 Balmes, Barcelona.

SWEDEN: Skandinaviska Grammophon-Aktiebolaget, Drottning Gatan No. 47, Stockholm.

RUSSIA: The Gramophone Co., Ltd., 45, Nevsky Prospect, Petrograd (Petersburg); No. 1 Solyanka, Solyanoi Dvor, Moscow; 9, Golovinsky Prospect, Tiflis; Nowy-Swiat 30, Warsaw; 11 Michailovskaya Ulitsa, Baku.

INDIA: The Gramophone Co., Ltd., 139, Balhaghatta Road, Calcutta; 7, Bell Lane, Fort, Bombay.

Great Britain:

The Gramophone Company, Ltd.

HAYES

MIDDLESEX

ENGLAND

AUSTRALIA: S. Hoffnung & Co., Ltd., Sole Concessionaries of The Gramophone Company, Limited, 163, Pitt Street, Sydney.

NEW ZEALAND: Gramophonium, Ltd., 118-120 Victoria Street, Wellington.

SOUTH AFRICA: Darter & Sons, Post Box 174, Capetown; Mackay Bros., Post Box 251, Johannesburg; Mackay Bros. & McMahon, Post Box 419, Durban; Ivan H. Haarbarger, Post Box 105, Bloemfontein; Franz Moeller, Post Box 108, East London; B. J. Ewins & Co., Post Box 86, Queens-town; Handel House, Kimberley; Laurence & Cope, Post Box 132, Buluwayo; The Argus Co., Salisbury.

EAST AFRICA: Bayley & Co., Lourenço Marques.

HOLLAND: American Import Co., 22a, Amsterd Veerkade, The Hague.

ITALY: A. Bossi & Co., Via Orefici 2, Milan.

EGYPT (Also for the Soudan, Greece and the Ottoman Empire): K. Fr. Vogel, Post Box 414, Alexandria.

FROM OUR LONDON HEADQUARTERS—(Continued from page 177)

well in the Irish newspapers of late. Dublin and Belfast are particularly active and traders in those towns have shown considerable enterprise in bringing before the public the varied "accomplishments" of the gramophone. Sales have been quite up to normal and remain steady.

During last month (Jan.) the Belfast City Council elections took place. Among the candidates for seats were well-known musical people.

Belfast continues to be interested, as, of course, intended, in the readable advertisements of Thos. Edens Osborne, whose new premises are of suitable capacity for an expanding business.

Far-Eastern Musical Instrument Trade

By all reports it would seem that China has really awakened to the musical qualities of Western instruments. The French National Bureau specifically mentions gramophones as being in great demand. Curious to relate, the cheap Japanese makes find little favor, and likewise the American types, owing to high prices. Moderate-sized horn machines of fairly good quality at reasonable prices are selling well. In records, only double-sided will find demand, and these must bear national airs and popular items in the vernacular. Catalogs should be printed in Chinese, says the report.

Expert Mechanics an Asset to Retailer

"The Voice" gives publicity for the first time to the very excellent idea that to properly look

after repairs someone connected with each retail establishment should undergo a course of training at the "His Master's Voice" factories. The company very rightly suggests that its instruments are far too good to be handled by inefficient or amateur workmen. Bad repairs are bad for business; the dealer's client naturally resents faulty work, and realizing the importance of this, the Gramophone Co. is prepared to offer training facilities in the adjustment and repair of its instrumental products. H. M. V. dealers are invited to send an employe to Hayes for that purpose.

Continental Money Values

The extremely low value of continental money in the U. K. is causing much anxiety to our manufacturers. For instance, the importation here of big consignments of musical instruments, parts and accessories, represents a serious menace to British trade, particularly as the German mark is worth but one penny at present exchange rates. Notwithstanding the 33½ per cent tariff, German musical products are delivered right to the buyer's door at prices which, in many instances, approximate closely to the actual British factory prices. This gives an idea how difficult conditions of British trading are to-day. Something must be done to meet the situation, and on behalf of the trade the Federation of British Music Industries is laying a scheme before the Government.

A Most Efficient Automatic Stop

Among the many useful accessories marketed by the Limit Engineering Co., this city, may be mentioned sound boxes, tone arms, case fittings, interior metal horns, and the "Limit" automatic stop. I refer particularly to the latter because it is of an entirely different pattern than the many auto-stops with which the trade here is familiar. The "Limit" eliminates the ordinary brake stop, its function being of threefold value, i. e., start, stop and auto-stop, all in the one device. It is brought into operation by the use of three typewriter keys. The auto key-arm is wonderfully sensitive, responding to the least touch when set to release the brake gear at the finish of the record. Easily fitted to any gramophone, the "Limit" is of compact and nice appearance, thoroughly reliable in action, and, to my mind, a very necessary and convenient equipment of any gramophone. This auto-stop is fathered by many wholesalers, and machines so equipped are very popular with the public.

Gramophone Art—New Sonora Models

Messrs. Keith Growse & Co., U. K. agents for the Sonora, inform me that some new period models will shortly reach them from America. Prints depict these instruments as being of a super-artistic character, true in every detail to the period they represent. They represent most exquisite perfection of workmanship and art, and set a standard with which the British market is more or less unfamiliar. The Keith Growse service is backed up by liberal poster advertising and, what is more important still, this side, attractive newspaper and trade journal publicity.

Brief Trade Paragraphs of Interest

The Federation of British Music Industries will hold its second annual dinner on January 27 at the Hotel Cecil, London. There is promised a large attendance of members of the trade and gentlemen eminent in the world of music.

British concerns having claims against German nationals in respect of pre-war debts are notified that no claim will be allowed by the B. O. T. clearing office after March 31.

Widespread sympathy has been expressed at the news of the death of Mr. Callow, who for over fifty years was in the service of Messrs. Metzler & Co., Ltd., for a good part of the time as head of the musical instrument department.

A very satisfactory feature of progress in Provincial trade circles is the number of Midland and North Country factors who now advertise nationally, as it were. Hitherto they were content with local county trade, but now realize the necessity of expansion. That's the way to do it—advertise!

Charles F. Higham, M. P., told members of the British music industries that they must advertise or stagnate. He said publicity would cure any trade disease—even the "blues." The occasion was the first of a series of lectures arranged by the Federation of British Music Industries.

↓ ↓
"PERFECT
POINTS"



**BRITAIN'S BEST
Gramophone Needle**

(Guaranteed made from High Carbon Steel)

IS MADE BY

W. R. STEEL, of REDDITCH,
Head Office and Works—QUEEN ST.

Scientifically pointed, Hardened and Tempered on the latest up-to-date machinery and plant by skilled craftsmen only.

RESULT:

A FIRST QUALITY NEEDLE far ahead of anything of pre-war quality

INQUIRIES SOLICITED

Special Quotations for Quantities

Manufacturer of all Kinds of Sewing Needles

EDISON BELL **WINNER** GRAMOPHONE RECORDS

CABLE
"PHONOKINO,
LONDON"

ARE THE GREATEST VALUE FOR MONEY PRODUCED IN GREAT BRITAIN
TEN INCH DOUBLE SIDED NEEDLE CUT
PLAY ON ALL GRAMOPHONES

Catalogue contains 4000 Titles by the Premier Artistes, Instrumentalists, Orchestras and Bands of the British Empire

DEALERS PREPARED TO DO BUSINESS ARE INVITED TO COMMUNICATE WITH

Proprietors and Manufacturers, **J. E. HOUGH, Ltd.**, 62 Glengall Road, London, S. E. 15, England

Winner Products at the Fair

Messrs. J. E. Hough, Ltd., announce that they will exhibit a full range of Edison Bell "Discaphones" and Winner records at the British Industries Fair, White City. Invitations have been sent to all their dealers to visit the company's spacious stand, P-32, and as admission is by ticket only, it will be necessary to make arrangements accordingly. This matter has been well looked after by Messrs. J. E. Hough, who are out to ensure a big attendance of dealers at their booth.

"Pirates of Penzance" on "His Master's Voice"

Gramophonic art is progressive; it has yet to reach its zenith. Towards that desideratum we are carried well forward by the operatic issues of the Gramophone Co., Ltd. Many complete albums of records of popular operas have already been issued, including several of the Gilbert & Sullivan series. Of the latter the latest is the "Pirates of Penzance." The complete opera has been beautifully recorded on eleven double-sided Black label discs, which are put up in a special album. This truly important event has been well advertised in the press, and dealers have received for display a finely colored poster and descriptive leaflet. A big demand naturally follows such enterprise and I hear that the company is well satisfied with the resultant sales.

Railways Refuse Lower Rates

Dealers here are just now making a fight through the Association of Gramophone & Musical Instrument Manufacturers and Wholesale Dealers to have gramophone records conveyed by passenger train at the railway company's risk, or else that the records, if they are carried at the owner's risk, as at present, should be accepted at the owner's risk rate instead of at the company's risk rate. So far the railway companies have refused to comply with these suggestions, giving the fragile nature of the records as their reason for demanding higher rates on them.

FROM OUR LONDON HEADQUARTERS—(Continued from page 178)

Music Trades Diary Yearbook and Directory

Under the above title, a very ambitious work has been published by G. D. Ernest & Co., 5 and 6 Duke street, Adelphi, London. As the name implies, it is a book of some trade importance, combining as it does a yearbook of useful commercial information with special reference to the music trades; a three-days-to-the-page diary on good paper with blotter-marker; and more useful still—a directory (officially compiled) of all the U. K. music trade associations and musical societies. Certainly, the Music Trades Diary, Yearbook and Directory, 1921, is the most valuable and useful publication yet offered to the British trade. No merchant's desk is complete without it.

Registration of the British Music Trades

Apart from the Music Trades Diary, Yearbook and Directory, there are two book publications claiming to contain a fairly accurate registration of the British music trades. Notwithstanding, I am informed that the Federation of British Music Industries is compiling a new trade directory. Quite frankly, it seems to me that the funds of the Federation might be more usefully employed than upon the duplication of a work already in existence. On the other hand, if present directories are considered incomplete, the publishers would doubtless be quite prepared to place their existing organization in co-operation with the Federation and thus save funds for other purposes.

New Records by the British Zonophone Co.

Well on time is the issue of the No. 2 February program of records by Zonophone. A wide variety of instrumental and vocal numbers, of which there are twenty-eight all told (fourteen records), will serve to please the dealer and his customers. It might truly be said that there is a record for everyone, so carefully has the list been compiled to cover every musical

taste. If variety is charming, it is no secret to the Zonophone people, and that is a characteristic of their record programs which the trade has come to welcome and expect. Of the many interesting records I would mention particularly "On the Quarter Deck" and "Voice of the Guns" (marches), and "Bo la Bo" (fox-trot), and "When That Harvest Moon Is Shining," all by the famous Black Diamond Band. The Picture Palace Orchestra gives a most acceptable rendering of "La Reine de Saba," selection and waltz. Among the vocals, a good seller will be "Reet oop t'Mark" and "Mary Ann," by Jack Pleasants, whose North Country vernacular and yokel comicalities have made for his great popularity. A favorite is "The Song of My Heart" and "Twas an Old Fashioned Love Song," by Miss Jessie Broughton, and a goodly record is Harold Wilde's "God Gave Me Wonderful Dreams" and "There's Another Little Girl I'm Fond Of."

A New Gramophone Introduced

Under the name "Algraphone," Alfred Graham & Co., of Crofton Park, are offering a new gramophone worthy of special notice. It is of the cabinet type, of pleasing proportions and design, equipped with the new "Graham" spring motor, playing five twelve-inch or eight ten-inch records per wind. The cabinet is fitted with a

(Continued on page 184)

Horn, Hornless and Table-Grand GRAMOPHONES

FOR EXPORT

Please State Your Requirements

REX GRAMOPHONE CO. 2 Elizabeth Place Rivington Street, LONDON, E.C. 2, England
Cable Address "Lyrecodisc, London"

AUSTRALIA.

Herbert G. Polyblank,
SYDNEY,
N.S.W.

BELGIUM.

P. Carton,
Rue Karel Ooms, 11,
ANVERS.

ITALY.

G. Menaboni,
Via S. Sebastiano 2,
LIVORNO.

SPAIN.

Ernesto Verdu,
ALICANTE.

ENGLAND.

A. Waite & Co., Ltd.,
15-17 Figtree Lane,
SHEFFIELD.

*Songster
Talking
Machine
Needles*



Manufactured by **J. STEAD & CO. LTD.**
MANOR WORKS. SHEFFIELD ENGLAND.

LATEST PATENTS RELATING TO TALKING MACHINES AND RECORDS

WASHINGTON, D. C., February 8.—**Sound Box.** Max Krauss, Philadelphia, Pa., assignor to Franklin E. Barr, same place. Patent No. 1,359,713.

This invention relates in general to sound boxes for talking machines but is applicable with great advantage to boxes which comprise a dished or bulged diaphragm; that is to say a diaphragm having a concave-convex form with the convexity facing outward.

The object of the invention is to employ a preferably but not necessarily dished diaphragm with a sound box of special and novel construction, the casing of which embodies, and may be said to be essentially composed of, a vibratory back made of mica or equivalent vibratory substance, so that between the inner face of the diaphragm and the fronting face of said back there exists a sound chamber, essentially and, so to speak, entirely composed of vibratory material, within which the entering sound waves occasion the vibration not only of the diaphragm, but also of the back or rear face of the sound box itself, with the result that the acoustic properties of the sound box as an entirety are greatly improved.

Referring to the drawings, Figure 1 represents a front elevational view of a sound box embodying the invention; Fig. 2 represents a transverse, sectional elevation of the sound box represented in Fig. 1, the dimensions, for clearer illustration, being enlarged, and the section taken on line 2—2 of Fig. 1; Fig. 3 represents in transverse, sectional detail a modified form of the separating ring represented in Fig. 2, removed from the sound box; Fig. 4 similarly represents another modified form of said separating ring, likewise removed; Fig. 5 represents a front, elevational view similar to that of Fig. 1 of a modified form of the sound box; Fig. 6 represents an enlarged

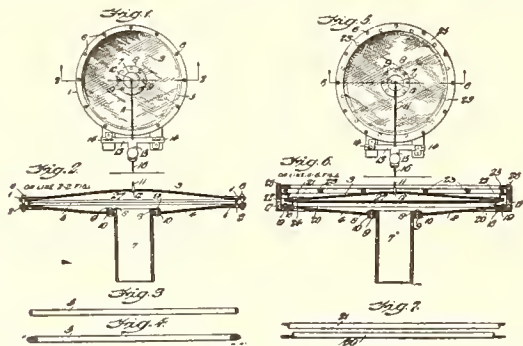

transverse, sectional elevation of the sound box represented in Fig. 5, the section being taken on line 6—6 of Fig. 5; Fig. 7 represents, removed from the casing, a separating ring in the form of two knife-edged rings, which in their mounting, as illustrated in Fig. 6, serve, when desired, to effect the dishing of the diaphragm.

Lid Supporter. Raymond T. Bell and Louis Mandel, Chicago, Ill., assignors to Ben F. Goldstein, same place. Patent No. 1,359,953.

This invention relates to improvements in lid supporters particularly adapted, though not necessarily limited in its use with the lids of sound reproducing machines, and one of the objects of the invention is to provide an improved device of this character which will be of a unitary structure whereby the parts may be all mounted upon the same base and whereby the device may be readily installed and at the same time insure the proper positioning of the parts with relation to each other.

A further object is to provide an improved device of this character having means whereby a predetermined degree of friction may be provided between the parts for maintaining them under normal conditions in their adjusted positions with respect to each other but which will, under abnormal conditions, yield to pressure or force to allow the lid to be shifted. A further object is to provide improved means whereby the friction between the parts may be varied at will.

Figure 1 is a vertical sectional view of a por-

tion of a cabinet having a lid supporter applied thereto and constructed in accordance with the principles of this invention; Fig. 2 is an enlarged detail view of one of the joints of the lid supporter showing the friction-creating surface; Fig. 3 is an enlarged detail sectional view with parts omitted on one end of the base member; Fig. 4 is a side elevation of Fig. 3; Fig. 5 is an end elevation of the parts shown in Fig. 2; Fig. 6 is a modification of the form shown in Fig. 2; Fig. 7 is a view similar to Fig. 1 of another form of the invention; Fig. 8 is an enlarged detail view of

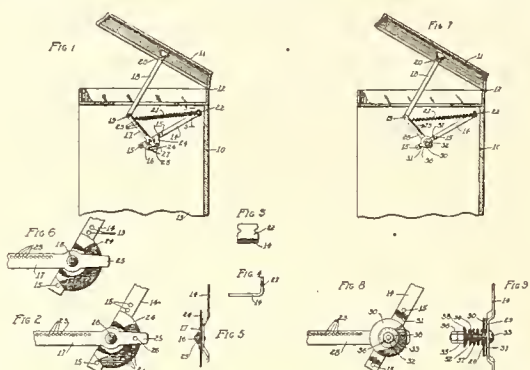

one of the joints of the lid supporter showing the friction-producing means; Fig. 9 is an end elevation of Fig. 8.

Phonograph. John P. Constable, West Orange, N. J., assignor to the New Jersey Patent Co., same place. Patent No. 1,359,966.

This application is a division of a co-pending application Serial No. 35,265, filed June 21, 1915, entitled Phonographs or talking machines, which has resulted in Patent No. 1,265,179, dated May 7, 1918.

This invention relates to phonographs and more particularly to phonographs in which the reproducer is caused to move across the record by mechanical feeding means.

The principal object of the invention is to provide improved means for controlling the mechanical feeding means, to render the same operative or inoperative, and for controlling the movement of the reproducer stylus to and from operative position with reference to the record surface.

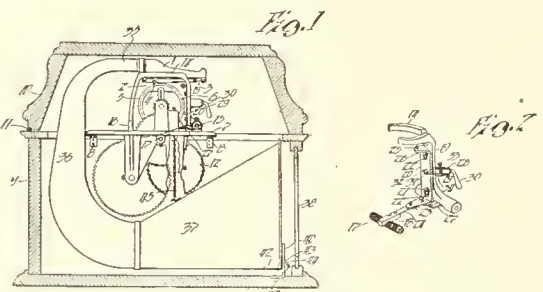

Figure 1 represents a view partly in elevation and partly in section, showing the preferred embodiment of the invention; and Fig. 2 represents a view in perspective of parts of the device shown in Fig. 1.

Repeating Attachment for Sound Reproducers. Albert Bruce Puddicombe, Canton, China. Patent No. 1,361,405.

The present invention relates to a repeating attachment applicable to sound reproducers, and aims to provide a novel and improved device of that character for accomplishing the repetition of the tune played.

It is the object of the invention to provide an automatically operating repeating attachment, whereby, when the needle of the sound box reaches the inner end of the phonic groove of the record, the needle will be automatically lifted off the record, the sound arm then being returned to starting position, and the needle lowered onto the record to enter the phonic groove at the starting point, whereby the operation of the sound reproducer will be repeated, such repetition being continued until the machine is stopped.

A further object of the invention is the provision of a repeating mechanism of the nature indi-

cated which is comparatively simple and inexpensive in construction, which can be readily applied to sound reproducers, and which will operate in a simple yet efficient manner to accomplish the desired results.

Figure 1 is a plan view of a fragmental portion of a sound reproducer, showing the attachment applied; Fig. 2 is a side elevation thereof; Fig. 3

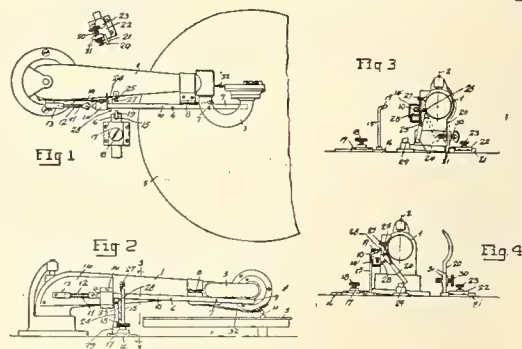

is a cross section of the line 3—3 of Fig. 2 showing the tone arm near stopping position; Fig. 4 is a view similar to Fig. 3 showing the tone arm at the end of its movement, ready to be returned to the starting position.

Phonograph. Newman H. Holland, West Orange, N. J., assignor to the New Jersey Patent Co., same place. Patent No. 1,359,991.

This invention relates generally to phonographs and particularly to memorandum attachments for dictating machines. Attachments of this general character are well known in the art. They enable the dictator to indicate on a prepared memorandum slip instructions for any part of the record, so that the operator or typist on taking up a record for transcription, by referring to the corresponding slip, can have, in advance, full information as to the manner, order, etc., the different matters recorded are to be transcribed.

The object of the invention is to provide an attachment which will not interfere with or retard the free movement of the recorder carriage or obscure the memorandum while the machine is being used.

In the drawing which forms a part of this specification—

Figure 1 is side elevation of a portion of a well-

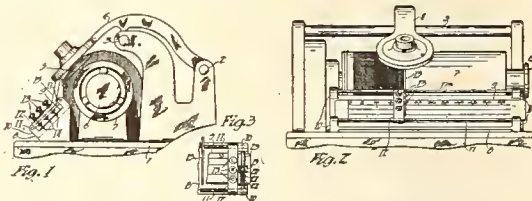

known type of phonograph, showing the improved attachment applied thereto; Fig. 2 is a front elevation of the same; and Fig. 3 is a view showing a modification.

Sound-Modulating Device. Henry K. Sandell, Chicago, Ill., assignor to Herbert S. Mills, same place. Patent No. 1,361,500.

The present invention relates to devices for modulating the tone emitted by sound reproducing devices of the phonograph or gramophone type, wherein the desired sounds are produced by the vibration of a resiliently held diaphragm. It will be clearly understood from the following description thereof, illustrated by the accompanying drawings, in which—

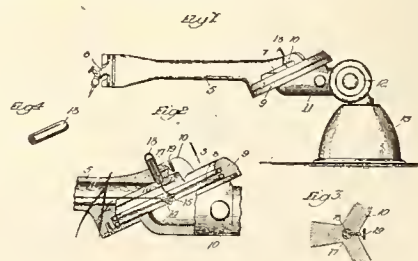

Figure 1 is a side elevation of a phonograph tone arm provided with a sound box containing a vibrating diaphragm as well as with a modu-

LATEST PATENTS RELATING TO TALKING MACHINES AND RECORDS—(Continued from page 180)

lating device constructed in accordance with the present invention; Fig. 2 is a sectional view on enlarged scale through the sound box of Fig. 1; Fig. 3 is a broken sectional view on line 3 of Fig. 2, and Fig. 4 is a detail view of an element of the modulator construction.

Sound Box for Talking Machines. Lambert Salvi, Pittsburgh, Pa. Patent No. 1,361,620.

This invention relates to improvements in sound boxes for talking machines, and particularly of the type utilizing a horizontal disc record.

One object of the invention is to provide an improved pivotal support for the needle arm, whereby the pivots are adjusted to tight positions by a simple construction.

Another object is to provide the needle arm with a pivotal support, comprising a plate having inturred pivotal ends adapted to engage notches in the outer sides of the vertical arms which form

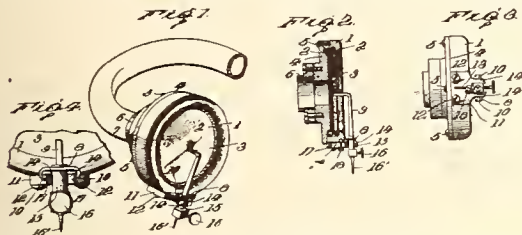

a part of the pivotal support, and to separate these arms by a tapered screw for causing a tight pivotal connection between the needle arm and its support.

A further object is to provide a simple construction of sound box for supporting the sound reproducing disc.

Figure 1 is a perspective view of a sound box embodying the improvements.

Figure 2 is a central sectional view taken longitudinally of the needle arm; Fig. 3 is an edge view looking toward the needle arm support; Fig. 4 is an enlarged top plan view of the needle arm pivot and its support.

Cover Support for Phonographs. Martin C. Bersted, Chicago, Ill. Patent No. 1,361,223.

This invention relates to a cover support for phonographs or the like and has for its object the provision of simple and compact means for securely holding the cover in closed or open position, the cover being readily adjustable by simply grasping the same and moving it to the desired position.

Another object of the invention is to provide a cover support which can be easily and quickly secured in place with the spring detached within the phonograph or other cabinet and the spring thereafter arranged in place and tensioned to operate the cover in the desired manner.

A further object of the invention is to enable the use of a comparatively short spring and to prevent the spring from pulling sidewise when it is stretched during the closing of the cover.

Further objects of the invention are to enable the device to be made principally by stamping the parts out of sheet metal; to make the parts of comparatively small size so that the whole device will be compact and light in weight; to construct and arrange the parts so that the spring will be arranged to operate substantially within the device but without interfering with or interference from any of the parts thereof; to provide enlarged pivot bearings for the pivotal connections, thereby to reduce wear and insure noiseless operation; to provide a novel form of pivot struck up from the sheet metal and of

comparatively large diameter to form an integral substantial and noiseless pivot bearing

Figure 1 is a side elevation of the device applied to a phonograph, the parts being in their closed position; Fig. 2 is a similar view showing the parts in the opened position; Figs. 3 and 4 are enlarged detail sectional views on the lines 3-3 and 4-4 of Figs. 1 and 2 respectively; Figs. 5 and 6 are enlarged detail views illustrating the method of forming one of the pivots, and Fig. 7 is an enlarged detail sectional view on the line

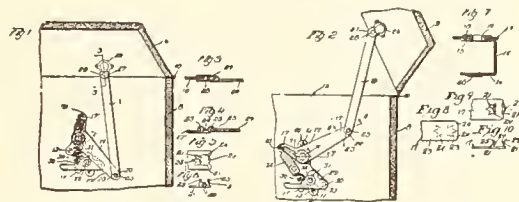

7-7 of Fig. 2; Fig. 8 is a plan view of a portion of a blank plate showing in broken lines where the plate is severed in striking up the lugs; Fig. 9 is a top plan view of the plate shown in Fig. 8 after the first operation of striking up the lugs; Fig. 10 is a side elevation of the plate as shown in Fig. 9.

Phonograph Horn. Edward A. Leet, New York, assignor to the Mirrorphon Talking Machine Co., Inc., Brooklyn, N. Y. Patent No. 1,361,164.

This invention relates to phonographs, and particularly to horns or amplifying passages therefor, and has for its object to provide a horn and tone arm which will produce a louder, purer and clearer tone than previous constructions, and at the same time to reduce the cost of manufacture of such parts so that the phonograph may be sold to the public for less money than those now on the market.

Figure 1 is a front elevation of a phonograph constructed in a preferred manner and containing a horn and tone arm made substantially in accordance with this invention. Fig. 2 is a central vertical section taken on the line II-II of Fig. 1; Fig. 3 is a horizontal section on the line III-III of Fig. 2; Fig. 4 is a horizontal section taken on the line IV-IV of Fig. 2; Fig. 5 is a detailed

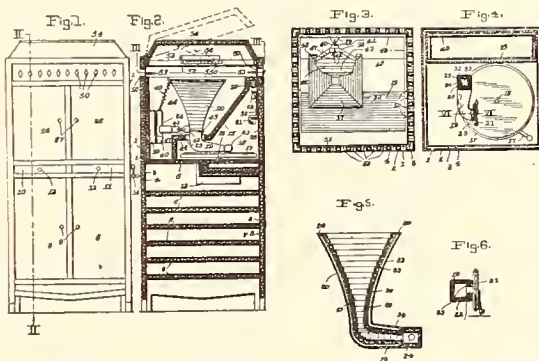

vertical section of the combined horn and tone arm drawn to a larger scale, and Fig. 6 is a section on the line VI-VI of Fig. 4, showing the connection of the sound box to the tone arm.

Phonograph. Nicholas Grey, New Brunswick, N. J. Patent No. 1,361,717.

This invention relates to sound reproducing machines and has for its object the provision of automatic means by which phonograph disc records may be continuously played in succession without interruption of the sound when a change is made from one record to another. A further object is the provision of a disc record which will act as the means for initiating the change from one playing mechanism and record to another similar mechanism and record.

Figure 1 is a plan view of the invention; Fig. 2 is a vertical section of the same; Fig. 3 is a perspective view of one of the devices for disengaging the playing means from one record and for causing a second playing means to engage another record; Fig. 4 is a similar view of the other of said devices, made of opposite hand to that shown in Fig. 3; Fig. 5 is a perspective view of a fragment of the record.

Mr. Grey is also the patentee of a phonograph (Patent No. 1,361,718) which has for its object the provision of simple means, operated by the

tone arm of the machine, for continuously playing records in succession without interruption of the sound while the change is being made from one record to another.

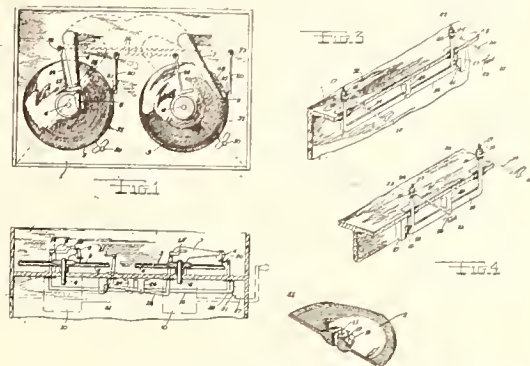

A further object of this invention is the provision of a disc record for speeding up the action of the mechanism which operates to shift the playing from one record to another.

Figure 1 is a plan view of the invention; Fig. 2 is a vertical, longitudinal section and partial ele-

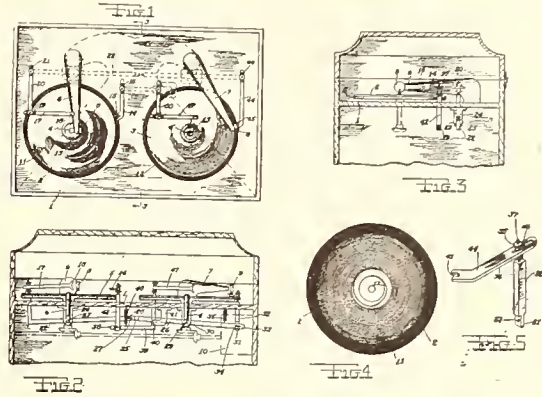

vation of the same; Fig. 3 is a vertical transverse section of the same on line 3-3 of Fig. 1; Fig. 4 is a plan view of one of the improved records; Fig. 5 is a perspective view of one of the diaphragm-holding arms and adjusting means.

Talking Machine Register. James P. Carey, Brooklyn, N. Y. Patent No. 1,359,962.

This invention relates to a talking machine register and has for its principal object the production of a simple and efficient signal so as to prevent the spring of any talking machine from being wound too tightly and thus being broken or having an undue strain put thereon. This register will indicate the number of turns which will be required of the crank in order to wind the spring to the desired tension.

Another object of the invention is to provide an audible signal which will warn the operator

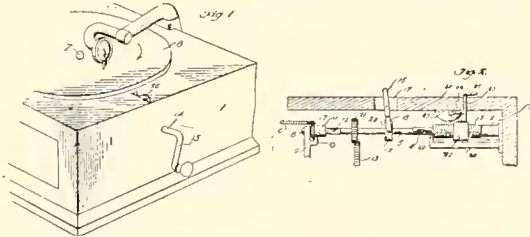

when the spring is about to reach the desired tension if he should not be looking at the indicator dial. In the several drawings: Figure 1 is a fragmentary perspective view of a phonograph showing the invention attached thereto and Fig. 2 is a section taken through the phonograph showing the invention in side elevation.

SCHUMANN-HEINK TO FAR EAST

Schumann-Heink, exclusive Victor artist, will sail, the last of the month, for the Orient, where she will make her initial tour through Java, East India, China, Japan and India. The Victor records which have been sold in the Far East have already created a tremendous prestige there for this famous artist.

REPAIRS

All Makes of Talking Machines Repaired Promptly and Efficiently

ANDREW H. DODIN

28 Sixth Avenue

New York

TELEPHONE, SPRING 1194

PATENTS
Hand Books on Patents, Trade Marks, etc., sent free. Our 74 years of experience, efficient service, and fair dealing, assure fullest value and protection to the applicant. The Scientific American should be read by all inventors.
MUNN & CO., 617 Woolworth Bldg., N. Y.
Tower Bldg., Chicago. 625 F St., Washington, D.C.
Hobart Bldg., 582 Market St., San Francisco, Cal.

Advance RECORD BULLETINS for March, 1921

VICTOR TALKING MACHINE CO.

POPULAR SONGS

18723 Down by the O-hi-O... Billy Murray-Victor Roberts 10
 Marimba (Sweet Marimba Mine)... Billy Murray 10
 18725 I Used to Love You, but It's All Over Now,
 Henry Burr and Peerless Quartet 10
 Dolly (I Love You)... Peerless Quartet 10
 18724 Rose of My Heart... John Steel 10
 When I Looked in Your Wonderful Eyes,
 John Steel 10
 18726 Beautiful Annabell Lee,
 Charles Hart-Elliott Shaw 10
 Louisiana... Sterling Trio 10
 18718 Biddy-Fox-trot... Benson Orch. of Chicago 10
 Somebody-Medley One-step,
 Benson Orch. of Chicago 10
 18719 Honeydew-Medley Waltz,
 Joseph C. Smith's Orch. 10
 Honeydew-Medley One-step,
 Joseph C. Smith's Orch. 10
 18722 Broadway Rose-Medley Fox-trot,
 Original Dixieland Jazz Band 10
 Sweet Mamma-Medley Fox-trot,
 Original Dixieland Jazz Band 10
 18721 Rosie-Medley Fox-trot,
 Paul Whiteman and His Orch. 10
 Honolulu Eyes-Medley Waltz,
 Paul Whiteman and His Orch. 10

VOCAL RECORDS

45216 I Have a Dream... Merle Alcock 10
 I Cannot Sing the Old Songs... Merle Alcock 10
 45215 A Young Man's Fancy... Olive Kline 10
 Roses of Memory... Lambert Murphy 10
 35705 Gems From "Jimmie,"
 Victor Light Opera Company 12
 Gems From "Honey Girl,"
 Victor Light Opera Company 12
 18727 Medley of Irish Jigs... John Kimmel 10
 Medley of Irish Reels... Patrick J. Touhey 10

RED SEAL RECORDS

FRANCES ALDA, *Soprano*

64927 Thoughts of You... Gray-Novello 10
 EMILIO DE GOGORZA, *Baritone*

64928 John Peel... FLONZALEY QUARTET 10
 Interludium in Modo Antico (From "Five
 Novelettes")... Glazounow 12
 AMELITA GALLI-CURCI, *Soprano*

64929 When Chloris Sleeps... Pierson-Samuels 10
FIRST VICTOR RECORD BY A FAMOUS TENOR
 BENIAMINO GIGLI, *Tenor—in Italian*

64933 Mefistofele—Dai Campi, Dai Prati (From the
 Fields)... Boito 10
 JASCHA HEIFETZ, *Violinist*
 (Piano accompaniment Sam. Chotzinoff)

74660 (a) Berceuse (Paul Juon) (b) Valse du Ballet
 Raymonde... Glazounow 12
 MME. LOUISE HOMER, *Contralto—in French*

88627 Samson et Dalila—Printemps qui commence
 (Delilah's Song of Spring)... 12
 EDWARD JOHNSON, *Tenor*

64930 Lassie o' Mine... Bowles-Walt 10
 HANS KINDLER, *Violoncellist*

64932 Nina... Pergolesi 10
 JOHN McCORMACK, *Tenor*
 (Piano accompaniment, Edwin Schneider)

64926 (a) The Next Market Day (b) A Ballynure
 Ballad... 10
 REINALD WERRENATH, *Baritone*

64931 Colleen o' My Heart,
 Gretchen Dick-Arthur A. Penn 10
**FIRST RECORDS BY LA SCALA ORCHESTRA UNDER
 THE DIRECTION OF ARTURO TOSCANINI**
 ARTURO TOSCANINI and LA SCALA ORCHESTRA

74668 Symphony in E Flat Major—Menuetto (Third
 Movement)... Mozart 12
 74669 Symphony in E Flat Major—Allegro (Finale),
 Mozart 12

COLUMBIA GRAPHOPHONE CO.

SYMPHONY RECORDS

49903 Jota de Pablo... Kerekjarto 12
 49912 Humoresque (Dvorak)... Kerekjarto 12
 49870 Maria, Mari! (Marie, Ah, Marie!)... Rosa Ponselle 12
 49758 La Paloma... Riccardo Stracciari 12
 49747 Un Ballo in Maschera. "Re Dell' Abisso" (King
 of the Shades)... Jeannet Gordon 12
 A-6176 Angelus from "Scenes Pittoresques" (Massenet)
 Philharmonic Orch. of New York 12
 Spanish Dance (Moszkowski),
 Philharmonic Orch. of New York 12
 79213 Happy Days... Hulda Lashanska 10
 A-3340 Calling Thee... Virginia Asher-Homer Rodeheaver 10
 Transformed... Virginia Asher-Homer Rodeheaver 10
 A-3341 Bugle Calls in Ragtime... Marconi Brothers 10
 Imp March... Marconi Brothers 10
 A-3342 Barcarolle from "Tales of Hoffmann",
 Clyde Doerr-Bert Ralton 10
 Intermezzo from "Cavalleria Rusticana",
 Clyde Doerr-Bert Ralton 10

POPULAR HITS

A-3344 When the Autumn Leaves Begin to Fall,
 Fred Hughes 10
 Like We Used to Be... Fred Hughes 10
 A-3350 Mandalay... Campbell-Burr 10
 Luana... Campbell-Burr 10
 A-3353 Grieving for You... Marion Harris 10
 Yankee... Marion Harris 10

DANCE RECORDS

A-3351 Margie-Fox-trot... Ted Lewis Jazz Band 10
 Broadway Rose-Fox-trot... Ted Lewis Jazz Band 10
 A-3343 Honolulu Eyes (Intro. "The Rose I Call Sweet-
 heart")—Medley Waltz... Prince's Dance Orch. 10
 June (Intro. "Look What You've Done With
 Your Dog-Gone Dangerous Eyes")—Fox-trot,
 Art Hickman's Orch. 10
 A-3352 Rose-Fox-trot... Paul Biese Trio 10
 Timbuctoo—Song Fox-trot,
 Paul Biese Trio-Frank Crumit 10

NOVELTY RECORD

E-4919 Impressions of Naples. No. 1—Waltz,
 La Nuova Orch. di Napoli 10
 Italian One-step... La Nuova Orch. di Napoli 10
BAND RECORDS FOR COMMUNITY SINGING

A-3107 The Star-Spangled Banner (Key) and Good
 Night, Ladies... 10
 Aloha Oe (Liliuokalani) and O, Come, All Ye
 Faithful (Reading)... 10
 A-3108 America (Smith) and Home, Sweet Home
 (Payne)... 10
 Annie Laurie (Douglass) and Out of the Deep
 (Lohr)... 10

A-3109 Battle Hymn of the Republic (Howe) and My
 Old Kentucky Home (Foster)... 10
 Believe Me, if All Those Endearing Young
 Charms (Moore) and Stars of the Summer
 Night (Pease)... 10
 A-3110 Columbia, the Gem of the Ocean (Shaw) and
 I Need Thee Every Hour (Lowry)... 10
 Sweet and Low (Barnby) and Aunt Dinah's
 Quilting Party (Seeing Nellie Home)... 10
 A-3111 America, the Beautiful (Ward) and A Merry
 Life (Denza)... 10
 Old Folks at Home (Swanee Ribber) (Foster)
 and When Johnny Comes Marching Home
 (Lambert)... 10
 A-3112 Dixie (Emmett) and Drink to Me Only With
 Thine Eyes (Johnson)... 10
 Auld Lang Syne (Burns) and The Little Brown
 Church in the Vale (Pitts)... 10
 A-3113 Old Black Joe (Foster) and Yankee Doodle...
 Juanita (Norton) and Nearer, My God, to Thee
 (Mason) (This record included in regular
 Sample Set)... 10
 A-3114 Massa's in the Cold Ground (Foster) and Jingle
 Bells... 10
 Love's Old Sweet Song (Molloy) and Come,
 Thou, Almighty King (Wesley)... 10
 A-3115 Tenting To-night (Kittredge) and Long, Long
 Ago (Bayly)... 10
 Silent Night (Gruber) and My Bonnie... 10
 A-3116 Onward, Christian Soldiers (Sullivan) and
 Nellie Was a Lady (Foster)... 10
 Levee Song (I've Been Wukkin' on de Railroad)
 and Santa Lucia... 10

THE MID-MONTH RECORDS

A-3347 I Could Have Had You (But I Let You Get
 By)... Nora Bayes-Art Hickman's Orch. 10
 Love Nights... Nora Bayes 10
 A-3346 Rosie... Frank Crumit 10
 My Gee Gee (From the Fiji Isle)... Tod Weinhold 10
 A-3348 Love, Honor and O-Baby... Benny Davis 10
 Look What You've Done With Your Dog-Gone
 Dangerous Eyes... Benny Davis 10

DANCE RECORDS

A-3345 Grieving for You (Intro. "Rose of My Heart")
 —Fox-trot... The Happy Six 10
 Feather Your Nest (Intro. "A Young Man's
 Fancy")—Fox-trot... The Happy Six 10
 A-3349 Caresses—Fox-trot... Vincent Lopez Orch. 10
 Palesteen—Fox-trot... Vincent Lopez Orch. 10
 A-6177 Baby Dreams (Intro. "She Alone Could Under-
 stand" from "Jimmie")—Medley Waltz,
 Prince's Orch. 12
 I'll Be With You in Apple Blossom Time (Intro.
 "When Shadows Softly Come and Go")—
 Medley Waltz... Prince's Orch. 12

SYMPHONY RECORD

79283 Je Sais Que Vous Etes Gentil (It's Our Wed-
 ding Day)... Charles Hackett 10

AEOLIAN CO.

OPERATIC SELECTION (IN LATIN)

52003 Stabat Mater—Quis Est Homo (Who Would Not
 Pity?) (Rossini)—Soprano and Mezzo Soprano
 Vocalion Orch. accomp.,
 May Peterson-Rita Fornia 12

STANDARD SELECTIONS

30116 Out Where the West Begins (Esther Philleo)—
 Baritone—Vocalion Orch. accomp.,
 John Charles Thomas 10
 24013 Colleen Aroon (Strickland)—Tenor—Vocalion
 Orch. accomp. ... Colin O'More 10
 When (Benham)—Tenor—Vocalion Orch. accomp.
 Colin O'More 10

INSTRUMENTAL SELECTIONS

24014 Love's Old Sweet Song (Molloy)—Cello—Piano
 accomp. ... Maurice Dambois 10
 Let the Rest of the World Go By (Ball)—Cello
 Piano accomp. ... Maurice Dambois 10

ORCHESTRAL

36211 Ballet Egyptian (Luigini),
 The Aeolian Symphony Orch. 12
 Praeludium (Jarnefeldt),
 The Aeolian Symphony Orch. 12

POPULAR SELECTIONS

14140 Why Don't You? (From "Afgar") (Tierney)—
 Orch. accomp. ... Hugh Donovan
 County Kerry Mary (Pease-Nelson)—Orch.
 accomp. ... Hugh Donovan 10
 14141 I Want to Be the Leader of the Band (A. Gum-
 ble)—Orch. accomp. ... Harmonizer's Quartet 10
 I Wish I Had Been Born in Borneo (Donaldson)
 —Orch. accomp. ... Harmonizer's Quartet 10
 14142 When You're Gone I Won't Forget (Peter de
 Rose)—Orch. accomp. ... Shannon Four 10
 Mother of Pearl (Ball)—Orch. accomp.,
 Arthur Burns 10
 14143 All She'd Say Was Umh Huh—(MacEmery-
 King-Zany-Van and Schenck)—Orch. accomp.,
 McMurray & Shields 10
 Somebody Put the Jinx on Me (Lada-Spencer-
 Hare)—Orch. accomp. ... Ernest Hare 10
 14144 When You Look Into the Eyes of a Mule
 (Creamer-Layton)—Orch. accomp. ... Ernest Hare 10
 Strut, Miss Lizzie (Creamer-Layton)—Orch.
 accomp. ... Ernest Hare 10

DANCE SELECTIONS

14145 Broadway Rose (Intro. "Dolly, I Love You")
 (West-Fried-Spencer-Wadsworth-Arden)—Fox-
 trot... Al. Jockers' Dance Orch. 10
 Rose (Seymour-Magine-Biese)—Fox-trot,
 Selvin's Dance Orch. 10
 14146 Rosie (Merkur)—Fox-trot,
 Al. Jockers' Dance Orch. 10
 Why Don't You? (From "Afgar") (Tierney)—
 Fox-trot... Al. Jockers' Dance Orch. 10

HAWAIIAN SELECTIONS

14147 Isle of Paradise (Earle-Fiorita)—Waltz,
 Ferera-Franchini-Green 10
 On Hilo Bay (Breau-Levy)—Waltz,
 Ferera-Franchini-Green 10

EDISON RE-CREATIONS

82572 A te grave cagion m'adduce, Aida (Grave cause
 leads me to seek thee here, Aida)—Aida
 (Verdi)—Soprano-baritone, in Italian,
 Marie Rappold and Taurino Parvis
 Su dunque! (Up, then!)—Aida (Verdi)—So-
 prano-baritone, in Italian,
 Marie Rappold and Taurino Parvis
 82206 Ballet Music—Orpheus (Gluck-Ries)—Violin,
 Albert Spalding

Chanson—Méditation (Cottenet)—Violin,
 Albert Spalding

82207 How the Gates Came Ajar (Eastburn)—Soprano,
 Anna Case and Lyric Male Quartet
 Rolling in Foaming Billows—The Creation
 (Haydn)—Bass-baritone... Arthur Middleton
 82208 Ouvre ton coeur (Sérenade Espagnole) (Bizet)
 —Baritone, in French... Mario Laurenti
 So anch'io la virtù magica (Thy magic virtues
 I know)—Don Pasquale (Donizetti)—Soprano,
 in Italian... Consuelo Escobar de Castro
 80587 Der Tambour Der Garde Overture (The Drum-
 mer of the Guard) (Titl),
 American Symphony Orchestra
 Fingal's Cave Overture (Mendelssohn-Bartholdy),
 American Symphony Orchestra

80588 Seek Ye the Lord—Anthem (Roberts)—Tenor
 and mixed voices,
 Hardy Williamson and Calvary Choir
 Will There Be Any Stars? (Sweny)—Mixed
 voices... Metropolitan Quartet
 80589 Fantasia from Simon Boccanegra (Verdi)—Flute
 and clarinet... Pietro Caso and Anthony Giammatteo
 Saxophone Fantasic (Rosebrook)—Saxophone,
 Rudy Wiedoefft
 80590 Love Will Find the Way (H. Von Tilzer)—
 Tenor... Reed Miller
 Wind's in the South (J. P. Scott)—Soprano,
 Betsy Lane Shepherd
 80591 Keep All Your Love for Me (Motzan)—Soprano,
 Leola Lucey
 My Garden of Love (Polla)—Tenor... Lewis James
 Cupid's Frolic (Miles)... Peerless Orchestra
 Ma Bella Charmante—Concert Waltz (Roberts),
 Peerless Orchestra
 80593 Dream of the Tyrolienne (Labitsky)—Violin,
 violoncello, flute and harp,
 Venetian Instrumental Quartet
 O Sole Mio (Di Capua-Vecsey),
 Armand Vecsey and his Hungarian Orchestra
 50706 Aloha Oe—Paraphrase (Liliuokalani-Sodero),
 Sodero's Band
 Our Director March (Bigelow)... Conway's Band
Edison Re-Creations—Bits of Broadway Special

50707 Chili Bean (A. Von Tilzer)... Billy Murray
 My Little Bimbo (Down on the Bamboo Isle)
 (Donaldson)... Aileen Stanley
 50708 Just Like a Rose (Hubbell)—"Good Times"—
 For dancing... Max Fells' Della Robbia Orchestra
 Love Boat (Herbert)—"Ziegfeld Follies of 1920"
 —Tenor... Lewis James and Mixed Chorus
 50709 Honeydew Waltz (Zimbalist)—"Honeydew"—
 For dancing... Lenzberg's Riverside Orchestra
 Japanese Sandman (Whiting)—Fox-trot, for danc-
 ing... Max Fells' Della Robbia Orchestra
 50710 Avalon (Jolson-Rose)—Fox-trot, for dancing,
 Harry Raderman's Jazz Orchestra
 Jene Sais Pa Pa (I Do Not Know) (Fisher-
 Coleman)—Fox-trot, for dancing,
 Harry Raderman's Jazz Orchestra
 50711 Feather Your Nest (Kendis-Brockman-Johnson)—
 Fox-trot, for dancing... Lenzberg's Riverside Orchestra
 Whispering (Schonberger)—Fox-trot, for danc-
 ing... Green Brothers' Novelty Band

Edison Re-Creations—February Special

50725 Humming (Breau-Henderson)—Fox-trot, for danc-
 ing... Orlando's Orchestra
 Palesteen (Conrad-Robinson)—Fox-trot, for
 dancing... Green Brothers' Novelty Band
 50726 Bright Eyes (Motzan-Jerome)—Fox-trot, for
 dancing... Orlando's Orchestra
 Broadway Rose (West-Fried-Spencer)—Fox-trot,
 for dancing... Harry Raderman's Jazz Orchestra
 50727 Home Again Blues (Berlin-Akst)—Fox-trot, for
 dancing... Harry Raderman's Jazz Orchestra
 Sleepy Hollow (Flower-Klickmann)—Waltz, for
 dancing... Green Brothers' Novelty Band
 50728 Rosie (Clarke-Merkur)—Fox-trot, for dancing,
 Max Fells' Della Robbia Orchestra
 Caresses (Monaco)—Fox-trot, for dancing,
 Lenzberg's Riverside Orchestra
 50737 I've Got the Blues for My Kentucky Home
 (Gaskill)—Male voices... Premier Quartet
 Timbuctoo (Kalmar-Ruby)... Al Bernard

EDISON AMBEROL RECORDS

ROYAL PURPLE RECORDS

29070 Serenade (Schubert-Remenyi)—Violin, piano ac-
 comp. by André Benoist... Albert Spalding
 29071 In mezzo al mare (On the Sea) (De Luca)—
 Baritone, in Italian... Mario Laurenti

REGULAR LIST

4185 Down in Chinatown (Meyer-Hulten)—Male
 voices... Premier Quartet
 4186 The Crocodile (Motzan-Akst),
 Imperial Marimba Band
 4187 Tarantella Siciliana (Lucanese)—Accordion, clari-
 net and guitar... The Three Vagrants
 4188 Sleep, Little Babe (Zimmermann)—Yodel song,
 tenor-soprano,
 Fritz Zimmermann and Marcelle Grandville
 4189 Son-o'-Mine (Zamecnik)—Soprano... Elizabeth Spencer
 4190 Speed (Biese)—One-step, for dancing,
 Lenzberg's Riverside Orchestra
 4191 Pickaninny Rose (Sheppard)—Soprano,
 Margaret A. Freer
 4192 Life Insurance Policy... Billy Golden and Joe Hughes
 4193 Jene Sais Pa Pa (I Do Not Know) (Fisher-Cole-
 man)—Fox-trot, for dancing,
 Harry Raderman's Jazz Orchestra
 4194 Haste to the Wedding—Medley of Irish Jigs—
 Accordion... John J. Kimmel
 4195 Les Cloches de St. Malo (The Bells of St. Malo)
 (Rimmer)... Conway's Band
 4196 Sudan (Pollack)—Fox-trot for dancing,
 Green Brothers' Novelty Band
 4197 Perfect Day (Jacobs-Bond)—Xylophone,
 Signor Lou Chiha "Friscoe"
 4198 Sweet Hour of Prayer (Bradbury)—Mixed
 voices... Metropolitan Quartet
 4199 Land of Sweet Erin Medley—Jigs—Violin,
 Joseph Samuels
 4200 Hula Blues (Cunha-Noble)—Fox-trot, for danc-
 ing... Harry Raderman's Jazz Orchestra
 4201 Sighing (Bridges)—Male voices... Crescent Trio
 4202 Lassie o' Mine (Walt)—Tenor... Albert Lindquest
 4203 Romance (David)—Waltz, for dancing,
 Max Fells' Della Robbia Orchestra
 4204 Where-Is-My-Daddy-Now Blues (Motzan-Olman),
 Aileen Stanley
 4205 La Chanson des Nids (Bout)—Fantaisie-Polka—
 Clarinets... Anthony Giammatteo and Fred J. Brissett

ADVANCE RECORD BULLETINS FOR MARCH—(Continued from page 182)

FRENCH RECORDS

- 27196 Le Moulin de Maitre (Master John's Mill) (Borel-Clerc)—Baritone...Torcom Bézazian
27197 Le Dernier Tango (The Last Tango)—Chanson Argentine (Doloire)—Baritone...Torcom Bézazian

PATHE FRERES PHONOGRAPH CO.

"POP" SUPPLEMENT NO. 42

POPULAR VOCAL

- 22493 With the Coming of Tomorrow (Creamer-Layton)—Tenor...Robert Bruce 10
Dearest One (Kahn-Blaufuss)—Tenor and baritone...Lewis James-Elliott Shaw 10
22494 Bonnie Lassie (Bratton-Santly)—Tenor, Charles Hart 10
Mello 'Cello (Williams-Moret)—Baritone, dance rhythm...Elliott Shaw 10
22495 The Arabian Yogi Man (Kendis-Brockman-Russell)—Male trio...Crescent Trio 10
My Mammy (Young-Lewis-Donaldson)—Tenor, Carlton Williams 10
22496 Timbuctoo (Kalmar-Ruby)—Tenor...Billy Jones 10
Something (Theile-Crane)—Male quartet, The Harmonizers 10
20484 Crazy Blues (Bradford)—Tenor, dance rhythm, Noble Sissle 10
Great Camp Meetin' Day (Mikell-Sissle)—Tenor, Noble Sissle 10
22497 Strut, Miss Lizzie (Creamer-Layton)—Baritone Ernest Hare 10
Home Again Blues (Berlin-Akst)—Baritone—Dance Rhythm...Ernest Hare 10

DANCE

- 22498 Humming (Breau-Henderson)—Fox-trot, Joe Gihson and His Orchestra 10
I Never Knew (I Could Love Anybody Like I'm Loving You) (Pitts-Egan-Marsh)—Fox-trot...Joe Gihson and His Orchestra 10
22499 O-H-I-O (O-My!-O) (Yellen-Olman)—One-step, Bennie Krueger and His Orchestra 10
Learning (Tucker-Buffano-Steiger)—Fox-trot, Bennie Krueger and His Orchestra 10
20485 Love Bird (Earl-Fiorito)—Fox-trot, Casino Dance Orchestra 10
The Legend, from "Lady Billy" (Sears-Levy)—Waltz...Casino Dance Orchestra 10
20486 Bright Eyes (Smith-Motzan-Jerome)—Fox-trot, Casino Dance Orchestra 10
Look for the Silver Lining (From "Sally") (DeSylva-Kern)—Fox-trot, Casino Dance Orchestra 10
20487 Persia (Senna)—Fox-trot, Eddie Kuhn and His Orchestra 10
(Kansas City, Mo.)
Now and Then (Spencer)—Fox-trot, Duane Sawyer and His Novelty Orchestra 10
22501 Make Believe (Shilkret)—Fox-trot, Nicholas Orlando's Orchestra 10
Two Sweet Lips (Ager)—Fox-trot, Nicholas Orlando's Orchestra 10
22502 I Never Realized (Gideon)—Fox-trot, Piedmont Dance Orchestra 10
I Lost My Heart to You (Snyder-Merkur-Davis)—Fox-trot...Piedmont Dance Orchestra 10

REGULAR PATHE MARCH LIST

OPERATIC AND OTHER VOCAL RECORDS

- 54064 Old Folks at Home (Swanee River) (Foster)—Soprano...Yvonne Gall 12
54065 Eugene Onyegin (Tschaikowsky) "Prince's Aria," Basso, in Russian...Adamo Didur 12
60086 Carmen (Bizet) "Habenera" (Love Is Like a Wood-Bird)—Contralto, in French, Kathleen Howard 12
Mireille (Gounod) "La Chanson de la sociere" (This is the season)—Contralto, in French, Kathleen Howard 12
59088 Barber of Seville (Rossini) "Una voce poco fa" (A Little Voice I Hear)—Soprano, in Italian, Helen Yorke 12
Lucia Di Lammermoor (Donizetti) "Mad Scene"—Soprano, in Italian...Helen Yorke 12

STANDARD SONGS SUNG IN ENGLISH

- 22475 A Dream (Bartlett)—Tenor...Charles Harrison 10
The Old Refrain (Mattullah-Kreisler)—Tenor, Charles Harrison 10
22474 Wait 'Till Ah Put On My Crown (Arr. by Reddick)—Soprano...Rosalie Miller 10
Leatin' On De Lawd (Arr. by Reddick)—Soprano...Rosalie Miller 10
25050 The Palms (Faure)—Baritone...Percy Hemus 10
The Resurrection (Shelly)—Baritone, Percy Hemus 10
20479 Jerusalem (Parker)—Cornets and trombones, Jules Levy, Jr.'s Brass Quartet 10
The Holy City (Adams)—Cornets and trombones, Jules Levy, Jr.'s Brass Quartet 10
27037 The Song of Volga (Glazounow)—Modest Altschuler, director...Russian Symphony Orchestra 10
Entrée Triomphale Des Boyards (Halvozen)—Modest Altschuler, director, Russian Symphony Orchestra 10
40214 Rhapsodie No. 2 (Part I) (Liszt)—Artur Bodanzky, director...New Symphony Orchestra 12
Rhapsodie No. 2 (Part II) (Liszt)—Artur Bodanzky, director...New Symphony Orchestra 12
22477 Spring Song (Mendelssohn)—Whistling solo, Margaret McKee 10
The Star (Rogers)—Whistling solo, Margaret McKee 10

POPULAR CLASSICS

- 22478 Alice, Where Art Thou? (Ascher)—Violin, flute and piano, Longo Trio—F. Longo, N. Laucella, S. Guidi 10
Kathleen Mavourneen (Crouch)—Violin, flute and piano, Longo Trio—F. Longo, N. Laucella, S. Guidi 10

PARAMOUNT RECORDS

INSTRUMENTAL

- 50039 American Fantasia—Part 1...Creatore and His Band 10
American Fantasia—Part 2...Creatore and His Band 10
50040 Barcarolle (From "Tales of Hoffmann"), Creatore and His Band 10
Blue Danube Waltz...Creatore and His Band 10
50041 Schubert's Serenade—Saxophone Solo, Saxophone With Creatore and His Band 10
Spring Song—Clarinet Solo, Clarinet With Creatore and His Band 10
33077 Blaze Away March (Holzman)—Military Band, Roger's Band 10
Pasadena Day March (Vesselle)—Military Band, Roger's Band 10
33078 Aloha Oe—Cornet Solo—Orch. accomp., Pietro Capodiferro 10
Angels' Dream Waltz (Herman), Paramount Miniature Symphony Orch.

VOCAL RECORDS

- 33076 Carry Me Back to Old Virginny (Bland)—Soprano Solo with Quartet—Orch. accomp., Elizabeth Spencer-Stellar Quartet 10
Old Black Joe (Foster)—Soprano Solo with Quartet—Orch. accomp., Elizabeth Spencer-Stellar Quartet 10
20042 Margie (Conrad-Robinson)—Vocal Solo—Orch. accomp., Aileen Stanley 10
My Mammy (Lewis-Young-Donaldson)—Vocal Solo—Orch. accomp., Aileen Stanley 10
20035 Old Pal, Why Don't You Answer Me?—Tenor Solo—Orch. accomp., Sam Ash 10
Tired of Me—Tenor Solo—Orch. accomp., Sam Ash 10
20038 Honolulu Eyes (Violinski)—Waltz Medley (Intro. "Aloha Oe"), Merry Melody Men Caresses (James V. Monaco)—Fox-trot, Merry Melody Men 10
20043 Old-Fashioned Garden (Intro. "Just Like a Rose")—Medley One-step...Yerkes' Jazzrimba Orch. 10
Rosie, Make It Rosy for Me (Intro. "I'm Saving My Dough for Rae and Me")—Medley Fox-trot...Yerkes' Jazzrimba Orch. 10
20044 That Naughty Waltz—For Dancing, Selvin's Novelty Orch. 10
My Isle of Golden Dreams Waltz, Selvin's Novelty Orch.

OKEH RECORDS

- 4228 Mem'ries of You, Mammy—Popular Blues (Vocal)...Mamie Smith and Her Jazz Hounds 10
If You Don't Want Me Blues—Popular Blues (Vocal)...Mamie Smith and Her Jazz Hounds 10
4229 Broadway Rose—Tenor, orch. accomp., Billy Jones 10
Little Crumbs of Happiness—Tenor, orch. accomp., Lewis James 10
4243 One, Two, Three, Four—Vocal trio, with Hawaiian guitars...Crescent Trio 10
Maui Aloha—Hawaiian guitar duet, Ferera-Franchini 10
4244 County Kerry Mary—Tenor-quartet, orch. accomp., Sam Ash and Shannon Four 10
Bonnie Lassie—Tenor, orch. accomp., Shannon Four 10
4245 Like We Used to Be—Baritone, orch. accomp., Elliott Shaw 10
There Is One Girl (Will She Ever Be Mine) (From the musical play, "Hearts of Erin")—Tenor-quartet, orch. accomp., Sam Ash and Shannon Four 10
4246 One Sweet Day—Tenor, orch. accomp., Lewis James 10
In the Heart of Dear Old Italy—Vocal, orch. accomp., Crescent Trio 10
4247 Pickaninny Rose—Baritone, orch. accomp., Ernest Hare 10
Lindy—Vocal, orch. accomp., Shannon Four 10
4248 Annie Laurie—Scotch ballad...Shannon Four 10
Carry Me Back to Old Virginny—Vocal, orch. accomp., The Three Virginians 10
4249 Turkey in the Straw—Comic vocal—Baritone, orch. accomp., Billy Golden 10
Rabbit Hash—Monologue...Billy Golden 10
4230 June (I Love No One But You)—Fox-trot, Joseph Knecht's Waldorf-Astoria Dance Orch. 10
Drop Me a Line (Intro.: "My Husband's Dearest Friend") (From musical play, "Honeydew"), Orlando's Orchestra 10
4231 Caresses—Fox-trot...Lanin's Roseland Orchestra 10
Hindoo Hop—Fox-trot...Rega Dance Orchestra 10
4232 Palesteen—Fox-trot, Green Brothers' Novelty Band 10
Honolulu Eyes—Waltz, Green Brothers' Novelty Band 10
4233 No Wonder I'm Blue—Fox-trot, Joseph Samuels' Jazz Band 10
Somebody's Eyes—Fox-trot, Harry Raderman's Jazz Orchestra 10
4234 Humming—Fox-trot...Rega Dance Orchestra 10
Rosie—Fox-trot...All Star Trio 10
4235 Rose—Fox-trot...Rega Dance Orchestra 10
Beautiful Faces (From "Broadway Brevities")—Fox-trot...Vernon Trio 10
4236 Show Me How—Fox-trot...Vernon Trio 10
Sweet Love—Fox-trot...Orlando's Orchestra 10
4237 Now and Then—Fox-trot, Harry Raderman's Jazz Orchestra 10
Dolly, I Love You—Fox-trot, Harry Raderman's Jazz Orchestra 10
4238 Lotus Flower—Waltz, Joseph Knecht's Waldorf-Astoria Dance Orch. 10
Midnight—Fox-trot...Orlando's Orchestra 10
4239 Nightingale—Fox-trot...Rega Dance Orchestra 10
Algiers—Fox-trot...Rega Dance Orchestra 10
4240 You're Just Like a Rose (Introducing "Hello, Imagination") (From "Hippodrome Show, Good Times")—One-step, accordion...Perry 10
It Isn't What She Does That Makes Me Love Her (Introducing "I Told You So")—Fox-trot, accordion...Perry 10

GENNETT LATERAL RECORDS

- 2514 God Be With You 'Till We Meet Again (Tomer)—Accomp. by instrumental quartet, Hammond Mixed Quartet 10
Come, Wanderer, Come—Accomp. by instrumental quartet...Hammond Mixed Quartet 10
2515 Carmen Selections—Part I (Bizet), His Majesty's Scots Guards Band 10
Carmen Selections—Part II (Bizet), His Majesty's Scots Guards Band 10
9101 Irish Jigs—Part I...His Majesty's Scots Guards Band 10
Irish Jigs—Part II...His Majesty's Scots Guards Band 10
9106 Christine de Suede (Schottische), 1st Infantry Regiment Band of Belgium 10
Premier Pas (Mazurka), 1st Infantry Regiment Band of Belgium 10
9107 Silver Threads Among the Gold (Danks-Rexford)—Trio, orch. accomp., Knickerbocker Trio 10
When You and I Were Young, Maggie (Johnson-Butterfield)—Tenor, orch. accomp., Geo. Wilton Ballard 10
4659 When Irish Eyes Are Smiling (Ball)—Tenor, orch. accomp., Terence O'Connor 10
It Takes an Irish Heart to Sing an Irish Song (David)—Tenor, orch. accomp., Terence O'Connor 10
4660 Paddy's Reel—Piccolo, orch. accomp., R. Murchie 10
Sailor's Hornpipe—Piccolo, orch. accomp., R. Murchie 10
4661 Home Again Blues (Berlin-Akst)—Medley Fox-trot, introducing "Broadway Blues," Joe Coleman's President Orchestra 10
Toodles (Green)—One-step, Green Brothers' Xylophone Band 10
4662 Rosie Medley (Clarke-Merkur)—Fox-trot, intro-

- ducing "Tell Me, Little Gypsy"—Song chorus by Robert Hudson, Joe Coleman's President Orchestra 10
Now and Then (McKierman-Spencer)—Medley, Yerke's Dance Orchestra 10
4663 Rose (Magine-Biese)—Medley Fox-trot...Vernon Trio 10
Dolly (I Love You) (Wadsworth-Arden)—Medley Fox-trot, introducing "You're the Only Girl That Made Me Cry"...Yerke's Dance Orchestra 10
4664 Memories of Virginia (Wilnorf-Atkinson)—Tenor, orch. accomp., Arthur Hall 10
County Kerry Mary (Nelson)—Tenor, orch. accomp., Robert Hudson 10
4665 Isle of Paradise (Earl-Fiorito)—Hawaiian guitars and xylophone...Honolulu Trio 10
Mahaina Malamalama—Hawaiian guitar duet, Ferera-Franchini 10
4666 The Blue Bells of Scotland—Concertina solo, piano accomp., Alexander Prince 10
Estudiantina Waltz (Waldeufel)—Concertina solo, piano accomp., Alexander Prince 10
4653 Hi and Si and the Line Fence (Porter)—Comic dialogue...Porter-Jones 10
The Country Postmaster (Porter)—Comic dialogue...Porter-Jones 10

EMERSON PHONOGRAPH CO.

LATEST SONG HITS

- 10327 You Oughta See My Baby (Turk-Ahlert)—Comedy song, orch. accomp., Eddie Cantor 10
Give Me a Million Beautiful Girls (But Give Me Them One at a Time) (Pease-Nelson-Parish)—Character song, orch. accomp., Irving Kaufman 10
10329 Bright Eyes (Motzan-Jerome-Smith)—Tenor solo, orch. accomp., Irving Kaufman 10
My Home Town Is a One-Horse Town (But It's Big Enough for Me) (Gerber-Silver)—Comedy duet, orch. accomp., Irving and Jack Kaufman 10
10324 My Mammy (Donaldson-Lewis-Young)—Novelty song, orch. accomp., Arthur Fields 10
O-H-I-O (O-My-O!) (Olman-Yellen)—Novelty song, orch. accomp., Irving Kaufman 10
10326 Crazy Blues (Perry Bradford)—"Blues" character song, accomp. by Eubie Blake...Noble Sissle 10
Melinda Lee (Al. Bernard)—Comedy song, orch. accomp., Al. Bernard-Ernest Hare 10
10316 Feather Your Nest (Kendis-Brockman-Johnson)—Baritone solo, orch. accomp., Arthur Fields 10
Grieving for You (Gibson-Ribaud-Gold)—Baritone solo, orch. accomp., Arthur Fields 10
10320 I'm Saving Up My Dough for Rae and Me (Kilgour-Akst)—Novelty song, orch. accomp., Arthur Fields 10
He Always Goes Farther Than Father (Blanche Franklyn)—Comedy song, orch. accomp., Fred Hillebrand 10
10325 There Is One Girl (Will She Ever Be Mine?) (Scanlan-Kershaw)—Tenor solo, orch. accomp., Walter Scanlan 10
Killarney (Michael Balfe)—Tenor solo, orch. accomp., Walter Scanlan 10

BIG DANCE HITS

- 10317 Rosie (Make It Rosy for Me) (J. L. Merkur)—Fox-trot...Plantation Dance Orchestra 10
Kentucky Blues (Clarence Gaskill)—Fox-trot, Merry Melody Men 10
10321 No Wonder I'm Blue (Fred E. Ahlert)—Fox-trot...Lanin's Roseland Orchestra 10
Humming (Breant-Henderson)—Fox-trot, Lanin's Roseland Orchestra 10
10328 Home Again Blues (Berlin-Akst)—Fox-trot...Plantation Dance Orchestra 10
Palesteena (Conrad-Robinson)—Fox-trot, Plantation Dance Orchestra 10
10315 Broadway Blues (Carey Morgan)—Fox-trot, Merry Melody Men 10
Now and Then (Norman Spncer)—Fox-trot, Selvin's Novelty Orchestra 10
10318 Honeydew Medley—Introducing "Drop Me a Line" and "My Husband's Dearest Friends" (From musical production, "Honeydew") (Efrem Zimhalist)—Fox-trot, Joseph Knecht's Waldorf-Astoria Dance Orchestra 10
Pitter Patter Medley—Introducing "Pitter Patter" and "I Saved a Waltz for You" (From musical production, "Pitter Patter") (Wm. B. Friedlander)—Waltz, Joseph Knecht's Waldorf-Astoria Dance Orchestra 10
10322 Kiss-a-Miss (Maurice Baron)—Waltz, Selvin's Novelty Orchestra 10
I Told You So (Von Tilzer-Masloff-Gottler)—Medley Fox-trot...Joseph Samuels' Music Masters 10
10319 Rose (Arthur Sizemore)—Fox-trot, Sherbo's Mont Martre Orchestra 10
Old-Fashioned Garden (Cole Porter)—One-step, Joseph Knecht's Waldorf-Astoria Dance Orchestra 10
10323 My Wild Flower (M. L. Lake)—Fox-trot, Lakesonian Brass Sextet 10
Ouija (M. L. Lake)—One-step, Lakesonian Brass Sextet 10
10330 Honolulu Eyes (Violinsky)—Waltz, Orlando's Society Orchestra 10
I Never Knew (Pitts-Egan-Marsh)—Fox-trot, Orlando's Society Orchestra 10

CARDINAL PHONOGRAPH CO.

- 2013 Oh, Gee, Say, Gee, You Ought to See My Gee Gee From the Fiji Isle—Orch. accomp., Ernest Hare 10
Get Up—Orch. accomp., Ernest Hare 10
2014 Rose—Fox-trot...Rudy Wiedoeft's Palace Trio 10
Show Me How—Fox-trot...Rudy Wiedoeft's Palace Trio 10
2015 County Kerry Mary—Orch. accomp., Chas. Harrison 10
It's All Over Now—Orch. accomp., Helen Bell Rush 10
2016 My Mammy, with Vocal Chorus—Fox-trot, Selvin's Orch. 10
Why Don't You?...Selvin's Orch. 10
2017 Now and Then...Selvin's Dance Orch. 10
I Never Knew...Selvin's Dance Orch. 10
2018 Honeydew, Jos. Knecht's Waldorf-Astoria Dance Orch. 10
Lotus Flower, Jos. Knecht's Waldorf-Astoria Dance Orch. 10
2019 Strut, Miss Lizzie—Orch. accomp., Ernest Hare 10
I'm a Ladies' Home Companion—Orch. accomp., Fred Whitehouse 10
2020 Bright Eyes—Fox-trot, Harry Raderman's Dance Orch. 10
Broadway Rose—Fox-trot, Harry Raderman's Dance Orch. 10
2021 When You and I Were Young, Maggie...Taylor Trio 10
Sweet Genevieve...Taylor Trio 10
2022 That Old Irish Mother of Mine—Orch. accomp., Chas. Harrison 10
That Tumble Down Shack in Athlone—Orch. accomp., Chas. Harrison 10
2023 Romance—Waltz...Jos. Knecht's Waldorf-Astoria Orch. 10

(Continued on page 184)

RECORD BULLETINS FOR MARCH

(Continued from page 183)

- Margie—Fox-trot...Nicholas Orlando's Dance Orch.
 2024 Blue Jeans—Orch. accomp.....Chas. Harrison
 Out Where the West Begins—Orch. accomp.,
 Chas. Harrison
 2025 Deenah (My Argentine Rose),
 Harry Raderman's Dance Orch.
 MazieHarry Raderman's Dance Orch.
 2026 Lights Out—MarchCardinal Concert Band
 American Patrol—March.....Cardinal Concert Band

ARTO RECORDS

DANCE RECORDS

- 9047 Mazie. Fox-trot. Chorus sung by Arthur
 HallSelvin's Novelty Orchestra
 Love Bird. Fox-trot.....ARTo Dance Orchestra
 9048 Make Believe. Fox-trot. Chorus sung by Arthur
 HallMoulin Rouge Orchestra
 I Lost My Heart to You—Fox-trot,
 Selvin's Novelty Orchestra
 9046 Home Again Blues. Fox-trot...Merry Melody Men
 Look for the Silver Lining. Intro.: "Whip-
 poo-will" from "Sally." Medley Fox-trot,
 Merry Melody Men

VOCAL RECORDS

- 9050 Over the Hill.....Ernest Hare
 Answer Saying That You Love Me.....Billy Jones
 9049 The Rose I Call Sweetheart.....Charles Harrison
 I Used to Love You But It's All Over Now,
 Arthur Ha'l
 9045 The Jazz Me Blues. Accomp. by Harris' Blues
 and Jazz Seven.....Lucille Hegamin
 Everybody's Blues. Fox-trot. Chorus sung by
 Lucille Hegamin.....Harris' Blues and Jazz Seven
 3054 Danny Deever.....Herbert Palmer
 Oh, Dry Those Tears.....Walter Barnby
 3055 A Dream.....Walter Barnby
 Sing Me to Sleep—Soprano Solo..Nevada Vanderveer
 3056 Nearer, My God, to Thee.....Shannon Four
 Onward, Christian Soldiers.....Shannon Four
 INSTRUMENTAL RECORDS
 3057 Baltimore Centennial March...ARTo Military Band
 Second Regiment Connecticut March,
 ARTo Military Band
 3015 HumoresqueE. B. Thiele
 Traumerei.....E. B. Thiele

PARCEL-POST WEIGHT INCREASED

Twenty-two Pounds Now Limit of Packages
 Sent From United States to France

Under an agreement made with the postal administration of France, effective February 1, 1921, the maximum weight limit of parcel-post packages exchanged between the United States and France is increased from 11 pounds (5 kilos) to 22 pounds (10 kilos).

The foregoing is applicable to parcels for and from the United States and its island possessions on the one hand and continental France, Corsica, Algeria, Tunis, French Morocco, and the principality of Monaco, on the other hand.

H. C. Russell has opened a new talking machine store in Fillmore, Cal., where he features the Brunswick phonograph.

MONTHLY NEWS BUDGET FROM LONDON HEADQUARTERS

(Continued from page 179)

record filing arrangement which is described as the most convenient method of storing and indexing records yet devised, arranged upon the sectional or unit principle.

The Musico's Club

Under the above title a chatty little pocket-size monthly is being published by the Columbia Co. It is for trade distribution only, and presumably is in the nature of what has come to be described as a house organ. Anyway, if it reflects only the doings of Columbia, it will be welcomed and accepted in that regard as a guarantee of its interests to dealers in general. The Musico's Club is designed to "keep you well informed on records and musical matters in a newsy fashion," say the Columbia people. It is issued free of any charge and dealers who desire to receive this interesting monthly have but to register their name and address with the Columbia Co.

A Repeating Gramophone

The very latest introduction here is a repeating gramophone. It was demonstrated before a large audience of musical people at the Royal College of Music, London, and evoked warm praise of its very fine tonal qualities. The mechanism can be set to repeat a record as many times as one likes, needle-wearing and motor-strength restrictions considered. An auto-brake is incorporated with the repeating device. On the whole, Repeating Gramophones, Ltd., have certainly introduced something that carries the trade a step forward along the path of progress.

Dance Records All the Vogue

Dance music on records is so much in demand by the public and the exponents of the art that the chief gramophone companies find it really necessary to make special arrangements for a complete service featuring the latest terpsichorean melodies. The program of new issues advertised by the "His Master's Voice" Co. is alive with real "hits" by popular orchestral and band organizations, as instance Paul Whiteman and His Ambassador Orchestra, the Benson Orchestra of Chicago, Joseph C. Smith's Orchestra, All Star Trio, Palace Trio, Green Brothers' Novelty Band, Mayfair Dance Orchestra, etc. These records will be eagerly welcomed and are to be specially advertised.

The "His Master's Voice" dealers are particularly pleased with the support they receive in the way of advertising. Apart from the provision of free electros, steady issue of publicity literature, and a continuous press campaign, the company makes a special splash about once a month. This month it is another £1,000 advertisement on the front page of the Mail to feature the service of Celebrity Artistes (who record exclusively for the "His Master's Voice") at prices which bring their fine records within the reach of all. Dealers received in advance duplicate pages of the advertisement for window display purposes.

Mr. Sternberg in the States

At the time of writing Mr. Sternberg is not expected back until at least the end of the month. He left rather hurriedly just before Christmas week at the dictates of social as well as business reasons. The Sterno Manufacturing Co., of which David Sternberg is chief, has for some time past been out to develop its interests abroad, and in this connection it is expected that Mr. Sternberg will have something to say upon his return to London.

TRYING TO REDUCE CANCELLATIONS

"Your order is your word of honor. Protect it."

The above slogan has just been adopted by the executive members of the Credit Co-operation and Credit Methods Committee of the National Association of Credit Men which is trying to reduce the number of cancellations so prevalent to-day. The committee, of which H. F. Barker, of Providence, R. I., is chairman, suggests that salesmen should be given the following instructions before being sent out to solicit orders:

1. Get the order signed by the buyer or an authorized agent.
2. Order forms should contain a cancellation clause.
3. If the terms of the contract are set forth on the back of the order blank the following statement should appear above the signature of the buyer: "Please ship the above goods subject to the terms as set forth on the reverse side of this order blank"

You Ought to Know

In case you are contemplating expanding the sphere of your business to include departments devoted to Pianos, Player-Pianos, Musical Merchandise or Sheet Music, that you'll find news and comments about them all in



ESTABLISHED 1876

The oldest and leading music trade weekly, which covers every branch of the industry

It Contains

Instructive and educational articles. Hints on salesmanship and advertising. Editorials that are timely and authoritative. Facts about the new things in the trade. Trade happenings in all parts of the United States

"Review the Music Trade With Us"

Send your \$2 now for a full year's subscription to

THE MUSIC TRADE REVIEW
 373 FOURTH AVENUE
 NEW YORK

Some Leading Jobbers of Talking Machines in America



TEST IT. OUR VICTOR Record Service

has a reputation for efficiency.
Suppose you try it.
E. F. DROOP & SONS CO.
1300 G. STREET, WASHINGTON, D. C.
231 N. HOWARD STREET, BALTIMORE, MD.

William Volker & Co., Kansas City, Mo.; Houston Tex., and Denver, Col.

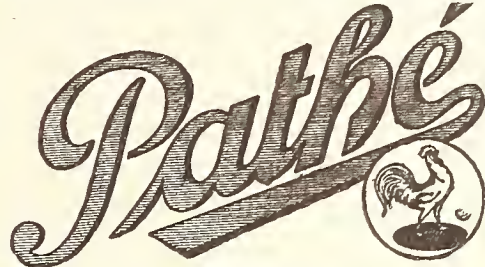

DISTRIBUTORS
Complete Pathephone and Pathe Record Stocks.
The best proposition for the progressive dealer.

Sherman, & Co.

San Francisco, Los Angeles, Portland, Seattle, Spokane
PACIFIC COAST DISTRIBUTORS OF
VICTOR PRODUCTS

The PERRY B. WHITSIT CO.

Distributors of
Victrolas and Victor Records
COLUMBUS, OHIO



Where Dealers May Secure

COLUMBIA

Product

Ready, Full Stocks, and Prompt Deliveries
from Convenient Shipping Centers
all over the United States.

Distributors

- Atlanta, Ga., Columbia Graphophone Co., 63 N. Pryor St.
- Baltimore, Md., Columbia Graphophone Co., 16 South Howard St.
- Boston, Columbia Graphophone Co., 1000 Washington St.
- Buffalo, N. Y., Columbia Graphophone Co., 737 Main St.
- Burlingame, Cal., Columbia Graphophone Co., 1130 Balboa Ave.
- Chicago, Ill., Columbia Graphophone Co., 325 W. Jackson Blvd.
- Cincinnati, O., Columbia Graphophone Co., 317-321 East 8th Street.
- Cleveland, O., Columbia Graphophone Co., 1812 East 30th St.
- Dallas, Tex., Columbia Graphophone Co., 316 North Preston St.
- Denver, Colo., Columbia Stores Co., 1608 Glenarm Ave.
- Detroit, Mich., Columbia Graphophone Co., 115 State St.
- Indianapolis, Ind., Columbia Graphophone Co., 209 W. Washington St.
- Kansas City, Mo., Columbia Graphophone Co., 2006 Wyandotte St.
- Los Angeles, Cal., Columbia Graphophone Co., 809 S. Los Angeles St.
- Minneapolis, Minn., Columbia Graphophone Co., 18 N. 3rd St.
- New Haven, Conn., Columbia Graphophone Co., 206 Meadow St.
- New Orleans, La., Columbia Graphophone Co., 517-525 Canal St.
- New York City, Columbia Graphophone Co., 121 West 20th St.
- Omaha, Neb., Columbia Graphophone Co., Eighth and Jackson Sts.
- Philadelphia, Pa., Columbia Graphophone Co., 40 N. 6th St.
- Pittsburgh, Columbia Graphophone Co., 632-640 Duquesne Way.
- Salt Lake City, Utah, Columbia Stores Co., 221 South West Temple.
- Seattle, Wash., Columbia Graphophone Co., 911 Western Ave.
- Spokane, Wash., Columbia Stores Co., 161 South Post St.
- St. Louis, Mo., Columbia Graphophone Co., 1127 Pine St.
- Tampa, Fla., Tampa Hardware Co.

Headquarters for Canada:

Columbia Graphophone Co., 54-56 Wellington St., West, Toronto, Ont.

Executive Office

COLUMBIA GRAPHOPHONE CO.

Woolworth Building New York

W. J. DYER & BRO.

DYER B'LD'G, ST. PAUL, MINN.
NORTHWESTERN DISTRIBUTORS
OF THE



VICTOR

Machines, Records and Supplies

Shipped Promptly to all
Points in the Northwest

Wholesale Exclusively
EASTERN TALKING MACHINE CO.
85 Essex Street, Boston
VICTOR DISTRIBUTORS

Mickel Bros. Co.

Omaha, Nebraska
Des Moines, Iowa

Victor Distributors

Every talking machine jobber in this country should be represented in this department, no matter what kind he handles or where he is located. The cost is slight and the advantage is great.

ARTICLES OF INTEREST IN THIS ISSUE OF THE WORLD

Ready Reference for Salesmen, Dealers and Department Heads

The Growth of Talking Machine Exports..	3	Electric Signs as an Aid to Business.....	42
Industry Facing a Period of Genuine Development	3	Why Readjustment Must Begin With the Farmer	46
Ideas That Increase Interest in the Sales of Talking Machine Records.....	4	Talking Machine Trade Facing Show-Down Period	48
The Dealer Who Works in 1921 Will Win..	8	Foreign Countries Which Buy American Talking Machines	55
Business Situation Steadily Bettering.....	8	Fraudulent Sales Practices Stopped by Federal Commission	56
Why People Buy by Mail, With Suggestions for Meeting Mail Order Competition..	10-11	Money Spent for Musical Instruction in America	59
How the Show Window Can Help Develop Prosperity	15-16	Why Depression Is Due to Pessimism.....	68
Shakespeare Recorded for Posterity.....	18	Is Your Sales Service Taken for Granted, Or Do You Know It's Right.....	74-75
How Record Makers Are Immortalized...	19	Facts That Save Time and Money.....	92
Why Talking Machine Trade Should Support Movement to Encourage Buying Now	21	Why the Dealer Should Concentrate on Music	97
Successful Selling Essentials.....	23	Sales Ideas From the Mid-West.....	128-129
The Important Part Salesmen Can Play in Bringing About Better Conditions.....	26-27	Talking Machine Business Can Be Had, Go Get It	141
Various Methods of Increasing Talking Machine Sales	33	Why We Must All Now Get to Work.....	142
"No Purchase Hour" A New Sales Development	37	Timely Constructive Talk by Robert Gordon	159
Changes in Regulations Anent War Excise Taxes	40		

A C B J A C O F H K L N P Q S U A X V B D F G I J L N P Q S U V X Z V C E F H J K W O P R T A C E M O N
 E F J K W
INDEX TO ADVERTISERS
 P Q N
 T S R P Q M K V H F E C V B C E F H J K W O P R T U V W Y L B D E G I J M N O P Q R S T V M N V B D

A

Acme Die Casting Corp. 170
 Acme Engineering & Mfg. Co. 144
 Aeolian Co., New York. 87
 Alto Mfg. Co. 146
 American Mica Works 75
 American Odeon Corp. 49
 American Talking Machine Co. Inc. (Bloomsburg) 113
 American Walnut Mfrs. Ass'n. 11
 Andrews, Curtis N. 55
 Argus Phono. Supply Co. 88
 Armstrong Furn. Co. 76
 Arto Co., The 153
 Associated Phonograph Supply Co. 162

B

Badger Talking Machine Co. 79
 Bagshaw Co., W. H. 100
 Barnhardt Bros. & Spindler. 116-117
 Becroft, Clement 156
 Bell Hood Needle Co. 66
 Blackman Talking Machine Co. 85
 Blood & Kloer 141
 Boenning, Garrison & Co. 96
 Brandts, Edmund 147
 Brandts Furn. Co. 19
 Brilliantone Steel Needle Co. 14
 Brooks Mfg. Co. 82
 Bruno & Son, Inc., C. 53, 81, 86, 95, 105, 157
 Brunswick-Balke-Collender Co. Insert following page 18
 Bubble Book Sales Service. 30
 Buegeleisen & Jacobson 125
 Buehn Co., Louis 109
 Buffalo T. M. Co. 79

C

Cabinet & Accessories Co. 46
 Cardinal Phono. Co. 119
 Carter, W. A. 134
 Celina Spec. Co. 127
 Charmaphone T. M. Co. 61
 Cheney Talking Machine Co. 63
 Chicago Talking Machine Co. 130
 Classified Want Ads 175, 176
 Cole & Dunas 139
 Collings & Co. 33
 Columbia Graphophone Co. 12, 13, 16, 23, 31, 42, 51, 62, 70, 91, 107, 118, 126, 157
 Consolidated Talking Machine Co. 135
 Co-operative Mfg. Co., The. 144
 Copper Process Co. 127
 Cressey & Allen 101

D

Dalion T. M. Co. 54
 Deterling Mfg. Co. 156
 Deutsch Bros. 154
 Ditson Co., Oliver 50
 Doctorow, D. R. 43
 Dodin, Andrew H. 181
 Doehler Die-Casting Co. 65
 Droop & Sons Co., E. F. 185
 Drying Systems, Inc. 144
 Duo-Tone Co. 26
 Dutton Corp. 110
 Dyer & Co., W. J. 185

E

Eastern Talking Machine Co. 99, 185
 Eclipse Musical Co. 42
 Edison, Inc., Thos. Back Cover, 36, 120, 164
 Eight Famous Victor Artists. 18
 Einson Litho, Inc. 92
 Elyea T. M. Co. 31
 Emerson Phonograph Co. 122
 Empire Phono. Parts Co. 43
 Everybody's Talking Machine Co. 83, 113

F

Federal Electric Co. 34
 Feist, Leo 59, 78, 98, 115, 154
 Ferro Phono. Parts Co. 146
 Fletcher All Tones Needle Co. 75
 Fletcher-Wickes Co. 56
 Flexlume Sign Co. 40
 Forster Music Publisher, Inc. 153
 Fox Pub. Co., Sam. 151
 Fulton Talking Machine Co. 160, 162

G

General Phonograph Corp. Inserts following pages 34, 66, 82
 General Phonograph Mfg. Co. 35, 64
 General Sales Corp. 52
 Germain Bros. 90
 Gibson-Snow Co. 39
 Globe Decalcomanie Co. 107
 Glynn, W. B., Distributing Co. 39
 Gramophone Co., Ltd. 177
 Granby Phono. Corp. 32
 Grand Rapids Brass Co. 53
 Gray Co., Walter S. 65
 Gray & Dudley Co. 148

Gretsch Mfg. Co., Fred. 149
 Grey Gull Records 104
 Griffith Piano Co. 39
 Grinnell Bros. 163

H

Hall Mfg. Co. 73
 Handy Mfg. Co. 142
 Harponola Co. 19
 Hessig-Ellis Drug Co. 39
 Himmer, Jr., Vitalis. 167
 Hoffay Phono. Co. 162
 Horton-Gallo-Creamer Co. 101
 Hough, J. E., Ltd. 179
 Hough, L. W. 101
 Howe & Co., C. W. 145
 Hunter Mfg. Co., Everett. 169

I

Ilsley, Doubleday & Co. 59
 International Mica Co. 67

J

Jewel Phonoparts Co. 69
 Jewett Phono. Co. 97
 Jones-Motrola, Inc. 71

K

Keen Talk. Mach. Supply Co. 147
 Kennedy-Green Co. 10
 Kent Co., F. C. 107
 Keystone Die Casting Co. 110
 Keystone Minerals Co. 27
 Keystone Printed Specialties Co. 78
 Kichler Co., L. A. 171
 Kiefer-Stewart Co. 39
 Kirkman Engineering Corp. 25
 Knickerbocker T. M. Co. 37
 Knight Campbell Music Co. 171
 Kraft, Bates & Spencer, Inc. 102

L

Lakeside Supply Co., Inc. 140
 Lansing Co. 103
 Lee-Coit-Andreesen Hdwe. Co. 39
 Lesley's 83
 Long Cabinet Co., Geo. 108
 Lorentzen, H. K. 50
 Lundstrom Mfg. Co., C. J. 47
 Lyon & Healy 132
 Lyons, W. H. 144

M

Magnavox Co. 24, 39
 Magnola Talking Machine Co. 34, 84, 133, 146, 176
 Mandel Mfg. Co. 143
 Manophone Corp., The 48
 Marshall Co., Inc., C. L. 39
 Matthews, F. W. 90
 Mellor's 23
 Mellowtone Needle Co. 98
 Mel-O-Dee Music Co. 124
 Mercantile Finance Co. 76
 Mermod & Co. 61
 Meyercoed Co. 135
 Michigan Phono. Co. 74
 Mickel Bros. Co. 185
 Milwaukee T. M. Mfg. Co. 54
 Minneapolis Drug Co. 39
 Modernola Co. 161
 Montagnes, I., & Co. 39
 Morris Co., J. O. 60
 M. S. & E. 39
 Multiplex Display Fixture Co. 158
 Munn & Co. 181
 Music Trade Review 184
 Mutual Phono. Parts Mfg. Co. 118, 166

N

National Decalcomania Co. 112
 National Publishing Co. 6
 Netschert, Frank 105
 New England Talking Machine Co. 103
 Newton & Co., Inc. 94
 New York Album & Card Co. 4
 New York Talking Machine Co. 130
 Nice Co., B. D. 150
 Nupoint Mfg. Co. 136
 Nye, William F. 27

O

Ogden Sectional Cabinet Co., Inc. 72
 Ohio Sales Co. 39
 Operaphone Co., Inc. 125
 Ormes, Inc. 9
 Oro-Tone Co. 123, 137

P

Paramount Talking Machine Co. Inside Back Cover
 Parks & Parks 25
 Pathé Frères Phonograph Co. 28, 29
 Peabody & Co., Henry W. 106
 Peckham Mfg. Co. 43

Peerless Album Co. 6
 Penn Phonograph Co. 112
 Philadelphia Show Case Co. 111
 Phillips, Wm., Phono. Parts Co. 86
 Phonograph Appliance Co. 49
 Phonomotor Co. 84
 Phonograph Specialties Mfg. Co. 62
 Pkink Portable Phonograph, Inc. 168
 Player-Tone T. M. Co. 160
 Plywood Corp. 15
 Progressive Phonographic Supply Co. 165

R

Racine Phono. Co. 27
 Remington Phono. Corp. 41
 Rene Manufacturing Co. 66, 121
 Repeater-Stop Co. 142
 Rex Gramophone Co. 179
 Reynolds, Wm. H. 114
 Richmond, Inc., Maurice 169
 Rishell Phono. Co. 20
 Robinson, Pettit Co., Inc. 39
 Rountree Corp. 44

S

Seaburg Mfg. Co. 58
 Selle & Co., H. W. 136
 Shapiro, Bernstein Co. 152
 Shattuck Fibre Furn. Co. 105
 Sherman, Clay & Co. 185
 Smith Drug Co., C. D. 39
 Smith Laboratories, H. J. 16
 Smith-Schiffin Co. 67
 Sonora Co. of Philadelphia. 39
 Sonora Phonograph Co. of Pittsburgh. 39
 Sonora Distr. Co. of Texas. 39
 Sonora Phonograph Co., Inc., Inside Front Cover, 38, 39, 81
 Soss Mfg. Co. 92
 Southern Drug Co. 39
 Southern Sonora Co. 39
 Southwestern Drug Co. 39
 Sphinx Gramophone Motors. Insert following page 82
 Standard Music Roll Co. 153
 Standard Talking Machine Co. 185
 Starck & Cowan 151
 Starr Piano Co. 22
 Stead & Co., J. 178, 179
 Steel, W. R. 178
 Steger & Sons Piano Mfg. Co. 77
 Steinert & Sons Co., M. 99
 Stephenson, Inc. 89
 Sterling Devices Co. 138
 Sterno Manufacturing Co. 172
 Steurer Reproducer Co., Inc. 173
 Stewart T. M. Co. 59, 71
 Strevell-Patterson Hardware Co. 39
 Superior Die Casting Co. 168

T

Talking Machine World Dealer Service. 93
 Thomas & Proetz Lumber Co. 51
 Toledo Talking Machine Co. 68

U

Udell Works 91
 Unit Construction Co. 80
 Universal Fixture Corp. 155
 U-Sav-Your Mfg. Co. 21
 Usoskin Litho 173

V

Vallorbs Jewel Co. Insert following page 50
 Val Accessory House 174
 Van Houten, C. J., & Zoon. 39
 Van Veen & Co. 147
 Vector Co. 170
 Vicsonia Mfg. Co., Inc. 114
 Victor Talking Machine Co. Front Cover, 5, 7
 Volker & Co. 185

W

Wabash Cabinet Co. 45
 Wade Co., R. C. 57
 Wade & Wade 131
 Wade Talking Machine Co. 140
 Wade, W. H. 115
 Walthall Music Co. 39
 Ward Co., C. E. 126
 Wax & Novelty Co. 90
 Weber-Knapp Co. 70
 Weymann & Son, H. A. 110
 Whitsit Co., Perry B. 185
 Widdicomh Furniture Co. 17
 Wimpfheimer & Bro., A. 59

Y

Yahr & Lange Drug Co. 39
 Yeuell Co., E. V. 103

Z

Zega Mfg. Co., A. F. 170



Paramount Records

ALWAYS THE LATEST HITS

"If it's new—the Paramount dealer has it." That in a nutshell expresses the thought behind the Record Division of the Paramount factories.

Paramount has its own artists and every facility for producing quality records in double-quick time. Recordings are made in our own specially equipped laboratories in New York City and an entire plant is devoted to manufacturing Paramount records.

If you handle Paramount records you can quickly build a good record business. They'll soon get the habit of coming to your store first for the latest dance and song numbers.

Write to the jobber in your territory or to us for full information.

THE PARAMOUNT COMPANY
PORT WASHINGTON, WIS.

March Releases

INSTRUMENTAL RECORDS

- 50039 { AMERICAN FANTASIE—Part 1—Concert Band.....Creator and his Band
- 50039 { AMERICAN FANTASIE—Part 2—Concert Band.....Creator and his Band
- 50040 { BARCAROLLE (From "Tales of Hoffmann")—Concert Band.....Creator and his Band
- 50040 { BLUE DANUBE WALTZ—Concert Band.....Creator and his Band
- 50041 { SCHUBERT'S SERENADE—Saxophone Solo.....Saxophone with Creator and his Band
- 50041 { SPRING SONG—Clarinet Solo.....Clarinet with Creator and his Band
- 33077 { BLAZE AWAY MARCH (Holzman)—Military Band.....Roger's Band
- 33077 { PASADENA DAY MARCH (Vesselle)—Military Band.....Roger's Band
- 33078 { ALOHA OE—Cornet Solo, Orch. Accomp.....Pietro Capidiferro
- 33078 { ANGELS' DREAM WALTZ (Herman).....Paramount Miniature Symphony Orchestra

VOCAL RECORDS

- 33076 { CARRY ME BACK TO OLD VIRGINNY (Bland)—Soprano Solo with Quartette, Orch. Accomp.Elizabeth Spencer—Stellar Quartette
- 33076 { OLD BLACK JOE (Foster)—Soprano Solo with Quartette, Orch. Accomp., Elizabeth Spencer—Stellar Quartette
- 20042 { MARGIE (Conrad-Robinson)—Vocal Solo, Orch. Accomp.....Aileen Stanley
- 20042 { MY MAMMY (Lewis-Young-Donaldson)—Vocal Solo, Orch. Accomp.....Aileen Stanley
- 20035 { OLD PAL, WHY DON'T YOU ANSWER ME?—Tenor Solo, Orch. Accomp.....Sam Ash
- 20035 { TIRED OF ME—Tenor Solo, Orch. Accomp.....Sam Ash

DANCE RECORDS

- 20038 { HONOLULU EYES (Violinski)—Waltz Medley, Introducing "Aloha Oe".....Merry Melody Men
- 20038 { CARESSES (James V. Monaco)—Fox-trot.....Merry Melody Men
- 20043 { OLD-FASHIONED GARDEN—Medley One-step, Introducing "Just Like a Rose," Yerkes' Jazzarimba Orchestra
- 20043 { ROSIE, MAKE IT ROSY FOR ME—Medley Fox-trot, Introducing "I'm Saving My Dough for Rae and Me".....Yerkes' Jazzarimba Orchestra
- 20044 { THAT NAUGHTY WALTZ—For Dancing.....Selvin's Novelty Orchestra
- 20044 { MY ISLE OF GOLDEN DREAMS—Waltz.....Selvin's Novelty Orchestra



Style XXX

DISTRIBUTORS:

- | | | | |
|---------------------------------------------------------------------------------------------------------|----------------------------------------------------------------------------------------------------------|----------------------------------------------------------------------------------------------------|------------------------------------------------------------------------------------------------------------------------------------------------------|
| SHIPLEY-MASSINGHAM CO.,
Pittsburgh, Pa.,
For Western Penn. and West Virginia | BREWER & COMPANY,
Boston, Mass.,
For New England States | RICHMOND HAROWARE CO.,
Richmond, Va.,
For Virginia. | PEOEN IRON & STEEL CO.,
Houston, Texas,
For Texas |
| JOERNS BROS. MFG. CO.,
St. Paul, Minn.,
For Minn., So. Dak., No. Dak.,
East Montana | A. J. HARWI HOWE. CO.,
Atchison, Kans.,
For Kansas | WITTE HAROWARE CO.,
St. Louis, Mo.,
For Missouri | BRANON & TURNER,
Little Rock, Ark.,
For Arkansas. |
| E. R. GOOFREY & SONS CO.,
Milwaukee, Wis.,
For Iowa, Illinois, Michigan, Indiana
and Wisconsin | OKLAHOMA PHONOGRAPH CO.,
Oklahoma City, Okla.,
For Oklahoma | P. C. OERR CO.,
New Orleans, La.,
For Mississippi and Louisiana | H. O. TAYLOR CO.,
Buffalo, N. Y.,
For West New York |
| PETER-NEAT-RICHAROSON CO.,
Louisville, Ky.,
For Kentucky | PARAMOUNT DISTRIBUTORS, INC.,
Seattle, Wash.,
For Wash., No. Oregon, No. Idaho
and West Montana | SOUTHERN PARAMOUNT CO.,
Atlanta, Ga.,
For Georgia, No. Carolina, So. Carolina
and Florida | PARAMOUNT SALES CO.,
Denver, Colo.,
For Colorado, Wyoming, New Mexico,
Utah, Arizona, Eastern Nevada, South-
ern Idaho, Southern Montana |

Paramount Phonographs *and* Records

Should the Government
increase the Excise Tax
on phonographs, we shall
be forced to *increase*
our prices.

THOMAS A. EDISON, Inc.

ORANGE, NEW JERSEY

JOBBER OF THE NEW EDISON, EDISON RE-CREATIONS, THE NEW EDISON DIAMOND AMBEROLA
AND BLUE AMBEROL RECORDS

CALIFORNIA
Los Angeles—Edison Phonographs,
Ltd.
San Francisco—Edison Phonographs,
Ltd.

COLORADO
Denver—Denver Dry Goods Co.

CONNECTICUT
New Haven — Pardee-Ellenberger
Co., Inc.

GEORGIA
Atlanta—Phonographs, Inc.

ILLINOIS
Chicago — The Phonograph Co.
Wm. H. Lyons (Amberola only).

INDIANA
Indianapolis—Kipp Phonograph Co.

IOWA
Des Moines—Harger & Blish.
Sioux City—Harger & Blish.

LOUISIANA
New Orleans—Diamond Music Co.,
Inc.

MASSACHUSETTS
Boston—Pardee-Ellenberger Co.
Iver Johnson Sporting Goods
Co. (Amberola only).

MICHIGAN
Detroit—Phonograph Co. of
Detroit

MINNESOTA
Minneapolis—Laurence H.
Lucker

MISSOURI
Kansas City—The Phonograph Co.
of Kansas City.
St. Louis—Silverstone Music
Co.

MONTANA
Helena—Montana Phonograph
Co.

NEBRASKA
Omaha—Shultz Bros.

NEW YORK
Albany—American Phonograph
Co.
New York—The Phonograph
Corp. of Manhattan.
Syracuse—Frank E. Bolway & Son,
Inc. W. D. Andrews Co.
(Amberola only).

OHIO
Cincinnati—The Phonograph Co.
Cleveland—The Phonograph Co.

OREGON
Portland—Edison Phonographs,
Ltd.

PENNSYLVANIA
Philadelphia—Girard Phono-
graph Co.
Pittsburgh—Buehn Phonograph
Co.
Williamsport—W. A. Myers.

RHODE ISLAND
Providence—J. A. Foster Co.
(Amberola only).

TEXAS
Dallas—Texas-Oklahoma Phono-
graph Co.

UTAH
Ogden—Proudfit Sporting Goods
Co.

VIRGINIA
Richmond—The C. B. Haynes
Co., Inc.

WISCONSIN
Milwaukee—The Phonograph Co.
of Milwaukee.

CANADA
Montreal—R. S. Williams &
Sons Co., Ltd.
St. John—W. H. Thorne & Co.,
Ltd.
Toronto—R. S. Williams & Sons
Co., Ltd.
Vancouver—Kent Piano Co., Ltd.
Winnipeg—R. S. Williams & Sons
Co., Ltd.
Babson Bros. (Amberola only).
Calgary—R. S. Williams & Sons
Co., Ltd.

The TALKING MACHINE WORLD

For the
makers &
sellers of
talking
machines

Published Each Month by Edward Lyman Bill, Inc., at 373 Fourth Ave., New York, March 15, 1921

*The instrument by which
the value of all musical
instruments is measured*

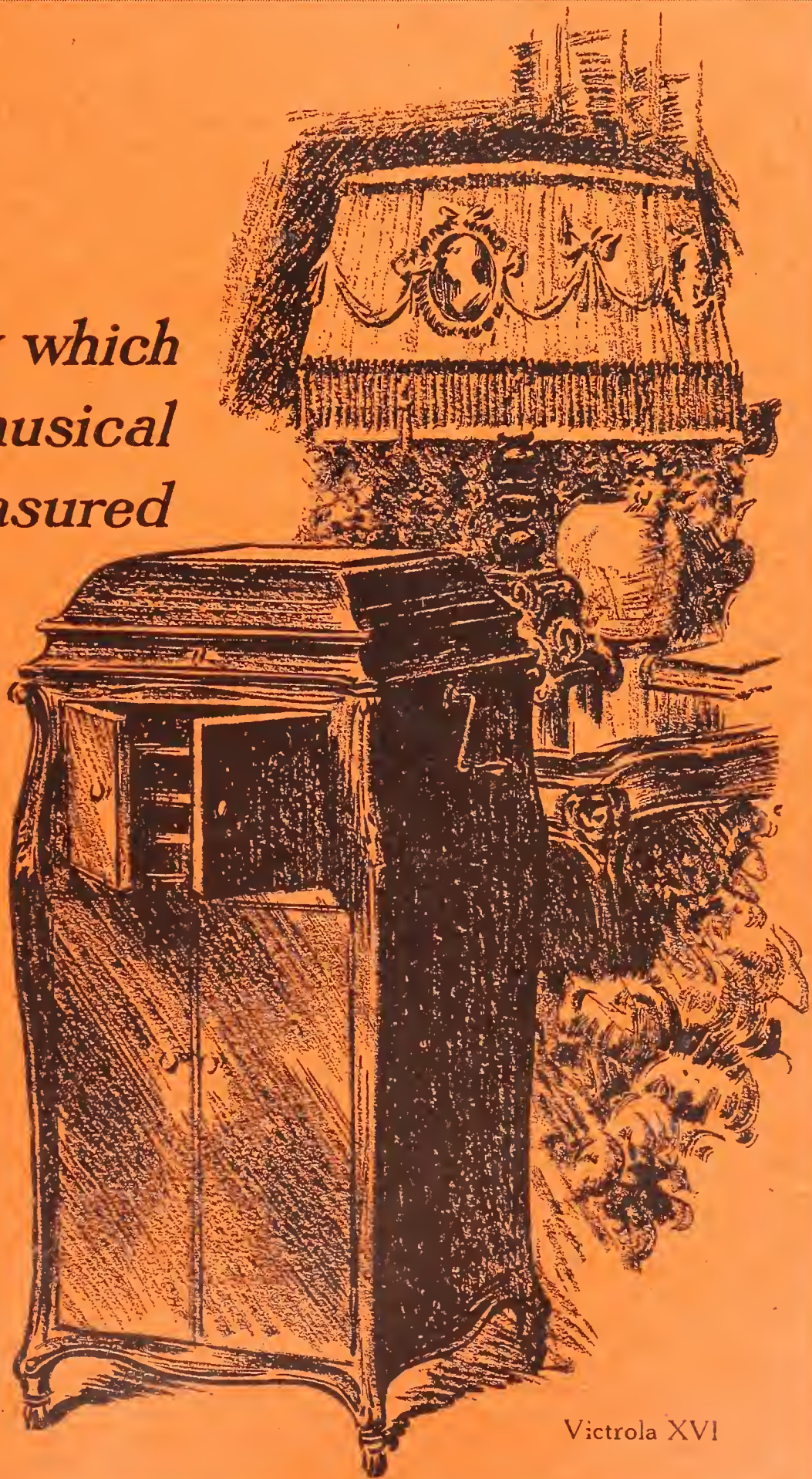

This trademark and the trademarked word
"Victrola" identify all our products. Look
under the lid! Look on the label!

VICTOR TALKING MACHINE CO.
Camden, N. J.

Victrola XVI



Minuet



Nocturne



Trovatore

People with **BUYING POWER** choose Sonora
—money well spent is *economy*

THE “class” buying power has been but little affected by present economic conditions and there is a big field for Sonora sales ready for you to cultivate.

The people who buy the Twin Sixes, the Dual Valve motors, the famous English, French and Italian automobiles, the magnificent sables and sealskins and the many-carat jewels, have still ample means to purchase the finest of all phonographs.

Sonora is a quality instrument. It is bought by men and women for whom the best is none too good, who are willing to pay a fair price for demonstrated value and who will go even to distant cities to get the Sonora if they can't get it in their home town. *To sell the Sonora is not, and never has been, difficult.*

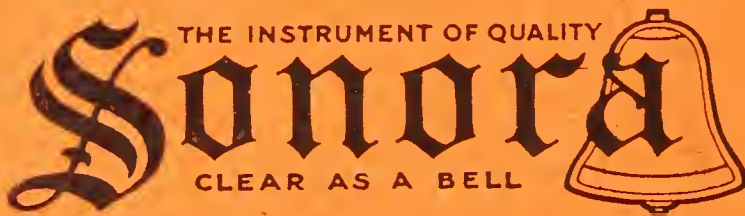

Sonora is not a “cheap” phonograph. It doesn't make its strongest appeal to people with “cheap” tastes. There are many well-to-do people who are splendid prospects for you to sell Sonoras to right now.

Sonora has never been sold with “easy” payments as the leading attraction and it brings in CASH. Sonora, besides being protected by many important patents of its own, is LICENSED AND OPERATES UNDER BASIC PATENTS of the phonograph industry, and with perhaps one exception is the only phonograph licensed under the basic patents. The future of Sonora and Sonora's representatives is secure.

Write regarding an agency.

24 periods, 7 upright styles and 1 portable, \$50 to \$1800.

SONORA PHONOGRAPH COMPANY, INC.

George E. Brightson, *President*

NEW YORK : 279 BROADWAY

Canadian Distributors: I. Montagnes & Co., Toronto

The Highest Class Talking Machine in the World

The Talking Machine World

Vol. 17. No. 3

New York, March 15, 1921

Price Twenty-five Cents

TALKING MACHINE EXPORTS GROW

Exports, Including Records, for Twelve Months Ending December, 1920, Total \$7,876,699

WASHINGTON, D. C., March 5.—In the summary of exports and imports of the United States for the month of December, 1920 (the latest period for which it has been compiled), which has just been issued, the following figures on talking machines and records are presented:

The dutiable imports of talking machines and parts during December, 1920, amounted in value to \$60,361 as compared with \$67,843 worth which were imported during the same month of 1919. The twelve months' total ending December, 1920, showed importations valued at \$875,830 as compared with \$558,253 worth of talking machines and parts during the same period of 1919.

Talking machines to the number of 8,041 valued at \$435,581 were exported in December, 1920, as compared with 7,286 talking machines valued at \$329,424 sent abroad in the same period of 1919. The twelve months' total showed that we exported 87,571 talking machines valued at \$4,130,312 as against 66,157 talking machines valued at \$2,490,719 in 1919, and 64,459 talking machines valued at \$1,906,052 in 1918.

The total exports of records and supplies for December, 1920, were valued at \$287,631 as compared with \$391,570 in December, 1919. For the twelve months ending December, 1920, records and accessories were exported valued at \$3,746,387; in 1919, \$3,702,668, and in 1918, \$2,276,357.

WANAMAKER NOW HAS FOUR LINES

Talking Machine Department of Large New York Store Finds Business Steady

The Wanamaker talking machine department, New York, is now handling four lines of talking machines and records instead of six and the energies of the department are devoted to selling the Victor, Brunswick, Sonora and Cheney. Manager Bertine declares that he is confident business will continue strong throughout the year. In spite of the fact that last year was a banner year, the department is equaling, and in some cases passing, the sales totals of 1920.

THE "WILL TO SELL" ESSENCE OF BUSINESS SUCCESS

This Policy Must Be Unflinchingly Sustained Until Every Prospect Has Been Solicited and the Last Lead Is Investigated—A Time for Real Strenuous Action

The importance of "getting busy"—of laying stress on the importance of selling—constitutes the subject of a very interesting talk by A. W. Shaw in "System" for March. Under the caption, "The Will to Sell," he points out:

"Most accomplishments in life, and most accomplishments in business, depend on the will to win, that intangible quality of determination which in all contests sustains the winners through those final deciding moments when losers weaken. It is renamed the more closely to fit each specific application, but fundamentally it remains the will to win—in warfare it becomes the will to kill, in business 'the will to sell.' This last particularly apt phrase I have borrowed from T. C. Powell, vice-president of the Erie Railroad Co.

"Just now the very essence of business management is 'the will to sell,' unflinchingly sustained until the last prospect has been solicited and the last lead investigated. Many a sales manager has sworn to meet the required quotas, many a sales force has to a man vowed to 'make the grade,' only to weaken and report that the business was not to be had.

"Yet here and there working under exactly the same conditions, a sales manager and his men have sustained their efforts a little longer, long enough to find the orders coming a bit easier as

NEW CONCERN TO MAKE RECORDS

Olympic Disc Corp. Organized With \$260,000 Capital to Make Records—Remington Phonograph Corp. Has Acquired a Controlling Interest—First Releases on April 15

The Olympic Disc Record Corp., with \$260,000 capital, was recently incorporated under the laws of Maryland. This new corporation announces that it "will manufacture the highest possible quality phonograph records, and plans to engage the best artists available." The New York office of the corporation is at 1666 Broadway, New York City. The laboratories and manufactory are located in Brooklyn, N. Y., and are already in operation.

The officers and directors are Philo E. Remington, president; James S. Holmes, vice-president; Everett H. Holmes, treasurer; John Fletcher, secretary; Walter W. Bock, assistant treasurer.

The Remington Phonograph Corp. has acquired a controlling interest in the capital stock of the Olympic Disc Record Corp. and will handle the distribution of the Olympic records throughout the United States. The initial catalog and first releases will appear April 15.

MAGNAVOX FOR WM. DE MILLE

Used to Direct the Making of Moving Pictures the Magnavox Proves Its Value

Another new use for the Magnavox has developed. Recently William de Mille, director of one of the largest moving-picture corporations, purchased a Magnavox which he now uses to direct the pictures as they are produced. While sitting leisurely in a chair with the transmitter of the Magnavox before him, he talks in a natural tone of voice and succeeds in directing his productions. The result is that the film is not only properly directed, but Mr. de Mille's vocal chords are saved considerable strain.

TAKE OVER PATHE AGENCY

Cure & Son, Martinsville, Ind., have taken over the Pathé agency formerly held by Frank and Fred Finney, of that city.

VOCALION DISTRIBUTORS IN TEXAS

J. W. Crowdus Drug Co., Dallas, to Act as Wholesaler of the Vocalion Products

It was announced by the Aeolian Co. this month that the J. W. Crowdus Drug Co., at Dallas, Texas, has been appointed wholesale distributor for Vocalion instruments and the new Red Vocalion records. This company is the



C. J. De Woody

oldest incorporated drug house in Texas, handling everything used or sold in a drug store. The president of this concern is C. J. DeWoody.

F. Z. Williams is sales manager of the company and R. M. Rankin is to act as manager of the wholesale Vocalion department and is well acquainted with business conditions in that section, having been with the company for fifteen years. At the present time there are twenty-one traveling salesmen in the organiza-



R. M. Rankin



F. Z. Williams

tion and three additional travelers will be added to take care of the Vocalion interests.

The J. W. Crowdus Drug Co. has adopted for its slogan, "The Sign of Quality," and has specialized consistently in quality products. The selection of the Vocalion line, therefore, is accepted as being in keeping with the company's policy and arrangements have been made to feature the line over a wide territory.

NEW STORE IN OMAHA FOR PATTON

Ed. Patton Opens Exclusive Victor Store in One of Omaha's Busiest Trade Centers

OMAHA, NEB., March 8.—Ed Patton, who has owned and operated his Victrola department in the J. L. Brandeis stores in this city for many years, is moving into a fine new location on the main corner of Omaha's busiest downtown thoroughfare, where he will have an exclusive Victor shop. He is closing out everything in the old location in the Brandeis stores. There is perhaps no one in the Middle West who is better known than Ed Patton, and there is no question but what this new Victor location is going to be the busiest place in the city.

Advantage of Record Purchase Cards in Keeping Record Stocks Up to Date

By R. Newbecker

While practically every talking machine dealer of necessity has adopted some method for keeping track of records in stock, it is surprising to find that a great number of them are following methods that not only prove ineffective in keeping an accurate track of records, but consume about as much time in operating as would a perfected system showing details regarding record purchases, the number of records of various sorts on hand at any one time, and other information of a similar nature.

In a great many cases an endeavor is made to keep record stocks up to date by inventories taken weekly or at other stated periods, but this method of checking often proves inadequate and quite as often makes it possible for stocks of certain records to become depleted before replacement orders can be arranged.

The system that is used in many stores with considerable success is the system calling for a continuous checking up, through stock record sheets and sales slips. This means in practically every instance that the checking up must be looked into after each sale, and this involves a considerable expenditure of time in the aggregate.

As a substitute for a continuous inventory, which frequently proves costly both in time and money, there is offered the record purchasing card which is being used by a number of enterprising dealers, and which enables them to tell how their stocks of various records stand at a glance. A reproduction of the card is shown herewith, it being about four by six inches in size, and designed so that each different make of record carried by the dealer can be listed. At the top there is entered the date of the first actual inventory, together with the total quantity of records on hand at that time. In order to facilitate comparison the quantity on hand at the last inventory is also entered.

On the body of the card in the first column the date is entered when each order is placed. In the next column the date is entered when the shipment is received; the third column is for the title, while the next four columns are for the size of the records and the amount of each ordered. The next column represents the title on the reverse side of the record, followed by the order number column and the retail price column. At the bottom of the card an entry is

made of the total quantity of each size of record purchased during the period covered by the card. If one card were used for one month's purchases the total at the bottom would show the total quantity purchased during this time

taken him to dispose of a certain number bought on the last order. From this he can then judge whether or not the amount of his order should be cut down.

By comparing his purchase cards with the

MAKE OF RECORD		INVENTORY DATE		AM'T SALES				
<i>Progressive</i>		<i>12.1</i>		<i>35</i>				
DATE		DATE		QUANTITY ON HAND				
DATE ORD'D	DATE REC'D	TITLE	AM'T	SIZE	REVERSE SIDE TITLE	NUMBER	PRICE	
<i>12.1</i>	<i>12.5</i>	<i>Oh, Such a Time</i>	<i>25</i>	<i>10"</i>	<i>2 12</i>	<i>Time, Not</i>	<i>5678</i>	<i>85</i>
<i>12.15</i>	<i>1.2</i>	<i>She Went Away</i>	<i>15</i>	<i>10"</i>		<i>Here She Is</i>	<i>7863</i>	<i>85</i>
<i>12.20</i>	<i>1.4</i>	<i>Oh, What a Gal</i>	<i>5</i>	<i>10"</i>		<i>Never Again</i>	<i>1243</i>	<i>1.00</i>
<i>12.20</i>	<i>1.12</i>	<i>The Ideal</i>			<i>12 12</i>	<i>The Locust</i>	<i>2467</i>	<i>1.00</i>
TOTAL NUMBER PURCHASED			<i>40</i>	<i>10"</i>	<i>2 12"</i>			
TOTAL ON HAND			<i>4</i>	<i>"</i>	<i>1 "</i>			

Monthly Inventory Record Sheet of Records

and the total amount of records left on hand at the time of the inventory.

When a card of this kind is used in record checking it is comparatively easy for the dealer to guard against overbuying. This card will show when the records were purchased and the quantity of the different titles. When it is necessary to reorder a certain number he can determine at a glance the length of time it has

stock of records on hand at as frequent intervals as possible the dealer can readily detect slow movers before the time comes for reordering. This helps him to keep his stock of records always up to date and avoid the loss and expense that come through the accumulation of a large amount of slow-selling records. Record cards of this kind are being used with success and with comparatively little extra labor.

NYACCO Albums At Pre-War Prices



FEATURES why NYACCO ALBUMS are the BEST as already proven by their great demand

1. Solid wood back re-inforced with cloth hinges which holds back firmly to the cover.
2. Two-in-one pockets secure each envelope from coming apart.
3. Each side edge metal piece reinforced by steel nails into the solid wood back together with staples that secure the pockets are made all-in-one.
4. Pockets can easily be removed by lifting staples from their places, new leaves can be inserted and the staples placed into position again by pressure of the thumb.
5. Specialize in making a ten-inch pocket into a twelve-inch cover, giving cabinet uniform appearance when equipped with ten and twelve-inch albums.
6. The pockets lie perfectly flat when the book is opened.

Sacrificing entire stock at less than to-day's market prices.
F. O. B. New York or Chicago.

Executive Office
23-25 Lispenard St.
New York, N. Y.

New York Album & Card Co.

Chicago Factory
415-17 S. Jefferson St.
Chicago, Ill.

Ask Your Jobber for Genuine NYACCO Albums---Accept no substitute.
Distributors throughout U. S.---Write Us for Name & Address of Jobber nearest you.

Victor supremacy

—all the time
and everywhere

Viewed from the standpoint of musical art, judged by the character and prestige of the stores that handle it, measured in dollars for its ability as a profit producer, the Victrola is supreme.

"Victrola" is the Registered Trade-mark of the Victor Talking Machine Company designating the products of this Company only.

Warning: The use of the word **Victrola** upon or in the promotion or sale of any other Talking Machine or Phonograph products is misleading and illegal.

Important Notice. Victor Records and Victor Machines are scientifically co-ordinated and synchronized in the processes of manufacture, and should be used together to secure a perfect reproduction.

Victor Wholesalers

Albany, N. Y.....Gately-Haire Co., Inc.
 Atlanta, Ga.Elyea Talking Machine Co.
 Phillips & Crew Piano Co.
 Baltimore, Md.Cohen & Hughes.
 E. F. Droop & Sons Co.
 H. R. Eisenbrandt Sons, Inc.
 Birmingham, Ala...Talking Machine Co.
 Boston, Mass.Oliver Ditson Co.
 The Eastern Talking Machine Co.
 The M. Steinert & Sons Co.
 Brooklyn, N. Y.....American Talking Mach. Co.
 G. T. Williams Co., Inc.
 Buffalo, N. Y.....Curtis N. Andrews
 Buffalo Talking Machine Co., Inc.
 Burlington, Vt....American Phonograph Co.
 Butte, Mont.Orton Bros.
 Chicago, Ill.Lyon & Healy.
 The Rudolph Wurlitzer Co.
 Chicago Talking Machine Co.
 Cincinnati, O.Ohio Talking Machine Co.
 The Rudolph Wurlitzer Co.
 Cleveland, O.The Cleveland Talking Machine Co.
 The Eclipse Musical Co.
 Columbus, O.The Perry B. Whitsit Co.
 Dallas, Tex.Sanger Bros.
 Denver, Colo.The Knight-Campbell Music Co.
 Des Moines, Ia....Mickel Bros. Co.
 Detroit, Mich.Grinnell Bros.
 Elmira, N. Y.....Elmira Arms Co.
 El Paso, Tex.....W. G. Walz Co.
 Honolulu, T. H....Bergstrom Music Co., Ltd.
 Houston, Tex.The Talking Machine Co. of Texas.
 Indianapolis, Ind...Stewart Talking Machine Co.
 Jacksonville, Fla...Florida Talking Machine Co.
 Kansas City, Mo...J. W. Jenkins Sons Music Co.
 The Schmelzer Co.
 Los Angeles, Cal...Sherman, Clay & Co.
 Memphis, Tenn. ...O. K. Houck Piano Co.

Milwaukee, Wis. ...Badger Talking Machine Co.
 Minneapolis, Minn..Beckwith, O'Neill Co.
 Mobile, Ala.....Wm. H. Reynalds.
 Newark, N. J.....Collings & Co.
 New Haven, Conn..The Horton-Gallo-Creamer Co.
 New Orleans, La...Philip Werlein, Ltd.
 New York, N. Y....Blackman Talking Mach. Co.
 Emanuel Blout.
 C. Bruno & Son, Inc.
 Charles H. Ditson & Co.
 Knickerbocker Talking Machine Co., Inc.
 Musical Instrument Sales Co.
 New York Talking Mach. Co.
 Ormes, Inc.
 Silas E. Pearsall Co.
 Omaha, Nebr.Ross P. Curtice Co.
 Mickel Bros. Co.
 Peoria, Ill.Putnam-Page Co., Inc.
 Philadelphia, Pa...Louis Buchn Co., Inc.
 C. J. Hepp & Son.
 The George D. Ornstein Co.
 Penn Phonograph Co., Inc.
 The Talking Machine Co.
 H. A. Weymann & Son, Inc.
 Pittsburgh, Pa. ...W. F. Frederick Piano Co.
 C. C. Mellor Co., Ltd.
 Standard Talking Mach. Co.
 Portland, Me.Cressey & Allen, Inc.
 Portland, Ore.Sherman, Clay & Co.
 Richmond, Va.The Corley Co., Inc.
 Rochester, N. Y....E. J. Chapman.
 Salt Lake City, U..The John Elliott Clark Co.
 San Francisco, Cal.Sherman, Clay & Co.
 Seattle, Wash.Sherman, Clay & Co.
 Spokane, Wash. ...Sherman, Clay & Co.
 St. Louis, Mo.Koerber-Brenner Music Co.
 St. Paul, Minn....W. J. Dyer & Bro.
 Syracuse, N. Y....W. D. Andrews Co.
 Toledo, O.The Toledo Talking Machine Co.
 Washington, D. C..Cohen & Hughes.
 E. F. Droop & Sons Co.
 Rogers & Fischer.



Victrola VI, \$35
Mahogany or oak



Victrola IX, \$75
Mahogany or oak



Victrola No. 80, \$100
Mahogany, oak or walnut



Victrola XVI, \$275
Victrola XVI, electric, \$337.50
Mahogany or oak

Victor Talking Machine Co.

Camden, N. J., U. S. A.



IMPORTANT TO THE TALKING MACHINE TRADE



SELECTING THEIR FAVORITES

NATIONAL PUBLISHING CO., 239 S. American St., PHILADELPHIA, PA.

Lower Prices for Record Albums

Yes, due to lower costs, we are making substantial reductions in prices.

We solicit your orders and correspondence.

OUR ALBUMS ARE MADE TO CONTAIN VICTOR, COLUMBIA, EDISON, PATHÉ, VOCALION AND ALL OTHER DISC RECORDS

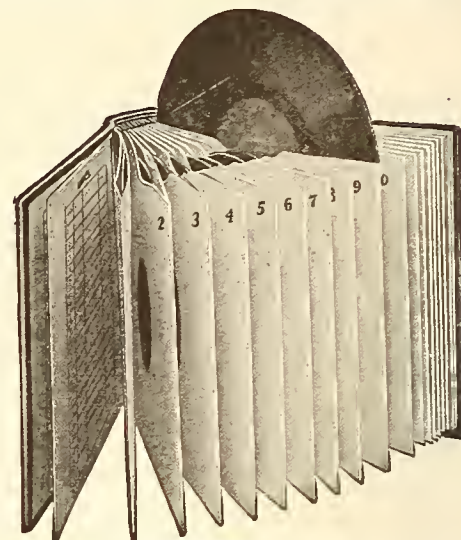

THE PERFECT PLAN

REFUSES TO HAVE VOICE RECORDED

Georges Clemenceau Says His Voice Sufficed for Present Generation and Future Will Not Want to Hear It—Institute to Try Again

The actual sound of the voice of the great Georges Clemenceau may never be heard by future ages if the great French statesman keeps to his recently formed decision. Just before he sailed for India recently he was asked by the Institute of the Sorbonne to allow a record to be made of his voice so that it could be preserved for future generations. He refused to allow this to be done, saying that the present generation has heard enough of his voice and people in the future would probably have no desire to hear it.

When he returns he will be asked to reconsider his decision, for a new scheme is on foot to complete as far as possible the collection of phonographic records of the voices of the famous men now in the Institute and at the same time to make a permanent collection of cinematograph films taken on famous occasions. In these joint libraries of discs and films, will be preserved for all time the voices and appearance of the famous men of this generation.

INCORPORATED FOR \$150,000

The Master Phone Corp. of America, New York, has been incorporated at Albany with a capital of \$150,000. The incorporators are H. Rein, F. C. White and A. M. Hahn, 431 East 136th street.

ATTRACTIVE MARSHALLTOWN STORE

Mickel Music Co.'s Establishment on Main Street Is Admirably Equipped

MARSHALLTOWN, IA., March 8.—One of the most attractive business establishments in this city is that of the Mickel Music Co., which is handling Victrolas and Victor records exclu-



Interior of Mickel Music Co.'s Store

sively. It is located in the center of the business district on Main street and has six 7x9 foot booths. The decorative scheme in blue and gray is in entire harmony with the light blue Wilton carpet on the floor. This attractive store, which was opened late last year, reports a steadily increasing patronage.

REGISTER TRADE-MARK "MASTER"

Argentine Firm Makes Application for This Mark Covering Pianos, Talking Machines, Accessories and Many Kinds of Merchandise

American manufacturers of the trade-mark "Master" should be interested in protecting their rights in South America. Word has been received by the Bureau of Foreign and Domestic Commerce in Washington that the firm of Halle & Co. has applied to the Argentine Government for the registration of the word "Master" for goods of several classes, among them being pianos, talking machines and all accessories coming under Class 10.

In view of the fact that in Argentina ownership of a trade-mark is based on the priority of registration, and not of use, as in the United States, it would be well for American manufacturers who have not authorized the Argentine registration of this mark to begin action for annulment. Under the Argentine law annulment proceedings may be brought within one year from the time when the facts came to the knowledge of the owner of the trade-mark, or within three years from date of registration with the authorities.

THE FACTS IN THE CASE

"Yes," admitted Nero, "I did burn Rome, and I fiddled while it was burning. The musical critic of the Morning Vox Populi had said that my fiddling would never set the Tiber afire, and I wanted to show him a thing or two."

Announcing PEERLESS RECORD FILES Nos. 80 AND 90

The logical and most complete filing system for the new models Victrola No. 80 and No. 90

An indestructible record filing cabinet that fits snugly into the machine and improves its appearance 100%.

PHIL. RAVIS, Pres.

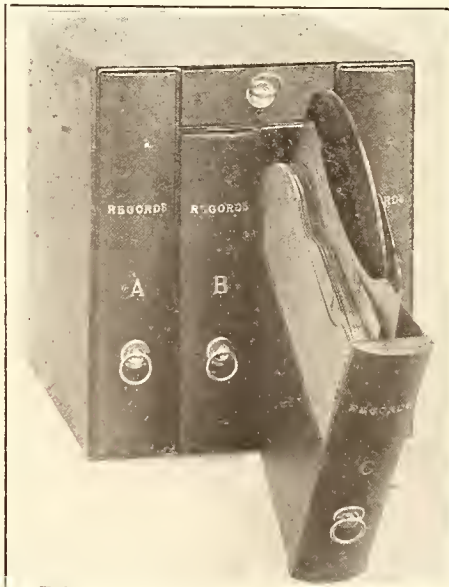

This outfit will make a wonderful selling combination with the new Victrola models.

We are ready to supply the trade at very attractive prices.

WRITE FOR PARTICULARS

PEERLESS ALBUM CO.

636-638 Broadway, New York City



Victrola IV, \$25
Oak



Victrola VI, \$35
Mahogany or oak



Victrola VIII, \$50
Oak



Victrola IX, \$75
Mahogany or oak



Victrola X \$125
Mahogany, oak or walnut



Victrola XI, \$150
Mahogany, oak or walnut

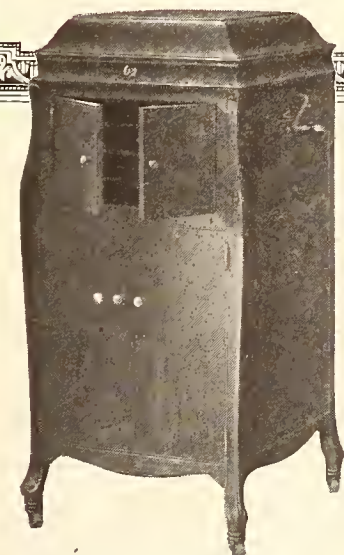

Victrola XIV, \$225
Mahogany, oak or walnut



Victrola XVI, \$275
Victrola XVI, electric, \$337.50
Mahogany or oak



Victrola XVII, \$350
Victrola XVII, electric, \$415
Mahogany or oak

Victor Supremacy

Victor supremacy is a real asset for every music retailer.

Just how much of an asset depends upon the retailer himself—with no limit to the measure of his success.

"Victrola is the Registered Trade-mark of the Victor Talking Machine Company designating the products of this Company only.

Warning: The use of the word **Victrola** upon or in the promotion or sale of any other Talking Machine or Phonograph products is misleading and illegal.

Important Notice. Victor Records and Victor Machines are scientifically co-ordinated and synchronized in the processes of manufacture, and should be used together to secure a perfect reproduction.

Victor Talking Machine Co.

Camden, N. J., U. S. A.

The TALKING MACHINE WORLD

For the makers & sellers of talking machines

PUBLISHED BY EDWARD LYMAN BILL, Inc.

President and Treasurer, C. L. Bill, 373 Fourth Ave., New York; Vice-President, J. B. Spillane, 373 Fourth Ave., New York; Second Vice-President, Raymond Bill, 373 Fourth Ave., New York; Secretary, E. L. Bill; Assistant Treasurer, Wm. A. Low.

J. B. SPILLANE, Editor

RAY BILL, B. B. WILSON, BRAID WHITE, Associate Editors

L. M. ROBINSON, Advertising Manager

L. E. BOWERS, Circulation Manager

Trade Representatives: A. F. CARTER, WILSON D. BUSH, C. CHACE, EDWARD LYMAN BILL, V. D. WALSH, E. B. MUNCH, CHAS. A. LEONARD, SCOTT KINGWILL, A. J. NICKLIN

Western Division: Republic Building, 209 So. State Street, Chicago, Ill. Telephone, Wabash 5774.

Boston: JOHN H. WILSON, 324 Washington Street

London, Eng., Office: 2 Gresham Buildings, Basinghall St. W. LIONEL STURDY, Mgr.

The Talking Machine World has regular correspondents located in all of the principal cities throughout America.

Published the 15th of every month at 373 Fourth Ave., New York.

SUBSCRIPTION (including postage): United States, Mexico, \$2.00 per year; Canada, \$3.00; all other countries, \$4.00. Single copies, 25 cents.

ADVERTISEMENTS: \$5.50 per inch, single column, per insertion. On quarterly or yearly contracts a special discount is allowed. Advertising pages, \$150.00.

REMITTANCES should be made payable to Edward Lyman Bill, Inc., by check or Post Office Money Order.

NOTICE TO ADVERTISERS—Advertising copy should reach this office before the first of each month. By following this rule clients will greatly facilitate work at the publication headquarters.

Long Distance Telephones—Numbers 5982-5983 Madison Sq.

Cable Address: "Elbill," New York.

NEW YORK, MARCH 15, 1921

CONCENTRATE ON A SELLING CAMPAIGN

THE slogan for the dealer who desires to be a winner during 1921 should be "Sales Promotion." This is the big thought that should be uppermost these Spring days. To this end every dealer should study his territory, formulate plans and prosecute them vigorously, to the common end of making several sales occur where only one occurred before.

The other day the publicity man of a large business institution, one that advertises widely and sells extensively, in the course of an address asked this significant and pointed question of the executives of the concern for whose products he prepares advertising: "What does it avail you to solve all of the other problems of your business if you do not sell your product?" Now this sounds rather a commonplace question, but doesn't it somehow give an unusually impressive and comprehensive idea of the importance which should be attached to the selling end of the business?

When we get it down to a final analysis, selling is one of the prime essentials and not merely an incidental factor in business. Too many business men seem to regard the selling of their product as a mere incident that can easily be attended to without great expense or much thought in preparation. The real fact of the matter is that the selling end of any business constitutes one of the basic, essential factors toward the achievement of success.

A great many business men—and the talking machine field is not exempt by any means—have not concentrated as they should on the proper method of selling their product—at least when present conditions are considered. There is room to put aside more in the cost division of the selling end of the business, and there is room for a number of activities to promote selling which heretofore have too often been neglected or only half-heartedly done. Boiled down to absolute fundamentals there is no commercial profit to be derived from a business unless the product is sold. And the selling, like manufacturing, when properly done costs money and requires persistent and intelligent effort.

There is no excuse for the dealer who is indifferent to these facts, because the manufacturer or jobber from whom he buys, or even the trade publication of his industry, is willing to give him suggestions and "leads" that will put him on the right road. Everybody is desirous of helping the dealer who gives evidence of a "will for knowledge" bearing upon sales promotion. The fact is, however, that a very large number are indifferent, and fail to make

any unusual efforts in the sales field, yet they complain when a competitor, or mail-order house, captures their trade. The man who is going to make the best record in sales during 1921 is the man who maps out a definite plan of campaign—the man who knows his territory and who gets after the people in that territory intelligently and persistently.

SOME CONSTRUCTIVE SUGGESTIONS ON TAXES

THE members of the talking machine trade who are, in some measure at least, affiliated with the Music Industries Chamber of Commerce should be much interested in the program put forth by the Chamber on the recommendation of its legal committee for providing the revenue required by the Government, while at the same time making possible the abolition of the excise and excess profits taxes. The Chamber, in short, goes on record as favoring some sort of limited sales or commodity tax, and an income tax levy on every wage-earner over twenty-one years old as means for providing the several billions of dollars required by the Government without necessitating further reliance upon excise and excess profits taxes.

For the first time the music industry, as represented by the Chamber of Commerce, has come forward with a constructive suggestion calculated to relieve the industry from obnoxious tax burdens, while at the same time providing means for raising the necessary revenues through other channels. In the several tax fights that have taken place during the past few years the trade has simply filed protests against the burdensome excise taxes and has left to Congress the problem of raising revenue by other means should those taxes be abolished. Congress, on the other hand, has been flooded with similar protests from members of many other industries who have likewise neglected to point a way out, with the result that the protestants have received very little consideration.

The suggestion made by the Chamber of Commerce that a general commodity sales tax be put into effect to replace other forms of taxation, and to simplify the tax problem generally, is in line with recommendations made by many other trade bodies in that it is designed to abolish obnoxious excise taxes and should receive the consideration and support of talking machine interests, either directly or through the Chamber. On the latter point it is to be noted that a solidly organized industry is likely to receive more consideration from the law-makers than an industry represented by several distinct units.

A TIME TO KEEP WATCH ON SALES METHODS

IN the world of merchandising it is easier to tear down than to build up; easier to upset values than to re-establish them. This fact in itself is axiomatic, and yet numerous dealers in the talking machine industry have apparently given scant heed to this fact in the carrying out of plans to stimulate business, or rather to give business a false stimulus. While general price-cutting may stimulate sales to a certain degree, it does so at the expense of profit and of confidence unless the price reduction is warranted by the lowering of production costs and there is a real reason for the product again approaching the normal in the matter of first cost.

In the talking machine field this condition does not prevail, for increased costs have been absorbed by manufacturers to such a degree that there is now no margin of inflated prices to give some leeway to price reductions to meet a real or fancied demand. Had prices been jumped two or three hundred per cent, as in some lines, instead of only from twenty to fifty or sixty per cent, as in the talking machine trade, they might have been reduced to the public without worrying about the results. It so happens that in this trade inflated margins do not exist.

The tendency toward price slaughtering in the talking machine trade is particularly unfortunate, inasmuch as the retail industry has always owed its real strength to a policy of price maintenance that was so generally observed as to be characteristic. Even after price fixing by manufacturers was frowned on by the courts, talking machine prices remained stable because business conditions were good—the public had been educated to standard prices and the retailers appreciated the fact that such prices kept their businesses sound and healthy.

Even the offering of talking machines on unusually long terms is generally to be condemned, for the average investment is not so heavy but that the buyer, if he is in any sense a good risk, should

be able to clear up his obligation in a very few months. But even long terms where the list price is observed are preferable to the general cutting of that list price, for they do not upset what may be termed an established precedent.

The trade as a whole is already feeling the effects of the wave of price-cutting by dealers that has swept through various sections of the country, and there are those who maintain that the practice has already reached the point where in some instances it will be extremely difficult to again re-establish the standard price as a trade characteristic. The unfortunate part of it is that those who adhere to, and have adhered to, established prices in the main, with possible exceptions to meet special conditions and occasions, are suffering, and will suffer, from the practices of those who evidently have little confidence in the recuperative powers of the industry and are taking the easiest way to build up current sales totals.

In the handling of products that cannot be considered seasonable, as, for example, talking machines, and which can be sold in the Fall as well as in the Spring and in the Summer as well as in the Winter, it seems unfortunate that the practice of demoralizing prices, so little warranted by manufacturing and selling costs, should have appealed to so many of those in the distributing field.

GREAT SINGERS HAVE NOW BECOME IMMORTAL

THE recent serious illness of Caruso emphasizes afresh that the grand opera tenor of international fame is a veritable monarch, not only in the realm of song, but in the hearts of his fellows the world over. No king, no matter how powerful the country he rules over, could have been accorded greater consideration by the newspapers, his thousands of friends and the general public than was Caruso during his illness. It will not be deemed amiss to assert that the great popularity of the great tenor can be attributed in a very large degree to his talking machine records, for they have brought Caruso's voice, personality and art into the homes of the humblest of people—into the backwoods as well as the Fifth avenue mansion. In this way there has been established an unusual intimacy—the closest possible relationship to the singer. Hence it was that the entire country was so keenly interested in the illness of this popular singer, who, we are glad to say, is now convalescing.

The important part the talking machine record plays in the perpetuation of the voices and fame of our famous singers was

thus elaborated in a recent editorial in the New York Times: "Public interest in the illness of Mr. Caruso has been of an unusually personal sort; it has considered not only the accomplished artist, but the well-loved personality. The possibility of his loss brought forth, as might have been expected, attempts at consolation by the reminder that his voice has been preserved on the talking machine, and that a hundred years from now he can still be heard in his great parts.

"In the course of a hundred years or so, however, the talking machine will have had a profound effect, not only on music, but on musical criticism. The first axiom of a certain school of critics is that all the great singers are dead. Too often this is carried on to the corollary that all the dead singers were great. For the last few decades young enthusiasts who ventured to express their admiration of the cherished tenor of the time have always had to risk the scorn of some veteran who would retort: 'Ah, but those of us who have heard the great Rutabago!' or 'When the divine Minestrone sang at the Academy of Music!'

"Such facile disparagement of those who have the misfortune to be alive and audible will be out of favor in another generation or so. The music lover of 2021 will be able to turn to his talking machine and hear, in a reproduction which one may suppose will be progressively more adequate, the voices of Caruso and his great successors. Their relative merits he can estimate for himself. But the critic, when a new vocal star appears, will have to make a serious effort to estimate his value for a public which has its own method of checking his observations."

It is rather interesting to note that talking machine dealers throughout the country reported a tremendous increase in the sales of Caruso records during his illness. It seemed as if people wanted to express their sympathy by hearing his records—a sort of psychological manifestation of their good will and friendship.

TRADE TREND IS DEFINITELY OPTIMISTIC

BUSINESS continues to show every evidence of improvement, although progress is slow. The characteristic steps in the liquidation process have occurred in established progression. One thing clearly ahead is a broad cycle of expansion. Hence the trend is now definitely optimistic, despite the numerous cross currents that may be encountered.

Wholesale



FROM THE FACTORY
SHIPPING DEPT.
TO THE DEALER

"In and Out the Same Day."

Exclusively

METROPOLITAN Dealers, do you use Pearsall's Back Order System?

Ask any Pearsall dealer—He will tell you.

"That's Pearsall Service."

"Desire to Serve PLUS Ability."

10 EAST 39th ST.



NEW YORK CITY

SILAS E. PEARSALL COMPANY.

DISTRIBUTORS



A Vital Message to Dealers

The Base of a Gilt Edge Phonograph Needle is manufactured by the firm that made the first talking machine needle—the oldest and largest manufacturers of phonograph and talking machine needles in the world

Try This Test With “Triple Plated” REFLEXO “Gilt Edge” Needles

Play any record ten times with a “Triple Plated” Gilt Edge Phonograph Needle. After 3000 revolutions of the record, you’ll hear as pure and mellow a tone as at the very first revolution. Here’s the explanation of the amazing qualities possessed by “Triple Plated” REFLEXO Gilt Edge Needles:

The point of a Gilt Edge Needle is treated by an exclusive REFLEXO process which adds to the needle point a layer of soft material, that will not wear off until at least 3000 revolutions of a phonograph record have been made. The grain of the steel does not come in contact with the record grooves. By minimizing the friction and by eliminating the scratching, scraping sound, the chemical layer on the needle not only produces a more beautiful tone, but actually prolongs the life of the record.

REFLEXO Gilt Edge Needles are triple plated and lacquered to insure them against tarnishing. From base to finished product, they are American made. May be had in Extra Loud, Loud and Medium tones.

REFLEXO Gilt Edge Needles are manufactured of the finest grade steel, and are guaranteed to be absolutely uniform in temper, length and taper. Line up any number of any of the three tones of Gilt Edge Needles, and see for yourself.

Write
for Samples
and Prices

Territories
Open for
Live
Distributors

REFLEXO PRODUCTS CO., Inc.

347 FIFTH AVENUE

At 34th Street

New York City

Suite 1003

Canadian Distributors: The Musical Mdse. Sales Co., Toronto
Foreign Export: Chipman, Ltd., 8-10 Bridge St., New York City

Making the Proper Preparations for a Large Crop of Business This Spring :: :: By Fred D. Parsons

The Spring of 1921 will be a Spring when results are going to be measured in terms of the preparations made. No campaign ever succeeded without ammunition—effective ammunition—as the world has learned full well. Conditions adverse to ready sales must be met by ammunition designed specially for this purpose. No general would attempt to batter down a wall with smoke bombs. And no talking machine dealer can expect to win for himself a trade victory without the real ammunition of warfare.

Every sales problem has its own kind of ammunition which, if properly used, will do its work in the proper way. Once the changed attitude of the public toward buying is recognized and means taken to combat it, the campaign must be drawn up and followed through to its conclusion. In some cases talking machine dealers this past Winter have allowed their stocks to sink perilously low. Some of them have held off buying new stock and have held off so long that unless they order at once they will not be in a position to supply a normal demand should this demand arise.

The mind of the average buyer, and this includes the buyer of talking machines and records, has become more critical. The customer, even though he comes into the store, does not evidence the old desire to buy. Once upon a time if he could not be supplied with a particular instrument or record he was satisfied with something else. But now this attitude has disappeared and the half-hearted desire to purchase may be killed by the failure of the dealer to have what is called for.

Particularly is this true in the matter of records. Failure to get a record at a certain store usually sends the trade of this particular disappointed customer to a competitor who is doubtless wise enough to see that it is kept there. This Spring there should be no excuse for shortage of records. Every record library should be carefully analyzed and the demands of the trade estimated to a nicety. Store equipment must be put in good shape, modernized if necessary, but in any case made to render the most efficient service possible.

The sales force, above all, should be intelligently trained. Too often a dealer will spend large sums of money on his store—remodeling and redecorating and installing new booths, rec-

ord racks, counters, etc.—and yet fail to accomplish anything in the way of increased trade. He has failed to realize that the personal contact with the customer is his best means of getting and holding trade. He cannot take care of everyone himself and so must depend upon his sales force to do this work for him. To-day the work of a talking machine salesman has so far advanced from what was required ten years ago that there is little in common between the two. Now a salesman must not only know all

The saying that "a salesman must be more than a salesman" is certainly true in the music industry, where a dealer is selling really a means to an end. He is selling the enjoyment which his product will bring to the home and family of the buyer. Consequently he must know the needs of the buyer, and in studying them he will know what particular design of machine or what type of records will appeal. This is why the dealer should take pains to train his salesmen before he can expect them to render real service.

Preparing for Spring business seems to consist in doing only a few things: seeing that the stock of machines and records is adequate to take care of the demands the dealer expects to create; making the store facilities equal to the work they are intended for, and, last of all, having the sales force trained in their task. Simple enough to say and some will no doubt say that it is likewise simple to do. That may be, but sometimes it is the simple thing that is left undone simply because the feeling that it can be done any time prevents prompt action. To get a store or a business in good running shape requires intelligent thought coupled with intelligent action. Each is powerless without the other.

The dealer may see that certain things are needed in his store if he is to cope with increased trade. He should see that a new record rack or a new booth is installed at once. He should order now if his stock is not up to standard. In other words, he must lay in his ammunition for his campaign. By doing so he prepares for success and if he carries his plans through he will achieve it.

What the Dealer Needs Is Sales Ammunition That Will Meet and Overcome the Present Attitude of the Public

about his product, but he must know furniture styles, finishes, interior decorating effects, and the like. He must be able to talk music, opera as well as popular. He must know about the artists, their personal traits and other interesting information. If he can do all these things he is the salesman who will make and keep patrons for any dealer.

A NEW MICHIGAN CORPORATION

Lind & Marks Music Co., Detroit, Chartered for Purpose of Distributing Vocalions

DETROIT, MICH., March 8.—The Lind & Marks Music Co. has been incorporated here for the purpose of jobbing and distributing the Vocalion instruments and Vocalion Red records in Michigan, Northern Ohio and Northern Indiana.

The incorporators are Louis M. Marks, M. Marks and S. E. Lind. Mr. Lind will act as president of the corporation. Mr. Lind is an outstanding figure in the phonograph field in Michigan as he has been for nineteen consecu-

tive years associated with the Columbia company, for the past several years as branch manager.

The Messrs. Marks, father and son, have been traveling the State of Michigan for a number of years selling phonographs and records. There is not a phonograph dealer in the State of Michigan who does not know all three of these people.

INCORPORATED IN BOSTON

The Hager-Mann Mfg. Co., Boston, has been granted a Massachusetts charter to manufacture talking machines. The capital of the company is stated to be \$500,000.



WHOLESALE THAT'S ALL

In order that we may more properly serve the Victor trade we have decided to discontinue, permanently and entirely, our retail activities, and have therefore sold that branch of our business.

The undivided efforts of this entire organization are now at your command, Mr. Victor Dealer, not only to supply you with Victor merchandise, but to provide you, as well, with sales helps and service that will assure you a bigger and better Victor business.



THE ECLIPSE MUSICAL CO.

Wholesale Only

Cleveland, Ohio

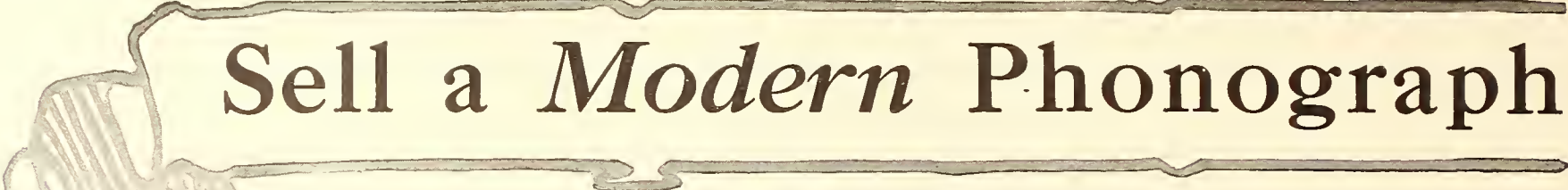

Sell a *Modern* Phonograph

WHICH is the easier to sell — a phonograph with all the up-to-date refinements and improvements that make a *modern* phonograph, or an old-style instrument without them?

Before you ask the public to pay good money for a phonograph, be sure that the instrument you offer has all the *modern* features.

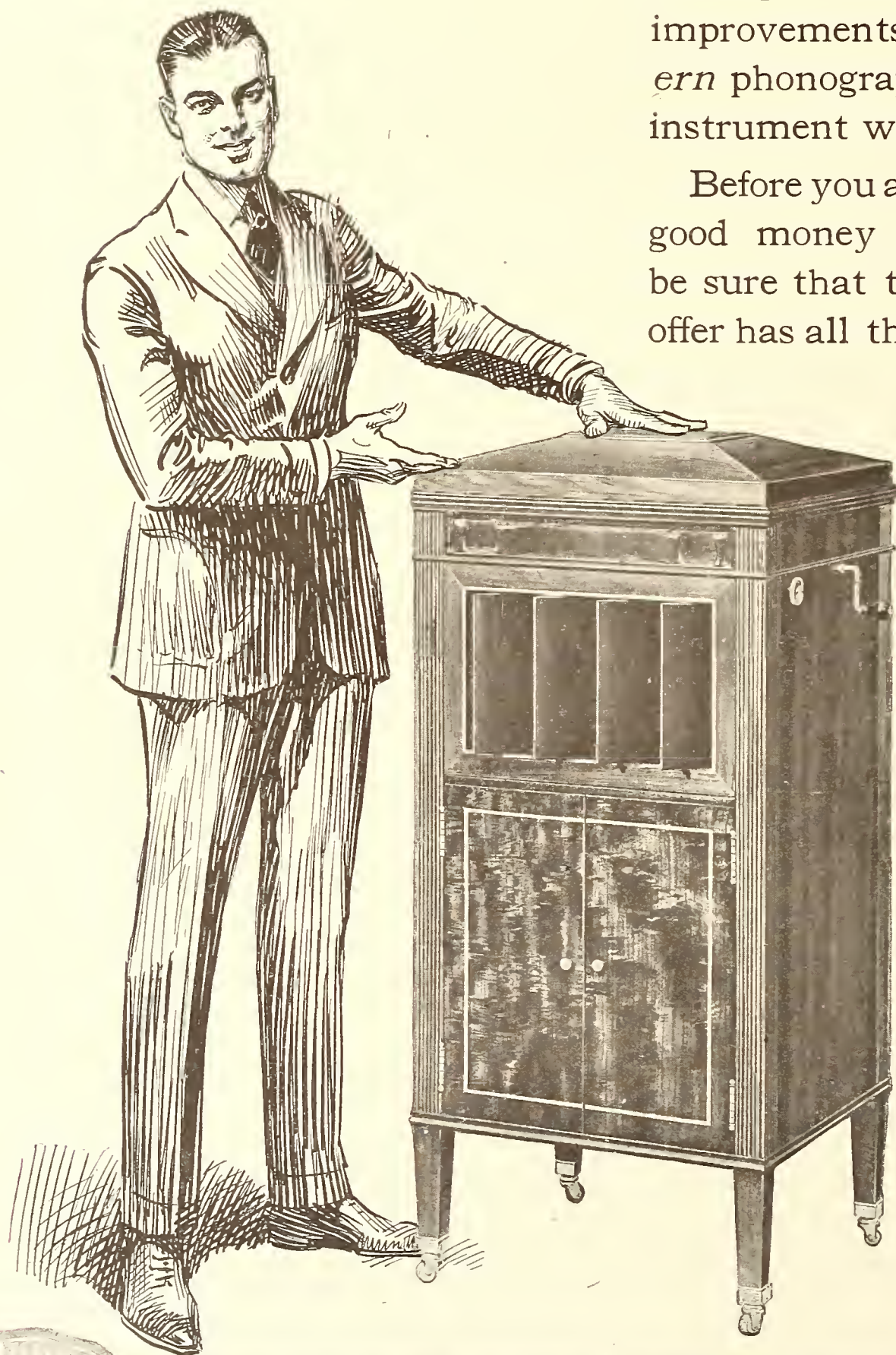

COLUMBIA

There Is Only One—Columbia

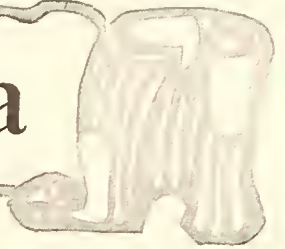

THE Columbia Grafonola not only has all the big and little refinements and improvements that make a *modern* phonograph, but there is no other *modern* phonograph, because most of these *modern* features are *exclusive* Columbia advantages.

The Columbia Grafonola has the *exclusive* Columbia Non Set Automatic Stop, which noiselessly switches off the motor at exactly the right moment when the end of each record is reached. Operates on any record, long or short.

All other stops have to be set by hand for every record, but no such preparation is necessary with this *exclusive* Columbia device. There's nothing to move or set or measure. Just start the Grafonola, and it plays and stops itself.

The Columbia Grafonola has the *exclusive* Columbia Adjustable Tone Leaves, by means of which its music can be made either loud or soft, as the selection requires, without sacrificing tone quality or any of the beauty of the record.

An additional *exclusive* feature of the Columbia Grafonola is its Straight Tone Arm, which allows the sound waves to develop fully and naturally. This, with its Scientifically Correct Acoustic Design, insures a tone of exquisite clearness and purity.

Finally, the Streamline Cabinets of all Columbia Grafonolas are *exclusive* models, each one made in strict accord with *modern* artistic furniture design. Every Columbia Grafonola is an instrument beautiful to see, easy to operate, and exquisite to hear.

Sales Department

COLUMBIA GRAPHOPHONE COMPANY
NEW YORK

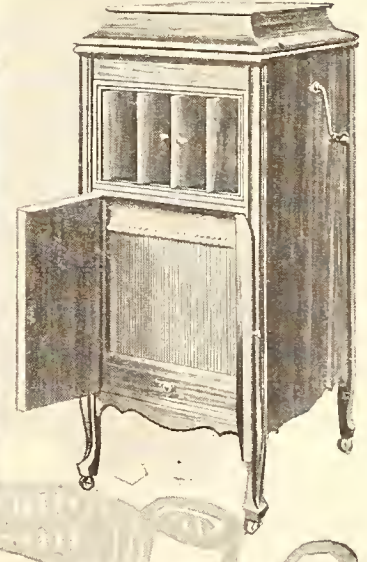
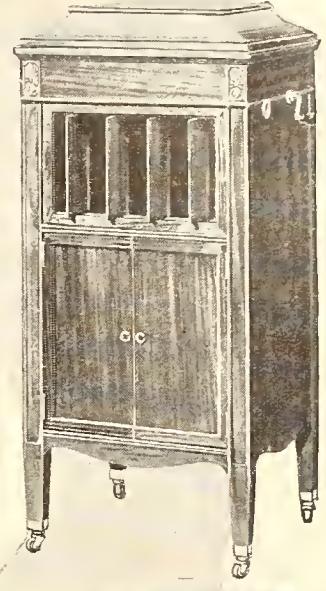
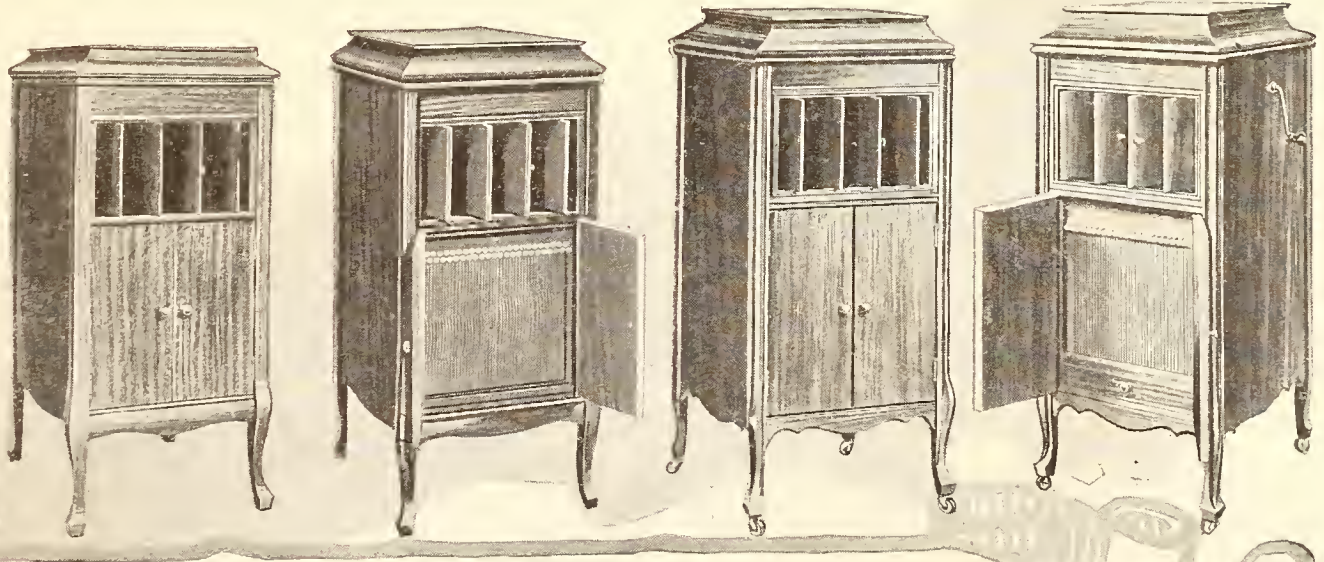
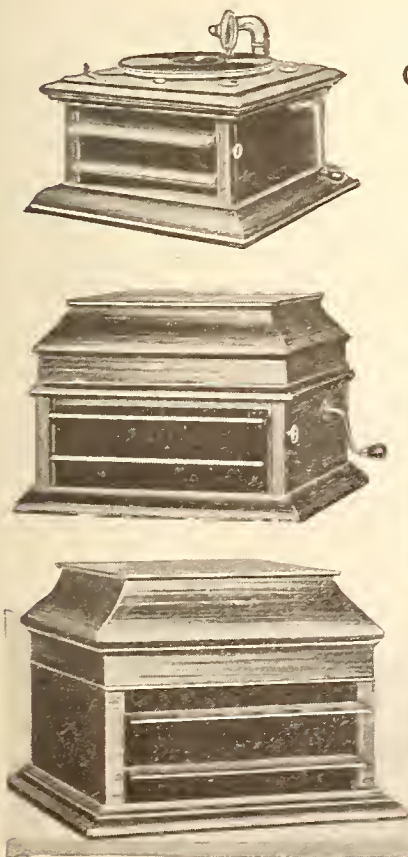

GRAFONOLA



H. A. BRENNAN WITH WURLITZER CO.

Appointed Manager of Victor Department of the New Wurlitzer Headquarters on Forty-second Street, in New York City

Herbert A. Brennan, member of the traveling department of the Victor Talking Machine Co. for the past three years, has resigned that position to manage the Victor department of the



Herbert A. Brennan

Rudolph Wurlitzer Co. in its new quarters on Forty-second street, New York. He will take up his new duties commencing March 1 and will begin immediately to gather an organization and to handle the many details which will go to make this one of the largest retail establishments in the United States.

Mr. Brennan's experience in the Victor business has covered a period of seven years, dur-

ing which time he has become recognized as one of the foremost of the younger generation possessing executive ability. The Wurlitzer Co. is to be congratulated on securing the services of a man so well fitted for this position.

Victor dealers in Brooklyn and Long Island express great regret in seeing him depart from this field which has shown such a vast improvement during his régime. His service to the dealer has brought about a betterment in Victor representation and has established for him the confidence and recognition of his superiors at Camden.

The Wurlitzer Co. will be in its new skyscraper, which it has just completed, about April 1. It is said to be the last word in musical merchandising, surpassing anything which has ever yet been attempted. The Victor department, which will be located on the first floor, is complete in every detail, having more than forty booths. Several floors above this will be given to pianos and musical merchandise. One of the features of the establishment will be the beautiful auditorium, which will be given to daily concerts.

TRAVELING FOR VICSONIA CO.

Frank Rudolph Now Handling Vicsonia Reproducer on the Road—Demand Growing

Frank Rudolph, who is quite familiar with the talking machine trade, is now traveling for the Vicsonia Mfg. Co., Inc., New York, makers of the Vicsonia reproducer for playing Edison records on Victor and Columbia machines. Mr. Rudolph is now in the South and is making very satisfactory reports from that region. The demand for the Vicsonia, it is stated, is continuing to increase despite general trade conditions. An interesting feature of the business is the number of orders received from foreign countries.

The joy of a kind act is from the same source as that of anything well done—it is all in the doing and not in the gratitude of those for whom it is done.

FEATURE COLUMBIA ARTIST

Harry Fox Featured in Window Display Made by Hartman Furniture Co. Store

The Dealer Service department of the Columbia Graphophone Co. received recently an interesting photograph from the Hartman Furni-



Display of Harry Fox Columbia Records Furniture Store, one of the largest stores in Omaha, Neb., portraying a recent window display used by this concern.

Harry Fox, exclusive Columbia artist, was featured in this display, which won the enthusiastic approval of passersby. On the floor of the display the word "Columbia" was formed through the use of Columbia publicity matter, making an artistic centerpiece for a very effective display. Mr. Sternburg, manager of the Hartman Furniture Store's talking machine department, reports a healthy Columbia trade that is steadily growing.

LOUISVILLE STORE REMODELED

The L'Harmonie Co., Victor dealer of Louisville, Ky., recently remodeled its store and increased its roster of booths from five to nine. A very handsome reception room has also been arranged in front of the store. Manager Calveard is quite pleased with the change which he believes will add considerably to the attractiveness of the store as a rendezvous for buyers.

Products are not things of steel and wood—they are the expression of dreams, experiments, skill, brains, organization and toil.

STATEMENT *OKeh* Records have proven themselves!

QUESTION—Has your service been as good as the record?

SUGGESTION - Try KENNEDY-GREEN service in connection with

OKeh Records
DEAN NEEDLES, etc.

ANOTHER SUGGESTION - Write

KENNEDY-GREEN COMPANY

1865 Prospect Avenue

Cleveland, Ohio

AND SEE WHAT HAPPENS

How a Local Trade Organization Can Work to Discourage the "Dead Beat" :: :: By D. G. Baird

Mrs. Henry Jones has selected a cabinet talking machine which she wishes to purchase from the Modern Phonograph Shop, paying therefor \$37.50 down and the remainder of the purchase price in weekly sums of \$5 each.

The salesman who has waited on Mrs. Jones prepares an application for credit, asking the usual questions about her address, husband's employment, property, references, and whether she has ever carried an account at another store in the city. Mrs. Jones answers the latter question in the negative. She has never liked to run an account, she says, but happens to be a little short of money just at present and has decided to take advantage of the shop's dignified credit plan and have music in her home at once instead of waiting a few weeks until she has all the money on hand at one time.

The application blank is filled out and she affixes her signature, thereby giving her written word that the above information is true. She makes her deposit of \$37.50.

Then the salesman asks Mrs. Jones to excuse him for a moment while he has her bill prepared and attends to some other little formalities. He is gone two or three minutes. He returns and enters into casual conversation with his customer for a few minutes more.

"How long did you say you have lived at your present address?" he asks presently. Mrs. Jones replies that she has resided at her present address for some six years.

"H'm! Let's see," pursues the salesman. "How long did you live at 234 Poplar street?"

"I?" exclaims Mrs. Jones in a surprised tone. "Why, I have never lived on Poplar street?"

"I see. Must have been some other Jones. There used to be some Joneses living at 234 Poplar street. They moved from there last January.

"Did you ever buy anything from the Melodious Shop, Mrs. Jones?"

"No, I don't believe I know anything about the Melodious Shop. Is it located in the city?"

"Oh yes. Right over on Main street. Seems rather odd, but a Mrs. Henry Jones bought a period Melodious from them last Christmas. This Mrs. Henry Jones lived at 234 Poplar street at the time, but removed from that address on January 1 without leaving a forwarding address."

The salesman steps to the door and admits another gentleman, whom he introduces as "Mr. Brown, of the Melodious Shop." Mr. Brown produces a paper which he and the salesman compare with Mrs. Jones' application for credit from the Modern Shop. The signatures are the same. But Mr. Brown's paper is the contract of the Mrs. Henry Jones who formerly resided at 234 Poplar street and who removed from that address several months before while owing the Melodious Shop nearly \$300 on a phonograph.

Mrs. Jones may doggedly deny that she is the one who skipped out from 234 Poplar street owing the Melodious Shop a sum of money, but the evidence is all against her. She is told that

street; occupation, husband, mechanic, Dodge's." This was the only information given on the card, and the pasteboard itself was white.

Another thirty seconds and the salesman had telephoned to Mr. Brown, credit manager of the Melodious Shop, to bring over the contract of Mrs. Henry Jones of 234 Poplar street. He then returned and engaged Mrs. Jones in conversation for the few minutes it took Brown to hurry over with the convicting contract.

No, this didn't actually happen. It isn't being done among talking machine dealers. What actually did happen was that the salesman bade Mrs. Jones a cordial good-day and delivered the talking machine on the following morning. Two weeks later Mrs. Jones, having ignored the statements that had been sent to her, a collector called at her home and learned that she had moved and had left no forwarding address. The Modern Shop doesn't know yet that the same person also skipped out on the Melodious Shop, nor do the other talking machine dealers of the city know that such a party has beaten several other dealers and will very likely do the same for them in the near future.

Making Hard Times for the Crooks

The above incident is, however, illustrative of a system that is catching skips almost daily. The dealers in another line in a large city have organized a credit association that is protecting them from untold losses, while collecting thousands of dollars for them.

The system adopted by this association might very well be used by talking machine dealers to splendid advantage.

The system is this: The association employs a salaried secretary who devotes all her time to the work of preparing records of skips, rejections and undesirables. Each day the members prepare lists of their skips or of those who are so slow in paying as to be wholly undesirable and of those to whom they have refused credit. The secretary calls and collects these lists, returns to her office and prepares cards for each member of the association. These cards are then delivered on the following morning, when she collects the reports for the previous day.

Cards are the usual card-index kind and are of three colors: white, representing a skip or

(Continued on page 16)

By a Systematic Interchange of Information the Pathway of the Swindler Can Be Made Rough and Dangerous

there is but one thing for her to do—pay the Melodious Shop in full and let her deposit apply on a cash purchase from the Modern Shop.

There is no need for her to persist longer. The Modern Shop has her \$37.50, together with her new address, references and husband's place of employment. She is caught with the goods on and that is all there is to it. She will pay the Melodious Shop and if she ever buys anything in another talking machine shop in that city she will pay cash for it.

How It Was Done

What happened was this:

When the salesman asked Mrs. Jones to excuse him for a moment he stepped into another room and consulted a card file. In thirty seconds from the time he left Mrs. Jones he was reading a card that gave this information: Name, Mrs. Henry Jones; address, 234 Poplar

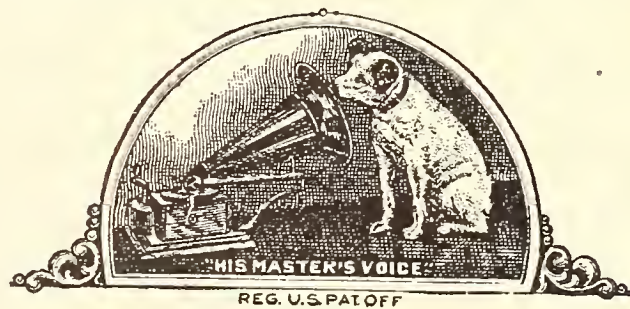

Anything Worth Doing Is Worth Doing Well

You are handling Victor merchandise.

We believe the logical way to handle it well is to handle it Exclusively.

ORMES, Inc.

103 E. 125th St. Wholesale Exclusively NEW YORK



"O-H-I-O (O-My!-O!)," sung by Al Jolson, and "I Want to Go to the Land Where the Sweet Daddies Grow," by Van and Schenck, will make people want to go to the only store that sells their records—yours. A-3361.

**Columbia Graphophone Co.
NEW YORK**

DISCOURAGING THE "DEAD BEAT"

(Continued from page 15)

one who is wholly undesirable; green, representing one who has been denied credit by a member of the association, and blue, representing women who are implicated in divorce proceedings or whose husbands have disclaimed responsibility for their debts.

The only information given on the cards, apart from that of color, is the name, address and occupation of the applicant, and the name, address and telephone number of the member who made the report.

Each member of the association has a set of the cards in his own shop. The number of cards is increased from day to day, as the secretary brings around from half a dozen to fifteen or twenty each morning.

Besides these cards, the secretary has another file, called the removal file, in her office, which is not kept by the individual members. In this file the secretary keeps a record of all removals into, out of, or within the city. The file is arranged alphabetically by streets and the names filed alphabetically under the street divisions of the file. The information for this file is gathered from a daily paper published by the city. A city ordinance requires all van and moving companies to report all removals to the Police Department and the information is published, along with other matters, of course, in this paper.

Cards are kept for one year in the removal file, the cards for the same months one year before being withdrawn each month. Cards in the files of the members are kept perpetually.

The information concerning women whose husbands have disclaimed responsibility for their debts is obtained from the personal columns of the daily newspapers.

How It Works

When this association was first formed the dealers found that there was a systematic business of robbery being carried on in the city. The same ones who were beating one dealer were also beating other dealers in the same way. Then they brought out their old books and prepared cards for the past five or six years, and they have been collecting these old debts ever since.

When Mrs. Jones applied for credit from the Modern Shop all the salesman had to do was to step into the next room and consult his file to

find that she had beaten the Melodious Shop some months before. A telephone was in the room and he immediately called up Mr. Brown and told him to hurry over with the contract of Mrs. Henry Jones, of 234 Poplar street, with what results we have seen.

If Mrs. Jones' card had been a green one the salesman would have called up the shop the name of which was given on the card and have inquired why they had rejected her account. He would then have used his own judgment as to whether his company should accept the account.

If, again, her card had been a blue one, he would have returned and said casually, "Now, of course, we'll have to have your husband's signature on the contract, Mrs. Jones." If Mrs. Jones knew this to be impossible that would have settled the matter and the company would have been saved a bad account. If, on the other hand, there had been a reconciliation of some kind and she could get her husband to sign the contract, well and good. Hers might be a very desirable account.

The old trick of opening an account and then moving to another address is defeated by the removal file, for the simple reason that the secretary of the association knows the customer's new address on the following day. When the customer fails to meet her payments as agreed and the collector finds that she has moved, all he has to do is to call up the secretary's office and get her new address.

Many impersonators are being caught by this association also. Each member of the body has his investigator, of course, and he readily learns whether or not the person of the name given has made the purchase. In the case of impersonators, two cards are made out, one of the impersonator and one of the person impersonated. The former is, of course, turned over to the police.

This association has succeeded in utterly wiping out the bands of crooks that formerly grew rich preying upon them. The dishonest ones can't understand how it is done, but they know such an organization exists and that they can't beat it.

So successful has the work of this association been that other dealers in the same and other cities are copying it with splendid results. Every large city has its credit men's association, but these organizations are of very little

value to their members. They are too large, for one thing. For another, the members do not have their files of undesirables. The central office of the association has huge files containing the names of all customers who carry accounts with members of the association, but if one wishes information about a certain person one must call up the central office and wait for it. Dealers very naturally do not care to use the telephone to make inquiries about every person who applies to them for credit, thereby exposing their business secrets.

How Talking Machine Dealers May Use System

Talking machine dealers in large cities could use the same plan that has been outlined above. Those in smaller cities would probably not need to employ a salaried secretary, but could entrust to a stenographer in one of the shops the task of getting out the cards. Such expense as is incurred would be borne by all the members.

It is not necessary or desirable that the members expose all their accounts. Only the cards of the bad ones should be prepared and filed. The idea is simply that of organization for mutual protection and assistance.

The success of the plan depends wholly upon co-operation of the members of the association and in getting out the cards promptly. There is little use to organize and adopt the system if the dealers are going to be backward about letting others know how many have beaten them or are beating them, or if the secretary is going to dally along and not get out the cards promptly.

The latter fault has almost dissipated the benefits of the association in one organization that has copied after the one described in this article. There are twenty large firms in this association and when they organized they presented lists of thousands of old accounts for which cards were to be prepared. Thereafter they sent in long lists daily, with the result that the secretary has been utterly swamped and has been unable to keep up with the current lists, much less make out cards for the old accounts.

Hardly any organization of talking machine dealers would be so large as to cause this difficulty, however.

Dealers in any town or city who organize such an association and co-operate heartily will be protected from untold losses and will collect thousands of dollars from old accounts which they had almost despaired of ever realizing on.

SOME LATE HOUSEHOLD HINTS

We live to learn. Here is a person who is sold on the idea of having music in the home. In order to make housework easier it is suggested that by sprinkling the silver polish on the turntable of the family talking machine the family silverware may be cleaned with neatness and dispatch. This ought to be good for the turntable! The idea might be carried out in other household ways, such as sharpening razor blades, manicuring, shining shoes and then, if there were any time to spare—playing records!

H. J. SMITH LABORATORIES

Jewel Manufacturer

EXECUTIVE OFFICES,
FINISHING and
RECORDING
LABORATORY JEWELS

Plant No. 1
833 Broad Street
Tel. 2896 Market
NEWARK, N. J.

SAWING
GRINDING
ROUGHING
ROLLING and
EXPERIMENTAL
LABORATORY

Plant No. 2
54½ Franklin St.
NEWARK, N. J.

MANUFACTURER OF

Phonograph Diamond and Sapphire Reproducing Points—Recording Laboratory Jewels—Rough Diamond—Diamond Powder—Experimental Work. Jewels manufactured for all talking machine records. Consulting Specialist on all experiments relating to any new recording grooves. Recording problems satisfactorily worked out.

Reduced Prices

Lundstrom CONVERTO

PATENTED DEC. 11, 1917

Talking Machine Cabinets

VICTOR DEALERS handling Lundstrom Converto Cabinets will be interested in knowing that in keeping with the times we have recently reduced our prices on all Standard Design Converto Cabinets; at the same time improving the construction by adding casters and ferrules to all of these models heretofore without same.

We are also offering wholesalers direct shipment from factory to their customers, which considerably reduces the cost of handling. These important changes will enable Converto Dealers to continue to meet competition of the low price cabinet machines by offering a GENUINE VICTROLA with cabinet type advantages at a lower price than usually charged for machines with reputation yet to be established.



THE C. J. LUNDSTROM MFG. CO.

LITTLE FALLS, N. Y.

Lundstrom "Converto" Cabinets are broadly covered by patents. Infringements will be promptly prosecuted.

CONVERTO WHOLESALE DISTRIBUTORS

- | | |
|---------------------|-----------------------------------|
| Albany, N. Y. | Gately-Haire Co., Inc. |
| Atlanta, Ga. | Elyea Talking Machine Co. |
| | Phillips & Crew Piano Co. |
| Baltimore, Md. | Cohen & Hughes, Inc. |
| | E. F. Droop & Sons Co. |
| Birmingham, Ala. | Talking Machine Co. |
| Boston, Mass. | Eastern Talking Machine Co. |
| Buffalo, N. Y. | W. D. & C. N. Andrews |
| Burlington, Vt. | American Phonograph Co. |
| Chicago, Ill. | Lyon & Healy |
| Cincinnati, Ohio | Rudolph Wurlitzer Co. |
| Cleveland, Ohio | Cleveland Talking Machine Co. |
| Columbus, Ohio | The Perry B. Whitsett Co. |
| Dallas, Texas | Sanger Bros. |
| Denver, Colo. | The Knight-Campbell Music Co. |
| Des Moines, Ia. | Mickel Bros. Co. |
| Elmira, N. Y. | Elmira Arms Co. |
| El Paso, Tex. | W. G. Walz Co. |
| Houston, Texas | The Talk. Mach. Co. of Texas |
| Indianapolis, Ind. | Stewart Talking Machine Co. |
| Jacksonville, Fla. | Florida Talking Machine Co. |
| Kansas City, Mo. | J. W. Jenkins' Sons Music Co. |
| | Schmelzer Co. |
| Memphis, Tenn. | O. K. Houck Piano Co. |
| Milwaukee, Wis. | Badger Talking Machine Co. |
| Mobile, Ala. | Wm. H. Reynolds |
| Newark, N. J. | Collings & Co. |
| New Orleans, La. | Philip Werlein, Ltd. |
| New York City | Emanuel Blout |
| | Cabinet & Accessories Co., Inc. |
| | Knickerbocker Talking Machine Co. |
| Omaha, Nebr. | Mickel Bros. Co. |
| | Ross P. Curtice Co. |
| Peoria, Ill. | Putnam-Page Co. |
| Philadelphia, Pa. | C. J. Heppe & Son |
| | Penn Phonograph Co. |
| | H. A. Weymann & Son, Inc. |
| Pittsburgh, Pa. | Standard Talking Machine Co. |
| | W. F. Frederick Piano Co. |
| Portland, Me. | Cressey & Allen, Inc. |
| Richmond, Va. | The Corley Co., Inc. |
| St. Paul, Minn. | W. J. Dyer & Bro. |
| San Francisco, Cal. | Walter S. Gray Co. |
| Syracuse, N. Y. | W. D. Andrews Co. |
| Toledo, Ohio | Toledo Talking Machine Co. |
| Washington, D. C. | Cohen & Hughes, Inc. |
| | E. F. Droop & Sons Co. |

FINK HEADS KRANZ-SMITH CO.

Purchases Interests of Well-known Baltimore Music House Formerly Controlled by F. G. Smith, Inc.—C. B. Noon Is Manager

BALTIMORE, Md., March 4.—After eleven years Joe Fink, at twenty-eight years of age, has realized the dream of his youth, for he is now president of the Kranz-Smith Co., in addition to being president of the Kranz-Fink Talking Ma-



Joseph Fink

chine Co., of this city. The realization of this dream has just come with the announcement of the purchase of the piano company, which was controlled by F. G. Smith, Inc., New York, with C. B. Noon as vice-president and manager of the Baltimore store. The firm, which was a \$30,000 corporation, is now a \$200,000 corporation.

The Kranz-Smith Piano Co. is one of the best-established music houses in the city and was

founded by the late G. Fred Kranz, who passed away in 1916. The firm handles the Mason & Hamlin, the Artrio-Angelus and the Bradbury and Webster lines. It is quartered in a very imposing home at Fayette and Charles street in a five-story building.

Joe Fink started, when a lad of twelve, working in a small talking machine store in East Baltimore. After he had been in the business about five years he came uptown and the late Mr. Kranz took him into his employ as a clerk in the Victrola department. That was in 1910. Three years later he acquired half interest

in the talking machine business of the firm and the Kranz-Fink Talking Machine Co. was organized. The business went ahead with a rush and this continued and the place expanded to meet the ever-growing demand of the trade. When Mr. Kranz died in 1916 Joe acquired from the widow the interest in the business and became the sole owner.

The firm will retain its name. There will be no changes in the policy. Mr. Noon, who has been managing the piano end of the business for some years, will continue as general manager of the business.

NICHOLS & FROST TO OPEN SOON

Fitchburg Brunswick Dealers Buy Victor Department of Hardware Concern and Consolidate the Two—Improvements Planned

FITCHBURG, MASS., March 5.—A modern music store is being opened by Nichols & Frost in the store formerly occupied by B. L. Rich & Co., at 365 Main street. The store will be connected with the present Nichols & Frost stores by the installation of a connecting passage in the rear and will be fully equipped with everything necessary to make it a high-class store for the sale and demonstration of Brunswick and Victor machines and records, music rolls and sheet music.

Nichols & Frost have had a very successful season with the Brunswick line and have outgrown the present space on the third floor. More room was needed. The Victor department carried by the Fitchburg Hardware Co. was bought by Nichols & Frost, now Fitchburg agents for that popular machine.

The Victor machines have been added to the Brunswick department and the firm will carry both makes in their new store. Plans have been made by which the new quarters will contain sound-proof record booths and demonstrating rooms equipped with all modern devices to accommodate customers.

NOTED ARTISTS HELP RECORD SALES

Artists' Department of Werlein's Brings Famous Artists to New Orleans—Business Is Very Active With This Institution

NEW ORLEANS, LA., March 5.—Business with the talking machine department of Philip Werlein, Ltd., is proving to be very active, and the supply of Victrolas and Victor records now being received and being sold is a strong indication not only of present conditions, but of future prospects. Harry B. Loeb, manager of the artists' department of the Werlein house, is bringing a number of famous artists to the city. We recently heard Bonci, Schumann-Heink, Tetrzzini, and Godowsky and Max Rosen are scheduled for March 16, Titta Ruffo April 4, and Jan Kubelik April 13. The appearance of these artists in the city has greatly stimulated the demand for their records.

TO OPEN EXCLUSIVE VICTOR STORE

COLUMBUS, NEB., March 4.—The C. D. French Furniture Co., Victor dealer in this city, is closing out its furniture store and is going into the exclusive Victor business and will open up an attractively arranged Victor store just as quickly as the furniture stock can be closed out to advantage.

GRANBY SALESMEN

Salesmen who **know** the Talking Machine business, and have a large acquaintance among better class dealers, can have unoccupied territory, to open and develop, and profit in its future development.

The unusual Granby Cooperation will be tendered to both the dealer and salesman.

Name your territory, past performances, and references, in first letter, which will be held confidential.

GRANBY PHONOGRAPH CORPORATION

■ N O R F O L K - V I R G I N I A ■

.. Factory · Newport News..



*The Brunswick Ultona playing
a Brunswick Record*

The Brunswick Method *of* Reproduction

A THOROUGH understanding of the Brunswick Method of Reproduction arms the dealer with one of the strongest selling arguments in the phonograph field. It is much more than a phrase. It is a principle, so tangible, so definite, so easily demonstrated to the prospect, that it is practically irresistible.

The Brunswick Ultona, an all-record reproducer, and the Brunswick Oval Tone Amplifier, an all-wood tone chamber, are the two outstanding features of this method, which are in every way exclusive with the Brunswick Phonograph.

From the moment a salesman lifts the top and begins his story, he has at his command an all-enveloping, comprehensive, and most powerful selling appeal.

THE BRUNSWICK-BALKE-COLLENDER COMPANY

General Offices: 623-633 South Wabash Avenue, Chicago

Branch Houses in Principal Cities of United States,
Mexico and Canada

New England Distributors:

Kraft, Bates & Spencer, Inc., 1265 Boylston Street,
Boston, Mass.

Canadian Distributors:

Musical Merchandise Sales Co., 79 Wellington St., West,
Toronto

The Brunswick-Balke-Collender Company,
1a La Calle De Capuchinas No. 25,
Mexico City, Mexico



*The Brunswick Oval Tone Amplifier,
with grill removed*

Brunswick

PHONOGRAPHS AND RECORDS

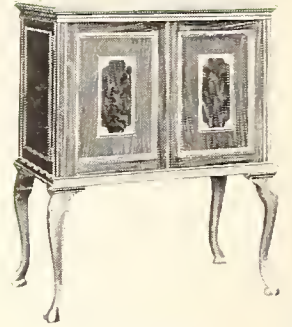

The Gotham



Style 135

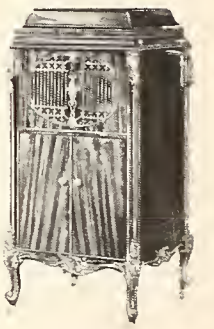

Style 122

Brunswick

PHONOGRAPHS AND RECORDS



The Georgian

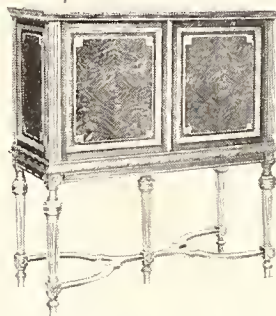
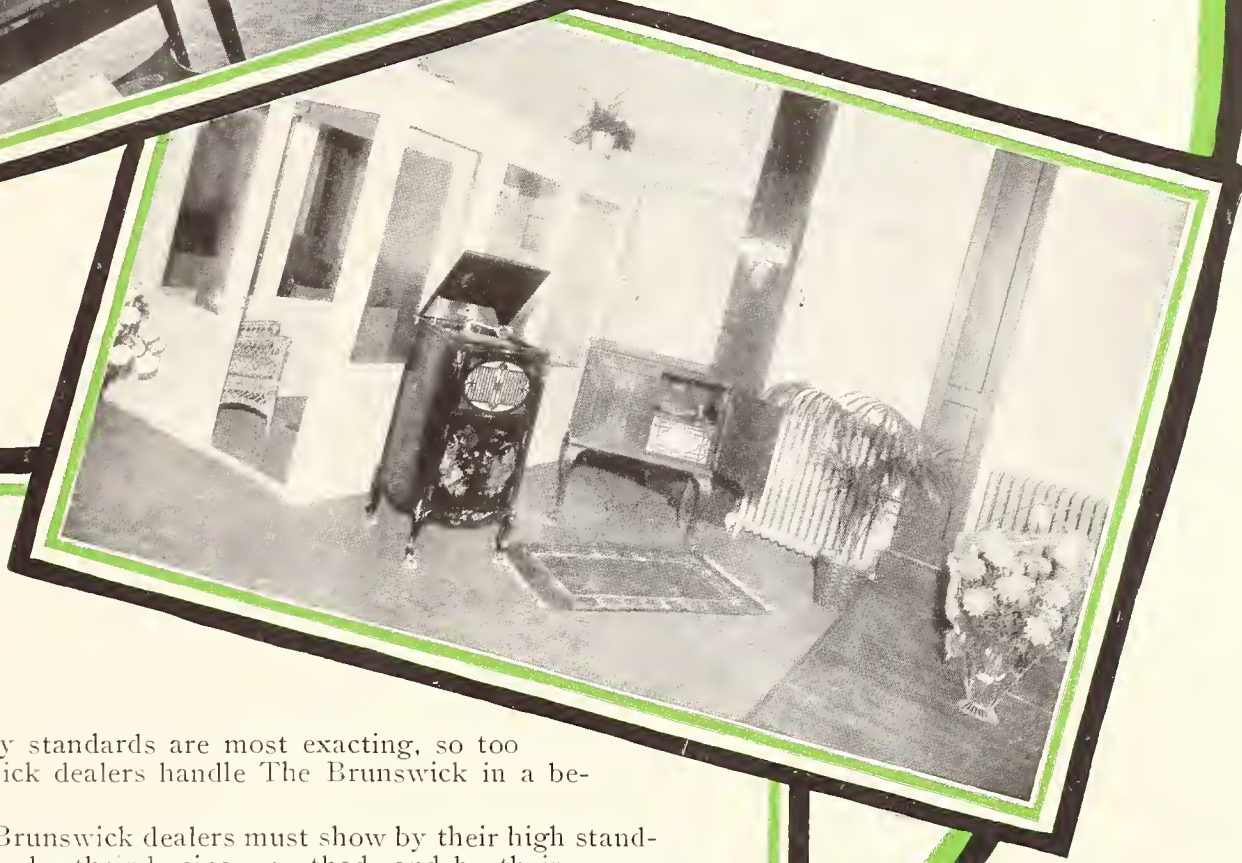

The Beaux Arts

Appropriate Atmosphere

JUST as Brunswick factory standards are most exacting, so too it is desired that Brunswick dealers handle The Brunswick in a befitting manner.

Those who would become Brunswick dealers must show by their high standing in their own communities, by their business methods and by their appreciation of and sympathy with Brunswick policies, that they are ready, able and willing to carry out Brunswick ideals.

The Brunswick is a musical instrument in every sense of the term, and it has always been the aim of its makers to have it displayed and sold as such.

Brunswick would rather have The Brunswick in the hands of a few selected dealers in each community than entrust it indiscriminately to all who may desire to carry it.

THE BRUNSWICK-BALKE-COLLENDER COMPANY, CHICAGO

Brunswick

PHONOGRAPHS AND RECORDS



*Individuality graven
into them*

The Brunswick Method *of* Interpretation

THE sensational success of Brunswick Records is one of the topics of the hour in the phonograph world.

Buyers and dealers often ask why Brunswick Records are so superior, and what is done in Brunswick Studios that is not done in other studios to make them so.

While recording itself requires both the skill of the artist and the knowledge of the scientist, there is no magic formula which makes superior records: in the last analysis it is the combination of the best men, methods, materials and machines—and the taking of infinite pains in every detail.

Brunswick Records are often made and remade many times before Brunswick standards are entirely satisfied.

THE BRUNSWICK-BALKE-COLLENDER COMPANY

General Offices: 623-633 South Wabash Avenue, Chicago

Branch Houses in Principal Cities of United States,
Mexico and Canada

New England Distributors:

Kraft, Bates & Spencer, Inc., 1265 Boylston Street,
Boston, Mass.

Canadian Distributors:

Musical Merchandise Sales Co., 79 Wellington St., West,
Toronto

The Brunswick-Balke-Collender Company,
1a La Calle De Capuchinas No. 25,
Mexico City, Mexico



Brunswick

PHONOGRAPHS AND RECORDS

TRADE CONDITIONS IN MALTA

**Practically No Demand for Cabinet Machines—
Cheaper Grades Most Popular**

WASHINGTON, D. C., March 7.—Practically all the talking machines sold in Malta, we are informed by Consul Carl R. Loop of Valetta, are known as American machines, but they are imported from England. One make retails for £4 10s. (\$21.90); one for £7 (\$34.06), and another for £7 to £24 (\$34.06 to \$116.80). A great many more of the cheaper grades are sold than of the more expensive. So far there is no appreciable demand for machines in cabinets. The total sale per annum runs from 100 to 150 machines.

Records retail from 3s. (\$0.73) to 8s. (\$1.95), the most demanded selling for 7s. 6d. (\$1.83). It is estimated that about 2,000 records are sold per annum. About 90 per cent of these are records of Italian opera, the remaining 10 per cent being of dance and lighter music. The Maltese people are partial to Italian operas, and the other records are purchased almost exclusively by the English residents.

The Maltese importer is averse to opening foreign credits for the purchase of goods. Ordinarily he has not a large capital, and does not care to tie it up by opening foreign credits. He prefers to pay cash against documents, if credit is not allowed.

A list of dealers, all of Valetta, Malta, who may be interested in handling machines and records, may be obtained from the Bureau of Foreign and Domestic Commerce or its district or co-operative offices by referring to file No. NE-16002.

EMERSON JOBBER ATTAINS SUCCESS

**Emerson Ohio Co. Making Rapid Progress—
S. W. Goldsmith Is General Manager**

COLUMBUS, O., March 7.—The Emerson Ohio Co., of this city, which was appointed distributor of Emerson phonographs and records on the first of the year, has signed up a number of important accounts in this territory. The company occupies the first floor and basement of the building at 36 West State street, which it uses as an office, display room and shipping room. A stock of phonographs is kept at the W. Lee Cotter warehouses.

S. W. Goldsmith, vice-president and secretary of the Goldsmith Music Store Co. for the past eight years, is general manager of the Emerson Ohio Co., and associated with him is S. M. Hyneman. James W. Pommer, of Albany, Ind., and Charles Usher, of Brooklyn, N. Y., experienced wholesale talking machine salesmen, are representing the new company in this territory.

FINDING ITS POLICY SUCCESSFUL

Believing that a hit sells other records, the Standard Talking Machine Co., Pittsburgh, has prepared for its dealers mailing cards and stuffers of the current hits. The company is having much success with this plan. The hit selected last month was "Rosie."

**Your Opportunity to
Buy at the Right Price**

We manufacture 3 and 5-ply panel stock in all thicknesses and woods. Also 3-ply shelf stock for *Talking Machine Cases*.

Ask for quotations on our Talking Machine Crating Boxes. They are built of solid woods.

THE BRANDTS FURN. CO.
CELINA, OHIO

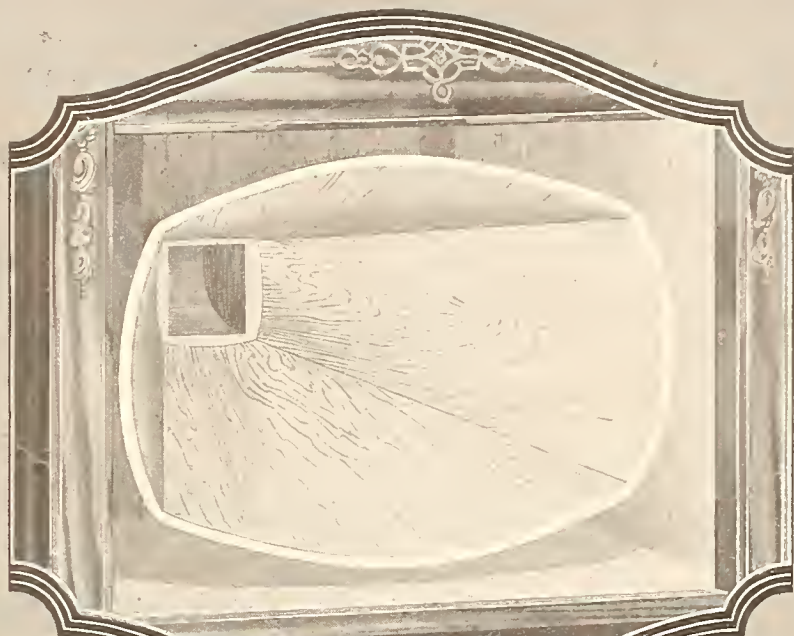

HARPONOLA

The
PHONOGRAPH
with the
GOLDEN VOICE

**To
Dealers**

who apply, I am ready to make the most interesting and profitable talking machine proposition that could be extended.

The bigger your field and facilities the greater the proposition I can make, so write me fully in your inquiry.

EDMUND BRANDTS,
President

The Harponola Co.

.101 MERCELINA PARK

CELINA, OHIO

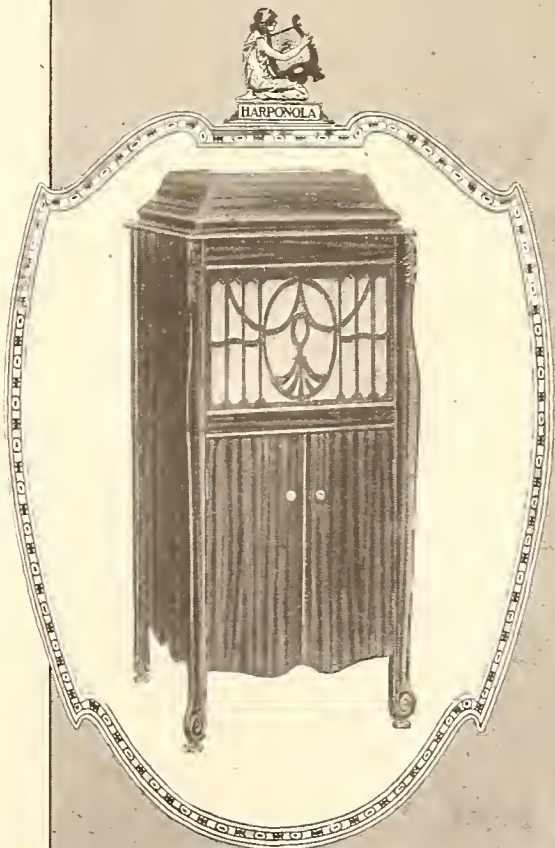



Rishell
THE MIRROR OF TONE
A
Master Phonograph

Reliability

Every Rishell Phonograph is typical of the house back of it—and the 55 years of that house's consistent record for *reliability*. Every Rishell Phonograph is always in order; always ready for producing that marvelous tone that is the wonder of the trade and the despair of other phonograph makers. Every Rishell Phonograph is cased in the perfection of cabinet work, exquisitely finished by master craftsmen. Every Rishell Phonograph prepares the way for another Rishell sale.

Write today for particulars of our liberal jobber contract.

RISHELL PHONOGRAPH CO.

WILLIAMSPORT, PA.

New York Distributor: GRAND TALKING MACHINE CO.
268-270 Flatbush Avenue Extension, BROOKLYN, N. Y.

The Talking Machine Is Now Entering the Realm of Literature in the Home :: By Lee Howard

Just as the talking machine has been the most effective means of increasing the musical knowledge of the great mass of the people of the world, so is it now entering the realm of literature and is making it possible to bring the world's best prose, poetry, drama or fiction within reach of the average man and woman. Good music in the home—good literature in the home. Each seems to be the logical supplement of the other. Now that the place of music has become established the talking machine will establish literature in the home. It will add to the effectiveness of the best library and will take the place of a library among those who have not sufficient means to purchase expensive books.

The recent recording of standard passages from Shakespeare's plays is the first step toward the higher goal of progress. To everyone has come the pleasure of hearing some talented actor or some trained reader render some pleasing bit of prose or poetry.

Theatre lovers go often to hear their favorite stage characters because there is something about their particular style of speaking that appeals. To be able to bring the very voice of this favorite into the home, to be heard whenever desired, is truly an accomplishment which would appeal to everyone. The recording of Shakespeare is, as we have said, the first step. From this basis the work of recording good literature can and should be extended until it embraces a record library as varied and as excellent as the present-day musical library.

Realizing that education must begin with the child, the talking machine industry has already

prepared records for children. These little records of nursery rhymes or the songs of childhood have become very popular with the youth of the nation. But as yet their field has been but slightly developed. The larger records should contain standard literature for the children, too. Imagine, for a moment, the value of these records in the modern educational system, elementary or secondary. After studying

Now That the Place of Music Has Become Established the Talker Will Bring Good Literature to the Home

some piece of literature the child could hear this spoken and spoken correctly, every syllable clear and distinct. In this way the child would quickly learn to speak correctly and also appreciate what is best in the literature of the world. The appeal to the eye and ear is the ideal combination.

The appeal to the eye alone is not sufficient, as educators have learned. It is useless to try to learn to speak a foreign language merely by

gazing at the printed page. The moving picture theatre offers a good example of the appeal to ear and eye. To have films alone without music does not satisfy. Consequently orchestras and organs have come to be necessary adjuncts to the modern motion picture house. The appeal to the ear.

Much as these educational records are needed at the present time, their development waits upon the development of the record-making industry. Larger records are needed or else records upon which a great deal more can be recorded. Records larger than the present twelve-inch size have been regarded as impracticable by record manufacturers as a whole. But the twelve-inch record is hardly large enough to be used in the field of literature. In the necessity of changing records so frequently lies the greatest handicap. Surely here is a field for development. Either in the modification of the talking machine or the record must the answer lie. Once this problem is successfully solved the industry will have made another step forward.

KEWANEE BRUNSWICK SHOP MOVES

Business Formerly Associated With Furniture House Now Becomes Independent

KEWANEE, ILL., March 3.—The Brunswick Shop, which is managed by Miss Grayce C. Van Couteren and has been located in the building with the Ogle Furniture Co., 219 West Second street, is now in its new location in the Sugar Bowl Building, at 118 North Tremont street, and becomes a separate enterprise, to be known as the Brunswick Shop Co.

The new location will display the Brunswick products to a much better advantage. With a few changes the south side of the building will be fitted up appropriately with demonstration booths, new record cases and decorated in a blue and white color scheme as a splendid setting for this music shop.

Brunswick phonographs and records will be featured and a full line of Emerson and Gennett records also will be carried.

D. M. SMITH ON LENGTHY TRIP

Sales Manager of Rishell Phonograph Co. Visiting Trade in West—Important Dealer Accounts Established Recently

WILLIAMSPORT, PA., March 5.—Douglas M. Smith, sales manager of the Rishell Phonograph Co., of this city, manufacturer of the Rishell phonograph, left recently on an extended Western trip, which will include a visit to the leading trade centers as far West as Kansas City, Mo. It is possible that Mr. Smith will proceed to the Pacific Coast, as inquiries for Rishell representation have been received from a number of prominent concerns in that part of the country.

During the past few weeks good-sized orders have been received by the Rishell Phonograph Co., and accounts have been opened in important territories, including the establishment of several dealers in active Ohio industrial centers. The Rishell phonograph is steadily increasing in popularity, and the company has received numerous letters of commendation from its dealers as to the quality of the product it is now turning out.

INCORPORATED IN CINCINNATI

The Market Music Co., Cincinnati, O., has been incorporated with a capital of \$20,000. The incorporators are: M. B. Fishel, D. B. Stone, S. H. Miller, R. E. Stein and B. R. Kohn.



THE VICTOR RECORD



A series of

ACHIEVEMENTS

of the

VICTOR TALKING MACHINE CO.

¶ The Victrola No. IV was really the first type of hornless machine to appear on the market and tended to eliminate the unsightly horn models.

¶ The immediate popularity of this type, and the enormous sale of same, led to the development of the large type Victrolas.

A SUGGESTION

¶ The Knickerbocker "Ready-to-Play" Carrying Case, made to fit the Victrola IV, and having compartments for a record album, the needles and winding crank, now listed at \$20.00, together with the Victrola IV listed at \$25.00, makes a \$45.00 portable outfit—the ideal equipment for campers, travelers, etc.

¶ Write us for prices or communicate with your nearest Victor Wholesaler.

KNICKERBOCKER TALKING MACHINE CO.

Victor Wholesalers

138-140 West 124th Street

New York

"A new Gennett"



REFLECTIONS

As the face in the crystal mirror is true to the gazer, so are Gennett Records faithful to the original voice or instrument.

To know the utmost in music's reproduction hear Gennett No. 4661. In the "Home Again Blues" Medley Fox-trot Joe Coleman's President Orchestra makes your toes fairly tingle and on the reverse Green Brothers Xylophone Band brings out with great vivacity the snappiness of "Toodles," a One-step.

Gennett Records

Manufactured by

THE STARR PIANO COMPANY

RICHMOND, INDIANA

New York—Chicago—Los Angeles—Birmingham

Detroit—Cincinnati—Cleveland—Indianapolis

Boston—Jacksonville—London, Canada

Marion Harris' new "blues" are "Look for the Silver Lining," from *Sally*, and "I'm Gonna Do It If I Like It." This exclusive Columbia song bird's latest will line your pockets with silver—if you like it. A-3367.

Columbia Graphophone Co.
NEW YORK



TIME TO HUSTLE, SAYS HOWARD

Large Part of Dullness in Talking Machine Industry Is Psychological Rather Than Real, Is Belief of Granby General Sales Manager

After five years or more of watchful waiting a photographer was at last able to induce E. C. Howard, general sales manager of the Granby Phonograph Corp., Norfolk, Va., to enter his



E. C. Howard

studios. It took a New York photographer to accomplish this task.

Mr. Howard spent about three weeks recently in the metropolis in the interest of the Granby Phonograph Corp., and in that period found time to get in touch with his many friends in the industry. He is known as a human dynamo and accomplished much in the furtherance of Granby interests in the short time he was in the city.

Mr. Howard believes that a good deal of the inaction in the talking machine business is psychological rather than a fact, and believes that "any merchant who will get up and hustle instead of sitting around cussing the country" will find good business during the year. He is practicing what he preaches, and as a result the distribution of the Granby phonographs is growing steadily.

The Granby factory at Newport News, according to Mr. Howard, is exceedingly busy and the outlook for the balance of the year is very bright.

MONTALVO IN NEW LOCATION

M. Montalvo, Jr., talking machine dealer of Plainfield, N. J., has moved to a new location in the Strand Theatre Building, East Front street, that city.

SCHMELZER CO. ACTIVITIES

Great Gathering of Victor Dealers—New Monthly Records Demonstrated—Addresses by Prominent Individuals—Third Salesmanship Class Just Opened—Many Practical Talks

KANSAS CITY, Mo., March 4.—A very interesting gathering of Victor dealers and their salespeople within a radius of seventy-five miles of this city was held under the auspices of the Schmelzer Co., Victor distributor, at its wholesale building, 2015 Grand avenue, on the evening of February 8. This meeting was primarily for the purpose of hearing the new monthly records presented to the listeners by David R. Walsh, manager of the service educational department. This program was interspersed with addresses pertaining to dealers' service and helps by Arthur A. Trostler, secretary of the Schmelzer Co., and T. La Rue Husselton, field representative of the Victor Co.

This was the first meeting of this kind called by the Schmelzer Co., and all present were quite delighted with its success and unanimous in the wish that this plan of hearing the records demonstrated be carried out each month hereafter. Those present were:

Miss Wooley and H. McArthur, Wunderlich Piano Co., Kansas City, Mo.; S. F. Butler, Butler & Sons, Kansas City, Kan.; Mae McJilton and Sadie Spanger, Smith, Barnes & Strohber Co., Kansas City, Mo.; Mr. Boice, Miss Lyon, Miss Miller and H. W. Harper, Boice Voice Shop, Kansas City, Mo.; E. P. O'Connell, Miss

Tower, Miss Hanes and Mrs. Godfrey, Jones Store Co., Kansas City, Mo.; Miss Emerson and R. G. Haynes, Von Hershner & Trudell Music Co., Kansas City, Mo.; W. H. Hader, A. H. Hader, Higginsville, Mo.; Miss Clara Kaiser, G. F. Kaiser, Ottawa, Kan.; Mrs. L. H. Houston, J. H. Bell Music Co., Lawrence, Kan.; Mr. Stephens, Stephens Furniture Co., Liberty, Mo.; Everett Gibson and G. F. Wise, Carl Hoffman Music Co., Leavenworth, Kan.

The Schmelzer Co., by the way, just closed its second salesmanship class, which was well attended, the dealers in this territory being most appreciative of this very important means of increasing their knowledge of how best to serve the public. Moreover, each dealer returned to his field of Victor endeavor full of inspiration, with a knowledge of the product and ideas of better service to his customers, all leading to increased sales. During the course of the sessions addresses were made by Dr. Edward Geraughty, one of the leading physicians in Kansas City, who has made a considerable study of music as related to economics; C. J. Schmelzer, treasurer; Arthur A. Trostler, secretary of the Schmelzer Co.; the managers of the record, advertising and repair departments, and by W. A. Fritschy, impresario. These classes have been under the direction of David R. Walsh, who has found the dealers most keenly interested. The third salesmanship class was opened late last month.

Why worry about the past? The best way to redeem it is to forget all about it.

The KENT MASTER ADAPTER



plays ALL RECORDS at their best
on the
EDISON DISC PHONOGRAPH



Write for particulars concerning this, the best known and largest seller of its kind in the market. Attractive prices and terms will be quoted you.

WE specialize in attachments for Edison and Victor machines; also soundboxes, diamond, sapphire and steel needles. Drawn brass tone arms made to order. Tube and pipe bends of all kinds successfully executed.

F. C. KENT CO. :: Specialty Manufacturers
IRVINGTON, N. J.

whose phonograph accessories "win their way by their play"

HARRY A. BEACH
PRES AND MGR.

C. F. REDMOND
VICE-PRES

CHAS. F. WALL
SEC AND TREAS

THE MUSIC SHOP, INC.

KALAMAZOO, MICH.
SUCCESSORS TO THE FISCHER MUSIC SHOP
SECOND FLOOR FIRST NATIONAL BANK BLDG
TELEPHONE 566

KALAMAZOO HEADQUARTERS FOR VICTROLAS AND VICTOR RECORDS

December 31 1920

The Magnavox Co.,
Oakland, Calif.

Dear Sirs:

As a real sales promoter your Magnavox is the best ever; aside from the wonderful advertising value, the actual sales made have more than paid for the instrument in this short time that we have owned it.

You are overlooking a good bet if you do not sell every live wire talking machine shop in the country, and here hoping you do.

With the seasons best greetings we beg to remain

Yours very truly,

The Music Shop, Inc.,

Per. *Harry A. Beach*

- PIANOS
- PLAYER PIANOS
- GRANDS
- BAUER
- KIMBALL
- WHITNEY
- HINZE
- LYON & HEALY
- SCHAAF
- RECORD CABINETS
- ROLL CABINETS
- MUSIC CABINETS
- PLAYER ROL
- POPULAR AND STAND-
- ARD SHEET MUSIC
- CENTURY SECTION
- BAND AND
- ORCHESTRA
- INSTRUMENTS
- CONN
- MARK
- WUETZLER
- LYON & HEALY
- SCHMIDT
- NO-MADE
- VIOLES
- GIBSON
- MANDOLIN
- AND GUITAR
- MOTROLAS
- REPEATOGRAPHS
- ALL SMALL
- MUSICAL
- MERCHANDISE
- INSTRUMENT CASES
- AND SUPPLIES

MAGNAVOX

*Music and Voice
Telemegaphones will
increase your Sales.*

Write Your Nearest Distributor for Further Information and Details of Dealers' Proposition

J. O. MORRIS CO., INC.,
1270 Broadway, New York City.
New England, New York and Pennsylvania.

J. W. SANDS COMPANY,
123 East 5th St., Dayton, Ohio.
Entire State of Ohio.

MINNEAPOLIS DRUG COMPANY,
Minneapolis, Minn.
States of Minnesota, Montana, North and South Dakota.

C. L. MARSHALL COMPANY,
82-84 Griswold St., Detroit, Mich.
Lower Peninsula of Michigan.

KIEFER STEWART COMPANY,
Indianapolis, Ind.
Entire State of Indiana.

SONORA DISTRIBUTING COMPANY,
1707 Elm St., Dallas, Texas.
Entire State of Texas, except northern Panhandle.

SOUTHWESTERN DRUG COMPANY,
217 So. Market St., Wichita, Kan.
States of Kansas and Oklahoma.

CANADIAN DISTRIBUTORS
I. MONTAGNES & COMPANY, Ryrie Bldg., Toronto, Canada.

Manufactured By
THE MAGNAVOX CO. **Oakland, Calif.**
Pacific Coast Distributors of Sonora Phonographs

Victor Dealers of the Rocky Mountain Region

Put Your Selling Problem Up To Us

Our expert staff of Victor merchandising specialists are at your command at all times—each offering you a real service in helping you to solve your retail problems.



Our five floors devoted exclusively to Victor goods, and to the needs of Victor dealers, are admirably equipped to offer a genuine service.

We Back the Dealer Who Backs the Victor

Knight-Campbell Music Co., 1608 Wynkoop Street, Denver, Colo.

WIRELESS MEGAPHONE CONCERT

Music on Steamship on High Seas Heard by Audience in College Laboratory

Tossing on the waves somewhere off Sandy Hook the steamship "Gloucester" was proceeding on its way, while below decks the crew were entertaining themselves by playing the latest records on the ship's talking machine. But only half of the audience was present. The other hearers were waiting in the laboratory of Professor A. N. Goldsmith at the College of the City of New York. Professor Goldsmith adjusted three needles on a dial, threw a switch and a motor began to hum beneath a large megaphone of wood. Immediately the voice of the radio operator on board the "Gloucester" was heard telling the concert was about to begin.

The next moment the sound of the music on board the ship was heard as plainly in the laboratory as though the instrument were actually in the room. Each note was loud and clear. By means of a localizer and an amplifier all other air noises except the music were excluded. A slight movement of the needles on the dial and the music faded and the crackle of the high-powered wireless stations on all sides took its place.

NEW MUSIC SHOP IN MEMPHIS

MEMPHIS, TENN., March 3.—Arrangements have been completed for the opening of a new shop at 108 Madison avenue, to be occupied by a branch of Fortune's Music Shop, operated by the Fortune-Ward Drug Co., just opposite the present location.

The interior will be thoroughly overhauled and remodeled to accommodate the new shop, it was announced. Saul Bluestein is manager of the department. Mr. Bluestein is to leave tomorrow for a buying trip in the East. It is planned to open the shop within two weeks, with a complete line of talking machines, records and player rolls.

RECORDS TO TEACH HEALTH RULES

Chicago House Prepares New Series of Records for Course in Body Building

A Chicago health institute has adopted the talking machine record and put out a series of records on health. These records contain short talks on how to build up the body and maintain physical fitness. Music is combined with the talks in an effort to make the course as interesting as possible so that the patient will continue with the work once it is started. This system would seem to be a new application of the record and yet an entirely logical one, extending the field already covered by the language courses and other educational methods.

EXPANSION OF GRANBY BUSINESS

Plant at Newport News Very Busy—Distributing Center for New York District on Canal Street—Levy & Co., of Norfolk, Active

NORFOLK, VA., March 4.—The Granby Phonograph Corp. reports that the Granby factory at Newport News is working at full speed and that night shifts were put on several weeks ago to take care of the increased product requirements. Commodious warehouses have recently been secured at 365 to 367 Canal street, New York, which the Granby Phonograph Corp. will use as distributing center for the metropolitan district. E. C. Howard, director of sales, is highly pleased at the manner in which the Granby has taken hold, and reports that fourteen new retail accounts have been established from the new New York distributing center. Philip Levy & Co., Granby retailers of this city, have advised the Granby organization that they did a special holiday business of 500 Granby phonographs from their Norfolk store, and 250 from their Newport News establishment. This company is also featuring the Granby line in its new Washington, D. C., store on Seventh street. In the opening week 125 instruments were sold.

22 PURE VOICES OUT OF 3,800

Striking Advertisement by Thomas A. Edison, Inc., Uses Interview With Inventor as Basis of Interesting Discussion on Tone Quality

In a striking advertisement which will appear in national and farm magazines in all parts of the country the Thos. A. Edison, Inc., is using an interesting interview with Thomas A. Edison on the imperfection of the human voice. Mr. Edison makes the statement that out of the 3,800 singers who have made voice trials for him he has found but twenty-two who could sing pure notes. In explanation of this he says:

"I have collected, through my agents in Europe and America, phonographic voice trials by approximately 3,800 singers. Of these there are but twenty-two who sing pure notes, without extraneous sounds and the almost universal tremolo effect. A singer's trill is quite a different thing from a tremolo.

"A trill can be and is controlled by the brain, but a tremolo is not within brain control and, so far, there has been no means found for correcting it. Most singers cannot sustain a note without breaking it up into a series of chattering, or tremolos. The number of waves varies from two per second to as high as twelve. When at the latter rate the chatter can just be heard and is not particularly objectionable. When at a slower rate it is very objectionable.

"If this defect could be eliminated nothing would exceed the beauty of the human voice, but until this is done there will be only a few singers in a century who can emit pure notes in all registers. Patti, for example, was conspicuous for emitting pure notes, except in the lower part of her scale, and she was always reluctant to sing a song requiring the use of her lower register."

The interview goes on to tell Mr. Edison's reason for the "Realism Test," which demands that the hearer close his eyes in order to give his ears full play in comparing the living voice with the re-creation of it.

The whole advertisement is unusual in form and content and is one that will without doubt be read by music lovers and others in all parts of the world. A portrait of the famous inventor occupies a prominent place at the beginning of the interview.

CUBAN IMPORTERS ENLARGE CAPITAL

The well-known importing house of Quevedo & Cabarga, of Havana, Cuba, has admitted José Garcia Conde as partner and the concern will hereafter be known as Quevedo, Cabarga & Co. The capital of the company has been considerably increased.

The 1921 man is going to be one who tackles the most difficult problems confronting his department or his business or his industry, or his community, for that matter, and licks them.



We are introducing a reproducer which is different from anything on the market. In principle it is non-metallic, at the same time practically indestructible and not affected by moisture or temperature changes.

We guarantee it as a quality product.

All principles of construction covered by basic patents.

Samples to the trade \$7.00 each.

Requests for Tests and Demonstrations Are Solicited from Manufacturers, Jobbers and Dealers.

Steurer Reproducer Company, Inc.

158 West 21st Street

New York City

CONSTRUCTIVE FEDERAL TAX PROGRAM SUGGESTED BY MUSIC INDUSTRIES CHAMBER OF COMMERCE

Adoption of Some Form of Commodity Sales Tax Urged as Plan for Raising Necessary Revenue While Permitting of Abolishment of Excise and Excess Profits Taxes

At a meeting of the board of directors of the Music Industries Chamber of Commerce, held at the general offices in New York last month, at which Ralph L. Freeman, director of distribution of the Victor Talking Machine Co., was present, chief attention was given to the plans of the Chamber in connection with the Federal tax revision program and the tariff. The legal committee on Federal tax revision presented a comprehensive report embodying a number of recommendations favoring in a general way some form of sales tax and it was voted that the Chamber continue its present campaign. The program as outlined provides that:

The Chamber will urge Congress to abolish the excess profits and the so-called "war-time" excise taxes; to impose a minimum tax of \$5

upon all persons twenty-one years of age or older who receive an independent income; to raise the additional required estimated minimum revenue of \$2,000,000,000 for the most part by a uniform tax on all sales of commodities, wares and merchandise, not including capital assets, to be paid monthly by each seller.

The Chamber will recommend to the Ways and Means Committee of the House of Representatives that the present customs duty of 35 per cent ad valorem on musical instruments and parts be increased to 45 per cent ad valorem; that player-piano actions be added to the list of parts specifically mentioned in the Tariff Act; that music wire be added at the rate of 35 per cent ad valorem, and that the present duties on raw ivory be eliminated.

The Chamber will advocate the more adequate

financial support of the Bureau of Foreign and Domestic Commerce and the Consular Service.

The report of the legal committee, the gist of which is given above, upon being accepted was ordered printed so that copies may be sent to members of Congress, to the principal newspapers, business magazines and trade papers of the country and to local commercial and national trade associations. It was also decided to obtain the approval of as many national associations as possible for the commodity sales tax and have them give it active support.

Calculating that the requirements of the Government would amount to four billion dollars in revenue, it was recommended that Congress be urged to revise the present Federal tax system as follows:

1. That the excess profits tax and so-called "war-time" excise taxes be abolished, and that the individual income surtax rates be materially reduced.

2. That all persons residing in the United States and having reached the age of twenty-one years be compelled to report income, and that a minimum tax of \$5.00 be imposed upon all persons who receive an independent income.

3. That the additional revenue required (estimated maximum, \$2,000,000,000) be raised, for the most part, by a uniform tax on all sales of commodities, wares and merchandise, not including capital assets, to be paid monthly by each seller.

In the preparation of the report the committee went with great detail into governmental finances to provide a basis for argument, and its recommendations included those to the effect that the excess profits tax should be repealed, surtaxes should be revised, and that wartime excise taxes should be eliminated, as they violate the principles of justice and fairness in taxation, and will not yield the expected revenue because such taxes will serve to restrict sales in the industries upon which they are levied.

Evidences of Discrimination

The report says specifically:

"As illustrative of how some of the commodities now subject to excise taxes conform to these tests, the products of the music industry may be cited. Musical instruments, particularly pianos and phonographs, which are the most important, are purchased usually with the expectation of lasting a lifetime. They are in the nature of investments, being an essential part of the home, and usually require a relatively large investment for the purchaser. The retailer almost never makes a cash sale and in the great majority of cases the initial payment scarcely offsets the tax which has been advanced to the Government months previously by the manufacturer. In normal times the transaction is not completed by the final payment for two, three and often four years after the initial sale is made by the retailer. The instrument is not infrequently returned and has to be sold again. No industry operating under such conditions can flourish with the extra burden of an excise tax draining a large part of its cash resources in a constant stream. The sales and credit methods of such an industry cannot be changed without entailing a serious decrease in volume of sales and consequent loss of revenue to the Government and profit to the industry. It is absurd and indefensible to retain a special excise tax on such an industry.

"Excise taxes have been defended at times on the grounds that they are usually imposed on luxuries which can stand them without curtailment, or whose curtailment does not deprive the public of anything which is essential to its welfare or which is even desirable. From a tax standpoint, such a theory is indefensible, for a tax which curtails the taxable source, irrespective of the desirability of curtailment, defeats its only real purpose, namely, that of obtaining revenue. As a method of curtailing alleged luxuries, it is sufficient to point out that Government curtailment of industries which are harmful to neither public health nor morals, and indirect Government regulation of the buying habits of the people, is contrary to the true American conception of the rights of the individual

The PHONOMOTOR

Trade Mark Registered U. S. Pat. Office

THE STANDARD ELECTRIC PHONOGRAPH DRIVE OF THE WORLD

Patented in U. S. and Canada

Mr. Manufacturer,

DO YOU KNOW?

That the PHONOMOTOR was and is, the first in the field, that many owners testify to its wonderfully perfect service.

It is progressive, in pace with the electric age.
It is a UNIVERSAL Motor, and perfectly silent.
There are NO REPAIRS needed for years.
Its constant speed is guaranteed.
There are thousands in use today, many of them for nine years.

IT IS FOOL PROOF

We guarantee this motor to be as represented in every respect.
And DO YOU KNOW that the PHONOMOTOR will add to your profits?

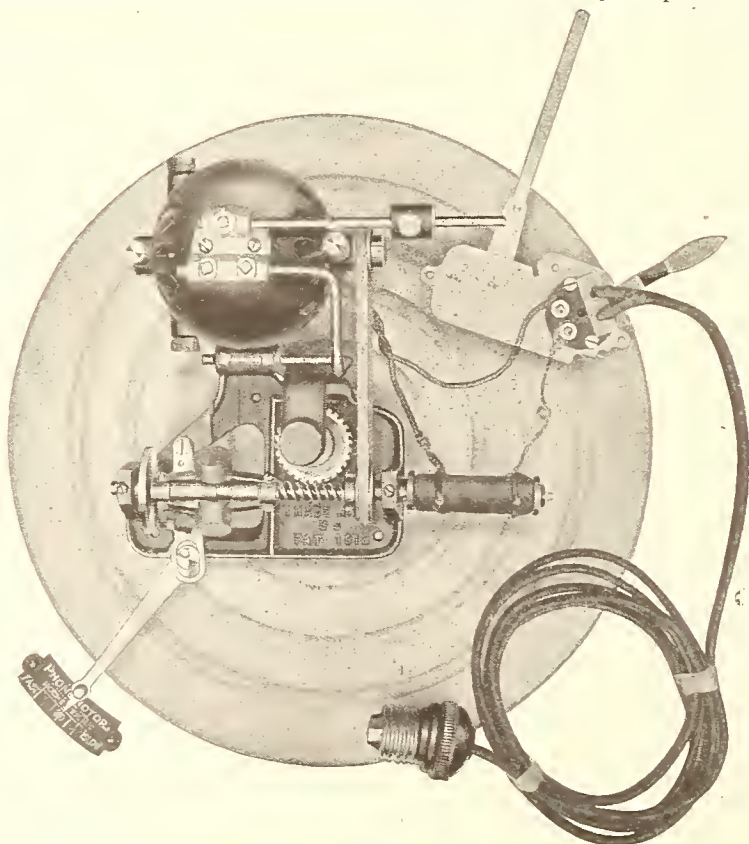

A word to phonograph repair men: You will find a profitable business in replacing spring motors with the electric, the PHONOMOTOR is adapted to any PHONOGRAPH, a great number of repair concerns from coast to coast have added this motor to their line of accessories, send for a sample. On application prices will be quoted on quantity orders.

GEORGE CLAY COX

73 State Street

Rochester, N. Y.

IN THE
HANDY
CAN



NYOIL

FOR YOUR
PHONOGRAPH

**Made in Our
Watch Oil
DEPARTMENT**

which for half a century
has made 80% of all the
watch, clock and chromom-
eter oil used in America.

The Best Oil For Any Talking Machine
In refining, Nyoil is given the same care as our famous watch oil receives. All gums and impurities are removed, leaving it

Colorless, Odorless and Stainless.
Housekeepers say they would not be without Nyoil because it is best for phonographs and sewing machines—for polishing furniture and woodwork and is odorless and will not stain. It is free from acid and will not gum, chill or become rancid. Sportsmen find it best for guns because it prevents rust.

NYOIL is put up in 1-oz., 3/4-oz. and 8-oz. Bottles and in Quart and Gallon Cans.
For Sale by all Talking Machine Supplies Dealers
WILLIAM F. NYE, New Bedford, Mass., U.S.A.

and the function of government. Furthermore, if such were not the case excise taxes could be defended as luxury regulations only if applied to all luxuries, and to luxuries only. Such is decidedly not the case with the present excise taxes.

"The existing excises tax the motor truck, but not the horse-drawn vehicle doing the same work; they tax the fur coat of the farmer and lumberman which he could scarcely do without, but not a cloth coat which for many uses is less desirable; and they tax the piano necessary for the child to obtain its proper musical education, or the band instrument with which he may later earn his living, but not the toy with which he amuses himself.

Non-Luxuries Subject to High Excises

"Even though it were either just or possible to tax luxuries in a proper manner, musical instruments and many other commodities now subject to high excise taxes should not be so taxed, as they are not luxuries. Musical instruments are essential to the education of the child, constitute the means whereby thousands of persons earn their living, are essential to religious worship, and indispensable to many forms of public life. Music is the most potent, universal and cheapest factor in making life worth living as distinct from making mere existence possible; and in these days of advanced civilization to exist merely is not really to live. The typical piano or phonograph is not the expensive concert grand nor the phonograph de luxe. On the contrary, the great bulk of these products go into humble homes, where they become the most potent factor in keeping the home together, especially when the children grow old enough to be allured by outside attractions, unless there is a pleasant home life. A discriminatory tax on music is a blow at the home and at education.

"Under no circumstances should the discriminatory wartime excise taxes be continued longer."

After urging that some system be adopted whereby everyone should be required to pay an income tax, the report went on to say that the taxes already discussed will provide a revenue amounting to about \$2,000,000,000, and that the problem is to raise a similar amount by new taxes. This problem can best be met by a sales tax, either a general sales or turnover tax, applying to the sale of all goods and services in lieu of all other business taxes, the rate

usually favored being one per cent, or the commodity sales tax applying to the sale of all goods and merchandise, but not to capital assets or services. The committee favors the commodity sales tax for the following definite reasons:

1. It is simple to administer by the Government, and easy to compute and pay by the business concern.
2. It is definite, and the exact amount which the tax adds to the cost of doing business is known at the time of the transaction, which is not true of profits taxes.
3. It avoids the necessity of making a huge increase in the corporation income tax rate. Such increases would add materially to the evil of price "loading" as a means of insuring against a profits tax which cannot be anticipated. An increase in a profits tax causes much more than an equivalent increase in price "loading." An increase in profits taxes would also add to the enormous difficulties which business faces under the necessity of providing large sums of money as tax payments, which, even though they have been collected from customers, are often tied up in the form of accounts receivable, raw materials and merchandise.
4. It avoids the necessity of expanding the present discriminatory excise taxes, and in effect substitutes a low rate and just sales tax on all business for a special high rate and discriminatory sales tax which is levied on a few businesses.

The various arguments presented against the proposed commodity sales tax are also carefully analyzed in the report.

The legal committee consists of J. Harry Shale, treasurer of the A. B. Chase Piano Co., chairman; E. B. Bartlett, W. W. Kimball Co., Chicago; J. Newcomb Blackman, Blackman Talking Machine Co., New York; George L. Cheney, Pratt, Read & Co., Deep River, Conn.; Walter Fischer, Carl Fischer Co., New York; Kirkland H. Gibson, Ivers & Pond, Boston; R. W. Lawrence, New York; Frederick Sunder-

man, Bennett & White, Inc., Newark, N. J.; H. L. Willson, Columbia Graphophone Co., New York; Howard E. Wurlitzer, Rudolph Wurlitzer Co., Cincinnati, and Alfred L. Smith, general manager of the Music Industries Chamber of Commerce.

Program Is Getting Support

With the purpose of formulating a co-ordinated movement for tax revision which will be fair to all trades without being a burden to the consumer, the Music Industries Chamber of Commerce has sent individual letters to more than 150 trade organizations which, like the music industry, are affected by the discriminatory wartime excise taxes still in force, stating the industry's position as adopted by the board of directors of the Chamber, and arranging for the presentation of arguments at Washington in such a form as not to result in conflict and confusion in the minds of the legislators. With each letter was enclosed a copy in pamphlet form of the tax report made by the legal committee of the Chamber to the board of directors, adopted by the board at its meeting on February 4.

Letters have also been sent by the Chamber to hundreds of commercial organizations urging that, as Congress is looking to the business men of the country to make constructive suggestions for tax revision, they build their recommendations to Congress along the lines of those formulated by the Chamber's legal committee.

Besides taking the tax matter up with the commercial and trade organizations, the Chamber laid its recommendations, with a personal letter, before every member of the Ways and Means and Finance committees and sent them to all the other members of Congress, old and new. Responses to the Chamber's appeal to trade and commercial organizations already are beginning to reach the general offices in New York in gratifying numbers. Almost without exception they are in accord with the position taken by the music industry.

The Mutual No. 6 Reproducer



No screws nor adjustments on the stylus suspension. A GREAT ACHIEVEMENT finally mastered.

A patented device of springs now holds the stylus on a knife-edged suspension which entirely eliminates the annoyances and blasts caused by the loosening of screws and various adjustments on the reproducer and stylus.

If you are looking for a sound box that will stand the test of time, our No. 6 is exactly what you want. It is the only reproducer on the market containing this new invention which is the fruit of many years of hard, experimental labor devoted to the improvements in the phonograph industry.

Quotations sent upon request.

The Mutual

.. FOR ..

Record Manufacturing

THE PECKHAM MFG. CO., 238 South Street NEWARK, N. J.

PHONO PARTS MFG. CORP.

HERMAN SEGAL, Pres.

149-151 Lafayette St. New York City

COTTON FLOCKS

.. FOR ..

Record Manufacturing

THE PECKHAM MFG. CO., 238 South Street NEWARK, N. J.



Remington

PHONOGRAPH CORPORATION



The action of the Remington Reproducer has a uniform freedom of vibration throughout its entire surface, while in other instruments the diaphragm is immovably held in a casing.

Thus the Remington permits the reproduction of the minutest detail tone wave and prevents all unpleasant nasal and screechy effects.

The volume and clearness of tone is easily 25 per cent. to 30 per cent. superior in the Remington Phonograph.

Progressive dealers desiring information relative to our agency proposition, are invited to write.

Remington

PHONOGRAPH CORPORATION

1662-64-66 BROADWAY, NEW YORK, U.S.A.

Various Methods of Increasing Talking Machine Sales Interestingly Described

By
W. Bliss Stoddard

Greeting Tags Good Publicity

The W. G. Groffman Co., Berlin, Wis., adopted a clever advertising scheme on New Year's Day which could be practiced to equal advantage at Easter, these being the special days on which greetings are sent. Early on New Year's morning the firm sent a number of young men throughout the residence district of the city to tag every home with bright red cards, on which were printed in green letters the words "Wishing you a Happy New Year! W. G. Groffman Co., 1921." There was no advertising on the cards and the hundreds of bright tags looked very gay and cheerful fluttering in the wind. The simple and appropriate greeting was generally appreciated rather than otherwise by the householder—while the bright colors and uniformity of card made them easily recognizable, once one had been observed at close range, as representing the Groffman Co.

What's Your Number?

A clever plan to arouse interest of the citizens in talking machines was adopted by W. Howard Sallee, Litchfield, Ill. The plan is one which would, of course, work to the best advantage in small cities, where there is considerable rivalry among several towns of about the same size. This enterprising dealer, using Litchfield as a hub, sold machines in all the adjoining towns. After conducting an energetic campaign therein he reverted to Litchfield business, and in order to attract attention advertised:

LITCHFIELD! WHAT WILL YOUR NUMBER BE?

Hillsboro will have a number. Gillespie has already gotten one. Litchfield will have one. What number will you have? Gillespie's number is 31. Now, Litchfield, listen. Will your number be larger than Gillespie's? Why not? Aren't you as musical as Gillespie? I have just installed 31 talking machines there. How many are there in Litchfield who want one? Come down and look over my large stock. Ask to hear them demonstrated—and to hear the latest records. And then resolve to have one for your own—and to swell Litchfield's number to a point exceeding Hillsboro and Gillespie.

W. HOWARD SALLEE

The clever way in which he appealed to the pride of local patrons induced many to go to see his machines—and resulted in a number of additional sales.

Making the Window Pay at Night

A progressive talking machine merchant of Utica, N. Y., has solved the problem of how to make his windows pay for themselves in the evening hours. Realizing that a good display in a well-lighted window will attract attention he aims to have novelties and standard goods always on exhibition. Many evening promenaders see merchandise in the window that appeals to them and which they would purchase if the store were open, but by morning they have forgotten all about it or it is not convenient for them to come down. In order to catch these orders this firm has a pad of printed forms affixed to a shelf outside the door, near which is a pencil, attached by a little chain. If a person sees anything he fancies in the window all he has to do is to fill out a blank form and drop it through a slit in the door into a letter box on the inside. The merchandise is delivered C. O. D. the following morning. The order blank reads:

PLEASE SEND ME:

QuantitySize.....
Name
Address

Concerts to Increase Trade

The Broadway, Los Angeles, Cal., has recently increased its music department space to a considerable extent. Formerly located on the

fourth floor, it is now on the eighth floor in a specially designed auditorium, where an extensive line of musical instruments, including a large stock of talking machines, is carried. There are a number of demonstration booths, and a handsomely arranged recital hall where records will be played for the general public two hours daily. An interesting series of concerts is being arranged, under the direction of one of the well-known artists of the city, and here vocal and instrumental selections will be given by conservatory students, in addition to numbers on the phonograph. These concerts will be well advertised in the papers and by personal invitation. A. H. Snyder, head of the music department, says that the talking machine concerts have already proven very successful in stimulating the sales of both machines and records.

Sidewalk Display Sells Machines

A spectacular method of introducing a new talking machine department to the public was adopted by Arthur J. Smith, Hazleton, Pa., not long ago. Mr. Smith believes in adopting aggressive methods and when he decided to add talking machines to his stock he ordered one hundred as a starter. For several days he took full-page space in the papers, announcing the coming of the machines, and when they finally arrived he had the entire lot dumped down in front of his store—strewn out along the walk for a quarter of a block. He reckoned on the crowds going to the post office and to the State Hospital on visiting day to make a big audience, and the plan worked well. Demonstrations were given on each of the machines as soon as it was unpacked and this unconventional method of

doing business drew crowds all day long. Another method he took of introducing the machines was to give a number with every machine sold, with the announcement that two of the first one hundred machines sold would have the money refunded. The numbers were in a sealed envelope and were unknown to the firm itself. At the end of the month the lucky numbers were announced and the parties who produced the tickets received back the entire price of the machine.

Novel Plan of Payments

In order to start the 1921 partial-payment season with a rush the C. T. Sherer Co., Worcester, Mass., offered to the first fifty people who joined the Grafonola Club an instrument for an initial payment of 5 cents, and delivery of the machines at their homes. The payment the second week is to be 10 cents, the third week 15 cents, rising 5 cents a week until a weekly payment of \$2.50 is reached, after which the payments decline in the same ratio. Worcester is the hub of some thirty large and small suburban towns and the firm does a large business with the farmers and suburbanites. Each Spring the Sherer Co. presents all its customers with the Farmers' Almanac, as a token of appreciation of their patronage.

Guarantee Phonograph Prices

Goodwins, Ltd., Montreal, Can., anticipates customers' fears of reduced prices by assuring them that "We protect our customers with the promise to refund any difference if prices are lowered prior to May 1, 1921." They also advise "money cheerfully refunded" if the instrument sold fails to fully satisfy the customer.



Simply Wonderful! Marvelous! Beautiful!

THAT'S WHAT U-SAV-YOUR USERS SAY

WHOLESALE DISTRIBUTORS

(Watch this list grow)

Florida Talking Machine Co., Jacksonville, Fla. Collings & Company, Newark, N. J. Ross P. Curtice Co., Omaha, Nebr. Talking Machine Co., Birmingham, Ala. Wm. H. Reynolds, Mobile, Ala. Horton-Gallo-Creamer Co., New Haven, Conn. Emanuel Blout, 108th St. and Broadway, New York City. Standard Talking Machine Co., Pittsburgh, Pa.	Silas E. Pearsall Co., 10 East 39th St., New York City. Mickel Brothers, Des Moines, Ia. Schmelzer Co., Kansas City, Mo. Philip Werlein, Ltd., 521 Bienville St., New Orleans, La. John Elliott Clark Co., Salt Lake City, Utah. C. Bruno & Son, Inc., 351 Fourth Ave., New York City. Bergstrom Music Co., Honolulu, Hawaii.
-------------------------------------------------------------------------------------------------------------------------------------------------------------------------------------------------------------------------------------------------------------------------------------------------------------------------------------------------------------	-------------------------------------------------------------------------------------------------------------------------------------------------------------------------------------------------------------------------------------------------------------------------------------------------------------------------------------------------

Our business is, making just **one thing**, and making that **the best**.

No paraffin, no wax, no ammonia,—to cause you to worry—to kill the cabinet—to lose customers.

OUR GUARANTEE—If U-Sav-Your Cleanser and Dressing is not the finest you ever used, the purchase price will gladly be refunded.

Send for large sample—50c delivered

U-SAV-YOUR MFG. COMPANY

33 PERKINS AVENUE

WARREN, MASS.

A query.
 * * *
 OF THE dealer.
 * * *
 WHO wants.
 * * *
 SERVICE.
 * * *
 BUT DOESN'T get it.
 * * *
 BEEN WATCHING.
 * * *
 EMERSON-OUT-FIRST
 * * *
 FOR MONTHS back.
 * * *
 THE EMERSON dealer.
 * * *
 HAS had.
 * * *
 THE LATEST hits.
 * * *
 FIRST!
 * * *
 AND AHEAD of.
 * * *
 HIS competitor.
 * * *
 AS A consequence.
 * * *
 HIS SMILE is broad.
 * * *
 FOR.
 * * *
 HIS CASH register.
 * * *
 TINKLES and chinkles.
 * * *
 WITH a music.
 * * *
 AS cheering.
 * * *
 AND pleasant.
 * * *
 AND joyous.
 * * *
 TO him.
 * * *
 AS his.
 * * *
 EMERSON RECORDS.
 * * *
 SOUND.
 * * *
 TO HIS customers.
 * * *
 WE THANK YOU.
 EMERSON—
 OUT—FIRST!

(With apologies to K. C. B.)



Emerson records play wonderfully on all phonographs. But of course they are at their very best on the Emerson—the phonograph with the concealed Emerson Music Master Horn, made of rounded solid spruce, of all woods the most resonant and sound amplifying. Ten Emerson models in all, priced from \$80 to \$1,000.

Play Emerson Records with Emerson Needles, a QUALITY product.



A Call to Red Corpuscles

Goodbye, Care—farewell, Worry!
 Here's your Stetson—what's your hurry?
 No time, this, for Grouch and Gloom.
 For such as these we have no room.
 Only thing we're thinking 'bout,
 Is beating competition out.

Doing it? Yes, right along—
 Consequence—We're going STRONG!
 Join our happy family,
 We're not long on DIGNITY,
 But Oh Boy! You'll wear a grin,
 As you rake the shekels in!

All Emerson Records Now 85c.

- 10334 BRIGHT EYES—Fox Trot.....Plantation Dance Orchestra
 Deenah—Fox TrotPlantation Dance Orchestra
- 10341 MAKE BELIEVE—Fox Trot.....Selvin's Novelty Orchestra
 Love in Lilac Time—Waltz.....Selvin's Novelty Orchestra
- 10342 WOULD YOU? I'LL SAY YOU WOULD—
 Fox TrotJoseph Knecht's Waldorf-Astoria Dance Orchestra
 Congo Nights—Fox Trot.....Joseph Knecht's Waldorf-Astoria Dance Orchestra
- 10343 TWO SWEET LIPS—Fox Trot.....Lanin's Roseland Orchestra
 My Mammy—Fox Trot.....Lanin's Roseland Orchestra
- 10327—YOU OUGHTA SEE MY BABY—Comedy Song.....EDDIE CANTOR
 Give Me a Million Beautiful Girls—Character Song.....Irving Kaufman
- 10330 HONOLULU EYES—WaltzOrlando's Society Orchestra
 I Never Knew—Fox Trot.....Orlando's Society Orchestra
- 10336 LOVE BIRD—Fox Trot.....Green Brothers' Novelty Band
 Mazie—Fox TrotGreen Brothers' Novelty Band
- 10332 "SALLY"—Medley—Fox Trot.....Merry Melody Men
 Lady Georgia—Fox Trot.....Plantation Dance Orchestra
- 10335 I NEVER REALIZED—Fox Trot.....Joseph Samuels' Music Masters
 Spread Yo' Stuff—Fox Trot.....Joseph Samuels' Music Masters
- 10338 WHAT ARE WE GOIN' TO DO?—Comedy Song.....Arthur Fields
 Rosie—Baritone SoloArthur Fields
- 10333 IT'S ALL OVER NOW—Baritone Solo.....Arthur Fields
 Roaming—Baritone SoloArthur Fields
- 10329 BRIGHT EYES—Tenor Solo.....Irving Kaufman
 My Home Town—Comedy Duet.....Irving and Jack Kaufman
- 10337 SPOOKY-OOKY BLUES—Fox Trot.....Green Brothers' Novelty Band
 Just Another Kiss—Medley—Waltz.....Green Brothers' Novelty Band
- 10328 HOME AGAIN BLUES—Fox Trot—Toddle.....Plantation Dance Orchestra
 Palestena—Fox TrotPlantation Dance Orchestra
- 10339 OUT WHERE THE WEST BEGINS—Baritone Solo.....Royal Dadmun
 Bedouin Love Song—Bass Solo.....Charles Laird

Emerson Records in German,
 Polish, Italian and Jewish
 are a big asset to the dealer
 catering to these nationalities.

Records

EMERSON PHONOGRAPH CO., Inc.

NEW YORK: 206 Fifth Avenue

CHICAGO: 315 South Wabash Avenue



Folks will fox-trot happily to "Remember Me" by the Paul Biese Trio, and "Happy Hottentot," with Frank Crumit's rapid rhythmic patter. Profits you'll remember in this double. A-3359.



Columbia Graphophone Co.
NEW YORK

NEW MANOPHONE TRAVELER

H. D. Frost Now Represents Manophone Corp. in Michigan and Indiana—Well Equipped to Give Dealers Service and Co-operation

The Manophone Corp., Adrian, Mich., manufacturer of the Manophone phonograph, recently appointed H. D. Frost a member of the wholesale traveling staff, with Michigan and Indiana as his territory. Mr. Frost has been associated



H. D. Frost

with the wholesale and retail divisions of the music industry for more than fifteen years and is, therefore, well equipped to give maximum service and co-operation to Manophone dealers in his territory.

During the past few months the Manophone Corp. has received quite a number of applications from dealers throughout the middle West for Manophone agencies. These dealers state that business conditions are improving steadily, and, without exception, they emphasize the fact that the industrial outlook in their localities gives substantial reason for optimism.

AN ACCOMPLISHED MUSICIAN

ELLENSBURG, WASH., March 4.—Ned Douglas, head of the sales promotion department of the Seattle branch of the Columbia Graphophone Co., was a recent visitor to this city, calling at the establishment of E. W. Moore, local Columbia dealer. While in Ellensburg, Mr. Douglas consented to play the expensive Wurlitzer organ which was installed in Ellensburg Theatre, and the patrons of this theatre were given a delightful entertainment.

Mr. Douglas is a musician and a composer of considerable ability, and prior to joining the Columbia sales staff played the mammoth organ in the Liberty Theatre of Seattle.

PLANNING EXPERT SALES PROMOTION WORK FOR DEALERS

Buffalo Talking Machine Co. Engages Ed. J. Curren to Be Head of Advanced Type of Service Department—A Move That Is Calculated to Meet New Business Conditions

BUFFALO, N. Y., March 5.—The Buffalo Talking Machine Co., exclusive Victor wholesaler in this city, has recently inaugurated a sales plan which might properly be adopted by other Victor wholesalers and a great many other merchants, too. Alert to the necessity of adapting its policies to existing conditions, this company has employed an expert for special "sales promotion" work for its dealers.

Ed. J. Curren, who is the man chosen for the job, is a graduate of the William N. Albee school, and his work heretofore has been selling for his customers, rather than to them. Selling for the dealer—or at least helping him sell—is just what the country needs at this time.

It is the plan of the Buffalo Talking Machine Co. to visit its dealers, show them how to work up a prospect list, supply them with real sales literature, including special letters, convincingly written, for prospects to fit the dealer's individual requirements and aid the dealer to find the most logical channels for the distribution of the sales literature available from the manufacturers.

This work is particularly opportune because so many merchants who have been able to sell all the merchandise they could get without making any sales effort have gotten out of the

habit of really selling goods and now are at a loss to know where to turn for machine prospects and sales.

Because of the industrial depression, wholesalers were able to divert stock from the affected centers so as to supply other dealers more bountifully, and this, coupled with the fact that the gigantic Victor plant is now producing machines and records greatly in excess of its past performance, insures dealers actually having enough merchandise to justify a sales effort.

Good service on the part of the wholesaler will always be a vital essential to the industry, but very likely the term "sales promotion" will be heard throughout the trade even more often than "service" has been heretofore.

Intensive selling efforts are now required because of the demoralization ensuing from post-war conditions.

"We earnestly solicit competition in this field," said V. W. Moody, manager of the Buffalo Talking Machine Co., in discussing the intelligent plan of sales promotion work for which this company is sponsor.

No matter what your troubles are, come up smiling. If you do this the biggest prize in the world is ready for you—success.



HENRY BURR



ALBERT CAMPBELL



JOHN MEYERS

EIGHT FAMOUS VICTOR ARTISTS

In Concert and Entertainment

Personal Appearance of

Eight Popular Victor Favorites on One Program

A live attraction for live dealers and jobbers

Bookings now for season 1921-1922

A few available dates for Spring, 1921

Sample program and particulars upon request

P. W. SIMON, Manager

1604 Broadway

New York City



BILLY MURRAY



FRED VAN EPS



FRANK CROXTON



MONROE SILVER



FRANK BANTA

Famous Ensembles including
Campbell & Burr - Sterling Trio - Peerless Quartet

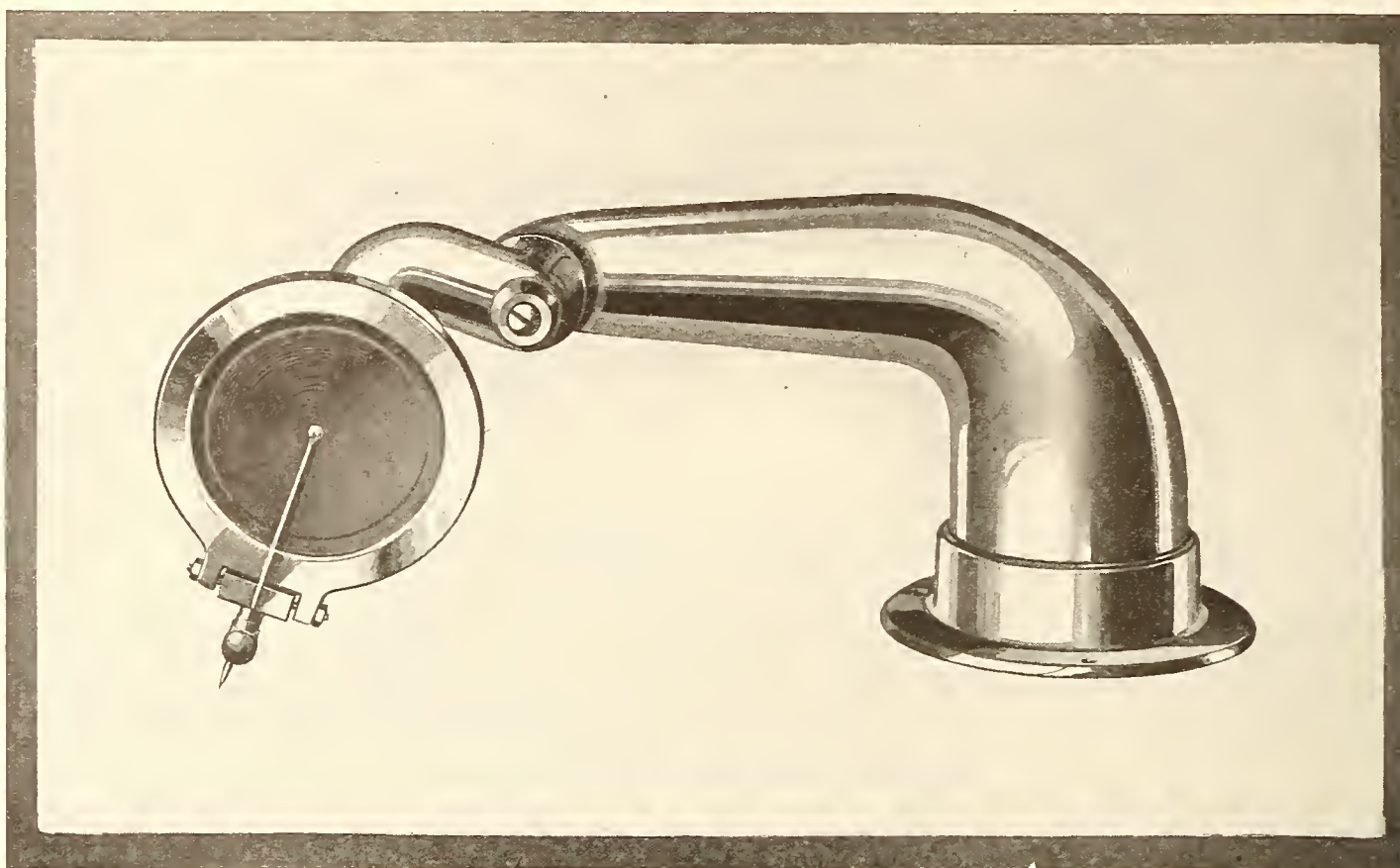

The Jewel Tone Arm and Reproducer 8½ inch length

We have changed the name and improved the product.

EDISON

Universal Attachments

VICTOR

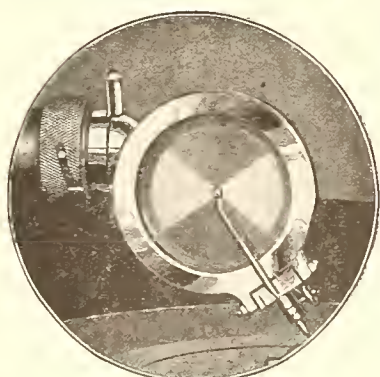

Fig. A

Every owner of an Edison phonograph is a prospect for this attachment. Plays Victor records with that superior, mellow quality of tone so characteristic of the "Jewel."

Victor Position

Fig. A shows Jewel Reproducer in position for playing Victor and other lateral cut records.



Fig. B

Hill and dale records are reproduced correctly by the "Jewel" method. A demonstration will convince you of its superior playing qualities.

Edison Position

Fig. B shows Jewel Reproducer in position for playing Pathé and other hill and dale records.

W
R
I
T
E
T
o
d
a
y
f
o
r
S
A
M
P
L
E
S

Victrola owners can now enjoy the wonderful creations of SERGEI RACHMANINOFF, the celebrated Russian pianist, so artistically reproduced in Edison records.

Edison Position

Fig. C shows Jewel Reproducer in position for playing Edison and Pathé and other hill and dale records.



Fig. C

Equipped with the "Jewel" mute and Nomika diaphragm, every note and every word is reproduced in all its original clearness and beauty.

Victor Position

Fig. D shows Jewel Reproducer in position for playing Victor and other lateral cut records.

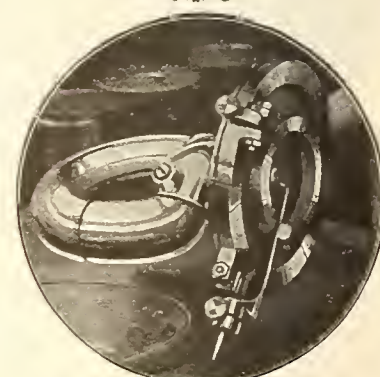

Fig. D

Every piece of apparatus that leaves our factory is covered by the "JEWEL" guarantee—SATISFACTION OR MONEY REFUNDED. Let's get acquainted now.

Jewel Phonoparts Company
670 W. Washington Blvd. Chicago

The New
JEWEL
AUTOMATIC STOP
is now ready

Jewel
TONE ARM & REPRODUCER

Immediate Deliveries on
Tone Arms, Uni-
versal Attachments,
Automatic Stops

U. S. DISTRICT COURT DISMISSES RECORD SUIT BROUGHT BY VICTOR CO. AGAINST STARR PIANO CO.

Action Instituted by Victor Talking Machine Co. for Alleged Infringement of Johnson Patents Covering the Manufacture of Lateral-cut Records Dismissed—Full Text of Decision

Judge Hand, in the United States District Court for the Southern District of New York, on Friday, February 11, dismissed the action brought by the Victor Talking Machine Co., Camden, N. J., against the Starr Piano Co., Richmond, Ind., charging infringement of certain Johnson patents held to cover the manufacture of lateral-cut records. In his decision Judge Hand says the bill was dismissed for "lack of invention and for abandonment."

The decision in full reads as follows:

UNITED STATES DISTRICT COURT
SOUTHERN DISTRICT OF NEW YORK

VICTOR TALKING MACHINE CO.

against

THE STARR PIANO CO.

WILLIAM HOUSTON KENYON and JOHN D. MYERS
for the Plaintiff.

DRURY W. COOPER and P. W. PAGE for the
Defendant.

LEARNED HAND, D. J.: The result in this case seems to me to depend altogether upon how the patent in suit is regarded, and once that is settled the whole situation is not unmanageably confused. If the patent is interpreted (as the plaintiff wishes) to include any sort of direct lateral cut with an elliptical section, then for the reasons I shall give below it appears to me void, both because it was anticipated and because it was abandoned long before 1907. If it includes only the cut made by the tool disclosed in the original application, while it may be of small consequence, I think that it may be valid notwithstanding the interval after which it was granted, and that it may not be a departure from the original application. If so interpreted, as it is entirely valueless to the plaintiff, it would be useless to spend any further time upon it.

The general understanding of the art in the years 1897 and 1898 seems to me proved as adequately as contemporaneous documents are apt to prove it, except in those rare cases in which they attempt to explain or to teach a part of the common stock of information. That understanding appears from the three applications about whose results Johnson patents; Jones, 688,739, and Johnson, 778,975. They show that the method of "cutting" or "engraving" (I do not distinguish them) a lateral groove direct on the wax was treated as a commonplace in the art, in which there remained no room for invention, except in the means used, or the character of the result. Figures three and four of Clark & Johnson's patent for a sound box filed in the very beginning of 1897 (January ninth), together with the text (page 1, lines 24-28, lines 96-100, page 2, lines 26-36), imply that the machine was addressed to an art at the time supposed by the patentees to be familiar with the "cutting" of a lateral groove. The patent was only for an "improvement" to produce "clearer records" than those then in use, by a machine which could only operate to make a lateral groove and that, too, by cutting out a "shaving." If the direct lateral cut was not known to the art, the disclosure was inadequate, for there is no description of how the cutting tool is to work. That could be inferred only from the figures themselves and the statement (page 1, lines 32-33) that the cutting tool is to be "of the ordinary construction."

The same considerations apply with even greater force to Johnson's two patents applied for on July 1, 1897 (No. 655,556, No. 655,557), because, although the claims are for both a reproducing and a recording sound box, there is no recording tool shown, unless it be the "needle k," and there is no description whatever of how the groove is to be cut. Certainly the patent was intended to be complete, and that was impossible unless everyone in the art would see at a glance that only a cutting tool "of the usual construction" need be applied. See especially in No. 655,556 the following language: "It will to a much greater extent overcome the resistance to the stylus caused by friction or resistance in cutting or making the record of the sound-waves."

Jones' original application (Nov. 18, 1897) described his object as "being to produce a more accurate copy of original record and to dispense with the old method or process of etching." Berliner had made durable records, but they were imperfect; Jones would make them durable and perfect. His process included everything from the wax blank to the final commercial article and was in six parts: (1), the beeswax plate; (2), "an instrument commonly employed for the purpose of recording sound vibrations" which "engraved" "a helical groove of even depth"; (3), a coat of graphite or the like upon the engraved record; (4), electroplating the coated record; (5), removing and reinforcing the matrix so as to make a die; (6), striking out the commercial records. Now, the only relevant element here is number two, and that is not described at all except by reference to machines in common use. Nothing is said as to how that machine shall be made to cut a groove of even depth, no intimation that he claimed to have discovered it, or that everyone would not know how to do it. This application was patently inadequate unless the art already knew that by turning the sound box and repositioning the tool one could engrave a lateral cut. A little more than two years later (March, 1900) he spoke of this portion of his invention as "the use

of a sound-recording machine in a well-known manner" to produce "a spiral groove of practically uniform depth." Here it is the method itself which is spoken of as "well known." Of course, it may be argued that in those two years he had learned of Johnson's work, but the closeness in meaning of the earlier and the later language leaves the most improbable. They were rather a mere rephrasing of the same idea. Jones thought that this invention rested not in making lateral cuts, but in using them as the basis of his electroplated matrix, rather than vertical cuts as in the graphophone (page 2, lines 36-82). Thus he preserved the original record from filling up during electroplating and the die from filling during stamping. The fineness of the record would so be better preserved. The existence of a lateral cut was a presupposition to his whole discovery.

In Johnson's sound box patent, filed February 3, 1898 (No. 651,076), there is another instance of an implied appeal to the common knowledge of the art. It was obviously for a lateral groove and is described as a recording as well as a reproducing machine. We know that Johnson at that time never meant to claim his supposed invention for direct lateral cut. If so, how was the art to employ this sound box as a recorder if it did not already know the process of direct lateral cutting? The same observations apply to Johnson's patent, filed December 22 (No. 781,424), another recorder as well as reproducer. The following language may be noted (page 1, lines 48-51): "The sound-record or undulations are in the sides of the groove and the stylus is positively vibrated thereby." Now, it may be asked, was the disclosure to record the undulations in the side of the groove? No method is described; certainly the patent must have been intended to be adequate. Clearly it was presupposed that given the mechanisms everyone would know how to produce them. They could be "cut" as the Clark & Johnson patent had already implied.

In the tool patent the same thing appears, though it must be owned not so clearly. In the original application—and the same language remained to the end (page 1, lines 15-21)—he contrasts the lateral cut machines to which his inventions especially, but not exclusively, applied with the vertical cut. The reference is as to a process already well known, and his primary purpose was merely to better the walls of a lateral cut (page 1, lines 22-30). Later, however, he did in some detail disclose the whole process of making a lateral cut, including the manufacture of the wax plate and its engraving by the tool. This was the "gramophone" to which he had already referred. He refers to it "briefly," "so that the cutting operation may be

understood, but as the cutting tool alone is the subject of my present invention, I have not deemed it necessary to herein illustrate, or further describe, the construction of the machine to which it may be applied." His understanding of the existing art, as shown in this "brief reference," depends upon whether he inserted it only for identification of the process, or as a disclosure necessary to the operation of the tool claimed. It is true that it would have been more consistent with his other specifications before and after to omit any description whatever and that perhaps the description was in itself enough for a disclosure. Yet I must judge his understanding at the time by what he said, and it appears that he did not think it a disclosure. If so, I can only conclude that he put it in for identification only, and was addressing an art which he assumed to be fully advised. The passage, which was eventually canceled (June 29, 1904), is the single suggestion anywhere in his applications of 1897 and 1898, that he did not assume that the process of direct lateral cut was a commonplace in the art.

From all the evidence, at the very best—in fact at much better than the best—Johnson is in this dilemma: either he knew the direct lateral cut to be old, or, supposing himself to be the first inventor, he thought it was not a patentable step in advance. The second hypothesis is a remote possibility. Pettit and he patented everything conceivably new which he discovered down to the very labels upon the record. To suppose that they could have refused to apply for a patent upon so obviously important a thing as the direct cutting of a lateral groove on the wax, because they feared the invalidity of the patent when issued, is to my mind inconceivable, though honestly enough now so remembered at so long a period of time. Moreover, I think it strange that Johnson should not have suggested it in the Universal case, where it would at least have supplied one link in the chain.

But whether or not Jones and Johnson knew it, or acted on such an assumption, the fact unquestionably was that the art did contain entirely adequate disclosures of the idea, and—what is perhaps more significant—had treated the lateral cut as an alternative open to anyone who might prefer it. Bell & Tainter, 341,214, make it entirely clear that their tool "cut" or "cut out" the groove (page 1, lines 59-69, page 3, lines 72-76, page 4, line 25, page 6, lines 70-79), and that its walls should be sloping (page 1, lines 76-83, page 7, lines 56-61) (claim 23). The shape of their tool, figures five and six, though of metal, necessitated a true cut and not a "snow-plow" action, and its "clearance" was sufficient, even for a lateral cut, had they wished to use it for that purpose. They had used it in fact for lateral cuts in their experiments in 1881, and have so sworn in 1896 in a suit in New Jersey, and though they discarded it, probably because their cuts were too wide, it is not improbable that the art had generally come to

(Continued on page 34)

We Are Prepared

to consider

Additional Contracts for 1921

Fifteen years' experience in the
manufacture of highest grade

Talking Machine Cabinets

Large modern factory, thoroughly equipped
with latest up-to-date machinery especially de-
signed for this work.

Highest Financial and Business Standing

We have a most wonderful proposition for export business

Write today for particulars

The Wabash Cabinet Company

Wabash, Ind., U. S. A.

DECISION IN VICTOR-STARR SUIT
(Continued from page 33)

know that it could be, and had been, so used. Moreover, as we now know, their tool and practice were fitted to produce as good records as Johnson's 1898 tool.

In 1887 Berliner disclosed his etched lateral groove record, and in 1888 Adams Randall, in perhaps a somewhat impractical way, suggested, if he did not disclose, a direct lateral cut record. The disclosure has been held insufficient of itself to constitute an anticipation of Jones, American Graphophone Co. vs. Leeds & Catlin, 170 Fed. R. 327, and will not anticipate here either, but it is none the less a relevant step of the art.

In 1888 Edison, in his first British patent (Gouraud, 12,503, 1888), disclosed in figures eleven and twelve a mechanism necessarily operating laterally and these he adequately described. The plaintiff argues that it is not shown to be a "cutting" machine, and it is true that that does not expressly appear. Yet it does appear that the record was to be made directly on the blank, and if it was not a cut it was at least a "displacement." Nothing remained in any event but to do the same thing with a genuine cutting tool. Moreover, in the later part of this very patent a genuine cutting tool is disclosed applied to a vertical cut and the later part is spoken of (page 9, lines 7-9) as "the second part of this invention." I must own that it seems to me a hair's-breadth distinction to suppose that the alternative shown in figures eleven and twelve

was not supposed to have the same kind of equipment as was shown in the rest of the patent.

However that may be, in 1891 he filed a second British patent (Gouraud, 15,201, 1891), which lays at rest any possible doubt. In this he shows, figure twenty, a mechanism which is adequately described (page 11, lines 22-40), to give a better record than "in the usual way," i. e., hill and dale. There can be no doubt that this was a groove directly "cut out" upon a wax blank not only because that appears throughout, but also and specifically because "a jewel cutting tool" is recommended (page 10, lines 31-55), which is spoken of as having a "cutting point or edge," made with "a curved sharp edge for cutting the surface of the blank." Whether ever used commercially or not, the whole invention was here described beyond any question, and if all else is disregarded it leaves nothing, so far as I can see, for the basic claims.

At about the same time Bruening, 462,687, threw out as a mere optional embodiment (page 2, lines 105-133) the translation of the sound box through an angle of ninety degrees to effect a lateral cut, and this in what was certainly a cut record. As in itself a disclosure, I agree that this is not enough, but its force does not end there. It shows that Bruening at least supposed that the direct lateral cut was known and could be practiced by anyone, and it is strong evidence of the understanding of the art at the time. Perhaps Bruening had heard of Bell's and Tainter's work, or seen Edison's disclosure, but in some way he clearly assumed that both kinds of cut were already in the public domain.

Thus we know that Jones and Johnson were correct in their tacit assumptions in 1897 and 1898, that the question was not of making a direct lateral cut which would reproduce, but of improving it so that it might displace the imperfect embodiments up to that time. That it had not been satisfactory Berliner's etched method does indeed show well enough, but the experiments made in this case also show that the earlier disclosures were tolerable as they stood, and as good as what Johnson had contributed up to 1898. Such inventions as are to be attributed to him must lie in the work which he did thereafter. Indeed, from Royal's testimony I conclude that the whole disclosure in 1899 proved of little value. It was only when Turner arrived later with changes that the market began to yield to Johnson's devices. Concededly shop practice counts largely in the result, and it would ignore all the evidence to attribute the plaintiff's eventual success to what was shown in the application of August 16, 1898. My own belief is that it was substantially valueless, but whether or not that be correct, certainly it was at some time later that Johnson finally got a machine which could occupy the field. It would be an entire perversion of the past to attribute to anything he did in 1897 or 1898 the sources of his later success. To succeed he must show that he was the first to embody any form of direct lateral cut, and to that it may be answered without doubt that not only was he not, but that for nine years thereafter neither he nor anyone else supposed that he was.

Against this is urged the decision of the Circuit Court of Appeals in American Graphophone Co. v. Universal Co., 151 Fed. R. 595. That arose over Jones' patent, and the argument is that the only invention as there found lay in the substitution of a lateral, for a vertical, cut. The significance of the decision is lost, however, if it be forgotten that the lateral cut was but a step in Jones' process, which consisted of making the eventual discs or tablets (Claims 1 and 2). It was this which had never been done before, and there is, as I have said, no reason to suppose that Jones had any idea that besides the combination as a whole any single element was patentable. Nor is there sufficient evidence that the Circuit Court of Appeals thought so, either. Thus, in the reference to the Edison patents (p. 597), they were thinking of "the electrotype deposit" referred to in Edison's British patent (1644,1878) (page 7, lines 34-39), as appears by their quotation from Judge Hazel's opinion (145 Fed. R. 636, 640). Furthermore, in considering Young's patent, the best reference, they adverted to the fact, as in the case of Edison, that matter of course that you could electroplate discs, as you could cylinders. Finally, they noticed that Jones had observed the advantages of discs struck from a lateral cut matrix over vertical cuts, an advantage which, so far as appears, he was the first to seize and make use of. There is, therefore, no ground for saying that they held the lateral cut, simpliciter, as invention, or that they sustained Jones' patent except by virtue of the combination which he claimed.

Concededly nobody had ever thought of such a possibility at any time, but Pettit, after the decision on Jones' patent, at once jumped to the conclusion that its effect was as broad as the plaintiff now insists, and that view he succeeded in getting two examiners-in-chief to accept, over the dissent of the other and the ruling of the primary examiner, Mr. Newton, himself later a Patent Commissioner. Ignoring for the moment the interval of time, and any departure or abandonment, it appears to me that Johnson and Pettit were right in 1897 and 1898 in supposing that Johnson was not the first to make a direct lateral cut, and that the only inventions open lay in its perfection, either by the tool which cut it or by the dimensions of the grooves, or by other details of the process through which the early and rude embodiments of the basic idea might be refined. For this reason I think the claims invalid for lack of invention.

If this be true, it is strictly speaking unnecessary to consider the other defenses, but that of abandonment is so interwoven with invalidity that I think it ought to be decided. The facts are simple and need only be recapitulated. On January 9, 1897, Johnson with Clark filed the sound box application which issued in 1899. On August 16, 1898, Johnson filed the tool application out of which the application in suit was later divided. During 1897 and 1898 he filed four other applications ancillary to lateral cut machines. In 1896 he spoke to Pettit about patenting the direct lateral cut and was told that it would not support a patent. He does not remember Pettit's reasons except that they covered the broad features now in question. This advice he accepted and filed both the sound box and tool applications and the four others above mentioned. Moreover, he and Pettit both remained of this opinion until 1907 after the decision in American Gramophone Co. v. Universal Co., supra, which Pettit construed as showing that he had been mistaken.

Taking these facts and no more, was there an abandonment? For argument's sake, I shall assume that the only reason for failing to include the broad features was the mistaken advice of counsel and further I assume that they would have constituted a valid invention. I agree, moreover, that when an inventor files a specification, and neither claims nor disclaims any part of the disclosure, he does not dedicate or abandon what he fails at first to claim, Battin v. Taggart, 17 How. 74, 83. Yet the act of filing the specifications may be an overt act of abandonment of what is not claimed, if other evidence shows it to have been so intended. Abandonment is quite another thing from forfeiture because of prior use, Consolidated Co. v. Wright, 94 U. S. 92. It arises whenever an inventor by some overt act or inaction shows an intention to abandon his invention, Kendall v. Winsor, 21 How. 322; Planing Co. v. Keith, 101 U. S. 479; Rifle, etc., Co. v. Whitney Arms Co., 118 U. S. 22; Compograph Co. v.

FEDERAL ELECTRIC SIGN



A Permanent Fixture That Soon Pays for Itself—

Every one who passes within blocks of your store is a prospective customer. But the store that is lost in darkness loses many a sale.

A Federal Electric sign gives a timely suggestion to the prospective customer that here is a store ready to take care of his needs. And a timely suggestion brings many a sale.

But it pays to invest in a sign that will be a permanent fixture.

This glittering Federal Electric

Sign is made of porcelain enameled steel, will not rust, decay or fade—never needs refinishing. An occasional washing keeps it sparkling like new.

Costs but a few cents a day for electricity—no other expense. It is strongly legible both day and night from a distance in either direction—attracts business like a magnet—pays for itself many times over. It produces results.

Mail coupon today for free sketch showing how your sign will look, also full information and price—no obligation.

Tear Off and Mail Coupon Now

FEDERAL ELECTRIC COMPANY

Representing Federal Sign System (Electric), 8700 South State Street, Chicago, Ill.

Please send me full information, price and free sketch of a Porcelain-enameled Steel Sign for my business. Explain your 12-months-to-pay Plan.

Name City State.....

Street and No..... Business

Store Frontage No. of Floors.....

TMW-3

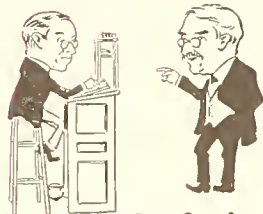

"Credit the Sign for that Last Sale, Joe"

12 Months to Pay!

The first payment brings you your sign—you have twelve months to make the final payments.

QUALITY

JOHN McCORMACK

*The World-Famous Irish Tenor, the Greatest Tenor on the Concert Stage.
(Recorded in London for the International Talking Machine Company)*

- 50001 { 12 in. } I HEAR YOU CALLING ME (Marshall) - John McCormack with Orchestra
\$1.50
- 50005 { 12 in. } CELESTE AIDA (From "Aida") (Verdi) - John McCormack with Orchestra
\$1.50

HENRY HADLEY

Associate Conductor of the New York Philharmonic Orchestra

- 5001 { 12 in. } DANCE OF THE HOURS (From Opera, "La Gioconda") (Ponchielli)
\$1.75 { Henry Hadley's Symphony Orchestra
- MERRY WIVES OF WINDSOR (Overture From Opera, "Merry Wives of Windsor") (Nicolai) - - - - - Henry Hadley's Symphony Orchestra
- 5002 { 12 in. } LARGO FROM THE NEW WORLD SYMPHONY (Part 1) (Dvorak Op. 95)
\$1.75 { Henry Hadley's Symphony Orchestra
- LARGO FROM THE NEW WORLD SYMPHONY (Part 2) (Dvorak Op. 95)
Henry Hadley's Symphony Orchestra
- 6004 { 10 in. } NARCISSUS (E. Nevin) - - - - - Henry Hadley's Symphony Orchestra
\$1.25 { MINUET (Op. 14 No. 1) (Paderewski) - Henry Hadley's Symphony Orchestra
- 6005 { 10 in. } THE JEWELS OF THE MADONNA (Intermezzo-Introduction to Act 3)
\$1.25 { (Ermanno Wolf-Ferrari) - - - - - Henry Hadley's Symphony Orchestra
- MALAGUENA (From Opera, "Boabdil") (M. Moszkowski)
Henry Hadley's Symphony Orchestra

MARINA CAMPANARI

Another great singer for Okeh, Mme. Campanari is a Coloratura Soprano

- 6006 { 10 in. } ROMEO ET JULIETTE (Waltz Song) (Ah! Je Veux Vivre) (Ch. Gounod)
\$1.25 { Soprano with Orchestra - - - - - Marina Campanari
- VOCE DI PRIMAVERA (Spring Voices) (Johann Strauss) Soprano with Orchestra
Marina Campanari
- 5003 { 12 in. } CARO NOME (Dear Name) (From Opera, "Rigoletto," Act Two) (Verdi)
\$1.75 { Soprano with Orchestra - - - - - Marina Campanari
- CAVATINA (From Opera, "Don Pasquale") (Donizetti)
Soprano with Orchestra - - - - - Marina Campanari

Okeh Records

GENERAL PHONOGRAPH CORPORATION

OTTO HEINEMAN, *President*

25 West 45th Street New York City, N. Y.





DECISION IN VICTOR-STARR SUIT
(Continued from page 34)

Universal Co., 146 Fed. R. 981. The latest instance of sufficient evidence is Macbeth-Evans Co. v. General Electric Co., 246 Fed. R. 695. No doubt a specific intent to abandon must be shown, a purpose not to seek a patent upon the invention, but once that exists, and he takes some overt step in execution of that purpose, then the invention is abandoned. Kendall v. Winsor, supra, did not, I think, turn on estoppel or an implied license; the judge's charge is possibly susceptible of that interpretation, but was not properly so intended, nor has the case been so treated. It was a case of straight abandonment and turned upon the plaintiff's intent, which would not have been so had it been an estoppel.

So viewed I can see no escape here from holding that Johnson abandoned the invention—if there was one, which I deny. With its character fully in mind he filed both applications, and four more, intending at the time not to include it in any. Indeed, in the passage already quoted from the tool patent he expressly announced that the tool as distinct from the process was "alone * * * the subject of my present invention," and this is an application which fully identified all its steps. Such language is quite different from filing a disclosure without disclaimer; it appears to me the equivalent of a disclaimer. Whether it be or not, it was intended to be an abandonment and that intention continued for nine years. If the plaintiff is right as to the existence of any invention at all, it has nothing to stand on but that Johnson was misled by Pettit's advice.

Now, mistake is a good excuse for reissue by statute (R. S. Sec. 4916), and indeed earlier by decision, Grant v. Raymond, 6 Pet. 243, but the statute (R. A. Secs. 4886, 4920, sub. 5) makes no such exception in cases of abandonment, nor have the courts. Moreover, the dedication involved in the issue of a patent is imputed, and need not be conscious; there is perhaps more ground for relief in such cases. But abandonment must be deliberate and unequivocal to be such at all, and may justly be treated as irrevocable. And if it were not, what equity is there in the case at bar to unravel the past? The mistake was of what the courts would hold, and therefore only a wrong guess on precisely that question as to which they knew they were guessing. They cast and their cast betrayed them, but it was a deliberate acceptance of the hazard. Such a mischance gives no ground for equitable intervention, if equity had anything to do with the situation at all.

Finally, in 1899 Johnson meant to include within the secrecy which the English contract enjoined this feature of the process, if he thought it an invention at all, which I do not believe. At best his escape can be only through the clause excepting from secrecy those inventions which might eventually be patented. But the difficulty is that at that time, and for eight years more, it is conceded that

he thought it could not be patented, and never meant to try to cover it. As he did not, I fail to see what possible loophole there is from the conclusion that, as to it, he meant to rely upon his power of secrecy. And if he meant forever to keep it secret, it was because he had abandoned it, under Macbeth-Evans Co. v. General Electric Co., supra, and under Pennock v. Dialogue, 2 Pet. 1. Indeed, the case is much stronger than Macbeth-Evans Co. v. General Electric Co., supra, because there the patentee always meant to patent, if he had to, supposing the invention patentable, while in the case at bar he never meant to patent at all, supposing he could not. His conduct was therefore without any ambiguity and indicated his purpose permanently to substitute secrecy for legal monopoly. The suggestion that the discs themselves disclosed the invention seems hardly to require an answer.

Bill dismissed for lack of invention and for abandonment with costs.

Attorneys for the Victor Talking Machine Co., when seen after the decision had been handed down, stated that in all probability the case would be appealed, although no definite announcement to that effect could be made just now.

PLAZA CO. FILES SCHEDULES

The Plaza Music Co., at 18 West Twentieth street, New York, and 718 Atlantic avenue, Brooklyn, has filed schedules in bankruptcy, with liabilities of \$492,233, of which \$344,710 are unsecured claims, and assets of \$507,288, the main items of which are: Bills, etc., \$13,949; stock, \$97,038; machinery, equipment, fixtures, etc., \$32,458; accounts, \$361,032, and deposit in bank, \$1,351. Among the creditors are Herman Germain, \$20,869; Warmser & Co., \$12,714, and Sol Kronberg, \$3,543.

VICTOR REPAIR PARTS CATALOG

In the March advertising material which the Victor Co. has sent to its dealers are copies of the new catalog of repair parts for Victrolas XIV and XVI. These catalogs give the name of every repair part carried for these instruments, together with an illustrated plate showing each part in detail. Dealers will find this a useful aid in ordering.

INTERESTING REMINGTON SOUVENIR

Group of Photographs Tells History of Remington Family Since 1816 and Shows Three Living Generations—Prepared in Poster Form

One of the most interesting and attractive dealer-helps, which has been issued by the Remington Phonograph Corp., New York City, is a panel or poster, entitled "Remington Genius—1816-1921."

The poster consists of an artistic layout of sepia half-tone reproductions of photographs of the noted Remington family, together with the four models comprising the Remington line. The center picture depicts the Remingtons, father and son, listening to their phonograph. Model No. 2, shown therein, is the favorite instrument of Philo E. Remington, president of the Remington Phonograph Corp. Another view shows them at work in the Remington phonograph laboratory, also Philo E. Remington at work on the latest Remington invention—the Remington reproducer. The old forge, where the first Remington gun was produced in 1816 by Eliphalet Remington, is shown. This date marks the introduction of the Remington name in the world of commerce.

Hale and hearty at ninety-three years of age, Eliphalet Remington, son of the famous inventor of the gun, retains all of his faculties, and is an exponent of the outdoor life. He is a director of the phonograph corporation which bears his name, and of which his son, Philo E. Remington, is president. Eliphalet Remington is also photographed with an early model of the typewriter that bears his name.

The Remington homestead is shown, as well as a group picture of the three living generations of the Remington family—Eliphalet, Philo E. and Miss Jessie Remington, daughter of Philo E. and granddaughter of Eliphalet.

Remember that selling things is not a low affair, but a great, bully game.

IF YOU WANT THE BEST

Insist on Getting

DE LUXE NEEDLES

The Best Semi-Permanent Needle Made

Let the De Luxe Speak for Itself and Send for Samples, Discounts and Full Particulars

DUO-TONE COMPANY, INCORPORATED

Sole Manufacturers of De Luxe Needles

ANSONIA, CONN.

Don't Forget These Facts

Perfect Reproduction of Tone

No Scratchy Surface Noise

Plays 100-200 Records



Full Tone



Medium Tone

Three for 30 cents

Edison Message No. 91

We shall be compelled to advance Edison phonograph prices, if the Excise Tax on phonographs is increased.

THOMAS A. EDISON, Inc.

ORANGE, NEW JERSEY

CONDITIONS STEADILY IMPROVING

Wm. Maxwell, in Interview With The World, Says Retail Dealers Are Experiencing an Increasing Demand—Good Outlook Ahead

ORANGE, N. J., March 2.—In an interview with The World, William Maxwell, vice-president of Thomas A. Edison, Inc., stated that conditions in the retail end of the Edison industry are satisfactory and that the outlook is very good. The Edison organization has received reports from a representative list of its dealers located in every section of the country and in Canada, covering the retail sales for each store during the month of January, 1921. These reports show that the retail merchants are moving goods on a healthy basis. In the Middle West, where the crop situation has been most severe, a shrinkage in sales has occurred, although a good volume of business is still being done. In practically every other section the sales are within 10 per cent of, equal to, or in excess of the instrument sales for January, 1920. The sale of Edison re-creations is in every case considerably in excess of that for January, 1920, so that nationally speaking the sales turnover in total for the retail merchants runs ahead of the same month last year. The telegraphic and other reports covering February already received show that sales that month ran ahead of the previous month.

In view of these facts, Mr. Maxwell feels most optimistic because, after all, the success of the business depends primarily on the retailer moving his stock. He looks for a steady growth in sales from now on, and believes that the industry as a whole is now operating under normal conditions, which means products must be sold upon their own merit.

Mr. Maxwell, vice-president of Thomas A. Edison, Inc., plans to leave for an extended Western trip this month, during which he will call on the Edison jobbers located in various sections of the country.

USES THE MAGNAVOX IN PUBLICITY

Ohio Dealer Uses Magnavox to Advantage in Publicity Work—Produces Tangible Results and Enhances Prestige of His House

The Magnavox Co., Oakland, Cal., received recently an interesting letter from the Drake & Moninger Co., Alliance, O., successful talking machine dealer, stating how this company is using the Magnavox in its publicity work. This letter, which is representative of many communications received by this company in the past few months, reads as follows:

"We have had our Magnavox about three weeks now and each day new uses for it as a publicity agent are suggested. Possibly the best we have so far tried was its use last week in conjunction with the orchestra at one of the local theatres.

"We used the record 'Whispering,' allowing it to play until just after the whistling part in the dark—then the spot light was thrown on the Magnavox, underneath which was a card announcing the name of the record and where it could be obtained. At this time the orchestra started playing with the record. We are still having calls for 'that record you played at the Columbia.'

"We are sending you this because we feel that if passed on it may help some one to an idea on which they, too, may 'cash in.' There are, however, so many uses for the Magnavox that its value as an advertising medium is limitless. We have the Magnavox attached to our truck—this attracts attention wherever the truck goes. We are very enthusiastic about the Magnavox."

Kapps Music Store, 2847 West Madison street, Chicago, is now attracting attention of the public, thanks to a huge electric Columbia Grafo-nola sign which has recently been erected in front of that building. The sign can be seen for blocks away.

ARTISTS VISIT SCHMELZER CO.

Efrem Zimbalist, Madame Homer and Her Daughter Speak to Dealers in Educational Classes Conducted by Kansas City Jobbers

KANSAS CITY, Mo., March 4.—The Schmelzer Co., wholesale Victor distributor of this city, recently received a visit from the famous violinist and Victor artist, Efrem Zimbalist, who was appearing here in concert. At the time of Zimbalist's visit to the store one of the educational classes was in progress in the Model Shop and the dealers present were delighted at the opportunity to meet the artist, who told them of his experiences in making Victor records. Madame Homer and her daughter also paid the Schmelzer store a visit and furnished the dealers with autographed photographs. The visit of these three Victor artists aroused great enthusiasm among the dealers.

VICTROLA NO. 90 NOW ARRIVES

Second New Model Announced by the Victor Talking Machine Co. Listed at \$125

Closely following the announcement last month of the new Victrola No. 80, which was received with enthusiasm by all Victor dealers, the Victor Talking Machine Co. has put forth another new style, known as Victrola No. 90, listed at \$125. This latest model is made in the usual variety of finishes, but for the time being will be available only in mahogany, English brown and American walnut. The Style X Victrola will be discontinued. Victrola No. 90 has concealed door hinges and the back of the cabinet is completely finished. It is equipped with all patented Victrola features.

HANDLES KENT LINE IN NEW YORK

Louis A. Schwarz, 1265 Broadway, New York City, the well-known manufacturers' representative, has been appointed an Eastern agent for Kent attachments, tone arms and small parts by the F. C. Kent Co., Irvington, N. J. This company specializes in attachments for the Edison, Victor and Columbia machines and manufactures tone arms and sound boxes, as well as steel, sapphire and diamond-point needles.

Nothing can be put across in this world without enthusiasm. It is enthusiasm that makes long hours pass quickly, and hard work a pleasure.—John J. Commons.

ARTIST'S TRIBUTE TO THE "TALKER"

Famous Singer Philosophizes on Advantages Artists Now Possess Through the Preservation of Their Voices on the Record

The wonderful perfection of the modern talking machine record has excited more interest among operatic singers than perhaps any other section of our community. The other day a great singer whose position many years ago in the operatic and concert field was the equal of many of our present-day artists was chatting in the lobby of the Manhattan Opera House between the acts of one of the performances of the Chicago Opera Co. "What a blessing," he remarked, "that these great voices that I have heard to-night will be preserved in all their glory and perfection for posterity. In my time," he continued, "the talking machine was in its infancy. It was merely a toy which nobody ever really conceived would be a factor of importance in the musical world. We singers of that day, of course, heard of what was being done, but we paid little attention to it. Moreover, the records of those days are not the records of to-day, owing to the amazing development of the art. To-day the singer whose tones are pouring forth so gloriously from those round, black discs can listen to himself almost as he actually is—in fact, the artist of the record is the artist whom I have been hearing to-night. The difference is so slight that even my trained ear can scarcely detect it."

The remarks of this artist superinduced some comments on his own career, and he was taken back again to the past with its triumphs and an obvious desire was evident that he wished there existed some such perfected mechanism when he was in his prime so that his voice could have been so photographed and preserved for future generations. He really lived over again the scenes of many an operatic climax, amid the enthusiasm of the public, regretting that his voice now is something beyond recall.

But when you stop to consider it, what a tribute there is in the remarks of this artist to the power and potency of the talking machine record as a great factor for musical advancement in our community! Those who use the talking machine are not prone to look upon it in its true light as a missionary for musical advancement, more particularly of America, where real music, outside of the big cities, was practically unknown up to the production of the modern talking machine. No longer does a great singer's voice die with him.



Business is being done.

But not by the man who is still looking for the "soft things" of 1920.

Elyea Talking Machine Co.

Atlanta, Georgia

Exclusively Victor

Strictly Wholesale



Gothic—Normandy



Grand



Minuet

32 Wonderful Models—

Supreme in tone, design and important features of construction

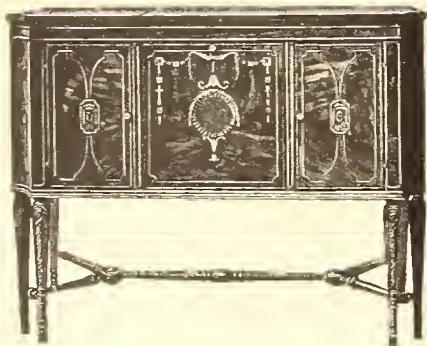

Hepplewhite—Traymore



Louis XVI—Richelieu



Louis XV—Lorraine

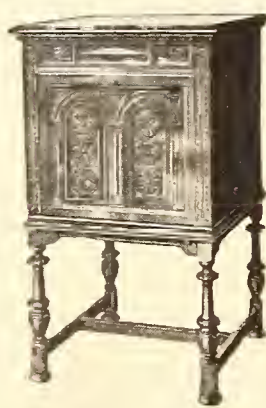

Jacobean, Jr.—Lancaster



Hepplewhite—Pembrook

You can satisfy every visitor who enters your doors if you handle the Sonora. People who should be your customers are buying Sonoras. Do you wish to sell them Sonoras or are you willing to let this valuable business go to your competitors? Sonora offers a remarkable line of both upright and period styles.

Remember, Sonora's 24 period styles are all standard (in stock and not made-to-order specials) and you can secure any design which you may not have on your floor in reasonable time from the Sonora factories.

Sonora maintains its leadership in giving the public what it wants.

On these pages are shown but a few of the many models which are ready. Sonora has consistently advertised all its styles and they are familiar to thousands of interested prospective buyers. Prices \$50 to \$1,800.

For the building of a substantial business you need the Sonora.

It is easy to sell the famous instrument which, at the Panama Pacific Exposition, won highest score for TONE against all competition

Your customers will enjoy the pride of possessing a

THE INSTRUMENT OF QUALITY

Sonora

CLEAR AS A BELL





Nocturne



Elite



Louis XV—Du Barry

Write regarding an agency to the jobber covering your territory. Sonora is LICENSED AND OPERATES UNDER BASIC PATENTS of the phonograph industry and you are safe from troublesome patent litigation.

Gibson-Snow Co.,
Syracuse, N. Y.
State of New York with the exception of towns on Hudson River below Poughkeepsie and excepting Greater New York.

W. B. Glynn Distributing Co.,
Saxtons River, Vt.
States of Maine, New Hampshire, Vermont and part of Massachusetts.

Griffith Piano Co.,
605 Broad St., Newark, N. J.
State of New Jersey.

Hessig-Ellis Drug Co.,
Memphis, Tenn.
Arkansas, Louisiana, Tennessee, Mississippi.

Kiefer-Stewart Co.,
Indianapolis, Ind.
Entire State of Indiana.

Lee-Coit-Andreesen Hardware Co.,
Omaha, Nebr.
State of Nebraska.

The Magnavox Co.,
616 Mission St., San Francisco, Cal.
Washington, California, Oregon, Arizona, Nevada, Hawaiian Islands, Northern Idaho.

C. L. Marshall Co., Inc.,
514 Griswold St., Detroit, Mich.
409 Superior St., Cleveland, O.
Michigan and Ohio.

Minneapolis Drug Co.,
Minneapolis, Minn.
States of Montana, North Dakota, South Dakota, Minnesota.

Moore-Bird & Co.,
1751 California St., Denver, Colo.
States of Colorado, New Mexico and Wyoming east of Rock Springs.

M S & E,
221 Columbus Ave., Boston, Mass.
Connecticut, Rhode Island and Eastern Massachusetts.

Robinson-Pettet Co., Inc.,
522 West Main St., Louisville, Ky.
State of Kentucky.

Sonora Phonograph Co. of Pittsburgh,
820 Liberty Ave., Pittsburgh, Pa.
Western Pennsylvania and West Virginia.

C. D. Smith Drug Co.,
St. Joseph, Mo.
Missouri, Northern and Eastern part of Kansas and five counties of N. E. Oklahoma.

Sonora Co. of Phila., Inc.,
1214 Arch St., Philadelphia, Pa.
Eastern Pennsylvania, Maryland, Delaware, District of Columbia and Virginia.

Sonora Distributing Co. of Texas,
Dallas, Texas.
Western part of Texas.

Sonora Phonograph Co., Inc.,
279 Broadway, New York
Distributors for Greater New York and towns on Hudson River below Poughkeepsie.

Southern Drug Co.,
Houston, Texas.
Southeastern part of Texas.

Southern Sonora Co.,
310-314 Marietta St., Atlanta, Ga.
Alabama, Georgia, Florida and North and South Carolina.

Southwestern Drug Co.,
Wichita, Kans.
Southern part of Kansas, Oklahoma (except 5 N. E. counties), and Texas Panhandle.

Strevell-Paterson Hardware Co.,
Salt Lake City, Utah.
Utah, Western Wyoming and Southern Idaho.

C. J. Van Houten & Zoon,
Marquette Bldg., Chicago, Ill.
Illinois and Iowa.

Yahr & Lange Drug Co.,
Milwaukee, Wis.
Wisconsin, Upper Michigan.

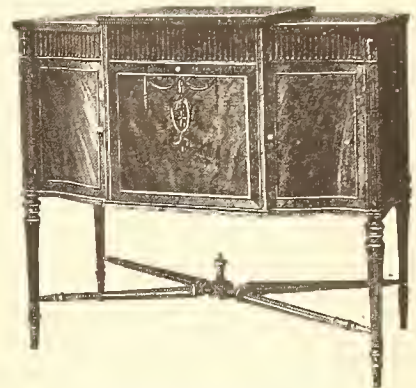

Adam—Westminster



Colonial—Mt. Vernon

The Highest Class Talking Machine in the World



Italian Renaissance, Jr.—Luzerne



Hepplewhite—Islington



Italian Renaissance—Verona



“A Southern Lullaby” with its sleepy clarinet and humming bees, “Mammy Dear” with its unusual climax will soon be well-loved songs of the Southland. Barbara Maurel sings them. A-3355.

**Columbia Graphophone Co.
NEW YORK**

WHY THE POPULAR RECORDS SELL SO WELL

By R. D. GALT

John Barber smiled as he placed another record of late popular music to one side. I looked up just in time to catch the twinkle in his eye. I wondered at it for a second, but finally I forgot to be puzzled in the ecstasy of a new dance record. In the short second that I raked my brain for an explanation of that amused grin, the proprietor of the Barber Phonograph Shop had slipped another late hit into place.

It little mattered that this should be a vocal variation of the same popular music. I listened eagerly to catch each new melodic variation that I had come to expect in the popular songs. Something about it enthused me greatly and I waved the piece into the pile to one side.

Again I looked up just in time to glimpse the vanishing curves of a smile on my friend's lips. I call John Barber my friend, as he lives next door to me when we are at home. I had just stepped in on my way home, for I knew John would be going soon. It was almost midnight.

You would hardly expect to find the proprietor in shirt sleeves at that time of night, but it was no new thing for John Barber. I had found him in that state many times before. And I always knew that he had received a shipment of late records when I saw him thus. Strange, too, but I always was eager to stop on those evenings.

“What's the joke?” I asked, rather abruptly.

John flashed another generous smile.

“I was just thinking how you would enjoy this next one-step,” he replied. “A new orchestra, and they certainly know how to put jazz into their playing. Muted trombone and a regular cascade of tumbling notes on the saxophone—falling downstairs, I believe you

call it. Everything that can be done, and more. You'll like it.”

I took John's explanation badly. I had gotten the idea that he was laughing at me. I watched him sharply all through the playing of the new record and quite forgot to applaud in my usual fashion. When John glanced up to see what was wrong, he noticed my vigilant gaze.

“Well,” he said, “don't you want this one?” He eyed the stack of records as he spoke and I imagined the same twinkle tried to break out.

“No,” I said vehemently. “And I won't listen to another record unless you tell me what you think is so funny. You're laughing at me. I feel it. What's the joke?”

He paused in the act of picking out another popular hit. Replacing the record he sat down and began unrolling his shirt sleeves.

“It's not really a joke, old man,” he said good-naturedly. “I was just ruminating on people as I have found them in a music shop. A few things struck me as being amusing.”

“Yes?” I said coldly.

“Oh, not you in particular. You're one of many. They are all alike. Almost all of them. And the strange thing about it is that they know what I smile at and do not care.”

“Here's one that . . .”

“Doesn't,” interrupted John. “See here. If I were to tell you that I wouldn't let you have that pile of records you've picked out, you'd kick like a ——. Well, maybe you wouldn't either. You'd march out like a proud peacock and buy the same records at my competitor's shop.”

I stared at him. “What if I would?”

“That's what I was smiling about. Every month when I get in the new records you stop in and buy a stack like the one you have bought

to-night. It's the same every month. There must be a reason. What is it?”

I shook my head. Come to think of it, I did not really know.

“I know, or at least I have figured it out as nearly as possible,” continued my friend, letting his face wrinkle itself into a fresh burst of merriment. “I live next door to you and in that way the mystery has been solved. For months I wondered why my customers bought more popular music records than others. I always ran short on the one and had plenty of the others. I didn't uncover the real reason until a few weeks ago.”

“The majority of my customers buy both the high-priced and the so-called popular records. But not in the same proportion by any means. Living next door to you I have fathomed the reason.

“Every month you buy a dozen or two popular records. When another month ushers in a new list, you promptly shove those you have into a corner of your record cabinet and buy the late ones. I never hear a three-month-old popular piece on your machine. Very seldom I hear one that is over a month old. They lose their novelty hold and go into discard.

“It's different with the high-priced records. Only yesterday I heard a vocal selection by John McCormack that I sold you two years ago. Of course, that doesn't make business for the Barber Phonograph Shop, but it explains the twinkle in my eye. I make my money on the popular pieces because people soon tire of them and come for a new supply. The others are slower to go into the discard and sometimes never go. That's why I sell fewer. They entertain as much now as they did when they were first purchased. And that's why I smiled.”

“Meaning me?” I said, showing my teeth.

John nodded.

“Well—wrap those few up anyway, John. You don't need to cut down your order on popular stuff on account of what you have told me. I'll be back again next month.”

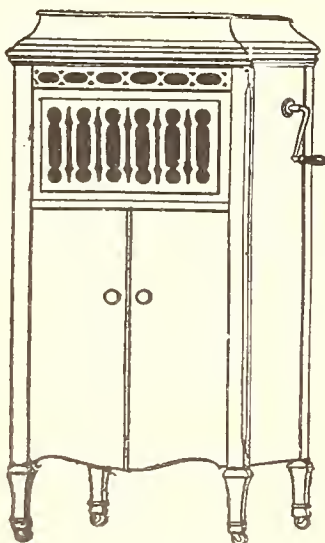

SOUTHERN DISTRIBUTORS

Pathé PHONOGRAPHS
and RECORDS



GRAY & DUDLEY CO.

Write Today for Agency Proposition

NASHVILLE

TENNESSEE

NEW CLUETT PHONOGRAPH MANAGER

Raymond H. Clarke Takes Important Post With Cluett & Sons in Troy, N. Y.

Troy, N. Y., March 7.—Cluett & Sons have just appointed Raymond H. Clarke as manager of their phonograph department and he has already taken up his new work. Mr. Clarke is well qualified for this position, inasmuch as he



Raymond H. Clarke

has had considerable experience in phonograph merchandising, having been associated with the Aeolian Co. both in New York and Boston. He is a native of New Haven, Conn., and is quite well known through that section as a tenor soloist. He also played a prominent part in "Goodbye Bill," one of the soldier shows that was presented in New York during the war.

HOPKINS BACK FROM THE WEST

General Sales Manager of the Columbia Co. Reports Improving Conditions in That Territory—O. F. Benz Visits Boston

Geo. W. Hopkins, general sales manager of the Columbia Graphophone Co., returned a few days ago from a Western trip, which included a visit to the Columbia branches in St. Louis, Cincinnati and Indianapolis. Mr. Hopkins states that business conditions in this territory are steadily improving and that the dealers are optimistic to a marked degree in their predictions for Spring business.

O. F. Benz, record sales manager of the Columbia Graphophone Co., spent a few days in Boston last week in conference with Fred E. Mann, manager of the Boston branch. On Saturday Mr. Benz addressed a meeting of the sales staff of this branch, giving them interesting data regarding record sales plans for the coming year.

W. H. Lawton, manager of the Buffalo branch of the Columbia Graphophone Co., was a visitor to the Columbia executive offices in New York this week.

ARTHUR D. GEISSLER RETURNS

Arthur D. Geissler, president of the New York Talking Machine Co., New York, and the Chicago Talking Machine Co., Chicago, Victor wholesalers, returned to New York a few days ago after spending a month in Chicago. According to his present plans Mr. Geissler will spend quite some time at the executive offices of the New York Talking Machine Co., keeping in touch with Chicago activities.

P. J. Mann, Victor dealer at Worcester, Mass., was a caller recently at the offices of the New York Talking Machine Co.

The Brunswick phonograph is now handled by the Anderson Piano Co., 291 Livingston street, Brooklyn, N. Y. The arrangement was consummated by Edward N. Strauss, manager of the phonograph division of the New York house of Brunswick.

JAZZ INVADES SOUTH SEA ISLANDS

Silent Bliss of Mystic Tropics Broken by the Music of Broadway on the Talking Machine

The South Sea Islands are no longer the home of quiet and blissful solitude. Talking machines equipped with jazz records have invaded the silences of the cocoanut groves and vie with the ukulele in the mystic moonlight on the beach at Waikiki and parts west and south.

American sailors are said to have introduced the "talker" in Tahiti, the island of Yap and other places where Uncle Sam's fleet touches. They made a big hit with the natives and talking machine house drummers who followed found a ready market for their wares.

Every native that could scrape together the wherewithal invested in one of the musical instruments. Bananas and yams and other tropical fruits flooded the markets in the search of the elusive peso to buy the machines. Planters found the brown-skinned natives willing to work at least three days a week in order to lay up enough to make a first payment on a "talker."

So now the peaceful silences, broken heretofore only by the wash of the sea on the beach or the boom of the breakers over the coral reef, are disturbed by a version of the "Memphis Blues" as interpreted by a Broadway cabaret's orchestra or by the siren voice of the current vaudeville favorite.

NEW CORPORATION IN OLEAN, N. Y.

The Houghton & Rungle Music Co., Olean, N. Y., has been incorporated under the laws of New York State to do business in talking machines and other musical instruments. The capital is \$10,000 and the incorporators are J. V. and L. A. Houghton and H. P. Rungle.

NEW RECORD ALBUM COMPANY

The Two-Size Record Album Corp., New York, has been incorporated to manufacture record envelopes. The capital is \$100,000 and the incorporators are J. W. Johnson, H. S. Wisner and G. C. Luebbers, 574 West End avenue.

MAIN SPRINGS AT LAST

Packed in RUST-PROOF, DUST-PROOF INDIVIDUALLY NUMBERED CONTAINERS indicating their use, at no advance in price.

We want a portion of your business.

(No Shipment Made Less Than Six Springs)

	Lots of				
	6 each	12 each	25 each	50 each	100 each
No. 24 1/2"x.018x8 feet, for small toy motors, pear shape hole	.20	.18	.17	.16	.15
No. 25 5/8"x.020x8 feet, for Sonora, Swiss, Pathé, pear shape hole	.22	.20	.19	.18	.17
No. 26 5/8"x.020x11 feet, for Edison Gem, loop end	.30	.28	.27	.26	.25
No. 28 3/4"x.022x9 feet, for Carola, Triton, Melophone, etc., pear shape hole	.38	.37	.35	.33	.31
No. 29 3/4"x.022x10 feet, for small Columbia, Universal, Heineman, Harmony, Vanophone, Pathé, pear shape	.43	.42	.40	.38	.35
No. 30 7/8"x.022x10 feet, for Blick, Wonder, Premier, Meisselbach, Nos. 9 and 10, square hole	.47	.46	.44	.42	.40
No. 31 1"x.025x9 feet, for Swiss motors, small Columbia, Stewart, pear shape hole	.54	.52	.50	.48	.45
No. 32 1"x.020x13 feet, for small Victor, pear shape hole	.54	.52	.50	.48	.45
No. 33 1"x.025x12 feet, for Pathé, Heineman, Mandel, Aeolian, Meisselbach, Vitanola, pear shape hole	.70	.67	.60	.55	.50
No. 34 1"x.025x14 feet, for Sonora, Saal, Thomas, Silver-tone, oblong hole	.75	.70	.65	.60	.55
No. 35 1"x.028x10 feet, for all styles Columbia machines, pear shape	.54	.52	.50	.48	.45
No. 36 1"x.025x9 feet, for Meisselbach, No. 12, Thomas, oblong hole	.54	.52	.50	.48	.45
No. 37 1"x.025x16 feet, for Meisselbach, Saal, Thomas, Silver-tone, Modernola, Rishell, Widdicomb, Sonora, Stephenson, oblong hole	.85	.83	.80	.75	.70
No. 38 1"x.025x16 feet, for Vitanola, pear shape	.85	.83	.80	.75	.70
No. 39 1"x.028x11 feet, for Edison Standard, pear shape	.59	.57	.53	.50	.47
No. 40 1 3/16"x.028x16 feet, for Heineman, Pathé, Rex, pear shape	.90	.88	.85	.80	.75
No. 41 1 1/2"x.027x25 feet, for Edison Diamond Disc, pear shape hole	1.80	1.70	1.65	1.55	1.50

(If the above are desired in assorted sizes, the quantity price will be allowed.)

TERMS: 2% 10 days or 30 days net, to houses with satisfactory commercial rating. To others, 3% discount, cash with order. Please enclose Parcel-post charges, if wanted that way.

Write for our latest catalogue, now on the press, containing hundreds of needed repair parts. Ask for catalogue W.

EVERYBODY'S TALKING MACHINE CO.

Largest Distributors of Main Springs in America

38 North Eighth Street

PHILADELPHIA, PA.

Exclusive Distributors for the General Phonograph Corporation

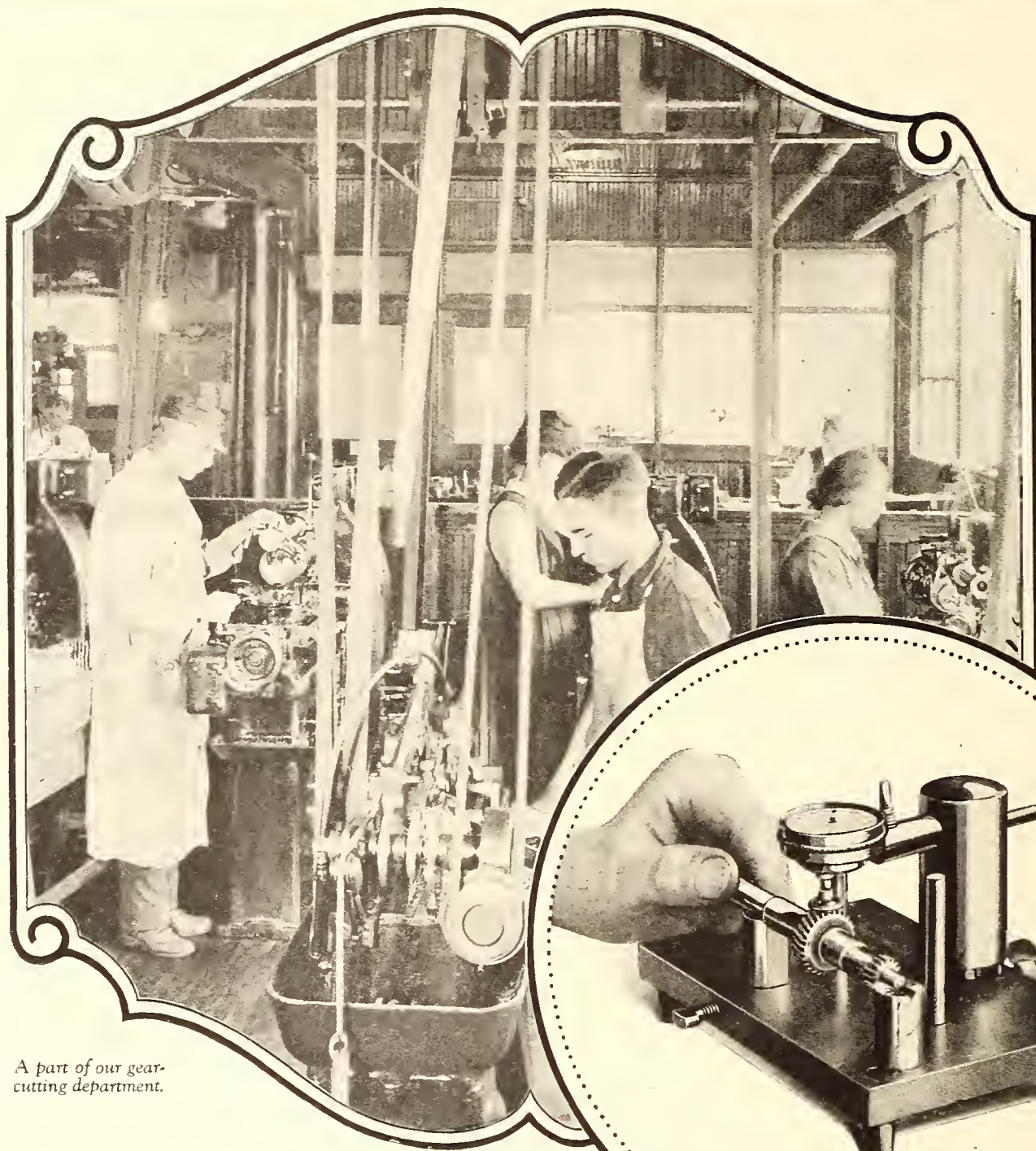

A part of our gear-cutting department.

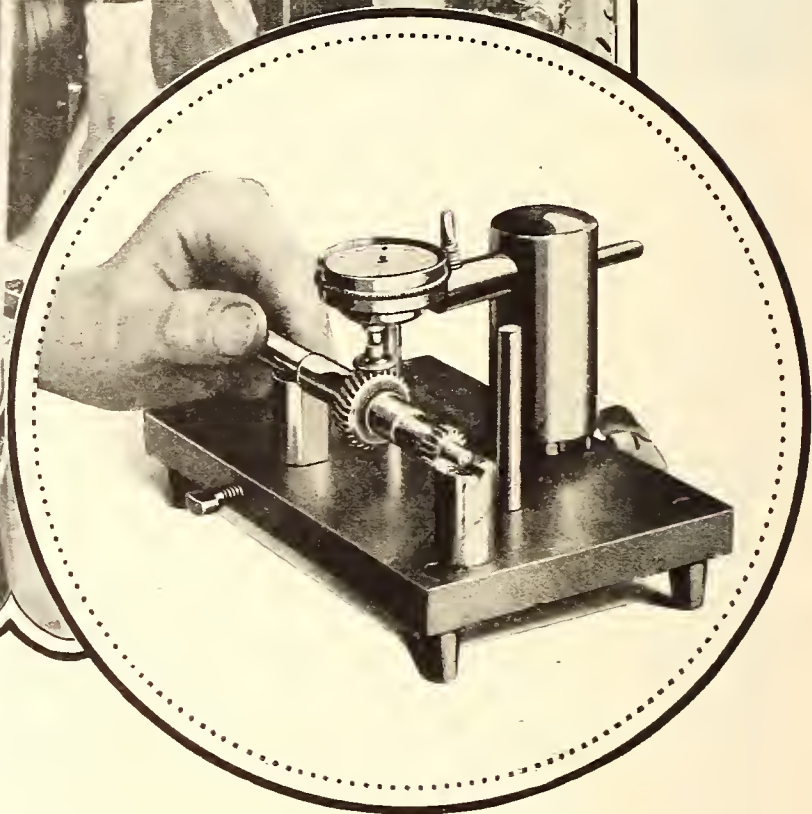

This delicate gauge easily detects variations of less than 1-1000 of an inch in Cheney mechanism.

Splitting Hairs Over 1-1000 of an Inch

You should see the care we take in our factory to make each part of The Cheney perfect—to make the finished Cheney the finest of reproducing instruments.

The CHENEY

The public is critical, searching for quality. Such conditions give us utmost confidence in the future—for coupled with our high manufacturing standards are basic and exclusive principles of Cheney construction found in no other phonograph. Its rich tone quality, beautiful cabinets and perfect service bring Cheney dealers repeat business which is very significant.

CHENEY TALKING MACHINE COMPANY
New York Chicago



Yet, Cheney Regular Models sell for ordinary prices, \$125 to \$385.

**CRYSTAL EDGE
MICA
DIAPHRAGMS**
The Standard of Quality
PHONOGRAPH APPLIANCE CO.
174 Wooster St., New York

PENNSYLVANIA WANTS A 'MUSIC BOX'

Talking Machine or Similar Instrument Would Be Welcomed for Entertaining the Inmates of the State Sanitarium at Mont Alto

MONT ALTO, PA., March 7.—The State of Pennsylvania is hunting a music box. It wants the box for the State sanitarium here, where the box which has made melody flow for several years is showing signs of age, as it has been in use almost as much as the thermometers. Under the State laws the Commonwealth cannot buy a music box for such an institution, although it owns and conducts the establishment, and Director George O. Keck has asked anyone having a phonograph or similar instrument not needed to give it to the sanitarium. There is really need for two, as the children have been clamoring for one for their part of the institution.

OPENS NEW MUSIC STORE

A. J. Hobbie has opened a music store in Willmar, Minn., and will carry a line of high-grade pianos, players, talking machines and musical merchandise.

When we catch hell it's usually because we've been pursuing it.

MUSIC WEEK COMMITTEE COMPLETE

Bishop-elect Wm. T. Manning and Miss Isabel Lowden, Sister of Illinois Governor, to Take Part in the Music Week Work in This City

The personnel of Music Week Committee, under whose direction New York's second Music Week, April 17-24, will be conducted, was completed last month by the acceptance of membership in it by the Rev. Dr. William T. Manning, bishop-elect of the Episcopal diocese of New York.

At the same time Miss Isabel Lowden, sister of Governor Frank O. Lowden, of Illinois, accepted the post of assistant secretary of the committee in charge of details. Miss Lowden comes to the committee from the People's Liberty Chorus, of which she was secretary.

Work of enrolling the various organizations, churches, clubs, etc., which participated in last year's Music Week and urging others to take part already is well under way.

PLAN "CONSTRUCTIVE" CAMPAIGN

PEORIA, ILL., March 5.—B. J. Oltmann, manager of the repair department of the Putnam-Page Co., Victor wholesalers of this city, has just returned from Camden. He spent two weeks there in the Victor factory, and is now planning to conduct a constructive and vigorous effort for the development of the repair service offered by the Victor dealers to whom the Putnam-Page Co. sells merchandise. Within a short time he will start out on a trip among the dealers with this end in view.

INCORPORATED

The Ware Campbell Co., Hammonton, N. J., has received a charter to manufacture talking machines. The capital of the new corporation is \$50,000 and the incorporators are Charles M. Ware, Albert Campbell and Ernest D. Ware, Millville, N. J.

THE VOCALION LINE IN MILWAUKEE

J. B. Bradford Piano Co. to Handle All Aeolian Co. Products After April 15

MILWAUKEE, Wis., March 7.—On April 15 the J. B. Bradford Piano Co., the oldest and one of the largest music houses in Wisconsin, having been established in 1872, will become representatives in this city for the complete Aeolian line of instruments, including not only pianos and Pianola pianos, but Vocalions and Vocalion records.

SUFFERS HEAVY LOSS FROM FIRE

Stock and Fixtures of E. C. Malarkey in Shamokin, Pa., Damaged to Extent of \$15,000

SHAMOKIN, PA., March 7.—Fire, which occurred on February 17 in the basement of the E. C. Malarkey piano and music store here, swept through the first and second floors of the building, effecting damage to the extent of \$25,000. Mr. Malarkey lost \$15,000 in stock and fixtures.

The blaze was located in the Windsor block, half of which was laid in ruins by a disastrous \$250,000 fire last November. Firemen were handicapped by dense smoke and the flames raged for two hours before they were brought under control.

AN OLD ADAGE, BUT A TRUE ONE

"He who serves best serves most" is an old adage, but a true one, because no better definition of retail merchandising success has ever been written. Under the broad classification of service come such things as advertising, the arrangement of store interiors, technical knowledge of the sales force and the intelligent combination of these. To help you serve your customers better and with a minimum of effort is our reason for supplying new sales helps, says the Victor Talking Machine Co. in sending out its March letter to dealers.

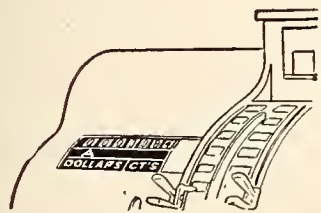
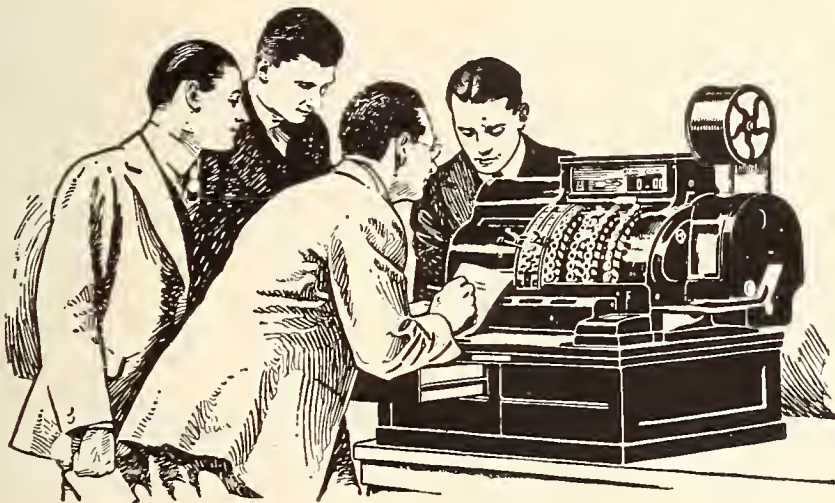

This adding counter, at the left side of the register, shows that Clerk A took in \$39.84 during the day. Similar counters show what the other clerks took in.



These adding counters, at the front of the register just above the cash drawers, show how many customers each clerk waited on, and the total number of customers.

The record of each clerk

An up-to-date National Cash Register shows you exactly what each one of your clerks does every day. Adding counters on the register tell:

- ① How many customers each clerk waited on.
- ② The total amount of each clerk's sales.

These daily records show you which clerks are most industrious, which clerks sell the most goods, which clerks are most accurate.

They enable you to fix wages on actual selling ability.

They give you the figures needed for a bonus or profit-sharing system.

These clerks' records, together with the many other printed and added records made by an up-to-date National Cash Register, enable you to control your business.

We make cash registers for every line of business. Priced \$75 and up.

**NATIONAL
CASH REGISTER CO.**
DAYTON, OHIO.

You Can Now Buy
Brilliantone Needles
 in These Attractive Counter Display Cartons

THESE handsome counter display cartons will prove efficient sales-stimulators. Each carton contains a supply of BRILLIANTONE NEEDLES in the following tones: Extra Loud, Full Tone, Half Tone, Medium Tone, Light Tone, Combination Tone. Each tone is put up in a different colored envelope. This makes it easy to select quickly the envelope containing the desired tone.

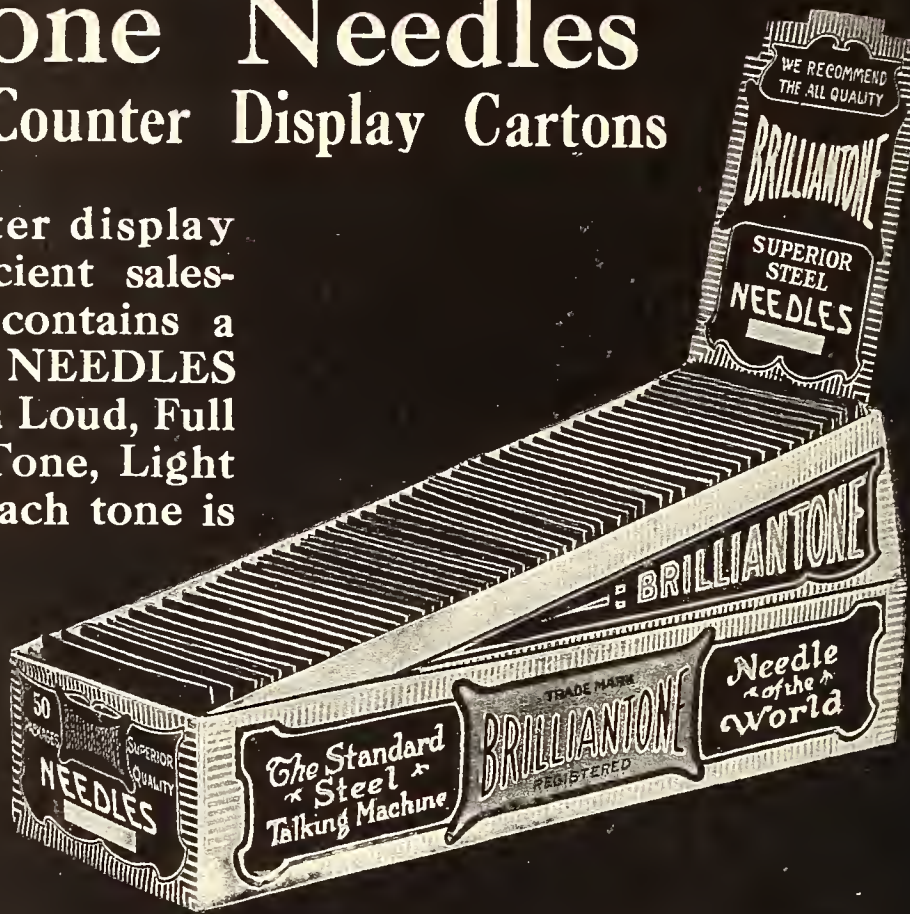

500 DANCE TONE NEEDLES
 in This Screw Top Metal Container

Also in Containers
 of 200 Needles

Write now for
 samples and prices

BRILLIANTONE
STEEL NEEDLE CO. of America,
 Incorporated

Selling Agents for

W. H. BAGSHAW & CO. Factory, Lowell, Mass.

347 FIFTH AVENUE,
NEW YORK

AT 34th STREET

SUITE 1003

Canadian Distributors: The Musical Mdse. Sales Co., 79 Wellington St. W., Toronto
 Foreign Export: Chipman Ltd., 8-10 Bridge St., New York City

W.H.BAGSHAW CO.

Oldest and Largest Manufacturers
of Talking Machine Needles
in the World

Fifty Years of Needle Making

ESTABLISHED 1870

INCORPORATED 1917

FACTORIES: LOWELL, MASS.



SELLING AGENTS

BRILLIANTONE STEEL NEEDLE CO. OF AMERICA
INCORPORATED

347 FIFTH AVENUE

AT 34th STREET

NEW YORK

SUITE 1003

Canadian Distributors: The Musical Mdse. Sales Co., 79 Wellington St. W., Toronto
Foreign Export: Chipman, Ltd., 8-10 Bridge St., New York City

NEW REMINGTON APPOINTMENTS

O. W. Newiger Now Assistant Sales Manager—Austin L. Fordham Is Wholesale Sales Representative—Both Experienced Men

O. W. Newiger has been appointed assistant sales manager of the Remington Phonograph Corp. by Everett H. Holmes, sales manager.

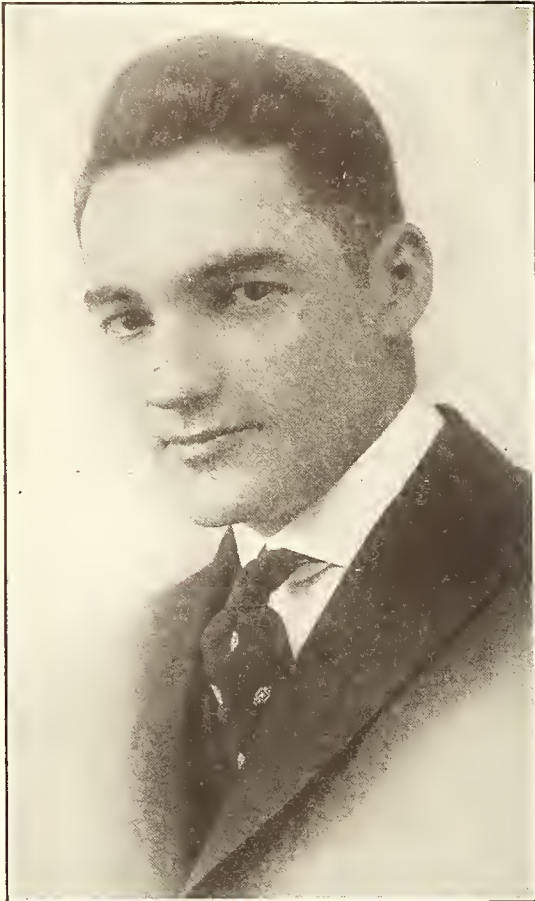

O. W. Newiger

Mr. Newiger has been connected with the Remington Corp. since its inception in the capacity of auditor, and is thoroughly familiar with all the details incident to the sales department. He will relieve Mr. Holmes of numerous duties in connection with the marketing of the Rem-



Austin L. Fordham

ington product. His headquarters will be at 1664 Broadway, New York.

Austin L. Fordham recently returned from an entirely successful trip through his territory in the capacity of wholesale sales representative of the Remington Phonograph Corp.

Mr. Fordham was for some years connected with the Columbia Co. in various capacities and more recently was New England sales representative for the Brunswick phonograph.

Some time ago Mr. Fordham conducted the

phonograph department for Landsberg Bros. in Washington, D. C., and as a result of his experience, both in the retail and wholesale ends of the industry, he is in a position to render efficient service and co-operation to Remington dealers throughout his territory.

DENVER TO HAVE MUSIC WEEK

May 15 Set as Probable Date for Big Musical Event—Dealers and Civic Authorities Co-operate to Make Day a Success

DENVER, COLO., March 4.—Denver is to have a Music Week, the opening date of which has been tentatively set as May 15. Free concerts appealing to every taste will be held in different parts of the city at various hours during the seven days.

The first step in the novel plan, which will mean something entirely new in musical entertainment for the citizens of Denver, was taken at a meeting of twenty prominent business men, public officials and musicians at the Metropole Hotel.

F. H. Talbot, secretary of the local branch of the community service, was named chairman of the committee to perfect arrangements for the week. Mrs. Blanche Dingley Mathews, chairman of the municipal music commission, was named on the committee, as was Charles MacAllister Willcox.

Public schools and churches will have special musical programs during the week and pastors will include the subject of music in their sermons. Dealers in musical instruments in the city are back of the movement, in addition to the various business men's clubs, choral clubs, the municipal music commission and other organizations. A pageant to be held in the municipal auditorium is being planned by the musical instrument dealers of the Rocky Mountain region. Free hourly concerts will be held in churches, schools, parks, downtown streets, or wherever a crowd can be assembled. The public schools have offered to bear the expense of publishing programs.

A musical festival was held in Denver last year, but only for a few days and not all of the concerts were free. This year's festival is expected to be a big success.

New Pathé dealers recently established by the Buffalo Wholesale Hardware Co., Pathé distributors, are: Robt. E. Schwalk, 285 Genesee street, Buffalo, and Gerald Arndt, Townline, N. Y.

ILSLEY'S GRAPHITE PHONO SPRING LUBRICANT

Ilseley's Lubricant makes the Motor make good
Is prepared in the proper consistency, will not run out, dry up, or become sticky or rancid. Remains in its original form indefinitely.
Put up in 1, 5, 10, 25 and 50-pound cans for dealers.

This lubricant is also put up in 4-ounce cans to retail at 25 cents each under the trade name of

EUREKA NOISELESS TALKING MACHINE LUBRICANT

Write for special proposition to jobbers.

ILSLEY-DOUBLEDAY & CO., 229-231 Front St., New York

SWEDEN HAS TALKING PICTURE

After ten years of experimenting the Swedish engineer, Sven Bergieuse, is reported to have produced a speaking moving picture, which recently was exhibited before scientists and other distinguished persons in Stockholm.

Professor Svente Arrhenius, director of the physico-chemical department of the Nobel Institute, says the invention solves a long-attempted problem.

News of the above invention sent newspaper reporters to interview Thomas A. Edison at the Edison factories in Orange. Here they were enlightened in the matter and reminded that Mr. Edison produced talking motion pictures nine years ago and these pictures were shown both in this country and in Europe.

L. P. GERBER WITH BOOTH FELT CO.

The Booth Felt Co., Inc., 473 Nineteenth street, Brooklyn, N. Y., manufacturer of mechanical felt goods, including washers and packing, as well as special material for talking machines, has appointed Leo P. Gerber manager of its city sales department, to succeed F. S. Warren, who recently severed his connections with the organization. This company has one of the largest as well as best-equipped factories for production of mechanical felt goods, including much special equipment of dies and cutting machines, which insures quantity output.

PARCEL POST PACKAGES TO SPAIN

According to a recent cablegram from Commercial Attaché C. H. Cunningham, Madrid, orders have been issued authorizing the admission of parcel-post packages to Spain up to ten kilos (twenty-two pounds) each, provided that total shipments from one consignor to one consignee by the same boat do not amount to more than twenty-five kilos (fifty-five pounds). The weight limit had been five kilos (eleven pounds) until this order was issued.

The Mellor Idea of Service

SERVICE for Victor Dealers that is really worth while must be broad enough to cover a great many forms of real and measurable assistance. It must penetrate beneath the surface far enough to make itself felt. That's the way we interpret it, at any rate.

C. C. Mellor Company

1152 Penn Avenue,

Pittsburgh, Pa.

Here Are Three Selling Points

You Get Only With

THE VOCALION

Aeolian Quality and Reputation—The Vocalion is the only phonograph made by a great music house. That is—by a house that had achieved a world-wide reputation for making musical instruments of the highest grade, before the phonograph became a factor in the music business. Aeolian quality and reputation not only make selling the Vocalion easy, but help build up the prestige of every store that sells it.

The Graduola—the only satisfactory tone control. Here is the strongest exclusive selling feature in the whole phonograph industry. The Graduola enables anyone to *play the record himself*—to control its tone, as easily and instinctively as he controls his own voice. No other phonograph in the world has the Graduola or anything that can take its place. And no customer who sees the Graduola and tries it, is ever satisfied with a phonograph that doesn't have it.

Real Reproducing—The phonograph today is so much better than it used to be, that everyone connected with its development must be given credit. It is a fact nevertheless that until The Aeolian Company took up its manufacture, phonograph "tone" left much to be desired. It remained for this house to handle the problem *scientifically*. That is, to use the same scientific apparatus and methods in developing the phonograph that it had used so successfully in developing its other famous instruments. There is no guess work about the Vocalion's tone. It reproduces voices and instruments more *naturally* than any other phonograph. And customers are quick to recognize the difference when the Vocalion is played for them.

The Vocalion and the distinctive Vocalion RED records give the dealer a competitive lead that cannot be overcome

The AEOLIAN COMPANY

*Makers of the Duo-Art Pianola Piano
Foremost Manufacturers of Musical Instruments in the World*

NEW YORK

LONDON

PARIS

MADRID

MELBOURNE

SYDNEY

Nestle In Your Daddy's Arms

A LULLABY FOX-TROT

Published by LEO. FEIST Inc.
FEIST Bldg N.Y.C.

"YOU CAN'T GO WRONG
WITH ANY FEIST SONG."

THE IMPORTANCE OF TALKING MACHINE MERCHANDISING

The Fundamental Principles of Success in Selling Talking Machines Interestingly Explained—
The Right Way to Get Salesmen Enthused

The business principles applying to the successful management of a phonograph store have no essential points of difference from those followed in a multitude of other lines, says a writer in a late issue of *The Puritan*.

If the phonograph were an inert article such as a sideboard, it would be sold on its appearance and construction. Everybody knows what it is for. But the talking machine is in a sense a living thing, like a piano or violin. It must be made to perform before the customer decides whether he wants to buy it. It would seem, therefore, that the salesman or store manager should specialize on the job of putting the phonograph "through its paces," and do it so cleverly that the prospect will be properly impressed. A piano is never sold until the purchaser has heard its tone. It is useless to say that

pianos sell outright on their reputation. Reputation has much to do with the sale, of course, but the tone of all pianos of the same make, size and design is by no means alike. The variation is very great in the majority of the best instruments.

So it is with phonographs. The reason for these variations is not easy to understand, but they are sufficient to make it advisable to demonstrate every phonograph sold before the purchaser receives it in his home.

The other points in successful phonograph merchandising are of a general character. When an instrument is sold to a family there is small chance of selling another in the same house; but if the dealer can get the owner to purchase records frequently, so that the instrument will not grow stale through over-use, it will be an

ever-present advertisement for the phonograph and the store that sold it. It is well to bear this fact in mind. Supposing a lady visits a friend who has just bought a few new records. The hostess will be more likely to suggest playing the phonograph at this time than she would if she herself were tired of the old ones in the cabinet. The conversation would doubtless turn to phonographs, and the visitor, pleased with the model, the tone and the records, naturally gets a favorable impression of that particular instrument. That is a form of advertising that is far stronger than the merchant's printed appeal.

Coming back to the fundamental principles of success in selling phonographs, the elements may be listed roughly in four groups:

- (1) The business ability of the manager.
- (2) The quality of service given the public; whether it is in small things or big.
- (3) The extent of good-will that the store management and sales force can build up.
- (4) The advertising and teamwork that are built up within the organization itself.

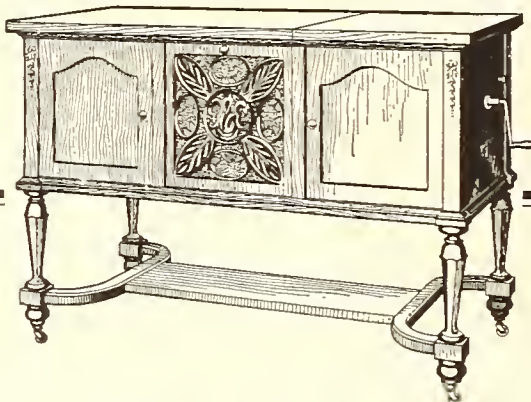
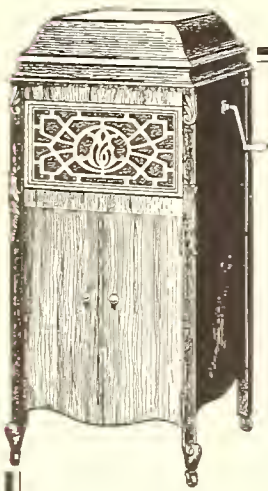

The Manophone

—Unequaled in Beauty
and Tonal Qualities

A TRADE-MARK and What It Means

Below is shown a cross section of the Tone Chamber in the Manophone, which partially explains the wonderful tonal qualities of this beautiful instrument.

Just at the point where the "horn" begins, you will notice the "voice-box" or "throat" of the Manophone, which is carved from solid wood and so fashioned that it gives the fullest tones possible.

For
Exquisite
Tone



The Music Master
of Phonographs

The exquisite piano finish that is given the Manophone is merely one indication of the care exercised in the manufacture of this wonderful instrument. The men who fashion and finish the various parts of the Manophone cabinets take personal pride in the production of only worth-while results.

And the wonderful Tonal Qualities of the Manophone are another indication of an intimate knowledge of the principles of acoustics and of their relation to music. Only Nature herself could rival the remarkable resonance and fidelity of tone production which so clearly distinguishes the Manophone.

In every city there is a particularly live Dealer who realizes the advantages of these Qualities in a phonograph. He knows how fundamental they are in the building of a permanent and satisfied trade. And our Business Building Plan is sure to interest him.

If you are that Dealer, write us, TODAY!

The Manophone Corporation

Adrian, Mich.

DIRECT FACTORY PRICE—JUST MENTION THE QUANTITY

MOTORS	CASTINGS Grey Iron and Brass for	TURNABLES MOTOR FRAMES TONE ARMS HORNS and THROATS	Stylus Bars
TONE ARMS			Screw Machine Parts
REPRODUCERS			Talking Machine Hardware

Direct Quantity Importations On { JEWEL and STEEL (Bulk or Packed)
PHONOGRAPH NEEDLES
GENUINE RUBY BENGAL MICA

EASTERN REPRESENTATIVE
CHERINGTON MFG. CO. **D. R. DOCTOROW**
IRONCLAD MOTORS

Vanderbilt Ave. Bldg.
51 East 42nd St., New York
Tel. Vanderbilt 5462

AN AID TO GOOD PENMANSHIP

Talking Machine Helps Pupils to Learn Difficult Art in a Considerably Shorter Time

CONNELLSVILLE, PA., March 3.—The talking machine as an aid to penmanship is an innovation in the school curriculum at Dawson, and so well does music function with writing that the pupils are earning the highest marks in the county in that study.

A. J. Emos, principal of the Dawson schools, said that he would use a talking machine in every room if the Board of Education would furnish the instruments.

Several educators who visited the schools on a tour of inspection were amazed at the penmanship specimens shown by Miss Alpha French, who teaches the primary grades. She said she always gave the children "something snappy" on the talking machine during the writing lessons and the music appeared to inspire the children. This plan of stimulating penmanship has been tried by teachers in other States with considerable success.

The most successful stores are those that have a fixed plan, understood by the entire staff, and then steadily worked out. Such an establishment is not given to "stunts" in selling, but rather undertakes a cool, deliberate progression along safe lines. Jumping from one plan to another without giving any one of them time for development is never successful. There must be some sound reason for making changes in selling plans before they are undertaken. Guessing is only gambling. You are likely to make a wrong guess.

Better take time to think out the right way, get your assistants into sympathy with your plan, and then work steadily ahead, without being forced from your path by listening to the advice of some expert who doesn't understand your local trade or your special problems.

TO MAKE RECORD EXCHANGES

Victor Retailers of New Jersey Discuss Trade Questions at Monthly Gathering

The Victor Retailers of New Jersey, an association formed several months ago, held its regular monthly meeting at the Robert Treat Hotel, Newark, N. J., on February 15. An unusually large attendance was on hand, and matters of great interest to Victor retailers came up for general discussion.

A plan of making record exchanges between the various members was inaugurated and other co-operative measures were considered. Many new applications for membership were submitted. The next meeting of the association is scheduled to be held on March 15 at the Robert Treat Hotel, at 12 o'clock noon.

Definition of a pessimist: a man who wears both suspenders and belt.

**Why Break Records?
Just File Them!**

That is if you have the wonderful Record filing system which is a feature of

The Marvelous MAGNOLA

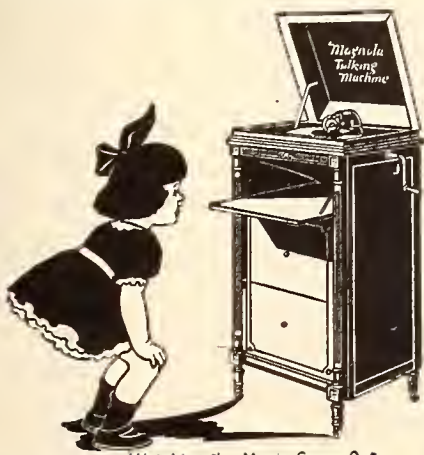

Watching the Music Come Out

This is only one feature of many that will command your interest and attention. Let us send you handsome illustrated catalog and information as to our plans for helping you to make money with MAGNOLA.

MAGNOLA TALKING MACHINE COMPANY
OTTO SCHULZ, President
General Offices Southern Wholesale Branch
711 MILWAUKEE AVENUE 1530 CANDLER BLDG.
CHICAGO ATLANTA, GA.

MANY ORDERS FOR VICTROLA NO. 90

The Putnam-Page Co., Victor distributor of Peoria, Ill., was among the first to announce to dealers the arrival of the new Victrola No. 90. The opportunity to order these instruments was seized at once by the dealers in the territory covered by the Putnam-Page Co. and this house reports receipt of large orders for the new No. 90.

**INDIVIDUALITY IN YOUR PRODUCT
WILL MEAN MORE SALES FOR YOU!**

Competition in talking machines is growing more strenuous each day. It is not a question of price any longer but of quality—higher quality and better tone. Maintain the claims of quality and tone reproduction in your product—make it be individual.

**Equip Your Phonographs With the New
EMPIRE UNIVERSAL TONE ARM and REPRODUCER**

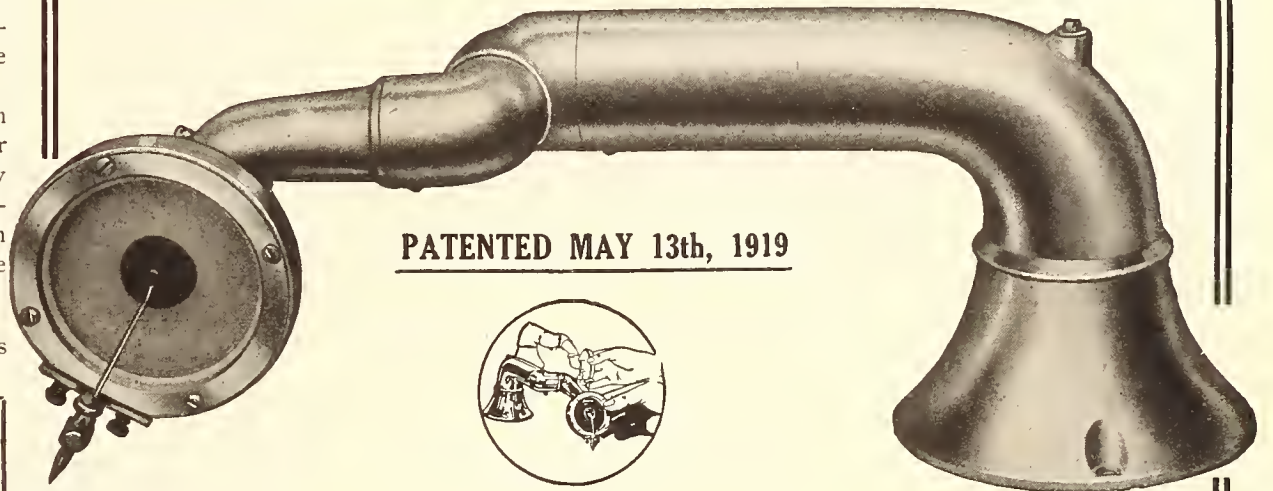

PATENTED MAY 13th, 1919

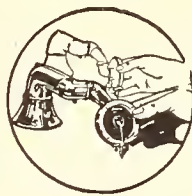

We are prepared to submit to reliable manufacturers samples of our tone arms and reproducers in order to enable them to determine the merit of our product. Our prices are low and the quality of our product is second to none. Write or wire us for samples and quotations and give us an outline of your 1921 requirements.

We Also Manufacture Attachments for Edison Phonographs

No. 1
Plays
only lateral
cut records.
Retail
at \$5.00



No. 2
Plays all
records.
Retail
at \$7.50

THE EMPIRE PHONO PARTS CO.
1362 EAST 3rd STREET CLEVELAND, OHIO
Branch Office: 33 Auditorium Bldg., Chicago, Ill.

H.K. Lorentzen

Manufacturer of
Exclusive Cabinet Hardware and Accessories
 60 Grand Street
 New York City

MUSIC MEMORY CONTEST ON COAST

School Children Taking Active Interest in Musical Appreciation Competition Begun by Sherman, Clay & Co. Educational Department

PORTLAND, ORE., March 4.—The school children of Portland are to compete in a music memory contest which began Monday, February 14, and will continue to April 1. This contest is being promoted largely by Mrs. Evelyn McFarland-McClusky, director of the educational department of Sherman, Clay & Co., whose idea in promoting the contest is to increase the musical appreciation in the city. In these efforts she is assisted by the Women's Club, Collegiate Alumni Association, MacDowell Club, Opera Association, Parent Teachers' Association and all of the various music shops in Portland. Forty-eight compositions of well-known composers have been chosen by the committee and plans have been completed for the children to hear them repeatedly at certain of the moving picture houses, music stores and at concerts to be given at Lincoln High and Couch Schools, on the West Side, and at Washington, James John and Jefferson High Schools on the East Side, every Saturday afternoon at 2 o'clock. The concerts will be under the direction of the various clubs and associations, who are assisting in the contest.

Mrs. McClusky and her assistant, Mary Elizabeth Goodwin, also of Sherman, Clay & Co., are meeting with great success in this contest. Prior to the Portland Symphony concerts, Mrs.

McClusky gives lectures in the schools on the music to be played, visiting several schools every day, giving music appreciation lectures, and the past week talked to the Collegiate Alumni Association, the Federation of Women's Clubs and the History Club. On Saturday morning she has a children's music hour at Sherman, Clay & Co., and in the afternoon in the music hall of the store, her assistant, Miss Goodwin, plays records for the memory contest.

The final contest will be held at the Municipal Auditorium, April 1, at which time a large concert will be given by the various artists and organizations of the city. Certain sections of the building will be reserved for the contestants, who will be seated every third seat and will write down the names of the compositions and their composers as they are played.

GEORGE W. POUND BACK AT DESK

George W. Pound, general counsel of the Music Industries Chamber of Commerce, who has been ill at his old home in Buffalo, N. Y., since before the holidays, returned to his desk at the general offices of the Chamber last week. Mr. Pound is now fully restored to health, and will again assume his legal duties in connection with the Chamber work.

SYMPHONIA MUSIC SHOP

The Symphonia Music Shop, New York City, has been incorporated by H. Shapiro, W. Robinson and R. Hammer. Capital is \$10,000.

ADD NEW FINISHES TO LINE

Parks & Parks Increase "Tonar" Brush Line—Repeat Orders Being Received From Dealers

Troy, N. Y., March 7.—Parks & Parks, of this city, manufacturers of the "Tonar" record brush, have recently advised the trade that these brushes can be secured in mahogany and light oak finishes, in addition to the standard black finish. The company has for some time past been desirous of adding these two finishes to its line, in order to accommodate the requirements of the talking machine dealer. "Tonar" brushes are now packed in the assorted finishes, or in any one finish that the dealer may desire. These brushes have met with a very cordial reception from the trade, and Parks & Parks are particularly pleased with the large percentage of repeat orders they are receiving from dealers in all parts of the country.

AL JOCKERS' VOCALION RECORDS

Al Jockers' Dance Orchestra has recently recorded a number of some excellent Vocalion records for the Aeolian Co. Among the first of these records to be released are to be found in the March supplement, and include "Broadway Rose," introducing "Dolly I Love You," and "Rosie," introducing "Why Don't You?" from "Afgar."

Don't look for a safe place to linger in. Get out into the thick of the action.

GARFORD "BABY" PHONOGRAPHS

A Popular Line of
 Toy Phonographs

Nothing More-Nothing Less

The "BABY" Model
 RETAILS AT \$6



A Splendid Dealer Proposition Is Available

MODEL X RETAILS AT \$12

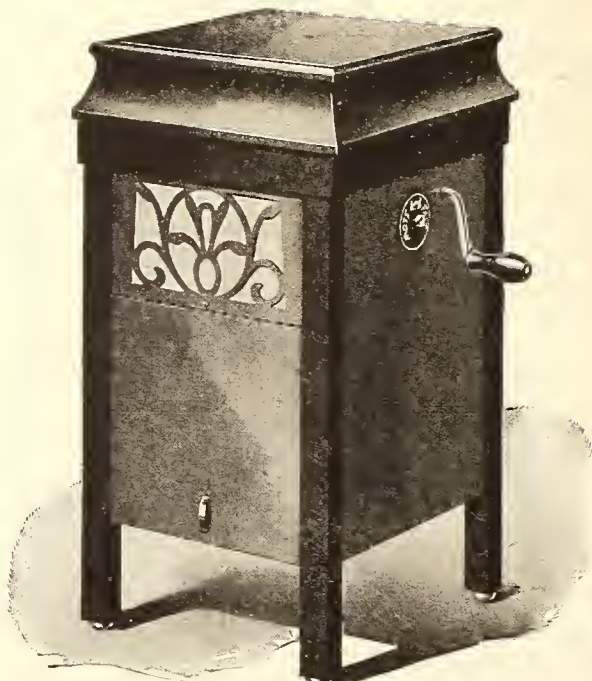

CLOSED

GENERAL PHONOGRAPH MFG. CO., Elyria, Ohio

ATLAS PACKING CASES

“Atlas” Packing Cases, made from “Atlas” Plywood Box Shooks, are the acknowledged standard of the Talking Machine Industry.

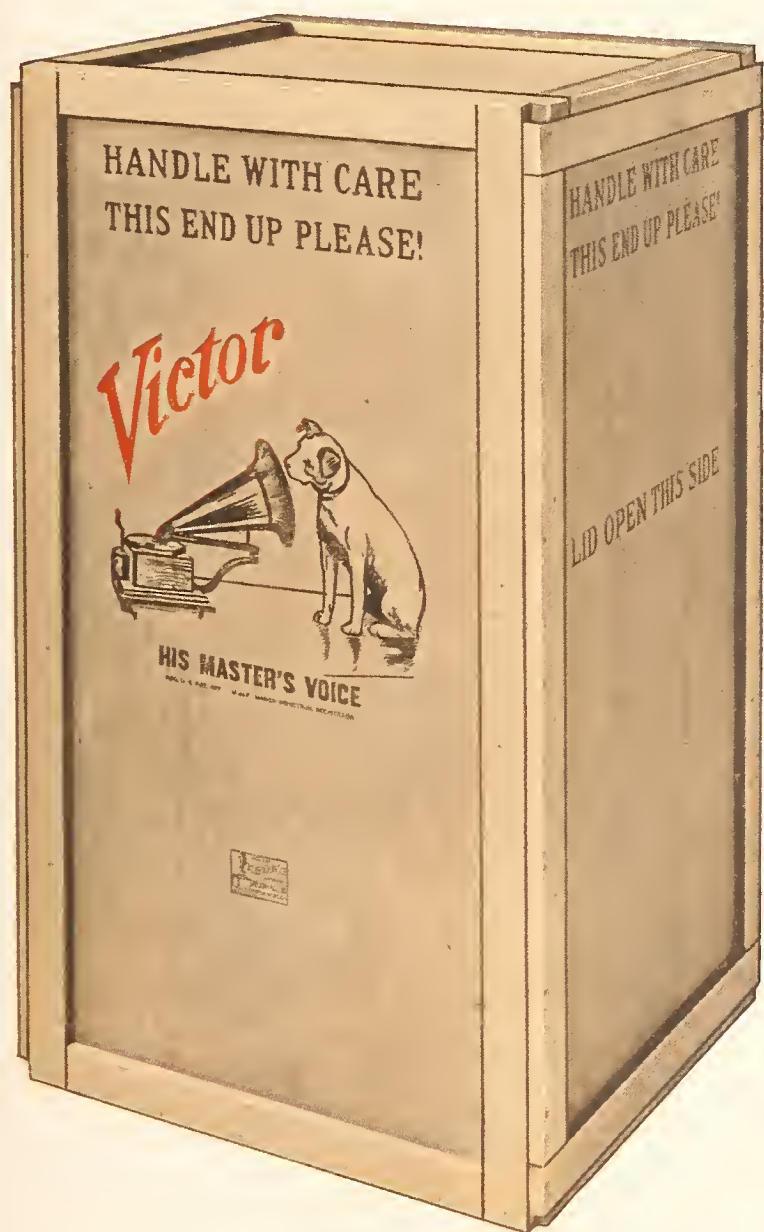

This is an exact reproduction of an “Atlas” Packing Case manufactured, printed and shipped to the Victor Talking Machine Co., Camden, N. J.

The use of “Atlas” Packing Cases indicates the high quality of the contents.

They have been trade-marked as a protection to the particular manufacturers who long ago realized that their use would result in efficiency and economy.

“Atlas” Packing Cases make a better appearance, give greater protection and save freight.

The thoroughly coordinated quantity production of our four mills insures the Talking Machine Industry unusually prompt and sure service.

For years we have made it our business to know the needs of this industry, so that we are authorities on packing cases.

ATLAS PLYWOOD CORPORATION

10 HIGH STREET

BOSTON, MASS.

Exclusive Selling Agents for

Nelson & Hall Company, Montgomery Center, Vt.
Veneer Products Company, Greenville, Maine

Richford Manufacturing Company, Richford, Vt.
Blair Veneer Company, North Troy, Vt.

LARGEST MANUFACTURERS OF TALKING MACHINE PACKING CASES

Toscha Seidel's sympathetic violin brings out the full beauty of Schubert's "Serenade." Here's Schubert's best-known work by one of the best-known violinists. Stock Columbia 49453 for big sales.

**Columbia Graphophone Co.
NEW YORK**



EXPORT MANAGER VISITS AMERICA

A. F. Bramley, General Manager for J. & C. Fischer, Arrives Here for Short Visit—Has Established Many Sonora Agencies Abroad

A. F. Bramley, general manager for J. & C. Fischer, New York, foreign distributors for the Sonora, visited this country recently, spending some time in conference with the Sonora executives regarding business conditions abroad. Mr. Bramley had been in Europe for two years,



A. F. Bramley

establishing Sonora agencies throughout England and in most of the continental countries, including Switzerland, Holland, Norway, Sweden, Denmark, Belgium, Spain and Italy. In the course of his travels Mr. Bramley went through Servia and covered practically the whole of Europe.

After conferring with the New York officials and laying out plans for the new year Mr. Bramley sailed for England on the "Aquitania," to remain there for the rest of the year. In 1922 he will return to the United States and again become active manager for J. & C. Fischer.

INSTALLS UNICO EQUIPMENT

DARBY, PA., March 3.—C. G. Martin has just opened a new exclusively Victor store, which is said to be among the most attractive in this city. The interior is handsomely decorated in ivory finish and a large number of Unico rooms, racks and counters has been installed.

MULTUM IN PARVO

No matter how many college degrees a man has, if he can not earn an honest living he is an educated ignoramus, and is one with the yesterdays, doing pedagogic goose-step adown the ways to dusty death.

NEW STEWART EDUCATIONAL CLASS

Fifth Class of Series, Held Under Auspices of Stewart Talking Machine Co., Indianapolis, Proves a Great Success—Largely Attended

INDIANAPOLIS, IND., March 1.—Filling the note books of the representatives of ten different Victor dealers in this territory, the fifth educational class, under the auspices of the Stewart Talking Machine Co., closed this week the most interesting three-day session ever held in the offices of the Indianapolis jobber. These classes, instituted a year ago under the direction of Miss Caroline Hobson, head of the Stewart Educational Department, had for their purpose mainly the furtherance of activity in the local Victor educational departments, instructing dealers in how to co-operate with public schools in developing the use of Victrolas. The sessions just closed mark a distinct growth in the original purpose of the class. Although the building of the educational departments in the Victor stores formed the fundamental part of instruction, the class was given illuminating lectures on other branches of the Victor business.

Boyd Kasey, experienced in the building of talking machine motors, took apart a Victrola motor before the class and lectured on the construction of each part. A star salesman from one of Indiana's largest Victor stores presented points on salesmanship in the merchandising of both records and instruments. Answers to questions on the conduct of retail sales and the

development of different departments were given by George E. Stewart, who also delivered an illustrated lecture on record making. A representative of the Stewart road sign factory made an interesting talk on the effectiveness of the product, and other advertising topics were represented by experienced speakers. But not the least interesting part of the class program were the round table discussions and an old-fashioned spelling match on the names of artists and composers and the titles of Red Seal records.

The Stewart classes will be conducted periodically throughout the year. Those who attended the last class are: Ferne Whisman, Mrs. June Stafford, Esther Smith, Ellen Enswiler, Miss Kemp, Miss Carr, Miss Wilhoit, F. J. Dunlevy, E. F. Routh and Mr. Laidle.

DEATH OF MRS. W. P. CAMPBELL

It is with great regret that The World announces the death of Mrs. W. P. Campbell, who for several years had represented this paper as its Portland, Ore., correspondent. Mrs. Campbell had been ill for several months, her work having been taken care of by her daughter, Miss Irene Campbell, who will continue to represent The World in the trade centers of the Pacific Northwest.

U. S. PHONOGRAPH CO. DISSOLVED

Notice has been published of the dissolution of the U. S. Phonograph Co., of Brooklyn, N. Y.

TO SELL

EDISON PHONOGRAPHS

Is a most pleasant, happy and lucrative occupation. As we are

Exclusive Edison Jobbers

We Know

Frank E. Bolway & Son

INCORPORATED

Exclusive Edison Distributors

SYRACUSE

:::

:::

:::

NEW YORK



A few valuable Pathé franchises are available to live wide-awake merchants.

Pathé dealers are in a non-competitive class.

**Only Pathé dealers can sell
the Pathé Actuelle and the
Pathé Electric—the best
sellers in the world today.**

Pathé dealers make a larger margin of profit.

Pathé dealers are always busy.

Better telegraph now.

Address Sales Department H

Pathé Frères Phonograph Co.
Brooklyn, New York

HITS FIRST AND BEST ON PATHE (Sapphire) RECORDS ACTUELLE (Needle Cut)

Order These from Your Distributor by Wire

POPULAR VOCAL "HITS"

P. PATHE
 A. ACTUELLE

- | | |
|------------------------------------------------------------------------|-----------------------------------------------------------------------------------------------------------------------------------------------------------------------|
| P. 20490--(Valvate)
A. 020490--(Valvular)
Size 10--Price 85c. | { MAKE BELIEVE--Tenor Duet..Stanton Rhodes and Vincent Francis
AUNT JEMIMA'S JUBILEE - The Harmonizers (Male Quartet) |
| P. 20491--(Valvulitis)
A. 020491--(Vamplate)
Size 10--Price 85c. | { ANGELS - - - - - James Douglas, Baritone
SWEET BELLS OF SAN JOSE--Tenor and Baritone Duet
Robert Bruce and James Douglas |
| P. 22505--(Legicide)
A. 022505--(Legitim)
Size 10--Price \$1.00 | { LOVE IN LILAC TIME - - - - - William Lowe, Baritone
WHIP-POOR-WILL, from "Sally" - - - Gladys Rice, Soprano |
| P. 20492--(Vanadate)
A. 020492--(Vandalism)
Size 10--Price 85c. | { SUNNY SUE - - - - - Ernest Hare, Baritone
A DREAM OF YOUR SMILE - - - - Carlton Williams, Tenor |
| P. 22506--(Legless)
A. 022506--(Leguan)
Size 10--Price \$1.00 | { I'M MISSIN' MAMMY'S KISSIN' - Orpheus Trio (Male Trio)
OVER THE HILL - - - - - Lewis James, Tenor |
| P. 20493--(Vanguard)
A. 020493--(Vanillate)
Size 10--Price 85c. | { LOVELESS LOVE - Noble Sissle and His Sizzling Syncopaters
ROYAL GARDEN BLUES.Noble Sissle and His Sizzling Syncopaters |
| P. 20494--(Vanishing)
A.020494--(Vanquisher)
Size 10--Price 85c. | { NA-JO--Fox-trot - - - - - Lanin's Roseland Orchestra
(Saxophone Passage by Rudy Wiedoeff)
HAPPINESS--Fox-trot - - - - Lanin's Roseland Orchestra |
| P. 20495--(Vantbrace)
A.020495--(Vantmure)
Size 10--Price 85c. | { ALL FOR YOU--Fox-trot - - - - - Casino Dance Orchestra
OH! BOY--One-step - - - - - Casino Dance Orchestra |
| P. 20496--(Vanward)
A. 020496--(Vapidly)
Size 10--Price 85c. | { ON A FAR ALONE ISLE--Fox-trot
Vernon Country Club Orchestra
SWEET LOVE--Fox-trot - - - Vernon Country Club Orchestra |
| P. 20497--(Vaporize)
A. 020497--(Vareuse)
Size 10--Price 85c. | { CALLING--Fox-trot - - - - - Vernon Country Club Orchestra
HONEY--Fox-trot - - - - - Vernon Country Club Orchestra |
| P. 20498--(Variable)
A. 020498--(Variation)
Size 10--Price 85c. | { MAZIE--Fox-trot - - - - - Green Brothers' Novelty Band
DO YOU EVER THINK OF ME?--Fox-trot
Green Brothers' Novelty Band |
| P. 20499--(Variator)
A. 020499--(Varicella)
Size 10--Price 85c. | { RAILROAD BLUES--Fox-trot - - - - - Synco Jazz Band
SWEET MA MMA--Fox-trot - - - - - Synco Jazz Band |
| P. 40217--(Eudermol)
A. 040217--(Excursus)
Size 12--Price \$1.25 | { RAGAMUFFIN--Fox-trot - - - - - Hub Dance Orchestra
(Werner Janssen At Piano)
MA JAVA BELLE--Fox-trot - - - - Hub Dance Orchestra
(Werner Janssen At Piano) |

Pathé Frères Phonograph Co.

Grand Avenue, Brooklyn, New York



CONFERENCE OF EDISON DEALERS OF PITTSBURGH ZONE

Interesting Addresses Made at Great Gathering of Edison Dealers at Fort Pitt Hotel—Spontaneous Tribute of Esteem Paid Vice-president Maxwell at Notable Banquet

PITTSBURGH, PA., March 1.—The culmination of the annual conference of the new Edison dealers of the Pittsburgh zone, which was held at the Fort Pitt Hotel, Pittsburgh, Wednesday and Thursday last, was marked by an enthusiastic demonstration at the dinner held Thursday evening in the Norse Room of the hotel, when close to 200 persons arose and paid a lofty tribute to William Maxwell, vice-president of Thomas A. Edison, Inc. The dinner was just about over and Mr. Maxwell quietly arose from his seat at the table and started to leave the dining hall to begin his journey back to New York. He was seen by some of the Edison dealers who had heard his powerful talk earlier in the day, and Mr. Maxwell was halted on the stairway by the spontaneous display of affection and esteem manifested in cheers and applause. Mr. Maxwell halted, and then, in response to cries of "speech," made a farewell talk, ending by wishing that the entire company would come to the New York convention in June.

The dinner was an elaborate one. Music was furnished by the Nirella Orchestra and the singing was in charge of James W. McKelvie, the well-known Pittsburgh baritone. There were good cheer and good fellowship galore and the evening wound up with a dance which lasted until after midnight. The meeting was the most successful ever held by the new Edison dealers under the auspices of the Buehn Phonograph Co., the Edison distributors. A. A. Buehn, the well-known and popular treasurer of the company, was given a rising vote of thanks by the guests on motion of N. W. Russler, of Cumberland, Md. Mr. Buehn responded briefly.

One of the amusing events of the evening was the mock dance staged by Messrs. J. C. Dilts, Sr., of Wheeling, and N. W. Russler. They brought down the house in a very literal sense by their antics and romping.

The conference was opened on Wednesday afternoon in the assembly room of the hotel, with Mr. Buehn presiding and H. M. Swartz, the assistant manager, acting as secretary. Thomas G. Shearman, of Salem, Ohio, and S. A. Phillips, of Morgantown, W. Va., spoke on "Tone Tests"; "The Value of Window Dressing" was pointed out by Leo Half, of Homestead, while H. O. Keefer, of McKeesport, spoke on "Sales Aid Service." J. K. Nichol, one of the live wire staff of the Buehn organization, talked very entertainingly on "Pushing the Laboratory Model."

Thursday morning the opening talk was made by J. C. Dilts, Sr., of Wheeling, who spoke on "Circularizing." It remained for E. J. Condon, another of the Buehn roadmen, to explain "Edison Men and Concerts." This he did in a very pleasing and instructive manner. H. H. Findt, of Steubenville, and C. C. Keys, of Salem, W. Va., spoke on "Trucks and Canvassing" and explained the methods they used to promote sales of Edison phonographs in that way. They insisted that, as they always got results, all live Edison dealers would be able to do the same if they went out after business in a systematic way. Nelson W. Russler, of Cumberland, Md., gave some timely pointers to the dealers on "Advertising." Adjournment was then taken for luncheon.

The feature of the afternoon session was an intensely interesting and instructive "Turntable Demonstration," staged by Mark M. Mitchell, the efficient manager of the retail department of the Buehn company. He was assisted by Mrs. C. Barnes, one of his sales staff, the latter assuming the role of a prospective patron. She acted the part well and her conversation with Mr. Mitchell relative to the merits of the Edison phonograph and comparisons with other makes of talking machines was most interesting and

gave the Edison dealers new light on the advantages to be derived from the use of the "Turntable."

Harvey C. Trader, another of the Buehn roadmen, gave some new ideas on "Developing Re-creation Sales"; E. J. Hayes, of Clarksburg, W. Va., spoke on "Making Every Edison Owner a Salesman."

The big event of the final session was the "Message From the Laboratories," which was delivered in a talk by Mr. Maxwell. In brief, Mr. Maxwell was most optimistic concerning the future of the Edison phonograph trade and his remarks and enthusiastic spirit were contagious, so much so that when he ceased speaking his message had "gone home," as was evidenced by the appreciation and interest manifested by the Edison dealers in his timely and well-chosen remarks.

One of the Edison dealers, E. F. Hodgkin, of Chesterhill, Ohio, was applauded when he told that in order to reach the conference on time he was compelled to use "three automobiles and a hack" to make the trip, due to bad roads.

Those present at the convention were: William Maxwell and Charles S. Gardner, Orange, N. J.; Mr. and Mrs. John Ament, Apollo, Pa.; Mr. and Mrs. T. Anderson, Blairsville, Pa.; Mr. and Mrs. George K. Barkell, Scottsdale, Pa.; Miss McGeary, Monaca, Pa.; Mr. and Mrs. Elmer Law and William Seaman, Cambridge, O.; Paul P. Brooks and Miss E. McConville, Altoona, Pa.; Mr. and Mrs. Ross Burns, Waynesburg, Pa.; J. O. Clawson and M. S. Hommel, Belle Vernon, Pa.; Mr. and Mrs. J. M. Stewart, Mr. and Mrs. W. D. Bowser and Mr. and Mrs. L. P. Marlin, Clymer, Pa.; R. G. Commons and C. W. Peterson, Patton, Pa.; J. W. Cunningham, Reynoldsville, Pa.; Mrs. C. H. and Miss Pearl Dufford, New Castle, Pa.; Miss Laura Fawcett, B. R. Fawcett and Mr. and Mrs. T. G. Shearman, Salem, O.; Miss Helen Duke and Mrs. G. M. Fincik, Latrobe, Pa.; Mr. and Mrs. H. H. Findt, Miss Marie Huber and R. L. Welsh, Steubenville, O.; S. B. Foust and Miss H. Bardsley, Juniata, Pa.; J. B. Kenner-



A WALNUT TALKING MACHINE CABINET

The finest phonograph is appropriately encased in

AMERICAN WALNUT

"The Cabinet-wood Superlative."

AN "added attraction" to the rich beauty of AMERICAN WALNUT as an appropriate encasement for such a fine example of a

Phonograph Cabinet

as is illustrated here, is that of *permanence*—or, "fidelity to fashioned form." AMERICAN WALNUT does not warp, shrink or swell.

The doors or drawers in an AMERICAN WALNUT Cabinet will never stick or refuse to slide. It's an impressive selling argument—a clincher.*

* Manufacturers of high-grade cabinets and phonographs appreciate this fact.

Send for valuable data for manufacturers—or data for dealers. Also the WALNUT BOOK de luxe, an instructive treatise on Walnut and Walnut Furniture, Free.

Write to the producers of American Walnut Lumber, the

AMERICAN WALNUT MANUFACTURERS' ASSOCIATION
Room 1022, 616 So. Michigan Boulevard
Chicago.

dell, Kittanning, Pa.; Mr. and Mrs. R. Gerecter, Elmer Heneke, Miss E. Mullin and Mrs. S. Seidle, Mt. Pleasant, Pa.; Leo L. Half, Miss Sophie Easer and Miss Marion Steinberger, Homestead, Pa.; Mrs. O. Powell and Miss Margaret Hempstead, Masontown, Pa.; C. R. Henry, New Lexington, Pa.; Mr. and Mrs. Oscar Ohringer, Mr. and Mrs. Abe Ohringer, Mr. and Mrs. A. Goldsmith, Mr. and Mrs. Zeider, Mrs. Feebles and Mrs. Fetterhoff, Braddock, Pa.; Harley Howard, Cameron, W. Va.; C. H. Hutchison and A. H. Hutchison, New Bethlehem, Pa.; E. G. Bierer, California, Pa.; Mr. and Mrs. Roy Keefer, Irwin, Pa.; H. O. Keefer, W. O. Altman, Ethel Wegley and Ethel Stuchul, McKeesport, Pa.; C. C. Keys, Salem, W. Va.; J. R. Klingensmith, Mr. and Mrs. W. R. Klingensmith and Mrs. Bessie Kline, Greensburg, Pa.; Mr. and Mrs. E. E. Koontz, Moundsville, W. Va.; R. A. Lambert, Roaring Springs, Pa.; Fred D. and Evan A. Lodge, Columbiana, O.; Louis Luxenberg, Barnesboro, Pa.; Samuel Moore, Monessen, Pa.; Mr. and Mrs. G. A. Mytinger, Miss Ruth Mytinger, Mr. and Mrs. N. G. Dunbaugh and Miss Althea Fisher, Ambridge, Pa.; Mr. and Mrs. H. Levine, McDonald, Pa.; Mr. and Mrs. L. F. Barker, Johnstown, Pa.; Mrs. Victor Nelly, Miss Anabel Nelly and Victor Nelly, Jr., Carnegie, Pa.; Mr. and Mrs. C. A. Nessler, Monongahela, Pa.; J. C. Dilts, Sr., Wheeling, W. Va.; J. Boehn, F. Whitman, E. J. Hayes and E. G. Long, Shinnston, W. Va.; Mr. and Mrs. S. G. Patterson, Beaver Falls, Pa.; Mr. and Mrs. W. B. Pflughardt, W. J. Pflughardt and Miss M. Ellison, Charleroi, Pa.; Mr. and Mrs. S. A. and Alan Phillips, Morgantown, W. Va.; C. A. Puffinburg, P. W. Puffinburg, Miss K. Strickler and Miss T. W. Strickler, Wilkesburg, Pa.; Mr. and Mrs. S. Layton and P. Ellovich, Coraopolis, Pa.; Chester Reed, Kingwood, W. Va.; Mr. and Mrs. Joe F. Reich and M. M. Smith and Miss Sarah Smith, Meyersdale, Pa.; Mr. and Mrs. H. L. Rosenberg, Joe Iando, South Fork, Pa.; C. S. Holland, Fairmont, W. Va.; Mr. and Mrs. N. W. Russler, Cumberland, Md.; R. A. Kirkman, Windber, Pa.; C. B. Smith, Philippi, W. Va.; Mr. and Mrs. R. D. Stephens, Barnesville, O.; Mr. and Mrs. Harvey U. Tobias, Grafton, W. Va.; E. S. Tyler, Point Marion, Pa.; Miss Anna Miller, Ruth McAllister, Clark Wright, Arthur Jones, East Pittsburgh, Pa.; A. R. Webber, Lisbon, O.; W. P. Costo, Buckhannon, W. Va.; C. T. Williams and A. J. Wilker, Hollidaysburg, Pa.; Mr. and Mrs. H. W. Sutch, Tarentum, Pa.; R. D. Rewbridge, Woodlawn, Pa.; George Koyle, East Palestine, O.; W. Brown, Miss

Addis Dunn, Connellsville, Pa.; G. E. Sharps and R. Thomas, Uniontown, Pa.; E. F. Hodgkin and Miss E. Stevenson, Chesterhill, O.; W. H. Young, New Galilee, Pa.; G. W. P. Jones, Washington, Pa., and Dr. W. V. Bingham, Dr. E. L. Gatewood, Miss G. G. Brainard, O. R. Johnson, C. C. Latus, George Schroeder, Jr., Miss A. Hildebrand, Miss G. St. Clair, H. Lechner, John Haggerty, Miss Lillian M. Scholl, Miss Marie Kinney, Miss Madeline Lergenmiller, Miss Ethel Chilly, Miss Marie Toole, Mrs. C. Barnes, Mrs. R. Owens, Mr. and Mrs. James W. McKelvie, Mr. and Mrs. C. W. English, Mr. and Mrs. A. H. Hunt, Mr. and Mrs. A. J. Boehm, Mr. and Mrs. H. C. Trader, Mr. and Mrs. L. A. O'Neill, Mr. and Mrs. E. J. Condon, J. R. Madden, A. W. Chilcott, John K. Nichol, R. P. Chilcott, David Boustead, M. M. Mitchell, Mr. and Mrs. Albert A. Buehn, Mr. and Mrs. H. M. Swartz, all of Pittsburgh.

A CLEVER WINDOW ARRANGEMENT

Comparison of Talking Machine With Small Musical Instruments Makes Strong Point

Here is an idea which one dealer used in designing a window display on the value of the talking machine. And it's a good one, too. In the center of the window he placed a talking machine. Around it he grouped a large number of musical instruments, banjos, ukuleles, guitars, violins, harps, band instruments, etc. The price of each instrument was shown on a small card. A large card at one side had the prices of each instrument arranged in a column and added up. The card read something like this: "To have all these instruments in your home would cost you \$1,500 and even then you could not play all of them yourself. But by owning this talking machine you can have every instrument and play them whenever you wish—and the cost is only \$150." This card proved a very effective argument.

TAKES CHARGE IN ROCHESTER

Palace Music Shop Now in Charge of E. E. Little, of That City

E. E. Little, formerly manager of the Columbia distributing agency in Rochester, N. Y., has taken over the management of the Palace Music Shop in that city. E. E. Wallace, formerly of the Columbia distributing agency in Buffalo, is now in charge of the Rochester Columbia agency.

Distinctively Designed

Phonograph Accessories and Furniture Hardware

—For Immediate Delivery—

**Needle Cups, Lid Supports, Automatic Stops,
Tone Rods, Knobs, Escutcheons, Sockets**

FURNITURE TRIMMINGS

A complete offering in all the Period and Commercial Furniture Lines.

REFRIGERATOR HARDWARE

All sized Locks and Hinges

Samples and complete information on request

GRAND RAPIDS BRASS COMPANY
Grand Rapids, Michigan New York: 7 E. 42nd Street



For profitable repeat orders

"FOR every three sample needles I give out I am sure to get at least one regular customer," said a dealer, speaking of the



Semi-Permanent

NEEDLES

"And I notice," he continued, "that most of our customers buy three packages at a time."

Sonora Semi-Permanent Needles are called for not only by purchasers of Sonora phonographs, but by owners of all other instruments as well.

These needles play ALL MAKES of steel needle records, are vigorously advertised, are popular and are in demand, being most economical, giving a mellow, rich tone, and preserving the records. If you haven't these needles, order now.

Three grades—Loud, Medium, Soft
25c per card of 5
40c in Canada

Sonora Phonograph Company, Inc.

GEORGE E. BRIGHTSON, President
New York, 279 Broadway

Canadian Distributors: I. Montagnes & Co.
Toronto

CAUTION! Beware of similarly constructed needles of inferior quality.

We Can Manufacture Your Phonograph Records

UNITED STATES RECORD MANUFACTURING CORP.

206 FIFTH AVENUE, NEW YORK

is equipped for pressing 10-inch phonograph records. Machinery of latest construction and designed for a quantity and quality product.

Can Also Furnish High-Grade Record Stock for Other Pressing Plants.

INQUIRIES INVITED

TALKER HELPS SOVIET PROPAGANDA

Official Machine Used to Reproduce Speeches of the Leading Soviet Officials

In writing of her experiences in Soviet Russia, where she went as correspondent for the New York World, and spent six months in prison, Mrs. Stan Harding, the well-known British woman journalist, in her story now running in The World, throws some interesting light on the Bolshevik methods, and particularly upon the system of propaganda.

In the course of her story Mrs. Harding tells of the use of the talking machine for reproducing the speeches of Soviet officials, and says in part:

"Rosinsky and Mogilewsky took me to what they called 'The agitation point'—really a literary propaganda bureau, an institution common to every railway station in Russian to-day. "There was a magnificent gramophone with

a repertoire of speeches by famous Commissaries. One could also hear recitations by revolutionary poets and 'The International,' as sung by famous choirs on state occasions.

"There was a record by the Commissary of Hygiene on how to combat lice, and another by Trotzky recommending a 'fight to the finish' against the counter-revolutionaries.

"Mogilewsky asked me if I would like to hear Trotzky's speech, and a chubby little girl took up the disc reverently and placed it in position. Trotzky's voice, even on the gramophone, was too big for the little room and awakened some soldiers sleeping on the floor in the adjoining waiting-room. Through the open door I saw them rouse up to listen, clad in their long Summer military overcoats.

"Though I could not understand a word of Trotzky Russian I guessed at the furious energy of the man and gathered that the universal war slogan of the 'knockout blow' came in pretty frequently."

ATTRACTIVE STORE IN ALLENTOWN

Block's Music House Featuring the Vocalion Line Exclusively With Much Success

Among the enthusiastic dealers in Pennsylvania handling the Vocalion line exclusively is Block's Music House, at 25 North Sixth street, Allentown, Pa. The company's quarters in the Lyric Theatre Building are distinctly attractive and homelike, the bareness of the usual ware-



View of Interior of Block's Store room being relieved with potted palms and other plants and numerous floor lamps of elaborate design. Large portraits of Vocalion artists also add to the decorative effect. The accompanying picture gives some idea of the general appearance of the store, although the camera fails to give a proper idea of its real size.

Plan wisely and work hard, expecting nothing from luck, and all the merry villagers will say, "Oh, he is a lucky dog."

Men who succeed have faith in themselves, and faith in their fellows.

LIBROLA PERIOD MODELS

Louis XVI Model—also Queen Anne Period
A High Grade Phonograph and Library Table Combined
Now Ready for Delivery

To
Retail
at
\$150.00

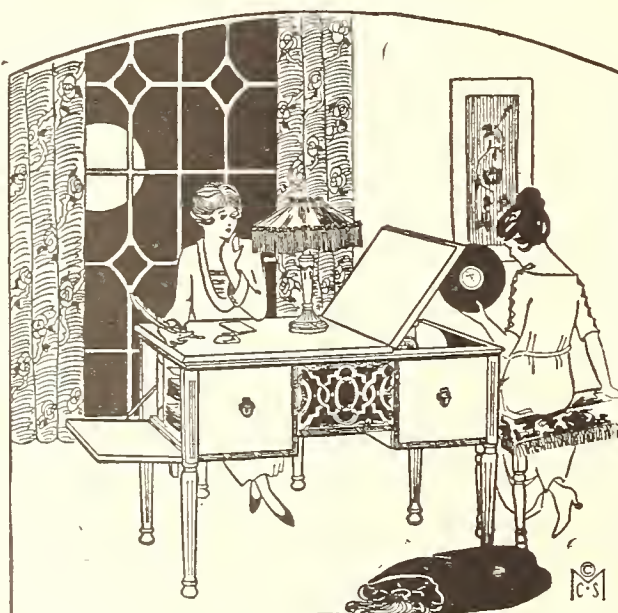

No. 175. Pat. applied for. 42" long, 26" wide, 31" high. Finished on all sides—golden oak, mahogany or walnut

Write
for
Dealers'
Discounts

Complete Your Line with These High Class Library Table Models

This high class instrument will enable you to meet any competition, because of its beauty, clarity of tone and utility.

You are missing Dollar profits if you do not write for information—Today.

SEABURG MANUFACTURING COMPANY
JAMESTOWN, NEW YORK

Stewart Talking Machine Company

JOBBERS
for the
Victor
Talking
Machine
Company



Indianapolis

New "12 for 25c"
Package Sent

FREE

to Prove a
"Point" to
3,000 More Dealers

OVER 3,000 dealers already know and attest the remarkable degree of perfection attained by TONOFONE needles. They sell and use them in demonstrating because the soft, flexible point produces pure, unmixed and undistorted tones, in the volume recorded in the record. They are not made "loud" to intensify tones. Loud needles ruin records. TONOFONE improves records. Each needle plays 20 to 50 records—any disc record on any phonograph.

To prove it and that the soft, flexible point of TONOFONE gives more accurate reproduction of original tone and expression and less surface noise—that TONOFONE prolongs the life of records and is more convenient and economical to the user and more profitable to the dealer—we will gladly send a full package FREE to any dealer. *Just mail coupon below.*

Or, better still, send an order now for full carton of the new bigger-value, bigger-profit "12 for 25c" package. Remember, you take absolutely no risk because every TONOFONE is positively guaranteed. Use coupon order at right, giving the big value-big profit price. Don't wait. Begin now.

Send one of the coupons at once.

R. C. WADE CO.
110 South Wabash Avenue Chicago, Ill.

Tonofone

The Phonograph Needle With the Flexible Point



—Or Order a Carton
at Special Price

To introduce our new, bigger-value, bigger-profit package, which gives your customers 12 TONOFONE Needles for 25c, we offer a price of \$14.00 a carton of 100 packages.

This \$14.00 carton retails for \$25.00, giving you a profit of \$11.00 a carton, or 11c a package. This is 44% on your selling price and 79% on your investment—a very exceptional profit.

Please order direct from this advertisement, using coupon below. The needles will be shipped on our positive guarantee. Terms: Cash with order, less 2%, or 30 days net on approved reference or established credit rating.

ORDER BLANK

R. C. WADE CO.
110 S. Wabash Ave., Chicago, Ill.
Gentlemen:—Please enter our order for TONOFONE Needles as follows, which may be shipped through one of your wholesale distributors:
.....Cartons, 100 Packages, at \$14.00.....
Firm Name
Street
CityState
Above is purchased subject to your positive guarantee.

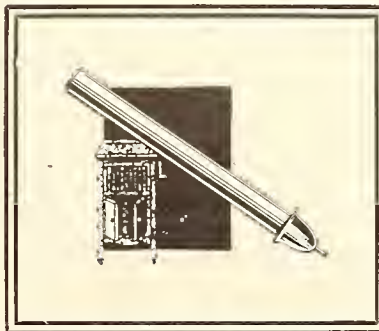

R. C. WADE CO., 110 So. Wabash Ave., Chicago, Ill.
Gentlemen:—Please send FREE, one "12 for 25c" package of TONOFONE Needles, for us to test.
Firm Name
Street
CityState

EUGENE and WILLIE HOWARD'S TERRIFIC HIT in THE PASSING SHOW of 1921

UNDERNEATH HAWAIIAN SKIES

The most beautiful Fox-Trot Melody
in years Published by LEO FEIST INC
FEIST BLDG.
NEW YORK

"You can't go wrong
with any Feist Song."

OPENS NEW SONORA DEPARTMENT

Fraser Paterson Co., Seattle, Opens Handsome Sonora Department—Store and Window Displays Exceptionally Artistic

The Fraser Paterson Co., Seattle, Wash., one of the leading mercantile establishments in that city, opened recently a Sonora department, which to date has proven a signal success. The company adopted unique methods for introducing the Sonora to its clientele, using full-page advertisements in the newspaper and mailing engraved announcements to 15,000 of the city's residents.

The entire center aisle of this store was devoted to a Sonora display, the counters and showcases being moved back so that a width of sixty-five feet was available, with a depth of 180 feet. In the rear of the store and at the end of the center aisle there was erected a very

beautiful piece of colored art glass which reached from the floor to the ceiling. Around this was draped black velour and just below the center of this art glass was hung the well-known Sonora gold-lettered sign. From the ceiling to the floor were draped handsome Oriental rugs, valued at \$200,000.

Added to the attractiveness of the center aisle were displays in all five of the windows on Second avenue devoted entirely to Sonora period models. Window number one, which was a corner window, prominently displayed the Louis XV De Luxe model in American walnut finish. Window number two displayed the popular Duncan Phyfe model, with a handsome background, including artistic gold curtains. Window number three displayed the Jacobean model in antique walnut, with a background of black velour. Window number four used a similar background prominently displaying the Sonora Gothic, Jr. Window number five displayed the

Chippendale model in mahogany, and the background and floor coverings consisted of handsome Oriental rugs in orange and blue.

The center aisle display was thrown open to the view of the public at seven o'clock on a Saturday evening and remained open until six o'clock Monday morning. During this time it was estimated that over 50,000 people actually visited this display.

BATES MUSIC STORE DESTROYED

Colorado Dealer, However, Secured More Stock and Opened for Business the Next Day

GREELEY, COL., March 4.—George Bates, head of the Bates Music Co. of this city, doesn't let even a disastrous fire discourage him a bit. Last month his entire store was destroyed in a fire which broke out early in the morning. Hardly had the burning timbers been quenched when he had secured a temporary location, prepared to resume business. The next morning papers carried large advertisements telling the public that they could still get the pianos, talking machines and other musical goods from the Bates Music Co. in the temporary headquarters at 812 Eighth avenue.

The Bates Music Co. handles the Victor, Brunswick, Columbia and Edison machines and immediately following the fire a supply of these instruments was drawn from the Bates storehouse and a special shipment of records rushed by express.

HAD NARROW ESCAPE IN ACCIDENT

A. L. Jewett, general sales representative of the phonograph department of the Starr Piano Co., Richmond, Ind., has been receiving the congratulations of his friends on his narrow escape from death in a train smash-up which occurred the last week of January. The train in which Mr. Jewett was traveling left the tracks due to a split rail at Greenville, O., and the Pullman crashed into a freight car on a siding. Mr. Jewett was badly shaken up, but is now "on the job" again.



KICHLER VALANCES

especially designed for the windows of the Talking Machine Dealer. We can reproduce and embroider any trade-mark and any type of lettering.

KICHLER VALANCES will improve the appearance and increase the sales value of your show windows. Write us for our descriptive literature.

THE L. A. KICHLER CO.

717 Lakeside Ave. N. W.

(Dept. W)

CLEVELAND

Eastern Representative—Louis A. Schwarz, 1265 Broadway, New York City



No. 35216 Basket filled with flowers, as hyacinths, tulips, maybells, etc., each \$1.50, per dozen \$15.00.

My ILLUSTRATED CATALOGUE No. 35, containing Everlasting Decorative Flowers, Plants, Vines, Garlands, Hanging Baskets, Etc., FREE FOR THE ASKING.

FRANK NETSCHERT
61 BARCLAY ST. NEW YORK, N. Y.

GREAT GATHERING OF VICTOR DEALERS IN PEORIA, ILL.

Over 75 Dealers From Various Parts of Illinois Entertained by Putnam-Page Co., Victor Wholesaler—Notable Addresses Made by Prominent Speakers—Attend Banquet at Crève Coeur Club

PEORIA, ILL., March 4.—The Putnam-Page Co., Victor wholesaler of this city, held a very successful Victor meeting on Washington's birthday, which was attended by about seventy-five of the retail dealers to whom this concern caters. During the morning everybody gathered at the offices of the Putnam-Page Co. and mingled together on an informal basis. At noon the entire party adjourned to the Palm Room of the Jefferson Hotel, which had been reserved for the exclusive use of the Putnam-Page guests. Here, amid attractive patriotic and floral decorations, everybody enjoyed a most palatable repast to the accompaniment of music by the Inglaterra Trio.

P. A. Ware, general manager of the Putnam-Page Co., acted as master of ceremonies. Following a few typically Ware humorous stories he introduced Jerry McQuade, whose subject was "A Little Scotch." He told a number of very entertaining Scotch stories.

Miss Mabel H. Rich, of the Victor educational department, next spoke on "How the Dealer May Profit Through Educational Work."

Artists. He explained the results which have been attained for Victor dealers, under whose auspices the Eight Famous Artists have given concerts, and announced that this group of Victor record makers will appear in a number



The Banquet Held in the Palm Room of the Jefferson Hotel

of concerts in Illinois cities this Spring. He asked any merchants interested in making bookings for their cities to make their requirements known right away, so that due provision could be made to take care of the needs of as many of the Illinois Victor dealers as possible during the coming tour.

Raymond Bill, associate editor of The Talking Machine World, followed with an informal discussion on "What the future holds in a business way for the retail merchants who apply vigorous and intelligent sales efforts."

Joseph J. Rockwell, counselor of the Reincke-Ellis Co., Chicago, next spoke on "Advertising," and gave a very interesting discourse on the history of advertising and the vital part it plays in modern business as an accelerator of sales.

Duane Wanamaker, Western manager of the Talking Machine Journal, offered some interesting comment and observations on current conditions in the industry.

The next speaker was John Gregg Paine, of the legal department of the Victor Talking Machine Co. His speech was the principal feature of the convention, and his subject was "Marketing Victor Goods Is More Than Merchandising." During the course of his address, which proved most interesting and illuminating

to all present, he explained fully the responsibility which the Board of Directors of the Victor Co. feel towards every retail Victor dealer, and how they are striving in every way possible to use the resources of this company to the end that each dealer may be assured of a very successful business, and to the end that his individual investment in the Victor business may be assured as a permanent source of income. In this connection Mr. Paine spoke

of the utilization of the most efficient and high quality methods in the factory. He traced in detail the sources from which various raw materials are secured and the conditions under which they are obtained. After offering many very interesting details on this side of the Victor business, all of which demonstrated the responsibility which the Victor Co. feels towards Victor dealers, he then explained how the company looks upon each retail merchant handling the Victor product as the custodian of its goodwill. He explained the responsibility which this guardianship involves, and how the Victor Co. looks to each retailer to uphold in the finest



Putnam-Page Officials—Left to Right (Sitting), Roy Page, Miss Cloud, F. H. Putnam. (Standing) L. S. Putnam, A. E. Severe, P. A. Ware.

In the course of her talk she mentioned many new avenues through which the retail Victor dealer can develop machine and record sales and offered some very practical ideas for securing this business. She also touched on the great vision with which the educational department of the Victor organization is inspired.

The next speaker was L. C. Mountcastle, assistant manager of the Eight Famous Victor



Visiting Speakers—Miss Mabel Rich, L. C. Mountcastle and (Standing) J. G. Paine

manner possible the great prestige, good-will and reputation which have been built around the Victor trade-mark, Victrolas and Victor records. In closing, Mr. Paine touched most inspiringly on the idea that in selling music to the American people the retailer is in fact performing a truly God-like mission. This part of Mr. Paine's address made a very deep impression on all his hearers and left everyone inspired with a deeper understanding of the business in which he is engaged.

The program closed with some interesting remarks by F. H. Putnam, president of the Putnam-Page Co., during which he emphasized the value of dealers and their sales representatives attending the school of salesmanship at Camden, and also of attending the Victor educational convention, which is to be held in Chicago the latter part of March under the auspices of ten of the Victor wholesalers located in the Middle West.

In response to a motion by unanimous consent a telegram was sent to Enrico Caruso at the Hotel Vanderbilt, New York City, which read as follows: "Seventy-five Illinois Victor dealers meeting in Peoria to-day joining with the Putnam-Page Co., Victor distributor, extend to you their best wishes and express their sincere hope for a speedy and complete recovery of yourself and your glorious voice."

(Continued on page 61)



Putnam-Page Company
VICTOR DISTRIBUTORS

¶ Our Dealers' Service Department really serves and has profited our dealers.

¶ The head of our Repair Department has just returned from the Victor Factory, and to dealers who maintain their own repair department we extend instruction and co-operation without cost.

¶ There are other features of Putnam-Page service which are profitable to dealers—ask those who know.

PUTNAM-PAGE COMPANY

Exclusive Victor Wholesalers

PEORIA, ILLINOIS

A New Source of Profit for the Phonograph Dealers

Some uses for
the Magnavox

Churches
Schools
Concerts
Entertainments
Playgrounds
Dances
Fairs and
Exhibitions
Open Air
Y. M. C. A. Work
Lodges
Directing
Construction Work
You'll think of
many others.

MANY dealers have doubled their sales of phonograph records by using the Magnavox attachment. Large crowds gather in front of their stores whenever they play the new records, which are heard by everyone within a block. It is an entirely new way of advertising phonographs and records.

Now dealers are selling this attachment to schools, churches, movie houses, dance-halls and wherever the phonograph is used. Considerable profit is realized on each sale of a Magnavox.

The Magnavox so magnifies the sound of a record (or the voice) that it will fill a big auditorium. A record can be heard a mile in the open. Yet it can be modulated at will to become a mere whisper. Write us for full particulars.

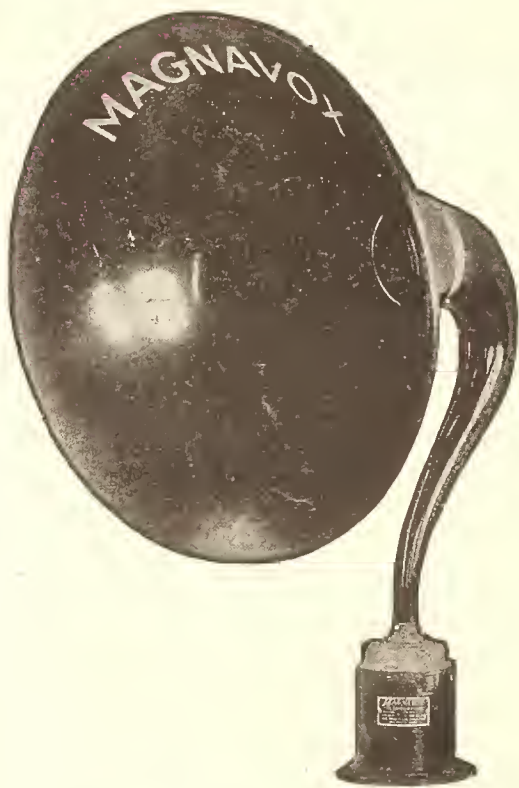

J. O. Morris Co., Inc.

Eastern Distributors

1270 Broadway, New York

Magnavox

VICTOR DEALERS MEET IN PEORIA
(Continued from page 59)

During the evening of Washington's birthday all of the conventionites were entertained by the Putnam-Page Co. at the Crève Cœur Club. This local non-sectarian and non-partisan club held its twenty-third annual banquet at the Shrine Temple, in celebration of the birth of George Washington, and it is needless to say the decorations, the spirit and the meal proved most effective.

The invocation to the banquet was given by Rev. Joseph C. Hazen, and the speakers after dinner included the Hon. J. F. T. O'Connor, of Grand Forks, N. D., who spoke on "The Citizen of To-morrow"; Admiral Samuel McGowan, Washington, D. C., who discussed "Some Side-lights on the Navy"; Rev. Nathan Krass, D. D., of New York, who spoke on "Washington's Strength and Democracy's Weakness"; and the Most Rev. Austin J. Dowling, D. D., St. Paul, Minn., whose subject was "The Melting Pot and the Mould."

The whole affair from start to finish was very enjoyable and provided the retail Victor dealers with many new ideas about the industry of which they are a part and of practical ways to meet current business conditions. Everyone felt most grateful to the hosts.

The day following the meeting proper a number of guests stayed over, and informal discussions were held in the offices of the Putnam-Page Co. during the morning. An informal luncheon at the Crève Cœur Club was given at noon. The last of the invading contingent left by Wednesday evening.

Among those present were: Alex Meyer, Meyer's Music House, Carlinville; J. W. Hammer, Hammer & Webb, Farmer City; C. D. V. McKinley, C. D. V. McKinley, Mason City; J. Anthony Hoppe, Western Record, Chicago; J. J. Rockwell, Reincke-Ellis Co., Chicago; Thor Norberg, of Norberg Music House, Rock Island and Moline; O. D. Ehrlicher, Ehrlicher Bros. Co., Pekin; W. F. Haley, J. Haley & Son, Arcola; Geo. H. Thompson, Thompson Drug Co., Spring Valley; E. F. Bohn, P. F. Cutner Music House, Lincoln; P. F. Cutner, P. F. Cutner Music House, Lincoln; I. J. Whitten, Sundquist & Whitten, Wyoming; F. J. Everson, T. S. Gravenhorst, Effingham; E. T. Froyd, Froyd's Music Shop, Paxton; H. C. Duncan and Harry A. Duncan, Duncan-Schell Furn. Co., Keokuk, Ia.; F. A. Doyle, Doyle Furniture Co., Galesburg; A. E. Sundquist, A. Sundquist & Son, Toulon; H. J. Waldschmidt, H. J. Waldschmidt, Metamora; J. G. Paine and Miss Mabel Rich, Victor Talking Machine Co., Camden, N. J.; Raymond Bill, Talking Machine World, New York City; Mrs. Donald Gordon, J. A. Gordon, Hamilton; Mrs. Thor Norberg, Norberg Music House, Rock Island; Mrs. Ray E. Bannon, Bannon's Music Shop, Ottawa; D. A. Craine and H. O. Hartley, Hartley's Pharmacy, Galva; Donald Gordon, J. A. Gordon, Hamilton; George Cheatle, The Music Shop, Springfield; F. L. Fell, R. L. Berry's House of Music, Springfield; G. E. Lester, G. E. Lester, Hoopston; T. J. Griggs, Griggs Music House, Kewanee; Ray E. Bannon, Bannon's Music Shop, Ottawa; Harry K. Onken, John Onken & Brother, Chapin; Ed. F. Ritter, Ed. F. Ritter, Mattoon; J. L. Murray, The Murray Co., Davenport, Ia.; S. B. Bolton, Bolton Electric

Co., Aledo; C. N. Lenhart, C. N. Lenhart, Mattoon; A. R. Meyer, A. R. Meyer, Havana.

R. E. Gardner, R. E. Gardner, Washington; E. E. Hanger, Hanger Brothers, Lincoln; R. L. Stutzman, P. A. Bergner & Co., Peoria; F. R. Bailey, King & Bailey, Virginia; H. C. Kupfer, Mandel & Schwarzman, Bloomington; Russell N. Smith, Russell N. Smith, Carthage; Lyle Straight, A. Livingston & Sons, Bloomington; Rufus L. Berry, R. L. Berry's House of Music, Springfield; L. C. Mountcastle, P. W. Simon Concert Co., New York City; C. H. Hammond, C. H. Hammond, Rushville; F. M. Leslie, F. M. Leslie, Urbana; W. E. Rouch, Linn & Scruggs, Decatur; W. L. Barnett, Barnett Drug Co., Watseka; J. W. Pauly, The Music Shop, Burlington, Ia.; Louis Heckman, Louis Heckman, Manito; Duane Wanamaker, Talking Machine Journal, Chicago; Ralph W. Wheelock, C. E. Wheelock & Co., Peoria; Ben. H. Brunswick, Brunswick's Music Shop, Pittsfield, Ill.; J. D. O'Malley, Block & Kuhl Co., Peoria; C. W. Fitzgerald, C. W. Fitzgerald, Morrison.

The Putnam-Page Co. was represented by Carl Carey, Miss M. A. Cloud, Ben Oltmanns, W. P. Mosher, P. A. Ware, Miss Rose Herndon, F. H. Putnam, L. S. Putnam and Roy Page.

ARTISTIC STORE IN CHESTER, PA.

CHESTER, PA., March 5.—Miss E. V. Martin has just completed negotiations for opening an exclusive Victrola shop in the Edgemont Theatre Building. This location is considered one of the most desirable in the city. She has placed an order for eight Unico demonstrating rooms and will have an attractive decorative treatment across the entire width of the store. An efficient record department, equipped with eight Unico racks and four efficiency counters, has been provided.

Do not surrender your individuality, your identity. Stand for something. The carbon copy is seldom sent out of the office.

ENJOY THE



COOPERATION AND SERVICE



of the

Scoville Mercantile Company

Distributors of

The Record of Quality

OKeh Records

Our service is dependable and merits your participation as our dealer.

Scoville Mercantile Company
ATLANTA, GA.

NEEDLES

WE MANUFACTURE

Diamond needles for Edison
Sapphire needles for Edison
Sapphire needles for Pathe
in stock ready for delivery

MERMOD & CO., 874 Broadway, N. Y.



Pablo Casals, the famous 'cellist, lends new popular interest to Handel's "Largo" on this Easter-tide record that will sell the year round. Keep this in mind when you order. Columbia 49802.

**Columbia Graphophone Co.
NEW YORK**

PITTSBURGH CONTINUES TO BE A BUSY TRADE CENTER

Group Meeting of Victor Jobbers, Held Under Auspices of C. C. Mellor Co., Great Success—New Quarters for National Phonograph Co.—Opera Window Wins Praise—Talkers Exhibited at Show

PITTSBURGH, PA., March 1.—A group meeting of Victor jobbers was held recently in the Crystal Room of the William Penn Hotel. The hosts were the C. C. Mellor Co., the Standard Talking Machine Co. and the W. F. Frederick Piano Co., Victor distributors. Out-of-town Victor jobbers present were: H. J. Shartle and C. H. Deacon, of the Cleveland Talking Machine Co., Cleveland, O.; Charles Bennett and Earl Poling, of the Eclipse Musical Co., Cleveland; Curtis N. Andrews, of Buffalo, N. Y.; Perry B. Whitsit, of Columbus, O.; V. W. Moody, Buffalo Talking Machine Co., Buffalo, N. Y.; C. A. Grinnell, of Grinnell Bros., Detroit, Mich., and Arthur Bates, of the Ohio Talking Machine Co., Cincinnati, O. The Pittsburghers who participated in the meeting included: French Nestor and Wallace Russell, of the Standard Talking Machine Co.; Thomas T. Evans and R. R. Myers, of the C. C. Mellor Co., and George H. Rowbridge and Robert Boycott, of the W. F. Frederick Piano Co. Following the business session dinner was served and later all occupied a box in the Alvin Theatre, where "Linger Longer, Letty," was played.

An enterprising show window display was engineered by Fred J. Drake, manager of the C. C. Mellor Co.'s retail Victrola department, and O. B. Dean, the versatile and resourceful window designer of the department, the past week. Practically the entire window was given over to a small-sized replica of a stage scene depicting the production of an act in "Rigoletto," the celebrated opera by Verdi. At the side an automatic electric sign displayed moving placards telling, in part, the story of the opera. Just at the dramatic point instead of the story continuing a card is shown asking the reader to call inside the store and secure a little pamphlet giving in full the story of "Rigoletto."

The show window display proved a means of attracting large crowds the entire day, as high as three hundred persons viewing the scene in less than forty-five minutes. The display was made in connection with the coming of the Chicago Grand Opera Co. to Pittsburgh this month.

Mr. Drake stated that there was considerable activity in high-priced Victrolas and that either cash sales or sales in which first payments were substantial sums were a feature of business in his department the past few weeks.

The National Phonograph Co. will move from its present location in the Jenkins' Arcade to 633 Penn avenue, a six-story building, which will be entirely occupied by the company in connection with the sale and distribution of the Ultraphone phonographs. The first floor will be elaborately fitted up for a retail department.

Jean J. Marceis, formerly in charge of the talking machine department of Spear & Co., has resigned and returned to New York City. L. Weinberg, who for many years has been connected with the firm, has succeeded to the managership. Mr. Weinberg reports satisfactory sales of talking machines and records. The department sells the Victrola, Vocalion, Sonora and Vitanola.

The Pittsburgh Food Show and Household Exposition held the past ten days in Motor Square Garden was noted for the fact that two lines of talking machines were on exhibition. The W. F. Frederick Piano Co. had on display a line of Victrolas, while the Vocalion-Melodee Shop had a number of the Vocalions on show. At frequent intervals during the afternoon and evening concerts were given at each of the booths, which attracted large crowds.

The partnership lately existing between Jacob Hirsh and David Busis, trading as the Oakland Music Shop, 3531 Forbes street, was dissolved

by Mr. Hirsh withdrawing from business. Mr. Busis will continue the Oakland Music Shop.

S. H. Nichols, manager of the Pittsburgh branch of the Columbia Graphophone Co., stated that sales for February showed a decided improvement over business handled in January. He anticipates a brisk trade in the Columbia Grafonola line as soon as business and industrial conditions here are on a more settled basis.

H. Milton Miller, sales manager of the Sonora Co., distributor of the Sonora phonographs, reports a very satisfactory number of sales during the past month. His roadmen, he said, have had exceptional success in making sales and some big orders for the Sonora have been put through.

SONORA PORTABLE NOW \$50

The Sonora Phonograph Co. announced recently that the price of the Sonora portable machine had been placed at \$50. The company stated that one of the main items in the course of producing this model is leather, and the leather market has dropped so materially that this revision in price was made possible. In its letter to the trade the company also stated: "It should be particularly noted that the change in the price of the Sonora Portable is due to unusual conditions in the leather market and does not in any way affect the remainder of the Sonora line. There is no change in prices of the upright and period models in contemplation at the present time."

L. H. Murray, the exclusive Victor dealer of Davenport, tells a good one. We can't vouch for its truthfulness, but it gave us a laugh, so we'll pass it on to you. A customer asked him for the new record, "Bubbles," from "Lux."

To get a raise where you now are means that you are making good; to be hired away from one firm on promise by another of a higher wage is in the expectation that you will make good. And it's ten to one you won't.

<p>WALL KANE NEEDLES Play 10 Records Extra Loud Medium Loud</p>	<p>EUREKA GRAPHITE and PHONOGRAPH LUBRICANT THE BEST</p>	<p>"IMICO" DIAPHRAGMS Superior Quality For All Reproducers</p>	<p>VALLORBS SEMI-PERMANENT ONE PIECE TYPE PHONOGRAPH NEEDLES</p>	<p>RECORD ALBUMS AND CLEANERS MOVING COVERS</p>
<p>MAINSPRINGS AND REPAIR PARTS FOR ALL MAKES OF PHONOGRAPHS</p>	<p>RAYSOLO SALES COMPANY :: DISTRIBUTORS :: LANCASTER - PENNA. Your Patronage Solicited Our Service Excels WE AIM TO QUOTE PRICES THAT INSURE THE DEALER THE LARGEST PROFITS</p>			<p>Send Us Your Repair Troubles We Do The Work Right and Return Quickly Prices Very Reasonable</p>
<p>BRILLIANTONE REFLEXO STEEL NEEDLES</p>	<p>SOLOTONE PHONOGRAPHS Very Liberal Dealers Proposition</p>	<p><i>We Issue a Monthly Bulletin</i> Send Us Your Name and Address for Our Mailing List</p>	<p>PIANO BENCHES DUET BENCHES High Quality Low Price</p>	<p>PATHE and EDISON JEWEL POINTS</p>



Widdicomb

PHONOGRAPH

The Aristocrat of Phonographs

DEALERS tell us that the Widdicomb appeals to all and everyone alike. Primarily, this is due to two main facts:

First: In the Widdicomb Phonograph the Amplifying Tone Chamber does full justice to the lower as well as to the higher musical tones. When playing an orchestral record on the Widdicomb, the deeper, richer tones are given equal prominence. And because the Amplifying Tone Chamber is vibrationless there is no suggestion of metallic harshness.

Second: The simple grace of all Widdicomb cabinet work depicts the fine art of true period interpretation. In this character of workmanship, where genuine knowledge of art and decoration is essential, the fame of Widdicomb cabinetmakers is known broadcast. Yet so subtle is the adaptation that the Widdicomb is at home in any furniture setting.

Write for latest catalog showing the many styles of Widdicomb Art Phonographs.

The Widdicomb Furniture Co.

Grand Rapids

Michigan

Fine Furniture Designers Since 1865

DEALERS SEEKING TRADE DO BUSINESS IN TWIN CITIES

Trade Not as Active as Many Would Like to Have It, but Distributors and Dealers Are Making Every Possible Effort to Revivify and Develop Trade—News of the Month

MINNEAPOLIS and ST. PAUL, MINN., March 5.—In common with the other business men of the Northwest the talking machine dealers are accepting what the fates hand out to them gracefully and even cheerfully. Trade is hardly as profitable as they would like to have it, but while the process of adjustment is going on they are resigned that the pain is no greater than it has proven thus far.

There is nothing to be gained by comparing the results obtained by the talking machine merchants a year ago with the present, as the figures will not look good in print. At the same time there is something doing for everyone who will hustle. The downward trend of wages undoubtedly has had a deterring effect upon buying, but it is well that the fight for new wage scales should come at the present time when building and other industries are slack rather than later on when the customary Spring activities are under way.

"All wholesale trade is slow and logy due to conditions that are familiar to everyone," said Sewell D. Andrews, head of the Sonora department of the Minneapolis Drug Co. "We find that many of the country dealers are pretty well stocked with machines. Some think that they are overloaded, but we are glad to say that they are not exclusive Sonora dealers. We are very hopeful as to the future, but concede that the Spring and Summer may not be quite as active as usual. The Okeh records are going nicely, I might say 'big,' and the various McCormack releases prove very popular with the retailers. We are pushing the Magnavox and are meeting with excellent success in this line."

The Columbia Graphophone Co. is having fair success in this territory, according to W. L. Sprague, Northwestern manager. The record trade is good and there is a continual demand for such favorites as "Bright Eyes," "Honolulu Eyes" and the like. Mr. Sprague says that the

future continues to brighten, but like other Northwestern managers will not be surprised if the recovery should prove somewhat slow.

Plans for the manufacture and distribution of a phonograph service counter and for a publicity campaign to accompany the enterprise have been completed by the Beckwith-O'Neill Co., of Minneapolis. L. M. Willis, formerly connected with the Unico and the Victor companies, will be in general charge, with M. J. Jenson as mechanical superintendent. Contracts for the manufactured parts have been let and the new selling device will soon be on the market.

It is claimed for the service counter that it will serve the dual purpose of a demonstration booth and a service counter. It is adaptable to any modern talking machine. The new device has been improved in various ways as the result of experience and use of two models tried out by the Foster & Waldo Co. and the Cable Piano Co.

The new home of the New England Furniture Co., Fifth street and First avenue north, Minneapolis, will have a commodious, well-equipped and well-arranged talking machine department. Charles S. Harris, of the company, has been visiting around to obtain ideas and has planned to embody all the latest innovations in the new quarters. The company handles the Victor, Columbia, Edison and other lines of machines.

The Beckwith-O'Neill Co. is now able to accumulate a stock of machines and records. While the latter have been coming along in goodly quantities they also are going out rapidly and the reserve supply is still far short of what the company wants.

More Edison machines were sold by the Minnesota Phonograph Co. in January and February of the present year than during the corresponding months of 1920, says Milton Lowy,

its manager. The increase will figure about 30 per cent. This experience, it may be stated, is somewhat unique in Twin City business annals. Laurence H. Lucker, Northwestern distributor, indicates that he is satisfied with the jobbing end of the Edison business. He was fortunate in not having any large accounts in the sections of the Northwest that have been hit the hardest by the wave of readjustment.

January reports on the Brunswick sales in this territory show an increase in dollars of 32 per cent, says E. L. Kern, director of the Brunswick-Balke-Collender Co. February also shows considerably better than the corresponding month of last year and the Brunswick folk are completely satisfied with their exceptional success in view of the general dislocation of business. George M. Nye, manager of the phonograph branch, states that the record demand is growing rapidly.

Samuel Levinson has succeeded Jay H. Wheeler as manager of the Pathé department of G. Sommers & Co. The Pathé business is holding its own, according to the reports.

AN OBSERVANT BUYER!

Talking Machine Dealers in Harlem Are Anxious to Meet Gentleman of Color Who Has Santa Claus Pockets and Artistic Tastes

A character of former days is reported to have returned to and again departed from the dealers in the Harlem section of the metropolis. Several dealers on 125th street have received a call from a gentleman of color, clothed in a long overcoat, who is said to be a devotee of grand opera records of the higher price. The more they cost the better he likes them. In calling for the record it is said he notices where the clerk selects the record from. He is described as particular and consumes much time in the selection of his records. Dealers report that after purchasing one record he departs—with other records as well which he has dexterously slipped into concealed pockets on the inside of his long coat.



OPLEX SIGNS BRING SALES

OPLEX Electric Signs have a happy cheerfulness which encourages the buying of musical instruments.

They are day signs as well as night signs—raised snow-white glass letters on a dark background. They have greatest reading distance, lowest up-keep cost, most artistic designs.

Let us send you a sketch showing an Oplex Sign for YOUR store.

FLEXLUME SIGN COMPANY

36 KAIL ST. BUFFALO, N. Y.

NOTABLE CONTRIBUTOR TO THE POPULARIZATION OF ART

Interesting Tribute Paid to the Paramount Influence of the Talking Machine as a Developer of Musical Knowledge and Appreciation

While it is true that the talking machine industry has made wonderful progress spreading immeasurable good on every side, yet its position as a paramount influence in the development of musical knowledge and appreciation has not been given the recognition that it deserves. Consequently it is pleasing to note the following tribute to the industry which recently appeared in the Charleston, S. C., News:

"Recent publication of figures on the talking machine trade serves as a reminder of the wonderful part which this new factor for human education is playing in the daily life of the world. From the tinny, cacophonous talking-box of comparatively few years ago to the truly amazing reproducer of human and mechanical sound is far more than a story merely of the perfection of a musical instrument. A much more wonderful phase of it has been the development of the use of the instrument, includ-

ing the perfection of record-making, the enrolment of the finest vocalists and instrumentalists in its service, and, last but not least, the world-wide distribution of machines and records and the accompanying education of people to enjoyment of good music.

"The talking machine's work is not spectacular and does not have a fraction of the attention that the public bestows on the progress of some other forms of entertainment or instruction. That is human nature, too, because the talking machine being at home, convenient, easy to play, and inexpensive, is not likely to be so much appreciated by the average person as, say, the movies, to see which he has to go to a good deal more trouble and expense. Yet it is not so certain that for all that has been written about the wonders of the motion picture—and it is wonderful—the educational value of the talking machine may not prove fully as great in the long run as that of the cinematograph—perhaps greater. To begin with, the talking machine has a far larger proportion of 'good and a far smaller proportion of evil than the movie; again, a far greater percentage of the total offered the public by the record manufacturers consists of genuine art.

"Perhaps the great triumph of the talking machine is due in largest measure to the excellent policies adopted and adhered to by all the large record manufacturers. Although the commercial talking machine is not so many years older than the commercial cinema, nevertheless the owners of talking machines were feasting on the finest in opera when patrons of the movies still saw horseplay and slapstick as the highest efforts of the screen artists. Through the talking machine hundreds of thousands of homes that formerly knew and cared little about music have become well acquainted with the compositions of Wagner, Mozart, Beethoven, Grieg, Tschaiikowsky, Chopin, Gounod, Verdi, and other noted composers of every nation; with the voices of Caruso and Scotti, Farrar and Galli-Curci, Alda, Homer and Gluck; with the violins of Elman and Heifetz, Kreisler and Powell; with the work of the greatest 'cellists, the greatest pianists; with the directing genius of such leaders as Sousa; with the best comedy singers. While the motion picture producers still announce with great emphasis the entry of a great dramatic star into the movies or the production of a scenario by a great living author, it has become the accepted thing that the best talent in the musical world shall, as soon as discovered, be recorded for the talking machine. The talking machine industry has wrought worthily by lofty standards and has made notable contributions to the popularization of art. Its leaders deserve praise and congratulation and their methods and ideals may be copied with great benefit by leaders in cognate fields."

USING AGGRESSIVE METHODS

Lyll Music Co., Shreveport, La., Closing Splendid Sonora Business—Timely Advertising a Valuable Help in Developing Trade

SHREVEPORT, LA., March 5.—The Lyll Music Co., of this city, Sonora representative, is closing an excellent business and Mrs. C. L. Lyll, owner of the establishment, is enthusiastic regarding the progress that the store has made with the Sonora line, which it handles exclusively. From a very small beginning the Lyll Music Co. has grown to be one of the most important music establishments in this city, and whereas in the beginning an order for a few Sonoras was quite an event, it is not unusual at this time for the firm to take a solid carload on one order.

Recently the Lyll Music Co. carried large advertisements in the local newspapers, reading as follows: "Eight Sonoras in 1918—now by solid

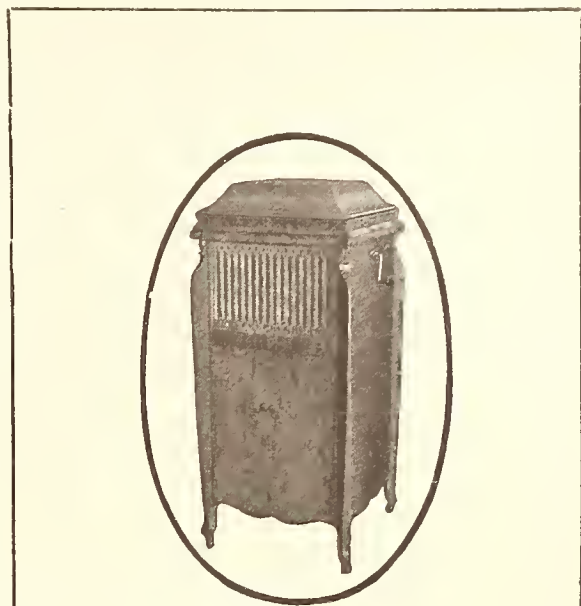

BLANDIN

IT is indeed gratifying that music lovers should so promptly assign the Blandin Phonograph the leadership in musical re-production.

A comparative demonstration in your store will reveal Blandin qualities heretofore unknown to you.

Racine Phonograph Co., Inc.
RACINE, WISCONSIN.



carload. Our first shipment from the Hessig-Ellis Drug Co., Memphis, Tenn., on February 23, 1918, consisted of eight phonographs. To-day we order these machines by the carload."

The success of the Lyll Music Co. may be attributed to the able salesmanship of the organization, headed by Mrs. Lyll, and the fact that the company has left nothing undone that might add to the public's appreciation of the Sonora.

VISITORS AT NEW YORK OFFICE

Among recent visitors to Aeolian Hall were H. D. Felix, of Schuylkill Haven, Pa., who was recently appointed a Vocalion dealer; A. E. Stone, of the Parker-Gardner Co., Charlotte, N. C., and A. T. Sayward, of the M. Steinert & Sons Co., Boston.

Quality *Distinction*

The "VICSONIA" Reproducer

Recognized for its *Perfect* interpretation of *Edison Disc Records* on *Victrolas* and *Grafonolas*.

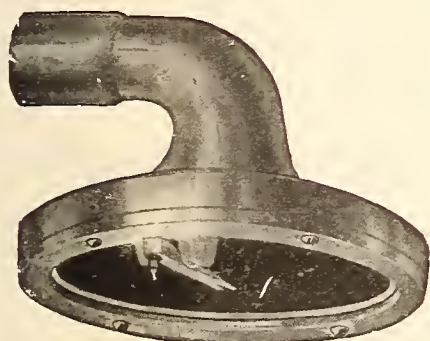

Fitted with permanent jewel point.

No loose parts.

Note: The Vicsonia is made of *Bronze*, sand casted and machined to measurement. Finished in heavy *Nickel* or *Gold Plate*. Flexible stylus.

Meet the Demand
Serve Your Customers

Sample Model "A" or "B" Vicsonia will be sent on receipt of \$4.50. Retail price \$7.50.

Note: Model "B" Vicsonia plays both *Edison* and *Pathe* records.

Vicsonia Mfg. Co., Inc.
313 EAST 134th STREET
NEW YORK, N. Y.

ARTIST WRITES HIS OWN REVIEW

Reinald Werrenrath Proves Himself a Writer as Well as a Singer—Famous Victor Artist Tries to See Himself as Others See Him

After a most successful concert in Louisville, Ky., Reinald Werrenrath, popular baritone and a celebrated Victor artist, was invited by a newspaper of that city to write his own review. Taking his pen in a firm grip he wrote:

"You see, I never would have gone to hear this bird Werrenberg, or whatever his name is. hes a wop or something, if Loo hadent got stuck on a record she hird last Summer when she was to her folkes in Guthrie, only God knows where they get the coin to buy such tripe. They always sponge on me every time they get a chanct. Well, I coffs up four good iron men plus a war tax, although there aint no more war, and we goes to the consert as it is called, Loo looking like \$1000000 and me all dressed up like a plush hors. We set around awhile with a lot of fokes that seemed to know why they was there. The men had mostly forgot there vests and the women had mostly forgot a lot of front and back. Well, this guy comes out at last tall and skinny with his shirt stikking out in front like he was proud or something, followed buy a little red-headed-what-there-was-of-it feller, and the crowd begins to clap and stomp before he opens his face. Whats the big idear, I says to Loo. Shut up you poor sap, she says clapping her hands so hard she bust a new pr. gloves I bot her only last Oct. when she was to Nashville. Thats to let him know were all with him, she says. Is that so, I says, if thats the case Im dum as a oister becaus Im off him, the big stiff. After the crowd stops there noyse Red begins to tease the ivorys, and, the big bum starts in.

"Was he good? Well, yes and no. The 1st song wasent so rotten. It was about a guy who wants his dame to get up and rush the growler for him. He says hell take creem and if thers no creem hell take beer. Hes foolish just like a fox, only a swell chanct hes got to get beer

these days after what them prohibition guys did to us. I know where he could get a good shot oi hootch right in Louisville too, but beer, nix. Anyway this Werrenstein sings some more and I don't make it. Whats he doing, I says. Thats Italian says Loo and shut up, so I get sore and shuts up. Well to make a long story short he sings or thinks he does, the big stuffd shirt; and Red plays and the crowd claps there hands and I says to Loo, I gotta smoke and she says its all right with me and stay as long as you want.

"So I beats it out in the street and finds I left my strikes to home, so I asks a guy would he lend me one and he does. He says what do you think of the consert and I says rotten. Same here, he says who told that big rummy he could sing anyway. I never did and I never will, I says and then the guy, not Werrenrash—the guy in the street, says your all right and gives me a hole pack of strikes. He says my name is Coals and Im the Louisville Conservatory of Music and if you want singing lessons Ill give them to you free. Not for mine, I says. If I cant sing right now a lot better than that big stew inside I hope I never drive another taxi. A little chicken trys to hold me up for a tikket when I come in, but nothing doeing.

"The big slob on the stage is singing right

along as if he didnt care where I was, and say I gotta hand it to him on one song he sung as I blue in the dore something about donna and the stars and hills and streams and everything. It sure was a bird of a song and when I slides in with Loo again she didnt see I set on her new lid becaus her eyes were full of tears.

"Whats the idear I says. She says you wouldent understand, and I lets it go at that. Well to make a long story short he keeps on singing, and the guys in the seats keeps on claping and I says come on Loo well have a Coco Coler and go home. Wasent it beautiful Loo says and I says it may of bin but it was over my head. What does that bird get for his troble? More than you make in a month you poor cluck, Loo says. Pretty soft I says, but if I gotto were trick close and no vest and come my hare back with a fork like that wop Ill stick to the taxi."

USE ORNAMENTAL LOBBY EFFECT

ELYRIA, O., March 8.—Herbert Day & Sons are completing extensive alterations to their talking machine warerooms in this city, which will add materially to their attractiveness and efficiency. An entirely attractive and ornamental lobby effect has been made and seven Unico demonstration rooms have been installed.

Do You Throw Money Away?

It is not a popular pastime—but still it is unconsciously done by many who just don't know that *Repair Parts* can be bought for less

**RENE MADE SPRINGS AND PARTS LAST LONGER
COST LESS**

RENE MFG. CO.

Montvale, N. J.

BELL HOOD *Semi-Permanent Needle*

THE NEEDLE WITH TONE QUALITY

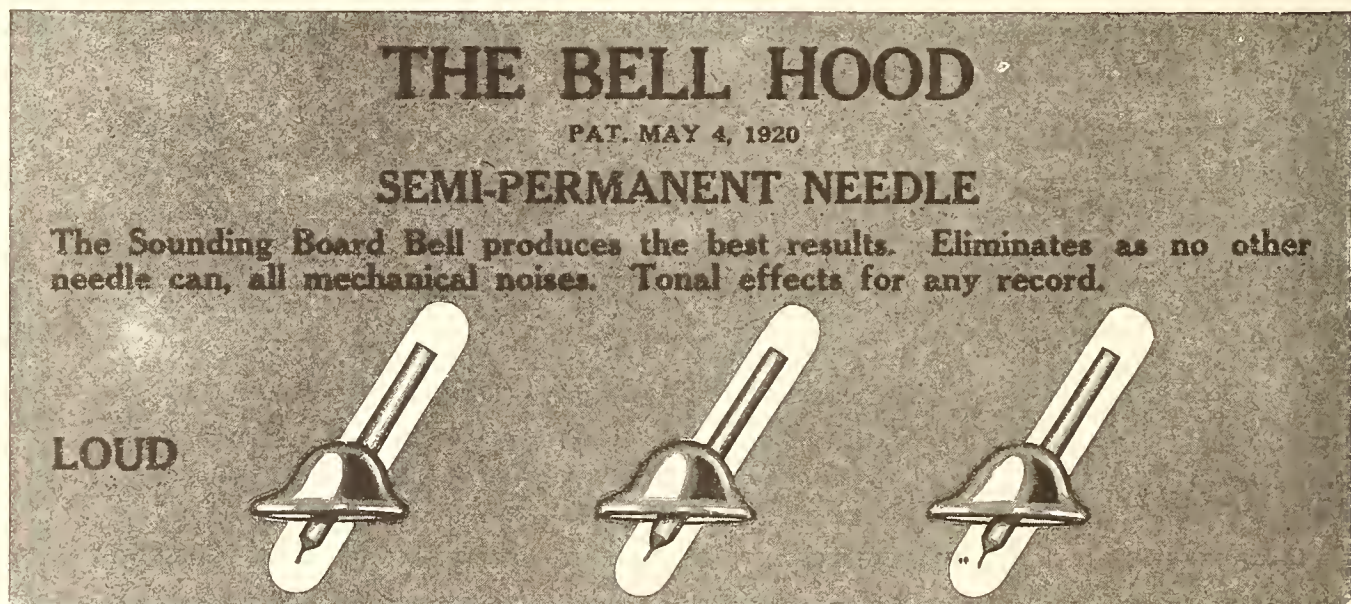

Made by the Bell Hood Needle Co., New Haven, Conn., U. S. A.

IMPROVES YOUR PHONOGRAPH 100 PER CENT
"The Bell Does It"

Purifies the tone, reduces the scratching and mechanical sounds to a minimum.

SEMI-PERMANENT POINT—Loud—Medium—Soft

A profitable needle for dealers to sell. More than 2000 Dealers are now selling them with splendid success. Order from the nearest branch.

THE BELL HOOD NEEDLE CO.

183 CHURCH STREET

NEW HAVEN, CONN.

GENERAL PHONOGRAPH CORPORATION

OTTO HEINEMAN, *President*

25 West 45th Street New York City, N. Y.

Factories: Newark, N. J. Elyria, Ohio Putnam, Conn. Springfield, Mass. Kitchener, Ont.
Branch Offices: Chicago, Ill. Toronto, Can. London, Eng.

If you contemplate building a *Quality*
Phonograph at a *reasonable price*, use our

Motor of Quality

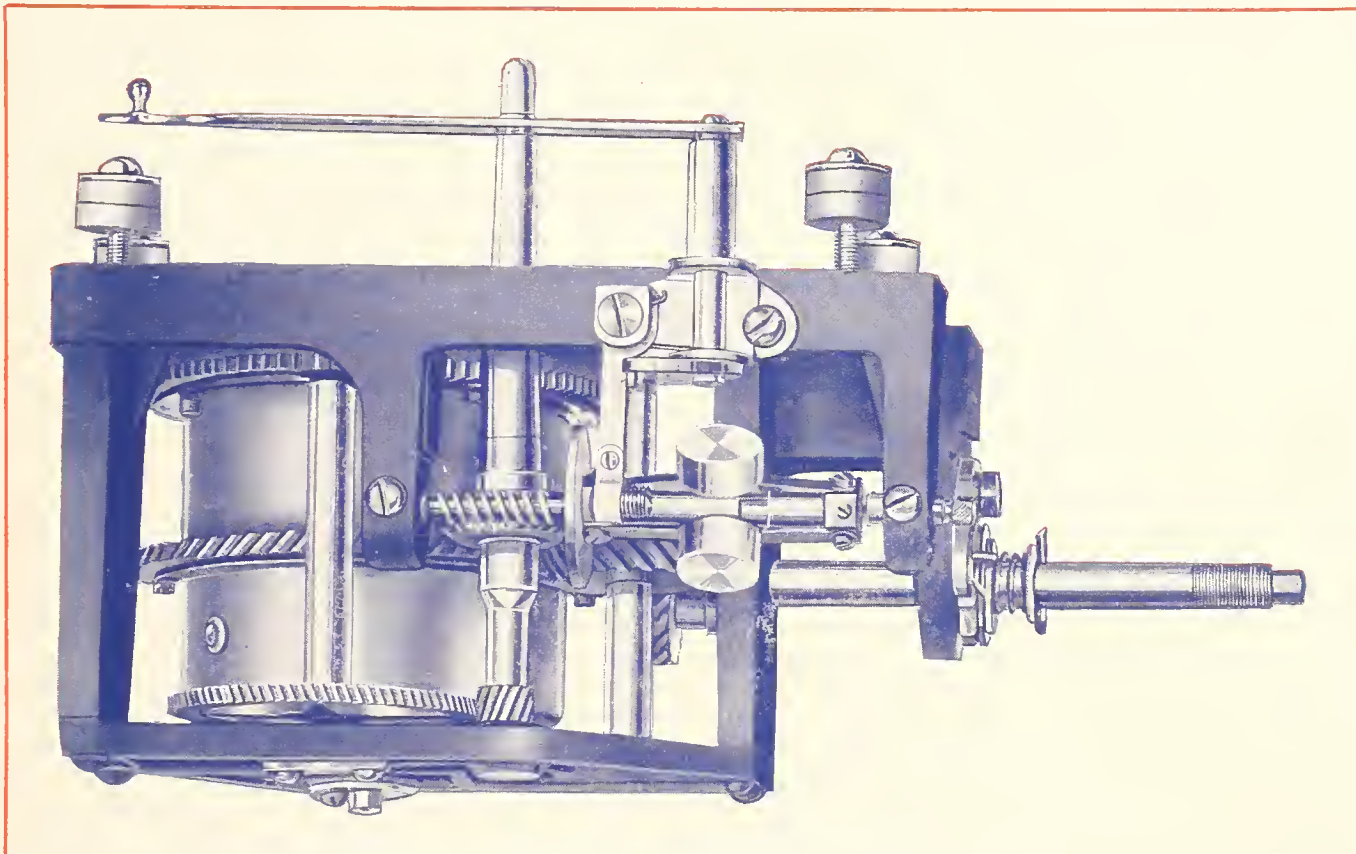

HEINEMAN MOTOR No. 77

We have manufactured and sold over 1,000,000
No. 77 Motors and have only satisfied customers

Motor No. 77 is the Best Known Motor in the Phonograph Trade

GENERAL PHONOGRAPH CORPORATION

OTTO HEINEMAN, *President*

25 West 45th Street New York City, N. Y.

Factories: Newark, N. J. Elyria, Ohio Putnam, Conn. Springfield, Mass. Kitchener, Ont.
Branch Offices: Chicago, Ill. Toronto, Can. London, Eng.

Get the swing of this native Orquesta Argentina—piano, two violins, two flutes and a bandoleon—on this month's Columbia Novelty Record. "Song of Sadness" is a native tango, "Delfos" a waltz. They'll sell! E-4959.

Columbia Graphophone Co.
NEW YORK



WILL MAKE RECORDS ON COAST

Art Hickman to Make Series of Records for Columbia Graphophone Co.—E. N. Burns in Charge of Recording in San Francisco

SAN FRANCISCO, CAL., March 2.—Art Hickman, the famous musical director of the Art Hickman Orchestra, exclusive Columbia artist, is making arrangements for an exhibition of record making that will undoubtedly attract considerable attention. Mr. Hickman is also assistant manager of the Hotel St. Francis, and after extensive tests and investigation he selected the Borgia Room at the Hotel St. Francis as being acoustically perfect for recording purposes. The recording will be under the direction of E. N. Burns, vice-president of the Columbia Graphophone Co., who is at present in San Francisco, accompanied by A. L. Hausmann, recording expert.

The necessity for absolute silence in the recording laboratory has made it necessary for Mr. Hickman to exclude large audiences, with the exception of one test to which invitations have been extended to Mayor James Rolph, Jr., Chief of Police Daniel O'Brien and a limited number of prominent officials.

Thomas J. Coleman, manager of the Hotel St. Francis, has granted the Columbia Graphophone Co. the use of the Borgia Room during the test period and thirty or forty numbers will be recorded during the month. Mr. Hickman, who has a two-year contract with the Columbia Co., is famous the country over as one of the greatest orchestra directors of the present day and his Columbia records have met with a phenomenal sale.

CO-OPERATES WITH MANUFACTURER

NEWARK, N. J., March 5.—The U-Sav-Your cleanser and dressing, manufactured by the U-Sav-Your Mfg. Co., of Warren, Mass., was featured on the inside of a cover which L. Bamberger & Co., the big Newark department store, attached to the recent list of Victor records which they distribute. Under the heading of "How to Care for Your Phonograph" they state the many merits of the U-Sav-Your dressing and announce it for sale in the talking machine department on the sixth floor. It is reported that this publicity had a decidedly favorable effect upon the sale of U-Sav-Your in this department store.

PORTABLE PHONOGRAPHS IN FAVOR

PHILADELPHIA, PA., March 6.—The Cirola Distributing Co., of this city, has added many new dealers to the list of retailers of the portable phonograph of the same name. An energetic sales campaign is under way, and under the direction of G. D. Giacomo, president of the company, the sales staff of the company will be increased and an intensive cultivation of the territory will follow so as to capture a big Summer business.

REORGANIZING THE WONDER CO.

H. Radt Retires as New York Representative and Is Succeeded by G. L. Jones

H. Radt, former stockholder and New York representative of the Wonder Talking Machine Co., 105 East Twelfth street, New York, with a factory in South Norwalk, Conn., recently severed his connections with that concern.

The Wonder Co. is undergoing reorganization and plans are being prepared to greatly increase the production of the talking machines manufactured by this organization.

H. B. McNulty, the president of the company, will continue to make his headquarters in South Norwalk, Conn. G. L. Jones has been appointed manager of the New York offices, which will be continued at the same location. All the stockholders of the organization are now residents of South Norwalk, Conn.

EDISON ARTISTS IN OHIO

YOUNGSTOWN, O., March 1—Under the auspices of the Homer S. Williams Co., Glen Ellison, the famous Scotch baritone, assisted by Alta Hill, both Edison artists, gave a most pleasing concert Thursday night, February 24, in Masonic Hall.

The following Sunday night the artists appeared in person at a concert at the Union Opera House, New Philadelphia, O., under auspices of George E. Buss, Edison dealer there.

BECOMES EMERSON REPRESENTATIVE

S. W. Goldsmith to Look After Emerson Interests in State of Ohio

COLUMBUS, O., March 3.—S. W. Goldsmith, vice-president and secretary of the Goldsmith Music Store Co. for the past eighteen years, has been appointed wholesale distributor for the State of Ohio for the Emerson Phonograph Co., Inc. Associated with Mr. Goldsmith in business is S. M. Hyneman.

The new company occupies the first floor and basement at 36 West State street, which they use as office, display room and record stock and shipping room. A stock of Emerson phonographs is kept ready for quick shipment at the W. Lee Cotter Warehouse Co.

James W. Pommer, of Albany, N. Y., and Charles Usher, of Brooklyn, N. Y., experienced phonograph salesmen, are representing the new company in this territory and report that conditions are satisfactory.

IN FINANCIAL DIFFICULTIES

A petition in bankruptcy has been filed against the Binger Co., 43 West Thirteenth street, New York, by these creditors: William Berg, Andrew C. Frommelt, Paterson Typewriter Exchange. Judge Manton appointed Jeremiah F. Connor receiver under \$10,000 bond. Liabilities are said to be \$300,000 and assets estimated at \$200,000.

OKeh Records

Artists of distinctive qualities are heard on OKeh Records.

We are prepared to sign up and take care of new dealers.

We offer a proposition that is of advantage and interest to you.

Write today for particulars.

ARTOPHONE COMPANY

1103 Olive Street

St. Louis, Mo.



New Unico Establishment—E. Paul Hamilton, Inc., Baltimore, Md.

SERVICE IS ESSENTIAL TO SUCCESSFUL MERCHANDISING

Talking Machines and Records are sold at prices standard throughout your community—therefore, your salvation lies in Superior Service.

When the Talking Machine Merchant reaches a determination to give his patrons the Maximum in Efficient Service, he has won half his battle to make his store the leading establishment in his Community. When he decides to install the Unico System—*The Standard Musical Merchandising System of the World*—he wins the other half.

This has been proven by 1750 dealers who have installed Unico Equipment, a quality product, fairly priced.

Unico Service functions with surprising rapidity. Unico Demonstrating Rooms, Counters, Record Racks and Decorations are available in twelve designs and standard finish for *Immediate Shipment*.

Unico Traffic Service expedites transportation to your establishment in minimum time.

Unico Installation Service provides speedy and satisfactory erection in your store, complete and ready for use.

Wire, write or phone today to our nearest office.

Your problem will receive immediate expert attention.

*Unico Construction
is patented.*



*Unico Designs
are patented.*

UNIT CONSTRUCTION COMPANY

NEW YORK
299 Madison Ave.
Corner 41st St.

Rayburn Clark Smith, President
58th Street and Grays Avenue
PHILADELPHIA

CHICAGO
Willoughby
Building

Featuring the **MUSICAL** POSSIBILITIES of the **TALKING MACHINE**

[Editor's Note:—This is the fifth of a new series of articles by William Braid White, devoted to the various interesting opportunities which prevail in the domain of education for the retailer of talking machines. The subject is one of great interest and we commend these articles to the consideration of all who are devoting attention to the featuring and developing of the musical possibilities of the talking machine.]

OLD STUFF THAT IS NEW

Now that things are gradually clearing up and the business atmosphere throughout the country is becoming less and less murky, business men are recovering their health and spirits, as it were, and are beginning to sit up and take notice. The talking machine trade is able again to take a little nourishment. But if the period of convalescence is to be not only interesting to the spectators, but easy to the patient, it is obvious that some sort of regimen must be prescribed and that the immediate future activities must be conducted according to some sort of a rule.

The Raison d'Être

It is absurd to suppose that the talking machine appeals to its purchasers as a piece of furniture or as something to put in the home to be looked at. It is part of the idea of the talking machine that it should be used more or less constantly. The music it gives, which means in another sense the records to be bought for it, constitutes the *raison d'Être* of the machine, and it is wholly absurd to suppose that anything but the enjoyment of wanted music can form the basis of the idea in the prospective purchaser's mind.

That being so, one is tempted to ask why dealers in talking machines throughout the country do not show more interest in the musical side of the machine. Of course, large merchants throughout the country, as may be seen by consulting the reading columns of this magazine, are doing admirable work in pushing the music side of the business before the people, but the larger merchants do not comprise the greater part of the trade. It is the small dealer, the man in the small town or city, who has a small store and a few machines, who, collectively, constitutes the big end of the business. It is this man who holds in his hand the destiny of the talking machine business. It is he who can make or mar the annual output of talking machines and records. Individually, perhaps, he cannot do a great deal, measuring effort in figures, but in the aggregate he swings the balance up or down and controls the situation.

A Word to the Smaller Merchant

This is why I must to this man definitely appeal. It is to him that I must now speak. The talking machine business at this moment needs only one prescription to restore it to immediate health. The prescription it needs is one which

anybody can easily apply and which is bound to be immediately effective. That prescription is "Music." Let "Music" become the slogan of every talking machine merchant in the land and business will at once begin to pick up.

Is this practical stuff or is it mere theory? Let us consider for just a moment.

The Life of the Business

In the first place, music is the whole meaning, the whole significance of the talking machine. Take away music from the idea of the talking machine and you take away its life. The person who buys a talking machine does not buy a machine. He or she buys the means for getting music in the home; that is to say, music. That is the object of the purchase and the subject of the sale—music.

Now, if the people stop buying talking machines that can only be because they have temporarily lost the realization that the talking machine is the popular means to music par excellence. It cannot possibly be that the people don't want music any more. That is absurd. The people do want music and in every line of musical endeavor there is throughout the country a greater stirring of activity than ever before.

If, then, the people stay away from the talking machine store this can only be because they do not see quite clearly enough what the talking machine will do for them. Secondarily, it is because many of them have been infected by the general feeling of pessimism and have been holding off.

The second of these conditions disappears as soon as the first has been visualized and understood by the merchant. The people require only some honest stimulation. That stimulation is to be had only from the plain recognition, as a basis, that it is not talking machines which are sold, but that the sale of a talking machine is only the form in which is wrapped up the first of a long series of sales of "music."

That is what the merchant who is going to make a success this year ought to realize quite clearly. He ought to recognize distinctly that it is music which his customers want to buy. When he thinks of that, and of that only, he will wake up, reform his advertising and selling plans and get out after business in a different spirit.

Renewing the Spirit

Now is the time when the whole spirit of advertising and selling should be renewed. Every merchant whose business means anything to him ought to survey his store and figure out how he can use it to better advantage in bringing to the people of his community the beauty and desirability of talking machine music. There are numerous methods, and many of

them have already been worked out effectively by the great manufacturers. I need not go into details in striving to tell the dealer in Victors, Edisons, Columbias, Brunswicks and other well-known machines that the promotion departments of these great companies are only too eager to assist the retail men in promoting the music side of his business. Let us consider one or two "stunts" that the merchant can "pull off" which will increase his profits and double his prestige in short order.

Some "Stunts"

In a small community nothing is more popular than music in the schools. A clever dealer in a community where school music is not yet well developed can study with profit the wonderful educational work of the Victor Co. and can himself, as a volunteer, undertake to introduce it along the simplest lines into the schools. A series of concerts, using educational records, given in the schoolhouses in turn, utilizing some period of recreation or recess, will serve, if properly advertised, to bring pleasure to hundreds of children and to engrave the dealer's name so deeply on their hearts that every parent will hear and remember it.

That is only one thing. In just the same way it would be quite easy to give a weekly concert in the Y. M. C. A. Building, properly advertised. And there are many other ways in which the name of the dealer, the job he is pursuing can be brought home forcibly to the hearts of every man and woman in his community.

Every church, every lodge almost, every society of any kind in a small city is always glad of opportunities for good musical entertainment. Let it be known that the opportunity is there and it will not be neglected.

Not "Old Stuff"

All this sounds like "old stuff," but it is not old stuff. It is in reality very new stuff. It is this because dealers do not practice it. Dealers cannot say that they have pushed music in the talking machine business. They have sold their machines as furniture and they have let the records take care of themselves. There is one way to cure that. That way is to saturate every man, woman and child in the community with the knowledge that Mr. Dealer has music to sell and is willing to let any respectable person sample his wares free.

Our slogan must be, "Every family a talking machine owner; every talking machine owner a record buyer." But to make this practically possible we must hook up the magic of music to the consciousness of the prospective buyer. Let the talking machine store cease to be called that, and instead be called a "music" store, and then we shall see something.

VICTOR DEALERS of OHIO, INDIANA, MICHIGAN

Toledo is the third-largest railroad center in the United States. We can reach you with direct freight and express service.

THE TOLEDO TALKING MACHINE CO.
TOLEDO, OHIO

WHOLESALE



EXCLUSIVELY

FACTORY WILL PRESS RECORDS

U. S. Record Mfg. Corp. Equipped to Press Records in Quantities—Contracts Now Being Closed Will Keep Factory Very Busy

The United States Record Mfg. Corp., whose plant is located in Long Island City, has advised the trade that it is prepared to press ten-inch talking machine records in substantial quantities and is also equipped to furnish high-grade record stock to those concerns whose facilities do not permit of their mixing their own stock. The plant is equipped with the most up-to-date machinery for the manufacture of high-grade records in quantities and good-sized orders have already been received from record companies who are desirous of taking advantage of the company's extensive facilities.

The manufacturing staff of the United States Record Mfg. Corp. includes a number of men who are thoroughly experienced in every phase of the record industry and who have made a special study of record pressing. The splendid machinery equipment installed in the plant will enable the company to give maximum service and co-operation to its clientele and the orders received to date indicate that the plant will be kept busy during the year.

NOTED VISITORS AT UNIT PLANT

Members of Salesmanship Course at Victor Factory Much Interested in Production at the Spacious Plant of the Unit Construction Co.

PHILADELPHIA, Pa., March 9.—On two different occasions the members of the salesmanship course of the Victor factory in Camden visited the large plant of the Unit Construction Co. in this city. One delegation consisted of the male members of the class, the other of the ladies. Both groups were much interested in the entirely modern manufacturing methods employed in the production of Unico equipment. Rayburn Clark Smith, president of the company, welcomed the guests and under the guidance of the executives of the company they were taken through the factory from top to bottom and each interesting process was carefully described. The almost human machinery and the efficient manner in which each process is related to the other earned enthusiastic commendation. Much interest was also evidenced in the extensive welfare work conducted by the Unit Construction Co. in the interest of its many employes. The men were entertained at luncheon in the model restaurant at the Unico plant and afternoon tea was served to the ladies.

Intensive selling develops the most sterling qualities of Americanism if carried on under the American rule for all sport—fairness.

There is much incitement in real salesmanship—for yourself, your honesty, perseverance, optimism, courage, loyalty and religion.

Window Displays

that make the dealer *glad* to put them up—and, when set up, *sell* goods from the window, are being created and lithographed for the great national advertisers as well as those whose appropriation is more modest, by

EINSON LITHO INCORPORATED

Executive Offices and Art Studios
71 West 23rd Street, New York, N. Y.

Factory and Plant
327 East 29th Street, New York, N. Y.

VICTROLA AT STATE CONFERENCE

Music Supervisors of California Meet in Sacramento and Hear Addresses by Mrs. Agnes M. Fryberger in Conjunction With Victrola

SACRAMENTO, CAL., March 3.—Mrs. Agnes M. Fryberger, one of the prominent speakers be-



School Victrola in Senate Chamber, Sacramento fore the State conference on music, held in the Senate chambers here for two days recently, used the school Victrola to good advantage in explaining its part in the school educational system. Supervisors of music from all parts of California were present. Women prominent in the Parent-Teacher Association work, repre-

senting schools in all parts of the State, attended in large numbers. Before this large audience the school Victrola had a prominent place and received some very valuable publicity. The Victrola used was furnished by the local branch of Sherman, Clay & Co., Victor dealers.

COLUMBIA ARTISTS IN AKRON, O.

Marion Harris, Saxophone Sextette and Yerkes' Orchestra Give Concerts in That City

AKRON, O., March 1.—Under auspices of the Standard Music Co. here, Marion Harris, the well-known Columbia artiste, with the Columbia Saxophone Sextette and the Yerkes' Novelty Orchestra, gave a concert which proved one of the most enjoyable musical events of the season for Akron music lovers and the attendance was evidence that Columbia artists have many loyal supporters in Akron. In the afternoon the Sextette gave a concert in the parlors of the Standard Music Co., on South Howard street. The artists are now concluding a most successful tour of the mid-West, and after playing at Erie, Pa., and several other cities in western Pennsylvania they will return to New York. Record sales were stimulated by their presence here, according to the retail Columbia dealers.

Two sales every day beat ten sales every once in a while and beat them by a big margin.

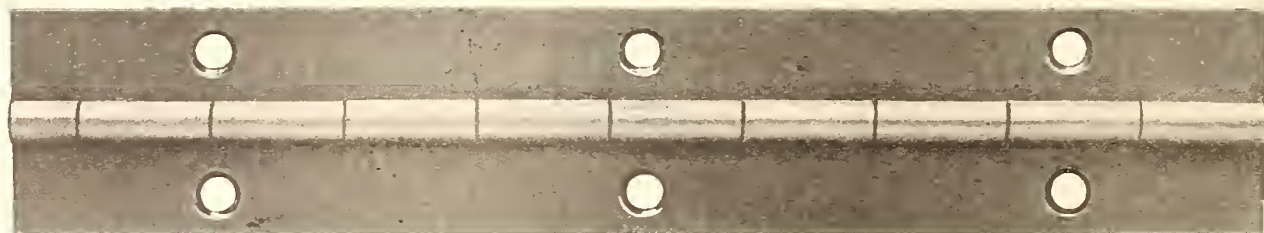

WE DO NOT MAKE MOTORS

But we can supply you any other Phonograph Hardware or Fittings

Let Us Make Your

HINGES
LID SUPPORTS
NEEDLE CUPS

KNOBS
TONE RODS
DOMES OF SILENCE

AUTOMATIC STOPS
DOOR CATCHES
NEEDLE RESTS

WEBER-KNAPP CO.

Jamestown, N. Y.

INTRODUCES \$5,000 MODEL

Sonora Phonograph Co. Adds Magnificent Instrument to Period Line—Superb Cabinet Work a Feature of This Artistic Design

The Sonora Phonograph Co. made an important announcement recently to the effect that it had added to its line of period models a new

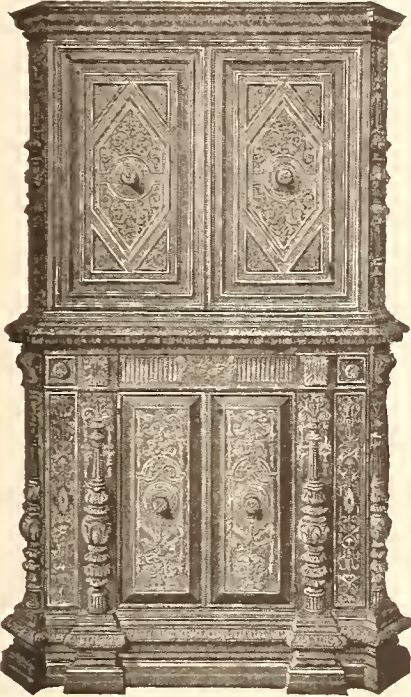

The Sonora \$5,000 Model

instrument which will retail at \$5,000. It is named the "Bardini" and is one of the finest instruments that has ever been offered to the talking machine trade.

An illustration of the Bardini is shown herewith, but the black and white reproduction hardly does justice to its remarkable beauty. The magnificent cabinet is hand-carved and the designs are replicas of famous originals.

The technical description of the new Bardini model is as follows: Wood, polychrome; cabi-

net, width 44 inches, height 72 inches, depth 24 inches, antique gold trimmings, second half XVI Century, after the manner of cabinet in Bardini collection at Florence; motor, extra heavy, triple-spring motor, gold-plates, plays nearly forty-five minutes, or fifteen ten-inch records, with one winding; motor meter, automatically indicates at all times number of records that can be played before rewinding is necessary; tone passage, continuous all-wooden tone passage from sound box to end of tone chamber; tone arm, with appropriate carving, made under scientific principles of wood throughout, playing all makes of disc records; tone modifier permits regulation of tone from full to subdued without interfering with quality; automatic stop thoroughly reliable, operating with one simple setting; needles, Sonora semi-permanent, diamond and sapphire; certificate of guarantee, broad in scope, emphasizing manufacturer's confidence in product.

OPERAPHONE CO. TO WITHDRAW

Now Winding Up Affairs and Will Cease the Manufacture of Records

The Operaphone Co., Inc., which has for a number of years manufactured the Operaphone records and whose factory and executive offices are at Creek and Meadow streets, Long Island City, N. Y., is winding up its affairs and will shortly withdraw from the record field. It is understood that a large talking machine company is now negotiating for the matrices and other manufacturing equipment and will doubtless take over the activities of the Operaphone Co.

GOOD REPORT FROM PENNSYLVANIA

J. C. Biekarck, a Vocalion dealer of Warren, Pa., visited Aeolian Hall recently just before sailing for Europe, where he is going to visit his mother, whom he has not seen in thirty-one years. He expects to return to the United

What More Can You Ask

All the features that go to make a talking machine *Profitably Salable* you will find as regular equipment of *Magnola*: "Built by Tone Specialists."

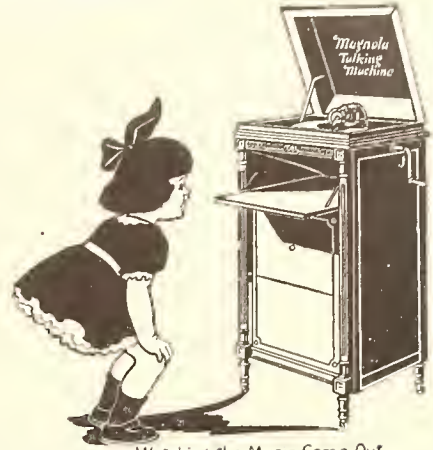

Watching the Music Come Out

Complete description of all these features is to be found in our *handsome illustrated catalog*, which we should like to send you. May we? Ask us to tell you our plans for your benefit!

MAGNOLA TALKING MACHINE COMPANY

OTTO SCHULZ, President
 General Offices 711 MILWAUKEE AVENUE CHICAGO
 Southern Wholesale Branch 1530 CANDLER BLDG. ATLANTA, GA.

States in May. Mr. Biekarck reported that conditions in his section were improving steadily, and was enthusiastic regarding the Vocalion.

SERVICE BEGINS AFTER THE SALE

When a man pays you for your time it is no sign that he pays for nothing else. Service begins after the sale.



Satisfaction and Performance Above All

A wonderful performance, successful to the last degree, has created for Mirrolike Products a country-wide demand.

Extensive advertising—plus merit—makes it easily the foremost polish in the field.

Dealers who consider the customer's interest and satisfaction will establish a very profitable business by carrying Mirrolike Polish.

Superior merit has attained the huge success of Mirrolike.

Special Dealer Display Stands—Elaborate Dealer advertising matter—furnished free.

Your business card or letterhead will bring full size sample and full particulars to your store.

Put up in attractive cartons. All sizes, 4 oz. to 1 gallon.

For shine—our only rival is the sun.

Mirrolike Mfg. Co., Long Island City
 8th Street, Near Jackson Ave.

BUSINESS CONDITIONS SHOWING SIGNS OF IMPROVEMENT

Review of General Conditions Issued by Chamber of Commerce of the U. S. Points Out Evidences of Returning Activity in All Lines of Trade—Hard Work Will Assure Prosperity

WASHINGTON, D. C., March 5.—Business conditions will improve from now on, says Archer Wall Douglas, chairman of the Committee of Statistics and Standards of the Chamber of Commerce of the United States, in his monthly review of business recently issued.

"The most convincing evidence that we are on the high road to recovery," Mr. Douglas says, "is found in the universal report brought by traveling salesmen from every section of the country of steadily growing sentiment that 'business will be better in the Spring'—not a sudden return to prosperity, which is neither likely nor desirable, but a slow and natural working out of those processes of liquidation which are now in full operation.

"There are few who are more responsible than these same traveling salesmen for the growth of this healthy sentiment, which, in effect, is the recognition of the inherent soundness of the situation, and that the remedies for it lie largely in constructive action. Not only is sentiment improved, but there is definite increase in the volume of business done. It is not a very great increase, but, as Mercutio says, 'Twill do,' for it forecasts the beginning of better days. Farmers are gradually bringing their produce to market. Bankers are slowly 'loosening up' and extending to farmers and dealers money and credit, the two vital factors needed to restore the situation. In the tobacco districts of Kentucky, where the deadlock between sellers and buyers seemed unbreakable, there are increasing reports of agreements made and sales consummated.

"Despite the general story of farmers withholding their products there is daily a steady stream of grain and live stock coming to market, not in full volume, but enough to assist in alleviating the situation. Shipments of early

fruits and vegetables from California and the South are running heavily, some 10,000 cars per week, thus distributing much-needed cash among the growers. Caution and conservatism are still universal among merchants in buying and most orders are restricted to immediate wants for keeping up assortments.

"Out in the world of cold, hard facts few take much stock in the current prophecies of the coming of a new prosperity at any specific date, nor yet in those mystic charts which foretell when declines will cease and business resume its upward march. For it is perfectly obvious that prices have not reached bottom in all lines, and even a Wall Street lamb does not buy heavily on a falling market. The general thought inclines to early Spring, March or April, as the date when distinctly definite improvement will set in, though in many parts of the Cotton Belt the belief is that June is early enough to expect a decided change. Yet scarce any believe that present conditions will prevail throughout the year.

"All are agreed that the only way to hasten matters is by the general exercise of the homely virtues of hard work and economy.

"The South intends to illustrate this theory in a very practical fashion this year by raising the cheapest cotton crop in years; a crop grown on a 'cornmeal and syrup' diet system of expense. Also farm labor everywhere will be cheaper this year and improved farm machinery is decreasing the cost of production and increasing efficiency per man.

"Production is now, and will continue to be, the dominant factor in the business situation. Yet it must be accompanied by intelligent forethought as to adequate distribution of the thing produced. Last Summer a large proportion of the garden truck crop in a section of the Rio

Grande Valley was a dead loss to growers because of lack of cars. Somewhere there has been lack of co-ordination between production and transportation.

"A recent expression of opinion by a number of representative business men throughout the country brought out the significant fact that they were not so much concerned about the problems of labor, material, prices, transportation and collection on the whole as they were with the question of sales. In other words, when demand starts up the whole tangled economic skein will begin to unwind like the nursery rhyme when the butcher began to kill the ox, and the ox began to drink the water, then the pig at the other end of the rhyme began to get over the fence and the woman got home that night.

"While unemployment is still large, there is more work and less idleness on the whole in industrial sections. The lessened production in manufacturing has naturally resulted in decreased output of coal. Also in the oil fields there are falling prices accompanied by cutting down the output."

TWO MODELS ADDED TO LINE

SAGINAW, MICH., March 5.—The Brooks Mfg. Co., manufacturer of the well-known Brooks automatic repeating phonograph, has added two new models to its line, and Brooks dealers are evincing keen interest in these additions. The company states that its sales the past month have attained a marked improvement and that, judging from all indications, business conditions are growing better day by day. New agencies are being established in the leading trade centers and the executives of the company are making every effort to co-operate with their dealers in developing Brooks sales in their own territories.

Lots of men expect opportunity to carry a letter of introduction.

THE NEW MODEL E GARFORD PHONOGRAPH

The Greatest Value on the Market
IMMEDIATE DELIVERIES IN ANY QUANTITY



New Model "E" Garford Phonograph
Plays All Makes of Records Superior Tone Quality
Write for Proposition

The General Phonograph Mfg. Co.
ELYRIA, OHIO

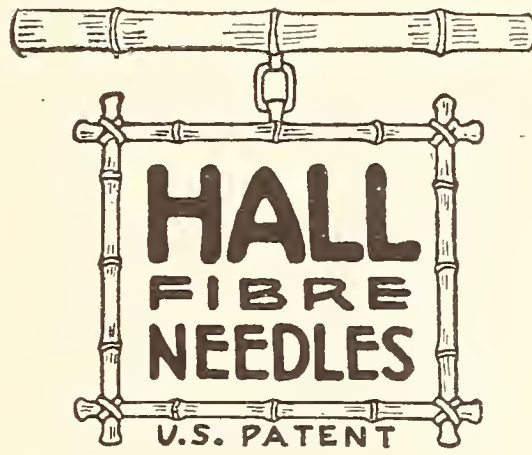

Years Afterward—

When the talking machine has become a fixture in the home and the shelves are filled with records, the merits of the fibre needle become most strikingly evident.

They mean an instrument still with a voice, with all the original charm of its music retained.

Think what this means in the greater popularization of the talking machine!

—And the continued sale of records, year in, year out!

HALL MANUFACTURING CO.

(Successors to B & H Mfg. Co.)

33-35 W. Kinzie St., Chicago, Ill.

NEW UPRIGHT PERIOD MODEL VOCALIONS INTRODUCED

Ten Handsome and Authentic New Period Styles Just Placed on the Market by the Aeolian Co.—
Notable Additions to Present Line of Standard Upright Models

One of the surprises of the new year in the talking machine field is the new line of Vocalions just put on the market by the Aeolian Co., and consisting of a series of ten upright

models of talking machines in upright cabinets. In the matter of attractiveness and case design, it is only necessary to state that these new products are fully up to the Aeolian Co.

trained for years to look for upright models, and are inclined to favor models that occupy only a limited space.

The new Vocalion upright period styles are offered in ten different models—each replete with "period personality" and each a faithful reproduction of the spirit of the times in its decorative treatment.

Of particular interest and attractive design is the Jacobean, a beautiful example of this period, finished in shaded walnut, the panels immediately below the top being of burl redwood, shaded to a deep rich brown. There is a sturdiness about Jacobean characteristics that is well exemplified in this case and is followed out to the finest detail—even to the handles on the doors.

A complete contrast is the delicate grace of the Florentine model—illustrating the technique of Italian styles at a time when they represented world leadership in arts and crafts. The decorations are in polychrome or walnut finish, in which the greatest taste has been used, resulting in an artistic whole that would lend a touch of distinction to any attractively finished room.

Simplicity bordering on austerity marks the Hepplewhite model, 1769-1820, which is not shown. The beautiful mahogany case makes the exquisite workmanship the more apparent and makes it possible to introduce this style in a living room in which several different furniture periods are represented. The prices of the several new upright period models range from \$300 to \$600.

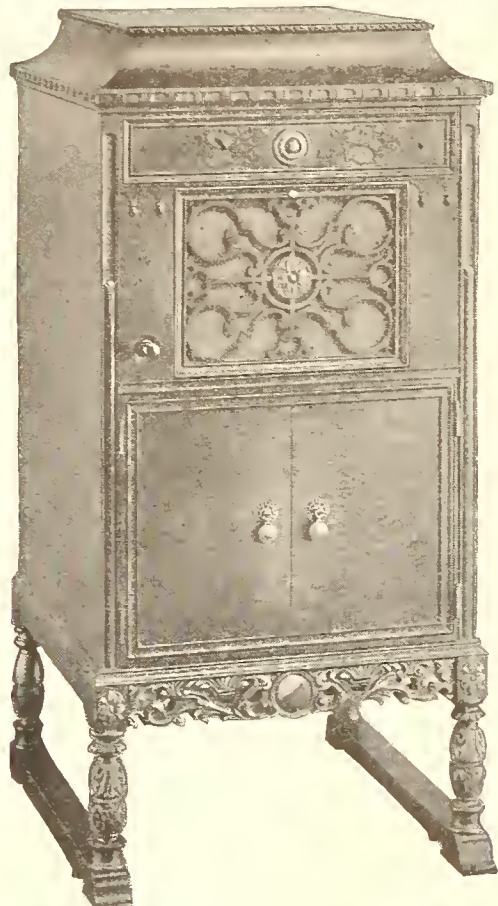

Period Model: Florentine

period styles of unusual attractiveness. The announcement of the new style is regarded as particularly important in that the introduction of the new line is said to represent the first serious attempt to offer a full range of period

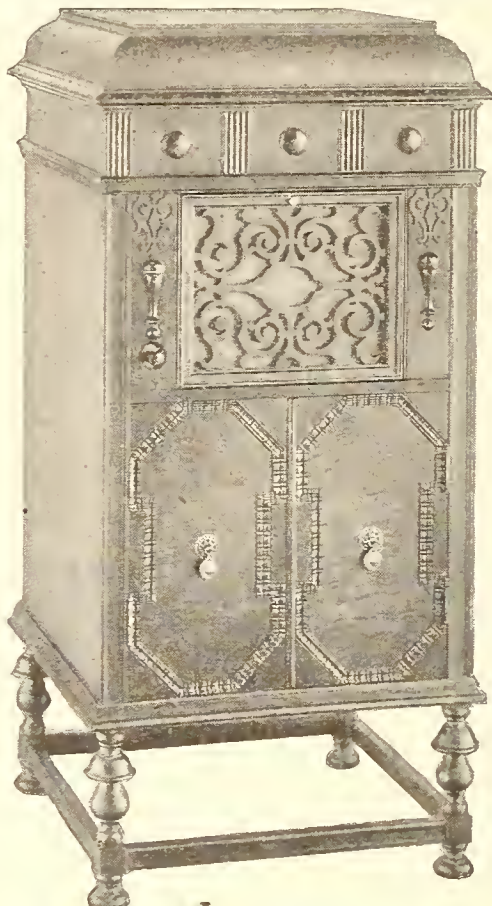

Period Model: Jacobean

standard in those particulars. In producing these fine models of upright period styles the thought was to meet the requirements of that portion of the public who think of phonographs in upright terms because they have been

NEW BILLBOARD CAMPAIGN

Redfield & Fisher, advertising agents, with headquarters in New York, have introduced a billboard advertising campaign for Victor dealers exclusively which is meeting with considerable success. Quite a number of Victor dealers have arranged to use these displays regularly during 1921 and the agency is co-operating with the dealers in every possible way.

MERCHANDISING VALUE



Style K4—Top 40 5/8" x 22"; Height 35"



Style K5—Top 41" x 22 1/2"; Height 35"

\$150

Retail Price

\$160

LAUZON QUALITY

The foresighted merchant with a hand on the pulse of public demand will immediately perceive the opportuneness of the above popular priced consoles.

Lauzon quality assures honest value and the price is a 1921 proposition calculated to build sales throughout the year.

MICHIGAN PHONOGRAPH CO.

Phonograph Division, Lauzon Furniture Co.
Office, National City Bank Bldg. Factory, Monroe avenue and 6th street
GRAND RAPIDS, MICH.

WORTH-WHILE HINTS ON CANVASSING

Practical Suggestions Offered by Collings & Co. to Help the Talking Machine Dealer

The following excellent article on canvassing as a means of getting and increasing retail talking machine business appears in the March issue of *The Record*, published by Collings & Co., Victor distributors of Newark, N. J. The suggestions offered are so good that they are well worth passing along for the consideration of talking machine dealers in general.

"Any dealer who hopes to increase his volume of business during 1921 knows by this time that he must resort to methods which were naturally inapplicable during the shortage. We have learned of dealers who are advertising, for the first time, in newspapers and other good publicity mediums, with constant regularity; some are employing outside-men to make a systematic canvass; here and there we find retailers mailing prospect letters as a business stimulant and there are a few, we fear, who are trusting to good fortune to pull them through. Happily, the latter class is so far in the minority that their inconspicuousness is pronounced.

"Canvassing is certainly very timely and should be a part of your program for increased business. It is a subject which requires considerable concentration. Only by a well defined campaign can this procedure be of practical value.

"One of our very aggressive dealers related his experiences in canvassing and his ideas were of such constructive value that we believe every dealer can profit by them. He is of the opinion that preparatory to a canvass the homes to be visited should be circularized with prospect letters. These act as an entree and acquaint the party to be visited with the purpose of your business and the name of your company. Then when your representative calls his chances of an interview are greatly augmented as the letters are bound to create both confidence and an interest in your proposition.

"The selection of reliable men or women to canvass is highly important. If possible it is best to get some one with experience in this work. They must be hardened to rebuffs and discouragement. You must be fairly liberal in compensating them for their work so that they will keep interested. This is also necessary if you expect to employ the right caliber of solicitors. Some dealers are paying a straight ten per cent on business brought in from prospects of the canvassers; five per cent when the lead has been furnished by the department. Of course, you can best determine the percentage you can appropriate for this purpose.

"One feature which impresses us as being exceptionally good is the psychology of working two canvassers together; one covering one side of a street while the other covers the opposite. As a rule this will keep them both active and discourage loafing, as the spirit of competition is aroused and one will endeavor to excel the other in volume of business.

"Where a dealer has one or more inside salesmen capable of fulfilling a solicitor's duties he could send them out in the mornings when store business is usually slack, having them return in the afternoon to resume their regular work. There is a distinct advantage in this procedure. The salesman is familiar with the line and the policies of your business and you have a fairly accurate knowledge of his dependability and selling strength.

"Reports should be furnished on each call giving information as to the kind of instrument in the home, if the party visited has already purchased, where they are buying their records and whether they are receiving the monthly supplement.

"If this party doesn't happen to have a machine data should be furnished as to when they will be in the market, if they have not been interested at the time of the first visit, etc.

"There is just one way to get more business to-day and that is by going out and creating it. Surely it is more satisfying to acquire business that is the result of your ingenuity and hard

work than to just fill the demand which voluntarily comes your way."

PLAN TO MANUFACTURE MACHINES

Independent Talking Machine Co. of Virginia to Bring Out New Table Model

RICHMOND, VA., March 2.—The Independent Talking Machine Co. of Virginia, with executive offices in this city, announces that in a short time it will begin the manufacture of a table type cabinet talking machine to be offered at an attractive price. LeRoy Goldberg, president of the company, states that the plan is to bring out a quality machine with high-grade equipment, and believes that there is a market for a table machine of that type.

The Independent Talking Machine Co. of Virginia will continue to act as distributor in this section for the Lyric records.

It will never profit you to run down a rival's product.

Knick Super Automatic Stop and Brake
means
Life Insurance to Your Motors
GOVERNOR STOP

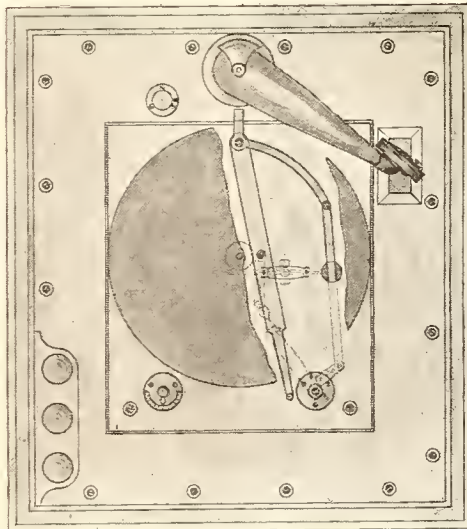

Governor Stop—Pat. Feb. 17, 1921

Operates the starting and stopping by push button.

Operates on motor's governor, being mechanically the correct principle of braking.

Will prolong life of motor as it eliminates jerking of governors.

Gives that high-class braking feature found only on the highest priced motors.

TURNTABLE STOP

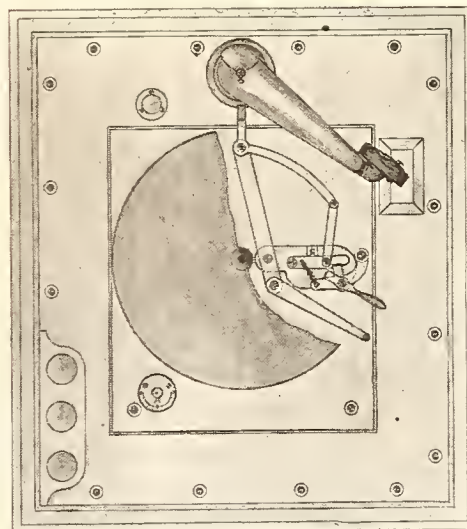

Turntable Stop—Patent Pending

Positively eliminates brake troubles, giving a silent and smooth stopping of motor.

Patent cam brake shoe allows adjustment for wear.

Positively accurate to the line.

Will function on any record.

Can be accurately set in the dark.

Noiseless in operation.

All bearings in both stops bronze bushed.

Both stops permit setting from front of machine.

A perfect combination stop and hand brake combined.

Easy to mount on motor board; requires no drilling.

If not perfectly satisfied with your present equipment, put your troubles up to us, which will place you under no obligation whatsoever.

Both stops equipped with automatic lighting feature at a slight additional cost.

UNIVERSAL DEVICES CO. :: Cincinnati, Ohio

Manufacturers of TONE ARMS—REPEAT PLAYERS—AUTOMATIC STOPS

ROTTEN STONE

We are the only miners and manufacturers in this country of Rotten Stone for use in Phonograph Record making. Our product is now in use by practically every record manufacturer in this country. We are also headquarters for all other minerals for record making and everything we handle is made especially for this purpose and absolutely guaranteed. Expert advice given upon any formula.

KEYSTONE MINERALS CO.

41 Union Square, New York City

A GOOD CABINET

is essential for a good Talking Machine

People will first look at the cabinet, before they will listen to the music.

If the *appearance and the quality* of the cabinet do not appeal to them, *they will not buy.*

Our aim is, and always has been, to make good cabinets only.

The ever-increasing demand for our product bears out this statement.

For more information write to

The Celina Specialty Co.
CELINA, OHIO

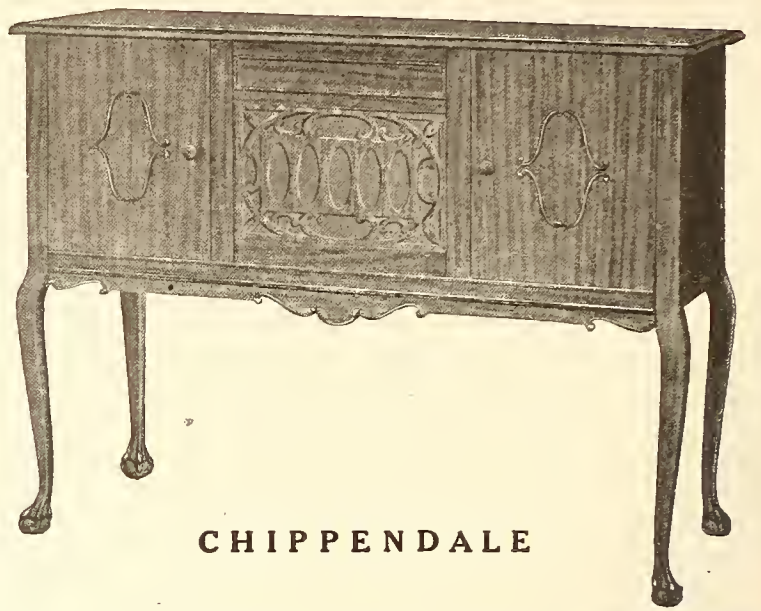

CHIPPENDALE

AN APPROPRIATE WINDOW DISPLAY

Strand Temple of Music, Albany, Couples Up Window Treatment With Showing of Cannibal Film at Neighboring Theatre

In many articles on window displays in The Talking Machine World there has been empha-



A Very Striking and Effective Window Display

sized the desirability and effectiveness of hooking up the display with some local event of importance in order to secure a maximum amount of publicity. An interesting example of the successful carrying out of this idea is found in the accompanying reproduction of a window display by the Strand Temple of Music, Inc., at 121 North Pearl street, Albany, N. Y.

Recently the Clinton Square Theatre, opposite the Strand Temple, featured an elaborate motion picture entitled: "Shipwrecked Among Cannibals," and Albert Edelstein, head of the Strand Temple, immediately saw the opportunity for arranging an attractive window display on the subject. A hut built of straw, with large pictures of cannibals, formed the background

of the display and an exploring expedition by the window trimmer resulted in the gathering of skeletons of a water buck, a gazelle with a horn broken in battle, a rhinoceros hoof, poisoned arrows from the Kia Kia country, a zebra skin, an African turtle shell, and battle spears and shields such as are used by cannibals. Action was given to the display by the shimmying figure of Siam Soo, in front of which was a card reading: "Cannibals Cannot Dance to 'Palesteena,' but Who Wants to Be a Cannibal? Come in and Hear Record 18717, 85c."

Mr. Edelstein reports that the display not only attracted wide attention, but resulted in many sales of "Palesteena," "Margie," and other timely records. It demonstrated, moreover, that it pays to be original.

termingling of extraneous supplies is avoided.

The metal part of the top of the bench is pierced so that the motor can be turned upside down and the shaft will not interfere with its stability. A concealed pan beneath this hole collects all drainage of oil or graphite from the motor. No detail for the convenience of the repair man has been omitted.

Coincident with the advent of the Efficiency Bench is the announcement of the Unico Portable Window Screen, another new Unico product. This is planned to fill a decided demand on the part of the dealer for background and window dividing purposes and its popularity is, therefore, assured.

CLOSES EXCELLENT BUSINESS

The Sonora sales department at the executive offices received recently an interesting letter from Joseph Kessler, Sonora dealer at Glen Cove, L. I. In his letter Mr. Kessler enclosed his check in full payment for the first shipment of Sonoras which he received, and ordered the following instruments for immediate delivery: Two baby grands, three Nocturnes, two Trovatores, one Etude and one Minuet.

Mr. Kessler commented upon the fact that his first order consisted of eight Sonoras, and that he had sold nine instruments in the first week. This is particularly interesting in view of the fact that Glen Cove is primarily a Summer resort and business is unusually dull during the Wintertime.

Sometimes it's a good thing when troubles come together—we get rid of 'em so much the sooner.

TWO CONVENIENT UNICO PRODUCTS

New Efficiency Bench and Unico Portable Window Screen Are Meeting With a Great Deal of Favor Throughout the Trade

PHILADELPHIA, Pa., March 8.—Production on the Efficiency Bench, which was recently announced by the Unit Construction Co., is progressing rapidly and early delivery is expected.

The bench illustrated herewith is, as its name



Unico Efficiency Bench

implies, efficient in every respect, and it is expected will be very popular in the repair de-

partment of the dealer. Space has been provided for every repair part needed and each unit is properly partitioned into the required spaces for

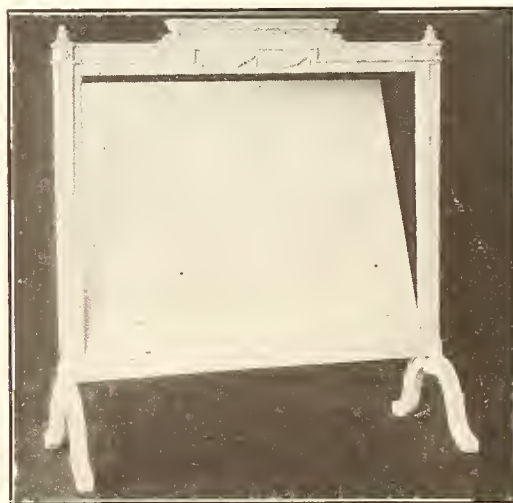

Unico Portable Window Screen

these parts. One of the merits of this bench is that all repair parts for any one particular branch of the work are together in one unit. For example, when a sound box is being repaired at the Efficiency Bench the drawer or unit containing repair parts for the sound box is opened and every other unit is kept closed. Thus the in-

Japanese Harmonicas at Importers' Prices

- Coronation Key of C
\$3.70 per dozen
- Butterfly No. 1 Key of C
\$4.10 per dozen
- Oseisaphone Key of C
\$5.00 per dozen
- Marine Band Key of C
\$6.25 per dozen
- Travelers Key of F
\$6.50 per dozen
- Army Band Key of E
\$6.80 per dozen
- Nightingale Key of C
\$7.50 per dozen

WALTER S. GRAY COMPANY
942 Market St. San Francisco



STEGER

*the finest reproducing
Phonograph in the World*

The Steger Phonograph is Your Big Opportunity



Model
506
\$295.00



Model
502
\$145.00



Model
503
\$165.00



Model
509
\$235.00

ITS distinction in the phonograph world is supported and emphasized by its marvelous ability to play all records correctly — no parts to change.

The wonderful Steger tone chamber of even-grained spruce and the patented adjustable tone arm make perfect rendition of every disc record certain.

The tones that issue from the Steger are true echoes of the human voice or instrumental skill of the master.

The ornamental side of the Steger pleases the critical eye. The different style cabinets show rare skill in design and workmanship.

We prepare the way for each Steger sale by our extensive advertising campaign. It makes each sale easier for you. The Steger is half sold when a customer comes into your store.

Explain how different, how superior it is. Play it and you will find how the wonderful music helps the sale to a successful consummation. Build up your phonograph business with the beautiful Steger.

Desirable territory open.

Write for Steger proposition and Steger Phonograph Style Brochure Today.

Phonograph Division

STEGER & SONS

Piano Manufacturing Company

Steger Building, . . . CHICAGO, ILL.

Factories: Steger, Illinois, where the "Lincoln" and "Dixie" Highways meet.

"If it's a Steger—it's the most valuable Piano in the world."



Model
505
\$220.00



Model
504
\$200.00



Model
501
\$115.00



Model
510
\$290.00



Model
500
\$95.00

No Red Tape About Getting Grey Gull Records

Order *what* you want, *when* you want, and *no more than* you want.

Sell the records *fast*, and order more as you need them. Don't carry a large stock, and turn over your investment *quickly and often*. Get in early with the hits. Retail at 85 cents for the *entire* list without exception. Handle any phonograph you want.

These are the policies that are bringing big profits to Grey Gull dealers. They are based on sound merchandising principles. You can get all the records you want for immediate delivery from the distributors listed below. Send in an order today.

Grey Gull Records are one of the few makes which are recorded and manufactured *complete in one plant*. That insures Quality, Service and PERMANENCE. Pick out a few of the good numbers in the following list and send in a trial order at once.

Distributors

Associated Furniture Manufacturers
1209 Washington Ave.,
St. Louis, Mo.

Joseph Barnett & Co.
218 Fourth Ave., East,
Cedar Rapids, Iowa

Capital Paper Company
South St.,
Indianapolis, Ind.

Chapman Drug Co.
Knoxville, Tenn.

Cole & Dunas Music Co.
54 W. Lake Street,
Chicago, Ill.

Excelsior Music Co.
Cape Girardeau, Mo.

Fuller Phonograph Co.
101 N. Water Street,
Wichita, Kansas

Grey Gull Records, Inc.
295 Huntington Ave.,
Boston, Mass.

National Phonograph Co.
518 Penn Avenue,
Pittsburg, Pa.

Richardson Drug Co.
Omaha, Neb.

Scott Weighing Machine Co.
Topeka, Kan.

Smith & Phillips Music Co.
409 Washington St.,
E. Liverpool, Ohio

T. & H. Specialty Mfg. Co.
Charleston, W. Va.

Twin City Talk. Mach. Co.
Uhrichsville, Ohio

United Music Stores
619 Cherry Street,
Philadelphia, Pa.

Dance Hits

- MAZIE—Fox-trot.....Bennie Krueger's Orchestra } L-1048
BLUE JEANS—Fox-trot.....Bennie Krueger's Orchestra } 10-in.
85c.
- HOME AGAIN BLUES—Fox-trot, } L-1046
SPREAD YO' STUFF—Fox-trot, } 10-in.
Bennie Krueger's Orchestra } 85c.
- LOOK FOR THE SILVER LINING, from "Sally"— } L-1050
Fox-trot.....Ray Miller's Black and White Melody Boys } 10-in.
NIGHTINGALE—Fox-trot, } 85c.
Ray Miller's Black and White Melody Boys }
- BRIGHT EYES—Fox-trot.....Bennie Krueger's Orchestra } L-1045
TOOLES—One-step.....Samuels' Music Masters } 10-in.
85c.
- MAKE BELIEVE—Fox-trot.....Bennie Krueger's Orchestra } L-1049
DARLING—Fox-trot.....Ray Miller's Melody Boys } 10-in.
85c.
- PALESTEENA—Fox-trot...Banjopators and Ernest Hare } L-1040
ONE HORSE TOWN—Fox-trot, } 10-in.
Banjopators and Ernest Hare } 85c.
- OH, GEE! YOU OUGHT TO SEE MY GEE GEE— } L-1039
Fox-trot.....Sung by Ernest Hare } 10-in.
ROSIE—Fox-trot.....Sung by Ernest Hare } 85c.
- MARGIE—Fox-trot.....Selvin's Novelty Orchestra } L-1046
BIDDY—Fox-trot.....All Star Trio } 10-in.
85c.
- ROSE—Fox-trot.....Banjopators and Ernest Hare } L-1041
DOG-GONE DANGEROUS EYES—Fox-trot..Banjopators } 10-in.
85c.
- WHISPERING—Fox-trot.....Samuels' Music Masters } L-1031
KISMET—Fox-trot.....Samuels' Music Masters } 10-in.
85c.
- FEATHER YOUR NEST—Fox-trot.....Banjopators } L-1037
WAKE UP IN MAMMY'S ARMS—Fox-trot, Banjopators } 10-in.
85c.
- PICKANINNY BLUES—Fox-trot.....Starita Sax. Sextet } L-1024
PITTER PATT WALTZ....Grey Gull Dance Orchestra } 10-in.
85c.

Song Hits

- MY MAMMY.....Sung by Ernest Hare } L-2046
HAPPY HOTTENTOT.....Sung by Patricola } 10-in.
85c.
- CRAZY BLUES.....Sung by Noble Sissle } L-2047
LOW DOWN BLUES.....Sung by Noble Sissle } 10-in.
85c.
- BROADWAY ROSE.....Sung by Charles Harrison } L-2043
BLUE DIAMONDS.....Sung by Henry Burr } 10-in.
85c.
- FEATHER YOUR NEST.....Sung by Charles Harrison } L-2044
MOTHER OF MINE.....Sung by Henry Burr } 10-in.
85c.
- OLO PAL, ANSWER ME.....Sung by Charles Hart } L-2036
PRETTY KITTY KELLY.....Sung by Charles Hart } 10-in.
85c.
- LET THE REST OF THE WORLD GO BY, } L-2017
Sung by Henry Burr } 10-in.
WOND'RING.....Sung by Charles Hart } 85c.
- DOWN THE TRAIL TO HOME, SWEET HOME, } L-2025
Sung by Charles Hart } 10-in.
WHEN I LOOK IN YOUR WONDERFUL EYES, } 85c.
Sung by Henry Burr }
- APPLE BLOSSOM TIME.....Sung by Henry Burr } L-2020
LITTLE TOWN IN THE OULO COUNTY DOWN, } 10-in.
Sung by Henry Burr } 85c.

Standard Songs

- OLO BLACK JOE.....Sung by Ernest Hare } L-2045
ANNIE LAURIE.....Sung by Louise Terrell } 10-in.
85c.
- WHEN YOU AND I WERE YOUNG, MAGGIE, } L-2021
Sung by Charles Hart } 10-in.
A PERFECT OAY.....Sung by Henry Burr } 85c.
- MY WILD IRISH ROSE.....Sung by Charles Hart } L-2039
HOME TO OUR MOUNTAINS (From Il Trovatore), } 10-in.
Sung by Hart and Terrell } 85c.



INCORPORATED

295 HUNTINGTON AVENUE, BOSTON, MASS.

VETERAN SALESMAN ENTHUSES OVER VICTOR CO. COURSE

Edward G. Evans, of C. Bruno & Son, Inc., With Seventeen Years of Victor Selling Experience Back of Him, Emphasizes the Practical Value of the Victor Salesmanship Course

There are some talking machine salesmen who, after three or six months spent in the trade, feel that their knowledge is complete and therefore cease studying. There are others, however, the successful men, making up the great majority, who realize that only by adding to their knowledge constantly can they expect to keep in touch with latest trade developments and maintain their selling efficiency at the highest point.

Among the latter is to be included Edward G. Evans, of C. Bruno & Son, Inc., well-known Victor wholesalers of New York, who, after seventeen years spent in active selling of the Victor line, saw the opportunity offered for self-development by the Victor salesmanship course and took advantage of that opportunity. Mr. Evans, he it said, has spent twelve years with Bruno & Son and is recognized as one of the really live Victor wholesale salesmen in the New York territory. Prior to coming with Bruno he was for five years connected with the Victor Co. at the factory in Camden, and received an excellent training both in factory matters and as a traveler.

Mr. Evans is particularly enthusiastic over the value of the Victor salesmanship course, and upon his return to New York after the completion of the course expressed himself as follows to a representative of *The World*:

"Those dealers who have been identified with the industry since its inception will recollect that in the early days, because of the newness of the talking machine idea, the device was bought as a novelty rather than because it represented a perfected musical achievement. Only a limited number of records had then been released, hence it was an easy matter to practically memorize all of them, and if the words were reasonably intelligible, or the tune familiar or catchy, with very little publicity effort, sales continued to flow in and the dealer did a thriving business.

"But while time and tide have forced out many of the pioneers it is unfortunate that some of their obsolete methods of presenting the merchandise still survive. The public has been buying records all these years and many enthusiasts have musical libraries of considerable pretensions. Many of these libraries are made up very largely of selections that either did or do now enjoy general popularity, and too frequently are representative of the tastes of persuasive but none too well informed sales people. The result is that in many cases the customer has become pretty well satiated with this kind of entertainment and his conclusion is that a Victrola is something of which one must ultimately tire.

"Many dealers have found that a considerable part of their record stocks are lamentably inactive. Experience proves that this is largely due to the inability of the average sales person to keep in mind the characteristics of upward of 5,000 listings, and the result is that, aside from those that are called for or that may at the time be remembered, many of the most interesting and beautiful records are never submitted for purchase.

"Much of the instruction given in the Victor salesmanship class embraces the explanation of systems designed to familiarize dealers and their clerks with the desirability of every record in the catalog. These systems have all been subjected to most severe tests in a practical way, and their value proven not only in increasing a dealer's business, but in the stimulation and revival of interest of his customers.

"Products of the Victor Co. of which the average dealer has but little understanding are the Period Models. Being considerably higher in price than their other types of instruments, more than a rudimentary knowledge is required for one to talk with the conviction necessary to gain the confidence of the prospective pur-

chaser. Applying the knowledge that is acquired in the salesmanship course will go a long way in convincing the customer of the desirability of the instrument as applied to his own particular needs.

"An outstanding impression that one receives during the two weeks' stay at the Victor plant is the idea of thoroughness and permanency that prevails in all their undertakings. From the testing of the steel of which the motor springs are made—the various inspections of the motor itself before its fitness to be installed in the cabinet is determined; the millions and millions of feet of lumber, much of which has yet to have months of seasoning before it is regarded as suitable for cabinet construction; the battery of buildings, each designed for some particular purpose, but all having this characteristic in common, stability; down to the fleet of Pierce-Arrow motor trucks—the thought is driven home of the determination to maintain Victor supremacy.

"And of all the happy recollections that linger with one at the conclusion of this course of study, the pleasure of having been associated with F. A. Delano, class instructor, is unquestionably the most prominent. A broad experience in the operatic field, as well as an intimate study of the dealer's needs, has peculiarly fitted Mr. Delano for tutorship in this work; and the painstaking care given to insure every member of the class receiving the maximum of benefit from the training, bears fruit not only in the way that interest is so generally sustained, but in the expressions of regret at the brevity of the course.

"Summing up the benefits that one derives from the salesmanship course, there is no Victor dealer, no matter how remotely located, but who will be handsomely compensated by avail-

ing himself of the instruction that this privilege yields. He will leave with an added respect for the achievements and ambitions of the Victor Co., and the zest with which his activities will be resumed upon returning to his field will prove that the training has actually accomplished its purpose—it has made him a real 100 per cent Victor dealer."

DEATH OF DAVID F. TAUBER

General Manager of Progressive Phonographic Supply Co. Passes Away Suddenly in New York Hospital on February 25

David F. Tauber, general manager of the Progressive Phonographic Supply Co., New York, manufacturer of the Wall-Kane needle, and one of the best-known talking machine accessory salesmen in the Eastern trade, died at a local hospital on Friday, February 25, after a sudden attack of heart failure. Mr. Tauber, who was about forty-two years old, is survived by a widow and five small children. Funeral services were held on February 27, and were attended by his business associates and a large number of friends in the talking machine industry.

Mr. Tauber had occupied the position of general manager of the Progressive Phonographic Supply Co. since 1917, and previous to that time had been connected with a number of other concerns in the talking machine field.

PUBLICITY FOR RECORD REDUCTION

The Schmidt Music Co., Davenport, Ia., recently got out a most attractive mailing card calling the attention of the company's customers to the fact that the Vocalion Red records had been reduced in price from \$1 to 85 cents. In addition to announcing the reduction and listing a few of the popular numbers, the card bore a piece of string held in place by a sticker in the form of a miniature Red record, to emphasize the caption, "A String for Your Finger."

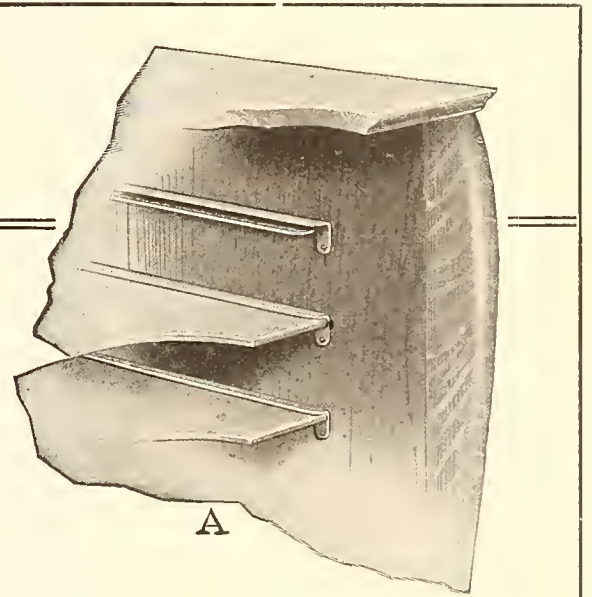

AN interior view of all Udell Record Cabinets when arranged with horizontal shelves. This shows the pressed steel support that the shelf slides in. You can appreciate how substantial it makes the shelf and also that the possibility of the shelf warping is reduced to the very minimum. Send for Blue Book today.

The UDELL trade-mark insures an honest product and an honest price.

The UDELL WORKS

Indianapolis—1252 West 28th St.



ROUNTREE CORPORATION, Distributors

Emerson Records



Your Trade Will Want These Emersons; Get Them *Quick* From Rountree!

April 1921 Releases—On Sale March Fifteenth

- 10331--Traumerei. Violin Solo - Milan Lusk
Cavatina. Violin Solo - - Milan Lusk
- 10332--Medley from "Sally."
Fox Trot - - - Merry Melody Men
Lady Georgia, Sweet Georgia Rose.
Fox Trot - Plantation Dance Orch.
- 10333--It's All Over Now. Baritone Solo.
Arthur Fields
Roaming. Baritone Solo.
Arthur Fields
- 10334--Bright Eyes. Fox Trot.
Plantation Dance Orchestra
Deenah. Fox Trot.
Plantation Dance Orchestra
- 10335--I Never Realized. Fox Trot.
Joseph Samuels' Music Masters
Spread Yo' Stuff. Fox Trot.
Joseph Samuels' Music Masters
- 10336--Love Bird. Fox Trot.
Green Brothers' Novelty Band
Mazie. Fox Trot.
Green Brothers' Novelty Band

- 10337--Spooky-Ooky Blues. Fox Trot.
Green Brothers' Novelty Band
Just Another Kiss. Medley. Waltz.
Green Brothers' Novelty Band
- 10338--What Are We Goin' To Do?
Comedy Song - - - - Arthur Fields
Rosie, Make It Rosy for Me.
Baritone Solo - - - - Arthur Fields
- 10339--Out Where the West Begins.
Baritone Solo - - - Royal Dadmun
Bedouin Love Song. Bass Solo.
Charles Laird
- 10340--E Lucevan Le Stelle (The Stars
Were Shining).
Tenor Solo in Italian - Max Bloch
Vesti La Giubba (On With the Play)
Tenor Solo in Italian - Max Bloch
- 10341--Make Believe. Fox Trot.
Selvin's Novelty Orchestra
Love in Lilac Time. Waltz.
Selvin's Novelty Orchestra

ORDER BLANK Emerson Records

Rountree Corporation,
Richmond, Va.

Kindly ship by first express and charge our
account the following EMERSON RECORDS,
for release March 15th.

Record No.	Quantity
10331	
10332	
10333	
10334	
10335	
10336	
10337	
10338	
10339	
10340	
10341	
Total	

Check

() Also send me full particulars about the
Here ARIETTA PHONOGRAPH and your
agency proposition, without obligating me.

Name.....

Address.....

Post Office.....

Ordered by Mr..... W.3-21



PHONOGRAPH

The ARIETTA has every-
thing your most exacting cus-
tomer can ask for—sweetness of
tone, beauty of design, quality of
materials and workmanship—and
the prices are right!

Three handsome upright
models and a popular portable
style, all beautifully finished in
mahogany. Universal tone arm
and all latest improved features.

The ARIETTA is the *satisfy-
ing* Phonograph—it makes *satis-
fied customers* and nets you a
satisfying profit. Check the
order blank and get our exclusive
agency proposition by return
mail.



Arietta
Model IV

ROUNTREE CORPORATION

Manufacturers of
ARIETTA PHONOGRAPHS

Distributors of
EMERSON RECORDS

Richmond, Virginia

BRUNO

The word "pessimism" doesn't appear in the dictionary of the Victor dealer.

BRUNO

PROSPECTS' FADS AS A SELLING AID

Watching the Individual Idiosyncracies of Customers Will Prove Profitable to the Salesmen Who Desire to Build Up Trade

Every prospective purchaser of a high-class talking machine has a fad or a special interest, aside from music, and such a person is more easily approached from that angle, if tact is used. A little list of prospects in an indexed vest pocketbook is a valuable companion in selling work. You cannot hope to remember the individual idiosyncracies of people without the aid of notes on the subject, and it is a simple thing to jot down opposite any person's name the peculiar interests of that individual and to put there any item of interest picked up by the way.

If you have a prospect who is interested in motoring, note the kind of car used and be prepared to say something interesting along that line. The same way if it is amateur photography or dramatic work or fishing or hunting.

You see, your "talker" or record sales are often made to a member of the family who is more interested in other things than in music, so get a line on those interests whenever you can.

When you talk to a man along the line of his special interests you find him a willing listener. Thus you get the prospect into a good humor and make him feel that you are a human being instead of a mere salesman trying to put something over on him. Prospects are often, without reason, suspicious and anything we can do to disarm suspicion and develop friendliness will help sales.

SPECIAL VOCALION RELEASE

The Aeolian Co. early this month brought out a special release of Vocalion record 14155, bearing two fox-trots, "Do You Ever Think of Me," and "Love Bird," both played by Selvin's Dance Orchestra. Both numbers are distinctly popular and were, therefore, released as an extra feature in order to permit the dealers to realize upon that popularity.

GET IN ON THE PROFITS



CHART SHOWS BUSINESS PROGRESS

Pathé Frères Co. Sending Out Interesting Chart Showing Upward Trend of Labor and Material Prices—Extensive Pathé Sales Campaigns—Co-operating With Theatres

The rise and fall of the cost of labor, materials and the cost of the Pathé instrument are graphically portrayed in a red and black chart which the Pathé Frères Phonograph Co., of Brooklyn, N. Y., is sending to Pathé dealers. This chart also forms the subject for the dealer ads which the Pathé Co. supplies in matrix form. The starting points of the lines on this graphic chart begin at a period before the war and show the upward trend of the price of labor and material and also shows the estimated future price line where the three lines in the chart will converge. This chart is being used to excellent advantage by Pathé dealers everywhere in getting their prospects to "buy now."

Pathé dealers in all sections of the country are inaugurating intensive sales campaigns with excellent results. Pathé headquarters are in receipt of many encouraging reports of the results already accruing from these campaigns. Many dealers are employing a house-to-house canvass campaign with excellent results.

In a recent issue of Pathé News, the dealer newspaper, a valuable record list for Pathé dealers has been compiled. Many requests have been received for information regarding Pathé selections which have been recorded from various plays, so that the inquiring dealer could feature the selections while the plays were being presented in his city. As a result of this demand a classification of records has been compiled and printed as a part of Pathé News, listing the popular theatrical productions of the season, and those upon the road, with a concordant list of the Pathé recordings of the various numbers from these productions and their numbers. It is expected that this list will prove very valuable to dealers. A suggestion is also made that the dealer divert a portion of his advertising appropriation to space in the show program calling attention to the fact that records of the plays can be secured at his warehouses.

Helpful articles regarding the proper use by Pathé dealers of the mat, the electro and the stereo in their advertising campaigns as well as the new Pathé metal road signs appear. Announcement is made of four new Pathé Actuelle moving picture slides in color.

A grouch puts sand in the bearings of your machine. Enthusiasm makes the wheels turn easily. Which is better?



Model No. 8
Retail at \$100.00

Height, 45 inches; depth, 23 inches; width, 19 inches. Equipped with a large double-spring motor. Velvet turntable.

Here is a sales creator that will bring profits into your store.

This quality machine, designed to sell, attracts immediate attention.

Now is the time to place the fast-selling Charmaphone line on your floors.

Price List and dealers' arrangement sent on request.

Write for wonderful sale arrangement on our discarded models.

CHARMAPHONE COMPANY

39 West 32nd St., N. Y. City

Factory: Pulaski, N. Y.

DISCUSSES SALES CONDITIONS

C. E. Richardson Gives Timely Advice on Closing Sales To-day—An Interesting Sales Talk Which Is Worthy of Close Consideration

In a letter received recently by the sales division of the Sonora Phonograph Co., New York, C. E. Richardson, manager of the talking machine department of the Clarke Music Co., Syracuse, N. Y., comments as follows regarding the outlook relating to general business:

"Our phonograph business has been remarkable, with sales far in excess of any previous year. We note with interest the statement made by a dealer recently that his business will not exceed his sales of last year, and we believe this may be true unless an intensive sales campaign is laid out and carefully followed.

"The day of easy sales is past, and now comes the test of the real salesman. We have just passed through, no doubt, the greatest era of easy selling we have ever seen, and to-day we are going through a period of readjustment, which will not only test the stamina of salesmen, but bring to light all business weaknesses.

"The call-and-buy customer of several months ago has been succeeded by a more conservative type of buyer, a buyer who has been so saturated with newspaper price reduction advertisements that much shopping is done before a decision is made. Retail selling has fallen off and it is a good thing for the salesman, because many salesmen have been spoiled by people walking in and saying 'I'll take that \$700 piano,' or 'I'll take that \$200 machine.' It is just that abnormal condition of the past months which makes it difficult for salesmen to reaccustom themselves to the old, before-the-war method of selling, which necessitated intensive outside work.

"It is estimated that during 1921 there will be an output of 5,000,000 talking machines, not including toy phonographs, and undoubtedly the next ten years will be the best in the history of the phonograph business."

NEW TRUCK ATTRACTS ATTENTION

Landay Bros. Add Handsome Truck to Delivery Equipment—Victor Trade-mark Hand-painted

Landay Bros., Inc., well-known local Victor dealers, have received many encomiums from their patrons on the appearance of the new truck which the company recently added to its delivery equipment. Landay Bros. for several years past have made a specialty of utilizing

A.F.Co.

felts

for Turntables

It's a fact that the sale of a talking machine often depends on appearance. Beautiful, lustrous Turntable Felts do their part along with careful wood finish and smooth, bright metal parts.

American Felt Company Turntable Felts are used exclusively in some of the best-known Talking Machines. This is because our Turntable Felts have elegance as well as uniformity.

If you have a felt problem, ask us about it without incurring obligation.

American Felt Company

TRADE MARK



BOSTON
100 Summer St.

NEW YORK
114 East 13th St.

CHICAGO
325 S. Market St.

distinctive automobile trucks and the publicity received from the use of these trucks has been very gratifying.

In a chat with The World Max Landay points out that the distinctive feature of this truck is



Landay's Imposing New Truck

the way in which it is decorated. The average truck has too much decoration, and on the majority of trucks used by Victor retailers the famous Victor trade-mark is merely a decalco-

mania. However, the trade-marks on the new Landay truck were painted by a well-known artist, and the celebrated Victor dog appears almost lifelike.

GUARANTEE MACHINE PRICES

Hanford & Horton Co., Middletown, N. Y., Make Public Announcement of Their Belief in the Stability of Present Prices

Faith in the stability of the present talking machine prices, particularly the Victor and Sonora lines, was indicated in a recent advertisement published by the Hanford & Horton Co., talking machine dealers of Middletown, N. Y. The company reports that following the publication of the price guarantee business was stimulated materially. The announcement read: "EXTRAORDINARY ANNOUNCEMENT"

"The Hanford & Horton Co. is the first phonograph dealer in this section, if not in the world, to insure its customers against 'sales value losses' in a falling market.

"We guarantee to rebate to all purchasers from our store on any phonograph, either Victrola or Sonora, bought between the dates of February 1, 1921, and January 1, 1922, the cash value difference that may be shown, because of a lower price market during the balance of this year.

"Cash customers to keep their sales slips to prove purchase price.

"Charge customers can refer to our book records for this proof.

"Business conditions are improving—We now do 'our bit' to further the improvement and to make it safe for you to purchase a phonograph and be enabled to enjoy it without the fear that its purchase will result in a loss to you through reduction in prices later.

"It takes courage and faith in the business future of our country to establish this policy. This store has both of these qualities and the desire to help as well as to serve.

"This is the square deal game. Come and sit in with us.

"HANFORD & HORTON CO.

"The Store on the Square."

A new talking machine and record store has been opened in Pullman, Wash., by Elmer Armstrong. The location is considered a very good one, as the building is next door to the Liberty Theatre.

MR. RETAILER:

Here are just four facts we want to impress upon your mind about

SUPERB STYLUS

Semi-permanent

- 1 Each needle will play 100 to 200 records
- 2 Will not wear the records
- 3 Absolutely no scratching or hissing
- 4 Will play any make record using steel needle

Packed 4 needles on a card, 100 cards to a neat counter display carton. Circulars and display cards furnished.

Retail price 25c. per card

SEND FOR SAMPLE AND DISCOUNTS TO

Mellowtone Needle Co., Inc. SOLE MANFRS. Ansonia, Conn.

Okeh Records

Place Orders Now for April Bulletin

- 50001 { I HEAR YOU CALLING ME—Tenor with Orchestra,
12-in. { John McCormack
\$1.50
- 50005 { CELESTE AIDA (From "Aida")—Tenor with Or-
12-in. { chestra John McCormack
\$1.50
- 5003 { CARO NOME (Dear Name) (From Opera, "Rigo-
12-in. { letto," Act 2)—Soprano with Orchestra,
\$1.75 { Marina Campanari
- 4272 { CAVATINA (From Opera, "Don Pasquale")—So-
10-in. { prano with Orchestra.....Marina Campanari
85c.
- 4272 { THE PALMS—Baritone with Orchestra—(Sacred),
10-in. { Bernard Ferguson
85c.
- 4273 { CRUCIFIX—Tenor-Baritone Duet with Orchestra—
10-in. { (Sacred) Charles Henry-James Jordan
85c.
- 4273 { BEAUTIFUL SAVIOUR—(Sacred),
10-in. { Shannon Four-Jane Neilson
85c.
- 4273 { WHEN CATHEDRAL BELLS AT TWILIGHT
10-in. { CHIME Shannon Four-Jane Neilson
85c.
- 4253 { LOVIN' SAM FROM ALABAM—(Popular Blues)—
10-in. { Vocal Mamie Smith and her Jazz Hounds
\$1.00
- 4253 { DON'T CARE BLUES—(Popular Blues)—Vocal,
10-in. { Mamie Smith and her Jazz Hounds
\$1.00
- 4267 { KUU PUA LOKE (Our Blossom Rose)—Hawaiian
10-in. { Yodeling Prince Lei Lani
85c.
- 4268 { KAWAIIHAU—Hawaiian Guitar Duet...Ferera-Franchini
10-in. {
- 4268 { OVER THE HILL—Tenor with Orchestra...Billy Jones
10-in. {
- 4268 { PLAYMATES—Tenor with Orchestra.....Charles Hart
10-in. { 85c.
- 4269 { SCANDAL—Tenor Duet with Orchestra,
10-in. { Billy Jones-Ed. Smalle
85c.
- 4269 { SHE WALKS IN HER HUSBAND'S SLEEP—
10-in. { Tenor with Orchestra.....Billy Jones
85c.
- 4270 { I'M MISSIN' MAMMY'S KISSIN'—Vocal with Or-
10-in. { chestra Crescent Trio
85c.
- 4270 { SIGHING—Vocal with Orchestra.....Crescent Trio
10-in. { 85c.
- 4271 { LITTLE DAVID PLAY ON YOUR HARP—(Negro
10-in. { Spiritual) Southland Jubilee Singers
85c.
- 4271 { GREAT CAMP MEETING—Jubilee Song,
10-in. { Southland Jubilee Singers
85c.
- 3001 { TROVATORE (Grand Selection from Opera, "Trova-
12-in. { tore") Conway's Band
\$1.35
- 3001 { REMINISCENCES OF VERDI (Introducing "Il
12-in. { Lombardi, Rigoletto, Il Trovatore, Un Ballo in
\$1.35 { Maschera, La Traviata") Conway's Band
- 3002 { GRAND MARCH FROM TANNHAUSER,
12-in. { European Symphony Orchestra
\$1.35
- 3002 { WEDDING MARCH (Mendelssohn),
12-in. { European Symphony Orchestra
\$1.35
- 3003 { SELECTIONS FROM "LA TRAVIATA"—Part 1,
12-in. { European Symphony Orchestra
\$1.35
- 3003 { SELECTIONS FROM "LA TRAVIATA"—Part 2,
12-in. { European Symphony Orchestra
\$1.35
- 3004 { HUNGARIAN RHAPSODY NO. 2—Part 1 (Fr. Liszt),
12-in. { European Symphony Orchestra
\$1.35
- 3004 { HUNGARIAN RHAPSODY NO. 2—Part 2 (Fr. Liszt),
12-in. { European Symphony Orchestra
\$1.35
- 4242 { IL BACIO (The Kiss)—Waltz—Whistling with Or-
10-in. { chestra Guido Gialdini
85c.
- 4242 { TOUT PASSE—Waltz—Whistling with Orchestra,
10-in. { Guido Gialdini
85c.

- 4250 { CRAZY BLUES—Fox-trot...Joseph Samuels' Jazz Band
10-in. { HOME AGAIN BLUES—Fox-trot,
85c. { Joseph Samuels' Jazz Band
- 4251 { BRIGHT EYES—Fox-trot,
10-in. { Ray Miller, Melody King, and His Black and White
85c. { Melody Boys
- 4251 { MOLLY—Fox-trot,
10-in. { Ray Miller, Melody King, and His Black and White
85c. { Melody Boys
- 4252 { OH GEE! SAY GEE! YOU OUGHT TO SEE MY
10-in. { GEE GEE FROM THE FIJI ISLE—Fox-trot,
85c. { Joseph Samuels' Jazz Band
- 4252 { O-HI-O (O-MY-O)—Fox-trot...Hager's Dance Orchestra
10-in. {
- 4254 { SHIM-ME-KING'S BLUES—Fox-trot,
10-in. { Mamie Smith's Jazz Hounds
85c.
- 4254 { ROYAL GARDEN BLUES—Fox-trot,
10-in. { Mamie Smith's Jazz Hounds
85c.
- 4255 { MY MAMMY—Fox-trot...Green Brothers' Novelty Band
10-in. {
- 4255 { SWEET MAMA—Fox-trot...Joseph Samuels' Jazz Band
10-in. { 85c.
- 4256 { I USED TO LOVE YOU BUT IT'S ALL OVER
10-in. { NOW—Fox-trot Orlando's Orchestra
85c.
- 4256 { PITTER PATT—Waltz....Hager's Dance Orchestra
10-in. {
- 4257 { UNDERNEATH THE DIXIE MOON—Fox-trot,
10-in. { Ray Miller, Melody King, and His Black and White
85c. { Melody Boys
- 4257 { JUNGO LAND—One-step,
10-in. { Ray Miller, Melody King, and His Black and White
85c. { Melody Boys
- 4258 { SALLY MEDLEY (Intro. "Whip-Poo-Will" and
10-in. { "Look for the Silver Lining") (From Musical
85c. { Play, "Sally")—Fox-trot..... Rega Dance Orchestra
(Bird Voices and Whistling by Sibyl Sanderson Fagan)
- 4258 { LOVE BIRD—Fox-trot.....Rega Dance Orchestra
10-in. { (Bird Voices and Whistling by Sibyl Sanderson Fagan)
85c.
- 4259 { A LA PAREE—One-step.....Rega Dance Orchestra
10-in. {
- 4259 { I NEVER KNEW—Fox-trot.Lanin's Roseland Orchestra
10-in. { 85c.
- 4260 { THE ST. LOUIS BLUES—Fox-trot,
10-in. { Rudy Wiedoeft's Palace Trio
85c.
- 4260 { SPREAD YO' STUFF—Fox-trot,
10-in. { Joseph Samuels' Jazz Band
85c.
- 4261 { CHINA MOON—Fox-trot.Green Brothers' Novelty Band
10-in. {
- 4261 { MIDNIGHT MOON—Waltz.....Orlando's Orchestra
10-in. { 85c.
- 4262 { IN MADAGASCAR LAND—Fox-trot,
10-in. { Rudy Wiedoeft's Palace Trio
85c.
- 4262 { ARABIA—Fox-trot.....Green Brothers' Novelty Band
10-in. { 85c.
- 4263 { DREAMY PARADISE—Fox-trot...Okeh Marimba Band
10-in. {
- 4263 { JUST WE TWO—Waltz.....Okeh Marimba Band
10-in. { 85c.
- 4264 { THE SCHOLAR—(Irish Reel)—Accordion,
10-in. { Peter J. Conlon
85c.
- 4264 { HARVEST HOME AND GALWAY BAY—(Horn
10-in. { Pipes)—Accordion Peter J. Conlon
85c.
- 4265 { AVE MARIA—Part 1—Violin Solo.....M. Michailow
10-in. {
- 4265 { AVE MARIA—Part 2—Violin Solo.....M. Michailow
10-in. { 85c.
- 4266 { ANGEL SERENADE—Violin, Flute and Harp,
10-in. { Instrumental Trio
85c.
- 4266 { INTERMEZZO FROM "CAVALLERIA RUSTI-
10-in. { CANA"—Violin, Flute and Harp...Instrumental Trio
85c.

GENERAL PHONOGRAPH CORPORATION

OTTO HEINEMAN, President

25 West 45th Street

New York City, N. Y.

Factories: Newark, N. J. Elyria, Ohio Putnam, Conn. Springfield, Mass. Kitchener, Ont.

Branch Offices: Chicago, Ill. Toronto, Can. London, Eng.



THE idea behind this advertisement forms the biggest phonograph sales franchise ever granted. Seriously interested? Piknik Portable Phonograph, Inc., Lakewood, N. J.

CARUSO'S VOICE IS NOT IMPAIRED

Doctors Declare Great Tenor's Voice Will Benefit From First Real Rest in Twenty-five Years—C. G. Child a Visitor at Bedside

Enrico Caruso will sing better than ever after he has fully recovered from his present illness, is the report issued by the Metropolitan Opera House in denying reports that the great tenor and Victor artist would never sing again. In reference to these reports the bulletin said:

"There is nothing whatever in Mr. Caruso's condition to warrant any such supposition. The indications are that, once he recovers, he will sing better than ever. This illness, unfortunate as it has been, has given his voice and throat the first real rest they have had in twenty-five years, and this must be of great advantage to the most strenuously exercised vocal organs in the world.

"There remains, then, merely the question of complete recovery of constitutional strength, with probable freedom from the minor lapses

in health that troubled him for some time before his final breakdown in December. It is only proper to state now that at no time has there been any injury to or difficulty with his voice.



Enrico Caruso

Certain diagnoses preceding his present illness now are known to have been incorrect."

Among the few intimate friends who were permitted to visit the singer at the Hotel Vanderbilt during the serious stage of his illness was Calvin G. Child, of the Victor Talking Machine Co., and a close friend of Caruso for the past eighteen years. When Caruso heard that his friend was waiting he insisted that Mr. Child be brought to the bedside.

"I went into the room," said Mr. Child later, "and as soon as I appeared Caruso recognized me. Before I could say a word, however, he appeared to be seized with a nervous attack. He burst into tears and said:

"Tell me how long this will last."

"I tried to cheer him as best I could and he speedily returned to cheerfulness."

Mr. Child was highly pleased over the report of the doctors that the tenor's voice would be stronger than ever after his enforced rest. He declared that Caruso would make new records for the Victor Co. which would be even better than the others, if that were possible.

The talking machine industry and the public in general are rejoicing over the fact that Signor Caruso is now convalescing. The tremendous demand for his records during the past few weeks has been convincing testimony to the fact that people in every walk of life wanted to have some permanent record of the singer's art in case his person should be lost to them. The news of his gradual recovery has been received with great joy and music lovers are happy that the great star will continue to shine in the world of music in the future as in the past.

PATHE FOR AMERICAN LEGION

Rockwell City Post Chooses That Instrument After Careful Test

ROCKWELL CITY, IA., March 4.—The local post of the American Legion recently conducted an interesting contest for the purchase of a phonograph intended for the use of their handsome clubroom. The competition involved a test of the volume, rhythm and resonance of tone and, after a rigid test of a series of records on all of the points, the committee decided upon the Pathé Actuelle as best adapted to fill the requirements of the large hall.

The Pathé Actuelle was entered by Fred Beauchamp, local Pathé dealer.

Mayo Magoon, of Bailey's Music Rooms, Lancaster, N. H., Victor retailers, left recently to take the course of salesmanship in the Red Seal School at the factory of the Victor Talking Machine Co., in Camden, N. J.

"The Music Without the Blur!"

This ideal of talking machine manufacture is attained more nearly than by any other, in the construction of the

MARVELOUS MAGNOLA
"Built by Tone Specialists"

"Magnola's Tone Deflector eliminates the scratch"

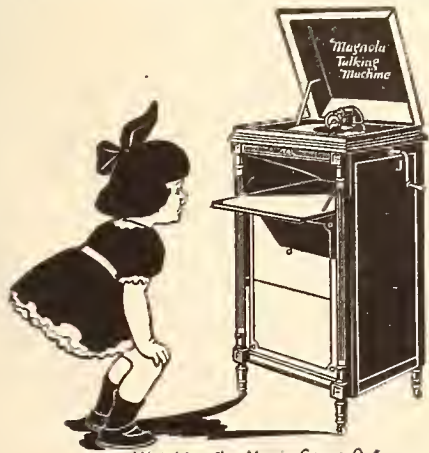

Watching the Music Come Out

We want to show you how to make money with MAGNOLA; and how MAGNOLA is the best buy on the Talking Machine Market to-day.

Send us your name and let us send you some real Talker Tips.

MAGNOLA TALKING MACHINE COMPANY

OTTO SCHULZ, President

General Office 711 MILWAUKEE AVENUE CHICAGO
Southern Wholesale Branch 1530 CANDLER BLDG. ATLANTA, GA.



PHONOGRAPH CASES
Reinforced 3-ply Veneer

The Standard Case for Talking Machines and Records

Let us figure on your requirements

MADE BY **PLYWOOD CORPORATION, Goldsboro, N. C.**
Mills in Va., N. C. and S. C.

MILWAUKEE TRADE ACTS IN EXCISE TAX FIGHT

Local Association Maps Out Energetic Plan of Campaign—Clarence C. Warner Heads Milwaukee Association of Music Industries—Retail Business Moving Along Steadily

MILWAUKEE, Wis., March 11.—Aroused to a keen appreciation of the dangers to the future of the talking machine industry lurking in the proposal of Congress to double the excise tax on musical instruments, the local trade, from largest manufacturer to smallest retailer, is engaged in a vigorous and determined fight, under the direction of the Milwaukee Association of Music Industries. The legislative battle, which is being carried on in co-operation with the national organizations of the Music Industries Chamber of Commerce, almost overshadows the struggle to get a fair share of business.

Working in close harmony with the Milwaukee Association, the Wisconsin Association of Music Industries has aroused the trade of the entire State to the same degree as the local men of the talking machine business. An appeal has been directed at every individual or concern dealing in musical instruments in Wisconsin to write a letter of protest to the Representative in the House and the two United States Senators. It has been put up to the dealers that this is virtually a life and death fight for the industry and that no time should be lost in getting a protest before members of Congress, and one which will make it clear to the legislators that to increase the present 5 per cent excise tax to 10 per cent will practically ruin the chances of progress, if not ruin the business entirely.

The importance of the talking machine industry was recognized in a conspicuous manner at the annual meeting of the Milwaukee Association of Music Industries when it elected Clarence C. Warner, one of the real pioneers of the Victor business in this city, as president for 1921. Mr. Warner has served two terms as vice-president and always has been one of the most active workers in the organization. Frederick W. Carberry, an exclusive piano merchant, was elected vice-president. For secretary the Association called back into official service another prominent Victor dealer, namely, Richard H. Zinke, president of the R. H. Zinke Music Co., who served as secretary in 1918 and in the following year he was honored with the presidency as an appreciation of his splendid work. Since then he has been a member of the board of directors. William R. Winter, a veteran Columbia dealer and president of the Winter Piano Co., was re-elected treasurer, a post which he has held since the organization was founded.

With this staff of officers the Milwaukee Association is exceptionally well equipped to carry on a determined fight against unjust and discriminatory taxation. Secretary Zinke wields a heavy influence with the State trade, being the

president of the Wisconsin Association. This combination of effort doubtless will make the local fight against doubling the excise tax an outstanding one.

The local and State associations are heartily in accord with the Chamber of Commerce for the elimination of the excise tax entirely, and the substitution of a gross sales tax. Stress is being laid on this point, so that it may be clear that the music dealers of Wisconsin are not trying to evade their just share of the tax burden, but seek only a just and equitable distribution of the burden.

During the last three or four weeks trade in talking machines has been rather quiet and featureless, but at the same time local dealers have made tremendous strides forward in developing record business. There is not a dealer in Milwaukee who has failed to show a very generous increase in this department since January 1, compared with the same period of 1920. The active business in records has made it impossible for manufacturers and jobbers to make the headway they figured they might be able to make by this time in keeping retail stores supplied in an adequate way with catalog and current numbers. The shortage of records remains rather acute, but promise is held out that this condition will gradually be remedied.

Dealers have been working down their stocks of instruments steadily since the holidays, but for the most part their floors and stockrooms are quite amply supplied for some time to come. However, there is hope that improvement in the demand is coming soon, and it may then not take long to wipe out existing stocks and create a rush of buying among dealers.

"Our dealers have been giving us a very satisfactory amount of patronage in the past month or two and we have no complaint to make," said Harry A. Goldsmith, secretary of the Badger Talking Machine Co., Victor jobber. "It cannot be denied that trade has borne the accustomed brisk tone of last year and two years ago, nevertheless we feel that we have been very fortunate, for Victor business always is well sustained, even under the most unfavorable conditions. Since the beginning of March we have noticed an improvement. It looks as if this will mark the revival, and that the resumption of public demand has come."

According to Thomas I. Kidd, manager of the

Let Us Prove
That "Badger" Service
Is the Kind You Want

G. F. RUEZ
Pres. and Treas.

H. A. GOLDSMITH
Secretary

S. W. GOLDSMITH
Vice-Pres. and
General Mgr.

BADGER TALKING MACHINE CO.

Wisconsin Victrola Distributors

135 Second St.

Milwaukee, Wis.

local branch of the Brunswick-Balke-Collender Co., signs are steadily manifesting themselves that public confidence is returning and the "buyers' boycott" is a thing of the past. Brunswick instrument and record business as well is improving to a remarkable extent throughout the branch territory. Dealers are beginning to make requisitions more nearly like those of "the good old days."

Columbia business is making excellent progress in Wisconsin and the recent marketing of the older record numbers at reduced prices has been a remarkable stimulant to trade, which has given the Columbia line increased popularity. Since the attitude of the public for six months or longer has been to buy only when prices go lower, the reduction on records was a decidedly popular thing and as the result of it Columbia dealers have been able to clean house and pave the way for a very respectable volume of new purchases.

An important change in the Aeolian-Vocalion representation in the Milwaukee territory will take place on April 15, when Edmund Gram, Inc., relinquishes the entire Aeolian line. After this date the local dealers will be the J. B. Bradford Piano Co., 411 Broadway, with a south side branch at 596 Mitchell street.

The business founded by Charles J. Orth, who died February 1, will be continued without change of name or policies by his brothers, according to an official announcement just made. The Orth concern is the exclusive wholesale distributor in Wisconsin and upper Michigan of the Puritan line, and also conducts one of the leading piano stores on Grand avenue, this city.

The Strand Theatre, one of the leading motion picture houses in the downtown district of Milwaukee, last week staged, as a widely advertised specialty of its musical program, the accompaniment by its big orchestra of the Victor record by Caruso of Bartlett's "A Dream." It was a most effective presentation and attracted wide attention.

The "Zinke Musics," a bowling team representing the R. H. Zinke Music Co., won high honors in the recent Wisconsin State Bowling Tournament in Milwaukee. It held first place for many days and was outranked in the final hours of the rolling, capturing second money. On the day following the first place achieve-

(Continued on page 86)

THE PHONOSTOP

In its fifth year. Best and most popular. Set in one second. Better than any Non-Set stop yet invented. Perfect *Service* and *Satisfaction*. Made in Gold and Nickel Plate. *Universal*.

Give us your trade—we will hold it by **MERIT**

THE PHONOMOTOR CO. - 121 WEST AVENUE
ROCHESTER, N. Y.

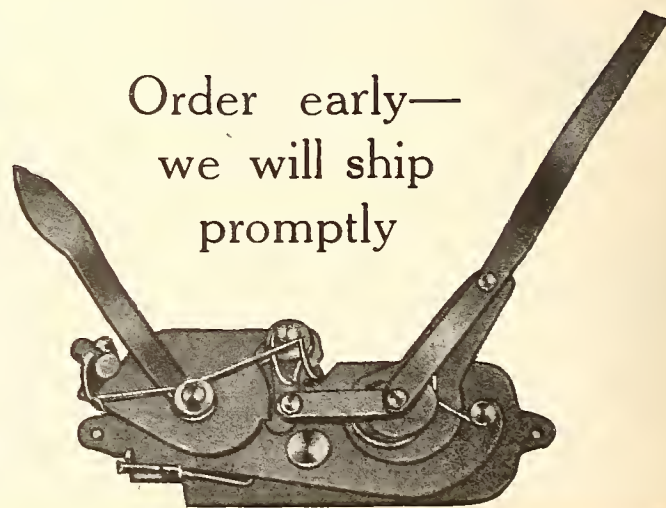

Order early—
we will ship
promptly



THE PROCESS OF ELIMINATION

By J. NEWCOMB BLACKMAN

We are now experiencing the process of elimination in all lines of business. This is particularly true in the Talking Machine business.

This elimination process is reflected in a refusal on the part of the buying public to accept something claimed to be "just as good."

Special sales at reduced prices do not seem to help much when the buying public *refuse* a substitute.

Greatly increased Victor supply of Victrolas and records is no longer a promise but a fact.

Prospective buyers are "looking under the lid" for the genuine Victrola trade-mark of "His Master's Voice."

Don't overlook this, Mr. Victor Dealer, if you value your "good will."

It takes a smart man to know when to get "in" the stock market, but a smarter one to know when to get "out."

Give the Victor line the representation it deserves and you will get all you deserve. You can't shut out or entirely avoid all competition.

The most effective competition you can experience is the competition of other Victor dealers. In 1921 Blackman dealers will not be at any disadvantage in both avoiding and meeting competition.

The process of elimination and the greatly increased supply of Victrolas and records, we believe, will enable us to take good care of Blackman's present dealers and to accept some accounts heretofore regrettably declined.

We are going to be very much on the job, Mr. Victor dealer. Seeing us will be believing us.



Blackman
TALKING MACHINE CO.
81 READE ST. NEAR CHURCH ST. NEW YORK
VICTOR DISTRIBUTORS EXCLUSIVELY WHOLESALE



Our traveling representatives are masters in the planning of musical merchandise equipment; their advice may be helpful to you without expense. Write us—one of them may be in your locality now.

Plans and estimates promptly submitted.

VANVEEN & COMPANY INC.

12 YEARS OF STUDY AND EXPERIENCE IN
BUILDING AND PLANNING MUSIC STORES

• HEARING ROOMS • RECORD RACKS • COUNTERS •

EXECUTIVE OFFICE
47-49 WEST 34th STREET
NEW YORK CITY

SALES OFFICE
1711 CHESTNUT STREET
PHILADELPHIA

MILWAUKEE TRADE AID TAX FIGHT (Continued from page 84)

ment the sporting pages of all Milwaukee newspapers announced the fact in screaming headlines, which is not the worst kind of advertising a Victrola shop can get, judging from the comment in the home and on the street.

Talking machine business in general has gained at least some benefit from the columns that have been published in local newspapers concerning the purchase of a Victor for the House of Correction. The fact that a dozen or more "bootleggers" of prominence have recently been committed to the prison by the Federal

Court, made the acquisition of the instrument especially an object of special writers and paragraphers. This and other publicity is regarded as splendid "propaganda."

At the recent exposition held in conjunction with the annual convention of the Wisconsin Retail Hardware Association, the Pathé phonograph was exhibited by the Morley-Murphy Hardware Co. of Green Bay, Wis., one of the largest jobbing houses in northeastern Wisconsin. The Morley-Murphy Co. also displayed the line at the first annual Industrial Exposition conducted by the jobbers' division of the Green Bay Association of Commerce.

WIDENER'S SHOP TO MOVE

Columbia Headquarters to Be Located at 4 West Thirty-seventh Street After April 1

Widener's Columbia Shop, which for the past few years has been established at Fifth avenue and Thirty-seventh street, New York, will move on April 1 to 4 West Thirty-seventh street, two doors west of Fifth avenue. According to present plans, Widener's Shop will occupy exceptionally attractive warerooms at the new address, and decorations and furnishings are now being completed.

In a chat with The World, Mr. Widener stated that the reason for this move was the fact that the rental asked by the owners was exorbitant, and that plans are being made for an intensive campaign after the establishment is located in its new home.

SCHEU TO OPEN IN DOVER

DOVER, O., March 3.—It is announced that a new music store will be opened here next week on East Third street in the George T. Ruefly Building by Archie W. Scheu. He is agent for the W. D. Lerch Music Co., of Canton. Scheu announces the store will handle player-pianos, upright pianos, talking machines.

TO ENTER FIELD IN ALLIANCE, O.

Drake & Moninger Co. Plans Big Opening Ceremony for March 24

ALLIANCE, O., March 5.—Among the new stores to make their appearance here this month will be that of the Drake & Moninger Co., on March 24, when a reception to the people of this city will be given with musical numbers by Blaine and Mrs. Dan Cochran, of East Liverpool, and Mack's Orchestra of Canton. The entire first floor of this establishment will be given over to Victrola business, with one window constantly in use for this purpose. R. E. Rosenberger will be manager of the department. A special advertising number of eight pages, prepared by Advertising Manager Ed Hunt, will appear in local daily newspapers. Officials of the Eclipse Musical Co., of Cleveland, will assist at the opening.

MUSIC WEEK IN YOUNGSTOWN

Ohio Dealers Co-operate With Civic Authorities to Make Affair Success

YOUNGSTOWN, O., March 1.—Music dealers of Youngstown contributed to the observance last week of "Music Week" here. They lent every co-operation to Mayor Fred J. Warnock and his committee. Commencing Monday and continuing every day throughout the week either the dealers or the committee promoted special music events, which, according to Youngstown music dealers, stimulated piano, talking machine, musical merchandise, player roll, record and sheet music sales.

Leading the movement were the following downtown music dealers who used generous newspaper advertising space: The Brunswick Shop, W. F. Frederick Piano Co., Owl Drug Co., Cahn's, Schuman's, the Hawaiian Music Studio and Ress Brothers, who handle Victor, Columbia and Okeh records and Victrolas.

A billboard is the large edition of a business card and, like all big things, it brings big results. Now, honestly, Mr. Victor Dealer, are you satisfied with a 2 x 4 business card?

BRUNO

HOW TOLEDO SHOP SELLS RECORDS

Brunswick Dealer Gets Big Results by Securing Co-operation of Theatrical Interests—Girls of Salesforce Dress in Appropriate Costumes

TOLEDO, O., March 7.—Featuring one record for three days or a week and doing a record business on the basis of 50,000 a year, although open only a couple of months, is the accomplish-



A Window Idea Worth Emulating

ment of the Record Shop, at Toledo, owned by Robinson & Compton and managed by W. A. Grubbs. This little place is featuring Brunswick records and is located near two theatres. Manager Grubbs picks a record, such as "June," embellishes his window with appropriate settings, has the girls dress in costume appropriate to the story in the record, and the populace comes in to hear—and buy. The help of the theatre people is also obtained. Through the co-operation of P. H. McCulloch, phonograph division sales manager in the Northern Ohio territory, the Brunswick organization supplies orchestrations and these are given to the artists and orchestras at the theatres, and these pieces are gladly played and sung. After hearing these pieces and seeing them featured in the windows as noted, people can't resist buying records.

BERRY WITH DWYER PIANO CO.

Former Victor Traveler Appointed Manager of Victor Department of New Orleans Store

NEW ORLEANS, LA., March 7.—Wm. P. Berry, formerly traveling representative of the Victor Talking Machine Co., and more recently associated with Philip Werlein, Ltd., wholesale Victor distributor, has just been appointed manager of the Victor department of the Dwyer Piano Co., 131 Carondelet street, this city.

The Dwyer Piano Co. has recently been made a Victor retailer and will handle Victrolas and Victor records exclusively. Upon completion of the new department, which will consist of ten demonstration booths, the Dwyer Piano Co. will have one of the finest equipped talking machine departments in New Orleans.

APPOINT NEW OKEH JOBBERS

Sterling Roll & Record Co. Expands Its Territory to Include Pittsburgh—Lind Music Co., of Detroit, Is New Okeh Jobber

The General Phonograph Corp. announced recently that the Sterling Roll & Record Co., Okeh jobber, at Cincinnati, O., had also been appointed an Okeh jobber in Pittsburgh. A. B. Smith, formerly assistant manager of the Pittsburgh branch of the Columbia Graphophone Co., has been appointed manager of the Sterling Roll & Record Co.'s Pittsburgh division. Temporary headquarters have been established at 436 Fourth avenue and F. F. Dawson, general manager of the Sterling Roll & Record Co., is planning to give the dealers in his territory practical service and co-operation.

The Lind Music Co., Detroit, Mich., a newcomer in the wholesale field in that city, has been appointed an Okeh jobber. S. E. Lind, head of this company, is one of the most popular members of the Detroit talking machine trade, and under his direction Okeh records will undoubtedly receive splendid representation in this important territory.

THE VICTROLA AND EDUCATION

New Sales Help Prepared by the Victor Talking Machine Co. Distributed to Dealers

The latest addition to the educational literature issued by the Victor Talking Machine Co. is a small illustrated pamphlet featuring the use of the Victrola in the home and in the school. Now that the educational records are available in greater quantities this new pamphlet is of value to dealers in their advertising to their own local school and educational circles. The cover of the booklet contains an illustration in color, taken from the book, "Music Appreciation for Little Children," put out by the Victor Co.

The inside pages are covered with small pictures showing the uses of the Victrola, both in the school and in the home. Some interesting facts about music are contained on the back cover. It is stated that music educates by securing attention, interest, participation and expression, through sense perception, emotional response, mental discipline and analysis. Music

stimulates the imagination, discrimination, selection, correlation, association and aids concentration, appreciation, interpretation, assimilation and composition. The total helps to give knowledge, culture, poise and power. Other uses for the Victrola are given and the complete library of educational literature is listed.

ATTEND NORA BAYES SHOW

A group of the executives and department heads of the Columbia Graphophone Co. were the members of a theatre party a few days ago, at which they were the guests of D. G. Slatery, manager of Nora Bayes, popular musical star and exclusive Columbia artist. The Columbia party thoroughly enjoyed the presentation of "Her Family Tree" at the Lyric Theatre, where Miss Bayes has attained phenomenal success. Among the Columbia executives and department heads in this party were Geo. W. Hopkins, Frank K. Pennington, W. A. Willson, Lester L. Leverich, O. F. Benz, H. L. Pratt, L. C. Stowell and John Bryant.

YOU WOULD NOT

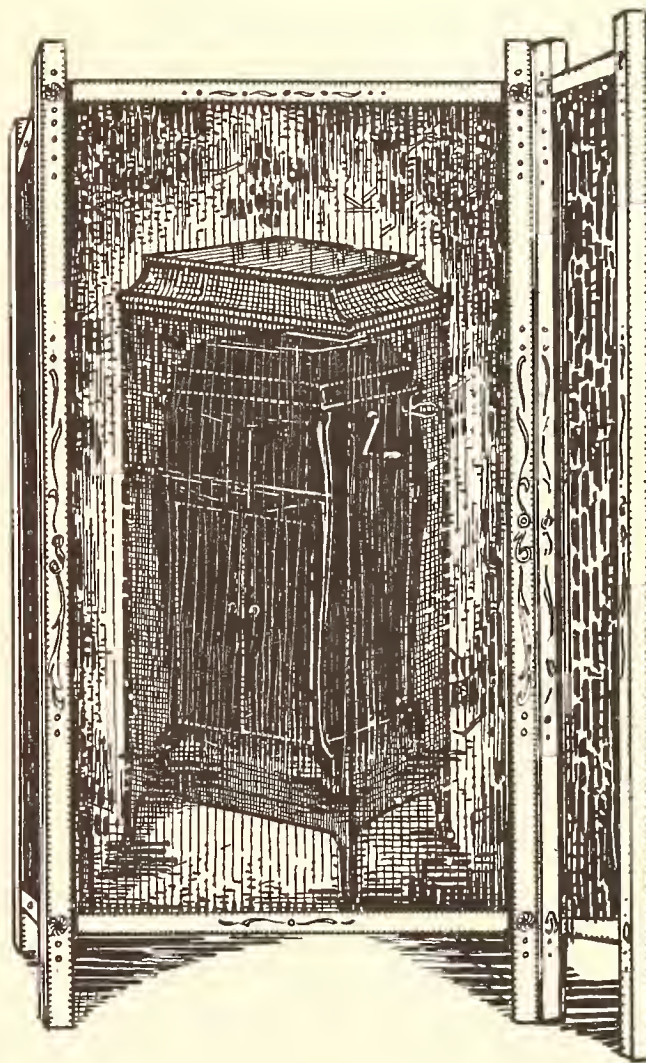

No good merchant would set up a screen in front of the goods he wants to sell.

Don't cloud the superior points of the Victor.

Even at a 3-Ring Circus everything stops when the big Features go on.

The VICTOR is the biggest thing in the music field

Investigate transportation from Buffalo to your city.—Try our Victor service

BUFFALO TALKING MACHINE CO.

Wholesale Victrola Distributors

BUFFALO, N. Y.

CONVINCING EVIDENCE OF BETTERMENT IN CLEVELAND

New Dealers Opening Up, Old Dealers Expanding—Eclipse Co. to Wholesale Exclusively—Edison Tone-test Plans—Pathé Dealers Convene—Cleveland Talking Machine Co. News—Other Items

CLEVELAND, O., March 7.—Regardless of conditions in other businesses, any doubt as to the standing of the talking machine industry, in the Ohio territory at least, appears to be set at rest in the light of developments in the immediate Cleveland and more distant districts during the last few weeks. New dealers are opening up in many communities. Old dealers are enlarging their establishments. New business with all is being booked by jobbing interests. Machine business is satisfactory, showing a fair gain over last year at this time. In a few instances remarkable gains have been made. Probably the most conspicuous instance recently is the distribution of more than 3,000 machines by the Fischer Co., Pathé distributor, in thirty-five days with five men, under leadership of Ralph J. Jamieson, sales manager in the Ohio territory. This feat was accomplished through their ability to guarantee prices to dealers. In record and supplies distribution an equally sensational gain must be mentioned, in that an average increase of business by one-third over the same time last year is being done.

Among the newest establishments for Cleveland proper is the "live" new department of S. Kohn & Sons, in the East End. This firm has acquired the retail Eclipse Musical Co. account and will have a formal opening as soon as the department is ready. Norman H. Cook, formerly retail sales manager of the Eclipse, takes charge of this department with the old retail Eclipse staff.

In announcing the disposal of the retail division the Eclipse Musical Co., Victor jobber, will concentrate exclusively upon wholesale business from now on, according to C. K. Bennett, general manager. The elimination of any retail connection will place this firm in an even better position to serve retailers, explains Mr. Bennett. The wholesale business will be enlarged and extended, and all departments developed to a high degree of efficiency.

With a view toward aiding retailers in filling orders for records that could not be had easily until lately, dealers are being urged to send in their back orders now by Mrs. I. M. Howard, manager, Eclipse Musical Co.'s record department. It is pointed out that ability to meet the demands of customers now is giving dealers who do this added business and those who have not sent in back orders are heeding the urge.

March will be replete with tone tests in which the Phonograph Co., Edison distributor, and all Edison dealers are taking a big part. First of these was held by Claus & Schroeder at the Lyceum Theatre, where 2,400 persons were entertained and 1,000 turned away. The artists appearing in Cleveland this month are Miss Marie Morissey, Walter Chapman and Harold Lyman. The second big event was held at B. of L. E. Auditorium under direction of E. A. Friedlander, Bailey Co. talking machine

department. This program was divided into eight numbers with about twenty selections. Several other affairs of this kind will be held through the month, ending on March 31 with a grand concert at Masonic Auditorium, where 4,000 Al Sirats are expected to be present. Personal assistance to dealers in conducting these tone tests is being given by L. M. Bloom, general manager; Harry Tucker, sales manager; M. G. Kreuzsch, E. S. Hirschberger, Richard Goss and other members of the Phonograph Co. organization.

In connection with its campaign on machine sales lately the Fischer Co. held a successful convention of Pathé dealers, who came from all parts of the Ohio territory to hear James Waters, Pathé Co. secretary, outline the plans of the home organization for dealers in the country. The meeting was called on less than twenty-four hours' notice and well attended. Publicity, sales and production features were demonstrated to dealers, with the result that they are convinced that the year will be quite productive of new business for them.

Seventy sales people entered the sales contest conducted by the Cleveland Talking Machine Co. during February and data to ascertain the leaders in this event, so that the award of a free trip to the Victor factory for the Cleveland girl and the out-of-town girl making the best showing may be made, are now being compiled. Dealers say the event has served not only to increase sales over January, which month was taken as the basis for the contest, but that it also will aid in knowing what records are more desired, who the customers are that buy the most records, and how to plan their business for the future.

As an additional aid to dealers in Cleveland and vicinity in pushing records of the classics during March, the Cleveland Talking Machine Co. has issued a supplementary list to that of the regular Victor listing. A feature of this supplementary list is the schedule of dates and the artists who will appear here on those dates, which is expected to arouse added interest on the part of dealers' clients in the work of these artists in person as well as their recordings.

Setting the example for dealers, following an urge of long standing by both the Victor organization and Victor jobbers, the Cleveland Talking Machine Co. takes the lead for what is believed to be the first time for a jobber in advertising in a daily newspaper the new records as listed in national advertising by the Victor Co. This advertising uses the famous Victor dog and lists all Victor dealers in Cleveland, and advises the public that the new records can be obtained from these dealers. The advertising was so placed that it appeared on a page opposite to that of the Victor national advertising. It is believed that dealers will not only gain added business in records from this move,

but that they will see the advisability of cooperating in a practical way with the national advertising in future.

More than 5,000 children from public, junior and high schools of Cleveland have entered the music memory contest being conducted by the Musical Arts Association. First tests will be held in conjunction with the Cleveland Symphony Orchestra at Masonic Hall March 12. Ten selections will be played. Teams of fifteen students from each school will try to name the composition, the composer, the nature of the selection and something of its history. The winning team will receive a bronze cup which will be held for one year, at which time it will be competed for again. To the individual pupil making the largest number of winning points a talking machine may be given as a personal reward by the talking machine trade here. Orchestra leaders at motion picture houses have been aiding the movement here by playing selections at the request of pupils entered in the contest.

Motion picture orchestra directors also have been a help in another way toward increasing interest in music and incidentally aiding the sale of records. This has been accomplished by Mrs. Loretta B. Flading, manager of the talking machine department of the Aldrich-Howey Co. Good new records which have been slow movers because people did not know these selections were entirely too numerous at the Aldrich-Howey. So Mrs. Flading has been asking the movie musicians to play such selections, which they always are glad to do in order to enliven their own programs. The following day a large sign with a list of the selections played usually appears in the Aldrich-Howey window, and a little later buyers of these records appear in the store. This plan has served not only to reduce such record stocks, but offers a new avenue to machine sales with the increasing line of new customers.

Another influence for better business for dealers is seen by F. C. Erdman, district representative of the Victor Talking Machine Co., back in town after an extensive tour of the Ohio territory. Dealers everywhere welcome the new Victrola 80 and report it moving well with the arrival of first shipments.

NEW PATHE DISTRIBUTOR

Fones Bros Hardware Co., of Little Rock, Ark., Secures Distributing Agency at That Point

The important announcement of a new Pathé distributor has been made at the headquarters of the Pathé Frères Phonograph Co., in Brooklyn, N. Y. Sales Manager George W. Lyle informed The World of a new Pathé distributing point at Little Rock, Ark., where Fones Bros. Hardware Co. has been appointed distributor. Fones Bros. are well and favorably known in this section of the country and have a large, efficient sales organization that will be well able to take care of the efficient distribution of Pathé products in that territory.

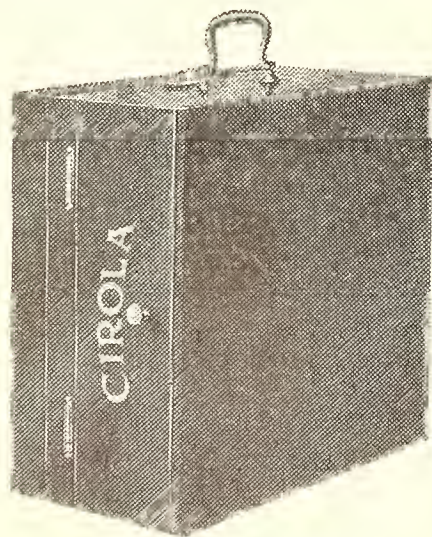

Size: 12½ x 11½ x 6

"Take Your Music With You"

"CIROLA," the only PORTABLE Phonograph without sound chamber; has twin spring motor; highly nicked metal parts; is finished like a Piano; built like a Battleship; folds like a suitcase; weighs 16 lbs.; plays all records better because the good fresh air is its sound amplifier; and we will give \$10,000.00 for any Cabinet Phonograph at \$100.00 that will produce a larger volume of tone. Write for our proposition quickly. Enterprising dealers everywhere are rapidly stocking these Spring and Summer Whirlwinds. Covers may be had if desired.

CIROLA DISTRIBUTING CO., Inc.

Distributors of the

CIROLA PHONOGRAPH

PROMPT
DELIVERIES



203-04 Colonial Trust Bldg.

Phone Spruce 6340

PHILADELPHIA, PA.

U. S. A.



“Satisfaction”

The real acid test for any new proposition is not passed until it has been sold, paid for, and given highly satisfactory service to the purchaser.

* * * *

When this has been done, such a proposition in the hands of capable men, coupled with integrity, provides the safest form of industrial investment.

* * * *

The TALKING MACHINE WORLD SERVICE is not a new proposition. It is an established Service which has been successfully rendering service for the past two years.

* * * *

WHEN YOU SIGN UP for the TALKING MACHINE WORLD SERVICE exclusively in your city, you secure the best that money can buy in the way of a high-class sales stimulator.

* * * *

This is What the TALKING MACHINE WORLD SERVICE has done for others. It will do the same for you

“You may be interested in knowing that we attribute a very large volume of business which we are doing to the TALKING MACHINE WORLD SERVICE, and if, at any time, you have any individuals who want to know what this Service will do for them, you need not hesitate giving us their addresses because we absolutely know that your Service is the finest that money can buy.”

* * * *

“We find your Service very helpful by using it to the utmost, and are finding it effective and profitable.”

* * * *

“We are pleased indeed with your prospect card and know it must have taken a lot of time and study to get one so thoroughly practical.

Beyond question, this will prove a great help to any dealer who needs a system of this nature.”

* * * *

“Your ads are exceptionally fine because even the person who hurriedly picks up a paper and reads it at a glance will be compelled to read your ads. They have class to them and are out of the ordinary.”

* * * *

“Your ads and letters speak for themselves. We think your Service is great, and are using it to the limit.”

* * * *

“‘What else can we do for you?’ That always makes me feel good when I see it at the end of my Service order, and I always want to sit down and tell you again what I think of the Service, but you already know.”

THE COST? NOTHING—when you notice the results obtained for the money invested

<p>The Talking Machine World Service, 373 Fourth Avenue, New York City.</p> <p>If other dealers in big cities as well as small towns are getting results and making a big profit on The Talking Machine World Service, I'd like to know all about it. Without obligation, send me sample copies of ads, form letters, ideas, etc. Tell me what it will cost per month for exclusive use in my territory.</p>	<p>The population of my city is.....</p> <p>I sell the following machines.....</p> <p>My firm name is.....</p> <p>By</p> <p>My address is.....</p> <p style="text-align: right;">K-3-15-21.</p>
------------------------------------------------------------------------------------------------------------------------------------------------------------------------------------------------------------------------------------------------------------------------------------------------------------------------------------------------------------------------------------------------------------------	-------------------------------------------------------------------------------------------------------------------------------------------------------------------------------------------------------

MAIL THE ABOVE COUPON TODAY—WITHOUT FAIL

OHIO MUSIC CLUBS MEET MARCH 30

Mrs. Frances Elliott Clark to Address State Federation on Educational Work

CINCINNATI, O., March 7.—The Ohio Federation of Music Clubs will hold its annual convention in this city on March 30 and 31 and April 1, at which time the members will be addressed by Mrs. Frances Elliott Clark, of the educational department of the Victor Talking Machine Co. The organization is preparing to extend its work among the younger folk through the junior clubs of the Federation, of which division Miss Grazella Puliver, educational director of the Cleveland Talking Machine Co., has been elected chairman. The junior division will provide ways and means for the youngsters to perform in public and demonstrate what they are learning in music.

TALKING MACHINE MEN, INC., MEET

Dr. Frank Crane Addresses Monthly Gathering of Local Association—Nominating Committee Presents Slate—To Vote on Sunday Closing

The monthly meeting of the Talking Machine Men, Inc., was held at the Pennsylvania Hotel on Wednesday afternoon, February 16. The attendance was quite large owing, no doubt, to the fact that Dr. Frank Crane addressed the gathering and an announcement of his talk had previously been forwarded to the members.

Dr. Crane made a very enlightening and constructive address along business lines and put forth what he considered the ten commandments of a salesman, which are set forth at length in another page of The World this month. His reference to situations that arise daily as the result of sales was very pointed and instructive, and at the close of his remarks a spontaneous rising of those assembled, followed by a unanimous rising vote of thanks, supported the statement.

It was voted to send E. G. Brown, secretary of the Association, to the annual meeting of the National Association of Music Merchants, to be held in Chicago in May, at which time, it is understood, there will be a gathering of talking machine dealers, particularly those from Los Angeles and Pacific Coast territory, for the purpose of either joining the National Association of Music Merchants or forming a national association of talking machine dealers.

It was decided to place the question of Sunday closing before the Association in a questionnaire form, and a committee was appointed to gather data covering the newspaper publicity of mail order houses and place it before the Merchants' Association of New York.

The nominating committee presented the following names as officers to be elected at the annual meeting and banquet at the Hotel Pennsylvania, to be held on March 27: President, Irwin Kurtz; vice-president, E. Leins; secretary, E. G. Brown, the present incumbent; treasurer, A. Caluchie.

The names presented for the officers of the executive committee were: M. W. Gibbons, L. R. Yeager, Harold Bersin, Theodore Arison, Sol Lazarus and A. H. Meyers.

Everett W. Richards is now in charge of the talking machine department of the Johnston-Hatcher Co., in Springfield, Ill.

THE FINEST OF
CORE STOCKS

For Phonographs and Record Cabinets

Are supplied by the

GERMAIN BROS. CO.

Makers of the Famous
"Germain Piano Backs"

SAGINAW

MICHIGAN

WINS A PRIZE FOR POLITENESS

Miss Lorraine Templeton, of Famous & Barr Co. Talking Machine Department, Secures Award for Politeness and Good Nature

Several newspapers in the West have been endeavoring recently to test the standard of politeness among sales people in retail stores by offering a substantial prize each day to the person whom a special investigator believes is the most polite. In Chicago, Milwaukee and other cities clerks in music stores have been successful in capturing several prizes, and in St. Louis one of the young ladies in the music section of the Famous & Barr Co. won the award offered by the St. Louis Times. In his story the investigator said:

"Where are the phonograph records?" Investigator asked an elevator starter.

"Sixth floor, sir. Take the end car, please."

The answer was given in such a pleasing manner that Investigator fingered the voucher in his vest pocket. Here, indeed, was a worthy person who might warrant further investigation. If none better could be found Investigator would return to him.

On the sixth floor the quest began in earnest. Investigator took a stand at the counter. Came three young ladies at one time.

"Are you waited on, sir?" in chorus.

Now someone has said, "Music hath such charms." Perhaps that accounted for the action of the young ladies.

Anyhow, Investigator was stumped. So his eyes just chanced to catch those of a certain young lady among the three whose smile proved an undeniable magnet. To her Investigator said he would like to hear some new records.

"Certainly, sir. Step right this way."

Investigator availed himself of the opportunity to watch the young lady. A row of

booths and a mixture of jazz and the classics. Always the young lady appeared in the booth at the right time, changed the records and inquired whether the selections were suitable to the taste of the individual. To her were allotted five of the booths. It was tiresome work, but well handled.

Always there was a smile for each customer, and always the spirit of willingness to oblige appeared uppermost in the girl's countenance. Hearing some half a dozen records Investigator prepared to depart. On the way he was greeted by still another lady, who seemed solicitous. Puzzled, Investigator turned over in his mind this question: Was it permissible to award three prizes on the same day? Hardly, and yet each of the girls seemed deserving.

A chance incident settled it. "Now that I've heard the records you played for me I want 'Grieving,'" Investigator said.

"Certainly," replied the young lady who had waited upon him, returning anon with the record. "Don't you think you had better hear it played? Sometimes, you know, they sound differently the second time you hear them."

Investigator didn't wait. The voucher was placed into the hands of Miss Lorraine Templeton, 1226 North Taylor avenue.

MAIN-SPRINGS

For any Phonograph Motor
Best Tempered Steel

1	in. x 10 ft. for Columbia.....	Each \$0.50
1	in. x 13 ft. for Victor.....	Each 0.50
1 1/4	in. x 18 ft. for Victor.....	Each 0.75
1	in. x 12 ft. for Helneman.....	Each 0.60
7/8	in. x 10 ft. for Col. Pathé-Helneman	Each 0.50
1 1/8	in. x 16 ft. for Helneman	Each 1.20
1	x 16 ft. for Saal or Silvertone....	Each 0.90
1	in. x 10 ft. for Saal or Silvertone..	Each 0.60
1	in. x 16 ft. for Sonora or Brunswick	Each 0.90
3/4	in. x 10 ft. for all small type machines	Each 0.45
1 1/2	in. full size for Edison Disc.....	Each 2.10

SAPPHIRES—Genuine

Pathé very best loud tone genuine, each 15c; 100 lots, \$11.50.
Edison very best loud tone, 15c each or \$12.00 in 100 lots.

MOTORS

Special price on Krasberg motors.
Order right from this ad.
Send for price list of other repair parts.

The Val's Accessory House
1000-1002 Pine St. St. Louis, Mo.

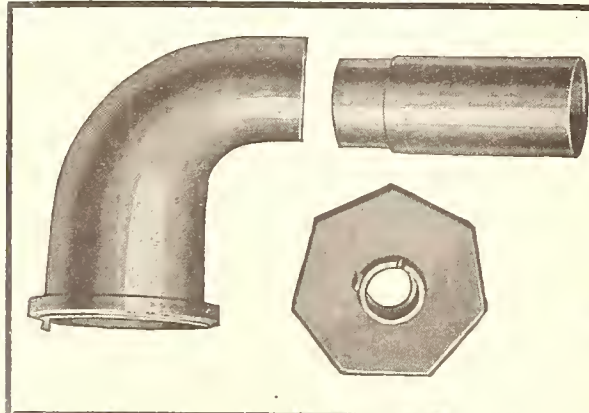

Exclusive and better methods are making phono-parts with better finish
HAVE THEM SUPERCAS

Dependable  Economical

The Superior Die Casting Co.
Cleveland, O.

"The Lure of Music" is a book that tells folks all about the music great exclusive Columbia artists make. The convenient Columbia Record Album is a constant invitation to fill it with records. Our Dealer Service man has supplies of both.

**Columbia Graphophone Co.
NEW YORK**



INCREASED BUYING REPORTED BY TRADE IN ST. LOUIS

Conditions Interestingly Reviewed—Important Discussions at Music Merchants' Meeting—F. C. Schuyler With Local Columbia Branch—Death of J. E. Medairy—Kieselhorst Study Hour

St. Louis, Mo., March 3.—There is improvement in the talking machine situation in St. Louis. February was a better month than January and all the indications are that March is going to be a great deal better than February. This does not mean that people are falling over each other to buy talking machines, as they did in a well-remembered and well-beloved recent past, but the people are buying them and buying them in increasing quantities, as compared to the sales during the early part of the Winter and just after the holidays. Period designs are growing in favor and dealers anticipate that it will not be long until the best of the demand for the highest-grade instruments will favor the period models. A development not unlike the rise of the grand in piano circles is anticipated for the period designs in talking machine circles. Dealers' stocks are low. They are not buying any more than they have to because they are not sure whether there are going to be any price changes. They are not holding out for reductions, but they are simply uncertain what to do. Record sales continue remarkably good. The records never shared to any great extent in the depression which affected the machines. The rush on release dates seems as great as ever.

Talking machine matters held as large a place as pianos at the last meeting of the Music Merchants' Association of St. Louis, the membership of which includes both branches of the business. First off, Manager Jackson, of the Brunswick Co., had a little crow to pick with the president of a local piano house, which advertised a clearing sale of talking machines at reduced prices, and, lo, the Brunswick name led all the rest. Manager Jackson contended that the wording did not make it clear that it was used Brunswicks that were being offered. The piano man said there had been no intention to confuse the public. Everybody agreed that the piano house was entirely within its rights in advertising what it did in the way that it did, but it was felt to be unfortunate in that the price prestige of a nationally advertised machine was brought into jeopardy. The upshot of it all was that a resolution was adopted that hereafter members of the Association, in advertising used instruments not regularly handled by the dealer, will see that the word "used" is placed in direct conjunction with the name of the manufacturer or the trade-mark in order that standardization of values shall not be disturbed.

Talking machines, too, share with pianos in the benefits of a more closely drawn declaration on the subject of breaking sales. Under this declaration a sale is a sale when a contract has been signed and a payment has been made, either in cash or musical merchandise, to the amount of the initial payment, as per contract.

The Association's attitude against announcements of reductions in prices was reaffirmed, with the understanding that if new prices were

announced they are not to be designated as reductions.

Mark Silverstone's merry-go-round, being the turntable on which he exhibits to hesitating customers the leading makes of talking machines along with the Edison came in for a few animadversions in the informal discussion toward the close of the meeting. Silverstone defended his turntable and contended that it was fairer than comparing machines under different conditions, as, he said, was done in other stores.

Edward J. Brennan, manager and attorney of the Better Business Bureau, addressed the members on advertising of talking machines and pianos. He said that he had had a complaint against a St. Louis dealer advertising a machine he did not have. The classified advertising, he said, was pretty clean. The principal trouble

his organization was having was with residential dealers. He declared that musical advertising was cleaner in St. Louis than in any other large city in the country, but said there was still room for improvement.

A. H. J. Dickhaus, formerly manager of the piano and talking machine departments of the Famous & Barr Co., who resigned to go into the navy when the country went to war, and has been a star salesman since his return, has resigned from the Famous & Barr Co. after a service of about seven years. He has offers from other St. Louis houses but may conclude to locate in another city.

Manager E. A. Fay, of the Connorized Music Roll Co., Thirteenth and Olive streets, says there has been a marked improvement in business in the past two weeks, both in music rolls and in Starr talking machines and Gennett records, for which the St. Louis branch is distributor. In the talking machines Style 15, a table period design, is in strong demand. J. A.

(Continued on page 92)

THOS. A. EDISON, Inc.,

by

NATIONAL ADVERTISING

now appearing in periodicals and daily papers is emphasizing the ability of the New Edison to play the various talking machine records with highly improved tone quality.

Edison Jobbers and Dealers

you will be best prepared to make capital of that advertising by stocking only the highest quality Reproducer attachment.

The Newton Reproducer

WITH EDISON ATTACHMENT

leads all others in performance, quality and finish. It embodies a highly scientific diaphragm of double construction made expressly for and adapted to the throat and amplifier of the New Edison.

The NEWTON Reproducer is guaranteed indefinitely

List Price Complete—G. P. \$12.00, N. P. \$10.00

Sold by Leading Edison Distributors

Direct shipments to Dealers in territories where we are not represented by Jobber. Write for discounts and particulars.

MANUFACTURED EXCLUSIVELY BY

W. L. NEWTON & CO., INC.

SCRIBNER BUILDING
597 FIFTH AVENUE, NEW YORK CITY

INCREASED BUYING IN ST. LOUIS

(Continued from page 91)

McNabbs, of the Frankfort Music Co., West Frankfort, Ill., was in the other day and Manager Fay almost forced him to take a Style 15. As soon as the machine reached the store he called up on the long distance and ordered two more. He had sold the one and had received a payment of \$100 on another. Dan Reardon, who was with the company several years ago, has returned from four years' service in the navy and has again taken a position with the company, visiting the city trade. Frank L. Fay is on an extended trip through Missouri, Iowa, Nebraska, Kansas, Oklahoma and Arkansas and is getting good orders. He will return to St. Louis about March 25.

F. C. Schuyler, heretofore connected with the main office of the Columbia Graphophone Co., has been assigned to the St. Louis branch, where he will have charge of the international records for St. Louis and the St. Louis trade territory. General Sales Manager G. W. Hopkins and International Record Manager R. F. Bolton were in St. Louis recently. Manager E. M. Morgan has returned from a trip to Arkansas. Assistant Manager A. W. Roos has returned from a Southern trip. Manager Morgan announces that February business scored a material advance over January totals.

Edwin Schiele and Herbert Schiele, president and vice-president of the Artophone Corp., have returned from a business trip to Chicago. Sales Manager Salmon reports a fine business in Okeh records in February and March, with the opening of many new accounts. Large orders have been received for the John McCormack records, which were made in Europe. The first releases of German, Polish and Italian Okeh records have been received.

Fred Lehman, of the Lehman Music House, East St. Louis, has been honored recently by his fellow citizens, being elected a member of the Board of Directors of the Southern National Bank. A newspaper account of the election carries a history of Mr. Lehman's career in East St. Louis and appreciation of the qualities that have made him successful.

A music memory contest is scheduled in the schools of St. Louis for the month of April. Teachers and pupils are already at work and the co-operation of the parents in the home, of music and civic clubs is being asked. The effects of such a contest are far-reaching and will soon raise appreciation of music in the community to a higher plane.

SOSS

INVISIBLE HINGES



Soss Invisible Hinges

are essential to preserve the beauty of design, particularly when it is desired to disguise the talking machine cabinet. In many of the better cabinets of today Soss Hinges are used. They are mechanically accurate and can be installed quickly and easily.

Write for Catalogue

SOSS MANUFACTURING COMPANY
778 Bergen Street, Brooklyn, N. Y.



Joseph E. Medairy, whose critical illness was noticed in this correspondence last month, died recently at the home of relatives here, following his return from Atlanta, where he was stricken and was compelled to relinquish his position as manager of the Goodart-Tompkins Co. Before going to Atlanta he was manager for several years of the Stix, Baer & Fuller talking machine department. Before that he was with the Bollman Bros. Piano Co. and the Aeolian Co. and with F. Loeser & Co., Brooklyn. He was thirty-seven years old and is survived by his widow and one child. He was one of the charter members of the Tri-State Victor Dealers' Association. Members of the Tri-State Association and the Stix, Baer & Fuller talking machine department attended the funeral.

St. Louis audiences have been treated to some rare musical events within the last month. Sergei Rachmaninoff carried off the piano honors of the season, when he was enthusiastically greeted by a full house.

The La Scala Orchestra with Arturo Toscanini gave one of the finest orchestral evenings ever heard in St. Louis and impressed deeply the immense audience.

Fritz Kreisler appeared again just four weeks after a previous concert, this time as guest artist with the St. Louis Symphony Orchestra. It proves his immense popularity that he was just as enthusiastically received in his Symphony appearance as in his concert when he played more popular numbers.

Hans Kindler surprised music lovers in the city, for he came a practically unknown artist, but left with the highest praise of everyone who heard him.

In all of these concerts, save that of the La-Scala Orchestra (when the New York Souvenir Program was used), the programs were used by the Kieselhorst Piano Co., the Smith-Reis Piano Co. and the Lehman Music House, of East St. Louis, to advertise their Victor service on records by the artists appearing.

The Music Merchants' Association of St. Louis has contributed \$150 and 25 per cent of its income for the rest of the year toward the deficit of the St. Louis Symphony Society.

Manager R. W. Jackson, of the Brunswick Co., announces a very good demand for the Brunswick console type machine that sells for \$300 and says the trend is toward the higher-priced machines. Manager Jackson has returned from a business trip to Chicago.

The February business of the Stix, Baer & Fuller talking machine department was 55 per cent ahead of February, 1920, according to F. J. Ennis, the new manager of the department. The best demand was for the most expensive and the cheapest machines. Medium-priced machines did not go so well.

A. E. Whitaker has closed his piano and talking machine business in the Arcade Building and has taken a position with the Scruggs, Vandervoort & Barney music department.

Miss Emma Hammer, formerly with the Kieselhorst Piano Co. talking machine department, has taken a position with the Wurlitzer talking machine department.

George E. Brightson, president of the Sonora Phonograph Co., New York, was here recently.

The Kieselhorst Piano Co., of St. Louis, has organized a study hour for the Victrola department covering the first hour of the day and including the machine and record sales people and manager, T. L. Maetten. One sales person will have charge each week under the general supervision of Mr. Maetten.

YAZOO RIVER RED GUM

Specials for prompt shipment:

- 4 cars 1 1/4" 1st and 2nd Plain Red Gum.
- 2 cars 1 1/2" 1st and 2nd Plain Red Gum.
- 2 cars 2" 1st and 2nd Plain Red Gum.
- 10 cars 2" 1st and 2nd Qrtd. Red Gum.
- 5 cars 2 1/2" Common and Btr. Qrtd. Red Gum.
- 4 cars 3" Common and Btr. Qrtd. Red Gum.
- 8 cars 1 1/4" No. 1 Common Plain Red Gum.
- 10 cars 2" No. 1 Common Plain Red Gum.
- 10 cars 2" No. 1 Common Qrtd. Red Gum.
- 3 cars 3" No. 1 Common and Btr. Plain Red Gum.
- 5 cars 1 1/4" 1st and 2nd Sap Gum.
- 5 cars 1 1/2" 1st and 2nd Sap Gum.
- 2 cars 2" 1st and 2nd Sap Gum.
- 2 cars 3" 1st and 2nd Sap Gum.
- 5 cars 1 1/4" No. 1 Common Sap Gum.
- 10 cars 2" No. 1 Common Sap Gum.
- 2 cars 3" No. 1 Common Sap Gum.
- 5 cars 1 1/2" No. 1 Common and Btr. Qrtd. White Oak.
- 5 cars 3" No. 1 Common and Btr. Qrtd. White Oak.
- 5 cars 4" No. 1 Common and Btr. Qrtd. White Oak.
- 10 cars 1" No. 1 Common and Btr. Qrtd. Red Oak.
- 6 cars 1 1/2" No. 1 Common and Btr. Qrtd. Red Oak.

Our Red Gum is of soft texture and rich dark color. Specially manufactured and seasoned.

Send us your inquiries for all kinds of cabinet woods.

THOMAS & PROETZ LUMBER CO.

3400 Hall St., St. Louis, Mo.

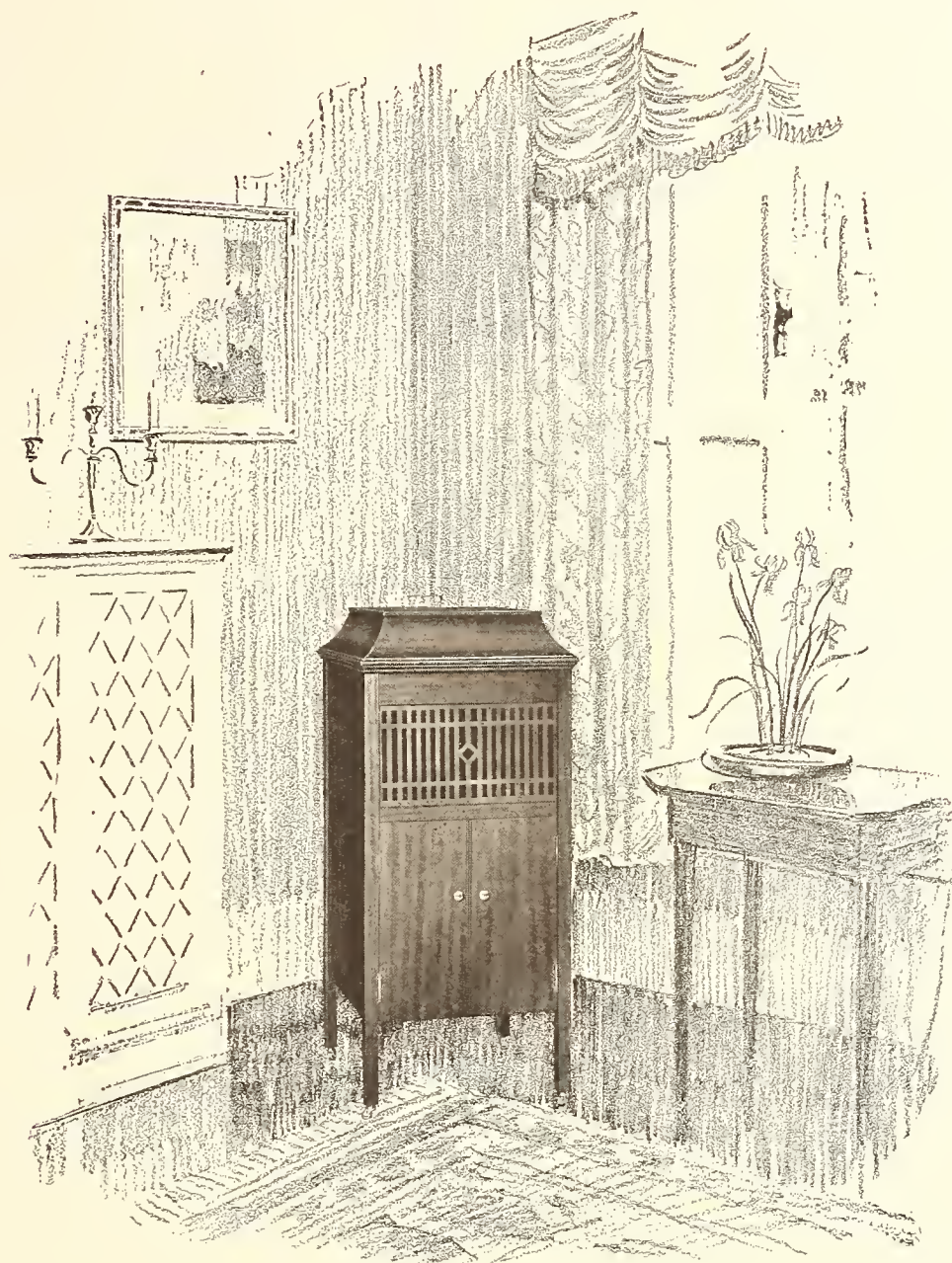

Model No. 1
List Price:
\$125

Height, 44"
Width, 19½"
Depth, 21½"

A Real Merchandising Proposition

We are not exaggerating in the least when we say that the new Jewett Phonograph has created a very real sensation in the phonograph field.

Besides being an exquisitely beautiful instrument in design and finish, it possesses a tone decidedly more lifelike in quality, we believe, than any other phonograph on the market.

And the entire Jewett line, including both upright and console models, is priced so far below the usual prices of high grade phonographs as to be truly astonishing.

Here is a merchandising proposition of real merit, backed by a company of unquestioned financial standing—the same strong financial interests that have been behind the Paige-Detroit Motor Car Company and other equally large and successful enterprises.

A broad-gauged policy will be followed in marketing it—a policy featured by liberal discounts and generous co-operation in local advertising.

Details of agency proposition may be had upon request.

The Jewett Phonograph Company

General Sales Offices: 1730 Penobscot Bldg., Detroit Mich.

JEWETT
PHONOGRAPHS

EDISON JOBBERS MEET IN ORANGE

Two-day Session at Edison Laboratories Sees New Mood Change Tests—Thomas A. Edison Makes Timely Address to Eastern Jobbers

The eastern Edison jobbers and their travelers held a two-day session at the Orange Laboratories on March 1 and 2. The Fourteen Sales Propositions were again the basis for the discussions, with particular stress laid on Sales Aid Service, means of obtaining salesmen and their training, methods of assisting dealers in the financing of their business and the promotion of Re-creation sales. One of the most interesting features of the meeting was the demonstration of a Mood Change Party. This new Edison psychological stunt is being widely discussed throughout the country at present and the jobbers and their travelers thought they would like to undergo a practical test. Mood charts were distributed, four Re-creations were played and those present noted down their various reactions. The whole conference was marked

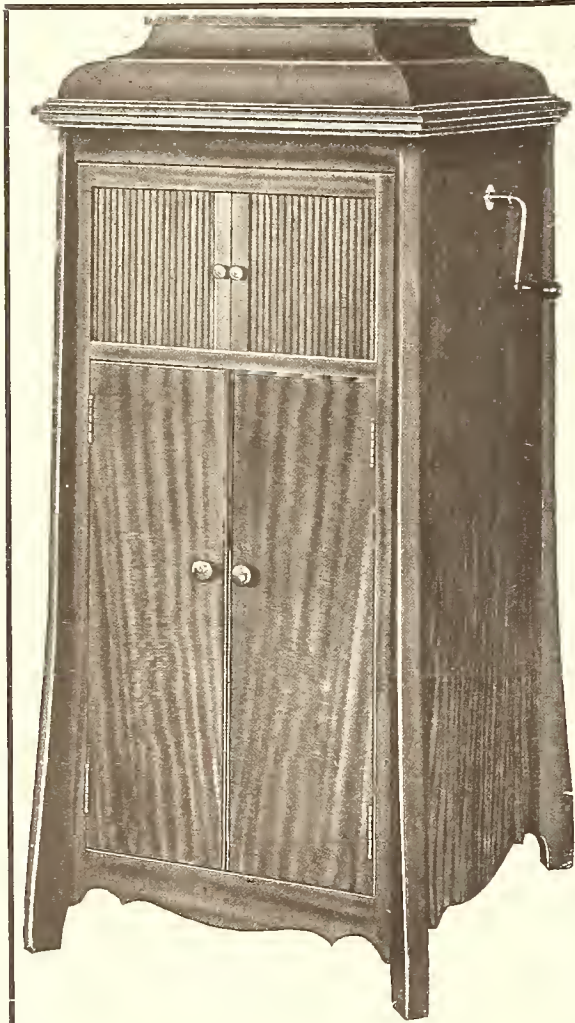

Jobbers Wanted FOR THE Deterling Line

We have a few States open for "live," progressive jobbers.

The proposition is an excellent one, with possibilities for substantial profits.

Write today for open territory

The prices and the goods are right.

**DETERLING
MFG. CO.**

TIPTON

INDIANA

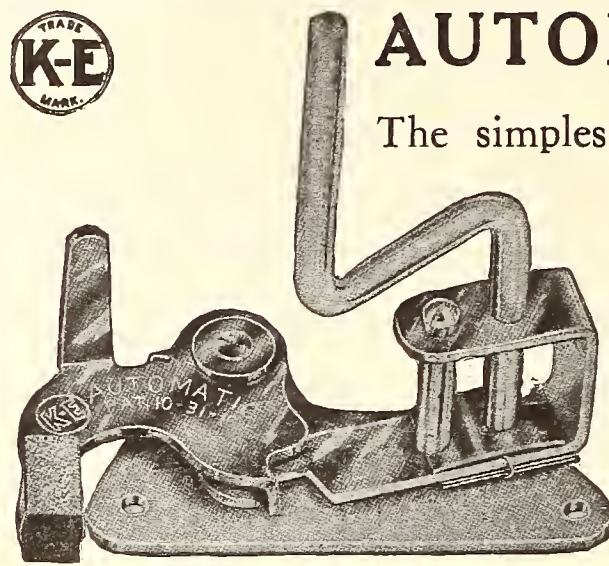

AUTOMATIC STOPS

The simplest and most efficient Automatic Stop on the market. They give excellent service, are easily installed and are absolutely guaranteed.

Send 50 cents for Sample Stop

Kirkman Engineering Corporation
484-490 Broome St., New York

by most intense earnestness and enthusiasm.

It is not often that Thomas A. Edison himself attends a meeting of this description, but he decided to join those assembled for a short time. The company received him with an outburst of spontaneous applause as he made his appearance, and for about half an hour he held their close attention by his wit and wisdom. He touched on financial and business conditions, making some shrewd deductions, and he indulged in several humorous anecdotes, which were keenly enjoyed.

Jobbers and jobbers' travelers at the conference were: N. D. Griffin, P. R. Hawley, American Phonograph Co., Albany; F. H. Silliman, T. E. Dean, F. S. Boyd, L. H. Ripley, G. R. Coner, The Pardee-Ellenberger Co., Boston; F. T. Keeney, F. G. Cook, C. H. De Forest, The

Pardee-Ellenberger Co., New Haven; E. C. Boykin, A. W. Toennies, P. J. Burns, J. R. Lewis, J. B. Gowdy, The Phonograph Corp. of Manhattan, New York City; R. B. Cope, H. G. Hurrell, T. A. Dillon, W. C. Stiver, Girard Phonograph Co., Philadelphia; F. E. Bolway, C. L. Eddy, H. D. Bush, G. C. Cooke, F. E. Bolway & Son, Inc., Syracuse; G. E. Garnett, The C. B. Haynes Co., Inc., Richmond; W. A. Myers, Williamsport.

The Edison Laboratories' representatives who attended were: Thomas A. Edison, Charles Edison, William Maxwell, S. B. Mambert, E. H. Philips, T. J. Leonard, J. A. Shearman, J. B. Gregg, A. L. Walsh, D. B. Babcock, D. E. Wheeler, E. Trautwein, H. R. Skelton, C. S. Gardner. The Federal Advertising Agency was represented by Henry Eckhardt.

HINTS FOR ASSOCIATION MEMBERS

Some "Don'ts" Which May Apply to Members of Any Association—If the Shoe Fits Put It on and Profit by These Examples

One of the members of the trade has suggested that the following hints from the American Furniture Manufacturer might apply to some of the dealers who somehow forget all about their association, organized expressly to better conditions in the talking machine industry:

1. Don't come to the meetings.
2. But if you do come, come late.
3. If the weather doesn't suit you don't think of coming.
4. If you do attend a meeting find fault with the work of the officers and other members.
5. Never accept an office, as it is easier to criticize than to do things.
6. Nevertheless, get sore if you are not appointed on a committee, but if you are, do not attend committee meetings.
7. If asked by the chairman to give your opinion regarding some important matter tell him you have nothing to say. After the meeting tell everyone how things ought to be done.
8. Do nothing more than is absolutely necessary, but when other members roll up their sleeves and willingly, unselfishly, use their ability to help matters along howl that the association is run by a clique.
9. Hold back your dues as long as possible or don't pay at all.
10. Don't bother about getting new members. Let the secretary do it.
11. When a banquet is given tell everybody money is being wasted on blow-outs which made a big noise and accomplished nothing.
12. When no banquets are given say the association is dead and needs a can tied to it.
13. Don't ask for a banquet ticket until all are sold.
14. Then swear you've been cheated out of yours.
15. If you get a ticket don't pay for it.
16. If asked to sit at the speakers' table modestly refuse.
17. If you are not asked resign from the association.

18. If you don't receive a bill for your dues don't pay.

19. If you receive a bill after you've paid resign from the association.

20. Don't tell the association how it can help you, but if it doesn't help you in the way you want, resign.

21. If you receive service without joining don't think of joining.

22. If the association doesn't correct abuse in your neighbor's business howl that nothing is done.

23. If it calls attention to abuse in your own resign from the association.

24. Keep your eyes open for something wrong and when you find it, resign.

25. At every opportunity threaten to resign and then get your friends to resign.

Try these: a kind thought, a kind word, a kind deed.

ASSOCIATED No. 70 UNIVERSAL TONE ARM*

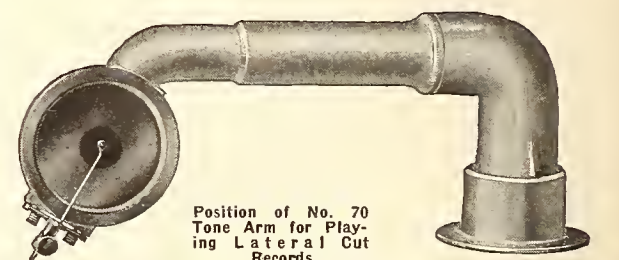

Position of No. 70
Tone Arm for Play-
ing Lateral Cut
Records

**Quality Construction
Unusually Good Tone No Blasting**

For use in Phonographs retailing up to \$100.

Price for sample—\$2.00.

Quantity price on application.

Associated Phonograph Supply Co.
Dept. 71 Cincinnati, Ohio



A. G. KUNDE

MILWAUKEE, WIS.

has been appointed the exclusive importer and distributor for the United States of the famous Homokord Talking Machine Records made by the Homophon Co. of Berlin.

The Homophon Company is one of the largest record manufacturing concerns in Europe and produces records of thirty-one different languages and dialects.

These records have long been known for the acoustic properties and the physical composition used, for the faithfulness of the recordings, the high accomplishments of the recording artists and the judicious selection of the vocal, speaking and instrumental numbers recorded.

Mr. Kunde has arranged to carry a very large stock in Milwaukee of Homokord records for the American trade.

A large stock of the German records will be in shape for distribution from Milwaukee headquarters about April 15th.

The April bulletin, covering vocal, instrumental, yodel, dance and humorous records, covers only a part of the April releases.

*Address all requests for catalogues, bulletins
and complete information to:*

A. G. KUNDE

*U. S. Importer and Distributor
of Homokord Records*

297 THIRD STREET
MILWAUKEE, WIS.

DOEHLER

DIE-CASTING CO.

WORLD'S LARGEST PRODUCERS

OF

DIE-CASTINGS

TIN, LEAD, ZINC, ALUMINUM-ALLOYS, OO-DI BRASS.

EASTERN PLANT	CENTRAL PLANT	WESTERN PLANT
BROOKLYN N.Y.	TOLEDO O.	CHICAGO ILL.
COURT, 9 TH & HUNTINGTON STS.	SMEAD & PROSPECT AVES.	COTTAGE GROVE AVE & 97 TH ST.

MODEL SHOP IN CLEVELAND

Columbia Headquarters to Aid Dealers in Planning Own Stores

CLEVELAND, O., March 5.—A model store, wherein Columbia dealers will have an opportunity to see how they can plan their new stores or improve their present stores, has been completed in the wholesale establishment of the Columbia Graphophone Co. here, and an informal opening will be held for dealers by Manager J. L. Du Breuil in the near future. The store occupies space about thirty by fifty feet, is equipped with two demonstration rooms and two hearing rooms, the most up-to-date record sales system, and is furnished with upholstered chairs and divans. The interior is decorated in cream and gold, the exterior in mahogany. Two large show windows, which will contain frequent changes of window suggestions, are included. The new model machines as they arrive will be installed,

making a constant change of display. Unique lighting fixtures, designed especially for the Grafonola store, are used. Stanley Lee, manager of the Dealer Service department, will be in charge of the model store.

FRANCIS ALFRED RUSSELL ARRIVES

For Frank E. Russell, manager of the Victor department of J. N. Adam & Co., Buffalo, February 22 was more than merely a holiday to celebrate the anniversary of Washington's birthday, because on that date Mrs. Russell presented him with a baby boy, who was promptly christened Francis Alfred Russell.

In making a statement to some of his friends, Mr. Russell said as soon as possible this young man will go to the Victor School of Salesmanship. His father went to it and liked it, and has increased the business of J. N. Adam & Co. from knowledge obtained there, hence his desire to pass it on.

J. E. MAUNDER BECOMES MANAGER

Takes Charge of the Talking Machine Department of C. D. Smith Drug Co., St. Joseph, Mo.

J. E. Maunder, formerly manager of the Stix, Baer & Fuller talking machine department, has been appointed manager of the St. Louis branch of the C. D. Smith Drug Co., St. Joseph, Mo., district distributor for the Sonora talking machines. Preparations are under way for opening at 613 and 615 Arcade Building, where a complete line of uprights and art models will be carried for the convenience of dealers in St. Louis and the eastern half of Missouri. The western half of the State and half of Kansas and ten counties in Oklahoma will be looked after from the St. Joseph headquarters.

We all know the old saying that "Honesty is the best policy," but how often some forget to practice it!

MASTER WAX

BUSINESS BLANKS

The Wax and Novelty Company

67-69 Paris Street, Newark, N. J.

Manufacturers of

Special Waxes for Recording and Black Diamond Business Blanks

The Black Diamond Blank for Dictating Machines is made of the finest materials and will give cheaper and more satisfactory service than any other blank.

We would be glad to discuss a sales proposition from different territories for our output.

F. W. MATTHEWS

NORTHERN CALIFORNIA ASSOCIATIONS TO AMALGAMATE

Allied Music Trade in San Francisco Bay Region to Meet at Commercial Club March 15—Important Program Outlined—Will Help Trade Solidarity—Robinson Has Edison—Brunswick Progress

SAN FRANCISCO, CAL., March 5.—One special benefit of a deflation period is that at such a time the merchants are brought to a realization of the absolute necessity of getting together in order to uphold standardization in business methods. The panicky few have altogether too much influence on the trade and the buying public and it is only by the contacts possible in forward-looking associations that general confidence can be effectively stimulated. Business conditions on the Pacific Coast are not up to normal, yet there is no reason to be unduly concerned because of that fact. The merchants are well trained in handling difficult problems arising from uncertain economic conditions; they have been conducting business for some months, having in mind a possible slump, and now they are well fortified against the embarrassments of a declining market and curtailed demand. No business failures of importance in the California music trades have been reported recently.

To Organize New Association in the North

A new business organization, which will undoubtedly be a great force in maintaining trade confidence here, is to be formally organized in San Francisco on March 15. This is the Music Trades Association of Northern California, which will be an amalgamation of the talking machine, piano merchants and sheet music dealers' associations, and will also include the small goods dealers. The Music Trades Association of Southern California, which has a paid secretary and permanent office, has done a vast amount of good in the South, especially in promoting business harmony, beneficial legislation, standardization of business procedure, etc. Now San Francisco will fall in line under the banner of co-operation. Several meetings of the organization committee have already been held and the outlook for a large charter membership

is splendid. On March 15 a dinner will be given at the San Francisco Commercial Club, to which all the members of the allied music trades in the San Francisco Bay region have been invited. A set of by-laws has been prepared and at the meeting the dealers will be given the opportunity to sign up, a method of financing the organization will be devised and officers will be elected. The principal speakers at the dinner will be A. G. Farquharson, secretary of the Music Trades Association of Southern California, who will address the company on "What the Music Trades Association Has Accomplished in Southern California," and Robert W. Martland, secretary of the California Auto Trades Association, who will talk on "Co-operation." The organization committee is as follows: Temporary chairman, George Hughes, of the Wiley B. Allen Co.; acting secretary, Shirley Walker, of Sherman, Clay & Co.; Irving C. Franklin, district manager of the phonograph division of the Brunswick-Balke-Collender Co.; G. McConnell, of McConnell & Fraser; John D. Loder, Pacific sales manager of the Sonora Co.; Walter S. Gray, the talking machine accessories jobber, and Byron Mauzy, of the Byron Mauzy Co.

Installs Complete Edison Department

Robinson & Sons Co., large furniture dealers of San Jose, have done so well with Edison merchandise since they took on the line last December that the company has added a complete Edison department on the main floor, making extensive alterations and improvements to accommodate the department. The department is one of the most attractive in Santa Clara County. The main display and demonstration room is twenty by twenty feet and there are three other soundproof rooms, each twenty by ten feet. Later three additional demonstration rooms will be installed on the balcony. Adjoining the demonstration rooms is an Edison

Well Rated Dealers
Can Discount Their
**PHONOGRAPH INSTALLMENT
CONTRACTS**
WITH US
Thereby Turning Their Accounts
INTO WORKING CAPITAL



459-465 Montgomery St.
San Francisco, Cal.

turntable room. The department office, on the main floor, and the other rooms are all finished in ivory and French gray and luxuriantly furnished. The record racks are under the grand staircase leading to the balcony. The manager of the new department is Frederick Orr, formerly with Gallegher & Cole, of San Jose, and prior to that sales engineer for the Pathé Co. Mr. Orr originally received his training with the Edison Co., and he is an enthusiastic believer in Edison goods and methods of merchandising. He will take advantage of all the Edison "go-getter" interlocking plans of merchandising and will carry a complete representative Edison line exclusively. A feature of the new department will be daily recitals in the concert hall on the second floor of the building. The grand opening is planned for March 15.

Remember the Fancy Ball on April 2

Folks, get your costumes ready for the grand fancy dress and mask ball in the Gold Room of the Palace Hotel on April 2! The arrange-
(Continued on page 98)

When a customer walks into your store and says "Gimme" 16950, 51630, etc.—
Do you "fumble and fool" until he's gone or do you???

File Your Records so you can find them for quick sale and service

This System pays for itself by increasing Sales through better service and Automatic ordering of "Sold-Out" Records

OGDEN'S PATENTED RECORD FILING CABINETS AND VISIBLE TAB INDEXES ARE GUARANTEED

MODEL No. 2150 DD
2 UNITS ILLUSTRATED

LOCKING ROLL TOP PREVENTS DUST AND THEFT, ALSO SUPPLIED WITH SPANISH LEATHER CURTAIN

350 10" OR 10 1/2" RECORDS ON EACH SHELF, FILED IN SALES SYSTEM COVERS AND WITH INDEX GUIDES.

350 10" OR 10 1/2" RECORDS ON THIS SHELF, ALSO 3 SHELVES ABOVE.

SOFT FLAT SUPPORTING SPRINGS PREVENTS WARPING (PATENTED), HOLDS 350 10" OR 12" RECORDS.

10" AND 12" RECORDS FILED ON SAME SHELF, HELD FLUSH AT THE FRONT BY PATENTED ADJUSTE

93 inches

48 inches

48 inches

15 inches

2150 THIN RECORDS IN EACH UNIT.
4300 RECORDS IN 2 UNITS.
2150 EDISONS IN 2 UNITS. STOCK FINISHES:
WHITE IVORY & PEARL GRAY
MAHOGANY & OAK

OGDEN SECTIONAL CABINET CO., INC., LYNCHBURG, VA.

Immediate Shipments

on all models in standard finishes. Light and Golden Oak, Red and Brown Mahogany, Enamels, White, Old Ivory and French Grey.

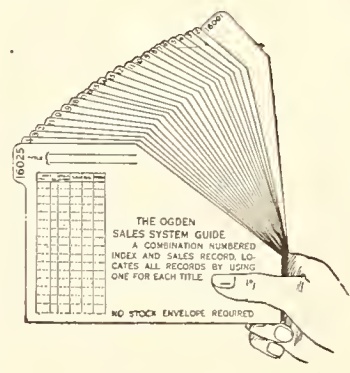

Visible Tab Paperoid Index

The Tab extends in front of the record with numbers always visible. Used the same as a stock envelope, one for each title, leaving all records in their envelopes. Is used to re-order by and keeps "Sold-out" numbers continually before you. Shows quick and slow sellers. The best and simplest "Sales and Ordering" index ever devised and rapidly replacing the stock cover because of its many advantages. Fits any filing system, shelving or racks. Printed both sides for right or left hand flat or upright filing.

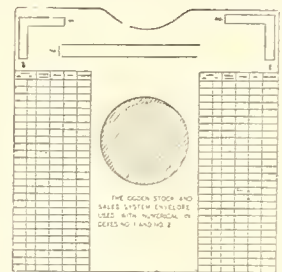

SALES SYSTEM ENVELOPES keep track of what you sell and what you need—an automatic inventory, showing profitable and slow sellers. Arranged for upright or flat filing and will fit any system.

Sectional Models! Fit Any Size Stock and Help You Grow.

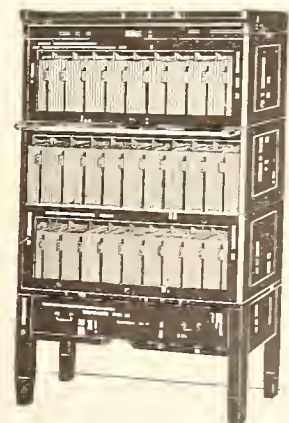

CALIFORNIA ASSOCIATIONS TO MERGE
(Continued from page 97)

ments for the big affair have all been made and without question this will be the most interesting function to be held in a long time by the talking machine and music trade merchants of the San Francisco district. Billy Morton, manager of the retail talking machine department of Sherman, Clay & Co., has been working overtime preparing for the ball.

Brunswick Record Stars in Concert

Irving C. Franklin, of the San Francisco office of the Brunswick-Balke-Collender Co., says February business shows an improvement over January. The recent tours of Godowsky, Rosen and Virginia Rea on the Coast have created much interest in Brunswick records. Mr. McNeil of McNeil & Co., Stockton, has won local fame as an impresario by reason of a stunt he maneuvered this month. Mr. McNeil thought it would be a treat for his fellow citizens, as well as a fine business expedient, to have Miss Rea, Godowsky and Rosen give a concert together at the T. & D. Theatre, and he went to work accordingly. Luck favored and he was able to secure the services of the three Brunswick stars. Many record sales resulted.

ADAM AND EVE ON DISPLAY

San Francisco House Has Novel Window Display to Feature Columbia Record Hit

SAN FRANCISCO, CAL., March 5.—Among the interesting and attractive window displays seen recently at the music houses of this city was that of the G. A. Einselen Music Co., featuring



Unique Window of G. A. Einselen the Columbia record, "Eve Cost Adam Just One Bone." Two large Kewpie dolls were placed in the center of a display representing the ancient Garden, and the entire background was made up of a large cut-out of the record. In his hand Adam held the rib bone which started all the controversy. The window was designed by R. C. Coltart.

SPECIAL WINDOW FOR GRAND OPERA

Unusual Treatment of Display Carried Out by the R. H. White Co. in Boston

BOSTON, MASS., March 7.—Quite an ambitious undertaking has been achieved at the R. H. White Co.'s Washington street establishment, where one window is given over to grand opera tableaux wherein are featured the Victor records. In the window a miniature stage has been built and throughout the day there are different scenes from such operas as "Carmen," "Aida" and "Faust" shown, a change being made hourly. In each scene there are two, three or more characters represented, all in costume. In the foreground are the Red Seal Victor records of the selections from the operas illustrated on the little stage. The window has been arranged by Ford M. Sperry, the manager of the R. H. White Co.'s talking machine department, who worked out the scheme in co-operation with local Victor representatives.

EDISON 1921 AMBEROLA DISPLAYS

New Series Is Considerably Larger Than 1920 Displays and Is Prepared in Many Colors

The accompanying illustration shows one of the first 1921 series of Edison Diamond Amberola window displays prepared by Einson Litho, Inc. Edison dealers have already received this display and are enthusiastic regarding its artistic appearance and sales value.

The new series will be considerably larger than the 1920 displays and every display will involve the use of many colors. The April window which is reproduced is entitled "Amberola Nights," the general design typifying the famous "Arabian Nights." A pleasing Oriental color scheme is introduced in this display and the window as a whole is well calculated to attract the attention of passers-by.

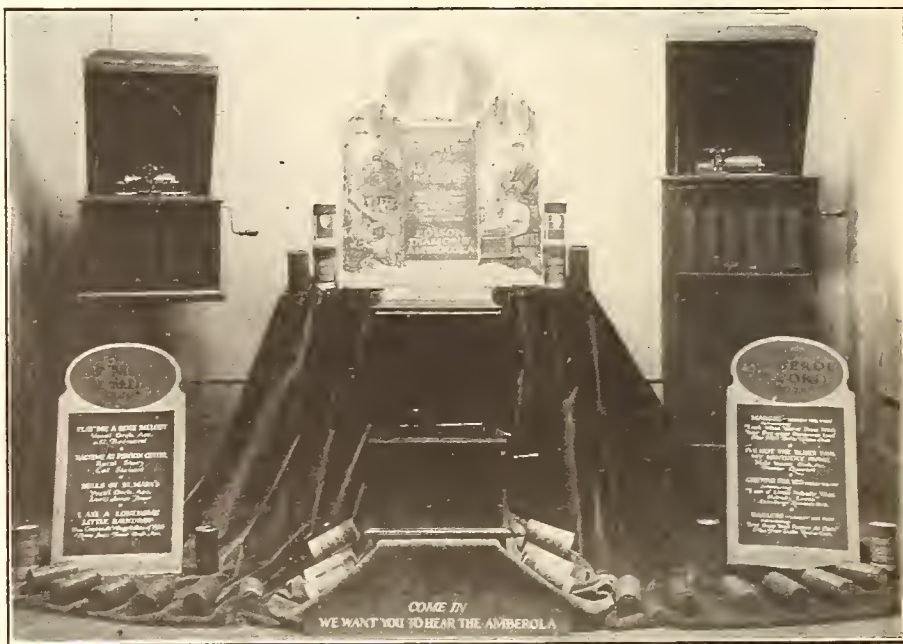

Edison Diamond Amberola Window Display for Dealers

THE PHONOLAMP IN TRENTON

The Electric Phonograph Corp. has opened an establishment at 15-17 North Montgomery street, Trenton, N. J., for the sale of the Phonolamp. Roberts & Jammer have been made the New Jersey distributing agents for the Phonolamp. The instrument is a novelty in musical contrivances, being a phonograph and lamp.

Victor Dealers

The Usoskin Victor Monthly Window Display Service is the ideal salesman.

It stays on the job day and night.
It makes sales for you at all hours.
It never goes on strike.
Its salary is only a few cents a day.

Let us send you a sample set and tell you more about it.

USOSKIN LITHO, Inc.
230 WEST 17th ST., NEW YORK CITY

AUTOS AND TALKING MACHINES

Harry C. Wood, proprietor of the West End Garage, on West Hanover street, Trenton, N. J., is the only automobile dealer in that city to become a talking machine dealer. Mr. Wood has devoted his attractively arranged showroom facing on West Hanover street to the display of talking machines. "The sale of talking machines," he said, "aids my auto business and

vice versa. Garage owners have plenty of time just now and I devote it to the sale of the 'talkers'."

OPENS IN PRINCETON, N. J.

B. Franklin Bunn, manager of the University Store, Princeton, N. J., has opened a musical establishment on Nassau street, that city, after having thoroughly renovated the building for that purpose. Mr. Bunn handles talking machines, records and other musical instruments.

DON'T SPECULATE

on slow service—It hurts trade

MOORE-BIRD COMPANY

Distributors of **OKeh Records**

Gives best attention and quickest delivery on all orders. Your business requires *speed*

MOORE-BIRD COMPANY, 1751 California Street, Denver, Colorado

A Sales Builder

THE

DANCE NEEDLE



The new DANCE NEEDLE which we introduced last month has already won countrywide popularity and dealers are enthusiastic regarding its sales appeal.

The DANCE NEEDLE is the only one of its kind in the market, and this name alone will make it an ideal selling proposition.

The DANCE NEEDLE is a decided novelty that can be featured as a direct attraction to the consumer. Every buyer of dance music is a prospect for substantial sales of the DANCE NEEDLE. Approximately 75% of all records sold are dance records, and this means that 75% of all needles sold will eventually be the DANCE NEEDLE.

There is no other needle manufactured that has such a unique and direct appeal to the consumer.

The DANCE NEEDLE is only one of the ten standard styles of needles we manufacture.

GENERAL PHONOGRAPH CORPORATION

OTTO HEINEMAN, *President*

25 West 45th Street

New York City, N. Y.

Factories: Newark, N. J. Elyria, Ohio Putnam, Conn. Springfield, Mass. Kitchener, Ont.

Branch Offices: Chicago, Ill. Toronto, Can. London, Eng.

The Trade in **BOSTON** *and* **NEW ENGLAND**

JOHN H. WILSON, Manager
324 WASHINGTON ST., BOSTON, MASS.

BOSTON, MASS., March 4.—General business conditions in the talking machine industry are showing marked signs of improvement. The money question is playing its part in retarding progress with the small dealers who are running close on stocks. The partial payment plan is not being seized with any great degree of avidity by the buying public, though there has been great pressure brought to bear through the medium of daily newspaper advertising by many dealers throughout the city. This class of patronage, however, is being very closely scrutinized by dealers who are not disposed to let the buyers get a bit behindhand.

Hope Prof. Day Is a True Prophet

According to a speaker who addressed the Dartmouth Club at the City Club yesterday, business will begin to boom this Spring. This speaker, Professor E. E. Day, of the economics department of Harvard, showed charts by which he said the trend of business can be forecasted six months ahead. He declared the process involves nothing mysterious or occult, but follows well-defined economic lines.

"The Wandering Minstrel" Makes Its Debut

"The Wandering Minstrel," in its dress of green, made its initial appearance about the middle of February and the second issue is awaited with interest. Miss Frances Hanson, of the Steinert forces, is the editor and she is to be congratulated on bringing together some readable material. Frank S. Horning, of the F. S. Horning Co., Inc., Victor dealer, at 22 Boylston street, is represented with a good article, and the next issue should find others of the talking machine dealers included within its pages.

New England Columbia Salesmen Gather

All the New England salesmen of the Columbia Co. gathered late in February at the Boston branch headquarters for the February-March sales conference, at which the selling program for the following month was launched. The conference was attended by O. F. Benz, the record sales manager of the Columbia Co., who came over from New York especially for this occasion. Manager Fred E. Mann presided and in his talk to the assembled men he imparted some of his well-known energetic and

**Optimism, Confidence
and
Steinert Service**

Overcome and surmount any and all
obstacles or difficulties and help make



LOYAL DEALERS

VICTOR-IOUS

M. STEINERT & SONS CO.
VICTOR WHOLESALERS

35 Arch Street :: :: :: :: Boston
STEINERT SERVICE SERVES

enthusiastic sales ideas. Plans were outlined for further development of the house-to-house campaign, which has been in progress since before the holidays and which has met with marked success in this territory. Complete plans for the sale of the Musi-Call, the Columbia's novelty self-starting device, were also dwelt upon. Messrs. Mann and Benz described the various uses to which this attachment may be applied.

According to Manager Mann the Columbia's new retired record plan, inaugurated on the first of this month and which calls for the sale of discontinued numbers at fifty-nine cents

each, has met with general approval among the company's dealers, who appreciate the possibilities of the plan for stimulating trade. On the whole, the dealers are appreciative of the company's purpose to dispose of the outnumbers in this manner rather than by means of the return system hitherto in force. The first of the month found Mr. Mann quite optimistic with regard to the immediate outlook for continued improvement of business in this territory. February, he reports, made a better showing than January, which had shown a gain over December.

Some Cause for Optimism

The Eastern Talking Machine Co. is finding no cause for complaint, especially when it received an order yesterday from a dealer not far from Boston for twenty-four \$150 Victor machines. February, according to one of the Eastern Co.'s staff, was the biggest of any similar month in the history of the company, and from the talks that the company's representatives have had with dealers there is every reason to believe that business is coming along rapidly. The output of the factory is now such that the records are coming along better than ever and dealers are experiencing no difficulty in getting all the popular numbers they desire, so the Eastern Co. reports. Hovey Dodge was over to the factory a fortnight ago and Herbert Shoemaker plans a trip over within the next fortnight.

Alex. Steinert Visiting Panama Zone

Alexander Steinert, head of the Steinert house, is enjoying a trip to the Panama Zone, taken in company with several members of the Boston Athletic Association. On his return he plans to stop at some of the Florida resorts and perhaps do a little golfing, at which sport he is quite an adept.

Business with the C. C. Harvey Co.

Business in the Edison, Brunswick and Victor lines has been more than good at the C. C. Harvey Co.'s Boylston street warerooms. Manager Francis T. White, who lately suffered the loss of a brother, felt the necessity for a change and rest and, accompanied by his wife and family, he took a trip into the White Moun-

(Continued on page 100)

EASTERN SERVICE

"NEW ENGLAND SERVICE FOR NEW ENGLAND DEALERS"



IT'S the "student" among dealers who keeps growing. You'll learn more about good service by using Eastern Service, altho' the endorsement of others is flattering. Eastern Service specializes on the Victrola and Victor Records in New England.

Eastern Talking Machine Co.
85 Essex Street
Boston, Mass.

THE TRADE IN BOSTON AND NEW ENGLAND—(Continued from page 99)

fains, where they were able to enjoy some of the healthy outdoor Winter sports. Mr. White returned to his labors greatly benefited by the change.

Miss Her Genial Presence

Manager Reed of the Steinert house is lonesome these days for he has lost his secretary, Miss Esther Samuels, who, though she had married some months ago and is now Mrs. Max Alman, had returned to take up her official duties. Now, however, she has departed for good and her presence will be greatly missed by those of the trade who were wont to drop into Reed's cheery office. It's domestic life that is now engrossing Mrs. Alman's attention

Brunswick Artists in Concert Here

There was a large audience at Symphony Hall Sunday evening, February 27, when the Brunswick local management undertook a concert, the artists being two of the Brunswick stars, Max Rosen, the American violinist, and Miss Virginia Rea, coloratura soprano. The hall was well filled and the violinist and singer gave great pleasure. Similar concerts were given at several other places throughout New England. Harry Spencer, the New England wholesale manager of the Brunswick, is to be congratulated on the success of the affair.

Eight Victor Artists Will Not Appear

The concerts planned by Manager Reed of the Steinert house by the Eight Famous Victor Artists have been given up largely because of conditions in some of the New England cities.

Brilliantone Man in Town

L. J. Unger, of the Brilliantone Steel Needle Co., was a visitor in Boston the end of February. He stopped over en route back to New York after a profitable trip among some of the New England cities. He reports the gilt edge new Brilliantone needle as becoming very popular with talking machine users.

Dan Creed Drops in

Another local visitor, always welcome, has been Dan Creed, general manager of the New

York Talking Machine Co., who dropped in at the offices long enough to say "howdee."

Pathé Dealers Hold Conference

Forty New England Pathé dealers came to Boston in February to have an all-day conference at the Hallet & Davis Co.'s warerooms in Boylston street. The dealers came from Portland, Bangor, Lewiston and Biddeford, Me.,

Providence and Woonsocket, R. I., New London and Danielson, Conn., and Springfield, Worcester, Fitchburg, North Adams, Mass., Keene, N. H., and other places. It was a regular "get-together" occasion and its prime purpose was to instill new hope in the minds of the dealers and to convince them that despite conditions there was business to be had if only

HORTON-GALLO-CREAMER CO.

NEW HAVEN  **CONNECTICUT**

VICTOR SERVICE SPECIALISTS

•••

The appreciation of
Victor Supremacy
and the
Horton-Gallo-Creamer Service
increases proportionately as
the year advances

•••

**Okeh
Records**



**Okeh
Records**

The E. B. Shiddell Co., the biggest equipped and only New England Distributor for *Okeh* Records, offers helpful cooperation and prompt service to new Dealers. *Become one today!*

Okeh Records are assured sellers. They are superior recordings of nationally and internationally famed artists.

Dance Records excel because of their fertile originality, volume and tonal qualities. It is the record that suits every taste. Get acquainted with our proposition.

E. B. Shiddell Co., 142 Berkeley St., Boston, Mass.
Okeh Distributors

the dealers would go after it the right way. R. O. Ainslie, manager of the New England department, presided at the conferences and gave an address. Others to speak were President E. A. Widmann, of the Pathé Frères Phonograph Co., and Mr. Watters, also of the company, both of whom came over from New York for this conference. All of these men made good addresses and gave the dealers some spirited advice as to how to get business. Because of his keen knowledge of retail business W. W. Radcliffe, of the Hallet & Davis forces, gave an inspiring talk on retail merchandising. In the evening the company repaired to the Hotel Brunswick for dinner, following which there was an impromptu entertainment to which some of the talented members of the Pathé staff contributed. It is expected that this conference will be the means of greatly stimulating the Pathé business throughout New England.

Hartford House Takes on Sonora

Manager Joseph Burke, of the Musical Supply & Equipment Co., was over in Connecticut lately and was able to sign up with a new house to handle the Sonora line. It was G. Fox & Co., of Hartford, an enterprising house, which should be able to do a good deal for the Sonora in that territory. A new electric sign has lately been installed on the top of a building at the corner of Washington and Essex streets, a most excellent location, as it can be seen from quite a distance down Washington street. Manager Burke says the Sonora business is coming along very well, all things considered.

National Jobbers' Meeting Is Postponed

The meeting of the Executive Committee of the National Association of Talking Machine Jobbers, which was to have been held in this city on March 10 and 11, has been postponed until next month due to the fact that several members of the committee are being held in New York to attend to legal matters.

Building More Sales for the Victor Dealer

We consider it highly important to co-operate with our dealer clients to the end that their Victrola sales may obtain a maximum volume and yet involve a minimum of expense per unit of sale.

Concrete practical help along this line is a fundamental part of Cressey & Allen service to New England Victor dealers. Try us.

CRESSEY & ALLEN

PORTLAND, MAINE



According to the present schedule the executive committee will meet in St. Louis on April 4 and 5, and will then journey to Boston to hold another meeting on April 7 and 8. The two meetings will be held in order to enable the membership of the Association at large to confer with the executives on various matters.

Henry Winkelman, head of the Victor department of the Oliver Ditson Co., is a local member of the Jobbers' Committee.

Silliman a Visitor From London

Frederic H. Silliman, president of the Pardee-Ellenberger Co., Inc., had the pleasure of enter-
(Continued on page 102)

KRAFT-BATES AND SPENCER INC.

NEW ENGLAND DISTRIBUTORS

Brunswick

PHONOGRAPHS AND RECORDS

A Romance Written in Dollars and Cents

THE sales history of The Brunswick is sensational. We can give it to you here in our office in facts and figures instead of the usual high-sounding words of a prospectus of business to be done.

The Brunswick Method of Reproduction has basic improvements which no other phonograph has or ever can have. People who know ordinary phonographs note the different quality of Brunswick tone at the first hearing. No one who hears The Brunswick and understands its advantages and conveniences in addition to its better tone is ever contented with any other phonograph.

Brunswick owners seem to take delight in explaining to their friends exclusive Brunswick features, such as The Ultona, the only real all-record reproducer ever invented, and the Oval Tone Amplifier, an all-wood tone chamber. Brunswick dealers have something better, different and exclusive to offer the customer at the first step in the sale—something that nine customers out of ten understand and appreciate without any discussion.

The Brunswick sells itself.

KRAFT-BATES & SPENCER, Inc., 1265 Boylston Street, BOSTON, MASS.

NEW ENGLAND DISTRIBUTORS

Steel Needles
Albums
Record Brushes
Khaki Covers

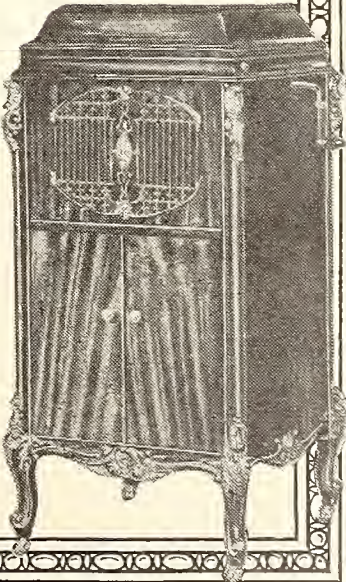

THE TRADE IN BOSTON AND NEW ENGLAND—(Continued from page 101)

LONGMUSIC CABINETS
See Display Ad in This Issue

Peerless Record Albur

See Display Ad in This Issue
SPECIAL

I am prepared to ship all orders on either line promptly.

Send your orders for both these lines to
L. W. HOUGH, 20 Sudbury St., Boston, Mass.
New England Representative

taining his son, Horace Silliman, who is now in business in London, England, and who came over for a few weeks, sailing toward the middle of February. Mr. and Mrs. Silliman, it may be recalled, visited their son in London last Summer. President Silliman says that he sees a constant improvement in the Edison business, and in the New England field he has added a few dealers in the State of Maine.

Changes on Staff of Steinert House

Several changes were scheduled to take place within the ranks of the Steinert Boston house beginning on March 1. The new member of the Victor staff is Mr. Bothwell, who has been out of the talking machine business for a couple of years, but who now becomes retail manager at the Boylston street store of the company. He succeeds G. Frank Baldelli, who has been transferred to the Arch street store to take the place of Guy L. Foote as retail manager. Mr. Foote has been with Steinert's fourteen years and his experience has been such that the house feels warranted in advancing him to be wholesale representative with New Hampshire and Vermont as his territory.

Features Al Jolson's Records

Manager Arthur Erisman, of the Grafonola Co. of New England, had a very attractive window in his Tremont street store the middle of

February in which Al Jolson was featured. There was a tall pasteboard figure of this comedian in the center and grouped around were the records of this popular entertainer. Manager Erisman's other shop around the corner in Boylston street is constantly proving itself an admirable location because of the popularity of this street, which is much traveled all through the day.

Fitzgerald to Open in Framingham

William Fitzgerald, who has a well-appointed Victor headquarters in the Studio Building at the corner of Tremont and Bromfield streets, is branching out, and about the middle of March he will open up a new shop in Framingham, which is twenty miles out of the city. He has taken a large floor space and basement at 59 Concord street, which is centrally located, and he is fitting the place up in a most attractive style. He will have an electric sign on the outside and he will carry a full line of Victor machines and records. The store will be in charge of "Billy" Fitzgerald's nephew, William J. McCarthy, who under his uncle has had a thorough and valuable training in handling the Victor product.

ACCEPT 25 PER CENT ON CLAIMS

Unsecured Creditors of New England Piano & Phonograph Co. Meet and Adjust Affairs

BOSTON, Mass., March 2.—There was an informal meeting last evening of the unsecured creditors of the New England Piano & Phonograph Co. at the warerooms, 405 Boylston street, and of the seventy-five or so creditors thirty-two were in attendance. J. W. Connolly was present to represent the W. W. Kimball Co., of Chicago, which is the largest creditor, and he also represented the New England's interests. Charles G. Faux, the head of the company, was present and he answered such questions as were put to him regarding the

The "Perfection" Universal Ball-Bearing Tone Arm No. 6 With New Pur-i-tone Reproducer (attached)



Set in position for playing "lateral" cut records

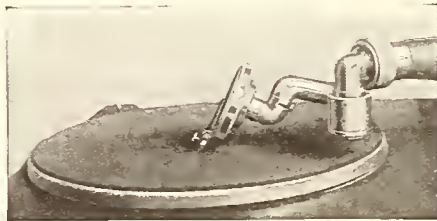

Set in position for playing "hill and dale" records with diaphragm facing front of machine

The "Perfection" Universal Ball-Bearing Tone Arm No. 6 with New Pur-i-tone Reproducer attached plays Victor, Columbia and all other makes of disc records on all types of Edison Disc Machines, producing with clarity and volume of tone excelled by no other attachment. This attachment is manufactured in Gold, Nickel and Oxidized finish (William & Mary) with the best of India Mica Discs.

WRITE FOR DESCRIPTIVE CATALOG AND PRICES

Manufactured by

New England Talking Machine Co.
16-18 BEACH STREET BOSTON, 11, MASS.

DISTRIBUTORS:

CALIFORNIA
San Francisco—Walter S. Gray Co.
COLORADO
Denver—Denver Dry Goods Co.
GEORGIA
Atlanta—Phonographs, Inc.
IOWA
Des Moines—Harger & Blish
MASSACHUSETTS
Boston—Pardee-Ellenberger Co.

MISSOURI
St. Louis—Silverstone Music Co.
NEBRASKA
Omaha—Shultz Bros.
NEW YORK
Albany—American Phonograph Co.
New York—The Phonograph Corp. of Manhattan

OHIO
Cleveland—The Phonograph Co.
PENNSYLVANIA
Pittsburgh—Buehn Phono. Co.
Philadelphia—Girard Phono. Co.
UTAH
Ogden—Proudfit Sporting Goods Co.
VIRGINIA
Richmond—C. B. Haynes Co., Inc.

Factory Representative—Louis A. Schwarz
1265 BROADWAY, NEW YORK, N. Y.

Your Guarantee Mr. Dealer LANSING KHAKI COVERS

For All
Phonographs

Unqualified Endorsement
of Biggest Manufacturers
and Dealers



Slip
and Rubber
Covers
for
Phonographs

Slip
and Rubber
Covers
for
Pianos

Factory Representatives:

L. A. SCHWARZ, 1265 Broadway, New York City.
BRUNSWICK-BALKE-COLLENDER CO., 623-633 So. Wabash Ave., Chicago, Ill.
ALL-IN-ONE PHONOGRAPH CORP., 21 East Van Buren St., Chicago, Ill.
WALTER S. GRAY CO., 942 Market St., San Francisco, Cal.

Lansing
SALES CO.

Eliot and Warrenton Sts.
BOSTON, 11, MASS.

company's business. There were a number present who were willing, apparently, to accept twenty-five per cent on their claims and to-day there was filed with the United States Court of Bankruptcy an offer of composition by Mr. Connolly.

The total liabilities of the New England have been placed at \$225,000, this being divided between the secured creditors (\$150,000 and the secured creditors (\$75,000). It is understood that the assets amount to about \$210,000.

Some of the largest creditors are the W. W. Kimball Co., of Chicago, \$11,000; a local trust company, \$12,500; Biddle Piano Co., \$3,212; Empire Talking Machine Co., \$1,385. Several of the Boston daily papers are in the list with good-sized claims for advertising.

"Nameplates With a Personality"

For Manufacturers and Dealers of Talking Machines,
Phonographs, Musical Instruments, etc.

E. V. YEUELL CO., Malden, Mass.
When You'll Think of Nameplates
You'll Think of Yeuell.



DITSON SERVICE

Has back of it years of successful experience and an understanding of dealer problems that will make the road smoother during the coming months.

VICTOR EXCLUSIVELY

Oliver Ditson Co.
BOSTON

Chas. H. Ditson & Co.
NEW YORK

A REVIEW OF TRADE CONDITIONS AT SOUTHERN POINTS

Business Showing Better Trend Despite the Fact That Prices for Farm Products Are Extremely Low—Price-Cutting Somewhat in Evidence—Suggestions on Moving Merchandise

ATLANTA, GA., March 6.—The month of February, while the shortest of the year, seems to have been productive of a good volume of business in the talking machine and record field in this city. Several important changes in price and special sales have marked the month as bringing the first price reduction in phonograph products in several years.

The prices being received for farm products in this section, particularly cotton, are almost ruinous, but most of the planters and cotton factors have simply charged off last year's crop to profit and loss and are looking to the future with renewed hope. The cotton crop next Fall will be the smallest in the memory of those now living, if all signs do not fail.

Dealers in talking machines and records in the strictly cotton States are, in many instances, "loaded to the guards" with stock and all kinds of prices are heard of. One dealer is reported to have offered his stock of standard make product at 20 per cent less than the wholesale cost. Another offers a stock of 3,000 standard make records costing him 51 and 60 cents each at a flat price of 40 cents apiece. It is hoped, however, that these cases are the exception rather than the rule. Locally there seems to have been a fair volume of trade.

The Phillips & Crew Piano Co., Victor dealer, hopes to move into the new store in the next few weeks. Business with them is good and the out-

look for the year encouraging. Manager Robinson has just returned from a trip to the Savannah, Ga., branch and found things moving nicely.

The special features of the month were reductions in the price of records. The Columbia Graphophone Co. brought out reduced prices on many of the ten-inch records. The Emerson Co. reduced ten-inch \$1 records, except those of one artist, to 85c. Okeh \$1 records were all reduced

LEON F. DOUGLASS IN HONOLULU

Prominent Victor Official and Motion Picture Inventor Goes to Hawaii to Try Out Perfected Color Photography Process There

HONOLULU, HAWAII, February 21.—Hawaii's wondrous rainbow-hued fishes will be photographed in their natural colors by Leon F. Douglass, chairman of the board of directors and one of the founders of the Victor Talking Machine Co.

Accompanied by Robert Carson, a camera man who has "shot" films for Mary Pickford, Douglas Fairbanks and other movie stars, Mr. Douglass has arrived here on the Pacific Mail liner "Creole State." With him are Mrs. Douglass and his sister, Mrs. Florence Egan.

Mr. Douglass has gained world fame by his invention and perfection of an apparatus for taking action motion pictures. Heretofore the best

to 85 cents, except those of one noted artist.

It occurs to the writer that if any dealer, or any number of them, would guarantee the sale price against their own decline during the life of the lease contract many sales could be made that would otherwise not materialize, due to the lack of confidence that the buying public feel in present prices and the fact that they think that the prices of most phonographs are too high. This, we know, is not always a pleasant suggestion, but it would seem better to move the merchandise, even though some unusual inducement is offered, rather than have it "eat its head off in the stable."

French color motion picture machine could not take pictures faster than one second for each section of film exposed. Mr. Douglass, after twenty years of experimentation and study—color photography being his hobby—has produced a process by which color photographs can be taken with an exposure speed of 1-100 of a second. This makes regular motion picture features in color possible.

Mr. Douglass had charge of Thomas A. Edison's first motion picture machine, the kintoscope, in 1890, and helped devise the first projecting machine five years later. His color process for motion pictures gains its effects by subtracting colors instead of mixing them as an artist does. He has secured forty patents.

Speaking of conditions in the talking machine business, Mr. Douglass said the Victor Co. is \$130,000,000 worth of contracts behind in production and that it has had to hire more men instead of letting any go.

FOUNDED 1835

ARMSTRONG'S



Distributors

There are numerous reasons why Pathé Dealers are satisfied.
Write today for full information.

ARMSTRONG FURNITURE CO.
59 and 61 North Main Street
Memphis, Tenn.



UTILITY

BEAUTY

Modernola

THE INSTRUMENT
UNIQUE

TONE

Modernola

BEAUTY

EXTERIOR BEAUTY IS A GREAT HELP IN SELLING AN INSTRUMENT, BUT IN PHONOGRAPHY BEAUTY MUST BE MORE THAN CASE DEEP.

MODERNOLA EXPRESSES BEAUTY FROM TONE TO TIP OF LAMP SHADE AND HAS THE OUTWARD ORIGINALITY THAT GIVES THE CROWNING TOUCH TO ITS GOOD LOOKS — INDIVIDUALITY.

THE
MODERNOLA COMPANY
JOHNSTOWN, PA.
Eastern Distributors:
EASTERN
PHONOGRAPH CORPORATION
100 WEST 21st STREET, NEW YORK

BRIGGS



“The Palms” and “The Holy City,” in the great baritone of Louis Graveure, are in such close harmony with the Easter season that you will find enthusiastic response to these sacred solos. A-6179.

**Columbia Graphophone Co.,
NEW YORK**

LOS ANGELES TRADE PERFECTS PLANS FOR MUSIC WEEK

Will Be Held Week Commencing May 29—Commendable Ethics—New Remington Distributors—National Association Discussed—Sibley Pease With Barker—Interesting Budget of News

LOS ANGELES, CAL., March 3.—Announcement has been made that Los Angeles will have a Music Week commencing May 29. Alexander Stewart, official organizer from New York, has outlined his proposals and plans to have a special committee formed for the purpose, and F. W. Blanchard, the most popular and capable of music men in this part of the country, was elected chairman. There are well-founded rumors that the Music Trades Association of Southern California will take advantage of the occasion and put on a Music Show at the same time. A Music Show has never been held in Los Angeles, although often discussed; the chief difficulty has been the organizing of a suitable site. It is certain, however, that, if the project is attempted, it will be staged in a fashion and on a scale in keeping with the high-class standards set by the music merchants in this section.

Sales Ethics Exemplified

A striking example of the high regard for a strict observance of ethics in respect to competitive sales was revealed last week in the following manner: A lady customer entered the Victrola department of one of the leading music stores in Los Angeles and, after purchasing a Victrola, remarked that she desired that due credit should be given to the salesman who had called at her home and first awakened her interest in the purchase of a Victrola. She gave the name of the salesman—although she confessed that she was not quite certain that the name was the right one. The sale being completed, the lady left the store. But the house had no salesman with the name given by the lady, so every Victor department in town was telephoned to and asked if they had a salesman of that name—the management declaring that the sale would be turned over to the store whose salesman had been first responsible for the

lady's desire to purchase a talking machine. The above is surely a splendid example of observance of the Golden Rule and strictest regard for a square deal.

Aeolian General Sales Manager Here

W. H. Alfring, general sales manager of the Aeolian Vocalion, was in Los Angeles during the last week of February accompanied by H. M. Hull, Pacific Coast manager, as well as E. R. Darvill, Southern California representative, who has just returned from an extended trip in Arizona and New Mexico, where he found conditions, from a Vocalion standpoint, very satisfactory. Mr. Alfring expressed himself well pleased with the prospects for the future all along the Coast.

Charlie Ruggles Visits San Diego

After many moons Charlie Ruggles, manager of the Los Angeles branch of Sherman, Clay & Co., Victor distributor, visited San Diego. Victor dealers in the Southern city had looked forward to such a visit for a long time and gave him a warm welcome. He found business in a very healthy state and the outlook for the future bright. Visiting Tijuana in company with Manager La Motte, of the Thearle Music Co., as a sightseer only he distributed a small amount of change and returned across the border free of any desires to alter his regular habitat.

Santa Barbara Dealer Uses Historic Building

Ralph H. Paulin, of the Paulin Music Co., recently found it necessary to enlarge his talking machine and piano departments and accordingly leased an old adobe building which stands in the rear of his store. This old Spanish house is a century old and the walls are three to four feet thick. Extensive alterations were made and the services of a high-class decorator engaged, with the result that the new department is at once unique and attractive. A separate entrance

gives the opportunity of holding attractive recitals and entertainments which have been planned on an extensive scale.

Becomes Remington Distributor

Gilbert B. Pelton, 533 South Spring street, has been appointed distributor for the Remington phonograph on the Pacific Coast. Mr. Pelton is well known in Los Angeles business and financial circles and has considerable experience in wholesale lines other than talking machines. He expects to receive a shipment of Remingtons in the near future.

Photographer Selects Model Store

A specialty company, investigating model layouts and arrangements in retail stores, recently invaded the Andrews Talking Machine Co.'s store on Broadway, which has recently been remodeled and decorated. Misunderstanding, purposely or otherwise, a refusal of Irving Andrews to permit the taking of a photograph, the visitors set up a camera and took a flashlight of the interior while everyone was busy with customers. The muffled explosion and smoke from the flashlight almost created a panic among persons inside and outside the store—newspaper stories of hold-ups, kidnappings and unusual happenings being responsible for a nervous state of mind of the public.

San Francisco Visitors

Distinguished members of the San Francisco music trade visiting Los Angeles last week included Fred Sherman, of Sherman, Clay & Co., and George R. Hughes, secretary of the Wiley B. Allen Co. The former was en route for Mazatlan, Mexico, while the latter was paying an official visit at the Wiley B. Allen Co.'s Los Angeles branch. Mr. Hughes also brought the news of the definite date, March 15, of the organization meeting of the proposed Music Trades Association of Northern California.

Sibley Pease Joins Barker Bros.

J. W. Boothe, general manager of the music department of Barker Bros., has appointed Sibley Pease as his assistant. Mr. Pease is well

(Continued on page 107)



Okeh Records



We are ready to supply you with **MAMIE SMITH** records—the best recorded dance hits on the market. Vocal recordings that are perfect in tone and clarity. Your orders will receive immediate shipment.

Don't make the mistake of not being an Okeh Record Dealer. We shall be glad to furnish particulars upon request.

INDEPENDENT JOBBING CO., Okeh Distributors, Goldsboro, North Carolina

Slides for Talking Machines



Over Five Hundred Thousand

Talking Machines are annually being equipped with

DOMES OF SILENCE

There's a reason!

In addition to the fact that they save strain on Cabinet legs, save floors and rugs, they permit of the Cabinet setting closer to the floor. Thus you obtain Harmony of Design as well as easy moving qualities.

Manufacturers will gladly put them on the Cabinets you order if you specify them.

HENRY W. PEABODY & CO.

Domes of Silence Division

17 STATE STREET, NEW YORK

SPECIFY DOMES of SILENCE

BRUNO

Even Govern-
ment bonds are
selling below
par; not so with
a Victor.

BRUNO

LOS ANGELES PLANS MUSIC WEEK
(Continued from page 105)

known in Los Angeles music trade circles and has had many years of experience in the business. He is, in addition, well known as the official organist for the Elks' Lodge 99, as well as organist of the First Presbyterian Church, of Los Angeles, having held both positions for a number of years.

A branch store of Barker Bros. will be opened this month in Pasadena. Very high-class studio and period furniture will be carried in addition to the phonograph department.

National Talking Machine Association Discussed

Members of the music trades directly concerned with talking machine and phonograph retail departments unanimously maintain that a national association or distinct unit of the National Association of Music Merchants should be formed and organized in order that matters affecting the retail talking machine and phonograph business generally throughout the country might be properly discussed and handled for the common good. In other words, they believe that a committee consisting of retail talk-

ing machine and phonograph dealers only should be representative and active enough to discuss the various problems which peculiarly affect the retail dealers only.

Gives Daily Lectures

A series of interesting lectures in conjunction with the Brunswick phonograph and Brunswick records have been given daily for the last week or two by Ruth Howard, manager of the record department of Long's Music Store, Pasadena. This very clever advertising plan was scheduled at the local Y. M. C. A.

KURTZ SPEAKS TO PIANO MEN

Tells of Plans to Make the Talking Machine Men, Inc., an Active Organization

Irwin Kurtz, president-elect of the Talking Machine Men, Inc., made up of the leading talking machine dealers in New York, New Jersey and Connecticut, was present at the March meeting of the New York Piano Merchants' Association and took advantage of the opportunity to tell the piano men something of the plans which he has in mind for the talking machine trade in and about New York for the coming year. In speaking of the talking machine association he declared that it was a potential factor in the development of better trade conditions and while for some time past it has been more or less inactive he plans to revive it and make it accomplish what it was organized to do. The talking machine dealers will be called upon to do many things to help better the standards of their trade and in so doing will be working with their officers.

Standing by the officers of an association is of greatest importance and Mr. Kurtz emphasized this fact to the assembled piano men. Attending meetings should be considered the duty of every member of the association and the coming year this will be impressed on the talking machine dealers by their president.

W. H. TYLER NOT WITH SONNENBERG

We have been requested by the Sonnenberg Music Co. to state that there is no truth in the statement recently made that W. H. Tyler has been appointed manager of the Victrola department of the New Haven store. Mr. Tyler is not in the employ of the Sonnenberg Co.

Don't cry over your mistakes. Profit by them and resolve never to make the same mistake.



A Musical Merchandise Department Is an Asset

You can serve thousands of your neighbors with all of their Musical needs

It means

NO ADDITIONAL EXPENSE

QUICK SALES

LIBERAL PROFITS

FINE WINDOW DISPLAYS

REPEATING CUSTOMERS

We have the most extensive and finest line of Musical Merchandise in the trade at the very lowest prices.

Write for Our 1921 Catalog Fully Illustrated

Special Assortments for Phonograph Dealers



Buegeleisen & Jacobson
5-7-9 Union Square
New York

HAS OWN STORE MUSIC DIRECTORY

Sherman, Clay & Co. San Francisco Establishment Is So Large That Guide Is Needed

Some idea of the extent and size of the music establishment of Sherman, Clay & Co., in San Francisco, may be obtained from a glance at a little pocket folder which the company has recently prepared for the convenience of its patrons. In this folder are listed in alphabetical order all the instruments and accessories of a complete music house, the names of the members of the organization and such other information as might be required in cases of emergency. Opposite each item is given the floor number where it may be found. This has been found to be of great aid to customers in quickly locating whatever they may desire to purchase.

Shed no tears over your lack of early advantages. No really great man ever had any advantages that he himself did not create.

READJUSTED PRICES

SPRINGS

- No. 200—5/8-inch x 10 ft., Pathé, Sonora. \$27
- No. 201—3/4-inch x 10 ft., Columbia, Heineman 29
- No. 202—7/8-inch x 10 ft., Meisselbach.. 35
- No. 203—3/4-inch x 9 ft., Blick, Melophone 35
- No. 204—1-inch x 10 ft., Col. all styles 50
- No. 205—1-inch x 9 ft., Meiss No. 2.. 45
- No. 206—1-inch x 12 ft., Pathé, Heineman, Meisselbach 55
- No. 207—1-inch x 13 ft., Small Victor 55
- No. 208—1 1/4-inch, New Victor..... 85
- No. 209—1-3/16-in. x 16 ft., Heineman & Pathé 90
- No. 210—1 1/2-inch x 11 ft., Edison Diamond Disc 1.50

OTHER SIZES UPON REQUEST

SAPPHIRES

GENUINE EDISON TYPE SAPPHIRE POINT NEEDLES

In lots of.....	12	25	100	500
	11c	10 1/2c	9 1/2c	8 1/2c

GENUINE PATHE TYPE SAPPHIRE POINT NEEDLES

In lots of.....	12	25	100	500
	10c	9 1/2c	9c	8 1/2c

GENUINE EDISON TYPE DIAMOND POINT NEEDLES

In lots of.....	12	25	100	500
	1.50	1.40	1.25	1.15

We also handle a complete line of

MOTORS, TONE ARMS, REPRODUCERS, Etc.

SPECIAL QUANTITY PRICES. WRITE TODAY

THE ARGUS PHONOGRAPH SUPPLY CO.

30 EAST 23d ST., Tel. 1749 Gramercy NEW YORK CITY





Sheraton



Colonial



Louis XV



Chippendale



Hepplewhite

QUALITY
HANOVER, PA., U.S.A.

This Is the Day of The Console

This type of talking machine cannot be bought today except at a very high price—a price beyond the means of many people who want that type machine.

We have solved the problem by designing the five period models shown. These designs faithfully represent the periods. The cabinet work and finish are up to the usual LONG QUALITY standard.

These five "CONSOLES" are intended to be used in connection with the popular Victrola VI, producing a combination outfit that *looks like* a complete unit costing \$250.00, but which you can sell at a very moderate price—a price within the reach of all.

Orders received for them indicate that these cabinets have caught the popular fancy, and they are bound to be big sellers. Place your orders NOW.

Write for copy of catalogue.

**The Geo. A. Long
Cabinet Company**
HANOVER, PA.

The Trade in PHILADELPHIA and LOCALITY

PHILADELPHIA, PA., March 5.—The talking machine business in Philadelphia during the past month was very much better than during the month of January, and the prospects at the beginning of March are most gratifying. There seems to be plenty of everything on the market at present—but customers—and they seem now to be getting about in greater numbers. This pleasing development has undoubtedly conduced to the general feeling of optimism which is now apparent at every turn.

Mobilizing to Fight Tax

In order to relieve the trade of too much burden in the way of taxation, C. J. Heppe & Son have taken it upon themselves to begin a crusade in this city to try to get the next Congress to come to the relief of the talking machine dealers as well as piano dealers. The Heppe house has sent a letter to all the dealers here asking them to write to their Congressmen and Senators to this effect:

"Dear Sir: In your consideration of the various tax problems which are before Congress, I wish to request your particular attention to the suggested tax on sales. I think you will agree with me that the present excess-profits tax, surtaxes and the excise taxes on certain industries are injurious and discriminating. Of course, I am particularly opposed to the 5 per cent excise tax on the music industry. Our business has been seriously affected by this tax.

"I think a limited sales tax on all gross sales of every kind would be far more practical and not so discriminatory as the present taxes. I am sure it would be much easier to collect, more satisfactory to the general public and more encouraging to industries in general. I sincerely

hope you will lend your efforts to the adoption of such a tax policy."

Columbia Business Improves

The Columbia Graphophone Co. reports that business in February was very much improved over January and the outlook for a steady improvement is most encouraging. The entire sales force of the firm met the last Saturday in February to discuss the standard monthly sales plan for March. The men were addressed by H. L. Tuers, who had come over from New York for that purpose. During the month Manager Cummin, of the Columbia, visited all sections of his territory. W. L. Lorenzo, who has been connected with the New York advertising department, has come to Philadelphia to become the new dealer service manager.

On the evening of February 17 the "Note-the-Notes" Club of the Columbia, the women's club of the firm, held a meeting to which they had invited the male members of the house. They had as their guest of honor W. A. Willson, who came over from New York, and who made a long and interesting address. The ladies served refreshments and the affair was very much enjoyed.

J. Wood, who was with the Columbia some time ago, has returned to the firm's employ and has taken charge of the record department. J. T. Callahan, former Columbia sales manager, was married the middle of the month to Miss Helen Perry. The office force presented him with a very handsome mahogany clock and candlesticks to match.

Among recent Columbia visitors were S. P. Spiger, Woodbury, N. J.; J. H. Bartlett, Wilmington, Del.; O. K. Fink, Pottstown; A. Wol-

ston, Chester; H. C. Jarvis, Millville, N. J., and R. Sloan, Lansdale. Among the men over from the main offices were Geo. W. Hopkins, general sales manager, and O. F. Benz, assistant general sales manager.

Pathé Dealers Hold Meeting

Business with the wholesale and retail departments of Pathé Frères is reported satisfactory and dealers have begun to stock up in a very satisfactory way. Among the recent Pathé visitors were S. Fellman, of Fellman Brothers, Salisbury, Md.; Messrs. Lea and Lewis, of the Lea-Lewis Furniture Co., Danville, Pa., and Fred Whitenight, of Wilkes-Barre. The Pathé people have opened up new accounts in Scranton, Danville and Old Forge, Pa., and Burlington, N. C. During the month the Pathé men held a meeting at the Hotel Adelphia, which was attended by all the dealers in this city and vicinity, and was very much of a success. It was addressed by President E. A. Widmann, Sales Manager George W. Lyle, and others.

Vocalion Shop Now Open

The old Sonora Shop, at 1626 Chestnut street, has been changed to the Vocalion Shop, and is in charge of John P. Foley, who was formerly connected with the Philadelphia Show Case Co. It handles Aeolian-Vocalion machines and records exclusively, as well as the Melodee music roll and sheet music. Mrs. Caroline Ross, who was for some time connected with the Gimbel talking machine department, has gone with the Vocalion Shop to be in charge of its record section.

Buehn Establishes New Victor Agencies

Louis Buehn, of the Louis Buehn Co., Inc.,

(Continued on page 110)

We Are Prepared

To aid **Our Dealers** in making this their biggest year in **Victor Merchandising**.

Increased **Victor Production** will call for more intelligent and concentrated application in sales methods. Constructive counsel will be given, when desired, on **Business Problems**.

We place at your command careful, fair and dependable methods of distribution. Also the use of our **Victor Period Model Salon**.

The Louis Buehn Company

OF PHILADELPHIA

TRADE NEWS FROM PHILADELPHIA

(Continued from page 109)

reports that business generally is quiet in comparison to what he feels should be reasonably expected. Goods have been coming in from the factory in a most satisfactory way and for the first time in several years, he says, he is beginning to get stock on the shelves. The firm has put several new accounts into operation, including the Arco Drug Store, of Waynesboro, Pa., which has opened a Victor department in the store, and the Buehns have shared with the Weymann firm in establishing M. P. Malarky as a Victor dealer at Pottsville, Pa. On Saturday, February 19, the Goodenough Piano Co., of Bethlehem, Pa., opened a Victor talking machine department in its store, located on Main street. J. R. Wilson, who has several Victor stores in different parts of the city, is about to open another one at 5029 Baltimore avenue.

New Accounts for Penn Co.

The Penn Phonograph Co. reports that its business was quite satisfactory in February. During the month the Penn Co. treated the interior of the building, 913 Arch street, to a new coat of paint, remodeled the display window, and altogether has greatly improved the place. The company reports that its Miniature Victor Dog business has been very good of late. Several new agencies have been established in February, including Charles G. Martin, Main street, Darby, Pa., who opened his place on the 20th, following a complete installation of Unico booths; and W. A. Stallsmith, of Gettysburg, Pa.

Big Victor Store in Atlantic City

At Atlantic City Braunstein & Black have opened the largest department store of any city along the Coast. They have devoted half of the first balcony to the handling of Victor machines and records, and have made it the most attractive talking machine place at this famous resort.

Blake & Burkart Find Business Good

Blake & Burkart report that they have been enjoying a fair business, with February better than January. Mr. Blake states that machines and records are coming through in very good shape.

Diegel Bros. Buy Reichwein Store

Fred Reichwein, who conducted for some years a Victor establishment at 2908 North Fifth street, has just sold his business to Diegel Bros., two young men whose father has a large furniture store across the street. The sons will operate the store at the present address.

Takes on Various Lines

The Fonotipia Co. will hereafter be represent-

ed in this city by the United Music Stores Co., 619 Cherry street. This firm deals exclusively in foreign records. It has also put in the New Century line of sheet music, one of the largest of the standard selections of sheet music in the country. Otto Jordan, of T. B. Harms & Co., was a visitor recently, as well as Harry Unger, of the Brilliantone Co.

Brilliantone Interests Active

The Talking Machine Co., Eighth and Juniper streets, has begun the exclusive introduction here of the Gilt Edge Needle and the Cracker Jack Needle. Both are the product of the Brilliantone Co. The Talking Machine Co. was chosen by the Brilliantone Co. to be the first to put these needles on the market here, although other firms were very anxious to do so. They had as a recent visitor R. B. Forster, president of the Brilliantone Co.

A. J. Heath Features Okeh Records

A. J. Heath & Co. have been making a special drive on the Okeh records, and are also doing a large business on the Mamie Smith records.

At the end of the month C. A. Malliet, a member of the firm, spent several days among the firm's trade in Wilkes-Barre and Scranton. The firm have appointed G. W. Freede to go on the road to sell the Granby talking machine, of which the Heath firm are the exclusive distributors here. D. C. Faber, of the sales force, has just returned from a few weeks' trip. He visited Jacksonville, Fla., and other points.

Congratulations to T. W. Barnhill

The many friends of T. W. Barnhill, president of the Penn Phonograph Co., of this city, Victor distributor, will welcome the news of his recovery and the resumption of his many and accustomed duties as co-executive with H. W. Miller in the administration of the affairs of this company.

On Washington's Birthday Mr. Barnhill was operated upon in the Jefferson Hospital in this city. During the convalescing period Mr. Barnhill was the recipient of many calls and written greetings from his interested friends. Mr. Barnhill states that he feels better than ever and is resuming his duties with renewed enthusiasm.

Miss Lillian Wood a Visitor

Among the recent visitors to the Quaker City was Miss Lillian Wood, who is in charge of the educational department of the C. C. Melloi Co., Ltd., Victor distributor of Pittsburgh, Pa. Miss Wood attended the Victor salesmanship course at Camden and while there found time to visit many of her friends in the Victor trade in this city.

Emerson Records Sell Well at 85 Cents

Manager. Fox, of the Emerson Philadelphia Co., is selling the Emerson records at 85 cents. He states that his business has been most satisfactory and has taken on a number of new accounts in February, and he believes that March is going to be a very satisfactory month. Mr. Fox says that Emerson records are being received in large quantities and that they are shipping them out as fast as they are being received. They have finally gotten their business in such a shape that they have really been able to give twenty-four hour service. Irving Lieb, the Eastern representative of the Philadelphia Emerson Co., who is now on the road, is making a

(Continued on page 112)





SONORA SERVICE

Insures

Quick Delivery of Latest Dance and Vocal Hits

Our dealer proposition is worth knowing
Write for details

SONORA COMPANY OF PHILADELPHIA

1214 Arch Street, Philadelphia, Pa.



WEYMANN 1108 CHESTNUT ST. PHILADELPHIA, PA.
ESTABLISHED 1864

Victor
Wholesale
Distributors

Q.R.S.
PLAYER
ROLLS

WEYMANN
KEYSTONE STATE
STRING
INSTRUMENTS

Victor Supreme

The Victor dealer who devotes his entire energy to the advancement of Victor merchandise in his Talking Machine Department will find that in turn his entire business will be greatly benefited.

At Your Service.

H. A. WEYMANN & SON, Inc.
1108 Chestnut Street Philadelphia, Pa.

Keystone Die-Casting Co.

Norristown, Pa.

ALFRED C. RANTSCH
Pres. and Gen. Sales Mgr.

E. J. W. RAGSDALE
Treas. and Gen. Mgr.



Recording the Points of our Service

A duty due to the Vocalion dealer of the present and to the Vocalion dealer who will be:: placing an emphasis upon Quality and Consumer-Prestige and Profit and Sales-Help. And now most opportune on our assumption of the representation in this territory of The Aeolian Company, the Foremost Manufacturers of Musical Instruments in the World, featuring:

VOCALION

Made by THE AEOLIAN COMPANY

PHONOGRAPHS AND RED RECORDS

- POINT ONE: The Vocalion line is backed by the combined strength of The Aeolian Company and of this company as distributors.
- POINT TWO: Vocalion is a trade name to conjure with—a name that your customers will ask for, and by that token, the more easily sold by you.
- POINT THREE: Holding to our policy of developing our chosen dealers—helping those dealers to truly expand—rather than appointing so many dealers that expansion is impossible.
- POINT FOUR: To advise you as to the stocks you should carry. To co-operate with you in the advertising that will give life to business, and to further help you to develop the policies that your own knowledge and experience show to be the most desirable.
- POINT FIVE: Our Service in a nutshell: To Sell for You, Rather Than Just to You.

Write us for the Vocalion Proposition

PHILADELPHIA SHOWCASE CO

123 North 13th Street, Philadelphia

1001 Jenkins Arcade, Pittsburg

THE TRADE IN PHILADELPHIA AND LOCALITY—(Continued from page 110)

very nice showing, lining the dealers up in good shape in his territory.

Weymann Finds Business Satisfactory

H. A. Weymann & Son report that the business of their firm in the handling of the Victor product is getting to a most satisfactory point, and they hope soon to be in a position to consider some of the many dealers who have been making application for the handling of the Victor in the Weymann territory. It has been a considerable time since the Weymann firm has taken on any new dealers, for it has been Mr. Weymann's purpose to take the very best kind of care of his dealers already on his list. Now that the Victor Co. is sending in very much larger shipments, both in machines and records, Mr. Weymann is giving these dealers every advantage possible.

Charles W. Miller, Jr., Arrives

Charley Miller, of the Buehn sales force, is the proud father of a ten-pound boy born in February, and whom he has named Charles W. Miller, Jr.

Sonora Warerooms in Good Shape

The Sonora Co. of Philadelphia has gotten its warerooms in first-class running shape. There is a big stock of Sonora machines and records on hand, in spite of the fact that business is increasing rapidly. The front offices and showrooms of the firm, on the sixth floor of the building, are light and airy, and in the rear there is ample space for a great quantity of machines. They were somewhat delayed in getting started with their Okeh record proposition, but now have it in full swing, and have a stock of more than 45,000 records. Among the recent visitors to the company were W. C. Fuhri, of the General Phonograph Corp., and Vice-president F. J. Coupe, of the Sonora Co.

T. W. Barnhill "Makes a Killing"

In the theatrical production, "The Storm," Katherine Hayden, star of the drama, is promised a talking machine. She asks whether it will be one of those which one associates with "the little dog with his head turned to one side."

DECALCOMANIA

Name Plates for Talking
Machines, Pianos, etc.

High Class Workmanship

Write us for further information

National Decalcomania Co.

220-230 N. 60th St., Philadelphia, Pa.

T. W. Barnhill, president of the Penn Phonograph Co., Victor distributor, and who is responsible for the production of the now famous Penn-Victor miniature dogs, witnessed a production of "The Storm" and was much impressed with the query of the star.

The following day he presented Miss Hayden with a Penn-Victor dog and in return received a note acknowledging its receipt and expressing appreciation. Miss Hayden stated that she was very fond of dogs, but never took them on the road with her because of the baggage car trouble. "Vic," as she named the Penn-Victor dog, will accompany her hereafter in all her travels, she assures Mr. Barnhill.

Manager Boyd, of F. A. North & Co.'s chain of stores handling the Pathé and other machines, states that business has been fine, especially at the Trenton branch.

NOTABLE UNICO INSTALLATIONS

Dealers at Home and Abroad Make Improvements in Store Equipment by Adding Unico Booths—Company's Designers Solve Problems of Gramophone Co., of London, England

PHILADELPHIA, PA., March 1.—An optimistic view of the future good business expected by the talking machine dealer is found in the many orders for Unico installations received at the headquarters of the Unit Construction Co., of this city. It is reported that the majority of the installations are of considerable size.

The Unit factory is on an excellent production basis and many remarkable records are being made in the rapid installing of the required equipment.

On February 19 an order was received from Baker & Green, of Whiting, Ind., for installation of Unico racks and counters. Five days later the installation was shipped complete. Another instance is given in the case of the Colonial Music Shop, of Cleveland, O. An order for three rooms, four record racks and one counter show-case was given on January 6. On Monday morning, January 10, the installation was completed and the shop open for business.

The demand for Unico equipment is not alone confined to this country. Officials from the Gramophone Co., of London, England, recently visited this country investigating the methods pursued by enterprising dealers in merchandising talking machines. Upon returning to England they sent a diagram of their floor plan to the Unit Construction Co. Plans, designs and an estimate were furnished and as a result the Unit Construction Co. has its representative in England supervising an extensive Unico installation at the headquarters of the Gramophone Co. The floor space, which was very irregular, has been utilized to excellent advantage. Attractive paneling is being constructed in the foyer, from which lead entrances to a series of salons for the display of the machines and a well-equipped record department with a series of audition rooms, as they are called on the other side of the Atlantic. The decorative scheme will be in the Louis XVI period. The use of Unit equipment abroad is a decided tribute to its distinctiveness and merits.

Good health is the most precious possession of life. Strive to attain it and keep it.



SERVICE



—A. J. HEATH & CO.

Distributors for

Okeh Records

The Record of Quality

Our superior service guarantees the quickest delivery possible of latest hits.

We are well equipped to take care of and satisfy new dealers. Write for our proposition, it offers big profits to the ambitious dealer.

A. J. HEATH & CO.

PHILADELPHIA, PA.
27 South Seventh Street

BALTIMORE, MD.
110 Calvert Street



JOHN McCORMACK

greatest of concert tenors

APRIL RELEASE:

- 50001 { I HEAR YOU CALLING ME (Marshall). Tenor
12-in. { with Orchestra Accompaniment.
\$1.50
- 50005 { CELESTE AIDA (From "Aida") (Verdi). Tenor with
12-in. { Orchestra Accompaniment.
\$1.50

Another important announcement is the addition of 25,000 Foreign Records—seven recordings, twenty-eight languages—the music of all Europe.

Okeh Records

MAMIE SMITH

and her Six Jazz Hounds add two characteristic numbers this month:

- 4253 { LOVIN' SAM FROM ALABAM (Popular Blues).
10-in. { Vocal (Perry Bradford).
\$1.00
- { DON'T CARE BLUES (Popular Blues). Vocal (Perry
Bradford).

RAY MILLER

the Melody King, comes into the April list with new phases of alluring syncopation:

- 4257 { UNDERNEATH THE DIXIE MOON (Miller-Fazioli-
10-in. { Klages). Fox-trot.
\$.85
- { JUNGO LAND (Joe Bren). One-step.

RISHELL INSTANT SERVICE is at your command. Phone, write, wire **TODAY**

Rishell Phonograph Co., Williamsport, Penna.



(Half Size)

Questionnaire

VICTROLA DEPARTMENT

R. L. FOORD FURNITURE CO., Wilmington, Delaware

- Do you own a Talking Machine (yes or no).....
- What Make
- Is it in good playing condition (yes or no).....
- Is your Talking Machine in active use (yes or no).....
- Have you ever thought of exchanging it for a newer or larger model (yes or no).....
- Do you receive the Victor Record Supplement each month (yes or no).....
- Have you ever thought of buying a Victor Victrola (yes or no).....
- Name
- Address
- City

The questionnaire shows you who has a Victrola; who has not a Victrola; who has the desire for a Victrola; who has a machine of another make and wishes to exchange it in part payment for a Victrola; whose name is not on your mailing list for the monthly supplement, but wants it there.

OPPORTUNITY

The Victor dealer enjoys an opportunity at this time such as no other talking machine dealer has. He has back of him a factory and organization whose finished product is recognized everywhere as the best. During the last three years many new machines and several makes of records have been placed on the market. Some have survived, others have fallen by the way-side. The opportunity which is now afforded you is to bring the owners of all these other machines under the Victor banner and to make good Victor customers of them.

How to do this in the most effective way would be a problem if the Penn-Victor dog had not solved the question for you. Before telling you about it, it was tried out in a number of instances and the results have been surprising.

What you want is to get as many talking machine users acquainted with you as possible. Very good. The thing to do is to get them in your store, and you to get acquainted with them. How? That's easy! Here is the plan,—

FIRST—Order 500 or more Penn-Victor dogs with your name cast in the pedestal at no extra cost.

SECOND—Have printed questionnaires as per illustration.

THIRD—Advertise in your home paper, or by any other plan which seems best, announcing that you will give away absolutely free to every person calling at your store on certain dates a plaster paris reproduction of the dog in the Victor trade-mark.

You may be sure the public will respond. When a person enters your store hand him or her a questionnaire, saying: "Please fill out the card and present it at (specify the place) and receive your dog." Have plenty of small sharpened lead pencils handy so there will be little delay in filling out the questionnaire.

The questionnaire gives you just the information you desire and provides many prospects for Victrolas.

One dealer gave 5,000 dogs away and did as much business in the first three days of the month as during all the corresponding months in the previous year. Another dealer of whom we know did \$3,000 in three days. He gave 3,500 dogs away and did nearly \$1 worth of business for each dog.

The dog is a binder between the prospect and you, making it easy for your canvasser when he calls at the home to secure a hearing. The Penn-Victor dog is a little missionary, and has been doing good work in the home all the while spreading Victor propaganda. Shall he work for you? It's for you to say. Place the order at once and prove our assertions.

- | | |
|--------------------------------------------------|-------------------------------------------------|
| Albany, N. Y.Gately-Haire Co., Inc. | New Haven, Conn...The Horton-Gallo-Creamer Co. |
| Atlanta, Ga.....Elyea Talking Machine Co. | Newark, N. J.....Collings & Co. |
| Baltimore, Md.....Cohen & Hughes. | New Orleans, La.....Philip Werlein, Ltd. |
| Birmingham, Ala....E. F. Droop & Sons Co., Inc. | New York City.....Emanuel Blout. |
| Boston, Mass.....Talking Machine Co. | C. Bruno & Son. |
| Oliver Ditson Co. | Charles H. Ditson Co. |
| Eastern Talking Machine Co. | Knickerbocker Talking Machine Co. |
| The M. Steinert & Sons Co. | New York Talking Machine Co. |
| Brooklyn, N. Y.American Talking Machine Co. | Ormes, Inc. |
| G. T. Williams Co. | Silas E. Pearsall Co. |
| Buffalo, N. Y.....Buffalo Talking Machine Co. | Louis A. Schwarz, Inc. |
| Burlington, Vt.....American Phonograph Co. | Omaha, Neb.....Mickel Bros. |
| Butte, Mont.....Orton Bros. | Philadelphia, Pa....H. A. Weymann & Son. |
| Chicago, Ill.....Chicago Talking Machine Co. | Pittsburgh, Pa.....W. F. Frederick Piano Co. |
| Cincinnati, O.....Ohio Talking Machine Co. | Portland, Me.....Cressey & Allen, Inc. |
| Cleveland, Ohio....Cleveland Talking Machine Co. | Richmond, Va.....The Corley Co. |
| The Eclipse Music Co. | Rochester, N. Y....E. J. Chapman. |
| Denver, Colo.....The Knight-Campbell Music Co. | St. Louis, Mo.....Koerber-Brenner Co. |
| Elmira, N. Y.....Elmira Arms Co. | St. Paul, Minn....W. J. Dyer & Bro. |
| El Paso, Tex.....W. G. Walz Co. | Toledo, Ohio.....The Toledo Talking Machine Co. |
| Honolulu, T. H....Bergstrom Music Co., Ltd. | Washington, D. C....Cohen & Hughes. |
| Indianapolis, Ind..Stewart Talking Machine Co. | E. F. Droop & Sons Co. |
| Jacksonville, Fla....Florida Talking Machine Co. | Robt. C. Rogers Co. |
| Memphis, Tenn....Houck Piano Co. | |
| Kansas City, Mo....J. W. Jenkins Music Co. | |
| Milwaukee, Wis....Badger Talking Machine Co. | |
| Minneapolis, Minn..Beckwith-O'Neill Co. | |
| Mobile, Ala.....Wm. H. Reynolds. | |

Dealers not served by any of these distributors will be sold direct by us or we will charge through your preferred distributor if so requested.

PENN PHONOGRAPH COMPANY, Inc.

Victor Distributors—Wholesale Only

913 ARCH ST.

PHILADELPHIA, PA.

INTERNATIONAL MICA CO. BUSY

L. Hammond Crabtree Keeps in Touch With World Markets—Trade in Ruby Mica Diaphragms Enjoys Steady Growth

PHILADELPHIA, PA., March 1.—The International Mica Co., of this city, reports that the demand for "Imico" India ruby mica diaphragms is increasing as the year advances. L. Hammond Crabtree, who directs the affairs of the company, is an authority on mica and no small portion of the popularity of Imico products in the talking machine industry is due to his careful study of the manufacturers' requirements and the providing of the proper mica for the specific purpose intended. Mr. Crabtree has made it a purpose to keep directly in touch with the manufacturer and much of his time is spent on the road. In addition to the factory in West Philadelphia the company also maintains offices near both railroad terminals and in the heart of the hotel district for the convenience of out-of-town visitors.

TAKE CARE OF YOUR MOTOR

Dealers Should Always Take Care to Inform Purchasers on Proper Care

* The following instructions on the care of the talking machine motor could be used to advantage by dealers in educating their patrons in this matter:

The motor in your talking machine should be looked over once or twice a year to preserve the life of your machine. Like your automobile or watch, it requires expert attention and, given to anybody that happens along, the best your motor will get is the worst of it, as most talking machine motors are as delicately adjusted as the finest grade watch or clock, one little screw, a turn too tight or a turn that loosens it too much will a good many times ruin your motor and any number of new parts will be needed to get the proper adjustment. The mainsprings in motors run from twelve to nineteen feet in length and as all mainsprings of talking machine motors are of unfinished material they require fresh lubrication every nine to twelve months or the friction wear will deprive you of power in your springs and will make the motor run unevenly and will eventually break the springs. The same is true of the reproducer, as constant vibrations will loosen the tension springs and cause harsh overtones.

FEATURING PRINCESS WATAHWASO

Collings & Co., Newark, Booking Prominent Victor Artist in Northern New Jersey

Collings & Co., the well-known Victor Talking Machine Co., distributors of Newark, N. J., have been booking Princess Watahwaso, the well-known Victor artist, in northern New Jersey territory.

Princess Watahwaso's program includes Indian songs, dances and folklore and she is appearing early this month in a number of assembly halls of the public schools in the territory mentioned.

Consider the postage stamp. It secures success through its ability to stick to one thing until it gets there.

WE Will Buy for Cash Job Lots of Machines, Records, Motors, Tone Arms, Parts, and Everything in the Talking Machine Line.

Keen Talking Machine Supply Co.
49 N. 10th ST., PHILADELPHIA, PA.



PAUL WHITEMAN'S Big Fox Trot Hit
"I NEVER KNEW"
 (I COULD LOVE ANYBODY LIKE I'M LOVING YOU)
 Published by LEO. FEIST Inc., FEIST BLDG. New York

YOU CAN'T GO WRONG WITH ANY FEIST SONG

BIG TALKING MACHINE MEN'S BANQUET ON MARCH 29TH

Elaborate Plans for Entertainment Have Been Made and Prospects Are That This Year's Affair Will Be the Most Successful in the History of the Organization

Can you keep a secret? Then here's a whisper to the effect that the annual Talking Machine Men's banquet will be held this year on March 29 at the Hotel Pennsylvania, New York, U. S. A. Not only a banquet, but an

and Miss Irene Williams, from the Brunswick Co., while the Columbia Co. has pledged its support with other entertainers of high caliber.

Victor Arden, of the All Star Trio, and his partners in crime, Wadsworth and Green, have

made arrangements with the committee to play five special selections of his or her choice for the Victor clerk selling the most of the Victor record 18713, entitled "Dotty Dimples."

It's also whispered that checking privileges will be extended this year by Revenue Agent Joe Bryant, detailed from Washington. The password is a check to E. G. Brown, 719 Broadway, Bayonne, N. J., to the amount of \$6.00. And, postscripts the committee, "B. Y. O. L. because W. H. G."

Seriously, the plans of the entertainment committee and the responses of the membership indicate that the affair will by long odds be the most successful ever held under the

auspices of the organization. The co-operation of the various talking machine companies has insured a program that probably could not be arranged for under any other auspices, and the indications are there will not be a dull or idle moment from the time the doors are opened until the banqueters wend their weary ways homeward in the wee sma' hours.

James J. Davin, who heads the entertainment committee, has had long experience in arranging just such affairs and his efforts this year indicate that he has profited by his experience. He is assisted by such able lieutenants as Hugh Ernst and Joseph Bryant, also committee veterans, together with other active members of the trade, and it is understood that although the announced program is elaborate enough to gratify the most exacting there are several surprises in store for those who take advantage of the opportunity of attending.

Special arrangements have been made whereby the employees of the various association members will be admitted to the entertainment and dance without charge after 9.30 p. m. upon presenting the business card of their employer.

Sh-h-h—It's going to be a great night.

MONARCH T. M. CO. INCORPORATES

The Monarch Talking Machine Co., New York, has been incorporated to manufacture talking machines. The capital is \$10,000 and the incorporators are N. Meadow, I. Weber and S. Wainlash, 230 East Fourth street.

WALLACE BROWN VISITS WEST

Wallace Brown, head of the wholesale Vocalion department of the Aeolian Co., returned last week from a short business trip through the Middle West, in the course of which he visited Detroit and Pittsburgh.

DILLON HEADS AEOLIAN DEPT.

Thomas F. Dillon has been appointed manager of the department of the L. C. Fenner Music Store, in Port Jervis, N. Y., devoted to the handling of Aeolian Co. products, including the Vocalion and the red Vocalion records, regarding which Mr. Dillon is very enthusiastic. He paid a visit to Aeolian Hall last week.



The All Star Trio Who Will Entertain Talking Machine Men

entertainment and dance also. The Eight Famous Victor Artists have promised to attend and make their usual melodious noises within the secret confines of the banquet room. And Jimmy Davin adds that Paul Whiteman will have his gang down from the Palais Royal to help the restless dancers break the Blue Laws. Also the Van Eps Quintet, Lynch & Sheridan

New! New! APEX Fibre Needle Cutter

Cuts with the grain to the point.
 Makes the use of fibre needles as cheap as steel.
 No variation in angle or size of cut.
 Does not crush the shell.

Small Size—Simple Construction
 For sale through jobbers and dealers.

Retail Price \$1.50

Manufactured by

W. H. WADE 14 N. Michigan Avenue CHICAGO

New! New!

Patented Nov. 2, 1920

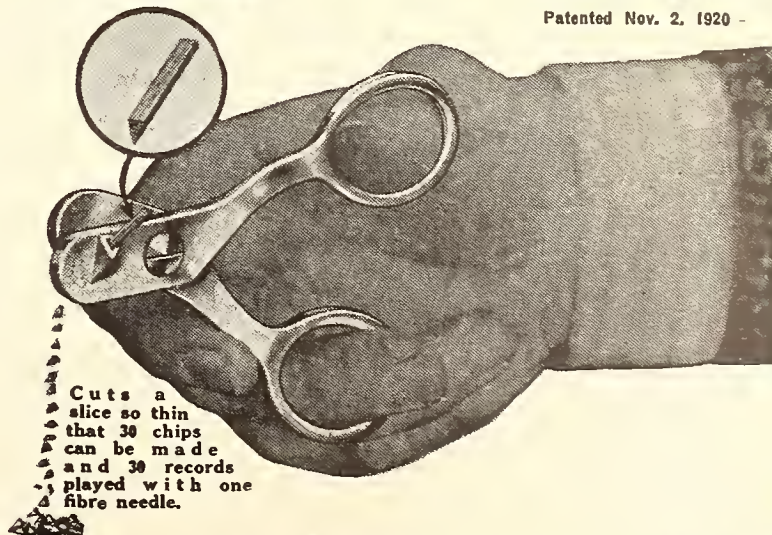



New Releases

Now Ready

ODEON

Lateral Cut

RECORDS

Lateral Cut

16 Sparkling Popular Selections 16
8 10-Inch Lateral Double Discs 8

Fox Trots

One-Steps

Waltzes

American Dance Selections

- Od 20020 { BOW-WOW (Puppy Love) (Wheeler Wadsworth) One Step.....Allstar Trio
10-inch { HOLD ME (A. Hickman—B. Black) Fox trot
85 Cents { Jos. Samuels' Jazz Band
- Od 20021 { WHY DON'T YOU? (Harry Tierney) Fox Trot
10-inch { Harry Raderman's Jazz Orch.
85 Cents { GOOD-BYE (Intro. Chorus—Just Plant a Kiss)
Fox Trot
Jos. Knecht's Waldorf-Astoria Dance Orch.
- Od 20022 { MAZIE (Sid Caine, Eli Dawson & Lew Gold)
10-inch { Fox Trot.....Harry Raderman's Jazz Orch.
85 Cents { BIDDY (J. S. Zamecnik) Fox Trot
Green Bros.' Novelty Band
- Od 20023 { "SIREN" OF A SOUTHERN SEA (Harold
10-inch { Weeks) Fox Trot..Green Bros.' Novelty Band
85 Cents { MY BUDDING ROSE (L. Wolfe Gilbert &
Cooper) Fox Trot
Jos. Knecht's Waldorf-Astoria Dance Orch.

- Od 20024 { TWO SWEET LIPS Fox Trot
10-inch { Jos. Samuels' Jazz Band
85 Cents { MELLO CELLO (Neil Moret) Waltz
Jos. Knecht's Waldorf-Astoria Dance Orch.

American Vocal Selections

- Od 20025 { I'M IN HEAVEN WHEN I'M IN MY MOTH-
10-inch { ER'S ARMS (Johnson-Hess-Ager) Tenor
85 Cents { with Orch.....Lewis James
HONOLULU EYES (Johnson-Violinsky) So-
prano-Tenor Duet with Orchestra
Jane Neilson—Lewis James
- Od 20026 { MOONLIGHT IN MANDALAY (Yellen-Ol-
10-inch { man) Tenor-Baritone Duet with Orch.
85 Cents { James-Shaw
NORAH ACUSHLA! (Cooper-Millard) Tenor
with OrchestraWill Oakland
- Od 20027 { JUST LIKE A GYPSY (From the Musical
10-inch { Play, "Ladies First") (S. S. Simons-Nora
85 Cents { Bayes) Male Trio with Orch....Sterling Trio
SWEET LUANA (Norma Burt-J. S. Zamec-
nik) Vocal Duet with Hawaiian Guitar
Accomp.Jane Neilson—Lewis James

**Ask for Our Catalogues of Foreign Language Records
and
FAMOUS-ARTISTS Selections**

Ours is a big proposition for high-class distributors

Write for particulars

We are now appointing Jobbers

American Odeon Corporation

100 WEST 21ST STREET
NEW YORK



STEADY IMPROVEMENT EVIDENT IN CINCINNATI TRADE

Chat With A. H. Bates, of Ohio Talking Machine Co.—New Victor Agencies—Successful Convention of Edison Dealers—Starr Expansion—Baldwin's Red Seal Demand—News of Month

CINCINNATI, O., March 6.—A canvass of the talking machine trade in Cincinnati shows a very optimistic spirit prevailing among dealers and manufacturers. The last month, taking all things into consideration, has been generally satisfactory. Business has held up amazingly well for February. Machines have moved right along and the sale of records has been unusually good. Orders coming in show business conditions are getting better and the outlook is exceedingly good, according to local dealers.

A. H. Bates, of the Ohio Talking Machine Co., who recently returned from a trip through southern Ohio, West Virginia, Kentucky and Indiana, found signs of renewed activity among the dealers and a feeling of confidence that is very encouraging. Mr. Bates says many of the smaller dealers are doing more business than they realize. There are more small dealers than large ones, he says, and these men are all making sales right along, and taken altogether it amounts to quite a large amount of business.

The Ohio Co. has just established a new Victor agency at Middletown, the Cappel Co., which held its opening March 1. The opening was made a big event. Full-page advertisements in the local paper and a truck, on which was mounted a large Victor machine equipped with Magnavox, driven through the streets, announced the opening of the new music house. Another promising new agency is the one just established at Corbin, Ky., which also will be an exclusive Victor shop. Corbin has become a boom town since the recent opening of the L. & N. railroad shops and outlook for business there is considered exceptionally good. The agency will be known as the Corbin Music Shop. A third new Victor account is the Cumberland Music & Machine Co., Harlan, Ky. Mr. Bates believes the West Virginia field is still the best of all local territory and is way ahead of other sections in live business. The Ohio Co. has started an active campaign for business and has three traveling men so routed that they will visit every dealer in the territory once a month. Numerous applications have been received for new accounts that show the demand for talking machines is increasing and that business is picking up.

A convention of Edison dealers was held at the Sinton Hotel during the last week in February at which reports were received and plans and suggestions for future business discussed. Manager P. H. Oelman, of the Edison Co., states that a very marked spirit of optimism prevailed among the dealers at this gathering. The men present were from Ohio, West Virginia, Kentucky and northern Tennessee, and they were a unit in predicting an early boom in the talking machine business. One of the delegates handed out a very good piece of advice to those who had been complaining of the present quiet conditions in their sections. His advice was to "do less sighing and more selling." By hard work, he declared, it was possible to get all the business a man wanted. Manager Oelman states that the month was one of the best Februaries they have had and orders that are now coming in make the outlook for the month of March very encouraging. R. T. Carroll, of the Edison Co., is taking an extended trip through the territory visiting various dealers.

C. R. Anderson, of the Wurlitzer Co., states the company had a very fair month's business and the outlook for next month was very much brighter. The tobacco situation in Kentucky is clearing up, he says, and this will have a marked effect on the business there. Manager T. F. Sigman is making a trip through the territory.

Manager Pauling, of the Starr Co., is finding their new table machine is making a decided hit. This machine, he states, has been given the best workmanship in the factory and its appearance has made it an attractive piece of

library furniture. The talking machine business has been rather quiet, but there is, of course, a steady demand for machines, and the record business has been very good.

Miss Leola Ranshaw, buyer of Victor records at the Baldwin Piano Co.'s new department, states that the record business has been exceptionally good with them. January and February shipments on Red Seal and other records received have sold as fast as they could be obtained. This department is endeavoring to work up a large Red Seal business. During the past month the Baldwin Co. has installed an educational department under the supervision of Miss Florence McMahon, who for some time devoted her time to the schools of Cincinnati and vicinity and has succeeded in placing Victor school machines in a number of schools. The record department has greatly assisted Miss Mc-

Mahon in her school work by supplying the schools with the desired records.

R. C. Swing, manager of the Crystola Co., says that, according to all the information they can get from their dealers, there will be a decided improvement in business by the middle of March. The dealers are not laying in big stocks but buying cautiously.

Manager F. F. Dawson, of the Sterling Roll & Record Co., has announced the opening of a new branch at Pittsburgh, Pa., which will handle the Okeh records. The shop is located at 436 Fourth avenue and will be in charge of A. B. Smith, who formerly was assistant manager of the Columbia Co. at Pittsburgh. Mr. Dawson has just returned from a trip through the South and states that during the last month they have established 150 new agencies to handle the Okeh records. The record business has been good during the past month and he is looking for increased business right along.

The talking machine department of the Gau Co. did a very good business during the month and the demand for records has not diminished.



Promote Your Business

by getting

Best Service

given by

Lind Music Company

Distributors Exclusively

of

Okeh Records

The Record of Quality

LIND MUSIC COMPANY

Okeh Distributors

Congress and Bates Street

DETROIT, MICH.





Is your store on the Great White Way? A Columbia Electric Sign will put you there—a night-and-day magnet drawing people from all directions. Ask our Dealer Service man.

**Columbia Graphophone Co.
NEW YORK**

REFERENDUM FAVORS EXCISE TAXES

Proposal of Chamber of Commerce of U. S. Carried by Small Majority—Other Questions Upon Which Members Expressed Opinions

WASHINGTON, D. C., March 5.—The Chamber of Commerce of the United States has just reported that the proposal of its Committee on Taxation that excise taxes be put on some articles of wide use, but not of personal necessity, received slightly more than the necessary two-thirds vote to carry when the question was put to the referendum vote of the membership.

It was this proposal that was so strongly opposed by the Music Industries Chamber of Commerce, not only because it appeared to favor increases in excise taxes, but because there were specified no articles upon which the proposed excise taxes should be placed, which left the way open for considerable discrimination in the selection of such articles.

There was a majority voting against any form of sales tax, and of the minority who favored such a tax, therefore, the greater number were favorable to a retail sales tax. The principal objection to a turnover tax was that it would be pyramided and would prove unfair to many of the smaller industries while favoring larger industrial establishments.

The committee's proposal that the Government should ascertain the exact amount of income taxes before payment is made was based on the fact that, no matter how conscientious a taxpayer may be, he at present never knows when he is through. If a treasury ruling is revised new assessments may be made. Under the present law the taxpayer makes payment of

a tax which he assesses on himself. He then waits for years to see if he paid the correct amount of taxes.

The final recommendation of the committee, that administration of income taxation should be decentralized, was held to be necessary because of the great inconvenience occasioned by the fact that so many taxpayers have to journey all the way to Washington to take up taxation matters when they should be able to take them up in their own districts.

ELECT NEW COLUMBIA DIRECTORS

Decision Also Reached to Pass Quarterly Dividend on Common Stock of the Company

The passing of the regular quarterly dividend of 25 cents a share on the common stock of the Columbia Graphophone Co. was announced by the board of directors March 1. The regular quarterly dividend on the preferred stock was declared, however.

Van Horn Ely, president of the company, in announcing the passing of the common dividend issued the following statement:

"In view of the present industrial conditions and the desirability of maintaining the present strong cash position of the company the board decided to declare no dividend on the common stock. The annual report for 1920 will be mailed to stockholders within the next few days."

At the meeting of directors the following were added to the board: G. Hermann Kinnicutt, of Kissel, Kinnicutt & Co.; E. E. Thompson, of Crane, Pariss & Co., and Howard Coonley, president of the Walworth Mfg. Co.

THE BRUNSWICK RECORD POLICY

P. L. Deutsch on Company's Ideas as to Size of Catalog of Records

CHICAGO, ILL., March 8.—In an interview with The World P. L. Deutsch, assistant secretary of the Brunswick-Balke-Collender Co., of this city, stated that the Brunswick Co., has found the retail talking machine trade very favorably impressed with the Brunswick policy of a comparatively small record catalog. Mr. Deutsch attributes this feeling to the fact that the dealer is enabled to turn his stock over much faster and has to tie up a much smaller amount of money in record inventory. He explained that one method the Brunswick Co. has pursued to limit the size of its record catalog is the marrying of two very popular selections on the same record. This is directly in contrast to the policy which is adopted by a number of record makers of linking a big hit with a lesser hit and thereby helping to move the less popular selection.

THE VOCALION IN AUSTIN, TEX.

The J. R. Reed Music Co., Austin, Tex., which has been handling Duo-Art pianos and other Aeolian Co. products for some time past, has recently taken the agency for the Vocalion phonograph and records, and has arranged to open a large department to feature that line. The Reed Music Co. started in business in Austin in 1891 and has been very successful.

Many a man who wouldn't commit larceny will cheerfully steal a busy man's time.

The William Phillips Phono Parts Corp.

Big Value
in
Both Tone and Price

Suitable for Medium Priced
Machine

8 1-2 inches, centre to centre
Large size Sound Box

Sample to manufacturers \$3.00

Send for quantity prices

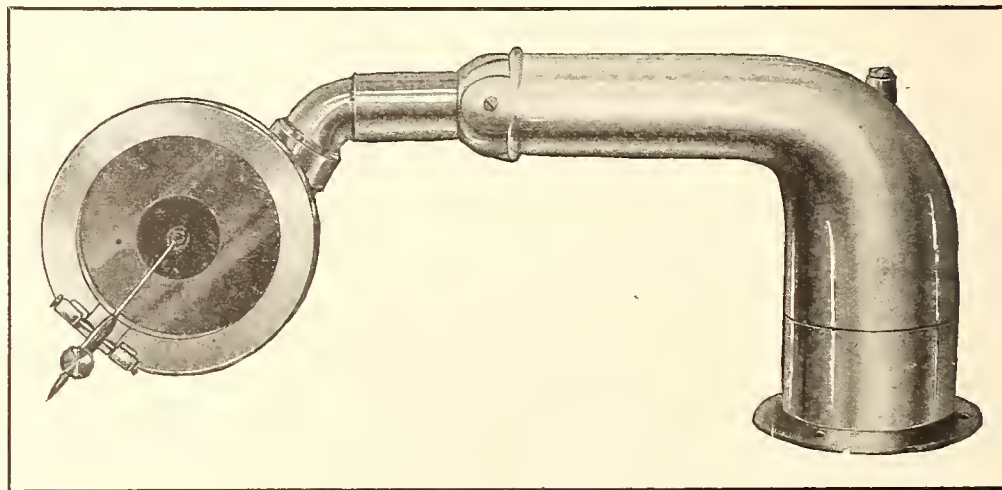

The William Phillips Phono Parts Corp.

145 West Forty-fifth Street

New York City

INCREASED ACTIVITY NOW EVIDENT IN BUFFALO TRADE

Review of Conditions Shows Betterment—No Legislation Necessary Anent Misleading Advertising—Pathé Dealers Hold Conference—New Manager for Hengerer Co.—Victor Records by Wireless

BUFFALO, N. Y., March 9.—There is practically little complaint among talking machine dealers of Buffalo these days of any dullness in business. Most of them report trade as exceptionally brisk, so much so that some of them have found it necessary to make additions to their staffs.

Industries generally here are beginning to show signs of activity. Many of the cities' larger plants which were forced to shut down or make large reductions in their working forces are beginning to take their employes back and as a result the buying public has more money to spend. This in turn is reflected in the talking machine business.

The music group of the Buffalo Chamber of Commerce has found that no new legislation will be necessary in making misleading advertising an actionable offense. Investigation has brought to light the fact that such offenses are covered by both State and city laws, which provide severe penalties for violations. The agitation for legislation covering misleading advertising was started a short time ago, when there were brought to the attention of the music group some advertisements of talking machines which, it was claimed, made it appear that the customer was getting more for his money than was really the case. No action will be taken, however, in regard to these advertisements, it is said, as it is believed sufficient warning has been given through the publicity which was given the matter.

Victor dealers here are doing a good business. Sales of records and machines are going well.

A new manager has been appointed for the talking machine department of the William Hengerer Co., which has one of the largest Victor agencies in the city. He is A. H. Fleischman, who was formerly with the Musical Instrument Sales Co. at New Haven, and who has had a long experience in the talking machine industry, having been connected with the business at Cincinnati and Louisville. Mr. Fleischman plans to make a feature of a department for the sale of Red Seal records. He has already developed a considerable business for this kind of record at the store.

A number of Victor dealers found that sales of Caruso records went up greatly during his recent serious illness. The public, fearing that his great voice would be lost forever, hastened to preserve it for themselves by insuring a large purchase of his records.

Recent visitors were: H. A. Brennan, representative of the Victor Co.; Mr. Forbes, of the New York store of the James McCreery Co., and C. R. Wagner, of the Musical Instrument Sales Co.

Buffalo has a special interest in "Humming," which is making such a hit among records. Ray Brost, a Buffalo man, who writes under the name of Ray Henderson, is the composer. He is the son of William Brost, of J. N. Adam & Co.

F. E. Russell, of the talking machine department of J. N. Adam & Co., reports that the Victor model "80," which sells for \$100, is making a great hit with the buying public.

One hundred and fifty Pathé dealers of this district held a convention at the Chamber of Commerce here February 21 and made plans for this district's part in the Little Red Fly campaign. N. A. Taber, of the Buffalo Talking Machine Co., acted as chairman. There were sales talks by R. H. Arnault, of the Pathé Co., and C. R. Mosch, leading Pathé dealer at Elmira. Their pepful talks inspired the workers and the general enthusiasm displayed at the convention indicated that as far as this district is concerned, at least, the campaign will be a sweeping success.

"Business is extra good," is the report of H. J. Hermansdorfer, of the local Brunswick branch. "We are doing a very fine record business," said Mr. Hermansdorfer. "There has been such an increase in volume that we have found it necessary to add two packers to our force." Miss Gladys Kimmel, the Brunswick Record

Girl, has been paying this vicinity a visit. She visited the offices here and also called on a number of dealers in this district.

Lionel M. Colc, general sales manager for the Iroquois Sales Corp. and one of the liveliest wires in the talking machine business in this city, has been doing some hard work in pushing Granby phonographs and Okeh records. He has mailed a large number of attractive booklets showing the artistry and advantages of the Granby and also leaflets telling about Okeh records.

He reports that the foreign Okeh records are making a great hit in Buffalo. There is a large foreign population in this city and the success of the Polish and Italian records was instantaneous.

Wireless operators in Buffalo now have a chance to "listen in" on concerts of Victor records every month. The Wurlitzer Co. is flashing through the air each month the latest Vic-

tor releases, and their Buffalo store carried extensive advertising announcing this and instructing the operators here how to "tune" their apparatus so as to catch the notes. William B. Damsel, manager of the Wurlitzer stores at Buffalo and Columbus, O., says that data at the latter city which he has gathered shows that the plan is meeting with great success and that he means to gather data here as to how many wireless operators are availing themselves of the opportunity to hear these "wireless concerts."

G. W. Hopkins, general sales manager of the Columbia Co., was in town the first of the month. While he was here a number of dealers in this district called on him.

The local Columbia office reports that the 59-cent record sale in this district is meeting with great success. Dealers report that the sales have drawn to their stores people whom they have not seen in months.

The Thomas Piano Co., of Lockport, which has an extensive talking machine department, is moving into new quarters in that city—a commodious three-story building, which is admirably equipped.

Pride of Possession



At this time, when there are so many talking machines of questionable quality on the market, the dealer who has a Victor franchise should be exceptionally proud of his possession.

Since the inception of the talking machine industry, Victor supremacy has been recognized everywhere.

To all your prospective customers emphasize Victor supremacy.

CURTIS N. ANDREWS

Victor Wholesale

BUFFALO, NEW YORK



Model B—The quaint Queen Anne. One of the most desirable designs. In keeping with the furnishings of many music rooms in modern American homes.

Made in Mahogany and American Walnut.

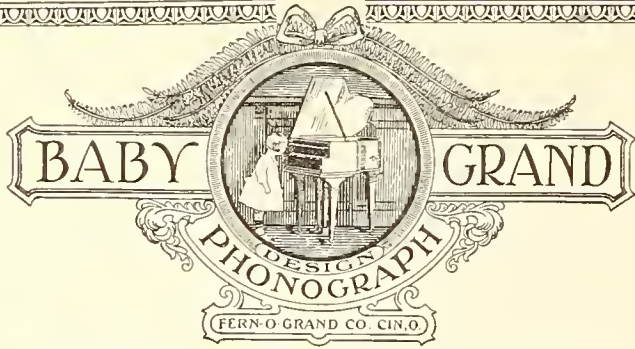

KNOWN FOR STYLE AND TONE

**BABY GRAND
DESIGN
PHONOGRAPH**

The most distinctive type of phonograph on the market. Provides the dealer with unlimited sales possibilities. A welcome addition to any high class lines.

New and Exclusive in Design our Ellis Reproducer and large amplifying Chamber is the secret of its wonderful vocal and instrumental tone.

The only Fibre Reproducer on the market.

Its Musical Qualities are Incomparable PROTECT YOUR TRADE and stimulate your phonograph business by having THE BABY GRAND DESIGN LINE on your floor.

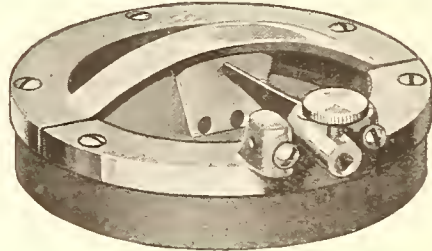

Our Reproducer

Patented U. S. A.

(Guaranteed for Twenty Years)

1. Its light weight will always keep your records new.
2. Plays all makes of records without any extra attachments.
3. Diaphragm is insulated from all metal parts, assuring natural tone without the metallic phonograph tones.
4. By off-setting the bridge connection to the diaphragm provides a short and long area over which the high and low notes respectively must travel for best results.
5. Oval bar provides ample protection for bridge connection.

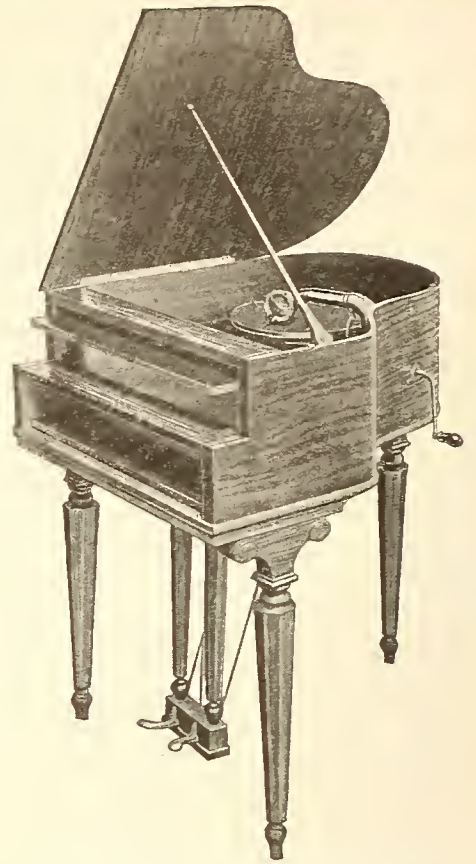

Model C—The Hexagon design fits in with almost any character of home furnishing. Its solid and artistic appearance is in keeping with the best of periods.

Made in Mahogany and American Walnut.

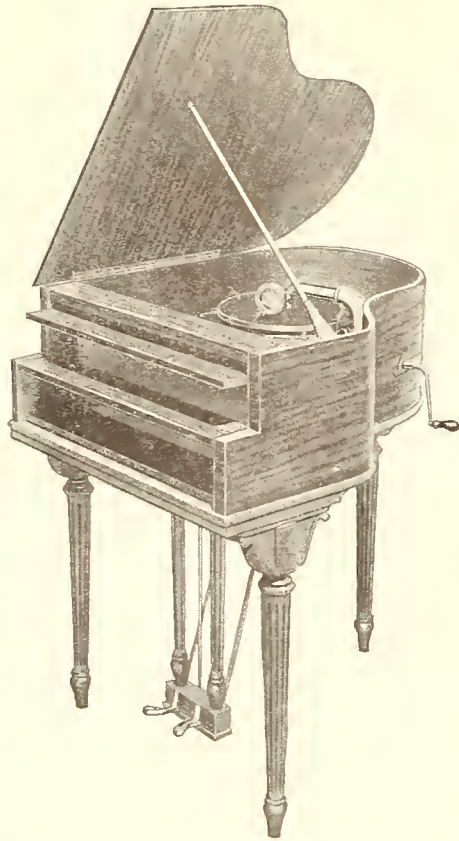

Model D—The ever-popular Louis XVI, an especially favored design which finds its place in the drawing rooms of prosperous Americans all over the land.

Made in Mahogany and American Walnut.



Model E—For the Chippendale room. Delicate carvings, perfect design and the last word in arts and crafts workmanship. Study the perfection of this design.

Made in Mahogany and American Walnut.

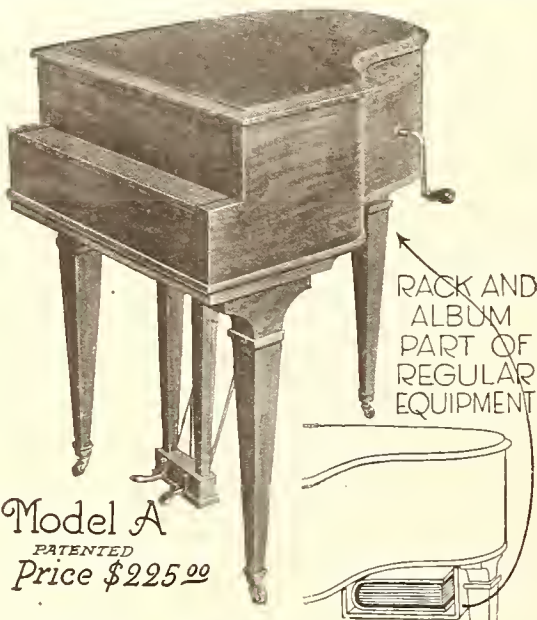

Model A
PATENTED
Price \$225.00

Model A—Baby Grand in Adam period design. The marvelous simplicity and beauty of the period faultlessly carried out. Much favored by the critical buyer.

Made in Mahogany and American Walnut.

**The Fern-O-Grand
Company**

"Makers of the Baby Grand Design Phonograph"

212-220 West Canal Street
Cincinnati : : Ohio

FULLY PROTECTED BY PATENTS, DEALERS' DISCOUNTS PROMPTLY FOLLOW UPON YOUR REQUEST

The Dimensions of the Amplifying Chamber are 24 ins. in width and 10 ins. in height. Think of that. The Cabinet is 36 ins. high, 27 ins. wide and 34 ins. in depth—Shipped K. D., which assures lowest freight rates.

Distributors for New York and surrounding territory: Kroll-Horowitz Furniture Co., Inc., 258 Canal St., New York.

Distributors for Denver and West: Cassell Bros. Music Co., Denver, Colo.

Distributors or Agencies write for prices and territory.

HAPPENINGS IN THE DOMINION OF CANADA

TORONTO TRADE CRITICIZE CERTAIN RETAIL PUBLICITY

Small Payments and Long Terms Not Favored—Hockey Fans Enjoy the Columbia—Canadians Sympathize in Caruso's Illness—Value of a Mailing List—New Concerns and Changes in Trade

TORONTO, ONT., March 3.—“Already we are beginning to see entirely too much of the ‘one dollar per week’ variety of talking machine advertising,” said a prominent Ontario retailer to your correspondent. “I would like to have some one tell me just what advantage any one talking machine merchant thinks he has when perhaps a dozen other of his weak-spined brethren are indulging in this same kind of advertising, as far as the securing of immediate sales is concerned. It doesn't take a smart merchant or a literary genius to write an advertisement which chiefly features low prices and long terms.” Aside from the fact that the selling and advertising of talking machines on this basis is bad business from an economic standpoint, is it not also true that such advertising has a tendency to cause the public at large to have less respect for our business?”

Robert Shaw, manager of the wholesale Grafonola department of Cassidy's, Ltd., Winnipeg, Man., was a recent visitor to the Columbia headquarters. He was greatly pleased with the immense new Columbia factory and also the new executive offices of the company and the greater co-operation with Columbia dealers that the new factory makes possible both in Grafonolas and records.

The Adams Furniture Co. showed a progressive spirit when recently it demonstrated to several thousand hockey fans, assembled at the Toronto arena to witness a senior O. H. A. hockey game, that the Columbia Grafonola was very much on the musical map. Before the game was called, and during intermission periods, this company had a Grafonola playing for the benefit of the spectators. Although the arena is large, the music of the instrument, amplified by the Magnavox, was heard distinctly in every corner of the rink. In order that the Adams Co. might reap the rewards of this effective publicity a large size easel, on which were printed the words “The Home of the Grafonola—Adams Furniture Co., Ltd.” with the address, was placed in the middle of the ice between periods.

Deep concern was felt throughout the Dominion over the illness of the great Victor artist, Enrico Caruso. The news of his gradual return to health was received with widespread rejoicing. The Montreal Star paid him a fitting tribute in an editorial and declared that his brave fight against great odds would serve to deepen the affection and admiration of his many friends for him.

That a dealer's mailing list if kept up to date will yield handsome dividends—perhaps more so than any other feature of the dealer's phonograph department—is evidenced by the action of His Master's Voice, Limited, Toronto, in supplying at small cost its dealers with a card system which will enable them to keep their mailing lists in good order. On the face of each card are shown the customer's name and address, make and size of instrument he owns, what repairs have been made, etc., and on the reverse side can be tabulated the customer's record purchases.

Brunswick Phonograph Week was celebrated recently at the Heintzman & Co., Ltd., Toronto store by the holding of a complimentary concert at which Miss Grace Johns, a well-known contralto, sang.

W. D. Stevenson, vice-president of the Starr Co. of Canada, Ltd., London, Ont., spent a few days recently at the factory of the Starr Piano Co., Richmond, Ind., the United States headquarters of Starr phonographs and Gennett records.

At a recent general meeting of the shareholders of Ideal Cabinets, Ltd., manufacturers of Ideal phonographs, the following directors were elected: Edwin A. Stevenson, W. Norman Martin, Henry V. Kautzman and William H. Lantz. Mr. Stevenson was appointed president and Mr. Martin secretary-treasurer.

The Toronto Music Co., Ltd., has assigned, according to the Canada Gazette, and a meeting of the creditors has already been held at the offices of the authorized trustee.

The A. C. Gilbert-Menzies Co. has, it is understood, brought out the Bobolink phono-

graph for juniors. It has a case 26 inches high and will play six-inch records.

L. C. LeVoi has joined the wholesale selling staff of Gerhard Heintzman, Ltd., in the phonograph division.

The Empire Phonograph Co., of 234 Queen street, has just taken on the Brunswick record agency.

A. E. Landon, Canadian manager of the Columbia Co., has returned to his desk in Toronto after a business trip to Winnipeg, Man. From his first visit to the great Canadian West Mr. Landon has been enthusiastic over the future of the provinces of Manitoba, Saskatchewan and British Columbia, and every trip brings him back surer than ever of a wonderful future for talking machine dealers in that part of the Dominion of Canada.

MEETING OF PHONOGRAPH MANUFACTURERS' ASSOCIATION

Important Subjects Discussed by Prominent Members of the Phonograph Industry at the Annual Meeting Held at National Club—Election of Officers Results in W. B. Puckett as President

TORONTO, ONT., March 4.—The annual meeting of the Canadian Phonograph Manufacturers' Association was held at the National Club, Toronto, last month, the business session being preceded by a dinner. W. D. Stevenson, London, the retiring president, occupied the chair. A representative gathering of the trade was present.

After the reading of the minutes Mr. Stevenson addressed the meeting. He said in part: “In common with various other industries we found that the application of what is most easily described as the luxury tax has had a considerable psychological effect upon the buying public. Although it is true the excise tariffs upon phonographs and records were not changed, but remained both in respect to amount and system of collection as established in 1918 other than the addition of the sales tax, the newspaper prominence given to all taxation items at the time undoubtedly started a wave of public determination not to purchase goods subject to the excise tax that even affected commodities not so taxed. This was the condition facing the phonograph and record manufacturers prior to December 20 last. On that date the Government saw fit to abolish the luxury tax entirely, and, while this was welcomed by the manufacturer, it caused an immediate hardship on many jobbers and distributors who had finished products on hand unsold. It also had the effect of slowing up public buying, as is ever the case on a falling market. If honest, we will admit that the public buying of phonographs and records is, to say the least, not so spontaneous as it was.”

Secretary James G. Merrick gave a short, pointed talk on the need for a strong manufacturers' association in Canada this year as never before. Co-operation was an urgent business need. “Take the matter of adverse legislation alone,” said Mr. Merrick; “you have to watch the possibilities of that constantly, because political expediency knows no economic

laws nor how they work out.” In the interests of the entire industry the constantly changing transportation rulings have to be vigilantly watched.

To develop a strong, effective organization Mr. Merrick stressed several requisites, such as: 1. Regular and prompt attendance at meetings. 2. Confidence in the given word of each other. 3. That only the head of the house or a representative with full power to act for the house be delegated to attend meetings; and 4. Banning criticism after the meeting of the decisions reached at any meeting, unless such criticism was voiced in the meeting; or, in other words, lodge any objections at the proper time, which is during the discussion in meeting, not after.

Complaints were voiced at the quality of the containers the members of the trade were receiving for shipping talking machines. The suggestion was made that the manufacturers might co-operate in buying from one source, thereby being in a position to demand better containers. No definite action was taken.

A resolution was unanimously adopted whereby the Phonograph Manufacturers' Association will take steps to become a subsection of the Canadian Manufacturers' Association, thereby securing the benefits of the latter's organization for watching against hurtful or discriminating legislation, of which the luxury tax was a shining example of what governments will sometimes attempt, and also to keep an eye on all new transportation rulings. Watchfulness in these two directions are of immense importance to the retail dealers all over Canada.

The question of a suitable building during the two weeks of the Canadian National Exhibition was also discussed. These vocal and instrumental exhibitions had been increasingly appreciated by the exhibition management, the public, the contestants, and the industry. It was suggested and urged that they be continued on a larger scale each year. Mr. Ford thought that

(Continued on page 123)

Talking Machine Supplies and Repair Parts

SPRINGS, SOUND BOX PARTS, NEEDLES

THE RENÉ MANUFACTURING CO.
MONTVALE, NEW JERSEY

Edison Message No. 92

We hope the Government will not find it necessary to increase the Excise Tax on phonographs, for, if it does, we shall be forced to advance our prices.

THOMAS A. EDISON, Inc.
ORANGE, N. J.

HAPPENINGS IN CANADIAN TRADE

(Continued from page 121)

as each year the accommodation for the musical competitions would become worse it would help squeeze the exhibition directors into providing the much-needed Temple of Music. The secretary outlined the growth of the Music Temple idea at the Canadian National Exhibition and thought the building could now be considered a possibility. The exhibition management was prepared to put up a suitable Music Temple if certain prescribed arrangements could be guaranteed for carrying and maintenance charges. Until such a building were erected he saw no signs of a suitable, permanent home at the exhibition for the phonograph industry. The incoming exhibition committee was asked to do everything possible to bring about a "Music

Day" as a feature of the Canadian National Exhibition. Just as there is a Farmer's Day, American Day, Women's Day, President's Day, etc., it was thought there should be and might be a "Music Day." The election of officers resulted as follows: President, W. B. Puckett; vice-president, E. C. Scythes; secretary, J. G. Merrick; treasurer, W. N. Martin; export committee, S. J. Cook, O. C. Dorian, O. Wagner; exhibition committee, J. D. Ford, B. A. Trestail, A. E. Landon; finance committee, D. R. Gourlay, Thomas Nash, E. Van Gelder; legislation and tariff committee, Armand Heintzman, John E. Hoare, W. D. Stevenson; nominating committee, J. D. Ford, W. B. Puckett, D. M. Wright.

The executive committee of the association consists of the elected officers, with the chairman of each of the standing committees.

HAPPENINGS OF THE TRADE IN MONTREAL BOILED DOWN

Champion Music Co. Buys Phonograph Shop—Brunswick Billboards Attract—A. J. Freiman Honored—Child & Gower Co. Buys Williams Business in Regina, Sask.—Other Trade Changes

MONTREAL, CAN., March 3.—There have been several changes in trade circles during the past month. A number of houses have fallen by the way, while others have engaged in new ventures. Dealers in established lines are finding business good and are doing all in their power to keep it so.

The stock and good will of the business carried on under the name of the Phonograph Shop of Montreal, Regina, have been purchased by the Champion Music Co., which is already operating eight stores throughout the city. It will continue to handle His Master's Voice records and the Starr, Windsor and Cecilian machines. A. Robitaille, manager of the firm, is delighted over the acquisition of this business, which now gives him entree into the West End of the city and a share of the English-speaking trade.

Gray & Jacquest, cabinet makers of Lachine, Que., and the Caron Piano & Phonograph Co. have made assignments.

Congratulations are being extended to Gilbert Layton, youngest son of Philip E. Layton, of Layton Bros., upon his recent marriage to Miss Norah Estelle England, of Montreal.

Ed Archambault, Reg., Canadian phonograph distributor, and the Phonograph Sales Co., Ltd., all of Montreal, have registered as dealers in talking machines.

During the recent Edison jobbers' convention in Montreal Layton Bros., Edison dealers, extended through the press an invitation to all delegates to make use of their warerooms as headquarters during the conference.

Billboards advertising Brunswick phonographs greet one from all sides, and this, together with heavy newspaper advertising exploiting the new arrival of Brunswick records, places this make most prominently before the public.

N. G. Valiquette, Ltd., was the only exhibitor of talking machines at the recent Montreal

Motor Show and had on display a Pathé Actuelle model and an open model showing the mechanism.

The Zionists of Canada at the closing session of the seventeenth convention held in Montreal recently unanimously endorsed the selection of A. J. Freiman, the well-known Columbia dealer of Ottawa, as president of the organization.

To Tony Ramsperger, of the Brunswick Shop, falls the honor of selling locally the first two Brunswick period models, Botham and Stratford console. This firm reports a spirited demand for Brunswick dance records.

The Child & Gower Piano Co., Ltd., Regina, Sask., has purchased the entire stock of Columbia Grafonolas and records of the R. S. Williams & Sons Co., Ltd., and is now exclusive representative for Columbia product in that city.

Norman F. Rowell, manager of the talking machine department of C. W. Lindsay, Ltd., is now the proud father of a baby girl, born February 5.

Musical Studios, Ltd., Quebec City, during the recent appearance of Lazaro, the Columbia artist, advertised the fact in numerous ways and reaped the benefit in large sales of records previous to and after the recital.

There will be opened in Montreal one of the largest dance halls in America and the largest in Canada. The location is the whole of the first floor of the new building now being erected just behind the Engineers' Club, on Phillips square. The name of the place will be "Dancing Carnival." The floor space will give accommodation to over 1,200 couples. Two orchestras will be in attendance, playing continuously from 4 p. m. to midnight.

Montreal dealers will, no doubt, notice a stimulation of sales of dance records as a result of the opening of this new dance hall.

C. W. Lindsay, Ltd., has on exhibition in the show windows the first Magnavox which has reached this city.

BRUNO

Sending your sales staff to the Red Seal School, Mr. Victor Dealer, shows more wisdom than an investment in gilt edge securities. The former requires no capital and you receive all the "Velvet" of the latter.

BRUNO

COVERING NEW ENGLAND TRADE

Wm. T. Gibbs Introducing New Device of Phonograph Specialties Co. to Dealers in That Section—Harry Leonhardt on Traveling Staff

William T. Gibbs, of Providence, R. I., who was recently appointed New England representative of the Phonograph Specialties Mfg. Co., well-known manufacturer of a patented motor and spring safety device to prevent overwinding, recently departed on a trip covering Maine, New Hampshire, Vermont, Massachusetts and Rhode Island territory.

Mr. Gibbs is a well-known mechanical engineer who has had long experience in the sales field. He is particularly well acquainted in New England territory and expects to introduce his firm's products to the trade in the States mentioned.

Harry Leonhardt has also been appointed representative for the firm in the States of Pennsylvania, Ohio, Michigan and Illinois. While Mr. Leonhardt expects to make his headquarters in Philadelphia, he will shortly make a trip thoroughly covering all the trade centers in the States mentioned.

O. W. Weisenborn, president of the Phonograph Specialties Mfg. Co., whose executive offices are at 69 Fleet street, Jersey City, N. J., recently stated: "The results we have obtained from the initial introduction of our device have been most gratifying and lead us to believe that the trade appreciates the merits of our goods. We have received a series of letters from numerous interested parties, particularly repair men, who state that the product has a ready sale."

ATTRACTIVE DEALER PROPOSITION

ON

Okéh Records

OFFERED BY

Sterling Roll & Record Co.

We handle a complete line of phonograph accessories

PITTSBURGH, PA.
436 4th AVE.

Sterling Roll & Record Co.

CINCINNATI, OHIO
137 W. 4th ST.

New Distributing Territories Open

WE invite inquiries from progressive houses with efficient facilities for the sale and distribution of Emerson Records.

The territories which are open contain many Emerson dealers who are now doing a good Emerson Record business. This already-developed business is waiting to be absorbed by satisfactory distributors with efficient organizations.

Product and Price Are Right

All Emerson 10" Gold Seal Records retail at eighty-five cents. All are double discs. Included are foreign language records, also operatic and classical selections by well-known artists.

Emerson recordings are noted for their novelty, originality and popular appeal. Prominent musical comedy stars and vaudeville headliners record exclusively for Emerson.

Small Stock, Quick Turnover

The catalogue is small, consisting largely of quick-selling popular numbers of the type which constitutes 90% of the dealer's business. Quick turnover and steady demand are thus ensured.

Out First With New Hits

The Emerson policy of releasing records of the new dance and song hits FIRST gives the Emerson distributor great advantage over his competitor.

Write today, as the territory still open is limited.

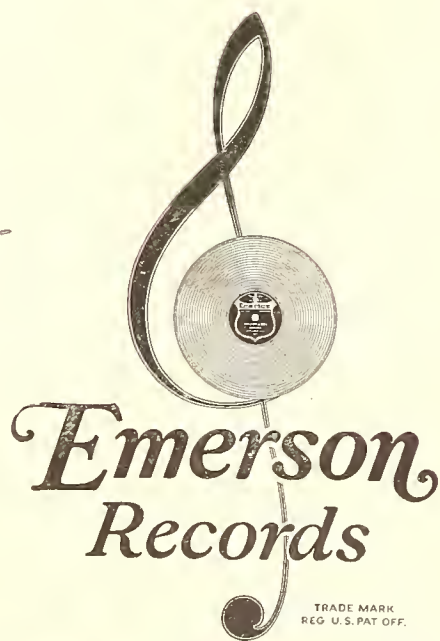

EMERSON PHONOGRAPH CO., INC.

NEW YORK
206 Fifth Avenue

CHICAGO
315 South Wabash Avenue

Makers of Emerson Standard 10-inch Gold Seal Records

Emerson Records

A DECIDEDLY BETTER FEELING IN INDIANAPOLIS TRADE

Columbia Co. Occupies New Home—Latest Brunswick Dealers—Edison Expansion—Indianapolis Co. in New Quarters—Senate Bill Defeated—Stewart Co.'s Good Work—Other News

INDIANAPOLIS, IND., March 1.—The Columbia Graphophone Co. moved today to its new quarters in the Capital Paper Co.'s building at 221-25 West South street. The new plant gives the company 32,000 square feet of floor space, which Manager Scott says contains the most up-to-date distributing plant in the Middle West. The building in which the company has located is of concrete construction and is six stories high. The Columbia Co. has part of the first floor and all of the second and sixth floors.

The plant is the newest of the standardized branches of the company and has every modern convenience known to the trade for purposes of repairing, packing and shipping. On the first floor is the receiving department with trackage facilities to the door. The second floor contains the office and record department, the shipping department, service department, Dealers' Service department and dictaphone department. The sixth floor is used for the storage of stock.

J. M. Bayliss, who has charge of the work of standardizing the Columbia branches, has been in the city assisting Manager Scott in the arrangement of the new plant. Others who have been recent visitors from the home office are George W. Hopkins, general sales manager; R. F. Bolton, international record sales manager, and O. F. Benz, record sales manager.

Business among the Columbia dealers in this district, says Mr. Scott, has shown an increase in January and February over the same months of last year. This has been particularly true of the Louisville dealers, he says, where remarkable things have been accomplished in building up trade. Business all over the district is showing a firmer trend with buying more conservative.

Many New Brunswick Dealers

Manager Burr, of the Brunswick-Balke-Collender Co., reports new contracts for Brunswick dealers coming in at the rate of two a week. Business is keeping up largely, he says, on the higher-priced machines. A representative of Thoma & Son, Brunswick dealers at Bluffton, a town of 5,000, visited the distributing plant last week and reported they had sold six of the Stratford models since the first of the year. They are specializing in that model.

The Isham Jones Orchestra, an exclusive Brunswick aggregation, is having big receptions in many Indiana towns. The orchestra is being featured at Terre Haute this month under the auspices of the Brunswick Shop and the Knights of Columbus; at Fort Wayne under

the auspices of the Spiegel Music Co. and B. J. Dresler; at South Bend under the auspices of the Lenhart Brunswick Shop and at Goshen under the auspices of the Newel Bros. Dry Goods Co. C. A. Grossart, manager of the Brunswick Shop of this city, says he has had a tremendous record business during the last few weeks. His business in machines, he says, has been largely in the higher-priced instruments.

Edison Trade Here Improves

Mr. Cartmil, secretary of the Kipp Phonograph Co., Edison distributor, is spending a few months in Miami, Fla. He reports that he is having an excellent time; that he has forgotten all business cares and has nothing to do but fish, bathe and listen to Pryor's Band, which gives concerts twice daily at Miami. Walter E. Kipp, president of the company, has just returned from a visit to the Edison laboratories and to Montreal, Canada, at which latter place the Edison Jobbers Association held its annual meeting.

"Reports from our travelers indicate that conditions are improving very steadily in our territory," said H. G. Anderson, general sales manager of the Kipp Co. "The dealers that are using the Edison sales plans are finding them an excellent aid in producing business. Orders from the dealers in the last two weeks for instruments go to show that stocks carried over from the holidays are practically gone. Recreation sales were exceedingly heavy for February and showed quite an increase over our January sales."

T. W. Hendricks, manager of the talking machine department of the Pearson Piano Co.'s store, reports a record business doubled in the last ten days under the stimulus of steady newspaper advertising in which he features Victor, Edison and Vocalion service. Miss Estella Carr, Miss Esther Hartwig, Miss Mary Fultz and Harry Jones have been added to the record department by Mr. Hendricks. Miss Carr takes the place of Miss Freda Booth, who went to the W. L. Taylor Carpet Co. Miss Hartwig was formerly in the talking machine department of the L. S. Ayers Company, and Miss Fultz formerly was with the Spence Music Co., of Columbus, Ohio.

According to present plans the Indianapolis Talking Machine Co. will move to its new store at 134 North Pennsylvania street March 5. Manager William S. Cooke says his new place of business will be the finest talking machine shop in the Middle West.

February business in talking machines as well as records showed a decided improvement over the business of January, according to Manager C. P. Herdman, of the talking machine department of the Baldwin store.

E. L. Arthur has been employed as retail sales manager of the Indianapolis store of the Starr Piano Co., to succeed B. T. Clay, who becomes a city salesman. Mr. Arthur formerly was with Chas. Mayer & Co. as manager of the Sonora department.

Victor dealers are reaping benefits from the many entertainments that have been given in this city during the Winter by famous artists. Sophie Braslau, contralto, sang here February 13, as one of the features of the free municipal concerts given by the Indianapolis park board and the school commissioners. The dealers have been featuring their Braslau records. Now a large sale of the new La Scala Orchestra records is anticipated in view of a recent appearance of that famed aggregation before a crowd that filled the Murat Theatre.

Trade Defeats Senate Bill

Able assistance in securing the death of Senate Bill No. 57, a legislative measure, was given by Victor dealers throughout the State. The plan of the bill was to require the transfer of the title of goods bought on deferred pay-

(Continued on page 126)

CABINETS

6

Models in All Sizes at a Big Cut in Prices

GENUINE MAHOGANY, AMERICAN WALNUT and GOLDEN QUARTERED OAK



Height 49 inches
Width 21 "
Depth 22 1/2 "

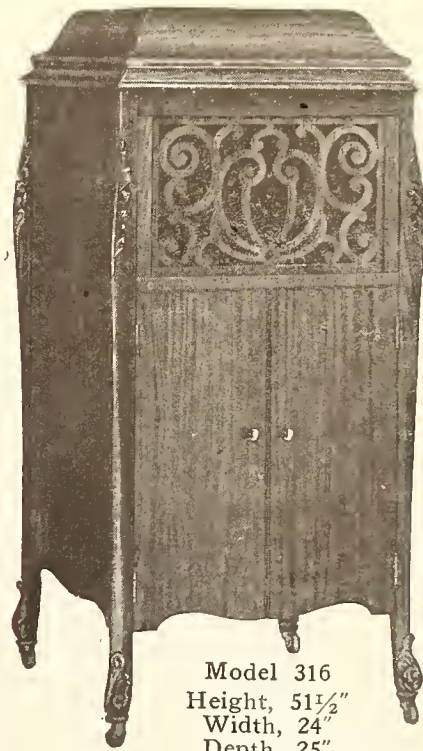

Model 316
Height, 51 1/2 "
Width, 24 "
Depth, 25 "

SIX MODELS, ALL SIZES and FINISHES, IN COMPLETE PHONOGRAPHS AT A PRICE

A-1 Cabinet Work in Construction and Finish
Large Double Spring Motors and Universal Tone Arms

Write for Special Prices on Large and Small Quantities

Player-Tone Talking Machine Co.
967 LIBERTY AVE., PITTSBURGH, PA.

Stewart
Talking Machine Company

JOBBERS
for the
Victor
Talking
Machine
Company

Indianapolis



Bert Williams, "blue" as usual, wails "My Last Dollar" and "I'm Gonna Quit Saturday." Bert's "grief" brings joy to your customers and dollars to your cash register. Order big. A-3356.

**Columbia Graphophone Co.
NEW YORK**

BETTER FEELING IN INDIANAPOLIS

(Continued from page 125)

ments from the seller to the purchaser with the first payment. Similar action has been undertaken by many other legislatures.

The Stewart Talking Machine Co. interested the dealers in the bill by distributing bulletins issued by the Indiana Retail Dry Goods Association, in which the evils of the proposed legislation were set forth. Every Victor dealer received a copy of the bulletin and a letter urging him to telephone each merchant in his community urging a combined remonstrance against the passage of the bill. The following week the bill was killed.

The Herz Co., Victor dealer in Terre Haute, is enlarging its record sales by supplementing the monthly announcement of new records with postal cards sent to customers. An ordinary Government card is used and on the last ones sent out the company featured popular songs.

"Do you like popular songs?" was used as a headline and was printed in bold-faced type. Directly under this suggestive title the names of four popular songs were listed with the names of the artists and also the price of each record. This simple sentence, "We have 'Margie'," was written on each card with ink, and results showed the sentence to be a worth-while booster for that popular selection. Everyone on the entire mailing list received the card and the results were gratifying.

Miss Caroline Hobson, head of the educa-

tional department of the Stewart Talking Machine Co., has been placed on the program of the Educational Conference, to be held this month in Chicago. The Stewart Co. is extending its Dealers' Service department to include assistance not only in advertising but also in all the work arising from the retail end of the Victor business. Victor dealers for some time have had the privilege of obtaining lay-outs, campaigns and all other needed assistance in carrying out their advertising programs. Now they are to be given the opportunity of obtaining accounting service, arrangement of stock service and any other desired aid from their distributor.

T. A. Wright, formerly of the Holloway-Wright Co., furniture dealers and exclusive Victor agents, of Newcastle, died suddenly February 25, of apoplexy. He was fifty-four years old and was prominent as a Rotarian and live business man of the community.

As a step toward making his store the music headquarters of the city, W. S. Barringer, Victor dealer of Kokomo, is issuing a bulletin each week announcing the musical events of the week. The bulletin is posted at the store.

Pathé Dealers Meet

The retail Pathé dealers of this territory met in a sales conference February 23 at the store of the Mooney-Mueller-Ward Co., Pathé distributor. The meeting was called mainly to hear James Watters, of Brooklyn, secretary of the Pathé Frères Co., who spoke on the general condition of the talking machine business. The

dealers are now facing a buyers' market, said Mr. Waters, and it is necessary for the dealer to return to the selling tactics prevailing before the war.

The consensus of opinion at the meeting was that those dealers who intensified their selling efforts and went after business energetically would win a large share of prosperity during the year. Forty dealers were present at the meeting, including E. P. Hawkins, of the Connersville Furniture Co., Connersville, Ind., exclusive Pathé cabinet manufacturer; Mr. Snapp, of the Brooks & Snapp Co., of Paris, Ky.; P. G. Miller, of Central City, Ky., and Mr. McDonald, of McDonald & DeWitt, Greenville, Ky. Mr. Hawkins spoke briefly in outlining reasons for his belief that the dealers face a prosperous season. The Kentucky dealers reported conditions in that State to be very much on the up grade.

Edgar Eskew, manager of the Pathé Shop, says that the last week in February was the best week he has had this year in both record and machine sales.

OPTIMISM MORE EVIDENT

L. A. Kichler Co., Cleveland, O., Reports Increasing Demand for Valances—Dealers Are Confident Regarding Future

CLEVELAND, O., March 5.—Talking machine dealers are evidently regarding the future with a more optimistic eye than they were a few months back and on all sides can be found indications that the trade has not been dead, but merely sleeping. Evidence of this is shown in one instance by the activity of the L. A. Kichler Co., makers of window valances, in this city.

A. M. Emerling, designer for the Kichler Co., says: "Despite the general quietness in the trade we have enjoyed a wonderful response to our new specially designed valances for retail talking machine stores. It is very plain to us that behind this demand there is a general feeling of optimism and determination to go after business."

"Dealers realize that the successful merchant must above all things have an attractive display window—one with that air of refinement and exclusiveness which should always be associated with a good music store. We are receiving orders for window valances of special designs from dealers handling all makes of machines, thus indicating that this feeling of optimism is general throughout the trade."

AUBURN MUSIC CO. EXPANDS

The Auburn Music Co., located at 8 Exchange street, Auburn, N. Y., has leased the store adjoining its present quarters and will throw the two stores into one in order to provide the required room for the expansion of its business. New piano warerooms will be provided and several record-demonstrating booths installed. The company features the Mehlin pianos and Victor talking machines.

Ward's Khaki Moving Covers



Grade "D" Cover with

No. 3 Straps

THE C. E. WARD CO.

(Well-Known Lodge Regalia House)
101 William Street New London, Ohio
Also Manufacturers of Rubberized Covers
and Dust Covers for the Wareroom

Distributors

- BRISTOL & BARBER, INC.
111 E. 14th St., New York City
- YAHR & LANGE DRUG CO.
207-215 E. Water St., Milwaukee, Wis.
- COHEN & HUGHES, INC.
Washington, D. C.
- BECKWITH-O'NEILL CO.
Minneapolis, Minn.
- STREVELL-PATERSON HARDWARE CO.
Salt Lake City, Utah
- C. L. MARSHALL CO., INC.
Beckman Bldg., Cleveland, O.
Butler Bldg., Detroit, Mich.
- THE REED CO.
237 Fifth Avenue, Pittsburgh, Pa.
- C. J. VAN HOUTON & ZOON
140 S. Dearborn St., Chicago, Ill.
- SONORA DISTRIBUTING CO. OF TEXAS
Dallas, Texas
- KNIGHT-CAMPBELL MUSIC CO.
1608 Wynkoop St., Denver, Colo.
- CHAS. H. YATES
311 Laughlin Bldg., Los Angeles, Cal.
- W. D. & C. N. ANDREWS
Buffalo, N. Y.
- SACHS & CO.
425 So. Wabash Ave., Chicago
- SHERMAN, CLAY & CO.
741 Mission St., San Francisco, Cal.
- JOHN A. FUTCH CO.
35 Auburn Ave., Atlanta, Georgia
1500 South Boulevard, Charlotte, N. C.
630 Washington St., Jacksonville, Fla.
- ORTON BROTHERS MUSIC HOUSE
Butte, Mont.
- GRAY & DUDLEY CO., Nashville, Tenn.
- ASSOCIATED FURNITURE MFRS.
St. Louis, Mo.
- W. J. DYER & BRO., St. Paul, Minn.
- AMERICAN PHONOGRAPH CO.
Burlington, Vt.
- JOSEPH BARNETT & CO., Cedar Rapids, Ia.

BRUNSWICK RECORD OUTPUT GROWS

New Mid-West Pressing Plant Planned to Give More Direct Service to Dealers

CHICAGO, ILL., March 9.—P. L. Deutsch, assistant secretary of the Brunswick-Balke-Collender Co., announced, in the course of a chat with The World, that the production of Brunswick records is being steadily increased and that plans are now being inaugurated to erect and equip a record-pressing plant, which will be located in the Middle West, and which will enable the Brunswick Co. to give more direct shipping service to the dealers located in this section of the country.

INCREASES CAPACITY OF PLANT

Wax & Novelty Co. Enlarges Factory Facilities—Demand for Product Steadily Increasing

The new plant of the Wax & Novelty Co., at 57-59 Paris street, Newark, N. J., has been fitted out to take care of the increased business of this company. The plant is up-to-date and modern in every respect with plenty of floor space, so that the company can take care of its fast-growing business. F. W. Mathews, owner of the company, states that business is improving, and a general feeling of optimism prevails. In addition to the manufacture of wax for phonograph records, this company also manufactures wax blanks for use on dictaphones. Mr. Mathews is well known in the industry as an expert in the manufacture of wax and enjoys the confidence of the trade.

NEW FIRM IN WAUKEGAN, ILL.

Alden & Kastner Title of New Firm of Piano and Music Dealers in That City

WAUKEGAN, ILL., March 4.—Earl G. Alden and W. A. Kastner have organized the firm of Alden & Kastner in this city for the purpose of engaging in the retail piano and music business, with quarters at 318 South Genesee street. Both men are experienced tuners and have worked in Waukegan for the past fifteen years. Both also were formerly connected with the Fulton-Alden Music Co. before that concern entered the talking machine manufacturing field.

ISSUES SERIES OF CATALOGS

The American Odeon Corp., New York City, has announced to the trade that catalogs of foreign records are now ready for distribution. These include recordings in Bohemian, Polish, Servian, Hungarian, German and Jewish. This company is also offering to the trade Fonotipia records of Italian selections. A new catalog of Odeon records featuring the first American releases has been well received by the trade, and future additions to the catalog will be made regularly each month.

ISSUES TWO NEW RECORD ALBUMS

The New Models Offered by Peerless Album Co. Made to Fit Latest Style Victrolas

The Peerless Album Co., which recently moved to its new home, 636 Broadway, New York, has just announced two new record files, to be known as No. 80 and No. 90. The Peerless Album Co., which has one of the most efficient manufacturing establishments of its kind in this country, has been in the forefront in the matter of progress and has produced these new files for the purpose of creating an indestructible filing cabinet to fit the new Victrola models.

The albums include some very unique features. They are alphabetically arranged and there are special styles for both the ten and twelve-inch records. On the top of the ten-inch albums, in order to make the files uniform in size, there has been added a patented receptacle, in the form of a drawer, to hold needles and accessories.

Phil Ravis, president of the company, recently stated that they are prepared to take care of a very heavy demand on these goods. In commenting on the general trade he said: "Since moving into our new quarters we have installed much new machinery, all modern equipment, adding to the efficiency of our plant. This, together with the lowering of labor costs and the improvement in general business, allows us to market these goods at attractive prices."

INSTALLS ADDITIONAL MACHINERY

Superior Die Casting Co. Increases Factory Equipment—Opens Two Branch Offices

CLEVELAND, O., March 5.—The Superior Die Casting Co. has just completed the installation of air-operated die-casting machinery of the firm's own special design.

"This equipment is productive of better quality castings, which can be turned out at a more rapid rate and at a minimum of labor," said A. E. Weiss, general manager of the company. "I don't care to go into detail about the new machines, but we are now able to take care of a larger volume of business at a price that is very attractive, and which increases rather than merely maintains our quality."

The Superior Co. has opened an office in Philadelphia, which is in charge of D. B. Wilson and D. H. Ensign. It is located at 105 Real Estate Trust Building. A Detroit connection has also been made with F. L. Neward and M. F. McManus, whose offices are in 1250 Book Building.

TO MAKE RECORDS IN NEWARK

The Phonographs Recording Co., Newark, N. J., has been incorporated for the purpose of making records. The capital is \$500,000 and the incorporators are Charles P. Gambee, Elmer M. Harrison and George L. McCracken, Newark.

Motor and Spring Safety Device

(PATENTS APPLIED FOR)

IMPOSSIBLE TO OVERWIND THE MOTOR

When sufficiently wound, the handle automatically ceases to wind. Thus, any child can wind the talking machine with safety.

A Simple Fool-Proof Device—Fills a Long-Felt Want—

Can be attached by anyone in a few minutes. Once placed needs no attention—graphite lubricated.

NOW READY FOR VICTOR MACHINES—SAME ATTACHMENT FOR ALL SIZE VICTROLAS

Territory Open to Jobbers and Dealers

PHONOGRAPH SPECIALTIES MFG. CO.
67-69 Fleet St. Jersey City, N. J.

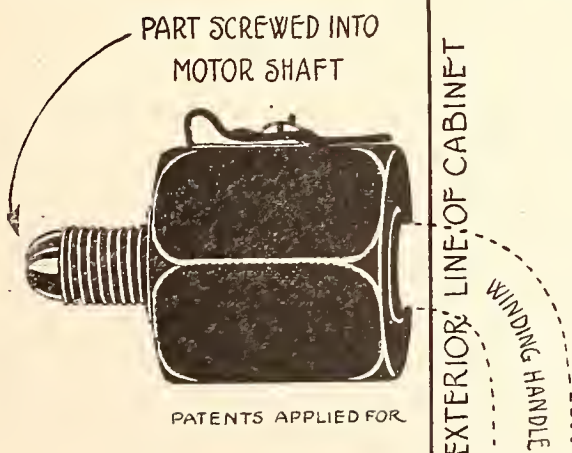

RETAIL PRICE \$3.75

Samples sent post paid on receipt of \$2.25
LIBERAL DISCOUNTS TO THE TRADE

THE MID-WEST

WESTERN DIVISION OF THE WORLD, CHICAGO, ILL., MARCH 8, 1921. IF WE all practiced what we preach this would be a lovely world. One can have a sneaking sympathy with the hard-boiled gents who don't like to be reminded each and every day of their shortcomings in this or that direction. Still, a good sermon has its values and just now it seems that scarcely anything is needed more than a general good dressing-down for the crape hangers who for so many weeks past have been holding the center of the stage. We arrive at this comforting conclusion just in time to begin writing these paragraphs, and as we do so our eyes are drawn to a late issue of the Music Trade Review, wherein are to be found some hot texts for a sermon which will be found interesting to readers of The Talking Machine World. Our very well-known friend, W. S. Miller, who is vice-president of the Bush & Gerts Piano Co. of Chicago, is one of those who believe that half the world's troubles are to be traced to an inability or unwillingness to tell the truth; and in The Review the other day he sets forth his views on things in general with a directness and conciseness at once practical and delightful. "Since I was a boy," says Mr. Miller in substance, "we have had all sorts of patent remedies for the various ills from which business suffers, or is supposed from time to time to suffer. I can well remember when 'efficiency' came in. We were all going to run our businesses by such wonderful automatic methods that it would be necessary to do nothing save sit back and count the money as it rolled in. And even the counting would be done by machinery. Well, some of us found out, rather late, too, that a business can be so blamed efficient that the efficiency system absorbs all the energy of the business and leaves none for making or selling goods. Well, 'efficiency' sort of went out. Then in came 'Service.' Service was a fine new remedy. It sounded awfully good and everybody was going in for it, till some one found out that 'Service' in business meant what the word itself means, and then its popularity sort of fell off.

Advises
"Take No
Substitute"

Real Work
Is the
Remedy

So FAR our friend as we interpret him, freely as to the letter but accurately as to the spirit. How easy it is to know the truth when one meets it! Always the truth is distinguished by its fitness, by its instant applicability to our own special case. The old prescription that stands revealed in the one word work is plain and simple; and it fits the talking machine business just as much as it fits the building or the steel business. What we need just now is to get away from words, from cloudy piffle, and to get down to work. Let every dealer throughout this land realize that music is one of the prime necessities of the age, and that the talking machine is the music bringer par excellence; and he will lose no further time before buckling down to work and going out after sales. The way to get sales to-day is to go out after them. For five years there has been little or no need to go out after sales, for sales have been coming in faster than they could be attended to. But before 1914 no one used to worry about having to go out and hustle up sales. Take the piano business, which is harder than the talking machine business ever has been or ever will be. Those who know how the piano business was run before the great war know that there was nothing more natural than to go out and ring door bells until the prospect had been discovered and then to induce the coy and newly discovered one to come to the store and submit to being "sold" on the proposition. That sort of process was well known, in fact it was the only normal process seven years ago. Is there any special reason why that process should not become popular again?

"WHEREUPON," continues substantially our good and highly sensible friend, "psychology came in. To-day it is all 'psychology.' We are all to solve the problem of merchandising by learning the rules of this great science. Of course, it is true that most of the psychologists are individually of the opinion that all the other psychologists are quacks, if not something worse. It is equally true that no one seems to be quite certain what the 'psychology of business' really is or how it works; but it is grand stuff just the same. Still—still—to a fellow who has seen this sort of thing come and go for a good many years, to a fellow who is perhaps not quite so up-to-date as some of the young fellows, there is something wanting in all this hullabaloo. When I was a boy it was a case of get up at 5:30 a. m., break the ice in the water pitcher, dress in the cold and get out to work: hours 6 a. m. till dark, three square meals a day, and bed and board for pap. Now, all that strenuous stuff sums up in the one word, work, w-o-r-k. Am I wrong in believing that, with all the wonderful increase in comfort, not to say luxury, with all the great wonder of a workman to-day having comforts which a rich man did not have fifty years ago, there is still something very much lacking at this moment in our world? Is it not just this simple, plain, homely word, w-o-r-k, with which the world needs to acquaint itself again? In a word, I believe that the trouble with business is three parts plain disinclination to work. Our youngsters dream only of sitting at mahogany desks, being 'executives.' Our girls won't look at a fellow who has not a car. Our workmen dream of seizing the factory and sitting in the boss's office. Everybody wants the money, nobody wants to work. Well, we've got to learn that work is a necessity, not a luxury. The world is going to learn this sooner or later. The process of education may be long or short, easy or painful. That depends on how willing we are to take our medicine. Yet, take it we must, until we have learned that the world goes by work, by plain, honest work, without frills on it."

The Old,
Old
Remedy

Portable
Will Be
Popular

THE WISE agents who gather up the news for our columns, and who thus satisfy each month the impatience of thousands of palpitating persons who live, so they tell us, only from issue to issue of The Talking Machine World, have been sleuthing again, and again returning with wise prophecies as to what is going to happen. They are always doing this sort of thing, and sometimes they do it well. The very latest is that there will be a big boom in portable machines this Summer. Can any one imagine why? Simply because there will be a boom in vacation parties of the camping, motor-touring and similar simple kinds, as against the expensive hotel kind which was so popular last year and the year before. The reasons can be imagined. But the main point is that if our staff sleuths are right there ought indeed to be a big boom in small talking machines of every kind, especially in the sort of machine which can be folded up and carried around like a grip. Everybody who ever passed down Wabash Avenue in the Summertime knows that the enterprising talking machine men at Lyon & Healy's get the big corner window as often as they can so that they may set therein a camping or boating scene, life size, with the usual little Victor portable in a prominent place. Certainly! And this year they are likely to have more than ever of the good excuses which ingenious managers put up to window-dressing experts in these big establishments. For the portable is on the cards and the campers in their thousands will want it.

BY THE same token our sleuths tell us that there is a widespread tendency to talk and think about small and moderate-priced console machines. Just how much this means cannot be said at the moment, but the idea suggests something interesting. For the parallel is almost complete with the small grand which, during the last three or four years, has so come to the front in the piano world. The small grand piano is the logical result of attempting to find something which will fit into the small apartment or bungalow of the prosperous urban dweller, and which at the same time will be superior in construction, in tone and in musical worth to the ordinary upright piano. The prosperous citizen, or his wife, wants something better than the ugly and inartistic upright. Yet the large grand piano is both very expensive and much too large for ordinary living rooms. Hence the small grand. So, too, along parallel lines of rea-

Enter
Console
Junior

POINT OF VIEW

soning, we may see the desire for the small console machine. In the first place, the man who has a little money and is learning to achieve taste as well as mere comfort, wants something less obtrusively obvious than the ordinary cabinet talking machine. Up till recently the console machine has been a very exclusive affair altogether. Well, now the masses are beginning to want exclusiveness, if the epigram may be pardoned, and yet they do not want and cannot appreciate the very expensive console machine done in some elaborate reproduction of an authentic period and costing a great deal more than a good cabinet machine will fetch on the market. So the logical answer to the want is the small and moderate-priced console. It is not at all unlikely that we shall see a great deal of this sort of thing during the year and the manufacturers out in this part of the world will have much to do with putting it across. For our own part we are heterodox enough to believe that the cabinet type of talking machine is not the ultimate standard type, not by a jugful, as the old saying goes.

THE TRUTH is, some wise men in the talking machine trade are already seeing that the prospect has to be dug up and sold. We learn that so keen a merchant as William Wade of Chicago is employing canvassers to dig up prospects from the homes of the people in his community, and that he is meeting with eminent success. There is every reason why this should be so. Human nature is curious enough in all conscience, but nowhere is it more curious than in its schemes to get something for nothing. Thus the busy Wade canvassers are finding, so we hear, that a great many excellent folks are declining to come into town to the stores, although they profess themselves sympathetic toward the idea of a talking machine in the home. They say, however, that when some one takes the trouble to look them up and run after them, as it were, that is proof that the some one in question has a bargain of some kind to offer. Whereupon the bond of sympathy is established and there is no longer much difficulty in getting things going toward a successful sale. Now, that sort of thinking does not seem to be very logical, but it is the sort of thinking which a great many folks are doing just now. The idea is that the man who sends after one must need business; and if he needs business he must surely be ready to offer bargains, wherefore the willingness to listen. For it cannot be denied that this desire for bargains is uppermost in the public mind. The one dominating notion with thousands of buyers just now is that prices must come down, and that the thing to do is to wait for the bargains to come along, as, in the popular belief, they will be coming along sooner or later. When the people have become firmly convinced that a declining market exists it is hard to hold them at any point long enough to sew them up on a deal. They always want to wait a week or two longer. Hence the philosophy of the canvass. Hence, also, the further fact that there are more ways of killing a cat than the well-known method of drowning. Hence, also, the wisdom of getting out and "diggin' 'em up." Hence, also, the justification of that simple prescription for all industrial ills: WORK. Work till you find a new way to sell, and then hop to it!

Victor's National Service

VICTOR dealers, distributors and other members of the great Victor family in the mid-West will be stirred by the news of the elaborate educational conference which is to be held in Chicago toward the end of this month. The work which the Victor Co. is doing in the schools, through community agencies and in other cognate ways to promote the gospel of good music among the people of the United States has, of course, its selfish, that is to say, its commercial side. But there is no disgrace in that. What for the present purpose is more to the point is that the people of this country need, and need most thoroughly, a general process of familiarization with music. Here is a nation with more potential art-wealth than any in the world, for it numbers among its people representatives of

every artistic race. Yet, apparently, these immigrants are permitted neither to retain their native culture nor to obtain an American culture in its place. The tendency is to crush all that they have brought to us of native art, music, tradition. Those who, like the experts of the Victor Co., have deeply studied these questions in relation to music teaching in this country, know that it is essential to retain the foreign arts which come to us, and especially the foreign folk-songs, dances and traditional melodies. They know that the way to a truly musical America is along the path of least resistance. They realize that that is exactly why every talking machine man who cares for the future of his business and of his country should welcome the constructive work of the Victor Co. Granted that its immediate object is to promote the sales of Victor machines, records and educational methods in music teaching throughout the schools of the country. What of it? Business makes the mare go. The direct result is more business. The indirect result is more music. More music again means more business, and once more the circle is traversed.

WE NOTE that the energetic advertising manager of the Steger & Sons Piano Manufacturing Co. is at it again. This time his department is occupied immediately in pushing the sale of Steger phonographs, which worthy work is being done through the agency of some very artistic and worth-while advertising, especially prepared for the use of Steger dealers. This co-operative advertising has been found by the Steger folks to be most useful in promoting the sale of their well-known pianos and its extension to the field of phonographs is likewise expected to product parallel results. The fact is that the average retail merchant, supposing that abstraction for the moment to assume concrete form, does not usually think very deeply on the subject of advertising any sort of specialty, even one so obviously interesting as the talking machine. His copy writing is not likely to be expert. Now, expert copy writing is very much needed just now. In fact, it is probably more needed at just this moment than ever it was before. It is not that the people have less of a desire than before for music. Far from it. Rather it is that public ideas as to values are rather too confused, so that the people do not know quite where they are standing in respect to judgment of worth. Here is where the expert copy writer comes in. He knows his case and knows how to put it before the casual reader of a newspaper or magazine, how to put it so that the wandering attention shall be caught and focused and trains of thought set in motion which shall crystallize into definite and favorable action. Expert copy writing is the thing just now, and the Steger co-operative advertising shows the expert.

WHICH leads us to observe in conclusion that the columns of our newspapers, not to mention the magazines, and even the trade journals, show less than a desirable attainment of expert writing in their talking machine advertisements. A great deal of money is spent on advertising talking machines, but it must be confessed that the work of the original Big Three stands out far above all others in respect of originality, clear thought and force, even to-day. There are some very close competitors, but in general it must be said that talking machine retail advertising does not stand at the 100 per cent level. The reason may be conjectured more or less accurately. There has not been time yet to develop a consciousness of the economic and social significance of the talking machine, and advertising writers have not yet studied it thoroughly or with understanding. A man cannot write convincing copy about an article of which he knows nothing, or with which he is not in sympathy. No first-class advertising agency in the country any longer dreams of cooking up copy over the fire of the imagination of a writer who never leaves his office to mingle with the world which both makes and consumes the subjects of his appeals. Expert advertising presupposes a knowledge of the subject.

Engaged in "Digging 'Em Up"

learn that so keen a merchant as William Wade of Chicago is employing canvassers to dig up prospects from the homes of the people in his community, and that he is meeting with eminent success.

Steger Selling Sense

ment is occupied immediately in pushing the sale of Steger phonographs, which worthy work is being done through the agency of some very artistic and worth-while advertising, especially prepared for the use of Steger dealers.

A Talk Regarding Publicity

nals, show less than a desirable attainment of expert writing in their talking machine advertisements. A great deal of money is spent on advertising talking machines, but it must be confessed that the work of the original Big Three stands out far above all others in respect of originality, clear thought and force, even to-day.

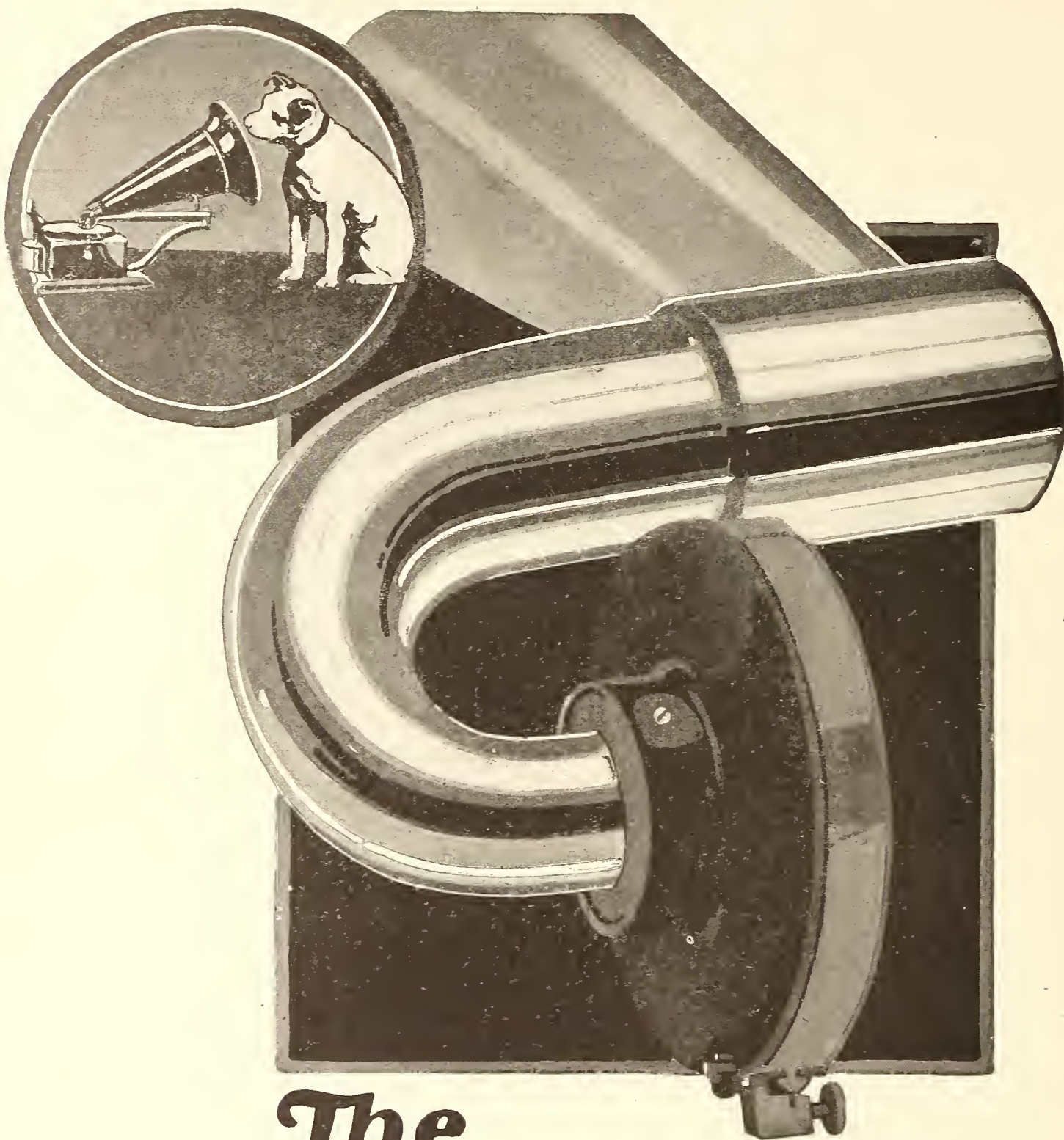

The
“Goose Neck”
Sound Box Tube—
exclusively VICTOR

NEW YORK

Talking Machine Co.
○ 119 West 40th St.

CHICAGO

Talking Machine Co.
○ 12 N. Michigan Av.

Victor Wholesalers Exclusively

From our CHICAGO HEADQUARTERS

REPUBLIC BLDG., 209 SOUTH STATE ST TELEPHONE WABASH 5774

EDWARD VAN HARLINGEN

WILLIAM BRAID WHITE

EUGENE F. CAREY

ARTHUR E. NEALY

A. SNYDER

CHICAGO, ILL., March 8.—A great many men in the trade have recently asked, "When business picks up, what will be the general trend in the domain of designs?" It is evident that these questioners have been asleep to some extent—if they weren't they wouldn't consider probabilities. Anyone who has been keeping abreast of the times knows that business in the past two or three weeks has already begun to pick up. We have recently made a round of the supply houses and in our interviews with these people we learned that, as a whole, more supplies were sold in the first two weeks of February than during the months of January and December combined. Then again we learn that these supply houses are receiving more inquiries from new sources than ever before. This would seemingly imply that a large number of new concerns contemplate making an entry into the talking machine field.

Now, as regards new designs. From what we can learn, there will be little change in styles. Perhaps the only instruments that will be affected along this line will be the console models. Many of the manufacturers in and about Chicago are figuring on bringing out instruments of this kind which may come to be known as miniature or midget model consoles. This change is deemed necessary because of the increasing numbers of inquiries from dealers all over the country for extra small sized consoles.

From present indications there will be an exceptionally large number of small portable machines sold this year. In trying to find the wherefore of this expected business we are told that dealers have been feeling their regular patrons out, and after more or less conversation pertaining to the coming vacation season have concluded that this year many of their patrons are figuring on spending their vacations in camps and on auto tours. If this really be the case, it is fair to assume that the vacationists will want portable instruments to take along with them.

One thing we have noticed in particular is that some manufacturers are complaining about loss of business, while others are saying that, although business is nothing to brag about, still they have no kick coming. In making a diagnosis of this situation, we find that the fellows who are doing the kicking are those who have

been overconservative in their business. By which we mean that, when it became necessary to curtail expense, the kickers began curtailing and didn't know when to stop. They not only cut out their advertising, but they cut out their sales help as well, whereas the fellows who are not kicking cut out everything they could with the exception of their advertising and their sales help. This is evident from the fact that many out-of-town dealers tell us that it is an unusual sight nowadays to see a traveling representative of a talking machine company. These dealers admit that because of present circumstances they are forced to buy from hand-to-mouth, but the travelers who call on them and study their particular situation are finding ways to help them get business. These travelers in turn are repaid by getting the dealer's business. Other things being equal we can, therefore, readily see why the wise manufacturer or jobber is keeping his sales force on the road, as he had in a measure the field to himself and a great opportunity to build for the future.

Speaking of advertising, it might be well to suggest, for the benefit of the dealer, that he should pay more attention to his local advertisements. There has been some tendency to advertise "bargains." The word bargain has been appearing so much in the newspapers recently that the public at large is coming to regard the word as a joke. It is believed that anyone who advertises a bargain is trying to unload some old stuff, which is really not worth the price asked for it. Therefore, it might be a wise plan for the dealer to advertise "quality" and "value" instead of "bargain," and in that way bring about a new line of thought for prospective purchasers of talking machines, records, etc.

Something to Think About

J. C. Dunas, of Cole & Dunas, puts forward the following thoughts which we believe ought to be taken into consideration by talking machine dealers at large: "Many dealers in the field are doing good business in spite of the so-called depression in buying, and if one stops to inquire how these fellows are still making money he will find several reasons. Of course, it goes without saying that these successful ones are not letting the grass grow under the

feet of their canvassers, but another reason that is just as important to my mind is that all of them seem to have their own repair departments.

"In the past two years business has been so thriving that the average dealer didn't want to stop in the midst of his sales of talking machines and records to give the repair side of his business a thought, being content to recommend any inquiries along this line to repair shops located in places other than his own place of business. However, there are quite a few dealers who did stop and think, and they soon found out that their inquiries for repairs would supply enough work for a department of their own. After establishing such a department they soon found it to be one of the most profitable parts of their business. Another thing brought to their attention was that when an outsider came in to have a repair made he usually became a steady customer, and bought all his records and accessories in that dealer's store. The customer realized that this dealer was a dependable man and there was the feeling of satisfaction that if anything went wrong he knew where he could get it fixed right. Further than that, he would become a booster for that dealer, advising his friends, if they contemplated purchasing a machine, to go to the dealer with a repair department and save themselves the trouble of running all over town looking for a repair man in case their machine went wrong. When it comes right down to the point, there is really nothing in the way of repairs in a talking machine that requires a great outlay of money on the part of the dealer, while the cash intake from this line of work is astonishing in many respects. Take, for example, when a main spring needs packing with graphite lubricant, the can of graphite costs very little, but the amount that you get for this is enough to pack ten or more machines and the return on that outlay is, in many cases, from 200 to 1,000 per cent."

Another Firm Moves

The Chicago office of Jones-Motrola, Inc., announces this week that it will soon move to larger quarters at 58 E. Randolph street. This company has been located at 57 E. Jackson
(Continued on page 133)

When in the market for Fibre Needle Cutters
Always get our prices
Do not be put off with any other cutter
Efficiency is our first object

& we want your valued orders

Will we hear from you soon?
Allow us to quote you on a quantity
Do not wait until the other fellow outsells you
Enter your order at once. (Today.)

WADE & WADE

3807 LAKE PARK AVE.

CHICAGO, ILL.

The Third

Example of the Dealers' Helps prepared by Lyon & Healy



Honeydew—
Medley Waltz played by
Jos. C. Smith's
Orchestra
Victor Double-Faced Record No. 18720-55



Beniamino Gigli
sings
Mefistofele—
Dai Campi. Dai Prati

Victor Red Seal Record No. 64933-47



Beautiful
Annabelle Lee
sung by
Charles Hart and
Elliott Shaw

Victor Double-Faced Record No. 18726-55



Colleen o' My Heart
sung by
Reinold Kerrenath
Victor Red Seal Record No. 64934-47

The Victrola Art Window Display Cards are drawn by the best artists and printed in several rich colors. There are four issued each month, two cards 11 x 14 inches, two cards 14 x 22 inches, each featuring one of the records in the monthly list. Put them in your window, on your counter or in your demonstration rooms.

Lyon & Healy Dealers' Helps Increase Your Sales

All of the Lyon & Healy services are well tested and tried. We use them for our own retail trade—one of the largest in the country.

They are sold exclusively to the most progressive Victor dealer in each city. If you are that man, write for a complete list of our services, full information and samples.

LYON & HEALY

Victrola Distributors

CHICAGO

The Fonolier

FOR ANY
Talking Machine or Phonograph

Place a Fonolier near the turntable and by turning the button it will illuminate the

RECORD
and
REPRODUCER

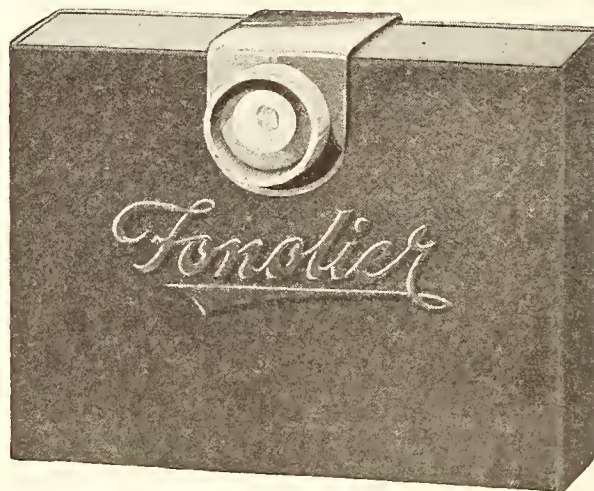

No screws or tacks to mar the woodwork.

"KEEP A FONOLIER
ON YOUR
PHONOGRAPH"

PAT. PEND.

The Only Portable Phonograph Light
SIMPLE, EFFICIENT, ATTRACTIVE AND A SELF SELLER

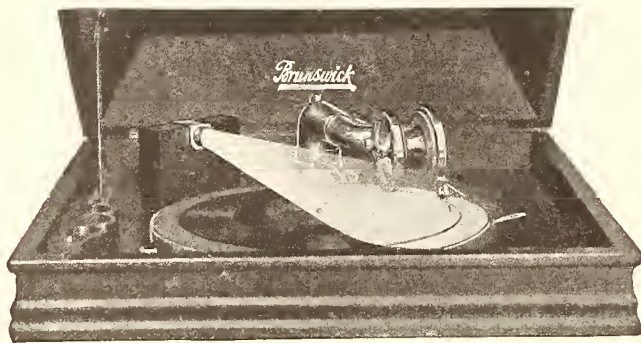

RETAIL
PRICE
COMPLETE

\$2.00



Regular Trade Discount. Six (6) Fonoliers Are Packed to a Carton for the Dealer

Order a Carton From Your Wholesale Distributor
OR WRITE US GIVING HIS NAME

Extra Batteries Retail .75 each

We Sell Through Wholesale Distributors Only

Batteries Guaranteed Against Shelf Depreciation for Six Months

Manufactured by Fonolier Division

STUART PRODUCTS CORPORATION, Chicago, Illinois

SOLE SALES AGENT

W. A. CARTER

56 and 58 East Randolph Street

Chicago, Illinois

NOTE—Send All Inquiries to W. A. Carter

FROM OUR CHICAGO HEADQUARTERS
(Continued from page 133)

Ernest Hare, Aileen Stanley, Charles Hart, Helen Bell Rush, Vera Barstow, Mme. Fonarova, and others.

Another thing that Mr. Silverman will elucidate to the dealers he calls on is the new Mandel plan to finance and advertise dealers. This company considers that this new plan is one of the most practical co-operative propositions ever presented to the dealer. It is said to be a liberal time payment sales plan which relieves the burden of financing from the dealer and causes the same to be assumed by the Mandel Co. The effect is said to be to advertise and finance the Mandel dealer's business without immediate cost to him.

Sells to High Schools

W. H. Wade, president of the Wade Talking Machine Co., has closed a contract with the Chicago Board of Education for the sale of specially constructed talking machines for the high schools of the city. The instruments will be of the Wade make, fifty-one-inch cabinet models and equipped with handles and wheels for pushing about from one room to another.

An Employees' Rest Room

An outgrowth of the Lyon & Healy personnel department and its work in behalf of the employes of this concern is shown in their new rest room for women on the sixth floor. This was opened on the tenth of the month and



Rest Room at Lyon & Healy's

already has come into great popularity. Rest periods of fifteen minutes both in the morning and afternoon are granted the workers and it is at these times that the women like to come up and spend the time in the rest room with the magazines that are there supplied.

In the Spring it is proposed by the personnel department to open up a lunch room in connection with the rest room, where employes who care to can bring and eat their lunches.

Preparing for Summer

Cole & Dunas have recently taken over additional space in the building where they are located, and this space is being equipped as a wareroom for small goods such as ukuleles, violins, harmonicas, strings and instrument picks. This company believes that by Spring the majority of talking machine dealers will be preparing to take on additional lines of small goods,



Repair Parts

For All and Every Motor That Was Ever Manufactured



We can supply any part. The largest and most complete assortment of repair parts—in the United States—on hand, for old, obsolete and present-day motors. If your order cannot be filled from stock, we will make it up special.

Special prices* on main springs, governor springs, micras, repair parts, motors, tone arms, steel needles, etc., in quantity lots.

Expert repairing on all makes of phonographs and motors.



INCORPORATED UNDER THE LAWS OF ILLINOIS

SUCCESSORS TO
Standard Talking Machine Co.
United Talking Machine Co.
Harmony Talking Machine Co.
O'Neill-James Co.
Aretino Co.

Manufacturers of
High Grade Talking Machines, Disc Records,
Talking Machine Supplies, Etc.

227-229¹/₂ W. Washington St., Chicago, Ill.



TRADE MARK
'CONSOLA'
CABLE ADDRESS
CONSOLA

thereby placing themselves in a position to handle extensive small goods trade this Summer. Several months ago their attention was called to the small goods trade by several inquiries they received from dealers, and this caused them to wonder to what extent this trade could be pushed. In one of their advertisements in *The World* at that time they decided to use their space exclusively for the announcements of ukuleles, violins, etc., and tried to find out how goods of this sort would appeal to the talking machine trade at large. The inquiries they got on this line of goods were so satisfactory that they decided to make small goods a permanent feature in their business, and accordingly took over the additional space for the aforesaid stockroom.

This company believes in keeping their customers well informed regarding everything they carry, and some time ago hit upon the plan of sending out a monthly bulletin, showing the goods on which they were in a position to make immediate delivery. This plan proved to be a good one, for it saved the customer the trouble of writing in to the company. The latest monthly bulletin is just off the press and is taken up with an announcement of a large volume of goods especially adaptable to the Spring trade.

F. E. McCullough, who has been connected with several of the well-known talking machine concerns in Chicago, was recently appointed as head of the house-sales department. He will

handle the customers who call at the sales-rooms of Cole & Dunas.

How About It?

Why is it that more popular songs are not recorded vocally as well as instrumentally? We wonder, for instance, why that famous song written in its entirety by Chicago talent, "I Love You, Sunday," would not make an excellent vocal record?

New Record File

The Phonograph Accessories Co., of Milwaukee, Wis., has prepared something new in the way of record filing systems for cabinet talking machines. These consist of little indexes which slip into the regular shelves of a cabinet. They eliminate all need for a separate index directory, and make every record instantly accessible. The name of the filing system is the "Paco" and it automatically dusts the records as they are inserted or withdrawn. Spring hooks hold the files in place and special reinforcements are incorporated to assure strength and durability. As an economical and effective system of equipping a phonograph cabinet with a filing system it is excellent.

Walter Scanlan Appears in Chicago

Walter Scanlan, exclusive Emerson artist, was in Chicago during the early part of the month, appearing at Shubert's Central Theatre in "Hearts of Erin." This is an Irish play to which Mr. Scanlan's talent is admirably adapted, and admirers all over the city are seizing the

(Continued on page 136)

TRANSFER NAME-PLATES

We make the Transfer Name-Plates and Trade-Marks for the largest talking machine manufacturers in this country and for dealers in every state.

YOUR NAME, Mr. Dealer, on every machine brings the owner back to you or records and his friends to you for a machine.

Samples, Suggestions and Sketches Furnished Free

THE MEYERCORD COMPANY, CHICAGO

Largest Manufacturers of **DECALCOMANIA** Transfer Name-Plates

FROM OUR CHICAGO HEADQUARTERS—(Continued from page 135)

opportunity of seeing him in person at the above theatre. The appearance of this exclusive Emerson artist in Chicago has also appreciably increased the sale of Emerson records throughout the city.

New Sheridan Road Store

F. A. Dempsy, in charge of city sales of the Emerson Phonograph Co., announces the opening of a new exclusive Emerson Shop to be known as the Sheridan Music Shop, and which is located at Wilson avenue and Sheridan road. It is owned by Joseph R. Lynch, who will handle talking machines, records and player rolls and sheet music. It is ideally situated in the heart of the Wilson avenue district, where record sales have always been exceedingly good. An excellent future is predicted for the new establishment.

Returns From Trip

I. A. Lund, traveling representative of the Mandel Mfg. Co., returned from a three weeks' trip through the East, and reports business "as usual." Although the dealers are still holding off to a great extent in their buying, their stocks are being gradually reduced and small orders here and there indicate that it will not be long before the old business volume is attained. Mr. Lund visited the cities of Pittsburgh, Toledo, Buffalo, Cleveland, Cincinnati, Dayton and Rochester.

Brunswick Night at Marigold Gardens

On Monday night, February 28, the Ernie Young Agency, which provides music and entertainment features for the Marigold Gardens, this city, entertained a number of the officials of the Brunswick-Balke-Collender Co. and also thirty or more of Brunswick retail dealers and their families from Chicago and its environs. The party was staged at the Marigold Gardens and was known as Brunswick night.

The Ipsham Jones Orchestra, which records dance music exclusively for the Brunswick Co., is now under engagement with the Marigold

LAKESIDE PHONOGRAPH PRODUCTS

ELECTRIC MOTORS FOR ANY CURRENT



SINGLE MOTOR \$19.50

Can Be Installed in Any Machine

MANUFACTURERS OF THE

ELECTRO-PHONE

Electrically Driven Phonographs

The **F & L AUTOMATIC STOP**

For Both Electric and Spring Motors

Distributors of

LYRIC RECORDS



Lateral Cut Prompt Service Latest Hits

Special Prices in Quantities

I-HAND AUTOMATIC COVER SUPPORTS.
BALL TIP BUTT HINGES.

COMPLETE LINE OF MOTORS, TONE ARMS, ACCESSORIES
SEND FOR BULLETINS

LAKESIDE SUPPLY CO.

416 SO. DEARBORN ST. **CHICAGO** PHONE HARRISON 3840

Gardens, and the playing of this famous orchestra at the Marigold Gardens was the occasion for Mr. Young's party. Everybody had a most enjoyable time and, needless to say, danced with great pleasure to the tunes played by the Jones orchestra.

Deterling Representative Cheerful

H. T. Carroll, of the Mid-West Specialties Co., announces this month that he has been

made territorial representative of the Deterling Mfg. Co., of Tipton, Ind. Mr. Carroll has been visiting the dealers in Chicago who handle the Deterling machine and reports that these dealers are well pleased with this instrument. Mr. Carroll's territory covers Illinois and a part of Wisconsin.

He also is Western representative of the International Mica Co. In a recent round of the



To the Wide-awake Dealer eager for—
An increased business with substantial profits,
The pleasure of selling that which the public wants,
And satisfied customers

We Recommend

Okeh Records

Decide to become this successful dealer. Send your name and address to us—and we'll do the rest with constructive help and a

big stock of **Okeh Records**
WADE TALKING MACHINE CO.

Okeh Distributors

14 North Michigan Ave.

Chicago

Wade Talking Machine Co.

14 N. Michigan Ave., Chicago, Ill.

Please send us your Dealer's Proposition on **Okeh Records**
We handle

Machines (Insert lines carried)

Records (Insert lines carried)

Name

Address

(Write name and address plainly)



**SHARPENS
FIBRE NEEDLES
WITHOUT REMOVING
THEM FROM THE
TONE ARM**

*Convenient
Perfect
Cut*

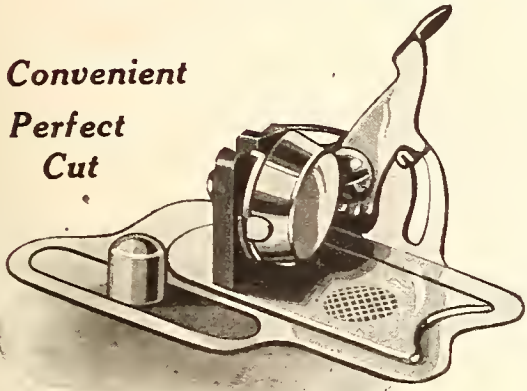

Patents Pending
LIDSEEN
FIBRE NEEDLE CUTTER
Simple in Construction—Jobbers, Attention
LIDSEEN PRODUCTS
850-860 So. Central Ave. CHICAGO

central Western States he called on many manufacturers and states that he found to his surprise that most of these have not been asleep during the past few months, but have been making up stock in preparation for the coming Spring and Fall business. The machines he saw in every direction were superior in quality and workmanship and their makers are preparing for a stiff campaign, for they intend to move their goods on a value basis rather than one of bargain. The International Mica Co., he says, is now furnishing genuine India mica in larger quantities than ever before because of the improvement in the import situation. It is said that India mica is far superior to the American and Brazilian micas. The price is practically the same.

New Fibre Cutter

During the month there was announced to the Chicago trade a new fibre needle cutter, manufactured by Gustave Lidseen, manufacturer of dies, tools and machinery, who has a very large plant located at 850 to 860 South Central avenue, Chicago. This needle cutter is different in construction from any to which the trade has been



The Lidseen Cutter

accustomed, in fact, the plate is a rotary disc which clips the delicate needle without pressure. When one is using this cutter the needle is left in position on the machine. The method of clipping is made possible by reason of the cutter itself not being held in the hand. While the operation is being carried out, the cutter is placed on the turntable shaft, the sound-box holding the needle is swung over the cutter, the needle is dropped into place, the lever is pushed and the cutting is finished.

F. D. Hall to Orient

F. D. Hall, president of the Hall Mfg. Co., manufacturer of the well-known fibre needle, left the first of March for a six months' trip to Japan. Mr. Hall is making the trip for com-

FROM OUR CHICAGO HEADQUARTERS—(Continued from page 136)

bined business and pleasure purposes, and expects while in the Orient to look into the matter of securing bamboo shipments for the manufacture of his product. One of the most important items in the manufacture of Hall fibre needles is the securing of suitable bamboo stock. Only the largest and best can be used.

Some Cheery News From Ohio

Among the recent visitors to the executive offices of the Brunswick-Balke-Collender Co. in Chicago was Stanley Reis, district manager of the phonograph division, Cincinnati branch of the Brunswick Co. In a chat with The World Mr. Reis stated that conditions throughout the territory in which the Cincinnati branch operates are showing steady improvement. The retailers, without exception, are feeling more optimistic,

and the general business situation is clearing up in a manner which permits the energetic sales force to reap a really good harvest.

Sterling Devices in Demand

The Sterling Devices Co., of this city, reports that the demand for its Victor-Edison attachments is still keeping up very satisfactorily. This proves to the company's satisfaction that dealers have not laid down on buying. It also shows that the people are interested in whatever will improve the efficiency or the convenience of the talking machine. The Sterling Devices men are well pleased with the state of things.

Proofs of Increasing Business Activity

The Oro-Tone Co., of 1000 to 1010 George street, reports that from present inquiries the

(Continued on page 138)

The Oro-Tone
QUALITY FIRST
Just Say
"Send Samples On Approval"

For the Edison

No. I-E ORO-TONE
For Playing All Records on the Edison
Reproducers Fitted With Special Oro-Tone Diaphragms
Attached in one second. Needle retains perfect center in playing either hill and dale or lateral cut records.
NOTE—Operates the same as the regular Edison reproducer with the raising and lowering lever.
TONE QUALITY—Full, rich and glowing, with great carrying power and absence of metallic shrillness and surface noises.
Retail Price, Nickel Plated, \$7.50. Highest Grade Gold Plate, \$10.50

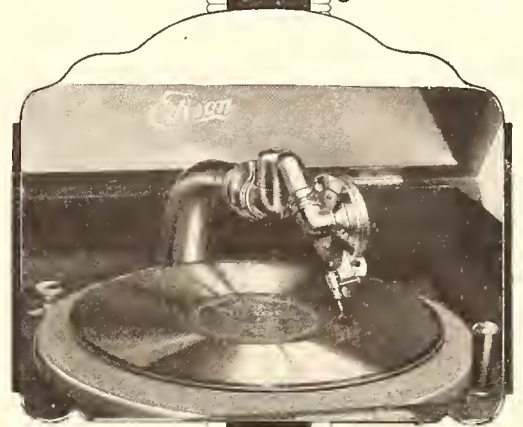

For the Victor

No. LS-V ORO-TONE
For Playing All Records on the Victor
Reproducers Fitted With Special Oro-Tone Diaphragms
Attached in one second. Needle retains perfect center in playing either lateral or hill and dale cut records.
TONE QUALITY—Deep, rich and mellow, with great volume, eliminating thin metallic tones and surface or needle noises on the records.
Retail Price, Nickel Plated, \$6.50. Highest Grade Gold Plate, \$9.50

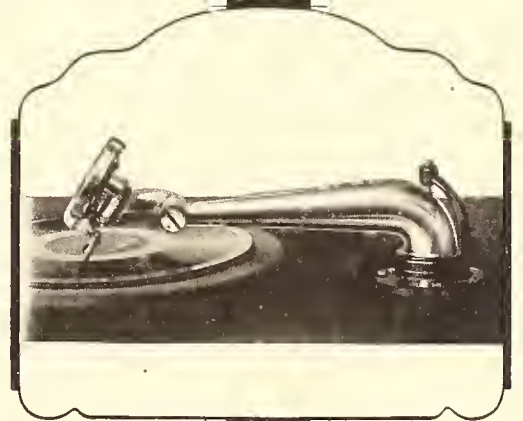

For the Columbia

No. I-C ORO-TONE
For Playing All Records on the Columbia
Reproducers Fitted With Special Oro-Tone Diaphragms
Attached in one second. Needle retains perfect center in playing either hill and dale or lateral cut records.
TONE QUALITY—Rich and musical with splendid volume and definition. Surface or needle noises practically eliminated.
Retail Price, Nickel Plated, \$6.50. Highest Grade Gold Plate, \$9.50

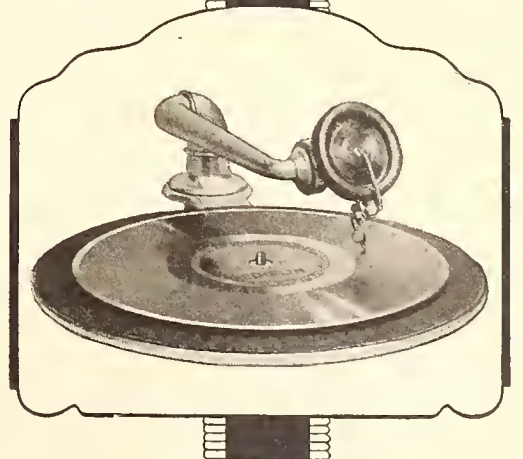

SEND FOR
Copy of the "Oro Tone" Illustrating the Complete Oro-Tone Line

The Oro-Tone Co.
QUALITY FIRST
1000 to 1010 GEORGE STREET
CHICAGO, ILLS.

FROM OUR CHICAGO HEADQUARTERS—(Continued from page 137)

coming year will see many new faces in the talking machine business. They have received numerous orders from large concerns which at present are manufacturing other lines of goods, but which are contemplating entering the talking machine field. The new Oro-Tone arm is making a hit with the trade, as its telescopic feature permits it to be used in any machine, whether the call is for a lengthy low arm, a high short arm or vice versa. This telescopic feature is an extension immediately behind the elbow, which by means of a set screw permits the extension of the elbow to slide into the arm proper and allows an adjustment from seven and three-quarter inches to nine and a half inches. An adjustment screw engages an index channel in the extension and this index channel, which is measured by quarter inches, assures perfect alignment. At the base of the arm there is also an index channel, which is locked by a thumb-screw, and this permits the raising or lowering of the arm and adjusting to height. This arm is also equipped with the new type throw-back improvement which permits the reproducer to clear the tone arm when the latter is thrown back, regardless of whether the producer is in position for playing hill-and-dale or lateral-cut records.

Blood & Kloer Activity

This month sees the new firm of Blood & Kloer located at its new headquarters, 400 West Erie street. All the machinery necessary for the assembling of tone arms and sound boxes has been set up for a week or more and the new Blood tone arms are being put up in fairly large quantities.

The new Blood tone arm is claimed by this company to be "non-infringing." It is composed of a new metal, said to have greater tensile strength and to be lighter than any ever put out before. This permits them to make their new sound box much larger than heretofore, while at the same time the weight is approximately half of that of the older sound boxes.

**Burr Blood**

Judging from the numerous orders received, the new Blood tone arm has met with instant favor. In their new location they have ample

**O. J. Kloer**

facilities to take care of all customers and make immediate shipments. The extreme simplicity

and construction of their new arm and reproducer enables them, they say, to turn out their goods in a very short time, because of the small amount of assembling necessary. The simplicity of construction also enables them, by virtue of its time-saving features, to cut the assembling costs to a minimum. This assembly cost-saving, they say, is passing on to all purchasers of their goods.

In a recent letter to the Chicago office of The Talking Machine World Messrs. Blood & Kloer mention, in view of the numerous inquiries they have received from their recent advertisements in The Talking Machine World, that many manufacturers are making preparations for a large Spring output. They also say that these inquiries seem to show that manufacturers in general are taking a keen interest in securing high-grade equipment. These inquiries also prove to their satisfaction that The Talking Machine World is an excellent advertising medium, as the largest part of their inquiries came from this source.

For the time being Blood & Kloer will only manufacture the one design of arm and sound box. The latter, of course, will be equipped with either mica or composition diaphragm. They believe that demand for an arm such as they turn out is very large and in sticking to one design they will be enabled to insure a production that will tend to keep the price down.

B. B. Blood has been connected with the talking machine industry for a number of years and has been connected with many of the best firms in the central West, especially in and around Chicago. He claims to have devoted more than twenty years to mechanical inventions. The last twelve years have been devoted in the main to bringing out inventions and improvements applicable to talking machines. The object of the present organization is to market exclusively new devices which Mr. Blood con-

(Continued on page 140)

Sterling

STONE ARMS REPRODUCERS and ATTACHMENTS

High Class Workmanship

Beautiful Finish
(Nickel or Gold)

Simple, Practical Design
are features of

Sterling Guaranteed Products

Send for Bulletin No. 9

STERLING DEVICES CO.

534 Lake Shore Drive
CHICAGO

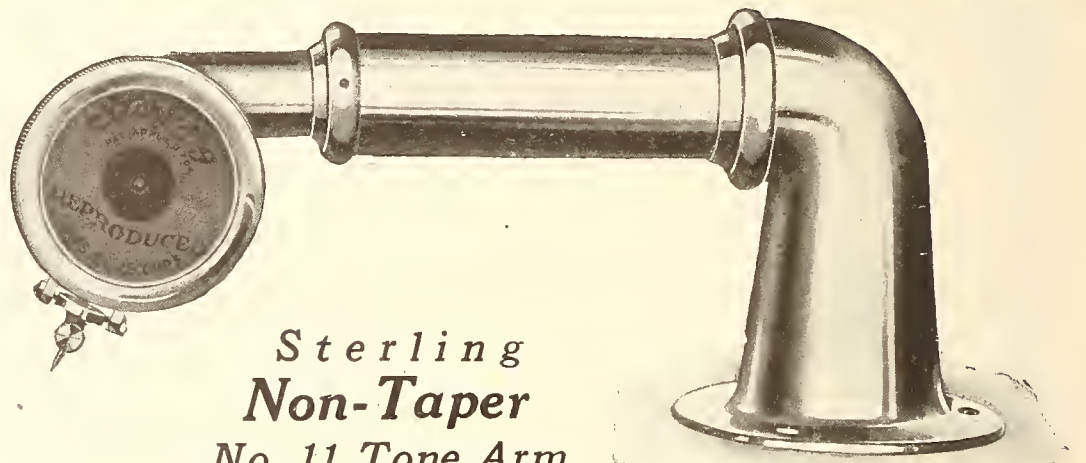

*Sterling
Non-Taper
No. 11 Tone Arm*

Sterling Reproducers Play All Records

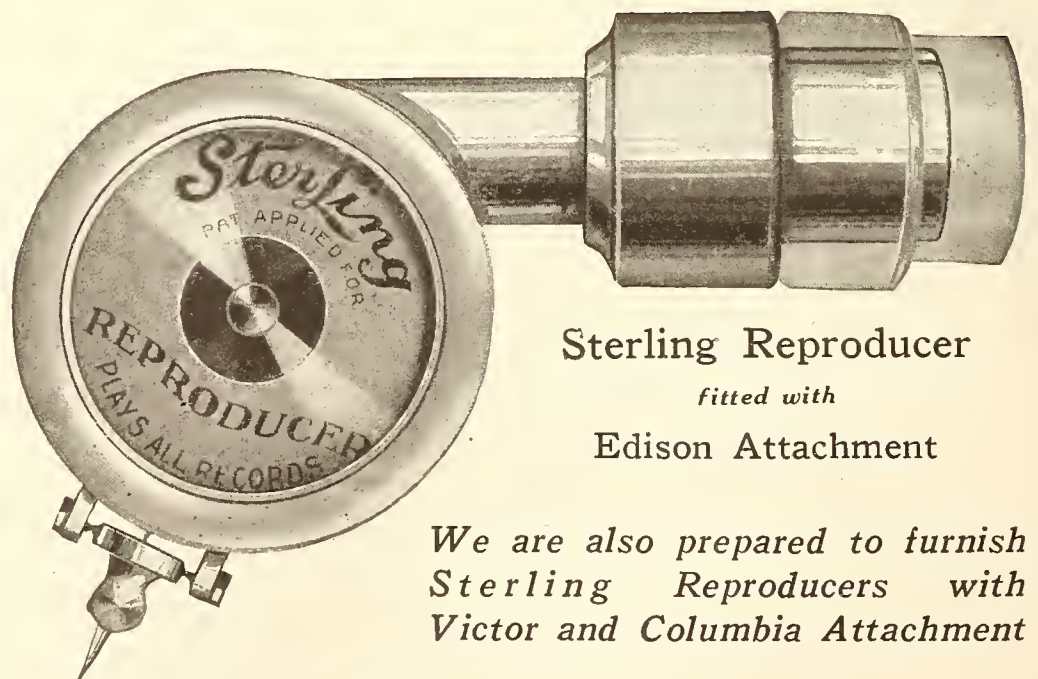

Sterling Reproducer
fitted with
Edison Attachment

*We are also prepared to furnish
Sterling Reproducers with
Victor and Columbia Attachment*

OKeh Records



LATEST
DANCE
RECORDS



Mr. Dealer:

Are you ready to meet the big increase in the Spring record business? Its coming is assured!

Quickest releases of latest hits are your only weapons in trade competition.

OKeh makes a point of *rapid releases* of latest hits.

Become a dealer in *OKeh* Records and your business will feature tremendous profits.

Prompt service is our specialty—

Write today for our terms.

Consolidated Talking Machine Co.

227 W. Washington St.

Chicago, Ill.

FROM OUR CHICAGO HEADQUARTERS—(Continued from page 138)

THE \$1.00 CUTTER—HERE IT IS

Retail Price **\$1.00**

A better Fibre Needle Cutter for less money

The ALTO

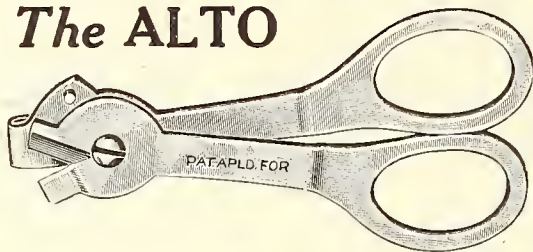

Send for a Sample and Convince Yourself

ALTO MFG. CO.

1801 Cornelia Avenue, Chicago, Illinois

templates bringing out in the near future. All of these devices he claims will be covered by patents owned by himself. He believes that the talking machine field offers greater opportunities than any other field in the country to-day and he can see no reason why the future of this industry is not destined to become one of the largest in the world.

The other member of the firm, Oscar J. Kloer, has been associated with Mr. Blood for a great number of years. He is very familiar with the trade and for the past few years has canvassed nearly every talking machine manufacturer in the industry. In the new organization Mr. Kloer will devote all of his time to the sales management and from time to time will make personal calls on manufacturers of machines. Mr. Kloer is also an optimist and is of the opinion that

those who are in the business now, and who will be able to hold out, will not be sorry they stuck to the ship.

Vitanola Sued by Victor

The Victor Talking Machine Co. has entered suit against the Vitanola Talking Machine Co., of Chicago, charging the latter with infringement of its patents. In the bill of complaint filed in the office of the clerk of the Northern District Court of Illinois infringements are alleged on the amplifying horn patents Nos. 814786 and 814848. An injunction is asked, as well as an accounting and payment of the profits realized on the alleged infringed patents. The Victor Co. also requests a settlement for damages sustained as a result of the alleged infringements, the amount of this to be three times as much as the profits.

lecturers, print programs and enrolment cards, and send literature to the conference. Distributors are expected to send letters to their dealers urging enrolment, to send follow-up letters and programs to dealers and also to have their traveling representatives seek to interest dealers in the value of the conference and persuade them to attend in person if possible. Dealers will assume traveling and hotel expense of their own representatives. They must respond promptly, as the enrolment of necessity must be limited.

The lecturers are to be Mrs. Frances E. Clarke, Miss Edith M. Rhett, Mabel Rich, Margaret, M. Streeter and Caroline Hobson. Also John G. Paine and S. Dana Townsend. A tentative synopsis of lectures, subject to slight changes, is as follows:

- Mr. Paine:
1. Opening Address: Victor Ideals.
- Mrs. Clark:
1. Our Educational Work—Retrospect and Prospect.
 2. Songs—Primary and Intermediate Grades.
 3. Folk, Art and Part Songs for Grammar Grades and High Schools.
 4. Nationality in Music.
- Miss Rhett:
1. Cultural Hearing.
 2. Instruments of the Orchestra.
 3. Form in Music.
 4. Music History.
 5. Program and Pure Music.

EDUCATIONAL CONFERENCE TO BE HELD IN CHICAGO

Western Victor Distributors Planning Important Gathering for March 28, 29 and 30—Impressive Program of Addresses Along Educational Lines Scheduled—Dinner-concert Planned

CHICAGO, ILL., March 5.—There will be held a most important educational conference, under the auspices of ten Western Victor distributors, at the Congress Hotel, Chicago, on March 28, 29 and 30. All Victor dealers are heartily invited to attend and may be assured that they will receive a vast amount of information and inspiration regarding the promotion of the Victor in the schools and incidentally about how the talking machine can be used as an educational medium in respect of musical appreciation in the home as well as the school.

The committee having charge of the preliminary arrangements consists of representatives of the following houses: Lyon & Healy, Chicago Talking Machine Co., the Wurlitzer Co., the Toledo Talking Machine Co., of Toledo; Grinnell Bros., Detroit; Stewart Talking Machine Co., Indianapolis; Putnam-Page Co., Peoria, Ill.; Badger Talking Machine Co., of Milwaukee; Beckwith, O'Neil Co., of Minneapolis, and W. J. Dyer & Bro., St. Paul. A meeting of this committee was held in Chicago on Tuesday, February 14, with L. C. Wiswell as chairman. A tentative plan for the conference was adopted.

One notable feature of the conference will be a dinner-concert in honor of the Victor Co., given by the jobbers through whose co-operation the Chicago educational conference has been made possible. It is planned to have a number of Victor artists in attendance who will entertain the guests in a display of their individual vocal and instrumental talents.

The Victor Talking Machine Co. will provide

Magnifies Sound 50 Times
ACME SOUND AMPLIFIER

Enables the repairman to locate the precise point of origin of unnecessary noise in the motor without loss of time or useless disorganization of the mechanism which results from guessing or the sense of hearing alone.

MAKES EVERY MOVING PART IMMEDIATELY ACCESSIBLE

"Guesswork Won't Do"

The ACME allows a test with the drag of the needle throughout the length of the record.

A
C
M
E

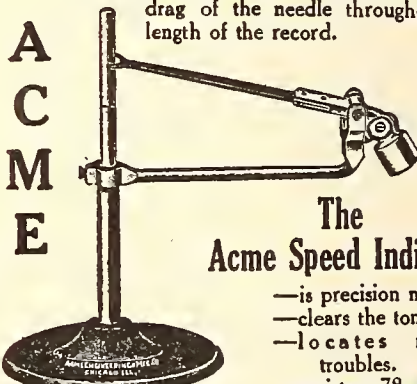

**The
Acme Speed Indicator**

- is precision made.
- clears the tone arm.
- locates motor troubles.
- registers 78 and 80 revolutions.

"The repairman's stethoscope."

Made by
Acme Engineering & Mfg. Co.
355 Union Park Court CHICAGO

VARNISH DRYROOMS





MODERN CHROMOGRAPH CABINET INSTALLATION

MAKE EVERY DAY A PERFECT DRYING DAY

DRYING SYSTEMS, INC. 11-17 So. Desplaines St. CHICAGO

Edison Diamond Amberolas--Plus Service

You know the quality of Edison instruments. Until you have placed a trial order with us, you are unfamiliar with SERVICE.

A TRIAL CONVINCES

Our Service Covers the Country

William H. Lyons

Formerly Jas. I. Lyons
17 W. Lake St. Chicago



FROM OUR CHICAGO HEADQUARTERS—(Continued from page 140)



Order From This Ad.
Nupoint Ass't
100 Pkgs. Assorted
Dealer's Price \$7.00
Retail Value \$15.00
FREE!!
Display Stand and
Sample Packages
With Each Order

PHONOGRAPH SURGERY
LET US CO-OPERATE WITH YOU

Jobbers in
Phonograph
Motors
Tone Arms
Records
Hardware
Needles and
Repair Parts
All Makes

We Operate the Largest and Most Up-to-date Equipped
Phonograph Repair Shop in the West

Have You a Phonograph Repair Agency?

Send for our Catalog and Particulars. It Tells You What We Can Do for You

The Co-Operative Manufacturing Company

Loud—Extra Loud
Medium
50 Needles, 15 Cents
MAIN OFFICE
1867 Milwaukee Avenue

ALL PHONES, HUMBOLDT 3345
CHICAGO

SALES OFFICE & SHOWROOM
637 Milwaukee Avenue

Miss Streeter:

1. Rhythm—Free and Suggested Expression.
2. Rhythmic Songs and Games.
3. Meter Sensing and Rhythmic Form.
4. Music in the Rural School.
5. County Institutes.

Miss Rich:

1. "Making Believe" with Little Children.
2. Children of Other Lands.
3. Making the Most of a Record.
4. The Project Method—Correlating with Nature Study.

Mr. Townsend:

1. Stories for the Littlest Ones.
2. Readings for Intermediate and Grammar Grades.
3. High School English.
4. History—European and American.

Miss Hobson:

1. What Educational Work Means to the Live Dealer.

Folk Dancing—Class from the Chicago School of Physical Culture.

TO OPEN IN SALEM, O., SOON

The rebuilding of the talking machine department of the Wilson Co., at Salem, O., is completed, and there will be a formal opening in the near future. This firm has done more business in 1920 than in any year since it has been operating, in spite of the quarantining of that city during an epidemic last Fall.

The T. E. Rice Co., Wooster, O., has increased its business more than 75 per cent.

AN OPTIMISTIC OUTLOOK

General Manager Travers, of Magnavox Co.,
Writes Interesting Article—Company Is Making Remarkable Progress

In a recent issue of The Magnavox, the successful house organ published monthly by the Magnavox Co., there appeared an interesting article, entitled "Our Optimistic Outlook," by F. B. Travers, general manager of the company, which emphasized the progress attained by this company in the past year, as follows:

"Much space in newspapers and magazines of national distribution has of late been devoted to prophecies of business conditions for the coming year. Our survey of these articles leads us to feel (as they are in a great measure of a pessimistic nature) that they have had a great influence over the rank and file of business men. In consequence, an expression, far-reaching in its effect, has been greatly used—'The country is going to the bow-wows.'

"We are inclined to think that much of this propoganda is being sown by, and is the result of the efforts of, those who would really be happy if such a condition actually should prevail.

"This company finds great pleasure in looking

forward in the future at the high point of production curve, rather than at the lower limit of the line, where it is an easy matter for anyone to remain in a state of lethargy.

"Our Oakland factory has now been in operation for approximately a year and a half, and only once during this period have we discovered any attempt to distribute radical literature to the employes by a co-worker. This man, incidentally, was the highest paid hourly man in our employ. This would indicate that our organization is composed of a class that has more than an ordinary interest in the products we are developing, and when one considers that there is a publishing house in Chicago eight floors high, covering an entire city block, that is devoted exclusively to printing, in twenty-seven languages, radical literature encouraging destruction of business and endeavoring to promote class hatred, there is no wonder that some of it eventually percolates into practically every industrial plant in America.

"We merely mention this in passing, but nevertheless, there is food for thought in the above paragraph—it pays to be square—square with one's employer and square with one's self.

"We have made a special effort to keep the interest of our customers, as well as our employes, well stimulated with propoganda of a constructive nature instead of propoganda leading to destruction, and it is such a policy that will ultimately insure gratifying results. We appreciate the chaotic state of the period through which we are now passing, and that it tests equally the fiber of both the employer and employe.

"As an employer, we aim through just and fair treatment to gain the respect and sincere allegiance of every employe, welcoming at all times suggestions that will benefit our material condition. All we ask of our employes is fairness of mind, confidence and thrift, which will bring results such as will make each and every one feel proud of his efforts."

It's Non-Infringing

We've told you about it in Previous World Advertisements. Send in your order now. We can make immediate shipments. *Tonal Supremacy Guaranteed.*

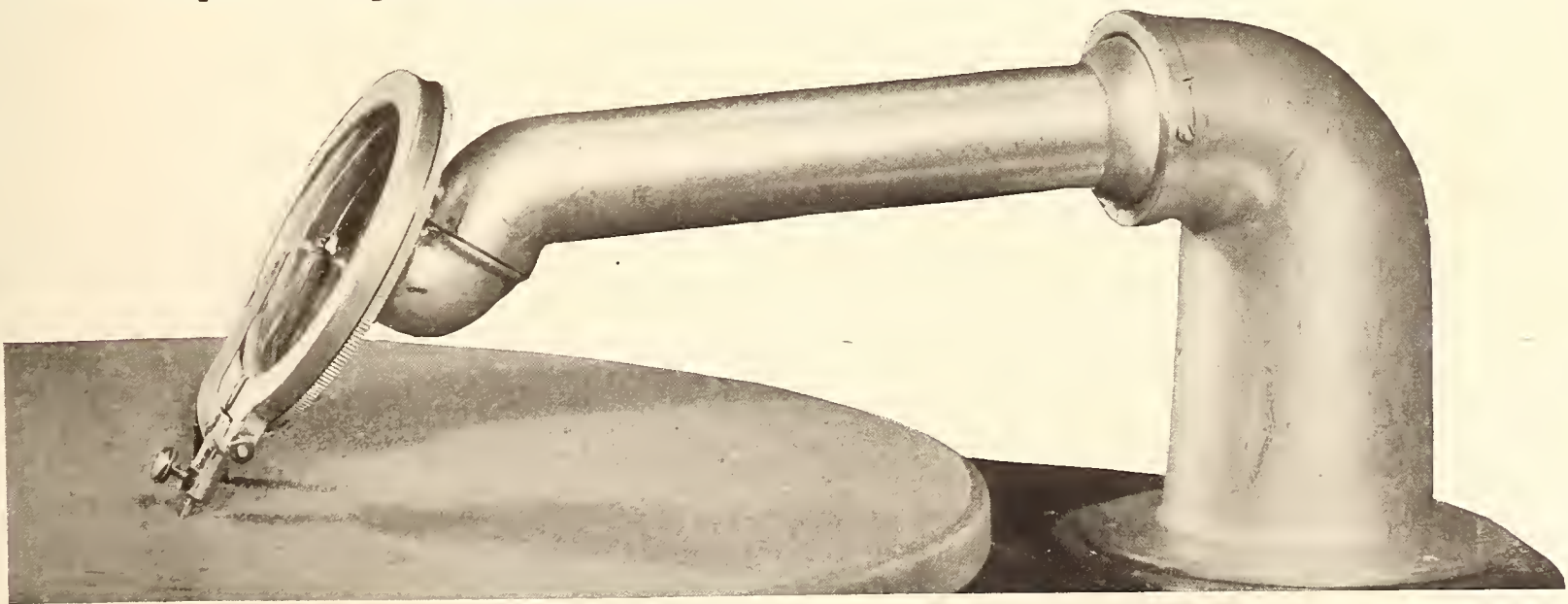

BLOOD & KLOER
MANUFACTURERS

400 West Erie Street

Chicago, Ill.

FROM OUR CHICAGO HEADQUARTERS—(Continued from page 141)

BETTER DEALER SERVICE

Charles E. Byrne, of Steger & Sons, Believes the Present Is the Time to Give Dealers Greatest Co-operation in Advertising

CHICAGO, ILL., March 8.—Now, more than ever before, talking machine manufacturers have an opportunity to aid and increase the business of their dealers through co-operative advertising.

a remarkably attractive series of hand-lettered announcements suitable for use of dealers in their local newspapers.

Dropping in upon Mr. Byrne the other day, The World representative happened to see the series of advertisements on the former's desk. They were precisely of the sort necessary in this day and age to help the dealer put his product across with the public. From the standpoint of art-work, especially, the series is

in the various departments. A number of these prestige-building messages inserted in Chicago papers, over the signature of the Steger phonograph shop, have demonstrated in a convincing manner the pulling power of this carefully prepared campaign.

"The public admires and respects the high-grade, progressive merchant who uses well-directed, carefully thought-out newspaper advertising," remarked Mr. Byrne. "People like to

STEGER
The finest reproducing phonograph in the world

Plays all records correctly - No parts to change

CLEAR, resonant, life-like the voice of the artist who entertains you through the Steger Phonograph. All the thrills and pleasure of hearing the living voice are yours when you have the Steger in your home. It brings to you all of the world's best music and plays it with a fidelity to life that no other phonograph can surpass.

Hear the beautiful Steger before choosing your phonograph - compare it with other makes. It will meet every test! The Steger alone will satisfy you. Many artistic styles at attractive prices. You are always welcome to call

(Dealer's Name Here)

Convenient terms. You are cordially invited to call -

STEGER
The finest reproducing phonograph in the world

THE UNIVERSAL FAVORITE

If you have ever had a phonograph in your home you can readily recall the fun and happiness it brought. The wonderful Steger is a phonograph for everyone - and every occasion.

You can enjoy its infinite repertoire of the world's best music - sing with it or dance to its realistic reproduction of the latest hits. As an entertainer its possibilities are unlimited.

The Steger Phonograph is as beautiful in finish and design as it is charming in its tone-reproducing qualities. There is a variety of artistic Steger styles at a wide range of attractive prices.

Before you select your phonograph, be sure to see and hear the Steger. You are cordially invited to visit our store at any time.

Styles and Prices for Everyone

(Dealer's Name Here)

Convenient terms. You are cordially invited to call -

STEGER
The finest reproducing phonograph in the world

We believe the only sure way to judge the merits of a phonograph is to hear it and play it yourself. Five minutes spent in actually listening to the beautiful Steger Phonograph will give you a far better idea of its marvelous tone-reproducing qualities than all we can say or write.

That is why we invite you to visit our store to see and hear the wonderful Steger. We want you to be convinced beyond a shadow of doubt that the Steger is the finest of reproducing phonographs. It plays all records correctly.

Call any time - you are always welcome

(Dealer's Name Here)

Artistic!

You can be justly proud of the Steger Phonograph in your home.

For no phonograph in the world excels it in beautiful design and elegance of finish. It is the "last word" in artistic craftsmanship.

And it is as beautiful in its musical results as in appearance. It plays all records correctly - and there are no parts to change.

Hear the voice of your favorite artist, or the music of any instrument, on the Steger - and be convinced.

Just call any time - you are always welcome

Convenient terms

All artists are at your command, instantly, when you have the incomparable Steger Phonograph.

You can enjoy the Steger Phonograph reproduces their voices with absolute fidelity.

The Steger plays all standard records correctly - there are no parts to change. Hearing is believing - you are invited to call and hear the Steger Phonograph.

Bring in your finest records, no matter what make. We will play them for you on the Steger - the phonograph unequalled and unexcelled.

Then, and not until then, will you realize that any disc record, made specially for any other phonograph, sounds better when played on the Steger.

Claims are easy to make - but the fact of hearing the Steger will convince you. Play it yourself in our store.

Made in the world's greatest piano factories, the Steger is the most beautiful of phonographs. You are cordially invited to hear it.

Dance

When the mood strikes you, for the Steger Phonograph always is ready. It has no mood, no "off" days; it never tires.

And its repertoire is unlimited. It brings to you the voices of all the greatest artists. No matter what music you prefer, on whatever record it may be, the Steger will play it perfectly, without change of parts.

No wonder it is the choice of hostesses who wish to give their guests the widest selection of phonograph music.

Beautiful styles. Convenient terms. Call and hear it - you will select the Steger!

How the Steger & Sons Piano Mfg. Co. Co-operates With Dealers

This is the belief of Charles E. Byrne, advertising manager of Steger & Sons Piano Mfg. Co. In line with the well-established Steger policy of assisting its representatives, in every possible way, to build up a greater volume of sales and to increase the prestige of their stores, the phonograph division of the company has issued

unique. Clever line illustrations drawn in the artistic wood-cut style are combined with a pleasing display of hand-lettering to form attractive announcements well calculated to compel favorable attention. All references to price have been eliminated. There is originality and distinctiveness in the thoughts expressed

patronize his store. His announcements appeal to prospective buyers and impress them most favorably. The character of his publicity reflects the standard of his merchandising service and the public is glad to have the opportunity of increasing the prestige and profits of such a dealer."

THE MOST THOROUGH NEEDLE OFFER KNOWN

NUPOINT NEEDLES SELL AND SATISFY. EVERY NEEDLE AMERICAN MADE—UNIFORM POINT—UNIFORM HARDNESS—UNIFORM LENGTH

FREE-DISPLAY STAND AND SAMPLE PACKAGES

A beautiful display stand holding 100 packages is given Free. In order to introduce Nupoint Needles we have put up sample packages of needles to be distributed Free to the people who come into your store. We also furnish two large window strips inviting requests for these Free Nupoints.

50 BRASS NEEDLES TO PACKAGE
EACH NEEDLE PLAYS 10 RECORDS
100 PACKAGES (40 Loud, 40 Extra Loud, 20 Medium) to Carton

Dealer's Price	Dealer's Profit	Retail Value
\$7.00	\$8.00	\$15.00
per Carton		

Jobbers—write for samples and attractive proposition!

NUPOINT MANUFACTURING CO., 59 E. Van Buren, Chicago, Ill.

ALL-IN-ONE PHONOGRAPH CORP., 21 E. Van Buren St., Chicago, Ill.
FACTORY REPRESENTATIVES: LOUIS A. SCHWARZ, 1265 Broadway, New York
I. W. BECKER, 226½ Peachtree St., Atlanta, Ga.

EACH NEEDLE WILL PLAY 10 RECORDS OF ANY MAKE ON ANY PHONOGRAPH

PROLONG THE LIFE OF YOUR RECORDS BY USING NUPPOINT NEEDLES

MADE BY A SPECIAL PROCESS FROM THE HIGHEST GRADE MATERIALS

THE TENTH RECORD WILL PLAY AS CLEARLY AS THE FIRST

GUARANTEED

LOUD - MEDIUM - EXTRA LOUD

FROM OUR CHICAGO HEADQUARTERS—(Continued from page 142)

MID-WEST VICTOR DEALERS ORGANIZE AN ASSOCIATION

Large Assemblage of Victor Dealers in Chicago and Adjacent Territory Form Mid-West Victrola Association on March 2—Interesting Talk by F. A. Delano—Dinner an Enjoyable Affair

CHICAGO, ILL., March 6.—With the object of promoting whatever may benefit the Victrola and Victor record business, as well as to encourage good fellowship among its members, about 150 Victor dealers got together in the Crystal Room of the Sherman Hotel, Wednesday evening, March 2, at 6:30, and launched the Mid-West Victrola Dealers' Association. Membership is confined exclusively to Victor dealers whose places of business are located in and about Chicago. The affair started off with a dinner, during which John Steel, of the Ziegfeld Follies, rendered some vocal selections, such as "I Found the End of the Rainbow," "Sweet Tulip Time," "Tell Me Little Gypsy" and "Rudolph's Narrative" from "La Boheme." Other artists who furnished entertainment for the evening were Van and Schenck, who pleased the audience by singing "Um-m-m-m," "Gypsy" and "Ohio." The Misses Lucile Hayley, Olive McCormick and Mary Malone, all of the Lyon & Healy Victrola department, gave some very satisfactory vocal selections, with Miss Malone at the piano. Instrumental music was furnished during the evening by Benson's Victor Orchestra, which kept everybody banging away on their plates, keeping time. The chairman of the evening was Burt Corcoran, of the Music Shop, who had been appointed temporary chairman.

After the entertainment and dinner had been disposed of the meeting was called together by Mr. Corcoran for the purpose of discussing the by-laws that were submitted and electing officers. The by-laws adopted by the association fix the dues at \$25 a year.

After the adoption of these by-laws the fol-

lowing officers were elected: B. F. Corcoran, president; Ed. Dublin, vice-president; T. B. Stone, treasurer, and T. P. Flannery, secretary. The executive committee appointed was for both one and two-year terms. The two-year members are H. P. Hopkins, of Toledo, and E.

ways and means whereby the Victor dealers can improve their business. He also talked at length on the recording of music. He pointed out that not only the public, but the trade also suppose that all the artist does is to sing into the record and let it go at that. In fact, the artist not only sings or plays, as the case may be, but after this is done he or she must approve the record and pass upon it; and even after that it must pass through the hands of a corps of expert critics, who go into minute detail as



Dinner of the Mid-West Victrola Dealers' Association at the Hotel Sherman

Sayre, Elgin. The one-year members are G. McCauley, of McCauley & Nevers; William Cotton, of Oak Park, and A. C. Fenton, of Chicago.

The principal speaker of the evening, F. A. Delano, of the Victor Talking Machine Co.'s educational department, was introduced immediately after the installation of officers. Mr. Delano gave a mighty interesting talk on the

to tonal quality, tempo and everything else, before the record is finally okayed and sent to the presses. The reason for all this is that the artist must uphold his reputation; and the company must do exactly the same thing.

Mr. Delano also dwelt at length upon the Red Seal School, giving its history from the

(Continued on page 144)

The HOWE

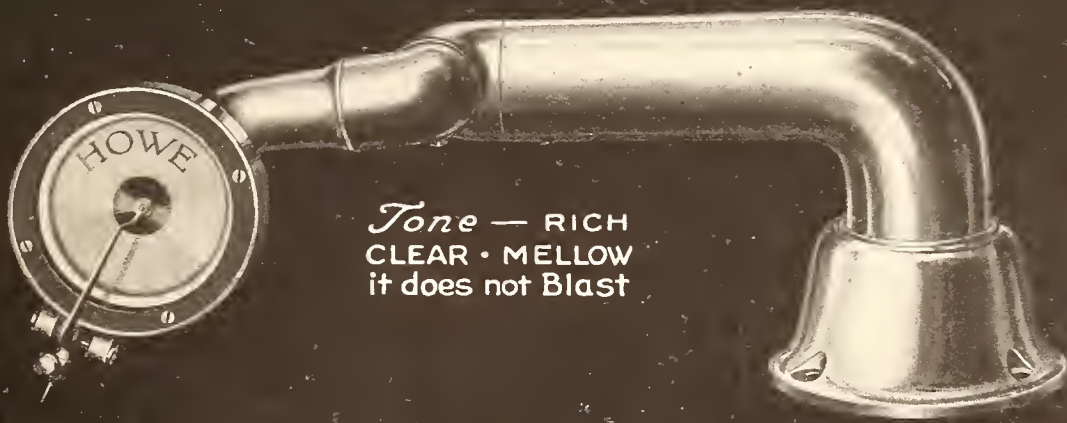

Tone — RICH
CLEAR · MELLOW
it does not Blast

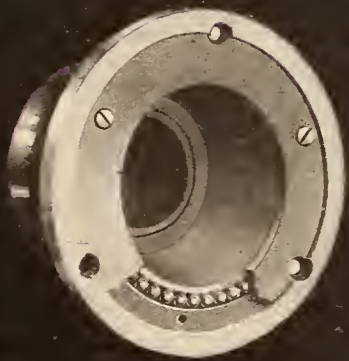

BALL BEARING
No obstruction
in the base

C.W. Howe & Company
21 East Van Buren St. Chicago, Ill.

FROM OUR CHICAGO HEADQUARTERS—(Continued from page 143)

time it started, about three years ago, to the present, during which time they have had about six hundred students. He told of the praise these students have given the school, and how they all approve of it because it has helped them in their business life.

One thing that Mr. Delano did not approve of was self-service counters, as he believes that individual service is far better, if in charge of a competent sales person who really knows records. It is necessary also, he believes, to have a knowledge of various types of people as well as a thorough knowledge of the record stocks, as this will tend to eliminate the inevitable question of "just what do you want," or "what can I do for you," when a customer comes in to make a purchase.

If a sales person knows how to handle a customer there is no reason why that customer should not buy a well-balanced program of records instead of a single one. Further than that, a knowledge of the record will bring more enthusiasm, not only on the part of the dealer, but the owner as well, and this will mean more money to the dealer, as enthusiasm means success. Herein he quoted a little remark that was once made by President Johnson, of the Victor Co., who said that he wouldn't consider himself or the Victor Co. a success unless he was sure every dealer was a success. Mr. Delano closed his talk by calling attention to the fact that there would be a special Red Seal Course given at the Congress Hotel, Chicago, March 27, 28, 29.

Mr. Delano was followed by Mr. Corcoran, who spoke of his appreciation in being chosen president of the new association and also thanked the members in behalf of the officers. He then asked for a rising vote of thanks for Mr. Delano and those who entertained. The meeting was then adjourned.

Among those present were George Wiswell, H. B. Hopkins, West Music Co., Joliet; M. Shepard, Armbuster Bros., Chicago; R. B. Noll, H. Davidson, Talking Machine Shop, Chicago; J. H. Ellis, B. A. Lampe, W. E. Tieste, Mark L. Duncan, C. W. Hyde, T. W. Williams, J. J. Walsh, B. E. Webster, P. T. Griffiths, W. P. Geissler, A. P. White, W. C. Griffiths, G. F. Denig, Chicago Talking Machine Co., Chicago; J. J. Welker, Woodlawn Talking Machine Shop, Chicago; Mrs. F. O. Edwards, Chicago; I. Platt, Platt's Music Shop, Chicago; Joseph J. Rock-

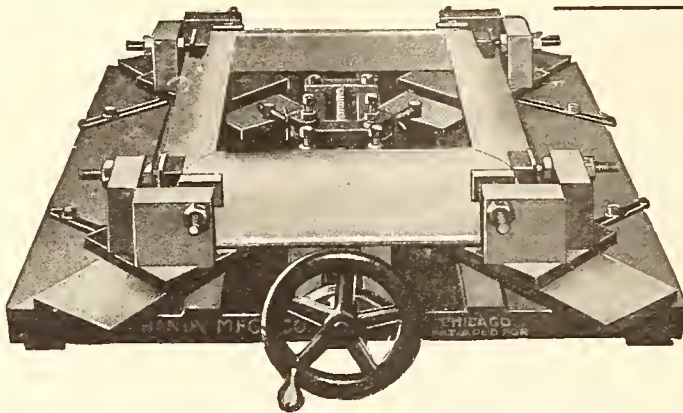

WE ILLUSTRATE THE
"Handy" Dome Clamp

Quick action for clamping domes and frames on Talking Machine Cabinets
Write for Catalogue of clamping machines for Cases and for all purposes.

VENEER PRESSES AND CLAMPS

HANDY MFG. CO.

27 E. Madison St., Chicago, Ill.

well, Reincke-Ellis Co., Chicago; L. C. Wiswell, W. P. Roch, E. M. Schultz, E. H. Ryckoff, A. F. Samuel, C. T. Landhew, R. E. Agnew, H. R. Fitzpatrick, R. C. Keenan, Lyon & Healy, Chicago; Mrs. Campbell, Elgin; Gus Mayer, William B. Richards, Unit Construction Co., Philadelphia; E. A. Sayre, Elgin; Hans Schoessling, Lester E. Noble, Rudolph Wurlitzer Co., Chicago; Mrs. A. F. Cotton, W. F. Cotton, Cotton's Music Shop; E. Sherry, I. Sherry & Son, Chicago; Raymond Bill, Talking Machine World, New York; F. M. Leslie, Urbana; Lillian L. Heaney, Ruth Wood, T. P. Flannery, T. P. Flannery Co., Chicago; Mrs. Isabella Loomis, Edith L. Hilderbrandt, S. Sachs, Sachs Music Shop, Chicago; A. Bell, East Chicago, Ind.; Thomas B. Stone, William G. Wise, of Thomas B. Stone, Chicago; Miss G. Cassadine, Charles M. Bent, R. B. Corcoran, Sarah Berlin, Henry J. Macfarland, Louis J. Hogle, Mrs. R. B. Corcoran, Music Shop, Inc., Chicago; J. P. Nosling, Nosling Music Co., Chicago; J. J. Stasulonis, Chicago; E. Nevers, A. B. Musson, Miss L. Brown, Macauley & Nevers, Chicago; Mr. and Mrs. Ray E. Bannon, Morris, Ill.; Otis Bigelow, Chicago; A. N. Hansen, Maude Winfield, George H. Bent, Chicago; Carl Glick, Abraham Glick, Glick's Music Store, Chicago; Mrs. A. Leithardt, A. Witzel, E. Witzel, A. Leithardt, Witzel Music Co., Chicago; Mr. and

Mrs. A. M. Gordon, Gordon's, Chicago; J. M. Dvorak, J. M. Dvorak Music Co., Chicago; H. C. Petersen, Gary, Ind.; H. A. Renholm, F. J. Hassmer, Hassmer Bros., Chicago; F. A. Delano, Victor Talking Machine Co., Camden, N. J.; R. H. Zinke, R. H. Zinke Music Co., Milwaukee, Wis.; James Kroupa, Raymond Kroupa, Chicago; Leopold Krchma, Miss Bernice Krolick, Leopold Krchma Co., Chicago; E. M. Perz, Chicago; William Launer, H. H. Kessler, Chicago; S. I. and H. H. Kessler, Laporte, Ind.; Roy Sonneborn, Sonneborn's Sons, Laporte, Ind.; A. Bauman, Oak Park Music Shop, Chicago; John G. Willis, A. Willis & Son, Chicago; J. B. Seufert, M. Brelsford, H. W. Brelsford, Chicago; J. K. Patterson, Patterson Music Co., Chicago; F. O. Edwards, F. C. Henderson Service Shop, Chicago; Mr. and Mrs. E. Dublin, West Side Talking Machine Co., Chicago; H. B. Forsen, A. B. Forsen & Son, Chicago; F. J. Dornseif, A. C. Fenton, Hyde Park Music Shop, Chicago; J. B. Klein, Patterson Bros., Chicago; A. G. Ogren, G. L. Brundine, A. G. Ogren Music Co., Rockford, Ill.; J. Corngold, Roseland Music Shop, Chicago.

The Diamond Disc Shop, of Atlanta, Ga., suffered some damage by a fire on February 27, which was confined to the storeroom.

SPECIAL!!



Needle Cups, at 1c. ea.
Needle Cup Covers, at 1/2c. ea.

Order right from this ad—any quantity! Quality and immediate delivery guaranteed. Terms—5% discount for cash with order—or net 10% deposit to accompany C. O. D. order.

COLE & DUNAS MUSIC CO.
52 W. Lake St., Chicago, Ill.

EXCELSIOR PADS

The most satisfactory packing material for packing phonographs for shipment. Used to advantage by the largest manufacturers. Send for prices and samples.

H. W. SELLE & COMPANY
Manufacturers
1000-1016 N. Halsted St., Chicago, Ill.

Lyon & Healy Khaki Moving Covers

Modern Method Insures Safe Handling



Extra Heavy
Khaki
Padded and
Quilted Fleece
Lined

We make them
up promptly
to order, to
your measure-
ment or to fit
any machine

Special Inducement to Jobbers

LYON & HEALY - Chicago, Ill.

THE SCOTFORD TONEARM AND SUPERIOR REPRODUCER

Manufactured under the Patents of Louis K. Scotford

PROFITABLE SPECIALTIES FOR THE DEALER



On the EDISON

The Ideal All-Record Reproducer for the Edison Disc Phonograph

Superior Reproducer with 21-E Connection for Edison— Sample prepaid, Nickel \$7.50, Gold \$10.00



On the VICTOR

CA Mellow, More Musical Tone on All Makes of Records

Superior Reproducer with 21-VE Vitor Elbow— Sample prepaid, Nickel \$6.50, Gold \$8.50



On the COLUMBIA

Makes the Owner of an Old Machine a "Live" Record Buyer

Superior Reproducer with 21-CC Columbia Connection— Sample prepaid, Nickel \$7.00, Gold \$9.50



On the VICTOR On the COLUMBIA

SCOTFORD MODEL I REPRODUCER

Plays Only Vertical (Hill and Dale) Cut Records, but Plays Them at Their Best

Scotford Model I Reproducer 1-V for Victor— Sample prepaid, Nickel \$6.00, Gold \$7.50

Scotford Model I Reproducer with 1-C Columbia Connection— Sample prepaid, Nickel \$6.75, Gold \$8.75



The fault of most tonearms is that they copy the tapering shape and curving turns of the original model used in the first successful phonograph. These imitations possess no individuality or distinctive merit of their own. But the Scotford Tonearm is different. The design is not a copy of any other, and none of the mechanical features are the same. It does not follow the common theory of developing the sound waves within a tapering tube of curving turns, but obtains superior results through a straight tube of unobstructed angle turns — the proven method of the "speaking tube."

The Superior Reproducer plays all makes of records as they should be played, the needle retaining the same center and same correct angle in both positions. Note the split, springlike frame, with perfect insulation between frame and backplate and between reproducer and tonearm connection. Note also the sensitive pivoting of the needle bar, imparting a hammerlike movement to the diaphragm. These patented features, obtainable only in the Scotford inventions, give a tone of mellow richness, genuinely musical in quality, positively not equalled by any other

Samples Will be Submitted on Approval

Style 1 (as illustrated) is a combination of Japanned and Plated parts—Tonearm long tube and main elbow, Reproducer face ring and back Japanned; other parts Plated

Style 2. Tonearm long tube and main elbow Japanned, base Plated; Reproducer back Japanned, face ring and frame Plated

Style 3. All parts of Tonearm and Reproducer are Plated

No. 1 Scotford Tonearm and Superior Reproducer	Nickel \$7.00, Gold \$ 9.00
No. 2 Scotford Tonearm and Superior Reproducer	Nickel 7.75, Gold 10.00
No. 3 Scotford Tonearm and Superior Reproducer	Nickel 8.50, Gold 11.00

Samples Prepaid at the Above Prices — Quantity Prices on Application

THE SUPERIOR LID SUPPORT

The Spring Balance that Does Not Warp the Lid

Noiseless in operation. The simplest balance support made. Easiest to install. It positively will not warp the cover. Lids warped by other supports can easily be brought back to correct shape by the Superior

Theoretically, any lid support will warp any lid if placed singly at either side, as the warping is not done when the lid is down. Leaving the cover open causes the warping, as the unsupported corner will sag

But actually, the Superior Support overcomes this common fault. When down, the support exerts a slight downward pull which corrects any warping that develops when the lid is up

A light touch of one finger lifts or closes the lid, which stops at any point desired

As the Lid is lowered the Roller rolls into the Notch of Trackarm

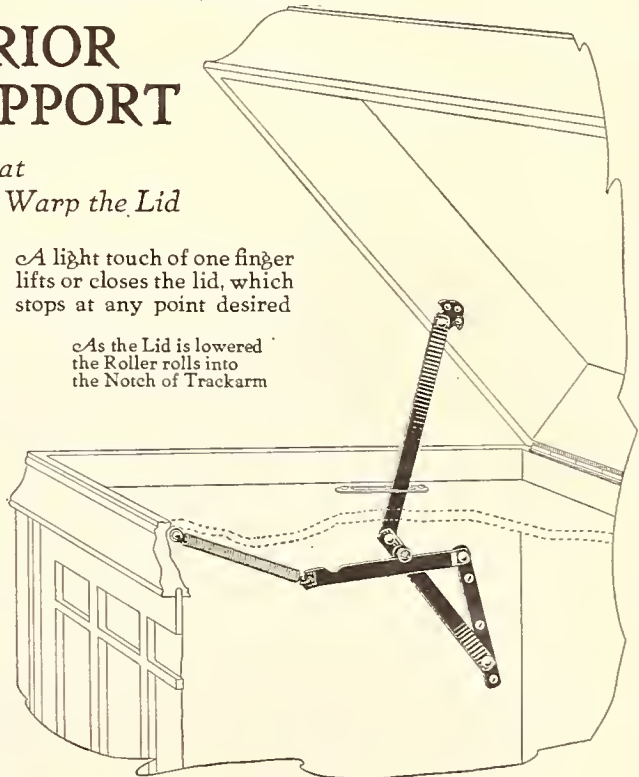

Price of Sample Prepaid

Superior Lid Support with Escutcheon	Nickel \$0.75	Gold \$1.25
--------------------------------------	---------------	-------------



Sample of Any Superior Specialty on Approval

If not rated, deposit the price, which will be refunded on return of samples Write for Quantity Price List of Superior Specialties

BARNHART BROTHERS & SPINDLER

Monroe and Throop Streets CHICAGO

"This is the Day of the 'DALION'!"

Present-day conditions have made necessary the adoption of unusual selling methods to maintain the volume of phonograph sales. Dealers today are as much concerned about the selling *plan* and factory co-operation as they are about the necessary details of the cabinet, the finish and tone qualities.

Every Demonstration Spreads the DALION Reputation

The DALION has long been regarded as an instrument of superior qualities. There are nine models in the line. It is unsurpassed in finish, in design and in reproduction of either vocal or instrumental records.

So the dealer's success depends largely upon the number of demonstrations he can make. Shrewd buyers have come to distinguish between finish and "tin pan" reproduction. So our campaign—the first of its kind that has ever been successfully attempted—is built entirely around the DALION demonstration.

Dealers Must Qualify

There are thousands of phonograph dealers who have never had the proper factory support. The past demand for phonographs has largely accounted for their success, combined with the aggressive methods they have themselves originated.

The dealer who sells the DALION is guaranteed success because he must first qualify as the type who can successfully demonstrate the DALION.

He must have a good store in a good location. He need not be the largest phonograph dealer in his locality. But he should be the most aggressive. He should be prepared to canvass for country business. He should appreciate the value of local newspaper advertising which we carry on with him. He should aspire to be the *biggest* phonograph dealer in his locality. Honesty is an essential in all business.

Inquire About the DALION

May we present the DALION line for your examination? Will you please indicate what line of phonographs and records you have been selling? And the territory you serve?

Milwaukee Talking Machine Mfg. Co., Milwaukee, Wisconsin



COLUMBIA GRAFONOLA PRICES RADICALLY READJUSTED

Columbia Graphophone Co. Announces Price Changes in All the Standard Model Grafonolas to Figures That Average Below the Pre-War Level—The New Prices in Detail

The Columbia Graphophone Co. of New York announced this week a radical readjustment in the prices of the entire line of standard model Grafonolas. This readjustment has carried the average price of the whole line of standard model Columbia Grafonolas below the pre-war level, but this is hardly an adequate comparison because of the many improvements that have been introduced since the pre-war period. All but the two portable models are now equipped with the new Columbia non-set automatic stop, which has proved such a valuable feature that the company has devoted the major part of its advertising to it for a year past.

The new price schedule for standard model Columbia Grafonolas is as follows:

	Old Price.	New Price.
A-2	\$32.00	\$30.00
C-2	50.00	45.00
D-2	75.00	60.00
E-2	125.00	85.00
F-2	140.00	100.00
G-2	150.00	125.00
H-2	165.00	140.00
K-2	225.00	150.00
L-2	275.00	175.00

There is no change in the price of Columbia period models, and this readjustment in the prices of standard model Columbia Grafonolas follows closely on the 59-cent sale of Columbia Retired Records and the restoration of the pre-war 85-cent price to all Columbia 10-inch blue label A series records, except records made by ten exclusive artists, who are nationally prominent.

Referring to these important announcements made by the Columbia Graphophone Co. during the past fortnight, a local Columbia dealer stated as follows:

"The sale of instruments is, of course, the fundamental thing in the talking machine industry. The sale of records never ceases, but it

varies to some extent with the sale of instruments. Therefore, every instrument that is sold broadens the channel for the flow of record sales, and the flow of records rapidly eats away the sales resistance to instrument purchasers.

"The Columbia Graphophone Co. has had the foresight to add fresh impetus to both these mutually helpful sales streams at once, and I believe that this readjustment in the prices of their instruments, together with the recent restoration to pre-war prices of Columbia records, will give a great impetus to the sale of both."

PLANNING TO CHECK CANCELLATIONS

National Association of Purchasing Agents Seeks to Have Adopted a Standard Form of Sales Contract That Will Be Binding

The National Association of Purchasing Agents, with headquarters in New York, is now working on a plan for having drawn up and adopted some standardized form of sales contract that, while fair and equitable to both buyer and seller, will still be of a nature to represent a definite fixed contract that will be enforceable and serve to check the wave of cancellation of orders that has been sweeping the country.

Various trade organizations are asked to bring their buyers and sellers together in order to reach an agreement regarding a contract that will meet the requirements of both factors. These contracts in turn will be placed in the hands of a committee representing the National Association of Purchasing Agents, and that committee will endeavor from the several forms of contracts to evolve a standard form applying to all lines of business. It is felt that only through the co-operation of both buyers and sellers can effective steps be taken to insure the strict observance of contractual obligations.

VICTROLA WEEK AT HAHNE & CO.

Talking Machine Department of Newark Department Store Plans Big Event—Manager J. A. Bliesenick Has Praise for Red Seal School

NEWARK, N. J., March 8.—Manager J. A. Bliesenick, of the talking machine department of Hahne & Co., is planning a Victrola Week for the week of March 14-19. During this week there will be special musical features at the store and special terms will be offered to the public. Large newspaper ads have been prepared and will be carried in all the local papers. Mr. Bliesenick, by the way, attended the twenty-first course at the Victor Red Seal Salesmanship School at Camden and declared, in a chat with a representative of The World, that he can trace a 25 per cent increase in record sales directly to this course. His sales force have all attended this school and the great increase in the sale of records followed the installation of the methods used at Camden. The whole department will attend the talking machine frolic on March 29 which will be held at the Hotel Pennsylvania, New York.

Attention to the operatic records pays well, Mr. Bliesenick declared, and added that every week his department meets and plays and discusses the records of an entire opera, exchanging views on the music and discussing the artists and the interesting bits of information furnished about them in the record supplements. In addition to the Victor this department also carries the Sonora.

At the Griffith Piano Co., Harry Griffith said that one of the features of the trade during the past week or two was the sale of period Sonoras, quite a number having been sold to music lovers of the city.

HOWISON ASSIGNED TO PITTSBURGH

PITTSBURGH, PA., March 7.—Hugh A. Howison has been assigned to the Pittsburgh district by the Victor Talking Machine Co. as official representative to the Victor dealers.

Mr. Manufacturer, Mr. Jobber or Mr. Dealer

"SWEETEN UP" your line of "upright" talking machines with these handsome console types and *move* your whole stock.

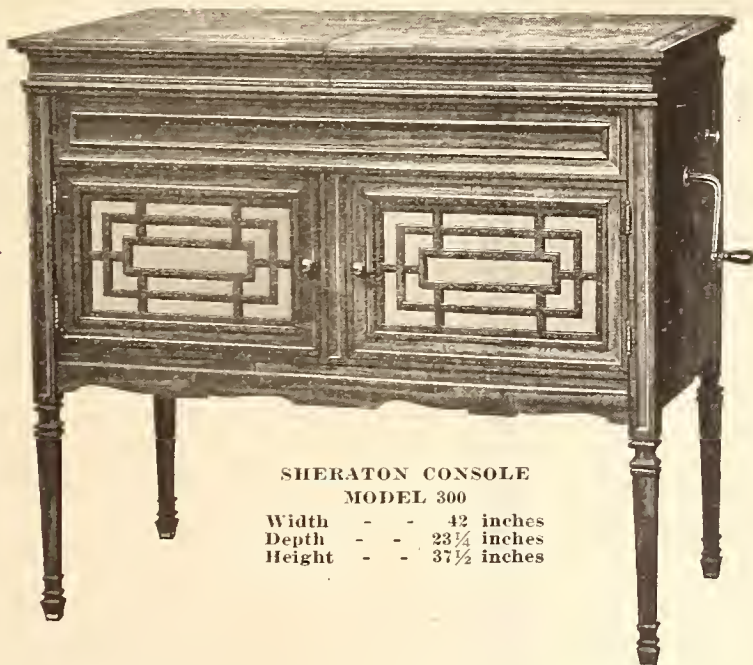

**SHERATON CONSOLE
MODEL 300**
Width - - - 42 inches
Depth - - - 23 3/4 inches
Height - - - 37 1/2 inches



**QUEEN ANNE CONSOLE
MODEL 200**
Width - - - 40 inches
Depth - - - 24 inches
Height - - - 36 1/4 inches

We will furnish you the cabinets alone, or equipped, or you may furnish the equipment and we will install it—expertly.

The cabinets are beautiful, attractive designs, superior cabinet work, perfectly finished. Limited stock ready for immediate delivery.

Better order mighty quick. Prices right.

SINGER TALKING MACHINE CO., 575 to 579 Market St., Milwaukee, Wis.

TRADE NEWS IN BROOKLYN AND LONG ISLAND TERRITORY

Talking Machine Sales Active in This Section of Greater New York—Progressive Body of Men Both in the Jobbing and Retail Field Who Are "Doing Things"—Gleanings by The World Man

For several years past Brooklyn and Long Island territory has been recognized as one of the most important centers of talking machine and record distribution in this section. Many of the most attractive talking machine establishments in Greater New York are located in Brooklyn territory, and the dealers in this metropolis are constantly expanding in order to accommodate the requirements of their patrons. When a representative of The World visited the Brooklyn trade he found a feeling of optimism and confidence which was reflected in healthy sales totals.

Business Is Steadily Improving

Business is more than holding its own with the Victor department of the Sterling Piano Co., at 518 Fulton street. E. T. Leture, manager of this department, is greatly pleased with the upward trend of business, and believes that it will continue for some time. V. A. Hurst, a member of the sales staff, sold a model eighty Victrola a few days ago to a lady customer, who was so well pleased with the attention given her that she came back the following Monday and brought with her two friends, who both purchased Victrola 80's for their homes. Instances like this prove beyond doubt that it certainly pays to make a friend of every customer and to give just a little bit more by way of service. It brings home the sales.

Saunders with G. T. Williams Co.

S. A. Saunders, an experienced wholesale talking machine salesman, has joined the sales force of the G. T. Williams Co., Victor wholesaler. Mr. Saunders comes back to the Victor business after an absence of some time in another field. He will represent this well-known Victor jobber as a traveling representative in Brooklyn and Long Island, and his former experience will enable him to give dealers practical service in merchandising Victrolas and Victor records.

Making Plans for Spring Trade

W. P. Doing, talking machine manager of Abraham & Strauss, Columbia dealers, is very busy these days preparing intensive selling plans for Spring business, which he believes will be very encouraging. Nineteen twenty-one sales to date have more than held their own and, in fact, February showed an increase, but Mr.

Doing states this was the result of carefully laid plans and real salesmanship. In discussing dealer problems Mr. Doing emphasized the importance of timely and intelligent buying of records. Dealers should study carefully their customers' demands for every class of records, keeping a check on these demands, so that when new or special numbers are issued they can anticipate the sale and order accordingly. Only in this way can dealers order intelligently without having a large surplus stock on their shelves, while, on the other hand, they will have enough stock available while the records are popular.

New Location Attracts Business

The new quarters of Geo. S. Uniss, Inc., exclusive Victor retailers, at 121 Court street, are certainly arranged to care for the customers' needs. Two very attractive show windows can be viewed from both Court and State streets, giving ample opportunity to display to advantage the Victrola models. Mitchell S. Trabulsi, who manages this exclusive Victor store, believes that Spring business will be active, but that it will require hard work in order to bring the sales into the winning column. The interior of the store is neatly finished in gray with a comfortable reception room at the entrance with booths on each side, and the record stock adjoining the booths. This exclusive Victor establishment recently moved from 117 Court street to take advantage of the fine corner location at 121 Court street. It was a splendid move, according to Mr. Trabulsi, as this corner location is much more desirable.

New Pathé Dealers in Brooklyn

Live dealers recently added to the Pathé fold include Hill & Sons, 1365 Myrtle avenue, and Wick & Wick, Flushing, L. I. The former, which is well known as one of Brooklyn's foremost piano houses, engaged forty-eight crowing red rooster decalcomanias to tell passers-by of Pathé's arrival. Wm. Hill, Jr., spent considerable time promoting Actuelle sales in Nevada, and his return to Brooklyn was, to a great extent, responsible for the signing of the contract with Pathé. Wick & Wick, exclusively Pathé, plan an extensive selling campaign, and their outside salesmen will carry the Pathé message over many square miles of Long Island territory. C. E. Kennel's attractive store on

Fourth avenue continues as a Mecca for music lovers from all over Brooklyn, thanks to the personal service which Mrs. Kennel has injected into the business.

Moves into Larger Quarters

The Rowes Music Shop, Lynbrook, L. I., has recently moved from 8 to 20 Atlantic avenue, into new and larger up-to-date quarters. Every convenience has been installed to give efficient service, and no detail has been spared to make the store as attractive as possible. The ever-increasing business of this progressive shop has more than warranted this removal into new quarters.

Victor Dealers Using Outdoor Advertising

Considerable activity is being shown in Brooklyn by Victor dealers, who are anticipating a healthy Spring business. R. H. Morris, of the American Talking Machine Co., Victor wholesaler, believes that the dealers will show gratifying sales totals, and states that his company is urging the dealers to stimulate this business by intensive local advertising. He states that outdoor advertising has met with considerable favor among Brooklyn dealers and he believes that Brooklyn leads all sections of the country in this kind of advertising. The majority of dealers are advertising their stores and their product by attractive billboard designs, which are meeting with favorable comment in Brooklyn territory.

Foreign Record Business Increasing

W. H. Relling, of Ridgewood, and Peter Pendola, of 564 Hicks street, have developed an active trade among foreign record buyers. Mr. Pendola plans to open a second store to accommodate his continually expanding business. Miss Evelyn Bedell, proprietress of the Jamaica Music Store, has created a sensation in that corner of Brooklyn by employing a sound amplifier at her window, which literally enables the window to talk out loud. The effectiveness of this attraction is reflected in Miss Bedell's sales reports.

Optimistic Report by Jobber

A noticeable improvement in business during the past few weeks is reported by John Streiff, distributor of the Remington phonograph in Brooklyn and Long Island. The location of his retail store on Flatbush avenue is one of the best in Brooklyn and it is equipped with the most modern appliances for the retailing of phonographs.

Using Windows to Advantage

Albert and Otto Ruckgaber, the popular proprietors of the "Arthora," exclusive Victor shop, are very enthusiastic regarding February sales. They are both "live wires" and are bending every effort to increase their Victrola business now in the anticipation of a possible "let-up" in the Summer months. A show window has been attractively arranged to display a period model Victrola, Gothic type, and this window attracted the attention of passers-by and produced sales.

Carry Full Page in Newspaper

Michaels Bros., of Brooklyn, N. Y., are firm believers in the power of advertising. This long-established furniture house recently took on the Granby line, manufactured by the Granby Phonograph Corp., of Norfolk, Va. This important fact was announced to the residents of Brooklyn by a full-page advertisement appearing in the local paper, Chat. Each model of the Granby line was shown and the effect was very impressive. These progressive dealers report that they are doing very well with the Granby line and expect that the demand will continue throughout the balance of the year.

A New Firm in Brooklyn

The new firm of Sheiman & Scharfsstein have taken over the business of the Flatbush Talking Machine Co., 1135 Flatbush avenue, Brooklyn, N. Y., and will handle the Columbia, Sonora and Brunswick lines. Joseph Sheiman, the senior partner, has been in the talking machine business for ten years, being connected at various times with S. A. Sherman in New York and the Grand Phonograph & Piano Co., Inc., in Brooklyn.



NOTICE

To Our Brooklyn and Long Island Dealers

The "WORLD" has recognized the fact that Brooklyn and Long Island are entitled to a "Special News Section" in its monthly issue.

To insure the success of this news section, we ask our dealers in the localities interested to send to the news editor of the "WORLD" any items of interest that they may have from time to time.

Help Boost This Section





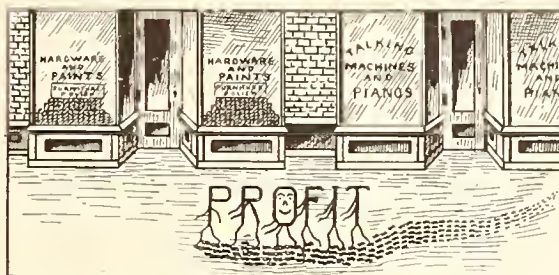

Are Good Profits Going By Your Door?

Where do your talking machine and piano customers buy their musical merchandise?

If you are among those who haven't as yet installed a money-making musical merchandise department, think it over.

A Gretsch special assortment at \$500.00 will start the profits coming your way.

The well-known Gretsch quality enables you to unqualifiedly place your endorsement behind the instruments you sell.

Send for our new confidential price list, just off the press.

THE FRED. GRETSCH MFG. CO.

MUSICAL INSTRUMENT MAKERS

Since 1883

54-82 BROADWAY

BROOKLYN, N. Y.

To
ALL DEALERS
of
RECORDS and
WORD ROLLS

Biggest selling Record and Roll successes. The most played numbers in the country. Every dealer should get in quick.

“LOVE BIRD”

By Mary Earl and Ted Fiorito

April release, Victor and Columbia Records

“ROYAL GARDEN BLUES”

By Clarence and Spencer Williams

The “Blues” Hit of the Year

“BEAUTIFUL HAWAII”

By Mary Earl

The Writer of “Beautiful Ohio” and “Love Bird”

“MY LAST DOLLAR”

By Charles Bayha and Chris Smith

Bert Williams’ Big Hit in the “Broadway Brevities”

“REMEMBER ME”

By Ted Fiorito

Writer of “Love Bird”

ALL FROM THE GREAT MUSIC HOUSE *of*
SHAPIRO BERNSTEIN & CO.
INC.
 BROADWAY AT 47th St. . NEW YORK

GLEANINGS *from the* WORLD *of* MUSIC

Leading Orchestra Leaders Tell the Most Popular Hits

This is a new feature that will serve the interests of the dealers, record manufacturers and music publishers. In each issue of *The World* this section will print reports from the country's leading orchestra leaders direct, who will report the most popular numbers in their respective territories. The list of leaders has been carefully selected—they are prominent figures in Eastern, Middle West and Pacific Coast musical circles. The records quoted give an important "lead" to dealers.

PAUL WHITEMAN SAYS:

- "Rose"
- "Underneath Hawaiian Skies"
- "Now and Then"
- "I Never Knew"
- "Darling"
- "Caresses"
- "Home Again Blues"
- "My Mammy"



ART HICKMAN SAYS:

- "Bright Eyes"
- "Dream of Me"
- "Do You Ever Think of Me"
- "Rose"
- "My Mammy"
- "Margie"



EDDIE KUHN SAYS:

- "Home Again Blues"
- "I Never Knew"
- "My Mammy"
- "Now and Then"
- "O-Hi-O"
- "Sunshine"
- "Some Little Bird"
- "Coral Sea"



D. SHERBO SAYS:

- "Rosie"
- "Margie"
- "Whispering"
- "I Never Knew"
- "Now and Then"
- "Make Believe"



AL JOCKERS SAYS:

- "Grieving"
- "My Mammy"
- "Now and Then"
- "Bright Eyes"
- "Make Believe"
- "Margie"
- "You Ought to See My Baby"



ISHAM JONES SAYS:

- "Bright Eyes"
- "Rose"
- "My Mammy"
- "Humming"
- "Darling"
- "Caresses"
- "Underneath Hawaiian Skies"
- "Na-Jo"



TAKES STAND FOR CLEAN LYRICS

Publishers' Association to Take Action for Good of Industry—Vaudeville Circuit Puts Ban on Suggestive Songs and Lyrics

That the vogue of melody songs is not to mark the end of progress in the standard of present-day popular songs has recently been evidenced by the action of the leading vaudeville circuit, which has announced that all "Blue" and double-meaning lyrics are to be banished from vaudeville programs. Also, no matter how slight the degree of suggestiveness, it must be eliminated.

The following letter has been sent out by E. C. Mills, chairman of the Executive Board of the Music Publishers' Protective Association, which also shows that body is to take action on the works of its members along the above lines to forestall any outside reform:

"I take the liberty of suggesting a very careful scrutiny of the lyrics of songs hereafter accepted, with a view to eliminating entirely the suggestive, lascivious, double entendre or 'blue' material.

"Outside of the fact that as publishers we do
(Continued on page 152)

JOSEPH KNECHT SAYS:

- "Rose"
- "Home Again Blues"
- "Kiss-A-Miss"
- "Darling"
- "Whispering"
- "Mello 'Cello"
- "Dreaming of Your Eyes"
- "Humming"



HARRY RADERMAN SAYS:

- "Grieving"
- "Rose"
- "Rosie"
- "Home Again Blues"
- "I Never Knew"
- "My Mammy"
- "Caresses"
- "Bright Eyes"



We refused \$25,000 advance royalty, in cold cash, for this number, from three different publishers. A lot of money these days, but real hits are scarce. This song is the biggest hit on the market.

Recorded by every Talking Machine Record and Player Roll Manufacturer and booked for early release.

SCANDINAVIA

(SING DOSE SONG AND MAKE DOSE MUSIC)

By RAY PERKINS

Be Sure to have a good supply of Records, Player Rolls and Sheet Music on hand.

STARK & COWAN, Music Publishers, Inc., 234 W. 46th St., N.Y. C.

MCCARTHY AND TIERNEY'S NEW ONE
"WHY DON'T YOU"
THE BIG MELODY HIT FROM "AFGAR"
SUNG BY ALICE DELYSIA
PUBLISHED BY LEO FEIST Inc. FEIST BLDG. NEW YORK

"You can't go wrong with any Feist Song"

TAKES STAND FOR CLEAN LYRICS
(Continued from page 151)

not wish to be sponsors for indecent material or songs that are capable of wrong construction, the fact is that from now on in increasing measure such songs are going to be barred from the better vaudeville theatres, and the publisher who sponsors them may find all professional publicity sources withdrawn.

"Clean fun, wit and humor, yes, and plenty of it. The more the better. Lyrics that inspire lewd thought or action, NO! and none of them. Let us attend to this now ourselves and out of our own initiative, before others attend to it for us and compel the action we should be proud to voluntarily take.

"Will you please make it a point to make your writers understand? The subject will come up for discussion at our next meeting."

Following the receipt of the communication

there were several meetings between the heads of various houses and their writing staffs and the order went out that in the future no writer could hope to receive consideration for any lyric that bordered on the suggestive or lewd.

There is no doubt that many of the present-day songs are not only objectionable for home use, but also are entirely out of place in the theatres or any other places where ladies and gentlemen congregate. The large number which have during the past year or so been published and exploited have in almost all instances failed to sell in any large quantities, and their presence in the market has doubtless contributed in some measure at least to the big music slump from which the business is slowly but surely emerging.

It is a source of satisfaction that the lyrics of the type of songs complained of rarely find their way into the record field. For this we must be thankful.

NEW COLUMBIA ARTIST

Miss Blossom Seeley, Musical Comedy Star, to Make Columbia Records

G. C. Jell, manager of the Columbia Recording Laboratories, announced this week that arrangements had been completed whereby Miss Blossom Seeley, popular vaudeville and musical comedy star, will make Columbia records exclusively. Miss Seeley, who is well known to theatregoers throughout the country, has already made several records, which will be announced in an early Columbia supplement, and the prominence of this artist in the theatrical field will enable Columbia dealers to feature her records to advantage in their sales campaigns throughout their territory.

The way to begin living the Ideal Life is to begin.

FREE!

YOUR DISTRIBUTOR WILL GLADLY FORWARD ON REQUEST, AT ONCE, Cut-outs, window strips and other display material for the "MY MAMMY" week, commencing Saturday, April 2 to April 9 inclusive.

During the week, April 2 to 9, vaudeville acts, orchestras everywhere, in vaudeville theatres, motion picture theatres, hotels, cafes and wherever music is sung or played will feature this

Cyclonic Phenomenal Hit of Hits

MY

MAMMY

(The Sun Shines East) ————— (The Sun Shines West)

Write Your Jobber—Distributors Prepare The Biggest Week for the Biggest Hit

Distributors, write for plans, details and display matter. Dealers, if your jobber is unable to supply you write direct

IRVING BERLIN, Inc., 1587 Broadway, New York

THE NEXT WALTZ
HIT
WILL BE
KISS A MISS

THE NEXT BIG SONG
HIT
WILL BE
OHIO
O M Y O

PUBLISHED BY THE
HOUSE THAT PUT OVER

"MISSOURI"
"HINDUSTAN"
"SWEET AND LOW"
"NAUGHTY WALTZ"



FORSTER
MUSIC PUBLISHER INC.
235 SOUTH WABASH AVE.
CHICAGO

**HANDLING SHEET MUSIC
TO HELP SALES TOTAL**

Where Additional Income Is Desired a Line of Popular Music Fits in Logically With Other Musical Goods—Can Be Handled Without Any Considerable Outlay of Capital

[EDITOR'S NOTE.—The suggestions regarding the opportunities of talking machine dealers to carry sheet music, as a side line, appearing in this department have not been written with the intention of convincing the trade that it is the proper thing for them to do, but rather in an effort to show the dealer who needs some additional stimulant in the way of sales and profits that it would be far better for him to carry active sellers in sheet music than to stock a product totally unrelated to his line.]

Stores in larger cities, at least those in the shopping centers and, indeed, those in the buying centers of even smaller communities, hardly need to look beyond their own talking machine and record business to keep their sales force active.

For those, however, located in districts or territory where business and profits must be taken from all sources found available there is no question but that sheet music of the popular type, and at its present wholesale and retail selling figure, does appear to be the logical line to insure added activity.

The proper results cannot be obtained from even a limited sheet music department, however, unless some definite plan for the department is laid out and prepared for operation before the music stock is installed. In other words, it is not fair to the sheet music line to handle it on a hit-or-miss basis.

If a dealer contemplates stocking the active sellers and does not want to become involved in carrying a large stock there should be no more than fifty of the best sellers selected. This will eliminate any gamble that might be found in the business and, in addition, reduce the space required for such a purpose to a minimum.

The goods should be purchased from centrally located jobbers so that the stock, when necessary, can be replaced overnight. Of the fifty best sellers probably twenty will be showing unusual activity. These twenty selections then should be stocked the heaviest—probably at the start ten or twenty copies of each. The next ten numbers would be what are known as second-best and, of course, should be stocked in proportion, while the last twenty, which might be termed the mediocre sellers, should be stocked with care and with the chief idea of presenting an assortment.

Any one of the leading jobbers will willingly offer his co-operation and assistance in the selections of the titles and of the amount of goods to stock of the individual numbers. It will be well for the dealer, opening such a department, to select his jobber with a view to obtaining the best co-operation, suggestions, ideas, plans, etc.

The best method to display the music is in a wall rack occupying less than five feet of wall space and practically no floor space—a rack that displays each and every title, making it a self-service proposition. This rack need not be located in any particular spot, but our suggestion would be that it be placed adjacent to the cashier's desk or the counter where records are wrapped. In that manner the usual record sales are made, following which the customer, more often than not, steps toward the rear of the store and the conspicuousness of the titles in the rack will create the sale of the sheet music. In this manner the sales of one department do not conflict with those of another.

Since sheet music has been practically eliminated from the ten-cent syndicates many merchandising organizations which heretofore gave departments devoted to such goods no consideration have taken very kindly to the idea of opening up sheet music sections. During the past two years many of the very highest type of department stores have opened sheet music departments. These are more often than not opened in obscure corners of the store and one of the primary purposes of this, after a reasonable profit is considered, is the attracting

(Continued on page 154)

ARTo RECORDS



85c. ARTo 10 Inch Phonograph Records 85c.
THE LATEST DANCE AND SONG HITS

FOR APRIL, 1921

DANCE RECORDS

- Humming. Medley Fox-trot. Introducing: "Stars of Normandy." Chorus sung by Arthur Hall. Moulin Rouge Orchestra
- 9051 Na-Jo. Fox-trot. Rudy Wiedoeft playing the Saxophone. Selvin's Novelty Orchestra
- 9052 Do You Ever Think of Me? Fox-trot. Chorus Sung by Arthur Hall. Selvin's Novelty Orchestra
- Kiss-A-Miss. Waltz. ARTo Dance Orchestra
- 9055 I Like It. (Fox-trot Tempo). Tenor solo. Arthur Hall
- Down by the O-h-i-o, D-My-o. (One-step Tempo). Tenor solo. Billy Jones

VOCAL RECORD

- 9054 I'm Missin' Mammy's Kissin' and I Know She's Missin' Mine. (Fox-trot Tempo). Baritone solo. Ernest Hare
- Angels (We Call Them Mothers Down Here). Tenor solo. Charles Harrison

COLLRED VOCAL RECORD

- 9053 Arkansas Blues. Vocal Blues. Lucille Hegamin Accompanied by The Blue Flame Syncopaters.
- I'll Be Good But I'll Be Lonesome. Vocal Blues. Lucille Hegamin Accompanied by The Blue Flame Syncopaters.

STANDARD VOCAL AND INSTRUMENTAL RECORDS

- 3061 Dear Little Boy of Mine. Tenor solo. Thomas Mitchell
- 3060 Long Ago in Alcalá. Baritone solo. George Dexter
- Gypsy Love Song. Baritone solo. George Dexter
- 3060 Gypsy John. Baritone solo. George Dexter
- 3058 French National Defile March. ARTo Military Band
- Father of Victory March. ARTo Military Band
- 3059 Invincible Eagle March. ARTo Military Band
- The American Republic March. ARTo Military Band

JEWISH SDNG RECORD

- 3062 Auf Dem Schlechten Weg. Alto solo. Esther Feinberg
- Der Chuppe Tug. Alto solo. Esther Feinberg

ARTo Word Rolls \$1.00
VOCo Word Rolls 85c.
ARTo Popular Rolls 50c.

Subject to Liberal Trade Discounts

FOR APRIL, 1921

- 1361 All For You. Fox-trot.
- 1359 Angels (We Call Them Mothers Down Here). Ballad.
- 1373 Baby Dreams. From "Jimmie." Ballad.
- 1363 County Kerry Mary. Waltz Song.
- 1364 Dream of Your Smile, A. Fox-trot.
- 1366 I Call You Sunshine. Fox-trot.
- 1370 I Found a Rose in the Devil's Garden. Fox-trot.
- 1360 I Like It. Fox-trot.
- 1358 I'm Missin' Mammy's Kissin'. Fox-trot.
- 1365 Lilah Sugar Baby of Mine. Fox-trot.
- 1362 Nestle in Your Daddy's Arms. Fox-trot.
- 1357 Nesting Time. Fox-trot.
- 1375 Pekin. Fox-trot.
- 1368 Secrets of Love. Fox-trot.
- 1367 She Knows It. Fox-trot.
- 1369 Some Little Bird. Fox-trot.
- 1371 Someone Else. Fox-trot.
- 1372 There Comes a Some Day (From "The Rose Girl") One-step.
- 1374 Vamping Rose. Fox-trot.

The above Songs without words can be had in the ARTo POPULAR Rolls, which retail at 50c.

THE ARTo CO.
STANDARD MUSIC ROLL CO.
Factories, Orange, N. J.
New York Offices, 1604 Broadway

OUR PRINCIPAL JOBBERS ARE:

- CRDWN MUSIC CO., New York City.
- PLAZA MUSIC CO., New York City.
- FULTON TALKING MACHINE CO., New York City.
- GRIMLER SALES CO., New York City.
- ARTo DISTRIBUTING CO., New York City.
- ARTo RECORD SALES CO., Brooklyn, N. Y.
- WILLIAM H. FERRIS CO., INC., Brooklyn, N. Y.
- THE MORRIS MUSIC PUBLISHING CO., Philadelphia, Pa.
- CHAS. W. HDMEYER & CO., Boston, Mass.
- CONDOLIDATED TALKING MACHINE CO., Chicago, Ill.

The RAGE of TWO CONTINENTS AN ABSOLUTE SENSATION

WYOMING WALTZ by GENE WILLIAMS
 VOCAL INSTRUMENTAL

2 NATURAL HITS WATCH THEM GROW
 Published by M. WITMARK & SONS
 WITMARK BUILDING NEW YORK

Deenah My Argentina Rose
 NOVELTY FOX TROT
 LYRIC BY AL DUBIN
 MUSIC BY HENRY SCHARF
 VOCAL INSTRUMENTAL

of customers to departments which would be otherwise overlooked or infrequently visited. The syndicate stores use the same methods to carry their customers to the rear of their floors. Where there is a basement a music counter will always be found there, or, if there is a rear balcony, that will be chosen for its situation. Of course, this has no application to the average talking machine shop other than to show that some of the biggest merchandisers in the country acknowledge sheet music as a product holding sufficient attraction to create unusual interest, sales and profits.

VISITORS AT PEARSALL OFFICES

Among the recent visitors at the office of the Silas E. Pearsall Co., New York, Victor wholesaler, were J. H. Barney, Newport, R. I., and John Williams, of Fall River, Mass. Both of these Victor dealers spoke optimistically of the business situation in their cities, stating that they were making plans for an active Victrola and Victor record trade this Spring.

Men Who Make Popular Songs

No. 20—Arnold Johnson

One of the younger song writers who has made a name for himself during the past year is Arnold Johnson, whose first work to bring him into the limelight was the novelty song "Oh," written in collaboration with Byron Gay. His newest song is called "All for You," a ballad number shortly to be released by his publishers and one which created some attention in manuscript form.

Besides his other activities Mr. Johnson heads the Arnold Johnson Novelty Orchestra, now



Arnold Johnson

playing an extended engagement at the Café de Paris, New York City. He personally arranges all the numbers his orchestra renders and this, too, in an impressively original style.

Of the newer writers devoting their efforts to writing popular songs none is better equipped from a musical standpoint than Mr. Johnson.

HAYS FROM A MUSICAL FAMILY

Grandfather of New Postmaster-General Won Considerable Fame as Composer

It was somewhat of a surprise to musical circles of Washington to find that the new Postmaster-General comes of a line of song writers.

Will Hays, the paternal grandfather of the present member of the Cabinet, composed a long list of songs well known in his generation, and indeed the ballads, "No One to Love" and "Nobody's Darling," are found in many present collections of old-time songs and are said to compete for popularity with the works of Stephen C. Foster.

The father of the Mr. Hays of this generation is also said to have shown the same musical bent, having written a number of hymns and having won something of a local reputation as a musician in his younger days.

In some cases, if you don't know what to say, it is best to say nothing.

"THE HORRORS OF PROHIBITION"

Popular Hits of the Day Inspire a Paragapher in a Gainesville, Tex., Paper to Inflict a Sad Story on His Readers

Under the title, "The Horrors of Prohibition," a columnist in the Gainesville, Tex., Register recently contributed the following, which shows hits in New York are hits on the Pacific Coast or in Texas!

You ought to see "Margie," from "Ohio," eating some "Chile Bean" at the "Moving Picture Ball," dressed in her "Alice Blue Gown," and making "Honolulu Eyes" at "Chong," who is "Whispering" to "Rose" and saying, "I Told You So," and entreating her to "Let the Rest of the World Go By." And you can see "Jean" from "Avalon," with "The Alcoholic Blues," because, as she said to "Rosie," "Mandy" is "Tired of Me" and won't "Feather Your Nest." And you can see a "Crocodile" at "Ching-a-Ling's Bazaar," where a band plays "That Naughty Waltz." You might take "Irene" to the "Tripoli" in your "Blue Jeans" and chase away the "Hula Blues" beneath the "Venetian Moon" in "The Dusk," and then go to "My Little Home on the Hill."

SOLICITATION BRINGS RESULTS

The value of personal solicitation among likely and even the not so likely prospects has been proved by F. M. Smith, of his own establishment at Ashland, O., and Mrs. E. J. Wahl, manager of the record department, who have booked some extraordinary orders for machines and records in and near that city.

THE SWEEPING HIT

"Carolina Lullaby"

Lyric by WALTER HIRSCH Music by LOUIS PANELLA

THREE WONDERFUL SONGS
 by HAGER & GOODWIN

Writers of

"Wonderful Mother of Mine," etc.

"Mumsy My Own"

"Just a Little Sympathy"

"Rainbow Sal"

On All Records and Rolls

Harrison Music Co.

438 W. Larned St.
 Detroit

310 Strand Theatre Bldg.
 New York

BIDDY WEEK

MARCH 14-20
 DON'T FORGET MARCH 17

VICTOR RECORD

No. 18,718

On March List

"BIDDY"

An Irresistible Irish
 Fox Trot Song

Will Be Nationally
 Exploited

Week of **March 14 to 20**

Records and Rolls are Being
 Released By All Leading
 Companies

Sam Fox Pub. Co.
 CLEVELAND NEW YORK

BIDDY WEEK **March 14-20**

J. D. MOORE ASSUMES NEW DUTIES

Well-known Victor Wholesale Man Is Appointed General Manager of Talking Machine Co. of Texas — Thoroughly Familiar With Every Department of the Industry

J. D. Moore, manager of the wholesale Victor division of Philip Werlein, Ltd., New Orleans, I.a., for the past few years, has been appointed



J. D. Moore

general manager of the Talking Machine Co. of Texas, Houston, Texas Victor wholesaler. This company is one of the recognized leaders in the Victor industry in the Southwest, and T. E. Swann, president of the company, is a foremost factor in Victor activities in that section of the country.

Mr. Moore, who assumed his new duties on March 7, is enthusiastic regarding the possi-

bilities for extending valuable service and cooperation to the Victor dealers in the territory of the Talking Machine Co. of Texas. Mr. Moore has been identified with the Victor industry for many years and is recognized as one of the most capable Victor wholesale men in the country. The Victor trade in Texas will receive the benefits of his extensive knowledge of the industry generally and, according to Mr.

Moore's present plans, a number of important announcements relative to progress and expansion will be announced in a few weeks.

Prior to assuming his new position Mr. Moore was presented with a diamond Masonic Shrine emblem by his New Orleans Masonic friends, who keenly regretted his departure from their city, where he had won the esteem and affection of all his personal and business associates.

SONORA RECORD TO BE SOON INTRODUCED TO THE TRADE

President Geo. E. Brightson Announces Plans Almost Completed for the Introduction of New Sonora Lateral-cut Double-faced Records—A Talk With Mr. Brightson on the Subject

George E. Brightson, president of the Sonora Phonograph Co., announced this week that the company is about ready to place on the market the Sonora record. Full details in connection with the record line will be announced by Mr. Brightson in the course of the next few weeks, but it is understood that the company will manufacture a complete line of ten and twelve-inch lateral-cut, double-faced records. The library will be complete in every detail, and the personnel of the record division will be ready for announcement to the trade very shortly.

In an interview with The World, Mr. Brightson stated: "The Sonora Phonograph Co. had never in the past deemed it necessary to have a record line in conjunction with the Sonora phonograph because the company had found it impossible to secure a quality record that would be in keeping with the world-wide prestige of the Sonora phonograph. It was also impossible for the company to supply itself with a quality record product that would compare with the best that the market afforded.

"During the past year, however, we have devoted considerable time to a thorough investigation of the record field and arrangements have been recently completed whereby we will be in a position to offer the trade a record that will be in entire accord with the high position occupied by the Sonora phonograph."

In the course of the past few weeks, several Sonora jobbers have visited the offices of the Sonora Phonograph Co., and Mr. Brightson has taken advantage of the opportunity to play some of the new Sonora records. These jobbers have advised Mr. Brightson that they are most enthusiastic regarding the tone quality and the recording of the records, and predict that they will meet with a hearty reception.

W. I. BRUNNER JOINS OKEH STAFF

Well-known Wholesale Man Joins New York Distributing Division—L. C. Ziegler Resigns

Lambert Friedl, manager of the New York distributing division of the General Phonograph Corp., announced this week with regret the resignation of Louis C. Ziegler, who had been a member of the traveling staff of this division, covering the trade in Brooklyn and the East Side section in New York City.

W. I. Brunner, who has been identified with the local talking machine trade for many years, has been appointed a member of the sales staff of the New York distributing division, and will give Okeh dealers the advantage of his thorough knowledge of the trade. Mr. Brunner was formerly associated with the local wholesale branch of the Columbia Graphophone Co.

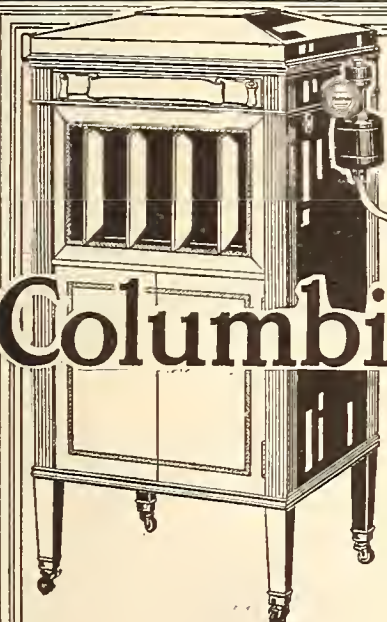

Columbia

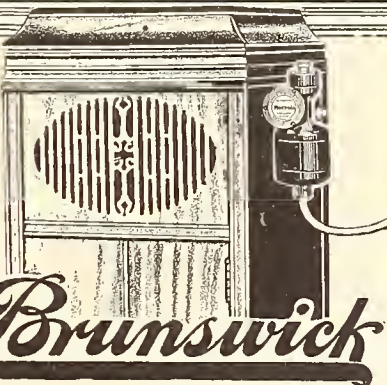

Brunswick



Starr

and the Motrola



The Columbia Graphophone Co., The Brunswick-Balke-Collender Co., and the Starr Piano Co., are now co-operating with the Jones-Motrola Co., by placing with all of their distributors a complete line of Motrolas.

This little electrical, self-winding instrument can be simply and instantly attached to any make of phonograph and winds exactly to the proper tension—without danger of over-winding.

Protect your demonstration phonographs by attaching MOTROLAS. This will double their period

of usefulness and, at the same time, give customers, who are in the habit of dropping in to try out the latest records, a chance to become personally acquainted with the MOTROLA.

Nobody who has ever touched the magic button is satisfied to revert to hand-cranking. When a customer once operates a MOTROLA your \$30.00 sale is made. Some profit, we'll say!

MOTROLA window displays and store demonstrations, to tie up with our National Advertising Campaign, will bring MOTROLA BUSINESS to your very door. Are you ready to welcome it?

DETROIT
83 E. Woodbridge St.

ATLANTA
226½ Peachtree St.

JONES-MOTROLA, Inc.
29 West 35th Street, New York, N. Y.

KANSAS CITY, MO.
1104 Walnut St.

CHICAGO
57 E. Jackson Blvd.

LOS ANGELES
6019 Hollywood Blvd.

Back to Pre-War Prices

COLUMBIA, as usual, leads the way. Columbia has authorized the most radical price re-adjustment ever made in the phonograph industry.

The new prices quoted on the opposite page are below the pre-war level. And this for much improved models.

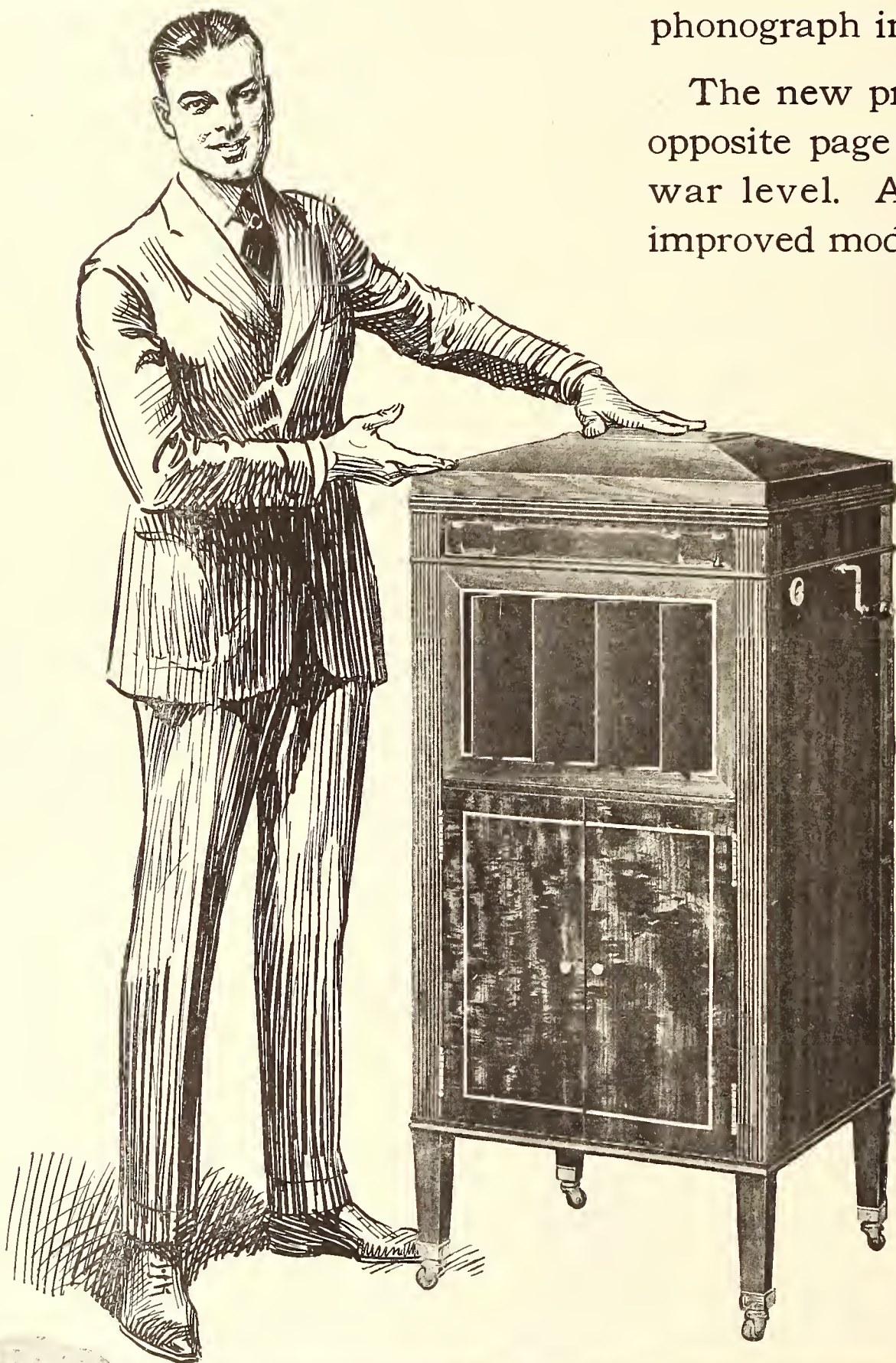

COLUMBIA

Columbia Leads the Way

Here Are the Figures

Models	Present Prices	NEW PRICES
L-2	\$275.00	\$175.00
K-2	225.00	150.00
H-2	165.00	140.00
G-2	150.00	125.00
F-2	140.00	100.00
E-2	125.00	85.00
D-2	75.00	60.00
C-2	50.00	45.00
A-2	32.50	30.00

These figures speak for themselves. They will also speak for you. Take full advantage of the fact that we are the first to readjust prices. Here is your chance for immediate sales, new customers, and permanent business.

All these Standard Models are equipped with the *Non Set Automatic Stop*, an exclusive Columbia feature.

COLUMBIA GRAPHOPHONE COMPANY
NEW YORK

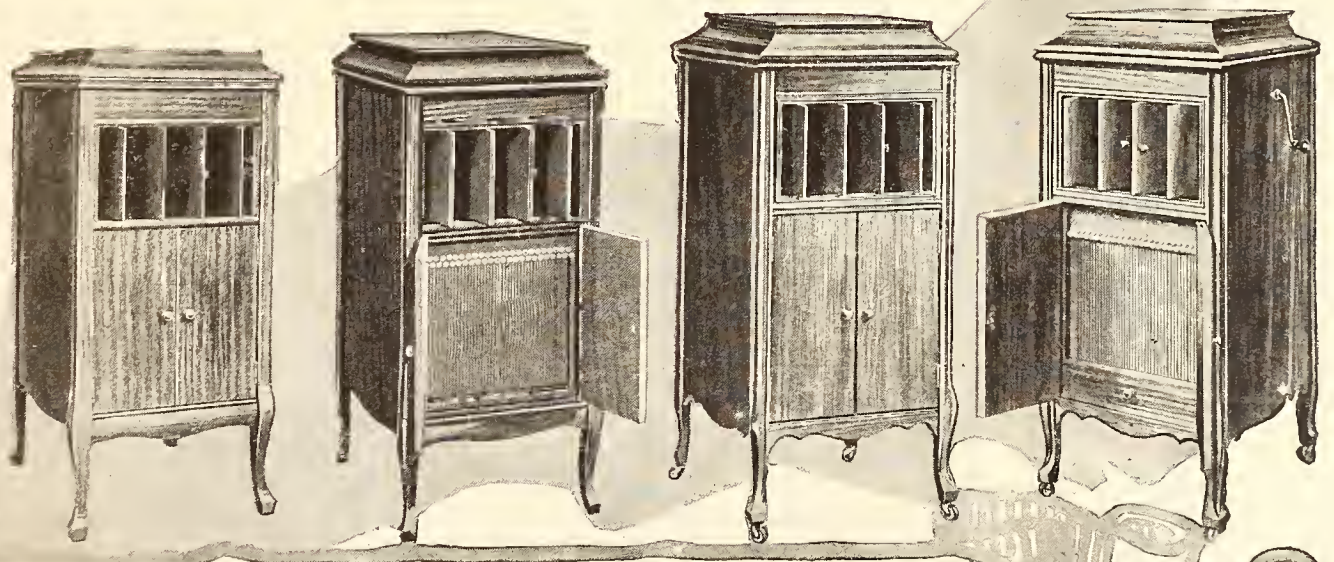
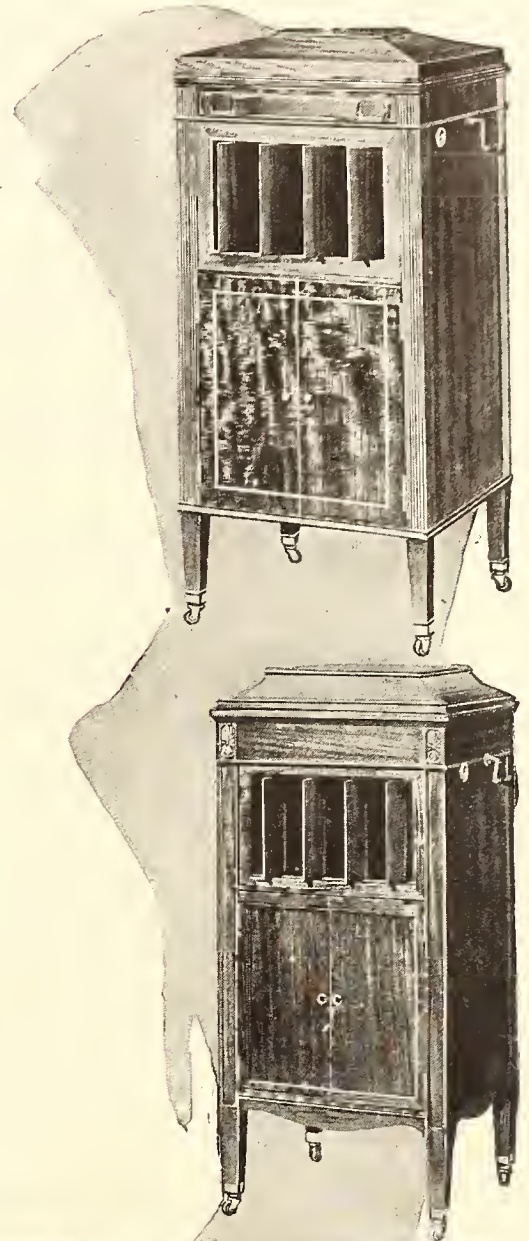

GRAFONOLA

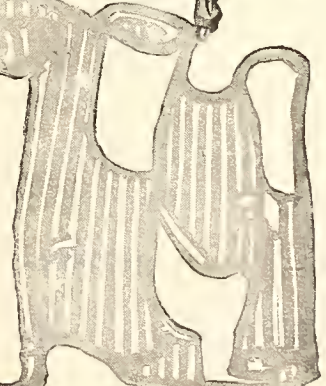

MELLOR SALES STAFF INCREASED

George C. Baish to Cover Territory East of Pittsburgh — Educational Department Now Has Special Office, in Charge of Miss Lillian Wood, Who Recently Returned From Camden

PITTSBURGH, PA., March 7.—The Victor wholesale and distributing department of the C. C. Mellor Co. sales staff has been increased by the addition of George C. Baish, of Altoona, Pa., an expert Victor man, who will cover the territory east of Pittsburgh. The other salesmen are R. R. Myers, with the title of assistant manager, and F. H. Burbick. The latter will cover the western territory. Thomas T. Evans is the manager of the department. He has established headquarters in the wholesale department at Penn avenue and Twelfth street for Miss Lillian A. Wood, who is well known for her activities in the Mellor Co.'s Victor educational department. In the future Miss Wood will co-operate with the Victor dealers, under the direction of Mr. Evans. Miss Wood just returned from Camden,

where she took the Red Seal salesmanship course.

The Victor retail educational department will be under the supervision of Miss H. H. Taudte, at the retail department, 604 Wood street, which is managed by Fred J. Drake.

DEATH OF M. H. ANDREWS

Well-known Dealer Dies in Bangor, Me.—Prominent in Musical Activities

BANGOR, ME., March 6.—The many friends of M. H. Andrews, president of the Andrews Music Co., of this city, were grieved to hear of his death, which occurred here a fortnight ago. Mr. Andrews was one of the oldest and best-known music dealers in this section of the country, having been in business in Bangor since the Civil War. He was an orchestra director, violin player, violin maker and composer, and in his younger days a teacher of dancing.

Mr. Andrews was the organizer of the Maine Piano Dealers' Association, and was twice

BRUNO

When you sell a man a Victor, don't think of your profit. Think of the world of pleasure it is going to give him—and others.

BRUNO



Patent Pending

Fletcher Alltones Needle

The only Semi-Permanent Needle made, each of which will play either **LOUD, SOFT** or **MEDIUM**, by simply turning it in the needle holder as shown in the above cut. This is why it is called "**ALL-TONES**" or All-tones-in-one.

To give long life to the record and to get the best possible results while playing, recommend **FLETCHER ALLTONES NEEDLES** to your customers.—They will appreciate it.

Stocking this one needle meets every demand at a saving in space and capital.

Retail price per card of four needles 25c
Boxes of 100 cards, to dealers \$15
Valuable selling helps free

Jobbers—Write for Territory and Proposition

FLETCHER ALLTONES NEEDLE CO., INC.

205 Travis Street San Antonio, Texas

New York Distributor:
ANDREW H. DODIN, Inc., 28 Sixth Ave., New York, N. Y.

Chicago and Northern States Distributor:
W. R. PATTEN 8th Floor, 25 E. Jackson Blvd., Chicago, Ills.

president of this organization. He was interested in all musical activities and since the formation of the Maine Music Festival was one of its chief supporters. Mr. Andrews was intimately acquainted with many of the great musical artists of the last fifty years and his loss will be keenly felt in the musical organizations with which he was affiliated, as well as in the trade, where he had a host of friends who esteemed him for his many fine qualities.

CLOSES MANY NEW ACCOUNTS

L. M. Cole, of Iroquois Sales Corp., Establishes New Okeh and Granby Accounts—Arranges for Extensive Advertising Campaigns

BUFFALO, N. Y., March 8.—L. M. Cole, general sales manager of the Iroquois Sales Co., Okeh and Granby jobber, returned a few days ago after a trip through New York State and a visit to New York City. While in New York Mr. Cole conferred with the General Phonograph Corp., manufacturer of records, and also spent some time with E. C. Howard, general sales manager of the Granby Phonograph Corp., Norfolk, Va., who happened to be in New York at that time.

As a result of Mr. Cole's trip, Howard & Winslow, Inc., Middletown, N. Y., are now Granby dealers, and are also handling a complete line of Okeh records. Hills, McLean & Haskins, Binghamton, N. Y., are handling the Granby and Okeh lines, and Week & Dickinson, Binghamton, among the most successful talking machine dealers in the State, have arranged to handle the Okeh record line.

In addition to signing up four new Okeh dealers in Syracuse, N. Y., Mr. Cole also made arrangements whereby the Venetian Music Co. will handle the Okeh line in Utica, Binghamton, Syracuse, Rochester and Buffalo.

Mr. Cole states that a deal was closed calling for a good-sized advertising contract for Okeh records in Polish, German and Italian papers throughout New York State, and that there will also be an extensive bill-board advertising campaign for the Granby line in Middletown, N. Y., with an extensive newspaper campaign in Binghamton.

MOREHOUSE CO. ENLARGING

COLUMBUS, O., March 7.—About May 1 an important opening will be held at the Morehouse Co., this city, where Manager L. I. King is completing extensive alterations. The plan is to make this establishment one of the most beautiful as well as one of the largest in the State.



THE TALKING MACHINE WORLD SERVICE

Robert Gordon's Page -

A DEPARTMENT DEVOTED TO PROMOTING RETAIL SALES



Get the "March" on Your Competitor

PRACTICALLY every one in the talking machine field concedes to-day that an owner's interest in his machine will wane if he is not educated to buying high-class selections. Therefore, you should continually center a large amount of your sales efforts on records featuring operatic, instrumental and vocal music of the very best class. This thought comes to mind at this time because of the fact that Eastertime is always associated with music of the highest standard. Connect up the theme of Easter with your store, featuring in your windows those selections which portray its spirit. Also give a list of seasonable selections to each salesman on Monday of the week prior to Easter, and instruct these salesmen to call to the attention of all customers the fact that these selections may be of interest to them. If you have a machine playing in your foyer most of the time, see to it that selections of a character in keeping with the Easter season are played.

* * *

THERE'S many a clever little wrinkle which, if employed, will create good feeling and stimulate action. From time to time you probably circularize your prospective customers with literature pertaining to the purchase of a talking machine. In one of these circulars, cut your story short by asking them to inquire of you about your "easy payment plan." Enclose therein a postal card—on one side of which is your name and address, on the other a formal inquiry for more detailed information concerning your plan, with a place for the name and address of the prospect. Now, the little wrinkle is as follows: On the place where the stamp should be affixed have a square printed and within the square the following: "A Penny for Our Thoughts." A dealer who employed this wrinkle informed us that many of the customers, to whom he had finally sold through the form letter, told him that they answered the original postal card because it only cost "a penny for our thoughts."

* * *

ACHILD when shown a new toy immediately reaches out its hands to play with it. Grown folks feel the same desire, although they do not express it. When demonstrating your next machine, show the customer how the needles are attached, how the machine is started and stopped, and then permit the customer to do it himself. You will be surprised how quickly the customer will take genuine interest in the demonstration.

* * *

IT is an old saying that "Whether the hen faces East, West, North or South in the nest, it lays the same egg." Equally true is the statement that "No two salesmen present their proposition in the same manner." In order that a second salesman might try his method of approach when the first salesman had failed, the following system was devised: A push button was placed in the booth behind the talking machine, or in any other place where it was inconspicuous. This in turn rang an indicator which was located in the rear of the shop. When a salesman realized that he had practically lost the sale he would ring the bell, whereupon another salesman would appear and would apologetically inform the first one that he was wanted. The second salesman would then remain in the booth and would re-discuss with the prospective customer the entire proposition.

* * *

HERE is a system which is being used to increase the mailing-list for the record bulletins and is meeting with quite considerable approval in different parts of the country: Hung in each booth is a neat card, measuring about 9x12 inches—which has a bulletin attached to it and carries the following words: "DO YOU WISH ONE OF THESE ATTRACTIVE BULLETINS SENT TO YOUR HOME EACH MONTH? IF SO, WE WILL GLADLY PLACE YOUR NAME ON OUR MAILING LIST."

* * *

A DEALER who did quite a large mail order business hit upon the scheme of keeping his regular customers supplied with printed postal cards bearing his address on one side and ruled lines for orders on the other. On the first of the month, when the new

supplements were mailed to his customers, he attached to the supplement one of these ruled postal cards. When the order for records came in a delivery boy was sent out to take these packages to the different homes. On receipt of the package the customer would pay the boy for the amount of money due for the records. Of course, before sending the records out, they should be sealed to show that they have never been used. The sealing of your records will inspire confidence in your customers, and they will have no fear of ordering records from you through the mails.

* * *

ONE of the hardest things to do is to get rid of your old records, or stickers. Here is a little idea which will help you to solve that problem. Build a record rack in each booth which will just hold four records. Over the top of this rack have the following words neatly printed: "Here are the records we recommend this week." Then place a classification over each one of the four record spaces. One should be "Operatic," another "Dance Hit," a third "Popular Song," and a fourth "Instrumental." Place records that are stickers under their appropriate titles. Change the four selections each week.

* * *

GROWN folks will stop and watch a steam-engine or any other mechanical device in operation. Take your repair department and move it, or at least a part of it, into one of your show-windows. A work bench, a foot lathe, a few springs and motors will be sufficient. Let your best repair man sit in the window and clean and repair your motors. About the window have several signs placed, which will convey the following messages: "Our Expert Repair Department Is Always at Your Disposal"; "This Is a Practical Demonstration of the Expert Work Which We Do"; "The Oil Used on Your Machine Gums Up—Therefore Your Motor Should Be Cleaned, Oiled and Adjusted at Least Once Each Year"; "We Will Call for Your Motor and Return It to You Within a Period of Two Days." Such a window will bring you some unexpected business and will definitely impress the public with the fact that you have a repair department.

* * *

ONCE upon a time Mrs. Browning, the poetess, seated herself and wrote:

"But so fair
She takes the breath of men away
Who gaze upon her unaware."

And this makes me think that after all very few dealers have put to advantage the charms of the feminine sex toward helping to stimulate record sales. Recently the writer came across a dealer who had secured the services of a very charming young lady. To his surprise, the record sales jumped up immediately, and he also noted that the people who called once became steady customers. And why? First—because the beauty of the young lady captivated them. Second—her winning smile helped them to feel more at home. Third—after trading for several times she came to know the exact type of music which the different individuals cared for so that their record buying became a genuine pleasure. Although I do not recommend that the selection of record girls be made for beauty alone, I do suggest that more attention be given to their attractiveness.

* * *

ATALKING machine dealer once openly made a statement that he was selling talking machines and records. Get that idea out of your head and realize that you are selling music. Talk, deal and think in terms of music. In this way, you will develop your store into a music center, so that you will be respected in your community as a judge, critic and patron of music. One way to establish such a reputation in your community of being more than just a talking machine shop is by always making it a point to sell tickets to the musicales which are given in town. Whether or not you make money at selling these tickets is not so important. The good-will you can build up as a music lover and as a promoter of art and music in your city will more than compensate you for your efforts.

EDITOR'S NOTE—Mr. Gordon, who writes this monthly page, is also director of "The Talking Machine World Service." Mr. Gordon will publish on this page any good ideas submitted by you for the benefit of the trade, and also answer any questions you ask him concerning merchandising problems. Use this department as much as you like. It is intended to serve you.

Edison Amberola Message No. 15

The Amberola Co-Operative Newspaper Advertising Campaign makes it possible for Edison Diamond Amberola dealers to cash in on the demand that is created by satisfied Amberola owners. It makes the name of the dealer known to the public. It identifies his store as headquarters for the phonograph of high quality and fair price.

THOMAS A. EDISON, Inc.

AMBEROLA DEPARTMENT

ORANGE, N. J.

CABLE ADDRESS REG'D
"FILASSE—PHILA."

THE MARK OF

LONG DISTANCE PHONE
BARING 535

ANY { Size
Quantity
Quality

SERVICE AND
Phonographically Speaking



SATISFACTION

Quotation
Delivery
Product } RIGHT

They Talk For Themselves

IMICO INDIA RUBY MICA DIAPHRAGMS

INTERNATIONAL MICA COMPANY PHILADELPHIA, PA.
U. S. A.

INTERNATIONAL MICA CO., 106-110 W. Lake St., Chicago, Illinois

FACTORY AND SALES DEPT.,
37TH AND BRANDYWINE STS.,
WEST PHILA., PA.

MOORE & WHITESIDE
MONTREAL, CANADA

RAYSOLO SALES CO.
LANCASTER, PA.

FEDERAL PHONO SUPPLY CO.
3009 JENKINS ARCADE
PITTSBURGH, PA.

WALTER S. GRAY
SAN FRANCISCO, CAL.

LAKESIDE SUPPLY CO.
416 SOUTH DEARBORN ST.
CHICAGO, ILLINOIS

STEINOLA COMPANY
Kansas City, Mo.

INTERNATIONAL MICA CO.
101 a-BLUFF
YOKOHAMA, JAPAN

Write for "IMICO" representation in your territory—domestic or foreign. Special facilities for Export Business.

"IMICO" and "SERVICE" are SYNONYMOUS

THE TRADE SITUATION IN DETROIT SHOWS IMPROVEMENT

Talking Machine Business Better in March Than for the Past Two Months—Why the Jewett Manager Is Optimistic—J. Henry Ling to Retire—New Brunswick Dealers—News of Month

DETROIT, MICH., March 10.—Regular business in talking machines is better in March than it has been in either January or February, but there is a lot of new business being stimulated due to the special liberal time payments, the small payments down and the cut in prices on some makes of records.

The industrial situation in Detroit is showing improvement every day, and by April 1 we look for conditions to be almost normal. Dealers report that the machines they are selling are not to the motor workers, but are to people not affected by the lull in the motor car business. However, the motor workers have always been heavy buyers of talking machines, and once they get back to their jobs buying will be in evidence.

A. A. Fair, general sales manager of the Jewett Phonograph Co., is very enthusiastic and optimistic and says that business at the present time is very good considering the short time that the factory has been producing. For the time being he is concentrating on Middle West territory. In Michigan he has already signed up some of the leading stores for Jewett agencies. The Renwick & Wimer Co., of Pontiac, is opening an exclusive Jewett shop. The Martin Furniture Co. at Defiance, Ohio, has taken on the Jewett line. "In fact," says Mr. Fair, "we are selling almost everyone we call on. We never fail to interest a dealer once we can get him to hear the Jewett."

J. Henry Ling, one of the oldest music dealers in Detroit, the business being founded by his father more than fifty years ago, has decided to retire from business and is now offering his entire stock for sale. Mr. Ling has been handling the Columbia line in connection with pianos and players, and when he gives up his present quarters in the L. B. King Building he plans to open a downtown office for the collection of his instalment contracts.

P. J. Gordon, of Detroit, district manager for the Brunswick-Balke-Collender Co., reports excellent business, especially on records. He states that the Isham Jones records, in the popular music class, are in the greatest demand. Isham Jones, who gave a concert and dance in Saginaw, Mich. (his home town), in February to a capacity crowd, is scheduled to give a number of such affairs in Michigan within the next ninety days. He has already been scheduled to appear at the Arcadia some time in May, under the auspices of the Brunswick Shop. He will be here in person with his orchestra of nine

men, and will also appear in Flint, Battle Creek and Jackson. Mr. Gordon reported that since the personal appearance of Godowsky in a personal recital in Detroit his Brunswick records have been selling much better.

A number of Brunswick artists are to appear in recital throughout the State. Already Virginia Rea has made several appearances and she will make four personal appearances, in co-operation with Brunswick dealers, some time during April and May.

Don Buchanan, of the Buchanan Co., at Hillsdale, visited Detroit recently on his way back from New York City, where he visited the Brunswick laboratories. He also had the pleasure of meeting Isham Jones while in New York. He says record business is exceedingly good.

The J. L. Hudson Music Store, which handles Victor and Brunswick records, is having big business on both lines. In talking machines, the Hudson store handles the Victrola, Brunswick, Cheney, Sonora and the Widdicomb.

P. J. Gordon, Brunswick district manager, says business all over the territory is most satisfactory. He is constantly taking on new dealers and in Detroit he is figuring on a number of new ones in the eastern and northern parts of the city. He recently added the University Music Co., at Ann Arbor, and the Chafee Jewelry Co., at Pontiac. The latter concern is installing a special department with booths and display rooms to handle the Brunswick line.

The C. E. Marsh Co., of Albion, has added the Jewett phonograph line. E. H. Jewett, president of the Jewett Phonograph Co., left in February for California and expects to be gone until about the first of April.

A. J. Kendrick, general sales manager of the

Brunswick Co., was a recent visitor to Detroit.

W. H. Huttie, manager of the Starr Piano Co., is getting his plans ready for his new store, which he plans to occupy on May 1. Mr. Huttie will devote much space to the Starr phonograph department, which will be located in the basement, with more booths than he now has and with more room for display.

The Home Furniture Co. at Kalamazoo, after handling another line of phonographs for five years, is giving it up to handle the Brunswick exclusively.

B. A. Dickerson, of Constantine, Mich., recently visited Detroit and spent several days here getting new ideas for an exclusive Brunswick Shop, which he will open at Three Rivers, Mich.

Harold Barnard, of the Barnard Music Co., of Jackson, was also a recent visitor to the wholesale headquarters of the Brunswick. He reported that business is improving now that industrial conditions in his town have bettered. He handles the Brunswick line and is pushing the period models with splendid success.

NEW PITTSBURGH SONORA ACCOUNTS

Manager H. M. Miller Is Optimistic Over Outlook for Sonora in His Field

PITTSBURGH, PA., March 7.—Among the new Sonora retail dealers who will be cared for by the Sonora Co., H. Milton Miller, general sales manager, are Ross Drug Co., Ridgway, Pa.; H. H. Medsger, Scottdale, Pa.; A. J. Johnson & Son, Berlin, Pa.; Fayette Bargain Co., Fayette City, Pa.; Dollard & Salyards, Pitcairn, Pa.; E. S. Smith, Sykesville, Pa., and the Freed-Grim Music Co., Connellsville, Pa. Mr. Miller stated that sales for February showed a marked increase over the same period a year back. He is quite optimistic concerning the Spring business.

The New York Recording Laboratories offer to the Phonograph Industry thoroughly up-to-date facilities for Recording, Plating and Pressing 10-inch Disc Records.

Laboratories located in the heart of New York's musical life.
Extensive manufacturing facilities at Port Washington, Wisc.
Inquiries regarding recording, selection of artists, songs, etc., invited.

THE NEW YORK RECORDING LABORATORIES
1140 BROADWAY Established 1917 NEW YORK, N. Y.

Pathé

REG. U.S. PAT. OFF.



EASTERN PHONOGRAPH CORPORATION

GEO. SEIFFERT, Pres.

WHOLESALE DISTRIBUTORS

OFFICES AND SHOWROOMS

101 West Twentieth St. 100 West Twenty-first St.

Cor. Sixth Avenue

Telephone: Chelsea 2044

NEW YORK

Pathé

REG. U.S. PAT. OFF.



Hoffay Phonographs
Resurrectone Reproducers
Airtight Tone-Arms
Famous the World Over.
HOFFAY PHONOGRAPH CO.
59 4th Ave. New York City

CONSOLE MODELS A SUCCESS

George A. Long Cabinet Co. Receiving Many Orders for New Cabinets — Dealers Report Active Demand for Console Models

The George A. Long Cabinet Co., Hanover, Pa., manufacturer of Long quality cabinets, recently sent out an important announcement to the trade, whereby it offers the dealers special readjustment prices on all standard cabinets in the Long line. This offer attracted considerable attention, and in response to the requests of the dealers the company extended the time of the special offer so that it included the entire month of March. The dealers have placed good-sized orders for these cabinets and a steady improvement in record business throughout the country has proven a stimulus to cabinet sales.

The new console models, which were recently introduced by this company, have met with a most enthusiastic reception from the trade, and the company has received orders from dealers in all parts of the country. These cabinets materially enhance the appearance of the table type of machine, and the George A. Long Cabinet Co. is co-operating with the dealers in making prompt shipments of these cabinets so as to meet their needs.

H. C. Naill, secretary of the George A. Long Cabinet Co., was a recent visitor to New York, bringing with him optimistic reports of business conditions in the East. Mr. Naill states that there is an undercurrent of confidence in the talking machine industry which indicates that the dealers are preparing for an active Spring trade.

"SIAM SOO" CREATING A SENSATION

Unique Dancing Figure Attracts Attention of Passers-by—Handled by Columbia Dealers

The Dealer Service department of the Columbia Graphophone Co. advised its dealers recently that the company had secured exclusive rights to "Siam Soo," an artistic figure that can be placed on any talking machine and which keeps perfect time with the rhythm of the modern dance records. The figure goes through all

a year ago Mrs. Florence Burgess Meehan, a member of the Bray Powell expedition, visited the palace of the King of Siam, where she saw all of the native dancers. In Cambodia the same dances were performed for her in the King's palace, and she became more interested in bringing this dancer to America. On reaching Java she found a Malay boy who was able to make a very good reproduction of the dancing figure, carved out of wood, and this constitutes the origin of "Siam Soo."



"Siam Soo" in Operation

the movements of the "Shimmy" dance, and wherever it has been displayed has served to attract crowds of interested passers-by.

The Grafonola Co. of New England, well-known Columbia dealer, recently placed a "Siam Soo" in the window of its shops and traffic was blocked so seriously that it was necessary to call out the police reserves. "Siam Soo" can be used as a record sales stimulant, and in addition is an accessory that will give the dealer a substantial profit.

A well-known music publishing house in New York is about ready to introduce the words and music of a song entitled "Siam Soo," and this unique dancing novelty is meeting with an enthusiastic reception from Columbia dealers.

It is stated that "Siam Soo" is an exact reproduction of the figure of one of the royal dancers in the King of Siam's palace. About

REPORTS BETTER CONDITIONS

William Phillips, president of the William Phillips' Phono Parts Corp., New York City, reports that this company is receiving steadily increasing demands for its tone arms and reproducers and that orders now call for increased quantity. Mr. Phillips reports the general conditions in the trade are on the upward trend and that from now on they will progress rapidly towards normal.

We have a great dealer proposition

on

OKeh Records

The OKeh Library includes the world famous

John McCormack

In addition to Mamie Smith "Blues" and all of the latest dance and vocal hits.

Immediate Deliveries

Lee-Coit-Andreesen Co.

OKeh Distributors

OMAHA NEB.

THE VISION

Devoted to the Interest of the Educational Work Being Conducted by the Talking Machine Dealers and Jobbers

Miss Grace Barr, educational director of M. Steinert & Sons, Boston, Mass., has recently completed an extensive survey of New England school conditions in the interests of Victor dealers throughout the territory.

* * *

A recent number of The Music Review issued by the American Book Co., New York City, contains three articles by leading music supervisors stressing the primary importance of music appreciation in grade, high school and university courses.

* * *

Owens & Beers, Inc., 81 Chambers street, New York City (Mrs. May White Sears, educational director), have just issued an eight-page booklet featuring their New York and Brooklyn establishments and the industrial welfare work in which the Victrola serves in recreation. This firm have sold over 150 instruments for such purposes.

* * *

This picture shows Miss Helen Colley, educational director of Emanuel Blout, Broadway and 108th street, New York, with a group of



Children's Class in Musical Appreciation her Saturday morning class of children taking music appreciation lessons. Among the artists who have appeared to greet these children are Sally Hamlin, the inimitable story-teller; Rein-ald Werrenrath and Princess Watahwaso.

* * *

Oklahoma is a leading State in progressive school methods. The Victrola is in use throughout the length and breadth of this former Indian Territory.

* * *

At the National Education Association Convention of Superintendents, held February 24 to March 3 in Atlantic City, N. J., the talking machine trade was represented by both the Victor and Columbia educational departments.

The Victor display attracted a great deal of attention and favorable comment for its beauty and originality. From the pictures of twelve leading Victor artists white ribbons were strung through the horn of a Victor school instrument

Bliss Reproducer

"Known From Coast to Coast"

Diaphragm is made of specially treated silk under patented process. Solid silver plate, 1/2 inch in diameter, is used as a resonator. The larger portion of the diaphragm is insulated in the back with cork. The result is a reproducer that is very highly sensitive and brings out every note that is recorded on the record. Has sold for \$6.00 everywhere. Offered here now at the unheard of price of \$1.00 each in nickel and \$1.50 in gold. (Reproducer only.)

On Victor Machines

is used to play Pathé and Edison records. Price complete with attachment, \$1.75 each in nickel, \$2.50 in gold.

On Edison Machines

is used to play Victor and Columbia records. Furnished with universal Kent attachment. Price complete, in nickel \$2.95, in gold \$3.45.

COLE & DUNAS MUSIC CO.
52 W. Lake St., Chicago, Ill.

to two little doll figures of children seated in regular school desks looking at copies of the newest Victor publication, "Music Appreciation for Little Children."

Both Columbia and Victor booths were kept busy meeting hundreds of school superintendents intent on learning all the new things for schools this year.

Mrs. Frances E. Clark, Victor educational director, and W. A. Willson, Columbia educational director, were in charge of the respective exhibits.

TONE-ARM CASES POSTPONED

Arguments in Actions Brought by Victor Co. Against Brunswick-Balke-Collender Co. and General Phonograph Corp. to Be Heard in U. S. Court, Grand Rapids, on March 12.

GRAND RAPIDS, MICH., March 8.—Arguments in the suits brought by the Victor Talking Machine Co., Camden, N. J., against the Brunswick-Balke-Collender Co., Chicago, and the General Phonograph Corp., New York, for alleged infringement of the Johnson Tone-Arm Patents, Nos. 814,786 and 814,848, which were scheduled to be heard before Judge Sessions in the United States District Court here yesterday, were postponed until next Saturday, March 12. Testimony in the cases was taken during the week of January 24, and briefs were filed by opposing counsel late last month.

FIVE NEW VOCALION DEALERS

O. J. DeMoll & Co., Washington, Southern Vocalion Distributors, Make Good Report

O. J. DeMoll & Co., Washington, D. C., Southern distributors for the Vocalion and Vocalion records, announce the appointment of five new Vocalion dealers in the company's territory as follows: Susquehanna Furniture Co., Asheville, N. C.; William C. Dean, Rockville, Md.; Young Furniture Co., Fredericksburg, Va.; and Philip Levy & Co., for both Richmond, Va., and Washington stores.

DeMoll & Co. report that there is a growing appreciation among the retail trade of the Vocalion and Vocalion records owing to their distinctive merits.

INCREASED DEMAND FOR RECORDS

Densite Products Mfg. Co. Reports Greater Activity Apparent Among Manufacturers

S. Carr, head of the Densite Products Mfg. Co., 315 Ellery street, Brooklyn, New York, manufacturers of talking machine records, recently stated that the past few weeks have shown an increased demand for records. He states that he arrives at this conclusion through the increased demand, as well as the renewed activity shown by various record companies.

In reviewing the general trade situation he said: "Every indication points to a most healthy situation during the coming months. The action of various companies in reducing the prices of records has already shown some increased demand and all the organizations with which we do business are arranging plans to care for an increased business. To say the least, the future months look very promising."

ACTIVITIES OF EMERSON TRAVELERS

H. E. Morrison, sales manager of the Emerson Phonograph Co., is now en route to New York after spending some time on the Pacific Coast. He is expected at his desk almost any day, and judging from his reports business conditions in the West are improving steadily.

Chas. F. Usher, field representative of the company, returned a few days ago after doing some excellent work in conjunction with the sales staff of the Emerson Ohio Co., Columbus, O., Emerson distributors. Morton Lucas, field representative of the Emerson foreign language record division, is now in Columbus, co-operat-



Delivery Envelopes

Art Series
New Designs

NEW LIST OF RECORDS

Every 60 Days

A Selected List of Victor Records

We Will Gladly Play Any of THESE for You

6042	Ensemble America March (New)	New York, N. York Band
6043	Washington Forefront (New)	New York Military Band
6044	Pan and Pagan Overture, Part 1 (New)	Admiral's Orchestra
6045	Pan and Pagan Overture, Part 2 (New)	Admiral's Orchestra
6046	Wanderful Thing (New)	Admiral's Orchestra
6047	Parade-March (New)	Admiral's Orchestra
6048	Social March (New)	Admiral's Orchestra
6049	Contra (New)	Admiral's Orchestra
6050	Egypte (New)	Admiral's Orchestra
6051	Forward Song (New)	Admiral's Orchestra
6052	Brilliant March (New)	Admiral's Orchestra
6053	Charmant (New)	Admiral's Orchestra
6054	March (New)	Admiral's Orchestra
6055	March (New)	Admiral's Orchestra
6056	March (New)	Admiral's Orchestra
6057	March (New)	Admiral's Orchestra
6058	March (New)	Admiral's Orchestra
6059	March (New)	Admiral's Orchestra
6060	March (New)	Admiral's Orchestra
6061	March (New)	Admiral's Orchestra
6062	March (New)	Admiral's Orchestra
6063	March (New)	Admiral's Orchestra
6064	March (New)	Admiral's Orchestra
6065	March (New)	Admiral's Orchestra
6066	March (New)	Admiral's Orchestra
6067	March (New)	Admiral's Orchestra
6068	March (New)	Admiral's Orchestra
6069	March (New)	Admiral's Orchestra
6070	March (New)	Admiral's Orchestra

Very attractive proposition to Jobbers
Write for trial shipment

CLEMENT BEECROFT
5546 North 5th Street
PHILADELPHIA

ing with this jobbers' sales staff in the promotion of foreign record language business.

ALL EMERSON RECORDS 85c

Eddie Cantor Records Will Now Be Listed at This Price—Grand Opera Records Included in New Price List Issued by the Company

The Emerson Phonograph Co. announced this week that the price of all Emerson records had been reduced to eighty-five cents. A few weeks ago the company advised the trade that Emerson records, with the exception of Eddie Cantor selections, would be retailed at eighty-five cents, but the new announcement provides for a list price of eighty-five cents for every Emerson record, including Eddie Cantor records. Included in this eighty-five-cent library of Emerson records will be double-faced grand opera records made by Max Block, of the Metropolitan Opera Co., and other well-known artists, in addition to a series of violin selections by Milano Lusk.

Victor Service to the South

PHILIP WERLEIN, Ltd.

VICTROLAS VICTOR RECORDS-TUNGS-TONE NEEDLES
NEW ORLEANS

IMPORTANT COURT RULING

Appellate Court Finds Error in \$2,000 Verdict Against Victor Co. Under Anti-Trust Laws

The United States Circuit Court of Appeals at Philadelphia handed down its opinion in the appeal of the Victor Talking Machine Co. from judgment of \$2,000 entered against it last May in favor of Louis Kemeny, of Perth Amboy, N. J. Kemeny brought suit in October, 1918, in the United States District Court for the District of New Jersey for \$300,000 as trebled damages under the Anti-Trust Laws, alleged to have been suffered by him as a result of his suspension as a dealer in Victor talking machines in March, 1917.

The trial of the case occupied two weeks, commencing March 30, 1920, the complainant's claim being vigorously contested throughout. Kemeny admitted extensive price-cutting in the year previous to his suspension and other violations of the license agreement in force at that time. The result of the trial was a verdict for the plaintiff in the sum of \$666.66, which, trebled, amounted to \$2,000.

The Appellate Court now finds that the trial judge erred in permitting a recovering for anticipated profits which the plaintiff claimed he would have made if he had not been suspended, and holds that Kemeny must accept a reduction of \$1,000 in the amount of the verdict or the judgment will be reversed and a new trial granted.

MARCH PROSPECTS ENCOURAGING

Dealers in Canton, O., Report Progress—Klein & Heffelman's New Building—Other Items

CANTON, O., March 8.—After experiencing one of the slowest Februarys in many years Canton music dealers are encouraged over prospects for March and report increased activity in the talking machine and record business since the first of the month.

E. J. Heffelman, head of the Klein & Heffelman Co., which is now completing a \$500,000 seven-story department store building at Market avenue N. and Fourth street, told The World representative that the new store would open to the public the last of this month. The exact date is not yet determined. With the opening of this store the three individual stores of the company here will be consolidated under one roof. The music store at Market avenue N. will be the first to vacate its present quarters. In the new building there will be more spacious warerooms and adequate booths to care for the rapidly expanding business. Many innovations in music store equipment will be available.

The Van Fossen-Smiley Piano Co. opened its new store in South Market street last week and is now firmly established. Associated with S. B. Van Fossen, president of the concern, are five other well-known music store men of many years' experience in various phases of the game. This store announces it has taken over the agency for the Sonora phonograph.

The William R. Zollinger & Sons Co. was congratulated for its unique window display in its music department Washington's Birthday. The window was appropriately trimmed and the whole window devoted to the exhibition of the latest Victor records.

All Canton is agog over the announcement that Earl Fuller's Novelty Orchestra, with Earl Fuller himself, will appear here Wednesday evening, April 13, under the auspices of the Canton Elks lodge. Dealers here plan special displays and a newspaper advertising campaign boosting Victor records. It will be the first appearance here of the well-known orchestra and its leader.

SUES ON JOHNSON RECORD PATENT

On March 8, 1921, the Victor Talking Machine Co. filed its bill of complaint against the Brunswick-Balke-Collender Co. in the United States District Court at Wilmington, Del., in which State the Brunswick-Balke-Collender Co. is incorporated, for infringement of the Johnson cut record patent, No. 896,059, dated August 11, 1908. Injunction is sought against the manufacture, sale or use of the Brunswick lateral cut record in violation of the Johnson patent, together with an accounting for damages and profits.

The Victor Talking Machine Co. has declared a quarterly dividend of \$10 a share on the common stock, together with the regular dividend on the preferred stock.



This handsome metal enamel display stand holds 60 packages, 2 doz. extra loud, 1 doz. medium, and 2 doz. loud; each package containing 50 WALL KANE NEEDLES, retailing for 15c. Price of Stand to dealers, \$4.60; \$4.90 Far West. Single packages, 7½c; 8c in the Far West.



PROGRESSIVE PHONOGRAPHIC SUPPLY CO.

145 WEST 45th STREET
NEW YORK CITY



WALL-KANE NEEDLES

One of the important reasons why you should sell Wall-Kane Needles is:

They have made good. On the market for many years and the demand for them is greater than ever before.

Attractive display containers, each holding 100 packages of a tone of WALL-KANE Needles, cost the dealer \$7.50; \$8 in the Far West

Some Jobbing Territory Still Open

BRUNO



PERFORMANCE

THE VICTROLA is made with one specific purpose in mind—the perfect reproduction of sound—always was, and always will be.

The performance of this specific purpose has made the Victrola distinctly supreme in the realm of music and caused it to be universally recognized as the "world's musical instrument."

Faultless in cabinet construction, excellent in finish, exclusive in equipment, and vastly superior in other refinements, the true value of the Victrola is its performance in accurately and faithfully reproducing the voice of the artist and the instrument of the master musician. This, in truth, is the purpose of the Victrola.

Others may sell "fine furniture," fancy knobs, nickel hinges, and other trivial effects, but you, Mr. Victor Dealer, should never lose sight of the fact that the real issue is perfect reproduction of sound—the very thing that the prospective buyer starts out to buy, really wants, and will ultimately insist upon having.

C. BRUNO & SON, Inc.

351-353 Fourth Avenue

New York

Victor Distributors to the Dealer Only

BRUNSWICK ALPHABETICAL CATALOG

Volume of Fifty Pages Lists All Selections Up to and Including December, 1920.

Just as we close our last form the new alphabetical record catalog issued by the Brunswick-Balke-Collender Co. reaches us. This is a most comprehensive volume of fifty pages, which lists all numbers issued up to and including December, 1920. The names of selections, artists and organizations appear in their proper alphabetical order, along with catalog number, size and price, so that there is no difficulty for the dealer, salesman or purchaser in securing the exact records he may desire. The arrangement is very effective and convenient. A special section of the catalog is devoted to the Brunswick exclusive artists, such as Richard Bonelli, baritone; Elias Breeskin, violinist; Mario Chamlee, tenor; Leopold Godowsky, master pianist; Dorothy Jardon, soprano; Theo Karle, tenor; Elizabeth Lennox, contralto; Irene Pavloska, mezzo-soprano; Virginia Rea, coloratura soprano; Max Rosen, violinist; Marie Tiffany, soprano, and Irene Williams, soprano, which is accompanied by biographical sketches, portraits and the list of Brunswick records which they have recorded. The volume is admirably conceived and emphasizes the growth in popularity of the Brunswick record. Lack of space prevents a lengthier mention this month.

TELLS OF STRONGER BUSINESS TONE

CLEVELAND, O., March 7.—A rapidly improving condition is evident in the talking machine industry, according to W. J. McNamara, president of the Empire Phonoparts Co., of this city. "While definite orders are still coming slowly, we notice a very decided revival of inquiries," said Mr. McNamara, "and on all sides are indications of a new and stronger tone. Optimism is very apparent and this optimism seems to be based on far-reaching trade investigations.

"We have made a number of improvements in our plant and products and so far as the Empire Phonoparts Co. is concerned, we are facing the future with every confidence."

REPORTS INCREASING ORDERS

The Eastern Phonograph Corp., distributor of both the Tonofone needle and the Jones-Motrola, reports excellent business in both these accessories. George Seiffert, president of the company, states that although they have only handled these lines for a comparatively short time, the results are already very encouraging and orders are coming in in increasing quantities.

Your Problem Is Ours

Good Profits (to you)

+ Good Service (to your customers)

Answer: TONAR RECORD BRUSHES

(Trade Mark)



Have we solved the above problem correctly?

Write to-day for prices and sample and see for yourself

PARKS & PARKS, Inc.

TROY, N. Y.

New York Office, C. E. Peabody & Co., 186 Greenwich St.

Southern Representatives: I. W. Becker & Co., 226½ Peachtree St., Atlanta, Ga.

HOFHEINZ WITH WERLEIN

Has Been Appointed Wholesale Manager of This Enterprising New Orleans Institution

NEW ORLEANS, LA., March 8.—John A. Hofheinz, well known in the Victor trade, has been appointed manager of the wholesale Victor division of Philip Werlein, Ltd., Victor wholesaler. He assumes his new duties on March 10, succeeding J. D. Moore, who has become general manager of the Talking Machine Co. of Texas. Mr. Hofheinz will announce interesting plans for the company's Victor division in the course of the next week or so, and in the meantime two experienced travelers have been added to the wholesale Victor staff.

The Recreation Phonograph Corp., Boston, Mass., and Long Island City, N. Y., has been incorporated under the laws of Massachusetts with a capital stock of \$250,000, to engage in the manufacture of phonographs. Incorporators: J. A. Perrault, of Lowell, Mass., Henry Lube, of College Point, N. Y., A. E. O'Toole, of Brockton, Mass., and F. C. Stanton, of Allston.

NEW MODERNOLA PLANT OPERATING

Addition to Company's Plant in Johnstown, Pa., Permitting of Increased Production

George E. Seiffert, president of the Eastern Phonograph Corp., Eastern distributor of the Modernola talking machine, recently returned from a visit to the headquarters of the Modernola Phonograph Co., in Johnstown, Pa. The new factory is already well proving its worth in the increased production of Modernola phonographs. Mr. Seiffert stated that the new factory not only allows for larger production, but also provides facilities for the highest class of workmanship. In a tone contest held in Johnstown, the home of the Modernola, the factory entered a Modernola phonograph in competition with the result that it was awarded highest honors by the local judges.

Mr. Seiffert reports that business has improved remarkably within the past ten days and expects that 1921 will prove an exceptional year. He gives as the remedy for slow business—good salesmanship, good merchandise and good service.

A NEW FLETCHER PRODUCT THE FLETCHER STRAIGHT LINE TONE ARM



Lengths 8½ in. and 9 in.
Ready for Delivery April 20th

Straight inside and taper outside, equipped with the regular FLETCHER Reproducer, giving the same unusual tone quality.

Write for Terms and Prices

FLETCHER-WICKES CO., 6 East Lake St., Chicago, Ill.

GEORGE McLAGAN FURNITURE CO., Stratford, Ont., Exclusive Canadian Agents

THE MACY-VICTOR CASE IS NOW COMING TO A CLOSE

Defense Now Reaching the End of Its Case, to Be Followed by the Summing Up—Several Victor Jobbers Appear as Witnesses and Offer Interesting Testimony—Charles E. Hughes Appears in Behalf of Victor Co.—Summary of the Month's Progress of the Trial of This Suit

The action brought by R. H. Macy & Co. against the Victor Talking Machine Co. and a number of Victor jobbers, which went on trial before Judge Mack and a jury in the U. S. District Court on January 17, is still occupying the attention of that court, although the end is now in sight. The plaintiffs rested their case on February 17, having taken just one month to present their side, and on the afternoon of the same day the defense began. The plaintiffs' side was summarized in *The World* last month.

Amount of Damages Reduced

As a result of the discussion on the law by and with the court shortly before the plaintiffs rested their case, damages asked for in the suit were reduced from a basic figure of \$190,000 to a sum approximately \$60,000, including \$15,000 counsel fees paid by Macy in the patent case brought against the company by the Victor Co. The damages asked for, trebled under the Sherman Act, will amount to something like \$150,000, or slightly over 25 per cent of the original amount asked.

The first witness called by the defense was C. H. North, formerly connected with the legal and contract departments of the Victor Talking Machine Co. and at present connected with the Ohio Talking Machine Co. in Cincinnati. The direct and cross-examination of Mr. North occupied about a week, and he was called upon to give testimony relative to the production of the Victor plant during the several years from 1914 to 1917, the systems used to keep track of machine and record orders from and deliveries to distributors and dealers, various correspondence, direct and general, passing between the Victor Co. and the recognized distributors and dealers, and other matters of similar nature. Par-

ticular attention was called to the letters received from representatives complaining of the price-cutting tactics of Macy & Co.

Mr. North told of the manner in which the Victor Co. handled its distribution, how an effort was made to serve various communities without having dealers in too close proximity to each other, how the Victor travelers studied conditions and aided dealers in various ways in getting the maximum business out of their territories, and rehearsed other details connected with the Victor distributing program with which the majority of the trade is quite familiar through experience.

Chas. E. Hughes Appears for Victor Co.

The case came in for considerable newspaper and public attention on Saturday, February 26, through the fact that former Supreme Court Justice Charles E. Hughes, as a member of the law firm of Hughes, Brown, Schurman & Dwight, made his last appearance as counsel before taking up his portfolio as Secretary of State under President Harding.

Mr. Hughes appeared in behalf of the Victor Talking Machine Co. and in presenting his arguments analyzed various Sherman Act suits involving patent rights. In speaking of Federal Court decisions in such cases he remarked that: "A monopoly granted by the Patent Office cannot in any way be interfered with by the Sherman law." He said that in the period from April 14, 1914, to May, 1917, the system of agreements entered into by the Victor concern and dealers in records was lawful and insisted that the defendant should not be mulcted for doing what the law sanctioned.

He based his main argument on the contention that after the decision of the United States Supreme Court in the case of *Henry vs. A. B. Dick Co.*, rendered on March 11, 1912, and up to the decision of the same court in the case of the *Motion Picture Patents Co.* on April 9, 1917, the course of action pursued by the Victor Co. was legal in placing restriction upon its machines and records.

Mr. Hughes said that the Supreme Court had reversed itself, and cited a case in which the court had held that the Legal Tender act was unconstitutional, later holding that the law was constitutional, the change of opinion affecting many suits in the same way that the *Henry-Dick* opinion and others had affected the actions of his clients. He added that in the *Henry-Dick* case the court had ruled that the method and system of distributing patented machines did not violate the Sherman Act.

"They charge," he said, "that the Victor Co. cloaked a sale under a license. But the defendant did it exactly as the courts said it had a right to do. The question narrows itself down to whether the patentee has a right to make a licensed agreement."

Judge Mack took Judge Hughes' arguments under consideration.

During the past week other notables called to testify for the Victor Co. included former Judge Lacombe, of the United States Circuit Court of Appeals, who testified to the legal ability and knowledge of the law generally, and particularly of the anti-trust laws, held by the late Horace Petit, counsel for the Victor Co., who drew up the Victor Co. license agreements, and by John R. Johnson, who acted as consulting attorney in connection with the drafting of the agreement. Judge Lacombe paid particularly high tribute to the standing of Mr. Johnson in his profession. The witness also testified to the standing of attorneys representing the Victor Co. in the action brought by that company against R. H. Macy & Co. some years ago for alleged infringement of patent for failing to observe fixed resale prices on products manufactured by the Victor Co.

Another witness for the defense was Judge Lawrence Maxwell, Solicitor-General of the

United States under President Cleveland, and since that time a leading attorney in actions brought under the Sherman Act. Judge Maxwell proved a very willing witness and seemed desirous of telling considerably more than Judge Mack was willing to allow to be inserted in the testimony.

J. L. Spillane's Interesting Evidence

An interesting witness for the defense was John L. Spillane, who in 1913 was assistant manager of the Blackman Talking Machine Co. Mr. Spillane recited experiences he had with Macy & Co. in connection with the threat of that company to offer some shop-worn and cut-out records to the public at reduced prices, following the alleged refusal of the Victor Co. to take back or exchange the records direct. According to the witness the records were offered to the public at special prices, and at the suggestion of Mr. Blackman he went to Mr. Gillam, buyer for the music department of Macy's, and offered to have the Blackman Co. take back the records providing the price-cutting was stopped. The terms were agreed to, declared Mr. Spillane, but after the records had been taken back by the Blackman Co., Macy's continued to cut prices, proffering as an explanation that Mr. Straus was pleased with the success of the sale, for it brought people to the store to shop.

It developed in the testimony that before the record question between Blackman and Macy could be adjusted the plaintiffs had been cut off as dealers by the Victor Co. In the course of his testimony Mr. Spillane explained the various features of the cut-out and exchange plan of handling old records, as put in force by the Victor Co.

J. N. Blackman a Most Important Witness

The most important witness was J. Newcomb Blackman, president of the Blackman Talking Machine Co., the first of the defendant jobbers to be called to the stand. Mr. Blackman had an impressive amount of testimony to offer and got the bulk of it in the records. He declared that he had refused to sell Macy's when approached by Williams, a Macy buyer, "because of my previous experience based on my dealings with R. H. Macy & Co.; because of conversations with me by representatives of Macy & Co. or in my presence, and because of investigations personally made by me regarding Macy & Co. methods of doing business and of price cutting in general."

In explanation of his business dealings with Macy & Co., to which reference had been made, Mr. Blackman said:

"We were doing business with R. H. Macy & Co. up to the early part of May, 1914. At that time they started to cut prices on Victor goods. As a customer, I was interested in that

(Continued on page 166b)

CABINETS

MODERATE PRICES
IMMEDIATE DELIVERY



Cut shows our
new 48"
E Model

Send for circular of our line

Everett Hunter Mfg. Co.
McHENRY, ILL.

**WALL-KANE
PHONOGRAPH
NEEDLES**

*Brilliantone
Steel Needles
Tonofone
Flexible Needles*

*Send for complete
price list to*

MORRICE RICHMOND
1552 Broadway
NEW YORK

DISTRIBUTORS

MACY-VICTOR CASE NEARING CLOSE

(Continued from page 166a)

occasion and I instructed our Mr. Spillane to call on R. H. Macy & Co., see the proper representative and ascertain the reason for price cutting on Victor records. He reported back to me that the reasons they gave were because they had on hand a stock of records, which were 'cut-outs' and which the former buyer for Macy had neglected to return when given that opportunity, and which he, the new buyer, wanted to return, but after taking the matter up at the suggestion of our representative to allow their return to the factory, he had been unsuccessful. I further instructed Mr. Spillane, after giving the matter due thought and consideration, to go back and tell Mr. Gillam, who, I believe, was the buyer at that time, that this was hurting our business; that I did not think it was necessary and that we desired to do everything possible to make it unnecessary and that, therefore, if he would stop his price-cutting we would take back the records—Mr. Spillane was authorized to tell him that we would do so and those were my instructions to Mr. Spillane. Those records were finally taken back under the instructions and with the understanding in accordance with the same. Meanwhile, later on I found, however, that the price-cutting continued. I then again instructed Mr. Spillane to go up and see Mr. Gillam, and ascertain for me why, after I had taken back those records, after I had apparently met the objections and had covered the reasons for the price-cutting, the price-cutting continued. Mr. Spillane came back and reported that Mr. Gillam said that Mr. Percy Straus and his associates had decided to continue the price-cutting; that they were surprised at the advertising effect and that they proposed to sell such records as were not easily disposed of, and to offer them at cut prices. I then told Mr. Spillane that if that was the way R. H. Macy & Co. were going to deal with us, then I believed and considered they had not treated me fairly, and that I did not desire to do any more business with them, if they continued price-cutting, and especially in view of their treatment after I had tried to meet their objections in the manner already stated."

Offers His Three Reasons

Anent the conversations referred to, Mr. Blackman told of the meeting held in January, 1917, in the committee room of Interstate and Foreign Commerce Commissions in Washington, when he stated that Percy Straus, in the course of conversation explaining Macy & Co.'s methods of doing business, said, "that it was their custom to cut prices on well-known and advertised branded articles and at the same time to sell their goods in substitution. I recall many instances which Mr. Straus quoted which influenced me materially, and I could easily refresh my recollections on those cases."

In the course of the examination Mr. Black-

THE CABINET and ACCESSORIES COMPANY

Otto Goldsmith, President

145 East 34th St. New York City

We are
Sole Metropolitan Distributors
of
The CIROLA



Price Now, \$35.00

**Special Introductory Discount
to Dealers**

*Write or Phone for Representative
to call*

**Get All Your Accessories
from One Source**

- Lundstrom Converto Cabinets
- Record Albums
- Record Delivery Envelopes
- Hotrolas
- Record-Lites
- Fibre Needle Cutters
- Tonofone Needles
- Phonograph Cabinets
- Table Cabinets, All Kinds
- Talking Machine Toys
- Brilliantone Needles
- Fletcher Needles
- Red, White & Blue Needles
- Polishes and Oils
- Eject-O-File Cabinets
- Repeaters and Rotometers
- Wall-Kane Needles
- Record Cleaners
- Dust and Moving Covers
- Standard Phonographs
- Motor Spring Safety Device

All from One Source

man was asked: "Now just tell us what occurred or what Percy Straus said at that time," and answered:

"Percy Straus said that R. H. Macy & Co. sell the well-known advertised branded Cuticura Soap, which is sold elsewhere at 25c., for 18c. The cost is 17¼c., and the gross profit is three-quarters of a cent or less than 5 per cent of the transaction. Whereas they sold their own brand of similar soap at 12c., which cost 7½c., a profit of 4½c., gross." The handling of other advertised branded products was also referred to.

"One of the things that I was particularly interested in," said Mr. Blackman, "was his statement regarding B. V. D. underwear, because that was almost a household word. He stated that the B. V. D. underwear that was sold regularly elsewhere for 50c., they sold for 44c. The cost to them was 33 1/3c., the profit 10 2/3c., gross, or about 31 per cent, whereas Macy had an underwear of their own which he claimed was even better than B. V. D. and which they sold for 44c., and it cost Macy 30c., making a profit of 14c. against 10 2/3c. on the B. V. D., or a profit of 46 2/3 per cent."

It is also stated that figures had been offered to show that 12,000 pieces of Macy underwear had been sold as compared to 600 pieces of B. V. D. underwear. Continuing, Mr. Blackman said: "I have other illustrations, but the thing that impressed me mostly was that Macy

somehow seemed to have some of their own brand always ready for the customer to take the place of the advertised brand, and my mind ran in the talking machine direction and I was looking forward to the time, if it was not then present—I think it was at that time—when Macy would be more interested in selling their own brand of talking machines or some other talking machine than that in which I was interested, and I did not believe that their advertising was to the benefit of the advertised article, that it was for the purpose of substitution and would injure my business and had injured it."

Mr. Blackman told of his personal visits to the Macy store, and of his experiences with the sales service, which he declared was unsatisfactory. He also testified that the volume of Victor business handled by Macy each year had not progressed in volume to a satisfactory degree.

The Effects of Macy Advertising

The witness was asked if Macy's advertisements prior to April, 1917, had any or played any part in his reasons for declining to sell Macy. Mr. Blackman declared: "They had a great influence." Following along this line he repeated a Macy advertising statement published on April 21, 1912, reading as follows: "When, in a moment of desperation, others cut to meet our prices we, in turn, cut again, and as often as necessary to sustain the Macy reputation for underselling." There was also offered

PHONOGRAPH RECORD LABELS



That will meet the requirements of the manufacturer of Records. Our experience along this line assures you of the best of results, quality as well as artistic in design. We make record labels for some of the largest record manufacturers.

If we are not making any of the following Specialties for you we would be pleased to quote you as our experience enables us to give you the desired results.

KEYSTONE PRINTED-SPECIALTIES COMPANY

321-327 Pear Street
SCRANTON, PA.

—O—

Our Specialties—

- Phonograph Record Labels
- Gummed Stickers of large quantities
- Trading Stamps, etc.

—O—

MACY-VICTOR CASE NEARING CLOSE
(Continued from page 166b)

in evidence another Macy ad on May 24, 1915, reading: "Macy's is not bound by any agreement to sell Victor machines and records at prices fixed by manufacturers."

Mr. Blackman told of the alleged effect of advertising upon recognized dealers doing business with him, and cited one Macy advertisement announcing "A complete collection of the new November records," which announcement he declared tended to injure his trade. "In my opinion," said Mr. Blackman, "I was in a position where I either had to antagonize my trade and go Macy's way and help them in their attitude, or preserve my business and show good faith by refusing to sell Macy and doing everything I could because I did not believe in Macy methods."

The witness also told of the visits of Macy representatives in search of Victor goods, and particularly of conversations with Oliver and Gillam, Macy representatives, following the U. S. District Court's decision in favor of Macy in the suit over the Victor license agreement.

P. E. W. Carlson Testifies

Following Mr. Blackman, the next witness for the defense was Paul E. W. Carlson, manager of the wholesale Victor department of Charles H. Ditson & Co., who, in the course of his testimony, stated that his company had never sold goods to Macy and had, in fact, up to a very few years ago devoted the bulk of attention to the retail business.

Louis Buehn a Witness

The next witness was Louis Buehn, president of the Louis Buehn Co., Inc., Victor wholesalers of Philadelphia, who, in the course of his testimony, declared that he was opposed to selling to price cutters, and had had, moreover, no desire to sell to Macy & Co., because of the fact that the company's store was in New York and outside of what he considered the boundary of his legitimate territory as wholesaler, even though that territory was not definitely limited by any rule.

Following Mr. Buehn's testimony on March 1, the trial was halted temporarily owing to the illness of a juror which necessitated an adjournment until Saturday.

V. D. Moody on the Stand

On the resumption of the trial March 7 the principal witness was V. W. Moody, general manager of the Buffalo Talking Machine Co. and who was formerly connected with the New York Talking Machine Co. Several minor witnesses were also examined, and the court adjourned again until March 9, when several wit-

nesses, including two of the defendants, were called to the stand.

Clarence Price Testifies

The first witness was Clarence Price, manager of Ormes, Inc., New York, who testified that for a number of years his company was primarily a retail Victor house, and did little or no wholesaling, the jobbing business having been gone into in a big way only within the past few years. He testified, however, that Ormes, Inc., enjoyed the privileges of a jobber's franchise which had previously been held by Sol Bloom, the founder of the business which Ormes, Inc., now control.

The next witness was W. Wolff, who had been general manager of Ormes, Inc., before Mr. Price took the managership, and when the business was entirely a retail one. Mr. Wolff declared that during his regime no wholesale business whatever was done by the Ormes interests.

H. W. Weymann a Witness

H. W. Weymann, of H. A. Weymann & Son, Victor jobbers in Philadelphia, was on the stand for a brief period, and after giving some details regarding the shortage of Victor goods as his company had experienced it, brought out the fact that orders were not accepted from Macy & Co. because that concern was located outside the territorial boundaries observed by Weymann & Son.

Thomas F. Green an Interesting Witness

The last witness of the day was Thomas F. Green, president of the Silas E. Pearsall Co., who proved an interesting and at times entertaining witness. Mr. Green was very free with facts and figures regarding the business of his company, and offered considerable testimony to prove that a shortage of Victor goods had existed for a number of years. Mr. Green brought out the fact that a number of accounts distant from New York had been cut down, or eliminated altogether because the shortage of goods made it necessary to give chief attention to retailers in this section. He explained that although the volume of business handled by his company each year increased substantially between 1914 and 1917, and larger amounts of goods were received each year from the Victor factory, the demand from dealers increased even more rapidly so that the shortage of goods persisted.

Following Mr. Green's testimony, Mr. Blackman was called back to the stand to testify regarding certain sales figures.

Emanuel Blout on the Stand

On Friday morning, as The World goes to press, the witness was Emanuel Blout, Victor



IROQUOIS SALES CORPORATION
BUFFALO, N. Y.

Wholesale Distributors



Oké Records

distributor, of New York, who testified regarding the manner in which he conducted his business during the several years in dispute and in connection with the shortage of Victor goods during that period. It is expected that Mr. Blout will be the last of the jobbers to go on the stand, although the defense has several other general witnesses.

NOW MRS. DAVID SMITH

Janette Miller, of the phonograph department of Seiberling & Lucas, Portland, Ore., was married recently and is now Mrs. David Smith. This store reports business in the small goods department picking up considerably, the reason being the reopening of the lumber mills.

APPOINTED GRANBY DISTRIBUTORS

The M. M. Romer Sales Corp., of New York City, has secured the wholesale distributing rights for the Granby phonograph in the metropolitan district. This new distributor has opened a large number of new accounts for the Granby during the past few weeks.

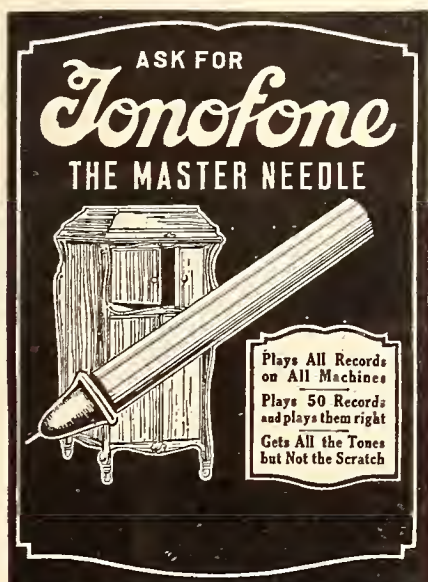

Write us for free samples!

EASTERN PHONOGRAPH CORPORATION

GEO. SEIFFERT, Pres.

Wholesale Distributors

OFFICES AND SHOWROOMS

101 West Twentieth St. }
100 West Twenty-first St. } Cor. Sixth Avenue

Telephone: Chelsea 2044

New York

Equip your Demonstration Machines with



And Watch Results

Write us for information

**MICA
DIAPHRAGMS**

Absolutely Guaranteed Perfect
We get the best India Mica directly.
We supply the largest Phonograph Manufacturers.
Ask for our quotations and samples before placing your order.

American Mica Works
47 West St. New York

TRADE NEWS FROM PORTLAND, ORE.

MacDougal Music Co. Opens New Store—
Opera Helps Record Sales—Recent Visitors

PORTLAND, ORE., March 8.—Business has been fair in Portland in February and the phonograph and record dealers have found, as the most encouraging sign of all the business, that persons who have been buying on contracts have resumed payments after getting far behind. The G. F. Johnson Co., Sherman, Clay & Co., Lipman, Wolfe & Co., Wiley B. Allen Co. and the MacDougal Music Co. all unite in reporting a fair business for the month. D. P. Peyton, of the phonograph department of the big Meier & Frank store, however, reports business far from being up to standard.

One big new store opened in Portland on March 1, or rather one store which was formerly in small quarters opened in new quarters much larger and finer than those occupied formerly. This is the MacDougal Music Co., which will handle primarily talking machines (the Columbia), records and sheet music and small goods. The new location is on Tenth street in the center of the retail district. The new store consists of three stories and a mezzanine, occupying 25 by 100 feet. Although the store opened for business March 1, the formal opening is set for later in the month after everything will have been made ship-shape. The heads of the concern are W. A. and R. S. MacDougal, brothers. C. H. Williams has been placed in charge of the phonograph and record department and Miss Octavia Stone in charge of the sheet music department. Miss Stone was formerly in a similar position with the Graves Music Co. in Portland.

P. T. Clay, president of Sherman, Clay & Co.; Richard Ahlz, of the purchasing department of the same company; Neil Wilson, general advertising manager of the San Francisco house, and George W. Bates, comptroller, last month visited J. M. Dundore, manager of the local house. Mr. Dundore showed a good report and they were pleased with the outlook for future business.

A. S. Cobb and G. R. Guppy, managers of the Spokane and Seattle talking machine departments of Sherman, Clay & Co., were also Portland visitors, and together with W. G. Gas-

VELVET COVERED TURNTABLES

ADD TO THE QUALITY OF MACHINES

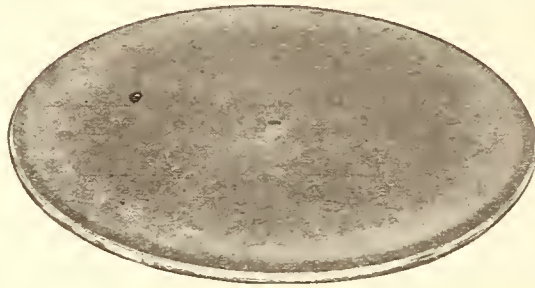

A.W.B.

Boulevard
VELVETS

THE BEST TALKING MACHINES ARE EQUIPPED WITH

A. W. B. BOULEVARD VELVETS

GRAND PRIZE—GOLD MEDAL, ST. LOUIS EXHIBITION

WRITE FOR SAMPLES AND PRICES

A. WIMPFHEIMER & BRO., Inc.
450-460 Fourth Avenue, New York

ESTABLISHED 1845

ton, traveling representative of the Victor Talking Machine Co., who was also in Portland, held a conference at the Sherman, Clay & Co. house with Manager Dundore.

The San Carlo Grand Opera Co., which played in Portland at the municipal auditorium for one week in February, created a great amount of interest in the Victor Book of the Opera. Sherman, Clay & Co., who handled the seat sale for the opera performances from their store, report the sale of these books as enormous and in far greater demand than last year during the grand opera season. Much of this is due to the work of Mrs. Evelyn McFarland McClusky, educational director of the Sherman, Clay & Co. store, who is stirring up interest in music appreciation among the people of Portland.

Patrons and friends of Sherman, Clay & Co. are being invited to a musical hour, which is held every week in the concert hall of this attractive store. The new favorite records are played with many request numbers. A monthly Victrola concert is also held, at which time the Red Seal records constitute the program. Mrs. McClusky is also in charge of this feature.

Milton E. Kieule, who was in charge of the phonograph department at the Edwards Furniture store, has resigned his position to go into business with his father and brother, who have a well-established music store at Newberg, Ore., a thriving little town up the Willamette Valley. They have the agency for the Victor, Columbia and Brunswick machines and carry

a good line of pianos, and have also a complete small goods department.

J. H. Martin has succeeded Mr. Kieule as manager of the Edwards phonograph department, which carries a full line of Brunswick machines.

J. D. Fleming is again with the Bush & Lane phonograph department, having returned from Seattle. Mr. Fleming will assist Harold Raynor and H. Ben Street in this busy department.

VICTOR CO. APPEALS STARR CASE

The Victor Talking Machine Co. has announced that an appeal will be taken from the recent decision of Judge Learned Hand in the United States District Court in New York against the Starr Piano Co., involving the Johnson cut record patent.

Albert Lindo, who handles the Victor line in the Canal Zone, Panama, with headquarters at Ancon, is spending a short vacation with his family in New York City.

The executive office employes of the Columbia Co., New York, held a dance on Friday evening, March 11, at the Hotel McAlpin. It was a gala event and largely attended.

Hugh Bryce has opened a musical establishment at 362 South Broad street, Trenton, N. J., and handles the Columbia machines and records.

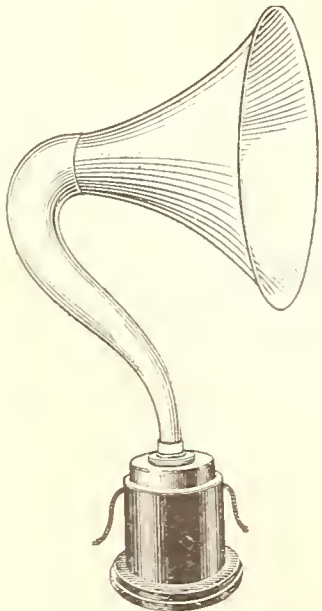

PLAIN PLAYING UNIT

**PHONOGRAPH MUSIC, OVER A WIRE REPRODUCED,
AMPLIFIED, TRANSMITTED ELECTRICALLY**

Big, round, full tone.
Electric Arm attaches to any phonograph without tools.
Playing Unit has 12-inch aluminum horn.
Needle noise inaudible.

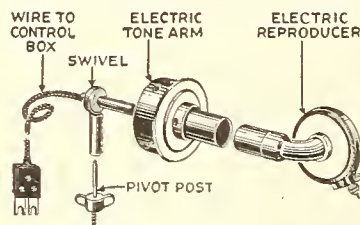

Volume Control.
Tone quality superb.
Rich, full, natural.
Operates on small storage battery.
Can be heard mile away in the open.

Reproduces all there is on the record. **For Homes, Churches, Dancing, Clubs, Schools, Restaurants, Dance Halls, Sea Shore, Summer Resorts, Porches, Gardens, Motor Boats.** **New possibilities** for the phonograph.
Live dealers secure exclusive territory. **Fully guaranteed.** **Retail Price,** only \$150.00. **Lamp complete,** without shade, \$220.

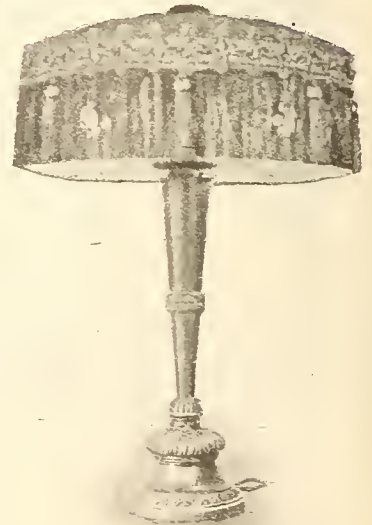

INSTALLED IN LAMP

VITALIS HIMMER, Jr.

205 Sixth Ave., New York

The Value of Display

F. W. Woolworth made millions of dollars in his 5 and 10 cent store business. He built the Woolworth Building downtown in New York, the tallest office building in the world, which stands as a monument to his success.

His success was accomplished by displaying the goods he had to sell.

Properly displaying goods is one of the sure methods of making a sale.



No. 567

Universal Displayors

Save room and present your records to your customers in a most appealing way.

They move the records which have been pigeonholed and forgotten.

They sell new goods without the aid of a salesman.

They offer a self-service to your trade which your trade likes.

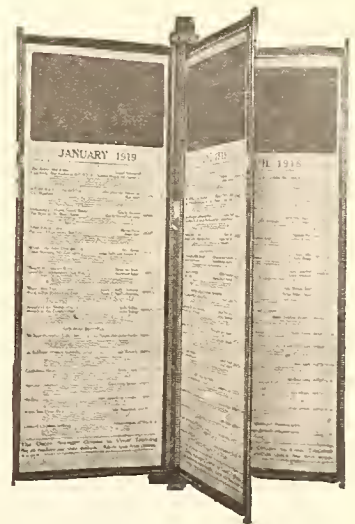

No. 558



No. 551

Fifty different models that fit every need in the phonograph record store, for the display of records, music rolls and sheet music. One catalogue shows the whole list, free for the asking. A postal card will bring it.

Universal Fixture Corporation

133 WEST 23rd STREET, NEW YORK CITY

A. G. KUNDE'S NEW ENTERPRISE

Prominent Milwaukeean Secures Importing and Distributing Rights for Homokord Records, Which He Is Now Introducing to the Trade.

MILWAUKEE, WIS., March 5.—As briefly stated in last month's issue of The World, A. G. Kunde, of this city, has secured the importing and distributing rights for the Homokord records, made by the Homophon Co., of Berlin, Germany. Mr. Kunde, who recently discontinued jobbing Co-



A. G. Kunde

lumbia machines and records for Milwaukee and Milwaukee County, last week sold his retail store at 516 Grand avenue to the Winter Piano Co., of this city, who will continue to do business under the name of the Grafonola Shop and will handle the Columbia product as in the past.

Mr. Kunde has secured the entire third floor of the building at 297 Third street, with a floor space of about 5,000 square feet, and is rapidly getting it into shape for his new wholesale Homokord record business. The Homophon Co. makes singing and speaking records in thirty-four different languages and dialects, namely, German, English, Scottish, Irish, Kaffir dialect, Austrian, Hungarian, Croatian, Slovene, Ruthenian, Russian, Little Russian, Tartar, Polish, Spanish, Flemish, Galician, Basque, Argentine, Creole, Mexican, Portuguese, Brazilian, Italian, Holland, Danish, Roumanian, Serbian,

Arabian, Moroccan, Yiddish, Hebrew and Ukrainian.

It is Mr. Kunde's desire to accumulate a large working stock of the records at first. The new quarters on Third street are being fitted up and the stock being got in shape. They expect to be ready to make deliveries from stock in America to the general trade about April 15. He is furnishing the trade with an original catalog and will commence in a week or two the issuance of monthly record bulletins.

In writing this story the writer has been telling what Mr. Kunde has done, and in referring to the activities of the Kunde concern has been using the pronoun "he" instead of "they." Now, enter Mrs. Kunde. She has been his helpmate not only in life, but in business, ever since he started in the talking machine business in Milwaukee some twelve years ago. She is a finely educated woman and knows all about music, literature and art, but she has got honest-to-goodness commercial sense, too. She has been a big factor in the upbuilding of the Kunde business and Mr. Kunde fully recognizes it. Fine team work this merry couple are doing. There are some



Mrs. A. G. Kunde

little Kundes, too, and it is a marked example of both Mr. and Mrs. Kunde's executive ability that the junior members of the family have not been neglected while a very remarkable retail and wholesale business was built up, which, with the money made and the experience gained, forms the basis for the house of A. G. Kunde.

Equip Your Phonographs

with Triangle tone arms and sound boxes

and raise the standard of your product.

The Triangle is a perfect sound reproducing combination. Harsh and metallic sounds so common to the average tone arm and sound box are entirely eliminated. Only a trial can prove to you the sterling quality of this tone arm and sound box. It is a marvel of beauty with a surprising and wonderful tone, clear as a bell. Every detail of the record is brought out in a marvelous manner.

Manufactured in two lengths, 8 1/4" and 9", in both nickel and gold finish.

We make everything for the phonograph manufacturer except the cabinet—motors, tone arms and cabinet hardware, samples upon request.

Triangle Phono Parts Company

722 Atlantic Ave., Brooklyn, N. Y.

NEW STORE IN LANSDOWNE, PA.

M. E. Luckenbach to Handle the Vocalion Phonograph and Melodee Music Rolls

LANSDOWNE, PA., March 10.—M. E. Luckenbach has opened a music store to be known as the Music Shop in this city. It is located at 33 South Lansdowne avenue, in the old Post Office Building, and is to be an exclusive Vocalion shop, also handling Melodee player rolls, which are likewise made by the Aeolian Co. Mr. Luckenbach has over fifteen years' musical instrument and talking machine experience, starting in when he was practically a boy with Godfrey at Atlantic City. A few years later he moved to Philadelphia and secured a place with Weymann & Sons, where he was connected both with the talking machine and musical instrument department and was very successful, becoming manager of their wholesale department.

It has always been his desire to have a store of his own and the opening of the new store in Lansdowne is the result of that intention. He is most enthusiastic about the Vocalion and within two or three days after the opening of the store had sold one instrument and practically closed the deals for three other Vocalion prospects, to say nothing of a lively business on the new Red Vocalion record.



HERE IT IS

The

FLETCHER UNIVERSAL TONE ARM and REPRODUCER

Gives Proper Playing Weights for all Records. No Adjustment Screws or Springs.

SAMPLES \$8.00 Specify 8 1/2" or 9 1/2" arm

FLETCHER-WICKES CO., 6 East Lake Street, Chicago, Illinois

THE GEORGE McLAGAN FURNITURE CO., STRATFORD, ONTARIO, EXCLUSIVE CANADIAN AGENTS

PETITIONED INTO BANKRUPTCY

Receivers Appointed for the Cathedral Phonograph Co. in the U. S. District Court of Omaha on February 25—Assets Scheduled to Be Sold by Receiver's Order on March 11

CHICAGO, ILL., March 8.—A petition in bankruptcy was filed against the Cathedral Phonograph Co. in the United States District Court of Omaha on February 25. The petitioners include the Universal Stamping Co., Warren Veneer & Panel Co., Mohawk Veneer Co., and the Alemite Die Casting & Mfg. Co. The receivers appointed for the Nebraska district at Omaha are: E. L. Akres, president of the company, and Harry Hildreth, Jr., treasurer. The receivers intend, if possible, to continue the business, as they have nearly three thousand cabinets on hand. Edwin D. Buell was appointed receiver for the Northern District of Illinois, Eastern division and Nebraska. Ancillary receivers were appointed for the Northern District of Ohio.

Latest reports are to the effect that the assets of the Cathedral Phonograph Co. are scheduled to be sold at public auction on Friday, March 11, at the Consumers Building, this city, by S. L. Winternitz & Co., by order of Edwin D. Buell, receiver.

WIDE RANGE OF PRODUCTS COVERED

The Fred Gretsch Mfg. Co. Issues Confidential Trade Price-List of Musical Merchandise

The Fred Gretsch Mfg. Co., Brooklyn, N. Y., manufacturer and wholesaler of musical merchandise, has just issued a confidential trade price-list covering the Spring of 1921. This book represents the result of days of careful concentration and much detail work and presents to the trade a remarkably wide range of musical merchandise with the latest prices. The strong spirit of co-operation manifested by the Fred Gretsch Mfg. Co. to its dealers is summarized on the first page of this book in referring to the prices therein. "Whenever we make a saving in the cost of production we give our customers the benefit."

The Fred Gretsch Mfg. Co. also produces the Violaphone which it describes as "the talking machine with the violin tone." The new model, known as style 100, has been recently introduced to retail at a popular price. It contains the distinctive features of the Violaphone line of talking machines.

IMPORTANT TRADE ANNOUNCEMENT

Emerson Phonograph Co. Sends Out Letter Denying Malicious Rumors

The Emerson Phonograph Co. sent out an important notice to its trade this week relative to certain rumors which have reached the company's executive offices regarding its financial affairs. This announcement read in part as follows:

"We desire to take this opportunity of calling to your attention certain unfounded and malicious rumors that have been circulated in regard to the Emerson Phonograph Co. These are to the effect that this company is liquidating its affairs and going out of business.

"These rumors are not only unfounded, but are absolutely untrue. The best answer to these unfounded rumors is the fact that during the receivership new releases have been issued with the same regularity and promptness as heretofore, and that there has been no let-up in the supply of Emerson records required by our distributors and dealers.

"In order to put a stop to these reports, we ask the co-operation of our jobbers and dealers by immediate notification as soon as any of these rumors are brought to their attention and, if possible, with information as to their source. We are particularly anxious to trace the responsibility for these statements and will deal with those responsible in such manner as we deem necessary under the circumstances."

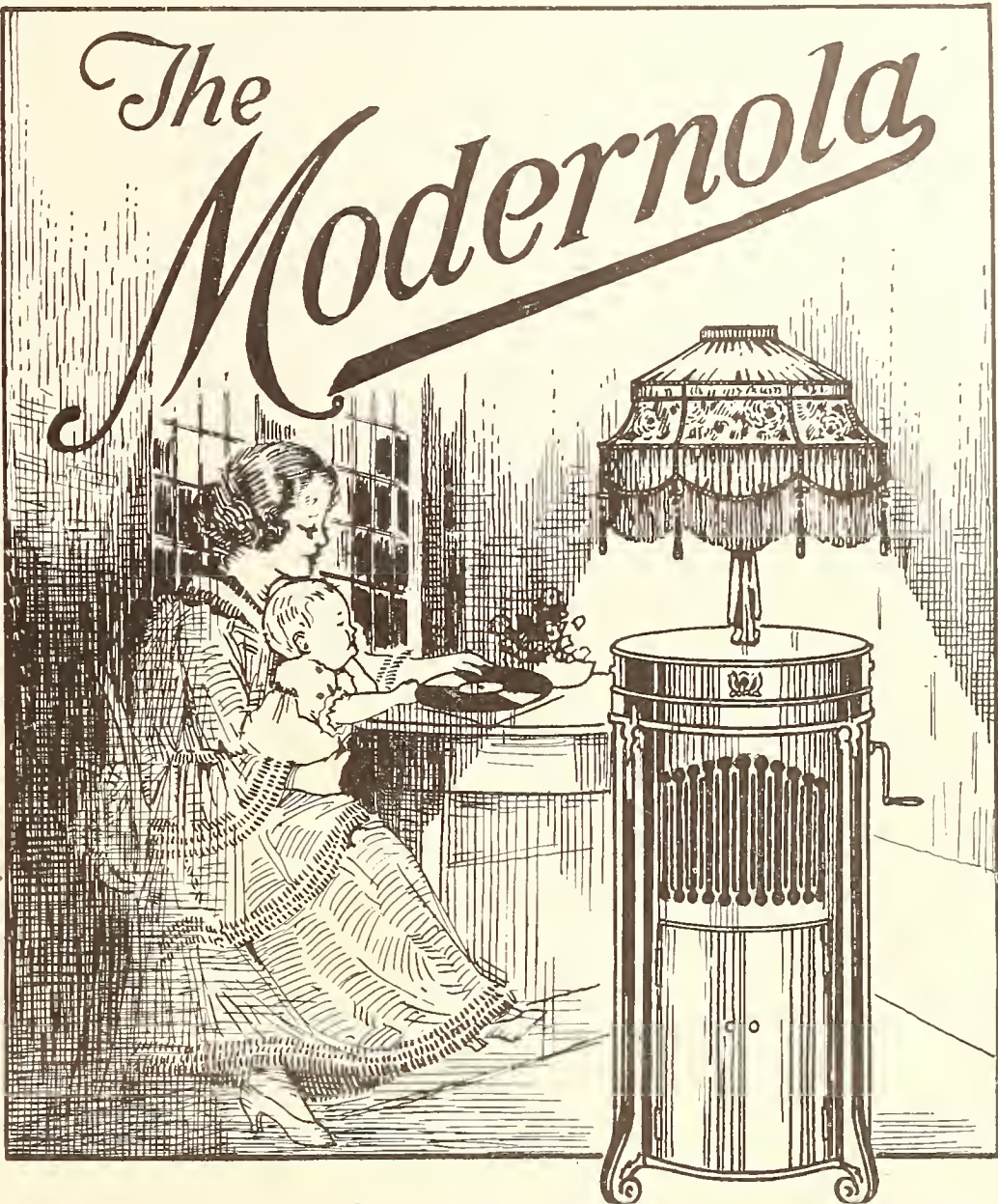

MODERNOLA

Features

TONE

BEAUTY

UTILITY

Retailers of the Modernola are finding 1921 a big year.

There is an irresistible charm about this phonograph in both tone and appearance that has placed it among the leading makes.

Write us regarding Modernola representation in your locality.

Exclusive Eastern Distributors

EASTERN PHONOGRAPH CORPORATION

GEO. SEIFFERT
PRESIDENT

Office and Showrooms:

101 West 20th Street }
100 West 21st Street } Corner Sixth Avenue, New York
Telephone Chelsea 2044

NEW PARAMOUNT DISTRIBUTORS

Burton H. Corbett Appointed Pacific Coast Manager—New Jobbers Appointed in Cleveland, O., and in Baltimore, Md.—Important Moves

CHICAGO, ILL., March 9.—The Paramount Co., Port Washington, Wis., has appointed Burton H. Corbett Pacific Coast sales manager for Paramount phonographs and records. Mr. Corbett has been connected with the talking machine trade for the past twenty years and is considered an expert on merchandising.

The Paramount Co. also announces the appointment of the Widman Co., Cleveland, O., as distributor for Paramount phonographs and records for northern Ohio, and of the American Wholesale Corp., Baltimore, Md., as distributor for Paramount records. Both concerns stand high in their respective territories.

INDEPENDENT CO. FILES SCHEDULES

Liabilities of New York Concern Given as \$301,662—Assets Are \$198,435

The Independent Talking Machine Co. of Manhattan, Inc., New York, has filed schedules in bankruptcy with liabilities of \$301,662, and assets of \$198,435, the main items of which are stock, \$59,200, bills, etc., \$14,970, furniture, fixtures, machinery, etc., \$2,350, accounts, \$113,301, and deposits in banks, \$7,007. There are four secured creditors named for a total of \$36,000.

ERNEST C. SCHEFFT HONORED

MILWAUKEE, WIS., March 10.—Ernest C. Schefft, head of Charles H. Schefft & Sons, a leading Northside Victrola shop, has been elected vice-president of the Upper Third Street Advancement Association, which was organized four years ago and now has a membership of more than one hundred. The purpose of the Association is to promote the civic and commercial advancement of this neighborhood.

WILL FEATURE POLISH RECORDS

Polonia Phonograph Co., Milwaukee, Elects Officers and Establishes Plant

MILWAUKEE, WIS., March 9.—The Polonia Phonograph Co. of this city held a meeting of the stockholders yesterday and elected the following officers: C. P. Dziadulewicz, president; L. A. Pions, vice-president; F. X. Swietlik, secretary; C. A. Krzewinski, treasurer, and S. J. Zowski, director. All the new officers are prominent business men of Polish birth or ancestry, and the company has built and equipped a pressing plant at the foot of Grove street, Milwaukee, and has established a laboratory in New York City. The company is now producing characteristic folk songs and instrumental numbers of interest to the general public as well as to Polish people.

FEATURING THE PERIOD STYLES

Bloomington Bros. Have Excellent Window Display of Those Models

An unusually attractive window display devoted to period models was recently shown by Bloomington Bros., the well-known department store of New York City. The talking machine department of this store, which carries Victrolas, Sonora, Brunswick, and Columbia machines, has for some time past made a feature of these art styles and the giving over to a window for the special display of such machines is in line with the campaign they had inaugurated to make their store a center for such styles.

H. K. Berkely, manager of the talking machine department of Bloomington Bros., intends to make the department the most complete period model display in the city. His firm has adopted the slogan, "Anything and Everything for Your Phonograph at Bloomington's." In a statement to The World he said: "Business during the past few weeks has been most satisfactory and the increased activity shows a greater interest as well as sales. We have been very fortunate in presenting period models to the public and our recent window display was a means of creating purchases for the goods displayed. We think the coming season will be one of great activity for period models."

THE VOCALION IN CAMDEN, N. J.

Samuel Kotlikoff, who has a music store at 3406-08 Federal street, Camden, N. J., has been appointed Vocalion agent. He has two demonstrating booths and is doing very well with the Vocalion line. Mr. Kotlikoff is one of the oldest merchants in the city of Camden.

MOTROLA GROWS IN FAVOR

KANSAS CITY, Mo., March 8.—The distributing branch of Jones-Motrola, Inc., located at 1104 Walnut street, this city, has experienced an entirely satisfactory demand for this electric winding device in its territory. This organization now covers the States of Missouri, Kansas, Nebraska and Iowa. B. A. Silliman, manager of the company, has thoroughly recovered from an attack of ptomaine poisoning and is now on a trip through his territory covering the States of Iowa and Nebraska.

ACME-DIE
- CASTINGS -
 ALUMINUM-ZINC-TIN & LEAD ALLOYS
Acme Die-Casting Corp.
 Boston Rochester Brooklyn N.Y. Detroit Chicago

INTRODUCES DISPLAY STAND

Mirrolike Mfg. Co. Furnishes Dealers With Attractive Counter Display

The Mirrolike Mfg. Co., Long Island City, N. Y., manufacturer of Mirrolike polish, is offering its dealers an attractive counter display stand for bringing to the attention of the trade its Mirrolike polish for talking machines.



K. Sandhop, president and general manager of the company, states that the growth of the Mirrolike polish business has been extraordinary the past year. Dealers everywhere are very enthusiastic about the results obtained from the use of this polish and new clients are being steadily added to their already large list.

The growth of the company is reflected in the fact that it is now making preparations to move into a new and modern factory, where it will be able to take care of an increased business. Mirrolike polish has been advertised extensively by this company throughout the country for the past five years and the use of the "Mirrolike Kids" is a distinctive feature of this advertising. In addition to the talking machine polish the company is to announce very shortly a lubricating oil for talking machine motors which should meet as ready a demand as the polish.

COMPLETES EASTERN TRIP

L. Levenson, secretary of the Player-Tone Talking Machine Co., Pittsburgh, Pa., was a recent visitor to New York, calling at the offices of The World. He just completed an Eastern trip, and has closed several important deals which will be announced in detail in the near future. There have just been added to the Player-Tone line two art models which are meeting with considerable success, and in order to take care of its fast-growing business the company recently opened a branch at Jamestown, N. Y.

MAIN SPRINGS

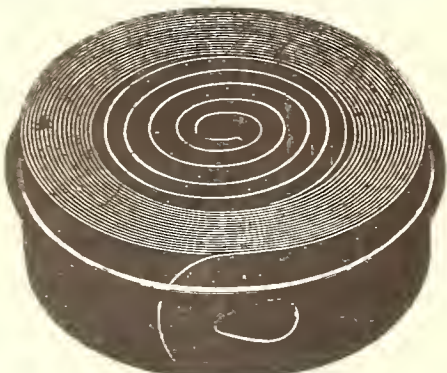

Order Right From This Ad.

FOR ANY PHONOGRAPH MOTOR

Dependability is tempered right into C. & D. crucible main springs. Our main springs are made under one roof—from the rolling of the steel to the winding of the spring. Each piece of steel that leaves the mill has passed the inspection of a specialist. This assurance of quality is protection to both you and your customer.

FOR VICTOR MOTOR

- No. MSA18—7/8 inch wide, .025x10 feet long, marine end 55c.
- No. MSA 1—1 inch wide, .023x12 feet long, marine end 60c.
- No. MSA 2—1 1/4 inch wide, .023x18 feet long, marine end 95c.

FOR COLUMBIA MOTOR

- No. MSA21—25/32 inch wide, .025x10 feet long, marine end 55c.
- No. MSA22—29/32 inch wide, .023x11 feet long, marine end 55c.
- No. MSA 3—1 inch wide, .028x10 feet long, marine end 55c.

FOR HEINEMAN MOTOR

- No. MS21—25/32 inch wide, .025x10 feet long, marine end 55c.
- No. MSA6—1 inch wide, .025x12 feet long, marine end 60c.

FOR KRASBERG, SAAL, SONORA, STEVENSON OR THOMAS MOTORS

- No. MSA8—1 inch wide, .026x13 feet long, square hole 60c.
- No. MSA9—1 inch wide, .026x16 feet long, square hole 75c.

FOR OTHER STANDARD MAKES

- No. MS17—3/4 inch wide, .025x10 feet long, marine end 56c.
- No. MS18—7/8 inch wide, .025x10 feet long, marine end 55c.

NOTE

Every main spring for which there is a consistent demand is listed here on this page. Many of these springs are interchangeable, for example, springs that are listed for Victor and Columbia motors can be used for Patbé, Swiss, Edison and many miscellaneous motors, etc. These prices are F. O. B. Chicago. Send enough to cover postage if wanted by parcel post, or we will ship by express.

COLE & DUNAS MUSIC CO.
 52 W. Lake St., Chicago, Ill.

Order Right From This Ad

Main springs are carried in stock for immediate delivery. Order right from this Ad. Terms—5% discount for cash in full with order, or net C. O. D. 10% deposit with order. 48-HOUR DELIVERY.

HERE AT LAST—A Phonograph of Supreme Quality

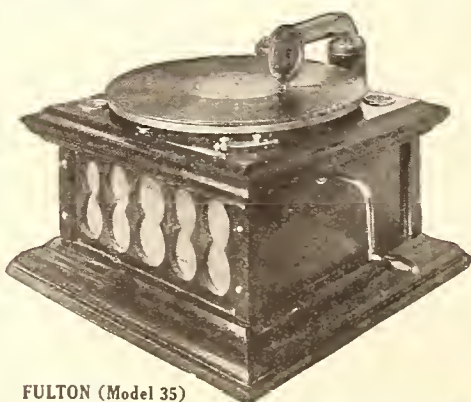

FULTON (Model 35)

Mahogany, 16x16x10 in., double spring motor, universal tone arm. Back casting and metal horn.

Price for Sample NOW \$15.75

Write for discounts in quantity lots.

We are also Wholesale Dealers and Jobbers of—
Phonographs, Records, Cabinets, Motors, Tone Arms, Needles and Accessories, Repair parts for all makes.
 Distributors of the Arto Phonograph Records and Arto Music Rolls. Write for details.

Cash with order

FULTON TALKING MACHINE CO.
 253-255 Third Avenue New York City
 Between 20th and 21st Streets

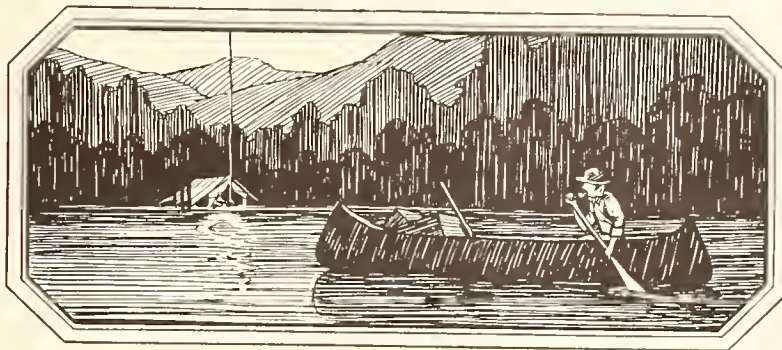

Quietness

Quietness in the operation of the Stephenson Precision-Made Motor is not a matter of chance, but, rather, a result of sound engineering and right manufacturing. The triple thread worm of the Stephenson Motor, by allowing the maximum number of teeth to be constantly engaged with the fibre gear, reduces noise, reduces vibration to a minimum. The wind of the motor is smooth and even; the familiar click as the ratchet drops into place has been eliminated. Both in design and manufacture of this motor, all possible has been done to make its operation quiet; all possible has been done to make it truly a Precision-Made Motor.

STEPHENSON
DIVISION
DE CAMP & SLOAN INC.
One Hundred and Seventy Pennington Street
Newark, New Jersey



MANUFACTURERS OF THE STEPHENSON PRECISION-MADE MOTORS AND TONE ARM AND SOUND BOX

NELSON TAKES CHARGE IN ATLANTA

Becomes District Manager of the Phonograph Division of the Atlanta Branch of the Brunswick-Balke-Collender Co.

CHICAGO, ILL., March 10.—Richard M. Nelson was appointed, the early part of March, to the position of district manager of the phonograph division, Atlanta branch, of the Brunswick-Balke-Collender Co. He will represent the Brunswick wholesale interests in Georgia, Alabama, Florida and South Carolina, working out of Atlanta.

He left Chicago the first week in March for

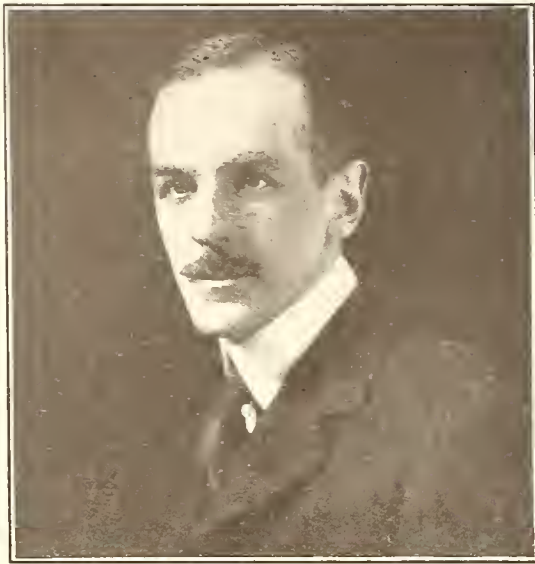

Richard M. Nelson.

a short stay in St. Louis, where he familiarized himself with the modus operandi of the Brunswick branch office in that city. Later he left for Boston and was joined by Mrs. Nelson on his way to Atlanta. He took up his active duties as district manager shortly before the middle of March.

Mr. Nelson has had an extensive experience in the talking machine industry and his activities have covered the retail, wholesale and manufac-

Pat. Dec. 1, 1919—2 other patents appl'd for.

The New Automatic Cover Support

Noiseless in Operation Foolproof in Construction
 Made With Both Bent and Flexible Hinges
 Heavily Nickel Plated or Specially Finished to Order
 Send \$1 for 3 samples—one of each model
 WRITE FOR CATALOGUE

A. F. Zega Mfg. Co.

Main Office: 810 Broad Street, Room 601, NEWARK, N. J.

Factory: 77-81 Mill Street, BLOOMFIELD, N. J.

turing ends. For two years he was president of a chain of retail stores in New England. Following this, for three years, he was general manager of an important wholesale institution operating throughout New England. Later he was vice-president and general manager of a concern manufacturing talking machines. The variety of his past experience should, therefore, stand him in good stead in his new work.

USES MAGNAVOX TO ADVANTAGE

Columbia Dealer in New England Carries Out Unique Idea—Bert Williams and Magnavox Make a Successful Combination

The Grafonola Shop of Boston, well-known Columbia dealer, carried out a unique idea recently with the Magnavox during the appearance of the "Broadway Brevities" in Boston. Bert Williams, exclusive Columbia artist, who is appearing in the "Brevities," also participated.

A Magnavox Telemegafone was installed in the lobby of the theatre, and the transmitter was wired back to Mr. Williams' dressing room. While he was getting his make-up ready for the show he ran a rapid fire of conversation with the people coming into the theatre something like this: "Good evenin', folks! Bert Williams is talkin'. How're yo' all? Jes gettin' ma duds on—see yo' all a little later inside the show,"

etc., etc. In addition a number of Columbia records by Bert Williams were played, all of which contributed to the success of the idea. Incidentally, the sale of Bert Williams records increased several hundred per cent in Boston territory.

SHERMAN REOPENS NEW QUARTERS

Now Occupying New Building at 2138 Third Avenue—Formally Opened March 5

S. A. Sherman, the enterprising Victor dealer at 2138 Third avenue, New York City, whose quarters were completely destroyed by fire in December, held a formal opening on March 5 to 12 of his new Victrola and sporting goods salesrooms. Mr. Sherman has a very imposing line of Victor talking machines, records and other specialties on display at the above address and reports a steadily increasing patronage which his enterprise so justly merits.

SEEN ON THE BOARDWALK

Jerome Harris, secretary of C. Bruno & Son, Victor wholesalers, New York City, was recently seen on the boardwalk at Atlantic City, accompanied by Mrs. Harris. Mr. Harris took a few days' well-earned respite from his many duties at this popular resort.

85c NEW CARDINAL RECORDS 85c
NOW READY FOR DELIVERY

10—NEW CARDINAL RECORDS—10
ALL HITS

<p style="font-size: small;">The Phonograph With The Tongue</p>	<p>2019 { STRUT, MISS LIZZIE.....By Ernest Hare I'M A LADIES' HOME COMPANION By Fred Whitehouse</p> <p>2020 { BRIGHT EYES.....By Raderman's Orchestra BROADWAY ROSE..By Raderman's Orchestra</p> <p>2022 { THAT OLD IRISH MOTHER OF MINE By Charles Harrison THAT TUMBLE-DOWN SHACK IN ATH- LONEBy Charles Harrison</p> <p>2023 { ROMANCE.....By Waldorf-Astoria Orchestra MARGIEOrlando's Orchestra</p> <p>2025 { DEENAHRaderman's Orchestra MAZIERaderman's Orchestra</p> <p>2027 { YOU OUGHT TO SEE MY BABY By Ernest Hare LOVELESS LOVE.....Ernest Hare</p>	<p>2028 { COOK IN THE KITCHEN—Medley of Irish ReelsBy Tom Ennis LITTLE JUDY—Medley of Irish Reels By Tom Ennis</p> <p>2029 { TRIM THE VELVET—Reels....By Tom Ennis HUMORS OF BANDON—Irish Long Dance By Tom Ennis</p> <p>2030 { WRAP THE GREEN FLAG 'ROUND ME, BOYS—Irish Song Patriotic Sung by Hugh Donovan SINN FEIN AWAIIN—Irish Song Patriotic Dennis O'Hara</p> <p>2031 { NOW I LAY ME DOWN TO SLEEP—Quartet New Stellar Quartet DOWN AROUND THE 'SIP 'SIP 'SIPPY SHORE—Quartet....New Stellar Quartet</p>	<p style="font-size: small;">The Record That Talks</p>
-----------------------------------------------------------------------------	---------------------------------------------------------------------------------------------------------------------------------------------------------------------------------------------------------------------------------------------------------------------------------------------------------------------------------------------------------------------------------------------------------------------------------------------------------------------------------------------------------------------------------------------------------------------------------------------------------------------------------	------------------------------------------------------------------------------------------------------------------------------------------------------------------------------------------------------------------------------------------------------------------------------------------------------------------------------------------------------------------------------------------------------------------------------------------------------------------------------------------------------------------------------------------------------------------------	--------------------------------------------------------------------

Jobbers and Dealers—Write for Information

CARDINAL PHONOGRAPH CO.
106 EAST 19th ST., NEW YORK CITY
FACTORIES — NEWARK, OHIO — ZANESVILLE, OHIO — PT. PLEASANT, N. J.

Dr. Crane Defines the Ten Commandments of Salesmanship for Talking Machine Men

One of the most interesting and helpful addresses delivered before a trade organization for many moons was the talk given recently by Dr. Frank Crane, the noted publicist, at the meeting of the Talking Machine Men, Inc., in New York City. Dr. Crane chose for his subject the Ten Commandments of Business and in the course of his address emphasized the following points:

"The first commandment of all is 'Be agreeable.' The best thing you have to sell is your disposition and the beauty of it is that you make the greatest profit on it because it doesn't cost you anything at all and you sell it for all kinds of money. No matter what other merchandise you have, if you haven't any agreeableness to sell, why, you are going to have hard work selling it.

"For instance, I may wish to buy a shirt. There are two haberdasheries along the street. I look over the shirts at one and the salesman is grouchy and indifferent and snippy, and the other one is pleasant and good-natured and human. I will buy from the second man even if the shirts are not as good. I want salesmen first of all to be agreeable—not too agreeable, not too darned agreeable.

"Did it ever occur to you why women like to shop? Women don't particularly shop when they need anything. They shop as a pastime. Most of them like to shop because they want to get away from home. They may be abused around home and people are tired of them and they are tired of the old man. They like to go into a store where they will be treated

pleasantly. That is the reason they go to see you; and, for heaven's sake, be pleasant to them. It is cheap enough and you may sell something in the meanwhile.

"The second commandment is, 'Know your business.' If there is anything I don't like when I go to buy anything of a man it is to ask him a question and have him say, 'I don't know.' He ought to know all about it.

"It is very irritating when you ask a man about something and he says, 'I don't know.' He ought to know—it is his business to know. You are selling talking machines, for instance, and if I ask you what is the difference between the Edison and the Victrola, don't shrug your shoulders and say, 'It is just a trade-mark,' because it isn't, you know. I happen to know the difference. You ought to know it. It is a different kind of a thing entirely, different scheme. You ought to know that. I went into a talking machine store and was told the difference by a salesman. Whether he told the truth or not I don't know, but it was interesting. I enjoyed it. He said that one of the machines went up and down and the other went sideways. That interested me right away. He put up an awfully good bluff, whether it was so or not. You can do that if you will remember that when you are in business one of the first things you want to do is to make use of every opportunity to improve your mind.

"That is what a salesman ought to be doing all the time—he ought to be studying. You waste enough time every four years to get another college education. Let me tell you that

a man's efficiency depends almost entirely upon what is in his 'bean.' There isn't any man in the world worth more than a dollar and a half a day from his chin down. But from his chin up he is just worth anything at all. That is what counts.

"The third commandment is, 'Tell the truth.' You notice that these are all old commandments—there is nothing new about them, but the old things are what count. I don't tell you to tell the truth because you will go to heaven or because it is a pious thing to do, but because it pays, and the reason it pays is that it is according to the law of averages. Some of you may play poker once in a while. You know that the good poker player, the man who wins steadily year in and year out is the man who watches the averages and the fool poker player who loses his money is the man who takes a chance.

"So, why waste time lying? The simplest thing is to tell the truth. If you are in a business where you can't tell the truth, quit. That is all. I would not work for any man, I don't care who he is, or any concern which requires me to tell a lie, because it doesn't pay him. He is a fool if he thinks it does. There are plenty of businesses that don't require lying. If you have got it in your head at all that lying is necessary just cut it out. It isn't.

"The fourth commandment is 'Don't argue.' If I say something never try to prove to me that I am wrong. If I tell you that the hummingbird machine is better than yours, don't

(Continued on page 175)

The Brooks Automatic Repeating Phonograph

is justly termed The Wonder Instrument. It has all the good

qualities of other high grade makes, but is completely put in a class by itself by virtue of the inbuilt Repeating Device, which enables the operator to play any make of record, any desired number of times.



Model 145

DEALERS
There are some communities where the BROOKS is not represented effectively as yet. Write us at once regarding your territory. We are planning a sales campaign of wide scope this year and large distributors and dealers will find the acquisition of the BROOKS line a big factor for business volume during 1921.

THE REPEATING DEVICE

The Brooks Automatic Repeating and Stop Device is an exclusive Brooks feature. It gives this phonograph a broader scope than any other make and requires no attention beyond setting the needle and turning a little knob. It is to the phonograph what the self starter was to the automobile.



Model 165

Shown are three Brooks models of different sizes, all beautifully carved and finished. Each style is identically equipped with the repeating and stop device.

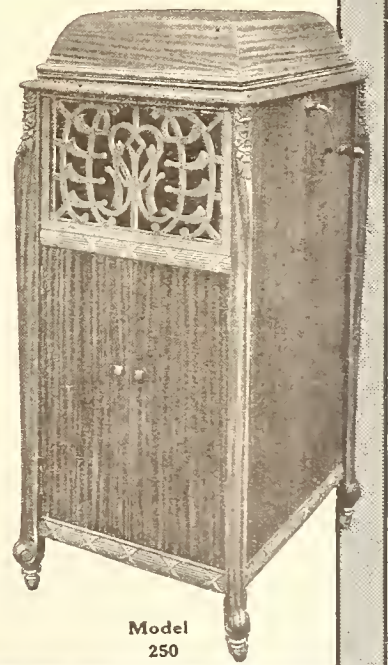

Model 250

Brooks
The Wonder Instruments

Automatic Repeating
Phonographs

BROOKS MANUFACTURING COMPANY, SAGINAW, MICH.

IMPORTANT NOTICE

TO THE AMERICAN TRADE

The Sterno Manufacturing Company
19 CITY ROAD LONDON, E. C. ENGLAND

Manufacturers of the world known COMPACTOPHONE—the most complete portable gramophone extant—beg to announce the conclusion of arrangements for the EXCLUSIVE SELLING RIGHTS IN THE UNITED STATES OF THE

High Grade Motors Manufactured By **Mermod Freres** St. Croix Switzerland

WONDERFUL MECHANISM

These motors represent the acme of workmanship and quality. Each part is made to the finest gauge limits and assembled to run with the precision of a watch—silent and true. Messrs. Mermod Freres is an old established Swiss manufacturer. Back of their motors are years of hard practical experience. The experimental stage was left behind a decade or more ago. Reliability and quality are therefore assured.

DIFFERENT MODELS

Mermod Freres motors comprise several types—single and double spring worm and pinion-gear drive, the very latest and scientific method of construction.

CONSULT US

Before placing your orders elsewhere consult us as to prices and terms of trading. We are out for quick shipments and prompt delivery direct from the factory to the buyer.

SPECIAL TERMS TO JOBBERS

Within the near future it is proposed to establish
A CENTRAL DISTRIBUTING DEPOT IN NEW YORK
Meanwhile trade inquiries should be directed to

THE STERNO MANUFACTURING CO.
19 CITY ROAD LONDON, E. C., ENGLAND

Nora Bayes sings "Why Worry," from *Her Family Tree*, and "Just Snap Your Fingers at Care," from *The Greenwich Village Follies*. You can take her advice if you order enough. A-3360.

**Columbia Graphophone Co.
NEW YORK**



TEN SALESMANSHIP COMMANDMENTS
(Continued from page 173)

argue at all. You know, I am very ticklish and sensitive; I am a customer of yours and what you are after is not to prove that I am wrong and you are right—what you are after is to get the money out of my pocket. Don't argue with me because that makes me mad, and it doesn't do any good. Suppose you convince me. Well, I may be convinced; I may not be as good a talker as you are and can't talk as fast, but when I go away, why, I can lose—I don't stay convinced. Then I send around and say, 'I guess I won't take it, after all.' Then I keep away from you because you are unpleasant. I don't like to argue because you beat me; I don't like to be beaten.

"The fifth commandment, 'Make it plain.' Whatever you have to say, say it so I can understand what you are talking about. I don't want to know how many big words you know and how smart you are and how big the concern is. I want to understand what it is you are talking to me about. I would like to say that to everybody in the world. I would like to go to all the preachers and the lawyers and the doctors and everybody and say, 'Whatever you have to say, say it so that the man who is listening to you can understand it.'

"The sixth commandment is, 'Remember names and faces.' Remember the biggest asset you have is being personal. Don't forget my name. My name is Crane; don't call me Graham; don't call me Cohen, nor Green. I can forgive you for forgetting anybody else, but not me, because I am the most important person in the world, to me, you know. That is the touchiest part about anybody. Remember his name—all of it. That is possible by practice, you know. You can develop that highly.

"When a customer first visits your store put down his name, look him up in the telephone directory and get his address; get it fixed in your mind where he lives. Put down some characteristic mark about him. He is lop-eared or he has a cock-eye, maybe. Observe some peculiarity about the man, and if anything leaks out in conversation don't forget to put it down in your book. The next time he comes in bring it up, but not too boldly; you know, be slick about it, but bring it up.

"The seventh commandment is, 'Be dependable.' That is, whatever you say, let people depend on it. If you make an appointment to be at a place at two o'clock, be there five minutes before two. Never keep anybody waiting. If you promised to send anybody an article at three o'clock in the afternoon and you can't do it, telephone or telegraph, or hire a taxi and go up and see him and explain that you tried to get it there at three o'clock and couldn't. It will pay you to do it. If you promised to meet a man in Cleveland on Wednesday and you can't get there, you have broken a leg or somebody has bit off an ear or something has happened to you, send a telegram. The Western Union has saved many a reputation. Make

the man feel good, and when it comes to three o'clock and you are not there when you said you would be there your stock goes down so much every time. Always make that a point of scrupulous honor. If you promise anything fulfill your promise and just a little bit better.

"The eighth commandment is, 'Don't be egotistic.' Don't show off. I don't want to admire you. I want you to admire me. I am the little candy boy in this affair. I want you to make me feel good. Don't show me how much you know about the business. Don't show me how dressed you are and all that sort of thing. You comment on my personal appearance.

"The ninth is, 'Think success.' Don't think failure. Why think fifty cents when it is just as easy to think fifty dollars? Same amount of gray matter exactly. Don't indulge in anything that lowers your personality, because everything begins with the thoughts, and if you start out in the day with thoughts of failure and humiliation the day is very likely to be that way; but if you start out with thoughts of success and triumph, why, you are going to meet them all day. They will come out of the woods to meet you. That is the way we are made. Don't have any premonitions that you are not going to have a good to-day. That is just clean dirt, that is all, mental dirt. Any premonition of any kind or superstition is bad. Don't indulge in them. They are just mental nastiness because there is no sense in them at all.

"The tenth commandment is the greatest of them all, 'Be human.' You know that is what you get your money for—for being human. If the boss didn't need human beings he wouldn't have you, he would have a catalogue. He has got you just because you are a human being and the human being is the best selling machine in the world. Being a human being simply means being yourself. Don't pose. The most winsome thing in the world is that you can be just exactly what you are. You have noticed

that, perhaps, in actors. The best actors you have ever seen are those that were just themselves, perfectly natural. Study yourself and express yourself. The most winsome thing you can be is yourself because that is perfectly human.

"Laugh, not too loud, but just laugh once in a while and be pleasant, not too pleasant; all these things have to be watched. Life is like walking a tight rope. You can't do anything too much, but these are good hints."

ADDITIONS TO OKEH SALES STAFF

F. R. Smith and A. McL. Bennett Join General Sales Staff—J. A. Sieber Joins Dealer Service Department—Report Business Active

W. C. Fuhri, general sales manager of the Okeh record division of the General Phonograph Corp., New York, announced recently that F. R. Smith had been appointed a member of the sales department and would concentrate his activities on the development of Okeh record business. Mr. Smith has had a number of years' experience in the talking machine trade, having been assistant manager of the Boston and New Haven branches of the Columbia Graphophone Co.

A. McL. Bennett, formerly a member of the traveling staff of the local branch of the Columbia Graphophone Co., has been appointed special traveling representative for the Okeh division of the General Phonograph Corp.

John A. Sieber, formerly associated with the Dealer Service department of the Columbia Graphophone Co., has joined the general sales department of the General Phonograph Corp., and is doing excellent work in connection with dealer service and sales promotion activities.

The Venetian Music Co., 122 Shenango street, Binghamton, N. Y., is a new concern engaged in the handling of talking machines in that city.

\$10,000 A YEAR—

Not One Penny Investment

SELLING THE

The Only
Life-Time-
Guaranteed-
Phonograph

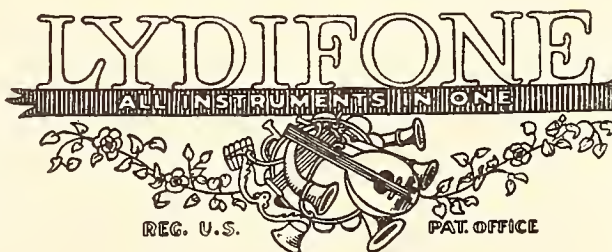

No Collecting
No Repairing
No Delivery
No Risk

Write for Particulars

LYDIFONE CO.—DEUTSCH BROS., Sole Distributors
2265 THIRD AVENUE, NEW YORK

WORLD'S CLASSIFIED ADVERTISING

Any member of the trade may forward to this office a "Situation" advertisement intended for this Department to occupy a space of four lines, agate measure, and it will be inserted free. Replies will also be forwarded without cost. Additional space will be at the rate of 25c. per line. If bold faced type is desired the cost of same will be 25c. per line. Rates for all other classes of advertising on application.

WANTED—Unusual opportunity for man capable of managing phonograph, small goods and sheet music department in growing Western city of 130,000 population. Man from New England States preferred. Address "Western Opportunity," care The Talking Machine World, 373 Fourth Ave., New York City.

WANTED—An experienced salesman and capable manager, with thorough knowledge of buying and selling Victrolas and records, desires connection with a substantial house as manager of Victor department. Can furnish unquestionable references. Married man. No objection to relocating. Address Box "912," care The Talking Machine World, 373 Fourth Ave., New York City.

EXPERIENCED music roll salesman desires to represent abroad a standard line of music rolls, pianos, player-pianos, talking machines, etc. A-No. 1 references. Address Box "910," care The Talking Machine World, 373 Fourth Ave., New York City.

WANTED—Experienced young men and women to assist our dealers in every department of retail talking machine business. State qualifications fully in first letter. Ross P. Curdice Co., Victor Distributors, Eleventh and Dodge Sts., Omaha, Neb.

PLATER and MATRIX MAKER wanted. Must be familiar with modern processes and be able to handle work from wax to finished stampers. Confidential. Reply to W. L., Box "916," care The Talking Machine World, 373 Fourth Ave., New York City.

WANTED—Salesmanager for mid-West territory by Eastern record manufacturer. Excellent opportunity for capable man of wide experience with the trade. Write fully regarding qualifications. Confidential. Box "918," care The Talking Machine World, 373 Fourth Ave., New York City.

RECORDING EXPERT, by a well established company. Opportunity for betterment and to learn working of other record manufacturing departments. Give full particulars regarding experience. Replies treated confidentially. Address H. W., Box "915," care The Talking Machine World, 373 Fourth Ave., New York City.

DEPARTMENT MANAGER WANTED—Good opening for man of ability and talking machine experience. Must be competent to undertake entire management of Victrola department in large city store and increase volume of sales. Address, stating qualifications, "Box 896," care The Talking Machine World, 373 Fourth Ave., New York City.

VICTROLA SALESMAN WANTED—One of experience and proven ability, who can direct the work of other salespeople, place record orders and, above all, stimulate sales. Good proposition in medium-sized city for right man. Address, stating qualifications, "Box 897," care The Talking Machine World, 373 Fourth Ave., New York City.

WANTED—Specialty men and accessory houses to handle our line of record envelopes and pockets with the talking machine trade. Some very desirable territory still open. We are the largest producers of this line to-day and have most attractive prices and prompt delivery. Address J. L. Gillespie Co., 237 Fifth Ave., Pittsburgh, Pa.

OPPORTUNITY FOR EXTRA COMMISSION. Men now selling phonographs or benches will find it entirely profitable to sell our popular line of pianos and players. Fine as side line. Address Opportunity, "Box 848," care The Talking Machine World, 373 Fourth Ave., New York City.

WANTED—Salesmen for splendid side line, all over the country. Pocket sample. Ten to twenty dollars easily made daily. Demonstration requires few minutes only. Write Puritone, Room 1408, 347 Fifth avenue, New York City.

A RECORD MAN FOR SOMEBODY—Man, age 30, college education, eight years' selling and executive experience in wholesale and retail talking machine business, desires real proposition. Chicago, West preferred, where personality, knowledge, initiative count. Address "M. H., 4," The Talking Machine World, 209 So. State St., Chicago, Ill.

WANTED—Experienced Victrola salesman to canvass and follow up prospects in the city of Brooklyn, N. Y. Salary and commission. If you are thoroughly reliable and can furnish good reference address "H. A. F.," care The Talking Machine World, 373 Fourth Ave., New York City.

POSITION WANTED by married man, having 14 years' experience in all phases of phonograph cabinet and motor manufacturing. Can take charge of any department or entire firm. Address F. Y. 18, care Talking Machine World, 209 So. State St., Chicago, Ill.

WANTED—Position as manager of phonograph department, retail or wholesale. Eight years' experience. Would prefer South. Best references. Box "406," care The Talking Machine World, 373 Fourth Ave., New York City.

POSITION WANTED—Material maker seeks engagement. Ten years' experience with leading record makers. Can install a plant and run it on a good production basis. Formulas and all necessary knowledge. Good references. Apply "Rolls," care The Talking Machine World, 373 Fourth Ave., New York City.

POSITION WANTED—Experienced Victrola and record salesman, manager, wholesale or retail, twelve years' experience, desires locating in New York or vicinity. Moderate salary. Box "911," care The Talking Machine World, 373 Fourth Ave., New York City.

YOUNG MAN with eight years' experience wishes to connect with some reliable concern as either salesman or manager. Box "886," c/o The Talking Machine World, 373 Fourth Ave., New York City.

PARTS FOR SALE

Quantity of Columbia repair parts. New. For sale. Write L. W. Kremer, 317 East 83rd St., New York City.

BUSINESS FOR SALE

Established accessory and repair business, located in Philadelphia, for sale on account of other interests. Splendid opportunity for wide-awake man to get into a well-paying business. Address Box "917," care The Talking Machine World, 373 Fourth Ave., New York City.

TURN YOUR DEAD RECORDS

into cash on live, salable merchandise. We can use any quantity of records of standard makes for which we will give you in exchange phonographs of a prominent make or spot cash. Send us lists of your overstock and quantities on hand. No war songs. Address Box "914," care The Talking Machine World, 373 Fourth Ave., New York City.

FOR SALE

Phonograph oil and polish. Anything required in the phonograph line we sell at reduced prices. Will also buy anything you have to sell in the phonograph line. Mandell & Co., 88 Rivington St., New York City.

RECORD MANUFACTURERS

Let us save you 60% of your time and cost of matrix production. Complete equipment for record plant. The Vector Co., Electrical and Mechanical Engineers, 225 Fifth Ave., New York City. Phone Madison Square 9305.

BUSINESS OPPORTUNITY

WANTED—Salesmen to sell a line of metal nameplates to talking machine dealers and manufacturers. Big profits. No bulky samples. Commission paid on receipt of orders. Can be handled in connection with any line. Write for our proposition to-day. Fogarty Manufacturing Co., Dayton, O.

CABINETS

Beautiful new design in mahogany, oak and walnut. Send for circular. Everett Hunter Mfg. Co., McHenry, Ill.

FOR SALE

200 Lateral cut records. All new stock. Good sellers. Will sell in one lot. Box "920," care The Talking Machine World, 373 Fourth Ave., New York City.

RECORDS FOR SALE

15,000 standard lateral cut records, not over five of a number and no war numbers. Will sell from 200 to 300 at 37½ cents each net. 500 or over at 35 cents each net. Cash. Player-Tone Talking Machine Co., 967 Liberty Ave., Pittsburgh, Pa.

FOR SALE

Complete Stock Columbia Records. Closing out our Columbia records. Complete stock, in A-1 perfect condition. New envelopes. Contains good stock popular and dance numbers. All new; no cut-outs. Tri-State Talking Machine Co., El Paso, Tex.

FOR SALE

10,000 phonograph motor springs, 16 ft. by 1¼, by .025. First quality and in perfect condition. Will sell at a sacrifice. Box "921," care The Talking Machine World, 373 Fourth Ave., New York City.

BEST PRICES

Paid for job lots of motors and tone arms. In the market for large quantities. State price and quantity in first letter. Address Box "922," care The Talking Machine World, 373 Fourth Ave., New York City.

ASSEMBLING WORK WANTED

All kinds of light phonograph parts assembling, such as tone arms, sound boxes, automatic stops, etc. Also drilling, tapping, grinding and general phonograph repair work. All work guaranteed strictly first-class. Brosseit Phonograph Repair Co., 4154 N. Maplewood Ave., Chicago, Ill.

FOR SALE

Single spring motors, 75c. up; double spring motors, \$2.00 up; one-inch main springs for Victor and Columbia, 28c. Bargains, job lots, parts, motors, machines and records in any quantities. Main Musical Supply Co., 2010 Fifth Ave., New York City.

FOR SALE

Fifty Columbia Gramofones, new, never been removed from original packing case. Have all styles of cabinets shown in Columbia catalogs. 12,000 Columbia records, including records for the present month. Carleton & Cross, Gallipolis, O.

Attractive Proposition

A well-known manufacturer of phonograph records with national distribution and popularity will negotiate with a musical merchandise house for the sale of part of its product on a commission basis.

Progressive concerns whose salesmen cover music or chain store outlets will find a substantial additional profit in the handling of these records. The product, which is now firmly established, has little or no competition. New records are released monthly.

Opportunity, Box No. 919, care of Talking Machine World, 373 Fourth Avenue, New York, N. Y.

FOR SALE

Mr. Piano Merchant. Are you looking for a new location? A music store in town of five thousand, located in the wealthiest territory in the State of Wisconsin. Practically without competition and doing a fine business in pianos, phonographs and small goods. This store is in a cash territory. The building is strictly modern with fine show windows and the best location in town. Present owner has the agency for several standard makes of pianos, phonographs and records. Small goods will pay all overhead expenses and show a profit. Rent reasonable. If interested, write G. W. G., care The Talking Machine World, 373 Fourth Ave., New York City.

For Sale—Elegant, Clean, New Stock

Business opportunity worth while

Pianos and general musical merchandise. Business located in Wichita, Kansas. Present owner wishes to retire from active selling end of business and will contract with the purchaser of this establishment to carry all instalment paper on very attractive basis. Will require about \$18,000 to \$20,000 to handle deal. Might consider selling half interest to thoroughly reliable experienced piano man. Have good lease and elegant location. Fully equipped in every respect. Doing good business. Address Mr. Wyotte Alvin, 1444 Park place, Wichita, Kansas.

REPAIRS

TALKING MACHINE TROUBLES AND HOW TO REMEDY THEM

Conducted by Andrew H. Dodin

PROPER DIAPHRAGM THICKNESS

Trenton, N. J., February 22, 1921.

Editor Talking Machine World:

I have just received a shipment of repair parts which includes mica diaphragms to fit various types of speakers. There is also a Sonora-Columbia type of sound box which I took apart to investigate because it played with an intense thin metallic vibration. The diaphragm in this sound box measures 7/1000 thickness and I replaced it with one measuring 11/1000 thickness and got better results with equal volume. I would like to try a thicker diaphragm but have none to hand.

I think the thickness of diaphragms in relation to their diameters to be of sufficient importance for a word of caution and instructive ad-

vice through your department in The World as many will no doubt take it for granted that the micas they receive from their supply house to be all right and fail to make inspection.

Edward Aller.

Answer—Your letter draws attention to one of the most abused ends of the talking machine business. There are any number of sound box manufacturers whose products are marketed without the least attention being given to the most vital detail of the proper construction and size of the diaphragm. It is so easy to test the various thicknesses of diaphragms that it is surprising that so many sound boxes are assembled inaccurately and sold.

As you state in your letter a sound box received by you had a diaphragm measuring 7/1000 thick and you found that one 11/1000 thick gave you better results. Would it not have been just as easy for the manufacturer of that sound box to have conducted those tests himself and to have found through experimenting just the proper thickness in relation to the diameter that the diaphragm should be? Then it would be only a question of gauging all diaphragms that went into sound boxes of that style and the

500 Phonographs Complete

51 INCH

Positively high class in quality, finish, workmanship and mechanical accuracy. Equipped with Heineman 77 motors, Blood tone arms. Samples will be sent upon request.

Write or wire

The H. Victor Phonograph Co.
6129 Page Avenue
St. Louis, Mo.

WANTED

Phonograph superintendent. Large phonograph factory situated in Chicago district wants efficient superintendent. Must be good producer and know both machinery and men, must be able to administer factory as economically as consistent with supreme quality of product. Married man preferred. Honest references, not simply those from boosting friends. Good job with opportunity for advancement for right man. Address M. H. 9, care of The Talking Machine World, 209 So. State St., Chicago, Ill.

RECORDS PRESSED

With or without your stock

STOCK ROLLED or
BLANKED or BOTH

Brooklyn, N. Y. Plant now prepared to accept additional contracts, large or small. Densite Products Mfg. Co., 311-313-315 Ellery St., Brooklyn, N. Y.

FOR SALE

41 Tiffany electric motors (dry battery type) 1200 metal horns. Dimensions: height 9", length 13½", opening 9½"x3½". Also 45 completed period model table phonographs (electric motor). Will sell all or any part of this stock at a bargain price. Address Box "913," care The Talking Machine World, 373 Fourth Ave., New York City.

EXCEPTIONAL OFFER

Your opportunity to buy at the right price. Several hundred cabinets, not equipped. Write or wire for particulars. The H. Victor Phonograph Co., 6129 Page Ave., St. Louis, Mo.

result would be uniform tone in all assembled.

It was only last month (February) that a customer handed me a sound box, of a well-known make, with the remark that he "could not get any tone out of it." Apparently the sound box was O. K. but still, when tested, it had no volume and a dead tone. Upon taking it apart the minute I felt the thickness of the mica diaphragm I knew the trouble. It was, I think, the thickest piece of mica I ever saw in a sound box. Assembling the box with the proper diaphragm it was tested and played excellently. Now in this case I would not say it was the fault of the manufacturer, but more than likely the work of some repairman, who replaced the original diaphragm with whatever mica he could obtain at the time.

Mica for use in sound boxes where the diameter of the diaphragms is one and eleven-sixteenths of an inch should gauge about 7/1000 of an inch thick to give the best results; thinner than this will give a shrill tone and thicker a dull tone. For sound boxes where the diameter of the diaphragm is about two inches, mica should gauge about nine one-thousands of an inch thick for best results.

J. J. Farling, Mifflinburg, Pa., has opened a new music store in the Kleckner Building, where he is featuring the Pathé phonograph and other musical instruments.

SEND FOR ILLUSTRATED PRICE LIST AND FREE SAMPLE

"GLOBE" TRANSFER NAME PLATES

DEALERS EVERYWHERE APPLY THEM ON PHONOGRAPHS, PIANOS, ETC.

GLOBE DECALCOMANIE CO.

263 SUSSEX ST., NEWARK, N. J.



EUROPEAN HEADQUARTERS

2 GRESHAM BLDG., BASINGHALL ST., E.C. LONDON

W. LIONEL STURDY, MANAGER

Emphasizing Need of Special Effort to Overcome Depressed Condition of Trade—Government Preparing Bill to Prevent "Dumping" of Foreign Goods—Gramophone Co., Ltd., Not to Open Chain of Retail Stores—Teachers Visit "His Master's Voice" Factories—Activities of Federation of British Music Industries—Gramophone Dealers' Association Meets and Adopts Distinctive Insignia—British Industries Fair Opens—Trade News of General Interest

LONDON, E. C., February 28.—Just at this time when world trade is fast on ebb, it is fitting to remind ourselves that not only England and America, but all other countries are affected by reactionary economic conditions. There is, in fact, a trade depression of world-wide extent. It is a reminder of some value to those whose insular thoughts can find outlet only in a diatribe against their particular government. Let us realize that governments cannot control the barometer of trade and commerce any more than that the sun will not shine at their bidding, and we arrive at the position where individualism counts. In other words, unless we each do our best to keep the machinery of industry on the move and cut out this reliance upon the "other fellow," our present clouds of business depression will last the longer. At a recent lecture on advertising, Charles F. Higham, M. P., said to an audience of music traders: "What is this fit of blues that holds you all? Get active; your groans at bad business make bad business. You've either to get on or get out," and similar direct remarks, all pointing to the fact that individual energy alone, in conjunction, of course,

with good advertising, counts for progress these extremely critical times.

Special Effort Is Required

That is what must actuate the British gramophone trade, for without special effort the "blues" and the "groans" will not easily subside and even may finish up in a final wail before the official receiver. Fortunately, gramophone manufacturers and wholesalers are really alive to the necessity of stimulating retail activity. It is quite true that the public is not so free with its money as in recent years, but isn't that the time when retailers should devise a particular stunt to extract some of the "necessary" from the pockets of the local public?

Fortunately there are distinct signs of improving trade and though at the moment it is nothing very material, I am one of those in the gramophone industry who believe that we have passed the corner. The abandonment of the Excess Profits duty is looked upon as a splendid step toward the resuscitation of trade because it will release money for business development and tends to produce a feeling of greater confidence throughout commercial circles. Another important consideration is that labor is settling down to work.

Sliding Scale of Import Duty

The Government has under preparation a "Safeguarding of Industries Bill." This will provide against "dumping" a sliding scale of import duties and power to make orders for the specific marking of imported goods. "Dumping" is defined as "the importation of goods for sale in this country at prices lower than their price in the country of origin." The British music trade

is directly interested in this, because pianos, gramophones and parts are being imported from Germany, for instance, and sold here at ridiculously low prices. I heard of a case where sound boxes, priced in marks, 15 to 20, were offered and bought in London for less than 2/-. Of this particular pattern, the lowest British factory price would be at least 4/-. A typical case is this, where protection could only be secured by a sliding scale of import duty which should rise or fall according to the state of exchange between the respective countries. With the German mark worth about a British penny, instead of the normal 1/-, the urgent need for some protection is too obvious to be ignored.

Not to Open a Chain of Retail Premises

At the recent general meeting of the Gramophone Dealers' Association a matter of great import was reflected in a members' resolution that "this association learns with much concern that the Gramophone Co., Ltd., have acquired premises in Cheapside and in Oxford street (London) for retail sales, and also it has been suggested that a number of premises are to be opened in the Provinces by that firm."

Speaking on behalf of the "His Master's Voice" Co., Mr. Druker, who had come to the meeting specially to deal with this question, emphatically contradicted the idea that his firm would open a chain of retail premises. The shops in Cheapside and Oxford street are to be developed in a way that will do justice to his company and at any time a dealer wishes to purchase these businesses he could do so, on one condition, that he only sells the H. M. V. products. Members present thought that was good



"His Master's Voice"

Copyright

This intensely human picture stands for all that is best in music

—it is the "His Master's Voice" trade-mark, and it brings to you, no matter where you are, the very best music of every kind, sung and played by the world's greatest artists—the greatest singers, pianists, violinists, orchestras and bands—all enshrined in the unequalled "His Master's Voice" records

'His Master's Voice'

—the trade-mark that is recognized throughout the world as the

HALL-MARK OF QUALITY

DENMARK: Skandinavisk Grammophon-Aktieselskab, Frihavn, Copenhagen.

FRANCE: Cie. Française du Gramophone, 115 Boulevard Richard Lenoir, Place de la République, Paris.

SPAIN: Compañía del Gramófono, 56-58 Balmes, Barcelona.

SWEDEN: Skandinaviska Grammophon-Aktiebolaget, Drottning Gatan No. 47, Stockholm.

RUSSIA: The Gramophone Co., Ltd., 45, Nevsky Prospect, Petrograd (Petersburg); No. 1 Solyanka, Solyanoi Dvor, Moscow; 9, Golovinsky Prospect, Tiflis; Nowy-Swiat 30, Warsaw; 11 Michailovskaya Ulitsa, Baku.

INDIA: The Gramophone Co., Ltd., 139, Balhaghatta Road, Calcutta; 7, Bell Lane, Fort, Bombay.

Great Britain:

The Gramophone Company, Ltd.

HAYES

MIDDLESEX

ENGLAND

AUSTRALIA: S. Hoffnung & Co., Ltd., Sole Concessionaries of The Gramophone Company, Limited, 163, Pitt Street, Sydney.

NEW ZEALAND: Gramophonium, Ltd., 118-120 Victoria Street, Wellington.

SOUTH AFRICA: Darter & Sons, Post Box 174, Capetown; Mackay Bros., Post Box 251, Johannesburg; Mackay Bros. & McMahon, Post Box 419, Durban; Ivan H. Haarbarger, Post Box 105, Bloemfontein; Franz Moeller, Post Box 108, East London; B. J. Ewins & Co., Post Box 86, Queens-town; Handel House, Kimberley; Laurence & Cope, Post Box 132, Buluwayo; The Argus Co., Salisbury.

EAST AFRICA: Bayley & Co., Lourenzo Marques.

HOLLAND: American Import Co., 22a, Amsterd Veerkade, The Hague.

ITALY: A. Bossi & Co., Via Orefici 2, Milan.

EGYPT (Also for the Soudan, Greece and the Ottoman Empire): K. Fr. Vogel, Post Box 414, Alexandria.

FROM OUR LONDON HEADQUARTERS—(Continued from page 178)

enough and expressed their satisfaction accordingly.

Meeting of Gramophone Dealers' Association

The above took place last month, the president, Raisin Jones, in the chair. Matters of trade interest were discussed and plans for the settlement of retail problems examined and agreed upon by members present. The following gentlemen were elected to serve on the committee: R. W. Centland, Edinburgh; W. W. Cooke, Dublin; E. H. Aird, of Harrod Stores, and G. H. Russel, of the Gramophone Exchange, London.

Approval was given to the design and use of a badge and a certificate by members, who also agreed upon a small transfer for use on gramophones. These will serve to promote public confidence in the distinction of the association members as being reliable and legitimate dealers.

A proposal to join the Federation of British Music Industries was left to the committee to effect, financial and other circumstances permitting.

Of special interest was the proposal "To consider the committee's recommendation regarding increase of price, deposit and monthly payment for hire-purchase business." The committee's recommendation took the following form: (1) That no instrument of less value than £20 be supplied on hire-purchase; (2) that 10 per cent be added to the cash price when payment is spread over twelve months; (3) that 25 per cent of the full amount be paid as deposit and the balance be divided into twelve equal monthly instalments. To the foregoing it was difficult to obtain general consent and in the end it was left to the discretion of members how far they would conform to the recommendations.

London School Teachers Visit Hayes

"A real educational experience," was the verdict of the twenty-one L. C. C. school teachers who, in parties of six at a time, were recently afforded the pleasure of being conducted over the great "His Master's Voice" factories. These teachers formed the committee of the London Teachers' Association. They expressed keen admiration of the company's organization.

Music Federation News

The Federation of British Music Industries is a very active body, particularly so since its energetic organizing director has been at work.

On January 27, at the Hotel Cecil, the Federation held its second annual dinner, the popular president, Alexander Dow, being in the chair. About 300 members and guests sat down to a repast of Cecil excellence, amid a jolly good spirit of friendly intercourse actuated by common interest.

Sir Frederick Bridge, C. V. O., proposed in suitable terms the toast of "Success to the Federation," to which the chairman made reply. Mr. Dow described the progress of the Federation since the inaugural dinner. It was then an idea, a soul without a body! The Federation was now fully incorporated and needed only the support of the publishers (whose association still stands aloof) to make it a strong coherent whole, powerful enough to influence the Government, the municipalities and the educational bodies. Concluding with a review of the Federation's activities during the past year, Mr. Dow sat down to the accompaniment of cheering approbation from all present.

The toast of "The Music of the Empire," proposed by Sir Hugh Allen, was replied to by Mr. Landon Ronald. C. F. Higham, M. P., made a rousing speech in reply to "The Visitors," proposed by M. E. Ricketts. In proposing the Board of Trade, Lt. Col. R. H. Tatton coupled with the toast the name of L. A. Paish, of that department, who made an interesting response. Proposing the health of the chairman, Keatley Moore, Mus. Bac., J. P., said that the success of the Federation was due to the genius of Mr. Dow. Very true!

The Federation of British Music Industries now exerts a decided influence throughout the whole trade, every section of which, bar one—the publishers—owes it allegiance. The com-

mercial aspects of British musical art and commerce are the brighter and healthier for the helpful guidance of the Federation. I look forward to the day when every national and individual effort in the cause and propagation of British art and commerce will, if not solely, at least to a very great extent, be directed and encouraged under the official seal of the Federation of British Music Industries. This happy result may not be without the pale of accomplishment if the Federation continues to act whole-heartedly in the interests and for the benefit, not of a selected few, but of every department of every section and branch of the British music trade. The protective cloak of the Federation must cover the small trader, be he manufacturer or dealer, equally as much as the larger trader. That, I know, is the aim of the Federation, that is its mission—to consolidate the various interests of all in one single front of unity and strength so that the British musical art and manufactures may hold a high place throughout the markets of the world.

The British Industries Fair Opens

The British Industries Fair, with its three or four miles of exhibits, was opened under the auspices of the Board of Trade on February 21, at the former pleasure grounds known to all as the White City, Shepherd's Bush, West London. It is quite easily the largest exhibition ever held under one roof. The music section is separately housed in a suitable hall which opens almost on to the entrance to Shepherd's Bush tube railway station. In this section there are some fine exhibits of all kinds of musical instruments, from the latest production in player and organ-piano to the modern gramphonic creation in period-art style.

Such is the attraction of the B. I. F. that fully twenty-five applications from gramophone houses alone could not be accepted "owing to lack of space." In all, the musical exhibits total about seventy.

Among interesting gramophone exhibits I would mention the Repeating Gramophone—an ingenious contrivance which permits of a record being played over and over again, without attention, until the motor spring is exhausted. Messrs. Alfred Graham are showing for the first time a new cabinet gramophone of exquisite design and purity of tone. A fine range of instruments, also the new Tower Record, may be seen at the Sterno Manufacturing Co.'s stand. The display of Discaphones and Winner records by J. E. Hough, Ltd., is a very attractive feature

**Horn, Hornless and Table-Grand
GRAMOPHONES**

FOR
EXPORT

Please State Your Requirements
**REX GRAMOPHONE CO. 2 Elizabeth Place
Rivington Street, LONDON, E.C. 2, England**
Cable Address "Lyrecodisc, London"

of the gramophone section. It is early yet to speak of trade results, but I shall deal with this side of the Fair in my next month's report.

A Compendium of Useful Information

Probably the most interesting item of publicity literature issued by a record manufacturer is the pantomime list to hand from the British Zonophone Co. It consists of a program of all the big panto hits on Zonophone records, against each item being set out the pantomimes in which the song is featured, name of the artist singing it and where the pantomimes are playing. Such a list is readily appreciated by Zonophone dealers, as it enables them to feature special window shows and get active in pushing the sale of these particular records. A most excellent scheme!

Two Shifts Working at the Edison Bell Factory

Quite recently I was informed of the above fact, which is all the more significant in view of the general slackness in the gramophone industry here. Record and machine trade is holding up remarkably well and the necessity of keeping the factory going throughout every hour of the day is really the finest possible testimony to the quality of Messrs. Hough's products. Maintenance of this happy state should result from the company's enterprise in exhibiting at the British Industries Fair, where the prospect of new business is certainly good.

General News Items of Trade Interest

The price of shellac is rapidly on the decline. At £900 per ton two years ago, present-day quotations are at £300, and futures still less. This, I doubt not, is responsible for a reduction recently in the price of four different makes of records.

Thomas Edeus Osborne, the popular gramophone factor of Belfast, is now advertising from his new premises, 4 College Square, North. North Ireland trade is good, and his service is as enterprising as ever!

The eleventh British Music Trade Convention
(Continued on page 180)



"PERFECT POINTS"

BRITAIN'S BEST
Gramophone Needle

(Guaranteed made from High Carbon Steel)

IS MADE BY

W. R. STEEL, of REDDITCH,

Head Office and Works—QUEEN ST.

Scientifically pointed, Hardened and Tempered on the latest up-to-date machinery and plant by skilled craftsmen only.

RESULT:

A FIRST QUALITY NEEDLE far ahead of anything of pre-war quality

INQUIRIES SOLICITED

Special Quotations for Quantities

Manufacturer of all Kinds of Sewing Needles

EDISON BELL

WINNER
 TRADE MARK
 GRAMOPHONE RECORDS

 CABLE
 "PHONOKINO,
 LONDON"

ARE THE GREATEST VALUE FOR MONEY PRODUCED IN GREAT BRITAIN
 TEN INCH DOUBLE SIDED NEEDLE CUT
PLAY ON ALL GRAMOPHONES
Catalogue contains 4000 Titles by the Premier Artistes, Instrumentalists, Orchestras and Bands of the British Empire

DEALERS PREPARED TO DO BUSINESS ARE INVITED TO COMMUNICATE WITH

Proprietors and Manufacturers, J. E. HOUGH, Ltd., 62 Glengall Road, London, S. E. 15, England
FROM OUR LONDON HEADQUARTERS—(Continued from page 179)

tion will open up on May 24 at Ramsgate. It lasts till May 30.

The distribution here of the well-known Fonotopia records has been taken up by the Gramophone Exchange, New Oxford street, London. These fine records were not obtainable during the war; their re-advent has been heartily welcomed by the trade.

A welcome announcement is made by the "His Master's Voice" Co. of the issue of six double discs bearing English folk dance items from Cecil J. Sharp's collection of "Country

Dance Tunes." A most acceptable issue that will be welcomed by many people.

New Zonophone Records of Interest

The many overseas traders who read these notes will welcome the news of the issue of another fine sales list of records by the British Zonophone Co. At any rate they are in good demand here, and I am inclined to think it a fact that what England buys to-day the world buys to-morrow. Indicative of the general quality of this month's program are the following: (2103) "Treasureland," selection I and II, a potpourri

of "hits," by the Black Diamonds Band; (2114), "Le Cygne," and "The Valse Song," violin solos by Miss Elsie Southgate, accompanied the former with celeste, the latter with mustel organ; (2110) "Mammy's Mississippi Home," and "Fly Away, I'm Busy," by G. H. Elliott; (2109) "My Baby's Eyes," by Murray and Fay, and "Then You'll Remember Me," by Fay and Pike; (2107) "Your Wonderful Heart of Gold" and "I'll See You in C. U. B. A.," by Herbert Payne; (2106) "Bideford Bay" and "My Sword and I," by Foster Richardson.

TALKER GUIDES LONDON CROWDS
Enormous Gramophone in Tube Station Shouts Orders to the Passengers

According to a report from London the subway system in that city has a new feature of which even the New York Subway cannot boast. It is the "automatic stentophone," a large gramophone placed at the foot of the stairway to the congested Oxford Circus station. As the crowds come down the narrow stairway at the rush hour they hear the gramophone roaring at them:

"Keep moving, please."

"Let others pass on the left."

"If you must stand, stand on the right."

"Now, then, keep moving on the left."

The machine is worked by compressed air. The records last about a week each. A sound-intensifying device increases the volume of the stentophone voice, so that its hoarse shout rises above the sound of the passing trains.

INTRODUCES THE MUSI-CALL
Columbia Graphophone Co. Places Novelty on the Market—Well Received by Dealers

The Columbia Graphophone Co.'s Dealer Service department recently introduced the Musi-call, an alarm clock device which, when placed on the Columbia Grafonola or on any other phonograph, with the record and tone arm in position, will automatically start the record playing at the time for which the Musi-call is

set. The Musi-call has unlimited possibilities, for it can be used as a pleasant reminder that the day's work is about ready to start, or it can be utilized as a novelty when entertaining friends.

It is suggested that dealers should keep a Musi-call set at ten-minute intervals throughout the day, so that practically every customer who enters the store will unconsciously receive a demonstration. Columbia dealers have evinced a keen interest in the Musi-call and are using it to advantage in their establishments.

HOW LAWN PARTIES BOOST SALES
Enterprising Dealer Features Magnavox at Lawn Parties—Increase Machine and Record Sales—Pointers for Interested Dealers

The J. O. Morris Co., Inc., distributor for the Magnavox in New York and New England territory, received recently an excellent suggestion from a talking machine dealer in Michigan outlining a new use for the Magnavox. This dealer stated that this particular "stunt" increased his sales several hundred per cent.

Operating in the rural sections, he gets permission from a farmer who is one of the leading citizens in his locality and who owns a pretentious home and grounds to use his place for a lawn party. The dealer decorates the lawn with lanterns and conducts a gala party with the Magnavox as the chief form of entertainment. He states that as a result of these parties he has secured substantial talking machine orders, and his record sales have increased materially.

REMINGTON REPRODUCER FEATURED
Is Described at Length in a Special Article in the Scientific American

The Remington reproducer used in the phonograph manufactured by the Remington Phonograph Corp. was the subject of a lengthy illustrated article in the Scientific American of February 26. The article was written by R. G. Skerrett and the various distinctive features of the reproducer were strongly emphasized.

The Diamond Disc Shop, at 9 Alabama street, Atlanta, Ga., retail headquarters for Edison phonographs, was damaged by fire recently.

"Does It Play All Records?"

Certainly MAGNOLA does; and without any extra attachments, too. This is only one feature, albeit a most important one, in the thoroughly up-to-date equipment of the MARVELOUS MAGNOLA.

MAGNOLA "Built by Tone Specialists"

Watching the Music Come Out

May we send you our handsome illustrated catalog chock full of information concerning the wonderful construction system of Magnola and the beauties of its musical results, its artistic appearance and its moderate price?

Send your name and let us tell you more!

MAGNOLA TALKING MACHINE COMPANY

OTTO SCHULZ, President

General Offices
 711 MILWAUKEE AVENUE
 CHICAGO

Southern Wholesale Branch
 1530 CANDLER BLDG.
 ATLANTA, GA.

"MAGNET" DECALCOMANIE NAMEPLATES

SOLD BY
HURTEAU, WILLIAMS & CO., LTD.
 MONTREAL — OTTAWA

Kunkel Piano Co.
 BALTIMORE

FOR TALKING MACHINE CABINETS ETC.

Pamphlets with fac-simile illustrations and prices mailed on request.

SMITH-SCHIFFLIN CO.

149 Church Street New York City



SOLD BY
WALTER D. MOSES & CO.
 Oldest Music House in VA and N.C.
 103 E. BROAD STREET
 RICHMOND, VA.

SOLD BY
J. E. STRATFORD
 AUGUSTA, GA.

LATEST PATENTS RELATING TO TALKING MACHINES AND RECORDS

WASHINGTON, D. C., March 8.—**Reproducer for Talking Machines.** John William Kaufman, Baltimore, Md. Patent No. 1,367,979.

This invention relates to reproducers for talking machines and it contemplates certain improvements in Patent No. 1,354,197, dated September 28, 1920.

It is a purpose of the invention to provide a reproducer in which the resilient member between the needle and the diaphragm is mounted to materially increase its responsiveness to the vibrations of the needle and to amplify such vibrations by allowing the use of resilient members of greater rigidity. It is also a purpose of the invention to provide a reproducer which can be used on records having vertical undulations as well as those formed with horizontal undulations.

In the accompanying drawings Figure 1 is a perspective view of one form of reproducer embodying the invention, showing the arm in active position upon a record; Fig. 2 is a view showing in front elevation the reproducer shown in Fig. 1; Fig. 3 is a vertical sectional view of the sound box shown in the preceding views; Figs. 4 and 5 are views showing in front and side elevation, respectively, another form of reproducer embodying the invention; Figs. 6 and 7 are views

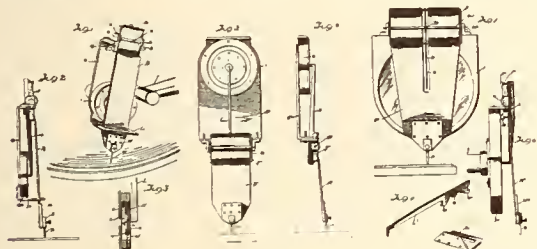

showing in front and side elevation, respectively, still another form of reproducer embodying the invention; Figs. 8 and 9 are detail views showing certain parts of the reproducers. Similar reference characters refer to similar parts in each of the several views.

Stylus or Needle for Phonographs and Means for Regulating Same. Ray A. Frisbis and George Baty, Brooklyn, N. Y. Patent No. 1,367,956.

This invention is a new and useful improvement in styli or needles for phonographs and means for regulating the same.

The object of the invention is to provide a device of this class in which a wire may be fitted an exact and predetermined distance in the needle, so as to reproduce the sound recorded in the instrument where the device is used, and a further object is to provide a needle which may be fitted in any instrument.

Figures 1, 2 and 3 illustrate one embodiment, Fig. 1 being a sectional view taken on the line 1—1 of Fig. 2, and Fig. 3 is a sectional view taken on the line 3—3 of Fig. 1, and Fig. 2 is a plan view of this form of needle. Figs. 4 and 5 show another form of needle, these two views being side elevations taken at right angles to each other. Figs. 6 and 7 show yet a further modification, Fig. 6 being partially in section and Fig. 7 being a sectional view taken on the line

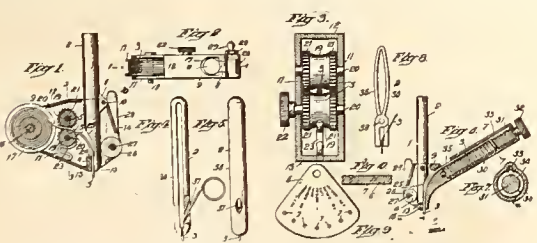

7—7 of Fig. 6. Fig. 8 is a side elevation of yet a further modification and shows a needle embodying the invention. Figs. 9 and 10 show an adjusting device, Fig. 10 being a sectional view showing two adjusting holes and the part of the device adjacent thereto.

Reproducer for Phonographs. Burr B. Blood, Chicago, Ill. Patent No. 1,365,298.

This invention relates more particularly to the construction of the reproducer shell or back and means for providing a connection between the reproducer and the tone arm of a phonograph; and has for its object the provision of a construction whereby a connection between the reproducer and tone arm may not only be quickly effected, but a connection provided which will be free from the serious objections heretofore encountered because of the tendency of such connections to loosen and thereby producing improper noises or vibrations during the operation of the phonograph.

An object of the invention is to provide means whereby the proper relation between the tone arm and reproducer will be insured and the connection easily and quickly provided without the possibility of such connection to cause any chatter or vibration between the parts; the means enabling the connection to be made by the manipulation of a single element after the respective parts have been properly assembled; thus obviating the necessity for the use of a plurality of screws, or the like, which have heretofore been generally employed.

Figure 1 is a rear elevation of a reproducer provided with the invention. Fig. 2 is a cross-sectional view taken on the line 2—2 of Fig. 1 looking in the direction of the arrows. Fig. 3 is a perspective view of the rear or back wall of the reproducer. Fig. 4 is a perspective view

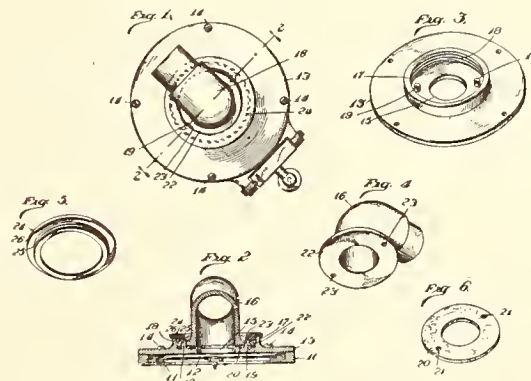

of the tone arm connection. Fig. 5 is a perspective view of the connection forming or locking element, while Fig. 6 is a perspective view of a type of washer or gasket that may be employed in the improved construction.

Phonograph Horn. Edward H. Koehler, Chicago, Ill. Patent No. 1,365,249.

This invention relates to phonograph horns, and its object is to improve the tone quality and increase the volume and eliminate the metallic character of tone.

In the accompanying drawing Figure 1 is a side view of a phonograph panel horn, showing

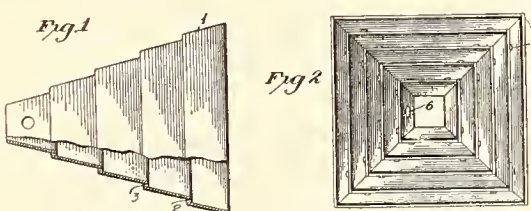

the panel construction to better illustrate the features of the invention. Fig. 2 is the front view of a phonograph panel horn.

Reproducer. Jobby Belpedio, Bridgeport, Conn. Patent No. 1,365,146.

The primary object of the invention is to provide a reproducer for talking machines which is readily adapted to playing diamond disc records, records in which the sound undulations are on the side of the groove and discs in which the sound undulations are in the bottoms of the grooves. To this end the invention comprises a tone arm and a sound box universally connected to the tone arm, the sound box carrying stylus or a needle attachment for records in which the sound undulations are on the sides and bottoms of the

grooves respectively and carrying a diamond for use with a diamond disc record.

Figure 1 is a view in side elevation of a tone arm and sound box embodying the invention, the sound box being shown in the box for playing diamond disc records. Fig. 2 is a top plan view of the structure shown in Fig. 1, but shows the sound box in the position for playing discs in which the sound undulations are on the side of the groove. Fig. 3 is a perspective view of one of the two connectors by which the sound box is attached to the tone arm. Fig. 4 is a side elevational view of the structure shown in Fig. 2. Fig. 5 is a section on the line 5—5 of Fig. 4. Fig. 6 is a section on the line 6—6 of Fig. 4. Fig. 7 is a detailed sectional view of the diaphragm, showing how provision is made for connecting therewith the arm which connects with the stylus bracket. Fig. 8 is a perspective view of the arm which connects with the diaphragm, this figure showing also the lever carrying the diamond and the connection between it and the arm. Fig. 9 is a section on the line 9—9 of Fig. 5. Fig. 10 is a section on the line 10—10 of Fig. 6. Fig. 11 is an enlarged detail sectional

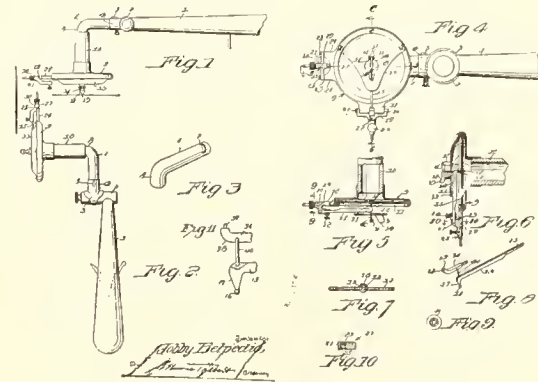

view, showing the connection between the lever carrying one kind of record-engaging element and the arm operatively connecting with other kinds of such elements.

Tone Arm for Phonographs. Alexander F. Bruhy, West End, Wis., assignor to Plymouth Phonograph Co., Patent No. 1,364,180.

This invention relates to improvements in tone arms employed in connection with phonographs or talking machines, and especially to that particular construction of tone arm in which the same, in addition to being mounted to oscillate upon the base-plate, is spring-balanced so as to support or counter-balance the outer end of the tone arm carrying the sound box and thereby prevent the stylus or needle from bearing too heavily upon the record and unduly wearing the same.

Heretofore in tone arms, constructed as described, it has been customary to connect the inner portion of the elbow of said arm with a spring balance, the idea, as stated, being to overcome to a certain extent the weight of the outer free end of the arm and the sound box, so that the stylus or needle traveling in the groove of the record will not subject the same to undue

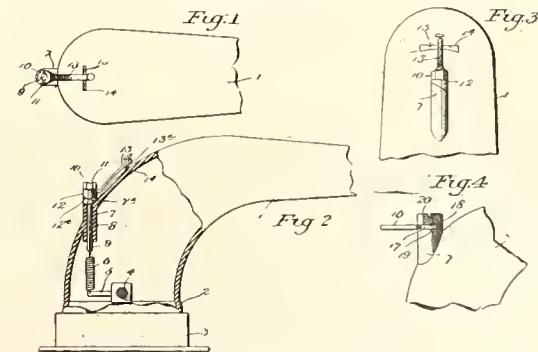

wear. It has been found, however, that the weight of the tone arm and consequently the bearing pressure of the needle in the groove of the record should vary to produce the best results from different makes of records, thus ver-

(Continued on page 182)

LATEST PATENTS RELATING TO TALKING MACHINES AND RECORDS—(Continued from page 181)

tically cut records requiring more pressure than those laterally cut, and even some records of these two classes will be found to give better results if the pressure is regulated somewhat.

Figure 1 is a top-plan view of a spring-balanced tone arm having the invention applied thereto, the outer end of the arm being broken away. Fig. 2 is a side elevation and partial sectional view of the same; Fig. 3 is a rear elevation thereof; and Fig. 4 shows a modified construction that may be employed in lieu of that shown and which will accomplish the same purpose.

Graphophone. Arthur Laurencich, Washington, D. C. Patent No. 1,364,201.

This invention relates, generally, to disk graphophones, but more particularly to a novel sound-producing and amplifying device therefor; and the object is to provide such a device which shall be exceedingly economical in construction, easily and quickly adjusted in position, and thoroughly efficient in operation, for the purpose intended.

Figure 1 is a top-plan view of a disk graphophone equipped with improvements; Fig. 2 is a view in side elevation thereof; Fig. 3 is a view taken at right angles to the position shown in Fig. 2; Fig. 4 is a detached detail view, in perspective, of the combined needle and sound-amplifier holder; Fig. 5 is a similar view of a somewhat modified form of combined needle and sound-amplifier holder; Fig. 6 is a fragmental view, partly in section, of the swinging reproducer arm; Fig. 7 is a similar view, but showing the bushing for the reception of the tubular shank of the needle-holder slightly removed from the end of the reproducer arm, instead of at the end thereof, as in Fig. 6; Fig. 8 is a fragmental view, in side elevation, of a reproducer arm carrying a slightly modified form of bushing for the reception of the tubular shank of the needle-holder; Fig. 9 is a fragmental view, in bottom plan, of the reproducer arm and bushing shown in Fig. 8;

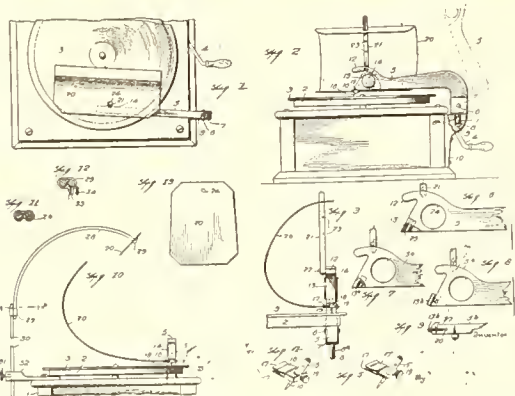

Fig. 10 is a view in elevation of a disk graphophone, showing a slightly modified form of means for holding the upper end of the sound-amplifying member; Fig. 11 is a sectional view on the line 11—11, Fig. 10, looking in the direction of the arrows; Fig. 12 is a sectional view taken similarly to Fig. 11, but showing a slightly modified form of clamping means for the curved supporting arm shown in Fig. 10; and Fig. 13 is a view in front elevation of the flexible sound-producing plate or sheet.

Latch. Francis M. Wagner, Pittsburgh, Pa. Patent 1,364,661.

This invention relates to latches, and more particularly to a latch adapted for use in connection with phonographs and similar structures having hinged lids.

One of the main objects of the invention is to provide simple and efficient means for holding the lid of a phonograph case raised, this means permitting ready lowering of the lid by raising the same to a predetermined extent beyond its normal raised position and then lowering the lid. Another object is to provide a device which will permit the lid to be lowered, in the ordinary manner, and will not require any special skill or practice in its operation.

In the drawings Figure 1 is a fragmentary side view of a phonograph case of conventional type,

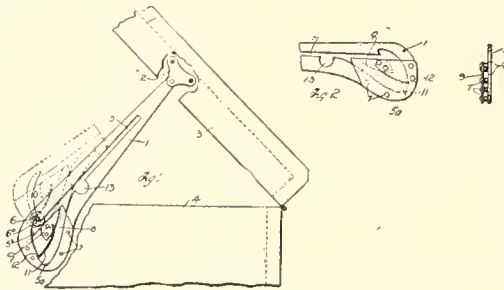

showing the latch applied; Fig. 2 is a fragmentary inner side view of the lower portion of the latch arm; Fig. 3 is a forward end view of the same.

Needle Changing Device for Talking Machines. Donato Di Carlo, Philadelphia, Pa. Patent No. 1,364,428.

One object of this invention is to provide an improved structure for automatically moving the needle holder of a sound box into a position from adjacent to the record to a position remote from the record so that the needle can be conveniently changed without injuring the record.

Figure 1 is a fragmentary top plan view illustrating the invention; Fig. 2 is a side elevation of Fig. 1; Fig. 3 is a section taken on the line 3—3 of Fig. 1 showing the sound box and the locking parts in outside view; Fig. 4 is a view of similar character to Fig. 2, showing the same after having been automatically operated to move the needle holder into a position to permit the needle to be conveniently changed without pos-

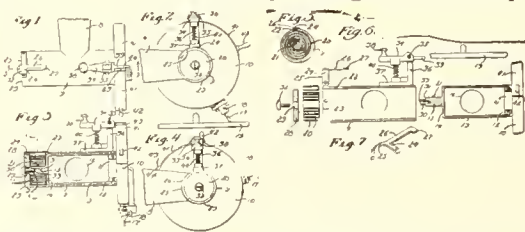

sible injury to the record; Fig. 5 is a transverse section taken on the line 5—5 of Fig. 3; Fig. 6 is a detached view shown partly in section of the parts of the invention and illustrating how the same can be taken apart or put together; and Fig. 7 is a perspective view of a spring retaining member which forms a part of the invention.

Sound-Reproducing Machine or Phonograph. David H. Wilson, Philadelphia, Pa. Patent No. 1,363,946.

This invention relates to sound-reproducing machines or phonographs. More particularly the invention relates to improvements in the tone chamber or horn of such instruments.

One important object of the invention is to provide, in a cabinet phonograph, an improved

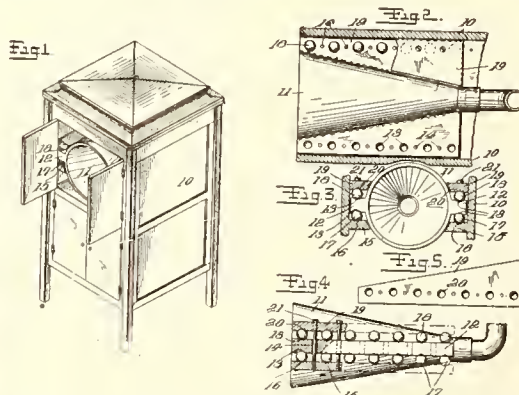

form of mounting for the tone chamber so arranged as to give greatly increased volume, clearness and brilliancy of tone.

A second important object of the invention is to provide, in a cabinet phonograph, an improved mounting for the tone chamber which is

so arranged as to eliminate the damping of the tone chamber vibrations by the cabinet or casing, the tone chamber being free to vibrate independently of such casing.

A third important object of the invention is the provision of an improved form of tone chamber capable of being molded in a single piece or made from a number of pieces separate from the cabinet and, after being so made, assembled in its cabinet.

Figure 1 is a perspective view of a cabinet phonograph constructed in accordance with this invention; Fig. 2 is a horizontal section through the upper part of the casing of a phonograph constructed in accordance with this invention, the view being taken to show the tone chamber in position; Fig. 3 is a vertical section on the line 3—3 of Fig. 2; Fig. 4 is a side view of the tone chamber, showing the manner of supporting the same; Fig. 5 is a bottom or under side view of a lock plate used herewith.

Sound-Recording and Sound-Reproducing Machine. John H. Neher, Princeton, N. J. Patent No. 1,363,903.

This invention relates to the recording and reproducing of lengthy speech or music on a plurality of records, and its object is to provide certain new and useful improvements in sound-recording and sound-reproducing machines whereby the continuous recording or the continuous reproduction of speech or music can be readily obtained without noticing the transition from one record to another. Another object is

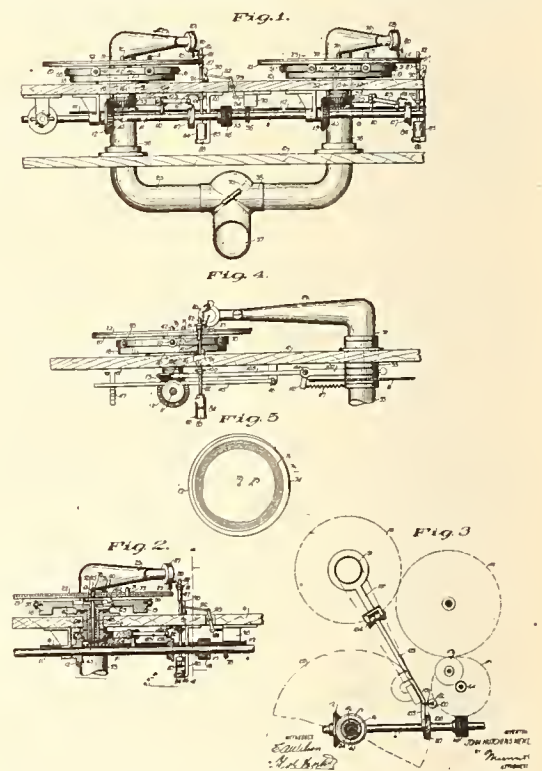

to give the operator ample time for placing the next record in position on the machine prior to the stylus, in engagement with an active record, reaching the end of the sound groove, thus insuring the continuous recording or continuous reproduction of the subject matter.

Figure 1 is a side elevation of the improved sound-recording machine; Fig. 2 is a sectional side elevation of the same and showing more particularly the inactive unit; Fig. 3 is a sectional plan view of the same on the line 3—3 of Fig. 2; Fig. 4 is a cross section of the same on the line 4—4 of Fig. 2; and Fig. 5 is a plan view of one of the records.

The National Phonograph Exchange, Memphis, Tenn., has been organized with \$5,000 capital.

DAMAGED VARNISH

can be permanently and invisibly repaired by using **LESLEY'S PATCHING VARNISH**

Price: 1 pt., \$1.00; 1 qt., \$1.90
Complete repair outfit, \$3.50

Write for catalogue

LESLEY'S CHEMICAL CO.

10 S. New Jersey St.

Indianapolis, Ind.

REPAIRS

All Makes of Talking Machines
Repaired Promptly and Efficiently

REPAIR PARTS FOR ALL MACHINES

ANDREW H. DODIN

28 Sixth Avenue

New York

TELEPHONE, SPRING 1194

Advance RECORD BULLETINS for April, 1921

VICTOR TALKING MACHINE CO.

- POPULAR SONGS
18730 My Mammy... Peerless Quartet
Undeineath Hawaiian Skies, Albert Campbell-Henry Burr
18731 Look for the Silver Lining, Edna Brown-Charles Harrison
Wandering Home... Helen Clark-Charles Hart
18732 She Gives Them All the Ha! Ha! Ha!, Billy Murray
Stop! Look! Listen... American Quartet
DANCE RECORDS
35706 Sally-Medley Fox-trot, Joseph C. Smith's Orchestra
Lady Billy-Medley Fox-trot, Joseph C. Smith's Orchestra
18729 Home Again Blues-Medley Fox-trot, Original Dixieland Jazz Band
Crazy Blues-Fox-trot, Original Dixieland Jazz Band
18733 Rose-Nightingale-Medley Fox-trot, All Star Trio, assisted by their Orchestra
Tip-Top-Medley One-step, Joseph C. Smith's Orchestra
18734 I Never Knew-Fox-trot, Paul Whiteman and His Orchestra
Do You Ever Think of Me?-Medley Fox-trot, Paul Whiteman and His Orchestra
18735 Bright Eyes-Medley Fox-trot, Paul Whiteman and His Orchestra
Love Bird-Medley Fox-trot, Paul Whiteman and His Orchestra
VOCAL AND INSTRUMENTAL RECORDS
55135 Aida-Ritorna Vincitor (Return Victorious), Lucy Isabelle Marsh
Aida-O Patria Mia (My Native Land), Lucy Isabelle Marsh
45241 Hush-a-Bye, Baby Mine... Elsie Baker
Mammy Dear... Elsie Baker
18720 Carry Your Cross With a Smile, Homer Rodeheaver
Tell Me the Story of Jesus... Homer Rodeheaver
18728 Valse Erica-Saxophone solo... Rudy Wiedoeft
Saxophobia-Saxophone solo... Rudy Wiedoeft
RED SEAL RECORDS
64937 Just a Little House of Love... Glanville-Wood
88628 Serenata... Enrico Caruso, Tenor-In Italian
474670 Hungarian Rhapsody, No. 2-Part 1... Liszt
GIUSEPPE DE LUCA, Baritone-In French
64934 Beau Soir (A Beautiful Evening), Bourget-Dehussy
64938 La Gioconda-Cielo e Mar (Heaven and Ocean), Ponchielli
MME. LOUISE HOMER, Contralto, and Miss LOUISE HOMER, Soprano
87575 Oh Morning Land... Rexford-Phelps
JOHN McCORMACK, Tenor, and FRITZ KREISLER, Violinist (Piano accomp., Edwin Schneider)
87574 O Cease Thy Singing, Maiden Fair..Rachmaninoff
PHILADELPHIA ORCHESTRA (Leopold Stokowski, Director)
74671 Samson et Dalila-Bacchanale... Saint-Saëns
SERGEI RACHMANINOFF, Pianist
64935 Study from "The Children's Corner" (No. 1-Doctor Gradus and Parnassum)... Debussy
TITTA RUFFO, Baritone-Neapolitan
87323 Munasterio (The Monastery), di Giacomo-P. Mario Costa
E. H. SOTHERN and JULIA MARLOWE
74673 The Merchant of Venice-(1) Shylock's Speech; (2) The Mercy Speech... Shakespeare
TOSCANINI and LA SCALA ORCHESTRA
74672 Gagliarda... Vincenzo Galilei
EFREM ZIMBALIST, Violinist
64936 Serenade... Pierne

COLUMBIA GRAPHOPHONE CO.

- SYMPHONY RECORDS
A-6179 The Palms... Louis Graveure, Baritone
The Holy City... Louis Graveure, Baritone
49453 Serenade (Schubert-Elman), Toscha Seidel, Violinist
49802 Largo (Handel)... Pablo Casals, Cellist
A-3354 Nearer, My God, to Thee, Seagle and Columbia Quartet
I Love to Tell the Story, Seagle and Columbia Quartet
POPULAR HITS
A-3365 Crazy Blues..Mary Stafford and her Jazz Band
Royal Garden Blues, Mary Stafford and her Jazz Band
A-3363 Rose of My Heart-Tenor solo... Samuel Ash
Beautiful Hawaii-Tenor duet... Campbell-Burr
A-3367 Look for the Silver Lining (From "Sally"), Marion Harris, Comedienne
I'm Gonna Do It If I Like It, Marion Harris, Comedienne
NOVELTY RECORD
E-4959 Song of Sadness... Orquesta Argentina
Delfos... Orquesta Argentina
A-3118 Bird Calls-A Day With the Birds, Edward Avis
Bird Calls-Spring Birds... Edward Avis
DANCE RECORDS
A-3364 Rosie-Medley Fox-trot. Intro.: "Beautiful Faces"... Yerkes Jazarimba Orchestra
You Oughta See My Baby-Medley Fox-trot. Intro.: "No Wonder I Am Blue," Yerkes Jazarimba Orchestra
A-3366 Bright Eyes-Fox-trot, The Leo F. Reisman Orchestra
Love Bird-Fox-trot, The Leo F. Reisman Orchestra
THE MID-MONTH RECORDS
A-3361 O-HI-O (O-My!-O!)... Al Jolson, Comedian
I Want to Go to the Land Where the Sweet Daddies Grow... Van and Schenck
A-3356 My Last Dollar... Bert Williams, Comedian
I'm Gonna Quit Saturday, Bert Williams, Comedian
A-3360 Just Snap Your Fingers at Care. Intro.: "The Greenwich Village Follies," Nora Bayes, Comedienne
Why Worry?-From "Her Family Tree," Nora Bayes, Comedienne
SYMPHONY RECORDS
A-3355 A Southern Lullaby-Mezzo-Soprano, Barbara Maurel

- Mammy Dear-Mezzo-Soprano..Barbara Maurel
DANCE RECORDS
A-3359 Remember Me-Fox-trot... Paul Biese Trio
Happy Hottentot-Song Fox-trot, Paul Biese Trio and Frank Crumit
A-3358 Humming-Fox-trot... The Happy Six
Now and Then-Fox-trot. Intro.: "Granada," The Happy Six
A-6180 Down the Trail to Home, Sweet Home-Waltz, Yerkes Jazarimba Orchestra
Dearest One-Medley Waltz. Intro.: "Your Eyes Have Said Remember," Prince's Dance Orchestra

AEOLIAN CO.

- OPERATIC SELECTIONS
52004 Favorita-Spirito Gentil (Spirit so fair) (Donizetti)-Tenor, in Italian, Vocalion Orch. accomp. ... Giulio Crimi
52005 Voce di Primavera-Valse (Johann Strauss)-Soprano, in Italian, Vocalion Orch. accomp., Evelyn Scotney
STANDARD SELECTIONS
30117 The Star (Rogers)-Soprano, Vocalion Orch. accomp. ... May Peterson
30118 Abide With Me (Monk)-Baritone, Vocalion Orch. and Quartet accomp., John Charles Thomas
24015 Macusbla (MacMurrough)-Tenor, Vocalion Orch. accomp... Charles Harrison
Mother Machree (Olcott-Ball)-Tenor, Vocalion Orch. accomp... Charles Harrison
INSTRUMENTAL SELECTION
52008 Indian Lament (Dvorak-Kreisler)-Violin, piano accomp. ... Sasha Culbertson
NOVELTY SELECTIONS
14148 The Nightingale and the Rose (Thompson)-Whistler, Orch. accomp... Margaret McKee
Bird Imitations-Whistler, Orch. accomp., Margaret McKee
POPULAR SELECTIONS
14149 Dearest One (Blaufuss)-Orch. accomp., Arthur Burns
Drifting Apart (Johnston-Ager-Schuster)-Orch. accomp. ... Hugh Donovan
14150 Hi-Yo (Fairchild-Green)-Orch. accomp., Harmonizers' Quartet
Answer Me (Vause)-Orch. accomp., Charles Hart-Elliot Shaw
14151 O-HI-O (Yellen-Olman)-Orch. accomp., Eileen Stanley
Boll-Weevil Blues (Cliff Hess)-Orch. accomp., Ernest Hare
14152 In the Heart of Old Italy (West-Glogau)-Orch. accomp. ... Crescent Trio
Aunt Jemima's Jubilee (Tracey-Pinkard)-Orch. accomp. ... Harmonizers' Quartet
DANCE SELECTIONS
14153 Bright Eyes (Intro.: "Make Believe") (Smith-Motzan-Jerome-Davis-Shilkret)-Fox-trot, Al Jockers' Dance Orchestra
Na-Jo (Wiedoeft-Holliday)-Fox-trot, Al Jockers' Dance Orchestra
14154 Arabia (G. H. Green)-One-step, Green Brothers' Novelty Band
Mazie (Crain-Dawson-Gold)-Fox-trot, Green Brothers' Novelty Band
14155 Do You Ever Think of Me? (Burnett)-Fox-trot ... Selvin's Dance Orchestra
Love Bird (Earl-Fiorito)-Fox-trot, Selvin's Dance Orchestra
14156 I Never Knew (Intro.: "Two Sweet Lips") (Pitts-Egan-Marsh)-Fox-trot, Al Jockers' Dance Orchestra
Look for the Silver Lining (Intro.: "Whip-poor-will") (Jerome Kern)-Fox-trot, Al Jockers' Dance Orchestra

EDISON RE-CREATIONS

- 82205 Kashmiri Song-Indian Love Lyrics (Woodforde-Finden)-Soprano ... Maggie Teyte
Pale Moon-Indian Love Song (Logan)-Bass-baritone ... Arthur Middleton
82209 Oh, Mother, My Love (Farley)-Soprano, Anna Case
Yeomen's Wedding Song (Poniatowski)-Bass, Henri Scott
82210 Donna non vidi mai (Never did I behold so fair a maiden!)-Manon Lescaut (Puccini)-Tenor, in Italian... Guido Cicolini
Stances (Stanzas)-Lakmé (Delibes)-Baritone, in French... Torcom Bézazian
82573 Mira, di acerbe lagrime (Let my tears implore thee)-Il Trovatore (Verdi)-Soprano-baritone, in Italian... Marie Rappold-Taurino Parvis
Te souvenir-il (Dost thou recollect-Méditation)-Thais (Massenet)-Soprano-bass-baritone, in French ... Alice Verlet-Arthur Middleton
80594 Casse-Noisette Suite, Part I (Nut Cracker Suite)-Overture Miniature; and Danse Chinoise (Tschaikowsky)... American Symphony Orchestra
Casse-Noisette Suite, Part II (Nut Cracker Suite)-Danse de la Fee Dragee; and Danse des Mirlitons (Tschaikowsky), American Symphony Orchestra
80595 Our Little Love Affair-Fifty-Fifty (Swanstrom)-Soprano-tenor-Betsy Lane Shepherd-Lewis James
Until I Say Good-Bye (Hill)-Contralto-tenor, Louise Terrell-George Wilton Ballard
80596 Songs of Other Days, No. 5, Metropolitan Mixed Chorus
Songs of Other Days, No. 6, Metropolitan Mixed Chorus
80597 Nightingale's Song-Pinafore (Gilbert-Sullivan)-Tenor ... Vernon Dalhart and Chorus
Your Eyes Have Told Me So (Blaufuss)-Soprano ... Gladys Rice
80598 II Guarany Overture, Part I (Gomez), Sodero's Band
II Guarany Overture, Part II (Gomez), Sodero's Band
80599 Parted (Tosti)-Baritone... Thomas Chalmers
Were My Song With Wings Provided (Hahn); and Serenata-I Wait Beneath Thy Window, Love (Moszkowski)-Soprano, Betsy Lane Shepherd
80600 Adagio Cantabile (Quartet Op. 64, No. 5) (Haydn)-First violin, second violin, viola and violoncello ... Zoellner String Quartet
To a Wild Rose (MacDowell-Zoellner)-First violin, second violin, viola and violoncello, Zoellner String Quartet

- 80601 Gethsemane (Ackley)-Baritone... Robert E. Clark
Home Over There (O'Kane)-Mixed voices, Calvary Choir

Edison Re-Creations-"Bits of Broadway"

- 50730 I Never Knew (Intro.: "Marimba")-Medley Fox-trot, for dancing, Max Fells' Della Robbia Orchestra
Sweet Lavender (David)-Fox-trot, for dancing, Max Fells' Della Robbia Orchestra
50738 Na-Jo (Wiedoeft-Holliday)-Fox-trot, for dancing... Max Fells' Della Robbia Orchestra
Mazie (Gold-Dawson-Caine)-Fox-trot, for dancing ... Orlando's Orchestra
50739 O-HI-O (Intro.: "Thy Troubadour")-Medley One-step... Max Fells' Della Robbia Orchestra
Sally (Intro.: "Look for the Silver Lining," "Whip-poor-will" and "Wild Rose")-Medley Fox-trot, for dancing, Harry Raderman's Jazz Orchestra
50740 Do You Ever Think of Me (Burtnett)-Fox-trot, for dancing... Harry Raderman's Jazz Orchestra
Arabia (G. H. Green)-One-step, for dancing, Green Brothers' Novelty Band
50741 My Mammy (Donaldson)-Male voices, Premier Quartet
Look for the Silver Lining (From "Sally") (Kern)-Soprano-tenor, Betsy Lane Shepherd-Lewis James
50742 Answer (Vause)-Fox-trot, for dancing, Lenzberg's Riverside Orchestra
Sweet Love (Smalle)-Fox-trot, for dancing, Lenzberg's Riverside Orchestra

Edison Re-Creations-April Special

- 80609 Lassie o' Mine (Walt)-Tenor... Albert Lindquest
When I Looked in Your Wonderful Eyes (Osborne)-Baritone ... Edward Allen
50700 Anytime, Anyday, Anywhere (Intro.: "Just for To-day")-Fox-trot, for dancing, Green Brothers' Novelty Band
In Sweet September (Monaco)-Fox-trot, for dancing... Green Brothers' Novelty Band
50713 Hula Blues (Cunha-Noble)-Fox-trot, for dancing... Harry Raderman's Jazz Orchestra
If a Wish Could Make It So (Stothart) (From "Tickle Me")-Medley Fox-trot, for dancing, Lenzberg's Riverside Orchestra
50714 Broadway Blues (Morgan)... Al Bernard
My Lovin' Sing Song Man (Bernard), Al Bernard-Frank M. Kamplain
50715 Darling (Intro.: "Just Snap Your Fingers at Care")-Medley Fox-trot, for dancing, Max Fells' Della Robbia Orchestra
Wedding Blues (Friedlander) (From "Pitter Patter")-Fox-trot, for dancing, Lenzberg's Riverside Orchestra
50716 My Home Town Is a One-Horse Town (But It's Big Enough for Me) (Silver)-Tenor, Jim Doherty
Wonderful Girl, Wonderful Boy (Caryll) (From "Tip Top")-Soprano-tenor, Helen Bell Rush-Reese Jones
50717 Baby Dreams (Stothart) (From "Jimmie")-Soprano... Elizabeth Spencer and Mixed Chorus
Margie-Medley Fox-trot, for dancing,

EDISON AMBEROL RECORDS

- ROYAL PURPLE RECORDS
29072 Old Fireside (Towner)-Baritone, Thomas Chalmers and Mixed Chorus
29073 Largo-Sonate in G Minor (Marcello)-Violoncello ... Maurice Maréchal
REGULAR LIST
4206 Biddy (Zamecnik)... New York Military Band
4207 Lindy (Berlin)-Male voices... Premier Quartet
4208 Garden of Roses (Schmid)-Tenor... Lewis James
4209 Broadway Rose (Spencer-Fried)... Lyric Male Quartet
4210 Beela Boola (Rosey)-Male quartet, Electric City Four
4211 Bells of St. Mary's (Adams)-Tenor... Lewis James
4212 I'm a Lonesome Little Raindrop ("Greenwich Village Follies of 1920") (Hanley)-Tenor, Reese Jones
4213 Darling-Intro.: "Just Snap Your Fingers at Care"-Medley Fox-trot, for dancing, Max Fells' Della Robbia Orchestra
4214 12th Street Rag (Bowman), Imperial Marimba Band
4215 Ragtime at Pun'kin Center (Stewart)-Rural story ... Cal Stewart
4216 Sparklets (Miles) ... Conway's Band
4217 Annie, My Own (Scharf)-Fox-trot, for dancing... Harry Raderman's Jazz Orchestra
4218 Satisfied (Briers)... Albernad and Ernest Hare
4219 I've Got the Blues for My Kentucky Home (Gaskill)-Male voices... Premier Quartet
4220 Margie-Intro.: "Look What You've Done with Your Dog-Gone Dangerous Eyes"-Medley Fox-trot... Max Fells' Della Robbia Orchestra
4221 Play Me a Dixie Melody (Rose)... Al Bernard
4222 Miss Johnson's Party Medley-Hornpipes, violin, Joseph Samuels
4223 Grieving for You-Intro.: "I'm a Little Nobody That Nobody Loves"-Medley Fox-trot, for dancing... Lenzberg's Riverside Orchestra
FRENCH RECORDS
27198 Ma Vigne et Ma Mie (My Vine and My Beloved) (Cuvillier)-Tenor... Paul Dufault
Chanson de l'Adieu (Song of Farewell) (Tosti)-Tenor ... Paul Dufault
WELSH RECORDS
14213 Mentra Gwen (Stars in Heav'n Are Bright)-Tenor ... R. Festyn Davies
GERMAN RECORDS
26208 An der Isar Ländler (By the River Isar), Oberbayerische Bauernkapelle
26209 "S Almstrausli" Ländler, Oberhayerische Bauernkapelle

PATHE FRERES PHONOGRAPH CO.

- "POP" SUPPLEMENT NO. 43
POPULAR VOCAL
22505 Love in Lilac Time (Furber-Lensen)-Baritone, William Lowe
Whip-poo-will, from "Sally" (DeSylva-Kern)-Soprano ... Gladys Rice
20490 Make Believe (Davis-Schilkret)-Tenor duet, Stanton Rhodes-Vincent-France
Aunt Jemina's Jubilee (Tracey-Pinkard)-Male quartet ... The Harmonizers
20491 Angels (We Call Them Mothers Down Here) (Kalmar-Ruby)-Baritone ... James Douglas

(Continued on page 184)

ADVANCE RECORD BULLETINS FOR APRIL—(Continued from page 183)

- Sweet Bells of San Jose (MacBoyle-Rosemont-Kortlander)—Tenor-haritone duet, Robert Bruce-James Douglas 10
- 20492 Sunny Sue (Lewis-Young-Donaldson)—Baritone, Ernest Hare 10
- A Dream of Your Smile (Conrad)—Tenor, Carlton Williams 10
- 22506 I'm Missin' Mammy's Kissin' (Clare-Pollock)—Male trio.....Orpheus Trio 10
- Over the Hill (Klein-Allen-Rubens)—Tenor, Lewis James 10
- 20493 Loveless Love (Handy), Noble Sissle and His Sizzling Syncopaters 10
- Royal Garden Blues (Williams-Williams), Noble Sissle and His Sizzling Syncopaters 10
- 20494 Na-Jo (Wiedoeft-Holliday)—Fox-trot—Saxophone passage by Rudy Wiedoeft, Lanin's Roseland Orchestra 10
- Happiness (Meyer)—Fox-trot, Lanin's Roseland Orchestra 10
- 20495 All For You (Davis-Johnson)—Fox-trot, Casino Dance Orchestra 10
- Oh! Boy (I've Found the Baby for Me) (Little-Stanley-Dellon)—One-step, Casino Dance Orchestra 10
- 20497 Calling (Freedman-Squires)—Fox-trot, Vernon Country Club Orchestra 10
- Honey (Ager)—Fox-trot, Vernon Country Club Orchestra 10
- 20496 On a Far Alone Isle (Brennan-Rule)—Fox-trot, Vernon Country Club Orchestra 10
- Sweet Love (Smalle)—Fox-trot, Vernon Country Club Orchestra 10
- 20498 Mazie (Caine-Dawson-Gold)—Fox-trot, Green Brothers' Novelty Band 10
- Do You Ever Think of Me? (Burnett)—Fox-trot.....Green Brothers' Novelty Band 10
- 40217 Ragamuffin (DeWitt-Janssen)—Fox-trot, Werner Janssen at piano.....Hub Dance Orchestra 10
- My Java Belle (Spear-Janssen)—Fox-trot, Werner Janssen at piano.....Hub Dance Orchestra 10
- 20499 Railroad Blues (Roberts)—Fox-trot, Synco Jazz Band 10
- Sweet Mamma (Papa's Getting Mad) (Little-Frost)—Fox-trot.....Synco Jazz Band 10
- REGULAR PATHE APRIL LIST
- 54068 Inter Nos (Stidman-MacFadyen)—Basso, in English.....Adamo Didur 12
- 27518 Cradle Song (Wiegenlied) (Brahms)—Contralto, in German.....Kathleen Howard 10
- Dream Faces (Hutchison)—Contralto, Kathleen Howard 10
- 54067 Jean (Stanton-Burleigh)—Soprano, Claudia Muzio 12
- STANDARD SONGS SUNG IN ENGLISH
- 22488 Love's Old Sweet Song (Bingham-Molloy)—Contralto.....Marion Cox 10
- Little Bunch O' Honeyess (Deacey-Hahn)—Contralto.....Marion Cox 10
- 25051 Bring Back the Golden Days (Gillespie-Stickles)—Baritone.....Percy Hemus 10
- Ashes of Dreams (Gillespie-Harling)—Baritone, Percy Hemus 10
- 22489 The Want of You (Gillespie-Vanderpool)—Baritone.....William Simmons 10
- Duna (Pickthall-McGill)—Baritone, William Simmons 10
- 22476 Mother of Pearl (McCarthy-Graff-Ball)—Tenor, William Rees 10
- Because (Teschemacher-D'Hardelot)—Tenor, William Rees 10
- 40216 Gems, from "Mlle. Modiste" (Herbert), Pathé Light Opera Co. 12
- Gems, from "The Mikado" (Gilbert-Sullivan), Pathé Light Opera Co. 12
- 20483 Steal Away to Jesus (Freman)—Negro Spiritual, Noble Sissle's Southland Singers 10
- Hallelujah to the Lamb (Freman)—Negro Spiritual.....Noble Sissle's Southland Singers 10
- NEW INSTRUMENTAL RECORDS
- 22490 Twilight Hour (Savino)—Intermezzo, Pathé Concert Orchestra 10
- A Kiss to Remember Me By (Hamilton-Breir-Weinstein).....Pathé Concert Orchestra 10
- 22491 Witch of the Waves (Medley Irish Reels)—Intro.: "Half Penny," "Parnell's," "Temperance," "Blodgett's"—Violin.....Joseph Samuels 10
- Miss Johnson's Party (Medley Irish Hornpipes)—Intro.: "Mississippi," "Fisher's," "Ladies' Triumph," "Saratoga"—Violin, Joseph Samuels 10
- 59089 Liebeswalzer (Love Waltz) (Moszkowski)—Piano solo.....Rudolph Ganz 12
- 2me Mazurka (Godard)—Piano solo, Rudolph Ganz 12
- 22492 (Pathé) Velma (Rosebrok)—Saxophone solo, Rudy Wiedoeft 10
- 022492 (Actuelle) Marriage Bells (O'Reardon)—Banjo-saxophone-piano.....Van Eps-Banta Trio 10

BRUNSWICK RECORDS

- 10027 Witches' Dance (Hexentanz-MacDowell)—Piano Solo.....Leopold Godowsky 10
- 10028 Annie Laurie (Douglass-Scott)—Soprano, with orch. accomp.....Dorothy Jardon 10
- 10029 Orientale (Cui-Persson)—Violin Solo.....Max Rosen 10
- 13018 Mother Machree (O'cott-Ball)—Tenor, with orch. accomp.....Theo Karle 10
- Come Back to Erin (Claribel)—Tenor, with orch. accomp.....Theo Karle 10
- 13017 Old Refrain (Kreisler-Loesser)—Violin Solo, Elias Breeskin 10
- Serenade (Pierne-Gruen)—Violin Solo, Elias Breeskin 10
- 5042 Still Sweeter Every Day (Martin-Miles)—Male Quartet.....Criterion Quartet 10
- Brighten the Corner Where You Are (Gabriel)—Male Quartet.....Criterion Quartet 10
- 5040 Tales of Hoffmann—Barcarolle—(Oh, Night of Love—Act III) (Offenbach)—Soprano-Contralto, with orch.....Marie Tiffany-Elizabeth Lennox 10
- Elegie (Song of Mourning) (Massenet-Courben)—Soprano, with piano accomp. and violin obbligato Marie Tiffany 10
- 25003 Marche Slave (Tschaiakowsky)—Concert Band, Vessella's Italian Band 10
- Danse Macabre (Death Dance—Op. 40) (Saint-Saens)—Concert Band.....Vessella's Italian Band 10
- 2074 Love Bird (Earl-Fiorito)—Baritone, with orch. accomp. (Saxophone passages by Wiedoeft's Saxophone Trio).....Ernest Hare 10
- Why Don't You? (From "Afgar") (McCarthy-Tierney)—Baritone, with orch. accomp. Ernest Hare 10
- 5044 My Husband's Dearest Friend (From "Honeydew") (Herbert-Zimbalist)—Duet, with orch. accomp.....Irene Williams-Sam Ash 10
- Whispering (Schonberger)—Soprano and Male Trio, with orch. accomp., Irene Williams-Crescent Trio 10
- 2078 My Isle of Golden Dreams (Intro. "Hiawatha's Melody of Love") (Blaufuss-Meyer)—Hawaiian Players.....Frank Ferera-Anthony Franchini 10

- Tripoli (Intro. "Let the Rest of the World Go By") (Weill-Ball)—Hawaiian Players, Frank Ferera-Anthony Franchini 10
- 2072 In the Dusk (Grey)—Fox-trot—For Dancing, Rudy Wiedoeft's Californians 10
- Midnight Moon (Bernard Hare)—Waltz—For Dancing.....Carl Benton's Orch. 10
- 2069 I Never Knew (Intro. "Two Sweet Lips") (Pitts-Egan-Marsh-Agar)—For Dancing—Accordion Solo.....Mario Perry 10
- Blue Jeans (Intro. "Biddy") (Traveller)—Fox-trot—For Dancing—Accordion Solo.....Mario Perry 10
- 5045 Whip-Poor-Will (Intro. "Wild Rose," from "Sally")—Fox-trot—For Dancing, Isham Jones' Orch. 10
- Look for the Silver Lining (From "Sally")—Fox-trot—For Dancing.....Isham Jones' Orch. 10
- 5046 Rose (Intro. "Soft and Low") (Magine-Biese-Westphal)—Fox-trot—For Dancing, Isham Jones' Orch. 10
- My Mammy (Donaldson)—Fox-trot—For Dancing, Isham Jones' Orch. 10
- 2077 Crazy Blues (Bradford-Bernard)—Fox-trot—For Dancing.....Bennie Krueger's Orch. 10
- Royal Garden Blues (Williams)—Fox-trot—For Dancing.....Bennie Krueger's Orch. 10
- 2070 Honolulu Eyes (Johnson-Violinsky)—Duet with Orchestra.....Charles Hart and Charles Harrison 10
- O-H-I-O (O-MY-O) (Yellen-Olman)—Tenor with Orchestra.....Billy Jones 10
- 2079 Bright Eyes (Motzan-Jerome)—Fox-trot—For Dancing—Saxophone passages by Rudy Wiedoeft.....Carl Fenton's Orchestra 10
- Honolulu Eyes (Violinsky)—Waltz—For Dancing, Carl Fenton's Orchestra 10

GENNETT LATERAL RECORDS

- 4683 I'm Gonna Do It If I Like It (Berlin)—Tenor, Orch. accomp.....Billy Jones 10
- Blue Jeans (Traveler)—Tenor, Orch. accomp., Chas. Harrison 10
- 4684 Dearest One (Blaufuss)—Tenor and Baritone Duet, Orch. accomp.....Hart-Shaw 10
- Playmates (Fisher)—Tenor and Soprano Duet, Orch. accomp.....Ballard-Kyzer 10
- 4685 Molly (Ring-Baag-Miller)—Fox-trot, Ray Miller's Black and White Melody Boys 10
- Underneath the Dixie Moon (Miller-Fazioli-Klages), Ray Miller's Black and White Melody Boys 10
- 9114 Swanee River (Foster)—Violin Solo, Piano accomp. by Paul Wagner.....Rex Taylor 10
- Believe Me, If All Those Endearing Young Charms (Moore)—Violin Solo, Piano accomp. Paul Wagner.....Rex Taylor 10
- 4680 Ah, Fors' E Lui, Part I (Verdi) (The One of Whom I Dreamed)—From "Traviata"—Soprano, Orch. accomp.....Madam Jomello 10
- Ah, Fors' E Lui, Part II (Verdi) (The One of Whom I Dreamed)—From "Traviata"—Soprano, Orch. accomp.....Madam Jomello 10
- 4681 Somewhere a Voice Is Calling (Tate)—Contralto, Piano accomp. by Hugo Manself, Violin obbligato by Percy Knowelman.....Ethel Toms 10
- Until (Sanderson)—Contralto, Piano accomp. by Hugo Manself, Violin obbligato by Percy Knowelman.....Ethel Toms 10
- 4682 Mother Machree (Ball)—Tenor, Orch. accomp., Tom Sullivan 10
- A Little Bit of Heaven (Ball)—Tenor, Orch. accomp.....Denis O'Brien 10
- 4679 My Mammy (Lewis-Donaldson)—Baritone, Orch. accomp.....Ernest Hare 10
- Over the Hill (Allen-Rubens-Klein)—Tenor, Orch. accomp.....George Wilton Ballard 10
- 2516 La Feria 2 "La Zarauella" (Gacome), Garde Republicaine Band 10
- Salut au 85 (Defile) (Pares), Garde Republicaine Band 10
- 2517 Ciribiribin (Bucalossi)—Waltz, J. H. Squire's "Karsino" Orchestra 10
- Dance of the Hours (Ponchielli)—From "La Gioconda".....J. H. Squire's "Karsino" Orchestra 10
- 2518 Love's Old Sweet Song (Malloy)—Contralto, Piano accomp. by Hugo Manself.....Ethel Toms 10
- Good-Bye (Tosti)—Contralto, Piano accomp. by Hugo Manself, Violin obbligato by Jean Frosoni.....Ethel Toms 10
- 4671 Mazie (Gold-Dawson-Caine)—Fox-trot, Green Bros. Novelty Band 10
- Two Sweet Lips (Ager)—Fox-trot, Lanin's Roseland Orchestra 10
- 4672 Mutt and Jeff (At the Shooting Gallery) (Kennedy)—Dialogue.....Porter-Kennedy 10
- Bringing Up Father (In the League of Wives) (Kennedy)—Dialogue.....Porter-Kennedy 10
- 4673 I Want to Be Ready (Burlough)—Negro Spiritual Song—Baritone, Orch. accomp.....Royal Dadman 10
- Hard Trials—Negro Spiritual Song—Baritone, Orch. accomp.....Royal Dadman 10
- 4674 The Old Gray Coat—Comic Song, Orch. accomp., Billy Williams 10
- My Girl From London Town—Comic Song, Orch. accomp.....Billy Williams 10
- 4675 Home, Sweet Home (Payne-Bishop)—Banjo and violin.....Olly Oakley and Victor Opferman 10
- Happy Scotch Homestead—Xylophone Solo, Orch. accomp.....Billy Whitlock 10
- 4676 Fairy Voices (Crowe)—Waltz—Accordion Solo, Piano accomp.....Pamby Dick 10
- Love's Dreamland (Roder)—Accordion Solo, Piano accomp.....Pamby Dick 10
- 4677 Bright Eyes Medley (Conrad-Robinson)—Fox-trot, Intro.: "Singing the Blues," Joe Coleman's President Orchestra 10
- You Ought to See My Baby Medley (Ahlert)—Fox-trot, Intro.: "No Wonder I'm Blue," Joe Coleman's President Orchestra 10
- 4678 Answer (Saying That You Love Me) (Vause)—Medley Fox-trot, Intro.: "Someone Cares," Yerkes' Dance Orchestra 10
- Make Believe (Shilkret)—Fox-trot, Lanin's Roseland Orchestra 10
- 9109 Make Up Your Mind, Maggie Mackenzie—Comic Scotch Song, Orch. accomp.....Hector Gordon 10
- Sandy, Take Hold of My Hand—Comic Scotch Song, Orch. accomp.....Hector Gordon 10
- 9110 Scots Wha Hae—Scotch Song, Orch. accomp., Archie Anderson 10
- A Man's a Man for a' That—Scotch Song, Orch. accomp.....Archie Anderson 10
- 4670 Amoureuse Waltz—Accordion Solo.....Signor Frosini 10
- Belphigor March—Concertina Solo.....Alex Prince 10
- 9111 Patience Selections, Part I (Sullivan), Gennett Military Band 10
- Patience Selections, Part II (Sullivan), Gennett Military Band 10
- 9108 Mikado Selections, Part I (Sullivan), His Majesty's Scots Guards Band 10
- Mikado Selections, Part II (Sullivan), His Majesty's Scots Guards Band 10

- 4668 The Old Rustic Bridge—Soprano and Baritone, Orch. accomp.....Trimble-Wiederhold 10
- In the Gloaming—Soprano and Baritone, Orch. accomp.....Trimble-Wiederhold 10
- 4669 The Rosary (Nevin)—Baritone, Orch. accomp., Robert Carr 10
- A Perfect Day (Bond)—Baritone, Orch. accomp., Archie Nicholson 10
- 9112 Pirates of Penzance, Part I (Sullivan), His Majesty's Scots Guards Band 10
- Pirates of Penzance, Part II (Sullivan), His Majesty's Scots Guards Band 10
- 9113 H. M. S. Pinafore, Part I (Sullivan), His Majesty's Scots Guards Band 10
- H. M. S. Pinafore, Part II (Sullivan), His Majesty's Scots Guards Band 10

PARAMOUNT RECORDS

- INSTRUMENTAL RECORDS
- 50041 Schubert's Serenade—Saxophone Solo, Saxophone With Creatore and His Band 10
- Spring Song—Clarinet Solo, Clarinet With Creatore and His Band 10
- 33077 Blaze Away March (Holzman)—Military Band, Rogers' Band 10
- Pasadena Day March (Vesselle)—Military Band, Rogers' Band 10
- 33080 Medley of Southern Melodies—Banjo Solo, Fred Van Eps 10
- Dixie Medley—Banjo Solo.....Fred Van Eps 10
- 33081 Carnival of Venice (Arban)—Xylophone Solo, Raymond C. Ellis 10
- Estudiantina Waltz (Emil Waldteufel)—Xylophone Solo.....Raymond C. Ellis 10
- 33082 Schubert's Serenade—Violin Solo, Leopold Lichtenberg 10
- Traumerei (Reverie)—Violin Solo, Leopold Lichtenberg 10
- VOCAL RECORDS
- 33079 Hosanna (Jules Granier)—Tenor Solo.....Ernest Davis 10
- The Palms (J. Faure)—Tenor Solo.....Ernest Davis 10
- 20045 Why Don't You? (Tierney-McCarthy)—Soprano-Tenor Duet, orch. accomp.....Young-Harrison 10
- O-H-I-O (Yellen-Olman)—Baritone Solo, orch. accomp.....Ernest Hare 10
- DANCE RECORDS
- 20046 Love Bird (Earl-Fiorito)—Fox-trot, The Frisco Syncopaters 10
- Oriental Blues (Charles Bird)—Fox-trot, Merry Melody Men 10
- 20047 Bright Eyes (Motzan-Jerome-Smith)—Fox-trot, The Frisco Syncopaters 10
- Cuban Melodies (Arranged by C. Coleman)—Fox-trot.....The Frisco Syncopaters 10
- 20044 That Naughty waltz—For Dancing, Selvin's Novelty Orch. 10
- My Isle of Golden Dreams—Waltz, Selvin's Novelty Orch. 10

OKEH RECORDS

- 50001 I Hear You Calling Me—Tenor, with Orch., John McCormack 12
- 50005 Celeste Aida (From "Aida")—Tenor, with Orch., John McCormack 12
- 5003 Caro Nome (Dear Name) (From Opera, "Rigoletto," Act 2)—Soprano, with Orch., Marina Campanari 12
- Cavatina (From Opera, "Don Pasquale")—Soprano, with Orch.....Marina Campanari 12
- 4272 The Palms (Sacred)—Baritone, with Orch., Bernard Ferguson 10
- Crucifix (Sacred)—Tenor-baritone duet, with Orch.....Charles Henry-James Jordon 10
- 4273 Beautiful Saviour (Sacred), Shannon Four-Jane Neilson 10
- When Cathedral Bells at Twilight Chime, Shannon Four-Jane Neilson 10
- 4253 Lovin' Sam From Alamam (Popular Blues)—Vocal.....Mamie Smith and Her Jazz Hounds 10
- Don't Care Blues (Popular Blues)—Vocal, Mamie Smith and Her Jazz Hounds 10
- 4267 Kuu Pua Loke (Our Blossom Rose)—Hawaiian yodeling.....Prince Lei Lani 10
- Kawaihau—Hawaiian guitar duet, Ferera-Franchini 10
- 4268 Over the Hill—Tenor, with Orch., Billy Jones 10
- Playmates—Tenor, with Orch.....Charles Hart 10
- 4269 Scandal—Tenor duet, with Orch., Billy Jones-Ed. Smalle 10
- She Walks in Her Husband's Sleep—Tenor, with Orch.....Billy Jones 10
- 4270 I'm Missin' Mammy's Kissin'—Vocal, with Orch., Crescent Trio 10
- Sighing—Vocal, with Orch.....Crescent Trio 10
- 4271 Little David, Play on Your Harp (Negro Spiritual).....Southland Jubilee Singers 10
- Great Camp Meeting—Jubilee song, Southland Jubilee Singers 10
- 3001 Trovatore (Grand selection from Opera, "Trovatore").....Conway's Band 12
- Reminiscences of Verdi (Intro.: "Il Lombardi," "Rigoletto," "Il Trovatore," "Un Ballo in Maschera," "La Traviata").....Conway's Band 12
- 3002 Grand March From "Tannhauser," European Symphony Orchestra 12
- Wedding March (Mendelssohn), European Symphony Orchestra 12
- 3003 Selections From "La Traviata"—Part 1, European Symphony Orchestra 12
- Selections From "La Traviata"—Part 2, European Symphony Orchestra 12
- 3004 Hungarian Rhapsody No. 2—Part 1 (Fr. Liszt), European Symphony Orchestra 12
- Hungarian Rhapsody No. 2—Part 2 (Fr. Liszt), European Symphony Orchestra 12
- 4242 Il Bacjo (The Kiss)—Waltz—Whistling, with Orch.....Guido Gialdini 10
- Tout Passe—Waltz—Whistling, with Orch., Guido Gialdini 10
- 4250 Crazy Blues—Fox-trot, Joseph Samuels' Jazz Band 10
- Home Again Blues—Fox-trot, Joseph Samuels' Jazz Band 10
- 4251 Bright Eyes—Fox-trot.....Ray Miller (Melody King) and His Black and White Melody Boys 10
- Molly—Fox-trot.....Ray Miller (Melody King) and His Black and White Melody Boys 10
- 4252 Oh Gee! Say Gee! You Ought to See My Gee Gee From the Fiji Isle—Fox-trot, Joseph Samuels' Jazz Band 10
- O-H-I-O (O-MY-O)—Fox-trot, Hager's Dance Orchestra 10
- 4254 Shim-Me-King's Blues—Fox-trot, Mamie Smith's Jazz Hounds 10
- Royal Garden Blues—Fox-trot, Mamie Smith's Jazz Hounds 10

RECORD BULLETINS FOR APRIL
(Continued from page 184)

- 4255 My Mammy—Fox-trot,
Green Brothers' Novelty Band 10
Sweet Mama—Fox-trot,
Joseph Samuels' Jazz Band 10
- 4256 I Used to Love You, But It's All Over Now—
Fox-trotOrlando's Orchestra 10
Pitter Patter—Waltz...Hager's Dance Orchestra 10
- 4257 Underneath the Dixie Moon—Fox-trot,
Ray Miller (Melody King) and His Black
and White Melody Boys 10
Jungo Land—One-step,
Ray Miller (Melody King) and His Black
and White Melody Boys 10
- 4258 Sally Medley (Intro.: "Whip-poor-will" and
"Look for the Silver Lining") (From Musical
Play, "Sally")—Fox-trot...Rega Dance Orch. 10
Bird Voices and Whistling by Sihyl Sanderson
Fagan 10
Love Bird—Fox-trot.....Rega Dance Orch. 10
Bird Voices and Whistling by Sihyl Sanderson
Fagan 10
- 4259 A la Patee—One-step.....Rega Dance Orchestra 10
I Never Knew—Fox-trot,
Lanin's Roseland Orchestra 10
- 4260 The St. Louis Blues—Fox-trot,
Rudy Wiedoeft's Palace Trio 10
Spread Yo' Stuff—Fox-trot,
Joseph Samuels' Jazz Band 10
- 4261 China Moon—Fox-trot,
Green Brothers' Novelty Band 10
Midnight Moon—Waltz.....Orlando's Orchestra 10
- 4262 In Madagascar Land—Fox-trot,
Rudy Wiedoeft's Palace Trio 10
Arahia—Fox-trot...Green Brothers' Novelty Band 10
- 4263 Dreamy Paradise—Fox-trot...Okeh Marimba Band 10
Just We Two—Waltz.....Okeh Marimba Band 10
- 4264 The Scholar (Irish Reel)—Accordion,
Peter J. Conlon 10
Harvest Home and Galway Bay (Horn Pipes)—
AccordionPeter J. Conlon 10
- 4265 Ave Maria, Part 1—Violin solo...M. Michailow 10
Ave Maria, Part 2—Violin solo...M. Michailow 10
- 4266 Angel Serenade—Violin, flute and harp,
Instrumental Trio 10
Intermezzo From "Cavalleria Rusticana"—Violin,
flute and harp.....Instrumental Trio 10
- 4241 El CapitanConway's Band 10
The New Colonial March.....Conway's Band 10

CARDINAL PHONOGRAPH CO.

- 2013 Oh, Gee, Say, Gee, You Ought to See My Gee
Gee From the Fiji Isle—Orch. accomp.,
Fred Whitehouse
- 2014 Get Up—Orch. accomp.....Ernest Hare
Rose—Fox-trot.....Rudy Wiedoeft's Palace Trio
Show Me How—Fox-trot.Rudy Wiedoeft's Palace Trio
- 2015 County Kerry Mary—Orch. accomp...Chas. Harrison
It's All Over Now—Orch. accomp...Helen Bell Rush
- 2016 My Mammy, with Vocal Chorus—Fox-trot,
Selvin's Orchestra
Why Don't You?.....Selvin's Orchestra
2017 Now and Then.....Selvin's Dance Orchestra
I Never Knew.....Selvin's Dance Orchestra
- 2018 Honeydew,
Jos. Knecht's Waldorf-Astoria Dance Orchestra
Lotus Flower,
Jos. Knecht's Waldorf-Astoria Dance Orchestra
- 2019 Strut, Miss Lizzie—Orch. accomp.....Ernest Hare
I'm a Ladies' Home Companion—Orch. accomp.,
Fred Whitehouse
- 2020 Bright Eyes—Fox-trot,
Harry Raderman's Dance Orchestra
Broadway Rose—Fox-trot,
Harry Raderman's Dance Orchestra
- 2021 When You and I Were Young, Maggie..Taylor Trio
Sweet GenevieveTaylor Trio
- 2022 That Old Irish Mother of Mine—Orch. accomp.,
Chas. Harrison

- That Tumble-Down Shack in Athlone—Orch.
accomp.....Chas. Harrison
- 2023 Romance—Waltz,
Jos. Knecht's Waldorf-Astoria Dance Orchestra
Margie—Fox-trot..Nicholas Orlando's Dance Orchestra
- 2024 Blue Jeans—Orch. accomp.....Chas. Harrison
Out Where the West Begins—Orch. accomp.,
Chas. Harrison
- 2025 Deenah (My Argentine Rose),
Harry Raderman's Dance Orchestra
MazieHarry Raderman's Dance Orchestra
- 2026 Lights Out—MarchCardinal Concert Band
American Patrol—March.....Cardinal Concert Band

EMERSON PHONOGRAPH CO.

LATEST DANCE HITS

- 10334 Bright Eyes (Motzan-Jerome)—Fox-trot,
Plantation Dance Orchestra
Deenah (Henry Scharf)—Fox-trot,
Plantation Dance Orchestra
- 10335 I Never Realized (Melville Gideon)—Fox-trot,
Joseph Samuels' Music Masters
Spread Yo' Stuff—Blues DeLuxe (Bernard-Levy-
Crane)—Fox-trot..Joseph Samuels' Music Masters
- 10336 Love Bird (Earl-Fiorito)—Fox-trot,
Green Brothers' Novelty Band
Mazie (Caine-Dawson-Gold)—Fox-trot,
Green Brothers' Novelty Band
- 10332 Medley from "Sally"—Intro.: "Look for the Sil-
ver Lining" and "Whip-poor-will" (Jerome
Kern)—Fox-trot.....Merry Melody Men
Lady Georgia, Sweet Georgia Rose (Hugo Frey)
—Fox-trotPlantation Dance Orchestra
- 10337 Spooky-Ooky Blues (Carl Vandersloot)—Fox-trot,
Green Brothers' Novelty Band
Just Another Kiss—Intro.: "Valse Inspiration"
(J. and N. Hilbert-Thomas-Eckstein)—Waltz,
Green Brothers' Novelty Band
- 10341 Make Believe (Jack Shilkret)—Fox-trot,
Selvin's Novelty Orchestra
Love in Lilac Time (Lensen-Furher)—Waltz,
Selvin's Novelty Orchestra

LATEST SONG HITS

- 10338 What Are We Goin' to Do? (When There's
Nothing to Do on Sunday) (Pease-Nelson-
Parish)—Comedy song, Orch. accomp.,
Arthur Fields
- Rosie (Make It Rosy for Me) (Clarke-Merker)
—Baritone solo, Orch. accomp.....Arthur Fields
- 10333 I Used to Love You, But It's All Over Now
(Brown-Von Tilzer)—Baritone solo, Orch. ac-
comp.....Arthur Fields

- Roaming (Straight-Bargy)—Baritone solo, Orch.
accomp.....Arthur Fields
- 10339 Out Where the West Begins (Estelle Philleo)—
Baritone solo, Orch. accomp.....Royal Dadmun
Bedouin Love Song (Pinsuti)—Bass solo, Orch.
accomp.....Charles Laird

ARTO RECORDS

DANCE RECORDS

- 9051 Humming—Medley Fox-trot—Intro.: "Stars of
Normandy"—Chorus sung by Arthur Hall,
Moulin Rouge Orchestra
Na-Jo—Fox-trot—With Rudy Wiedoeft playing
the saxophone.....Selvin's Novelty Orchestra
- 9052 Do You Ever Think of Me?—Fox-trot—Chorus
sung by Arthur Hall...Selvin's Novelty Orchestra
Kiss-A-Miss—Waltz.....ARTO Dance Orchestra

VOCAL RECORDS

- 9054 I'm Missin' Mammy's Kissin' and I Know She's
Missin' Mine.....Ernest Hare
Angels (We Call Them Mothers Down Here),
Charles Harrison
- 9055 I Like It.....Arthur Hall
Down by the O-H-I-O, O-MY-O.....Billy Jones

COLORED VOCAL RECORD

- 9053 Arkansas BluesLucille Hegamin
Accomp. by "The Blue Flame Syncopators"
I'll Be Good, But I'll Be Lonesome..Lucille Hegamin
Accomp. by "The Blue Flame Syncopators"

STANDARD VOCAL AND INSTRUMENTAL RECORDS

- 3061 Dear Little Boy of Mine... Thomas Mitchell
Long Ago in Alcalá.....George Dexter
- 3060 Gypsy Love SongGeorge Dexter
Gypsy JohnGeorge Dexter
- 3058 French National Defile March..ARTO Military Band
Father of Victory March.....ARTO Military Band
- 3059 Invincible Eagle March.....ARTO Military Band
The American Republic March..ARTO Military Band

JEWISH SONG RECORD

- 3062 Auf Dem Schlechten Weg.....Esther Feinberg
Der Chuppe Tug.....Esther Feinberg

TO ORGANIZE ACCEPTANCE BANK

Paul M. Warburg Forming Corporation to
Finance Foreign Trade by Granting Accept-
ance Credits—Hopes to Begin April 1

Organization of a new corporation, to be
known as the International Acceptance Bank,
Inc., with a fully subscribed capital of \$10,000,-
000 common and \$250,000 special stock and a
subscribed surplus of \$5,000,000, is about to be
effected, under the laws of New York, by Paul
M. Warburg, former member of the Federal Re-
serve Board, and associated interests. Mr. War-
burg will become chairman of the new bank;
F. Abbot Goodhue, now vice-president of the
First National Bank of Boston, its president,
and P. J. Vogel, of the Chase National Bank,

and E. W. Davenport, vice-president of the
First National Corp., New York, will become
vice-presidents. It is expected that the bank
will open for business April 1 at 31 Pine street.

The activities of the new bank will be con-
cerned primarily with financing American fore-
ign trade, mainly by granting acceptance
credits. It will operate under the provisions
of Section 25 of the Federal Reserve Act. In
this connection it may be noted that it will not
compete with the \$100,000,000 Foreign Trade
Finance Corp., which contemplates the issuance
of debentures, and is thereby precluded from
doing simultaneously a general acceptance busi-
ness, whereas this bank will not have this power.

Instead of establishing branches abroad the
International Acceptance Bank has arranged for
the co-operation of European banking interests.

You Ought to Know

In case you are contemplating expanding the sphere of your business to include departments devoted to Pianos, Player-Pianos, Musical Merchandise or Sheet Music, that you'll find news and comments about them all in



ESTABLISHED 1876

The oldest and leading music trade weekly, which covers every branch of the industry

It Contains

Instructive and educational articles. Hints on salesmanship and advertising. Editorials that are timely and authoritative. Facts about the new things in the trade. Trade happenings in all parts of the United States

"Review the Music Trade With Us"

Send your \$2 now for a full year's subscription to

THE MUSIC TRADE REVIEW
373 FOURTH AVENUE NEW YORK

Some Leading Jobbers of Talking Machines in America



TEST IT. 
 OUR VICTOR
Record Service
 has a reputation for efficiency.
 Suppose you try it.
E. F. DROOP & SONS CO.
 1300 G. STREET, WASHINGTON, D. C.
 231 N. HOWARD STREET, BALTIMORE, MD.

William Volker & Co., Kansas City, Mo.; Houston, Tex., and Denver, Col.

Pathé
 DISTRI
 Complete Pathephone and Pathe Record Stocks.
 The best proposition for the progressive dealer.

Sherman, Clay & Co.

 San Francisco, Los Angeles, Portland, Seattle, Spokane
 PACIFIC COAST DISTRIBUTORS OF
 VICTOR PRODUCTS

The PERRY B. WHITSIT CO.
 Distributors of
Victrolas and Victor Records
 COLUMBUS, OHIO

 Where Dealers May Secure
COLUMBIA
 Product
 Ready, Full Stocks, and Prompt Deliveries
 from Convenient Shipping Centers
 all over the United States

W. J. DYER & BRO.
 DYER B'LD'G, ST. PAUL, MINN.
 NORTHWESTERN DISTRIBUTORS
 OF THE
VICTOR
 Machines, Records and Supplies

 Shipped Promptly to all
 Points in the Northwest

Mickel Bros. Co.
 Omaha, Nebraska
 Des Moines, Iowa
Victor Distributors

Wholesale Exclusively
EASTERN TALKING MACHINE CO.
 85 Essex Street, Boston
VICTOR DISTRIBUTORS

Every talking machine jobber in this country
 should be represented in this department, no
 matter what kind he handles or where he is
 located. The cost is slight and the advantage
 is great.

ARTICLES OF INTEREST IN THIS ISSUE OF THE WORLD

Ready Reference for Salesmen, Dealers and Department Heads

The "Will to Sell" Essence of Business Success	3	Importance of Talking Machine Merchandising	48
Advantage of Record Purchase Cards in Keeping Record Stock Up to Date.....	4	Notable Contributor to the Popularization of Art	65
Constructive Suggestions on Taxes.....	8	Featuring the Musical Possibilities of the Talking Machine	69
A Time to Keep Watch on Sales Methods	8	Business Conditions Show Signs of Improvement	72
How Singers Have Become Immortal.....	8	Worth-While Hints on Canvassing.....	75
Concentrate on a Selling Campaign.....	8	Veteran Salesman Enthuses Over Salesmanship Course	79
Making the Proper Preparations for a Large Crop of Business This Spring.....	11	Caruso's Voice Not Impaired	83
How a Local Trade Organization Can Work to Discourage the "Dead Beat".....	15-16	Some Hints for Association Members.....	94
The Talking Machine Entering the Realm of Literature in the Home.....	21	Conditions in Mid-West Reviewed.....	128-129
Twenty-two Pure Voices Out of 3,800.....	25	Educational Conference to Be Held in Chicago	140
Federal Tax Program Suggested by Music Industries Chamber of Commerce.....	26	Leading Orchestra Leaders Tell the Most Popular "Hits"	151
Methods of Increasing Talking Machine Sales Interestingly Described.....	29	Handling Sheet Music to Help Sales Totals	153
Planning Expert Sales Promotion Work for Dealers	31	Getting the March on Your Competitor...	159
Artist's Tribute to the Talking Machine....	37	Robert Gordon's Page of Sales Suggestions	159
Why the Popular Record Sells So Well..	40	Ten Commandments of Salesmanship Defined for Talking Machine Men by Dr. Frank Crane	173-175

Distributors

Atlanta, Ga., Columbia Graphophone Co., 63 N. Pryor St.
 Baltimore, Md., Columbia Graphophone Co., 16 South Howard St.
 Boston, Columbia Graphophone Co., 1000 Washington St.
 Buffalo, N. Y., Columbia Graphophone Co., 737 Main St.
 Burlingame, Cal., Columbia Graphophone Co., 1130 Balboa Ave.
 Chicago, Ill., Columbia Graphophone Co., 325 W. Jackson Blvd.
 Cincinnati, O., Columbia Graphophone Co., 317-321 East 8th Street.
 Cleveland, O., Columbia Graphophone Co., 1812 East 30th St.
 Dallas, Tex., Columbia Graphophone Co., 316 North Preston St.
 Denver, Colo., Columbia Stores Co., 1608 Glenarm Ave.
 Detroit, Mich., Columbia Graphophone Co., 115 State St.
 Indianapolis, Ind., Columbia Graphophone Co., 209 W. Washington St.
 Kansas City, Mo., Columbia Graphophone Co., 2006 Wyandotte St.
 Los Angeles, Cal., Columbia Graphophone Co., 809 S. Los Angeles St.
 Minneapolis, Minn., Columbia Graphophone Co., 18 N. 3rd St.
 New Haven, Conn., Columbia Graphophone Co., 206 Meadow St.
 New Orleans, La., Columbia Graphophone Co., 517-525 Canal St.
 New York City, Columbia Graphophone Co., 121 West 20th St.
 Omaha, Neb., Columbia Graphophone Co., Elgth and Jackson Sts.
 Philadelphia, Pa., Columbia Graphophone Co., 40 N. 6th St.
 Pittsburgh, Columbia Graphophone Co., 632-640 Duquesne Way.
 Salt Lake City, Utah, Columbia Stores Co., 221 South West Temple.
 Seattle, Wash., Columbia Graphophone Co., 911 Western Ave.
 Spokane, Wash., Columbia Stores Co., 161 South Post St.
 St. Louis, Mo., Columbia Graphophone Co., 1127 Pine St.
 Tampa, Fla., Tampa Hardware Co.

Headquarters for Canada:
 Columbia Graphophone Co., 54-56 Wellington St., West, Toronto, Ont.

Executive Office
COLUMBIA GRAPHOPHONE CO.
 Woolworth Building New York

Edison Message No. 93

It is the record of this company that the prices of Edison Phonographs increased less than 15%, including War Tax, since 1914.

We should regret a further advance in Edison Phonograph prices, especially at this late date, but such must be the case, should the Government increase the Excise Tax on phonographs.

THOMAS A. EDISON, Inc.

ORANGE, NEW JERSEY

JOBBER OF THE NEW EDISON, EDISON RE-CREATIONS, THE NEW EDISON DIAMOND AMBEROLA AND BLUE AMBEROL RECORDS

CALIFORNIA
Los Angeles—Edison Phonographs, Ltd.
San Francisco—Edison Phonographs, Ltd.

COLORADO
Denver—Denver Dry Goods Co.

CONNECTICUT
New Haven—Pardee-Ellenberger Co., Inc.

GEORGIA
Atlanta—Phonographs, Inc.

ILLINOIS
Chicago—The Phonograph Co.
Wm. H. Lyons (Amberola only).

INDIANA
Indianapolis—Lupp Phonograph Co.

IOWA
Des Moines—Harger & Blish.
Sioux City—Harger & Blish.

LOUISIANA
New Orleans—Diamond Music Co., Inc.

MASSACHUSETTS
Boston—Pardee-Ellenberger Co.
Iver Johnson Sporting Goods Co. (Amberola only).

MICHIGAN
Detroit—Phonograph Co. of Detroit

MINNESOTA
Minneapolis—Laurence H. Lucker

MISSOURI
Kansas City—The Phonograph Co. of Kansas City.
St. Louis—Silverstone Music Co.

MONTANA
Helena—Montana Phonograph Co.

NEBRASKA
Omaha—Shultz Bros.

NEW YORK
Albany—American Phonograph Co.
New York—The Phonograph Corp. of Manhattan.
Syracuse—Frank E. Bolway & Son, Inc. W. D. Andrews Co. (Amberola only).

OHIO
Cincinnati—The Phonograph Co.
Cleveland—The Phonograph Co.

OREGON
Portland—Edison Phonographs, Ltd.

PENNSYLVANIA
Philadelphia—Girard Phonograph Co.
Pittsburgh—Buehn Phonograph Co.
Williamsport—W. A. Myers.

RHODE ISLAND
Providence—J. A. Foster Co. (Amberola only).

TEXAS
Dallas—Texas-Oklahoma Phonograph Co.

UTAH
Ogden—Proudfit Sporting Goods Co.

VIRGINIA
Richmond—The C. B. Haynes Co., Inc.

WISCONSIN
Milwaukee—The Phonograph Co. of Milwaukee.

CANADA
Montreal—R. S. Williams & Sons Co., Ltd.
St. John—W. H. Thorne & Co., Ltd.
Toronto—R. S. Williams & Sons Co., Ltd.
Vancouver—Kent Piano Co., Ltd.
Winnipeg—R. S. Williams & Sons Co., Ltd.
Babson Bros. (Amberola only).
Calgary—R. S. Williams & Sons Co., Ltd.

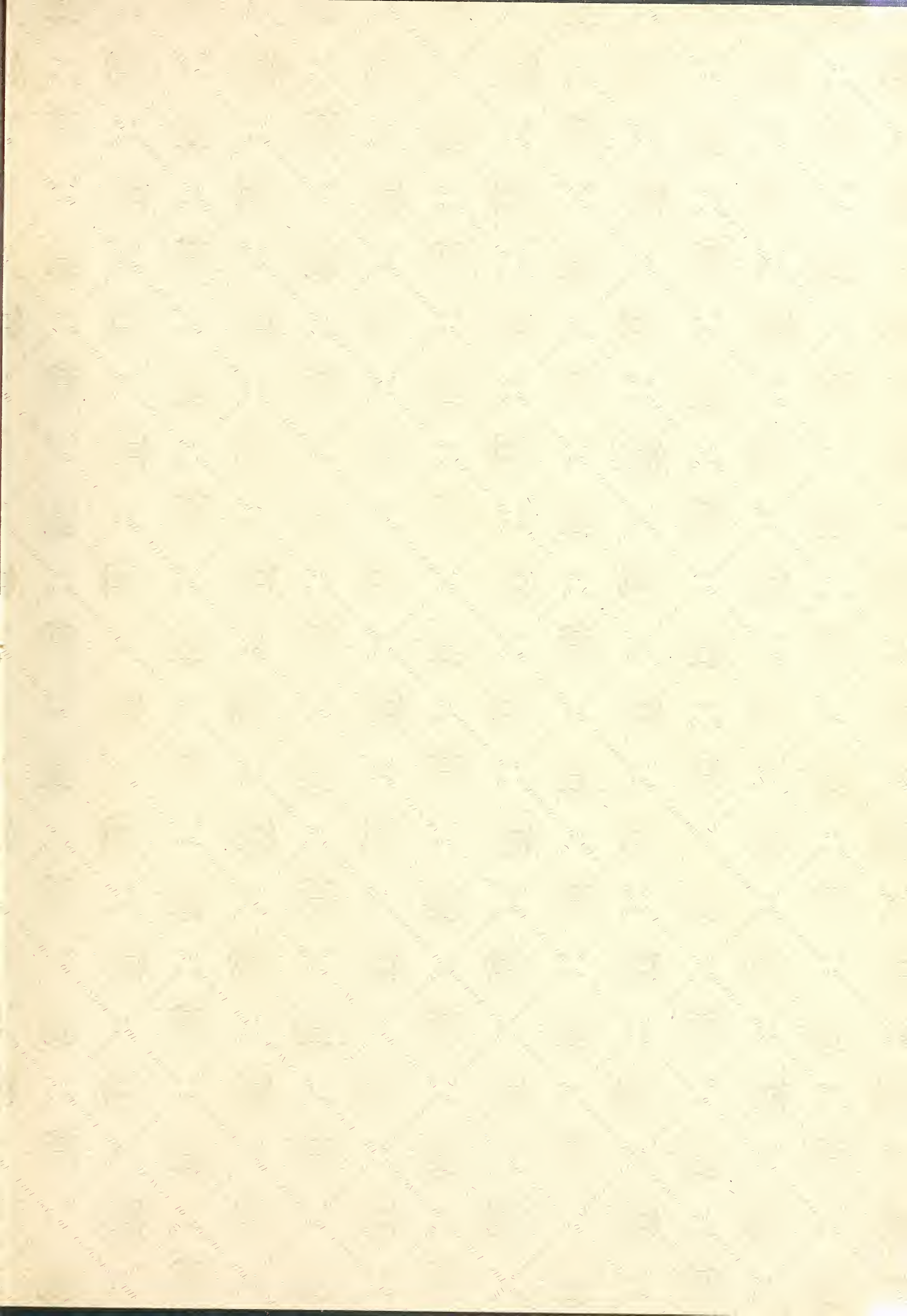

LIBRARY OF CONGRESS



0 021 248 787 9