

UC-NRLF



5C 15 775



















# Building the New Rapid Transit System of New York City

*Written by*

FRED LAVIS

From personal studies for ENGINEERING  
NEWS with use of official data and photo-  
graphs of the Public Service Commission

## Design of the New Elevated Railway Lines

*By* MAURICE E. GRIEST

Assistant Designing Engineer Public Service  
Commission for the First District

REPRINTED FROM ENGINEERING NEWS  
HILL BUILDING, NEW YORK

1915

UNIVERSITY OF  
CALIFORNIA



TF847  
N5L3

*Copyright 1915*  
HILL PUBLISHING CO.

THE  
HILL  
PUBLISHING  
CO.

1915



## Preface

It is not generally realized how huge an engineering work it is which is now going forward in the city of New York on extensions of the underground rapid-transit railway lines. The best way to compare the relative magnitude of engineering works is to compare the total expenditure involved. The total cost of building and equipping New York's new rapid-transit lines will be in the neighborhood of \$366,000,000. This is substantially equal to the entire cost of the Panama Canal. It is three times the cost of the New York barge canal. It is a greater amount than the total investment in road and equipment of the Chicago, Milwaukee & St. Paul Railway Company, or the Rock Island, or the Chicago & North Western, or the Great Northern, or the New York Central & Hudson River.

The building of underground rapid-transit lines in great cities is comparatively a new development in engineering. New York was not the pioneer in this field. The first underground city railway lines were those in London, operated for many years with steam locomotives. Underground lines operated by electric traction were built in London and Budapest and Boston before the first New York rapid-transit subway was in operation. The development of the system in New York, however, has far exceeded that in any other city of the world. In fact, with the completion of the new extensions the investment in underground rapid-transit lines in New York will probably be as great as that in all the other great cities of the world combined.

The building of subways, however, is well recognized to be the next step in rapid-transit development for the congested districts of other large cities. Philadelphia, Chicago, Cleveland, and a number of other American cities have subways under way or projected. The work carried on in New York during the past dozen years, and especially that now in progress, has developed a large amount of experience in street excavation with avoidance to traffic interruption, in the underpinning of buildings, and in the solution of a hundred different problems in connection with the work of construction which are of general interest to the engineering profession.

The editors of *ENGINEERING NEWS* deemed it important that a thorough expert study of the New York subway work should be made for the benefit of its readers, and arranged with Mr. Fred Lavis, M. Am. Soc. C. E., to undertake this work and present the results in the columns of *ENGINEERING NEWS*. The articles written by Mr. Lavis were published in *ENGINEERING NEWS*, beginning Oct. 1, 1914, and concluding Dec. 31. In response to numerous requests it was deemed advisable to reprint these articles in book form.

Acknowledgment is here made to the engineering and executive staff of the Public Service Commission for the courtesies and aid extended to Mr. Lavis and to the editors in connection with the preparation of the articles here reprinted and

for the furnishing of the drawings and photographs here reproduced. In fact, it was only through the coöperation of the engineering staff that it was possible to prepare an adequate account of the work.

As was remarked in an editorial published in the issue of *ENGINEERING NEWS* in which Mr. Lavis' first article appeared, the greatest difficulty in describing a work of such a magnitude is to know what to put in and what to leave out. As every engineer who has been connected with a great enterprise knows, the complete story of the work, with all its problems and difficulties, from the original plans to the final completion, would make a volume of ponderous size. The attempt of the author has been to record in this book the facts of chief importance and interest to the engineering profession at large, and to do it in such a manner as will make the articles of general interest and at the same time convenient for reference by those who at any time may have to deal with similar problems.

The preparation of the present book was delayed to secure the addition of a paper by Mr. Maurice Griest, of the design staff of the Public Service Commission, *on the design of the elevated railways* which form part of the new rapid-transit system. This paper, which appears in *ENGINEERING NEWS* of May 20, 1915, is printed as the last chapter. It is a notable contribution to the literature of structural engineering, being the first discussion of elevated-railway design that has appeared for 15 years or more.

More than this, however—every engineer interested in the extension of rapid transit needs to study this paper. For some years fashions have run to subways, while elevated railways have been under a cloud. There is good prospect that views will shift again on these subjects. The tremendously heavy cost of subway construction, which already has discouraged or postponed progress in rapid transit in more than one city, will lead to recognition of the fact that subways are suited for only the heaviest traffic requirements. The elevated railway, bridging the long gap between trolley-car conditions and subway conditions, is sure to receive increased attention in the future.

EDITOR *ENGINEERING NEWS*.



# Contents

	<i>Page</i>
HISTORY AND EXTENT - - - - -	1
ORGANIZATION AND PERSONNEL OF THE ENGINEERING STAFF - - -	7
GENERAL ARRANGEMENTS FOR CONSTRUCTION—THE OPERATING CONTRACTS	14
DESIGN OF STRUCTURE AND TRACK - - - - -	21
VENTILATION, DRAINAGE AND WATERPROOFING—VENTILATION - - -	27
SEWERS, PIPES AND CONDUITS—ELECTRIC CONDUITS - - - - -	30
METHODS OF TIMBERING TO SUPPORT THE STREET SURFACE - - -	37
EXCAVATION - - - - -	41
UNDERPINNING BUILDINGS ALONG THE LINE - - - - -	47
TUNNELS IN CITY STREETS—THE LEXINGTON AVE. TUNNELS - - -	53
THE RIVER TUNNELS—THE HARLEM RIVER TUNNELS - - - - -	58
CONCRETE WORK - - - - -	63
DESIGN OF STEEL ELEVATED RAILWAYS - - - - -	67







# Building the New Rapid Transit System of New York City

## History and Extent

Extensions to the existing systems of rapid transit in the City of New York have been planned which will involve an estimated expenditure of \$366,000,000. The construction of these lines is now well under way and is being rapidly pushed forward at a rate which, it is hoped, will insure their completion by the end of the year 1917. The length of new line is altogether 110 miles, comprising 325 miles of single main-line track. These additions will make the total length of the completed system of rapid-transit railways in the city 230 miles, with 621 miles of single main-line track. The mileage of main-line track will thus be approximately doubled, though it is expected that the capacity for handling passengers will be increased threefold or fourfold.

The magnitude of this work may be at least partly realized by comparison of its cost with that of the Panama Canal, which, including the \$50,000,000 paid to the French, is to cost about \$375,000,000. This vast enterprise in the City of New York is progressing literally under the feet of its five million inhabitants and the other several millions of the adjacent territory whose business brings them frequently to the city, with hardly any notice or disturbance of the regular routine of business.

The cost is to be borne in approximately the following proportions, partly by the city and partly by the two operating companies which will divide the territory between them:

City of New York.....	\$200,000,000
Interborough Rapid Transit Co.....	105,000,000
New York Municipal Railway Corporation.....	61,000,000

The first of these two operating companies, the Interborough Rapid Transit Co., generally spoken of as "The Interborough," operates the present subway which traverses the length of Manhattan Island, reaching into the Borough of Bronx at one end and a short distance into Brooklyn at the other. It also operates the four lines of elevated railway in Manhattan and the Bronx, as well as the surface lines in those boroughs. The so-called Steinway or Belmont Tunnel, running from 42nd St., New York, under the East River to Long Island City, was built about five years ago by interests closely associated with the Interborough but has never yet been utilized. It is now, however, to be finished, equipped and operated by that company, in conjunction with the other lines of its system.

The New York Municipal Railway Corporation is a company formed by the Brooklyn Rapid Transit Co. to finance and operate that part of this new system of railways which falls to its share. The Brooklyn Rapid Transit Co. is familiarly known as the "B. R. T." and both it and the New York Municipal Railway Corporation will be generally so referred to hereafter. It controls all the elevated and surface lines in Brooklyn including those which reach the famous ocean summer resort at Coney Island.

Heretofore, the operations of these two systems, the In-

terborough and B. R. T., have been almost exclusively confined to territories divided by the East River, the former to Manhattan and the Bronx on its west side, and the latter to Brooklyn and the Borough of Queens on the other side.

By the new arrangement, the B. R. T. gains an entrance into Manhattan by a new tunnel from the business center of Brooklyn to the lower end of New York, thence via Broadway and 7th Ave. through the center of the business and amusement districts to 59th St. Thence it turns eastward and crosses the East River on the Queensborough Bridge to a connection with the proposed lines to Astoria and Flushing. It also reaches lower New York by a series of underground loops connecting the three lower East River bridges and the new tunnel just referred to, which will permit also continuous circulation of its trains instead of bringing them in as at present to stub-end terminals at the New York ends of the bridges.

The Interborough, besides a new north and south line in Manhattan, will reach the Borough of Queens and will have two lines to Astoria and Flushing from 42nd St., via the Steinway Tunnel. Its present line to Brooklyn



FIG. 1. ROUTE OF AN ELEVATED RAILWAY THROUGH A CABBAGE FARM IN QUEENS BOROUGH

is to be extended by two branches, each to a point some five or six miles beyond its present terminus at Atlantic Ave. into the residential section of that borough.

The Borough of Queens, comprising Long Island City, Astoria, Jamaica, Flushing, etc., which, up to the present, has never been served by any so-called Rapid Transit Lines, will now have the two elevated lines referred to which are to be operated jointly by the two companies, linked up to both the Queensborough Bridge, the Steinway Tunnel and the 2nd Ave. elevated, and thus connecting directly with all lines in Manhattan and other boroughs.

It is of some interest perhaps to note that part of this route in Queens through Roosevelt Ave., is through a street not yet constructed and marked on the ground only by monuments, being now actually used for market garden purposes, as may be seen by the accompanying photographs, Figs. 1 and 2, which were taken looking along the center line of the street.



The Borough of Richmond (Staten Island) is eventually to be connected with the B. R. T. system by a tunnel under the "Narrows," the main channel connecting the outer bay with New York Harbor. This, however, does not form part of the present definitely decided-on scheme of construction.

As part of its system of records the Commission has had many hundreds of photographs taken, showing in detail the character of the streets and of each building adjacent to or near the proposed route which might be expected to be affected in any way by the construction. This series of photographs is not only of great value for reference in case of dispute or claim for damages, which might be due to the work in hand, but forms a unique and interesting historical record of the appearance of the city at this time.

#### RECENT HISTORY

The adoption of the present scheme and the consummation of the contracts under which the work is now being carried out is the result of negotiations which have been carried on continuously almost ever since the completion of the present subway in 1904.

Almost as soon as operation of that line was started it was seen that the profits from operation were going to be much greater than had been expected. The public lost sight of the fact that when the contracts had been first proposed it was with considerable difficulty that anyone had been induced to accept them, and there was a great outcry, especially by the sensational newspapers, against the so-called monopoly of the Interborough, and the alleged one-sided bargain with the city, and the



FIG. 2. A STREET IN QUEENS BOROUGH ON WHICH AN ELEVATED RAILWAY WILL RUN

demand arose that any future subways be operated as well as owned by the city.

Various forms of contract were therefore proposed, but none of them which required the use of private capital for construction was acceptable to bidders (see *ENG. NEWS*, Mar. 10, 1910, p. 288 for a discussion of the so-called Triborough route). Finally it was determined to start to build certain sections with the City's money, and contracts were let for the construction of part of the Fourth Ave. subway in Brooklyn, and the Centre St. loop in Manhattan, but no arrangement was made for their operation, nor was any made until the final agreement arrived at between the Public Service Commission, the City and the two operating Companies on Mar. 19, 1913.

The Public Service Commission, which succeeded the old Rapid Transit Commission, was appointed and took office in July, 1907. A new city administration under Mayor Gaynor, and including among its members Messrs. Mitchell (now Mayor), Prendergast and McAneny, came into office Jan. 1, 1910.

The bids for the Triborough were called for in Octo-

ber of that year. As noted there were no bids for construction by private capital, but numerous bids were received for construction alone with city funds. The awards for this latter were, however, held up for various reasons in spite of strenuous protests from that section of the press and public which allowed the large profits of the Interborough and the alleged monopoly of this latter to obscure their judgment as to the best interests of the city and the traveling public, which many competent authorities considered were not met by the proposed scheme for the Triborough route.

The objections to the Triborough were principally because it was proposed to build the lines without any arrangement for their operation, because it was felt that the new lines should be linked up to and form a part of the present system (the Triborough as laid out would not have permitted transfer except on payment of an extra fare), because the route was not considered well laid out, and because it was inadequate to meet the growing needs of the city and to properly provide for all the boroughs, and, above all, because at the time the amount of city money available for railway construction was very limited (not more than 60 to 70 million dollars).

From the beginning, Mayor Gaynor's administration, through the Board of Estimate (the approval of which is required on all expenditures of the city's money) adopted an attitude of coöperation with the Public Service Commission, and the present contracts are the result of nearly three years of very hard work and the most persistent, patient and diplomatic negotiation between these bodies and the companies which have now finally undertaken the operation. It was necessary that the city's credit be strengthened and its borrowing capacity be enlarged, and this in itself was no small part of the task.

During all this period, certain sections of the public press were very bitter in urging their own views, and there were many committees of citizens, public meetings, etc. At one time the Interborough entirely withdrew and everything was to be given to the B. R. T. The delay was well nigh intolerable owing to the congested and crowded condition of the present lines of transport; but it is felt now that the delay has been more than justified by the comprehensiveness of the scheme evolved, the consolidation of the lines into two large systems, either of which can be traversed throughout its length for a single fare, and the conclusion of equitable contracts by which not only will the city own the lines free of cost at the end of 49 years, but will have shared in such profits as there may be beyond a certain stated amount.

It may not be out of place to emphasize the advantage to the city from the perpetuation of the virtual monopoly of these two companies under fair and efficient regulation. The public is not only allowed a ride for a single five-cent fare over the lines of a complete system reaching almost to every part of the City of Greater New York, but the city shares in such profits as there may be from the consolidation of the management and its own contribution of credit in obtaining the greater part of the money at low rates of interest. A most important consideration is also that which provides complete plans in detail of the operation of all routes in advance of design and construction, so that these latter can proceed with an intelligent conception of the operating requirements.



## CHARACTER OF THE LINES

The 325 miles of new lines already decided on will be built underground in the more thickly populated sections of Manhattan and Brooklyn and elevated in the outlying districts. The subway will embrace various types of structures, both for two, three and four tracks, the latter in some cases all at the same level; in others as a double-deck structure, each level having two tracks. There are to be several tunnels under the rivers, some sunk from the surface by methods similar to those developed at the Detroit tunnel, and others probably to be driven by the shield method. The elevated will be mostly a steel structure of the familiar type, though of modern construction, but in some cases where parkways or boulevards are crossed or traversed it is being built of reinforced concrete with special attention to artistic architectural design, as illustrated in Fig. 3.

## IMPROVEMENTS IN DESIGN

On all the new lines a special effort will be made to locate all the stations on tangents so as to avoid the in-

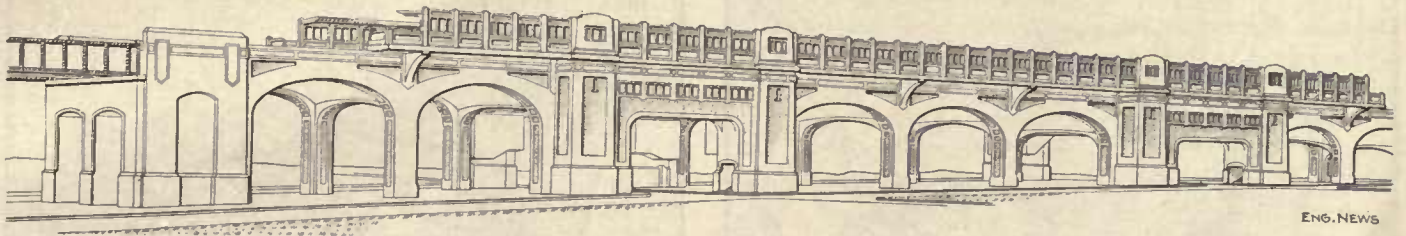

ENG. NEWS

FIG. 3. DESIGN FOR ORNAMENTAL REINFORCED-CONCRETE VIADUCT ON QUEENS BOULEVARD

convenience and possibility of danger from the space between the car and the platform on curves, which occurs at some places on the existing subway lines. An endeavor has also been made in so designing the structure at the junctions and connections of main lines and branches, etc., to avoid grade crossings of the various tracks. With the abnormal density of traffic during the rush hours this is very desirable, as the slightest delay at any one point may be, and generally is, reflected over the whole system. Footpaths at the sides of the tunnels at the level of the car platforms, similar to those built in the Pennsylvania R.R.'s New York tunnels, are to be constructed so as to provide a walk for passengers in case a train should meet with an accident and be stalled.

The new subway will be divided by partitions so as to separate the trains going in different directions, with the expectation of thereby so improving the ventilation by utilizing the piston-like action of the trains to change the air that the accumulation of excessive heat so noticeable in the summer in the present subway may be avoided.

In furtherance of this also, waterproofing will be omitted when it is possible to do so, as it is thought that the practical inclosure of the existing subway in a waterproof envelope materially helps to prevent the diffusion of the generated heat through the walls of the structure. As is well known, locally at least, this accumulation of heat in the subway in the summer time, due to the heating of the motors, the friction of brakeshoes on wheels, the wheels on the tracks, etc., has made traveling very uncomfortable at times, the installation of expensive ventilating apparatus having only partially alleviated the trouble. In the present subway there are no division walls between the tracks, and while the

trains stir up the air in passing, they do not change it very much, and not nearly to the extent so noticeable in all the single-track tube tunnels already built under the waters of New York Harbor and on all the lines of the Hudson & Manhattan Co.

Another point of interest is the provision of or for three tracks on the lines in the outlying districts where the density of travel does not require four tracks for continuous express service. This allows express service one way during the rush hours.

## EXISTING LINES

The principal features of the rapid transit lines now in operation in Manhattan are the four elevated lines running north and south through Second, Third, Sixth and Ninth Aves., the principal parts of which were built between 1870 and 1880, and the present subway, built between 1900 and 1904.\* In Brooklyn the existing elevated lines, which were built soon after those in Manhattan, radiate from the old Brooklyn Bridge, one group westerly toward Jamaica and the other toward Coney

Island. Some of these last-mentioned lines, after reaching a point some five or six miles from the bridge, drop to the surface and remain there for the rest of the way to Coney Island, and all these are to be elevated (or depressed in open cuttings), and are shown on the map as new elevated lines of the B. R. T., although through trains from the bridge to Coney Island are operated over them now.

## TRAFFIC

Almost ever since the elevated lines were first put into operation, it has been notorious that the congestion and crowding of the transportation lines of New York have been unequalled on any other transportation system in the world. The opening of the present subway in 1904, although it had then a capacity of 400,000 passengers per day, afforded little relief. By the lengthening of the express platforms to accommodate 10 instead of eight cars, the installation of the most modern and approved types of automatic block signals, brakes, car and air-line couplings, center side doors, etc., its capacity was increased so that 1,250,000 passengers can be and have been handled in 24 hours, but the crowding during the rush hours is as bad as ever on all lines.

The following figures, condensed from a table given in the last report of the Public Service Commission, with the addition of the figures for 1913, show the great and greatly increasing amount of travel, and justify the

\*A history of the rapid transit situation up to that date and a full description of the construction features of the original subway were published in a series of articles in "Engineering News," Vol. XLVII, Jan. to June, 1902, while a description of the proposed Triborough Route and further notes to date will be found in the "Engineering News" of March 10, 1910, p. 288.



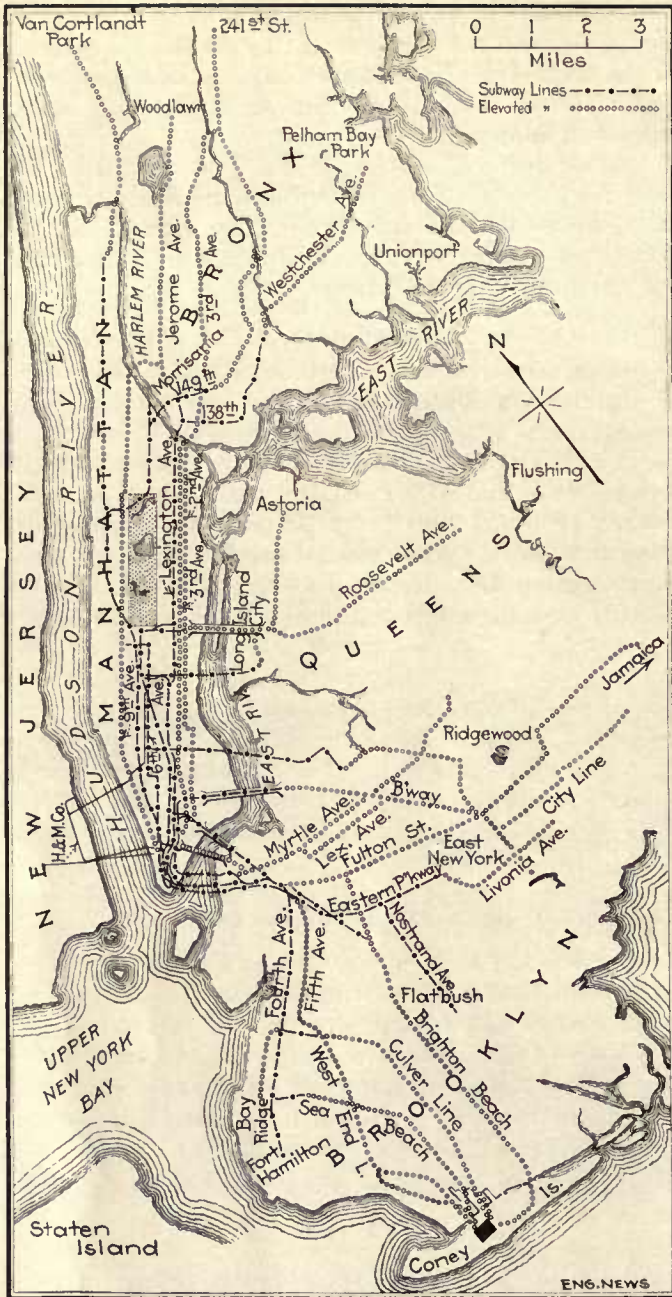

FIG. 4. THE OLDER NEW YORK RAPID TRANSIT SYSTEM AND THE NEW LINES NOW UNDER CONSTRUCTION AND PLANNED

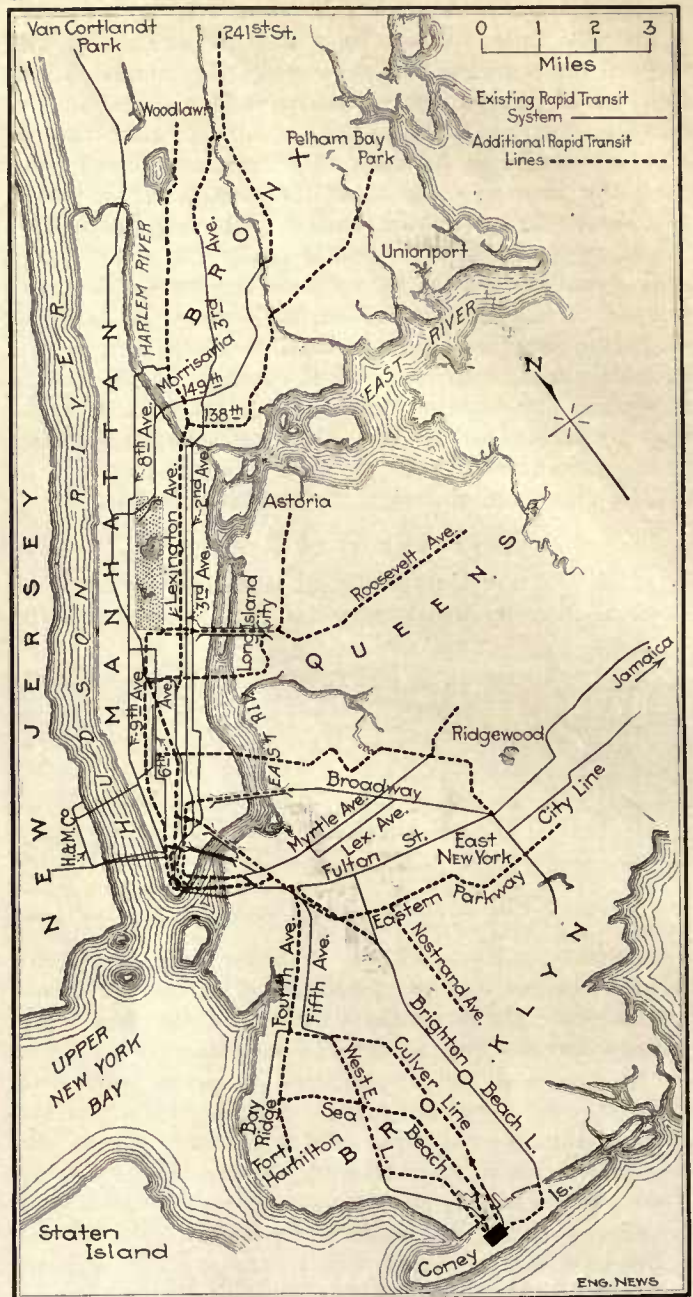

FIG. 5. SUBWAY LINES AND ELEVATED LINES IN THE COMPLETED RAPID TRANSIT SYSTEM

attempt to meet the requirements by the system now proposed, enormous though its cost will be:

NUMBER OF FARES COLLECTED (MILLIONS)

	Manhattan and Bronx		Brooklyn	Queens	Total	
	Subway	Elev. Surface	All lines	Surface		
1898.....	...	184	321	221	9	735
1903.....	...	246	427	304	16	993
1908.....	200	202	411	419	30	1342
1913.....	327	307	494	484	47	1659

(Note.—In 1905, its first year of operation, the Subway carried 75,000,000 passengers. In 1914 it carried 340,400,000 passengers.)

Ever since the opening of the present subway in 1904, plans for extensions have been under consideration, first by the old Rapid Transit Commission and since then by its successor, the Public Service Commission for the First District of New York, but for the reasons already given there were various delays until the present comprehensive scheme of routes was developed to give so far as possible and, as may be seen by the maps, fair and equitable service to all parts of the greater city.

There had been for some time a feeling that Manhattan had been unduly favored at the expense of the other boroughs, and while this to some extent is reasonable, both that it had, and that it should be, there can be little fault found with the scheme now laid out.

The routes of the various extensions and their character are shown on the maps, Figs. 4, 5 and 6, but for the benefit of those not entirely familiar with the situation it may be well to briefly enumerate their salient features and some of the details of the scheme.

NEW LINES

THE INTERBOROUGH—In Manhattan the Second, Third and Ninth elevated lines will complete the installation of third tracks from the down-town business section to above 125th St., thus enabling express trains to be run down-town in the morning and up-town at night. The present subway will be divided at 42d St., the





FIG. 6. THE SYSTEMS OF THE TWO OPERATING COMPANIES, THE INTERBOROUGH AND THE BROOKLYN RAPID TRANSIT

lower part being connected with the new Lexington Ave. subway, giving a four-track line all the way up the East Side, splitting into two three-track branches in the Bronx after it crosses under the Harlem River; the upper part will be connected to the new Seventh Ave.-Varick St. line, thus giving a through route up and down the West Side, and placing the Pennsylvania Terminal at 33d St. on a main line of the Rapid Transit system. The present West Farms branch of this line in the Bronx will be extended some five miles farther to the Mount Vernon line at the northerly boundary of the city.

The Brooklyn end of the present subway will be extended from Atlantic Ave. by two branches via Flatbush Ave. and Eastern Parkway into the residential sections of Brooklyn.

The part of the present subway on 42d St. between the Grand Central Station and Times Square will be

operated by a shuttle service between the main lines on the East and West Sides.

The Steinway tunnel will be extended back to Times Square and forward to the east end of the Queensborough Bridge, where it will connect with the two lines to Astoria and Flushing, over which both systems are to have trackage rights. The Second Ave. elevated will be connected to the Queensborough Bridge and so to these same two lines.

There will be certain other small extensions and connections to allow the proper linking up of the various lines and permit desirable or convenient combinations in the operation of trains, all of which are shown on the maps.

The Interborough will thus have, besides its four elevated lines, four double- or three-track branches in the Bronx leading to two main trunk lines (four-track) throughout the length of Manhattan on Fourth and Seventh Aves. to two tunnel routes under the East River, joining under Fulton St., the main business street of Brooklyn, and then spreading out again into two branches into the residential section of that borough. The distance from the upper end of the Bronx to the ends of the lines in Brooklyn is about 26 miles. From the center of this system there will be the offshoot at 42nd St. via the Steinway tunnels to the lines in the Borough of Queens to Astoria and Flushing.

**THE BROOKLYN RAPID TRANSIT**—Besides certain extensions of various lines in Brooklyn and the construction of the elevated structures in South Brooklyn on the Coney Island lines, as already referred to, the main features of the contract of this company with the city are those which provide for its entrance into New York and the linking up of the four bridges across the East River into lines of through travel instead of establishing terminals at their ends. There is one important new line in Brooklyn, the Fourth Ave. subway, which was started some five years ago, a considerable part of which is now nearly completed; this route extends from the Manhattan Bridge through Fourth Ave. to Fort Hamilton, and will be part of an important new route to Coney Island.

The principal line of the B. R. T. in New York will be that already described, running from the center of Brooklyn under the East River and via Broadway and Seventh Ave. to 59th St., the Queensborough Bridge and to Astoria and Flushing. This will be a four-track line in Manhattan above City Hall (Park Place).

From a certain point of view, the linking up of the New York end of the three down-town East River bridges, the old Brooklyn Bridge, the Manhattan just above it, and the Williamsburg Bridge, a mile farther up the river, is one of the most interesting features of the whole scheme. For years the crowding and congestion at the ends of the Brooklyn Bridge were worse than even on the elevated and subway lines. Nearly all the travel from the lines of the B. R. T. was concentrated at this one bridge and brought over to a stub-end terminal at the New York end. In an attempt to provide better means of communication between Brooklyn and New York, the Williamsburg Bridge was built and opened in 1905 and the Manhattan Bridge in 1908. No provision was made, however, for the operation of these bridges or their



proper connection with any of the existing lines of communication, and the people from Brooklyn have been brought over to the New York ends and dumped there, to make the best of their way to their destination. The travel between Brooklyn and New York is nearly all toward New York in the morning and toward Brooklyn at night, all four of the East River bridges providing for lines of rapid transit (two or four tracks) as well as for street cars, ordinary vehicular traffic and pedestrians.

To eliminate the stub-end terminals the so-called Centre St. loop was planned to connect up the New York ends of these three bridges, and its construction was started in 1907, though no arrangement was made for its use. Now, however, it is to be completed to a connection with the new tunnel which is to connect the B. R. T. with its Broadway line. This will enable all the trains to circulate, coming over on one bridge, continuing and returning via another instead of coming into a terminal in the congested district and having to back out.

There will be also another new route established under 14th St., New York, and the East River, to the easterly section of Brooklyn (East New York).

#### FARES

The contracts between the city and the two operating companies provide for a single fare of five cents on each system, with free transfers at intersecting points for a continuous ride in the same general direction. On the Brooklyn system, transfers will be exchanged between the elevated lines and the subway lines, but on the Interborough only such transfers as are now given will be provided between the elevated railroads and the subway. On the existing lines, as they stand today, the longest ride obtainable for five cents is through the subway from Atlantic Ave., Brooklyn, to Van Cortlandt Park or 242nd St. on the Broadway branch, a distance of  $17\frac{1}{2}$  miles. Under the dual system, as the new system has been commonly called, it will be possible to travel over the Interborough subway from the terminus of the White Plains Road line, near the northern city boundary, the whole length of the Bronx and Manhattan, under the East River to Brooklyn, and through the Eastern Parkway subway and its extensions to New Lots Ave.—a distance of about 26 miles—for one fare and without change of cars.

The longest ride on the Brooklyn system will be from Flushing, at the end of the Corona branch, to and across the Queensborough Bridge, through the Broadway subway in Manhattan, under the East River to Brooklyn and through the Fourth Ave. subway and its connections to Coney Island, about 21 miles, for five cents.

The fare from the center of Brooklyn to Coney Island had always been 10 cents (15 cents from New York) up to within the last few years, when a general agitation for its reduction was started.

As soon as the connections of the Fourth Ave. subway in Brooklyn with the elevated lines are made and through-train operation is possible from Manhattan to Coney Island, the five-cent fare between these points will apply. This, it is estimated, will take about 18 months.

#### CHANGES IN METHODS OF COMMUNICATION IN NEW YORK

Before leaving the general subject of routes, it may not be amiss to call attention to the radical change in the character of the means of communication between New York City proper (Manhattan) and the surrounding territory, which has taken place in the last six or eight years. Direct land communication has never been possible except to the north, while the most densely populated of the surrounding districts have been to the east in Brooklyn and the west in New Jersey, with which communication was only possible by means of boats of one kind or another, and from both of which districts enormous numbers of people come to Manhattan daily.

Brooklyn was connected with Manhattan by means of the famous Brooklyn Bridge as long ago as 1883; but with the completion of that structure progress along these lines stopped for almost a quarter of a century. Within the last eight years, however, three more bridges have spanned the East River and six pairs of railway tunnels have been put into service under the rivers, one pair more has been built, three pairs are to be built under the present scheme, making four bridges and ten pairs of tunnels for railways, besides which there have been built two tunnels for gas and one for water-supply, and thus making practical the direct physical connection of Manhattan by land lines of communication with the populous districts to the east and west.



# Organization and Personnel of the Engineering Staff\*

Few people, even in New York City, realize the gigantic task of constructing 230 miles of rapid-transit lines into and through the heart of the most congested districts of New York City—a system of elevated and underground electric railways of far greater mileage and more complete in every respect than any similar system in the world. This work is being carried on under the direction of the Public Service Commission of the First District of the State of New York, which besides having direct charge of the construction of these new rapid transit lines also supervises the operation of all public utilities companies, inspects and passes upon equipment, services and rates of all existing transportation lines, whether surface, rapid transit, interurban or regular steam railroads, etc., as well as gas, electric light, power and telephone companies.

## ORGANIZATION

The chart, p. 8, shows graphically the organization of the engineering staff engaged in subway and rapid-transit design and construction and incidental work. Not shown on the chart is an Electrical Engineer, the head of a separate bureau of some 60 engineering employees, a bureau of gas and electricity, and a transportation bureau, each employing several engineering inspectors. The titles of the various employees and the salaries of each grade are shown in a table accompanying the chart.

Complex as the organization appears, it is founded on strictly military principles. There are two grand divisions, roughly the groups on the right and left respectively: (1) the actual supervision of construction, under Robert Ridgway, Engineer of Subway Construction; (2) the administrative and executive work, design, subsurface structures, estimates, etc., under Daniel Lawrence Turner, Deputy Engineer of Subway Construction. Through these lieutenants all the various subordinates report, except the Electrical Engineer, who reports directly to the Chief Engineer. To each subordinate is designated his explicit authority and responsibility, to which he is held strictly accountable.

**EFFICIENCY RECORDS**—To foster enthusiasm and assure promotion to the deserving, a quarterly record is kept of each employee's ability rating and efficiency rating as determined by his immediate superior. Each rating has an established value which is added to or subtracted from the employee's efficiency percentage. The system is quite elaborate, but has been in service for more than four years and is giving eminent satisfaction. It is the aim of the Chief Engineer to fill all the responsible positions by promotion, and whenever a vacancy occurs, promotion examinations are held, which are open only to those who have served in lower positions for a predetermined period of time and have maintained an efficiency record of at least 60%, for a given period.

**PROMOTION EXAMINATIONS**—An example of such an examination was one held a year ago for the position of Assistant Division Engineer. This was open only to As-

sistant Engineers and Designers of Grade 10. The subjects of the examination and the relative weights were: (a) A paper on some subject relevant to the work of the applicant, weight 1; (b) efficiency, weight 3. The paper was to be typewritten and illustrated with drawings or photographs, and accompanied by an affidavit to the effect that it was an original composition of the applicant. The practicability of such a test is readily appreciated and illustrates how an enthusiastic, loyal and efficient staff may be built up and maintained, while still keeping strictly both to the letter and the spirit of the civil-service laws.

**DUTIES OF EACH RANK**—The specific duties of the members of each rank (in the subordinate positions there are several grades in each rank according to salary) are given below:

**CHIEF ENGINEER**—In general charge over all work under the Engineering Department, including the preparation of plans for and the construction of subway and elevated work by the City, and the approval of plans for and supervision over the construction and equipment of subway and elevated lines by the operating companies under the Dual Contracts, aggregating a total cost of nearly \$350,000,000.

**ENGINEER OF SUBWAY CONSTRUCTION**—Deputy having general supervision in the field over the construction of all subway and elevated work prosecuted by the City or companies, including general supervision over the five field divisions and the Divisions of Sewers and Inspection of Material. Acts as Chief Engineer in the absence of Chief Engineer.

**DEPUTY ENGINEER OF SUBWAY CONSTRUCTION**—Deputy having general supervision over all administrative and organization work, including general supervision over the general office and Divisions of Designs, Subsurface Structures, Track Work and Estimates, and the Electrical Engineering Division with respect to new subway work. Acts as Chief Engineer in the absence of the Chief Engineer and the Engineer of Subway Construction.

**PRINCIPAL ASSISTANT ENGINEER**—In charge of the Division of Designs. In direct charge of the designing of all subway and elevated work and preparing contract and detailed plans with respect thereto, and also examines and passes upon construction plans for work prosecuted by the operating companies.

## ABBREVIATIONS USED ON ORGANIZATION CHART ON THE NEXT PAGE

Abbreviation	Title	Salary
C. E. ....	Chief Engineer .....	\$20,000
E. Sub. Con. ....	Engineer of Subway Construction .....	12,000
Dep. E. ....	Deputy Engineer .....	8,000
P. A. E. ....	Principal Assistant Engineer.....	7,000
D. E. ....	Division Engineer .....	7,000
Elec. E. ....	Electrical Engineer .....	6,000
G. I. M. ....	General Inspector of Materials....	4,500
A. I. M. ....	Assistant Inspector of Materials...	2,400
E. Sub. Surf. Str.	Engineer Sub-Surface Structures..	4,500
Des. E. ....	Designing Engineer .....	3,750
Des. Ar. ....	Designing Architect .....	4,200
S. A. D. E. ....	Sr. Assistant Division Engineer...	4,200
S. A. Des. E. ....	Sr. Assistant Designing Engineer..	4,200
S. A. Des. Ar. ...	Sr. Assistant Designing Architect.	3,750
A. D. E. ....	Assistant Division Engineer .....	3,750
A. Des. E. ....	Assistant Designing Engineer .....	3,750
A. E. ....	Assistant Engineer .....	1801-2700
Des. ....	Designer .....	1801-2400
Ar. Des. ....	Architectural Designer .....	1801-2400
J. E. ....	Jr. Engineer .....	1201-1800
Df. ....	Draftsman .....	1201-1800
Ar. Df. ....	Architectural Draftsman .....	1201-1800
J. A. ....	Jr. Assistant .....	901-1200
Che. ....	Chemist .....	901-2700
I. ....	Inspector .....	901-2700
T. ....	Tester .....	901-2700

\*Although this article was prepared by the editors of "Engineering News," it is made a part of this series of articles on the construction of the new subway and elevated lines in New York City, in order that the presentation may be complete as a whole.







**DIVISION ENGINEER**—In direct charge of a division of construction work in the field covering subway and elevated construction. Has charge of construction work amounting to from \$30,000,000 to \$35,000,000.

**DIVISION ENGINEER OF SEWERS**—In charge of Sewer Division, having direct charge of the preparation of designs and plans and supervision in the field over all sewer reconstruction work resulting from subway or elevated construction.

**ENGINEER OF SUBSURFACE STRUCTURES**—In charge of the Division of Subsurface Structures. In direct charge of the preparation of all designs and plans covering the reconstruction and readjustment of all subsurface structure work in connection with the construction of subway and elevated lines.

**GENERAL INSPECTOR OF MATERIAL**—Has direct charge over the inspection of all materials of construction.

**SENIOR ASSISTANT DIVISION ENGINEER**—In charge of administrative work of a field division, under the Division Engineer. Acts as Division Engineer in the absence of Division Engineer.

**ASSISTANT DIVISION ENGINEER**—In direct charge of a subdivision of field work under the Division Engineer consisting of four contract sections of subway or elevated construction, covering work amounting to from \$10,000,000 to \$12,000,000.

**ASSISTANT DIVISION ENGINEER**—In charge of Estimates Division, under the Deputy Engineer of Subway Con-

struction work of a contract section or of a field party giving lines and grades, under Assistant Engineer.

**DESIGNER**—In charge of a squad of Draftsmen and Junior Assistants in computing and preparing designs and plans, under Assistant Designing Engineer.

**DRAFTSMAN**—Does detail work in preparing designs and plans, under Designer.

**ARCHITECTURAL DESIGNER**—In charge of a squad of Architectural Draftsmen and Junior Assistants in computing and preparing architectural designs and plans, under Assistant Designing Architect.

**ARCHITECTURAL DRAFTSMAN**—Does detail work in preparing architectural designs and plans, under Architectural Designer.

**JUNIOR ASSISTANT**—Acts as a member of field party giving lines and grades, under Junior Engineer; or does detail work on tracings, plans, etc., under Draftsman or Architectural Draftsman.

**CHEMIST**—Makes chemical analyses of materials, under the General Inspector of Material.

**CEMENT TESTER**—Tests cements, under the General Inspector of Material.

**INSPECTOR OF STEEL**—Inspects the manufacture and fabrication of steel at the mills and shops and the erection of the steel in the field, under the General Inspector of Material.

**INSPECTOR OF CONDUITS**—Inspects the manufacture of conduits, under the General Inspector of Material.

**CHIEF CLERK**—Secretary to Chief Engineer. Has direct supervision over Engineering Department general files and clerical and stenographic work in the general office, under the Deputy Engineer of Subway Construction.

**ASSISTANT CHIEF CLERK**—Has charge of filing and clerical work under Chief Clerk.

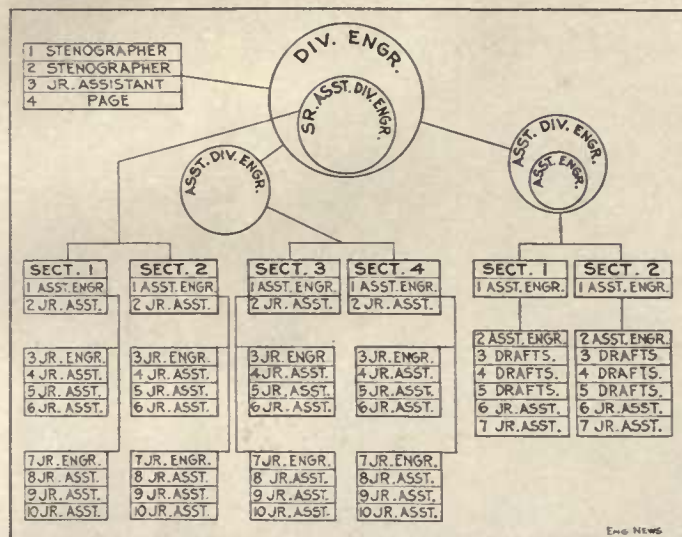

ORGANIZATION CHART OF THE SEWER DIVISION OF THE PUBLIC SERVICE COMMISSION

struction, having direct charge of the compilation and preparation of Chief Engineer's determinations with respect to the cost of construction and cost of equipment of all railroads constructed by the City and by the operating companies under the Dual Contracts and Certificates.

**SENIOR DESIGNING ENGINEER**—In charge of administrative work of Designs Division, under Principal Assistant Engineer. Acts as Principal Assistant Engineer in the absence of Principal Assistant Engineer.

**DESIGNING ENGINEER**—In charge of a subdivision in the Designs Division, under the Principal Assistant Engineer, having direct charge over the designing of subway and elevated work and the examination of designs and plans prepared by the operating companies.

**ASSISTANT DESIGNING ENGINEER**—Assistant to Designing Engineer in the Designs Division. Acts as Designing Engineer in the absence of the Designing Engineer.

**DESIGNING ARCHITECT**—In direct charge of the architectural design in connection with subway and elevated work under the Principal Assistant Engineer.

**SENIOR ASSISTANT DESIGNING ARCHITECT**—In charge of administrative work in connection with designing, under Designing Architect. Acts as Designing Architect in the absence of Designing Architect.

**ASSISTANT DESIGNING ARCHITECT**—In direct charge of a subdivision, under the Designing Architect, in the designing work and the examination of designs and plans prepared by the operating companies.

**ASSISTANT ENGINEER**—In direct charge in the field of the details of construction of one contract section of subway or elevated work, under the Assistant Division Engineer, approximating \$1,000,000 to \$3,000,000 in cost.

**JUNIOR ENGINEER**—Has charge of the administrative

The lowest engineering grade is that of Junior Assistant, with an entrance salary of \$901, with promotion to \$1200 without change of rank. By passing the requisite examinations and fulfilling the efficiency conditions, the Junior Assistant is eligible to the position of Junior Engineer at a salary of \$1201 to \$1800, or the same rank in the drafting-room force, and so on; so that a capable man is assured of reasonable progress as his value increases. The Junior Assistant corresponds to the rank of axman, rodman, chainman, etc., in other city work, but is better paid.

**DIVISION ORGANIZATION**—Each field division in itself requires an elaborate suborganization, as shown in the chart. The organization chart for the sewer division will also serve as an example to illustrate how the military scheme is followed out in more detail. There are at present five field Division Engineers, each with such a semi-independent organization as shown. Each field division comprises approximately \$25,000,000 to \$30,000,000 in work, the division being so made rather than to contain a certain mileage or a geographical district.

The field divisions are subdivided as follows: three subdivisions, each in direct charge of an Assistant Division Engineer; each subdivision into four sections, each comprising a normal contract of from \$1,000,000 to \$3,500,000, each section being in charge of an Assistant Engineer. The sections, like the divisions and subdivisions are groups of construction work of approximately the same character or cost, rather than divisions of length. Each Assistant Engineer has, under the full organization scheme, 4 Junior Engineer assistants, and the 4 Junior Engineers have 5 Junior Assistants, the lowest engineering grade on the staff. A section usually covers a distance of from 2000 to 3000 lin.ft. of trackway.

Besides the salaried engineering staff of each division, there are about two masonry inspectors of construction to each section, who are paid \$4.50 to \$5.50 per day, and who are not included in the organization scheme. The inspectors report to the Assistant Engineers in charge of their respective sections.



A similar scheme of subdivision exists in the office divisions of inspection of material, subsurface structures, station finish and estimates, and the divisions of design and of sewers. The various designers and draftsmen are divided into groups and squads in charge of Division Engineers, Assistant Division Engineers, Designers, etc., with ranks, grades and salaries corresponding to the field positions. Positions such as the one previously noted for Assistant Division Engineer are usually open to both field and office men, so it is possible for a man to be promoted from office to field, or *vice versa*.

#### WORK OF THE ENGINEERING STAFF

It is almost impossible within a brief space to give an adequate idea of the breadth and scope of the engineer-

other subsurface structures, the passing upon all the equipment for the operation of the new railways, and other problems too numerous to mention. Besides these there are the disposition of complaints, the maintenance of existing subsurface structures and street traffic to be looked after during the period of construction.

The rapid-transit construction work has been outlined in 15 steps, as follows:

- (1) Preliminary survey of streets to be traversed.
- (2) Preparation of route maps and resolutions.
- (3) Application to and approval by the Board of Estimate and the Mayor.
- (4) Consent of property owners or of the Appellate Division.
- (5) Survey of surface and subsurface structures.
- (6) Preparation of contract plans.
- (7) Preparation of form of contract.

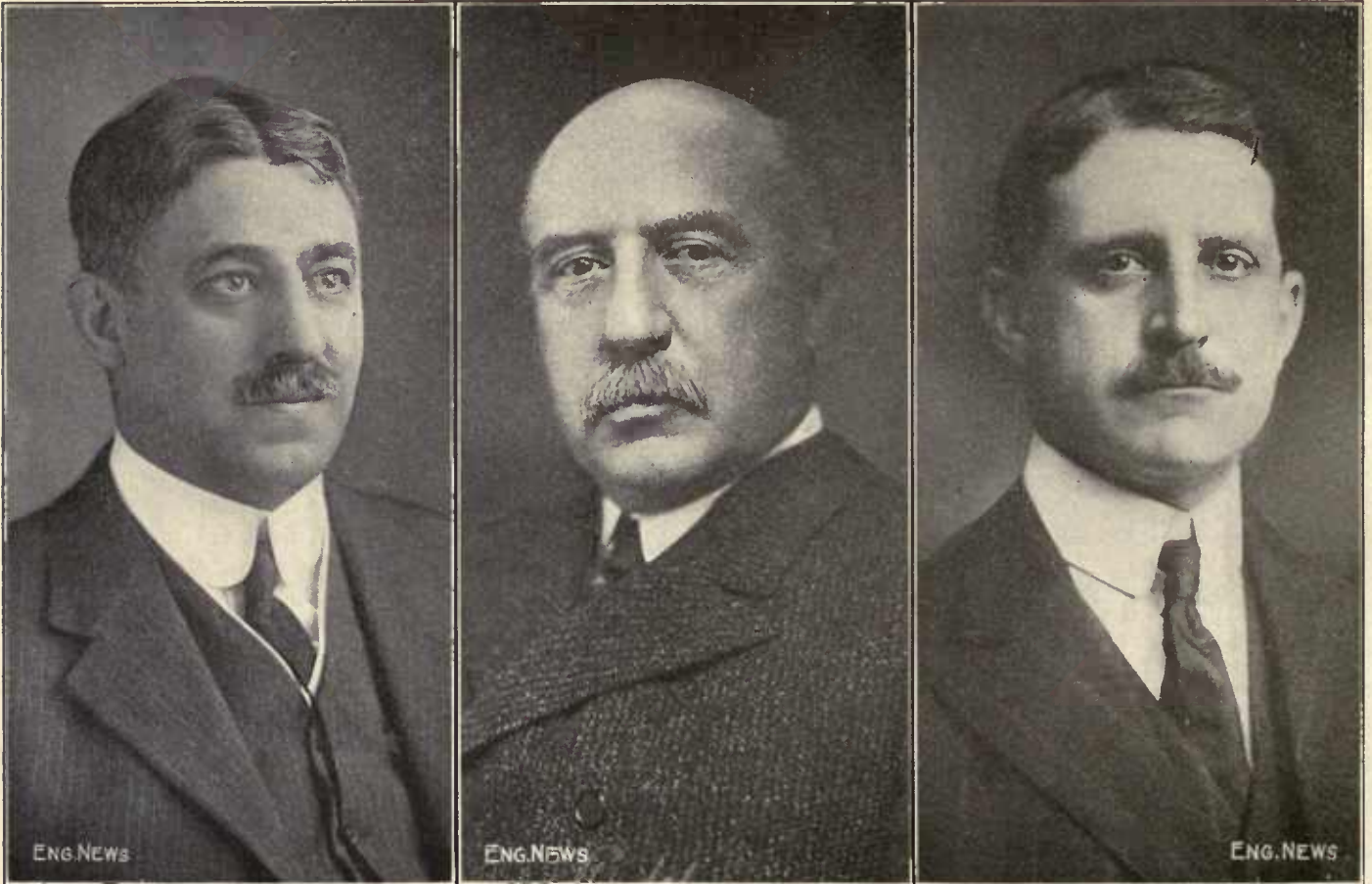

*J. J. Dumes*      *Alfred Gram*      *Robt. Ridgway*

Chief Engineer (center), Engineer of Subway Construction (right), Deputy Engineer Subway Construction (left), of the Public Service Commission, First District, New York.

ing work the Public Service Commission's engineers are called upon to perform. The rapid-transit work alone requires careful surveys of the streets and subsurface structures, the examination of buildings before and during the construction of subways on account of the possibility of damages, the preparation of contract and detail plans, the examination of steel plans, the testing and inspection of materials such as cement and steel at the mills where they are manufactured, the close supervision of the construction work as it progresses, the preparation of the estimates upon which the payments to contractors are made, the redesign and construction of sewers and

- (8) Public hearing on form of contract.
- (9) Approval of form of contract by Corporation Counsel.
- (10) Advertisement for and receipt of bids.
- (11) Acceptance of bids and submission to Board of Estimate for approval and appropriation.
- (12) Execution of contract and commencement of work.
- (13) Preparation of working plans and examination of the working steel plans.
- (14) Preparation of record plans.
- (15) Arbitration of disputed items of cost.

The rapid-transit construction work cannot be compared with the work of any other commission in this country except the Boston Rapid Transit Commission, but it must be remembered that besides construction



work, the Public Service Commission of the First District also performs the regulatory work of supervising all the public services of the Greater New York District, the transportation, gas and electric businesses of which amounts to about 20% of the total for the entire United States. The number of passengers carried annually on the existing transportation lines in the city is some 60% more than the number carried by all the steam railways of the country.

**ELECTRICAL ENGINEER**—The Electrical Engineer, Clifton W. Wilder, maintains a bureau, not shown on the organization chart, employing about 60 engineering assistants. His work is divided into four main divisions as follows: (1) Passing on all plans for the electrical equipment; (2) cost accounting of equipment; (3) supervision of operation of the existing lines; (4) valuation of public-utility corporation properties. On the first two divisions, as a part of the new subway construction, he reports to the Chief Engineer, but on the supervision of operation and valuation work he reports directly to the Public Service Commission as its Electrical Engineer. He has one Principal Assistant Engineer and six Assistant Engineers. The supervision of operation includes such work as investigating complaints of equipment, accidents, regular inspection of equipment, special investigations, etc.

#### PERSONNEL

The scheme of an engineering organization plays only a small part in its successful operation. Much depends on the men who are at the head of it. The Chief Engineer of the Public Service Commission is himself the kind of man to appreciate the importance of personality in the efficient working of the splendid organization he has achieved; and he not only takes a kindly interest in his many subordinates and makes himself accessible to them, but has so designed the working of the entire organization as to promote individual effort, enthusiasm and loyalty.

#### ALFRED CRAVEN

The Chief Engineer of this great organization, which at present includes approximately 1000 engineering employees—and it is growing—is a descendant of a distinguished family of naval officers and engineers. He was the son of Rear-Admiral Thomas T. Craven, who served throughout the Civil War and was afterward Commandant of the Mare Island Navy Yard. He is a nephew of Alfred W. Craven, Chief Engineer of the old Croton Aqueduct, builder of much of the original sewer system of lower Manhattan, the Central Park Reservoir, and many other historic engineering works in and about New York City.

Alfred Craven was born at Bound Brook, N. J., Sept. 16, 1846. At 17 years of age, at the height of the Civil War period, he was appointed to the United States Naval Academy, then conducted at Newport, R. I. Later, after the coming of peace, the Academy returned to Annapolis, Md., where Mr. Craven was graduated in 1867. After a few years' service, and while on the Pacific Coast, he retired from the Navy with the rank of Master, to devote his life to engineering.

In 1871, he joined the California Geological Survey. Later, he was engaged in irrigation work in the Sacramento and San Joaquin Valleys, and then began private practice in Virginia City, where he established a reputa-

tion as a mining engineer in connection with the development of the famous Comstock lode. On this work he was associated with Adolph Sutro in the construction of the well known Sutro tunnel.

Mr. Craven returned East in 1884 to become Division Engineer of the new Croton Aqueduct for the additional water supply for the City of New York, where he was in charge of a construction division and later of the Carmel and Titicus dams and reservoirs. On this work he established an enviable reputation for rugged honesty in the midst of graft and corruption on the part of contractors and politicians. After some straightforward and unimpeachable testimony before a legislative committee, an incensed politician is said to have told Mr. Craven, "You've done the last stroke of work you ever will do on this job." Whereat, Mr. Craven is said to have quietly replied, "I'll be here when you're all gone"—which proved correct, for the Aqueduct Commission was subsequently reorganized by Mayor Hewitt, and men of a caliber to appreciate honest service were appointed.

For eleven years, Mr. Craven was Division Engineer on the Croton Aqueduct and Reservoirs, and then in 1895 he was placed in charge of the construction of the Jerome Park Reservoir. Following a change in the Engineering Staff of the Commission, the plans of the work were altered in a way which did not meet with Mr. Craven's approval and early in 1900 he was transferred to another division of the work. For what happened afterwards at Jerome Park, he is in no way responsible.

In May, 1900, when the first New York City subways were begun, Mr. Craven joined the engineering staff of the Rapid Transit Commission as Division Engineer, in charge of construction of the division from Forty-first St. and Park Ave. through Forty-second St. and up Broadway to 104th St., the section through Forty-second St. and under the Times Building being one of the most difficult and delicate pieces of the whole work. He succeeded George S. Rice as Deputy Chief Engineer of the Rapid Transit Commission in 1904, when Mr. Rice became Chief Engineer, and succeeded to the office of Deputy Engineer of Subway Construction under Mr. Rice, when the Public Service Commission was organized in 1907. In 1910, Mr. Craven succeeded H. B. Seaman as Chief Engineer of the Commission.

Mr. Craven has not only distinguished himself in his 44 years of varied experience as a great engineer and executive, but has gained a reputation as an arbiter and peacemaker in solving the intricate problems in relation to the control and operation of the dual transit system now under construction. For days at a time he has appeared as a witness at the hearings of the Commission and of the courts and has won the respect of lawyers, capitalists, railway-operating officers, and commissioners, not only by the breadth and accuracy of his technical knowledge, but by the clearness and force with which he presented it.

#### ROBERT RIDGWAY

Mr. Craven's first lieutenant, Robert Ridgway, was born in Brooklyn, N. Y., Oct. 19, 1862. He lived in Brooklyn and on a New Jersey farm until he was 19 years of age. He never attended a college or technical school.

In May, 1882, he went West and joined the engineer corps of the Northern Pacific Ry., serving as chainman, rodman and leveler on preliminary surveys in Montana.



and on location and construction in Wisconsin. Mr. Ridgway returned to the East in the summer of 1884 to accept a position as a leveler with the Croton Aqueduct Commission, New York City.

For 16 years he was a member of the Commission's engineering staff. His first important assignment was as Assistant Engineer in charge of the construction of the gate-house and appurtenances at the Croton dam and the northerly  $1\frac{1}{2}$  miles of the new Croton Aqueduct, from 1886 to 1890. On the practical completion of this work he was made Assistant Engineer of Construction of Reservoir M and appurtenances, on the Titicus River, which included the construction of a masonry dam having a maximum height of 130 ft., with earth wings 100 ft. in height. Subsequently, he was Assistant Engineer in charge of the construction of the Jerome Park reservoir, serving there under his present chief, Mr. Craven, who was Division Engineer.

He followed his chief to the Rapid Transit Commission in 1900 as his Senior Assistant Engineer on the Second division. In March, 1903, Mr. Ridgway was promoted to be Division Engineer and was placed in charge of the Fifth division, including the construction of the South Ferry loop, the tunnels under the East River from the Battery to Brooklyn and the Brooklyn subway.

When the Board of Water Supply was organized in 1905 for the construction of an additional system for the water-supply of New York City, he joined the staff of its Chief Engineer, J. Waldo Smith, as Division Engineer, and was promoted the following spring to the position of Department Engineer in charge of the Northern Aqueduct Department, which included the location and construction of the upper 60 miles of the Catskill Aqueduct. The Hudson River crossing at Storm King mountain was in his department. Here he continued until the practical completion of most of the work under construction, in January, 1912, when he was again called to serve under his former chief, Mr. Craven, with the Public Service Commission.

#### DANIEL LAWRENCE TURNER

Daniel Lawrence Turner was born in 1869. He graduated from Rensselaer Polytechnic Institute with the degree of C. E. in 1891.

For a year he was assistant in mathematics at the Institute, and then for three years he was Assistant Engineer in charge of the location and construction of a standard-gage switchback railway near Middletown, Conn., for the Columbia Granite Co.

In 1893, he was engaged in railway location work and as Engineer for Ernest Flagg, Architect, New York City. For nine years following, Mr. Turner was Instructor in surveying, railway engineering and hydraulics at Harvard University. While at Harvard he inaugurated the Harvard engineering camp and established and conducted for a number of years the present camp at Squam Lake, N. H. During this period, he was also engaged in private practice with special reference to hydraulic engineering.

Mr. Turner, like his chief and Mr. Ridgway, is also a pioneer New York City subway engineer. His experience in this work dates from the beginning of the subway work in 1900 when he became a member of the engineering staff of the Rapid Transit Commission. During the life of the Rapid Transit Commission 1900-1907, he

served in various capacities, first on the preparation of drainage plans, as Assistant Engineer in charge of stations and in charge of surveys for subway extension to Brooklyn, including the East River triangulation. Later he was Division Engineer in charge of stations.

Upon the establishment of the Public Service Commission, First District, in 1907, Mr. Turner became Division Engineer of Stations and Chief of the Bureau of Transit Inspection, in which latter position he originated and formulated the methods of supervising the operation of the various street railways coming under the Public Service Commission's jurisdiction. For a year he was Division Engineer of the Seventh division of the new subways, and since 1912 he has been Deputy Engineer of Subway Construction.

#### DIVISION ENGINEERS

Sverre Dahm, Principal Assistant Engineer in charge of the Division of Design, was born in Norway, in 1858. His technical education was received at the Polytechnicum, Munich, Bavaria. He began his engineering experience as an Assistant Engineer on the Norwegian Government railways. His first work in America was as Assistant Engineer for Theodore Cooper, Consulting Engineer, New York City. Subsequently he was in bridge and structural work with the Long Island R.R., and with contractors in Chicago and New York City, until June, 1900, when he was appointed Assistant Engineer of the Rapid Transit Commission. Since then he has passed through various grades in the Rapid Transit Commission and its successor, the Public Service Commission, and since 1909, has been Principal Assistant Engineer.

Frederick W. Carpenter, Division Engineer of construction, was born in 1859, and graduated from Cornell University in 1884. For 10 years he was in railway construction and municipal work in the East and Middle West. In 1895 he was appointed Assistant Engineer, Bureau of Highways, Brooklyn, N. Y., where he remained until 1900, when he became Assistant Engineer of the Rapid Transit Commission. He continued as Assistant Engineer of the Public Service Commission, and in 1910 was promoted to be Senior Assistant Division Engineer, and Division Engineer in 1913.

John H. Myers, Division Engineer of construction, was born in 1869 and graduated from Rensselaer Polytechnic Institute in 1893. After a few years' experience in general surveying and engineering work in and about New York City, he spent six years as Assistant Engineer with the Department of Water Supply of Brooklyn, N. Y. In 1900 he joined the engineering staff of the Rapid Transit Commission as Assistant Engineer, and in 1906 he was promoted to be Division Engineer, which office he continued to hold under the Public Service Commission.

Frederick C. Noble, Division Engineer of construction, is a son of the late Alfred Noble. He was born in 1872 and graduated in civil engineering at the University of Michigan in 1894. Most of his experience until 1900 was in bridge and structural work. He entered the service of the Rapid Transit Commission as a draftsman in June, 1900. He was promoted to be Assistant Engineer the following summer and to be Division Engineer in 1905. Mr. Noble has had immediate supervision of the design and preparation of contracts and spe-



cifications for the four East River tunnels for which contracts have recently been awarded.\*

Cornelius V. V. Powers, Division Engineer of construction, was born in 1860. He is a graduate of the Columbia University School of Mines and his first experience was as Chemist and Metallurgist for a smelting company. His civil engineering experience began as a laborer with the New Croton Aqueduct Commission in 1885. He was successively promoted through subordinate positions to be Assistant Engineer. In 1900 he joined the staff of the Rapid Transit Commission as Assistant Engineer. He was promoted to be Division Engineer in 1903.

Jesse O. Shipman, Division Engineer of construction, was born in 1868. He graduated from Bucknell University, Pennsylvania, in 1890. The first 10 years of his engineering experience were spent mostly in railway survey and construction work. In June, 1900, he was appointed transitman with the Rapid Transit Commission and a year later Assistant Engineer. In April, 1910, he was promoted to be Senior Assistant Division Engineer and in October, 1911, Division Engineer.

Louis D. Fouquet, Division Engineer of Sewers, was born in 1867. He was in railway work in the East. From 1904 to 1908, he was Assistant Engineer of the New

---

\*Mr. Noble resigned as Division Engineer of the Public Service Commission to take up the consulting work of his father, the late Alfred Noble.

York, New Haven & Hartford R.R., and had charge of construction of two large Scherzer rolling lift draw bridges, one four-track and the other six-track. He joined the staff of the Public Service Commission in 1908 as Division Engineer.

The Division Engineer in charge of Subsurface Structures is C. N. Green, and George L. Lucas is Division Engineer in charge of Inspection of Materials and Construction.

#### ELECTRICAL ENGINEER

The Electrical Engineer of the Public Service Commission, Clifton W. Wilder, was born in Leominster, Mass., in 1876, and graduated from the Massachusetts Institute of Technology in 1898. For several years he was engaged in various kinds of electrical and mechanical engineering in and about Boston and New York City. He first became connected with New York City electric railway work in April 1905, as Assistant Engineer of Construction with the New York City Interborough Railway Co. He joined the staff of the Public Service Commission in November, 1907, as Assistant Electrical Engineer, becoming the head of the department in 1909. This position requires not only wide technical knowledge and experience in electrical engineering, but also the ability to appear as an advocate and expert at public hearings of the Commission.



# General Arrangements for Construction

## The Operating Contracts

Stated briefly, the original contract\* for the present subway provided for its construction by the city or with the city's money, its equipment of power stations, electrical apparatus, signals, telephones, rolling stock, etc., being furnished by the operating company, which had a lease for 50 years, with privilege of renewal for 25 more. Contract 2, Brooklyn extension, was for 35 and 25 years. These two contracts with the renewals would, therefore, run to 1979 and 1965, respectively. The operating company was to pay a rental sufficient to cover the interest and amortization on the bonds issued by the city in payment of the cost of construction. At the end of the lease, the city to own the structure free and clear, with the right to purchase the equipment.

The elevated lines in Manhattan have a perpetual franchise, so that under the new arrangement, the lease for the extensions to these lines and the third tracks was made to run for 85 years, and is not included in the agreement covering the other lines.

By the terms of the new contracts, the leases of all the new lines as well as those of the existing subway are to run for 49 years from Jan. 1, 1917, and provide that the city shall share in the profits of operation, which are to be determined in the following manner:

The revenues of all operated lines of each system will be pooled, the two companies will be allowed to retain all the earnings (after payment of rentals, interest, amortization, etc.) on the lines they now operate, and the city will share in the profits of the rest. The contracts provide for quarterly settlements, which will provide for the following payments:†

into the depreciation funds and if any excess occurs, it may be withdrawn from such funds.

5. (Interborough Contract). For the first year of operation an amount equal to 5 per cent. of the revenue for depreciation of such portions as are not repaired or replaced through expenditures for maintenance. Two depreciation funds are established—one for the existing subway, and one for the new lines, and they will be under the control of the Depreciation Fund Board. Depreciation for future years to be agreed upon.

5. (Brooklyn Contract). For the first year of temporary operation an amount equal to 3 per cent. of the year's revenue for depreciation of such portion of roads and equipment as are not repaired or replaced through expenditures for maintenance. This amount for each year will be paid into three depreciation funds—"Depreciation fund for the railroad and equipment," "Depreciation fund for the plant and property of the extensions and additional tracks," and "Depreciation fund for existing railroads." Such funds shall be under the control of the Depreciation Fund Board. Depreciation for future years to be agreed upon.

The Depreciation Fund Board is to consist of three members—one to be chosen by the company, one by the Commission and the third by both jointly, or in case of failure to agree, by the Chief Judge or an Associate Judge of the Court of Appeals, or by the President of the Chamber of Commerce.

6. (Interborough Contract). One-quarter of the sum of \$6,335,000 to be retained by the company, as representing the average annual income from the operation of the existing railroads.

6. (Brooklyn Contract). One-quarter of the sum of \$3,500,000 to go to the company "as representing the average annual income from the operation of the existing railroads during the two years prior to the beginning of initial operation, out of which the lessee shall pay interest charges on obligations representing the capital investment (preceding the date of this contract) on the existing railroads."

7. One-quarter of an amount equal to 6 per cent. of the company's contribution toward the cost of construction and equipment for initial operation. Out of this payment the company must set aside amounts sufficient, with interest and

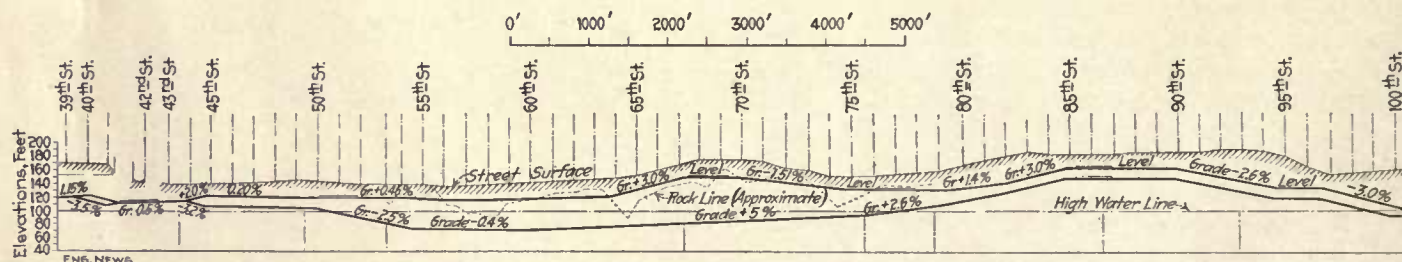

FIG. 7. PROFILE OF THE

1. To the City (in the Interborough contract only) rentals now required to be paid under Contract No. 1 and Contract No. 2, such rentals to continue through the life of the new contract; also (in case of both companies) such rentals actually payable by the company for the use of property in connection with the system, such as are not included in operating expenses.

2. Taxes and governmental charges of every description against each company in connection with the system.

3. All expenses, exclusive of maintenance, actually and necessarily incurred by either lessee in the operation of its system.

4. Twelve per cent. of the quarter's revenue for maintenance, exclusive of depreciation. "Maintenance" shall include repair and replacement of tracks, but not the replacement of any principal part of structure and equipment. If the maintenance cost in any quarter year shall be less than 12 per cent. of the revenue, the unexpended balance shall go

accretions, to amortize within the terms of the lease such contribution and cost.

8. If additional equipment is provided an amount to be retained by the company equal to one-quarter of the annual interest payable by it upon the cost of such additional equipment; together with a sum equal to 1/4 of 1 per cent. for the amortization of such cost.

9. (Interborough Contract). If the company shall share the cost of construction of additions to the Dual System, an amount equal to one-quarter of the annual interest payable by the company upon its share of such cost, together with 1/4 of 1 per cent. for amortization.

9. (Brooklyn Contract). To be paid to the city an amount equal to one-quarter of the annual interest payable by the city upon its share of the cost of construction and 3/8 of 1 per cent. of the city's share of such cost.

10. (Interborough Contract). An amount to be paid to the city equal to 1/4 of 8.76 per cent. of that portion of the cost of construction paid by the city.

11. An amount to be paid to the city equal to one-quarter of the annual interest actually payable by it upon

\*See "Eng. News," Feb. 13, 1902, p. 127, for details.

†From pamphlet issued by the Public Service Commission.







tion 13 has a high price per lin.ft. of structure, as this, as will be noted later, provides for a very elaborate system of track crossings. Section 14 is the Harlem River crossing. The sections north of the Harlem, Route 5, Section 15, Routes 19 and 22, Sections 1 and 1a, where only part of the street is required to be decked and where the street cars are operated by the overhead trolley, show a considerable decrease in the cost per foot, as do also the elevated structures on Jerome Ave. and White Plains Road.

On the down-town lines, Route 5 (Broadway), Section 1 involves the support of the elevated railroad structure; Section 1a the two reversed curves driven in tunnel; Section 2a the crossing of Canal St., where the underground conditions are very bad. The other sections, which are perhaps more nearly normal, show approximately an approach to the commonly accepted rough estimate figure of \$1,000,000 per mile of track, built in subway.

#### EQUIPMENT

There has been no announcement so far of any change in type of rolling stock of the Interborough, but the B. R. T. has had a larger type of car designed, Fig. 9, providing considerably greater capacity, which will, it is thought, owing to the arrangement of the doors, permit such easy ingress and egress that there will be no more delay in loading and unloading than there is with the small cars now in use. The principal dimensions of these two cars are as follows:

	Interborough	B. R. T.
Length over all, ft.....	51.0	67
Width over all, ft.....	9.5	10
Weight of empty car on each axle of motor truck, lb.....	30,800	(a)
Weight of the other two axles, lb.....	22,200	(a)
Number of seats.....	48	78
Capacity, sitting and standing.....	175	270

(a) Not to exceed 31,000 lb. per axle when fully loaded.

There have been many difficulties to overcome in connection with the design of these larger cars. Axle loads of 31,000 lb. cannot be exceeded, as this is fixed by the bridge department for the East River bridges. The motors are arranged one on each truck, instead of both on one truck, as on the present Interborough car, this, of course, giving a better distribution of the weight and taking care of some of the increase in the weight of the body and number of passengers. The limitation as to the axle loadings could not be overcome by the adoption of six-wheeled trucks, even though their use were not prohibited by the sharp curvature, as this would only involve a heavier truck with practically the same concentration of load so far as the bridge structures are concerned.

Some important improvements are to be introduced in the equipment of the cars. The combined car and air-line couplers (described in *ENGINEERING NEWS*, Feb. 29, 1912) have proven very satisfactory, and in addition to these couplers a device is to be installed in the new equipment which will also permit the automatic coupling of the electrical connections (10 in all). The coupling and uncoupling will be entirely under the control of the motorman in the cab and be governed by an interlocking device so that the electrical connection cannot be made until the air-line coupling is complete and the brakes are under control. Similarly to uncouple, the release of the electrical connection by the motorman permits him to release the devices so that the air and

train couplings will part. It is hoped by these devices to materially decrease the number of accidents to ten uncoupling cars, and also to reduce the time and expense of making up trains.

Before the introduction of this automatic coupler the link-and-pin type had been in general use, but even with eight-car trains on the Interborough, the breaking in two of the trains was frequent enough to show that the limit had been reached for this type of couplings. Automatic stops in connection with the signals are in use in the present subway, and the sudden setting of the brakes produces heavy stresses on the couplings. The new coupler has satisfactorily stood all the strains due to these causes, and the introduction of 10-car trains made it almost an absolute necessity. Electric pneumatic brake control will be used on the new equipment, insuring more nearly simultaneous action of the brakes on all the cars.

The signal to the motorman is given by the closing of an electric circuit when all the doors of the train are closed. This has been in use successfully for some little time already, and not only saves the delay due to transmitting the signal from car to car by hand but also acts as a safety device in preventing the starting of the train while any door is open.

A species of weighing device has been introduced in connection with the air-brake system to maintain the same ratio of braking power on loaded and empty cars. As the car is stopped at the station, the variation in the load due to the discharge or receipt of passengers actuates a piston in an auxiliary air cylinder, directly connected to the jam-cylinder. The variation in the position of this piston in the auxiliary cylinder regulates the volume of the jam cylinder, thereby regulating the effective pressure obtained from a given amount of air; thus when the car is fully loaded the volume of the auxiliary cylinder is at its minimum, and when the car is empty it is at its maximum. When the doors are closed it is automatically locked in this position until they are opened at the next station, thus preventing any change from variations in the loading due to the vibration and oscillation of the moving train.

A similar device is to be applied to the accelerating system. At present this has to be adjusted so that it will not slip the wheels of an unloaded car. With the proposed device, however, it will be so adjusted that it will be increased under load.

By these various devices it is expected to save six minutes in time between 59th St. and Coney Island. Deceleration from 50 miles per hour will be accomplished at the rate of 3 mi. per hr. per sec. (on the emergency) as compared with the present maximum of 2 mi. per hr. per sec., and from the lower rates of speed at higher rates of deceleration, while acceleration will beat the rate of 1½ mi. per hr. per sec.

Comparison of this with some comparatively recent practice on electrified steam railroads is of interest.

*N. Y., N. H. & H. R.R.*—Multiple unit trains, motor 2 trailers, acceleration 0.5 mi. per hr. per sec. Schedule speed from Grand Central Station to Mt. Vernon 13½ miles, with 1 stop in 28 minutes.

*Lancashire & Yorkshire R.R., England*—Acceleration to 30 mi. per hr. in 30 sec. Schedule speed, 18½ miles with 14 stops in 37 minutes.



## POWER

Power for the Interborough system is to be furnished from the power houses at 59th St. and the North River and at 4th St. and the East River. The former, built to furnish power for the present subway, was originally equipped with nine reciprocating units with a total normal capacity of 7500 kw. each. This was increased later by the addition of five low-pressure turbines each having an additional capacity of 7500 kw. and using exhaust steam from the original units to a total of 105,000 kw. This plant is now to be enlarged by the addition of two 30,000-kw. turbine units, each unit consisting of a high-pressure-high-speed set exhausting into a low-pressure low-speed turbine, making the total normal capacity about 165,000 kw.

The 4th St. power house was built only 13 years ago when the elevated lines were electrified, but owing to the rapid change or improvement which is continually tak-

ing place in electrical machinery and apparatus, part of this plant is to be replaced. The old equipment consisted of eight units (reciprocating) and one turbine unit of 7500 kw. each. Four of these are to be taken out and three turbine generators of 30,000 kw. each are to be installed, which, with the five old units remaining, will make a total normal capacity of 127,500 kw.

The contracts between the operating companies and the city call for an average speed on express tracks between main-line terminals of 25 miles per hour, including stops of 30 seconds at each intermediate station, and an average speed on local tracks between terminals of 15 miles per hour, including stops of 20 seconds at each intermediate station.

## GRADIENTS AND ALIGNMENT

Unlike the location of steam railroads, the location of such lines as these under consideration is governed only to a comparatively small extent by questions of gradient

or alignment as they affect economy of operation. The primary consideration, of course, is the general location of the lines through or under streets in those sections of the city where the service is needed. The second consideration is, the location of the various stations, which, in the lower part of Manhattan (below 42d St.) are about five or six blocks (1200 to 1500 ft.), and in the outlying sections about 2500 ft. apart, and which is generally arbitrarily fixed by local conditions. Then the grades and alignment (within certain fairly wide limits) are made to fit these conditions. At present, owing to the fact that some sections of the line are not definitely designed, it is not possible to make an exact and complete statement covering the gradients and alignments of the whole system, but the following is approximately correct.

**GRADIENTS**—Gradients up to 3% may be considered normal, this upper limit being used with considerable frequency, though generally in comparatively short stretches.

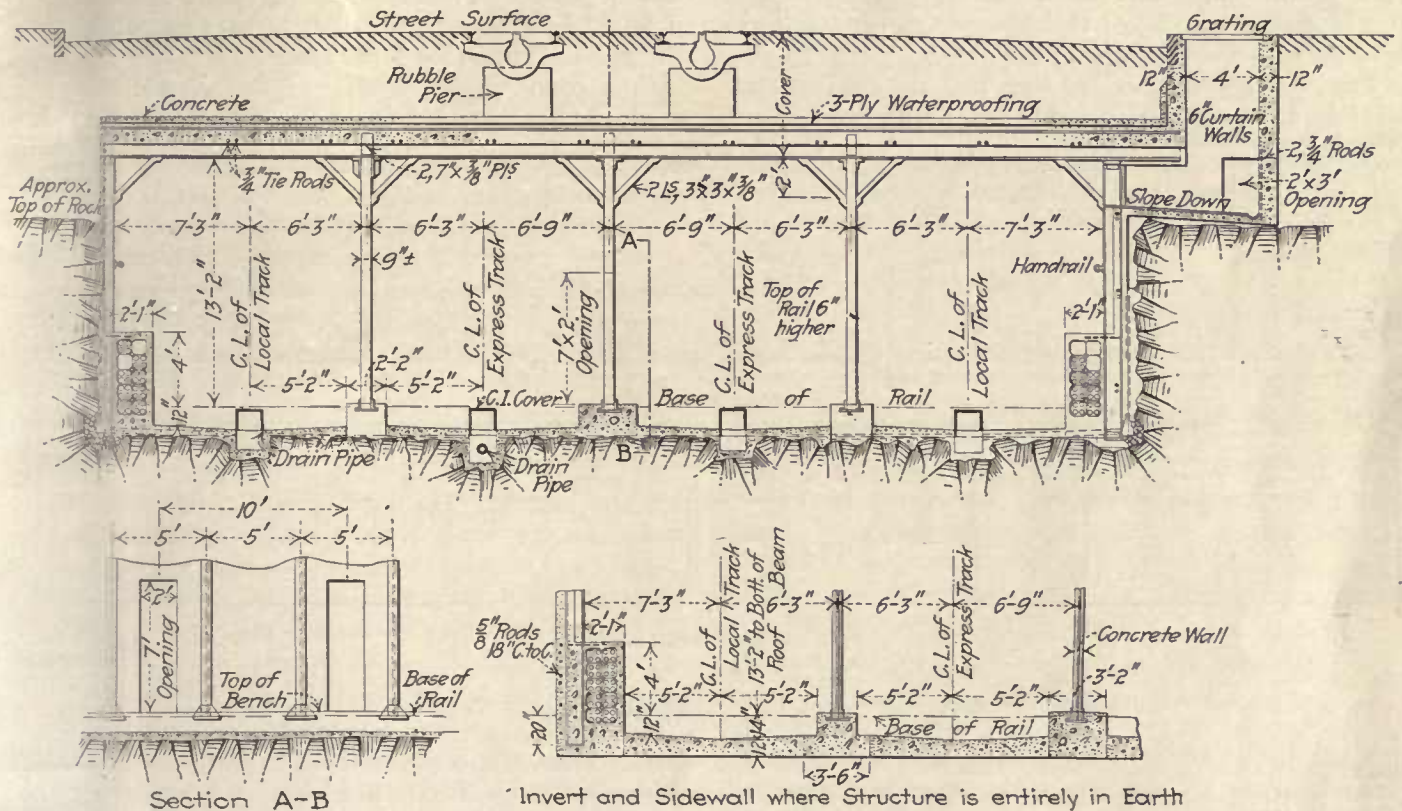

Section A-B

Invert and Sidewall where Structure is entirely in Earth

FIG. 8. TYPICAL SECTION OF RAPID TRANSIT SUBWAY ON SEVENTH AVE. AT 23RD ST.

Some of the longest are nearly 1500 ft. in length, and in a very few cases 3% grades as long as this occur as ascending grades immediately beyond a station stop on the local lines. There are gradients in excess of this up to 4.5%, and in one case where the Centre St. loop connects to the old Brooklyn Bridge it has been necessary to use 5.4%. The higher rates of gradient occur mostly in connection with the approaches to the East River Bridges or the tunnels under the rivers, the grades on the former being 3.4% on the three newer bridges and 3.75% on the old Brooklyn Bridge.

With electrical operation and especially with the dense traffic conditions which exist or which will exist on the Rapid Transit lines in New York, the question of gradients is not so important as it is in connection with the locations of railroad lines for operation by steam locomotives, or where continuous sustained effort is required on long supported gradients.



For short sections of heavy grade, extra power is supplied through an additional feed wire or wires to the points where it is needed. The electric motor, as is known, can stand a heavy overload of as much as 100%, or even more for short periods, the amount of the load and the time which it can be carried being limited by the heating which takes place under these conditions. Short stretches of steep gradient are not, therefore, limiting or as important as longer ones would be. Considering the requirements for some reserve power for ordinary operation which have to be fairly liberal, on account of the great seriousness of any delay as well as the short distance between stations, it can be seen that the limits controlling the gradients which may be used are rather wide.

In the operation of self-contained motor cars also, there is the advantage over trains hauled by locomotives that all additional load increases the adhesion and, therefore, permits application of the power necessary to haul it. It may also be noted that the new motors are to be artificially cooled by blowers.

The general procedure has been that the gradients are fixed by local conditions within the limits given above,

depressions even, or perhaps especially, if stations happen to be located at such points; and it has seemed better to put in escalators or elevators than to drop the track grade down, involving braking on a descending grade and acceleration against an opposing grade.

In one instance at least, on the original subway (at 33d St. and Park Ave.) on the four-track section, the two center tracks, which are used for the expresses, are carried through on an even grade, while the outer two local tracks are raised up at the station. On the new lines the tracks generally all follow the same grade except on Lexington Ave., where the express tracks are located on a lower grade in the tunnel through the hill; but here, on account of the necessity of having an express stop at some point as nearly as possible midway between 42d St. and 125th St., it was necessary to bring the express tracks up near the surface at 86th St., as shown in the profile, Fig. 7, which is very typical of the way local conditions absolutely control the profile. From an operating standpoint, of course, it would have been much better to have run all the way through the hill on the lower grade.

On account of the capacity of the electric motor for overload also, there is little necessity for, or benefit to be

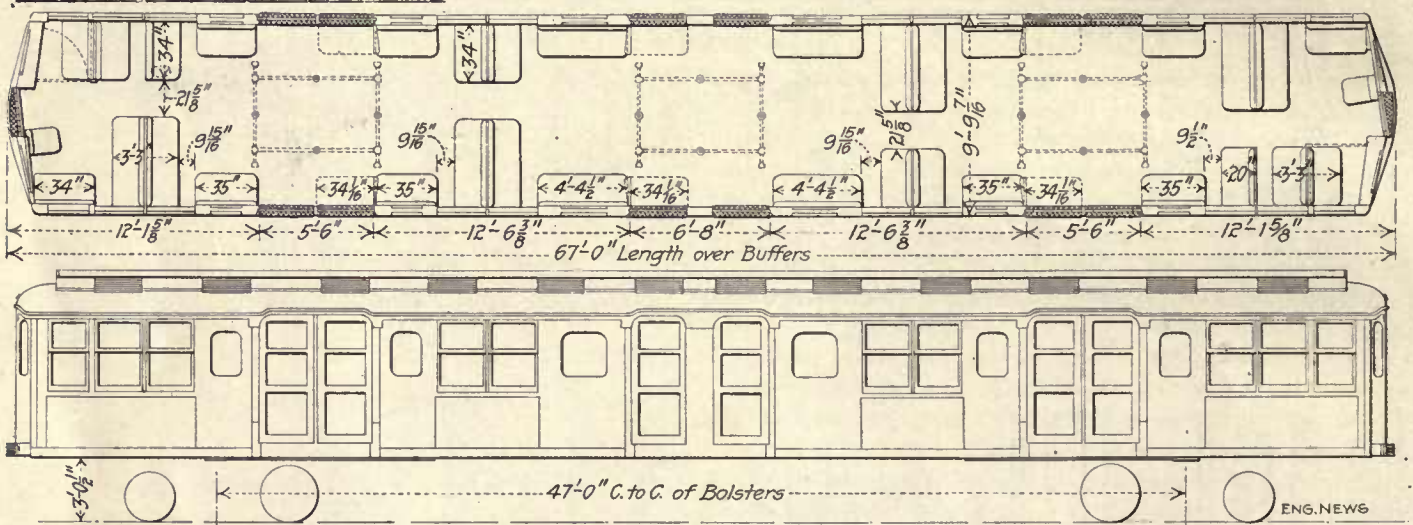

FIG. 9. DESIGN FOR STEEL CAR; BROOKLYN RAPID TRANSIT SYSTEM

then the motors are designed to carry the load. Momentum is availed of wherever possible, where under normal conditions trains may be expected to utilize it in overcoming ascending gradients, and this can be quite safely done, because in case a train is stopped on an up grade, the motors can be relied on to start it and move it along, even though at low speed, on account of their great capacity for overload. The original subway equipment was designed on a basis of about 60% motors and 40% trailers, but the tendency is toward the equipment of all cars with motors.

On the underground lines so far as possible, stations have been located at summits of gradients, both in order to get them as near the surface as possible and also that the ascending gradient may be utilized in braking, and the descending grade to help acceleration. While, however, these two purposes mutually help each other on the subway lines, and the rise and fall involved is, therefore, not an operating expense, this is not the case on the elevated lines. These latter, of course, must maintain a certain minimum elevation over summits, but the comparatively slight additional cost of longer columns is so little that there is every inducement to avoid dipping down into

derived from, the compensation of grades for curvature, although it is not uncommon to find the heavier rates of gradient combined with quite sharp curvature, as for instance, at Vesey St. and Broadway, where there is a 4% grade on a curve of 200 ft. radius.

By reference to the profile of the original subway line (ENG. NEWS, Feb. 20, 1902) it will be seen that much steeper gradients have been found necessary on the new routes than are used on the present line, but this, as is explained above, has virtually been forced by the conditions which have had to be met, which are more onerous in many cases on the new routes than on the old.

On the old line, the Broadway section has no gradient in excess of 1.5%, and the Bronx branch has 3% grades only at the crossing of the Harlem River and 2.2% just beyond where the line comes out on to the elevated structure.

In a way the profile given, Fig. 7, of the Lexington Ave. line from 40th St. to 138th St. may be considered fairly typical, though on the other hand, the Varick St.-Seventh Ave. line from the Battery to 42d St. has light grades



throughout its length, comparing favorably with the old line, with which it will connect at 42d St.

**ALIGNMENT**—The alignment, of course, is governed by the same considerations of the necessity of following the streets, and so far as possible, avoiding encroachment on private property. This is especially difficult in the lower part of Manhattan where the streets are narrow and crooked, and where it is especially difficult to turn the curves, so that in some instances, notably at St. Paul's Churchyard at Vesey St. and Broadway, and also at 42d St. and Lexington Ave., it has been necessary to acquire easements under private property at considerable expense. On the new lines all stations are to be located on tangents, to avoid the difficulties found on the original subways with stations on curves.

On the present subway in which cars 51 ft. long and 9 ft. 0½ in. wide are operated, there are the following sharp curves:

	Ft. rad.
City Hall loop.....	147¼
Forty-second St. and Park Ave.....	180
South Ferry loop.....	191
Main express tracks.....	225

The outer rails on curves were elevated for speeds of 30 mi. per hr. with a maximum of 6½ in., and this practice is followed in designing the new lines, though in some cases the operating company has increased the elevation in the old subway to permit speeds of 40 mi. per hr. on some of the curves of large radius.

On the new lines 500 ft. has been considered the minimum radius for ordinary cases, 200 ft. the absolute minimum, except that there is one curve of 150 ft. radius. On the B. R. T. lines additional clearance has to be provided on curves to provide for the extra overhang of the larger cars, 67 ft. long and 10 ft. wide, which that company proposes to use.

Transition curves of a uniform length of 150 ft., irrespective of the degree of curvature, are used wherever it is possible to get them in. Crandall's formulas and tables are used. It may be noted that curves are usually laid out with radii of even feet instead of with even degrees of curvature.

#### CONTRACTS AND SPECIFICATIONS

**GENERAL CLAUSES**—The clauses of the specifications indicating the character of the work to be performed under each item or type of construction, will be discussed or quoted under each separate heading, together with the descriptions of the work. The general clauses of the contract and specifications where they differ from ordinary practice, or where they have particular applications on this work are briefly noted below.

The contracts are printed in pamphlet form, letter-size sheet (8x11). There is a table of contents at the beginning and a complete index at the end. Plans were published originally on large sheets about 22x30, lithographed and bound together, but this has been changed for smaller-sized plans which are lithographed on thin paper uniformly 11 in. wide, and bound into letter size (8x11) pamphlets the same as the contracts, thus making them very easy and convenient to handle.

The contracts for the general construction do not include any station finish of any kind, nor the track, ballast, or electrical equipment except such parts as necessarily have to be incorporated in the main structure, such as conduits for electric wiring, power cables, etc., and the ducts or pipes for lighting wires at the stations. The

automatic pumps at the pumping stations are included as, of course, the drainage has to be taken care of from the beginning. The contract drawings usually include enough plans showing the general scheme of station finish, so that the contractor may have this as a guide in carrying out his work and that he may make due allowances for it. All necessary changes in location of sewers, water and gas pipes, electrical conduits, etc., required by the construction of the subway are included in the contract. The principal changes of the larger structures are shown on the plans, but exact details of smaller pipes, conduits, etc., are left until the existing pipes are uncovered and all subsurface structures definitely and exactly located.

Approximate quantities of each item are given for the purpose of comparing the bids on a basis of total cost. The time may be extended or diminished if there is any material change in total quantities.

There are provisions calling special attention to the necessity of compliance with state and city laws, especially the eight-hour law and the requirement that contractors shall pay the union scale of wages.

As the work is to a large extent to be carried out in residential districts, there are provisions which give the engineers adequate control of night work of any kind which might disturb people living near the line. Blasting is not permitted between the hours of 11 p.m. and 7 a.m. There are strict provisions (regular city ordinance) for the storage of explosives, the maximum capacity in any magazine being 250 lb., and in most of them not over 100 lb.

**BOND**—A certified check for a stated sum, varying from \$10,000 to \$25,000, according to the size of the contract, is required with all proposals and a bond of a stated sum of approximately 10% of the amount of the contract from the accepted contractor, 15% being retained from the monthly payments up to a total of about 10% of the amount of the contract, after which only 10% is deducted.

**TIME**—The following clause is of interest in the provision for completion within the specified time:

In the event of delay . . . . . the city . . . . . shall be paid damages for such delay. Inasmuch as the amount of such damages will be extremely difficult to ascertain, especially in view of the fact that the railroad herein contracted for is only a part of a complete system, the remainder of which is to be constructed under other contracts, it is hereby expressly agreed that damages shall be liquidated and paid by reducing the price to be paid the contractor as follows:

The provision then is for the retention of 1% of the amount due for the work done in the first month after the time elapses, 2% for the second month, and so on.

The following "blanket" clause is of interest in connection with works of large magnitude, where the subsurface conditions are as uncertain as they may be in a city:

The specifications and contract drawings hereinafter mentioned and taken in connection with the other provisions of this contract, are intended by the Commission to be full and comprehensive, and to show all the work required to be done. But in a work of this magnitude it is impossible either in advance to show all details, or precisely to forecast all exigencies. The specifications and contract drawings are to be taken, therefore, as indicating the amount of work, its nature and the method of construction so far as the same are now distinctly apprehended. The railroad is intended to be constructed for actual use and operation as an intraurban railroad of the highest class, adapted to the necessities of the people of New York, in the best manner, according to the best rules and usages of railroad construction, and in the event of any doubt as to the meaning of any portion or portions of the specifications or contract drawings, or of the text of the contract, the same shall be interpreted as calling



for the best construction, both as to materials and workmanship, capable of being supplied or applied under the then existing local conditions. All the clauses of the specifications, and all the parts of the contract drawings are, therefore, to be understood, construed and interpreted as intending to produce the results hereinbefore stated.

**MONTHLY ESTIMATES**—The engineer shall make an estimate of the amount and value of the work done as in his opinion shall be just and fair, but shall not necessarily be governed by the unit prices contained in the contractors' proposal, and provided that such estimate shall be withheld or reduced if in the opinion of the engineer the work is not proceeding in accordance with the contract.

An allowance is made for structural steel delivered, at the rate of \$40 per ton.

The contracts provide that the city shall make payment on estimates within 30 days after a certificate is issued

by the commission. As a matter of fact, payments are usually made within 30 days of the end of the month covered by each estimate. Final payments are to be made 90 days after the filing of a certificate of completion.

**SHAFTS AND OPENINGS**—Plans showing the location of all shafts, plant to be erected in the streets, supports of street decking, openings in decking, etc., must be submitted to the engineers, and receive their approval before work is commenced. This, of course, is in addition to the regular permits to be obtained from the city.

**LIABILITY**—The contractor admits (under the form of contract) that if the work be done without fault or negligence on his part that the plans, etc., do not involve any danger of foundations, walls, or other parts of adjacent buildings, etc.



# Design of Structure and Track

**LOADINGS**—The subway and elevated structures are all designed in accordance with the specifications for assumed loadings, and strengths of materials and methods of calculation, as given in detail in a paper presented to the American Society of Civil Engineers by Henry B. Seaman, formerly Chief Engineer of the Public Service Commission, and under whose direction they were worked up (*Trans. Am. Soc. C. E.*, Vol. LXXV, p. 313). The principal provisions governing the design for steel structures are given below:

The railroad trains on bridges shall be estimated as required by specifications of railroad company.

Elevated or subway trains shall be estimated as a continuous load of 2000 lb. (2k) per lineal foot of each track, or a single local concentration of two adjacent motor trucks with axle loads spaced as follows:

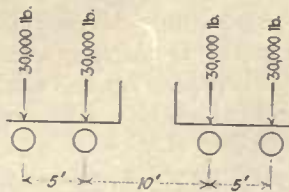

Trolley cars shall be estimated as continuous at 1500 lb. (1½k) per lineal foot of each track, or as a local concentration of one ash car with axle loads spaced as follows: (Note, the ash cars are special cars used by the B. R. T. for removing ashes, etc.)

The roadway for trolley cars on bridges shall be assumed as 12 ft. wide, and shall be capable of carrying the loads specified for roadway of bridges.

The roadway load for bridges shall consist of a uniform load of 120 lb. per sq.ft. of surface, or a local concentration of 40k on one axle with a wheel gage of 8 ft. This load may be assumed to cover a space of 12 ft. wide by 40 ft. long.

The roadway load over subways shall consist of a uniform load of 600 lb. per sq.ft. of surface, or a single local concentration of 200k on four wheels, 12 ft. between axles and 8 ft. gage. These concentrated loads shall be assumed to

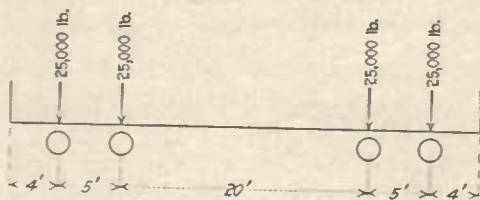

be distributed over an area of 2x2 ft. on the pavement and thence through the earth at a slope of one-half to one. Sidewalks over subways shall be assumed as loaded at 600 lb. per sq.ft.

Footwalks for bridges and platforms of elevated R.R. station shall be estimated as loaded at 100 lb. per sq.ft. of surface. Subway platforms shall be estimated as loaded at 150 lb. per sq.ft. of surface.

**IMPACT**—Loads due to trains or trolley cars shall be increased for impact in accordance with the following formula:

$$S = 125 - \frac{1}{2} \sqrt{2000L - L^2}$$

where  $S$  = Increase in per cent.  
 $L$  = Length, in feet of applied loading which produces maximum stress in the member.  
 Not to exceed 1000 ft.  
 ( $S = 0$  when  $L = 1000$  ft.)

No increase shall be made for impact to horizontal loading (centrifugal or traction forces.)

**Wind**—Provision shall be made for wind pressure acting in either direction, horizontally, of 30 lb. per sq.ft.

**Traction**—Provision shall be made for the sudden starting or stopping of a train 500 ft. in length, estimating the coefficient of sliding friction at 10%.

**Temperature**—Provision shall be made on bridges for a variation in temperature at 120° F. (a difference of 40° in the temperature of the chords of the same truss, or in that of adjacent trusses of the same structure shall be considered in spans of more than 300 ft.)

The following table shows the unit stresses (1 k = 1000 lb.) allowed for steel used in the structure taken in conjunction with the foregoing loadings:

Nature of stress	Steel Medium structural	Cast
Tension (Net).....	20k	16k
Compression (1 Diam.) (Gross).....	20k	20k
Compression (12 Diam.) (Gross).....	16.5k	
Compression, Columns.....	20k*	
	$\frac{1^2}{8000r^2}$	
Bending (Beams, outer fiber).....	20k	
Bending (Pins, Rivets and Bolts).....	30k	
Shear (Pins, Rivets, web) (Net sec.).....	15k	16k
Bearing (Pins, Rivets and Bolts).....	30k	
Bearing (Roller) per lineal in.....	0.75kd	

l = Length of column, in inches.  
 r = Least radius of gyration of cross-section, in inches.  
 d = Diameter of roller, in inches.

\*Note: Compression members in steel and iron shall not receive greater unit stress than that allowed for 12 diameters.

When beams and girders are embedded in concrete, the concrete will be assumed to take 20% of the loading.

In case of field rivets 25% excess will be added to the number of rivets required as above. (When machine-driven this may be reduced to 20% excess.)

## PRELIMINARY INVESTIGATION

Extensive borings, both wash and core, were taken before construction to determine as nearly as possible the character of the subsoil, depth to rock, etc., although the

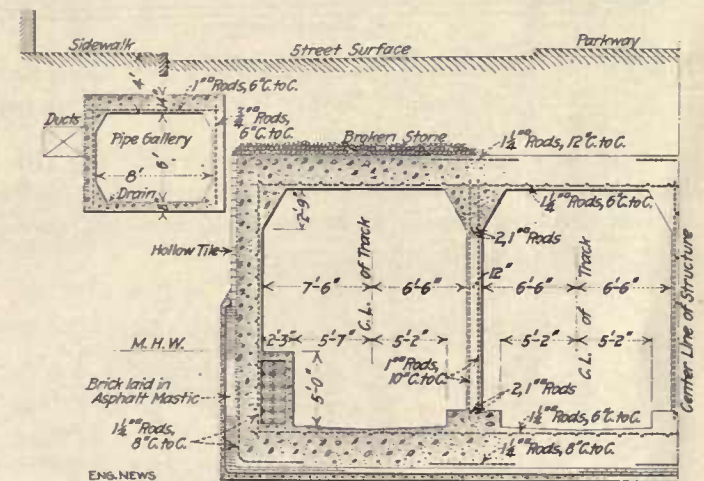

FIG. 10. HALF SECTION OF B. R. T. SUBWAY ON FOURTH AVE., BROOKLYN, BUILT IN REINFORCED CONCRETE WITH PIPE GALLERY UNDER SIDEWALK

latter is extremely irregular. All existing structures, both above and below ground, were located as well as possible so that proper provision might be made for taking care of them, though the actual final disposition of many of the small pipes, etc., was not determined until they were all uncovered by the excavation and accurately located.

## GENERAL DESIGN

Speaking generally, the present designs are based on the use of structural-steel frames with concrete jack arches between. The use of reinforced concrete is very limited. It seems to be generally considered that the use of the structural-steel frame greatly facilitates the support of the street decking during construction, because just as soon as a bent is set up and riveted, the load may be transferred to it.

Under the requirement that the street surfaces shall be maintained and their use for vehicular and other traffic



be uninterrupted, it is generally necessary, on account of the width of the excavation, to carry this decking on timber supports, which, as will be seen later, fill up a large part of the excavated space. The construction of reinforced-concrete structures under these conditions is, therefore, somewhat difficult and liable to be patchy, but by proper care in arranging the timbering, the steel-framed bents can be erected easily.

The usual members employed in the steel-frame type of construction in these subways are small enough to be easily handled, so that reinforced concrete has little advantage in the use of small construction units. The ease of construction of the steel-frame structure and advantages of support more than outweigh any disadvantage in the necessity of using skilled steel erectors, as against the supposed ability to use unskilled labor for reinforced concrete, even though the form work for the concrete with the steel structure is little less than

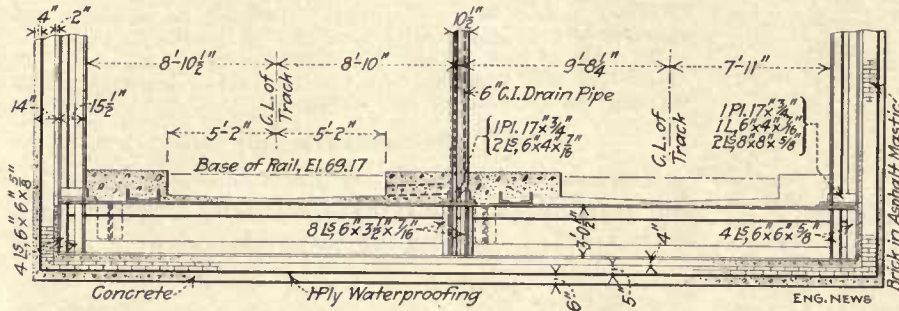

FIG. 11. B. R. T. SUBWAY ON BROADWAY AT CANAL ST., SHOWING VERY HEAVY FLOOR TO RESIST UPWARD PRESSURE OF WATER

it would be for ordinary reinforced concrete. Fig. 10 shows the reinforced-concrete design adopted in 1908 for the 4th Ave., Brooklyn, lines, which, however, were built mostly in open cut.

The use of the specially rolled "bulb" angles, used on

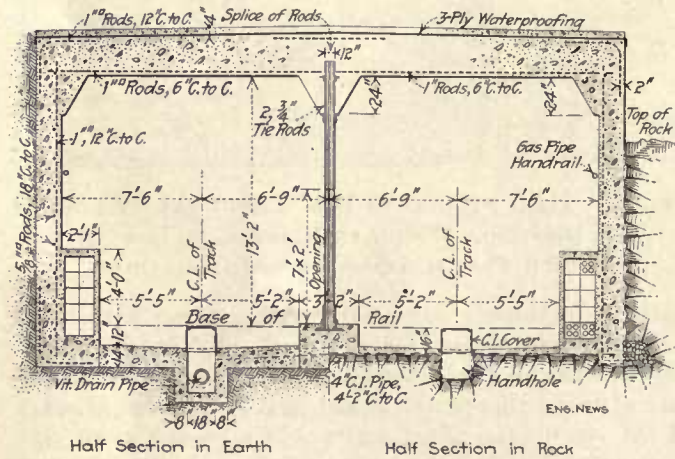

FIG. 12. REINFORCED-CONCRETE SUBWAY ON LEXINGTON AVE.

(This shows the upper level. The tracks on the lower level are in tunnel with a roof of two arches supported on a center wall and the sidewalls.)

the original subway, has been abandoned and only standard steel shapes are used. Usually the columns rest directly on the concrete, as shown in the normal sections, Fig. 8, but in certain places I-beam grillages are provided. No stone-block footings are used. Where the ground is soft or where water pressure exists, specially designed floors are necessary. One of the most important of these places is at Canal St., where the sub-

grade of the lower level is 40 ft. below M. H. W. or normal ground-water level. The heavy girders and thick concrete floor required at this point are shown in Fig. 11. A typical floor to meet conditions below ground-water level is shown in Fig. 15, which is a cross-section of part of the Lexington Ave. subway, where the line passes over what seems to have been an old swamp. This special type was designed principally for the purpose of carrying the structure on the soft ground. Just north of this, at Lexington Ave. and 128th St., where the subgrade is considerably below the water level, a typical design (Fig. 16) of reinforced concrete, for resistance to water pressure in rock, is used.

On account of the fact that the New York rock, a micaceous gneiss, is well known to present difficulties of support—that is, on account of bad seams, etc., to be "heavy" in places—it was decided to use a reinforced-concrete lining for the deep-level tunnels under Lexington Ave. It was found on opening up the work, however, that the necessary temporary supports of timber made this type of construction difficult to execute satisfactorily, and a change was, therefore, made to the design shown in Fig. 13. This, as will be seen, permits the construction of the center wall and the haunches with the steel columns and longitudinal I-beams, so that a direct center support can be built to the roof, which is generally sufficient for the support of the overlying rock without timbering during the construction of the concrete arches.

The unstable character of the rock and the variation in thickness of the cover involved some changes in the location of the tunnel portals, making it necessary to shift them back in almost every case to get sufficient depth

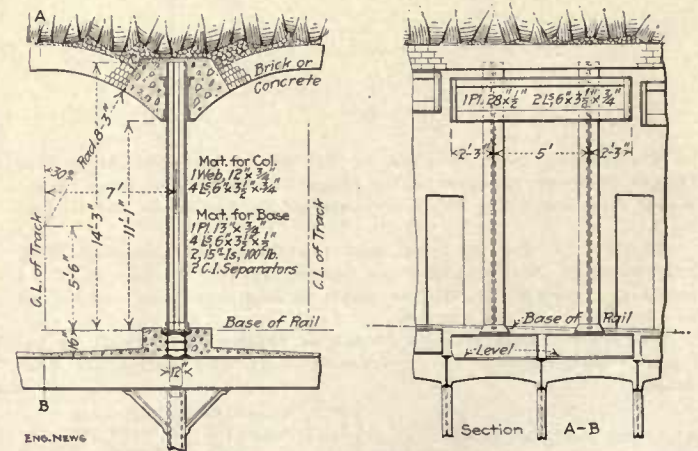

FIG. 13. ALTERNATIVE DESIGN FOR CENTER WALL USING STRUCTURAL STEEL INSTEAD OF REINFORCED CONCRETE

of overlying rock cover. This contingency is, of course, covered by the provision in the contract for slight variations in total quantities. The heavy ground on some of the sections on Lexington Ave. necessitated the design of considerably heavier steel sections, as shown in Fig. 17, for use at these places.



Further notes in regard to the construction of special sections, such as the Harlem River Tubes, steel and reinforced-concrete elevated sections, etc., will be found under their respective headings.

CROSS-SECTIONS—During the early days of the Public Service Commission (1907-08), there was considerable discussion in regard to the desirable dimensions of the cross-section of the new lines proposed at that time

the table herewith and in more detail in the typical cross-sections shown.

In Fig. 8 (of the previous article) is shown a cross-section of the 7th Ave. line of the Interborough, which is the minimum section for the new lines. Figs. 12 and 14 show the Lexington Ave. line, which is to be operated by the Interborough, but which was designed before the question of operation was definitely decided. Fig. 11

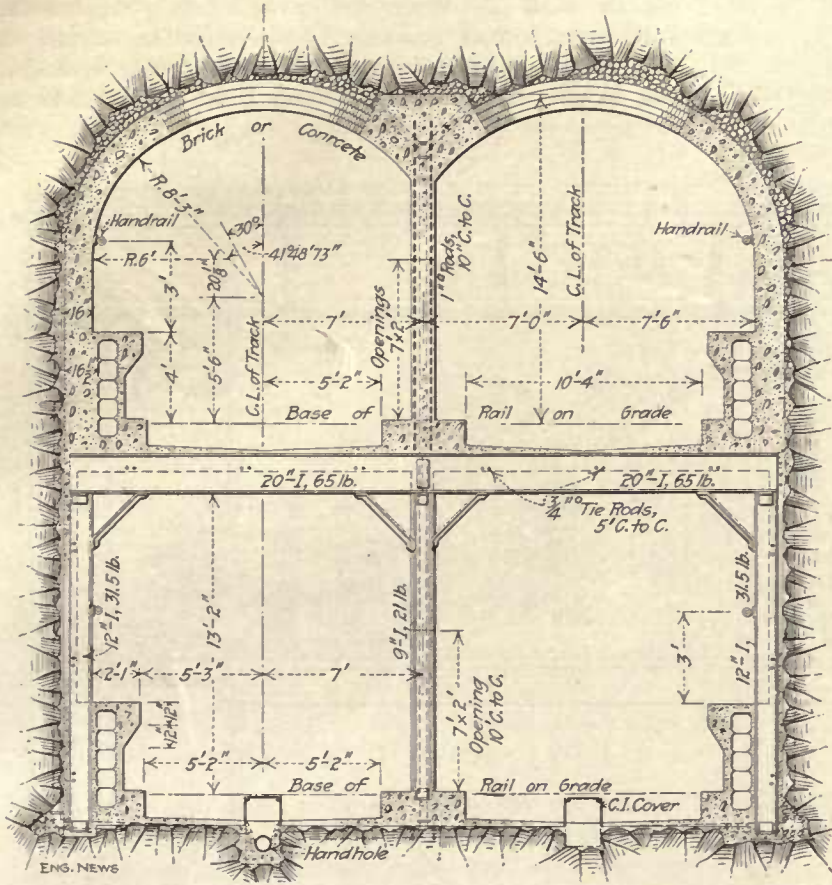

FIG. 14. DOUBLE-DECK SUBWAY ON LEXINGTON AVENUE BUILT WHOLLY IN TUNNEL

as extensions and further developments of the rapid transit lines then in operation. It was not thought advisable to conclude further operating contracts on the basis of those made for the original subway, and it was found difficult to arrive at any other which was agreeable to both parties. It was then decided to go ahead with the construction of the 4th Avenue, Brooklyn, line and Centre St. loop, leaving the question of operation to be decided later. It was thought that if neither the Interborough nor the B. R. T. would meet the views of the Commission in regard to terms of operation, a third party might be found, and as there then seemed to be a possibility that this might be one of the existing steam railroad lines, it was decided to provide clearance for standard railroad equipment and the designs of these two sections were modified accordingly to provide this. As all doubt in regard to the future operation has now, however, been eliminated, it has not been thought necessary in the design of the new lines now to be built to provide for larger equipment than it is known will be used, and the clearances decided on for the new lines are only slightly larger than those provided in the present subway, as is shown in

shows the cross-section of the Broadway-59th St. route of the B. R. T. The following table shows a general comparison of the dimensions of the original subway and those since adopted:

	Height above top of rail	Width*
Original subway.....	12 ft. 4 in.	12 ft. 6 in.
Fourth Ave., Brooklyn, and Centre St. loop.....	14 ft. 6 in.	14 ft. 0 in.
New subways:		
B. R. T.....	12 ft. 8 in.	14 ft. 3 in. & 13 ft. 6 in.
Interborough .....	12 ft. 3 in.	13 ft. 6 in. & 13 ft. 0 in.

\*From center of columns between tracks to face of side wall. (Columns about 8 in.)  
 Note—These are dimensions on tangents and are increased on curves to provide equivalent clearance.

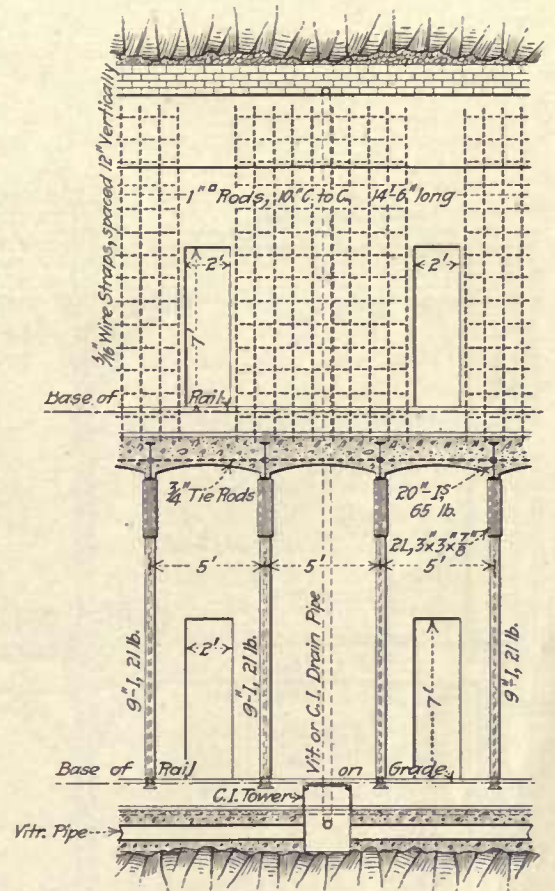
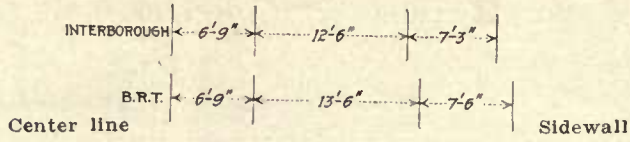

FIG. 15. FLOOR ON SECTION 12 OF I-BEAMS AND CONCRETE



As is shown on the various cross-sections, provision is made for building the conduits for the electric wires, in a side-bench wall with a walk on the top, instead of placing them in the sidewalls, as in the old subway.

The standard track spacing for four-track subways finally adopted is as follows, from the center line of the four tracks to face of sidewalls:



press stations during the rush hours. Under present operating conditions, the spacing of trains is determined probably as much by the length of station stops as by ability to run the trains more closely together between stations. It is probably difficult to determine the exact economic dimensions of a car which will hold the maximum number of people and at the same time permit the minimum time of stopping. As has already been pointed out, the B. R. T. has decided to use a larger car, but the Interborough will probably of necessity be obliged to continue the use of equipment interchangeable with that now in use, and therefore all new lines which are to be

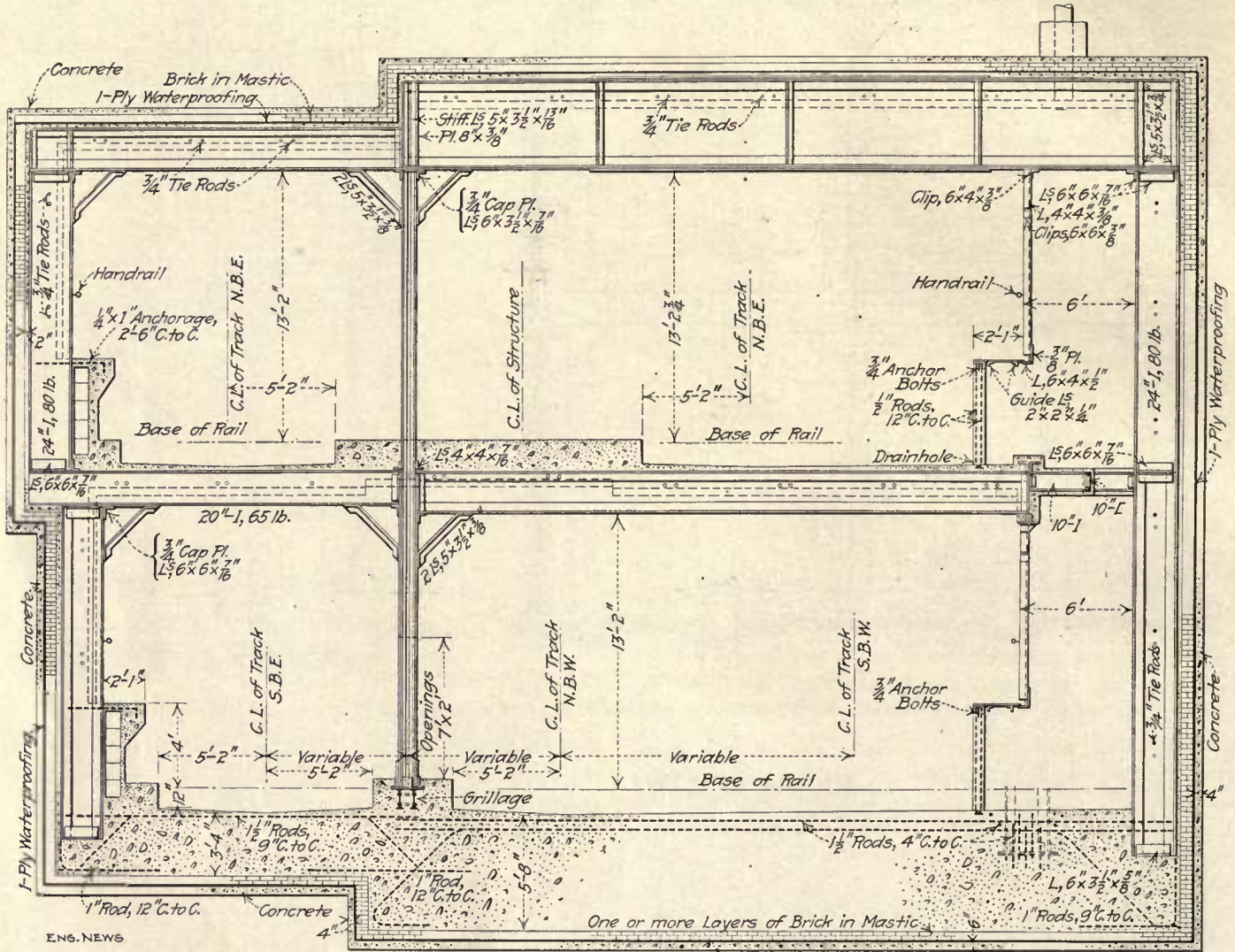

FIG. 16. LEXINGTON AVE. SUBWAY AT 129TH ST. DOUBLE-DECK STEEL-FRAME CONSTRUCTION WITH HEAVY REINFORCED-CONCRETE FLOOR

Cross-sectional dimensions of other rapid transit subways in the United States are approximately as follows, there being many minor variations:

	Height above top of rail	Clear width
Boston, Tremont St., 1898.....	13 ft. 10 in.	12 ft.
Boston, Washington St., 1905...	14 ft. 5 in.	12 ft. 2 in.
Cambridge, 1910.....	14 ft. 9 in.	12 ft. 6 in. (a)
Philadelphia, 1907.....	14 ft.	12 ft.
H. & M., 6th Ave., 1908.....	12 ft. 10 in.	13 ft. (b)

Note (a)—The Cambridge subway is large enough to take standard steam railway equipment; the tracks are 12 ft. on centers.

Note (b)—Sidewalk over duct bench at side.

The question of cross-section is one of considerable importance. It is determined largely by the size of the cars, the economic limit of which is controlled largely by the time necessary to load and upload them at ex-

used exclusively by this latter company are designed on that basis, only very slightly larger than that now in use.

The cross-section has also, of course, an important bearing on the question of ventilation; this, however, is discussed more fully under that heading.

On some of the routes when the designs were made and construction started, it was uncertain whether they were to be operated by the B. R. T. or the Interborough; Fig. 18, for an adjustable edge to the platforms, so that either the 9-ft. Interborough or 10-ft. B. R. T. cars could be used.

TRACK CONSTRUCTION—A standard track construction



has been adopted for all the new lines, by conference and agreement between the two operating companies and the Public Service Commission. Rails are to be 100 lb. openhearth B section of the Am. Ry. Eng. Assoc. Ties, yellow pine 6x8x8 untreated, with flat-bottom shoulder tie-plates  $7\frac{1}{2} \times 9 \times \frac{1}{2}$  in., and 6-in. cut spikes. In the subways trap-rock ballast  $\frac{1}{2}$  to 1 in. will be used as a cushion over the concrete floor; as the head room is limited, there will be only about 6 in. of ballast under the ties. Ample drainage is provided by drains in the concrete floor.

Judging by experience with the ties in use on the present rapid transit lines it has been thought that treatment by creosote or other preservative will not be necessary.

Guard rails are to be used on all curves of less than 2000 ft. radius; those under 700 ft. radius will also have

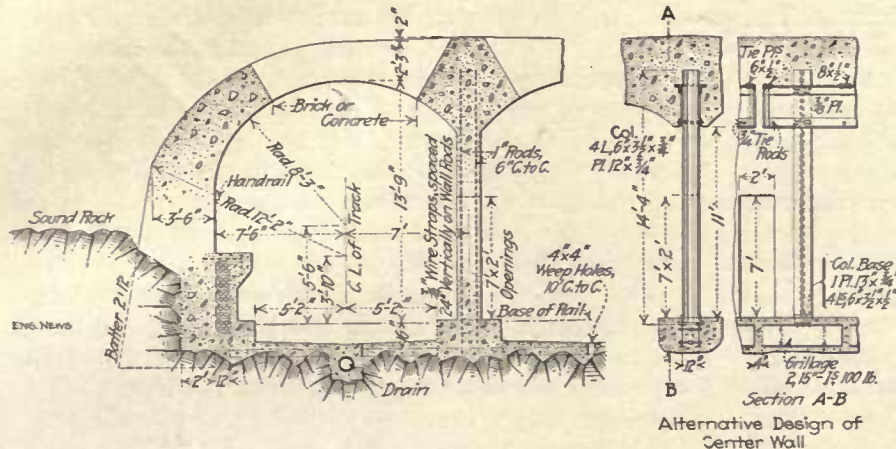

FIG. 17. HEAVY STEEL SECTIONS IN CENTER WALL, LEXINGTON AVE. LINE AT 59TH ST.

rail braces on the guard rails, as well as for the outside rails. Rolled manganese rails are to be used practically entirely for all frogs, switches, cross-overs, etc., and on all curves less than 700 ft. radius. In regard to the necessity for the use of manganese rails, which cost about  $2\frac{1}{2}$  times as much as openhearth, reference may be made to the experience of the Boston Rapid Transit lines (ENG. NEWS, Oct. 22, 1908, p. 458), where on a certain curve

bessemer rails lasted only 60 days, but a cast manganese rail had shown only about  $\frac{1}{2}$  in. wear in six years. There is, of course, not only the wear of the rail to be considered, but the cost of changing due to the abnormally high cost of track work under the extremely heavy traffic and in the confined space in the subways.

At stations, in order to facilitate cleanliness and sanitation, a special type of track construction similar to that used in the Pennsylvania terminal station in New York\* and the Detroit River tunnels† is to be used. A cross-section is shown in Fig. 19.

The track material is to be bought by the Public Service Commission under contracts and at unit prices to be bid for the various items required; it is to be stored and issued on requisition to the operating companies who will install the track as part of the "equipment."

\*"Trans.," Am. Soc. C. E., Vol. LXIX, p. 305.  
 †"Trans.," Am. Soc. C. E., Vol. LXXIV, p. 349.

TRACK LAYOUTS—The arrangement of tracks at junction points, so as to avoid crossings at grade, with the consequent delay, as well as danger, has been the subject of considerable thought and study. In the present subway there are three junction points, at Bowling Green, City Hall, and at 96th St. The first two being merely junctions of double-track lines, where only one class of trains, either local or express, has to be cared for on each route, did not present any particular difficulty, it being only necessary to depress one track under the other two. At 96th St., however, where two double-track lines come together into a four-track section, and where express and local trains have to be directed from any one line to any of the others (in the same direction), the problem is more complicated.

The present layout at 96th St. is shown diagrammatically at D, Fig. 20; it will be noted that the switches and slip crossings are all on the north side of the station, and that as trains from either branch may and do continue as either local or express, there is frequently some delay to trains before they can approach the crossings to enter the station on the proper track. This would not be noticeable on lines of ordinary traffic, but under the conditions existing during the morning and evening rush hours in New York, the slightest delay may be magnified into a serious congestion of the whole system.

The number of such junction points on the new lines has been considerably increased and typical methods of

overcoming the difficulties are shown in the three diagrams A, B and C of Fig. 20.

So far as possible in all the designs for the new lines the engineers have tried to avoid any slow points, such as switches, crossings, etc., at places other than close to stations where trains must stop, and to locate them on the farther side rather than on the near side where they

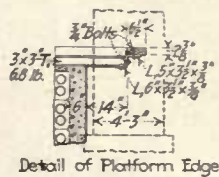

FIG. 18. DETAIL OF ADJUSTABLE PLATFORM EDGE

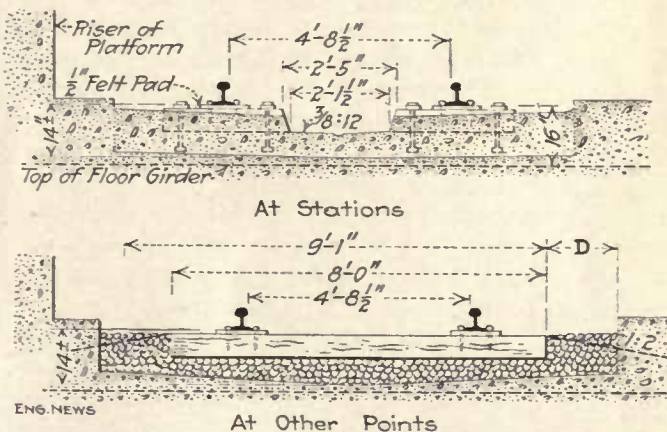

FIG. 19. TYPICAL CROSS-SECTIONS OF TRACK

would be reached before the train enters the station, and where in case the line is not clear the train would have to make a signal stop before reaching the switch as well as the station stop after.

The diagram at A shows the track layout at 125th St. on the Lexington Ave. line. It will be noted that com-



ing from the north, trains from either branch reach the station without crossing any switches, are both on the same level and on their same respective sides of the station. Continuing south, those trains which become ex-

ment of the local trains is concerned, as their next station stop is at 116th St.

Coming from the south the expresses reach the upper level in the east side over practically a straight line with no switches, with just enough ascending grade to slow them down. Leaving, they take one or two switches as they are diverted to either the east or west branch, but both within 300 ft. of the station. The locals coming from the south have one or more switches to pass before they reach the station; this, however, is not of importance especially as they do not anywhere come in contact with the expresses. As may be seen these latter switches are not necessary for the operation of through trains, as trains from either side of the station going north reach either branch without crossing the tracks of trains going in the opposite direction, but are put in for convenience, to provide two extra side tracks for any emergencies of operation at this junction.

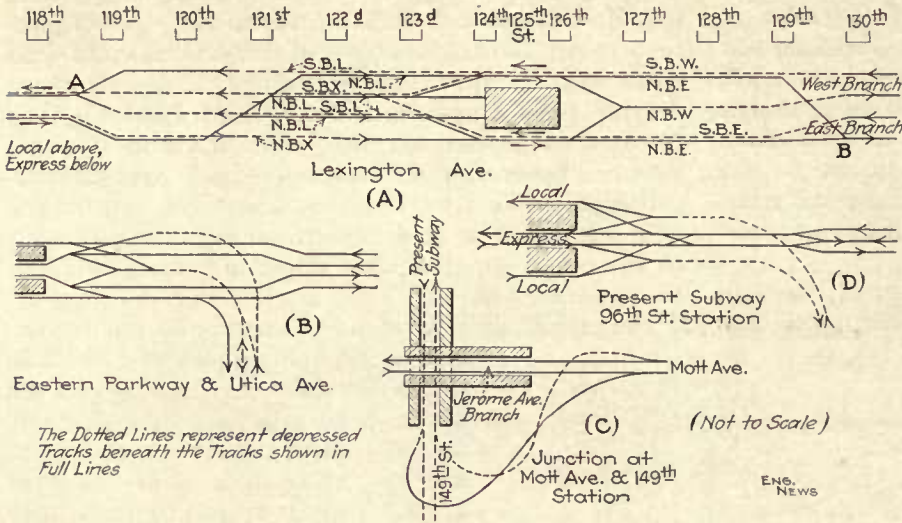

FIG. 20. VARIOUS TRACK INTERSECTIONS

presses from this point, pass the required switches within 300 or 400 ft., while the locals have a switch, which is, of course, a slow point, at 119th St. (about 1500 ft. beyond the station). This, however, is of little importance, so far as causing any delay in the south bound move-

The other two diagrams are self-explanatory, except to say that at Eastern Parkway and Utica Ave., diagram B, the arrangement is not quite so elaborate as there is not expected to be such heavy travel on this section.



# Ventilation, Drainage and Waterproofing

## Ventilation

Every effort has been made to so design the new subways that the excessive heating which occurs at times in the summer in the present subway may be avoided. The tracks are to be divided so that trains going in one direction will be in a separate tube or tunnel from those going the opposite way; by this means it is expected to utilize the movements of the trains (the so called piston action where there is only one track in a single tube) to push the air ahead and out through the openings which are provided for this purpose.

The original subway is completely surrounded by an envelope of waterproofing, and it has been thought that this has prevented the dissipation of some of the heat generated by the motors, brakes, friction, etc., into the ground surrounding the structure. On the new lines waterproofing will generally only be used where actually necessary to keep out water, that is, below the ground-water line, in earth, and on the roof.

Openings in the roof of the tunnel, with sidewalk gratings, are provided over the station platforms, and generally one about half way between each station and one at each end of the stations on the side toward the approaching train, these latter being expected to take care of most of the draft caused by the train, instead of allowing it to create a current at the platform and up the stairways. The general form of these openings and the details of their construction are shown in Fig. 22, and a typical arrangement of location in Fig. 21 (7th Ave., 17th to 24th St.). The dimensions and numbers of these openings have been so fixed that it is expected that the current of air coming through the gratings in the sidewalk will be barely noticeable to pedestrians.

Fan chambers, which are all arranged so that they may be also used as emergency exits to the streets, are provided, one about midway between each station. They are so arranged that they will draw the air from the tunnel at points intermediate between the stations and blow it out through the gratings already described, thus, of course drawing fresh air in at the stations. It is expected that the openings alone combined with the action of the trains will ordinarily provide sufficient ventilation, the fans being used only occasionally when circumstances require.

The piston action of the trains in the single-track tube of the Hudson & Manhattan R.R. has been noticeably efficacious in promoting efficient ventilation, but except on the Fourth Ave., Brooklyn, line, where there is a parked space in the center of the street and where walls are provided between each track, it was not considered practicable to divide all the tracks of the new four-track lines so that each would be in a separate tube, on account of the difficulty of providing outlets for the center tracks. It would be impractical, of course, to provide openings in the roadway of the streets, and in order that the openings in the sidewalks might be used, the center wall only was built dividing the traffic going in opposite directions, but leaving the two tracks on one side in the one space. If

this does not produce the required movement of the air—that is, actual propelling movement, not mere stirring up as in the present subway—the fans must be utilized to supplement it. Openings about 2 ft. wide and 8 ft. high are provided at every 10 ft. in the center wall as a means of communication between the two sides, and as refuge niches, and these may tend to reduce the piston effect to some small extent.

Although this arrangement in the four-track section will reduce somewhat the positive piston action of the trains, it will be beneficial to the extent that it will tend to reduce the air resistance, which has been shown\* to be by no means a negligible factor in cost of operation in single-track tubes, though this cost may be offset by the benefits of more efficient ventilation.

The actual effect of all these different items and of the size of the cross-section, both on the efficiency of ventilation as well as the cost of operation, is something of which little is actually known, but in view of the enormous expenditures which are being made and which undoubtedly will continue to be made in underground railways for rapid transit, in subaqueous tunnels, etc., it is hoped that further experiments along the lines of these already referred to\* and others of like nature may be continued.

As will be seen by the diagrams, the object of the design of the openings has been to provide at the track level a space into which the air pushed ahead of the train may expand and be detained, instead of being pushed by, and then provide an opening above through which it may escape to the surface, there being apparently little reason to doubt the efficacy of this proposed scheme.

## DRAINAGE AND WATERPROOFING

In the general clauses of the specifications it is stated that "it is the very essence of these specifications to secure a railroad structure underground which shall be free from the percolation of ground or outside water. The mixing and placing of the concrete and the placing and protection of the waterproofing shall be with this end in view.

"In general, waterproofing of the structure will be limited to the roof and sidewalls at the stations and over the roof between stations, and to those surfaces near ground water or mean high water if ground-water level is found for any reason to be below mean high water. At other places free drainage shall be provided by pipe drain, hollow tile or broken stone."

The specifications provide for the use of fabric waterproofing, laid in hot pitch or asphalt, and in from three to six thicknesses or plies, and for brick or hollow tile, laid in pitch or asphalt mastic, the latter to contain "one-third pure bitumen, and sand and cement or lime dust in proportions governed by local requirements and weather conditions."

At temperatures of 50° to 70°, the proportions used are usually one-third asphalt, one-third cement, one-third sand; in colder weather the proportion of asphalt is in-

\*J. V. Davies, "Air Resistance in Tube Tunnels," "Trans." Am. Soc. C. E., Vol. LXXXV, 1912.



increased as required up to a maximum of 60%, though 50% is seldom exceeded. Lime dust is apparently not used in place of the cement, as it appears to require a larger proportion of asphalt to make it workable.

The fabric waterproofing is generally used on the roof or other horizontal surfaces where it may be required, and the brick in mastic on the sidewalls or on any vertical

troweled as may be directed in order to add to its imperviousness.

Reference has already been made to the fact that on account of the supposed influence of the waterproofing envelope inclosing the present subway, in retaining the heat, that waterproofing is only carried out in the new lines where the evident necessity shows the need of pro-

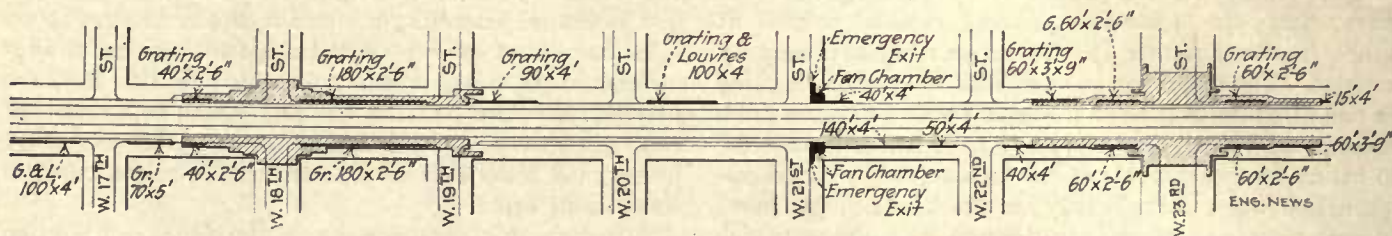

FIG. 21. PLAN OF PORTION OF SEVENTH AVE. SUBWAY, SHOWING PROVISION FOR VENTILATION

surfaces and under the floor when required there. At stations brick and mastic are used over the roof.

In the concrete specifications, the following clauses apply to the waterproofing:

The proportions of cement and sand and stone (or gravel) used in making protective concrete outside of waterproofing lines on sides and roof, shall be as follows: 1 part of cement, 4 parts of sand and 8 parts of stone.

tection to keep the structure reasonably dry. Much greater reliance is being placed on the provision of free drainage to take care of small quantities of water, than has been done heretofore, this being in line with recent experience.

The question of waterproofing tunnels is comparatively modern and its importance is due principally to the de-

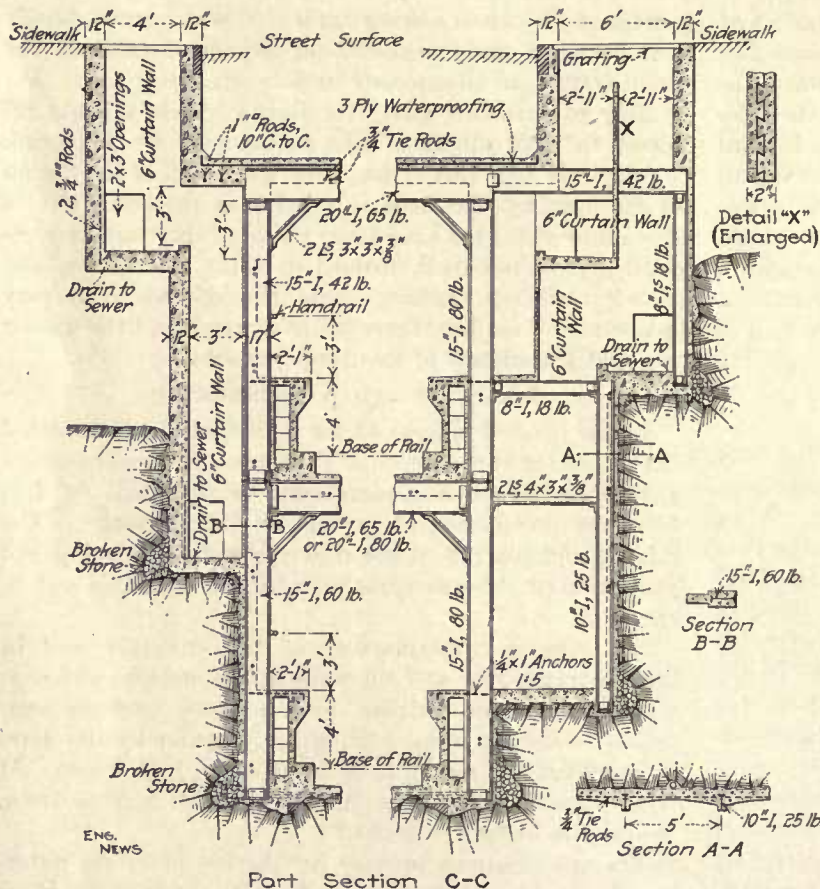

FIG. 22. PARTIAL CROSS-SECTIONS AND PLANS OF DOUBLE-DECK SUBWAY, SHOWING TYPICAL ARRANGEMENT OF VENTILATING OUTLETS

Concrete to which waterproofing is to be applied shall be made smooth at the time of laying and shall be carefully protected from injury by barricades or otherwise, if necessary until thoroughly set.

It is intended to obtain concrete impervious to water; the concrete shall be mixed and deposited with this end in view, and on the roof of the railroad, if waterproofing is not used, the top surface of the concrete shall be carefully

velopement of electric traction and of the numerous underground lines for urban rapid transit. On that section of the Pennsylvania Railroad's New York tunnels which passes under the Bergen Hill\* on the Jersey side

\*"The Bergen Hill Tunnels of the P. R.R." "Trans.," Am. Soc. C. E., Vol. LXVIII, p. 146.



of the Hudson River, and where there was a considerable seepage of ground water, the ample and careful provision of free drainage without the general use of waterproofing has resulted in a remarkably dry structure.

On all the new subway lines, drain pipes are laid in the floor (under the center of each track) which lead to sumps at pump chambers, from which the drainage is discharged by automatic electric pumps into convenient sewers.

These floor drains have grating openings in the concrete floor every 50 ft. and the floor grades are arranged (irrespective of the track grades) so that there is a summit between each grating (in the case of steep grades 2 or 3%, the summit is just below the grating); 4-in. pipes lead to these center drains from the sides, and, if necessary, part or all the way up, to take care of any seepage there may be. In the case of the Lexington Avenue rock tunnels, these side drain pipes generally reach up to the bottom of the loose rock packing over the roof. See Figs. 12 and 14.

Speaking generally, there are two typical methods of waterproofing. The first where the structure is in earth, where the water level (mean high water or ground water) is above the bottom of the structure. In these cases the waterproofing is carried across the bottom and up the

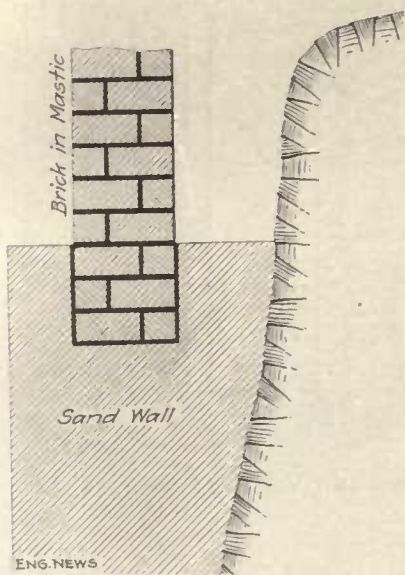

FIG. 23. EXAMPLE OF WATER-PROOFING STRUCTURE IN ROCK WITH BRICK WALL LAID IN MASTIC

sides to about 2 ft. above the level of the water. See Fig. 15. This drawing also shows the waterproofing carried over the roof, as the section is taken at a station.

The second where the structure is partly in rock and where the water level is above the rock. In these cases the waterproofing is carried from a point 2 ft. above the water level to the rock or more commonly sealed into a trench in the sand wall, as shown by the sketch, Fig. 23.

When the water level is below the top of the rock, waterproof-

ing is not generally used except over the roof (see Fig. 12), and in the case of the Lexington Ave. tunnels, even this is omitted.

The necessity or otherwise of using the waterproofing is, of course, governed entirely by the local subsurface

conditions. The plans provide for what may reasonably be expected, based on the results of the borings, but the judgment of the field engineers is relied on largely to modify this to conform to actual conditions developed as the work progresses.

In that section of Lexington Ave. south of 100th St., where the structure is in rock tunnel and wholly above the water level, no waterproofing at all is used; on the other hand, just above this point, at about 102nd St., though the structure is wholly in rock, the water level is about 10 ft. above the bottom of the structure and the brick in mastic is, therefore, carried down below the floor at the sides, and the top is covered with 1 ply of fabric and two layers of brick in mastic. Burlap coated with an asphalt compound is generally used for the fabric, but where there is water, as in the bottom under the floor or in depressed bays, etc., one layer of felt is used first.

At stations the waterproofing (3-ply fabric or 1-ply and two layers of brick in mastic) is carried over the roof and down the sides to below the track level, in order to prevent any damage to the decorations, as well as to protect the offices and passengers.

When the floor is to be waterproofed, a 6-in. concrete base is laid in the bottom of the excavation, and two layers of brick laid flat in mastic laid on this; at the sides, if the sheeting is to be left, the two courses of brick in mastic are generally laid right against it; otherwise, where the sides require waterproofing, the steel is first erected, then a hollow-tile or concrete-sand wall is built behind it, on which the waterproofing fabric is hung and then the concrete sidewalls are built. Loose rock is packed behind the hollow tile as it is built up.

In many cases the protection wall of 4-in. hollow tile, or a concrete sand wall is built, then the steel is erected before the brick in mastic is laid up. The steel columns then act as braces for the rough board forms necessary to support this latter until the mastic hardens. These boards are usually painted with a good thick coat of cement grout to prevent their sticking to the mastic; the grout sticks to the mastic and the boards are easily removed.

An inspection of the various bids made up to the present time shows the general average prices for the above classes of work on the contracts awarded to be approximately as follows:

Waterproofing, 1 ply per sq.yd.....	\$0.50 to \$0.60
Waterproofing, 2 ply per sq.yd.....	0.80 to 0.90
Waterproofing, 3 ply per sq.yd.....	1.10 to 1.20
Waterproofing, 4 ply per sq.yd.....	1.35 to 1.50
Waterproofing, 5 ply per sq.yd.....	1.55 to 1.75
Waterproofing, 6 ply per sq.yd.....	1.75 to 2.00
Brick in mastic, per cu.yd.....	27.00 to 30.00
Vitrified drain pipes, 4 in. per lin.ft.....	\$0.40
Vitrified drain pipes, 6 in. per lin.ft.....	0.50
Vitrified drain pipes, 8 in. per lin.ft.....	0.75
Vitrified drain pipes, 10 in. per lin.ft.....	0.90
Vitrified drain pipes, 12 in. per lin.ft.....	1.10
Cast-iron drain pipes, 4 in. per lin.ft.....	\$0.75 to \$1.00
Cast-iron drain pipes, 6 in. per lin.ft.....	1.00 to 1.25







the bypassing of all the gas mains—that is, the construction of new pipes for gas—on the surface of the street and the stoppage of the flow in the pipes underneath before commencing the excavation. This, of course, involves also new temporary house connections as well, but the danger of the accumulation of gas underneath the decking is thereby eliminated. The very great danger from this source was demonstrated by the recent explosions at 23rd St. and 5th Ave. (ENG. NEWS, Mar. 12, 1914), which while generally attributed by the public press to the subway construction, were caused if at all only very indirectly by this work. The following description of the method of dealing with the gas mains is contributed by C. N. Green:

“The present specifications for subway construction call for the street to be planked or decked over in the business

A temporary system of wrought-iron pipes or bypasses for gas distribution is laid in the gutters and connected with the live mains in the transverse streets and the house and street-lamp services are transferred from the cast-iron mains below the street surface to the temporary system. There is then no live main or pipe containing gas below the street surface.” (Figs. 26 to 29.)

“An 8-in. gas pipe broken off in the excavation might, under existing conditions, deliver 1000 cu.ft. of gas per minute. A 10% mixture of gas and air will perhaps not always produce a maximum explosive effect, but this is assumed for convenience and is very near a maximum. This would make 10,000 cu.ft. of explosive mixture per minute. A subway cut 25 ft. deep, 60 ft. wide, would contain 390,000 cu.ft. in a city block, so that theoretically in 39 minutes the block would be filled with an explosive

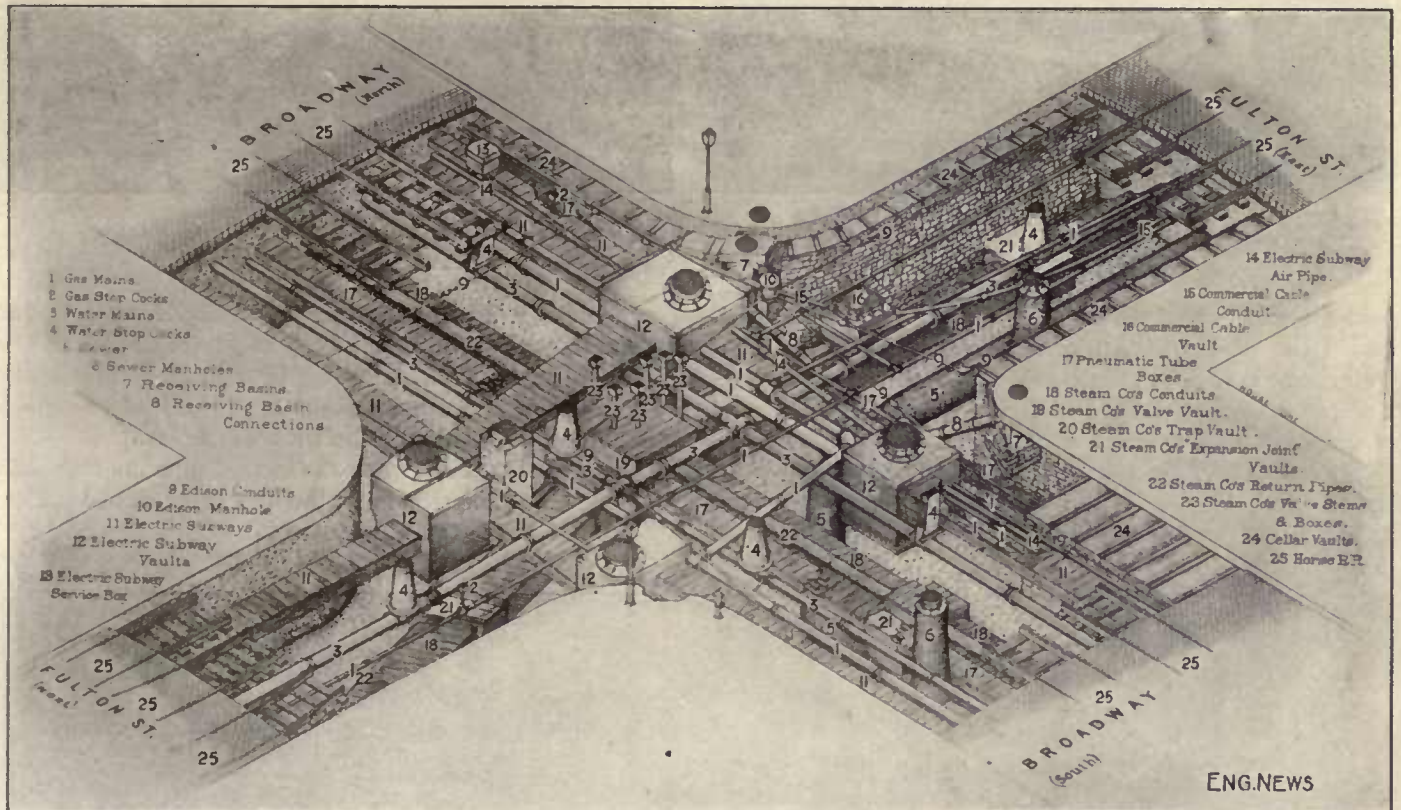

FIG. 25. ISOMETRIC VIEW OF UNDERGROUND PIPING AT THE INTERSECTION OF BROADWAY AND FULTON ST. IN 1890

sections or where traffic is heavy, so that business may be carried on as usual and with as little inconvenience to the public as possible. This decking then forms a temporary street surface under which the excavation is carried on. In time dirt and the sweeping of the street make the decking tight and prevent a circulation of air that would free the excavation of gas if a main should leak.

“Cast iron is used for gas and water mains when they are laid underground for the reason that it lasts much longer under such conditions than wrought iron. It is difficult, however, to keep the lead-calked joints of such pipe tight even when they are undisturbed, but when they are moved in excavating and hung up on the timbering, some joints are sure to be strained and begin to leak.

“All gas mains are, therefore, ‘killed’ where they would be underneath a closely decked street, except in rare cases where small transverse cast-iron mains are replaced under the decking by wrought-iron pipes with screw connections.

mixture. This, of course, would not be absolutely true as the gas would not diffuse itself with such rapidity and the mixture would be higher in gas near the break in the main and perhaps be too low in gas at the farthest point to explode. If the mixture should explode, however, the gas would burn where there is an excess and probably set fire to the timber with results as disastrous as the explosion itself.

“Gas mixed with air forms a very explosive compound which only needs a spark to ignite it. This spark might be furnished by the underground trolley of the surface railway, by one of the numerous cables exposed during the excavation, by a lighted match thrown away, by fire engines, by the shoe of a horse, or by blasting, etc. The violence of such explosions has been frequently shown when manhole heads have been blown into the air, and by numerous sewer explosions which have occurred in the last few years. Philadelphia and Boston had examples



in the construction of their subways and various minor instances have attested to the power of such a mixture.

“Knowing the danger from gas, both the gas company and the engineers of the Public Service Commission have taken every precaution to avert it. It was, therefore, decided not to leave any cast-iron mains, carrying gas, under the decking unless properly ventilated by means of gratings or protected by watchmen. Where mains crossing the subway excavation could not be cut out of service temporarily, wrought-iron pipe bypasses were to be built

Commission could be maintained. The pressures were taken continuously for several days and if these readings were satisfactory the longitudinal mains were cut off and capped at intervals of two blocks. In the meantime the bypass pipes were laid in the gutter and connected up. These were 6, 8, 10 or 12 in. in diameter, depending on the requirements of the different districts. Depending on conditions, one or two lengths of pipe were used to

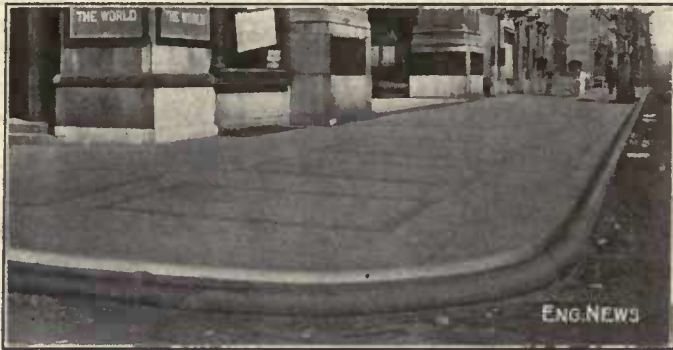

FIG. 26. A TEMPORARY GAS MAIN RUN NEXT THE STREET CURB

over the street or in the case of small pipes carried across under the decking. All connections between the cast-iron mains and the wrought-iron bypasses were to be carried far enough back into solid earth to avoid the danger of breaking off the pipe if a slide or cave-in should occur.

“In mains to be ‘killed,’ the flow of gas was first stopped by inserting bags in the pipe and readings were taken to see if the pressure prescribed by the Public Service



FIG. 27. OVERHEAD GAS MAIN AT LEXINGTON AVE. AND 112TH ST.

carry back in the transverse street and the turn at the curb was made with a pipe bent to fit the radius of the curb corner, Fig. 26. The pipes in each transverse street were then cut and capped about 10 ft. back of the sheeting line on both sides of the proposed excavation. Connection was then made with the largest pipe underground on each side of the street and the bypass continued underground across the transverse street.



FIG. 28. OVERHEAD GAS MAIN ON LOWER BROADWAY



"Generally there are from one to five pipes on each side of the transverse streets. Where there is more than one pipe on the same side of the street, each is connected back of the caps with a 1½-in. circulation connection, the vertical legs of which are tapped into the top of the pipe.

"In laying the first bypasses little attention was paid to the necessity of keeping the tops of the pipes level

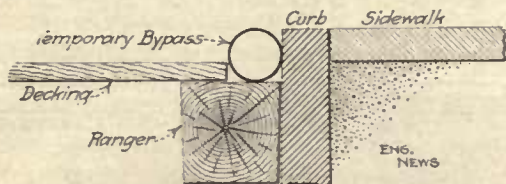

FIG. 29. TYPICAL METHOD OF PLACING GAS MAIN AT CURB

with or below the curb. As a consequence, numerous accidents occurred, due to persons slipping or tripping over the pipe. In one instance where the pipe did not lie close to the curb, a boy's leg was broken by being caught between it and the curb. Now all pipes are laid close to the curb, with the top not higher than the curb even if necessary to remove the gutter stones, and the remaining space is filled with concrete.

"Extra heavy wrought-iron pipe has been used generally, so that when the bypasses are moved the pipe can be used to relay the cast-iron mains over the subway. The gas company has found this desirable, as the vibration from the passing trains loosens the calking in cast-iron pipes.

"In Lower Broadway from Canal St. south are two mains 16 and 20 in. in diameter, respectively, supplying the lower part of the city. These mains were bypassed during the building of the subway from Vesey St. to Canal St. Wrought-iron pipes with flanged connections were laid about 14 ft. above the sidewalk. The trestle bents were so placed as to avoid entrances and interfere with business as little as possible. At cross streets where trestle bents could not be erected, the pipe was trussed with wire rope anchored to the pipe with clamps.

"In 138th St. are one 16-in., one 20-in. and one 24-in. gas mains forming a crosstown connection between the works and the lower west side of the Bronx. As these were within the sheeting lines, they were killed, and to take their place two 24-in. riveted steel pipes were laid on trestles, one on each side of the street.

"In various locations are large feeder or pumping mains crossing the line of the subway, and these mains generally were bypassed overhead, giving about 14 ft. clearance for the street cars and other vehicles. A description of one would be typical of all. Fig. 27 shows the bypass for the 36-in. main crossing Lexington Ave. at 112th St. The bypass pipe is a 30-in. wrought-iron riveted pipe carried on two gallows-frame supports back of the building line in the side street. Between these frames the pipe is suspended from two wire ropes carried over the gallows frames and each anchored back to a deadman. The deadman consisted of an inclined I-beam carried well below the street surface and its lower end embedded in a block of concrete. The main in the street was bagged off, the pipe cut and a three-way and valve inserted in the line of the pipe. This operation was repeated on the other side of Lexington Ave. The bypass was then connected to the three-ways on either side of the avenue, the bags removed and the valve

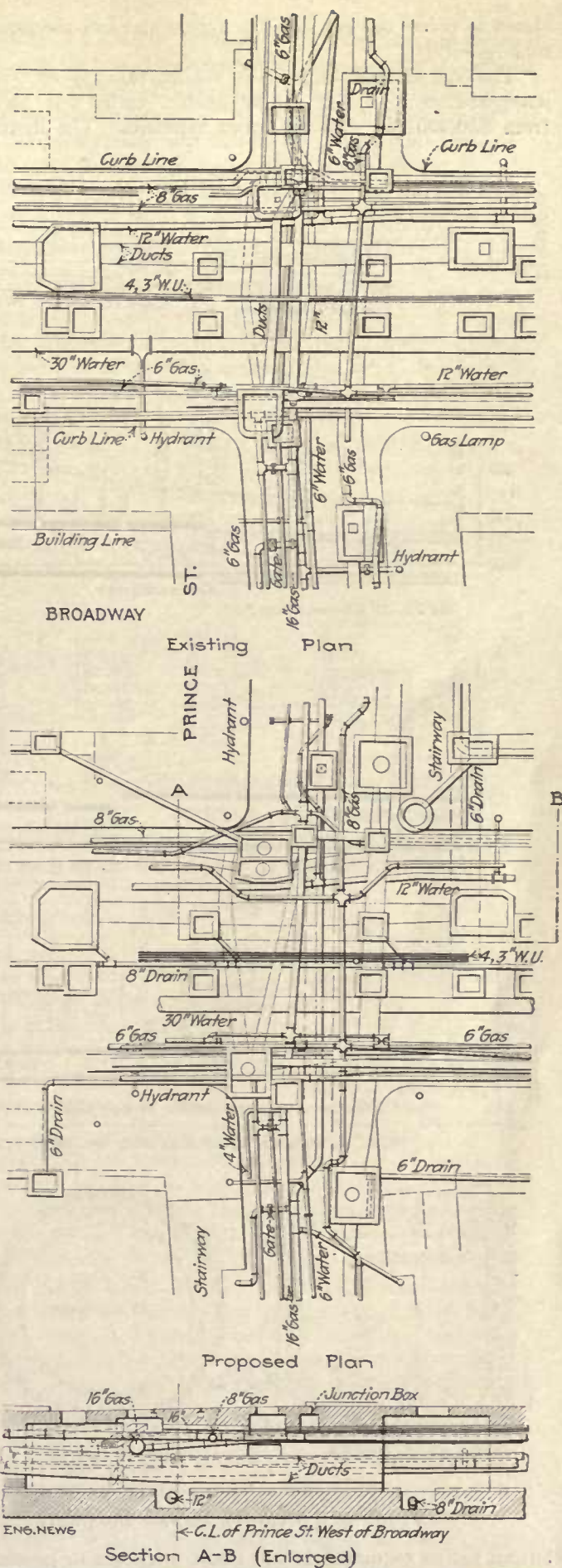

FIG. 30. A TYPICAL REARRANGEMENT OF UNDERGROUND PIPING AT A STREET INTERSECTION, OLD AND NEW PLANS OF UNDERGROUND PIPING AT BROADWAY AND PRINCE ST.



closed to throw the gas into the bypass and kill the main underground.

"The cost of bypassing service mains, using 6- or 8-in. wrought-iron pipe laid in the gutter, varies but little from \$50,000 per mile of street bypassed. The distri-

on local conditions. The average cost, however, should be about \$2500.

"After the construction of the subway and the restoration of the underground pipe, the bypasses are removed and the street restored to its original condition."

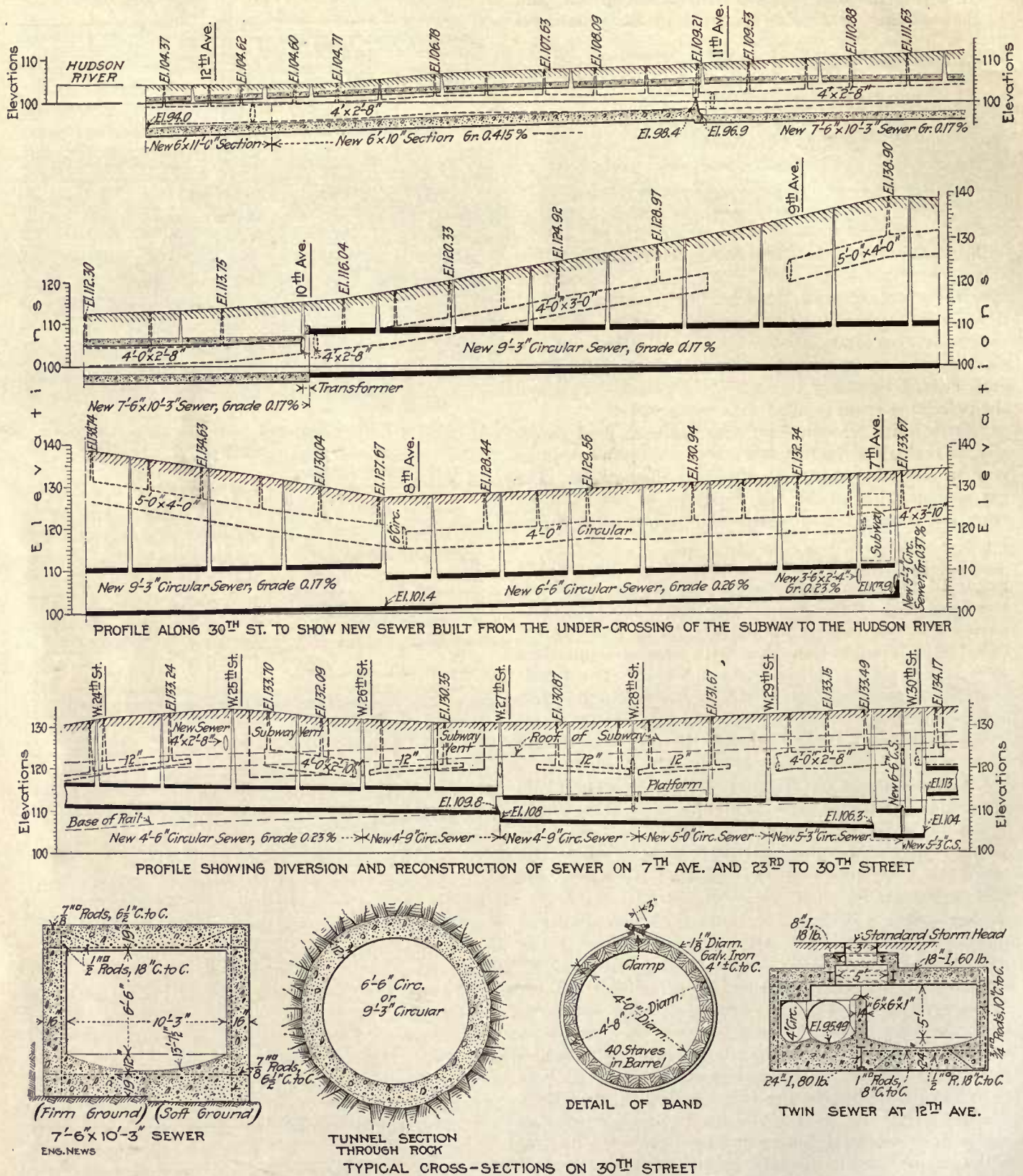

FIG. 31. TYPICAL SEWER RECONSTRUCTION WORK ON 30TH ST. AND SEVENTH AVE.

tution mains requiring 16- to 30-in. bypasses in general run across the island from the east to west, thus crossing most of the subway lines nearly at right angles. The cost of carrying a distribution main across the street on trestle may vary from \$1000 to \$10,000, depending

SEWERS—The work of the department in charge of the necessary sewer relocations commences as soon as a new route is proposed, as, although the subways are generally located with little regard for existing subsurface structures, minor changes and adjustments in elevations and



gradients are quite often found to be desirable. General studies of the sewer situations are, therefore, necessary from the beginning. The sewer changes are worked out in consultation with the city authorities and the plans are made part of the contract drawings. This same department makes the preliminary studies, final plans and supervises construction.

Generally the existing sewer line is located in the center of the street. The construction of a subway therefore usually involves its complete elimination, and the substitution of two lines, one on either side. In Manhattan also the main trunk sewers and intermediate main lines are generally located in the cross streets running east and west to the Hudson or East River. The construction of a subway on one of the main north and south avenues therefore cuts these all off, as they are nearly always located below the level of the roof.

On what may be referred to as the down stream side of the avenues the problem is usually comparatively simple. A new line is laid between the subway and the

Generally speaking, however, the large sewers where they have been encountered have been passed under the subway by means of siphons, and while this is not generally considered desirable for sewers, those so far built seem to be working satisfactorily. The general principle on which they are designed is much the same for all; that is, a comparatively small pipe for the so called "dry-weather" flow, with one or two larger pipes for the storm flow. The plan and section shown, Fig. 32, of the siphon at 110th St. and Lexington Ave. is quite typical. Most of the siphons have been built with easy slopes for the drop or rise, but in one instance in Brooklyn, at Hudson St., perpendicular raises were required on account of the cramped conditions. In this case a wide, very shallow additional safety overflow was provided over the roof of the subway.

Cross-sections of particular forms of construction not usually met with in sewer work, but required by the exigencies of limited clearance in many cases in connection with the subways, are shown in Fig. 33. An interesting temporary expedient was adopted on the

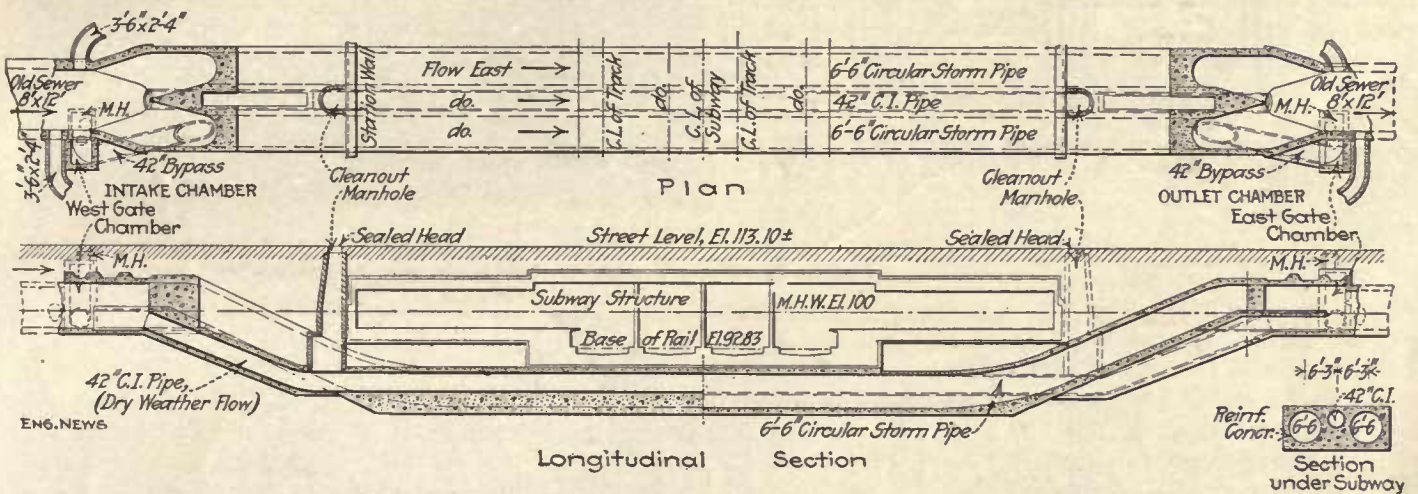

FIG. 32. INVERTED SIPHON CARRYING SEWER UNDER SUBWAY AT 110TH ST.

buildings, connecting at the cross streets to the existing sewers, which, however, of course only get part of their former flow. On the up stream side, however, not only do the buildings adjacent to the subway have to be taken care of, but also the flow from the cross drains which have been cut off. The least important of these cross sewers are, therefore, collected in a main laid parallel to the subway and carried to some convenient crossing point, where either the subway can be lowered, to pass the sewer over the top, or where topographical conditions permit the sewer to go under and continue with sufficient fall to the point of discharge into the river. The conditions at 30th St., New York, are quite typical of this condition, Fig. 31. The construction of this one line, giving a new outlet all the way to the North River, cost over \$500,000.

In a very few instances there have been large trunk sewers which could not be changed and which have necessitated a very considerable adjustment of the gradients of the subway to enable the line to pass them. At Canal St. and Broadway and at Duane St. and West Broadway, Manhattan, the subways were depressed to go under the sewer, while at Brook Ave. and 138th St., in the Bronx, the surface of the street was raised 5 ft. to enable the subway to pass over the top of the sewer.

Fourth Ave. subway in Brooklyn. At one place on this line it was necessary to take care of quite a large volume of sewage until such time as a new relief trunk sewer could be built by the city. The subway at this point was built for six tracks, so one whole bay at one side for a length of 2200 ft. was isolated by being walled in, waterproofed and turned into a sewer until such time as the relief sewer was built.

The Duane St. sewer in Manhattan is typical of certain conditions which have to be met and where advantage was taken of the peculiar topography of New York and the long established habit of drainage into the rivers on both sides of the city. The drainage from Centre St., through which the so-called Loop line runs from Duane to Delancey, was to the East River. This was cut off by the construction of the Loop, which was too deep to permit the construction of the sewer underneath, so a deep-level sewer was built under the original subway, through Duane St. to the North River, thus reversing the flow from what was formerly the up-stream side of Centre St. It is this new sewer that the Seventh Ave. route in West Broadway has to go under, as referred to.

The numerous questions which come up in connection with the relocation of these existing underground struc-



tures are only hinted at, but enough is given to show work and the skill and ingenuity often necessary in work- at least generally the importance of this part of the ing this out.

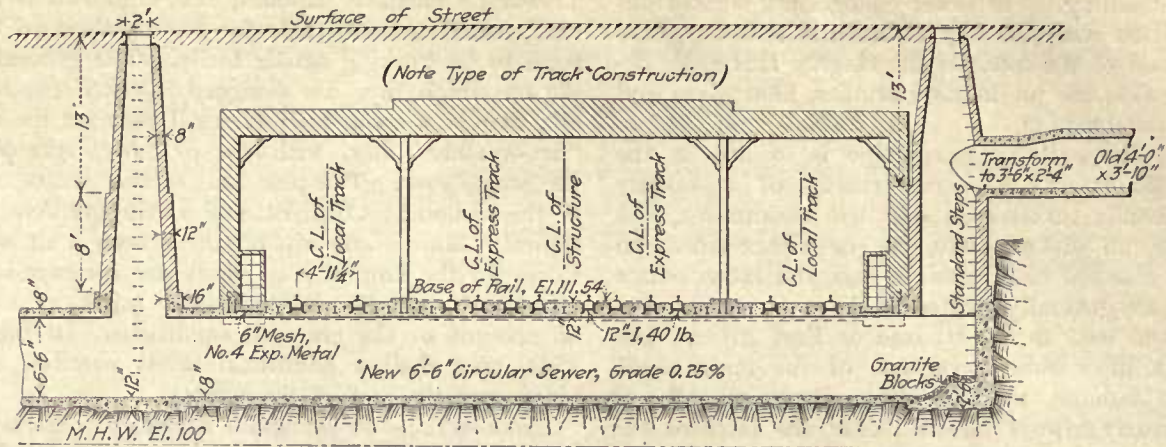

CROSSING UNDER SUBWAY AT 7<sup>TH</sup> AVE. AND 30<sup>TH</sup> STREET

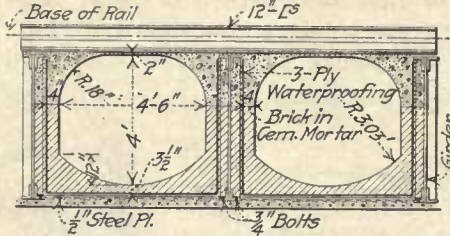

SECTION UNDER SUBWAY AT TILLY STREET AND FLATBUSH AVE. BROOKLYN

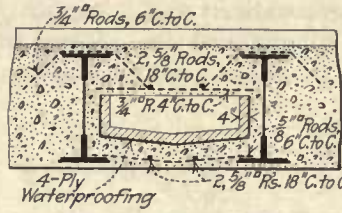

SECTION OF STORM SEWER OVER SUBWAY AT HUDSON AVE. AND FULTON STREET, BROOKLYN

ENG. NEWS

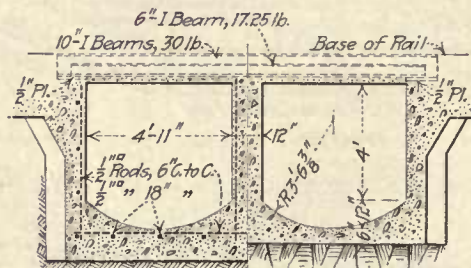

(In firm Earth) (In Rock)

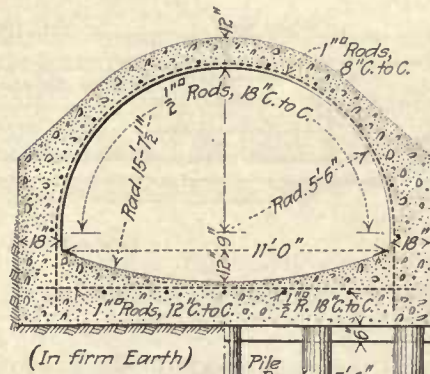

(In firm Earth)

(In soft Ground)

SECTION OF 7-3 x 11-0" SEWER

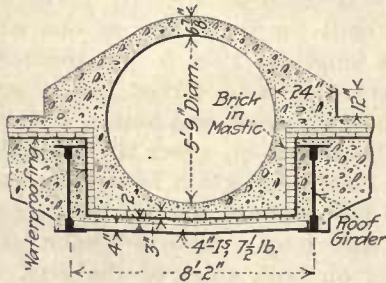

SEWER CROSSING AT DUANE STREET

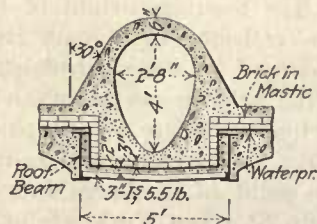

SEWER CROSSING AT LEONARD STREET

FIG. 33. TYPICAL CROSS-SECTIONS OF NEW SEWERS



# Methods of Timbering to Support the Street Surface

The specifications for the construction of the subways in Manhattan and in most of the streets in Brooklyn require that the work be "carried on under covered roadways." This practically means that the paved surface of the street and generally also of the sidewalks has to be taken up and replaced by a timber deck, under which the excavation and construction may proceed with little or no interruption of the ordinary street traffic. Openings for shafts to give access to the excavations are permitted at inter-

tracks, putting in the decking and track supports in the form shown in the accompanying views. When one side of the street is decked over, the other side is taken care of in the same way.

Excavation is then carried on under this decking, the first lift being from 10 to 15 ft. in depth, practically the depth of the ordinary cellars and basements, the walls of which usually form the sides of the excavation. In very wide streets the full width is, of course, not taken out, but where the additional width beyond the neat lines is not excessive, the whole width is excavated in this first lift, as this permits easy access to the buildings for the underpinning operations. Where the full width to the cellar or vault walls at the sides is taken out, no sheeting is required on this first lift, but if this is not done sheeting must necessarily be driven from the surface.

Below this first lift, the ordinary form of timbering, using rangers and braces (see Fig. 35), may be continued in much the same manner as for the excavation of any trench, though, of course, on a larger scale, or one of the many special forms hereinafter described and illustrated may be used. There are two general types, one for earth and one for rock, the former well illustrated on the left and the latter on the right in Fig. 35 and in Fig. 38 and the accompanying drawings.

The essential differences are the necessity in earth excavation of supporting the side sheeting as well as the decking and in rock the provision of a clear working space and to guard against disaster by the loosening or destruction of one or more supports by the blasting operations or by slides in the very unstable New York rock.

One of the most interesting of the methods used for support in a deep rock excavation is that developed on Section 13, Lexington Ave., by Messrs. McMullen, Snare & Triest and illustrated quite clearly in the photograph, Fig. 38, and the sketch, Fig. 39.

On this section the concrete troughs which support the street-railway tracks are first supported longitudinally by the three or more 6x12-in. timbers laid flat (more



FIG. 34. TYPICAL TIMBER DECKING OVER SUBWAY EXCAVATION, SHOWING STRINGERS SUPPORTING STREET PLANKING

vals of 300 to 500 ft. in the upper part of the city, but are about 1000 ft. apart in the lower section.

In nearly all the streets in Manhattan where the subways are being or are to be built, there is a double-track street railway with underground contact system which has to be supported. In Brooklyn, the Bronx and Queens, the overhead trolley is used, which makes the problem of track support somewhat easier, though of course the poles have to be taken care of.

The usual method of procedure is first to excavate about 3 ft. of the street surface on one side of the



FIG. 35. TIMBERING IN EARTH EXCAVATION AT LEFT AND ROAD EXCAVATION AT RIGHT, ON LEXINGTON AVE.





FIG. 36. STEEL GIRDERS ON STREET SURFACE CARRYING TIMBERING AND DECKING, LEXINGTON AVE., SECTION 11, ROUTE 5.

than three when there are ducts to be taken care of). These, as the drawing, Fig. 39, shows, are held up by 12x12-in. cross-beams 18 ft. long, which are blocked up from the "needle beams" *F*, which are 12-in. 31½-lb. I-beams 30 ft. long spaced 10 ft. apart. It may be noted that it was not usually possible to put these needle beams directly under the blocking of the troughs of the street-railway tracks, on account of the presence of various gas and water pipes, etc., at about that level, a condition which obtains quite generally.

These needle beams have two pairs of 6x12-in. yellow-pine blocks about 5 ft. long bolted to them, one on each side and spaced so that they will come directly under the tracks, as shown on the sketch. These wooden blocks have their corners cut away so that they fit tight against the web and under the flanges of the I-beams, making at these blocks solid points of support for the longitudinal I-beam stringers underneath or for any temporary blocking or posts which may be required, and tending to prevent any overturning of the needle beam. Long X-braces and turnbuckles are also used between the needles.

At the end of the needle beam, holes are drilled so that 6x12-in. struts to the sides can be bolted to it, the 6x12's being fitted tight to the I-beam the same as the needle blocking.

The needle beams are then supported on the timber towers shown in the photograph, Fig. 38, by two pairs of 20-in. 65-lb. I-beams (*A* in Fig. 39), which are bolted together by long plates to develop full strength at the joints, making them equivalent to a continuous beam the whole length of the work. On either side of these two pairs of what might be called permanent longitudinal supports, are two pairs of the same size I-beams, bolted together the same way, the outer ones *C* 80 ft. long, and the inner ones *B* 120 ft. long, these latter being used as supports from the last timber tower over the face of the excavation to give a clear span of 50 to 60 ft. over the working space.

The inside 120-ft. pair is supported on the tower and on blocking just back of the working face, but also projects back of the tower and beyond the blocking, and these overhanging portions are wedged down tight from the decking, making it act as a cantilever (see sketch, Fig. 39). The 80-ft. pair spans from the tower to blocking ahead of the working face.

The towers are spaced 40 ft. c. to c., and as the excavation progresses, and space is cleared for a new tower,

these pairs of I-beams are moved ahead for another space.

In the timbering to support the street decking and the electric-car tracks the plan adopted on Section 9, giving continuous support to the street-car tracks by means of I-beams spliced so as to develop full strength, is worthy



FIG. 37. STREET DECKING AND TIMBERING CARRIED ON HOLLOW STEEL PILES UNDER CHURCH ST., SECTION 1, ROUTE 5

of note. As shown in Fig. 40, there are three pairs of these beams directly under the decking. The cross-timber on which the tracks are supported is suspended from the I-beams. The side struts or diagonals also give additional arching support so that the danger due to the displacement of any of the posts in the excavation is reduced to a minimum. Fig. 40 shows an effective method of obtaining clear support over the rock excavation for the construction of the lower-level tracks.

On Sections 10 and 11, after some trouble with slipping and sliding rock, an additional means of supporting the street decking was adopted. Continuous girders about 4 ft. high and 150 to 200 ft. long were erected on top of the decking near the edge of the sidewalk and the timbering was virtually suspended from them, as is



shown in Fig. 41, and the photograph, Fig. 36. These girders were generally intended to be supplementary to the system of supports beneath the deck and to be necessary only in case of the displacement of these latter. As a matter of fact, however, they proved useful in spanning

awanna steel, 14-in. arched-web, 41-lb., but some 6-in. plank (plain) is used. The steel piling mostly showed up quite well, although there were numerous boulders; and, of course, in some places where they were struck, the piling was more or less out of line toward the bottom.

On this section careful additional horizontal cross-bracing was carried diagonally from the center at each of the shafts through several bents to the sides, which added materially to the rigidity of the whole structure.

On the down-town sections, nearly all of which are in earth, more or less similar types of timbering are used. The sides are necessarily held by sheeting, generally wood, and the timbering is the usual system of rangers, braces and posts, though varied in detail by each of the several contractors.

The street decking is, of course, laid first, in some cases with a heavy wearing surface of 6-in. planks, in others 2-in. planks on closely spaced 6x6-in. timbers or 6-in. I-beams. The first lift of the excavation is then taken out to a depth of 10 or 15 ft., the street-railway tracks and pipes secured and generally one brace is carried across the whole width of the excavation, this first long brace being usually not less than 5 or 6 ft. below the surface. Great care, of course, is taken in all these sections to arrange the timbers so that they will clear the steel when the latter is erected.

The two principal variations seem to be in making either the posts or the braces continuous. On Section 2, the first operation was to sink the posts in sheeted pits to subgrade. The material was sand, and many men in New York now have become quite expert in sinking these 4x4-ft. pits in soft material by the use of horizontal sheeting (which will be described in more detail under the head of underpinning), so that the sinking of this large number of pits is not so serious an operation as might

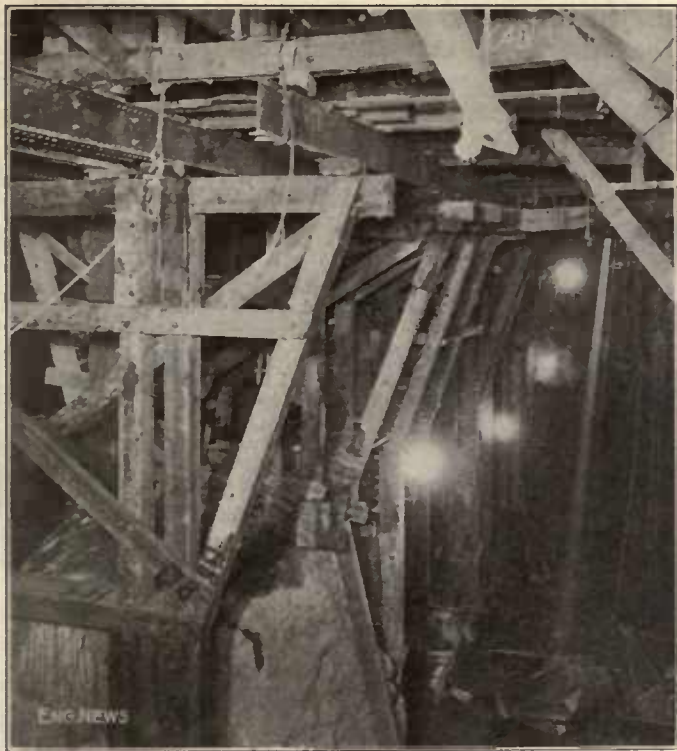

FIG. 38. TOWER SYSTEM OF TIMBERING IN ROCK EXCAVATION, LEXINGTON AVE., SECTION 13

the spaces where work was actually being carried on where changes and replacements of these lower supports were frequently necessary. Their disadvantage is that they occupy space on the street surface.

Where the regular system of cross-bracing and rangers are required, as in Section 14, Lexington Ave. (McMullen & Hoff contractors), where there is earth nearly to subgrade, some very elaborate systems of timbering are necessary. The type of timber construction on this section is shown in the photographs, Fig. 35; there are seven sets of braces in a depth of about 40 ft. below the

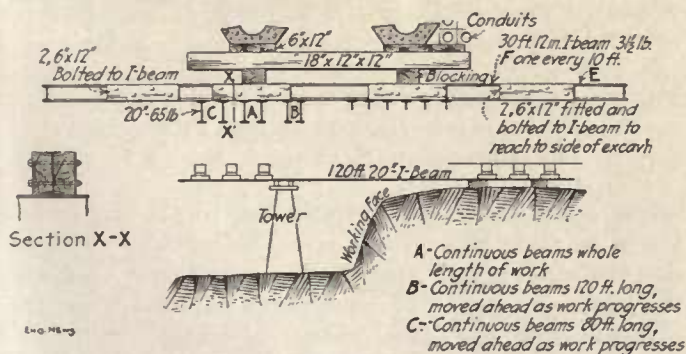

FIG. 39. SKETCH SHOWING STEEL BEAM SUPPORTS FOR TRACKS OVER ROCK EXCAVATION, LEXINGTON AVE., SECTION 13.

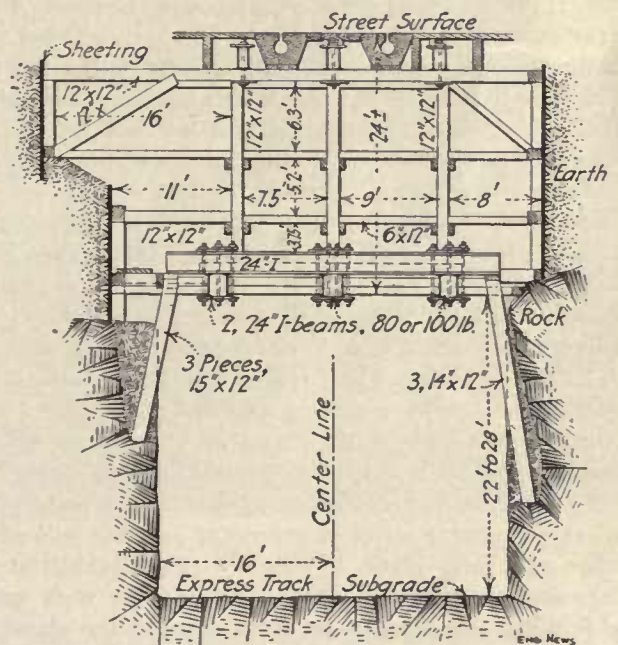

FIG. 40. TIMBERING FOR ROCK EXCAVATION FOR DOUBLE-DECK SUBWAY, LEXINGTON AVE., BETWEEN 78TH AND 79TH ST., SECTION 9.

deck and the bents are about 10 ft. apart. Tension rods are put in to help hold up the bottom braces during excavation. The sheeting on this section is mostly Lack-

be imagined. No water, of moment, was encountered on this section above subgrade. Once the posts were down, of course, the deck was held in safety for any operation and



the continuance of the excavation and timbering was a matter of routine.

A method used on part of Section 3 is clearly shown in Fig. 42, which needs little explanation. The building of the concrete sidewall was not followed throughout the section. The method of framing the timbers to get

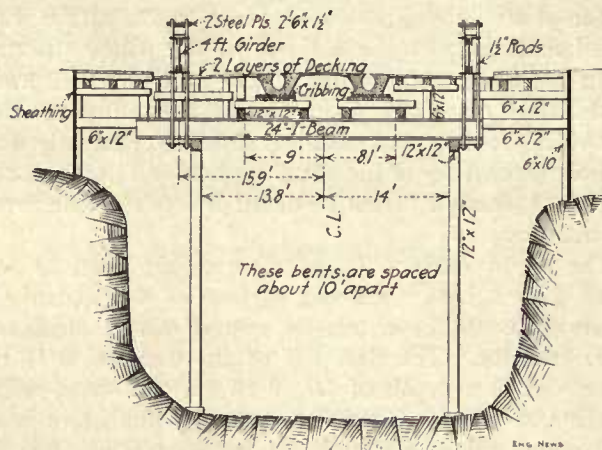

FIG. 41. TIMBERING SUPPORTED FROM LONGITUDINAL GIRDEES ON STREET SURFACE, LEXINGTON AVE., SECTION 10.

an arching effect is, however, to be noted, as this principle was applied also on Section 1.

The features of this system as developed on Section 1, by J. C. Meem, who was the engineer in charge for the contractors, are the combined arching and bracing effect secured and the use of the continuous girder throughout the length of the excavated section, supported on posts or hollow piles.

At a convenient distance below the decking, continuous 12x12-in. cross-braces spanning the whole width of the excavation were put in, 10 ft. apart. These were usually made up of two 6x12-in. timbers bolted together in as long lengths as it was practical to use. The short 12x12-in. cap, with the ends cut as shown, was then placed under the cross-braces and supported temporarily while the next lift of 5 or 8 ft. was excavated to the level of the next cross-brace.

The hollow-steel piles were then driven, a 10x10-in. post fitted inside of them, the longitudinal girders extended, and the arch legs and posts put in position. The appearance of the lowest level is shown in Fig. 37.

The use of continuous I-beams for the support of the street decking or for tying together the timbering or supports is a feature of quite a number of the sections, differences in detail, of course, having been developed by each individual contractor, but in general the principle is that of a group or series of groups of I-beams spliced together with long plates to obtain 100% strength at the joints and running the whole length of the work under the decking and often supporting directly the street-car tracks. The advantage of this method, of course, is in its general security in case of accident to any one or even more of the supporting columns or bents and also to permit easy removal or change of supports during erection.

An interesting and unusual example of the method of timbering by rangers and braces applied to the excavation of a large area in water-bearing material is that of Sec 2-a at the intersection of Broadway and Canal St.,

which, on account of its difficulty, was let as a separate contract. A double-deck structure is being provided to permit the future Canal St. cross-town line to pass under the Broadway line. The excavation at this point is some 55 to 60 ft. deep and for four-track lines approximately 250 ft. long on Broadway and 150 ft. on Canal St., joined by a connecting curve in the northeast corner. The extremely heavy floor of steel girders and concrete placed in the bottom of this section to resist the water pressure, as shown in Fig. 11, will convey an idea of the conditions which were successfully overcome.

The normal water level on this section is about 15 ft. below the surface of the street, but water was actually not found in quantity until a depth of about 23 ft. was reached. This left, however, a depth of 30 ft. to be excavated in water-bearing sand and gravel. The entire area is surrounded by buildings and there is a very heavy travel to support on both streets, so that it was necessary to exercise extreme care to avoid losing ground.

The area excavated is surrounded by 6-in. tongued-and-grooved sheathing driven in three lifts, and great care was necessary in spacing the elaborate system of cross-bracing to permit the erection of the steel. There is nothing particularly novel in the layout of this latter, except its great extent over such a large area; special care, of

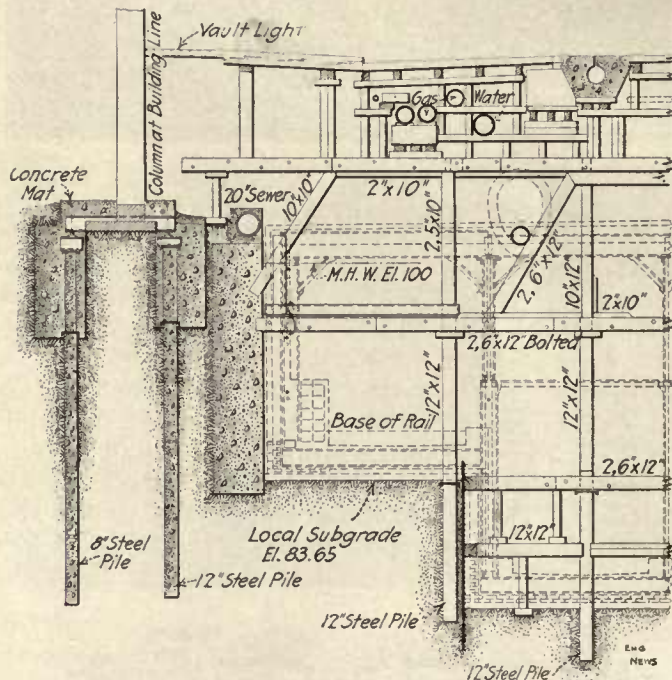

FIG. 42. CONCRETE SIDEWALLS AND ARCHED TIMBER SUPPORTS WITH HOLLOW STEEL PILES USED ON BROADWAY, SECTION 3, ROUTE 5

course, being necessary to keep the long line of rangers and braces in place with proper cross-bracing, and to so design the whole layout that the steel could be erected with the minimum amount of interference with the timbering.

Fortunately, the large amount of water coming into the excavation seems to be quite clear, and the most careful levels, carried out for a considerable distance in every direction from the excavation and continually checked, indicate little, if any, settlement of the adjacent ground or buildings. The total capacity of the pumps is about 20 million gallons daily, and while the whole capacity has only been infrequently required, a large proportion of it has been needed continuously.



# Excavation

The general specifications provide for the classification of excavation as earth and rock, rock being ledge rock in place and boulders over 1/2 yd. Earth excavation is classified as above or below mean high water, and the prices "include the cost of the disposal of the materials excavated, of backfilling, of all decking and bridging for support of street travel, of all sheeting and bracing,

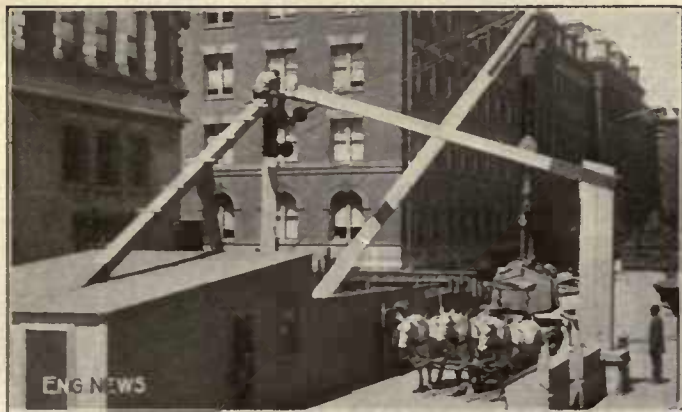

FIG. 43. DERRICK FOR HOISTING SKIPS AT 77TH ST. AND LEXINGTON AVE.

and of maintenance and supporting of trenches during and after excavation, of all pumping or bailing, and of the maintenance and support, with all incidental work, labor and material of any kind, of all surface, subsurface and overhead structures and surfaces." (Support of street-railway tracks and elevated railroads is paid for separately as noted below. Underpinning of buildings when required is also paid for separately.)

Rock excavation is paid for, for 6 in. outside the neat line at the sides, but no allowance is made on the bottom. It is required that all excavation in rock beyond the side neat lines of the structures shall be refilled solid with concrete, which, except for the first 6 in., is at the expense of the contractor; so there is every incentive to avoid excessive excavation and for the use of care in drilling and blasting at the sides.

When pipes, sewers, electric-wire conduits, etc., have to be removed and rebuilt elsewhere, the work is paid for separately. All structures of this kind, however, which do not require change have to be supported and maintained by the contractor, the cost being included in the price paid for excavation. All gas pipes are removed and placed above ground during construction, and replaced afterwards, the necessary house connections, of course, having to be changed each time. This work is paid for at a price bid per linear foot for each size of pipe which has to be taken care of. The ordinary 4- and 6-in. pipes from which the house supplies are taken are usually relaid along the edge of the sidewalk, on top of the timber decking. The large 10- and 12-in. mains are usually supported overhead.

In planning the excavation it has generally been found advisable to so arrange the work that if the material is suitable there will be sufficient left till the end to complete or nearly complete the backfill, which the specifications require shall be made with "sand, gravel or other good, clean earth, free from perishable material, or stones exceeding 6 in. in diameter, and not containing

in any place a proportion of stone of or below that size exceeding one part of stone to five parts of earth."

Usually there is no opportunity to store material for this purpose, but on some sections, where there is earth, a certain portion at the ends of the section is left to be excavated after most of the structure is completed. Where this is not possible, or where there is little or no earth, dependence is usually placed on material excavated elsewhere, mostly from cellars, etc., of which there is usually sufficient available at all times and in nearly all sections of New York. In one case the contractor was able to get a vacant lot for disposal of his earth excavation, conveniently located so that it will be practical to remove the material (by steam shovel and train) when required and use it for backfill.

The following table will give a general idea of the range of prices bid for excavation under the many varying conditions:

COST PER CUBIC YARD OF EXCAVATION

	Earth		Rock	Sewers	
	Above m.h.w.	Below m.h.w.		Earth	Rock
In the lower part of Manhattan below 10th St...	\$4.50	\$7.00	\$7.00	\$4.00	\$6.00
	to 6.00	to 9.00	to 10.00	to 5.00	
From 10th to 42d St....	4.00	....	5.00	4.00	6.00
	to 5.00	....	to 6.00	to 5.00	
From 42d to 125th St....	3.50	6.00	5.00	4.00	6.00
	to 5.00	to 8.00	to 8.00	to 6.00	to 8.00
Bronx .....	2.25	3.00	3.00	2.00	4.00
	to 3.00	to 4.00	to 4.00	to 3.00	to 5.00

The cost of supporting the tracks of the street or elevated railways is not included in the excavation price.



FIG. 44. GANTRY HOIST FOR SKIPS AT 121ST ST. AND LEXINGTON AVE.

but is paid for separately. The prices bid on the contracts thus far awarded range approximately as follows:

For the support of elevated-railway columns, from \$300 to \$500 each, though in one case where there were only two, the bid price was \$1000 each.

For the support of main electric-railway tracks with underground trolley conduits, from \$5 to \$20 per lin. ft. of single track. A fair average seems to be about \$10.

For horse-railway tracks, about \$5 per lin.ft.



The excavation price does not include the relaying of the sidewalks or curb or repaving the streets, within the neat lines of the excavation; this is paid for at prices bid per square yard, for the various types of pavement. All street surfaces are first repaved with Belgian blocks and maintained by the contractor for six months, after which the final form of new pavement is laid.

The eight-hour labor law is strictly applied to all this work. No blasting is allowed between 11 p.m. and 7 a.m., and of course all charges of explosives have to be quite light on account of danger to the timbering or adjacent buildings. On most of the work two shifts are employed, the men generally working from 6 a.m. to 2:30 p.m. and from 3 p.m. to 11:30 p.m., with half an hour for a meal.

All, or nearly all, the material taken from the excavation in Manhattan has to be disposed of, usually by haulage to the water front, where it is loaded on scows and towed to the point of disposal. This involves the renting

tion is nearly all in earth. A small amount of rock is found in places, but not enough to influence the methods. On account of the timbering and the necessary supports of the street decking, it has apparently been found most convenient and practical to handle all the material by hand. It is shoveled into buckets of about 1 yard capacity, hauled to shafts, hoisted and dumped into storage hoppers holding 25 to 50 yards, from whence it is discharged into wagons. Haulage to the water front is done almost wholly by teams, but auto-trucks are used on Section 1.

A very efficient and convenient arrangement of hoist and storage hoppers, Fig. 46, was installed at Broadway and Waverly Pl., on Section 4, by the Dock Contractor Co. A vacant lot permitted the construction of a long narrow head-house parallel to the street and over the sidewalk. A telpher was arranged over the shaft and hoppers, which allowed a much more rapid, because better controlled,

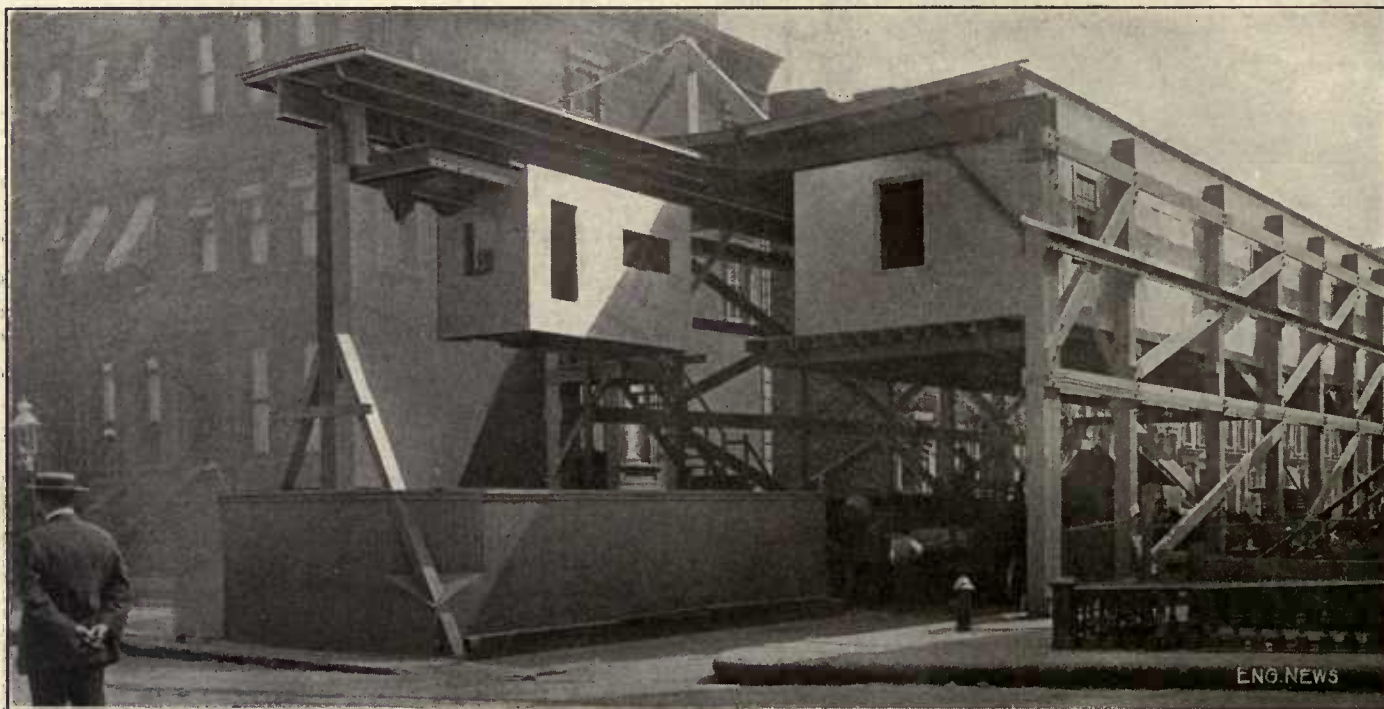

FIG. 45. TELPHER HOIST AT 74TH ST. AND LEXINGTON AVE.

of pier or dock facilities by contractors and a haul varying from  $\frac{1}{2}$  to 1 or 2 miles in wagons or auto-trucks. The latter, holding from 3 to 4 cu.yd., are being quite commonly used, and are generally said to be more satisfactory and cheaper than horse-drawn wagons. It is necessary that they be fully utilized—that is, that there be the least possible delay at loading and unloading points; otherwise the overhead charges, chauffeur's wages, and interest on investment amount to too large a proportion of the unit cost.

Where auto-trucks are used for disposal of excavation, a storage hopper is usually provided at the head of the shaft, which will hold at least one load (or more, depending on the number of trucks in use, and the kind of material), so that there is no more delay in loading than that necessary to open the mouth of the hopper and fill the truck. The general practice seems to be to use hoppers and chutes when the excavated material is earth or a mixture of earth and boulders and to use some form of skip or bucket for rock.

On the Broadway line below 23rd St. the excava-

handling of the buckets than is possible with a derrick boom. A structure of this type would not have been permitted in front of an occupied building.

On one section on Broadway, where the excavation was mostly sand, a belt conveyor was used in the bottom which dumped the material into a hopper, from whence it was elevated to the bin above the street by an endless chain of buckets.

On these downtown sections fewer shafts are permitted, and they are usually from 1200 to 1500 ft. apart, making the necessary maximum haul on the bottom about half that. Track of 24-in. gage is generally used, two or sometimes three lines, with mules for haulage. In many places on the upper levels between timbers, small  $\frac{3}{4}$ -yd. cars are used, which are pushed by hand short distances to where they can be dumped to the lower level. A typical bridge over the street for handling materials is shown in Fig. 47.

Where the line crosses Union Square, most of the work was done in open cut, an electrically operated shovel being used. Shovels and trains were used on the open-cut work



of the Sea Beach line in Brooklyn, and part of the Var-  
rick St. line is in open cut.

The rock excavated from the subways is of little general  
use for structural purposes. A certain amount of the  
best of it is permitted to be used in any walls or

plest form of block and tackle being used to haul out and  
lift the boulders or pieces of rock too large to be conven-  
iently handled by one or two men.

In one case where turntables were tried opposite the  
shaft, the tracks being arranged as shown at *A*, Fig. 49,  
it was found that they frequently got out of order and  
caused considerable delay; so they were taken out and  
the tracks arranged as shown at *B*, the shaft being en-  
larged to permit of this being done. On Sections 8 to 11  
on Lexington Ave., transfer tables were used at the shafts  
as shown in Fig. 52.

On certain sections 3- to 4-yd. skips of the type shown  
in Fig. 48-C are used. They are hoisted to the surface,  
and either dumped into a wagon or auto-truck or placed  
on the wagon bed, and hauled to the place of disposal,  
where they are again lifted and then dumped. The skips  
are handled underground on small cars drawn by mules,  
or in one case where the timbering was very close and  
the headroom low, pushed by hand, the work being ar-  
ranged so that there was a down grade to the shaft.

The advantage of these large skips over the smaller  
buckets is greater facility in loading. They are taken  
off the cars and placed on the ground at the working  
face, a hoisting engine with a fall suspended from the  
timbering of the street decking being used for the  
purpose. There is no lift for the shovelers, and, of  
course, very much larger pieces of rock can be handled  
without block-holing and handled more easily.

On Sections 8, 9, 10 and 11, on Lexington Ave., a  
type of bucket known on the work as a "battleship"  
(Fig. 43) is used. These buckets hold from 11½ to  
2 yards; they are handled in the excavation and tun-  
nels of these sections on small cars (3-ft. gage) with

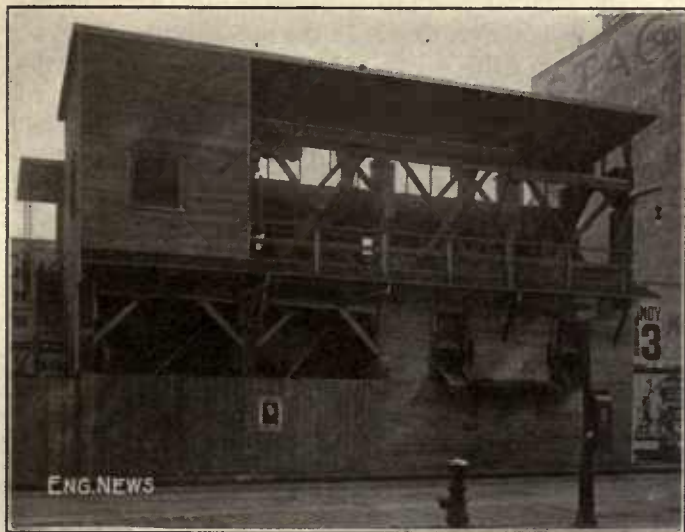

FIG. 46. HEADHOUSE OVER SHAFT AT WAVERLY PL.  
AND BROADWAY

masses of concrete over 30 in. in thickness, and some of it  
is used for rubble for blocking up the yokes of the street-  
railway tracks in Manhattan.

#### BUCKETS AND SKIPS

On many parts of the work, ¾- to 1-yd. buckets as  
shown at *A* and *B*, Fig. 48, are used. These are handled



FIG. 47. BRIDGE AND DERRICKS AT GRAND ST. AND BROADWAY

in the excavation on small flat-cars on 24-in.-gage track,  
hauled by mules to the shafts, hoisted by derricks to the  
surface and dumped into the trucks or hoppers. At the  
face of the cut the buckets are loaded by hand, the sim-

cradles shaped to fit. The cars coast down grade either  
to or from the working face as the case may be, and are  
hauled up grade by small stationary hoisting engines.  
The line from the hoisting engine is usually carried out



by hand, and this method of haulage does not seem very efficient.

The buckets are hoisted to the surface by derricks, Fig. 43, or telpher, Fig. 45, placed on wagon beds and hauled to the dock by horses. This type of bucket with the top

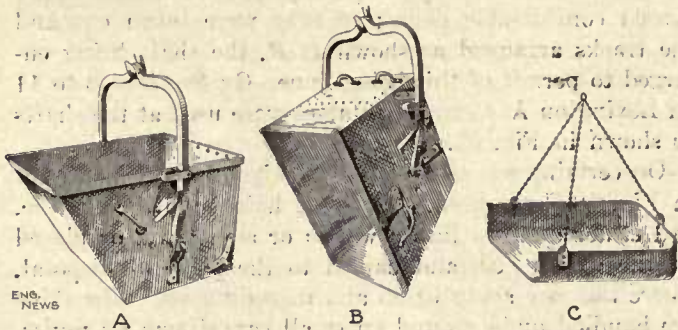

FIG. 48. DUMP BUCKETS FOR HANDLING MATERIAL.

some 3½ or 4 ft. above the ground (as it remains on the cars while being loaded) involves a fairly high lift for the shovelers, and the necessity of keeping the tracks up close to the face does not permit the flexibility which is possible with the skips, which are taken off the cars and placed in the most convenient position for loading. Many of these small tunnel cars consist merely of a rectangular frame of 6-in. I-beams to which the axle boxes for two axles are fastened. Those for use with the "battleships" have two or three wooden cross-pieces or cradles cut to fit.

The contracts for Sections 8, 10 and 11, Lexington Ave., are being executed by the Bradley Contracting Co., that for Section 9 by Patrick McGovern & Co. Nearly the whole length of the lower level tracks is in tunnel, the excavation of which is described separately, but the upper-level double track has generally been built as cut and cover. An arrangement has been made whereby the Bradley Company takes care of the disposal of all the material, that from the upper section being hauled to

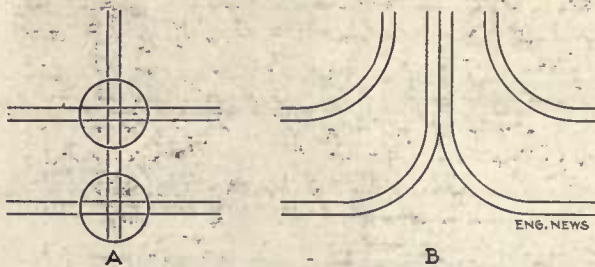

FIG. 49. SKETCH OF TRACK ARRANGEMENTS AT SHAFT the dock at 96th St. and the East River, and from the lower sections to 76th and 68th Sts.

The use of these skips or the "battleships" is probably of greater advantage in rock excavation than in earth, as some kind of mechanical apparatus for handling the rock is generally necessary at the face and is therefore available to handle the skips on and off the cars and to load large pieces of rock. Small power shovels, operated by electricity or air, are often used for loading the spoil on underground work, but on most of the subway work, the extensive and close system of timbering hardly admits of their use.

The system used for the rock excavation on Section 13 (McMullen, Snare & Triest) seems to be quite effective. Here the rock face is 25 to 35 ft. high, and 40 to 50 ft. wide. After the street decking was put in, a top lift,

from 12 to 15 ft. high and mostly earth was taken off the whole length of the section, this permitting working access to the whole job, for underpinning, support of pipes, conduits, etc. A shaft was sunk to subgrade at every other cross street, about every 450 ft., and outside the main excavation. The location of the shafts in the cross streets is shown clearly in the photographs, Figs. 44 and 45. From this shaft a cut was drifted across the full width of the work and the excavation carried forward in both directions from it. About 120 skips were used on this section, and about 400 yd. of rock (place measurement) was handled each 24 hours from the two working faces with the two gantries.

The tower form of timbering (as described under Timbering) was used, the working space being spanned by continuous I-beams reaching from the last towers to blocking on the floor of the first lift, as shown in the sketch, Fig. 50. Two side cuts, each about one-third the width of the excavation, were driven ahead 35 to 40 ft., then the center was blasted sideways into these cuts. This,

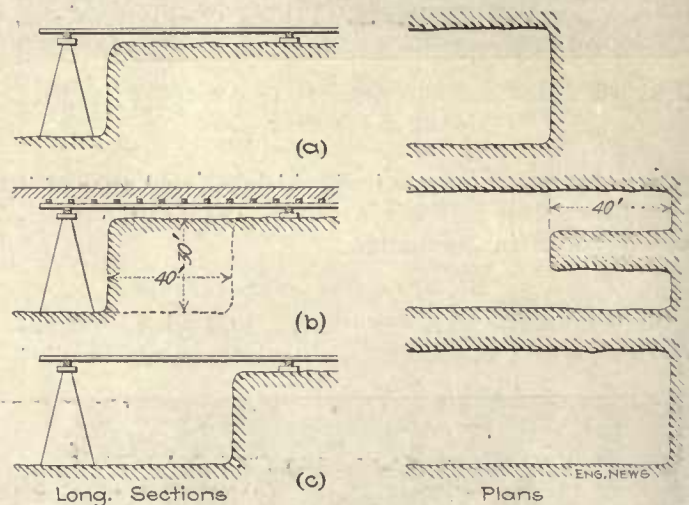

FIG. 50. SKETCH ILLUSTRATING PROGRESS OF EXCAVATION IN DEEP ROCK TUNNEL ON SECTION 13, LEXINGTON AVE.

as will be seen, protected the timbering, at least to a considerable extent, from direct blasting against it. When the face at the center was advanced 40 ft., another tower was erected, the girders were moved ahead, the process was repeated, etc.

Two double-drum air hoisting engines were located back from the face on top, with single fall lines leading over sheaves suspended from the timbers of the street decking above the working space. These two lines (two on each side) handled the larger pieces of rock and the skips on and off the cars, and were also used in handling timbers, etc.

#### DERRICKS AND GANTRIES

On Section 13, Lexington Ave. (McMullen, Snare & Triest), gantries, as shown in Fig. 44, have been installed at the shafts, instead of derricks, for hoisting material out of the excavation and for lowering the structural material. The advantages of these gantries are said to be greater safety to the public in the streets, greater rigidity, and therefore more security; better speed in hoisting; easier spotting of the skips over the wagon bed, less power required for hoisting, and the elimina-



tion of booming up and down with loads. It is said that the saving of power (in regard to which no definite data are available) is due largely to the elimination of the swinging engines which are necessary with derricks. It is also stated that there is a considerable saving in the wire hoisting ropes, which lasted only two to four weeks on the derricks, but which last from three to four times as long on the gantries.

These gantries will also handle heavy loads with much greater security; those now in use have handled loads up to 25 tons. This is of considerable advantage in the rock excavation, as it permits the handling of large rocks without breaking them up. They are so arranged that from 20 to 25 loaded skips can be stored at them (see Fig. 44), thus permitting night work when the teams are not available to haul this material and also permitting considerable flexibility. This latter is a great advantage, owing to the difficulties of disposal, which is dependent on the availability of the scows, a somewhat uncertain item in some of the severe winter weather, the dif-

where more latitude was allowed in the matter of opening up the streets, only part of the excavation being decked over, the excavated material was handled in 4-yd. Western dump cars hauled by dinkeys (3-ft. gage) to the disposal grounds  $\frac{1}{2}$  to  $\frac{3}{4}$  mile distant.

On the next section to the north at the junction of the Southern Boulevard and 138th St., a model 49 Marion shovel is just being installed for loading the cars and a model 60 Marion was used in the deep rock cut through Franz Sigel Park, on the northwest end of Section 15.

On the steep hill on Lexington Ave. between 102nd and 103rd St. where the traffic is light (on account of the steepness of the hill) and where the tunnel with all four tracks at the same level changes to a cut-and-cover section, one side of the street was left open and a cableway was installed for handling the material.

Varick St. is being widened from its original width of about 60 ft. to 100 ft. and the excavation in this widened portion is being made in open cut, the original width of the street being decked over and the material



FIG. 51. A ROCK SLIDE, LEXINGTON AVE. SUBWAY

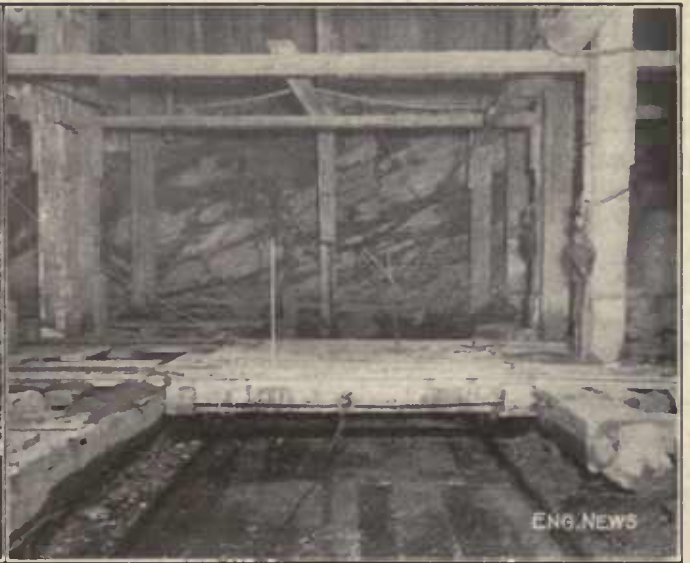

FIG. 52. A TRANSFER PLATFORM, LEXINGTON AVE. SUBWAY

difficulties of haulage in bad weather, and many other factors, as already noted. The teams which haul the spoil to the dock work only eight hours, and by storing the material under the gantries, delays are avoided and the work is accomplished in this length of time. On this work, the big stone is generally loaded into the skips during the day and the finer material, which must be shoveled, is handled by the night shift.

The first of these gantries was made about 40 ft. long and 22 ft. high, but those built afterwards were made 60 ft. long and 27 ft. high, thus giving more storage room, and the extra height greater facility in handling some of the structural steel. There are altogether seven of these in use on Section 13 and one shaft with a derrick. Their use on Section 13 has been apparently very successful, but it is to be noted that they are peculiarly well adapted to the conditions there, and it cannot be assumed that they would replace derricks to so great advantage under other conditions.

#### MISCELLANEOUS EXCAVATION METHODS

On the first section north of the Harlem River (Section 15, Route 5—Rodgers and Hagerty, contractors),

under it taken out at the open sides. The first lift of 10 to 12 ft. is loaded directly into wagons by shoveling, inclines being built from the surface down to this depth. Much of the excavation is sand, and below the first lift this is loaded into 1-yd. V-shaped Koppel cars which are dumped sideways into a hopper, under which runs a short belt conveyor, which in turn carries the material to a bucket elevator which raises it into a storage hopper above the street level.

Steam shovels were quite generally used on the construction of the 4th Ave., Brooklyn, lines in 1909-10 and are being used now on the open-cut work of the Sea Beach line, but generally speaking, very little use is made of mechanical apparatus of any kind on the subway excavation, most of the excavated material being shoveled by hand.

#### DRILLING

On Section 13 the drillers work in two 8-hr. shifts, from 6 a.m. to 11 p.m., and the muckers in two shifts, from 8 p.m. to 1 a.m. One feature of considerable interest is the quite extensive use of the so-called Jap or hand hammer drill with hollow drill steel. The New York



rock, a soft to medium hard gneiss or mica schist, seems to lend itself particularly well to the operation of this kind of drill in excavations where most of the holes are down holes. The type which is in most general use, is the Ingersoll-Rand B.C.R. 33, which weighs about 90 lb., using air at 80 to 90 lb. pressure. The hollow drill steel is usually about  $1\frac{1}{8}$  in. octagon, the holes are drilled dry, the air through the steel blowing out most of the dust, therefore keeping the holes clean and consequently increasing the effectiveness of the machines. These drills are used for drilling holes to depths up to 12 and 14 ft.; it is stated that they require from 50 to 75% less air at the same pressure than the usual tripod drill does, and only one man is required to operate each of them. The general opinion seems to be that unskilled laborers with very little instruction could use these drills, though, of course, in New York the labor unions compel the employment of regular union drill runners.

On Section 14 (McMullen & Hoff) four men with as many drills were averaging from 80 to 90 ft. of hole per man per day of eight hours. There was one record of 113 ft. for one man in eight hours. It was considered advisable to keep a number of spare drills on hand, so that in case anything went wrong, there was no delay, and any damaged drill could be taken to the shops, where it could be carefully repaired by a competent machinist, even though the trouble was very slight. This was considered to be better than to have an ordinary drill runner try to fix it with the spanner or sledge hammer, the tools usually used by them when anything is wrong with a drill. These drills were also used on the heavy rock excavation of Section 13, a cut 30 to 50 ft. wide and as many feet deep, with excellent results.

On some sections a lighter type of drill weighing about 40 lb. and using about 50 ft. of air per min. is being used; this is the Ingersoll-Rand B.R.C. No. 430 or so called Jackhammer type, used for holes up to 6 and 8 ft. in depth using  $\frac{7}{8}$ -in. hollow steel.

Another point of interest is the almost universal use of machine drill sharpeners, nearly all of which are of the Leyner type. This use of machine sharpeners is possibly due, to some extent, to the use of the hollow steel and the rose-shape form of bit generally used with these hand drills, though of course, it has been shown even with the old type of cross bit, that where the number of

drills warranted, the installation of a drill sharpener was an economy.

It was noted that in many cases the heads of the steel drills had sheared square off just back of the head. This type of failure has not previously come to the writer's notice, and no adequate explanation was offered by the men on the work, but it would seem that it might be due to the severe internal stresses set up by the much greater force used in the machine sharpeners in forming the heads, and the fact that possibly in these machine sharpeners, the steel can be, and is, worked at a lower temperature than by hand.

It is stated by the contractors on Sec. 13 and 14 that the general breakage and wastage of steel used is rather greater than with the ordinary steel, and, of course, the hollow steel is more expensive, but it is thought this is much more than compensated by the greater amount of work done. The Leyner drill sharpeners are used to make all the bolts for the timbering on one section, where it was stated that 400 bolts were headed per hour.

Electric current is used for power at most of the compressor plants, and air is usually piped to all points of the work for use in drills, pneumatic riveters, etc. In some cases the air is used for operating hoists and derricks, in other cases electric power is used directly for this purpose; this apparently is governed most generally by the plant the contractor may have had on hand, but the use of air for hoists and derricks, so long as it has to be installed in any event, seems to be the most satisfactory and most generally used.

Various schemes for heating the air during cold weather were noted, some of the apparatus home-made and other manufactured especially for the purpose. On one section (McMullen, Snare & Triest) an upright coil of about 6 to 8 rings, 15 to 18 inches in diameter, was made in the air line near the point where it was to be used, and a fire built and maintained inside the coil. In another case a piece of 6- or 8-in. pipe about 3 ft. long was capped at the ends to take the regular air line (about 2 in.) and a fire built under the larger section. These home-made schemes are probably somewhat wasteful of fuel, but this amounts to very little and they probably stand up better under the rough usage they get on this kind of work than the manufactured heaters.



# Underpinning Buildings Along the Line

Under the general heading of "Protection of Adjacent Buildings," the specifications provide for three classes of work.

A. Buildings "which are supported on firm soils" and bearing such a relative position in regard to the subway structure that a slope "represented by 1 ft. vertical to 2 ft. horizontal, incline downward from the bottom outer edge of the building foundation, passes beneath the bottom outer edge of the completed subway structure" have to be taken care of by the contractor, and such cost as there may be is included in the price for excavation.

B. When necessary to secure adjacent buildings or to prevent bringing an unusual pressure on the subway

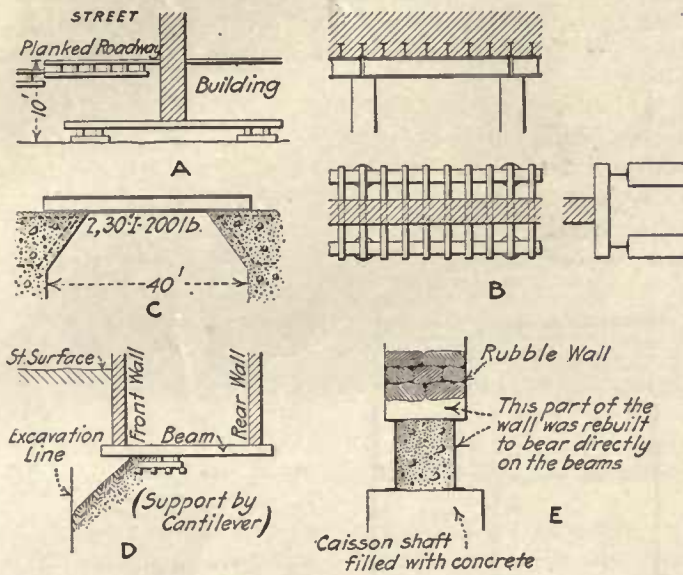

FIG. 53. SKETCHES ILLUSTRATING VARIOUS TYPICAL METHODS OF UNDERPINNING BUILDINGS

- A—Underpinning by needles, ordinary form.
- B—Underpinning by pile and short cross I-beams.
- C—Underpinning by piers and I-beam between.
- D—Underpinning by cantilever.
- E—Underpinning by caisson and I-beams.

structure when completed, the contractors are required to "safely and permanently underpin adjacent buildings the foundations of which are above the bottom of the adjacent subway excavation." This work is paid for at a price bid per front foot of the building. The latter are classified according to height, less than seven stories, seven to twelve stories, and over twelve stories. The prices for this work on contracts let so far range from \$50 to \$100 per front foot for 7-story buildings and from \$75 to \$200 with an average of about \$150 for buildings 7 to 12 stories. The prices are, however, very irregular and there is little distinction in the bidding between uptown and downtown. Bids for underpinning buildings over 12 stories range from \$90 to \$400 per front foot and are too few and erratic to be of any use as a guide to the cost of the work.

C. In certain cases where underpinning is not considered necessary but where buildings have to be secured and maintained during construction, there is a price bid per front foot for "maintaining, protecting and securing." These prices range from \$15 to \$60 and average about \$40.

It is generally required that underpinning be carried down to solid rock or to at least 2 ft. below the lowest excavation for the subway, if rock is not encountered before that depth is reached.

Often when the necessary excavation for the subway structure takes a fairly large proportion of the width of the street, the excavation of the "first lift" is carried out to the full width of the street between building lines and to the depth of the cellar, thus providing easy access for working as is shown in Fig. 53A. The excavation of this first 10 ft. is generally first carried ahead the whole length of the section, or for a considerable portion of it, and this is followed by the underpinning before any further excavation is undertaken.

Probably the most common way of supporting ordinary buildings is to temporarily carry the walls to be supported on needles, generally I-beams, as shown in Fig. 53A and extend the foundation walls down to rock if this is not too deep.

In cases where the depth of rock or to the required bottom of foundation is deep, piers (from 2 to 3 ft. square for ordinary buildings 5 or 6 stories high) are usually sunk at intervals of 10 to 15 ft. The spacing of the piers depends, of course, on the position of the piers or columns of the building which require direct support, and the front wall of the building between the piers is supported on two or more I-beams spanning the space between these piers. The excavation of the pits for the piers is usually made by hand, the well being sheeted, and the piers are built of concrete. In some cases, instead of the concrete piers, 12-in. pipes in short lengths are sunk either by driving with a weight or with a water jet, the subsequent procedure being the same.

To avoid supporting the buildings on needles, two methods have been used, somewhat similar in principle. Concrete piers 2 ft. square are sunk to rock in pairs, one inside and one outside the wall, each pair 10 to 12 ft. apart, or instead of the piers, 12-in. wrought-iron pipes in lengths of about 4 ft. with inside sleeve couplings are sunk and filled with concrete, the tops of these piers or pipes being 20 to 30 in. below the cellar floor. I-beams of suitable size (50 to 60 lb. generally for ordinary buildings) are then laid on top of these piers or pipes parallel and adjacent to the walls of the buildings; small holes are then broken through the wall and smaller I-beams put through spanning the first two and the walls caught up on these, as shown in the sketch in Fig. 53B.

On one section where a building of moderate size had to be taken care of, piers were sunk to rock (or to the required depth) and then the wells were widened out at the top in the direction of the line of the building, as shown in Fig. 53C, and filled with concrete, in which reinforcing rods were placed. These piers were 30 to 40 ft. apart and the space between them was spanned by two 30-in., 200-lb. Bethlehem beams, which were placed in niches cut in the wall to receive them.

On Section 14, Lexington Ave., W. Melvin, Superintendent for the McMullen & Hoff Co., devised a form of shield on the principle of the tunnel shield, but reduced







A method which obviates the necessity of supporting the buildings on needles was developed and used on Sections 1 and 3 of the Broadway line. It consists essentially in tying the foundation columns together with a

along on either side of the columns and parallel to the face of the building, at about the level of the basement floor, or just below it, one outside and one inside and tied to each column and to each other. These girders are made up of short sections, on account of the confined space in which they have to be handled, and a convenient form is one made up of four angles latted together, and riveted so as to be continuous for the length of the front of the building (see Fig. 58), though I-beams are used in some cases. Light hitches are cut in the piers to get a firm bearing, and the girders or I-beams are tied together firmly with rods or sometimes with steel-wire ropes, the whole being then concreted, making a continuous reinforced-concrete girder supporting the whole front. The photograph, Fig. 58, shows in the foreground the two latted girders and behind that the completely concreted beam or girder.

Rectangular pits are then sunk at intervals under this girder, as shown in the sketch, Fig. 59, and in spaces between the column footings so that the ground under these latter remains undisturbed. The pits are sheeted with horizontal sheeting, and are sunk to the necessary depth, i.e., to 2 or 3 ft. below the subgrade of the subway structure, and filled with concrete. Care is taken not to have the open pits close together. About two at a time, some distance apart, are put down, filled and blocked under the concrete girder before others are started. If water is encountered, hollow steel piles in short sections are sunk from the bottom of the pits below the water level and filled with concrete. All piles are tested by hydraulic pressure to take up any slight settlement.

There are two methods of sinking these hollow steel piles which are quite extensively used, one by the use of hydraulic or screw-jacks reacting against the building above, as shown in the photograph, Fig. 56, and the second, to drive them by a hammer. The first is, it is stated, a patented process. Where the hammer is used it generally consists solely of a weight, about 300 lb.,

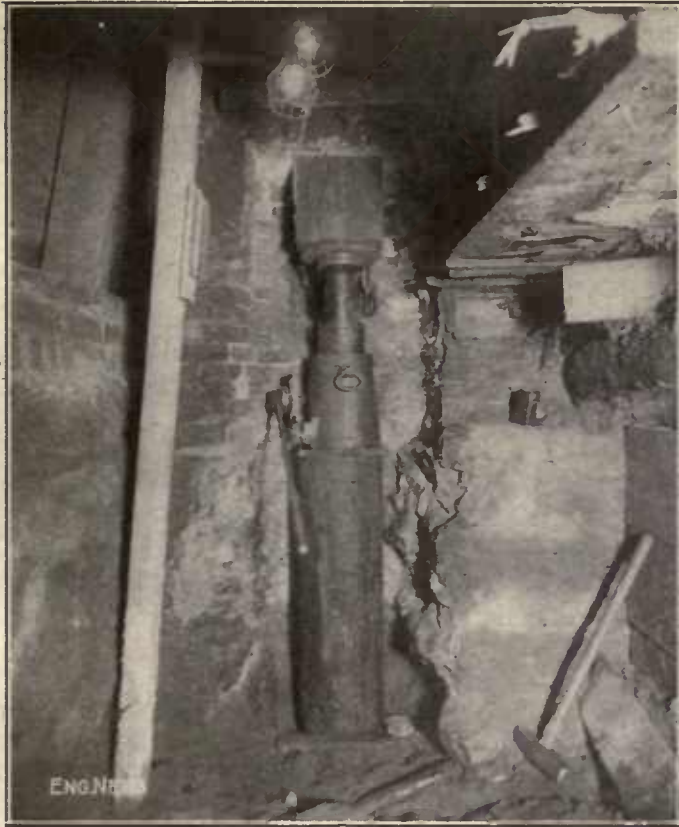

FIG. 56. PUTTING DOWN HOLLOW STEEL PILE WITH HYDRAULIC JACK REACTING AGAINST BUILDING

reinforced-concrete mattress or girder, as shown in Fig. 59, then sinking pits or piles under it to the required depth. Built-up steel girders or I-beams are first laid



FIG. 57. UNDERPINNING WITH NEEDLES BUILDING AT 459 BROADWAY



FIG. 58. UNDERPINNING WITH A LATTICED GIRDER



suspended from a rope passing over a single block attached to the floor above the pit, and running to a small single-drum hoist. The fall is usually only a few feet and the hammer is guided by hand by a man standing near the pile being driven. A square cast-iron cap is used on top of the pile.

An interesting detail of the horizontal sheeting so generally used in sinking the pits for underpinning and other purposes is the method of chamfering the corners of the boards so as to allow of packing the ground solid behind them as they are placed (see Fig. 60). The boards on two opposite sides are cut so that they fit inside those on the other sides, making a brace, and short blocks are

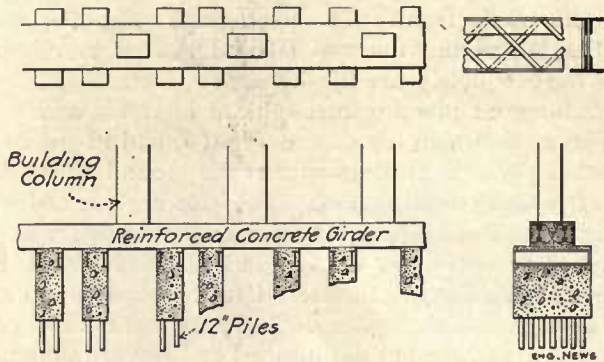

FIG. 59. SKETCH ILLUSTRATING UNDERPINNING WITH REINFORCED-CONCRETE GIRDER

spiked on to hold the short sides as shown in the plan. The long sides are placed first, and made to give a firm driving fit to the short ones. Each width is firmly packed as it is placed.

The pits are filled with concrete up to within about 12 or 15 in. of the bottom of the concrete girder. When the concrete in the pit has set, short sections of I-beams are placed on top of it and wedges are firmly driven between these I-beams and the bottom of the foundation girder. This holds the latter while the other pits are being put down, the shrinkage in the concrete in the pits being taken up from time to time by the wedges and the whole finally completely filled in, after all shrinkage and settlement of the new foundation have taken place.

The foundations of the Havemeyer Building (14 stories) are on spread brick piers on wooden piles, the bottom of the brick and the top of the piles being at approximately the level of the floor of the subway. To protect these foundations, additional hollow steel piles were sunk under the front edges of the building piers and then a double row of steel sheet piling 10 or 12 ft. long and with a space of about 3 ft. between the rows was driven as additional protection. This acts as a coffer-dam and not only will tend to prevent any disturbance of the ground

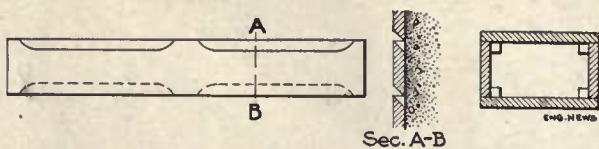

FIG. 60. HORIZONTAL SHEETING FOR SINKING PITS

around the piles, but also to retain the level of the ground water.

In turning from Church St. through Vesey St. to Broadway, it was necessary to obtain easements un-

der private property at each of the corners in order to get around. One of these is under Trinity Parish House and the other under the old Astor House. That portion of the latter under which the tunnel passes was dismantled and taken down, the city agreeing to provide foundations for a new building along each street line. Open trenches were sunk through the sand

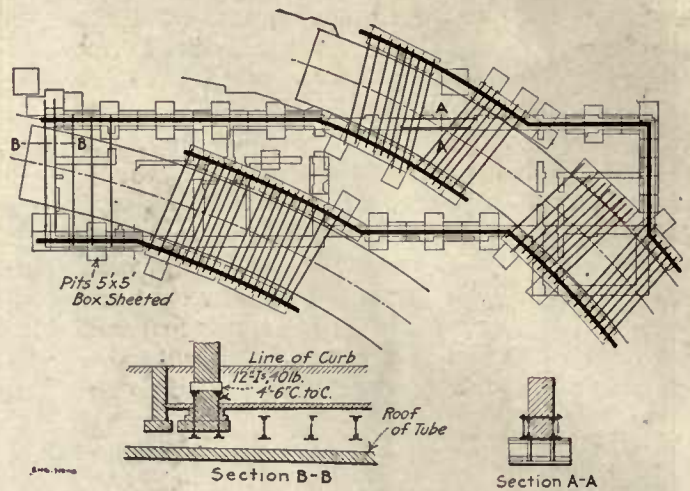

FIG. 61. LOCATION OF SUBWAY TUNNELS UNDER TRINITY PARISH HOUSE

to a depth of about 30 ft. and from the bottom of these trenches pneumatic caissons are being sunk to the required depth. The sinking of the caissons is done under a special subcontract by the Foundation Company.

The Trinity Parish House is a four-story brownstone building about 30 ft. wide and 160 ft. long. The tunnels pass under it as shown in the sketch, Fig. 61. Rectangular pits were sunk as shown by the drawing, there being 115 of these pits. Part of these pits supported the building directly; at other places the walls are supported on cross-girders over the tunnel, as indicated on the sketch. With the exception of part of the ground floor and basement the building has been continuously in use during the whole operation.

A method of underpinning was developed on Sec. 3 of Route 5 (see Fig. 42) by the Underpinning & Foundation

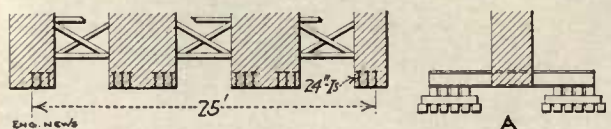

FIG. 62. UNDERPINNING WITH NEEDLES 6-STORY BUILDING, BROADWAY AND 17TH ST.

Co., which consists essentially of the construction of a retaining-wall, the face of which is practically at the neat line of the structure. This is made practicable by reason of the fact that along most of the route the space underneath the sidewalks is occupied by vaults used by the owners of the adjacent buildings under revocable permits from the city. The width of the subway structure makes it necessary to occupy part of these vaults, though any remaining portion is afterward restored for the use of the abutting property owners. Most of the excavation of this section is in sand and the depth is comparatively shallow. The contractor, therefore, took advantage of the situation to build his sidewalls as retaining walls,



working from the bottom of the vaults before commencing the main excavation. This effectually prevented any disturbance of the ground under the building and less-

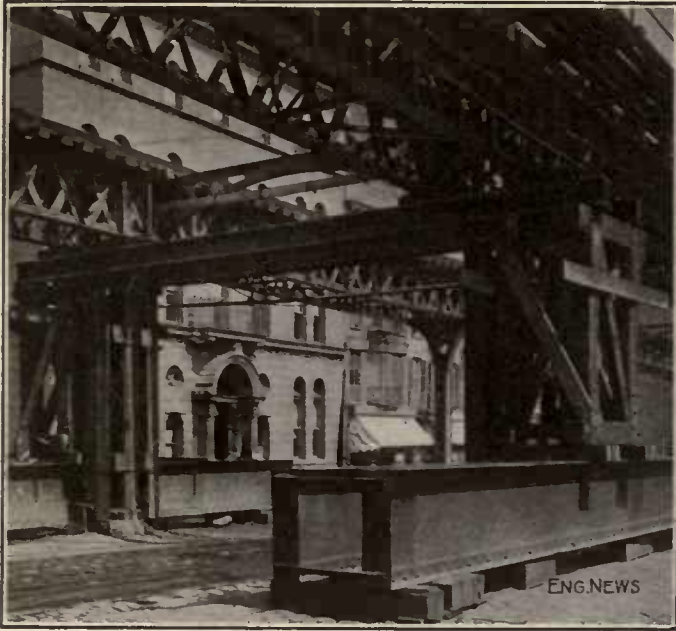

FIG. 63. TEMPORARY SUPPORT FOR ELEVATED-RAILWAY COLUMNS

ened the amount of timber, as no bracing for the sides was required. The retaining wall was built in sections by sinking 4 ft. square pits or wells (using the horizontal sheeting) separately, and some distance apart, then

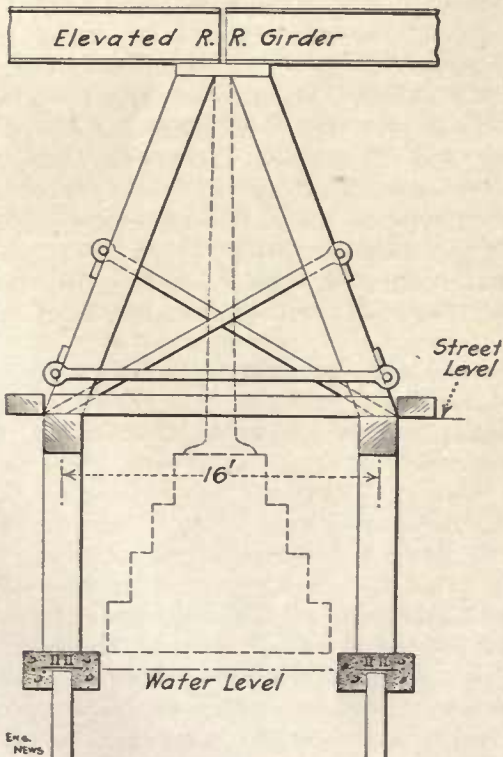

FIG. 64. SUPPORT OF ELEVATED-RAILWAY COLUMNS ON CHURCH ST.

intermediate pits were put down and finally the whole closed up to make a continuous wall.

At the lower end of this section, the two middle tracks are depressed for the Canal St. connection, and as this is

mostly below ground-water level and quite deep, the method above described did not wholly apply. It served, however, for the upper level and steel sheeting was then driven between the outer tracks and the inner pair, to enable these latter to be taken down to the required depth.



FIG. 65. HOLLOW PILES FOR FOOTING OF ELEVATED-RAILWAY COLUMNS

The six-story brick building at the corner of Broadway and 17th St. was held on needles while it was underpinned, and is a good example of what this method involves for a heavy building. The length of the front which was supported is about 25 ft., and eighteen 24-in. I-beams each about 25 ft. long were required to hold the weight. There were two piers between the corners and the three spaces between them were filled with heavy timber bracing and blocking before operations were commenced,

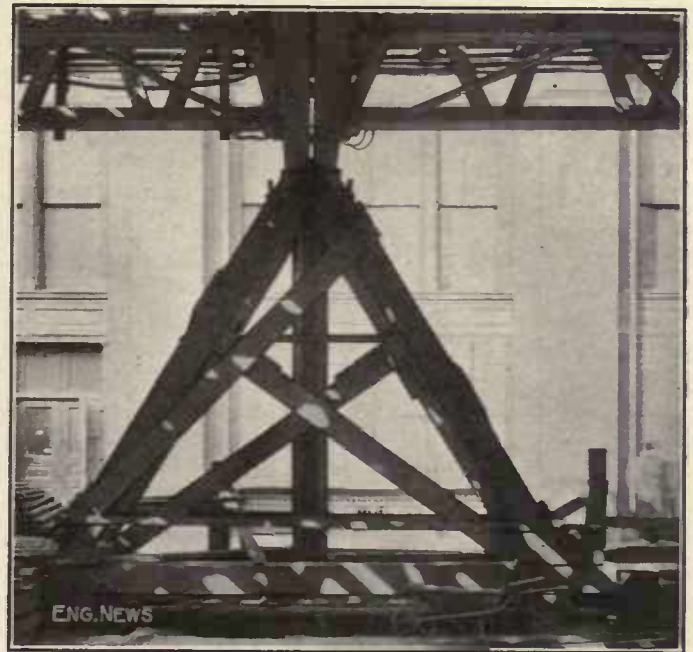

FIG. 66. TIMBER A-FRAME WITH EYE-BAR CLAMP SUPPORTING ELEVATED-RAILWAY COLUMNS, CHURCH ST.

as is shown in the sketch, Fig. 62. The I-beams were used in groups of three, supported on a continuous grillage built up on the cellar floor inside and on the vault floor outside. Hitches were cut, one at a time in the sides of the columns to take the three I-beams, and the whole load finally transferred to them while the foundations were carried down.



## ELEVATED-RAILWAY COLUMNS.

The columns of the elevated railway as originally built were generally supported beneath the surface of the street on spread brick footings, the removal of which is made necessary by the construction of the subway. Temporary supports as shown in the photograph, Fig. 63, are built to hold the elevated structure during construction and considerable care is necessary to prevent any settlement and to provide as nearly as possible absolute safety;

On Sec. 1, Route 5, which is under Church St. and the Sixth Ave. Elevated, the A-frame supporting the cross-girder above the column is supported on timber bents resting on steel piles. The spread brick footings are uncovered and spaces are cleared at the two sides of the structure in each of which three 14-in. steel piles are sunk to below subgrade and to a firm bearing; these are capped on each side by a reinforced-concrete beam on which a perpendicular timber bent is erected to about the level of the street surface as shown in the sketch, Fig. 64. These bents are about 16 ft. apart and an A-frame is then erected on them. The legs of the A-frame are held together by eye-bars and pins or timber brac-

ing, as shown in Fig. 66. When the final support of the columns is to be below or at subgrade, clusters of hollow steel piles are driven and capped with reinforced concrete, to form the new footing, as shown in the photograph, Fig. 65. In many cases, however, the new column footings are carried directly on the roof of the completed subway structure.

The method of support adopted where the construction of a new sewer, on Third Ave., required temporary support of one pair of columns, is shown in the photograph, Fig. 66, the structure being blocked up from two pairs of girders laid direct on blocks on the paved surface of the street.

On West Broadway, at the lower end of the Seventh Ave.-Varick St. line, the elevated columns are supported above the street surface by a timber tower. Immediately below this and supporting it are two heavy 30-in. Bethlehem beams about 20 ft. long, laid on either side of the brick footing parallel to the street line. Both ends of these are in turn supported by a pair of 24-in. I-beams which rest on timber blocks on the ground outside of the brick footings.



# Tunnels in City Streets

## The Lexington Ave. Tunnels

With the exception of the tunnels under the rivers, referred to in the next article, practically the only parts of the subway lines as now laid out, to be built as true tunnels, are those under Lexington Ave. for the two lower-level tracks from about 53rd St. to 78th St., and for all four tracks from about 91st St. to 102nd St. The total length of these four sections is about 2.6 miles, of which about 2 miles is to be built in tunnel. The tunnels on Sec. 9 are being driven in part by Messrs. Douglas & Shailer, under a subcontract for P. McGovern & Co. The rest are parts of Sec. 8, 10 and 11, and are being built by the Bradley Contracting Co.

No particularly new methods of driving these tunnels or of handling the material have been used, but some features of the work are of interest on account of the difficult and uncertain nature of the rock which has been encountered. This is the typical gneiss or mica schist which underlies the whole of Manhattan, varying from quite hard to very soft and partially disintegrated material, containing many seams and dipping and striking very irregularly, thus tending to cause slips and slides, which the utmost vigilance and care cannot always avoid. Driving a tunnel, therefore, or even making an open cut through this kind of material under a street carrying heavy city traffic, and with important buildings on both sides of it close to the work, requires most careful methods of excavation.

On Sec. 11, the situation is complicated by the change from double-deck two-track tunnels, one over the other, to a four-track section with all the tracks at one level, making a tunnel section of practically rectangular shape 16 ft. high and nearly 60 ft. wide (see Fig. 68-I).

A power plant which supplies air to all four of these sections was established by the Bradley Contracting Co., at 96th St. and the East River. It contains five compressors, each of a rated capacity of about 2100 cu.ft. of free air per min., which is piped through a 10-in. main to all sections, the distance from the power house to the center of the farthest section being about 2½ miles. Comparatively little trouble has been experienced with this line, though, of course, with four separate and fairly large organizations depending on one source for their supply of air, there have been times occasionally when all would be working or attempting to work at full capacity and the pressure would consequently drop.

A supplementary compressor of about 1500-cu.ft. capacity, connected to an electric motor for use in emergencies, has been installed in a part of the completed subway on Sec. 9, at 77th-81st St., but so far it has not actually been used. There has been some trouble on the long main-feed lines with freezing in cold weather, but nothing of importance. The main is carried underneath the decking of the street.

The Bradley Contracting Co. arranged for the hauling and disposal of the muck from Sec. 9, as well as from all its own sections, so the same type of buckets are used throughout all four sections; they are the so called battleships already referred to (in the article on excavation).

In the tunnels, four small power shovels (Marion model 40) were used for handling the muck in as many

headings, where there was room for them, but a great deal of the material was handled by hand shoveling. Some experiments were made with other types of mechanical excavators, designed for use in a more limited space than that necessary for the operation of a shovel, but they were not successful enough to warrant their continued use.

The buckets, placed on small four-wheel cars (Fig. 66, lower view), were hauled back and forth between the shafts and the headings by various means, but no mechanical locomotive power was used. Single-drum air hoisting machines were arranged on platforms above the floor of the tunnel to haul the cars up grade, either the loads out of the heading or the empties back as the case might be, the cars being allowed to coast down grade. A single haulage line was used, the end being carried back by hand or by a mule.

Where the rock was good the full section of double track was usually taken out by driving a top center heading about 8 ft. high and 12 ft. wide, keeping the enlargement close up. The heading was pulled by the usual V-shaped center cut, with necessary side rounds, 20 to 40 holes 6 to 8 ft. deep, according to the character of the rock, being required for the whole heading. About 3 lb. of 60% forcite was required per cu.yd. in the headings in hard rock; 40% was used in the softer rock.

In one case a pilot heading was first driven all the way through between two of the shafts to permit better ventilation, especially for the erection of the structure, which it was desired to keep fairly close up to the excavation.

Timbering was required to support the rock in many places, and although segmental timbering was used, the arch was so flat that some center supports were almost always required. The original design for the double-track tunnels provided for a reinforced-concrete center wall, but here as in the use of this class of material in the cut-and-cover sections, where the ground or the street surface required continuous support, it was found to be difficult to make a good job with it. The type of structure shown in Fig. 9 permits the construction of the center wall with the two haunches, as shown in outline, before the rest of the structure is built and permits support on the permanent steel structure at once. The method is shown also in the sketch, Fig. 67, which shows the various steps of construction in the double deck, double-track tunnels on Sec. 11 and also incidentally the enlargement for the upper level local station at 96th St.

Figs. 69 and 70 show typical methods of supporting the timbering and the rock above, where the latter was generally fairly good. The methods used varied in detail in different headings, but in general were more or less alike. The flatness of the arch will be noted and the supports on either side of the center wall, permitting the construction of this latter and the transference to it of the load, thus permitting the construction of the two arches.

Near the upper end of Sec. 8 and 9, from 56th to 78th St., very soft disintegrated rock, carrying considerable water, was found, necessitating typical soft-ground tunneling methods. Timbered side drifts were driven for





The general appearance of this timber section is shown in the upper left view above, but in some parts of the work where the ground was particularly heavy, the space between the timber rings was filled with concrete, as soon as possible after they were erected, and the ground overhead was thoroughly grouted. Even then it was necessary to use some temporary supports for the center. Details of two types of timbering used are shown in Figs. 69 and 70.

As is indicated in this latter drawing, the wall plates were sometimes supported on a ledge of rock, but more often were posted down to subgrade when the bench was excavated. The raking braces shown were usually only used temporarily to help support the wall plate while the posts were set under in very soft material, but occasionally they were left in.

Fig. 71 shows a method of timbering used as part of Sec. 9 south of 78th St., where the rock, while quite hard, required support to prevent slides or the possible move-



#### TWO VIEWS IN LEXINGTON AVE. TUNNEL

Segmental roof timbering (upper). Shovel and car (battleship) for handling muck (lower).

the wall plates, segmental timbering tightly lagged was erected from them with about twelve inches between each ring, crown bars and poling boards were used, but the latter were not usually driven, as the rock would hold for a short time. The method actually used was really to place lagging over the top of the arch in the position of poling boards, wedged down at one end, over the last ring erected, in the position in which poling boards would usually be driven. These projected forward over the position of the next ring and were blocked up from it after it was erected. This slight variation from the method of placing the lagging provided some protection from small dropping rocks, and was more easily accomplished than driving the poling boards, which would have been difficult in the material excavated.

ment of large masses. A center top heading was driven and as soon as the enlargement was made, which was kept close up, the timber was erected, as shown in the "first stage" cross-section. In the "second stage" the two pairs of continuous I-beams are placed to span the bench excavation as shown in the longitudinal section in Fig. 70. These I-beams were joined with long splices to develop full strength at the joints and were made continuous throughout the work. The muck from the heading and enlargement was brought out in small buckets on the tracks, laid on the cross-braces at the springing line and dumped into the buckets on the tracks below, at a point back of the face of the bench.

All timber is provided and placed by the contractor at his own expense, the cost being included in the



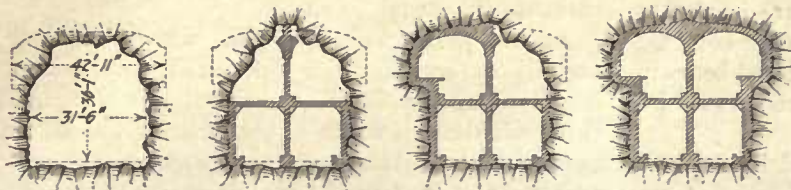

DIAGRAMS SHOWING METHOD OF ROOF SUPPORT FROM CENTER PARTITION WALL - SECT. II R.5 LEXINGTON AVE. FIG. 67

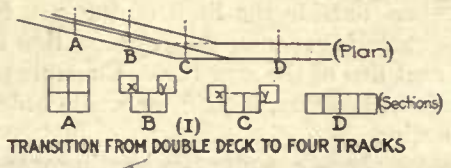

TRANSITION FROM DOUBLE DECK TO FOUR TRACKS (Plan) (Sections) A B (I) C D  
Arrows indicate direction of progress of steel erection  
METHOD OF CATCHING UP PORTAL UP PORTAL AT 102<sup>ND</sup> ST. (Plan) (III)  
FIG. 68

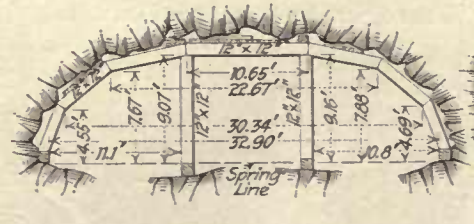

FIG. 69 - TIMBERING METHODS, SECTION 8 LEXINGTON AVE. TUNNEL

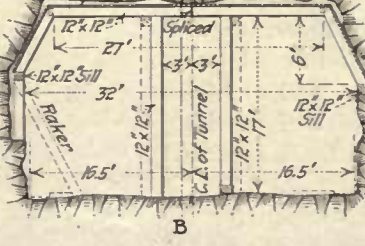

FIG. 70 - TIMBERING METHOD, SECTION 9 - LEXINGTON AVE. TUNNEL (X & Y)

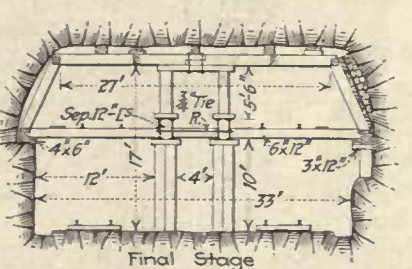
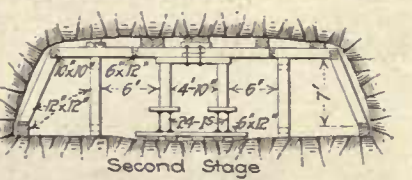
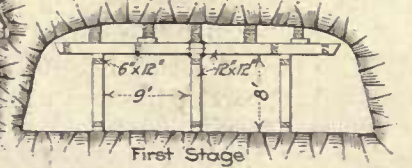

FIG. 71 - SKETCHES SHOWING TIMBERING SUPPORTS ETC. SECT. 9

LEXINGTON AVE. TUNNEL

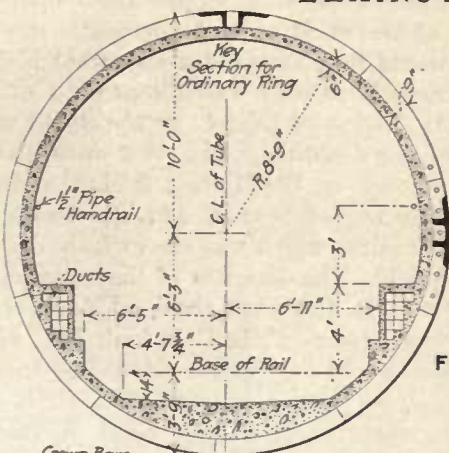

FIG. 72 CROSS-SECTION AND PART ELEVATION OF VESEY STREET CAST-IRON LINED TUNNEL

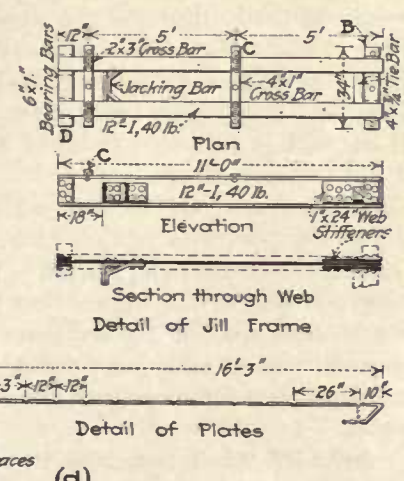
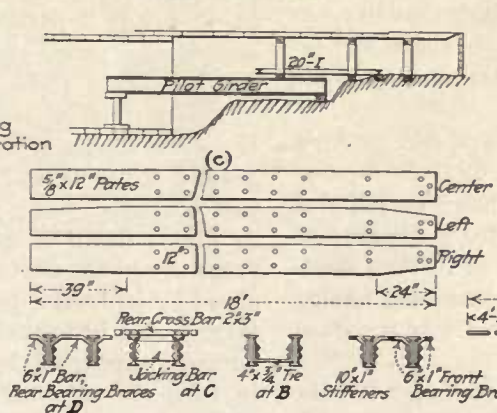
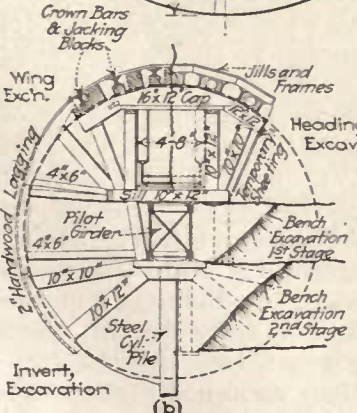
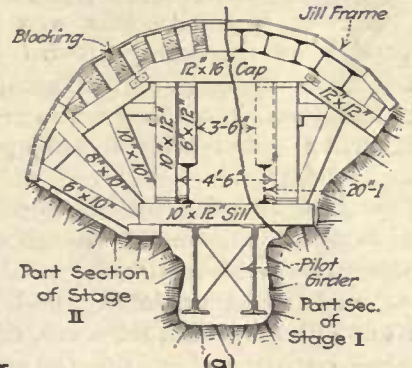
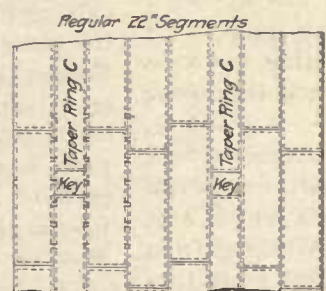

FIG. 74 - SKETCHES SHOWING MEEM'S METHOD OF TUNNELING (a, b, c, d) VESEY ST. TUNNEL

Eng. News



excavation price. The extra excavation necessary to place the timbers outside the lines of the structure is also at the contractor's expense, the payment line being confined to the neat line of the structure. Concrete placed between the timbers, however, is paid for where ordered, as is also the grouting.

At some places a center top heading was driven ahead, then the enlargement was made all on one side just large enough to permit the steel and concrete structure for one track to be built in it, then the further enlargement was made for the second tunnel, the top of the center wall forming the abutment for the arch first erected being necessarily braced to the sides until the second arch was erected. This method obviated the necessity of anything but occasional support of the rock where there appeared to be a tendency to slip.

On Sec. 8 and 9, the cut-and-cover excavation for the upper-level tracks was quite generally completed and the structure erected in it before the tunnel underneath was driven. No damage to the upper structure or difficulty of moment has been experienced due to this method of procedure except in one or two cases, where the extremely heavy rains of last fall, working under the completed upper structure, washed some of the material under it, into the excavation of the tunnel below, the heading of which happened at that time to be in very soft disintegrated rock. The upper tunnel structure at this point was temporarily supported by heavy timbers and girders which spanned the washed-out portion and the latter was then thoroughly grouted and the trouble remedied. Close watch was kept at all times of the upper tunnel at points just above the places where work was being carried on below, and any indications of trouble, as were shown in one or two cases by small cracks, were investigated and the ground below thoroughly grouted if this appeared necessary. The efficiency of this grouting under high pressure was shown in one case where grouting was done from below, the grout being forced up into the upper tunnel.

Just north of 98th St., the two upper tunnels spread out, and as soon as they get far enough apart, drop down to the level of the lower tunnels, until all four are at the same grade, as shown in Fig. 68-I. Working from the shaft at 97th St. toward the north, the two lower tunnels are being driven first and the steel and concrete structure erected in them, then the two upper tunnels are to be driven at the sides. The cross-section *C* will show the necessity of this, as it will easily be seen that the corners *X* and *Y* will probably break through, and the character of the rock is such that it would hardly be possible to hold up the mass between.

At the upper end of this section at 102nd St., working southerly in the four-track section (Fig. 68), the method which has been developed and started is based on the idea of driving one side of the tunnel first for a distance of about 80 ft., then erecting the structure in it, then starting the second tunnel, and so on, thereby avoiding having the excavation open for more than the width of one tunnel at once.

Some difficulty was experienced in catching up some of the portals, a typical method of overcoming it being shown in the sketch, Fig. 68-II. At the beginning of the double-deck tunnel just south of 95th St., the lower level was driven through, the steel structure erected and con-

creted, then the upper level was worked back from the inside to the portal, as shown.

At the portal at 102nd St., where the four tracks are all at one level, a side drift was driven for a length of almost 80 ft., a crosscut was then made from this drift the full width of the structure, as shown in the sketch, Fig. 68-III, and the structure then erected so that the rock was caught up and then the excavation carried back out to the portal.

#### VESEY ST. IRON-LINED TUNNELS

On Sec. 1-A of the Broadway line there is a reversed curve where the route passes from Church St. through Vesey St. to Broadway, and the narrowness of the streets makes it necessary to pass under private property at each of the corners. The material for a considerable depth (50 to 60 ft.) below the streets in this section is sand, but it is comparatively dry down to the level of the bottom of the subway structure, which latter is about 4 ft. below M.H.W.

Easements were obtained under the two pieces of private property referred to, namely, the Trinity Parish House and the old Astor Hotel, on condition that the former should be properly supported on new foundations, bridged over the tunnel, and that on the site of the latter (which was razed) suitable foundations for the heaviest type of building should be provided, also, of course, bridged over the tunnel where this passed through them. Under these conditions it was thought desirable to design two separate circular cast-iron lined tunnels or tubes. The two tubes together have a length of about 1200 ft. and will require about 4350 tons of cast iron for the lining and about 17,000 cu.yd. of concrete.

As these sections of iron-lined tunnel are comparatively short, the use of the usual type of pneumatic shield for driving them would have involved a somewhat high cost for plant, chargeable to only a small amount of work. Besides this, the driving of tunnels by the shield method on curves of as small radius as this is a somewhat difficult operation, though on the Hudson & Manhattan R.R. there is at the corner of Morton and Greenwich St. a curve of 150-ft. radius, which was successfully driven by the use of the shield. The diameter of these tunnels was, however, some  $3\frac{1}{2}$  ft. less than those at Vesey St.

The contractors, Messrs. F. L. Crawford, Inc., adopted therefore, for this work, a method developed by them and their engineer, J. C. Meem, M. Am. Soc. C. E., some years ago in the construction of some large circular brick trunk sewers in Brooklyn and which was quite fully described in a paper presented by Mr. Meem to the Brooklyn Engineers' Club in May, 1905.

This method as modified for the construction of these tunnels is shown quite clearly in the drawings and photographs, Figs. 73 and 74. A top heading is driven, the roof protection being afforded by the five sectional shields or jills, a detail of which is shown in Fig. 74d, and the front end in the photograph, Fig. 73-1. These are shoved ahead by hydraulic jacks, and a lining of 2-in. hardwood lagging put in behind them, under the tail; this is temporarily supported by crown bars and blocking, which in turn are supported by segmental timbers consisting of the cap made of a 16x12-in. cut on top to chords of the curve and flat underneath to take the posts, and the two side pieces, as shown in the drawing, Fig. 74, a and b, and the photograph, Fig. 73-3.



From the heading, the sides are worked down to about the springing line (horizontal diameter) by placing the 5-ft. lengths of horizontal lagging much as it is placed in the pits for underpinning and as shown in the photograph, Fig. 73-3. To get out the excavation in the center

The girder itself is made up in 12-ft. sections arranged so that the rear section can be detached and bolted on to the front, overlapping about 3 ft. Extra holes are provided so that the progress can be made either in a straight line or deflected to fit the curvature. The girder flanges

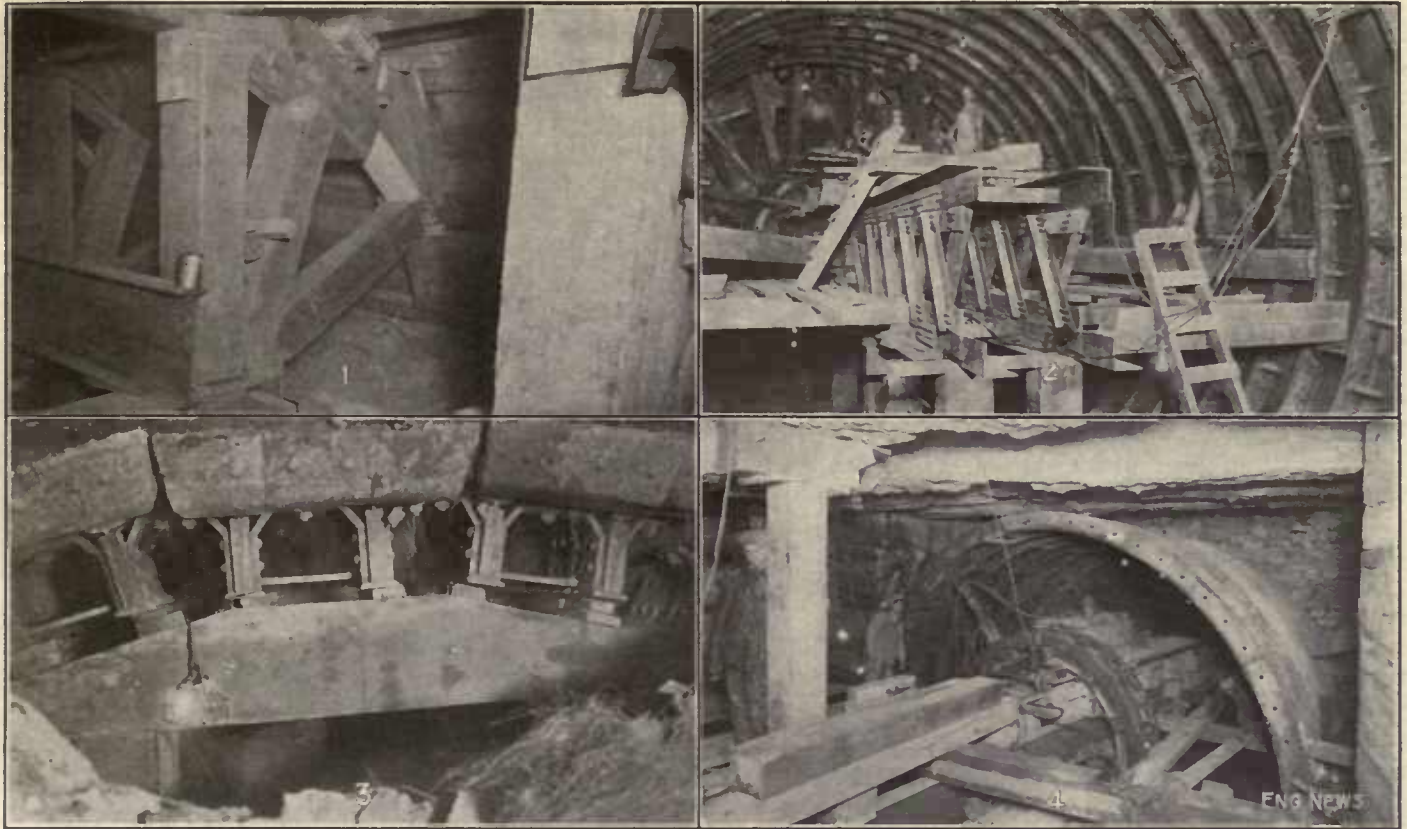

FIG. 73. VIEWS IN VESEY ST. TUNNEL

- |  |   |
|--|---|
| <p>1. Temporary bracing and lagging.</p> <p>3. Segmental roof shields—jills.</p> | <p>2. Iron-lined tunnel and pilot girder.</p> <p>4. Tunnel and pilot girder, erector.</p> |
|--|---|

below the heading, the top cap is carried temporarily on the 20-in. I-beams shown in Fig. 74(a), spanning the working space from the erected intermediate sill (the one just above the center of the circle) to the firm ground in the bottom of the heading.

This permits the advancement of the so called pilot girder, which is advanced along the center in the position of the pilot tunnel of the old Anderson & Barr method. The girder in the present instance, however, only serves a purpose similar to that of the temporary I-beams above, that of supporting the overhead structure of timber blocking, over the working space, its rear end being supported on blocking from the erected iron lining, its front end on the unexcavated ground of the second lift just below the center. The photographs, Fig. 73 (2 and 4), show the method of using the erector around the pilot girder, and the latter part of the tunnel under the Trinity Parish House, which had previously been underpinned and the space above the tunnel bridged over.

are 8x8x $\frac{1}{2}$ -in. angles, and the latticing 4x4x $\frac{1}{2}$ -in. angles. The girders are 3 ft. on centers held together and braced by 4x $\frac{3}{4}$ -in. bars. The roof load of the tunnel, which the girder supports, is estimated to be about 10 tons per lin. ft., but the girders are designed to carry a maximum load of 40 tons per lin.ft. for spans of 12 ft., thus providing for uncertainty and probable irregularity of loading and support.

The hardwood lagging is left in place when the cast-iron lining is erected. This latter weighs approximately 6600 lb. per lin.ft. of tunnel and it is cast in the usual segmental form. The individual segments are 6 ft. 2 in. long, 20 in. wide and weigh about 1500 lb. each. Every fifth ring is a taper ring for the curves, other taper rings (with considerably less taper) are provided for correcting the alignment when this becomes necessary.

In making the excavation the ground at the breasts, as well as the sides, is usually held at all points by lagging or poling bounds to prevent any subsidence.



# The River Tunnels

## The Harlem River Tunnels

The general design of these tunnels is shown in the cross-section, Fig. 76. It was determined by two principal factors: First, the necessity on account of the conditions under which the approaches were located of keeping the tunnels as near the surface as possible; second, the desirability of obtaining a minimum total width to avoid encroachments on valuable private property.

The methods developed in the construction of the tunnels under the Harlem River for the original subway (see *ENGINEERING NEWS*, Oct. 13, 1904) and at Detroit† for the tunnels of the Michigan Central Ry., had shown the practicability of sinking tubes from the surface, and these methods also permitted much closer spacing than would have been possible with shield-driven tunnels, which latter would necessarily or at least most conveniently have had to be circular, with a reasonable space, say 10 ft. or so between each tube. It may be noted, however, that the tunnels which had been previously built by sinking from the surface were for two tracks only, whereas, the new Harlem River tunnel is for four.

Bids were originally called for late in 1910 on two types, H and K. Type H was similar to that of the original Harlem River tubes, and type K similar to the Detroit River tubes.

The bid prices were as follows, per lin.ft. of four-track tube:

Type K—Lowest \$1925, highest \$3000, per lin.ft. of four-track tube.  
Type H—Lowest \$2200, highest \$3000, per lin.ft. of four-track tube.

Before the contracts were awarded it was decided to change the dimensions; the bids were therefore rejected and the work readvertised, this time calling for bids on three types, H, K and L. Types H and K remained the same except for the changes in dimensions. Type L was a modification of Type H, having the four tubes all together instead of in two pairs.

The bids on the latter two types were all rejected and that of Messrs. Arthur McMullen and Olaf Hoff, the lowest bidders on type K, was accepted; the range of bids at this last letting for the tube-tunnel section having been as follows, per lin.ft. of four-track tube:

Type K, \$1500 to \$1800, 8 bids.  
Type H, \$1650 to \$2000, 3 bids.  
Type L, \$1550 to \$2000, 6 bids.

The contract price of \$1500, equal to \$375 per lin.ft. of track, may be compared with the cost of the Detroit River Tunnels, which has been given as \$332.29, exclusive of contractors' profits. However, the inside diameter of the Detroit tunnels was 20 ft., as compared with 16 ft. 6 in. for the Harlem River tubes.

The method adopted by the contractors with very few modifications was that developed for the construction of the Detroit River Tunnels, which has been quite fully described‡ in various papers and articles in the technical press. The article in *ENGINEERING NEWS*, of Feb. 15, 1906, is interesting as showing the development of the process. It consists essentially in the erection of the steel tubes in suitable lengths on shore, bulkheading the ends to get flotation, launching these sections, towing

them to the site which has previously been dredged to the required depth, and sinking them in place by filling them with water (see photographs in Fig. 75). The concrete is then deposited around the outside by means of tremies, the sections unwatered and the inner concrete lining placed. This method, of course, obviates the necessity of general work in compressed air, though divers are used to a limited extent.

The accompanying drawings and photographs show the essential details of the structure and the methods of sinking and as the general methods have already been so fully described, it seems only necessary to call attention to such changes and improvements as experience and the particular conditions of the Harlem River work have shown to be desirable. The tunnel was divided into five sections, four of 220 ft. each and one of 200 ft.

In the Detroit River tubes, the circular stiffening angles, which are spaced about 8 ft. apart, were placed on the inside, as then it was thought necessary to provide temporary interior bracing in the form of the spokes of a wheel. Experience showed, however, that this might be dispensed with, and on the Harlem River tubes the stiffening angles were placed on the outside. This permitted the construction of the braces or struts to the wooden bulkheads or forms at the sides, which materially decreased the necessary thickness of the timber, which latter, in the case of the Detroit tunnels, was 6 in. thick at the bottom and 4 in. thick at the top. For the Harlem River Tunnels, 4-in. plank was used for the lower half and 3-in. for the upper.

The manner of making a tight joint between each of the sections shows an important modification in the direction of simplicity. The old joint with the pilot pin is shown in the drawing, Fig. 77a. This joint was not altogether satisfactory, as it was somewhat difficult to fit and the rubber gaskets are, of course, perishable. The new joint (see Fig. 77b) is a butt joint instead of an overlapping or sleeve joint, and the bolts on the outside are easily placed by divers. The inner plate, which, of course, is riveted in place after the tubes are unwatered, assures practical water-tightness. It will be remembered that the concrete is placed outside this joint before the tubes are unwatered, and tests made with the concrete deposited by the tremies at Detroit showed it to be of very good quality, sufficiently impervious to prevent any leakage of moment. The space between the joint in the shell and the inner plate is to be filled with grout after the latter is riveted in place. There is a pilot pin on each of the two outer tubes, and when both are home, the accuracy of the construction insures a good fit everywhere. The unwatering of the tunnels has shown these joints to be remarkably tight.

Attention may be called to the method of tying the tubes and the partition walls together, as shown in detail, Fig. 76. Reinforcement of 1-in. square rods is placed in the inner concrete lining. Longitudinal rods are spaced 12 in. apart at the sides. It is probable that this might be omitted and still leave the tunnels entirely safe, but is an added precaution thought advisable in view of the comparative novelty of the method.

†*Eng. News*, Feb. 15, 1906, and Mar. 17, 1910. *Proc. Inst. C. E.*, Vol. CLXXXV, 1910-1911. *Trans. Am. Soc. C. E.*, Vol. LXXIV, 1911.



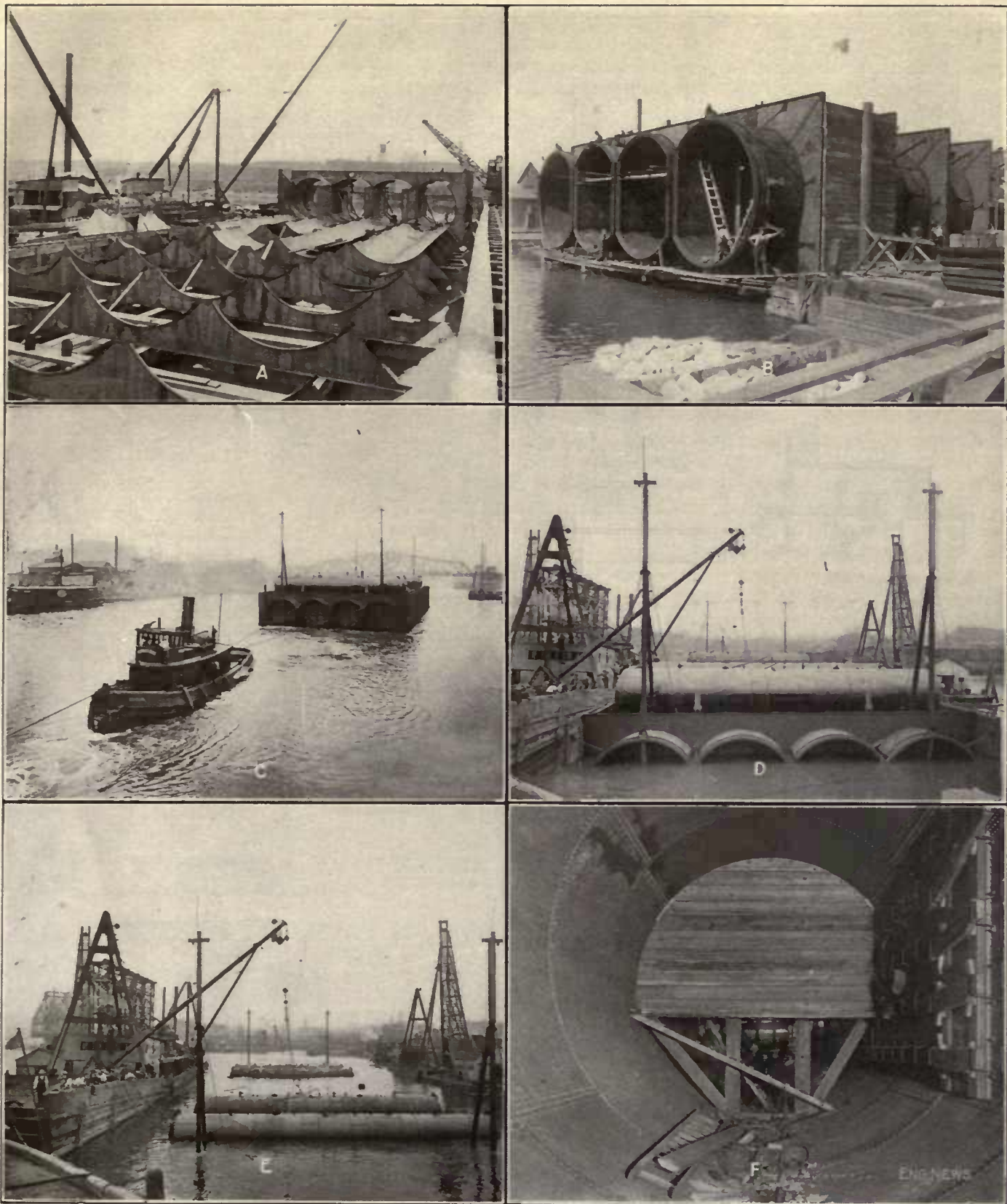

FIG. 75. VIEWS OF THE HARLEM RIVER TUBES DURING CONSTRUCTION

A—Construction, partial. B—Construction, completed. C—Towing to site. D and E—Sinking. F—Inside.

Before launching a section, the two outer tubes were tightly bulkheaded at both ends, but the inner tubes only about 4 ft. up, as shown in the sketch, Fig. 78, that is, just high enough to provide flotation while being towed to the site. The outer ends of the *end* sections are, of course, tightly bulkheaded on all four tubes with bulkheads to stand total pressure for the depth, so they will hold when the tubes are unwatered. Photograph 75D shows the south-

erly end of the first section *A* with all the bulkheads in. At Detroit the tubes were actually launched, by allowing them to slide down the ways as a ship is launched; on the Harlem River, however, it was thought best to build the structure on an open platform over the water, so that flat-decked lighters could be floated underneath to lift them off. The lighters used were water boats which could be filled by the opening of valves provided for the purpose



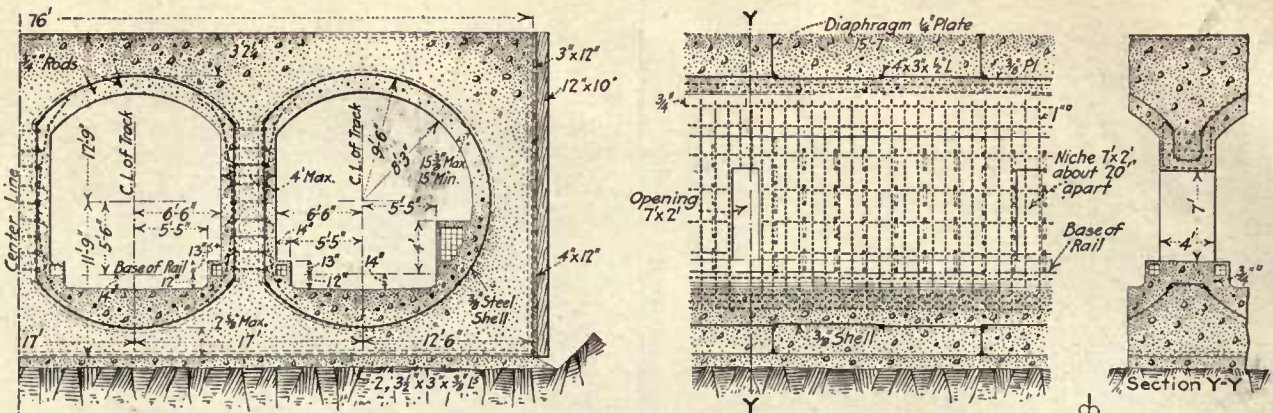

FIG. 76 - SECTIONS OF HARLEM RIVER TUNNEL

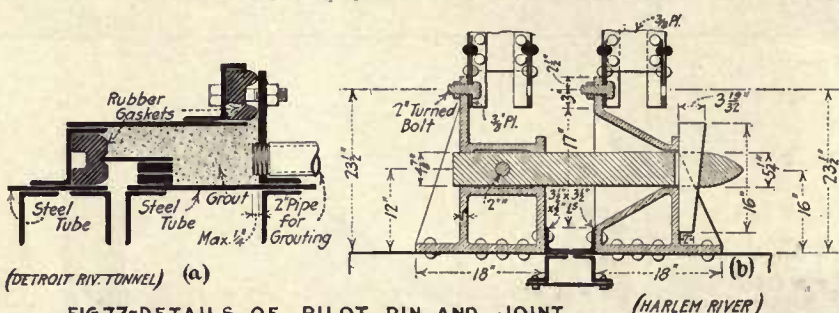

FIG. 77 - DETAILS OF PILOT PIN AND JOINT

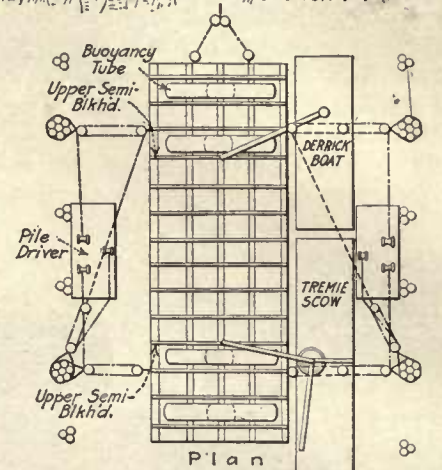

FIG. 79 - FLOATING EQUIPMENT FOR SINKING TUBES

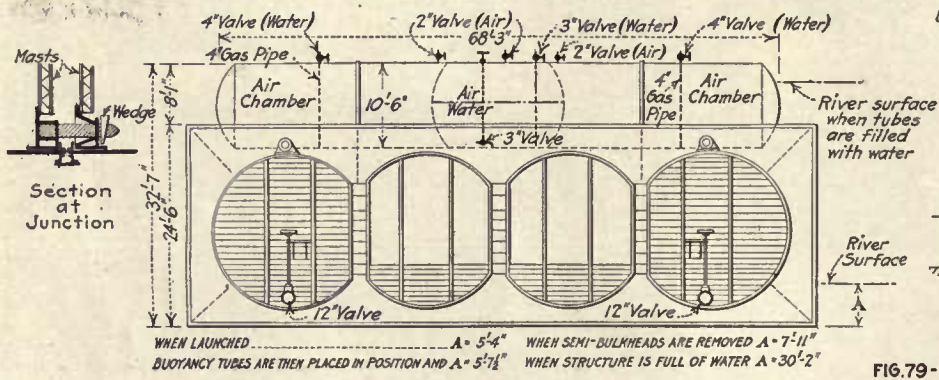

FIG. 78 - DETAIL OF BULKHEADS

HARLEM RIVER TUNNEL

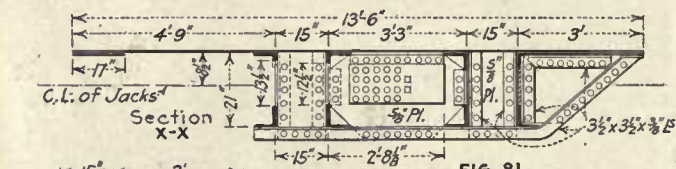

FIG. 81 - DETAILS OF DOUBLE ROOF SHIELD TO BE USED FOR TUNNEL UNDER N.Y.C. & H.R.R. JUST NORTH OF THE HARLEM RIVER

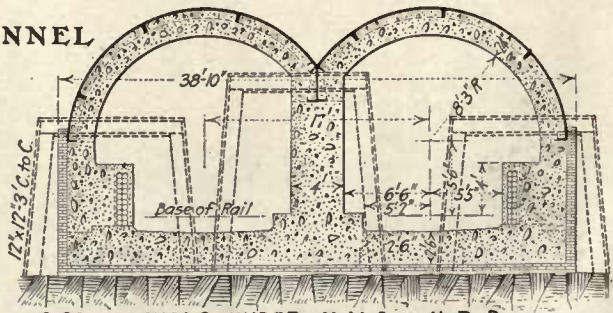
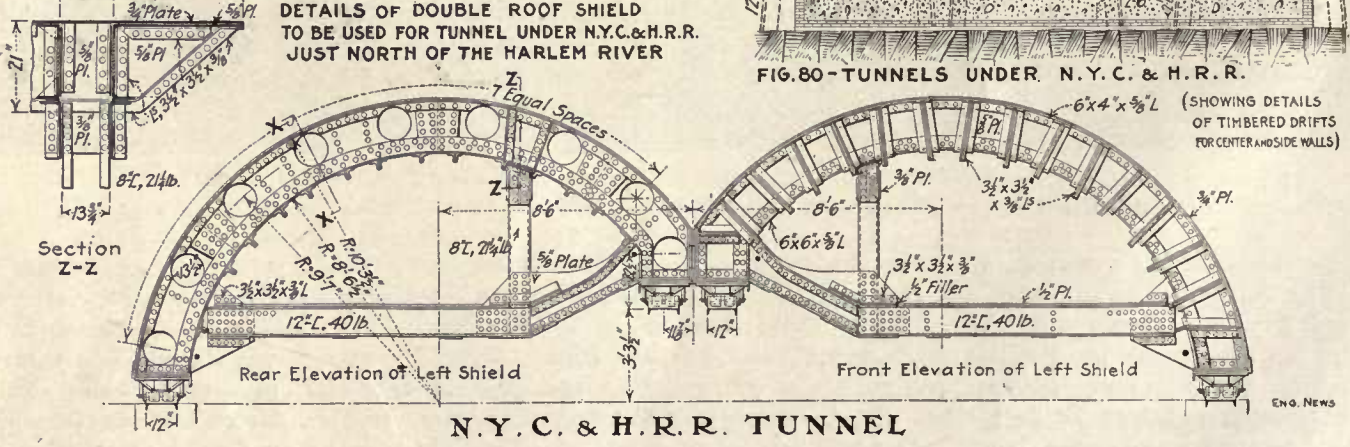

FIG. 80 - TUNNELS UNDER N.Y.C. & H.R.R.



N.Y.C. & H.R.R. TUNNEL



and emptied by pumps. They were floated under at low water, raised by the tide to lift the tubes off the platform, and then when the tubes were moved over deep water were scuttled, leaving the tubes floating. On account of the narrowness of the Harlem River, there would have been some difficulties attending launching, but, in any event, the method used was thought to be better, and proved to be practical and very satisfactory.

The method of depositing the concrete around the outside of the tubes, and tests showing the good quality of concrete so deposited, were fully described in *ENGINEERING NEWS*, Mar. 17, 1910; the method and plant used on the Harlem River was almost exactly the same with one important improvement in the control of the tremies. The tremies are so arranged that they can be raised or lowered to accelerate or retard the flow of the concrete. At the head of each tremie and attached to it, is a platform on which stands the man who controls it. Individual hoists were provided for each tremie, controlled by a continuous rope passing by the platform, so that at any position of this latter the rope could be reached by the man, and the raising or lowering of each separate tremie made almost instantly and as required.

At the Detroit River a steel grillage embedded in concrete was placed in the bottom of the trench at the joints between each section, but at the Harlem River timber bents were driven. There were 4 to 6 bents at each joint; they were framed on shore and driven by two piledrivers, moored facing each other with long followers to reach to the necessary depth. On the first section the bents were driven an inch or two low so that the tubes might be blocked up; it was found, however, that such good control was possible that they were afterwards driven almost exactly to grade.

The method of sinking the tubes is very simple; 12-in. valves are opened in the bottom of the bulkheads in the two outside tubes, allowing these latter to fill gradually with water; the two inner tubes are entirely open. The rate of sinking after the tubes are half full is controlled by air valves at the top of the main tube, if necessary. There is apparently no difficulty in keeping them level, but to aid in this two cross bulkheads are provided, reaching half-way down from the top, providing three sections from which, after the tubes are half full, the air escapes and, consequently, the amount of water entering can be controlled by opening or closing the air valves. The tendency of either end or corner to get out of level was, therefore, easily controlled. As the tubes become completely filled, the flotation is carried by the four cylinders on top, which are in turn gradually partially filled and the excess weight, which is not great, is taken by derrick boats moored on either side during the sinking. The method of control of position is shown in the diagram, Fig. 79.

Some interesting statistics are as follows:

Weight of steel per lin.ft. of structure.....	5600 lb.
Amount of exterior concrete per lin.ft. of structure	30.0 cu.yd.
Amount of interior concrete per lin.ft. of structure	11.6 cu.yd.
Maximum depth M.H.W. to subgrade.....	57.2 ft.

The weight of the structure equipped for sinking, with masts, bulkheads, sheeting, buoyancy cylinders, etc., complete is 646 tons.

Buoyancy of four cylinders (on top) .....	722 tons
Excess buoyancy four cylinders .....	76 tons

requiring 19 tons of water in each to overcome buoyancy. One hour is required to fill the structure with water.

Cross passages are provided between the tubes at approximately every 50 ft., in the outer partitions, and two openings in the whole length of the tubes through the center partition. There is a sump in each tube at the lowest point, universal-joint cast-iron pipe being used for discharge. Access shafts—one for each tube—are provided near the ends of the end sections, by which access can be obtained to the interior of the tubes after the outside concreting is completed. The ends of the last sections are fitted with slots (two angles) to take the sheeting of the coffer-dams which are built to connect them with the land sections built in open cut. The connecting coffer-dam is of a single row of steel sheet piling; clay being dumped on the outside, if necessary, to make it tight.

#### ROOF SHIELDS

Just north of the Harlem River the westerly branch of the subway passes under the main line of the N. Y. C. & H. R. R.R., which at this point carries all the traffic from its own lines as well as from those of the N. Y., N. H. & H. R.R., to and from the Grand Central Terminal. The railway has five tracks and is carried on a fill between high masonry retaining-walls. The base of rail of the subway line is to be between 40 and 50 ft. below that of the railway above.

It was at first thought that this work might be carried out in open cut, carrying the railroad on timber falsework, but the acute angle of the crossing, depth and character of material would have made this a somewhat hazardous undertaking, and it was finally decided to adopt the method shown in the accompanying drawings.

Timbered drifts have been driven, as shown in Fig. 80, the center one, as will be noted, being considerably higher than the other two on the outsides. The material encountered has been mostly rock, but the work was rendered quite difficult in parts by reason of the fact that the top of the rock was just below the top of the drifts, requiring the support of the earth overhead and blasting of the rock below.

In these drifts the side and center walls are to be built of concrete and then the balance of the excavation is to be taken out under the protection of the double, segmental roof shields, details of which are shown in the drawings, Fig. 81. These shields, as will be seen, are quite unique in design and form. It is intended to work each independently of the other, shoving one at a time, but, of course, not to the extent of one entirely clearing the other, as they necessarily react on each other to take up the side thrust.

The writer is especially indebted to Mr. Olaf Hoff, of the firm of McMullen & Hoff, the contractors for this work, for the above information, for the plans and details of these shields, and of the Harlem River tubes, he being principally responsible for the design and execution of this portion of the work.

#### THE EAST RIVER TUNNELS

The additional connections between the new lines in Brooklyn and those in Manhattan are to be by means of two pairs of tunnels under the lower end of the East River, as described in *ENGINEERING NEWS*, Apr. 30, 1914. The contracts for all four tunnels were recently awarded to the Flinn-O'Rourke Co. for a total amount of about \$12,500,000, and work was actually started about Nov. 1 on the sinking of the shafts.



The tunnels are to be driven by the shield method and there are two novel features which are to be tried to which attention may be called at this time.

In several places the roofs of the tunnels are quite close to the river bed, so that additional cover must be provided. Owing to the swiftness of the tidal current at this point and its scouring action, the problem of retaining a clay blanket in place according to the method heretofore used in East River tunneling seemed to be one of some difficulty. The method proposed, however, will not only probably retain the clay, but by placing the material at this time (November, 1914) it will settle well into position and become nearly impervious, by the time the tunnels are driven. A comparatively narrow, thin blanket of clay is

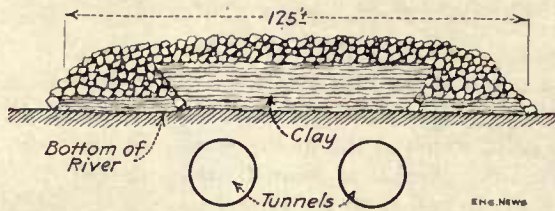

FIG. 82. METHOD OF COVERING RIVER BOTTOM OVER EAST RIVER TUNNELS

first deposited on a line on each side of the location of the tunnels. Rock from any of the numerous excavations always going on in and around New York is dumped on top of this and a clay blanket varying in thickness from 5 to 15 ft. is then dumped between these piles of rock, and is finally covered with other rock, as shown in the sketch Fig. 82. This blanket will be approximately 125 ft. in width over all. It is believed this clay blanket will stay in position and effect the desired purpose. The contractors have been fortunate in being able to obtain an excellent grade of clay from dredging in progress on the Hudson River, near Edgewater, N. J., which ordinarily would have to be towed to sea for disposal.

The second feature is a method of filling the annular space around the outside of the tunnel left behind the tail of the shield, when the latter is shoved ahead. The outside diameter of shields used for tunneling is usually from 6 to 8 in. greater than the outside diameter of the tunnel,

this leaving a space of 3 or 4 in. all around to be filled by the movement of the surrounding material or in some other manner, as the shield is forced forward. This movement, while not always of importance, does tend to produce distortion to the cast-iron lining and to settlement of the ground above the tunnel, which latter may be undesirable by reason of possible damage to overhead structures, as in the street approaches to these East River tunnels, and as happened in Joralemon St., Brooklyn, during the construction of the Battery tunnel for the first subway line to Brooklyn. In such material as that under the East River, which is mostly sand and gravel, and especially with the tunnels so near the surface, any disturbance of the ground above the tunnels, even in the river with no buildings above, is undesirable. Its prevention will probably also tend to lessen the waste from escaping air.

The shield is to be built with a double skin of  $\frac{1}{2}$ -in. plates separated by a space of  $1\frac{1}{4}$  in. The clearance between the shield and the tunnel is  $\frac{3}{4}$  in. The two skins are separated by  $1\frac{1}{4} \times 3\frac{1}{2}$ -in. separators. Eight rectangular pipes  $\frac{7}{8} \times 1\frac{1}{8}$  in. inside,  $\frac{3}{8}$  in. thick, project through the back of the shield, and gravel similar to that used for roofing purposes, is blown through these pipes by air pressure to fill the space as the shield is shoved ahead.

Experiments on a small scale have already been made which show fairly conclusively the feasibility and practicability of this method for preventing any movement of the surrounding material into the space left by the shield, but a full-size shield is now nearing completion with which final tests are to be made with the complete apparatus.

If the two improvements above described succeed in any marked degree in overcoming the difficulties usually experienced in tunneling through water-bearing loose sand and gravel, with light cover, by reason of blowouts, the generally quite considerable loss of air, consequent heating of the tunnel, and the settlement of the ground above, they must be considered as a distinct advance in the art of subaqueous tunneling.

The writer is indebted to John F. O'Rourke and W. Gray, who have developed these methods, for the above information.



# Concrete Work

The total amount of concrete to be used on the whole of the subway construction is, of course, quite large, but speaking generally there is little of the work where there are large masses, or where a great deal is required at one time, so that there are no elaborate plants for turning it out in large quantities. Three general methods are used, a central mixing plant of comparatively small capacity, the material being hauled in motor trucks to the point of delivery into the forms, a portable or movable mixer at the site, and hand mixing on the planking of the roadway immediately over the work. This latter seems an anomaly in these days of the very general use of machinery; but in reality on account of the relatively small amount of material usually required to fill a considerable space in the forms, this latter method in many cases seems to be quite as economical and efficacious as any of the others.

## CONCRETING PLANTS

The few specific plants and methods described below are fairly typical. On Sec. 8, 10 and 11, Lexington Ave., the concrete was all mixed dry in two 1-yd. batch mixers, at the 96th St. Dock on the East River, from whence it was hauled in wagons holding about 3 cu.yd. to the point at which it was to be used. The use of horse-drawn wagons prevented the addition of the water before hauling on account of the length of time required to make the trip. It was usually dumped on the street decking, water added, and the mixture shoveled into chutes directly into the work in the cut-and-cover sections, or delivered down the shafts into 1-yd. cars for the tunnels. These cars were hauled to the point where the material was to be used and there dumped directly when the material was placed in the floors or footings of the walls, or hauled up a short section of movable inclined track to a platform at about the level of the springing line, where they were

dumped and the material shoveled into the forms for the arches and sidewalls.

In one case in the tunnels on Sec. 9, a timber platform was suspended at about the springing-line level from eyebolts, built into the concrete arch. The concrete was delivered into cars at the level of this platform at the shaft, and pushed along a track on it to the point where it was to be used. This required the permanent use of a considerable quantity of timber, however, and after a length of some 300 or 400 ft. had been built this way, a small traveler with an elevator was built to hoist the cars from subgrade level to the springing line. This was in a sec-

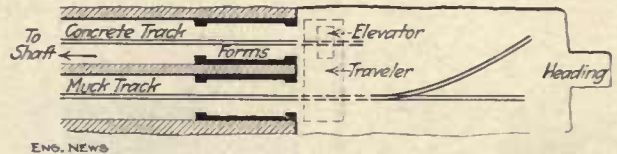

FIG. 83. LAYOUT OF PLANT FOR PLACING CONCRETE IN DOUBLE-TRACK TUNNELS, LEXINGTON AVE.

tion where the rock required no support so that the whole section was clear. The platform of the traveler at the springing line reached across both tunnels and was located in the clear excavation ahead of the forms. The footings of the sidewalls were built first and kept ahead, and tracks for both the traveler and the forms were laid on them. The track in one tunnel was used for concrete cars, and in the other for the muck cars. The concrete cars were brought in under the traveler, hoisted by the elevator to the upper platform, from which both arches could be reached. The general layout is shown in the sketch, Fig. 83.

Wooden and steel forms have both been used on all four of these sections; the general opinion seems to be that where there is a length of say over 300 or 400 ft. of

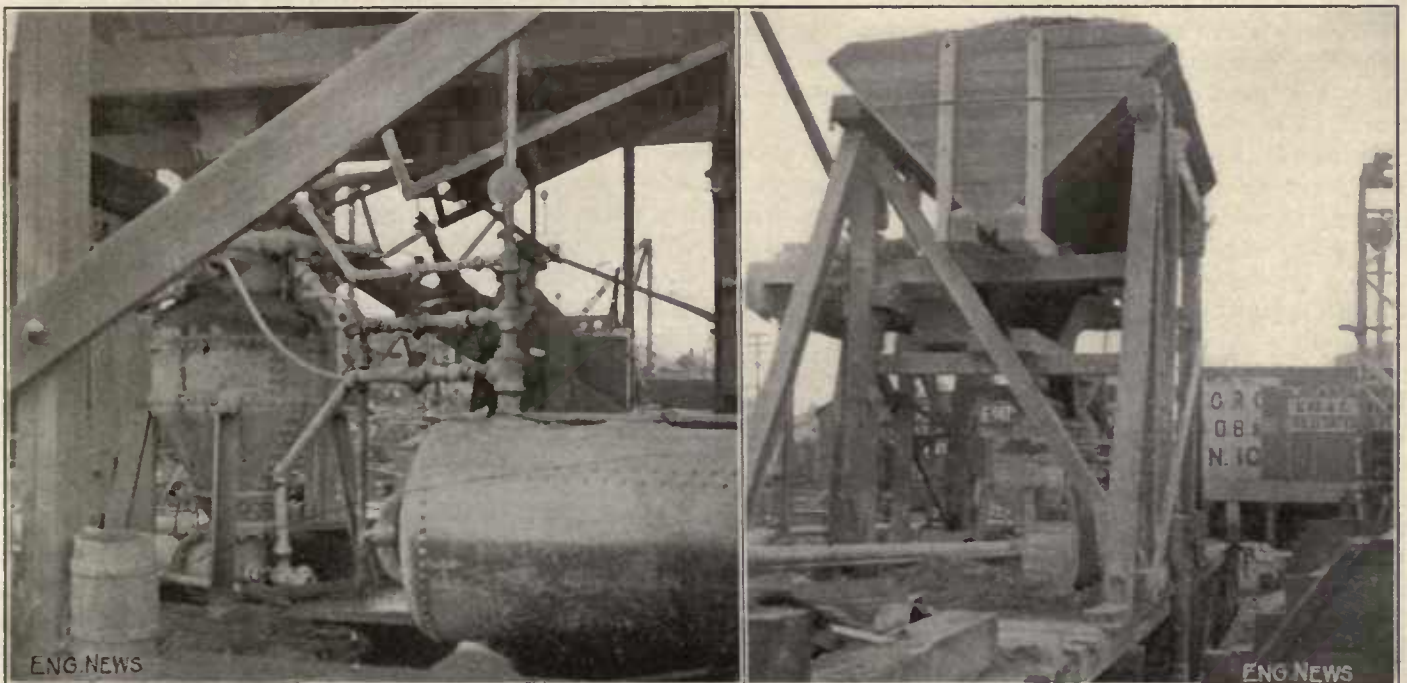

FIG. 84. PNEUMATIC CONCRETE MIXING AND CONVEYING PLANT FOR HARLEM RIVER TUNNELS (Mixer on left, bins on right.)



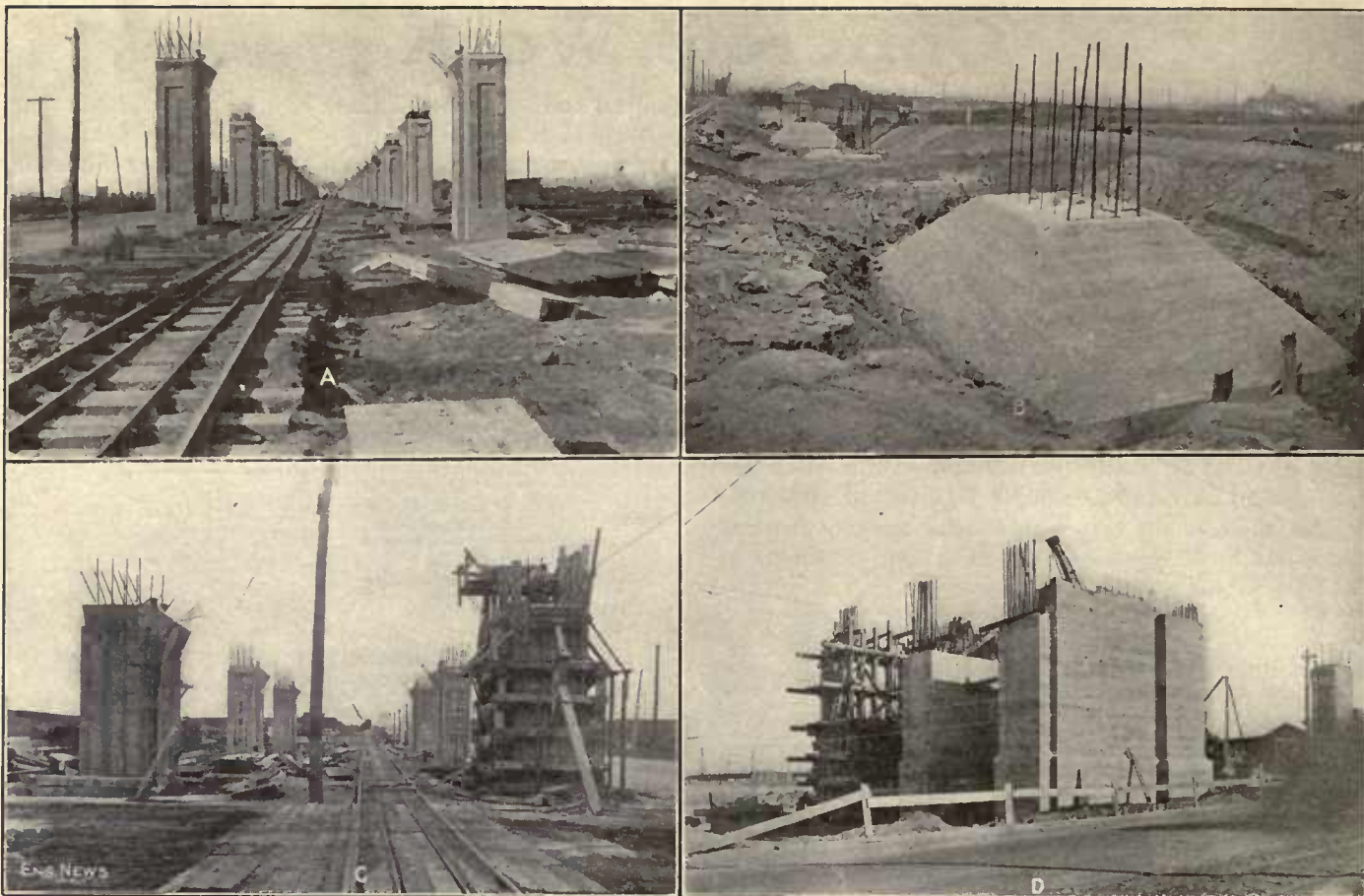

FIG. 85. VIEWS OF QUEENS BOULEVARD REINFORCED-CONCRETE VIADUCT DURING CONSTRUCTION

(A) Columns completed. (B) Foundation for columns. (C) Columns showing forms. (D) Abutment at New York end.

lining all of the same section, steel forms of the Blaw type are cheaper and quite satisfactory. The Blaw forms keep their shape quite well under ordinary conditions; but they could not be used to advantage in the sections where continuous support of the ground by posts was necessary, and, of course, not at all in sections where posts had to be left in while the lining was placed and only removed after the arch had taken the weight.

On Sec. 9 motor trucks were used for the concrete, thus permitting the complete mixing with water at the dock, which was possible by reason of the rapid means of transit these trucks provided.

On Sec. 12 a  $\frac{3}{4}$ -yd. batch mixer was used, set up along the side of the street and moved along as the work progressed, the concrete being mixed at the point where used. Blaw forms were used, but on account of the continually varying dimensions of structure, were found to be not as easily adaptable as on work where they could be used over and over again without change.

On Sec. 13 the concrete-mixing plant is located at the dock at the foot of 125th St., the average haul to the work being about half a mile. A 2-yd. batch mixer is used, arranged with the necessary bins, etc., for convenient feeding of the materials, and so as to deliver the mixed concrete about 10 ft. above the ground. Two motor trucks with self-tipping bodies holding 4 yd. each are used for hauling the mixed concrete to the work. The latter is mixed fairly wet at the mixer, and a little more water is added for cleaning as it is dumped; an air pipe is kept in readiness to be used if necessary, to help get it out and clean the wagon. This is just a short length of 5 or 6 ft. of inch pipe at the end of a hose, capped at the end and

with small holes bored in it. It can be pushed into any mass which has shaken down so as to become a little tight and so start it. At the work when a section is ready for concrete, holes are cut in the wooden street decking at suitable intervals and a line of 8-in. conical sheet-metal spouts in 5-ft. sections is hung to lead from the hole in the decking to the forms. The sections are slung one below the other by chains. Over the hole in the decking is placed a wooden hopper 7x13 ft. and 2 ft. deep, into which the truck dumps its load and is away in about two minutes.

The hoppers are on skids and are not connected with the spout or the decking. They are moved by hitching them by a chain to a truck. The trucks make a round trip from the mixer to the place of dumping and return to the mixer in from 15 to 20 min.

On Sec. 15 there is a central mixing plant with a 1-yd. batch mixer. The concrete is carried in 1-yd. double-hinged bottom-dumping buckets, two of which are mounted on a flat-car; two cars are hauled together by a dinkey on 3-ft. gage track. The cars are arranged on the flat-car frame so that they can be dumped through it without removing them. On this section the work is only partially decked over and the track is laid over the open trench. The cars with the buckets are run to the point where the work is being done, spotted over the top of a chute and hopper and each bucket dumped in succession into it.

For the Harlem Tubes, the outer concrete, as has already been described, was mixed by machinery on a lighter and deposited by means of tremies. For the lining of the inside of the tubes, the compressed air or pneumatic sys-



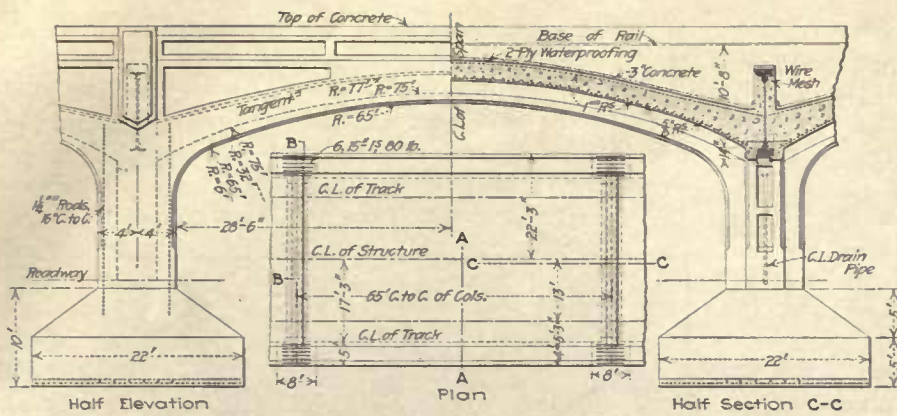
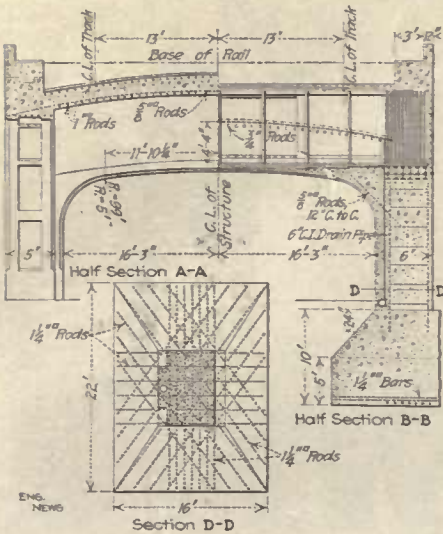

FIG. 86. DETAILS OF DESIGN OF TYPICAL SPAN, QUEENS BOULEVARD VIADUCT



tem controlled by the Chicago Concrete Placing Co. was tried at the northerly end for a part of the section.

The views in Fig. 84 show the general layout of this plant, which it was expected to use for the lining of half the length of the tubes. It is installed on a platform built over the water. The materials are fed in the proper proportions from the overhead bins into the cylinder of the machine in half-yard batches. Water is added from a pipe leading into the top of the cylinder at the same time as the dry material enters from above, the quantity being carefully measured, as it is of some importance to get the proper consistency. An air valve is then opened, and used as a blower to clean the gasket forming the seat of the top door which is then closed. Air is then admitted from the second valve over the top of the mixture to seal the top door, and apply pressure behind the mass, then the lower air valve opening into the elbow in the pipe just below the discharge at the bottom of the cylinder is opened, to loosen up the material as it feeds into the pipe, and both these last two valves are kept open until the drop in the pressure shows that the batch has been discharged from the end of the pipe.

Normally, very little, if any, trouble has been experienced in discharging the concrete at distances up to 500 ft., for which an air pressure of about 80 lb. is used, and the material has been carried over 800 ft. in the work, but to do this the air pressure had to be increased to 100 lb. and there were some few difficulties which, however, should be overcome in similar work as the men get used to the apparatus.

On leaving the main cylinder the pipe runs horizontally for 25 or 30 ft., then drops vertically 50 ft. or so to the bottom of the tunnels, and then along the

floor to the point of discharge. Only the bottom of the tunnels was put in by this method, which for this kind of work probably has few advantages over any other method. In placing the sides and arch, however, which it was expected to be able to accomplish at one operation, the method should have advantages if successful, as it would avoid lifting the cars or buckets up onto a platform and the necessary shoveling into the forms.

As many as 40 batches (20 yd.) have been placed in one hour but the

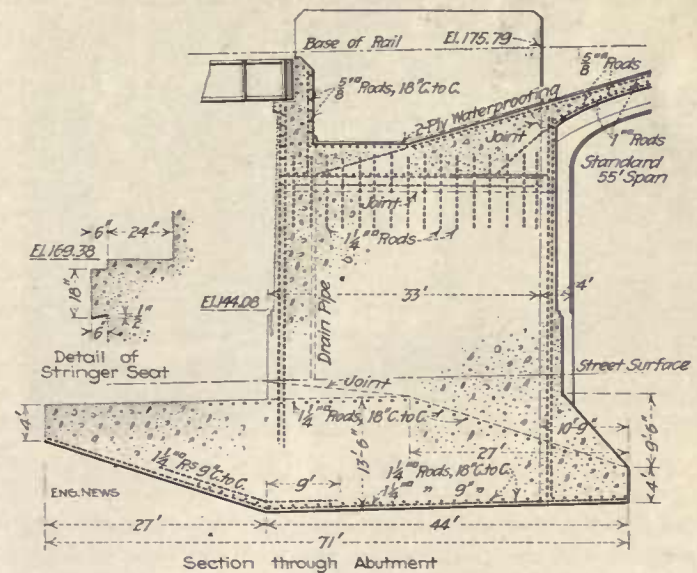
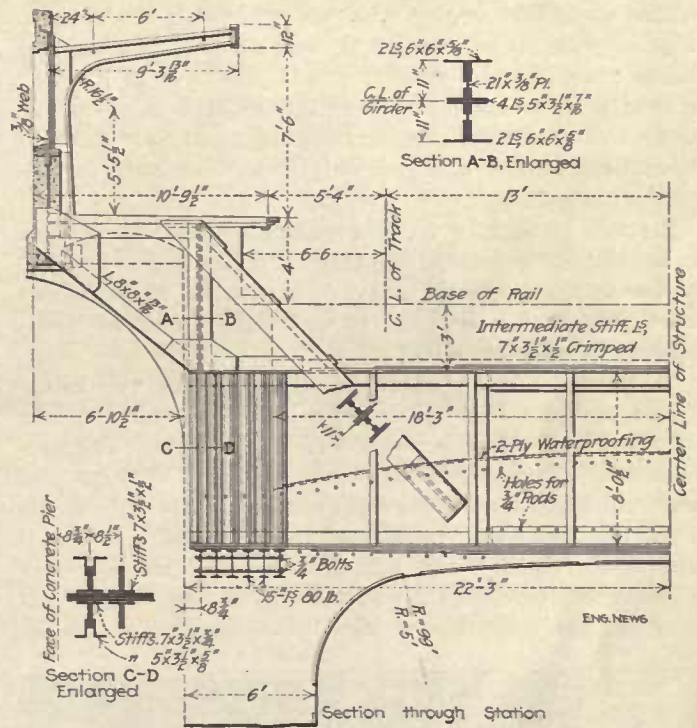

FIG. 87. SECTION THROUGH STATION AND DETAILS OF ABUTMENT, QUEENS BOULEVARD VIADUCT

average for an 8-hr. shift is not over 65 to 70 yd., due to delays for shifting forms, shifting the pipe, etc. The work is being prosecuted continuously day and night, three 8-hr. shifts being worked.



## REINFORCED-CONCRETE ELEVATED RAILWAY

A part of the elevated structure to be built between the Queensboro Bridge Plaza in Long Island City and Corona is of reinforced concrete. This section, which is 4271 ft. in length, is that which traverses Queens Boulevard, a parkway 200 ft. in width and one of the main arteries of travel from New York City out into Long Island. It was desired to make this an ornamental structure, and the drawing reproduced in the first of this series of articles (Fig. 3) gives an idea of the appearance of the completed structure.

The views in Fig. 85 show the construction of the column foundations, the columns and the abutment at the New York end. A longitudinal section on the center line of the structure through the end abutment, is shown in Fig. 87, and longitudinal and cross-sections of the main viaduct arches and piers in Fig. 86. The type of stations, of which there are three in this reinforced-concrete section, is shown in the perspective drawing already referred to and the details, and particularly the overhang for the platforms, in Fig. 87.

As will be seen by the photographs, the columns were first built up to a point slightly above the springing line of the arches, then the heavy cross-girders at each bent were placed in position, after which the arches and parapet walls were poured.

A central mixing plant for the concrete was established near the New York end with a 1-yd. batch mixer operated by an electric motor with chain drive. The concrete was distributed from this point by dinkeys and trains of small four-wheel flat-cars, each carrying a single 1-yd. double-hinged, bottom-dumping bucket. A standard-gage railroad track was first laid the whole length of the work, between the two rows of columns. This was used for the operation of two 15-ton locomotive cranes,



FIG. 88. CONCRETE BUCKETS ABOUT TO BE LOADED

and for the distribution of material. The cranes were used for various purposes in place of derricks, and for handling the forms and the concrete in the buckets, the latter being picked up off the cars and dumped directly into place. The concrete train and dinkeys were operated on the 2-ft. gage track laid in the center of the standard gage, during the construction of the piers, five cars being used in each train.

As soon as the construction of the columns was finished, the cross-girders, which weighed 27 tons each, were

placed on top of them, being handled by a derrick car, as they were rather too heavy for the locomotive cranes.

For the construction of the arches, a standard-gage track for the two cranes was laid just outside the westerly row of columns, and a double-track narrow-gage line for the concrete train outside of this. When concreting from 1000 to 2000 ft. away from the mixer, three trains of



FIG. 89. LIFTING CONCRETE BUCKETS INTO PLACE, QUEENS BOULEVARD VIADUCT

five cars each were used to distribute the concrete. Clean, rounded gravel of fairly uniform size, graded from  $\frac{3}{8}$  to  $1\frac{1}{2}$  in., is used for the aggregate, making a mixture which will probably give good results for the proposed hammered finish for the surface.

It will be noted from Fig. 86 that the arches curve both ways, giving somewhat the effect of a dome. The central third of each arch extending right across the structure, together with a part of the two side parapet walls, was first poured, then when that had set, the two sides between the central third and the cross-girders were poured together. The forms are left in place 28 days and it is expected to use each set of forms three or four times.

For pouring the arches, hoppers are erected above them into which the buckets (Fig. 88), lifted off the cars by the cranes, are dumped (Fig. 89). The concrete is then distributed from the hopper by short chutes as required. For the central section one hopper is used, for the end sections two hoppers, one for each; the central section is placed without top forms, but these latter are required for the steeper slopes of the two end sections.

It is proposed to hammer-finish all exposed concrete faces, using a patent-hammer for all plain surfaces and a bush-hammer for recessed panels. The ends of the cross-girders on top of the columns and the longitudinal panels of the parapet walls are to be faced with colored ornamental tiling.



# Design of Steel Elevated Railways

The new rapid-transit lines now under construction in New York City include 144 miles of subway and 106 miles of elevated track to be built by the city, and also third-tracking and extensions of their present elevated lines by the operating companies totaling 67 miles of track. Plans for the city-built lines are made by the Public Service Commission, while plans for the extensions of the present elevated lines are being made by the companies subject to the approval of the commission. In this chapter some features of the design of the city-built elevated lines will be considered.

## OPEN-FLOOR OR SOLID-FLOOR CONSTRUCTION

A subway is preferable to an elevated line from the standpoint of the property owners along the route, and a general policy of not constructing elevated lines in the central congested districts has been followed. On the other hand, the cost of a subway is so great that, with the city's present financial condition, a universal subway system is out of the question. The program therefore provides trunk-line subways through the central districts of Manhattan and Brooklyn, with elevated feeders in the outlying districts.

When the Triborough system was under consideration in 1910 it was proposed to build elevated extensions or feeders with ballasted track on a solid concrete floor to reduce the noise to a minimum, thereby reducing somewhat the objections to the elevated lines. When the present dual-system contracts were prepared the city's financial condition made it imperative that the feeders be built as cheaply as possible. The relative cost of subway and elevated lines with ballasted floor and with open floor for the 106 miles of proposed elevated tracks are as follows:

### COST OF SUBWAY AND ELEVATED STRUCTURE

	Per Lin.Ft. of Structure	Total
Three-track subway.....	\$300 to \$500	\$63,000,000 to 105,000,000
Three-track elevated { Solid floor.	\$200	42,000,000
{ Open floor.	125	26,000,000

The open-floor construction would cost about \$16,000,000 less than the solid-floor and from \$37,000,000 to \$69,000,000 less than the subway. It is therefore evident why open-floor elevated construction was used for the feeders in outlying districts.

### TYPE OF BENT

The elevated lines consist largely of a three-track construction, providing two tracks for local service and a center track for rush-hour express service in the direction of the maximum traffic (returning the express trains empty over the local track). In general a two-column bent was found to be most satisfactory and most economical; it has been adopted uniformly except in special cases, such as at stations, where the structure is widened to such an extent that three or four columns are necessary.

### COLUMNS IN ROADWAY

With the two-column bent there are in general two practicable positions for the columns—namely, in the roadway and on the sidewalk near the curb. As any obstruction in the roadway is always a source of danger to traffic, it is desirable to keep the roadway clear of columns as far as possible. On the other hand, in wide streets a material saving in cost is effected by placing the columns in the roadway. Furthermore, the appearance is largely im-

proved by eliminating wherever possible the long transverse girders projecting beyond the longitudinal stringers. The cost, appearance and obstruction to street traffic were therefore factors in determining the column location. The widths of roadway for various street widths have been fixed by resolution of the Board of Estimate and Apportionment as follows:

Street width, feet.....	100	80	70	60
Roadway width, feet.....	60	44	36	30

With a 60-ft. roadway it was not considered practicable to place the columns on the sidewalk, as the cross-girders would be over 63 ft. long and would project 16.5 ft. on each side beyond the outside longitudinal stringer. With columns in the roadway the exact location was determined by their relation to the longitudinal stringer (affecting the strength, rigidity, appearance and cost of the structure), to surface-car tracks, and to the lines of vehicular traffic.

Structurally it is desirable to place the columns under the outside stringer. With this construction, longitudinal curved brackets can be placed advantageously on the column under the stringer, thus reducing the unsupported length of column, increasing the rigidity of the structure and producing a pleasing appearance. By placing the columns between the stringers of the outside tracks the section of the cross-girder is reduced slightly and the section of the column increased correspondingly, as longitudinal brackets are not feasible with this construction. The brackets increase the cost by \$1 to \$1.50 per foot of structure; but this cost, other things being equal, would be warranted by the additional rigidity of the structure and the improved appearance.

Cars to be operated by the Interborough Rapid Transit Co. are 9 ft. wide, 52 ft. long and 36 ft. c. to c. of trucks; those to be used by the New York Municipal Railway Corporation are 10 ft. wide, 66 ft. long and 47 ft. c. to c. of trucks; all are standard-gage. Stringers are spaced 5 ft. c. to c., so that practically all stress in the ties except direct compression is eliminated. For safety it is desirable to have about 3 ft. clear between cars on adjacent tracks. For Interborough operation, however, the tracks were spaced 12½ ft. c. to c. on tangents, to provide additional clearance to the through girders over the station mezzanines, while for the Municipal corporation's operation they were kept 13 ft. c. to c. With the columns placed under the stringers the transverse column spacing is therefore 30 ft. and 31 ft. c. to c. respectively for the two companies, dividing the roadway as shown in Fig. 90.

Trolley tracks are usually spaced about 10 ft. c. to c., except where a greater width is required on account of center poles, in which cases 12½ ft. and 13 ft. are the most common spacings. When an elevated structure is built over such a line the poles are removed and the trolley wires supported from the structure. The tracks can then be spaced 10 ft. For safety to passengers a clearance of about 3 ft. from the side of the car to the face of the column is desirable—that is, about 7½ ft. from the center line of track to face of column (although some lines are now operated in Manhattan with only 1 ft. 10 in. clear). With tracks spaced 10 ft., and 7 ft. 4 in. clear from center of track to face of a 16-in. column, the minimum spacing of columns transversely is 26 ft.



It is essential that the columns be placed far enough from the curb to allow two lines of vehicles to pass between. A minimum of from 15 to 16 ft. is required for safety. To place the columns, therefore, for greatest safety and efficiency of roadway requires a spacing of about 26

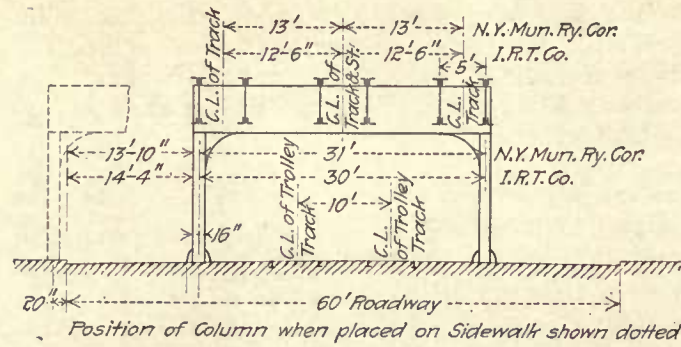

FIG. 90. TWO POSSIBLE LOCATIONS OF ELEVATED-RAILWAY COLUMNS IN STREET  
(Columns at curb and column under outer stringer)

ft., as shown in Fig. 2. With columns spaced 26 ft. two lines of vehicles can pass between the curb and column and one line on each car track, six in all. With 30- or 31-ft. spacing, only one line can safely pass between the curb and column, or four in all, thus giving a 66⅔% roadway efficiency as compared to the 26-ft. spacing. The conservation of the street was deemed of greater importance than the slight structural advantage of the wider spacing. Therefore 26 ft. was adopted as the transverse spacing, except in a few isolated cases affected by special local conditions.

#### COLUMNS ON SIDEWALK

With roadway width 44 ft. or less, it is evident that columns cannot advantageously or safely be placed in the

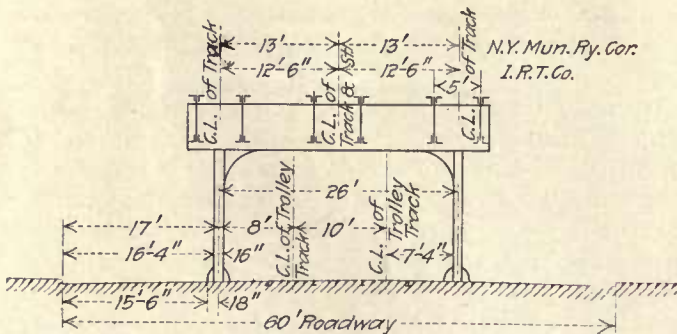

FIG. 91. LOCATION OF COLUMNS ADOPTED FOR WIDE STREETS

(On streets 44 ft. wide or less, the columns are placed inside the curb, with 47 ft. 4 in. maximum spacing)

roadway. In order that the columns may occupy as little of the sidewalk space as possible, and at the same time be protected from traffic by the curb, they have been placed uniformly with the center 1 ft. 8 in. from the curb. With 44-ft. roadway the transverse spacing is therefore 47 ft. 4 in.

#### LONGITUDINAL SPACING OF COLUMNS

Except as affected by local conditions, the longitudinal spacing of columns was determined by economy. Fig. 92 shows diagrammatically the cost of those items of typical elevated construction between stations which vary with the span length, plotted for various spans both for 26 ft.

and for 47 ft. 4 in. transverse spacing of columns.\* An inspection of this diagram shows that 50 ft. is the economical spacing and that there is little choice of other span lengths from 40 ft. to 60 ft., above which point the cost increases rapidly with the span length. The 50-ft. longitudinal spacing of bents was therefore adopted as the standard.

At the cross-streets columns are spaced so that the interference with traffic is the minimum, 60 ft. and longer spans often being required at these points. Uniform spacing of bents between streets is often impossible on account

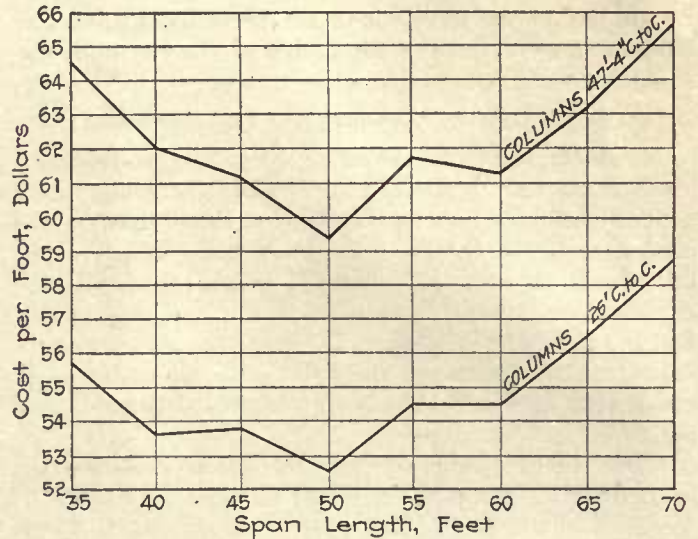

FIG. 92. EFFECT OF SPAN LENGTH ON COST OF THREE-TRACK ELEVATED RAILWAY

(Excludes track, stations and ducts. Average prices of recent contracts used as follows: Steel, \$54 per ton; cast iron, \$48 per ton; concrete, \$7 per cu.yd.; excavation, \$2 per cu.yd.; paving, \$3 per sq.yd.)

of local conditions, varying block lengths and interference with surface and subsurface structures. The 50-ft. spacing, however, has been used as far as practicable.

#### TYPE OF CONSTRUCTION

A deck plate-girder type of construction has been used exclusively, except over station mezzanines and in isolated cases where special conditions require other construction.

A half-through girder construction with longitudinal girders between the tracks has been used over the station mezzanines to reduce the depth of construction so that the climb from street to platforms will be a minimum. It is uneconomical, however, and if continuous would be a source of danger to workmen, as it gives them less chance to escape from approaching trains, particularly on the center track.

A through-truss construction is evidently impracticable with columns placed in the roadway. With columns in the sidewalk it is uneconomical and undesirable, as it obstructs light from abutting property to a greater extent.

Latticed stringers are from 10 to 15% lighter than plate-girder stringers of the same span. The cost of fabrication of the latter, however, particularly without cover-plates, is about 10% less than of a latticed girder without connection plates and 15% less than of a latticed girder with connection plates. The first cost, therefore, is practically the same in either case. Depreciation and maintenance costs of plate-girder construction are less than for

\*These costs are based on present average prices, which are unusually low, particularly for steel, whose cost makes up about 80% of the cost of an elevated structure exclusive of track, signals and station finish.



latticed girders; details are simpler and the structure is more rigid. Plate-girder stringers were therefore adopted.

### EXPANSION JOINTS

On the elevated extensions of the present subway, expansion joints were placed about 200 ft. apart, or about every fourth bent. In order to reduce to a minimum the tension of the top rivets of the stringer connection due to the combination of the deflection of the stringer and contraction, the distance between joints has been reduced to

The expansion joint which has been used exclusively on city-built lines is shown in detail in Fig. 93. It consists essentially of a 4-in. half-round pin bearing on pin-plates on the stringer and sliding on a seat bearing made up of angles and plates attached to the cross-girder. The thickness of plates on both seat and stringer has been made uniformly 3 in. for all spans. The pin is held in place and the stringer held in line by small guide-angles attached to the end stiffeners on the stringer. The particular advantages of this joint are its simplicity of construction

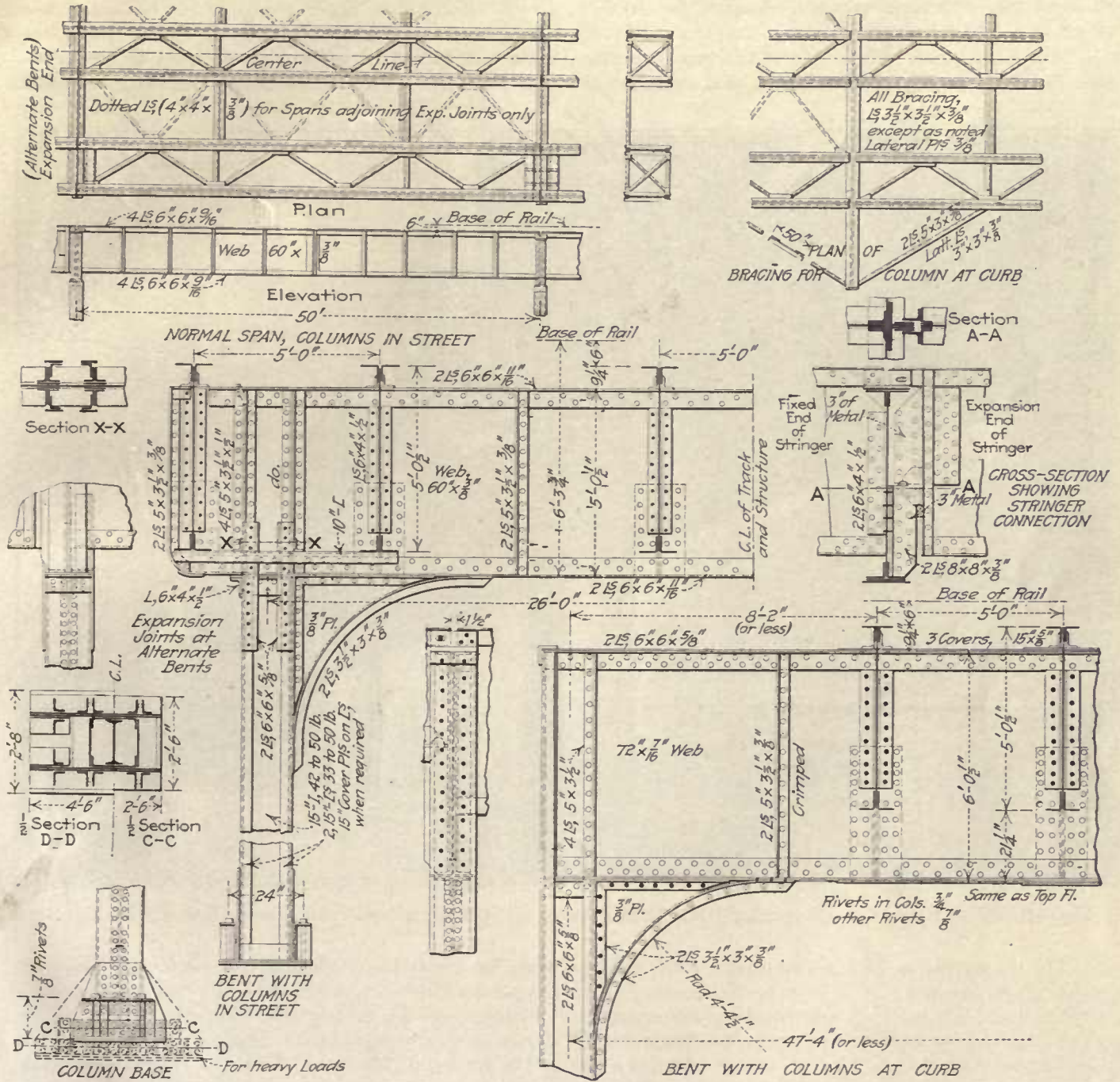

FIG. 93. DETAILS OF ELEVATED-RAILWAY CONSTRUCTION  
(New city-built lines of dual rapid-transit system, New York City)

about 100 ft., or an expansion joint is provided at alternate bents. The cost is thus slightly increased, as the expansion detail of the stringer is slightly heavier than the detail at the fixed end, and additional bracing is required. It is expected, however, that this increase in first cost will be more than offset by a reduction in maintenance charges for replacing rivets in the stringer connections.

and ease of erection, its accessibility for painting and inspection and the certainty of a uniform bearing on the seat. The connection of the seat to the cross-girder has been designed for the maximum shear combined with the tension on the rivets due to the maximum moment with the pin bearing on the extreme edge of the seat.



Provision has been made for a contraction or expansion of  $1\frac{1}{2}$  in. from normal temperature, which is undoubtedly slightly in excess of the maximum to be expected, but allows for slight inaccuracies in placing columns and in the milled length of stringers. It is desirable to reduce the opening as far as possible, in order that the pin will not approach dangerously near the edge of the seat at extreme low temperatures.

This joint has been used satisfactorily on previous elevated extensions of the subway (contract 1).

The elevated structures have been designed for the following loads:

1. Dead-load. The weight of track, including ties, rails, guard-rails, service walk, signals, etc., estimated at

4. Impact. With the track resting directly on the stringers the effect of the impact from the live-load will be as great as, if not greater than, on bridge spans. Live-load stresses (except for horizontal forces) have therefore been increased for impact in accordance with

$$I = 125 - \frac{1}{8} \sqrt{2000 L - L^2}$$

where  $I$  = impact increment in per cent. and  $L$  = length in feet of loaded track which produces the maximum stress in the member.\*

On a three-track line it has been assumed that the tractive force will at no time exceed the effect of two trains acting in the same direction at the same time. On a two-track line, where the probability of trains on each track acting together is greater in proportion, provision has been



FIG. 94. NEW ELEVATED STRUCTURE WITH COLUMNS IN STREET (WHITE PLAINS ROAD, BRONX BOROUGH)

about 400 lb. per lin.ft. track, in addition to the weight of the structure itself.

2. Live-loads. A series of concentrations approximating the weight of the heaviest equipment it is proposed to operate on the dual system:

22,750 lb.—5 ft. 6 in.—22,750 lb.—29 ft. 11 in.—30,240 lb.—6 ft. 8 in.—30,240 lb.—8 ft. 8 in.—30,240 lb.—6 ft. 8 in.—30,240 lb.—29 ft. 11 in.—22,750 lb.—5 ft. 6 in.—22,750 lb.—9 ft. 3 in.—30,240 lb.—6 ft. 8 in.—30,240 lb.

3. Horizontal forces. (a) Wind pressure of 30 lb. per sq.ft. on the exposed surface from the top of train to the bottom of structure; (b) the sudden starting or stopping of a 500-ft. train, estimating the coefficient of sliding friction at 10%; (c) centrifugal force equal to 0.020 time the product of weight of moving cars and degree of curve, the coefficient to be reduced by 0.001 per degree for curvature between  $3^\circ$  and  $20^\circ$ .

made for five-sixths of the full tractive force. These assumptions, which are based on the fact that a considerable (though indeterminable) part of the tractive force is transmitted to adjacent spans through rails and expansion joints, are believed to be conservative. No data are available to determine the amount of distribution, but observation of the present lines shows that it is material. Furthermore, the probability of a train on each track at any span starting or stopping at the same time, so as to exert full tractive force on each track in the same direction, is remote. Designed on these assumptions, the new structures, at a very small additional initial cost, will have greater

\*For example, with 50-ft. spans,  $L$  for the stringer is 50 and  $I$  = 86%; for a cross-girder in which maximum stress is produced with one track loaded  $L$  = 100 and  $I$  = 70%; and for a cross-girder in which maximum stress is produced with three tracks loaded  $L$  = 300 and  $I$  = 36%. Impact is added similarly to column stresses.



rigidity against horizontal forces than the existing elevated extensions. This rigidity, it is believed, will increase the life of the structure and reduce the maintenance costs.

#### DESIGN OF STRINGERS

For spans varying in length from 45 to 60 ft. the economical depth of stringer is about 5 ft. For uniformity of appearance and details it is of course desirable to keep the depth constant as far as possible. As the number of spans exceeding 60 ft. is small, 5 ft. was adopted as the standard depth, except for spans of 70 ft. or over.

It is desirable to avoid cover-plates on stringers to reduce the cutting of ties over rivet heads. In addition the top cover-plate must be extended full length to maintain a uniform distance from top of steel to base of rail. With

where  $U$  = the usual allowable unit-stress and  $H$  = the depth of the girder in inches.

To support the compression flanges of stringers and provide the usual truss for horizontal forces, lateral bracing between the stringers of each track was provided as shown in Fig. 93, with cross-frames at intervals varying from  $12\frac{1}{2}$  to 20 ft., depending on the span lengths. In addition lateral bracing was placed between stringers of adjacent tracks in one fixed span in each expansion panel in order that the tractive force from the center track should be transferred to the columns without producing lateral bending on the cross-girder.

Where the columns are outside of the outside stringer the tractive force was carried to the column by a strut from the outside stringer at the first cross-frame. The stress to be transmitted was small, requiring only two

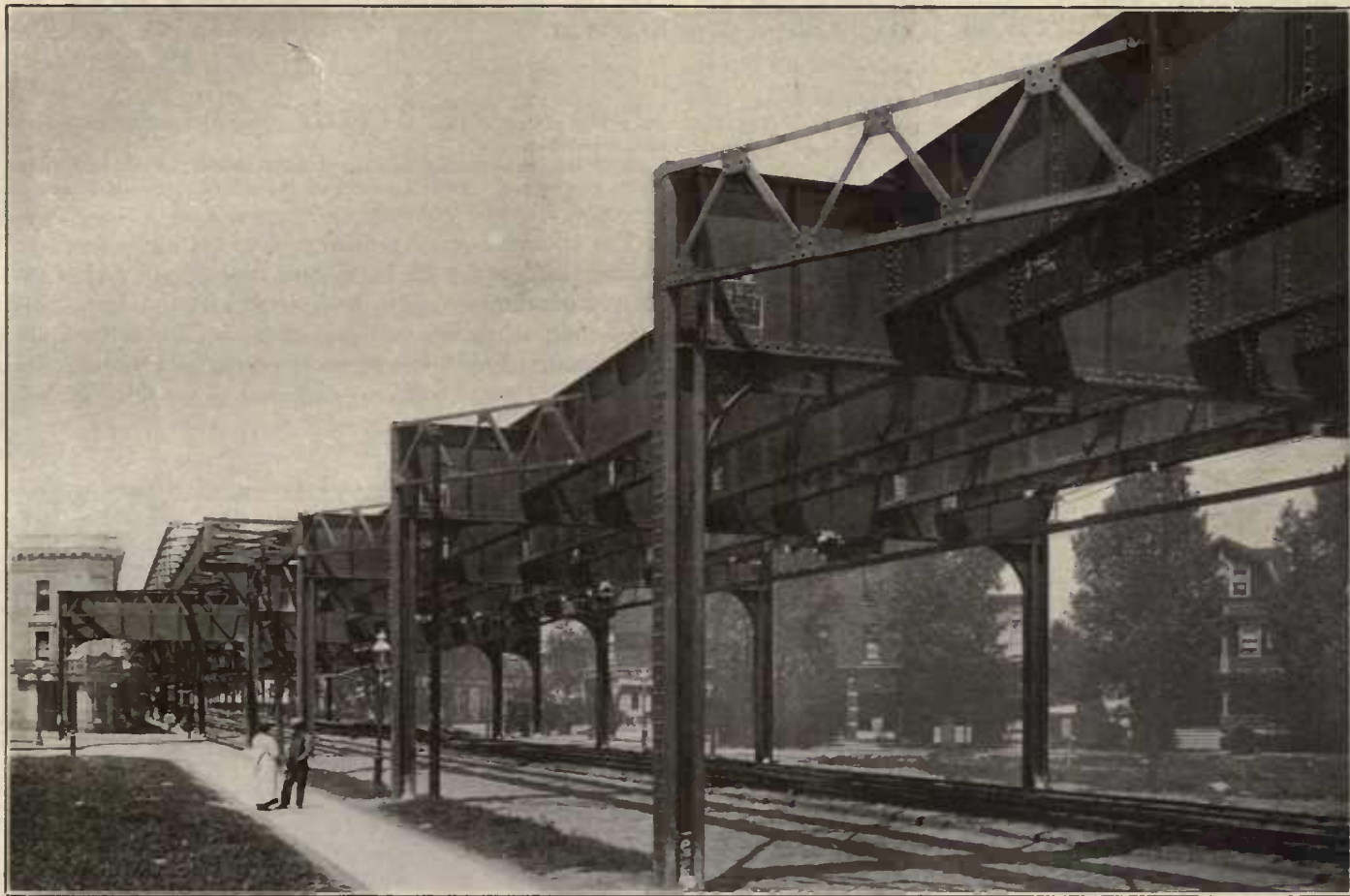

FIG. 95. NEW ELEVATED STRUCTURE WITH COLUMNS AT CURB (NEW UTRECHT AVE., BROOKLYN BOROUGH)

70-ft. span and 5-ft. depth, either cover-plates or flange angles thicker than  $\frac{7}{8}$  in. (which must be drilled from the solid) are required. Furthermore, in the long spans the 5-ft. depth is uneconomical and the deflections are excessive unless the allowable flange stress is reduced. It seemed necessary, therefore, to sacrifice appearance to economy and good practice by increasing the depth to 72 in. and 78 in. for spans 70 ft. long or over.

In cases where the length exceeded twelve times the depth of stringer, in order that the deflection (in inches) should not exceed  $\frac{1}{50}$  the span (in feet), the allowable stress was reduced to the value given by the following formula:

$$\text{Stress} = \frac{UH}{\text{span in feet}}$$

angles. For stiffness, however, latticed struts were provided, which will be further discussed under the head of columns. Where the columns are between the stringers of the outside tracks, the tractive force was transmitted by a channel riveted to the bottom flanges of the stringers, to the stiffeners of the cross-girder over the column and thence to the column.

The top of the stringer is  $9\frac{1}{4}$  in. above the top of the cross-girder, so that the top flange angles extend over to the center of the cross-girder and are supported on it by seat-angles. This detail is arranged to provide continuous support for the ties, to make unnecessary special wide spacing at the flanges of cross-girders. The rivets in these seat-angles are intended to support the ends of flange angles only and are not intended to produce continuity in the stringers—which were in all cases designed



as simple spans. Splicing the stringers for continuity was considered, but was abandoned because the detail was too heavy for ultimate economy, and continuity over expansion joints was impossible. The end-connection angles were set against the webs without fillers and not carried over the lower flange angles to a bearing on the outstanding leg, as this was considered unnecessary. A

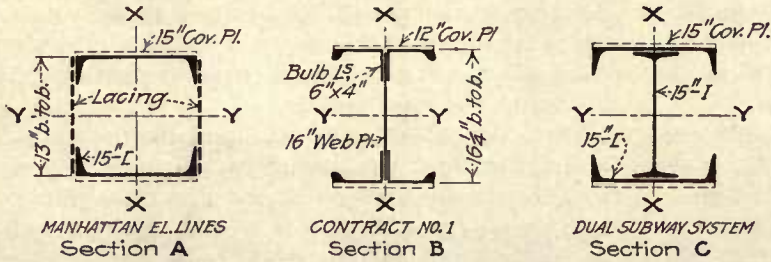

FIG. 96. COLUMN SECTIONS OF ELEVATED RAILWAYS

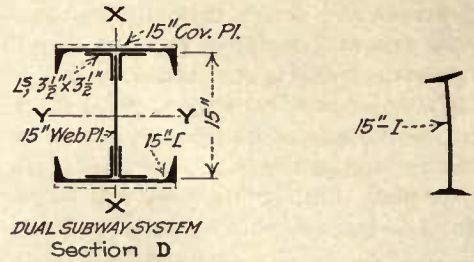

FIG. 97. I-BEAM DISTORTION

saving of nearly \$1 per lin.ft. of structure was thereby effected.

### CROSS-GIRDERS

As previously described, all transverse bending stresses have been eliminated so far as practicable, so that the design of the cross-girder followed the usual practice of girder design. For column spacing of 47 ft. 4 in., a 6-ft. girder was used generally, while a 5-ft. girder was more economical for the 26-ft. column spacing. Stiffeners

1. With the direct load alone, the stress per square inch should not exceed that allowed by the Public Service Commission formula

$$S = \frac{20,000}{1 + \frac{l^2}{8000 r^2}}$$

with a maximum of 14,000 lb. per sq.in.

2. With direct load combined with bending in one direction

only the stress should not exceed 20,000 lb. per sq.in. on the extreme fiber.

3. With direct load combined with bending in both directions at the same time the stress should not exceed 25,000 lb. per sq.in. on the extreme fiber.

The allowable stress is increased in the latter cases due to the infrequency of maximum direct load and maximum horizontal forces in both directions simultaneously.

In computing the bending stress in the column due to horizontal forces it was assumed that the column was fixed both top and bottom (see detail of base in Fig. 93).

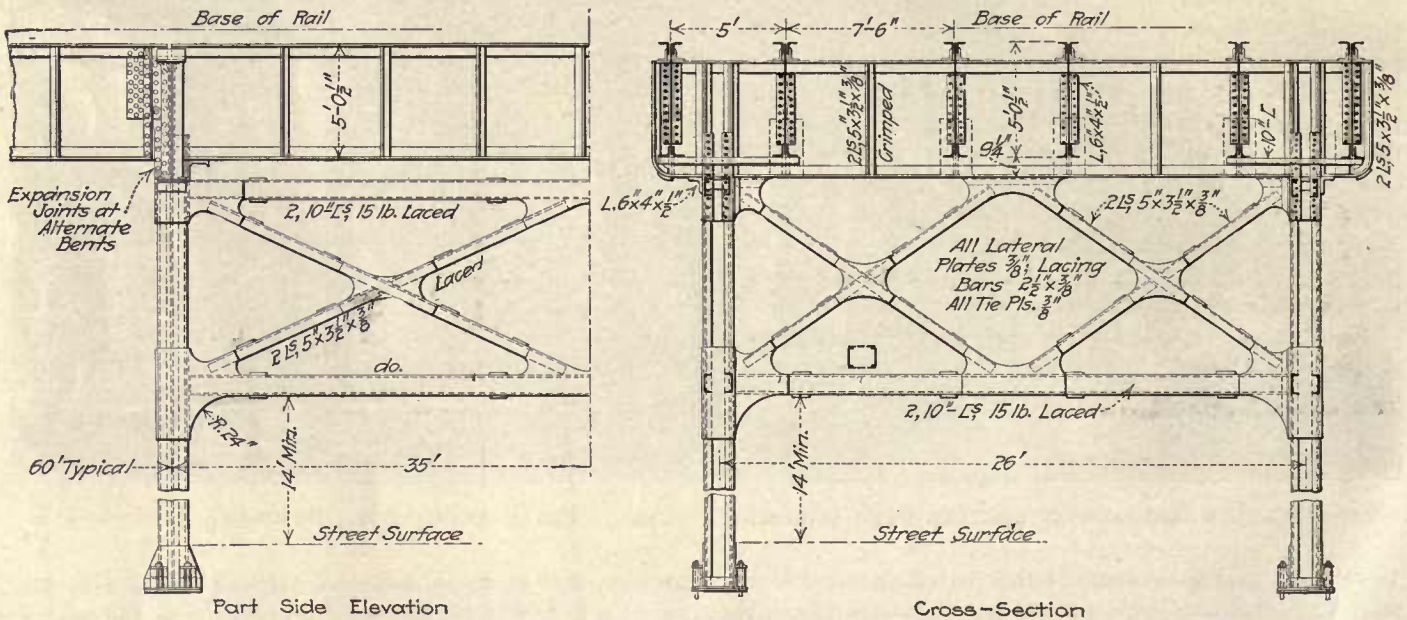

FIG. 98. TOWER CONSTRUCTION, USED FOR HEIGHTS OVER 30 FT.

are of course provided over the column to transfer the reaction to the column. Intermediate stiffeners were provided to stiffen the girder in shipping and handling only, as the stringers when connected stiffen the web sufficiently to prevent buckling.

### DESIGN OF COLUMNS

The columns have been designed for a combination of direct load and bending stresses due to wind, centrifugal and tractive forces. In combining the direct and bending stresses the following limits were adopted as giving a safe design:

Four 1 1/4-in. anchor bolts attached to the base of the column by seat-angles, with stiffeners so arranged that the nut has a direct bearing over the stiffeners, have been designed to anchor the columns.

With the columns spaced 26 ft., longitudinal bending stresses are transmitted into the column by 5x1/2-in. splice-bars attached to the stiffeners on the cross-girder and to the column channels. The stiffeners on the cross-girder over the columns are fixed at the bottom of the stringers by the channels previously described, while fixity at the top is secured to a large extent by the transverse stiffness of the top flange of the girder, which is held rigidly by the



adjacent stringers, less than 2 ft. from the column. This bending in the flange occurs at a point where the vertical bending stresses are small and does not therefore overstress the flange. While no tests of this detail have been

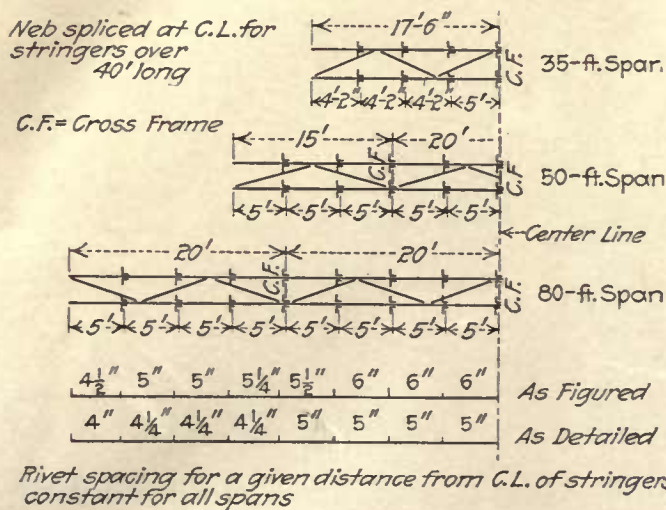

FIG. 99. LATERAL BRACING AND STRINGER RIVETING

made, it is believed that at least a fair degree of fixity in the column longitudinally is obtained.

When the columns are placed beyond the outside stringers, in place of the splice-bars just described, the outside channel of the column is extended to the top of the cross-girder and riveted to the end stiffeners, transmitting the longitudinal bending from the girder to the column. A latticed strut 50 in. deep extends from the stringer at the first cross-frame to the column (see Fig. 93; the strut is also shown clearly in the view, Fig. 95). With this depth it is believed that the column is fixed at the top.

The columns and the cross-girder being connected to form a rigid portal, the wind force produces a bending stress in the cross-girder. This, however, is small, amounting with columns spaced 47 ft. 4 in. to less than 1%, and with columns spaced 26 ft. to only 5% of the maximum stresses due to direct load. The effect of wind on the cross-girder has therefore been neglected.

In selecting the type of column no section was considered which did not permit inspection and painting, thus eliminating all box types (see Fig. 96).

Section A, with two channels laced, was used extensively on the present Manhattan Ry. Co. elevated lines. With the loads for which the columns on the new lines are designed, cover-plates would be required in practically all cases. The main material is economically placed, but this advantage is more than offset by the loss (so far as effective section is concerned) in the lacing bars, amounting to about 12% of the total weight of the column, or 15 to 18% of the weight of main material. As a result the column is not so economical as Section C, and is less satisfactory as to details.

The elevated extensions of the present subway, Contract 1, have bulb-angle columns, Section B, usually with-

out cover-plates. On account of the difficulty of obtaining bulb angles except in large quantities, and also because the section is less efficient and economical than a channel-and-I-beam column, a bulb-angle type has not been used on the dual system.

Section C is similar to Section A, except that the channels are connected by an I-beam instead of by lacing. The beam is ineffective in resisting bending about axis X-X. The material is effectively placed, however, for resisting bending about axis Y-Y and for carrying direct load. For the elevated loading this section is particularly efficient and economical. The material in the column with a built-up instead of a rolled I-beam, Section D, is slightly less economical, and in addition there are two extra lines of rivets. The I-beam-and-channel type, Section C, was therefore adopted.

In fabricating these columns, however, some difficulty has developed. The beams as they come from the rolls are invariably slightly warped, as shown exaggerated in Fig. 97. When the channels are attached it has been difficult to avoid a wind in the column. This trouble developed after the details for a number of sections were completed. To avoid this difficulty it has been suggested that on future work the I-beam-and-channel column, Section C, be abandoned for the built-up Section D.

Fig. 98 shows the typical arrangement of tower construction which has been found to be economical where the height from street to base of rail exceeds 30 ft. A spacing of 35 ft. between bents of tower span, with standard 5-ft. stringers, proved to be more economical than a shorter span with shallower stringers, and in addition permitted greater duplication of stringers and details and maintained a uniform appearance. The long spans are varied to suit local conditions, a length of about 60 ft. being the most economical.

In order to duplicate pieces, details have been standardized wherever possible. Stiffeners and flange rivets on the stringers and the arrangement of lateral bracing and cross-frames are shown typically in Fig. 99. Cross-frames were spaced at intervals not exceeding 20 ft. Stiffeners were in general spaced about 5 ft. apart, but were placed between the panel-points of horizontal bracing except at cross-frames, thus avoiding notching lateral plates at intermediate points.

The average weight of steel, including stations, on two contracts with columns spaced 47 ft. 4 in. is about 1 1/8 tons (2250 lb.) per lin.ft. structure.

The design of the subway and elevated structures of the city-built lines of the dual subway system is made by the Public Service Commission's engineering staff, of which Alfred Craven is Chief Engineer; Robert Ridgway, Engineer of Subway Construction; D. L. Turner, Deputy Engineer of Subway Construction; Sverre Dahm, Principal Assistant Engineer, in charge of design, and A. I. Raisman, Senior Designing Engineer. The design of the major portion of the elevated lines was made under the immediate supervision of the writer.



THE  
LIBRARY OF THE  
CONGRESS

26-5733



























U. C. BERKELEY LIBRARIES



C057823290



