

1.9
= 7627A
Cop. 2

ANNUAL REPORT 1962

U. S. DEPT. OF AGRICULTURE
NATIONAL AGRICULTURAL LIBRARY

JUN 19 1963

CURRENT SERIAL RECORDS

ROCKY MOUNTAIN FOREST AND RANGE EXPERIMENT STATION
Fort Collins, Colorado
FOREST SERVICE

Raymond Price, Director
U. S. DEPARTMENT OF AGRICULTURE

PROJECT LOCATIONS

Albuquerque, New Mexico
New Federal Building
Marron Hall
University of New Mexico

Flagstaff, Arizona
Arizona State College

Fort Collins, Colorado
Forestry Building
Colorado State University

Laramie, Wyoming
University of Wyoming

Lincoln, Nebraska
Plant Industry Building
University of Nebraska

Rapid City, South Dakota
South Dakota School of Mines
and Technology

Tempe, Arizona
Agriculture Building
Arizona State College

Tucson, Arizona
University of Arizona

Station headquarters is at Fort Collins, Colorado,
in cooperation with Colorado State University

ANNUAL REPORT

ROCKY MOUNTAIN FOREST AND RANGE EXPERIMENT STATION

CALENDAR YEAR 1962

Mention of a trade product does not constitute endorsement

March 1963

contents

	<u>Page</u>
A BRIEF SUMMARY	1
WATERSHED MANAGEMENT RESEARCH	5
FOREST MANAGEMENT AND FOREST FIRE RESEARCH	19
FOREST INSECT RESEARCH	33
FOREST DISEASE RESEARCH	41
FOREST UTILIZATION RESEARCH	51
FOREST ECONOMICS RESEARCH	59
RANGE MANAGEMENT AND WILDLIFE HABITAT RESEARCH	67
FOREST BIOLOGY RESEARCH	85
PUBLICATIONS	89

a brief summary . . .

Watershed Management Research expanded snow-control investigations to include possibilities of snow-avalanche damage. In cooperation with Colorado State University, the Rocky Mountain avalanche areas were surveyed by an avalanche-control specialist from Switzerland. Recommendations for possible control by structures and research priorities were made. More efficient spacing and location of fences for snow trapping were also developed.

The use of prescribed fire and chemical sprays is giving leads for possible improved management of chaparral watersheds in Arizona. Fall burning of contour strips reduces the shrub overstory without exposing soil to serious erosion. Apparently, controlled burning can be used to favor establishment of some desirable shrub species. Annual spraying with herbicides for 4 years after a wildfire has kept shrub canopy density at 7 percent as compared with 27 percent where natural regrowth has been undisturbed since the fire. This control of shrub density has increased water yield.

Comparisons of measured vapor loss from trees with sap velocity as indicated by heat-pulse measurements have shown that indicated sap velocity is closely correlated with transpiration. This means that the relatively simple heat-flow method will be a useful tool for determining transpiration, even on large trees.

Forest Management Research continued to emphasize forest reproduction. Deadening dense herbaceous vegetation with herbicides conserved soil moisture more effectively than removing the vegetation. Ponderosa pine seedlings grew fastest when air temperature was 15° C. and soil temperature 23° C. They grew faster when temperatures remained constant than when temperatures changed from night to day. Planted pines grew lateral roots as much as 7 feet long in 2 years and 13 feet long in 4 years. Spruce seedlings grown in partial shade photosynthesized more rapidly than seedlings grown in full sun or dense shade.

Trees growing in windbreaks used water from at least 11 feet deep in the soil, and used water more extravagantly when available.

Windthrow around clear cuttings in spruce can be minimized by following a few guidelines when boundaries for cutting units are laid out. Thinned ponderosa pines started growth earlier in the spring and continued later in the fall than did unthinned pines. This accelerated growth may be due in part to more rainfall reaching the ground.

Forest Fire Research emphasized use of fire in land management. Herbicides sprayed on an area of chaparral killed and dried the leaves of the bushes, while leaves on unsprayed areas remained green and moist. The sprayed area was then burned effectively with little tendency for the fire to spread.

Forest Insect Research continues to be directed toward ecology and biological control of some of the most important pests. Two new species of internal nematode parasites were discovered on the fir engraver beetle. Evidence in the field, followed by life-history studies in the laboratory, showed that these two parasites are highly efficient biological-control agents. A commercial bacterial preparation fed to Great Basin tent caterpillars stimulated the development of a polyhedrosis virus disease in the caterpillars.

Basic research is being started on environmental factors suspected of influencing population buildups of the Black Hills beetle and spruce budworm. The round-headed pine beetle was found to have a 1-year life cycle, with the flight period in October. Studies of the pinyon needle scale pinpointed the egg stage as the most vulnerable period in its life cycle. Insecticides used in other stages had been unsuccessful. Formulation of emulsifiable ethylene dibromide for bark beetle control was improved.

Forest Disease Research intensified work on the mistletoe problem. Studies on the spread of lodgepole pine dwarfmistletoe from mature stands into reproduction and on the effects of this dwarfmistletoe on yields in immature stands in Colorado were completed, and will provide useful new guides in the sound management of this species. Estimates on seed production, dissemination, and interception by trees were obtained in life-table studies of ponderosa pine and lodgepole pine dwarfmistletoes, but several more years must elapse before final results, in terms of new infection, can be anticipated. Greenhouse tests of ponderosa pine from several seed sources demonstrated that Black Hills ponderosa pine is susceptible to dwarfmistletoe. In the Southwest, technical assistance was given for the first recleaning of the Whitetail Dwarfmistletoe Control Unit on the Mescalero-Apache Indian Reservation.

Work on conifer rusts terminated with completion of a study of Comandra blister rust, which revealed that this rust has not been increasing in recent years in Region 2. In the central Great Plains major emphasis was placed on basic studies of infection processes of Phomopsis juniperovora, the cause of cedar blight. In greenhouse tests, several common fungicides did not reduce germination when pelleted to ponderosa pine seed. New advances of Dutch elm disease into the Great Plains were discovered in 1962.

The continued decline in the board market, coupled with the general increase in production costs, stimulated increased activity in Forest Utilization Research in improved harvesting and recovery practices, and in the manufacture of products other than lumber. Industry also quickened interest. Evidence of this was the

marked increase in pulp-chip production. Roughly a third of the sawmill capacity shifted or is contemplating a shift to chip production to salvage some additional revenue from mill residues. A significant shift also occurred in the production of dimension lumber when a number of mills diverted a greater share of production to framing material in an effort to reduce the inventory of 4/4-inch boards.

Forest Economics Research continues to reveal increasing opportunity for expansion of the timber industries in the Central and Southern Rockies. The recently completed Colorado Forest Survey revealed a current sawtimber inventory of 53 billion board feet, which represents a substantial increase over previous estimates.

Forest Recreation Research was highlighted by a new study that explored the use of 12 existing recreation sites by summer recreationists for camping and day use. Preliminary analysis shows (1) a high proportion of out-of-State users, (2) a high percentage of visitors in the 21-39 and 13-or-less age classes, and (3) certain units received from 3 to 19 times more use than other units. Factors responsible for the disparity of use and choice of units are under investigation.

Range Management and Wildlife Habitat Research is becoming increasingly concerned with reasons why plants and grazing animals behave as they do. Past studies have shown that grass production of weedy ranges may be increased through use of herbicides; present studies are revealing how individual species of plants compete with one another and how they respond to release from competition.

Evidence of protein deficiency in range forage during certain periods has been observed from subalpine range in Wyoming to desert grasslands in Arizona. Analyses of the contents of animal rumens, however, are revealing that protein content of the diet of animals on the range is much higher than that of the major forage plants available for grazing. This implies that certain minor components of the range forage are important in the animal diet.

Under three-unit rotation grazing trials in Wyoming, important grasses in the unit grazed last in the season are generally grazed more closely than in the unit grazed first. Consequently, by altering the period of use of individual units from year to year, a change in intensity of use, as well as in season of use, is achieved.

In the field of wildlife habitat research, the fertility of various soils in Colorado is being investigated as a basic step in learning where and how best to manage mountainmahogany for greater production of deer browse. Mountainmahogany is one of the most widespread and important deer browse species in the central Rocky Mountains. In Arizona and the Black Hills of South Dakota, the relationships of timber-cutting practices and forest conditions to big-game use are being studied. Studies of nutritional values of browse plants for game are underway.

A new study in northern Arizona is designed to determine capability of ponderosa pine forests, thinned at different intensities, to produce forage for livestock and game.

Details of these and other findings are presented in the following pages. Complete accounts of our research are released through various publications. An annotated list of publications issued in 1962 is included in the bibliography at the end of this report.



Watershed Management Research



Possibilities for control of avalanches

Avalanches endanger lives and property during winter in the high-mountain country. National Forest personnel connected with ski-area operations have successfully developed methods of recognizing and controlling these hazards. The methods used depend on the continuous observation and action of highly skilled men who are assigned to areas of concentrated use.

The structural works so common in the Alps have been little used in this country. To learn where and how European methods might be usefully applied here, a cooperative project with Colorado State University was started. A specialist in avalanche control from Switzerland studied Rocky Mountain conditions, particularly snowslides along major highways.

Figure W-1. — A large, dry, snow avalanche. The snowdust cloud was estimated to be 130 feet high. Such dust clouds move very fast and have tremendous force.

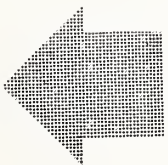

Figure W-2. — Slides on the Stanley avalanche area near Berthoud Pass cross the road one or more times most winters. Control could be achieved by structures in the 20-acre starting zone above timberline, or by avalanche sheds over the road. The main track is 4,400 feet long with an average slope of 55 percent, and twice crosses the highway.



Figure W-3. — Seven Sister avalanche area near Loveland Pass, Colorado, starts near timberline. The combined area of the starting zones is 20 acres. Average track length is 1,400 feet with a slope of 64 percent. Avalanches run 4 to 6 times each winter between mid-November and April. Such avalanches could be controlled by structures to stabilize snow and control snowdrifting combined with afforestation.

Characteristics of 71 avalanche areas throughout Colorado were considered in relation to possible control methods. The size of the starting zone of these avalanches ranges from 1 to 150 acres. The most common size is between 2 and 30 acres. Most start at elevations between 10,000 and 12,000 feet.

The paths of 33 avalanches is between 1,000 and 3,000 feet in length with an average slope of 50 to 70 percent. Only 7 tracks are shorter than 1,000 feet and the longest is 6,000 feet. Short tracks are usually steeper than long ones.

About half of the avalanches could probably be controlled by structures and afforestation in the starting zone as commonly used in Europe. On 6 tracks, diversion or catching structures might be useful. On 10 others, avalanche sheds would be more practical than control works.

Figure W-4. — Snow from the East Guadalupe avalanche area south of Ouray, Colorado, crosses the highway only during extreme conditions. Snow usually stops on the gentle slope of the alluvial cone in the runout zone. The 150-acre basin of the starting zone is too large and rugged for practical use of structures. A diversion dam in the runout zone would help protect the road.



Figure W-5. — Remnants of two houses show the distance avalanches can reach out even on near-level terrain. When the interval between avalanches is long, there is a false sense of security, which may encourage dangerous encroachment into avalanche paths



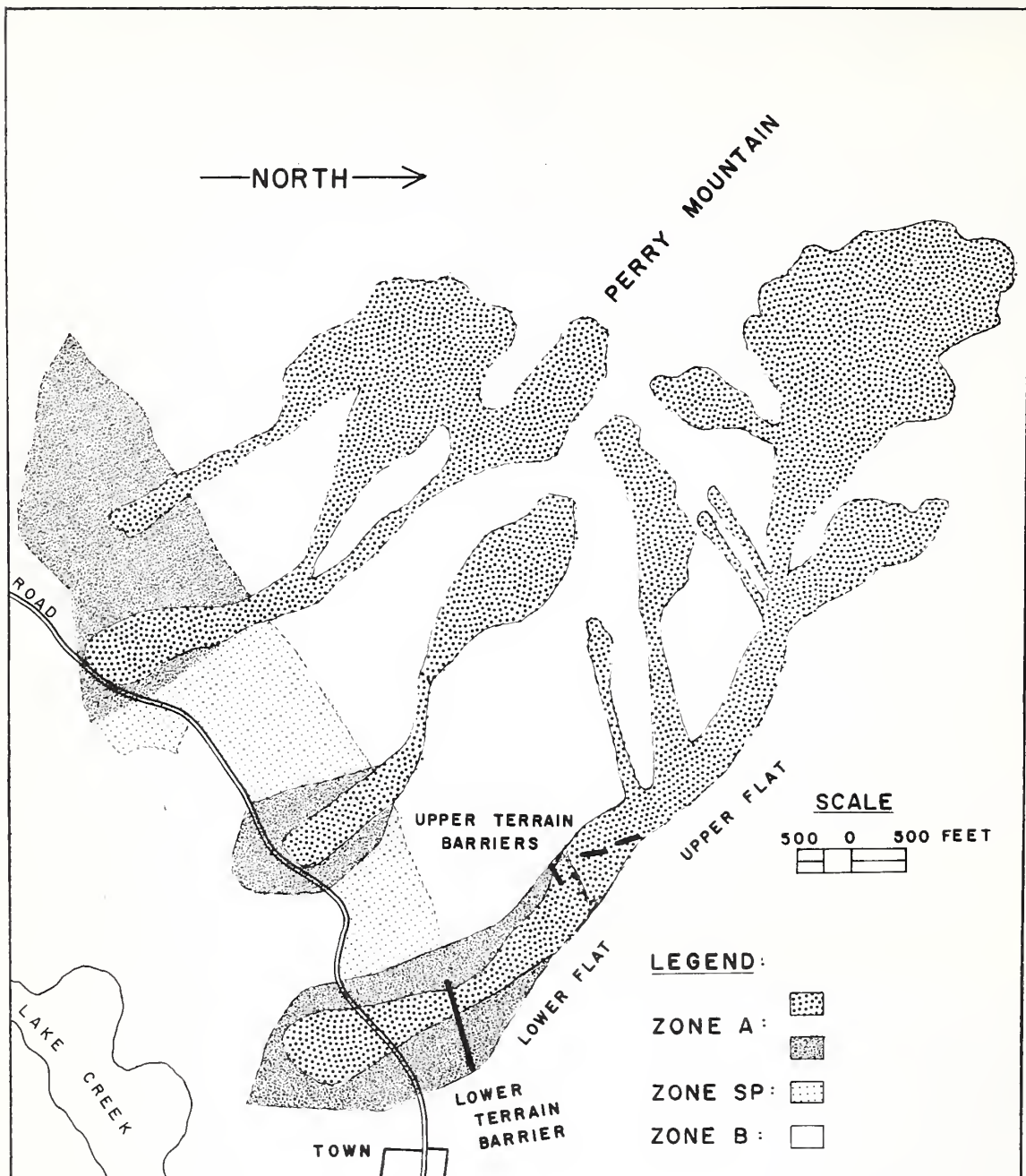

Figure W-6. — This map is an example of how the classification of avalanche areas could help in the safe development of mountainous regions.

Zone A: Main path and potential runout zone for infrequent, very large avalanches;

Zone SP: Free of avalanche scars, but so steep there is still some risk;

Zone B: Safe from avalanches.

To avoid sudden and unpleasant surprises, avalanche-hazard zones should be based on the occasional, very large avalanche which can travel a great distance over level terrain and even up adverse grades. For example, last year, for the first time in 80 years, an avalanche ran from the top of the lower avalanche track all the way to the valley floor. As a rule, avalanches on this track stop on the upper flat or against the upper terrain barriers. However, this large, fast-moving mass of snow crossed the two flat areas, jumped both sets of natural-terrain barriers, and destroyed two homes before coming to rest on the valley floor (see fig. W-5).

Snow trapping for water-yield improvement

Snow on mountains and plains rides the wind, and accumulates only where the wind cannot reach it. When it is formed into deep drifts, the melt period is prolonged. Often it would be desirable to hold snow on certain parts of a watershed to better meet late-season demands for water. Pole Mountain between Cheyenne and Laramie seems to be one such area. Snow held here feeds important reservoirs while that blowing off to surrounding plains is less useful.

Various spacings of 4.5-foot high ordinary slatted snow fence were tested to determine their efficiency for gathering snow. The most efficient spacing, 325 feet between fences, trapped about 120 cubic feet of water per lineal foot of fence, compared with 90 cubic feet per lineal foot held by 175- and 250-foot spacings. With the 325-foot spacing, the water equivalent of snow trapped was 0.4 acre-foot per acre.

Snow began to accumulate in areas protected by fence in November, reached maximum depth in late March, and melting was complete by May 15.

The main crest of the Rockies may be an even more effective place to trap snow. Snow held above timberline melts late and little is lost to evaporation. A fence near Loveland Pass, Colorado, piled up so much snow that on July 1 there was 700 more cubic feet of water equivalent for each lineal foot of fence than in the unfenced check area. In mid-August almost half of this snow remained, although no snow was left on the check area.

Figure W-8. — Snow trapped behind a snow fence on the Continental Divide in Colorado was so deep that this much was still left in August. Fences located here must resist extreme wind velocities. A large gap is left between the bottom of the fence and the ground to move the drift away from the fence to maintain aerodynamic efficiency.



Figure W-7. — The importance of wind barriers for holding snow is shown by this aerial view of a snow-fence spacing trial on Pole Mountain, Wyoming. The picture was taken on February 7 when the accumulation was about half the maximum finally reached on March 22.





Figure W-9. — About two-thirds of the cover on the sagebrush-test watersheds near Dubois, Wyoming, is big sagebrush, (*Artemisia tridentata* Nutt.) with an average density of 6,400 plants per acre and an estimated age of 30 years.

Hydrology of high-elevation sagebrush

Sagebrush covers large areas in Wyoming and other States of the Rocky Mountains. Opinions concerning its utility are divergent, however. Although increased production of forage usually follows eradication of sagebrush, there is little information to indicate how conversion from sagebrush influences snow accumulation, soil moisture, soil stability, and streamflow.

Detailed study of a high-mountain sagebrush-covered area in northwestern Wyoming began in 1959. Streamflow, sediment, snow cover, precipitation, plant cover, and soil moisture are observed on three watersheds of 60, 66, and 106 acres. The watersheds are at elevations of 9,500 to 10,000 feet.

The following are averages for the three watersheds during the period of measurement:

Annual precipitation	14.5 inches
Precipitation received in summer	5.4 inches
Streamflow	1.5 inches
Maximum suspended sediment	480 p. p. m.
Herbage production	470 pounds per acre
Bare soil and rock	15 percent

All streamflow has been during spring-season snowmelt. The 3 years' record indicates consistent relationships among the watersheds, which will aid determination of the effect of sagebrush eradication.

Figure W-10. — Root systems of big sagebrush were studied on different parts of the watershed. A woody tap root rapidly tapered to a diameter of 0.1 inch within 2 feet of the soil surface, but penetrated to depths of 4 to 6 feet. The greatest depth of rooting was on the drier ridge and west-facing sites. The maximum radial spread was greatest for plants on sidehill sites. The range in radial spread was 3.5 to 6 feet.



Prescribed fire and chemical sprays tested on chaparral watersheds in Arizona

Results from experimental watersheds in chaparral indicate that there is greater streamflow after severe wildfires, but that this increased water yield is accompanied by severe erosion and sediment movement. Systems of prescribed burning are being evaluated to discover whether some of the benefits of shrub reduction can be obtained without such disastrous consequences.

Contour strips 50, 100, and 200 feet wide have been burned at Sierra Ancha Experimental Forest in September 1961 and 1962. Strips are sprayed with herbicide to kill foliage and cause it to dry. This creates good burning conditions on the strip while surrounding brush is less flammable (see page 32).

Original plant cover consisted primarily of shrub live oak (Quercus turbinella Greene), mountainmahogany (Cercocarpus spp.), Wright silktassel (Garrya wrightii Torr.), and desert ceanothus (Ceanothus greggii A. Gray), with an average crown density of 60 percent. Soils are derived from diabase and are coarse textured. Slopes average 33 percent with a range of 8 to 50 percent.

The test fires have successfully reduced the shrub cover while leaving most of the soil-protecting litter. There has been no increase in erosion or sediment movement from the burned strips. Another result of the fire was an increase in the new seedlings of both desert ceanothus and manzanita (Arctostaphylos spp.). Before and after comparisons of plant and litter cover on contour strips burned in September 1961 showed:

	Preburn	Postburn (May 1, 1962)	Percent reduction
Percent of living crown cover	60.8	4.5	92.6
Tons of oven-dry litter per acre	6.80	4.85	28.7
Number of seedlings on 4,700 square feet of sample plots:			
Desert ceanothus	2	232	--
Manzanita	0	74	--



Figure W-11(upper left). — A winter snow helps delineate the strips burned' in September 1961, at Sierra Ancha Experimental Forest. Foliage-killing, spray was used to prepare the strips for burning. Strip widths of 50, 100, and 200 feet were tested. Such tests will furnish management tools to increase water and forage on steep, brush-covered watersheds.

Figure W-12(lower left). — This shrub live oak had its top killed by a wildfire in June 1959. It has been allowed to sprout and grow naturally, and had made this much growth by the summer of 1962. The original canopy density of shrubs on the watershed where this shrub is growing was 70 percent. It is 27 percent four growing seasons since the fire.

Figure W-13(below). — The top on this shrub live oak was also burned in June 1959, but the watershed on which it is growing has been sprayed with 2,4,5-T each of the four growing seasons since the fire. The density of shrub cover on this watershed is only 7 percent. Spraying has retarded height growth by 39 percent and reduced number of stems by 29 percent. This control of shrub regrowth is associated with greater streamflow from the sprayed watershed.



Clearing tamarisk reduces
draft on ground water

Observations were made in a five-stamen tamarisk (Tamarix pentandra Pall.) thicket on the Salt River above Granite Reef, Arizona, to learn how growth of this plant influenced water tables. New leaves appeared in early February and water-table fluctuations were noticeable by early April. The withdrawal of ground water by plants during the day and its replenishment at night caused characteristic water-table fluctuations. Diurnal changes in water level of 0.2 foot were recorded in June and July, and were much less by the end of September. Relationships were established between the fluctuations shown in 1960 by two wells equipped with water-level recorders. In 1961 all tamarisk and arrowweed pluchea (Pluchea sericea (Nutt.) Coville) in a 25-foot-diameter circle surrounding one well was cut (fig. W-14). This cutting greatly reduced the diurnal fluctuation in the water table.

Later the same season, the circle of cleared vegetation was enlarged twice, to a final diameter of 61 feet. These increases in cleared area could not be detected by changes in water level. The conclusion is that the diurnal change in water table was caused by the trees that were within 25 feet of the well.



Figure W-14. — Cleared site around ground-water well where diurnal fluctuations in water table were recorded. Trees removed were up to 25 feet high and 6 inches d.b.b. Later enlargements of the cleared circle to diameters of 35.4 and 61 feet had no further effect in reducing daily water-table fluctuation.

Sap flow a good index to transpiration

Direct measurement of transpiration is a goal of watershed research. Two comparatively simple methods are proving to be extremely useful. One is to enclose a plant in a ventilated tent of transparent plastic film. The humidity of the air leaving the tent is compared with that of entering air to determine water evaporated from the plant. This method is limited by the size of the plant that can be enclosed. The second method is to measure heat-pulse velocity in the stem as an index to sap flow. This method gives qualitative rather than quantitative results. It is well adapted to use with large trees in the forest, and is extremely useful as a survey device. Detailed descriptions of both methods have been published.

Results by the two methods have been compared on aleppo pine (*Pinus halepensis* Miller), Utah juniper (*Juniperus osteosperma* (Torr.) Little), and alligator juniper (*J. deppeana* Steud.) (fig. W-15). Indicated sap flow was closely correlated with the transpiration rate measured by the tent method. Response of sap velocity to changes in environment induced by artificial shading was slower, but sap velocity was a reliable indicator of transpiration.

Measurements of heat-pulse velocity on juniper trees growing naturally near Flagstaff, Arizona, indicate that transpiration rate is closely correlated with soil-moisture level. The rate of sap flow was highest in April when soil moisture was at a maximum rather than in June when evaporation stress was at its peak.

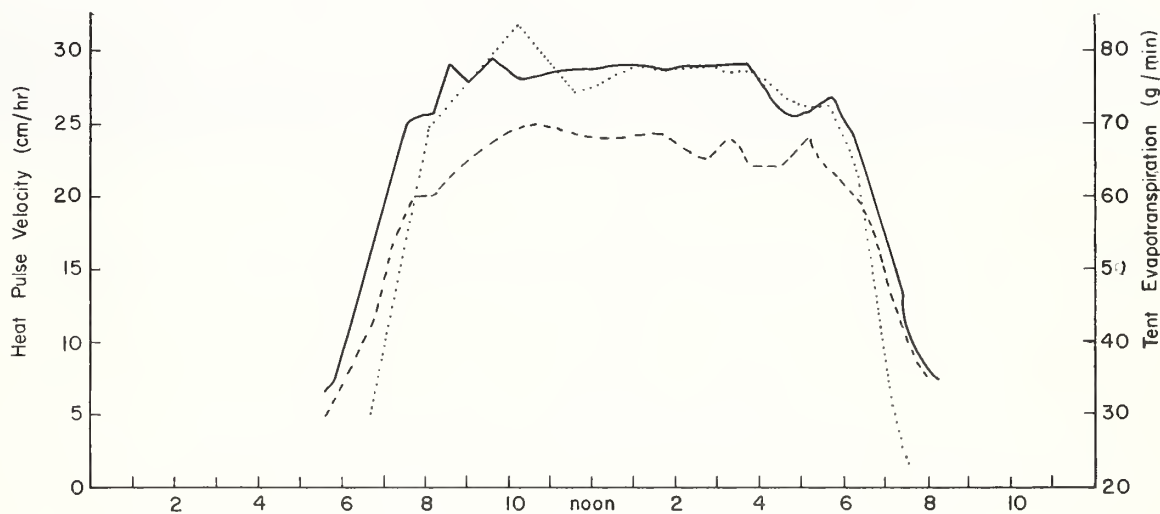

Figure W-15. — Comparison of relative sap velocity and transpiration measured by the tent method for an alligator juniper tree 12 feet tall. The solid line indicates heat-pulse velocity measured at a height of 5 feet in the stem, while the dashed line indicates heat-pulse velocity at a height of 0.5 foot. The dotted line indicates evaporation measured by the tent method. The close correlation of the two methods is evident.

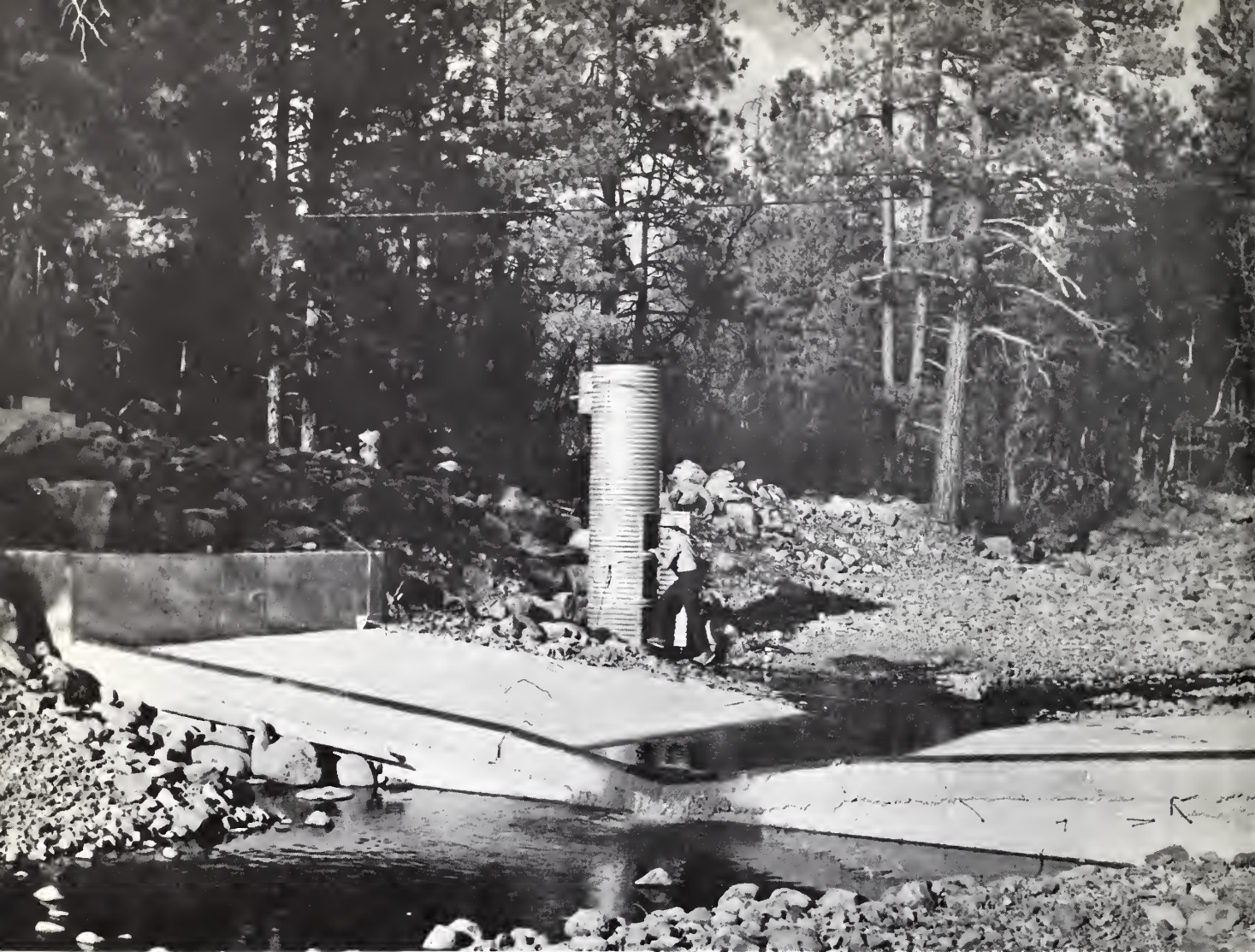

Figure W-16. — A new type of stream gage now in operation at Woods Canyon and Bar M Canyon on Beaver Creek. Features of the gage are a combined control and measuring section, and a lip which impounds enough water to permit metering at low stages.

New type of stream gage for Beaver Creek Project

One purpose of the Beaver Creek Project in central Arizona is to determine the effect of forest treatments on streamflow from watersheds of 10,000 to 15,000 acres. A pair of watersheds, Woods Canyon and Bar M Canyon, were selected for this job and stream gages were constructed during the fall of 1961.

The design and performance of these gages are of considerable interest. The basic requirement was for an installation that will measure discharges up to 2,000



Figure W-17. - Current meter measurements at Bar M stream gage. The discharge was about 10 second-feet.

cubic feet per second (c. f. s.) with the same relative accuracy as the trapezoidal venturi flumes being used to gage smaller watersheds on the project.

The new gages have a combined control and measuring section made of concrete, with a 6-inch triangular lip along the downstream edge (fig. W-16). The lip serves as the primary control and also impounds enough water to permit metering at low stages. Stages below 0.2 foot were measured volumetrically; stages between 0.2 foot and 2 feet were metered by wading along a line near the upstream edge of the structure (fig. W-17); stages above 2 feet were metered along the same line from a cableway.

The tentative rating curve for Woods Canyon is shown in figure W-18. The points represent actual discharge measurements, and the line was computed by the following discharge formulas:

$$Y = 12.432 X^{2.65807} \quad \text{for gage heights 0 to 1.32 feet}$$

$$Y = 10.972 X^{3.09675} \quad \text{for gage heights 1.32 to 2.69 feet}$$

A similar number of discharge measurements was made to rate the Bar M gage. This rating reflected slightly more variability than Woods Canyon. It also showed a more cyclic behavior, which necessitated a polynomial type of equation to obtain best fit. Nevertheless, variability in the stage-discharge relationship was substantially less at Woods Canyon and Bar M than at other gaging installations on the project. Thus, for the flows encountered so far, water has been measured as accurately on these large watersheds as on the smaller ones.

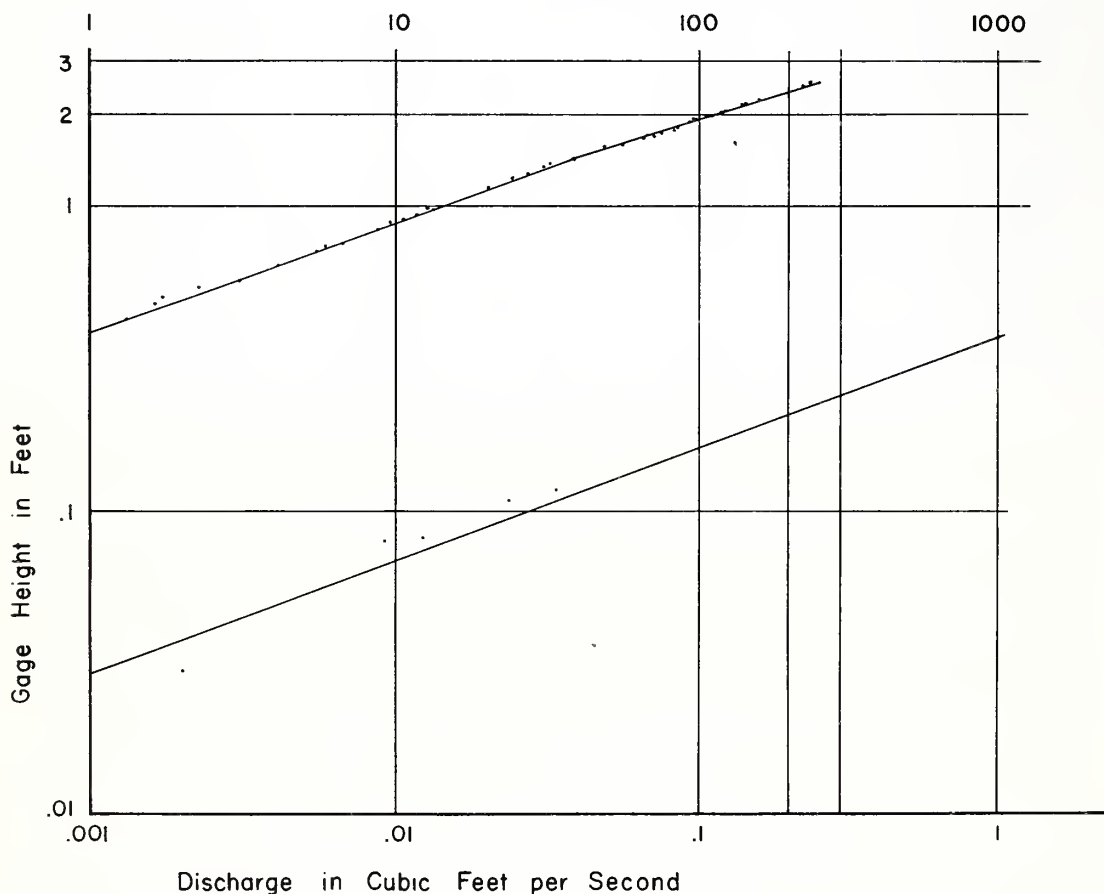

Figure W-18. — Rating curve for the Woods Canyon stream gage. The tight fit of discharge measurements along the curve indicates a capability for accurate measurements over a wide range of stages.

Forest Management & Forest Fire Research



Soil-moisture regime under Nebraska windbreak

Soil moisture has been measured for 2 years (1960-61) by the neutron method at 1-foot increments to a depth of 11 feet in a 10-row, 20-year-old windbreak near Seward, Nebraska. The windbreak was composed of Russian-olive (*Elaeagnus angustifolia* L.), eastern redcedar (*Juniperus virginiana* L.), green ash (*Fraxinus pennsylvanica* Marsh), hackberry (*Celtis occidentalis* L.), honeylocust (*Gleditsia triacanthos* L.), Siberian elm (*Ulmus pumila* L.), cottonwood (*Populus sargentii* Dode), and Russian mulberry (*Morus alba f. tartarica* Seringe). The trees apparently utilized soil moisture to the 11-foot depth investigated (figs. F-1, F-2). Water was apparently used most abundantly from the shallower soil early in the growing season and then from progressively deeper soil as the growing season progressed.

Efficiency of water use during the 2 years was particularly striking. Twice as much water was removed from the soil in 1960 as in 1961, but diameter growth of the trees was practically the same both years. Precipitation and potential evaporation were similar during the two growing seasons, but the soil profile contained much more water at the beginning of the 1960 growing season. The study appears to substantiate the theory that soil water is not equally available throughout the theoretical range of availability.

Simazine controls weeds in plantation

Four pounds per acre of simazine in water solution sprayed in strips 3 feet wide in early spring kept the strips essentially free of weeds until August in eastern Nebraska. Although the spray was applied directly over rows of Scotch pine (*Pinus sylvestris* L.) that had been planted 1 year earlier, the pines were not damaged (fig. F-3).

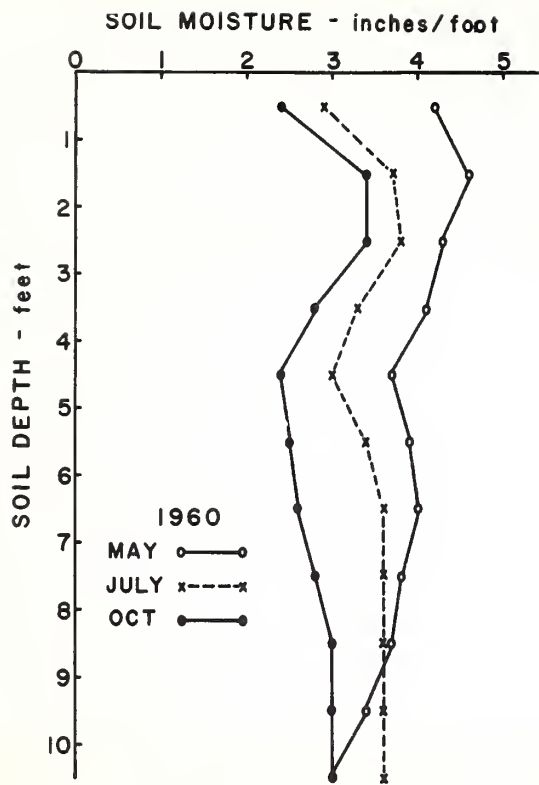

Figure F-1. — Soil-moisture measurements under a 20-year-old windbreak to a depth of 11 feet show water depletion as the 1960 growing season progressed. Seward County, Nebraska.

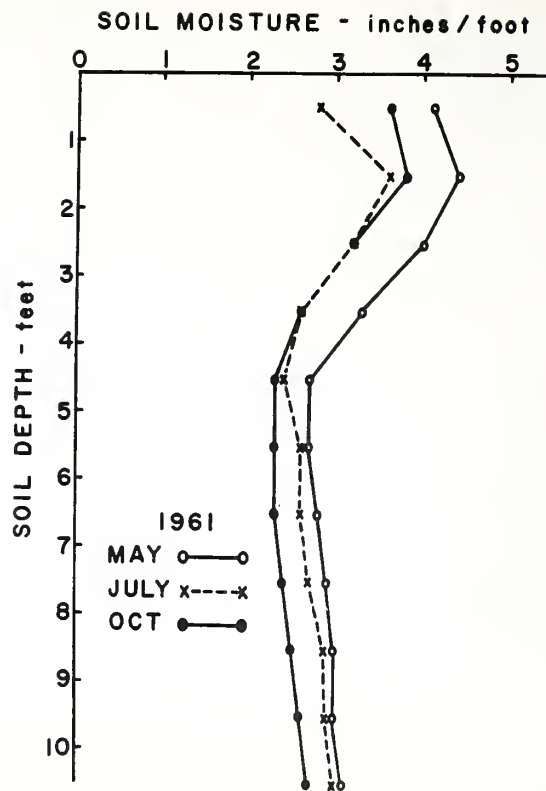

Figure F-2. — Soil-moisture measurements under a 20-year-old windbreak to a depth of 11 feet show water depletion as the 1961 growing season progressed. Seward County, Nebraska.

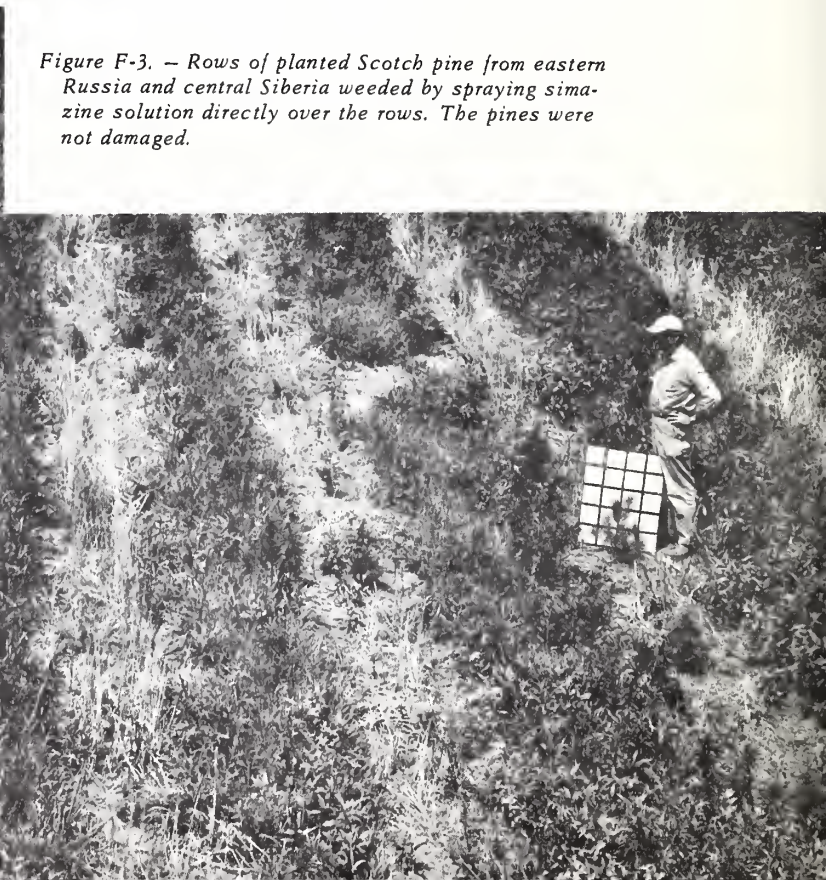

Figure F-3. — Rows of planted Scotch pine from eastern Russia and central Siberia weeded by spraying simazine solution directly over the rows. The pines were not damaged.

Herbicides show promise
as site-preparation tool
in Southwest

Several herbicides tested for preparing ponderosa pine (Pinus ponderosa Lawson) planting sites in northern Arizona gave satisfactory first-year control of perennial grasses. Best results were obtained with dalapon, diethylene glycol bisester of dalapon, simazine, and amitrol T. Amitrol and ammonium thiocyanate were less effective.

<u>Herbicide</u>	<u>Rate of application</u> (Pounds per acre)	<u>Estimated kill</u> (Percent)
Dalapon (sodium salt)	5	80
	10	85
	15	90
Diethylene glycol bisester of dalapon	5	70
	10	90
	15	100
Simazine	10	80
	20	90
	40	90
Amitrol	10	40
	20	60
	40	75
Amitrol T	10	70
	20	95
	40	100
Ammonium thiocyanate	10	10
	20	10
	40	35

The herbicides were applied at three rates to dense stands of Arizona fescue (Festuca arizonica Vasey) and mountain muhly (Muhlenbergia montana (Nutt.) Hitchc.) (fig. F-4).

Ponderosa pine transplants were planted in April 1962 on each plot to check for residual toxicity in the soil.

Figure F-4. — Dense stand of Arizona fescue and mountain muhly in northern Arizona.



Site preparation improves soil moisture

Deadening vegetation with herbicides appears more effective than scalping for conserving soil moisture in the Southwest.

During the spring drought period of 1961, soil moisture at 0 to 8 inches depth remained substantially higher on both sprayed and scalped plots than on plots where the dense cover of Arizona fescue and mountain muhly was left intact (figs. F-5, F-6). During the fall drought period, however, the soil at 0 to 8 inches depth dried almost the same on the scalped and untreated plots, but remained much more moist on the sprayed plots.



Figure F-5. — Sprayed, scalped, and untreated plots in a soil-moisture study, northern Arizona. Sprayed plots (light tone) were treated with dalapon and 2,4-D.

PERCENT SOIL MOISTURE AT 0-8 INCH DEPTH AT WING MOUNTAIN IN 1961

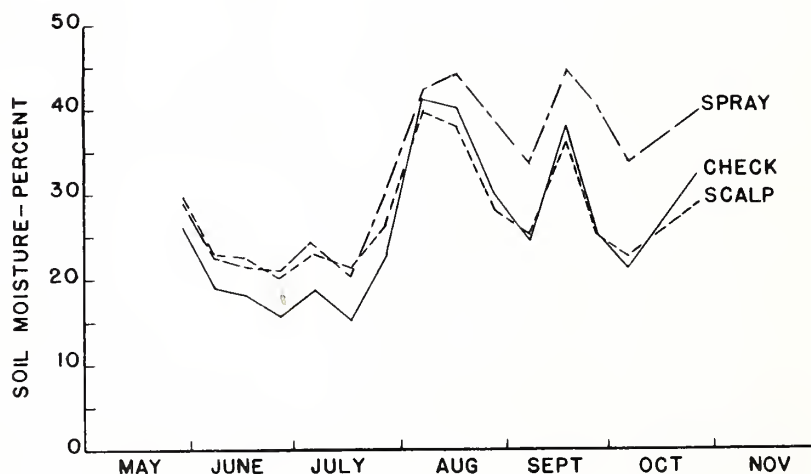

Figure F-6. — Moisture in the top 8 inches of soil after grasses were sprayed with herbicides, removed by scalping and left intact. Northern Arizona, 1961.

The differences are attributed to three things: (1) During the spring the pre-dominant grass, Arizona fescue, was growing actively and probably using water abundantly. In late summer and fall the fescue is less active. (2) In the spring the scalped plots were free of vegetation; by fall they had been invaded by numerous annuals. (3) The sprayed plots remained quite free of new vegetation, and the mat of dead grasses provided an excellent, moisture-conserving mulch (fig. F-5).

Soils 8 to 44 inches below the surface remained about equally moist throughout the growing season on sprayed and scalped plots, but were consistently drier on the untreated plots.

Air and soil temperatures affect initial growth of ponderosa pine seedlings

Root growth of ponderosa pine seedlings may be retarded by either unfavorable air or soil temperature. Best seedling root growth (penetration, dry weight, and number of laterals) was found when seedlings were grown at 15° C. air temperature combined with 23° C. soil temperature (fig. F-7). A high air temperature (31° C.) or either a high or low (7° C.) soil temperature invariably restricted penetration of roots and numbers of laterals.

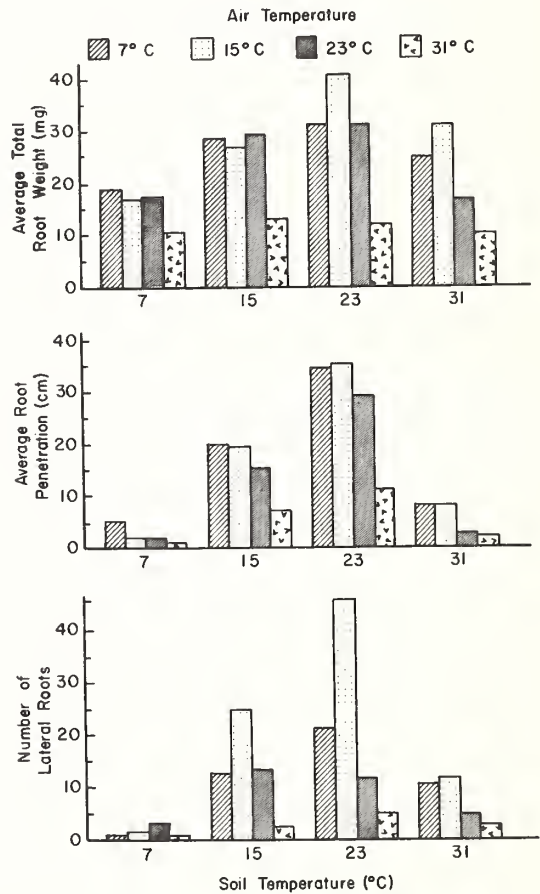

Figure F-7. — Total root weight, root penetration, and number of lateral roots for ponderosa pine seedlings grown in several combinations of air and soil temperatures.

Root growth was influenced almost as much by air temperature as by soil temperature. Top growth (top dry weight and epicotyl length), on the other hand, was influenced more by air temperature than soil temperature (fig. F-8).

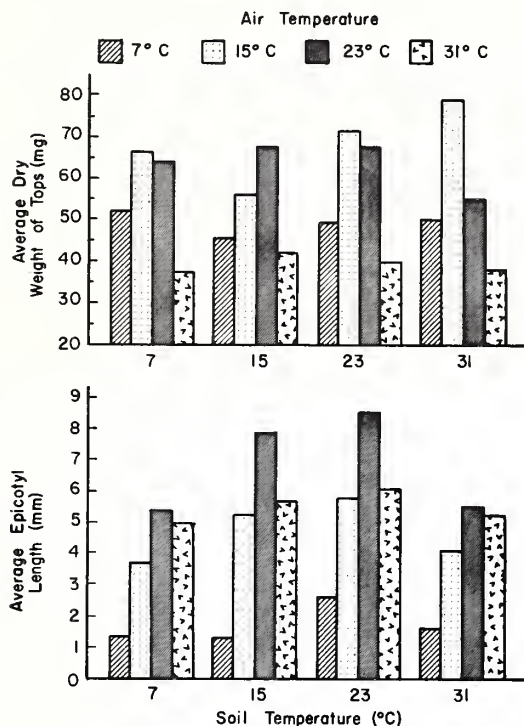
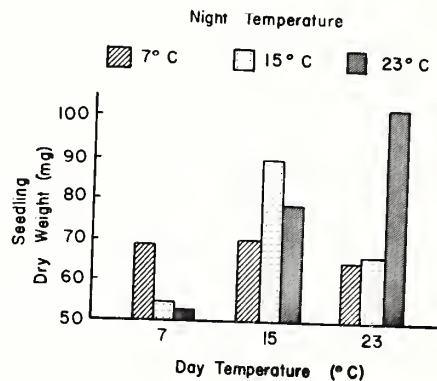

Figure F-8. — Top dry weight and epicotyl length of ponderosa pine seedlings grown in several combinations of air and soil temperature.

At all soil temperatures, top dry weights were greatest when seedlings were grown at air temperatures of either 15° or 23° C., and least when the air temperature was 31° C. Epicotyls grew most when both the air and soil temperatures were maintained at 23° C. An air temperature of 7° C. greatly inhibited epicotyl length, regardless of the soil temperature.

Warm constant temperatures produced better growth of seedlings than alternating day and night temperatures. Seedlings grown at either 15° or 23° C. constant temperatures increased in dry weight more than those exposed to alternating day and night temperatures (fig. F-9)

Figure F-9. — Average seedling dry weight for each day-and-night temperature combination.



**Pine transplants exhibit
surprising potential for
root development**

Young ponderosa pines can extend their root systems at astonishing rates after they are transplanted if environmental conditions are favorable.

Trees transplanted as bare-root, 2-1 stock into a deep, fertile, silt-loam soil of alluvial origin near Lincoln, Nebraska, were grown practically free of competition from other plants. One tree was excavated 2 years after it was transplanted, and another after 4 years.

After two growing seasons, the one tree had extended some of its lateral roots more than 7 feet, and vertical roots had penetrated almost 5 feet (fig. F-10). After four growing seasons, the other tree had lateral roots as long as 13 feet, and numerous vertical roots reached the water table at a depth of more than 6 feet (fig. F-11).

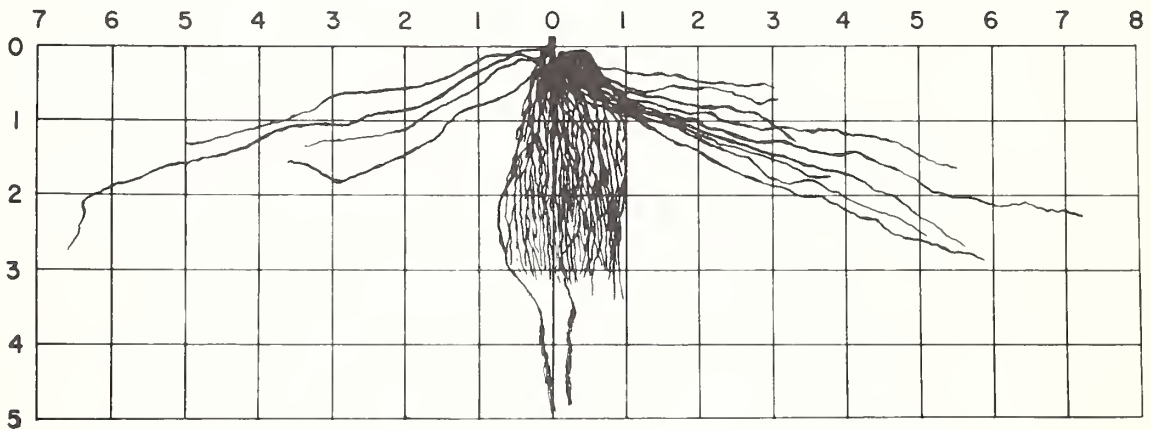

Figure F-10. — Root-system profile of a ponderosa pine two growing seasons after it was transplanted.

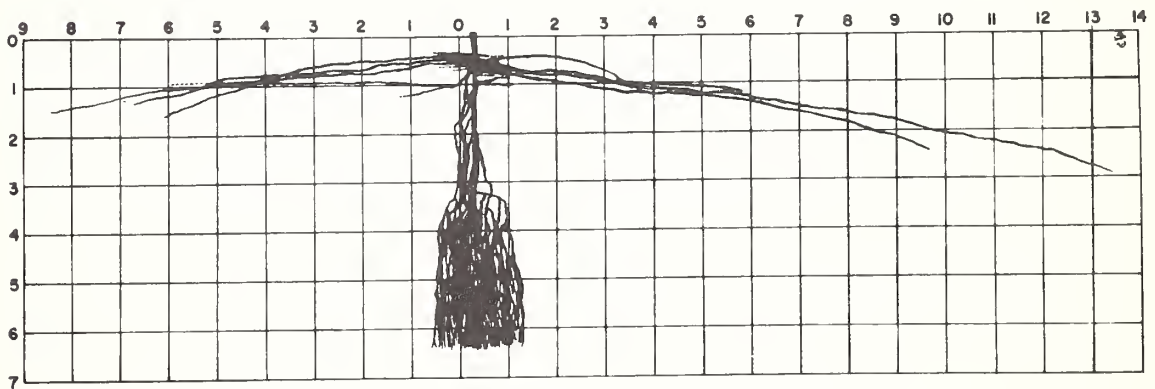

Figure F-11. — Root-system profile of a ponderosa pine four growing seasons after it was transplanted.

The impressive root growth of these trees clearly shows the beneficial effect of keeping a tree plantation free of competing vegetation. Transplants that develop extensive root systems rapidly have greatly improved chances of surviving drought, and attacks by insect, disease, and animal enemies.

Photosynthesis of spruce seedlings favored by partial shade

Three-year-old seedlings of Engelmann spruce (*Picea engelmannii* Parry) were planted in pots in June and grown under three light conditions: full shade, partial shade, and full sun. Full shade was approximately 3,500 foot-candles. Under partial shade, the seedlings were shaded by a shingle for about 4 hours each day and were in full sun the remainder of the time. Carbon dioxide assimilation was then measured for eight seedlings from each treatment when exposed to 1,500, 3,000, and 12,000 foot-candles of light in mid-July and again in early September (fig. F-12).

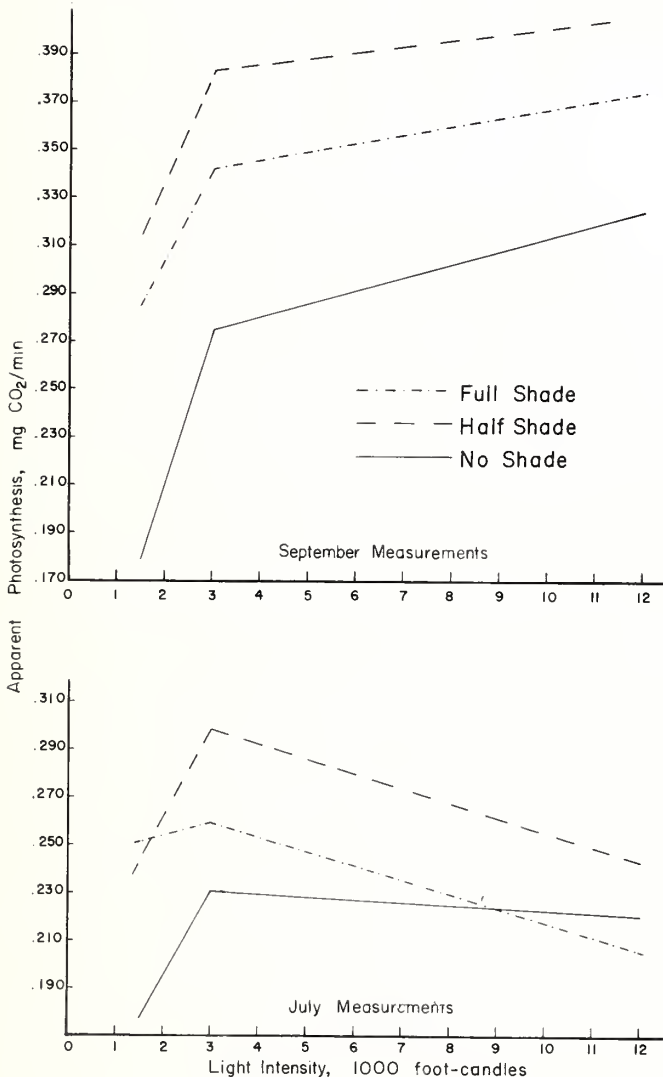

Figure F-12. — Apparent photosynthesis of individual Engelmann spruce seedlings grown under full shade, half shade, and no shade, when exposed to light intensities of 1,500, 3,000, and 12,000 foot-candles.

In July, seedlings from all treatments assimilated CO₂ most rapidly at 3,000 foot-candles. At that light intensity, seedlings grown under partial shade assimilated CO₂ most rapidly and seedlings grown under full sunlight assimilated the slowest. At 1,500 foot-candles, seedlings grown under full shade assimilated most. At 12,000 foot-candles the seedlings grown under full shade assimilated least.

By September the rate of assimilation had increased markedly for seedlings from all treatments. The increases might be associated with the larger size of the trees and better rooting brought about by half a summer's growth. In September the trees grown under partial shade assimilated CO₂ most rapidly and those grown under full sun the slowest at all light intensities tested. In September also, trees from all treatments assimilated more rapidly at 12,000 than at 3,000 foot-candles.

The rates of assimilation at the three light intensities tested suggest that the optimum light intensities were somewhere between 3,000 and 12,000 foot-candles in both July and September for all shade treatments, and that the optimum was probably higher in September than in June.

Proper boundary layout minimizes
windthrow around spruce-fir
clear cuttings

A study of windfalls along the boundary around the cutting units on 15 sale areas in Colorado identified many situations where windthrow hazards were above and below average:

Windthrow Hazard

Above average

1. Boundaries across which wind leaves a cutting unit (leeward boundaries).
2. Cuttings in narrow strips and small patches.
3. Cutting boundaries at right angles to contours.
4. Cutting boundaries in saddles in ridges, on ridgetops, and lower and middle slopes.
5. Slopes facing the wind.
6. Moderate to steep slopes.
7. Abrupt changes in direction, long straight lines and square corners, or indentations in cutting boundaries.

Below average

1. Boundaries across which wind enters a cutting unit (windward boundaries).
2. Cuttings in wide strips and large patches.
3. Cutting boundaries parallel to contours and along roads.
4. Cutting boundaries in stream bottoms and on upper slopes.
5. Slopes facing away from the wind.
6. Flats and gentle slopes.
7. Irregular or smoothly curved boundaries.

- | | |
|----------------------------------------------------------------|------------------------------------|
| 8. Shallow soils. | 8. Medium to deep soils. |
| 9. Poorly drained soils. | 9. Moderate to well-drained soils. |
| 10. Stands of old trees, especially if defective. | 10. Young stands of sound trees. |
| 11. Trees grown in forest stands. | 11. Open-grown trees. |
| 12. Special situations where topography will accelerate winds. | |

Success in laying out windfirm boundaries to cutting units will depend in large measure on being able to recognize the exceptionally hazardous situations where winds are accelerated by topography (item 12 above). Those situations are: (1) ridgetops and saddles on ridges within the sale area, (2) ridgetops on secondary drainages that are at right angles to a main drainage in a narrow valley with steep sides, and (3) areas immediately leeward of a saddle in a high ridge through which storm winds will be accelerated.

The first step in sale-area layout should be to examine the local topography and the topography outside the area on the upwind side to determine whether any special topographic situations are present that might funnel accelerated winds into the sale area. If no special situations are present, wind exposure may be considered normal, and the guidelines for sale layout are definite.

- A. Try to locate all cutting boundaries on topographic situations, soils, and in stand conditions where windthrow hazards are below normal (items 4-11).
- B. Be particularly careful to locate the highly vulnerable leeward cutting boundary (item 1) on topography and soils or in stands where hazards are below average.
- C. Avoid laying out dangerous wind-catching indentations or long straight lines and square corners in the leeward boundary, or in boundaries that are parallel to storm winds (item 7).
- D. Make cutting units as large as regeneration requirements, topography, soils, and stand conditions will permit (item 2).
- E. Try to locate the long axis of cutting units parallel to the contour or along roads wherever topography, soils, and stand conditions will permit (item 3).

Where exceptional hazards from accelerated winds are found, the wind problem may be handled in two ways:

1. Minimize all other hazards (items 4-11) when the cutting units are laid out.
2. Modify the pattern of cutting.

Where the common practice of removing timber from one-half of the area in alternating units is to be followed, the first approach must be used. All boundaries, and especially leeward boundaries, should be located where windfall hazards are below average.

A modified pattern of successive strip cutting can be used in some high-hazard areas to eliminate the vulnerable leeward boundaries by progressive cutting into the wind. The first cut would be made in a strip at the bottom of a slope that faces away from the wind, which would leave a relatively windfirm base leeward boundary. Subsequent cuts would then be made in successively higher strips. Cutting would proceed up the downwind slope and down the upwind slope without exposing another leeward boundary to the wind (fig. F-13).

Ideally, a sale area should be large enough so that it will require one rotation to remove all timber. Each successive cut would then constitute a cutting cycle. Thus a series of age classes would be developed, the youngest on the upwind slope and the oldest on the downwind slope (fig. F-13).

Where to start cutting is important. The first strip to be cut will have a leeward boundary. That boundary should be located where all wind hazards (items 3-11) are minimized.

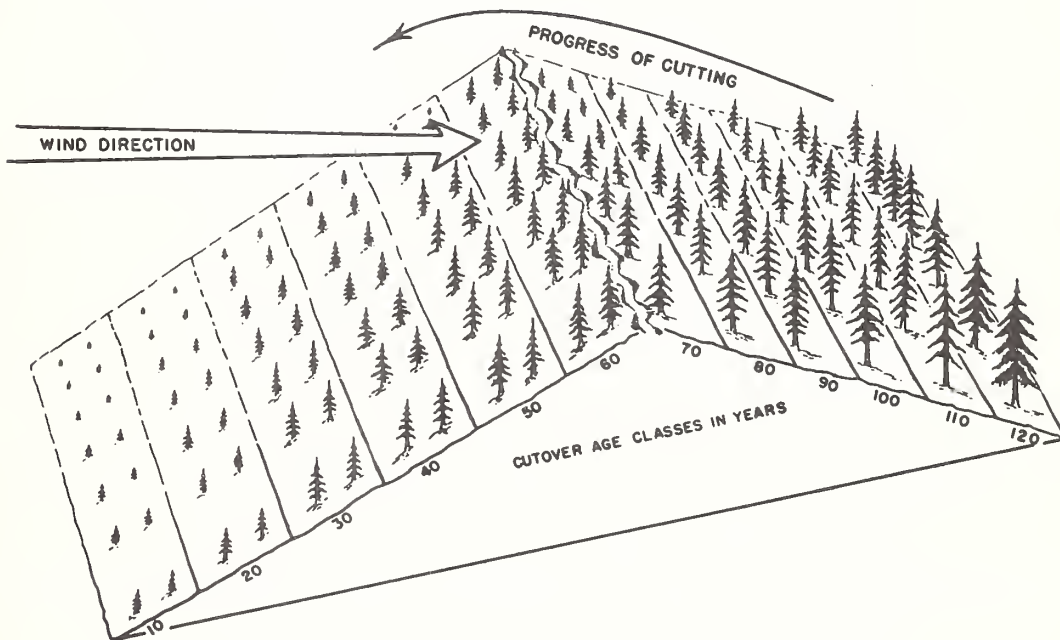

Figure F-13. - Distribution of age classes after one rotation of progressive strip cutting.

**Black Hills ponderosa pine
responds to thinning**

Growth of 70-year-old ponderosa pine in the Black Hills thinned to 475 trees and 71 square feet of basal area per acre in 1957 was better in several ways than that of an unthinned stand that contained 2,838 trees and 187 square feet of basal area.

For four growing seasons, 1958-61, trees in the thinned stand have averaged 2-1/2 times more diameter growth (breast height) than trees in the unthinned stand (fig. F-14).

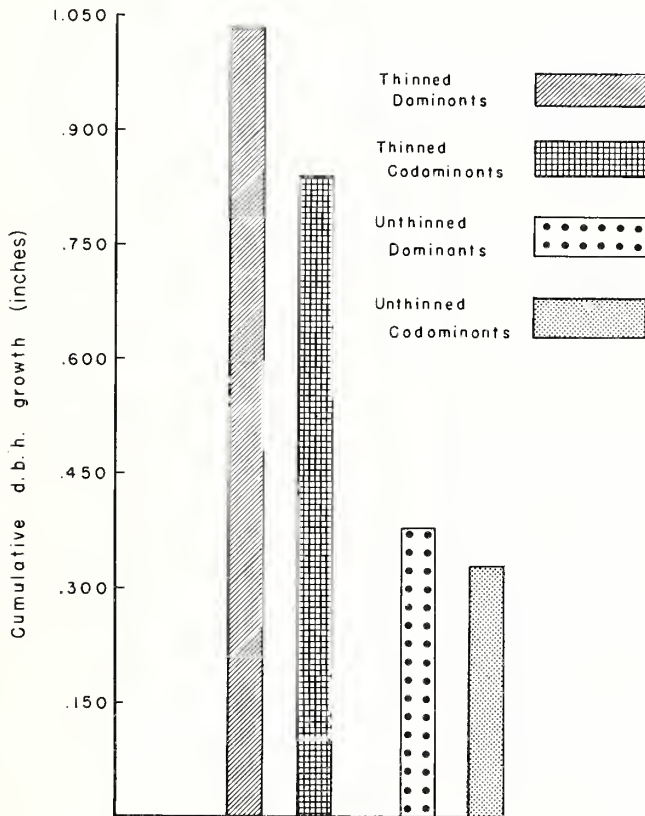

Figure F-14. - Cumulative diameter growth for immature Black Hills ponderosa pines, 1958-61.

Diameter growth of thinned trees commonly started earlier each spring and continued later into the fall (table F-1).

Despite a progressive decline in annual precipitation for the 4 years, average diameter growth of the thinned trees increased each year. Average diameter growth of unthinned trees decreased.

Height growth was the same for trees in thinned and unthinned stands in 1958 and 1961, but was greater in the thinned stand in the intervening years. Height growth appears to be closely related to the amount of precipitation that reached the ground under each stand (fig. F-15).

Table F-1. --Average dates of beginning and ending of diameter growth for immature Black Hills ponderosa pines, by plot treatment and crown class

Year and crown class	Thinned		Unthinned	
	D. b. h. growth-- Began	Ended	D. b. h. growth-- Began	Ended
Dominants and codominants:				
1958	May 11	Sept. 29	May 11	Aug. 11
1959	May 5	Sept. 22	May 23	Sept. 22
1960	Apr. 25	Sept. 26	May 10	Aug. 25
Dominants:				
1961	May 5	Oct. 9	May 21	Aug. 6
Codominants:				
1961	May 5	Aug. 14	June 1	Aug. 6

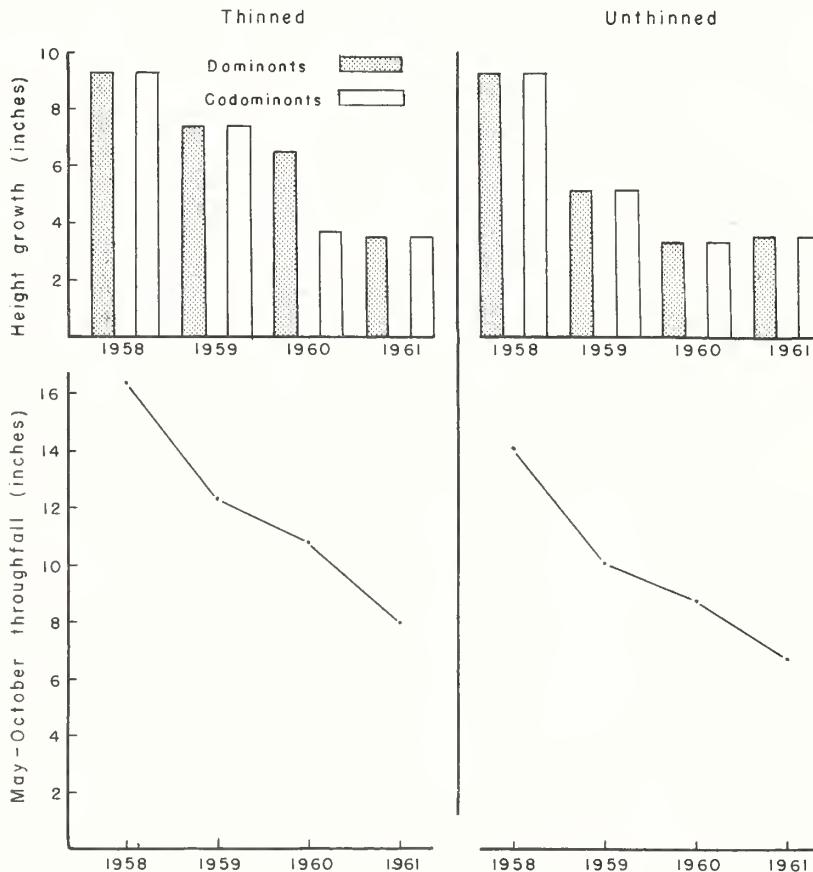

Figure F-15. -- Annual height growth for dominant and codominant trees on thinned and unthinned plots, and amount of rainfall reaching the forest floor, 1958-61.

**Chemically desiccated chaparral
successfully burned under control**

Contour strips 50 to 200 feet in width (right to left, fig. F-16) on three chaparral watersheds were sprayed July 31, 1961, with a mixture of 2, 4-D and 2, 4, 5-T to kill the leaves. The treated areas were burned about 6 weeks later. Remaining strips will be sprayed and burned through 1964.

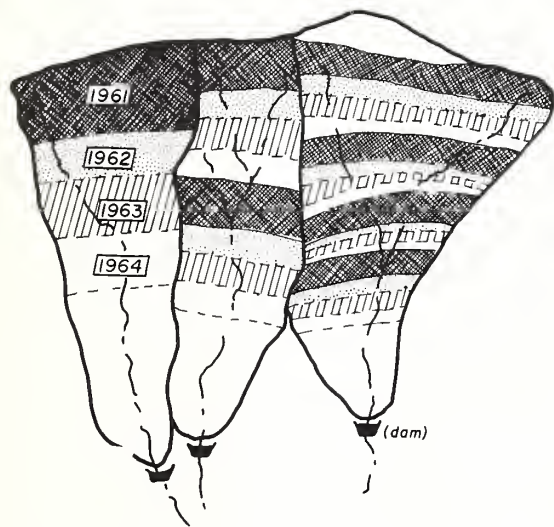

Figure F-16. - Contour strips 200 feet wide (left), 100 feet wide (center), and 50 feet wide (right) are being burned on three watersheds for four successive years.

The chemically killed leaves had dried to about 10 percent moisture at time of burning; untreated leaves remained above 90 percent (fig. F-17).

The strips burned reasonably well, but they were somewhat difficult to ignite. Fuel moisture conditions appeared ideal for burning, but fire-danger ratings were lower than wanted--drought index was moderate, rate-of-spread index low to moderate.

The strips burned without notable tendencies to spread. Spraying and burning in combination reduced live brush cover by 93 percent, about three times more than spraying alone would accomplish. The fire consumed 29 percent of the litter on the ground. Soil movement during the first winter, with normal precipitation, was not increased.

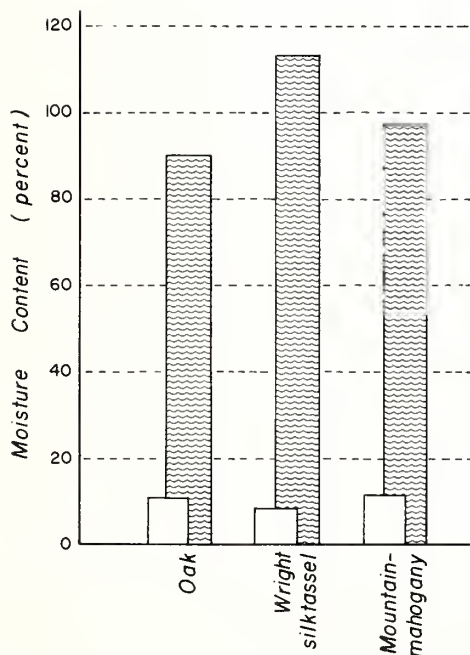

Figure F-17. - Moisture content of treated leaves was 8.3 to 11.4 percent; untreated leaves (wavy bars), 90.5 to 113.5 percent.

Forest Insect Research

Two important nematode parasites discovered on fir engraver beetle

Two species of nematodes, Parasitylenchus elongatus Massey and Parasitylenchus (new species), were found to be important biological enemies of the fir engraver beetle (Scolytus ventralis Lec.). Female beetles infested with the nematodes lay no eggs. Male beetles also are sterile. Evaluation of an outbreak of the fir engraver beetle on the Lincoln National Forest in southern New Mexico indicated that the nematodes were responsible for its control.

Laboratory studies showed that the life cycles of these two parasites are closely synchronized with that of the beetle, and they are highly efficient biological control agents. While the infested beetles are unable to produce eggs or sperm, they do carry the parasites with them to the new host tree to infest the progeny of non-infested beetles. The infested beetles construct short galleries--no more than an inch in length (fig. 1-1)--before being killed by the nematodes. The free living stage of the nematode is deposited in these galleries. After they are fertilized, the female nematodes migrate and infest beetle larvae produced from nonparasitized parents. Males of both nematodes are free living and are found only in the egg galleries of the beetles.



Figure 1-1. — Egg galleries made by the fir engraver beetles. (a) Abnormally short galleries made by beetles infested with nematode. (b) Galleries made by beetles not infested with nematodes. Free living nematodes are deposited in the short galleries before death of the beetles.

Formulation and standards of ethylene
dibromide emulsifiable concentrate
for bark beetle suppression

Some noteworthy improvements have been made in the formulation of ethylene dibromide emulsion for bark beetle control since its development by the Rocky Mountain Station more than 10 years ago. The formulation in current use is as follows: 2 or 3 pounds of ethylene dibromide (2 pounds for pine bark beetles and 3 pounds for Engelmann spruce beetle); 8 ounces of emulsifier (blend of 1 part Triton X-151 and 5 parts Triton X-171); 0.05 pound of epichlorohydrin (prevents corrosion of metal containers); and fuel oil to make the 1 gallon of concentrate. That amount of concentrate is mixed with 4 gallons of water at the time and place of use. If the concentrate is stored for more than 6 months, additional emulsifier may need to be added before it is used. The acceptable standard requires that the emulsion be able to stand for 1 hour after the water has been added and mixed with no separation of the oil and no less than 80 percent of cream by volume.

Ethylene dibromide emulsion is receiving wide acceptance for bark beetle control. It is economical to use because only 20 percent of its volume is transported into the woods. The balance, 80 percent water, comes from streams or ponds. It can be used on wet bark, thereby minimizing delay from rainy weather. It leaves no long-lasting deposits that may be hazardous to woodpeckers (an important biological enemy of many bark beetles) or to insect parasites and predators.

Roundheaded pine beetle
has 1-year life cycle

Outbreaks of this bark beetle, *Dendroctonus convexifrons* Hopk., in second-growth ponderosa pine in the Southwest are sporadic and generally short lived, but cause serious damage when underway (fig. I-2). Prior to studies started the past year on the Lincoln National Forest in southern New Mexico, knowledge of its biology and ecology was sparse and empirical. Its life cycle was found to be as follows: One full year is required to complete the cycle. Beetles emerge from the host during October, fly and attack groups of 5 to 30 green trees. Eggs are laid soon after the attack. The winter is spent in the egg stage or as small larvae. After they feed on the inner bark in the spring (fig. I-3), the larvae bore into the outer bark where they continue to feed and develop (fig. I-4).



Figure I-2. — A group of eight red-top ponderosa pines infested with the roundheaded pine beetle. Fading generally begins in June. Rate of fading of the foliage is associated with density of attack, kind of attack (new or fill-in), amount of blue staining in the wood, and vigor of trees.

Many larvae are full grown by mid-June, but pupation does not begin until mid-July and August. Considerable overlapping of the larval, pupal, and callow adult stages is found in August and early September. By late September most of the brood is in the adult stage and ready to emerge.

Figure 1-3. — A 6- by 6-inch sample of ponderosa pine bark removed from tree shows egg and larval galleries of the roundheaded pine beetle. Samples like this were taken at regular intervals to study rate of development, brood densities, and amount and cause of natural mortality.



Figure 1-4. — Inner bark cut away to show the mature larvae, pupae, and pupal cells of the roundheaded pine beetle in the outer bark.



Basic research on Black Hills beetle started

Research on the Black Hills beetle, Dendroctonus ponderosae Hopk., has developed an essential understanding of its life history and habits, kinds of biological enemies, effects of unseasonably low temperatures upon survival, a technique for measuring survival in the pre-flight adult stage and predicting infestation trends, survey techniques for detecting and estimating size of infestation by ground or aerial methods (fig. 1-5), the use of water emulsions and oil solution of ethylene dibromide for treatment of infested trees, and protection of green trees with DDT.

In a typical infested ponderosa pine, five or six pairs of beetles enter each square foot of inner bark in August and lay about 350 eggs. About half this number reach the small to mature larval stage in October, and only about half of these



Figure 1-5. — The first sign of a Black Hills beetle epidemic is group killing of trees that show as red-tops the year after attack.

survive the winter and spring (fig. 1-6). Six survive to July in typically declining infestations, 25 in static infestations, and 58 in increasing infestations. Future research is pointed toward learning the reasons for the low survival, less than 2 percent, from egg to the adult stage in some cases, and a comparatively higher survival, 17 percent, in others. All avenues will be explored, including tree and stand conditions, nutrition and fecundity, role of biological control factors, role of associated blue stain, host resistance and attraction, and mechanisms within the beetles for attraction to and aggregation in a host tree.

Current laboratory work is aimed toward finding the optimum temperature and humidity and standardizing a rearing technique for testing each environmental factor. Cabinets with controllable temperature, humidity, and light are now being modified and calibrated for this work.

A useful field technique for studying habits of flight and attack of the beetles, attraction, and host resistance was discovered last year. This involves caging laboratory-reared beetles on a tree or attaching a short laboratory-infested bolt on a tree just prior to the beginning of beetle flight in August (fig. 1-7). In every instance, the trees to which beetles were attached were the first to be infested, followed by large numbers of adjacent trees.



Figure 1-7. — Group killings of pines illustrated in figure 1-5 can be induced by wiring a newly infested bolt to a tree, or by placing beetles in a wire cage on a green tree (not illustrated). The feeding beetles attract other beetles into the area. After the tree with the attraction is fully occupied, the beetles infest adjacent trees.

Figure 1-6. — The Black Hills beetles make long, vertical galleries in the inner bark of healthy trees and lay their eggs as they go. The larvae that hatch from the eggs feed on the inner bark.



Control developed for
pinyon needle scale

Throughout much of the Southwest, pinyon pine, Pinus edulis Engelm., is a scrubby tree of little value for lumber, but of considerable worth to the picnicking vacationist. The pinyon needle scale, Matsucoccus acalyptus Herbert, an insect pest that causes especially severe defoliation in recreational areas (figs. I-8, I-9), is not vulnerable to conventional insecticides applied in late spring and summer.

A study of the insect's life cycle pinpointed a vulnerable stage -- when the scales lay their eggs, either at the base of the pinyon (fig. I-10), or in the rough bark on the stem in early spring (fig. I-11). Dimethoate in water (1-percent solution) was used successfully against the egg stage. The spray must be applied to the egg masses at the base of the trees or on the rough bark.



Figure I-8. - Immobile scales, with their beaks in the pinyon needles, feed on the juices.



Figure I-9. - Heavy infestation of the pinyon needle scale causes the needles to turn yellow and fall.



Figure 1-10. — Female scales crawl to the base of the pinyon in early spring and lay eggs in masses.



Figure 1-11. — On larger trees with rough bark, the scales may lay eggs on the stem.

**Combining pathogens greatly
increased mortality of
Great Basin tent caterpillar**

High mortality was obtained in tests to control the Great Basin tent caterpillar, Malacosoma fragilis Stretch, when a native polyhedrosis virus was combined with a commercial preparation of a bacterium, Bacillus thuringiensis. About 15 percent of the native populations of the caterpillars normally die from the polyhedrosis virus disease. This virus apparently is present in all of the caterpillars but is virulent only during certain years, when mortality approaches 100 percent.

Environmental requirements for natural outbreaks of the disease are not yet fully understood. There are indications, however, that mortality from the virus can be increased by the presence of the bacterium. When larvae were fed for 24 hours on foliage treated with a water suspension of the bacterium, mortality rose to 35 percent regardless of the bacterial concentration. When the foliage was dipped in suspension of both virus and bacterium each at concentrations that caused few additional deaths when used separately, larval mortality increased to 81 percent (71 percent from the virus disease and 10 from the bacterium). These results suggest that the bacterial pathogen stimulates the virus to a change from the latent to the active state.

Research started on causes of spruce budworm outbreaks

Spruce budworm, Choristoneura fumiferana (Clem.), populations in the central and southern Rocky Mountains fluctuate drastically. Of the many infestations discovered in the past, only a few have reached serious proportions. The objectives of current research are to determine the components of the pest's environment responsible for the fluctuations, how to use this information in predicting infestation trends, and to determine when chemical and management control measures are needed to supplement natural control. Emphasis will be placed upon discovering how behavior differs in our area. The spruce budworm is a most serious pest of true firs, Abies spp., and Douglas-fir, Pseudotsuga menziesii (Mirb.) Franco, in North America, and the subject of much research. Information from the research being started is needed for adapting that knowledge to our problem.

The first part of the investigation will be a close examination of each stage of the insect's life cycle for natural mortality factors. Significant ones will then be studied separately in the field and in the laboratory. Some of the factors suspected of being important include insect parasites and predators, insectivorous birds, late frosts that kill the new growth, and changes in the egg-laying capacity of the female moths as influenced by age of the infestation.

Malathion tested against the spruce budworm

Dosages of 1/4 and 1/2 pound of malathion in 1 gallon of fuel oil per acre, when applied by helicopter, gave some promising results against the spruce budworm on Douglas-fir. The malathion was used in a small pilot control project, 100 acres for each dosage, on the Rio Grande National Forest. Spruce budworm mortality was 86 and 94 percent, respectively, for the two dosages. On 87,500 acres sprayed with DDT at a rate of 1 pound in 1 gallon of fuel oil applied by fixed-wing airplanes and helicopter, the overall budworm mortality was 95 percent.

There is yet more to learn about the use of malathion on larger areas and the advantages and disadvantages over DDT.



Forest Disease Research

Spread of dwarfmistletoe from mature stands of lodgepole pine into reproduction

Mature, even-aged lodgepole pine (*Pinus contorta* Dougl.) is typically harvested by clear cutting. The uncut stands adjacent to the clear-cut areas often contain dwarfmistletoe-infected trees, so a study was made to determine the amount of infection in newly regenerated stands that might be expected from these sources.

Lodgepole pine reproduction was examined in the vicinity of infected residual stands on 79 plots in Colorado, Wyoming, and Montana (fig. D-1). The proportion of young trees infected in relation to stand age is shown in figure D-2.

The average proportion of trees visibly infected in reproduction 10, 15, 20, and 25 years old was 3, 9, 19, and 32 percent, respectively. The amount of dwarfmistletoe (*Arceuthobium americanum*) was highest in reproduction on the better sites. The average maximum spread of infection into reproduction was 26 feet from the infected residual stand. Dissections of the oldest infections on the plots showed that 14 percent of the stands that had dwarfmistletoe were infected before they were 4 years old, and 84 percent were infected before they were 11 years old. Control suggestions based on these findings are: (1) if the residual stands are harvested before the reproduction is about 15 years old, cutting or pruning infected trees to sanitize the young stand might be the most practical control method, and (2) if the residual stands are not harvested until the reproduction is over 15 years old, the

most practical means of control might be to destroy the young stand (by bulldozing) for a distance of 30 feet out from the residual stand. An additional zone 30 feet or so wide should be examined and the infections killed as outlined above for younger stands. The suggested control scheme cannot be followed rigidly, because the best treatment must be decided for each stand.



Figure D-1. — A study area established on the Roosevelt National Forest, Colorado, to measure the spread of dwarfmistletoe from a residual lodgepole pine stand into reproduction.

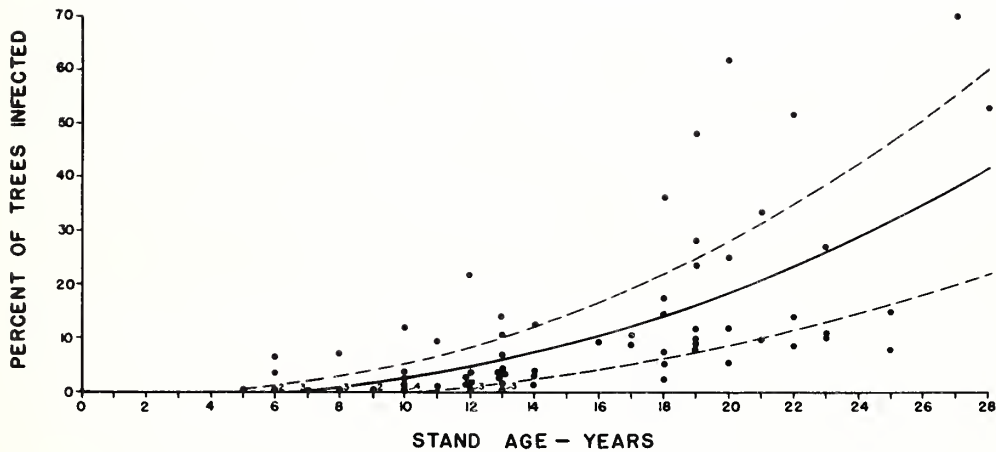

Figure D-2. — Proportion of young lodgepole pines infected by dwarfmistletoe within 30 feet of infected residual stands on 79 plots. The dotted lines indicate 95 percent confidence limits for the regression line.

**Effects of dwarfmistletoe
on immature lodgepole
pine stands in Colorado**

A frequently asked question about lodgepole pine infected with dwarfmistletoe is "can infected young stands be expected to produce acceptable yields if nothing is done about the parasite?" A study to determine the effects of different intensities of dwarfmistletoe on growth, mortality, and yields in immature lodgepole pine stands in Colorado showed that acceptable yields cannot be expected in lodgepole pine stands that are infected while they are young.

A total of 25 transects, with more than 6,000 trees, were studied in 3 National Forests. The stands studied were even-aged and averaged about 85 years old.

The results show that damage caused by dwarfmistletoe is most directly correlated with the length of time the stands had been infected. The effects of dwarfmistletoe, in relation to time infected, are shown in figure D-3 for size of the dominant and codominant trees and in figure D-4 for average plot cubic-foot volume.

The cubic-foot volumes in 50-, 75-, and 100-year-old lodgepole pine stands that have been infected for various lengths of time are shown in figure D-5 for total volume and in figure D-6 for merchantable volume. These graphs were prepared by applying the percentage reduction data (figs. D-3, D-4) to the average volumes measured in healthy stands of the ages given.

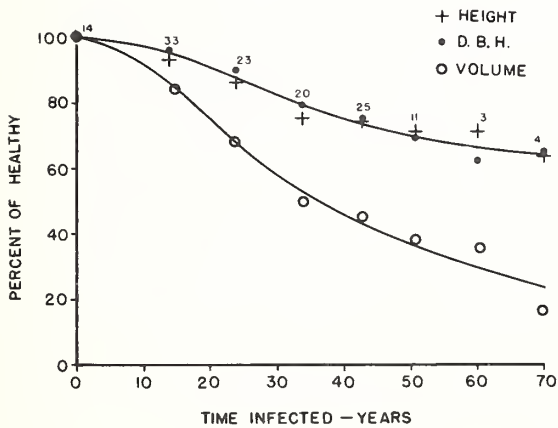

Figure D-3. - Relative height, d.b.h., and cubic-foot volume of dominant and codominant lodgepole pines in relation to time since infection. Basis: 133 plot pairs. The figures shown give the basis for each curve.

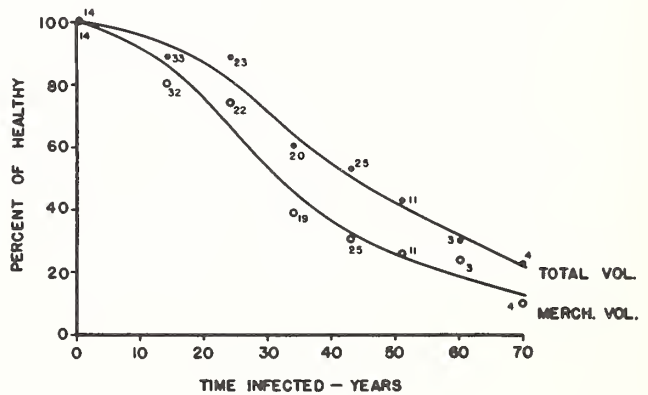

Figure D-4. - Relative total and merchantable cubic-foot volume per plot in relation to time since infection. Basis: 133 plot pairs. Total volume is all volume in trees over 2.5 inches d.b.h., while merchantable cubic-foot volume is volume in trees over 4.5 inches d.b.h.

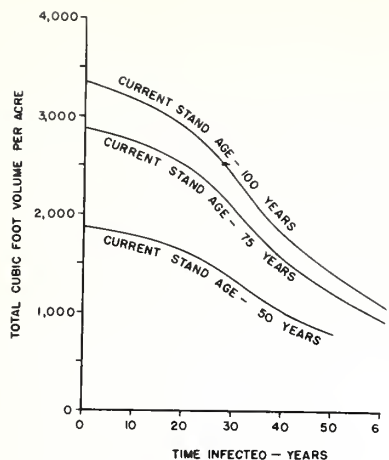

Figure D-5. — Total cubic-foot volume per acre in 50-, 75-, and 100-year-old lodgepole pine stands in relation to length of time dwarfmistletoe has been present.

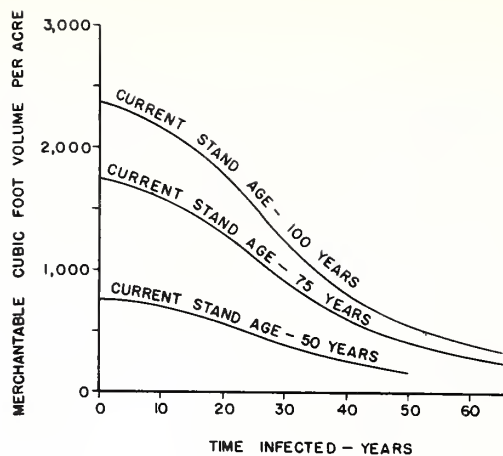

Figure D-6. — Merchantable cubic-foot volume per acre in 50-, 75-, and 100-year-old lodgepole pine stands in relation to length of time dwarfmistletoe has been present.

Black Hills ponderosa pine susceptible to a dwarfmistletoe

A greenhouse study of ponderosa pine (*Pinus ponderosa* Lawson) from the Black Hills of South Dakota showed no differences in susceptibility to dwarfmistletoe (*Arceuthobium vaginatum*) between this source and several others within the range of the parasite (San Juan and Pike National Forests, and Black Forest, Colorado and the Coconino National Forest, Arizona). A climatic factor presumably restricts the distribution of this dwarfmistletoe into South Dakota and Wyoming.

Life-table studies of ponderosa pine and lodgepole pine dwarfmistletoes continued

A study was started in 1960 to learn what proportion of dwarfmistletoe seed produced actually causes infection. Some interim findings from this study are tabulated below. For these data, the total number of seeds produced on the plots is taken as 100 percent.

	<u>A. vaginatum</u> on ponderosa pine (Percent)	<u>A. americanum</u> on lodgepole pine (Percent)
Seeds intercepted by trees	44	38
Seeds on twigs October of 1st year	10.1	17.1
Seeds germinated on twigs October of 2nd year	3.8	10.7
Seeds germinated on twigs October of 3rd year	1.2	4.8

Thus, the number of seeds in position to cause infection is four times as great in A. americanum as in A. vaginatum. The reasons for this difference are not yet understood. Several hundred seeds from four seasons' seed crops are being followed through to infection so answers to this and many other questions relating to an important segment in the life history of the dwarfmistletoes should eventually be provided.

Vigor improved in trees pruned of dwarfmistletoe

Many large ponderosa pines were pruned during dwarfmistletoe-control operations at Grand Canyon National Park, Arizona. Some trees so heavily infected that the crowns were declining in vigor were also pruned (fig. D-7). Note the greatly improved vigor of the crowns of the pruned trees.



Figure D-7. — Ponderosa pines pruned for dwarfmistletoe at Grand Canyon National Park, Arizona. (Left) Two trees in 1950 just before pruning; (right) the same trees in 1961.

Recleaning continues on Whitetail Dwarfmistletoe Control Unit

Except for spots where dwarfmistletoe infection was heavy prior to control operations, the first recleaning of the Whitetail Dwarfmistletoe Control Unit on the

Mescalero-Apache Reservation in south central New Mexico is removing fewer trees than were removed originally, and a greater number of trees are being pruned. Even in drastically treated areas, the recleaning has not markedly reduced the stocking, which was beginning to show definite increases as early as 1959 (fig. D-8).



Figure D-8. — Heavily infected ponderosa pine stand in the Whitetail Dwarfmistletoe Control Unit:

Before treatment of infected unmerchantable-sized trees in 1954.



One year after treatment.



After recleaning in 1961.

Cold severely domoges desert
mistletoe in Arizona

The desert mistletoe, Phoradendron californicum, was severely damaged by cold over much of its range in southeastern Arizona in 1962. The damage apparently occurred in January, when unusually low temperatures were recorded. The critical temperature for this mistletoe is apparently about 10° F. All aerial mistletoe shoots were killed in an area of several hundred square miles extending from Clifton to Douglas. The host plants (mesquite, Prosopis juliflora; catclaw, Acacia greggii; etc.) apparently were not affected. The mistletoe plants seem to have been killed in these areas, but observations will be made to determine if resprouting occurs.

Comondro blister rust
declining in Region 2

Inspection of outbreaks of Cronartium comandrae on ponderosa and lodgepole pines reported during the past 50 years showed that the rust is still abundant but currently declining in Region 2. Relatively few infections less than 30 years old were found in Colorado and South Dakota; old cankers that have not yet girdled their hosts range up to a record 22 feet in length. Damage is abundant in Wyoming stands of lodgepole pine, but, even here, a sample indicated that over 50 percent of living cankers are more than 30 years old and most of the remainder are 20 to 30 years old. Conditions that might favor renewed outbreaks of the disease are not known.

In twenty-four 0.1-acre sample plots in rusted stands in the Big Horn, Absaroka, and Wind River Mountains, old C. comandrae cankers accounted for 69 percent of recent mortality on a basal-area basis. By killing larger trees and causing spike-tops, comandra rust tends to shift growth to smaller stems and thus delays the time of profitable harvest.

Good germination obtained
with fungicide-pelleted seeds
of ponderosa pine

Fungicides of known or expected value in controlling damping-off disease of pine seedlings were pelleted to ponderosa pine seed for germination studies. Seeds were sown in sterile sand flats in a greenhouse. A fungicide that has been widely used as a pine seed protectant did not reduce germination when temperatures did not rise above 80° F. When temperatures sometimes reached above 100° F., however, this fungicide caused a significant reduction in germination. Another fungicide, whose protectant value has been demonstrated on seed of numerous plants but not on pine, did not reduce amount of germination.

Unwounded eastern redcedar
inoculated with
Phomopsis juniperovora

The fungus Phomopsis juniperovora causes a devastating disease of juvenile eastern redcedar, Juniperus virginiana, in Great Plains nurseries. Growth of the

fungus in culture spore germination, and germ-tube development was best with incubation at 24° C. Infection of redcedar seedlings was readily obtained by inoculating seedlings with spore suspensions and placing them in 24° C. chambers with 100 percent relative humidity.

Success in inoculating unwounded seedlings is a prerequisite to future studies on the pathology, ecology, and control of P. juniperovora.

Dutch elm disease advances in the Central and Southern Great Plains

The Dutch elm disease fungus (Ceratocystis ulmi) continues its westward course into the Great Plains. First detected in Kansas (Kansas City) in 1957, it has now been found more than 100 miles west in that State. It was not observed in Nebraska (Omaha) until 1960, but in 1962 it was found more than 140 miles to the west. The fungus has also been detected in southeastern Nebraska (1962) and in northeastern Oklahoma (1961).

Windthrow losses increasing in beetle-killed Engelmann spruce

Rate of deterioration of beetle-killed Engelmann spruce has been under observation since 1951. In 1961, a second 5-year reexamination was made on permanent study plots located in 4 areas in which trees had died in 1951 or had been dead for 5 or 10 years: 3 on the White River National Forest and 1 on the Routt National Forest. Cubic-foot volume losses from decay in standing trees and from windthrow are shown below by 5-year periods since the time of peak mortality:

	<u>5 years</u>	<u>10 years</u>	<u>15 years</u>	<u>20 years</u>
	- - - - - (Percent) - - - - -			
Decay in standing trees:				
Butt and trunk rots	3	7	7	4
Sap rots	1	3	5	8
Windthrow	0	10	19	27
Total	4	20	31	39

Nearly 40 percent of the cubic volume has been lost after 20 years. Sap rots have accounted for a progressively larger part of the total loss from decay. Volumes of butt and trunk rots declined between 15 and 20 years, presumably because the most decadent trees have been windthrown. Windthrow is now the primary cause of loss in these stands, and it is anticipated that this factor will be progressively more important in the future.

Photographic method developed to
record red rot in mill-scale studies

A photographic method was adopted for determining red rot (Polyporus anceps) in sound logs (less than one-third defective) run through a sawmill at near-normal operating speeds. Black and white photographs (35 mm.) of the boards from each decay-containing cant were taken immediately after it had passed through the gang resaw. Boards were freed of sawdust and arranged on the conveyor by a board-spreading crew, and photographed from an oblique overhead focal distance of 12 feet at f. 8 with illumination from two strob units. Approximately 700 frames were exposed. The finished prints (fig. D-9) provide better profiles of rot columns than can be prepared from measurements ordinarily recorded in log and tree dissections.

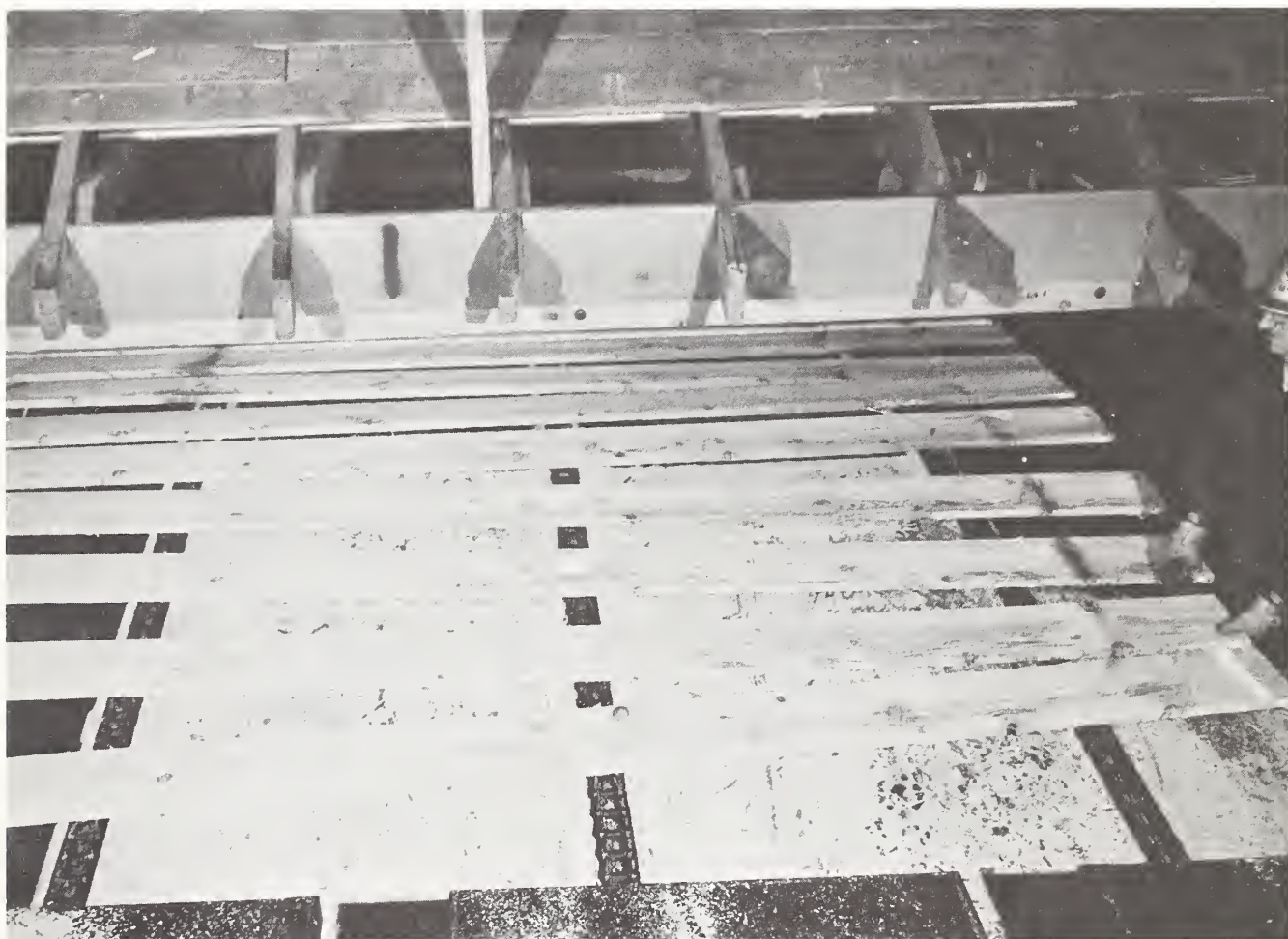

Figure D-9. — Red rot in boards cut from a single cant by a gang resaw.



Figure U-1(left). – Low-grade ponderosa pine logs used in veneer and plywood evaluations.

Figure U-2(below). – Veneer from grade 5 ponderosa pine logs.



Forest Utilization Research



Search for profitable outlets
for low-quality ponderosa pine
reveals promising products

The utilization of low-quality sawtimber poses severe economic problems to the forest products industry throughout the Nation. The problem is not new, but has become more acute with the decline in demand for lumber during the past several years.

How to lessen the problem in the ponderosa pine (*Pinus ponderosa* Lawson) areas of the Southwest has been the major objective of a coordinated industry and Forest Service study during the past year. Typical samples of the lumber and logs of problem grades were processed at the U. S. Forest Products Laboratory into products that offered promise for the successful utilization of this quality material. These included: veneer and plywood, paper-overlaid siding, laminated beams, composite types of flooring, and particle board.

Initial interest by industry appeared greatest in the following items:

Veneer and plywood. --The properties of good-quality ponderosa pine logs for veneer and plywood are well established. Little has been done, however, to evaluate low-quality grade 5 logs for this purpose. As shown in figure U-1 (opposite page) such low-quality logs were purposely selected for evaluation. Conditions were varied to test such factors as log-processing temperature, knife angle, veneer thickness, drying rate and quality, and general behavior of major defects, especially knots.

The veneer cut to an acceptable smoothness and dried without difficulty (fig. U-2, opposite page). No serious problems were encountered with shattering or checking of knots. Intergrown knots remained intact and did not loosen. They likewise glued without difficulty even when located on adjacent plies. Test samples subjected to standard sheer and delamination tests performed satisfactorily and exceeded Commercial Standard requirements for interior plywood.

In table U-1, the yields of veneer and 3/8-inch plywood equivalent are compared with the board-foot volume of the study logs and bolts. The resulting recovery rate of approximately 2.4 square feet of plywood per board-foot net log scale compares favorably to yields obtained by the Douglas-fir plywood industry.

Table U-1. --Study log and bolt volume, and associated veneer recovery

Log number	Volume, Scribner Decimal C	Trim loss ¹	Bolt number	Volume, Scribner Decimal C	Dry veneer recovery			Equivalent ³ 3/8-inch plywood
	Bd. ft.	Bd. ft.		Bd. ft.	Thickness Inches	Quantity Sq. ft.	Volume ² Bd. ft.	Sq. ft.
2	170	21	2-1	78	0.292	289	84.3	193
			2-2	71	.138	508	70.0	169
3	60	7	3-1	27	.138	221	30.5	74
			3-2	26	.292	102	29.8	68
4	120	15	4-1	53	.138	398	54.9	133
			4-2	52	.292	185	54.1	123
5	190	24	5-1	84	.138	686	94.5	229
			5-2	82	.292	250	72.9	167
Total	540	67	--	473	--	--	491.0	1,156

¹ Loss shown was incurred in cutting 10-foot test logs into 52-inch bolts.

² Actual dry recovery, in board-foot units of 144 cubic inches.

³ Based upon nominal veneer thicknesses of 1/8 inch and 1/4 inch.

Table U-2 shows the veneer grade recovery according to Commercial Standard Grades and Improvised Grades. A high proportion of the veneer recovered had no appreciable amount of large or nonpatchable open defects. A product such as underlayment, which requires a high proportion of sound but not necessarily clear veneer,

Table U-2. --Veneer grade recovery

Veneer grade	Bolt number							
	3-1 ¹	4-1 ¹	5-1 ¹	Total	3-2 ²	4-2 ²	5-2 ²	Total
	----- Lineal inches -----							
Commercial standard:								
A	110	31	571	712	0	13	390	403
B	0	0	0	0	0	0	0	0
C	303	273	255	831	89	0	20	109
D	200	799	1,073	2,072	194	500	282	976
Dry recovery	613	1,103	1,899	3,615	283	513	692	1,488
Cull	25	16	3	44	3	67	3	73
Improvised:								
Clear	111	37	562	710	0	13	404	417
To 1-1/2-inch knot	304	254	228	786	63	0	6	69
Over 1-1/2-inch knot	168	290	855	1,313	184	323	274	781
Open, patchable	34	509	201	744	36	132	8	176
Open, nonpatchable	0	11	53	64	0	86	0	86
Dry recovery	617	1,101	1,899	3,617	283	554	692	1,529
Cull	21	18	3	42	3	26	3	32

¹ Nominal veneer thickness = 1/8 inch.

² Nominal veneer thickness = 1/4 inch.

should find this a suitable source of raw material. A significant result of the study was the high proportion of intergrown tight knots found, which can be attributed to the fact that logs of grade 5 come largely from the live crown portion of the stem.

Vertically laminated beams suitable for floor joists or roof beams were also investigated as a means of utilizing low-grade pine lumber.

Eleven test beams were made, each consisting of 5 laminations of 4/4 lumber, 10 inches wide, and 16 feet in length. The boards were randomly selected with grade 3 common assigned to the front and back face for appearance. Inner laminations were of grades 4 and 5 common, with lamination 2 and 4 being of the same grade. In five beams, the boards were assembled exactly as they occurred with regard to location of defects (fig. U-3). In another five beams, the strength-reducing characteristics were oriented to provide for the best quality on the tension side of the beam. The last beam was oriented to obtain worst possible concentration of defects on the tension side.

The beams were glued with a phenol resorcinol resin, cured and conditioned, and tested in static bending over a span of 15 feet (fig. U-4).



Figure U-3(above). — Quality and orientation of laminations in test beam No. 1.

Figure U-4(below). — Beam No. 1 under static bending.

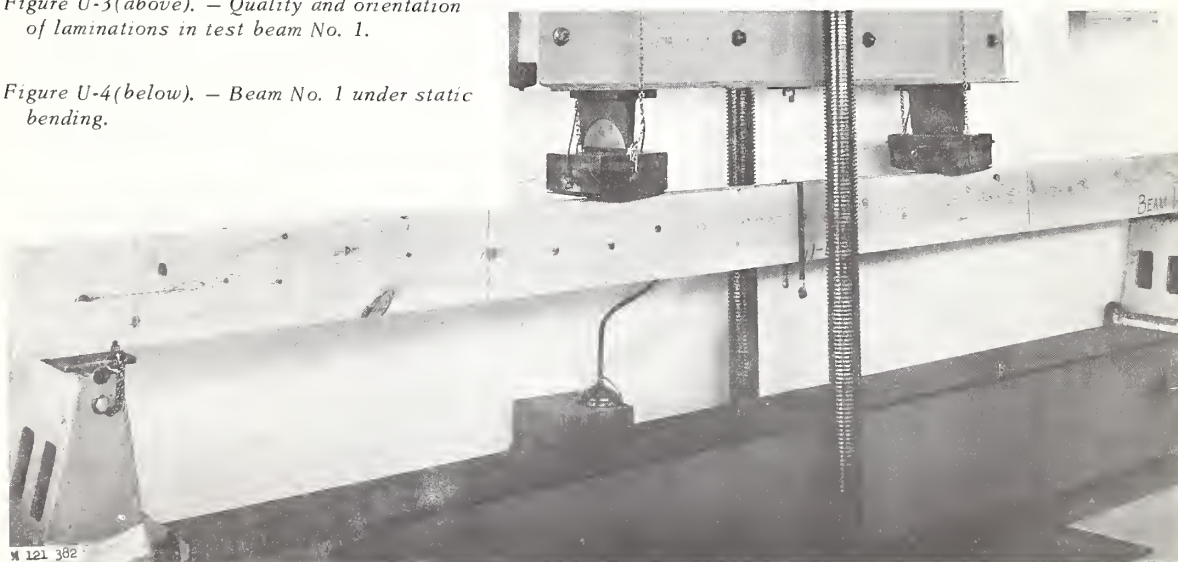

The results indicate that beams of this type have considerable promise for use in floor and roof systems in housing. Strength and stiffness appeared adequate for spans up to 13 feet. A strength difference of approximately 35 percent was observed between beams with random and selected orientation of defects. The quality of the glue bonds was not affected by the quality of the lumber.

Paper-overlaid siding was made in both the standard beveled pattern and a proposed new combination intended to serve as sheathing and siding in one application (fig. U-5). Paper overlays offer a means of overcoming two major limitations of low-grade ponderosa pine lumber: narrow widths and numerous pitchy knots.

Figure U-5. — Types of paper-overlaid products investigated: (left) combination sheathing-siding; (right) bevel siding. Double broken line shown in bevel siding illustrates how material is resawed after application of paper overlays.

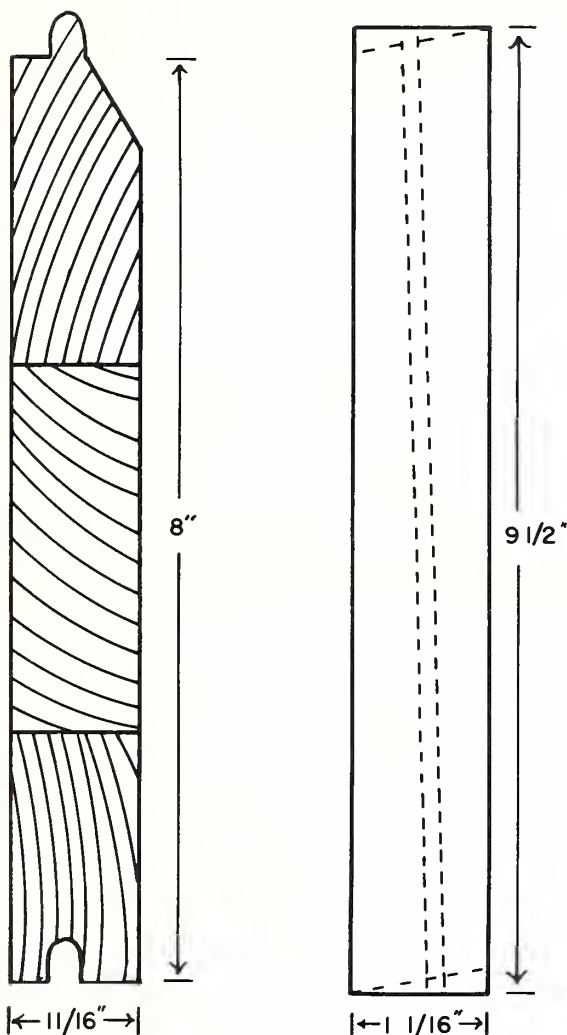

Narrow boards are first edge-glued into panels of the desired size (fig. U-6). Boards can contain the sound knots common to grades 4 and 5 ponderosa pine lumber, if they are not deeply chipped. Pitch pockets and stains are likewise permissible as are small open defects generally less than 1/16 inch in size. Larger open defects must be plugged or removed. Sheets of resin-impregnated paper are then glued to both sides of the panel with a cold-setting, acid-catalyzed phenolic resin. An overlay of proper quality and correctly applied to a low-grade board can provide a surface equivalent to a clear grade in appearance, paintability, and performance.

A kraft paper 0.015-0.020 inch thick with good dimensional characteristics was used for the basic paper for the overlay on the combination siding. For the bevel siding, a commercial vulcanized-fiber type 0.005 inch thick was used. The latter paper has dimensional characteristics similar to wood, and thus can be used on one side only, as results when the panel is resawed (fig. U-5).

The upper exposed edge of the combination siding-sheathing was beveled to provide some deep-edge and shadow-line effect. A 10-degree bevel was machined on each longitudinal edge of the bevel siding to provide an undershot drip edge (fig. U-7).



Figure U-6(above). —
Lumber panels with a
wide range of quality
used for paper-over-
laid siding.

Figure U-7(right.) —
Paper-overlaid siding
panels ready to be re-
sawn into two pieces
of bevel siding. Double
tongue-and-groove
feature provides for
tongues and grooves
on individual resawn
boards.



While this evaluation was the first of its type on low-grade ponderosa pine lumber, the principles involved, such as the durability of the paper bonded to a wood surface, have been well established. This evaluation was concerned primarily with recovery of material suitable for the purpose, and the gluability and general performance of material containing a high concentration of large pitchy knots. No serious problems were encountered, and in general the technique appeared to be a feasible means of upgrading the material and making it more salable.

Solar heat used to season lumber

A common criticism of locally produced lumber is the poor quality of the seasoning, because many small operators do not have the means or the timber supply needed to purchase a dry kiln or write off the investment.

A study was started with Colorado State University to evaluate the use of an inexpensive solar-heated lumber dryer in the Rocky Mountain area. Similar dryers have been investigated at Madison, Wisconsin, and in Puerto Rico with generally favorable results. The Rocky Mountain area, with its high percentage of sunny days and generally high intensity of sunlight, appeared to offer some additional advantages for the method over the other locations tested.

As shown in figure U-8, the dryer is basically a simple frame structure enclosed by two successive sheets of a tightly stretched, tough, clear plastic, in storm-window fashion. Part of the solid north wall is hinged to allow easy loading and unloading. Interior wood parts of the dryer are painted a dull black to better absorb solar radiation. Circulation is provided by a series of fans, controlled by a photoelectric cell. Moisture is exhausted through vents regulated by a wood-element hygostat.

In operation, the structure serves as a heat trap. The forced-air circulation is controlled to continue during periods when the kiln temperature is above that outdoors. The moisture-venting system provides for controlling the rate of drying. The initial test run began in the last weeks of 1962.

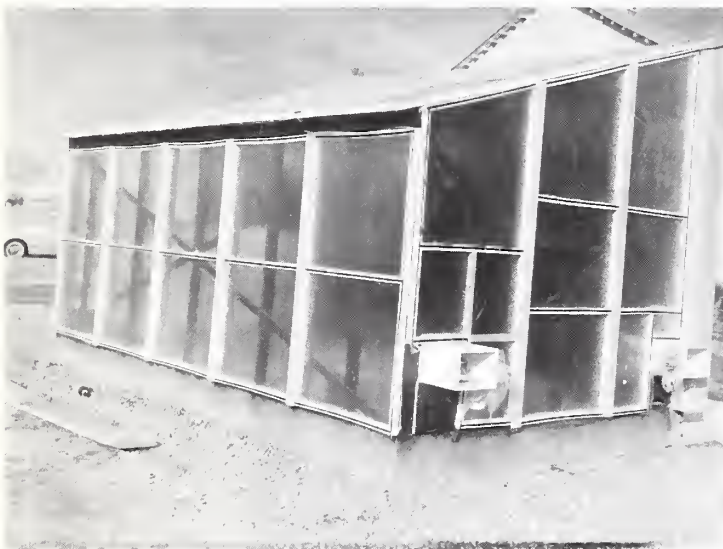

Figure U-8. — Experimental solar-heated lumber dryer.

Pulpwood industry growing in Black Hills

The pulpwood industry in the Black Hills, which was established in 1955, is now producing a total of about 42,000 cords of ponderosa pine roundwood and chips per year for Wisconsin pulp and paper mills. About 20 percent of this production is in form of chipped sawmill residue (fig. U-9) and the remainder is roundwood. Ponderosa pine roundwood shipments started in 1955 when about 330 cords were shipped. Occasional and sporadic white spruce (*Picea glauca* (Moench) Voss) shipments had been made previously and still continue. Favorable freight rates put into use on multiple-car shipments in 1958 were a major factor in increasing total production of pine pulpwood from 330 cords to about 27,000 cords in 1959 (fig. U-10).

Growth of the industry was spurred in 1960 when a central chipping plant near Custer, South Dakota, started producing pulp chips, and in August of 1962 when the Homestake sawmill at Spearfish, South Dakota, installed a debarker and chipper and began producing pulp chips from sawmill residues.

Pulp chips are produced from sawmill residues that result from sawing bark-free logs. For this reason, chip production is closely geared to lumber production. Current pulp chip production capacity in the area is approximately 15 carloads per week or about 330 units (2,400 pounds dry weight). During the past year, lumber production was below that required to yield the volume of residue needed to operate the chipper plant at full capacity.

Concentration of roundwood activity so far has been along the northern and eastern flanks of the Black Hills because of the location of railroad loading points. Future growth of the industry should shift to timber sources throughout the central portion of the Hills.

In addition to direct employment and monetary benefits, an expanding pulpwood industry greatly enhances forest management and utilization opportunities. The benefits of thinning pulpwood-sized stands are reflected in all the major uses the forest land serves. Recovery of the large volumes of waste that result from lumber conversion offers a means of writing off some of the production costs, and also benefits the resource.

Figure U-9. — Pulp chips from sawmill residues and roundwood from thinnings are shown at a railroad siding ready for shipment to Wisconsin pulp and paper mills.

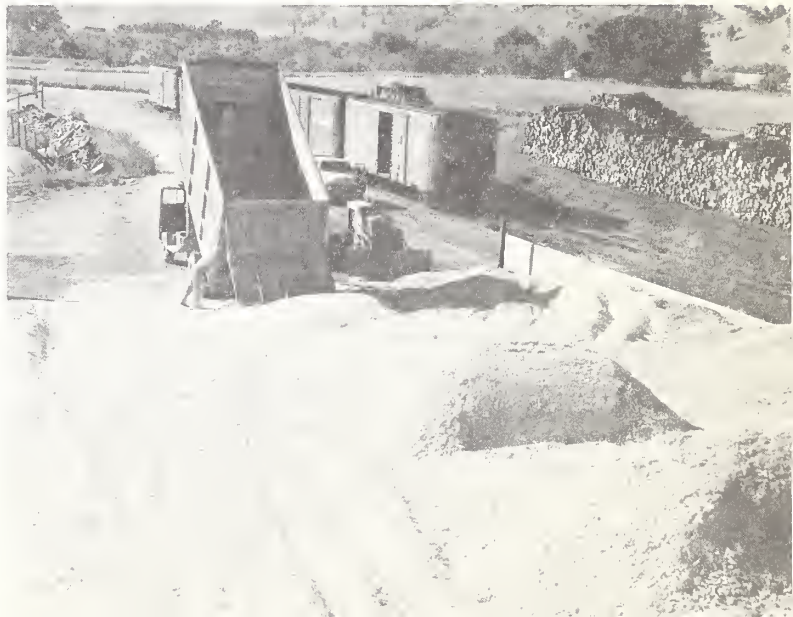

Carried out to its full potential as based on the sustainable cut volumes of 80 million board feet of lumber and 80,000 cords of pulpwood, the gross net return on current market prices could be approximately \$3-1/2 million annually.

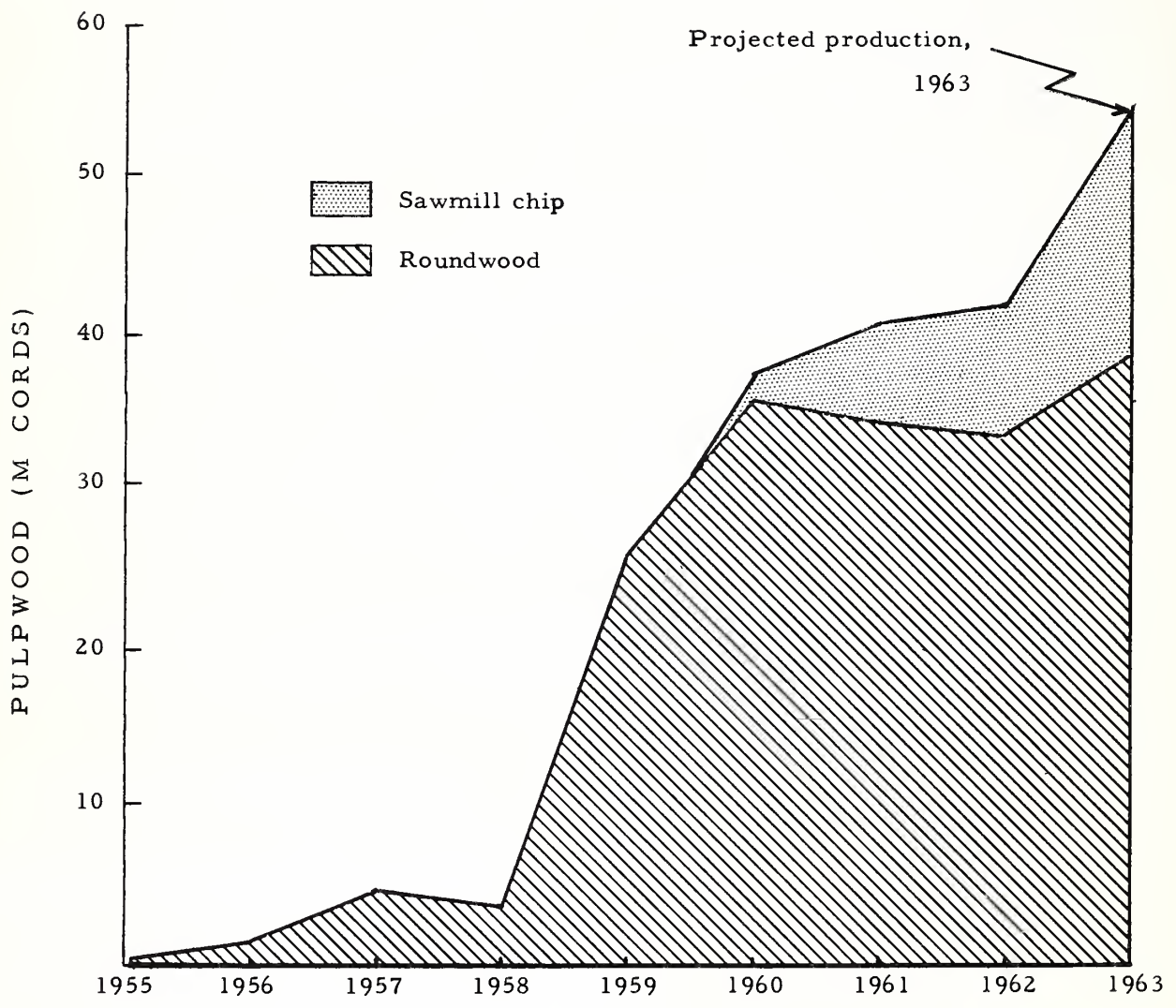

Figure U-10. - Production of ponderosa pine roundwood and sawmill residue pulp chips in the Black Hills, 1955 to 1963. Projected 1963 total volume of roundwood and chips is based on current rates of production.

Forest Economic Research



FOREST PRODUCTS MARKETING

Good opportunity for pulp-
and papermaking in West
Central Colorado

A minimum production of 600 tons of newsprint per day is possible, based on the wood and water resources of a 13-million-acre study area in west central Colorado (fig. E-1). This and many other facts pertaining to the feasibility of pulp and paper mill development in this area have been developed in a recently completed study.

One of the more important facts is that there are over 28 million cords of live green pulpwood of desirable pulping species in the current timber inventory. There are an additional 9 million cords of pulpable dead timber, mostly Engelmann spruce, Picea engelmannii Parry, concentrated adjacent to likely millsites on the Colorado River.

The surface water supply is large enough to accommodate both trout and pulp-mills if reasonable waste-treatment practices are followed by industry. The effluent assimilative capacity of the Colorado River alone will permit either 2,000 tons a day of sulfate pulp production, 360 tons a day of semichemical pulp- and paper-making, or well over 4,000 tons a day of groundwood pulping. Water quality will not present significant problems, and enough water is available by various means for acquisition by pulp and paper firms.

At present costs (excluding stumpage and roads), around 8 million cords of wood could be obtained at Kremmling for less than \$20 a cord. Stump-to-truck costs will probably average between \$9 and \$10 a cord.

A number of other factors were also considered, including adjacent paper markets, paper freight costs, fuels, power, chemicals, labor, and taxes. None of these detract from the opportunity. One large cost advantage to the study area is offered by its nearness to growing western paper markets.

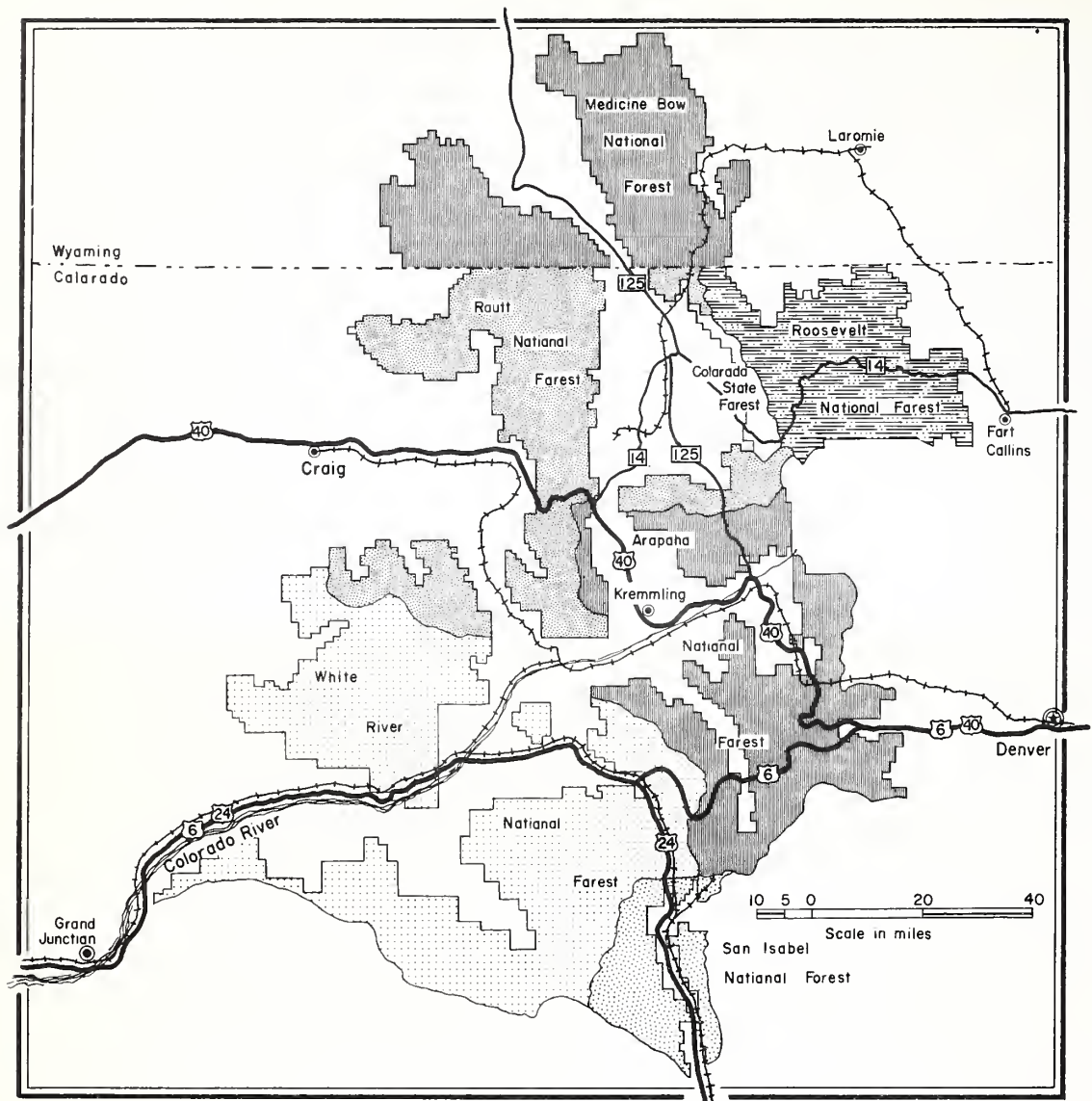

Figure E-1. — Pulpmill study area.

FOREST SURVEY

First Forest Survey of Colorado completed

Colorado has more than 22 million acres of forest land. About 12 million acres are in commercial forest and bear a volume of 53 billion board feet of saw-timber. These are preliminary results of the Colorado Forest Survey, and are based on data collected during the period 1956-60.

Spruce-fir is the most important commercial forest type in Colorado, in terms of area and timber volume. Commercial forest areas by type and percent in sawtimber stands are as follows:

<u>Type</u>	<u>Thousand acres</u>	<u>Percent in sawtimber stands</u>
Spruce-fir	3,393	81
Aspen	2,794	7
Ponderosa pine	2,347	64
Lodgepole pine	2,068	35
Douglas-fir and others	<u>1,673</u>	<u>64</u>
Total	12,275	

The portion of the type that is in sawtimber is an indicator of commercial value. Aspen and lodgepole pine types, although low in sawtimber, contain large acreages of potentially usable poletimber stands.

Spruce-fir stands occur at the higher elevations throughout the forested parts of the State. The principal aspen stands are west of the Continental Divide, while ponderosa pine is concentrated in the southwestern and in the eastern portions of the general forested area. Lodgepole pine is limited mainly to mountain ridges and slopes of intermediate elevations in northern Colorado and does not occur as plateau forest. Douglas-fir type concentrations occur in scattered areas in the south-central part of the State.

Engelmann spruce dominates in commercial timber volume. Almost one-half of the sawtimber volume and more than one-third of the growing stock volume in Colorado is Engelmann spruce. The following is a tabulation of volumes of Engelmann spruce and other commercial species in Colorado:

<u>Species</u>	<u>Sawtimber (Million bd. ft.)</u>	<u>Growing stock (Million cu. ft.)</u>
Engelmann spruce (<u>Picea engelmannii</u> Parry)	25,592	6,201
Lodgepole pine (<u>Pinus contorta</u> Dougl.)	6,024	3,286
Subalpine fir (<u>Abies lasiocarpa</u> (Hook.) Nutt.)	5,455	2,081
Douglas-fir (<u>Pseudotsuga menziesii</u> (Mirb.) Franco)	5,411	1,590
Ponderosa pine (<u>Pinus ponderosa</u> Lawson)	3,783	1,017
Aspen (<u>Populus tremuloides</u> Michx.)	3,482	2,358
Other	<u>2,984</u>	<u>804</u>
Total	52,731	17,337

Field work completed
commercial forest land in
first Forest Survey in
Arizona and New Mexico

Sample plot work on commercial forest land has been completed on the initial Forest Surveys of Arizona and New Mexico. Data are now being compiled.

These surveys are designed to use available inventory data on Indian Lands and National Forests, and to supplement where necessary with additional sample plots on all lands. The new multiple-point acre-sampling system was employed. In addition to furnishing the items of data that have been standard in previous Forest Surveys, this system provides for classification of forest areas according to condition and is designed to provide an accurate index of the management need on the sample acre. Types of information gathered for the latter purpose include data on crop trees, excess and competing trees, site, and age.

Field work on wood-
density study completed

Data on wood density of softwood species were obtained on Forest Survey plots in Arizona, New Mexico, Colorado, and Wyoming. The data will be used in a study of wood strength.

Wood density in terms of pounds per cubic foot is becoming recognized as a useful quality measure for primary products such as sawtimber and pulpwood. It is a reliable indicator of strength properties and of fiber yields.

Volume of logging
residues studied

On 12 sample sawtimber logging operations surveyed in Colorado and Wyoming, the average volumes of main stem residue to a minimum diameter of 4 inches ranged from 6 to 26 percent of the net cubic volume removed. Residues measured included tops, broken sections, cut-outs, long butts, and (infrequently) portions of stumps above 1 foot in height. On all operations, the stem above the top cut to a diameter of 4 inches inside bark accounted for most of the residues. Upper stem residues were frequently 20 feet or more in length, and ranged up to more than 40 feet.

Quality of residues was found to be influenced greatly by species characteristics. Potential utility of ponderosa pine upper stem residue is seriously limited by the closely spaced large limbs and consequent large volume in large knots. Residue in the form of broken pieces was found to be more frequent on ponderosa pine operations. The presence of many small limbs is a problem on lodgepole pine, Engelmann spruce, and subalpine fir residues.

The economics of potential use of residues were found to be influenced by logging methods. Three different procedures in bucking and skidding were encountered in the study. On some operations, trees were bucked where they fell, in

lengths up to 32 feet, and tops were bucked free. In other operations, the faller made a top cut only and the entire merchantable length was skidded. Other operators skidded the entire tree, butt first or top first, to a landing. Many limbs were broken off when trees were skidded top first. Residues from tree-length skidding are economically more available for potential use, since almost all residues are accumulated and piled relatively limb-free at roadside landings (fig. E-2).

Figure E.2. — Engelmann spruce logging residues at a landing for a sawtimber operation on Roosevelt National Forest, Colorado. These residues average about 7 inches in diameter inside bark at the large end, and range up to 20 feet or more in length to the diameter point of 4 inches.



Wood residues from sawtimber operations in the two States are not being used commercially at the present. They represent a possible source of low-cost wood raw material because the costs of roads, felling, partial bucking, and in many cases skidding have already been fully charged against the saw logs removed.

FOREST RECREATION

Patterns of campground use

An exploratory study has been started to determine the patterns of visitor use and visitor preference for established recreation units on 12 sites in National Forests of the Central Rocky Mountain and Southwestern regions. A basic understanding of these use and preference patterns is essential to further research on the effects of recreation use on resources, and the economic and social values of outdoor recreation.

An analysis of observations at two sites -- Walton Creek in northwestern Colorado and La Sombra-Capulín in northern New Mexico -- illustrates camping and day-use

patterns by recreationists. Usage was observed over two 4-day periods (Friday-Monday), one in mid-July, the other at the end of August.

So far the study of the two sites shows:

1. A high proportion of out-of-State users (over half).
2. A high percentage of visitors in the 21-39 and 13-and-under age classes (about 2/3 of the total).
3. A nearly equal distribution between males and females.
4. A nearly equal use of tents and travel trailers for camping.
5. An average of four people per vehicle and of five people per party.
6. A nonuniform use of the units--some units receiving up to 40 times more use than others (figs. E-3).
7. A nonuniform preference of units--some units receiving up to 10 times as many new parties as others.

The peak use of the Colorado site came in July, when out-of-State users predominated. The level of use by in-State recreationists was about the same for both observation periods. Use of the New Mexico site was more uniform, with slightly more campers and fewer day users during the later period.



Unit 2 picked by many recreationists.



Unit 9 received little use, though available most of the time.

Figure E-3. - Walton Creek Recreation Site, Colorado.

MULTIPLE-USE EVALUATION

Beaver Creek multiple-use evaluation project

The operations of the Beaver Creek Project near Flagstaff, Arizona, have made possible comparison of product yields and the costs of some of the land treatments. The time period is still short, so the indicated numbers must be considered as approximate. The data obtained and the analysis framework devised will provide guidance information for land management for efficient integrated production of the various products under a multiple-use system.

Table E-1. --A first approximation of the product mixture from the pine pilot watersheds on Beaver Creek

Product	Measurement units	Average production		Periodic annual production
		1960	1961	
Water	Streamflow, in inches ¹	5.5	1.7	
Forage:				
Grass	Pounds per acre, air-dry ²	50.0	95.0	
Total herbage	Pounds per acre, air-dry ³	--	145.0	
Timber	Cubic feet, periodic annual growth ⁴	--	--	35
Game	Acres, per deer ⁵	--	90.0	
Hunter use	Acres, per hunter day ⁶	--	25.0	

¹ Measured from six watersheds of 500 to 2,000 acres in size. 1960 data range between watersheds, 4.1 to 7.5 inches; 1961 range, 0.73 to 2.39 inches.

² Estimated from 150 plots randomly located in groups of 5 with estimates adjusted from 30 clip plots--only perennial grasses.

³ Estimated as above including annual grass, perennial and annual herbs, and browse as well as perennial grass.

⁴ From 42 plots on Beaver Creek measured in 1950 and remeasured in 1961. Most of this growth occurs on saplings and poles.

⁵ From 120 1/100-acre pellet plots randomly located in groups of 4 adjusted by a rate of 13 pellet groups per day. New data from a more vigorous sample suggest this figure may be lower.

⁶ Estimated from traffic counter and hunter check station data.

Table E-2. --Typical costs for Beaver Creek treatments (all costs refer gross acreage)

Treatments	:	Costs
		<u>Dollars</u>
Juniper removal:		
Light stands		7.00-11.00
Heavy stands		11.00-13.50
Juniper broadcast seeding		1.50- 2.50
Pine conversion 1959 (in saw log market only):		
Clearing	52.40	
Seeding	<u>8.60</u>	
Project cost		61.00
Timber returns per acre:		
Stumpage	4.40	
Timber stand improvement	5.90	
Slash disposal	5.00	
Erosion control	<u>2.00</u>	
Total returns		<u>17.30</u>
Net cost of converting pine to grass		43.70
Precommercial thinning		6.00- 9.00
Machine slash piling		6.00- 8.00

Range Management and Wildlife Habitat Research



Range plants differ in their response to competition in the Southwest

Common plants on the Santa Rita Experimental Range in southern Arizona generally were found to grow best in the absence of competition from other species. Responses of different plants to competition were considerably different, however.

Production of perennial grasses, mainly Arizona cottontop (Trichachne californica (Benth.) Chase) and three-awns (Aristida spp.), was essentially the same in 1961, regardless of the presence or absence of annual grasses or burroweed (Haplopappus tenuisectus (Greene) Blake). In contrast, crowns of individual burroweed plants grown in pure stands increased in size 74 percent between June and November; where grown in association with annual or perennial grasses, their size changed little, if at all. Total crown area of burroweed increased 26 percent on plots with no competing vegetation and decreased 24 percent under competition with perennial grasses (fig. R-1).

Annual grasses, primarily needle grama (Bouteloua aristidoides (H. B. K.) Griseb.) were affected most by competition. They produced nearly three times as much herbage where grown alone as where they competed with perennial grasses (Fig. R-2). Their production was curtailed about 200 pounds per acre by burroweed alone and 440 pounds by perennial grasses alone, but production was reduced no further by a combination of burroweed and perennial grasses.

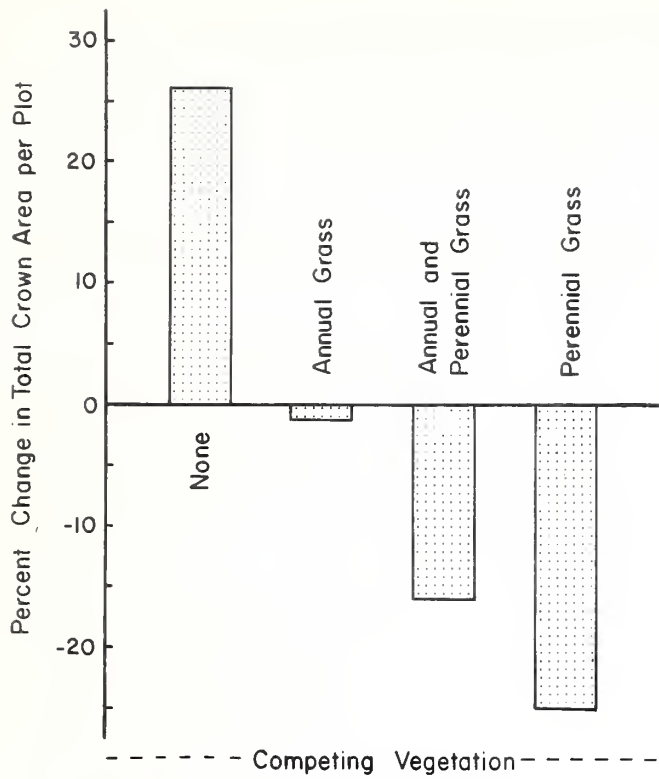

Figure R-1. — Changes in crown cover of burweed from June to November 1961 when grown alone and when competing with other plants (Santa Rita Experimental Range).

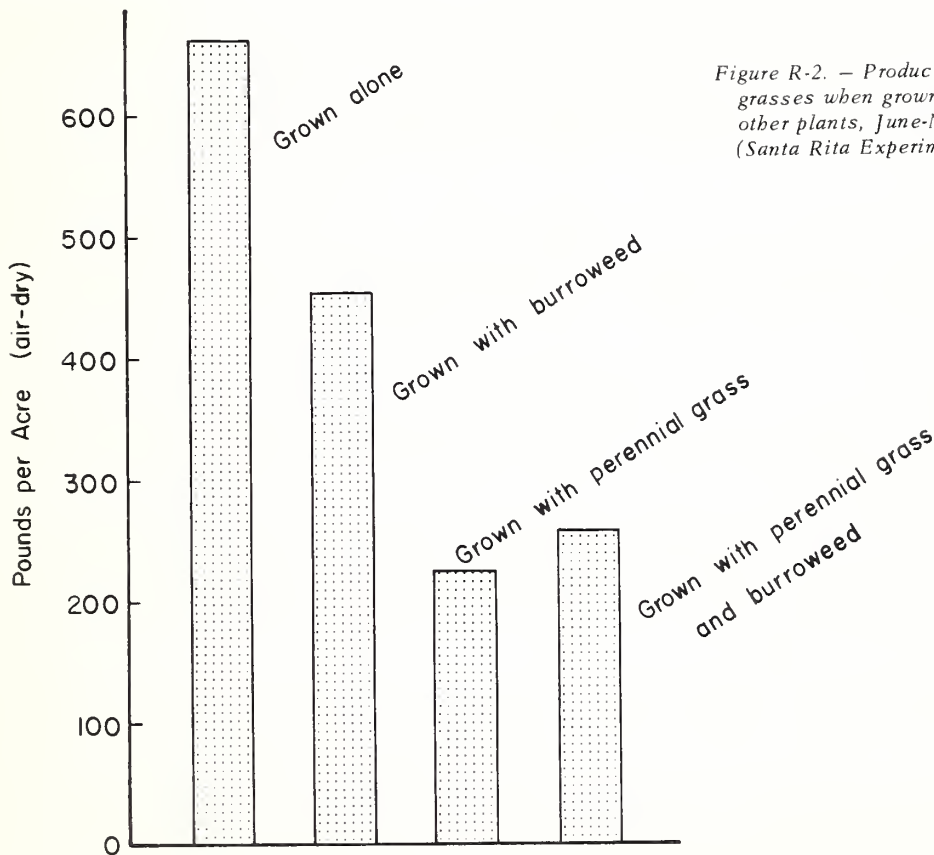
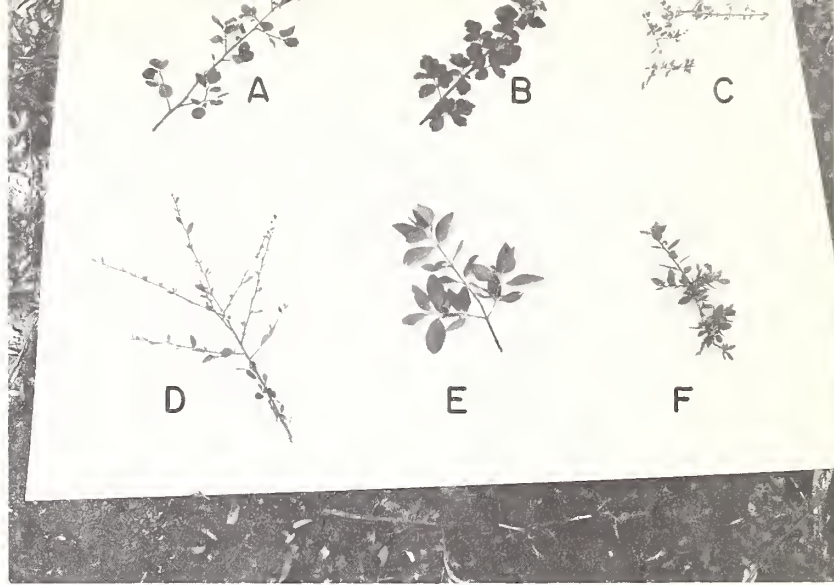

Figure R-2. — Production of annual grasses when grown alone and with other plants, June-November 1961 (Santa Rita Experimental Range).

Figure R-3. — Growth characteristics were observed for these six Arizona chaparral species:

- A, Hollyleaf buckthorn
(*Rhamnus crocea* Nutt.)
- B, Skunkbush sumac
(*Rhus trilobata* Nutt.)
- C, Desert ceanothus
(*Ceanothus greggii* A. Gray)
- D, Hairy mountainmahogany
(*Cercocarpus breviflorus* A Gray)
- E, Wright silktassel
(*Garrya wrightii* Torr.)
- F, Shrub live oak
(*Quercus turbinella* Greene)



Chaparral shrubs differ in growth characteristics

Common shrubs in the chaparral of central Arizona differ not only in time and amount of twig growth, but also in time of flowering and fruiting. These differences, if found to be consistent in subsequent years, will help point the way to selective control of the less desirable plants or to a type of management that would benefit the more desirable ones. Because of variations in plant growth and development, control measures may be more damaging to one plant species than another at a given time.

Measurement of tagged twigs in 1962 (figs. R-3, R-4) before and during the growing season revealed that desert ceanothus was first among six common shrubs to begin growth. Flower buds began to swell in mid-February and twig growth began the middle of March (fig. R-5). Plants flowered in early April when twig growth was still active, and produced mature fruit soon after the first of June. This was about 5 weeks earlier than fruit of hairy mountainmahogany matured.

Hollyleaf buckthorn was last to begin growth. It did not start until after twig growth of ceanothus had been completed. Though its flowering period was similar to that for some other shrubs, its fruits were still immature on October 1.

Wright silktassel was just beginning to flower on November 1. Another oddity was that hairy mountainmahogany flowered twice, first in late May and again in September.

Figure R-4. — Measuring twig length on a desert ceanothus branch. The beginning point for measurement is the first lateral or pair of lateral twigs above the metal tag.



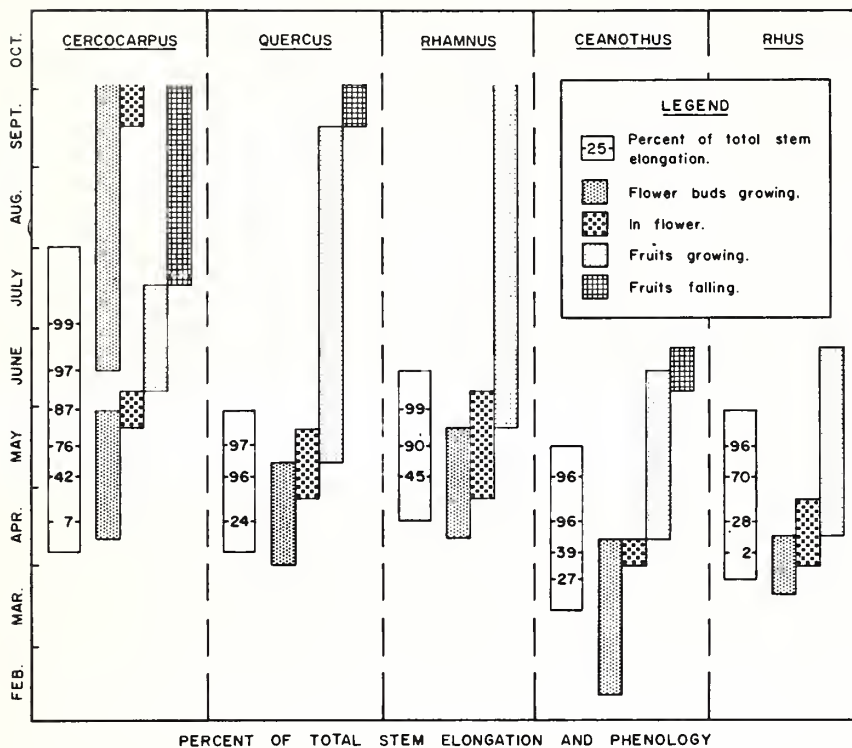

Figure R-5. - Period of growth and development of common shrubs in the chaparral of central Arizona, 1962.

Growth of mountainmahogany believed related to soil fertility

True mountainmahogany (*Cercocarpus montanus* Raf.) is widely distributed along the Front Range of the Rockies, and existing plants are browsed extensively by deer. That the plants are larger and more numerous on some soils than others appears to be due partly to differences in soil nutrients.

Because the growth of Moravian barley (*Hordeum vulgare* L.) on soils in the greenhouse is positively related to the size and stand density of mountainmahogany growing on the same soils in the field, barley was used in greenhouse soil-fertility studies to help determine how and where production of mountainmahogany might be increased most efficiently.

Analyses of surface soils taken from several parent materials near Woodland Park, Colorado, showed considerable differences in amount of organic matter, total nitrogen (N), phosphorus (P), and potassium (K) in the soils (table R-1). The production of barley also varied sevenfold among the soils.

When different fertilizers were applied to test for nutrient deficiencies, it was found that nitrogen was most limiting in some soils, and phosphorus in others (fig. R-6). Also, findings indicate that present production of all soils studied must be much lower than their potential.

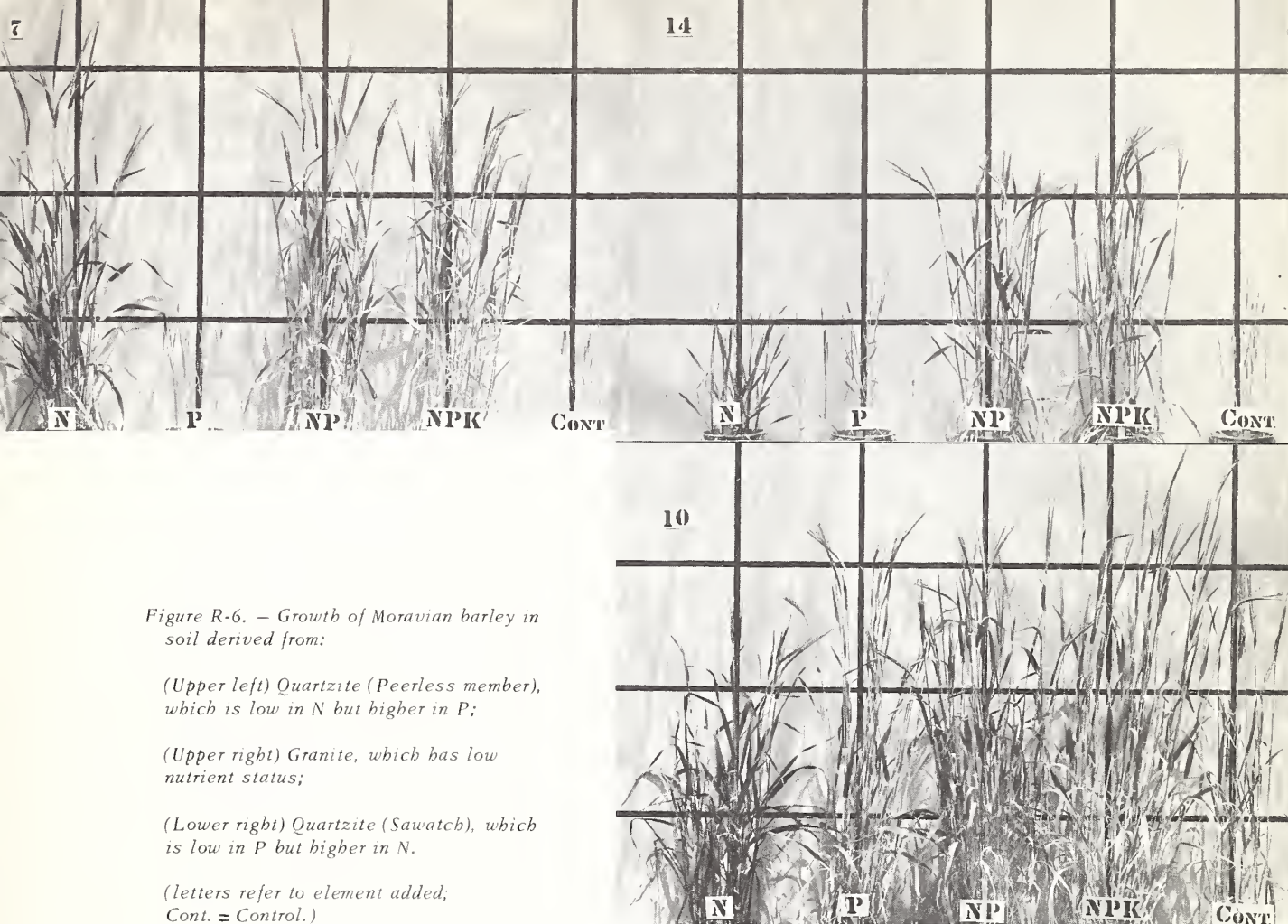

Figure R-6. - Growth of Moravian barley in soil derived from:

(Upper left) Quartzite (Peerless member), which is low in N but higher in P;

(Upper right) Granite, which has low nutrient status;

(Lower right) Quartzite (Sawatch), which is low in P but higher in N.

(letters refer to element added; Cont. = Control.)

Table R-1. -- Barley yield as related to organic matter and nutrient content of soils ("A" horizons only) derived from different parent materials in the Front Range of Colorado

Soil parent material	Yield	Organic	Nitrogen	Phosphorus	Potassium
	per pot	matter	(N)	(P)	(K)
	Grams	Percent		Pounds per acre ¹	
Quartzite (Sawatch)	12.8	7.4	0.29	23	325
Limestone:					
(Madison or Manitou)	12.2	5.9	.26	30	315
(Williams Canyon)	7.2	6.9	.21	34	265
Quartzite (Peerless)	6.5	2.1	.06	86	150
Arkose (Fountain)	3.8	3.4	.09	13	120
Granite (Pikes Peak)	1.7	2.0	.05	17	190

¹In upper 6 inches of soil.

Germination of mountainmahogany seed speeded by chilling

Seed of true mountainmahogany that had been wetted and chilled germinated more rapidly than untreated seed in recent tests at Fort Collins, Colorado. Chilling for 22 days at 5° C. resulted in faster initial germination than chilling for 14 days. Final germination at the end of 3 weeks was essentially the same, however, whether the seed had been treated or not:

Number of days in germinator:	No treatment	14 days, 5° C.	22 days, 5° C.
	(Percent germination)		
2	0	0	6
3	0	4	24
7	4	37	60
14	48	54	62
21	68	54	62

During the tests, daytime temperatures were maintained at 30° C. and nighttime temperatures at 20° C. Untreated seed had been in dry storage for 2 months, and treated seed for 4 months.

Seedlings from treated seed were more vigorous and freer from mold than those from untreated seed. This might make a difference in their survival.

Elk and cattle prefer forest openings

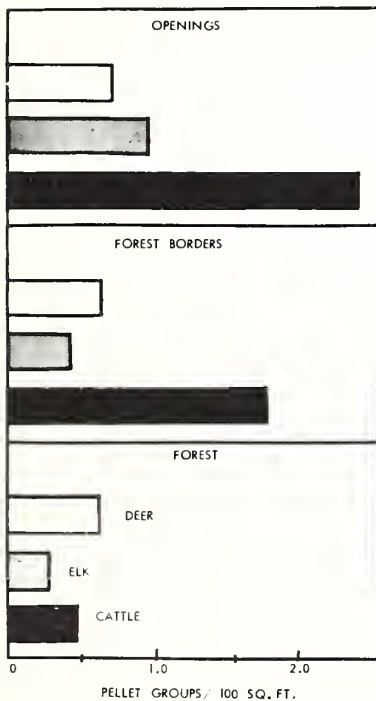

Elk and cattle were found to make more use of the natural openings than forest borders or adjacent selectively cut ponderosa pine (*Pinus ponderosa* Lawson) forests in eastern Arizona (fig. R-7). Cattle used forest borders, the areas adjacent to open grasslands, nearly as much as the openings, while elk used borders only half as much as openings.

On the other hand, deer used all the habitats studied about equally. Selective cutting of the pine forests during the past 5 to 15 years had opened the forest sufficiently to promote growth of good deer forage.

Natural openings studied ranged from less than an acre to almost 40 acres. The findings are based on counts of accumulated droppings, which reflect use of the different habitats for cover as well as for food.

Figure R-7. — Use of different habitats in cutover ponderosa pine forests by deer, elk, and cattle as indicated by accumulated droppings.

**Understory vegetation in
pine most productive
6 years after logging**

The herbaceous understory in selectively cut stands of ponderosa pine in northern Arizona apparently is the most productive, and perhaps the most attractive to deer during a period 5 to 10 years after logging.

Comparisons in 1962 of understory vegetation in stands cut 1, 2, 4, 6, 8, and 11 years ago showed that herbage production peaked 6 years after logging at about 200 pounds per acre (fig. R-8). Though grasses and sedges comprised most of the herbage, forbs also were relatively abundant at that time.

Herbage production in 1962 in an area cut 11 years earlier averaged 85 pounds per acre, only 13 pounds more than that in nearby uncut stands. Grasses, sedges, and forbs evidently were still decreasing, but quaking aspen (*Populus tremuloides* Michx.) sprouts continued to increase slowly (fig. R-9). Grasses were more abundant than sedges at the end of the 11-year period, a reversal of conditions in uncut stands.

Pellet-group counts indicated that deer prefer unlogged areas over logged areas for the first 2 years after logging. Thereafter, they apparently prefer cut-over areas, for pellet groups were several times as numerous there as in uncut stands.

Tentative conclusion from this exploratory study is that selective cutting in ponderosa pine may improve deer habitat for as long as 15 years. Further study of these relationships is underway.

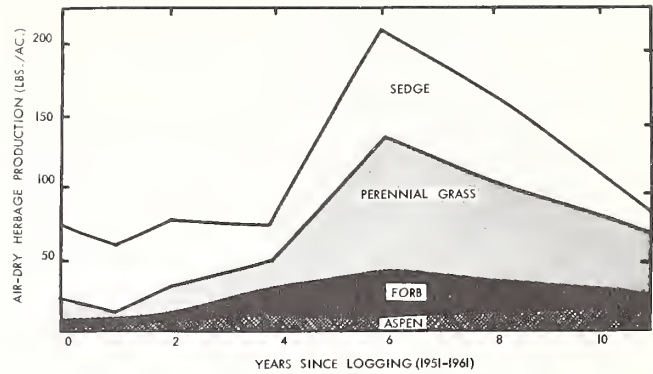

Figure R-8. — Understory vegetation in selectively cut pine stands in northern Arizona is most abundant 5 to 10 years after logging.

Figure R-9. — Aspen sprouts continued to develop 11 years after this pine stand was cut over. Other herbaceous plants that increased after logging are inconspicuous.





Figure R-10. - (Upper) fistulated steers with "plugs" in place; (lower) removing a sample of rumen contents for chemical analysis.

Protein in steer rumen is higher than protein content of main forage grasses

Crude protein content of rumen samples from fistulated steers on the Santa Rita Experimental Range in southern Arizona (fig. R-10) was found to be consistently higher than that of Arizona cottontop and Lehmann lovegrass (Eragrostis lehmanniana Nees), the principal forage grasses present.

Records taken at intervals during 1961 and 1962 in a cooperative study with the University of Arizona suggest that cattle on semidesert range may be quite selective in their eating habits. Evidently they select plants or plant parts that are much higher in protein than run-of-the-mill herbage. Among the plants present that might contribute to the diet are mesquite (Prosopis juliflora var. velutina (Woot.) Sarg.), false-mesquite (Calliandra eriophylla Benth.), catclaw acacia (Acacia greggii A. Gray), and Engelmann pricklypear (Opuntia engelmannii Salm-Dyck). Several annual grasses and forbs were also abundant during early spring and midsummer when protein content was high.

Table R-2 shows crude protein in the grasses was much below that in the rumen samples on all dates.

Table R-2. --Comparison of crude protein content of principal grasses and rumen samples from three steers, Santa Rita Experimental Range, Arizona

Date sample was taken	Principal grasses			Rumen samples
	Lehmann lovegrass	Arizona cottontop	Average	
----- Percent -----				
1961: May 24	2.5	4.0	3.2	6.8
June 17	2.6	4.0	3.3	6.5
August 25	9.4	8.5	9.0	17.9
September 28	9.6	8.2	8.9	12.9
November 22	5.1	3.9	4.5	9.3
1962: February 21	6.2	3.2	4.7	10.4
March 30	5.2	3.8	4.5	15.9
April 25	7.1	6.1	6.6	12.3

**Crested wheatgrass makes
good lambing range**

Over a 3-year period, 1957-59, seeded crested wheatgrass (Agropyron desertorum (Fisch.) Schult.) was found to be as good or better lambing range than native sagebrush (Artemisia spp.) and woodland range in northern New Mexico (fig. R-11). Five to seven percent larger lamb crops were obtained on the crested wheatgrass. Gains of individual lambs on native and seeded lambing range were similar, although gains tended to be somewhat higher on crested wheatgrass stocked lightly (table R-3).

Reasons for the higher lamb crops on crested wheatgrass are not readily apparent. Nutritive values of both native browse and crested wheatgrass are generally high during spring months, and nutrient deficiencies at that time would not be expected.

Sheep from the various lambing ranges grazed together on summer range. The market weights of the lambs in early October were about the same, regardless of the kind of lambing range used. Nevertheless, the acreage required to produce each lamb was much less on crested wheatgrass than on native range.

to lambing on crested wheatgrass. Only 4 to 7 years would be needed to repay the investment in seeded grass.

Figure R-11. - Lamb crops will be larger, ewe death losses smaller, and net returns higher if sheep operators shift from lambing on sagebrush range like this,



or this,



Table R-3. --Comparison of lamb crops on native and seeded ranges in northern New Mexico, 1957-59

Kind of range and stocking rate (sheep days per acre)	Average range utilization	Daily gain of lambs	Fall records (market time)	
	Percent	Pounds	Lamb crop Percent	Weight of lambs Pounds
Native range:				
¹ 40	(²)	0.55	78	74
Crested wheatgrass:				
75	39	.62	83	76
99	53	.56	85	73
115	72	.57	85	73
150	84	.54	85	73

¹ Estimated; unfenced in 1957.

² Native grasses--up to 19%; forbs--up to 32%; shrubs--up to 16%.

Lambing on wheatgrass is profitable

Sheep ranchers in northern New Mexico can increase their operating return if their ewes lamb on crested wheatgrass instead of on native sagebrush and woodland range, according to budgets prepared as part of a cooperative study with the New Mexico Agricultural Experiment Station. Net cash income, based on an average sheep enterprise of 650 ewes, might be as much as \$4,417 when they lamb on wheatgrass compared with only \$3,664 on native range (table R-4). The increased return from lambing on wheatgrass would range from \$440 to \$608, or 19 to 27 percent, depending on how heavily the seeded range is grazed. Four to seven years would be required to repay the investment in crested wheatgrass.

Table R-4. --Net returns from lambing 650 ewes on native range and crested wheatgrass grazed at different intensities, northern New Mexico, 1957-59

Kind of range and grazing intensity	Cash income	Returns to operator	Returns above native range	Time needed to repay investment
	----- Dollars -----			Years
Native range	3,664	2,270	--	--
Crested wheatgrass:				
39 percent use	4,329	2,762	492	7
53 percent use	4,417	2,878	608	4
72 percent use	4,364	2,805	535	4
84 percent use	4,266	2,710	440	4

Steers graze certain
forbs when available

Some forbs on mountain grasslands in western Colorado are grazed as closely as grasses by cattle during midsummer. After the first heavy frost, however, usually in early September, many become dry and brittle and apparently lose most of their value as forage.

On August 1, 1961 and 1962, 2 weeks after yearling steers were turned into experimental pastures on Black Mesa, average utilization of grasses ranged from 2 to 7 percent. Average utilization of common grasses and forbs, in percentage of herbage weight, measured at various intervals after opening of the grazing season, was as follows (forbs not measured at 10 weeks):

	<u>2 wks.</u>	<u>5 wks.</u>	<u>10 wks.</u>
	- - -(Percent)- - -		
GRASSES:			
Idaho fescue (<u>Festuca idahoensis</u> Elmer)	7	10	34
Slender wheatgrass (<u>Agropyron trachycaulum</u> (Link) Malte)	6	13	31
Letterman needlegrass (<u>Stipa lettermanii</u> Vasey)	3	6	27
Thurber fescue (<u>Festuca thurberi</u> Vasey)	4	12	26
Elk sedge (<u>Carex geyeri</u> Boott.)	2	7	21
Subalpine needlegrass (<u>Stipa columbiana</u> Macoun)	2	7	17
Prairie Junegrass (<u>Koeleria cristata</u> (L.) Pers.)	2	4	17
FORBS:			
Agoseris (<u>Agoseris</u> spp.)	9	14	--
Common dandelion (<u>Taraxacum officinale</u> Wiggers)	8	14	--
Aspen fleabane (<u>Erigeron macranthus</u> Nutt.)	3	13	--
Aspen peavine (<u>Lathyrus laetivirens</u> Greene)	2	5	--
Fremont geranium (<u>Geranium fremontii</u> Torr.)	1	2	--
Beauty cinquefoil (<u>Potentilla pulcherrima</u> Lehm.)	1	1	--
Hairy goldaster (<u>Chrysopsis villosa</u> (Pursh) Nutt.)	1	1	--
Douglas knotweed (<u>Polygonum douglasii</u> Greene)	0	0	--

At 2 weeks, use of agoseris averaged 9 percent, and common dandelion 8 percent. Three weeks later, use of these forbs amounted to 14 percent. Aspen fleabane was utilized 13 percent, the same as slender wheatgrass, which had been grazed as heavily as any other grass.

Several grasses were grazed proportionately more during the last half of the season than during the first half. For example, Idaho fescue, utilized 34 percent by the end of the season, received two-thirds of that use after midseason. The fact that forbs furnish little forage in late season may explain in part why utilization of grasses and sedges tends to accelerate at that time.

Rotation grazing alters
use of Idaho fescue

Different grazing systems in the Bighorn Mountains of Wyoming have resulted in markedly different use of Idaho fescue, the principal forage plant. On range grazed seasonlong, June 20 to September 20, utilization of Idaho fescue averaged 42 percent from 1959 to 1961. On adjacent range stocked at the same rate, but on which cattle were rotated among three units during the season, utilization of Idaho fescue averaged only 21 percent. Meanwhile, on a third range on which cattle were rotated among three units, but where stocking was 50 percent greater than on range grazed seasonlong, utilization of Idaho fescue was 37 percent.

Under the rotation systems, Idaho fescue tended to be utilized more closely on range units grazed last in the season than on those grazed first (table R-5). Over the 3-year period, this difference averaged 16 percent under the lighter stocking and 26 percent under the heavier stocking. Because individual units were grazed at different times from year to year, however, average use of all units in a particular rotation system was about the same for the 3-year period. Under the lighter stocking, average use of Idaho fescue on individual units varied from 18 to 24 percent, and under the heavier stocking it varied from 36 to 38 percent.

Table R-5. --Utilization of Idaho fescue in individual range units grazed seasonlong as compared with use under three-unit rotation grazing. Bighorn Mountains, Wyoming

Grazing system and period	1959		1960		1961		Average utilization
	Grazing unit	Utili- zation	Grazing unit	Utili- zation	Grazing unit	Utili- zation	
	No.	Pct.	No.	Pct.	No.	Pct.	
<u>Seasonlong grazing:</u>							
June 20-Sept. 20	--	43	--	47	--	35	42
<u>Rotation grazing:</u>							
(stocking rate same as seasonlong)							
June 20-July 20	1	6	2	23	3	18	16
July 21-Aug. 20	2	10	3	21	1	19	17
Aug. 21-Sept. 20	3	27	1	29	2	40	32
Average		14		24		26	21
(stocking rate 1-1/2 times seasonlong)							
June 20-July 20	1	6	2	35	3	30	24
July 21-Aug. 20	2	23	3	37	1	50	37
Aug. 21-Sept. 20	3	45	1	51	2	55	50
Average		25		41		45	37

Motion picture highlights
range management research

Results of 17 years of research at the Manitou Experimental Forest near Colorado Springs, Colorado, were highlighted in a 20-minute motion picture film entitled "Rangeland Research at Manitou." Relative benefits in terms of forage and beef production, watershed stabilization, and net income from grazing pine-bunchgrass ranges at different degrees are presented and discussed. The film is available for loan from the Station and from USDA film libraries.

Range rested without
reducing stocking

Under a four-unit rotation grazing system on a cattle allotment in southern Wyoming, one-fourth of the range has been rested each year without increasing the degree of utilization on the heavily grazed portions of the remainder of the allotment (table R-6).

In 1956 and 1957, when the 15,000-acre allotment was being grazed seasonlong, principal grasses in the bottoms were utilized about 41 percent, based on plant height. In 1958 the allotment was divided into four units. Grazing was rotated among three of the units and the fourth unit was rested. In the 4-year period, 1958-61 inclusive, utilization of the principal grasses on the three units grazed each year averaged 34 percent, but varied from 28 to 41 percent. Except in 1961, utilization on the bottomlands was less than in either 1956 or 1957, when the area was grazed as a single unit.

Similarly, average use of upland slopes was reduced from an average of 16 percent when the whole area was grazed on a summerlong basis to an average of 10 percent when three-fourths of the area was grazed under the rotation. The fairly gentle slopes are occupied by sagebrush and grassy areas; bottomlands support a mixture of grasses and sedges (Carex spp.). Stocking rate was the same under both systems of grazing.

Vegetation changes resulting from the rotation and periodic resting of the range are being evaluated.

Table R-6. --Use of important forage plants on a large cattle allotment under continuous summerlong grazing and under rest-rotation grazing. North Pasture Allotment, Medicine Bow National Forest, Wyoming

Forage type, grazing system, and year	: Unit 1	: Unit 2	: Unit 3	: Unit 4	: Average
	- - - Percent of plant height - - -				
BOTTOMLAND (GRASS)					
Continuous grazing:					
1956	31	33	51	46	40
1957	35	38	45	46	41
Average	33	36	48	46	41
Rotation grazing:					
1958	19	31	33	(¹)	28
1959	(¹)	36	40	38	38
1960	39	(¹)	23	25	29
1961	33	51	(¹)	40	41
Average	30	39	32	34	34
UPLAND (GRASS AND BROWSE)					
Continuous grazing:					
1956	17	21	19	25	21
1957	6	12	16	11	11
Average	12	16	18	18	16
Rotation grazing:					
1958	8	15	19	(¹)	14
1959	(¹)	7	12	5	8
1960	8	(¹)	9	10	9
1961	11	14	(¹)	9	11
Average	9	12	13	8	10

¹Not grazed.

Seeding of fourwing saltbush on
western New Mexico rangelands
appears feasible

Five thousand fourwing saltbush (Atriplex canescens (Pursh) Nutt.) plants per acre were present in 11-year-old range seedings near Magdalena, New Mexico, in 1962. Though not a dense stand, that number of plants might aid substantially in overcoming nutrient deficiencies for game and livestock during winter months. Fourwing saltbush is noted for its high protein content during much of the year.

Especially encouraging is the fact that a fairly good stand of the shrubs developed on an unprepared seedbed (fig. R-12). Whether seeding was by grain drill or cultipacker-seeder made little difference. Native plant cover on the seeded areas consisted of a moderately dense stand of blue grama (Bouteloua gracilis (H. B. K.) Lag.), ring muhly (Muhlenbergia torreyi (Kunth) Hitchc.), and broom snakeweed (Gutierrezia sarothrae (Pursh) Britt. & Rusby).

Considerably better stands of fourwing saltbush developed where the land was pitted, plowed, or plowed and pitted before it was seeded, but costs were much higher. Listed below are numbers of saltbush plants per mil-acre that had emerged 2 months after seeding in 1951 and corresponding numbers in 1962 on the seedbeds prepared and seeded by different methods. All plots were seeded June 25-29, 1951.

	<u>No. plants per mil-acre</u>	
	<u>1951</u>	<u>1962</u>
Drilled:		
No preparation	10	5
Pitted	24	12
Plowed	30	11
Plowed and pitted	25	9
Cultipacked-seeded:		
No preparation	5	5
Pitted	30	10
Plowed	60	13
Plowed and pitted	49	16

Not only did more seedlings emerge from prepared seedbeds, but more survived as 11-year-old plants. Of the methods of seeding and mechanical preparations of the seedbeds tested, none proved definitely superior. Results suggest, however, that loose seedbeds should be cultipack-seeded and that firm seedbeds should be drilled.

Size of plants was about the same on all plots in 1962, regardless of how or whether the seedbed had been prepared. Thriftiness of stands was also similar. Recent mortality of fourwing saltbush was less than 2 percent on any plot.

How well fourwing saltbush holds up under grazing and how widely these findings may apply must await further tests.



1951

Figure R-12. - Fourwing saltbush planted in New Mexico 11 years ago.

A relatively good stand was obtained by cultipack seeding directly in an unprepared seedbed,

but a better stand resulted from plowing, then cultipack-seeding.

1962



Big bluegrass seedings
are highly productive

In pounds of beef produced and animal-days of grazing, Sherman's big bluegrass (*Poa ampla* Merr.) is proving to be superior to other seeded species in the ponderosa pine type at Manitou Experimental Forest in Colorado.

	Pounds of beef per acre	Animal-days per acre
Big bluegrass	113	74
Crested wheatgrass (<i>Agropyron cristatum</i> (L.) Gaertn.) and smooth brome (<i>Bromus inermis</i> Leyss.)	72	40
Crested wheatgrass	59	34
Intermediate wheatgrass (<i>A. intermedium</i> (Host) Beauv.)	52	29
Russian wildrye (<i>Elymus junceus</i> Fisch.)	40	36
Smooth brome	40	22

As shown above, big bluegrass produced over 50 percent more beef and nearly twice as many animal-days of grazing per acre as its nearest rival, a mixture of crested wheatgrass and smooth brome.

The intensity of grazing on big bluegrass during the summers of 1951-61 had little effect on the amount of herbage produced. Production was closely related, however, to the amount of rainfall received during the growing season:

	1959	1960	1961
	(Pounds per acre, air dry)		
Grazing intensity:			
Heavy (2-inch stubble)	1,649	1,226	2,330
Moderate (4-inch stubble)	1,693	1,344	2,492
Light (6-inch stubble)	1,564	1,234	2,361
		(Inches)	
Rainfall: (April-August)	7.83	6.69	16.25

As experienced elsewhere, big bluegrass was slow to become established. Consequently, grazing trials were delayed until those for other species had been nearly completed. Even when the 3-year-old stands of bluegrass were first grazed in 1959, many young plants were pulled up by cattle (fig. R-13). Once established, however, big bluegrass appears to be outstanding in its ability to produce forage and beef.



Figure R-13. — These young plants of big bluegrass were pulled up by cattle before they were firmly established.

Plant counts are better than distance-measure methods to determine range-plant density

Although the angle-order method of estimating plant density gives accurate results, this distance-measure method is not efficient when time requirements are considered (fig. R-14).

The point-centered quarter method is rapid but gives biased estimates of density when plants are non-randomly distributed. The angle-order method took about four times as long as the plant-count method in this range type. Because little, if any, gain in precision was achieved, the angle-order method was less efficient than the plant-count method. Neither the point-centered quarter or the angle-order method is recommended for estimating density of range plants. Tests conducted at the Santa Rita Experimental Range in southern Arizona provided the following comparisons:

		<u>Arizona cottontop</u>	<u>Cholla</u> (<u>Opuntia spp.</u>)	<u>Velvet mesquite</u>
1959	Plant-count	4,304	1,215	103
	Point-centered quarter	1,792	535	98
	Angle-order	4,665	1,107	110
1960	Plant-count	960	279	99
	Angle-order	942	297	105

Ranked sets increase efficiency in estimating herbage production

A method of selective sampling that involves ranking shows great promise in estimation of plant weight, height, or other plant characteristics that can be ranked in relative order. For example, where three plots in a set or cluster are ranked according to weight of herbage present, the highest ranking plot would be clipped at the first location, the middle rank at the second location, and the lowest rank at the third location (fig. R-15). The whole process is repeated until a sufficient number of plots is clipped. Tests conducted with sets of three plots, in cooperation with the Pacific Southwest Forest and Range Experiment Station in California and with the Southern Forest Experiment Station in Louisiana, show that a sample of 100 clipped plots from ranked sets would give about the same precision as 160 clipped plots from a completely random sample with one size of plot.

Figure R-15, - One set of three plots used in the "ranked-sets" method of estimating herbage production.



Figure R-14. - The angle-order method of measuring plant density is based on the distance from a sample point to the third nearest plant in each of four quadrants around the point.





Figure R-16. - (Left) Thickets of ponderosa pine are being cut to give grass and selected trees a chance to grow;



(Right) Trees thinned to a basal area of 60 square feet per acre. Slash will later be piled and burned and the understory vegetation allowed to grow.

Relation of timber and range production being studied

Ability of ponderosa pine forests in northern Arizona to produce forage and beef, as well as, or instead of, timber, is being studied near Flagstaff. Forage and timber production values are being compared under existing conditions of dense ponderosa pine stands and when thinned to leave basal areas of 0, 20, 40, 60, and 80 square feet per acre (fig. R-16). Understory vegetation will be allowed to develop naturally on these areas. In addition one area will be clear cut and seeded to crested and intermediate wheatgrasses. These species are well adapted to ponderosa pine ranges in Arizona. Most of these cuttings and thinnings are more severe than generally recommended for timber production alone.

Records of herbage production, grazing patterns, nutrient value of forage, and beef production under the various conditions are expected to provide guides to future management and more economical use of those lands.

Black Hills bluegrass deficient in nutrients in fall

Protein and phosphorus levels in Kentucky bluegrass (*Poa pratensis* L.), the main forage plant in the Black Hills, were found to be near or below minimum requirements for livestock during fall months over a 3-year period.

Herbage samples collected in September and October from limestone- and metamorphic-derived soils contained an average of 7.7 percent protein and 0.13 percent phosphorus. Minimal levels of these nutrients for livestock are 8.0 and 0.18 percent, respectively, according to standards of the National Research Council Committee on Animal Nutrition.

Whenever bluegrass constitutes the bulk of the animal diet during late fall or winter months, supplements of protein and phosphorus appear to be needed.

Forest Biology

In cooperation with the U.S. Forest Service
and the Department of Agriculture



Meadow voles more abundant on
ungrazed than grazed range

Meadow voles (*Microtus pennsylvanicus*), considered detrimental to livestock ranges when abundant because of the forage they consume and waste, were found to be more abundant in ungrazed exclosures than on paired areas of native range grazed by cattle at light, moderate, and heavy intensities (table B-1). Except in 1958, a peak year for voles on ungrazed range, none were taken on sampled areas in the light, moderate, or heavy grazing treatments. Even in 1958, few animals were caught on grazed range. Thus grazing seems to have kept meadow vole populations low.

The investigation was made on ponderosa pine-bunchgrass range at the Manitou Experimental Forest in Colorado. Three intensities of grazing have been used for 21 years (fig. B-1). Small mammal populations were sampled each August by snap methods through a 6-year period. In three of the years, snap trapping was supplemented by the live trap mark-and-release technique.

Figure B-1. — Heavy herbaceous ground cover in the exclosures supported higher meadow vole populations than did grazed range in ponderosa pine-bunchgrass type at the Manitou Experimental Forest, Colorado.



Meadow vole population
related to precipitation

A relationship is apparent between high meadow vole populations and amount of precipitation that occurred during the growing season (April 1 to August 31) the preceding year at the Manitou Experimental Forest, Colorado (table B-1). When 10 or more inches of precipitation were received during the growing season, meadow vole populations increased the following summer. When less than 10 inches fell, meadow vole numbers were low the next summer.

The percentage of young animals in the population was high in good vole years (table B-1). Fifty-nine percent of the animals examined in 1958 and 70 percent in 1962 were either young or subadults. These percentages indicate high reproductive success the year following summers of high precipitation. Production of herbaceous vegetation is high in the more moist summers. This, presumably, permitted the vole population to increase the following year by providing quality cover and food for survival of overwintering animals, and maintaining them in good physical condition for conceiving and rearing young in the spring.

Table B-1. --Number of meadow voles caught per 1,080 trap nights in early August on permanent transect lines on ponderosa pine-bunchgrass range, and precipitation, April 1 to August 31, Manitou Experimental Forest, Colorado

Year	Precipitation Inches	Voles caught on--			Voles examined	Ratio	
		Grazed range	Exclosures in timber	Exclosures in grassland		Young	Old
		Number				Percent	
1956	8.73	(¹)	(¹)	(¹)	(¹)	(¹)	
1957	15.62	0	(¹)	(¹)	0	0	
1958	10.18	3	(¹)	231	149	59 41	
1959	7.83	0	(¹)	49	27	52 48	
1960	6.69	0	0	0	0	0 0	
1961	16.25	0	1	0	2	(¹) (¹)	
1962	6.39	0	4	62	64	70 30	

¹ Not determined.

Pocket gophers at Black
Mesa increasing

After an ebb in population since the fall of 1959, pocket gophers (Thomomys talpoides) appear to be increasing on the Black Mesa Experimental Area in western Colorado in 1962. Counts of fresh mounds and peep holes increased from a low of 14 in September 1961, to 123 in 1962 (table B-2). Mound counts have been made annually since 1957 to study population trends of this fossorial rodent in relation to three intensities of cattle grazing on mountain grassland range.

The mound counts were made on paired native range of Thurber fescue (Festuca thurberi Vasey) and forbs, subjected to light, moderate, and heavy summer and fall grazing by yearling steers. To date the data do not show any trend in pocket gopher population related to specific grazing treatment. When the number of pocket gophers was high, it was high for all treatments and, when low, low for all intensities of use.

Table B-2. --Number of new pocket gopher mounds and peep holes counted in a 48-hour period in September on 20 permanent 1/100-acre plots per pasture, Black Mesa Experimental Area, Colorado

Treatment and pasture number	:	1957	:	1958	:	1959	:	1960	:	1961	:	1962
Light												
2		28		48		8		13		0		21
4		22		52		2		7		1		20
Total		50		100		10		20		1		41
Moderate												
1		45		68		3		9		4		17
6		41		64		9		12		2		43
Total		86		132		12		21		6		60
Heavy												
3		18		52		10		10		1		6
5		28		54		16		6		6		16
Total		46		106		26		16		7		22
All pastures		182		338		48		57		14		123

Pocket gophers active at Black Mesa under 64-inch snowpack

Pits dug in a 64-inch snowpack in early April 1962 showed that pocket gophers were active in the snow mantle. Cores of dirt pushed from below-ground burrow systems were found in the snow mantle along the surface of the ground, and as high as 15 inches in the snowpack (fig. B-2). Active pocket gopher burrows in the snow along the surface of the ground and up to 15 inches in the snowpack were also observed. This snow tunneling was quite extensive and, as snowmelt took place, single burrow systems were traced as far as 150 feet.

Some grass and forb species were green under the 64-inch snowpack. By tunneling in the snow, pocket gophers have access to this green vegetation for food long before the continuous snow cover is broken and snowmelt completed. Burrow systems leading to Thurber fescue and rabbitbrush (*Chrysothamnus* spp.) plants with clipped stems were in evidence beneath a 64-inch snowpack (fig. B-3). These observations showed that utilization of range plants by pocket gophers is not confined to the snow-free period.

In addition, these winter observations pointed out that some vegetation clipped by pocket gophers is wasted. Cores of vegetation, composed of clipped plant fragments 1 to 2 inches long, were found exposed in the melting snowpack in about mid-May (fig. B-4).



Figure B-2. — Active snow tunnels and dirt cores pushed from underground burrow system found beneath a 64-inch snowpack, Black Mesa Experimental Area, Colorado. (Top left) a snow tunnel and dirt core at ground level; (top right) a dirt core in the snowpack 15 inches above ground surface; (right) depression in melting snowpack indicates remains of a tunnel system.



Figure B-3(below). — Snow tunnel under 64-inch snowpack leads to a closely cropped rabbitbrush plant.



Figure B-4(left). — Cores of vegetation clipped and placed in tunnels in the snow by pocket gophers are exposed by melting snowpack.

Publications

WATERSHED MANAGEMENT RESEARCH

Berndt, H. W.

Watershed management research in Wyoming. Wyo. Univ. Ext. Serv. Range Mangt. Notes, April - May - June. 2 pp.

A brief summary of watershed management studies being made in Wyoming by the Rocky Mountain Forest and Range Experiment Station.

Brown, Harry E.

The canopy camera. U. S. Forest Serv. Rocky Mountain Forest and Range Expt. Sta. Paper 72, 22 pp., illus.

Describes a new type of camera for taking wide-angle photographs of vegetation canopy and other subjects. The optical system, consisting of two lenses and a pinhole, gathers light from a 180° field of view and forms a circular image on 4 x 5 film. Two interpretive grids are also described.

Decker, John P.

Some photosynthetic problems of tree growth. In Tree Growth, edited by Theodore T. Kozlowski. Chap. 9, pp. 165-170. Internatl. Tree Growth Symposium. New York: The Ronald Press.

States and discusses seven unsolved problems. Each is worthy of a graduate thesis, and each is approachable via the infrared photosynthetic apparatus.

Water relations of plant communities as a management factor for western watersheds. *Science* 138 (3539): 532-533, illus.

A summary report of a set of physical, conceptual, and logical tools that will help to solve many problems involving water relations of plants that still baffle managers of western watersheds.

Gaylor, William G., * and Cole, Frank D. *

Measuring transpiration of undisturbed tamarisk shrubs. *Plant Physiol.* 37: 393-397, illus.

Describes apparatus for direct measurement of evapotranspiration in the field, and summarizes several field studies.

Dortignac, E. J.

An 1890 irrigation venture in the Rio Puerco. *N. Mex. Prof. Engin.* 14 (3): 8-11, 20-21, illus.

A documentary account of an irrigation development in the Rio Puerco in the 1890's. The history of settlement and occupation of the main Rio Puerco by the Spaniards, including Spanish grants, is given.

Frutiger, Hans.

Avalanche control in the starting zone (translation of Swiss guidelines). Guidelines for the planning and design of permanent supporting structures. U. S. Forest Serv. Rocky Mountain Forest and Range Expt. Sta. Sta. Paper 71, 60 pp., illus.

A technical report on how open structures should be built and arranged in the starting zone of avalanches for avalanche control. Theoretical and engineering aspects are covered. An extensive glossary provides background material as well as definitions.

Gary, Howard L.

Removal of tamarisk reduces water-table fluctuations in central Arizona. U. S. Forest Serv. Rocky Mountain Forest and Range Expt. Sta. Res. Note 81, 6 pp., illus.

Reports effects of tamarisk removal on diurnal water-table fluctuations in shallow wells. Fluctuation was significantly reduced after tamarisk and arrowweed were removed from an area 25 feet in diameter around one well site. Two enlargements of the cleared area, however, did not further decrease the fluctuations.

Goodell, Bertram C.

An inexpensive totalizer of solar and thermal radiation. *Jour. Geophys. Res.* 67: 1383-1387, illus.

Described is the development of a totalizer for use with the Suomi economical radiometer to permit the efficient, spatial sampling of solar and thermal radiation over natural landscapes where topographic relief and vegetation impose great variation. Low unit cost, battery power, and the integration of radiation with respect to time make practical the simultaneous sampling of numerous points in the landscape.

* Private, State, or Federal cooperator.

Research on landscaping for water yield in Colorado. U. S. Forest Serv. Intermountain Region and Idaho Univ. Forestry Col. Water Mangt. Study Conf. Proc. 1961: 100-105.

Research by the Rocky Mountain Forest and Range Experiment Station toward increasing and regulating streamflow from mountain lands of the central Rockies includes not only the manipulation of forest cover, but also the minor modification of topography. Reviewed are the Fraser Experimental Forest studies on forest manipulation; also studies on the use of snow fences in alpine and high plains areas to promote drifting and prolong snowmelt.

Hardaway, George D.,^{*} and Thompson, J. Robert.

A study of water yield from the Santa Fe River watershed. U. S. Forest Serv. Rocky Mountain Forest and Range Experiment Sta. Sta. Paper 70, 18 pp., illus.

Compares water yield before and after the area was closed to all use, and indicates the basic precipitation-runoff relationship for the watershed.

Hoover, Marvin D.

Forest influences. 2. Water action and water movement in the forest. FAO Forestry and Forest Prod. Studies 15: 29-80, illus.

Describes influence of forest cover on rainfall, soil moisture, evaporation, and transpiration. Modification of plant cover to control streamflow and water yield is considered. Watershed research methods and results are presented.

and Shaw, Elmer W.

More water from the mountains. U. S. Dept. Agr. Yearbook 1962: 246-252, illus.

A nontechnical condensed account of watershed research in the Colorado mountains.

Horton, Jerome S., and Flood, John E.^{*}

Taxonomic notes on Tamarix pentandra in Arizona. The Southwest. Nat. 7 (1): 23-28, illus.

Tamarisk specimens collected in Arizona are described in detail. The Arizona shrubs are compared to the descriptions of Tamarix contained in various Old World treatments of the genus. Our species appears to be Tamarix pentandra Pallas.

Pase, Charles P.

The Sierra Ancha Experimental Forest. Amer. Soc. Range Mangt., Ariz. Sect. Proc. 1962: 43-45.

Briefly describes environmental conditions and major installations at the Sierra Ancha Experimental Forest. Discusses the early and more recent research objectives, and lists the more significant findings to date.

____ Glendening, G. E., and Lillie, D. T. *

Aerial spraying of shrub live oak-dominated chaparral watersheds in Arizona. West. Weed Control Conf. Res. Com. Prog. Rpt. 1962: 13-14.

Reports results and costs of helicopter spraying on a burned chaparral watershed.

Retzer, J. L.

Soil Survey of Fraser alpine area, Colorado. U. S. Dept. Agr. Forest Serv. and Soil Conserv. Serv. in cooperation with Colo. Agr. Expt. Sta. Series 1956, No. 20, 47 pp., illus.

Soil-land types of 86,000 acres of rugged mountains between Loveland Pass and Fraser, Colorado, are described and shown on aerial photographs at a scale of 1:31680. General descriptions are given of the plants, animals, climate, and landforms. Soils are classified as to suitable land uses.

Rich, L. R.

Erosion and sediment movement following a wildfire in a ponderosa pine forest of central Arizona. U. S. Forest Serv. Rocky Mountain Forest and Range Expt. Sta. Res. Note 76, 12 pp., illus.

Summarizes erosion and sediment movement after a 60-acre wildfire in a 318-acre ponderosa pine watershed. During the first summer approximately 1 acre-foot of sediment was eroded from the burn. Sediment was deposited in unburned forest vegetation immediately below the burn, in the stream channel, and in the weir pond. Only 2 percent of the sediment eroded from the burn was trapped in the weir pond.

Swanson, Robert H.

Circuit for simultaneous recording of millivolt and thermocouple outputs. U. S. Forest Serv. Rocky Mountain Forest and Range Expt. Sta. Res. Note 84, 5 pp., illus.

Describes a method that allows both thermocouples and nonthermocouples to be recorded on the same recorder.

An instrument for detecting sap movement in woody plants. U. S. Forest Serv. Rocky Mountain Forest and Range Expt. Sta. Sta. Paper 68, 16 pp., illus.

Describes the heat-pulse method of determining sap movements. Also describes in detail how to construct a field instrument for detecting sap movements.

A thermistor bridge for use with null balance recorders. U. S. Forest Serv. Rocky Mountain Forest and Range Expt. Sta. Res. Note 83, 4 pp., illus.

Describes a wheatstone bridge circuit with both temperature span and output voltage adjustable over a wide range.

FOREST MANAGEMENT AND FOREST FIRE RESEARCH

Heidmann, L. J.

Longevity of ponderosa pine seed. Ecology 43: 344.

Seed of ponderosa pine collected in northern Arizona from 1909 to 1960 was tested for germination in the winter of 1960-61. Even after 35 years in storage, 16 percent of the seeds germinated.

Jones, John R.

Review of "Studier Över Klimatets Humiditet I Sverige" [Studies on the humidity of Sweden's climate] by Olof F. S. Tamm. Forest Sci. 8: 283.

Evapotranspiration (E) in millimeters related to mean annual temperature (T) in Centigrade degrees for the whole of Sweden by the equation $E = 115 + 28.1 T$. The equation is useful for estimating annual streamflow, for studies of habitat, and for characterizing seed source provenances.

Translation of "Skogsmark Och Bonitering I De Nordiska Landerna" [A symposium on forest land and classification of site in the Fennoscandian Countries] by the Fennoscandian Forestry Union. U. S. Forest Serv. 42 pp.

Defines, discusses, and compares the different classifications of forest land and site quality used in Denmark, Finland, Norway, and Sweden as of 1954.

Larson, M. M.

Construction and use of glass-faced boxes to study root development of tree seedlings. U. S. Forest Serv. Rocky Mountain Forest and Range Expt. Sta. Res. Note 73, 4 pp., illus.

Describes construction of glass-faced planter boxes that slip into a wooden frame buried in the soil for studying root development of tree seedlings in a field environment. The following are also discussed: packing the boxes with soil, planting the boxes with seed and transplants, making root measurements, and some precautions in the use of the boxes.

Lindenmuth, A. W. Jr.

Effects on fuels and trees of a large intentional burn in ponderosa pine. Jour. Forestry 60: 804-810, illus.

A low ratio of benefits to damages was found on 27,000 acres of intentionally burned ponderosa pine forest. Major changes in fuels and understory trees were found on only the 23 percent of the total area that burned by hot surface or crown fire. The burning released 4 percent of the total number of potential crop trees, or 24 percent of the number needing release. For every potential crop tree released nearly six potential crop trees were damaged or killed.

_____ and Davis, James R.

Chemical treatment helps burn brush safely in Arizona. The Timberman 43 (7): 9, illus.

Part of a brush field, desiccated by spraying with 2,4,5-T, was successfully burned at a time when fire would not spread in surrounding green brush.

_____ and Glendening, G. E.

Controlled burning of Arizona chaparral. A 1962 Progress Report. Ariz. Watershed Symposium Proc. 6: 23-24, illus.

First-year results of burning chemically treated narrow strips of Arizona chaparral under prescribed conditions.

Myers, Clifford A.

Twenty-year growth of Utah juniper in Arizona. U. S. Forest Serv. Rocky Mountain Forest and Range Expt. Sta. Res. Note 71, 2 pp.

Net annual increment per acre was 2.9 cubic feet, or one 7-foot fence post.

and Van Deusen, James L.

A quick method of predicting growth of even-aged immature stands. Jour. Forestry 60: 824-825.

Average stand diameter, basal area, and cubic feet per acre in 10 and 20 years can be estimated from measurements of current diameter, basal area, cubic volume, site index, trees per acre, and stand age. Equations are presented for estimating future conditions in immature stands of ponderosa pine in the Black Hills.

ander, D. H.

Growth curves for ponderosa pine in Nebraska windbreaks. U. S. Forest Serv. Rocky Mountain Forest and Range Expt. Sta. Res. Note 82, 3 pp., illus.

The growth curves presented can be used to rate site productivity or to predict heights of ponderosa pines in windbreaks up to 22 years after planting.

Van Deusen, James L., and Myers, Clifford A.

Porcupine damage in immature stands of ponderosa pine in the Black Hills. Jour. Forestry 60: 811-813, illus.

Nearly 10 percent of 7,364 trees observed had been damaged by porcupines. Trees from 6.0 to 7.9 inches in diameter were most commonly injured, and 86 percent were dominants and codominants. Merchantable volumes of 75 percent of the trees attacked were permanently reduced because of crook, fork, or dead tops.

FOREST INSECT RESEARCH

Massey, Calvin L.

Life history of Aphelenchulus elongatus Massey (nematoda), an endoparasite of Ips confusus Le Conte, with a description of the male. Jour. Insect Path. 4: 95-103, illus.

Laboratory studies reveal that the life history of the nematode Aphelenchulus elongatus Massey is closely synchronized with its host, Ips confusus Le Conte. Egg productivity of female beetles infested with the nematode is greatly reduced.

New species of Diplogasteridae (nematoda) associated with bark beetles in the United States. Helminthol. Soc. Wash. Proc. 29 (1): 67-75, illus.

Several new species of nematodes are described. The genus Acrostichus is given full generic rank. Several species formerly described in the genus Diplogaster are placed in the genus Acrostichus.

McCambridge, William F.

Sexing Black Hills beetles, Dendroctonus ponderosae Hopkins. Ent. Soc. Amer. Ann. 55 (6): 723-724.

Describes a method of determining the sex of live beetles with a minimum of handling.

FOREST DISEASE RESEARCH

Hawksworth, Frank G.

Fairy rings associated with Polyporus confluens. Amer. Midland Nat. 68 (2): 495.

First report of fairy rings (sporophores produced on the ground around the circumference of a circle) for this group of fungi.

_____ and Mielke, James L.*

Witches' broom of Gambel oak associated with Articularia quercina var. minor. Phytopathology 52: 451-454, illus.

First report of this witches' broom, which is common on Gambel oak in Colorado, Utah, Arizona, and New Mexico. The fungus is consistently associated with the disease and is presumably the causal agent.

Hinds, Thomas E.

Inoculations with the sooty-bark canker fungus on aspen. U. S. Agr. Res. Serv., Plant Dis. Rptr. 46: 57-58, illus.

Results of inoculation tests with Cenangium singulare (Rehm.). Davidson and Cash confirm that this fungus is the causal agent of sooty-bark canker of aspen.

Peterson, Glenn W.

Necrotic ring spot virus content of American plum in plains windbreaks. U. S. Forest Serv. Rocky Mountain Forest and Range Expt. Sta. Res. Note 74, 1 p.

Reports that extensive decline of American plum in windbreaks in several Plains States was not associated with necrotic ring spot virus.

_____ Root lesion nematode infestation and control in a plains forest tree nursery. U. S. Forest Serv. Rocky Mountain Forest and Range Expt. Sta. Res. Note 75, 2 pp.

Reports damage by root lesion nematodes (Pratylenchus pentrans) to nursery stock of eastern redcedar, Rocky Mountain juniper, white spruce, and blue spruce in Bessey Nursery, Halsey, Nebraska, and gives methods used for control.

Peterson, Roger S.

Comandra blister rust in the central Rocky Mountains. U. S. Forest Serv. Rocky Mountain Forest and Range Expt. Sta. Res. Note 79, 6 pp.

There is little new infection by Comandra rust in the Rocky Mountain Region, but outbreaks 20 to 40 years old continue to cause heavy damage to lodgepole pine by killing the larger trees and causing spiketops.

Consider plant rusts in your plans. Green Thumb 19: 113-115, illus.

Separation of alternate-host pairs (as junipers and fruit trees, or pines and Indian paintbrushes) should be considered in landscape planning to avoid unnecessary damage from rust fungi.

Notes on western rust fungi I. Chrysomyxa. Mycologia 53: 427-431.

Problems in the geographic and altitudinal distribution of spruce yellow witches' brooms are solved by studies of the alternate hosts of the causal rust fungus. New distribution records for spruce cone and needle rusts are given.

Notes on western rust fungi II. Pucciniaceae. Mycologia 54: 389-394.

Phragmidium ivesiae Syd. ssp. wyomingensis is described, with a key to subgenus Earlea on Potentilla. Distributional and descriptive data are given for five species of Puccinia, two Uromyces, and five Gymnosporangium.

Wyoming pinyon revisited. Madrono 16(8): 269.

Confirms early reports of pinyon (Pinus edulus Engelm.) in southern Wyoming.

FOREST UTILIZATION RESEARCH

Landt, Eugene F., and Woodfin, Richard O., Jr.

Effect of resaws on performance of circular headrig sawmills. Forest Prod. Jour. 12: 172-176, illus.

Shows how the efficiency of circular headrig sawmills can be improved by installing resaws. Operating time, grade recovery, sawing accuracy, and other effects were evaluated.

FOREST ECONOMICS RESEARCH

Hughes, Jay M.

Pulp- and papermaking opportunities in west central Colorado. U. S. Forest Serv. Rocky Mountain Forest and Range Expt. Sta. Sta. Paper 73, 48 pp., illus.

An evaluation of cost, quantity, and quality of wood and water shows that good opportunity exists for pulp- and papermaking near large and growing markets. Factors such as labor, freight, power, fuels, chemicals, and taxes are also favorable.

Worley, David P.

Some problems in range economics research. Amer. Soc. Range Mangt., Ariz. Sect. Proc. 1962: 37-38.

Shows how economics research differs from research in the physical fields in method and content. Illustrations are presented that show the kinds of problems toward which an economist might direct his effort.

RANGE MANAGEMENT AND WILDLIFE HABITAT RESEARCH

Dietz, Donald R., Udall, Robert H.,* and Yeager, Lee E.*

Chemical composition and digestibility by mule deer of selected forage species Cache la Poudre range, Colorado. Colo. Game and Fish Dept., Tech. Bul. 14, 89 pp., illus.

Summarizes the results of a 3-year study on the nutritive value of summer and winter deer ranges used by the Cache la Poudre deer herd in north-central Colorado. Includes proximate chemical analyses of major deer browses and forages, and gives results of digestibility trials on the three important winter deer browses.

Udall, Robert H.,* and Yeager, Lee E.*

Differential digestibility of nutrients in bitterbrush, mountainmahogany, and big sagebrush by deer. Wildlife Soc., Southeast Sect., Natl. White-tailed Deer Disease Symposium Proc. 1: 29-50, illus.

Two methods of determining digestibility of three staple deer browses in north-central Colorado were compared. Annual growth of these browse species were fed to mule deer fawns both separately and in combination with alfalfa pellets. Digestion coefficients were determined for crude protein, crude fat, crude fiber, and nitrogen-free extract of alfalfa, big sage, bitterbrush, and mountainmahogany. Total digestible nutrients (T.D.N.) and nutritive ratios (N.R.) were also determined. The addition of alfalfa to browse diet lowered the digestibility of the combined feed

Fisser, H. G.,* May, M., Johnson, W. M., Stratton, P.,* and Smith, D. R.
Comparison of rotation and season-long summer grazing on subalpine range
in Wyoming. Progress Report -- 1961. Wyo. Agr. Expt. Sta. Mimeo. Cir.
177, 3 pp.

Summarizes the progress and results of the comparison of
rotation and season-long grazing on the Bighorn National
Forest. Shows the weight gains of steers used in the study,
and utilization on the pastures for the period 1959-61.

Froiland, Sven G.

The genus Salix (willows) in the Black Hills of South Dakota. U. S. Dept. Agr.
Tech. Bul. 1269, 75 pp., illus.

Describes and illustrates 20 species and varieties of willow,
including their habitat and distribution in the Black Hills and
on the North American continent. Identifies willows suffering
high mortality and speculates as to the probable causes of
mortality.

Gray, James R.,* and Springfield, H. W.

Economics of lambing on crested wheatgrass in northcentral New Mexico.
N. Mex. Agr. Expt. Sta. Bul. 461, 34 pp., illus.

Economic analyses showed (1) the investment in seeding could
be repaid in 4 to 7 years, and (2) net returns were highest when
the grass was utilized at the 53 percent level.

Jameson, Donald A.

Effects of burning on a galleta-black grama range invaded by juniper.
Ecology 43: 760-763, illus.

Galleta and black grama quickly recovered from effects of
burning. Damage to juniper varied with size of tree, abun-
dance of tumbleweeds under the tree, and wind direction
during the fire.

Williams, John A.,* and Wilton, Eugene W.*

Vegetation and soils of Fishtail Mesa, Arizona. Ecology 43: 403-410, illus.

Describes vegetation and soils on an ungrazed mesa in the
Grand Canyon. Principal plants were sagebrush, pinyon,
and Utah juniper. Grasses were unimportant.

Johnson, W. M.

Vegetation of high-altitude ranges in Wyoming as related to use by game and
domestic sheep. Wyo. Agr. Expt. Sta. Bul. 387, 31 pp., illus.

Summarizes results of a survey of alpine and subalpine sheep
ranges in Wyoming. Discusses composition, production, and
utilization of seven major vegetation types and shows species
relationships as they occur.

Judd, B. Ira.

Principal forage plants of southwestern ranges. U. S. Forest Serv. Rocky Mountain Forest and Range Expt. Sta. Paper 69, 93 pp., illus.

Describes and illustrated 89 common grasses, forbs, and shrubs and the major range types in which they occur.

Martin, S. Clark, and Cable, Dwight R.

Grass production high 14 years after mesquite control. Ariz. Cattlelog 18(12): 58-61, illus.

Summarizes results of a study on the Santa Rita Experimental Range in southern Arizona, which shows that mesquite control not only will greatly increase forage production but is effective for a long time.

_____ and Tschirley, Fred H.*

Mesquite seeds live a long time. Prog. Agr. in Ariz. 14 (1): 15, illus.

Seeds of velvet mesquite from a herbarium sheet germinated after 50 years. Seeds buried in the soil have germinated after 10 years. Another germination test will be made when the seeds have been in the soil 20 years.

McEwen, Lowell C.

Leaf longevity and crude protein content for roughleaf ricegrass in the Black Hills. Jour. Range Mangt. 15: 106-107, illus.

Roughleaf ricegrass (Oryzopsis asperifolia) leaves were found to remain green a maximum of 25 months. Crude protein content also remained high through the winter months.

National Research Council.

Basic problems and techniques in range research. Natl. Acad. Sci. - Natl. Res. Council Pub. 890, 341 pp., illus.

A textbook on range research methods prepared by a joint committee of the American Society of Range Management and the National Research Council.

Paulsen, Harold A., and Ares, Fred N.*

Grazing values and management of black grama and tobosa grasslands and associated shrub ranges of the southwest. U. S. Dept. Agr. Tech. Bul. 1270, 56 pp., illus.

Vegetation changes on the Jornada Experimental Range in southern New Mexico over nearly 40 years are summarized. These are interpreted in light of the erratic precipitation, and management practices best suited to the region.

Pond, Floyd W.

Shrub live oak limits production of weeping lovegrass. Ariz. Cattlelog 18 (7): 60-61, illus.

Reports the production of seeded weeping lovegrass growing under varying amounts of shrub live oak crown cover.

_____ and Cable, Dwight R.

Recovery of vegetation following wildfire on a chaparral area in Arizona. U. S. Forest Serv. Rocky Mountain Forest and Range Expt. Sta. Res. Note 72, 4 pp., illus.

Basal cover of weeping lovegrass seeded on the 1951 Pinal Mountain burn increased in the exclosed area during the 4 years immediately after the fire. By 1958, however, sprouting shrubs were rapidly approaching pre-burn density and this, combined with a drought year, had caused rapid and severe deterioration of the grass stand.

Price, Raymond.

Progress in the integration of forestry and grazing -- The United States and Canada. In Multiple use of forest lands. Fifth World Forestry Cong. Proc. 1: 329-337, illus.

Reviews progress in the United States and Canada in meeting problems of integration of forestry and grazing on forest and associated lands used by domestic livestock and wildlife, especially big game.

Reppert, Jack N., ^{*}Morris, Meredith J., and Graham, Charles A. ^{*}

Estimation of herbage on California annual-type range. Jour. Range Mangt. 15: 318-323, illus.

The use of several height-cover relationships to estimate weight were compared for the annual grass type.

Reynolds, Hudson G.

Effect of logging on understory vegetation and deer use in a ponderosa pine forest of Arizona. U. S. Forest Serv. Rocky Mountain Forest and Range Expt. Sta. Res. Note 80, 7 pp., illus.

Describes and compares vegetation and deer use in uncut and selectively cut stands of ponderosa pine on the North Kaibab Plateau.

_____ Selected bibliography on range research in Arizona. Amer. Soc. Range Mangt., Ariz. Sect. Proc. 1962: 50-68.

Arranges 237 references on range management in Arizona into subject matter categories of range botany, zoology and soils, climatic influence, grazing management, range condition and utilization, range improvement, revegetation, woody plant control, range rodents, poisonous plants, range economics, soil and water conservation, and range methodology.

Arizona's population growth and its effects on native plants and animals: A symposium. Part 2 - Some characteristics and uses of Arizona's major plant communities. *Ariz. Acad. Sci. Jour.* 2: 62-71, illus.

Describes several major plant communities of Arizona. Explains how reduction of dominants favors plants of a subclimax status for each community. Evaluates multiple use potentials and functions of each community, and pleads for additional information on structure, composition, and management of plant communities in the interest of developing full land use without impairing basic site productivity.

Use of natural openings in a ponderosa pine forest of Arizona by deer, elk, and cattle. U. S. Forest Serv. Rocky Mountain Forest and Range Expt. Sta. Res. Note 78, 4 pp., illus.

Preliminary findings suggest that: Deer use of natural forest borders, and cutover forests is virtually equal. Cattle and elk prefer habitats in the order of openings, borders, and cutover forest. Management implications of findings are that elk habitat and cattle range might be improved by seeding or planting of proper forage species in natural openings, and by managing ponderosa pine by clear cutting in small patches.

Springfield, H. W.

Activities of sheep on crested wheatgrass lambing range. U. S. Forest Serv. Rocky Mountain Forest and Range Expt. Sta. Res. Note 77, 6 pp., illus.

Observations during two lambing seasons indicate sheep activities were influenced by availability of forage, weather conditions, and confinement within small pastures.

Ward, A. Lorin, and Keith, James O. *

Feeding habits of pocket gophers on mountain grasslands, Black Mesa, Colorado. *Ecology* 43: 744-749, illus.

The summer diet of pocket gophers consisted of 6 percent grasses, 93 percent forbs, and 1 percent shrubs where vegetation consisted of 50 percent grasses, 42 percent forbs, and 8 percent shrubs; 74 percent of the food was stems and leaves and 26 percent was roots.

FOREST BIOLOGY RESEARCH

Goodrum, Phil D., * and Reid, Vincent H.

Browsing habits of white-tailed deer in the western gulf region. *Wildlife Soc., Southeast Sect., Natl. White-tailed Deer Disease Symposium Proc.* 1: 9-14.

Describes forage-deer productivity relationships in study of enclosed deer in the longleaf pine forest type through a 14-year period.

FOREST SERVICE - U.S. DEPARTMENT OF AGRICULTURE

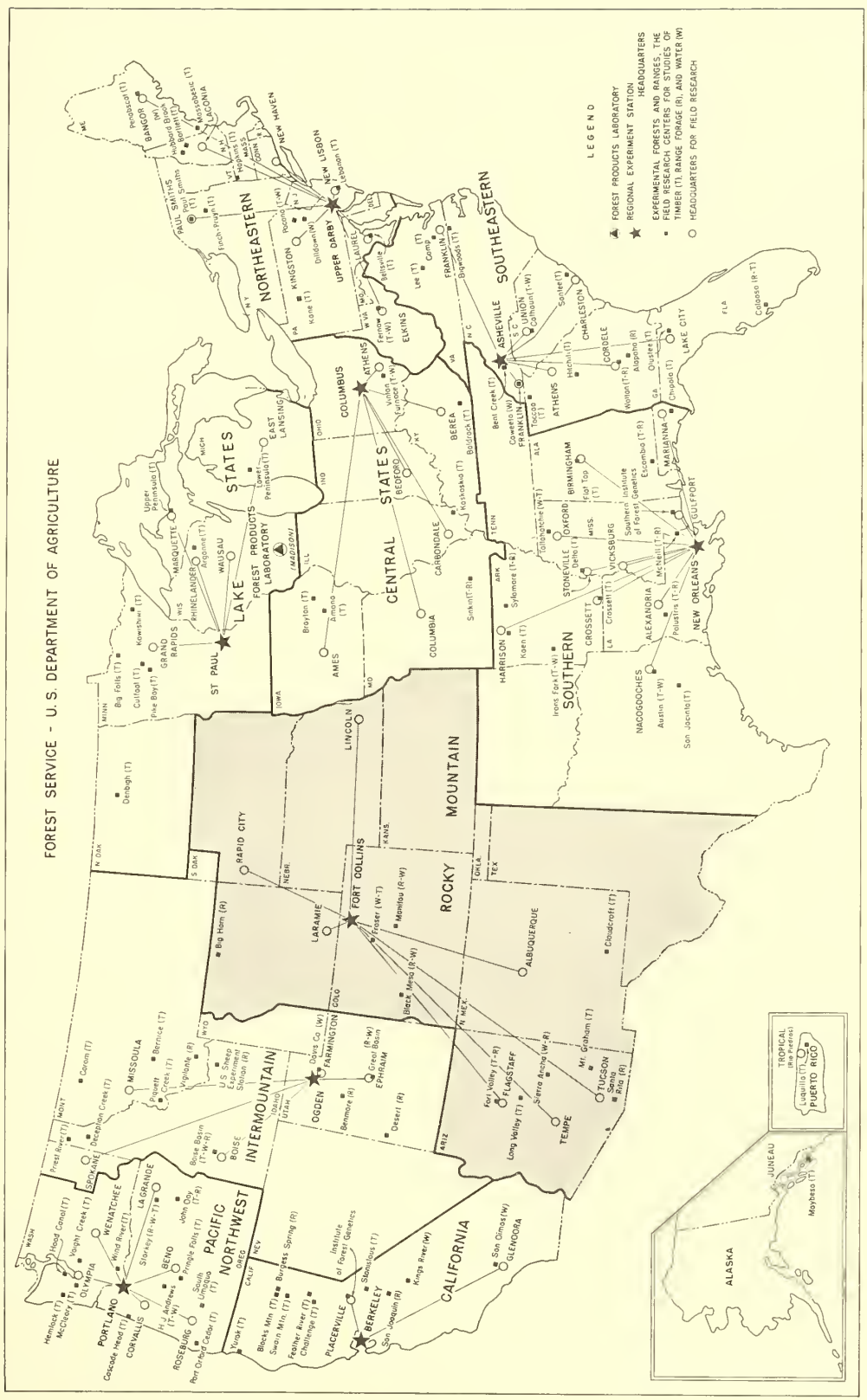

Location of the Forest and Range Experiment Stations and the Forest Products Laboratory

