

LUBRICATION

ORDER

26 MARCH 1971 (Supersedes L05-3810-201-12-1, dtd 9 Feb 1968 and L05-3810-206-12-1, dtd 18 MAR 1968)

CRANE-SHOVEL, BASIC UNIT, CRAWLER MOUNTED, 40 TON, 2 CU YD,
DIESEL DRIVEN, (HARNISCHFEGER MODEL 855-BC, 855 BG-2 AND
855 BG-3) W/HARNISCHFEGER ENGINE MODEL 687C-18-ES AND
CATERPILLAR ENGINE MODELS D333TA AND D333C

Reference: L05-3810-206-12-2,-3,-4 and -5 C9100-IL

Intervals are based on normal hours of operations. Adjust to compensate for abnormal operations and severe conditions. During inactive periods sufficient lubrication must be performed for adequate preservation.

Clean fittings before lubricating.

Relubricate after washing or fording.

Clean parts with SOLVENT, dry-cleaning, or with OIL, fuel, Diesel. Dry before lubricating.

Lubricate points indicated by dotted arrow shafts on both sides of equipment.

Drain crankcases and gear cases when hot. Fill and check level.

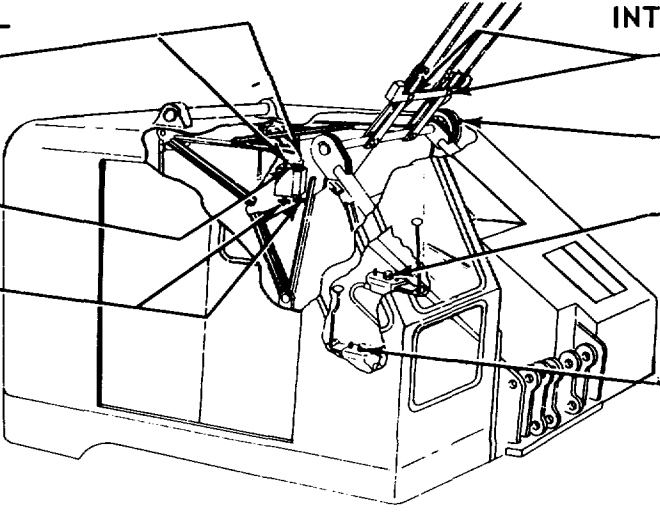
LUBRICANT ● INTERVAL		INTERVAL ● LUBRICANT
Hydraulic Oil Tank Dipsticks (Check level.)	10	10 GAA Spreader Bar Sheaves
Hydraulic Oil Tank Fill Plug (See key.)	HB	10 GAA Gantry Sheave
Hydraulic Oil Tank Drain (Drain and refill) (Every 1000 service hours disconnect oil lines from tanks, drain and re-install oil lines. Keep all connections tight.)	1000	50 HB Swing Brake Hydraulic Master Cylinder Fill and Level Plug. (See key) (Fill to level.)
		50 HB Dipper Trip Hydraulic Master Cylinder Fill and Level Plug. (See key.) (Fill to level.)

FOLD

FOLD

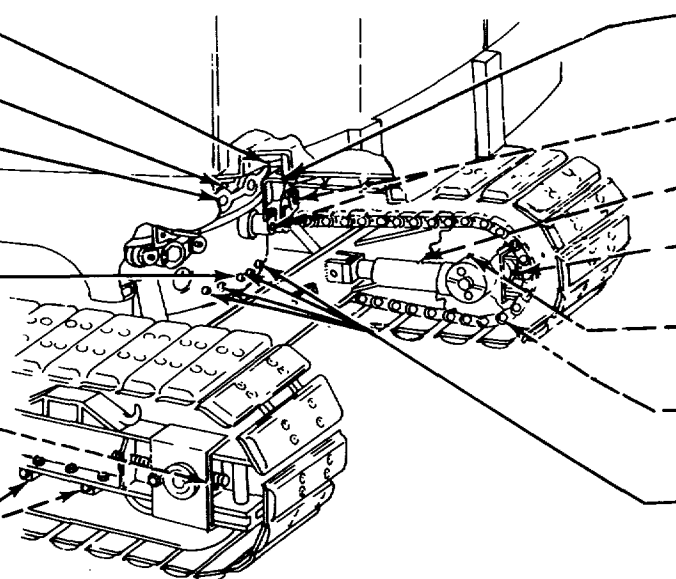
Intermediate Swing Shaft	GAA	25		1000	Jack Shaft Pedestal Case Drain Plug (Drain and refill.)
Propel Idler Shaft	GAA	25		10	GAA Rear Hook Rollers
Live Roller Circle Shaft Bushings (24 fittings.)	GAA	10		10	GAA Adjusting Bolt
Lower Vertical Propel Shaft Bushing (See note 4.)	GAA	5		10	GAA Inner Drive Shaft Bearing (See note 4.)
Outer Drive Shaft Bearing (See note 4.)	GAA	10		10	GAA Drive Sprocket Hub (See note 4.)
Lower Track Roller Shafts (8 fittings each side) (See note 4.)	GAA	10		10	HDO Propel Chain (Clean and Coat) (See note 4.)
				10	GAA Horizontal Propel Shaft Inboard and Outboard Bearings (See note 4.)

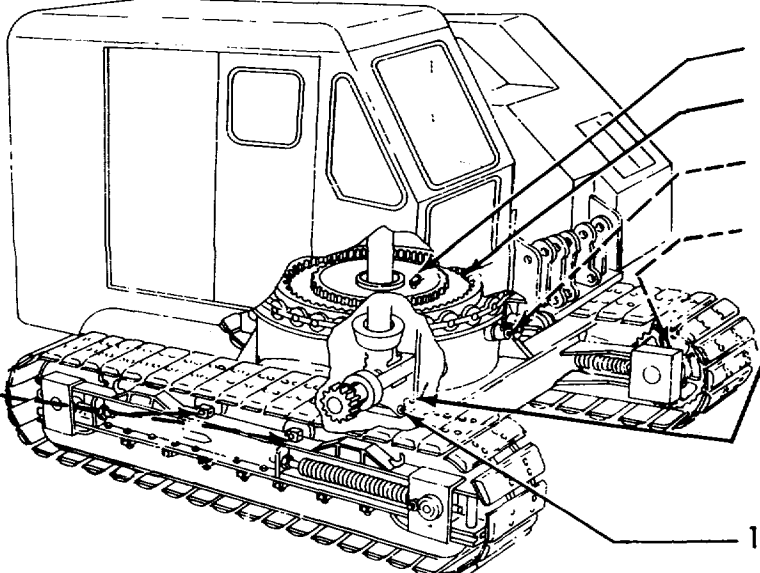
				10	GAA Propel Gear Bushing
				10	CW11 Main Swing Gear
				10	GAA Front Hook Rollers
				10	GAA Idler Sprocket Bearing (See note 4.)
Upper Track Support Rollers (2 fittings each side) (See note 4.)	GAA	10		50	GO Propel Shaft Bevel Gear Case Fill and Level Plug (See key) (Check level.)
				1000	Propel Shaft Bevel Gear Case Drain Plug

LUBRICANT ● INTERVAL

INTERVAL ● LUBRICANT

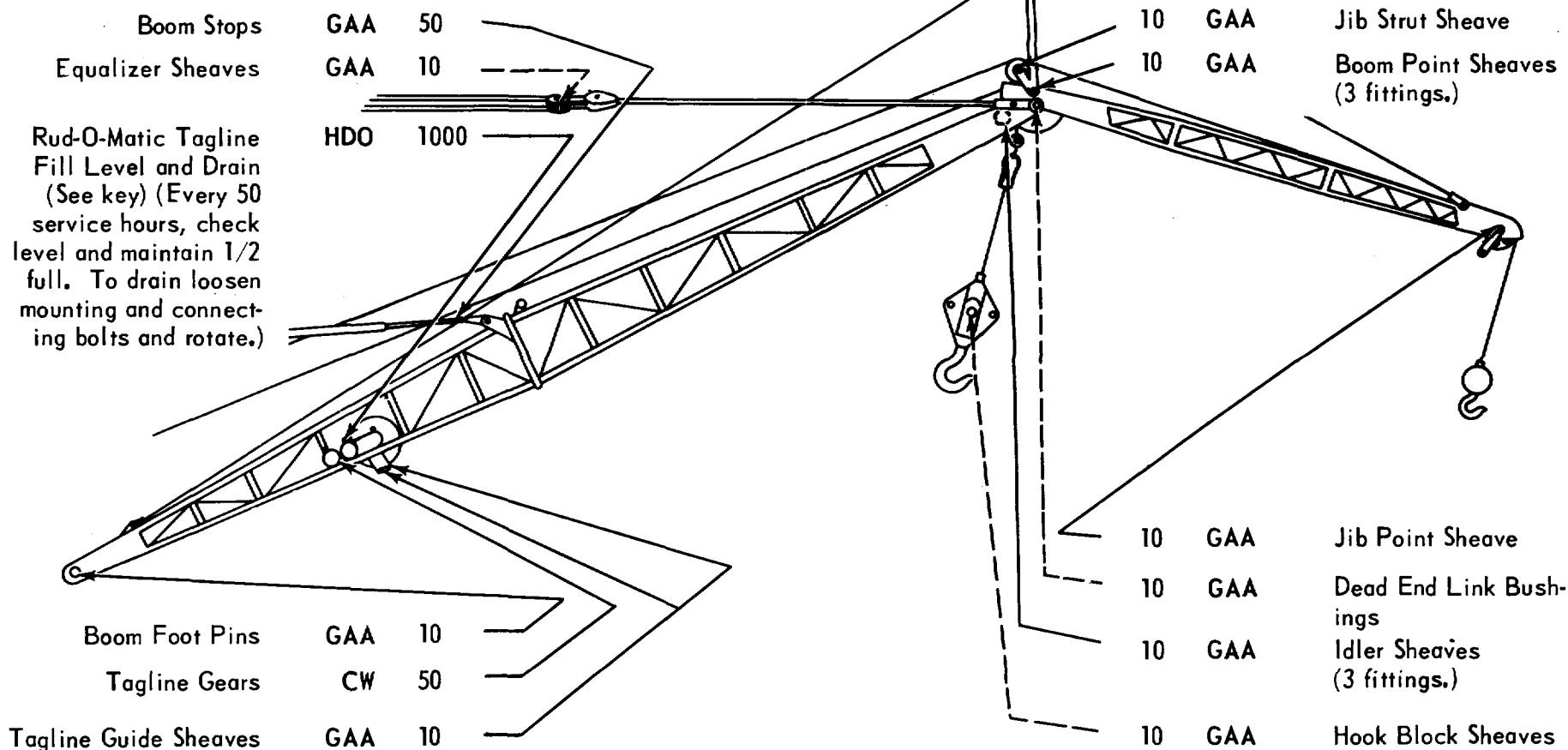

-KEY-

LUBRICANTS	CAPACITY	EXPECTED TEMPERATURES			INTERVALS
		Above +32°F	+ 40°F to -10° F	0°F to -65°F	
HDO-OIL, Engine, Heavy Duty					
Rud-O-Matic Tagline	8 qts. ea. bbl.	HDO 30	HDO 10	OES	
OES-OIL, Engine, Sub-zero					
GO-LUBRICANT, Gear, Universal		GO 90	GO 80	GOS	
Propel Shaft Bevel Gear Case	12 qts				
FOLD					FOLD
GOS-LUBRICANT, Gear, Universal, Sub-zero					Intervals given are in hours of normal operation.
HB-BRAKE FLUID, Automotive					
Hydraulic Oil Tank	10 qts				
Swing Brake Master Cylinder	1/2 qt	HB	HB	HBA	
Dipper Trip Master Cylinder	1/2 qt				
HBA-BRAKE FLUID, Automotive					
CW-11-B LUBRICATING OIL., Exposed Gear		ALL TEMPERATURES			
GAA-GREASE, Automotive and Artillery					

NOTES:

- FOR OPERATION OF EQUIPMENT IN PROTRACTED COLD TEMPERATURES BELOW - 10 F. Remove lubricants prescribed in the key for temperatures above - 10° F. Relubricate with lubricants specified in the key for temperatures below - 10° F. HB FED
- OIL CAN POINTS. Every 10 service hours lubricate all linkage, pins and devises with HDO.
- CABLES. Keep cables clean and lubricated with HDO. CAUTION. Do not lubricate cables coming in contact with excavated materials.
- TRAVELING. When traveling, lubricate the following points every 2 service hours; lower vertical propel shaft bushing, lower track roller shafts, upper track support roller, outer and inner drive shaft bearings, propel chain, drive sprocket hub, horizontal propel shaft inboard and out-board bearings and idler sprocket bearing.
- EXPOSED GEARS AND PINIONS. Keep all exposed gears and pinions coated with CW-11.

6. LUBRICANTS. The following is a list of lubricants with the Military Symbols and applicable Specification numbers.

GO MIL-L-2105	GOS MIL-L-10324	GAA MIL-G-10924
HDO MIL-L-45199	OFS MIL-L-10295	CW11-B VV-L-751
VV-B-680	HBA MIL-H-13910	

Copy of this Lubrication Order will remain with the equipment at all times; instructions contained herein are mandatory.

BY ORDER OF THE SECRETARY OF THE ARMY:

W. C. WESTMORELAND
General, United States Army
Chief of Staff.

OFFICIAL:

KENNETH G. WICKHAM,
Major General, United States Army,
The Adjutant General.

L0 53810-206-12-1

PIN: 029961-000

This fine document...

Was brought to you by me:



[Liberated Manuals -- free army and government manuals](#)

Why do I do it? I am tired of sleazy CD-ROM sellers, who take publicly available information, slap “watermarks” and other junk on it, and sell it. Those masters of search engine manipulation make sure that their sites that sell free information, come up first in search engines. They did not create it... They did not even scan it... Why should they get your money? Why are not letting you give those free manuals to your friends?

I am setting this document FREE. This document was made by the US Government and is NOT protected by Copyright. Feel free to share, republish, sell and so on.

I am not asking you for donations, fees or handouts. If you can, please provide a link to liberatedmanuals.com, so that free manuals come up first in search engines:

<A HREF=<http://www.liberatedmanuals.com/>>Free Military and Government Manuals

– Sincerely
Igor Chudov
<http://igor.chudov.com/>