

RA
409.5
N28
1984
v.1

Division of Computer Research and Technology
Fiscal Year 1984 Annual Report
Volume I

DCRT
20TH
ANNIVERSARY

U.S. DEPARTMENT OF HEALTH AND
HUMAN SERVICES
Public Health Service
National Institutes of Health

**Division of Computer Research and Technology
Fiscal Year 1984 Annual Report
Volume I**

**DORT
20TH
ANNIVERSARY**

U.S. DEPARTMENT OF HEALTH AND
HUMAN SERVICES
Public Health Service
National Institutes of Health

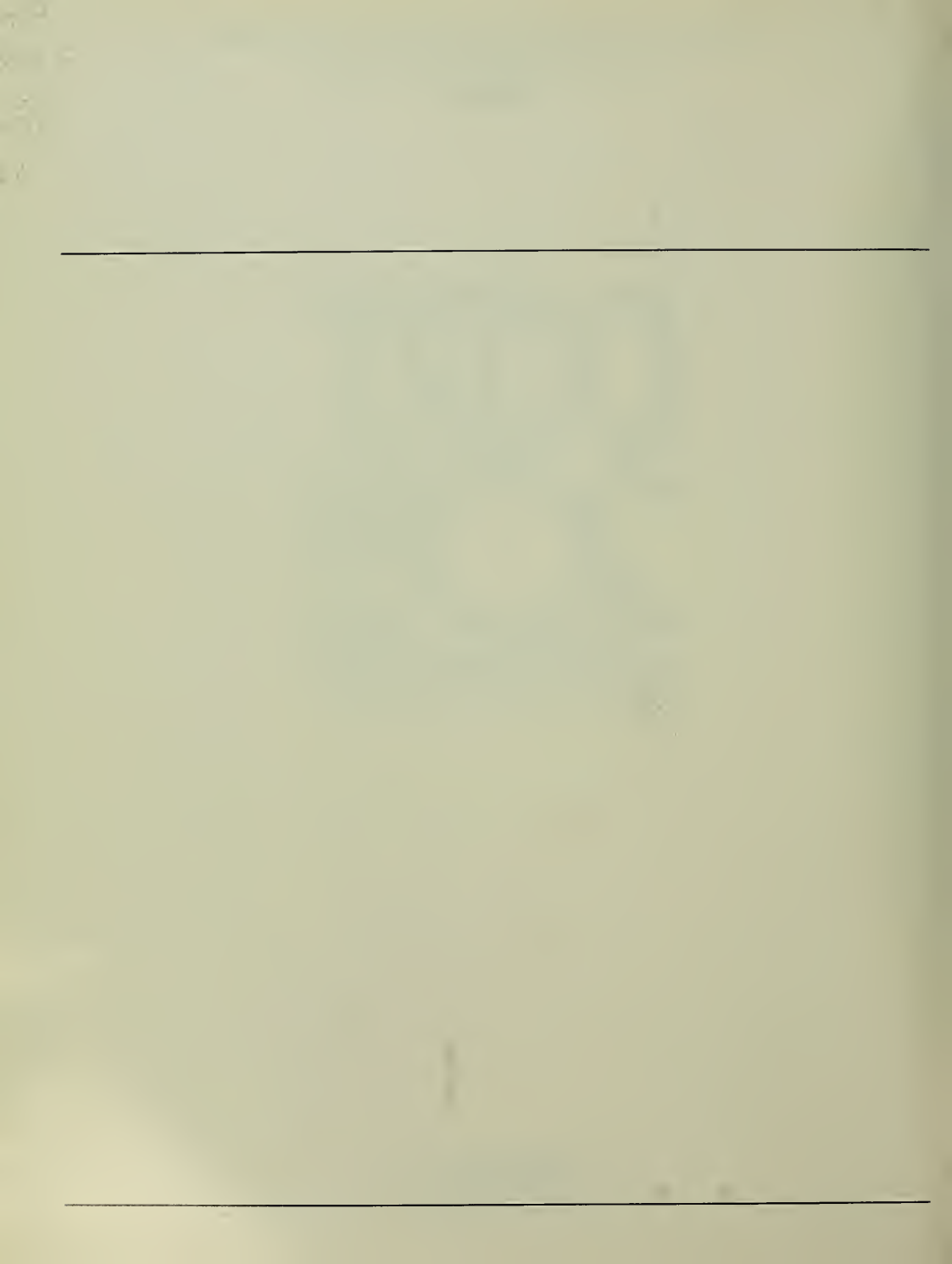

Foreword

The Division of Computer Research and Technology has primary responsibility for incorporating the power of modern computers into the biomedical programs and administrative procedures of NIH. DCRT serves as a scientific and technological resource for other parts of PHS, and for other Federal organizations with biomedical and statistical computing needs.

DCRT programs focus on three primary activities: conducting research, developing computer systems, and providing computer facilities.

The *DCRT Fiscal Year 1984 Annual Report* describes our work in two volumes:

Volume 1 gives an overview of the work of each group, highlighting the year's accomplishments;

Volume 2 gives details about the projects and activities of each group.

From the Director

The cover of this *Annual Report* notes that DCRT was established 20 years ago. The contents of the report show that biomedical computing has flourished throughout NIH during those two decades.

In the early 1960's, computing was separate from the mainstream of research at NIH, and computing itself was a set of separate, laborious tasks. The present extent of integration across biomedical computing at NIH was not even imaginable at the time DCRT was established.

Today it is the rare NIH laboratory or clinical department that does not have at least one display terminal linked to the NIH central computer facility. Many use special purpose computer systems developed by DCRT to collect and process data. When appropriate these smaller computers link to the computer center, a set of integrated systems of a power and complexity far beyond the comprehension of the 1960's.

The growth of systems hardware and software has been matched by the growth of computing applications in the conduct, support, and management of science. In these applications mathematics, statistics, logic and other information disciplines guide--literally inform--the processing of scientific data. When embodied in the language of computers and supported by good systems, these disciplines turn the elementary symbol processing abilities of computer hardware into powerful tools for scientific endeavor.

The foresight, indeed the genius, of NIH was to see in the early 1960's that mathematics, engineering, and computer science and technology should grow together and serve as a unifying force within the variety of biomedical science.

The growth of knowledge and technique continues: across computer science and systems engineering; across mathematics, statistics and other information disciplines; as well as across all areas of biomedicine, from the chemical physics of molecular interaction to the social psychology of human interaction.

The inescapable "interconnectedness" among all the various facets of biomedical computing remains at the heart of the challenge for DCRT and NIH. The challenge includes maintaining continuity and compatibility while pursuing and benefitting from advances in knowledge and technology.

Over the last 20 years many innovations have been created or adopted by DCRT scientists, mathematicians, engineers, and computer professionals. These were integrated incrementally to the network of central and peripheral computers built by DCRT staff.

In the last two years one challenge has come from the many types of personal computers and scores of commercial software packages that have appeared. A new organizational approach, a project drawing from the expertise in all DCRT laboratories and branches, was needed to maintain the connectedness among systems and to achieve a measure of compatibility.

NIH will face more such challenges over the coming decade. Biomedical science, computer science, mathematics, and engineering will provide more innovations for incorporation into the physical and intellectual network of biomedical computing at NIH. The scientific opportunities stand before us. The opportunities imply imperatives to find new ways to bring them to fruition.

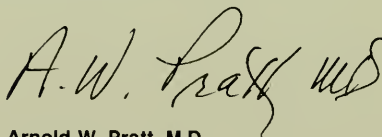

Arnold W. Pratt, M.D.

DCRT Director

Contents

DCRT: Two Decades of Growth	1
Office of the Director	11
Computer Center Branch	15
Data Management Branch	21
Computer Systems Laboratory	25
Laboratory of Statistical and Mathematical Methodology	31
Laboratory of Applied Studies	37
Physical Sciences Laboratory	43



The Division has grown under the leadership of Dr. Arnold Pratt (right), first and only DCRT Director, shown here with key staff members Dr. William Mohler, Deputy Director, and Lee Manuel, Executive Officer.

DCRT: Two Decades of Growth

Twenty years ago, in April 1964, the Department of Health, Education, and Welfare approved the establishment of a new Division of Computer Research and Technology (DCRT) at the National Institutes of Health. In those 20 years, computing has become an essential aspect of all NIH activities; and DCRT has become an integral part of the conduct and management of biomedical science at NIH. Its role continues to evolve to meet the challenge of new opportunities in both biomedical and computer science.

Origins

Computing at NIH actually began 30 years ago with the establishment in 1954 of a small central punched card processing facility in the Office of the Director, NIH. The facility was used mostly for work in biometrics--the tabulation and analysis of biological data--and in 1956 it became the Biometrics Branch in a new Division of Research Services at NIH. In 1958 NIH got its first digital computer and in 1960 the Biometrics Branch became the Computation and Data Processing Branch (CDPB).

During the early 1960's, the demand increased for computing services in both administrative and scientific work at NIH. In May 1962, NIH Director Dr. James A. Shannon appointed a Steering Committee to examine and evaluate NIH's automatic data processing (ADP) needs. The committee concluded from its year-long study that NIH needed to broaden its commitment in computing to more than just providing ADP services.

It recommended that a new NIH Division be created to, among other things, conduct research in such areas as mathematics, computer science, computer systems

design and engineering, data systems design, and programming.

First Decade

On April 16, 1964, the Division of Computer Research and Technology was given life, but its actual birth and development required several years and much hard work. The existing CDPB was transferred from DRS to the new Division in 1965 and three new units, recommended by the Steering Committee report, were added: Computer Equipment Laboratory (CEL); Data Systems Analysis Branch (DSAB); and Mathematical and Programming Research Laboratory (MPRL).

DCRT's life gained new energy with the appointment of Dr. Arnold W. Pratt as the Division's first Director in August 1966.

In 1967, CEL became the Computer Systems Laboratory; DSAB was renamed the Laboratory of Applied Studies (LAS); and MPRL changed to the Physical Sciences Laboratory (PSL). The new names reflected the new emphases of the groups.

During 1968, a new Heuristics Laboratory (HL) was established, and CDPB was divided into the Computer Center Branch (CCB) and the Data Management Branch (DMB).

In the early 1970's, while the use of computers at NIH continued to expand rapidly, DCRT faced a continuing decline in personnel ceilings. The Heuristics Laboratory was abolished in 1974, and the Laboratory of Statistical and Mathematical Methodology (LSM) was created, consolidating some of the work from HL with functions from DMB and LAS.

Historical Organizational Development

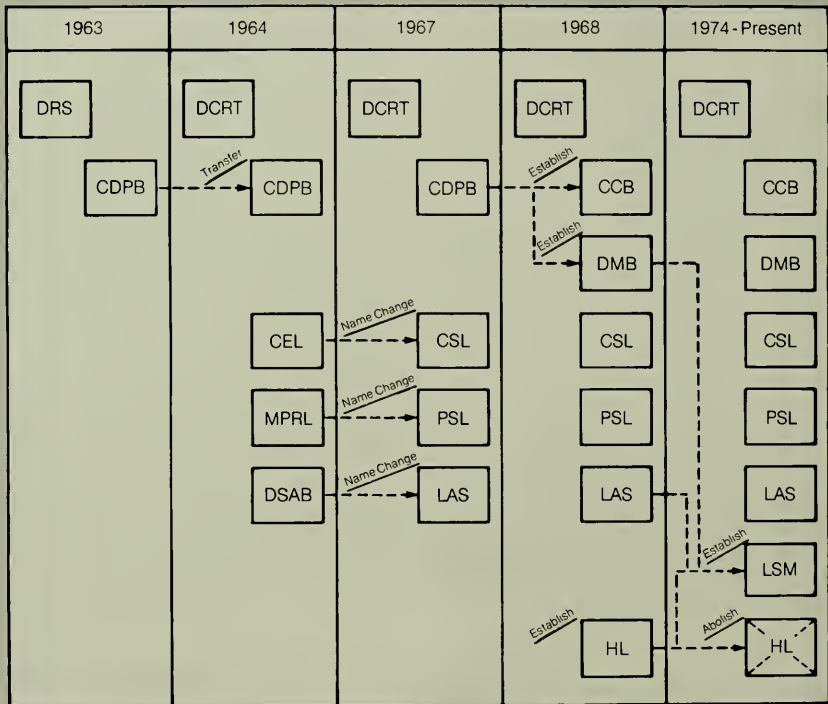

- | | |
|--|--|
| <p>CCB — Computer Center Branch
 CDPB — Computation & Data Processing Branch
 CEL — Computer Equipment Laboratory
 CSL — Computer Systems Laboratory
 DCRT — Division of Computer Research & Technology
 DMB — Data Management Branch
 DRS — Division of Research Services</p> | <p>DSAB — Data Systems Analysis Branch
 HL — Heuristics Laboratory
 LAS — Laboratory of Applied Studies
 LSM — Laboratory of Statistical & Mathematical Methodology
 MPRL — Mathematical & Programming Research Laboratory
 PSL — Physical Sciences Laboratory</p> |
|--|--|

The Division of Computer Research and Technology has undergone several reorganizations in the past 20 years. Today, DCRT comprises four laboratories and two branches working in many areas of collaborative research involving biomedical computing.

Second Decade

DCRT's capabilities grew throughout the 1970's, to include innovative facilities for biomedical modeling in both the mathematical and physical sciences, scores of small computer systems designed and installed in NIH laboratories and clinics, and new systems for maintaining data bases and analyzing data.

The Division became a scientific and technical resource for other parts of the Department and for other Federal organizations. In 1979, the NIH Computer Utility at DCRT was designated a Federal Data Processing Center, primarily for biomedical and statistical computation. Twenty-four other government agencies now share this resource.

In 1982 a Task Group reviewed ADP management functions at NIH and recommended that these be consolidated in a single location. The NIH ADP Policy Office (NAPO) was established in DCRT during the following year.

Exemplary Achievements

After 20 years the Division maintains a strong balance between research and service, and good computing and good science. Each year NIH central computer facilities run millions of computing jobs for thousands of scientists and administrators and the DCRT staff works on hundreds of projects. The following ten examples provide a glimpse of the breadth of DCRT activity over the years.

Nuclear Cardiology. In the late 1960's, staff members of DCRT's Laboratory of Applied Studies proposed using computers in the field of nuclear medicine. With the NIH Nuclear Medicine Department and the DCRT Computer Systems Laboratory, they developed a small computer system to collect scintillation data from a patient's heart and other organs. On a larger computer they used the data to create motion pictures of a heart beating. Once the technique was refined, a new version was developed to provide these movies on the small computer in the NIH Clinical Center for use by NIH cardiologists. The technique was rapidly adopted and supported by private industry and is now used throughout the world.

NIH WYLBUR. The Computer Center Branch introduced WYLBUR at NIH in 1969 as an online interactive text editor/job entry facility for use by DCRT programmers. Now hundreds of terminals connected by telephone lines to the NIH Computer Utility allow WYLBUR users to create, change, search, and display all kinds of text ranging from computer programs to sets of research data and office memoranda.

Other features of the latest NIH WYLBUR now include powerful facilities for dataset management, document formatting, batch job control, and electronic mail. Command Procedures allow users to write programs of WYLBUR functions, which include most of those found in conventional programming languages.

Molecular Graphics. In the mid-1960's, crystallographers worldwide began to determine the coordinate structures of many proteins and nucleic acids. DCRT staff created a computer system to turn the coordinate numbers into graphic "TV" drawings of the molecules. The molecules could be rotated in three dimensions and inspected by the scientist. This stereographic capability allowed scientists to see and think of these images as real objects. A microfiche output device was used to create inexpensive sets of selected stereo images for use by scientists and students who did not have computers.

In the late 1970's a new display system was developed to generate surface pictures of molecules with color spheres to represent specific types of atoms. Many of the images have appeared in scientific journals and textbooks.

Laboratory Data Acquisition and Control Systems. In the late 1960's the Computer Systems Laboratory began work on a timeshared minicomputer system to collect, store, and analyze data from scientific instruments in the then National Institute of Arthritis and Metabolic Diseases. The network design allowed the laboratories to function independently yet share the computational power of the computer. In the late 1970's the system was redesigned as a network of satellite microcomputers, each connecting a laboratory instrument to the minicomputer through a controlling microcomputer.

MLAB. MLAB (Modeling LABoratory) combines a set of powerful computer programs developed by the staff in several DCRT laboratories and progressively enhanced since 1971 as an interactive system for mathematical modeling. It allows the user to define mathematical models, to fit models to experimental data, and to produce high-quality graphic plots. It also solves differential equations. MLAB is now used at over 100 scientific facilities worldwide.

Shared Spool. This concept was developed by Computer Center Branch staff in the early 1970's to allow several computers in the NIH Computer Center to work together and accept jobs from one common queue or spool. In the past, each computer had its own independent queue from which it would receive jobs.

The shared spool facility balanced use of all the computers in the central NIH computer utility by giving jobs to the next computer available for work. This concept subsequently was picked up by computer manufacturers and has become an industry standard.

Cardiology/Surgery Data Base. The Data Management Branch set up this data base in the mid-1970's to provide the Cardiology and Surgery Branches of the National Heart, Lung, and Blood Institute with comprehensive information on their patients.

The system produces several types of output: reports that list tests, procedures, and operations previously performed on a patient; counts of the number of patients as a function of specific data items; and statistics to allow physicians to calculate various risk factors involved in surgery. The system also helps to keep track of patients after their release by automatically flagging the records of patients who have not been heard from for a year.

Voice Output Terminal. In 1978 Computer Systems Laboratory engineers began a collaboration with a blind computer programmer to design and develop a voice output computer terminal. A "voicebox" unit combining a commercially available voice synthesizer unit with a microcomputer controller is connected to a conventional terminal.

Using programmed rules of English speech, the unit converts words and numbers coming from the computer into spoken words. Additional terminals have helped other blind Federal programmers in their work. The design has been given to private companies, and several similar models are now on the market.

NIH Administrative Data Base. Material and financial management functions were unwieldy tasks at NIH until Data Management Branch computer professionals began in the late 1970's to devise an automated system to handle these complex functions.

By the early 1980's, a Materiel Management System was in place, to automate the ordering/receiving/paying process from terminals throughout NIH. This eliminates manual processing of orders, speeds bill payments, and reduces paperwork throughout NIH. Other administrative and accounting systems were developed and incorporated in the ADB.

Intermolecular Forces. Scientists in the Physical Sciences Laboratory have used x-ray diffraction to provide the first direct measurement of intermolecular forces that occur between large biological molecules (macromolecules) in water soluble environments. Computerized molecular graphics have helped to picture these forces and to explain the repulsion or attraction that occurs. Results from these studies have disproved earlier theories of forces between molecules or between cell membranes in aqueous solution and have led to the development of new theories.

Overview of DCRT Resources Funding

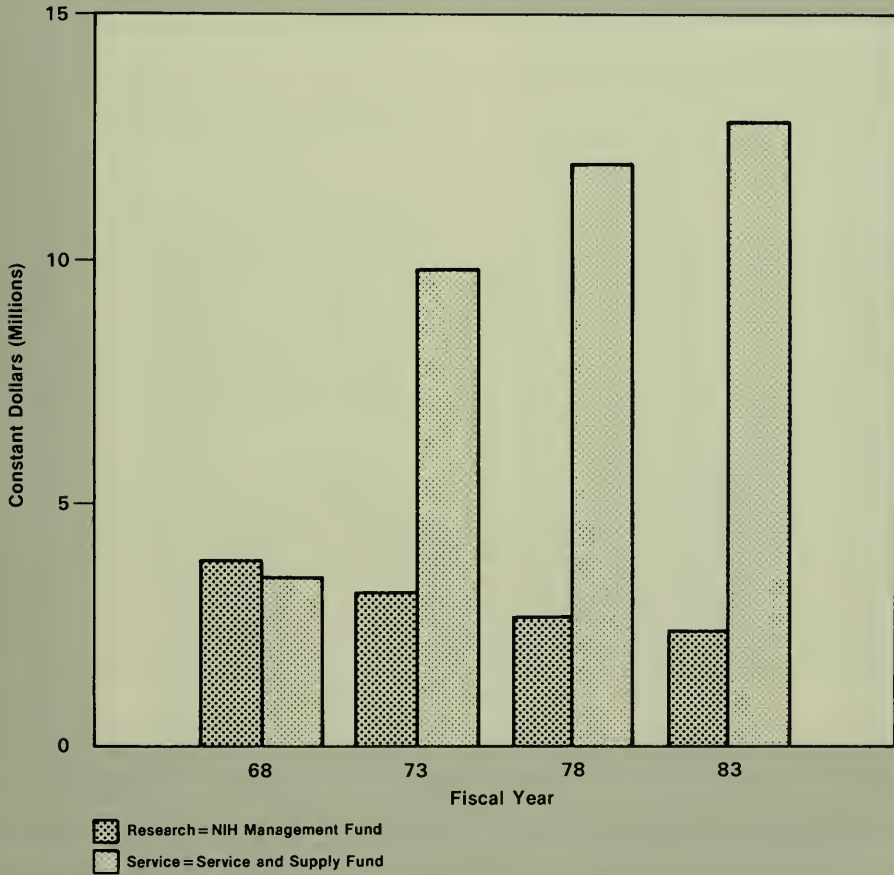

Over the years, DCRT management fund dollars have decreased by nearly half, while its service and supply fund dollars have nearly quadrupled.

Overview of DCRT Resources Staffing

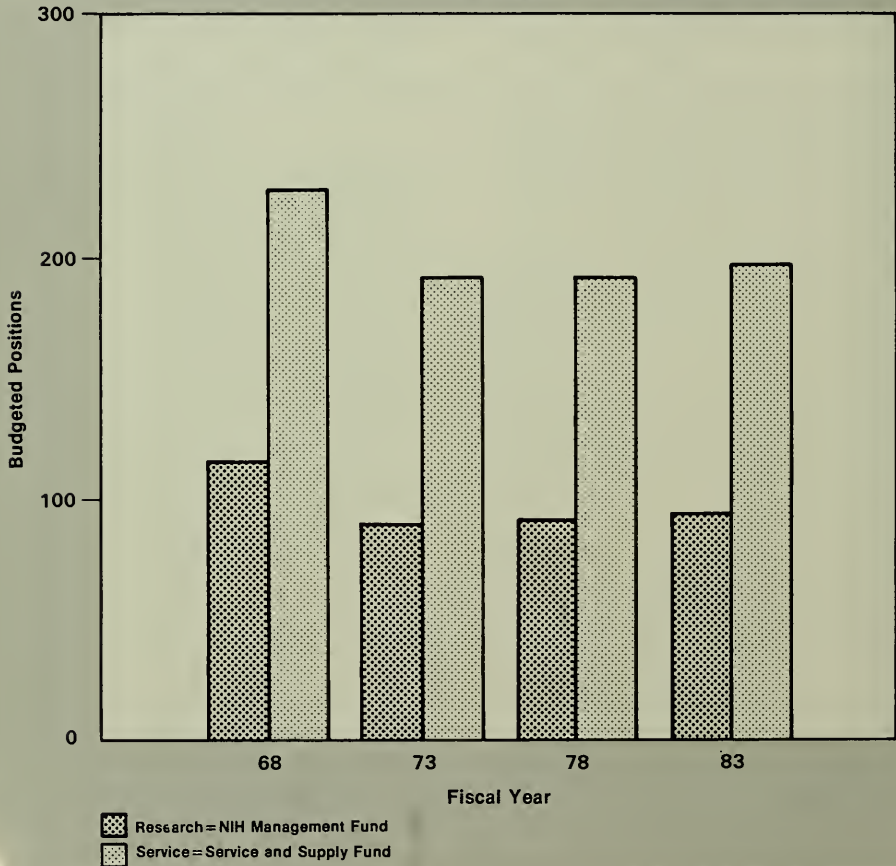

Staff expertise has enabled the Division to flourish, despite a decrease in budgeted positions.

Evolution of Computing

DCRT continues to reflect the dynamics of technology that pervades computing around the world. Computing at NIH has evolved from separate rudimentary machines to integrated systems of progressively powerful computers.

Automatic data processing at NIH in the 1950's used punched card accounting machines. These required people to move information in stacks of cards from machine to machine for each process.

The first NIH electronic digital computer, an IBM 650, was installed in 1958. It was first generation (vacuum tube) technology. Information was still entered on punched cards but could be stored on computer tapes and all computing functions were done on one machine.

A Honeywell H-800 computer was installed in 1961. It used second generation (transistor) technology. A second Honeywell H-800 computer was installed in 1963 and soon a Honeywell 200 machine was added to serve the other two.

In 1965, NIH began to install third generation computers, the IBM 360 series. These computers used integrated circuits rather than transistors, which allowed even faster computing, and offered direct access disc storage as well as tapes. Computer jobs still were entered on batches of punch cards.

Initially each computer still handled its stream of batch jobs one at a time. The operating system, the computer program that controlled the IBM 360 computer while it ran user programs, evolved. This evolution and systems programming work by DCRT staff produced a powerful and advanced central NIH computer facility. Entry of data and programs from terminals via WYLBUR gradually replaced punched cards.

The first timeshared operating system came with the PDP-10 computer installed at DCRT in 1968. Now called the DECsystem-10, this machine served as the focus for a number of computer research and development projects that provided interactive computing with graphic output on terminals with display screens.

Linked to the PDP-10, a special purpose AGT 30 computer was developed to display three-dimensional images, which could be rotated and even enlarged to look at details. Projecting two images on the screen and using polarized glasses allowed true 3D viewing.

In 1969 DCRT began to install the first of its many minicomputer systems at NIH. Some of these smaller computers connect directly to laboratory instruments throughout NIH to record and rapidly analyze data. Others are coupled to instruments for the diagnosis of disease and the monitoring of patients in the NIH Clinical Center.

During the 1970's DCRT's expertise in all of these areas continued to advance. Links were provided between minicomputer systems around NIH and the DECsystem-10. The latter was linked to the IBM 360 computers.

By the mid-1970's the powerful central computer facilities became known as the NIH Computer Utility. Advances continued in communication techniques and in computer machinery and operating system programs. DCRT added sophisticated data base systems and statistical analyses systems for scientists and administrators throughout NIH. This work progressed into the late 1970s to data bases employing true data base management system technology.

In the mid-1970s the emergence of microprocessors--computers on a single silicon chip--spawned a new and now pervasive technological challenge. In 1977 DCRT began putting microcomputer systems into NIH laboratories and replacing shared minicomputers with networks of microprocessors and minicomputers.

In the early 1980's, those adaptations of microprocessors called personal computers were sufficiently powerful to make them useful workstations in the overall network of central and distributed computers at NIH.

Beyond personal computers, even more powerful microprocessors lead the way to creation of specialized computing devices that can be shared on the Computer Utility or in local networks for scientific computing tasks. These devices include powerful array

processors, specialized graphic display devices and even devices designed to optimize the performance of specific computer languages.

The Future

Mathematics, statistics, engineering, and other elements of computer science are now recognized throughout the world as essential elements in biomedical science. The task is now to build upon the high level of technological success and move to one that truly can be called an intellectual era of biomedical computing.

The growing capacity of computer systems to store, manipulate, analyze and display information of many types now opens the way to useful work on Information Science in a variety of biomedical settings. However, this technological advance alone is not enough to create the linkage between the power of computers and the substance of modern science.

The committee report in 1963 that led to formation of DCRT recognized this, when it said at the outset: 'The Committee was deeply impressed by the power of this technology and the promise it holds for contributing a new level of insight into problems in the life sciences. It was equally impressed by the

magnitude of the resources, especially intellectual, that its large scale application demands.'

Only an intellectual union of computing and science can move forward to advance the underlying theory of biomedical science and to generate advances in the information sciences. Progress arises from the engagement of first class minds in a context where the focus of information processing is engaged fully in the environment of biomedical research.

Progress has occurred on the analysis of information in two-dimensional images, particularly where the intellectual base includes an adequate theory of interpretation. Currently there is also great activity in processing strings of nonnumeric symbols, especially those representing the nucleotide and amino acid sequences essential to the intellectual core of molecular biology. Computer processing of the information and knowledge embodied in natural language remains, after 20 years, a difficult but provocative goal.

The challenge to DCRT and NIH in 1984 is still the one presented in 1964, to amass and focus the best available intellectual and technical resources on important and pervasive opportunities for biomedical computing at NIH. It remains a very dynamic and demanding challenge. Neither biomedical science nor computer science shows any signs of slowing its pace.



During FY84, DCRT's newly-formed Personal Workstation Office advised several hundred NIH individuals and groups who sought guidance on personal computers. Examining one of the commercial software packages are Brian McLaughlin and David C. Songco, Office Head.

Office of the Director

Arnold W. Pratt, Director

Function and Scope of Work

The Office of the Director provides overall program and management direction for DCRT. It includes an **Equal Employment Opportunity Office** and three offices whose activities supplement the work of the DCRT laboratories and branches:

- **NIH ADP Policy Office (NAPO)** is the central NIH focus for advice and assistance on matters related to the complex policy and procedures governing the procurement and management of computers in the Federal Government. It serves as the point of contact on these matters with Federal agencies outside of NIH.
- **The Office of Administrative Management (OAM)** provides administrative and managerial support for the work of DCRT. OAM includes the Administrative, Personnel, Financial Management, and Project Control Offices.
- **The Office of Scientific and Technical Communication (OSTC)** serves as a central source of information about DCRT activities and about computing and related disciplines. It includes the DCRT Information Office and the DCRT Library.

In addition, the Office of the Director sponsors several research and development projects.

FY84 Highlights

Throughout the year, DCRT observed the 20th Anniversary of its 1964 establishment. On the official anniversary day, April 19, the Director recognized those who had been with DCRT for the full 20 years along with several people who had made outstanding contributions to DCRT programs. In May, Dr. Franklin C. Stamer (Duke University) and Dr. S. Marsden Blois (University of California) presented lectures surveying facets of biomedical computing. The Computer Systems Laboratory and the Computer Center Branch held open houses in May and June, respectively.

Efforts at evaluation and planning moved along several related paths. A number of experts in computer science, mathematics, engineering, and biomedical applications of computing reviewed the DCRT. A small

ad hoc DCRT committee compiled a list of planning items and the Division leadership spent two days on a retreat to consider known resource constraints and proposed laboratory and branch plans. The DCRT Director and the new Assistant Director also served on a DHHS Information Resource Management Committee to develop Departmental guidelines for computer and telecommunications systems.

The NIH ADP Policy Office gave advice, counsel, and occasional critique on proposed NIH computer systems. This Office also provided leadership in the NIH response to requirements from the Department, GSA, and OMB: a program for risk analysis of computer systems at NIH, security clearance for key ADP personnel, improved mechanisms for clearance of key ADP systems contracts, and inventories and reports on ADP systems.

The NAPO was also active in the formative stages of the DCRT Personal Workstation Project (PWP).

The PWP guided the specification, procurement, and installation of some three dozen personal computer workstations throughout the Division. PWP members examined, used, and evaluated a large number of commercial software and hardware products and served as expert consultants to the users at the test sites in DCRT. During this in-house learning period, the PWP advised several hundred NIH individuals and groups who sought guidance on personal computers.

In May the project was recast as the Personal Workstation Office (PWO), a functional focus to which selected staff throughout the Division were detailed for the next phase of the DCRT initiative on personal computers at NIH. Toward the end of FY84 the PWO "went public," formally offering coordinated support throughout NIH for selected hardware configurations and software packages for the IBM PC.

The Office of Administrative Management continued to conduct the broad range of administrative functions required to support the Division's programs. The Administrative Office processed the continuing flow of actions and reports associated with procurement, space, travel, renovations, repairs, communication, property, etc., for the complex DCRT functions. In

addition it coordinated the new internal control system procedures mandated by OMB Circular A-123.

The Project Control Office participated in the implementation of a new system for maintaining Computer Center user registration information. During FY84 it added over 3,000 new users and 200 accounts to the system. In addition to the normal budget functions, the Budget Office began its participation in the Personal Workstation Project. It formulated the 1986 preliminary budget using a personal computer software package and captured historical data for reference and trend analysis.

The DCRT Personnel Office recruitment functions remained active, although complicated by new restrictions imposed by a DHHS reduction-in-force. This past year new Federal Computer Operator Standard required the classification of all DCRT computer operator positions in the new factor evaluation format. Also, the Personnel Office provided support for some NIH personnel activities and was a major participant in a job analysis project conducted by the Department for computer occupations.

The Information Office coordinated the events and publicity for the Division's 20th anniversary, including open houses, lectures, and demonstrations. These events enhanced understanding of both DCRT's programs and biomedical computing among more than 3,000 attendees.

In addition to its ongoing work in preparing and distributing informational documents and answering public inquiries, the Information Office began to capture on videotape work being done throughout NIH by DCRT members. The first effort, completed this year, covers several NIH laboratories that have been automated by Computer Systems Laboratory engineers and scientists.

The computerized bibliography of DCRT staff publications was expanded to include the capability of preparing individual bibliographies for DCRT authors. Many of the Information Office administrative and reporting functions were automated, using the newly available DCRT personal computers.

In the third quarter, Public Affairs Specialist Joan Sobel joined the Office, bringing new dimensions in audiovisual, public inquiry, and exhibit skills to the staff.

The Information Officer provided computer typesetting advice to several NIH components, including the NIH Office of Communications, and was once again active in Women in Communications, Inc., chairing the Speaker's Bureau for its D.C. Chapter and serving on its national by-laws committee.

The DCRT Library had another busy year serving its active community of users with a 15 percent increase in books circulated. There was a 50 percent increase in interlibrary loans requested by the DCRT staff, but even this surge barely reached half the number of items requested from DCRT by other libraries. This reflects the quality of the DCRT collection, which the library again pruned to make room for new monographs, reports, and journals in its very limited space. A new microform reader now makes microform collection of old journals more useful.

The Library was a site for testing one of the PC's in the Personal Workstation Project. In addition to testing and using software packages for word processing, communications, file transfer and spreadsheets, the library staff finally had its long awaited opportunity to examine commercial microcomputer packages for library operations. The Library installed a serial control package and helped NIH scientists learn and use the BIOSIS Information Transfer System (BITS).

The Librarian organized a computer book fair for NIH; agreed to be the circulation control for the growing collection of books, manuals, etc., in the Personal Workstation Office; and became president of the Washington, D.C. Chapter of the Special Libraries Association.

The DCRT Molecular and Cellular Graphics Project (MCGP), transferred to the Office of the Director in FY84, began putting together its new MCG Network. This is a local area network integrating a variety of powerful new specialized computing "engines." By the end of the year most of the system problems encountered during shakedown had been addressed



The Information Office coordinated the events and publicity for the Division's 20th anniversary, including open houses, lectures, and demonstrations. Preparing one of the computer-typeset publications are (left to right): Patricia Miller, Joan Sobel, Arthur Bailey, and Suzanne Kuldell.

and work moved forward on application to computing models of large molecules and membrane segments.

Two talented DCRT scientists working under the aegis of the Office of the Director were recruited by the private sector. Dr. Stephen Brenner left for the DuPont Corporation, and Dr. Judith Prewitt went to the Information Systems Laboratory at AT&T Bell Laboratories.

Future Plans/Trends

Plans for the future of the Division will be discussed with the Office of the Director, NIH. New steps may be taken to incorporate advances in computer science, engineering, and mathematics into the programmatic structure of the Division and the work of NIH. Within the DCRT Office of the Director emphasis in the coming year will focus on the Personal Workstation and the Molecular and Cellular Graphics initiatives.

The Division will sponsor a symposium, *Biomedical Computing: Beginnings and Prospects*, on October 22-24 and on November 9 the Laboratory of Statistical and Mathematical Methodology will host an open house, the last event commemorating DCRT's 20th anniversary.

Publications

- Brenner, S. L., and Korn, E. D.: Evidence that F-actin can Hydrolyze ATP Independent of Monomer-Polymer End Interaction. *J. Biol. Chem.* 259:1441-1446, 1984.
- Brenner, S. L., and Korn, E. D.: On the Mechanism of Actin Monomer-Polymer Subunit Exchange at Steady State. *J. Biol. Chem.* 258:5013-5020, 1983.
- Computing Resources of the Division of Computer Research and Technology*. Fall 1983 edition, 24 pp.
- Computing Resources of the Division of Computer Research and Technology*. Summer 1984 edition, 28 pp.
- Division of Computer Research and Technology Fiscal Year 1983 Annual Report, Volume 1*. October 1983, 36 pp.
- Division of Computer Research and Technology Fiscal Year 1983 Annual Report, Volume 2*. October 1983, 86 pp.
- Lamy, J., Lamy, J., Sizaret, P. Y., Billiard, P., Jolles, P., Jolles, J., Feldmann, R. J., and Bonaventura, J.: Quaternary Structure of Limulus Polyphemus Hemocyanin. *Biochemistry* 22:5573-5583, 1983.
- DCRT Library*. Reprinted December 1983, 20 pp.
- Li, S. S. L., Feldmann, R. J., Okabe, M., and Pan, Y. C. E.: Molecular Features and Immunological Properties of Lactate Dehydrogenase C4 Isozymes from Mouse and Rat Testes. *J. Biol. Chem.* 258:7017-7028, 1983.
- Tobacman, L. S., Brenner, S. L. and Korn, E. D.: Effect of Acanthamoeba on the Pre-Steady State Kinetics of Actin Polymerization and on the Concentration of F-actin of Steady-State. *J. Biol. Chem.* 258: 8806-8812, 1983.



The Computer Center recognized the 20th anniversary of DCRT with 3 days of tours and demonstrations of the NIH Computer Utility General Systems Unit Chief Elliot Alterman (center) conducted several tours of the machine room.

Computer Center Branch

Joseph D. Naughton, Chief

Function

The Computer Center Branch, the largest component of DCRT, designs, implements, operates, and maintains the NIH Central Computer Utility and its associated telecommunications facilities. To insure the most effective use of the Utility, the Center staff provide direct support to the users of the Utility by conducting a formal computer user training program, by writing and publishing technical documentation, and by providing programming assistance and consultation on the use of the Utility in support of both scientific and administrative programs. Chartered as a Federal Data Processing Center, the NIH Computer Center also provides data processing services on a cost reimbursable basis to authorized users in 26 agencies throughout the Federal Government.

The NIH Computer Utility consists of two large multicomputer facilities designed around large-scale IBM and DEC mainframe processors. The facilities are linked together by high-speed telecommunication lines and are connected by standard telephone lines to thousands of remote interactive terminals and computers located at NIH and many other Federal agencies throughout the United States. The systems hardware is complemented by an extensive array of software that has been designed and implemented by Computer Center personnel, or acquired from other sources and adapted to meet the unique needs of the NIH biomedical research and administrative user community.

The Computer Center employs a highly specialized staff of professional, technical, and management personnel to ensure smooth functioning of the NIH Computer Utility 24 hours a day, 7 days a week. Systems software is developed and maintained by a staff of experienced computer systems programmers and analysts, who also provide technical consultation on program design, teach training courses, and write technical documentation describing the effective use of the Utility. The Computer Utility's hardware and telecommunications networks are operated and maintained by computer systems technicians and

operations personnel. Data conversion services are provided by a staff of skilled data entry personnel. Systems design and management professionals are responsible for long-term program goals and the design integrity of the Utility. Because the Computer Center receives no appropriated funds from Congress, all services of the NIH Computer Utility and facilities are financed exclusively on a fee-for-service, cost recovery basis.

The Computer Center also conducts a number of research and development projects to increase the effectiveness of computers in support of modern biomedical research. Current ongoing research projects include development of facilities that will enable microcomputers to be used in conjunction with the Utility; enhancements of output devices to permit high-quality printing of display mathematics; installation of a data base management facility; and the integration of high-speed array processors into the central Utility.

Scope of Work

The NIH Computer Utility provides timesharing, data base, graphic, and batch processing services to over 14,000 research scientists, administrators, secretaries, analysts, and programmers. It is comprised of two large interconnected digital computer facilities. The larger, IBM System 370 facility is designed around 6 IBM 370/3081 processors (CPU's) with a total of over 192 million bytes of directly addressable memory. The peripheral complex includes: 360 630-million byte disk drives; 52 200-million byte disk drives; 2 mass storage units with a combined capacity of 401-billion bytes; 109 730KB tape drives; 6 200KB tape drives; 6 18,000 and 5 1,100-line-per-minute page printers; two 1,000-card-per-minute card reader/punches; and 10 telecommunications controllers supporting a teleprocessing network of over 1,300 lines.

This facility is complemented by a large DECsystem-10 facility designed around 2 KL10 and 1 KS10 processors with 1.5 million words of main memory; 6 400M-byte disk drives; 17 167M-byte disk drives; 7 780KB tape

NIH Computer Utility Technology Changes

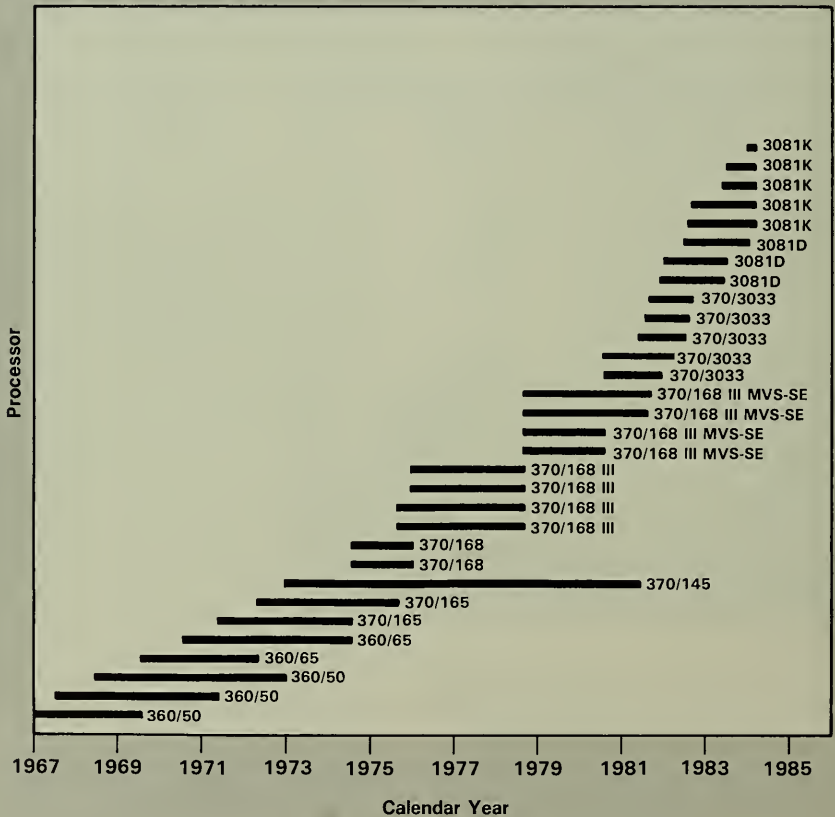

There have been several changes in technology over the history of the NIH Computer Utility. Today, the IBM System 370 facility is designed around 6 IBM 370/3081 processors.

drives; and 11 communications processors supporting over 50 simultaneous timesharing users.

The two computer facilities are interconnected by telecommunications facilities and are linked by standard telephone lines to thousands of interactive terminals and 249 remote job entry (RJE) computers located throughout the United States. Ancillary equipment includes 2 computer output microfiche units and file processors, 2 four-color high-resolution plotters, and miscellaneous other devices.

The Utility provides services using three interactive programming systems--DECsystem-10 timesharing, TSO, and WYLBUR--and a large interactive data base management system (IMS) with subsecond response time for over 85 percent of all commands. Batch jobs are submitted to the Utility in four classes (1 small, 2 medium and 1 large), with respective turnaround times of less than 30 minutes, 1 hour, 2 hours, and overnight. Programming languages include FORTRAN, COBOL, PL/1, BASIC, Assembly Language, WATFOR, SAIL, and SPEAKEASY. An extensive variety of statistical analysis, modeling, and utility programs is available, as well as the TELL-A-GRAF, POSTER, and OMNIGRAPH interactive graphics packages for generating graphic output on paper or microfiche.

Users of the Computer Utility are informed of programming standards and available services and facilities through two comprehensive manuals, the *Computer Center Users Guide* and the *DECsystem-10 Timesharing Guide*. Changes in the Utility were announced through seven issues of *INTERFACE*, a periodic technical newsletter. An in-house training program offered classroom lecture service to students this year. In addition 3,000 users took advantage of the interactive, computer-aided instruction program.

Highlights of the Year's Accomplishments

FY84 has been a year of burgeoning growth for the NIH Computer Utility. New records were set this year as the total number of batch jobs and interactive sessions processed per month reached 900,000. Seventeen thousand batch jobs were processed each

day with over 90 percent of them being completed and available to the user in less than 2 hours. Sixteen thousand interactive sessions and 40,000 data base transactions were processed in less than 1 second each day. The focus of the staff effort this year has been on system enhancement to maintain the efficiency and responsiveness for which the Utility is known.

Maintaining open lines of communication between users and the staff has long been an important priority of the Computer Center. This year a major effort was made to improve not only this interchange, but also to encourage communication among users. An entirely new system called Information EXCHANGE was made available to allow users to share ideas about computing and other professional pursuits.

A variant on the "bulletin board" concept, the Information EXCHANGE enables users to share computer programs, research plans, statistical data, interesting articles, and other potentially useful information quickly and easily. Entries are made through WYLBUR and classified into categories to encourage browsing. Direct communication between submitters and requestors is encouraged via WYLBUR MAIL. The EXCHANGE system was developed as a direct result of dramatic increase in users' requests for information resulting from the explosion in the use of microcomputers in offices and laboratories.

Other projects completed this year included the installation of new CRT and hardcopy interactive terminals, a major expansion of the Mass Storage System, the implementation of new features to enhance system security and data set integrity, the introduction of communications packages to allow microcomputers to exploit the full power of the mainframes, and a number of operating system software improvements.

The smooth but inexorable growth of WYLBUR was interrupted this year by a sudden and dramatic increase in usage far exceeding its typical peak load of 550 concurrent users. The unexpected increase in the use of WYLBUR caused some performance problems and system delays, and the Computer Center responded by

accelerating its plans for increased WYLBUR capacity. A number of short-term enhancements brought immediate relief and helped minimize performance difficulties. To meet the increased long-term demand for WYLBUR services, a second WYLBUR system was installed. Twin WYLBURs, running on two independent 3081s, effectively doubled the number of simultaneous users that can access the system and improved response time for all commands. Although a great deal of computer hardware, software, and telecommunications facilities had to be modified or relocated to accommodate two WYLBURs, the addition of a second WYLBUR system was almost imperceptible to users. Now capable of accommodating over 800 users simultaneously, the twin WYLBURs should be able to provide excellent performance well into the foreseeable future.

The Computer Center recognized the 20th anniversary of DCRT by conducting 3 days of tours and demonstrations of the NIH Computer Utility. Featured were the WYLBUR system, computer-assisted instruction, sharing information via computer, data base applications, graphics, and other services, as well as tours of the Computer Utility machine room. The event proved to be a huge success and was thoroughly enjoyed by over 1,200 users and guests who visited the Center.

A discussion of the highlights of the year would hardly be complete without mention of the latest rate reductions. FY84 marked the 17th consecutive year of steadily declining rates for services provided on the NIH Computer Utility. Reductions were announced on the first day of the fiscal year, when the cost of public online data storage space was lowered 8 percent and the printing charge was eliminated completely for output that is routed to an RJE workstation or purged.

At the same time, the 60 percent off-hours discount was extended to include printing for batch jobs that began execution during the discount period and for offline listings submitted during the discount period. A second set of rate reductions became effective on February 1, 1984. Timesharing services on the DECsystem-10 were reduced by 20 percent and rate reductions for IBM 3081 services enabled users to save up to 26 percent on batch processing services.

The continual growth in the use of the NIH Computer Utility has been a major reason for the steadily decreasing rates. Because fixed costs and overhead of the system do not rise in direct proportion to its processing capacity, the effect of increased utilization is lower rates for all users. This economy of scale is an important advantage of the Computer Utility concept as implemented at NIH.

Future Plans

Support for microcomputers will continue to be an important priority of the Computer Center during the coming year. Work is underway on extending and improving the existing file transfer services and plans for the support of a terminal emulator package are progressing well. Procurement has been initiated for an array processor to be integrated into the IBM 3081 system to facilitate processing large scientific problems involving significant amounts of matrix mathematics. A new easy-to-use data base system that supports mainframes and microcomputers will be considered for installation in FY85. Work will continue on connecting the NIH Computer Utility to a public communications network to minimize communication costs for long distance users.

Improvements in the printing facilities should facilitate the printing of high-quality scientific notation. New hardware will be added to the DECsystem-10 to improve response time and the IBM 3081 will begin the transition to the new XA (Extended Architecture) operating system.

Plans are also underway to develop additional computer-assisted training courses in various subject areas such as JCL, Introduction to Computers, and advanced features of WYLBUR.

Presentations

Havekost, C.: Independent Training Assisted by Computer. SIGUCCS Conference, New Orleans, LA, October 6, 1983.



The Clinical Support Section develops and maintains the Clinical Information Utility as a data base for research and patient care in the NIH Clinical Center (left to right): Nhung Pho, Ronald Edwards, Aileen Kelly, Nanette Miller, Renee Edwards, David Blessley, and Section Head Doug Vincent.

Data Management Branch

J. Emmett Ward, Chief

Function and Scope of Work

The Data Management Branch (DMB) provides advice and assistance to research investigators, program officials, and administrators throughout NIH in planning for and obtaining computer data processing services. In this role the branch is a central NIH resource for systems analysis, design, and programming. The branch is also responsible for the development, maintenance, and processing of the NIH Administrative Data Base and the Clinical Center's Clinical Information Utility. There are currently 50 permanent full-time employees whose disciplines include computer science, mathematics, and statistics.

DMB staff design and create computer-based data management systems that provide practical solutions to the unique mix of administrative, scientific, and management data processing problems encountered at NIH. Each new computer system user is provided comprehensive training in all system facilities and functions of the system provided by DMB. In addition DMB staff teach courses about programming tools; provide advice on data management techniques to NIH programmers; serve as consultants to the B/I/D's for obtaining and monitoring contracting services for computer systems development; and create and maintain general purpose, user-oriented programming tools to speed building and improve operation of applications systems.

DMB comprises four sections. The **Applied Systems Programming Section** (ASPS) and the **Scientific Applications Section** (SAS) provide general computer systems analysis and programming services for all of the B/I/D's. The ASPS supports general data management, and the SAS handles those projects that require scientific data analysis.

The **Data Base Applications Section** develops and maintains the central administrative data base for NIH materiel and financial management. The **Clinical Support Section** develops and maintains the Clinical Information Utility as a data base for research and patient care in the Clinical Center.

FY84 Accomplishments

The NIH Administrative Data Base (ADB) is an ongoing developmental project that uses data base technology in support of NIH-wide materiel and financial management. Progress to date has seen major improvement in:

1. the control of central and delegated ordering, receiving, and payment procedures
2. the elimination of 100 percent of delegated and over 75 percent of central paperwork and paper flow, and
3. the replacement of intermediate data collection procedures by electronic data transfer.

In October 1983, stock requisitioning was made available to all appropriate users at NIH and the new central stores inventory system went into production test. In April 1984, the central stores inventory system was added to the ADB.

In May 1984, a new self-service stores system was implemented and interfaced with the ADB. Market Requisitioning has been programmed summer of 1984. Full implementation of this system is planned for January 1985.

Plans to implement the new Financial Management System (FMS) were terminated by a directive from the Assistant Secretary for Management and Budget, DHHS. The new Assistant Secretary is examining options for implementing a Department-wide financial management system and the proposed system may also include many of the materiel management/ accounts payable functions already available in the ADB.

The Clinical Information Utility (CIU) has been a long-term effort. When completed it will provide a unique archive of integrated data for use in patient care and research. To date, data from the Clinical Center's Medical Information System and clinical service activities have been integrated and made available for retrieval. This year, use of the CIU was extended to include the Medical Records Department (MRD). This extension allows the MRD to formulate individual CIU retrievals and to select clinical laboratory data by

category. An interactive retrieval assistance program also was developed for the integrated data base.

BRIGHT STAT-PAK is an online computer system designed to run on the DECsystem-10 and allow clinical investigators to directly perform analysis on their data. This system was expanded to provide bar charts with confidence limits, output in SAS and SPSS formats, and life table statistics.

The current awareness search facilities for Biosciences Information System (BIOSIS) and Chemical Biological Activities (CBAC) were dropped at the end of calendar year 1983. CBAC support was totally eliminated due to lack of interest, and the BIOSIS system was turned over to BIOSIS, Inc. The new BIOSIS service provides the same current awareness searches previously offered by DMB and also makes its output available in various Personal Computer (PC) diskette formats. This latter facility, called BIOSIS Information Transfer System (BITS), and complementary PC software developed in DMB permit scientists to maintain a comprehensive file of bibliographic data on diskette and to retrieve data as it is needed using various search criteria.

Information on all Federal Government-supported human nutrition research and training now is collected and made available to all Federal agencies, Congress and its staff, and the scientific community by way of a computer system developed by DMB for the Office of the Director, NIH. This system provides online query and batch reporting for all nutrition research activities in a fiscal year.

Other important projects in which DMB has been involved are too numerous to highlight here. Please refer to the DCRT *FY84 Annual Report, Volume 2* for these reports.

In the area of general support for NIH activities, DMB continued to maintain and teach courses on the Inquiry and Reporting System (IRS) and MARKIV; to maintain and distribute the NCI Survival System; and to consult with and assist NIH programmers and contractors, enabling facile use of DCRT computer facilities.

Future Plans/Trends

Recent initiatives in the DHHS Office of the Secretary (OS) indicate a trend toward standardizing the software for materiel, financial, contracts, and grants management. A major effort has begun to select common data base software and related applications software to perform the materiel and financial management functions. As proposed, any common data base system must be relational and must make available a fourth generation language for application design and development. The application software must represent a 70 percent accommodation of common DHHS processing requirements. DMB will assist OS in their evaluation of data base and applications software.

NIH has volunteered to be the pilot agency for implementing any newly-acquired software. If this occurs, a major impact will probably accrue to new development for and enhancement of the ADB. It is not possible at this time to estimate this impact.

The selection of user-oriented data base software will also be affected by the OS decision concerning data base software for Department-wide applications. In the interim, DMB will concentrate on providing management information support using existing technology. This new ADB support will provide standard software at the mainframe and personal computer level. It will also make all of the necessary links among software packages, thus making each individual utility transparent to the user. The personal computer support will be coordinated with other labs and branches in DCRT through the recently established Personal Workstation Office (PWO).

CIU efforts will concentrate on advertising the new facilities available from the Medical Records Department and on expanding retrieval and analysis capabilities. This latter expansion will require examination of alternatives for making retrieval data available to mainframe analysis packages and for downloading data to personal computers for further manipulation.

The DMB role of central resource for computer applications development for all of the B/I/D's will continue to receive priority support.

Publications

Magnuson, R.A.: SASM--A Structured Programming Macro Library for the IBM PC. *Softalk for the IBM Personal Computer* (in press).



Image processing is one of the areas in which CSL staff members have had a long-term involvement. Here (left to right) Arthur Pashayan, William Rizzo, and Dr. Benes Trus review some of the biomedical imagery.

Computer Systems Laboratory

Alan M. Demmerle, Chief

Function and Scope of Work

The Computer Systems Laboratory (CSL) develops and implements specialized computer systems for all segments of NIH. The CSL staff contribute expertise in the fields of engineering, computer science, mathematics, chemistry, and medicine.

Areas of application in which CSL staff members have maintained a long-term involvement include: research and clinical laboratory automation, physiological monitoring, image processing, nuclear medicine applications, and processing of medical records in the physicians office. Our level of involvement varies from project to project; however, a typical project involves the development or acquisition of both specialized hardware and software, system integration and testing, and then continuing support in the form of system refinements.

As digital computer technology evolved during the last two decades, CSL has designed computer systems ranging from medium-size mainframes with custom designed process-control interfaces, through minicomputers and microcomputers of many types, to the newest personal computer systems.

The microprocessor revolution of the last 10 years contributed greatly to the impact of computers on biomedical research. Microprocessors and microcomputers have allowed CSL engineers, programmers, and scientists to apply innovative approaches to the challenges they face. The custom designed analog/digital interfaces, which previously served as the connecting port between the biomedical signal source and the host computer, now are frequently replaced by low-cost dedicated microcomputers. These intelligent ports can provide such valuable functions as data preprocessing, quality assurance, feedback for control of the signal source, and communication with the user.

FY84 Highlights

CSL staff members have collaborated with clinicians and scientists from other NIH Divisions and Institutes on over two dozen projects this year. The laboratory also is working on areas in the fields of computer

science and electrical engineering, which will be of value to our future collaborative efforts; specific areas are Local Area Networks and Personal Computers. Among the ongoing projects, the following five are noteworthy examples.

In the Clinical Center, our laboratory provides continuing support for the Medical Intensive Care Unit (MICU) operated by the Critical Care Medicine Department. The multidisciplinary medical staff use a variety of techniques for the diagnosis and therapy of critically ill patients. CSL staff members were involved in the specification, procurement, installation, interconnection, and/or modification of the several computer-based systems that support patient care within the MICU.

To assess the status of cardiac function in the typical MICU patient, several minimally invasive techniques are utilized:

- physiologic waveform processing allows the determination of heart rate and intravascular pressures by a cardiac catheterization computer system
- nuclear medicine technology allows the assessment of cardiac function through computerized detection and analysis of radioactive tracer carried by the blood
- cardiac function can be visualized directly by the use of ultrasonic imaging techniques, which make use of computerized image generation and enhancement.

During FY84, CSL staff assisted the Nuclear Medicine Department in pursuing promising techniques for the introduction of a nonimaging cardiac probe into the MICU environment. In addition, development was initiated on software techniques for the automated extraction of information from images obtained through cardiac ultrasound methods. The goal of both efforts is the development of rapid methods for the determination of clinically useful cardiovascular indices of performance, such as left ventricular ejection fraction.

For many years, CSL has supported laboratory automation in the form of the Distributed Laboratory Data Acquisition and Control System (DLDACs) that serves the NIADDK laboratories in Building 2. This

year, a significant improvement to DLDACS was completed. A major software package was developed to allow the scientist user to rapidly specify or modify a sequence of operations for processing, formatting, and displaying data collected during experiments. This package is known as APR, and runs on the PDP-11/70 host computer.

Local Area Networks (LAN's) are a potentially valuable technology for the transmission of medical information and images in a complex multiuser environment.

CSL is implementing an LAN within DCRT to allow for efficient communication between the many personal computers, computer terminals, and the medium- and large-size host systems utilized by DCRT staff. This LAN will allow CSL to gain experience with LAN technology, and will provide a test bed for biomedical applications elsewhere at NIH.

The commercially available Ethernet Standard has been selected for the LAN. Initial plans call for the LAN to serve many personal computers, a PDP-11/70 system, a Masscomp MCS-553 system, as well as numerous CRT terminals. In addition, ports from the network to the DECsystem-10 and the IBM System 370 central facilities will be investigated. Interterminal and intercomputer transfer of programs, datasets, and messages will be possible among all users of the network.

Another noteworthy CSL project involves the widespread use of personal computers throughout NIH. DCRT branches and laboratories are contributing to the evaluation of the IBM personal computer technology and the evaluation and development of personal computer software. CSL's particular interest lies in the development of analog and digital interfaces that will support biomedical waveform processing and laboratory automation applications. Analog/digital conversion and digital input/output capabilities are the principal facilities necessary for these applications.

In addition, the user interface to the personal computer will be expanded beyond the usual keyboard input and CRT display. CSL efforts in support of integrated input/output facilities include the development and modification of hardware and software to support many desirable user interface features. Areas of interest include: speech recognition and voice response, touch sensitive CRT faceplates, bar code interpretation, touch tablet input, and free-form graphics.

CSL's goal is to utilize these features in the development of new tools and concepts within personal computer technology. Specific applications range from the microbiology laboratory--where the user is occupied with the manual task of operating a sophisticated microscope--to the handicapped user's environment--where sight, hearing, or neuromuscular impairment must be overcome.

Future Plans/Trends

CSL staff members will continue to focus their efforts on problem areas that appear to possess a maximum impact on the NIH-wide biomedical research community. High priority areas include direct patient care, medical imaging, laboratory automation, and user-friendly input/output interfaces.

There will be a substantial increase in the number of personal computers in place in clinical and research laboratory applications. CSL will contribute to the efficient and effective implementation of personal computers in these environments.

The year to come will see an increase in CSL efforts in support of the Clinical Center's Nuclear Medicine Department. The planned implementation of a multicomputer data collection, processing, storage, and display network will challenge the imagination of staff from both CSL and the Nuclear Medicine Department.

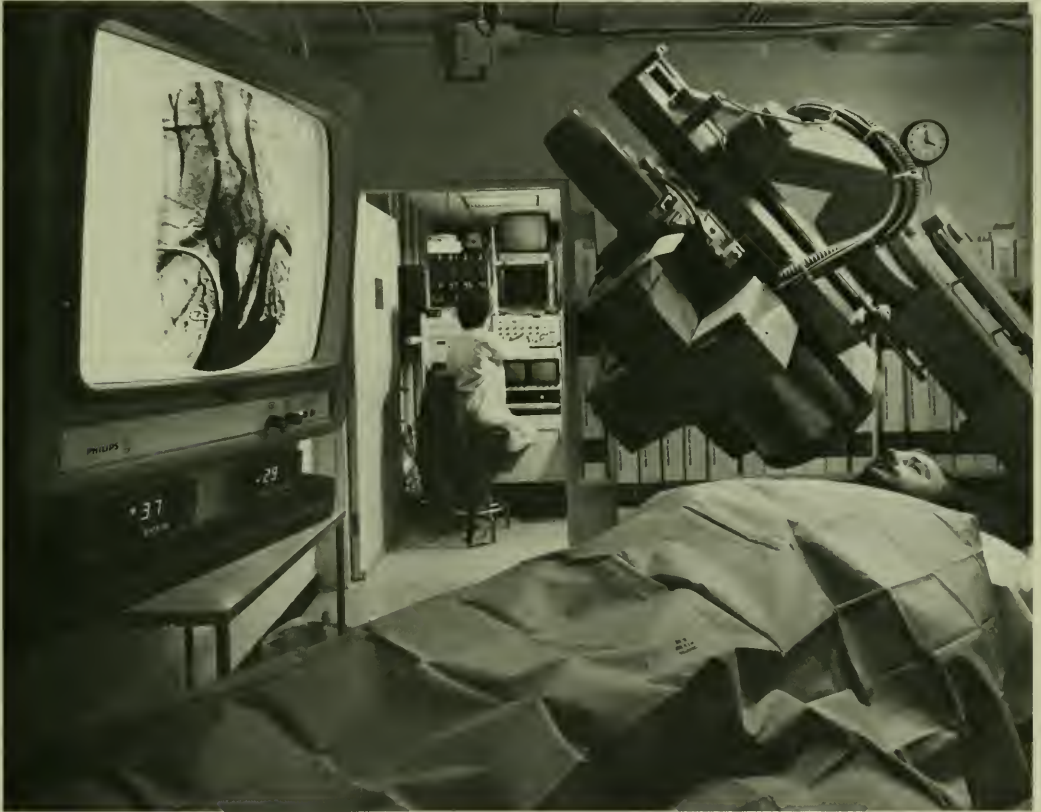

CSL provides continuing support for the Medical Intensive Care Unit (MICU) operated by the Critical Care Medicine Department, NIH Clinical Center. CSL staff members were involved in the specification, procurement, installation, interconnection, and/or modification of the several computer-based systems that support patient care within the MICU.

Publications and Presentations

- Bacharach, S., Green, M., Parentesis, P., Sindelar, A., Bonow, R., Ostrow, H., and Larson, S.: Underestimation of Cardiac Diastolic Parameters Using High Phase Reconstruction. *J. Nucl. Med.* 25: 30, 1984.
- Betocchi, S., Lesko, L., Ostrow, H., Bonow, R., Cannon, R., Watson, R., and Rosing, D.: Nifedipine Concentration and Hemodynamic Effects in Patients With Hypertrophic Cardiomyopathy. *American College of Clinical Pharmacology* (in press).
- Bonow, R., Ostrow, H., Cannon, R., Lipson, L., Maron B., Kent, K., Bacharach, S., and Green, M.: Effects of Verapamil on Left Ventricular and Diastolic Function in Patients with Hypertrophic Cardiomyopathy: Pressure Volume Analysis with a Nonimaging Scintillation Probe. *Circulation* 68(5): 1062-1073, 1983.
- Fiori, C., Swyt, C., and Gorlen, K.: Continuum Correction of X-ray Images in Scanning Electron Column Instruments. In Goldstein, J.I., and Romig A.(Eds.): *Microbeam Analysis* (in press).
- Gorlen, K.: The Computerization of an Analytical Electron Microscope. The Joint Meeting of Electron Microscopy Society of America and Microbeam Analysis Society, Phoenix, Arizona, August 1983.
- Gorlen, K., Barden, L., Del Priora, J., Fiori, C., Gibson, C., and Leapman, R.: A Computerized Analytical Electron Microscopy for Elemental Imaging. *Rev. Sci. Instrum.* 55: 912-921, 1984.
- Gorlen, K., Barden, L., Del Priora, J., Kocher, A., Fiori, C., Gibson, C., and Leapman, R.: A Data Acquisition System for an Analytical Electron Microscope. *Proceedings of the Digital Equipment Users Society USA*. Fall DECUS, 1982, pp. 181-187.
- Leapman, R., Fiori, C., Gorlen, K., Gibson, C., and Swyt, D.: Combined Elemental and STEM imaging under Computer Control. *J. Ultramicrosc.* 12: 281-292, 1984.
- Leapman, R., Fiori, C., Gorlen, K., Gibson, C., and Swyt, D.: Combined Elemental and Structural Imaging in a Computer Controlled Analytical Electron Microscope. *Proc. Electron Microsc. Soc. Am.* 1983, pp. 10-13.
- Leapman, R., Gorlen, K., and Swyt, C.: Background Subtraction in STEM Energy Loss Mapping. In Bailey, G.W. (Ed.): *Proceedings of the 42nd EMISA Meeting*. (in press).
- Leapman, R., Gorlen, K., and Swyt, C.: Digital Processing of Electron Energy Loss Spectra and Images. In Johnson, D. (Ed.): *Proceedings of SEM 84*. (in press).
- Kempner, K.: Computers Within the Critical Care Unit. The 19th Annual Meeting of the Association for the Advancement of Medical Instrumentation. April 14-18, 1984.
- Martino, R., and Gerber, L.: An Automated Biomechanics Laboratory Applied to Rehabilitation. *Proceedings of the Fifth Annual Conference of the IEEE Engineering in Medicine and Biology Society*. September 1983, pp. 150-153.
- Nikodem, V., Huang, D., Trus, B., and Rall, J.: The Effects of Thyroid Hormone on In Vitro Phosphorylation, Acetylation, and ADP Ribosylation of Rat Liver Nuclear Proteins. *Horm. Metab. Res* 15: 550-554, 1983.
- O'Bryan, E.: Counter/Timer Peripheral for the DEC Q-Bus. *Proceedings of the Digital Equipment Computer Users Society USA*. Fall DECUS, 1983, pp. 217-221.
- Pannell, L.K., Fales, H.M., Scovill, J.F., Klayman, D.L., West, D.X., and Tate, R.L.: Californium Plasma Desorption Mass Spectrometry of Some Metal-Ligand Complexes. ASMS 32nd Annual Conference, San Antonio, Texas, May 27 - June 1, 1984.
- Pannell, L.K., Fales, H.M., Sokoloski, L.C., and Tate, R.L.: Californium Plasma Desorption Mass Spectrometry of Cationic, Anionic, and Neutral Dyes. ASMS 32nd Annual Conference, San Antonio, Texas, May 27 - June 1, 1984.
- Pun, T., Trus, B., Grossman, N., Leive, L., and Eden, M.: Automated Computer Analysis of 1D Electrophoresis Gels by Image Processing. Symposium on Biomedical Applications of Computers, National Institutes of Health, August 6-10, 1984.
- Sabrin, H., and Kertesz, A.: The Effect of Imposed Fixational Eye Movements on Binocular Rivalry. *Perception and Psychophysics* 34(2): 155-157, 1983.
- Schwartz, M., DeLeo, J., Creasy, H., Duara, R., Renfrew, J., Rapoport, S., and Cutler, N.: Increase in Cerebrospinal Fluid Volume and Decrease in Gray Matter Volume of Brains During Aging of Healthy Men. *Neurology* 33(2): 160, 1983.
- Steinert, P., Parry, D., Rocoosin, E., Idler, W., Steven, A., Trus, B., and Roop, D.: The Complete cDNA and Deduced Amino Acid Sequence of a Type II Mouse Epidermal Keratin of 60,000 Molecular Weight: Analysis of Sequence Differences Between Type I and Type II Keratins. *Proc. Natl. Acad. Sci. USA* (in press).
- Steven, A., Hainfeld, J., Trus, B., Steinert, P., and Wall, J.: Radial Distributions of Density Within Macromolecular Complexes Determined from Dark-Field Electron Micrographs. *Proc. Natl. Acad. Sci. USA* (in press).
- Steven, A., Hainfeld, J., Trus, B., Wall, J., and Steinert, P.: Epidermal Keratin Filaments Assembled In Vitro Have Masses-per-Unit-Length That Scale According to Average Subunit Mass: Structural Basis for Homologous Packing of Subunits in Intermediate Filaments. *J. Cell Biol.* 97: 1939-1944, 1983.
- Steven, A., Hainfeld, J., Trus, B., Wall, J., and Steinert, P.: The Distribution of Mass in Heteropolymer Intermediate Filaments Assembled In Vitro: STEM Analysis of Vimentin/Desmin and Bovine Epidermal Keratin. *J. Biol. Chem.* 258 (13): 8323-8329, 1983.
- Steven, A. C., Trus, B. L., Hainfeld, J. F., Wall, J. S., and Steinert, P. M.: Conformity and Diversity in the Structures of Intermediate Filaments. International Conference on Intermediate Filaments, NY Academy of Sciences, New York, New York, May 21-23, 1984.
- Tate, R.: Microcomputer Systems in the Laboratory. An Introduction. *Computers in Endocrinology*. Seroon Symposium Series, Raven Press, 1984, pp. 63-74.
- Taub, F., DeLeo, J., and Thompson, E.: Laboratory Methods Sequential Comparative Hybridizations Analyzed by Computerized Image Processing Can Identify and Quantitated Regulated RNA's. *DNA* 2(4): 309-327, 1983.
- Taylor, W., Camalier, R., Trus, B., and Sanford, K.: Differences in Area and Distribution of Focal Adhesion Sites Accompany Cell Shape Changes after Neoplastic Transformation. *J. Cell Biol.* 97: 451a, 1983.
- Thomas, D., Newcomb, W., Brown, J., Wall, J., Hainfeld, J., Trus, B., and Steven, A.: Mass Determination and Molecular Composition of Vesicular Stomatitis Virus: A Stem Analysis. Annual Meeting of the French Society of Electron Microscopy, Lyon, France, May 12-24, 1984.
- Trus, B.: Image Processing in Biomedical Research. Rotary Club, Overton, Texas, August 26, 1984.
- Trus, B., and Steven, A.: Comparison of Diffraction Patterns from Stained and Unstained Helices: Simulations with Defined Model Structures. In Csanady, A., Rohlich, P., and Szabo, D. (Eds.): *Proceedings of the Eighth European Congress on Electron Microscopy*. Budapest, Hungary, 1984, pp. 1355-1356.
- Trus, B., and Steven A.: Diffraction Patterns from Stained and Unstained Helices: Consistency or Contradiction. *Ultramicroscopy* (in press).
-



LSM members interact with all NIH Institutes, with other Federal agencies outside HHS, and with biomedical researchers worldwide. Reviewing one of the Lab's projects are (left to right, foreground): George Dunham, Fred Yamada, and Verdell Mabry.

Laboratory of Statistical and Mathematical Methodology

James E. Mosimann, Chief

Function and Scope of Work

The Laboratory of Statistical and Mathematical Methodology (LSM) combines research in mathematical statistics, mathematics, and computer and information science with collaboration and service in these areas to NIH researchers and administrators. LSM staff interact with all NIH Institutes, with other Federal agencies outside HHS, and with biomedical researchers worldwide.

In addition to the position of chief, the laboratory has 14 full-time professional positions distributed among four sections:

The **Statistical Software Section (SSS)** provides consultation to and collaboration with NIH researchers and administrators in all computational aspects of biomedical data analysis, including selection and support of large systems/packages. Three specialists in scientific programming are led by a computer systems analyst whose specialty is statistics.

The **Statistical Methodology Section (SMS)** works closely with the Statistical Software Section. Three professionals in mathematical statistics, assisted by a computer systems analyst, provide biostatistical consultation and do independent research.

The **Biomathematics and Computer Science Section (BCS)**, directed by a mathematician, performs independent research and provides consultation and collaboration in the specialties of its three computer and mathematical scientists. (One computer analyst currently is on assignment outside LSM.)

The **Medical Information Science Section (MIS)** investigates and develops methods for application of

information and computer science to medical language data processing. Two computer specialists work under the direction of a computer systems analyst who is an expert in computational linguistics.

A major part of LSM activity is the offering of statistical and mathematical systems/packages to the NIH user community. LSM accepts responsibility for evaluation of new systems/packages and their suitability for NIH. When it offers a system/package to the NIH community, LSM makes three basic commitments:

1. Maintenance of the package, with adequate documentation, through NIH computer system changes, system/package updates, and corrections.
2. Rapid response to queries concerning user access to a system/package program, including job control language and program parameters.
3. Assistance in interpretation of results.

As a result of LSM's policy of not only supporting the use of these systems/packages but also aiding in the interpretation of their output, the statisticians of the Statistical Methodology Section provide consultation over a wide range of scientific fields. Some very brief consultations are very successful because there is a known answer to the question at hand. Other consultations involve extensive time and statistical/mathematical/computer science research as well.

Research projects in LSM vary widely from studies of natural language processing for medical information systems and studies of efficient algorithms for information retrieval to studies in mathematics and statistical methodologies for biomedical applications.

Statistical Packages Supported by LSM*

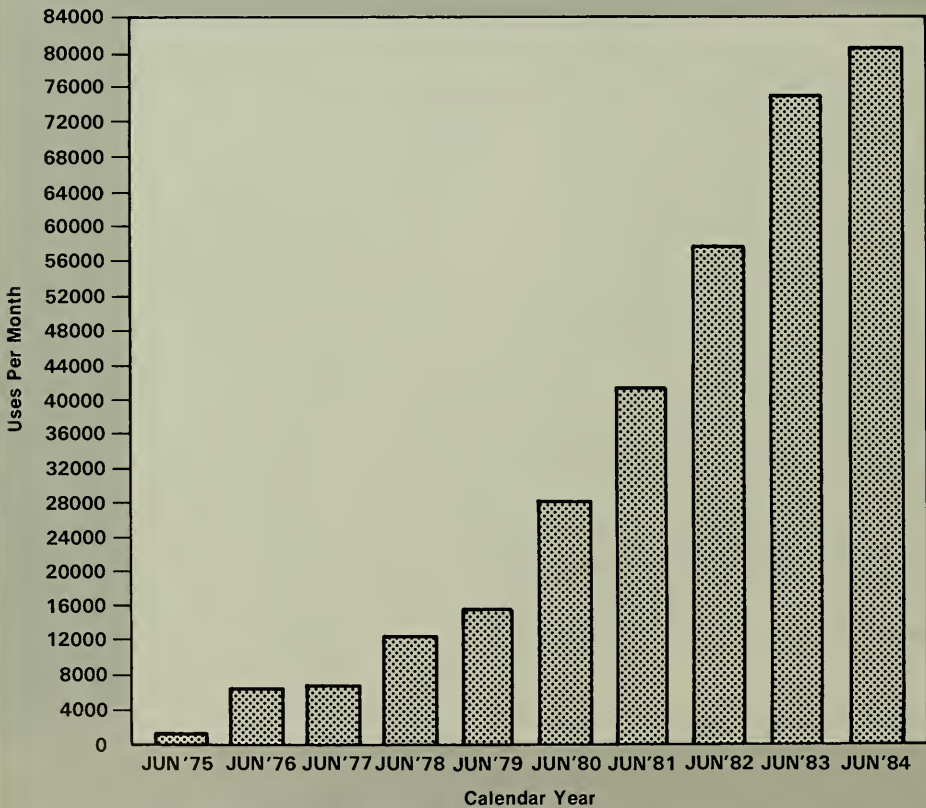

* Packages supported by the Statistical Software Section only. Does not include packages supported by the Biomathematics and Computer Sciences Section.

In LSM's 10th year as a separate entity, within 1985, the use of the program packages it supports continues to increase.

FY84 Accomplishments

FY84 was LSM's 10th year as a separate entity within DCRT. The volume of its computational and consultative services continued to expand. Its research activities decreased, with two projects terminated and one project initiated.

Computation

During this year, the Statistical Software Section of LSM maintained the following systems/packages and programs on the IBM System 370 of the DCRT Computer Center:

- BMD and BMDP, BMDP Statistical Software.
- SPSS, SPSS-X, and SCSS, Statistical Package for the Social Sciences, SPSS, Inc.
- SAS, SAS/GRAPH, and SAS/ETS, Statistical Analysis System, SAS Institute, Inc.
- P-STAT Statistical Package, P-STAT, Inc.
- IMSL, International Mathematical and Statistical Libraries, IMSL, Inc.
- MSTAT1, Collection of Mathematical and Statistical Programs, DCRT.

In FY84 alone the SSS staff responded to over 8,000 queries concerning use of these packages. Also during this year, SAS, SPSS-X, BMDP, PSTAT, IMSL, and MSTAT1 went through major updates.

The Biomathematics and Computer Science Section maintains several systems/packages and specialized systems on the DECsystem-10 of the Computer Center. Foremost in use is the interpretive system MLAB, designed (by LSM scientists) for biomathematical modeling, for cluster analysis, and for computer graphics.

LSM stresses the importance of teaching the effective use of systems/packages to the biomedical scientists and other users of DCRT.

In FY84, LSM maintained teaching and documentation for supported systems/packages. LSM taught eight introductory courses for SAS, two for SPSS, and two for BMDP. In addition, two introductory courses and two advanced courses were taught for MLAB. The second

edition of the *Beginner's Guide to MLAB* was distributed, and an *MLAB Reference Handbook* was prepared and is now being printed. BCS staff augmented MLAB in FY84 by adding new mathematical operators and a graphical polygon fill operator.

The GRAPH system (formerly GRAPH1) for easy computer generation of data graphs has increased in usage about three-fold in FY84. A number of enhancements to GRAPH were made during FY84, including: new point displays, axis types, text facilities for labels and titles, positioning by crosshair controls, and a data smoothing operator. Four courses on GRAPH were taught during FY84, and the third edition of the reference manual was produced and distributed.

Consultation, Collaboration, and Research

LSM consultation and research in FY84 was closely tied to the use of the computer. Most consultations (55 percent) involved statistical advice combined with considerable computer use. Others (40 percent) involved computer use alone and a small fraction (5 percent) involved mathematical or statistical advice with only limited computer use. The percentages are unchanged from FY83.

In FY84, LSM research, collaborative, and consultative efforts were expressed in a number of studies. Statistical methodologies were developed for, or modified to suit, specific biomedical problems.

Studies of discriminant methods continued in collaboration with Dr. J. Darroch, Flinders University, South Australia, and a paper has been submitted for publication. One application of these methods, in collaboration with Dr. H. Hoffman, formerly of DRS, is the study of morphological variation in inbred strains of laboratory mice with reference to purity of breeding stocks. Discriminant methods also were used in a collaboration with Dr. M. Harrington (NIMH/LGCB).

Significant new results were obtained for the problem of optimally estimating variance components in an analysis of variance. These new methods and ideas essentially resolve this problem, which has been

outstanding for nearly 30 years. The results in some situations provide counterexamples to some earlier work in the field, as well as unify the subject, bringing together many separate lines of research. Further, the basic result on which these new methods depend was recently extended as well as greatly simplified. Together this line of research produced three papers, which have been submitted to the *Journal of Multivariate Analysis*. The first paper is now in press.

Collaborative work in various studies of schistosomiasis (with Dr. A. Cheever, NIAID, LPD) continued. This joint effort continues to be a fruitful association, leading to new statistical methodologies and insights. Most recently, a thorough study of what precisely is being tested by the usual sums of squares in a repeated measures analysis has led to a paper and has formed the basis for an invited talk to a neuroscience group in NINCDS on the problems of repeated measures analysis.

A study of nonparametric multiple comparisons was initiated in FY84, with particular attention being given to theoretical as well as computer simulated behavior of various procedures. The optimal selection of a sequence of items based on relative ranks with ties has been investigated, as well as an evaluation of tests for correlated proportions with incomplete data.

A collaborative study of the spatial distribution of blue cones in the retina continued with Dr. S. Schein (NEI/CB) and F. de Monasterio (NEI/LVR). Various models based on different spatial distribution of the blue cones were tested using several statistical techniques. A final model, with the blue cones having a hard center with a soft outer shell, was postulated. The results have been submitted for publication.

Also, studies of "size and shape" variables were continued. These studies provide methods for studying random proportions or ratios of common occurrences in biomedical data. Definitions of independence for such random varieties were studied. Other work on proportions continued. A paper on the evaluation of tests for correlated proportions with incomplete data has been accepted for publication. Further work is in progress on the correlational structure of proportional data in biology. The investigation of nonparametric

methods using weighted observations has been undertaken. Such weights can arise from covariates or as estimated probabilities.

The study of nonparametric methods for simultaneously comparing more than two treatment groups was continued in FY84. Powerful new methods for multiple comparisons have been developed in collaboration with Dr. J. Skillings, Miami University, (Ohio). This has been submitted for publication. These procedures have been successfully applied in collaborative work with Dr. P. Turkeltaub (BB/DPB) on clinical symptoms and allergic reaction to pollen, and a paper on this topic has been submitted for publication.

In computer science, a method was implemented for generating scientific text output using the IBM 6670 laser printer. This pilot program was used successfully by a number of DCRT scientists to prepare scientific manuscripts. Work is continuing on an expanded version of the program, which will be offered for general use at NIH. Studies in information storage and retrieval continued, and a new project on the use of intelligent terminals to enhance performance of graphics workstations was begun. Mathematical research continued, studying inclusion relations for vector spaces and modules and structure of Boolean algebras.

In FY84 research in medical linguistics continued on further development of a methodology for automated morphosemantic segmentation and semantic interpretation (paraphrasing rules) of medical compound words derived from Greek and Latin. Possible applications of this methodology include the construction of computer-based medical dictionaries, automated processing of medical language, facilitation of international communication through national medical language, and vocabulary training for medical and paramedical personnel.

The preparation and use of a lexicon of morphosemantic constituents results in both a net saving in required storage space and an increase in the lexicon's interpretative power because it is possible to derive semantic interpretation from words that are not listed in a dictionary in their full form. The identification

of morphosemantic distribution patterns for constituents of medical compound words, and the determination of semantic relations that occur between the constituents are important steps in providing the capability for automated processing of medical text.

MIS also continued its collaboration with the Laboratory of Pathology, NCI, and the Clinical Support Section, Data Management Branch, DCRT, to maintain and improve the data base of Clinical Center surgical pathology reports. The automatic encoding system provided by MIS computed representations of the summary diagnoses of the surgical pathology report as written by the pathologist, in a language based on the vocabulary of the Systematized Nomenclature of Pathology (SNOP-NIH). Collaboration continued with Dr. Donald E. Henson, NCI, concerning changes in the SNOP dictionary.

Future Plans/Trends

No major shift in laboratory service or research is anticipated in the coming year; however, a crisis in the support of MLAB is anticipated because of the probable retirement of its senior author. Current levels of

statistical and mathematical systems/packages support, consultation, and user assistance will be maintained, although reduction of MLAB support may be necessary. Research projects will be continuations of those already initiated and reported in Volume 2.

Publications

- Campbell, G.: Optimal selection based on relative ranks of a sequence with ties. *Adv. in Applied Probability* 16: 131-146, 1984.
- Campbell, G.: Testing equality of proportions with incomplete correlated data (Incomplete Correlated Proportions). *J. Stat. Planning and Inference* (in press).
- Dunham, G. S.: The role of syntax in the sublanguage of medical diagnostic statements. Conference on Sublanguages, NY University (in press).
- Dunham, G. S., Henson, D. E., and Pacak, M. G.: Three solutions to problems of categorized medical nomenclatures. Linguistic String Project (in press).
- Knott, G. D.: Direct chaining with coalescing lists. *J. Algorithms* 5 (1): 7-21, 1984.
- Knott, G. D.: A language for modeling and an MLAB example: multiple-site binding analysis. U.S. Public Health Service Professional Association, 19th Annual Meeting, June 3-6, 1984.
- Laboratory of Statistical and Mathematical Methodology*. Reprinted June 1984, 12 pp.
- Malley, J.D.: Optimal estimates for variance components. *J. Multivariate Analysis* (in press).
- Santner, J. S., and Campbell, G.: A constant amplitude fatigue study of an aluminum powder metallurgy alloy. *J. Testing and Evaluation II*, pp. 333-339, 1983.



Systems Analyst Margaret Douglas examines a Gallium image of the lungs. Quantifying such images is of extreme importance to the biomedical community.

Laboratory of Applied Studies

John E. Fletcher, Acting Chief

Function and Scope of Work

The Laboratory of Applied Studies (LAS) is a multidisciplinary laboratory whose staff includes physicians, computer scientists, engineers, and biomathematicians. LAS operates in a task-oriented mode rather than along the lines of the separate component disciplines. The majority of projects in this laboratory are direct involvements with bench scientists or clinical investigators both at NIH and at other research centers. In many cases, a project is brought to LAS by these investigators, but often LAS develops a concept within DCRT then takes it to an NIH Institute or another research center for implementation or further development. This laboratory's approach to research problems is: to examine the underlying scientific principles, to identify the appropriate quantitative and engineering techniques, and to utilize computing systems to carry out the research objectives.

Collaborative research is therefore the primary activity of the Laboratory of Applied Studies and the multidisciplinary nature of the approach is its essential feature. Computing science is the common vehicle by which the various disciplines are integrated--namely basic biology, (including biophysics, biochemistry, molecular biokinetics, cellular physiology, etc.), conceptual models, and engineering technology. Scientific objectives of these research collaborations include: a quantitative analysis of complex interacting systems, a deeper understanding of basic physiologic and pathophysiologic processes, and advancement of diagnostic and measurement methodologies.

The scope of these investigations ranges from direct involvement in clinical activities, through the medical staff fellowship program, to the abstract development of quantitative methods and computational algorithms essential to computer modeling systems that are used as general research tools. These activities are carried out by two sections, the **Medical Applications Section (MAS)**, whose staff includes physician-scientists, electronics engineers, and computer systems analysts; and the **Applied Mathematics Section (AMS)**, whose staff includes specialists in applied mathematics, computer science, biomathematics, and bioengineering.

FY84 Accomplishments

In FY84 LAS continued to progress in the several collaborative projects reported during the previous year. In addition LAS played a strong role in intradivision cooperation with all LAS personnel participating in the new DCRT Personal Workstation Project (PWP).

In collaboration with NHLBI a minicomputer-based laboratory system for studying delivery, uptake, and utilization of oxygen by tissues during exercise through breath-by-breath analysis of pulmonary gas exchange has reached production status. The equipment interfaces designed and fabricated by LAS in FY82 are now controlled by LAS-developed software drivers linked to the main laboratory computer operating system. Continuous automatic operation of the entire system, including acquisition and analysis of ventilatory flow and gas concentrations, as well as control of the bicycle and treadmill, now regulates the study of each patient.

The systems programming, which is in its final stages, enables computation, in a turnkey manner, of noninvasive indices of patient functional status and automatic reporting of collected data. Serial measurements obtained in this exercise testing laboratory provide an objective indication of severity of disease and efficacy of treatment in patients with lung and blood disorders.

This method of testing the cardiovascular, pulmonary, and hematological systems during the stress of exercise allows detection of subtle manifestations of the early stages of a disease process as well as more sensitive discrimination of physiologic change than can be obtained by testing the patient at rest. Drawing together the computer science, instrumentation, and clinical medical skills of the Medical Applications Section, LAS is collaborating with the Clinical Hematology and Pulmonary Branches, NHLBI, to complete several clinical studies of experimental treatments for disorders of oxygen transport.

In a collaborative study with the Nuclear Medicine Department, the Medical Applications medical imaging group has obtained and studied radionuclide

ventriculograms from three patient groups: normals, those with coronary artery disease and wall motion abnormalities, and those with diffuse contraction abnormalities. Twelve of seventy parameters studied were identified as having the ability to separate groups. The preliminary results suggest that combinations of the independent parameters can be effective in distinguishing regionally abnormal cases from normal or diffusely abnormal groups.

In FY83 a collaboration was initiated with FDA physiologists to use rodent ECG's as a means of testing for cardiotoxicity of drugs and fad diets (e.g., liquid protein). The analysis of rodent ECG's requires application of LAS expertise in engineering, statistics, and electrophysiology to design the most appropriate signal processing algorithms and to determine the most sensitive parameters of cardiac pathology. During FY84, the redesign of instrumentation and analysis software to deal with the high frequency content of rodent ECG's was completed. Also in FY84, these methods were extended to include the study of mouse models of Chagas' disease in collaboration with investigators from NIAID and WHO.

Implementation of network modeling software on dedicated scientific systems such as the VAX 11/750-780 has made network modeling more available to investigators on the NIH campus. The VAX, which is much less expensive, is used for network modeling in place of the IBM mainframe. Consultation, instruction, and maintenance activities by LAS senior staff have resulted in the establishment of network modeling languages at NIH as an irreplaceable tool for simulation of complex biological systems.

Among the laboratory's currently active collaborative projects employing these languages is an anatomically-based model for the dendritic field of a CNS neuron. This problem is anatomically very complex, resulting in a model of a large number of coupled differential equations. Despite this complexity, the model has no free parameters. Simulation results obtained with a network analog are in close accord with electrophysiological measurements on the cells. This work is performed in collaboration with laboratory scientists in NINCDS.

The Applied Mathematics Section (AMS) staff are also investigating network models of cochlear function (NIADDK), respirator design (OSHA), and active membrane transport (Medical College of Virginia).

Adaptive finite element methods, which feature automatic adjustment of space and time discretizations, have been studied over the past several years in LAS. Several improvements were made in the software implementing these techniques during FY84. FEMOL1 now has capabilities to solve problems in which the diffusive and convective transport terms and boundary conditions depend nonlinearly on solution components. The program has been restructured so that it is accessible at three levels: by a casual user, by one wishing to control many of the program's internal numerical parameters, and by one studying or wishing to override the automatic decisions that are made. Applications of FEMOL1 have been made to models of substrate transport, nerve conduction, mobile populations in ecosystems (i.e., planktonic predator-prey system), and simple flows in porous media (i.e., contaminant dispersion in groundwater).

During FY84 many state-of-the-art mathematical subroutine packages have been obtained and tested by LAS staff. These routines provide capabilities:

- to solve directly and iteratively sparse matrix equations, which arise from discrete representations of hyperthermia, circulatory flows, and other complex biological models;
- to solve time-dependent partial differential equations with unchanging space grids in two space dimensions, which occur in many distributed parameter systems that evolve with time (e.g., gel electrophoresis);
- to solve stiff and nonstiff implicit systems of ordinary differential and differential/algebraic equations, which model coupled chemical reactions proceeding at greatly disparate rates; and
- to solve steady state partial differential equations with adaptive discretizations in two space dimensions (e.g., substrate distributions in cellular aggregations).

During FY84, LAS played a central role in investigating various aspects of scientific computing on the IBM PC

XT Personal Computer in addition to continuing its traditional role as a strong collaborative link between computing science and laboratory science at research centers both at NIH and elsewhere. LAS made a strong voluntary commitment to integrating the personal computer into the scientific computation environment at NIH. This activity placed heavy demands on LAS time. Because no scientific publications are forthcoming from this effort the usual recognition mechanisms are not available.

Three configurations of IBM PC XT are under intense study. One system is dedicated to high-quality graphics and imaging; a second is configured for large-scale scientific computation with the INTEL 8087 numeric coprocessor; and a third is being tested for laboratory data acquisition and analysis. All three systems are equipped with modems and are capable of communicating with each other and with the two NIH mainframe systems. The LAS mix of scientific disciplines has provided an ideal environment for the testing of these systems. The preliminary test results are being reported in documents issued through the newly formed DCRT Personal Workstation Office (PWO).

During FY84 LAS staff members participated in various teaching and consulting, or advisory activities.

J. Fletcher continued to serve as Chairman of the Mathematics and Computer Science Department of the Foundation for Advanced Education in the Sciences. He served on a Planning Committee for the Director, DCRT and on a DRR ad hoc committee to oversee a series of National Academy of Sciences Modeling Workshops. He has completed a second term as DCRT representative to the NIH Advisory Committee for Computer Usage, and also has served on a number of study section panels as an expert consultant.

J. Bailey continued as a consultant on Common Standards for Quantitative Electrocardiography, a program in medicine and public health, sponsored by the European Economic Community. He was appointed a member of American Heart Association Committee on Electrocardiography and Cardiac Electrophysiology and was subsequently Cochairman of its Subcommittee on Computers. He is also a consultant for the Tri-

Services Medical Information System (DOD) for evaluation of computer ECG programs.

Future Plans/Trends

The support of scientific uses of personal computers in the laboratory setting will continue at levels dictated by manpower availability. Volunteer employees and LAS scientific staff will investigate the feasibility of such modeling activities as curve fitting, numerical solution of systems of ordinary differential equations, and other tasks requiring high levels of technical knowledge. Scientific software from vendors will be tested and those programs suitable for NIH scientific applications will be identified.

With the arrival of new medical staff fellows, the Critical Care Monitoring System and other MAS projects will move forward. Hardware revisions and interfacing are expected to be completed in FY85 and on-site testing can begin. The development of signal analysis and reporting software can begin as soon as equipment modifications are completed.

The Exercise Testing Laboratory is expected to become a fully automated turnkey operation, with LAS personnel training technical operators and participating in a number of investigative protocols.

Rodent ECG data bases acquired by LAS in FY84 will be used to refine signal processing algorithms and extract parameters to measure the effects of cardiotoxicity due to drugs, fad diets, parasitic diseases, or other cardiac pathology. LAS will collaborate with investigators from NIAID, WHO, and FDA in several experimental protocols using computer ECG analysis as a major method of bioassay.

New directions and quantitative measures are to be investigated for the emerging medical imaging technologies. The viability of PET, NMR, ultrasound, and other imaging technologies as quantitative measures of both structure and function will be given serious attention. It is hoped that a multidisciplinary critical examination and appraisal can begin to identify models and techniques that can convert these technologies into useful quantitative noninvasive tools.

Such an ambitious undertaking is clearly long-term, but is of extreme importance to the biomedical community.

Efforts will be made to refocus LAS activities along sharper lines of clinical applications and biomedical science. Improved technology transfer and wider scientific contacts are the objectives of such a reorganization. Every effort will be made to optimize

existing resources to accomplish DCRT and NIH research objectives within current severe budgetary and personnel constraints. Guest workers, visiting scientists, visiting fellows, and Burroughs Wellcome senior research fellows will be sought from whatever sources are available.

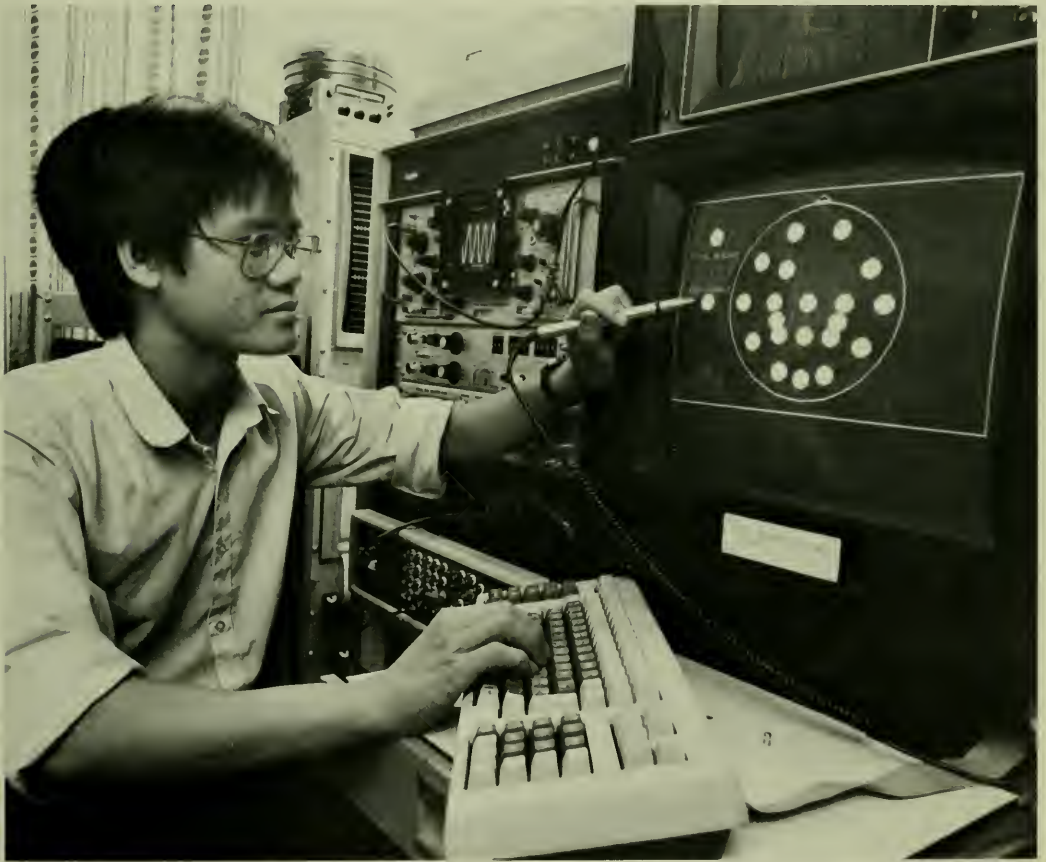

LAS' Medical Applications section is responsible for the Critical Care Monitoring System. Hung Le works on the final phase of equipment modifications

Publications and Presentations

- A User's Guide to Least Squares Model Fitting. Reprinted April 1984, 26 pp. Bacharach, S.L., Green, M.V., Vitale, D., Bonow, R.O., Douglas, M.A., Jones, A.E., and Larson, S.M.: Fourier filtering cardiac time activity curves: Sharp cutoff filters. 8th International Conference on Information Processing—Medical Imaging (in press).
- Bacharach, S.L., Green, M.V., Vitale, D., White, G., Douglas, M.A., Bonow, R.O., and Jones A.E.: Optimum number of harmonics for filtering cardiac volume curves. *J. Nucl. Med.* 24:17, 1983.
- Bailey, J.J., Douglas, M.A., van Rijk, P.P., Green, M.V., Bacharach, S.L., and Bonow, R.O.: Parameters of regional wall abnormalities from radionuclide ventriculography. *Computers in Cardiology* (in press).
- Bieterman, M.: Accuracy estimation and control in a method for diffusion-dominated transport problems. *Proceedings of the First Internat. Conf. on Accuracy Estimates and Adaptive Refinements in Finite Element Computations (ARFEC)*. Lisbon, Portugal, 1984.
- Bieterman, M.: A posteriori error estimation and adaptive finite element grids for parabolic equations. In Babuska, I., Chandra, J., and Flaherty, J.E. (Eds.): *Adaptive Computational Methods for Partial Differential Equations*. SIAM Publications, 1983.
- Bieterman, M.B.: On using local solution information in regridding for time-dependent equations. NASA-ICASE Workshop on Grid Methods, 1983.
- Bieterman, M., and Babuska, I.: An adaptive method of lines with error control for nonlinear parabolic equations of the reaction-diffusion type. *J. Computational Physics* (in press).
- Bunow, B.: Determination of the distribution of catalyst activity across a permeable membrane containing an immobilized enzyme. Indeterminacy of a Functional Approach to a Structural Problem. *Biophys. J.* 45: 1065-1071, 1984.
- Ferenci, P., Covell, D., Schafer, D.F., Waggoner, J.G., Shrager, R., Berman, M., and Jones, A.E.: Metabolism of the inhibitory neurotransmitter alpha-aminobutyric acid in a rabbit model of fulminant hepatic failure. *Hepatology* 3(4): 507-512, 1983.
- Fletcher, J.E.: *Some mathematical questions arising from modeling of the microcirculation*. SMU Math Series, Dallas, Texas, 1983.
- Fletcher, J.E., and Schubert, R.W.: Capillary wall permeability effects in capillary-tissue structures. In Bruley, D., Horton, C., and Buerk, D. (Eds.): *Oxygen Transport to Tissue-VI*. New York, Plenum Press, (in press).
- Fletcher, J.E., and Schubert, R.W.: Diffusional coupling and wall permeability effects in perfused capillary-tissue structures. *J. Math. Biol.* (in press).
- Fletcher, J.E., and Schubert, R.W.: Diffusional coupling in a hemoglobin-free perfused capillary-tissue structure. In Lubbers, D., Acker, H., Leniger-Folterl, E., and Goldstick, T. (Eds.): *Oxygen Transport to Tissue-V*. New York, Plenum Press, 1984, pp. 145-160.
- Fletcher, J.E., and Schubert, R.W.: The theoretical prediction of substrate levels and their histograms in cell free perfused tissues. *Oxygen Transport to Tissue-IV*. In Bicher, H., and Bruley, D. (Eds.): New York, Plenum Press, 1982.
- Fletcher, J.E., Schubert, R.W., and Reneau, D.D.: An analytical model for axial diffusion in the Krogh cylinder. In Bruley, D., Horton, C., and Buerk, D. (Eds.): *Oxygen Transport to Tissue-VI*. New York, Plenum Press (in press).
- Hendler, R.W., Bunow, B., and Rieske, J.: Thermodynamic and kinetic considerations of Q-cycle mechanisms. *Rev. in Bioenergetics* (in press).
- Hendler, R.W., Setty, O.H., Shrager, R.I., Songco, D.C., and Friauf, W.S.: Instrumentation and procedures for real time measurements of proton motive force, membrane potential, delta pH, proton extrusion, and oxygen uptake in respiring cells and vesicles. *Rev. Sci. Instrum.* 54(12): 1749-1755, 1983.
- Horton, M. R.: Human Factors in Computing Systems. *Computing on a Shoestring: Initial Data Entry for Service Organizations*. December 1983.
- Le, H. T., Van Arsdell, W. C., Makowski, A., Pottala, E. W., and Bailey, J. J.: Automated analysis of rodent electro-and vectorcardiograms. *IEEE Trans. Biomed. Eng.* (in press).
- Setty O.H., Hendler, R.W., and Shrager, R.I.: Simultaneous measurements of proton motive force, delta pH, membrane potential, and H/O ratios in intact *Escherichia Coli*. *Biophys. J.* 43: 371-381, 1983.
- Shrager, R. I.: A rapid robust rootfinder. *Mathematics of Computation* (in press).
- Shrager, R.I.: A rapid robust rootfinder. SIAM Fall Meeting, Norfolk, Virginia, Nov. 1983.
- Shrager, R.I.: Optical spectra from chemical titration: An analysis by SVD. *SIAM J. Alg. Disc. Meth.* (in press).
- Shrager, R.I.: Some pitfalls in the use of derivative spectra. *Photochem. Photobiol.* 38(5): 615-617, 1983.
- van Rijk, P.P., and Bailey, J.J.: Nuclear cardiology. In van Rijk, P.P. (Ed.): *Nuclear Techniques in Medicine*. Den Haag, Nederland, Martinus-Nijhoff (in press).
- van Rijk, P.P., Bailey, J.J., Bacharach, S.L., Bonow, R.O., Green, M.V., and Palmeri, S.T.: Computerized methods for detecting regional wall motion abnormalities using radionuclide ventriculography. *Eur. Heart J.* (in press).
- Winslow, R.M., Samaja, M., Winslow, N.J., Rossi-Bernardi, L., and Shrager, R.I.: Simulation of continuous blood O₂ equilibrium curve over physiological PH, DPG, and PCO₂ range. *J. Appl. Physiol.* 54: 2, 1983.
-



Dr. B.K. Lee (left) discusses his study of the structure and dynamics of dense macromolecular systems with PSL chief Dr. George Weiss.

Physical Sciences Laboratory

George H. Weiss, Chief

Function and Scope of Work

The Physical Sciences Laboratory (PSL) consists of chemists, physicists, and applied mathematicians who work on problems related to applications of the physical sciences in biology and medicine. Current projects of the laboratory involve both experimental and theoretical work, the experimental work following on earlier theoretical analyses developed by members of the laboratory. The research is generated both by members of the laboratory and in collaboration with scientists inside and outside of NIH.

The PSL consists of four permanent staff members and several visitors on temporary appointments. Some of the projects currently under study include:

1. The use of laser light scattering from gels to study the physical and chemical properties of these biologically interesting substances.
2. The study of the structure and dynamics of dense macromolecular systems. This includes both a theoretical component, which seeks to develop phenomenological models for disordered media, and an experimental component using small angle neutron scattering to determine structural ordering of macromolecules in dense solutions.
3. The role of water in determining the interaction of nonpolar materials.
4. The development of exact formulae for the probability densities of scattered intensities in x-ray crystallography.
5. Optimal methods for the design of NMR and other imaging techniques to provide accurate parameter estimates.
6. The structure of membranes and the mechanism by which ions move through channels in these membranes is under investigation by means of measurements measuring volume changes in the channels.

Many of these projects are collaborative both within NIH and with other investigators in other parts of the world. Some of the data which bear on the role of water in biological structures is being furnished by chemists at Brock University, Canada. Neutron scattering experiments are being conducted collaboratively with scientists at the National Bureau of

Standards. The development of models for the structure of disordered structures has been done with a visiting scientist from Israel, and the crystallographic techniques have been developed together with an Israeli and an English crystallographer.

FY84 Accomplishments

PSL studies in past years as well as in FY84 have established the role that water plays in determining the forces at short distances between membranes and other biological structures. For many years scientists have investigated the many types of forces, typified by electrostatic or van der Waal's forces, that occur between condensed media. The combination of crystallographic and thermodynamic methods pioneered by Dr. Parsegian and his collaborators, applied to phospholipid systems, have shown that surface water is a principal determinant of interactive forces between membranes. The effects of several condensing agents on double helical DNA have been investigated by Dr. Parsegian leading to the conclusion that they act by modifying surface water rather than by other mechanisms suggested by earlier workers in this area. These results suggest that controlled molecular hydration is the primary influence in the determination of molecular association and assembly.

The nature and mechanism of action of channels that allow transport of ions through a membrane have been subjects that have engaged biophysicists for many years. For the first time, Drs. Zimmerberg and Parsegian have been able to measure the volume change occurring with the opening and closing of pores in voltage-dependent ionic channels in membranes. These measurements, made on the voltage-dependent anion channel in mitochondria, show that there is a considerable structural reorganization associated with ionic passage through a membrane. The type of experiment developed in the PSL will allow investigators to discriminate between different models of transmembrane ionic models that have appeared in the literature.

The reduction of crystallographic data to deduce structural information has always relied on approximate

mathematical representations of probability distributions of structure functions as well as other quantities typically measured in an experiment. While this often leads to correct inferences, the presence of atomic heterogeneity can lead to serious errors. Within the past year Dr. G. Weiss and his collaborators have found exact, readily computable, solutions for these quantities. These allow one to calculate exactly the parameters used to infer structure from data and can be used to replace the approximations used in computerized analyses.

Future Plans/Trends

The force measurements initiated by Dr. Parsegian and his collaborators will be continued, and extended to a variety of nucleic acids, peptides, and polysaccharides. These will allow the deduction of how molecular interactions affect biological activity. As a long-term goal, one hopes to understand the processes of molecular assembly, as well as the strength and specificity of protein interactions. The experimental work will be expanded considerably in collaboration with NIADDK. Laboratory modules, as well as some visiting positions, will be made available by that Institute.

As a longer-term project Dr. Parsegian hopes to integrate the current experimental results with the molecular graphics capabilities developed in DCRT, to develop a clearer picture of intracellular assembly. The measurements of volume change in voltage-dependent ionic channels also will be extended to a number of different biological systems to try to identify operative forces in ion transport.

As a start in the integration of information obtained on the forces that are important for the structure and configuration of biological surfaces, PSL plans to hire a chemist working in statistical mechanics to study the behavior of large aggregates of molecules. Some of this work undoubtedly will relate to and exploit the capabilities of the molecular graphics.

Neutron scattering studies will be undertaken on bovine serum albumin, in collaboration with scientists at the National Bureau of Standards and at MIT, to investigate physical properties of dense proteins in solution. Experiments will be carried out to investigate the

feasibility of laser scattering from single cells to study their properties. A study has been initiated on the manner in which pulsed infrared radiation causes optical breakdown and plasma formation in polymer gels. This project will provide important information on the use of YAG lasers in ophthalmological surgery.

Publications and Presentations

- Aizenbud, B., and Gershon, N. D.: Diffusion of molecules on microvillous biological membranes. In Perelson, A. C., DeLisi, C., and Wiegel, F. W. (Eds.): *Cell Surface Phenomena*. New York, Marcel Dekker (in press).
- Ben-Avraham, D., and Havlin, S.: Self-avoiding walks on finitely ramified fractals. *Phys. Rev.* 29: 2309-2311, 1984.
- Evans, E. A., and Parsegian, V. A.: Energetics of membrane deformation and adhesion in cell and vesicle aggregation. *Ann. NY Acad. Sci.* 416: 13-33, 1983.
- Griffith, J. P., Lee, B. K., Murdock, A. L., and Amelunxen, R. E.: Molecular symmetry of glyceraldehyde-3-phosphate dehydrogenase from bacillus coagulans. *J. Mol. Biol.* 169: 963-974, 1983.
- Gruen, D. W. R., Marcelja, S., and Parsegian, V. A.: Water structure near the membrane surface. In Perelson, A. (Ed.): *Membrane Surfaces*. New York, Marcel Dekker, Inc. (in press).
- Havlin, S., Ben-Avraham, D., and Movshovitz, D.: Percolation on fractal lattices. *Phys. Rev. Lett.* 51: 2347-2350, 1983.
- Havlin, S., and Nossal, R.: Topological structure of percolation clusters. *J. Phys. A (Math. Gen.)* 17: L427-L430, 1984.
- Havlin, S., Trus, B., and Stanley, H. E.: Cluster growth model for branched polymers that are chemically linear. *Phys. Rev. Lett.* (in press).
- Havlin, S., Weiss, G. H., Kiefer, J. E., and Dishon, M.: Exact enumeration of random walks with traps. *J. Phys. A* 17: L347-L350, 1984.
- Hong, D. C., Havlin, S., Herrmann, H. J., and Stanley, H. E.: Breakdown of Alexander-Orbach conjecture for percolation. Exact enumeration of random walks on the percolation backbone. *Phys. Rev.* (in press).
- Kiefer, J. E., and Weiss, G. H.: The Pearson random walk. *AIP Proc.* 109: 11-32, 1984.
- Lee, B.: An anatomy of hydrophobicity. *Proc. IMACS Symp. Biomedical Modeling* (in press).
- Nossal, R.: Network formation in polyacrylamide gels. *Macromolecules* (in press).
- Nossal, R., Weiss, G. H., Nandi, P. K., Lippold, R. E., and Edelhoeh, H.: Sizes and mass distribution of clathrin coated vesicles from bovine brain. *Arch. Biochem. Biophys.* 226: 593-603, 1983.
- Otteman, J., and Weiss, G. H.: Reflection from a field of randomly located vertical protrusions. *Appl. Optics.* (in press).
- Parsegian, V. A.: Dimensions of the 'intermediate' phase of dipalmitoylphosphatidylcholine. *Biophys. J.* 44: 413-415, 1983.
- Parsegian, V. A.: Molecular forces governing tight contact between cellular surfaces and substrates. *J. Prosthetic Dentistry* 49: 838-842, 1983.
- Parsegian, V. A., and Rand, R. P.: Membrane interaction and deformation. *Ann. NY Acad. Sci.* 416: 1-12, 1983.
- Parsegian, V. A., and Rand, R. P.: Membrane transport and the activity of water near the membrane surface. Physical Methods in the Study of Epithelia. *Membr. Biophysics II.* 283-295, 1983.
- Parsegian, V. A., Rand, R. P., and Gingell, D.: Lessons for the study of membrane fusion from membrane interactions in phospholipid systems. *Cell Fusion. Ciba Found. Symp.* 9-27, 1984.

-
- Parsegian, V. A., and Rau, D. C.: Water near intracellular surfaces. *J. Cell Biol.* (in press).
- Physical Sciences Laboratory*. Reprinted January 1983, 9 pp.
- Rand, R. P., and Parsegian, V. A.: Force considerations in model and biological membranes. *Can. J. Biochem.* (in press).
- Rau, D. C., Lee, B., and Parsegian, V. A.: Measurement of the repulsive force between polyelectrolyte molecules in ionic solution: hydration force between parallel DNA double helices. *Proc. Natl. Acad. Sci. USA* 81: 2621-2625, 1984.
- Rish, B. L., Dillon, J. D., and Weiss, G. H.: Mortality following penetrating craniocerebral injuries. An analysis of deaths in the Vietnam Head Injury Registry population. *J. Neurosurg.* 59: 775-780, 1983.
- Shmueli, U., Weiss, G. H., Kiefer, J. E., and Wilson, A. J. C.: Exact random walk models in crystallographic statistics. I. Space groups P1 and P1. *Acta Crystallographica* (in press).
- Steiner, C. A., Litt, M., and Nossal, R.: Applications of dynamic light scattering to studies of mucin structure. *Biorheology* 21, 1984.
- Steiner, C. A., Litt, M., and Nossal, R.: Effects of calcium ions on the structure of canine tracheal mucin. *Biorheology* 21, 1984.
- Stone, M., Sories, B. C., Shawker, T. H., Weiss, G. H., and Nadel, L.: Analysis of real-time ultrasound images of tongue configuration using a grid-digitizing system. *J. Phonetics.* 11: 207-218, 1983.
- Szabo, A., Lamm, G., and Weiss, G. H.: Localized partial traps in diffusion processes and random walks. *J. Stat. Phys.* 34: 225-238, 1984.
- Weiss, G. H.: A perturbation analysis of the Wilemski-Fixman approximation for diffusion-controlled reactions. *J. Chem. Phys.* 80: 2880-2887, 1984.
- Weiss, G. H.: First passage times for correlated random walks and some generalizations. *J. Stat. Phys.* (in press).
- Weiss, G. H.: Passage times. *Ency. Stat. Sci.* (in press).
- Weiss, G. H.: Random walks. *Ency. Stat. Sci.* (in press).
- Weiss, G. H.: Saddle-point approximations. *Ency. Stat. Sci.* (in press).
- Weiss, G. H.: Tauberian theorems. *Ency. Stat. Sci.* (in press).
- Weiss, G. H.: Wald's identity. *Ency. Stat. Sci.* (in press.)
- Weiss, G. H., and Aron, J. L.: Note on the formulation of a stochastic model of super-infection. *Math. Biosci.* 67: 213-223, 1983.
- Weiss, G. H., and Ferretti, J. A.: Accuracy and precision in the estimation of peak areas and NOE factors. *J. Magnet. Resonance* 55: 397-407, 1983.
- Weiss, G. H., Ferretti, J. A., Kiefer, J. E., and Jacobson, L.: A method for eliminating errors due to phase imperfection in NOE measurements. *J. Magnet. Resonance* 53: 7-13, 1983.
- Weiss, G. H., and Havlin, S.: Trapping of random walks on the line. *J. Stat. Phys.* (in press).
- Weiss, G. H., and Kiefer, J. E.: On the probability density of the envelope of a sum of random vectors. *J. Sound and Vib.* (in press).
- Weiss, G. H., and Kiefer, J. E.: Random walks in crystallography. *Studies in Stat. Mech.* (in press).
- Weiss, G. H., and Szabo, A.: First passage time problems for a class of master equations with separable kernels. *Physica* 119A: 569-579, 1983.



<http://nihlibrary.nih.gov>

10 Center Drive
Bethesda, MD 20892-1150
301-496-1080

DISCRIMINATION PROHIBITED: Under provisions of applicable public laws enacted by Congress since 1964, no person in the United States shall, on the grounds of race, color, national origin, handicap, or age, be excluded from participation in, be denied the benefits of, or be subjected to discrimination under any program or activity (or, on the basis of sex, with respect to any education program or activity) receiving Federal financial assistance. In addition, Executive Order 11141 prohibits discrimination on the basis of age by contractors and subcontractors in the performance of Federal contracts, and Executive Order 11246 states that no federally funded contractor may discriminate against any employee or applicant for employment because of race, color, religion, sex, or national origin. Therefore, the Division of Computer Research and Technology must be operated in compliance with these laws and Executive Orders.

NIH LIBRARY



3 1496 00210 8481



Division of Computer Research and Technology
National Institutes of Health
Bethesda, Maryland 20205