

UC-NRLF

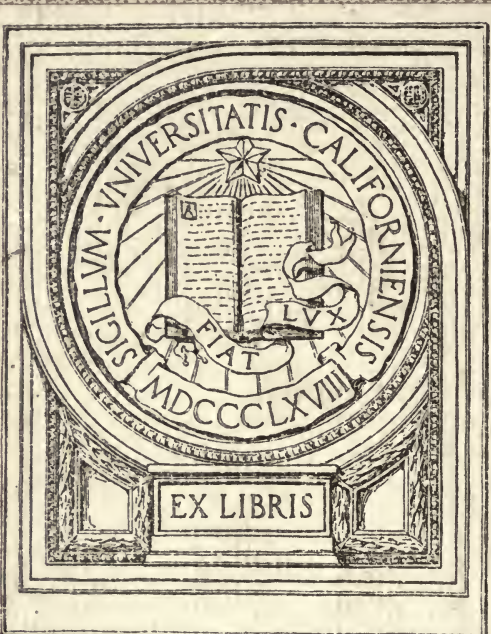

8 33 306



EX LIBRIS





ELECTRICAL ENGINEERING
FIRST COURSE

McGraw-Hill Book Company

Publishers of Books for

Electrical World	The Engineering and Mining Journal
Engineering Record	Engineering News
Railway Age Gazette	American Machinist
Signal Engineer	American Engineer
Electric Railway Journal	Coal Age
Metallurgical and Chemical Engineering	Power

ELECTRICAL ENGINEERING

FIRST COURSE

BY

ERNST JULIUS BERG, Sc. D.

PROFESSOR OF ELECTRICAL ENGINEERING
UNION COLLEGE, SCHENECTADY, N. Y.

AND

WALTER LYMAN UPSON, E. E., M. S.

ASSOCIATE PROFESSOR OF ELECTRICAL ENGINEERING
UNION COLLEGE, SCHENECTADY, N. Y.



FIRST EDITION

McGRAW-HILL BOOK COMPANY, Inc.

239 WEST 39TH STREET, NEW YORK

6 BOUVERIE STREET, LONDON, E. C.

1916

TK145
B4

COPYRIGHT, 1916, BY THE
MCGRAW-HILL BOOK COMPANY, INC.

TO THE
LIBRARY OF

THE MAPLE PRESS YORK PA

PREFACE

A text-book in electrical engineering emanating from Union College may be the occasion of some surprise to those who have been conversant with the development of the electrical course in that institution. The authors have, it is true, recorded their objections to the use of a prescribed text. These objections still hold good. In brief, they are, first, that a prescribed text tends to take the life out of the class room, whether the course be conducted by lectures or recitations, and second, that it tends to take the life out of the study by relieving the student of responsibility of continued effort.

At Union College the fundamental aim is that the student shall first *comprehend*, and then, *create*. Comprehension comes through directed effort. This, the student acquires readily in the laboratory, but in the class room, it is not so easy. The recitation falls short because it deals with the individual rather than the class. The lecture fails when the student knows he can fall back upon the text-book. The fault, however, is not with the text-book itself, but with the use that is made of it.

Obviously, then, its proper use is as a means of directing the student's effort toward comprehension. Indeed, it should compel effort, not in order to make up for an author's failure to express himself clearly, but in order that the ideas shall sink in and make permanent impressions on the mind. The book should, therefore, be so constructed and used that it shall be an additional aid to the student in creating his own expression of the ideas with which he is brought into contact in the lecture, the recitation and the laboratory. It is desirable that fundamental ideas shall become fixed and clear in the student's mind as soon as possible, thus leaving him in a position to exert his full mental effort on that which is more advanced.

As he progresses, he should acquire, more and more, the power of self-direction, that is, the power to create or construct his own ideals. Creative work finds its primary impulse in imitation. The student should have before him, at the outset, a model, which he is faithfully to copy.

In attempting to embody these principles in the present volume, the authors have sought to maintain a harmonious inter-relationship between the book and the class room. The lectures which form the basis of the book were first delivered eight years ago. In that, and subsequent years, students have had to rely for assistance upon their own notes and on help received individually from instructors. Many of the problems assigned are now worked out completely or in part in the text. They thus cease to be available for assignment, but the ideas contained in them have been extended to form new problems whose solutions will be obtained only after study of the problems solved.

These new problems have generally remained unsolved, in the past, owing to lack of available time. It is believed that they may now be carried through with fair completeness and, indeed, that many other suggestions coming from them may be followed.

It is the belief of the authors that no book on Electrical Engineering can now be produced which does not bear testimony to the pioneer work of such writers as Fleming, Silvanus Thompson, Bedell and Crehore, Steinmetz and McAllister.

In addition, the authors desire to acknowledge their indebtedness to Dr. A. S. McAllister who has critically gone over the manuscript, to Mr. N. S. Diamant for suggestions relating to material contained in the earlier portions of the book, and to Mr. E. S. Lee for assistance in reading the proof.

CONTENTS

	PAGE
PREFACE	v
CHAPTER I	
UNITS	1
Development of Ohm's Law—Two Resistances in Parallel— General Solution of a Network by KIRCHOFF'S LAWS—Effects of Current in a Wire—Power.	
CHAPTER II	
FORM OF WORK	9
Object of Problems—Summary.	
CHAPTER III	
MAGNETISM	14
Cylindrical Poles—Flat Poles—Magnets as Commonly Used in Meters—Energy Density in a Field—Limits of Pole Intensity— The Magnetic Cycle—Permeability.	
CHAPTER IV	
PRINCIPLE OF THE ELECTRIC MOTOR	20
Determinations of Magnetic Intensity—Magnetic Intensity at Any Point along the Axis of a Coil—Magnetic Intensity in the Center of a Long Coil—Application of Magnetic Formulæ to Instruments.	
CHAPTER V	
DESIGN OF A LIFTING MAGNET	26
CHAPTER VI	
GENERATION OF ELECTROMOTIVE FORCE IN A DYNAMO	29
E.m.f. Waves in Fields that are not Uniform—E.m.f. Wave when the Coil is Wound on an Iron Core—Additional Problems for the Determination of E.m.f. Waves.	
CHAPTER VII	
INDUCTANCE	33
The Rate of Energy Supply or Power Equation—Starting and Stopping Current in an Inductive Circuit.	

CHAPTER VIII

	PAGE
ALTERNATING CURRENTS	38
Average Value of a Sine Wave—Effective Value of a Sine Wave.	

CHAPTER IX

DIRECT-CURRENT GENERATORS	44
Homopolar Generators—Direct-current Machines with Commutators—Types of Direct-current Commutator Machines—Armature Reaction—Characteristics of Direct-current Generators—Numerical Application.	

CHAPTER X

A STUDY OF THE DESIGN OF A DIRECT-CURRENT GENERATOR	55
Flux Calculation—The Magnetic Circuit—Area of Flux Path through Teeth—Area of Flux Path through Gap—Areas of Armature Core, Pole Core and Yoke—Materials—No-load and Full-load Saturation Curves—Armature Reaction—The Shunt Field Winding—The Series Field Winding—Armature Resistance—Brush Resistance—Series Field Resistance—Commutator and Brushes—Flux Distribution around the Armature—Losses and Efficiency—Copper Losses—Core Loss—Summary of Losses, Output and Efficiency—Temperature Rise.	

CHAPTER XI

ELECTRICAL CONSTANTS OF A DIRECT-CURRENT GENERATOR HAVING COMMUTATING POLES AND COMPENSATING WINDING	74
Commutation.	

CHAPTER XII

DIRECT-CURRENT GENERATORS IN PARALLEL AND SERIES	88
Direct-current Generators in Series—The Three-wire System—Boosters.	

CHAPTER XIII

DIRECT-CURRENT MOTORS	97
Types of Direct-current Motors—Speed Characteristics of Direct-current Motors—Power and Torque—Torque Characteristics.	

CHAPTER XIV

THEORY OF THE BALLISTIC GALVANOMETER	102
--	-----

CHAPTER XV

VECTOR REPRESENTATION OF ALTERNATING-CURRENT WAVES	105
Use of the Symbol j —Circuit of Resistance in Series with an Inductive Impedance—Impedances in Parallel.	

CONTENTS

ix

CHAPTER XVI

PAGE

- THE SYMBOLIC METHOD IN TRANSMISSION LINE CALCULATION . . . 113
Addition—Multiplication—Power—Average Value of Power during a Period—Power Factor—Transmission Line Calculation—Power of Generator.

CHAPTER XVII

- CONSTANT POTENTIAL—CONSTANT CURRENT TRANSFORMATION . . . 120

CHAPTER XVIII

- CAPACITY AND CAPACITY REACTANCE 123
Condenser—Expression of Condensive Impedance—Circuit Containing Resistance, Inductance and Capacity in Series—Resonance.

CHAPTER XIX

- PARALLEL CIRCUITS 129
Transmission Line Supplying Power to Parallel Loads—Approximate Transmission Line Calculation.

CHAPTER XX

- DISTORTED WAVES—RESONANCE EFFECTS 133
E.m.f. Which Causes Distorted Current waves.

CHAPTER XXI

- CONSTANT POTENTIAL—CONSTANT CURRENT TRANSFORMATION (Continued from Chapter XVII) 140
Power and Wattless Components of Volt-amperes.

CHAPTER XXII

- THEORY AND USE OF THE WATTMETER 146
Wattmeter Connections.

CHAPTER XXIII

- SIMPLE PROBLEMS IN ELECTRO-STATICS. 152
Potential—Intensity—Capacity of a Sphere—Potential Gradient—Capacity of a Spherical Concentric Condenser—The Capacity of a Concentric Cylinder—Capacity of Two Parallel Plates so Large that the Effects of their Edges may be Neglected—Capacity of a Transmission Line—Capacity of a Three-phase Cable—Inductance of a Concentric Cable—Inductance of a Transmission Line.

CHAPTER XXIV

- DISTRIBUTED INDUCTANCE AND CAPACITY 162

	PAGE
CHAPTER XXV	
NOTES ON THE MATHEMATICS OF COMPLEX QUANTITIES	169
Representation of Complex Quantities—Addition of Two Complex Quantities—Multiplication of Two Complex Quantities—Division of Two Complex Quantities—Multiplication—Involution and Evolution—The Roots of a Complex Quantity—Exponential Representation of Complex Quantities—Differentiation of a Complex Number or Vector—Logarithm of a Complex Number or Vector.	
CHAPTER XXVI	
THE TRANSFORMER	174
The Transformer Diagram—Equivalent Transformer Circuit—Example of Transformer Calculation—Approximate Method of Determining the Regulation, Efficiency and Power Factor of Transformers.	
CHAPTER XXVII	
HYSTERESIS AND EDDY-CURRENT LOSSES	186
Hysteresis Loss—Eddy-current Loss.	
CHAPTER XXVIII	
WAVE DISTORTION IN TRANSFORMERS	189
Effect of Hysteresis—Dependence of Core Loss on the Shape of the E.m.f. Wave.	
CHAPTER XXIX	
DISTORTED WAVES	196
Application of FOURIER'S Theorem to Wave Analysis.	
CHAPTER XXX	
MECHANICAL STRESSES IN TRANSFORMERS	202
Determination of the Leakage Inductance of the Primary and Secondary—Calculation of Stresses.	
CHAPTER XXXI	
GENERAL PRINCIPLES OF TRANSFORMER DESIGN	209
Type—Efficiency—Losses— B and V —Hysteresis and Eddy-current Loss per Cubic Inch—Magnetizing Current—Number of Turns, Total Flux, Area and Length of Magnetic Circuit—Resistance, Length of Mean Turn, Total Length and Size of Windings—Per Cent. Magnetizing Current and Core Loss—Efficiency—Regulation—Heating—Weight and Cost of Material.	

CONTENTS

xi

CHAPTER XXXII

	PAGE
COMBINATIONS IN MULTIPHASE TRANSFORMER SYSTEMS	226
The Three-phase System—Voltage Waves in Three-phase, Four-wire System—Three-phase, Y-connected Transformers—Three-phase Δ -connected Transformers—Voltage Waves with Y-connected Transformers—Three-phase Transformers—Shell-type Three-phase Transformers—Open Delta Transformer Connection—T-connection of Transformers—Rating of T-connected Transformers—Two-phase, Three-phase Transformation—Auto-transformers—Compensators for Two-phase, Three-phase Transformation—Dissimilar Transformers in Series—Dissimilar Transformers in Parallel—Three-phase Connection for Dissimilar Transformers.	

CHAPTER XXXIII

ALTERNATORS	246
One-, Two- and Three-phase Connection—Voltage to Neutral—Rating of Alternators.	

CHAPTER XXIV

ARMATURE REACTION	252
-----------------------------	-----

CHAPTER XXXV

CHARACTERISTICS OF ALTERNATORS WITH DEFINITE POLES	258
--	-----

CHAPTER XXXVI

APPROXIMATE DETERMINATION OF THE SELF-INDUCTION OR LOCAL MAGNETIC LEAKAGE REACTANCE OF AN ALTERNATOR	270
--	-----

CHAPTER XXXVII

ARMATURE REACTION IN MULTIPHASE MACHINES	278
Effect of Distributed Winding on the Armature Reaction.	

CHAPTER XXXVIII

HUNTING	283
-------------------	-----

CHAPTER XXXIX

STUDY OF THE DESIGN CONSTANTS OF ALTERNATORS	289
General Constants—Slot Dimensions—Flux Determination—Air Gap—Teeth Flux Density—Armature Length—Armature Resistance—Magnetic Circuit Dimensions—The Main Field Magnetomotive Force—Losses and Efficiency—Temperature Rise—Regulation.	

CONTENTS

	PAGE
CHAPTER XL	
SHORT-CIRCUIT OF ALTERNATORS	301
Stresses on End-connections of the Armature Coils—Multiphase Short-circuits—Armature Reaction—Electromotive Force and Current Induced in the Field Windings.	
CHAPTER XLI	
SYNCHRONOUS MOTORS	324
Synchronous Motor Equations.	
CHAPTER XLII	
INDUCTION MOTORS	342
The Rotary Field—Theory of Operation—Case 1. Armature at Standstill—Case 2. Armature at about Half-speed—Motor Assumed Y-connected—Motor Assumed Δ -connected—Motor and Transmission Line—Motor with Auto-transformer.	
CHAPTER XLIII	
STUDY OF THE DESIGN CONSTANTS OF AN INDUCTION MOTOR	365
Air Gap—Rotor Diameter—Stator Slots per Pole—Slot and Tooth Dimensions—Main Flux—Stator Length—Rotor Slots—Slot and Tooth Dimensions—Rotor Secondary Resistance—Leakage Reactance.	
CHAPTER XLIV	
ROTARY OR SYNCHRONOUS CONVERTERS	383
Voltage and Current Ratios—Voltage Control—Heating of the Armature—Voltage Control—Numerical Application—Voltage Control by Use of the "Split Pole"—Transformer Connections for Rotary Converters—Synchronous Condensers.	
CHAPTER XLV	
SINGLE-PHASE ALTERNATING-CURRENT MOTORS	400
The Series Motor—Compensated Series Motor—Repulsion Motor.	
INDEX	411

ELECTRICAL ENGINEERING

CHAPTER I

UNITS

As it is assumed that the student has had an elementary course in Physics, it seems feasible to omit herein the definition of the fundamental mechanical and electrical units. However, before taking up the electrical engineering problems, it is essential that a review be made of the chapters in physics relating to these units.

The student should be able to present, not only by means of equations, but in words—for this is far more important—the relations between force, work, energy, power, torque, etc.

In regard to electrical units it is assumed that he is already familiar with such terms as “current” and “electromotive force” and appreciates that . . .

Current is analogous to water flowing. The absolute unit of current is the *abampere*. The practical unit is the *ampere*. One abampere is 10 amperes.

Quantity, likewise, is analogous to water at rest. The practical unit of quantity is the *coulomb*, which is the amount of electricity involved when 1 amp. flows throughout 1 sec., or, 1 amp. sec.

Difference of potential is analogous to pressure-difference and is the electromotive force which causes current to flow in a circuit.

The absolute unit of potential-difference is the *abvolt*. The practical unit is the *volt*, which is 10^8 *abvolts*.

Resistance is that property of the material of a circuit which impedes the flow of electricity. The absolute unit of resistance is the *abohm*. The practical unit is the *ohm*, which is 10^9 *abohms*. Resistance depends on material and temperature. With constant temperature,

$$R = \rho \frac{l}{A}$$

where

R = resistance of a given conductor,
 ρ = specific resistance or resistivity of the material,
 l = length, and A = area of cross-section, of the conductor.

[Specific resistance or resistivity, is the resistance of a unit cube of any material taken between opposite faces.]

In practice it is sometimes convenient to use the resistance of a wire 1 ft. long and 0.001 in. in diameter as the unit of resistivity. This unit is called the circular-mil-foot.

In problems involving resistance, it is frequently convenient to use the reciprocal of resistance, known as the *conductance*. $G = \frac{1}{R}$, where G is the conductance of a circuit of resistance R . Likewise the reciprocal of resistivity, called conductivity, is often used.

The resistance of a wire at any temperature t , when its resistance at any other temperature is known can be calculated by the following equation

$$R_t = R_{t_1}[1 + \alpha_{t_1}(t - t_1)]$$

When $t_1 = 0^\circ\text{C}$. then $R_t = R_o(1 + \alpha_o t)$

where R_t is the required resistance at any temperature, t , R_o in this case is the resistance at 0° , and α is a constant, called the temperature coefficient.

For copper, $\alpha_o = 0.004$ (approximately) when t is given in Centigrade degrees.

At any other temperature the value of α is:

$$\alpha_t = \frac{1}{234.5 + t}$$

where t is the temperature in degrees C.

Since α depends upon the temperature, in all calculations involving α its value is calculated for that temperature at which the resistance is known.

Knowing the resistance R_1 at a temperature t_1 the resistance R_2 at temperature t_2 is thus accurately determined from the following relation:

$$\frac{R_1}{234.5 + t_1} = \frac{R_2}{234.5 + t_2}$$

TABLE I

Table I gives approximately the temperature coefficients and resistivities in ohms per centimeter cube of some of the more common electrical conductors at ordinary temperature.

Conductor	Temp. coefficient α	Resistivity
Aluminium.....	0.0042	2.9×10^{-6}
Carbon.....	-0.00052	720×10^{-6}
Copper.....	0.004	1.6×10^{-6}
German silver.....	0.00027	20.9×10^{-6}
Iron.....	0.0046	9.7×10^{-6}
Nickel.....	0.0062	12.4×10^{-6}
Platinum.....	0.0036	9×10^{-6}
Silver.....	0.004	1.5×10^{-6}
Tungsten.....	0.005	5×10^{-6}

Development of Ohm's Law.—According to OHM's law the current in a circuit at any instant is equal to the potential difference divided by the resistance, or,

$$I = \frac{E}{R}$$

Obviously, where a number of resistances are in series, the total resistance is the sum of the individual resistances, or,

$$R_{total} = \Sigma r = r_1 + r_2 + r_3 + \dots$$

Two Resistances in Parallel.—To find the total current I , and the currents I_1, I_2 in the resistances r_1 and r_2 , when a potential difference E is applied (Fig. 1).

By OHM's law,

$$I_1 = \frac{E}{r_1}; I_2 = \frac{E}{r_2}$$

and

$$\begin{aligned} I &= I_1 + I_2 \\ &= \frac{E}{r_1} + \frac{E}{r_2} = E\left(\frac{1}{r_1} + \frac{1}{r_2}\right) \\ &= E \left[\frac{r_1 + r_2}{r_1 r_2} \right], \end{aligned}$$

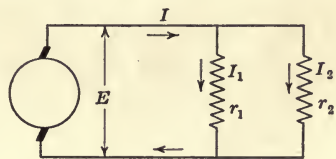

FIG. 1.

To find a single resistance, r_o , which shall be the equivalent of r_1 and r_2 in parallel, evidently

$$I = E \frac{r_1 + r_2}{r_1 r_2} = \frac{E}{r_o}$$

Whence,

$$r_o = \frac{r_1 r_2}{r_1 + r_2}$$

Having two resistances in parallel, in series with a third resistance (Fig. 2), to find the combined resistance. Let the combined resistance of r_1 and r_2 be r_o . Then $r_o = \frac{r_1 r_2}{r_1 + r_2}$.

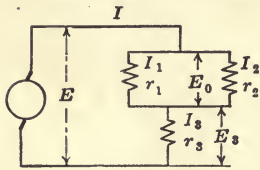

FIG. 2.

The condition is, then, that of two resistances r_o and r_3 in series and the total resistance $R = r_o + r_3$.

Hence

$$I = \frac{E}{R} = \frac{E}{r_o + r_3}$$

To find I_1 and I_2 .

It is evident that $I = I_3$.

Knowing I_3 and r_3 , we may at once determine E_3 which is the potential difference, or drop, across r_3 . Thus, by OHM'S law,

$$E_3 = I_3 r_3.$$

It is evident that the potential difference E_o , across r_1 and r_2 is $E - E_3$.

$$\therefore I_1 = \frac{E_o}{r_1}; I_2 = \frac{E_o}{r_2}$$

General Solution of a Network by Kirchoff's Laws.—In circuits or networks of a more complicated nature in which the resistances and electromotive forces are known, the currents in the various branches may be calculated by the application of KIRCHOFF'S laws which may be stated as follows:

Law I.—The algebraic sum of all the currents flowing toward a branch point is equal to zero.

Law II.—The algebraic sum of all the e.m.fs. acting around a closed circuit is equal to the sum of the products, ri , around the mesh. Or the impressed e.m.f. is equal to the sum of all e.m.fs. consumed by the resistances.

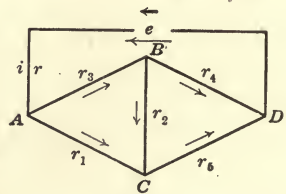

FIG. 3.

For example, let the circuit be as shown in Fig. 3 where arrows represent arbitrarily chosen directions of current. For the points A, B, C, D, applying Law I, equations may be written:

- A. $i - i_1 - i_3 = 0$ (1)
- B. $i_3 - i_2 - i_4 = 0$ (2)
- C. $i_1 + i_2 - i_5 = 0$ (3)
- D. $i_4 + i_5 - i = 0$ (4)

Applying Law II, where the short arrow represents the direction of the e.m.f., to the meshes (a) e, r_3, r_4 , (b) e, r_1, r_5 , (c) r_1, r_2, r_3 , (d) r_2, r_5, r_4 , always keeping an arbitrarily chosen counter-clockwise direction, we have,

- (a) $ri + r_3i_3 + r_4i_4 = e$ (5)
- (b) $ri + r_1i_1 + r_5i_5 = e$ (6)
- (c) $r_1i_1 - r_2i_2 - r_3i_3 = 0$ (7)
- (d) $r_2i_2 + r_5i_5 - r_4i_4 = 0$ (8)

There is one extra equation in each group as there are only six unknown quantities, $i, i_1, i_2, i_3, i_4, i_5$.

In calculating the resistance of more or less complex circuits - it is helpful to remember that current does not flow between points of the same potential.

If, in Fig. 3, there is no difference of potential between points B and C there will be no current in the branch r_2 .

PROBLEMS

Problem 1.—If the resistivity (resistance of a cubic centimeter between parallel faces at 0°C.) of copper is 1.6×10^{-6} ohm, (a) show that the resistance of an inch cube of copper is 0.63×10^{-6} ohm; (b) show that if the temperature coefficient, $\alpha = 0.004$, the resistance of a centimeter cube at 20°C. is 1.73×10^{-6} ohm; (c) show that the temperature coefficient per degree Fahrenheit is 0.0022.

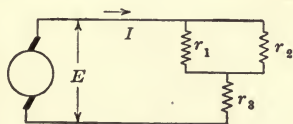

FIG. 4.

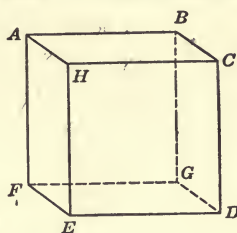

FIG. 5.

Problem 2.—If a wire be connected across the terminals of a source of constant e.m.f., a current will flow. Will this current increase, decrease, or remain constant as time goes on, and why?

Problem 3.—Deduce the equation for the equivalent resistance of three resistances connected in parallel.

Problem 4.—Find the line current I , and the voltage across r_3 in the circuit, shown in Fig. 4. $E = 100$ volts, $r_1 = 1, r_2 = 2, r_3 = 3$.

Problem 5.—Let the outline of a cube, Fig. 5, consist of resistances, each

edge being 1 ohm. Prove that the total resistance between *A* and *B* is $\frac{1}{12}$ ohm; between *A* and *C* is $\frac{1}{4}$ ohm; between *A* and *D* is $\frac{1}{6}$ ohm.

Effects of Current in a Wire.—When a current is set up in a wire three effects may be noted, namely: (1) the wire gets warm, (2) a compass needle placed near the wire is deflected, and (3) when the voltage is high enough bits of paper may be attracted.

The amount of energy delivered through the wire does not bear a relation to any one of these effects, but if the second and third effects are multiplied together, or, as commonly expressed, if the strength of the magnetic and electric fields are multiplied together the product is a value which is proportional to the amount of energy transmitted through the wire per second, or to the power. Thus we may write,

$$P = kei$$

where *P* is the power and *k* is a constant. *k* is unity when *e*, which is proportional to the strength of the electric field is expressed in volts, *i*, which is proportional to the strength of the magnetic field is expressed in amperes, and *P* is in watts.

The first effect, that is, the production of heat is due to consumption of energy in the wire due to its resistance. The second effect is due to the setting up of a magnetic field about the wire by the current. The third effect is due to the setting up of an electric or electro-static field in the region about the wire by the difference of potential between the wire and other points in space.

Power.—In a given circuit, then,

$$P = EI = IR \times I = I^2R$$

in which *E* is the total e.m.f., *I* the current, and *R* the total resistance of the circuit.

This relation, known as JOULE'S law, is very important, as it shows that the power is proportional to the square of the current strength and to the first power of the resistance.

The heat developed by this power depends upon the duration of the current, and is expressed in *joules*. Thus, heat energy = $EIt = I^2Rt$ joules, where *E* is in volts, *I* in amperes, and *t* in seconds (the current and voltage being assumed constant during time *t*).

In general, the energy converted to heat is $W = \int_{t_1}^{t_2} i^2 r dt$.

Problem 6.—Prove that if the current is represented by equation

$$i = I \sin \omega t,$$

the energy per cycle is $W = I^2 r \frac{T}{2}$ where T is the time of a complete cycle.

The average power is then $\frac{W}{T} = \frac{I^2 r}{2}$.

Problem 7.—Prove that the average power is: $P = \left(\frac{I_1^2}{2} + \frac{I_3^2}{2} \right) r$ when $i = I_1 \sin \omega t + I_3 \sin (3\omega t + \alpha)$.

Heat Units.—The practical heat units most frequently dealt with are the British thermal unit (B.t.u.), and the large and small calories (C. and c.).

One B.t.u. is the energy required to raise the temperature of 1 lb. of water 1°F.

$$1 \text{ B.t.u.} = 1.055 \text{ kw. sec.}$$

One large calorie is the energy required to raise the temperature of 1 kg. of water 1°C.

$$1 \text{ C.} = 4.2 \text{ kw. sec.}$$

One small calorie is the energy required to raise the temperature of 1 gram of water 1°C.

$$1 \text{ c.} = 0.0042 \text{ kw. sec.}$$

Problem 8.—A 16-cp. lamp which consumes 3 watts per cp. is immersed in a quart of water at 20°C. Assuming no loss of heat, (a) what will the temperature of the water be after 2 min.? (b) How long would it take to evaporate the water?

Solution.—(a) Temp. will be 20° + °C. rise.

$$^\circ\text{C. rise} = \frac{\text{kw. sec.}}{4.2} \times \text{qt. in 1 kg.}$$

$$\text{kw. sec.} = \frac{3}{1000} \times 16 \times 2 \times 60 = 5.76$$

$$\text{qt. per kg.} = 1.057$$

$$\therefore ^\circ\text{C. rise} = \frac{5.76}{4.2} \times 1.057 = 1.45.$$

$$\text{Temp. after 2 min.} = 21.45^\circ\text{C.}$$

(b) Time to evaporate = time to raise to boiling + time required to furnish latent heat of vaporization.

Time required to boil 1 qt. = time to raise 1 qt. 1° × (100° - 20°)

$$= \frac{2 \text{ min.}}{1.45^\circ} \times 80 = 110.3 \text{ min.}$$

Time required to evaporate = calories required to evaporate ÷ calories per min. supplied by lamp.

$$= \frac{537 \text{ C.}}{\text{kg.}} \times \frac{\text{kg.}}{\text{qt.}} \div \frac{2.88}{4.2} = 508 \div 0.685 = 742 \text{ min.}$$

$$\therefore \text{Total time required} = 110.3 + 742 = 852.3 \text{ min.} = 14 \text{ hr. } 12 \text{ min.}$$

Problem 9.—Transform problem 8 into °F. and B.t.u.

Problem 10.—If electric energy costs 10c. per kw. hr., how much would it cost to prepare a hot bath by electric means, if the bath required 50 gal. of water raised in temperature by 50°F.?

Solution.—Cost = kw. hr., \times \$0.10

$$\text{Kw. hr.} = \frac{\text{kw. sec.}}{3600} = \frac{\text{kw. sec. to raise 1 gal. } 1^\circ \times 50 \times 50}{3600}$$

1 gal. weighs approx. 8.4 lb.

$$\therefore \text{kw. sec. to raise 1 gal. } 1^\circ = 8.4 \times 1.055 = 8.86$$

$$\therefore \text{kw. hr.} = \frac{8.86 \times 2500}{3600} = 6.15$$

$$\text{Cost} = 6.15 \times 0.10 = \$0.615.$$

Problem 11.—Four car heaters each take 4 amp. at 125 volts. Find the cost per 10-hr. day at 10c per kw. hr., to operate them on a 500-volt circuit, (a) when they are connected in series, (b) when they are connected in parallel.

Answer.—In series, \$2.00; in parallel, \$32.00.

Problem 12.—If the car contains 3000 cu. ft. and is insulated against loss of heat, how much time is required for a rise in temperature of 20°C. when the heaters of problem 11 are connected (a) in series, (b) in parallel?

Answer.—In series, 12 min. 44 sec.; in parallel, 48 sec.

NOTE.—Specific heat of air at constant volume = 0.167.

CHAPTER II

FORM OF WORK

In order that students may gain the greatest possible advantage from pursuing the course of study, it has been thought best to include in the body of the book, at this point, a brief statement of the procedure which the student should adopt in the working out of the problems. He is urged to familiarize himself with the method, and to follow it rigidly until, in so doing, he has thoroughly acquired the habit of careful and accurate work.

Object of Problems.—Problems are almost universally considered to be indispensable in any engineering course. Their function is similar in many respects to that of laboratory experiments. They illustrate the theory. In this respect problems may be divided into two groups, namely:

(a) Those in which the general equation is applied to a definite concrete case, and

(b) Those in which the general equation is investigated for the purpose of finding out the whole range of definite value which may be obtained from one variable by assigning definite values to one or more other variables.

As an illustration of the first group, we will take the following example:

Problem 13.—Ten arc lamps, in series, are used to light a certain building. They require 6.6 amp., and the potential-difference (drop) across each lamp is 80 volts. Current is supplied from a power house 2000 ft. distant, by means of No. 6 B. & S. wire. If the energy is measured at the power house, find the cost at 10c. per kw. hr. to light the lamps 8 hr. per day.

Solution.—Cost per day = power \times hr. \times \$0.10

Power,

$$P = P_L + P_W$$

where

$$P_L = \text{power required by lamps} = nEI$$

where

$$n = \text{number of lamps}$$

and

$$P_W = \text{power lost in the wire}$$

$$P_W = I^2R$$

where

R = total resistance of wire

$$R = \text{resistance per 1000 ft.} \times \frac{\text{length}}{1000}$$

resistance per 1000 ft. of No. 6 wire = 0.4 ohms at 75°F.

Then

$$R = 0.4 \times \frac{4000}{1000} = 1.6 \text{ ohms.}$$

$$P_W = 6.6^2 \times 1.6 = 70 \text{ watts}$$

$$P_L = 10 \times 80 \times 6.6 = 5280 \text{ watts}$$

$$P = P_L + P_W = 5350 \text{ watts} = 5.35 \text{ kw.}$$

$$\text{Cost} = 5.35 \times 8 \times 0.10 = \$4.30. \text{ Ans.}$$

Such problems are typical of existing conditions. An engineer continually meets them where he is trying to find what results are being obtained from a given installation. In solving them, accuracy is the prime consideration, and this is obtained by avoiding short cuts and following through, step by step, a logical development. These problems are of far less importance and interest to the engineering student than problems of the second group.

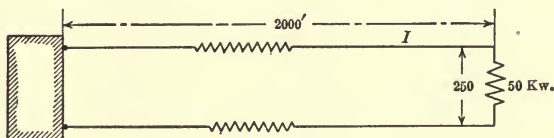

FIG. 6.

As an illustration of these take the following example:

Problem 14.—A load of 50 kw. at 250 volts is to be supplied by a power house distant 2000 ft. from the load. If the line costs 20c. per lb. of copper laid, find and plot (a) efficiency of transmission against size of wire; (b) cost of copper against size of wire; (c) efficiency of transmission against cost of copper.

$$\text{Solution.}—\text{Efficiency} = \frac{\text{load}}{\text{load} + \text{line loss}} = \frac{50,000}{50,000 + I^2 R}$$

$$I = \frac{50,000}{250} = 200 \text{ amp.}$$

$$\therefore \text{Efficiency} = \frac{50,000}{50,000 + 40,000R}$$

$$R = \frac{\text{length}}{1000} \times \text{resistance per 1000 ft.} = 4 \times r$$

$$\text{wt.} = \frac{\text{length}}{1000} \times \text{wt. per 1000 ft.} = 4w.$$

Tabulation:

Wire No. (B. & S.)	0000	00	1	4	8	12	16
r per 1000 ft. ¹	0.049	0.078	0.125	0.25	0.64	1.60	4.0
$R = 4r$	0.196	0.312	0.50	1.0	2.56	6.4	16.0
Wt. per 1000 ft. = w	641	403	253	126	50	20	7.9
Wt. = $4w$	2,564	1,612	1,012	504	200	80	31.6
Cost at \$0.20.....	512.8	322.4	202.4	100.8	40	16	6.32
$40,000R = I^2R$	7,840	12,480	20,000	40,000	102,400	256,000	640,000
$50,000 + 40,000R$..	57,840	62,480	70,000	90,000	152,400	306,000	690,000
Efficiency.....	0.865	0.8	0.715	0.55	0.33	0.16	0.072

The curves are plotted in Fig. 7.

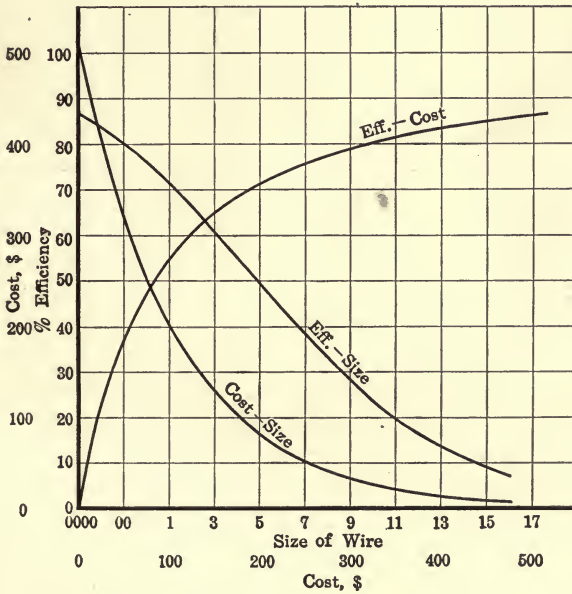

FIG. 7.

Summary.—The curves show (1) efficiency of transmission decreases as wire becomes smaller, at first slowly, then rapidly, and then, for very small wires, slowly again; (2) the cost of wire decreases as wire becomes smaller, at first very rapidly, then more and more slowly; (3) efficiency increases with cost, rapidly at first, for low efficiencies and costs, then more and more slowly.

¹ From wire tables.

It is evident that this problem could be greatly extended so as to include other variables, such as current density in the wire, cost of lost energy, etc., and indeed it is characteristic of this type of problem that there are always suggestive lines of investigation which tend to stimulate the student's interest.

The work of solving the problem may be divided into a number of parts, thus: (1) statement of problem, (2) diagram of circuit, (3) analytical work, (4) tabulation of values, (5) plotting of curves, (6) summary, or statement in words, of the results obtained.

The statement of the problem should be concise. The diagram should be an illustration of the statement, and should contain the symbols to be used.

The analytical work should be carried out as far as possible with symbols before the numerical values are substituted. In the above example there is very little opportunity for the use of symbols, owing to the shortness of the problem. In later problems this feature will be more apparent.

Tabulation should be arranged with care, and should be planned so that columns can be conveniently added. As a rule, it is well to assign along the horizontal various values of the independent variable, and proceed, step by step, to the dependent variable. As in this case, there may be different combinations of variables, as number of wire, cost, and efficiency. This makes the tabulation more complex, as it would be by any other procedure, but it is still entirely clear. The plotting of curves is then carried out, and this should be done neatly and preferably in ink.

The problem should then be completed with a brief statement of the results obtained. It is not always easy to make students take this last step, but they should be required to do so, and to follow this general plan throughout, until they have formed the habit of doing it and need no further compulsion.

There may be other ways of working these problems efficiently, but it seems justifiable to urge teachers and students to adopt this method in preference to any other to which they are accustomed. It will insure uniformity and logical arrangement, will make correcting easy, and will commend itself to the student as well as the teacher.

In working problems of this nature there are other objects than merely to illustrate and enforce the theory.

Great stress is laid on them, not only for the engineering knowl-

edge which they contain, but because of their structure, which, it is believed, strongly tends to develop those qualities most essential in an engineer. For instance, the mathematical development calls for insight and understanding, the tabulation calls for concentration of mind, the summation of results calls for accuracy, and a study of the plotted curves calls for judgment. At the same time, efficiency, the keynote of the engineer, would be lacking if the problems were not done in the shortest and best way consistent with obtaining the desired results, and it is obvious that many hours will be wasted, both to student and instructor, unless the work is done with order, accuracy and neatness.

CHAPTER III

MAGNETISM

FARADAY explained magnetic phenomena by assuming that surrounding a magnet or a wire carrying current were lines of force.)

The stronger the magnet or current, the stronger is the magnetic field, that is, the more lines of force per square centimeter.

The introduction, then, of a magnet into a space means the establishing of a field of force.

To get quantitative ideas about field strength he made use of the symbol H which was called the *intensity of the field*, or the force on unit pole placed in the field. It seems an unfortunate term since intensity and density are readily confused.

B , the *density of the field*, or the number of lines of force per square centimeter, is proportional to H , and also to a quantity μ , the permeability or magnetic conductivity of the medium in which the intensity, H , exists. Thus

$$B = \mu H.$$

In air, where $\mu = 1$, it follows that the number of lines of force per square centimeter is numerically the same as the intensity of the magnetic field H .

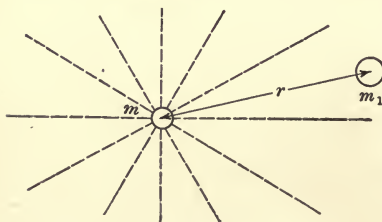

FIG. 8.

H , the force per unit pole, is expressed in dynes.

The force exerted on a pole not of unit strength, but of strength m , is

$$F = mH \text{ dynes,}$$

where, of course, H is caused by other poles than m .

Consider, now, an isolated elementary pole of strength m , from which n lines of force, per unit pole, protrude radially and uniformly in all directions (Fig. 8).

At a distance r from m , no matter what the medium is provided it is uniform, the density of the field is $B = \frac{nm}{4\pi r^2}$, since the area of a sphere of radius r is $4\pi r^2$. The force, H , on unit pole is then $\frac{B}{\mu} = \frac{nm}{4\pi r^2 \mu}$. Thus the force on pole m_1 is $F = \frac{nm m_1}{4\pi \mu r^2}$.

COULOMB, working in air, found experimentally that the force between two poles of strength m and m_1 could be expressed by $F = k \frac{m m_1}{r^2}$, and he would have found $F = k \frac{m m_1}{\mu r^2}$ had he experimented in a medium of permeability, μ .

Therefore, k may be written unity if $n = 4\pi$. In other words, if it is assumed, as is the case, that 4π lines protrude from unit pole.

GAUSS came to the same conclusion from another point of view, and the relation $\phi = 4\pi m$ is called GAUSS'S theorem.

In words, GAUSS'S theorem states that from a pole of strength m radiate outward $4\pi m$ lines of force, or the total outward flux, ϕ , from pole m is $4\pi m$ lines.¹

Cylindrical Poles.—To find the intensity of the magnetic field H at a point distant r from a uniform cylindrical pole of strength m (Fig. 9). By GAUSS'S theorem the flux $\phi = 4\pi m$, and $B = \mu H = \frac{\text{flux}}{\text{area}}$. The area of a cylinder of radius r and length l is $2\pi r l$. Thus B , at p , is $\frac{4\pi m}{2\pi r l} = \frac{2m}{r l}$, and $H = \frac{2m}{\mu r l}$.

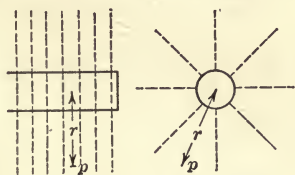

FIG. 9.

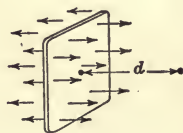

FIG. 10.

Flat Poles.—To find the intensity of the field, H , at a point distant d from one side of a flat pole of strength m (Fig. 10). Assume that the lines of force are perpendicular to the surface. Let $B =$ flux density at any distance. Then the flux coming from one of the surfaces of the magnet is $\phi = \frac{4\pi m}{2} = 2\pi m$.

If the area of the pole face is S , then $B = \frac{2\pi m}{S}$, and $H = \frac{2\pi m}{\mu S}$.

¹ For a more complete discussion of GAUSS'S theorem see "Advanced Course in Electrical Engineering."

Magnets as Commonly Used in Meters.—To find the magnetic intensity between poles (Fig. 11). Let S be the area of a pole face and d the distance between poles.

The density in the gap between the two pole faces is due to the magnetic north pole, N , as well as to the south pole, S .

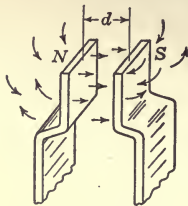

FIG. 11.

If the lines of force flow outward from the north pole, they flow inward from the south pole. Thus a simple examination will show that the fluxes add in the gap and cancel each other in the outside region.

The total flux from N is $4\pi m$ and one-half of this flux is assumed to be in the gap, the other half extending outward.

The density in the gap due to N will then be

$$B_n = \frac{4\pi m}{2S} = \frac{2\pi m}{S}$$

Similarly, due to S ,

$$B_s = \frac{4\pi m}{2S} = \frac{2\pi m}{S}$$

$$\therefore B = \frac{4\pi m}{S} \quad (9)$$

and

$$H = \frac{B}{\mu} = \frac{4\pi m}{S\mu}$$

In all practical problems where magnets act in air only, μ is, of course, unity.

Consider, now, the pull between the faces of a magnet as shown in Fig. 11.

The flux density at the south pole due to the flux from the north pole is $B_n = \frac{2\pi m}{S}$. $\therefore H = \frac{2\pi m}{\mu S}$ = force on unit pole at the surface of the south pole.

Since the south pole has a strength m , the force on it is therefore

$$F = mH = \frac{2\pi m^2}{\mu S} \quad (10)$$

Usually the density, B , in the gap is known.

Substituting the value of m from (9) into (10) gives

$$F = \frac{2\pi}{\mu S} \frac{B^2 S^2}{4^2 \pi^2} = \frac{B^2 S}{8\pi \mu}$$

or the force in dynes per sq. cm. is $F_o = \frac{B^2}{8\mu\pi}$

In air, where $\mu = 1$,

$$F_o = \frac{B^2}{8\pi} \text{ dynes per sq. cm.} \quad (11)$$

In lb. per sq. in., the formula becomes

$$F_o = \frac{B^2}{72,134,000} \text{ lb. per sq. in.}$$

It is seen that if the pole strength, m , remains the same while the faces of the magnet approach each other, the density, and thus the force, is constant.

The work done is then Fd , where d is the distance between the poles, or $W = \frac{B^2 Sd}{8\pi}$.

Energy Density in a Field.—The volume of space through which the body is moved is Sd . The energy density, or joules per cu. cm. of space between poles, is then:

$$\frac{B^2 Sd}{8\pi} \div Sd = \frac{B^2}{8\pi} \text{ ergs} = \frac{B^2}{8\pi \times 10^7} \text{ joules.}$$

The conception of energy density is merely mentioned at this point. Similarity of magnetic and electric fields will be shown later on together with the development of theory and problems in electro-statics.

Limits of Pole Intensity.—In practice it is found that the limits to which pole intensity $\frac{m}{S}$ can be pushed are as given in the following table:

TABLE II.—APPROXIMATE LIMITING VALUES OF $\frac{m}{S}$

For wrought iron magnets,	1600 units of pole strength per cm. ²
For soft steel magnets,	1600 units of pole strength per cm. ²
For cobalt magnets,	1300 units of pole strength per cm. ²
For nickel magnets,	500 units of pole strength per cm. ²
For permanent steel magnets,	800 units of pole strength per cm. ²

The Magnetic Cycle.—According to the molecular theory of magnetism, magnetic bodies are composed of minute magnets which attract and repel each other, and which are partly free to turn under the influence of magnetizing forces. When strongly magnetized, these molecular magnets are pointed in the direction of the magnetic force. When the force is removed, they still tend to point in the same direction, and thus the body exhibits magnetization, which is called residual magnetism.

The magnetic state of a body is shown with reference to the "magnetizing force" by a curve called the hysteresis loop (Fig. 12).

Magnetization of an iron bar is ordinarily accomplished by sending current through a number of turns of wire wound around the bar. The magnetization is thus produced by the ampere-turns ($A.T.$). The number of lines of flux set up per unit area enclosed by the turns will with a long bar be shown to be $\frac{0.4\pi A.T.\mu}{l} = B$, where μ is the permeability of the bar and l is its length. Since in air $\mu = 1$ and $H = B$, it follows that the intensity of the magnetic field in a solenoid is:

$$H = \frac{0.4\pi A.T.}{l}$$

The hysteresis loop is drawn with flux density, B (in lines per square centimeter or per square inch), as ordinates and the magnetic field intensity, H (or frequently, for convenience, ampere-turns per inch length of magnetic circuit, $\frac{Hl}{4\pi}$), as abscissæ.

The construction of the loop is as follows: Imagine a bar of iron wound with many turns of insulated wire. If the iron has

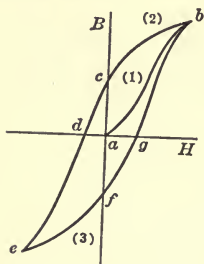

FIG. 12.

no residual magnetism at the beginning, before current is sent through the wire, there will be no magnetizing force and no flux, and consequently the first or starting point on the curve will be at a (Fig. 12). As more and more current is sent through the wire, that is, as the magnetizing force is increased proportionally to the current, the flux or induction density, B , is increased, not according to a simple law, but in such a way as to give the characteristic curve (1) from a to b .

If the magnetomotive force (m.m.f.) expressed in ampere-turns is now decreased, the curve (1) is not retraced, but B follows curve (2) from b to c . At c , $H = 0$, while B continues to have a value represented by the line ac . This value of B corresponds to the residual magnetism of the iron.

If, now, the current be reversed, so that H is given negative values, B continues to decrease from c to d . At the point d , $B = 0$, while H has the negative value ad . This value of H is

called the "coercive force" of the magnet. It is the magnetizing force necessary to reduce the remanent magnetism, ac , to zero. As H is further increased, negatively, B follows the curve de . At e , which corresponds to b with positive H , the current is again reduced, and B follows curve (3) to f , which gives the value, af , of negative remanent magnetism corresponding to ac for $H = 0$.

Thus, the point a is not reached again, but as H is now given increasing positive values, the curve goes through g to b , completing the loop.

In obtaining a single loop, the points do not usually come into such close agreement, due primarily to the fact that there is always some remanent magnetism at starting, which prevents the curve from beginning exactly at a . But in the case of many uniform reversals of H , as occurs in electrical machinery, the loop is retraced uniformly so long as the limiting values of H remain constant.

It will be later shown, in connection with the study of hysteresis losses, that the area enclosed by the loop is proportional to the work done on the magnet per cycle.

Permeability.—The ratio $\frac{B}{H}$ is called the permeability, and is a measure of ease with which lines of flux are set up in a given material. Permeability is denoted by the symbol μ . Numerically, $B = H$ in air (or vacuum) since $\mu = 1$. In the magnetic metals, particularly iron, steel, nickel and cobalt, μ undergoes wide variation in value, with different values of H .

For a more complete discussion of the subject of magnetism the student is referred particularly to EWING'S "Magnetic Induction in Iron and Other Metals."

CHAPTER IV

PRINCIPLE OF THE ELECTRIC MOTOR

A wire carrying a current was discovered by OERSTED to be surrounded by a magnetic field, which is strongest near the wire. A small needle, placed in the field (Fig. 13), is directed along the lines of force, but there is practically no tendency for it to move toward the wire as the forces of attraction exerted on its poles are equal and opposite. A long needle, however, tends to move toward the wire as there is a component of force on each pole in the direction of the wire.

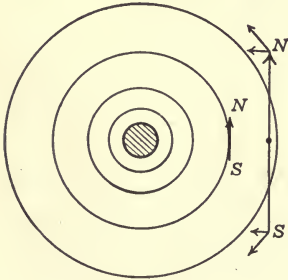

FIG. 13.

A wire carrying current, placed in a field perpendicular to the lines of force (Fig. 14), causes the flux to be distorted, and this tends to force the wire in such a direction that the lines shall again take up their normal position. This is the principle of the electric motor.

The electric motor consists (Fig. 15) of a number of wires wound on a drum, and so placed in a magnetic field that the current is caused to flow downward (toward the plane of the paper) on, say, all the wires adjacent to the north pole,¹ and upward on all the wires adjacent to the south pole. The wires on

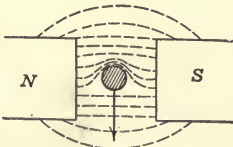

FIG. 14.



FIG. 15.

the left, then, tend to move downward, and those on the right upward, and thus rotation is produced.

¹ In the diagram a cross, \otimes , is used to represent down-flowing current and a dot, \odot , up-flowing current in accordance with notation in common use.

The current which, when flowing in a wire 1 cm. long placed at right angles to a field having a density of 1 line per sq. cm., gives a force of 1 dyne is called the *abampere*.

The force, in dynes, is then

$$F = IlB$$

where I is the current in abamperes, l the length of wire in centimeters, and B the flux density of the field in lines per square centimeter. The force is due to the interaction of flux and current.

If, however, the lines are not at right angles to the wire, B must be replaced by its component which is at right angles to the wire. If the angle is α (Fig. 16), then the force is $F = IlB \sin \alpha$, where $B \sin \alpha$ is the component of flux at right angles to the wire.

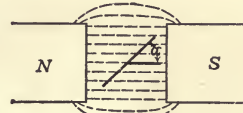

FIG. 16.

Problem 15.—A copper wire carrying 10 amp. is placed in a magnetic field of 10,000 lines per sq. cm.

What is the force in pounds on each centimeter of the wire (a) if it lies perpendicular to the direction of the magnetic field, (b) if it lies parallel to the field, (c) if it makes an angle, α , with the direction of the field?

Solution.— $F = IlB \sin \alpha$
 F , per cm. = $IB \sin \alpha$.

(a) $\sin \alpha = \sin 90^\circ = 1$
 $I = 10$ amp. = 1 ab amp.
 $B = 10,000$
 $\therefore F$, per cm. = 10,000 dynes.
 $10,000$ dynes = $\frac{10,000}{981} = 10.2$ grams
 $= \frac{10.2}{453.6} = 0.02245$ lb.

(b) $\sin \alpha = \sin 0^\circ = 0$
 $\therefore F$, per cm. = 0.

(c) For any angle, α ,
 F , per cm. = 10,000 $\sin \alpha$ dynes
 $= 0.02245 \sin \alpha$ lb.

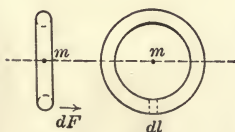

FIG. 17.

Determinations of Magnetic Intensity.—

Magnetic intensity at the center of a coil (annulus). Let a magnet pole, m , be placed at the center of a coil (Fig. 17). It will send out lines in all directions, some of which will strike an element of the coil, dl ,

at right angles. Thus a force, dF , will be generated in the direction of the axis, as indicated, and its value will be

$$dF = IBdl = I \frac{m}{r^2} dl$$

since

$$B = \frac{m}{r^2}.$$

The total force on the coil will be

$$F = \int_0^{2\pi r} I \frac{m}{r^2} dl = \frac{2\pi r I m}{r^2} = \frac{2\pi I m}{r}.$$

This will be the force, due to m , with which the coil will tend to move along its own axis. It is obviously also the force on m due to the coil. Thus if a unit pole ($m = 1$) replaces the pole of strength m the magnetic field intensity at the center of the coil is found. It is:

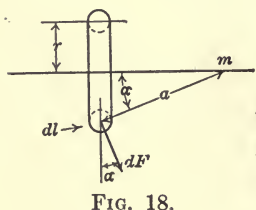

FIG. 18.

$$H = \frac{2\pi r I}{r^2} = \frac{2\pi I}{r}.$$

Magnetic Intensity at Any Point along the Axis of a Coil.—The force dF will act at right angles to the line joining m and dl (Fig. 18). Thus,

$$dF = IBdl = I \frac{m}{a^2} dl$$

dF has components, $dF \cos \alpha$ and $dF \sin \alpha$ where $\sin \alpha = \frac{r}{a}$ and

$$a = \frac{r}{\sin \alpha}$$

The component of force which tends to move the coil in the direction of its axis is $dF \sin \alpha$. Call this component dF_1 .

Then

$$dF_1 = I \frac{m}{r^2} \sin^3 \alpha dl$$

and

$$F_1 = \int_0^{2\pi r} I \frac{m}{r^2} \sin^3 \alpha dl = \frac{2\pi m I \sin^3 \alpha}{r}.$$

For

$$m = 1 \quad F_1 = H$$

$$H = \frac{2\pi I \sin^3 \alpha}{r},$$

since the component $dF \cos \alpha$ is balanced around the coil and thus exerts no force.

Magnetic Intensity in the Center of a Long Coil.—The force at m , due to an element of the coil, dx (Fig. 19), is $dF = \frac{2\pi m I \sin^3 \alpha}{r}$, where I is the current in abamperes, in the element dx .

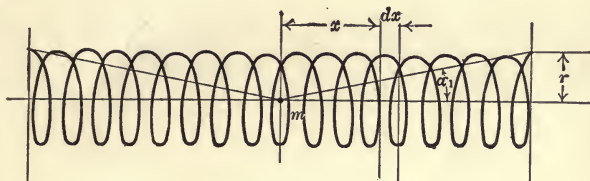

FIG. 19.

If the current per centimeter length of the coil is I_c , then $I = I_c dx$, and $dF = \frac{2\pi m I_c dx \sin^3 \alpha}{r}$.

But $\frac{x}{r} = \cot \alpha$. Differentiating, $dx = r \left(-\frac{1}{\sin^2 \alpha} \right) d\alpha$.

Substituting this value of dx in the formula,

$$dF = -\frac{2\pi m I_c r \sin^3 \alpha}{r \sin^2 \alpha} d\alpha$$

$$= -2\pi m I_c \sin \alpha d\alpha.$$

$$\therefore F = \int_{\alpha = \pi - \alpha_1}^{\alpha = \alpha_1} 2\pi m I_c \sin \alpha d\alpha = 4\pi I_c m \cos \alpha_1.$$

or $H = 4\pi I_c \cos \alpha_1.$

For very long coils, $\cos \alpha_1 = 1$, and

$$H = 4\pi I_c.$$

The relation between H and the ampere-turns of a coil may be found as follows:

Let there be a current of I abamp. in the coil, and let $n =$ number of turns. Then $nI =$ abamp.-turns. Abamp.-turns per cm. $= \frac{nI}{l} = I_c$, where $l =$ length of coil in centimeters.

Then $H = 4\pi I_c = \frac{4\pi n I}{l}$.¹ When the current is in amperes,

¹ NOTE.—It should be noted that the above value of $H = \frac{4\pi n I}{l}$ holds only for infinitely long solenoids since it was derived on that assumption. For practical purposes, according to the accuracy required, this value of H may be

$$H = \frac{0.4\pi nI}{l}, \text{ whence, amp.-turns} = 0.8Hl. \quad (12)$$

If l is in inches, amp.-turns = $0.313Hl$.

When the coil has an air core, H is numerically equal to B , and amp.-turns = $0.8Bl$ or = $0.313Bl$.¹

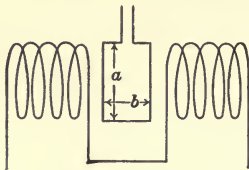

FIG. 20.

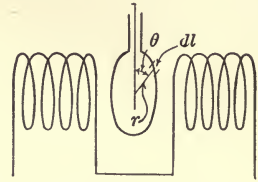

FIG. 21.

Application of Magnetic Formulæ to Instruments.—Let a rectangular coil of height, a , and width, b , be suspended in a magnetic field of uniform density, B (Fig. 20). The two sides, a , are perpendicular to the flux, and therefore, with a current of I abamp., there will be a force on each wire of $F_a = IBl = IBa$ dynes.

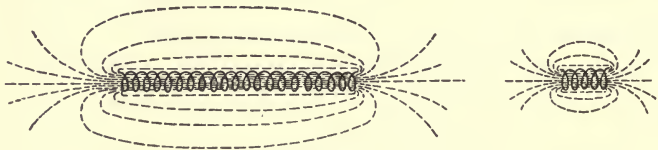

FIG. 22.

This force will produce a torque around the axis, on each wire, of $T_a = IBa \frac{b}{2}$ dyne-cm. The total torque per turn = $2T_a = IBab$, and if there are n turns, $T = InBab$, dyne-cm.

In practical instruments, T should be about 1 gram-cm.

Let a circular coil of radius r , as in Fig. 21, be suspended in the field. To find the torque on any element dl . The useful part

used whenever it is desired to find the magnetic field intensity along the axis of a solenoid, and not very near the ends, provided the length of the coil is about 50 times its diameter.

It is necessary to observe this (always depending on the accuracy desired) on account of the disturbing effects of the ends, as can be easily seen by comparing the figures. (Fig. 22.)

¹ NOTE.—It can be proven that the density in the middle of such long coil is uniform, thus if A is the area inside of the solenoid the total flux is AB , or $\varphi = 0.4\pi nI \frac{\text{area}}{\text{length}}$.

of dl is its component perpendicular to the lines of flux, $= dl \sin \theta$. Then, $dF = InB \sin \theta dl$. This force acts with a lever arm $= r \sin \theta$, and the torque is therefore $dT = InB \sin \theta \times r \sin \theta dl$. But

$$dl = r d\theta. \text{ Hence } dT = InBr^2 \sin^2 \theta d\theta, \text{ and } T = \int_0^{2\pi} InBr^2 \sin^2$$

$$\theta d\theta = InBr^2 \left[\frac{\theta}{2} - \frac{1}{4} \sin 2\theta \right]_0^{2\pi}$$

$$= InBr^2 \pi = InBA, \text{ where } A = \text{area of the loop.}$$

In practice, permanent magnets are generally used to produce the flux.

CHAPTER V

DESIGN OF A LIFTING MAGNET

It has been shown that for a path of magnetic lines in air, the following relation obtains: amp.-turns = $0.313 B l''$, if inch measurements are used. For an iron path, the necessary ampere-turns are obtained from a curve of B vs. AT , where B is the flux density. Such a curve called either magnetization or "saturation" curve, is obtained experimentally from a sample of any desired magnetic material. The curve thus obtained will be approximately correct for that material, but variations are always

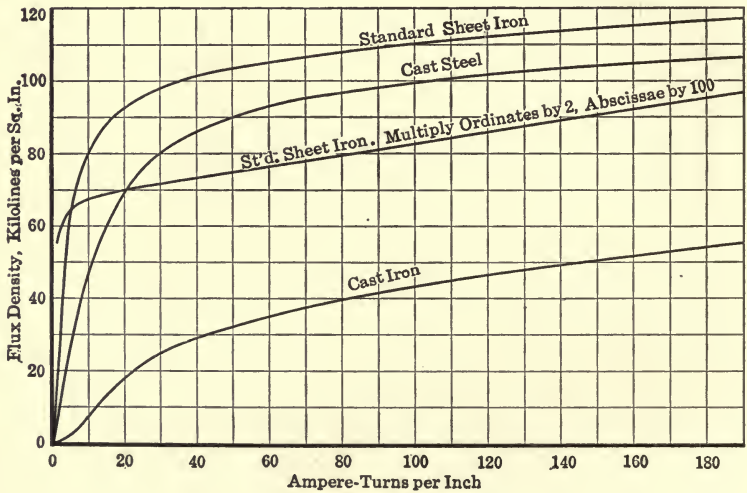

FIG. 23.

liable to occur due to either physical or chemical influences by which any portion of the material is made to differ from the sample used to derive the curve.

By testing many samples a typical curve is obtained for any given material. In Fig. 23 is given a set of these saturation curves of iron and steel as commonly employed in electrical machinery.

Let it now be required to make the calculations for the design of a cast-iron electromagnet to lift a weight of 1000 lb. through a gap of 1.5 in. Let it be assumed that the magnet core is of the shape and dimensions given in Fig. 24. Then the area of a pole face is $10 \times 5 = 50$ sq. in. The two pole faces have an area of $2 \times 50 = 100$ sq. in. Then the weight to be lifted per square inch of area is

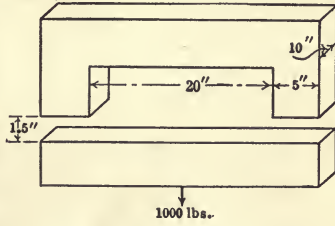

FIG. 24.

$$\text{Wt. per sq. in.} = \frac{1000}{100} = 10 \text{ lb.} = F.$$

$$\text{But, from (11), } F = \frac{B^2}{72,134,000}$$

$\therefore B$, the flux density in air, $= \sqrt{721,340,000} = 26,800$ lines per sq. in. From (12), the amp.-turns required for each gap $= 0.313 Hl$ in. $= 0.313 \times 26,800 \times 1.5 = 12,600$.

AT required for two gaps $= 2 \times 12,600 = 25,200$.

AT required for the iron, from the magnetization curve for cast iron $= 32$ per in. length of the flux path in the iron.

Length of mean path in the iron $= 70$ in.

\therefore Total AT required for the iron $= 70 \times 32 = 2240$, and total AT for both air and iron $= 25,200 + 2240 = 27,440$.

It is now necessary to arrange the winding so that the heat developed by the current in the coil shall not cause an excessive temperature in the coil.

Assuming a permissible power loss of 0.4 watt per sq. in. of exposed coil surface, an estimate can be made of the proper amount of space to be occupied by the coil. Assuming, as a guess, a depth of winding of 3 in. and a coil length of 20 in. (Fig. 25), the exposed surface of the

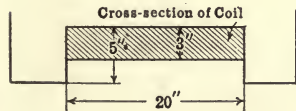

FIG. 25.

coil is 1270 sq. in. The total watts developed should then be $0.4 \times 1270 = 508$. Assuming, further, that the magnet is to be designed for operation on a 100-volt circuit, the current is

$$\frac{508}{100} = 5.08 \text{ amp.}$$

The number of turns = $\frac{27,440}{5.08} = 5400$, and the resistance of the coil = $\frac{W}{I^2} = \frac{533}{(5.33)^2} = 19.7$ ohms.

The mean length of one turn may be estimated to be 42 in. Then, total length of wire = $5400 \times \frac{42}{12} = 18,900$ ft.

Res. per 1000 ft. = $\frac{19.7}{18.9} = 1.04$ ohms.

From tables, the nearest size wire is No. 10. Diameter of No. 10, with double cotton covering, is 0.112 in. It must then be found out if there will be room enough for the turns in the space allowed.

Problem 16.—Assume cast iron to cost $1\frac{1}{2}$ c. per lb. and copper 16c. per lb. Find the least cost of a magnet, of any desired shape, to lift 1000 lb. with a gap of 1.5 in.

Use 0.4 watt per sq. in. of coil surface as permissible power loss.

CHAPTER VI

GENERATION OF ELECTROMOTIVE FORCE IN A DYNAMO

FARADAY found in 1831 that the electromotive force produced in a circuit was proportional to the rate of change of the lines of force enclosed in the circuit. That is, he found that $e = k \frac{d\phi}{dt}$. This discovery was really the foundation upon which electrical engineering was built.

The truth of the relation may be seen by considering a rectangular loop of wire carrying current I moved a short distance dx in time dt , the motion being at right angles to the direction of the lines of force (Fig. 26).

The force on 1 cm. of wire, A , which is in the field is $F = IB$. Thus the mechanical work done in moving the loop from AB to $A'B'$ is $Fdx = IBdx$.

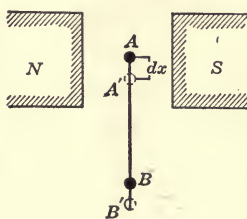

FIG. 26.

As has been shown, the electrical work is $eIdt$ and the mechanical and electrical work must be equal and opposite.

$\therefore IBdx = -eIdt$ or $e = -B \frac{dx}{dt}$. But Bdx is the change of flux $d\phi$ enclosed in the loop. Thus

$$e = - \frac{d\phi}{dt}$$

Consider now that the loop revolves in a uniform magnetic field. When the loop encloses the entire field it may be said to be in the zero position. Let it be assumed that in zero position it encloses 100 lines. In position 1, displaced 10° , it will then enclose 98.5 lines. The loss of 1.5 lines from the loop has resulted in a generated e.m.f. or, in general,

$$e = - \frac{d\phi}{dt} = - \frac{\phi_2 - \phi_1}{t_2 - t_1} = - \frac{\Delta\phi}{\Delta t}$$

If the coil rotates at the rate of 1 r.p.s., the time required for it to move 10° is $\frac{10}{360}$ of 1 sec. = 0.0277 sec. = Δt .

Then

$$e = -\frac{\phi_2 - \phi_1}{0.0277} = \frac{1.5}{0.0277} = 54ab \text{ volts.}$$

This procedure may be followed and a tabulation made for every 10° , so as to obtain data from which to plot, point by point, an e.m.f. wave, thus:

Angular position of coil	0°	10°	20°	30° , etc.
Flux enclosed, ϕ	100	98.5	94.0	86.6
Change of flux, $\phi_2 - \phi_1$	-1.5	-4.5	-7.4
$e = -\frac{\Delta\phi}{\Delta t}$	54.0	163.0	267.0
Plotted at angle.....	...	5°	15°	25°

Values of e.m.f. are plotted at angles given in the last line, that is, at the mid-angular divisions, since they represent average values of e over each 10° of displacement of the loop.

Problem 17.—Assuming the field to be uniform, carry out the procedure as just indicated for a complete rotation of the loop, and show by plotting volts against angular displacement that the curve is a sine wave.

E.m.f. Waves in Fields that are not Uniform.—Consider a

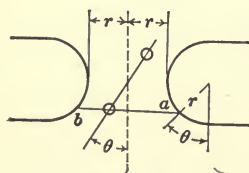

FIG. 27.

field between rounded poles of radius r , distant $2r$, in which a coil, of width $2r$, revolves (Fig. 27).

The field will be most dense in the middle. The density will be assumed to be inversely proportional to the distance between poles. To find the density along any line ab . The length, $ab = 4r - 2r \sin \theta$.

Then

$$B = \frac{-k}{4r - 2r \sin \theta},$$

where k is some constant—*i.e.*, proportionality factor.

This equation holds only for θ from 0 to π , in a revolution.

If θ is taken from π to 2π , $B = \frac{k}{4r + 2r \sin \theta}$.

When the coil moves a distance ds , there is a change $d\phi$, in the amount of flux enclosed by the coil, per unit length of the coil parallel to the shaft. $d\phi$ is proportional to the component of ds at right angles to the direction of the flux, or to dx (Fig. 28).

Thus, $d\phi = 2Bdx$ is the change in flux per centimeter length of coil, due to both conductors. Then $d\phi = -2Br d\theta \sin \theta$, since $ds = r d\theta$, and $dx = -ds \sin \theta$.

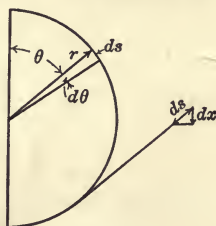

FIG. 28.

Substituting,

$$Bdx = -\frac{kr \sin \theta d\theta}{4r - 2r \sin \theta} = -\frac{k \sin \theta d\theta}{4 - 2 \sin \theta}.$$

Then,

$$e = -\frac{d\phi}{dt} = \frac{1}{dt} \left(\frac{2k \sin \theta d\theta}{4 - 2 \sin \theta} \right) = \frac{k \sin \theta}{2 - \sin \theta} \frac{d\theta}{dt}$$

$\sin \theta$ may be written $\sin 2\pi nt$, where θ is expressed in radians and $2\pi n$ denotes angular velocity. Then $\frac{d\theta}{dt} = 2\pi n$, and n is in revolutions per second, or is frequency in a two-pole machine. For machines of any number of poles $\frac{d\theta}{dt} = 2\pi f$ where $f =$ frequency.

$$\therefore e = \frac{k \sin \theta}{2 - \sin \theta} \times 2\pi f.$$

Let

$$e_{max} = 100 \text{ volts. This occurs when } \theta = \frac{\pi}{2}.$$

Then

$$e_{max} = 100 = \frac{k2\pi f}{2 - 1} = 2\pi f k,$$

and

$$k = \frac{e_{max}}{2\pi f}.$$

Substituting this value of k ,

$$e = \frac{e_{max}}{2\pi f} \times \frac{2\pi f \sin \theta}{2 - \sin \theta} = \frac{e_{max} \sin \theta}{2 - \sin \theta}.$$

Problem 18.—Calculate and plot the e.m.f. for the above condition, for one-half wave.

E.m.f. Wave when the Coil is Wound on an Iron Core.—In all these cases it is sufficiently correct to consider only the lengths

of the flux path in the air. By following the general procedure of the preceding paragraph, the e.m.f. of a coil on the iron core is found to be

$$e = e_{max} \frac{(m - 1) \sin \theta}{m - \sin \theta}$$

where

$$m = \frac{D}{2r}, \text{ or } D = 2mr$$

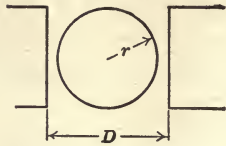

FIG. 29.

Problem 19.—Calculate and plot for one-half wave, the e.m.f. for this case, when $e_{max} = 100$ and $m = 1.1$. (Fig. 29.)

Additional Problems for the Determination of E.m.f. Waves.—

It is very good experience for the student to work out and plot a number of these waves. For this purpose a few additional problems are suggested.

Problem 20.—Determine the e.m.f. of a coil wound on a wooden drum when $B_{max} = 100$ lines per sq. cm., speed = 1 r.p.s. and the dimensions of the dynamo are as given in Fig. 30. Dimensions are given in centimeters. Plot the wave, point by point, for each millimeter of distance across the pole face.

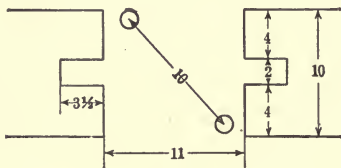

FIG. 30.

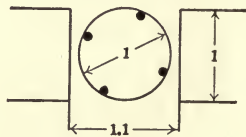

FIG. 31.

Problem 21.—On an iron armature between rectangular poles as in Fig. 31, let two coils, at right angles to each other (that is, in space quadrature), be joined in series, so that their e.m.f. waves add. Plot the resultant e.m.f. per centimeter length of the armature. Show that the resultant e.m.f. due to the two coils is less than their sum.

Problem 22.—Same as last, but for three coils spaced 120° apart.

Problem 23.—Continue the development of the method of the last two problems and finally obtain the average value of the e.m.f. of an armature whose conductors are spaced uniformly around the periphery.

CHAPTER VII

INDUCTANCE

Inductance.—When a circuit connected to a source of e.m.f., e , is closed through a switch, S (Fig. 32), a current is established in the coil, and sets up a magnetic flux which links with the turns of the coil. This flux produces a back, or counter e.m.f. in each turn, $e = -\frac{d\phi}{dt}$, or in the N turns, $e = -N\frac{d\phi}{dt}$. Expressed in volts this is

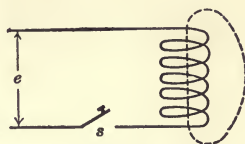

FIG. 32.

$$e = -\frac{N}{10^8} \frac{d\phi}{dt} \quad (13)$$

Inductance is defined as the number of interlinkages of flux with turns, per unit current, or, in symbols,

$$L = \frac{N\phi}{I}$$

Expressed in practical units it is:

$$L = \frac{N\phi}{i \times 10^8} \text{ henrys} \quad (14)$$

where i is the current in amperes.

Problem 24.—Let a coil of 200 turns be supplied with various amounts of current, and let the flux produced, when 1 amp. flows, be 1000 lines. Find the inductance. Tabulating from Eq. (14):

i	1	2	4	10
ϕ	1000	2000	4000	10000
N	200	200	200	200
$N\phi$	0.2×10^6	0.4×10^6	0.8×10^6	2×10^6
$\frac{N\phi}{i}$	0.2×10^6	0.2×10^6	0.2×10^6	0.2×10^6
L^1	0.002	0.002	0.002	0.002

¹ Students almost invariably have difficulties with inductance. This problem is given solely for the purpose of impressing upon them the fact that inductance is a "constant" of the circuit.

From the values of L , thus obtained, it is seen that L is a constant, and is independent of the current; it is a "circuit constant" similar to resistance in a coil having a non-magnetic core.

Transposing Eq. (14),

$$Li = \frac{N\phi}{10^8}$$

Differentiating with respect to time,

$$L \frac{di}{dt} = \frac{N}{10^8} \frac{d\phi}{dt}$$

Substituting into (13),

$$e = -L \frac{di}{dt},$$

which is the common expression for induced electromotive force, or counter e.m.f. of self-induction.¹

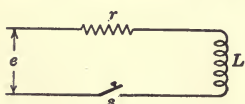

FIG. 33.

In Fig. 33 is represented a circuit of resistance, r , and inductance, L , which is connected to a source of e.m.f., e . When the switch, S , is closed, the e.m.f. has to overcome the resistance, r , and also the counter e.m.f. of self-induction due to the setting up of flux in the coil. Therefore we may write:

$$e = ir + L \frac{di}{dt} \quad (15)$$

This equation is fundamental, and is general for circuits possessing only resistance and inductance of constant value.

An algebraic relation between the impressed e.m.f. and the current—assuming in this case that the e.m.f. is kept constant—is found as follows:

$$L \frac{di}{dt} = e - ir$$

$$dt = \frac{Ldi}{e - ir}$$

$$\int dt = \int \frac{Ldi}{e - ir}$$

¹ In an ironclad magnetic circuit the inductance is not a constant. It depends upon the permeability.

The flux is not proportional to the current producing it but is a complicated function thereof. In that case $\frac{N}{10^8} \frac{d\phi}{dt} = \frac{d}{dt} (Li) = L \frac{di}{dt} + i \frac{dL}{dt}$.

$$\therefore t = -\frac{L}{r} \log(e - ir) + C,$$

$$C = \frac{L}{r} \log e$$

whence

$$\log(e - ir) = -\frac{rt}{L} + C_1,$$

and

$$e - ir = \epsilon^{-\frac{rt}{L} + C_1} = C_2 \epsilon^{-\frac{rt}{L}}$$

$$\therefore i = \frac{l}{r} \left[e - C_2 \epsilon^{-\frac{rt}{L}} \right] \quad (16)$$

C_2 is determined from the nature of the problem.

The rate of energy supply or power equation corresponding to (15) is obviously

$$ei = i^2 r + Li \frac{di}{dt}$$

and the energy supplied by the generator is

$$\int_0^T e i dt.$$

The energy dissipated in heat is

$$\int_0^T i^2 r dt$$

and the energy supplied and thus stored in the magnetic field is

$$\int_0^T Li \frac{di}{dt} dt = \int_0^T L i di = \frac{1}{2} LI^2$$

where I is the value of the current at time T .

Starting and Stopping Current in an Inductive Circuit.—Referring to equation (16) it is evident that for $t = 0$, $i = 0$ when starting the current and $i = I$ for $t = 0$ in stopping the current, since energy cannot be altered in an infinitely short time and therefore current cannot be established or changed in an infinitely short time.

Thus when considering the starting of a current we have for $t = 0$, $i = 0$.

Substituting these values in (16)

$$0 = \frac{1}{r} [e - C_2 \epsilon^0] = \frac{1}{r} [e - C_2],$$

whence,

$$C_2 = e,$$

and

$$i = \frac{1}{r} \left[e - e\epsilon^{-\frac{rt}{L}} \right] = \frac{e}{r} \left[1 - \epsilon^{-\frac{rt}{L}} \right] \quad (17)$$

This equation gives the value of the current at any instant after the closing of the switch, S .

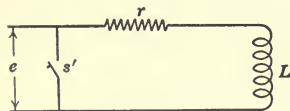

FIG. 34.

If the impressed e.m.f., e , is suddenly short-circuited by the closing of the switch, S' (Fig. 34), then $e = 0$, and, at the instant of closing, $t = 0$, $i = I$,

where I is the current in the circuit just before closing the switch.

Substituting these values into (16)

$$I = \frac{1}{r} [0 - C_2],$$

whence,

$$C_2 = -rI,$$

and

$$i = \frac{1}{r} \left[Ir\epsilon^{-\frac{rt}{L}} \right] = I\epsilon^{-\frac{rt}{L}} \quad (18)$$

This equation gives the current at any instant, t , as it is dying away in the circuit after the e.m.f. has been suddenly removed.

The inductance of coils varies with the size, shape and number of turns. If a given length of wire of definite size is to be made into a coil, maximum inductance will very nearly be obtained

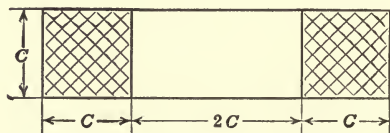

FIG. 35.

if the coil has the proportions given in Fig. 35.¹ The value of the inductance, in this case, will be:

$$L = \frac{0.27 \text{ cm.}^2}{10^9 \times c} \text{ henrys,}$$

where the length of the coil is given in centimeters, and c is in centimeters.

¹ BROOKS and TURNER, "Inductance of Coils," Bulletin No. 53, Univ. of Illinois Engineering Experiment Station.

Problem 25.—Find and plot current vs. time when the circuit is closed on a coil of 1 km. of No. 15 B. and S. wire (diam., d.c.c., = 0.066 in.; $r/1000' = 3.17^{\omega}$), designed for maximum inductance. $e = 100$ volts.

Problem 26.—Find and plot the curve of dying away of the current when the coil of problem 25 is short-circuited.

Problem 27.—Find the average value of the inductance of the lifting magnet previously designed (Chap. V), and determine how long it will take for the current to rise to 90 per cent. of its permanent value.

CHAPTER VIII

ALTERNATING CURRENTS

It has been shown that the fundamental equation in an inductive circuit where the resistance and inductance are constants and not depending upon the current is:

$$e = ri + L \frac{di}{dt} \quad (15)$$

This equation gives the relation between the particular values of e.m.f. and current at any instant.

In the case previously discussed it was assumed that the impressed e.m.f., e , was constant.

In most engineering problems the e.m.f. is, however, not constant but it varies from instant to instant. Almost all electrical installations now use alternating current rather than direct current. In this case it will be seen that the e.m.f. and current can almost always be assumed to vary according to a simple sine law.

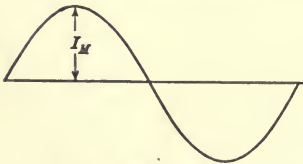

FIG. 36.

In other words it can be assumed that the instantaneous value of the current at any time, t , can be found from equation $i = I_m \sin \omega t$ (Fig. 36), where $\omega = 2\pi f$ = angular velocity, and f = frequency of alternation of the current = number of cycles, or complete reversals, per second. I_m = maximum value of current. For 60 cycles, $\omega = 2\pi 60 = 377$.

$$\therefore i = I_m \sin 377t.$$

Differentiating eqv: $i = I_m \sin \omega t$
we get

$$\frac{di}{dt} = I_m \omega \cos \omega t.$$

Substituting in (15),

$$\begin{aligned} e &= r I_m \sin \omega t + L I_m \omega \cos \omega t \\ &= I_m (r \sin \omega t + L \omega \cos \omega t) \end{aligned} \quad (19)$$

Thus e is the sum of two component waves, one depending on the sine of ωt , and the other on the cosine.

Problem 28.—Let $I_m = 1$, $r = 0.5$, $L\omega = 0.4$. Find and plot the component waves of e.m.f.

ωt	0°	30°	60°	90°	120°	150°	180°
Sin ωt	0.0	0.5	0.866	1.0	0.866	0.5	0.0
$I_m r \sin \omega t = ir$	0.0	0.25	0.433	0.5	0.433	0.25	0.0
Cos ωt	1.0	0.866	0.5	0.0	-0.5	-0.866	-1.0
$LI_m \omega \cos \omega t = L \frac{di}{dt}$	0.4	0.346	0.2	0.0	-0.2	-0.346	-0.4
e	0.4	0.596	0.633	0.5	0.233	-0.096	-0.4

These waves are shown plotted and combined in Fig. 37.

Problem 29.—A similar set of waves should be obtained by each student from values of I_m , r , $L\omega$, assigned at random.

By inspecting these waves it is seen that i lags behind e , that

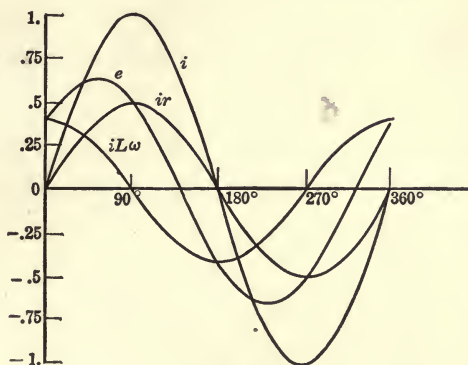

FIG. 37.

it passes through zero later than e by about 40° . This illustrates one of the characteristic features of inductive circuits. It should also be noted that ir is in time phase with i , and that $iL\omega$ is in time quadrature with i , being 90° in phase ahead of i .

The quantity $L\omega$ is called *reactance*. It is measured in ohms, and denoted by the letter X . Thus $L\omega = X$, where L is the inductance in henrys, $\omega = 2\pi f$ is the angular velocity in radians per second, and X is the reactance in ohms. X is not, like L , a property of a coil or circuit, but depends on the frequency.

The *average* value of the e.m.f. generated in a coil of a dynamo, depends only on the speed of rotation and the number of lines of

flux cut; that is, it depends on the average rate of cutting of the lines of flux, by the conductors, and not on the distribution of the lines under the poles. The *effective* value of e.m.f. does, however, depend on the distribution of the flux.

Frequency has been defined as number of cycles per second. A two-pole generator, at 1 r.p.s. has the frequency, $f = 1$.

A four-pole generator, at 1 r.p.s., has $f = 2$.

A p -pole generator, at N_s r.p.s., has $f = \frac{p}{2} N_s$.

The coil, in position 1 (Fig. 38a), contains the whole flux. The coil, in position 2, contains no flux. Thus, a change of the whole flux takes place in a quarter of a revolution.

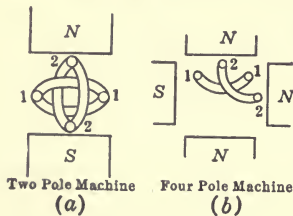

FIG. 38.

If T is the time of 1 cycle, the whole flux is therefore cut in the time $\frac{T}{4}$.

The average rate of cutting is then $\frac{\Phi}{\frac{T}{4}} = \frac{4\Phi}{T}$ where Φ is the total flux.

Therefore, the average e.m.f. is $\frac{4N\Phi}{T}$, where N is the number of turns, and $2N$ is the number of conductors per circuit.

At 60 cycles,

$$T = \frac{1}{60}$$

In general,

$$T = \frac{1}{f}$$

\therefore Average e.m.f. = $4N\Phi f = 4N\Phi f \times 10^{-8}$ volts.

In a four-pole machine (Fig. 38b) all flux is cut in $\frac{1}{8}$ revolution. The average rate of cutting is therefore $\frac{8\Phi}{T_1}$, where T_1 is the time of a revolution.

Average rate = $\frac{8\Phi}{T_1} = 8\Phi N_s = \frac{16\Phi f}{p} = 4\Phi f$ where N_s is the number of revolutions per second, and $f = \frac{p}{2} N_s$.

With N turns, average rate = $4fN\Phi =$ average e.m.f.

$$= 4fN\Phi \times 10^{-8} \text{ volts} \quad (20)$$

This equation is identical with that for a 2 pole machine. It applies regardless of the number of poles as long as N is the number of turns in series per circuit.

Average Value of a Sine Wave.—The e.m.f. induced by rotation of the armature conductors in the field is

$$e = -N \frac{d\varphi}{dt}.$$

Let $\varphi = \Phi_m \cos \omega t$, be the flux enclosed at any instant. Then, $\frac{d\varphi}{dt} = -\omega \Phi_m \sin \omega t$ is the rate of change of the flux, and $e = \Phi_m N \omega \sin \omega t$.

In practical units,

$$e = \frac{N \Phi_m \omega \sin \omega t}{10^8} \text{ volts.}$$

Since $\omega = 2\pi f$ this may be written,

$$e = \frac{2\pi f N \Phi_m \sin \omega t}{10^8}.$$

For maximum e.m.f.,

$$\sin \omega t = 1, \text{ and } E_m = \frac{2\pi f N \Phi_m}{10^8} \text{ volts} \quad (21)$$

To obtain the average value of e.m.f., integrate a half-wave and divide by π , that is, by the length of a half-wave.

Thus,

$$e_{av.} = \frac{1}{\pi} \int_0^{\pi} \sin \theta d\theta = \frac{1}{\pi} \left[-\cos \theta \right]_0^{\pi} = \frac{2}{\pi} = 0.636.$$

\therefore The average value = $\frac{2}{\pi} \times E_m$. Multiplying (21) by $\frac{2}{\pi}$,

$$\text{Av. } e = \frac{2}{\pi} \times \frac{2\pi f N \Phi_m}{10^8} = \frac{4f N \Phi_m}{10^8},$$

which agrees with the average value previously found (20).

Effective Value of a Sine Wave.—Let $i = I_m \sin \theta$.

If this current flows through a resistance r , it has been seen that the heat developed at any instant is $i^2 r$.

Thus, the heat developed per cycle may be expressed as,

$$r \int_0^{2\pi} I_m^2 \sin^2 \theta d\theta.$$

By trigonometry,

$$\sin^2 \theta = \frac{1}{2} - \frac{1}{2} \cos 2\theta.$$

Substituting,

$$r I_m^2 \left[\int_0^{2\pi} \frac{d\theta}{2} - \int_0^{2\pi} \frac{\cos 2\theta d\theta}{2} \right] = r I_m^2 \pi$$

The average value of energy flow or the rate at which energy is being dissipated, or the power, is

$$\frac{r I_m^2 \pi}{2\pi} = \frac{r I_m^2}{2}$$

Thus, the rate of heat dissipation is $\frac{r I_m^2}{2}$.

The effective value of the current corresponds to a constant or direct current which would give the same heat in the same time if flowing through the same resistance.

$$\therefore i_{eff}^2 r = \frac{I_m^2 r}{2}; i_{eff}^2 = \frac{I_m^2}{2}, \text{ and } i_{eff} = \frac{I_m}{\sqrt{2}} = 0.707 I_m.$$

Similarly, the effective value of e.m.f. is obtained, and $e_{eff} = 0.707 E_m$, where E_m is the maximum value of the sine wave of electromotive force.

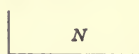

The ratio $\frac{\text{effective value}}{\text{average value}}$ is called the form factor.

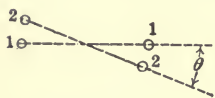

With sine waves form factor (f) = $\frac{0.707}{0.636} = 1.1$.

The equation for the effective value of the e.m.f. is obtained from (21) by multiplication

by $\frac{1}{\sqrt{2}}$.

$$\therefore E_{eff} = \frac{2\pi f N \Phi_m}{\sqrt{2} 10^8} = \frac{4.44 f N \Phi_m}{10^8} \text{ volts} \quad (22)$$

This applies to a concentrated coil of N turns.

If, however, the turns are distributed over the periphery, as in a direct-current armature, from Fig. 39 it is seen that coil 1 contains all the flux, while coil 2 contains the flux $\times \cos \theta$. Therefore the effectiveness of coil 2 is $N_c \cos \theta$, where $N_c =$ number of turns of the coil.

Let $N =$ total number of turns. Then the turns per cm. of armature periphery = $\frac{N}{2\pi r}$, where $r =$ radius of armature.

Then the effectiveness of the turns per cm. is $\frac{N}{2\pi r} \cos \theta$. The average effectiveness of the turns per cm. is

$$\frac{1}{\pi} \int_{-\frac{\pi}{2}}^{+\frac{\pi}{2}} \frac{N \cos \theta}{2\pi r} d\theta = \frac{N}{\pi^2 r}$$

The total effectiveness is therefore $2\pi r \times \frac{N}{\pi^2 r} = \frac{2}{\pi} N$.

Therefore, in a distributed winding, the turns are not so effective as when they are concentrated.

Thus, for distributed winding,

$$E_{eff.} = \frac{4.44fN\Phi_m}{10^8} \times \frac{2}{\pi} \quad (23)$$

CHAPTER IX

DIRECT-CURRENT GENERATORS

Homopolar Generators.—These are also called by the names “acyclic” and “unipolar.” They are a small class of machines, distinguished from the usual types of direct-current machinery in that the conductors always move through the magnetic field in a constant direction with respect to the direction of the lines of flux.

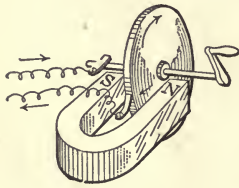

FIG. 40.

Among the earliest of dynamos may be mentioned one of this type known as “FARADAY’S Disc Dynamo,” in which a copper disc was rotated between the poles of a permanent magnet.

Current was collected by means of two brushes making contact, respectively, with the rim and axle of the disc (Fig. 40). A more modern type of homopolar generator is shown diagrammatically in Fig. 41. For the permanent mag-

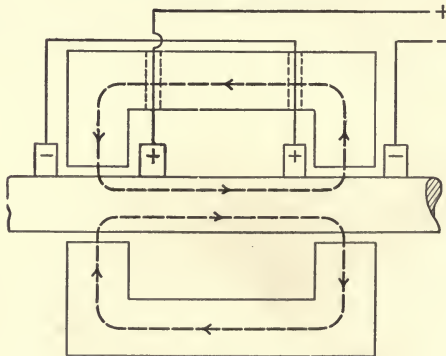

FIG. 41.

net is substituted a powerful electromagnet, and two sets of brushes are used instead of one. By connecting these brushes in series outside of the machine the total e.m.f. at the terminals is doubled.

From the fundamental considerations developed in Chap. VI it is evident that the voltage between each set of brushes is

$$e = \frac{N\Phi}{10^8}$$

where N = revolutions per second and Φ = total flux, since there is only one conductor between the brushes. With any arrangement which permits the use of additional sets of brushes, as in Fig. 41, the voltage is increased in proportion to the number of sets of brushes connected in series, and becomes

$$e = \frac{cN\Phi}{10^8}$$

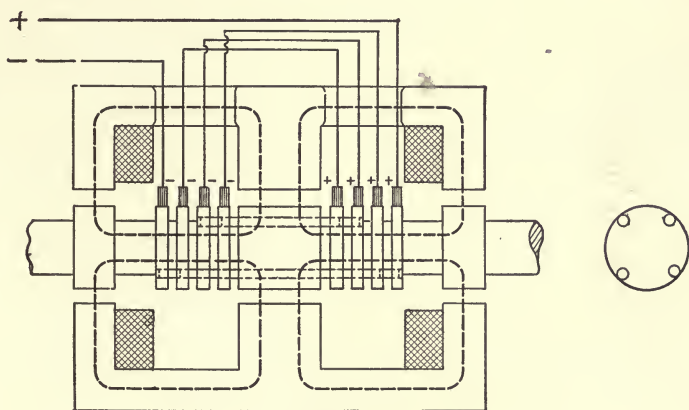

FIG. 42.

where c is the number of conductors and is equal to the number of sets of brushes in series. Fig. 42 illustrates the use of bar conductors on the armature. Each conductor is connected to two slip rings on which brushes bear. There are thus twice as many slip rings as conductors. Since the conductors are insulated, they may be put in series by properly connecting their brushes outside of the machine.

Direct-current Machines with Commutators.—On most direct-current machines use is made of commutators. To understand these machines a knowledge of the principle of windings on the armature is needed. In Fig. 43 a single coil is represented in a magnetic field. The ends of the coil are connected to the segments of a two-part commutator. In the position

shown, the e.m.f. is maximum. As the coil moves in the field, the segments move under the brushes and the e.m.f. at the brushes, *AB*, during a half revolution, has the values of a half-sine wave. When this e.m.f. reaches zero, the segments pass from under the brushes. The same operation is then repeated

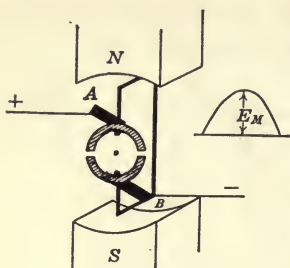

FIG. 43.

and gives a succession of half waves, all in the same direction. If now another loop is placed on the armature at 90° to the first one, a new series of half waves will be added at 90° to the first series. By connecting these loops in series, suitably joining to commutator segments and continuing to use only two brushes, the e.m.fs. of the loops are added together and produce a resultant e.m.f. shown in heavy dots by the wave "*d*" (Fig. 44). This wave never reaches zero and is much more steady than that produced by a single coil. By continuing this process, all irregularities are virtually wiped out and there results a smooth wave of constant e.m.f. A simple example of armature winding with commutator and brushes

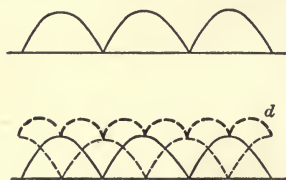

FIG. 44.

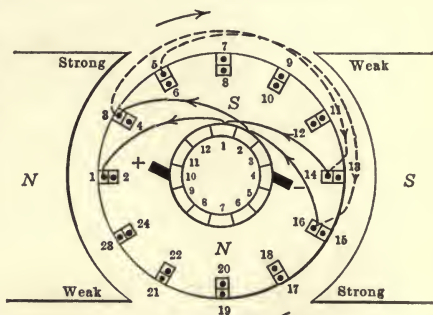

FIG. 45.

is shown in Fig. 45, for the purpose of illustrating the connection of coils in series.

Types of Direct-current Commutator Machines.—Direct-current machines are usually divided into groups according to the method of exciting the field magnets, as follows:

1. *Permanent Magnet Machines.*—These have no field windings, but the field structure consists of hard-steel permanent magnets. They constitute a small group, used chiefly for telephone signalling and gas engine ignition.

2. *Separately Excited Machines.*—In these, the field winding is supplied with current from an external source. The chief advantage of this type is that it enables a steady field excitation to be maintained at all times regardless of the fluctuations in voltage at the brushes.

3. *Shunt Machines.*—In this type the source of excitation of the field is derived from the terminals of the machine itself. The field circuit is connected in parallel with the external circuit and the field current varies as the voltage of the machine changes.

4. *Series Machines.*—The current in the armature is made to flow also through the field windings; that is, the field and armature coils are connected in series with the external circuit. Thus the field excitation is proportional to the load current.

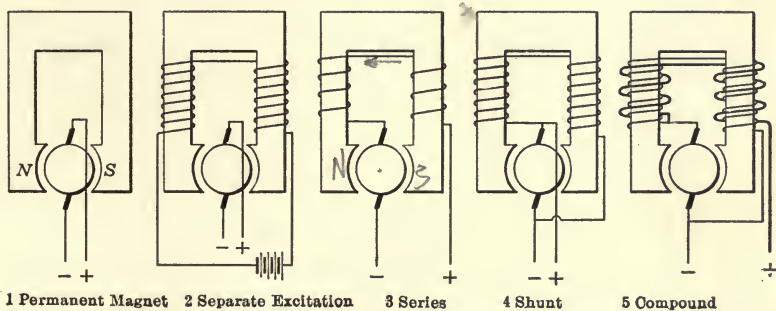

FIG. 46.

5. *Compound Machines.*—These are excited partly by a shunt winding and partly by a series winding, each pole being provided with both a shunt and series coil. The total field excitation thus depends upon the voltage of the machine as well as on the load current.

These five types are illustrated in Fig. 46. Other combinations are sometimes used in special cases. The performance characteristics of these various types of generators differ greatly. In general, the characteristic of a generator is a curve showing the relation between terminal voltage and the load current, the latter being the independent variable. These curves and others of a similar nature should be thoroughly studied, especially in the laboratory.

Armature Reaction.—When a generator is delivering no current the direction of the field flux is along the axis of the poles.

When current is flowing, however, the armature becomes an electromagnet on its own account, and the field flux becomes the resultant of that produced by the field windings and that due to the armature winding.

Fig. 47a shows a bipolar dynamo with a ring armature. Arrows show the direction of current and also of flux. Starting from the negative brush, the current divides as it enters the armature, one half winding around to the left, the other half pursuing a similar path to the right, and both finally joining again to enter the positive brush. It is to be noted that the flux set up by these armature currents is, in general, in space quadrature to the flux due to the field winding.

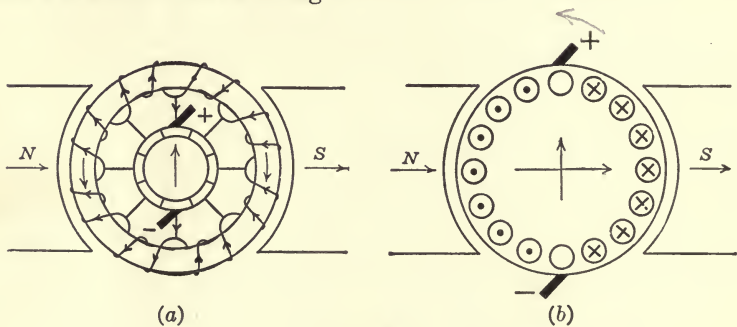

FIG. 47.

Fig. 47b shows an equivalent diagram representing a drum armature. When once the principles of current action in the armature are understood, it is simpler to make use of the representation of Fig. 47b than of Fig. 47a. For clearness, the commutator is omitted in the case of the drum, the position of the brushes being indicated with reference to the armature itself. It makes no difference how the end connections are made, so far as the armature m.m.f. is concerned. In this case, since the brushes are not shifted but are placed on the so-called neutral axis midway between the poles, the armature magnetomotive force is directed vertically upward, while the field magnetomotive force is, as always, along the pole axis. The resultant magnetomotive force is the vector sum of these two. Since the armature m.m.f. acts at right angles to the field m.m.f., its effect is said to be wholly cross-magnetizing.

When the brushes are shifted α° the armature m.m.f., still acting along the brush axis, may be resolved into components.

$F_c = F_A \cos \alpha$, the cross-magnetizing component, acting at right angles to the field, and $F_D = F_A \sin \alpha$, the demagnetizing component, acting directly in opposition to the field. The resultant m.m.f., OR , Fig. 48, is then due to the m.m.fs. of the field OF and the armature OA , the latter being composed of OC , cross-magnetizing, and OD , demagnetizing.

Cross-magnetization is always present when the armature carries current. It distorts the field and displaces the neutral axis, necessitating thereby a shifting of the brushes. When the brushes are shifted, demagnetization also enters in, weakening directly the field strength. Under such conditions the resultant flux takes up a general direction as indicated by the shading in the air gap in the figure. The pole tips are unequally magnetized, the leading tips being weakened and the trailing tips strengthened.

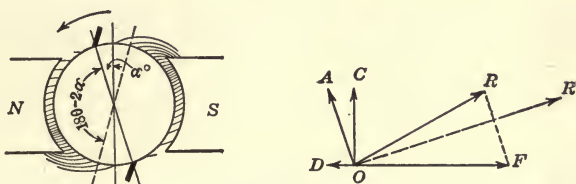

FIG. 48.

The actual direction of the resultant flux is not along OR but along OR' , a line of somewhat less deviation from OF . This is because of the unequal reluctances of the paths along the directions of the component m.m.fs.

Consider, for example, a generator whose flux per pole entering the armature is ϕ_r , under conditions of normal operation, that is, voltage and speed.

To generate this flux at no load would require F_o amp.-turns on the field core if all the flux generated in the field passed through the armature. Some flux, however, passes around the armature without cutting its conductors. This is called leakage flux, and amounts to 15 or 20 per cent. of the net flux, in ordinary machines. To provide this leakage flux as well as the net flux, ϕ_r , requires kF_o field amp.-turns, where k is the leakage coefficient and may be taken as 1.15.

Let I_c amp. now flow in each armature conductor, and let the

total number of conductors be C . Then total turns = $\frac{C}{2}$, and turns per pole = $\frac{C}{2p}$, where p = number of poles.

The total armature amp.-turns per pole = $\frac{CI_c}{2p}$.

Let the brushes be on the geometrical neutral, that is, midway between the poles. Then, since the conductors are distributed over the entire periphery, the effective armature $A.T.$ per pole = $\frac{2}{\pi} I_c \frac{C}{2p} = \frac{I_c C}{\pi p}$.

The effect of these distorting ampere-turns has been shown to be to weaken the flux in the leading pole tips and to strengthen that in the trailing tips. The net result owing to unequal saturation of the iron, is to reduce the actual amount of the flux. In order to compensate for this reduction extra ampere-turns must be placed upon the field core to the amount of about 40 per cent. of the armature cross-magnetizing ampere-turns. Thus,

$$F_c = \frac{0.4 I_c C}{\pi p}, \text{ if there is no brushshift}$$

and the total field amp.-turns per pole are

$$F_f = kF_o + \frac{0.4 I_c C}{\pi p}.$$

When the brushes are shifted α° , the cross-magnetizing amp.-turns are $F_c = \frac{180 - 2\alpha}{180} \times \frac{I_c C}{2p}$ (Fig. 49).

Their effective value is $k_c \frac{180 - 2\alpha}{180} \frac{I_c C}{2p}$

where

$$k_c = \frac{1}{\theta} \int_{-\frac{\theta}{2}}^{+\frac{\theta}{2}} \cos \theta \, d\theta, = \frac{2 \cos \alpha}{\pi - 2\alpha}$$

where

$$\theta^\circ = \pi - 2\alpha$$

The demagnetizing turns consist of a belt of conductors of width $2\alpha^\circ$. The effective demagnetizing amp.-turns are then

$$F_d = k_d \frac{2\alpha}{180} \frac{I_c C}{2p},$$

where

$$k_d = \frac{1}{\theta} \int_{-\frac{\theta}{2}}^{+\frac{\theta}{2}} \cos \theta d\theta = \frac{2 \sin \alpha^1}{2\alpha}$$

These latter ampere-turns act in direct opposition to the field. If there were no leakage of flux between field and armature, they would be compensated by placing an equal number of additional ampere-turns on the field. Owing to leakage this number must be multiplied by k .

The total required field ampere-turns under the condition of brush shift of α° and I_c amp. in the armature conductors is then

$$F_f = k \left(F_o + k_d \frac{I_c C \alpha^\circ}{180p} \right) + 0.4 k_c \frac{(90 - \alpha^\circ) I_c C}{180p},$$

in order that the flux entering the armature shall be φ_r . With constant generated voltage the terminal voltage falls off as the load increases, due to the IR drop of the armature. φ_r must therefore be increased sufficiently to make up for the IR drop.

CHARACTERISTICS OF DIRECT CURRENT GENERATORS

From the discussion given above it should be possible to calculate the change of voltage with load in any of the different types, provided that the saturation curve could be expressed in a simple manner. This is unfortunately not possible, but it can be approximated by FROELICH'S equation, which is:

$$e = \frac{km}{1 + k_1 m}^2$$

where m is the excitation in ampere-turns and e the corresponding voltage. k and k_1 are constants depending upon the shape of the saturation curve which constants can be determined by substi-

¹ It is seen that $\frac{F_c}{F_d} = \cot \alpha$. Thus, on the basis given above, the ratio between the actual ampere-turns needed to compensate for the cross-magnetizing and demagnetizing ampere-turns is $.34 \cot \alpha$.

² e is the induced e.m.f. due to the rotation of the armature conductors in the magnetic field. m is the resultant m.m.f. of the amp.-turns on field and armature referred to the field structure. At no-load, m is obviously the field excitation alone.

tuting two known values of e and m from the actual saturation curve.

Consider a compound wound generator. Let the terminal voltage be e and the load current i . If the resistance of the shunt field winding is r_f the shunt field current is $i_f = \frac{e}{r_f}$.¹ If each field spool has t turns then the m.m.f. of the field winding, per pole, is $m_1 = i_f t = \frac{e}{r_f} t$. If the series winding has t_1 turns, per pole, the m.m.f. per pole of the winding is $m_2 = it_1$. Let the demagnetizing ampere-turns per pole of the armature with full-load current as determined above be D ; then the demagnetizing ampere-turns, with load current i , is $m_3 = \frac{D}{I}i$, where I is full-load current. Let the equivalent demagnetizing ampere-turns with full-load current, due to the "cross magnetizing" ampere-turns be C ; then the demagnetizing effect of i amp. is $m_4 = \frac{C}{I}i$.

The total m.m.f., m_0 , on each pole—were there no leakage—is:

$$m_0 = m_1 + m_2 - m_3 - m_4$$

Due to the leakage between the field poles the equation is obviously modified. Assuming 15 per cent. leakage:

$$m_0 = 0.85(m_1 + m_2) - m_3 - m_4,$$

m_0 then being the m.m.f. which causes flux to interlink with the armature conductors.

If the saturation curve were plotted on the basis of these ampere-turns the corresponding voltage could be obtained either directly or through FROELICH'S equation. This is, however, not the case but the saturation curve takes into consideration the leakage, therefore, in order to use the saturation curve we have to use a new value of m_0 , namely:

$$m = \frac{1}{0.85} m_0$$

$$\therefore m = m_1 + m_2 - \frac{m_3 + m_4}{0.85}$$

Numerical Application.—Let the no-load voltage e_0 , the no-load excitation, and the full-load current be taken as unity, then

$$m_1 = e$$

¹ It is really $\frac{e-ir}{r_f}$, but ir is usually very small.

Let the full-load series excitation be 40 per cent. of the no-load excitation, then

$$m_2 = 0.4i$$

Let the demagnetizing ampere-turns of the armature with full-load current be 10 per cent. of the no-load field excitation, then $m_3 = 0.10i$, and let the equivalent demagnetizing ampere-turns of the cross-ampere-turns with full-load current be 20 per cent., then $m_4 = 0.20i$.

(This relation between m_3 and m_4 corresponds to 11° brush shift.)

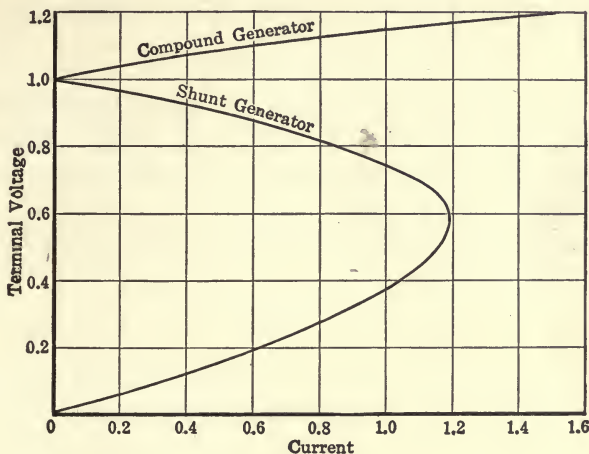

FIG. 49.

Then
$$m = e + i \left(0.4 - \frac{0.10 + 0.20}{0.85} \right) = e + 0.05i$$

Referring now to FROELICH'S equation and assuming the saturation curve to be such that for $e = 1, m = 1$; for $e = 0.6, m = 0.5$; then it is readily proven that $k = 1.5$, and $k_1 = 0.5$

$$\therefore e = \frac{1.5m}{1 + 0.5m} \text{ or } m = \frac{e}{1.5 - 0.5e}$$

$$\therefore \frac{e}{1.5 - 0.5e} = e + 0.05i, \text{ or } e = 0.5 - 0.025i + \sqrt{(0.5 - 0.025i)^2 + 0.15i}$$

The voltage at the terminal of the machine is less than e by the ir drop in the armature winding, brushes and series field.

If at full-load the drop is 3 per cent. then at any other load it is $0.03i$.

Thus e_1 the terminal voltage is

$$e_1 = e - 0.03i = 0.5 - 0.055i + \sqrt{(0.5 - 0.025i)^2 + 0.15i}$$

The student should verify curves *a* and *b*, Fig. 49. Curve *a* applies to the compound wound generator discussed above. Curve *b* to a typical shunt generator in which the ratio between the armature reaction and the no-load excitation is less than with a compound wound generator, and in which the saturation at normal voltage is usually higher.

The constants used for the shunt generator are:

$$k = 2.33, k_1 = 1.33, m_1 = e, m_2 = 0, m_3 = 0.05i, m_4 = 0.10i,$$

$$Ir = 3 \text{ per cent.}$$

It is seen that as the resistance of the load is gradually decreased the current increases up to a certain maximum value, in this case 20 per cent. more than rated current; after that, the current and voltage both decrease.

The student should study the effect of the saturation on the shape of these curves.

CHAPTER X

A STUDY OF THE DESIGN OF A DIRECT-CURRENT GENERATOR

All the underlying principles of the direct-current generator may be studied to good advantage from the basis of a concrete example. The example here chosen is an ordinary compound-wound generator with the following specifications:

M.P. 12 - 500 - 375 - 250 volts, which means that it belongs to the general multipolar class (M.P.), has 12 poles, 500 kw. rated output, 375 r.p.m. at normal speed, and the voltage is 250 at both no-load and full-load. The normal-load current may also be given. It is

$$I = \frac{500,000}{250} = 2000 \text{ amp.}$$

Other data for this machine are: Armature external diameter = 64 in., from which is obtained what is called diameter per pole = $\frac{64}{12} = 5.33$ in.

Armature internal diameter = 44 in.

Number of armature slots = 216.

Dimensions of slots, 0.465 in. wide by 1.3 in. deep.

Armature winding is of the multiple drum type.

Current in each effective conductor is

$$I_c = \frac{2000}{12} = 167 \text{ amp.}^1$$

Each effective conductor consists of two bars in parallel. Each bar is 0.075 in. \times 0.45 in., without insulation.

Area of each effective conductor = $2 \times 0.075 \times 0.45 = 0.0675$ sq. in.

\therefore Current density in conductor = $\frac{167 \text{ amp.}}{0.0675} = 2470$ amp. per sq. in.

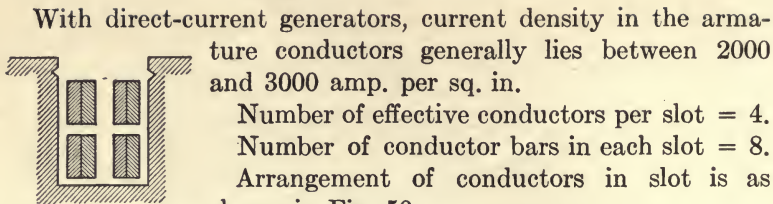

FIG. 50.

With direct-current generators, current density in the armature conductors generally lies between 2000 and 3000 amp. per sq. in.

Number of effective conductors per slot = 4.

Number of conductor bars in each slot = 8.

Arrangement of conductors in slot is as shown in Fig. 50.

Number of effective turns per pole,

$$t = \frac{\text{conductors per slot} \times \text{number of slots}}{\text{conductors per turn} \times \text{poles}} = \frac{4 \times 216}{2 \times 12} = 36.$$

Flux Calculation.—There are now sufficient data to apply the fundamental e.m.f. equation to the determination of the flux. The equation is

$$E = \frac{4f\phi_a t}{10^8} \text{ volts.}$$

Supplying numerical values,

$$250 = \frac{4 \times 37.5 \times \phi_a \times 36}{10^8},$$

whence

$$\phi_a = 4,630,000.$$

ϕ_a here is the required flux per pole entering the armature at no-load. Neglecting the effect of the small shunt field current flowing in the armature, the generated voltage and terminal voltage are the same at no-load.

At full-load, in order to maintain the same terminal voltage, 250, it would be necessary to generate a slightly higher voltage to supply the drop in the armature, series field and brushes. Assuming this drop to be $2\frac{1}{2}$ per cent., the required flux entering the armature at full-load is

$$\phi'_a = 1.025 \times 4,630,000 = 4,750,000.$$

The total flux which must be generated is made up of the armature flux and that which leaks across from pole to pole without passing through the armature. Assuming the leakage flux to be 15 per cent., the total flux in the pole core at no-load will be

$$\phi_c = 1.15 \times 4,630,000 = 5,320,000.$$

At full-load the total flux will be

$$\phi'_e = 1.15 \times 4,750,000 = 5,450,000.$$

The Magnetic Circuit.—In order to produce this flux it is necessary to employ the required number of ampere-turns per pole of the field winding. These are determined as the sum of the ampere-turns required for each part of the magnetic circuit supplied by the windings on a single pole. The separate parts are (1) the armature teeth, (2) the air gap, (3) the armature core, (4) the pole core, (5) the yoke.

The relations between ampere-turns per inch length of the magnetic path and flux density in lines per square inch are given by the saturation curves for the various materials com-

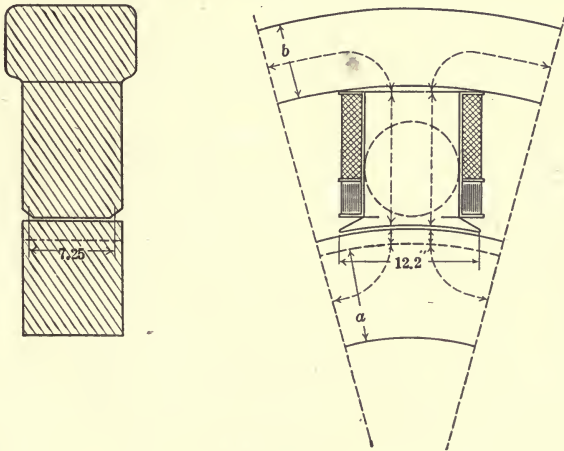

FIG. 51.

posing the magnetic circuit. To ascertain the ampere-turns it is necessary to know the cross-sectional area and length of each component part of the magnetic circuit. These are best determined with the help of a scale drawing showing the armature and the field cores in their relative positions. Such a drawing is reproduced in Fig. 51.

Here the mean flux paths are indicated by heavy dotted lines. The cross-sectional areas through which they pass are ascertained directly from the given dimensions, except in the cases of teeth and gap.

Area of Flux Path through Teeth.—Since the slot is of uniform width, the tooth must be narrower at the base or “root” than

at the face. The ampere-turns required for the teeth may be taken as the mean of the ampere-turns which would be required if the teeth area throughout were that at their face, and if it were that at their base. This is not the same as the ampere-turns required for the mean area of the teeth.

Width of tooth at face = slot pitch - slot width

$$= \frac{\pi \times 64}{216} - 0.465 = 0.465 \text{ in.}$$

Width of teeth at face = 0.465 in. \times number of teeth under one pole = 0.465 \times teeth per pole $\times \frac{\text{pole arc}}{\text{pole pitch}} \times 1.08$

$$= 0.465 \times \frac{216}{12} \times 0.72 \times 1.08 = 6.53 \text{ in.}$$

The factor 1.08 is inserted to allow for fringing, that is, the spreading of the flux to teeth not immediately under the pole.

Teeth area at face = 6.53 \times net armature length = 6.53 \times (gross armature length - air duct width) \times 0.9. This armature has a gross length, parallel to the shaft, of 9 in.; the air ducts are six in number, each $\frac{3}{8}$ in. wide, making a total width of air duct of 2.25 in. The factor 0.9 is commonly used to allow for space lost between the laminations due to the presence of Japan insulation or natural inequalities in the material. Substituting these numerical values, the teeth area at face is = 6.53 \times (9 - 2.25) 0.9 = 6.53 \times 6.07 = 39.6 sq. in.

Width of tooth at base = $\frac{\pi \times 61.4}{216} - 0.465 = 0.428 \text{ in.}$

Teeth area at base = 0.428 $\times \frac{216}{12} \times 0.72 \times 1.08 \times 6.07 = 36.4 \text{ sq. in.}$

Area of Flux Path through Gap.—It might be assumed that a mean area between that of the pole face and that of the teeth should be taken for the gap. Consideration, however, will show that this will give too small a result.

The flux in the gap fills practically the whole of it, though near the teeth the distribution is no longer uniform. A fairly satisfactory approximation to the effective gap area is obtained by taking one-fourth of the sum of three times the pole face area plus the teeth area. Thus, gap area,

$$A_p = \frac{3 \times \text{pole face area} + \text{teeth area}}{4}$$

Pole face area = pole arc \times pole length = $12.2 \times 7.25 = 88.4$ sq. in.

$$\therefore A_p = \frac{3 \times 88.4 + 39.6}{4} = 76 \text{ sq. in. approx.}$$

Areas of Armature Core, Pole Core and Yoke.—The armature core section perpendicular to the flux path is taken radially, and is the product of the radial distance, a , in Fig. 51 and the net length of the core. Thus

$$A_a = 8.7 \text{ in.} \times 6.07 \text{ in.} = 52.8 \text{ sq. in.}$$

The pole core section is circular in this machine, the area being

$$A_p = \pi r_p^2 = \pi \times (4.4375)^2 = 62 \text{ sq. in.}$$

The effect of any variation due to the pole shoe is very slight and may be neglected.

The yoke section is taken radially as at b , in the figure. Its form is somewhat irregular.

In this instance the area is

$$A_y = 83.5 \text{ sq. in.}$$

Materials.—The armature core is of soft sheet-iron laminations of high permeability, the poles are of soft steel and the yoke is of cast iron. Magnetization curves of these materials are given in Fig. 20.

No-load and Full-load Saturation Curves.—Having now determined the fluxes, areas, lengths and materials, it is in order to put these together in tables to show the flux densities, ampere-turns per inch, and ampere-turns for each part of the magnetic circuit, and finally the total ampere-turns. This is done for both no-load and full-load. In the former case a point is obtained on the no-load saturation curve, Fig. 52. Other points on this curve are obtained by repeating the tabulation process, starting with any desired values of voltage, such as 80, 150, 200, 260, 280, determining the fluxes from the e.m.f. equation, then flux densities and ampere-turns.

With the rest of the design the student should hand in both curves with complete tabulation of points.

Tabulations for 250 volts, no-load and full-load, are given in Tables III and IV.

In the case of full-load there must be added the ampere-turns required to overcome the armature reaction, in order to give the total required ampere-turns and the resultant point on the full-load saturation curve.

TABLE III

Part	No-load. $E = 250$ volts					
	Flux (mgl.)	Area	B	$A.T./in.$	Length, in.	$A.T.$
Teeth.....	4.63	(face) 39.6 (base) 36.4	117,000 127,000	180 } 480 } 330	1.3	429
Gap.....	4.63	76.0	61,000	19,100	0.3125	5,970
Armature..	2.315	54.5	42,500	3	7.0	21
Pole.....	5.32	62.0	86,000	40	12.0	480
Yoke.....	2.66	83.5	32,000	50	12.0	600
Total required amp.-turns.....						7,500

TABLE IV

Part	Full-load. $E = 250$ volts						
	Flux (mgl.)	Area	B	$A.T./in.$	Length, in.	$A.T.$	
.....	(face) 39.6 (base) 36.4	120,300 130,700	230 } 550 } 390	1.3	507	
Teeth.....	4.75	76.0	62,600	19,600	0.3125	6,140	
Gap.....	4.75	54.5	43,600	2.8	7.0	19.6	
Armature..	2.375	62.0	88,000	43	12.0	516	
Pole.....	5.45	83.5	32,800	52	12.0	624	
Yoke.....	2.725						
Amp.-turns.....						7,807	
Amp.-turns required to overcome armature reaction.....						2,620	
Total required amp.-turns.....						10,427	

Armature Reaction.—"Armature reaction" means effective ampere-turns per pole on the armature. The actual ampere-turns per pole, in this case, are $167 \times 36 = 6000$.

Since the turns are distributed over the armature surface the effective ampere-turns are

$$\frac{2}{\pi} \times 6000 = 3820.$$

If there were no shift to the brushes, these ampere-turns would all be cross-magnetizing, or distorting. To compensate for them, it is necessary to supply about 40 per cent. of their value in additional ampere-turns on the field core.

It is assumed, however, that the brushes will be shifted 15° , giving a distorting belt of $180^\circ - 30^\circ = 150^\circ$. To overcome the distorting ampere-turns at full-load there will then be required-

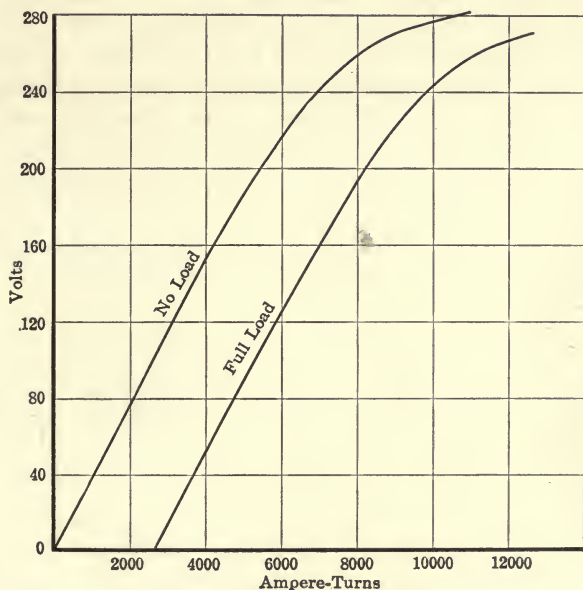

FIG. 52.

$$\frac{150}{180} \times 36 \times 167 \times k_c \times 0.4 = 1480,$$

where

$$k_c = \frac{1}{\theta} \int_{-\frac{\theta}{2}}^{+\frac{\theta}{2}} \cos \theta d\theta = \frac{1}{2.62} [1.9318] = 0.737.$$

The demagnetizing ampere-turns constitute a belt 30° wide. To compensate for them would require their exact numerical equivalent, were there perfect mutual induction between these turns and the field. Owing to magnetic leakage there should be added about 15 per cent. to the effective demagnetizing ampere-

turns. To compensate for these, therefore, will require

$$\frac{30}{180} \times 36 \times 167 \times k_d \times 1.15 = 1140 \text{ amp.-turns,}$$

where $k_d = 0.99$.

To overcome armature reaction at full-load will require $1480 + 1140 = 2620$ additional amp.-turns on the field core.

For any other load, keeping the same shift, the required ampere-turns will be proportional to the load current.

No-load and full-load saturation curves are shown in Fig. 52.

The Shunt Field Winding.—Under no-load conditions it is evident that the shunt field current must supply the entire excitation. In this machine, therefore, the shunt field m.m.f. must consist of 7500 amp.-turns per pole when an e.m.f. of 250 volts is being generated.

Actually, each shunt spool is wound with 460 turns of No. 7 B. & S., D.C.C. wire. The field current is therefore

$$i_f = \frac{7500}{460} = 16.3 \text{ amp.}$$

The shunt coil has an actual length of 6.25 in. As the diameter of No. 7 wire is 0.16 in., including insulation, there will be $\frac{1}{0.16} \times 6.25 = 39$ turns per layer of wire. There will be $\frac{460}{39} = 11.8$ layers, or practically 12 layers, giving a depth of winding of $0.16 \times 12 = 1.92$ in.

The mean radius of the coil, allowing for spool thickness, is then

$$\text{Mean radius} = \frac{4.5 + 6.42}{2} = 5.46 \text{ in.}$$

\therefore Mean length of turn = $2\pi \times 5.46 = 34.35$ in.

Total length of wire on each shunt spool is

$$\frac{34.35}{12} \text{ in.} \times 460 = 1316 \text{ ft.}$$

Resistance of No. 7 wire at $65^\circ\text{C.} = 0.586$ ohm per 1000 ft.

\therefore Resistance of each shunt spool is

$$0.586 \times 1.316 = 0.77 \text{ ohm.}$$

The resistance of the entire shunt field is

$$r_f = 0.77 \times 12 = 9.24 \text{ ohm.}$$

The voltage drop on the shunt field is

$$i_f r_f = 16.3 \times 9.24 = 151 \text{ volts.}$$

The voltage drop in the shunt field rheostat is

$$e_{rh.} = 250 - 151 = 99 \text{ volts.}$$

The Series Field Winding.—Consider two cases: (1) the generator to be flat-compounded, (that is, the no-load and the full-load voltages are equal, as specified), and (2) the generator to be 5 per cent. over-compounded.

In the first case, it is evident that the shunt field ampere-turns will remain the same at full-load as at no-load since the same voltage, 250, is impressed on the shunt circuit.

But by Tables III and IV, it is seen that at full-load there will be required $10,427 - 7500 = 2927$ additional amp.-turns. These must evidently be supplied by the series field m.m.f.

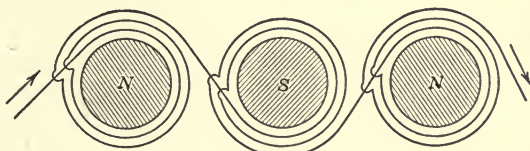

FIG. 53.

The actual winding consists of $2\frac{1}{2}$ turns per pole. Each turn is made up of 5 strips of conductor in parallel, each strip being $3\frac{1}{8}$ in. wide by 0.095 in. thick. The accomplishment of half a turn is illustrated in Fig. 53 which represents the arrangement, in plan, of the series field winding.

The series field current must then be

$$i_s = \frac{2927 A.T.}{2.5 \text{ turns}} = 1170 \text{ amp.}$$

This means that with full-load current $2000 - 1170 = 830$ amp. must be diverted from the series turns by a shunt connected in parallel with them. This shunt is, in practice, usually composed of German silver strips whose length is so adjusted by test as to divert exactly the required amount of current.

In the second case, the full-load voltage with 5 per cent. over-compounding is $1.05 \times 250 = 262.5$.

To obtain this voltage requires the addition of $11,700 - 7500 = 4200$ amp.-turns to the no-load ampere-turns. This additional

excitation is not all supplied by the series field m.m.f., however, since the shunt field current is affected by the increased terminal voltage. The shunt field m.m.f. now consists of $1.05 \times 7500 = 7875$ amp.-turns.

Therefore, the series field m.m.f. must consist of

$$11,700 - 7875 = 3825 \text{ amp.-turns.}$$

The current in the series winding is then

$$i_s = \frac{3825}{2.5} = 1530 \text{ amp.}$$

The current diverted through the shunt to the series field is

$$2000 - 1530 = 470 \text{ amp.}$$

The shunt field current is

$$i_f = 17.1 \text{ amp.}$$

Consideration of the saturation curves will show that this is nearly the limit of over-compounding for this machine. If full-load voltage of 275 were desired, it would be necessary to add another half turn to each series coil.

The series field m.m.f. has been made to compensate for the armature reaction and the ir drop (assumed $2\frac{1}{2}$ per cent.) in the armature. So far as the field design is concerned, this is satisfactory. These calculations are, however, only approximate and the actual values should now be determined from the known data of the machine.

Armature Resistance.—Being multiple wound, there are 12 paths in parallel in the armature. Each path includes 72 conductors, or 36 turns. The length of a turn is twice the gross length of the armature plus the end connections. The end connections for one turn may be taken as $9 \times$ diameter per pole of the armature $= 9 \times 5.33 = 48$ in.

Length of one turn is thus 2×9 in. $+ 48$ in. $= 66$ in.

Length of one path of 36 turns $= \frac{66 \times 36}{12} = 198$ ft.

Since the area of each effective conductor section is 0.0675 sq. in., its resistance is found to be 0.142 ohm per 1000 ft. at 65°C .

Resistance of one path is thus $0.142 \times 0.198 = 0.02812$ ohm.
Resistance of 12 paths in parallel is

$$\frac{0.02812}{12} = 0.00234 \text{ ohm.}$$

The true armature resistance will be somewhat less than this owing to the intermittent short-circuiting of coils by the brushes, and its average value may be taken as

$$r_a = 0.00226 \text{ ohm.}$$

Voltage drop in the armature is

$$e_a = r_a I_a = 0.00226 \times 2017 = 4.55 \text{ volts.}$$

Brush Resistance.—There is always a drop in voltage at the brushes due to the true brush resistance and also to the resistance of the sliding contact between brushes and commutator. This combined resistance has no definite value which may be calculated, but it is found by experiment that the drop which it causes amounts to 2 volts when the current density in the brushes is 30 amp. per sq. in. or more, while for densities less than 30, the drop is proportional to the current density. 30 amp. per sq. in. is about the usual current density in brushes. Drop across brushes is thus $e_b = 2$ volts.

Series Field Resistance.—Total thickness of series conductor = 0.095 in. \times 5 strips = 0.475 in. Area of series conductor = $0.475 \times 3.125 = 1.485$ sq. in. Mean radius of series turn, allowing $\frac{1}{32}$ in. insulation between turns, is found to be 5.12 in.

$$\begin{aligned} \text{Mean radius} &= \frac{\text{mean radius, 3 turns} + \text{mean radius, 2 turns}}{2} \\ &= \frac{(4.5 + 0.475 + 0.0313 + 0.233) + (4.5 + 0.475 + 0.0156)}{2} \\ &= \frac{5.24 + 5}{2} = 5.12 \text{ in.} \end{aligned}$$

\therefore Mean length of series turn = $2 \times 5.12 \times \pi = 32.2$ in.

Length of series winding = $\frac{12 \times 32.2 \times 2.5}{12} = 80.5$ ft. approx.

To this should be added about 5 ft. for connections between coils, making the series winding 85.5 ft. long. Resistance per 1000 ft. of series conductor is found to be 0.00645 ohm at 65°C.

Series field circuit resistance is therefore

$$r_s = 0.00645 \times 0.0855 = 0.000552 \text{ ohm.}$$

As it was found that only 1170 amp. go through the series field coils at full-load, the voltage drop on the series field winding is

$$e_s = r_s i_s = 0.00055 \times 1170 = 0.645 \text{ volt.}$$

Total voltage drop in the machine is therefore

$$e_a + e_b + e_s = 4.45 + 2 + 0.645 = 7.095 \text{ volts.}$$

or $\frac{7.095}{250} = 0.0284$, or, approximately, 2.5 per cent. as assumed.

If the assumption of percentage drop is not considered to have been sufficiently close, the magnetic calculations should be repeated using the new percentage just found.

Commutator and Brushes.—The size of the commutator is determined chiefly by the brush requirements. The number of commutator segments is 432, that is, one segment to each effective turn on the armature.

The brushes rest perpendicularly on the commutator. There are 12 studs of brushes, each stud holding 10 brushes. Each brush has a cross-section of 1.25 in. \times 0.75 in., giving a brush area of 0.94 sq. in., or 9.4 sq. in. per stud.

As there are six positive and six negative studs, the area of the positive (or negative) brushes is $6 \times 9.4 = 56.3$ sq. in.

Therefore the current density in the brushes at full-load is $\frac{2016.3}{56.3} = 35.8$ amp. per sq. in.

The commutator length must exceed that of the brushes on the stud, that is, it must exceed $10 \times 1.25 +$ some space of separation between adjacent brushes. In this case the commutator length is 17.5 in.

The commutator diameter is influenced by the peripheral speed. Being built up of numerous copper segments each separated by sheets of mica, the commutator is usually mechanically weaker than any other revolving part. It must not only be protected from forces which would cause it to fly apart, but there must be no force acting upon it which will be strong enough to cause even slight warping of its surface. Good commutation demands smooth, even contact between the segments and the brushes at all times.

On the other hand, too small a diameter results in very narrow segments, thin and wide brushes and then, in turn, a longer commutator.

The commutator diameter for this machine is 39 in., which is approximately 60 per cent. of the armature diameter. From

this it is found that the width of segment plus the mica insulation is

$$\frac{\pi 39}{432} = 0.284 \text{ in.}$$

The brushes will therefore extend over $\frac{0.75}{0.284} = 2.64$ segments.

Flux Distribution Around the Armature.—It is of interest at this point to investigate the distribution of the flux around the armature periphery on account of its bearing on the commutation and also in order to be able to determine the potential difference between any two adjacent commutator segments. This is best accomplished with the help of a diagram in which is shown a pair of poles drawn to scale in relation to the armature, developed along the horizontal line.

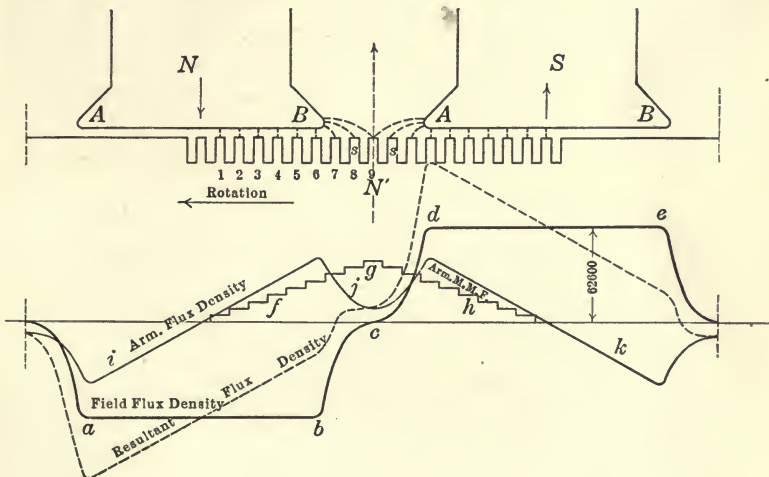

FIG. 54.

A curve *abcde*, Fig. 54, is first constructed to represent the flux distribution around 360 electrical space degrees of the armature periphery. This curve is based on the assumption of flux density, being inversely proportional to the flux path in the air. Thus, the density is uniform under the pole and is so represented by the line *ab*. To determine the densities between the poles, empirical mean flux paths to the teeth are drawn, and the flux along each path is taken as inversely proportional to its length. The curve *cde* will obviously be the reverse of curve *abc*.

The second step is the construction of a curve of armature magnetomotive force. This m.m.f. will act in the direction of an axis midway between the poles (assuming brushes to be set on the geometrical neutral).

Along this axis the m.m.f. will consist of all the armature ampere-turns per pole. Acting through the next adjacent teeth s, s , the m.m.f. will be diminished by the amount of armature ampere-turns included between these teeth. These ampere-turns may be plotted, tooth by tooth, in the manner thus indicated, and the result will be a curve, fgh , in the form of successive steps corresponding to the armature teeth. To construct the flux curve of the armature reaction from the m.m.f. curve, reluctance of the air paths alone need be considered. To be sure, the rest of the flux path, especially that of the teeth, would have some effect on the accuracy of the curves so obtained. But the error would not be great, being anywhere from 2 per cent. to 8 per cent. according to the position of the point on the curve. The flux density for each tooth is therefore determined from the formula:

$$B = \frac{3.19A.T.}{l},$$

where l is the length of the path in air.

This is plotted as curve, ijk , to the same scale as the curve of the field flux density— $abcde$.

The actual densities along the periphery will vary from tooth to slot, and, indeed, this variation is noticeable on many oscillograms of alternator voltage. The ripples which occur in the flux wave due to alternate teeth and slots would exist equally with reference to the field flux, armature flux and resultant flux. In order to avoid confusion the ripples have not been shown on the armature density curve, but all the waves are plotted as smooth lines.

A study of the resultant wave reveals the great distortion caused by the armature current, the strengthening of the flux in the pole tips at A , the weakening at B , and the shifting of the neutral point, c , in the direction of rotation.

The student may well discuss the effect on the flux density waves of giving a shift of the brushes.

Losses and Efficiency.—The efficiency of a machine is given by the equation,

$$\text{efficiency} = \eta = \frac{\text{output}}{\text{output} + \text{losses}}$$

The full-load output of the generator has been given as

$$P = EI \div 1000 = 500 \text{ kw.}$$

The problem of the efficiency is then one of determining the losses. The losses of a generator may be considered under three heads: (1) copper losses, due to heat developed by the currents in the windings; (2) core losses, due to hysteresis and eddy currents set up by the changes of magnetic flux in the iron and, to a slight extent, in the copper of the machine and (3) friction losses, including that of the bearings, the brushes and windage.

Copper Losses.—These consist of I^2r loss in the armature, the shunt field circuit including the rheostat, the series field coils, and that of the brushes and commutator.

It is not sufficient to ascertain these losses for full-load only. The quality of a generator is displayed by its performance at all reasonable loads. The efficiency will in this case, therefore, be calculated for loads from zero to 150 per cent. of full-load.

The armature copper loss is $I_a^2r_a$, where $r_a = 0.00226$ ohm. Shunt field copper loss is I_fE_f , where E_f is the voltage impressed on the field circuit, and is in this case 250 volts. $I_f = 16.3$ amp.

$$\therefore \text{Shunt field copper loss} = 16.3 \times 250 = 4075 \text{ watts.}$$

The series field loss is I_sE_s , where I_s is the line current = $I_a - I_f$, and E_s has been found to be 0.645 volts at full-load and varies directly with I_f for other loads.

TABULATION OF COPPER LOSSES

Per cent. load	0	25	50	75	100	125	150
I_a	16	516	1,016	1,516	2,016	2,516	3,016
I_a^2	256	266,000	1,037,000	2,300,000	4,075,000	6,330,000	9,100,000
$I_a^2r_a$	0.58	600	2,340	5,200	9,200	14,300	20,550
I_fE_f	4,075	4,075	4,075	4,075	4,075	4,075	4,075
I_s	0	500	1,000	1,500	2,000	2,500	3,000
E_s	0	0.161	0.322	0.484	0.645	0.806	0.968
I_sE_s	0	81	323	725	1,290	2,018	2,905
E_b	0	0.6	1.2	1.8	2	2	2
I_aE_b	0	310	1,220	2,730	4,032	5,032	6,032
Total loss	4,075	5,066	7,958	12,730	18,597	25,425	33,562

Brush loss = $I_a E_b$, where E_b is the voltage drop in commutator and brushes, being approximately proportional to current density in the brushes up to a density of 30 amp. per sq. in. and being 2 volts for higher current densities.

Core Loss.—The hysteresis loss is principally in the armature and is due to the reversal of direction of the flux in the metal as the armature spins around. The amount of energy expended in reversals of the magnetic molecules is proportional to the frequency and approximately proportional to (flux density)^{1.6}. Thus,

$$\text{Hysteresis loss} = kfB^{1.6}.$$

The exponent 1.6 was found experimentally, by STEINMETZ; it holds with sufficient accuracy for the usual range of flux densities obtained in electrical machinery.

In direct-current armatures hysteresis loss usually amounts to about 2.8 watts per lb. at $f = 60$ and $B = 64,500$. Assuming this value as standard, the armature core loss and teeth loss are expressed by the equation

$$W_h = 2.8 \times \frac{f}{60} \times \left(\frac{B}{64,500} \right)^{1.6} \times \text{wt. of core or teeth in lb.}$$

For both core and teeth, $f = 37.5$.

B , in core = 43,600 at 250 volts, full-load. B , corresponding to average amp.-turns required by the teeth = 126,000.

Weight of armature core = vol. \times wt. of 1 cu. in.

$$= 0.28 \times 6.05 \times \pi(\overline{30.7^2} - \overline{22^2}) = 2430 \text{ lb.}$$

$$\begin{aligned} \text{Weight of teeth} &= 0.28 \times 6.05 \times [\pi(\overline{32^2} - \overline{30.7^2}) - 216 \times 1.3 \times 0.465] \\ &= 0.28 \times 6.05 \times [258 - 130] = 217 \text{ lb.} \end{aligned}$$

Substituting these values, the total hysteresis loss in teeth and core is

$$\begin{aligned} W_h &= 2.8 \times \frac{37.5}{60} \left[\left(\frac{43,600}{64,500} \right)^{1.6} \times 2430 + \left(\frac{126,000}{64,500} \right)^{1.6} \times 217 \right] \\ &= 1.75 [\overline{0.676}^{1.6} \times 2430 + \overline{1.95}^{1.6} \times 217] = 3340 \text{ watts.} \end{aligned}$$

The eddy current loss is due to the heating of the core by local or eddy currents set up in the material of the core by the changing flux within it.

It is therefore an I^2R loss, or $\frac{E^2}{R}$, where E is the e.m.f. set up, which is expressed by the equation

$$E = \frac{4.44f\phi t}{10^8}$$

where $\phi = B \times \text{area} = \text{total flux}$.

From this it may be seen that the eddy current loss may be written

$$W_e = k_1 f^2 B^2.$$

The eddy current loss may be reduced as much as desired by making the laminations of the armature core sufficiently thin. A satisfactory value for this loss may be obtained by assuming it equal to the hysteresis loss. In that case, $W_e = 3340$ watts and the total core loss is

$$W_c = 2 \times 3340 = 6680 \text{ watts.}$$

Losses in pole faces and copper due to eddy currents are here too small to consider.

There will also be slight changes in the values of the core loss as the load changes, due to variation in magnetic densities, especially in the teeth. This variation is also slight, however, and will be neglected.

Friction Losses.—Loss due to brush friction is based on a coefficient of friction of 0.3, and a brush pressure of 1.2 lb. per sq. in. of brush surface. From this, the friction per sq. in. is $0.3 \times 1.2 = 0.36$ lb. Surface area of one brush = $1.25 \times 0.75 = 0.9375$ sq. in.

Total brush friction force is then,

$$F = 0.9375 \times 10 \times 12 \times 0.36 = 40.5 \text{ lb.}$$

Power loss,

$$W_b = \frac{2\pi r n F}{33,000} \times 746 \text{ watts,}$$

where

$$r = \text{radius of commutator in ft.} = 1.625$$

and

$$n = \text{speed in r.p.m.} = 375.$$

Thus,

$$W_b = \frac{2\pi \times 1.625 \times 375 \times 40.5 \times 746}{33,000} = 3500 \text{ watts.}$$

¹ This is the equation for induced e.m.f. in a transformer. It holds also in this case as will appear later when the transformer is studied.

Bearing friction and windage, together, make a complicated loss to determine with accuracy. This loss is, however, one which may be assumed with quite sufficient accuracy from the data obtained in practice. A fair assumption to make for generators of this type is 1 per cent. of the rated output of the generator. In this case then

$$W_f = 500,000 \times 0.01 = 5000 \text{ watts.}$$

Summary of Losses, Output and Efficiency.—The combined losses of the generator for different per cent. loads is given in Table V.

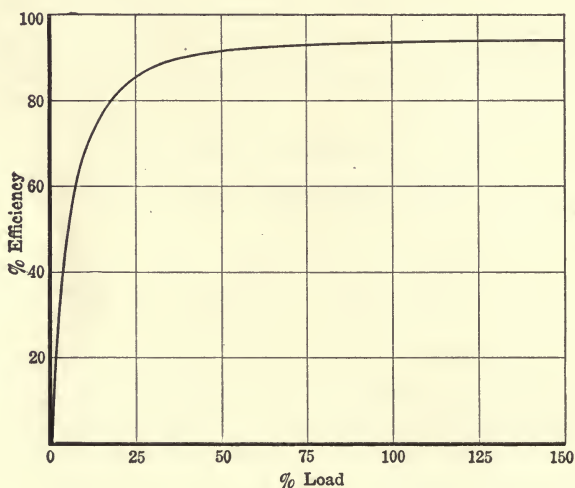

FIG. 55.

TABLE V

The efficiency curve is shown plotted against per cent. load in Fig. 55

Per cent. load	0	25	50	75	100	125	150
Copper loss.....	4,076	5,066	7,958	12,730	18,597	25,425	33,562
Core loss.....	6,680	6,680	6,680	6,680	6,680	6,680	6,680
Friction loss....	8,500	8,500	8,500	8,500	8,500	8,500	8,500
Total loss.....	19,256	20,246	23,138	27,910	33,777	40,605	48,742
Output.....	0	125,000	250,000	375,000	500,000	625,000	750,000
Input.....	19,256	145,246	273,138	402,910	533,777	665,605	798,742
Efficiency.....	0	0.86	0.915	0.93	0.936	0.939	0.939

Temperature Rise.—The final limit to the output of the generator is the permissible temperature rise. The effect of

temperature on copper is to increase its resistance to a slight extent; the effect on iron is to increase its permeability. These effects tend to offset each other so that, as far as these two materials go, it would be permissible to attain very high temperatures.

On the other hand, the insulation is the real limiting feature. Of the many insulating materials, none possesses the combination of qualities necessary in the ideal insulator for electrical machinery. This material should be of high insulation strength, strong mechanically, and its insulating and mechanical qualities should not change under long-continued heating. Mica is the best insulator in these respects, except that it is poor from the mechanical standpoint. Asbestos is useful owing to its heat-resisting qualities, but it is a rather poor insulator and its mechanical possibilities are limited. Cotton tapes and varnishes do not withstand the high temperatures.

In attempting to extend the limit of output of machines of a given size there are two lines along which lie the main possibilities of success.

Either some new insulating material, more satisfactory than those at present in use, may be discovered or invented, or improvement in ventilation and heat radiation may be accomplished by alteration of the mechanical design.

Under existing conditions a temperature rise of 40°C . above that of the surrounding air is quite conservative. The temperature which different parts of a machine will attain is hard to predetermine accurately from the design. Practical studies have afforded certain empirical constants which permit approximate determinations to be made, but in any case, practical experience will greatly assist the designer in his attempts to keep close to the limits.

For the present it will be sufficient to determine the watts per square inch of surface of field spools and armature. For rotating machinery 0.5 watt per sq. in. will correspond roughly to a temperature rise of 40°C .

The external surface of a field spool, only, should be taken, and the same applies to the armature. These should, of course, be calculated separately.

Problem 30.—In the machine just studied, show by calculation, as indicated above, that the temperature rise in the field and armature coils will not be excessive.

CHAPTER XI

ELECTRICAL CONSTANTS OF A DIRECT-CURRENT GENERATOR HAVING COMMUTATING POLES AND COMPENSATING WINDING

As a typical generator of this more complex type will be taken the following:

M.P. 6 — 1000 — 600 — 1200/1260 volts.

The generator is thus 5 per cent. over-compounded. Being designed for comparatively high voltage, commutation becomes a matter of special importance.

To insure proper neutralization of the armature reaction, therefore, special field windings are supplied, and these are so placed as to counteract the armature m.m.f. in space as well as in amount. That is, neutralization is accomplished by means of a compensating winding placed in the pole faces symmetrically with respect to the armature conductors under the pole arc, and an auxiliary commutating pole inserted between the main poles, where the armature magnetomotive force is the strongest, and whose duty is not only to neutralize this magnetomotive force about the neutral point in which the brushes are placed, but to supply a flux which will be in proper direction to balance the e.m.f. of self-induction of the commutated coil. With such an arrangement the brushes are given no shift, and, consequently, the armature m.m.f. is entirely cross-magnetizing.

The series field m.m.f. proper is thus relieved of every duty except those of compensating for IR drop in the armature and over-compounding. The circuit diagram of this machine is given in Fig. 56.

General dimensions and specifications are as follows:

Armature outside diameter, 48 in.

Armature inside diameter, 28 in.

Armature gross length diameter 15.5 in.

Armature effective diameter, 11.7 in.

Armature ventilating ducts, $4\frac{1}{2}$ in. wide.

$2\frac{3}{8}$ in. wide.

Slots, number and dimensions, 144; 0.44 in. \times 1.53 in.

Effective conductors per slot, 6.

Effective armature conductor section, 0.55 in. \times 0.09 in.

Armature winding, multiple drum.

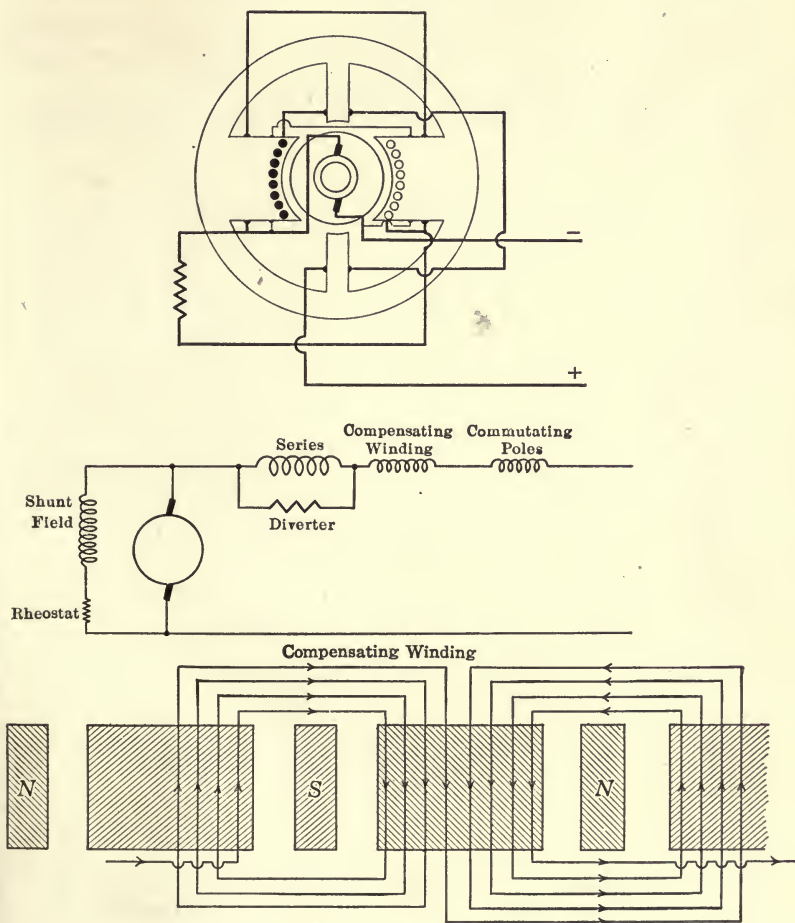

FIG. 56.

Yoke section, rounded, 17 in. \times 6.5 in.

Main pole core section, 14.5 in. \times 14.5 in.

Main pole core length, including pole shoe, 14 in.

Main pole core length, allowed for field spool, 13 in.

Main pole arc, 17.5 in.

Commutating pole section, 13.5 in. \times 2.25 in.

Commutating pole length, 14 in.

Main air gap length, 0.3125 in.

Air gap under commutating pole, 0.5 in.

Shunt field winding; 2256 turns per spool of No. 15 B. & S. triple cotton-covered wire.

Series field winding; 3 turns per spool. Each conductor built up of 4 strips giving total section, 1.5 in. \times 0.35 in.

Commutating pole winding; 5.5 turns of copper ribbon 12 in. wide \times 0.05 in. thick.

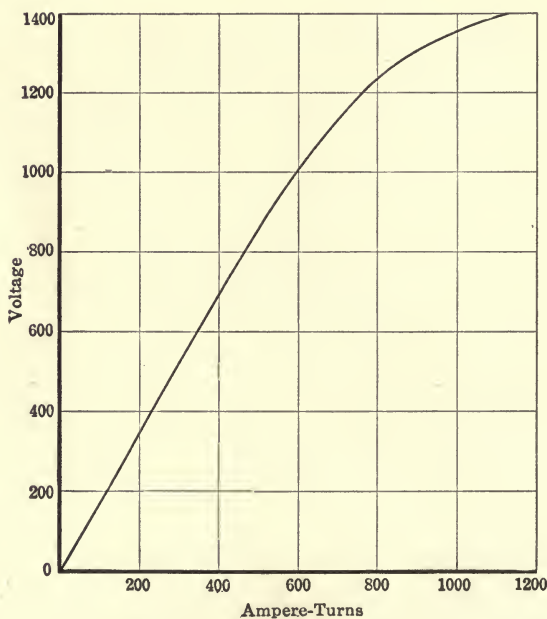

FIG. 57.

Compensating (pole face) winding consists of 16 conductors per pole contained in 8 holes in the pole face. Each hole has 2 conductors, one, a tube, the other a rod within the tube. Tube outside diameter, $1\frac{1}{8}$ in., inside diameter $2\frac{7}{32}$ in.

Rod diameter, $\frac{3}{4}$ in.

Commutator diameter, 30 in.

Commutator length, 14 in.

Commutator segments, 432.

Segment width, 0.219 in.

Brushes per stud, 7.

Brush section dimensions, 1.25 in. \times 0.875 in.

The armature flux at no-load is readily found to be 13.9 megalines per pole.

The no-load saturation curve is given in Fig. 57, having been determined in exactly the same manner as that of the previous machine, given in Fig. 52.

This curve shows that 7600 amp.-turns are required to give normal voltage at no-load. At full-load, the shunt field m.m.f. will supply $\frac{1260}{1200} \times 7600 = 7980$ amp.-turns.

Assuming 2 per cent. voltage drop in armature and brushes, the total e.m.f. which must be generated is $1.02 \times 1260 = 1285$ volts. From the saturation curve, this voltage requires 8750 amp.-turns. Therefore the series field m.m.f. must supply $8750 - 7980 = 770$ net amp.-turns per pole.

To supply these, however, account must be taken of the unfortunate situation of the series field winding with respect to magnetic leakage. Being placed close to the yoke, the leakage factor should probably be 1.50 instead of 1.25 as used for the shunt field calculation. This factor could, of course, be calculated, but it is hardly desirable to introduce such a refinement when the means of adjustment of the series field current render a reasonable assumption entirely satisfactory. On the basis of a leakage factor of 1.50, the series amp.-turns are $\frac{1.50}{1.25} \times 770 = 924$.

The series field current is $I_s = \frac{924}{3} = 308$ amp.

Current diverted around the series field is

$$I_d = 793 - 308 = 485 \text{ amp.}$$

The entire load current of 793 amp. passes through the 9 turns per pole of the compensating winding, and the $5\frac{1}{2}$ turns of each commutating pole.

SATURATION CURVE CALCULATION

No-load. $E = 1200$.

$$\phi_a = \frac{E \times 10^8}{4ft},$$

where

$$f = \frac{600}{60} \times \frac{6}{2} = 30,$$

$E = 900$

Teeth (face).....			82,000	11.0	} 12.75	19.5
Teeth (base).....			87,500	14.5			
Gap.....							4,594
Arm.....			52,500		3.77		35.8
Pole.....			61,900		15.9		222.5
Yoke.....			60,200		15.1		367
Total.....							5,239

 $E = 1400$

Teeth (face).....			127,400	420	} 842	1,290
Teeth (base).....			136,100	1,264			
Gap.....							7,150
Arm.....			81,600		10.8		102.7
Pole.....			96,200		79		1,107
Yoke.....			93,600		63.8		1,660
Total.....							11,310

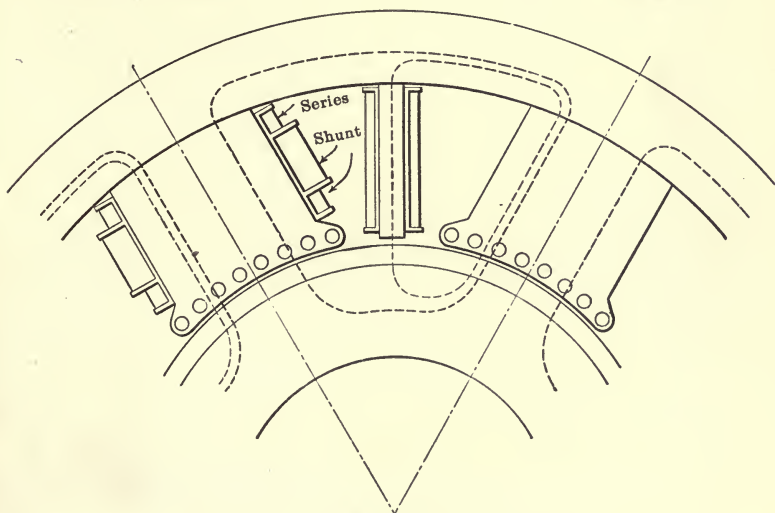

FIG. 58.

Calculations of armature, shunt and series field windings, as well as brush losses and friction loss are made in exactly the same manner as in the preceding example. The difference in location of the shunt and series windings is given in Fig. 58. The division of the shunt into two coils per pole is made to

allow the necessary room for end-connections of the compensating winding.

The calculation of the commutating pole winding is likewise a matter of applying the old principle.

The conductor itself is of extreme dimensions, being a band of sheet copper 1 ft. in width.

For the compensating winding the mean length of 1 turn is found to be $2 \times$ (length of pole parallel to shaft + 4 in. (extension)) + $2 \times$ mean span between poles, = $2 \times (14.5 + 4) + 2 \times 19$ in. = 75 in.

$$\text{Total length of winding} = \frac{75}{12} \times 8 \times 6 = 300 \text{ ft.}$$

$$\text{Area of conductor section} = 0.442 \text{ sq. in.}$$

$$\text{Resistance of winding} = \rho \frac{l}{a} = \frac{7.95}{10^7} \times \frac{300}{0.442} = 0.0054 \text{ ohm.}$$

$$\text{Voltage drop in winding} = 793 \times 0.0054 = 4.28 \text{ volts.}$$

$$\text{Loss in winding} = 4.28 \times 793 = 3400 \text{ watts.}$$

Voltage drops and losses at full-load in other parts of the generator are as follows:

	Voltage drop	Loss
Armature.....	14.75	11,700
Shunt field.....	(1,008)	
including rheostat.....	4,500
Series field.....	0.636	505
Compensating winding.....	4.28	3,400
Commutating field.....	1.19	945
Brushes (I^2R).....	2	1,590
Brushes (friction).....	1,760
Hysteresis loss.....	7,220
Eddy current.....	7,220
Friction and windage.....	10,000
<hr/>	<hr/>	<hr/>
Total voltage drop.....	22.856	
Per cent. voltage drop.....	1.82	
Total energy loss.....	48,840

$$\text{Efficiency} = \frac{\text{output}}{\text{output} + \text{losses}} = \frac{1,000,000}{1,048,840} = 0.953.$$

Efficiencies for all loads are as follows:

Per cent. load	0	25	50	75	100	125	150
Per cent. eff.	0	88.5	93.5	94.85	95.3	95.5	95.5

Fig. 59 shows the efficiency curve.

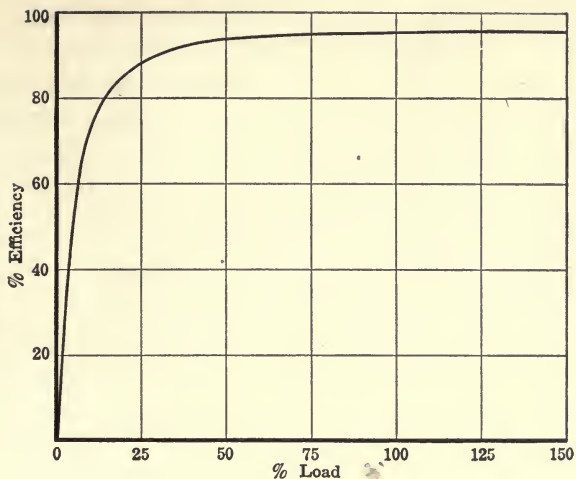

FIG. 59.

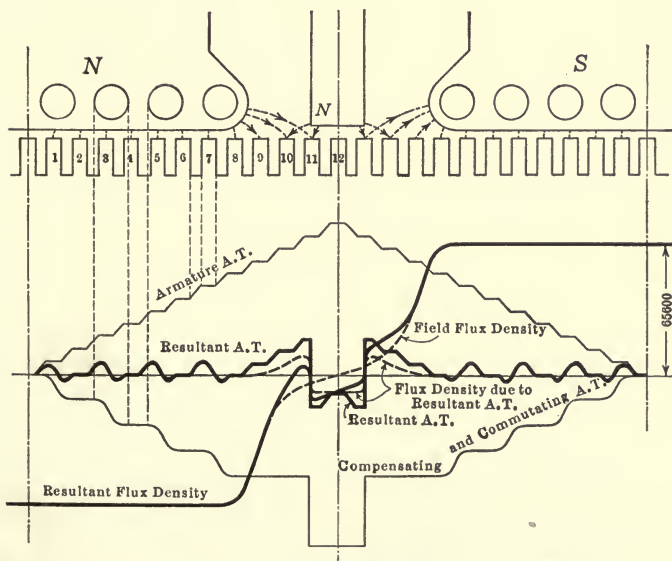

FIG. 60.

EFFECT OF COMPENSATING WINDING AND
COMMUTATING POLES

To study the effect of these windings in neutralizing armature reaction, it is best to construct a curve of magnetomotive forces showing their distribution along the armature periphery. From this and the curve of field flux density the resultant flux density along the periphery is obtained. Such curves are given in Fig. 60. The armature ampere-turns and field flux density in the gap are plotted to separate scales as was done in Fig. 54. The commutating pole and compensating winding ampere-turns are likewise plotted, but their direction is, of course, opposite to that of the armature m.m.f. The resultant m.m.f. of these three is given by the heavy irregular line. The average of this resultant m.m.f. is seen to be very nearly zero, showing the effective compensation of the armature reaction. It is also observable that the commutating pole m.m.f. is made sufficiently strong to overbalance considerably the armature m.m.f. in the neutral axis, thus creating a resultant flux oppositely directed to the armature m.m.f.

The maximum armature m.m.f. which acts along the commutating pole axis is 9564 amp.-turns. Opposing this is the m.m.f. of the compensating winding which is 6344 amp.-turns, and the m.m.f. of the commutating pole which is 4360 amp.-turns. Thus the resultant amp.-turns amount to $(6344 + 4360) - 9564 = 1140$. When the armature is in the less advantageous position (that is, with a slot in the commutating pole axis), the resultant amp.-turns are $10,704 - (11.5 \times 797) = 1554$.

The average resultant amp.-turns along the commutating pole axis are therefore 1350.

These ampere-turns, acting through a gap of $\frac{1}{2}$ in. produce a flux density of

$$B = \frac{1350}{0.313 \times 0.5} = 8620 \text{ lines per sq. in.}$$

Commutation.—If the field in the neutral axis were completely neutralized, commutation would still be poor due to the reversal of the current in the conductors during the period of commutation. Therefore, to balance the e.m.f. induced in the short-circuited coil under the brush, an approximately equal e.m.f. is created in the opposite direction in this coil by causing it to cut through the flux due to the commutating pole.

Exact neutralization of the induced e.m.f. in the short-circuited

coil is practically impossible by this means. Current in the conductors does not vary logarithmically as in an ordinary circuit when the impressed e.m.f. is removed. If it did, the fundamental equation, (15),

$e = ir + L \frac{di}{dt}$, where r and L are approximately constant, would apply for the induced e.m.f. of the coil. But in this case, r is by no means constant due to the varying brush surface on the commutator segments. The value of r is therefore some function of the time. Putting $r = f(t)$, and considering the variability of L , due to change of permeability in the iron part of the flux path, the induced e.m.f. would be expressed by the equation

$$e = i f(t) + \frac{d}{dt} (Li).$$

To solve this equation to a satisfactory degree of approximation, certain assumptions may be made. First, let it be assumed that the current dies down in the coil as a sine wave (Fig. 61). The induced e.m.f. would then be maximum when the coil axis passed through the center of the brush.

If this maximum value were determined, it could be made equal to the e.m.f. produced by rotation of the coil through the field set up by the commutating pole. Other values than the maximum could be left to care for themselves, being of secondary importance. The maximum value of the e.m.f. of self-induction is

$$E_m = IX$$

where I is the current in the armature conductor at the moment when commutation begins, and, in this case, is 133 amp. and X is the reactance of the coil.

The second assumption is that L , the coil inductance, is constant. Hence

$$X = 2\pi f_c L,$$

where f_c = frequency of current during commutation.

$f_c = \frac{1}{2T_c}$ where T_c is the time of cummutation, since this time evidently corresponds to one-half wave length. The time of

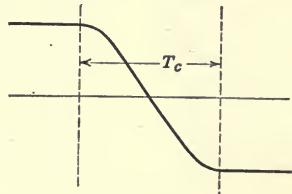

FIG. 61.

commutation is that time taken by the commutator to move a distance equal to the thickness of a brush. In the machine under consideration each brush covers four segments.

$$\begin{aligned} \therefore T_c &= \frac{1}{\text{r.p.s.}} \times \frac{\text{segments covered by brush}}{\text{total segments}} \\ &= \frac{1}{10} \times \frac{4}{432} = 0.000952 \text{ sec.}, \end{aligned}$$

and

$$f_c = \frac{1}{2 \times 0.000925} = 540 \text{ cycles per sec.}$$

In calculating the coil inductance, L , it is not sufficient to consider only the interlinkage of each coil with the flux which it produces. Mutual induction is also present, the value of L desired being therefore not strictly the self-inductance, but including that due to the interlinkage of the flux produced by the current in all 6 turns with each single turn. In this machine the conductors in each slot are all in parallel; thus N is 1 turn, composed of 2 conductors. It should be noted that of the 2 conductors composing any turn, one of them lies in the lower half of its slot, while the other lies in the upper half of its slot. The interlinkage of each conductor with the total flux will not be the same in the 2 cases.

However, by considering the total flux as due to the $6I$ amp.-turns of a slot acting through an effective magnetic conductance, G , and surrounding each of the 6 conductors, the inductance thus calculated will be correct, provided the proper value of G is determined. Thus,

$$\phi = 6I \times G,$$

where ϕ is the equivalent flux surrounding all conductors in 1 slot. (The inductance due to end-connections must also be ascertained, as is done later.)

The magnetic conductance per centimeter effective length of the armature is calculated by means of the general formula,

$$g = \frac{\text{area}}{\text{length}} \times 0.4\pi\mu.$$

Considering the magnetic circuit (Fig. 62), it is seen to consist of 3 parallel paths in air, namely: that of section A and length B through the conductors, that of section C and length B above

the conductors, and that of section F and length D , from the top of 1 tooth to the top of the other. The common path through the iron may be neglected as offering comparatively little resistance.

To find the effective magnetic conductance per centimeter length across the section A , consider an elementary section, dx , at distance, x , from the bottom of the conductors. The conductance across this section is

$$dg = \frac{0.4\pi dx}{B}.$$

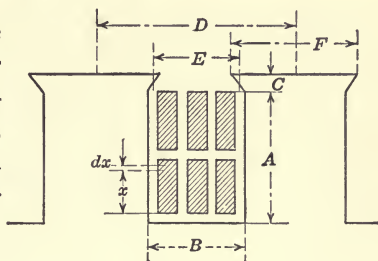

FIG. 62.

The amp.-turns acting in this conductance are $\frac{6Ix}{A}$, where I is in amperes.

Therefore the flux set up through dx is

$$d\phi = \frac{0.4\pi dx}{B} \times \frac{6Ix}{A} = \frac{2.4\pi I x dx}{AB}.$$

This flux interlinks with only $\frac{6x}{A}$ conductors.

Thus,

$$Nd\phi = \frac{14.4\pi I x^2 dx}{AB},$$

and

$$\begin{aligned} N\phi &= \frac{14.4\pi I}{A^2 B} \int_0^A x^2 dx \\ &= \frac{14.4\pi IA}{3B} \end{aligned}$$

is the interlinkages of the flux with all 6 conductors.

Thus, if the flux is considered to be due to $6I$ amp.-turns acting through conductance, g , and this interlinks with each conductor, the total number of interlinkages is

$$6Ig \times 6 = \frac{14.4\pi IA}{3B},$$

whence,

$$g = \frac{14.4\pi IA}{3BI \times 36} = \frac{0.4\pi A}{3B}.$$

The other two paths are entirely outside of the conductors,

and hence are acted on by all of the ampere-turns in the slot. These conductances are then, respectively,

$$0.4\pi \frac{C}{E} \text{ and } 0.4\pi \frac{F}{D}$$

The total effective conductance is then

$$G = 0.4\pi \left[\frac{A}{3B} + \frac{C}{E} + \frac{F}{D} \right]$$

per cm. length of armature, and the flux per slot is

$$\begin{aligned} \phi &= ING \times 2.54l \\ &= 6I \times 3.2 \left[\frac{A}{3B} + \frac{C}{E} + \frac{F}{D} \right] l, \end{aligned}$$

where l is the effective length of the armature, in inches. For both slots and 1 complete turn the inductance is

$$L_s = \frac{\phi N}{10^8 I} = \frac{2 \times 6 \times 3.2 \times 11.7 \text{ in.}}{10^8} \left[\frac{A}{3B} + \frac{C}{E} + \frac{F}{D} \right]$$

Substituting numerical values for the slot and tooth dimensions,

$$\begin{array}{lll} A = 1.233 & B = 0.44 & C = 0.213 \\ D = 1.047 & E = 0.51 & F = 0.607, \end{array}$$

this inductance becomes

$$L_s = 449 [0.934 + 0.417 + 0.58] \times 10^{-8} = 867 \times 10^{-8} \text{ henrys.}$$

To this must be added the inductance of the end-connections. The flux produced by the end-connections per ampere-turn per inch of coil length may be taken as one-twentieth of that in the slot.

It is, therefore, $\frac{1}{20} \times 3.2 \times 1.931 = 0.309$ lines.

The coil divides as it passes out from the slot, so that only 3 conductors are grouped together. Therefore there are $3I$ amp.-turns producing flux

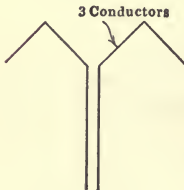

FIG. 63.

around each conductor. If the length of the end-connections for 1 turn is assumed as $8 \times$ diameter per pole, $= 8 \times 8 = 64$ in., the flux surrounding each turn is $\phi = 0.309 \times 3I \times 64 = 59.4I$ lines. The inductance is then

$$L_e = \frac{\phi N}{I \times 10^8} = \frac{59.4 \times 1 \times I}{10^8 \times I} = 59.4 \times 10^{-8} \text{ henrys.}$$

The total inductance is thus

$$L = L_s + L_e = (867 + 59.4) \times 10^{-8} = 926.4 \times 10^{-8} \text{ henrys.}$$

The reactance of the short-circuited coil is

$X = 2\pi f_c L = 6.28 \times 540 \times 926.4 \times 10^{-8} = 0.0314$ ohm,
and the maximum e.m.f. of self-induction is

$$E_m = IX = 133 \times 0.0314 = 4.17 \text{ volts.}$$

To overcome this e.m.f. the short-circuited coil is made to rotate in the field of the commutating pole. This field has been found to have an average density around the neutral axis of about 8620 lines per sq. in.

In this case, the commutated coil has only one turn. Thus e.m.fs. are generated in one conductor under a "north" commutating pole, and in the other conductor under a "south" commutating pole. These e.m.fs. are similar, and together make up the total e.m.f. generated in the coil by rotation in the commutating field. The maximum value of this induced e.m.f. corresponds to the rate of cutting the flux in the center under the commutating pole.

Consider a small distance, dx , Fig. 64, at this point. The flux through the area of width, dx , and average length, 11.7 in., of the iron in field and armature is



FIG. 64.

$$d\phi = 8620 \times 11.7 dx = 101,000dx.$$

The speed of conductors at the armature periphery is $\pi D \times$ r.p.s. $= \pi \times 48 \times 10 = 480\pi$ in. per sec.

The time required for a conductor to go the distance dx , is

$$dT = \frac{dx}{480\pi}$$

$$\therefore e_{\text{induced}} = \frac{d\phi}{10^8 dT} = \frac{101,000dx}{10^8 \frac{dx}{480\pi}} = 1.53 \text{ volts}$$

per conductor, or 3.06 volts per coil.

This voltage opposes that due to self-induction, leaving as a resultant,

$$4.17 - 3.06 = 1.11 \text{ volts}$$

acting in the circuit.

Since experience has taught that two volts potential difference can be taken care of by the resistance of the carbon brush no difficulties from sparking need be anticipated.

CHAPTER XII

DIRECT-CURRENT GENERATORS IN PARALLEL AND SERIES

Shunt generators operate in parallel without the slightest difficulty. Generator No. 1 is first started and thrown on the line. Generator No. 2 is then brought up to about normal speed, the voltage is adjusted and the line switch is closed. Since generator and line voltage are the same, no-load is taken by generator No. 2. By adjusting the field excitation of No. 2 the generator takes the desired share of the load. As its load increases its engine slows down, the governor opens and the speed is restored to normal.

Series generators do not operate naturally in parallel. Assume, for example, that two series generators are in parallel, each taking its share of the total load. Suppose then that for some

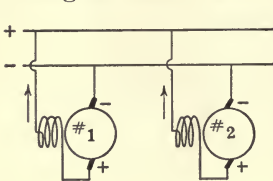

FIG. 65.

reason the voltage of No. 2 (Fig. 65) becomes slightly reduced. Its share of the load will fall off proportionately and, with this, its field excitation. Falling off of the field excitation further reduces the voltage and, consequently, the load, the excitation, and so on. The current is reduced to zero, then reversed in direction in both the field and the armature coils. The rotation of No. 2 remains the same, but the machine now acts as a series motor driving its engine. In practice, the rush of current during this period when the counter e.m.f. of generator No. 2 has been destroyed is so great that the circuit is opened by its fuses or circuit breakers. Series generators are not in common use, but this principle of instability in parallel operation applies equally to compound generators through their series field windings.

With shunt generators there is no such instability. If the voltage of No. 2 falls off, its current likewise is reduced. But the effect of reduced current is to lessen the armature reaction, thus

bringing up the voltage. The shunt field current is not affected since it is derived from the bus bars.

Series generators and, more particularly, compound generators may be made stable in parallel operation by the use of an "equalizer bus." This consists of a very heavy copper connection situated, as shown in Fig. 66, between the inner terminals of the series field circuits of the two (or more) generators. If, now, the voltage of No. 2 becomes reduced to a slight extent, current will flow from the + brush of No. 1 through the equalizer and into the series field coils of No. 2, maintaining the strength of the field of the latter.

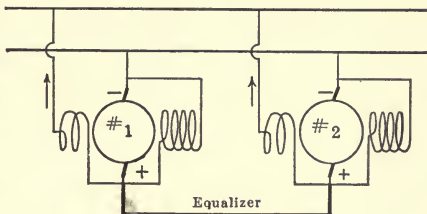

FIG. 66.

If the two generators, in normal operation, do not divide the load properly in the proportion of their respective ratings, this may be corrected by inserting resistance in the series field circuit of that generator which takes too much of the load. The effect of the equalizer is to put the series field coils always in parallel. The voltage across these coils is therefore the drop between the positive brushes and the positive bus. The resistance of the equalizer is so low that its drop is negligible, so that the drop across all the series field coils is the same. Putting a shunt or diverter around one of the series field coils has no effect on the distribution of the load on any particular generator, as it affects all the series field currents alike, the proportions remaining the same.

Direct-current Generators in Series.—No inherent difficulty is encountered in connecting direct-current generators in series. Owing to the limited possibilities of constructing commutators that will permit the generation of very high voltages, where these are required in direct-current machines recourse is usually had to series connection.

In electric railway work it is the general rule to employ both series and parallel connection of the motors to give flexibility in speed control.

The Three-wire System.—Two generators in series afford the simplest means of obtaining the three-wire system. This system, invented by EDISON, was devised to enable the use of large

numbers of low voltage incandescent lamps without, at the same time, entailing the use of a prohibitive amount of copper in the distribution system. As seen in Fig. 67, the voltage of the system is $2E$, while that across any element of the system is only E .

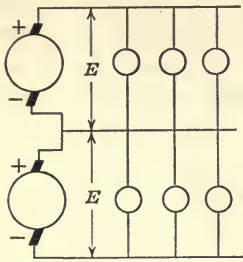

FIG. 67.

There are other ways by which power may be supplied to such a system. Thus, the source of power may be a single generator of voltage, $2E$, across whose terminals may be connected either a storage battery, as in Fig. 68, or two small generators mounted on the same shaft, called a balancer, and shown in Fig. 69. In either case the necessary condition is to have available some connection point the potential of which is intermediate between those of the outer wires.

The amount of current actually flowing in

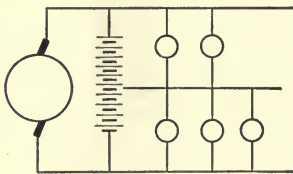

FIG. 68.

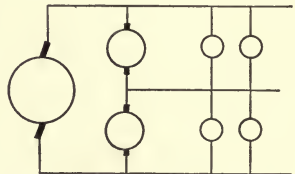

FIG. 69.

either the battery or the balancer set is small in case the two sides of the load are reasonably well balanced.

Another scheme consists in the use of the three-wire generator. This is illustrated in Figs. 70 and 71. Fig. 70 shows a bi-polar machine constructed by reversing the windings on two adjacent

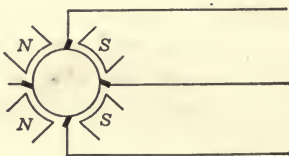

FIG. 70.

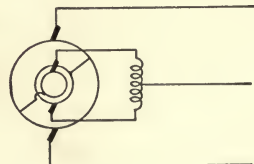

FIG. 71.

poles of a four-pole generator. The potentials of the two brushes on the horizontal axis are the same and are midway between the potentials of the two other brushes. The object of making the machine bi-polar is to give an intermediate inactive

belt along the commutator on which a brush may be placed without causing disruptive sparking. A better scheme is that of DOBROWOLSKY shown in Fig. 71. The armature is tapped at two opposite points which are connected, through slip rings, to a "choke" coil, which is simply an induction coil. This coil is wound upon a laminated iron core, and therefore is of high inductance. The e.m.f. impressed upon it is evidently alternating, and therefore very little alternating current can flow through the coil.

The middle point of the coil must always be at a potential midway between those of the brushes. It may therefore be connected to the middle wire of the system.

The disadvantage of using a battery is that some cells may be called on to supply more energy than others. It then becomes difficult to keep the battery uniformly charged, and deterioration results.

No such difficulty occurs with the use of balancers. They may be small, inexpensive machines, which when running idle take only a small current.

As an example of the use of balancers and the economy of the three-wire system, consider the circuit illustrated in Fig. 72.

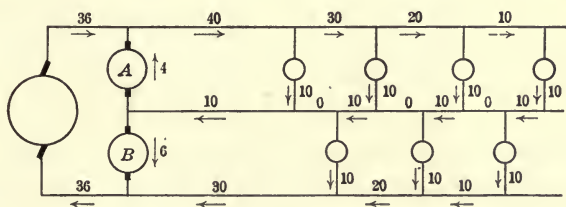

FIG. 72.

The load consists of 40 amp. on the upper branch and 30 amp. on the lower. The system is therefore unbalanced. Currents and directions of flow are indicated for each portion of the circuit. The current in the middle or neutral wire varies, being 10 amp. in some sections and 0 in others. Let it be assumed that the current required to run the balancer set is 1 amp. which would be indicated, if shown in the figure, by an arrow pointing downward in the balancer set. The current returning to the balancer over the middle wire is 10 amp. This current divides equally, 5 amp. flowing upward in balancer A, combining with its downward flowing 1 amp. to give $5 - 1 = 4$ amp. in A, and 5 amp.

flowing downward in B , combining with its downward flowing 1 amp. to give $5 + 1 = 6$ amp. in B . Current in A flows similarly to that in the main generator. Thus A acts as a generator, supplying 4 amp. to the load. Current in B flows in the opposite direction; thus B acts as a motor and drives A . The difference in current between that in B and that in A is 2 amp., which, when multiplied by E , the voltage across B , gives $2E$, the power required to drive the balancer set.

If the generator voltage be assumed as 200 (that is, $2E = 200$), then the generator output, or rating, if this be full-load, is $200 \times 36 = 7.2$ kw. The balancer, A , rating, as a generator, is $100 \times 4 = 0.4$ kw.; the balancer B , as a motor, receives input $= 100 \times 6 = 0.6$ kw. The line drop from the generator to the load is $(40 + 30)r = 70r$, where r is the resistance of each of the outer wires. The line loss, in transmission, is $(40^2 + 30^2)r = 2500r$.

If the entire load were on the two-wire system, the current in each wire would be 70 amp., the line drop, using the same size wires, would be $140r$, and the line loss would be $(2 \times 70^2)r = 9800r$. Comparing the two-wire system, using the same size of outer wire,

$$\frac{\text{drop, three-wire}}{\text{drop, two-wire}} = \frac{70}{140} = 0.5,$$

$$\frac{\text{loss, three-wire}}{\text{loss, two-wire}} = \frac{2500}{9800} = 0.255.$$

The middle wire, carrying 10 amp., has no effect on the total drop between the outer wires. It does have some effect in slightly unbalancing the voltage of the two branches of the system. Thus, assuming the voltage across the two machines of the balancer to be exactly equal, which is very nearly true, and taking this voltage as E , the voltage across each branch of the load may be found. Across the upper branch it is,

$$E - 40r - 10r = E - 50r.$$

Across the lower branch the voltage is

$$E - 30r + 10r = E - 20r.$$

The amount of unbalancing of the voltage is therefore

$$(E - 50r) - (E - 20r) = 30r.$$

To get a concrete idea of the amount of this unbalancing, let the line drop, $70r$, = 10 per cent. Then $30r = \frac{30}{70} \times 0.1 = 0.043 = 4.3$ per cent.

When the load consists of lamps it is necessary that the two branches shall be sufficiently well balanced to prevent excessive variation in voltage. This is usually very easily accomplished.

The middle wire adds, directly, a small amount to the line loss. In this instance, the loss in this wire is $\overline{10^2}r = 100r$.

The total loss in the system is therefore $2600r$, and the ratio of losses of the two systems is $\frac{2600}{9800} = 0.265$.

Where the percentage line drop or the percentage line loss is specified, and must be the same with either system, the advantage of the three-wire system is in the saving in the cost of copper. On that basis, let the calculations as already carried out for the three-wire system be assumed as fulfilling the requirements, that is,

$$\text{Line drop} = 70r.$$

$$\text{Line loss (two-wire)} = 2500r.$$

The two-wire system, to give equal line drop must be composed of wires determined by the equation,

$$2 \times 70 \times r' = 70r,$$

where r' = resistance of one wire of the two-wire system, and r , as before, is the resistance of one of the outer wires of the three-wire system. Then

$$r' = \frac{r}{2},$$

and each wire of the two-wire system will be twice as large as each outer wire of the three-wire system. Assuming the middle wire equal to the outer wire, the two-wire system will require four-thirds as much copper as the three-wire system.

Since, however, the variation in voltage is felt by all the lamps on the two-wire system, while on the other system approximately one-half the variation in voltage is felt by each branch, it is more reasonable to calculate on the basis of equal percentage drop in the two systems.

$$\begin{aligned} \text{Percentage drop, three-wire,} &= \frac{70r}{2E} = 35 \frac{r}{E} \\ \therefore \frac{2 \times 70r'}{E} &= 35 \frac{r}{E} \\ \frac{r'}{r} &= \frac{35}{140} = 0.25. \end{aligned}$$

For equal percentage drop, therefore, the two-wire system will require eight-thirds as much copper as the three-wire system.

On the basis of equal power loss in the outer wires,

$$\begin{aligned} 9800r' &= 2500r, \\ \therefore \frac{r'}{r} &= \frac{2500}{9800} = 0.255. \end{aligned}$$

Adding the middle wire, equal to an outer wire, the two-wire system will require $\frac{1}{0.255 + 0.1275} = 2.61$ times as much copper as the three-wire system.

Problem 31.—What saving in copper does the three-wire system give over the two-wire system, when the load is balanced, on the basis of (a) equal percentage line drop, (b) equal line loss?

1. Middle wire equal to outer wire.
2. Middle wire one-half of outer wire.
3. Show that with a balanced load no current flows in the middle wire.

Problem 32.—One hundred 60-watt tungsten lamps are to be supplied with power at 3 per cent. line loss. The line length is 600 ft. Lamp voltage is 120. The neutral wire is to be one-half the cross-section of each outer wire.

Find the size of the required wires, and show that the weight of copper is approximately 190 lb. Show that on the two-wire system 610 lb. would be required.

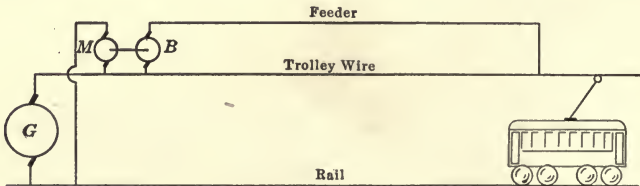

FIG. 73.

Boosters.—Generators are frequently connected in series for the purpose of regulating the voltage and equalizing it along a line in which there is considerable voltage drop.

Fig. 73 shows a simple arrangement of a street railway circuit in which a booster is used. The generator, *G*, supplies power

to the system, including that delivered directly to the car and that used in driving the motor *M*. The motor and booster form, usually, a directly connected set. One terminal of the booster is connected to the trolley wire at the station, the other is connected through a heavy feeder to some distant point on the trolley wire.

As an example of the effect of using a booster, consider the following:

Problem 33.—A trolley line 3 miles long is supplied with power by a generator at 600 volts. The trolley wire is of No. 00 B. & S. wire, having a resistance of 0.4 ohm per mile. The rail return has a resistance of 0.05 ohm per mile. A feeder, consisting of three No. 0000 B. & S. wires, of 0.087 ohm per mile, extends from the station to a point 2 miles distant, where it connects with the trolley wire. The booster voltage is maintained at 40. Find the voltage on the car as it proceeds from the distant end of the line toward the station, assuming that the current taken is at all times 200 amp.

Solution.—It will be of interest, first, to determine the voltage on the car at the distant end when the booster is disconnected.

Drop in the trolley wire is $200 \times 0.4 \times 3 = 240$ volts.

Drop in rail = $200 \times 0.05 \times 3 = 30$ volts.

∴ Voltage on car without booster = $600 - 270 = 330$.

This is to illustrate the necessity of doing something to improve the regulation of the line. With the booster connected, the problem becomes one for the application of KIRCHOFF'S laws.

The circuit is represented diagrammatically, in Fig. 74, for the case of the car at the end of the line. Arrows indicate arbitrary directions of flow of current. Let the voltage on the car be denoted by *E*.

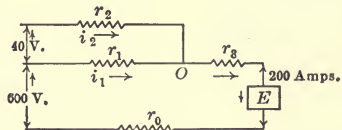

FIG. 74.

By KIRCHOFF'S laws,

$$i_1 + i_2 = 200$$

and

$$40 - i_2 r_2 + i_1 r_1 = 0,$$

whence, eliminating i_1 between the equations,

$$i_2 = \frac{200 r_1 + 40}{r_1 + r_2}$$

$$r_1 = 0.4 \times 2 = 0.8 \text{ ohm}$$

$$r_2 = 0.087 \times 2 = 0.174$$

$$r_3 = 0.4$$

$$r_0 = 0.05 \times 3 = 0.15$$

Substituting values,

$$i_2 = \frac{200 \times 0.8 + 40}{0.8 + 0.174} = 205 \text{ amp.}$$

$$i_1 = 200 - 205 = -5 \text{ amp.}$$

The equation of the mesh composed of the generator, r_1 , r_3 , E and r_0 is

$$600 = i_1 r_1 + 200 r_3 + E + 200 r_0.$$

Substituting values and solving for E ,

$$E = 600 + 4 - 80 - 30 = 494 \text{ volts.}$$

Thus, there is a total drop of 106 volts instead of 270 volts without the booster.

Now let the car be at the point, O , where the feeder joins the trolley wire. Evidently the same equations hold, and $i_2 = 205$ amp., $i_1 = -5$ amp.

$$r_0 \text{ is now } 0.05 \times 2 = 0.1 \text{ ohm.}$$

The mesh equation is now

$$\begin{aligned} 600 &= i_1 r_1 + E + 200 r_0. \\ \therefore E &= 600 + 4 - 20 = 584 \text{ volts.} \end{aligned}$$

When the car is at a point 1 mile from the generator, the current and voltage equations are:

$$i_1 + i_2 = 200$$

and

$$40 - i_2 \left(r_2 + \frac{r_1}{2} \right) + i_1 \frac{r_1}{2} = 0.$$

Solving for i_2 gives

$$i_2 = 123 \text{ amp.}$$

and

$$i_1 = 200 - 123 = 77 \text{ amp.}$$

The mesh equation of voltage is

$$600 = i_1 \frac{r_1}{2} + E + 200 r_0,$$

where r_0 is now 0.05 ohm.

$$\therefore E = 600 - 31 - 10 = 559 \text{ volts.}$$

Thus, it is seen that, by this simple connection of the booster to a point chosen more or less at random, the voltage has been rendered much more nearly uniform than it would be without the booster.

Problem 34.—As a further study of the booster problem, consider that in the above case the feeder is to be connected to the trolley wire at two points, namely, at 1.5 and 2.5 miles from the generator.

Find the voltage on the car at each half-mile point, and plot against distance from the generator.

CHAPTER XIII

DIRECT-CURRENT MOTORS

If two shunt generators connected in parallel supply power to a certain load, as in Fig. 75, the division of the load between the generators will depend upon their respective degrees of excitation.

By weakening the field of No. 1, it will take less of the load until, by continued weakening, it takes none at all and finally receives current from No. 2, thus being run as a motor.

With a change in direction of flow of current in the armature comes a change in the direction in which the armature tends to rotate due to its current, the direction of the field remaining constant in shunt machines.

As a generator the rotational force of the armature is counter to the actual direction of rotation which is due to the driving engine. However, the actual direction of rotation does not change when the machine ceases to act as a generator and becomes a motor.

With the series generator, reversal of the armature current also reverses the field. To obtain a generator action from a series motor, therefore, requires reversal of rotation.

It has been shown that, with generators, a forward shift of the brushes increases the armature demagnetization.

With a shunt motor the armature currents are reversed, the armature ampere-turns are reversed, and the effect of the armature, in shifting the resultant flux, is consequently reversed. Therefore, the brushes of a motor require to be given a backward shift. The effect of a backward shift on a motor, like the forward shift on a generator, is to increase the armature demagnetizing ampere-turns.

With direct-current motors, the impressed e.m.f. is the sum of the counter e.m.f. and the ir drop.

Thus, the fundamental equation is

$$E = E_i + ir$$

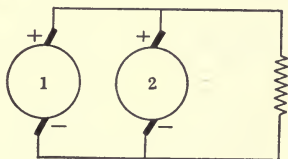

FIG. 75.

where E = impressed e.m.f.,

E_i = counter e.m.f.,

i = current,

and

r = resistance of armature, brushes, etc.

The generator equation (20) also applies to the counter e.m.f., since the counter e.m.f. is the generated e.m.f. of the motor due to the rotation of its armature conductors in the field.

$$\therefore E_i = \frac{4f\phi t}{10^8} = kf\phi,$$

where

$$k = \frac{4t}{10^8}.$$

Substituting this value of E_i ,

$$E = kf\phi + ir \quad (24)$$

whence

$$f = \frac{E - ir}{k\phi} \quad (25)$$

f = frequency. To transform frequency to speed,

$$f = \frac{\text{r.p.m.}}{60} \times \frac{p}{2},$$

where

p = number of poles.

For ordinary operation,

$$f = \frac{E}{k\phi}, \text{ approximately.}$$

There are three ways of changing the speed of a direct-current motor: (1) by changing E , the impressed voltage; (2) by changing ϕ by means of a field rheostat; (3) by changing ϕ by shifting the brushes.

Shifting the brushes is not an effective means of speed regulation since it introduces trouble from sparking at the brushes.

Types of Direct-current Motors.—The principal types of direct-current motors are known as shunt, series, cumulative-compound, in which the series and shunt turns act in the same direction, and differential-compound, in which the two field m.m.fs. are arranged to oppose each other.

Speed Characteristics of Direct-current Motors.—These are curves between speed and load, the latter being the independent variable. To determine the effect of load upon speed, in the case of shunt motors, it is seen from Eq. (25),

$$f = \frac{E - ir}{k\phi},$$

that an increased ir drop tends to reduce the speed. It has also been shown that ϕ is reduced by armature reaction, in proportion, roughly, to the load. Therefore, for shunt motors, the relation between the armature reaction and the ir drop will determine whether the motor will speed up or slow down with an increase of load. In general, if the magnetization of the field extends above the knee of the saturation curve, the motor will slow down, while below the knee the motor will speed up. Evidently, a degree of magnetization might be obtained which would result in practically constant speed.

The cumulative-compound motor slows down with increase of load, since the effect of the series turns is to strengthen the field.

The differential motor speeds up with increasing load, due to the opposition of the series and shunt field m.m.fs.

The series motor speed is governed almost entirely by its field, which is nearly proportional to the load current. At light loads, the speed becomes high and the operation of the motor is unstable. In Fig. 76 is shown a set of speed characteristic curves.

The student should be able to establish the general speed equations and derive curves for each type of motor.

Power and Torque.—Power input to the motor is obtained by multiplying Eq. (24) by i , thus

$$W_i = Ei = E_i i + i^2 r = kf\phi i + i^2 r.$$

In this, equation $E_i i$ represents the output of the motor in mechanical work, including bearing friction and windage; $i^2 r$ is the power lost as heat developed in the armature.

Expressed in horsepower, the output is

$$\text{Hp.} = \frac{E_i i}{746}.$$

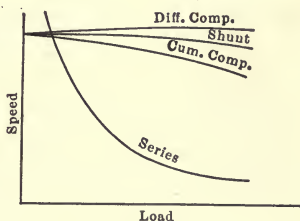

FIG. 76.

Horsepower may also be expressed as

$$\text{Hp.} = \frac{2\pi R n F}{33,000}$$

where R = radius of armature in feet,

n = revolutions per minute,

F = force in pounds on the armature conductors.

$2\pi n = \omega$ = angular velocity,

and $RF = T$ = torque.

Thus
$$\frac{E_i i}{746} = \frac{2\pi n T}{33,000}$$

and

$$T = \frac{33,000 E_i i}{2\pi n \times 746}$$

But output is also, by (24), $kf\phi i$.

$$\therefore T = \frac{33,000 kf\phi i}{2\pi n \times 746}$$

Also, since $f = \frac{pn}{120}$, where p = number of poles,

$$T = \frac{33,000 kp\phi i}{2\pi \times 746 \times 120} = 0.0587 kp\phi i = k'\phi i.$$

This expression may be reduced still further, since $k = \frac{4t}{10^8}$, where t = number of turns in series on the armature. Thus, for a motor of p poles and t turns in series,

$$T = 0.2348 tp\phi i \times 10^{-8} \text{ ft.-lb.}$$

Torque Characteristics.—From the above equation of torque it is possible to construct curves showing torque variation with load current. It is necessary, however, to be able to find the value of ϕ in each case. With shunt motors ϕ is nearly constant, and torque is therefore nearly proportional to current. With series motors ϕ increases with i , and torque therefore goes up as the square of the current, approximately.¹ Fig. 77 gives a set of torque characteristics for the four types of direct-current motor.

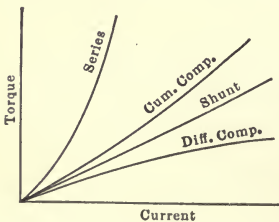

FIG. 77.

¹ When the field core becomes saturated, increase of current does not produce much increase of flux. Under heavy loads, therefore, the torque of a series motor increases more nearly in direct proportion to the current.

Problem 35.—Direct-current motors and generators being entirely similar as respects fundamental equations, armature reaction, etc., it is thought best to submit to the student the problem of the direct-current shunt motor instead of presenting it here in detail. Let the generator whose design was worked out in Chap. X be now considered as a shunt motor. The series turns will then be disconnected. With 250 volts impressed on the armature and maintaining constant shunt field amp.-turns of 7500, let it be required to calculate the speed and plot its values against those of the load current.

Choose current values of 0, 1000, 2000, 3000 amp. Assume a constant brush shift of 15°.

The fundamental speed characteristic, Eq. (20), has been found to be

$$f = \frac{E - ir}{k\phi},$$

where $f = \frac{\text{number of poles} \times \text{r.p.m.}}{2 \times 60} = \frac{pn}{120},$

E = impressed voltage,

r includes both armature and brush resistance.

$$k = \frac{4t}{10^8},$$

where t = number of turns per pole on the armature and ϕ is the flux cutting the armature conductors. For this last it is sufficiently exact to assume

$$\frac{\phi \text{ at load}}{\phi \text{ at no-load}} = \frac{\text{amp.-turns at load}}{\text{amp.-turns at no-load}}.$$

(See armature reaction, Chap. X.)

Problem 36.—The same problem as the preceding should now be worked out, using (1) $E = 270$ volts, (2) $E = 220$ volts.

Question.—What, in general, is the effect on shunt motors of increasing or lowering the terminal voltage, as regards (a) speed, (b) torque, (c) output, (d) efficiency?

Problem 37.—Let the above motor be calculated as a differential-compound machine, the series ampere-turns to be so adjusted as to give the same field strength at full-load as at no-load.

Plot speed vs. armature current for impressed voltage $E = 250$.

Problem 38.—Same as 37 only the motor is to be connected as cumulative compound.

Problem 39.—If, now, the entire field strength were determined by the series turns, so that at full-load there should be 10,427 series amp.-turns,¹ calculate and plot the speed for variation of load.

Series field circuit resistance may be taken as 0.00134 ohm.

Problem 40.—In problems 35, 37, 38 let the speed be maintained constant by variation of the shunt field current. Let this speed be that of the shunt motor at no-load ($E = 250$).

Plot curves between field current and load current.

Problem 41.—Show how to obtain constant speed by shifting the brushes, and work out numerically, as far as possible, the case of the shunt motor. Plot a curve between degrees of brush shift and load current.

¹ Same as required for the generator at full-load, Chap. X.

CHAPTER XIV

THEORY OF THE BALLISTIC GALVANOMETER

This particular type of galvanometer is of importance in magnetic measurements, especially in the determination of the hysteresis loop.

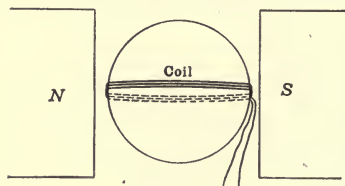

FIG. 78.

It consists, usually, of a coil of fine wire wound upon a steel cylinder, freely suspended between the poles of a magnet as illustrated in Fig. 78.

It has been shown that the force exerted on a wire carrying current, when placed in a field perpendicular to the lines of flux, is

$$F = Bli \text{ dynes,}$$

where i is current in abamperes, l is length of wire in centimeters and B is flux density in lines per square centimeter.

If the wire is one side of a rectangular loop, then the turning couple of the loop is

$$C = 2\rho Bli \text{ dyne-cm.}$$

When the loop is displaced by an angle, θ° , from the direction of the flux lines (Fig. 79), the couple is

$$C_\theta = 2\rho Bli \cos \theta = ABi \cos \theta,$$

where $A = 2\rho l = \text{area of the loop.}$

When the current is sent through the loop, the action of the couple produced is to turn the loop through an angle, θ . In order to oppose this action, a spring is so attached to the loop as to introduce an opposing couple, $k\theta$, which balances the swing of the loop. Then

$$k\theta = ABi \cos \theta$$

and

$$i = \frac{K\theta}{AB \cos \theta}$$

where k is a constant of the spring.

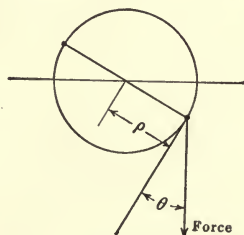

FIG. 79.

For small angles, $\theta = \sin \theta$. Substituting this,

$$i = \frac{k \sin \theta}{AB \cos \theta} = \frac{k}{AB} \tan \theta.$$

Thus, the current in the loop is directly proportional to the tangent of the angle of deflection; hence, the "tangent" galvanometer.

For small angles, also, $\theta = \tan \theta$.

$$\therefore i = \frac{k\theta}{AB} = k_1\theta.$$

Thus, the galvanometer may be used as an ammeter to measure directly the current, so long as the angle of deflection is kept small.

In the ballistic galvanometer the moving part is designed to have much inertia, so that its natural period of vibration shall be long in comparison with the time of change of the flux to be measured. Thus, a change of flux, produced in a sample of iron under test by altering the number of ampere-turns on the iron, will take place before the loop can move, that is, while $\theta = 0$ and $\cos \theta = 1$.

The couple on the loop is then

$$C = ABi,$$

which causes the loop to accelerate.

Therefore, ABi is the couple of angular acceleration, and

$$ABi = I_0 \frac{d\omega}{dt},$$

where I_0 = moment of inertia of the moving element, and ω = angular velocity.

But idt is the quantity of electricity flowing in any time, dt . Therefore the total quantity

$$Q = \int idt = \frac{I_0}{AB} \int d\omega = \frac{I_0 \omega_0}{AB} \quad (26)$$

where ω_0 is the final velocity attained.

The deflection is, however, limited by $k\theta$, the torsion of the spring. The work done in overcoming this torsion is then

$$W = \int_0^{\theta_0} k\theta d\theta = \frac{1}{2} I_0 \omega_0^2$$

where θ_0 is the maximum deflection.

Solving this equation,

$$\frac{k\theta_0^2}{2} = \frac{1}{2}I_0\omega_0^2$$

$$\theta_0 = \omega_0\sqrt{\frac{I_0}{k}}$$

But by (26),

$$\omega_0 = \frac{QAB}{I_0}$$

Substituting this value of ω_0 ,

$$\theta_0 = \frac{QAB}{\sqrt{I_0k}}$$

whence,

$$Q = \frac{\theta_0}{AB} \sqrt{I_0k} \quad (27)$$

In this equation all terms are constant except θ_0 , the maximum deflection of the loop.

If, now, the change of flux is $d\phi$ in a time dt , the e.m.f. induced in the coil surrounding this flux is

$$e = -\frac{N}{10^8} \frac{d\phi}{dt} = ir,$$

where N is the number of turns of the coil, r is the resistance of the circuit, and i is the current set up in the circuit.

Then, transposing,

$$idt = -\frac{Nd\phi}{r \times 10^8}$$

The total quantity of electricity set flowing by the change of flux is then

$$\begin{aligned} Q &= \int idt = -\frac{N}{r \times 10^8} \int_{\phi_m}^0 d\phi \\ &= -\frac{N}{r \times 10^8} [0 - \phi_m] = \frac{N}{r \times 10^8} \phi_m, \end{aligned}$$

whence, from (27),

$$\phi_m = \frac{Qr \times 10^8}{N} = \frac{\theta_0 r \times 10^8 \sqrt{I_0k}}{ABN}$$

is the maximum value of the flux.

There is thus a direct relation between flux and maximum deflection, and θ_0 is therefore a measure of the flux.

CHAPTER XV

VECTOR REPRESENTATION OF ALTERNATING-CURRENT WAVES

In Chap. VIII the graphical relationships of the waves of voltage and current in an alternating-current inductive circuit have been developed, and the values and meaning of average and effective values of a sine wave have been discussed.

The waves of Fig. 37 may also be represented as vector projections of their maximum values on the vertical axis, as shown in Fig. 80.

Since $i = I_m \sin \theta$ the length of the current vector is taken as I_m and the value, i , at any instant, is the vertical projection of I_m as it uniformly rotates, at speed $2\pi f$ about the origin.

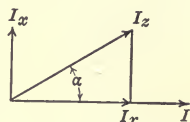

FIG. 80.

The vectors all have the same speed of rotation so that their relations to each other are constant. Hence their position in space at any desired instant may be chosen. Let that instant be when $\theta = 0$, in Fig. 37. Then $i = I_m \sin \theta = 0$, and I_m must be laid off horizontally. rI_m , the maximum value of the e.m.f. consumed by the resistance, since it is in time-phase with I_m , is also laid off horizontally; xI_m , the maximum value of the e.m.f. consumed by the inductive reactance, x , is 90° ahead of I_m , and is therefore laid off vertically upward. Thus xI_m is positive maximum when I_m is at zero, becoming positive. rI_m and xI_m may now be added vectorially, giving ZI_m or E_m which is the maximum value of e . E_m is seen to be placed at an angle α ahead of I_m , such that $\tan \alpha = \frac{xI_m}{rI_m} = \frac{x}{r}$. This relation is also of fundamental importance. The numerical value of E_m is obtained by the relation

$$E_m = \sqrt{I_m^2 r^2 + I_m^2 x^2} = I_m \sqrt{r^2 + x^2}$$

The quantity $\sqrt{r^2 + x^2}$ is called the impedance and is denoted by the letter z .

Problem 42.—Draw the vectors of e.m.f. and current of problem 28, Chap. VIII, and show that the angle of lag of current behind e.m.f. is $38^\circ 40'$.

In the representation of waves by vectors, the vectors are not, in reality, moved, but their relative positions in space are considered. Since no rotation is required, they may therefore be drawn in length equal to their effective values, and this is the common method of representation.

Also, since
$$(I_m z)^2 = (I_m r)^2 + (I_m x)^2 \quad (28)$$

$$z^2 = r^2 + x^2 \quad (29)$$

and the vector relationship holds for (29) as for (28). There can be constructed what is known as the impedance triangle, Fig. 81, in which $a = r$, $b =$

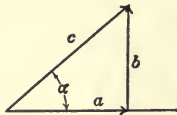

FIG. 81.

x , $c = z$, and $\tan \alpha = \frac{b}{a} = \frac{x}{r}$.

Thus,

$$r = z \cos \alpha,$$

$$x = z \sin \alpha.$$

Substituting these values in (19), $e = I_m(r \sin \theta + x \cos \theta)$, gives,

$$\begin{aligned} e &= I_m z (\sin \theta \cos \alpha + \cos \theta \sin \alpha) \\ &= I_m z \sin (\theta + \alpha), \end{aligned}$$

or, substituting for θ , its equivalent, ωt ,

$$e = I_m z \sin (\omega t + \alpha), \quad (30)$$

in which ωt is a variable angle depending on t , and α is a constant angle determined by the relative values of x and r . Eq. (30) shows that e , like i , is a sine wave quantity, but that there is a constant angular or phase difference, α , between them. α is called the angle of lead or lag, depending on whether it is positive or negative.

The relations indicated in Fig. 81 may also be expressed by the notation of complex quantities.

Thus,

$$c = a + jb.$$

The addition of the letter j to the equation simply means that the quantity, b , is to be drawn vertically upward. If it were $-j$, b would be drawn vertically downward. A dot is put under

c which means that c is dealt with as a vector quantity. Without the dot, the scalar or numerical value of c , only, is meant.

Thus,

$$c = \sqrt{a^2 + b^2}.$$

Problem 43.—Show graphically that $3-j3$ is a vector of length 4.24, which makes an angle of -45° with the horizontal axis. Show that a vector of length 12, at angle 120° , is represented by the expression, $-6 + j10.4$.

Calculate and draw the following vectors: $c = 3 - j2$, $c = 4 + j$, $c = -2 + j3$, $c = -4 - j2$.

j also means a rotation of 90° in the positive or counterclockwise direction. If the vector, a , is multiplied successively by j , several times, its direction is shown as follows:

Vector	Angle
a	0°
ja	90°
$jja = -a$	180°
$jja = -ja$	270°
$jja = a$	$360^\circ = 0^\circ$

Thus may be written,

$$j^2 = -1,$$

whence

$$j = \sqrt{-1}.$$

or, j is identical with i , used commonly in mathematics to denote imaginary quantities.¹

If it is desired to rotate a through 30° , we can write

$$a = a \cos 30^\circ + j a \sin 30^\circ.$$

To rotate α° correspondingly,

$$\begin{aligned} a &= a \cos \alpha^\circ + j a \sin \alpha^\circ, \\ &= a (\cos \alpha^\circ + j \sin \alpha^\circ). \end{aligned}$$

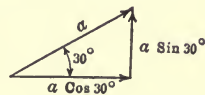

FIG. 82.

Suppose a is first rotated 30° , then 60° more. Then $a' = a (\cos 30^\circ + j \sin 30^\circ) (\cos 60^\circ + j \sin 60^\circ)$.

Problem 44.—Prove that this double rotation results in

$$a' = ja$$

Consider the simple case of alternating current in an inductive resistance, Fig. 83, where current, I , resistance, r , and reactance,

¹ In electrical engineering j is used instead of i , because i is used to denote current.

x , are known. I is chosen as the zero vector. Then $I = i$. Frequently it is well to choose as the zero vector, or vector drawn at 0° , some known quantity. In order to determine the positions of the vectors of electromotive force, etc., with respect to the zero vector, there are two rules, previously brought out, which are important to remember:

Rule I.—The e.m.f. consumed by resistance is in time-phase with the current, and in the same direction.

Rule II.—The e.m.f. consumed by inductive reactance is in time-phase 90° ahead of the current

By these rules may be drawn the vector diagram, Fig. 84, in which the vector sum of ix and ir is iz , which is the total electromotive force consumed.

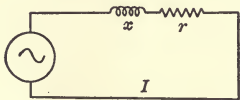

FIG. 83.

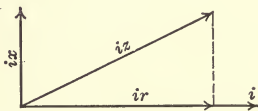

FIG. 84.

This electromotive force consumed, or vector E , numerically equal to iz , is represented by the relation

$$E = ir + jix = i(r + jx).$$

The impedance is thus expressed as $r + jx$, and it is a vector of magnitude $z = \sqrt{r^2 + x^2}$, and the angle between the impedance and the resistance is defined by the relations.

$$z \cos \alpha = r$$

and

$$\tan \alpha = \frac{x}{r}.$$

The e.m.f. consumed in the circuit is, in general,

$$E = IZ = (i \pm j'i')(r + jx).$$

The current may or may not be chosen as the zero vector. If it is so chosen, $I = i$. If not, then $I = i \pm j'i'$, where i' is the wattless component of the current.

The impedance is always $z = r + jx$.

Assigning positive or negative values to the wattless component i' , we may write, in any case,

$$I = i + j'i'.$$

It should be remembered that a leading component requires a + sign, and a lagging component requires a - sign.

Therefore,
$$E = IZ = (i + j'i')(r + jx) = ir - i'x + j(i'r + ix) \tag{31}$$

If the current is taken as the zero vector, then

$$E = i(r + jx) \tag{32}$$

In the general expression (31), an arbitrary zero line is chosen, as in Fig. 85. In the simpler case (32), the direction of I is chosen as the zero line, whence $I = i$ and $i' = 0$, and the vector diagram becomes that of Fig. 86.

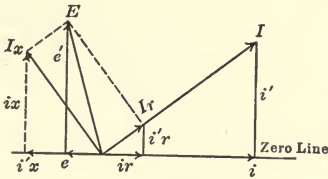

FIG. 85.

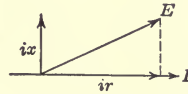

FIG. 86.

Problem 45.—One ampere flows in a circuit of 1 ohm resistance and a variable reactance. Plot curves of Ir , Ix , Iz drops and phase angle against x , when x varies from 0 to 5 ohms. Take I as the zero vector. Then $I = i = 1$.

Solution.—

$$i = 1; r = 1; i'r = 1; z = \sqrt{r^2 + x^2}; \tan \alpha = \frac{x}{r}$$

Tabulating:

x	0	0.5	1	2	3	4	5
ix	0	0.5	1				
z	1	1.12					
iz	1	1.12					
$\frac{x}{r}$	0	0.5					
α°	0	26° 35'					

The blank spaces may be filled in by the student.

Consider the same case, Fig. 79, but with E known and I unknown. E , then, may conveniently be chosen as the zero vector, and

$$I = \frac{e}{z} = \frac{e}{r + jx} = \frac{e(r - jx)}{(r + jx)(r - jx)} \tag{33}$$

The last expression of (33) is obtained in accordance with a third rule, as follows:

Rule III.—Never allow an equation to remain with a complex denominator. Thus (33) becomes

$$I = \frac{e(r - jx)}{r^2 + x^2} = e(g + jb) \quad (34)$$

where

$$g = \frac{r}{r^2 + x^2} = \frac{r}{z^2}, \quad b = -\frac{x}{z^2}. \quad (35)$$

$g + jb = Y$, is called the admittance; g is called the conductance, and b the susceptance of the circuit. The diagram of currents may now be drawn to correspond with Fig. 87, for e.m.fs., in which eg is the component of the current in phase with e , that is, it represents energy expended, and $-eb$ is the component 90° behind e , called the reactive or wattless component because it does not represent any expenditure of energy.

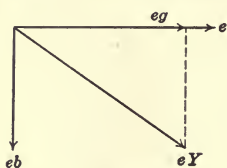

FIG. 87.

The power input to the circuit is then

$$\text{Power input} = e \times eg = e^2g,$$

and this is found equal to I^2r .

The numerical value of the current = $I = e\sqrt{g^2 + b^2}$.

Problem 46.—Let $E = e = 1$; $x = 1$; r varies from 0 to 10. Plot curves of I vs. r , and I^2r vs. r .

Calculate the maximum value of the power loss and find the value of the resistance which gives the greatest dissipation of power.

Plot the 3 current waves, that is, the power current, eg , wattless current, eb , and total current, ey , for the condition of maximum power loss.

Solution.—

$$E = e = 1; \quad x = 1; \quad I = \frac{e}{\sqrt{r^2 + x^2}} = \frac{1}{\sqrt{1 + r^2}} = \frac{1}{z}.$$

$$g = \frac{r}{z^2}; \quad b = -\frac{x}{z^2}; \quad y = \frac{1}{z}.$$

Tabulating:

r	0	2	4	6	8	10
Z	1	2.27	4.12			
I	1	0.44	0.242			
I^2	1	0.194				
I^2r	0	0.388				

Power,
$$W = I^2 r = \frac{e^2}{z^2} r = e^2 \frac{r}{r^2 + x^2}$$

$$\frac{dW}{dr} = e^2 \left[\frac{(r^2 + x^2) - 2r^2}{(r^2 + x^2)^2} \right] = \frac{x^2 - r^2}{(x^2 + r^2)^2}$$

For maximum power $\frac{dW}{dr} = 0$. $\therefore x^2 - r^2 = 0$, and $r^2 = x^2$. $\therefore r^2 = 1$,
 $r = 1$, and $W = 1 \times \frac{1}{1+1} = 0.5$ watt.

To get current waves for maximum power loss, then

$$r = 1; x = 1; Z = 1.41.$$

$$I = \frac{e}{r + jx} = \frac{e(r - jx)}{r^2 + x^2} = \frac{er}{Z^2} - j \frac{ex}{Z^2} = e(g + jb)$$

where
$$g = \frac{r}{Z^2} \text{ and } b = -\frac{x}{Z^2}$$

The effective values of current are, therefore,

$$eg = 1 \times \frac{1}{2} = 0.5, \text{ in phase with } e,$$

$$jeb = -je \frac{x}{Z^2} = -j 1 \times \frac{1}{2} = -j0.5, \text{ or } 0.5, 90^\circ \text{ behind } e,$$

$$e(g + jb) = eY = \frac{e}{Z} = \frac{1}{\sqrt{2}} = 0.707, \text{ lagging behind } e, \text{ by an angle } \tan^{-1} \frac{x}{r} = 45^\circ.$$

Maximum values are $E_m = \sqrt{2}E = 1.41$,
 $(Eg)_m = 0.707$; $(Eb)_m = 0.707$; $(EY)_m = 1$.

Circuit of Resistance in Series with an Inductive Impedance.—The impressed e.m.f., E , of the circuit is known, also the resistance, r , and impedance, $Z_1 = r_1 + jx_1$ (Fig. 88). E is taken as the zero vector. Then,

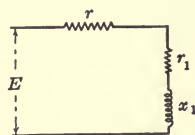

FIG. 88.

$$I = \frac{e}{r + Z_1} = \frac{1}{r + r_1 + jx_1} = \frac{e}{r_0 + jx_1} = e(g + jb),$$

where

$$g = \frac{r_0}{Z_0^2}; b = -\frac{x_1}{Z_0^2}; Z_0^2 = r_0^2 + x_1^2$$

and $r_0 = r + r_1$.

The drop across the impedance, Z_1 , is

$$E_1 = I Z_1 = e(g + jb) (r_1 + jx_1)$$

$$e(gr_1 + jgx_1 + jbr_1 - bx_1)$$

$$e(gr_1 - bx_1 + j(gx_1 + br_1))$$

$$e(a_0 + jb_0),$$

where $a_0 = gr_1 - bx_1$; $b_0 = gx_1 + br_1$.

Problem 47.—In the above circuit, Fig. 88, let $E = 10$, $r = 1$, $r_1 = 0.5$, $x_1 = 2$.

Draw the vector diagram and waves of e , E_1 and I .

Circuit of Two Inductive Impedances in Parallel.—Let E , Z_1 and Z_2 be known (Fig. 89). To determine I , I_1 and I_2 .

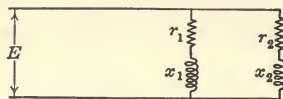

FIG. 89.

We have:

$$\begin{aligned} \dot{I}_1 &= eY_1, & \dot{I}_2 &= eY_2, \\ \dot{I} &= \dot{I}_1 + \dot{I}_2 = e(Y_1 + Y_2). \end{aligned}$$

Or,

$$\begin{aligned} \dot{I}_2 &= e(g_1 + jb_1), \\ \dot{I}_2 &= e(g_2 + jb_2), \\ \dot{I} &= e(g_1 + g_2 + j(b_1 + b_2)) = e(G + jB), \end{aligned}$$

where

$$\begin{aligned} g_1 &= \frac{r_1}{z_1^2}, & g_2 &= \frac{r_2}{z_2^2}, \\ b_1 &= -\frac{x_1}{z_1^2}, & b_2 &= -\frac{x_2}{z_2^2}, \\ G &= g_1 + g_2, & B &= b_1 + b_2. \end{aligned}$$

$\text{Tan } \alpha = \frac{B}{G}$, gives the phase relation of I and e .

Problem 48.—In the circuit of Fig. 89, let $E = 1$, $r_1 = 1$, $x_1 = 0.5$, $r_2 = 2$, $x_2 = 2$.

Draw vector diagrams and waves of E , Eg , Eb , and I .

CHAPTER XVI

THE SYMBOLIC METHOD IN TRANSMISSION LINE CALCULATION

KENNELLY AND STEINMETZ have introduced the so-called symbolic method of representing electrical relations.

This method is neither vector analysis nor quaternions, but is in many ways similar to both. It enables the use of simple algebraic transformation when dealing with vector quantities of the same rate of rotation or frequency. Thus, it is directly applicable when, for instance, multiplying a current by an impedance, since the resultant e.m.f. is of the same frequency as the current. But when multiplying current and e.m.f., it is applicable only after some modification, since the product represents power, which is a vector of double frequency.

Addition.—Let there be two vectors,

$$a_1 + ja_2, \text{ and } b_1 + jb_2, \text{ and let their sum be a vector } C.$$

Then,

$$C = a_1 + ja_2 + b_1 + jb_2 = a_1 + b_1 + j(a_2 + b_2) = c_1 + jc_2,$$

where

$$c_1 = a_1 + b_1 \text{ and } c_2 = a_2 + b_2.$$

Multiplication.—We have, evidently,

$$(a_1 + ja_2)(b_1 + jb_2) = a_1b_1 - a_2b_2 + j(a_1b_2 + b_1a_2) = d_1 + jd_2,$$

where

$$d_1 = a_1b_1 - a_2b_2; \quad d_2 = a_1b_2 + b_1a_2.$$

In general, if $a_1 + ja_2 = b_1 + jb_2$ then $a_1 = b_1$ and $a_2 = b_2$.

Power.—At any instant,

$$p = ei,$$

where e and i are instantaneous values of voltage and current.

In the case of sine waves, where $e = E_m \sin \omega t$ and $i = I_m \sin(\omega t + \alpha)$,

$$p = ei = E_m I_m \sin \omega t \sin(\omega t + \alpha).$$

Problem 49.—Plot waves of voltage and current, and by multiplying their values at certain instants along the curves show that the resulting power curve is a sine wave of double frequency.

Let $E_m = 1.4$, $I_m = 0.7$

(1) $\alpha = 0^\circ$

(2) $\alpha = 45^\circ$

(3) $\alpha = 90^\circ$.

Fig. 90 shows the curves plotted for the case of $\alpha = 0^\circ$. The energy developed in the circuit, in any time dt is pdt . The total energy during a cycle is then $\int_0^T pdt$, where T is the time of one complete cycle. But this is the area enclosed by the power curve and axis, shown shaded. As the values of power are always positive, the area represents energy expended, or work done.

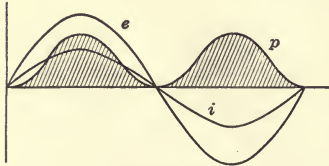

FIG. 90.

The student should show that when α is not 0, there is also negative power, which represents energy returned to the source, the total energy expended during a cycle being the difference between the positive and negative areas enclosed by the power curve and the axis.

Average Value of Power during a Period.—This will be,

$$\begin{aligned} P &= \frac{1}{T} \int_0^T pdt \\ &= \frac{1}{T} \int_0^T E_m I_m \sin \omega t \sin (\omega t + \alpha) dt, \end{aligned}$$

which, the student should show, is

$$P = \frac{E_m I_m}{2} \cos \alpha.$$

This may be written

$$P = \frac{E_m}{\sqrt{2}} \frac{I_m}{\sqrt{2}} \cos \alpha = EI \cos \alpha \quad (36)$$

where E and I are effective values as usual.

Thus the important result is found, that, in case of sinusoidal current and voltage waves, the average power is equal to the effective value of the current times the effective value of the voltage into the cosine of the phase angle between the two. This is illustrated in Fig. 91, and it is seen that when I is zero vector = i , $P = EI \cos \alpha = eI = ei$. Similarly, when E is zero vector = e , $P = Ei = ei$.

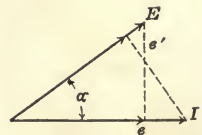

FIG. 91.

Power is obtained by multiplying either quantity by the projection of the other upon it.

In general, if E makes an angle γ , and I an angle β with the zero axis,

where $\alpha = \beta - \gamma$,

Therefore, $\beta > \gamma$.

$$P = EI \cos \alpha = EI \cos (\beta - \gamma) = EI (\cos \beta \cos \gamma + \sin \beta \sin \gamma) \tag{36}$$

But $\cos \beta = \frac{i}{I}$; $\cos \gamma = \frac{e}{E}$;

$$\sin \beta = \frac{i'}{I}$$
; $\sin \gamma = \frac{e'}{E}$.

Substituting these values in (36)

$$P = ei + e'i' \tag{37}$$

which is the general expression for the average power.

Example.—Let $E = e + je'$

$$I = i + ji'$$

Then by (37) $P = ei + e'i'$.

Suppose, however, that we carry out the multiplication of the vectors. Thus,

$$\begin{aligned} EI &= (e + je')(i + ji') \\ &= ei - e'i' + j(ei' + e'i). \end{aligned}$$

The numerical value of this expression is

$$\sqrt{(ei - e'i')^2 + (e'i + ei')^2}$$

which is obviously not the same as (37), neither is its real component the power, since it has a minus sign.

It has been shown in Fig. 90, that power is a quantity of double frequency. It can therefore have no phase relationship with E or I . Hence, in the case of power or any double frequency quantity, the operation of multiplying single frequency quantities is inadmissible.

On the other hand, it is known that the product

$$(i - ji')(r + jx) = E$$

is quite correct, since the fundamental frequency only is involved.

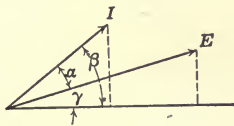

FIG. 92.

The operation of obtaining the power from two vectors E and I , is called "telescoping" the vectors. Thus, the product of the "real" components is added to the product of the "imaginary" components, without any change of sign due to the presence of j .

Power Factor.—In the expression for power (36) the term $\cos \alpha$ is called the power factor. The product EI represents true power only in certain special cases, particularly with direct currents.

Power factor may be defined as the ratio $\frac{\text{true power}}{\text{apparent power}}$, where apparent power = EI .

EI is also called the volt-amperes.

Since $EI \cos \alpha$ is the true power,

$$\text{power factor} = p.f. = \frac{EI \cos \alpha}{EI} = \cos \alpha.$$

Transmission Line Calculation.—The calculation of circuits may now be continued to include the case which represents a simple transmission line possessing concentrated resistance and inductive reactance, being supplied with power at one end by a generator, or source of alternating current, and terminating at the other end in any prescribed load. A customer usually desires constant voltage, E , at the load.

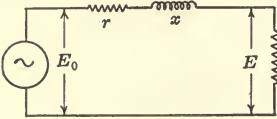

FIG. 93.

In Fig. 93 is shown a generator supplying power over a transmission line of impedance, $Z = r + jx$, at voltage E_0 to a load, the current of which is $i + ji'$ at voltage E . E and i are in time phase; E and i' are in time quadrature.

(1) Let E be known, and be taken as the zero vector, = e . Then, the voltage at the generator terminals,

$$\begin{aligned} E_0 &= e + IZ = e + (i + ji')(r + jx) \\ &= e + ir + jix + ji'r - i'x \\ &= e + ir - i'x + j(ix + i'r) = a + jb, \end{aligned}$$

where

$$\begin{aligned} a &= e + ir - i'x, \\ b &= ix + i'r. \end{aligned}$$

The power factor of the load, $\cos \alpha = \frac{ei}{eI} = \frac{i}{I}$.

Generator volt-amp. = IE_0 .

Power of Generator.— $P_0 = E_0I \cos \gamma$, where γ is the angle between E_0 and I .

Vector relationships are shown in Fig. 94: (a), for leading and (b), for lagging current. In the first case

$\gamma = \alpha - \beta$ is the angle between E_0 and I .

$$\therefore \cos \gamma = \cos (\alpha - \beta) = \cos \alpha \cos \beta + \sin \alpha \sin \beta.$$

But $\cos \alpha = \frac{i}{I}$, and $\sin \alpha = \frac{i'}{I}$.

Likewise, $\cos \beta = \frac{a}{E_0}$ and $\sin \beta = \frac{b}{E_0}$.

$$\therefore \cos \gamma = \frac{1}{IE_0} (ia + i'b).$$

Substituting this value into the equation for power of generator,

$$P_0 = E_0I \cos \gamma = ia + i'b.$$

P_0 could be more quickly obtained by simply telescoping the vectors $a + jb$ and $i + ji'$.

$$\text{Power factor at the generator} = \frac{\text{power}}{\text{volt-amp.}} = \frac{P_0}{E_0I}.$$

$$\text{Efficiency of transmission} = \frac{Ei}{P_0}.$$

$$\text{Apparent efficiency} = \text{ratio, } \frac{\text{output}}{\text{V.A. input}} = \frac{Ei}{E_0I}.$$

$$\text{Regulation} = \frac{E_0 - E}{-E}.$$

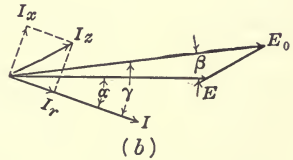
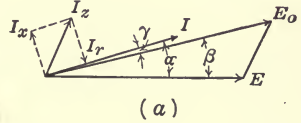

FIG. 94.

Having obtained the general expression for the various quantities which enter in, we may now take a specific example of transmission line calculation.

Problem 50.—In Fig. 93, let $E = 1$, $r = 0.1$, $x = 0.2$, $i = 1$.

Let i' vary from -1 to $+1$.

Determine all the quantities, *i.e.*, current, generator voltage, volt-amperes, power factor, power, transmission efficiency, apparent efficiency and regulation.

Tabulating:

i'	-1.0	-0.75	-0.5	-0.25	0.0	0.25	0.5	0.75	1.0
ir	0.1	0.1	0.1	0.1	0.1	0.1	0.1	0.1	0.1
$-i'x$	0.2	0.15	0.1	0.05	0.0	-0.05	-0.1	-0.15	-0.2
a	1.3	1.25	1.2	1.15	1.1	1.05	1.0	0.95	0.9
ix	0.2	0.2	0.2	0.2	0.2	0.2	0.2	0.2	0.2
$i'r$	-0.1	-0.075	-0.05	-0.025	0.0	0.025	0.05	0.075	0.1
b	0.1	0.125	0.15	0.175	0.2	0.225	0.25	0.275	0.3
a^2	1.69	1.56	1.44	1.32	1.21	1.10	1.0	0.90	0.81
b^2	0.01	0.0156	0.0225	0.0306	0.04	0.0506	0.0625	0.0756	0.09
$a^2 + b^2$	1.7	1.5756	1.4625	1.3506	1.25	1.1506	1.0625	0.9756	0.9
$\sqrt{a^2 + b^2}$	1.31	1.25	1.21	1.16	1.12	1.08	1.03	0.985	0.95
E_0	1.31	1.25	1.21	1.16	1.12	1.08	1.03	0.985	0.95
i'^2	1.0	0.56	0.25	0.0625	0.0	0.0625	0.25	0.56	1.0
$i^2 + i'^2$	2.0	1.56	1.25	1.0625	1.0	1.0625	1.25	1.56	2.0
$\sqrt{i^2 + i'^2}$	1.41	1.25	1.12	1.03	1.0	1.03	1.12	1.25	1.41
I	1.41	1.25	1.12	1.03	1.0	1.03	1.12	1.25	1.41
E_0I	1.85	1.56	1.36	1.23	1.12	1.11	1.15	1.23	1.34
i/I	0.707	0.8	0.895	0.94	1.0	0.94	0.895	0.8	0.707
ai	1.3	1.25	1.2	1.15	1.1	1.05	1.0	0.95	0.9
bi'	-0.1	-0.0937	-0.075	-0.0437	0.0	0.0563	0.125	0.206	0.3
P_0	1.2	1.156	1.125	1.106	1.1	1.106	1.125	1.156	1.2
i'/i	-1.0	-0.75	-0.5	-0.25	0.0	0.25	0.5	0.75	1.0
$\tan \alpha$	-1.0	-0.75	-0.5	-0.25	0.0	0.25	0.5	0.75	1.0
α	45°	37°	26° 30'	14°	0°	14°	26° 30'	37°	45°
$\cos \alpha$	0.707	0.8	0.895	0.94	1.0	0.94	0.895	0.8	0.707
P_0/E_0I	0.65	0.742	0.827	0.9	0.982	0.999	0.978	0.941	0.895
$\cos \gamma$	0.65	0.742	0.827	0.9	0.982	0.999	0.978	0.941	0.895
$\text{Eff.} = \frac{Ei}{P_0}$	0.834	0.864	0.89	0.903	0.907	0.906	0.89	0.865	0.835
App. eff. = $\frac{Ei}{E_0I}$	0.54	0.64	0.735	0.813	0.894	0.9	0.87	0.813	0.74
Regulation = $\frac{E_0 - E}{E}$	0.31	0.25	0.21	0.16	0.12	0.08	0.03	-0.015	-0.05

Problem 51.—Draw vector diagrams for the cases of $i' = -1, -0.5, 0, 0.5, 1$, of problem 50 showing the relative positions of E_0, E and I . Also plot the curves of regulation vs. power factor of generator and load.

The preceding example, like many others included in this book, is constructed on the basis of percentages. That is, by choosing $e = 1$ and $i = 1$, whence $p = ei = 1$, the results obtained may be made to apply to any case in which the constants, r and x , give the same percentage of ri and xi drops. In this example, $\frac{ri}{e} = 0.1 = 10$ per cent., $\frac{xi}{e} = 0.2 = 20$ per cent.

If, now, 10 per cent. resistance drop and 20 per cent. reactance drop be specified, let it be required to find, with varying power factor of the load, the same quantities determined in problem 50, when $e = 2200$ volts and $i = 300$ amp.

All that is necessary, now, is to multiply those quantities representing voltage by 2200, those representing current by 300, and those representing watts, or volt-amperes, by $2200 \times 300 = 660,000$.

Thus, for $i' = -1 \times 300 = -300$, $E_0 = 1.31 \times 2200 = 2882$, $I = 1.41 \times 300 = 423$, $E_0 I = 1.85 \times 660,000 = 1,221,000$, $P_0 = 1.2 \times 660,000 = 792,000$.

The other quantities sought—power factor of load and of generator, efficiency, apparent efficiency and regulation—are the same as already calculated.

The advantages of problems on the percentage basis are thus quite obvious.

Problem 52.—A transmission line 1 mile long supplies power to a load of 100 kw. and 1000 volts at power factor of 0.8 and frequency of 60 cycles.

The line is composed of two parallel No. 000 B. & S. wires, 18 in. apart.

Find generator voltage, current, power factor, power output, line efficiency, apparent efficiency, regulation, with the current both lagging and leading.

The resistance of No. 000 B. & S. hard-drawn copper wire may be taken as 0.06 ohm per 1000 ft. at 20°C.

The reactance is $2\pi fL$, where L is the inductance, in henrys, per centimeter length of wire. L may be calculated from the formula,

$$L = \frac{\frac{1}{2} + 2 \log_e \frac{D-r}{r}}{10^9}$$

where D and r are, respectively, the distance between centers of wires and the radius of the wire (Fig. 95).

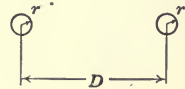

FIG. 95.

CHAPTER XVII

CONSTANT POTENTIAL—CONSTANT CURRENT TRANSFORMATION

It is sometimes desirable that the current in a circuit shall remain constant while the load varies. In series lighting circuits, for example, the current through each lamp must be nearly constant, while the number of lamps may vary from none at all up to the most that the system can sustain. Generally, however, it is desirable that the energy shall be supplied from a source of constant potential, such as a constant potential generator. Such a system is possible with a circuit arrangement like that shown in Fig. 96. Here, a high resistance, r , is placed in series with the lamps. When the lamps are comparatively few, changing their number will not alter the total resistance of the circuit very much, and the current will therefore be fairly constant.

This arrangement is not, however, economical, as a large proportion of the power developed is always lost in the resistance, r .

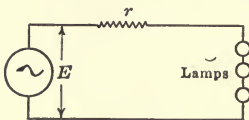

FIG. 96.

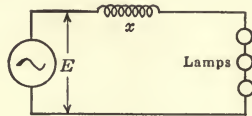

FIG. 97.

We may, therefore, try substituting inductive reactance, x , for r , and determine if this will give better results.

In this case, Fig. 97, let the generator voltage be unity, that is $e = 1$. Let the largest value of the permissible current in the circuit also be unity, that is, $I = 1$, and let the resistance of the lamps, that is, the number of the lamps, vary. We may then find the maximum resistance of the lamps which may be obtained without reducing the current lower than, say, 0.925, which will be considered the minimum, permissible current. The current is obviously a maximum when the resistance is zero, that is, when no lamps are used.

Then,

$$x = \frac{e}{I} = \frac{1}{1} = 1 \text{ ohm.}$$

Let r be the resistance of the lamps. r is variable, depending on the number of lamps in circuit at any time.

Let E be made the zero vector, $= e$.

Then
$$I = \frac{e}{z} = \frac{e}{r + jx} = \frac{e(r - jx)}{r^2 + x^2}$$

$$= e(a + jb)$$

where
$$a = \frac{r}{r^2 + x^2}, \quad b = -\frac{x}{r^2 + x^2}$$

$$I = e\sqrt{a^2 + b^2}. \tag{38}$$

Tabulating for varying r :

r	0	0.1	0.2	0.4	0.6	0.8	1
$r^2 + x^2$	1	1.01	1.04	1.16	1.36	1.64	2.0
a	0	0.099	0.192	0.345	0.441	0.488	0.5
b	-1	-0.99	-0.96	-0.861	-0.735	-0.61	-0.5
a^2	0	0.0098	0.0369	0.119	0.195	0.238	0.25
b^2	1	0.98	0.921	0.741	0.54	0.373	0.25
$a^2 + b^2$	1	0.9898	0.9579	0.86	0.735	0.611	0.5
$\sqrt{a^2 + b^2}$	1	0.994	0.978	0.927	0.857	0.782	0.707
I	1	0.994	0.978	0.927	0.857	0.782	0.707

It is evident from the calculation that the limit of current is reached by a resistance of 0.4 ohm. This resistance could evidently be obtained by directly substituting the value $I = 0.925$ into Eq. (38) and solving for r . However, it is frequently preferable to carry out the tabulation, thus gaining the material for plotting the curves. These curves are far more instructive than the mere numerical answer.

In this case, where reactance has been used instead of resistance in order to obtain (approx.) constant current, all the energy is consumed in the lamps themselves since the reactance (assuming zero resistance) does not consume any energy. Thus the system is efficient. However, the power factor appears to be very low.

Problem 53.—Determine the power factor of the circuit and plot it against the resistance of the lamps.

Altogether, it may be said that in practice this arrangement is cheap and practical. A constant-current "tub" transformer has a higher power factor, but is also more expensive. In this machine regulation is obtained by altering the reactance in the circuit by means of the repulsion between the primary and the secondary coils.

Problem 54.—A constant-current system is supplied with power by a

generator at 2300 volts and 60 cycles. The line resistance is negligible. Each lamp has 6 ohms resistance. Current must be maintained between the limits of 7.2 and 6 amp.

Find the maximum number of lamps, both by the "resistance" and by the "reactance" method of obtaining constant current. Plot and compare curves of number of lamps vs. current for the 2 cases.

Solution.—(a) Resistance method.

Let r = res. in series, r_L = res. of lamps.

$$\text{Then } r = \frac{2300}{7.2} = 320 \text{ ohms.}$$

$$r + r_L = \frac{2300}{6} = 383.3 \text{ ohms.}$$

$$r_L = 383.3 - 320 = 63.3 \text{ ohms.}$$

$$\text{No. lamps} = \frac{63.3}{6} = 10.5 = 10 \text{ lamps.}$$

Lamps	0	2	4	6	8	10	12
r_L	0.0	12.0	24.0	36.0	48.0	60.0	72.0
$r + r_L$..	320.0	332.0	344.0	356.0	368.0	380.0	392.0
I	7.2	6.93	6.68	6.46	6.25	6.05	5.87

(b) Reactance method. Neglecting the resistance of the reactance coil,

$$x = \frac{2300}{7.2} = 320 \text{ ohms.}$$

$$z = \frac{2300}{6} = 383.3 \text{ ohms.}$$

$$\sqrt{r_L^2 + 320^2} = 383.3 \quad \therefore r_L = 210.8$$

$$\text{No. lamps} = \frac{210.8}{6} = 35.1 = 35 \text{ lamps.}$$

Lamps	0	10	20	30	35	40
r_L	0	60	120	180	210	240
r_L^2	0	3600	14,400	32,500	44,200	57,700
x^2	102,500	102,500	102,500	102,500	102,500	102,500
$r_L^2 + x^2$	102,500	106,100	116,900	135,000	146,700	160,200
$\sqrt{r_L^2 + x^2}$	320	326	342	369	383	400
I	7.2	7.05	6.72	6.23	6.00	5.75

NOTE.—In an example of this kind it may be as convenient to work directly, without the use of complex quantities as has just been done. With more complicated circuits, however, it may be far more convenient and far safer to adhere strictly to the complex method.

There are many other schemes for obtaining constant current. Some of these involve the use of condensers which are treated in the next chapter.

This subject will be discussed further in Chap. XXI.

CHAPTER XVIII

CAPACITY AND CAPACITY REACTANCE

Two conducting surfaces, insulated from each other, are said to possess electro-static *capacity*. Such an arrangement embodied as a piece of apparatus is called an electrical condenser.

Condenser.—When the plates of a condenser are connected respectively to the positive and negative terminals of a direct-current generator, the condenser becomes charged. That is, when a switch, *s*, Fig. 98, is closed, completing the circuit containing the generator and the condenser, ammeters *A*, placed in the leads,

will indicate a momentary current in the direction of the arrows. No current, in the ordinary sense, could pass between the plates. The phenomenon thus resembles the piling up of electricity, as so much material, on one plate, the positive plate, since

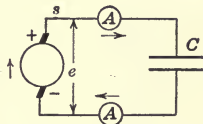

FIG. 98.

it is connected to the positive terminal of the generator, and the withdrawing of an equal amount of electricity from the other, the negative plate. This quantity of electricity which seems to have been transferred from one plate to the other is the charge placed upon the condenser. The condenser is maintained in an unstable state by the e.m.f. of the generator. If the generator is disconnected, the condenser continues to remain charged so long as its plates remain insulated from each other, but as soon as electrical connection is made between them, the condenser discharges itself by a rush of electricity from the positive to the negative plate, as indicated by the flow of electricity or current through the meters. If the condenser is charged to a difference of potential which is excessive, the insulating dielectric breaks down, allowing a discharge to take place between the plates. This indicates that the dielectric is placed under a strain when the condenser is charged. In fact, the dielectric behaves much like an elastic medium compressed between plates. When the pressure is removed the medium assumes its normal condition.

The plates act merely as carriers or distributors of the charge,

while its actual seat, as found out by FRANKLIN, is the surface of the dielectric.

The capacity of any given condenser is determined by the dimensions of its plates, their distance apart, and the nature of the dielectric which separates them.

Capacity is not a property solely of apparatus arranged in the form of a condenser, but any body may be said to possess capacity—for instance, a metallic sphere, insulated and isolated in space. But this may also be considered as a limiting form of condenser in which one plate is the surface of the sphere and the other is a surrounding sphere of infinite radius. In this case the strain in the dielectric may be represented by the lines of force, or tubes of force, extending radially outward from the surface of the sphere and terminating on the surface of the imaginary sphere infinitely distant. This conception of lines, or tubes of force, due to FARADAY, makes the direction of a line or axis of a tube the direction of the force at any point, and the number per square centimeter, or density, of lines or tubes becomes a measure of the force at the point.

FARADAY assumed that the number of tubes is the same numerically as the charge per unit surface, and that the number of lines emanating from a charge Q is $\phi = 4\pi Q$. Thus each tube contains 4π lines of force.

By connecting a sphere to one terminal of a battery, Fig. 99, and connecting the other terminal to earth, assumed infinitely distant, we establish a number of electric lines of force extending outward from the sphere. The number of lines established is $4\pi Q$,¹ where Q is the amount of the charge placed upon the sphere.

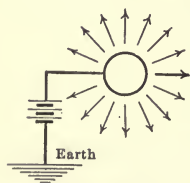

FIG. 99.

If the sphere is in air, the practical limit to the number of lines which it is possible to establish is very closely 100 per sq. cm. of surface. Thus, to produce 100 lines per sq. cm. requires a charge $Q = \frac{100}{4\pi} = 8$ absolute electro-static units per sq. cm.

To increase the number of lines established in any given case, the difference of potential, or voltage, should be increased. These lines are conceived to displace the ether, until by continually increasing the voltage, the crowding of them becomes so

¹ See Advanced Course in Electrical Engineering.

great that the dielectric breaks down. The ability of any dielectric to withstand rupture under the strain of potential-difference is called "dielectric strength."

With a parallel plate condenser, Fig. 100, the lines or tubes are parallel, except at the edges, where they bow outward.

By definition, the charge due to current i during interval dt is:

$$dq = idt. \quad (39)$$

The practical unit of charge or quantity, q , is the coulomb. Another fundamental relation is that

$$q = Ce \quad (40)$$

where C is the capacity, and e the e.m.f. or difference of potential. This law, found experimentally, shows that the number of tubes which can be set up in a condenser of capacity C depends directly on the potential difference. In practical units, the charge in coulombs is equal to the product of the capacity in farads and the potential difference in volts. "Charge" is not a material quantity, but may well be thought of as a measure of "tubes."

Substituting from (39) into (40), since

$$i = \frac{dq}{dt},$$

and

$$\begin{aligned} dq &= Cde, \\ i &= C\frac{de}{dt} \end{aligned} \quad (41)$$

which is called the charging current, or capacity current of the condenser.

Assuming a sine wave of e.m.f., impressed on a condenser then,

$$e = E_M \sin \omega t \quad (42)$$

$$i = CE_M \omega \cos \omega t. \quad (43)$$

The capacity, C , is a constant of the circuit, that is, like resistance and inductance, it is a quantity fixed by the mechanical arrangement of the circuit.

Eq. (42) may be written:

$$i = CE_m \omega \sin (\omega t + 90^\circ). \quad (43a)$$

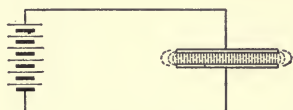

FIG. 100.

Comparing (42) and (43a) it is seen that the charging current is 90° in time phase ahead of e . Also,

$$I_m = CE_m\omega.$$

The effective value of the charging current is then

$$I = \frac{I_m}{\sqrt{2}} = \frac{CE_m\omega}{\sqrt{2}} = CE\omega = 2\pi fCE$$

whence

$$\frac{E}{I} = \frac{1}{2\pi fC} = x_c.$$

The quantity x_c is called capacity reactance, and its use in circuit calculations is similar to inductive reactance.

Expression of Condensive Impedance.—It has been shown that the charging current leads the impressed e.m.f. 90° in time.

Thus, if the charging current I is made zero vector, the impressed e.m.f. is $-jkI$ where k is some constant and is obviously x_c . Thus $E = -jx_c I$.

In an inductive circuit the current lags 90° behind the impressed e.m.f.

Thus $E = jxI$.

Convention has settled that an inductive impedance is $Z = r + jx$; thus the condensive impedance is $Z = r - jx_c$ where x_c as well as x is always a positive number.

Circuit Containing Resistance, Inductance and Capacity in Series.—To find the current. Let E , the impressed e.m.f., be the zero vector. Then

$$I = \frac{e}{r + jx - jx_c} = \frac{e}{r + j(x - x_c)} = e(a + jb)$$

where

$$a = \frac{r}{r^2 + (x - x_c)^2},$$

$$b = -\frac{(x - x_c)}{r^2 + (x - x_c)^2}.$$

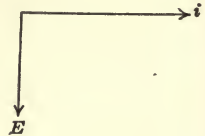

FIG. 101.

To find the voltage E_c across the condenser. We have:

$$E_c = I(-jx_c)$$

$$= e(a + jb)(-jx_c) = e(-ajx_c + bx_c).$$

Similarly, the voltage across the inductance is

$$E_L = I \times jx$$

$$= e(a + jb)jx = e(ajx - bx).$$

Problem 55.—Let the constants of a circuit be $r = 1$ ohm, $L = 0.0265$ henry, $C = 0.000265$ farad, and let 100 volts be impressed on the circuit at variable frequency. Find, and plot against the frequency, I , E_c , E_L , E_r for frequencies from 0 to 100 cycles per sec.

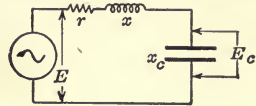

FIG. 102.

Solution.—We have:

$$I = e(a + jb); I = e\sqrt{a^2 + b^2}.$$

$$E_c = e(-ax_c + bx_c); E_c = e\sqrt{(a^2x_c^2 + b^2x_c^2)} = ex_c\sqrt{a^2 + b^2}.$$

$$E_L = e(ax - bx); E_L = e\sqrt{(a^2x^2 + b^2x^2)} = ex\sqrt{a^2 + b^2}.$$

Also,

$$E_r = e(a + jb)r; E_r = er\sqrt{a^2 + b^2}.$$

Tabulating:

f	0	20	40	50	55	60	65	70	100
$2\pi f$	0	125.6	251.2	314.0	345.2	376.8	408.0	440.0	628.0
x	0	3.33	5.65	8.33	9.15	10.0	10.8	11.65	16.66
x_c	∞	30.0	17.65	12.0	10.92	10.0	9.25	8.57	6.0
$(x - x_c)$	$-\infty$	-26.67	-12.0	-3.67	-1.77	0.0	1.55	3.08	10.66
$(x - x_c)^2$	$+\infty^2$	712.0	144.0	13.5	3.14	0.0	2.4	9.5	114.0
$r^2 + (x - x_c)^2$	∞^2	713.0	145.0	14.5	4.14	1.0	3.4	10.5	115.0
a	0	0.0014	0.0069	0.069	0.242	1.0	0.294	0.095	0.0087
b	0	0.0374	0.0827	0.253	0.428	0.0	0.455	-0.293	-0.0925
a^2	0	0.000002	0.000048	0.0048	0.059	1.0	0.086	0.009	0.000076
b^2	0	0.0014	0.0068	0.064	0.183	0.0	0.207	0.086	0.0086
$a^2 + b^2$	0	0.0014	0.0069	0.0688	0.242	1.0	0.293	0.095	0.0087
$\sqrt{a^2 + b^2}$	0	0.0374	0.0828	0.262	0.492	1.0	0.54	0.308	0.093
I	0	3.74	8.28	26.2	49.2	100.0	54.0	30.8	9.3
E_c	0	112.2	146.1	314.0	537.0	1000.0	500.0	264.0	55.8
E_L	0	12.5	46.8	218.0	450.0	1000.0	583.0	370.0	155.0
E_r	0	3.74	8.28	26.2	49.2	100.0	54.0	30.8	9.3

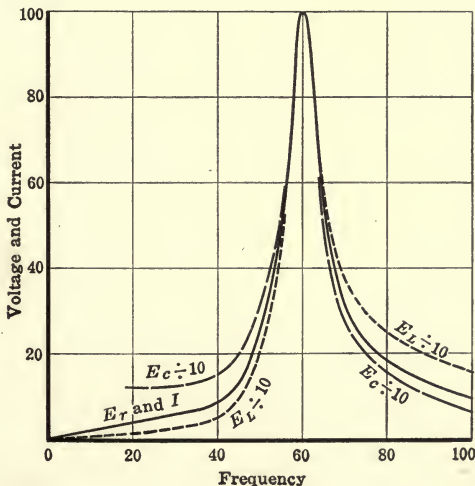

FIG. 103.

Resonance.—Curves of the form shown in Fig. 103 are called resonance curves, and their maximum points of the dependent variables are called resonance points. In this case, it is said that 60 cycles is the frequency of resonance.

On examining the problem it is seen that resonance is attained at that frequency for which $x - x_c = 0$, or when the effect of inductance is just nullified by that of capacity. The circuit then behaves as though it possessed resistance only.

CHAPTER XIX

PARALLEL CIRCUITS

Let I_1 and I_2 be any currents in the branches of a parallel system, such that $I_1 = i_1 + ji'_1$ and $I_2 = i_2 + ji'_2$.

Laying off these vectors (Fig. 105), and adding them, gives

$$I = I_1 + I_2 = i_1 + i_2 + j(i'_1 + i'_2). \quad (44)$$

Let the impedances of the branches (Fig. 104) be $Z_1 = r_1 - jx_1$ and $Z_2 = r_2 + jx_2$, respectively.

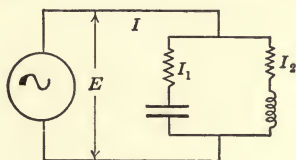

FIG. 104.

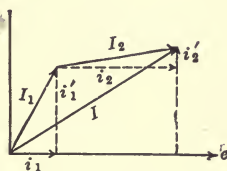

FIG. 105.

To find the currents I_1 , I_2 , and I . We have:

$$I_1 = \frac{e}{Z_1} = \frac{e}{r_1 - jx_1} = e \frac{(r_1 + jx_1)}{r_1^2 + x_1^2} = e(g_1 + jb_1) = eY_1$$

where $g_1 = \frac{r_1}{r_1^2 + x_1^2}$ is the conductance,

$$b_1 = \frac{x_1}{r_1^2 + x_1^2} \text{ is the susceptance,}$$

and $Y_1 = g_1 + jb_1$ is the admittance of the first branch circuit.

eg_1 is the power component of I_1 .

eb_1 is the wattless component of I_1 .

Similarly,

$$I_2 = \frac{e}{Z_2} = \frac{e(r_2 - jx_2)}{r_2^2 + x_2^2} = e(g_2 + jb_2) = eY_2$$

where

$$g_2 = \frac{r_2}{r_2^2 + x_2^2},$$

$$b_2 = -\frac{x_2}{r_2^2 + x_2^2},$$

and

$$I = I_1 + I_2 = e(g_1 + g_2 + j(b_1 + b_2)) = eY. \quad (45)$$

To find the joint impedance, Z , of the branches,

$$Z = \frac{e}{I} = \frac{e}{eY} = \frac{1}{Y}$$

Example.—In Fig. 104 let $r_1 = r_2 = 0$, and $x_1 = \frac{1}{2\pi fC}$, $x_2 = 2\pi fL$.

Then

$$\begin{aligned} g_1 &= \frac{r_1}{r_1^2 + x_1^2} = 0, \quad g_2 = 0, \\ b_1 &= \frac{x_1}{r_1^2 + x_1^2} = \frac{x_1}{x_1^2} = \frac{1}{x_1} = 2\pi fC, \\ b_2 &= -\frac{x_2}{r_2^2 + x_2^2} = -\frac{1}{x_2} = -\frac{1}{2\pi fL}. \end{aligned}$$

Then, from (45),

$$I = e \left(0 + j(2\pi fC - \frac{1}{2\pi fL}) \right). \quad (46)$$

From this it is seen that the line current is in time quadrature with the voltage.

If $I = 0$, then from (46) we have the relation

$$2\pi fC = \frac{1}{2\pi fL},$$

or

$$4\pi^2 f^2 CL = 1.$$

$$\therefore f = \frac{1}{2\pi\sqrt{LC}},$$

that is to say, that if in a circuit such as is here considered the frequency be varied, a value may be reached for which the line current will be reduced to zero. In such a case the currents in the branches will be

$$\begin{aligned} I_1 &= e(0 + jb_1) = e(j2\pi fC), \\ I_2 &= e\left(-j\frac{1}{2\pi fL}\right). \end{aligned}$$

Both of these currents are in time quadrature with the voltage, but I_1 is leading while I_2 is lagging.

Thus, they are in time phase opposition to each other.

Problem 56.—In the circuit of Fig. 104 let $e = 100$, $r_1 = r_2 = 1$, $L = 0.0265$, $C = 0.000265$. Let the frequency vary, as in problem 54. Find I , I_1 , I_2 , and plot them against the frequency.

Transmission Line Supplying Power to Parallel Loads.—Let a transmission line of impedance $Z_0 = r_0 + jx_0$ be used to supply power to a load consisting of two impedances, $Z_1 = r_1 + jx_1$ and $Z_2 = r_2 + jx_2$, which are in parallel. Besides the impedances, let E the voltage at the receiving end be known.

Find I , I_1 , I_2 , E_0 , P.F. of generator and of combined load, regulation and efficiency of the line.

E is chosen as the zero vector = e .

Then

$$\begin{aligned} \dot{I}_1 &= \frac{e}{Z_1} = \frac{e}{r_1 + jx_1} = \frac{e(r_1 - jx_1)}{r_1^2 + x_1^2} \\ &= e(g_1 + jb_1), \end{aligned}$$

where

$$g_1 = \frac{r_1}{r_1^2 + x_1^2}, \quad b_1 = -\frac{x_1}{r_1^2 + x_1^2}.$$

Similarly,

$$\dot{I}_2 = e(g_2 + jb_2)$$

where

$$g_2 = \frac{r_2}{r_2^2 + x_2^2}, \quad b_2 = -\frac{x_2}{r_2^2 + x_2^2}.$$

And

$$\begin{aligned} \dot{I} &= \dot{I}_1 + \dot{I}_2 = e(g_1 + g_2 + j(b_1 + b_2)) \\ &= m + jn, \end{aligned}$$

where

$$m = e(g_1 + g_2), \quad n = e(b_1 + b_2).$$

Then

$$\begin{aligned} \dot{E}_0 &= e + \dot{I}Z_0 = e + (m + jn)(r_0 + jx_0) \\ &= e + mr_0 - nx_0 + j(nr_0 + mx_0) \\ &= a_0 + j\dot{b}_0, \end{aligned}$$

where

$$a_0 = e + mr_0 - nx_0, \quad b_0 = nr_0 + mx_0.$$

Power of generator, by telescoping \dot{E}_0 and $I = P_0 = a_0m + b_0n$.

$$\therefore \text{P.F. of generator} = \frac{P_0}{E_0I} = \frac{a_0m + b_0n}{E_0I},$$

$$\text{P.F. of combined load} = \frac{P}{eI} = \frac{em}{eI}.$$

$$\text{Regulation} = \frac{E_0 - e}{e}.$$

$$\text{Efficiency} = \frac{P}{P_0} = \frac{em}{a_0m + b_0n}.$$

Problem 57.—In the same circuit (Fig. 106), let \dot{E}_0 be known and \dot{E} unknown. Find all the quantities obtained in the last problem.

NOTE.—In solving this problem the student is again urged to pay particular attention to the form of his work. In order to add emphasis to this matter these similar problems are here given, the one being worked out and the other left for the student to do.

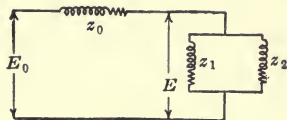

FIG. 106.

The numerical or scalar expressions are not put down. It is assumed that they may always be obtained when needed by the simple process of rationalizing a simple complex expression. By omitting them in the process, confusion is eliminated.

Approximate Transmission Line Calculation.—The two parallel wires of a transmission line may be regarded as constituting the plates of a condenser. When alternating e.m.f. is impressed upon the line there will therefore flow a charging or capacity current over the line, whether the distant end is open or closed. Fig. 107 gives an approximate representation of such a line in

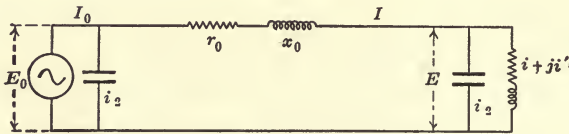

FIG. 107.

which the line capacity is replaced by two condensers, one at each end, so proportioned that each shall take one-half of the charging current. The charging current is taken as $2i_2$. i_2 is always positive, whereas i' , the wattless component of the load current, is positive or negative depending on the load.

Then

$$\dot{I} = i + j(i' + i_2) = i + ji_3.$$

$$\dot{E}_0 = e + \dot{I} Z_0 = a_0 + jb_0,$$

where $a_0 = e + ir_0 - i_3x_0$,

$$b_0 = i_3r_0 + ix_0.$$

$$\dot{I}_0 = \dot{I} + ji_2 = i + j(i' + 2i_2) = i + ji_4.$$

From these, the power, power factor, efficiency, etc., may be determined. Expressions should be obtained by the student for practice, as follows:

$$\text{Power given by generator} = P_0 =$$

$$\text{Apparent power at generator} = E_0 I_0 =$$

$$\text{P.F. at generator} = \cos \alpha_0 = \frac{P_0}{E_0 I_0} =$$

$$\text{Efficiency of transmission} = \frac{Ei}{P_0} =$$

$$\text{Apparent efficiency} = \frac{Ei}{E_0 I_0} =$$

CHAPTER XX

DISTORTED WAVES. RESONANCE EFFECTS

So far, only current and voltage waves have been dealt with which followed a sinusoidal variation with respect to the time and had the same frequency or period. In the laboratory, results obtained are found not always to agree with those expected from the theory. This is frequently due to the assumption in theory of pure sine waves, whereas, in practice, a pure sine wave is only approximately attainable, and the actual waves may differ greatly from that form.

It can be proven that any curve representing changes occurring with time can be resolved into a number of sine waves of different frequency—as long as the curve representing the changes is a univalent function of time—which it always is in electrical problems.

It can also be proven that if the curves traced are symmetrical above and below the axis—no matter how distorted—the sine waves contain only the odd frequencies.

Thus assume as the simplest case that the current is distorted in such a way that it can be represented by the first two terms of the series, that is that:

$$i = I_{1m} \sin \omega t + I_{3m} \sin (3\omega t + \alpha).$$

It is seen that the frequency of the second component wave is three times that of the first.

The first wave is called the fundamental of the complex wave, the second wave is called the third harmonic. The angle α denotes the permanent phase difference between the waves. Such a combination of waves is seen to be a distorted wave, as shown in Fig. 108. To find the amount of heat such a wave will develop in a circuit, that is, to find the effective value of the complex wave.

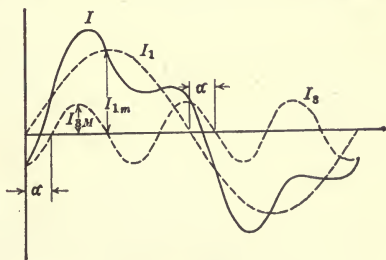

FIG. 108.

Evidently the heat developed at any instant is proportional to i^2 , and

$$i^2 = [I_{1m} \sin \omega t + I_{3m} \sin (3\omega t + \alpha)]^2.$$

The mean value of the heat developed during a cycle of the wave will then be proportional to

$$\text{mean } i^2 = \frac{1}{T} \int_0^T [I_{1m} \sin \omega t + I_{3m} \sin (3\omega t + \alpha)]^2 dt. \quad (47)$$

Thus, the effective value of the current is

$$\sqrt{\text{mean } i^2} = I = \sqrt{\frac{1}{T} \int_0^T [I_{1m} \sin \omega t + I_{3m} \sin (3\omega t + \alpha)]^2 dt.} \quad (48)$$

The student should solve (47) and (48), and show that

$$\left. \begin{aligned} \text{mean } i^2 &= \frac{I_{1m}^2}{2} + \frac{I_{3m}^2}{2} \\ I &= \sqrt{I_1^2 + I_3^2} \end{aligned} \right\} \quad (49)$$

and

where I_{1m} = maximum value of the fundamental current wave,

I_{3m} = maximum value of the third harmonic,

$$I_1 = \frac{I_{1m}}{\sqrt{2}} = \text{effective value of the fundamental,}$$

$$I_3 = \frac{I_{3m}}{\sqrt{2}} = \text{effective value of the third harmonic.}$$

Also, in general, where there are any number of component harmonic waves in a circuit,

$$I = \sqrt{I_1^2 + I_3^2 + I_5^2 + \dots} \quad (50)$$

Thus is found the important rule that the effective value (ammeter reading) of any number of currents of different frequencies is equal to the square root of the sum of the squares of the individual effective values.

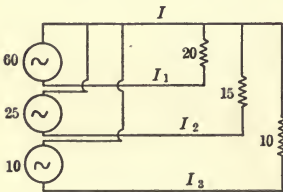

FIG. 109.

NOTE.—Eq. (50) holds for any combination of harmonics whatsoever. With alternating-current machinery, we have to deal only with odd harmonics, as the positive and negative waves are always symmetrical

except during transient periods not considered in this volume.

Example.—In Fig. 109 are represented three generators which supply respectively 20 amp. at 60 cycles, 15 amp. at 25 cycles, and 10 amp. at 10 cycles. They all use a common wire for a part

of their circuits. Then the current which flows in the common wire is

$$I = \sqrt{20^2 + 15^2 + 10^2} = 27 \text{ amp.}$$

Problem 58.—If still another generator is added to the above system and it supplies 12 amp., direct current, to its load, using the common wire, find the current, I , that will then be in the common wire and explain the result.

E.m.f. Which Causes Distorted Waves of Current.—If the current in any circuit is given by the equation

$$i = I_1 \sin \omega t + I_3 \sin (3\omega t + \alpha) \quad (51)$$

the question may naturally arise as to what kind of e.m.f. wave will cause such a current to flow. Will the e.m.f. wave be more or less distorted when the current is supplied to a circuit of resistance and inductive reactance?

We have (Eq. 15),

$$e = ir + L \frac{di}{dt}$$

Substituting from (51),

$$\begin{aligned} e &= I_1 r \sin \omega t + I_3 r \sin (3\omega t + \alpha) + L(I_1 \omega \cos \omega t + \\ &\quad 3I_3 \omega \cos (3\omega t + \alpha)) \\ &= I_1 r \sin \omega t + LI_1 \omega \cos \omega t + I_3 r \sin (3\omega t + \alpha) + \\ &\quad 3LI_3 \omega \cos (3\omega t + \alpha) \\ &= I_1 r \sin \omega t + I_1 x \cos \omega t + I_3 r \sin (3\omega t + \alpha) + \\ &\quad I_3 x_3 \cos (3\omega t + \alpha). \end{aligned} \quad (52)$$

Let $\frac{x}{r} = \tan \beta$; $\frac{x_3}{r} = \tan \beta_3$.

Then

$$r = z_1 \cos \beta = z_3 \cos \beta_3.$$

Substituting these values in (52),

$$\begin{aligned} e &= I_1 Z_1 (\cos \beta \sin \omega t + \sin \beta \cos \omega t) + I_3 Z_3 (\cos \beta_3 \sin \\ &\quad [3\omega t + \alpha] + \sin \beta_3 \cos [3\omega t + \alpha]) \\ &= I_1 Z_1 \sin (\omega t + \beta) + I_3 Z_3 \sin (3\omega t + \alpha + \beta_3) \\ &= E_1 \sin (\omega t + \beta) + E_3 \sin (3\omega t + \alpha + \beta_3). \end{aligned} \quad (53)$$

Thus the amplitude, E_1 , of the fundamental voltage wave is Z_1 times that of the current fundamental; the amplitude E_3 of the triple frequency voltage wave is Z_3 times that of the current triple frequency harmonic.

The difference between the multipliers, Z_1 and Z_3 , is due to their respective reactances, x and x_3 , since r is the same in each. But x_3 is $3x$.

Therefore, it is seen that the triple frequency voltage wave is greater in proportion to its fundamental than the triple frequency current wave to its fundamental. In other words, the voltage wave is more distorted.

Conversely, it may be said that when a distorted voltage is impressed on a circuit, the effect of the inductive reactance is to smooth out some of the distortion in the current wave.

Problem 59.—Show that when the e.m.f.,

$$e = E_1 \sin \omega t + E_3 \sin (\omega t + \alpha),$$

is impressed on a circuit of resistance only, the current flowing will have the same amount of distortion as the voltage has.

Problem 60.—Show that when the e.m.f. of problem 59 is impressed on a circuit containing resistance and capacity, the effect of the capacity is to increase the distortion of the current.

If the voltage (53) is measured by a voltmeter, what will the reading be? From the development of (51) in respect to distorted currents, since both currents and voltages are similar in form it follows that the effective e.m.f. shown by a voltmeter will be

$$E = \sqrt{\frac{E_{1m}^2}{2} + \frac{E_{3m}^2}{2}} = \sqrt{E_1^2 + E_3^2}$$

Problem 61.—In Fig. 110 let E be the known impressed voltage, let capacity = C farads, inductance = L henrys and resistance = r ohms. Then

$$X_c = \frac{1}{2\pi f C}; X_L = 2\pi f L.$$

Find the current, and the voltage drops across the inductive impedance and the capacity, when the impressed voltage is composed of a fundamental and a third harmonic. The fundamental component of current will be

$$I_1 = \frac{e_1}{z_0} = \frac{e_1}{r + jx_0} = \frac{e_1}{r + j(x_L - x_c)} = e_1(g + jb),$$

where

$$g = \frac{r}{z_0^2},$$

$$b = -\frac{(x_L - x_c)}{z_0^2},$$

and

$$z_0^2 = r^2 + (x_L - x_c)^2,$$

and $E_1 = e_1$ is the zero vector.

The voltage drop across the inductive impedance, z , due to I_1 , is

$$E_{1z} = I_1 Z = e_1(g + jb)(r + jx_L) = a + jb'$$

where

$$a = e_1gr - e_1bx; b' = (br + gx)e_1.$$

The voltage across the capacity reactance due to I_1 is

$$E_{1c} = I_1(0 - jx_c) = d + jf,$$

where

$$d = e_1bx_c; f = -e_1gx_c.$$

The third harmonic components of current and voltage are similarly determined, remembering that

$$x_{3L} = 3x_L,$$

$$x_{3c} = \frac{x_c}{3}.$$

Problem 62.—In the circuit of Fig. 110, let $r = 1$, $L = 0.0265$, $C = 0.000265$, $E = 100$, $E_3 = 30$. Find and plot the current waves I_1 , I_3 and I , as the fundamental frequency is varied.

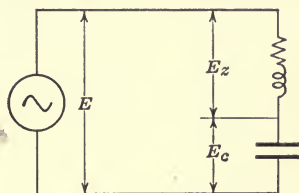

FIG. 110.

NOTE.—Solve for frequencies of 15, 20, 25, 35, 50, 55, 60, 65, 75, 100.

Solution.—We have, first,

$$E_1 = \sqrt{E^2 - E_3^2} = \sqrt{100^2 - 30^2} = 95.$$

Then

$$I_1 = \frac{95}{r + jx_1} = \frac{95(r - jx_1)}{r^2 + x_1^2} = \frac{95r}{r^2 + x_1^2} - j \frac{95x_1}{r^2 + x_1^2} = i_1 + j i'_1,$$

where

$$x_1 = x_{1L} - x_{1c} = 2\pi f_1 L - \frac{1}{2\pi f_1 C} = 0.167f_1 - \frac{600}{f_1}.$$

$$I_3 = \frac{30}{r + jx_3} = \frac{30r}{r^2 + x_3^2} - j \frac{30x_3}{r^2 + x_3^2} = i_3 + j i'_3,$$

where

$$x_3 = x_{3L} - x_{3c} = 2\pi f_3 L - \frac{1}{2\pi f_3 C} = 0.167f_3 - \frac{600}{f_3} = 0.5f_1 - \frac{200}{f_1}.$$

Waves of I_1 , I_3 and I are plotted in Fig. 111.

It is seen that the maximum I_1 occurs when $x_{1L} = x_{1c}$, *i.e.*, when $0.167f_1 = \frac{600}{f_1}$, or, at the frequency $f_1 = 60$, and it is $I_{1m} = \frac{95}{1} = 95$ amp.

Maximum I_3 occurs when $x_{3L} = x_{3c}$, *i.e.*, when $0.5f_1 = \frac{200}{f_1}$, or, at the frequency $f_1 = 20$ and it is $I_{3m} = \frac{30}{1} = 30$ amp.

Tabulating:

f_1	15	25	30	35	50	55	60	65	75	100
$0.167f_1$	2.5	4.167	5.0	5.83	8.33	9.16	10.0	10.83	12.5	16.7
600	40.0	24.0	20.0	17.14	12.0	10.91	10.0	9.23	8.0	6.0
f_1	-37.5	-19.833	-15.0	-11.31	-3.67	-1.75	0.0	1.6	4.5	10.7
x_1	1406.0	394.0	225.0	128.0	13.47	3.07	0.0	2.56	20.25	114.5
x_1^2	1407.0	395.0	226.0	129.0	14.47	4.07	1.0	3.56	21.25	115.5
$r_1^2 + x_1^2$	0.0675	0.24	0.42	0.736	6.57	23.35	95.0	26.67	4.47	0.822
i_1	-3562.0	-1885.0	-1425.0	-1076.0	-349.0	-166.3	0.0	152.0	428.0	1018.0
$95x_1$	2.535	4.77	6.3	8.34	24.15	40.9	0.0	-42.7	-20.15	-8.8
f_1^2	0.00456	0.0578	0.1763	0.542	43.2	54.5	9025.0	712.0	20.0	0.677
i_1^2	6.42	22.75	39.7	69.5	584.0	1675.0	0.0	1825.0	406.0	77.5
$f_1^3 + i_1^3$	6.425	22.6	39.9	70.0	627.2	2220.0	9025.0	2537.0	426.0	78.2
I_1	2.535	4.775	6.31	8.36	25.01	47.1	95.0	50.35	20.62	8.84
$0.5f_1$	7.5	12.5	15.0	17.5	25.0	27.5	30.0	32.5	37.5	50.0
00	13.33	8.0	6.67	5.71	4.0	3.64	3.33	3.08	2.67	2.0
f_1	-5.83	4.5	8.33	11.79	21.0	23.86	26.67	29.42	34.83	48.0
x_2	34.0	20.25	69.5	139.0	442.0	570.0	712.0	868.0	1215.0	2304.0
x_2^2	35.0	21.25	70.5	140.0	443.0	571.0	713.0	869.0	1216.0	2305.0
$r^2 + x_2^2$	0.858	1.411	0.426	0.214	0.0677	0.0525	0.0421	0.0345	0.0247	0.013
i_2	-554.0	427.5	792.0	1120.0	1995.0	2267.0	2535.0	2800.0	3310.0	4560.0
$95x_2$	15.52	-20.1	-11.21	-8.0	-4.5	-3.97	-3.55	-3.225	-2.72	-1.975
f_1^2	0.738	2.0	0.182	0.0459	0.0046	0.00275	0.00178	0.00119	0.00061	0.00017
i_2^2	241.5	405.0	126.0	64.0	20.25	15.8	12.6	10.4	7.4	3.9
$r_2^2 + i_2^2$	242.2	407.0	126.2	64.0	20.3	15.8	12.6	10.4	7.4	3.9
I_2	15.55	20.15	11.22	8.0	4.5	3.97	3.55	3.225	2.72	1.975
I_2^2	6.425	22.8	39.9	70.0	627.2	2220.0	9025.0	2537.0	426.0	78.2
I_2^3	242.2	407.0	126.2	64.0	20.3	15.8	12.6	10.4	7.4	3.9
$I_2^2 + I_2^3$	248.625	429.8	166.1	134.0	647.5	2235.8	9037.6	2547.4	433.4	82.1
I_2	15.75	20.7	12.9	11.57	25.4	47.2	95.04	50.4	20.8	9.06

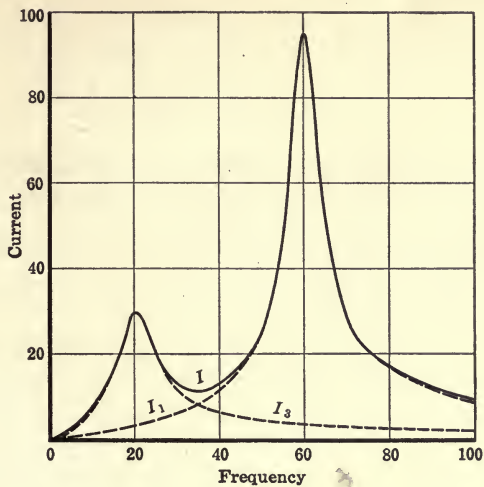

FIG. 111.

Fig. 111 gives a striking illustration of resonance, in that there are two distinct resonance points.

Correspondingly more points of resonance would be produced if the e.m.f. wave possessed more harmonics. The higher the harmonic, the lower the frequency at which resonance occurs.

CHAPTER XXI

CONSTANT POTENTIAL—CONSTANT-CURRENT TRANSFORMATION (Cont'd from Chapter XVII)

It has already been shown how a fairly constant current may be obtained from a constant potential source by the use of resistance and inductive reactance.

It is recollected that either the efficiency or the power factor is poor, and that the range of fairly constant current is quite narrow.

While a far better control can be obtained by the introduction of a condenser in connection with the reactance, this latter method has found little practical application because of the rather high cost of condensers and their unsatisfactory operation with the distorted current taken by arc lamps. It is, however, probable that such system will be extensively used in the future on account of the fact that series incandescent street lighting is being used to an increasing extent.

In Fig. 112, let E_0 be the constant voltage impressed on the system, and let E be the variable voltage across that part of the

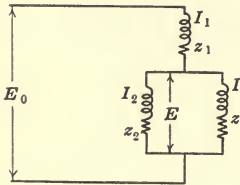

FIG. 112.

system in which the constant current, I , is to be maintained. Let the system be composed of $z_1 = r_1 + jx_1$, in series with the parallel circuits, $z_2 = r_2 + jx_2$ and the variable load impedance, $z = r + jx$. E , the voltage across the variable impedance, will be taken as zero vector, $= e$, although it might seem more logical to use E_0 which is known. (With E_0 chosen, the calculations are somewhat more involved, yet, of course, perfectly possible, and the student is advised to apply both methods and verify results.)

$$I = \frac{e}{z} = e(g + jb), \quad (54)$$

$$I_2 = \frac{e}{z_2} = e(g_2 + jb_2), \quad (55)$$

$$I_1 = I + I_2 = e(g + g_2 + j(b + b_2)) = e(g_0 + jb_0) \quad (56)$$

$$E_0 = e + I_1 Z_1 = e(h + jl).$$

Numerically,

$$E_0 = e\sqrt{h^2 + l^2},$$

and

$$e = \frac{E_0}{\sqrt{h^2 + l^2}} \tag{57}$$

which is the value of the zero vector.

Substituting this value of e into (54), (55) and (56),

$$I = \frac{E_0}{\sqrt{h^2 + l^2}} (g + jb), \tag{58}$$

$$I_2 = \frac{E_0}{\sqrt{h^2 + l^2}} (g_2 + jb_2), \tag{59}$$

$$I_1 = \frac{E_0}{\sqrt{h^2 + l^2}} (g_0 + jb_0). \tag{60}$$

These equations give the currents in the three branches of the circuit, but there is nothing about them which determines that I shall be constant. E_0 , g_2 and b_2 are constants, g and b are variable, and g_0 and b_0 are, respectively, $g + g_2$ and $b + b_2$. h and l are made up of combinations of g , g_2 , b , b_2 and r_1 and x_1 , where r_1 and x_1 are constants. I_1 and I_2 are essentially variable because of the variation of z , the load impedance.

Problem 63.—Let a circuit be chosen as in Fig. 113,

such that $r_1 = r_2 = 0$
 $x_1 = -x_2 = 125$ ohms
 $x = 0$.

Let

$$E_0 = 250 \text{ volts.}$$

Find e , I_1 , I and the power factor, and plot them against r for varying values of r from 0 to 500 ohms.

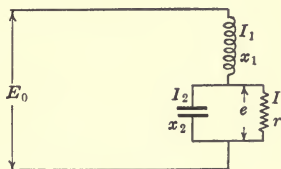

FIG. 113.

Solution.—

Since

$$x = 0, g = \frac{1}{r}; b = 0.$$

∴ (54) becomes

$$I = \frac{e}{r}.$$

Similarly, (55) becomes

$$I_2 = -j \frac{e}{x_2},$$

and (56) becomes

$$I_1 = e \left(\frac{1}{r} - j \frac{1}{x_2} \right).$$

and

$$\begin{aligned} E_0 &= 250 = e + e \left(\frac{1}{r} - j \frac{1}{x_2} \right) jx_1 \\ &= e + j \frac{ex_1}{r} + \frac{ex_1}{x_2} = e(h + jl), \end{aligned}$$

whence

$$h = \left(1 + \frac{x_1}{x_2} \right); \quad l = \frac{x_1}{r}.$$

$$\therefore \sqrt{h^2 + l^2} = \sqrt{\left(1 + \frac{x_1}{x_2} \right)^2 + \frac{x_1^2}{r^2}} = \sqrt{1 + \frac{2x_1}{x_2} + \frac{x_1^2}{x_2^2} + \frac{x_1^2}{r^2}}.$$

Substituting values for x_1 and x_2 ,

$$\begin{aligned} \sqrt{h^2 + l^2} &= \sqrt{\left(1 - \frac{250}{125} + \frac{125^2}{125^2} + \frac{125^2}{r^2} \right)} = \\ &= \sqrt{\left(1 - 2 + 1 + \frac{125^2}{r^2} \right)} = \sqrt{\frac{(125)^2}{r^2}} = \frac{125}{r}. \end{aligned}$$

(57) then becomes

$$e = \frac{250}{\frac{125}{r}} = 2r.$$

(58) becomes

$$I = \frac{2r}{r} = 2 = \text{constant for all values of } r.$$

(60) becomes

$$I_1 = 2r \sqrt{\frac{1}{r^2} + \frac{1}{x_2^2}} = \frac{\sqrt{r^2 + 125^2}}{62.5}.$$

This case is, of course, ideal in that it assumes absence of resistance in both reactive branches of the circuit.

In Chap. XVII, it was found that with the system which used only inductive reactance to obtain constant current, the power factor was quite low.

To obtain an expression for the power factor in the present case,

$$E_0 = e(h + jl) = eh + jel,$$

$$I_1 = \frac{e}{r} - j \frac{e}{x_2}$$

whence, by telescoping, the power is

$$\begin{aligned} P_0 &= \frac{e^2 h}{r} - \frac{e^2 l}{x_2} \\ &= \frac{e^2}{r} \left(1 + \frac{x_1}{x_2} \right) - \frac{e^2 x_1}{x_2 r} = \frac{e^2}{r} \end{aligned}$$

Substituting numerical values, $P_0 = 4r$.

$$\begin{aligned} \text{Volt-amp.} &= E_0 I_1 = (eh + jel) \left(\frac{e}{r} - j \frac{e}{x_2} \right) \\ &= \frac{e^2 h}{r} + \frac{e^2 l}{x_2} + j \left(\frac{e^2 l}{r} - \frac{e^2 h}{x_2} \right) = e^2 \left(\frac{h}{r} + \frac{l}{x_2} + j \left(\frac{l}{r} - \frac{h}{x_2} \right) \right) \\ &= e^2 \sqrt{\frac{h^2}{r^2} + \frac{l^2}{x_2^2} + \frac{2hl}{rx_2} + \frac{l^2}{r^2} + \frac{h^2}{x_2^2} - \frac{2hl}{rx_2}} \end{aligned}$$

Substituting values for h and l ,

$$E_0 I_1 = e^2 \sqrt{\frac{\left(1 + \frac{x_1}{x_2}\right)^2}{r^2} + \frac{x_1^2}{r^2 x_2^2} + \frac{x_1^2}{r^4} + \frac{\left(1 + \frac{x_1}{x_2}\right)^2}{x_2^2}}$$

This equation reduces to

$$E_0 I_1 = \frac{e^2}{r^2} \sqrt{r^2 + x_2^2},$$

when $x_1 = -x_2$, and, substituting numerical values,

$$E_0 I_1 = 4 \sqrt{r^2 + 125^2}$$

$$\begin{aligned} \therefore \text{Power factor} &= \frac{P_0}{E_0 I_1} = \frac{e^2}{4r \sqrt{r^2 + x_2^2}} \\ &= \frac{r}{\sqrt{r^2 + 125^2}} \end{aligned}$$

Tabulating:

r	0	10	20	50	100	200	500
e	0	20	40	100	200	400	1,000
r^2	0	100	400	2,500	10,000	40,000	250,000
$r^2 + 125^2$...	15,625	15,725	16,025	18,125	25,625	55,625	265,625
$\sqrt{r^2 + 125^2}$	125	125.2	126.5	134.5	160	236	515
P.F.....	0	0.080	0.158	0.372	0.625	0.847	0.97
I_1	2	2.00	2.02	2.15	2.56	3.78	8.25
I_2	0	0.16	0.32	0.8	1.6	3.2	8.0

Fig. 114 shows the curves of current, voltage, and power factor for change of resistance of the load.

In this case, the power factor is seen to be very much better than it was found to be where inductive reactance alone was used.

Problem 64.—Let the load in the preceding problem be made up of both r and x . Find the effect of reactance in the load and make a general study of the conditions under varying power factor of the load.

This may be done as follows: Imagine the load to consist of any number of lamps, each lamp possessing a certain resistance and a certain reactance.

Then the ratio of $\frac{x}{r}$ will be constant.

1. Let $x = 0.5r$. The power factor of the load will then be

$$\frac{r}{\sqrt{r^2 + 0.25r^2}} = \frac{1}{\sqrt{1.25}} = 0.895$$

2. Let $x = r$. The load power factor is then 0.707.

Supplying these values in turn to Eqs. 54, etc., as in the previous problem, tabulations and curves may be obtained from which a report on the effect of power-factor variation of the load may be made.

In order to bring the subject to a practical basis, the effects of actual constants of the apparatus should be investigated. It

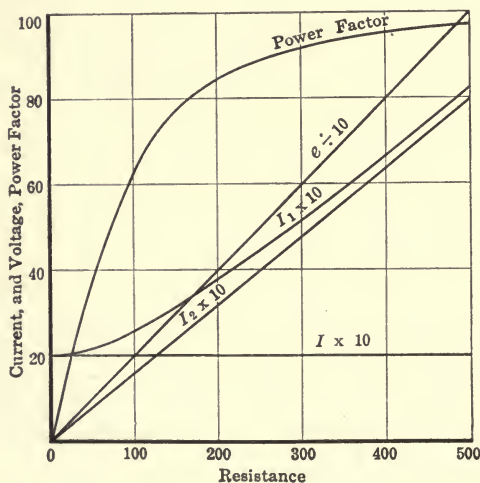

FIG. 114.

will be found that the resistance of a suitable reactive coil for such a case as developed above, would not need to be above 0.5 ohm, and that the resistance in the condenser circuit would be very much less. Consequently the effects of resistance are extremely small, and the case, as worked out, may be considered as approximately attainable in practice.

Many schemes have been proposed for the attainment of constant current from a constant potential source, in which more or less elaborate combinations of reactances have been arranged. A

study of the possibilities of different schemes is profitable for the student as it affords excellent practice in circuit calculation.¹

Power and Wattless Components of Volt-amperes.—The quantity $EI \cos \alpha$ is called the power component P of the volt-amperes.

By a similar conception, $EI \sin \alpha$ is called the “wattless” component P^1 of the volt-amperes.

Thus

$$EI = \sqrt{(EI \cos \alpha)^2 + (EI \sin \alpha)^2}$$

Referring to Eq. (36)

$$EI \sin \alpha = EI \sin (\beta - \gamma)$$

$$= EI (\sin \beta \cos \gamma - \cos \beta \sin \gamma)$$

$$= EI \frac{i'e - e'i}{EI} = i'e - e'i. \tag{61}$$

¹ For some of these developments see STEINMETZ, “Alternating-current Phenomena,” Chap. X.

CHAPTER XXII

THEORY AND USE OF THE WATTMETER

The most accurate way of obtaining results in the measurement of alternating current, voltage or power is by the use of the electro-dynamometer.

As generally employed the electro-dynamometer, invented by SIEMENS is a combination of 2 coils, one movable and the other fixed, whose planes are set at right angles to each other. When current is sent through the coils, each sets up a magnetic field in the region occupied by the other, thus causing forces which tend to move the coils relatively to each other. The forces are balanced by tension on a calibrated spring.

If the same current is sent through both coils, the scale, properly calibrated, measures the current. If the instrument is placed in series in a circuit, the current measured is that of the circuit, and the meter becomes an ammeter. If it is placed in shunt to a given circuit, the current in the coils is proportional to the voltage drop in the circuit, and the meter becomes a voltmeter.

If, however, one coil is placed in series and the other in shunt to a given circuit, the effect on the instrument is proportional to the product of the amperes and the volts at any instant, and the electro-dynamometer becomes a wattmeter and measures power.¹ For practical construction, the coil to be connected in series is made of few turns of comparatively heavy wire, and is usually the fixed coil, while the coil to be connected in shunt is made of very many turns of fine wire and is movable.

Accurate results are obtained by the dynamometer because the coils, while readings are made, are always kept in the fixed rela-

¹ The flux set up by 1 coil (fixed) is proportional to the current flowing in the circuit, while the flux set up by the other coil (movable) is proportional to the voltage across the circuit. But the force at any instant acting on the coils is proportional to the product of the fluxes set up by the coils, that is, the force on the coils is proportional to the product, $E \times I$, where

E = voltage across the circuit, and

I = current in the circuit.

tive position at right angles to each other, thus eliminating mutual flux,¹ also because no iron is used in construction, and there are no other materials which might cause variation in the results.

Accuracy must be obtained, however, by the correction of certain errors in the readings. The error due to friction of the movable coil is small. The error due to changes of resistance by temperature is obviated in good instruments by the use of resistance which is not affected by change of temperature. When used as a wattmeter, the readings of the dynamometer must be corrected for error due to the manner of connection in the circuit. This correction is of great importance.

Let the wattmeter be connected as in Fig. 115 (A), in which the power consumed by the impedance, $Z = R + jX$, is to be measured.

The current coil is represented by the impedance $z = r + jx$; the voltage coil by the impedance $z_1 = r_1 + jx_1$. The load voltage is e , which is chosen as the zero vector.

The meter should be first calibrated by direct current, so that its reading for any given direct-current power is known.

Wattmeter Connections.—Connection (A) is wrong, because the current coil has to carry I_1 , the current taken by the voltage coil, in addition to the load current I , thus causing the wattmeter to indicate the power lost in the voltage coil, plus the load. There will thus be a reading even at no-load. If $I_1^2 r_1$, the power lost in the voltage coil, is subtracted from the wattmeter reading this error is eliminated. This error is usually negligible in connection with circuits carrying large current at low voltage.

In the connection shown in Fig. 115 (B), the current coil carries only the load current. The voltage coil, however, is so connected as to include the drop in the current coil as well as that across the load. Thus the wattmeter indicates the power

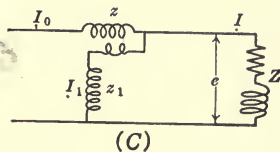
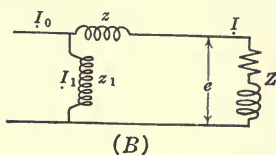
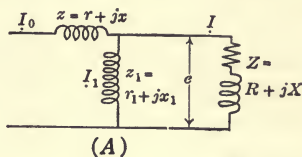

FIG. 115.

¹ Mutual induction will be treated more fully in connection with the study of the transformer. See Chap. XXVI.

lost in the current coil in addition to the load. This error may be corrected by subtracting the $I_0^2 r$ power lost in the current coil. Connection, (B), is best adapted to measurements at high voltage and low current.

A third arrangement, Fig. 115, (C), is known as the compensated wattmeter. In this there is wound a fine wire coil of the same number of turns as the current coil directly upon the latter. By its connection, it is seen that this coil, c , carries the current of the voltmeter coil. It therefore supplies to the current coil just enough back ampere-turns to neutralize those due to that excess of current in the current coil. This arrangement causes the wattmeter to read correctly so far as its connections are concerned.

Readings of the dynamometer calibrated by direct current must also be corrected for an error due to change in frequency. In connection (A), Fig. 115, the load current is

$$I = \frac{e}{Z} = \frac{e}{R + jX} = e(G + jB).$$

Current in the voltage coil is

$$I_1 = \frac{e}{z_1} = e(g_1 + jb_1).$$

Current in the current coil is

$$I_0 = I + I_1 = e(g_0 + jb_0).$$

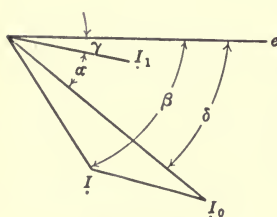

FIG. 116.

These currents are plotted in Fig. 116. Usually, the angle of lag of I_1 , is very small, even less than 1° . This slight lag may, however, give a large error.

$$\tan \gamma = \frac{b_1}{g_1}.$$

Since the coils are at right angles, the torque at any instant on the movable coil is proportional to the product of the currents.

Thus,

$$T = ki_0 i_1,$$

where i_0 and i_1 are instantaneous values of current in the two coils.

Let

$$i_0 = I_{0m} \sin \omega t, \text{ and } i_1 = I_{1m} \sin (\omega t + \alpha).$$

Then the average value of the torque through one-half cycle is

$$\begin{aligned} & \frac{k}{\pi} \int_0^\pi (I_{0m} \sin \omega t)(I_{1m} \sin (\omega t + \alpha)) dt \\ &= \frac{2kI_0I_1}{\pi} \int_0^\pi (\sin^2 \omega t \cos \alpha + \sin \omega t \cos \omega t \sin \alpha) dt \\ &= \frac{2kI_0I_1}{\pi} \int_0^\pi \left[\frac{1 - \cos 2\omega t}{2} \cos \alpha + \frac{\sin 2\omega t}{2} \sin \alpha \right] dt \\ &= \frac{2kI_0I_1}{\pi} \left[\frac{\omega t \cos \alpha}{2} - \frac{\cos \alpha \sin 2\omega t}{4} - \frac{\sin \alpha \cos 2\omega t}{4} \right]_0^\pi \\ &= \frac{2kI_0I_1}{\pi} \left[\frac{\pi}{2} \cos \alpha - \frac{\sin \alpha}{4} + \frac{\sin \alpha}{4} \right] = \frac{2k}{2} I_0I_1 \cos \alpha \\ &= kI_0I_1 \cos \alpha, \end{aligned}$$

I_0 and I_1 being, as usual, the effective values.

The wattmeter reading is then proportional to

$$I_1I_0 \cos \alpha,$$

where α is the angle between I_0 and I_1 .

But the true power is $eI \cos \beta$ where β is the angle between e and I .

In order that the wattmeter shall read true power it is therefore necessary to correct each term in the reading. These corrections are: (a) for the current in the voltage coil; (b) for the current in the current coil; (c) for the angular displacement.

(a) Assuming the meter to be calibrated by direct current, the current in the voltage coil at any frequency, f , will be less in the ratio $\frac{r_1}{\sqrt{r_1^2 + x_1^2}}$, due to the inductance of the coil.

The reading should therefore be corrected by the factor $\frac{z_1}{r_1}$, in order to bring it proportional to e .

(b) The current in the current coil is too large in the ratio, $\frac{I_0}{I}$.

The correction factor is therefore,

$$\frac{I}{I_0} = \sqrt{\frac{G^2 + B^2}{g_0^2 + b_0^2}}.$$

(c) The correction factor for angular displacement is evidently $\frac{\cos \beta}{\cos \alpha}$, where β and α are as shown in Fig. 116. The complete correction factor is then

$$k = \frac{z_1}{r_1} \sqrt{\frac{G^2 + B^2 \cos \beta}{g_0^2 + b_0^2 \cos \alpha}}$$

The constants of the wattmeter are assumed known, which permits of obtaining all angles except the phase angle of the load. Thus, α is known, but not β . In order to obtain β , a reading may be taken of the wattmeter, voltmeter and ammeter as in the example below. Then, roughly,

$$\cos \beta = \frac{W}{EI} \quad (62)$$

Substituting this value of $\cos \beta$ into the correction factor, a new value of W is obtained. Replacing the approximate W of (62) by this new value, a new value of $\cos \beta$ is obtained in which the error is of the second magnitude. By repeating this process any desired degree of precision may be obtained.

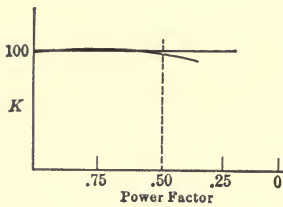

FIG. 117.

Example.—To find $\cos \beta$, when by reading of instruments the approximate power factor is found to be

$$\text{P.F.} = \frac{\text{watts}}{\text{volt-amp.}} = \frac{50}{100} = 0.5.$$

There must be a correction-factor curve of the dynamometer for varying power factor.

From this curve, let the value of k be 0.99 for P.F. = 0.5. Then multiplying, $0.5 \times 0.99 = 0.495 =$ power factor to second approximation. It is evident that a repetition of the process will be hardly necessary in most practical cases.

Problem 65.—With the wattmeter connected as above (115, A), determine and discuss the correction factors: (1) with non-inductive load; (2) when the power factor of the load is just equal to the power factor of the voltage coil; (3) in the theoretical case when there is no self-induction in the voltage coil.

Problem 66.—By a process similar to that just given, find the correction factors for wattmeters when connected according to (Fig. 115, B and C).

The errors actually obtaining in practice with good commercial indicating wattmeters are quite small. Thus, at normal voltage,

2000 cycles and power factor from 0.8 leading to 0.8 lagging, the error is usually less than $\frac{1}{4}$ per cent.

As the power factor is lowered the error becomes larger. At normal voltage, 60 cycles, the error may be less than 0.2 per cent. with the power factor down to 0.1.

If the impressed voltage is low, say 15 per cent. of normal, the error may, however, be several per cent.

In operation there are also errors which enter with the use of "current" and "potential" transformers. When these are used, the error is practically negligible for power factors above 0.8 except for small loads. With non-inductive-load of, say 10 per cent. normal, the error may, however, be several per cent.

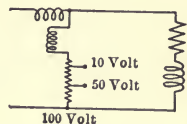

FIG. 118.

Problem 67.—An uncompensated wattmeter (Fig. 115, *A* and *B* and Fig. 118) has a rating of 400 watts. At 100 volts the resistance of its voltage coil is 2000 ohms. At 50 volts the resistance is 1000 ohms, at 10 volts it is 200 ohms. The inductance of the voltage coil is 0.007 henry. Resistance of the current coil is 0.03 ohm. Inductance of the current coil is 0.0003 henry. Find the wattmeter reading, the actual watts and the correction factor for all combinations of voltage, current and power factor, when

- | | | | |
|------|--------------|---------------|-------------|
| e | = 100, | 50.0, and | 10.0, volts |
| I | = 4, and | 0.4 amp., | |
| P.F. | = 1, | 0.1 lead, and | 0.1 lag. |
| f | = 60 cycles. | | |

CHAPTER XXIII

SIMPLE PROBLEMS IN ELECTRO-STATICS

It is desirable at this point to introduce certain principles of electro-statics. These should, of course, be more or less familiar to every student who has had an adequate course in physics.

Potential.—By definition, the potential at a point in an electric field is equal to the work done per unit charge in bringing a positive charge from a place of zero potential (usually infinity) to the point.

Intensity.—Also by definition, the intensity of the electric field (lines per square centimeter in air) is numerically the same as the force which that field exerts on unit charge.

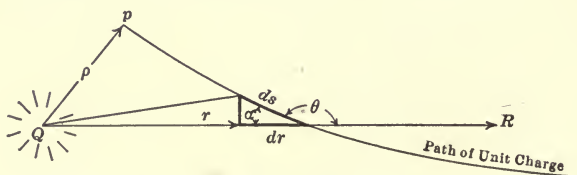

FIG. 119.

Thus, if R is the intensity of the field at a distance r from a point charge, Q (Fig. 119). See also Chap. XVIII.

$$R = \frac{4\pi Q}{\text{area of sphere of radius } r} = \frac{4\pi Q}{4\pi r^2} = \frac{Q}{r^2}$$

Therefore the potential at p is

$$V_p = - \int R dr = - \int R \cos \theta ds \quad (63)$$

where ds is an element of the path of the unit charge and

$$dr = ds \cos \theta.$$

The minus sign is used because work is done in bringing unit positive charge against the charge Q which is also assumed positive. Thus, the repulsion between the charges must be overcome

and work has to be supplied. This designation is, of course, a matter of convention.

Substituting the value of R , just obtained,

$$V_{\rho} = - \int_{\infty}^{\rho} R dr = - \int_{\infty}^{\rho} \frac{Q}{r^2} dr = - \frac{Q}{r} \Big|_{\infty}^{\rho} = \frac{Q}{\rho},$$

where ρ is the distance from Q to ρ .

Capacity of a Sphere.—Suppose the charge, Q , to be on an isolated sphere of radius, r_1 . Then, at the surface of the sphere $\rho = r_1$, and the potential is $V_1 = \frac{Q}{r_1}$.

The capacity of a condenser is defined as the charge per unit potential. Thus, $C = \frac{Q}{V}$, where C is capacity, and V is the potential of the charge Q .

Since, therefore, with an isolated sphere, $V_1 = \frac{Q}{r_1}$, the capacity of the sphere is

$$C = \frac{Q r_1}{Q} = r_1 \text{ in cm.}$$

Thus, the capacity of a sphere is numerically equal to its radius; the value of the capacity expressed in farads, C is found by dividing C in centimeters by the constant 9×10^{11} .

Potential Gradient.—The potential gradient, usually denoted by G , or the rate at which the potential changes at a given point, is of very great practical importance since it is a measure of the electric stress to which the dielectric is subjected. The potential gradient, G , and the electric field intensity, R , are the same numerically. Thus, if the potential of a certain point falls at the rate of 5 units of potential per cm., the actual number of lines per sq. cm. at the point is also 5.

By definition,

$$G = - \frac{dV}{dr}.$$

Since,

$$dV = - R dr$$

$$G = R.$$

In a dielectric of specific inductive capacity, κ , the intensity as well as the potential gradient for a given charge is less than in

air. It is $\frac{1}{\kappa}$ times the intensity in air. Thus, in the case of a sphere,

$$G = R = \frac{1}{\kappa} \frac{Q}{r^2}.$$

The maximum possible value of G , or R , under ordinary conditions in air, is not known exactly, but is in the neighborhood of 30,000 volts per cm., or 100 electro-static units of potential.

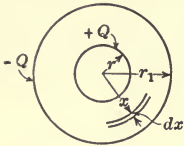

FIG. 120.

Capacity of a Spherical Concentric Condenser.—Consider 2 spherical concentric bodies with charges plus and minus Q .

By (63), the potential difference is

$$V = - \int_{x=r_1}^{x=r} R dx,$$

where r and r_1 are radii respectively of the inner and outer surfaces of the condenser.

But

$$R = \frac{Q}{x^2}.$$

$$\begin{aligned} \therefore V &= - \int_{r_1}^r \frac{Q}{x^2} dx = \frac{Q}{x} \Big|_{x=r_1}^{x=r} = Q \left[\frac{1}{r} - \frac{1}{r_1} \right], \\ &= Q \frac{r_1 - r}{rr_1} \end{aligned} \quad (64)$$

Therefore the capacity of the condenser is

$$C = \frac{Q}{V} = \frac{rr_1}{r_1 - r} \text{ in cm.} \quad (65)$$

Potential gradient between concentric spheres.
Since

$$G = - \frac{dV}{dr},$$

and

$$dV = - R dr,$$

$$G = R = \frac{Q}{x^2} = \frac{CV}{x^2}.$$

But

$$C = \frac{rr_1}{r_1 - r}$$

$$\therefore G = \frac{rr_1}{r_1 - r} \frac{V}{x^2}$$

At the surface of the smaller sphere, $x = r$, whence the gradient is

$$G = \frac{r_1}{r} \frac{V}{(r_1 - r)}$$

The Capacity of a Concentric Cylinder.—Let the charges be $\pm Q$ per cm. of length of the cylinder (Fig. 121). Then, by GAUSS' theorem, the flux emanating from each centimeter of length = $4\pi Q$.

Lines of flux are here assumed to extend radially, which they actually do.

At any distance, x , from the center of the cylinder the intensity at a point is the total number of lines divided by the area, or,

$$R_x = \frac{4\pi Q}{2\pi x} = \frac{2Q}{x}$$

Thus, the potential difference is:

$$e = - \int_{r_1}^r R dx = - \int_{r_1}^r \frac{2Q}{x} dx = - 2Q[\log r - \log r_1]$$

$$= + 2Q \log \frac{r_1}{r} \quad (66)$$

and the capacity is

$$C = \frac{Q}{e} = \frac{1}{2 \log \frac{r_1}{r}} \text{ in cm.} \quad (67)$$

per cm. length of the concentric cylinder.

The gradient at any distance, x , from the center is

$$G = R = \frac{2Q}{x} = \frac{2Ce}{x} = \frac{2e}{x} \times \frac{1}{2 \log \frac{r_1}{r}} = \frac{e}{x \log \frac{r_1}{r}} \quad (68)$$

At the surface of the inner conductor, $x = r$.

$\therefore G = \frac{e}{r \log \frac{r_1}{r}}$, and this is the greatest value of the gradient.

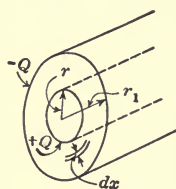

FIG. 121.

¹ See "Advanced Course in Electrical Engineering."

In these formulæ no account is taken of any effects due to the ends of the concentric cylinder. For the special case of an outer cylinder of radius $r_1 = \infty$, $C = 0$.

Capacity of Two Parallel Plates so Large that the Effects of Their Edges may be Neglected.—The total flux set up by a charge, Q , is $4\pi Q$ (Fig. 122).

The intensity, $R = \frac{4\pi Q}{A}$,

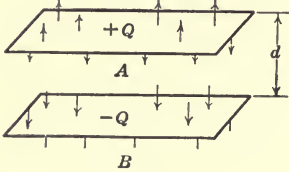

FIG. 122.

where A is the area of one side of the plate.

The potential difference is:

$$e = - \int_d^0 R_t dx = - \int_d^0 \frac{4\pi Q}{A} dx$$

$$= - \left. \frac{4\pi Q}{A} x \right|_d^0 = \frac{4\pi Qd}{A} \quad (69)$$

where d is the distance between the plates.

The capacity

$$C = \frac{Q}{e} = \frac{A}{4\pi d} = \frac{\kappa A}{4\pi d} \text{ in cm.} \quad (70)$$

where the dielectric has a specific capacity κ .

The potential gradient, G , is a constant in the dielectric between the plates, since the flux lines are parallel.

Thus,

$$G = - \frac{de}{dx} = \frac{4\pi Q}{A} = \frac{4\pi C e}{A} = \frac{ek}{A}$$

in which e is the difference of potential of the plates and k is a constant, $= 4\pi C$.

Capacity of a Transmission Line.¹—The line is represented in section in Fig. 123, with, r , the radius, and, D , the distance between centers, of the wires A and B . Let A be charged $+Q$, and B , $-Q$. The flux lines emanating from A enter B . The intensity at a point, p , due to the charge on A , is R_A ; that due to the charge on B is R_B .

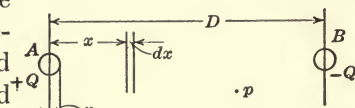

FIG. 123

¹ For more exact deduction see "Advanced Course in Electrical Engineering."

Then

$$R_A = \frac{4\pi Q}{2\pi x} = \frac{2Q}{x}$$

$$R_B = \frac{4\pi Q}{2\pi(D-x)} = \frac{2Q}{(D-x)}$$

The intensity due to the two charges is the sum of R_A and R_B , since the direction of the lines of electro-static force from A , due to a positive charge, is the same as that due to B , which has a negative charge.

$$\therefore R = 2Q \left[\frac{1}{x} + \frac{1}{D-x} \right].$$

The potential difference is:

$$e = - \int_{D-r}^r R dx = - 2Q \int_{D-r}^r \left(\frac{1}{x} + \frac{1}{D-x} \right) dx$$

$$= 4Q \log \frac{D-r}{r} \quad (71)$$

and the capacity is therefore

$$C = \frac{Q}{e} = \frac{1}{4 \log \frac{D-r}{r}} \quad (72)$$

per cm. length of circuit not of wire.

This capacity is expressed in centimeters. If the line is in a dielectric of specific inductive capacity, κ , the capacity in air as determined above, must be multiplied by κ .

To transform capacity, expressed in electro-static units in (72), into electromagnetic units, the former should be multiplied by $\frac{1}{v^2}$ where v is the velocity of light = 3×10^{10} cm. per sec.

The practical electromagnetic unit of capacity is the farad.

$$\text{Capacity in farads} = \frac{C}{v^2} \times 10^9,$$

where C is capacity expressed in electro-static units.

$$\therefore \text{Farads} = \text{electro-static units} \times \frac{1}{9 \times 10^{11}} = \frac{\text{cm.}}{9 \times 10^{11}}$$

Thus, $C/\text{cm.}$ of circuit, in farads, =

$$\frac{k}{4 \log \frac{D-r}{r} \times 9 \times 10^{11}} = \frac{0.434k}{\left(4 \log_{10} \frac{D-r}{r} \right) \times 9 \times 10^{11}}$$

When connected to a source of alternating e.m.f., the effective value of the charging current is $I_c = 2\pi fCE$, where E is the effective value of the line voltage.

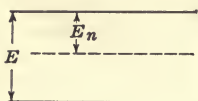

FIG. 124.

The voltage is frequently taken from one side of the line to neutral, that is, to the point of zero potential of the system (Fig. 124). When this voltage to neutral is used, the capacity to ground, or to neutral, is twice as great as the capacity between lines.

This follows since $I_c = 2\pi fC_nE_n$, where C_n and E_n are capacity and voltage to neutral, and for single phase systems, $E_n = \frac{E}{2}$.

For three-phase systems, $E_n = \frac{E}{\sqrt{3}}$.

$C_n = \frac{k}{2 \times 9 \times 10^{11} \times \log \frac{D-r}{r}}$, farads per cm. of line, since in

using the neutral, the length of line is the transmission distance.

Reducing values to practical units, $C_n/1000' = \frac{0.0074}{\log_{10} \frac{D-r}{r}}$

is the capacity to neutral per 1000 ft. of line, in micro-farads.

$I_c/1000' = \frac{2\pi fC_nE_n}{10^6}$ is the charging current per 1000 ft. of line, in amperes.

Capacity of a Three-phase Cable.—Capacity to neutral per 1000 ft. of line is given in micro-farads by the formula

$$C_n/1000' = \frac{0.0074}{\log_{10} \frac{\sqrt{3}a}{r} \frac{R^2 - a^2}{\sqrt{R^4 + a^4 + R^2a^2}}}$$

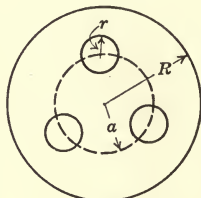

FIG. 125.

Such a cable is represented in section in Fig. 125, where R is the radius of the surrounding sheath, a is the distance from the center, or neutral point, to the center of one of the wires and r is the radius of 1 wire.

Problem 68.—(a) Prove that the greatest charge which may be put on a ball of 10 cm. radius is 10,000 electro-static units. (Assume that the maxi-

¹ This will be understood from later discussion of polyphase systems and deduced in the volume dealing with advanced electrical engineering.

mum gradient is 30,000 volts per cm. when air at atmospheric pressure "breaks down" and a glow called corona appears around the wire.)

(b) Prove that the greatest surface charge, in coulombs per sq. cm., is $\frac{2.65}{10^9}$.

(c) Show that if the inside conductor of a concentric cable has a radius of 1 cm., and the outside conductor is 2 cm. in radius, 0.0027 coulombs must be put into 1 mile of cable to cause it to glow (corona). Show that the potential difference between the 2 conductors is 20,800 volts.

Inductance of a Concentric Cable.—The inductance is recollected to be the interlinkages of the flux and turns per unit current.

In general, if the m.m.f. acting in a circuit is F then the flux is $\frac{4\pi F \times \text{area of magnetic circuit}}{\text{length of magnetic circuit}}$.

The interlinkage factor is the fraction of the total current enclosed by the flux, and

$$L = \frac{1}{I} \Sigma \text{flux} \times \text{interlinkage factor.} \tag{73}$$

Consider first the flux in the inside conductor due to the assumed uniform distribution of the current in it.

At a distance x from the center (Fig. 126), the m.m.f. is $\frac{\pi x^2}{\pi r^2} I$ where I is the total current.

The area enclosing the flux per centimeter length of conductor is dx and the length of the magnetic circuit is $2\pi x$

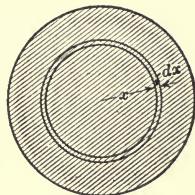

FIG. 126.

$$\therefore d\phi_1 = 4\pi \frac{x^2}{r^2} I \frac{dx}{2\pi x} = 2I \frac{x}{r^2} dx$$

This flux interlinks with $\frac{\pi x^2}{\pi r^2}$ of the total current; thus the interlinkage factor is $\frac{x^2}{r^2}$

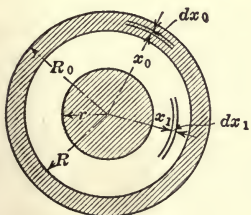

FIG. 127.

$$\therefore L_1 = \frac{1}{I} \int_0^r 2I \frac{x^3}{r^4} dx = \frac{1}{2} \tag{Assuming that } \mu = 1 \tag{74}$$

Between the conductors, the flux interlinks with the whole current (Fig. 127). Thus by a similar reasoning we get:

$$L_2 = \frac{1}{I} \int_r^{R_0} 2I \frac{dx_1}{x_1} = 2 \log \frac{R_0}{r}$$

The current in the inner conductor interlinks with the entire flux which is in the outer conductor but which is caused by the difference in m.m.f. in the inner and outer conductors.

At distance x_0 the m.m.f. is thus

$$I - \frac{x_0^2 - R^2}{R_0^2 - R^2} I = I \frac{R_0^2 - x_0^2}{R_0^2 - R^2}$$

The interlinkage of this flux with the current in the inner conductor is, of course, unity, thus

$$L_3 = \frac{1}{I} \int_R^{R_0} \frac{2I}{x_0} \frac{R_0^2 - x_0^2}{R_0^2 - R^2} dx_0 = \frac{2R_0^2}{R_0^2 - R^2} \log \frac{R_0}{R} - 1$$

The inductance of the outer conductor should be added to give the total inductance of the cable.

The m.m.f. is shown above to be

$$\begin{aligned} & - I \frac{R_0^2 - x_0^2}{R_0^2 - R^2} \\ \therefore L_4 &= - \frac{1}{I} \int_R^{R_0} \frac{2I}{x_0} \frac{(R_0^2 - x_0^2)}{(R_0^2 - R^2)^2} (x_0^2 - R^2) dx_0 \\ &= - \frac{1}{2} \frac{R_0^2 + R^2}{R_0^2 - R^2} + \frac{2R_0^2 R^2}{(R_0^2 - R^2)^2} \log \frac{R_0}{R} \end{aligned}$$

The total inductance $L = L_1 + L_2 + L_3 + L_4$ which is readily proven to be

$$L = \frac{1}{2} + 2 \log \frac{R}{r} + \frac{2R_0^4}{(R_0^2 - R^2)^2} \log \frac{R_0}{R} - \frac{1}{2} \frac{3R_0^2 - R^2}{R_0^2 - R^2} \text{ cm.}$$

This inductance is expressed in the absolute system of units. By dividing by 10^9 the inductance is expressed in henrys.

Problem 69.—Prove that there is no flux outside of the sheath, the flux set up there by the current in the sheath being exactly neutralized by the flux set up in the same space by the oppositely directed current in the inner conductor.

Inductance of a Transmission Line.—Let a transmission line be represented as in Fig. 128 by 2 conductors, A and B , of radius r . Let the distance between their centers be D . Each conductor surrounds itself with flux lines, the directions of which are indicated by arrows. The flux through any zone of width, dx , between the conductors, due to the current in A , is

$$d\phi_A = \frac{2F_x \mu dx}{x},$$

where x is the distance of the zone from the center of A , and F_x is the m.m.f. due to A .

Similarly, the flux through dx , due to the current in B is

$$d\phi_B = \frac{2F_x \mu dx}{D - x}.$$

The flux due to both A and B is then

$$d\phi = 2F_x \mu dx \left[\frac{1}{x} + \frac{1}{D - x} \right].$$

The inductance due to the interlinkages of the conductors with the flux between them is then, since $F_x = I$ in this case,

$$L = \frac{1}{I} \int_{x=r}^{x=D-r} 2I\mu \left[\frac{1}{x} + \frac{1}{D - x} \right] dx$$

$$= 4\mu \log \frac{D - r}{r}, \text{ cm. or } \frac{4\mu}{10^9} \log \frac{D - r}{r} \text{ henries per cm.}$$

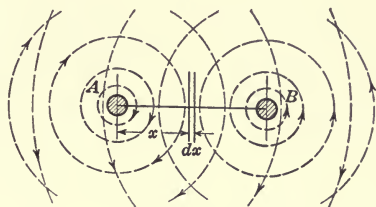

FIG. 128.

To determine the total inductance per centimeter length of circuit, that due to interlinkage within the material of each conductor must be added. This has been found (74) to be $\frac{\mu}{2}$ for each conductor. Therefore, the total inductance is

$$L \text{ (total)} = 4\mu \log \frac{D - r}{r} + \mu \text{ cm. per cm. of circuit} \quad (75)$$

In practical formulæ, this becomes

$$L = 0.000015 + 0.00014 \log_{10} \frac{D - r}{r}$$

in henrys per 1000 ft. of wire, not 1000 ft. of circuit.

Note that if the capacity between transmission lines is given in farads and the inductance in henrys $\frac{1}{\sqrt{LC}}$ is only very little less than the velocity of light which is 3×10^{10} cm. per sec. or 187,000 miles per second.

Problem 70.—Explain the effect of increasing the size of the wire on the inductance of a transmission line.

Similarly, explain the effect of increasing the distance between the wires.

CHAPTER XXIV

DISTRIBUTED INDUCTANCE AND CAPACITY

In the electric and magnetic problems dealt with so far it has been assumed that the electro-static and magnetic fields propagate with infinite velocity. In other words, it has been assumed that the instantaneous values of the currents and e.m.fs. are the same at all points of the circuit. This of course is practically true except in very long transmission lines, since the propagation of the electric and magnetic fields in a dielectric such as air is the same as that of light, or very nearly 3×10^{10} cm. per sec. or 187,000 miles per sec., and along a transmission line it is retarded only a small percentage due to the fact that the current is not confined to the surface of the conductor.

Assuming, however, that the transmission line is very long, say 300 miles, then the time interval between, say, the maximum

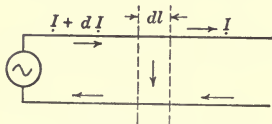

FIG. 129.

value of the current at the beginning and the end of the line is evidently $\frac{1}{620}$ sec., corresponding in a 60-cycle system to approximately one-tenth of one cycle, or, approximately, 36° in time phase.

It is thus seen that in a long transmission line not only do the instantaneous values of the currents and e.m.fs. vary from instant to instant, but at a given instant the values of the currents and e.m.fs. are different at different points of the line.

This problem has been treated very completely by many authorities. The simplest solution appears to be that by STEINMETZ,¹ which is largely followed in the succeeding paragraphs.

Let Fig. 129 represent a long transmission line. Let r_0 = resistance per unit length of line, x_0 = reactance per unit length of line, g_0 = leakage conductance per unit length of line, b_0 = capacity susceptance per unit length of line, $r = r_0 l$ = total resistance of the line. Let dl be any small section of the line.

Then assuming sine wave of current when complex representa-

¹ "Electric Discharges, Waves and Impulses."

tion can be used, the current entering this section is $I + dI$. The current leaving the section is I .

Then $I + dI - I = E(g_0 + jb_0)dl$ is the small difference in current in passing through dl , or is the combined leakage and capacity current across the section of width dl . This may be written

$$dI = EY_0dl \tag{76}$$

Likewise, $dE = I(r_0 + jx_0)dl$ is the e.m.f. consumed by the resistance and reactance of the section dl , or

$$dE = IZ_0dl \tag{77}$$

(76) and (77) become, then,

$$\left. \begin{aligned} \frac{dI}{dl} &= EY_0 \\ \frac{dE}{dl} &= IZ_0 \end{aligned} \right\} \tag{78}$$

Differentiating these,

$$\begin{aligned} \frac{d^2E}{dl^2} &= Z_0 \frac{dI}{dl} \\ \frac{d^2I}{dl^2} &= Y_0 \frac{dE}{dl} \end{aligned}$$

Substituting values of $\frac{dI}{dl}$ and $\frac{dE}{dl}$ from (78),

$$\left. \begin{aligned} \frac{d^2E}{dl^2} &= EZ_0Y_0 \\ \frac{d^2I}{dl^2} &= IZ_0Y_0 \end{aligned} \right\} \tag{79}$$

Thus, the second differentials of E and I are found to be proportional to E and I , respectively. Since the two equations are similar, their solutions are similar, differing only in integration constants.

The equations (79) are of the form

$$\frac{d^2y}{dx^2} = ay,$$

whose solution is

$$y = A\epsilon^{x\sqrt{a}} + B\epsilon^{-x\sqrt{a}} \tag{80}$$

The equation of the current then becomes

$$I = A\epsilon^{l\sqrt{Y_0Z_0}} + B\epsilon^{-l\sqrt{Y_0Z_0}}$$

or if, for the sake of briefness, $Y_0Z_0 = v$

$$I = A\epsilon^{lv} + B\epsilon^{-lv} \quad (81)$$

We also have, from (78),

$$E = \frac{1}{Y_0} \frac{dI}{dl} \quad (82)$$

Differentiating (81),

$$\frac{dI}{dl} = Av\epsilon^{lv} - Bv\epsilon^{-lv} \quad (83)$$

Substituting this into (82)

$$\begin{aligned} E &= \frac{1}{Y_0} [Av\epsilon^{lv} - Bv\epsilon^{-lv}] \\ &= \sqrt{\frac{Z_0}{Y_0}} [A\epsilon^{lv} - B\epsilon^{-lv}] \end{aligned} \quad (84)$$

Representing the exponentials of (81) and (84) in series,

$$\begin{aligned} \epsilon^{lv} &= 1 + lv + \frac{l^2v^2}{|2} + \frac{l^3v^3}{|3} + \dots \\ \epsilon^{-lv} &= 1 - lv + \frac{l^2v^2}{|2} - \frac{l^3v^3}{|3} + \dots \end{aligned}$$

Substituting these into (81) and (84) gives:

$$\begin{aligned} I &= A + Alv + A \frac{l^2v^2}{2} + \dots + B - Blv + B \frac{l^2v^2}{2} - \dots \\ &= A + B + lv(A - B) + \frac{l^2v^2}{2} (A + B) + \dots \\ &= (A + B) \left(1 + \frac{l^2v^2}{2}\right) + (A - B)lv + \dots \end{aligned}$$

and, similarly,

$$E = \sqrt{\frac{Z_0}{Y_0}} [(A - B) \left(1 + \frac{l^2v^2}{2}\right) + lv(A + B) + \dots] \quad (85)$$

If l is made any length counting from the receiving end of the line at $l = 0$, $E = e$, the receiving end voltage, and $I = I_1$, the load current, both of which may be known.

Substituting these values (85) becomes, for the receiving end,

$$\left. \begin{aligned} I_1 &= A + B \\ e &= \sqrt{\frac{Z_0}{Y_0}} (A - B) \end{aligned} \right\} \quad (86)$$

By substituting these values of I_1 and e in (85) we get finally:

$$\left. \begin{aligned} I &= I_1 \left(1 + \frac{l^2 v^2}{2} \right) + e \sqrt{\frac{Y_0}{Z_0}} l v \\ &= I_1 \left(1 + \frac{l^2 v^2}{2} \right) + e Y_0 l \\ E &= e \left(1 + \frac{l^2 v^2}{2} \right) + I_1 Z_0 l \end{aligned} \right\} \quad (87)$$

where I and E are the values of current and voltage at any point, l , along the line. The current and voltage at the generator are found by substituting in (87)

$$\frac{l_2 v_2}{2} = \frac{Z Y}{2}$$

where Z and Y are the values of impedance and admittance for the entire line. The equations (87) become

$$\left. \begin{aligned} I_0 &= I_1 \left(1 + \frac{Y Z}{2} \right) + e Y \\ E_0 &= e \left(1 + \frac{Y Z}{2} \right) + I_1 Z \end{aligned} \right\} \quad (88)$$

YZ is found from the constants of the line, thus:

$$\begin{aligned} YZ &= (g + jb)(r + jx) = gr + gjx + jbr - bx \\ &= gr - bx + j(gx + br). \end{aligned}$$

Problem 71.—Transmission Line Calculation.—A 200-mile, three-phase transmission line is composed of three No. 000 B. & S. wires, and runs at an altitude of 1200 ft. where it may be assumed that the corona loss is 1 kw. per wire per mile at a potential difference of 125,000 volts between the lines.

- Let $E = 125,000$ volts at receiving end, between wires;
 $f = 60$ cycles; $r = 64$ ohms per wire;
 $x = 154$ ohms per wire; $g = 0.000038$ per wire;
 $b = 0.00107$ per wire; $D = 10$ ft. = 304.5 cm. between wires.

Check the constants of the line and find:

Power per phase at the generator	= P_0 .
Current per phase at the generator	= I_0 .
Voltage per phase at the generator	= E_0 .
Volt-amp. per phase at the generator	= $E_0 I_0$.
Power factor at the generator	= $\frac{P_0}{E_0 I_0}$.
Power per phase of the load	= P .
Volt-amp. per phase of the load	= eI .
Power factor of the load	= $\frac{P}{eI}$.
Efficiency of transmission	= $\frac{P}{P_0}$.
Voltage regulation	= $(E_0 - e) \div e$.

Plot the voltage and current vectors for both ends of the line.

Solution.—Resistance of No. 000 B. & S. wire, from tables,
= 0.0605 ω /1000 ft. at 60°F.

$$\therefore r = 0.0605 \times 5.28 \times 200 = 64 \text{ ohms.}$$

Inductance = $0.00014 \log_{10} \frac{D - r_0}{r_0} = 0.00014 \log_{10} \frac{304.52 - 0.52}{0.52}$ per 1000 ft., where r_0 = radius = 0.5202 cm.

$$\therefore L/1000' = 0.00014 \log_{10} 585 = 0.00014 \times 2.767 = 0.0003874.$$

$$L = 0.0003874 \times 5.28 \times 200 = 0.409 \text{ henry.}$$

$$X = 0.409 \times 377 = 154.2 \text{ ohms.}$$

$$C/1000' = \frac{0.0074}{\log_{10} \frac{D - r}{r}} = 0.0074 \times 0.361 = 0.002672 \text{ micro-farad}$$

$$C = 0.002672 \times 5.28 \times 200 = 2.82 \text{ micro-farads.}$$

$$b = 2\pi fC = 377 \times 2.82 \times 10^{-6} = 0.00107$$

$$g = \frac{W}{e^2} = \frac{\text{corona loss per wire}}{(\text{voltage to neutral})^2} = \frac{200,000}{(72,250)^2} = 0.000038^1$$

¹ The voltage to neutral on a balanced three-phase system is the line voltage divided by $\sqrt{3} = \frac{E}{1.73}$.

The current supplied from the generator is found from (88) to be:

$$I_0 = I \left(1 + \frac{\dot{Y}\dot{Z}}{2} \right) + eY = (100 - j50) \left(1 + \frac{\dot{Y}\dot{Z}}{2} \right) + eY.$$

$$\dot{Y}\dot{Z} = gr - bx + j(gx + br); Y = g + jb; e = 72,250.$$

$$\therefore \frac{\dot{Y}\dot{Z}}{2} = -0.081 + j0.037.$$

$$1 + \frac{\dot{Y}\dot{Z}}{2} = 0.919 + j0.037; eY = 2.741 + j77.3.$$

Substituting values,

$$\begin{aligned} I_0 &= (100 - j50)(0.919 + j0.037) + 2.741 + j77.3 \\ &= 93.75 - j42.2 + 2.741 + j77.3 = 96.49 + j35.1 = 102.5 \text{ amp.} \end{aligned}$$

The voltage at the generator terminals is obtained in a similar way, and is

$$E_0 = e \left(1 + \frac{\dot{Y}\dot{Z}}{2} \right) + IZ = 72,250(0.919 + j0.037) + (100 - j50)(64 + j154) \\ = 80,625 + j14,928 = 81,200 \text{ volts.}$$

The power per phase at the generator is, by "telescoping" $E_0 I_0$,

$$P_0 = e_0 i_0 + e_0' i_0' = 80,625 \times 96.49 + 14,928 \times 35.1 = 8200 \text{ kw.}$$

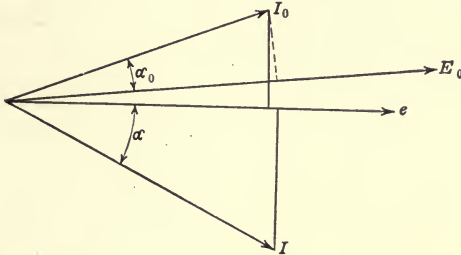

FIG. 130.

The apparent power input to the line is

$$E_0 I_0 = 81,200 \times 102.5 = 8325 \text{ k.v.a. at the generator.}$$

The power factor at the generator is

$$\text{P.F.}_0 = \frac{P_0}{E_0 I_0} = \frac{8200}{8325} = 0.985.$$

The power supplied to the load is

$$P = ei = 72,250 \times 100 = 7225 \text{ kw.}$$

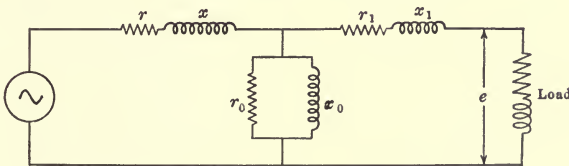

FIG. 131.

The apparent power supplied to the load is

$$eI = 72,250 \times \sqrt{100^2 + 50^2} = 72,250 \times 111.9 = 8060 \text{ k.v.a.}$$

The power factor of the load is

$$\text{P.F.} = \frac{P}{eI} = \frac{7225}{8060} = 0.895.$$

$$\text{Efficiency of transmission} = \frac{P}{P_0} = \frac{7225}{8200} = 0.882.$$

$$\text{Regulation} = \frac{81,200 - 72,250}{72,250} = 12.4 \text{ per cent.}$$

The vectors \dot{E}_0 , \dot{I}_0 , e and \dot{I} are plotted to scale in Fig. 130.

Problem 72.—Consider a circuit as shown in Fig. 131. Let the constants be:

$$r = 0.01$$

$$x = 0.02$$

$$r_1 = 0.01$$

$$x_1 = 0.02$$

$$r_0 = 0.01$$

$$x_0 = 0.002$$

When the load voltage is $e = 1$, and the load current is $\dot{I} = 1 + 0.5j$, find the generator voltage, current, power factor, and the voltage and current of the branch (r_0 , x_0).

CHAPTER XXV

NOTES ON THE MATHEMATICS OF COMPLEX QUANTITIES

This chapter is inserted in order that the common mathematical operations shall be kept fresh in mind by review and frequent practice. It is very desirable that the student shall possess and retain facility in common, though not always frequent, operations. For instance:

Solve $\sqrt[3]{0.008}$, using log tables.

Solve $e^{-0.216}$, using log tables.

Differentiate $y = ax^n$; $y = ae^{-ax}$;

$$y = \sin x; y = \cos x;$$

$$y = uv; y = \frac{u}{v}.$$

Find the log, and differential, of $4 - 3j$.

Find $\sqrt[4]{-3j}$.

Representation of Complex Quantities.—The general expression for a complex quantity is $A = a_1 + ja_2$. The numerical

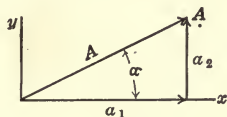

FIG. 132.

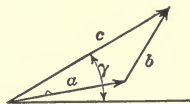

FIG. 133.

value, or modulus, of the complex is $A = \sqrt{a_1^2 + a_2^2}$ and the vectorial angle is $\tan^{-1} \alpha = \frac{a_2}{a_1}$.

These various quantities may be represented as in Fig. 132. Then $a_1 = A \cos \alpha$; $a_2 = A \sin \alpha$, whence $A = A(\cos \alpha + j \sin \alpha) = Ae^{j\alpha}$, the latter relation being proved later.

Addition of Two Complex Quantities.—

Let $C = A + B$ (Fig. 133).

Then

$$\begin{aligned} C &= a_1 + ja_2 + b_1 + jb_2 \\ &= a_1 + b_1 + j(a_2 + b_2), \end{aligned}$$

and

$$\begin{aligned} C &= \sqrt{(a_1 + b_1)^2 + (a_2 + b_2)^2} \\ \text{Tan } \gamma &= \frac{a_2 + b_2}{a_1 + b_1}. \end{aligned}$$

Multiplication of Two Complex Quantities.—

Let

$$\begin{aligned} C &= A \times B. \\ C &= (a_1 + ja_2)(b_1 + jb_2) \\ &= a_1b_1 - a_2b_2 + j(a_1b_2 + a_2b_1) \end{aligned}$$

and

$$\begin{aligned} C &= \sqrt{(a_1b_1 - a_2b_2)^2 + (a_1b_2 + a_2b_1)^2} \\ \text{Tan } \gamma &= \frac{a_1b_2 + a_2b_1}{a_1b_1 - a_2b_2}. \end{aligned}$$

Division of Two Complex Quantities.—

Let

$$\begin{aligned} C &= \frac{A}{B}. \\ C &= \frac{a_1 + ja_2}{b_1 + jb_2} = \frac{(a_1 + ja_2)(b_1 - jb_2)}{b_1^2 + b_2^2} \\ &= \frac{a_1b_1 + a_2b_2 + j(a_2b_1 - a_1b_2)}{b_1^2 + b_2^2}, \end{aligned}$$

and

$$\begin{aligned} C &= \sqrt{\left(\frac{a_1b_1 + a_2b_2}{b_1^2 + b_2^2}\right)^2 + \left(\frac{a_2b_1 - a_1b_2}{b_1^2 + b_2^2}\right)^2} \\ \text{Tan } \gamma &= \frac{a_2b_1 - a_1b_2}{a_1b_1 + a_2b_2}. \end{aligned}$$

Similar processes may be carried out when the complex quantities are expressed in polar coordinates.

Multiplication.—

$$\begin{aligned} C &= AB = a(\cos \alpha + j \sin \alpha)b(\cos \beta + j \sin \beta) \\ &= AB(\cos \alpha \cos \beta + j \sin \alpha \cos \beta + \cos \alpha j \sin \beta - \sin \alpha \sin \beta) \\ &= AB(\cos(\alpha + \beta) + j \sin(\alpha + \beta)). \end{aligned}$$

Involution and Evolution.—

$$\begin{aligned} A^2 &= A^2 e^{2j\alpha} = A^2(\cos 2\alpha + j \sin 2\alpha). \\ A^n &= A^n(\cos n\alpha + j \sin n\alpha). \\ \sqrt[n]{A} &= A^{\frac{1}{n}} = A^{\frac{1}{n}} \left(\cos \frac{\alpha}{n} + j \sin \frac{\alpha}{n} \right) \end{aligned} \quad (89)$$

Since $\cos \alpha = \cos (\alpha + 2\pi p)$ and $\sin \alpha = \sin (\alpha + 2\pi p)$ where p is any integer, the simple complex expression should be written:

$$A = A[\cos (\alpha + 2\pi p) + j \sin (\alpha + 2\pi p)],$$

where there is any question about the number of different solutions.

In evaluating such expressions, α is in radians.

$\sin X$ and $\cos X$ may also be written as series,¹ in which

$$\left. \begin{aligned} \sin x &= x - \frac{x^3}{3} + \frac{x^5}{5} - \dots \\ \cos x &= 1 - \frac{x^2}{2} + \frac{x^4}{4} - \dots \end{aligned} \right\} \quad (90)$$

Example.—Calculate, from series expression, the value of $\sin 2^\circ$. Since the angle must be expressed in radians,

$$x = \frac{2 \times 2\pi}{360} = \frac{\pi}{90} \text{ radians.}$$

Substituting this value into the series,

$$\sin 2^\circ = \frac{\pi}{90} - \frac{\pi^3}{6 \times 90^3} + \frac{\pi^5}{120 \times 90^5} - \dots = 0.0349.$$

The Roots of a Complex Quantity.—Using the more general expression, Eq. (89) may be written:

$$\sqrt[n]{A} = A^{\frac{1}{n}} \left[\cos \frac{\alpha + 2\pi p}{n} + j \sin \frac{\alpha + 2\pi p}{n} \right] \quad (91)$$

To find the roots, put $p = 1, 2, 3, 4$, etc., and solve, continuing until repetition begins.

Example.—Find $\sqrt[4]{1} = \sqrt[4]{A}$,

where

$$A = 1 = 1 + j0.$$

$$A = A (\cos \alpha + j \sin \alpha) = 1; a = 1; n = 4; \tan \alpha = \frac{0}{1} = 0; \alpha = 0.$$

Tabulating, and supplying values to (91):

p	0	1	2	3	4
$\cos \frac{2\pi p}{4}$	1	0	-1	0	1
$j \sin \frac{2\pi p}{4}$	$j0$	$j1$	$j0$	$-j1$	$j0$
$\sqrt[4]{A}$	1	j	-1	$-j$	1

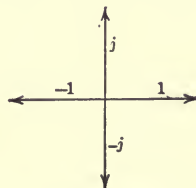

FIG. 134.

The roots are represented as vectors in Fig. 134.

¹ Developed by MACLAURIN'S theorem.

Exponential Representation of Complex Quantities.—The exponent ϵ^u may be written as a series known as the exponential series, developed from MACLAURIN'S theorem.

Thus,

$$\epsilon^u = 1 + \frac{u}{1} + \frac{u^2}{2} + \frac{u^3}{3} + \dots$$

Let

$$u = j\theta.$$

Then,

$$\begin{aligned} \epsilon^{j\theta} &= 1 + \frac{j\theta}{1} + \frac{j^2\theta^2}{2} + \dots \\ &= 1 + \frac{j\theta}{1} - \frac{\theta^2}{2} - \frac{j\theta^3}{3} + \frac{\theta^4}{4} + \dots \\ &= 1 - \frac{\theta^2}{2} + \frac{\theta^4}{4} - \dots + j\left(\frac{\theta}{1} - \frac{\theta^3}{3} + \frac{\theta^5}{5}\right) \end{aligned} \tag{92}$$

These two component series are seen to be those of the sine and cosine (90). Hence (92) may be written:

$$\epsilon^{j\theta} = \cos \theta + j \sin \theta \tag{93}$$

Since

$$A = A(\cos \alpha + j \sin \alpha),$$

substituting from (93),

$$A = A\epsilon^{j\alpha}.$$

Thus, a third form of writing the complex quantity, A , has been developed.

This last may be extended by letting $A = \epsilon^{\alpha_0}$. Thus,

$$A = \epsilon^{\alpha_0} \epsilon^{j\alpha} = \epsilon^{\alpha_0 + j\alpha}$$

in which the exponent is complex.

Differentiation of a Complex Number or Vector.—

Let

$$A = A\epsilon^{j\alpha}.$$

then

$$\begin{aligned} dA &= Aj\epsilon^{j\alpha}d\alpha + \epsilon^{j\alpha}dA \\ &= \epsilon^{j\alpha}[Aj d\alpha + dA] \end{aligned} \tag{94}$$

Logarithm of a Complex Number or Vector.—

$$\log u = \int \frac{du}{u}.$$

We have

$$\log A = \int \frac{dA}{A};$$

from (94),

$$\begin{aligned} \log A &= \int \frac{e^{j\alpha} A j d\alpha}{A e^{j\alpha}} + \int \frac{dA e^{j\alpha}}{A e^{j\alpha}} = \int j d\alpha + \int \frac{dA}{A} \\ &= j(\alpha + 2\pi p) + \log A. \end{aligned}$$

The logarithm of a vector has thus an infinite number of values.

CHAPTER XXVI

THE TRANSFORMER

The alternating-current transformer is used to change electric energy from one voltage to another. This is done by interlinking two electric circuits having different numbers of turns with the same magnetic alternating flux.

If the two circuits enclose exactly the same flux it is evident that the voltages induced in the windings will be proportional to the numbers of turns. If, however, as is the case, the flux is not exactly the same for each circuit, the ratio is slightly affected and, as will be shown later, the secondary voltage has a value differing slightly from what the ratio of turns would demand.

When one circuit is connected to an alternating e.m.f., the other circuit being open, a current flows in that circuit (Fig. 135). This current is called the no-load or the exciting current, and may be assumed to consist of two components, one of which

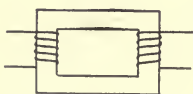

FIG. 135.

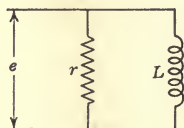

FIG. 136.

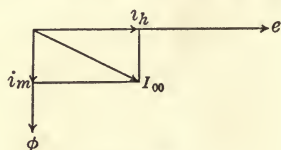

FIG. 137.

supplies magnetism to the core and is called the wattless component, while the other supplies power for hysteresis and eddy current losses and is called the power component.

These component currents of the exciting current may be represented as flowing in a circuit of resistance and inductance in parallel as in Fig. 136, where e is the e.m.f. which sets up these currents. They may be represented vectorially, as in Fig. 137. In the latter representation i_m , in quadrature with e , produces the flux ϕ , but no power; i_h , in phase with e , supplies the core loss. The exciting current, I_{00} , lags behind e by an angle $\tan^{-1} \frac{i_m}{i_h}$.

It is not strictly correct to represent the core loss by a resistance r , Fig. 136, with varying e , for part of the core loss is proportional to $e^{1.6}$ and part to e^2 .

Neither is it correct to assume that the magnetizing component is proportional to the e.m.f., since the magnetization curve is not a straight line. However, in most cases, the variation of e is slight, and proportionality may be assumed without appreciable error.

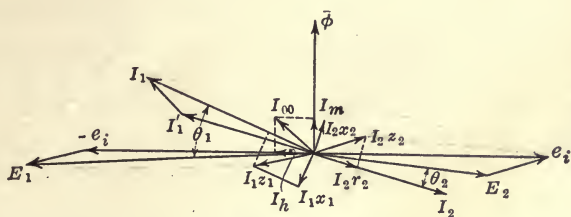

FIG. 138.

The Transformer Diagram.—The relations of voltage, current and flux which exist in a transformer under normal operation are shown with great clearness by the aid of the transformer diagram. ϕ represents the flux that interlinks with the primary and secondary of the transformer; e_i is the e.m.f. induced in the primary and secondary windings (assuming the same number of turns in each). This e.m.f. is 90° in time behind the flux, as is seen from Fig. 139 and by the following simple proof:

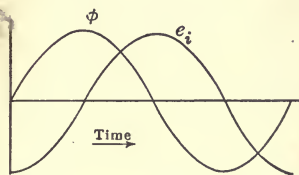

FIG. 139.

If

$$\phi = \Phi_m \sin \omega t,$$

then

$$e_i = - \frac{N}{10^8} \frac{d\phi}{dt} = - \frac{N}{10^8} \omega \Phi_m \cos \omega t.$$

I_2 is the secondary or load current which in this particular diagram is shown lagging behind the induced e.m.f. $I_2 r_2$ and $I_2 x_2$ are respectively the e.m.fs. consumed by the secondary resistance and reactance, $I_2 r_2$ being in phase with I_2 and $I_2 x_2$ being 90° ahead of I_2 . $I_2 z_2$ is the e.m.f. consumed by the secondary impedance, which subtracted vectorially from e_i gives E_2 as the secondary terminal voltage.

The primary current may be assumed to consist of three component parts: the first I'_1 , which corresponds to the secondary current and is equal and opposite thereto; the second I_m , which is

the magnetizing current producing the flux ϕ and is in phase with the flux; and the third I_h , which is the power loss current due to the core loss and is in quadrature to the magnetizing component, that is, in phase but opposite to the induced e.m.f. e_i .

I_m and I_h combine in I_{00} which is the exciting current.

To overcome the induced e.m.f. e_i in the primary winding an impressed e.m.f. $-e_i$ is required.

To overcome the resistance and reactance drop in the primary windings an e.m.f. $I_1 z_1$ needs to be supplied. Thus the primary impressed e.m.f. E_1 is the vector sum of these.

θ_1 is evidently the angle between the primary current and e.m.f.

θ_2 is the angle between the secondary current and e.m.f.

The total primary current, $I_1 = I'_1 + I_{00}$.

In phase with I_1 is the voltage, $I_1 r_1$, consumed by the primary resistance, r_1 , and at right angles ahead of I_1 is the voltage, $I_1 x_1$, consumed by the self-inductance of the primary coil.

These two voltages combine to form $I_1 z_1$, the voltage consumed in the primary of the transformer.

The total impressed primary voltage, E_1 , is the sum of $I_1 Z_1$ and $-e_i$. The angle θ_1 is the phase angle between E_1 and I_1 .

The transformer diagram is obviously not suitable for accurate calculation. For this purpose, another development will be made.

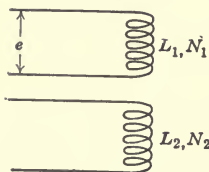

FIG. 140.

Let there be two mutually inductive coils, one of them, called the primary, having N_1 turns, r_1 ohms resistance, and L_1 henrys inductance, while the similar quantities of the other, or secondary coil, are N_2 , r_2 and L_2 respectively.

Then, in Fig. 140, if the secondary current $I_2 = 0$, the primary impressed voltage, $e_1 = i_1 r_1 + L_1 \frac{di_1}{dt}$, where e_1 and i_1 are instantaneous values of voltage and current, and L_1 is assumed constant. If a secondary current flows, there will be induced in the secondary an e.m.f. $e_i = -L_2 \frac{di_2}{dt}$. The secondary induced e.m.f.

$$\text{per turn} = -\frac{e_i}{N_2} = \frac{L_2}{N_2} \frac{di_2}{dt}$$

If it be assumed that there is no leakage, that is, that all the magnetic flux links with both the primary and the secondary

coils, then the induced e.m.f. in the primary due to I_2 must be

$$-\frac{N_1}{N_2} L_2 \frac{di_2}{dt}$$

Then,

$$e_1 = i_1 r_1 + L_1 \frac{di_1}{dt} + \frac{N_1}{N_2} L_2 \frac{di_2}{dt} \quad (96)$$

The sign of the last term changes from $-$ to $+$ because the induced e.m.f. must be overcome, or balanced, by an e.m.f. of the opposite sign.

But

$$\frac{N_1}{N_2} L_2 = \sqrt{L_1 L_2},$$

for, from fundamental relations,

$$L_1 = \frac{N_1 \phi_1}{10^8 i_1}, \text{ and } \phi_1 = \frac{i_1 N_1}{K}$$

Substituting,

$$L_1 = \frac{N_1^2}{10^8 K}$$

Similarly,

$$L_2 = \frac{N_2^2}{10^8 K}$$

Then the ratio

$$\frac{L_1}{L_2} = \frac{N_1^2}{N_2^2}, \text{ and } \frac{N_1}{N_2} = \sqrt{\frac{L_1}{L_2}},$$

whence

$$\frac{N_1}{N_2} L_2 = \sqrt{L_1 L_2}$$

(96) then becomes

$$e_1 = i_1 r_1 + L_1 \frac{di_1}{dt} + \sqrt{L_1 L_2} \frac{di_2}{dt}$$

Let $\sqrt{L_1 L_2}$ be denoted by M .

Then,

$$e_1 = E_{1m} \sin \omega t = i_1 r_1 + L_1 \frac{di_1}{dt} + M \frac{di_2}{dt} \quad (97)$$

Similarly for secondary,

$$e_2 = i_2 r_2 + L_2 \frac{di_2}{dt} + M \frac{di_1}{dt} = 0 \quad (98)$$

since no e.m.f. is impressed on the secondary coil.

The constant, M , is called the coefficient of mutual induction, and may be defined as the number of interlinkages of flux with both coils of a mutually inductive circuit when unit current is flowing in one of the coils.

Mutual inductance, like self-inductance, is measured in henrys.

It does not always follow that M is equal to $\sqrt{L_1 L_2}$. In fact, that condition is attained only when no magnetic leakage exists, which never occurs. If part of the flux set up by the primary does not interlink with the secondary, that part constitutes the primary leakage flux. Similarly, when current flows in the secondary, some secondary leakage flux is set up. Whenever there is leakage flux,

$$M < \sqrt{L_1 L_2}.$$

Eqs. (97) and (98) hold at all times provided the proper value of M is supplied, and M is usually about 95 per cent. of $\sqrt{L_1 L_2}$.

Equivalent Transformer Circuit.—The differential equations given above are not readily used, but, fortunately, STEINMETZ has evolved a simple treatment involving a diagram of simple series and multiple circuits, which, while not showing the physics of the phenomenon, lends itself to very simple and quite accurate treatment.

He represents the transformer by a circuit which is shown in Fig. 141.

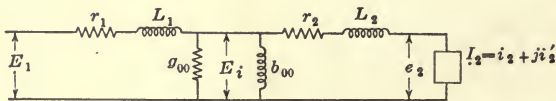

FIG. 141.

Let the secondary or load current be $I_2 = i_2 + j i'_2$, and let the secondary terminal voltage be e_2 , the zero vector.

Then the secondary induced e.m.f. $E_i = e_2 + I_2 Z_2 = e_2 + i_2 r_2 - i'_2 x_2 + j(i'_2 r_2 + i_2 x_2) = e_i + j e'_i$.

The exciting current is

$$\begin{aligned} I_{00} &= E_i Y_{00} = (e_i + j e'_i)(g_{00} + j b_{00}) \\ &= g_{00} e_i - b_{00} e'_i + j(b_{00} e_i + g_{00} e'_i) \\ &= i_{00} + j i'_{00}. \end{aligned}$$

The primary current is

$$I_1 = I_2 + I_{00} = i_2 + i_{00} + j(i'_2 + i'_{00}) = i_1 + j i'_1.$$

The impressed voltage is

$$\begin{aligned} E_1 &= E_i + I_1 Z_1 = e_1 + i_1 r_1 - i'_1 x_1 + j(e'_i + i_1 x_1 + i'_1 r_1) \\ &= e_1 + j e'_1. \end{aligned}$$

From these values may be obtained:

power output	$= e_2 i_2,$
power input	$= e_1 i_1 + e'_1 i'_1,$
power factor at primary terminals	$= \frac{\text{power input}}{\text{volt-amp.}} = \frac{e_1 i_1 + e'_1 i'_1}{E_1 I_1}.$
regulation	$= \frac{E_1 - e_2}{e_2},$
efficiency	$= \frac{e_2 i_2}{e_1 i_1 + e'_1 i'_1}.$

In using these equations r_1, r_2, x_1 and x_2 are positive, b_{00} is negative because the magnetizing circuit is necessarily inductive, i_2 is negative for lagging, positive for leading current.

Transformers are rated on the basis of kilovolt-amperes, not kilowatts.

Example of Transformer Calculation.—Given a 2200 to 220-volt, 60-cycle, 50-kv.a. transformer, in which $r_1 = 0.97, r_2 = 0.0097$. Assume that on test 98.5 volts on the primary produces full-load current in the short-

circuited secondary (142, a). At no-load, with the normal voltage (220) impressed on the secondary, the primary circuit being open, the watts input are $W_0 = 1000$, and the exciting current $I_{00} = 12.25$ amp. (Fig. 142, b). The percentage rI drop in the primary is

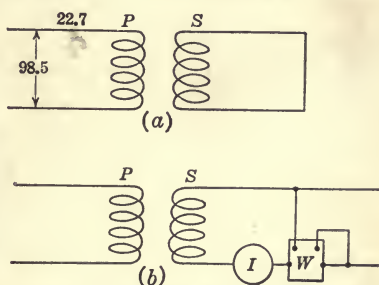

FIG. 142.

$$\frac{22.7 \times 0.97}{2200} = 0.01 = 1 \text{ per cent.}$$

where 22.7 is the normal primary current.

In the secondary,

$$\text{per cent. } rI \text{ drop} = \frac{227 \times 0.0097}{220} = 0.01 = 1 \text{ per cent.}$$

The total impedance, calculated from the short-circuit test (142, a), is

$$Z_{total} = \frac{98.5}{22.7} = 4.35 \text{ ohms.}$$

Total per cent. impedance drop, referred to the primary voltage, is

$$\frac{22.7 \times 4.35}{2200} = 0.0448 = 4.48 \text{ per cent.}$$

Percentage total reactance drop is then $\sqrt{4.48^2 - 2^2} = 4$ per cent.

total per cent. resistance drop = $1 + 1 = 2$).

Therefore, assuming primary and secondary percentage reactances to be equal,

per cent. $x_1 = 2$ per cent.; per cent. $x_2 = 2$ per cent.

Thus, on the percentage basis, or assuming $e_2 = 1$ and $i = 1$, then,

$$\begin{array}{ll} r_1 = 0.01 & x_1 = 0.02 \\ r_2 = 0.01 & x_2 = 0.02. \end{array}$$

The core loss of 1000 watts obtained on test is supplied at 220 volts by the component of no-load current, i_h .

$$\therefore i_h = \frac{1000}{220} = 4.55 \text{ amp.}$$

The per cent. i_h of the secondary current is

$$\text{per cent. } i_h = \frac{4.55}{227} = 0.02 = 2 \text{ per cent.}$$

$$\therefore g_{00} = \frac{i_h}{e} = \frac{0.02}{1} = 0.02.$$

The magnetizing component of the no-load current is obtained from I_{00} and the core-loss current. Thus,

$$i_m = \sqrt{I_{00}^2 - i_h^2} = \sqrt{12.25^2 - 4.55^2} = 11.35 \text{ amp.}$$

The percentage $i_m = \frac{11.35}{227} = 0.05 = 5$ per cent.

$$\therefore b_{00} = \frac{-i_m}{e} = -0.05.$$

Having obtained the above constants, values may now be tabulated to find the effect of variation of the load current with constant power factor.

Problem 72.—Let power factors of 100 per cent., 80 per cent. lagging and 80 per cent. leading be assumed, and let the calculations be made for secondary currents of 0, 0.5, and 1.

Tabulating:

	0.8 Lagging			P.F. = unity			0.8 Leading		
I_2	0.0	0.5	1.0	0.0	0.5	1.0	0.0	0.5	1.0
i_2	0.0	0.4	0.8	0.0	0.5	1.0	0.0	0.4	0.8
i_2'	0.0	-0.3	-0.6	0.0	0.0	0.0	0.0	0.3	0.6
$i_2'r_2$	0.0	0.004	0.008	0.0	0.005	0.01	0.0	0.004	0.008
$i_2'x_2$	0.0	-0.006	-0.012	0.0	0.0	0.0	0.0	0.006	0.012
i_2x_2	0.0	0.008	0.016	0.0	0.01	0.02	0.0	0.008	0.016
$i_2'r_2$	0.0	-0.003	-0.006	0.0	0.0	0.0	0.0	0.003	0.006
e_2	1.0	1.01	1.02	1.0	1.005	1.01	1.1	0.998	0.996
e_2'	0.0	0.005	0.01	0.0	0.01	0.02	0.0	0.011	0.022
$e_2'g_{00}$	0.02	0.0202	0.0204	0.02	0.0201	0.0202	0.02	0.01996	0.01992
$e_2'j_{00}$	0.0	-0.00025	-0.0005	0.0	-0.0005	-0.001	0.0	-0.00055	-0.0011
i_{00}	0.02	0.02045	0.0209	0.02	0.0206	0.0212	0.02	0.02051	0.02102
$i_2'g_{00}$	0.0	0.0001	0.0002	0.0	0.0002	0.0004	0.0	0.00022	0.00044
$e_2'j_{00}$	-0.05	-0.0505	-0.051	-0.05	-0.0505	-0.0505	-0.05	-0.0499	-0.0498
$i_2'j_{00}$	-0.05	-0.0504	-0.0508	-0.05	-0.05005	-0.0501	-0.05	-0.0497	-0.0494
i_1	0.02	0.42045	0.8209	0.02	0.5206	1.0212	0.02	0.4205	0.82102
i_1'	-0.05	-0.3504	-0.6508	-0.05	-0.05005	-0.0501	-0.05	0.2503	0.5506
I_1	0.054	0.547	1.046	0.0538	0.522	1.022	0.0538	0.4965	0.988
$i_1'r_1$	0.0002	0.0042	0.0082	0.0002	0.0052	0.0102	0.0002	0.0042	0.0082
$i_1'x_1$	-0.001	-0.007	-0.013	-0.001	-0.0010	-0.0010	-0.001	0.005	0.011
e_1	1.0012	1.0212	1.0295	1.0012	1.011	1.021	1.0012	0.997	0.993
$i_1'r_1$	-0.0005	-0.0035	-0.0065	-0.0005	-0.0005	-0.0005	-0.0005	0.0025	0.0055
$i_1'x_1$	0.0004	0.0084	0.0164	0.0004	0.0104	0.0208	0.0004	0.0084	0.0168
e_1'	-0.0001	0.01	0.02	-0.0001	0.0199	0.0403	-0.0001	0.0219	0.0443
E_1	1.001	1.021	1.03	1.002	1.012	1.022	1.0013	0.9974	0.9932
P_2	0.0	0.4	0.8	0.0	0.5	1.0	0.0	0.4	0.8
e_1i_1	0.02	0.49	0.854	0.02	0.5265	1.041	0.02	0.419	0.815
$e_1'i_1'$	0.0	-0.003	-0.013	0.000001	-0.001	-0.002	0.000001	0.0055	0.0242
P_1	0.02	0.426	0.841	0.02	0.525	1.039	0.02	0.424	0.839
E_1I_1	0.054	0.557	1.087	0.0538	0.5272	1.0404	0.0538	0.494	0.975
P.F. ₁	0.37	0.762	0.772	0.372	0.995	0.999	0.372	0.859	0.86
Eff.....	0.0	0.939	0.951	0.0	0.952	0.963	0.0	0.942	0.954
Reg.....	0.001	0.021	0.03	0.002	0.012	0.022	0.0013	-0.0026	-0.0068

Problem 73.—Write a discussion of the results obtained in problem 72 for the three values of current and the three power factors.

Approximate Method of Determining the Regulation, Efficiency and Power Factor of Transformers.—Let $I_2 = i_2 + j i_2'$ be the secondary current.

Then the primary current is approximately

$$I_1 = I_2 + i_h - j i_m = i_2 + i_h + j(i_2' - i_m) = i_1 + j i_1'$$

In the secondary winding only the secondary current, I_2 , flows; * in the primary winding, the primary current. The average current in the two windings considered as one is, then,

$$I_a = i_2 + 0.5i_h + j(i_2' - 0.5i_m).$$

If the secondary voltage, referred to primary, is the zero vector and is e_2 , then the primary voltage is

$$E_1 = e_2 + I_a Z_0,$$

where $Z_0 = r_0 + jx_0$ is the sum of the impedances of the primary and secondary referred to the primary.

$$\begin{aligned} E_1 &= e_2 + [i_2 + 0.5i_h + j(i'_2 - 0.5i_m)](r_0 + jx_0) \\ &= e_2 + i_2r_0 + 0.5i_hr_0 - i'_2x_0 + 0.5i_mx_0 \\ &\quad + j(i_2x_0 + 0.5i_hx_0 + i'_2r_0 - 0.5i_mr_0) = e_1 + je'_1, \end{aligned}$$

and the real value of the primary voltage is, neglecting second power of small terms,

$$E_1 = \sqrt{e_2^2 + 2e_2(i_2r_0 + 0.5i_hr_0 - i'_2x_0 + 0.5i_mx_0)} \quad (99)$$

Regulation is

$$\frac{E_1 - e_2}{e_2} = \frac{E_1}{e_2} - 1 \quad (100)$$

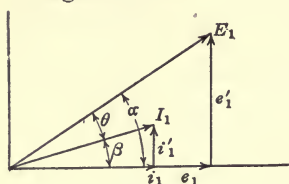

FIG. 143.

Let E_1 and I_1 represent the primary e.m.f., and current, as in Fig. 143. Then the power input is

$$P = E_1 I_1 \cos \theta.$$

But

$$\begin{aligned} \cos \theta &= \cos (\alpha - \beta) = \cos \alpha \cos \beta + \sin \alpha \sin \beta \\ &= \frac{i_1}{I_1} \times \frac{e_1}{E_1} + \frac{i'_1}{I_1} \times \frac{e'_1}{E_1} = \frac{1}{E_1 I_1} [i_1 e_1 + i'_1 e'_1]. \end{aligned}$$

$$\therefore P = E_1 I_1 \times \frac{1}{E_1 I_1} (e_1 i_1 + i'_1 e'_1) = e_1 i_1 + i'_1 e'_1.$$

The secondary output is $e_2 i_2$.

The primary input is $e_1 i_1 + e'_1 i'_1$,

$$\begin{aligned} &= e_2 i_2 + i_2 i_1 r_0 + 0.5 i_h i_1 r_0 - i'_2 i_1 x_0 + 0.5 i_m i_1 x_0 + i_2 i'_1 x_0 \\ &\quad + 0.5 i_h i'_1 x_0 + i'_2 i'_1 r_0 - 0.5 i_m i'_1 r_0 \\ &= e_2 i_2 + e_2 i_h + I_2^2 r_0, \text{ approximately.} \end{aligned}$$

The efficiency is

$$\frac{\text{output}}{\text{input}} = \frac{e_2 i_2}{e_2 i_2 + e_2 i_h + I_2^2 r_0} \quad (101)$$

Similarly,

$$P_i = -e_2 i'_2 + e_2 i_m + I_2^2 x_0, \text{ approximately.}$$

$$\therefore \tan \theta_1 = \frac{P_i}{P} = \frac{I_2^2 x_0 + e_2 i_m - e_2 i'_2}{I_2^2 r_0 + e_2 i_h + e_2 i_2} \quad (102)$$

and $\cos \theta_1$ is the power factor of the primary.

Problem 74.—(A) Determine the numerical values of the primary and secondary resistances and reactances, the core-loss current, the magnetizing current, the exciting current from the 1000-volt side, the core loss in watts,

and the short-circuit impedance when taken from the 1000-volt side, for the following, 1000-100 volt transformers. The primary and secondary resistance drops are each 1 per cent.; the primary and secondary reactance drops are each 2 per cent.

The conductances, g_{00} , and susceptances, b_{00} , are calculated at 1000 volts.

Rating in k.v.a.	10	20	40	80	160	320
g_{00}	0.0002	0.0004	0.0008	0.0016	0.0032	0.0064
b_{00}	0.0006	0.0012	0.0024	0.0048	0.0096	0.0192

Problem 74.—(B) Find the power factor, regulation and efficiency of these transformers by the approximate method, assuming unity power factor of load.

Problem 74.—(C) For any one transformer, plot the regulation and efficiency vs. power factor, and find the points of 0 per cent. regulation and maximum efficiency.

(A) *Solution for the 10 k.v.a., 1000-100 Volt Transformer.*—Since, with non-inductive load (on the secondary) the primary voltage and current will be nearly in phase, the approximate primary current is

$$I_1 = \frac{10,000 \text{ k.v.a.}}{1000 \text{ volts}} = 10 \text{ amp.}$$

$$r_1 I \text{ drop} = 1 \text{ per cent.} = 0.01 \times 1000 \text{ volts} = 10 \text{ volts}$$

$$r_1 = \frac{10 \text{ volts}}{10 \text{ amp.}} = 1 \text{ ohm.}$$

$$\therefore r_2 = 1 \times \left(\frac{1}{10}\right)^2 = 0.01 \text{ ohm.}$$

Similarly,

$$x_1 = 2 \text{ ohms.}$$

$$x_2 = 0.02 \text{ ohm.}$$

The core-loss current is

$$i_h = eg_{00} = 1000 \times 0.0002 = 0.2 \text{ amp.}$$

Magnetizing current is

$$i_m = eb_{00} = 1000 \times 0.0006 = 0.6 \text{ amp., lagging.}$$

\(\therefore\) no-load current is

$$I_{00} = \sqrt{i_h^2 + i_m^2} = \sqrt{0.04 + 0.36} = 0.632 \text{ amp.}$$

The core loss is

$$e^2 g_{00} = 1000^2 \times 0.0002 = 200 \text{ watts.}$$

The short-circuit impedance is

$$Z = \sqrt{\left(r_1 + r_2 \left(\frac{N_2}{N_1}\right)^2\right)^2 + \left(x_1 + x_2 \left(\frac{N_2}{N_1}\right)^2\right)^2}$$

$$= \sqrt{2^2 + 4^2} = \sqrt{20} = 4.47 \text{ ohms.}$$

(B) *Solution.*— $E_1 = 1000 = \sqrt{e_2^2 + 2e_2(i_2 r_0 + 0.5i_h r_0 + 0.5i_m x_0)}$

Tabulating for equations (100), (101), (102):

Kw.	10.0	$e_2 i_2$	9820.0
$I_2 = i_2$	10.0	$e_2 i_h$	196.4
r_1	1.0	i_2^2	100.0

$\left(\frac{n_1}{n_2}\right)^2 r_2$	1.0	$i_2^2 r_0$	200.0
r_0	2.0	Eff.	0.961
x_1	2.0	$i_2^2 x_0$	400.0
$\left(\frac{n_1}{n_2}\right)^2 x_2$	2.0	$e_2 i_m$	-589.2
x_0	4.0	$i_2^2 x_0 + e_2 i_m$	-189.2
$i_2 r_0$	20.0	$e_2 i_2 + e_2 i_h + i_2^2 r_0$	10,216.4
i_h	0.2	$\tan \phi$	-0.01853
$0.5 i_h r_0$	0.2	P.F. = $\cos \phi$	0.9998
i_m	-0.6		
$0.5 i_m x_0$	-1.2		
e_2	982.0		
$\frac{E_1}{e_2}$	1.018		
Reg.	0.018		

(C) Solution.—In finding the efficiency and regulation it makes no difference in the results whether the problem is solved on the percentage basis or by supplying numerical values for any given machine.

The former method is more general in its application, and it will be used here, percentage values being taken from the data of the 10-kw. transformer and applied in formulæ (100) and (101).

The percentage data then, are:

$$E_1 = 1, I_2 = 1, i_h = 0.02, i_m = -0.06, r_0 = 0.02, x_0 = 0.04$$

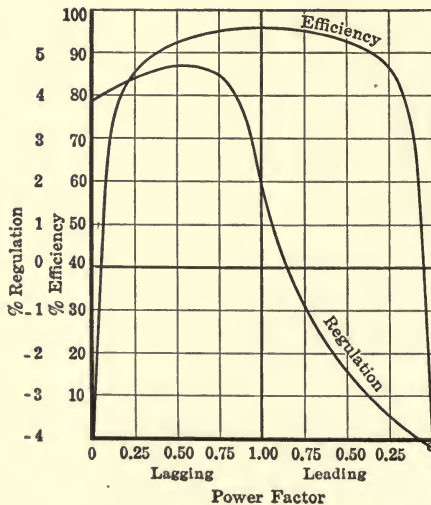

FIG. 144.

Tabulating:

	Lagging					Leading							
	0.0	0.25	0.5	0.75	1.0	0.75	0.5	0.25	0.0	0.25	0.5	0.75	1.0
P.F.	0.0	0.25	0.5	0.75	1.0	0.75	0.5	0.25	0.0	0.25	0.5	0.75	1.0
i_2	0.0	0.25	0.5	0.75	1.0	0.75	0.5	0.25	0.0	0.25	0.5	0.75	1.0
i_2'	-0.1	-0.968	-0.866	-0.661	0.0	0.661	0.866	0.968	1.0	0.968	0.866	0.661	0.0
(1) $i_2 r_0$	0.0	0.005	0.0125	0.01875	0.02	0.01875	0.0125	0.005	0.0	0.005	0.0125	0.01875	0.02
(2) $0.5 i_m r_0$	0.0002	0.0002	0.0002	0.0002	0.0002	0.0002	0.0002	0.0002	0.0002	0.0002	0.0002	0.0002	0.0002
(3) $-i_2' x_0$	0.04	0.0388	0.0347	0.0264	0.0	-0.0264	-0.0347	-0.0388	-0.04	-0.0388	-0.0347	-0.0264	-0.0002
(4) $0.5 i_m x_0$	-0.0012	-0.0012	-0.0012	-0.0012	-0.0012	-0.0012	-0.0012	-0.0012	-0.0012	-0.0012	-0.0012	-0.0012	-0.0012
(1) + (2) + (3) + (4)	0.039	0.0428	0.0462	0.0442	0.019	-0.0086	-0.0232	-0.0348	-0.041	-0.0348	-0.0232	-0.0086	-0.041
e_2	0.962	0.958	0.955	0.957	0.981	0.957	0.955	0.958	0.962	0.958	0.955	0.957	0.981
E_1	1.039	1.044	1.047	1.045	1.019	1.045	1.047	1.044	1.039	1.044	1.047	1.045	1.019
e_1	0.039	0.044	0.047	0.045	0.019	0.045	0.047	0.044	0.039	0.044	0.047	0.045	0.019
Reg.	0.0	0.2395	0.4775	0.718	0.981	0.718	0.4775	0.2395	0.0	0.2395	0.4775	0.718	0.981
(5) $e_2 i_2$	0.01924	0.01916	0.0191	0.01914	0.01962	0.01914	0.0191	0.01916	0.01924	0.01916	0.0191	0.01914	0.01962
(6) $e_2 i_2'$	0.02	0.02	0.02	0.02	0.02	0.02	0.02	0.02	0.02	0.02	0.02	0.02	0.02
(7) $I_2^2 r_0$	0.03924	0.2786	0.5166	0.7571	1.02	0.7571	0.5166	0.2786	0.03924	0.5166	0.7571	1.02	1.02
(5) + (6) + (7)	0.0	0.858	0.924	0.948	0.962	0.948	0.924	0.858	0.0	0.924	0.948	0.962	0.962
Eff.													

Curves of efficiency and regulation are given in Fig. 144.

CHAPTER XXVII

HYSTERESIS AND EDDY CURRENT LOSSES

Hysteresis Loss.—The hysteresis loop is interesting in that it indicates by its area directly the work done on the electromagnet per cycle of change of current.

The work done in an electric circuit has been shown to be $\int e i dt$. If T is the time of the cyclic variation of current then,

$$W = \int_0^T e i dt, \text{ is the work performed during the cycle.}$$

But the induced e.m.f. in a winding of N turns is

$$e = -\frac{N}{10^8} \frac{d\phi}{dt}, \text{ where } \frac{d\phi}{dt} \text{ is the rate of change of flux.}$$

$\therefore W = -\int_0^T \frac{N i}{10^8} \frac{d\phi}{dt} dt$. But $\phi = SB$, where S is the cross-sectional area of the magnetic circuit in square centimeters.

$$\therefore W = -\int_0^T \frac{N S i}{10^8} \frac{dB}{dt} dt.$$

Also the magnetizing force is:

$$H = \frac{0.4 \pi i N}{l},$$

where i is given in amperes.

Thus,

$$i N = \frac{l H}{0.4 \pi},$$

and, substituting this value,

$$W = -\int_0^T \frac{S l H}{0.4 \pi \times 10^8} \frac{dB}{dt} dt = -\frac{S l}{10^7 \times 4 \pi} \int_0^T H dB.$$

But $S l$ is the volume, V , of the magnetic structure. Thus,

$$W = -\frac{V}{10^7 \times 4 \pi} \int_0^T H dB.$$

But $H dB$ is the area of the hysteresis loop corresponding to maximum density, B , as seen from the loop. The work is given in joules.

STEINMETZ found that the hysteresis loss in watts could be expressed (approximately) by the following equation:

$$W = \frac{\eta V f B^{1.6}}{10^7}$$

where V is the volume and η is a constant which depends upon the quality of the iron. The equation shows that the loss is proportional to the 1.6 power of the maximum density and directly proportional to the frequency. In centimeter measurements η varies from 0.001 to 0.002 in ordinary sheet iron and may be 10 times as great in tempered steel. In the best silicon steel it is 0.0006, which corresponds to 0.54 watt per lb. at 60 cycles and a density of 64,500 lines per sq. in. or 10,000 lines per sq. cm.

Eddy Current Loss.—Eddy currents differ in no way from other currents, and the loss of power by them is therefore i^2R or if E is the e.m.f. causing the current and Z is the impedance of the path, then,

$$i = \frac{e}{Z}$$

and the loss is

$$i^2R = \frac{e^2}{Z^2}R.$$

It follows, then, that the loss is proportional to the square of the e.m.f. or, what is equivalent, to the square of the maximum density and to the square of the frequency, since the e.m.f. itself is proportional to the frequency of flux variation and the maximum density.

Even in the simplest cases it is difficult to calculate the loss since the distribution of the flux and, therefore, the e.m.f. in different parts of the material is often very complex.

Consider as an illustration the simple case of eddy current loss in transformer steel. The cores are built up of laminations in such a way that the flux path is divided up into a number of elements each having the section of the edge of a lamination and following parallel, or as nearly so as possible, to the sides of the laminations.

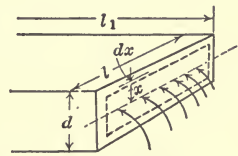

FIG. 145.

With the flux entering, as is shown in Fig. 145, currents will flow as indicated by the dotted lines. The current flowing

through a section of area $l_1 dx$ encloses a flux which is $\frac{2x}{d} \phi$, where ϕ is the flux passing through the entire area of one lamination (assuming uniform flux density).¹

The effective value of the e.m.f. induced is

$$\frac{4.44 \times \text{flux} \times \text{turns} \times \text{frequency}}{10^8} = \frac{\sqrt{2} \pi 2x \phi f}{10^8 d}$$

The resistance of the path, neglecting that of the ends, is

$$\frac{2l\rho}{l_1 dx}$$

$$\therefore i = \frac{\sqrt{2} \pi 2x \phi f l_1 dx}{10^8 d 2l\rho} = \frac{\sqrt{2} \pi \phi f l_1 x (dx)}{10^8 d l\rho}$$

where ρ is the specific resistance of the material.

$\therefore i^2 r$ in the elementary circuit is

$$\frac{2\pi^2 \phi^2 f^2 l_1^2 x^2 (dx)^2}{10^{16} d^2 l^2 \rho^2} \times \frac{2l\rho}{l_1 (dx)} = \frac{4\pi^2 \phi^2 f^2 l_1 x^2 (dx)}{10^{16} d^2 l\rho}$$

and the total loss is

$$W = \int_0^{\frac{d}{2}} \frac{4\pi^2 \phi^2 f^2 l_1 x^2 (dx)}{10^{16} d^2 l\rho} = \frac{\pi^2 \phi^2 f^2 l_1 d}{6 \times 10^{16} l\rho}$$

Since the volume is $l_1 d$, the loss per cm^3 is

$$\frac{W}{V} = \frac{\pi^2 \phi^2 f^2 l_1 d}{6 \times 10^{16} l\rho} \times \frac{1}{l \times l_1 d} = \frac{\pi^2 \phi^2 f^2}{6 \times 10^{16} l^2 \rho}$$

But $\phi = B \times ld$. $\therefore \phi^2 = B^2 l^2 d^2$,

and

$$\frac{W}{V} = \frac{\pi^2 B^2 l^2 d^2 f^2}{6 \times 10^{16} l^2 \rho} = \frac{\pi^2 B^2 f^2 d^2}{6 \times 10^{16} \rho} \text{ watts.}$$

ρ for sheet iron is about $\frac{1}{10^5}$ ohms.

¹ For a more complete discussion see "Advanced Electrical Engineering."

CHAPTER XXVIII

WAVE DISTORTION IN TRANSFORMERS

If on a transformer containing no iron a sine wave of e.m.f. were impressed at its terminals, the flux and the exciting current would also follow sine waves.

With the introduction of iron, however, while the flux values would still follow a sine wave, or very nearly so—being distorted only due to the ohmic drop of the distorted current—the exciting current wave would necessarily be considerably distorted.

Its shape is shown in Fig. 148, which is derived from the hysteresis loop given in Fig. 147.

Conversely, if by some arrangement the exciting current were made to follow substantially a sine wave, the flux wave, and therefore the wave of voltage across the transformer, would be greatly distorted.

This distortion in current or e.m.f. waves is of considerable importance in connection with the grouping of transformers in a three-phase system, as will be seen later. At present, however, only the condition in a single-phase transformer will be studied.

A representative hysteresis loop is shown in Fig. 147, which was obtained from actual tests with a sine wave of impressed e.m.f. The test data are recorded in Table VI.

If the effect of the ohmic drop be neglected, then the impressed and counter, or induced, e.m.f. are the same numerically and

$$e_i = -N \frac{d\phi}{dt},$$

where N is the number of turns and ϕ is the flux.

With a sine wave of flux $\phi = \Phi_m \sin \omega t$,

$$\frac{d\phi}{dt} = \Phi_m \omega \cos \omega t.$$

$$\therefore e_i = -N\omega\Phi_m \cos \omega t = -E_m \cos \omega t.$$

The induced e.m.f. has its negative maximum when the flux begins to rise, and lags behind the flux by 90 time degrees. Thus

the impressed e.m.f., E , which is equal and opposite to the induced e.m.f., leads the flux by 90° (neglecting the ir drop), Fig. 146.

If instead of being a sine wave the flux were distorted and yet symmetrical, it would be represented by FOURIER'S series of odd harmonics, thus:

$$\phi = \Phi_{1m} \sin \omega t + \Phi_{3m} \sin (3\omega t + \alpha) + \Phi_{5m} \sin (5\omega t + \beta) + \dots$$

$$\therefore e_i = -N \frac{d\phi}{dt} = -\Phi_{1m} \omega \cos \omega t - 3\Phi_{3m} \omega \cos (3\omega t + \alpha) - \dots$$

The e.m.f. wave would be relatively more distorted than the flux wave as is evident from the coefficients of the different trigonometric terms.

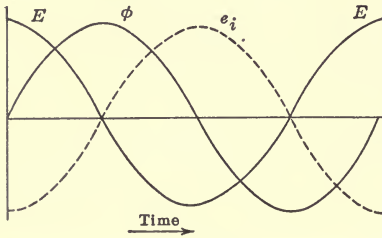

FIG. 146.

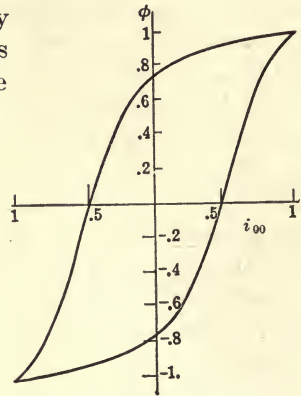

FIG. 147.

When a hysteresis loop is given, if either the flux wave or exciting current wave is known, the other may be at once obtained. For example, let the flux wave be assumed to be sinusoidal.

TABLE VI.—HYSTERESIS LOOP DATA

Ord.	Abs.	Abs.
0.0	0.5	-0.5
0.2	0.56	-0.43
0.4	0.63	-0.32
0.6	0.71	-0.18
0.8	0.82	0.08
0.9	0.9	0.35
1.0	1.0	1.0

EXCITING CURRENT DATA

Time	Flux	i_{00}
0	0.0	0.5
10°	0.174	0.55
20°	0.34	0.6

The exciting current data are obtained from the hysteresis loop by reading off the current values corresponding to the flux values which have been taken at uniform intervals along the flux wave. Thus, at 0° on the flux wave $\phi = 0$. This value of ϕ , on the hysteresis loop, corresponds to $i_{00} = 0.5$ amp. At 10° on the flux wave, $\phi = 0.174$. This value on the loop corresponds to $i_{00} = 0.55$, etc. Data for the exciting current are given in Table VI. It should be noted that the flux maximum and current maximum always occur at the same instant.

The phase relations and characteristic current wave shape for a sine wave of flux are shown in Fig. 148. The impressed voltage wave leads the flux by 90° . The scales to which the waves are plotted are quite independent of each other, and should be so chosen as to exhibit the waves most clearly.

When the induced e.m.f. is not a sine wave, the flux wave is also distorted. In this case the impressed e.m.f.

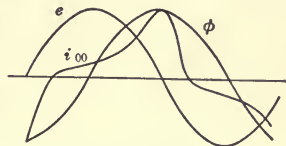

FIG. 148.

$$e = N \frac{d\phi}{dt}$$

Transposing,

$$edt = Nd\phi,$$

where N is the number of turns.

Hence

$$\int_{t=t_1}^{t=t_2} edt = \int_{\phi_1}^{\phi_2} Nd\phi.$$

If t_1 is chosen as the time when ϕ is zero, and t_2 is the time when ϕ is maximum, then

$$\int_{t=t_1}^{t=t_2} edt = \int_0^{\phi_m} \frac{N}{10^8} d\phi = \frac{N}{10^8} \phi_m.$$

This equation shows that the maximum value of the magnetic flux or flux density—in which the electrical engineer is very much interested, since it determines the magnetizing current and core loss—is proportional to a certain area of the e.m.f. wave, and it remains to determine where this area is located.

When the flux is a maximum then $\frac{d\phi}{dt}$ is zero; thus e is zero.

The value of t_2 is therefore easily ascertained, as is shown in Fig. 149.

The ordinate through t_1 must bisect the e.m.f. wave in order that the flux wave be symmetrical, as can also be seen by slight consideration, since the flux wave must be symmetrical above and below the zero line.

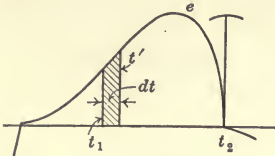

FIG. 149.

Thus, in finding the flux wave, the first step is to bisect the area of the e.m.f. half-wave, which gives the position of t_1 and the zero of the flux wave.

Problem 75.—From the following readings on a distorted e.m.f. wave obtain and plot the flux and current waves.

NOTE.—Choose a scale to give $\Phi_m = 1$.

t	e_i	t	e_i
0°	0.0	100°	0.73
10°	0.005	110°	0.90
20°	0.01	120°	1.0
30°	0.04	130°	0.98
40°	0.1	140°	0.91
50°	0.15	150°	0.78
60°	0.22	160°	0.5
70°	0.31	170°	0.12
80°	0.42	180°	0.0
90°	0.58		

Solution.—By bisecting the area of the e.m.f. half-wave it is found that the zero of the flux wave will be at 120° in this example. This is also the point of maximum e.m.f. Starting from 120° and tabulating values proportional to the areas enclosed for each 10° gives values proportional to the flux when these areas are successively summed up. Thus at 120°, flux = 0. At 130°, the area enclosed between 120° and 130° ordinates and the curve and base line is proportional to the mean ordinate, say $\frac{1.00 + 0.98}{2} = 0.99$. At 140°, the mean ordinate between 130° and 140° is 0.95.

The area from 120° to 140° is proportional to $0.99 + 0.95 = 1.94$. Thus, three points on the curve are obtained, namely, 0, 0.99, 1.94.

These values may conveniently be reduced by a factor to bring the maximum of the flux wave to unity.

The tabulation is as follows:

t	120°	130°	140°	150°	160°	170°	180°
e_i	1.00	0.98	0.91	0.78	0.50	0.12	0.0
Av.....	0.99	0.95	0.85	0.64	0.31	0.06
Area.....	0.0	0.99	1.94	2.79	3.43	3.74	3.8
0.263 × area.....	0.0	0.26	0.51	0.735	0.903	0.985	1.00

t	190°	200°	210°	220°	230°	240°
e_i	-0.005	-0.01	-0.04	-0.10	-0.15	-0.22
Av.....	-0.0025	-0.0075	-0.025	-0.07	-0.125	-0.185
Area.....	3.8	3.79	3.77	3.7	3.57	3.39
0.263 × area..	1.00	0.997	0.992	0.975	0.94	0.893

t	250°	260°	270°	280°	290°	300°
e_i	-0.31	-0.42	-0.58	-0.73	-0.90	-1.00
Av.....	-0.265	-0.365	-0.50	-0.655	-0.815	-0.95
Area.....	3.12	2.76	2.26	1.6	0.785	-0.165
0.263 × area..	0.822	0.727	0.595	0.421	0.206	0.0

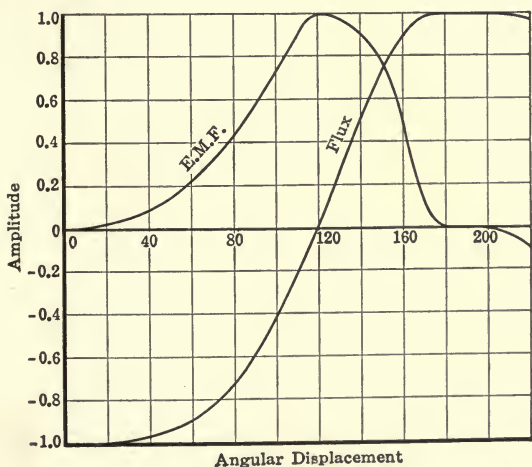

FIG. 150.

The tabulation is carried out for values of e_i from 120° to 300° , values from 180° to 300° being the same as from 0° to 120° but reversed in sign.

The flux wave is then plotted from 0° to 120° by reversing the sign of the values of flux obtained from 180° to 300° . These waves are shown in Fig. 150.

Problem 76.—With three-phase systems, the exciting current of Y-connected transformers resembles fairly closely a sine wave.¹ Assuming,

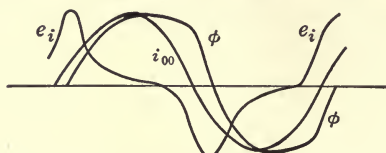

FIG. 151.

therefore, a sine wave of exciting current, determine the flux wave from the hysteresis loop (Fig. 147), and from this find and plot e_i . These waves are shown in Fig. 151, in which the characteristic form of the induced voltage, e_i , is noteworthy.

Problem 77.—Analyze, by FOURIER'S series,² the typical wave of exciting current shown in Fig. 148, determining and plotting the fundamental and third harmonic and, if sufficient time is available, also the fifth harmonic.

Dependence of Core Loss on the Shape of the E.M.F. Wave.—

The core loss of a transformer, which is due to hysteresis and eddy currents in the iron core and is equal to $e_i^2 g_{00}$, depends on the maximum value of the flux, since the greater the maximum flux the greater the area enclosed by the hysteresis loop. In modern transformers, hysteresis loss is about 70 per cent. and eddy current loss about 30 per cent. of the core loss.

But Φ_m depends upon the area of the e.m.f. wave, as has been illustrated in the problems, and hence on the average value of the e.m.f.

Hysteresis loss is approximately proportional to the 1.6th power of the maximum flux.

Thus, if a comparison is made of two e.m.f. waves of equal effective value, but of different shape and average value, the ratio

$$\frac{\text{Hysteresis loss in wave } A}{\text{Hysteresis loss in wave } B} = \left(\frac{\text{av. e.m.f. of } A}{\text{av. e.m.f. of } B} \right)^{1.6}$$

¹ This is demonstrated on p. 228, Chap. XXXII.

² See Chap. XXIX.

By definition,

$$\text{Form factor (f.f.)} = \frac{\text{effective e.m.f.}}{\text{average e.m.f.}}$$

$$\therefore \frac{\text{Hysteresis loss in } A}{\text{Hysteresis loss in } B} = \left[\frac{\text{f.f. (B)}}{\text{f.f. (A)}} \right]^{1.6}$$

Therefore, the higher the form factor the less the core loss. The form factor of a sine wave is 1.1. In general that of a flat-top wave is less; of a peaked wave, more.

Wave *A* (Fig. 152) has maximum core loss.

Wave *B* has minimum core loss.

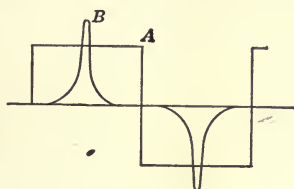

FIG. 152.

CHAPTER XXIX

DISTORTED WAVES

It is often necessary to express a distorted wave in the form of an equation. This can readily be done since it has been found that any periodic univalent curve can be expressed by a series of terms involving a constant and sine and cosine terms. That is,

$$y = a_0 + a_1 \cos \theta + a_2 \cos 2\theta + \dots + a_n \cos n\theta + b_1 \sin \theta + b_2 \sin 2\theta + \dots + b_n \sin n\theta \quad (103)$$

represents any distorted wave in which for every value of abscissa only one ordinate exists, provided that the abscissa is so chosen that the curve repeats itself at a value of $\theta = 2\pi$, i.e., the wave is periodic.

Obviously, if the distorted wave is given graphically it is always possible to read off the ordinate corresponding to each abscissa (Fig. 153).

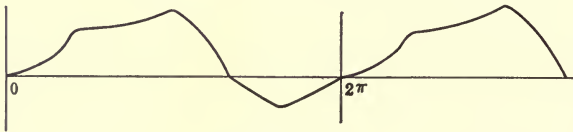

FIG. 153.

The problem then resolves itself into finding the coefficients $a_0, a_1, a_n, b_0, b_1, b_n$ in (103).

To do this a mathematical transformation has been worked out involving convenient integrations and the fact that sines and cosines have the same values at $\theta = 0$ as at $\theta = 2\pi$ or any multiple of 2π , that is, $2\pi n$, where n is an integer number.

To find a_0 integrate Eq. (103) between 0 and 2π . Thus,

$$\int_0^{2\pi} y d\theta = \int_0^{2\pi} a_0 d\theta + \int_0^{2\pi} a_1 \cos \theta d\theta + \dots + \int_0^{2\pi} a_n \cos n\theta d\theta + \int_0^{2\pi} b_1 \sin \theta d\theta + \dots + \int_0^{2\pi} b_n \sin n\theta d\theta.$$

From what has been said above, all integrals except the first must be zero. Thus

$$\int_0^{2\pi} y d\theta = \int_0^{2\pi} a_0 d\theta = a_0(2\pi - 0) = 2\pi a_0.$$

$$\therefore a_0 = \frac{1}{2\pi} \int_0^{2\pi} y d\theta.$$

But $\int_0^{2\pi} y d\theta$ is the area of the curve during one complete period and 2π is the abscissa.

$\therefore a_0$ is the average value of all the ordinates, or the average value of y .

To determine any other coefficient, for instance a_n , Eq. (103) is multiplied by $\cos n\theta$ and integration is again carried out between limits 0 and 2π .

In this case it is also remembered that the integral over one period of any product of sine and cosine terms is zero.

$$\therefore \int_0^{2\pi} y \cos n\theta d\theta = a_0 \int_0^{2\pi} \cos n\theta d\theta + a_1 \int_0^{2\pi} \cos \theta \cos n\theta d\theta$$

$$+ \dots \dots \dots a_n \int_0^{2\pi} \cos^2 n\theta d\theta + b_1 \int_0^{2\pi} \cos n\theta \sin \theta d\theta -$$

$$+ \dots \dots \dots b_n \int_0^{2\pi} \cos n\theta \sin n\theta d\theta.$$

All these integrals on the right-hand side must be zero with the exception of

$$a_n \int_0^{2\pi} \cos^2 n\theta d\theta,$$

and this integral, as is readily seen, is $= \pi$.

$$\therefore a_n = \frac{1}{\pi} \int_0^{2\pi} y \cos n\theta d\theta.$$

But $\int y \cos n\theta d\theta$ is the area, not of the original curve, but of another curve which is obtained by multiplying each value of y by the particular value, at phase angle θ , of $\cos n\theta$.

Since that area is divided by π the integral must be just twice the average of the instantaneous values of y , multiplied by $\cos n\theta$.

$$\therefore a_n = 2 \times \text{avg. of } y \cos n\theta \text{ between } 0 \text{ and } 2\pi.$$

In a similar way all values of b are obtained so that,

$$b_n = 2 \times \text{avg. of } y \sin n\theta \text{ from } 0 \text{ to } 2\pi.$$

$$\therefore a_0 = \text{avg. } (y) \Big|_0^{2\pi}$$

$$\begin{aligned}
 a_1 &= 2 \times \text{avg. } (y \cos \theta) \Big|_0^{2\pi} \\
 a_2 &= 2 \times \text{avg. } (y \cos 2\theta) \Big|_0^{2\pi} \\
 a_3 &= 2 \times \text{avg. } (y \cos 3\theta) \Big|_0^{2\pi} \\
 a_n &= 2 \times \text{avg. } (y \cos n\theta) \Big|_0^{2\pi} \\
 b_1 &= 2 \times \text{avg. } (y \sin \theta) \Big|_0^{2\pi} \\
 b_2 &= 2 \times \text{avg. } (y \sin 2\theta) \Big|_0^{2\pi} \\
 b_n &= 2 \times \text{avg. } (y \sin n\theta) \Big|_0^{2\pi}
 \end{aligned}$$

It should be noted that dividing the curve up, say every 10° from 0 to 360° , 37 readings are obtained. It is better then to use 36 and to take the average value of the values at 0° and 360° instead of using both of them.

In a symmetrical wave only those harmonics can exist, which, with an increase of the angle by 180° or π , reverse the sign of the function.

This is only the case when n is an odd number. Since, if n is 2, 4, 6, etc., then increasing the angle by π means 2π , 4π , 6π , etc., and the values of the sine and cosine are the same for α , $(\alpha + 2\pi)$, $(\alpha + 4\pi)$, etc., whereas if $n = 1, 3, 5$, etc., we get, π , 3π , 5π , in which the sign of the function reverses.

If $\sin \alpha$ is positive, then $\sin (\alpha + \pi)$ is negative.

If $\cos \alpha$ is positive, $\cos (\alpha + \pi)$ is negative, etc.

Thus, for symmetrical waves such as are given by alternators under stable conditions, the trigonometric series becomes:

$$\begin{aligned}
 y &= a_1 \cos \theta + a_3 \cos 3\theta + a_5 \cos 5\theta + \dots + b_1 \sin \theta \\
 &\quad + b_3 \sin 3\theta + b_5 \sin 5\theta + \dots
 \end{aligned}$$

Obviously, in that case, it suffices to analyze one-half a wave only.¹

Problem 78.—Plot the wave,

$$e = E_1 \sin \theta + E_3 \sin (3\theta + \alpha),$$

for

$$\begin{aligned}
 E_1 &= 1 \\
 E_3 &= 0.5 \\
 \alpha &= 30^\circ,
 \end{aligned}$$

and analyze the wave, proving that the analysis gives the original equation. Show also that no 5th harmonic exists.

¹For a more complete discussion of this method of wave analysis see STEINMETZ'S "Engineering Mathematics."

Tabulating:

θ°	0	10	20	30	40	50	60	70	80	90
$E_1 \sin \theta$	0.0	0.174	0.342	0.50	0.643	0.766	0.866	0.94	0.985	1.0
$3\theta + \alpha$	30.0	60.0	90.0	120.0	150.0	180.0	210.0	240.0	270.0	300.0
$\text{Sin } (3\theta + \alpha)$	0.5	0.866	1.0	0.866	0.5	0.0	-0.5	-0.866	-1.0	-0.866
$E_2 \sin (3\theta + \alpha)$...	0.25	0.433	0.5	0.433	0.25	0.0	-0.25	-0.433	-0.5	-0.433
e	0.25	0.607	0.842	0.933	0.893	0.766	0.616	0.507	0.485	0.567

θ°	100.0	110.0	120.0	130.0	140.0	150.0	160.0	170.0	180.0
$E_1 \sin \theta$	0.985	0.94	0.866	0.766	0.643	0.50	0.342	0.174	0.0
$3\theta + \alpha$	330.0	360.0	30.0	60.0	90.0	120.0	150.0	180.0	210.0
$\text{Sin } (3\theta + \alpha)$	-0.5	0.0	0.5	0.866	1.0	0.866	0.5	0.0	-0.5
$E_2 \sin (3\theta + \alpha)$...	-0.25	0.0	0.25	0.433	0.5	0.433	0.25	0.0	-0.25
e	0.735	0.94	1.116	1.2	1.143	0.933	0.592	0.174	-0.25

Analysis.— a_0 must be zero because the wave is symmetrical above and below the center line. The coefficients of the fundamental cosine and sine waves are found from

$$a_1 = 2 \times \text{avg. } e \cos \theta,$$

$$b_1 = 2 \times \text{avg. } e \sin \theta.$$

θ	$\text{Cos } \theta$	e	$e \cos \theta$	$\text{Sin } \theta$	$e \sin \theta$
0	1.0	0.25	0.25	0.0	0.0
10	0.985	0.607	0.598	0.174	0.1057
20	0.94	0.842	0.792	0.342	0.288
30	0.866	0.933	0.808	0.5	0.466
40	0.766	0.893	0.685	0.643	0.575
50	0.643	0.766	0.493	0.766	0.587
60	0.5	0.616	0.308	0.866	0.534
70	0.342	0.507	0.173	0.94	0.477
80	0.174	0.485	0.0844	0.985	0.478
90	0.0	0.567	0.0	1.0	0.567
100	-0.174	0.735	-0.128	0.985	0.725
110	-0.342	0.94	-0.322	0.94	0.885
120	-0.5	1.116	-0.558	0.866	0.966
130	-0.643	1.2	-0.772	0.766	0.920
140	-0.766	1.143	-0.875	0.643	0.735
150	-0.866	0.933	-0.808	0.5	0.466
160	-0.94	0.592	-0.556	0.342	0.202
170	-0.985	0.174	-0.171	0.174	0.0303
180	-1.0	-0.25	-0.25	0.0	0.0

The sum of the 18 cosine readings, using the average of 0° and 180° as one, is -0.2486 and the average value is -0.0138 .

Thus,

$$a_1 = 2 \times \text{avg.} = -0.0276.$$

Similarly, the sum of the sine readings is: 9.007

The average is 0.5004,

Thus,

$$b_1 = 2 \times \text{avg.} = 1.0008.$$

The coefficients of the 3d harmonics are found from,

$$a_3 = 2 \times \text{avg. } e \cos 3\theta,$$

$$b_3 = 2 \times \text{avg. } e \sin 3\theta.$$

θ°	3θ	$\text{Cos } 3\theta$	$e \cos 3\theta$	$\text{Sin } 3\theta$	$e \sin 3\theta$
0	0	1.0	0.250	0.0	0.0
10	30	0.866	0.525	0.5	0.304
20	60	0.5	0.421	0.866	0.730
30	90	0.0	0.0	1.0	0.933
40	120	-0.5	-0.447	0.866	0.774
50	150	-0.866	-0.664	0.5	0.383
60	180	-1.0	-0.616	0.0	0.0
70	210	-0.866	-0.439	-0.5	-0.254
80	240	-0.5	-0.242	-0.866	-0.420
90	270	0.0	0.0	-0.1	-0.567
100	300	0.5	0.368	-0.866	-0.637
110	330	0.866	0.815	-0.5	-0.470
120	360	1.0	1.116	0.0	0.0
130	390	0.866	1.040	0.5	0.600
140	420	0.5	0.571	0.866	0.990
150	450	0.0	0.0	1.0	0.933
160	480	-0.5	-0.296	0.866	0.513
170	510	-0.866	-0.151	0.5	0.087
180	540	-1.0	0.250	0.0	0.0

The sum of the 18 cosine readings is 2.251. The average is 0.125.

$$\therefore a_3 = 2 \times \text{avg.} = 0.25.$$

The sum of the sine readings is 3.899. The average is 0.2165;

$$\therefore b_3 = 0.433.$$

The exercise of proving that no 5th harmonic exists is left for the student.

Summing up the values already obtained, the equation may be written:

$$e = -0.0276 \cos \theta + 0.25 \cos 3\theta + 1.0008 \sin \theta - 0.433 \sin 3\theta$$

which is, approximately,

$$y = \sin \theta + 0.433 \sin 3\theta + 0.25 \cos 3\theta.$$

The second and third terms may be combined or added, being in quadrature, by the vectorial method in which

$$A \sin \theta + B \cos \theta = \sqrt{A^2 + B^2} \sin(\theta + \alpha),$$

where

$$\tan \alpha = \frac{B}{A}$$

Thus,

$$\begin{aligned} 0.433 \sin 3\theta + 0.25 \cos 3\theta &= \sqrt{0.188 + 0.0625} \sin(3\theta + \alpha) \\ &= 0.5 \sin(3\theta + \alpha), \text{ where } \alpha = \tan^{-1} \frac{0.25}{0.433} = 30^\circ. \end{aligned}$$

The complete wave is, therefore,

$$e = \sin \theta + 0.5 \sin(3\theta + 30^\circ).$$

The wave is shown plotted in Fig. 154, in which also the component waves are indicated by the dotted lines.

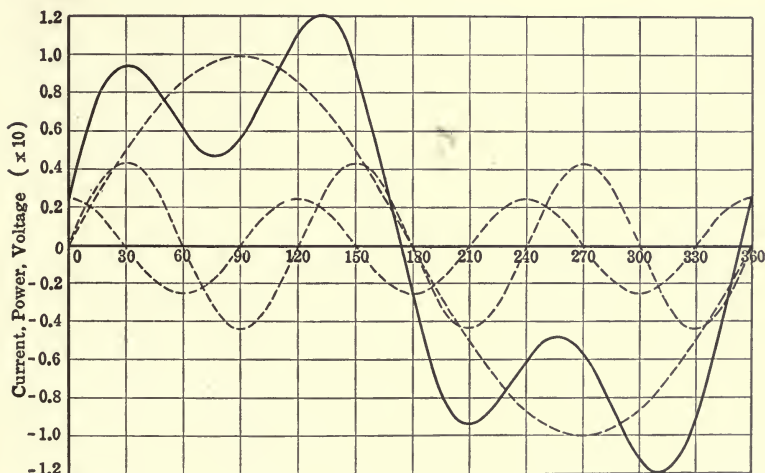

FIG. 154.

CHAPTER XXX

MECHANICAL STRESSES IN TRANSFORMERS

It is recollected that a mechanical force is exerted on a conductor carrying current if it is placed properly in a magnetic field, the force being 1 dyne per cm. of conductor per abamp. in a field intensity of 1 line per sq. cm. provided the field is at right angles to the conductor.

Referring to Fig. 155, which represents the cross-section of a transformer, it is evident that the main flux which interlinks with both the primary and the secondary windings and is confined to the iron does not cut through any part of the windings carrying current, but that the leakage flux more or less completely cuts the windings and therefore is responsible for a force which tends to warp the coils out of shape and thus to damage them. The determination of the mechanical stresses resolves itself therefore largely

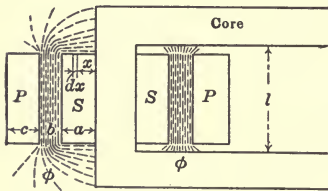

FIG. 155.

into the calculation of the leakage flux or leakage inductance of the transformer.

To calculate the leakage inductance of the secondary coil, consider this made up of the interlinkages of flux with turns in the space occupied by the secondary coil itself, plus the interlinkages of the

flux between the coils with all of the secondary turns. Similarly with the primary.

Approximation of the Leakage Inductance of the Secondary.—

In Fig. 155, a portion of the coil of depth x , has $N_2 \frac{x}{a}$ turns, where a is the total depth of the coil, and N_2 is the total number of secondary turns on 1 leg of the transformer.

The magnetomotive force of this part of the coil is

$$\text{m.m.f.}_x = I_2 N_2 \frac{x}{a}$$

The flux which this m.m.f. produces is

$$\text{flux} = \frac{4\pi I_2 N_2 x}{\rho a}$$

where ρ is the reluctance, and $\rho = \frac{l_0}{\text{area}} = \frac{l_0}{m dx}$ when we consider only the flux which passes through the small area of width dx and length m . m is the length of a turn at distance x in Fig. 155. It is almost impossible to determine accurately the length l_0 . It is the equivalent length of the lines of force which going through section $m dx$ return upon themselves. Part of these lines can be readily traced. They go almost straight across the transformer windings of length l_1 ; then they spread apart, and the equivalent length, as a result, is relatively short. Then, the majority of the lines enter the iron and their reluctance is insignificant. Some, however, enclose the winding that is outside of the iron and these meet with considerable reluctance. Therefore, it might be fairly conservative to assume l_0 , the equivalent length, as l the height of the "window" of the transformer.

If m_2 is the mean length of a secondary turn, this may be substituted for m , thus

$$\rho = \frac{l}{m_2 dx}$$

Then the flux in any elementary band, dx , is

$$d\phi' = 4\pi I_2 N_2 \frac{m_2 dx}{l} \frac{x}{a}$$

This flux interlinks with $\frac{x}{a} N_2$ turns. Therefore, the interlinkages with the flux $= 4\pi I_2 N_2 \frac{m_2 dx}{l} \frac{x}{a} \frac{x}{a} N_2$, and the inductance due to the interlinkages within the space occupied by the coil is

$$L'_2 = \frac{1}{I_2} \int_0^a 4\pi I_2 N_2^2 m_2 \frac{x^2}{a^2 l} dx = 4\pi N_2^2 \frac{m_2 a}{l \times 3} \tag{104}$$

To determine the inductance due to the flux in the gap between coils, consider Fig. 156 which shows a section through one side of the coils. The current is oppositely directed in the two coils, as indicated by dots and crosses. On a 1:1 basis, the turns and currents in the two coils are equal, and the figure may be regarded as merely showing a section through a single coil, of N_2 turns, or of $N_2 I_2$ amp.-turns.

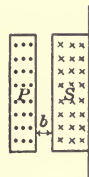

FIG. 156.

The area of the core of this imaginary coil will be bm_3 , where m_3 is the mean circumference between the actual coils, and b is

the distance between them. The flux produced in this region by the m.m.f., $I_2 N_2$, is then

$$\phi'' = 4\pi I_2 N_2 \frac{b}{l} m_3.$$

The number of interlinkages is $4\pi I_2 N_2^2 \frac{b}{l} m_3$.

This represents an inductance of $L''_2 = \frac{1}{2} \times 4\pi N_2^2 \frac{b}{l} m_3$, due to the secondary coil, since half of the inductance is due to the primary and the other half due to the secondary.

The total secondary inductance of this coil is then

$$L_2 = L'_2 + L''_2 = \frac{2\pi N_2^2}{l} \left[2m_2 \frac{a}{3} + m_3 b \right],$$

and the primary inductance is, similarly,

$$L_1 = \frac{2\pi N_1^2}{l} \left[2m_1 \frac{c}{3} + m_3 b \right],$$

where c is the depth of the primary coil.

Since $\frac{L_1}{L_2} = \frac{N_1^2}{N_2^2}$, the total inductance on 1 leg of the transformer, referred to the primary is

$$L = \frac{4\pi N_1^2}{l} \left[m_1 \frac{c}{3} + m_2 \frac{a}{3} + m_3 b \right] \text{ cm.} \quad (105)$$

If two legs are in series, $L_{(total)} = 2L$,

or, if in parallel, $L_{(total)} = \frac{L}{2}$.

In practical units,

$$L = 32 \times 10^{-9} \frac{N_1^2}{l} \left[m_1 \frac{c}{3} + m_2 \frac{a}{3} + m_3 b \right] \text{ henrys} \quad (106)$$

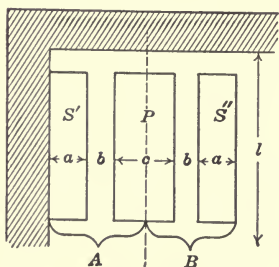

FIG. 157.

where the dimensions are in inches.

The same reasoning may be applied to a core-type transformer in which the coils are differently arranged, for example, as in Fig. 157.

Here are two secondary coils, with the primary placed between them. Consider the primary as if made up of two equal coils, separated by a dividing line shown dotted. The calculation should then be made of the combined inductance of the secondary, S' , and one-half of the primary, which are grouped

together as *A* in the figure, and similarly, the secondary *S''* and the other half of the primary grouped as *B*.

From (105), the inductance for *A* is,

$$L' = \frac{4\pi N_1^2}{l} \left[m'_1 \frac{c}{6} + m'_2 \frac{a}{3} + m_3 b \right],$$

and for *B*,

$$L'' = \frac{4\pi N_1^2}{l} \left[m''_1 \frac{c}{6} + m''_2 \frac{a}{3} + m_4 b \right],$$

in which

- m'_1 = mean length of inside one-half primary turn
- m''_1 = mean length of outside one-half primary turn
- m'_2 = mean length of inside secondary turn
- m''_2 = mean length of outside secondary turn
- m_3 = mean length of inside gap
- m_4 = mean length of outside gap

$$m'_1 + m''_1 = 2m_1$$

$$m'_2 + m''_2 = 2m_2$$

$$m_3 + m_4 = 2m.$$

If coils are symmetrical, $m_1 = m_2$.

Supplying all of these values, the total inductance is

$$L = L' + L'' = \frac{8\pi N_1^2}{l} \left[m_1 \frac{c}{6} + m_2 \frac{a}{3} + mb \right] \text{ cm.},$$

where N_1 is the number of turns in half the primary coil. If T_1 is the number of primary turns per leg of the core,

$$L = \frac{2\pi T_1^2}{l} \left[m_1 \frac{c}{6} + m_2 \frac{a}{3} + mb \right] \text{ cm. per leg.}$$

If dimensions are in inches,

$$L = \frac{16}{10^9} \frac{T_1^2}{l} \left[m_1 \frac{c}{6} + m_2 \frac{a}{3} + mb \right] \text{ henrys.}$$

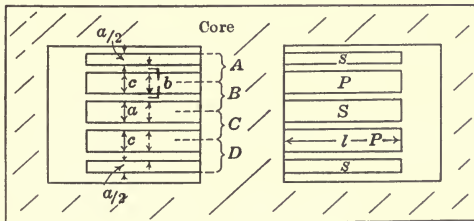

FIG. 158.

In a similar manner, shell-type transformers may be dealt with. Such a transformer is shown in Fig. 158. In this, let m = mean length of 1 turn, N_1 = number turns in half of a primary

coil, = one-quarter total primary turns. Using the same reasoning as with core-type transformers, the inductance of a unit combination, A , in the figure, is

$$L_A = \frac{4\pi N_1^2 m}{l} \left[\frac{a}{6} + \frac{c}{6} + b \right] \text{ cm.} \quad (107)$$

Note that $m \left[\frac{a}{6} + \frac{c}{6} + b \right]$ is the equivalent area, whence the total inductance is

$$\Sigma L = \frac{16\pi N_1^2 m}{l} \left[\frac{a}{6} + \frac{c}{6} + b \right] \text{ cm.}$$

In inch units,

$$\Sigma L = \frac{128}{10^9} N_1^2 \frac{m}{l} \left[\frac{a}{6} + \frac{c}{6} + b \right] \text{ henrys.}$$

Calculation of Stresses.—Under ordinary conditions of load, these would not be excessive, but for maximum current, as in the case of short-circuit, or heavy transient currents from switching, they may be very great. Calculation may properly be based on the short-circuit current, remembering again that a wire 1 cm. long, carrying 10 amp. (unit current), if placed perpendicular to a field of 1 line per sq. cm., is repelled by a force of 1 dyne; or the force in dynes = $BI'l$, where I' is expressed in absolute values—abamperes.

If the flux density in the gap, b , between coils, is B_{max} then it may be assumed that the average density of the flux leaking through the coils themselves is $\frac{B_{max}}{2}$, which is then the average density of the flux passing through the coils of any section A , Fig. 158, and the force per turn on any coil, will be

$$\begin{aligned} F_t &= \frac{B_{max}}{2} \times I'_2 \times m \text{ dynes} \\ &= \frac{B_{max}}{2} \frac{I'_2 m}{981} \text{ grams,} \end{aligned}$$

where m is the mean length of the turn.

If I_2 is in amperes,

$$F_t = \frac{B_{max}}{2} \frac{I_2 m}{9810} \text{ grams per turn.}$$

Let the effective value of the short-circuit current be I_2 , and let the total secondary turns be T_2 , then the turns in a half coil (Fig. 158) are $\frac{T_2}{4}$.

The maximum value of the force will be

$$\begin{aligned} F_{max} &= \frac{\sqrt{2}I_2 m B_{max.}}{2 \times 9810} \times \frac{T_2}{4} \\ &= \frac{\sqrt{2}I_2 T_2 m B_m}{8 \times 9810} \text{ grams} \end{aligned} \quad (108)$$

or in the case of the primary short-circuit current I

$$= \frac{\sqrt{2}ITmB_m}{8 \times 9810} \quad (109)$$

where I is the effective value of the primary short-circuit current and T the total number of primary turns.

The leakage flux must, in the case of short-circuit, be the main flux (neglecting the flux due to the voltage which is consumed by the ohmic drop), if it is assumed that the generating station is large and the voltage impressed upon the transformer is normal even though the transformer is short-circuited. (See note.)

The maximum value of the flux between a group of coils is obtained by multiplying the maximum value of the flux density B_m by the equivalent area as given in (107).

That is

$$\Phi_m = B_m m \left[\frac{a+c}{6} + b \right].$$

The group contains in this case one-quarter of the turns and the voltage per group is $\frac{E}{4}$ where E is the effective value of the impressed e.m.f.

The relation between the maximum value of the flux and the voltage is given by the well-known relation

$$\begin{aligned} \frac{E}{4} &= \frac{\sqrt{2}\pi f \frac{T}{4} \Phi_m}{10^8} \\ \therefore \Phi_m &= \frac{E10^8}{\sqrt{2}\pi f T} \end{aligned}$$

Substituting this in (109)

$$F_{max} = \frac{406IE}{f \left[\frac{a+c}{6} + b \right]} \quad (110)$$

The average value of the force is obviously one-half of the maximum value.

The force between the coils is proportional to the rating assuming the same regulation.

NOTE.—The actual flux enclosed by the secondary turns depends upon the terminal voltage and the ir drop.

At short-circuit the secondary terminal voltage obviously is zero. Thus if as a limiting case the ir drop is neglected the secondary winding encloses no flux.

As long as it is assumed that the primary voltage is normal voltage and that the ir drop is again neglected the primary coil encloses the same flux during the short-circuit as it does at no-load. The path of the flux must therefore be essentially different. In the latter case it traversed the two windings and is therefore mainly in the iron, while in the former case it must traverse only one winding—the primary. Thus the flux must find its way between the primary and secondary coils and is thus the so-called leakage flux.

CHAPTER XXXI

GENERAL PRINCIPLES OF TRANSFORMER DESIGN

Type.—Transformers may be classified as belonging either to the “core type” or the “shell type.”

Core-type transformers frequently have a single magnetic circuit of rectangular form. On the two vertical sides of this core are placed the windings, each side being provided with half of the primary and half of the secondary coils, the low-voltage coils usually being placed next to the core (Fig. 159).

Shell-type transformers usually have a multiple magnetic circuit the coils being placed upon a central core, the outer limbs of which extend around the coils, somewhat resembling a shell (Fig. 160). As illustrated diagrammatically in the figures, it is

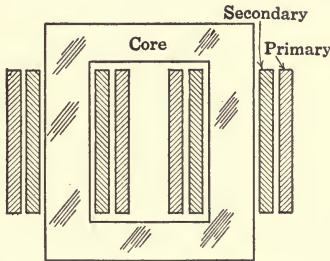

FIG. 159.

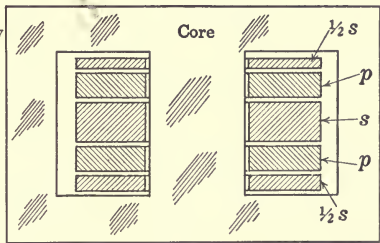

FIG. 160.

seen that the coils of the core-type transformer have the form of a cylindrical shell, while those of the shell type are in the form of discs. The former lend themselves readily to designs of great mechanical strength, while the latter tend to be mechanically weak.

The present tendency seems to be more and more toward the core type, and it remains for the superiority of the shell type to be demonstrated in any given case in order to justify its existence at all.

Recently transformers having a multiple magnetic circuit have been introduced. The coils are of the cylindrical form placed around the central core. Thus, this is called the cruciform type.

An important consideration with respect to the choice of type is the method of cooling the transformer. Core-type transformers are usually immersed in oil in such a way as to provide free circulation of the oil about all surfaces of the coils and core. The oil then receives the heat and carries it to the outside case which is frequently corrugated to present greater effective surface to the outer air.

Shell-type transformers are cooled by the above method, but more frequently this is augmented by the addition of coils of pipe through which is forced a stream of cool water. These coils are placed in the oil above the transformer.

The addition of the cooling water is essentially a feature of large transformers, since they have less area of possible cooling surface per unit volume than have smaller units.

A common form of the shell type is known as the air-blast type. The method of cooling consists in forcing a continuous blast of cool air up through the ducts with which the core is provided, and between and around the coils.

Efficiency.—Transformers are not designed to give the highest possible efficiency as this would involve too great an expense in materials and manufacture, but, rather, the highest practical efficiency, so as to meet competition both in price and in quality.

Consequently, from results obtained in practice, it is easy to construct a table of efficiencies which might reasonably be expected of various sizes of transformers of moderate voltages, say up to 10,000 volts. This table is as follows:

Kw. capacity	Efficiency	
	25 cycles	60 cycles
1	94.0	96.0
5	96.5	97.5
10	97.0	98.0
50	98.0	98.5
200	98.0	98.5

Knowing the approximate efficiency of the transformer which is to be designed, the total losses are of course also known. For example, let it be required to design a 10-kw., 60-cycle, 2000/100-volt core-type lighting transformer. The efficiency is to be about 98 per cent. The losses are 2 per cent., or $0.02 \times 10,000 = 200$ watts.

Losses.—These losses are made up of the I^2r loss in the copper windings and the hysteresis and eddy current losses in the iron core and windings.

Maximum efficiency is obtained at that load for which the copper and iron losses are equal. It becomes a matter of choice in design as to what ratio shall be given these losses or at what load they shall be equal. Thus, for power purposes, the copper and iron losses should be about equal at full-load, giving maximum efficiency at full-load. For lighting purposes, however, owing to the peculiar conditions of operation, this is not generally desirable. A lighting transformer carries full-load only for a very small period during each 24 hr., while the rest of the time it is operating practically at no-load. Thus the copper loss is quite small even with a large value of I^2r , while the core loss is larger since it is continuous through the whole day. It would be better, therefore, to make the copper loss relatively greater than the core loss, at full-load, and thus reduce the total losses for the daily operation. Fairly good values to choose for these losses are: copper loss = 60 per cent., core loss = 40 per cent. of the total loss.

In the example considered,

$$\begin{aligned}\text{copper loss} &= I^2r = 200 \times 0.60 = 120 \text{ watts,} \\ \text{core loss} &= 200 \times 0.40 = 80 \text{ watts.}\end{aligned}$$

The core loss may be further divided between loss due to hysteresis and loss due to eddy currents. The former is usually larger because it depends on the magnetic quality of the iron or steel used, whereas the latter depends largely on the degree of thinness of the laminations of the core, and this may be carried to any extent mechanically practical. Values of hysteresis and eddy current losses when silicon steel laminations .014 in. thick are used are:

$$\begin{aligned}\text{hysteresis loss} &= 0.7 \text{ watt per lb. at 60 cycles,} \\ \text{eddy current loss} &= 0.3 \text{ watt per lb. at 60 cycles,}\end{aligned}$$

when the maximum induction density is 64,500 lines per sq. in. (10,000 lines per sq. cm.).

Since 1 cu. in. of this material weighs 0.28 lb., the loss per cu. in. at 60 cycles and 64,500 lines per sq. in. is:

$$\begin{aligned}\text{hysteresis loss per cu. in.} &= 0.28 \times 0.7 = 0.196 \text{ watt,} \\ \text{eddy current loss per cu. in.} &= 0.28 \times 0.3 = 0.084 \text{ watt,} \\ \text{total core loss per cu. in.} &= 0.28 \text{ watt.}\end{aligned}$$

Hysteresis loss for any frequency and density is given approximately by the equation,

$$\text{hyst. loss} = W_h = 0.196 \times \frac{f}{60} \times \left(\frac{B}{64,500}\right)^{1.6} \times V,$$

where V = volume of iron.

Similarly, eddy current loss is

$$W_e = 0.084 \times \left(\frac{f}{60}\right)^2 \times \left(\frac{B}{64,500}\right)^2 \times V.$$

From these two equations and the core loss which is given, the volume may be obtained for any value of B . Assuming, as will later be done, that $B = 70,000$, in the example,

$$V = 80 \div [0.196 \times (1.086)^{1.6} + 0.084(1.086)^2] = \frac{80}{0.2205 + 0.099} = 250 \text{ cu. in.}$$

And the hysteresis loss is $W_h = 0.196 \times 1.125 \times 250 = 55.2$ watts, and the eddy current loss is $W_e = 0.099 \times 250 = 24.8$ watts.

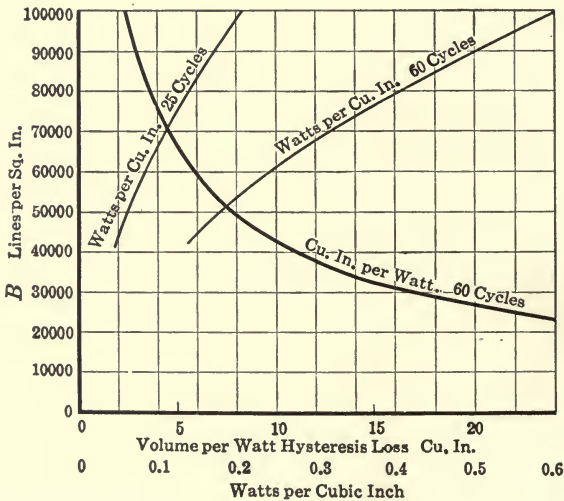

FIG. 161.

B and V.—The relation between B and V is shown by the following curve, Fig. 161, from which it is evident that values of B should lie between 50,000 and 90,000.

Hysteresis and Eddy Current Loss per Cubic Inch.—

$$\frac{W}{V} = 0.196 \frac{f}{60} \left(\frac{B}{64,500} \right)^{1.6} + 0.084 \left(\frac{f}{60} \right)^2 \left(\frac{B}{64,500} \right)^2$$

(1) $f = 60$

B	50,000	60,000	70,000	80,000	90,000	100,000
$\frac{B}{64,500}$	0.775	0.93	1.085	1.24	1.395	1.55
$\left(\frac{B}{64,500} \right)^{1.6}$	0.65	0.88	1.125	1.42	1.75	2.05
$W_h = 0.196 \left(\frac{B}{64,500} \right)^{1.6}$	0.127	0.1725	0.220	0.278	0.343	0.402
$\left(\frac{B}{64,500} \right)^2$	0.601	0.865	1.18	1.54	1.95	2.41
$W_e = 0.084 \left(\frac{B}{64,500} \right)^2$	0.0505	0.0727	0.099	0.1294	0.1639	0.2025
$\frac{W}{V}$	0.1775	0.2452	0.319	0.4074	0.5069	0.6045

(2) $f = 25$; $\frac{f}{60} = 0.417$; $\left(\frac{f}{60} \right)^2 = 0.174$

W_h	0.053	0.072	0.0917	0.116	0.143	0.1675
W_e	0.0088	0.0127	0.0172	0.0225	0.0285	0.0384
$\frac{W}{V}$	0.0618	0.0847	0.1089	0.1385	0.1715	0.2059

As a matter of fact the usual limits are:

for 60 cycles, B lies between 60,000 and 75,000,

for 25 cycles, B lies between 80,000 and 90,000.

In the example, let $B = 70,000$, which will be taken as a trial value.

From Fig. 162 the volume per watt loss by hysteresis is 4.55 cu. in. The total volume of iron is 4.55×55.2 watts = 250 cu. in.

Magnetizing Current.—Having chosen a suitable value of B , we can at once find out the required number of ampere-turns per inch length of magnetic circuit, from the saturation curve, p . Let

$M_0 =$ ampere-turns per inch and

$l =$ length of magnetic circuit.

Then total ampere-turns = $M_0 l = \sqrt{2} i_m t$, where $\sqrt{2} i_m =$ maximum value of magnetizing current and $t =$ number of turns on the primary.

Using the fundamental equation for e.m.f.,

$$E = 4.44 f t \Phi \times 10^{-8} = 4.44 f t B A \times 10^{-8},$$

the magnetizing volt-amperes are

$$\begin{aligned} E i_m &= \frac{4.44 f t B A M_0 l}{\sqrt{2} t \times 10^8} \\ &= \pi f B A M_0 l \times 10^{-8} = \pi f B M_0 V \times 10^{-8}, \end{aligned}$$

since

$$4.44 = \sqrt{2}\pi, \text{ and } V = Al.$$

The percentage magnetizing current is obtained by dividing by EI , thus,

$$\frac{i_m}{I} = \frac{\pi f B M_0 V}{10^{11} \times \text{kw.}}$$

In the example, M_0 is found to be 6.5. Therefore, substituting known values into the equation,

$$\frac{i_m}{I} = \frac{3.14 \times 60 \times 70,000 \times 6.5 \times 250}{10^{11} \times 10} = 0.0215,$$

or approximately 2 per cent.

This is a reasonable value. In practice, magnetizing currents range from 2 to 8 per cent., being larger in smaller transformers and at lower frequencies.

Number of Turns, Total Flux, Area, and Length of Magnetic Circuit.—Returning to the fundamental e.m.f. equation, it is seen that turns and flux are both unknown. A practical limit in helping to decide what value to assign to either one of these unknowns is found from the fact that the number of turns should depend upon the voltage. While it would not be safe to allow too great a difference of potential to exist between adjacent turns, this consideration is not the deciding feature. The choice of number of turns is governed largely by cost considerations. From practice it is known that volts per turn should lie between $0.4 \times \sqrt{\text{kw.}}$ and $0.6 \times \sqrt{\text{kw.}}$ in core-type transformers. The former value is more suitable for distribution transformers when it is desirable to keep down the core loss, while the latter is suitable for power transformers. The value for shell type is from two to three times as great.

In the example, it will be assumed that volts per turn = $0.5 \times \sqrt{10} = 1.56$.

Then, turns on primary

$$= t = \frac{2000}{1.56} = 1280,$$

and flux

$$= \Phi = \frac{E \times 10^8}{4.44ft} = 586,000,$$

area

$$= A = \frac{\Phi}{B} = \frac{586,000}{70,000} = 8.37 \text{ sq. in.},$$

and length,

$$l = \frac{V}{A} = \frac{250}{8.37} = 29.5 \text{ in.}$$

Resistance, Length of Mean Turn, Total Length and Size of Windings.—Returning now to the windings, it is possible at first to calculate the primary resistance, since the copper loss and the current are known.

In the example $I^2r = 120$ watts. This must be divided between primary and secondary, and half may be assigned to each, as a reasonable approximation.

Thus primary

$$I^2r = \frac{120}{2} = 60 \text{ watts.}$$

Also,

$$I_1 = \frac{W}{E_1} = \frac{10,000}{2000} = 5 \text{ amp.}$$

$$\therefore R_1 = \frac{60}{25} = 2.4 \text{ ohms.}$$

Knowing the resistance and number of turns, the size of wire may be found when the mean length of one turn is estimated. As a basis for this, the cross-sectional area, A , of the core is known, and experience tells about how much space is necessary for insulation between core and coils and for circulation of the cooling oil between the coils. Also, since the heat generated in the interior of the coils has to pass through the thickness of copper and insulation, it will be unwise to make the coils too thick.

Practical thickness of insulation against voltage is given in the following table.

TABLE VII

Volts	Insulation thickness (mils)
110	40
440	50
1,000	70
2,300	100
6,600	180
16,000	260

For circulation of oil, space of not less than $\frac{1}{4}$ in. width should be allowed. This width is governed by the height of the coils.

Thickness of the coils should hardly exceed 1 in., but may reasonably be $\frac{3}{4}$ in.

Applying this procedure to the example, it is found that with an area, $A = 8.37$ sq. in. of iron, the gross area occupied by the laminations will be about

$$A' = \frac{8.37}{0.9} = 9.3 \text{ sq. in.}$$

If this area is in the form of a square, the side of the square will be $\sqrt{9.3} = 3.05$ in. Fig. 162 is next drawn, showing the relative positions of coils, core, insulation, etc. In this case, the length of mean turn of the secondary winding is

$$L_2 = 4 \times 3.05 + 2\pi(0.25 + 0.04 + 0.375) = 16.4 \text{ in.}$$

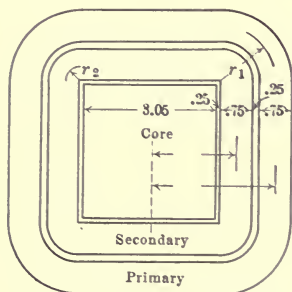

FIG. 162.

Since the secondary winding is nearest the core, its features will be discussed first, thus avoiding any error in the final determination of

the mean length of primary turn.

Total length of secondary is

$$L_2 \times t_2 = \frac{16.4}{12} \times t_2 \text{ ft.}$$

In general,

$$t_2 = \frac{E_2}{E_1} t_1 = \frac{100}{2000} \times 1280 = 64.$$

In practice, however, it is found convenient to put the two primary coils in series and the two secondary coils in parallel to obtain the 20:1 ratio.

If this procedure is adopted, the voltage impressed on one primary coil is $\frac{2000}{2} = 1000$, while the whole secondary voltage of 100 will be across each of the secondary coils.

The secondary turns per coil will then be

$$t_2 = \frac{100}{1000} \times 640 = 64$$

and each coil will carry half of the total secondary current, or $\frac{10,000}{2 \times 100} = 50$ amp.

Total length of each secondary coil is then

$$L_2 \times t_2 = \frac{16.4}{12} \times 64 = 87.3 \text{ ft.}$$

Resistance per 1000 ft. of secondary coil = $\frac{2R_2}{0.0873}$.

Since the coils are connected in parallel, the resistance of one coil is $2R_2$.

The resistance of a secondary coil is obtained from the fact that the secondary copper loss per coil is $\frac{60}{2} = 30$ watts.

Thus, the resistance of each secondary coil is

$$2R_2 = \frac{30}{(50)^2} = 0.012 \text{ ohm.}$$

Resistance per 1000 ft. of conductor is $\frac{0.012}{0.0873} = 0.1375$ ohm.

This corresponds to an area of 0.07 sq. in.

The conductor chosen must be of copper strip, of rectangular cross-section. In using strip, the practical dimensional limits are about 0.1 in. in thickness and 0.5 in. in width. These dimensions give an area of 0.05 sq. in. If greater area is required, any number of strips may be wound in parallel. Each strip is, however, insulated, usually with double cotton covering, to prevent too great eddy current loss in the copper.

In the present case there will be two strips required, each of 0.1×0.35 -in. section.

With insulation, the dimensions of the double conductor become 0.36×0.22 in.

It will be seen that the most practical arrangement of the turns will be to have two layers deep and 32 turns per layer. Then the thickness of the coil becomes 2×0.22 in. = 0.44 in.; the length of the coil is 32×0.36 in. $\times 11.5$ in.

The corrected mean length of turn is

$$L_2 = 4 \times 3.05 + 2\pi (0.25 + 0.04 + 0.22) = 15.4 \text{ in.}$$

$$\text{Total length} = \frac{15.4 \times 64}{12} = 82 \text{ ft.}$$

$$\text{Resistance per 1000 ft.} = \frac{0.012}{0.082} = 0.147 \text{ ohm.}$$

Corrected cross-section is $\frac{0.1375}{0.147} \times 0.07$ sq. in. = 0.0655 sq. in.

Maintaining the same thickness, *i.e.*, 0.1 in. the width of the strip, with insulation, now becomes 0.332 in., and the coil length is $32 \times 0.332 = 10.6$ in.

The mean length of the primary turn may now be found. It is

$$L_1 = 4 \times 3.05 + 2\pi (0.25 + 0.04 + 0.44 + 0.04 + 0.25 + 0.1 + 0.375) = 12.2 + 2\pi \times 1.495 = 21.6 \text{ in.}$$

Total length of primary is then

$$21.6 \times \frac{l_1}{12} = 21.6 \times \frac{1280}{12} = 2304 \text{ ft.}$$

Resistance per 1000 ft. of primary is $\frac{R_1}{2.304} = \frac{2.4}{2.304} = 1.042$ ohms.

Referring to wire tables, this resistance is found to be nearly that of No. 10 B. & S., which has resistance of 1.18 ohms per 1000 ft. at 65°C.

If now it should be desirable to use copper strip for the primary winding, the requisite area may be found by comparison with that of No. 10 wire. Thus,

$$\text{area} = \frac{1.18}{1.042} \times 0.00815 = 0.00922 \text{ sq. in.}$$

In this case, however, it will be practical to use No. 10 wire. Wire larger than No. 10 is not generally used, but smaller sizes are preferable to rectangular strip.

Choosing then No. 10 wire the space which the 640 turns of each coil will occupy must be determined.

With a layer 10.3 in. long there will be

$$\frac{10.3}{0.103} = 100 \text{ turns per layer,}$$

and

$$\frac{640}{100} = 6.4 \text{ layers.}$$

Obviously, the best arrangement of these 640 turns will be to have 8 layers of 80 turns each, giving a coil length of 8.24 in., and coil thickness of 0.824 in. The thickness will be slightly less, owing to the bedding of the layers. Perfect bedding would give $0.824 \times 0.866 = 0.714$ in. The value of 0.75 in. originally assumed may therefore conveniently be taken as correct.

The mean length of the primary turn is then $L_1 = 21.6$ in. as previously calculated.

Total length of primary = $\frac{21.6}{12} \times 1280 = 2300$ ft. Total primary resistance = $2300 \times 1.18 = 2.72$ ohms.

This resistance deviates considerably from the value of 2.4 ohms assumed, but not enough to warrant the choice of another size of wire for the primary.

Having determined the core cross-section, and the coils, an assembly sketch may be made, as shown in Fig. 163. Allowing 0.3 in. between the coils on the two legs, the size of the window is

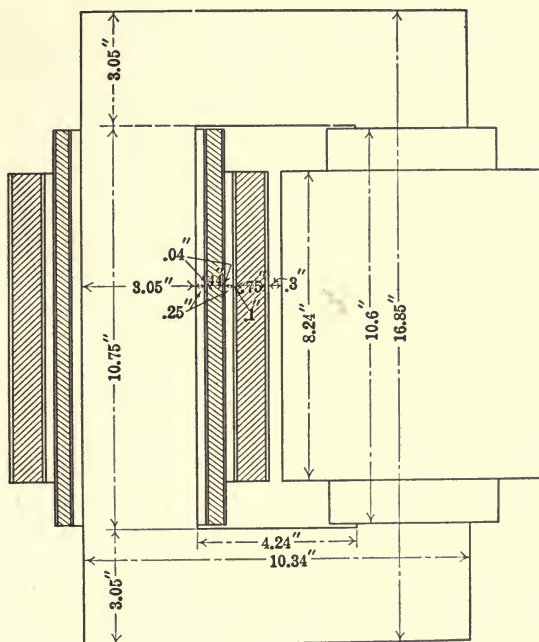

FIG. 163.

found to be 4.24 in. wide by 10.75 in. high. The total core height is $10.75 + 3.05 + 3.05 = 16.85$ in.; total core width is $4.24 + 3.05 + 3.05 = 10.34$ in.

The total volume of iron is length \times net cross-section, or,

$$\begin{aligned} V &= (2 \times 16.85 + 2 \times 4.24) \times 8.37 \\ &= 42.18 \times 8.37 = 354 \text{ cu in.,} \end{aligned}$$

which does not compare very favorably with the first assumption of 250 cu. in., but this is not very important since it should be noted that l calculated from core loss and l calculated from

the space required for the copper windings will generally not be in agreement. We must have sufficient space for the windings, but l should not be any greater than necessary. Therefore, unless we wish an entire recalculation of the design based on altered assumptions it is sufficient to accept the new value of l and the attendant new value of V . The mean length of the flux path is,

$$\begin{aligned} l &= 2(10.75 + 4.24) + 2\pi \times 1.5 \\ &= 29.98 + 9.44 = 39.42 \text{ in.,} \end{aligned}$$

as against 29.5 in. in the preliminary calculations.

Per Cent. Magnetizing Current and Core Loss.—Applying the new values of V and l , we may obtain new values for per cent. magnetizing current and the core losses. Thus,

$$\text{amp. turns} = M_0 \times l = 6.5 \times 39.42 = 256.$$

$$\text{Max. exciting current} = \sqrt{2}i_m = \frac{256}{1280} = 0.2.$$

$$i_m = \frac{0.2}{\sqrt{2}} = 0.141.$$

$$\text{Per cent. } i_m = \frac{i_m}{I_1} = \frac{0.141}{5} = 0.028.$$

Hysteresis loss, W_h , will be in the ratio of the two volumes thus far obtained, namely; 250 cu. in. and 354 cu. in.

$\therefore W_h = \frac{354}{250} \times 55.2 = 78.2$ watts, and similarly the eddy current loss is $W_e = \frac{354}{250} \times 24.8 = 35.1$ watts, giving a total core loss of 113.3 watts.

Efficiency.—The approximate efficiency is then

$$\eta = \frac{\text{input} - \text{losses}}{\text{input}},$$

where the losses are:

$$\text{Primary copper loss} = 5^2 \times 2.72 = 68 \text{ watts.}$$

$$\text{Secondary copper loss} = 2 \times 50^2 \times 0.012 = 60 \text{ watts.}$$

$$\text{Core loss} = 113.3 \text{ watts.}$$

$$\text{Total loss} = 241.4 \text{ watts.}$$

$$\therefore \eta = \frac{10,000 - 241.3}{10,000} = 0.976 = 97.6 \text{ per cent.}$$

It is seen that the efficiency is very nearly that which was assumed at the outset, so that the variations in values, even where

they have been large, as with volumes and length, have not been such as to produce any considerable effect.

However, the ratio of $\frac{\text{copper loss}}{\text{iron loss}}$ has decreased, the former now constituting only 53 per cent. of the total loss, instead of 60 per cent. as at first assumed.

There is, of course, nothing hard and fast about these relations as it is impossible to say just how the transformer will be operated from day to day. If it is desired to approximate more closely to the original assumptions of losses and efficiency, it will be necessary to go back to the beginning and choose from among the numerous variables, let us say, another value of turns and another value of the flux density.

However, in the present instance, the values so far obtained will be regarded as satisfactory, and then there remains only to determine the regulation, heating and cost of material, to see if these also will be satisfactory.

Regulation.—In Chap. XXVI, p. 182, the regulation of a transformer was found to be

$$\text{Reg.} = \frac{E_1}{E_2} - 1,$$

where $E_1 = \sqrt{E_2^2 + 2E_2(i_2r_0 + 0.5i_hr_0 - i'_2x_0 + 0.5i_mx_0)}$ approximately.

Of these quantities, $E_1 = 2000$ volts, assumed impressed on the primary, $i_2 = I_2 = 5$ amp. = the energy component of the load at unity power factor (assumed) and referred to the primary basis. On this assumption, the wattless component of the load current, $i'_2 = 0$.

i_h = energy component of the exciting current.

To obtain i_h , we have: core loss = $Ei_h = 113.3$ watts.

$$\therefore i_h = \frac{113.3}{2000} = 0.0566 \text{ amp.},$$

and

$$i_{00} = \sqrt{i_m^2 + i_h^2} = \sqrt{0.141^2 + 0.0566^2} = 0.152 \text{ amp.}$$

$$r_0 = R_1 + R_2 = 2.72 + 0.009 \times 400 = 2.72 + 3.6 = 6.32.$$

To determine x_0 , the combined leakage reactance of primary and secondary, we have

$$x_0 = 2\pi f (L_1 + L_2) = 2\pi f L_0.$$

L_1 and L_2 may now be calculated by the help of equations, p. 204, Chap. XXX, but each must be done separately since the

two primary coils are in series while the secondary coils are in parallel. We have

$$L_1 = 2 \times 32 \times 10^{-9} \frac{N_1^2}{l} \left[\frac{m_1 c}{3} + \frac{m_3 b}{2} \right] \text{ henrys,}$$

$$L_2 = \frac{32}{2} \times 10^{-9} \frac{N_2^2}{l} \left[\frac{m_2 a}{3} + \frac{m_3 b}{2} \right] \text{ henrys.}$$

Referring to Fig. 155, the constants in these equations are readily evaluated. Thus, we have,

$$N_1 = 640; N_2 = 64; l = 10.75,$$

$$m_1 = \text{mean length of primary turn} = 21.6 \text{ in.,}$$

$$m_2 = \text{mean length of secondary turn} = 15.4 \text{ in.,}$$

$$m_3 = \text{mean length of gap between coils} = 18 \text{ in.,}$$

$$a = \text{secondary coil thickness} = 0.44 \text{ in.,}$$

$$b = \text{distance between coils} = 0.39 \text{ in.,}$$

$$c = \text{primary coil thickness} = 0.75 \text{ in.}$$

Supplying these values,

$$L_1 = 64 \times 10^{-9} \times \frac{41 \times 10^4}{10.75} \left[\frac{21.6 \times 0.75}{3} + \frac{18 \times 0.39}{2} \right]$$

$$= 0.00244 [5.4 + 3.51] = 0.02175 \text{ henry}$$

$$L_2 = 16 \times 10^{-9} \frac{4100}{10.75} \left[\frac{15.4 \times 0.44}{3} + 3.51 \right]$$

$$= 6.1 \times 10^{-6} [2.26 + 3.51] = 0.0000352 \text{ henry,}$$

where L_2 is the actual secondary inductance.

Referred to the primary, $L_2 = 0.0000352 \times 400 = 0.0141$ henry.

$L_0 = L_1 + L_2 = 0.02175 + 0.0141 = 0.03588$ henry
and

$$x_0 = 2\pi f L_0 = 377 \times 0.03588 = 13.53 \text{ ohms.}$$

Supplying all the values into the formula for E_1 , we have,
 $E_1 = 2000 =$

$$\frac{\sqrt{E_2^2 + 2E_2(5 \times 6.32 + 0.5 \times 0.0566 \times 6.32 + 0.5 \times 0.141 \times 13.53)}}{E_1^2 = 4 \times 10^6 = E_2^2 + 2E_2(31.6 + 0.179 + 0.95) =}$$

$$\frac{E_2^2 + 65.32E_2}{E_2} - 1 = \frac{2000}{1968} - 1 =$$

$$1.016 - 1 = 0.016 = 1.6 \text{ per cent. for full non-inductive load.}$$

Heating.—The total radiating surface of each primary coil is found by calculation to be 388 sq. in. Therefore, the watts per square inch which must be radiated from the primary coil are

$$W_1 = \frac{34 \text{ watts}}{388 \text{ sq. in.}} = 0.0875.$$

Similarly, the area of the secondary coil radiating surface is 340 sq. in. The watts per square inch that must be radiated are

$$W_2 = \frac{30 \text{ watts}}{340 \text{ sq. in.}} = 0.0885.$$

The radiating surface of the core is about 400 sq. in. Therefore watts per square inch that must be radiated are

$$W_c = \frac{113.3 \text{ watts}}{400 \text{ sq. in.}} = 0.28.$$

Watts per square inch serve as an empirical guide by which it may be determined satisfactorily whether the design is sufficiently liberal to permit of dissipation of the heat without undue rise of temperature of any part. In general a loss of 0.4 watt per sq. in. of surface of the coils and core is quite satisfactory.

In designing the case, however, about 0.15 watts per sq. in. only should be allowed. In the transformer, then, since the entire loss in watts must be radiated from the case we should need an area of

$$\frac{241.3 \text{ watts}}{0.15} = 1610 \text{ sq. in., in contact with the oil.}$$

Weight and Cost of Material.—The core volume has been found to be 354 cu. in. At 0.28 lb. per cu. in. the core weight is

$$354 \times 0.28 = 99 \text{ lb.}$$

Cost of core at 3.5 c. per lb. is

$$99 \times 0.035 = \$3.46.$$

The primary copper volume is length \times section,

$$= 2300 \times 12 \times 0.00815 = 225 \text{ cu. in.}$$

Secondary copper volume is

$$82 \times 12 \times 0.0655 \times 2 = 129 \text{ cu. in.}$$

Total volume of copper is $225 + 129 = 354 \text{ cu. in.}$

Weight of copper at 0.32 lb. per cu. in. is

$$354 \times 0.32 = 113.4 \text{ lb.}$$

Cost of copper at 16c. per lb. is

$$113.4 \times 0.16 = \$18.15.$$

Total cost of iron and copper is $\$3.46 + \$18.15 = \$21.61$

Of course, such a calculation of cost has comparative merit only, as it does not include labor or such materials as insulation, oil and case.

Summary of data of 10-kw., 60-cycle 2000-100-volt core-type distributing transformer.

		High side	Low side
Kilowatts.....	10		
Frequency.....	60		
Ratio of transformation.....	20:1		
Volts.....		2,000	100
Amperes.....		5	100
Window dimensions, in.....	10 $\frac{3}{4}$ by 4 $\frac{1}{4}$		
Total width of iron, in.....	10.34		
Total height of iron, in.....	16.85		
Depth of lamination, in.....	3.05		
Electrical			
Number turns in series.....		1,280	64
Section of conductor.....		0.00815	0.0655
Amperes per square inch.....		614	763
Number of coils.....		2	2
Connection of coils.....		Series	Parallel
Width of coil.....		0.75	0.44
Height of coil.....		8.24	10.6
Number turns per coil.....		640	64
Mean length of turn.....		21.6	15.4
Resistance of circuit at 65°C.....		2.72	0.009
Magnetic			
Total maximum flux.....	586,000		
Effective core section, sq. in.....	8.37		
Effective core length, in.....	39.42		
Core density.....	70,000		
Effective core ampere-turns.....	180.5		
Magnetizing current.....	0.141		
Thermal			
I^2R loss.....		68	60
Radiating surface of coil.....		388	340
Watts per square inch.....		0.0875	0.0885
Core loss.....	113.3		
Radiating surface of core.....	400		
Watts per square inch.....	0.28		
Total loss, full-load.....	241.3		
External radiating surface.....	1,610		
Watts per square inch.....	0.15		
Efficiency and regulation			
Per cent. core loss, full-load.....	1.15		
Per cent. copper loss, full-load.....	1.3		
Per cent. efficiency, full load.....	97.6		

		High side	Low side
Per cent. magnetizing current.....	2.8		
Per cent. resistance.....	1.58		
Per cent. reactance.....	3.38		
Per cent. regulation.....	1.6		
Weight and cost			
Copper, pounds.....	113.4		
Iron, pounds.....	99.0		
Pounds copper per kilowatt.....	11.34		
Pounds iron per kilowatt.....	9.9		
Cost of copper at 16c.....	\$18.15		
Cost of iron at 3.5c.....	\$3.46		
Total cost.....	\$21.61		
Cost per kilowatt.....	\$2.16		

Having now developed the general principles and procedure in transformer design, it is desirable that the student should carry through the calculations for some assigned machines. Transformers of different capacity may be assigned to the students of a section, each student being required to complete the calculations for both 60 cycles and 25 cycles, tabulating the specifications and making sketches to scale of the core and windings.

Many of the finer points in design are omitted here, since the principles are the primary interest. For practical designing the fact that experience is a factor of the greatest importance should always be remembered by the student who is attempting to master the practical aspects of the subject.

To assist in the further study of the principles of transformer design, the following suggestive questions are added.

1. Find regulation at 80 per cent. power factor.
2. Why are less volts per turn used with lighting than with power transformers?
3. If the core loss is too great, how may it be reduced?
4. What relation does per cent. exciting current have to core loss, copper loss, efficiency and regulation?
5. How may per cent. exciting current be reduced?

CHAPTER XXXII

COMBINATIONS IN MULTIPHASE TRANSFORMER SYSTEMS

When the primary of a transformer is connected to a source of e.m.f. the following equation relating the impressed e.m.f. current, resistance and inductance obviously obtains

$$e = ri + \frac{d}{dt} (Li).$$

The drop, ri , is small, being perhaps 5 per cent. of 1 per cent. of the normal voltage, if the exciting current is 5 per cent. of normal current and the resistance drop at full-load is 1 per cent. Thus the e.m.f. consumed by the transformer counter e.m.f. is approximately

$$e = \frac{d}{dt} (Li).$$

If the transformer were merely a coil having an air core, the inductance would be constant, and the induced voltage would be

$$e = -L \frac{di}{dt}.$$

If i were a sine wave of current, e would also be a sine wave displaced 90° behind i . However, with iron cores, as with transformers, the inductance is not constant, but is a function of the current i . Hence

$$e_i = - \left(L \frac{di}{dt} + i \frac{dL}{dt} \right),$$

and if i is a sine wave of current, the counter e.m.f. of self-induction is no longer a sine wave. Similarly, if a sine wave e.m.f. is impressed on the transformer, the current will not have the sine shape, but will be made up of fundamental, 3d, 5th, etc., harmonics.

In Chap. XXVIII, the characteristic wave of exciting current with a sine wave e.m.f. impressed was determined. On analyzing this wave by FOURIER'S series as indicated in problem 78, it is found to consist of a fundamental and triple with higher har-

monics of lesser amplitudes. The presence of the triple-frequency wave is an important feature in the exciting current of every iron-cored transformer operating with impressed sine wave e.m.f.

If, however, the triple frequency wave is suppressed in some way, as is often the case in three-phase systems, so that the exciting current is of sine shape (neglecting small higher harmonics), the induced voltage, and consequently the terminal voltage, will not be of sine shape, but will have the characteristic form shown on p. 194.

The transformer, of course, must generate its own counter e.m.f. or the induced voltage, and hence may be regarded as a generator, electrical energy being supplied to it instead of mechanical energy.

So far the transformer has been dealt with as a single unit. It is common practice, however, to group transformer units in various ways so that they shall serve as group units in the transmission and distribution of energy in systems other than the single-phase system.

The Three-phase System.—While two-phase, four-phase and six-phase systems are used to some extent and under certain conditions, yet the three-phase system in its various forms is far more important than all of these. Its study forms a basis for the development of any multiphase theory. The principles of two-phase and three-phase working from the standpoint of the alternator are explained in Chap. XXXV. In the present instance, three-phase will be dealt with in reference to the transformer alone.

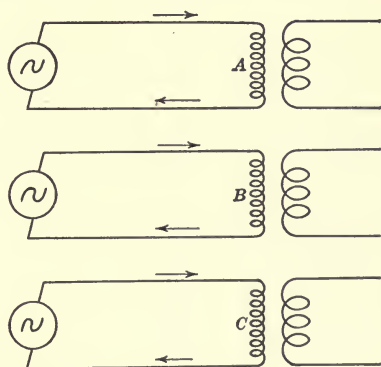

FIG. 164.

Consider three similar transformers, *A*, *B* and *C*, receiving current from three sources of simple sine waves of e.m.f. (Fig. 164). Let the voltage impressed on *A* be $e_1 = E_1 \sin \theta$, that on *B*, $e_2 = E_1 \sin (\theta + 120^\circ)$, that on *C*, $e_3 = E_1 \sin (\theta + 240^\circ)$. In each case the arrows in the figure indicate outgoing and return wires.

Neglecting higher harmonics the currents flowing will be, respectively

$$\begin{aligned}i_1 &= I_1 \sin (\theta - \phi) \\i_2 &= I_1 \sin (\theta + 120^\circ - \phi) \\i_3 &= I_1 \sin (\theta + 240^\circ - \phi).\end{aligned}$$



FIG. 165.

If the transformers are so arranged that the return currents shall flow through the same wire, as in Fig. 165, the value of the current in this return wire will be

$$i_n = i_1 + i_2 + i_3 = I_1 (\sin (\theta - \phi) + \sin (\theta + 120^\circ - \phi) + \sin (\theta + 240^\circ - \phi)).$$

The student should prove that this current is zero.

He should prove, also, that if there is current of triple frequency flowing in the lines, the triple frequency current in the fourth or neutral wire will be three times that in any line.

Problem 79.—Let the three line currents be given by the equations:

$$\begin{aligned}i_1 &= I_1 \sin (\theta - \phi_1) + I_3 \sin (3\theta - \phi_3) + I_5 \sin (5\theta - \phi_5) + \dots \\i_2 &= I_1 \sin (\theta + 120^\circ - \phi_1) + I_3 \sin [3(\theta + 120^\circ) - \phi_3] \\&\quad + I_5 \sin [5(\theta + 120^\circ) - \phi_5] + \dots \\i_3 &= I_1 \sin (\theta + 240^\circ - \phi_1) + I_3 \sin [5(\theta + 240^\circ) - \phi_3] + \\&\quad I_5 \sin [5(\theta + 240^\circ) - \phi_5] + \dots\end{aligned}$$

Prove that the current in the neutral wire will be

$$i_n = 3[I_3 \sin (3\theta - \phi_3) + I_9 \sin (9\theta - \phi_9) + I_{15} \sin (15\theta - \phi_{12}) + \dots],$$

that is, the current in the neutral wire is three times the sum of all odd harmonics which are multiples of three which are present in any line wire, all other harmonics becoming zero in the neutral.

Voltage Waves in Three-phase, Four-wire System.—The neutral wire serves to make the system virtually three single-phase systems instead of a three-phase system having peculiarities of its own. Thus if a sine wave e.m.f. is impressed on each transformer, the e.m.f. between lines is the vector sum of any two of these and is also a sine wave.

Since there is no current of fundamental frequency in the neutral wire, there is no necessity of having the wire there. Its absence will not be the occasion for any interruption in the circuit. However, since the circuit of the higher harmonics has been interrupted, it becomes of importance to study higher harmonic effects in connection with three-phase and with any other systems. Transformers so arranged with or without the neutral wire are

said to be Y-connected. If the circuits were unbalanced the situation would be somewhat different, as will be discussed later. For the present, however, it is sufficient to see that a three-phase circuit may be composed of only three wires, each representing the outgoing wire of one of the phases.

Three-phase, Y-connected Transformers.—Let it be assumed that the three, so-called, phase voltages are

$$\begin{aligned} OA &= e_1 = E_1 \sin \theta + E_3 \sin (3\theta + \alpha), \\ OB &= e_2 = E_1 \sin (\theta + 120^\circ) + E_3 \sin (3[\theta + 120^\circ] + \alpha), \\ OC &= e_3 = E_1 \sin (\theta + 240^\circ) + E_3 \sin (3[\theta + 240^\circ] + \alpha), \end{aligned}$$

these voltages being represented vectorially in Fig. 166. To find the line voltage AB . Evidently this is

$$e_{AB} = AO + OB = -e_1 + e_2,$$

since it is taken in direction from A to B . Directions from O outward are taken as positive. Therefore

$$\begin{aligned} e_{AB} &= -E_1 \sin \theta - E_3 \sin (3\theta + \alpha) + E_1 \sin (\theta + 120^\circ) + E_3 \sin (3[\theta + 120^\circ] + \alpha) \\ &= E_1[\sin \theta \cos 120^\circ + \cos \theta \sin 120^\circ - \sin \theta] \\ &\quad + E_3[\sin (3\theta + \alpha) - \sin (3\theta + \alpha)]. \end{aligned}$$

The last term vanishes since $\sin (3[\theta + 120^\circ] + \alpha) = \sin (3\theta + 360^\circ + \alpha) = \sin (3\theta + \alpha)$ and $e_{AB} = 1.73 E_1 \sin (\theta + 150^\circ)$.

The student should prove this by performing the intermediate operations.

Thus, it is seen that in a balanced three-phase Y-connected system, a triple frequency e.m.f. cannot exist in the voltage between the lines. The same will be shown to be true also for what is called the Δ -connection. This does not mean, as stated, that there can be no triple frequency e.m.f.s. in the phase windings, but simply that they cannot be between the lines.

Likewise, the other line voltages are:

$$\begin{aligned} e_{BC} &= -1.73 E_1 \sin (\theta + 90^\circ) \\ e_{CA} &= 1.73 E_1 \sin (\theta + 30^\circ). \end{aligned}$$

These voltages are represented in Fig. 167 (a) and (b), which give two ways of representing the same thing. The line and phase voltage relations may also be shown graphically, as in

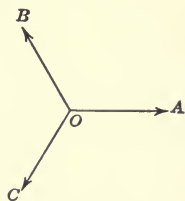

FIG. 166.

Fig. 168. Here, as in the equation for e_{AB} , OB is combined with OA reversed.

Carrying out the same process by which the assumed triple-frequency voltages in the line were eliminated, it could also be found that any higher harmonics which were multiples of 3, as 9th, 15th, 21st, etc., would vanish. Even harmonics are of necessity absent if the waves are symmetrical. Thus there remain only the 5th, 7th, 11th, 13th, 17th, 19th, etc., which could exist in the lines.

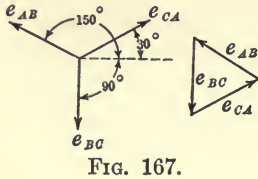

FIG. 167.

In the three-phase Y-connection, the triple frequency voltages in the phases are all in time-phase with each other, and the phase therefore acts like three circuits in parallel. Their extremities could be joined without causing any triple frequency current to flow. If the neutral point, O , be connected to ground, the triple frequency in the phases would cause all three transmission lines to oscillate just as would be the case with a single-phase line one side of which was grounded. In this case the three lines correspond to the ungrounded side of the single-phase line.

Three-phase Δ -connected Transformers.—When three transformers are so connected as to form a closed circuit, there are two facts in connection with their operation which are of great interest, namely: (1) there can be no circulating current of fundamental frequency in the windings; and (2) there always flows in the windings a current of triple frequency or an odd multiple of triple frequency.

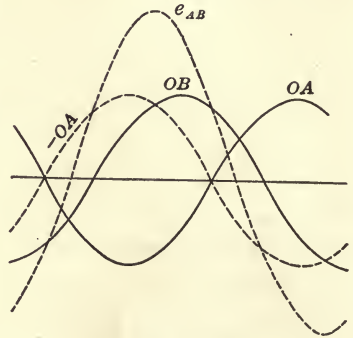

FIG. 168.

In proof of the first fact let the phase voltages be assumed, as before,

$$e_1 = E_1 \sin \theta + E_3 \sin (3 \theta + \alpha)$$

$$e_2 = E_1 \sin (\theta + 120^\circ) + E_3 \sin [3(\theta + 120^\circ) + \alpha]$$

$$e_3 = E_1 \sin (\theta + 240^\circ) + E_3 \sin [3(\theta + 240^\circ) + \alpha]$$

Adding the fundamental components,

$$E_1 [\sin \theta + \sin (\theta + 120^\circ) + \sin (\theta + 240^\circ)]$$

$$\begin{aligned}
 &= E_1 [\sin \theta + \sin \theta \cos 120^\circ + \cos \theta \sin 120^\circ + \sin \theta \cos 240^\circ + \cos \theta \sin 240^\circ] \\
 &= E_1 [\sin \theta + \sin \theta \times (-0.5) + \cos \theta \times (0.866) + \sin \theta \times (-0.5) + \cos \theta \times (-0.866)] \\
 &= E_1 [\sin \theta - \sin \theta] = 0.
 \end{aligned}$$

Thus, if there is no e.m.f. of fundamental frequency acting in the closed winding, there can be no current of fundamental frequency circulating in it.

In proof of the second fact, adding the triple-frequency components gives

$$E_3 \sin (3\theta + \alpha) + E_3 \sin [3(\theta + 120^\circ) + \alpha] + E_3 \sin [3(\theta + 240^\circ) + \alpha] = 3E_3 \sin (3\theta + \alpha).$$

Thus if the delta is open at one point (Fig. 169) the triple voltage across the opening is three times the triple-frequency voltage of one phase. Similarly, with a Y-connection with neutral point grounded, the triple-frequency current flowing into the ground is three times the triple-frequency current of one phase. When the neutral is grounded, it is no longer necessary to regard the system as three-phase, but it may be considered as three single phases having a common return, just as with the three-phase four-wire system already discussed.



FIG. 169.

The triple-frequency current is then perfectly free to flow in each line wire, returning by way of the neutral, whereas without the neutral, the triple-frequency current cannot exist.

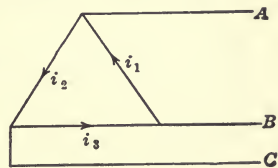

FIG. 170.

To find the relation between line current and phase current in a Δ -connected system.

Let the direction of the phase currents be assumed as indicated in Fig. 170 where

$$\begin{aligned}
 i_1 &= I_1 \sin \theta + I_3 \sin (3\theta + \alpha) \\
 i_2 &= I_1 \sin (\theta + 120^\circ) + I_3 \sin [3(\theta + 120^\circ) + \alpha] \\
 i_3 &= I_1 \sin (\theta + 240^\circ) + I_3 \sin [3(\theta + 240^\circ) + \alpha]
 \end{aligned}$$

Taking the direction of the arrows as positive, the fundamental line current,

$$i_A = i_1 - i_2 = I_1 (\sin \theta - \sin (\theta + 120^\circ)) = 1.73I_1 \sin (\theta - 30^\circ)$$

This relationship is similar to that of the voltages for Y-connection. Similarly, also, there can be no triple-frequency current in the line.

Voltage Waves with Y-connected Transformers.—In problem 76, was assumed a sine wave of exciting current. This is approximately the case with the three-phase Y-connection since there can be no triple-frequency current in the line or phase.

The phase voltage must then look like that of Fig. 151. The

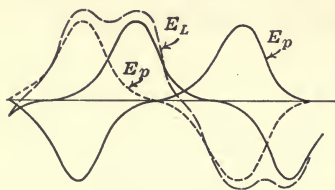

FIG. 171.

line voltage as previously seen will be a combination of two phase voltages, one of which is reversed, as in Fig. 171.

(The depression in the line voltage wave is not actually as deep as would appear from using sine waves of magnetizing current.)

If the generator develops a sine wave e.m.f. and the transformer counter e.m.f. is much distorted, due to the hysteresis loop effect, then the difference between these two waves must be taken up by drops along the lines and in the apparatus.

Problem 80.—Given three Δ -connected transformers. Make a picture of the e.m.f. and compare it with that of a single-phase circuit. What is the shape of the wave of phase current? What is the shape of the wave of line current? Show also, by a sketch that the sum of two exciting current waves of a three-phase Δ -connected system makes nearly a sine wave, the triple frequency vanishing. How does the core loss in this system compare with that of three single-phase circuits?

Problem 81.—Given three Y-connected transformers. The line current can contain no triple harmonics but only 1st, 5th, 7th, 11th, etc., harmonics. The phase voltage, however, has a large triple harmonic. The line voltage is a combination of two-phase voltages. What is the ratio of the phase voltage to the line voltage? Is it 58 per cent.? Evidently it is higher, as the phase voltage contains also the triple-frequency voltage. How does the core loss of this system compare with that of the Δ -connected system and with the single-phase?

The flux wave is flat, since there is no triple-frequency current. Therefore the maximum value of flux is less, and the core loss is less (by about 30 per cent.), than with sine waves of flux. Moreover, the exciting current is less because the max. value of the flux density is less.

With open delta connection what will the voltmeter read? Evidently three times the triple-frequency voltage per phase. Why? With the

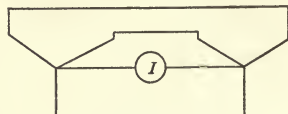

FIG. 172.

neutral wire connected in a Y-system as in Fig. 172, what would be the current in the neutral?

As has been pointed out, this is no longer a real three-phase system, but three single phases in which the neutral wire is common to all the phases.

Evidently the triple-frequency currents can flow in each phase, and since they are all in time-phase with each other the neutral will carry three times the triple harmonic current of each phase.

What then, will be the effect on the core loss of connecting in the neutral, as compared with leaving it out?

These problems are stated in such a way as to form the basis for a fairly complete discussion, on the part of the student, of the effects which would be produced by the different ways of connecting the transformer.

Three-phase Transformers.—A natural development in the use of three single-phase transformers for three-phase work is the substitution therefor of a single three-phase transformer.

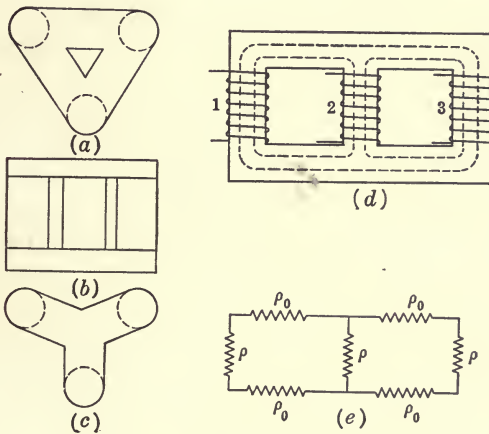

FIG. 173.

Let there be three cores of laminated iron, symmetrically placed, connected by legs, each core having on it the windings of one phase. This may be done as in Fig. 173, *a, b*. How, then, should the sectional area of the core be calculated? This should evidently be done in the regular way since each leg has its coil, and must have its flux set up by the coil. The yoke, however, corresponds to a Δ -connection, and the flux in any leg of the yoke is $\frac{1}{\sqrt{3}} = 58$ per cent. of the flux in any core.

The yoke may also be formed as a Y-connection (Fig. 173, *c, b*), in which the flux in any branch of the Y is the same as that in any leg.

In practice, however, it is common to employ a form such as Fig. 173, *d*, in which there are three equal legs carrying the coils and the yoke is straight across the top and bottom. The whole core is built up of laminations, which, except for the difficulty of placing the coils, could be of one piece. In Fig. 173, *d*, the flux paths are outlined by dotted lines, and it is evident that so far as the magnetic core is concerned, coils 1 and 3 are symmetrical with respect to each other, while coil 2 is unsymmetrical with respect to 1 and 3.

Assume the reluctance of one leg to be ρ , and the reluctance of one section of the yoke to be ρ_0 .

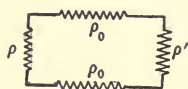

FIG. 174.

Then there may be constructed an analogous electric circuit, as in Fig. 173, *e*. This gives the magnetic circuit which is supplied with flux by the m.m.f. of coil 1, on leg 1. It may be simplified to Fig. 174, in which

$$\frac{1}{\rho'} = \frac{1}{\rho} + \frac{1}{\rho + 2\rho_0}$$

$$\rho' = \frac{\rho(\rho + 2\rho_0)}{2(\rho + \rho_0)}$$

The total reluctance of the magnetic circuit of coil 1, is thus

$$\rho_1 = \rho' + \rho + 2\rho_0 = \frac{\rho(\rho + 2\rho_0)}{2(\rho + \rho_0)} + \rho + 2\rho_0$$

$$= (\rho + 2\rho_0) \left[\frac{\rho}{2(\rho + \rho_0)} + 1 \right] = \frac{\rho + 2\rho_0}{2(\rho + \rho_0)} (3\rho + 2\rho_0)$$

It is also evident that $\rho_1 = \rho_3$.

For ρ_2 , the circuit may be considered as made of two parallel paths, as in Fig. 175. Here,

$$\rho_2 = \frac{1}{2} (3\rho + 2\rho_0).$$

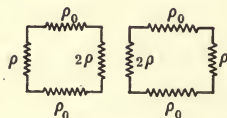

FIG. 175.

Thus the relative reluctances of the two circuits are

$$\frac{\rho_2}{\rho_1} = \frac{\rho + \rho_0}{\rho + 2\rho_0}$$

In a good transformer, the ratio of height to width of the window is from 4 to 8:1; the average is about 6:1.

$\therefore \rho$ is from 4 to 8 times as large as ρ_0 .

Assuming $\rho = 6\rho_0$,

$$\frac{\rho_2}{\rho_1} = \frac{7\rho_0}{8\rho_0} = \frac{7}{8}$$

$\therefore \rho_2$ has $87\frac{1}{2}$ per cent. as great a value as ρ_1 , and the exciting current in the middle coil is from 80 per cent. to 90 per cent. of that in the outside coils.

Suppose it were necessary to have equal exciting current in all the coils. This could be accomplished by reducing the section of the middle leg.

But, in this case, the core loss would be unbalanced, for it is approximately proportional to the square of the flux density which would be increased in the middle leg.

Therefore, there must be some unbalancing. In practice all parts are made of equal section, including the yoke. It is therefore easy to calculate the saving in material over three single-phase transformers.

Question.—Considering wave shapes as discussed above if the coils are connected Y, will there be a triple-frequency voltage?

It has been shown that the triple-frequency currents are in time-phase in the different phases. Hence they produce fluxes in time-phase with each other. These then neutralize each other or pass around through the air which makes them very weak. The induced triple-frequency voltages are therefore very small. Thus a three-phase Y-connected transformer acts like three choking coils as far as the triple-frequency current is concerned. Their flux paths being largely in air, the hysteresis loops are very thin, causing small distortion. Therefore, core-type three-phase transformers behave much like three Δ -connected single-phase transformers as regards triple-frequency harmonics.

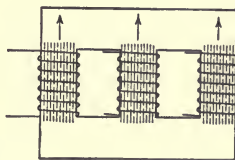

FIG. 176.

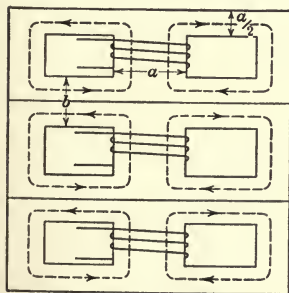

FIG. 177.

Shell-type Three-phase Transformers.—These could be made by placing three single-phase shell-type

transformers one on the other. In such a case, the leg with the coil has a width, a , while the other legs have widths $a/2$ (Fig. 177).

The combined intermediate sections or widths, b , could be reduced to $\frac{\sqrt{3}}{2} a$, since the fluxes differ by 30° in time-phase, in adjacent intermediate sections. This is seen to be the case by noting the dotted lines in the figure. Arrows indicate what may be called the positive direction of the flux and these directions are opposite in the adjacent intermediate sections.

If now the middle coil is reversed, the positive direction of the flux in the middle transformer is reversed, and the flux phases in intermediate adjacent sections have a 60° relation. The total

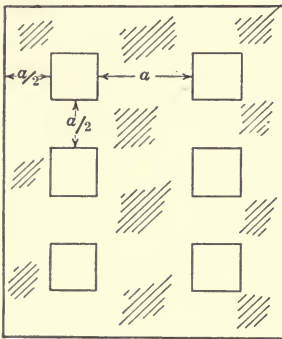

FIG. 178.

flux in these sections is therefore exactly the same as that in the outside section, and required width of section b is also that of the outside section namely, $a/2$. Transformers are therefore designed as in Fig. 178, with all width dimensions $a/2$, except the middle legs which have the width, a .

To prove that in reversing the middle coil the flux produced is in amount the same flux as when the coil is not reversed.

The flux produced by coil 1 is $\Phi \sin \theta$. Flux produced by coil 2, reversed, is $-\Phi \sin (\theta + 120^\circ)$. The flux due to the two coils is then

$$\begin{aligned} & \Phi [-\sin \theta - \sin (\theta + 120^\circ)] \\ &= \Phi [-\sin \theta - \sin \theta \cos 120^\circ - \cos \theta \sin 120^\circ] \\ &= -\Phi [0.5 \sin \theta + 0.866 \cos \theta] = -\Phi \sin (\theta + \alpha) \end{aligned}$$

where $\alpha = 30^\circ$.

Problem 82.—Discuss the wave shapes of three-phase transformers. Show that in the core type, it makes very little difference whether the neutral is connected or not.

Show that, in the shell type, the waves are essentially the same as those of three single-phase transformers.

Open Delta Transformer Connection.—If one of three delta-connected transformers is disabled it is possible to operate at reduced output with the remaining two, connected as shown in Fig. 179.

The following is a comparison of the use of two transformers

and three transformers when the power delivered is assumed equal in the two cases.

		Δ	$<$
Current in transformer.....	I_p	$\frac{I}{\sqrt{3}}$	I
Voltage across transformer...	E_p	E	E
Rating of each transformer...		$\frac{EI}{\sqrt{3}}$	EI
Rating of installation.....	$3 \frac{EI}{\sqrt{3}} = \sqrt{3}EI$		$2EI$

Ratio of transformer capacity = $\frac{\sqrt{3}}{2}$ in favor of the three transformers. However, it may be cheaper, in a given initial installation, to buy two large transformers than three small ones.

Now, assume a three-transformer installation in which one transformer has been disabled. How much should the load be reduced to give normal operation of the remaining two on open delta?

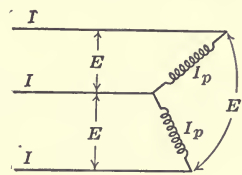

FIG. 179.

The line current must evidently be reduced in the ratio $\frac{1}{\sqrt{3}}$ since the line current and the phase current are now the same. The output, which was $\sqrt{3}EI$, therefore becomes $\sqrt{3}E \frac{I}{\sqrt{3}} = EI$.

Therefore the ratio of outputs is $\frac{EI}{\sqrt{3}EI} = 0.58$ or less than the ratio of transformer capacity which is $\frac{2}{3}$ or 0.667.

Two transformers are frequently used both for three-phase and for a combination of three-phase-two-phase transformation being connected in a manner known as the T- or Scott connection.

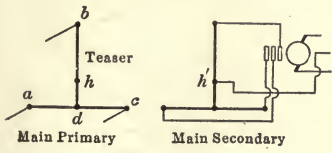

FIG. 180.

T-connection of Transformers.
 —This connection is illustrated in Fig. 180. The connection is used commonly in circuits with rotary converters, where a wire may be brought out from the neutral, h' , and connected to the middle wire of a three-wire system on the direct-current side. In this case the direct current flowing in the transformer wind-

ings has no magnetizing effect since it flows in opposite direction in the two halves of the transformer windings.

It consists of a so-called "main" transformer with a tap brought out at the middle points of its windings and a "teaser" transformer of 0.866 times as many turns, one terminal of which is connected to the tap, d , of the main transformer. The three-phase lines are brought to the terminals, a, b, c , which are at the three vertices of an equilateral triangle. Thus, if the base, ac , of the triangle has the length, l , its height, bd , will be 0.866. The center of this triangle will be at a point, h , called the neutral.

Rating of T-connected Transformers.—Three-phase output = $\sqrt{3}EI$, where E and I are line voltage and current, respectively. Rated output of the two transformers

$$= EI + 0.866EI = 1.866EI.$$

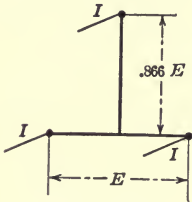

FIG. 181.

∴ Ratio of the output to the transformer rating is $\frac{1.73}{1.866} = 0.925 \approx 92.5$ per cent. This means that for the same values of E and I , three single transformers would need to have only 92.5 per cent. of the kva. rating which

the T-connected transformers would have. Thus, the T-connection is nearly as good. It may in some cases be cheaper, as it involves only two transformers.

Two-phase—Three-phase Transformation.—Let two-phase currents be led to the primaries, while three-phases are taken from the secondaries. Considered as 1:1 ratio of the main transformers for convenience only, the teasers would be in the ratio 1:0.866. Neglecting exciting current the two-phase input = $2EI$, = three-phase output = $\sqrt{3}EI_3$.

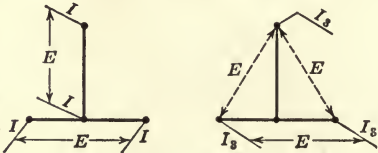

FIG. 182.

$$\therefore I_3 = \frac{2}{\sqrt{3}} I = 1.16I.$$

The rating of a transformer may be taken as the average of the input and output, and it is therefore,

$$\begin{aligned} \text{Rating} &= \frac{1}{2} [2EI + 1.16EI + (0.866E \times 1.16I)] \\ &= \frac{1}{2} [2EI + 1.16EI + EI]. \\ &= EI + 1.08 EI = 2.08 EI. \end{aligned}$$

The so-called cost efficiency is therefore $\frac{2}{2.08} = 0.96$, that is, the rating is 96 per cent. of that of two transformers for an ordinary two-phase transformation, or for two single-phase transformers. That is nearly as good as using three transformers for the three-phase and, there being only two transformers, possible economy is suggested.

The question arises as to how it is that, with such connections the magnetization is uniform. If it is not uniform, there will be complications due to over and under saturation in the different parts of the cores. Therefore, the sum of the magnetomotive forces due to the load current in the branches of the windings must add up to zero, that is, the two-phase load ampere-turns in each branch must be balanced by the corresponding three-phase ampere-turns.

Let oa , ob , oc (Fig. 183), represent the three-phase AT , in amount and direction. Let de represent the two-phase AT in the main transformer. To obtain the three-phase projections on the two-phase line, it is necessary to take the components of oc and ob on the horizontal.

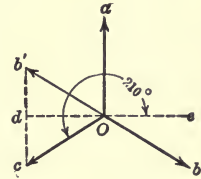

FIG. 183.

These equal de . The components, however, are in opposite directions, but due to the fact that the ampere-turns from c to b are evidently all in the same direction, ob must be projected backward to ob' . This causes the vertical components, $b'd$ and dc to be in opposition and they therefore cancel each other.

The proof of this by trigonometrical relations is as follows:
 m.m.f. of primary = $It \sin \theta$, where t is the number of primary turns.

$$\text{m.m.f. of } od = \frac{1.16It}{2} \sin (\theta + 210^\circ)$$

$$\text{m.m.f. of } oe = \frac{1.16It}{2} \sin (\theta - 30^\circ).$$

$$\begin{aligned} \text{Total m.m.f.} &= It \sin \theta + 1.16 \frac{It}{2} [\sin (\theta + 210^\circ) + \sin (\theta - 30^\circ)] \\ &= It \sin \theta - 0.58It [\sin (\theta + 30^\circ) + \sin (\theta - 30^\circ)] \\ &= It \sin \theta - 0.58It [\sin \theta \cos 30^\circ + \cos \theta \sin 30^\circ \\ &\quad + \sin \theta \cos 30^\circ - \cos \theta \sin 30^\circ] \\ &= It \sin \theta - 0.58It (1.73 \sin \theta) = 0. \end{aligned}$$

This means that the load current does not increase the magnetization of the transformer.

In the case of the teaser transformer, both the primary and the secondary are in the same direction in space and time, that is, they bear the same phase relation as with single-phase transformers. Therefore, the ampere-turns relation is; secondary A.T. = $0.866 \times 1.16EI = EI =$ primary ampere-turns. Therefore as turns are proportional to voltage, the m.m.fs. are equal. It is always possible to buy transformers of both 10:1 and 9:1 ratios from stock. For practical reasons 9:1 is used instead of 8.6:1. With these ratios, connection can be made to nearly any system in practical operation.

Auto-transformers (also called compensators).—Auto-transformers are transformers with only one winding. The primary voltage is applied to the coil terminals; the secondary voltage is obtained by connecting to taps at any desired places of the winding.

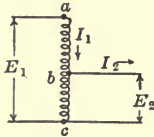

FIG. 184.

The general connections of the single-phase auto-transformers are as in Fig. 184. Let I_1 and I_2 be the primary and secondary currents, respectively.

Then

$$\begin{aligned} I_1 &= \text{current in } ab. \\ I_2 - I_1 &= \text{current in } bc. \end{aligned}$$

The rating of the section ab is $I_1(E_1 - E_2)$. The rating of section bc is $(I_2 - I_1)E_2$. The rating of the auto-transformer is the average of the sum, or

$$\begin{aligned} \text{rating} &= \frac{1}{2} [I_1E_1 - I_1E_2 + I_2E_2 - I_1E_2] \\ &= \frac{1}{2} [I_1E_1 + I_2E_2 - 2I_1E_2]. \end{aligned} \quad (111)$$

Neglecting exciting current, as in any transformer, the voltage and current ratios are $\frac{E_1}{E_2} = \frac{I_2}{I_1}$, or $I_1E_1 = I_2E_2$. Substituting for I_2E_2 in (111), the rating becomes,

$$\text{rating} = \frac{1}{2} [2I_1E_1 - 2I_1E_2] = I_1 [E_1 - E_2].$$

The per cent. rating for a given current is

$$\frac{I_1(E_1 - E_2)}{I_1E_1} = \frac{E_1 - E_2}{E_1}.$$

Thus, if $E_2 = 90$ per cent. of E_1 ,

Per cent. rating = $\frac{1 - 0.9}{1} = 0.1$, or 10 per cent. That is, it is

necessary to supply only 10 per cent. of the rating of an ordinary transformer to effect this transformation which is obviously a great gain in cost efficiency. If the voltage is to be reduced in the ratio 2:1 the economy of using an auto-transformer instead of an ordinary transformer is not so great. The saving is in this case about one-half.

Problem 83.—Show the advantage of using auto-transformers by plotting a curve between per cent. rating of the auto-transformers and transformation ratio.

Compensators for Two-phase—Three-phase Transformation.

—In Fig. 185, let the two-phase taps be cb and ef , and let the three-phase taps be a, d, g , and let E_2 and I_2 be two-phase voltage and current respectively and E_3 and I_3 be corresponding values for three-phase. Neglecting losses, $\sqrt{3}E_3I_3 = 2E_2I_2$, is the power relation between input and output.

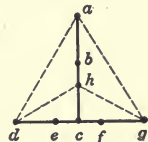

FIG. 185.

Considering separate parts of the windings, current in $ab = I_3$; voltage in $ab = 0.866E_3 - E_2$, since voltage in $ac = 0.866E_3$; rating of $ab = (0.866E_3 - E_2)I_3$; current in $bh = I_2 - I_3$. In this case $I_2 > I_3$, E_3 being $> E_2$. Voltage in $bh = E_2 - \frac{1}{3} 0.866 E_3$ since $hc = \frac{1}{3}ac$; rating of $bh = (I_2 - I_3)(E_2 - \frac{1}{3} 0.866E_3)$; current in $hc = I_2 - I_3$, since the resultant sum of two equal currents 120° apart is numerically equal to one of them. The three-phase current in hc is the sum of the currents of the phases hd and hg , indicated by dotted lines.

- Voltage in $hc = \frac{1}{3} 0.866 E_3$;
- rating of $hc = \frac{1}{3} 0.866 E_3 (I_2 - I_3)$;
- current in $de = I_3 =$ current in fg ;
- voltage of $de = \frac{1}{2} (E_3 - E_2) =$ voltage of fg ;
- rating of $de = \frac{I_3}{2} (E_3 - E_2) =$ rating of fg ;

current in $ec = \sqrt{(I_2 - I_3 \cos 30^\circ)^2 + (I_3 \sin 30^\circ)^2} =$ current in cf , that is, it is $I_2 -$ the component of I_3 , in phase with $I_2 + j \times$ the component of I_3 normal to I_2 .

Voltage of $ec = \frac{E_2}{2} =$ voltage of cf .

Rating of $ec = \frac{E_2}{2} \sqrt{(I_2 - I_3 \cos 30^\circ)^2 + (I_3 \sin 30^\circ)^2} =$ rating of cf .

The combined rating, which is one-half the sum of the ratings of all the parts, is

$$0.933E_3I_3 - 1.5E_2I_3 + 0.5E_2I_2 + 0.5E_2 \times \sqrt{I_2^2 - 1.73I_2I_3 + I_3^2}.$$

An examination of this rather complicated expression will show that the same ratio of cost efficiency holds with reference to the T-connected transformers having primary and secondary windings, as holds for single-phase auto-transformers compared with ordinary single-phase transformers.

Dissimilar Transformers in Series.—Transformers may not be indiscriminately connected in series with safety.

To connect two transformers of different design but proper rated voltages in series is not always safe, since they may not take their proper share of the total voltage. One may even burn out at no-load due to excessive core loss. Suppose that their normal exciting currents are different. Since the same amount of current must flow through each transformer (as they are in series), this current will be insufficient to give the proper flux in one of the transformers and will be more than necessary in the other. Thus the voltages will not divide according to the rating and the core loss will be low in one and excessive in the other. Let the open circuit or exciting impedance of *A*, Fig. 186, be

$$r + jx = z,$$

that of *B*,

$$r_1 + jx_1 = z_1.$$

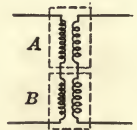

The total impedance is then $Z = z + z_1 = R + jX$. FIG. 186.

Then the exciting current of the two transformers in series is

$$I_0 = \frac{e_0}{Z} = \frac{\text{impressed volts}}{R + jX}.$$

The voltage across *A*, is

$$V_A = \frac{e_0}{R + jX} (r + jx).$$

Voltage across *B* is

$$V_B = \frac{e_0}{R + jX} (r_1 + jx_1).$$

Neglecting the power component, we get as a fair approximation,

since

$$I_0 = \frac{e_0}{j(x + x_1)}, \text{ approximately,}$$

$$V_A = \frac{e_0}{j(x + x_1)} jx = \frac{e_0 x}{x + x_1}; V_B = \frac{e_0 x_1}{x + x_1}$$

$$\therefore \frac{V_A}{V_B} = \frac{x}{x_1} = \frac{\frac{E}{I_{m1}}}{\frac{E}{I_{m,A}}} = \frac{I_{m,B}}{I_{m,A}}$$

where $I_{m,B}$, and $I_{m,A}$, are the normal magnetizing currents. Thus, the respective voltage drops across A and B , when in series, will be approximately inversely proportional to the normal magnetizing or exciting currents.

This assumes constant values of x and x_1 , which would not be true if the resultant exciting current differed widely from the normal values of exciting current of the two transformers.

If x is nearly equal to x_1 , the above ratios would hold. Where one transformer, however, is saturated, its reactance is greatly diminished, which allows a greater current to flow in the circuit but tends to equalize the voltages.

Dissimilar Transformers in Parallel.—This is the usual mode of connection and it offers no difficulty due to unequal exciting currents. The question, here, is one of proper division of the load. In giving orders for additional equipment, it is customary to specify what the percentage reactance of the new transformers shall be. With equal, or proportional, reactances there results a proper division of the load. Consider the parallel connection as shown in Fig. 187.

The two load currents are:

$$I_A = i + j'i',$$

$$I_B = i_1 + j'i'_1.$$

The total load current,

$$I = I_A + I_B.$$

Let

$$Z_A = r + jx \text{ and } Z_B = r_1 + jx_1,$$

be the impedances of A and B respectively.

Then, since the terminal voltages are the same on each, the voltage drops in the transformers are equal, and are:

$$(i + j'i')(r + jx) = (i_1 + j'i'_1)(r_1 + jx_1).$$

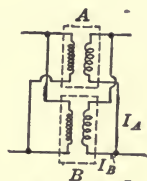

FIG. 187.

Multiplying out,

$$ir + jix + j'i'r - i'x = i_1r_1 + ji_1x_1 + j'i'_1r_1 - i'_1x_1.$$

Here, the real components must be equal and the imaginary components must be equal.

$$\therefore ir - i'x = i_1r_1 - i'_1x_1,$$

and

$$ix + i'r = i_1x_1 + i'_1r_1.$$

Neglecting resistances,

$$-i'x = -i'_1x_1$$

and

$$ix = i_1x_1,$$

whence

$$\frac{i'}{i'_1} = \frac{x_1}{x}, \quad \frac{i}{i_1} = \frac{x_1}{x}.$$

Thus, the load is divided in inverse proportion to the reactances.

The best method of connection is, as in Fig. 188. The student is advised to explain why this is so. *Is that so?*

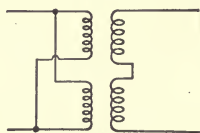

FIG. 188.

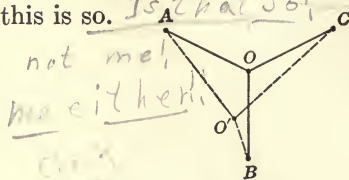

FIG. 189.

Three-phase Connection of Dissimilar Transformers.—If the three transformers are connected Y—Y there will not be symmetrical distribution of voltage. Consider the neutral point, O , Fig. 189, with reference to the transformers A and B . With line voltage impressed on AB , the potential at O may have any intermediate value, just as with two single-phase transformers in series, depending on the relative open circuit impedances of the two transformers.

The point of junction of the three transformers may, for instance, be displaced to O' . The secondary Y-voltages would have a similar relationship to each other. Dissimilarity may consist merely in variation in the iron of two supposedly similar transformers.

If the secondaries are connected in Δ , the primaries being Y-connected this difficulty of unbalanced potentials is eliminated.

The induced voltage in each secondary will, of course, be

proportional to that of its primary, giving the closed Δ , ABC , Fig. 190, when the primary circuit is balanced.

With unbalanced condition, if the Δ is left open at B , the voltage vectors will not make a closed figure, but as shown by the dotted lines, will leave an opening between B' and B'' . If the Δ is then closed, the voltage $B'B''$ will act in the Δ circuit, sending a local current which will increase the magnetization of the transformer whose flux is below normal and decrease that of the transformer whose flux is above

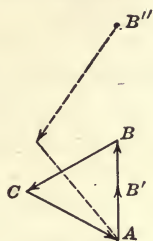

FIG. 190.



FIG. 191.

normal. Thus the magnetization is brought back to normal value, the local current in the Δ serving to anchor the neutral point of the Y.

Three-phase transformer systems may be extended in a variety of ways to cover cases where it is desirable to use six phases. This practice finds application especially with rotary, or synchronous, converters, and it will be discussed more fully under that heading. Such combinations of transformers as permit symmetrical grouping of voltages are illustrated by the double Δ , double T, or double Y shown in Fig. 191.

CHAPTER XXXIII

ALTERNATORS

Fundamentally, direct-current and alternating-current generators are alike. An alternator becomes a direct-current generator by adding a commutator. The essential principles of both machines have been developed in Chaps. VI and VII.

In Fig. 192, *a*, is represented a simple alternator with a two-pole field core magnetized with direct current from some independent

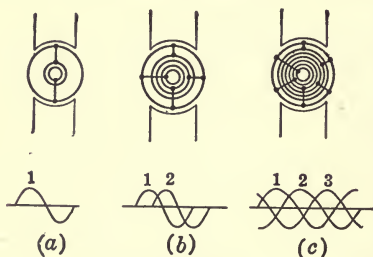

FIG. 192.

source, and an armature with a single coil. As this armature revolves there is generated in it an e.m.f. which follows closely a sine wave of time values. It is apparent that the space on the armature periphery is not all utilized, and that another coil could be put on in space quadrature to the first. In

such a case, two similar e.m.f. waves would be produced but in time quadrature with each other, or at 90° time-phase displacement, that is, one wave would reach its maximum one-quarter of a period later than the other (Fig. 192, *b*).

Such an alternator is called a two-phase, or, sometimes, a quarter-phase machine.

On the same principle, an armature may be supplied with three coils, or groups of coils, spaced 120° apart, each group giving its separate e.m.f. wave (Fig. 192, *c*).

In this way, any number of coils or groups of coils may be wound on an armature, giving any desired number of phases. In practice, however, the majority of alternators are three-phase, and very seldom is one built for a greater number of phases than three.

The voltages generated in the various phase windings may be conveniently shown in their proper relations by vectors.

If in the two-phase case, the ends 1' and 2' (Fig. 193, *b*), are

joined together, the voltages of the two coils will be added vectorially, so that a voltmeter placed across the terminals, 1, 2, would read $\sqrt{2}$ times the voltage of either coil taken separately, since the two voltages are in time quadrature. Likewise by connecting 1 and 2', the joint reading across 1' and 2 will obviously also be $\sqrt{2}$ times the voltage of one phase.

With a three-phase machine it is not quite so apparent that the voltage between the three collector rings is $\sqrt{3}$ times the voltage generated in one phase. At first sight it might be expected that the resultant voltage should be the same as that generated in each phase since the voltages are 120° apart.

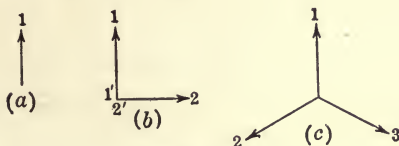

FIG. 193.

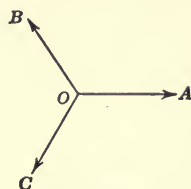

FIG. 194.

Let, in Fig. 194, OA , the voltage of phase A , be represented by

$$e_A = E_m \sin \omega t.$$

Then OB , the voltage of phase B , is evidently

$$e_B = E_m \sin (\omega t + 120),$$

and

$$e_C = E_m \sin (\omega t + 240).$$

The voltage between collector rings A and B is thus

$$e_A - e_B = E_m [\sin \omega t - \sin (\omega t + 120)],$$

which, by simple trigonometric transformation becomes,

$$e_A - e_B = \sqrt{3} E_m \sin (\omega t - 30^\circ).$$

Thus the numerical value of the potential difference between the collector rings is $\sqrt{3}$ times as great as the voltage generated in each phase and the resultant voltage is displaced 30° from the voltage generated in phase OA .

Problem 84.—Prove that the voltage between B and C is:

$$\sqrt{3} E_m \sin (\omega t + 90),$$

and that the voltage between C and A is:

$$\sqrt{3} E_m \sin (\omega t + 210).$$

It is seen, thus, that the voltages between the collector rings are also 120° apart.

It is interesting to note here that a single-phase machine might be treated as a two-phase machine in which the two phases are 180° apart as is shown in Fig. 195.

Let the voltage generated in OA be $E_m \sin \omega t$. Then that generated in OB is $E_m \sin (\omega t + 180)$. Thus the difference of potential between the collector rings at A and B is

$$e_A - e_B = E_m (\sin \omega t - \sin (\omega' + 180)) = 2E_m \sin \omega t.$$

The resultant potential difference is twice the voltage generated in each phase, as should, of course, be the case.

This fact could have been developed also geometrically.

To find the potential difference between A and B , Fig. 194, we should subtract OB from OA as shown in Fig. 196.

It is not necessary that the windings shall consist of separate coils. A closed ring winding, or Gramme ring, may be tapped at symmetrical points and these connected to slip rings, as in Fig. 197. Thus, if a voltmeter is connected across the slip rings (1, 1), the voltage of one phase is read. If connected across rings (2, 2), the same value of voltage will be indicated, but it is evident that the phase of this e.m.f. is displaced by 90 time degrees from that of the first.

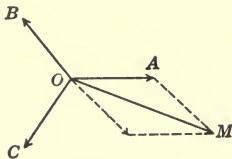

FIG. 196.

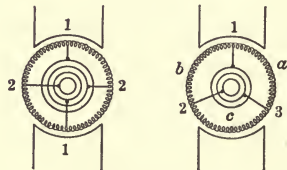

FIG. 197.

With the three-phase connection taps are brought out at points 120 space degrees apart and led to slip rings. A voltmeter, connected across any two rings, will read the voltage of one coil, say coil a , Fig. 197. But this must also be the sum of the voltages of the other two coils, since any one coil is in parallel with the other two coils with respect to the external circuit. The voltages in this case form a closed, so-called delta, Δ , and it is evident that the phase voltage and line voltage, or voltage between the collector rings, are equal.

In these diagrams only three collector rings and three lines are shown. Yet in the discussion it has been assumed that one side

of each winding is connected to a common point. It would seem, therefore, that at least four collector rings and lines might be necessary to form a complete system, in other words, that even a balanced three-phase system would involve four wires as is shown in Fig. 199. It is evident that if, with a balanced system, the current in an ammeter placed at N is always zero, then no return or fourth wire is necessary.

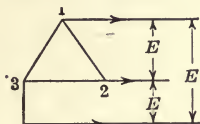

FIG. 198.

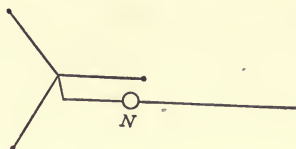

FIG. 199.

Let the current in phase A be

$$i_a = I_m (\sin \omega t) \text{ and the current in phases}$$

$$B \text{ and } C \text{ be } i_b = I_m \sin (\omega t + 120) \text{ and } i_c = I_m \sin (\omega t + 240).$$

The current in N is then

$$i_n = i_a + i_b + i_c = I_m \sin 0 = 0.$$

Problem 85.—Prove that no circulatory current of fundamental frequency flows in the delta-connected generator.

Since with the Y-connected generator the transmission lines really form extensions of the windings, it is evident that whatever current flows in the line also flows in each winding.

With the delta-connected generator this is not so, because the line current is the vector sum of the currents in the adjacent phases, as is shown in Fig. 198. The current in phase 1-2 may be considered the zero vector. Thus the currents in the phases are:

$$i_{12} = I_m \sin \omega t,$$

$$i_{23} = I_m \sin (\omega t + 120),$$

$$i_{31} = I_m \sin (\omega t + 240).$$

Then, since the sum of the currents flowing to a point is zero,

$$i_2 + i_{23} - i_{12} = 0,$$

$$\text{or } i_2 = i_{12} - i_{23} = I_m \sin \omega t - I_m \sin (\omega t + 120)$$

$$= \sqrt{3} I_m \sin (\omega t - 30).$$

The line current is thus $\sqrt{3}$ times as large as the current in the individual phases.

Referring to Fig. 198, it is evident that

$$i_3 + i_{31} - i_{23} = 0 \text{ and } i_1 + i_{12} - i_{31} = 0.$$

Problem 86.—Prove that the currents in lines 1 and 3 are, respectively, $\sqrt{3} I_m \sin (\omega t + 90)$ and $\sqrt{3} I_m \sin (\omega t + 210)$.

The power given by a three-phase alternator is

$$P = \sqrt{3} EI \cos \alpha,$$

whether the alternator is connected Y or Δ , where I is the effective value of the line current and E the effective value of the voltage between the lines, and α is the angle of lead or lag of the phase current in reference to the phase voltage, that is, $\cos \alpha$ is the power factor.

To prove this, consider a Y-connected generator.

Since I is the line current, it is also the current in each winding.

Since E is the line voltage, the voltage of each of the three phases of the generator is $\frac{E}{\sqrt{3}}$. Thus the power given by each of the three phases of the generator is $\frac{EI}{\sqrt{3}} \cos \alpha$, and the total power, $3 \frac{EI}{\sqrt{3}} \cos \alpha = \sqrt{3}EI \cos \alpha$.

Problem 87.—Prove that this also applies in the case of a delta-connected generator.

Voltage to Neutral.—In Y-connected alternators the neutral point is the center of the Y. On a three-phase distribution system it is often advantageous to run a fourth wire from the neutral.

The voltage between any of the other wires and the neutral is the phase voltage, and is equal to the line voltage divided by $\sqrt{3}$.

In a Δ -connected alternator there is no actual neutral point. However, for purposes of calculation, a neutral point is imagined at the center of the delta, and the voltage to neutral is then the phase voltage divided by $\sqrt{3}$, or, since the phase voltage and the line voltage are the same, it is equal to the line voltage divided by $\sqrt{3}$ as with Y-connected alternator. The voltage to neutral is

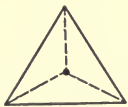

FIG. 200.

thus independent of the manner of connecting the alternator windings.

Rating of Alternators.—As with transformers, alternators are rated in kilovolt-amperes, not in kilowatts. This is because the permissible output of an alternator depends on the current in its windings, regardless of the phase relation between the current and the voltage.

The nominal rating of an alternator may be designated as, for example, *A.T.B.* 12-400-600-2300, where *A* signifies alternator, *T* signifies three-phase, (*S* is for one or single-phase), *B* signifies a

revolving field. If the armature is the revolving part, the third letter is omitted.

12 signifies the number of poles.

400 signifies the rating in k.v.a.

600 signifies the speed in r.p.m.

2300 signifies the rated voltage.

Sometimes a subscript is added to the second letter; thus, AT_2 signifies a three-phase revolving armature alternator having two slots per pole per phase on the armature.

If the above alternator is Y-connected, the phase voltage, or voltage to neutral, is $\frac{2300}{\sqrt{3}} = 1330$ volts.

The line and phase current is $\frac{400 \text{ k.v.a.}}{\sqrt{3} \times 2300} = \frac{400,000}{3 \times 1330} = 100$ amp.

If delta-connected, the voltage to the imaginary neutral is likewise 1330.

The line current is also 100, but the phase current is $\frac{100}{\sqrt{3}} = 57.7$ amp.

CHAPTER XXXIV

ARMATURE REACTION

The so-called armature reaction of a machine is a measure of the m.m.f. of the armature. It is thus expressed in so many ampere-turns, either on the whole circumference of the armature or, more often, the m.m.f. on one pole of the armature. This latter convention will be used in this book.

As will be seen, the m.m.f. of the armature current sometimes acts against the m.m.f. of the field excitation, sometimes it assists it, and often its effect is only to shift the flux.

In Fig. 201 the coil (1, 1) is in the position of zero, or minimum, e.m.f., assuming the flux to be symmetrical in the field system, or due to the field ampere-turns alone. The coil (2, 2) is in the position of maximum e.m.f. This condition may be assumed to hold for no-load. The coil (3, 3) is in an intermediate position. The current may or may not be in time-phase

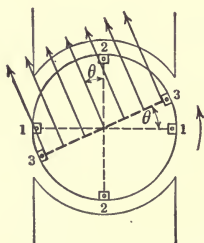

FIG. 201.

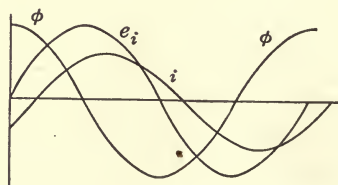

FIG. 202.

with the e.m.f., but whatever its time-phase relation may be, in space, it is evident from Fig. 201 that the m.m.f. of the coil is at right angles to the surface of the coil, and therefore at right angles to the line which represents the position of the coil.

In Fig. 202 let the armature current lag behind the e.m.f. Its m.m.f. is seen to be largely in opposition to that of the field which causes the main flux, and this opposition increases the greater the lag and becomes complete at 90° lag. Similarly a leading current

increases the flux. The current, i , may be divided into two components, one of which, i'' , is entirely wattless and exactly opposes the field flux, and the other, i' , the watt component in phase with e_i , which merely distorts the field. The effect of current in the armature is to weaken the resultant flux and to displace its maximum position, if the current lags, as shown in Fig. 203. The weakening is due to the wattless component, the displacement or distortion to the power component.

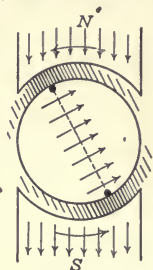

FIG. 203.

Thus the trailing pole-tip may even become saturated, while the leading pole-tip is robbed of a large part of its flux. The position of the coil for maximum induced e.m.f. is shifted ahead, with lagging current, and behind, with leading current. These relationships are shown in Fig. 204, where the induced e.m.f., e_i , is taken as the zero vector.

e_i is at right angles to the resultant flux, ϕ_r , and lags behind it. The armature current, I , is taken at any angle and produces a flux ϕ_a in time-phase with it. This flux vectorially subtracted from ϕ_r , gives ϕ_f , the field flux. In phase and 90° in time ahead of the current are respectively, Ir and Ix , the e.m.f. consumed by the armature resistance and that consumed by the armature reactance. These combine to make Iz , the impedance drop, which, subtracted from e_i , gives e the terminal voltage. The phase angle of the load is then θ .

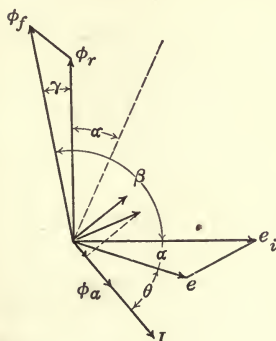

FIG. 204.

In constructing the diagrams there is some advantage in using ampere-turns instead of fluxes, since then no complications arise from variable magnetic reluctances. This has been done in Fig. 207, Chap. XXXV.

At no-load, $I = 0$, $e_i = e$ and $\phi_f = \phi_r$.

In Fig. 204 the angle γ is the angular space displacement of the armature with respect to the field poles, due to the load, that is, the angle between ϕ_f and ϕ_r , or, $\gamma = \beta - 90^\circ$, where β is the angle between e_i and ϕ_f . α is the angle between e_i and e . Considered on the basis of experimental data, e , I , r and x are known and e is chosen as the zero vector.

Then the induced e.m.f.,

$$\begin{aligned} E_i &= e + IZ = e + (i + ji_1)(r + jx) \\ &= e + ir + jix + ji_1r - i_1x \\ &= (e + ir - i_1x) + j(ix + i_1r) = a + jb \quad (112) \end{aligned}$$

where $I = i + ji_1$ for leading current, and i_1 is negative for lagging current. From the saturation (magnetization) curve of the generator the number of ampere-turns needed to produce this voltage is found. Let $F_r =$ the resultant m.m.f. = $C(a + jb)$ or, rather, $F_r = jC(a + jb)$ because, in space, as has been shown, the m.m.f. is rotated 90° with respect to E_i .

Then,

$$F_r = C(-b + ja).$$

But the resultant m.m.f. is the vector sum of the field and armature m.m.fs. That is,

$$F_r = F_f + F_a = F_f + m(i + ji_1) \quad (113)$$

Thus, C is the proportionality factor between the resultant field ampere-turns and the volts, and m is that between the armature ampere-turns and the current.

Examples.—If $E_i = 2500$ volts and $F_r = 3000$ amp.-turns, $C = \frac{3000}{2500} = 1.2$.

In a three-phase machine, $m = \frac{\sqrt{2} \times 1.5 \times It}{I} = 2.12t$, where $t =$ turns per phase on the armature. (This factor is discussed more fully later.) The quantity, $\sqrt{2}$, enters in order to derive

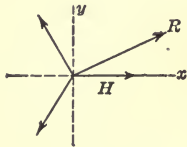

FIG. 205.

the maximum value of the ampere-turns from the effective value; 1.5 comes from the fact that the resultant field of a three-phase system, as an armature, or induction motor field, is 1.5 times that of a single-phase system. This is shown as follows: Consider the components of flux along the two axes (Fig. 205). The three x -components in space are H , $H \cos 120^\circ$, $H \cos 240^\circ$. The components along the y -axis in space, are 0, $H \sin 120^\circ$, $H \sin 240^\circ$. The components of all the phases in time are $H \cos \theta$, $H \cos (\theta + 120^\circ)$ and $H \cos (\theta + 240^\circ)$.

Hence the sum of components along the x -axis in time and space is $H \cos \theta + H \cos (\theta + 120^\circ) \cos 120^\circ + H \cos (\theta + 240^\circ) \cos 240^\circ = 1.5H \cos \theta$.

The sum of components along the y -axis in time and space, is
 $0 + H \cos(\theta + 120^\circ) \sin 120^\circ + H \cos(\theta + 240^\circ) \sin 240^\circ = 1.5H \sin \theta$.

Transposing (113), the field m.m.f. is

$$\begin{aligned} F_f &= F_r - m(i + ji_1) \\ &= C(-b + ja) - m(i + ji_1) \\ &= -bC + jaC - mi - mji_1 \\ &= -bC - mi + j(aC - mi_1) \end{aligned} \quad (114)$$

(With lagging current, i_1 is negative.)

$$\text{Numerically, } F_f = \sqrt{(-bC - mi)^2 + (aC - mi_1)^2} \quad (115)$$

Problem 88.—In a certain alternator let the reactance drop be 10 per cent., the resistance drop 2 per cent. and the armature reaction equal to no load one-half the field ampere-turns. How many ampere-turns are required in the field winding when the alternator is carrying full-load current at 80 per cent. power factor?

Since the drops are given in percentage, e will be taken = 1, and $I = 1$. Then at 0.8 P.F.,

$$i = 0.8, i_1 = 0.6,$$

$$\begin{aligned} \text{and} \quad a &= e + ir - i_1x \\ &= 1 + 0.016 + 0.06 = 1.076 \end{aligned}$$

$$\text{and} \quad b = ix + i_1r = 0.8 - 0.12 = 0.68.$$

On the percentage bases, also, let

$$C = 1.$$

$$\text{Then} \quad m = 0.5.$$

The ampere-turns required for the field will then be

$$F_f = \sqrt{(-0.68 - 0.4)^2 + (1.076 + 0.3)^2} = 1.45.$$

For non-inductive load, $i_1 = 0$ and $i = 1$. Then

$$E_i = \sqrt{a^2 + b^2} = 1.023,$$

$$\text{and} \quad F_f = 1.186.$$

As a continuation and amplification of this problem, consider the following:

Problem 89.—A three-phase generator has 2 per cent. resistance and 10 per cent. reactance. Its armature reaction is one-half the no-load field ampere-turns. The magnetic reluctance is uniform all around the periphery and the saturation curve is a straight line through the origin, at the point of operation.

Plot the field excitation (a) against armature current, with variable non-inductive load, up to high overloads; (b) at full-load current, but with variable power factor—leading and lagging; (c) with full-load power output and variable power factor; (d) same as (a) but at 20 per cent. higher voltage; (e) same as (b) but at 20 per cent. higher voltage; (f) same as (c) but at 20 per cent. higher voltage; (g) same as (a) but at 80 per cent. of rated voltage; (h) same as (b) but at 80 per cent. of rated voltage; (i) same as (c) but at 80 per cent. of rated voltage.

By equation (115)

$$F_f = \sqrt{(-bC - mi)^2 + (aC - mi_1)^2}$$

where

- $C = 1, m = 0.5$
- $r = 0.02, x = 0.1$
- $a = e + ir - i_1x,$
- $b = ix + i_1r$

(a) $e = 1, i = \text{variable}, i_1 = 0.$

$$F_f = \sqrt{(-0.1i - 0.5i)^2 + (1 + 0.02i)^2} = \sqrt{(-0.6i)^2 + (1 + 0.02i)^2}$$

$$= \sqrt{0.36i^2 + 1 + 0.04i + 0.0004i^2} = \sqrt{1 + 0.04i + 0.3604i^2}$$

Tabulating:

i	0.0	0.25	0.5	0.75	1.0	1.25	1.5	2.0
$0.04i$	0.0	0.01	0.02	0.03	0.04	0.05	0.06	0.08
i^2	0.0	0.0625	0.25	0.5625	1.0	1.56	2.25	4.0
$0.3604i^2$	0.0	0.0225	0.09	0.2027	0.3604	0.562	0.811	1.442
$(F_f)^2$	1.0	1.0325	1.11	1.2327	1.4004	1.612	1.871	2.522
F_f	1.0	1.014	1.052	1.109	1.182	1.269	1.366	1.587

(d) $e = 1.2; F_f = \sqrt{1.44 + 0.048i + 0.3604i^2}$

$0.48i$	0.0	0.012	0.024	0.036	0.048	0.06	0.072	0.096
$(F_f)^2$	1.44	1.4745	1.554	1.6787	1.8484	2.062	2.323	2.978
F_f	1.2	1.211	1.244	1.293	1.359	1.433	1.522	1.722

(g) $e = 0.8; F_f = \sqrt{0.64 + 0.032i + 0.3604i^2}$

$0.032i$	0.0	0.008	0.016	0.024	0.032	0.04	0.048	0.064
$(F_f)^2$	0.64	0.6705	0.746	0.8667	1.0324	1.242	1.499	2.146
F_f	0.8	0.819	0.863	0.93	1.014	1.115	1.222	1.463

(b) $I = 1, \text{P.F.} = \frac{i}{I} = \text{variable}, e = 1.$

$$F_f = \sqrt{(-0.6i - 0.02i)^2 + (1 + 0.02i - 0.6i)^2} = \sqrt{s^2 + t^2}$$

P.F.....	0.0	0.25	0.5	0.75	1.0	0.75	0.5	0.25	0.0
i	0.0	0.25	0.5	0.75	1.0	0.75	0.5	0.25	0.0
i_1	1.0	0.968	0.866	0.661	0.0	-0.661	-0.866	-0.968	-1.0
$0.6i$	0.0	0.15	0.3	0.45	0.6	0.45	0.3	0.15	0.0
$0.02i_1$	0.02	0.01936	0.01732	0.01322	0.0	-0.01322	-0.01732	-0.01936	-0.02
s	-0.02	-0.16936	-0.3173	-0.4632	-0.6	-0.4368	-0.2827	-0.13064	0.02
s^2	0.0004	0.0288	0.1008	0.215	0.36	0.191	0.08	0.017	0.0004
$0.02i_1$	0.0	0.005	0.01	0.015	0.02	0.015	0.01	0.005	0.0
$-0.6i_1$	-0.6	-0.58	-0.52	-0.3965	0.0	0.3965	0.52	0.58	0.6
t	0.4	0.425	0.49	0.6185	1.02	1.4115	1.53	1.585	1.6
t^2	0.16	0.181	0.24	0.383	1.04	2.03	2.35	2.515	2.56
$s^2 + t^2$	0.1604	0.2098	0.3408	0.598	1.4	2.191	2.43	2.532	2.5604
F_f	0.40	0.4575	0.584	0.772	1.182	1.48	1.56	1.59	1.6

(e) $e = 1.2, F_f = \sqrt{(-0.6i - 0.02i)^2 + (1.2 + 0.02i - 0.6i)^2} = \sqrt{s^2 + t_1^2}$

t_1	0.6	0.625	0.69	0.8185	1.22	1.6115	1.73	1.785	1.8
t_1^2	0.36	0.390	0.476	0.67	1.492	2.6	3.0	3.2	3.25
$s^2 + t_1^2$	0.3604	0.4188	0.5768	0.885	1.852	2.791	3.08	3.217	3.2504
F_f	0.6	0.646	0.758	0.94	1.36	1.67	1.755	1.792	1.8

(h) $e = 0.8, F_f = \sqrt{(-0.6i - 0.02i)^2 + (0.8 + 0.02i - 0.6i)^2} = \sqrt{s^2 + t_2^2}$

t_2	0.2	0.225	0.29	0.4185	0.82	1.2115	1.33	1.385	1.4
t_2^2	0.04	0.0508	0.084	0.176	0.673	1.475	1.77	1.92	1.96
$s^2 + t_2^2$	0.0404	0.0796	0.1848	0.391	1.033	1.666	1.85	1.937	1.9604
F_f	0.2	0.282	0.43	0.625	1.152	1.29	1.36	1.39	1.4

(c) $i = 1, \text{P.F.} = \frac{i}{I} = \text{variable}, e = 1.$

$$F_f = \sqrt{(-0.6i - 0.02i)^2 + (1 + 0.02i - 6i)^2} = \sqrt{s^2 + t^2}$$

P.F.	0.25	0.5	0.75	1.0	0.75	0.5	0.25
i_1	3.87	1.73	0.883	0.0	-0.883	-1.73	-3.87
$0.02i_1$	0.0774	0.0346	0.01766	0.0	-0.01766	-0.0346	-0.0774
s	-0.6774	-0.6346	-0.6177	-0.6	-0.5823	-0.5654	-0.5226
s^2	0.46	0.402	0.382	0.36	0.34	0.32	0.274
$-0.6i_1$	-2.322	-1.04	-0.53	0.0	0.53	1.04	2.322
t	-1.302	-0.02	0.49	1.02	1.55	2.06	3.342
t^2	1.7	0.0004	0.24	1.04	2.4	4.25	11.2
$s^2 + t^2$	2.16	0.4024	0.622	1.4	2.74	4.57	11.474
F_f	1.47	0.634	0.788	1.181	1.65	2.14	3.38

$$(f) e = 1.2, F_f = \sqrt{s^2 + (1.2 + 0.02i - 0.6i)^2} = \sqrt{s^2 + t_1^2}$$

t_1	-1.102	0.18	0.69	1.22	1.75	2.26	3.542
t_1^2	1.22	0.0325	0.476	1.49	3.07	5.11	12.6
$s^2 + t_1^2$..	1.68	0.4345	0.853	1.85	3.41	5.43	12.874
F_f	1.295	0.659	0.925	1.36	1.846	2.33	3.59

$$(i) e = 0.8, F_f = \sqrt{s^2 + (0.8 + 0.02i - 0.6i)^2} = \sqrt{s^2 + t_2^2}$$

t_2	-1.502	-0.22	0.29	0.82	1.35	1.86	3.142
t_2^2	2.26	0.0485	0.6841	0.673	1.82	3.45	9.9
$s^2 + t_2^2$..	2.72	0.4505	0.4661	1.033	2.16	3.77	10.174
F_f	1.65	0.671	0.682	1.015	1.47	1.94	3.182

Curves showing the variations brought out by this problem are given in Fig. 206.

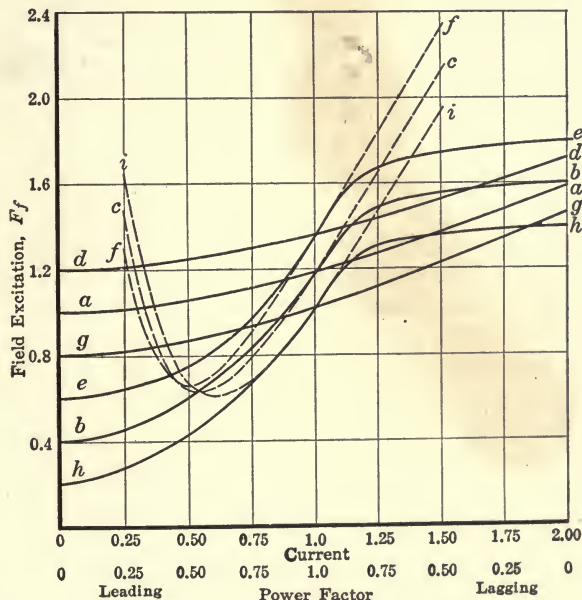

FIG. 206.

CHAPTER XXXV

CHARACTERISTICS OF ALTERNATORS WITH DEFINITE POLES

In the preceding chapter it has been assumed that the magnetic reluctance is uniform in the direction of the main field magnetomotive force as well as in the transverse direction along the armature surface. This condition exists practically in machines with distributed field structures as in induction generators, and, to a very fair degree, turbo-generators.

In engine-driven generators the condition of uniform magnetic reluctance rarely exists, since such machines are usually built with definite pole structures. In this type which includes the majority of machines, the magnetic reluctance in the direction of the field poles is almost constant for all m.m.f., and therefore the flux is proportional to the m.m.f. In the direction along the surface of the armature the shift of flux is by no means proportional to the m.m.f. but is largely limited by the mechanical construction, that is, the width of the poles, and it is always less than proportional to the m.m.f.

Similarly, the self-induction of an armature coil is greater when it is immediately under the poles than when it is midway between them. Thus, considering that the armature current is made up of two components, one, the power component which is maximum when the coil is under the pole, and the other, the wattless component, which is maximum when the coil is midway between the poles, it might be assumed that the reactance is greater for the power component than for the wattless component.

The general equation for the induced e.m.f. of such a machine can therefore not be expressed as simply as:

$$\begin{aligned} E_i &= e + IZ = e + (i + ji_1)(r + jx) \\ &= e + ir - i_1x + j(ix + i_1r), \end{aligned}$$

but must be written:

$$E_i = e + ir - i_1x_1 + j(ix + i_1r),$$

where x_1 belongs to the wattless component and is about $0.6x$, and x is the reactance belonging to the power component of the current.

In the synchronous impedance test, x_1 , is obviously determined since the current in that test lags nearly 90 degrees in time and hence in space.¹ Similarly, the expression for the field excitation is not

$$F_f = -mi - Cb + j(Ca - mi_1),$$

but is

$$F_f = -m_1i - Cb + j(Ca - m_1i_1),$$

where m is always smaller than m_1 since m determines the shift due to the power component of the current. The relative values of m and m_1 are not by any means fixed but vary over a considerable range. It may, however, be assumed that $m = 0.8m_1$.

The value of m_1 is determined from the winding data. For instance, in a three-phase machine it is, $\sqrt{2} \times 1.5 \times$ turns per pole and phase.

The constants for a definite pole machine of the same general dimensions as the generator previously calculated would thus be

$$C = 1, m_1 = 0.5, r = 0.02, x = 0.10, \\ m = 0.8 \times 0.5 = 0.4, x_1 = 0.6 \times 0.10 = 0.06.$$

The angular space displacement of the armature with reference to the field structure between no-load and any particular load is of interest. Consider first a machine with round rotor.

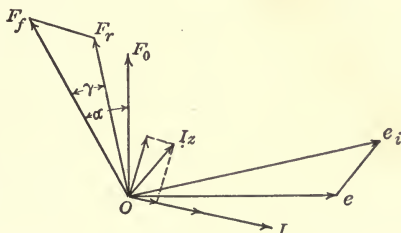

FIG. 207.

Let e be the Terminal Voltage. At no-load the axes of the field poles are in the directions of the field flux, that is, in direction OF_0 , in Fig. 207. With any load, OI , as shown in the figure, the direction and the magnitude of the field excitation, the former

¹ To calculate x_1 from synchronous impedance test, assume $i = 0$. Then, substituting in (115), $F_f = -Cb + j(Ca - m_1i_1)$, where $a = -i_1x_1$, $b = i_1r$.

assumed the same as the direction of the field poles, is F_f . Thus the angular space displacement of the field structure in reference to the armature is represented by the angle α , and $\tan \alpha$ has been shown to be

$$\tan \alpha = \frac{mi + Cb}{Ca - mi_1}$$

With "definite pole" machines this becomes,

$$\tan \alpha = \frac{mi + Cb}{Ca - m_1i_1}$$

where, of course, a and b are different from a and b in the "round rotor" case.

As an illustration consider the same two generators, whose constants have been given. To find α with varying power factor.

(1) For the round rotor type we have:

$$C = 1; m = 0.5; x = 0.1; r = 0.02; e = 1;$$

$$I = i + ji' = 1$$

$$a = e + ir - i'x = 1 + 0.02i - 0.1i'$$

$$b = ix + i'r = 0.1i + 0.02i'$$

$$\tan \alpha = \frac{0.1i + 0.02i' + 0.5i}{1 + 0.02i - 0.1i' - 0.5i'} = \frac{0.6i + 0.02i'}{1 + 0.02i - 0.6i'} = \frac{s}{t}$$

Tabulating:

	Leading current				Lagging current				
P.F.	0.0	0.25	0.5	0.75	1.0	0.75	0.5	0.25	0.0
i	0.0	0.25	0.5	0.75	1.0	0.75	0.5	0.25	0.0
i'	1.0	0.968	0.866	0.662	0.0	-0.662	-0.866	-0.968	-1.0
$0.6i$	0.0	0.15	0.3	0.45	0.6	0.45	0.3	0.15	0.0
$0.02i'$	0.02	0.01936	0.0173	0.01324	0.0	-0.013	-0.017	-0.019	-0.02
s	0.02	0.169	0.317	0.463	0.6	0.437	0.283	0.131	-0.02
$0.02i$	0.0	0.005	0.01	0.015	0.02	0.015	0.01	0.005	0.0
$-0.6i'$	-0.6	-0.5808	-0.519	-0.3972	0.0	0.397	0.519	0.58	0.6
t	0.4	0.425	0.491	0.618	1.02	1.412	1.529	1.585	1.6
$\tan \alpha$	0.05	0.397	0.645	0.75	0.588	0.31	0.185	0.0826	-0.0125
α	2° 52'	21° 40'	32° 50'	36° 53'	30° 27'	17° 15'	10° 30'	4° 43'	-45'

(2) For machines with definite poles.

By (112),

$$E_i = a + jb$$

where $a = e + ir - i'x_1; b = ix + i'r$.

By (114),

$$\tan \alpha = \frac{bC + mi}{aC - m_1i_1}$$

In this case,

$$C = 1; m_1 = 0.5; m = 0.8 \quad m_1 = 0.4; x = 0.1; x_1 = 0.6 \quad x = 0.06$$

$$r = 0.02; e = 1; I = i + ji' = 1.$$

$$a = 1 + 0.02i - 0.06i'$$

$$b = 0.1i + 0.02i'$$

$$\tan \alpha = \frac{0.1i + 0.02i' + 0.4i}{1 + 0.02i - 0.06i' - 0.56i'} = \frac{0.5i + 0.02i'}{1 + 0.02i - 0.56i'} = \frac{s'}{t'}$$

	Leading current					Lagging current			
P.F.	0.0	0.25	0.50	0.75	1.0	0.75	0.50	0.25	0.0
i	0.0	0.25	0.50	0.75	1.0	0.75	0.50	0.25	0.0
$0.5i$	0.0	0.125	0.25	0.375	0.5	0.375	0.25	0.125	0.0
i'	1.0	0.968	0.865	0.662	0.0	-0.662	-0.865	-0.968	-1.0
$0.02i'$	0.02	0.019	0.017	0.013	0.0	-0.013	-0.017	-0.019	-0.02
s'	0.02	0.144	0.267	0.388	0.5	0.362	0.233	0.106	-0.02
$0.02i$	0.0	0.005	0.01	0.015	0.02	0.015	0.01	0.005	0.0
$-0.56i'$	-0.56	-0.542	-0.49	-0.37	0.0	0.37	0.49	0.542	0.56
t'	0.44	0.463	0.527	0.644	1.02	1.39	1.50	1.55	1.56
$\tan \alpha$	0.046	0.31	0.51	0.60	0.49	0.26	0.155	0.068	-0.0127
α	2° 40'	17° 17'	26° 58'	31° 6'	26° 7'	14° 35'	8° 49'	3° 53'	-45'

The curves for both machines are plotted in Fig. 208.

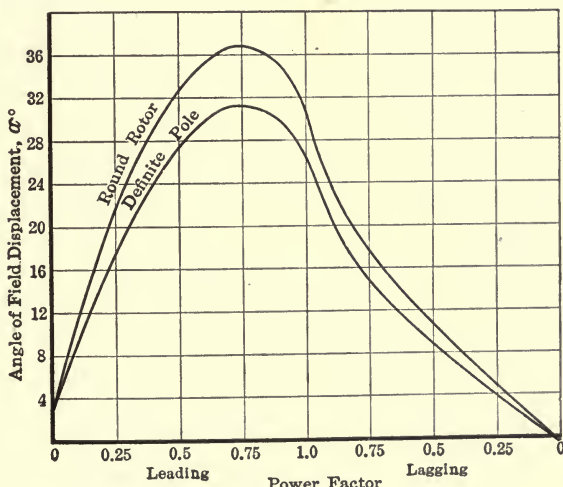

FIG. 208.

Let it be required to solve the following problem:

Problem 90.—An alternator has the rating:
A.T.B. 8-100-900-2300 volts Y.

The saturation curve is given by the following data:

A.T.	e	A.T.	e
400	250	3650	2300
1000	700	5000	2700
2000	1470	6000	2900
3000	2060		

The normal gap density is 40,000 and the average gap length is 0.25 in. The armature reaction is 1490 A.T. per pole.

The synchronous impedance test gives 1890 A.T. excitation with full-load current at 0.25-in. average gap, and 1990 A.T. with 0.1875-in. average gap.

The armature resistance per phase is 0.69 ohm.

The weight of the revolving element is 800 lb.; the radius of gyration is 0.86 ft.¹

First. Draw the saturation curves with 0.25-in. gap (data given above) and also with 0.1875-in. gap.

Second. Determine m , m_1 , x , x_1 both for round rotor and definite pole machines.

Third. Draw the curve of field excitation, F_f , for varying non-inductive load I , (compounding curve), for the two round rotor and the two definite pole machines.

Fourth. Calculate and plot the terminal voltage as the non-inductive load is increased and the field excitation kept at the normal no-load excitation.

Use 0.25-in. gap and 0.1875-in. gap with the two types of machines.

Solution.—First. From the saturation curve data, the total A.T. at 2300 volts, for 0.25-in. gap = 3650.

Thus, 3650 = gap A.T. + iron A.T.

From Eq. (12), gap amp.-turns = 0.313 × flux density × gap length.

∴ for 0.25-in. gap, gap A.T. = 40,000 × 0.313 × 0.25 = 3130; for 0.1875-in. gap, gap A.T. = 40,000 × 0.313 × 0.1875 = 2347. The iron A.T. are the same for both gaps.

To plot: (1) plot the given curve; (2) draw the straight line gap saturation (magnetization curve) for 0.25 in., through 0 and 3130 at 2300 volts; (3) draw the straight line saturation for 0.1875 in. through 0 and 2347 at 2300 volts; (4) add to (3) the difference between (1) and (2).

The curves are given in Fig. 209.

Second. To determine m , m_1 , x , x_1 .

(a) Definite pole machine; air gap = 0.25 in.

From p. 259, Chap. XXXV,

$$m_1 = \frac{\text{arm. reaction}}{\text{arm. current}} = \frac{1490}{I} = \frac{1490}{25} = 59.5,$$

since

$$I = \frac{100,000}{\sqrt{3} \times 2300} = 25 \text{ amp.}$$

¹ Data for later calculation of hunting. See Chap. XXXVIII.

Assuming

$$m = 0.8m_1,$$

$$m = 0.8 \times 59.5 = 47.6.$$

To determine x_1 . Under short-circuit test $e = 0$ and, in (112) therefore,

$$E_i = I(r + jx_1)$$

where I is the effective current.

And

$$F_r = jCIr - CIx_1.$$

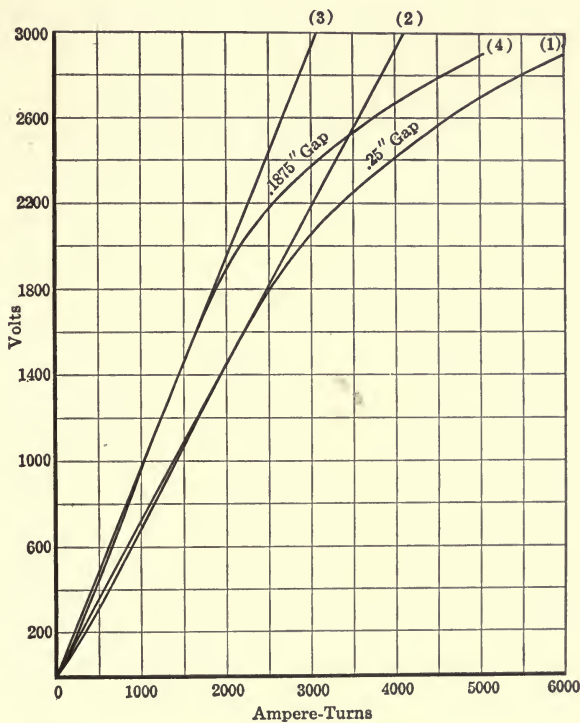

FIG. 209.

Since the current lags nearly 90° , $I = -ji_1$, and, neglecting r in comparison with x_1 , this last equation may be written.¹

$$F_r = -CIx_1 = -Ci_1x_1 + jCi_1x_1 = F_f + F_a$$

where

$$F_a = -m_1ji_1.$$

$$\therefore F_f = j(Ci_1x_1 + mi_1)$$

and

$$F_f = Ci_1x_1 + m_1i_1$$

whence

$$x_1 = \frac{F_f - i_1m_1}{Ci_1} \tag{116}$$

¹ When r is not neglected, $x_1 = \frac{\sqrt{F_f^2 - C^2i_1^2r^2} - m_1i_1}{Ci_1}$.

Supplying values:

(a) Definite pole machine, 0.25-in. gap

$$\begin{aligned} F_f &= 1890 \\ i_1 m_1 &= 25 \times 59.5 = 1490, \\ C &= \frac{3650}{1330} = 2.742. \\ \therefore x_1 &= \frac{1890 - 1490}{2.74 \times 25} = 5.84 \end{aligned}$$

and

$$x = \frac{5.84}{0.6} = 9.5.$$

(b) Round rotor machine, 0.25-in. gap.

$m = 59.5$, being the same as m_1 in definite pole machine.

$x = 9.5$, being the same as x in definite pole machine.

(c) Definite pole machine, 0.1875-in. gap.

m_1 and m are the same as for the 0.25-in. gap, since the armature ampere-turns are independent of the gap.

$$\begin{aligned} \therefore m_1 &= 59.5, m = 47.6. \\ x_1 &= \frac{1990 - 1490}{2.16 \times 25} = 9.25 \end{aligned}$$

since

$$\begin{aligned} F_f &= 1990, \text{ and } C = \frac{2870}{1330} = 2.16. \\ \therefore x &= \frac{9.25}{0.6} = 15.4. \end{aligned}$$

(d) Round rotor machine, 0.1875-in. gap.

$$\begin{aligned} m &= 59.5 \\ x &= 15.4. \end{aligned}$$

Third. Compounding curves, $-(F_f \text{ vs. } I)$. (a) Round rotor machine; gap = 0.25 in. Non-inductive load. By (115),

$$F_f = \sqrt{(-bC - mi)^2 + (aC - mi_1)^2},$$

where

$$\begin{aligned} C &= \frac{3650}{1330} = 2.742;^1 m = 59.5; i = \text{variable}; \\ i_1 &= 0; x = 9.55; r = 0.69; e = 1330 \\ a &= e + ir - i_1 x = 1330 + 0.69i \\ b &= ix + i_1 r = 9.55i. \end{aligned}$$

Whence,

$$\begin{aligned} F_f &= \sqrt{(-9.55i \times 2.742 - 59.5i)^2 + ((1330 + 0.69i) 2.742)^2} \\ &= \sqrt{13.3 \times 10^6 + 13,800i + 7354i^2} \\ &= 85.75 \sqrt{i^2 + 1.875i + 1802} = 85.75 \sqrt{i}. \end{aligned}$$

¹ C is constant only on the assumption of a straight line magnetization curve.

Tabulating:

<i>i</i>	0	10	20	25	30	40	50
1.875 <i>i</i>	0	18.75	37.5	46.85	56.2	75.0	93.6
<i>i</i> ²	0	100	400	625	900	1600	2500
<i>t</i>	1802	1921	2239	2474	2758	3477	4396
\sqrt{t}	42.5	43.8	47.25	49.6	52.5	58.9	66.2
<i>F_f</i>	3650	3760	4050	4250	4505	5050	5675

(b) Round rotor; gap = 0.1875 in. Non-inductive load.

$$C = \frac{2870}{1330} = 2.16; x = 15.38; b = 15.38i.$$

Other quantities are as in (a).

$$\begin{aligned} \therefore F_f &= \sqrt{(-15.38i \times 2.16 - 59.5i)^2 + ((1330 + 0.69i) 2.16)^2} \\ &= 92.7 \sqrt{i^2 + 0.995i + 960} = 92.7 \sqrt{t}. \end{aligned}$$

Tabulating:

<i>i</i>	0	10	20	25	30	40	50
0.995 <i>i</i>	0	9.95	19.9	24.95	29.85	39.8	49.75
<i>t</i>	960	1070	1380	1610	1890	2600	3510
\sqrt{t}	31	32.7	37.1	40.1	43.5	51.0	59.2
<i>F_f</i>	2870	3030	3440	3720	4030	4730	5490

(c) Definite pole machine; gap = 0.25 in. Non-inductive load.

$$F_f = \sqrt{(-bC - mi)^2 + (aC - m_1i_1)^2},$$

where $C = 2.742$; $m_1 = 59.5$, $m = 47.6$; i = variable; $i_1 = 0$; $e = 1330$; $x = 9.55$; $b = ix = 9.55i$; $a = e + ir - i_1x_1 = 1330 + 0.69i$.

$$\begin{aligned} \therefore F_f &= \sqrt{(-9.55i \times 2.742 - 47.6i)^2 + ((1330 + 0.69i) 2.742)^2} \\ &= 73.8 \sqrt{i^2 + 2.53i + 2430} = 73.8 \sqrt{t}. \end{aligned}$$

Tabulating:

<i>i</i>	0	10	20	25	30	40	50
2.53 <i>i</i>	0	25.3	50.6	63.25	75.9	101.2	126.5
<i>t</i>	2430	2555	2881	3118	3406	4131	5057
\sqrt{t}	49.3	50.5	53.6	55.8	58.3	64.3	71.0
<i>F_f</i>	3650	3735	3960	4120	4310	4750	5250

(d) Definite pole machine; gap = 0.1875 in. Non-inductive load.

$$C = 2.16; X = 15.38; m = 47.6; b = 15.38i.$$

$$\begin{aligned} \therefore F_f &= \sqrt{(-15.38i \times 2.16 - 47.6i)^2 + ((1330 + 0.69i) 2.16)^2} \\ &= 80.8 \sqrt{i^2 + 1.31i + 1265} = 80.8 \sqrt{t}. \end{aligned}$$

Tabulating:

i	0	10	20	25	30	40	50
$1.31i$	0	13.1	26.2	32.75	39.3	52.4	65.5
t	1265	1378	1691	1923	2204	2917	3831
\sqrt{t}	35.5	37.1	41.1	43.8	47.0	54.0	61.9
F_f	2870	2995	3320	3540	3800	4360	5000

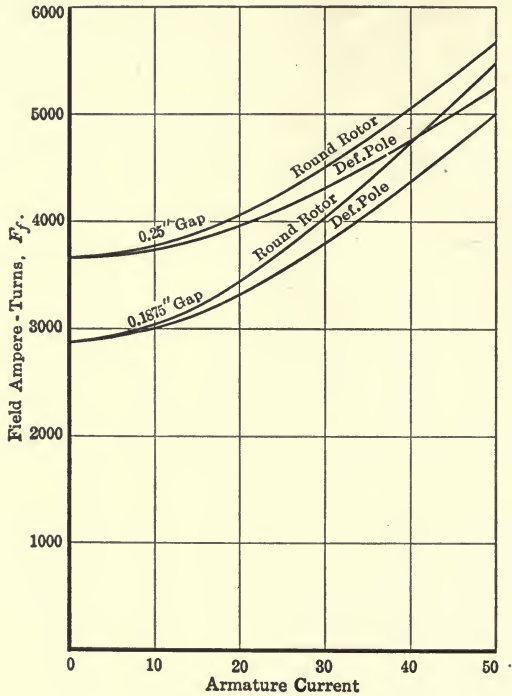

FIG. 210.

Compounding curves for all four machines are given in Fig. 210.

Fourth. (a) Round rotor machine; gap = 0.25 in.

At no-load, the induced voltage to neutral is $e_0 = 1330$.

The field ampere-turns are $E_f = 3650$.

Eq. (115) may be written

$$F_f = \sqrt{[-C(i_x + i_r) - mi]^2 + [C(e + ir - i_1x) - mi_1]^2}$$

or, since $i_1 = 0$

$$F_f = \sqrt{[-Cix - mi]^2 + [C(e + ir)]^2}$$

Numerical values previously found are:

$$C = 2.742; x = 9.55; m = 59.5; r = 0.69.$$

$$\begin{aligned} \therefore F_f &= \sqrt{[-2.742 \times 9.55i - 59.5i]^2 + [2.742(e + 0.69i)]^2} \\ &= \sqrt{7.54e^2 + 10.4ei + 7364i^2} = 3650. \end{aligned}$$

Squaring both sides and reducing, gives

$$(F_f)^2 = e^2 + 1.38ei + 977i^2 = 1.763 \times 10^6$$

whence
$$e = -0.69i \pm 31.25 \sqrt{1805 - i^2}.$$

Tabulating:

<i>i</i>	0	10	20	25	30	40	50
-0.69 <i>i</i>	0	- 6.9	-13.8	-17.25	-20.7	-27.6	-34.5
<i>i</i> ²	0	100	400	625	900	1600	2500
1805 - <i>i</i> ²	1805	1705	1405	1180	905	205	-695
$\sqrt{1805 - i^2}$	42.5	41.25	37.45	34.35	30.05	14.3	
31.25 $\sqrt{\quad}$	1330	1290	1170	1073	940	447	
<i>e</i>	1330	1283	1156	1056	919	420	
$\sqrt{3}e$	2300	2220	2000	1830	1590	726	

(b) Round rotor machine; gap = 0.1875 in.

The field ampere-turns are $F_f = 2870$.

$$F_f = \sqrt{[-Cix - mi]^2 + [C(e + ir)]^2},$$

where

$$C = 2.16; x = 15.38; m = 59.5; r = 0.69.$$

$$\begin{aligned} \therefore F_f &= \sqrt{[-2.16 \times 15.38i - 59.5i]^2 + [2.16(e + 0.69i)]^2} \\ &= \sqrt{4.68e^2 + 6.44ei + 8600i^2} = 2870 \end{aligned}$$

whence

$$e = -0.69i \pm 42.8 \sqrt{960 - i^2},$$

Tabulating:

<i>i</i>	0	10	20	25	30	40	50
-0.69 <i>i</i>	0	-6.9	-13.8	-17.25	-20.7	-27.6	-34.5
<i>i</i> ²	0	100	400	625	900	1600	2500
960 - <i>i</i> ²	960	860	560	335	60	-640	-1540
$\sqrt{960 - i^2}$	31	29.3	23.65	18.3	7.74		
42.8 $\sqrt{\quad}$	1330	1260	1013	783	331.5		
<i>e</i>	1330	1253	999	766	311		
$\sqrt{3}e$	2300	2170	1730	1325	538		

(c) Definite pole machine; gap = 0.25 in.

$$F_f = \sqrt{[-Cix - mi]^2 + [C(e + ir)]^2}$$

where

$$C = 2.742; x = 9.55; m = 47.6; r = 0.69.$$

$$\begin{aligned} \therefore F_f &= \sqrt{[-2.742 \times 9.55i - 47.6i]^2 + [2.742(e + 0.69i)]^2} \\ &= \sqrt{7.54e^2 + 10.4ei + 5464i^2} = 3650 \end{aligned}$$

whence

$$e = -0.69i \pm 26.9\sqrt{2430 - i^2}.$$

Tabulating:

i	0	10	20	25	30	40	50
$-0.69i$	0	-6.9	-13.8	-17.25	-20.7	-27.6	-34.5
i^2	0	100	400	625	900	1600	2500
$2430 - i^2$	2430	2330	2030	1805	1530	830	-70
$\sqrt{2430 - i^2}$	49.25	48.25	45	42.5	39.1	28.8	
$26.9\sqrt{\quad}$	1330	1300	1212	1144	1053	775	
e	1330	1293	1198	1127	1032	747	
$\sqrt{3}e$	2300	2240	2072	1950	1785	1293	

(d) Definite pole machine; gap = 0.1875 in.

$$C = 2.16; x = 15.38; m = 47.6; r = 0.69$$

$$F_j = \sqrt{[-2.16 \times 15.38i - 47.6i]^2 + [2.16(e + 0.69i)]^2}$$

$$= \sqrt{4.68e^2 + 6.44ei + 6532i^2} = 2870$$

whence

$$e = -0.69i \pm 37.3\sqrt{1265 - i^2}.$$

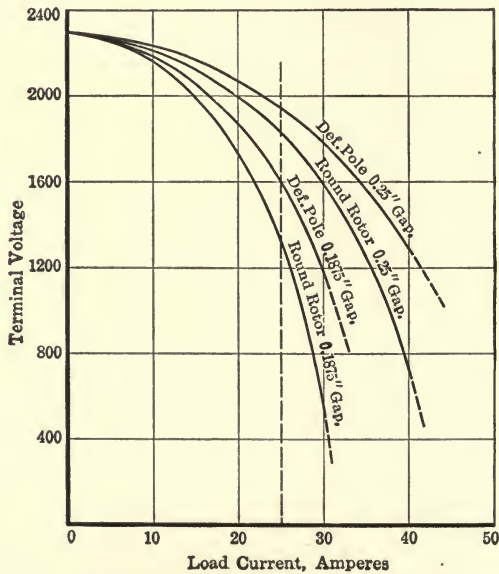

FIG. 211.

Tabulating:

i	0	10	20	25	30	40	50
$-0.69i$	0	-6.9	-13.8	-17.25	-20.7	-27.6	-34.5
i^2	0	100	400	625	900	1600	2500
$1265 - i^2$	1265	1165	865	640	365	-335	-1235
$\sqrt{1265 - i^2}$	35.5	34.1	29.4	25.3	19.1		
$37.3\sqrt{\quad}$	1330	1272	1097	944	712		
e	1330	1265	1083	927	691		
$\sqrt{3}e$	2300	2190	1875	1605	1196		

The curves of terminal voltage with varying non-inductive load are shown plotted in Fig. 211.

Problem 91.—Determine all the above quantities and plot the curves for the conditions of load power factor of 80 per cent., both lagging and leading.

Problem 92.—Carry out the above investigation for the same alternator when the phases are delta-connected.

CHAPTER XXXVI

APPROXIMATE DETERMINATION OF THE SELF-INDUCTION OR LOCAL MAGNETIC LEAKAGE REACTANCE OF AN ALTERNATOR

Consider a single slot of an armature situated directly underneath a pole. When current flows in the winding, lines of flux are set up, linking with the turns of wire. Thus, as in Fig. 212, some lines will pass across the space of width, a , occupied by the conductors; some will pass across the width, c , of the upper insulation;

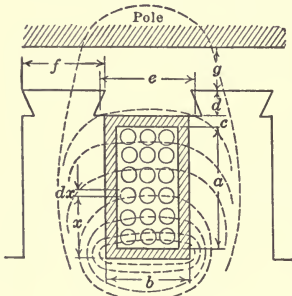

FIG. 212.

some across width, d , which is occupied by the wedge; and some will pass across the face of the tooth, f , and air gap, g , into the pole. Each of these fluxes is set up by a magnetomotive force acting through a reluctance, the values of both of which may be determined in each case. The reluctance, and consequently the flux and the inductance are, in the following, first determined per centimeter length of effective iron

parallel to the shaft. The inductance of the end connections or the parts of the coil which are outside of the iron is considered separately.

1. Inductance, L_1 , Due to Flux through Section a .—The magnetomotive force is $F_1 = nI \frac{x}{a}$, where n is the total number of turns in the slot and I is the current; $\frac{x}{a}$ is any portion of the depth of the coil. $n \frac{x}{a}$ gives the number of turns included in any distance x from the bottom of the coil. The flux set up by this

m.m.f., F_1 , is $d\phi_1 = \frac{4\pi nI \frac{x}{a}}{\rho_1}$, where $\rho_1 = \frac{b}{dx}$ = reluctance of a

small path of length b , in air, and of cross-section, dx sq. cm. ($dx \times 1$). The reluctance of the iron is neglected. Then,

$$d\phi_1 = 4\pi nI \frac{x}{a} \frac{dx}{b}.$$

The interlinkages or turns linking with this flux are $n\frac{x}{a}$. Hence, the flux-turns interlinkage per unit current, or the inductance across the width, a , of the coil, is

$$L_1 = \frac{1}{I} \int_0^a 4\pi \frac{n^2}{a^2} I \frac{x^2}{b} dx = \frac{a}{3} 4\pi \frac{n^2}{b}, \text{ per cm. length of effective iron.}$$

2. Inductance Due to the Flux through Section c .—The magnetomotive force is $F_2 = nI$. $\rho_2 = \frac{b}{c}$

The flux is

$$\phi_2 = \frac{4\pi nI}{\rho_2} = 4\pi nI \frac{c}{b}.$$

All the n conductors link with this flux.

$$\therefore L_2 = \frac{4\pi n^2 c}{b}.$$

3. Inductance Due to the Flux across the Section d .—This, by a similar process, is

$$L_3 = \frac{4\pi n^2 d}{e}.$$

4. Inductance over the Face of the Tooth.—The magnetomotive force is $F_4 = nI$. The reluctance, $\rho_4 = \frac{2g}{j}$. The flux set up is

$$\phi_4 = \frac{4\pi nI}{\rho_4} = \frac{4\pi nIj}{2g}.$$

All the n conductors link with this flux.

$$\therefore L_4 = \frac{4\pi n^2 j}{2g}.$$

5. Inductance of End-connections.—The inductance of the part of the winding that projects outside of the iron is almost impossible to estimate accurately. It depends largely on the mechanical design. If the end shields are some distance away from the winding, a fair approximation is obtained by assuming the flux per ampere-turn per centimeter of wire to be inversely proportional to the square root of the pole pitch, or what is equivalent, the square root of the armature diameter divided by

the number of poles. A fair approximation to the flux per absolute ampere-conductor, per centimeter of wire is

$$\phi'_5 = 13 \sqrt{\frac{p}{D}} \text{ (or } 1.3 \sqrt{\frac{p}{D}} \text{ when amperes are used),}$$

where p is the number of poles, and D = armature diameter.

If the length of the end-connections of a coil, counting both sides of the core, is $8 \times \frac{D}{p}$, then the flux per turn, per ampere-conductor, is

$$\phi''_5 = 8 \frac{D}{p} \times 13 \sqrt{\frac{p}{D}} = 104 \sqrt{\frac{D}{p}}.$$

Thus, with a single-coil winding, where all conductors of a coil are wound together, the flux per coil is

$$\phi_5 = 104nI \times \sqrt{\frac{D}{p}},$$

where n is the number of effective conductors and I is the current per conductor in absolute amperes.

The inductance, L_5 , will be due to only one-half of this flux since each coil occupies two slots.

$$\therefore L_5 = \frac{\phi n}{I} = 52n^2 \sqrt{\frac{D}{p}}.$$

The total inductance for a single slot exclusive of end-connections is then, per centimeter net length of armature iron,

$$L_{cm} = L_1 + L_2 + L_3 + L_4 = 4\pi n^2 \left[\frac{a}{3b} + \frac{c}{b} + \frac{d}{e} + \frac{f}{2g} \right],$$

and the total inductance, including end-connections for length, l , of iron, is, in henrys,

$$L = \frac{4\pi n^2 l}{10^9} \left[\frac{a}{3b} + \frac{c}{b} + \frac{d}{e} + \frac{f}{2g} + \frac{13}{\pi l} \sqrt{\frac{D}{p}} \right].$$

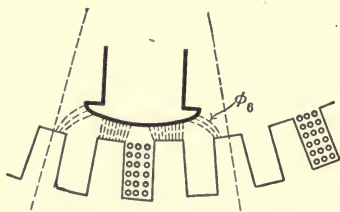

FIG. 213.

For a three-phase alternator, with one slot per pole per phase, there is also to be added a term due to the flux, ϕ_6 , in parallel with ϕ_4 , which passes from the next adjacent half tooth, across the gap (Fig. 213).

The inductance due to this flux will vary greatly, according to the air gap, whose cross-section and length may be very different from the values used in determining L_4 .

Problem 93.—Calculate the reactance per phase of the following alternator when the slots are under the poles.

A.T.B. 8-100-900-2300 v.

48 slots; 24-in. armature diameter; therefore, 2 slots per pole and phase; 28 effective conductors per slot. Dimensions, referring to Fig. 214, are:

$a = 1.0$	$g =$ average gap under adjacent teeth $= 0.25$
$b = 0.75$	$g' =$ average gap under distant teeth $= 0.5$
$d = 0.14$	$n = 28$
$e = 0.27$	$s = 2$
$f = 0.10$	$p = 8$
$h = 0.85$	$l = 9$
$k = 0.82$	$D = 24$

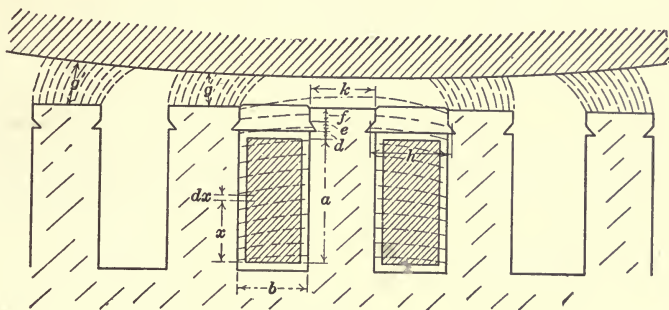

FIG. 214.

The wires are confined to the distance, a , of the slot.

Each slot has n effective conductors and there are s slots per pole per phase. Let ϕ_1 be the field which crosses the conductors due to the m.m.f. of the coil which is between the bottom of the slot and the distance X .

Then the m.m.f. is

$$F_1 = sn \frac{X}{a} I,$$

where I is the current in amperes in the conductor.

The flux, in section dx per cm. depth of magnetic circuit parallel to the shaft, is therefore,

$$d\phi_1 = \frac{4\pi F_1}{\rho_1} = \frac{4\pi snxI}{\rho_1 a}.$$

But the reluctance ρ_1 of the path is

$$\rho_1 = \frac{sb}{dx}, \text{ neglecting the iron.}$$

Thus,

$$d\phi_1 = \frac{4\pi snxI dx}{asb} = \frac{4\pi nI x dx}{ab}$$

This flux interlinks with $\frac{x}{a}$ *cs* conductors. Therefore the inductance of this part of the magnetic circuit, which is the interlinkages of the turns and flux across the conductors per unit current, is

$$L_1 = \frac{1}{I} \int_0^a \frac{4\pi n^2 s}{a^2 b} I x^2 dx = 4\pi n^2 s \frac{a}{3b}$$

Consider next the inductance of the part of the magnetic circuit which is above the coil proper.

The m.m.f. is that of all conductors, and is $F_2 = snI$.

The flux ϕ_2 , per cm. length, is

$$\frac{4\pi F_2}{\rho_2} = \frac{4\pi snI}{\rho_2}$$

In this particular case there are three magnetic paths in multiple, the first, of reluctance, $\frac{sb}{d}$, the second, of reluctance, $\frac{sh}{e}$, and the third, of reluctance, $\frac{sb}{f}$.

$$\therefore \frac{1}{\rho_2} = \frac{1}{\frac{sb}{d}} + \frac{1}{\frac{sh}{e}} + \frac{1}{\frac{sb}{f}} = \frac{d+f}{sb} + \frac{e}{sh}$$

$$\therefore \phi_2 = 4\pi snI \left(\frac{d+f}{sb} + \frac{e}{sh} \right) = 4\pi nI \left(\frac{d+f}{b} + \frac{e}{h} \right),$$

and

$$\begin{aligned} L_2 &= \frac{1}{I} 4\pi nI \left(\frac{d+f}{b} + \frac{e}{h} \right) sn \\ &= 4\pi sn^2 \left(\frac{d+f}{b} + \frac{e}{h} \right). \end{aligned}$$

Some flux crosses the two gaps from the teeth adjacent to the coils and causes an inductance which is similarly determined.

Thus, the m.m.f. is

$$\begin{aligned} F_3 &= snI. \\ \phi_3 &= \frac{4\pi snI}{\rho_3} = 4\pi snI \frac{k}{2g}. \\ \therefore L_3 &= \frac{1}{I} 4\pi snI \frac{k}{2g} sn \\ &= 4\pi sn^2 \frac{ks}{2g}. \end{aligned}$$

Similarly, the flux which crosses the gaps from the more distant teeth causes an inductance,

$$L_4 = 4\pi sn^2 \frac{ks}{2g'}$$

Thus, the total inductance per centimeter depth of magnetic circuit covered by the iron is

$$L_0' = 4\pi sn^2 \left[\frac{a}{3b} + \frac{d+f}{b} + \frac{e}{h} + \frac{ks}{2g} + \frac{ks}{2g'} \right]$$

If l is the net length in centimeters of the iron of the armature core, and p is the number of poles, then the inductance per phase of the part of the electric circuit which is in the slots is

$$L_0 = 4\pi sn^2 pl \left[\frac{a}{3b} + \frac{d+f}{b} + \frac{e}{h} + \frac{ks}{2g} + \frac{ks}{2g'} \right]$$

(The dimension of inductance and capacity in the absolute system of units is centimeters.)

By extending the reasoning in the case of a single slot, the inductance of the end-connections per phase is found to be

$$L_5 = 52s^2n^2p \sqrt{\frac{D}{p}} = 52s^2n^2 \sqrt{Dp}$$

With bar winding, when the coils are split up, as shown in Fig. 215, the inductance of the end-connections becomes $L_5 = 13s^2n^2 \sqrt{Dp}$, since the m.m.f. per end coil is $\frac{nsI}{2}$, and the interlinkages are $\frac{ns}{2}$. The inductance of the machine per phase is then

$$L = L_0 + L_5 \text{ in cm., or}$$

$$L = \frac{L_0 + L_5}{10^9} \text{ henrys.}$$

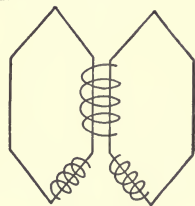

FIG. 215.

If inch measurements are used,

$$L_0 = 32sn^2pl \left[\frac{a}{3b} + \frac{d+f}{b} + \frac{e}{h} + \frac{ks}{2g} + \frac{ks}{2g'} \right],$$

and

$$L_5 = 83s^2n^2 \sqrt{Dp} \text{ for single coil winding, or} \\ = 20.8s^2n^2 \sqrt{Dp} \text{ for split coils, and}$$

the inductance in henrys is

$$L = \frac{L_0 + L_5}{10^9}$$

The inductance across the insulation, h , between the layers is

$$L_2 = \frac{\frac{1}{I} 4\pi \frac{N^2}{4} Ih}{b} = \pi N^2 \frac{h}{b}$$

The inductance across the upper coils is

$$\begin{aligned} L_3 &= \frac{1}{I} \int_0^a \frac{4\pi \frac{N^2}{4} I \left(1 + \frac{x}{a}\right)^2}{b} dx = \int_0^a \frac{N^2 \pi}{b} \left(1 + \frac{x}{a}\right)^2 dx \\ &= \frac{\pi N^2}{b} \frac{a}{3} \left(1 + \frac{x}{a}\right)^3 \Big|_0^a = \frac{8\pi N^2 a}{3b} - \frac{\pi N^2 a}{3b} = \frac{7\pi N^2 a}{3b} \end{aligned}$$

The inductance across the insulation, c , beneath the wedge, is

$$L_4 = \frac{\frac{1}{I} 4\pi N^2 I c}{b} = \frac{4\pi N^2 c}{b}$$

The inductance across the wedge is $L_5 = 4\pi N^2 \frac{d}{e}$.

The inductance across the face of the tooth is

$$L_6 = 4\pi N^2 \frac{f}{2g}$$

The inductance of end-connections is, as in the previous case,

$$L_7 = 52N^2 \sqrt{\frac{D}{p}}$$

The total inductance per centimeter effective length of core is

$$\begin{aligned} L &= \Sigma L = \pi N^2 \left[\frac{a}{3b} + \frac{h}{b} + \frac{7a}{3b} + \frac{4c}{b} + \frac{4d}{e} + \frac{2f}{g} + \frac{52}{\pi} \sqrt{\frac{D}{p}} \right] \\ &= \pi N^2 \left[\frac{8a + 3h + 12c}{3b} + \frac{4d}{e} + \frac{2f}{g} + \frac{52}{\pi} \sqrt{\frac{D}{p}} \right] \end{aligned}$$

Problem 94.—A certain three-phase, 60-cycle alternator has one slot per pole per phase. The dimensions in inches of slot, etc., are as in Fig. 216, where $a = 0.45$, $b = 0.75$, $c = 0.14$, $d = 0.37$, $e = 0.85$, $f = 0.82$, $g = 0.15$, $h = 0.1$. There are twenty-four slots, thirty-two effective conductors, the effective length of the armature core is 9 in., the armature diameter is 32 in. Show that the armature reactance is approximately 4 ohms.

CHAPTER XXXVII

ARMATURE REACTION IN MULTIPHASE MACHINES

With current in the armature of an alternator, two magnetomotive forces exist, one, that of the field winding, and the other, that of the armature winding.

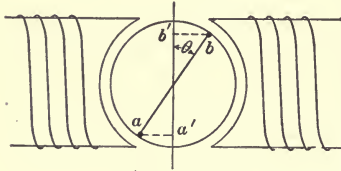

FIG. 217.

Sometimes these add directly but more often they are more or less in opposition.

If the resultant field flux is in the direction of the field poles, Fig. 217, and the armature winding is assumed concentrated in a coil in position $a-b$, then the induced e.m.f. due to the rotation of the coil in the field is

$$e_i = E_m \sin \theta$$

and the current is

$$i = I_m \sin (\theta + \alpha),$$

where α is the angle of lead of the current in respect to the e.m.f., that is, $\tan \alpha = \frac{x}{r}$, where x and r are the total reactance and resistance of the external and armature circuits, and E_M and I_M the maximum values of the e.m.f. and current respectively.

If the armature coil has T turns, the m.m.f. of the armature is obviously,

$$iT = I_m T \sin (\theta + \alpha),$$

In the position shown the m.m.f. of the armature does not act in line with the m.m.f. of the field winding, but its component in the direction of the field is $a'-b'$ or the total m.m.f. multiplied by $\cos \theta$.

The component $b-b'$ of the armature m.m.f. at right angles to the field is, of course, the total m.m.f. multiplied by $\sin \theta$. But this component does not increase or decrease the field, but only distorts it.

Let M be the component of the armature m.m.f. in the direction of the field m.m.f. Then

$$\begin{aligned} M &= I_m T \sin(\theta + \alpha) \cos \theta \\ &= I_m T (\sin \theta \cos \alpha + \cos \theta \sin \alpha) \cos \theta \\ &= I_m T (\frac{1}{2} \sin 2\theta \cos \alpha + \cos^2 \theta \sin \alpha). \end{aligned}$$

But

$$\cos^2 \theta = \frac{1 + \cos 2\theta}{2}.$$

$$\begin{aligned} \therefore M &= \frac{I_m T}{2} [\sin 2\theta \cos \alpha + \sin \alpha \cos 2\theta + \sin \alpha] \\ &= \frac{I_m T}{2} [\sin(2\theta + \alpha) + \sin \alpha]. \end{aligned}$$

It is seen that the average value of the armature reaction in the direction of the poles has a constant value which is $\frac{I_m T}{2} \sin \alpha$, and superimposed upon this is a pulsating reaction, a m.m.f. which pulsates at double frequency. The effect of the latter is zero when considering the average effect over a cycle.

$$\therefore M_{av.} = \frac{I_m T}{2} \sin \alpha,$$

But $I_m \sin \alpha$ is the maximum value of the wattless component of the current (Fig. 218).

Thus the armature m.m.f. (or armature reaction, as it is called), in the direction of the poles corresponds to the wattless component of the current.

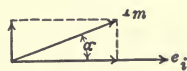

FIG. 218.

Thus, if the current is in time-phase with the induced e.m.f. (in which case there is no wattless component), the armature current neither magnetizes nor demagnetizes the field, but only distorts the distribution of the flux.

If the armature current leads the induced e.m.f., then it is seen that the armature reaction is positive. It helps the field m.m.f.

If the current lags, then α is negative and the armature reaction opposes the field m.m.f.

In a three-phase machine the e.m.fs. of the different phases may be expressed as

$$\begin{aligned} e_1 &= E_m \sin \theta \\ e_2 &= E_m \sin(\theta + 120) \\ e_3 &= E_m \sin(\theta + 240). \end{aligned}$$

Prove that the average armature reaction in the direction of the poles is $1.5I_m T \sin \alpha$, and is not pulsating but steady.

NOTE.—In specifications of alternators one item is usually called *armature reaction* and the value given is $\frac{I_m T}{2}$, in a single-phase machine, $I_m T$ in a two-phase machine, and $1.5I_m T$ in a three-phase machine.

In this case, however, I_m is the maximum value of the rated current, and T is the effective number of turns per armature pole per phase.

Example.—Find the so-called armature reaction in an 8-pole, 100-kw., 2300-volt, three-phase generator which has 224 armature turns per phase and which is Y-connected.

Answer.—The voltage per phase is

$$\frac{2300}{\sqrt{3}} = 1330.$$

The full-load effective current is

$$\frac{100,000}{\sqrt{3} \times 2300} = 25.1 \text{ amp.}$$

$$\therefore I_m = 25.1 \sqrt{2} = 35.5 \text{ amp.}$$

The winding is practically concentrated so that all turns are effective, thus

$$T = \frac{224}{8} = 28.$$

$$\therefore M_a = 1.5 \times 35.5 \times 28 = 1490 \text{ A.T.},$$

and this is the numerical value given to “armature reaction.”

If the armature actually carried full-load current and the current was lagging 90 time degrees behind the e.m.f., and hence was 90 space degrees displaced from the main field flux then the demagnetizing ampere-turns would be 1490.

If the current was leading then the armature current would assist the field to the extent of 1490 A.T.

With a phase angle, say 30° , the actual magnetizing or demagnetizing ampere-turns would obviously be only 745.

In an n -phase machine the armature reaction is not pulsating but has a constant value,

$$M_a = \frac{I_m T N}{2} \sin \alpha.$$

Consider any particular phase indexed m .

Its voltage is

$$e = E_m \sin \left(\theta + \frac{2\pi m}{n} \right);$$

its current is

$$i = I_m \sin \left(\theta + \frac{2\pi m}{n} + \alpha \right);$$

its m.m.f. is

$$\begin{aligned} M &= iT = I_m T \sin \left(\theta + \frac{2\pi m}{n} + \alpha \right) \cos \left(\theta + \frac{2\pi m}{n} \right) \\ &= \frac{I_m T}{2} \left[\sin \left(2\theta + \alpha + \frac{4\pi m}{n} \right) + \sin \alpha \right]. \end{aligned}$$

The total m.m.f. at any instant is, thus

$$M = \sum_{m=1}^{m=n} \frac{I_m T}{2} \left[\sin \left(2\theta + \alpha + \frac{4\pi m}{n} \right) + \sin \alpha \right].$$

But,

$$\begin{aligned} \sin \left(2\theta + \alpha + \frac{4\pi m}{n} \right) &= \sin (2\theta + \alpha) \cos \frac{4\pi m}{n} \\ &\quad + \cos (2\theta + \alpha) \sin \frac{4\pi m}{n}. \end{aligned}$$

The sum of all terms containing $\cos \frac{4\pi m}{n}$ must be zero, because the sum of the cosines of all sides in a closed polygon is zero. Similarly the terms containing $\frac{\sin 4\pi m}{n}$ are zero. Thus it follows that,

$$M_a = M \text{ (since it is constant for all values of } \theta) = n \frac{I_m T}{2} \sin \alpha.$$

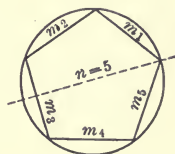
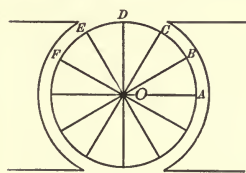

FIG. 219.



(a)

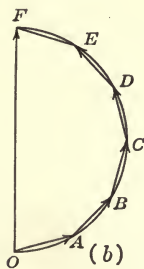

FIG. 220.

Effect of Distributed Winding on the Armature Reaction.—Consider a single-phase armature wound with a number of coils as is shown in Fig. 220, b, all of whose coils are connected in series.

The effective value of the e.m.f. generated in coil A may be represented by OA. The e.m.f. in coil B is then represented by AB, and so forth.

It is seen that in this case the resultant e.m.f. is less than the algebraic sum of the individual e.m.f.s. of the coils. It is the vector sum of the e.m.f.s and is $2/\pi$ times the algebraic sum.

If the total winding has N turns, the equivalent number of turns of a concentrated winding would be $T = 2/\pi N$.

If instead of being distributed all around the periphery the winding covered an arc of, say, 60° , as is shown in Fig. 221, the effectiveness would again, by a similar diagram, be found to be the ratio of the chord to the arc. Thus, the chord is evidently $2 \sin 30^\circ$ and the arc $\frac{2\pi}{6}$.

$$\therefore k = \frac{2 \sin 30^\circ}{\frac{2\pi}{6}} = \frac{3}{\pi}, \text{ or } 0.955,$$

and

$$T = 0.955N$$

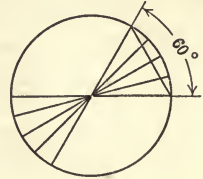

FIG. 221.

In general, if the winding covers α electrical degrees,

$$k = \frac{2 \sin \frac{\alpha}{2}}{\frac{\alpha}{360} 2\pi}$$

Example.—A completely distributed single-phase winding has

$$\alpha = 180^\circ.$$

$$\therefore k = \frac{2}{\pi}.$$

Three-phase winding uniformly distributed. In this case, the winding covers 60° . Thus, $k = 0.955$.

CHAPTER XXXVIII

HUNTING

The periodic oscillation of synchronous machinery is a familiar and oftentimes troublesome phenomenon. It manifests itself principally by the swinging of the needles of meters connected in the circuits. When the effect is cumulative, it continues to increase until rupture occurs somewhere in the system. Often it is not cumulative, and resembles simply the movement of any vibrating body such as a pendulum.

The difficulty of visualizing hunting of a revolving machine comes from the fact that the vibration is superposed on the steady rotation of the moving part. It can be well imagined as similar to the motion in space of a pendulum swinging east and west while at the same time the earth, on which the pendulum is fixed, is in rotation.

Hunting of electrical machines is possible because the position of the armature core in the field structure at any moment is determined by the balance of mechanical and electromagnetic forces. Assuming the mechanical force to be steady, as represented by the shaft or belt in connection with the prime mover or load, the electromagnetic force is variable owing to the highly elastic property of the magnetic field. Under absolutely steady conditions there would, of course, be no hunting. But such conditions do not exist, and any variation of the electromagnetic forces results in a change of speed as the machine re-establishes the momentarily lost equilibrium. Hunting, or oscillating, is thus started and continues as equilibrium is gradually restored in the elastic medium of the field.

The mechanical force is not always steady. Steam engines, and especially gas engines, are subject to pulsation of driving torque. This may appear in the generator in the form of forced electrical vibrations, especially where the machines are directly connected. When the generator is free to oscillate in response to any impulse, it does so at a definite rate called its natural period in distinction to a forced period.

The natural period of a pendulum depends on its length and mass, the length being the radius of gyration. Similarly the natural period of an armature or revolving field structure depends on its mass and radius of gyration.

To find the natural period of a machine, consider the motion of a stretched spring as illustrated in Fig. 222. The spring suspends a weight, and its motion is damped by a piston working in a dash pot.

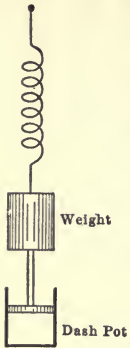

FIG. 222.

Let F = pulling down force in the spring, y = displacement of the weight. Then, $f_t = ay$ = tension on spring, where a = number of pounds, per unit length, of the downward pull.

If the friction force due to the dash pot is assumed proportional to the velocity, the force necessary to overcome friction = $f_f = k \frac{dy}{dt}$. (The power required varies as the square of the velocity.)

The force required to overcome inertia = $M\alpha$, where M = mass and α = acceleration, = $\frac{d^2y}{dt^2}$, or, $f_i = M \frac{d^2y}{dt^2}$.

$$\therefore F = f_t + f_f + f_i = ay + k \frac{dy}{dt} + M \frac{d^2y}{dt^2}$$

is the total force required to balance those acting in the system.

If the applied force is removed, or if $F = 0$, the equation becomes,

$$ay + k \frac{dy}{dt} + M \frac{d^2y}{dt^2} = 0.$$

Applying this equation to an alternator, the condition is as illustrated in Fig. 223. The moment equation is

$$F\rho = I \frac{d^2\theta}{dt^2} + \beta \frac{d\theta}{dt} + \alpha\theta,$$

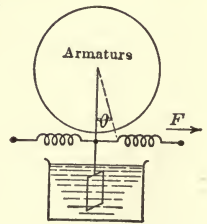

FIG. 223.

where $F\rho$ = the applied moment, F being the force and ρ the lever arm.

I = moment of inertia,

θ = initial angular displacement,

β = moment of retarding force per unit angular velocity,

α = twisting moment per unit angular displacement.

$\frac{d\theta}{dt}$ = angular velocity,

$\beta \frac{d\theta}{dt}$ = moment of angular velocity.

ρ = radius at which the force is applied.

$I\alpha$ = moment of angular acceleration.

This is, by ordinary mechanics,

$$\rho \frac{Md^2s}{dt^2} = \rho M \frac{d}{dt} \frac{ds}{dt} = \rho^2 M \frac{d}{dt} \frac{d\theta}{dt} = \rho^2 M \frac{d^2\theta}{dt^2} = I \frac{d^2\theta}{dt^2}.$$

When the force is released, $F\rho = 0$, and

$$I \frac{d^2\theta}{dt^2} + \beta \frac{d\theta}{dt} + \alpha\theta = 0.$$

The solution of this differential equation is

$$\theta = A\epsilon^{m_1 t} + B\epsilon^{m_2 t},$$

in which A , B , m_1 and m_2 are to be determined from known conditions.

Let

$$\frac{d^2\theta}{dt^2} = m^2, \text{ and } \frac{d\theta}{dt} = m.$$

Then,

$$m^2 I + \beta m + \alpha = 0,$$

and

$$m^2 + \frac{\beta}{I} m = -\frac{\alpha}{I},$$

whence,

$$m = -\frac{\beta}{2I} \pm \sqrt{\frac{\beta^2}{4I^2} - \frac{\alpha}{I}}.$$

$$m_1 = -\frac{\beta}{2I} + \sqrt{\frac{\beta^2}{4I^2} - \frac{\alpha}{I}}; \quad m_2 = -\frac{\beta}{2I} - \sqrt{\frac{\beta^2}{4I^2} - \frac{\alpha}{I}}.$$

If $\frac{\beta^2}{4I^2} - \frac{\alpha}{I}$ is positive, then δ is real, and the equation shows that θ gradually decreases to zero without oscillation. If, however, $\frac{\beta^2}{4I^2} - \frac{\alpha}{I}$ is negative then the square root is imaginary and θ reaches zero after a certain number of oscillations.

Thus, hunting can take place only when $\frac{\beta^2}{4I^2} - \frac{\alpha}{I}$ is negative. Let then

$$\delta = \frac{\alpha}{I} - \frac{\beta^2}{4I^2}.$$

Then

$$m_1 = -\frac{\beta}{2I} + j\delta$$

and

$$m_2 = -\frac{\beta}{2I} - j\delta$$

or putting

$$\gamma = \frac{\beta}{2I}$$

$$m_1 = -\gamma + j\delta,$$

$$m_2 = -\gamma - j\delta.$$

$$\begin{aligned} \therefore \theta &= A\epsilon^{-\gamma t}\epsilon^{j\delta t} + B\epsilon^{-\gamma t}\epsilon^{-j\delta t} \\ &= \epsilon^{\gamma t} [A\epsilon^{+j\delta t} + B\epsilon^{-j\delta t}] \\ &= A_1\epsilon^{-\gamma t} \sin(\delta t + \beta_1). \end{aligned}$$

When $t = T$, the time of one period,

$$\delta T = 2\pi$$

$$T = \frac{2\pi}{\delta}.$$

Assume the case of suddenly throwing off full-load from the alternator. Then $\theta = \theta_0$.

At $t = 0$, the hunting has not yet begun.

$$\therefore \frac{d\theta}{dt} = 0.$$

The period,

$$T = \frac{2\pi}{\delta} = \frac{4\pi I}{\sqrt{4\alpha I - \beta^2}},$$

where β is the friction torque, and has little influence on the period of hunting, but rather affects the amplitude.

We may assume $\beta = 0$.

Then

$$T = \frac{4\pi I}{2\sqrt{\alpha I}} = 2\pi\sqrt{\frac{I}{\alpha}},$$

where T is in seconds.

The beats, or oscillations per second, are $\frac{1}{T}$, or

$$\frac{1}{T} = \frac{1}{2\pi}\sqrt{\frac{\alpha}{I}}.$$

$$\text{Beats per minute} = \frac{30}{\pi}\sqrt{\frac{\alpha}{I}}.$$

The angular space position of the alternator armature with reference to the field pole may be determined for any load (Fig. 224). Let this angle be assumed to be 20° for a two-pole machine

at full-load, or 10° for a four-pole machine. If θ = mechanical angle, and ϕ = electrical angle,

$$\theta = \frac{2\phi}{p} \text{ where } p =$$

number of poles.

Torque,

$$T = \frac{7050 \times \text{kw.}}{\text{r.p.m.}} \text{ in ft.-lb.}$$

If α = torque per unit angular displacement,

$$\alpha = \frac{T}{\frac{\theta_0}{57.3}}$$

where θ_0 = angle in degrees for the load being considered.

Therefore,

$$\alpha = \frac{24.25 \times \text{kw.} \times f \times 10^6}{N^2 \phi}$$

where f = frequency, N = revolutions per minute and ϕ is in degrees.

Finally, the solution is,

$$\text{Beats per minute, } S_m = \frac{47,000}{N} \sqrt{\frac{\text{kw.} \times f}{I \phi^{\circ}}}$$

The number of beats per minute may be changed by changing I or ϕ° , the former by the addition of a fly-wheel, the latter by altering the gap. Bridges, or dampers, between the poles may also be used to produce eddy currents for the purpose of damping the oscillations.

Problem 95.—Determine the periods of the 100-kw. alternator of the previous problems, both as definite pole and as a round rotor machine, and with long and short gaps.

Solution.—The equation is

$$S_m = \frac{47,000}{N} \sqrt{\frac{\text{kw.} \times f}{I \times \phi^{\circ}}}$$

in which the constants previously given are.

$$N = \text{r.p.m.} = 900; \text{kw.} = 100; f = 60;$$

$$I = \text{moment of inertia,} = \frac{Wr^2}{g} = \frac{800^{\#} \times 0.86^2}{32.16} = 18.4.$$

$$\rho = 0.86 \text{ ft.} = \text{radius of gyration.}$$

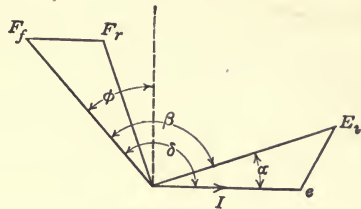

FIG. 224.

Supplying numerical values,

$$S_m = \frac{47,000}{900} \sqrt{\frac{100 \times 60}{18.4 \times \phi^{\circ}}} = 942 \sqrt{\frac{1}{\phi^{\circ}}}$$

To find ϕ° , in Fig. 224, $\phi = \beta' - 90^{\circ} + \alpha$.

Assuming non-inductive load,

$$E_i = e + Ir + jIx = a + jb.$$

$$F_f = -bc - mI + jaC = d + jf.$$

$$\tan \beta = \tan(\delta - \alpha) = \frac{\tan \delta - \tan \alpha}{1 + \tan \delta \tan \alpha} = \frac{\frac{f}{d} - \frac{b}{a}}{1 + \frac{bf}{ad}} = \frac{af - bd}{ad + bf},$$

where

$$a = e + Ir = 1330 + 25 \times 0.69 = 1347.25,$$

$$b = Ix = 25x,$$

$$d = -bC - mI = -25x C - 25m,$$

$$f = aC = 1347.25C.$$

Tabulating, for the four cases:

	Definite pole		Round rotor	
Gap, in.	0.25	0.1875	0.25	0.1875
x	8.15	14.1	8.15	14.1
C	2.75	2.18	2.75	2.18
m	47.5	47.5	59.4	59.4
f	3,700	2,940	3,700	2,940
b	204	353	204	353
d	-1,750	-1,960	-2,040	-2,250
af	4,980,000	3,960,000	4,980,000	3,960,000
bd	-357,000	-692,000	-416,000	-795,000
ad	-2,360,000	-2,640,000	-2,745,000	-3,030,000
bf	755,000	1,040,000	755,000	1,040,000
$af - bd$	5,337,000	4,652,000	5,391,000	4,755,000
$ad + bf$	-1,605,000	-1,600,000	-1,990,000	-1,990,000
$\tan \beta$	-3.32	-2.92	-2.71	-2.39
β	106.75	109°	110.25	112.7°
$\tan \alpha$	0.1514	0.262	0.1514	0.262
α	8.6°	14.67°	8.6°	14.67°
$\beta - 90^{\circ} + \alpha$	25.35°	33.67°	28.85°	37.37°
$1/\phi^{\circ}$	0.0394	0.0297	0.0346	0.0268
$\sqrt{1/\phi^{\circ}}$	0.190	0.172	0.186	0.1635
S_m	187	162	175	154

CHAPTER XXXIX

STUDY OF THE DESIGN CONSTANTS OF ALTERNATORS

Alternators differ primarily in respect to the number of phases, and whether the armature or the field structure is the revolving part. Secondly, they differ in respect to the frequency, voltage, output rating and speed.

In practice, the very great majority of alternators are of the three-phase, revolving-field type. In frequency, they are generally of either the 25-cycle or 60-cycle type in America; 25- and 50-cycle in Europe. Voltage may be any desired value up to about 13,000. In output rating alternators are built up to 30,000 kva.

The speed is limited by the prime mover and the frequency. Maximum speed, for 60-cycle machines is 3600 r.p.m., corresponding to the requirement of a bipolar field; for 25-cycles, the maximum speed is 1500 r.p.m. The chief types of prime mover used with alternators are the reciprocating engine, representing moderate speeds, the water turbine representing low speeds, and the steam turbine representing high speeds. Certain roughly approximate constants have been obtained from experience which may serve as guides in preliminary design. These are given in Table IX.

TABLE IX.—APPROXIMATE CONSTANTS OBTAINED FROM EXPERIENCE

Prime mover	Recip. engine		Water turbine		Steam turbine	
Frequency.....	25	60	25	60	25	60
Arm. dia. per pole.....	5	3	13	5	20	7.5
Arm. reac. per pole.....	3,200	1,800	8,500	3,200	13,000	4,800
No load A.T.-per pole .. Arm. reac.	2.5	2.5	2.5	2.5	2.5	2.5
Regulation (approx.), per cent.....	6	6	6	6	6	6
Sh. cir. cur. at 0 load exc. Full-load current	2.5	2.5	2.5	2.5	2.5	2.5

Using them as a basis, the design constants will be calculated for the following alternator:

A.T.B-8-100-900-2300 volt.

General Constants.—From the rating it is seen that the machine is a three-phase, revolving-field, 8-pole, 100-kilovolt-amp., 900-r.p.m., 2300-volt alternator, evidently to be driven by a reciprocating engine.

It is first necessary to decide whether the phase windings shall be connected Y or Δ . Y-connection is, in general, suitable for higher voltages and lower currents. Therefore Y-connection will be assumed in this case. The phase winding voltage is then

$$E_p = \frac{E_l}{\sqrt{3}} = \frac{2300}{\sqrt{3}} = 1330.$$

The phase current = line current

$$= \frac{Kva}{3E_p} = \frac{100,000}{3 \times 1330} = I_p = 25 \text{ amp.}$$

$$\text{Frequency} = \frac{\text{r.p.m.}}{60} \times \frac{\text{poles}}{2} = \frac{900}{60} \times 4 = 60 \text{ cycles.}$$

Slot Dimensions.—The development of the design now depends on the determination of size and number of slots and the conductors in the slot.

It has been found that for an n -phase machine, armature reaction per pole = $\frac{n}{2} I_p t$, where t = effective turns per pole and phase, and I_p is the maximum value of the current in the windings.

For three-phase, therefore, by Table IX,

$$1800 \text{ amp.-turns} = 1.5\sqrt{2} \times 25t.$$

$$\therefore t = 34.$$

This number serves as a good preliminary value. Actually, 28 turns per pole per phase were chosen. Conductors per pole and phase are then $2 \times 28 = 56$. The number of slots per pole per phase depends primarily on the armature circumference and the slot pitch. With many slots, a smoother e.m.f. wave is generally obtained. The number of slots is also usually greater in low voltage machines, where the requirements of higher insulation are not so severe. Practically, at least two slots per pole per phase are used.

From Table IX, the armature diameter per pole is found to be 3 in. Hence the diameter is $3 \times 8 = 24$ in. and the circumference is $\pi \times 24 = 75.5$ in.

The slot pitch may be determined for different numbers of slots per pole per phase, as follows:

Slots per pole per phase.....	1	2	3	4	6
Slots per pole.....	3	6	9	12	18
Slots.....	24	48	72	96	144
Slot pitch $\left(\frac{75.5}{\text{slots}}\right)$ in inches.....	3.14	1.57	1.05	0.785	0.524

About half of the slot pitch will be required for the tooth.

Considering, therefore, the insulation requirement given in Table X, it is fairly apparent that a small number of slots per pole per phase should be chosen. It will be assumed that there are 2 slots per pole per phase. Each slot will then contain,

$$\frac{56}{2} = 28 \text{ conductors.}$$

A very good arrangement of conductors in a slot is that shown in Fig. 225, which permits of easy insertion of the coils.

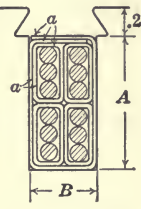

FIG. 225.

TABLE X

Voltage (phase)	Insulation, <i>a</i>
110	20 mils
440	25
1,000	35
2,300	50
6,600	90
16,000	130

The size of the conductor must next be determined. As a guide for this, it may be taken as permissible to use current densities up to 2500 amp. per sq. in. in low-voltage machines, and up to 1200 amp. per sq. in. in high-voltage machines. Assuming a density of 2000 as reasonable the required area of conductor to carry 25 amp. is

$$\frac{25}{2000} \times 1 = 0.0125 \text{ sq. in.}$$

It is seldom good practice to use wire heavier than No. 10 B. & S. As 0.0125 sq. in. corresponds nearly to No. 8, it will be preferable

to divide this area among several wires in parallel. The conductor used consists of four No. 14 wires in parallel, having a combined cross-section of $4 \times 0.00323 = 0.01292$ sq. in., and giving a resultant current density of 1925 amp. per sq. in.

The arrangement of wires in the slot is similar to that of Fig. 225. There are four groups of 28 wires each, the wires being placed four abreast and seven deep. Each layer of four wires is insulated from those above and below it.

Width of copper in the slot is 8×0.064 in. = 0.512 in.

Width of insulation = 0.238 in.

Width of slot = $0.512 + 0.238 = 0.75$ in.

Depth of copper in slot = $14 \times 0.064 = 0.896$

Depth of insulation = 0.59

Depth of wedge = 0.2

Depth of slot = $1.686 = 1 \frac{11}{16}$ in.

Width of tooth at face = slot pitch—slot width = $1.57 - 0.75 = 0.82$ in.

Width of tooth at base = $\frac{\text{circumference at base}}{\text{no. teeth}} - 0.75$
 $= \frac{\pi \times (24 + 3.375)}{48} - 0.75 = 1.038$ in.

Flux Determination.—The general equation for effective e.m.f. per phase is

$$E = \frac{4.44\phi_a t f k}{10^8}$$

where

$$4.44 = 4 \times \frac{\text{effective e.m.f.}}{\text{average e.m.f.}} = 4 \times \frac{\pi}{2\sqrt{2}} = 4 \times 1.11$$

ϕ_a = total flux per pole entering the armature at no-load,

t = total armature turns in series per phase, = $8 \times 28 = 224$,

f = frequency = 60,

k = constant depending on the distribution of conductors on the armature periphery.

If the conductors were concentrated in a single slot per pole per phase, k would be 1. With a three-phase machine, these conductors would never be spread out over the entire 180 electrical space degrees of the pole pitch as in single-phase or direct-current machines, but would be restricted to one-third of this amount, or to 60° , on account of the space required for the other

phases. Where there are two slots per pole per phase the e.m.fs. generated in the two slots add vectorially, as illustrated in Fig. 226, where $E = E_1 + E_2$. k is then evidently equal to $\frac{E}{E_1 + E_2}$.

For n slots per pole per phase,

$$k = \frac{1}{2n \sin \frac{60^\circ}{2n}}$$

Thus, for

$$n = 2, k = \frac{1}{4 \sin 15^\circ} = 0.966.$$

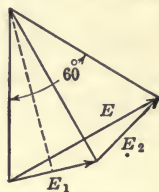

FIG. 226.

Supplying these values in the e.m.f. equation and solving for flux,

$$\phi_a = \frac{2300}{\sqrt{3}} \times 10^8 \times \frac{1}{0.966 \times 60 \times 224 \times 4.44} = 2.3 \times 10^6 \text{ lines}$$

= 2.3 megalines.

The flux leakage factor for this machine is 1.125.

∴ flux in the field at no-load is,

$$\phi_f = 2.3 \times 1.125 = 2.59 \text{ megalines.}$$

Air Gap.—An approximate average value for the gap length may be obtained by reference to Table IX. In the table is found,

$$\frac{\text{no-load A.T. per pole}}{\text{arm. reaction}} = 2.5.$$

$$\text{Armature reaction} = 1.5 \times \sqrt{2} \times 25 \times 28 = 1490.$$

Substituting this value of armature reaction,

$$\text{no-load A.T. per pole} = 2.5 \times 1490 = 3725.$$

These ampere-turns are mostly required for the gap. Assuming 80 per cent. for this,

$$\text{gap A.T.} = 0.8 \times 3725 = 2980.$$

Assuming, now, a gap flux density at no-load of 40,000 lines per sq. in., and substituting in the equation,

$$\text{A.T. (gap)} = 0.313 B_g \times l_g,$$

where l_g is the length of one gap,

$$2980 = 0.313 \times 40,000 \times l_g,$$

$$\therefore l_g = \frac{2980}{0.313 \times 40,000} = 0.238 \text{ in.}$$

With this value for a guide, definite values may be chosen. With alternators, it is usual to shape the pole pieces so that the generated e.m.f. may more nearly approach the sine form. The gaps chosen for this machine are:

$$\begin{aligned} \text{gap length in center of pole} &= 0.1875 \text{ in.} \\ \text{gap length at edge (maximum)} &= 0.386 \text{ in.} \\ \text{average gap length, } l_g &= 0.2535 \text{ in.} \end{aligned}$$

Gap area,

$$A_g = \frac{\text{flux}}{\text{flux density}} = \frac{2.3 \times 10^6}{40,000} = 57.5 \text{ sq. in.}$$

Armature Length.—The main factor bearing on armature length is flux density in the teeth. This in turn depends upon gap area, pole pitch and pole arc.

The pole pitch at the armature surface is

$$\frac{\pi D}{8} = \frac{\pi \times 24}{8} = 9.43 \text{ in.}$$

The pole arc is usually about $0.6 \times$ pole pitch.

In this machine, the ratio

$$\frac{\text{pole arc}}{\text{pole pitch}} = 0.53.$$

Assuming pole-face area = air-gap area, length of pole piece parallel to shaft is

$$\frac{A_g}{0.53 \times 9.43} = \frac{57.5}{5} = 11.5 \text{ in.}$$

The armature gross length may be slightly greater than this to assist in the free balancing in the field. The gross length is therefore taken as 12 in. This length would justify the use of four $\frac{1}{2}$ -in. ventilating ducts, one for every 3 in. The length of laminations is therefore 12 in. - 2 in. = 10 in. Assuming 10 per cent. loss of length due to insulation between laminations, the net armature length is

$$l_a = 10 \times 0.9 = 9 \text{ in.}$$

The ratio,

$$\frac{\text{effective length}}{\text{total length}} = \frac{9}{12} = 0.75.$$

Teeth Flux Density.—Allowing 10 per cent. extra for “fringing” of the flux entering the armature from the pole face, the average number of teeth under the pole is

$$\frac{\text{pole arc}}{\text{tooth pitch}} \times 1.10 = \frac{5}{1.57} \times 1.1 = 3.5$$

This number varies from moment to moment according as a slot or a tooth is in the center line of the pole. Teeth area at armature face is then,

$$A_t = 3.5 \times \text{tooth width} \times \text{effective length of armature.}$$

In order that this area shall carry a flux density of about 90,000 lines per sq. in. in the tooth,¹ it may be calculated on that basis. Thus, the flux entering the armature at no-load is 2.3×10^6 lines.

$$\therefore A_t = \frac{2.3 \times 10^6}{90,000} = 256 \text{ sq. in.}$$

From this value of area, the length obtained is,

$$\frac{256}{3.5 \times 0.821} = 8.9 \text{ in.}$$

Thus, the length of 9 in. previously obtained is quite satisfactory, giving, as it does, a slightly less teeth density at no-load, but, as will be seen, approximately 90,000 at full non-inductive load.

Armature Resistance.—All data has now been obtained that is necessary to calculate the resistance of the armature winding. The length of the mean turn may be taken as twice the gross length of the armature core plus nine times the diameter per pole; or the length of the mean turn

$$\begin{aligned} &= 2L + 9 D/\text{pole} \\ &= 2 \times 12 + 9 \times 3 = 51 \text{ in.} \\ &= \frac{51}{12} = 4.25 \text{ ft.} \end{aligned}$$

Total length = turns per phase \times mean turn.

$$= 8 \times 28 \times 4.25 = 954 \text{ ft.}$$

Resistance of four No. 14 wires in parallel = $\frac{2.9}{4} = 0.725$ ohms per 1000 ft.

$$\therefore R_a \text{ per phase} = \frac{954}{1000} \times 0.725 = 0.69 \text{ ohm at } 60^\circ\text{C.}$$

¹ For 25-cycle alternators 110,000 lines per sq. in. is suitable.

Voltage drop per phase = $IR_a = 25 \times 0.69 = 17.25$ volts.

The full-load e.m.f. per phase = $E + IR_a$ approximately.

$$= 1330 + 17.25 = 1347 \text{ volts}$$

Magnetic Circuit Dimensions.—Sufficient data is now at hand to enable the making of a sketch which shall show approximately how the available space may be utilized.

Fig. 227 represents such a section of the magnetic circuit. The next step is to construct a table for the condition of no-load and normal voltage, from which is obtained the total required number of field ampere-turns. Some of the data in this table have already been obtained, especially the required fluxes in the different parts.

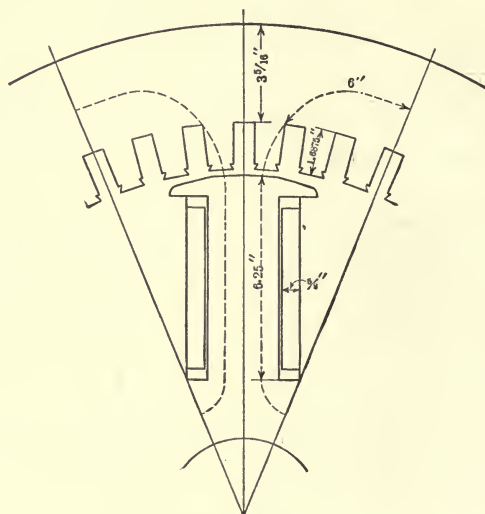

FIG. 227.

The yoke is left out of consideration, its magnetic length being very small in revolving field machines of few poles.

The armature and pole sectional areas are arbitrarily chosen to give appropriate densities. The length of the pole depends upon the space required by the field winding. The field values obtained for this machine are given in Table XI.

Material of the armature core is standard sheet iron of 0.014 in. thickness. The field core is built up of thick steel punchings.

TABLE XI

Magnetic data. No-load, normal voltage						
Part	Flux (mgl.)	Area	B	A.T. per in.	Length	A.T.
Teeth.....	2.3 (face)	26.0	89,000	15.6	11.3	1.6875
	(base)	32.8	70,000	7.0		
Gap.....	2.3	57.5	40,000	0.2535	3,150
Arm.....	1.15	28.2	41,000	2.8	6.0	17
Pole.....	2.59	27.5	94,200	74.2	6.25	464
Total amp.-turns.....						3,650
Full-load, normal voltage						
Teeth.....	2.34 (face)	90,500	17.4	12.2	21
	(base)	71,200	7.0		
Gap.....	2.34	40,700	3,203
Arm.....	1.17	41,700	2.85	17
Pole.....	2.64	96,000	77.5	484
Total amp.-turns.....						3,725

To the total required ampere-turns to excite the field at full-load must be added those necessary to compensate for the armature reaction. The number 3725 is the resultant, F_r , Fig. 228. The total ampere-turns on the field core, F_f , must be equal to the vector difference of F_r and F_a , where F_a is the armature ampere-turns multiplied by the field leakage factor. For full non-inductive load, approximately

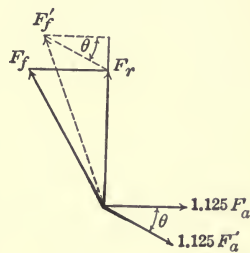

FIG. 228.

$$F_f = \sqrt{F_r^2 + 1.125F_a^2}$$

Supplying values already obtained,

$$F_f = \sqrt{3725^2 + 1.125 \times 1490^2} = 4090 \text{ A.T.}$$

For any other power factor, say 80 per cent., the required field ampere-turns are approximated as illustrated by dotted lines in Fig. 228. Thus,

$$\begin{aligned} F_f' &= \sqrt{F_r^2 + 1.125F_a \sin \theta^2 + 1.125F_a \cos \theta^2} \\ &= \sqrt{3725^2 + 1677 \times 0.6^2 + 1677 \times 0.8^2} = \sqrt{4732^2 + 1341^2} \\ &= 4920 \text{ A.T.} \end{aligned}$$

The Main Field Magnetomotive Force.—The ampere-turns which must be supplied to each field pole are:

for no-load, normal voltage, 3650
 full-load, non-inductive, 4090
 full-load, 80 per cent. lagging, 4920
 maximum exciter voltage = 110.

The field winding may be taken as composed of copper strip, edge wound. The depth of such a winding may vary from $\frac{1}{2}$ in. to $1\frac{1}{4}$ in. under ordinary circumstances, being usually deeper with short poles.

The choice of the actual dimensions for a given case is largely a matter of experience. The limiting factor is, of course, the amount of heat that may be radiated.

In this machine, the field conductor is 0.625 in. wide by 0.0175 in. thick.

Length of winding space, exclusive of that required for pole insulation = 5.5 in.

Turns in series per spool = 230.5

Field current, no-load = $\frac{3650}{230.5} = 15.8$ amp.

Field current, full-load, non-inductive = 17.8 amp.

Field current, full-load, 80 per cent. lagging = 21.3 amp.

Mean length of field turn = 2.72 ft.

Total length of field winding (8 spools) = $8 \times 230.5 \times 2.72$
 = 5020 ft.

Cross-section of conductor = 0.01095 sq. in.

Resistance, at 60°C. = 4.3 ohms.

Excitation volts, no-load = $15.8 \times 4.3 = 67.5$

Excitation volts, full-load, non-inductive = 76.5

Excitation volts, full-load, 80 per cent. lagging = 91.5

Current density in the field winding:

no-load = 1434 amp. per sq. in.

full-load, non-inductive = 1625

full-load, 80 per cent. lagging = 1945

Losses and Efficiency.—Full-load, non-inductive.

Armature copper loss per phase = $I^2 R_a = 25^2 \times 0.69 = 432$.

Total copper loss in armature = $3 \times 432 = 1296$ watts.

Field copper loss = $I_f^2 R_f = 17.8^2 \times 4.3 = 1370$ watts.

The core losses have already been calculated for direct-current machines. The hysteresis loss for alternators is determined on the same basis. The eddy current loss will not, as in direct-current machines, be equal to the hysteresis, but owing to the greater degree of lamination, will be much less.

In this case it will be assumed that the eddy current loss is 50 per cent. of the hysteresis loss.

Weight of armature core	= 806 lb.
Weight of teeth	= 180 lb.
Hysteresis loss in core	= 1130 watts
Hysteresis loss in teeth	= 730 watts

Total hysteresis loss	= 1800 watts
Total iron loss = 1.5×1860	= 2790 watts
Friction and windage loss, assumed 1 per cent.	= 1000 watts
Total loss, full-load, non-inductive	= 6460 watts
Efficiency = $\frac{100,000}{106,460}$	= 0.939.

Temperature Rise.—This is determined for the different parts by the use of coefficients obtained in practice. For rotating armature machines the radiation of 0.8 watt per sq. in. of surface corresponds approximately to a temperature rise of 100°C. Thus, for a rise of 40°, the radiating surface should be sufficient to dissipate 0.3 watt per sq. in.

With rotating field cores, owing to the greater fanning action a larger amount of energy is dissipated for the same temperature rise. In some cases, particularly with turbo-alternators, there are placed on the revolving structure fan blades which increase the heat dissipation still more. In such cases, 2 watts per sq. in. might correspond to a 100° temperature rise. The actual temperatures which different parts of a given machine will attain can only be estimated from experience, from the current and flux densities and from a study of the particular structure with relation to the ventilating action which it will produce.

In the machine under consideration, the copper loss in each field winding is $\frac{1370}{8} = 171$ watts.

The area of the coil surface, including both the external and the internal surfaces, is about 400 sq. in.

Watts per sq. in. radiated are therefore $\frac{171}{400} = 0.427$.

It is safe to assume that this will not cause a temperature rise greater than 40°C. The total loss in the armature is 4090 watts. This is dissipated from a total area, including air ducts, and allowing for extension of the end-connections, of about 8200 sq. in.

Watts per sq. in. radiated are therefore, $\frac{4090}{8200} = 0.5$, which is entirely conservative.

Regulation.—This may be determined directly from the saturation (magnetization) curve. Thus, the field excitation for full non-inductive load has been found to be 4090 amp.-turns. Referring to the curve for this machine, shown in Fig. 210, the no-load voltage with this excitation is 2440.

$$\therefore \text{Regulation} = \frac{2440 - 2300}{2300} = 0.061 = 6.1 \text{ per cent.}$$

Regulation may also be determined by adding, vectorially, the IR and IX drops to the full-load voltage, to obtain the no-load voltage. The reactance has been seen to have two component values representing that of the coils immediately under the poles, and that of the coils between the poles. These have been designated x and x_1 , respectively, and their values for this particular machine have been determined in connection with problem 90. The theoretical determination of x has also been carried out in connection with Fig. 210.

CHAPTER XL

SHORT-CIRCUIT OF ALTERNATORS

The short-circuiting of a direct-current generator is a very serious event. The commutator usually "flashes over" and the belts or shafts are dangerously strained. With alternators, except with large turbo-machines, such short-circuit results in practically no excessive stresses and of course not in any "fire-works."

However, the phenomena of alternator short-circuits are of great interest and importance. They involve the passage from one steady state—that of normal operation—to another steady state—that of the permanent short-circuited condition. Between these two steady states is what is called the transient period, during which the system is thrown out of equilibrium. It is during the transient period, especially its first part, that difficulties sometimes occur, and consequently the interest of the student lies chiefly here.

In any circuit of resistance and inductance, in which a constant e.m.f. is acting, the current flowing at any instant after the closing of the switch has a value expressed by the equation

$$i = I(1 - e^{-\frac{r}{L}t}).$$

Similarly, when the e.m.f. is removed and the circuit is closed upon itself, the current, and therefore also the flux, dies down according to the equation

$$i = Ie^{-\frac{r}{L}t}.$$

According to this latter equation the effect of resistance is to damp out the current, while the inductance tends to maintain it. A most striking illustration of these effects is afforded by the experiment of ONNES,¹ who withdrew a magnet from a closed coil immersed in liquid helium. The temperature of the coil was so low that the resistance became a negligible quantity, and the current continued to flow for hours.

¹ Communication No. 119 from the Physics Laboratory, Leiden.

Applying these equations to an armature under the condition of short-circuit, the current could be found from known values of r and L , were it not for the e.m.f. of rotation of the armature in the resultant field. To find the current under actual conditions requires first a knowledge of the flux at any instant, and then the derivation of the electromotive force from the flux.

Thus, at the instant of short-circuit, it may be assumed that the alternator has its full field flux. After the permanent short-circuited condition has been reached, the field has fallen to only a few per cent. of its normal value on account of the armature reaction (that is, the armature reactive magnetomotive force), which demagnetizes the field. During the transient period the field is not much affected by the fluctuations of armature current, these being balanced if the field-circuit resistance is low, as is always the case, by mutual induction with the field circuit, the field and armature ampere-turns acting in opposition to each other. At the instant of short-circuit, therefore, the value of the current produced depends almost entirely upon the resistance, r , and the reactance, x , of the armature. Armature reaction, or the demagnetizing effect of the armature current, has no appreciable effect, at first, in cutting down the resultant flux. The current may rise to, say, 20 times its normal value. To maintain this current would require an abnormally large field excitation, many, many times as great, in fact, as that which actually is available. Indeed, it might, without great error, be assumed that in comparison the actual excitation is practically zero. In that case, then, the main field flux is surrounded by a short-circuited winding, and it must therefore decrease in value according to some exponential law, such as,

$$\phi = \Phi_{\epsilon}^{-\frac{r_0}{L_0}t}.$$

or, if time is expressed in radians

$$\phi = \Phi_{\epsilon}^{-\frac{r_0}{x_0}\theta}.$$

The final value of the flux is determined by what is known as the synchronous impedance of the armature which consists of its resistance and the equivalent reactance of the armature magnetomotive force. This fact fixes the values of r_0 and x_0 .

The ratio $\frac{r_0}{x_0}$ is not readily calculated. It depends not only

upon almost all constants of the generator, such as the armature reaction, armature resistance, field-circuit resistance, field winding, eddy currents in field poles, etc., but also upon the nature of the short-circuit, whether single-phase or multiphase. Suffice it, therefore, in this elementary treatise, to state the fact that in almost all types of machines it is in the neighborhood of from 0.01 to 0.02. In other words, the field flux dies down very slowly, requiring several cycles before it reaches a small value. Since the speed, during the transient period, may be assumed uniform, the induced e.m.f. will decrease according to the same exponential as governs the flux.

If the initial value of the e.m.f. is

$$e = E_m \sin \omega t$$

and the final value is

$$e_2 = E_{2m} \sin \omega t,$$

then, during the transient period, the e.m.f. is

$$e = E_{1m} \epsilon^{-\frac{r_0}{L_0} t} \sin \omega t + E_{2m} \sin \omega t,$$

that is, it is the sum of the final value and a transient term, the latter being proportional to the instantaneous value of the flux.

Re-writing this equation in terms of the phase angle, θ ,

$$e = E_{1m} \epsilon^{-\frac{r_0}{x_0}(\theta - \theta_1)} \sin \theta + E_{2m} \sin \theta \quad (117)$$

in which θ_1 is the phase angle at the instant when short-circuit occurs.

$\theta - \theta_1$ represents any time elapsing after the instant of short-circuit.

At the moment of closing the switch,

$$E_m \sin \theta = E_{1m} \sin \theta + E_{2m} \sin \theta,$$

and

$$E_m = E_{1m} + E_{2m}.$$

Since the electromotive force in (117) acts through the armature circuit of resistance, r , and reactance, x , the fundamental Eq. (15) will evidently hold, and,

$$e = E_{1m} \epsilon^{-\frac{r_0}{x_0}(\theta - \theta_1)} \sin \theta + E_{2m} \sin \theta = ir + x \frac{di}{d\theta}.$$

The solution of this is

$$\begin{aligned} i &= \epsilon^{-\frac{r}{x}\theta} \left[\int \epsilon^{\frac{r}{x}\theta} \frac{E_{1m}}{x} \epsilon^{-\frac{r_0}{x_0}(\theta-\theta_1)} \sin \theta d\theta \right. \\ &\quad \left. + \int \epsilon^{\frac{r}{x}\theta} \frac{E_{2m}}{x} \sin \theta d\theta + C \right] \\ &= \epsilon^{-\frac{r}{x}\theta} \left[\frac{E_{1m}}{x} \epsilon^{-\frac{r_0}{x_0}\theta_1} \int \epsilon^{\frac{R}{X}\theta} \sin \theta d\theta \right. \\ &\quad \left. + \frac{E_{2m}}{x} \int \epsilon^{\frac{r}{x}\theta} \sin \theta d\theta \right] + C \epsilon^{-\frac{r}{x}\theta}, \end{aligned}$$

where

$$\frac{R}{X} = \left(\frac{r}{x} - \frac{r_0}{x_0} \right) = \cot \beta.$$

Substituting

$$Z^2 = R^2 + X^2,$$

and

$$\tan \beta_1 = \frac{x}{r},$$

and determining C from the condition that when $\theta = \theta_1$, $i = 0$ the final solution is given by

$$\begin{aligned} i &= \frac{E_{1m}}{x} \frac{X}{Z} \epsilon^{-\frac{r_0}{x_0}(\theta-\theta_1)} \sin(\theta-\beta) + \frac{E_{2m}}{z} \sin(\theta-\beta_1) \\ &- \epsilon^{-\frac{r}{x}(\theta-\theta_1)} \frac{E_{1m}}{x} \frac{X}{Z} (\sin(\theta_1-\beta) + \frac{E_{2m}}{z} \sin(\theta_1-\beta_1)) \quad (118) \end{aligned}$$

This equation may be greatly simplified by introducing certain approximations, which, for practical considerations, do not injure the value of the results obtained. Thus, in practice E_{2m} lies between 2 per cent. and 10 per cent. of E_m , being smaller in larger machines.

Neglecting E_{2m} in (118), and writing E_m for E_{1m} , (118) becomes

$$i = \frac{E_m}{x} \frac{X}{Z} \left[\epsilon^{-\frac{r_0}{x_0}(\theta-\theta_1)} \sin(\theta-\beta) - \epsilon^{-\frac{r}{x}(\theta-\theta_1)} \sin(\theta_1-\beta) \right] \quad (119)$$

Equation (119) is convenient for fairly accurate work and should be used for ordinary wave determinations. Nevertheless, rough approximations may be made by further simplification. Thus, assume $\beta = 90^\circ$; then $\sin(\theta-\beta) = -\cos \theta$. Also, assume $\frac{X}{Z} = 1$. Then (119) becomes

$$i = \frac{E_m}{x} \left[\epsilon^{-\frac{r}{x}(\theta-\theta_1)} \cos \theta_1 - \epsilon^{-\frac{r_0}{x_0}(\theta-\theta_1)} \cos \theta \right].$$

These assumptions are more or less reasonable since, in practice, β lies between 85° and 90° , and, in concentrated field windings, the reactance is much greater than the resistance.

The condition for maximum current is when $\theta_1 = 0$, and $\theta = \pi$. Then,

$$i = \frac{E_m}{x} \left[\epsilon^{-\frac{r}{x}\pi} + \epsilon^{-\frac{r_0}{x_0}\pi} \right].$$

The value of $\frac{r_0}{x_0}$ is about 0.02 in all alternators, and $\frac{r_0}{x_0}\pi = 0.06$, giving $\epsilon^{-0.06} = 1$ approximately.

Therefore the maximum current at short-circuit is

$$i = \frac{E_m}{x} \left[\epsilon^{-\frac{r}{x}\pi} + 1 \right].$$

Continuing the evaluation, $\frac{r}{x}$ is from 0.6 to 0.8.

$$\therefore i_{max} = \frac{E_m}{x} \times 1.75 \text{ (approximately).}$$

As an example, take an alternator which has 4 per cent. reactance. The greatest possible current that can be obtained on short-circuit is then

$$i_{max} = \frac{1}{0.04} \times 1.75 = 44 \text{ times normal current.}$$

To illustrate the effects of short-circuit, three typical generators are taken as examples, as follows:

Class A.—Engine driven generators. Reactance, $x = 12$ per cent., = 0.12, resistance, $r = 1$ per cent., = 0.01, short-circuit current under normal no-load excitation, $I_s = 2I$, where $I =$ full-load current.

Class B.—Turbo-generators. $x = 0.02$, $r = 0.01$, $I_s = 2I$.

Class C.—Turbo-generators with external reactance. $x = 0.06$ (0.02 internal, 0.04 external), $r = 0.01$, $I_s = 2I$.

All three machines are taken on the percentage basis; with $E_m = 1$, $I_m = 1$. All are single-phase generators, or, the short-circuit may be regarded as that of one phase only, of a multiphase generator.

Problem 96.—From the above data calculate and plot the first few cycles (2 to 4) of armature current, voltage and power.

The current may be determined from (119), the voltage from (117) in which E_{2m} is neglected, and the power from the fundamental relation, $p = ei$, where instantaneous values are considered.

The following values are at once obtained:

$$r_0 \text{ is taken equal to } r; x_0 = \frac{E}{I_s} = \frac{E}{2I} = \frac{1}{2} = 0.5; \frac{r_0}{x_0} = 0.02$$

	Class A	Class B	Class C
$\frac{R}{X} = \cot \beta = \left(\frac{r}{x} - \frac{r_0}{x} \right) \left\{ \begin{array}{l} 0.0833 - 0.02 \\ 0.0633 \end{array} \right.$	0.0833 - 0.02 0.0633	0.5 - 0.02 0.48	0.1667 - 0.02 0.1467
$\frac{X}{Z} = \sin \beta =$	0.998	0.9013	0.9894
$\beta =$	86° 20'	64° 20'	81° 40'

The only other constant factor remaining to be supplied is θ_1 , the time-phase angle representing the instant of closing the switch. θ_1 may be taken at any desired value, and it should be considered what effects are produced with different values. For convenience of calculation, and also to work under extreme conditions the following values of θ_1 may be chosen.

Class A	Class B	Class C
$\theta_1 = -3^\circ 40'$	$-25^\circ 40'$	$-8^\circ 20'$
$86^\circ 20'$	$64^\circ 20'$	$81^\circ 40'$
$41^\circ 20'$	$19^\circ 20'$	$36^\circ 40'$

For each value of θ_1 a set of three curves may be obtained, and a comparative study will then be possible, both in regard to the effect of closing the switch at a different point in the cycle and with regard to the influence of the constants of the different types of machine. In the present instance the curves for the engine driven generator (class A) are produced under the condition $\theta_1 = -3^\circ 40'$. The equations, with numerical values supplied, are:

$$\begin{aligned} i &= 8.32[\epsilon^{-0.02(\theta + 0.064)} \sin(\theta - 86^\circ 20') + \epsilon^{-0.0833(\theta + 0.064)}] \\ &= 8.32[\epsilon^{-x} \sin \alpha + \epsilon^{-y}] = 8.32[a + b] \\ e &= \epsilon^{-0.02(\theta + 0.064)} \sin \theta = \epsilon^{-x} \sin \theta \\ p &= ei = 8.32[\epsilon^{-0.04(\theta + 0.064)} (\sin^2 \theta \cos 86^\circ 20' \\ &\quad - \sin \theta \cos \theta \sin 86^\circ 20') + \epsilon^{-0.1033(\theta + 0.064)} \sin \theta]. \end{aligned}$$

It is not necessary to evaluate the power equation since the product ei may be taken for each angular position. The tabulation is given for 360° from the instant of closing the switch. The three curves are shown in Fig. 229 for something over two cycles. Figs. 230-237 are for the other cases which have been taken.

Tabulating: Case A. $\theta_1 = -3^\circ 40'$.

$\theta - \theta_1$	0	15	30	45	60	75	90	120
θ°	$-3^\circ 40'$	$11^\circ 20'$	$26^\circ 20'$	$41^\circ 20'$	$56^\circ 20'$	$71^\circ 20'$	$86^\circ 20'$	$116^\circ 20'$
$\sin \theta$	-0.064	0.1965	0.4436	0.6604	0.8323	0.9474	0.998	0.8962
$\alpha = \theta - 86^\circ 20'$	-90°	-75°	-60°	-45°	-30°	-15°	0.0	30°
$\sin \alpha$	-1.0	-0.9659	-0.866	-0.707	-0.5	-0.2588	0.0	0.5
$\theta(\text{rad.})$	-0.064	0.198	0.459	0.721	0.982	1.244	1.507	2.03
$\theta + 0.064\dots$	0.0	0.262	0.523	0.785	1.046	1.308	1.571	2.094
x	0.0	0.00524	0.01046	0.0157	0.02092	0.02615	0.03142	0.04188
ϵ^{-x}	1.0	0.9947	0.9895	0.984	0.979	0.974	0.969	0.959
y	0.0	0.0218	0.0436	0.0654	0.0872	0.109	0.131	0.1745
$b = \epsilon^{-y}$	1.0	0.978	0.957	0.936	0.916	0.898	0.878	0.841
a	-1.0	-0.96	-0.857	-0.695	-0.49	-0.252	0.0	0.48
$a + b$	0.0	0.018	0.1	0.241	0.426	0.646	0.878	1.321
i	0.0	0.15	0.832	2.01	3.55	5.38	7.30	11.0
e	-0.064	0.1953	0.439	0.65	0.815	0.923	0.967	0.86
p	0.0	0.0293	0.365	1.308	2.89	4.97	7.05	9.45

$\theta - \theta_1$	150	180	210	240	270	300	330	360
θ°	$146^\circ 20'$	$176^\circ 20'$	$206^\circ 20'$	$236^\circ 20'$	$266^\circ 20'$	$296^\circ 20'$	$326^\circ 20'$	$356^\circ 20'$
$\sin \theta$	0.5544	0.064	-0.4436	-0.8323	-0.998	-0.8962	-0.5544	-0.064
$\alpha = \theta - 86^\circ 20'$	60°	90°	120°	150°	180°	210°	240°	270°
$\sin \alpha$	0.866	1.0	0.866	0.5	0.0	-0.5	-0.866	-1.0
$\theta(\text{rad.})$	2.55	3.08	3.6	4.125	4.65	5.17	5.7	6.22
$\theta + 0.064$	2.614	3.144	3.664	4.189	4.714	5.234	5.764	6.284
x	0.05228	0.06288	0.07328	0.08378	0.09428	0.10468	0.11528	0.12568
ϵ^{-x}	0.949	0.939	0.929	0.9195	0.91	0.902	0.891	0.882
y	0.2175	0.262	0.305	0.349	0.393	0.436	0.48	0.524
$b = \epsilon^{-y}$	0.804	0.768	0.737	0.706	0.674	0.65	0.62	0.592
a	0.822	0.939	0.805	0.46	0.0	-0.451	-0.772	-0.882
$a + b$	1.626	1.707	1.542	1.166	0.674	0.199	0.152	0.29
i	13.53	14.2	12.85	9.7	5.6	1.66	-1.266	-2.415
e	0.525	0.060	-0.412	-0.765	-0.908	-0.809	-0.494	-0.0565
p	7.1	0.0851	-5.3	-7.42	-5.08	-1.343	0.625	1.364

Class A.— $\theta_1 = 41^\circ 20' = 0.718$ radian

$$i = 8.32[\epsilon^{-0.02(\theta-0.718)} \sin(\theta - 86^\circ 20') - \epsilon^{-0.0833(\theta-0.718)} \sin(-45^\circ)]$$

$$= 8.32[\epsilon^{-x} \sin(\theta - 86^\circ 20') + 0.707 \epsilon^{-y}]$$

$$e = \epsilon^{-x} \sin \theta$$

$\theta - \theta_1$	0	30	60	90	120	150	180	210
θ	$41^\circ 20'$	$71^\circ 20'$	$101^\circ 20'$	$131^\circ 20'$	$161^\circ 20'$	$191^\circ 20'$	$221^\circ 20'$	$251^\circ 20'$
ϵ^{-x}	1	0.989	0.979	0.969	0.959	0.949	0.939	0.929
$\sin \theta$	0.6604	0.9474	0.9805	0.7509	0.3201	-0.1965	-0.6604	-0.9474
α''	-45°	-15°	15°	45°	75°	105°	135°	165°
$\sin \alpha''$	-0.707	-0.2588	0.2588	0.707	0.9659	0.9659	0.707	0.2588
$\epsilon^{-x} \sin \alpha''$	-0.707	-0.256	0.2535	0.685	0.9255	0.916	0.664	0.2405
$707\epsilon^{-y}$	0.707	0.677	0.648	0.621	0.595	0.568	0.543	0.521
i	0.0	3.5	7.5	10.87	12.67	12.35	10.05	6.34
e	0.6604	0.936	0.96	0.728	0.307	-0.1864	-0.62	-0.88
p	0.0	3.28	7.2	7.9	3.89	-2.3	-6.23	-5.58

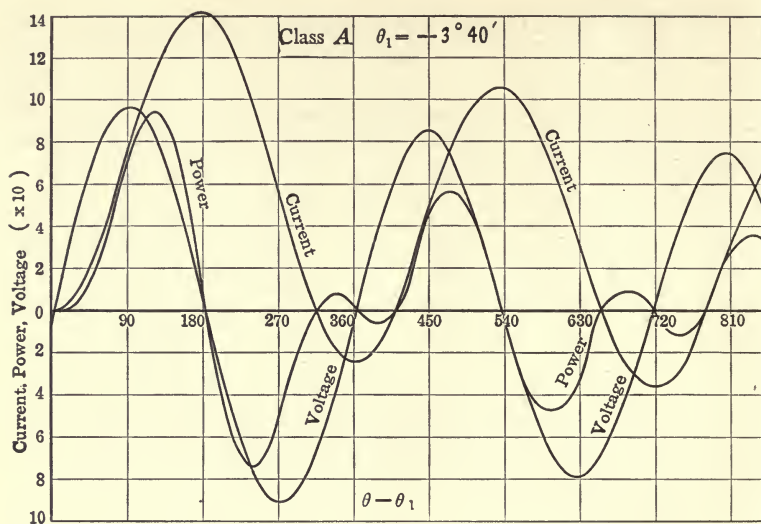

FIG. 229.

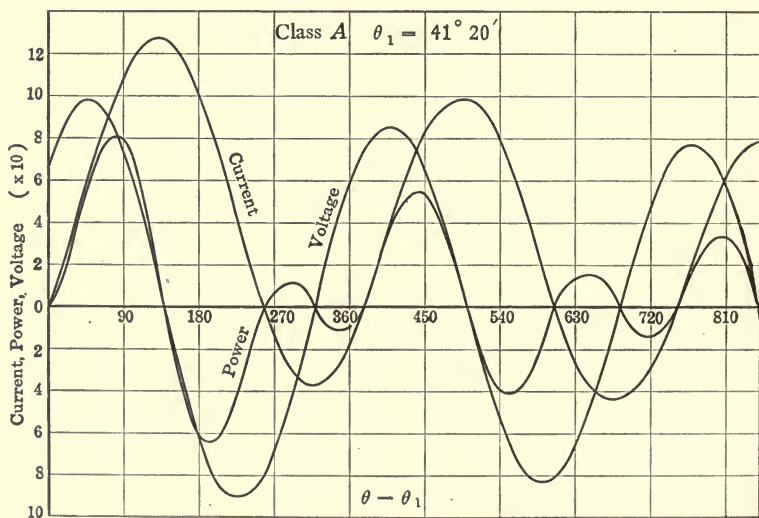

FIG. 230.

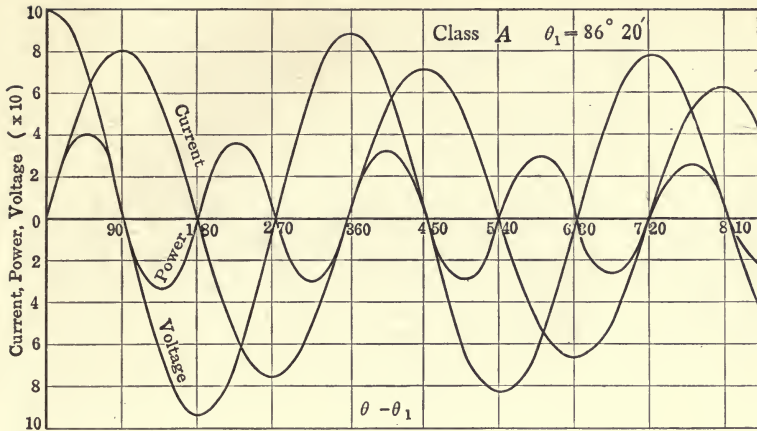

FIG. 231.

Class A.— $\theta_1 = 86^\circ 20' = 1.50$ radians.

The equations (423) and (421) become:

$$i = 8.32\epsilon^{-0.02(\theta - 1.5)} \sin(\theta - 86^\circ 20') = 8.32\epsilon^{-x} \sin \alpha,$$

$$e = \epsilon^{-0.02(\theta - 1.5)} \sin \theta = \epsilon^{-x} \sin \theta$$

Tabulating:

$\theta - \theta_1$	0	30	60	90	120	150	180	210
θ°	$86^\circ 20'$	$116^\circ 20'$	$146^\circ 20'$	$176^\circ 20'$	$206^\circ 20'$	$236^\circ 20'$	$266^\circ 20'$	$296^\circ 20'$
$\sin \theta$	0.998	0.8962	0.5544	0.064	-0.4436	-0.8323	-0.998	-0.8962
α°	0.0	30.0	60.0	90.0	120.0	150.0	180.0	210.0
$\sin \alpha$	0.0	0.5	0.866	1.0	0.866	0.5	0.0	-0.5
θ (rad.)	1.5	2.03	2.55	3.07	3.60	4.12	4.64	5.17
$\theta - 1.5$	0.0	0.53	1.05	1.57	2.10	2.62	3.14	3.67
x	0.0	0.0106	0.021	0.0314	0.042	0.0524	0.0628	0.0734
ϵ^{-x}	1.0	0.989	0.979	0.969	0.959	0.949	0.939	0.929
$\epsilon^{-x} \sin \alpha$	0.0	0.4945	0.848	0.969	0.831	0.4745	0.0	-0.4645
i	0.0	4.11	7.05	8.06	6.92	3.94	0.0	-3.86
e	0.998	0.886	0.542	0.062	-0.425	-0.79	-0.937	-0.833
p	0.0	3.64	3.82	0.50	-2.94	-3.12	0.0	3.22

$\theta - \theta_1$	240	270	300	330	360	390	420	450
θ°	$326^\circ 20'$	$356^\circ 20'$	$386^\circ 20'$	$416^\circ 20'$	$446^\circ 20'$	$476^\circ 20'$	$506^\circ 20'$	$536^\circ 20'$
$\sin \theta$	-0.5544	-0.064	0.4436	0.8323	0.998	0.8962	0.5544	0.064
α	240.0	270.0	300.0	330.0	360.0	390.0	420.0	450.0
$\sin \alpha$	-0.866	-1.0	-0.866	-0.5	0.0	0.5	0.866	1.0
θ (rad.)	5.69	6.21	6.74	7.26	7.78	8.30	8.83	9.35
$\theta - 1.5$	4.19	4.71	5.24	5.76	6.28	6.80	7.33	7.85
x	0.0838	0.0942	0.1048	0.1152	0.1256	0.136	0.1466	0.157
ϵ^{-x}	0.9194	0.91	0.902	0.89	0.881	0.872	0.864	0.855
$\epsilon^{-x} \sin \alpha$	-0.796	-0.91	-0.782	-0.445	0.0	0.436	0.749	0.855
i	-6.63	-7.57	-6.51	-3.74	0.0	3.63	6.24	7.11
e	-0.51	-0.0582	0.40	0.741	0.880	0.782	0.479	0.0547
p	3.38	0.441	-2.61	-2.77	0.0	2.84	2.99	0.39

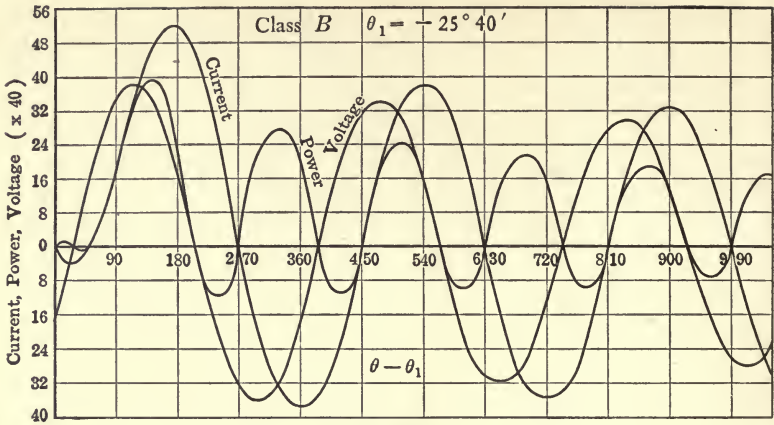

FIG. 232.

Class B. — $\theta_1 = -25^\circ 40' = -0.445$ radian

$$i = 45.1[\epsilon^{-0.02(\theta + 0.445)} \sin(\theta - 64^\circ 20') + \epsilon^{-0.5(\theta + 0.445)}]$$

$$= 45.1[\epsilon^{-x} \sin(\theta - 64^\circ 20') + \epsilon^{-y'}]$$

$$e = \epsilon^{-0.02(\theta + 0.445)} \sin \theta = \epsilon^{-x} \sin \theta$$

$\theta - \theta_1$	0	30	60	90	120	150	180	210
θ	$-25^\circ 40'$	$4^\circ 20'$	$34^\circ 20'$	$64^\circ 20'$	$94^\circ 20'$	$124^\circ 20'$	$154^\circ 20'$	$184^\circ 20'$
$\sin \theta$	-0.4331	0.0756	0.564	0.9013	0.9971	0.8258	0.4331	-0.0756
ϵ^{-x}	1.0	0.989	0.979	0.969	0.959	0.949	0.939	0.929
α'	-90.0	-60.0	-30.0	0.0	30.0	60.0	90.0	120.0
$\sin \alpha'$	-1.0	-0.866	-0.5	0.0	0.5	0.866	1.0	0.866
$\epsilon^{-x} \sin \alpha'$	-1.0	-0.856	-0.4895	0.0	0.4795	0.821	0.939	0.804
y'	0.0	0.265	0.525	0.785	1.05	1.31	1.57	1.835
$\epsilon^{-y'}$	1.0	0.767	0.592	0.456	0.35	0.268	0.208	0.158
i	0.0	-4.015	4.625	20.6	37.4	49.1	51.7	43.4
e	-0.4331	0.0748	0.552	0.874	0.955	0.784	0.407	-0.0702
p	0.0	-0.30	2.55	18.0	35.7	38.5	21.05	-3.04

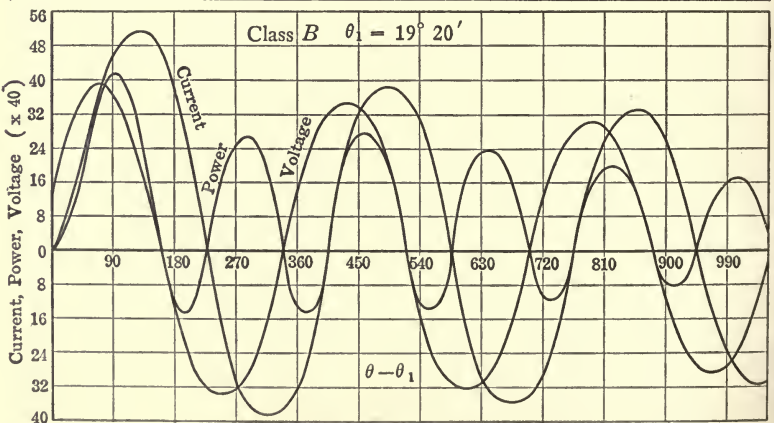

FIG. 233.

Class B.— $\theta_1 = 19^\circ 20' = 0.336$ radian

$$i = 45.1[\epsilon^{-0.02(\theta - 0.336)} \sin(\theta - 64^\circ 20') - \epsilon^{-0.5(\theta - 0.336)} \sin(-45^\circ)]$$

$$= 45.1[\epsilon^{-x} \sin(\theta - 64^\circ 20') + 0.707 \epsilon^{-y'}]$$

$$e = \epsilon^{-0.02(\theta - 0.336)} \sin \theta = \epsilon^{-x} \sin \theta$$

$\theta - \theta_1$	0	30	60	90	120	150	180	210
θ	$19^\circ 20'$	$49^\circ 20'$	$79^\circ 20'$	$109^\circ 20'$	$139^\circ 20'$	$169^\circ 20'$	$199^\circ 20'$	$229^\circ 20'$
$\sin \theta$	0.3311	0.7585	0.9827	0.9436	0.6517	0.1851	-0.3311	-0.7587
ϵ^{-x}	1.0	0.989	0.979	0.969	0.959	0.949	0.939	0.929
$\epsilon^{-x} \sin \alpha''$	-0.707	-0.256	0.2535	0.685	0.9255	0.916	0.664	0.2405
$0.707 \epsilon^{-y'}$	0.707	0.542	0.419	0.322	0.2475	0.1895	0.147	0.1118
i	0.0	12.9	30.35	45.4	53.0	49.9	36.6	15.9
e	0.3311	0.75	0.962	0.914	0.625	0.1758	-0.3108	-0.705
p	0.0	9.67	29.2	41.5	33.1	8.77	-11.39	-11.21

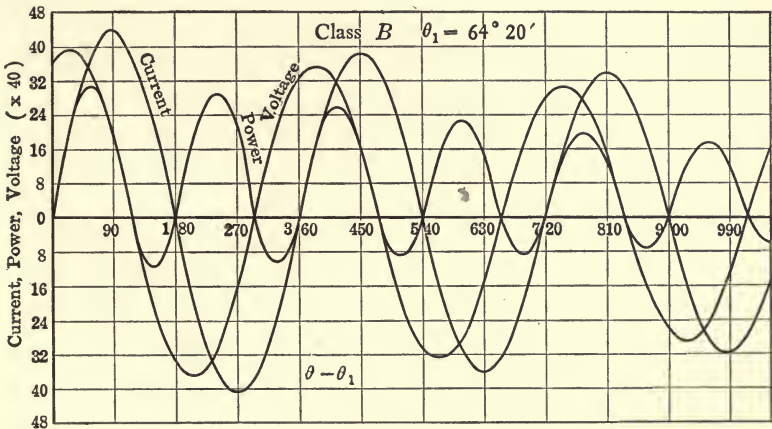

FIG. 234.

Class B.— $\theta_1 = 64^\circ 20' = 1.12$ radian

$$i = 45.1 \epsilon^{-0.02(\theta - 1.12)} \sin(\theta - 64^\circ 20')$$

$$= 45.1 \epsilon^{-x} \sin(\theta - 64^\circ 20') = 45.1 \epsilon^{-x} \sin \alpha'$$

$$e = \epsilon^{-0.02(\theta - 1.12)} \sin \theta = \epsilon^{-x} \sin \theta$$

$\theta - \theta_1$	0	30	60	90	120	150	180	210
θ	$64^\circ 20'$	$94^\circ 20'$	$124^\circ 20'$	$154^\circ 20'$	$184^\circ 20'$	$214^\circ 20'$	$244^\circ 20'$	$274^\circ 20'$
$\sin \theta$	0.9013	0.9971	0.8258	0.4331	-0.0756	-0.564	-0.9013	-0.9971
ϵ^{-x}	1.0	0.989	0.979	0.969	0.959	0.949	0.939	0.929
$\epsilon^{-x} \sin \alpha'$	0.0	0.4945	0.848	0.969	0.831	0.4745	0.0	-0.4645
i	0.0	22.3	38.25	43.7	37.5	21.4	0.0	-20.95
e	0.9013	0.985	0.809	0.42	-0.0725	-0.535	-0.846	-0.925
p	0.0	22.0	30.95	18.75	-2.72	-11.45	0.0	+19.4

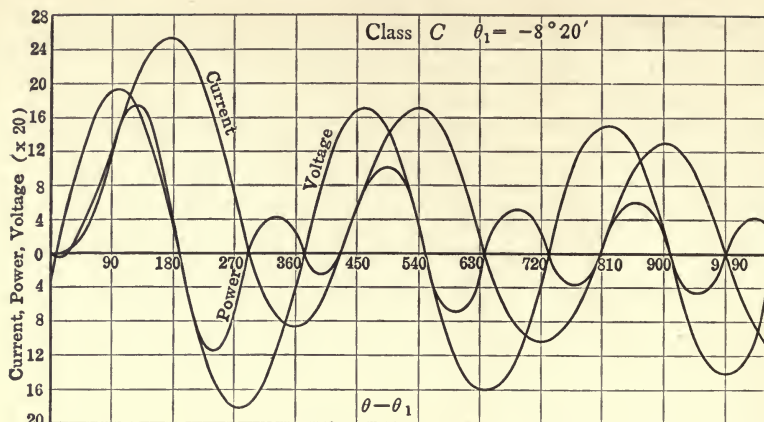

FIG. 235.

Class C.— $\theta_1 = -8^\circ 20' = -0.145$ radian

$$i = 16.5[\epsilon^{-0.02(\theta + 0.145)} \sin(\theta - 81^\circ 40') + \epsilon^{-0.1667(\theta + 0.145)}]$$

$$= 16.5[\epsilon^{-x} \sin(\theta - 81^\circ 40') + \epsilon^{-y'}]$$

$$e = \epsilon^{-0.02(\theta + 0.145)} \sin \theta = \epsilon^{-x} \sin \theta.$$

$\theta - \theta_1$	0	30	60	90	120	150	180	210
θ	$-8^\circ 20'$	$21^\circ 40'$	$51^\circ 40'$	$81^\circ 40'$	$111^\circ 40'$	$141^\circ 40'$	$171^\circ 40'$	$201^\circ 40'$
$\sin \theta$	-0.1449	0.3692	0.7844	0.9894	0.9293	0.6202	0.1449	-0.3692
ϵ^{-x}	1.0	0.989	0.979	0.969	0.959	0.949	0.939	0.929
α''	-90.0	-60.0	-30.0	0.0	30.0	60.0	90.0	120.0
$\epsilon^{-x} \sin \alpha''$	-1.0	-0.856	-0.49	0.0	0.48	0.821	0.939	0.804
y''	0.0	0.0883	0.175	0.262	0.35	0.437	0.523	0.611
$\epsilon^{-y''}$	1.0	0.915	0.84	0.769	0.705	0.647	0.593	0.543
i	0.0	0.973	5.77	12.7	19.55	24.2	25.3	22.2
e	-0.1449	0.365	0.767	0.959	0.89	0.589	0.136	-0.3427
p	0.0	0.355	4.425	12.18	17.4	14.25	3.44	-7.61

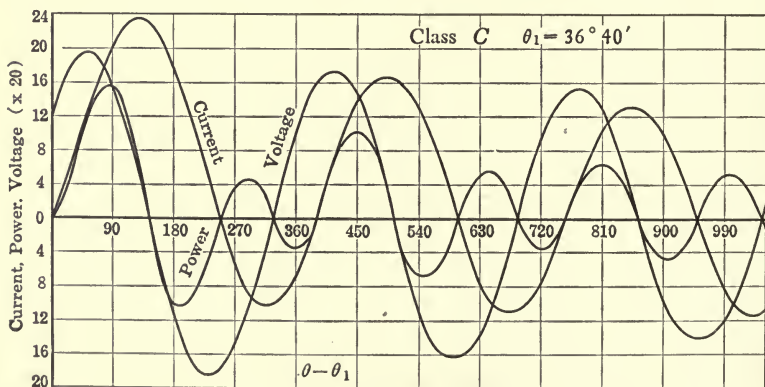

FIG. 236.

Class C.— $\theta_1 = 36^\circ 40' = 0.637$ radian

$$i = 16.5[\epsilon^{-0.02(\theta-0.637)} \sin(\theta - 81^\circ 40') - \epsilon^{-0.1667(\theta-0.637)} \sin(-45^\circ)]$$

$$= 16.5[\epsilon^{-x} \sin(\theta - 81^\circ 40') + 0.707 \epsilon^{-y''}]$$

$$e = \epsilon^{-0.02(\theta-0.637)} \sin \theta = \epsilon^{-x} \sin \theta.$$

$\theta - \theta_1$	0	30	60	90	120	150	180	210
θ	$36^\circ 40'$	$66^\circ 40'$	$96^\circ 40'$	$126^\circ 40'$	$156^\circ 40'$	$186^\circ 40'$	$216^\circ 40'$	$246^\circ 40'$
$\sin \theta$	0.5972	0.9182	0.9932	0.8021	0.3961	-0.1161	-0.5972	-0.9182
ϵ^{-x}	1.0	0.989	0.979	0.969	0.959	0.949	0.939	0.929
$\epsilon^{-x} \sin \alpha''$	-0.707	-0.256	0.254	0.685	0.926	0.916	0.664	0.241
$0.707 \epsilon^{-y''}$	0.707	0.647	0.594	0.544	0.498	0.457	0.42	0.384
i	0.0	6.45	14.0	20.25	23.5	22.65	17.9	10.3
e	0.5972	0.908	0.972	0.777	0.38	-0.1102	-0.5605	-0.853
p	0.0	5.85	13.6	15.74	8.93	-2.5	-10.05	-8.78

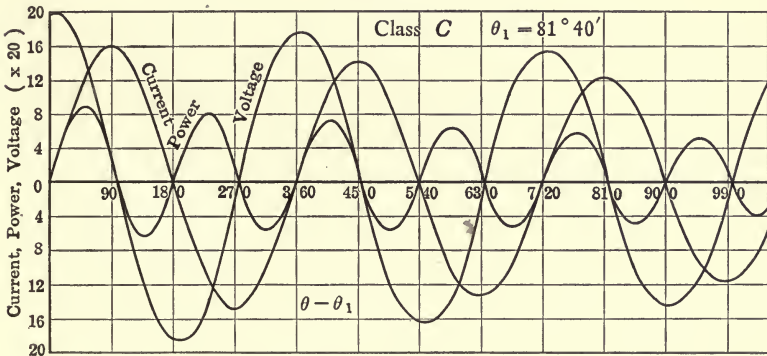

FIG. 237.

Class C.— $\theta_1 = 81^\circ 40' = 1.42$ radians

$$i = 16.5 \epsilon^{-0.02(\theta-1.42)} \sin(\theta - 81^\circ 40')$$

$$= 16.5 \epsilon^{-x} \sin(\theta - 81^\circ 40') = 16.5 \epsilon^{-x} \sin \alpha'$$

$$e = \epsilon^{-0.02(\theta-1.42)} \sin \theta = \epsilon^{-x} \sin \theta.$$

$\theta - \theta_1$	0	30	60	90	120	150	180	210
θ	$81^\circ 40'$	$111^\circ 40'$	$141^\circ 40'$	$171^\circ 40'$	$201^\circ 40'$	$231^\circ 40'$	$261^\circ 40'$	$291^\circ 40'$
$\sin \theta$	0.9894	0.9293	0.6202	0.1449	-0.3692	-0.7844	-0.9894	-0.9293
ϵ^{-x}	1.0	0.989	0.979	0.969	0.959	0.949	0.939	0.929
$\epsilon^{-x} \sin \alpha'$	0.0	0.495	0.848	0.969	0.831	0.475	0.0	-0.465
i	0.0	8.16	14.0	16.0	13.7	7.84	0.0	-7.67
e	0.9894	0.919	0.607	0.1403	-0.354	-0.744	-0.928	-0.862
p	0.0	7.5	8.5	2.245	-4.85	-5.83	0.0	6.61

It is important, in connection with the study of short-circuits, to determine how great will be the stress placed upon the shaft of the alternator. From the present calculations of power (class A),

the maximum value obtained was found to be 9.5 times normal. As an example, let the normal maximum output rating of the machine be assumed as 10,000 kw. Then the maximum power developed under short-circuit would be $9.5 \times 10,000 = 95,000$ kw.

A portion of this power will be supplied from the stored electromagnetic energy of the field, and the remainder must come from the stored mechanical energy, or from the shaft. Before short-circuiting, the stored electromagnetic energy amounts to $\frac{1}{2}Li^2$, where L is the inductance of the field system and i is the field current.

Since

$$L = \frac{n\phi}{i \times 10^8},$$

the energy is,

$$w = \frac{1}{2} \frac{n\phi i}{10^8} \text{ joules.}$$

Since it has been assumed that the flux at any instant is determined by the equation

$$\phi = \Phi e^{-\frac{r_0}{L_0}(\theta - \theta_1)},$$

the energy given out during any period of time is

$$W = \frac{1}{2} \frac{ni}{10^8} (\phi_0 - \phi_1),$$

which may be determined from the known constants.

As an example, let

$$\Phi = 150 \times 10^6 \text{ lines of flux per pole,}$$

$$n = 300 \text{ turns per pole,}$$

$$i = 100 \text{ amp. field current.}$$

Then

$$L = \frac{300 \times 150 \times 10^6}{100 \times 10^8} = 4.5 \text{ henrys per pole.}$$

If all the flux is destroyed the energy is

$$W = 4 \times \frac{1}{2} Li^2 = 4 \times 0.5 \times 4.5 \times 10,000 = 90,000 \text{ joules,}$$

or 90 kw. sec.

If this energy all disappears in $\frac{1}{25}$ sec., the average power during this short interval is

$$90 \times 25 = 2250 \text{ kw.,}$$

which is furnished by the destruction of the flux.

The total heat developed is i^2Rt , or

$$W = \int_{t_1}^t i^2Rdt = \int_{\theta_1}^{\theta} i^2Rd\theta,$$

where t_1 and θ_1 are used to designate the initial moment of short-circuit, and t and θ any subsequent moment. If, for instance, $\theta - \theta_1$ is made equal to $2\pi n$, w is the heat generated in n cycles. The complete expression for the heat developed is obtained as follows. From (119),

$$w = \int i^2Rd\theta = R \left(\frac{E_m}{x} \frac{X}{Z} \right)^2 \int [\epsilon^{-2\alpha_0(\theta-\theta_1)} \sin^2(\theta-\beta) - 2\epsilon^{-\alpha_1(\theta-\theta_1)} \sin(\theta-\beta) \sin(\theta_1-\beta) + \epsilon^{-2\alpha_1(\theta-\theta_1)} \sin^2(\theta_1-\beta)] d\theta,$$

where α_0 is written for $\frac{r_0}{x_0}$, α for $\frac{r}{x}$, and α_1 for $\frac{r_0}{x_0} + \frac{r}{x}$.

Carrying out the integration, this becomes

$$w = -\frac{R}{4} \left(\frac{E_m}{x} \frac{X}{Z} \right)^2 \epsilon^{-2\alpha_0(\theta-\theta_1)} \left[\frac{1}{\alpha_0} + \frac{\sin 2(\theta-\beta) - \alpha_0 \cos 2(\theta-\beta)}{\alpha_0^2 + 1} \right] + \frac{2R}{1 + \alpha_1^2} \left(\frac{E_m}{x} \frac{X}{Z} \right)^2 \epsilon^{-\alpha_1(\theta-\theta_1)} \sin(\theta_1-\beta) [\cos(\theta-\beta) + \alpha_1 \sin(\theta-\beta)] - \frac{R}{2\alpha} \left(\frac{E_m}{x} \frac{X}{Z} \right)^2 \epsilon^{-2\alpha(\theta-\theta_1)} \sin^2(\theta_1-\beta) + C.$$

The maximum heat is produced when the short-circuit occurs at such a time that $\sin(\theta_1 - \beta) = -1$. The maximum heat produced in n cycles is then:

$$W = \int_{\theta=\theta_1}^{\theta=\theta_1+2\pi n} i^2Rd\theta = R \left(\frac{E_m}{x} \frac{X}{Z} \right)^2 \left[\frac{1 - \epsilon^{-4\pi n\alpha_0}}{4\alpha_0} + \frac{1 - \epsilon^{-4\pi n\alpha}}{2\alpha} - \frac{2\alpha_1}{1 + \alpha_1^2} (1 - \epsilon^{-2\pi n\alpha_1}) \right] \text{ approx.} \quad (120)$$

The average power developed during n cycles is

$$P_{av.} = \frac{1}{2\pi n} \int_{\theta=\theta_1}^{\theta=\theta_1+2\pi n} i^2R d\theta \quad (121)$$

Since the rated power of an alternator is $\frac{E_m I_m}{2}$, the ratio

$$\frac{\text{Power during short-circuit}}{\text{rated power}} = \frac{\frac{1}{2\pi n} \int i^2Rd\theta}{\frac{E_m I_m}{2}} = \frac{W}{E_m I_m \pi n} = 2P_{av.}$$

On the percentage basis, $\frac{E_m I_m}{2} = \frac{1}{2}$, or if $EI = 1$, where effective values of voltage and current are used, the ratio becomes $\frac{w}{2\pi n}$.

Problem 97.—Calculate and plot the ratio of average power, under the condition of maximum heat (Eq. 120), to rated power, for values of n from 1 to 10, for the three classes of alternators.

Class A.—From the previous calculation (page 315),

$$r \left(\frac{E_m X}{x Z} \right)^2 = 0.01(8.32)^2 = 0.692$$

$$\frac{0.692}{2\pi n} = \frac{0.11}{n}$$

$$\alpha_0 = 0.02, \quad 4\alpha_0 = 0.08, \quad 4\pi\alpha_0 = 0.2515$$

$$\alpha = 0.0833, \quad 2\alpha = 0.1667, \quad 4\pi\alpha = 1.048$$

$$\alpha_1 = 0.1033, \quad 2\alpha_1 = 0.2067, \quad 2\pi\alpha_1 = 0.65$$

$$\alpha_1^2 = 0.0107, \quad 1 + \alpha_1^2 = 1.0107, \quad \frac{2\alpha_1}{1 + \alpha_1^2} = 0.2043.$$

Supplying these values (121) becomes

$$P_{av.} = \frac{0.11}{n} \left(\frac{1 - \epsilon^{-0.2515n}}{0.08} + \frac{1 - \epsilon^{-1.048n}}{0.1667} - 0.2043(1 - \epsilon^{-0.65n}) \right)$$

$$= \frac{2.01254}{n} - \frac{1.375}{n} \epsilon^{-0.2515n} - \frac{0.66}{n} \epsilon^{-1.048n} + \frac{0.02246}{n} \epsilon^{-0.65n}$$

$$= a - b - c + d.$$

Tabulating:

n	1	2	3	4	5	6	8	10
$a = \frac{2.01254}{n}$	2.01254	1.00627	0.67083	0.50314	0.40251	0.33542	0.25157	0.20125
$\frac{1.375}{n}$	1.375	0.6875	0.4583	0.3438	0.275	0.2297	0.1719	0.1375
$\frac{0.66}{n}$	0.66	0.33	0.22	0.165	0.132	0.11	0.0825	0.066
$\frac{0.02246}{n}$	0.02246	0.01123	0.00749	0.00562	0.004492	0.00374	0.00281	0.002246
$0.2515n$	0.2515	0.503	0.7545	1.006	1.2575	1.509	2.012	2.515
$\epsilon^{-0.2515n}$	0.778	0.605	0.47	0.364	0.284	0.22	0.134	0.081
$1.048n$	1.048	2.096	3.144	4.192	5.24	6.288	8.384	10.48
$\epsilon^{-1.048n}$	0.35	0.124	0.043	0.015	0.0058	0.0016	0.0	0.0
$0.65n$	0.65	1.3	1.95	2.6	3.25	3.9	5.2	6.5
$\epsilon^{-0.65n}$	0.523	0.272	0.142	0.074	0.038	0.019	0.006	0.0012
b	1.07	0.416	0.227	0.125	0.078	0.0505	0.023	0.01115
c	0.231	0.041	0.00945	0.00247	0.000765	0.000176	0.0	0.0
d	0.01175	0.003055	0.001063	0.000416	0.0001707	0.000071	0.000017	0.0000027
$P_{av.}$	0.7233	0.5523	0.4354	0.3761	0.3239	0.2848	0.2286	0.1901
Ratio	1.4466	1.1046	0.8708	0.7522	0.6478	0.5696	0.4572	0.3802

Class B.—

$$r \left(\frac{E_m X}{x Z} \right)^2 = 0.01(45.1)^2 = 20.34$$

$$\frac{20.34}{2\pi n} = \frac{3.24}{n}$$

$$\alpha_0 = 0.02, \quad 4\alpha_0 = 0.08, \quad 4\pi\alpha_0 = 0.2515.$$

$$\alpha = 0.5, \quad 2\alpha = 1.0, \quad 4\pi\alpha = 6.28.$$

$$\alpha_1 = 0.52, \quad 2\alpha_1 = 1.04, \quad 2\pi\alpha_1 = 3.267.$$

$$\alpha_1^2 = 0.271, \quad 1 + \alpha_1^2 = 1.271, \quad \frac{2\alpha_1}{1 + \alpha_1^2} = 0.817.$$

Supplying values (121) becomes

$$\begin{aligned}
 P_{av.} &= \frac{3.24}{n} \left[\frac{1 - \epsilon^{-0.2515n}}{0.08} + \frac{1 - \epsilon^{-6.28n}}{1} - 0.817(1 - \epsilon^{-3.267n}) \right] \\
 &= \frac{41.09}{n} - \frac{40.5}{n} \epsilon^{-0.2515n} - \frac{3.24}{n} \epsilon^{-6.28n} + \frac{2.65}{n} \epsilon^{-3.267n} \\
 &= a' - b' - c' + d'.
 \end{aligned}$$

Tabulating:

<i>n</i>	1	2	3	4	5	6	8	10
<i>a'</i>	41.09	20.54	13.7	10.27	8.22	6.85	5.135	4.109
$\frac{40.5}{n}$	40.5	20.25	13.5	10.125	8.1	6.75	5.063	4.05
$\frac{3.24}{n}$	3.24	1.62	1.08	0.81	0.648	0.54	0.405	0.324
$\frac{2.65}{n}$	2.65	1.325	0.883	0.663	0.53	0.442	0.331	0.265
$\epsilon^{-0.2515n}$	0.778	0.605	0.47	0.364	0.284	0.22	0.134	0.081
$\epsilon^{-6.28n}$	0.0016	0.0	0.0	0.0	0.0	0.0	0.0	0.0
$\epsilon^{-3.267n}$	0.038	0.0017	0.0	0.0	0.0	0.0	0.0	0.0
<i>b'</i>	31.53	12.25	6.34	3.688	2.3	1.485	0.678	0.328
<i>c'</i>	0.00518	0.0	0.0	0.0	0.0	0.0	0.0	0.0
<i>d'</i>	0.101	0.00225	0.0	0.0	0.0	0.0	0.0	0.0
<i>P_{av.}</i>	9.66	8.29	7.36	6.58	5.92	5.37	4.46	3.78
Ratio	19.32	16.58	14.72	13.16	11.84	10.74	8.92	7.56

Class C.—

$$r \left(\frac{E_m X}{x Z} \right)^2 = 0.01(16.5)^2 = 2.7225$$

$$\frac{2.7225}{2\pi n} = \frac{0.434}{n}$$

$$\alpha_0 = 0.02, \quad 4\alpha_0 = 0.08, \quad 4\pi\alpha_0 = 0.2515.$$

$$\alpha = 0.1667, \quad 2\alpha = 0.333, \quad 4\pi\alpha = 2.093.$$

$$\alpha_1 = 0.1867, \quad 2\alpha_1 = 0.3733, \quad 2\pi\alpha_1 = 1.173.$$

$$\alpha_1^2 = 0.035, \quad 1 + \alpha_1^2 = 1.035, \quad \frac{2\alpha_1}{1 + \alpha_1^2} = 0.361.$$

Supplying values (121) becomes

$$\begin{aligned}
 P_{av.} &= \frac{0.434}{n} \left[\frac{1 - \epsilon^{-0.2515n}}{0.08} + \frac{1 - \epsilon^{-2.093n}}{0.333} - 0.361(1 - \epsilon^{-1.173n}) \right] \\
 &= \frac{6.565}{n} - \frac{5.42}{n} \epsilon^{-0.2515n} - \frac{1.302}{n} \epsilon^{-2.093n} + \frac{0.157}{n} \epsilon^{-1.173n} \\
 &= a'' - b'' - c'' + d''.
 \end{aligned}$$

Tabulating:

n	1	2	3	4	5	6	8	10
$a'' = \frac{6.565}{n}$	6.565	3.283	2.155	1.641	1.313	1.078	0.8205	0.6565
$\frac{5.42}{n}$	5.42	2.71	1.807	1.355	1.084	0.903	0.677	0.542
$\frac{1.302}{n}$	1.302	0.651	0.434	0.326	0.260	0.217	0.163	0.1302
$\frac{0.157}{n}$	0.157	0.078	0.052	0.039	0.031	0.026	0.0195	0.0157
$\epsilon^{-0.2515n}$	0.778	0.605	0.47	0.364	0.284	0.22	0.134	0.081
$\epsilon^{-2.093n}$	0.124	0.015	0.0018	0.0	0.0	0.0	0.0	0.0
$\epsilon^{-1.173n}$	0.308	0.097	0.029	0.0095	0.0025	0.0005	0.0	0.0
b''	4.22	1.64	0.849	0.493	0.308	0.1988	0.0906	0.0439
c''	0.1615	0.00975	0.00078	0.0	0.0	0.0	0.0	0.0
d''	0.0483	0.00756	0.00151	0.0	0.0	0.0	0.0	0.0
$P_{av.}$	2.23	1.64	1.31	1.15	1.00	0.88	0.73	0.61
Ratio	4.46	3.28	2.62	2.30	2.00	1.76	1.46	1.22

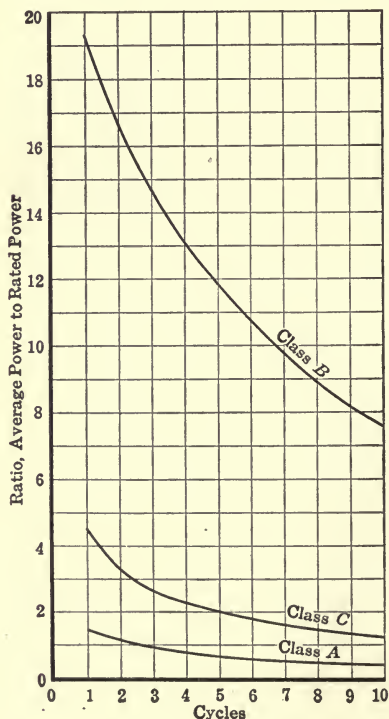

FIG. 238.

As an illustration of the power developed under short-circuit, consider the generator of class A. The average power developed in the first cycle under the worst condition is found to be 0.7233, where $E_m = 1$, $I_m = 1$, and $P_{av.} =$ normal power output $= \frac{E_m I_m}{2} = \frac{1}{2}$.

If, now, a 25-cycle machine of 5000-kw. rating of this type, is considered, the average power during the first cycle is $10,000 \times 0.7233 = 7,233$ kw. The instantaneous maximum of power has already been found to be 95,000 kw.

Problem 98.—Determine the above relation for the machines of classes B and C.

Stresses on End-connections of the Armature Coils.—When end-connections run parallel for some distance, the forces exerted on them are often very great at the instants of heavy current during short-circuit. The force at any time may be determined to a sufficient degree of approximation by multiplying the average density of the flux through one conductor due to the other conductor, by the current in that conductor.

Consider two similar conductors of radius, r , with a distance, d , between centers. To find the average flux through conductor B due to the current in conductor A . The flux through any element, dx , of B is, per centimeter length of conductor,

$$d\phi = \frac{4\pi I\mu dx}{2\pi x} = \frac{2I dx}{x},$$

where I is in abamperes, and μ is taken as unity. The average flux density is then:

$$\phi_{av.} = B = \frac{1}{2r} \int_{d-r}^{d+r} 2I \frac{dx}{x} = \frac{I}{r} \log \frac{d+r}{d-r}$$

In general, the force exerted is Bil dynes, where l is length of the wire in centimeters

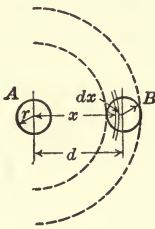

FIG. 239.

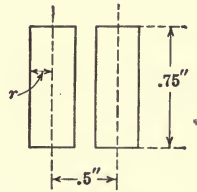

FIG. 240.

Thus, force per cm. = $\frac{F}{l} = \frac{I^2}{r} \log \frac{d+r}{d-r}$ dynes.

If I is in amperes, $\frac{F}{l} = \frac{I^2}{100r} \log \frac{d+r}{d-r}$.

If dimensions are given in inches, the formula remains the same.

Example.—Consider two adjacent conductors, as shown in Fig. 240. The area of each conductor is 0.2345 sq. in. The current density is taken as 2000 amp. per sq. in. under normal conditions. Therefore maximum normal current is

$$I_m = \sqrt{2} \times 0.2345 \times 2000 = 664 \text{ amp.}$$

$$d = 0.5, r = 0.1562, l = 20.$$

The maximum force under normal load is then

$$F = \frac{(664)^2 \times 20}{100 \times 0.1562} \log \frac{0.6562}{0.3438} = 366,000 \text{ dynes} = \frac{366,000}{445,000} = 0.822 \text{ lb.}$$

This shows that the force under normal conditions is very slight. Under short-circuit the ratios of maximum current to normal current for the three classes of machines considered, were, respectively:

for class A,	14.2
for class B,	52.0
for class C,	25.3.

Thus, the maximum short-circuit forces are, for the three classes under the dimensions assumed:

$$F_A \text{ (max.)} = 0.822 \times \overline{14.2^2} = 166 \text{ lb.}$$

$$F_B \text{ (max.)} = 0.822 \times \overline{52^2} = 2220 \text{ lb.}$$

$$F_C \text{ (max.)} = 0.822 \times \overline{25.3^2} = 527 \text{ lb.}$$

Problem 99.—Discuss the effects of changing the values of r and d on the forces exerted on the end-connections.

In general, the effect of short-circuit as obtained in machines of class B, was much decreased by the addition of external reactance, as exemplified in class C. What change in the relative positions of the end-connections would be necessary to reduce the force as obtained for class B to that of class C machines?

Multiphase Short-circuits.—The voltage of any phase, m , of a multiphase alternator in the steady period of operation is expressed by

$$e_m = E_m \sin \left(\omega t + \frac{2\pi m}{n} \right).$$

Thus, for a three-phase generator, the voltages are

$$e_1 = E_m \sin (\omega t + 0)$$

$$e_2 = E_m \sin (\omega t + 120)$$

$$e_3 = E_m \sin (\omega t + 240)$$

where m has the values, 0, 1, and 2, respectively. (For two-phase alternators, n must be taken as 4, not as 2, since the voltages differ by 90° , not by 180° .)

The currents of a three-phase alternator are:

$$i_1 = I_m \sin (\omega t + \beta)$$

$$i_2 = I_m \sin (\omega t + 120 + \beta)$$

$$i_3 = I_m \sin (\omega t + 240 + \beta).$$

The transient voltage, for example, of the second phase, is, from (117) in which E_m is substituted for E_{1m} , and E_2 is neglected, as in the later calculations,

$$e_2 = E_m \sin(\theta + 120) \epsilon^{-\frac{r_0}{x_0}(\theta - \theta_1)}$$

Equating this to $i_2 r + x \frac{di_2}{d\theta}$, as previously done for the single-phase machine, the current during the transient period is found to be

$$i_2 = \frac{E_m}{x} \frac{X}{Z} \left[\epsilon^{-\frac{r_0}{x_0}(\theta - \theta_1)} \sin(\theta + 120 - \beta) - \epsilon^{-\frac{r}{x}(\theta - \theta_1)} \sin(\theta_1 + 120 - \beta) \right]$$

A still shorter but less close approximation is made by considering $\frac{X}{Z} = 1$, and $\beta = 90^\circ$. The current is then

$$i_2 = \frac{E_m}{x} \left[\epsilon^{-\frac{r}{x}(\theta - \theta_1)} \cos(\theta_1 + 120) - \epsilon^{-\frac{r_0}{x_0}(\theta - \theta_1)} \cos(\theta + 120) \right]$$

In a polyphase generator, the current for any phase is given approximately by

$$i_m = \frac{E_m}{x} \left[\epsilon^{-\frac{r}{x}(\theta - \theta_1)} \cos\left(\theta_1 + \frac{2\pi m}{n}\right) - \epsilon^{-\frac{r_0}{x_0}(\theta - \theta_1)} \cos\left(\theta + \frac{2\pi m}{n}\right) \right] \quad (122)$$

where n is the number of phases and m has the values 0, 1, 2, . . . (n - 1).

Power developed in any phase, at any instant, is the product ei . The whole power of a three-phase generator is, at any instant, the sum of the three products, $e_1 i_1$, $e_2 i_2$, $e_3 i_3$, of the individual phases.

Problem 100.—Perform the operation just indicated and prove that the power of a three-phase generator is

$$P_{\text{three-phase}} = \frac{1.5E_m^2}{x} \epsilon^{-\left(\frac{r}{x} + \frac{r_0}{x_0}\right)(\theta - \theta_1)} \sin(\theta - \theta_1)$$

This equation shows that power of a polyphase generator is entirely independent of the time of closing of the switch. This time may have any value assigned to θ_1 , but the time at any instant after the switch is closed is represented by $\theta - \theta_1$, which is independent of θ_1 .

This is quite different from the case of single-phase short-circuits in which the power, similarly determined, is

$$P(\text{one-phase}) = \frac{E_m^2}{x} \left[\epsilon^{-\left(\frac{r}{x} + \frac{r_0}{x_0}\right)(\theta - \theta_1)} \cos \theta_1 \sin \theta - 0.5 \epsilon^{-2\frac{r_0}{x_0}(\theta - \theta_1)} \sin 2\theta \right].$$

In this equation, θ enters independently of θ_1 . $\cos \theta_1$ is, of course, a constant.

From the power equations, the torque on the shaft at any instant may be determined.

Problem 101.—Show that the maximum power of a single-phase short-circuit on a three-phase machine is two-thirds of that of a three-phase short-circuit on the same machine and explain in words the basis for this relationship.

Armature Reaction.—For a three-phase generator in the steady state of operation, the armature reactions of the three phases taken separately have been found to be:

$$F_{A1} = i_1 T \cos \theta,$$

$$F_{A2} = i_2 T \cos \left(\theta + \frac{2\pi}{3} \right),$$

$$F_{A3} = i_3 T \cos \left(\theta + \frac{4\pi}{3} \right) = i_3 T \cos \left(\theta + \frac{\pi}{3} \right),$$

where T is the number of effective turns per phase and θ , $\theta + \frac{2\pi}{3}$, $\theta + \frac{4\pi}{3}$ represent the angular space positions of the armature core with respect to the field core. Substituting the values of i from (122) the transient values of the armature reaction are:

$$F_{A1} = \frac{E_m T}{x} \left[\epsilon^{-\frac{r}{x}(\theta - \theta_1)} \cos \theta_1 \cos \theta - \epsilon^{-\frac{r_0}{x_0}(\theta - \theta_1)} \left(\frac{1 + \cos 2\theta}{2} \right) \right]$$

$$F_{A2} = \frac{E_m T}{x} \left[\epsilon^{-\frac{r}{x}(\theta - \theta_1)} \cos \left(\theta_1 + \frac{2\pi}{3} \right) \cos \left(\theta + \frac{2\pi}{3} \right) - \epsilon^{-\frac{r_0}{x_0}(\theta - \theta_1)} \left(\frac{1 + \cos 2\left(\theta + \frac{2\pi}{3} \right)}{2} \right) \right]$$

$$F_{A3} = \frac{E_m T}{x} \left[\epsilon^{-\frac{r}{x}(\theta - \theta_1)} \cos \left(\theta_1 + \frac{4\pi}{3} \right) \cos \left(\theta + \frac{4\pi}{3} \right) - \epsilon^{-\frac{r_0}{x_0}(\theta - \theta_1)} \left(\frac{1 + \cos 2\left(\theta + \frac{4\pi}{3} \right)}{2} \right) \right].$$

Adding these three equations, the total three-phase armature reaction is:

$$F_A = \frac{1.5E_m T}{x} \left[\epsilon^{-\frac{r}{x}(\theta - \theta_1)} \cos(\theta - \theta_1) - \epsilon^{-\frac{r_0}{x_0}(\theta - \theta_1)} \right].$$

Problem 102.—Prove that the armature reaction of a polyphase generator is:

$$F_A = \frac{n}{2} \frac{E_m T}{x} \left[\epsilon^{-\frac{r}{x}(\theta - \theta_1)} \cos(\theta - \theta_1) - \epsilon^{-\frac{r_0}{x_0}(\theta - \theta_1)} \right] \quad (123)$$

Problem 103.—Plot single-phase and three-phase armature reaction curves for the alternator for which waves of e , i , and p have been derived, and discuss their characteristic differences.

Electromotive Force and Current Induced in the Field Windings.

—Excessive voltage may be induced in the field windings and cause breakdown of insulation. In general, the induced voltage is proportional to $\frac{d\phi}{dt}$. It is, however, difficult to obtain a reliable

value of the voltage owing to the fact that the flux cannot penetrate uniformly into the magnet cores during the exceedingly short time allowed by the rapidly changing current.

The induced field current may also be abnormally great. By installing a circuit breaker in the exciter circuit, the rush of current may cause the circuit to be opened, thus taking off the field current from the short-circuited alternator.

Example.—Let the normal field excitation be 18,000 amp.-turns per pole, and the normal armature reaction be 9000 amp.-turns. If the armature reactance is 10 per cent., the maximum short-circuit current would be approximately seventeen times normal current. The armature short-circuit amp.-turns are then 153,000. Assuming 20 per cent. leakage between armature and field, the effective armature reaction is

$$0.8 \times 153,000 = 122,000 \text{ amp.-turns on the field core.}$$

The field current may then attain the value of

$$\frac{122,000}{18,000} \times \text{normal} = 6.8 \times \text{normal current.}$$

If the circuit breaker is set for twice normal current, it will open the circuit.

CHAPTER XLI

SYNCHRONOUS MOTORS

When the ordinary alternator is supplied with electrical energy and made to do mechanical work, it becomes a synchronous motor. The name is meant to indicate its chief characteristic, namely that of running in exact synchronism with the generator which supplies it with energy. If the frequency of the generator is 60 cycles per second, that of the motor—its counter e.m.f.—is also 60 cycles. This condition is the result of the electromagnetic relationship between the field and armature cores; the field core changes its position in space by means of mechanical rotation, the position of the magnetic field due to the armature magnetomotive force changes in space because of the time-phase relationships and alternation of the currents. The driving force of the motor is maintained only by the existence of a constant relationship between the field and armature m.m.f. The rate of rotation of the armature m.m.f. is fixed by the frequency of supply. The field has no fixed rate of rotation of its own and is therefore free to accept that imposed by the armature.

The operation of the synchronous motor may be affected either by changing its load or by altering its field excitation. These may be called primary means of adjustment since they are applicable to any motor in operation. Since, however, the speed cannot be changed, it becomes a matter of great interest and also of importance to find out what is changed, and what peculiar and valuable characteristics are associated with this hitherto unencountered characteristic of synchronous speed.

There are also secondary means of adjustment by which variation in the motor performance may be brought about. These involve changes in the constants of the line or the motor circuit. Thus, in the matter of design, it is important to study the effects of different values of resistance and reactance of the armature. In operation, with a constant generator terminal e.m.f., resistance and reactance may be inserted or withdrawn from the line, thus altering the total r and x of the circuit.

A thorough understanding of the effect of these constants is essential from a practical as well as a theoretical point of view. A motor which, for instance, operates perfectly satisfactorily on one line may be entirely unstable and even unable to carry its load or even a small fraction thereof on another line.

It will, for instance, be evident that a high resistance line tends to make the motor unstable unless the reactance is also considerable. In synchronous motor operation a fair amount of line reactance is essential; in fact, the very ability of the motor to carry load depends upon the presence of reactance in the motor circuit.

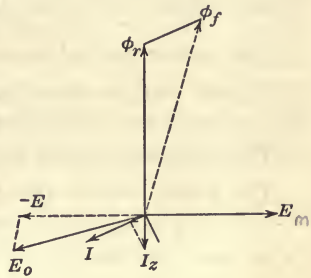

FIG. 241.

Let E be the e.m.f. counter generated in the motor. The resultant flux will then be 90° ahead of E . Assuming a current I , as shown in Fig. 241, this current produces a m.m.f. in phase with itself and which may be taken equal to it, by choosing a suitable scale. The armature m.m.f. thus produced, when added vectorially to the field m.m.f., will produce the resultant m.m.f., which gives the resultant flux ϕ_r . ϕ_f represents the direction of the field m.m.f.

In order to force the current through the impedance of the armature, it is necessary to have an e.m.f. equal to the impedance drop IZ . As shown in the figure, IZ is the voltage which overcomes the resistance and reactance of the armature. The impressed voltage, E_0 must be the vector sum of this IZ drop and the voltage $-E$, necessary to overcome the counter e.m.f. of the motor.



FIG. 242.

$$\therefore E_0 = IZ - E.$$

The space relations indicated by Fig. 241 are illustrated by the sketch of a two-pole machine in Fig. 242. The vector relationship may also be considered from a somewhat different point of view, illustrated in Fig. 243. Here there are two e.m.f.s., E and E_0 , acting in a circuit of impedance Z .

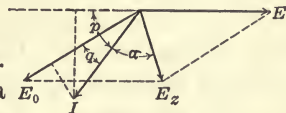

FIG. 243.

If E_0 is the generator terminal e.m.f., then z is the combined

impedance of the line and the motor. The counter e.m.f., E , of the motor, is naturally in a direction to more or less oppose E_0 . The vector sum of E_0 and E is E_z which is the e.m.f. which actually overcomes the impedance z , of the circuit. The current I lags behind E_z by an angle α , such that $\tan \alpha = \frac{x}{r}$.

The motor output is $-E \times I \cos p = P$.

This is seen to be negative thus representing power supplied to the machine or motor action.

The generator input is $E_0 \times I \cos q = P_0$.

The power lost in the circuit is then $P_0 - P = I^2r$.

If α is a large angle, representing large reactance, the motor is more stable than if α is small.

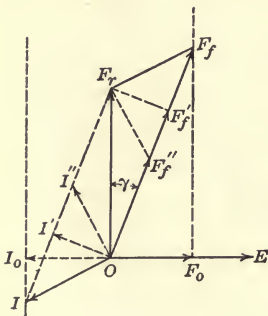

FIG. 244.

If α is small, the projection of I on E may even be positive, giving generator power instead of motor power in which case the motor cannot carry mechanical load. Oftentimes poorly acting synchronous motors may be greatly benefited by increasing the angle α by the insertion of self-inductance in the line. For a given load on the motor, the angle γ , between the field m.m.f. and the resultant m.m.f. is almost constant. OF_f evidently depends on both

the amount and the phase of the current. The counter e.m.f., E , on the other hand, is fairly constant for all loads. It depends on the actual resultant flux in the air gap which is fairly constant for all loads. For constant motor load, $P = oE \times oI_0$ (Fig. 244) and the locus of the ends of the current vectors will be along the dotted lines II_0 . The corresponding locus of field flux vectors will be along F_fF_0 . If, however, the angle γ is assumed constant the two loci will be IF_r and OF_f , for varying field excitation. But this condition will correspond to a variable load. If OF_r is great with respect to OI —that is, if the angle γ is small—the variation of both γ and the motor power is small for a considerable variation of the field flux about the normal value. Plotting the armature current against the field or the field current, gives the familiar “V-curves.”

As E cannot be assumed constant, especially where r or x is large, the condition of constant power output cannot be shown by the above vector diagrams, since the power is not represented by a constant projection of I on the horizontal. Constant power input may, however, be assumed with constant e_0 impressed, and the power input is then proportional to the projection of I on e_0 , Fig. 245. Moreover, constant power input, over a considerable range of current on both sides of the minimum, is approximately constant power output, since the difference is only I^2r which is small and which may have small variation. It is readily possible, therefore, to calculate E for constant power input, since

$$\begin{aligned} E &= \sqrt{(e_0 - IZ \cos(\theta + \alpha))^2 + (IZ \sin(\theta + \alpha))^2} \\ &= \sqrt{e_0^2 - 2e_0 IZ \cos(\theta + \alpha) + I^2 Z^2} \\ &= \sqrt{e^2_0 + I^2 Z^2 - 2e_0(r i - x i')}, \end{aligned}$$

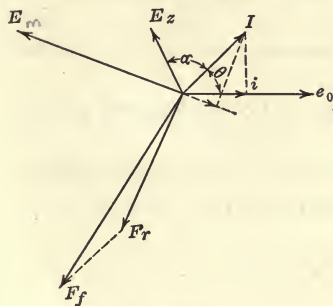

FIG. 245.

and this may be determined for varying I , since i is constant and known. Thus for any input,

$$P_i = e_0 i, \text{ and } i' = \sqrt{I^2 - i^2}.$$

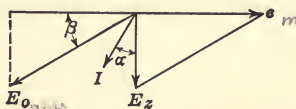

FIG. 246.

Synchronous Motor Equations.—Assuming e , the motor counter e.m.f. to be the zero vector,

$$\dot{E}_z = IZ = e + \dot{E}_0$$

$$\dot{E}_0 = -\dot{E}_0 \cos \beta - j\dot{E}_0 \sin \beta.$$

By using β the minus sign is introduced into the equation since the true angle is $180^\circ + \beta$.

$$\therefore \dot{I}z = e - \dot{E}_0 \cos \beta - j\dot{E}_0 \sin \beta.$$

and

$$\left. \begin{aligned} \dot{I} &= \frac{e - E_0 \cos \beta - jE_0 \sin \beta}{r + jx} \\ &= \frac{1}{z} \sqrt{E_0^2 + e^2 - 2eE_0 \cos \beta} \end{aligned} \right\} \quad (124)$$

Also,

$$I = i + ji'$$

whence,

$$i = \frac{e - E_0 \cos \beta}{r + jx}$$

$$= \frac{1}{z}(e \cos \alpha - E_0 \cos (\alpha - \beta))$$

and

$$i' = \frac{1}{z}(E_0 \sin (\alpha - \beta) - e \sin \alpha)$$

(125)

These values are obtained by clearing the denominator of (124) of imaginaries and remembering that $\cos \alpha = \frac{r}{z}$ and $\sin \alpha = \frac{x}{z}$.

Mechanical, or motor power $P = -ie$.

Hence the generated power $P_0 = -ie + I^2r$.

Substituting the values in (125) above, mechanical power =

$$P = \frac{e}{z}(E_0 \cos (\alpha - \beta) - e \cos \alpha) \quad (126)$$

If $\beta = 0$ and $E_0 = e$, $P = 0$ or there is no mechanical power. Also when $\beta = 2\alpha$, $P = 0$.

To determine the maximum output (126) may be differentiated with respect to β and the result equated to zero. Thus,

$$\frac{dP}{d\beta} = 0 = \frac{e}{z} E_0 \sin (\alpha - \beta).$$

In this, $\sin (\alpha - \beta)$ must equal zero, since $\frac{e}{z} E_0$ is not zero. This gives $\alpha = \beta$.

Hence, the power is maximum for $\alpha = \beta$ and is zero for $\beta = 0$ and $\beta = 2\alpha$.

If β is negative, there is generator action, or the motor acts as generator.

When E_0 and e are unequal, the limits of β are somewhat altered.

Problem 104.—Given:

Section A, $E_0 = 1.1$, $e = 1$

Section B, $E_0 = 1$, $e = 1$

Section C, $E_0 = 0.9$, $e = 1$

Assume the generator bus bars kept at constant voltage—not constant generator field excitation. The synchronous motor armature has 2 per cent. resistance, 10 per cent. reactance.

1. An overhead line connecting the machine has 8 per cent. resistance and 20 per cent. reactance, all referred to motor. Constants will then be, $r = 0.1$, $x = 0.3$, $\tan \alpha = 3$, rated power = 1.0 = P .

2. An underground cable connecting the machine has a high resistance of 18 per cent. and has negligible reactance. The constants will then be $r = 0.2$, $x = 0.1$. Find for the two cases, power output, total current, and power factor of the generator, and plot against β (Fig. 246).

3. Find the maximum output, for variable r , with (a) $x = 0.1$ (b) $x = 0.2$ and plot.

[(From Eq. 126,

$$P_{max.} = \frac{e}{z} (E_0 - e \cos \alpha)]$$

Solution of the first case. Section A.

$$E_0 = 1.1; E = 1; r = 0.02 + 0.08 = 0.1;$$

$$x = 0.10 + 0.20 = 0.30; \tan \alpha = \frac{0.3}{0.1} = 3; \alpha = 72^\circ:$$

$$\text{Mech. power, } P = \frac{E}{Z} [E_0 \cos(\alpha - \beta) - E \cos \alpha] \text{ watts}$$

$$Z = \sqrt{0.3^2 + 0.1^2} = 0.316; \frac{E}{Z} = 3.16; E \cos \alpha = 0.309.$$

β°	0	5	10	20	30	40	50	60	α
$\alpha - \beta$	72.0	67.0	62.0	52.0	42.0	32.0	22.0	12.0	0.0
$\cos(\alpha - \beta)$	0.309	0.391	0.469	0.616	0.743	0.848	0.927	0.978	1.0
$E_0 \cos(\alpha - \beta)$	0.34	0.43	0.516	0.677	0.818	0.933	1.02	1.075	1.1
$-E \cos \alpha$	0.031	0.121	0.207	0.368	0.509	0.624	0.711	0.766	0.791
P	0.098	0.383	0.655	1.16	1.61	1.97	2.25	2.42	2.5

$$\text{Current} = I = \frac{1}{z} \sqrt{E_0^2 + E^2 - 2EE_0 \cos \beta}$$

$$\frac{1}{z} = 3.16; E_0^2 = 1.21; 2EE_0 = 2.2$$

$\cos \beta$	1.0	0.996	0.985	0.94	0.866	0.766	0.643	0.5	0.309
$2EE_0 \cos \beta$	2.2	2.19	2.165	2.065	1.91	1.685	1.415	1.1	0.68
$E_0^2 + E^2 - 2EE_0 \cos \beta$	0.01	0.02	0.045	0.145	0.3	0.52	0.79	1.11	1.53
$E_0^2 + E^2 - 2EE_0 \cos \beta$	0.1	0.141	0.212	0.381	0.547	0.72	0.89	1.05	1.24
I	0.316	0.445	0.67	1.2	1.73	2.28	2.82	3.32	3.92

$$\text{Power factor} = \frac{P + I^2 r}{E_0 I} = \frac{\text{gen. power}}{E_0 I}$$

$I^2 r$	0.01	0.0198	0.045	0.144	0.3	0.52	0.795	1.1	1.54
Gen. power	0.108	0.403	0.7	1.304	1.91	2.49	3.045	3.52	4.04
$E_0 I$	0.348	0.49	0.737	1.32	1.91	2.51	3.1	3.66	4.31
P.F.	0.31	0.822	0.947	0.988	1.0	0.994	0.982	0.963	0.937

Section B. $E_0 = 1$

$$P = 3.16[\cos(\alpha - \beta) - 0.309]$$

β°	0	5	10	20	30	40	50	60	α°
$\cos(\alpha - \beta)$	0.309	0.391	0.469	0.616	0.743	0.848	0.927	0.978	1.0
$\cos(\alpha - \beta) - 0.309$	0.0	0.082	0.160	0.307	0.434	0.539	0.618	0.669	0.691
P	0.0	0.259	0.505	0.97	1.37	1.70	1.95	2.11	2.18

$$I = 3.16 \sqrt{2 - 2 \cos \beta}$$

$2 \cos \beta$	2.0	1.992	1.97	1.88	1.732	1.532	1.286	1.0	0.618
$2 - 2 \cos \beta$	0.0	0.008	0.03	0.12	0.268	0.468	0.714	1.0	1.382
$\sqrt{2 - 2 \cos \beta}$	0.0	0.0893	0.173	0.346	0.518	0.684	0.845	1.0	1.175
I	0.0	0.282	0.547	1.094	1.638	2.16	2.67	3.16	3.71

$$\text{Power factor} = \frac{P + 0.1I^2}{I}$$

$0.1I^2$	0.0	0.008	0.03	0.12	0.269	0.468	0.714	1.0	1.38
$P + 0.1I^2$	0.0	0.267	0.535	1.09	1.639	2.168	2.664	3.11	3.56
P.F.	0.947	0.978	0.995	1.0	1.0	0.998	0.984	0.96

Section C. $E_0 = 0.9$

$$P = 3.16 [0.9 \cos(\alpha - \beta) - 0.309]$$

β°	0	5	10	20	30	40	50	60	α
$0.9 \cos(\alpha - \beta)$	0.278	0.352	0.422	0.555	0.669	0.763	0.835	0.88	0.9
$0.9 \cos(\alpha - \beta) - 0.309$	-0.031	0.043	0.113	0.246	0.36	0.454	0.526	0.571	0.591
P	-0.098	0.136	0.357	0.777	1.138	1.435	1.662	1.805	1.87

$$I = 3.16 \sqrt{1.81 - 1.8 \cos \beta}$$

$1.8 \cos \beta$	1.8	1.792	1.772	1.691	1.56	1.38	1.158	0.9	0.556
$1.81 - 1.8 \cos \beta$	0.01	0.018	0.038	0.119	0.25	0.43	0.652	0.91	1.254
$\sqrt{1.81 - 1.8 \cos \beta}$	0.1	0.134	0.195	0.345	0.5	0.655	0.807	0.954	1.12
I	0.316	0.423	0.616	1.09	1.58	2.07	2.55	3.015	3.54

$$\text{P.F.} = \frac{P + 0.1I^2}{0.9I}$$

$0.1I^2$	0.01	0.0179	0.038	0.119	0.25	0.43	0.652	0.91	1.254
$P + 0.1I^2$	-0.088	0.1539	0.395	0.896	1.388	1.865	2.314	2.715	3.124
P.F.	0.309	0.405	0.712	0.913	0.975	1.0	1.0	1.0	0.98

2nd Case. Section A.

$$E_0 = 1.1, e = 1, r = 0.2, x = 0.1, \tan \alpha = \frac{0.1}{0.2} = 0.5, \alpha = 26^\circ 36'$$

$$Z = \sqrt{0.04 + 0.01} = 0.2236, \frac{e}{z} = 4.47, e \cos \alpha = 0.8942$$

$$P = \frac{e}{z} [E_0 \cos (\alpha - \beta) - e \cos \alpha] = 4.47[1.1 \cos (\alpha - \beta) - 0.8942].$$

β°	0	2.5	5	10	15	20	α
$\alpha - \beta$	26.6	24.1	21.6	16.6	11.6	6.6	0.0
$\cos (\alpha - \beta)$	0.8942	0.9128	0.9298	0.9584	0.9796	0.9934	1.0
$E_0 \cos (\alpha - \beta)$	0.984	1.004	1.022	1.055	1.078	1.093	1.1
[]	0.0898	0.1099	0.1278	0.1608	0.1838	0.1988	0.2058
P	0.401	0.490	0.571	0.719	0.822	0.889	0.92

$$I = \frac{1}{z} \sqrt{E_0^2 + e^2 - 2eE_0 \cos \beta} = 4.47 \sqrt{2.21 - 2.2 \cos \beta}$$

$\cos \beta$	1.0	0.999	0.9962	0.9848	0.9659	0.9397	0.8942
$2.2 \cos \beta$	2.2	2.198	2.192	2.165	2.126	2.067	1.967
$2.21 - 2.2 \cos \beta$	0.01	0.012	0.018	0.045	0.084	0.143	0.243
$\sqrt{2.21 - 2.2 \cos \beta}$	0.1	0.1093	0.134	0.212	0.29	0.378	0.493
I	0.447	0.489	0.599	0.948	1.297	1.69	2.204

$$\text{P.F.} = \frac{P + I^2 r}{E_0 I} = \frac{P + 0.2I^2}{1.1I}$$

$0.2I^2$	0.04	0.048	0.072	0.18	0.337	0.572	0.975
$P + 0.2I^2$	0.441	0.538	0.643	0.899	1.159	1.461	1.895
$1.1I$	0.4915	0.538	0.658	1.043	1.426	1.86	2.424
P.F.	0.897	1.00	0.978	0.861	0.811	0.785	0.781

2nd Case. Section B.

$$E_0 = 1; P = 4.47[\cos (\alpha - \beta) - 0.8942]$$

β°	0	2.5	5	10	15	20	α
$\cos (\alpha - \beta)$	0.8942	0.9128	0.9298	0.9584	0.9796	0.9934	1.0
[]	0.0	0.0186	0.0356	0.0642	0.0854	0.0992	0.1058
P	0.0	0.0832	0.1592	0.287	0.382	0.443	0.473

$$I = 4.47 \sqrt{2 - 2 \cos \beta}$$

$2 \cos \beta$	2.0	1.998	1.9924	1.9696	1.9318	1.8794	1.7884
$2 - 2 \cos \beta$	0.0	0.002	0.0076	0.0304	0.0682	0.1206	0.2116
$\sqrt{2 - 2 \cos \beta}$	0.0	0.0447	0.0871	0.174	0.261	0.347	0.46
I	0.0	0.2	0.39	0.779	1.168	1.552	2.06

$$\text{P.F.} = \frac{P + 0.2I^2}{I}$$

0.2I ²	0.0	0.008	0.0305	0.1216	0.273	0.483	0.85
P + 0.2I ²	0.0	0.0912	0.1897	0.4086	0.655	0.926	1.323
P.F.	0.456	0.485	0.525	0.561	0.597	0.643

2nd Case. Section C.

$$E_0 = 0.9; P = 4.47[0.9 \cos(\alpha - \beta) - 0.8942]$$

β°	0	2.5	5	10	15	20	α
0.9 cos($\alpha - \beta$)	0.805	0.822	0.836	0.863	0.882	0.894	0.9
[]	-0.0892	-0.0722	-0.0582	-0.0312	-0.0122	-0.0002	0.0058
P	-0.4	-0.323	-0.26	-0.1395	-0.0545	-0.00894	0.026

$$I = 4.47\sqrt{1.81 - 1.8 \cos \beta}$$

1.8 cos β	1.8	1.798	1.793	1.772	1.74	1.692	1.61
1.81 - 1.8 cos β	0.01	0.012	0.017	0.038	0.07	0.118	0.20
$\sqrt{1.81 - 1.8 \cos \beta}$	0.1	0.1093	0.1303	0.1947	0.2645	0.3435	0.447
I	0.447	0.489	0.583	0.871	1.183	1.535	2.0

$$\text{P.F.} = \frac{P + 0.2I^2}{0.9I}$$

0.2I ²	0.04	0.048	0.068	0.152	0.28	0.472	0.8
P + 0.2I ²	-0.36	-0.275	-0.192	0.0125	0.2255	0.463	0.826
0.9I	0.4025	0.44	0.525	0.785	1.066	1.382	1.8
P.F.	-0.894	-0.625	-0.3655	0.0159	0.2115	0.335	0.459

3d Case. Section A. $E_0 = 1.1$.

$$\text{Max. mech. power} = P_m = \frac{e}{z} [E_0 - e \cos \alpha] = \frac{1}{z} [1.1 - \cos \alpha]$$

(1) $x = 0.1; r = \text{variable}$

r	0.025	0.05	0.1	0.2	0.3	0.4	0.6
z	0.103	0.1118	0.141	0.223	0.316	0.412	0.608
cos α	0.2425	0.447	0.707	0.897	0.95	0.972	0.987
1.1 - cos α	0.8575	0.653	0.392	0.203	0.15	0.128	0.113
P _m	8.32	5.85	2.78	0.91	0.475	0.311	0.186

(2) $x = 0.2$

z	0.2015	0.206	0.223	0.273	0.36	0.447	0.632
cos α	0.124	0.2426	0.448	0.733	0.833	0.895	0.95
1.1 - cos α	0.976	0.8574	0.652	0.367	0.267	0.205	0.15
P _m	4.85	4.16	2.925	1.345	0.741	0.458	0.2375

3d Case. Section B. $E_0 = 1$.

$$(1) x = 0.1; P_m = \frac{1}{x} (1 - \cos \alpha)$$

$1 - \cos \alpha$	0.7575	0.553	0.293	0.103	0.05	0.028	0.013
P_m	7.35	4.95	2.07	0.462	0.158	0.068	0.0214

(2) $x = 0.2$

$1 - \cos \alpha$	0.876	0.7574	0.552	0.267	0.167	0.105	0.05
P_m	4.35	3.68	2.475	0.978	0.463	0.235	0.079

3d Case. Section C. $E_0 = 0.9$

(1) $x = 0.1$

$0.9 - \cos \alpha$	0.6575	0.453	0.193	0.003	-0.05	-0.072	-0.087
P_m	6.38	4.05	1.365	0.01346	-0.158	-0.175	-0.143

(2) $x = 0.2$

$0.9 - \cos \alpha$	0.776	0.6574	0.452	0.167	0.067	0.005	-0.05
P_m	3.85	3.19	2.015	0.611	0.1862	0.0112	-0.0791

Figs. 247, 248 and 249 show the curves plotted for the three cases of the problem.

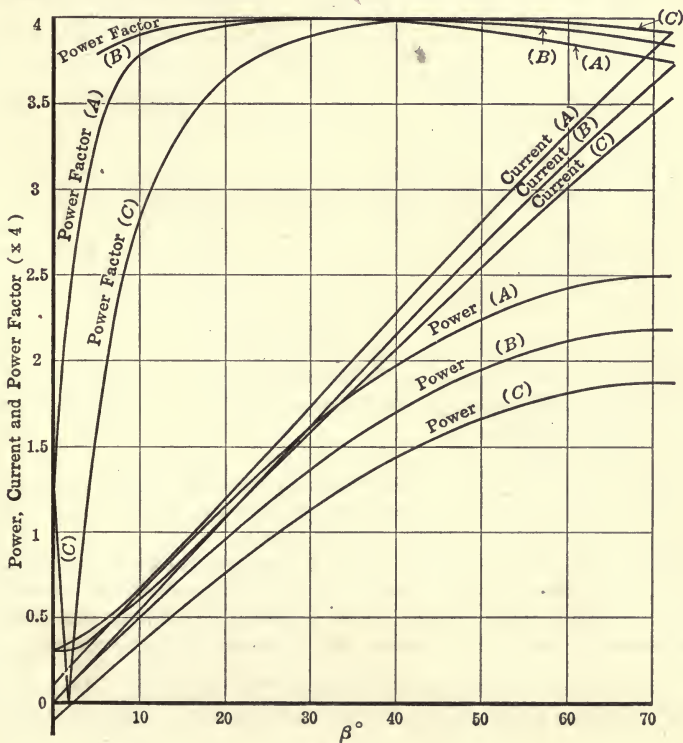

FIG. 247.

It is to be noted that the angle β , representing phase relationship of E_0 and E , is used as the independent variable, for convenience only. The real independent variable in the first and second cases of the problem is power. It is not so convenient to choose power for this calculation because its choice depends upon the angle β ; moreover, there would be little interest in making β the object of the calculation. The values obtained in the

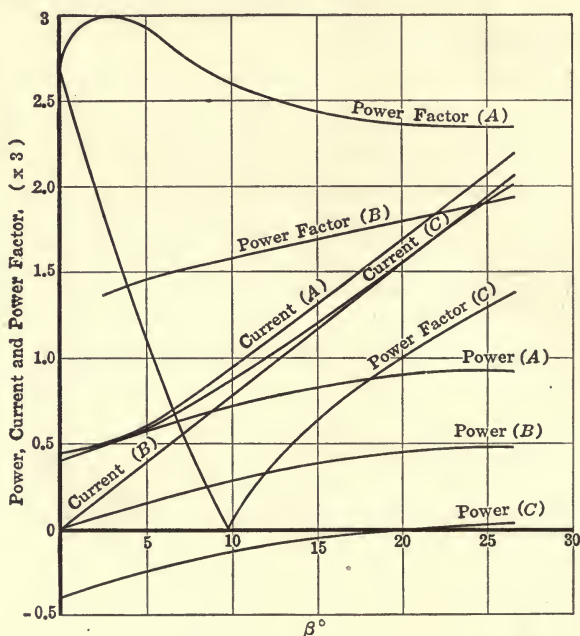

FIG. 248.

calculations permit of the plotting of other interesting curves, for example, the performance curves of current and power factor against the power.

Problem 105.—From the values obtained, plot and discuss the curves of current and power factor against the power for the three cases of constant impressed voltage and constant induced voltage.

Problem 106.—Show, from a study of the curves already obtained, that when a synchronous motor refuses to operate satisfactorily under load the remedy for the trouble may be found either in decreasing the resistance (increasing the copper cross-section) or in increasing the reactance.

The practical difficulty of looking at the motor from the point of view of these problems is that the induced voltage, E , is not

readily maintained constant. E depends upon F_r , the resultant magnetomotive force, or, more strictly, upon the resultant flux produced by F_r , whereas only the total field excitation F_f is under external control.

The practical problem, therefore, is to vary F_f under the condition of constant load, or its converse, to vary the load with

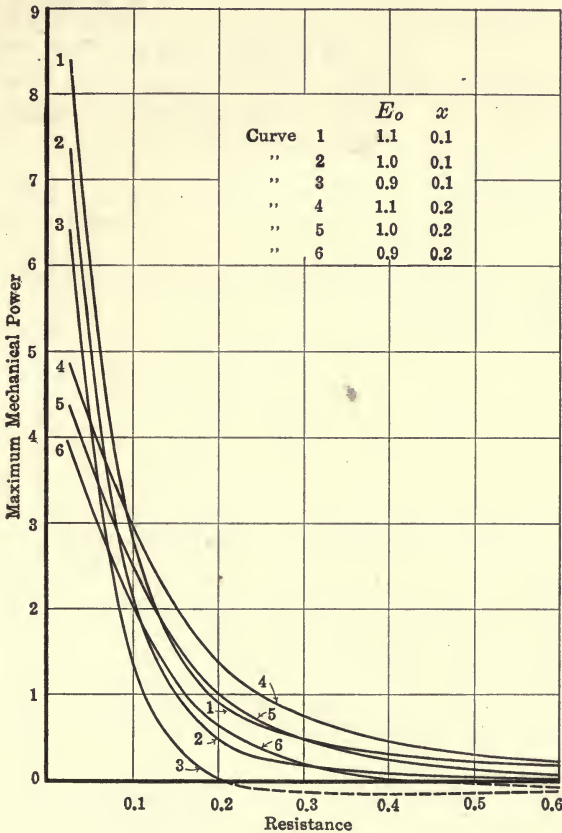

FIG. 249.

constant F_f . In such cases E will also vary, and its value may be determined by calculation. Curves plotted between the current input, I , and either E or F_f , the power of the motor being constant, are called phase characteristics. In Fig. 250 is shown the vector diagram of the synchronous motor drawn to show the cur-

rent, I , as the zero vector. The power factor is indicated by the phase angle, δ , between E_0 and I . As previously obtained,

$$\begin{aligned} E &= iz - E_0 \\ &= i(r + jx) - E_0 \cos \delta - jE_0 \sin \delta \\ &= ir - E_0 \cos \delta + j(ix - E_0 \sin \delta) \end{aligned}$$

and

$$E = \sqrt{(ir - E_0 \cos \delta)^2 + (ix - E_0 \sin \delta)^2}$$

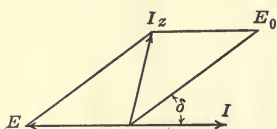

FIG. 250.

When δ is positive, the current lags. To find $\cos \delta$ and $\sin \delta$: Remembering that all values are per phase, the mechanical power is:

$$P = \text{elec. power} - I^2r = E_0I \cos \delta - I^2r \quad (127)$$

But P , E_0 and r are all known, being given or assumed.

Therefore, solving,

$$\cos \delta = \frac{P + I^2r}{E_0I}$$

and

$$\sin \delta = \sqrt{1 - \cos^2 \delta}.$$

It is then necessary merely to assume values of I . Evidently, for constant power, I will be minimum when $\cos \delta = 1$. Hence, from (127),

$$I_{min.} = \frac{E_0}{2r} - \sqrt{\frac{E_0^2}{4r^2} - \frac{P}{r}}$$

Assuming now values of I , beginning with $I_{min.}$, $\cos \delta$ and $\sin \delta$, and finally E , may be obtained and tabulated for each value chosen.

As δ may be either plus or minus, both values must be taken.

Under the conditions of test, E is not known, but the values of the field excitation or the field current which is proportional to it are known. Having just obtained E by calculation, the field excitation, F_f , is next determined as was done for the case of the generator (page 225). In this case, E terminal was the zero vector, and F_f was found to be

$$F_f = \sqrt{(-bC - mi)^2 + (aC - mi_1)^2}$$

where

$$a = e + ir - i_1x$$

$$b = ix + i_1r$$

$$C = \frac{F_r}{E} = 1 \text{ (for convenience)}$$

$$m = \frac{F_a}{I} = 0.5 \text{ (for convenience).}$$

Problem 107.—Determine and plot the phase characteristics for the motor problem for the three conditions:

A. $E_0 = 1.1, \quad E = 1$

B. $E_0 = 1, \quad E = 1$

C. $E_0 = 0.9, \quad E = 1$

when

$$P = 1, r = 0.1, x = 0.3.$$

Solution.—The curve between e and I is first obtained from the equation

$$E = \sqrt{(Ir - E_0 \cos \delta)^2 + (Ix - E_0 \sin \delta)^2}.$$

by substituting values of I , for which $\sin \delta$ and $\cos \delta$ can be determined, and solving for E .

This curve, E vs. I , is plotted.

Next, the field excitation is obtained from equation

$$F_f = \sqrt{(-bC - mi)^2 + (aC - mi_1)^2}$$

or, more simply,

$$F_f = \sqrt{(-mi)^2 + (CE - mi_1)^2},$$

since we deal directly with induced e.m.f. as the zero vector, and not with the terminal voltage and IZ drops. The curve F_f vs. I is then plotted.

The data given are:

$$E_0 = \text{(A) } 1.1, \text{ (B) } 1, \text{ (C) } 0.9, P = 1, r = 0.1, x = 0.3, C = 1,$$

$$m = 0.5, i = I \cos \delta, i_1 = I \sin \delta.$$

To get minimum current, $\cos \delta = 1, \sin \delta = 0$.

$$\begin{aligned} \text{(A) } I_{min.} &= \frac{E_0}{2r} - \sqrt{\frac{E_0^2}{4r^2} - \frac{P}{r}} = \frac{1.1}{0.2} - \sqrt{\frac{1.212}{0.04} - \frac{1}{0.1}} \\ &= 5.5 - \sqrt{30.3 - 10} = 5.5 - 4.5 = 1. \end{aligned}$$

$$\text{(B) } I_{min.} = \frac{1}{0.2} - \sqrt{\frac{1}{0.04} - 10} = 5 - 3.87 = 1.13.$$

$$\text{(C) } I_{min.} = \frac{0.9}{0.2} - \sqrt{\frac{0.81}{0.04} - 10} = 4.5 - 3.24 = 1.3$$

$$\text{Also, } \cos \delta = \frac{P + I^2r}{E_0I} = \frac{1 + 0.1I^2}{E_0I}; \sin \delta = \sqrt{1 - \cos^2 \delta}$$

$$\text{(A) } \cos \delta = \frac{1}{1.1I} + \frac{0.1I^2}{1.1I} = \frac{0.909}{I} + 0.0909I$$

$$\text{(B) } \cos \delta = \frac{1}{I} + 0.1I$$

$$\text{(C) } \cos \delta = \frac{1.11}{I} + 0.111I.$$

Tabulating, Case (A):

I	1.0	1.1	1.3	1.5	1.8	2.5	4.0	
I_r	0.1	0.11	0.13	0.15	0.18	0.25	0.4	
I_x	0.3	0.33	0.39	0.45	0.54	0.75	1.2	
$\frac{0.909}{I}$	0.909	0.826	0.7	0.605	0.505	0.363	0.227	
$0.909I$	0.0909	0.1	0.1181	0.1363	0.1637	0.2272	0.3633	
$\cos \delta$	1.0	0.926	0.8181	0.7413	0.6687	0.5902	0.5903	
$\sin \delta$	0.0	± 0.374	± 0.574	± 0.67	± 0.744	± 0.805	± 0.805	
$E_0 \cos \delta$	1.1	1.02	0.9	0.815	0.735	0.65	0.65	
$E_0 \sin \delta$	0.0	± 0.411	± 0.631	± 0.737	± 0.818	± 0.885	± 0.885	
$I_r - E_0 \cos \delta$	-1.0	-0.91	-0.77	-0.665	-0.555	-0.4	-0.25	
$(I_r - E_0 \cos \delta)^2$	1.0	0.83	0.593	0.442	0.308	0.16	0.0625	
$I_x - E_0 \sin \delta$	0.3	-0.081	-0.241	-0.287	-0.278	-0.135	+0.315	Where E $\sin \delta$ is +
$(I_x - E_0 \sin \delta)^2$	0.09	0.00657	0.0581	0.0875	0.0773	0.01825	0.0994	
E^2	1.09	0.83657	0.6511	0.5245	0.3853	0.17825	0.1619	
E	1.042	0.914	0.807	0.724	0.62	0.422	0.402	Lagging current.
$I_x - E_0 \sin \delta$	0.3	0.741	1.021	1.187	1.358	1.635	2.005	Where E_0 $\sin \delta$ is -.
$(I_x - E_0 \sin \delta)^2$	0.09	0.55	1.045	1.412	1.845	2.68	4.02	
E^2	1.09	1.38	1.638	1.854	2.153	2.84	4.0825	
E	1.042	1.172	1.278	1.36	1.466	1.681	2.02	Leading current.
i	1.0	1.02	1.064	1.113	1.204	1.478	2.362	
i_1	0.0	± 0.411	± 0.745	± 1.005	± 1.34	± 2.013	± 3.22	
mi	0.5	0.51	0.532	0.556	0.602	0.739	1.181	
$-mi_1^2$	0.25	0.26	0.284	0.31	0.363	0.547	1.4	
mi_1	0.0	± 0.205	± 0.372	± 0.502	± 0.67	± 1.006	± 1.61	
$(CE - mi_1)$	1.042	0.709	0.435	0.222	-0.05	-0.584	-1.208	Lagging.
$(CE - mi_1)^2$	1.09	0.503	0.19	0.0494	0.0025	0.341	1.46	Lagging.
$(CE - mi_1)$	1.042	1.377	1.650	1.862	2.136	2.687	3.63	Leading.
$(CE - mi_1)^2$	1.09	1.9	2.73	3.47	4.56	7.25	13.2	Leading.
F_f^2	1.34	0.763	0.474	0.3594	0.3655	0.888	2.86	Lagging.
F_f^2	1.34	2.16	3.014	3.78	4.923	7.797	14.6	Leading.
F_f	1.157	0.873	0.688	0.6	0.605	0.941	1.69	Lagging.
F_f	1.157	1.47	1.735	1.94	2.218	2.788	3.82	Leading.

Case B:

I	1.13	1.2	1.4	1.8	2.5	4.0	
I_r	0.113	0.12	0.14	0.18	0.25	0.4	
I_x	0.339	0.36	0.42	0.54	0.75	1.2	
$\frac{1}{I}$	0.885	0.833	0.714	0.555	0.4	0.25	
$0.1I$	0.113	0.12	0.14	0.18	0.25	0.4	
$\cos \delta$	1.00	0.953	0.854	0.735	0.65	0.65	
$I_r - E_0 \cos \delta$	-0.887	-0.833	-0.714	-0.555	-0.4	-0.25	
$(I_r - E_0 \cos \delta)^2$	0.788	0.695	0.51	0.308	0.16	0.0625	
$\sin \delta$	0.0	± 0.303	± 0.520	± 0.678	± 0.760	± 0.760	
$I_x - E_0 \sin \delta$	0.339	0.057	-0.10	-0.138	-0.01	0.44	Where $\sin \delta$ is +.
$(I_x - E_0 \sin \delta)^2$	0.115	0.00325	0.01	0.0191	0.0001	0.194	
E^2	0.903	0.69825	0.52	0.3271	0.1601	0.2565	
E	0.95	0.835	0.72	0.572	0.40	0.5065	Lagging
$I_x - E_0 \sin \delta$	0.663	0.94	1.218	1.51	1.96	Where δ is -

Case B:—(Continued)

$(I_x - E_0 \sin \delta)^2$	0.44	0.887	1.488	2.285	3.85	
E^2	1.135	1.397	1.796	2.445	3.9125	
E	1.064	1.18	1.34	1.56	1.977	Leading.
i	1.13	1.145	1.196	1.324	1.625	2.6	
mi	0.565	0.5725	0.598	0.662	0.8125	1.3	
$(-mi)^2$	0.32	0.328	0.359	0.44	0.66	1.69	
i_1	0.0	± 0.3635	± 0.728	± 1.22	± 1.9	± 3.04	
mi_1	0.0	± 0.18175	± 0.364	± 0.61	± 0.95	± 1.52	
$CE - mi_1$	0.95	0.653	0.356	-0.038	-0.55	-1.014	Lagging.
$(CE - mi_1)^2$	0.903	0.426	0.127	0.001445	0.303	1.03	
F_f^2	1.223	0.754	0.486	0.441	0.963	2.72	
F_f	1.105	0.868	0.697	0.664	0.981	1.648	Lagging.
$CE - mi_1$	1.246	1.544	1.95	2.51	3.50	Leading.
$(CE - mi_1)^2$	1.558	2.39	3.8	6.3	12.25	
F_f^2	1.886	2.749	4.24	6.96	13.94	
F_f	1.373	1.657	2.057	2.64	3.73	Leading.

Case C:

I	1.3	1.35	1.5	1.8	2.5	4.0	
I_r	0.13	0.135	0.15	0.18	0.25	0.4	
I_x	0.39	0.405	0.45	0.54	0.75	1.2	
$\frac{1.11}{I}$	0.854	0.823	0.74	0.617	0.444	0.2775	
$0.111I$	0.1444	0.15	0.1665	0.2	0.2775	0.444	
$\cos \delta$	1.0	0.973	0.9065	0.817	0.7215	0.7215	
$E_0 \cos \delta$	0.9	0.876	0.816	0.735	0.65	0.65	
$I_r - E_0 \cos \delta$	-0.77	-0.741	-0.666	-0.555	-0.4	-0.25	
$(I_r - E_0 \cos \delta)^2$	0.593	0.55	0.445	0.308	0.16	0.0625	
$\sin \delta$	0.0	± 0.2306	± 0.4222	± 0.5767	± 0.6925	± 0.6925	
$E_0 \sin \delta$	0.0	± 0.2078	± 0.38	± 0.519	± 0.623	± 0.623	
$I_x - E_0 \sin \delta$	0.39	0.1972	0.07	0.021	0.127	0.577	Where $\sin \delta$ is +.
$(I_x - E_0 \sin \delta)^2$	0.152	0.039	0.0049	0.00044	0.0161	0.333	
E^2	0.745	0.589	0.4499	0.30844	0.1761	0.3955	
E	0.8625	0.767	0.67	0.555	0.419	0.629	Lagging.
$I_x - E_0 \sin \delta$	0.6128	0.83	1.059	1.373	1.823	Where $\sin \delta$ is -.
$(I_x - E_0 \sin \delta)^2$	0.376	0.69	1.12	1.89	3.33	
E^2	0.926	1.135	1.428	2.05	3.3925	
E	0.961	1.065	1.193	1.43	1.84	Leading.
i	1.3	1.315	1.36	1.472	1.805	2.89	
mi	0.65	0.6575	0.68	0.736	0.9025	1.445	
$(-mi)^2$	0.423	0.4325	0.463	0.542	0.815	2.09	
i_1	0.0	± 0.3115	± 0.633	± 1.039	± 1.73	± 2.77	
mi_1	0.0	± 0.15575	± 0.3165	± 0.5195	± 0.865	± 1.385	
$CE - mi_1$	0.8625	0.6113	0.3535	0.0355	-0.446	-0.756	Lagging.
$(CE - mi_1)^2$	0.745	0.375	0.125	0.00126	0.199	0.572	
F_f^2	1.168	0.8075	0.588	0.54326	1.014	2.662	
F_f	1.08	0.898	0.766	0.736	1.007	1.63	Lagging.
$CE - mi_1$	1.117	1.382	1.7125	2.295	3.225	Leading.
$(CE - mi_1)^2$	1.25	1.915	2.945	5.29	10.4	
F_f^2	1.6825	2.378	3.487	6.105	12.49	
F_f	1.297	1.54	1.865	2.472	3.535	Leading.

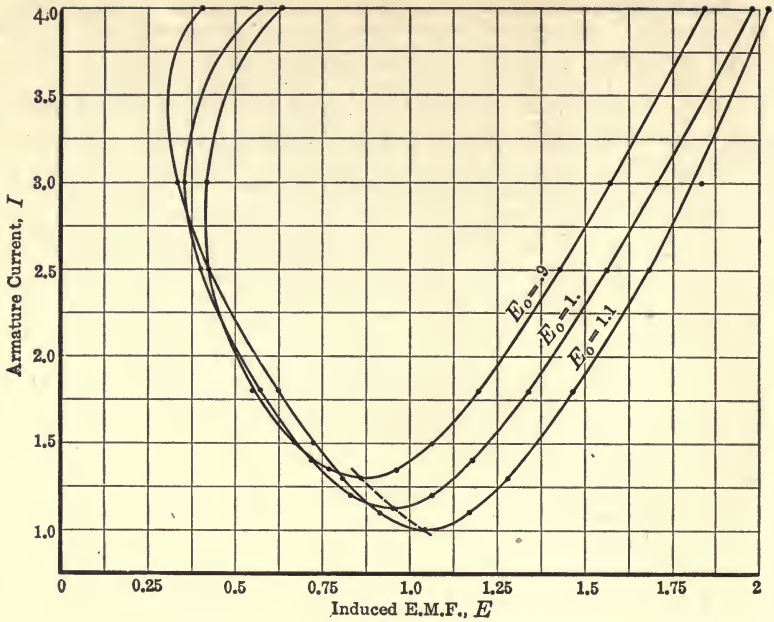

FIG. 251.

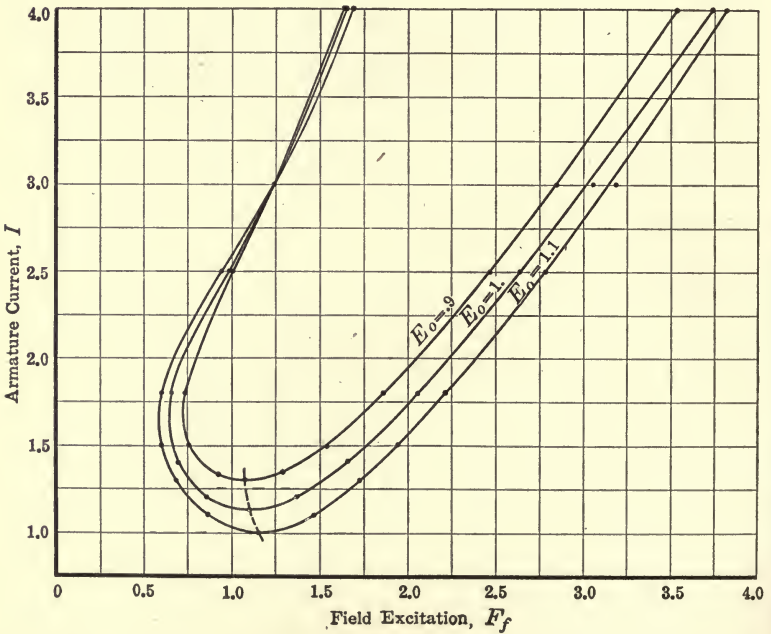

FIG. 252.

Phase characteristic curves are shown in Figs. 251 and 252 for the three cases considered.

It is also of interest to see how the phase characteristic is affected by a change in the amount of the motor load. Accordingly curves are drawn for the second case ($E_0 = 1, E = 1$), under

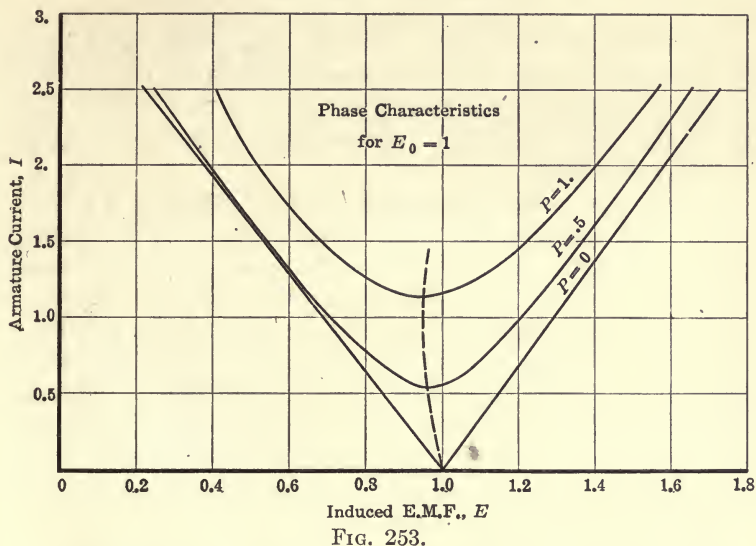

FIG. 253.

the three conditions $P = 1, P = 0.5, P = 0$. These are shown in Fig. 253. These curves are sometimes called V-curves. As the friction loss is included in the load, the condition $P = 0$ can never be attained. In practice, the curve obtained with the motor running light approximates to this, however. The dotted line gives the locus of the minimum current points which is also the current at unity power factor.

CHAPTER XLII

INDUCTION MOTORS

The production of torque, and the consequent operation, of direct-current motors is readily understood since the condition of wires carrying current placed in a field at right angles to the direction of the lines of force is quite apparent in both the shunt and the series types.

If alternating current is supplied to the terminals of a direct-current series motor, the motor might reasonably be expected to run. In such a case the current is the same in both the field and the armature coils and since the flux is in time-phase with the current which produces it, the condition for the production of torque is satisfied. Moreover, since the alternation of the flux and the current is simultaneous, the direction of the torque is not changed though it pulsates in value. Such a motor would have a low power factor, due to its great inductance, and low efficiency due to its great copper and core losses, the latter being excessive with unlaminated field structure.

When alternating current is supplied to a shunt motor, the condition for operation is not so well met. In this case, the currents in the armature and the field coils will no longer be in time-phase with each other. The current in the field coils will lag by nearly 90 time degrees behind the voltage, while that in the armature will have only a slight time lag. This difficulty might be obviated theoretically by placing a suitable condenser in series in the field circuit. Practically, however, such a condenser would be too large and expensive to warrant its use.

The question then naturally arises: Why not excite the field from the other phase of a two-phase supply? The trouble with such a solution, assuming that a two-phase supply is available, is that one-phase would be loaded with a wattless current; moreover, the armature reaction and the torque would be pulsating.

A natural suggestion might be to run two motors so as to balance the phases.

The next step in the development of the alternating-current motor would be to omit the commutator, applying the well-known

principle of the production of currents by induction, as is done in the transformer. In this case the field winding acts as the primary, and the armature winding as the secondary coil. Currents induced in the armature would have directions as shown by the crosses and dots in Fig. 254.

This arrangement would give no resultant torque, the torque due to the upper conductors being equal and opposite to that due to the lower conductors.

Therefore another set of poles (shown dotted) should be introduced in space quadrature to the original poles, and the flux due to these new poles should be in time-phase with the armature current.

This means a quadrature relationship in both time and space between the two sets of poles, exactly as is the case of a two-phase

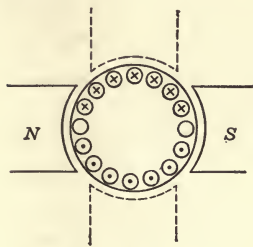

FIG. 254.

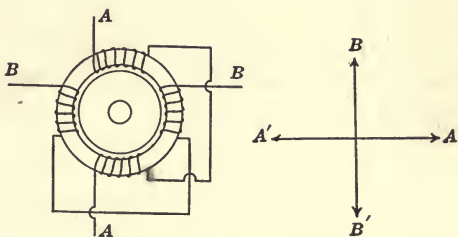

FIG. 255.

system. The resultant flux acting on the armature forms the well-known rotary magnetic field.

The Rotary Field.—The production of the rotary magnetic field may be considered as due to the currents in two sets of coils as shown in Fig. 255 (a). The current in phase *A* sets up an alternating flux through the armature in the horizontal direction, while that of phase *B* sets up a similar flux in the vertical direction. These fluxes have the space relationship shown in Fig. 255 (b).

The time relationship of the fluxes is shown by their equations. Thus

$$\begin{aligned}\phi_A &= \Phi_m \sin \omega t \\ \phi_B &= \Phi_m \sin (\omega t + 90)\end{aligned}$$

The resultant flux at any instant will then be composed of a horizontal component having the value of ϕ_A at that instant, and a vertical component ϕ_B at the same instant. This may be expressed as

$$\phi = \phi_A + j\phi_B = \Phi_m(\sin \omega t - \cos \omega t)$$

Tabulating:

(ωt°)	0	30	60	90	120	150	180
Sin ωt	0	0.5	0.866	1	0.866	0.5	0
Cos ωt	1	0.866	0.5	0	-0.5	-0.866	-1
Sin $\omega t - j \cos \omega t$	$0 - j1$	$0.5 - j0.866$	$0.866 - j0.5$	1	$0.866 + j0.5$	$0.5 + j0.866$	$j1$

These vectors are shown plotted through 360° in Fig. 257.

Thus, the locus of the ends of the resultant flux vectors is a circle of radius Φ_m , and the speed of rotation of the flux is f , the frequency of the alternating current.

Problem 108.—In a similar manner, show the relationship of the fluxes in a three-phase armature, and prove that the resultant flux is a uniformly rotating vector of magnitude $1.5\Phi_m$.

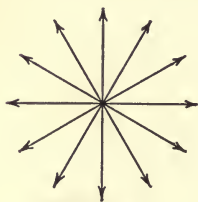

FIG. 256.

Considering, now, that such a rotating flux will be cutting the conductors of the armature; if the latter is short-circuited it is evident that very large currents would be induced in it. As the speed of the armature increases, the rate of cutting of its conductors by the flux decreases, with a consequent decrease of induced e.m.f. and current. If the armature were to run at synchronous speed, no current would be set up in its conductors, and hence there could be no torque.

Theory of Operation.—Assuming a 1:1 ratio of turns of the two windings, as was done in the case of transformers.

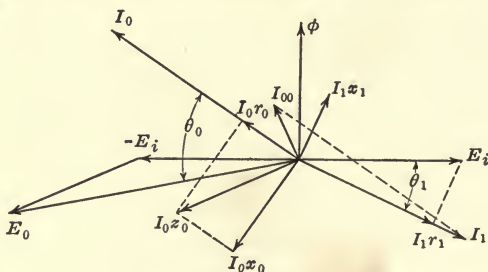

FIG. 257.

Case 1. Armature at Standstill.—Let an electromotive force be impressed upon the primary, or field, winding so as to cause the current I_{00} to flow. This current sets up a flux, ϕ , which induces electromotive forces, E_i , in both windings. Since the

secondary, or armature, is short-circuited, the current I_1 flows, so that E_i is used up in overcoming the resistance, $I_1 r_1$, and the reactance, $I_1 x_1$, of the secondary.

The primary current I_0 as in the transformer, must be the vector sum of I_{00} , the exciting current, and $-I_1$ the load component.

The impressed e.m.f. E_0 is, likewise, the sum of the $I_0 Z_0$ drop and $-E_i$, that which is supplied to overcome the induced e.m.f. in the primary. Primary and secondary phase angles are given by θ_0 and θ_1 , respectively (Fig. 257).

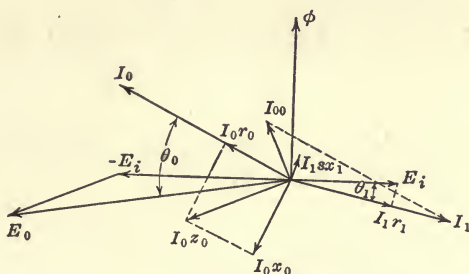

FIG. 258.

Case 2. Armature at about Half-speed.—With the same impressed e.m.f., E_0 , the vector diagram for half-speed becomes altered, due to the reduced E_i in the secondary and the reduced secondary reactance. Assuming constant secondary inductance, L_1 , the secondary reactance, $x_1 = 2\pi f_1 L_1$, is directly proportional to the difference in speed between the rotary field and the armature. This difference in speed, expressed in per cent. of synchronous speed, is called the “slip” of the motor, and is denoted by s . Thus, at standstill $s = 1$, and $x = x_1$; at half-speed, $s = 0.5$ and $x = 0.5x_1$. For any speed, $1 - s$, $x = sx_1$.

As the speed increases, therefore, the secondary reactance becomes less important, θ_1 decreases, and the value of I_1 is governed to a greater extent by the secondary resistance.

Since E_i decreases in the secondary, I_1 also tends to decrease, this tendency being counteracted in part, however, by the reduction in reactance. The primary current, I_0 and the $I_0 z_0$ drop are reduced nearly in proportion to I_1 . E_0 being constant, the voltage ($-E_i$) is somewhat increased since $-E_i = E_0 - I_0 z_0$. Therefore I_{00} is increased, and likewise the flux ϕ .

The entire induction motor circuit may be represented by an "equivalent circuit," as was done with the transformer, page 178, in which, however, the slip, s , enters as a factor with reference to both the secondary reactance and the load. This diagram, Fig. 259, refers to one phase only. E_0 is phase voltage, and $I_1^2 R$ is the n th part of the motor load, where n is the number of phases. The magnitudes of the various quantities are readily apparent from an inspection of the "equivalent circuit" diagram, whatever may be the load placed upon the motor.

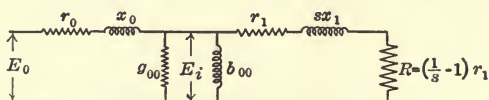

FIG. 259.

Referring to the vector diagrams, Figs. 257 and 258, or to the "equivalent circuit" diagram, Fig. 259.

Let

I_m = magnetizing current,

I_h = core-loss current,

$Z_0 = r_0 + j x_0$ = primary impedance,

$Z_1 = r_1 + j s x_1$ = secondary impedance.

Then

$$g_{00} = \frac{I_h}{e_i} = \text{conductance of exciting circuit,}$$

and

$$b_{00} = \frac{I_m}{e_i} = \text{susceptance of exciting circuit,}$$

where

$$e_i = \text{primary induced e.m.f.}$$

and I_m is a positive quantity so that b_{00} is always negative, these quantities being all taken per phase.

Also,

$$\dot{s} = \text{slip.}$$

At standstill, $s = 1$; at synchronous speed, $s = 0$; at normal full-load, s is usually about 0.02 in per cent. of synchronous speed.

Then,

$$s e_i = \text{secondary induced e.m.f.}$$

Let e_i be chosen zero vector. Secondary current may be written

$$I_1 = \frac{se_i}{r_1 + jsx_1} = ei(a_1 + ja_2)$$

where

$$a_1 = \frac{sr_1}{r_1^2 + s^2x_1^2}$$

and

$$a_2 = -\frac{s^2x_1}{r_1^2 + s^2x_1^2}.$$

The exciting current is

$$I_{00} = e_i Y_{00} = e_i(g_{00} + jb_{00})$$

The primary current is

$$\begin{aligned} I_0 &= I_{00} + I_1 = e_i(a_1 + g_{00} + j(a_2 + b_{00})). \\ &= e_i(b_1 + jb_2). \end{aligned}$$

The e.m.f. consumed by the primary impedance is $I_0 z_0 = e_i(b_1 + jb_2)(r_0 + jx_0)$ and the impressed voltage is

$$\begin{aligned} E_0 &= e_i + I_0 z_0 = e_i + e_i(b_1 + jb_2)(r_0 + jx_0) \\ &= e_i[(1 + b_1 r_0 - b_2 x_0) + j(b_1 x_0 + b_2 r_0)] \\ &= e_i(c_1 + jc_2) \end{aligned}$$

$$E_0 = e_i \sqrt{c_1^2 + c_2^2}$$

$$\therefore e_i = \frac{E_0}{\sqrt{c_1^2 + c_2^2}}$$

$$I_1 = E_0 \sqrt{\frac{a_1^2 + a_2^2}{c_1^2 + c_2^2}}$$

$$I_0 = E_0 \sqrt{\frac{b_1^2 + b_2^2}{c_1^2 + c_2^2}}.$$

The torque, in any motor, is proportional to the current and the flux in time-phase therewith.

If I_1 is the secondary current due to a certain phase of the primary, whose induced e.m.f. is e_i , then the power component of I_1 has been shown to be $e_i a_1$.

$-jI_1$ is evidently the secondary current due to a primary phase which is 90° in space and time behind the former. The induced e.m.f. of this phase is, of course, $-je_i$ and the flux causing the

e.m.f. is 90° in time ahead of the e.m.f. Thus the flux which reacts on the power component of the original secondary current is proportional to $j(-je_i) = ke_i$.

$$\therefore \text{The torque is } ke_i e_i a_1 = ke_i^2 a_1.$$

Torque is often expressed in "synchronous watts," a term which means the number of watts which would be required to give the torque if the motor were running at synchronous speed. k , then becomes 1, and

$$T = e_i^2 a_1 \text{ synchronous watts per phase.}$$

The horsepower per phase is

$$\text{hp./phase} = \frac{e_i^2 a_1}{746} = \frac{2\pi RN \times \text{lb.}}{33,000}$$

where

$$N = \text{r.p.m.} = \frac{120 \times \text{frequency}}{\text{poles}}$$

and R = radius of the rotor in feet.

Thus torque per phase is

$$T/\text{phase} = 0.059 e_i^2 a_1 \times \frac{\text{poles}}{\text{frequency}}, \text{ ft.-lb.}$$

For a three-phase machine

$$T = 3 \times \text{torque per phase} = 0.177 e_i^2 a_1 \times \frac{P}{f}.$$

Since $e_i^2 a_1$, as "synchronous watts" is the output of the motor at synchronous speed, then at any other speed the output, which includes friction would be

$$P_m = e_i^2 a_1 (1 - s).$$

The power input obtained by "telescoping" the vectors E_0 and I_0 is, per phase,

$$\begin{aligned} P_0 &= e_i^2 (c_1 b_1 + c_2 b_2). \\ &= \frac{E_0^2}{c_1^2 + c_2^2} (c_1 b_1 + c_2 b_2). \end{aligned}$$

If f_m = friction per phase, the efficiency is

$$\eta = \frac{\text{output}}{\text{input}} = \frac{P_m - f_m}{P_0}$$

Power factor is

$$\frac{P_0}{E_0 I_0}$$

Apparent efficiency is

$$\frac{P_m - f_m}{E_0 I_0}$$

The total output, neglecting friction, is approximately,

$$3 \times e_i^2 a_1 (1 - s) = \frac{3E_0^2 a_1 (1 - s)}{c_1^2 + c_2^2}$$

To find the maximum output, this quantity may be differentiated and equated to zero. The process is tedious, but by neglecting certain small quantities which appear, the result may be shown as approximately,

$$\text{max. } P_m = \frac{3E_0^2}{r + Z}$$

where

$$r = r_0 + r_1$$

and

$$Z = \sqrt{(r_0 + r_1)^2 + (x_0 + x_1)^2}$$

If there are p phases

$$\text{max. } P_m = \frac{pE_0^2}{r + Z}$$

From the equations just derived it is possible to construct the performance curves for any motor for which the constants are given. These curves show the efficiency, power factor, apparent efficiency, slip and line current, all plotted against the output, usually expressed in horsepower.

Another set of curves of great interest, particularly in respect to the performance of the motor at starting, consists of the speed and line current plotted against the torque.

In comparing actual motors by means of performance curves considerable difficulty is encountered in determining relative merits. If the curves are put on the percentage basis, however, this difficulty vanishes. In order to study properly the effects of different variables in the motor design a number of typical cases are worked out on the percentage basis, as follows:

Problem 269.—A. Let $E_0 = 1$, $r_0 = r_1 = 0.02$, $x_0 = x_1 = 0.12$, $I_m = 0.3$, $I_h = 0.02$, $f_0 = 0.01$ = friction loss.

At synchronous speed, the exciting current only, exists, and $E_0 = E$; approximately.

Therefore the constants g_{00} and b_{00} are obtained as:

$$g_{00} = \frac{I_h}{E_0} = 0.02; b_{00} = -\frac{I_m}{E_0} = -0.3.$$

Tabulating:

Slip	0	0.01	0.02	0.03	0.05	0.08	0.1	0.3	0.5	1.0
$s^2x_1^2$	0.0	0.00	5.76×10^{-6}	13×10^{-6}	36×10^{-6}	92×10^{-6}	1.44×10^{-4}	13×10^{-4}	36.1×10^{-4}	0.0144
Z_1^2	0.0004	0.00040	0.00040	0.00041	0.00044	0.00049	0.00054	0.00170	0.00401	0.0148
sr_1	0.0	0.0002	0.0004	0.0006	0.001	0.0016	0.002	0.006	0.01	0.02
a_1	0.0	0.498	0.988	1.455	2.29	3.25	3.68	3.54	2.49	1.35
s^2x_1	0.0	0.000012	0.000048	0.000108	0.0003	0.000768	0.0012	0.0108	0.03	0.12
a_2	0.0	-0.03	-0.1185	-0.262	-0.688	-1.56	-2.21	-6.75	-7.49	-8.57
b_1	0.02	0.518	1.008	1.475	2.31	3.27	3.7	3.56	2.51	1.37
b_2	-0.3	-0.33	-0.4185	-0.562	-0.988	-1.86	-2.51	-7.05	-7.79	-8.87
b_1^2	0.0004	0.268	1.018	2.18	5.35	10.68	13.7	12.7	6.31	1.88
b_2^2	0.09	0.109	0.176	0.316	0.978	3.44	6.3	49.7	60.8	79.0
$b_1^2 + b_2^2$	0.0904	0.377	1.194	2.496	6.328	14.14	20.0	62.4	67.11	80.88
$\sqrt{b_1^2 + b_2^2}$	0.305	0.614	1.092	1.578	2.515	3.755	4.46	7.9	8.2	8.97
b_1r_0	0.0004	0.0103	0.02016	0.0295	0.0462	0.0654	0.074	0.0712	0.0502	0.0274
b_2x_0	-0.036	-0.0396	-0.0502	-0.0675	-0.1185	-0.223	-0.3015	-0.846	-0.934	-1.065
c_1	1.0364	1.05	1.07	1.097	1.165	1.288	1.375	1.917	1.984	2.092
b_1x_0	0.0024	0.0623	0.121	0.177	0.2775	0.3922	0.444	0.4275	0.301	0.1645
b_2r_0	-0.006	-0.0066	-0.0084	-0.0112	-0.0198	-0.0372	-0.0502	-0.141	-0.1558	-0.1774
c_2	-0.0036	0.0557	0.1127	0.1657	0.2577	0.355	0.3938	0.2865	0.1452	-0.004
c_1^2	1.075	1.1	1.142	1.2	1.358	1.666	1.9	3.67	3.94	4.37
c_2^2	0.00	0.0031	0.0127	0.0275	0.0662	0.126	0.155	0.082	0.0211	0.0001
$c_1^2 + c_2^2$	1.075	1.103	1.155	1.228	1.424	1.787	2.055	3.752	3.961	4.37
$\sqrt{c_1^2 + c_2^2}$	1.036	1.051	1.073	1.109	1.192	1.338	1.432	1.938	1.99	2.09
E_1	0.966	0.95	0.93	0.903	0.838	0.748	0.697	0.516	0.502	0.488
E_1^2	0.932	0.901	0.866	0.815	0.702	0.56	0.485	0.266	0.252	0.238
I_0	0.295	0.583	1.015	1.422	2.11	2.81	3.11	4.01	4.12	4.19
T	0.0	0.45	0.856	1.185	1.608	1.82	1.785	0.943	0.627	0.322
PM	0.0	0.446	0.839	1.149	1.525	1.675	1.605	0.66	0.3135	0.0
$PM - f_0$	0.0	0.436	0.829	1.139	1.515	1.665	1.595	0.65	0.3035	0.0
c_1b_1	0.0207	0.545	1.08	1.618	2.685	4.22	5.08	6.84	4.98	2.865
c_2b_2	0.0011	-0.0184	-0.0472	-0.093	-0.2541	-0.661	-0.989	-2.02	-1.13	0.0355
$c_1b_1 + c_2b_2$	0.0218	0.5266	1.033	1.525	2.431	3.559	4.091	4.82	3.85	2.90
P_0	0.0203	0.474	0.895	1.242	1.705	1.992	1.985	1.282	0.991	0.69
$E_0^{1.0}$	0.295	0.583	1.015	1.422	2.11	2.81	3.11	4.075	4.12	4.34
Eff.	0.0	0.92	0.925	0.915	0.89	0.836	0.803	0.507	0.306	0.0
P. F.	0.069	0.812	0.88	0.874	0.808	0.71	0.638	0.314	0.236	0.159
App. eff.	0.0	0.748	0.814	0.80	0.72	0.594	0.513	0.162	0.072	0.0

B. Same constants as in A, except that the magnetizing current is taken as $I_m = 0.2$. $\therefore b_{00} = -0.2$. A summary of the tabulation is as follows:

Slip	0	0.01	0.02	0.03	0.05	0.08	0.1	0.3	0.5	1.0
I_0	0.205	0.55	0.998	1.40	2.09	2.77	3.11	3.96	4.07	4.15
T	0.0	0.46	0.875	1.2	1.63	1.85	1.82	1.00	0.635	0.33
$P_m - f_0$	0.0	0.445	0.85	1.16	1.54	1.69	1.63	0.69	0.308	0.0
P_0	0.020	0.485	0.91	1.26	1.73	2.03	2.03	1.325	0.98	0.675
Eff.	0.0	0.918	0.934	0.92	0.89	0.836	0.8	0.523	0.312	0.0
P.F.	0.097	0.882	0.908	0.898	0.827	0.722	0.653	0.334	0.241	0.163
App. eff.	0.0	0.81	0.85	0.825	0.737	0.603	0.523	0.175	0.076	0.0

C. Same as A, except that resistance is inserted in the secondary so that $r_1 = 0.05$.

Slip	0	0.01	0.02	0.03	0.05	0.08	0.1	0.3	0.5	1.0
I_0	0.29	0.36	0.50	0.665	1.01	1.5	1.79	3.36	3.8	4.07
T	0.0	0.184	0.362	0.532	0.85	1.24	1.44	1.74	1.34	0.77
$P_m - f_0$	0.0	0.172	0.344	0.505	0.8	1.12	1.29	1.21	0.66	0.0
P_0	0.0203	0.205	0.384	0.56	0.881	1.33	1.52	1.96	1.64	1.11
Eff.	0.0	0.84	0.895	0.902	0.894	0.87	0.845	0.612	0.405	0.0
P.F.	0.07	0.57	0.77	0.842	0.873	0.866	0.85	0.588	0.431	0.272
App. eff.	0.0	0.478	0.686	0.76	0.79	0.75	0.718	0.36	0.174	0.0

D. Same as A, except that the resistance of both windings has been increased so that $r_0 = r_1 = 0.05$.

Slip	0	0.01	0.02	0.03	0.05	0.08	0.1	0.3	0.5	1.0
I_0	0.29	0.358	0.498	0.658	0.82	1.445	1.705	3.15	3.6	3.92
T	0.0	0.181	0.355	0.519	0.665	1.145	1.315	1.525	1.19	0.714
$P_m - f_0$	0.0	0.17	0.338	0.494	0.625	1.043	1.174	1.058	0.586	0.0
P_0	0.023	0.206	0.386	0.558	0.716	1.307	1.475	2.03	1.85	1.485
Eff.	0.0	0.825	0.875	0.885	0.872	0.82	0.8	0.52	0.319	0.0
P.F.	0.0785	0.575	0.775	0.847	0.874	0.878	0.864	0.645	0.511	0.379
App. eff.	0.0	0.475	0.678	0.75	0.766	0.72	0.690	0.336	0.163	0.0

E. Same as A, except that the reactance of both windings has been increased, so that $x_0 = x_1 = 0.18$.

Slip	0	0.01	0.02	0.03	0.05	0.08	0.1	0.3	0.5	0.1
I_0	0.285	0.58	0.98	1.37	1.86	2.28	2.46	2.78	2.82	2.84
T	0.0	0.431	0.775	1.01	1.21	1.153	1.057	0.45	0.286	0.144
$P_m - f_0$	0.0	0.427	0.75	0.97	1.14	1.052	0.94	0.304	0.133	0.0
P_0	0.0196	0.456	0.81	1.06	1.29	1.267	1.173	0.615	0.57	0.308
Eff.	0.0	0.936	0.926	0.914	0.884	0.832	0.8	0.495	0.298	0.0
P.F.	0.069	0.786	0.826	0.774	0.692	0.555	0.5	0.218	0.16	0.11
App. eff.	0.0	0.736	0.765	0.708	0.61	0.461	0.4	0.108	0.047	0.0

F. Same as E, except that the secondary resistance is increased so that $r_1 = 0.05$.

Slip	0	0.01	0.02	0.03	0.05	0.08	0.1	0.3	0.5	1.0
I_0	0.285	0.356	0.484	0.66	1.016	1.4	1.64	2.53	2.7	2.83
T	0.0	0.178	0.354	0.506	0.795	1.04	1.16	0.954	0.651	0.358
$P_m - f_0$	0.0	0.1665	0.337	0.481	0.745	0.947	1.03	0.657	0.315	0.0
P_0	0.0197	0.1982	0.377	0.532	0.828	1.09	1.21	1.085	0.802	0.517
Eff.	0.0	0.84	0.90	0.906	0.9	0.87	0.85	0.606	0.393	0.0
P.F.	0.069	0.556	0.78	0.81	0.815	0.778	0.737	0.43	0.297	0.185
App. eff.	0.0	0.47	0.697	0.733	0.734	0.677	0.628	0.26	0.117	0.0

G. Same as A, except that only half-voltage is impressed on the motor, *i.e.*, $E_0 = 0.5$. Hence $I_m = 0.15$ and $I_h = 0.01$.

Slip	0	0.01	0.02	0.03	0.05	0.08	0.1	0.3	0.5	1.0
I_0	0.145	0.293	0.503	0.71	1.055	1.375	1.565	2.0	2.06	2.085
T	0.0	0.114	0.211	0.295	0.405	0.456	0.45	0.248	0.158	0.0814
$P_m - f_0$	0.0	0.103	0.197	0.276	0.375	0.41	0.395	0.164	0.069	0.0
P_0	0.0051	0.1195	0.221	0.308	0.428	0.497	0.503	0.329	0.244	0.1655
Eff.	0.0	0.86	0.89	0.895	0.875	0.825	0.785	0.5	0.283	0.0
P.F.	0.07	0.818	0.878	0.869	0.81	0.724	0.644	0.33	0.237	0.16
App. eff.	0.0	0.705	0.771	0.778	0.709	0.597	0.505	0.174	0.077	0.0

H. The same motor under normal operation as in A. In this case, however, the secondary is so arranged as to permit the insertion of extra resistances to improve the torque while the motor is coming up to speed. From standstill to half-speed the secondary resistance is $r_1 = 1$; from half-speed to nine-tenths of synchronous speed, $r_1 = 0.5$; over nine-tenths speed, $r_1 = 0.02$.

This is one way of meeting the condition of starting under load.

Slip	$r_1 = 1$				$r_1 = 0.5$			
	1.0	0.8	0.6	0.5	0.5	0.4	0.2	0.1
I_0	1.01	0.84	0.67	0.583	1.01	0.84	0.55	0.36
T	0.848	0.698	0.536	0.45	0.85	0.70	0.36	0.184
$P_m - f_0$	0.0	0.13	0.204	0.215	0.415	0.41	0.282	0.157
P_0	0.87	0.727	0.565	0.478	0.87	0.727	0.389	0.206
Eff.	0.0	0.18	0.36	0.45	0.477	0.564	0.725	0.762
P.F.	0.865	0.868	0.844	0.815	0.865	0.868	0.77	0.57
App. eff.	0.0	0.162	0.32	0.38	0.41	0.49	0.57	0.45

Performance curves are given for all cases calculated. Fig. 260 shows for case A, efficiency, apparent efficiency, power factor, current and slip, all plotted against the output. The scales show

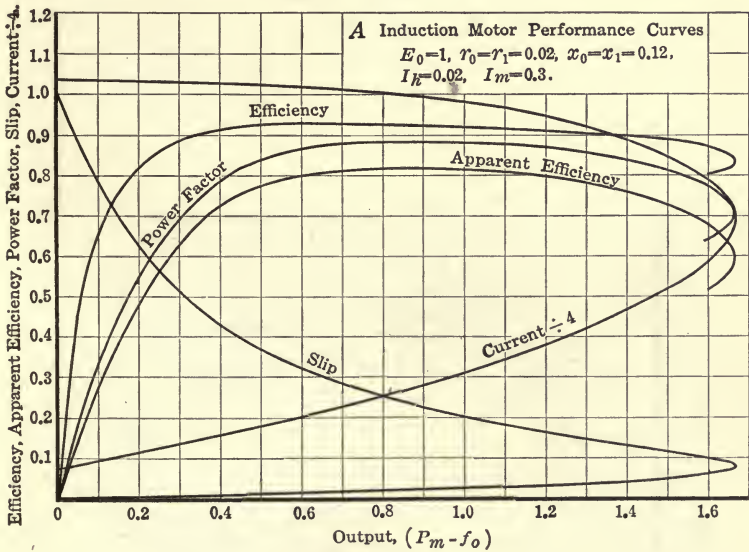

FIG. 260.

percentage values. Similar sets of curves are shown for the other cases in Figs. 261 to 266 inclusive.

These curves illustrate the capabilities of the various motors under normal running conditions.

Of equally great interest are the curves between speed, current

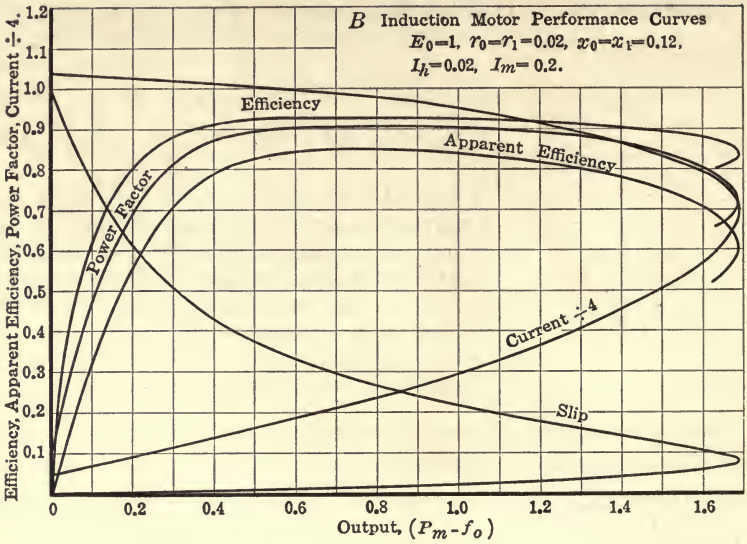

FIG. 261.

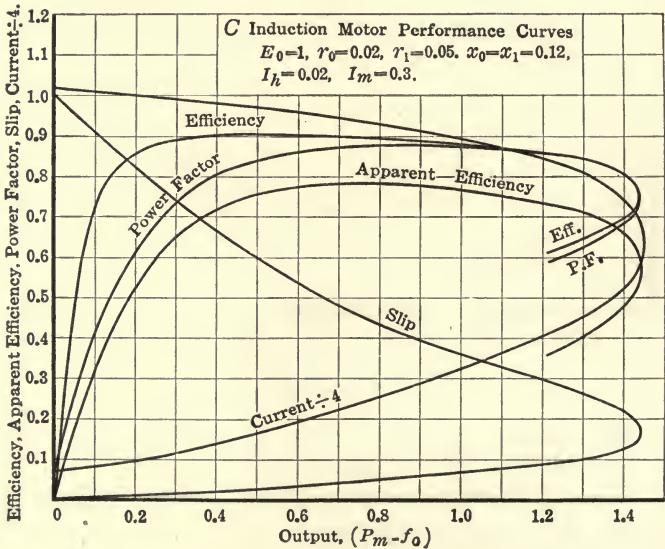

FIG. 262.

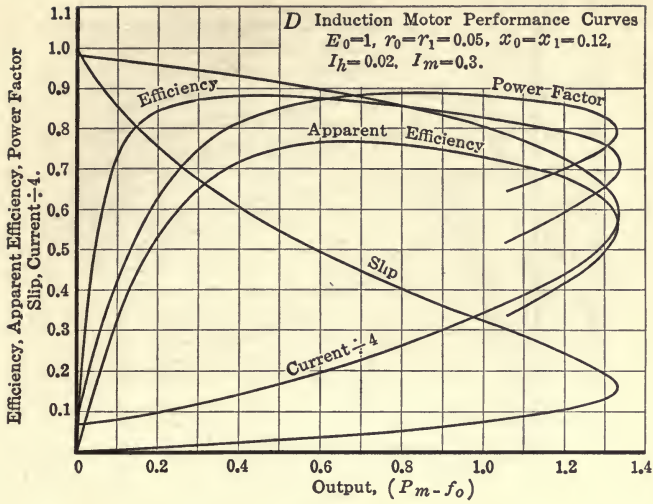

FIG. 263.

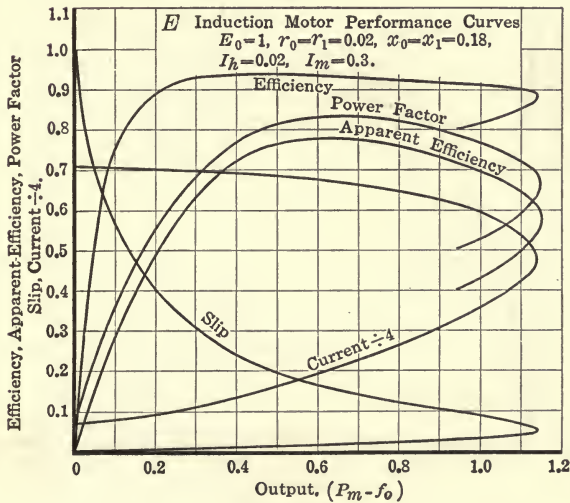

FIG. 264.

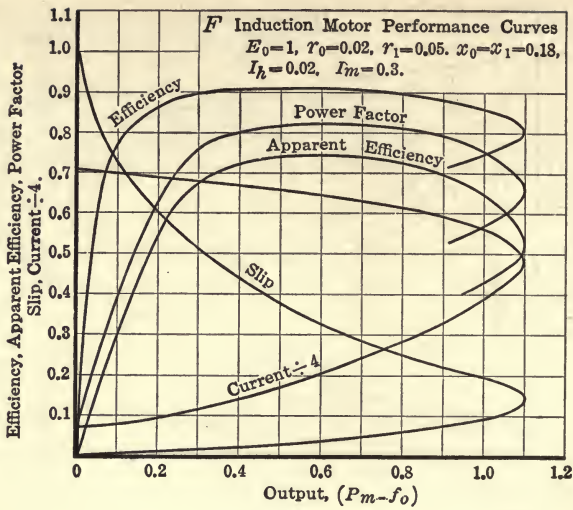

FIG. 265.

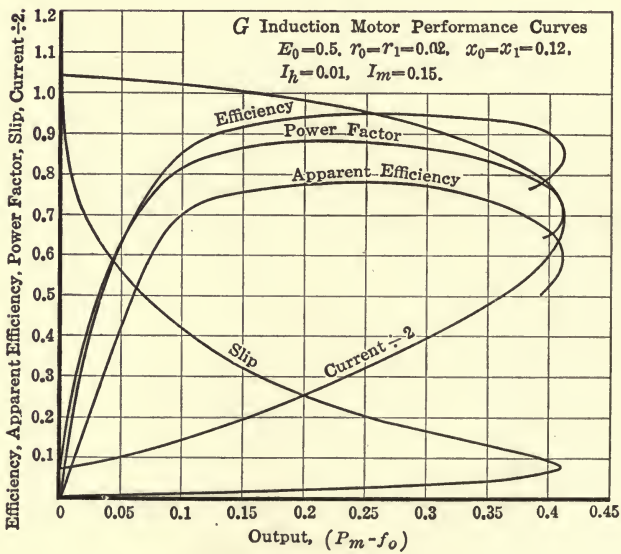

FIG. 266.

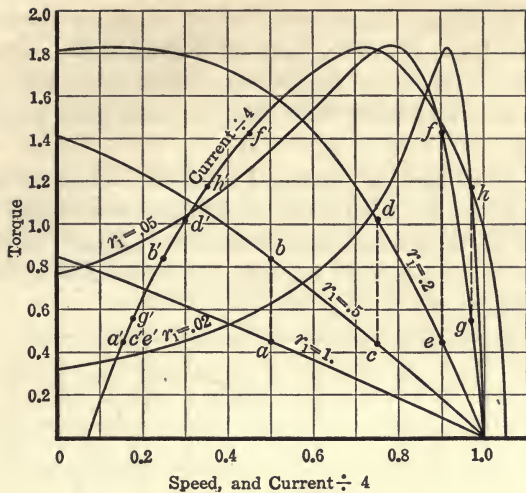

FIG. 267.

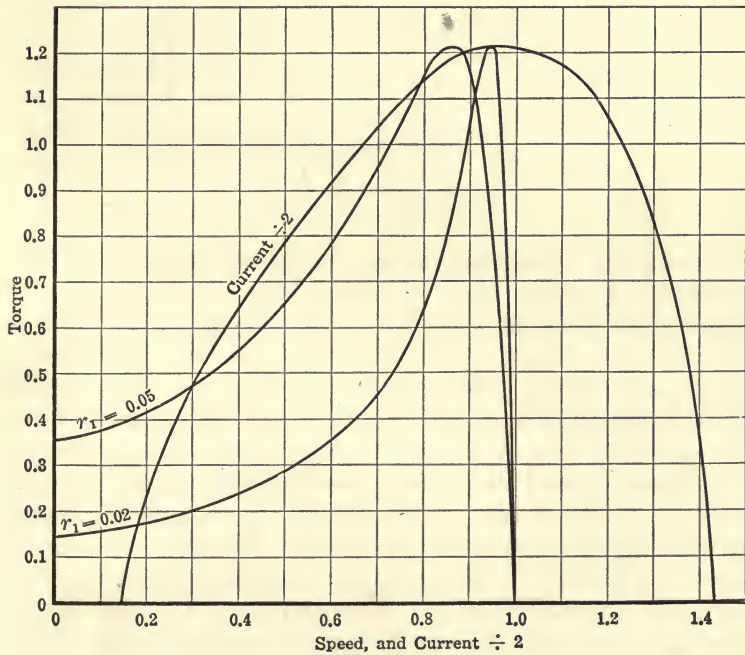

FIG. 268.

and torque, which are characteristic of starting conditions. These are shown in Figs. 267, 268, and 269 for all cases except B and D. In these two cases the curves are very nearly the same as for case A. The differences may be seen by a glance at the tabulations.

Fig. 267 is of special practical interest. Here torque-speed curves are given for a number of motors which differ only in the amount of their secondary resistance. There is practically no difference in the current curves, one curve giving the current for all motors.

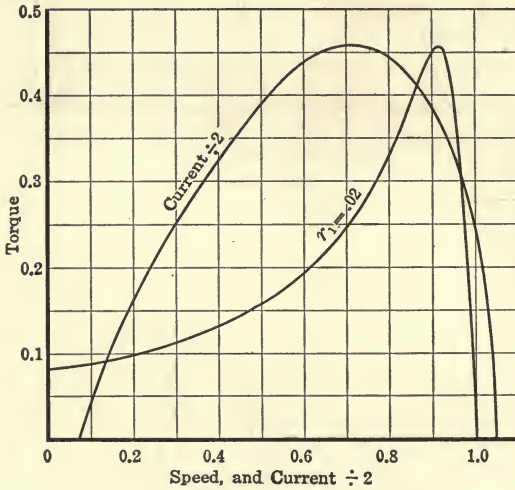

FIG. 269.

A motor may be imagined as supplied with a variable secondary resistance. Suppose that it starts with $r_1 = 1$ ohm. The torque will be 0.85, and the current will be $0.25 \times 4 = 1.00$ as is seen from the figure. Thus, the motor starts with full-load torque and current. When half-speed has been attained, the secondary resistance is changed by some device to $r_1 = 0.5$. The motor at once is changed from operation at the point, *a*, to the point, *b*, and the current rises from 0.6, to which it had fallen, back to the original value of 1.00. The motor now follows the second torque curve to *c*, then, by a change of resistance to $r_1 = 0.2$, it accelerates along the curve *de*, the current following curve *d'e'*. Another change to $r_1 = 0.05$ causes the motor to run along *fg*, the current following *f'g'*, at which latter points the final change to $r_1 = 0.02$ is made.

The motor now operates on its normal running speed-torque curve. During all these changes the current has remained low. It might, however, be more desirable to utilize the variation in the secondary resistance to maintain a very high torque from starting. In such a case, the start would be made with $r_1 = 0.2$. At half-speed a change to, say, $r_1 = 0.1$ would be made. In this way, approximately double full-load torque could be maintained during the accelerating period, the current, however, being correspondingly heavy.

Example.—As a particular example to illustrate the use of the preceding figures, consider a three-phase, 6-pole, 60-cycle motor of 75 hp. and 440 volts.

Let its constants, in percentage, be those of case A, and let it be required to find the following:

1. Full-load current.
2. Starting current.
3. Starting torque.
4. Impressed voltage to give normal current at starting.
5. Maximum output in horsepower.
6. Starting torque with normal current.
7. Maximum output under voltage required to give normal current at starting.

(a) **Motor Assumed Y-connected.**—Since, in the curves, output is expressed in watts per phase, the output of the motor considered becomes, at full-load,

$$P_m - f_0 = \frac{75}{3} \times 746 = 18,700 \text{ watts per phase.}$$

Since full-load has been taken as occurring at 2 per cent. slip, this occurs also at $(P_m - f_0) = 0.83$ in Fig. 260. Therefore unity on the output scale is, for the machine in question, $\frac{18,700}{0.83} = 22,500$. This gives the output scale.

All the ordinates, except current, *i.e.*, efficiency, apparent efficiency, power factor, and slip, remain as in the figure, being correct for any size motor of the constants, in percentage, of this particular case.

$$\begin{aligned} 1. \text{ Full-load current} &= \frac{18,700}{\frac{440}{\sqrt{3}}} \div \text{apparent efficiency at full-} \\ \text{load} &= \frac{18,700}{254 \times 0.814} = 90.3 \text{ amp.} \end{aligned}$$

To find the current at any other load, the reading on the current curve should be multiplied by $\frac{90.3}{1.02} = 88.5$, where 1.02 is the full-load current as read on the curve.

2. Starting current is, therefore, $4.19 \times 88.5 = 371$ amp. per phase.

3. The torque expressed in synchronous watts per phase, is shown in Fig. 267. Expressed in ft.-lb. at the pulley at synchronous speed the torque becomes, torque = "synchronous watts" $\times 0.059 \times$ number of phases $\times \frac{\text{poles}}{\text{frequency}} = 0.177e_i^2a_1 \frac{p}{f}$ for three-phase motors.

In the example, $p = 6, f = 60$.

Full-load torque, at synchronous speed, is

$$T = \frac{75 \times 33,000}{2\pi \times 1200} = 328 \text{ ft.-lb.}$$

Therefore, in synchronous watts, this is, $328 = 0.177e_i^2a_1 \times 0.1$, or

$$T = e_i^2a_1 = \frac{328}{0.0177} = 18,520 \text{ synchronous watts.}$$

As the curve ($r_1 = 0.02$, Fig. 267) gives full-load torque = 0.856 synchronous watts, to obtain values for the particular machine being considered, the torque at any point on the curve should be multiplied by $\frac{18,520}{0.856} = 21,650$, to give synchronous watts, or by $\frac{328}{0.856} = 383$ to give foot-pounds at synchronous speed.

Starting torque is, then, $0.322 \times 21,650 = 6970$ synchronous watts, or $0.322 \times 382 = 123.3$ ft.-lbs.

4. Having already found the normal and starting currents, and since the current is proportional to the voltage, the impressed voltage necessary to give normal current at starting is: normal phase voltage $\times \frac{\text{normal current}}{\text{starting current}}$, or $\frac{440}{\sqrt{3}} \times \frac{90.3}{371} = 61.8$ volts to neutral, or 107 volts between terminals.

5. Maximum output is (Fig. 260) 1.67 watts. This corresponds to a maximum torque of 1.82 synchronous watts at 8 per cent. slip (Fig. 267) these values being, of course, per phase. To change to horsepower, this gives

$$\text{max. hp.} = \frac{1.67}{746} = 0.00224 \text{ per phase.}$$

For the motor considered,

$$\begin{aligned} \text{max. hp.} &= \frac{\text{max. output}}{\text{normal output}} \times 75 \text{ hp.} \\ &= \frac{1.67}{0.83} \times 75 = 150 \text{ hp.} \end{aligned}$$

6. Starting torque, if normal current only is allowed, is, since torque is proportional to (voltage)²,

$$\begin{aligned} T &= \frac{(61.8)^2}{(254)^2} \times \text{starting torque at normal voltage.} \\ &= 0.0592 \times 6970 = 412.5 \text{ synchronous watts, or} \\ &= 0.0592 \times 123.3 = 7.3 \text{ ft.-lb.} \end{aligned}$$

7. Maximum output under impressed voltage of 61.8 volts per phase is equal to maximum output under normal voltage, multiplied by the factor $\left(\frac{61.8}{254}\right)^2 = 0.0592$, or maximum output at 61.8 volts = 150 hp. $\times 0.0592 = 8.88$ hp.

(b) **Motor Assumed Δ -connected.**—The student may show that in this case the required values are:

1. Full-load current = 90.3 amp.
Phase current = 52.2 amp.
2. Starting current = 214 amp. per phase.
3. Starting torque = 123.3 ft.-lb.
4. Voltage to give normal current at starting = 107.
5. Maximum output = 150 hp.
6. Starting torque, with normal current, = 7.3 ft.-lb.
7. Maximum output on 107 volts = 8.88 hp.

Questions.—Do these answers indicate that a motor built to be operated Y-connected, may be reconnected Δ and will then give substantially the same performance?

Show that if a certain motor Δ -connected is intended for operation at 100 volts, if it be reconnected Y, and operated at the same voltage, the output will be reduced to $\frac{1}{3}$. Discuss, also, the effect of this change on the power factor, maximum output, torque, etc.

Show that if the impressed voltage is reduced by 10 per cent., the maximum output and the starting torque are reduced by about 20 per cent., the starting current by about 10 per cent., while the efficiency remains about the same and power factor is slightly improved at light loads. This question is very practical

since a motor designed for and rated at 125 volts may often be available for operation on a 110-volt circuit.

Show that such operation might not always be practical on account of the reduction in the overload range.

Would it be practical to operate at 10 per cent. above normal voltage? Show that in this case the power factor will be much poorer, particularly at light loads.

Show that if the primary and secondary reactance are each 10 per cent., the starting current will be slightly less than five times the full-load current.

From the curves that have been given, discuss the value of the ratio, $\frac{\text{starting current}}{\text{running light current}}$. When considering the performance of the motor, especially the margin in output, show that the smallest ratio for a good motor should be about 12. The running light current is substantially equal to the magnetizing current.

Many other considerations are involved in the choice or operation of induction motors. Some of these may be briefly discussed.

It has been shown that a variation of the secondary (usually the rotor) resistance is accompanied by marked changes in the performance characteristics of the motor; that higher resistance means, roughly, increased starting torque but decreased normal running efficiency. For normal operation, therefore, the smallest possible secondary resistance is desirable. This is best obtained by a type of rotor winding construction known as the "squirrel cage." In this, the conductors are heavy copper bars, lightly insulated, with only one bar to a slot.

The ends of the bars are connected to copper rings which thus give a completely short-circuited winding. The resistance of such a squirrel cage affair is extremely low, and the starting torque of the motor is correspondingly low. There is no opportunity of inserting additional resistance in such a structure. For this reason, many rotors are supplied with definite windings the terminals of which may either be brought out to slip rings on the shaft, or be connected to a revolving resistance mechanism carried within the rotor spider.

The type of motor to be chosen depends on the use to which it is to be put. Induction motors cannot be used as indiscriminately as can direct-current motors, for example. Consider a

motor to be used in pumping against a high hydraulic head. The squirrel cage motor would not start. There might also be difficulty with the wound rotor type. In this case it would be necessary to have many steps in the secondary rheostat to insure against the torque falling at any instant below the required amount.

Another question of importance relates to the frequency. Assume, for example, that a 5-hp., 60-cycle, 220-volt motor is required. If it is found that there is a 5-hp., 40-cycle, 220-volt motor available, will it be practicable to utilize this machine, thus saving, perhaps, the cost of a new motor?

When a 40-cycle motor is operated on the 60-cycle circuit it is evident that the magnetizing current, and consequently the flux, will be reduced in amount approximately in the ratio $\frac{40}{60}$, while the reactance will be correspondingly increased. The motor would therefore be weak in operation, that is, it may have insufficient margin in overload range.

Changing from 60 cycles to 40 cycles would have just the reverse effect. The motor would have ample capacity. Magnetic densities might be excessive, and the power factor might be considerably poorer owing to the great increase in magnetizing current.

To operate the 40-cycle motor on 60 cycles would be most satisfactory if the voltage could be increased in the ratio $\frac{60}{40}$. This, however, is ordinarily impossible. It is sometimes possible, however, to accomplish approximately the same result by reconnecting the windings. Suppose, for instance, that the motor is Δ -connected. Consider changing to Y-connection, at the same time dividing each phase into two circuits and connecting them in parallel. Connecting in parallel changes the required voltage from 220 to 110. Changing to Y makes the required voltage $1.73 \times 110 = 190$. The change of frequency alone would suggest a voltage of $110 \times \frac{60}{40} = 165$. Perhaps, therefore, the change to the condition of 190 volts, that is to parallel Y-connection, will give satisfactory results in operation.

An approximate value for the power factor may be obtained as indicated in Fig. 270. A right triangle is formed, the perpendicular sides of which are per cent. load and per cent. I_m

+ per cent. reactance. The reactance is the sum of both the primary and the secondary reactance in per cent. The angle θ_0 is the phase angle. The basis for this approximation is found from a study of the vector diagrams, Fig. 257.

Motor and Transmission Line.—When an induction motor is at the end of a transmission line on which constant voltage is impressed, the constants of the line should be added to those of the motor windings in determining the performance characteristics. Thus, r_0 is the sum of the primary winding and the line resistances, and x_0 is the sum of the primary winding and the line reactances.

Let it be assumed that a 220-volt motor is at the end of a transmission line such that maximum output occurs when the line drop has reduced the voltage on the motor to 190.

The maximum output is then $\left(\frac{190}{220}\right)^2 = 0.75$ times its value under normal voltage.

If the performance curves at normal voltage are given, these may be changed to give approximately the performance under the conditions named by merely altering the scale of abscissæ so that the maximum output shall occur at three-quarters of its former value.

Motor with Auto-transformer.—If a motor is used where it does not have to start under heavy load, an auto-transformer may be introduced to reduce the starting current.

For instance, if the auto-transformer supplies half voltage the current will be reduced to one-half, and the volt-amperes will consequently be only one-quarter of normal starting amount. On the primary side of the auto-transformer, then, the current input will be only one-quarter of the normal starting current. Such an arrangement is advantageous from the standpoint of current, but is bad where a large starting torque is required, since the torque is reduced to one-quarter its normal starting value.

Many other considerations may naturally arise in reference to the induction motor, some of which may well be studied from the standpoint of its design which is taken up in the next chapter.

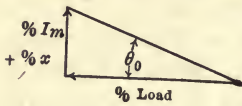

FIG. 270.

CHAPTER XLIII

STUDY OF THE DESIGN CONSTANTS OF AN INDUCTION MOTOR¹

The primary limiting features in induction motor design are (1) the possible amount of copper per inch of periphery, and (2) the smallness of the air gap. A small air gap means a cheap motor and high efficiency. Gap lengths ordinarily run from 0.02 in. to 0.06 in., the smaller values being for small machines. A relation between these two limiting features may be found in practice; thus, for each 0.01 in. of air gap, from 100 to 150 amp.-conductors per inch of periphery may be assumed as a starting basis.

Let it be required to design the following motor:

$$I-6-10-1200-110v.$$

Since practically all induction motors are three-phase, that feature is not indicated in the rating. If the motor were two-phase, its designation would be IQ . Otherwise, the rating indicates 6 poles, 10 hp., 1200 r.p.m. at synchronous speed, and 110 volts.

Air Gap.—The air gap may first be assumed in accordance with practical experience. As a safe average value, let this be chosen as 0.02 in. = l_g . The number of ampere-conductors per inch of periphery, from the relation given above, will then be

$$2 \times (100 \text{ to } 150) = 200 \text{ to } 300.$$

Rotor Diameter.—This, also, may be taken from experience. As a trial value, let the diameter per pole be assumed as 2.5 in. The rotor diameter is then $2.5 \times 6 = 15$ in. = d_2 .

$$\text{Pole pitch} = \frac{\pi d_1}{6} = \frac{15.04 \times 3.14}{6} = 7.88 \text{ in.},$$

where d_1 is the inside diam. of the stator.

¹ It is realized of course that since this is not a book on design of electric machines, the equations used are not claimed to be accurate, but they are sufficiently accurate for the purpose in view which is to give a fairly complete idea of how the various constants are derived. Indeed the methods suggested have been used in the design of a large number of machines that have been built.

Stator Slots per Pole.—This depends primarily on the slot pitch, but must be a multiple of three. For low-voltage motors the slot pitch may be quite small, say 0.65 in. As the voltage increases the space requirements of insulation will cause an increase in the pitch. Assuming 0.65 in., the number of stator slots per pole is

$$\frac{7.88}{0.65} = 12,$$

and the slot pitch revised is

$$\frac{7.88}{12} = 0.657 \text{ in.}$$

Slots per pole and phase are

$$\frac{12}{3} = 4.$$

Ampere-conductors per slot will be

$$(200 \text{ to } 300) \times 0.657 = 130 \text{ to } 200.$$

The number of conductors per slot will depend for their size on whether the motor is to be Δ - or Y-connected. The current they must carry may be calculated on the basis of 10 kv.a. input, or 3300 volt-amp. per phase.

If Δ -wound,

$$I_{\text{phase}} = \frac{3300}{110} = 30 \text{ amp.}$$

$$I_{\text{line}} = \sqrt{3} \times 30 = 52 \text{ amp.}$$

$$\text{Conductors per slot} = \frac{\text{amp. conds.}}{\text{amp.}} = \frac{130 \text{ to } 200}{30} = 4.3 \text{ to } 6.7$$

If Y-wound,

$$I_{\text{phase}} = I_{\text{line}} = 52 \text{ amp.}$$

$$\text{Conductors per slot} = \frac{130 \text{ to } 200}{52} = 2.5 \text{ to } 3.8.$$

Slot and Tooth Dimensions.—In general, it is good practice to use if possible four coils per slot. This arrangement lends itself readily to reconnection either in series-parallel, for double voltage, or in series for quadruple voltage. Therefore, selecting four as the number of groups of wires per slot we also get four effective conductors per slot. The next step is to design a suitable slot. The deeper the slot, the more copper per inch of periphery is possible.

In a given coil, however, it is not practical to wind more than four wires on edge. Therefore, a slot similar to that shown in Fig. 271 should be chosen. This gives four wires per coil, four effective conductors per slot, or a total of sixteen wires per slot. Either Δ - or Y-connection may be chosen. In this case it will be the latter. The actual slot dimensions for this motor are depth = 1.15 in., width = 0.34 in. Each effective conductor consists of four No. 10 B. & S. double cotton-covered wires. Each wire has a diameter of 0.112 in. over insulation, and the copper area is 0.00815 sq. in.

Current density is $\frac{52}{4 \times 0.00815} = 1600$ amp. per sq. in., which is a reasonable value.

The slot insulation is about 0.04 in. in thickness, being sufficient for 440 volts.

The slot opening is made as small as possible to permit convenient insertion of the coils. Its width in this case is 0.22 in., or about two-thirds of the slot width.

The tooth dimensions are: width at face = 0.43 in., width at narrowest point = 0.324 in., shown respectively at *a* and *b* in the figure.

Main Flux.—All data are now available to substitute into the fundamental equation

$$E = \frac{4.44f\phi tk}{10^8}$$

from which the required flux, ϕ , may be ascertained:

$$E = \frac{110}{\sqrt{3}} = 63.5 \text{ volts to neutral,}$$

$$f = 60 \text{ cycles,}$$

$$t = 2 \text{ turns per slot} \times 24 \text{ slots per phase} = 48 \text{ turns,}$$

$$k = \text{constant for winding distribution} = 0.96.$$

$$\therefore \phi = \frac{63.5 \times 10^8}{4.44 \times 60 \times 48 \times 0.96} = 516,000.$$

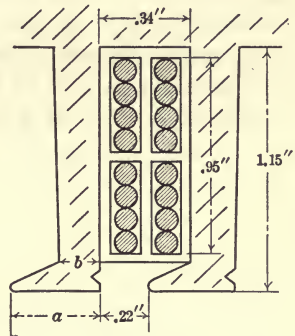

FIG. 271.

Stator Length.—The cross-sectional area of the iron necessary to accommodate this flux is limited by the maximum permissible flux density in the stator teeth. For 60-cycle motors the maxi-

imum density should not exceed 90,000 lines per sq. in.; for 25 cycles the density may reach 105,000. Higher densities are apt to cause excessive heating of the teeth.

It has been shown that although the windings on the stator are stationary, the effect due to the multiphase currents in them is similar to that of a revolving field structure. With alternators, the field flux is more or less evenly distributed along the surface of the pole, that is, the density is fairly uniform, and thus the flux, when plotted, approaches rectangular shape. With the distributed windings of multiphase induction motors, the space distribution of the flux is practically that of a sine wave, as will be seen by plotting the magnetomotive forces at different points along the stator periphery. With a sinusoidal space distribution, then, the maximum flux density is $\frac{\pi}{2}$ times the average density over the surface.

The net stator length may thus be determined by assuming maximum teeth density, from the relation,

$$\text{Net stator length} = \frac{\text{flux per pole}}{\text{max. flux density} \times \text{min. teeth width per pole}}$$

This equation may be used, however, more advantageously as a check in settling the final dimensions both of the teeth and the stator length. The latter may best be determined at the start, by assuming a value for magnetizing current and working through the gap.

Let the magnetizing current required to send flux through the gap be assumed as 20 per cent. of full-load current, $= 0.2 \times 52 = 10.4$ amp.

Gap amp.-turns $= \sqrt{2} \times 1.5 \times 10.4 \times 8 = 176.5$, since there are eight turns per pole and phase.

Average gap flux density is

$$B_{\text{avg. gap}} = \frac{176.5}{0.313 \times 0.02} = 28,200.$$

\therefore Gap area per pole,

$$A_g = \frac{516,000}{28,200} = 18.3 \text{ sq. in.}$$

teeth width per pole $= (0.43 + 0.02) \times 12 = 5.4$ in.; where 0.02 in. has been added to the tooth width on account of unavoidable irregularities in the stampings or laminations.

$$\therefore \text{gross stator length} = \frac{18.3}{5.4} = 3.4 \text{ in.}$$

Experience in design would now lead one to judge this length of 3.4 in. to be too short, as compared with a rotor diameter of 15 in. Therefore it will be advisable to repeat the calculations on the basis of, say, 12 in. rotor diameter, instead of 15 in.

The new slot pitch then becomes,

$$0.657 \times \frac{12}{15} = 0.525 \text{ in.}$$

The slot and the slot opening remain as before, but the tooth face is reduced to

$$0.525 - 0.22 = 0.305 \text{ in.}$$

Teeth width per pole = $(0.305 + 0.02)12 = 3.9 \text{ in.}$

$$\therefore \text{gross stator length} = \frac{18.3}{3.9} = 4.7 \text{ in.}$$

and effective stator length = $0.9 \times 4.7 = 4.23 \text{ in.}$

This value may now be applied to the stator teeth in order to ascertain whether the maximum flux density is satisfactory or not.

Minimum width of tooth = 0.19 in.

Minimum net area of teeth per pole = $0.19 \times 12 \times 4.23 = 9.65 \text{ in.}$

Therefore, maximum average flux density in teeth = $\frac{516,000}{9.65}$
 = 53,500 lines per sq. in., and maximum flux density in teeth
 = $\frac{\pi}{2} \times 53,500 = 84,000.$

Rotor Slots.—Consider, first, the squirrel cage rotor. In choosing the number of slots it is well to insure that there shall be no possible symmetrical arrangement of the stator and rotor slots with respect to each other. In practice it is common to take one-half the stator slots $\pm 1.$

In this case the number will be $\frac{72}{2} + 1 = 37$ slots. Such a choice is made to prevent the existence of so-called “dead points,” or positions of the rotor from which it may not start.

Slot and Tooth Dimensions.—At synchronous or operating speed the frequency of reversal of the flux in the secondary core is so low, being that of the slip, that the core loss in the secondary is negligible with proper teeth dimensions. This fact permits higher densities in the teeth than are permissible in the primary teeth. The maximum density occurs, of course, at the base of

the teeth. When the rotor diameter is not great, as in small motors, a deep slot means considerable reduction of tooth area at the base compared with the area at the top of the tooth. Usually rotor slots are fairly shallow. The dimensions in the present

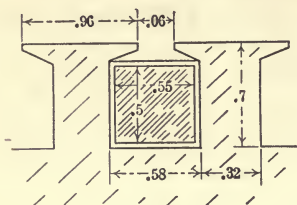

FIG. 272.

case are given in Fig. 272. The rotor bar is nearly square in section, and is inserted in the slot from the end. It is covered with a thin layer of paper insulation, although, since the bars are all short-circuited, even this is not essential. The opening between the

teeth is narrow in order to give a large flux area in the gap. At the same time, it is maintained for the purpose of reducing the leakage flux and thereby cutting down the self-inductive reactance.

Considering the dimensions, as given, the minimum net area of rotor teeth, per pole, is

$$\frac{37}{6} \times 0.32 \times 4.23 = 8.35 \text{ sq. in.}$$

∴ Average maximum flux density in rotor teeth is

$$\frac{516,000}{8.35} = 61,800 \text{ lines per sq. in.}$$

$$\text{Maximum density} = \frac{\pi}{2} \times 61,800 = 97,000.$$

If, instead of the squirrel cage, a wound rotor is desired, the number of slots chosen will in this case be 54, which will give nine slots per pole, and three slots per pole and phase.

The rotor need not necessarily have a three-phase winding; any multiphase winding with the proper number of poles will do. In fact, the squirrel cage may be regarded as a winding of many phases.

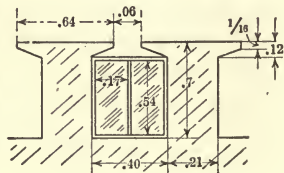

FIG. 273.

Slot and tooth dimensions are given in Fig. 273. From these, minimum teeth area per pole is $0.21 \times 9 \times 4.23 = 8$ sq. in.

∴ Average flux density in the rotor teeth at base is $\frac{516,000}{8} =$

64,500 lines per sq. in. Maximum density $= \frac{\pi}{2} \times 64,500 = 101,300.$

The remaining rotor calculations are made in essentially the same way for both the squirrel cage and the wound rotor types.

The former type will therefore, alone, be worked out. The student may, for practice, apply the process to the determination of constants and performance characteristics of the motor with wound rotor.

Rotor Secondary Resistance.—This is difficult to calculate by the usual method applied to definite windings, but may be deduced from a well-known fact that the loss, per cubic inch of copper, is 0.79 watt at 60°C. when the current density is 1000 amp. per sq. in., and this loss varies as the square of the current density.

The problem, then, is to find the volume of the rotor conductors and the current in them. The latter may be considered first.

Consider the revolving flux as represented at some given instant by a pair of poles, shown in Fig. 274. At that instant the current flows downward through the rotor bars under one pole, and upward through the bars, under the other pole. These currents are indicated by the crosses and dots in the figure. Maximum current will be in the bars under the middle of each pole where the flux is maximum. Between the poles there will be little current in the bars. In general, the distribution of current in the bars around the periphery will be proportional to the sine of the space angle between the bar and the neutral axis.

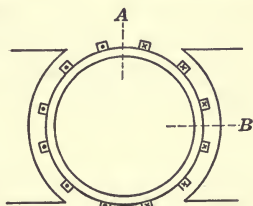

FIG. 274.

Since, now, there is an inductive relationship between the primary and the secondary windings, as in the transformer, if the exciting current is neglected and perfect mutual inductance is assumed, the ampere-conductors around the stator periphery must equal the ampere-conductors around the rotor periphery. But the former, denoted by

$$I_s C_s = 288 \times 52 = 15,000,$$

since there are 288 conductors on the stator, each carrying 52 eff. amp.

The effective rotor current per bar will then be

$$I_r = \frac{15,000}{37} = 405 \text{ amp.}$$

Maximum current in any bar is then,

$$I_r(\text{max.}) = 405 \times \sqrt{2} = 572 \text{ amp.}$$

$$\text{Average current per bar} = I_r(\text{av.}) = 572 \times \frac{2}{\pi} = 364 \text{ amp.}$$

In the end rings which short-circuit the bars the current will vary in amount along the circumference. The section of the ring at *A*, Fig. 275, will carry the most current, while at *B*, the current will be zero. One-quarter of the bars will send their currents through section *A*, or, in general, section *A* will contain the current from $\frac{\text{total bars}}{2 \times \text{poles}}$.

In this case, then, there will be $\frac{37}{12} = 3.08$ bars supplying this current. The current through *A* will be 3.08 times the average current per bar, or,

$$3.08 \times 364 = 1122 \text{ amp.}$$

The average current around the whole circumference of the ring is

$$1122 \times \frac{2}{\pi} = 715 \text{ amp.}$$

and the effective current in the ring is

$$I_R = 1122 \div \sqrt{2} = 794 \text{ amp.}$$

Volume of each rotor bar is

$$0.5 \times 0.55 \times 6.7 = 1.84 \text{ cu. in.}$$

Total volume of bars is

$$1.84 \times 37 = 68.1 \text{ cu. in.}$$

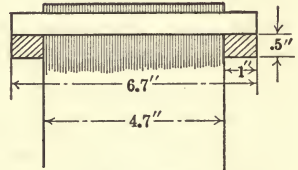

FIG. 275.

Since effective current per bar is 405 amp., and, assuming 0.79 watt per cu. in. loss at 1000 amp. per sq. in., the loss in the bars is

$$0.79 \times \left(\frac{405}{0.5 \times 0.55 \times 1000} \right)^2 \times 68.1 = 117 \text{ watts.}$$

$$\text{Loss in bars per phase} = \frac{117}{3} = 39 \text{ watts.}$$

Volume of end rings is

$$2 \times 0.5 \times \pi \times 10.1 = 31.75 \text{ cu. in.}$$

Effective current per ring is 794 amp.

∴ Loss in the rings is

$$0.79 \left(\frac{794}{0.5 \times 1000} \right)^2 \times 31.75 = 63.5 \text{ watts.}$$

$$\text{Loss in rings per phase} = \frac{63.5}{3} = 21.2 \text{ watts.}$$

Copper loss in rotor secondary per phase = 39 + 21.2 = 60.2 watts. This loss is I^2R , per phase, where I and R are certain "equivalent" values of current and resistance of the secondary. Referred to the primary on a 1:1 ratio basis as is usual in transformer calculations, this loss becomes

$$60.2 = I_p^2 r_1 = \overline{52^2} r_1.$$

∴ $r_1 = \frac{60.2}{2704} = 0.0223$ ohm, which is the desired rotor (secondary) resistance per phase reduced to the primary.

Although this calculation is based on two assumptions, namely; negligible exciting current, and perfect mutual induction between primary and secondary, both of which are false, yet the error introduced is so small as not to appreciably effect the correctness of the results.

The primary resistance may now be calculated in the usual way. Length of mean turn = twice the gross length of stator + eight times diameter per pole, = $2 \times 4.7 + 8 \times 2.22 = 27.16$ in.

Total length of effective conductor per phase is

$$27.16 \times \frac{48 \text{ turns}}{12 \text{ in.}} = 108.64 \text{ ft.}$$

Resistance per 1000 ft. of 4 No. 10 wires in parallel is $\frac{1.16}{4} = 0.29$ ohm at 60°C.

∴ Resistance per phase, of stator, is

$$r_0 = \frac{108.64}{1000} \times 0.29 = 0.0315 \text{ ohm.}$$

Primary Leakage Reactance.—This is determined in the same general manner that it was done in the case of the alternator. The facts that the air gap is uniform around the periphery, that it is comparatively very short and that the rotor teeth, instead of being opposite a solid pole, are opposite the stator teeth,

introduce important variations into the calculations. The leakage flux may be regarded as that which passes through and around the four slots of any pole and phase at right angles to the direction of the main flux, due to the current in those slots, together with that surrounding the end-connections due to the current in them. This flux may, for convenience, be divided into a number of parts, as follows:

ϕ_1 = flux which crosses the space occupied by the conductors. This space has an area, a , (Fig. 276), per centimeter length of conductor.

ϕ_2 = flux crossing the area, d , between the conductors and the gap.

ϕ_3 = flux in the gap but not cutting the rotor conductors. This is the so-called "zig-zag" flux, because it passes back and forth across the faces of rotor and stator teeth.

ϕ_4 = flux around end-connections.

ϕ_5 = belt leakage flux, due to the fact that the primary and secondary coils are not always in positions to react fully on each other. This flux has to be considered only with reference to rotors with definite phase windings. In such cases the inductance, L_5 , due to it may be taken as approximately 5 per cent. of the total primary self-induction.

Calculation of inductances due to ϕ_1 and ϕ_2 give

$$L_1 = 4\pi sn^2 \frac{a}{3b}$$

$$L_2 = 4\pi sn^2 \frac{d}{e}$$

cm., per cm. gross length of stator, where s = slots per pole and phase, and n = effective conductors per slot.

Similarly,

$$L_3 = 4\pi sn^2 \frac{f_o}{g_o}$$

where $\frac{f_o}{g_o}$ is the effective magnetic conductance of the path of the flux ϕ_3 , per centimeter gross length of stator.

This inductance is really the sum of two inductances, $L_3 = L'_3 + L''_3$, of which L'_3 is made up of the interlinkages per

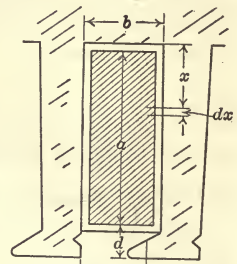

FIG. 276.

ampere of all the conductors of the phase with the flux, ϕ'_3 , which follows the path from *A* to *B*, and L''_3 is the interlinkages of the conductors in the two inside slots with the flux ϕ_3'' , which follows the path from *C* to *D* (Fig. 277).

Magnetic conductance across a rotor slot above the conductor is $\frac{m}{n} + \frac{k}{h}$, where the letters indicate dimensions, as given in Fig. 277, in inches. This magnetic conductance is in parallel

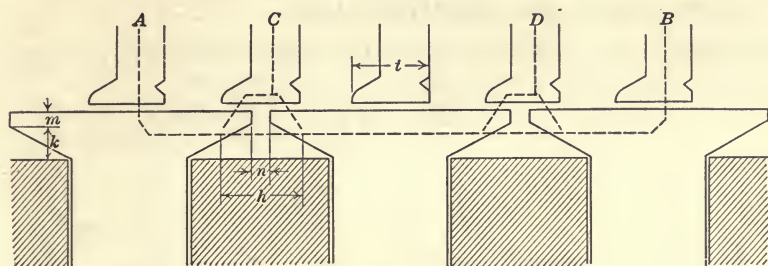

FIG. 277.

with a conductance of variable magnitude of the path across the gap into a stator tooth and back again. When a stator tooth is directly opposite a rotor slot, this magnetic conductance is $\frac{t}{4g}$ where *t* is the width of a stator tooth face. When the two slots are directly opposite, the magnetic conductance of this path may be neglected.

In the first case (tooth opposite slot), the magnetic conductance of the combined path is

$$\frac{m}{n} + \frac{k}{h} + \frac{t}{4g}$$

In the second case, it is

$$\frac{m}{n} + \frac{k}{h}$$

The average of these two values is

$$\frac{m}{n} + \frac{k}{h} + \frac{t}{8g}$$

The flux ϕ'_3 passes through this path twice, as the figure shows, and it also passes twice across the gap as it first enters and finally leaves the rotor. The reluctance of these latter portions of the path is $\frac{2g}{t}$.

∴ the total average reluctance is, approximately,

$$\rho'_3 = \frac{2}{\frac{m}{n} + \frac{k}{h} + \frac{t}{8g}} + \frac{2g}{t} = \left(\frac{g_0}{f_0}\right)',$$

and the required magnetic conductance is

$$\frac{1}{\rho'_3} = \left(\frac{f_0}{g_0}\right)'.$$

In the present case, supplying values,

$$m = 0.03, \quad n = 0.06, \quad k = 0.15, \quad h = 0.26, \quad t = 0.305, \quad g = 0.02$$

$$\therefore \rho'_3 = \frac{2}{0.5 + 0.577 + 1.91} + \frac{0.04}{0.305} = 0.8,$$

and

$$\left(\frac{f_0}{g_0}\right)' = \frac{1}{0.8} = 1.25.$$

Maximum magnetic conductance of the path from *C* to *D* occurs when the stator tooth is opposite a rotor slot. The middle of the phase is here opposite a rotor tooth.

In this case the magnetic conductance is

$$\frac{t}{4g} + \frac{1}{\frac{4g}{t} + \frac{1}{\frac{m}{n} + \frac{k}{h}}} = 4.65.$$

When the slots are opposite, the magnetic conductance is

$$\frac{1}{\frac{2g}{t} + \frac{1}{\frac{m}{n} + \frac{k}{h}}} = 0.944.$$

When the middle tooth of the phase is opposite a rotor slot, the magnetic conductance is

$$\frac{1}{\frac{2g}{t} + \frac{1}{\frac{m}{n} + \frac{k}{h} + \frac{t}{4g}}} = 2.98.$$

The approximate average magnetic conductance is the average of 4.65, 0.944, 2.98 and 0.944. This is

$$\left(\frac{f_0}{g_0}\right)'' = 2.38.$$

Inductance due to end-connections is, as has been stated in the study of the alternator, a difficult quantity to calculate with close approximation, due to the indefiniteness of the magnetic path in the air. In the case of induction motors with wound rotors, a fair value to assume for the flux per ampere-conductor per centimeter length of the end-connections is

$$\phi_4 = \sqrt{\frac{\text{poles}}{\text{diameter}}}$$

For squirrel-cage induction motors about 50 per cent. should be added to this, as the end-connections of the rotor may be regarded as having negligible self-induction, which affords, consequently, an increased path for the stator flux.

Since length of end-connections per coil = $8 \times \frac{D}{p}$, the flux per coil per ampere-turn is

$$\begin{aligned} \phi_4 &= 1.5 \times 8 \times \sqrt{\frac{D}{p}} = 12 \sqrt{\frac{D}{p}} \\ &= 120 \sqrt{\frac{D}{p}} \text{ per absolute amp.-turn.} \end{aligned}$$

With the usual double-layer winding of the stator (primary) the magnetomotive force per coil is $\frac{snI}{2}$.

Therefore, the total flux per pole about the end-connections of any phase is

$$\phi_4 = 120 \frac{snI}{2} \sqrt{\frac{D}{p}}$$

Linking with this flux are $\frac{sn}{2}$ turns,

∴ the inductance (interlinkages of flux turns per unit current) per phase is

$$L_4 = \frac{1}{I} \times p \times \frac{sn}{2} \times 120 \frac{snI}{2} \sqrt{\frac{D}{p}} = 30s^2n^2 \sqrt{Dp}$$

The total primary inductance is, then,

$$L_0 = \Sigma L = \frac{4\pi n^2 l p}{10^9} \left[\left(\frac{a}{3b} + \frac{d}{e} + \left(\frac{f_0}{g_0} \right)' + \frac{7.5}{\pi} \frac{s}{l} \sqrt{\frac{D}{p}} \right) s + \left(\frac{f_0}{g_0} \right)'' s' \right] \text{ henrys.}$$

Supplying numerical values,

$$s = 4; s' = 2; n = 4; a = 0.95; b = 0.34; d = 0.206; e = 0.244;$$

$$\left(\frac{f_0}{g_0}\right)' = 1.25; D = 30.46 \text{ cm.}; p = 6; l = 11.94 \text{ cm.}; \left(\frac{f_0}{g_0}\right)'' = 2.38$$

$$L_0 = \frac{13,088}{10^9} [(0.931 + 0.843 + 1.25 + 1.73)4 + 2.38 \times 2]$$

$$= 0.000249 + 0.0000686 = 0.0003176 \text{ henry.}$$

Primary leakage reactance is, therefore,

$$x_0 = 2\pi f L_0 = 0.12 \text{ ohm}$$

Secondary leakage reactance.

Self-induction of the secondary is obtained in the same way. Thus the total secondary inductance is

$$L_1 = \frac{4\pi s n^2 p l}{10^9} \left[\frac{a}{3b} + \frac{d}{e} + \frac{f_0}{g_0} \right] \text{ henrys,}$$

where all quantities are known except $\frac{f_0}{g_0}$.

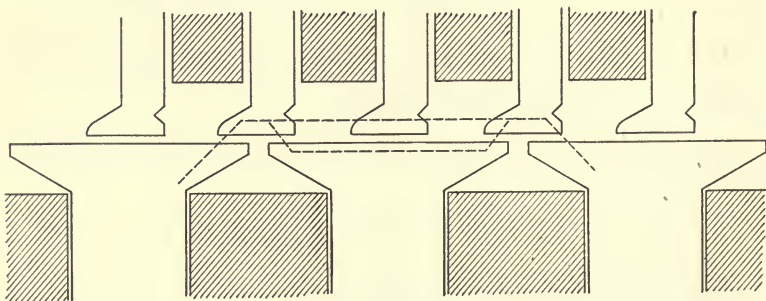

FIG. 278.

In Fig. 278 the leakage path is indicated by the dotted line for the relative position of rotor and stator teeth in which the magnetic conductance is maximum. The reluctance in this case is

$$\rho_3(\text{min.}) = \frac{4g}{t} + \frac{1}{\frac{t}{4g} + \frac{d}{2e}} = 0.2625 + \frac{1}{3.81 + 0.422} = 0.5,$$

and

$$\frac{f_0}{g_0}(\text{max.}) = \frac{1}{\rho_3} = 2.$$

Minimum magnetic conductance occurs when the stator and the rotor slots are directly opposite each other. Then

$$\rho_3(\text{max.}) = 2 \left[\frac{1}{\frac{1}{\frac{g}{t} + \frac{e}{d}} + s_0} \right] + \frac{e}{d} = 2.654.$$

The value s_0 is the magnetic conductance of the small path across the faces of the rotor teeth tips opposite a stator slot. It is, approximately,

$$\frac{0.08}{0.14} = 0.571.$$

$$\therefore \frac{f_0}{g_0}(\text{min.}) = \frac{1}{2.654} = 0.376,$$

and the average value of the magnetic conductance is

$$\frac{f_0}{g_0} = \frac{2 + 0.376}{2} = 1.2 \text{ approx.}$$

The rotor self-induction is then determined by supplying numerical values in the equation for L_1 (see page 370). Thus,

$$L_1 = \frac{4\pi \times \left(\frac{37}{3}\right) \times 11.94}{10^9} \left[\frac{0.5}{1.74} + \frac{0.19}{0.265} + 1.2 \right] = 4.09 \times 10^{-6} \text{ henrys.}$$

$$\text{Reactance} = 2\pi f L_1 = 0.00154 \text{ ohm.}$$

Reduced to the primary basis, this gives

$$x_1 = 0.00154 \times \left(\frac{288}{37}\right)^2 = 0.0935 \text{ ohm.}$$

The only quantities remaining to be determined are I_m and I_h , the magnetizing and core-loss currents. The core loss, or watts lost in hysteresis and eddy currents, is $E^2 g$, where $I_h = Eg$.

This loss is almost entirely in the primary core where the normal frequency of reversal of the flux obtains.

The secondary core loss is neglected.¹

As with the alternator, the eddy current loss will be taken as equal to one-half of the hysteresis loss.

To find the latter, then, the volume of stator teeth is

$$V_t = 72 \times 4.23 \times 0.45 = 137 \text{ cu. in.,}$$

where 0.45 = area of a tooth.

¹ It is neglected only in the case that the pulsation in flux due to the passing of the teeth is negligible, which is, however, not always the case.

Weight of teeth = $137 \times 0.28 = 38.4$ lb.

Hysteresis loss in teeth at 2.8 watts per lb. at 60 cycles and 64,500 lines per sq. in. is

$$38.4 \times 2.8 \times \left(\frac{84,000}{64,500} \right)^{1.6} = 170 \text{ watts.}$$

Outside diameter of the stator = 16.375 in.

Inside diameter of the stator = 14.34 in.

Volume of stator core is

$$V_c = \pi \times \frac{16.375 + 14.34}{2} \times 4.23 = 204 \text{ cu. in.}$$

Weight of core = $204 \times 0.28 = 57$ lb.

Flux density = $\frac{516,000}{2} \div (1.0175 \times 4.23) = 60,000$ lines per sq. in.

\therefore Hysteresis loss in core is

$$57 \times 2.8 \times \left(\frac{60,000}{64,500} \right)^{1.6} = 140 \text{ watts.}$$

\therefore Core loss = $1.5(170 + 140) = 465$ watts.

Core loss per phase = $\frac{465}{3} = 155$ watts = $E^2g = EI_h$, and $I_h = \frac{155}{E} = 2.44$ amp.

$$\text{Per cent. } I_h = \frac{2.44}{52} = 0.047.$$

That portion of the magnetizing current required by the air gap has been assumed as 20 per cent., or 10.4 amp. That required by the iron part of the flux path must be worked out from the known densities and dimensions of the magnetic circuit. The usual tabulation is as follows:

Part	Density	A.T. per in.	Length	A.T.		
Stator teeth	max.....	84,000	12.0	9.7	1.15	11
	min.....	72,500	7.4			
Rotor teeth	max.....	97,000	28.0	21.5	0.6	13
	min.....	88,000	15.0			
Stator core.....	60,000	4.5	4.0		18	
Rotor core.....	60,000	4.5	2.0		9	
Total iron amp.-turns.....						51

Since there are eight turns per pole per phase, the magnetizing current required for the iron is calculated from the equation for armature reaction.

$$\begin{aligned} \text{Arm. reac.} &= \sqrt{2} \times 1.5 \times \text{amp.-turns per pole and phase} \\ &= 2.12 \times 8 \times \text{amp.} = 51. \end{aligned}$$

$$\therefore \text{Current required for the iron part of the magnetic path} = \frac{51}{16.96} = 3.$$

Total magnetizing current per phase is

$$\begin{aligned} I_m &= 10.4 + 3 = 13.4 \\ \text{per cent. } I_m &= 0.26. \end{aligned}$$

Performance curves of the motor may now be worked out from the constants, reduced to percentages, as follows:

$$\begin{aligned} E_0 &= 1; \quad I_h = 0.047; \quad I_m = 0.26; \quad r_0 = \frac{0.0315 \times 52}{63.5} = 0.0258; \\ r_1 &= 0.0183; \quad x_0 = 0.0982; \quad x_1 = 0.069; \quad f = 0.01. \end{aligned}$$

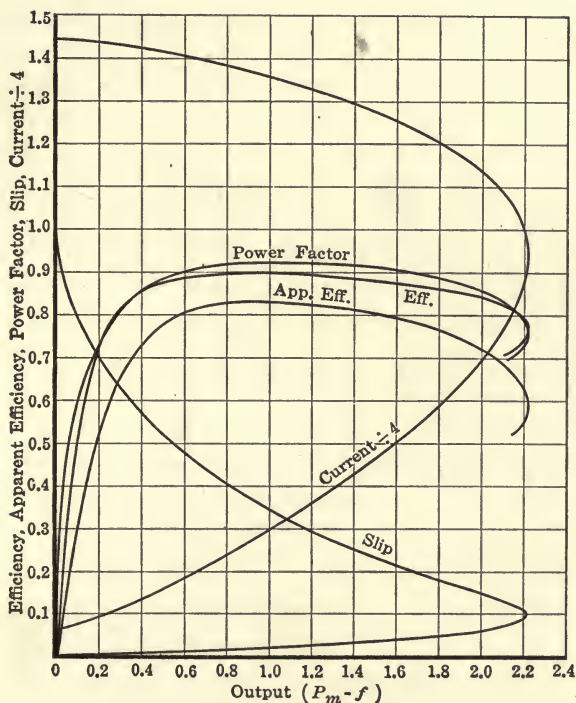

FIG. 279.

Tabulating as in the problems of the previous chapter, the resulting values are as follows:

Slip	0.0	0.01	0.02	0.03	0.05	0.08	0.1	0.3	0.5	1.0
I_0	0.257	0.626	1.107	1.57	2.38	3.32	3.775	5.34	5.64	5.82
T	0.0	0.498	0.95	1.337	1.925	2.37	2.475	1.675	1.12	0.6
$P_m - f_0$	0.0	0.483	0.921	1.288	1.82	2.17	2.217	1.163	0.55	0.0
P_i	0.0462	0.5525	1.022	1.448	2.11	2.675	2.867	2.425	1.953	1.484
$E_0 I_0$	0.257	0.626	1.107	1.57	2.38	3.32	3.775	5.34	5.64	5.82
Eff.	0.0	0.875	0.90	0.889	0.862	0.81	0.772	0.479	0.281	0.0
P.F.	0.18	0.883	0.922	0.921	0.887	0.805	0.76	0.455	0.346	0.255
App. eff.	0.0	0.773	0.83	0.819	0.765	0.652	0.587	0.228	0.0972	0.0

Performance curves are given in Figs. 279 and 280.

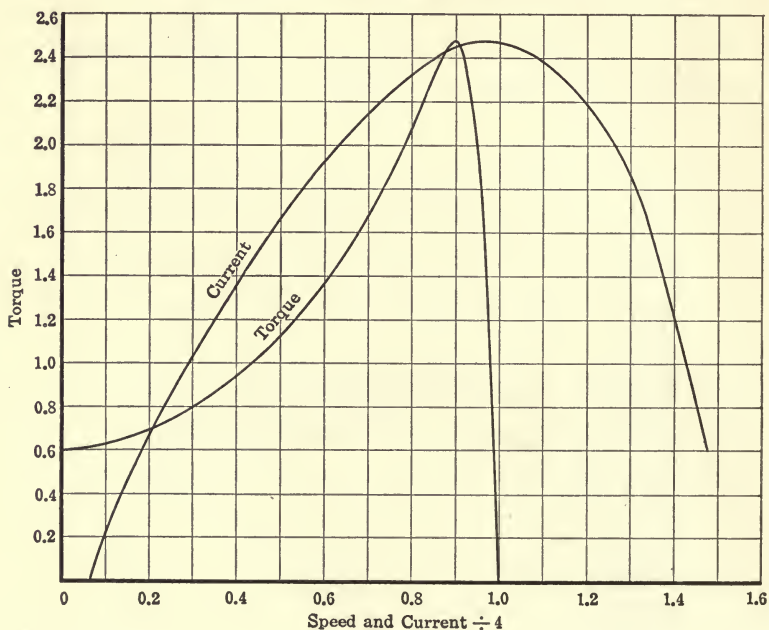

FIG. 280.

CHAPTER XLIV

ROTARY OR SYNCHRONOUS CONVERTERS

It is frequently necessary to obtain direct current when the available supply is alternating. Such, for instance, is the case with many electric railways, arc lighting systems, etc. Changing from direct to alternating current is also, but less frequently, required. The work of conversion from direct current to alternating current or *vice versa*, is done to great advantage by means of the rotary converter. Looked at from its commutator end, this machine is a direct-current generator; from the other end, it appears to be a synchronous motor with revolving armature.

Both receiving and transmitting electrical energy, it is motor and generator combined into one. If it be driven by mechanical power, it may give out electrical power, in the form of either direct current or alternating current, or both at the same time. Under its various phases of operation, then, the rotary converter may work as a direct-current generator, direct-current motor, synchronous motor or alternator. In any case its performance becomes that of one of these machines or a combination of them, and may be studied in that light.

Voltage and Current Ratios.—The fundamental equation of a direct-current generator has been found to be $E = \frac{4f\phi t}{10^8}$ volts, where f , ϕ and t , are respectively, the frequency of alternation of voltage in the conductors, the flux per pole cutting the conductors and the total number of turns between brushes. If the armature is tapped at two symmetrical points (for each pair of poles), and the taps are brought out to slip rings, then the voltage across the slip rings, by the fundamental equation for alternating-current generators, is $E_{eff.} = \frac{4.44f\phi t}{10^8}$ effective volts.

This equation holds, however, only for concentrated windings. For distributed windings, it is

$$E_{eff.} = \frac{2}{\pi} \times \frac{4.44f\phi t}{10^8}$$

and, substituting for 4.44 its derivation, $\sqrt{2}\pi$, the maximum voltage is $E_m = \sqrt{2} \times \frac{2}{\pi} \times \frac{\sqrt{2}\pi f \phi t}{10^8} = \frac{4f\phi t}{10^8}$ volts, which is the same as for direct current.

In calculations involving the voltage it is convenient to deal with the voltage to neutral, that is, one-half the direct-current or alternating-current single-phase voltage, and the phase voltage with polyphase connection. Thus, direct-current voltage to neutral is $E_n = \frac{E}{2} = \frac{2f\phi t}{10^8}$.

Single-phase effective voltage to neutral is

$$\frac{E_n}{\sqrt{2}} = \frac{E}{2\sqrt{2}}$$

In a three-phase machine maximum voltage between rings, = $\sqrt{3} E_n = \sqrt{3} \times \frac{2f\phi t}{10^8} = \sqrt{3} E_n$.

In an N -phase machine,

$$E_m = 2E_n \sin \frac{\pi}{N} = E \sin \frac{\pi}{n}$$

is maximum voltage between rings.

Effective voltage is $E_{eff} = \sqrt{2} E_n \sin \frac{\pi}{n} = \frac{E}{\sqrt{2}} \sin \frac{\pi}{n}$.

Current relations are determined by assuming 100 per cent. efficiency, or input = output. The direct-current output is $2E_n I$, where I = direct-current line current.

The input is $N \frac{E_m}{\sqrt{2}} I_p$, for N phases, where I_p = phase current.

Equating output to input, and solving for I_p ,

$$2E_n I = N \frac{E_m}{\sqrt{2}} I_p = \frac{2NE_n I_p \sin \frac{\pi}{N}}{\sqrt{2}}$$

$$I_p = \frac{2E_n I}{\sqrt{2}NE_n \sin \frac{\pi}{N}} = \frac{\sqrt{2}I}{N \sin \frac{\pi}{N}}$$

Effective line current is the vector sum of two adjacent effective phase currents. This may be proven to be

$$I_l = \frac{2\sqrt{2}I}{N}$$

Thus, for three-phase, effective phase current is

$$I_p = \frac{2\sqrt{2}}{3\sqrt{3}}I,$$

and effective line current is

$$I_l = \frac{2\sqrt{2}}{3}I.$$

Problem 110.—Assuming the direct-current voltage and current to be E and I respectively, deduce effective phase voltages and currents for one-, two-, three-, four-, and six-phase alternating input.

For single-phase, the values have already been indicated. They are

$$E_1 = \frac{E}{\sqrt{2}}; \quad I_1 = \sqrt{2}I.$$

They cannot be obtained from the general formulæ directly, but are easily found from the power equation. The general formulæ apply to polyphase machines.

Voltage Control.—Under the ideal conditions assumed, there is no voltage drop in the armature. Practically, however, there is a drop proportional to the load. With a constant impressed alternating-current voltage on either the rotary terminals or the supply generator, the drop in the armature, or in the armature and line, as the case may be, causes a variation in the terminal direct-current pressure.

It is frequently desirable to compensate for this voltage drop in line and armature, in order to maintain constant direct-current voltage across the brushes of the rotary converter. One method of doing this is by proper "compounding of the series field." In general, the procedure is to "under-excite the shunt field," so that at no load the machine, acting as a synchronous motor, will draw lagging current of about one-third normal value. At $\frac{3}{4}$ -load the current will be in time-phase with the voltage.

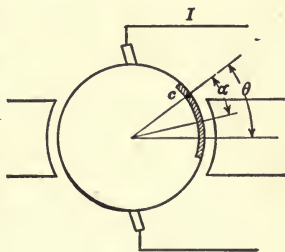

FIG. 281.

At full-load the current, due to the series field m.m.f., will lead somewhat, with the consequent increase in terminal voltage.

Heating of the Armature.—In Fig. 281 is shown one phase of a rotary converter, whose center line makes an angle $(\theta - \alpha)$ with the field axis. Let any coil, c , be displaced an angle, α , from the center line of this phase, or θ° , from the field axis.

To Find the Heating in this Coil.—Let the current and voltage be in time-phase with each other. Then maximum current will flow in the phase, and therefore in the coil, when $\theta - \alpha = 0$.

Thus the current in the coil is not maximum when the coil is on the axis, but when the center of the phase is on the axis. Therefore the alternating current in the coil may be written

$$i = I_m \cos(\theta - \alpha).$$

If I is the direct current in the line, $\frac{I}{2}$ is the direct current in the coil.

Therefore, the resultant current in the coil is

$$i_r = i - \frac{I}{2} = I_m \cos(\theta - \alpha) - \frac{I}{2}.$$

But it is known that, in general,

$$I_m = \frac{2I}{N \sin \frac{\pi}{N}}.$$

Therefore,

$$i_r = \frac{I}{2} \left(\frac{4 \cos(\theta - \alpha)}{N \sin \frac{\pi}{N}} - 1 \right).$$

The heating of the coil is proportional to the square of i_r ; the average heating to the average square of the resultant current taken over a half-cycle from $\theta = -\frac{\pi}{2}$ to $\theta = \frac{\pi}{2}$. Thus, average heating of coil =

$$\frac{1}{\pi} \frac{I^2}{4} \int_{-\frac{\pi}{2}}^{\frac{\pi}{2}} \left(\frac{4 \cos(\theta - \alpha)}{N \sin \frac{\pi}{N}} - 1 \right)^2 d\theta.$$

Comparing this heating to that of a direct-current generator with the same current output gives

$$\frac{\text{heating of rotary coil}}{\text{heating of d.-c. gen. coil}} = \frac{1}{\pi} \int_{-\frac{\pi}{2}}^{\frac{\pi}{2}} \left(\frac{4 \cos(\theta - \alpha)}{N \sin \frac{\pi}{N}} - 1 \right)^2 d\theta.$$

Problem 111.—Prove that this ratio is:

$$\frac{8}{N^2 \sin^2 \frac{\pi}{N}} + 1 - \frac{16 \cos \alpha}{N \pi \sin \frac{\pi}{N}}$$

Proof.—

$$\begin{aligned} & \frac{1}{\pi} \int_{-\frac{\pi}{2}}^{\frac{\pi}{2}} \left(\frac{4 \cos(\theta - \alpha)}{N \sin \frac{\pi}{N}} - 1 \right)^2 d\theta \\ &= \frac{1}{\pi} \int_{-\frac{\pi}{2}}^{\frac{\pi}{2}} \left(\frac{16 \cos^2(\theta - \alpha) - 8N \cos(\theta - \alpha) \sin \frac{\pi}{N} + N^2 \sin^2 \frac{\pi}{N}}{N^2 \sin^2 \frac{\pi}{N}} \right) d\theta \\ &= \frac{1}{\pi N^2 \sin^2 \frac{\pi}{N}} \int_{-\frac{\pi}{2}}^{\frac{\pi}{2}} \left(16 \cos^2(\theta - \alpha) - 8N \sin \frac{\pi}{N} \cos(\theta - \alpha) + N^2 \sin^2 \frac{2\pi}{N} \right) d\theta. \end{aligned}$$

Integrating the terms separately,

$$\begin{aligned} (1) \int_{-\frac{\pi}{2}}^{\frac{\pi}{2}} 16 \cos^2(\theta - \alpha) d\theta &= 16 \int_{-\frac{\pi}{2}}^{\frac{\pi}{2}} (\cos^2 \theta \cos^2 \alpha + 2 \cos \theta \sin \theta \cos \alpha \sin \alpha \\ &\quad + \sin^2 \alpha \sin^2 \theta) d\theta \\ &= 16 \left[\cos^2 \alpha \left(\frac{\sin 2\theta}{4} + \frac{\theta}{2} \right) + 2 \cos \alpha \sin \alpha \left(\frac{-\cos 2\theta}{4} \right) \right. \\ &\quad \left. + \sin^2 \alpha \left(\frac{-\sin 2\theta}{4} + \frac{\theta}{2} \right) \right]_{-\frac{\pi}{2}}^{+\frac{\pi}{2}}, \\ &= 8\pi \cos^2 \alpha + 0 + 8\pi \sin^2 \alpha = 8\pi(\sin^2 \alpha + \cos^2 \alpha) = 8\pi. \end{aligned}$$

$$\begin{aligned} (2) \int_{-\frac{\pi}{2}}^{\frac{\pi}{2}} -8N \sin \frac{\pi}{N} \cos(\theta - \alpha) d\theta \\ &= -8N \sin \frac{\pi}{N} \left[\cos \alpha \sin \theta + \sin \alpha (-\cos \theta) \right]_{-\frac{\pi}{2}}^{\frac{\pi}{2}} \\ &= -16N \sin \frac{\pi}{N} \cos \alpha. \end{aligned}$$

$$\begin{aligned} (3) \int_{-\frac{\pi}{2}}^{\frac{\pi}{2}} N^2 \sin^2 \frac{\pi}{N} d\theta &= \left[N^2 \sin^2 \frac{\pi}{N} \theta \right]_{-\frac{\pi}{2}}^{\frac{\pi}{2}} = \pi N^2 \sin^2 \frac{\pi}{N}. \\ \therefore \text{Ratio} &= \frac{8}{N^2 \sin^2 \frac{\pi}{N}} + 1 - \frac{16 \cos \alpha}{N \pi \sin \frac{\pi}{N}}. \end{aligned}$$

Prove that this ratio is maximum for that coil of the phase for which $\alpha = \frac{\pi}{N}$, that is, for the largest possible value of α , and that the ratio is minimum for $\alpha = 0$.

Problem 112.—Find the ratio between maximum and minimum heating on three-phase, four-phase, and six-phase converters.

$$\text{Solution.}—\text{Three-phase max.} = \frac{8}{9 \sin^2 60^\circ} + 1 - \frac{16 \cos 60^\circ}{3\pi \sin 60^\circ} = 1.21.$$

$$\text{Three-phase min.} = \frac{8}{9 \sin^2 60^\circ} + 1 - \frac{16 \cos 0^\circ}{3\pi \sin 60^\circ} = 0.226.$$

$$\text{Three-phase ratio, } \frac{\text{max.}}{\text{min.}} = \frac{1.21}{0.226} = 5.35.$$

$$\text{Four-phase max.} = \frac{8}{16 \sin^2 45^\circ} + 1 - \frac{16 \cos 45^\circ}{4\pi \sin 45^\circ} = 0.728.$$

$$\text{Four-phase min.} = \frac{8}{16 \sin^2 45^\circ} + 1 - \frac{16 \cos 0^\circ}{4\pi \sin 45^\circ} = 0.2.$$

$$\text{Four-phase ratio, } \frac{\text{max.}}{\text{min.}} = \frac{0.728}{0.2} = 3.64.$$

$$\text{Six-phase max.} = \frac{8}{36 \sin^2 30^\circ} + 1 - \frac{16 \cos 30^\circ}{6\pi \sin 30^\circ} = 0.426.$$

$$\text{Six-phase min.} = \frac{8}{36 \sin^2 30^\circ} + 1 - \frac{16 \cos 0^\circ}{6\pi \sin 30^\circ} = 0.199.$$

$$\text{Six-phase ratio, } \frac{\text{max.}}{\text{min.}} = \frac{0.426}{0.199} = 2.14.$$

Problem 113.—Find the ratio of average heating around the whole periphery to the heating of a direct-current armature.

To determine the ratio of average heating around the periphery the expression must be integrated for the ratio of heating of any coil of a phase for all possible values of α , and this must be divided by the angular width of the phase.

Thus, ratio of average heating is

$$\begin{aligned} & \frac{N}{2\pi} \int_{\alpha = -\frac{\pi}{N}}^{\alpha = +\frac{\pi}{N}} \left(\frac{8}{N^2 \sin^2 \frac{\pi}{N}} + 1 - \frac{16 \cos \alpha}{N\pi \sin \frac{\pi}{N}} \right) d\alpha \\ &= \frac{N}{2\pi} \left[\frac{8\alpha}{N^2 \sin^2 \frac{\pi}{N}} + \alpha - \frac{16 \sin \alpha}{N\pi \sin \frac{\pi}{N}} \right]_{\alpha = -\frac{\pi}{N}}^{\alpha = \frac{\pi}{N}} \\ &= \frac{8}{N^2 \sin^2 \frac{\pi}{N}} + 1 - \frac{16}{\pi^2} = \frac{8}{N^2 \sin^2 \frac{\pi}{N}} - 0.63. \end{aligned}$$

Problem 114.—Find the ratio of average heating to direct-current heating for three-phase, four-phase, and six-phase input.

$$\text{Three-phase: } \frac{8}{9 \sin^2 60^\circ} + 1 - \frac{16}{\pi^2} = 0.55.$$

$$\text{Four-phase: } \frac{8}{16 \sin^2 45^\circ} - 0.63 = 0.37.$$

$$\text{Six-phase: } \frac{8}{36 \sin^2 30^\circ} - 0.63 = 0.259.$$

In all of these problems the input is taken at unity power factor.

When there is also a wattless component of current in the winding the heating is due to this component which is not compensated for, as well as to the power component. Although the components are at right angles (Fig. 282), the heating due to them is added directly, since it is proportional to their squares, and the sum of the squares gives the total current in the winding.

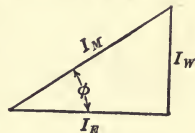

FIG. 282.

Another way to determine the heating of a rotary converter when the current has a wattless component is to resolve the current into its components and add their instantaneous values.

Let the power factor of the alternating current be $\cos \phi$. Then, if I_w is the maximum value of the wattless component of the current in the winding, and I_e is the maximum value of the power component,

$$\tan \phi = \frac{I_w}{I_e}$$

Thus, I_w is known, or,

$$I_w = I_e \tan \phi = \frac{2I}{N \sin \frac{\pi}{N}} \tan \phi$$

ϕ is positive for leading current. I_w is maximum for $\theta - \alpha = 90^\circ = \frac{\pi}{2}$.

$\therefore i_w = I_w \sin (\theta - \alpha)$ for a coil displaced α° .

Thus, the resultant current in a coil, m , is

$$\begin{aligned} i_r &= \frac{I}{2} \left[\frac{4 \cos (\theta - \alpha)}{N \sin \frac{\pi}{N}} - 1 + \frac{4 \sin (\theta - \alpha) \tan \phi}{N \sin \frac{\pi}{N}} \right] \\ &= \frac{I}{2} \left[\frac{4}{N \sin \frac{\pi}{N}} \left(\frac{\cos (\theta - \alpha) \cos \phi + \sin (\theta - \alpha) \sin \phi}{\cos \phi} \right) - 1 \right] \\ &= \frac{I}{2} \left[\frac{4}{N \sin \frac{\pi}{N} \cos \phi} \cos (\theta - \alpha - \phi) \right] \end{aligned}$$

Problem 115.—From this equation determine the maximum heating of an armature coil compared with that of a direct-current generator of the same output.

Solution.—

$$\text{Ratio of } \frac{\text{rotary current in any coil}}{\text{d.-c. current}} = \frac{i_r}{I} = \frac{1}{2}$$

The ratio of heating

$$\begin{aligned}
 &= \frac{1}{\pi} \int_{-\frac{\pi}{2}}^{\frac{\pi}{2}} \left(\frac{4 \cos(\theta - \alpha)}{N \sin \frac{\pi}{N}} - 1 + \frac{4 \sin(\theta - \alpha) \tan \phi}{N \sin \frac{\pi}{N}} \right)^2 d\theta \\
 &= \frac{1}{\pi} \int_{-\frac{\pi}{2}}^{\frac{\pi}{2}} \left(\frac{16 \cos^2(\theta - \alpha)}{N^2 \sin^2 \frac{\pi}{N}} + 1 + \frac{16 \sin^2(\theta - \alpha)}{N^2 \sin^2 \frac{\pi}{N}} \tan^2 \phi - \frac{8 \cos(\theta - \alpha)}{N \sin \frac{\pi}{N}} \right. \\
 &\quad \left. + \frac{32 \cos(\theta - \alpha) \sin(\theta - \alpha)}{N^2 \sin^2 \frac{\pi}{N}} \tan \phi - \frac{8 \sin(\theta - \alpha)}{N \sin \frac{\pi}{N}} \tan \phi \right) d\theta.
 \end{aligned}$$

Integrating and applying limits,

$$\begin{aligned}
 &= \frac{1}{\pi} \left[\frac{8\pi}{N^2 \sin^2 \frac{\pi}{N}} + \pi + \frac{8\pi \tan^2 \phi}{N^2 \sin^2 \frac{\pi}{N}} - \frac{16 \cos \alpha}{N \sin \frac{\pi}{N}} + 0 + \frac{16 \sin \alpha \tan \phi}{N \sin \frac{\pi}{N}} \right] \\
 &= \frac{8(1 + \tan^2 \phi)}{N^2 \sin^2 \frac{\pi}{N}} + 1 - \frac{16 \cos \alpha + 16 \sin \alpha \tan \phi}{\pi N \sin \frac{\pi}{N}}.
 \end{aligned}$$

But

$$1 + \tan^2 \phi = \sec^2 \phi = \frac{1}{\cos^2 \phi}, \text{ and } \tan \phi = \frac{\sin \phi}{\cos \phi},$$

and

$$\cos \alpha \cos \phi + \sin \alpha \sin \phi = \cos(\alpha - \phi).$$

$$\therefore \text{Ratio} = \frac{8}{N^2 \sin \frac{\pi}{N} \cos^2 \phi} + 1 - \frac{16 \cos(\alpha - \phi)}{\pi N \sin \frac{\pi}{N} \cos \phi}.$$

The maximum heating occurs in that coil for which $\cos(\alpha - \phi)$ is minimum.

Problem 116.—Compare the average heating around the whole periphery with that of a direct-current generator.

Solution.—For this, it is necessary simply to integrate the above ratio between the limits of a phase, or between $-\frac{\pi}{N}$ and $+\frac{\pi}{N}$, and divide by $\frac{2\pi}{N}$.

$$\therefore \text{Ratio} = \frac{N}{2\pi} \int_{\alpha = -\frac{\pi}{N}}^{\alpha = \frac{\pi}{N}} \left(\frac{8}{N^2 \sin^2 \frac{\pi}{N} \cos^2 \phi} + 1 - \frac{16 \cos(\alpha - \phi)}{N \pi \sin \frac{\pi}{N} \cos \phi} \right) d\alpha.$$

Substituting the expression

$$\cos(\alpha - \phi) = \cos \phi \cos \alpha - \sin \phi \sin \alpha, \text{ and integrating,}$$

$$\text{Ratio} = \frac{N}{2\pi} \left[\frac{8\alpha}{N^2 \sin^2 \frac{\pi}{N} \cos^2 \phi} + \alpha - \frac{16(\cos \phi \sin \alpha - \sin \phi \cos \alpha)}{N \pi \sin \frac{\pi}{N} \cos \phi} \right]_{\alpha = -\frac{\pi}{N}}^{\alpha = \frac{\pi}{N}}$$

$$\begin{aligned}
 &= \frac{N}{2\pi} \frac{8 \times \frac{2\pi}{N}}{N^2 \sin^2 \frac{\pi}{N} \cos^2 \phi} + \frac{2\pi}{N} - \frac{16 \cos \phi \left(2 \sin \frac{\pi}{N} \right) - \sin \phi (0)}{N\pi \sin \frac{\pi}{N} \cos \phi} \\
 &= \frac{8}{N^2 \sin^2 \frac{\pi}{N} \cos^2 \phi} + 1 - \frac{16}{\pi^2} = \frac{8}{N^2 \sin^2 \frac{\pi}{N} \cos^2 \phi} - 0.63.
 \end{aligned}$$

Problem 117.—Calculate maximum and minimum heating for a power factor of 0.9, lagging and leading, for three-phase, four-phase, and six-phase rotaries, also the average heating.

Solution.—Maximum heating is obtained by substituting $\alpha = \frac{\pi}{N}$ and minimum heating by substituting $\alpha = 0$, in the equation

$$\text{ratio} = \frac{8}{N^2 \sin^2 \frac{\pi}{N} \cos^2 \phi} + 1 - \frac{16 \cos (\alpha - \phi)}{\pi N \sin \frac{\pi}{N} \cos \phi}$$

For average heating,

$$\text{ratio} = \frac{8}{N^2 \sin^2 \frac{\pi}{N} \cos^2 \phi} - 0.63,$$

where $N = 3, 4, 6$, and $\cos \phi = 0.9$ and -0.9 .

The final substitution of values is here left to the student.

A good physical idea of the distribution of current in the windings of a rotary armature may be obtained from diagrams showing the direct-current output as a constant fixed in space with reference to the brushes, while the alternating-current input varies according to the angular position of the phases, by the equation $i = I_m \sin \theta$.

Let θ vary by steps of 30° , and write down on the diagrams the values of both the direct and alternating current, with direction arrows, and also the resultant current in each part of the winding. This may be done both for single-phase and three-phase armatures.

If the unidirectional line current is 100 amp., then the maximum alternating current is 200 amp. for single-phase and 133 amp. for three-phase.

These diagrams are given in Fig. 283.

Voltage Control.—The voltage of rotary converters for railway work is controlled by variation of the phase of the current input. In general the machine is over-compounded to neutralize the drop in feeders. Therefore, the alternating-current voltage impressed on the rotary, must vary to make up the necessary over-compounding as well as the drop in the armature.

The phase of the current, as in a synchronous motor, depends on the field excitation. A reactive coil is placed in series, as shown in Fig. 284. If the current is lagging there will be a big drop in the line and coil, and the voltage impressed on the rotary will be reduced.

Current Relations in Single-Phase Converter

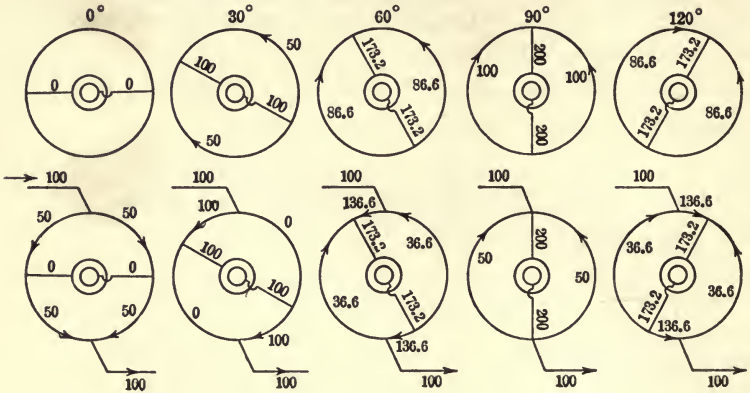

Three-Phase Converter

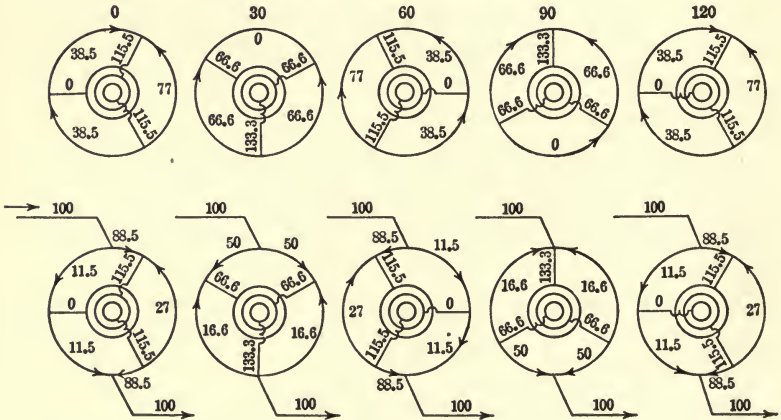

FIG. 283.

If the series field m.m.f. is so adjusted as to give leading current at full-load, then at light-load, the current will be lagging. By this means of adjustment, a constant direct-current voltage may be maintained. To get this adjustment, the shunt and

series field m.m.f. should give unity power factor at about $\frac{3}{4}$ -load.

Question.—In a given case, it may be required to obtain constant direct-current voltage from a given constant generator voltage, E_0 , of such a value as to require the interposition of transformers. How shall the transformer ratio be determined, so as to give the most efficient operation?

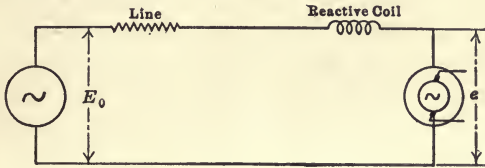

FIG. 284.

If constant voltage, e , impressed on the rotary is assumed, the fundamental equation is

$$E_0 = e + (i + ji')(r + jx)$$

where $r + jx =$ impedance of line and coil.

But generally, e is not constant, but should vary with the load—that is, with i . The equation is

$$\begin{aligned} E_0 &= e + ik + (i + ji')(r + jx) \\ &= e + ik + ir - i'x + j(ix + i'r) \end{aligned} \tag{128}$$

where k is the percentage of over-compounding.

Assuming that $i' = 0$ at, say, $\frac{3}{4}$ -load, the first step is to find i' at no-load, to ascertain that it is not excessive.

Let $e + ik = e'$. Then (128) becomes

$$\begin{aligned} E_0 &= e' + (i + ji')(r + jx) \\ E_0^2 &= (e + ik + ir - i'x)^2 + (i'r + ix)^2 \\ &= e^2 + I^2Z^2 + i^2k^2 + 2ei(k + r) - 2ei'x \text{ approx.} \end{aligned}$$

Let $i = i_0$ at non-inductive load. Then

$$\begin{aligned} E_0^2 &= e^2 + i^2(Z^2 + k^2) + 2ei_0(k + r) \\ \therefore \frac{E_0}{e} &= 1 + i_0^2 \frac{Z^2 + k^2}{e^2} + \frac{2i_0}{e} (k + r) \end{aligned} \tag{129}$$

At no-load $i = 0$.

$$\therefore E_0^2 = e^2 + i'^2Z^2 - 2ei'x = e^2 - 2ei'x \text{ (approx.)}$$

$$\therefore i' = -\frac{E_0^2 - e^2}{2ex} = -\frac{e}{2x} \left[\left(\frac{E_0}{e}\right)^2 - 1 \right].$$

The value of $\frac{E_0}{e}$ is obtained from Eq. 129.

Numerical Application.—Let $e = 1$, $r = 0.10$, $x = 0.30$, $k = 0.10$, $i = 1$ at full-load, and $i_0 = 0.75$.

Then $\frac{E_0}{e} = 1.12$ and i' at no-load = -0.38 .

The generator voltage should thus at no-load be 12 per cent. higher than the desired voltage at the rotary at no-load, or, in other words, the voltage at the line coming into the substation should be 12 per cent. higher than is actually wanted at the collector rings of the rotary. The rotary will reduce the no-load voltage by taking a large lagging current (in this case 40 per cent. of full-load current).

Thus if, for instance, a single-phase 500-volt rotary is to operate from a 10,000-volt generating station, the transformer ratio would not be $\frac{10,000}{354} = 28.2$, but $\frac{28.2}{1.12} = 25.2$.

If I_1 is the secondary current due to a certain phase of the primary, whose induced e.m.f. is e_i , then the power component of I_1 has been shown to be $e_i a_1$.

$-jI_1$ is evidently the secondary current due to a primary phase which is 90° in space and time behind the former. The induced e.m.f. of this phase is, of course, $-je_i$, and the flux causing the e.m.f. is 90° in time ahead of the e.m.f. Thus the flux which reacts on the energy component of the original secondary current is proportional to $j(-je_i) = ke_i$.

\therefore the torque is $ke_i e_i a_1 = ke_i^2 a_1$.

Voltage Control by Use of the "Split Pole."—The "split pole" converter has found extensive application more especially in the field of lighting service, where the fluctuations of the load are not so persistent as they are in railway work.

It is based upon the principle that the voltage ratio is altered by shifting the brushes.

Ordinarily, the brushes on a direct-current generator are set at or near the neutral point, and when they are in that position, the generator gives maximum voltage. If shifted to any other point, the voltage is $E \cos \alpha$, where α is the angle between the neutral axis and that of the brushes, and E is the voltage when

the brushes are on the neutral axis. Under conditions of variable shift, the voltage ratio of a rotary converter is then,

$$\frac{E_{a.c.}}{E \cos \alpha}$$

In order to increase the amount of the variation of this ratio, the poles are slotted, or split, directly over the position chosen for the brushes, as shown in Fig. 285, thus enabling the brushes to take a position, which, otherwise, would be impossible owing to bad commutation.

Such an arrangement, while it permits a great shift, does not give variable shift. To obtain variation of the shift, which is indeed necessary in order to have voltage control, the poles may be split into two or more separate sections, each with its own exciting coil.

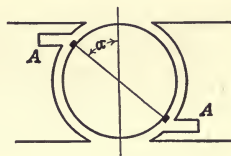

FIG. 285.

Suppose, for instance, an arrangement such as shown in Fig. 286. Let the poles N and S , alone, be excited. The axis of the main flux is then along the line making an angle α with the horizontal. Suppose, now, as the load comes on, poles N' and S' are excited by means of a series winding. The flux axis is then shifted

toward the horizontal, decreasing α , and consequently increasing the direct-current voltage. The amount of such variation of voltage is considerable. Tests on a certain three-phase machine showed that with constant impressed alternating-current voltage of 194 the direct-current voltage ranged from 317 to 200, giving at all times sparkless commutation.

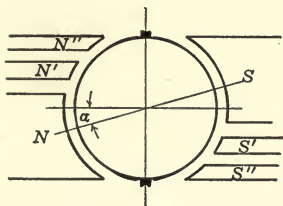

FIG. 286.

Poor commutation in rotary converters is due almost entirely to self-induction of the coil short-circuited by the brushes. This effect is of sufficient importance to justify the use of inter-poles.

Armature Reaction in Rotary Converter

Problem 118.—Prove that in an ordinary rotary converter the resultant armature reactive m.m.f. due to the direct current and the power component of the alternating current is zero.

Solution.—Consider a two-pole machine. Let I = direct current, and m = total turns. Then the ampere-turns due to direct current = $m \times \frac{I}{2}$.

As these turns are distributed, the direct-current armature reaction =

$$\frac{2}{\pi} \times m \frac{I}{2} = \frac{mI}{\pi}$$

This reaction, considering the brushes to be at 0° shift, is along the axis of the brushes.

Armature reaction due to the power component of the alternating current, is also along the brush axis, but opposite to the direct-current reaction. Alternating-current armature reaction due to the wattless component is

$$\frac{N}{2} \sqrt{2} \times i'_{a.c.} \times T_0$$

where $i'_{a.c.} = I_{a.c.} \sin \alpha$, and $T_0 =$ effective turns per phase.

With the power component, the expression for armature reaction is exactly the same but the direction of the reaction is along the brushes instead of along the field axis as with the wattless component.

∴ Alternating-current armature reaction = $N \sqrt{2} i_{a.c.} T_0$ where $i_{a.c.}$ is the power component, in the direction of the direct current.

But

$$i_{a.c.} = \frac{\sqrt{2}I}{2N \sin \frac{\pi}{N}}$$

Substituting this

$$\frac{N}{2} \sqrt{2} i_{a.c.} T_0 = \frac{IT_0}{2 \sin \frac{\pi}{N}}$$

Effective turns per phase, $T_0 = kt$, where $t =$ turns per phase.

$$k = \text{ratio, } \frac{\text{chord}}{\text{arc}} = \frac{N}{\pi} \sin \frac{\pi}{N}$$

$$\therefore T_0 = \frac{N}{\pi} t \sin \frac{\pi}{N}$$

Also,

$$Nt = m.$$

Substituting these values, alternating-current armature reaction due to $i = \frac{mI}{2} =$ direct-current armature reaction, and the total reaction in the brush axis is 0.

Armature reaction is present in split-pole rotaries to a limited extent. The direct-current reaction is always along the brush axis, while the alternating-current reaction due to the power component of the current is at right angles to the resultant flux.

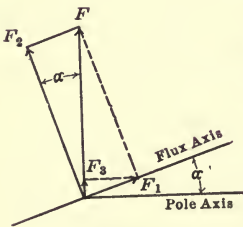

FIG. 287.

The angle, α , Fig. 286, is the angle of relative brush shift. The direct-current reaction, F , Fig. 287, may then be resolved into components, F_1 along the flux axis, and F_2 in line with the alternating-current reaction.

The alternating-current reaction due to the power component of current is in line with F_2 , and is $F_n = F \cos \alpha$.

$$\therefore F_2 = F \cos \alpha = F_n.$$

Also,

$$F_1 = F \sin \alpha = \frac{F_n}{\cos \alpha} \sin \alpha = F_n \tan \alpha.$$

Thus, F_2 is compensated by F_n , while F_1 has no compensation except in so far as this is accomplished along the lines of the main field excitation. There remains an uncompensated component F_3 , along the brush axis, which is

$$F_3 = F_1 \sin \alpha = F_n \frac{\sin^2 \alpha}{\cos \alpha}.$$

Example.—Let $\alpha = 30^\circ$.

Then $\sin \alpha = \sin 30^\circ = 0.5$. $\sin^2 \alpha = 0.25$. $\cos \alpha = 0.866$.

$$\therefore F_3 = F_n \times \frac{0.25}{0.866} = 0.29F_n.$$

That is, the uncompensated armature reaction amounts to about 30 per cent. of the alternating-current reaction.

Transformer Connections for Rotary Converters.—Most rotary converters receive energy from three-phase supply. In most cases it is simply a matter of connecting to the transformer terminals as would be done in the case of a synchronous motor. However, it is often economical to operate the rotaries as six-phase machines, receiving the energy, however,



FIG. 288.

as three-phase. In connecting six-phase, the principle is to always have the direction arrows as shown in Fig. 288, for either Δ or Y-connection. This is illustrated in Fig. 289 by what is called the double Δ -connection. Each primary supplies power for two secondaries whose terminals are led to the slip rings of

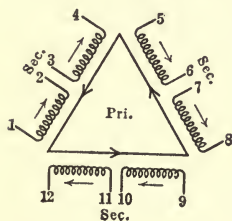

FIG. 289.

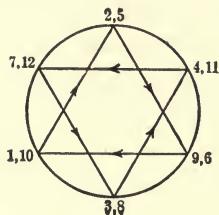

FIG. 290.

the rotary converter. There are six slip rings. Each slip ring is connected to two transformers. The terminals are indicated by corresponding numbers. Fig. 290 illustrates the double T-connection. The arrows show the only essential precaution that is necessary to take. There are still other ways of connecting six-phase, as the “diametrical,” in which the terminals of each

transformer are connected to diametrically opposite points on the armature.

Synchronous Condensers.—When a rotary converter or synchronous motor is over-excited so that it takes a leading current, it may be used on a system for the purpose of improving the power factor.

Such uses are of frequent occurrence where the load consists principally of induction motors with their large lagging components of current. Machines used for the purpose of neutralizing this lagging current by drawing on the supply for an equal leading current, are called "synchronous condensers."

The commercial problem is, in any case, to determine whether the saving in line and generator loss, improvement in regulation, and, with initial installations, the saving in capital expenditure, justify the additional expenditure required for the installation of synchronous condensers.

As a concrete illustration, consider a system with poor voltage regulation. Can the owners afford to buy synchronous condensers, at say, \$10 per kv.a., in order to improve the operation of the system? Let it be assumed that the power factor is ordinarily only 70 per cent., that the cost of energy to the station is 1c. per kw. hr., and that the load factor is 30 per cent.

At normal full-load, $i = 1 =$ load component of the current. Then, since $\cos \phi = 0.7$, $i' = 1 =$ wattless component, lagging, and the total current is $I = i - ji' = 1 - j1$.

To neutralize the lagging component, a leading component, $i'_c = 1$, is required. If this is the full-load current of the condenser, its rating is at once determined and, thereby, its cost. It would probably be better not to try to make the current lead by 90° . For instance, let the condenser also do some work, say $i'_c = 0.1$. Then

$$I_c = 0.1 + j1,$$

and

$$I_c = \sqrt{1.01} = 1.005.$$

Thus the condenser current is practically unaffected in amount by the addition of a 10 per cent. load.

The total station load is now $i + i_c = 1.1$. Whereas, previously its current was $I = 1.4$, it is now only 1.1, and yet the useful load is not only the same but is 10 per cent. greater. The voltage of the load is taken as $e = 1$.

The line loss has been reduced in the ratio $\left(\frac{1.1}{1.4}\right)^2$, or 38 per cent.

Assuming, previously, a line and generator loss of 20 per cent. which would be reasonable under the conditions, the saving amounts to $0.38 \times 0.2 = 0.076$ watt.

At 30 per cent. load factor, this saving is $0.076 \times 0.3 = 0.0228$. The gain in power from the condenser is $0.1 \times 0.3 = 0.03$. At 1c. per kw. hr., and assuming 7200 hr. per year, the value of energy saved is

$$\$0.00001 \times 7200 \times 0.0528 = \$0.0038$$

Cost of condenser at \$10 per kv.a. is

$$\$0.01 \times 1.0 = \$0.01$$

Interest at 6 per cent. on cost of condenser = $0.01 \times 0.06 = \$0.0006$.

Problem 119.—Apply the above reasoning to a system in which the normal load current is 1000 amp. at 250 volts, stating the conclusion with reference to the advisability of buying synchronous condensers. Considering the line to have resistance only, show how the voltage regulation would be affected by the change.

There is still one feature of the use of synchronous condensers that has not been considered. In the above example, the load has been taken as varying to give a load factor of 30 per cent., while the synchronous condenser was assumed to supply at all times a leading component exactly neutralizing the lagging component of the load. This assumption of flexibility of the condenser is hardly justified. At the same time it would be undesirable that the condenser should draw full-load leading current continuously. The field excitation may therefore be obtained by compound winding such that at full-load $i'_c = 1$, while at no-load $i'_c = -1$. The field of the condenser must therefore be made to depend on the entire load to be compensated.

By making the full-load and no-load wattless components equal and opposite, the smallest condenser is required. This gives, however, considerable no-load line loss.

The use of synchronous condensers has now been discussed sufficiently to enable the student to investigate any given case and make an engineering report on it.

The question of where to install the condensers, whether at the load, or at the power station, is also of interest, and should be discussed by the student, reasons being given why either position is to be preferred.

CHAPTER XLV

SINGLE-PHASE ALTERNATING-CURRENT MOTORS

Under this heading would naturally be comprised single-phase induction motors and the various types of commutator motors. The development of the latter class of machines, together with certain inherent defects in the former, has had the effect of rendering the single-phase induction motor nearly obsolete. When a polyphase induction motor is running, if one of the phase circuits be opened the motor will continue to operate as a single-phase machine. Its permissible output will be greatly reduced and, in general, its characteristics will be changed for the worse. The principal difficulty with the single-phase induction motor is its inability to start. Special means have to be supplied, such as "splitting" the phase, that is, dividing the primary winding into two circuits, one of which is provided with a condenser or resistance to give a time-phase displacement of one current relative to the other. In some such way the motor is temporarily converted into a poor polyphase motor with just sufficient torque to enable it to start without load. After coming up to speed, a switch is operated which causes the motor to run thereafter through power supplied to one phase.

The Series Motor.—It has already been pointed out that a direct-current series motor possesses, fundamentally, the qualifications for operation on alternating current. Practically, in direct-current motors, the field is made strong and the armature weak. In alternating-current series motors the reverse is the case; the armature m.m.f. is three or four times as strong as that of the field circuit.

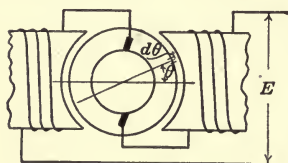

FIG. 291.

To determine the values of flux, current, torque, power, etc., we may proceed as follows:

Consider an armature coil displaced θ° from the horizontal (Fig. 291). The flux enclosed by the coil is

$$\phi = \Phi_m \sin \omega t \sin \theta$$

since the flux is alternating, the total flux at any instant being $\Phi_m \sin \omega t$.

Therefore the induced e.m.f. per coil is

$$de = - \frac{d\phi}{dt} = - \Phi_m \left(\omega \cos \omega t \sin \theta + \sin \omega t \cos \theta \frac{d\theta}{dt} \right).$$

Let, now, $\theta = \omega_1 t$, where $\omega_1 = 2\pi f_1$ and $f_1 =$ frequency of rotation, *i.e.*, due to rotation of the armature; the coil has moved through an angle θ in the time t , ω_1 being the angular velocity of the rotation.

Then

$$\frac{d\theta}{dt} = \omega_1,$$

and

$$de = - \Phi_m (\omega \cos \omega t \sin \theta + \omega_1 \sin \omega t \cos \theta).$$

If there are T turns between brushes, there are $\frac{T}{\pi} d\theta$ turns in the little element $d\theta$. Therefore the total induced e.m.f. is

$$\begin{aligned} e &= - \frac{T}{\pi} \int_{\theta = -\frac{\pi}{2}}^{\theta = \frac{\pi}{2}} \Phi_m (\omega \cos \omega t \sin \theta + \omega_1 \sin \omega t \cos \theta) \\ &= \frac{2T}{\pi} \Phi_m 2\pi f_1 \sin \omega t \\ &= \frac{4\Phi_m f_1 T \sin \omega t}{10^8} \text{ volts.} \end{aligned}$$

Thus, the induced e.m.f. is seen to be of fundamental frequency (ωt), and in time-phase with the flux.

Let the components of the flux be ϕ_f , the field flux along the pole axis, and ϕ_a , the armature flux along the brush axis. These component fluxes are then in space quadrature. Let, also, N_f be the number of field turns per pole, and N_a the equivalent number of armature turns ($N_a = \frac{2}{\pi} T$ for distributed winding).

If the magnetic reluctance were uniform about the armature periphery, $\frac{\phi_f}{\phi_a}$ would be equal to $\frac{N_f}{N_a}$.

In practice this is not the case. These motors are provided with definite poles, and therefore

$$\frac{\phi_f}{\phi_a} = m \frac{N_f}{N_a},$$

where $m > 1$.

Let
$$\frac{N_f}{N_a} = n,$$

where $n < 1$.

Then
$$\frac{\phi_f}{\phi_a} = mn.$$

Since, now, the conductors are rotating in a magnetic field, there is induced in them an e.m.f., E_r , of rotation, whose effective value is

$$E_r = \frac{4.44\Phi_f f_1 N_a}{10^8} \text{ volts.}$$

N_a , here, is used for the effective turns of an equivalent single-phase alternator.

The induced e.m.f. in the armature due to the alternation of the armature flux, ϕ_a , is

$$E_a = \frac{4.44\Phi_a f N_a}{10^8} \text{ volts,}$$

and, similarly, the induced e.m.f. in the field due to the alternation of the field flux, ϕ_f , is

$$E_f = \frac{4.44\Phi_f f N_f}{10^8} \text{ volts.}$$

The total e.m.f. induced either by rotation or by "transformer action" is the sum of these three e.m.fs. treated as time vectors.

E_r is in time-phase with ϕ_f , while E_a and E_f are in time-quadrature both with ϕ_a and ϕ_f .

\therefore the total induced voltage is

$$E_i = \sqrt{E_r^2 + (E_a + E_f)^2}.$$

But,
$$\frac{E_r}{E_f} = \frac{f_1 N_a}{f N_f} = \frac{s}{n},$$

where
$$s = \frac{f_1}{f}, \text{ and, as before, } n = \frac{N_f}{N_a}.$$

Also,
$$\frac{E_a}{E_f} = \frac{N_a \Phi_a}{N_f \Phi_f} = \frac{1}{mn^2}.$$

\therefore Substituting

$$E_r = \frac{s}{n} E_f \text{ and } E_a = \frac{E_f}{mn^2},$$

$$E_i = \frac{E_f}{n} \sqrt{s^2 + \frac{(mn^2 + 1)^2}{m^2 n^2}} = \frac{E_f}{n} \sqrt{A}.$$

If resistance drops in the field and armature coils are neglected, $E_i = E$, the impressed e.m.f. The reactance may be determined as in the case of the induction motor. Let $x_f =$ reactance of field winding. Then $x_f = \frac{E_f}{I}$.

Substituting in the equation for induced e.m.f.,

$$I = \frac{E_i n}{x_f \sqrt{A}} = \frac{E n}{x_f \sqrt{A}} \text{ approx.}$$

The electrical power input is

$$P_i = EI \cos \alpha.$$

Mechanical power output is

$$P = E_r I = \frac{E n}{x_f \sqrt{A}} \times E_r = \frac{E^2 n s}{x_f A}$$

$$\text{Torque} = T = \frac{P}{s} = \frac{E^2 n}{x_f A} \text{ synchronous watts.}$$

The ratio, $\frac{\text{torque at synchronous speed}}{\text{torque at standstill}}$

$$= \frac{T_s}{T_0} = \frac{A_0}{A_s} = \frac{(mn^2 + 1)^2}{m^2 n^2 + (mn^2 + 1)^2}.$$

As an example, assume a motor of uniform reluctance ($m = 1$), and of the same number of turns in the armature and field coils ($n = 1$).

Then

$$\frac{T_s}{T_0} = \frac{2^2}{1 + 2^2} = \frac{4}{5} = 0.8.$$

In such a machine the starting torque is not much greater than that of full-load, which is not very satisfactory for the class of work series motors are usually called on to perform.

An approximate ratio,

$$\frac{T_s}{T_0} = \frac{m^2 n^4}{m^2 n^2 + m^2 n^4} = \frac{n^2}{1 + n^2}.$$

Using this expression, if $n = 0.5$,

$$\frac{T_s}{T_0} = \frac{0.25}{1.25} = 0.2.$$

The starting torque is five times as strong as that at synchronous speed.

Compensated Series Motor.—The practical operation of the series motor is attended with difficulty owing to the tendency to excessive sparking. It also has poor power factor. In the short-circuited coils heavy electromotive forces are produced by the alternating flux. To overcome these electromotive forces compensating windings are supplied which under speed conditions act like inter-poles to neutralize the armature reaction and self-induction of the short-circuited coils. Fig. 292 gives the wiring diagram of the compensated series motor.

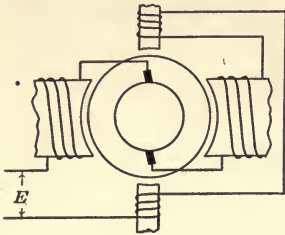

FIG. 292.

Problem 120.—Derive the complex equations for the series alternating-current motor with compensating coil.

Solution.—The impressed e.m.f. may be written

$$\underline{E} = \underline{IR} + \underline{E}_r + j(\underline{Ix} + \underline{E}_f),$$

where R = total resistance of armature, field and compensating coil,
 x = self-inductive reactance of armature and coil,
 E_r = e.m.f. due to rotation,
 E_f = induced e.m.f. in the field.

It has been shown that

$$E_r = \frac{s}{n} E_f,$$

also

$$E_f = 4.44\Phi_f N_f.$$

Substituting,

$$\Phi_f = \sqrt{2} \phi_f, \text{ and } \phi_f = \frac{N_f I}{\rho \times 10^8} = \text{effective value of the field flux,}$$

where N_f = field turns and ρ = reluctance, $E_f = \frac{4.44fN_f^2 I \sqrt{2}}{10^8 \rho}$.

Also,

$$x_f = \text{reactance of field,} = 2\pi f L_f,$$

and

$$L_f = \frac{\phi_f N_f}{I \times 10^8} = \frac{N_f^2}{\rho \times 10^8}.$$

$$\therefore x_f = \frac{2\pi f N_f^2}{\rho \times 10^8},$$

and

$$E_f = x_f I, \text{ by substitution,}$$

$$\begin{aligned} \therefore \underline{E} &= \underline{IR} + \underline{Ix}_f \frac{s}{n} + j(\underline{Ix} + \underline{Ix}_f) \\ &= \underline{I} \left[(R + x_f \frac{s}{n}) + j(x + x_f) \right] \end{aligned}$$

or,

$$E = I(a + jb), \text{ where } a = R + \frac{s}{n}x_f$$

and

$$b = x + x_f.$$

$$I = \frac{E}{a + jb},$$

and

$$I = \frac{E}{\sqrt{a^2 + b^2}}.$$

$$\text{Power factor} = \cos \phi = \frac{a}{\sqrt{a^2 + b^2}}.$$

$$\text{Power} = E_r I = \frac{s}{n} x_f I^2.$$

$$\text{Torque} = \frac{\text{power}}{s} = \frac{x_f I^2}{n}.$$

The general equations for series alternating-current motors may thus be written. They are:

$$E = I \sqrt{\left(R + \frac{s x_f}{n}\right)^2 + (x + x_f)^2}$$

giving the voltage and current relation,

Power factor = $\cos \alpha$, where

$$\tan \alpha = \frac{x + x_f}{R + \frac{s x_f}{n}},$$

$$\text{Power} = E_r I = \frac{s x_f}{n} \times \frac{E^2}{\left(R + \frac{s x_f}{n}\right)^2 + (x + x_f)^2},$$

$$\begin{aligned} \text{Torque} &= \frac{176 \times \text{syn. watts} \times \text{poles}}{s} \text{ ft.-lb.}, \\ &= \frac{\text{power}}{s} \text{ synchronous watts.} \end{aligned}$$

Problem 121.—A series alternating-current motor has the following constants: 2 hp., 4 poles, 60 cycles, armature has 29 coils, each coil having 9 turns. $\therefore N_a = \frac{2}{\pi} \times \frac{29 \times 9}{4} = 41.4$ effective turns per pole. Each field pole has 19 turns. $\therefore N_f = 19$. $n = \text{ratio} \frac{\text{field turns}}{\text{arm. turns}} = \frac{N_f}{N_a} = \frac{19}{41.6} = 0.46$. $x_f = 1.5$; $x = 0.3$; $x_f + x = 1.8$; $r_a = 0.3$; $r_f = 0.14$; $r_{comp.} = 0.3$; $R_{total} = 0.74$; voltage impressed = 110.

Find power output, power factor, efficiency, apparent efficiency, torque, at speeds in per cent. of synchronous speed.

$s =$ per cent. speed	0.0	0.2	0.4	0.6	0.8	1.0	1.5	2.0
$\frac{s}{n}$	0.0	0.435	0.87	1.3	1.74	2.17	3.26	4.35
$\frac{s}{n}x_f$	0.0	0.635	1.31	1.95	2.62	3.26	4.89	6.53
$a = R + \frac{s}{n}x_f$	0.74	1.393	2.05	2.69	3.36	4.0	5.67	7.27
$b = x + x_f$	1.8	1.8	1.8	1.8	1.8	1.8	1.8	1.8
$a^2 + b^2$	1.94	2.27	2.74	3.24	3.8	4.38	5.92	7.5
$I = \frac{E}{\sqrt{a^2 + b^2}}$	56.8	48.5	40.2	34.0	29.0	25.2	18.6	14.7
I^2	3230.0	2350.0	1620.0	1160.0	840.0	635.0	346.0	217.0
$P = I^2 \frac{s}{n}x_f$	0.0	1535.0	2120.0	2260.0	2200.0	2070.0	1690.0	1420.0
$P.F. = \frac{a}{\sqrt{a^2 + b^2}}$	0.381	0.615	0.75	0.83	0.885	0.914	0.95	0.97
$P_{input} = I^2 a$	2390.0	3280.0	3330.0	3130.0	2820.0	2540.0	1950.0	1580.0
$Ef. = \frac{P}{I^2 a}$	0.0	0.47	0.637	0.723	0.78	0.817	0.868	0.9
EI	6250.0	5340.0	4420.0	3740.0	3200.0	2780.0	2050.0	1620.0
App. eff.	0.0	0.289	0.477	0.6	0.69	0.747	0.823	0.872
Hp.	0.0	2.05	2.84	3.03	2.95	2.78	2.27	1.9
Torque	7700.0	5300.0	3770.0	2750.0	2070.0	1130.0	710.0
T. in. ft.-lb.	90.0	62.0	44.1	32.2	24.2	13.3	8.3

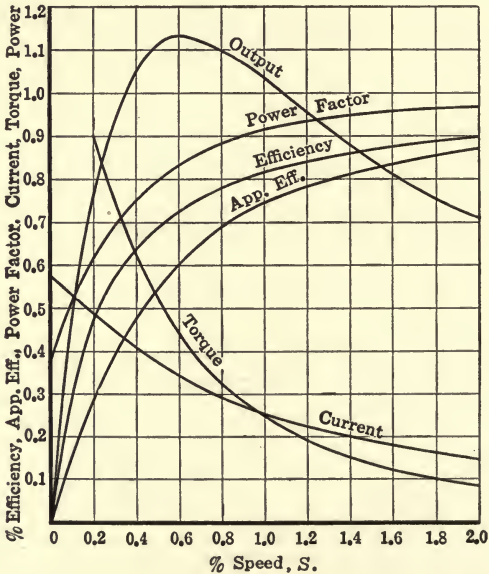

FIG. 293.

The performance curves of this motor are given in Fig. 293.

Repulsion Motor.—A different motor, but one whose characteristics are the same as those of the series type, is that which is known as the repulsion motor. Its principle was discovered by ELIHU THOMSON.

Its chief features are that the armature is short-circuited through the brushes, and that torque is obtained by giving the latter a shift of about 75° from the normal neutral position. The angle θ , Fig. 294, is that between the field axis and the brush axis.

If the brushes were set on the field axis ($\theta = 0^\circ$), the machine would act as a short-circuited transformer. If the brushes were set on the neutral axis ($\theta = 90^\circ$), no current would flow in the armature at standstill since there would be no resultant induced e.m.f. acting in the short-circuit.

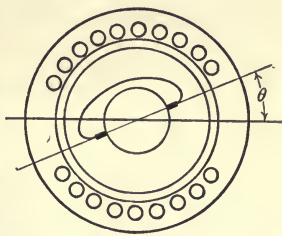

FIG. 294.

Two sets of brushes are sometimes used, one set being on the flux axis and the other on the neutral axis. A prominent example of this type is known as the WINTER-EICHBERG motor.

Considering now the theory of repulsion motor action, let the flux ϕ be resolved into two components, $\phi_t = \phi \cos \theta$ in the direction of the brush axis and $\phi_f = \phi \sin \theta$ at 90° from this axis.

ϕ_t may be called the transformer flux owing to its purely inductive action on the armature. Let the magnetomotive forces causing ϕ , ϕ_t and ϕ_f be, respectively, F , F_t and F_f , and that of the armature be F_a . These may be represented as acting in a motor as shown in Fig. 295. If there were perfect mutual induction between F_t and F_a , these would be equal at standstill, and the flux ϕ_t would cease

to exist. In that case there would be no xI drop across the "transformer" poles, and if the rI drop were neglected, the whole impressed voltage would be across the "field" poles.

Denoting by E the impressed e.m.f., by E_t the drop across the transformer poles, and by E_f the drop across the field poles, then, assuming perfect mutual induction at standstill,

$$E_t = 0, \text{ and } E_f = E.$$

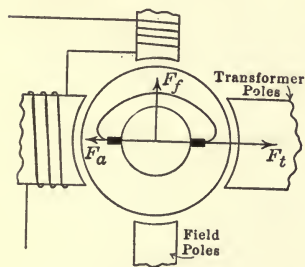

FIG. 295.

As the armature starts to revolve due to the torque between the field flux and current, an e.m.f. is generated in it by rotation. This e.m.f., E_r , is in time-phase with the flux ϕ_f , and generates current, I_r , in the short-circuited armature.

I_r must attain a value such that $L \frac{di}{dt} = E_r$. $L \frac{di}{dt}$ may be called the e.m.f. of alternation of the current.

It has been assumed that at standstill $\phi_t = 0$. With the production of I_r by rotation, ϕ_t is increased, and at synchronous speed the total current reactions cause ϕ_t to equal ϕ_f .

These relations may be seen with the aid of a vector diagram, Fig. 296. ϕ_f and ϕ_t are in space-quadrature, and also, due to the compensating action of the armature on the transformer poles, they are in time-quadrature as well. Their relative values are expressed by the equation

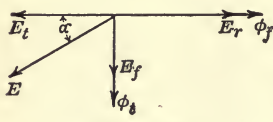

FIG. 296.

$$\phi_t = \frac{f_1}{f} \phi_f = s \phi_f,$$

where f_1 = frequency of rotation and f = synchronous frequency.

The instantaneous value of ϕ_f is

$$\phi_f (\text{inst.}) = \Phi_f \cos \theta,$$

and of ϕ_t , is

$$\phi_t (\text{inst.}) = s \Phi_f \sin \theta.$$

$$\text{Let } n = \frac{\text{turns on transformer poles}}{\text{turns on field poles}} = \frac{N_t}{N_f}.$$

It must be remembered that this machine is hypothetical; there are not actually two sets of poles. The relative values of N_t and N_f depend entirely on the brush shift. At 45° shift they are equal, and $n = 1$. At 75° , or $\alpha = 15^\circ$, $n > 1$.

The e.m.f. of rotation, then, evidently depends on the speed, the brush shift, and E_f , the voltage across the field poles. It is

$$E_r = snE_f.$$

These two e.m.fs., that of the field and that due to rotation of the armature, make up the total e.m.f., E . Since they are in quadrature,

$$E = \sqrt{E_r^2 + E_f^2} = E_f \sqrt{n^2 s^2 + 1}.$$

The current, since rI drop is neglected, is

$$I = \frac{E_f}{x_f}.$$

On the basis of perfect mutual induction, also, the transformer induced armature ampere-turns = ampere-turns on the transformer poles, or $I_t N_a = I N_t$.

$$\therefore I_t = I \frac{N_t}{N_a},$$

where I_t is the current in the armature due to the inductive action of the transformer poles.

Also, the current in the armature due to E_r gives

$$I_r N_a = \frac{f_1}{f} I N_f,$$

that is, the armature ampere-turns due to rotation are proportional to the ampere-turns on the field poles in the ratio $\frac{f_1}{f}$. These two currents, I_t and I_r , are evidently in time-quadrature although in space-phase. The total armature current is, therefore,

$$I_a = I \sqrt{\left(\frac{N_t}{N_a}\right)^2 + s^2 \left(\frac{N_f}{N_a}\right)^2}.$$

Power factor of the motor is determined from the components of the impressed e.m.f., E . Thus,

$$\text{power factor} = \cos \alpha = \frac{E_r}{E}.$$

Power developed is $P = E_r I$.

$$\text{Torque} = \frac{P}{\text{synchronous speed}}.$$

Current input,

$$I = \frac{E_f}{x_f} = \frac{E}{x_f \sqrt{n^2 s^2 + 1}}.$$

Where imperfect mutual induction exists it is necessary to introduce the term x_t to account for the self-induction of the transformer poles.

INDEX

- Abampere, 1, 21
Abohm, 1
Abvolt, 1
Admittance, 110
Air gap of alternators, 293
 of induction motors, 365
Alternating current, 38
Alternator, 246
 definite pole, 258
 design, 289
 field winding, 298
 heating, 299
 rating, 250
 reactance, 270
 regulation, 300
 round rotor, 259
 short-circuit, 301
 three-phase, 246
 two-phase, 246
Ampere, 1, 21
Apparent efficiency of transmission,
 . 117
Armature, drum, 48
 laminations, 296
 length, 58, 294
 reaction, 47, 60, 252, 278, 322,
 395
 resistance, 64, 295
 ring, 48
 winding, 46
Auto-transformer, 240
 for two-phase—three-phase
 transformation, 241
 with induction motor, 364
Average value of sine wave, 41
Balancer, 90
Ballistic galvanometer, 102
Bar windings, inductance of, 275
Battery for three-wire system, 90
Belt leakage flux, 374
Booster, 94
British thermal unit, 7
Brooks and Turner, 36
Brush design, 66
 resistance, 65
Calorie, 7
Capacity, 123
 distributed, 162
 of a concentric cylinder, 155
 of a sphere, 124, 153
 of a spherical concentric con-
 denser, 154
 of a three-phase cable, 158
 of a transmission line, 156
 of two parallel plates, 156
 reactance, 126
Characteristic, motor speed, 99
 torque, 100
Charge of a condenser, 123
Charging current of a transmission
 line, 158
Circuit, magnetic, 57
Coercive force, 19
Commutating pole, 74, 82
 winding, 80
Commutation, 82
Commutator, 66
Compensated A.-C. series motor,
 404
Compensating winding 74, 80, 82.
Compensators; see Auto-trans-
 formers.
Complex quantities, addition of, 169
 differentiation of, 172
 division of, 170
 exponential representation of,
 172
 involution and evolution of, 170
 logarithm of, 172
 multiplication of, 170
 representation of, 169
 roots of, 171
Compounding curves of alternators,
 266
Condenser, 123
 synchronous, 398

- Conductance, 2, 110
 Conductivity, 2
 Constant-current transformer, 121
 potential—constant-current transformation, 120, 140
 Core-loss current of induction motor, 379
 current of transformer, 176
 dependence on e.m.f. wave shape, 194
 relation to form factor, 195
 Cosine series, 171
 Cost of transformers, 223
 Coulomb, 1, 15
 Cross-magnetization, 49
 Current, 1
 density, 56
 in alternator armature, 291
 distribution in rotary converters, 391
 ratios in rotary converters, 383
 Cylindrical poles, 15

 "Dead points" in induction motor, 369
 Demagnetization, 49
 Density, current, 56
 energy, 17
 of magnetic field, 14
 Design of alternators, 289
 of D.-C. generators, 55, 74
 of induction motors, 365
 lifting magnets, 26
 Dielectric strength, 125
 Distorted waves, 133, 196, 232
 Distributed capacity, 162
 inductance, 162
 winding, 50
 three-phase, 281
 Distribution factor of three-phase winding, 292
 DOBROWOLSKY, 91
 Drum winding, 48
 Ducts, ventilating, 58, 294

 Eddy current loss, 187
 of D.-C. generator, 70
 in transformers, 211
 Edison three-wire system, 89

 Effectiveness of coil, 42
 Effective value, of distorted wave, 134
 of sine wave, 40
 Efficiency of D.-C. generator, 68
 of transformer, 210, 220
 of transmission, 117
 Electro-dynamometer, 146
 E.m.f. waves, generation of, 30
 End connections, inductance of, 271, 377
 stresses on, 319
 Energy density, 17
 of short-circuit, 314
 Equalizer, 89
 Exciting current of transformer, 174, 191
 Exponential series, 172

 Farad, 157
 FARADAY, 14, 29, 44, 124
 Field current at short-circuit, 323
 voltage at short-circuit, 323
 winding of alternators, 298
 Flat poles, 15
 Flux calculation, 56
 for alternators, 292
 density in teeth, 294, 367
 in transformers, 212
 distribution around armature, 67
 leakage, 56
 Fly-wheel effect on hunting, 287
 Force, lines of, 14, 124
 on wire in a field, 21
 tubes of, 124
 Form factor, 42
 relation of core loss to, 195
 FOURIER'S series, 190, 196
 FRANKLIN, 124
 Frequency, 38
 Friction loss in D.-C. generators, 70
 Fringing factor, 58
 FROELICH'S equation, 51

 Galvanometer, ballistic, 102
 as ammeter, 103
 GAUSS, 15
 GAUSS' theorem, 15

- Generator, alternating-current, 246
 design of a D.-C., 55
 direct-current, 45
 efficiency of a D.-C., 68
 homopolar, 44
 induction, 258
 losses in D.-C., 68
 three-wire, 90
 turbo-, 258
- Generators in parallel, 88
 in series, 89
- Gradient, potential, 153
- Heating of alternators, 299
 of D.-C. generators, 72
 of rotary converters, 385
 of transformers, 222
- Henry, the, 33
- Homopolar generator, 44
- Horsepower, 100
 of induction motor, 348
- Hunting, 283
- Hysteresis, 18
 constants, 187
 loop, 186, 190
 loss, 186
 in D.-C. generator, 70
 in transformers, 211
- Impedance, 105, 108
 condensive, 126
 triangle, 106
- Inductance, 33
 distributed, 162
 of bar windings, 275
 of concentric cable, 159
 of end connections, 271, 377
 of transformers, 202
 of transmission line, 119, 160
 maximum, of coil, 36
- Induction motor, 342
 abnormal operation of, 361
 air gap, 365
 at end of transmission line, 364
 core loss, 380
 current, 379
 "dead points," 369
 design, 365
 equivalent circuit, 346
- Induction motor, horsepower of, 348
 magnetizing current, 379
 maximum output, 349
 performance curves, 349, 381
 power factor of, 348
 reactance, 373
 secondary resistance, 352
 rotary field, 343
 single-phase, 400
 slip of, 345
 slot and tooth dimensions, 366
 squirrel-cage winding, 362
 theory of operation, 344
 torque of, 347
 types of, 362
 with auto-transformer, 364
 mutual, 117
- Inductive circuit, characteristic features of, 39
 current in, 35
 fundamental equation of, 38
- Instruments, formulæ of magnetic, 24
- Insulation in slots, 291
 thickness in transformers, 215
- Intensity of electric field, 152
 of magnetic field, 14
- Interlinkage factor, 159
- Joule, the, 6
- KENNELLY, 113
- KIRCHOFF'S laws, 4
- Laminations, 296
- Leakage factor, 77
 flux, 56
- Lifting magnet, 26
- Lines of force, 14, 124
- Losses in D.-C. generator, 68
- Magnet, lifting, 26
 for meters, 16
 pull of, 16
- Magnetic circuit, 57
 dimensions, 296
 cycle, 17
 density, 14
 field intensity, 14

- Magnetic intensity determinations
of, 21
- Magnetism, 14
molecular theory of, 17
residual, 17
- Magnetization, 18
curves, 26
- Magnetizing current of induction
motor, 379
of transformers, 176, 213, 220
- Magnetomotive force, 18
- Maximum output of induction
motor, 349
short-circuit current, 305
- Molecular theory of magnetism, 17
- Motor, A.-C. single-phase, 400
D.-C., 98
induction, 342
principle of, 20
repulsion, 407
speed characteristics, 99
synchronous, 324
WINTER-EICHBERG, 407
- Multiphase short-circuits, 320
- Mutual induction, coefficient of, 177
- Natural period of a machine, 284
- Network, solution of, 4
- OERSTED, 20
- Ohm, 1
- OHM'S law, 3
- ONNES, 301
- Open delta transformer connection,
236
- Parallel circuit calculations, 129
- Permeability, 14, 19
- Phase characteristics of synchron-
ous motors, 335
difference, 106
- Pole intensity, 17
- Potential, 162
difference, 1
gradient, 153
- Power, 6, 42
average value of, 114
by symbolic method, 113
equation, 35
- Power factor, 116
of A.-C. generator, 117
of D.-C. motors, 99
of short-circuit, 305, 318, 321
of three-phase alternator, 249
- Pull of magnet, 16
- Rating of alternators, 250
of auto-transformers, 240
of T-connected transformers,
238
- Reactance, 39
of alternators, 270
of armature coils, 258
of induction motors, 373
of synchronous motor, 324
of transformers, 221
- Regulation of alternators, 300
of transformers, 221
of transmission line, 117
- Reluctance, 68
of three-phase transformers, 234
- Repulsion motor, 407
- Residual magnetism, 17
- Resistance, 1
armature, 64
brush, 65
in induction motor secondary,
352
of rotor, 371
of synchronous motor, 324
series field, 65
shunt field, 62
- Resistances in parallel, 3
in series, 3
- Resistivity, 2
of conductors, 3
- Resonance, 128
effects, 137
- Resultant field of three-phase sys-
tem, 254
- Ring winding, 48
- Rotary converter, 383
armature reaction, 395
current distribution in, 391
heating of, 385
six-phase, 385, 397
transformer connections for,
397

- Rotary converter, voltage control,
385, 391
voltage and current ratios, 383
with split poles, 394
field, 343
- Rotor resistance calculation, 371
slots, number of, 369
- Saturation curves, 26
calculation of, 59, 78
- Scott connection, 237
- Series circuit calculation, 126
field winding, 63
lighting circuits, 120
motor, A.-C., 400
starting torque of, 403
compensated A.-C., 404
- Short-circuit current, maximum, 305
energy of, 314
field current of, 323
field e.m.f. of, 323
multiphase, 320
of alternators, 301
power of, 305, 318, 321
stress on shaft due to, 313
- Shunt field winding, 62
- SIEMENS'S electro-dynamometer,
146
- Sine series, 171
wave, average value of, 39
effective value of, 41
- Single-phase A.-C. motors, 400
- Six-phase rotary converter, 385, 397
- Slip of induction motors, 345
- Slot design, 276
dimensions of alternators, 290
of induction motors, 366, 369
insulation, 291
pitch, 290
- Slots, number of rotor, 369
- Speed characteristics of motors, 99
- Split pole rotary converters, 394
- Squirrel-cage winding, 362
- Starting torque of series A.-C. motor,
403
- Stator teeth flux density, 367
- STEINMETZ, 113, 162, 178, 187, 198
- Stresses in transformers, 202
calculation of, 206
- Stresses on armature end connec-
tions, 319
- Susceptance, 110
- Symbolic method, 113
- Synchronous condensers, 398
converters; see Rotary con-
verters.
impedance, 302
motor, 324
diagram, 325
equations, 327
phase characteristics, 335
reactance, 324
resistance, 324
V-curves, 326, 341
watts, 348
- Teeth flux density, 294, 367
- Temperature coefficient, 2
of conductors, 3
- THOMSON, ELIHU, 407
- Three-phase system, 227
resultant field of, 254
wave distortion in, 230
with neutral, 228
transformers, 229, 233
reluctance of, 234
- Three-wire generator, 90
system, 89
- Torque characteristics, 100
of D.-C. motors, 99
of induction motors, 347
- "Transformer action" in single-
phase motors, 402
- Transformer, auto-, 240
calculation, example of, 179
approximate method of, 181
coil connections, 216
connections for rotary con-
verters, 397
core area, 214
length, 214
loss current, 176
diagram, 175
design, 209
efficiency, 210, 220
equivalent circuit, 178
exciting current, 174
flux calculation, 214

- Transformer, flux density, 212
 heating, 222
 inductance, 202
 insulation thickness, 215
 losses, 211
 magnetizing current, 176, 213, 220
 number of turns of, 214
 rating, 179
 reactance, 221
 regulation, 221
 weight, 223
 winding calculations, 215
- Transformers connected open delta, 236
 three-phase, 244
 core type, 209
 cost of, 223
 cruciform type, 209
 for six phases, 245
 in parallel, 243
 in series, 242
 lighting, 211
 methods of cooling, 210
 power, 211
 rating of T-connected, 238
 shell type, 209
 stresses in, 202
 calculation of, 206
 T-connected, 237
- Transmission line calculation, 113,
 . 165
 approximate, 132
- Transmission line capacity, 156
- Tubes of force, 124
- Two-phase—three-phase transformation, 238
- Unit pole, 14
- Units, 1
- V-curves of synchronous motor, 326, 341
- Vector, see Complex quantities.
 addition, 113
 multiplication, 113
- Ventilating ducts, 294
- Volt, 1
- Voltage control of rotary converters, 385, 391
 ratios of rotary converters, 383
- Wattless component, 108, 110, 145
- Wattmeter, 146
 compensated, 148
 connections, 147
 correction factor, 150
 errors, 150
- Wave analysis, 196
 distortion in transformers, 189
- Waves, generation of e.m.f., 30
- Weight of transformers, 223
- WINTER-EICHBERG motor, 407
- Zero vector, 108
 "Zig-zag" flux, 374



THIS BOOK IS DUE ON THE LAST DATE
STAMPED BELOW

AN INITIAL FINE OF 25 CENTS
WILL BE ASSESSED FOR FAILURE TO RETURN
THIS BOOK ON THE DATE DUE. THE PENALTY
WILL INCREASE TO 50 CENTS ON THE FOURTH
DAY AND TO \$1.00 ON THE SEVENTH DAY
OVERDUE.

AUG 15 1944

3 Dec '48 JG

7 Mar '50 AP

21 Apr '51 GR

7 Apr '51 LU

26 Nov '57 MS

REC'D LD

NOV 12 1957

LD 21-100m-12,'43 (8796s)

YC 19682

342835

TK 145

B.4

UNIVERSITY OF CALIFORNIA LIBRARY

