

...in Street,
...delphia.

GIFT OF
Mrs. Stut

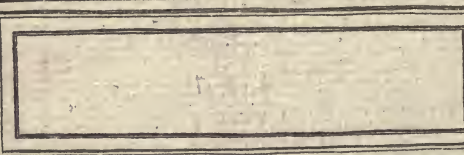

EX LIBRIS



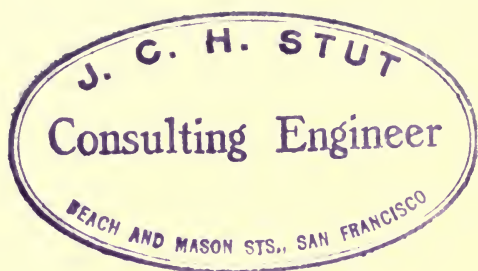

J. C. H. STUT

Consulting Engineer

BEACH AND MASON STS., SAN FRANCISCO

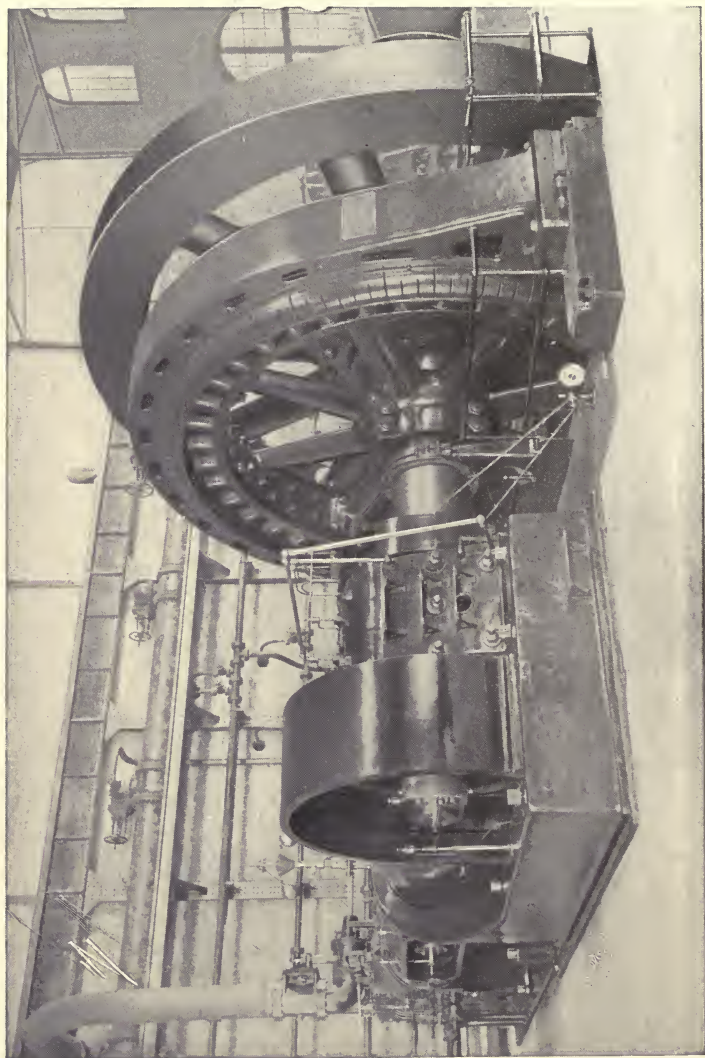

A. C. DYNAMO.

[Frontispiece.]

ELECTRICAL ENGINEERING

AN ELEMENTARY TEXT-BOOK

SUITABLE FOR
PERSONS EMPLOYED IN THE MECHANICAL AND ELECTRICAL
ENGINEERING TRADES, FOR ELEMENTARY STUDENTS
OF ELECTRICAL ENGINEERING, AND FOR
ALL WHO WISH TO ACQUIRE A KNOWLEDGE OF THE CHIEF
PRINCIPLES AND PRACTICE OF THE SUBJECT

BY

E. ROSENBERG

Chief Electrical Engineer at Messrs. Körting Bros., Hanover

TRANSLATED BY

W. W. HALDANE GEE AND CARL KINZBRUNNER

B.Sc. (Lond.), A.M.I.E.E.

Lecturer on Electrical Engineering at the

*Professor of Applied Physics at the Municipal
School of Technology, Manchester*

*Municipal School of Technology,
Manchester*

AUTHORIZED EDITION

REVISED AND BROUGHT DOWN TO DATE FOR THE AMERICAN MARKET

BY

EDWARD B. RAYMOND, B.S.

*Associate Member of the American Institute of Electrical Engineers
General Superintendent Schenectady Works of the General Electric Company*

NEW YORK

JOHN WILEY & SONS

43 AND 45 EAST NINETEENTH STREET

1907

UNIVERSITY OF
CALIFORNIA

TK145
R8

Gift

Copyright 1903, 1906

BY

JOHN WILEY & SONS

ROBERT DRUMMOND, PRINTER, NEW YORK

WILEY

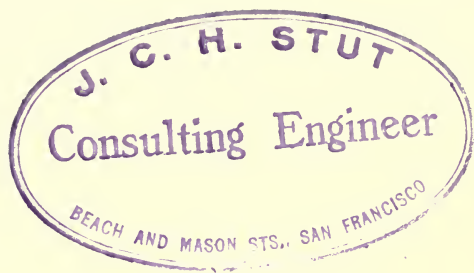

P R E F A C E

THIS book had its origin in a number of lectures which I delivered two years ago to the workmen and the staff of a large electrical manufacturing firm. The circle of readers for which this book is intended is, in the first place, the same as that to which my audience belonged. It should give to workmen of electrical engineering works the knowledge of the operation of machines and apparatus with which they are concerned. I have endeavoured to use such language that people who have only a general school education should be able to understand. For this reason several matters have been dealt with very completely which, to the mathematically educated man, could have been explained in a few lines—such as, for instance, Ohm's Law and resistance calculations. I have in these cases endeavoured to explain the matter first without the help of mathematics, and then have finally, as a keystone—after having worked some examples—stated the formulæ. In the part relating to the "output of a three-phase current system," in a similar way, there are calculations and formulæ, since it is necessary for the student to be acquainted with these. Generally, however, calculations and formulæ are avoided, as in the case of the whole chapter about dynamos. The book will not enable the reader to calculate the parts and windings of dynamos, and he should not even think that he is able to do so. For the elementary student, the wireman, for the engineer as well as for the general public who desire to know something about electrical engineering, it is quite sufficient if they understand the working of dynamos, their faults, and the reason and the cure of the latter.

The book covers a wide area. It comprises, besides the fundamental phenomena of the electric current, dynamos and motors for continuous, alternating, and three-phase current, then accumu-

lators and their apparatus, measuring instruments and electric lighting. All these things must be known by an electrical engineer. It was, of course, impossible to deal equally completely with all these themes. It is not possible to describe all shapes of dynamos, and many types of arc lamps and measuring instruments. Only the most important types are dealt with, and their working is explained. Further detail is impossible, having regard to the extent of the book, and I do not consider it to be necessary. Every electrical firm publishes complete pamphlets about their special manufactures, and in extraordinary cases the installer gets special diagrams of connections and specification for the plant he has to erect. Besides that, anybody who understands the machines and apparatus described in this book will be able to make himself clear as to other types.

About laying mains and about installation material but little is said in this book. The necessary information may be found elsewhere.

Although this book is chiefly for electrical men and for those who intend to become such, yet the general public desiring to get some general information about Electrical Engineering will read the book with advantage. I am also in hope that in some of the chapters useful hints may be found by the educated electrical engineer.

My object has been a practical one, and the arrangement of the material has been made from a practical point of view. I have, therefore, departed in some cases from the historical order; for instance, in the case of dynamos. Again, facts have been omitted which are indeed necessary for the scientific, but not for the practical treatment of the matter; for example, in describing accumulators and the induction effects of alternating currents.

E. ROSENBERG.

HANOVER,
January, 1902.

TRANSLATORS' PREFACE

WE have undertaken the translation of Herr Rosenberg's "Elektrische Starkstrom-Technik" with the idea that the book will be distinctly helpful to less advanced students of electrical engineering in the English-speaking countries.

It is the work of an electrical engineer, and is written from an engineering standpoint. Its origin is explained in the Author's Preface, and the opinion of German critics is seen to be favourable from the Press Notices which are given at the end of the volume.

In one way the work is different to others of an elementary kind—in the space that is given to alternating current electrical engineering. This subject is usually practically ignored, or is treated so mathematically that it is quite beyond the powers of most readers. We feel sure that here the work will not only be of value for its clear explanation of principles, but also for the useful practical hints relating to plant of this kind. In polyphase work, which is now becoming of importance in England, the author has been especially careful to make his explanations easy to follow.

Some change from the original has been inevitable in giving an English dress to the work. The illustrations have been revised, and a number from English firms have been added. We here tender our thanks to those firms who have been so good as to provide us with blocks. Their names are given with the illustrations.

We have also to thank our colleague Mr. Norman West, Demonstrator in Electrical Engineering, and several of our third-year students, for assistance in revising the final proofs.

W. W. HALDANE GEE.
CARL KINZBRUNNER.

MANCHESTER,
January, 1903.

REVISER'S PREFACE

IN revising this book for American readers, I have assumed that not only will interest in American practice and apparatus in general be equal to that in foreign, but also that the explanations on the topics presented in the previous edition can in this be extended considerably with complete understanding even by persons but little versed in electricity, satisfying in addition thereby a large class of readers with considerable electrical experience or preliminary training. Certain subjects essential to American practice have also been added in various parts of the book.

E. B. RAYMOND.

TABLE OF CONTENTS

CHAPTER I

FUNDAMENTAL PRINCIPLES

	PAGE
Electrical Phenomena.	1
Electro-motive Force.	3
Influence of the Electric Current on a Magnetic Needle.	10
Electric Units—Measurement of Currents—Ohm's Law.	14
The Calculation of Resistance.	23
Other Forms of Ohm's Law.	26
Internal Resistance—Drop of Potential.	27
Branching of Circuits.	29
Cells in Series and Parallel.	31
Voltmeters.	33
Electrical Power.	34
Equivalence of Electrical Mechanical and Heating Effects.	37
Electric Mains.	40

CHAPTER II

MAGNETS—MAGNETIC LINES OF FORCE

Influence of a Magnet on an Electric Current—Deprez Instruments.	56
Influence of Electric Currents on each other—The Electro-dynamometer.	60
Electro-magnets.	61
Induction	65
Electrical Machines.	68

CHAPTER III

THE CONTINUOUS-CURRENT DYNAMO

The Ring Armature.	74
Drum Armature.	79
Magnet System.	85
Self-excitation—Shunt Dynamo.	91
Series Dynamo.	94
Compound Dynamo.	97
Types of Dynamos.	98

	PAGE
Output of a Dynamo.	103
Multipolar Dynamos.	105
Armatures of Multipolar Dynamos.	109
Sparking and Displacement of Brushes.	118
Methods for changing Direction of Rotation.	121
Causes of the Non-excitation of Dynamos.	124
Automatic Shunt Regulator.	127
Efficiency of Dynamos.	129

CHAPTER IV

THE ELECTRIC MOTOR

The Shunt Motor.	136
Speed Regulation.	137
The Series Motor.	139
The Compound Motor.	143
Direction of Rotation of a Motor.	145
Armature Reaction with Motors.	149
Reversing Apparatus.	150
Sparkless Starters and Shunt Regulators.	153
Motors for certain Purposes.	159
Electric Traction.	164
The Sprague-General Electric Type M Control System.	169
The Electric Brake.	175
The Magnetic Blow-out.	177
Operating Troubles with Direct-current Motors.	178

CHAPTER V

ACCUMULATORS

Machines for Charging Accumulators.	187
Battery Switch.	189
Accumulator Apparatus.	191
Applications of Accumulators.	195

CHAPTER VI

WORKING OF DIRECT-CURRENT DYNAMOS IN PARALLEL

Switching Dynamos in Parallel.	201
--	-----

CHAPTER VII

ELECTRIC LIGHTING

Glow Lamps.	203
Arc Lamps.	207

CHAPTER VIII

ALTERNATING CURRENTS

	PAGE
Properties of Angles concerned with Alternating Currents.....	217
Experiments with Alternating Currents.....	221
Current Strength and Voltage of an Alternating Current.....	224
Induction Effects of an Alternating Current.....	225
Transformers.....	227
Shape of Transformers.....	229
Applications of Transformers.....	232
Phase-difference.....	233
Vector Diagrams.....	239
Wattmeter—Power-factor.....	244

CHAPTER IX

ALTERNATORS

Switching in Parallel of Alternating-current Machines—Synchronizer.....	265
---	-----

CHAPTER X

ALTERNATING-CURRENT MOTORS

Synchronous Motors.....	270
The Rotary Converter.....	276
Commutator Motors.....	281

CHAPTER XI

MULTIPHASE ALTERNATING CURRENT

Induction Motors—Rotating Field.....	283
Three-phase Current.....	290
Actions in Induction Motors—Squirrel-cage and Slip-ring Armatures.....	293
Slip.....	300
Single-phase Induction Motors.....	302
Phase-difference caused by Capacity.....	305
The Reversing of Alternating-current Motors.....	308
Faults with Alternating-current Motors.....	311
Transmission of Multiphase Currents.....	314
Power in a Three-phase System.....	322
Synchronizer for Multiphase Machines.....	324

CHAPTER XII

HIGH TENSION

Lightning Arresters.....	330
Switchboards.....	334

INDEX.....	339
------------	-----

ELECTRICAL ENGINEERING

CHAPTER I

FUNDAMENTAL PRINCIPLES

Electrical Phenomena

If, in a glass vessel, filled with water and dilute sulphuric acid, in the proportion of about one part of concentrated acid to ten parts of water, is placed a plate of zinc, Zn, (Fig. 1), and a plate of copper, Cu, which are connected by a wire, it will soon be observed that the wire gets hot. If the contact at any point of the wire be interrupted so as to make an air gap, a spark will be observed at the moment when the break is made. This is an electric spark. The name "electricity" is derived from the Greek word *electron*, meaning *amber*, because this substance, when rubbed, produces electricity. The spark produced with the apparatus of Fig. 1 is a very small one. But if we connect a number of these *galvanic cells* in series, as shown in



FIG. 1.—Galvanic Cell.

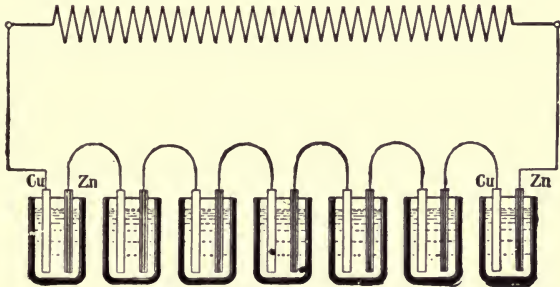

FIG. 2.—Galvanic Battery.

Fig. 2, taking care to connect the Zn of one cell with the Cu of the other, then, on bringing together the last Zn and the last Cu, sparks

of great length may be obtained, and long spirals of metal—as shown in the illustration—may be raised to red heat, and may even be melted. We call such an arrangement of cells a *galvanic battery*.

From the heat produced in the circuit we might infer that some kind of motion exists in the circuit. We know from experience that whenever a body is set in motion by a force, part, or in some cases the whole, of the force is expended in overcoming the frictional resistance and producing heat. If, for example, some bricks slip down an inclined plank, the latter becomes quite hot, especially if the bricks follow each other very quickly. Again, when a train passes along the rails, the temperature of the rails is raised, and the faster the train the greater the amount of heat.

In the case of the battery we may imagine a motion in the connecting wire, and the faster this motion the hotter the wire becomes. We shall call this motion which cannot be seen, and is known from its effects only, an **electric current**.

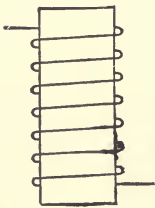

FIG. 3.—An Electro-magnet.

Now let us wind the wire connected with the battery in the form of a spiral, and slip it over a rod of soft iron (technically called a **core**), as shown in Fig. 3, then the iron becomes strongly magnetic. But if we break the battery circuit anywhere, so that no current can flow, the core will at once lose its magnetism. We conclude, then, that the electrical current has the power of converting an iron bar into a magnet. The

arrangement just described is termed an **electro-magnet**.

Again, if we take a bobbin wound with wire and pass a current through it, we shall find that a light piece of iron will be attracted into the interior of the bobbin (see Fig. 4). We learn from this experiment that a coil round which a current flows causes even the space it encloses to be a magnet.

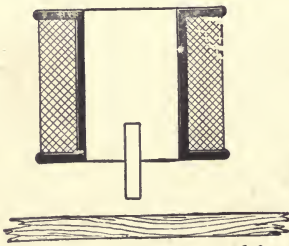

FIG. 4.—Iron attracted by Electro-magnet.

Another important experiment is to send the electrical current through acidulated water. Immediately the connection to the battery is made the water behaves as if it were boiling, and bubbles of gas rise up the wires and

escape into the air. With the apparatus shown in Fig. 5 the gases may be collected. The tubes are first filled with water, and then inverted over the wires, which should be of platinum. One gas is oxygen, and it will be found that this escapes from the end of the

wire connected with the copper plate; the other gas is hydrogen, and it will be double in volume to the oxygen. Now collect both gases in one tube, and bring a lighted match to the mouth of the tube, when the gases will instantly combine with explosion, and form water, which is composed of oxygen and hydrogen.

From the various experiments, we learn that the effects of the current are threefold, namely—

1. Heating and lighting effects.
2. Magnetic effects.
3. Chemical effects.

The student must try to remember that, technically, the upper end of the copper plate is termed the **positive pole**; and that from the wire connected to it oxygen escapes, as shown in Fig. 5. The zinc end is called the **negative pole**; from the wire connected to it hydrogen escapes.

The electric current is supposed to travel *from the positive to the negative pole*.

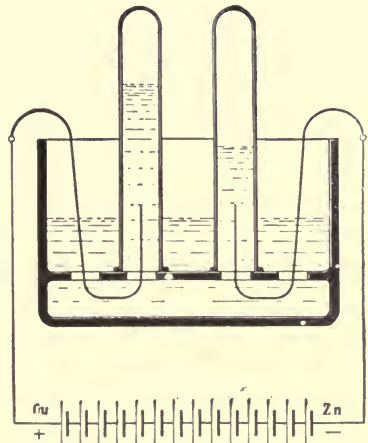

FIG. 5.—Decomposition of Water.

Electro-motive Force

From the foregoing experiments we come to the conclusion that a force exists which drives a current along the wire. This may be readily illustrated by the help of an analogy. Let there be two tanks (Fig. 6) filled with water, but to different levels, and connected by a pipe. Then the force due to the difference of heights of the water will produce a motion of the water in the pipe in the direction from the high to the low level, and will continue as long as there is a difference of level. In the case of electricity we must imagine a similar difference of pressure to cause an electric current. This

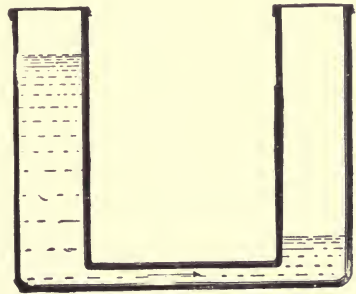

FIG. 6.—Hydraulic Analogy.

difference is termed a *difference of electrical potential*. When two metals of the same kind are immersed in an acid solution no difference of electrical potential is produced, and therefore, when the metals are connected by a wire, no current results. But if the metals are of different kinds a potential difference is produced, and a current will pass through a connecting wire. If the plates are of copper and zinc, the potential of the copper plate is higher than that of the zinc, and the current therefore flows from copper to zinc. The force causing the difference of potential is usually called by electricians the **electro-motive force**.

Again let us refer to the hydraulic analogy. The stream of water, which we compared with the electric current, flows only as

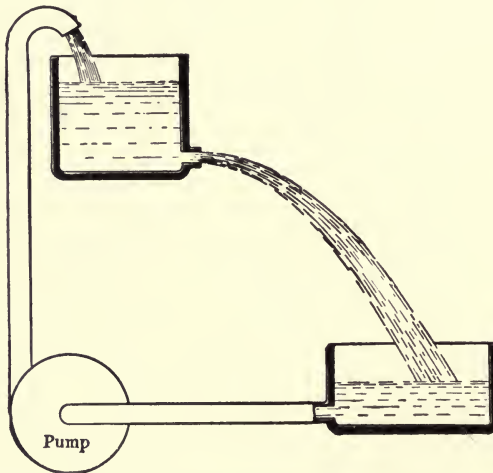

FIG. 7.—Production of Water Current.

long as there is a difference of levels. Now let it be considered what would have to be done to produce a continuous stream of water. If a pump be inserted in the circuit (Fig. 7), then the water may be forced to an upper tank, and will descend through the opening in the bottom, to be again pumped up once more. In the electrical circuit we have a similar action. When two different metals are immersed in acid, and one of them is acted upon by the acid, a continual

difference of potential is produced, the chemical action here producing the necessary, as it were, pumping action.

An electro-motive force may be produced by other than chemical means, and we shall show later that electro-motive force may be obtained by mechanical power. The galvanic cell is only one of several means of producing an electric current.

In electrical engineering galvanic cells, such as zinc-copper cells, are hardly ever used as current-generators, but the current is generally produced by dynamos. A most important part of a dynamo is the magnetic system, and we have therefore to deal in some detail with the properties of magnets.

There are different forms of magnets, such as, for instance, bar magnets (Fig. 8), horseshoe magnets (Fig. 9), magnetic needles



FIG. 8.
Bar Magnet.

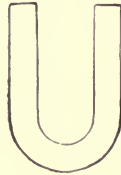

FIG. 9.
Horseshoe Magnet.



FIG. 10.
Magnetic Needle.

(Fig. 10). With a freely movable magnetic needle, such as shown in Fig. 11, a characteristic property can be observed. If there are

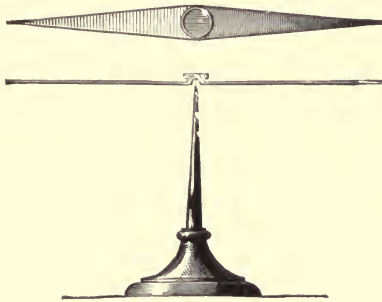

FIG. 11.—Pivoted Magnetic Needle.

no other forces acting on this needle, it sets itself in a certain direction, one of its ends pointing towards the north. This end is called the north pole; the other end, pointing towards the south, is called the south pole of the needle.

To distinguish the poles of a magnetic needle from each other, the north end or half is generally marked or coloured.

We explain the above phenomenon by imagining that the earth exerts upon the needle a force which, like the force of gravity, gives to a suspended rod a certain definite direction, viz. vertically downwards.

We can deflect the needle from the direction in which it has settled under the influence of the earth, by placing near to it another magnet. If we place the north poles of two freely movable needles near each other, then they repel each other. The same is the case with the two south poles. On the other hand, a north pole of one and a south pole of another needle attract. Hence the rule, "*Like poles repel, unlike attract.*"

We can observe similar repelling and attracting effects by approaching the magnetic needle to the poles of any magnet, and we are able to determine its poles by the use of the above rule.

As is well known, a bar magnet attracts soft iron. If a soft iron rod be attached to the north pole of a magnet, the rod behaves like a magnet, *i.e.* it is able to attract small pieces of iron and hold them fast.

By the aid of a magnetic needle we can convince ourselves that a rod of iron adhering to a magnet possesses "polarity," the end of the rod turned toward the north pole of the magnet being a south pole, the other end being a north pole.

Magnets exert actions at a distance. They do not only hold fast pieces of iron which have been brought to them, but also attract pieces of iron from some distance. The force of attraction becomes smaller the greater the distance. By the aid of very exact experiments the following law has been found: If the distance is doubled, then the force exerted is not half, but the fourth part of what it was previously; if the distance is three times as great, then the force is only the ninth part; with a tenfold distance the force is only one-hundredth, and so on. Hence we can say that *the force exerted by a magnetic pole decreases with the square of the distance.*

Let us now take a large horseshoe magnet, and proceed to hold near it a small magnetic needle in various positions. Fig. 12 shows

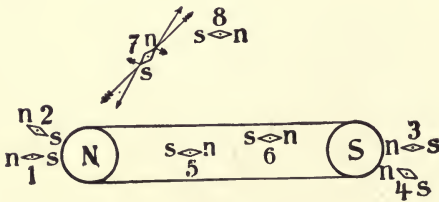

FIG. 12.—Magnetic Needle in Field of Large Magnet.

the poles of the magnet, seen from above, as well as the different positions of the needle. If the needle is near the north pole, then we observe that it comes to rest with the south end pointing to the centre of the north pole, whereas the north end of the needle is repelled in the opposite direction (positions 1 and 2 in Fig. 12).

In the opposite position, on the right of the south pole, the needle comes to rest in a similar way, so that its north end points right to the centre of the south pole (positions 3 and 4). At all points between the two poles (for instance, positions 5 and 6), the needle

settles parallel to a line joining the centre of the poles, its south end, *s*, turning towards the north pole, *N*, of the magnet, whilst the north end, *n*, is attracted towards the south pole, *S*. Why these directions are taken up by the needle the student will easily understand.

But if we now place the needle at any other point in the space surrounding the poles, such as, for instance, at position 7, it will again come to rest in a certain direction.

This position, however, will be such that neither the south pole of the needle turns directly towards the north pole of the magnet, nor the north pole turns directly towards the south pole of the magnet.

To explain why this should be, we have to consider the action of each of the magnet poles on each pole of our needle.

The south pole, *s*, of the needle is attracted by the north pole, *N*, in the direction of the simple arrow, and is also repelled in the direction of the double-barbed arrow by the south pole, *S*.

These two forces are not equal to each other, since the centre point of the needle is only half as far from the north pole as from the south pole, the force exerted by *N* being therefore four times as great as that by *S*. In the figure this is indicated by the length of the respective arrows.

If there are two forces acting on a body, trying to pull it in different directions, then the body can obviously follow neither of the forces entirely. The direction which the body then will occupy will be between the two forces, and that not exactly in the middle, but more towards the greater force.

Accordingly, the magnetic needle will set itself in the direction of the arrow with three barbs, with its south pole not pointing exactly to the centre of the *N* pole. Exactly the same considerations may be applied to the *n* pole of the magnetic needle.

In like manner, for each point in the space round the magnet a certain line of direction of the magnetic force can be determined.

A very good way to make this clear is the following one:—

Let us take a horseshoe magnet, fix it vertically, and over it place a sheet of thin cardboard. By means of a muslin bag filled with steel filings, sprinkle the filings lightly and very uniformly over the card. Then tap the card very gently. The steel filings will arrange themselves in beautiful curves (see Fig. 13).

Near the poles we observe rays, which are turned directly towards the centre; between *N* and *S* there are formed straight lines consisting of the filings, but at other places on the cardboard the lines are fewer and form wide bent arcs, which run from pole to pole.

These figures may be explained as follows:—

Each iron filing, when it comes within the influence of the strong magnet, becomes a small magnet, which can turn round on the card.

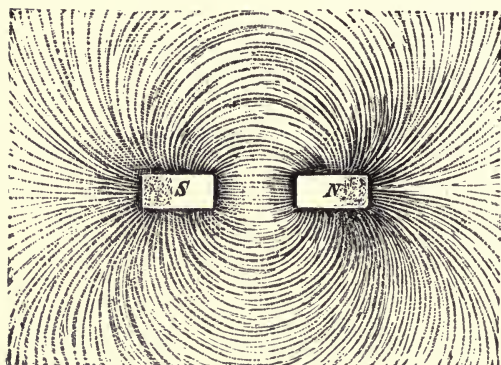

FIG. 13.—Magnetic Curves.

points 5 and 6, along the line joining the poles: but at all the other points the position will be an inclined one.

The small pieces of magnetized steel place themselves in a row, and so form continuous lines. These lines are absolutely straight in the space between the two poles, whereas beyond they are curves. These curved lines hence consist of a great number of short straight pieces (the single filings), and each of these short pieces indicates the direction of the resultant force, which the combined influence of the north and south pole produces at this point. These lines are called **lines of magnetic force**.

The lines of magnetic force do not only indicate the direction of the force at each point, but also give us a measure for the magnitude of this force. We observe that there are many lines in the immediate neighbourhood of the poles, and in the space between the poles, whereas elsewhere the lines are weaker. How is this to be explained?

As we know, the magnetic influence gets smaller with decreasing distance. Hence the iron filings in the immediate neighbourhood of the poles are acted on with great force, and some of them are pulled up against the poles. The influence on the iron filings, which are at a greater distance from the poles, is not sufficient to attract them, perhaps not even enough to turn them, if the friction on the cardboard is greater than the resultant force.

The easily movable iron filings only can follow this influence, and the further outside we go, the fewer filings will set themselves in the direction of the resultant force. Thus the lines of the mag-

netic force are getting weaker and less distinct the further we are from the poles.

We therefore learn that the density of the lines at any point gives us a measure of the magnitude of the force acting at this point.

We can further attribute a third meaning to the lines of force. Let us imagine that it were possible to have a small magnet with north magnetism only.

(As a matter of fact that is impossible, for, if we divide a bar magnet into as many pieces as possible, each of these pieces would still have its north and south pole.) If the north magnetic pole is brought into the sphere of activity of the two poles, which is called the **magnetic field**, then it would be repelled by the north, and attracted by the south pole. If, now, this pole is freely movable, it would always follow the course of one of the lines of magnetic force (as shown in Fig. 14), and would travel from the north pole towards the south pole.

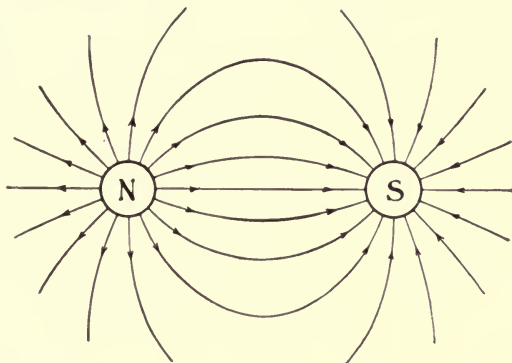

FIG. 14.—Field of Magnetic Force.

In the position of 7, in Fig. 12, the particle of iron will lie in the direction of the arrows with three barbs. If the iron be now shifted the direction it indicates alters, and is that of the lines shown in Fig. 14. The line at any particular place may be supposed to enter the south pole of the little magnet, and to leave at its north pole.

In order to measure magnetism as we do any other matter, it becomes necessary to define a unit for it. The unit of magnetism is an amount of magnetism which if concentrated in a point would exert a unit force on a similar amount of magnetism also concentrated at a point and located a unit distance away; *i.e.*, 1 centimetre (2.54 centimetres equals 1 inch). The unit of force used to measure these quantities is not the pound, but a small fraction of it. It is called a dyne and is equal, approximately, to $\frac{1}{445000}$ of a pound. Thus, units of magnetism at unit distance away exert a force of 1 dyne upon each other.

It is now assumed for convenience and uniformity that a unit pole as described has emanating from it one line of force, as described

above, per square centimetre (6.45 square centimetres equal 1 square inch) at unit distance away. Thus, a unit pole has streaming out from it as many lines of force as there are square centimetres in a sphere of unit radius, or four times π (the Greek letter π is generally used for convenience to represent the number 3.14159). Since at unit distance away a unit pole exerts a unit force on another unit pole, it follows that one line of force per square centimetre means a unit force on a unit pole at the point represented by this line of force density. Thus, in a magnetic field, whenever the density of magnetic flow is equivalent to one line per square centimetre, a unit pole there would be acted upon by a unit force of 1 dyne. In the air-gap of a dynamo, for instance, the pull on a unit pole equals perhaps 10,000, which means from the above definitions that in this magnetic field a unit pole would be pulled by a force of 10,000 dynes or $\frac{10000}{45000}$ pounds. It means also that the lines of force in this field are at a density of 10,000 per square centimetre or $10,000 \times 6.45$ per square inch. Faraday advanced these units and hypotheses, and they have been used ever since.

Influence of the Electric Current on a Magnetic Needle

Let us make the following experiment: Over a straight horizontal wire hold a magnetic needle (see Fig. 15). If there is no iron in the neighbourhood capable of deflecting the needle, the latter will set itself in a direction lying north and south with the *n* pole pointing towards the north. Now, taking care that the wire is parallel to the needle, let a current be sent through the wire. We observe that the needle is now deflected. If we increase the strength of the current, the deflection will be greater, and with a very strong current the needle will set itself nearly at right angles to the direction of the wire as shown in the figure. The deflection ceases immediately if we stop the current, the needle swings back, and after a few vibrations comes to rest exactly in the original direction. Now let the direction of the current be reversed by changing the connections of the wires with the poles of the battery. If the *n* end of the needle were deflected to the right hand in the first case, it will

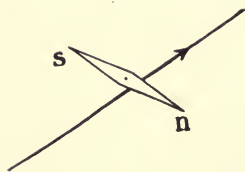

FIG. 15 —Action of Current on Magnet.

now be deflected to the left hand.

Next let the needle be held underneath the wire instead of above

it, and we shall find that the deflections are now opposite to those in the first case. Ampère, a celebrated French electrician, studied these phenomena, and found a very simple rule by means of which the direction of the deflection may always be predicted. "If we imagine a man swimming in the wire *with* the electric current and so as always to *face* the needle, then the **north** pole will be deflected to the **left** hand of the swimmer." This rule is called **Ampère's Rule**.

Hence, if we hold the needle above the wire, the swimmer must swim on his back and face the needle, whereas if the needle is under the wire the swimmer must have his face downwards, in order to apply the rule correctly.

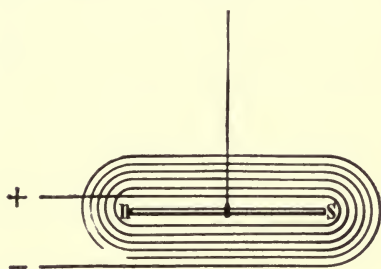

FIG. 16.—Simple Galvanometer.

As already stated, the deflection is greater the stronger the current. It is also increased by making the distance between wire and magnet smaller, and further by having a number of windings round the needle (Fig. 16). This gives a number of conductors above and below the needle, the current flowing to the right in the upper conductors, and to the left in the lower conductors. Applying Ampère's Rule, we find that the action of the upper wires will deflect the *n* pole in towards the paper; and in the case of the lower conductors, where the swimmer must lie on his back, in the same direction. All the twelve conductors therefore help each other in deflecting the needle.

A number of windings arranged in this way is called a **galvanometer coil**, and the tendency of the current is to bring the needle into the axis of the coil. When the deflecting force is far stronger than the directing action of the earth's magnetism, so that the latter is practically without effect, then the needle will be driven at right angles to the coil.

The force of the coil depends on the strength of the current and the number of turns on the coil. A coil having 10 turns with a current of 1 amp. flowing through it has the same effect as a coil of 100 turns and a current of $\frac{1}{10}$ amp., or one with 1000 turns and $\frac{1}{100}$ amp. Hence, the product of the two quantities is of great importance, and is called the **ampere-turns**, which in the above examples is equal to 10.

We have seen, in the previous section, that a freely movable magnetic needle always points out the direction of the lines of

magnetic force, and we must now come to the conclusion that the electric current produces a magnetic field inside the coil with lines of force in the direction of the axis of the coil.

Returning to the experiment shown in Fig. 15, let us move the magnetic needle to various positions round the wire, and we shall find that the lines of force encircle the conductor (see Fig. 17). The action of the conductor on the needle being more vigorous near the wire, we infer that the lines of force are here more numerous, and diminish as we are more distant from the wire. As to the direction of the lines it is the same as the handle of a corkscrew, if the current be assumed to flow from the handle to the point of the screw.

In order to see the circular lines of force, place a piece of cardboard horizontally and make a hole in the centre. Through this hole pass a copper wire which is held vertically. Sprinkle the card uniformly with fine iron filings, and now send a strong current through the wire. On tapping the card gently the filings will arrange themselves in a series of circles, as shown in Fig. 18.

If we wind wire in the form of a helix, or what is generally called a **solenoid**, then the circular lines of force around each part of the wire will combine in a way which will be understood from Figs. 19 and 20. Here several windings are shown in cross-section. In the upper part of the windings the current flows to us (marked by a dot), whilst in the lower part it flows from us (marked by a cross). Using the above rule, we find that the lines of force flow in the directions marked by the arrows. For the sake of simplicity, only a single circle is drawn round each wire. We notice that, when the lines of force are directed upwards and downwards in the neighboring circles, these destroy each other, and only those parts of the circles which are situated inside or outside the coil are effective. We have, therefore, as a resultant only straight lines inside and outside the solenoid. This is seen in Fig. 20. As a consequence, if a needle be placed within the coil it will tend to set itself along the axis of the coil.

From the action of a current on a magnet as found by Ampère, and from the fact that a free north pole moves in the direction of a line of force, it follows that the lines of force are created by a flow of electricity (or a current). It has been found that these lines of force are concentric circles about the wire. A current in a wire entering this page perpendicular to it creates lines of force in the plane of the page circulating around in the direction of the hands of a watch, or right-handed. Looking at the end of an electro-mag-

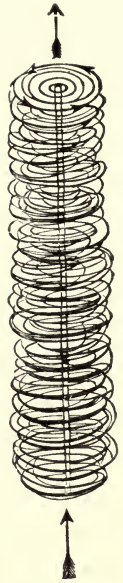

FIG. 17.—
Lines of Force
round Cur-
rent.

net, if the current circulates in the direction of the hands of a watch, or right-handed, the pole is a south pole. If counter clockwise, or left-handed, it is a north pole. From the fact that a free north pole moves along the lines of force, it naturally follows that when a north pole

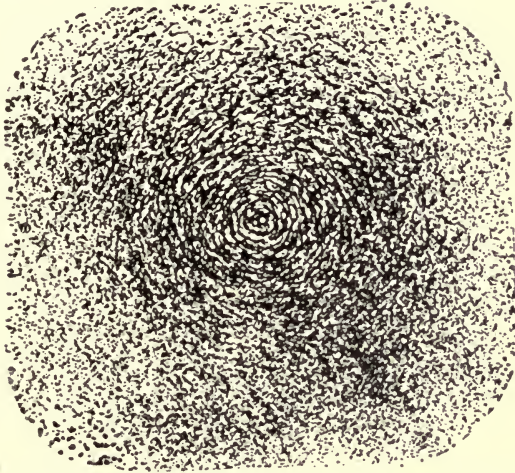

FIG. 18.—Arrangement of Filings round Current.

of one magnet is approached to the north pole of another it is repelled, since the lines of force come out from a north pole. Since the lines of force go into a south pole, the north pole is attracted

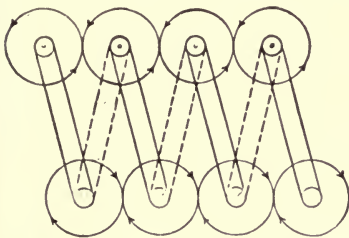

FIG. 19.—Lines of Force of Helix.

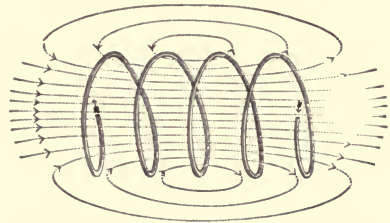

FIG. 20.—Resultant Field of Helix.

to a south pole. This, therefore, expresses the law of attraction and repulsion of magnets, as well as the influence of currents on magnets. It is only necessary to have in mind the direction of a north pole when under the influence of a line of force.

Another important law in connection with lines of force is that concerning the production of electro-motive force. While current and electro-motive force can be produced by a galvanic battery as described, the method employed in dynamos is that of moving a wire across a magnetic field. Faraday discovered this law of induced currents. He found that *if a wire were moved across a line of force produced by a magnet, that an electro-motive force was created in this wire, and that the greater the density of lines of force and the faster the movement the greater the electro-motive force created.*

Electricians have defined the unit of electric pressure as that resulting from cutting 100,000,000 lines of force per second. It is called a *volt*. If 200,000,000 lines of force are cut per second, two volts are created. If 200,000,000 lines of force are cut, but two seconds are consumed in cutting them, one volt is produced. Thus the rate of cutting of lines gives the resulting voltage produced. In a closed circuit, therefore, *the rate of change of lines of force in that circuit gives the voltage produced.* This is the essential principle of the modern dynamo. The large iron circuit with its spools creates the lines of force, and the armature with its revolving wires cuts these lines of force and produces electro-motive force. Since motion is relative, the same effect is produced if the armature stands still and the poles or line of force producers revolves. This latter arrangement is used for alternators where it is desirable, with the higher voltages created, to have the wires in which the voltage is created stand still, and thus be easier insulated and free from damage due to vibration of rotation.

Electric Units—Measurement of Currents— Ohm's Law

It is not possible to measure an electric current *directly*, as in the case of a stream of water we can measure its quantity. With the electric current we must judge of its strength by observing of the effects of the current. If, for example, we connect a piece of wire with the poles of a cell, and the wire does not get hot, and if we now remove the wire and connect it across the poles of a battery, and the wire now is heated, it is quite clear that the current has been stronger in the second case. Again, if a coil is connected firstly with a single cell and it is found that only small pieces of iron are attracted, whereas when the coil is connected with a battery heavy pieces are attracted, we infer that the current is of greater strength in the second case. A third example may be taken from the decomposition of water: when an electric current passes through

it, the greater the evolution of gas the greater must be the strength of the current.

In one of these ways the strength of an electric current may readily be determined, if only we have a unit strength of current with which to measure the effects. For this purpose the chemical effect may be best used, because the quantity of the gas produced can be measured by the help of a graduated tube. Electricians have fixed upon that current as a unit which will liberate in one minute 10.4 cubic centimetres of mixed gas. This unit is called after an eminent French scientific man—an **ampere** (often abbreviated to **amp.**).

If, then, we find that a certain current gives 20.8 cubic centimetres of gas per minute, we denote the current strength as of 2 amperes; if, on the other hand, the amount of gas per minute be 104 c.c. then the current is 10 amps.; and so on.

Another definition of unit current is as follows: Let the current be considered as flowing in a wire of infinite length perpendicular to and passing through this paper at some point. The magnetic current of the lines of force from this current circles in the plane of the paper. The density of the lines of force (or flux) is greater the nearer to the wire they are located. Consider one of the circuits whose length is one centimetre. Imagine a unit pole on this circle. A unit current can now be defined as that current in the above circuit which will produce on this pole a force of $\frac{4\pi}{10}$ dynes,

or, what is saying the same thing, the density of the lines of force at this point is $\frac{4\pi}{10}$ lines per square centimetre. This definition of unit

current is the same current as defined by the gas-freeing method. It is called an ampere. An ampere denotes a flow. It means a unit of electricity per second. This quantity passing per second is called a **coulomb**. Thus, one ampere is one coulomb per second. A coulomb can be moving or standing still. An ampere means motion. From this definition of current an excellent proof of what is called magneto-motive force can be deduced as follows: It has been stated that ampere turns create magnetism or flux. The term *magneto-motive force* or "driving power" for magnetism has been given to ampere turns. The ampere turns per inch of magnetic circuit is called *magnetizing force*. Thus, a bar 100 centimetres long, with a thousand ampere turns acting upon it, has a magneto-motive force of 1000, and a magnetizing force of $\frac{1000}{100} = 10$.

Thus,

$$\text{Magnetizing force} = \frac{\text{magneto-motive force}}{\text{length of magnetic circuit}}$$

Return now to the definition of unit current. A unit current exerts a force of $\frac{4\pi}{10}$ on a unit pole situated on a circle away from the wire such a distance that the length of the circle is 1 cm. Thus, in Fig. 21 the current of one ampere enters the paper and at right angles to it at the point A . A unit pole at b is acted upon by a force of $\frac{4\pi}{10}$; or the density of lines of force in air, which is expressed by the letter H by electricians, is $\frac{4\pi}{10}$, which is saying the same thing. Under the above conditions, b is located away from A by the distance $\frac{1}{2\pi}$ instead of 1 cm. (since the circumference of a circle = 2π times the radius when $\pi = 3.14159$).

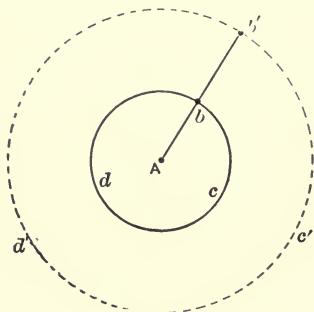

FIG. 21.

If b were one centimetre away from A at b' (Fig. 21) the flux density H would be less, since the circumference of the circle $b'-c'-d' = 2\pi \times$ radius, or $2\pi \times 1 = 2\pi$, and the circumference of this circle is the length of the magnetic circuit; for the lines of force produced by the current flowing into the paper at A have their path in various circles in the plane of this paper, and the larger these circles the less the flux, as has been shown on page 12 by the iron-filings experiment. As a matter of fact, the flow of flux in air with magnetic circuits follows the

law; flux density = H is proportional to $\frac{\text{ampere turns}}{\text{length of magnetic circuit}}$.

Thus, referring again to Fig. 21, if the flux density (or, what is saying the same thing, the force of dynes in a unit pole) at b with unit current at $A = \frac{4\pi}{10}$, the length of the magnetic circuit $b-c-d$ being 1, it

would be $\frac{4\pi}{10} \div 2\pi$ at point b' , since the length of the magnetic circuit at $b' = 2\pi$. Hence the force with one ampere one cm. away (at $b') = \frac{2}{10}$, or H at b' one cm. away = $\frac{2}{10}$. With I amperes the force

would be $\frac{2I}{10}$, and, if N turns were interlinked with the flux, the force

would be $\frac{2IN}{10}$, one centimetre away. At a distance T , since the length of the circles representing the magnetic circuits are propor-

tionate to the distance away from the point A, the flux per square centimetre, or

$$\text{Force } H = \frac{2IN}{10T} \dots \dots \dots (1)$$

We have previously stated the following definition:

$$\text{Magnetizing force} = \frac{\text{magneto-motive force}}{\text{length of magnetic circuit}} \dots \dots (2)$$

or, at the distance T, as shown, magnetizing force = $\frac{IN}{2\pi T}$,

or, rearranging, $T = \frac{IN}{2\pi \times \text{magnetizing force}}$.

Substituting this value of T in equation (1) we get

$$H = \frac{2IN}{10} \times \frac{2\pi \times \text{magnetizing force}}{IN},$$

or $H = \frac{4\pi}{10} \times \text{magnetizing force},$

or $H = 1.258 \times$ ampere turns per unit length of magnetic circuit. This formula expresses the law of production of flux, and is used in the calculation of all magnetic circuits.

There is another value expressed by the Greek letter μ , called permeability, which relates to magnetic circuits. The value H expressed above refers to air magnetic circuits. It is a fact, however, that with a given number of ampere turns acting upon a circuit more flux will be produced with circuit of one material than another. Thus, iron will produce perhaps 1500 times as much as air. The ratio of the flux produced in a material to that produced if the material were air is called the permeability of the substance, and is designated by the Greek letter μ . The μ for air = 1. While H means flux density per square centimetre (or force in dynes on a unit pole) with air only, B means the same thing with any material. Thus $\frac{B}{H} = \mu$. Thus B means the flux density per square centimetre with any material except air. Since iron is usually used for magnetic circuits, B usually means flux density in iron per square centimetre.

An apparatus for measuring the strength of an electric current by

means of the chemical effects is called a **gas voltameter**, after Volta, who was one of the first to study electric effects.

Although the voltameter will measure the strength of an electric current it is rather troublesome in practice, and is therefore almost exclusively used for laboratory work and for the testing of other instruments, as we shall presently see.

Instruments depending on the magnetic effect, as described above in the magnetic definition of unit currents, or the heating effect are very frequently used. In Fig. 22 is shown a current-measurer of the electro-magnetic type. It essentially consists of a coil of wire *a*, into which dips a thin and easily movable iron core, *e*. A pointer, *f*, is connected with a bent lever in such a way that when the core moves downwards the counter revolves, and its position will be indicated on a scale which is not shown in the figure. By the adjustment of the little weights at *d* and *d*, which are movable along the screws threaded on the short arms, the zero position of the index may be adjusted.

If we send a current through the coil the core will be drawn into the interior, and the pointer will therefore move to a new position;

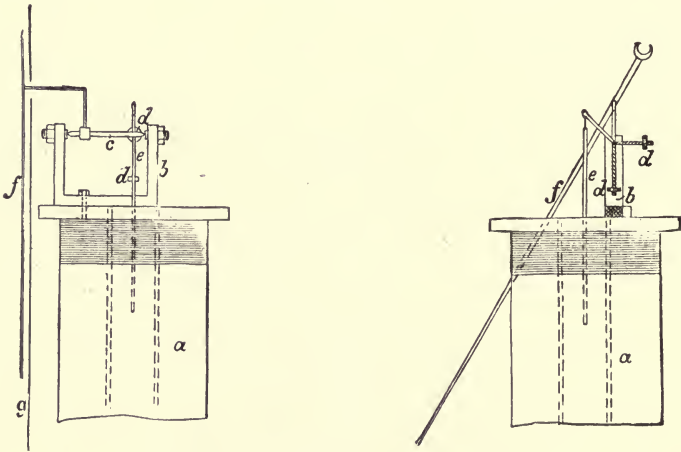

FIG. 22.—Electro-magnetic Ammeter.

and the stronger the current the greater will be the deflection of the pointer. To find the value of the current corresponding to the deflection it is necessary to submit the instrument to the process called **calibration**. For this purpose it is necessary to connect the instrument with the voltameter, in such a way as to cause the current to flow simultaneously through both. If we now regulate

the current so as to ensure the liberation of 10.4 c.c. of gas per second,

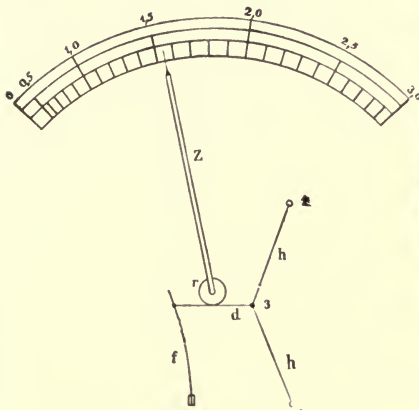

FIG. 23.—Hot-wire Ammeter.



FIG. 24 —Electro-magnetic Ammeter
(The Electrical Company).

then we know that 1 amp. is passing, and the position of the pointer can be marked accordingly. The current can now be increased so that 2 amps. pass and the new position of the pointer be marked. Let this process be continued until the highest possible deflection of the pointer is reached, when the calibration will be complete. We have now what is called an **ammeter**.

In Fig. 23 is shown an ammeter depending on the heating effect of the current. It is known as of the *hot-wire type*. It consists of a very fine platinum-silver wire, *hh*, which is fixed at the points 1 and 2, and is connected at the middle point, 3, to another fine wire, *d*. This latter is wound around a small roller, *r*, and is kept continuously strained by means of a spring, *f*. When a current is sent through the wire *hh* gets heated and expands, and so enables the spring *f* to pull



FIG. 25.—Electro-magnetic Ammeter
(Crompton & Co.).

When a current is sent through the wire *hh* gets heated and expands, and so enables the spring *f* to pull

the wire d forward, which action rotates the roller and moves the pointer z . The instrument can be calibrated in a similar way to the electro-magnetic instrument. Complete instruments of the two kinds are shown in Figs. 24, 25, and 26.

In Fig. 26 it will be seen that attached to the pointer and moving with it is a disc of aluminium. The upper edge of this moves between



FIG. 26.—Hot-wire Ammeter (*Johnson and Phillips*).

the poles of a horseshoe magnet. The purpose of this arrangement is to *damp* the motion so that the pointer is speedily brought to rest and the value of the current quickly known.

We must now examine the influence of the E.M.F. in producing a current. For this purpose let us go back to the hydraulic analogy. In the tube connecting the two tanks the water-stream will be the greater, the greater the difference of the heights of the columns of the liquid; but it does not depend on that alone. The resistance of the tube must have a considerable effect. If the tube is very long and the inside rough and the bore small, then but little water can pass through it. If, on the other hand, the tube is short with a large bore of polished material, then for the same water-driving force the stream of water must be much greater.

Exactly the same is the case with the electric current, for the

strength of the electric current depends not only on the E.M.F., but also on the resistance of the circuit. Through a short thick wire connecting the poles of a cell a stronger current will pass than if a long and thin wire be used.

This dependence of the intensity of the effect on the driving force and the resistance is to be met with, not only in the case of the water-stream and of the electric current, but also with many things in daily life. For example, imagine there are two countries with a great difference of density of population, then many people will emigrate from the country with the denser population to the country with the smaller one. The more crowded country produces, in a manner, a stronger pressure towards the other country, and the pressure difference can be considered as the driving force of emigration. But not only has this pressure difference an influence on the emigration, but it is of great importance what opposition is offered to the flow of the people between the two countries. If the countries are near each other, and a good and open road leads from one to the other, then the stream of people which flows from one country to the other may be a very great one; on the other hand, if the countries are separated by means of high mountains, wide seas, etc., then the resistance to the flow will be greater, causing a corresponding diminution of the emigration. If, finally, the boundary happens to be an impassable one, then, although a driving force may exist, yet the countries will be insulated from each other.

In a like manner, there are some materials which offer a very small, others which offer a very great resistance to the electric current. When the resistance is extremely great the substance is called an **insulator**. On the other hand, materials which do not much impede the current are termed **conductors of electricity**. To this latter class belong all metals: first of all, silver and copper; then gold, aluminium, zinc, platinum, iron, tin, lead, German silver, the liquid metal mercury; next carbon; and, finally, many solutions, such as sulphuric acid mixed with water, and salt solutions.

Insulators, or non-conductors, include the following: dry wood, silk, cotton, india-rubber, gutta-percha, asphalt, oil, porcelain, glass, dry air, and so on.

It must be clearly understood that the term conductor or insulator is not to be considered as an absolutely fixed one; this may be well understood by the reference to the example of two countries. In ordinary cases the impediment of great mountains will be sufficient to stop the passage of people between the two countries, but cases may arise in which the driving force may be so great that nearly all impediments can be overcome. In a like manner, materials which may insulate at lower voltages may become conductors at higher pressures. If we cover a conductor with an insulating substance in

order to prevent the escape of electricity, it follows, from what has been just said, that it will be necessary to make the covering thicker for higher than for lower voltages. For a wire which is connected with a single cell, an insulation of a winding of cotton or silk is quite sufficient, whereas a wire which is connected with a generator of some 1000 volts must be covered with several layers of india-rubber or other insulators.

The law which expresses the relation between current strength and electro-motive force tells us that the current is stronger the greater the E.M.F., and is smaller the greater the resistance of the circuit. For resistance a unit is also required. This may be definitely fixed as follows: If we have a wire of any size, and of any material through which flows a current of 1 amp., the difference of potential between the beginning and the end of the wire being equal to 1 volt, then the resistance is equal to the unit of resistance which is called the **ohm**. A convenient abbreviation for the ohm is the Greek letter ω .

The ohm can be made from any metal. To give a definite idea of its value it may be mentioned that about 10 feet of a copper wire of No. 33 S.W.G.,* which has a diameter of $\frac{1}{100}$ th of an inch, is 1 ohm in resistance. Again, 60 metres of copper wire 1 square millimetre cross-section has a resistance of about 1 ohm.

To make a standard resistance copper is not used, for the reason that it oxidizes in the air, and that it is difficult to obtain the metal quite pure. The best material for the purpose is mercury. By careful measurements it has been found that a column of mercury, 1 sq. mm. in section and 106.3 cm. long, has a resistance of 1 ohm.

Since 1 volt produces in a circuit of 1 ohm a current of 1 amp., therefore an E.M.F. of 10 volts will produce in the same circuit a current of 10 amps.; or, in other words, the strength of a current varies directly as the electro-motive force.

Let us now keep constant the pressure as 1 volt, and vary the resistance of the circuit; then through a resistance of 2ω will flow a current of $\frac{1}{2}$ amp., through a resistance of 10ω will flow a current of $\frac{1}{10}$ amp., and so on; in other words, the strength of a current varies inversely as the resistance. Let us next consider what will be the strength of a current which is produced by an E.M.F. of 10 volts, in a circuit of 2ω . If the resistance is 1ω the resulting current is 10 amps.; but since the resistance is twice as great, the strength of the current will only be one-half, or 5 amps.

An E.M.F. of 110 volts will produce in a circuit of 220ω a current of $\frac{110}{220} = \frac{1}{2}$ amp. It is obvious from these examples that

* S.W.G. is an abbreviation for the Standard, Imperial, or Board of Trade Wire Gauge.

the number of amperes passing through a circuit is obtained by dividing the number of volts by the number of ohms in the circuit, or—

Current strength = Electro-motive force ÷ Resistance.

Expressed by the initial letters of these words, we may write—

$$C = E \div R$$

or in the form of a fraction—

$$C = \frac{E}{R}$$

This last is the mathematical expression for the law that we have expressed in words above. It is called, after its discoverer, **the Law of Ohm.**

The Calculation of Resistance

To compare the electric resistance of different materials it is usual to find the resistances of the substances when all are of the same length and cross-section. If the materials are in the form of wires, each of some specified length and cross-section, say 1 m. in length and 1 sq. mm. in cross-section, then the number giving the resistance in ohms is called in each case the **specific resistance.**

From the data previously given, it will be easy to find the specific resistance of copper and mercury. We know that the resistance of 60 m. of copper wire, 1 sq. mm. in section, has a resistance of 1ω , hence its specific resistance is $\frac{1}{60}\omega$. Again, a mercury column of about 1.06 m. and of 1 sq. mm. cross-section has a resistance of 1ω , so the specific resistance of mercury is $\frac{1}{1.06} = 0.94\omega$.

The following numbers show approximately the specific resistance of most of the important metals:—

	Ohms.	
Silver.....	0.016	$=\frac{1}{62}$ about
Copper.....	0.0167	$=\frac{1}{60}$ “
Gold.....	0.02	$=\frac{1}{50}$ “
Aluminium.....	0.033	$=\frac{1}{30}$ “
Brass.....	0.070	$=\frac{1}{14}$ “
Iron.....	0.10	$=\frac{1}{10}$ “
Lead.....	0.22	$=\frac{1}{5}$ “
German silver.....	0.25	$=\frac{1}{4}$ “
Nickelin.....	0.35	$=\frac{1}{3}$ “
Mercury.....	0.94	$=\frac{1.9}{20}$ “

The numbers given above are average numbers, and assume that the temperature is about 60° F. In accurate work it is necessary to state the temperature for the reason that the resistance varies with the temperature.

The law of change of resistance with temperature is expressed as follows: Let R_0 = the resistance in ohms at the temperature of 0° Centigrade (to get Fahrenheit temperature from Centigrade, multiply the Centigrade reading by $\frac{9}{5}$ and add 32).

Let R_T = resistance at temperature T; then $R_T = R_0(1 + aT)$, when a is a constant depending upon the material. For copper $a = .0042$.

[The units, metre for length and sq. mm. for cross-section, are very convenient for practical work, and are much used abroad. In England, where the metric system has not yet been adopted, common units are the inch, foot, or yard for length, and the square inch for sectional area.

A system in which centimetre measure is used is recommended for universal use. To change the above numbers in accordance with this system it is necessary to remember that 1 metre is equal to 100 centimetres, and that 1 sq. cm. is equal to 100 sq. mm.; then, from what follows, the above numbers must be divided by 10,000; thus the specific resistance of silver in centimetre measure is 0.0000016.—TRANSLATORS.]

The purity of the metal has an important influence on the specific resistance. With alloys the proportions of the metals will give great changes in the resistance. For example, there are kinds of copper which have a specific resistance of $\frac{1}{50}$ and even greater; different kinds of the alloy nickelin have specific resistances ranging from $\frac{1}{3}$ up to $\frac{1}{2}$, while German silver may vary from $\frac{1}{7}$ to $\frac{1}{3}$ in specific resistance.

The different materials used for resistances in workshops and laboratories must therefore always be electrically tested, but for approximate purposes the numbers given above may be used.

With carbon the specific resistance differs greatly with the nature of the carbon. There are some kinds with a value of some hundreds of ohms, whilst carbon prepared under high pressure may be only 12.

From the table which we have given we may readily calculate the resistance of a wire of any of the materials, if we know the length and cross-section of the wire. As we have learnt from the analogy of water flowing through a tube, the resistance is greater the longer the tube, and is smaller the bigger the area of cross-section. A copper wire 10 m. long and 1 sq. mm. cross-section has a resistance of $10 \times \frac{1}{60} = \frac{1}{6} \omega$. A copper wire 1 m. long and 2 sq. mm. cross-section has only half as much resistance as the one of 1 m. and 1 sq. mm. area; thus $\frac{1}{60} \div 2 = \frac{1}{120} \omega$. We infer that a wire of 10 m. and 2 sq. mm. cross-section must have a resistance of $\frac{1}{12} \omega \times 10 = \frac{1}{12} \omega$.

These results we may express in words as follows:—

The resistance of a wire of certain cross-section and length is to be found by multiplying the specific resistance by the number of metres in length, and dividing by the number of square millimetres in cross-section; or—

Resistance = specific resistance \times length \div area of cross-section.

This may be abbreviated to—

$$R = K \frac{l}{a}$$

where R = resistance in ohms; l = length of the wire; a = the cross-section of the wire; K = the specific resistance.

EXAMPLES.

1. What resistance has a copper wire 1000 m. long and 4 sq. mm. cross-section?

Applying the formula we have—

$$R = \frac{1}{60} \times \frac{10000}{4} = 4.16\omega$$

2. There are **resistance frames**, as shown in Fig. 27, of frequent use in electro-technical work, for the purpose of regulating the strength of an electrical cur-

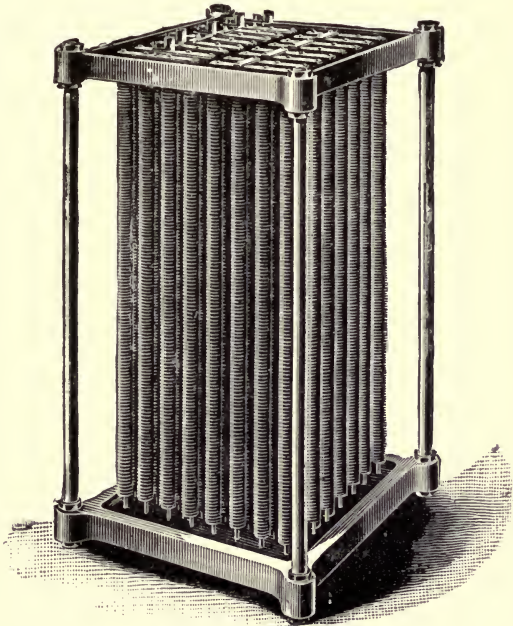

FIG. 27.—Resistance Frame.

rent. They are generally made with coils of metal having a high specific resistance. Let us suppose that German silver be chosen as the kind of wire. The

question is: How much wire, having a cross-section of 1 sq. mm., must be used to give a resistance of 100ω ?

Since German silver has a specific resistance of $\frac{1}{4}$, then 4 m. of a wire of 1 sq. mm. will have a resistance of 1ω , so that for 100ω we require 400 m. To place such a length of wire in a comparatively small space necessitates its winding in spirals as shown in the illustration.

3. If in the previous example we had used a wire of double the cross-section, then it would be necessary to take 800 m. On the other hand, if the cross-section had been halved the length would only be 200 m.

4. If a copper wire, 2000 m. long and 3 sq. mm. cross-section, be connected with an E.M.F. of 110 volts, find the current passing through the wire.

First we must find the resistance of the wire. This is—

$$R = \frac{1}{30} \cdot \frac{2000}{3} = 11.1\omega$$

The current strength is now found by dividing the voltage by this resistance; or—

$$C = \frac{E}{R} = \frac{110}{11.1} = 9.9 \text{ amps.}$$

Other Forms of Ohm's Law

We are now able to calculate the current, being given the voltage and the resistance. It is, of course, also possible to calculate the resistance of a circuit if the voltage and current strength be given. If, for instance, the voltage be 10 volts, and the current flowing be 2 amps., then we may find the resistance of the circuit as follows: If the resistance of the circuit be 1ω , then the number of the amperes must equal the number of the volts. On the other hand, if, as in our example, the amperes are smaller than the volts, it is obvious that the resistance is greater than 1ω . A moment's thought will show that it must be five times as great, or 5ω , for the current is one-fifth of the voltage.

In like manner, if the voltage be 110 and the current be $\frac{1}{2}$ amp., then the resistance of the circuit is $\frac{110}{\frac{1}{2}} = 220\omega$.

The general rule is, then—

The resistance of a circuit is to be found by dividing the E.M.F. by the current strength; or—

$$\text{Resistance} = \text{E.M.F.} \div \text{Current strength;}$$

$$\text{or } R = \frac{E}{C}$$

There is still one other way of stating Ohm's Law. Suppose that we know the current and the resistance, and require the voltage. Given, for example, a resistance of 220ω and a current of $\frac{1}{2}$ amp. What is the voltage? Since to get with a resistance of 1ω a current of $\frac{1}{2}$ amp. a voltage of $\frac{1}{2}$ volt must be used, we argue that

to get the same current with a resistance of 220ω we must increase the volts 220 times, or the volts must be $0.5 \times 220 = 110$ volts
 Writing this so as to apply in a general way, we say—

$$\text{E.M.F.} = \text{Current strength} \times \text{Resistance};$$

$$\text{or } E = C \times R.$$

The three formulæ:

$$C = \frac{E}{R} \dots \dots \dots (1)$$

$$R = \frac{E}{C} \dots \dots \dots (2)$$

$$E = C \times R \dots \dots \dots (3)$$

really mean one and the same law in different forms convenient for practical calculations.

Internal Resistance—Drop of Potential

If we connect any apparatus, A (Fig. 28) by means of copper wires with the battery B, our circuit consists of three parts, viz. the battery, the main conductors, and the apparatus. Each of these has a certain resistance, and that of the battery is called the *internal resistance*. The sulphuric acid or other liquid that may be used in the cells has, when compared with metals, a very high specific resistance, so that to prevent the internal resistance becoming too great it is necessary to have the cross-section of the liquid suitably large.

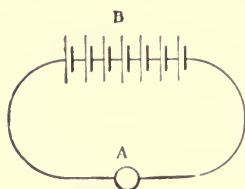

FIG. 28.—Simple Circuit.

Suppose that the internal resistance of the battery is 1ω , the resistance of the main conductors 2ω , that of the apparatus 3ω , and the voltage of the battery 12. Then, since $1+2+3=6$ is the combined resistance, the current flowing in the circuit will be $\frac{12}{6} = 2$ amps. Hence a voltage of 12 is required to give 2 amps. in the circuit with a total resistance of 6ω . If only the apparatus of 3ω had been in the circuit, then the pressure to produce the 2 amps. would have been but $3 \times 2 = 6$ volts. Now the conducting wires having a resistance of 2ω , a pressure of $2 \times 2 = 4$ volts will be required for them. Again, for the battery which has a resistance of 1ω , a voltage of $1 \times 2 = 2$ volts will be wanted. The total voltage of 12 is thus consumed in the whole circuit, but only 6 volts are usefully employed on the Apparatus A. The 4 volts

consumed by the conductors and the 2 in the battery represent a loss, or drop, of potential.

In consequence of the drop of potential in the battery, there is available at the poles, not the whole 12 volts that the battery produces, but a smaller number. If we measure, by the help of a suitable instrument (to be described later on) the terminal voltage of the battery, we shall find it to be 10 volts only when a current of 2 amps. flows through the circuit, giving under these conditions a drop of pressure of $12 - 10 = 2$ volts.

The drop of potential is larger if the external resistance becomes smaller. Thus, if we replace A by an apparatus with 1ω instead of 3ω , since the combined resistance is now $1 + 2 + 1 = 4\omega$, the current will be $\frac{12}{4} = 3$ amps. This current will give a potential drop, in the battery, of $3 \times 1 = 3$ volts; in the conductors, of $3 \times 2 = 6$ volts; and for the new apparatus, $3 \times 1 = 3$ volts. The terminal voltage of the battery is, in this case, $12 - 3 = 9$ volts.

Again, if we suppose that the resistance of the external circuit, consisting of the main conductors and the apparatus, be but 1ω , giving a total resistance of 2ω and a current of $\frac{12}{2} = 6$ amps., this will give a fall of volts in the battery of $6 \times 1 = 6$ volts, leaving only 6 as the terminal voltage.

The student will now perceive that, for a certain current that may be needed for any purpose, it may be necessary to reduce the potential drop in the battery. How can this be done? Obviously by decreasing the resistance of the battery. The largest part of the resistance of the battery is usually due to the liquid. We may diminish this by making the way through the liquid as short and its cross-sectional area as great as possible. The path may be shortened by placing the plates of the elements very near each other. The cross-sectional area of the liquid may be enlarged by making the plates that are immersed in the liquid as large as we may allow. It may be remembered that cells with large plates have exactly the same E.M.F. as cells with the smallest; but the drop of potential is for the small plates greater for the same current than for the largest, owing to the internal resistance. It will therefore follow that the cell with the larger plates must have a greater terminal voltage—assuming the current is the same. To take the case of the battery with an internal resistance of 1ω and an E.M.F. of 12 volts, at a current of 6 amps. there will be a potential drop of 6 volts, and therefore a terminal voltage of 6. Suppose, now, that the plates of this battery be made double the size, causing the internal resistance to be $\frac{1}{2}\omega$; then, with a current of 2 amps., the potential drop of the battery will be only $2 \times \frac{1}{2} = 1$ volt, leaving a terminal pressure of 11 volts. On increasing the current to 6 amps. the potential drop will become $6 \times \frac{1}{2} = 3$ volts, giving now a terminal voltage of 9.

Cells with very large plates are seldom employed, because they are difficult to manufacture and inconvenient in use. We shall presently see how we may make one large cell from a number of small ones.

Branching of Circuits

We have so far dealt with a simple closed circuit, so that the current coming from the battery had to flow through all parts of the circuit. If in a circuit be connected several pieces of apparatus A_1 , A_2 , A_3 , as shown in Fig. 29, having respectively the resistances 2, 3, and 1ω , then the current depends on the sum of these values. Suppose that the cross-sectional area of the battery and of the conductors be so great that their resistance is practically nothing when compared with the resistance of the rest of the circuit, as often is the case in practice, then we can at once obtain the current by dividing \mathcal{E} , which is the sum of the resistances, into the pressure. If the E.M.F. be 24 volts, the current will therefore be $\frac{24}{6} = 4$ amps., which will be the same at all parts.

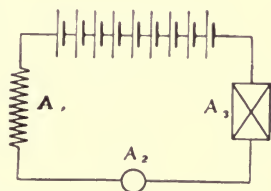

FIG. 29.—A Series Circuit.

But we can group the apparatus in another way. We can, for example, as shown in Fig. 30, connect A_1 , A_2 , and A_3 , all to the poles of the battery. This is called the method of connecting in **parallel**, whereas the former way was in **series**.

The problem now to be considered is how to find the current strength in each apparatus. First we will find the current through A_1 . Since this is connected with a battery of 24 volts, and assuming that the connecting wires and internal resistance of the cells are practically nil, then the current through A_1 will be obtained by dividing 24, the E.M.F., by 2, the resistance of the apparatus; or, writing this after Ohm's Law,—

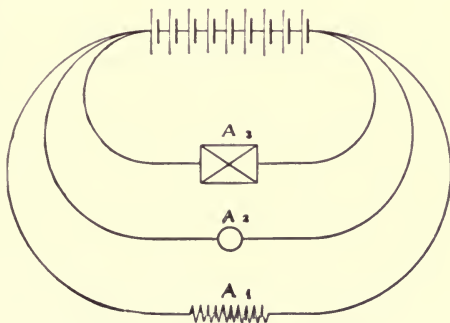

FIG. 30.—Circuits in Parallel.

$$C_1 = \frac{E}{R_1} = \frac{24}{2} = 12 \text{ amps.};$$

where C_1 denotes the current, and R_1 the resistance of A_1 .

In like manner we can write—

$$C_2 = \frac{E}{R_2} = \frac{24}{3} = 8 \text{ amps.};$$

$$C_3 = \frac{E}{R_3} = \frac{24}{1} = 24 \text{ amps.}$$

The battery therefore has to deliver the current to all four branches simultaneously, which amounts to $12 + 8 + 24 = 44$ amperes.

We may now ask: If we had, instead of the three parallel connected branches, a single outer resistance only, what must be its resistance that we may get a current equal to 44 amps.? This problem may be readily solved by means of Ohm's Law. To produce a current of 44 amps. in a circuit with 24 volts requires resistance in the circuit of $\frac{24}{44} = 0.545\omega$. This value is defined as the resultant resistance of the three branches. It is smaller than any of the three branch resistances. We may say, generally, that we make a combined resistance smaller by connecting in parallel, whereas the combined value of resistances in series is, of course, greater than any of them.

To work out the value of any resistances in parallel we may proceed as follows:—Imagine any voltage, preferably that of a single volt, to which the resistances are connected. Then, taking the three branches of the above example with resistances of 2, 3, and 1 ohm, the respective currents will be as follows:—

$$\begin{aligned} C_1 &= \frac{1}{2} = 0.500 \text{ amps.} \\ C_2 &= \frac{1}{3} = 0.333 \text{ " } \\ C_3 &= \frac{1}{1} = 1.000 \text{ " } \end{aligned}$$

Thus the total current flowing through the three branches is—

$$1.833 \text{ amps.},$$

and the combined resistance to replace the three would be—

$$\frac{1}{1.833} = 0.545\omega,$$

which is the same value as that obtained in the previous calculation. We may, then, state the law:—

To find the resultant resistance of a circuit consisting of any number of branches connected in parallel we imagine the branches connected with a pressure of one volt, then calculate the current strength of each of the branches, adding all these branch currents together. The resultant resistance is then found by dividing 1 volt by the sum of the currents.

The calculation becomes much simpler if the branch resistances are equal. If we had, for instance, two branches, each with a resistance of 10ω , the current in each branch, if connected with a voltage of 1, would be $\frac{1}{10}$ amp., and the combined currents would be $\frac{2}{10} = \frac{1}{5}$ amp., giving by our rule a resultant resistance of 5ω , which is half that of the branches. In the same way, the combined resistance of 10 branches, each with a resistance of 10ω , will be 1ω , *i.e.* the tenth part of any one of them, and so on.

Cells in Series and Parallel

The cells of a battery may be connected in series or parallel, and the effect on the internal resistance is exactly the same as we have found for the external part of the circuit. When two cells are connected in series the combined resistance is twice that of a single cell, and when they are in parallel the resultant resistance is half that of a single cell.

But in addition to the resistance, the effect on the E.M.F. must be thought of. In Fig. 31 are shown two cells in series, the copper of the second cell being connected with the zinc pole of the first cell by means of a wire, the external circuit being connected with the end poles. The effect of this arrangement is to add the pressures of the cells so that, if the cells are equal in pressure and each of one volt, there will be two volts available for producing a current through the circuit. In the same way a battery of 100 cells would give a voltage of 100 times that of a single cell.

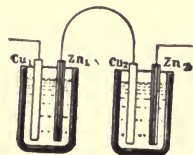

FIG. 31.—Two Cells in Series.

We will next consider the grouping of the cells in parallel. Fig. 32 shows two cells so arranged having the two copper plates connected, and also the two zinc plates. On joining a wire from the positive poles and the negative poles to an outer circuit, we have the effect of a single cell of double size.

The voltage of this battery is 1, but the internal resistance is half that of a single cell. If we connected 10 cells in parallel in this way, all the zinc poles being joined together and the same with all the copper poles, then the pressure will be as before, 1 volt;

but the internal resistance will only be the tenth part of a separate cell.

If no connection be made to an external circuit no current can flow if the cells are equal in voltage. On looking at Fig. 33, where

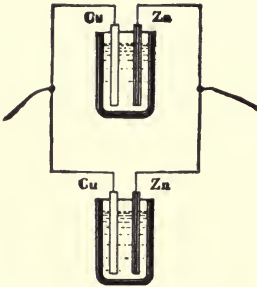

FIG. 32.—Two cells in Parallel.

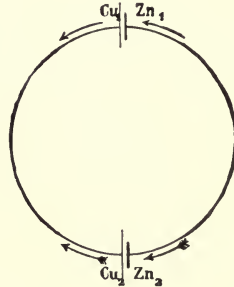

FIG. 33.—Cells in Opposition.

the arrows show the direction of the pressures in the two cells, we see that the first cell tends to send a current in the direction of the simple arrow, whilst the second cell would give a current as shown by the feathered arrow. These arrows, pointing in opposite directions, show that the E.M.F.'s of the cells are in opposition, and therefore no current can flow, just as a cart cannot be moved by two equally strong horses that are pulling in opposite directions.

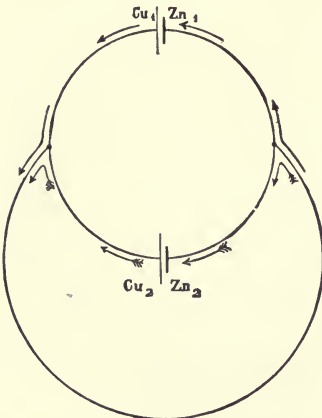

FIG. 34.—Cells jointly supplying an Outer Circuit.

Let us now connect the poles with an outer circuit; then, as shown in Fig. 34, one cell tends to send a current in the direction of the simple arrow, and the second cell in the direction of the feathered arrow, both arrows having the same direction in the outer circuit. Here the cells do not oppose, but assist each other in driving a current through the outside circuit. If each cell supplies 5 amps., then the current used in the external circuit will be 10 amps. Again, if we

have 10 equal cells in parallel, the current in any of the cells will be one-tenth part of the outer current.

When is it desirable to arrange the cells in parallel? The

answer is derived from the following considerations: If the external resistance is a great one, then a large E.M.F. is needed to produce a current of a certain strength. To secure such a pressure it is necessary to connect a number of cells in series. But in doing this we have at the same time increased the internal resistance. If, however, the external resistance is very great compared with the internal resistance, we shall gain more from the increase of voltage than we shall lose from the increase of the resistance of the battery.

If, on the other hand, the outer resistance is comparatively small, then we must diminish the internal resistance as much as possible by connecting the cells in parallel.

The strength of current given by any cell is, of course, limited. If, for example, a cell has a pressure of 1 volt and a resistance of $\frac{1}{10}\omega$, then it is impossible to get a bigger current than 10 amp., even if we short-circuit the cell by connecting its poles with a stout piece of copper wire. Usually such a short-circuit current will destroy a cell in a very brief time.

Even if we connect 100 such cells in series, we cannot get a greater current than 10 amps.; for although the E.M.F. is 100 volts, yet the internal resistance is $100 \times \frac{1}{10} = 10\omega$, giving on short-circuit a current of 10 amps.

On the other hand, if these cells are arranged in parallel and short-circuited, then the current obtainable will be $100 \times 10 = 1000$ amps. This result may be obtained at once by remembering that the resistance of the 100 branch circuits is $\frac{1}{100} \times \frac{1}{10} = \frac{1}{1000}$, and with the 1 volt available the current will be $\frac{1}{\frac{1}{1000}} = 1000$ amps.

Voltmeters

The voltage can be measured with a similar apparatus to the ammeter. Fig. 35 shows one of the electro-magnetic type. It is, of course, very important that the coil of such an instrument take as little current as possible. It accordingly consists

of many windings of a very fine wire, so that its resistance is a very high one. Although the current is very small, yet owing to its passing so often round the coil the magnetic effect may be as great



FIG. 35.—Voltmeter, Electro-magnetic Type. (*The Electrical Company.*)

as in the case of the ammeter, which is supplied with a strong current that passes round only a few times.

A hot-wire instrument may also be used as a voltmeter. But here, owing to the very small resistance of the short and fine wire, that expands when heated, it is necessary to put in series with it a resistance. This resistance consists of very many windings of fine wire. One or more of these resistance coils are placed either within



FIG. 36. —Hot-wire voltmeter (*Johnson and Phillips*).

the instrument or in separate boxes. Fig. 36 shows a hot-wire voltmeter.

The higher the voltage to be measured, the greater must the resistance in the circuit of the voltmeter be made.

Electrical Power

Let the following experiment be made: Take a spiral of German-silver wire of a certain length and a certain cross-section, and connect

it with a source of, say, 10 volts. Then, if the voltage is sufficient, the spiral will get hotter and hotter; and if the size of the wire be rightly selected, a certain temperature will be reached which will remain constant. We must, therefore, conclude that now the wire radiates as much heat to the surrounding air as is produced by the electric current.

The most common application of this principle is the electric incandescent, or glow, lamp.

In a closed glass bulb exhausted of air a carbon filament is fixed, and its ends are connected to two metallic contacts. Such a lamp is shown in Fig. 37. On arranging these contacts so that they receive an electrical pressure of a certain height, an electric current will flow through the carbon and raise it to white heat.

The most usual type of lamp has a candle-power of sixteen, and is made for a supply at 110 volts. It has a resistance of 220ω , and hence a current of $\frac{110}{220} = 0.5$ amp. will flow through it, which is just sufficient to keep the filament at white heat.

If we wish two glow lamps to give light we may connect them in series and provide a voltage of 220, when through each will pass a current of 0.5 amp., the resistance of the two filaments being 440ω .

The same result can be produced in another way. Let the two lamps be placed in parallel with 110 volts. The resulting resistance will now be 110ω , so that the total current will be $\frac{110}{110} = 1$ amp., and through each carbon will flow the necessary $\frac{1}{2}$ amp.

On comparison of these two cases we see that the same heating effect is produced with 220 volts and 0.5 amp. as with 110 volts and 1 amp. This shows that the heating effect is dependent, not only on the voltage or current, but on the product of these two quantities. This product, volts \times amperes, is defined as the *electrical power*. The unit *volt-ampere*, being rather long, is abbreviated to **watt**, after the name of the famous improver of the steam-engine.

The power of the current in the case of the lamps which we have been just considering is—

$$110 \text{ volts} \times 0.5 \text{ amp.} = 55 \text{ volt-amperes} = 55 \text{ watts.}$$

Generally we can write the equation—

$$\text{Power} = \text{Electro-motive force} \times \text{Current strength};$$

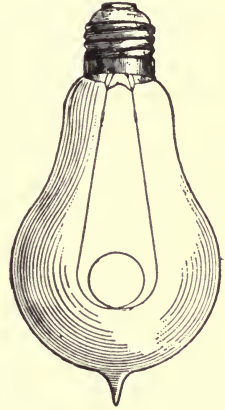

FIG. 37.—Incandescent or Glow Lamp.

or, in symbols,—

$$P = E \times C$$

If it so happens that the voltage and the resistance only be known, then it is easy to find the power by the aid of the preceding rule, first finding the current from—

$$C = \frac{E}{R}$$

hence—

$$P = E \times C = E \times \frac{E}{R}$$

Or, if the voltage and resistance be given to find the power, we must multiply the number of volts by itself, and divide the product by the number of ohms.

To take the case of the glow lamp above, to find the power from the voltage of 110 and the resistance of 220 we should have—

$$P = 110 \times 110 \div 220 = 55 \text{ watts,}$$

the same result as before.

Again, if the current and resistance be given, we can calculate the power from the third form of Ohm's Law—

$$E = C \times R$$

By substituting this value of the E.M.F. in—

$$P = E \times C$$

we get—

$$P = C \times R \times C$$

or—

$$P = C \times C \times R$$

that is, we find the number of watts by multiplying the number of amperes by itself, and then by the ohms.

Thus, for the case of the glow lamp, we have—

$$0.5 \times 0.5 \times 220 = 55 \text{ watts,}$$

—this being the same result as we previously obtained, proving that the three methods are equivalent.

For the value $C \times C$ the abbreviation C^2 (C squared or C raised to the second power) is generally used. The exact meaning of this will be understood from the following considerations:—

If we have to determine the area of a square we can do so by dividing its sides into equal parts, each of which is, say, 1 inch long; then, by drawing lines through these marks horizontally and

vertically the whole area of the square will be split up into a number of smaller squares, each having an area of 1 sq. inch. By counting the number of these we find that a square whose sides are 2 inches long has an area of $2 \times 2 = 4$ sq. inches, whilst one of 3-inch side has an area $3 \times 3 = 9$ (see Fig. 38). To multiply a number by itself is thus the same as to determine the area of a square whose side length is equal to this number. The three formulæ given above may therefore be written—

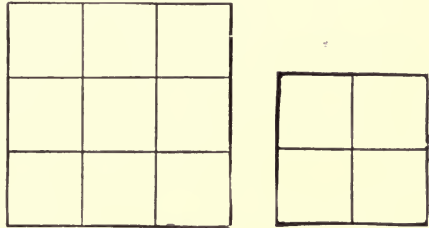

FIG. 38.

$$P = EC \quad (1)$$

$$P = \frac{E^2}{R} \quad (2)$$

$$P = C^2R \quad (3)$$

The fact that the power depends both on the voltage and on the current strength may be understood by reference to the hydraulic analogy. The effect of flowing water depends, not only on the pressure or water-driving force produced by a difference of levels, but also on the quantity of water per second, which corresponds to the strength of the electric current. A pound of water flowing down a height of 10 feet will be able to do ten times the amount of work—such as driving a water-wheel—as a pound of water flowing down a height of one foot only. The effect of flowing water is thus proportional to the product of the number of pounds of water and number of feet. This product is called foot-pounds. The power of a waterfall is estimated by the number of foot-pounds per minute or second.

Equivalence of Electrical Mechanical and Heating Effects

Heat can be produced both electrically and mechanically. A vessel containing water may be heated by placing in it an insulated spiral of wire which is connected with a current generator. Heating of water may also be caused by dropping from a height a stone into it; or a better example for our purpose would be the case of sand flowing continuously into water. In this case there will be a gradual

heating of the water, just as in the case of an electric current. After some time the temperature of the water will cease to rise, showing that the heat produced by the flowing sand is now equal to the heat radiated to the surrounding bodies, such as the vessel, air, etc.

Seeing that both by mechanical and electrical means heat may be produced, the question may be asked: How many mechanical units correspond to the electric unit, or 1 watt? This question may be answered by the help of the following experiment. Take two equal vessels containing equal quantities of water, and let one be heated electrically, and the other mechanically by the use of falling sand, so that the amount of heat passing in is the same in the two cases as shown by a thermometer. Let the voltage and current, and the rate at which the sand falls from a known height, be noted. By means of these values, and experiments of a similar kind, it has been found that—

$$\text{One foot-pound per second} = 1.356 \text{ watts.}$$

We shall, in subsequent pages, deal with machines which enable us to convert mechanical into electrical power. We may, for example, have an electrical machine driven by a water-wheel or a turbine; then, if we know the height of the fall and the amount of water per second, the electrical power can be estimated. If, for instance, 1000 lbs. of water falls down a height of 5 feet each second, then the mechanical value of this will be 5000 ft.-lbs. per second. If it were possible to convert all the mechanical into electrical power, or, in other words, if there were no losses, then the number of watts produced would be—

$$\frac{5000}{1.356} = 3687 \text{ watts.}$$

As a matter of fact the number of watts would be considerably smaller than this.

Being given the number of 3687 watts, we can calculate the number of 16-candle-power lamps that could be lighted. If each lamp required 55 watts, then the number would be $\frac{3687}{55} \approx 67$ nearly.

It is not the general custom with engineers to state the output of a machine, such as a turbine, or steam or gas engine, in foot-pounds per second, because of the large numbers that would have to be used. Instead, a much greater unit called the **horse-power** (abbreviated H.P.) is used. A horse-power is defined as that rate of doing work that is equal to raising 33,000 lbs. 1 foot high in 1 minute. This is equal to an effort of $\frac{33,000}{60} = 550$ ft.-lbs. a second. This unit was introduced by James Watt, and has since been used by British engineers in stating the power of engines. It is supposed to

represent the power of a very strong horse when working very hard. The equivalent electrical power is—

$$550 \times 1.356 = 746 \text{ watts nearly.}$$

If we know what is the output of any machine given in H.P., then we can, if it is coupled to an electrical generator, calculate the electrical output, providing that no losses be taken into account. Thus a steam-engine of 1 H.P. would drive a dynamo giving an output of 746 watts. The real electric output due to losses of friction, etc., is, of course, less than this, and generally varies between 700 to 600 watts per H.P., according to the size of the machines. For small machines it comes down to 500 watts. These numbers correspond with from 9 to 13 lamps per H.P., if 55-watt lamps be used.

A small dynamo, for example, driven by a 5-H.P. steam-engine, could feed about $5 \times 10 = 50$ lamps; whilst a large one of about 200 H.P. would supply $200 \times 13 = 2600$ lamps each of 16-candle-power. On the other hand, if this 200-H.P. engine had been used for driving a pump that was perfectly efficient, then it would lift $200 \times 550 = 110,000$ lbs. of water per second, a height of 1 foot.

The relation that exists between the electric and heating effects must now be studied. First, the unit of the quantity of heat must be defined. This unit is called the **calorie**; it is equal to the quantity of heat which is necessary to raise 1 grm. of water from zero to 1° on the Centigrade scale. Hence, to raise 1 kg. of water from zero to boiling-point (100° C.) will require $1000 \times 100 = 100,000$ calories.

The relation between the two effects can be determined by the following experiment: A vessel containing a known quantity of water is heated by means of an insulated wire through which a current is flowing, and the temperature ascertained by means of a thermometer before the current has been passed, and also after it has been flowing for a known number of seconds. At the same time the voltage and the current are noted. The quantity of heat, and the watts, and time are thence known. The result is, that 1 calorie corresponds to 4.2 watts per second; or the heat equivalent of 1 watt-second [1 watt-second is called a "joule"] is—

$$\frac{1}{4.2} = 0.24 \text{ calories approximately.}$$

We can now readily calculate the quantity of heat produced by a 16-candle-power glow lamp in one hour. Since in one second 55 watt-seconds are used, then in one hour the number will be $55 \times 60 \times 60 = 198,000$, so that the number of calories will be $198,000 \times 0.24 = 47,520$.

On flowing through the carbon filament the current causes

a temperature which rises until a bright white heat is reached. After this the temperature remains constant, because the heat is radiated as fast as it is produced by the current; or, in other words, a *stationary state* is reached.

Let us next ascertain what will happen if we connect this lamp with a voltage of 150 instead of 110. If we may make the supposition that the resistance of the lamp remains the same as before, the current now will be—

$$\frac{150}{220} = 0.68 \text{ amps.},$$

and its watts now become

$$150 \times 0.68 = 102 \text{ watts.}$$

The watts being nearly twice as great as previously, a double quantity of heat will be produced per second, and the carbon will reach a far higher temperature than before, and will give out more light. This, however, will not last for a long time, because the effect of the high temperature soon causes the filament to be broken. The "life" of such a lamp will thus be far shorter than when the voltage is normal.

Again, if we connect a 110-volt lamp with a voltage of 220 volts, then the power required is four times as great as before, for—

$$P = \frac{E^2}{R} = \frac{220^2}{220} = 220 \text{ watts.}$$

In this last case the heat produced is such as to ruin the filament immediately on switching the lamp into the circuit.

As a matter of fact the power taken by the filament in the two cases of 150 and 220 volts is far higher than our calculations indicate, because the resistance of carbon decreases—contrary to the case with metals—with a rise of temperature.

Electric Mains

To lead the electric current from the place of generation to the place where it is used we require leads or mains. Generally we want two mains, one leading in and one out, just as we must have two channels, to lead water to a water-wheel and to lead it away (see Fig. 39).

The first channel connects our water-wheel with the higher, the other channel connects it with the lower level. In a like manner the mains serve to connect the electric apparatus with the positive and negative poles of the current-generator.

The water-channels, which are generally made from earthenware or wood, always cause a loss of motive force. If the channel is not tight enough, some of the water will leak through the cracks. This part of the water will not reach the water-wheel at all, thus involving a direct loss of water. Further, a part of the whole pressure gets wasted in flowing through the channels; this loss is represented in Fig. 39 by the line h_1 for the upper channel, and by the line h_2 for the lower channel. Thus, the total height difference of water available for driving the water-wheel is not H , but H diminished by $h_1 + h_2$. Thus the heights h_1 and h_2 represent *pressure losses*.

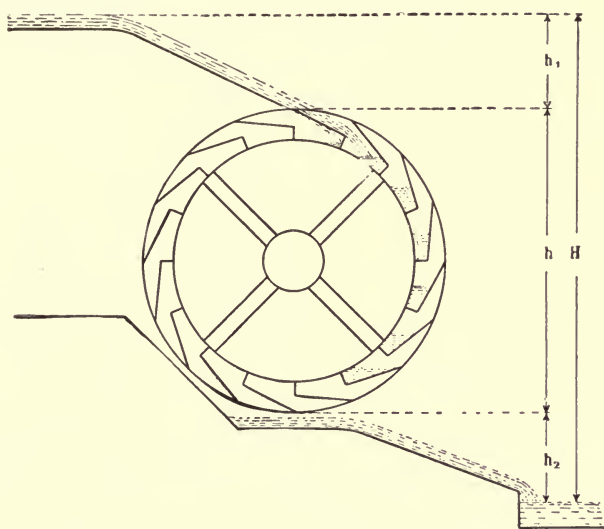

FIG. 39.

In like manner, we have with electric mains losses of current and losses of voltage or potential drop. The former occur with badly installed mains only. If, for instance, mains leading from a central electric station to a group of lamps are in several places in connection with the earth or with damp walls, then the current will not only flow through the lamps, but a part of it will also flow from the positive wire to the earth, and from the latter to the negative wire, without going through the lamps. The current lost in such a way will be greater the better is the connection of each of the mains with the earth, and the nearer the bad points of the positive main are to the bad points of the negative main. If these be very near each other, then the resistance of the earth

between them will be very small, and a comparatively large current will leak away.

To avoid such losses, and the risks connected therewith, mains have to be very well insulated.

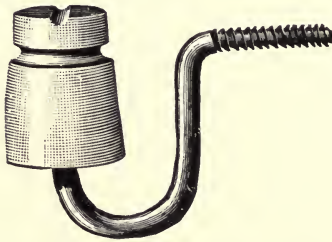

FIG. 40.—Porcelain Insulator
(General Electric Co.).

Mains are provided with a continuous insulating covering, or they may be left bare, but in this case they have to be fixed on bell-shaped insulators, as shown in Fig. 40. They are made of porcelain or glass in the shape of a bell, and fastened by means of insulating cement to an iron bracket. The latter is fixed on a mast or to a wall. The conductor is secured by wire to the groove of the insulator. Porcelain and glass are excellent insulating materials, and the wires fixed to the insulators are therefore entirely insulated from

the iron bracket. Owing to the special shape of the insulator even raindrops cannot make an electric connection, because the bell-shaped part is usually fixed in a vertical position. For extra high pressures—such as, for instance, 5000 or 10,000 volts, an insulator of the shape described would not be safe enough. In such cases double or triple bells are employed, as shown in Fig. 41.



FIG. 41.—High-tension Insulator.

This method of running mains is often used for overhead or aerial lines. In fixing such lines, care must be taken to avoid contact

of the wires with each other, and with other bodies. They must not be placed near trees, because the branches and leaves might then touch the wires, thus forming in damp weather a good connection with the earth.

The mains installed in the streets of large towns, or within houses, consist of insulated wires only. The method of insulation of these mains depends, on one hand, on the voltage of the current which they conduct, and, on the other hand, on the position in which they are fixed. Mains for low voltages, installed in dry rooms, may be covered with a thin layer of insulation only. In such a case it would, for instance, be sufficient to cover the wires with a thin winding of cotton or hemp, and to impregnate this winding with tar or asphalt. For high voltages and damp rooms, the wires must be covered with india-rubber, and several layers of cotton or hemp.

Cables laid in the earth or channels are exposed both to the influence of moisture and acids, and are liable to mechanical injuries. They have, therefore, to be protected in addition to the different insulation layers with a lead covering, which is further covered with an insulating layer. Protection against mechanical injuries is frequently guarded against by an iron or steel armouring, which latter may be protected against corrosion by a cotton or hemp network impregnated with bitumen.

Fig. 42 shows a cross-section through a cable, containing both the positive and the negative wire. The circles in the centre represent one main surrounded by an insulating layer. The second main consists of a number of thin copper wires arranged in a circle. Next to these wires is an insulation-layer, then a lead covering, and, finally, an outer casing. As the inner and outer wires form circles with the same centre, the cable is called a **concentric one**. Cables are also manufactured in which the single insulated wires are stranded with each other.

Exact specifications relating to the insulation and laying of cables may be found in the Board of Trade Regulations, the Rules of the Institution of Electrical Engineers, and those of Fire Insurance Companies.

The losses of current can be avoided by proper installation of the mains. Losses of voltage cannot be avoided, because the mains have

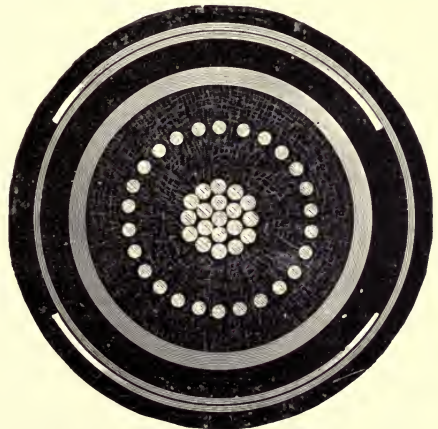

FIG. 42.—Section of Concentric Cable
(Siemens and Halske).

in any case a resistance, and thus a voltage drop must occur in them, which may be determined by Ohm's Law.

Let us now work out the following example: The distance between a current generator and a room which is lighted by 20 lamps, each of 16-candle-power, and connected with 110 volts, is 80 yards, and the cross-sectional area of the wire is 0.04 sq. inch. What is the voltage drop in the main, if all lamps are burning simultaneously?

Since we have to consider both the positive and the negative main, the total length of wire employed will be 160 yds. As is generally the case for mains, the wire consists of copper, whose specific resistance is $\frac{1}{40,000}$ ohms per yard per sq. inch; the total resistance of the mains is thus—

$$R = \frac{1}{40,000} \times \frac{160}{0.04} = 0.1\omega.$$

The current required for feeding 20 16-candle-power lamps is $20 \times \frac{1}{2} = 10$ amps.

Thus the voltage drop in this main—which may be called e , to distinguish it from E —will be—

$$e = R \times C = 0.1 \times 10 = 1$$

To get the proper voltage of 110 at the lamps, we want in the central station, say, 111 volts. The voltage drop in the main is thus not quite 1 per cent., which may be allowed in any case. Even if the pressure in the central station be only 110 volts, and the lamps therefore burn with 109 instead of 110 volts, this would not be any disadvantage, as the diminution of the light is not serious as long as the voltage falls 2 or 3 per cent. only.

The power lost in the main is 1 volt \times 10 amps. = 10 watts; or, using the formula—

$$P = C^2 \times R = 10 \times 10 \times \frac{1}{10} = 10 \text{ watts.}$$

The total power given to the lamps is—

$$EC = 110 \times 10 = 1100 \text{ watts.}$$

Let us now assume that we have to transmit through a main of equal cross-sectional area the same current a distance of 800 yards (total length of the wire = 1600). Then the resistance of the wire will be ten times as large as in the above example, viz. 1ω ; the voltage drop in the main will be 10, the power loss 100 watts.

These losses are comparatively very great. If in the central station a voltage of 110 be maintained, then the lamps at the end of the main would burn with 100 volts only, and would emit far less light than they would do if connected with their proper voltage; further, the loss in the main of 100 watts, that is more than 9 per cent. of the total output, is a very high one.

We may hence lessen the voltage and the power loss by diminishing the resistance of the main, *i.e.* by enlarging the cross-sectional area of the copper wire.

If we, for instance, quadruple the cross-sectional area of the copper wire, then its resistance becomes the fourth part only:—

$$R = \frac{1}{4} \times \frac{1}{0.16} = 0.25\omega$$

and then the voltage drop becomes one-fourth as well—

$$e = RC = 0.25 \times 10 = 2.5 \text{ volts.}$$

The power lost in the main will thus be—

$$P = C^2R = 25 \text{ watts.}$$

These values of voltage drop and power lost are allowable in practice, but, as we have seen from the example, we get these permissible losses only by employing wires having large cross-sectional areas. If the distance were still longer than 800 yards we must employ wires of still greater areas, and so the network of lines would become exceedingly costly.

We have, however, other means of reducing the losses due to voltage drop. Suppose we double the voltage in the central station, and connect the lamps in ten parallel groups, each of these groups consisting of two series connected lamps (see Fig. 43).

The resistance of each of these groups is $2 \times 220 = 440\omega$, and thus the current taken by each of the groups, if connected with 220 volts, would be $\frac{220}{440} = 0.5$ amp., *i.e.* the same as taken by a single lamp before. The 10 groups together require thus a current of $10 \times 0.5 = 5$ amps.

The power taken by the 20 lamps is obviously now the same as before. It was 110 volts \times 10 amps. = 1100 watts in our first example, and is $220 \times 5 = 1100$ watts in this one.

For the mains we employ the same wires as in the first example, with a cross-sectional area of 0.04 sq. inches. The voltage drop in this main, having a resistance of 1ω , is 5 volts at the current of 5 amps. These 5 volts are 2.3 per cent. of the voltage of 220 volts, thus being a permissible loss. The power lost in the mains is $5^2 \times 1 = 25$, *i.e.* again 2.3 per cent. of the total load. By doubling the voltage we obtain, thus, the same result as by quadrupling the area of the cross-section.

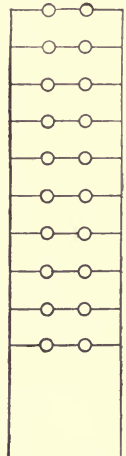

FIG. 43. — Lamps in Series and Parallel.

This reasoning explains why high voltages are employed whenever electrical energy is to be transmitted long distances. A pressure of 110 to 150 volts is generally used for current supplied to a single building only or to several buildings situated near each other. For providing small districts with electrical energy a pressure of 200 to 250, and for larger districts 400 to 500 volts is employed. But even these voltages are not sufficiently high for mains spread over large towns and districts. To get, in the latter cases, allowable losses, and yet not have too large a size of mains, voltages of 1,000, 2,000, 5,000, 10,000 and up to 80,000 are employed. In laying cables for such high voltages special care has to be taken to have good insulation. The direct connection with a high-tension line, or even through any substance which is not insulated perfectly from the line, may have a fatal effect.

At the end of this chapter a table is given, showing the approximate diameters and sectional areas of the wires and cables mostly employed in practice. Their resistance in ohms per 100 yards is also given. By means of this table we can calculate the sectional area of a main, if its length and the current be given, and the voltage drop has not to exceed a certain amount. This problem has to be solved frequently by electrical engineers.

If the dimensions of all lines are not determined before laying them, then it very often happens that the voltage drop is too large, and the lamps give a poor light.

Further examples of installation calculations will now be given.

EXAMPLES.

1. A group of ten 16-candle-power 110-volt lamps is to be fed by means of a cable whose single length is 100 yards: the voltage drop is not to exceed about 2 volts. What wire should be employed?

The current taken by the 10 lamps is 5 amps. The voltage drop in the line is $e = C \times R$. Hence, since the current $C = 5$ amps. and the voltage drop $e = 2$ volts, the resistance R of the line must be $\frac{2}{5} = 0.4\omega$, or less if a smaller voltage drop is taken. The length of the lead and return is 200 yards, thus the resistance per 100 yards of the wire to be employed must not exceed $0.4 \times \frac{100}{200} = 0.2\omega$.

As we see from our table, a cable of 7/18 S.W.G. has a resistance of 0.185ω per 100 yards. This cable is nearest to the one we want, whereas the resistance of the next smaller wire, 7/20, is 0.329ω , and therefore far too high. We shall prefer to employ a cable of 7/18 S.W.G. A glance at the table shows that the maximum current allowed for this cable is 21 amps., giving a considerable margin above the 5 amps. required for the lamps.

2. A current of 30 amps. at a voltage of 250 is to be conducted as far as 300 yards. The maximum voltage drop allowed is 3 per cent. of the total voltage, *i.e.* 7.5 volts. Then the resistance of the line may be $\frac{7.5}{30} = 0.25\omega$. The total length of the cable is $2 \times 300 = 600$ yards, the resistance allowable for 100 yards is thus $0.25 \times \frac{100}{600} = 0.0416$. As we learn from the table, a cable of 19/16 S.W.G. has to be employed in this case.

3. A current of 30 amps. is to be conducted 50 yards. The voltage drop allowed is 6 volts. Then the resistance allowed for the total length of wire, viz. 100 yards, is $\frac{6}{30} = 0.2\omega$. From the table we learn that 100 yards of a cable of 7/18 S.W.G. has a resistance of 0.185ω only. This cable would therefore be sufficiently thick with regard to the voltage drop. *Notwithstanding, we must not use this cable, because the maximum current allowed for it is only 21 amps.* We must therefore take the nearest cable for which a current of 30 amps. is allowable, i.e. 19/20 S.W.G.

Up to now we have considered in our calculations the voltage drop and the power loss only. But another very important point, viz. the heating of the line, must not be neglected. If we allowed for a short, fine wire a loss equal to that in a long, thick wire, then the former would be far more heated than the latter. To avoid excessive heating of a line, the current strength of any cable has not to exceed that value which is marked in our table as "Maximum Current Allowable," and which has been fixed by the Institution of Electrical Engineers. These maximum currents have been selected so that the rise of temperature in the cables will be about 20° Fahr. above the surroundings.

From a glance at the table, it will be noticed that for a sectional area of 0.0019 sq. inch the maximum current is 4.4 amps., whereas for a sectional area of 0.0198 not a current of 44, but only of 30 amps., is allowed. For 0.19 sq. inch a current of 190 amps. is allowed, instead of 440, as one should expect. One would imagine that a cable of tenfold sectional area could also safely carry the tenfold current; but, as a matter of fact, that is not so. The temperature which a wire attains depends on the rate at which it can radiate the heat produced in it to the surrounding bodies. To explain this fact, let us consider a piece of copper wire, having a sectional area of 0.0019 sq. inch, which is situated in the centre of a thick wire with a sectional area of 0.019 sq. inch. Suppose, now, that we send a current of 44 amps. through the thick wire; then, in the centre-piece of 0.0019 sq. inch sectional area obviously an equal quantity of heat will be produced as in the thin wire, having 0.0019 sq. inch cross-sectional area. But the heat produced in the centre of the thick wire cannot be led away as quickly as with the thin wire, because it has to go through the whole thickness before arriving at the surface. Thus a wire of 0.019 sq. inch sectional area carrying 44 amps. would get much hotter than a wire of 0.0019 sq. inch area carrying 4.4 amps. A wire with 0.19 sq. inch area, carrying 440 amps., would get so hot that the insulation would be burnt away after a short time.

To prevent an excessive load on a wire, and thus its dangerous heating, a fuse, or *cut-out*, is inserted in the main, the whole of the current therefore flowing through it, but its cross-sectional area is smaller than that of the line wire. It consists of an easily fusible metal, such as lead, tin, or alloys of them, and sometimes of silver and copper.

With the normal current, with which the beatings of the mains is hardly appreciable, the fuse, having a sectional area of the right size, should be little more than the temperature of the hand. If the current doubles in strength, then the heating of the fuse wire should be such as to cause it to melt. By this means the main current is broken, and no further heating can occur.

The double current does not involve any danger for the mains, for, as mentioned above, the heat produced by the maximum allowable current does not raise the temperature of the wire more than 20° Fahr. The heat now produced by the double current will be a four-fold one, the rise of temperature in the wire will thus not exceed 80° Fahr. Assuming a room temperature of 85° Fahr., the temperature of the main would come to about 165° Fahr. All kinds of insulating materials used for mains can stand this temperature, but a higher one would be dangerous.

Fuses hence furnish an excellent means of preventing dangers arising from electric mains. It is, of course, necessary to design fuses so that they cannot give rise to any dangers themselves by melting. They must be fixed on an incombustible base—for instance, marble or slate; and means have to be provided to prevent melted metal from falling on inflammable bodies. Figs. 44 and 45 show

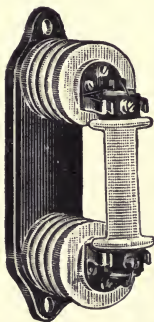

FIG. 44.—Fuse or Cut-out
(British Schuckert Co.).

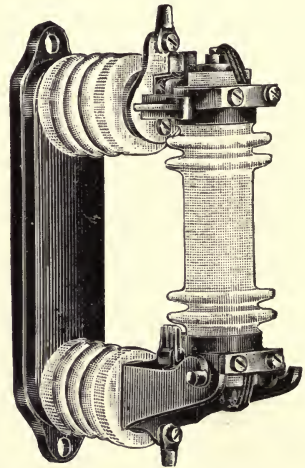

FIG. 45.—Fuse or Cut-out for Large
Current (British Schuckert Co.).

two designs of fuses, or cut-outs, in which the fusible wire is within a porcelain handle, enabling the cut-out to be also used as a switch. In Fig. 44 the handle is intended to be removed directly, but in Fig. 45 it may be hinged back.

Fig. 46 shows a form of fuse used extensively in America. It consists of a stout tube of fibre capped at the ends with brass. In this tube is the fuse, made of copper or lead-antimony alloy, packed about solidly with some fire-proof powder like lime or clay, thus excluding all air. The ends of the fuse wire are fastened to the blade terminals of the fuse which project inside for this purpose. When this fuse blows there is no sound whatever and no spark. An ordinary fuse wire when it melts in the open air makes a loud noise and a bad spark, particularly when inserted in a circuit of 500 volts. The result is that surrounding parts of apparatus, such



FIG. 46.—Enclosed Fuse.

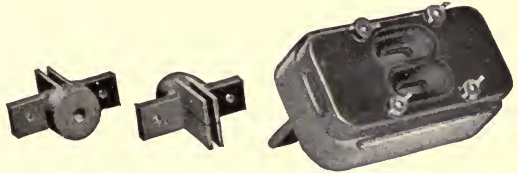

FIG. 47.—2300-volt Expulsion Fuse-block.

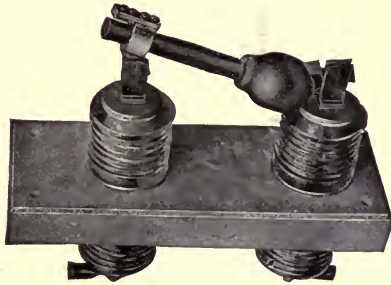

FIG. 48.—2360-volt Expulsion-tube Fuse-block.

as switchboards, terminal blocks, etc., are burned and injured in appearance. In addition, actual injury can occur to individuals if they should happen to be near at the time of the melting. Sparks may fly about also and cause an actual fire. Thus the "enclosed fuse" has a very wide use, and on circuits up to 750 volts and currents up to 400 amperes is a most satisfactory device to use.

Figs. 47 and 48 show two important types of fuse-block suitable for higher voltages, up to 5000 volts. Here the fuse is in an enclosed chamber as before, but it is not packed with any material. Instead an opening is purposely left to the open air, but so placed that the spark resulting from the interruption of the circuit from the melting of the fuse is directed in a proper and safe direction. The principle of this fuse-block is that the gases from the melted fuse, being

produced suddenly, "snuff out" the arc, the vapors shooting out of the opening at the same time. The tube type is the more effective. For higher currents and voltages, a device called a *circuit-breaker* is used in America. Fig. 49 shows one of them built for 600 volts and 300 amperes. The current is finally broken at the carbon points shown at the top of the figure. Carbon has the ability of standing, without particular injury, great heat. When the current is broken the flash and the arc resulting are at a great temperature. Copper is badly injured thereby, sometimes melting in drops. The current

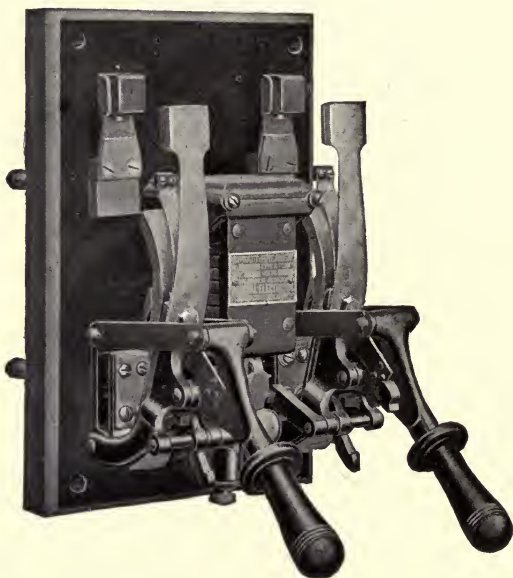

FIG. 49.—C. P. Circuit-breaker.

therefore is carried by the lower contacts in the figure, but the breaking is done at the carbon contacts, the copper and carbon being in multiple, but the carbon leaving last. A coil as shown in the figure acts as an electro-magnet. If the current gets excessive or above a certain desired point, the magnet pulls a piece of iron called a keeper, placed in front of it, which "trips" the breaker just as a rat-trap is tripped.

Fig. 50 shows another form of circuit-breaker capable of breaking 10,000 amperes at 750 volts without being injured in the slightest. The principle upon which this breaker acts is different from the other. Here, in addition to the magnet which trips the breaker when the current gets strong enough, there is another which is short-circuited

by brushes when the breaker is closed and carrying current. When the breaker trips these brushes leave their contact before the con-

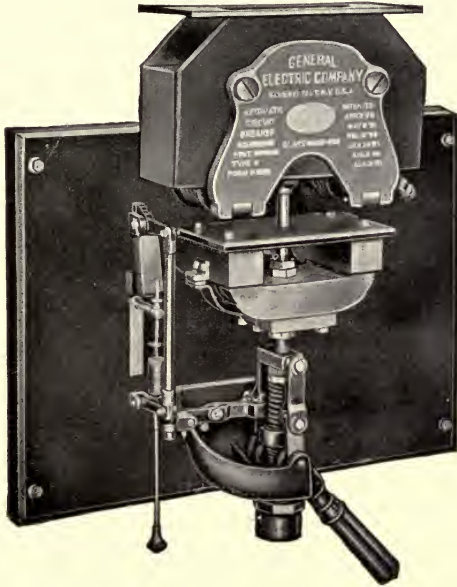

FIG. 50.—K Breaker, Large Current.

tacts which open the circuit leave. In so doing they therefore throw the current into the magnet which they short-circuited. The magnet is placed so that its field or lines of force pass across the contact at which the final break of current occurs. The result is that the arc resulting from the break is "blown out" by the magnetism and directed up a chute as shown in the figure, thus doing no harm. This blowing out of the arc is based upon Ampère's rule; the current in the arc, or the arc itself, being deflected up by the magnetism.

This same principle of blowing out arcs by magnetism is used in controllers, rheostats, etc.

A properly erected electric plant, which is always kept in order, can hardly ever cause any danger of fire. The fuses do not only prevent a permanent overload of a main and the excessive heating connected with it, but they also act momentarily when a short circuit takes place. If, for example, by any accident the positive and negative wires be connected by a bare metal rod, the resistance of the main becomes so small that a very great current, far exceeding double the normal current, flows through the line, causing the fuses to melt at once, and so preventing dangerous heating.

It is a different matter with badly installed plants or such as are not kept in order. If, for instance, due to a leakage to earth, the current flowing through the main is greater than that taken by the lamps, then a frequent melting of the fuses will, of course, happen. If, now, the person in charge of the plant or a thoughtless wireman puts thick metal strips instead of those of normal size into the fuses, then they will no longer melt. This is just as if any one tied down a safety-valve of a boiler so that it could not work when the pressure is excessive. The safety-valve will then no longer be of any use, and the boiler may burst. A similar thing may happen with electric mains when thin fuses are replaced by some of too great sectional area. The danger is especially great when increasing earth-currents are no longer indicated by the melting of cut-outs. Eventually the insulation may become so defective, and the earth-currents so strong, that the mains may themselves actually melt.

It is not absolutely inadmissible to replace thin fuse-wires by thicker ones. It may happen sometimes that the plant has been but little loaded originally, and therefore thin fuse-wires have been used, whereas the mains would have been able to carry a greater load. If, then, another number of lamps be connected with the mains, the replacement of the thinner fuse-wire by a thicker one is, of course, allowable. But the maximum thickness of the fuse-wire should always be limited by the fuse-current, which is given in the table for the copper wires of different cross-sectional area (see Table on next page). Thus the fuse-current of a wire, employed for a cable of No. 15 S.W.G., for instance, should never exceed 16.4 amps.

What current is necessary to melt a particular piece of tin or alloy used as a fuse-wire is best obtained by experiment, and should be noted on a label attached to the bobbin of wire.

The circuit-breaker being designed to care for large currents is used naturally in power stations and on switchboards where the energy is great. They are used in America on motor installations due to the ease of reclosing the circuit if it opens, which is accomplished by merely closing the circuit-breaker handle. Fuses are used usually on house circuit. The most used form for this purpose is shown in Fig. 51, which consists of a

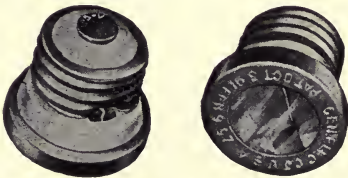

FIG. 51.—Plug Fuse.

plug just like a lamp-socket in an enclosure of which is located the fuse. Since they cost so little, they are thrown away, plug and all, after blowing, being replaced by a new one; thus no handling of the fuse proper is necessary.

TABLE OF SIZES, RESISTANCES, AND MAXIMUM CURRENTS OF COPPER WIRES AND CABLES.

Size S.W.G.	Cross-sectional area in		Approximate diameter in		Resistance per 100 yards in ohms.	Maximum current allowable.	Fusing current.
	Square inches.		Inches.				
	Sq. millimetres.		Millimetres.				
18	0.0018	1.167	0.048	1.22	1.31	4.2	12.0
3/22	0.0019	1.216	0.059	1.50	1.265	4.4	12.0
17	0.0024	1.590	0.056	1.42	0.961	5.4	12.0
3/20	0.0030	1.970	0.073	1.85	0.765	6.6	13.2
16	0.0032	2.075	0.064	1.62	0.736	6.8	13.0
15	0.0040	2.627	0.072	1.83	0.581	8.2	16.4
7/22	0.0044	2.808	0.084	2.13	0.538	8.7	17.4
14	0.0050	3.243	0.080	2.03	0.471	9.8	19.6
3/18	0.0054	3.502	0.093	2.36	0.430	11.0	22.0
7/20	0.0072	4.65	0.108	2.74	0.329	13.0	26.0
7/18	0.0128	8.26	0.144	3.66	0.185	21.0	42.0
19/20	0.0198	12.77	0.180	4.57	0.1196	30.0	60.0
7/16	0.0229	14.77	0.192	4.88	0.1039	34.0	68.0
19/18	0.0349	22.6	0.240	6.10	0.0679	48.0	96.0
7/14	0.0356	22.98	0.240	6.10	0.0665	49.0	98.0
19/16	0.0624	40.2	0.320	8.12	0.0379	77.0	154.0
19/14	0.0973	62.7	0.400	10.1	0.0243	110.0	220.0
37/16	0.1219	78.6	0.448	11.3	0.0194	130.0	260.0
19/12	0.1647	106.3	0.520	13.2	0.0144	170.0	340.0
37/14	0.1909	123.2	0.560	14.2	0.0125	190.0	380.0
61/15	0.2551	164.5	0.648	16.4	0.0092	240.0	480.0
61/14	0.3149	203.1	0.720	18.3	0.0076	290.0	580.0
37/12	0.3217	207.7	0.728	18.4	0.0073	300.0	600.0

DATA ON COPPER WIRE.

Diameter Mils Bare.	Nearest Gauge No.		Area Cross-section.		Diameter Mils Cotton-covered.			Per 1000 Feet.		
	B. & S.	B. W. G.	C. M.	Sq. Mils.	Single.	Double.	Triple.	Lbs. (Bare).	Ohms.	
									25° C.	65° C.
460	0000		212000	166000				641	.0503	.0584
410	000		168000	132000				509	.0633	.0735
365	00		133000	105000				403	.0800	.0928
325	0		106000	83000		339	343	320	.101	.117
289	1		83500	65600		303	307	253	.127	.147
258	2		66600	52300		272	276	202	.160	.185
229	3		52400	41200		242	247	159	.204	.235
223	4	5	48400	38000	211	233	238	147	.220	.255
204	4		41600	32700		216	220	126	.256	.297
182	5		33100	26000	189	194	198	100	.321	.373
180	5	7	32400	25400	187	192	196	98.2	.329	.381
165	5	8	27200	21400	172	177	181	82.4	.391	.454
162	6		26200	20600	169	174	178	79.5	.406	.472
148	6	9	21900	17200	155	160	164	66.4	.486	.563
144	7		20700	16300	151	156	160	62.8	.514	.596
134	8	10	18000	14100	141	146	150	54.5	.593	.688
129	8		16600	13100	136	141	145	50.4	.640	.743
120	8	11	14400	11300	127	132	136	43.6	.739	.858
114	9		13000	10200	121	126	130	39.4	.819	.951
109	9	12	11900	9350	115	119	123	36.0	.895	1.04
102	10		10400	8180	108	112	116	31.5	1.02	1.19
95	11	13	9030	7100	101	105	109	27.4	1.18	1.37
91	11		8280	6500	97	101	105	25.1	1.29	1.49
83	12	14	6890	5410	89	93	97	20.9	1.54	1.79
81	12		6560	5160	87	91	95	19.9	1.62	1.88
72	13	15	5180	4080	78	82	86	15.7	2.05	2.38
65	13	16	4230	3320	71	75	79	12.8	2.52	2.92

DATA ON COPPER WIRE (Continued).

Diameter Mils Bare.	Nearest Gauge No.		Area Cross-section.		Diameter Mils Cotton-covered.			Per 1000 Feet.		
	B & S.	B. W. G.	C. M.	Sq. Mils.	Single.	Double.	Triple.	Lbs. (Bare).	Ohms.	
									25° C.	65° C.
64	14		4100	3220	70	74	78	12.4	2.60	3.01
58		17	3360	2640	64	68	72	10.2	3.17	3.68
57	15		3250	2550	63	67	71	9.85	3.28	3.80
51	16		2600	2040	56	59	63	7.88	4.09	4.74
49		18	2400	1890	54	57	61	7.27	4.43	5.15
45	17		2030	1590	50	53	57	6.14	5.26	6.10
42		19	1760	1390	47	50	54	5.35	6.04	7.01
40	18		1600	1260	45	48	52	4.85	6.65	7.72
36	19		1300	1020	40	44	48	3.93	8.21	9.52
35		20	1230	963	39	43	47	3.71	8.67	10.1
32	20	21	1020	806	36	40	44	3.10	10.4	12.1
28.5	21		812	638	32.5	36.5	40.5	2.46	13.1	15.2
25.5	22		650	511	29.5	33.5	37.5	1.97	16.3	18.9
23	23		529	416	27	31	35	1.60	20.1	23.3
20	24		400	314	24	23	32	1.21	26.6	30.9
18	25	26	324	254	22	26		.982	32.9	38.1
16	26	27	256	201	20	24		.776	41.6	48.3
14		28	196	154	18	22		.594	54.3	63.0
12.6	28		159	125	16.6	20.6		.481	67.0	77.7
11	29		121	95.1	15	19		.367	88.0	102
10	30	31	100	78.5	14	18		.303	106	123
9	31	32	81	63.7	13	17		.245	131	152
8	32	33	64	50.3	12	16		.194	166	193
7	33	34	49	38.5	11	15		.149	217	253
6.3	34		39.7	31.2	10.3	14.3		.120	268	311
5.6	35		31.4	24.7	9.6	13.6		.0952	339	399
5	36	35	25	19.6	8.5	12		.0758	426	494

CHAPTER II

MAGNETS—MAGNETIC LINES OF FORCE

Influence of a Magnet on an Electric Current— Deprez Instruments

We have learned that a freely movable magnetic needle is deflected by a current flowing through a fixed conductor. If we make the magnet stationary and the conductor movable, we shall find that the latter will move when a current is passed through it. This can be well observed with the instrument shown in Fig. 52. A strong magnetic field is produced by the horseshoe magnet which is provided with soft iron pole-pieces. Within these is a fixed iron cylinder. By the action of the poles of the magnet the cylinder also becomes a magnet, with a north pole, *n*, and a south pole, *s*. In the air gap between the magnet poles and the cylinder a coil, consisting of very fine wire, is arranged so as to be easily movable. The ends of this coil are connected by means of very fine spiral springs with the two terminals of the instrument. These springs hold the coil, to which a pointer is attached, at a position of rest, and at the same time give a means of leading a current from the terminals of the instrument to the coil. Hence, if we connect the terminals of the instrument

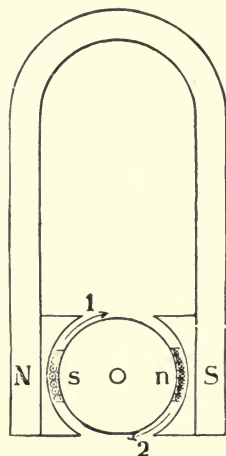

FIG. 52.—Deprez Instrument.

with a source of E.M.F., a current will flow through the windings of the coil. It flows, for instance, in the left part of the windings upwards, and in the parts to the right downwards. Now let us consider what deflecting actions will take place between electric current and magnet. Imagine the swimmer of Ampère's Rule in the part of the coil to the left hand of the reader. On this part the north pole of the magnet and the south pole of the cylinder are acting. Let the swimmer face the N pole, which would move towards his left hand if it were not fixed, then the swimmer being himself movable with the coil will be urged in the direction of the arrow 1. The effect of the inner *s* pole will be the same, because we must now suppose that the swimmer is facing this pole. The pole, being a south one, is pressed towards his right hand, but, not being capable of moving again, the coil must be driven to 1, just as if his right hand were pressing in such a way as to move him along the face of the *s* pole. Next considering the right-hand part of the coil, the swimmer must proceed with his head turned towards the paper and from the reader; then, exactly as before, we shall find the resultant action is to

drive the coil in the direction of the arrow 2. Thus the forces acting tend to twist the coil round until they are balanced by the effort of the springs to drive the coil in the opposite direction.

The stronger the current then of course the greater will be the deflection, so that if a pointer be fastened to the coil, arranged so that it moves over a scale, the strength of the current can be inferred from the amount of the deflection. Hence the new instrument with which we have become acquainted may be used as an ammeter. It is called after the inventor a **Deprez instrument**.

Important details of one make of a "moving coil instrument" (as it is often called) are seen in Fig. 53. These instruments have very

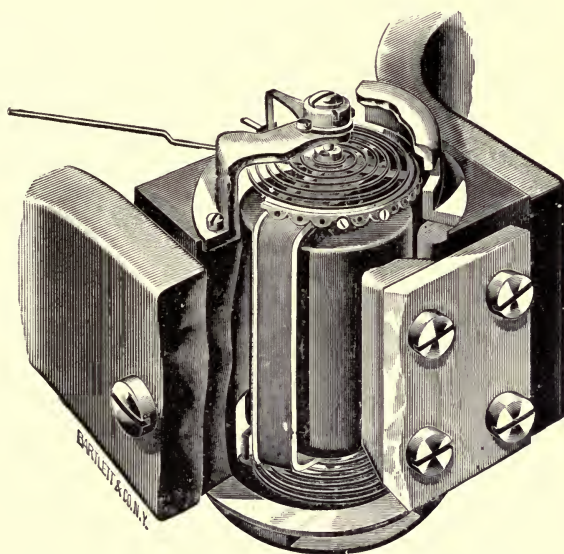

FIG. 53.—Construction of Moving Coil Ammeter
(Weston Electrical Instrument Co.).

useful properties. If the current be reversed, then the coil will obviously be deflected in the opposite direction. We can therefore furnish the instrument with a scale having a zero at the middle, and reading both to the right and to the left. Then the pointer gives not only a measure of the strength of the current, but also indicates its direction. If, however, the instrument is furnished with one scale only, reading, say, from zero to the right, then the current must always be sent through the instrument in a certain direction. The terminals of such an instrument are therefore marked + and - ,

telling us that the leads from the battery must be connected so that the positive and negative poles are respectively at these terminals.

A Deprez instrument may be used, it will be evident, as a **pole-finder**. If the deflection is along the scale, then we know that the + pole is connected to the + sign on the instrument; if otherwise, then the - sign is connected to the + pole.

A very fine wire being wound on the coil, the instrument can only be used for feeble currents. If a thick wire coil were used, then it might be serviceable for strong currents, but such an instrument would be clumsy and not sufficiently sensitive. It is quite possible to use the fine wire instrument for strong currents in the following way: Suppose that a coil is only able to stand a current of $\frac{1}{10}$ amp., but that we had to measure a current of 1 amp. Then, if we connect in parallel to the coil of the instrument, a resistance, called a **shunt**, through which nine parts of the whole current flow; so that only one part passes through the coil, the result will be that the shunt will take $\frac{9}{10}$ and the coil $\frac{1}{10}$ amp. This ratio can be obtained by making the resistance of the shunt $\frac{1}{9}$ of the resistance of the coil. Thus if the resistance of the coil were 1ω , then the shunt must be $\frac{1}{9}\omega$.

The same instrument may be used to measure a current of 10 amps., if we make the resistance of the shunt = $\frac{1}{9}\omega$; again, if a current of 100 amps. had to be measured, we should require a shunt of $\frac{1}{9}\omega$, and so on for still greater currents.

The Deprez instrument is easily adapted as a voltmeter by connecting a sufficiently large resistance in series with the coil. If we make the same assumption as before, and take as the maximum allowable current through a certain instrument to be $\frac{1}{10}$ amp., and its resistance 1ω , then it follows that we must not connect the instrument terminals with a voltage greater than $\frac{1}{10}$. For measuring higher pressures, say of 1 volt, we must place 9ω in series with the instrument; this will give a total resistance of 10, and a current of $\frac{1}{10}$ amp. To measure 10 volts the total resistance must be 100ω , so

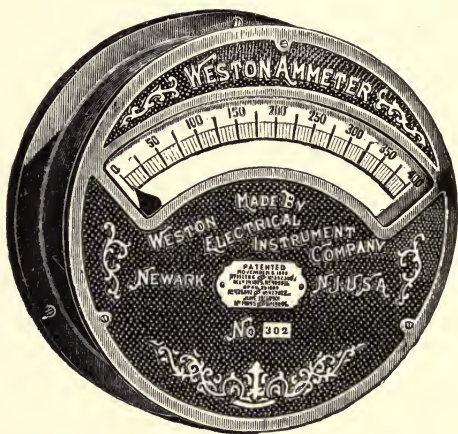

FIG. 54.—Weston Ammeter (Weston Electrical Instrument Co.).

that the extra resistance will have to be 99ω . In the same way a voltage up to 100 will require 999ω , and a voltage up to 1000 will require 9999ω to be added.

The same methods are applied to hot wire and other instruments in order to measure large voltages and currents.

In the case of voltages and currents that are not very great, the shunt or resistance is placed within the instrument.

For technical purposes the instrument is graduated so that the pointer directly shows the current or voltage of the circuit; thus in Fig. 54 an illustration of an ammeter is given capable of measuring up to 400 amps. The shunt for such an instrument would be like that of Fig. 55, which, however, is only for 150 amps., and generally

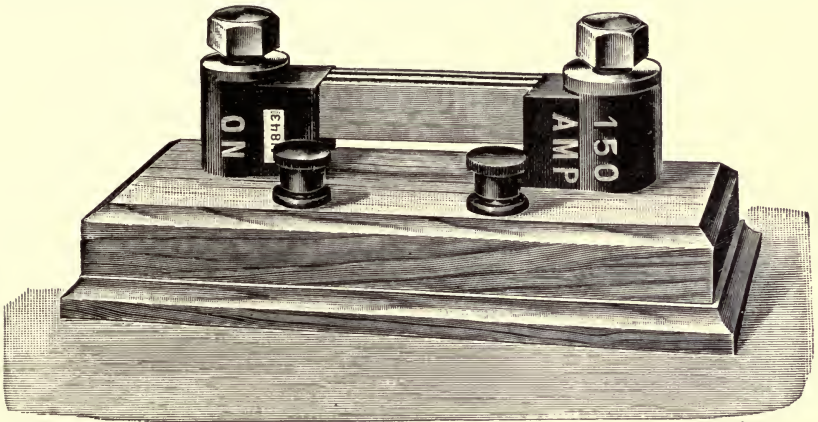

FIG. 55.—Shunt for Ammeter.

is made of a number of strips of manganin, an alloy which changes its resistance but little with rise of temperature.

The Weston instruments, used largely in the United States, operate under the same principle as the Deprez. The General Electric "astatic" instruments used on switchboards have the movable feature similar to the Deprez, but instead of using permanent magnets, a magnet produced by an exciting current (i.e., an electro-magnet) is used, the source of excitation being usually a storage battery. This avoids the varia-



FIG. 56.—Astatic instrument for Switchboards.

tion which may occur in residual or remanent magnetism. A picture of such an instrument is shown in Fig. 56. This instrument has a lamp behind a scale, thus illuminating it.

Influence of Electric Currents on each other— The Electro-dynamometer

We know that between an electric current and a magnet there is an action capable of causing motion. This follows from the fact that a pole tends to be forced along a "line of force," and currents produce lines of force. For instance, a helix carrying current acts precisely like a magnet, being influenced by magnets as well as by currents. Hence it should be expected that two currents, each producing lines of force, would act upon each other. To prove this experimentally, use a fixed coil, consisting of a number of windings of insulated copper wire. At right angles to this fixed coil is a movable one. A current can be passed into the latter by means of wires which dip into two cups containing mercury, as will be seen by examination of Fig. 57. Let currents be passed through the two coils, when it will be found that the outer coil will be deflected, and on reversing one of the currents—either in the outer or inner coil—the deflection will be reversed. Careful tests with this apparatus will prove that *when the direction of the current is the same in the wires, that is to say, both upwards or both downwards, then attraction results; but when the direction of the currents is opposed, then repulsion takes place.*

The influence of electric currents on each other is called **electro-dynamic** action. The word *dynamic* is derived from the Greek word *dynamis*, meaning force.

The arrangement just described may be used for the purpose of measuring current strengths. Instruments of this type are called **electro-dynamometers**, and usually have a pointer attached to the movable coil. A **wattmeter** of this type will be described in later pages.

An interesting and valuable rule results from the action described in Fig. 57. Let it be supposed for a moment that the coil B is stationary and carrying current as shown by the arrows. Let it be supposed that the coil A, carrying current as shown by arrows, can freely move. According to the rule just explained, the side C of coil A is attracted to side D of coil B; or, in other words, the coils tend to lie in the same plane. Consider the lines of force created by coil B; they come up *out* of the paper inside of the coil. If the coil A lies flat with B, it then contains all of the lines of force that it can. In other words, *a coil free to move under the action of electro-dynamic force, tends to move so as to include the maximum number of lines of force.*

If the current be reversed in A, the coil would tend to present its

other face to the reader, still following the above rule in so doing. In considering this valuable rule, remember that the lines of force

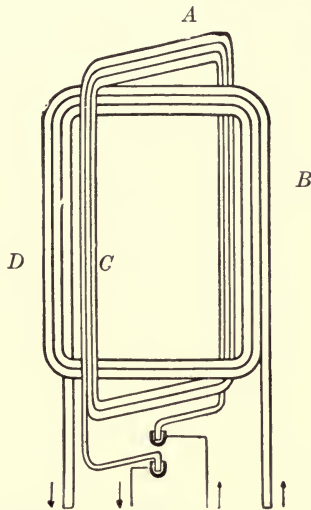

FIG. 57.—An Electro-dynamometer.

in one direction count positive (in the above figure, those coming up out of the paper), and in the other negative.

Electro-magnets

Our early experiments have taught us that a piece of soft non-magnetic iron placed within a coil becomes magnetic as soon as a current is sent through the coil. Such an arrangement is called an **electro-magnet**. The iron may have any shape; it is generally in the form of a bar or horseshoe.

How the iron acquires its magnetism is not very easily explained, but a comparison will enable us to understand what probably takes place. Suppose that, instead of the iron bar, we had a tube filled with a great number of exceedingly small magnetic needles. On shaking the tube the needles will so set themselves that the tube shows no or nearly no apparent magnetism. Place this tube within a coil through which a current is passed. A directing action will now be exerted on each of the magnetic needles, and they will attempt to turn in a certain direction. But the magnetic needles not being freely movable, hence offer a certain resistance to their rotation. If the current, and therefore the directing force exerted on the needles, is but small, then the resistance will prevent the needles from entirely following the directing force.

A certain amount of rotation of, at least, the easier movable needles will, however, take place. The poles of the needles will no longer be arranged in a confused manner, but their north poles are directed more or less towards one end, say to the right, the south poles more or less towards the left. The tube will now be magnetic. If we strengthen the current flowing through the coil, its directing force on the needles becomes a greater one, and with a very large current the directing force may overcome the resistance to motion entirely, and all the needles group themselves in the direction of the lines of magnetic force of the solenoid. The tube now shows very strong magnetism. If the current flows around the coil, as shown in Fig. 20, a north pole will be formed to the right, and a south pole to the left of the tube. If Fig. 20 be considered attentively, we are able to deduce the following rule:

At that end at which (*looking towards this end*) the current flows in a direction which is *counter-clockwise* round the coil there is a *north pole*; and at that end at which (*looking towards this end*) the current flows *clockwise* round a coil a *south pole* is formed.

From many other phenomena, not only of a magnetic nature, which could not have been otherwise explained, it has been concluded that the smallest parts of which a body consists are not joined together rigidly, but possess a certain mobility. These smallest parts, which cannot be made smaller by mechanical means, are called **molecules**.

We have now to imagine that every molecule of the iron is a diminutive magnet. If these, which we may call **molecular magnets**, lie in confusion, then the iron bar will be like that within the tube of the previous page, and have no apparent magnetism; but if we exert a directive action on the iron, by, for example, bringing near to it the north pole of a strong magnet, then all the south poles of the molecular magnets will turn towards the strong north pole and the north poles in the opposite direction, and the iron will now be magnetized. If the cause of the directing force be removed, then the molecular magnets return to their original position, either partially or entirely.

We say partially or entirely, for if the molecular magnets are difficult to move, a great force will be necessary to deflect them from the position of rest. If, then, the deflecting force ceases, the particles will not return to their original position because the resistance which opposed the first motion will also resist any retrograde action. Iron of this kind will show magnetic properties, even after the magnetizing force ceases. Such magnetism is called **residual magnetism** or **remanence**.

Iron having molecules that are easy to turn will be easy to magnetize, and will readily return to the non-magnetic condition.

Iron shows a different degree of remanence, according to its

hardness; hence it is rather difficult to magnetize hard steel, but its residual magnetism is of a large amount.

Very soft, especially annealed wrought iron can be magnetized very easily and strongly, and in a far higher degree than steel; its remanence is, on the other hand, small, and very much less than that of hard steel.

With steel we generally do not speak about a residual, but rather of a *permanent* magnetism.

It follows from the molecular theory of magnetism that, if we break a magnet into two parts, we cannot have one half containing north, and the other half containing south magnetism only. Even if we divide a magnet into exceedingly small parts, each of these will have both a north and a south pole.

A field of magnetic force exists both in the space outside a magnet and also in its interior; the lines are supposed to pass from a north pole to a south pole in the external field, and then to travel through the magnet from south to north pole, forming what is called a **magnetic circuit**. This magnetic circuit is very analogous to the electric one.

In our future discussions about magnets electro-magnets will be chiefly considered, as these are of much greater technical interest than permanent ones.

The exciting power of magnetism or **magneto-motive force** is represented by the effect of the current flowing through the solenoid. As we are aware, this effect depends merely on the strength of the current and the number of turns. Hence the number of ampere-turns is a measure of the magneto-motive force. The greater the latter is the larger is the number of lines of force, and the stronger the magnetic flux. But this flux depends not only on the exciting force, but also on the resistance which is opposed to the passage of the lines of force. This resistance is quite analogous to the electric resistance, and depends on the length of the path, the cross-section, and the kind of material.

Iron offers a low resistance to the lines, whereas air and all non-magnetic materials have a far higher resistance. Hence, if we wish a strong magnetic flux, we must make the path through the bad conductor (generally air) as short, and its sectional area as great, as possible.

We shall now be able to understand why a horseshoe magnet exerts a far stronger force than a bar magnet of equal strength of pole. If we bring the piece of iron called the keeper near a horseshoe magnet (see Fig. 58), the lines of force pass only a short distance through the air. The greater part of their path is through iron, either that of the magnet or of its keeper. Since the path through the keeper has a lower magnetic resistance than that through the air, nearly all the lines will go through the keeper, and only a com-

paratively small number of them will take other paths through the air. These last-mentioned lines are called **stray lines**. They are of no utility, for only those lines which reach the keeper can cause attraction.

If now we bring the same keeper, as in the previous example, to the pole of a bar magnet, then we observe that all the lines have an

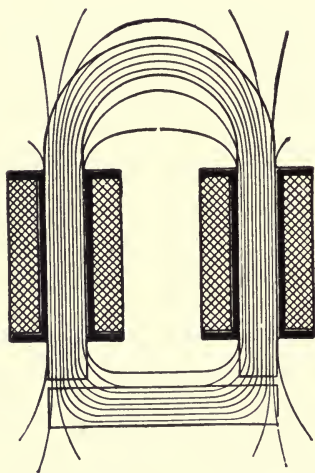

FIG. 58.—Horseshoe Electro-magnet.

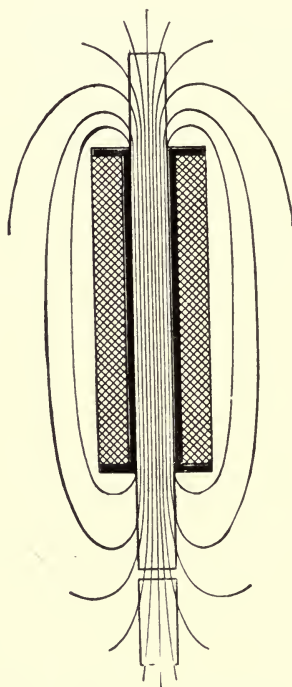

FIG. 59.—Straight Electro-magnet.

air path (see Fig. 59), and very few pass through the keeper, so that the useful lines are very few.

Owing to the long air path the magnetic circuit here has a very high resistance, and for the same magneto-motive force the number of lines will be far less than in the case of the horseshoe magnet. The flux into the keeper being small, the pull upon it by the magnet will be correspondingly small.

The law connecting the flux with the exciting power and resistance is known as **Ohm's Law for magnetism**. There is, however, a very important difference between this law and the Ohm's Law for the

electric circuit. In the case of the electrical current a double E.M.F. will cause a double current, and a pressure one hundred-fold will give a current one hundred times as great through any constant resistance. With the magnetic circuit this is by no means the case. As we understood from the discussion about magnets, there is a defined limit above which the magnetism cannot be further increased. This maximum is reached when all the molecular magnets are pulled into a straight line. Hence, as we approach this *condition of saturation* any increase of magneto-motive force is practically useless. Further, the magnetic resistance of such saturated iron is very great.

Nevertheless, up to a certain point the magnetic is like the electric circuit. A great increase of the electric pressure produces a very strong current, which heats the wire and causes it to have a higher resistance than before, preventing therefore the current from becoming so great as it would be if the wire had been kept at the original temperature. Compared with the corresponding increase of the magnetic resistance this change of electric resistance is small.

Induction

We have learnt that an electric current flowing through a conductor in a magnetic field is capable of producing motion of the conductor or of the magnet. From the law of production of electro-motive force by the cutting of lines of force, a volt being produced by the cutting of 100,000,000 lines of force per second, it follows that in a conductor which is made to move in a magnetic field an electric current is produced.

To prove this, let the following experiment be tried: In front of the poles of a horseshoe magnet move a copper rod, which has its ends connected by flexible wires to a sensitive Deprez ammeter, as shown in Fig. 60. If we move the copper rod in any direction, say from left to right above the north pole, the ammeter will show a sudden deflection. If we move the rod in the same way above the south pole, the deflection will be in an opposite direction. If now the rod be moved from right to left

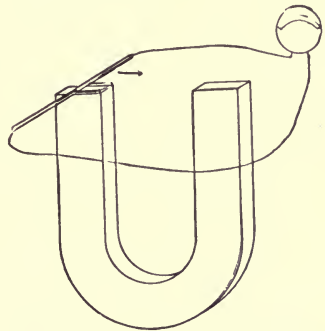

FIG. 60.—A Conductor in a Magnetic Field.

the deflections will be opposite to the corresponding ones of the first direction of motion for each pole. As the result of the motion, we therefore produce an E.M.F., whose direction depends both on the way that the lines of force proceed through the conductor, and on the way

the conductor is moved. On stopping the movement of the conductor the needle of the ammeter immediately comes to rest, proving that *motion is essential* for the maintenance of the generated electrical pressure. We shall further find that it is a matter of indifference whether we move the conductor or the field.

If there is no closed circuit, a current cannot of course be produced, but an E.M.F. will exist immediately the conductor moves; just as, in the case of a galvanic cell, an E.M.F. is present even if the poles are not connected.

It is of practical importance to determine in all cases the direction of the current in the moving rod.

It will have been remarked that, in Nature, whenever a motion takes place there exists some resistance which tries to bring the moving body to rest. To overcome this resistance work has to be done. The ground, for example, offers a resistance to the movement of a vehicle. Such resistance is known as friction. If the moving

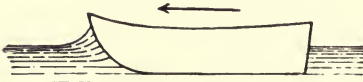

FIG. 61.—Action of Moving Boat.

force be withdrawn, friction will gradually cause the vehicle to stop. It is exactly as if there existed a force which acts in a direction opposite to that of the motion. If a boat is moved

on water (see Fig. 61), the water is raised in front of the boat, which will try to drive the boat in the opposite direction, and will really do so as soon as the moving force ceases.

It is precisely the same with the moving conductor. As it is

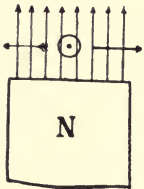

FIG. 62. —
Direction
of Induced
current.

made to travel in the magnetic field a current is produced in such a direction as to oppose the motion of the conductor. Ampère's Law will help us here. An experiment (Fig. 62) will show that if the conductor be moved to the right a current will be produced so as to flow towards the spectator (this direction is indicated by a dot in the diagrams). Such being the direction of the current the swimmer in the current may be thought of as pushing along the face of the fixed N pole with his left hand, and hence he tends to drive the conductor towards his right hand in the direction of the feathered arrow.

To overcome this backward force of the current we must do work to move the conductor in the intended direction. The larger the produced current—and we may alter this according to the resistance connected with the outer circuit—the larger will be the retarding force, and thus the greater must be the work which we have to exercise to move the conductor. Hence it follows that we

do not get the current for nothing, but we must employ a certain amount of mechanical effort. We therefore only transform mechanical into electrical energy.

A rule will now be given by the aid of which it is possible to determine the direction of the produced, or, as it is called, the **induced** current in a much simpler way than employing Ampère's Law each time.

Hold the palm of the right hand against the lines of force, the thumb in the direction of the motion, then the fingers point out the direction of the induced current (see Fig. 63).

In the case of the example of Fig. 62 the palm of the hand would have to be turned downwards, against the north pole, since the lines of force proceed upwards. On then holding the thumb to the right, the fingers point towards the spectator, indicating the direction of the current as proved by experiment. A very useful rule to bear in mind as to direction of induced currents, of course dependent upon the same principles laid down, *is looking at an electric circuit in the direction of the lines of force* (i.e., in the direction a free north pole would tend to go), *if the lines of force are increasing, a current tends to flow in a counter-clockwise direction. If decreasing, in a clockwise direction.*

There is another and important case of induction that must be studied. If we wind a wire round a core of soft iron, and connect its ends with the terminals of a Deprez ammeter, we can observe a deflection on the instrument immediately we approach a magnet pole to the core. When the magnet comes to rest the deflection at once ceases. If we take away the magnet from the core a deflection is produced in the opposite direction.

The same effects can be observed by winding another coil on the core which is connected with some source of E.M.F. As long as the current in the new coil remains constant—that is to say, as long as the flux does not alter—we cannot observe any current. But as soon as we strengthen or weaken, start or stop the magnetizing current we get a deflection of the ammeter which is greater the greater is the variation of the magnetizing current, and the more rapidly the alteration is caused.

Thus an E.M.F. is always induced in a winding surrounding an iron core if the magnetism of the core is either strengthened or weakened.

This law that the induced current is in such a direction that it tends to stop the motion, as described in connection with Fig. 62, is covered by what is now generally known as *Lenz's law*, which is that "*in all cases of magnetic induction the induced currents are in*

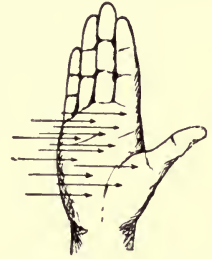

FIG. 63.—The Hand Rule.

such a direction that their reaction tends to stop the motion that produced them."

Electrical Machines

If we could by any special device move a conductor repeatedly backwards and forwards in front of a pole of a magnet, we should obtain a current which would change its direction with each alteration of the direction of motion. This would be the simplest form of an electrical machine serving for the transformation of mechanical into electrical energy.

A motion backwards or forwards, or up and down, is called a reciprocating motion, and is generally avoided from a mechanical point of view. A rotating motion is much more preferable and, as it is easy to construct an electrical generator or **dynamo** with conductors which rotate, this is the usual method of construction.

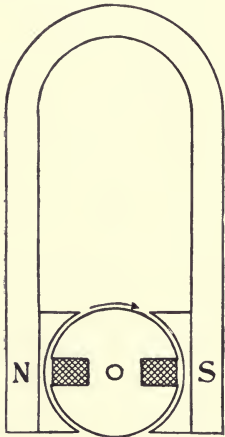

FIG. 64.—A Magneto-Generator.

In Fig. 64 is shown a horseshoe magnet, which is similar to that of a Deprez instrument, and is provided with **pole-shoes** of soft iron having a circular bore. To give the lines of magnetic force a very short air path, in the Deprez instruments a fixed iron cylinder is placed inside the circular space. Within the air gap the conductors are movable. The same device would serve as a dynamo too, but the rotation of a fine wire coil in so small a space is not a very practical construction, and would be far too fragile for a dynamo. A more satisfactory way is to fix the wire to the iron cylinder, and make them revolve together. To this part the name **armature** is given.

One method of making an armature is shown in Fig. 64, which is called, after its inventor, a Siemens armature, or, after its method of construction, a shuttle or H-shaped armature. It will be seen that the iron cylinder has two slots in which the wire is wound.

The effect of the winding in cutting through the lines of force is the same as in the case of the Deprez construction; for, the iron armature is not a permanent magnet, but serves only for transmitting the lines of force from the north to the south pole. Whether the armature is rotating or not, the lines of force always keep in the

same direction. They do not rotate together with the armature, but always flow in a horizontal direction from the north to the south pole.

The direction of the current produced in the windings we may easily determine by means of the various rules presented. Take, for instance, the hand rule. Let us assume the rotation of the armature to be clockwise. If we consider now those wires which pass the north pole at this moment, then we have to hold the palm towards the north pole (i.e. towards the left) and the thumb in the direction of motion, or upwards. The fingers are then directed behind the plane of the drawing. Hence in all wires to the left a current will be produced which flows from the spectator. (Marked, in Fig. 65, by crosses.) We have now to consider the wires to the right, which are near the south pole. The thumb in this case must be held downwards, because the armature with the wires moves downwards on this side also, and the palm must be turned towards the north pole as before. The fingers point towards the spectator, this direction of the current being indicated, in Fig. 65, by dots within the circles representing the wires. From the same diagram, which shows also a plan of the windings, we learn that all the induced E.M.F.'s add themselves. If, for instance, there be 6 windings or 12 conductors on the armature, the total E.M.F. produced in the latter will be 12 times that induced in a single wire. If we wind 1000 turns of a very fine wire on the armature, we may therefore get a considerable voltage, especially if there is any arrangement to make the armature rotate very quickly. This may, for instance, be accomplished by a suitable toothed wheel gearing.

Consider the production of electro-motive force by the rule that looking along the lines of force if the flux in the circuit is increasing, the electro-motive force is induced which tends to produce a current in a counter-clockwise direction. We must, in Fig. 64, look from the north to the south pole, for that is the direction of the lines of force. In the position shown in the figure the armature coil is containing no lines of force, being edgewise to them. As it turns clockwise it commences to take lines; hence the lines are increasing, and a current tends to flow counter-clockwise, or *from* the spectator on the left and *toward* on the right.

To connect the armature with the outer circuit, we fix each of the ends of the coil to a copper or brass slip-ring (see Fig. 66).

On these rings, metal springs or **brushes** press which may be connected with the outer circuit. For it is, of course, impossible to connect the wires of the outer circuit directly with the ends of the coil and yet permit free rotation.

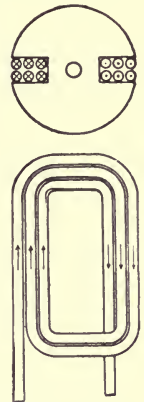

FIG. 65.—The Siemens Armature.

After the armature has made a quarter of a revolution we observe that the wires are neither within the influence of the north nor of the south pole. They are exactly as far from the north as from the south pole. Therefore at this moment no E.M.F. at all is induced in them. When the armature passes from this position, the wires, which before have been embraced by the north pole, come now to the south pole, and *vice versa*, thus the direction of the induced E.M.F. is altered. The current, flowing through the outer connection, hence alters its direction at each half revolution of the armature.

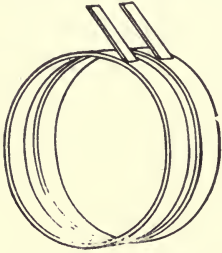

FIG. 66.—Slip-Rings.

At the position of the armature shown in Fig. 64, the current has its maximum value, for the lines of force are here being cut at the maximum rate. Then it decreases gradually, and becomes *nil* after a quarter revolution of the armature, and then gradually grows to a maximum (but in a reversed direction), becomes again *nil*, and so on. We shall be able to understand these changes better by drawing a wavy line, such as shown in Fig. 67. A point, moving on this wave line, has at a defined time its highest position, marked in the figure by *a*; its height decreases then gradually, and becomes zero at *b*. Then the point descends beneath the horizontal line, till it reaches its lowest position at *c*, which is exactly as far under the

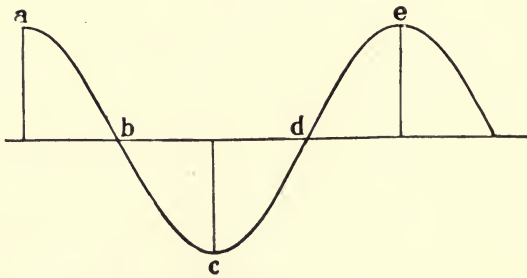

FIG. 67.—Alternating-Current Curve.

horizontal line as the point *a* is over the horizontal line. The point now ascends until it reaches at *d* the horizontal line, and continues to rise until at *e* its highest position is reached, which is equal to that of *a*. From here the previous changes are repeated.

The current thus generated is quite different to that taken from a galvanic cell, which is constant in strength and direction as long

as we do not alter the resistance of the circuit or the connection of the poles, and is therefore called a **constant current**. The current, on the other hand, taken from the armature just described, is called an **alternating current**, and each up-and-down change of the current, as from *b* through *c* to *d* (Fig. 67), is called an **alternation**. If the armature of such a **two-pole** or **bipolar** dynamo makes 1000 revolutions per minute, then the number of alternations in the same time is 2000.

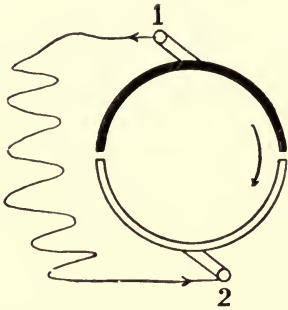

FIG. 68.—Simple Commutator.

For certain purposes the employment of alternating currents is of great advantage. It is, however, very often desirable to obtain a **rectified** or **continuous** current. If the armature be rotated very slowly, such a current may be obtained by changing the wires going to the slip-rings after each half revolution, at the moment the current is reversing its direction. Changing of the wires by hand is naturally im-

possible at the usual speed of rotation. A "commutator" enables this difficulty to be readily overcome. It consists (see Fig. 68) of two half rings, which are insulated from each other. One of these half rings is connected with the beginning, the other with the end of the armature coil. The brushes are opposite each other, one on the highest, the other on the lowest point of the split ring. With the brushes 1 and 2 the outer circuit is connected. The position of the commutator shown in Fig. 68 corresponds with the armature position of Fig. 64. Let the commutator revolve in the direction of the arrow. Then Fig. 69 will show its position a quarter of a revolution afterwards, and, until reaching this position, an E.M.F. will have been induced in a certain direction—say, so as to send a current from brush 1 to brush 2. At the moment that the position of Fig. 69 is reached the armature is short-circuited by each brush. This will be of no great disadvantage because, as we know, at this position no E.M.F. is induced. As the rotation of the commutator proceeds, the half shown black in the diagrams will come in contact with brush 2, and the white half will touch brush 1. Now, it must be remembered that the electrical pressure will be in the reversed direction; but, at the same time, the connections with the outer circuit have been changed, so

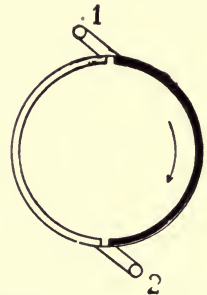

FIG. 69. — Second Position of Commutator.

that the current (as shown in Fig. 70) will again proceed from brush 1 to 2. No change in direction of the induced current will follow until the commutator from the position Fig. 69 has turned through half a revolution. Reversal of the current, and the change of brushes to rectify it, then takes place. This is repeated at all subsequent half turns.

The kind of current so produced is not really a constant current, such as can be obtained from a galvanic cell, but it rises to a maximum and falls to nothing repeatedly. The current is represented by the curve of Fig. 71, and consists of half waves all directed upwards. The peak of each wave corresponds to an armature position as shown in Fig. 64, and the zero positions show the absence of E.M.F. at a quarter turn later.

The dynamo we have described is generally employed for the generation of very small currents. As mentioned above, we can produce in the small armature a comparatively great E.M.F., by employing very many fine windings. Naturally, we obtain from this armature only a very small current on account of the fine wire used on the armature.

It is sometimes very useful to get a pressure of 100 volts from

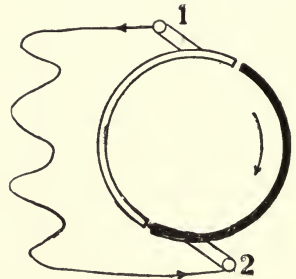

FIG. 70.—Third Position of Commutator.

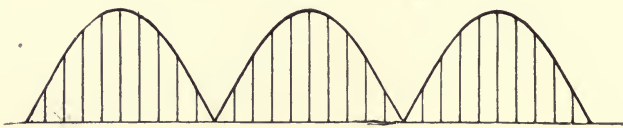

FIG. 71.—Rectified Current.

such a small portable machine. If a galvanic battery were used 100 cells would be required. This would be more bulky than a small dynamo, and have the further inconvenience of requiring recharging from time to time.

This simple form of a dynamo is therefore used as current generator for certain tests, such as that of insulation. If we require, for instance, to examine if a line is well insulated from earth, we should

connect one terminal of the dynamo with earth, and from the second terminal lead a wire to a *galvanometer*—an instrument similar to an ammeter. From the second galvanometer terminal a wire is led to the line to be tested. Then the armature is turned quickly. If the line is well insulated from earth, then although the machine produces an E.M.F., no current results, and the pointer of the galvanometer remains in its position of rest. If, on the other hand, the insulation is defective, the E.M.F. of 100 volts, produced in the armature, will be able to

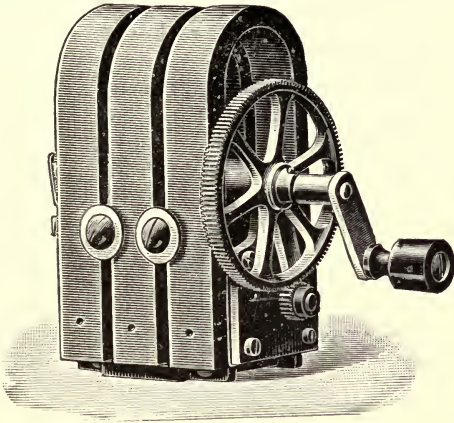

FIG. 72.—Magneto-Electric Machine
(Berliner Telephone Manufacturers' Co.).

send a current through the circuit, and the pointer of the galvanometer will be deflected.

We can, further, note from the force which has to be exerted for turning the armature whether the machine is supplying any current or not. In the former case it is rather difficult to turn the armature, because electric power is produced in the machine. In the latter case the turning is much easier, for, as there is no current, no electric power can exist, although we have E.M.F. present. Thus, only such power must be exerted as may be required to overcome the friction of the armature and the gearing.

This machine, which is generally called a **magneto**, is also used for ringing the kind of electric bells that are often used in connection with telephones. A complete machine is shown in Fig. 72.

CHAPTER III

THE CONTINUOUS CURRENT DYNAMO

The Ring Armature

WITH large dynamos, such as are employed for electric lighting or power transmission, the Siemens armature is not used. In these cases the ring armature invented by Gramme is sometimes employed, particularly for arc lighting.

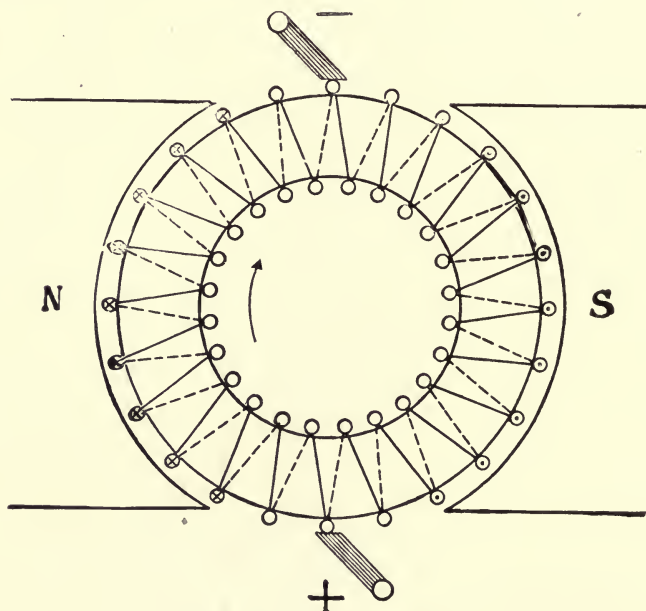

FIG. 73.—Ring Armature.

This will now be described. It is shown in Fig. 73, and it will be seen that it consists of a ring-shaped iron core, which is not cast or forged in one piece, but built up from a great number of thin sheets

of soft iron. Over the ring an insulated wire is wound in many turns. The ends of the windings are soldered together, so that the whole armature winding forms a circuit closed on itself. This is called a **closed-coil armature** in opposition to the *open-coil* type, which is, for instance, represented by the simple Siemens armature. If, now, the armature rotates between the poles N and S, an E.M.F. will be produced in each wire. We have to examine how the different E.M.F.'s produced in the wires behave towards each other.

We must, first of all, be clear about the course of the lines of force. To the latter, coming from the north, and going to the south pole a way is offered through the armature. They can either make a bend, and go through both halves of the iron core, or they can

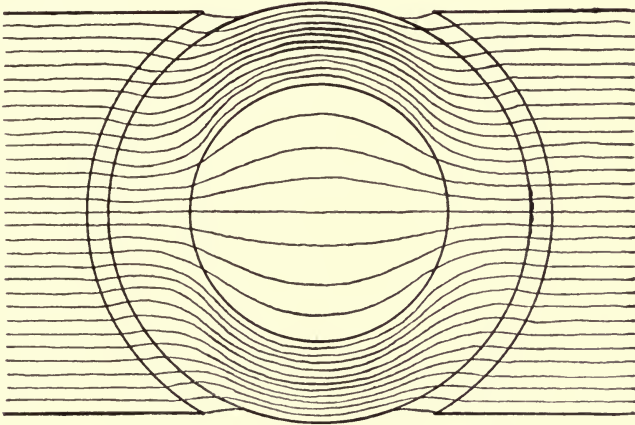

FIG. 74.—Lines of Force through Ring Armature.

go the shortest way, directly through the interior of the iron core, to the south pole. The first way offers much the lower resistance, because the path is only through iron having a small magnetic resistance. Hence, most of the lines of force will pass round the iron, and a small number only will go through the inside of the ring (see Fig. 74).

We have next to carefully distinguish between the *outer* and the *inner* wires of the armature winding. The outer wires cross the total number of lines of force in the air gap in passing the north or south pole. The result is that in the outer wires a considerable E.M.F. is induced, the direction of which we can determine if the direction of rotation is given. In all the outer wires passing the north pole an E.M.F. in one direction, in the wires passing the south pole an

E.M.F. in the opposite direction, is induced. From the inner wires and the lateral parts of the windings very little E.M.F. is obtained, because very few lines of force cross them. Hence the really effective portion of each winding is the outer wire, the other parts of the winding serving for connecting each wire with the next one. By means of these connections the pressures produced by the outer wires within the embrace of the poles are placed in series. The wires in the space between the upper tips and the lower tips of the poles, called the **neutral zone**, are ineffective, and serve as connecting wires only.

When this ring armature rotates no current will circulate through its wires, for the E.M.F. produced by one pole is equal and opposite to that produced by the other pole. Hence we have exactly the same case as in Fig. 33, where we had two cells in parallel without any external connection, so that the cells were in opposition. Immediately we provide an outer path the two pressures combine, and send a current in the same direction to feed the outside circuit, as shown in Fig. 34.

With the ring armature we can get connection with an outer circuit by removing the insulation from the portions of the wires lying on the outside surface of the ring, and fixing brushes in the neutral zone, which rub on the bared wire. On joining the + and - brushes (see Fig. 73) to lamps, etc., the right- and left-hand windings now work in conjunction, and each supplies half the current passing out from the brushes.

It is not very usual to collect the E.M.F. by baring the external wires. It is much more usual to have a special part, the **commutator**.

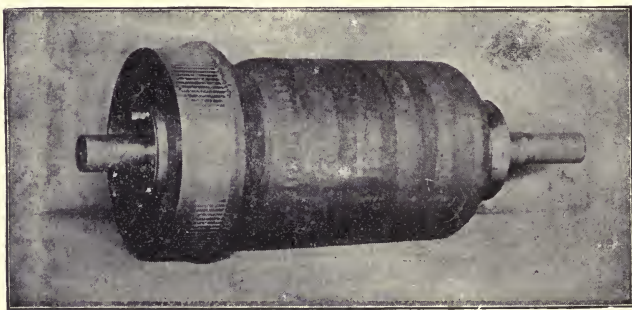

FIG. 75.—Ring Armature (*British Schuckert Co.*).

For this purpose every turn (or every second, third, or other turn, according to circumstances) is connected by a soldered wire with a bar or segment of hard copper. The single segments are of wedge

shape, and are insulated from each other by means of thin sheet-mica. The segments are then fixed on a metal cylinder, from which they are insulated. Along the surface of the segments brushes are so fixed that between them and the segments there is not much friction. The effect is just the same as if the wires were made to slide on the brushes. Fig. 75 is an illustration of a ring armature

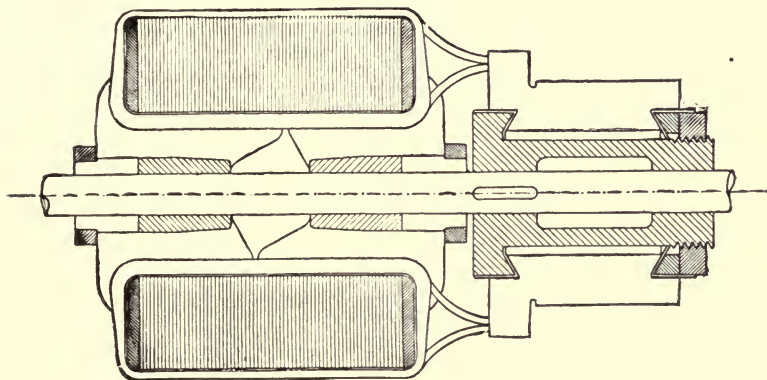

FIG. 76.—Section of Ring Armature and Commutator.

with commutator, and Fig. 76 gives a cross-section of such an armature.

We have still to explain why the armature is not made from solid iron, but is built up from a number of thin iron discs, and provided with insulation, so as to separate the iron discs from each other. If we let a solid iron ring rotate very quickly in a magnetic field, it will, after a short time, become exceedingly hot. This is explained by the fact that the ring crosses magnetic lines of force, hence inducing electromotive forces, which produce currents.

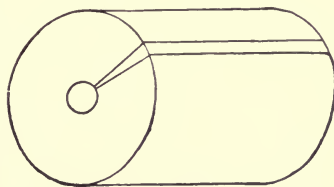

FIG. 77.—Eddy Currents in Iron.

Let us now consider what would happen, during the rotation in a magnetic field, in a solid piece of iron cut from the armature along its axis. This piece would have a shape similar to that of a commutator segment (see Fig. 77).

This armature sector would not cross the lines of force symmetrically. The uppermost part crosses very many, the lowermost part hardly any, and the intermediate parts always a less and less number of lines of force, according to their distance from the surface. If

we now imagine the sector to be divided into several strips (see Fig. 78), these strips

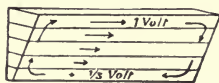

FIG. 78.—Eddy Currents in Iron.

will represent electric conductors, which, on rotation, cross lines of force, so that an E.M.F. is induced in them, which will be greatest in the uppermost strip, smaller in the second, finally smallest in the innermost strip. If we consider, for instance, the uppermost and the lowermost strips, then, if the E.M.F. induced in the former be, say, 1 volt, that induced in the latter might be $\frac{1}{2}$ volt only. As all these conductors form together one piece, they are connected electrically with each other. Against the large E.M.F. of the uppermost strip a small E.M.F. only of the lowermost strip will act. Thus in the closed circuit a current will flow which is produced by the difference of the two electro-motive forces. This difference is $\frac{1}{2}$ volt in our example. This E.M.F. can produce in a solid iron bar, which has a very low electrical resistance, exceedingly strong currents. These are transformed into heat, and may make a solid iron bar red hot after a short time.

Hence the generation of strong eddy currents is prevented by building up the iron core of thin sheet-iron discs and very thin paper alternately (marked, in Fig. 76, by vertically hatching). The single discs are insulated from each other by paper layers or insulation painted upon the sheets of iron themselves. An E.M.F. is now, of course, induced in each of the iron sheets. But if we, for instance, assume that the number of discs required for building up the armature be 200, then the E.M.F. produced in the uppermost part of each of the discs will be only the 200th part of that produced in the full armature length, i.e. $\frac{1}{200}$ volt. Further, this far smaller E.M.F. has to flow along a way, which offers to it a very high resistance. To come to the innermost part of the armature disc, the current has to flow through the very thin iron. As the resistance of the latter is a very considerable one, the eddy currents will be far smaller than those occurring with the solid iron armature. As a matter of fact, the temperature rise of a well-designed armature over that of surrounding air does not exceed 70° to 90° Fahr. This heating, however, is to a considerable extent produced by the current in the armature conductors; the eddy currents themselves alone cause a much less rise of temperature.

The method of building up the armature out of single sheets of iron is now generally followed. A slight difference in the construction happens, inasmuch as, in some cases, the single discs are insulated, not by thin paper, but by a coat of varnish or other special compounds. The ring armature is particularly suited for high potentials, since wires having much difference of potential are not brought near together. Thus such windings are used for arc dynamos, when the voltage at the brushes may be as high as 6000 volts. It is well to have the number of coils a multiple of the poles, so that the E.M.F. between brushes will balance on both sides.

Drum Armature

The interior part of each winding of a ring armature is useless for the generation of E.M.F., but is necessary for connecting every conductor with the next one so that the E.M.F.'s do not act against each other, but in the same direction. This series-connection of the electro-motive forces may be obtained in another way, viz. by connecting opposite conductors through a wire which is laid over the surface of the armature, as with the Siemens armature. If we consider Fig. 79, we shall see that 4 of the 12 armature wires are

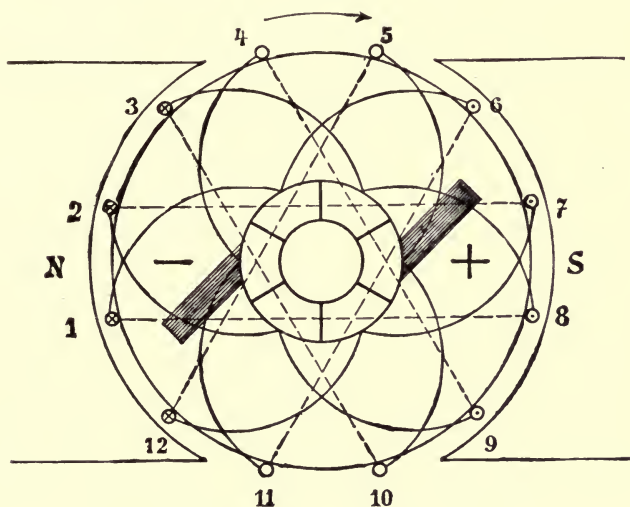

FIG. 79.—Drum Armature Connections.

situated within the reach of the north pole (viz. Nos. 12, 1, 2, and 3), 4 other wires are situated within the reach of the south pole (6, 7, 8, and 9), and the remaining 4 wires in the neutral zone. Thus if in the wires under the north pole an E.M.F. is produced which may be directed from the spectator, in the wires under the south pole an E.M.F. is produced which is directed towards the spectator; whereas in the wires 4, 5, 11, and 10 no E.M.F. at all is produced. It is now clear that we get a proper series-arrangement of the electro-motive forces if we connect the front end of wire 1 with the front end of any of the wires 6, 7, 8, or 9. It would be the nearest to connect wire 1 with the exactly opposite wire, 7. But this would not give a proper, continuous armature winding; for, if we connect

the back end of wire 7 with the opposite wire, we come back again to wire 1. To get a continuous armature winding, we have, thus to select as the **pitch** a number which is not exactly equal to half the number of the wires. To come from wire 1 to wire 7, we have to make six steps: the pitch is, therefore, said to be 6. Let us now select as the pitch the next smaller number, viz. 5. We have then to connect on the front wire 1 with 6. On the back of the armature we have to connect 6 with 11. The connections at the front of the armature are indicated in Fig. 79 by full, twice bent lines; those at the back of the armature, by dotted, straight lines. In proceeding with the connections, we come to a front connection from 11 to 4, then at the back from 4 to 9, front from 9 to 2, back 2 to 7, front 7 to 12, back 12 to 5, front 5 to 10, back 10 to 3, front 3 to 8, back 8 to 1—that is, back to the point of departure. The closed circuit, which is formed in such a way, comprises, thus, all the wires of the armature. In the middle of each of the front connections a joint is made with one commutator-bar.

This armature acts exactly like a ring-armature. Let us assume the brushes to lie on the commutator-bars, which correspond to the wires 4 and 11, and 5 and 10 respectively, and let us then follow the course of the current. There are two ways going from the left-hand brush—one to wire 4, the other one to wire 11. On the first way we come from 4 through the back connection to the wire 9, in which an E.M.F. directed towards the spectator is induced (indicated by a dot). If we proceed in this direction, we come through the front connection to wire 2, in which an E.M.F., directed from the spectator (indicated by a cross), is induced. Thus this E.M.F. is acting in a like direction to the first one. We reach now, through a back connection, wire 7, through a front connection wire 12, whereby all the electro-motive forces add themselves, and come further through a back connection to 5. Wire 5 is a neutral wire, in which no E.M.F. is induced, and which is in direct connection with the second brush. The current can thus flow from the second brush into the outer circuit. This brush is, therefore, the positive one, whereas the left brush is the negative one.

If we follow the second way, which is offered to the current from the left brush, we come from 11 to 6, from 6 to 1, from 1 to 8, from 8 to 3, in which wires the induced electro-motive forces add themselves, and at last from 3 to 10. On this second way we have as many series-connected wires as in the first way, viz. 4 effective and 2 neutral conductors. The E.M.F. of the second half of the armature is thus equal to that of the first one. Both halves of the armature are connected in parallel, like the halves of the ring armature. Fig. 80 shows, further, a diagram of connections for an armature with 24 conductors. In this case the pitch is 11, and it can be seen that the result is the same as with the armature with 12 conductors.

To get one continuous drum-winding, it is necessary to select as pitch an *odd* number. If in the last example we made the

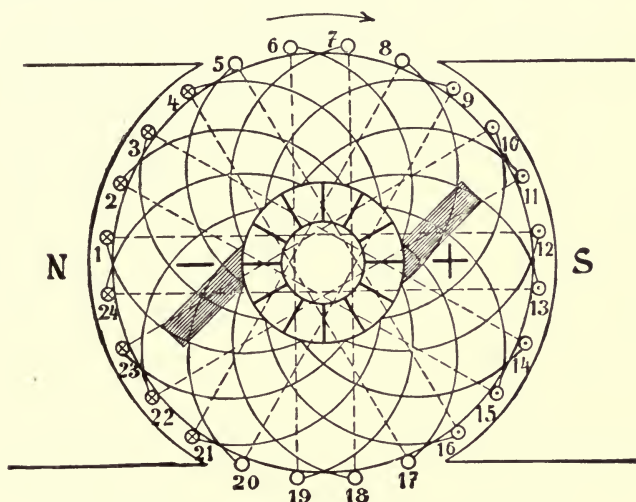

FIG. 80.—Drum Armature Connections.

step=10, then we go from 1 to 11, from 11 to 21, and so on, and can never arrive at conductors with even numbers, but combine half of the conductors, viz. the odd ones only, in a closed winding. Instead of *one* continuous armature winding, we get in this way two entirely separated windings.

On the other hand, it is not necessary to make the pitch just equal to a number smaller by one than the half of all wires. With 24 wires we could make the pitch either 11 or 13.

The pitch on the front need not always be equal to that of the back. If we had 22 wires, for instance (see diagram, Fig. 82), we could make the front step=11, the back step=9, and would then get a winding of quite the same kind as considered before.

It should be noted that in Figs. 79 and 80 the number of coils are even (i.e. one-half number of conductors), and hence a wire on one side of the armature is not connected by the end connections to a wire diametrically opposite. Thus, in Fig. 80, wire No. 1 cannot be connected to wire No. 13 diametrically opposite, so that they do not commutate under the brushes simultaneously. In the winding shown in Fig. 82, the number of coils is *odd*, so that, if desired, wires diametrically opposite could be connected by the end connectors.

The method more often used in practice is not as shown in Figs. 79, 80, 82, but as shown in Fig. 81, where the coils are in two layers. As shown in the figure, the outer layer is in multiple with the lower, and due to this there may be a little unbalancing. To make this perfect, in winding, instead of proceeding around in one layer, the

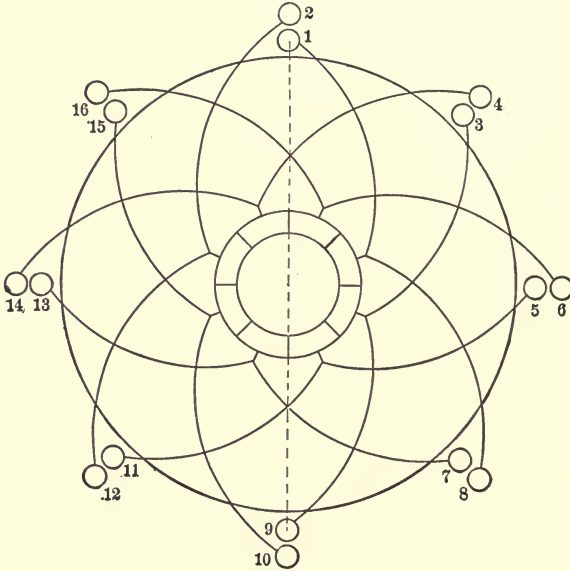

FIG. 81.

connections are made to wires first in the lower layer and then in the upper.

The drum armature was first employed by Hefner-Alteneck. It has certain advantages over the ring armature. Since no wires go through the interior of the armature, for small armatures the iron discs may be fixed directly on the armature shaft. The construction of the armature becomes therefore cheaper, and the winding simpler. Also for larger armatures the drum winding is preferred to the ring winding.

Special means must be provided to prevent the conductors from sliding on the smooth armature surface. For this purpose on the surface of the armature sometimes grooves are made, and rods are

put into these grooves, which prevent the conductors from sliding.

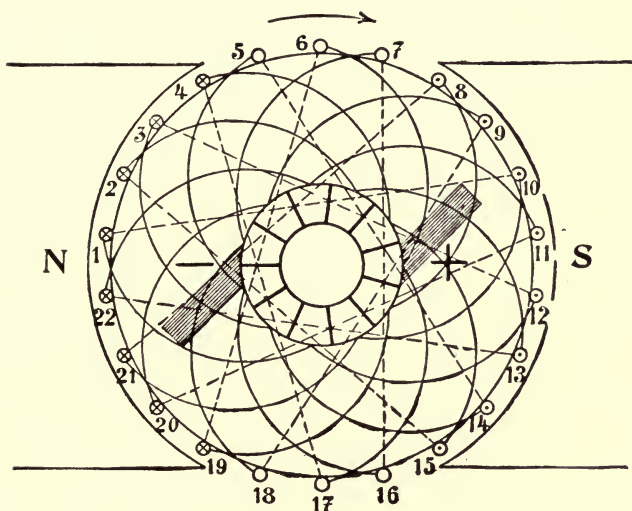

FIG. 82.—Drum Armature Connections.

These rods are called *driving-keys*. For smaller armatures about 4 to 10 driving-keys are required.

Generally this difficulty is overcome in quite another way, viz. by placing the conductors themselves into slots, which are either cut in the complete armature core, or stamped in the single discs which are fixed on the shaft, so that they form continuous slots, into which the armature wires are laid. In this case there are many slots, which are very near one another.



FIG. 83.—Open Slots.

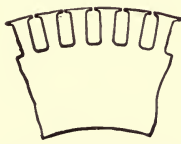

FIG. 84.—Nearly Closed Slots.

Between the single slots the teeth or small bridges of the armature iron project. In Figs. 83 and 84 portions of toothed discs are shown. Fig. 85 shows a toothed drum armature without, and Fig. 86 one with its winding, which lies well protected in the slots. These armatures are called **toothed armatures** in opposition to the above described **smooth armatures**, although the latter may have some slots for the keys.

Both the ring and the drum, the smooth and the toothed armatures

are capable of producing a continuous current of nearly the same kind as that delivered by a battery. As a rule, the armature winding consists of a great number of conductors; and, by the action of the commutator, at every moment all wires within the range of the lines of force act in the same manner, and give E.M.F.; whereas with the Sie-

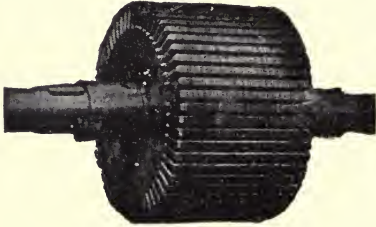

FIG. 85.—Armature-core, without Winding.

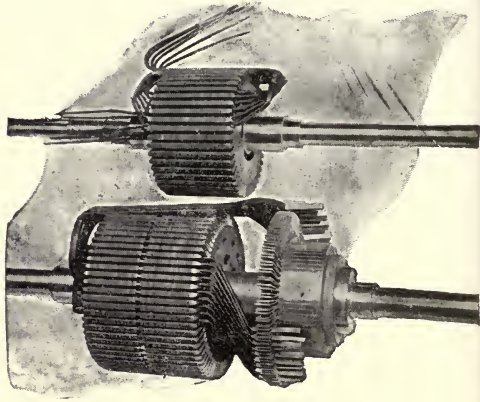

FIG. 86.—Armatures, Partially Wound.

mens armature the pressure oscillated at each half turn between zero and its maximum value. Certain fluctuations do, however, take

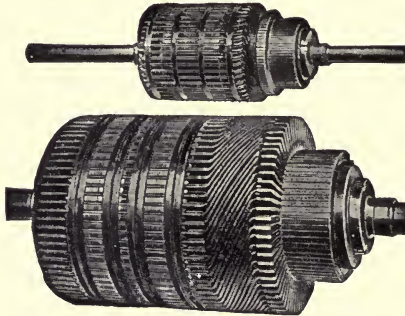

FIG. 87.—Finished Armatures.

place also with these armatures. It might happen that there are at

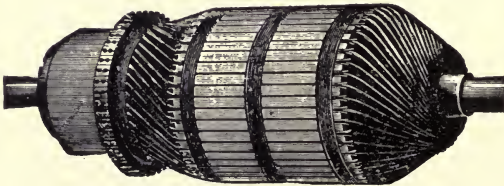

FIG. 88.—Wound Drum Armature.

one time 20, whilst in the next moment there are 21 slots under the

pole-shoe, so that the E.M.F. induced is alternately a little smaller and a little larger, but generally these fluctuations are unimportant.

The bipolar is manufactured in America for small dynamos and motors up to about 10 kilowatts, and in a few installations made by the old Edison Company they are in use up to 150 kilowatts. Also

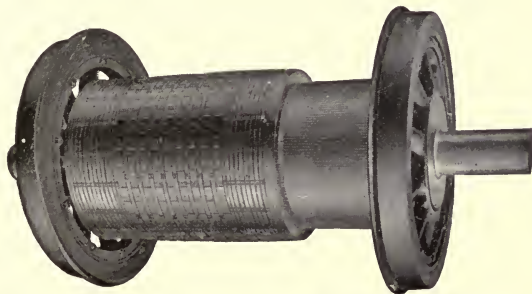

FIG. 89. —N. Y. C. Locomotive Motor Armature.

a recent type of locomotive motor, made by the General Electric Company, has been adopted by the New York Central Railroad Company, each armature being capable of delivering 600 H.P. Fig. 89 shows the general arrangement, the truck frame serving as part of the magnetic circuit. A bipolar winding has the full potential between layers, so that special care must be used in insulating, particularly on the ends.

Magnet System

Permanent steel magnets cannot be magnetized to as high a degree as electro-magnets. Hence, for dynamos, electro-magnets are exclusively employed. Fig. 90 shows a two-pole dynamo with horseshoe-shaped magnets. Over the arms of the latter two coils are wound, so as to drive all lines of force in the same direction through the magnet, and to make one pole north, the other one south, magnetic.

To get a strong magnetic field it is, as we know, essential to have the lines of force going as far as possible through iron only, and to make the way through air or any other non-magnetic materials as short as possible. Hence the air gap between armature and pole-shoes is kept very small. It is obvious that we can approach the armature core nearer to the pole-shoe with a toothed armature than with a smooth one, for with the latter the winding is arranged over

the iron core. This is a further reason why, nowadays, toothed armatures are generally employed for dynamos.

To get a current from the dynamo, it is necessary to “*excite*” the magnet system, *i.e.*, to send a current through the coils, by which a magnetic flux is produced. The current for exciting the magnet coils may be taken from any current generator, as, for instance, a

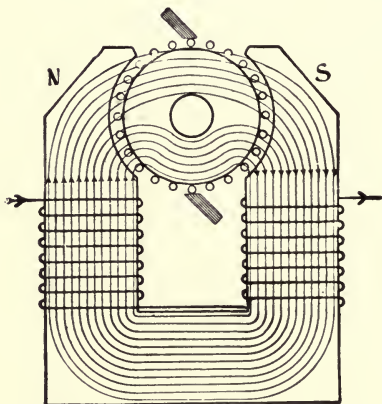

FIG. 90.—Magnetic Circuit of Bipolar Dynamo.

galvanic battery. We shall see, later on, that it is not necessary to use an external current generator for this purpose. But as this case is the simplest one, and easiest to be understood, we shall, first of all, take this as a basis for our consideration.

If we send a current through the magnet coils, and let the armature rotate, the dynamo will produce a definite voltage. The E.M.F. induced in each conductor is larger the stronger the magnetic field and the greater the speed of rotation of the armature. Since the coils of each half of the armature are connected in series, the E.M.F. of the whole armature will also increase with the number of armature wires. If we turn a certain armature, firstly with a speed of 500, and then with 1000 revolutions per minute, and leave unchanged the strength of the magnet current, then the E.M.F. of the armature will be twice as much in the second case as in the first one. If we strengthen the magnetizing current, the E.M.F. of the armature will also rise, but not quite in the same proportion. For, as we know, there is a limit to the magnetization of iron, and if we approach this limit, a great increase of the magnetizing ampere-turns causes only a small strengthening of the magnetic field. By

means of a diagram we can make this clear as follows:—Let us draw a horizontal line (Fig. 91), and divide it into parts, each of say 1 cm. The length of 1 cm. represents, then, about 1000 ampere-turns. Thus we mark the first division with 1000, the second one with 2000, the third one with 3000, and so on. Now let us draw a vertical line from each of these divisions. The length of these lines we make equal to that E.M.F. which is produced by the armature at a constant speed, if the magnet arms be excited with 1000 ampere-turns in the first, with 2000 in the second, 3000 in the third case, and so on. A height of 1 cm. of the vertical line has to represent about 20 volts. We observe that, with 2000 ampere-turns, the voltage is nearly double of that with 1000 ampere-turns.

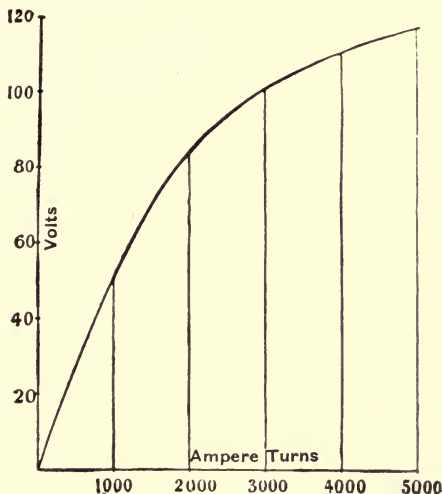

FIG. 91.—Magnetization Characteristic.

But as the excitation grows to 3000, the increase of the voltage is slower. At still higher excitations the voltage, increases but less and less. If we connect all the ends of the vertical lines by a line, we get a bent line or a curve. This line is steep at its beginning, and becomes rather flat at its end. This curve is called *the electro-motive force characteristic of a dynamo on open circuit*. A simpler name is the **magnetization characteristic** or **saturation curve**.

To obtain from the dynamo that we are considering a voltage of 110, we want on the magnet limbs about 4000 ampere-turns. We can get this by sending through a coil of thick wire, with 40 windings, a current of 100 amps., or by sending through a coil of fine wire, with 2000 windings, 2 amps., and so on. As, in the first case, the few windings of thick wire have a small resistance, the voltage required for this coil is small, say about two volts; whereas, in the latter case, the numerous windings of the fine wire have a very high resistance, and therefore a much larger voltage—about 100 volts—is required. The output in watts, however, which has to be spent for excitation is practically the same in all cases. In our examples, for instance, it would be 200 watts.

If the dynamo delivers current to an outer circuit, the voltage on the brushes decreases. We have observed the same case with the

battery. The dynamo armature has a definite internal resistance. If now through the armature a current is flowing, the resistance consumes a certain voltage. Thus the terminal voltage, *i.e.* the voltage of the brushes, is smaller than the E.M.F. induced in the armature. The larger the current the greater will, as we know, be the voltage drop.

But there is, in addition to the internal resistance, a further reason which causes this voltage drop. The currents flowing in the armature exert a reaction on the magnetic field, so as to weaken the latter. We shall deal, later on, separately with the question of the armature reaction. For the present moment it is sufficient to know that the armature reaction has an effect similar to the ohmic resistance of the armature. Both cause a voltage drop at an increased load.

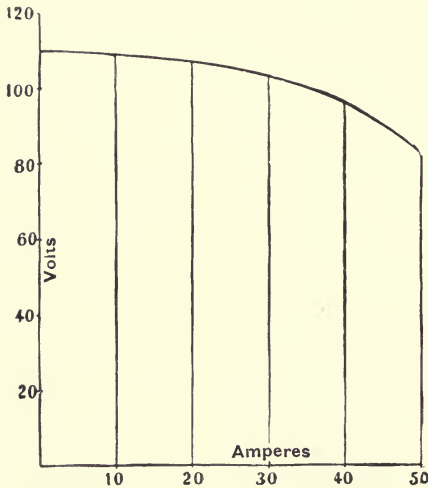

FIG. 92.—Closed Circuit Characteristic.

We can make this clearer by means of a diagram. Let us assume that the magnet system be magnetized constantly by 4000 ampere-turns, and that the current taken from the armature be 10, 20, 30 amps., etc., respectively. 1 cm. on the horizontal line may represent 10 amps. (see Fig. 92). On the vertical we plot the voltages as before. If the dynamo does not supply any current, its pressure is

about 110 volts. If it supplies a current of 10 amps., the pressure would go down to 109 volts, at a current of 20 amps. to 107 volts, at 30 amps. to 103 volts, and so on. By connecting all the ends of the vertical lines we get a curve, which shows the decrease of the voltage with increasing load. This curve is called the closed circuit characteristic or load characteristic.

It is, of course, desirable in many cases to get a constant dynamo voltage at a varying load. If, for instance, a dynamo supplies current for a lighting plant, it would be very objectionable, if the voltage fell from 110 to 103 volts, as we switched on more lamps. To bring the voltage back to its normal value of 110 volts, it is therefore necessary to increase the number of ampere-turns, so that, for instance instead of 4000 ampere-turns, 4200, 4500, 5000, and so on, ampere-turns may be produced. This can be effected by

means of a regulating resistance. To understand the action of a regulating resistance, let us consider the following example. Assume a dynamo, giving a voltage of 110, which requires for excitation at no load 4000 ampere-turns. The magnet coils consist of 2000 windings, having a resistance of 50ω . Hence, if we connect these magnet coils with a voltage of 100, the current would be 2 amps., and the number of ampere-turns $2000 \times 2 = 4000$, *i.e.* just what we want. But let us now connect the magnet coils with 110 volts; then the magnet current would be 2.2 amps., and the number of ampere-turns $2.2 \times 2000 = 4400$. As we have previously learned, an additional number of ampere-turns increases the voltage so that in our case the pressure would rise to, say, about 117 volts. To get only a voltage of 110, we have to connect a resistance of 5ω in series with the coils. Then the current becomes again 2 amps., and the number of ampere-turns 4000. But if we now load the dynamo, its voltage will come down to, say, about 109 volts. By increasing the number of ampere-turns, or, what is the same, by increasing the magnetizing current, we can increase the voltage. Thus we have to do nothing but switch out a part of the resistance connected in series with the coils. This is effected by approaching the lever of the adjustable resistance to its position of short circuit. The greater the load of the dynamo, the larger has to be the magnetizing current, the more resistance we have therefore to cut out of the circuit.

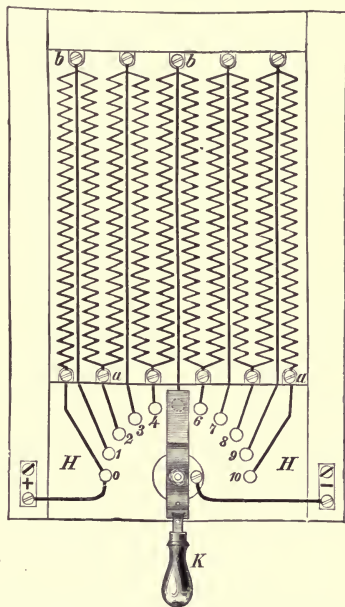

FIG. 93.—Regulating Resistance.

Fig. 93 serves as an illustration for a regulating resistance. The connection with the coil and the circuit is made as follows:—The centre-point of the lever *K* is connected with one pole of the battery, and the last contact on the left with one end of the coil. The other end of the coil is connected directly with the second battery pole. If the lever of the regulating resistance is over the last contact on the left marked 0, the current can go from the battery to the magnet coil directly, without flowing through the resistance spirals. We say, then, that the resistance is short-circuited. The further we

move the lever to the right, the more resistance spirals the current has to flow through.

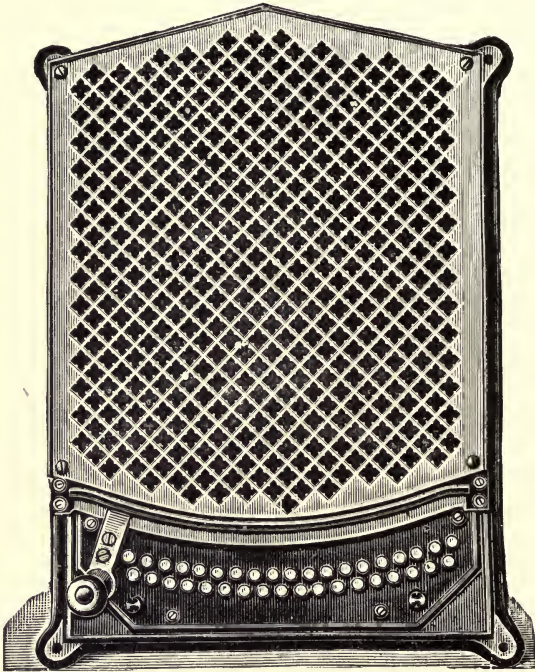

FIG. 94.—Enclosed Regulating Resistance (*Berend & Co.*).

Fig. 94 shows a regulating resistance covered with stamped sheet iron.

Figs. 95 and 96 show two rheostats as made by the General Electric Company, the first having a resistance of 20 ohms and a carrying capacity of 10 amperes, and the second a resistance of 832 ohms and a carrying capacity of 75 amperes. The formula for the E.M.F. of a direct current dynamo is derived as follows: Let n = the number of coils in series between brushes = number of external contacts divided by 4 in a bipolar. Let ϕ = the flux going from pole to pole being enclosed by the coils of the armature. Let N = the number of revolutions of armature (in a bipolar) per second. In connection with the production of E.M.F. in a dynamo, it has been shown and illustrated in Fig. 65, page 69, that in each revolution of the armature coil, starting say as shown in Fig. 65, the coil is filled full of lines of force twice and emptied twice, thus four times

in each revolution does the coil cut all the lines of force ϕ . Thus, since a volt is produced by cutting 100,000,000 lines of force per second, the average volts produced per coil = $\frac{4N\phi}{100,000,000}$. But there

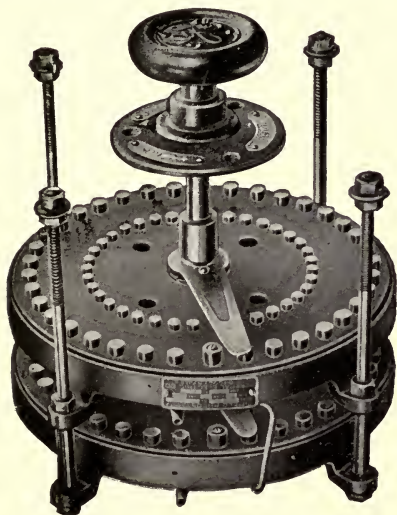

FIG. 95.

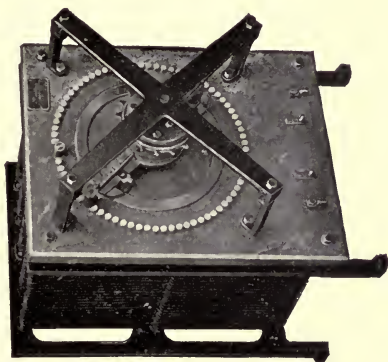

FIG. 96.

Field Rheostats.

are n coils in series between brushes. Therefore the E.M.F. of a D.C. dynamo having n coils on its armature = $\frac{4N\phi n}{100,000,000}$. On a two-pole dynamo n = the external conductors divided by 4. Representing the external conductors by C , the formula becomes $\frac{CN\phi}{100,000,000}$.

Self-excitation—Shunt Dynamo

As mentioned before, it is not necessary to use current from an external current generator for exciting a dynamo. It would be the simplest way to use the voltage of the dynamo armature, which was, for instance, 110 volts in the last example, for feeding the magnet coils, which had to be excited with 100 volts at no load, and with a somewhat higher voltage at full load. It is clear that, if the machine is brought to its full voltage, the magnet coils may be connected without any further difficulty with the armature, so that the machine

is able to work properly. The only question arising is now: How is it possible to bring the machine up to its voltage without the use of an external current generator?

For this purpose, that property of the iron which we know as residual magnetism is of great advantage. Iron which has once been magnetized always retains some traces of magnetism. It follows, therefore, that across the field of a non-excited dynamo a certain although it may be a very small, number of lines of force pass. If in this very weak magnetic field an armature is turned, a very small E.M.F. is induced, and since the magnet coils are connected with the armature, the small E.M.F. will send a defined, but small current through the magnet coils. We hence get a few magnetizing ampere-turns, which strengthen the residual magnetism. The strengthened field now induces a larger E.M.F., the latter again causing a stronger magnetizing current, which produces a stronger magnetism, so that, in this way, the machine, in a short time and without an outer source of current, is brought to its full voltage.

It is, of course, necessary to connect the magnet coils properly with the armature, that is to say, in such a way that the current produced by the armature, and flowing through the coil, really strengthens the existent magnetism. If we connected the magnet coils with the armature in a wrong way, then the current, flowing in the wrong direction, would not strengthen the residual magnetism, but destroy it, and the dynamo would give no voltage.

Werner Siemens was the first to find this principle of *self-excitation of dynamos*.

Fig. 97 is a diagram of connections for a self-exciting dynamo. To one side of the brushes is connected the load (the small circles represent lamps, connected in parallel), on the other side are the magnet coils (marked by a zigzag line). There might have been connected also a resistance in series with the magnet coils, but this is not considered in the diagram. The two circuits which branch off the armature terminals are called, respectively, the *main circuit* and the *shunt circuit*. The magnet coil acts as a shunt to the main circuit. A machine, having connections as shown in Fig. 97, is called a **shunt dynamo**.

How does such a shunt dynamo behave with various current intensities in the main circuit?

Suppose, first of all, that the main circuit is disconnected. We now have the circuit closed through the armature and the coils, and

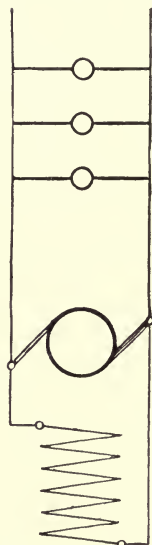

FIG. 97.—Shunt Dynamo Connections.

the machine therefore comes to a defined voltage—say, about 110 volts. Let us now switch on, in the main circuit, a number of lamps, so that the dynamo has to supply a current of 10 amps. As a consequence, the terminal voltage of the dynamo will fall, due to the ohmic resistance and the armature reaction, to, say, 109 volts. But, at this moment, the magnet coils are now no longer connected with 110, but only with 109 volts. The magnetizing current, and hence the excitation, will therefore become smaller, and the dynamo voltage will further fall. At a load of 20 amps. we had, with the separately excited machine (page 88), a voltage of 107; whereas the voltage of a self-excited dynamo at the same load will be only about 105 volts, and at 30 amps. load—about 100 volts (against 103 with the separately excited dynamo). Thus the self-excited dynamo shows the property of the separately excited machine—the falling of the voltage with increasing load—in a far higher degree. Naturally, we may use here the same auxiliary means—a regulating resistance—for keeping the voltage constant, as before.

The magnet coils of a 110-volt dynamo are, for instance, wound generally so as to get, at no load, a sufficient excitation for producing in the armature a voltage of 110, even if the voltage, measured at the magnet coil terminals, be 90 volts only. The remaining 20 volts are then absorbed by the shunt regulator. At an increased load, the resistance switched into the shunt circuit has to be diminished. The more the load increases, the more resistance of the shunt regulator has to be short-circuited.

Fig. 98 shows the external characteristic of a shunt dynamo of modern design. The line OB gives the current values delivered

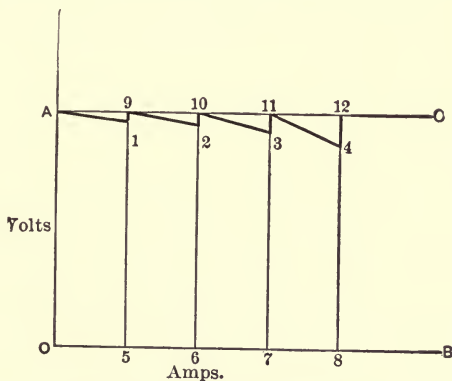

FIG. 98.—Shunt Characteristic.

by the dynamo, and the line OA the voltage values. When one-quarter load is put on at 5, the voltage drops at 1 below the normal value shown by the line AC. If it is raised again by means of the

field rheostat at 9, and another one-quarter load is put on, the voltage will again fall, a little more this time, to 2, and so on up to full load. A well-designed dynamo will drop at 2 about 5 per cent. Some machines will entirely lose their magnetism when one-quarter load is put on without any further adjustment of the field rheostat, particularly in going from three-quarters to full current, the voltage dropping and

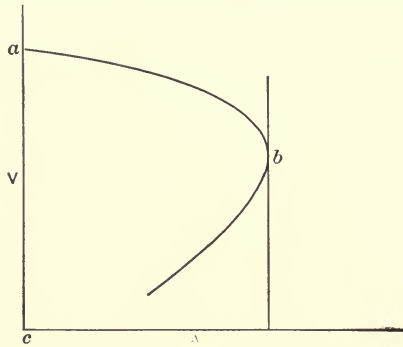

FIG. 99.—External Characteristic.

the field following till no voltage at all is reached. This is called unbuilding, but should not occur under ordinary conditions with well-designed machines. The external characteristic without adjustment of field rheostat is shown in Fig. 99. In this case the voltage starting at *a* drops till it reaches *b*, when the machine unbuilds and the voltage goes to 0.

Series Dynamo

In the case of a shunt dynamo the magnet coils are excited with nearly the full armature voltage, but only a small part of the armature current flows through them. The greatest part of the current goes through the main circuit. There is, however, possible another method of connection of the armature with the magnet coils. As we know, we can get any desired magnetic effect with a coil, having but few windings, through which a strong current passes. Hence we may send the whole dynamo current through a coil consisting of a few windings of comparatively thick wire (see Fig. 100). In this case the connections have to be as follows: One brush, say the right one, has to be connected with the main circuit directly. From the second brush no connection is made with the main circuit, but the current has first to flow through the magnet coil, and then enters the main circuit. The latter is again shown in the diagram as consisting of lamps. Thus in this case the full or *main current*

flows through the magnet windings. This is called a **series winding**.

As the armature, the magnet coils and the main circuit are connected in series, this dynamo is called a **series dynamo**. Let us now consider the behaviour of such a machine with various currents.

If we disconnect the main circuit, then the whole circuit is disconnected, and no current whatever can flow, neither in the mains nor in the armature nor the magnet coils. Notwithstanding, a very low E.M.F. is produced in the armature, originating in the residual magnetism. No strengthening of this E.M.F. can, however, take place. Thus the voltage of the machine is, with the main circuit open,

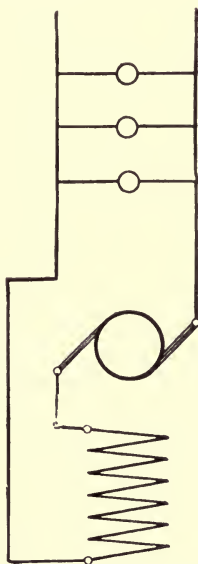

FIG. 100.—Series Dynamo Connections.

a very low one, or, practically speaking, nothing at all. If we now close the main circuit, a current produced by the small E.M.F. flows through the magnet coils. As a consequence, a strengthening of the field follows, with an increase of the E.M.F., producing a greater current, and causing a further strengthening of the field as before. If the main resistance happens to be a large one, the current (in this case the main current as well as the magnetizing current) and the E.M.F. will be small only. But if we diminish the main resistance (we may do so, for instance, by connecting some more lamps in parallel with

those which were already burning) the current flowing through the whole circuit is increased. Thus the machine will be more strongly magnetized, and hence produce a larger E.M.F. We thus learn that the E.M.F. of a series dynamo will grow with an increasing load, quite opposite to the case of the shunt dynamo.

But this growing of the E.M.F. at increasing load has naturally an end. The strength of the magnetic field cannot increase continually, but remains constant, after having reached a certain value. On the other hand, there is a voltage drop in the armature, which is greater the larger the armature current. After the machine has reached a certain voltage, it therefore follows that, since the strength of the magnetic field cannot further be increased, the growing voltage drop in the armature and armature reaction must cause the terminal voltage to fall when we put a greater load on the dynamo.

As long as the load of a series dynamo is not too high, its terminal voltage grows with an increasing load: if now the load

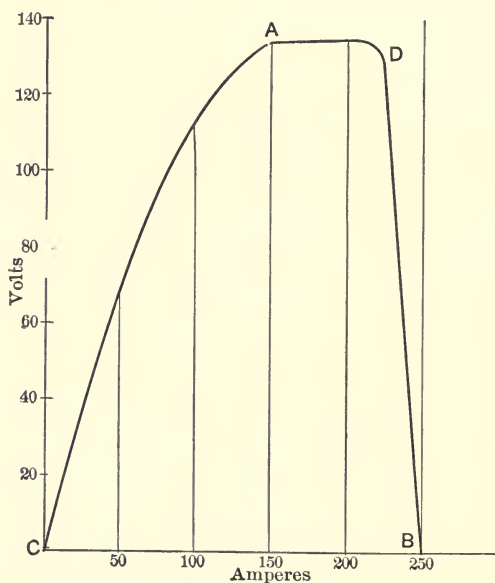

FIG. 101.—Closed Circuit Characteristic of Series Dynamo.

be further increased, the voltage remains constant for a certain period; then if the load is increased once again, a fall of pressure must ensue.

The diagram, Fig. 101, shows the characteristic curve for a series dynamo.

For feeding a variable number of glow lamps connected in parallel a series dynamo cannot be employed, for the voltage of the dynamo would vary with the number of lamps burning, and therefore the lamps would from time to time vary in candle-power. If the number of lamps burning can be kept constant, lighting with a series dynamo is possible, although this is seldom done. We may compare the difference in the behaviour of the shunt and series dynamos with the difference in the characters of two men. With one, his effort ceases if he has to do more work, whereas with the other, a greater demand strengthens his resolve and his power up to a certain point, beyond which, if his task be increased, he also breaks down.

The series dynamo is particularly suited for series arc lighting, where a constant current is desired and an increased voltage when the number of lamps in circuit is increased. It is customary to work such machines at the point D (Fig. 101) on the characteristic curve, which results in a constant current with varying voltage. Even at short circuit on such a machine, the current does not increase seriously (at B, Fig. 101). The large armature reaction, to be explained later, and high internal resistance, which naturally follow from a large number of armature turns, and high voltage generated, hold the increase of current in check. Sometimes series generators are used as *boosters*, being connected to constant voltage supplies to increase the voltage on a circuit in proportion to the load. Under such conditions the series dynamo would be operated on the characteristic between C and A, the voltage under such conditions rising with the load which is desired. In the latter condition, the iron of the magnetic circuit would be operated below *saturation*, so as to get a response to the increase in ampere turns. Also the dynamo would be designed with less armature reaction, so that the characteristic would not tend to drop, as shown in Fig. 101, but would continue in an approximate straight line. The designer, therefore, lays out his machine to meet the conditions imposed.

Compound Dynamo

Generally, it is required from a dynamo to supply constant voltage at varying loads. This may be effected, not only by a shunt dynamo having an adjustable shunt resistance, but also by a suitable winding of the magnet coils. For this purpose the dynamo is provided, besides the shunt winding, with a series winding, which latter is wound either over or under or beside the former. Care must be taken to wind both windings in such a way that they may act in the same sense. If the dynamo does not supply current, the series winding

has no effect at all. The shunt coil only has to be considered, and this brings the machine up to a certain voltage—say 110, for instance. If the machine supplies current, its terminal voltage would fall, if there were only a shunt coil; but now, since the main current flows through the series coil, the number of ampere-turns is increased, and the magnetic field is strengthened. With a proper proportion of the number of the two windings, we can, up to a certain limit, get a constant or nearly constant voltage at varying loads. If, however, the current taken from the dynamo exceeds the limit allowed, then the voltage falls. The diagram of connections for such a machine is shown in Fig. 102. The shunt winding is indicated by a fine, the series winding by a thick, zigzag line. A dynamo whose magnets are wound in the way described is called a **compound dynamo**.

With a series coil, having a sufficient number of turns, we may also obtain the result that, at an increased current, the voltage too is increased, so that the voltage drop in the mains which grows with a larger current, is compensated. In this way the pressure at a place distant from the dynamo may be kept constant. The dynamo in this case is said to be *over-compounded*.

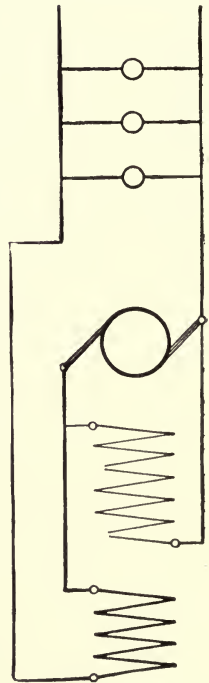

FIG. 102.—Compound Dynamo Connections.

Types of Dynamos

The essential parts of a dynamo are the magnetic frame, the armature, and the commutator. The magnetic frame may assume very many different shapes. For the actual working of the machine only the field between the pole-shoes is of special importance. But, to get a strong magnetic action, the connection between the two poles must be made of iron. The shape of this part of the magnetic circuit depends on the choice of the designer.

The magnetic frame may, for instance, have the shape of a horseshoe, with which we became acquainted in the previous chapter. The horseshoe may have the yoke upwards, so that the magnet stands in a manner on its poles (see Fig. 103). This type, which has been

employed by Edison, and is therefore called the *Edison type*, was very

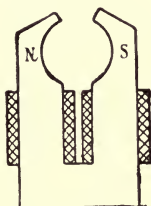
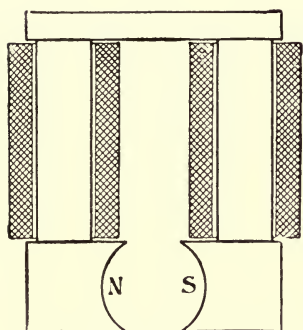

FIG. 103.—Edison Type. FIG. 104.—Kapp Type.

common some time ago, but is very seldom built now-a-days. When horseshoe magnets are employed, they are generally built with the yoke downwards, so that the yoke may either be used as base, or may be cast together with the base-plate. This type (see Fig. 104) is called the *Kapp type*, after Kapp, who first employed it. Fig. 105

shows a machine after the Kapp type, but the construction of which differs somewhat with regard to the arrangements of the bearings.

It is not necessary to employ two magnetizing coils. The

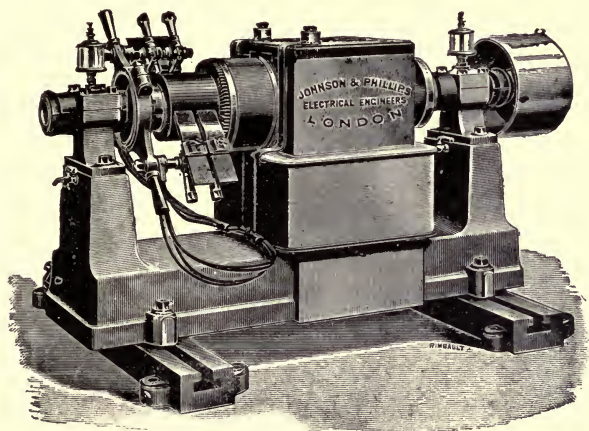

FIG. 105.—Kapp Type.

magnetic flux may, of course, be obtained as well by one coil, having double the number of ampere-turns. Fig. 106 shows a machine which is also of the horseshoe type, but with the windings on one coil—on that placed on the yoke. In this case the pole-shoes are one above

the other, whereas they are arranged side by side in all the types we have hitherto considered.

It is also not necessary to make the yoke between the two pole-shoes in one piece, but it may be divided into two parts. We have

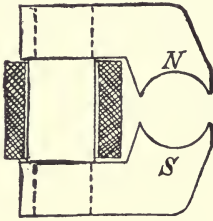

FIG. 106.—C Type.

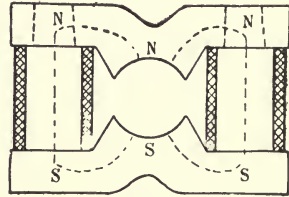

FIG. 107.—Manchester Type.

then a magnetic circuit, split into two branches, similarly to the branching of an electric circuit.

Fig. 107 shows a scheme of such a dynamo. The upper pole is a north, the lower one a south pole. The lines of force go, then,

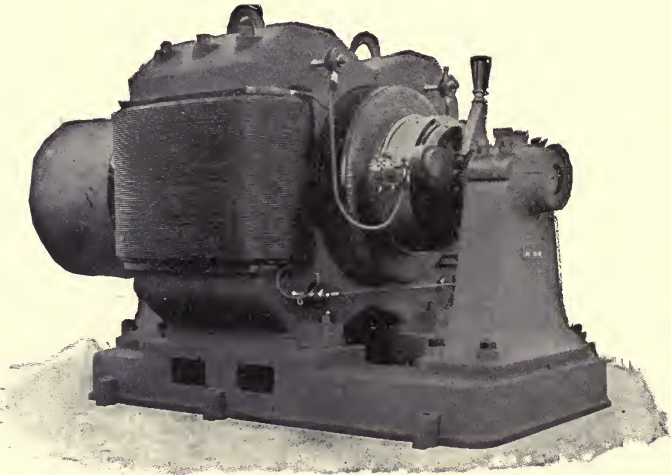

FIG. 108.—Manchester Type.

from the north pole, through the air gap and the armature core, downwards to the south pole, enter the yoke, and branch to the right and to the left. They go upwards through the two vertical columns

bearing the coils, and join again in the upper yoke. The coils have, of course, to be wound so that both tend to generate a flux of lines of force directed upwards. Thus the current must, seen from one side, flow in the same direction through the coils. The machine described here is called a **Manchester** machine. Fig. 108 is an illustration of a complete machine of this type. This was the type of magnetic circuit used in the old Sprague dynamo of several years ago.

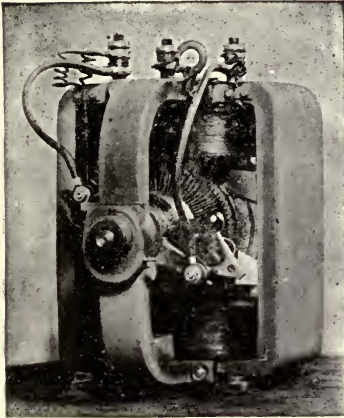

FIG. 109.—Lahmeyer type (*British Schuckert Co.*).

The magnet coils may also be arranged in another way. Fig. 109 shows a type of machine called the **Lahmeyer** or semi-enclosed type. With this machine the coils are arranged over and underneath the pole-shoe, and the yoke, which is split into two parts, partially encloses the machine. Fig. 110 is also built after this type.

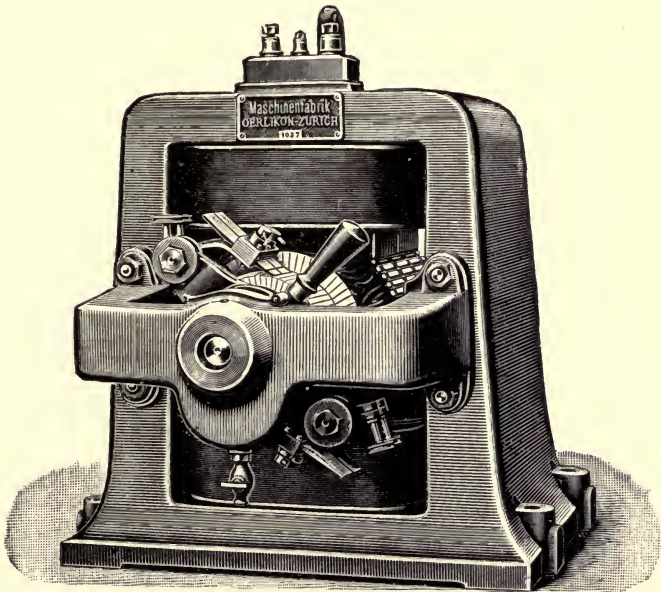

FIG. 110.—Lahmeyer Type (*Maschinenfabrik Oerlikon*).

The **Gramme** machine (see Fig. 111) has another arrangement of the magnetic field, which was employed in the early days of dynamo building. Its magnetic field consists of a double magnetic circuit, like that of a Manchester or Lahmeyer machine. With the Gramme machine, however, each half is provided with two coils, one at the top and one at the bottom.

There are, besides the types mentioned hitherto, a great number of different magnet shapes, but which are very seldom used. The most usual 2-pole machines are those after the Lahmeyer and the Kapp type.

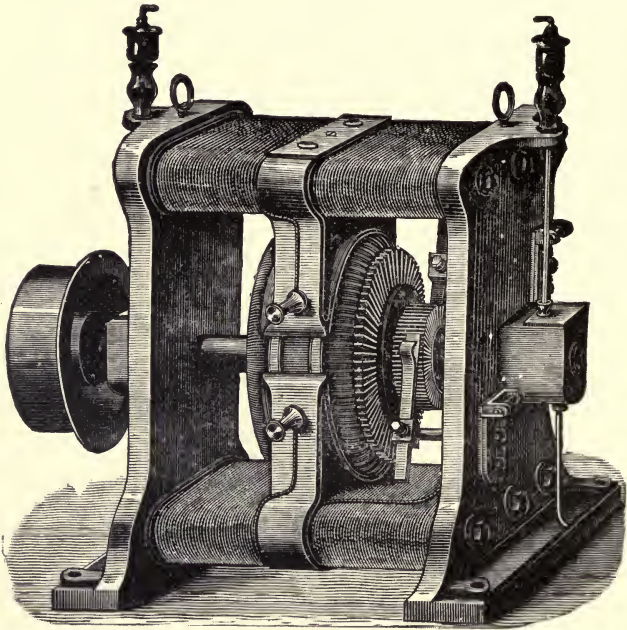

FIG. 111.—Gramme Dynamo.

As material for the construction of field magnets, formerly *wrought* iron was in general use, because this can be magnetized more strongly than other kinds of iron. *Cast* iron has a far lower magnetic conductivity, not much more than half that of wrought iron. Hence if we employ cast iron we have to make the cross-sectional areas of the limbs and the yoke twice as big as with wrought iron, in order to get the same number of lines of force. As, however, in spite of the double cross-sectional areas, the cast-iron machines can be more cheaply manufactured than the wrought-iron ones, the use of the latter material has been abandoned.

Lately, steel makers have succeeded in manufacturing by a process of casting a material similar to wrought iron. This is generally called *cast steel*. It is of quite another quality to the hard steel, such as is used for tools and permanent magnets. The magnetic properties of cast steel are very similar to those of wrought iron. Hence, in making the magnet frame from cast steel, we can make the cross-sectional areas as small as with wrought iron; that is, equal to about one-half of the cross-sectional areas of a cast-iron frame. On the other hand, cast steel is more expensive than cast iron. Hence none of these materials has come into exclusive use. In some cases magnetic frames are made of cast steel, in other cases cast iron is employed with advantage.

Output of a Dynamo

The strength of current which can be taken from a dynamo is limited chiefly by the heating of the armature wires. From an armature wound, for instance, with wire of No. 18 S.W.G. we cannot, of course, take a current of 30 amps. for a long time. As the armature has two parallel circuits, through each of them a current of 15 amps. would flow, which would obviously heat this wire far too much.

We must, however, not think that the table given at the end of the first chapter is a standard for the maximum current allowable in armature wires. For, firstly, the heating allowable for armature conductors is a far higher one than it is with main conductors; and, secondly, due to the quick rotation of the armature, the conductors are cooled continuously by a draught of air. Thus the current density used for armature wires varies between 650 and 4500 amps. per square inch, and even more with very small machines. There is no general rule with regard to current densities of armature wires, for according to the special designs of armatures the draught of air produced by them may be stronger or weaker. With regard to the heating of a dynamo, a rise of the dynamo-temperature of 70° to 90° Fahr. over that of the surrounding air is generally considered allowable.

Still, with any given type of dynamo, the maximum current allowable is determined by the thickness of the armature wires. Now, the output of a dynamo is determined by the product of the number of amperes by the number of volts. Hence we have to examine by what factors the voltage of a dynamo is determined.

We know that the voltage is greater, the greater the number of armature wires, the stronger the magnetic field or the number

of lines of force leaving the pole, and the quicker the conductors are moved. Now, the number of armature wires cannot be indefinitely increased. On a given smooth armature, having a certain distance from the pole-shoes, a limited number of wires only can be fixed. Similarly, into the slots of a toothed armature a certain number of wires only can be put. If, however, we employ a thicker wire in order to get a stronger current from the armature, we can, on the given space for winding, fix a smaller number of wires only; that is, with given armature dimensions we can wind the latter either for a smaller current and a larger voltage, or for a larger current and a smaller voltage. Hence we may, for instance, wind an armature so as to get from it either 10 amps. at a voltage of 110, or about 20 amps. at a voltage of 55. Thus the output of the armature remains about the same in both cases, provided that the other determinative factors are not altered.

These determinative factors are the number of lines of force, and the number of revolutions of the machine. The number of lines of force is greater the larger is the cross-sectional area of the magnetic frame, and the more it is saturated. As a rule, the saturation is never pushed to its limit, as in this case an extremely large number of magnetizing ampere-turns, and thus very big magnet coils, would be required. Generally the iron is magnetized up to three-quarters of its limit of saturation. Hence, if a field of a threefold strength is required, and we cannot further substantially increase the saturation, it will be essential to enlarge the cross-sectional area of the magnet limbs about threefold, thus making the machine bigger and heavier.

Naturally the number of revolutions of a machine is chosen as great as possible. With smaller dynamos, up to an output of about 3000 watts, a speed of about 2000 revolutions per minute is generally employed. If a machine be run at 1000 revolutions instead of 2000, we get half the voltage, and hence only half the output.

Another factor in heating an armature is what is called hysteresis. When the magnetism in the iron core is reversed, which occurs once in a revolution in a two-pole machine, the molecules of iron in the core tend to turn about with the magnetism. This naturally cannot occur only very partially. The effort to do this causes rubbing of the molecules one upon another and from this heating, due to the friction resulting. Mr. Charles P. Steinmetz in a series of experiments showed that the loss in hysteresis expressed in watt-seconds or joules per cm^3 and cycle of magnetism = $\frac{KB^{1.6}}{10^7}$, where B equals flux density per centimeter, and K is a constant depending upon the quality of the iron.

This loss must be added to the loss in the copper and to the loss due to eddy currents in copper and iron (previously discussed) to give the total armature loss. The radiating surface must then be found, from which the total loss in watts per square inch can be determined. Knowing the loss per square inch, the temperature can be accurately predicted, for the rise in temperature of any surface is proportional to the loss of energy that must be radiated from that surface. Thus from the surface of a spool a watt of energy from each square inch will raise the temperature of the spool about 70° Centigrade. A loss due to friction and I^2R of brush contact on a commutator amounting to 1 watt per square inch of commutator surface will raise the temperature of the commutator 10° .

Multipolar Dynamos

Large machines cannot be built without considerable difficulty for very high speeds, more especially if they have to be coupled directly to steam or gas engines. In the latter cases, their speed must not exceed 200 to 300 revolutions, and in a few cases only it may come to 400 to 500 revolutions per minute. With dynamos built in the way we have already described, built with only two poles, the cross-sectional areas of the magnetic frame would have to be made very large, and the whole machine would become too bulky and expensive when low speeds are required.

We may, however, design a machine from another point of view. Suppose we let every conductor at each revolution pass, not two only, but a row of several poles. Then we get, in spite of the lower speed, as large a number of alternations as with a high-speed machine, and the poles may then have a far smaller cross-sectional area. Fig. 112 shows, for instance, a 4-pole magnetic frame. The magnet coils are wound so as to produce north and south poles alternately. In our example the upper pole would, for instance, be a north pole, the one to the right a south pole, the lower one a north, and the one to the left again a south pole. Hence the lines of force leave the uppermost pole and enter the armature. Half of the lines go through the armature to the right, enter from there the south pole to the right, and come back again through the upper right part of the yoke to the upper north pole. The other half of the lines pass the

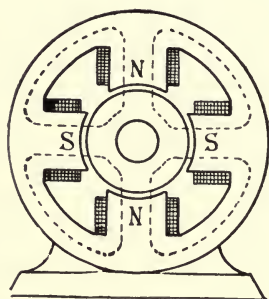

FIG. 112.—Four-Pole Magnetic Circuit.

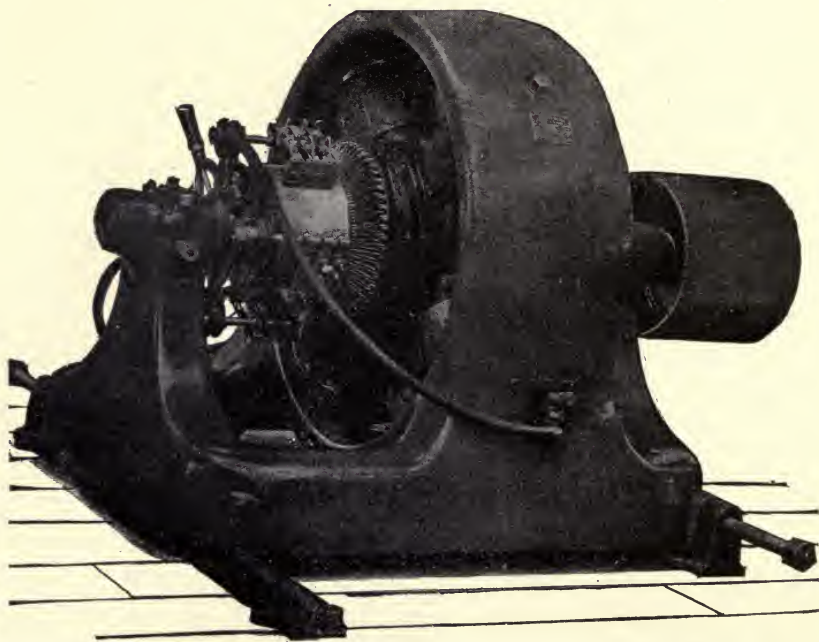

FIG. 113 —Four-Pole Dynamo of American Manufacture.

upper left quarter of the armature core, enter the left south pole, and then come back through the left upper quarter of the yoke to the upper north pole. In exactly the same way, we can follow the course of the lines of force of all the single poles. The yoke may be circular, or of polygon shape. Fig. 113 shows a complete 4-pole machine. This type is generally used for machines having an output of about 10 to 50 kilowatts; but these limits are by no means always followed, and dynamos for a far smaller output than 10 kilowatts, and sometimes for a higher output than 50 kilowatts, are made with four poles. But, as a rule, for machines

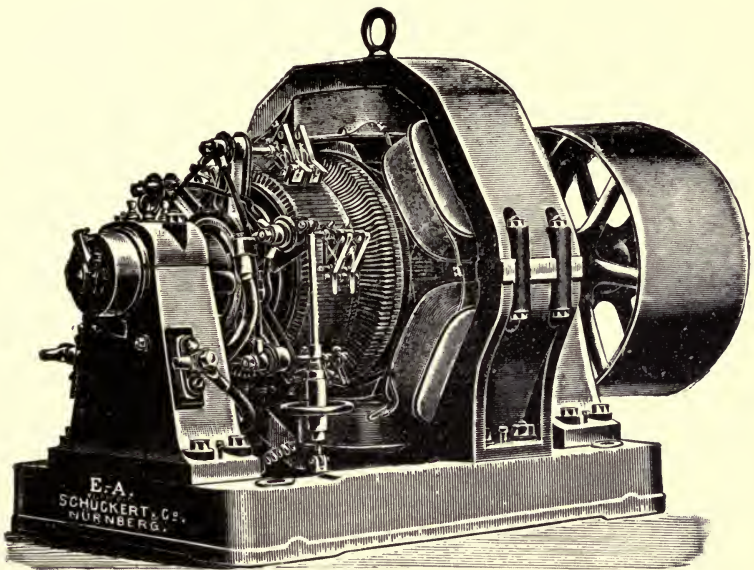

FIG. 114.—Six-Pole Dynamo (*British Schuckert Co.*).

having a large output, 6-, 8-, and more, pole magnetic frames are employed. Fig. 114 shows a 6-pole dynamo for an output of about 100 kilowatts; Fig. 115 the 18-pole magnetic frame of a dynamo, designed for direct coupling to a slow-speed steam-engine and for an output of 400 kilowatts.

It is not absolutely necessary that with multipolar machines every pole be provided with a magnetizing coil. In some cases there is a magnet coil over every second pole only. Fig. 117 shows a 4-pole dynamo, having only two poles provided with magnet coils. At a superficial glance, one might consider it to be a 2-pole machine.

The essential difference, however, between such a machine and a



FIG. 115.—Eighteen-Pole Magnet Frame (*Körting Bros.*).

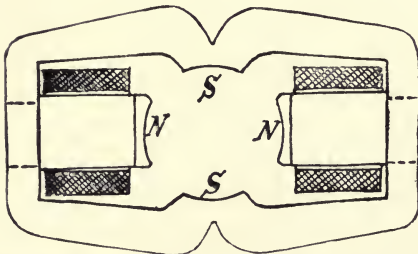

FIG. 116.—Two-Coil Four-Pole Dynamo.

right north pole, and, after having

passed the armature, one-half

of them enter the upper, and the other half the lower of the poles, having no coils. In a like manner, one-half of the lines, leaving the left north pole, enter the upper, the other half the lower one of the unwound south poles. Thus as many lines enter each of the unwound poles as leave each of the wound north poles. The strength of the unwound south poles is, therefore, as great as that of the wound north poles. The former are called **consequent poles**. There is naturally no saving of wire as we have one coil only for

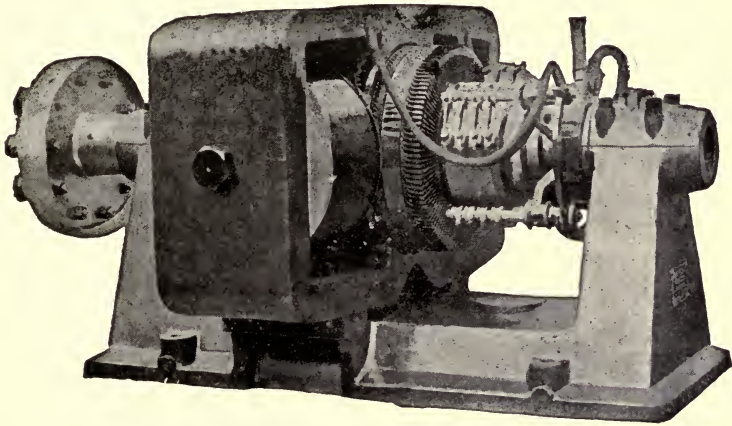

FIG. 117.—Four-Pole Dynamo with two Coils.

each magnetic circuit against two with the usual pole arrangement, and therefore each of the two coils has to have twice as many ampere-turns as each of the usual four coils.

In a like manner we could wind a 6-pole machine with three coils, and an 8-pole machine with four coils. This construction is, however, very seldom employed.

The formula for the E.M.F. of a 4-pole dynamo remains the same as for a 2-pole, but it must be remembered that the coils in series between brushes on a 4-pole multiple winding equal the external conductors divided by 8. With a series winding (described later) the coils in series may equal the external conductors divided by 4, as with a 2-pole machine.

Armatures of Multipolar Dynamos

The armatures of multipolar machines may be wound as ring or drum armatures, like those of 2-pole machines. The ring armature may even be used in quite an unchanged form for multipolar machines.

The machine has then to be provided with as many brush-holder studs as there are poles. In Fig. 118 a 4-pole ring armature is shown. If we imagine it rotating clockwise, then in the outer conductors, being under the influence of the north pole, currents are induced which are directed from the spectator, whereas, in the wires, being under the influence of the south pole, currents directed towards the spectator are induced, which are marked in the diagram by crosses and dots respectively. As we see now, the currents induced in the upper quarter of the armature are directed towards the left upper brush, thus making this a positive one, whereas the right upper

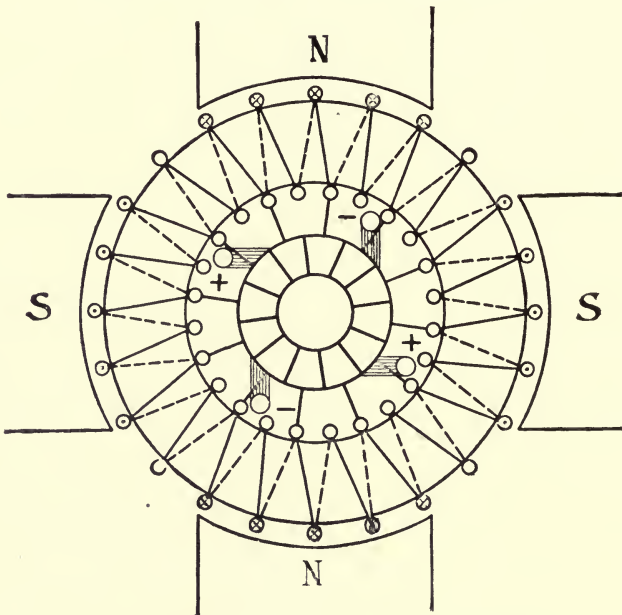

FIG. 118.—Four-Pole Parallel Ring Armature.

brush becomes a negative one. The currents of the right quarter flow from the right upper brush towards the right lower one. Hence the latter, too, is a positive brush. The currents of the lower quarter flow from the left lower brush towards the right lower one. Finally, the currents of the left quarter flow from the left lower brush towards the left upper one. Hence every two opposite brushes are of the same polarity. If we now connect two opposite, corresponding brushes with each other, by a metal bridge, such as, for instance, a bent copper strip, then we may connect the mains with any point of the two bridges (see Fig. 119). The E.M.F

of the armature is produced here from one-fourth of the windings being in series, and connecting these four quarters in parallel. Hence the main current is four times as great as the current flowing in each armature conductor. Such a winding is called a parallel winding. It is very suitable for comparatively low voltages and large currents, for we may even with large currents employ relatively thin wires, since each of the conductors has to carry the fourth part of the main current only, and not the half of it, as was the case with the 2-pole armature. For a 6-, 8-, 10-pole machine, 6, 8, 10 brush-holders are required, the current flowing in every armature conductor being equal to the 6th, 8th, 10th part of the main current respectively. The E.M.F. of the armature is produced by connecting in series the 6th, 8th, 10th part of all conductors.

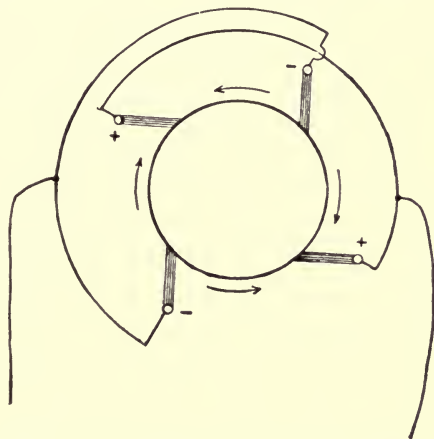

FIG. 119.—Brush Arrangement of 4-Pole Parallel Armature.

For higher voltages, however, this winding would require, for the reason just mentioned, a large number of windings. In these cases it is preferred to wind the armature so as to get, similarly to the 2-pole armature, but two parallel connected halves. The E.M.F. is then produced by connecting in series the half of all windings. For this purpose it is necessary to connect the single sections of the winding not directly with their neighbouring ones, but, by means of copper bridges, with the opposite sections, which are always under the influence of a like pole. A diagram of the connections is given in Fig. 120. The armature winding, shown in this diagram, consists of fifteen sections. Following the path of the current, we find that it branches, after leaving the right (negative brush), one part flowing through seven, the other one through eight sections, the electro-motive forces of which are added. The two current branches join again at the second (positive) brush. For this winding two brushes only are required, which are distant from each other, not the half, but the fourth part of the commutator circumference. This is called **series winding**.

If a drum winding is used for multipolar dynamos, its pitch has naturally not to be equal to about the half of the total number of

armature wires, but has in the case of a 4-pole machine to be equal to about one-fourth, with a 6-pole machine to about one-sixth of the total number of wires. Then a proper series connection of the electro-motive forces of the single wires will be secured. By the selection of corresponding pitches, we may, as with the ring armature, get either a series or a parallel connection of the armature. In Fig. 121—in which the front connections are marked by double bent lines inside, and the back connections by single bent lines outside the

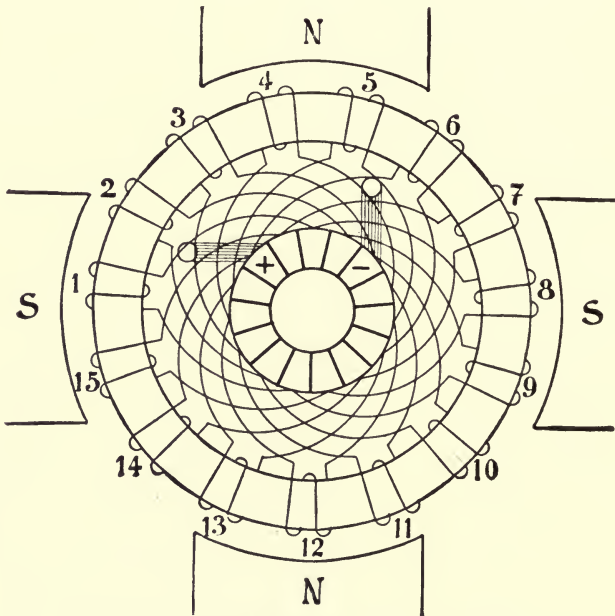

FIG. 120.—Four-Pole Series Ring Armature.

armature—the diagram of connections of a 4-pole armature, having 26 wires, is given. The pitch is 7 forwards and 5 backwards, and so that, at the front, wire 1 is connected with wire 8, and then, going backwards, wire 8 is connected with wire 3 at the back, at the front 3 with 10, at the back 10 with 5, and so on. In addition to being denoted as *parallel winding*, this is also called **loop winding**. On marking the brushes at 4 points, $\frac{1}{4}$ of the commutator circumference distant from each other, we find that there are four parallel circuits, which consist of nearly equal numbers of series-connected wires that are effective in producing voltage.

Next let us consider the diagram shown in Fig. 122. With this winding we do not go backwards in making the connections at the back, but always proceed in one direction. Thus at the front, wire 1 is connected with 8, at the back 8 with 13, at the front 13 with 20, at the back 20 with 25, and so on. In following the course of the current we find, starting from the positive brush (there are two collecting places only required with this winding), that there are two ways to reach the negative brush. Each of these ways comprises

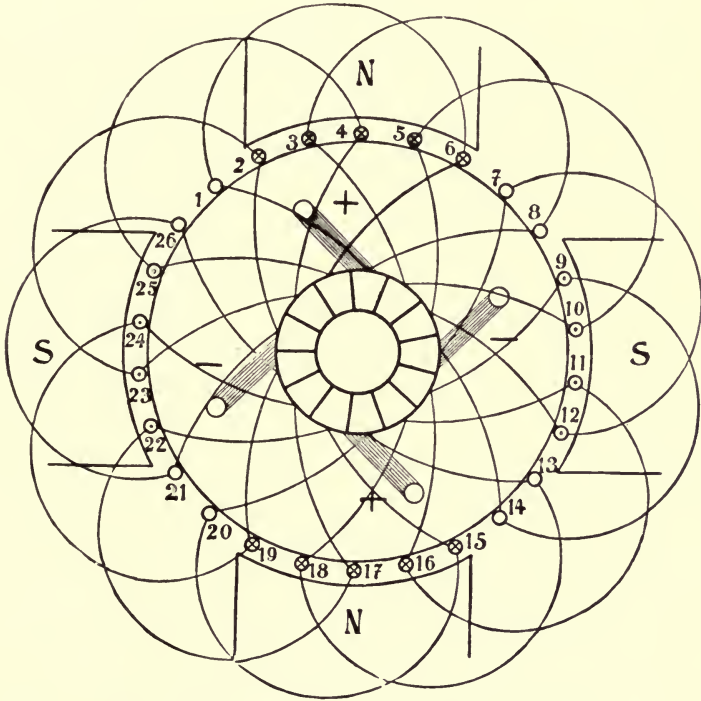

FIG. 121.—Four-Pole Drum Parallel Armature.

half of all the armature windings; we have therefore two circuits connected in parallel. This is called **series** or **wave winding**. Instead of two, we may employ four brush-holder pins. In this case, two opposite ones are of the same polarity, and there is between them but one winding, consisting of neutral wires. This winding is short-circuited by two brushes; but that is of no disadvantage.

It is, of course, impossible to deal here with all the winding combinations which can be made by employing various pitches for

multipolar machines. The few most important types of windings which have been described above will suffice.

The arrangements of the winding on a drum armature may vary in very many ways. With small armatures the connecting wires at both armature ends may be wound one upon another, in a manner forming a ball. Generally, however, the wires are arranged regularly, side by side. This type of winding is used in nearly all cases in which, on account of the large cross-sectional area, copper bars instead of wires

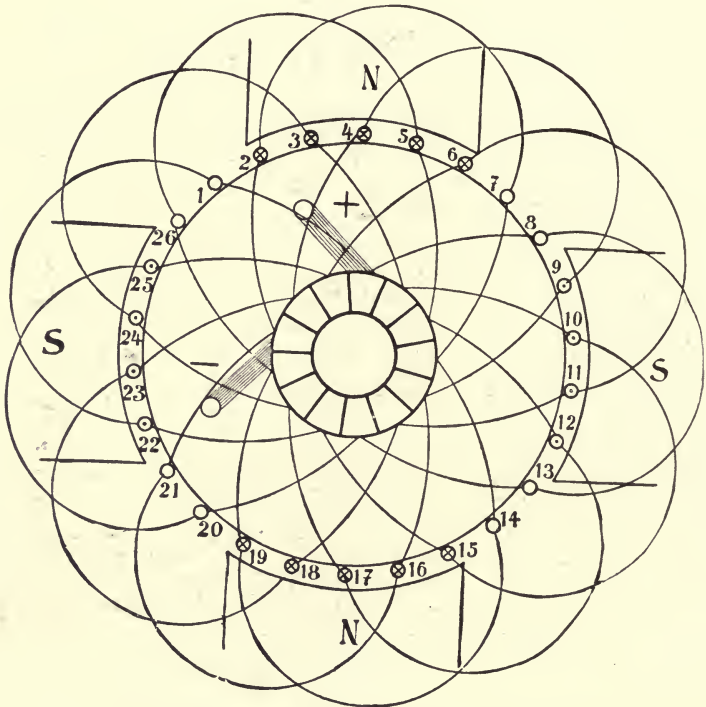

FIG. 122.—Four-Pole Drum Series Armature.

are employed. Frequently the connections between the single conductors are made by V-shaped copper strips, which are joined together with the conductors. Figs. 123 and 126 show a type of winding which is suitable for armatures, having thinner wires. The latter are bent over wooden formers, and then placed in position on the armature. These are called **former wound**.

From a glance at the figures, it may be seen that the pitch is in Figs.

123 and 126 smaller than one-half of the circumference of the respective armatures, and the latter therefore belong to multipolar machines.

The conditions to have in mind with parallel armatures of the drum type, which type is the usual one in America, is that the total number of conductors, counting each side of an armature coil as a conductor, should be even, and that the pitch front and back should be odd,

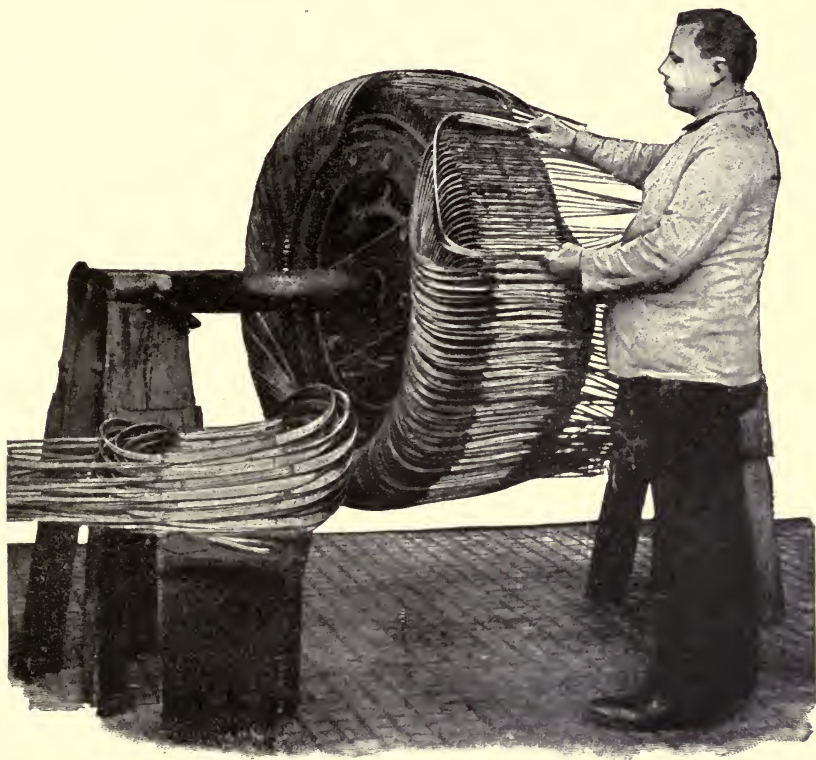

FIG. 123.—Former-wound Armature in course of construction.

differing by 2. Instead of being wound, as in Fig. 121, it is customary to have two layers, the odd numbers being on top and the even underneath, the location being as shown in Fig. 81 (p. 82). Where the armature core has slots, several conductors can be put in a slot. It is only necessary that the number of conductors be a multiple of the number of slots. A very common arrangement in dynamos is to have four conductors per slot, two on top of the other two. Since the pitch is odd both front and back and differs by 2, the average pitch is *even*. For winding series armatures a formula

is convenient. If N equals the number of conductors on the armature, and if y equals the pitch and p equals the number of poles, then $N = py +$ or -2 . y may be different at front or back, but must be *odd* in each case. If same at front and back, y must be *odd*. If different, the average pitch may be *even*.

Multiple windings are used on large apparatus, usually above 150 Kw. Series windings above 150 Kw. sometimes give trouble

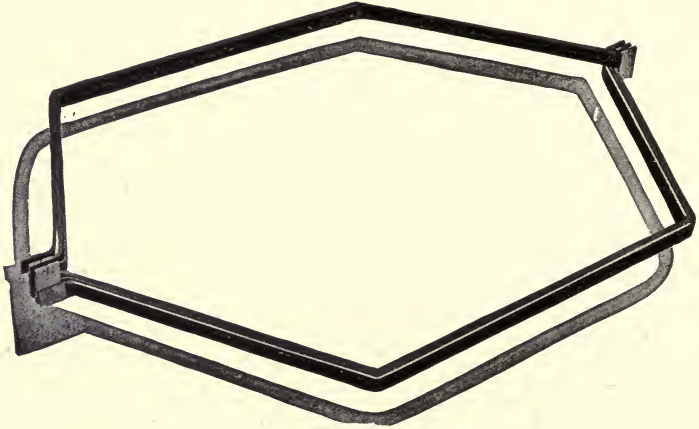

FIG. 124.—Multiple-formed Armature Coil.

from unequal drawing off of current from the brushes in the various studs. Theoretically, a series winding is independent of air-gap variations when a multiple must be uniform in this respect, as all

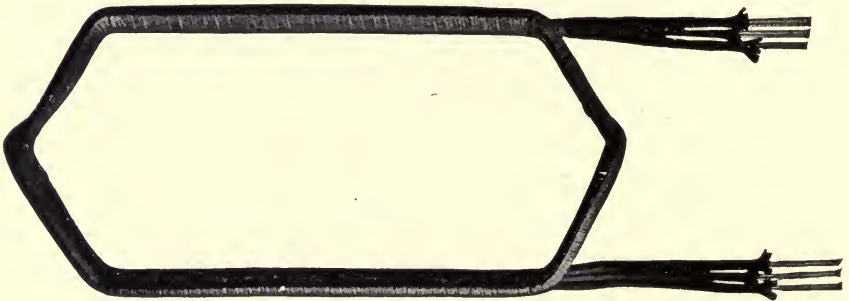

FIG. 125.—Series-formed Armature Coil.

the windings, being in multiple, must have equal voltages, else cross-currents will tend to occur or the various parts of the armature will do different amounts of work. The choice of series or multiple windings is one the designer has to carefully consider. Fig. 124 shows

a formed armature coil suitable for a multiple wound armature, and Fig. 125 shows a formed coil suitable for a series-wound armature.

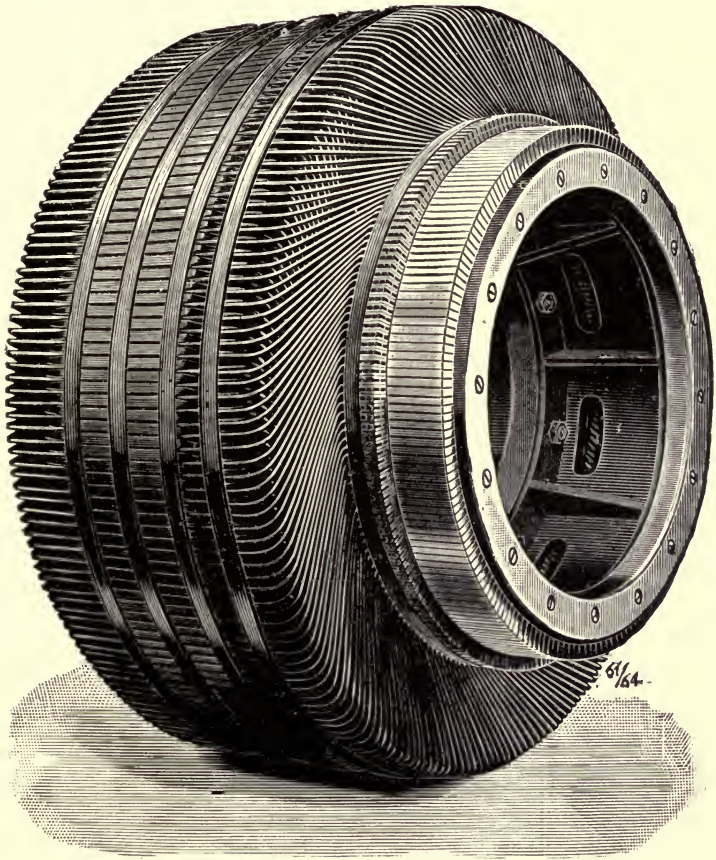

FIG. 126.—Former-wound Armature.

It will be noticed that in the multiple armature the leads come out near together for convenience of connecting to commutator. In the coil for series connected armature the leads come out apart.

Sparking and Displacement of Brushes

If the brushes on the commutator of a dynamo do not occupy their proper position, we may observe a sparking or flashing at the brushes. Sparking makes the commutator rough, and spoils the latter as well as the brushes. By carefully displacing the brush-rocker, we may easily find out a position for the brushes where the sparking ceases. If now, after stopping the machine, we examine to which armature wires those commutator-bars are connected which are under the properly adjusted brushes, we find that these are situated in the neutral zone, *i.e.* in the space between the two poles. They

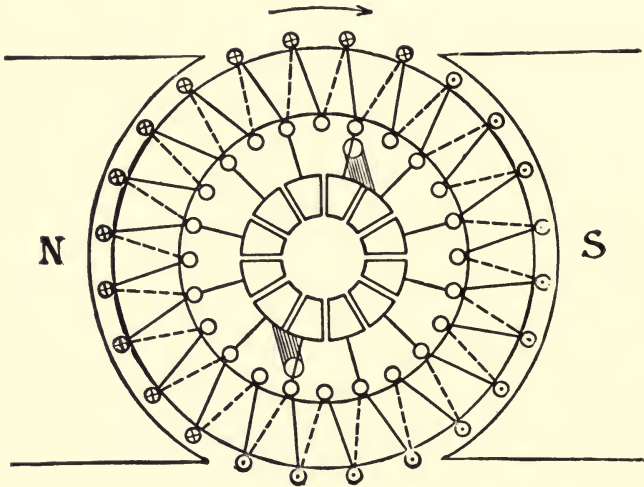

FIG. 127.

are not exactly in the middle of the neutral zone, but generally displaced a little forwards in the direction of rotation.

We are aware, that when a circuit is broken, sparking occurs. Let us consider any winding of the 2-pole ring armature (Fig. 127), then we find that through this winding, as long as it is on the right side of the armature, a current is flowing in a certain direction (marked by a dot). If then, on the rotation of the armature, the winding we are discussing passes the lower brush, the direction of the current is altered, for the current is flowing in the sense of the cross in the left side of the armature. The brush is always wide

enough to touch two commutator-bars simultaneously; hence the winding remains short-circuited as long as the brush touches at one time the two bars with which the ends of the windings are connected. During this brief period the winding belongs neither to the left- nor to the right-hand armature circuit. But the current in the short-circuited winding does not stop suddenly. A car which is unlinked from a running train does not stop suddenly, but follows a certain distance. Similarly, in the short-circuited winding the current flows for a certain, although it may be a very short, time in the same direction as before, and then decreases gradually to nothing. If during this period the armature be moved so much that the two bars connected with the ends of the winding are no longer covered by the brush, the current is interrupted, and there will suddenly flow through the winding a current in the opposite direction, *i.e.* in that of the current flowing in the wires on the left armature half, so that sparking would appear. To prevent this, the current must be brought down to nothing whilst the winding is still short-circuited; and immediately afterwards, but yet whilst the winding is short-circuited, a current must be induced in the latter which is in the same direction as the current which will flow through the winding during its movement on the left side. Then there is no sudden change of the current direction, and thus no reason for sparking. We may bring this about by moving the brushes from the middle of the neutral zone a little forwards in the direction of the armature rotation. In this case the influence of the forward pole induces in the short-circuited winding a small E.M.F., but which is just sufficient to destroy the current in the coil.

If the armature current of a given machine is but small, then we have to displace the brushes a very little from the middle of the neutral zone forwards. If, however, the armature current is a large one, for its sparkless collection a greater influence of the forward pole, and hence a further displacement of the brushes, is required. As a rule, we may note that, with an increasing load on a dynamo the brush-rocker is to be moved forwards in the direction of rotation, and with a decreasing load the rocker is to be moved backwards.

When the brushes are at the neutral point it will be noticed (see Fig. 127) that the magnetic influence of the armature is as shown by the dotted lines ABC, A'B'C'; the armature thus strengthening the pole tips at A and B' and weakening those at A' and B, since the increase of ampere turns due to increase of density at two of the pole tips is greater than the decrease of ampere turns due to lessening the density at the other two pole tips (which follows from the shape of the saturation curve as shown in Fig. 91). The result of this distortion is to add a necessity for increased ampere turns by the spools of the dynamo. Thus the less the distortion the better the regulation of the machine. The wires between the pole tips have no influence, as the current flows one way in half of them, neutralizing those in the

other half. (This latter effect is not shown in Fig. 127, since in this figure the brushes have a forward shift.) If, however, the brushes have a forward shift, as in Fig. 127, the strengthening and weakening of pole tips occurs as just described, but in addition the wires between pole tips now act to actually demagnetize, thus pulling down the voltage. Thus, shifting the brushes tends to make the dynamo less excellent in regulating properties. Looking at Fig. 127, just under the arrow and similarly below, the turns oppose the flow of flux. The reader can check this by remembering the rule of the production of magnetism from currents. In modern dynamos of say 500 Kw., these cross ampere turns may be 6000 per pole. The gap density at the pole face may be 60,000 per square inch, and the back ampere turns between pole tips due to the load of the brushes may be 1800. The total ampere turns required by the magnetic circuit, including gap, teeth, magnet yoke, armature core, back ampere turns, may be 50,000.

In many cases it is of great advantage to employ carbon instead of copper as the material for dynamo-brushes. Since the contact

FIG. 128.

FIG. 129.

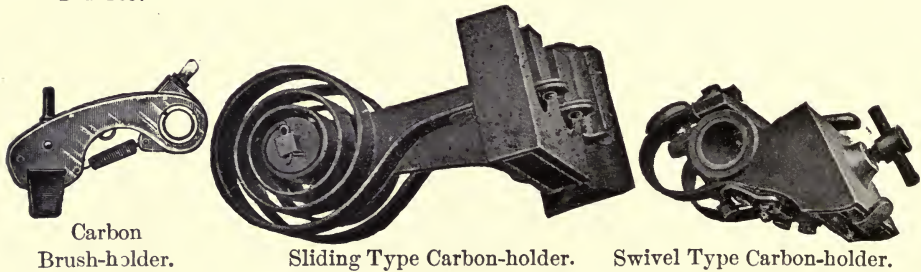

resistance of carbon on the commutator is comparatively high, the coils of the armature are not directly short-circuited, whilst the bars, connected with the ends of the coil, are simultaneously in contact with the brush. Thus, with a wrong position of the brushes, the current produced in the short-circuited winding cannot become so large as with copper brushes, and therefore the "commutation" is a more gradual one with carbon than with copper brushes. Hence it is no disadvantage with carbon brushes if they are rather wide and touch more than two bars at one time. Several of the machines shown in the illustrations are provided with carbon brushes. Some types of carbon and other brush-holders are shown in Figs. 128-130.

Carbon brushes cannot, however, be employed in all cases. To prevent the brushes from getting too hot, their number and contact-surface have generally to be larger than with copper brushes; and in many cases it is therefore impossible, with machines originally designed for copper brushes, to afterwards furnish them with carbon

brushes, because the commutator has usually not the width required for this purpose. Nowadays very many machines are provided from the first with carbon brushes, and these machines are generally less sensitive with regard to changes of load than machines furnished with

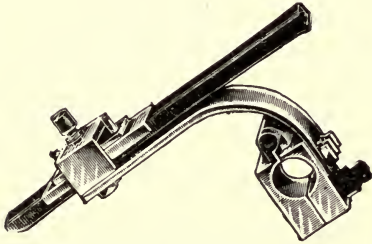

FIG. 130.—Copper Gauze Brush-Holder.

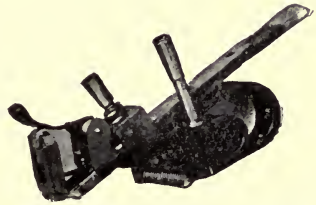

FIG. 131.—Brush-Holder with Metal and Carbon Brushes.

copper brushes. Sometimes a combination of carbon and copper brushes is employed (Fig. 131).

There are many modern machines not requiring a displacement of brushes at all, and which, nevertheless, run at all loads practically without sparking. The brush-rocker in this case must not be moved, if once adjusted properly. Such machines are said to have a **fixed lead**.

Methods for changing Direction of Rotation

We have learned, in the chapter about self-excitation, that we must connect the magnet coils with the armature brushes in a particular way, so that the armature may send a current through the magnet coils in such a direction as to strengthen the magnetism.

Let us imagine a machine excited separately (see Fig. 132). By connecting the upper end, III., of the magnet coil with the positive, and the lower end, IV., with the negative pole of the outer source of current, the latter may flow through the coil in the direction shown in the diagram. If now we turn the armature towards the right, then brush I. may, for instance, become a positive, and brush II. a negative one. (Whether that is really the case or not, does not depend on the direction of rotation only, but also on the direction of winding of the armature coils.) In altering the connections of the machine for self-excitation, we have, naturally, to connect magnet terminal III.,

which was previously connected with the positive battery pole, now with the positive armature brush I.; and terminal IV., in connection

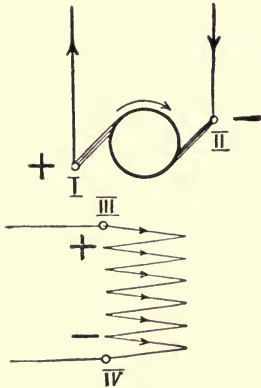

FIG. 132.—Separately excited Machine—Clockwise rotation.

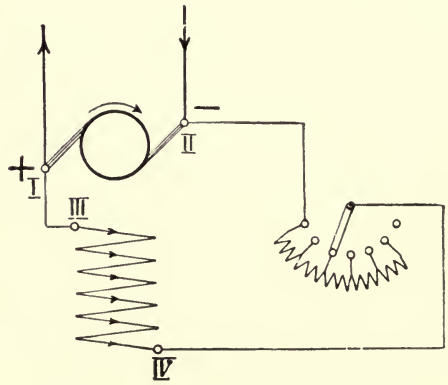

FIG. 133.—Shunt Dynamo—Clockwise rotation.

with the negative battery pole before, with the negative armature brush II., now. If, in addition, we use the necessary regulating resistance, we get the scheme of Fig. 133.

Now let us reverse the direction of the armature rotation.

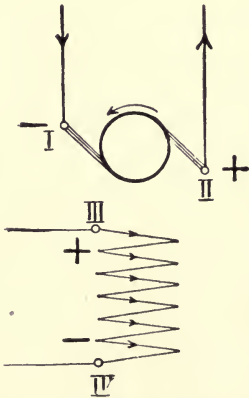

FIG. 134.—Separately excited Dynamo—Counter-clockwise rotation.

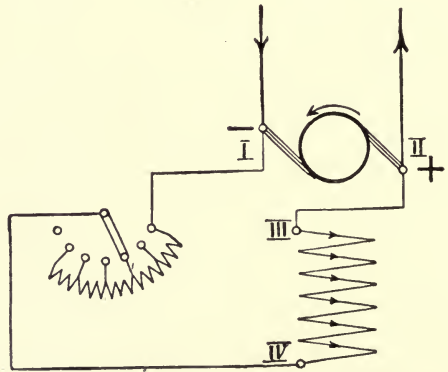

FIG. 135.—Shunt Dynamo—Counter-clockwise rotation.

Then brush I., which was positive before, becomes now negative,

and brush II. becomes positive (Fig. 134). If, now, we connect terminal III. with I., and IV. with II., as before, then the machine

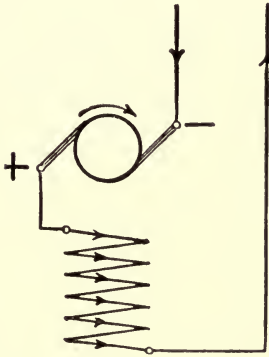

FIG. 136.—Series Dynamo—Clockwise rotation.

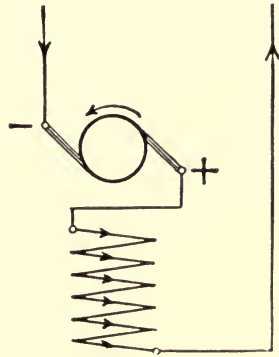

FIG. 137.—Series Dynamo—Counter-clockwise rotation.

loses its magnetism immediately, for the current in the magnets flows in the opposite direction. Hence, if we want the ma-

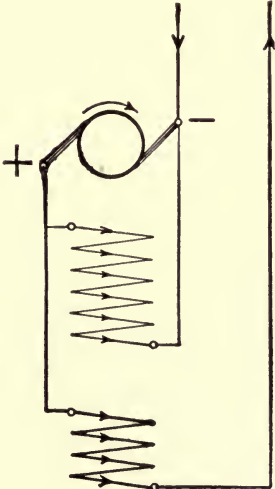

FIG. 138.—Compound Dynamo—Clockwise rotation.

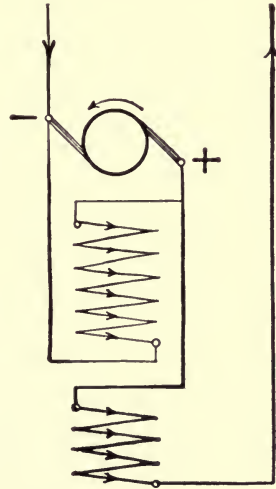

FIG. 139.—Compound Dynamo—Counter-clockwise rotation.

chine to excite itself, we have to connect terminal III. of the

magnets with brush II., and terminal IV. with brush I. (see Fig. 135).

As with shunt machines, so also with series machines. the connections must be altered for different directions of rotation of the armature. This will be readily understood without further explanation. The diagrams of connection for running a series dynamo clockwise and counter-clockwise respectively are shown in Figs. 136 and 137.

With compound machines, both the shunt and the series coil connections have to be altered. Figs. 138 and 139 show the respective schemes.

Although the left-hand brush is positive in the examples given in Figs. 132-139, it must not be supposed that, with a clockwise rotation, this is always the case.

Causes of the Non-excitation of Dynamos

The cause of a dynamo not exciting itself may very often be found in a wrong connection, *i.e.* in one for the opposite direction of rotation. In this case, the magnet terminals have to be changed, as shown in the previous paragraphs.

With some types of dynamos, more especially with multipolar machines, we may, instead of changing the magnet connections, get the same effect by moving the brush-rocker. With 4-pole machines we have to remove the brush-rocker one-fourth, with 6-pole machines one-sixth of the circumference. With 2-pole machines this displacement of the brushes is not usual, as in this case it would be equal to one-half of the circumference. Imagining the brush-rocker in Fig. 132 removed one half turn, so that brush I., which was before in the neutral zone to the left, comes now in the neutral zone to the right (provided that the cables, forming the connections between the terminals and the brush-holders, are of sufficient length to allow this turning), it is clear that we get exactly the same effect by displacing the brush-rocker as by changing the magnet connections as in Fig. 134.

There may also be other reasons for a machine failing to excite. In some cases the speed of the dynamo may, for instance, be too small. To be clear about this, let us consider the following case. Suppose that the magnets of a given dynamo had to be excited *separately* with 90 volts, in order to get, at the normal speed, an armature voltage of 110. (As we know in the case of self-excitation, the remaining 20 volts would be consumed by the shunt regulating resistance.) If this machine be run, not with its full speed, but only with two-thirds of it, the armature voltage would be equal to

two-thirds of 110, or about 73 volts. If, now, we switched over the machine, from separate to self-excitation, after a very short time the machine would lose its voltage; for, since the armature voltage is smaller than that required for the proper excitation of the magnets, the strength of magnetism will soon be decreased, and the armature voltage will become still smaller, the smaller voltage will again cause a weakening of the magnetism, and so on.

Exactly the same may happen at the proper speed of a dynamo, if too large a resistance is connected in series with the shunt coils. Thus, on starting a dynamo, the regulating resistance is short- or nearly short-circuited, and, after observing that the machine has started exciting itself, the resistance is gradually switched in.

Sometimes the resistance may also be increased by a bad contact between brushes and commutator. This may especially happen with carbon brushes, if they are not made to fit exactly the curved surface of the commutator, thus making contact with the commutator at a few points only. In this case, the contact resistance may be a very considerable one. But this may easily be remedied by grinding the carbon brushes so as to make them fit the surface of the commutator, and polishing the latter a little with emery.

Non-excitation of a dynamo may further happen, if the brushes are not in the neutral zone. If an armature is rotating, it is not always possible to find out the neutral zone of its commutator, for, very often, and especially with drum armatures, the armature wires are not led straight to the commutator, but the connecting wires are displaced by a certain part of the circumference—say, for instance, $\frac{1}{4}$, $\frac{1}{8}$, and so on. To be convinced that we have the proper position of the brushes, we have, therefore, to examine with which commutator-bar the wires in the neutral zone are connected. Non-excitation may also be accounted for by the loss of the residual magnetism. This may sometimes happen, if the polarity of the machine has been changed by any accident. In such a case sufficient magnetism may be regained by sending a current from a galvanic battery through the magnet coils.

Finally, if there is any fault with the connections, or any disconnection, either in the magnet or in the armature coils, excitation will be prevented. There might, for instance, be consequent magnet coils connected so as to give poles of the same name side by side, instead of different poles alternating. By carefully following the beginnings and the ends of the coils, such a fault may easily be found out. If there is any source of current available, this test may easily be made by sending a current through the coils, and examining, by means of a magnetic needle, whether the neighbouring poles are or are not of the same polarity.

Breaks in a circuit may sometimes be evident to the eye, but in other cases can only be found out by the electric current. If we

suppose a magnet coil to have a disconnection, then, by connecting

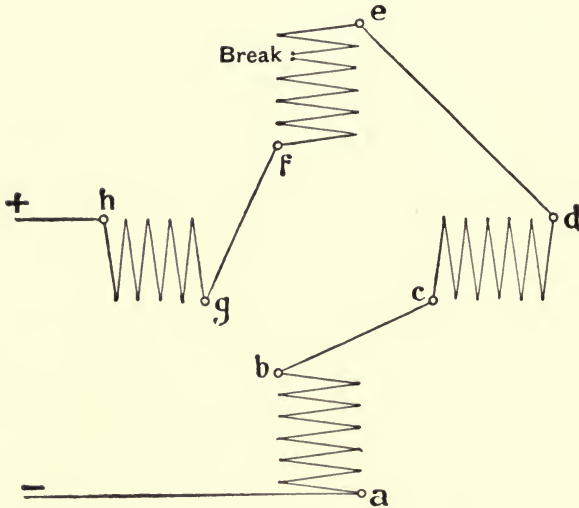

FIG. 140.

the magnet terminals with the two ends of a source of current, no current will flow through this circuit (see Fig. 140). If now we

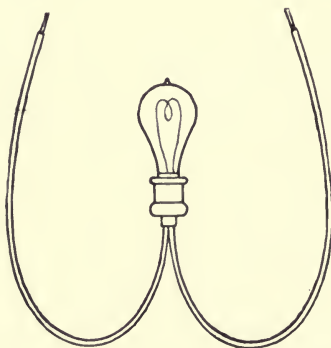

FIG. 141.—Testing Lamp.

connect one pole of a glow lamp, the terminals of which terminate in two long wires (see Fig. 141), with say the positive pole of the source of current, and touch with the other pole of the lamp the terminals of the magnet coils successively, we shall observe the following: On touching the magnet terminal *a*, the lamp will glow, as there is a connection between terminal *a* and the second pole of the source of current. The same will be the case if we connect the terminals *b*, *c*, *d*, *e*, respectively, as they are all in connection with the negative pole.

But if, further, we come to *f*, the lamp will no longer glow, showing that there is a disconnection between *e* and *f*. For *f* is not in connection with the positive, but

only with the negative pole, and, if we connect both terminals of a lamp with the same pole, it can, of course, not glow.

A lamp of suitable voltage should be used for the test. When the voltage is high we can employ several lamps connected in series, instead of one lamp.

With machines that are not too small, and with a suitable voltage of the outer source of current, a lamp serves as an excellent means for finding out disconnections of coils. Instead of a lamp, we can with greater certainty use a voltmeter. As long as the two ends of the voltmeter are on different sides of the point of disconnection, a deflection of the needle can be observed. The latter indicates the full voltage. But as soon as the point of disconnection is passed over, so that both terminals of the voltmeter are connected with one side of the point of disconnection only, the voltmeter needle stops at zero.

The magneto used for insulation tests (p. 73) may also be employed for finding out the point of disconnection.

Automatic Shunt Regulator

A compound winding can keep constant the voltage of a dynamo, provided that the latter is running with a constant speed. As sometimes the speed of the driving engine—such as, for instance, the steam-engine—varies according to the variation of the load, and, further, since the compound winding is not useful for all machines, *automatic shunt regulators* are employed whenever a constant pressure is required, without having a man always present to alter the shunt regulator as necessary. A simple construction for such an apparatus is shown in Fig. 142. The wire spirals, forming the regulating resistance, are arranged on an iron frame and supported by porcelain insulators in the usual way. The wires coming from the ends of the single spirals are not connected with the usual, circularly arranged contact pieces, but are fixed vertically side by side, and cut to different lengths. These wires dip into a movable glass vessel, filled with mercury, and fixed on the top of an iron core. The latter is suspended on one arm of a lever, and kept in balance by a weight fixed on the other arm of the lever. With its lower end the iron core dips into a fixed coil, consisting of very fine wire, the ends of which are switched on to the full dynamo voltage. If the dynamo pressure falls (for instance, through slower running of the dynamo), the current flowing through the coil decreases, the iron core

is therefore less attracted than before, and the counterweight is able to lift the iron core a little, so that the glass vessel, and with it the level of the mercury, is raised, touching some of the graduated wires, and the respective resistance coils are short-circuited by the mercury. Hence less resistance is now connected in series with the shunt, and the voltage of the machine can rise to its proper value.

If, on the other hand, the voltage of the machine grows too great,

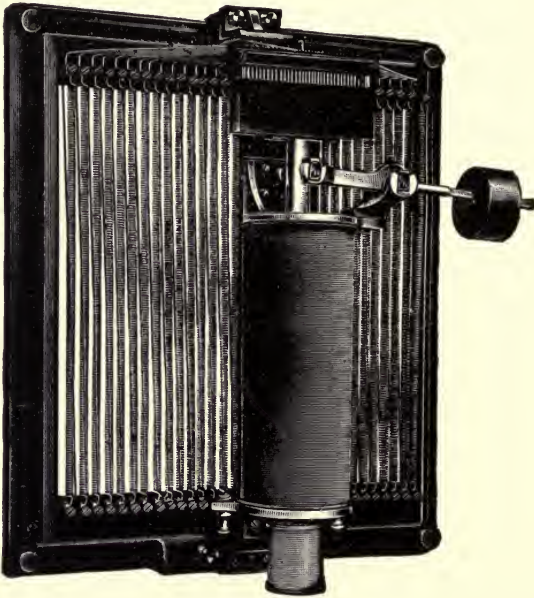

FIG. 142.—Automatic Shunt Regulator (*Voigt & Häffner*).

the current flowing through the coil will also become greater. The iron core will then be pulled down a little, and the vessel with the mercury is lowered, causing resistance to be again included in the shunt circuit, the shunt current therefore decreases, causing the dynamo voltage to be brought to its normal value.

There are, besides the apparatus described, many other ingenious constructions of automatic shunt regulators, but which we cannot deal with here.

Efficiency of Dynamos

With every kind of work we have also to do things that are useless, in order to get the intended effect. For example, to convey people or goods, it is also necessary to convey the carriage which is employed for the conveyance. The work which has to be spent in conveying the carriage represents, in this case, in which the main purpose is the conveyance of the people and goods only, a loss of mechanical energy. A stove, only intended to warm the air of a room, also heats a great quantity of air which does not remain in the room, but escapes up the chimney, hence causing a loss.

In like manner there are losses in the transformation of mechanical into electrical energy by means of a dynamo. These losses may be classified as follows:—

Firstly, work spent for excitation of the magnets.

Secondly, losses due to the resistance of the armature-winding.

Thirdly, due to eddy currents and to the varying magnetism of the armature core.

And *Fourthly*, losses due to mechanical friction.

The current which has to be sent through the magnet coils of a dynamo, in order to excite the magnets, is not available in the outer circuit. If with a machine, giving 100 amps. at a voltage of 110, the shunt current were 3 amps., then the loss due to excitation would be equal to 330 watts, or 3 per cent. of the total dynamo output.

A further loss depends on the ohmic resistance of the armature, including the resistance of the brushes and the connecting cables. If, in our example, this resistance were 0.02ω , then the voltage drop would be $0.02 \times 100 = 2$ volts, and the loss $2 \times 100 = 200$ watts—that is, nearly 2 per cent. of the total output.

There are, further, as we know, eddy currents in the armature. By employing very thin iron discs, these eddy currents may be reduced to a very small value, so that the loss depending on them may be but 1 per cent., or even less.

The continual reversal of the magnetism of the armature iron also involves a certain amount of work. As we know, the molecular magnets of the iron are not absolutely freely movable, but a kind of friction has to be overcome to turn the molecular magnets in the direction of the lines of force. For overcoming this resistance, however, a certain amount of work is required, which causes—like all other losses—a heating of the machine. This is generally called the **hysteresis** loss.

Finally, there is to be considered the mechanical loss due to friction in the bearings of a dynamo. These losses are, however, not great, for dynamo bearings are generally very well oiled.

Again, the air offers a certain resistance to the rapid rotation of the armature, thus involving a further small loss.

The total amount of all these losses is not considerable. With large dynamos it is equal to about 4 to 6 per cent., with dynamos of medium size 10 to 15 per cent., and with small ones up to 30 per cent. of the total output. Thus we get for mechanical power, supplied to the dynamo, and corresponding to 100 watts, according to the size and excellence of the machine, 96, 90, 85, 70 watts, respectively, or the efficiency of the dynamo is 96, 90, 85, 70 per cent.

Perhaps no other machine, employed for transforming one kind of energy into another, is so efficient as a good dynamo.

If all the losses mentioned above = L , and the output of the dynamo = W , then the efficiency = $\frac{W}{W+L}$. This is usually called the *commercial efficiency*.

To measure the efficiency of a dynamo, the losses are required. They are, first, loss in the field windings. If R_s = resistance of series field, and R_{sh} = resistance of shunt field, the loss in them can be calculated, since the current flowing in them is known. The loss equals I^2R , when I is the current and R the resistance.

If R_a = resistance of armature and R_b the resistance of brush contact on the commutator, the loss in copper of the armature and in contact brushes can be similarly calculated. The resistance of brush contact with carbon brushes is about .028 ohm per square inch. With copper brushes this resistance is about .003 ohm per square inch. The density of current with carbon brushes is usually from 30 to 40 amperes per square inch; with copper brushes about 150 amperes per square inch.

There remains to be found the friction and hysteresis loss. A convenient method to obtain this is to run the dynamo free until all friction becomes uniform. Put upon the armature a voltage equal to the operating voltage E at the terminals of the machine plus the voltage drop in the armature when operating under full load. This is equal to $E + IR_a$. The dynamo armature should then be run at full speed as a motor by adjusting the field current. Under these conditions, since so little current would be flowing into the armature, the back E.M.F. would be equal to the applied. But this is equal to $E + IR_a$, which is the voltage generated by the machine when operating as a dynamo at full load. And since the speed is set by adjusting the field current till normal dynamo speed is obtained, the flux must be the same as when the machine is operating as a dynamo. And thus the hysteresis loss is the same as when running as a dynamo. But the input measured by reading the current taken, I_1 , multiplied by $E + IR_a$ applied, measures all losses. Subtracting from this in-

put the small amount of armature resistance loss, or I_1^2R , created by the "running light" current just mentioned (I_1 equals a very small percentage of the full load armature current), leaves the hysteresis plus friction desired, and thus all the losses are determined. This is the *stray power* method first used by Dr. Hopkinson of England. This same method of getting efficiency can be applied to a motor, but in this case the voltage to apply to the commutator is $E - IR_a$, for a motor when running under load creates a back E.M.F. of this amount, since $E.M.F. = \frac{\text{flux} \times \text{external wires} \times \text{revolutions}}{100,000,000}$, as has been previously shown.

If the same E.M.F. and revolutions are set, then the flux must come the same, and if the flux and speed are the same, the hysteresis must be the same.

Another method of measuring the iron loss or core loss of a dynamo, as well as the friction, is to belt to the dynamo whose core loss is desired, a motor of such a size as to be capable of handling the load conveniently (say a motor of 10 per cent. of the size of the dynamo). Separately excite the field of the motor and keep it constant throughout the test. Thus the driving motor iron losses will remain constant as far as the field is concerned. Apply enough voltage to the motor armature to run the dynamo armature at normal speed, and measure the input to the motor by multiplying the current taken by the motor armature by the voltage applied. Repeat this reading with the normal voltage in the dynamo whose core loss is being measured. Then the difference between these two readings gives the loss due to putting on the field and therefore obtaining the normal voltage of the dynamo. To obtain the friction of the dynamo, subtract from the input of the driving motor, when running the dynamo without field current, the input of the driving motor with the belt removed (which thus records losses of the driving motor itself), and the remainder gives the friction of the dynamo. Knowing, therefore, the friction and the core loss, and adding to the other losses, the efficiency is calculated as before.

In reading the input to the motor, its speed, and that of the motor having core loss taken, is kept constant by means of a tachometer fastened to its shaft or to the dynamo shaft. Also it is proper for a refinement to take out from each input reading to the motor its own I^2R of armature and brush contact, since this value varies with the different inputs, and, being the only variable, its subtraction makes the remainder one of pure input transferred, barring the varying loss in the bearings due to the varying belt pull, which may be neglected. This last method is a very common method of measuring the core losses of dynamo machinery. In taking the curve, the voltage on the

driving motor should be approximately constant throughout the test. If it is not, a slipping of the belt must be occurring, or the internal drop of armature or brush contact resistance must be excessive. A driving motor fitted with copper brushes to reduce drop in brush contact and only loaded under maximum conditions of core loss on the dynamo to one-half load gives the best results.

CHAPTER IV

THE ELECTRIC MOTOR

IF we send a current through the armature of a dynamo, whose magnetic field is excited, the armature will be put into motion. This will be at once expected from our study of the action of the Deprez ammeter. With the dynamo armature there will, however, take place not only a single movement, but a permanent rotation. Owing to the action of the commutator, the current flows through all wires on one-half of the armature, which are under the influence of the north pole, in one direction, and through all wires which are under the influence of the south pole, in the opposite direction; hence, as long as a current from an outer source is sent through it, the armature will rotate. The machine now absorbs electrical and supplies mechanical energy. In this case the machine is called an **electric motor** or an **electro-motor**, which we may speak of simply as a **motor**; whereas a machine by producing current is called a **dynamo** or a **generator**.

The direction of rotation of the armature in Fig. 143 may easily be determined by Ampère's Rule. The armature will rotate counter-clockwise.

The scheme of the motor armature (Fig. 143) is strictly in accordance with that of the dynamo armature (Fig. 73). In both cases the pole to the left is a north pole, and the current in the left half of the armature is directed from the spectator. We had to turn the dynamo armature towards the right, in order to get a current in the direction marked; the motor armature will run towards the left, if a current having the same direction flows through it.

We have seen, when considering the current direction in a dynamo armature, that in each armature conductor a current is produced which would turn the armature in an opposite direction, if there did not exist any other force. In this case the induced currents produce an internal force in opposition to the external driving force supplied to the armature.

With the motor we find the same action, but with a remarkable difference. We know that in each wire, rotating in a magnetic field, an E.M.F. is induced. With the electric motor we have an armature,

which rotates in a strong magnetic field. Naturally it does not make any difference whether this rotation is effected by an electric current, or by an outside driving force. In each wire on rotation an E.M.F. is induced. To determine the direction of this E.M.F. we have simply to compare this scheme with that in Fig. 73, in which

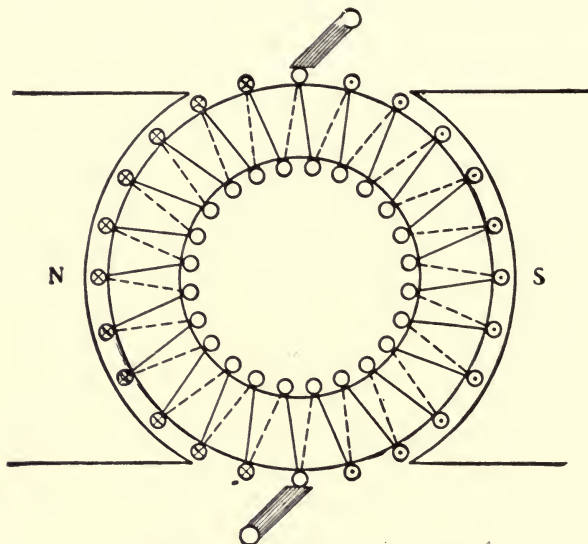

FIG. 143.—Motor Ring Armature.

we had the same armature rotating towards the right. The direction of the induced E.M.F. was there marked by dots and crosses. The lower brush was positive, the upper one negative. But now the armature is rotating in the opposite direction, hence the direction of the current in the armature is reversed, the upper brush becoming positive, the lower one negative; and we see, therefore, that the E.M.F. produced by the rotation of the armature acts against the current sent from the source of current into the armature. The result is that the E.M.F. produced by the rotation would, if no other E.M.F. existed in the circuit, cause a current to flow in a direction which is opposite to that of the current sent into the armature by the outer source. The E.M.F. produced by the armature of a running electric motor is therefore called the **back electromotive force** or **counter-electromotive force** of the motor. It follows the same law, of course, as the dynamo E.M.F. and therefore equals

$\frac{4N\phi}{100,000,000}$, as has been shown. It causes the current flowing through the armature to be far smaller than we should calculate it to be by dividing the terminal voltage by the resistance of the armature.

If, for instance, we connected a stationary armature, having a resistance of $\frac{3}{100}\omega$, suddenly with 110 volts, then, through the armature, according to Ohm's Law, a current of $\frac{110}{0.03} = 3666$ amps. would flow. This excessive current would instantly destroy the armature, and melt both the brushes and the mains. If, however, we do not connect the armature immediately with its full voltage, but first interpose in series with it a resistance of about 5ω , then a current of a little more than 20 amps. will flow through the armature and the resistance. The armature then starts to rotate, and produces by its rotation in the magnetic field a back electro-motive force, which soon reduces the current to a smaller value. The series resistance may now be reduced. The motor will then run faster, its back electro-motive force will grow, and, if we gradually short-circuit the series resistance, the motor will reach its full speed.

A simple consideration will show us what this speed must be. Obviously the motor will never run so fast as to produce a back E.M.F., equal to the E.M.F. of the source of current, since in this case no current would flow through the armature, and it would not exert rotary power. But a certain amount of power is required—although it may be quite small—for overcoming the friction in the bearings and the resistance due to the air. Thus the current can never become actually nothing, but must, for instance, with a motor which is designed for 100 amps., be at no load about 3 to 5 amps. If the outer E.M.F. or terminal voltage be 110, the back E.M.F. will not be quite 110 volts, but at no load nearly as much, viz. only some tenths of a volt less than 110.

If now we load the motor, for instance by putting a brake on, or by making it drive a shaft by means of a belt, the small current going through the armature at no load cannot exert sufficient power to overcome the load. Thus the motor speed will decrease a little. But as soon as the motor is running a little slower, say with 990 instead of 1000 revolutions, its back E.M.F. will decrease in the same proportion. The balance of the outer above the inner voltage is therefore greater, and the armature current can now grow to such an extent as to produce sufficient rotary power to counterbalance the load. The back E.M.F. will be in this case about 109 volts. If the load be doubled, the motor will run still slower, until its back E.M.F. falls to about 108 volts, the remaining difference of about 2 volts sending a current double in strength through the armature. If the load be removed, the motor will again run faster until its back E.M.F. becomes nearly 110 volts.

We may, then, conclude that an electric motor regulates in a perfect manner the absorption of electrical power according to the work to be done. With steam engines, turbines, etc., the steam or water supplied has to be regulated according to the load by means

of complicated governors. The electric motor, on the other hand, is self-governing.

The larger the armature resistance of a motor, the greater must, for a definite load, be the difference between the terminal voltage and back E.M.F., in order to get the necessary current to flow through the armature, and the greater, therefore, must be the drop of speed.

The Shunt Motor

In the above reasoning we have presumed that the magnetic field of the motor is of constant strength. This may be effected by connecting the magnet coils directly to the outer source of pressure. To the current two ways are then offered; one through the armature, and the other through the magnet coils. The latter are in shunt with the armature. This motor is called a **shunt motor**. About the working of such a motor we have spoken already. With regard to the speed of a shunt motor, we have just learned that the speed decreases with increasing load. This fall of speed is, at a constant voltage, small. It varies according to the type of motor, being from $\frac{1}{10}$ to 5 per cent., unless the motors are small, when the variation may be much greater. Practically speaking, the speed of a commercial shunt motor may be considered as nearly constant with varying loads.

It is most important to learn how a shunt motor should be started. To get a proper start, the magnetic field has to be fully excited.

It is, therefore, necessary to switch the magnet coils immediately on to the voltage of supply, whereas, as we have seen, with the armature a resistance must be connected in series at starting. To get both connections simultaneously, starters for shunt motors are constructed as shown diagrammatically in Fig. 144. The centre of the starting lever is connected with one main. The lever slides over a row of contacts, (which are connected with the ends of the resistance spirals,) and a slip-ring. The latter is connected with one end of the magnet

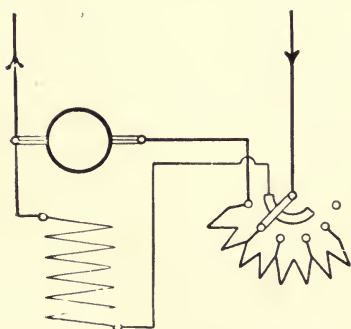

FIG. 144.—Shunt Motor with Starting Resistance.

winding, the last of the contact-pieces (on the left) with one armature brush. The other brush and the other end of the magnet winding are both connected with the second main.

As long as the lever is in its extreme position to the right the motor is at rest. Neither the slip-ring nor the contact-pieces, which are in contact with the resistance spirals, are touched by the lever, so that the motor is in connection with one (the negative) main only, and, naturally, no current flows through it. In moving the lever a little towards the left, it makes contact both with the slip-ring and the first resistance contact. As the slip-ring is connected with one shunt terminal, the magnet winding is immediately switched on the full voltage, and the full magnetizing current flows. If, for instance, the resistance of the shunt winding were 55ω , then, at a voltage of 110, the shunt current would be 2 amps. Although the magnets in this arrangement are fully excited, the armature is still in series with the whole of the starting resistance, which may be about 5ω . Through the armature a current of about 20 amps. therefore flows. It will start to rotate, and, gradually the lever is moved to its extreme position to the left, when finally the armature is switched on to the full voltage of 110. During the whole time of starting the motor, the magnets are fully excited.

Speed Regulation

The speed of a motor depends on the voltage of supply and the strength of its magnetic field. As we have learned, the motor always attempts to rotate so fast as to produce a back E.M.F. nearly equal to the terminal voltage. Hence, by doubling the latter, the motor will run with nearly double the speed. By decreasing the terminal voltage, we decrease the speed of the motor.

A reduction of speed may therefore be effected by switching permanently a resistance in series with the motor, since, in this case, the armature voltage will no longer be equal to the voltage of the outer circuit. The series resistance will consume a definite part of the voltage. If, for instance, the motor speed were 1000 revolutions at a voltage of 110, then, if we switch a resistance of 1ω in series with the armature, the terminal voltage, and with that the speed of the motor, will vary according to the load, or—what amounts to the same thing—according to the current strength required for overcoming this load. If the armature current were 11 amps., in the series resistance of 1ω a voltage of 11, *i.e.* the tenth part of the total voltage, would be consumed. The motor will therefore make 900 instead of 1000 revolutions per minute. If, due to an increasing load, the armature current grows to 22 amps., then in the series resistance 22 volts will be consumed. The motor speed will fall

down to about 800 revolutions per minute. At a current of 55 amps. the speed will be equal to about one-half of the normal speed. Thus we can regulate the speed of a motor by means of a series resistance when it is required to run *below* the normal speed.

Another way to regulate the speed is to vary the shunt current. If in the magnet circuit we arrange a shunt regulating resistance

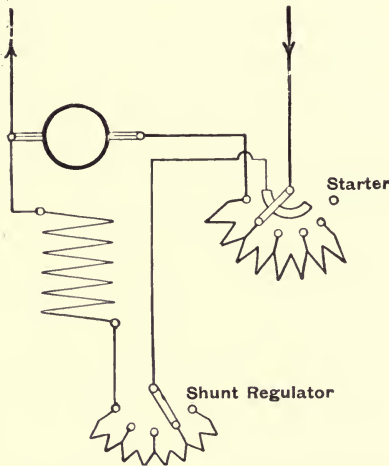

FIG. 145.—Shunt Motor with Starting Resistance and Shunt Regulator for Speed Regulation.

(see Fig. 145), as we have done with the dynamo, we may, by switching in some resistance, weaken the shunt current. Let us now start the motor and short-circuit the starter. To produce in the weakened field the same back E.M.F. as before, the motor has, naturally, to run much faster. Thus, by switching in some resistance in the shunt circuit, the motor speed may be increased above its normal value—say, for instance, from 1000 to 1100, 1200, and even 1400 revolutions per minute.

Care must, of course, be taken, not to disconnect the shunt circuit entirely, whilst the armature is still in circuit.

In such a case the strength of the magnetic field would be practically nil, since there would only be the weak residual magnetism. Two things may then happen. Either the motor reaches a dangerously high speed, in order to produce a sufficient back E.M.F., with the weak magnetic field, and in this case the excessive speed may cause the belt-pulley, the commutator, or the armature winding to burst into pieces; or, the motor is prevented from reaching such a high speed by a heavy load, then it can produce but a small back E.M.F., and consequently a current of so great a magnitude will flow through the armature as to destroy the latter and melt the brushes, or, what would be more desirable, to cause the fuses to go.

To prevent accidents of this kind, the shunt regulators for motors are generally made so as to render a disconnection of the shunt circuit impossible. The latter can then be switched off simultaneously with the armature-circuit, by means of the starting lever, but in no other way.

† Shunt motors are usually used for power in factories, workshops, etc., where constant speed under varying load is desired.

The Series Motor

Instead of exciting the magnetic field of a motor by many windings, which are switched directly on to the terminal voltage, this may, similarly to the series winding of a dynamo, also be done by providing the magnet coils of the motor with comparatively few turns of thick wire, connected in series with the motor armature. These motors are called **series motors**. A diagram of connections for a series motor, and the starter belonging to it, is shown in Fig. 146. As can be seen from the diagram, the starter is simpler than that of a shunt motor, on account of the omission of the shunt slip-ring.

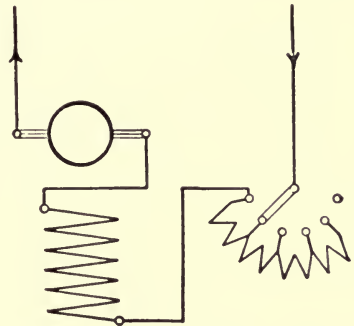

FIG. 146.—Series Motor with Starting Resistance.

The properties of the series motor are of quite another kind to those of the shunt motor. With the latter we have a magnetic field of constant strength, and the speed of the motor is practically constant at varying loads. With the series motor the field is stronger the larger the armature current of the motor, since the latter flows through the magnet coils as well. If the motor is loaded but little, and thus the armature current small, the magnetic field will be weak. If now the motor is switched on to a constant voltage, such as, for instance, the mains of a lighting plant, then it must run with a very high speed, to produce in the weak magnetic field a back E.M.F. corresponding to the outer voltage. If, on the other hand, the motor is loaded very heavily, its magnetic field will also be a very strong one. Thus the speed at which the motor produces a back E.M.F., corresponding to the outer voltage, will be far lower than before. A series motor must never run light or without load, for in this case its field would be very weak, so that it would run with a dangerous speed, or, as it is called, would "run away," almost like a shunt motor the shunt circuit of which is disconnected. Hence series motors are never employed where the load may be entirely removed. For driving by means of belts, for instance, series motors are generally not employed, because a sudden release of load may cause the belt to be ruptured or thrown off the pulley. On the other hand, they are more frequently used for driving pumps, fans, and so on, by means

of couplings, or for driving any machines by gearing. The latter itself provides a certain load on account of its frictional resistance in the toothed wheels and bearings. Very small motors may, even with belts, be built as series motors, as their comparatively large frictional resistance in the bearings represents in any case a certain, although small, load, allowing the motor to reach a rather high, but not a dangerous speed.

Series motors are for two reasons employed in some cases with great advantage. A single line only proceeds from the starter to the motor, so that, together with the direct return wire, two mains only are required, whereas with the shunt motor there are two lines from the starter to the motor, which, with the return wire, necessitates the use of three mains. This offers an advantage and a saving of cables when the distance between motor and starter is great. This may, for instance, happen with a motor, coupled directly to a fan, which is fixed on the ceiling of a very high room, and has to be controlled by a starter, fixed below. Since the load of such fan motors is constant, the speed of the series motor will also remain constant.

As we know, the magnetic field of a series motor is stronger the heavier its load. This makes it suitable for many special applications, such as lifting weights by means of cranes. A small weight is more quickly lifted than a heavy one. If a series motor is started under full load, it wants less current than a shunt motor of the same size. For let us presume the magnets of a series motor to be wound so as to produce, with a current of 25 amps., a magnetic field equal in strength to that of a corresponding shunt motor. If, further, we assume that the motors have to start under a very heavy load, so that the starting current grows to 50 amps., then it is clear that the field of the series motor will increase as well, although not to a double value. Naturally the armature of the series motor, running now in a stronger magnetic field, is, with twice the current, capable of developing more than double "torque." Thus the series motor has a greater starting power than the shunt motor, since the magnetic field of the latter remains constant at all loads, and its armature can, therefore, with twice the current, overcome only twice the load.

Hence the series motor will be able to overcome any given **overload** with a little less consumption of current than the shunt motor, but will run a little slower than the latter, and, on starting, the series motor will, with a given current, come sooner to its full speed than the shunt motor.

For electrically driven cranes, as well as for electric railways and motor cars, series motors are employed with great advantage. The starting of an electric car can be effected more quickly with a series than with any other motor. On gradients the car is running slower

and does not require so much current as one equipped with a shunt motor, whereas on the level the series motor enables the car to run with a far higher speed.

In all our discussions we have hitherto assumed that the series motor is supplied with a constant voltage. If we want it to run with a nearly constant speed at varying loads, we have to switch the motor on a low voltage if it is loaded but little, and on a higher voltage if it is loaded to a greater extent. This may be effected by a series resistance, because with a small load we could switch in much, and at a greater load less resistance.

This voltage regulation may be rendered quite automatic by employing a series dynamo as source of current for the motor, an arrangement which is

sometimes made for power transmission to long distances (see Fig. 147). The mains lead in this case from the dynamo to a single motor only. A starter is not required between the two machines, but the starting of the motor is done in the following way: The dynamo is run by the steam-engine or the

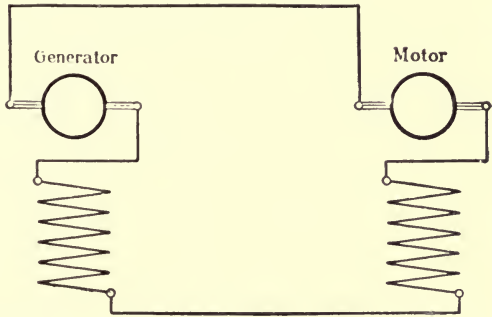

FIG. 147.—Series Method of Power Transmission.

turbine coupled to it, the motor being stationary and the circuit closed, the resistance of the mains and of the motor alone being in the external circuit of the dynamo. Since these resistances are comparatively small, even when the dynamo runs slowly a large current will flow through the circuit. This strong current in the armature and the field of the motor will cause it to start, thus producing a certain back E.M.F. The faster the dynamo runs the faster the motor runs, and the speeds will always be in the same ratio, for, since the same current is flowing through both dynamo and motor, their magnetic fields are always of equal strength. Owing to the loss of volts in the mains and the machines themselves, the back E.M.F. of the motor will always be a little smaller than the E.M.F. of the dynamo. Hence, if the machines are absolutely alike, the motor will always run a little slower than the dynamo.

When the load is small the motor only takes a small current, the dynamo, through the coils of which this small current is also flowing hence producing a small E.M.F. At an increased load the current, and with it the voltage of the dynamo, increases. The speed

of the motor is but little altered in this case, since it remains in a nearly constant ratio to the dynamo speed. Thus, if the dynamo is driven at a constant speed, that of the motor will, even at varying loads, remain practically constant.

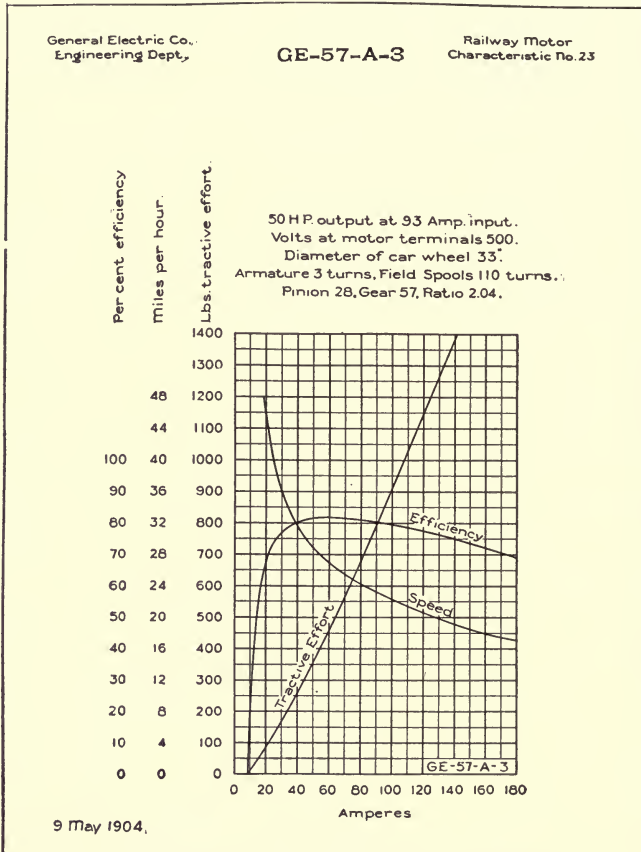

Fig. 148. —Speed and Torque Curves, Series Motor.

The speed and torque curve of a series railway motor is shown in Fig. 148, from which can be seen the variation of these factors with amperes taken by the motor. Fig. 148 also shows the speed curve of a shunt motor.

The Compound Motor

A compound winding may be used on motors for many different purposes. If the current flows in the same direction through both windings, then the effect of the series coil strengthens that of the shunt coil. This strengthening is greater the larger the armature current, *i.e.* the heavier the motor load. Thus the motor gets at increasing load a stronger magnetic field, and will, therefore, if the voltage remains constant, run slower than before. We hence infer that, for a given current, the starting power of a compound

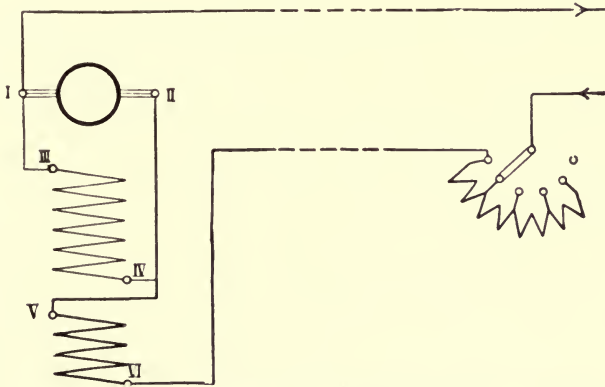

FIG. 149.—Compound Motor started from a distant point.

motor will be greater than that of a shunt motor. With a decreasing load the motor will run faster. A “running away,” however, cannot occur, because, even if the load be taken off entirely, the shunt coil produces a magnetic field of sufficient strength. The compound motor has, therefore, to a certain extent, the merits of the series motor without its disadvantages.

By means of compound motors the starting at a distance with only two mains may be effected, just as in the case of the series motor. In Fig. 149 a diagram for such a connection is shown. If we imagine

the motor without the shunt coil, then it is connected up exactly as the series motor in Fig. 146. The current coming from the starter enters the series coil in VI., flows through the series coil and leaves it at V., flowing from there to the armature brush II., through the armature to brush I., and from there through the second main back to the generator. The shunt winding is connected directly with the armature brushes I. and II., and gets at starting, therefore, a very small voltage only, hence its field is nearly ineffective. But on account of its series winding, the motor starts as a series motor. Obviously such a motor will not develop a very large starting power, like a real series motor, for, on account of the large space occupied by the shunt coils, there is less space available for the series coils than with a series motor. A compound motor may, however, even with this arrangement, be easily got into motion, provided that the load on starting is not too heavy. When once running the armature will produce a back E.M.F., and the shunt coil will be supplied with nearly the full terminal voltage.

This arrangement for starting at a distance may be employed in cases in which the motor is not coupled directly to a pump, fan, etc., but is driving the latter by means of a belt. Even if the belt slips off the motor the latter cannot run away, as would be the case with a series motor.

Sometimes it is wished to produce another effect with the compound winding. As we know, the speed of a shunt motor does not remain absolutely constant at all loads. Generally it decreases a little at an increasing load. Now there are some cases in which an absolutely constant speed is required, such as, for instance, when driving spinning machines. This may be got by winding over the shunt coil a series coil, consisting of a few windings only, and which act in an opposite direction. The result is that, as the load becomes heavier, the field of the motor is weakened, and the armature runs faster. Since now, on the other hand, the motor would run slower at an increasing load if it were a shunt motor only, this fall of the speed is compensated by the action of the series winding. Thus a compound winding is capable of giving a constant speed at all loads.

This statement is not absolutely true. There is a further reason for the variation of speed, which cannot be compensated by the series coil, namely, the gradually rising temperature of the motor. The resistance of the shunt coils is greater when hot than when cold, and if the coils are switched on to a constant voltage, a larger current will flow through them if they are cold than if they are hot. After the motor has been running for some time, its magnetism will gradually become a little weaker. We may therefore observe, with shunt motors, that the speed of the motor is smaller immediately after starting, but grows gradually with the rise of temperature. This increase of speed lasts only for a short time.

After some hours running, the motor does not get hotter, since it gives the heat produced in it to the surrounding air. After the motor has reached this state, its speed remains constant, providing that there has been no change in the voltage.

This influence of the temperature may be done away with, by connecting up in the shunt circuit of the motor a small regulating resistance, as shown in Fig. 145. Before starting, when the resistance of the coils is lower, some resistance is switched in the shunt circuit, and, as the coils heat up and increase in resistance, the auxiliary resistance is gradually short-circuited.

It must be added that compound windings are not much used for running motors at constant speed.

Direction of Rotation of a Motor

To alter the direction of rotation of a motor we have *either* to change the direction of the armature current, *or* to reverse the polarity of the magnetic field. If we reverse the armature current and the polarity of the magnetic field simultaneously, the direction of rotation will naturally remain the same as before.

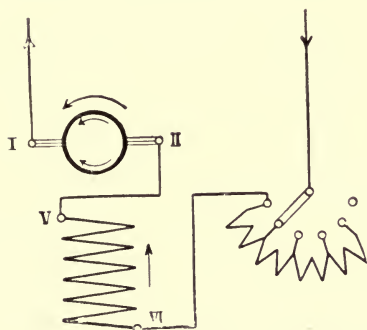

FIG. 150.—Series Motor—Counter-clockwise rotation.

Fig. 150 shows the diagram of connections for a series motor, which, seen from a certain side, rotates counter-clockwise. The current is flowing in the magnet coils from terminal VI. to terminal V., and in the armature from brush II. to brush I. For reversing the direction of rotation, we may either leave the direction of the magnet current, and alter

that of the armature current by changing the two cables leading to the brushes, thus connecting brush I. with magnet terminal V., and brush II. with the second main, as shown in Fig. 151; or we may, as shown in Fig. 152, leave the direction of the armature current, and reverse that of the magnet current.

There would be no reversal of the motor if we changed the mains leading to the starter and to the motor directly, since in this case both the armature and the magnet current would be reversed.

Similar diagrams of connections for the shunt motor are shown

in Figs. 153-155. In Fig. 153 the armature is rotating counter-clockwise. The armature current is flowing from brush II. to brush I., the magnet current from terminal IV. to III. Fig. 154 shows

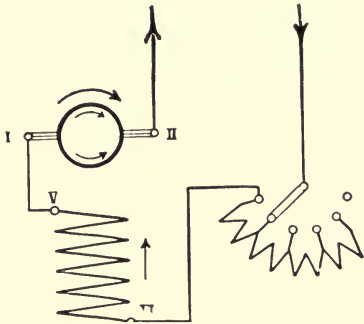

FIG. 151.—Series Motor—Clockwise rotation.

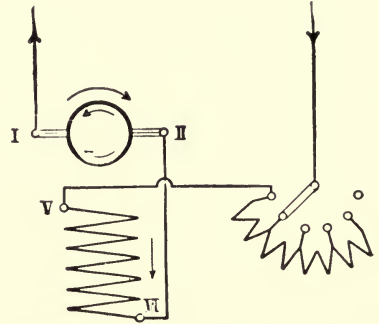

FIG. 152.—Series Motor—Clockwise rotation.

how the armature current may be reversed, whilst the magnet current remains in the same direction, and Fig. 155 how the magnet current may be reversed without changing the armature current.

Great care must be taken to always connect the magnet

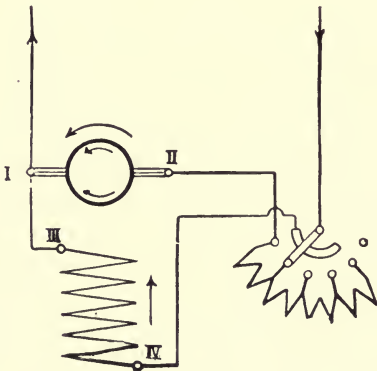

FIG. 153.—Shunt Motor—Counter-clockwise rotation.

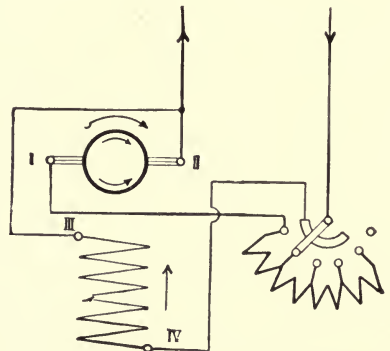

FIG. 154.—Shunt Motor—Clockwise rotation.

terminals so as to get the full terminal voltage on them as soon as the lever touches the first contact piece. This full terminal voltage has to remain on the magnets during the whole starting

period, and also when the starter has been short-circuited. If this is not the case, the consequences may be serious. If, in changing the armature cables as per Fig. 154, we had not connected magnet terminal III. with the main, but had left it on brush I. (see Fig. 156), then, at starting the motor the following would take place. If we put the lever on the first contact, the current will flow through the whole of the resistance, the latter consuming the greatest part of the voltage. Magnet terminal IV. is connected by means of the slip-ring directly with the main leading to the starter, whereas terminal III. is connected, not with the return main, but with brush I., a cable leading from this brush to the last contact piece of the starter. As long as the motor is stopped, there is only a very small voltage between I. and the return main II., the magnets are

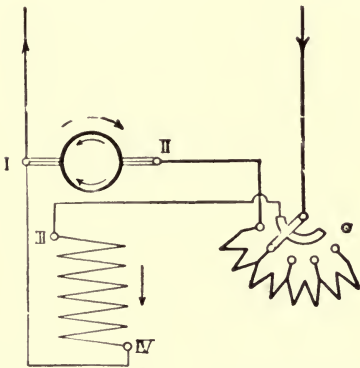

FIG. 155.—Shunt Motor—Clockwise rotation.

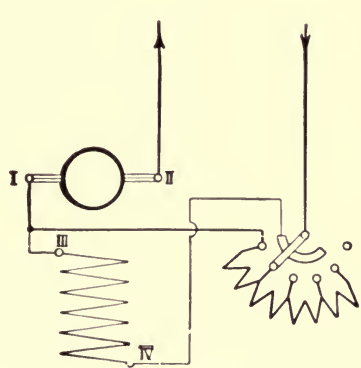

FIG. 156.—Shunt Motor with Wrong Connection.

on nearly the full voltage, the magnetic field will therefore have nearly its full strength, and the motor will start to run. If, then, the motor is running, it will produce a back E.M.F., and this voltage, arising between I. and II., will gradually diminish the voltage between I. and the main leading to the starter. But on this latter voltage the magnets are connected. Thus the magnetic field will become weaker in the same proportion as the motor runs faster. If finally we, as is generally done, short-circuit the starter, then the voltage between the two magnet terminals becomes *nil*, there would be practically no magnetic field, hence the motor would either "run away," or the fuses would go. It would also be wrong, to connect the two magnet terminals directly with the two armature brushes, or, what would be the same thing, to connect magnet terminal III. with the armature brush I., and magnet terminal IV.

with the short-circuiting contact of the starter, instead of connecting it with the slip-ring (see Fig. 157). In this case the magnets would at starting not get the full voltage, but only that of the armature; and since, due to the starting resistance, the latter is very small at the start, the magnetic field would be a very small one too. Thus the motor can, if it is not loaded, start, but will consume a very large current in doing so. If, however, the motor is loaded, it will, owing to the weak magnetic field, not be able to start at all. If, on the other hand, the motor is running, producing hereby a back E.M.F., the voltage of the magnet winding will gradually grow. When at last the starting resistance is short-circuited, the magnet will be excited with full terminal voltage. Thus a wrong connection, as described here, makes starting impossible, or renders it at least very difficult, but if once started the motor will run all right. The wrong connection described before, allows proper starting, but renders working of the motor impossible.

For all cases the following rule for connecting up a shunt motor should be noted by the student: One pole of the mains to be connected to a terminal *common* to the armature and the field; the second pole of the mains to be led to the starter, and to be branched there in such a way as to get at starting the full voltage on the second magnet terminal, while there is still in use the whole starting resistance in the armature circuit. The latter is then gradually to be short-circuited during starting.

For reversing the direction of rotation of a compound motor we have either to reverse the armature current or that of the shunt *and* series coils *simultaneously*. If we changed the connections of the shunt coil only, the motor would work quite differently. Consider, for instance, those connections with which we have become acquainted for starting at a distance (see Fig. 149); the following would happen: In the beginning, when the series coil only acts, the motor would start to run in a certain direction, but then the shunt coil, acting oppositely, weakens the field so much as to cause the motor to run away.

The reversal of direction of rotation may with many motors, especially with multipolar ones, be done simply by moving the

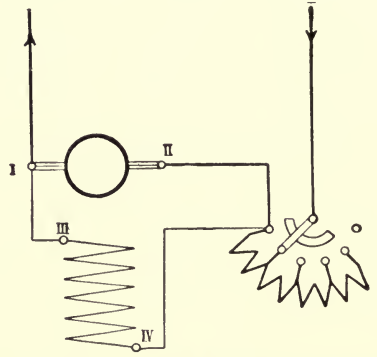

FIG. 157.—Shunt Motor with Wrong Connection.

brushes to another position, so that they are shifted the width of a pole from their former position. This causes the direction of the armature current to be reversed, and thus nothing further is needed.

Armature Reaction with Motors

With motors there is an armature reaction of the same kind as with dynamos, causing a weakening of the magnetic field. The armature reaction is greater the stronger the current flowing through the armature. Thus, with shunt motors under load, the field will be somewhat weaker than at no load. The motor will, therefore, due to the armature reaction, run somewhat faster under the bigger load if it were not for an Ohmic voltage-drop in the armature. Since this voltage loss tends to decrease the speed with increased load, there is generally no action of the weakened field to be observed; on the contrary, there generally occurs on loading the motor a decrease of its speed.

With motors having considerable armature reaction, it may happen that the speed increases with the load; but in many cases the action of the armature reaction and that of the Ohmic voltage-drop compensate each other, so that the motor speed remains practically constant.

With series motors the armature reaction is of less consequence because the main field is strengthened on increasing the load.

With motors which do not run without sparking at various loads an adjustment of brushes is required as the load varies. This movement of the brushes, the student should remember, has at an increasing load not to take place in the direction of rotation as with dynamos, but in an opposite direction. To reverse the current in the armature coil that happens to be short-circuited by the brush, we have to bring the latter within reach of a weak magnetic field, which induces an E.M.F. opposite to that which was previously induced in the coil. But, as we are aware, in each winding of the motor armature under the influence of a pole an E.M.F. is induced, which tends to produce a current in an opposite direction. Thus we have only to short-circuit each winding before it comes beyond the influence of the magnet pole. We therefore have to displace the brushes from the middle of the neutral zone backwards, and not forwards, as with a dynamo (see Fig. 158).

In comparing Fig. 158 with Fig. 127, we see that the direction of the current and displacement of brushes are the same as before; but the direction of rotation of the motor has been changed. We thence

note that the displacement of brushes has to be done *in* the direction of rotation with a dynamo, but *opposite* to the direction of rotation with a motor.

With motors which have to run in both directions (reversible

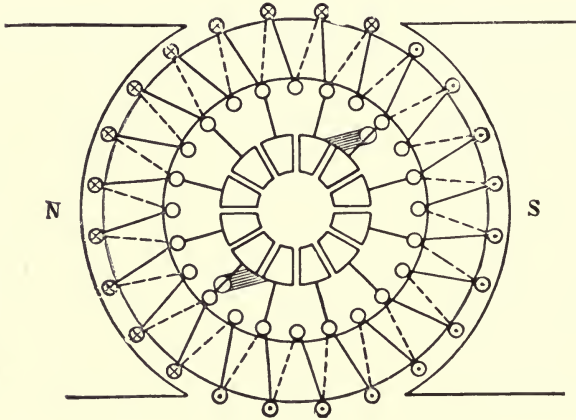

FIG. 158.

motors) it is naturally impossible to displace the brush-rocker at each change of the direction of rotation. These motors have to be designed so as to run without sparking, and without any displacement of the brushes whatever being necessary.

Reversing Apparatus

In many cases—such as, for instance, with lifts, cranes, electric trams, and so on—it is necessary to have the motors running at first in one and then in the other direction. In such cases it is, of course, impracticable to continually alter the position of the cables or the brushes.

Quick reversal may be effected by means of a “double-pole, throw-over” switch. This switch, the diagram of which is shown in Fig. 161, and a general view in Fig. 160, consists of two levers coupled to each other. The pivots of the levers form electric contact-pieces; the levers themselves are made of metal, being insulated from each other. By lifting the levers upwards, contact *a* is connected with *c*, and *b* with *d*. On pushing them downwards, contact *a* is connected with *e*, and *b* with *f*. As shown in Fig. 159, the contacts *c* and *f*, *d* and *e* are connected crosswise with each other.

Contact *d* is in connection with the positive, contact *c* with the negative main, whereas the middle contacts *a* and *b* are in connection

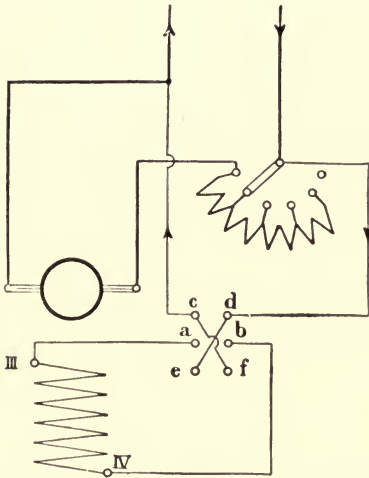

FIG. 159.—Shunt Motor with Change-over Switch.

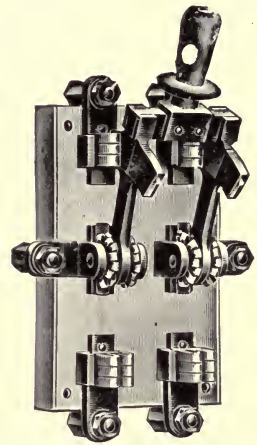

FIG. 160.—Two-Pole Change-over Switch.

with the magnet terminals of the shunt motor. On putting the lever upwards we connect magnet terminal IV. with the positive pole, and terminal III. with the negative pole of the mains, hence the current is flowing in the magnet-coil in the direction from IV. to III.

c ○ ○ d

a ○ ○ b

e ○ ○ f

FIG. 161.—Two-Pole Change-over Switch.

On putting the levers downwards we connect terminal IV. with the negative pole, and terminal III. with the positive pole, of the mains, thus reversing the direction of current flowing in the coil, and, as the current in the armature always keeps the same direction, we therefore reverse the direction of rotation of the motor.

Obviously we could also arrange the throw-over switch in the armature circuit instead of in the magnet circuit.

Such a reversing device would, of course, be suitable for the purpose, but it would be a dangerous one, for if we reversed the switch whilst the starter is short-circuited, the sudden reversing of the motor might cause its destruction.

To prevent accidents of this nature, the reversing switch is generally rigidly connected with the starter, so as to render the reversal only possible when the armature circuit is opened. Such an apparatus is called a **reversing and starting switch**. The diagram of connections for this apparatus is shown in Fig. 162. The left and right half of the apparatus are quite symmetrical. The single resistance spirals (marked by the vertically drawn zigzag line) are connected both with the contacts 1, 2, 3, . . . 9 to the left, and with the contacts 1, 2, 3, . . . 9 to the right. Those marked 1 represent

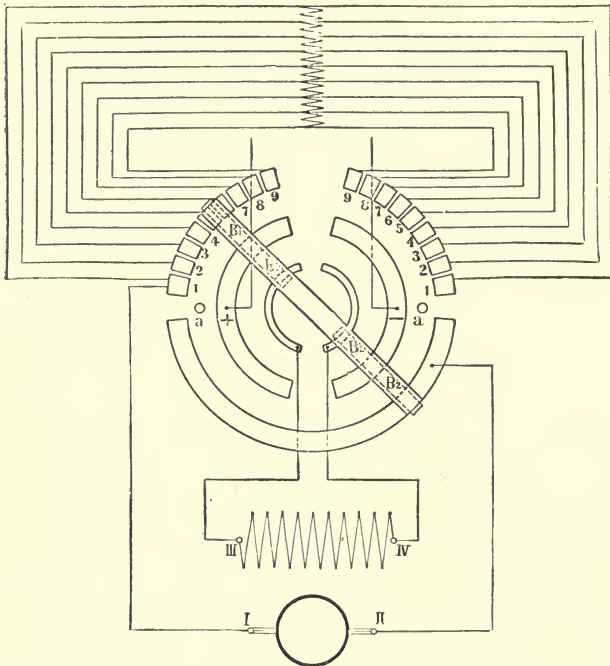

FIG. 162.—Starting and Reversing Switch for Shunt Motor.

the short-circuiting contacts. There are further some circularly arranged half-rings; the small ones that are innermost are connected with the magnet terminals III. and IV., whereas the next wider ones are connected with the positive and negative main respectively. Armature brush II. is connected with the large outermost half slip-ring, whereas armature brush I. is in connection with short-circuiting contact 1. On either side of the starting lever there are fixed brushes B_1 and B_2 , which are insulated from each other, but each of which covers simultaneously the three circles on either side. If now the lever be

put in the middle (vertically) neither of the two brushes will cover any of the two current-leading rings (marked as + and -) because these rings do not extend so far. By moving, however, the upper part of the lever to the left into the position which is shown in Fig. 162, the innermost half slip-ring and the starting contact 9 are connected with the positive slip-ring. Thus the current will branch, flowing on one hand directly to the magnet terminal III., on the other hand to the contact piece 9, and from there through the whole resistance to contact 1, which is connected with armature terminal I. At the same time both the magnet terminal IV. and the second armature terminal II. are connected by means of the lever brush B_2 with the negative main, and thus the motor can start to run. It may, for instance, run to the left. If then we move the lever further to the left, we gradually short-circuit the resistance, till finally we come to contact 1, when the armature is connected directly with the positive main, and the motor running with its full speed.

If, however, we move the lever from its middle position towards the right, instead of moving it to the left as before, the brush B_1 , covering the slip-ring marked -, connects the negative main both with the magnet terminal IV. and, through the resistance, with armature terminal I. At the same time the lower brush, B_2 , connects the positive main with the magnet terminal III. and the armature terminal II. Thus the current is flowing through the shunt coil in the same direction as before, but in an opposite direction through the armature. The motor will therefore run in the opposite direction.

To prevent the lever from being turned more than a quarter turn on either side, there are arranged two stops, a , on the apparatus.

Other reversing and starting switches are designed so as to reverse the magnet current, whilst the armature current remains in the same direction.

Starting and reversing switches for series motors are constructed in a very similar manner.

In Fig. 163 the construction of a simple reversing and starting switch is shown.

Sparking with Starters and Shunt Regulators

When a shunt circuit is broken a much longer spark results than in the case of a lamp circuit of equal current strength and voltage. The reason of this strong sparking lies in a property of the electric current, which is called **self-induction**, and with which we shall deal later on, in a more detailed fashion.

In a winding surrounding an iron core, an E.M.F. is induced as soon as we alter the strength of magnetism of the iron core (see p. 67). If, now, the strength of magnetism is changed by altering the current flowing round the core, there will be produced an induction effect in the coil resulting in a certain E.M.F. of "self-induction."

If a rapid alteration of the current occurs—for instance, on breaking a circuit very quickly—then at this moment a far greater E.M.F. may be induced than existed before.

The E.M.F. of the self-induction resists any alteration of the current, it tends to maintain the current at its original strength, just as the inertia does not allow a moving body to stop immediately the driving force ceases. If a running vehicle is suddenly stopped in its course by any impediment, such as a wall or a door, then the sudden stop will cause a force sufficient to destroy the wall or door. Here a far greater force is produced than had to be spent previously in continuously moving the vehicle.

It is exactly the same on stopping an electric current. The large E.M.F. of self-induction produced on the sudden disconnection of a 110 volt shunt circuit sometimes destroys the insulation of coils which could have withstood a voltage of even 500, and might start an arc which the normal voltage would be unable to keep up. As a consequence, the ends of the shunt slip-rings and the corresponding contact brushes of starters are generally burnt out after a short time.

To avoid this we must adhere to the rule of *never breaking a shunt circuit*. Referring to our analogy, the vehicle must not be stopped suddenly, but allowed to come to rest gradually. This may, in our case, be effected by making the connections between motor and starter according to the diagram in Fig. 164. By this arrangement it is possible to switch the motor off the main without disconnecting the shunt circuit. As may be seen from the diagram, the shunt slip-ring is in connection with the first resistance contact. Starting the motor



FIG. 163.—Motor Starting Switch (Vereingl. E. A. G., Vienna).

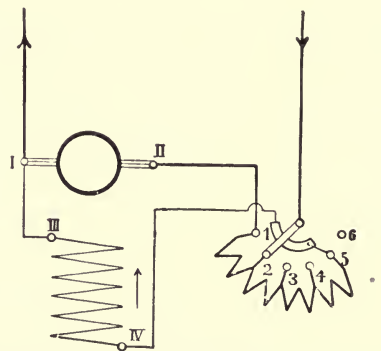

FIG. 164.—Starter with Inductionless Break, having Shunt Slip-Ring.

has to be done as with the usual starter. When the lever is put from the dead contact 6 to the first resistance contact 5, the shunt coils get full voltage, for the slip-ring is connected with this contact. The armature, as usual, is switched in series with the whole resistance. If, then, we move the lever gradually to the left—for instance, to contact 3—the shunt coils remain connected with the full voltage, because the lever always touches the slip-ring. The armature, however, is no longer in series with the whole of the resistance, but only with the part, which is between contact 3 and 1. The resistance spirals between 5 and 3 are without current. Contact 5, of course, is, by means of the shunt slip-ring, in connection with the starting lever, and thus with one main; but contact 3 is also in connection with the lever and the main; hence this part of the resistance (viz. that between 5 and 3) is connected at both ends with one pole only. Between the ends of this part of the resistance there is no voltage, and thus no current can flow through it. It will be exactly the same if we gradually short-circuit the motor. Thus we see that there is no difference whatever in starting by means of this apparatus compared with starting by means of the usual apparatus. In starting, the motor produces, as we know, a back E.M.F., which is nearly equal to the voltage of the current. If now we switch out the motor quickly, we do not interrupt the armature and the magnet circuit as we did with the usual apparatus. We break, of course, the outer circuit, but there is another closed circuit in the motor itself, viz. that from armature brush II. through the whole resistance, from there over the shunt slip-ring to magnet terminal IV., through the magnet coil, and from magnet terminal III. back to armature brush I. Now the armature has at the moment of the break, if this occurs quickly enough, still its full speed, and thus its full back E.M.F. This latter produces, if there is a closed circuit, a current opposite to the previous one. Thus this current leaves brush II., flowing through the resistance from 1 to 5, the magnet coils from IV. to III., and enters the armature again by brush I. The current flows through the magnets in the same direction as before. As no interruption, and not even a sudden alteration of the magnet current has taken place, there cannot be produced a considerable E.M.F. of self-induction, and thus there will be no sparking.

This starter, with “self-inductionless break,” has been further simplified by omitting the shunt slip-ring, and connecting the magnet terminal IV. directly with the first resistance contact 5 (see Fig. 165). There is obviously no alteration with regard to the self-inductionless break when compared with the previous case. On starting, however, there is an alteration. In putting the lever on contact 5, the shunt coil gets full voltage as before. But if we now bring the lever, for instance, to contact 3, magnet

terminal IV. is no longer connected directly with the starting lever, but is in series with the resistance between the contacts 3 and 5. In putting the lever on the short-circuiting contact 1, the magnet coil will be in series with the whole starting resistance, thus the magnet current will be weakened. This is of little importance, for, since the resistance of the starting spirals is very small, the voltage consumed by the spirals, and thus the weakening of the magnet current, will be negligible. Suppose, for instance, that the resistance of the starting coils is 5ω , so that the armature current, with the lever on the first contact, is with 110 volts about 20 amps., the normal shunt current being 2 amps., and thus the shunt resistance 55ω . In the diagram, Fig. 165, we have then, with a short-circuited starter, a shunt resistance of $5 + 55 = 60\omega$, and thus a shunt current of $\frac{110}{60} = 1.83$ amps., against the 2 amps. previously. This small weakening of the magnetic field will cause the motor to run a little faster.

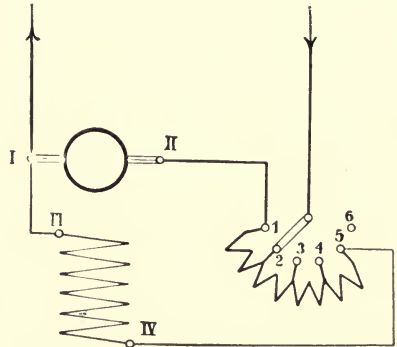
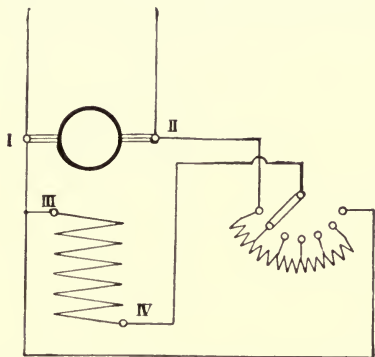

FIG. 165.—Starter with Inductionless Break, without Slip-Ring.

A sparkless breaking of the motor circuit can only be effected if there is at the moment of switching out no, or a very small, pressure difference between the starting lever and the last contact. Thus, to get a sparkless breaking of the motor circuit with a starter such as Fig. 164 or 165, a rapid switching out is required. For, if we moved the lever slowly from one contact to another one, the speed, and with that the back E.M.F., would gradually decrease, so that finally, if the back E.M.F. be only a very small one, we have to break a large current at the full voltage, thus getting a long spark in spite of the "self-inductionless" connection.

Sometimes it is impossible to avoid the interruption of the shunt circuit. Here we are generally helped by closing the shunt-circuit on itself whilst it is still being switched out, so that the self-induction current may flow in the circuit so formed. For a dynamo, this is shown in Fig. 166. With the exception of the dead contact the arrangement of the shunt-regulator is quite a normal one. The dead contact, however, which is usually without any connection whatever, is now connected with the shunt terminal III., and, since the latter is connected directly with the armature brush I., also with this. Hence, if we come from the last resistance

contact to the dead one, the shunt is short-circuited on itself, and



the self-induction current produced on breaking current flows in this circuit. Since the lever covers for a moment both the last resistance and the dead contact, we get, during this time, a current from armature brush II, through the resistance spirals and the connecting wire to I., but that is no disadvantage.

FIG. 166.—Shunt-Regulator, with Connection for short-circuiting the Magnet Coils in the "off" position.

The switching out of shunt regulators must not be done suddenly like the switching out of starters. It is, on the contrary, advisable to leave the lever for some time on the last resistance contact, in order that

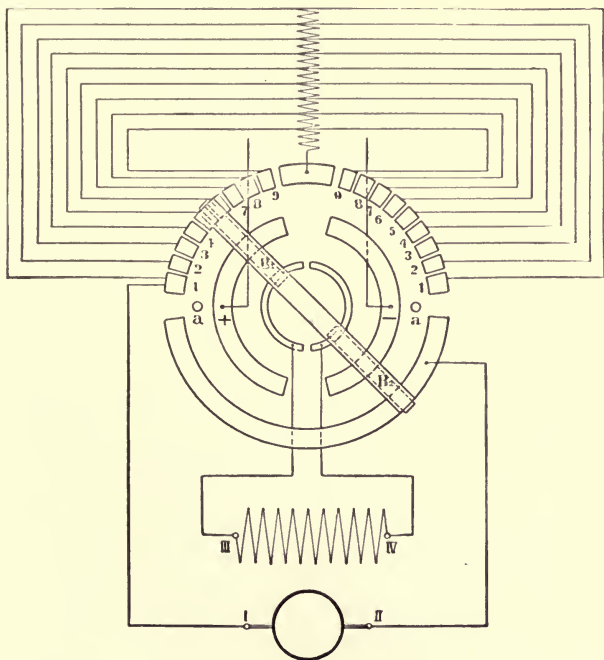

FIG. 167.—Starting and Reversing Switch with Connections for short-circuiting the Magnet Coils in the "off" position.

the voltage of the machine may meanwhile decrease. If the resistance of the shunt regulator be large enough, the machine will lose its voltage almost entirely. In such a case, even without the special connection between the dead contact and the second magnet terminal, an injurious self-induction voltage and flashing would not result.

A **reversing and starting apparatus** with "self-inductionless" break is shown in Fig. 167. If, in switching out, the brush B_1 leaves the wide slip-ring and the contact 9, the armature and the magnets are still in connection. If, then, we place the lever in the middle, the two shunt slip-rings are short-circuited. Care must be taken when using this apparatus, not to move the lever too soon over the middle position, for in this case the circuit of the short-circuited magnet coils would be again interrupted before the self-induction current had ceased, and consequently the self-induction would cause considerable flashing.

Another important mode of control used for shunt or series motors is called the Ward-Leonard system of control. In this system the motor field may be separately excited. The armature of the motor is connected directly to the armature of the generator without resistance. If there is no field on the generator, no E.M.F. will be generated, and no current will flow to the motor. If now a little field be put upon the generator, a small E.M.F. be generated in the generator, a current will flow at a few volts to the motor, and it will slowly start. As the field of the generator is strengthened the voltage continues to increase, and the motor continues to speed up until full field and full voltage is being produced by the generator. Reduction of speed can be effected by a reduction of field of the generator. Thus, by manipulating the small field current of the generator, a large armature current to the motor can be controlled. The controller, therefore, since it handles such small currents, as compared with the currents doing the work, is very many times smaller than if it were located in the armature circuit. This method of control has a very wide application. It is used on battleships, hoists, and to control at a distance. A good generator will operate without sparking under these low-voltage high-current conditions, for the voltage, being low with consequently low volts per bar on commutator, gives a very favorable sparking condition. As a matter of fact, a good generator will take 25 per cent. over normal current down to 0 volt between brushes without trouble from sparking.

Motors for Certain Purposes

A dynamo can usually, without any alteration, be also used as a motor, but, since motors are employed for so many different

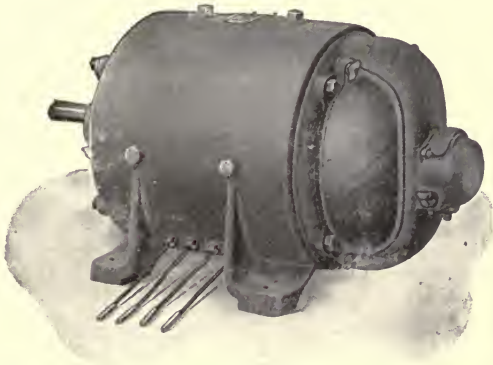

FIG. 162. —Enclosed Motor.

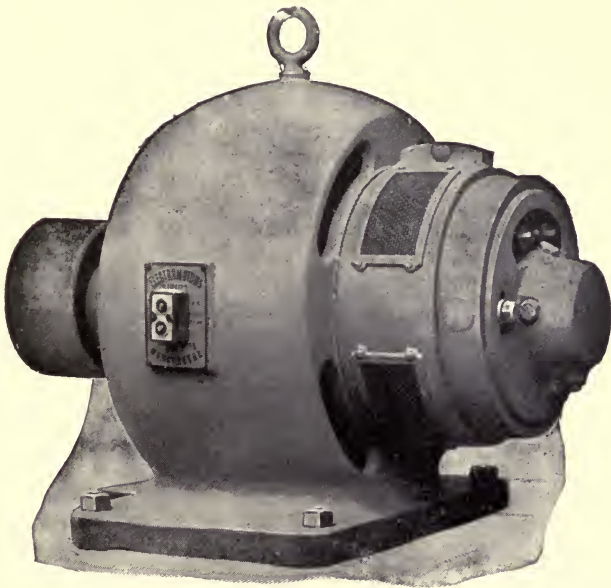

FIG. 169. —Enclosed Motor (*Electromotors Company, Manchester*).

purposes for which a special shape is desirable, a number of types of motors have been designed.

A special form is the **enclosed** motor, which is employed for damp and dusty rooms. The motor is entirely enclosed in a cast-iron or steel case, which has doors near the commutator, through which the latter may be inspected or cleaned. Figs. 168 and 169 are illustrations of enclosed motors.

For ventilating purposes there is sometimes, instead of a pulley, a fan fixed on the shaft of the motor. With larger fans the motor

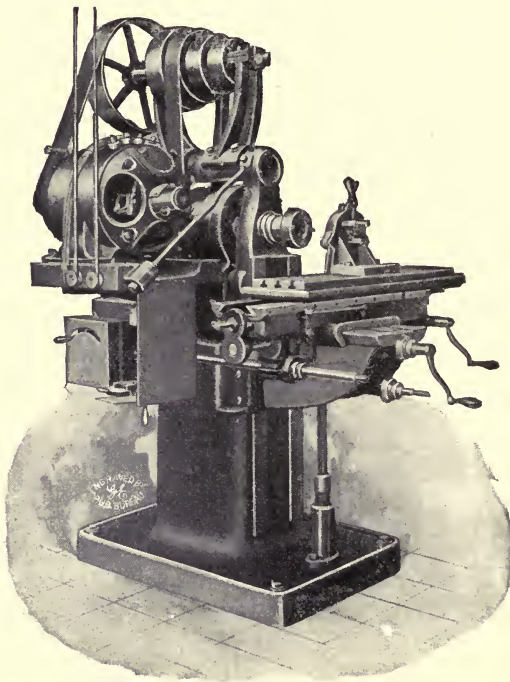

FIG. 170.—Motor connected to Machine Tool.

is fixed on the case of the ventilator. Fig. 175 shows a big fan combined with the motor.

Since smaller motors are generally built for high speeds, it is sometimes necessary to reduce these speeds by means of reduction gears. Even with belt driving it is sometimes desirable to reduce the speed by gearing. Generally the reduction gear is built together with the motor, and on the slow speed countershaft the coupling or the belt pulley is fixed.

Motors in America are used for a wide range of work.

Fig. 170 shows an application of an electric motor to a machine tool.

Fig. 171 shows an application to a pump.

Fig. 172 shows an application to an elevator.

Fig. 173 shows an application to a mine hoist.

On battleships, in America, a very extensive use of motors is made. One battleship has over 200 motors installed upon it; the turrets are turned by motor, the ammunition raised and pushed into

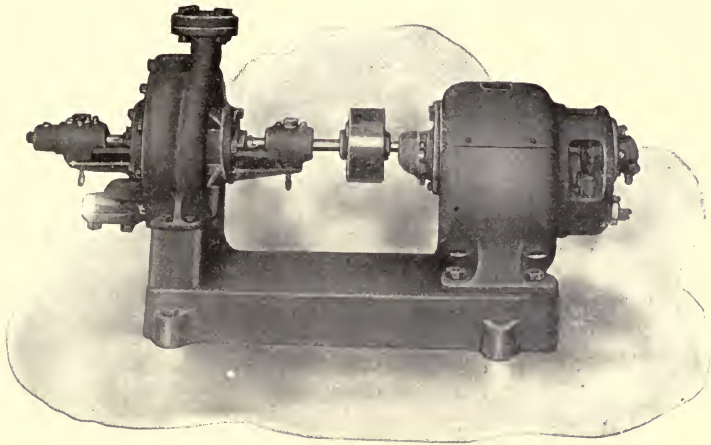

FIG 171.—Motor connected to Pump.

the guns, boat cranes operated, ventilating blowers driven, and rudder turned.

A special extra pole, or *commutating pole* motor, has recently been developed. It has a magnetic circuit, as shown in Fig. 174.

This figure shows a 4-pole motor of usual magnetic circuit, but in addition to the poles A, B, C, and D there are four other poles, *a'*, *b'*, *c'*, and *d'*, which are wound with wire in series with the armature, like a compound motor winding. The armature is wound for a 4-pole motor, although there are actually eight poles. The flux from these poles is in such a direction that the current is reversed in the coil which is short circuited under the brush without shifting brushes to the proper pole to get such a flux (forward in a generator and backward in a motor). Thus, such a motor runs without shift of brushes and in either direction equally as well. The turns on the

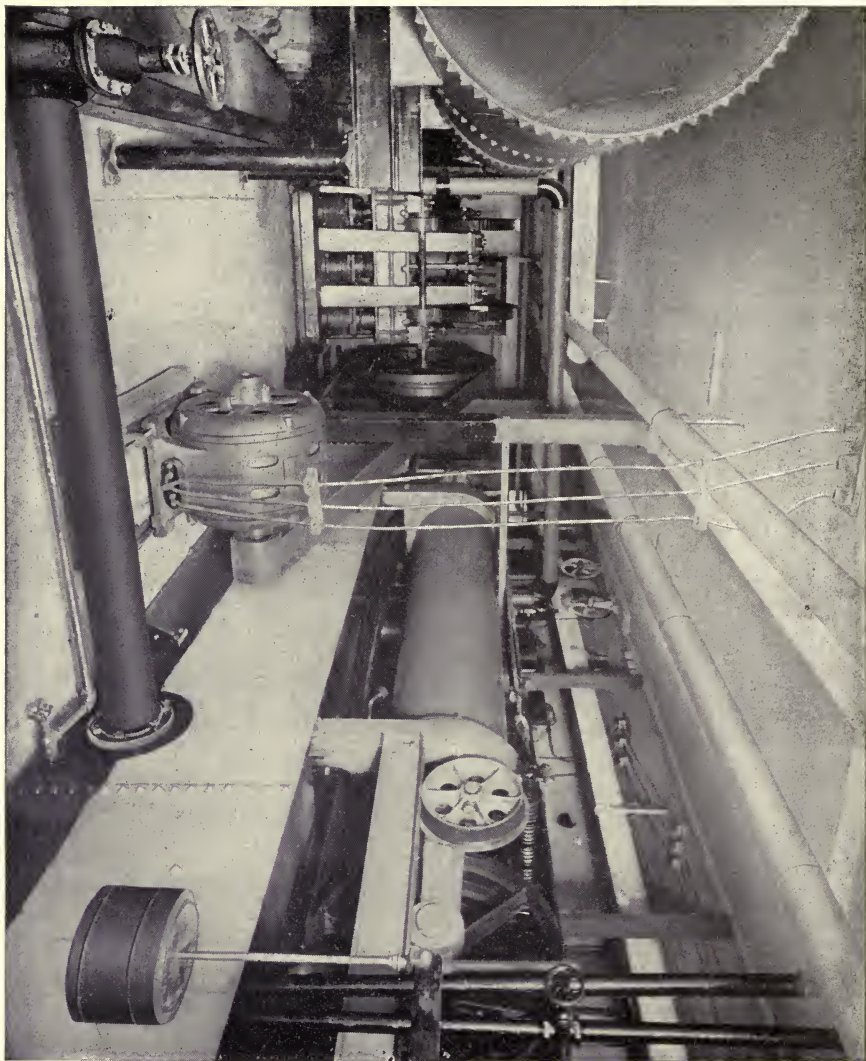

FIG. 172.—Application to Elevator.

commutating poles are chosen so that *just the right* amount of flux

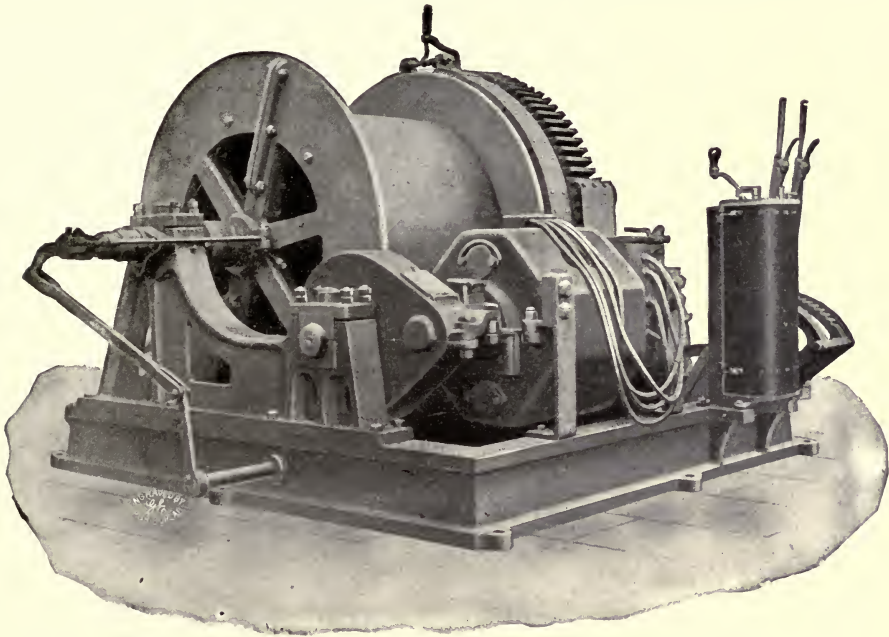

FIG. 173.—Application to Mine Hoist.

is obtained to give exact reversal, and no more; hence, such motor run sparklessly. They can be designed on closer lines than an ordinary motor, making their cost, therefore, less, since the commutating poles are wound with *series* spools. The balance of flux with reversing requirements of the armature coils when under the brush is the same at all loads. Such a motor, therefore, gives far better results under overload than the usual design. This extra pole application is just as useful for generators, and from present indications the commutating pole is to be rapidly extended in dynamo design.

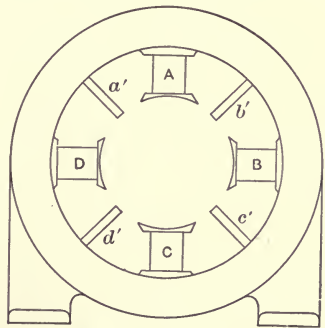

FIG. 174.—Four-pole Inter-pole Magnetic Circuit.

Electric Traction

An important application of electric motors is that for railways, especially street railways. In the latter case the current supply device consists generally of a hard-drawn copper wire, which is

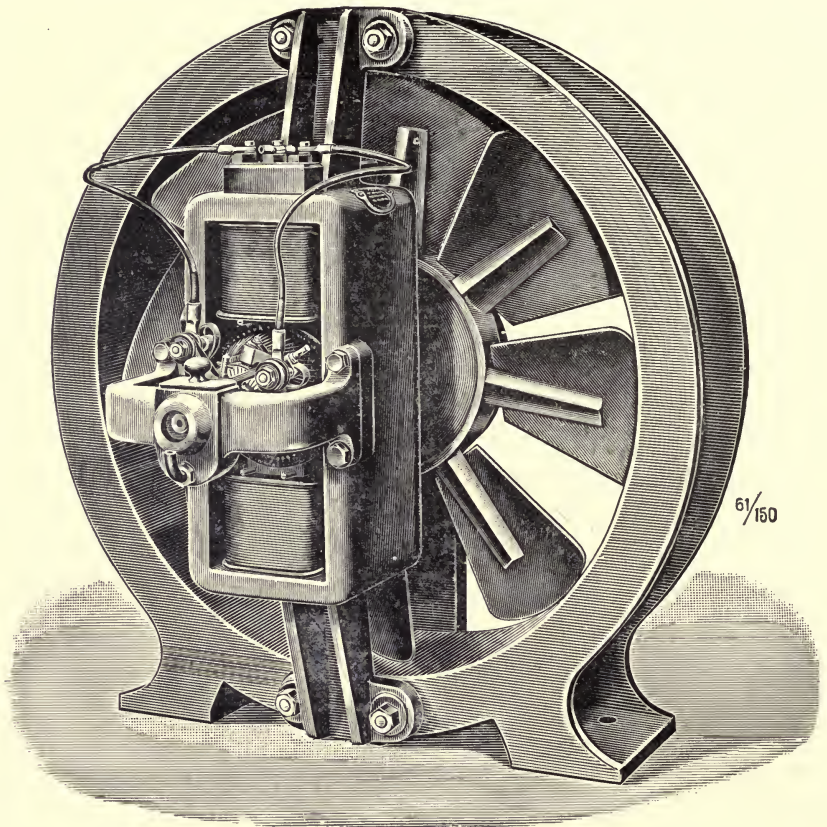

FIG. 175 —Electrically driven Fan (*Körting Brothers*).

suspended by means of insulators supported either by posts or by cross wires. The copper wire is in connection with the positive pole of the central station dynamo, the negative pole of which is connected with the rails. On the top of the motor car there is fixed

either a metal bow, or an iron tube, the top of which is provided with a little wheel, the "trolley." The bows or the trolleys are pressed by a spring arrangement against the overhead wire, and serve as the current supply device. Both the bows and the trolleys are very well insulated from all the iron parts of the car, and a cable leads from them to the motor starter and thence to the motor itself. The latter is fixed beneath the car, and drives the car-axle by means of a pinion and spur wheel. The second pole of the motor is connected with the car-axle,

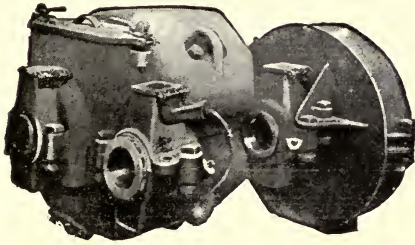

FIG. 176.—Street-car Motor, closed.

and thus through the wheels and the rails with the negative pole of the central station dynamo. Very often two motors are used for one car, each of which drives one axle.

The motors employed for driving electric cars have generally the characteristic shape, as shown in Figs. 176 and 177. The motor is entirely enclosed to prevent dust and moisture getting into its interior. To be able to inspect the commutator and the brushes, or to take out the bearings or the armature, the case is divided into two parts, hinged to each other; the upper part may be fixed and the lower one opened downwards, or *vice versa*. Since it is desirable to use as little space for the motors as possible, the magnet coils are not wound on separate bobbins, but are, after they have been wound on special wooden formers, and have been well insulated with impregnated cotton, mica and so on, pushed over the cores. Since street railways are generally worked with a voltage of 500-600, all the motor parts must be excellently

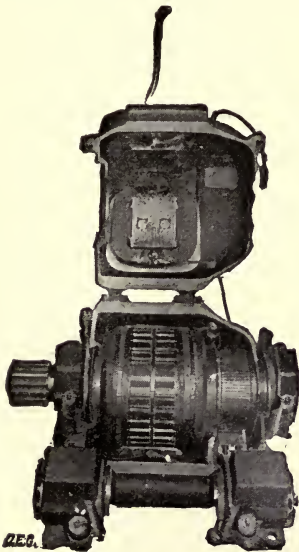

FIG 177.—Motor, open.

insulated.

About the working of these motors nothing special has to be remarked. They are four-pole motors with two brush-holder arms, each of which is provided with one or two carbon brushes. The motors

are reversible, and, according to the position of the starting lever, drive the car forwards or backwards.

The starter for street-car purposes is generally called a **controller**. Since it has, like the motors, to be protected against dirt and dust, it is entirely enclosed. Its internal construction (similar to that shown in Fig. 178) is entirely different from that of the starters with which we have hitherto become acquainted. The contact pieces

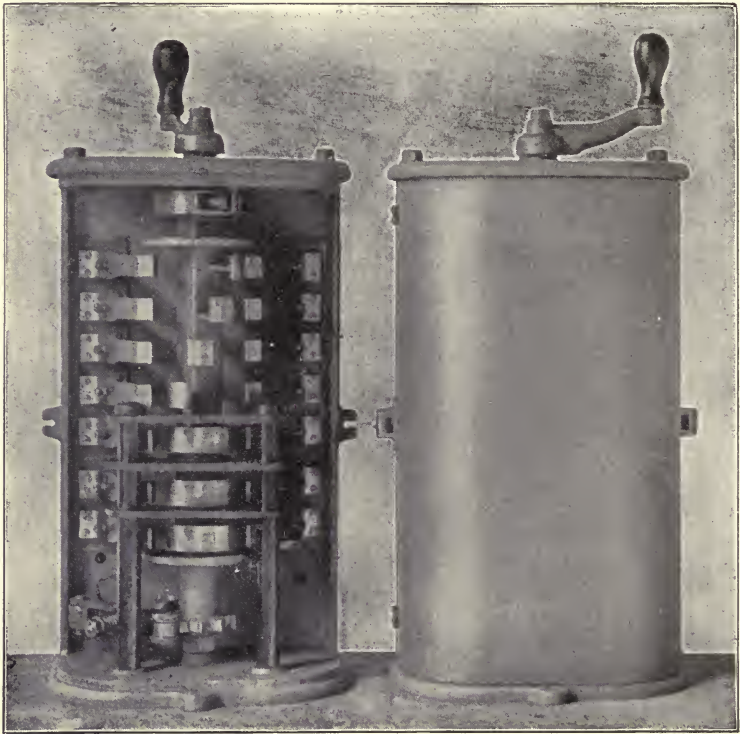

FIG. 178.—Controller suitable for Single Motor (Royce, Manchester).

by which the different connections are effected, are not arranged on a horizontal base, but fixed on the surface of a vertical cylinder. On the contact pieces or contact rings there are sliding brushes or contact levers which are fixed on a separate wooden plate, whereas the cylinder with the contact pieces is movable. On the top of the cylinder there is fixed a handle, by means of which the cylinder may be turned to different positions. By rotating the cylinder the

connections of the contact rings with the contact levers are altered, as with the usual starting apparatus.

A controller for a single motor-car is really little else than a common starter. It has a position of rest, marked "stop," and a number of starting steps. At the last step the whole of the starting resistance is short-circuited, when the motor is switched on the full voltage, and runs at full speed. The reversing of the motor for the opposite direction of rotation is generally effected by a reversing switch, which is separated from the controller, but mechanically connected with the latter in such a way as to make reversing impossible, unless the motor is stopped.

For cars which are provided with two motors, the controller becomes more complicated. In this case there are two main working positions, viz., firstly, a *series* connection of the motors, when each motor is switched on half the voltage only; and, secondly, *parallel* connection of the two motors, when each motor is switched on the full voltage, thus running twice as fast as before. Starting the motors is effected by connecting first of all the two series-connected motors in series with some resistance, and then gradually short-circuiting this resistance. The motors then run with half the voltage and a corresponding speed. But if the connection is altered, and the motors connected in parallel, they run with full speed.

Similar controllers are also employed for electric cranes.

Fig. 179 shows the cylinder of an American street-car controller for two motors, developed on a flat surface to show the contacts more easily.

Another form of controller mechanism is that known as the multiple-unit control system. In this case the controller is split up into its component parts, each being separate from the other, but operated from a master controller, which excites magnets, or contactors, located upon the component parts just at the right time, so that they take their turn in closing or opening the current circuits operating the motors on the cars, as the master controller regulates. These contactors, made to open heavy currents, may be placed under the car out of the way where room is available, and where the big arc resulting from their breaking large currents can give no trouble. The master controller, on the other hand, having only to direct the small current necessary to operate the magnets of the contactors, takes but little room and can be placed conveniently to the motorman. In addition, if several cars are connected together, all equipped with motors and contactors, one master controller can operate them all simultaneously. The figure shows the lines from the master controller to the contactor for one car. As many cars can be connected, in parallel to this same

controller, as desired. Thus, a whole train may be operated from one or more master controllers, and every axle helps the train along.

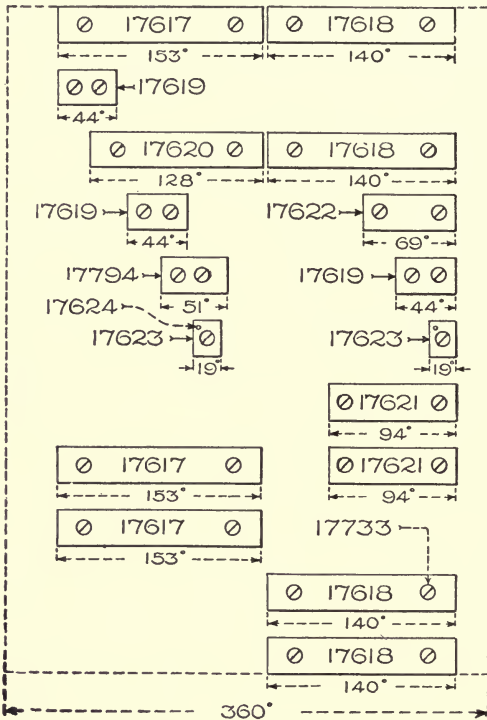

FIG. 179.—Cylinder Development of Street-car Controller (Two Motors).

In this way a very fast acceleration may be obtained. This system is much used in America on elevated trains and on large surface cars and locomotives, and is generally known as the multiple-unit control. By its introduction a great stride was made in electric traction, as unlimited power can be controlled by splitting it up into easily handled units.

Following is a detailed description of the multiple-unit system adopted by the General Electric Company of the United States of America.

The Sprague-General Electric Type M Control System

The Sprague-General Electric Type M Control is designed primarily for the operation of a train of motor- and trail-cars, coupled in any combination, and the whole operated as a single unit from any controller on the train. The system may also be used to advantage on individual equipments and locomotives.

The control apparatus for each motor-car may be considered as consisting essentially of a motor controller and a master controller.

The motor controller comprises a set of apparatus—usually located underneath the car—which handles directly the power circuits for the motors, connecting them in series and parallel and commutating the starting resistance in series with them. This motor controller is operated electrically, and its operation in establishing the desired motor connections is controlled by the motorman by means of the master controller, which is similar in construction to the ordinary cylinder controller, and is handled in the same manner. Instead of effecting the motor combinations directly, however, this controller merely governs the operation of the motor controller.

The master controller operates a number of electrically operated switches or "contactors," which close and open the various motor and resistance circuits, and an electrically operated "reverser" that connects the field and armature leads of the motors to give the desired direction of movement to the car. Both the contactors and reverser are operated by solenoids, the operating current for which is admitted to them by the master controller.

Each motor- and trail-car is equipped with train cable, consisting of nine or ten individually insulated conductors connected to corresponding contacts in coupler sockets located at each end of the car. This train cable is connected identically on each motor-car to the master-controller fingers and the contactor and reverser operating coils, and is made continuous throughout the train by couplers between cars, connecting together corresponding terminals in the coupler sockets.

All wires carrying current supplied directly from the master controller form the "control circuit"; those carrying current for the motors form the "motor" or "power circuit."

Inasmuch as the motor-controller operating coils are connected to this control train line, it will be appreciated that energizing the proper wires by means of any master controller on the train will simultaneously operate corresponding contactors on all the motor-cars and simultaneously establish similar motor connections on all cars.

ADVANTAGES

The Sprague-General Electric Type M Control permits a train of motor-cars and trailers to be operated as a single unit from any master controller on the train. If desired, a master controller can be placed on each platform of trail-cars, thereby providing for the operation of the train from any platform. With this arrangement the motorman can be always at the head of the train, regardless of the combination of the cars.

The entire train, equipped with Type M Control, may thus be regarded as a unit; the motorman has the same control over a train that he would have over a single car with the ordinary cylinder controller.

Should the motorman remove his hand from the operating handle of the master controller, the current will be immediately cut off from the entire train, thus diminishing the danger of accident in case the motorman should suddenly become incapacitated.

The system will operate at any line potential between 300 and 600 volts, and the action of all contactors is absolutely reliable and instantaneous.

On heavy equipments the effort of the motorman in operating the master controller is so much less than that required to handle a large cylindrical controller that he can give more attention to the air-brakes and other parts of the equipment, especially in cases of emergency. The ease with which it is operated also makes the Type M Control particularly well suited for use on large locomotives.

The approximate total weight per motor-car of control equipments, exclusive of supports, is as follows:

Aggregate H.P. of Motors.	Weight of Equipment in Pounds.
100	1500
200	2000
300	2500
500	4000
640	4500

The approximate weight of the apparatus for each trail-car, which comprises train cable, coupler sockets and connection boxes, is 100 pounds.

In many cases it will be found advantageous to anticipate the future growth of an interurban road by equipping each motor-car with Type M Control. In these cases it will be easy to change from single car to train service whenever warranted by traffic conditions.

The position of the handle on that master controller which the motorman is operating always indicates the position of motor-control apparatus on all cars.

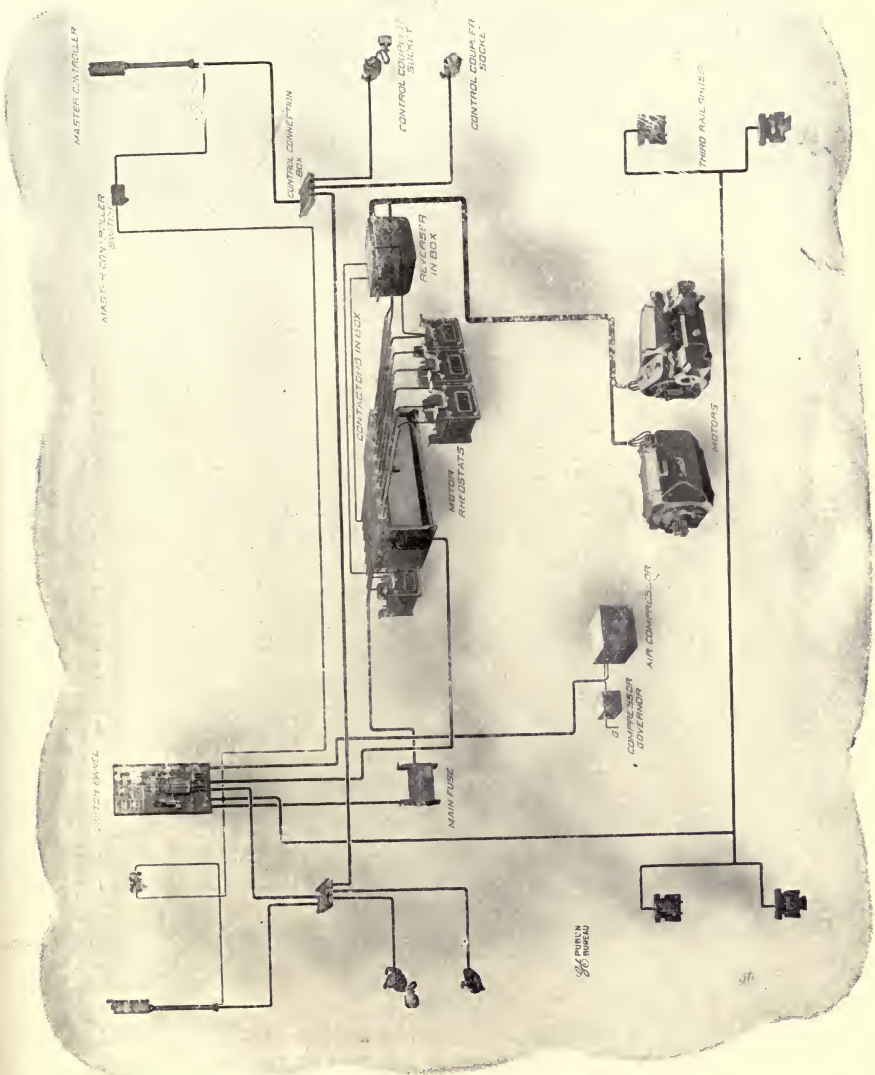

FIG. 189.—Train Control System.

On account of the great flexibility of this system, it can be readily adapted to many classes of service other than that of train operation. The small space occupied by the master controller and the ease with which the controller may be operated make this system for heavy hoists desirable in some cases, or other classes of severe direct-current service requiring a controller easily manipulated, or one which may be located at a considerable distance from the motors.

All parts subject to wear are readily replaceable.

CONTACTORS

The contactors are the means of cutting in and out the various resistances, of making and breaking the main circuit between trolley and motors, and of changing from series to parallel connection.

Each contactor consists of a movable arm carrying a renewable copper tip which makes contact with a similar fixed tip, and a coil for actuating this arm when supplied with current from the master controller. The contactor is so designed that the motor circuit is closed only when current is flowing through its operating coil; and gravity, assisted by the spring action of the finger, causes the arm to drop and open this circuit immediately, when the control circuit is interrupted. Each contactor has an effective and powerful magnetic blow-out, which will disrupt the motor circuit under conditions far exceeding normal operation. In closing, the copper tips come together with a wiping action, which cleans and smooths their surfaces.

All contactors in an equipment are practically identical, and the few parts which are subject to burning and wear are so constructed as to be readily replaceable.

In order to save space and eliminate interconnections as much as possible, several contactors are mounted on the same base. The contactors should preferably be located under the car, and boxes are therefore supplied which facilitate installation, protect the contactors from brake-shoe dust and other foreign material, and provide the necessary insulation. These boxes are built with perforated openings for ventilation, but shields are supplied for closing these perforations whenever desirable.

REVERSER

The general design of the reverser is somewhat similar to the ordinary cylindrical motor reversing switch, with the addition of electro-magnets for throwing it to either forward or reverse position. In general construction, the operating coils are similar to those used on the contactors, but in order to secure absolute reliability of action in throwing, the coil is given full line potential. The reverser is

provided with small fingers for handling control circuit connections, and, when it throws, the operating coil is disconnected from the ground and is placed in series with a set of contactor coils, thus cutting the operating current down to a safe running value. These coils are protected by a fuse, which will immediately open the circuit if the reverser fails to throw. If the position of the reverser does not correspond to the direction of movement indicated by the reverse handle on the master controller, the motors on that car cannot take current. While the motors are taking current the operating coil is energized, and the electrical circuits are interlocked to prevent possibility of throwing.

MASTER CONTROLLER

The master controller is considerably smaller than the ordinary street-car controller, but is similar in appearance and method of operation. Separate power and reverse handles are provided, as experience has led to the adoption of this arrangement in preference to providing for the movement of a single handle in opposite directions.

An automatic, safety, open-circuiting device is provided, whereby, in case the motorman removes his hand from the master-controller handle, the control circuit will be automatically opened by means of auxiliary contacts in the controller, which are operated by a spring when the button in the handle is released. This device is entirely separate and distinct in its action from that of the main cylinder. Moving the reverse handle either forwards or backwards makes connections for throwing the reverser to either forward or backward position. The handle can be removed only in the intermediate or off position. As the power handle is mechanically locked against movement when the reverse handle is removed, it is necessary for the motorman to carry only this handle when leaving the car.

When the master controller is thrown off, both line and ground connections are severed from the operating coils of important contactors, and none of the wires in the train cable are alive.

The current carried by the master controller is about 2.5 amperes for each equipment of 400 H.P. or less. This small current carrying capacity permits a compact construction, and the controller weighs only 130 pounds.

MASTER-CONTROLLER SWITCH

A small enclosed switch with magnetic blow-out is used to cut off current from each master controller, and is supplied with a small cartridge fuse enclosed in the same box. When this switch is open

all current is cut off from that particular master controller which it protects.

CONTROL CABLE

A special flexible cable, made up of different colored individually insulated conductors, is used for the train cable and, whenever possible, to make connections between the various pieces of control apparatus.

CONNECTION BOX

Connection boxes are provided for connecting the control circuit cables at junction points without splicing, and small copper terminals are supplied for attaching to the ends of the individual conductors.

CONTROL COUPLERS

The master-control cables of each car terminate in sockets and are interconnected by means of a short section of similar flexible cable fitted with plugs. Each socket contains a number of insulated, metallic contacts connected to the train wires, and the terminal plugs of the coupler contain corresponding contacts. The parts subject to wear are readily replaceable.

All coupler sockets are provided with spring catches which hold the plugs in contact under normal conditions, and permit them to automatically release in case two cars separate.

CONTROL CUT-OUT SWITCH

This is a switch, usually nine point, installed on each motor-car, and is used to disconnect the operating coils of the contactors and reverser from the train cable, and hence render them inoperative.

CONTROL FUSES

On each car several small enclosed fuses are placed in the control circuit at such points as to effectively protect the apparatus.

CONTROL RHEOSTAT

During acceleration, tubes of a high-resistance rheostat are connected in series with the contactor coils to cut down the operating current to a value approximating that for the running positions of the controller. This rheostat is enclosed in a sheet iron case for protection.

CIRCUITS

The motor circuit is local to each car, and on the first point the current on entering from the trolley or third-rail shoe passes through the following pieces of apparatus in the order named: main switch and fuse, contactors, resistances, reverser, motors; thence to ground.

In the control circuit, the course of the current from trolley to ground is through the master-controller switch and fuse, master controller, connection box, to the cut-out switch. From the cut-out switch the current passes through the control cable to the operating coils of the reverser and contactors, and thence through fuses to ground.

AUTOMATIC FEATURES

The apparatus described is used with the standard equipment for hand control. If automatic features are desired, certain minor changes will be entailed.

INSTALLATION

In order to insure economical operation, it is essential that the apparatus should be so located under the car as to be easily inspected and repaired. Attention should therefore be given to the disposition of the apparatus. The best results are obtained by first locating the contactors and reverser to the best possible advantage. The air-brake apparatus can be placed in the remaining space.

The Electric Brake

With street railway-cars it is of the greatest importance to be able to apply a brake quickly, especially in cases of danger, when, for instance, people are in the way of the car. The usual mechanical braking, as used for horse-cars, is not sufficient for the heavier and more quickly running electric car. A very effective kind of braking may be effected by disconnecting the motor from the mains, and then connecting the armature brushes with each other through a resistance.

Let us consider, first of all, a shunt motor, assuming the shunt coils to be connected with the outer mains during the whole running. If now we disconnect the armature from the latter, connecting the brushes to a resistance, the motor will, as long as it is rotating, act as a dynamo. The armature will deliver a current into the resistance, which current is greater the quicker the armature is running, and the smaller is the resistance. It is quite clear that for the production of this current mechanical work has to be spent. Thus the live energy, which the car still has after switching off the motors, is spent in generating a current, and will soon be consumed.

The car will therefore run slower and slower, just as if the wheels had been braked mechanically. This kind of braking is especially effective at a very high speed of the car, whereas at low speeds it is much less so. For absolutely stopping a car, this kind of braking cannot be employed at all, since there is only a braking effect if a current is really generated, and the latter can only occur when the armature is rotating. Each electric car has therefore, besides the electric braking arrangement, to be provided with a mechanically acting one.

When a car is provided with series motors, which is generally the case with street railways, a reversal of the magnet connections is required for getting a braking effect. Imagine the motor to be connected according to Fig. 181, the current flowing in the armature in the direction from I. to II., in the magnets from V. to VI. As we know, a back E.M.F. is produced in the armature, which, after disconnecting the latter from the mains, would tend to produce a current, leaving the armature in I., and entering it again in II. Hence if, for the purpose of braking the motor, we simply insert a resistance between I. and VI.

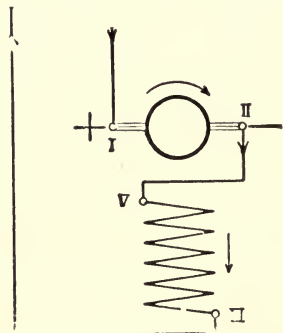

FIG. 181.—Running Position of Series Motor.

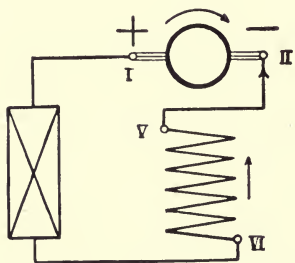

FIG. 182.—Incorrect Connection for Braking.

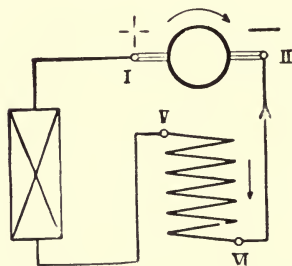

FIG. 183.—Correct Connection for Braking.

(see Fig. 182), then the current will leave the armature in I., flow through the resistance, through the magnet coils in the direction from VI. to V., and enter the armature at II. The current will therefore flow through the magnet coil in a direction opposite to that before. The magnetism of the machine will be destroyed, no current production is possible, and the braking effect will

instantly cease. To get a braking effect, we must connect the magnet coils so as to cause the armature current to flow through them in the same direction as when the machine was working as motor. The proper brake connections for a series motor are shown in Fig. 183.

The brake connections are generally executed by means of the controller. From the "stop" position to the left of the driver the different running, and to his right the brake positions of the controller handle, are generally arranged.

The Magnetic Blow-Out

A controller has generally far harder work to do than a common starter, since it has continually to be operated for starting the motor, altering its speed, and braking. To prevent the arcs and sparks, arising from the frequent disconnections made with the controller, from destroying the contact rings and the brushes, it is necessary to blow out the sparks quickly. This may be done by **magnetic blow-outs**.

If we bring a strong magnet near an electric arc, we observe that the arc is deflected, being bent in a large bow, and finally extinguished. The arc is an easily movable conductor. It consists of glowing metal or carbon vapour, through which the electric current flows. As we know, each movable electric conductor is deflected by a magnetic field, and therefore the deflection and rupturing of the electric arc may be understood.

Each controller is provided with a strong electro-magnet, the effect of its magnetic field extending over the fixed contact brushes. The sparks arising between these contact brushes and the contact rings are hence quickly extinguished.

Operating Troubles with Direct-current Motors

Fig. 184 shows a contactor equipped with a magnetic blow-



FIG. 184.—Contactor.

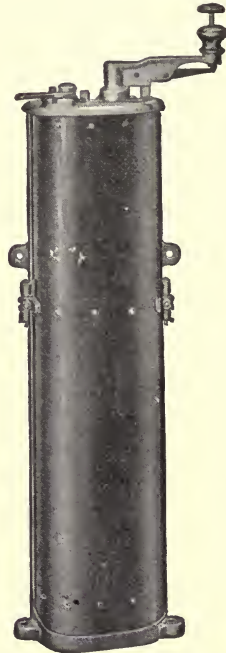

FIG. 185.—Master Controller.

out to extinguish the arc, and Fig. 185 shows a master controller operating many of these contactors.

CHAPTER V

ACCUMULATORS

WE have learned in the first chapter of this book, that if with the help of metal plates we pass a current through acidulated water, a decomposition results, with the separation of hydrogen and oxygen.

Another phenomenon also takes place with which we have not yet dealt. If the resistance of the voltmeter and the pressure at its ends be first measured, and from the values so obtained we calculate the current which ought to flow through the circuit in accordance with Ohm's Law, we shall find that what is actually measured by an ammeter is far smaller.

The explanation lies in the fact that in addition to the E.M.F. driving the current through the liquid there is a back or counter E.M.F., just as we have learnt is the case with an electro-motor.

At the positive electrode, which is the place of entrance of the current, the oxygen is liberated, whilst at the negative the hydrogen is evolved. The current flows in the liquid from the positive to the negative pole; the back E.M.F., on the other hand, is so directed that it tends to send a current in the liquid from the negative to the positive pole. Whenever a current passes through a liquid, as in the case of galvanic cells, the development of gas at the plates produces a back E.M.F., which tends to weaken the working pressure of the cell. This effect is called **electrolytic polarization**. The simplest element with copper and zinc in dilute sulphuric acid shows the property of polarization in a very marked manner, and causes the E.M.F. of such a cell to rapidly diminish when the cell is in use.

The separation of oxygen and hydrogen brings about a chemical alteration of the immersed metal plates, unless they are made of metals like platinum. For example, if we use as electrodes plates of iron, then the oxygen liberated at the positive pole will cause oxidation of the iron. We know that iron rusts on account of the oxygen in the air which combines with the metal. The compound so produced is known to chemists as **oxide of iron**. Exactly the same thing happens during electrolysis, when the positive plate is of iron. If we had used lead instead of iron a corresponding change takes place. On the surface of the positive electrode a layer of lead oxide would appear.

At the negative electrode hydrogen is liberated, but does not, as a rule, attack the electrode. If lead were used it would remain bright, or, if it had previously been covered with a thin film of oxide, this will now be destroyed, because the hydrogen, having an attraction for oxygen, will decompose the oxide, producing water and liberating lead.

After the passage of the current we have no longer two similar electrodes, but at the positive pole we have the metal coated with lead oxide, and at the negative a clean lead plate. Two different metals in a liquid give, as we are aware, an E.M.F. The origin of the back E.M.F. will now be self-evident. When gas is evolved, this collecting on the plates gives a further difference between the plates. Hence, to get a current through the liquid its voltage must be sufficient to overcome the back E.M.F. The voltage of such a cell may amount to more than 2 volts, *i.e.* twice as much as the E.M.F. of a simple galvanic cell.

When a cell is coupled to an outside source of pressure, so as to send a current through it, the process of *charging* is said to be in progress. On stopping the current the evolution of gas immediately ceases, but if we now connect the poles of the cell by a wire, a current is obtained, the direction of which is opposite to the charging current, and the cell is said to *discharge*. It may again be charged by coupling it to a pressure supply, then discharged, and the process may be repeated as often as may be desired.

An apparatus used in this way is called an **accumulator**—that is, a storage arrangement which is capable of accumulating energy and giving it back when desired.

The accumulator that we have so far considered can supply current for a short time only, for in charging it, only the surface of the plates, which is in direct connection with the liquid, can be chemically altered. When this is effected, further charging is useless. The liquid is then decomposed, but the oxygen formed on the positive plate, after the whole surface has been oxidized, is unable to further penetrate into the plate, and escapes, therefore, in the form of bubbles. Hence, if the charging be continued, the only effect will be to decompose the liquid.

If however, after the first charge, the accumulator is again discharged, then the plate has been mechanically altered. The surface of the lead plate has become spongy, and if we charge the accumulator again, the chemical change can penetrate a little deeper into the plate. If these charges and discharges be continued, the "capacity" of the accumulator is gradually increased.

This process of *forming* the plates was first used by the French experimenter **Planté**, and plates made in this way are called **Planté plates**. The process of formation is a very lengthy one, and must be **continued** for weeks, and even months if the cell is to have much

capacity. The process is completed when one plate is covered to a good depth with finely divided lead, and the other has a corresponding amount of lead peroxide.

It was again a Frenchman—**Faure**—who showed how the tedious process of forming might be much diminished in time. Instead of using pure lead plates, he applied to the lead a mixture of the two oxides of lead called *minium*. If as positive electrode a lead grid filled with minium be employed, and as negative electrode a pure lead plate, or a similar grid plate having the holes filled with spongy

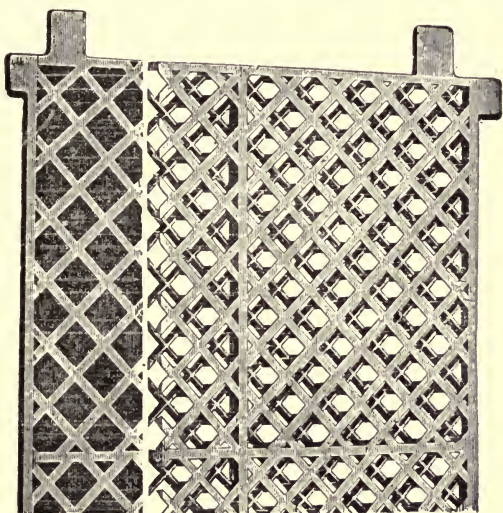

FIG. 186.—Accumulator Plate.

lead, then we have from the beginning two chemically different electrodes, which have already an E.M.F., and do not require a formation, or in some cases a formation lasting only a short time.

In the manufacture of accumulators it is extremely important that the greatest care be taken that the pasted substance is secured firmly to the lead grid. Various methods have been devised for locking the material within the openings of the lead grids, one example being shown in Fig. 186.

In order to give the Planté accumulators great capacity, it is essential that the acting surface be as great as possible. Now, the working surface of a plate of any particular size may be increased

by providing it with very many ridges and cavities such as shown in Fig. 187.

The chemical processes which take place in the accumulator are by no means as simple as we have hitherto assumed them to be. We have supposed that the water only in the cell is decomposed, and that the acid serves merely for the purpose of improving the conductivity of the water. The sulphuric acid really has an influence on the chemical process, and it has been found that the proportion of the

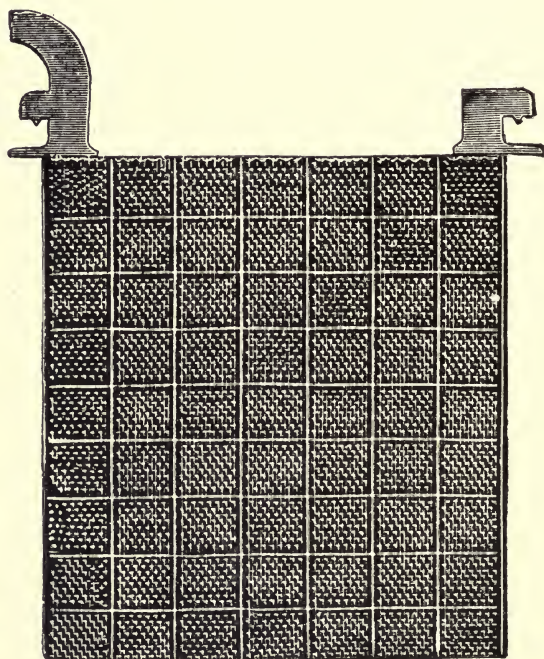

FIG. 187.—Accumulator Plate.

quantity of water to that of the acid is of great importance. The complete chemical changes which take place during the charging and discharging of an accumulator are too complicated to be described here. The main facts are these:—During charging, spongy lead is formed at one plate which is termed by cell makers the *negative plate*; whilst at the other plate, called the *positive*, a dark red oxide called lead peroxide is formed. On discharging the cell both the lead and lead peroxide are changed to lead sulphate.

Under normal conditions an accumulator should never be dis-

charged so that its E.M.F. falls lower than 1.80 to 1.83 volts. For the purpose of charging, a higher pressure is necessary. Soon after the beginning of the charge the E.M.F. of a cell rises to two volts, and when completely charged becomes 2.5 to 2.7 volts. When gas is evolved from both plates of the accumulator, the end of the charge is indicated, and that no more oxygen is being absorbed by the positive plate.

The rising of the voltage during charging is firstly due to the chemical change of the plates, and then for two other reasons. There are formed bubbles of hydrogen and oxygen, which increase the back E.M.F. of the accumulator, and further the accumulator has of course an ohmic resistance, to overcome which requires the expenditure of certain E.M.F.

After charging, the voltage of the accumulator falls immediately, down to 2.2 volts. If we connect the accumulator terminals with an outer resistance, so that it supplies current, its terminal voltage will fall still further, and more so the greater the current supplied. This is partly due to the chemical alteration of the plates, and partly due to the ohmic resistance of the cell. In charging we have to make the terminal voltage larger than the E.M.F. of the accumulator in order to overcome the ohmic resistance. But, in discharging, the voltage drop caused by the ohmic resistance takes away part of the E.M.F., so that the terminal voltage becomes smaller than the E.M.F. of the cell. Hence the ohmic loss works to our disadvantage, both in charging and discharging.

From an accumulator we cannot therefore get as much energy as we put into it. The ratio between the quantity of energy which we get in discharging to that energy which has to be spent for charging is called the **efficiency of the accumulator**. With good accumulators this is about 80 per cent. For 100 units of work put into the accumulator we get about 80 units from the accumulator, the remaining 20 units are transformed into chemical action and heat.

The accumulator is an excellent means for storing electrical energy. If at any time there is electrical energy at liberty, we may charge the accumulator, and afterwards obtain electrical energy from it. We may, for instance, charge an accumulator during 10 hours with 2 amps., and then take 20 amps. during nearly 1 hour; or we may charge it with 20 amps. during 1 hour, and then obtain nearly 2 amps. during 10 hours. The accumulator may be compared to a savings bank, to which we may pay money from time to time in pence, and get back in one payment a large sum; or to which we may pay at one transaction a large sum, to be withdrawn in small amounts as desired. We may also, of course, charge and discharge the accumulator exactly at the same rate.

This convenient transformation, of which we have just spoken, is, of course, limited. The current passed into or taken out of an

accumulator should never exceed a certain amount, or the plates will be injured. The current an accumulator can stand depends chiefly on the size of the plates. To obtain large currents with plates of reasonable size, they are not made in one piece, but consist of several plates connected in parallel. Figs. 188 and 189 are illustrations of accumulator cells, each consisting of several plates. They are placed side by side, so that any positive plate lies between two negative ones, and any negative (except the plates at the two ends) between two positive plates. Thick lead rods are used to connect all the positive plates together, and in a similar way all the negative plates are in connection. The voltage of the cell is, of course, equal to one consisting of two plates only.

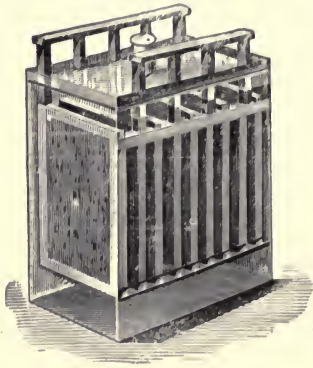

FIG. 188.—Storage Cell.

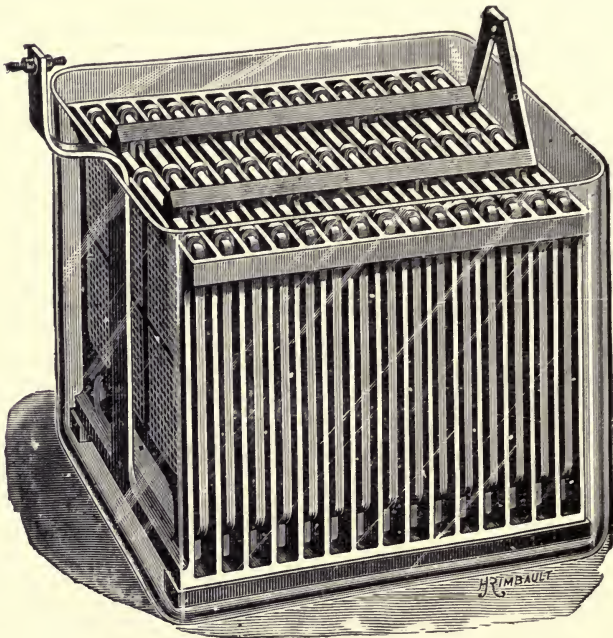

FIG. 189.—Storage Cell (General Electric Co.).

To get the resistance as small as possible the plates are placed very near each other. Direct contact of the plates is prevented by glass or rubber rods placed between them.

Since in most cases far higher pressures than 2 volts are employed, a number of accumulator cells are placed in series, forming an *accumulator battery*. The single cells have then to be connected so that the positive terminal of the first cell is connected with the negative terminal of the second; and so on in series. Since any other metal would be attacked and destroyed by the sulphuric



FIG. 190.—Portable Storage Battery

acid or the spray arising from it, lead strips or rods are used for connecting the poles. In Fig. 190 a battery is shown which consists of four cells, mounted in a wooden box, which is lined with celluloid.

If the battery has to feed 110 volt lamps, it must consist of about 60 cells; for, as we have learnt, accumulators are discharged down to a voltage of about 1.80 to 1.83, so that finally the voltage of 60 series-connected cells becomes 110.

If, on the other hand, we had the lamps continuously switched on the whole battery, this would be a great fault, for the voltage of a single cell is at the beginning of the discharge more than two volts. Thus the lamps at the beginning getting more than 120 volts, would

be overrun, and have a short life only. Further, the lamps would burn very brightly at the beginning, and darker later on. To prevent this the lamps must at the beginning of the discharge be in connection with a smaller number of cells.

If the cell voltage be, for instance, 2, then 55 cells at first are sufficient; then, as the discharge continues, 56, 57, etc., cells are necessary to give the voltage of 110. If the voltage per cell falls to 1.83, then all the 60 cells will be required.

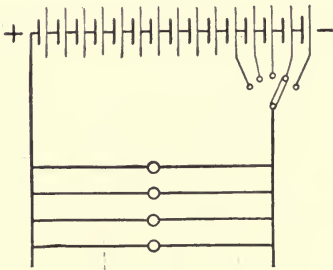

Fig. 191.—Cell Switch.

To easily secure this variation of pressure, *cell switches*, as diagrammatically shown in Fig. 191, are employed. From each of the last cells a cable leads to a number of contacts, which are arranged in a circle, and over which a metal lever slides. The lamps are between one

pole of the battery, and the lever of the battery switch. If the latter is in its extreme left position, the lamps are connected to the least number of cells. The cells on the right are then without effect, they do not supply any current. In moving the lever to the right to the next contact, one of the cells previously not in use is switched into the circuit. As the battery voltage decreases the lever is moved more and more to the right, and finally all the cells are in use.

As may be seen from the above, the *end cells* are not used so much as the others, and therefore it is not necessary to charge them as long as the main cells. The battery switch may therefore also be used with advantage for charging the cells. First of all, the cells are connected in series, the lever of the battery switch covering the last contact. At the last cell, which is discharged but little, a strong development of gas will soon be observed. If by means of a voltmeter we examine the voltages of the single cells, the last will probably show 2.5, whereas the voltage of the other cells will still be lower, probably 2.3. The last cell is then switched off by removing the lever of the battery switch to the last contact but one. When the last cell but one becomes fully charged, the lever is again moved back one contact. Thus we see that on charging it is necessary to move the lever gradually to the left, whereas on discharging we must move the lever to the right as required.

A battery recently developed in America by Thomas A. Edison has iron for its plates and for solution hydrate of sodium or caustic soda. The chemical action here is that of oxidation, just as with lead plates. The life of this battery is reported to be far longer than the lead battery, and its weight per horse-power less. Many difficulties have been met and overcome in manufacture, and while the sales have not been large, those produced have given very great satisfaction.

Machines for charging Accumulators

For charging a battery of 110 volts a pressure of $60 \times 2.5 = 150$ volts is required; sometimes the voltage per cell has to be raised up to 2.7–2.75, bringing the voltage of the whole battery up to 165. A dynamo employed for charging such a battery must therefore be built for a far higher voltage than that used on the lighting circuits.

For charging accumulator batteries, shunt dynamos are generally employed. We know that with these machines by means of a shunt regulator it is possible to alter the voltage within certain limits. Machines for charging accumulators are now built so that by means of a large shunt-regulating resistance their voltage can be varied between 110 to 160.

Series and compound dynamos are practically never used for charging accumulators. With a series dynamo the voltage increases with the current. Hence if, by any means—say by a resistance inserted in the circuit instead of the cells—we get such a voltage on the dynamo as to get a certain current in the cells, then, on switching in the latter, the E.M.F. of the accumulators will increase. The result will be that the difference between the E.M.F. of the dynamo and the back E.M.F. of the accumulators, and hence the current, will decrease. Due to this smaller current, the E.M.F. of the series dynamo will now fall, and it might then happen that a current will flow back from the battery to the dynamo, and reverse its polarity. The use of a series dynamo is therefore impossible.

Compound dynamos are, for similar reasons, also unsuitable for directly charging accumulators. If, however, the voltage of the compound dynamo be higher than the maximum accumulator voltage, then with such a machine the cells may be charged by employing a series resistance. In this case it is not to be feared that the dynamo voltage may fall so low that a current will be sent back from the accumulators through the resistance to the machine.

The most suitable and nearly exclusively employed machine for charging accumulators is the shunt dynamo. For, firstly, with decreasing current its voltage increases, and it can therefore hardly happen that its voltage should fall below that of the battery; and, secondly, even if this should take place (for instance, through the driving steam-engine running more slowly), a current would flow from the battery into the machine in an opposite direction through the armature only. The magnet coils are in this case traversed by a current flowing in the same direction as before, the only difference being that the current comes from the cells instead of from the

armature. Thus the polarity of the magnets is not reversed, and the reversal of the current does not cause any subsequent injurious effect, as it would do with series or compound dynamos.

With the means with which we have so far become acquainted, it would not be possible to employ a dynamo for lighting and charging accumulators simultaneously.

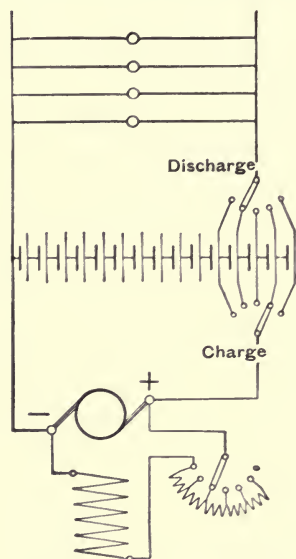

FIG. 192.—Double Cell Switch.

With two battery switches there is no difficulty in doing this. In Fig. 192 it is shown how the last few cells of the battery are connected with the contacts of two cell switches. The one which is below in the diagram is called the charging battery switch, the upper one the discharging switch.

The machine is connected with the first cell and the charging lever; the lamps are connected with the first cell and with the discharging lever. Now we may produce with the machine a voltage of 150, and charge with this voltage the 60 series-connected cells. The charging lever covers, for instance, the last contact, but the discharging lever is removed far to the left, so that probably only 44 cells are switched on the lamp mains. If the voltage of each cell be 2.5, then the 44 cells will just give the proper lighting voltage of 110. The battery is—in a manner—fully

charged and simultaneously partly discharged. If, for instance, we charge with 100 amps., and the lamps consume 10 amps. only, then the full current of 100 amps. will flow through those cells only which are between the charging and discharging levers. All the other cells are charged with $100 - 10 = 90$ amps. only.

As a matter of fact the lighting current of 10 amps. is not supplied by the battery, but by the dynamo. We have in this case a branched circuit. From the positive pole of the machine a current of 100 amps. is flowing to the charging lever, giving a current through the additional cells only. Through these the full current is flowing. When the current comes to that cell which is connected with the contact just covered by the discharging lever, the current has two ways—one through the whole battery to the negative pole, the other one through the discharging lever and the lamps to the negative pole. In the latter the branch currents are again combined, flowing back to the negative brush of the dynamo.

This arrangement is only employed in cases where the current

supplied to the mains during charging is small compared with the charging current of the battery, otherwise a far larger current will flow through the end cells than through the others. The former must then be made much larger than the latter, or, owing to the larger currents, they will be far sooner destroyed than the other cells.

Sometimes, for raising the voltage during charging a special machine, a so-called **booster**, is employed. The main dynamo then supplies the normal voltage, and it can therefore, during charging, supply current to the mains. With the main dynamo the booster is in series, by connecting the negative brush of the latter with the positive brush of the main dynamo (see Fig. 193). The battery is connected to the negative pole of the main dynamo and the positive pole of the booster. The booster can be regulated from a very low voltage up to about 50 volts (provided we have a main voltage of 110, and 60 cells).

When we commence to charge the cells the booster has to supply a very low voltage, the excitation is very weak, but the charging current might probably be very large. In such a case it may happen that, owing to the armature reaction, which weakens the magnetism, the polarity of the machine is changed. To prevent this, the booster is generally separately excited.

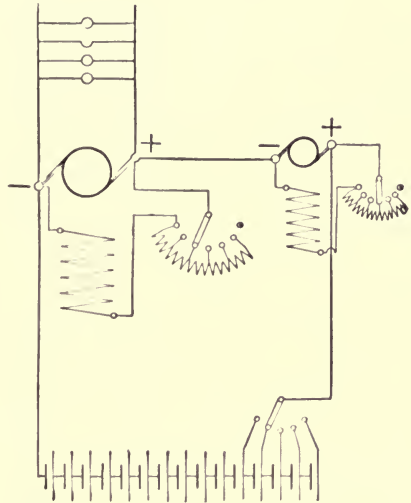

FIG. 193.—Connections for Booster when charging.

Battery Switch

Fig. 194 shows one type of an accumulator battery switch. We see from this illustration that the contact pieces are arranged in a circle, and that a lever with an elastic brush slides on them. The lever is not quite as simple as are those of regulating resistances. We observe a spiral of wire on it, and that there are fixed, not one, but two contact brushes on the lever. If we had a single contact

brush only, then there would be two possibilities: the brush may be either narrower or wider than the insulating space between the contact pieces. If we make the brush narrower, then in moving the lever a break in the current takes place. This will cause a violent sparking, and, if the motion of the lever be a slow one, the lamps will be extinguished. Certainly with a quick motion of the lever the current would not be entirely interrupted, nevertheless a flickering of the lamps would be caused, and the contacts burnt by the sparks. If, on the other hand, the contact brush be so wide as to touch the second contact before it has left the first one, then the flickering would, of course, disappear; but at the moment the brush

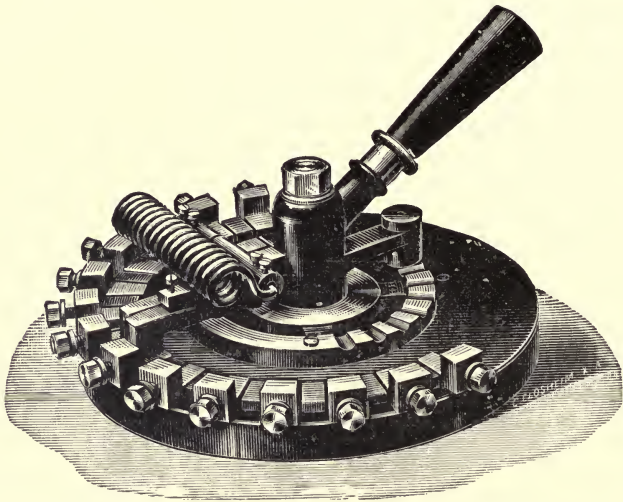

FIG. 194.—Battery Switch (*Voigt & Häffner*).

covers two contact pieces, one of the cells is entirely short-circuited thus causing a strong current, which would damage the cells. To avoid this, near the narrow main brush which serves for taking the current, another auxiliary brush is provided, which is connected with the main brush by means of a resistance spiral of German silver or nickelin, but is insulated from the lever. If the lever stops, then only the main brush covers the contact, the auxiliary brush is on the insulating piece between the contacts, and thus is without effect. If we move the lever, in order to switch in or off a cell, then, before the main brush has left the first contact, the auxiliary brush covers the next one. The cell being now between the two contacts is, of course, connected with a *closed* circuit,

but is not *short*-circuited, for the resistance of the spiral is in the circuit, and if this resistance be made sufficiently large, the current produced by the cell will be only a moderate one. At the next moment the main brush leaves the first contact, but since the auxiliary brush now covers the second contact, there cannot be a further interruption of the current, but the resistance spiral is inserted in the outer circuit. If we left this resistance continuously switched in the circuit, energy would be wasted, for the resistance spiral consumes nearly as much voltage as is supplied by the last added cell. Hence we must remove the lever a little more, until the main brush covers the contact piece, and the auxiliary brush stands again on the insulating piece. In this way both an interruption of the current and a short circuit is avoided, and on moving the lever violent sparking is prevented.

The same effect may be obtained by connecting each cell with two contact pieces, having one of them connected directly, and the other one through a resistance spiral. A brush of double width may then slide over the contacts. Battery switches of this construction have therefore twice as many contacts as those of the type previously considered.

Charging and discharging switches may be combined in a single apparatus, the **double-cell switch**. There is no difference in the arrangement of the contact pieces between this and a single-cell switch, but there are two levers insulated from each other, and having arms of different length, sliding over the contact pieces. This obviously produces exactly the same effect as if we had connected each of the end cells with the contacts of two different cell switches.

In some cases it is desirable to save, during the time current is taken from the battery, any attendance. In such cases an automatic cell switch may be employed with great advantage. The arrangement consists chiefly of a small motor, which, by a relay, is switched in so as to run either clock- or counter-clockwise, according to the voltage increasing above or decreasing below the normal value. The contact brush of the cell switch is, by the motion of the motor, then moved either upwards or downwards. When the normal voltage is reached, the motor is switched off by the relay.

Accumulator Apparatus

We have previously learned that when machines and accumulators work in parallel the current from the latter may possibly flow back into the dynamos. We have further learnt that this danger is least with shunt dynamos; but in this case, also, a reversal of the current is

liable to damage the accumulators. Assuming, for instance, that the steam-engine driving the dynamo runs somewhat slower, then there may come a moment in which the E.M.F. of the dynamo is smaller than that of the accumulators. The dynamo will then consume current, and run as a motor driving the steam-engine. Hence the accumulators are discharged with a current, which may be dangerously large. To prevent this **minimum cut-outs** are provided in the accumulator circuit. Fig. 195 shows such an apparatus. There are two cups filled with mercury, into which can dip a piece of metal, U-shaped and fixed on a movable lever. The latter has an iron axle, with which two small iron rods are connected, which project backwards. These iron rods are connected by a brass strip, on which is fixed

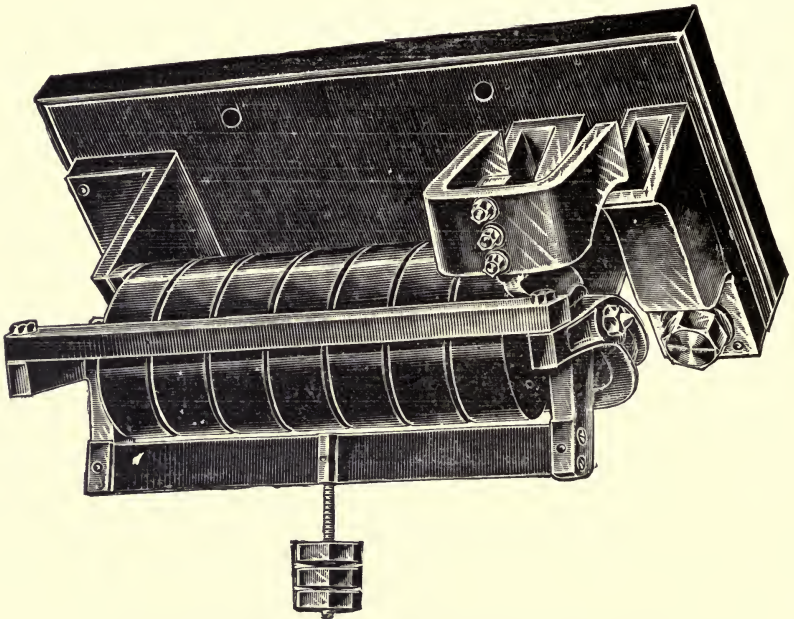

FIG. 195.—Minimum Cut-out (*The Electrical Company*).

a counter-weight, pulling downwards the back part of the apparatus, thus tending to lift the U-shaped piece out of the mercury. Over the iron axle a copper spiral is wound, one end of which is connected with the inner mercury-basin, the other end with one main terminal. The outer mercury-cup is in connection with the second main terminal. If a current flows through the copper spiral, both the iron axle and the two iron rods projecting backwards become

magnetized, the whole arrangement representing then a horseshoe electro-magnet. Imagine now one terminal to be connected with the machine, the other one with the accumulators, then, in the position of the apparatus shown in the figure, no current can flow through the spiral. If, now, we wish to charge the accumulators, we have to bring the dynamo to a voltage which is larger by a few volts than that of the accumulators. Then we have to lift the counter-weight of the minimum cut-out, so that the U-shaped metal piece dips into the two mercury-cups, and the limbs of the electro-magnet knock against the iron bar. In doing so we close the dynamo circuit. The current coming from the dynamo flows from the right main terminal to the mercury-cup, through the U-shaped metal bridge (which is insulated from the lever) to the second mercury-cup, from there through the copper spiral, and from the latter to the second terminal of the apparatus and to the accumulators. The current magnetizes the horseshoe-shaped iron pieces of the movable part, so that it sticks to the iron bar above. With a current over a certain value, this attraction is so great as to overcome the effect of the counter-weight, and to keep the movable part in this position. If, however, the dynamo voltage falls, then, at the moment in which the E.M.F. of the accumulators is equal to the charging pressure, the current flowing in the circuit will be nil, and the electro-magnet of the movable part will lose its magnetism. It no longer keeps fast the iron bar, and the counter-weight will lift the iron bridge from the mercury-cups, thus disconnecting the circuit.

If the electro-magnet touches the bare iron keeper, then, owing to the remanent magnetism, the proper working of the armature is prevented. To avoid this, two brass screws are provided, which project over the electro-magnet, thus preventing the armature from direct contact with the electro-magnets.

In some cases, instead of the minimum cut-outs, **maximum cut-outs** are employed. These act when the current exceeds a certain amount. The electro-magnet, excited by a current passing around the spiral, causes, in this case, by attracting the iron armature, a break in the circuit.

Maximum cut-outs, both for accumulators and for motors, prevent them from being heavily overloaded. As we know, fuses are generally selected so that they will melt with a current of double the normal value. Since, now, this increased current cannot do the mains any harm, but may in some cases seriously damage the motors or cells, a maximum cut-out is desirable, which is so adjusted that when the allowable current is exceeded, the circuit is automatically disconnected.

We have still to mention the current indicators, which are generally inserted in the accumulator circuit. When the current

flows through the accumulators in such a direction as to charge them, the pointer of the instrument indicates "charge;" if the current flows in an opposite direction the pointer indicates "discharge." See Fig. 196.

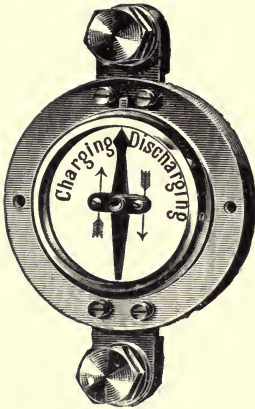

FIG. 196.—Current Indicator (General Electric Co).

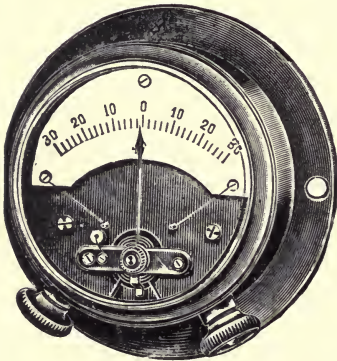

FIG. 197.—Ammeter with Central Zero Point (Berend & Co).

If in the accumulator circuit be inserted a Deprez ammeter, with the zero in the middle, as shown in Fig. 197, a current indicator becomes superfluous.

To examine the state of the single cells, a little voltmeter is used with a range of 3 volts, one

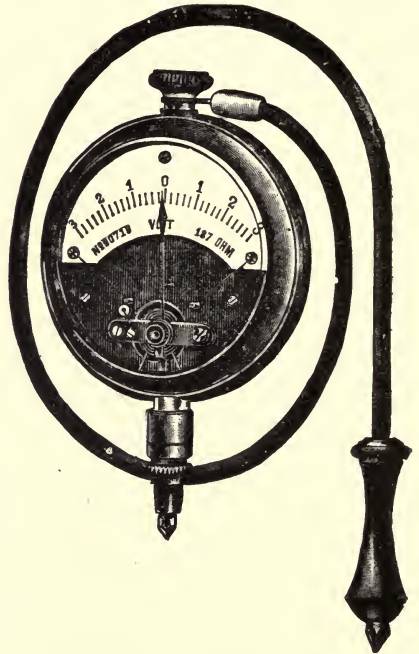

FIG. 198.—Voltmeter for Cell Testing (Berend & Co.).

terminal of which terminates in a point; the other end is connected with a short cable, the end of which also terminates in a point. The two points are then pressed against the positive and negative electrodes of the cell respectively, and so the cell voltage is measured. An accumulator tester of this kind is shown in Fig. 198.

Applications of Accumulators

Accumulators serve many purposes. In central stations for small towns the current consumption is considerable only during a few hours of the day, whereas during the remaining time comparatively few lamps are in use. It is then very uneconomical to run the machines during the whole day and night. If the machines run during the day, when the demand for current is little, they are under a small load. Dynamos and steam-engines running with a small load have a low efficiency. Whilst, for instance, with a full-loaded steam-engine plant the coal consumption per useful **kilowatt-hour** varies between $3\frac{1}{2}$ and 6 pounds (according to the size of the plant), this consumption may with machines that are very little loaded increase up to 12-20, and even more, pounds. But if an accumulator be used, this may be charged during some hours of the day, enabling the machines to run with greater load. During the whole time of small demand of current the accumulator alone is sufficient. The machines are stopped during this time, and are started again during the time of maximum demand, when they can be assisted by the battery, so that at the time of the maximum demand a larger current may be supplied to the mains than could be delivered by the machines themselves.

In factories where electricity is used both for lighting and power transmission, during the working hours much current is consumed by the electric motors, and, in addition, in the evening a large current is needed for lighting workshops, office-rooms, etc. After the working hours but little current is required for lighting special rooms, corridors, yards, etc. This current is then supplied by the accumulators, which may be charged again during the working hours. If the battery is of sufficient capacity, even motors for driving small lathes and other tools may, after the end of the general work, be provided with current from the battery.

Excellent service may be rendered by accumulators as **buffer batteries** when working in parallel with dynamos. In central electric stations, both for lighting and traction purposes, shunt dynamos are frequently employed. These dynamos have, as we know, the property, that with an increasing current the terminal voltage decreases. Now, in all central stations in which electro-motors are installed on the mains, sudden rushes of current occur, due to the switching in or sudden loading of motors. This causes a sudden fall of the voltage. Now the shunt regulator cannot be worked so quickly as to prevent fluctuation of the lamps on the network. The same thing takes place if the load is suddenly thrown off the dynamos. In this case the voltage increases rapidly. Again,

with central stations for traction purposes it may happen that the current consumption increases for short periods to three, four, or even five times the average demand, as when several cars start simultaneously. This will cause the voltage of the dynamo supplying the current to suddenly fall an undesirable amount. If, however, there is a battery of suitable size working in parallel with the dynamo, then it will supply current at these times of sudden demand, and prevent the voltage of the mains from falling lower than that of the battery. When a great number of amperes no longer is needed, the E.M.F. of the dynamo will tend to rise, and the battery will now be charged. In the opposite case when the current consumption increases beyond the normal output of the dynamo, the battery will again supply current to the mains. The battery thus is ready for any sudden rushes, and acts just like a buffer between dynamo and network. The dynamo will, therefore, if running in parallel with a battery, work with a far steadier load, and thus prove more economical than without the battery.

If there be water power of comparatively small amount, then we might accumulate in a battery energy during the whole day, and during the evening take a comparatively large amount of energy from the battery. This system is frequently used for lighting purposes.

In the cases hitherto dealt with, the batteries have been stationary. In many cases portable accumulators are employed, both for lighting and power purposes. For lighting railway cars, for instance, accumulators are charged at a terminus, and put in a special box beneath the car. From them glow lamps can be supplied with the necessary current to light the car.

When it is wished to avoid trolley wires in streets, the car can be provided with accumulators, which may be charged at special charging stations. If only at certain parts of a line trolley wires are not allowed to be used, a combined system is possible. The car is then provided both with accumulators and trolley equipment. On some parts of the line the current is taken from the overhead trolley wires, and at the same time the accumulators are also charged with this current. Along the other parts of the line the accumulators supply the necessary electrical energy to the motors.

Since storage batteries with a great capacity have a considerable weight, accumulator cars are generally far heavier than cars with motors only. It may also happen that, if the battery is not sufficiently charged, or the state of the street on account of dirt, snow, etc., is very difficult for traction, the car may be brought to a stop, because the battery is exhausted. For this reason neither the accumulator alone, nor the combined system is very reliable, and it is more satisfactory to have a special underground system whenever the overhead system cannot be employed.

Motor cars may also be driven electrically, and provide an extended application for portable batteries.

The same remark applies to boats and launches. The spindle of the screw is coupled directly with the motor, and the latter is fed by a battery.

The accumulator has a considerable advantage over primary galvanic cells. It can, by charging, be restored to its former state, whereas with primary cells this is not possible.

The student must clearly understand that the accumulator does not store *electrical energy*. It stores *chemical energy* which is converted into electrical energy when the cell is discharged, the *electrical power* depending on the rate of discharge. We must carefully distinguish between electrical power and electrical energy. For the former a convenient unit is the **watt**, for the latter the unit mentioned on p. 195, the **kilowatt-hour** is in commercial use.

CHAPTER VI

WORKING OF DIRECT-CURRENT DYNAMOS IN PARALLEL

ALTHOUGH dynamos are built of great output (2000 kilowatts and over), it is seldom the case that there is only a single dynamo erected for the whole output of a central station, but generally two or more dynamos are used, each of which has to supply a part of the total output. This division of the plant is for several reasons. First of all, continuity of service must be maintained. If an accident

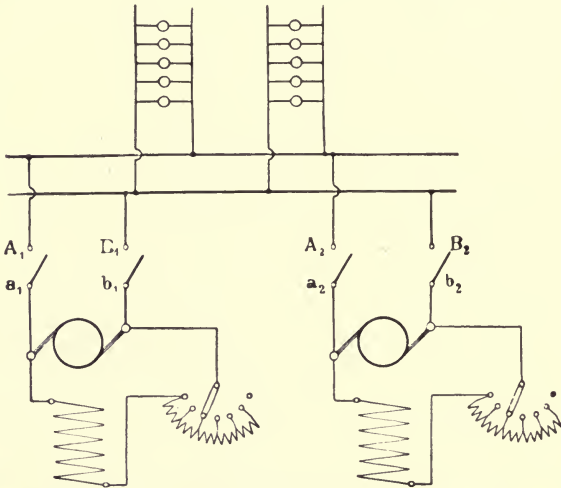

FIG. 199.—Shunt Dynamos ready for Switching in Parallel.

happens to one of the machines, there are still others to maintain, to a certain extent, the demand. Secondly, it is possible to run one or more machines nearly fully loaded, as required, and hence they will work at the highest efficiency.

When several dynamos are used, it is usual to arrange them in parallel on the same network. For this purpose shunt dynamos are

suitable (see Fig. 199) as well as compound. It is almost impossible to combine series dynamos in this way.

Imagine, for instance, two series dynamos working in parallel; these would alter their voltage continuously, according to their load. Assuming that their E.M.F.'s were, at a definite load, just alike; then, with an increasing load, their voltages would rise. It is, however, not at all certain that these pressures will rise equally. At the double load, the voltage of one dynamo may increase 20 per cent., whereas that of the other one perhaps only 15 per cent. But at the same moment the latter machine supplies less current, hence its armatures will instantly lose or nearly lose its voltage. The result will be that the current flows through it from the other dynamo, and, being in an opposite direction, reverses its poles. The same thing may take place without a variation of the load if the speed of one of the dynamos decreases.

With shunt dynamos we know that the voltage varies also according to the load, but in an opposite way. The voltage increases on decreasing, and decreases on increasing, the load. If, at a given time, the load be equally divided between two machines and then the load is suddenly decreased, it is also possible here that the E.M.F. of one dynamo is greater than that of the other, so that the E.M.F. of the first dynamo rises, say from 110 to 113, whereas that of the second dynamo changes from 110 to 112 volts. This will, however, have only the consequence that the first machine will supply more current than the second one until the E.M.F. of the first machine is equal to that of the second one. Even assuming that the second machine, due to the slower speed of the driving engine, remains with its E.M.F. so low as no longer to supply, but to consume, electrical energy, this will only cause the other machine to be overloaded. The dynamo taking current will now run as a motor, but a reversal of the poles does not occur, because the current flows around the magnets in the same direction as before.

It is quite another matter with compound dynamos. If with these a reversal of the current happened, great inconvenience would arise, since the reversed current, flowing through the series-coil, would weaken the magnetism, which is produced chiefly by the shunt-coil. A means of avoiding this by the use of a so-called **equalizing wire** (the connection of which with the poles of the dynamos is shown in Fig. 200) has been devised. This equalizing wire must be connected with those poles of the dynamos with which are also connected the ends of the series windings. As long as both armatures have the same voltage the current will not flow through the equalizing wire, but only through the two mains.

Now let us consider what will take place if, by any accident, the E.M.F. of one machine becomes lower than that of the other machine so that it now consumes, instead of delivers, electrical energy.

Assume that machine II. is taking, and machine I. is supplying, current, then the current will flow from the negative terminal of machine I. through the equalizing wire, through machine II. (in an opposite direction to that when supplying current), and through the positive bus-bar back to the positive brush of machine I. Thus a current flows in an opposite direction through the equalizing wire

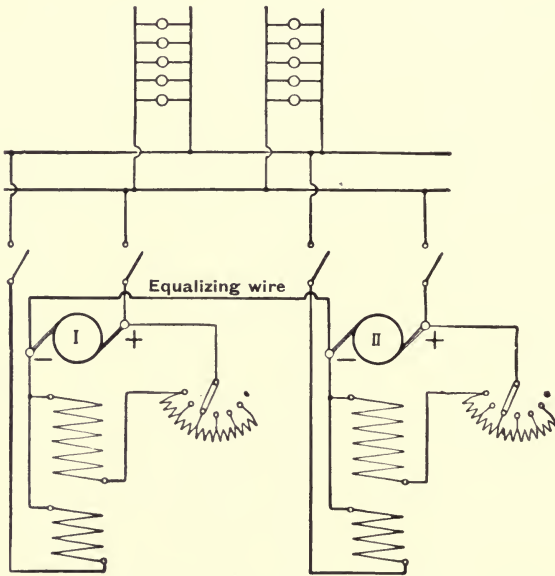

FIG. 200.—Compound Dynamos ready for Switching in Parallel.

wire and the armature of machine II., but not through its series coils.

When a dynamo is run in parallel with secondary batteries, the shunt dynamo only need be taken into consideration.

If there are neither secondary batteries nor other dynamos it is most suitable to employ the compound winding, since it gives a constant voltage as long as the armature speed does not vary.

The series dynamo is suitable for supplying current for a single circuit either for a large number of series-connected glow- or arc-lamps, or for a single motor as a generator for power transmission, as previously described, or for boosters to raise

the voltage in proportion to the current. In some cases several series dynamos have been connected in series, serving as generators for a number of series motors connected in series. With this arrangement of dynamos pressures of some thousands of volts have been produced and used for long-distance power transmission. The cases are, it must be added, quite exceptional. For power transmission over long distances alternating currents are employed almost exclusively.

Switching Dynamos in Parallel

When starting a dynamo which has to be run in parallel with either a secondary battery or another dynamo, we have to be quite certain that the leads are of the right polarity. For if we connected the positive pole of one machine with the negative pole of another, and *vice versa*, the two machines would not be connected in parallel, but in series without any external resistance, giving a short circuit supplied at double the voltage.

To make sure about the polarity, proceed in the following way: Bring both machines to the same voltage, say 110 volts, then close the switch 1 (see Fig. 201), and connect the ends of two series-connected 110 volt lamps with the contacts of the switch 2, which must be kept open. If the polarity of the two machines is all right, no voltage can exist between the poles of switch 2, and consequently the lamps cannot glow. If, on the other hand, the polarity of the two machines is wrong, then there will be a double voltage—220 in the case supposed

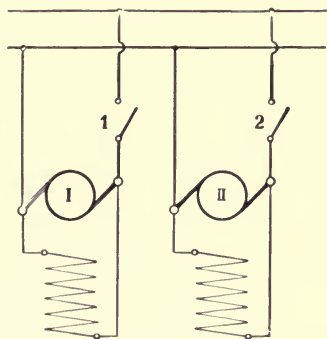

FIG. 201.—First Method of securing Right Polarity.

—between the two contacts, and the two lamps will glow with their normal intensity. The machines have then to be stopped, and the cables of one machine reversed.

Instead of changing the cable connections the polarity of the machines may be altered. For this purpose the brushes of machine 2 must be lifted off the commutator, and switches 1 and 2 closed. By doing this machine II. is excited in the right direction. Now

open switch 2, and put the brushes on the commutator, when it will be found that the polarity of the machine has been reversed.

If the machines are provided with two-pole switches instead of single-pole ones, the procedure for finding the polarity just described may be applied by connecting temporarily the contacts of one side of the switch of machine II. by means of a wire or strip of metal.

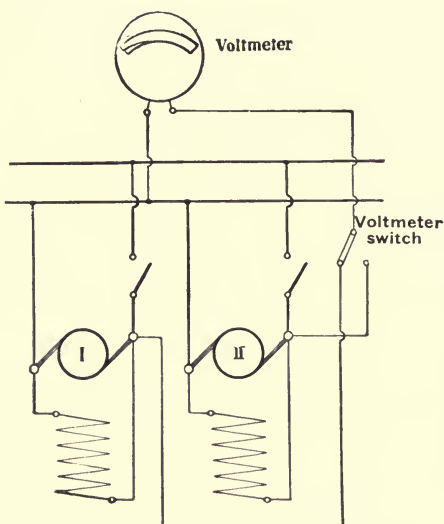

FIG. 202.—Second Method of securing Right Polarity.

the switchboard as shown in Fig. 202. If on closing the voltmeter switch, so that it indicates the voltage of first one machine and then the other, the pointer of the voltmeter is deflected in the *same* direction in both cases, the machines are of the same polarity; if otherwise, then the machines are of opposite polarity.

A similar method is used in putting compound dynamos in parallel, but after throwing them together for the first time it must be found that the series fields act together. It is necessary to close the equalizer connection switch either before or simultaneously with the other connections. Triple-pole switches are generally used for this purpose.

To ascertain the polarity of a machine, **Pole-finding Paper** is sometimes employed. It is made of paper impregnated with a chemical substance. When the paper is wetted and included in a circuit, the electrolytic action that ensues causes the paper at the end connected with the positive pole to become of one colour, whilst around the negative end a different colour will be noticed.

The examination becomes simplest if there is a Deprez voltmeter provided with a voltmeter switch fixed on

CHAPTER VII

ELECTRIC LIGHTING

Glow Lamps

ONE of the first phenomena of the electric current with which we became acquainted was the heating of a wire through which a current flows. The first idea was, therefore, to heat metal wires by the electric current to such a high degree as to cause them to glow and emit light. The common metals, however, alter their nature when heated in the air, and therefore a metal which has the property of not changing its nature, such as platinum, must be employed. The **incandescent** or **glow lamps**, manufactured in this way are very expensive, and, further, have a serious defect. Metals do not grow bright until they are raised to a temperature which is near to their fusing point. Hence, if through a platinum lamp a current flows which is a little greater than the normal one, the platinum filament will instantly fuse.

Fortunately there is a solid conductor which is neither a metal nor fusible. This conductor is carbon. If in the open air we heat a carbon filament to such an extent as to make it incandescent, it will soon be burnt. Hence the electric heating of the filament must be done in the absence of oxygen, a gas necessary for combustion. This has been effected by enclosing the filament in a glass bulb from which the air, and with it the oxygen contained in the air, has been carefully exhausted.

The greatest practical difficulty consisted in finding out a method of obtaining carbon strips of sufficiently small sectional area and regular structure. This has been overcome by either carbonizing a cotton or silk thread directly, or a filament formed by "*squirting*" a solution of **cellulose** through a fine nozzle at high pressure. Cellulose is the chief constituent of such vegetable substances as cotton, linen, paper, etc.

The first to make carbon lamps practical were **Edison and Swan**. The former used a carbonized and horseshoe-shaped fibre of bamboo,

enclosed in a glass bulb from which the air was exhausted. The connection between the carbon and the external conducting wires was secured by short pieces of platinum wire fused through the glass. Since then, the manufacture of glow lamps has been very much improved. Nowadays the filament is generally made from cellulose in the way described above.

We shall now briefly deal with the method of making modern glow lamps. The filaments of cellulose, having been dried, are cut to about the desired length, sufficient margin being allowed for making connections with the platinum wires, which pass through the bulb to the external circuit. They are then subjected to the process of "carbonizing," which converts them into solid carbon filaments. Each filament is then held by clips connected with suitable terminals, by means of which connection can be made with a dynamo or a secondary battery. Next, the suspended filament is placed in an atmosphere of gas rich in carbon, and a current sufficiently strong to raise it to a white heat is passed through the filament. If there should be, as is generally the case, any inequality in the filament, causing a variation in its resistance, one portion will be raised to a higher temperature, and upon this hotter section a greater deposit of carbon will take place. This process is therefore continued until the filament is of equal thickness, that is to say, until it becomes uniformly luminous throughout.

The glass in which the platinum wire with the carbon filament is fixed is now fused to the bottom part of the bulb, and finally the latter is exhausted of its contained air and moisture.

For connecting the filament to the external circuit many methods are employed. The type of holder generally used in England is known as the Swan or Bayonet holder. The lamp is, in this case (see Fig. 203), provided with an insulated brass collar fixed with cement, the filament being connected to the two brass segments embedded in the cement. The collar has two small side pins, which fit into the "bayonet joint" holder.

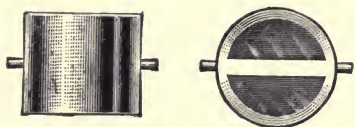

FIG. 203.—Brass Cap of Glow Lamp
(The General Electric Co.).

There are, besides this, many other types of lamp-holders, such as, for instance, the Edison, the Siemens, and others.

Generally glow lamps are tested by means of a photometer before they are sent out, and their candle-power, as well as the voltage at which they are to be used, is marked on them. If a lamp, designed to give 16-candle-power at a voltage of 110, be connected with a lower voltage, it will give out less than sixteen candles; if, however, it is connected with a higher voltage, it will burn with greater candle-power. The use of lamps on a higher voltage than that for which

they are designed and tested, destroys them after a short time. The life of an incandescent lamp, or the number of hours that it can maintain illumination, varies considerably, but as an average period for such lamps, which are used at the right voltage, about 1000 hours may be taken. With lamps that have been in use for some time, the vacuum deteriorates more or less, the carbon of the filament is deposited on the interior of the bulb, thus diminishing its transparency, till finally the filament is broken at its weakest point, and the lamp becomes useless.

If a lamp is supplied with a higher than its normal voltage, this reduction of the luminous effect and the destruction of the filament takes place much more rapidly.

Tests on lamps burning on a higher pressure than the normal voltage prove that their efficiency—that is to say, the ratio of the light emitted to the watts absorbed by the lamp—is higher than when the lamps burn at the proper voltage. The 16-candle-power glow lamps usually employed consume about 50 to 55 watts (in all the examples we have given in the first part of this book we have assumed this consumption to be 55 watts = 110 volts \times 0.5 amps.), whereas, lamps burning with a higher than their normal voltage consume a greater number of watts, but the light emitted by them is increased to a far greater extent than their watt consumption. This fact has been taken advantage of when manufacturing glow lamps of higher efficiency—for instance, lamps which require $2\frac{1}{2}$, 2, or even less watts per candle-power. These lamps deteriorate far more rapidly than those having a lower efficiency. Hence the advantage of the lower cost of current when employing “high efficiency” lamps is diminished by the necessity of frequent renewals. The lamps which are most generally in use consume about 3 to $3\frac{1}{2}$ watts per candle-power.

Until a few years ago, filaments for a higher voltage than 110 could not be satisfactorily manufactured. For a higher voltage the filament has, naturally, to be longer and, at the same time, thinner. Such a filament is, of course, very fragile, and for a long time the difficulty of manufacture was insurmountable. By improving the quality of the carbon, this difficulty has been overcome, and nowadays glow lamps for 220, and even 250 volts are manufactured almost of the same quality as 110-volt lamps.

A new system of electric incandescent lamps has been invented by Professor **Nernst**, of Goettingen. He employs as filaments second-class conductors—that is to say, bodies which are insulators in a cold state, but become conductors of the electric current when heated nearly to redness. The filament has therefore to be heated before the lamp can be made to glow. This may be effected either by means of a small spirit-lamp or, automatically, by means of a platinum coil, surrounding the filament.

The diagram of connections for a lamp in which the filament has to be heated by a flame, is shown in Fig. 204. The automatic type

is like Fig. 205. Here the current traversing the lamp from the + to

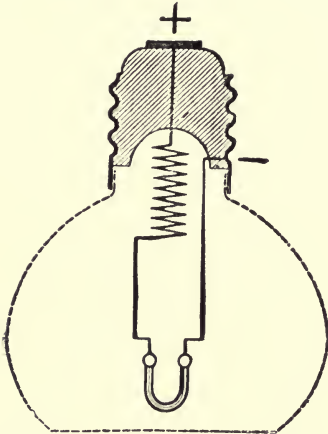

FIG. 204.—Nernst Lamp—Filament Heated by Flame.

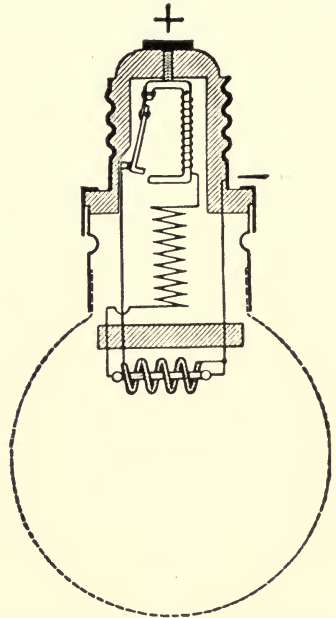

FIG. 205.—Nernst Lamp with Electric Heating.



FIG. 206.—Six-Glowler Outdoor Nernst Lamp.

the - pole has two ways open: one through the elastic armature of a small electro-magnet to the platinum heating-coil, and another one through the winding of the electro-magnet, next through a series resistance of iron wire (marked by a zigzag line in the diagram), and then through the short thick filament or rod made of the special substance. On switching in the lamp, the rod is still cold, and thus not conducting; the current can therefore only flow through the armature and the heating-coil. As soon as the rod is made to glow by the heating effect of the platinum coil, the current traverses the second path through the winding of the electro-magnet, the series resistance, and the rod itself; the electro-magnet is, therefore, able to attract the elastic armature, and disconnect the first circuit, the platinum coil being then switched out of circuit.

A resistance in series is required with both types of the Nernst lamp, since the rod of special material is very sensitive to variations of the current, and without this steadying resistance would melt at the slightest rise of voltage. The steadying resistance is made of iron wire, whose resistance increases comparatively rapidly with rise of temperature.

The materials from which the glow-rods are made stand a far higher temperature than platinum or carbon. The luminosity of a source of light being greater the higher the temperature of the glowing material, the Nernst lamp is more efficient than that of a carbon filament glow lamp. It consumes only about $1\frac{1}{2}$ watts per candle-power.

Since the materials employed for the Nernst lamp have, even in a hot state, a far higher specific resistance than carbon, the glow-rods are, for a given voltage and candle-power, far shorter and thicker than the corresponding carbon filaments. Thus the rods are much more solid, and can be manufactured for 220, 300, and even 400 volts.

Much thought has been given recently to produce a material which will stand a higher temperature than carbon for filaments for incandescent lamps. There has been brought out a lamp having a filament of titanium. This lamp will operate with a life of 1000 hours, consuming only 2 watts per candle instead of 3.1 taken by ordinary incandescent lamps. A filament made of uranium also gives excellent results. Unfortunately, these metals are not so common as to make the lamps cheap. Other metals are being tried, notably tungsten, which gives even better economy with satisfactory life. When it is realized how little of the energy delivered from a dynamo actually appears as light, it can be understood how important any developments of improvements in incandescent lamps are to the electrical industry. Undoubtedly, the time is not far off when lights will consume far less energy than at present.

Arc Lamps

Whenever a circuit is broken a spark is produced. We must now try to make clear why this should be. On opening a switch or disconnecting a live main, the actual breaking of the current requires a definite time. During this time the contact, originally a very good one, becomes worse and worse, and the surface of the touching parts becomes smaller and smaller. The result is that resistance is introduced, and heat is produced. The temperature becomes finally very great, so that the ends of the conductors begin to glow, and emit glowing metal vapour, which, even after some time, when the two conductors have been separated a little distance from each other, may cross the gap, and form a conducting luminous bridge, called the **arc**.

To obtain a continuous arc, metal rods are not suitable, because they soon fuse and evaporate. Carbons are in every way preferable. The carbons which are connected with the two mains are first of all brought together, so that the current can flow from one carbon to

the other. The contact surface offers a comparatively high resistance, so that the carbon ends begin to glow. Then they are removed some sixteenths of an inch from each other. The arc that is formed continues, since the highly heated air and the carbon vapour form between the two electrodes a conductor of very high resistance. The arc itself does not emit the greatest part of the light, but the carbon points, especially the positive, are the chief source of light.

The two carbons are not, with a continuous current, consumed at an equal rate, the consumption of the rod connected to the positive pole of the dynamo being approximately twice as fast as that of the other, or negative carbon. After burning some time, the end of the positive rod becomes concave, forming a *crater*, and in the hollow of this crater the most intense heat is developed, making it, therefore, the chief source of light. The negative rod is gradually consumed until its extremity is of a conical shape. With continuous-current lamps the lower or negative carbon is usually thinner than the upper one, the object being to make the consumption of the carbons equal as regards length.

If we calculate the current strength of an arc lamp after Ohm's Law, we arrive at an incorrect result, just as with the calculation of the current in a liquid (see p. 179). The arc is, like a storage cell, the seat of a back E.M.F., but which ceases immediately the current stops. The back E.M.F. of the arc is very considerable, and the current has also to overcome the ohmic resistance of the arc. Hence the applied pressure must be above a certain value. The voltage required for an ordinary arc is about 35 to 40 volts. With special types, where the arc is formed in a partial vacuum, and is very long, the voltage may be 80 or more. It is quite impossible to get a continuous arc with a voltage of less than 30 to 35. Glow lamps may, as we know, be built for any pressure, since they have an ohmic resistance only, and thus the dimensions of the filament may be made according to the voltage. There are, for instance, glow lamps which require a voltage of but 2, and can therefore be fed by a single accumulator cell. With arc lamps this is impossible.

For an arc lamp a special mechanism is necessary. First of all, the two carbon rods have to be placed in contact, and then have to be separated, so that an arc is formed between them. Further, in order to maintain the arc, it is also essential that some device should be provided for "feeding" the carbons together at a rate proportionate to their consumption. Generally the electro-magnetic effect of the current is used to operate this mechanism.

In Fig. 207 is shown one of the different types. The upper and lower carbon holders are suspended from a flexible wire or a chain,

passing over a roller. The upper carbon holder is provided with an iron core, which moves within a fixed coil. The latter is connected in series with the arc, so that the current forming the arc also flows through this coil. If, now, the iron core is pulled up by the action of the coil, the upper carbon holder is lifted, and the bottom carbon is lowered, so that the carbons are separated. If, on the other hand, the iron core is less attracted by the coil, it will descend, causing the carbons to approach.

By selecting the weight of the iron core, then, at a certain current strength, the attraction of the solenoid and the weight of the core are just balanced. Assuming now the arc lamp, having a resistance in series, to be connected to a constant voltage, then, after a short time, due to the burning, the resistance of the arc will be increased, and the current will be decreased. With the weakened current the attractive power of the coil becomes smaller, the weight of the carbon and its holder, therefore, causes the carbons to be brought nearer together, until the diminution of the arc resistance causes the current to be increased to such an extent as to again balance the weight of the carbon holder. If, on the other hand, the iron core falls too far down, so that the arc is shorter than normal, then, the resistance being decreased, the current becomes greater, and the attractive force of the solenoid overcomes the weight of the iron core, with the result that the carbons are separated a little.

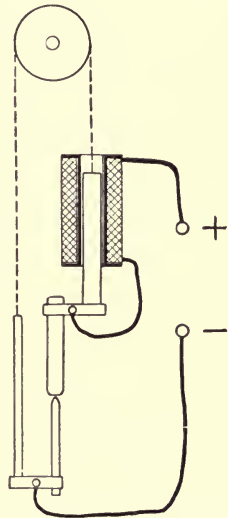

FIG. 207.—Series Arc Lamp.

The regulating solenoid being connected in series with the arc, this lamp is called a *series lamp*. It tends, as we have seen, to maintain a constant current, and is very suitable for use on a constant voltage supply.

Let us now arrange a number of such lamps in series, and in a circuit in which the current strength is kept constant by any means, then it will be found that the regulating mechanism is absolutely useless. For it is evident that as long as the current in the circuit remains constant, the lamp will not regulate—even if, owing to the consumption of the carbon, the arc much exceeds its normal length. Hence the voltage at the terminals of the lamp, which is usually 40 to 45, may grow to 80, and even more. If, finally, the resistance of the lamp becomes so great that the dynamo is unable to supply this higher voltage at the normal current, then the latter will decrease, thus causing all the solenoids to affect the length of

the arcs, although in some lamps the length of the arc might have been the right one.

In such cases, instead of series lamps, **shunt lamps** may be employed. A scheme of a shunt lamp is shown in Fig. 208. The solenoid, consisting of many turns of a very fine wire, is arranged so as to tend to lift the lower carbon holder. The solenoid itself is connected with the two terminals of the lamp, thus being in shunt with the arc; therefore the current traversing the solenoid is greater the higher the voltage of the arc. At the proper voltage of the arc, the weight of the iron core is just counterbalanced by the attraction of the solenoid. But if, due to a burning of the carbons, the length of the arc is increased, its voltage will also rise, provided that the current strength remains constant. Thus, if, owing to the higher voltage, a larger current flows through the shunt

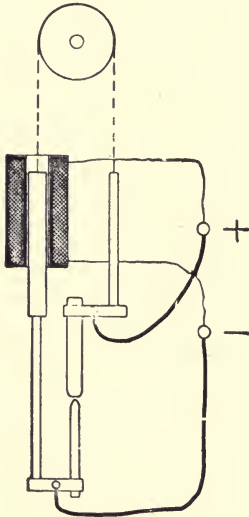

FIG. 208.—Shunt Arc Lamp.

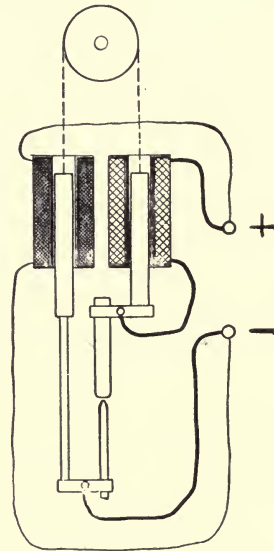

FIG. 209.—Differential Arc Lamp.

coil, the action of the solenoid will preponderate, lift the bottom, and lower the upper carbon holder, so that the arc is again shortened to its right length. This lamp therefore tends to maintain constant voltage.

A third kind of an arc lamp is the **differential lamp**, a scheme of which is shown in Fig. 209. In this lamp we have two coils, which act against one another. One of these coils is a series coil, tending to lift the upper carbon holder, and to lengthen the arc; the other a shunt coil, tending to lift the bottom carbon holder, and hence to shorten the arc.

This lamp will therefore combine the properties of the other two types, and be suitable for use on both constant current and constant voltage circuits.

An essential requirement of an arc lamp is a means of **damping** the regulating mechanism, so as to prevent any sudden or violent movement of the carbons, causing a flickering of the light. Several devices have been arranged for causing the mechanism to act in a gradual manner. One of the most usual consists of a roller, over which passes a flexible cord that carries the carbon holder. This roller drives through several toothed wheels a fan. The latter is made to rotate at a great speed against the resistance of the air. Any sudden increase of the speed of the roller is prevented, owing to the great resistance that the air offers to the increase of speed of the fan.

Another damping arrangement consists of a piston, moving within a cylinder, with but little play, so that the enclosed air is compressed or expanded, preventing sudden motion of the piston.

Fig. 210 shows the general arrangement of the parts of an arc lamp, and Fig. 211 shows the principle of a Křížik or Pilsen differential lamp. To the explanation given with the general scheme of a differential lamp, we have to add the following for the Křížik lamp:—The iron cores, *a* and *b*, are, as may be seen from the dotted lines in the figure, not cylindrical, but conical. They are enclosed within brass tubes, and by small guiding rollers a true vertical motion is ensured. Over the iron



FIG. 210.—Arc Lamp (*The Electrical Company*).

cores the series coil *g* and the

shunt coil f are respectively wound. When the lamp has been freshly trimmed and the carbons are long, the core of the upper carbon holder at its highest, and that of the lower carbon is at its lowest position, whereas at the end of the burning hours the opposite would be the case. With cores of a cylindrical shape, the attractive power of the coil on the core would vary according to the position of the core to the coil. On the other hand, the conical shape of the cores ensures that the attractive forces will at these and other positions be balanced, provided that through both the series and the shunt coil the normal current is flowing.

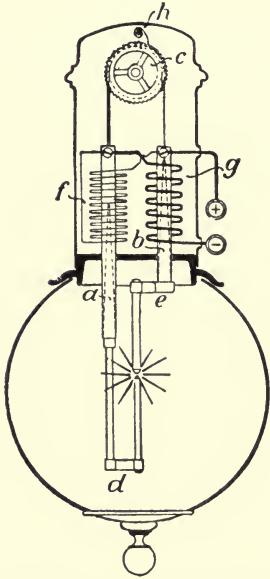

FIG. 211.—The Křizik Arc Lamp.

The roller c , over which passes the cord bearing the carbon holders, is provided on its circumference with fine teeth. Into the latter a ratchet h interlocks, which is not only movable about its axis, but, being fixed within an oval hole, is also movable for a short distance upwards. When the lamp is not in circuit, the two carbons touch each other, and the shunt coil is short-circuited. On closing the switch, the mains being connected to the terminals

marked + and -, then the series coil moves its core b upwards. This upward motion can, however, only take place so far as is allowed by the length of the oval hole. This length is selected so as to give the right length of the arc. The latter then has its normal voltage, and the series and shunt coil are therefore counterbalanced. As the lamp continues in use, the shunt coil f is able, without any impediment from the ratchet, to lift the lower carbon holder and shorten the arc, since this ratchet is arranged so as to stop a reverse motion.

There are numerous other types of arc lamps, which the limits of this book preclude us from describing.

It is of great importance to use a resistance in series with an arc lamp. If we connected an arc lamp directly on to a 40-volt circuit, then the variations of the current would be excessive, and quite beyond the power of the regulating mechanism to control. On switching on an arc lamp, the carbons are brought to directly touch each other, whilst the lamp does not yet produce any back E.M.F. Hence the lamp resistance is small, and the current therefore excessive. Any, even the smallest, lengthening or shortening of the arc would produce a great variation of the current, since any change of length

of the arc is followed by an increase or decrease of the back E.M.F. Assuming, for example, the back E.M.F. to be 39 volts in one, and 36 volts in another case, then the difference between the terminal voltage and back E.M.F. will be 1 and 4 volts respectively. The ohmic resistance of the lamp remaining the same, the current will be four times as much in the second as in the first case. In the feeding of arc lamps from a dynamo, the machine voltage is therefore always made larger than the lamp voltage should be, and a constant resistance is kept in series (see Figs. 212 and 213), which absorbs the superfluous voltage. The line voltage is then best selected about 60 to 65, so that in the resistance 20 to 25 volts are absorbed. If, now, by any change of the length of the arc its voltage be varied, say from 39 to 36, this will cause only an unimportant rise of current, because in the first case the difference between the electro-motive forces will be $65 - 39 = 26$ volts, and in the second case $65 - 36 = 29$ volts. Hence, if the total resistance be 3ω ,

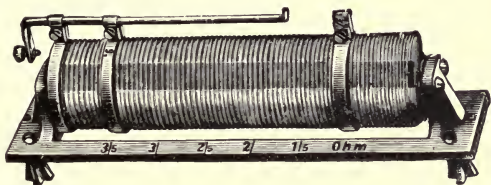

FIG. 212.—Arc Lamp Resistance without cover.
(The Electrical Company).

the current would be 8.6 amps. in the first, and 9.6 amps. in the second case, the difference between these two currents being only 1 amp. Further, when the lamp is first connected with the current supply, and the carbons are actually touching, nevertheless the current cannot become too large. Its maximum value, of course only for a brief period, will be $65 \text{ volts} \div 3\omega = 21.6$ amps.



FIG. 213.—Arc Lamp Resistance enclosed.
(The Electrical Company).

The larger the series resistance the steadier the lamp will burn. On the other hand, the resistance wastes electrical energy; hence, for economical working, the series resistance should be made as small as possible, *i.e.* just as small as will ensure good regulation.

If on 110-volt mains single lamps are used, then about 70 volts are absorbed by the resistance, *i.e.* about two-thirds of the total energy is rendered useless. Hence, with 110-volt mains, two lamps are often used in series, with a resistance absorbing about 30 volts;

with 150-volt mains, the lamps are switched in groups of three in series with a resistance; and with 220-volt, generally in groups of four. There are also special connections, where groups of three smaller arc lamps are run on 110- or 120-volt mains without a permanent resistance, but merely with a starting resistance. In these cases special precautions have to be made; nevertheless, the lamps can never burn as satisfactorily as in groups of two.

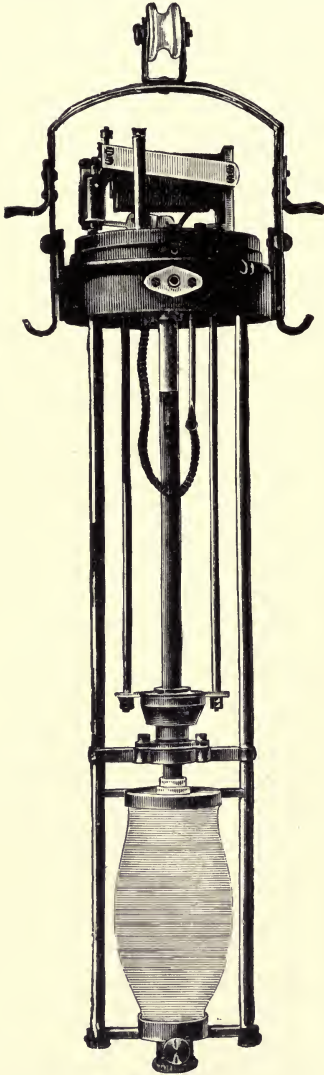

FIG. 214.—Enclosed Arc Lamp.
(The Electrical Company).

Where the lighting is exclusively by means of arc lamps, and the use of glow lamps need not be considered, connection of the lamps in series is a frequent method. In this case there is only one circuit, in which all the arc lamps—for example, 10, 20, or 30—are connected in series. The voltage of the dynamo, or **arc lighter**, has therefore to be high; viz., if for one lamp with its regulating resistance we assume a voltage of 50, then 30 lamps will need 1500 volts. Since the extinguishing of one lamp would prevent current supply to the remainder, there must be provided an alternative path in each lamp, which either short-circuits it, or inserts a compensating resistance. In this system the current of the machine, generally provided by a series dynamo, has to be kept constant, and its voltage must be varied according to the number of lamps running. This method is not now so commonly in use as it once was.

With arc lamps a more economical lighting is effected than with glow lamps. An arc lamp burning with 10 amps. has a luminous power of about 500 to 1000 candles. Since (including the resistance) an arc lamp requires about 55 volts, we get for an electrical power of 550 watts 500 to 1000 candles, from which it follows that we have to spend only $\frac{1}{2}$ to 1 watt per candle-power,

whereas a glow lamp requires 3 to $3\frac{1}{2}$ watts per candle. Arc lamps are also constructed for 8, 6, 4, and 2 amps., sometimes for even less. Smaller arc lamps, however, are not economical. Further, since arc lamps require far more attendance than glow lamps, small arc lamps are seldom used. On the other hand, for the lighting of streets, squares, shops, etc., where much light is required, the use of large arc lamps is common.



FIG. 215.—Magnetite Arc Lamp.

A special application of the arc lamp is as a search light. Very large arc lamps are used for this purpose, and the light is reflected by means of parabolic mirrors, so that it can be directed on any object.

With the arc lamps hitherto considered, the arc is formed in the

air, although for softening the exceedingly intense light glass globes are always used. Now there exists another kind of arc lamp, which burns with the arc enclosed. Over the carbons there is a small glass cylinder, so arranged that it fits round the carbons, making a small and nearly air-tight chamber (see Fig. 214). This cylinder is, of course, first filled with air, but, on burning for a short time, all the oxygen contained in the air in the small cylinder is consumed. Hence the carbons are consumed far less if burning in this enclosed manner, and these lamps may be manufactured to burn a hundred hours and longer, whereas the carbons of common arc lamps have generally a burning time of only five to ten hours.

With "enclosed arc lamps" the length of the arc is generally $\frac{1}{4}$ " to $\frac{1}{2}$ ", so that the voltage of the arc is equal to about 80. These lamps may therefore be connected singly, and with only a small series resistance, to 100- or 110-volt mains.

NEW TYPES OF LAMPS.

Dr. Auer, of Vienna, employs as a filament for a glow-lamp *osmium*, a material which conducts when cold, and therefore does not require any preliminary heating. The efficiency of these lamps is said to be equal to that of the Nernst lamps. On the other hand, owing to the low specific resistance of osmium, they can best be used for voltages from 20 to 50.

In the Bremer arc lamp the carbons used have certain salts added to them, with the effect of increasing the light, and, at the same time, making a great change in its colour.

The Cooper-Hewitt lamp consists of a long tube, in which mercury vapour is heated by an electrical current. It requires about half a watt per candle-power. The light is especially rich in blue and violet rays.

The General Electric Company is now producing an arc lamp which has one terminal of metal and the other a rod of magnetite. This gives a light quite similar to the ordinary carbon, but with the same energy gives 60% more light. It burns 150 hours, and does not have a glass enclosure around the arc with its attendant cleaning and breakage. This lamp has recently been placed upon the market. FIG. 215 is an illustration of this lamp.

CHAPTER VIII

ALTERNATING CURRENTS

Properties of Angles Concerned with Alternating Currents

ONE straight line intersecting another makes with it an angle. Examine Fig. 216.

The line $a-o$ intersecting the line $b-o$ at o makes with it the angle $a-o-b$; with $c-o$, the angle $a-o-c$ etc. Take any given angle, $a-o-b$, and from the point b drop a line perpendicular to the line $a-o$, striking it at F ; then $b-F-o$ is a right angle. Take any point on the line $o-b$, say g , and drop a perpendicular line $g-h$ to $o-a$. It can be easily shown by geometry that the ratio of the line $b-F$ to $o-F$ is the same as $g-h$ to $o-h$, or the same as any perpendicular to the base line. Also the ratio of $b-F$ to $b-o$ is the same as $g-h$ to $g-o$, or the same as any vertical to the amount of the diagonal cut off by its intersection with the vertical. This ratio of the vertical to the perpendicular is in Fig. 216 $\frac{b-F}{b-o}$ or $\frac{g-h}{g-o}$, and is called the sine of the angle $b-o-F$. Every angle has a definite sine. Thus, the sine of 30 degrees equals $\frac{1}{2}$.

The ratio of the horizontal part cut off by the perpendicular from the diagonal to the opposite side, that is, the ratio in the triangle $o-F-b$, of $o-F$ to $o-b$ is called the cosine. Every angle has a specific value of the cosine. For 30 degrees it is $\frac{\sqrt{3}}{2}$. Thus, the sine of an angle in a right-angle triangle is the ratio of the side opposite to the longest side. The cosine, the ratio of the side adjacent to the longest side. Consider in Fig. 216 the line $o-d$ to be an edgewise view of a coil revolving about o . Let $l-l-l$ represent lines of force

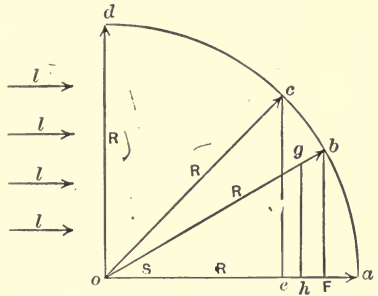

FIG. 216.—Properties of Angles.

flowing through this coil. At the position $o-d$ the coil contains the maximum number of lines of force. As the coil turns less and less lines of force go through the coil until, when it reaches the position $o-a$, no lines of force go through the coil, being then edgewise to them. The amount of area presented to the lines of force is represented by the vertical lines $c-e$, $b-f$, at the positions c and b .

Let the length of the line $o-d$ equal R ; then, since the sine of the angle $c-o-e$ equals $\frac{c-e}{R}$, $c-e$ equals $R \sin c-o-e$. Also $b-f$ equals $R \sin b-o-f$. Thus, at any angle movement from the zero reference line $o-a$, the amount of lines of force are equal to $R \times \sin$ of the angle away. At $o-a$ the angle is 0 . $\sin 0^\circ$ equals 0 , and the lines of force equal $R + 0$ equals 0 , or no lines go through, which is evident, since the coil is edgewise to the lines. At $o-d$ the angle from $o-a$ is 90 degrees. The sine of 90 degrees equals 1 , since at 90 degrees the perpendicular and the diagonal coincide and become one. If a curve be plotted giving for 360 degrees at each angular position from 0° the value of the flux going through a coil, it will be as shown in Fig. 216, or, what is the same thing, for all the values of the sine. The curve will look like Fig. 217, having a maximum value at d . This curve

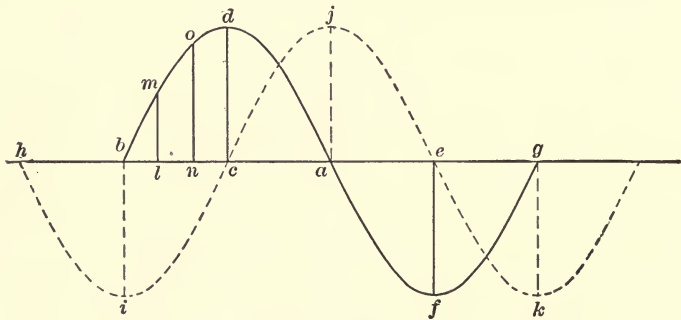

FIG. 217.—Sine curve of E.M.F. and Current.

is called a sine curve, and represents how the flux varies in a coil revolved in a uniform field of flux. Suppose the coil to be connected to collector rings, as shown in Figs. 64, 65, 66. Since in the coil the flux is changing, as shown in Fig. 216, a voltage must be generated, since voltage is produced by a change in the number of lines of force in a circuit, as has been shown. At d , Fig. 217, the flux is not changing at all. Hence, here the voltage is 0 , as shown by the dotted curve $h-i-j-k$. At b , the flux is having a maximum rate of change; hence the voltage is a maximum, as shown at i . If at each point of the curve $b-d-a-f-g$, the rate of change of flux be found, the corresponding voltage can be determined, as shown in the dotted curve $h-i-j-k$.

This curve is found to have the same shape as the other curve. Hence, the rate of change of one curve gives another curve of the same shape. This dotted curve is the voltage curve of an alternator. It is a sine curve. This curve has certain important characteristics. If the square root of the average of the squares of all the vertical lines $l-m$, $n-o$, $c-d$, etc., be taken, the result equals the maximum value $c-d \div \sqrt{2}$ equals $\frac{c-d}{1.414}$ equals $.707 c-d$. This value is called the square root of the mean square of all the values of the sine curve. The plain average of all the verticals equals $.637 c-d$. Thus, the average value divided by the square root of mean square value equals $\frac{.637}{.707}$ equals $.90$.

To return now to the alternator which with a single coil produces the voltage as shown in the curve called a sine curve; to determine the formula for the voltage we have shown previously that the average E.M.F. of a coil revolving in a uniform field equals $\frac{4N\phi}{100,000,000}$, where N equals the number of revolutions of armature (or coil) per second, and ϕ equals the number of lines of force threading through the coil. But in a sine curve the maximum value equals the average value multiplied by $\frac{\pi}{2}$ when π equals 3.14159, or the maximum voltage of a sine curve of E.M.F. equals $\frac{4N\phi}{100,000,000} \times \frac{\pi}{2} = \frac{2\pi N\phi}{100,000,000}$.

Also in a sine curve the square root of mean square value equals the maximum value divided by $\sqrt{2}$. Hence, the square root of mean square value of the E.M.F. of an alternator with an armature having one coil and with two poles equals $\frac{2\pi N\phi}{100,000,000} \div \sqrt{2}$ equals $\frac{4.44N\phi}{100,000,000}$. If there are n coils in series, the value is n times as much, or $\frac{4.44Nn\phi}{100,000,000}$.

The revolutions per second of a 2-pole dynamo, or the equivalent of a dynamo with more than two poles, are called the cycles of the dynamo, or of the circuit which the dynamo is feeding. If the speed per minute of a 2-pole alternator equals M , the cycles equal $\frac{M}{60}$. If the speed of a 4-pole alternator equals N , the cycles equal $\frac{N \times 2}{60}$. Thus, the cycles of a P -pole alternator running at N revolutions per minute equal $\frac{P}{2} \times \frac{N}{60}$.

All electrical measuring instruments record on their scale the

square root of mean square values. Hence, when the voltage of an alternator is read on an instrument the square root of mean square value is read. From this the maximum value can, of course, be calculated by multiplying by $\sqrt{2}$. Since the voltage of an alternator varies as shown in Fig. 217, and since the current is always proportional to the voltage, the current curve is the same as the voltage curve, having its square root of mean square value, etc., just as the voltage curve. Since heat from an electric current is proportional to the square of the current, the square root of the mean square value of current (called sometimes the effective or virtual current), when squared and multiplied by the resistance through which it flows, gives the same result as a direct current equal to the square root of mean square current when squared and multiplied by the resistance through which it flows. Hence, in calibrating A. C. instruments, direct current may be used, each value of direct current equalling in its effects on the instrument the square root of mean square, or virtual, A. C. current. Referring once more to Fig. 217, if the line $b-g$ be divided into 360 parts, representing 360 degrees, or one complete revolution, which gives a complete cycle, as shown, the number

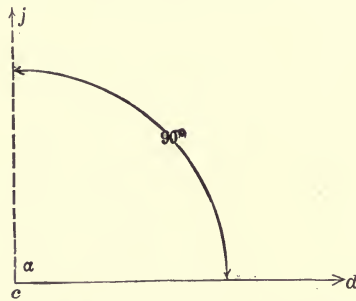

FIG. 218.—E.M.F. and Current 90° apart in Phase.

of degrees from a reference point b for any part of the curve is called its phase. Thus, the phase of the point m is $b-l$; of the point o , $o-n$. Thus, the point o differs in phase from the point m by the degrees represented by $l-n$. Thus, the plus maximum of the full curve, that is, $c-d$, differs in phase from the plus maximum of the dotted curve by 90 degrees; that is, the distance $a-c$. Thus, the rate of change of flux is 90 degrees lagging behind the flux itself. The sine curves, therefore, must be plotted 90 degrees apart, if one represents flux and the other the E.M.F. from that flux, the E.M.F. being later than the flux. A convenient method of showing sine curves is to represent them by their maximums or square root of mean square values. Thus, the two sine curves shown in Fig. 217 can be represented as shown in Fig. 218. Here $c-d$ represents the maximum value, or square

root of mean square preferably (either can be used, since one equals $\sqrt{2}$ times the other) of the flux, as shown in full line in Fig. 217, and $c-j$ shows the maximum value of E.M.F. resulting from this flux, differing in phase by 90 degrees as shown. This method of plotting alternating E.M.F.'s and currents is that generally used by electricians and gives an eye picture of the relations of alternating values. It is called the Vector Diagram method.

Experiments with Alternating Currents

THE first electrical machine with which we became acquainted produced alternating currents. On providing the Siemens H armature with slip-rings, and rotating it in a magnetic field, we were enabled to collect currents of an alternating kind. We then dealt with devices for commutating the alternating current, which originally is produced in any dynamo, into continuous current. We shall now consider the properties of the unrectified alternating current, and the special types of machines designed as alternating current dynamos.

First of all, let us try experiments similar to those we made with a continuous current. Connect a wire resistance with the terminals of an alternating current generator. On turning the armature the wire is heated, and, if the current be sufficiently strong, the wire may glow, and even melt. In like manner an alternating current will cause an incandescent lamp to glow. We see, therefore, that the heating effects of an alternating current are like those of a continuous current. This is easily understood. The heating of a conductor, traversed by an electric current, does not depend on the direction, but merely on the strength of the current, and continues therefore even if the current is continuously altering its direction.

On rotating the armature of our two-pole dynamo with a speed of about 3000 revolutions per minute, thus getting 6000 alternations per minute, or 100 per second, we observe a perfectly constant illumination of the lamp. If, however, we turn the machine with only the fourth part of this speed, and connect with it a lamp for a correspondingly lower voltage, we observe that the lamp is not giving a constant light, but flickers like a gas light supplied with gas at a fluctuating pressure. This phenomenon is readily understood. We know from our observations on page 69, that the strength of an alternating current increases gradually from zero to its maximum value, then decreases to zero, and, changing its direction, again reaches its maximum value, etc., as shown in Fig. 67.

Thus the carbon filament, traversed by the current, gets hotter and then cooler, hence alternately glowing brighter and then darker. At the moment when the voltage is zero, the lamp still gives out a certain amount of light, since sufficient heat is stored up in the filament to cause light to be emitted during the short period that the current is zero. Nevertheless the flickering light resulting would be very fatiguing to the eyes. When the alternations follow one another very quickly, at least 50 times per second, the fluctuations are not perceived, and a current of this periodicity can therefore be used for electric lighting.

Our second experiment consists in bringing two wires, connected with the terminals of an alternating current generator, into contact and then separating them. A **break spark** will be produced, like that with a continuous current, and, if we keep the two ends of the wire sufficiently near together, we may get a continuous arc. Alternating currents may therefore be employed, as well as continuous currents, for feeding arc lamps. The same systems of regulation with which we became acquainted in the continuous current lamps—viz. series-, shunt-, and differential-regulation—may be applied to alternating current lamps with almost equal success. There are, of course, certain differences in the construction of the lamps, which we shall deal with later on.

The property of the continuous current arc lamp, that the positive carbon is sooner consumed than the negative, is naturally not found with alternating current lamps, since the carbons are alternately positive and negative, hence they are consumed at an equal rate. The voltage required with the alternating current is lower (25–30 volts) than that necessary for the continuous current lamps.

The flickering of the light when the number of alternations is too small occurs here far earlier than with the glow-lamp; whilst with the latter we get a fairly constant light at 50 alternations per second, we can with an arc lamp hardly use a current of less than 80 alternations without getting a very unsteady burning of the lamp. Thus in installations where arc lamps are employed, a current of not less than 80, but generally 100, and in this country frequently 200, alternations per second is employed.

With a continuous current a magnetic needle was deflected by a current flowing through a wire, and an iron rod surrounded by a coil was magnetized as soon as a current flowed through the latter. In making the first of these experiments with alternating currents, we are unable to observe any deflection of the magnetic needle. If we watch the needle very attentively we find that it vibrates. On reducing the speed of the machine which supplies the current, so as to get but a few alternations per second, say two or three, we observe that the needle swings from side to side. As often as the current changes its direction, just as often the needle alters the direction of

its deflection. If, however, the number of alternations is greater, say twenty, thirty, or more, then the eye cannot any longer follow the quicker and shorter oscillations of the needle, and only the small and rapid vibrations of the needle about its position of rest can be observed.

If we wind a coil of wire over an iron core and send through it an alternating current, the core will be magnetized like a core surrounded by a continuous current. It will also become able to attract pieces of iron and keep them fast. In carrying out these experiments with alternating currents we observe two secondary phenomena, which we do not observe with continuous currents. Firstly there is a loud humming noise, and secondly both the magnetized and the attracted iron become strongly heated. The heating we shall deal with later on. The noise may readily be understood from the nature of an alternating current. At the moment the strength of the current passes the zero line, the attractive force ceases, and the iron pieces tend, and even begin, to fall off the core. The falling very quickly ceases, since a very brief time afterwards the current increases and the iron is again attracted. This proceeding, which is repeated as often as a change of the direction of the current occurs, causes naturally a corresponding noise or a sound, the pitch being higher or lower according to the number of the alternations.

As it is with the magnetic, so it is with the electro-dynamic effects. If through a fixed and a movable coil we send the same alternating current, we observe the attraction or repulsion as with a continuous current (see p. 61, Fig. 57). This is easily understood. Assuming that, at any instant, the current in the two coils have the same direction, then these coils attract each other. At the same instant as the current changes its direction in one coil, it will also do so in the other coil. Thus the two coils are again traversed by currents in the same direction and attract each other.

If, on the other hand, we send through one of the two coils a continuous, and through the other one an alternating current, then we shall observe neither an attraction nor a repulsion, but only a little vibration of the coils, since the first impulse of the attraction is immediately followed by the opposite impulse of repulsion, and these actions continue.

Next let us try to get a chemical effect with an alternating current. For this purpose we have to connect the two electrodes of a voltameter (see Fig. 5) with the slip-rings of an alternator. We can observe then a production of gas at both poles, although not at one pole oxygen and at the other hydrogen, as is the case with continuous current; but at both electrodes equal quantities of the explosive gas, consisting of a mixture of oxygen and hydrogen, are liberated. With an alternating current each pole is first positive, and immediately afterwards

negative, so that a bubble of oxygen, evolved from one pole, will immediately be followed by a bubble of hydrogen, this by a bubble of oxygen, and so on.

Although we thus get chemical effects with an alternating current, it is impossible to separate the elements of a substance. For electrolytic purposes and for electro-plating, where, with the aid of the electric current, we wish to separate metals from metal solutions—for instance, silver from a silver solution, or copper from a copper solution—alternating currents cannot be employed. It is also obvious that alternating currents cannot be employed for charging accumulators.

No magnetic or chemical effects of an alternating current can be observed if the number of alternations per second is extremely great—say, for instance, many thousands. Then the molecules of iron or of the liquid have not sufficient time to follow the very rapidly changing pulsations, which tend to drive them at one instant in one direction, and at the next instant in the opposite direction.

Current Strength and Voltage of an Alternating Current

We can measure the strength of an alternating current by means of its various effects; for instance, its heating or magnetic effects. It is, however, necessary, before dealing with the different methods of measurement, to make clear the meaning that electrical engineers attach to the strength of an alternating current, since the latter varies between its maximum positive value, zero, and its maximum negative value. In speaking about the current strength, we generally do not mean its maximum value. By an alternating current of 1 amp. we understand a current *which would cause the same heating effect as a continuous current of 1 amp.* This adopted value, also called the **effective** or **virtual** current, is naturally a mean value only. The maximum value of an alternating current is 1.41 times as great as the mean value; or, in other words, the effective current is equal to about two-thirds, or, speaking more exactly, to 0.707 of its maximum value.

A hot-wire instrument shows the right current both for alternating and continuous currents, since its reading depends on the heating effect. This follows from the definition of the strength of an alternating current; for the deflection of 1 amp. on the hot-wire ammeter, tells us that the measured alternating current produces in the instrument the same heating effect as a continuous

current of 1 amp., with which the instrument has been calibrated.

Exactly the same meaning is attached to alternating voltage. By *effective* or *virtual* voltage of an alternating current we understand the voltage of an equivalent continuous current, which produces the same heating effect, in a given ohmic resistance, as the alternating current. A glow-lamp manufactured for 110 volts continuous current will therefore glow with equal light if switched on to 110 volts alternating current, although the instantaneous values of the alternating pressure vary, at each half-alternation, from zero up to nearly $1\frac{1}{2}$ times the effective voltage, that is, up to about 155 volts.

Induction Effects of an Alternating Current

All experiments hitherto carried out with alternating currents have been similar to those with continuous currents. We must now deal with effects produced by alternating currents, which are not possible at all with continuous currents.

Let us wind over an iron core, consisting of a bundle of fine wires or iron disks, a coil, so that the iron core projects beyond the coil. Next let us lay on the top of the coil a metal ring. As soon as an alternating current passes through the coil, the ring is knocked upwards as if by an invisible hand (see Fig. 219). It floats freely in the air, as if it had no weight, and gets extremely hot. If now we open the circuit, the ring falls back on the coil, and gradually cools down.

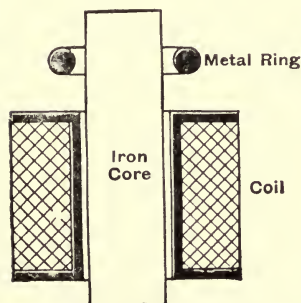

FIG. 219.—Repulsion of Metal Ring.

From the heating and motion of the ring, we conclude that an electric current has been induced in it; from the direction of the motion, we may deduce the direction of the current.

We know, from the experiments with the electro-dynamometer, that currents in the same direction attract each other, and when in the opposite direction, repel each other. Hence, we learn from the constant repulsion of the ring, that a current is induced in the latter which is always opposite to that of the coil. Representing this in a diagram, in Fig. 220, the full line shows the curve of the original (*inducing* or *primary*) current, and the dotted line the direction of the induced current. Fig. 220a indicates the same thing in another way. If, at any moment, the alternating current in the coil is directed upwards, then, at

the same moment, the current induced in the ring is directed downwards; if the current in the coil changes its direction, then the current in the ring does the same.

If the coil were traversed by a continuous current, one end of the iron core would be a north, and the other end a south pole, and the lines of force would therefore continuously flow in one and the same direction through the core. Since, however, the magnetizing coil is traversed by an alternating current, the magnetic field alters its direction repeatedly. Thus, through the interior of the metal ring, which lies on the coil, lines of force flow that continually change their direction. These lines of force produce in the ring, which represents a winding closed on itself (see p. 67), an E.M.F., and hence a current, of continually changing direction, the number of alternations of which is naturally equal to the number of alternations of the primary current.

Exactly the same action which arises in the metal ring or the *secondary winding* arises also in the primary coil itself, even if there is no secondary winding at all. Any winding of the primary coil encloses a magnetic field, the intensity and direction of which is perpetually altered. Thus, in each winding of the primary coil, there must, as in the secondary metal ring, be produced an E.M.F. which is opposite to the original one; that is to say, there exists a *back electro-motive force*, like that of the many examples with continuous currents we have considered; as in the cases of the electro-motor, the storage battery, and the arc lamp. The back E.M.F., produced by the inducing effect of alternating currents on their own circuit (thus, by *self-induction*), causes the current flowing through the coil to become far smaller than would be calculated by Ohm's law. Obviously the back E.M.F. can never be equal to the primary E.M.F., since in this case no current would flow through the coil, the iron core would therefore not be magnetized, and at this moment the production of the back E.M.F. would also cease. The back E.M.F. remains

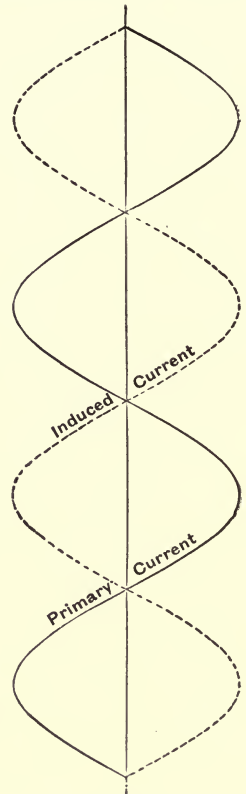

FIG. 220.

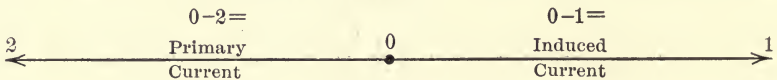

FIG. 220a.

—as in the electro-motor—always a little less than the primary E.M.F.

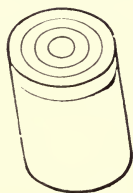

FIG. 221.

reason the iron cores of all alternating-current apparatus have—like the armatures of continuous-current machines—to be made of insulated iron wires, or from thin iron disks, which are insulated from each other by sheets of paper or by a layer of varnish (Fig. 222). Since with alternating currents a far greater number of alternations generally are employed than take place within the armature of a continuous-current dynamo, the subdividing of the iron core has to be carried out further with alternating- than with continuous-current armatures. Whilst with the latter, disks of 0.02 inch thickness are employed, the thickness is generally reduced to 0.012 inch, and even to 0.008 inch with alternating-current apparatus.

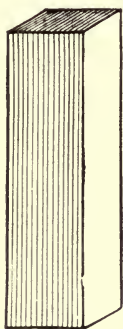

FIG. 222.

Again, the bobbins for alternating-current electro-magnets must never be complete metal bobbins. Whenever metal bobbins are employed, they have to be made with a slit (see Fig. 223), so that the bobbin itself cannot serve as a short-circuited secondary winding, and eddy currents, and therefore heating, is avoided. To entirely prevent the production of these currents the bobbins are in many cases made of insulating materials.

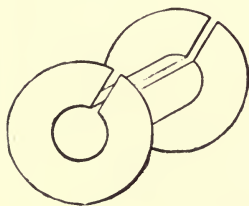

FIG. 223.

Transformers

The effects produced by alternating currents dealt with in the last chapter, are of the utmost importance in practice. These effects enable us to produce, without using any moving parts, an E.M.F., in a *secondary* coil which is wound over an iron core, providing that there is also a coil (the *primary*) traversed by an alternating current, wound over the iron. The voltage

produced in the secondary coil may have any value, it may be larger or smaller than, or equal to, the voltage of the primary coil.

The open iron core, employed in the experiment of Fig. 219, is not employed in this case. Obviously we want to get a strong magnetic field with the smallest possible magnetizing current, and must therefore provide for the lines of force a closed path through iron. With the dynamo, having a movable part, an air gap in the magnetic circuit cannot be avoided.

whereas with the transformer we may have an entirely closed iron circuit, as, for instance, the iron ring shown in Fig. 224. The ring looks like a gramme armature. Whilst, however, with the latter the lines of force enter the ring from outside, and the ring forms only a part of the magnetic circuit, with the

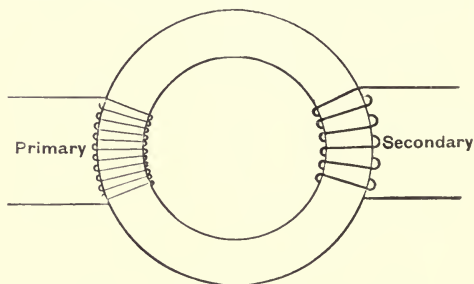

FIG. 224.—Ring Transformer.

transformer the lines of force are produced within the ring itself, and are closed in the ring, without leaving it. The secondary coil may be placed at any point of the ring. If the ends of the secondary coil are disconnected, then an E.M.F. is induced, whereas, if the ends are connected through an outer circuit—say, for instance, by lamps—a current will flow both through the coil and the circuit.

We have now to consider, how great the voltage produced in the secondary coil will be. Let us assume the number of windings on the primary coil to be 100, and that it is connected with an alternating supply of 100 volts. Let the secondary be first of all opened. Then, as we know, the back E.M.F. produced in the primary coil will be nearly as much as 100 volts—say, perhaps, 99 volts, or even a little more. For, since the lines of force are flowing entirely through iron, we want only a small number of ampere-turns for magnetizing the iron. Hence a very small pressure difference between primary and back E.M.F. is required for sending through the coil the magnetizing current for overcoming the ohmic resistance. Since now in the 100 windings of the primary coil a back E.M.F. of nearly 100 volts is produced, the back E.M.F. of each winding will be nearly 1 volt. Any winding of the secondary coil has, however, the same title to voltage as a winding of the primary, since both are traversed by the same magnetic flux. The voltage produced in any winding of the secondary coil will, therefore, be equal to nearly 1 volt. If, for example,

the secondary coil consist of 10 windings, then its voltage would be about 10, with 100 windings about 100 volts, with 1000 windings about 1000 volts, etc. The voltages of the secondary are to those of the primary coil exactly, or nearly exactly, as the number of windings on the two coils.

Now let us connect the ends of the secondary coil with an outer circuit, so that the E.M.F. of the secondary coil may produce a secondary current. Then the iron core will no longer be traversed by the primary current only, but also by the secondary current. The latter is, as we have learned from the experiment with the metal ring, in an opposite direction to the primary current; it tends therefore to demagnetize the iron core, and to weaken the flux of lines of force. As soon, however, as there occurs the slightest weakening of the flux, the back E.M.F. of the primary coil, which was before nearly equal to the terminal voltage, will naturally decrease. Even if the back E.M.F. decreases by 1 volt only, this will, at the small ohmic resistance of the primary coil, cause a considerable strengthening of the primary current. Thus through the primary coil as much more current will flow as is necessary to counterbalance the demagnetizing effect of the secondary coil. If, for instance, we had 10 secondary windings, and the current taken from them were 50 amps., then 500 secondary ampere-turns would cause demagnetization. Instantly 500 primary ampere-turns would result, and, since the number of windings of the primary coil is 100, its current would be equal to $\frac{500}{100} = 5$ amperes.

Such an apparatus is called a **transformer**, because it enables us to transform a current of high voltage and small amperage into one of low voltage and great amperage, or *vice versa*. It regulates its primary current consumption according to the current taken from its secondary side, and is therefore quite as excellent an automatic regulating apparatus as an electric motor.

Shape of Transformers

The ring, as shown in Fig. 224, is theoretically the best shape for a transformer core. This shape has, however, the disadvantage that the winding of the coils has to be done by hand, which is rather troublesome and expensive work. Hence shapes are generally employed which enable us to use machine-wound coils. In Fig. 225 such a shape is shown. The transformer consists of a horseshoe-shaped main part, built up from thin iron disks with

paper between them. The primary and secondary coils are pushed over the limbs of this part. After fixing the coils on the open end of the horseshoe, a straight piece, also consisting of iron disks and paper, is pressed to the top of the limbs and fixed by means of screws. We have now a closed magnetic circuit as before, but of a rectangular shape. The iron core of Fig. 225 is obviously not quite as good as that of Fig. 224. In the latter case, the magnetic circuit is entirely through iron; but in the core of Fig. 225 there is between the main horseshoe part and the straight end piece a joint, which, though it may be very small, still represents an air gap. This transformer requires, therefore, a little more magnetizing current than a ring

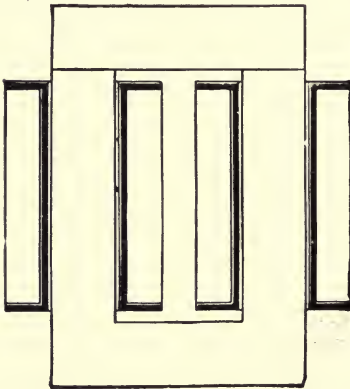

FIG. 225.—Transformer with Horseshoe-shaped Iron Core.

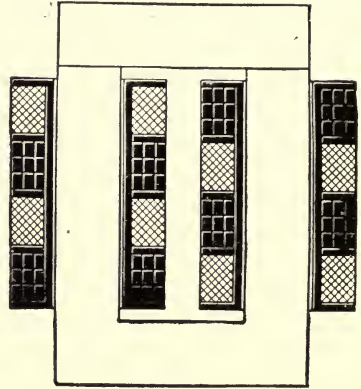

FIG. 226.—Transformer with Coils subdivided.

transformer, and will also have a greater magnetic leakage. If with this rectangular shape we fix a primary coil on one limb of the horseshoe, and the secondary on the other, then we are able to observe a considerable difference in the voltage of any primary and secondary winding. The reason for this is that all the lines of force produced in one limb do not pass the other limb, but a considerable part of them leaves the iron core at the edges and joints and flows through the air. To prevent the disadvantageous effect of the magnetic leakage, the primary and secondary coils are generally subdivided into a number of smaller coils, alternately placed over the iron core, as shown in Fig. 226. In this case we have four primary and four secondary coils, which are fixed two at a time on each transformer limb. Sometimes the internal diameter of one coil is larger than the

outer diameter of the other coil, so that on each limb the secondary coil may be pushed over the primary, or *vice versa* (see Fig. 227).

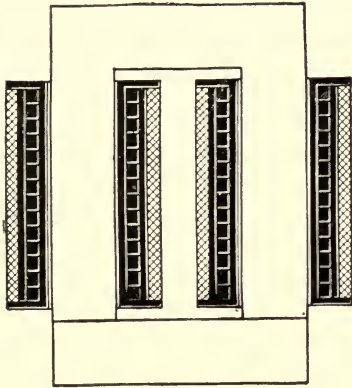

FIG. 227. —Transformer with Coils wound one on the other.

Another transformer shape is shown in Fig. 228. Here the coils are wound over the middle iron core, which is then completed by two U-shaped yoke-pieces. The flux of lines of force is spread over the two yoke-pieces. The working of this transformer is obviously quite the same as that of the transformers described before. Practically it has the advantage that the coils are protected by the two yoke-pieces against mechanical injuries and are enclosed as within a shell.

In no part of a transformer which is exposed to the changing magnetic field must solid iron parts be employed, because these would be dangerously heated. Hence the bobbins are generally made from insulating materials. Solid iron bolts and castings must never be used in connection with the iron

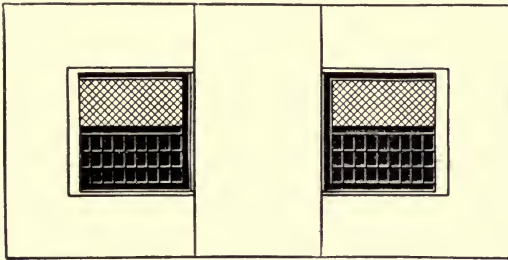

FIG. 228. —Shell Transformer.

core. For the constructive part, however, they may be employed, but care has to be taken to prevent them from being traversed by a considerable number of stray lines of force. In Fig. 229 the general construction of a transformer (Ferranti type) is shown.

Applications of Transformers

The transformer is of the utmost importance in the practical applications of the alternating current. The facility of change of pressure it affords has given it an important place in electrical engineering.

We know, from what we have learnt about mains (see page 46),



FIG. 229.—Westinghouse Oil-insulated Water-cooled Transformer
2250 K.W., 22,000 Volts.

the advantages high tension offers for the transmission of energy, but we are aware on the other hand how dangerous a high-tension main can become in inhabited rooms. It would, for instance, be possible to generate with continuous currents voltages of some thousands, thus

enabling an economical transmission of energy over distances of several miles. Since, however, the consuming apparatus, such as arc and glow lamps, can only be manufactured for comparatively low voltages, a series connection of many lamps would be required. Further, the dangers of high-tension circuits would have to be carried into each room in which a lamp is used, involving the special precautions which are specified in connection with high-tension mains.

The alternating-current transformer allows the transformation of high tension to any required low tension in a very simple and reliable manner. It does not require any attendance, is self-regulating, and, since in an apparatus in which the parts are all stationary the insulation between high- and low-tension coils can be made in a very perfect manner, a transformer is safer than any rotating machine can possibly be. From the secondary terminals of the transformer only low-tension cables lead, with which the house mains are connected: thus no special provisions have to be made in installing lamps, etc.

If we wish to obtain a similar transformation with continuous current, there is nothing left but to employ a high-tension continuous-current motor, which drives a generator supplying low-tension current. Continuous-current converters require, it must be remembered, since they are rotating machines, attendance and regulation. Further, their efficiency is far lower than that of stationary alternating-current transformers of the same output.

Sometimes alternating-current transformers are employed for the transformation of low into high tension. Nowadays alternating-current generators for 2000-5000, and even 10,000 volts, can easily be manufactured. For power transmission on extremely long distances, however, voltages up to 30,000 and even more are employed. It is then generally preferred to produce in the generators currents of comparatively low voltages; to transform these currents by means of transformers into the high voltage required, lead this high tension to the places of consumption, and there step it down again by transformers to a pressure low enough to be used without danger to life.

Phase-Difference

Not only in transformers, but also in all alternating-current circuits, self-induction causes specific phenomena. We know that any wire traversed by an electric current produces round it a magnetic field, the lines of force being in circles (see Fig. 17). With continuous currents this magnetic field is stationary and uniform as long as the current does not alter its strength. The field of a direct current, therefore, does not exert any reaction on the current itself, since, as we know, we must have an alteration of the field

intensity to produce induction effects. On the other hand, the field produced by an alternating current changes its direction and strength continually, thus inducing, both in the conductor itself and in all neighbouring conductors, electro-motive forces. With straight conductors, in the neighbourhood of which there is no iron, the electro-magnetic whirl of force, and hence the E.M.F. of self-induction, is comparatively small. If, on the other hand, there are coils in the circuit, especially if they have cores of iron, the influence of the self-induction on the circuit is considerable. The E.M.F. of self-induction may, of course, be also represented by a wave line, like any alternating current voltage and alternating current strength, but it does not reach its maximum value at the same time that the current strength reaches its highest value, and its zero occurs at a different time to that of the current.

In Fig. 230 the course of an alternating current is shown by the

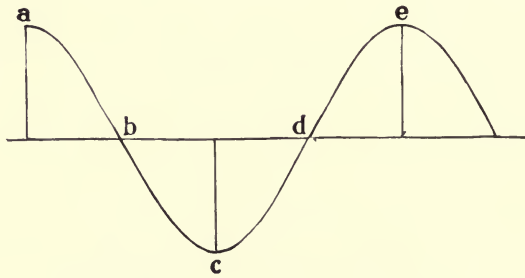

FIG. 230.—Alternating-current Curve.

wave line. The magnetic field naturally reaches its maximum value, its zero point, and its minimum (negative) value simultaneously with the current by which it is produced. If, for instance, the current reaches the zero line, then there are no magnetizing ampere-turns, and no magnetic field can exist. When the magnetizing current reaches its maximum value, then the strength of field also reaches its maximum value. When, on the other hand, the magnetizing current is in the opposite direction, then the direction of the lines of force must also be in the opposite direction. The E.M.F. of self-induction can only be produced **with an alteration** of the magnetic field. The more rapid the alteration, the stronger the E.M.F. of self-induction will be. Whether the field itself is strong or weak, or whether it is directed in one or the other sense, does not make any difference at all; the essential circumstance being only the rate of growth or decrease of the field.

The above figure represents the growth and decrease of the magnetizing current, and therefore also the growth and decrease of the strength of field. Considering the figure, we observe distinctly that at *a*, *c*, and *e*—that is, at the highest and lowest positions—the field for a moment does not alter its strength at all. Up to *a* the current has grown, but at *a* the growing of the current stops for a brief interval. From there it falls again, first slowly, then quicker and quicker. The inclination of the wave line, and hence the decrease of the current, is greatest at *b*, where the current passes the zero line. On the current falling still further, the inclination of the wave line becomes less steep, and the fall is slower, until the lowest point, *c*, is reached. At this moment a point of rest occurs again for a moment, then the field grows, first slowly, then more quickly up to *d*. Thence it continues to grow up to the highest point *e*, but the rate of increase is again a slow one. From this it is clearly seen that the rate at which the current, or the field which it produces, changes differs from point to point. When the current reaches its *maximum* value *there is no field alteration at all*, and when the current passes the zero line, the field changes at the most rapid rate.

We may compare this with the differences in the length of day and night at the different seasons. In winter and summer, when the days last eight hours less or more respectively than the nights, the alteration in length from one day to another is hardly perceptible; whereas in spring and autumn, when the days and nights are almost equal, the alteration in the length of consecutive days is very apparent.

The E.M.F. of self-induction depends on the rate of the alteration of the field. Hence it is greatest when the current passes the zero line, decreases with an increasing current, and becomes nil as the current reaches its maximum value. For determining the direction of the induced E.M.F. we have only to consider that it is always opposite to the alterations of the field, thus being positive when the field decreases, and negative when the opposite is the case. This rule enables us to draw a line in the form of a wave, representing the E.M.F. of self-induction (see Fig. 231). A glance at this diagram shows that the E.M.F. of self-induction is a quarter of a wave or a *quarter of a period* behind the producing current. This signifies that the current has at any definite moment a maximum value, which is reached by the E.M.F. of self-induction a quarter of a period later.

This is the case with the theoretical transformer, the secondary circuit of which is open. The transformer is then not loaded, therefore through the primary coil only a small magnetizing current flows, and this lags a full quarter-period behind the impressed voltage.

With continuous currents we calculated the watts required in any circuit simply by multiplying voltage and current, or—

$$\text{Volts} \times \text{amps.} = \text{watts.}$$

It is quite different with alternating currents. The power used at any instant is still, of course, determined by the product volts \times amps. at this particular moment, but we must never forget to multiply together the voltage and current that belong to each other. In other words, the product of the simultaneous values of current and voltage must be taken.

Now, just at the moment when the voltage has its maximum value the current is zero, and when the latter has its maximum value the voltage is zero, the product of voltage and current, the watts, thus being at these times, in both cases, without value.

This fact can be made clearer by an example from daily life.

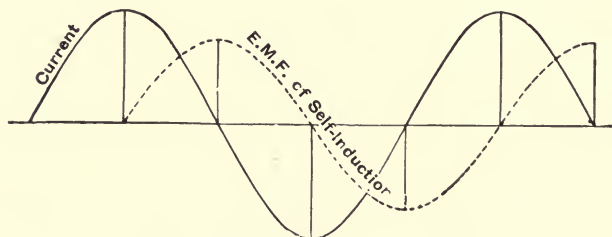

FIG. 231.

Imagine a workman who is sometimes diligent and at other times lazy, in an untidy workshop, where the tools are frequently lost. If he cannot find his tools just at the moment when he is most inclined to work, or again, if he discovers them when he is inclined to be lazy, he will not in either case do useful work. The phase-difference between the possession of tools and inclination to work brings about a working result of zero value, although there is sometimes inclination to work and sometimes these are tools. If the "phase-difference" is not quite as great—that is to say, if the man finds the tools just before he has lost his inclination to work, the result will not, of course, be nil, but it will surely be smaller than if the possession of tools and full inclination to work had been simultaneous.

Similarly, the electrical effect, the watt output, is smaller when a displacement of voltage, as regards the current, exists, and will be smaller the nearer the phase-difference approaches to a quarter-period. If the current has only magnetizing work to do, as is the

case with a theoretically unloaded transformer, then there is no watt output.

The magnetizing current which is displaced by a quarter-period from the voltage is therefore called a **wattless** current. In the case of a theoretical unloaded transformer, we have only wattless current.

The reverse of a wattless current is a watt current—that is, a current which has no phase-difference from the voltage. If the voltage reaches simultaneously with the current its highest, its zero, and its lowest value, then we get the maximum of work that can be done with these current and voltage values. The output may then easily be calculated by multiplying the effective voltage by the effective current. With a circuit without self-induction this is really the case. If, for example, we measure the effective voltage as 100 volts, and the effective current as 40 amps., then the output is 4000 watts, exactly as with a corresponding continuous current.

A circuit absolutely without self-induction does not exist, but frequently the self-induction is very small—for instance, with glow lamps. If with the secondary coil of a transformer we connect a number of glow lamps, then through the secondary circuit nearly a pure watt current flows. Thus to the wattless magnetizing current which was in the primary coil before, a watt current will be added. The resulting current now flowing in the primary coil is, of course, neither absolutely in phase with the voltage nor displaced by a quarter-period. Its displacement becomes smaller the more the secondary of the transformer is loaded. With a fully loaded transformer the small wattless magnetizing current is practically negligible when compared with the large watt current, so that a phase-difference can hardly be observed. Hence, if the fully loaded transformer takes 300 amps. at a voltage of 100, this will correspond practically with 30 kilowatts.

Our discussions about an unloaded transformer have hitherto referred to the theoretical case. With a commercial transformer the phase-difference is not really a quarter-period. We have learned that only a wattless current—that is, one which does not produce any effect, like the mere magnetizing current of the primary coil of an unloaded transformer—has a *lag* equal to a full quarter-period behind the voltage. As a matter of fact, even in transformers with an open secondary circuit, secondary currents are produced, since the separate iron disks form closed circuits, and, even if they are very thin and of high resistance, eddy currents flow through them. These currents act like those produced in the secondary windings when their circuit is closed. Now, whenever a current flows in the secondary circuit a watt current enters the primary coil. It will therefore be quite clear that through the primary coil of an unloaded transformer a certain amount of watt current must flow. The

transformer will always consume as much energy as is transformed by the eddy currents in its core into heat. The phase-difference between current and voltage of an unloaded transformer is therefore always somewhat less than a quarter-period, and the watts taken are always greater than zero, but far less than the product of voltage and current.

The self-induction of a coil with an iron core may be used with advantage in installations of arc lamps, so as to avoid loss of energy. If we connect a single alternating-current lamp, requiring a voltage of about 30, with 110-volt mains, we have to absorb about 80 volts in a series resistance. An 8-amp. lamp consumes 8 amps. \times 30 volts = 240 watts. In the series resistance, as much as 8 amps.

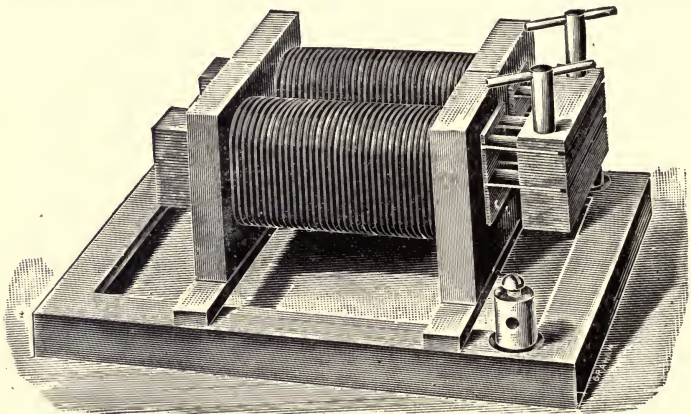

FIG. 232.—Choking Coil (*The General Electric Company*).

\times 80 volts = 640 watts would be lost! Thus the dynamo had to supply 880 watts for this single arc lamp only. If, on the other hand, we employ, instead of the series resistance, a “choking coil”—that is, a coil wound over an iron core, similarly to a small transformer, but with a single coil only (see Fig. 232)—then in this coil a back E.M.F. is produced, which causes a great phase-difference between current and voltage. The current will, of course, in this case have to be again 8 amps., also the voltage of lamp and choking coil together will be 110 volts; but the watts taken will be far less than 880—perhaps not much more than the 240 watts required by the arc lamp itself. Naturally this arrangement cannot be used with continuous currents.

The property of self-induction and phase-difference between current and voltage is inherent in all alternating-current circuits, especially in coils with iron cores. Hence electro-magnetic measuring instruments show different deflections with continuous and alternating currents of equal strength. If they be used for alternating-current

work they must be calibrated with an alternating current of the same number of periods. For the E.M.F. of self-induction is much less with a current of 50 than with one of 100 periods. The instrument will therefore be incorrect for any other periodicity than that for which it has been calibrated.

Vector Diagrams

Let us draw the vector diagrams of the cases just cited. Take the case of a voltage applied to a choking coil in series with an arc lamp. Let us assume the arc lamp takes 8 amperes at 30 volts, the current and voltage being in phase. Let us assume that the choking coil is entirely inductance, having no resistance or iron loss. The diagram would appear as in Fig. 233.

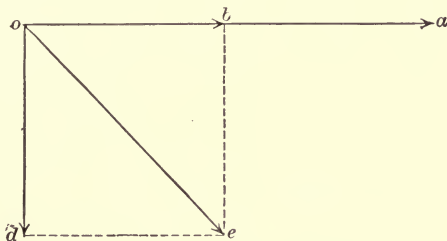

FIG. 233.—Vector Diagram.

In this figure the line $o-a$ represents in length and phase the square root of mean square value of current, that is 8 amperes, as read on an ammeter. The flux produced in the reactive coil is in phase with the current, since current produces flux.

We have shown in Fig. 217 and in the text covering it, that the E.M.F. produced by a flux is 90 degrees away from the flux. Thus, $o-d$, 90 degrees ahead of $o-a$, represents the E.M.F. produced by the flux in the reactive coil, which in turn is produced by the current flowing through the reactive coil. The line $o-b$ represents in length and direction the value of the E.M.F. at the arc lamp. This is in phase with the current $o-a$, since it is assumed that the lamp is non-inductive. Thus, the product of $o-b$ and $o-a$ gives the *energy in watts* taken by the lamp itself. The voltage required to overcome the voltage $o-d$, lost in the reactance, and the voltage $o-b$, required by the lamp, is now to be determined. This voltage is not the arithmetical sum of $o-b$ and $o-d$, because they are *out of phase with each other*, as shown in Fig. 233, and voltages or currents *can only be added*

directly in alternating circuits when they are in phase. How, then, should they be added? It can be shown that to add quantities out of phase, it is necessary to find the diagonal of the parallelogram whose sides compose the two values to be added. Thus, in Fig. 233, the line $o-c$ represents their vector sum. Thus, $o-c$ represents in phase and amplitude the value of the E.M.F. necessary to put 8 amperes through the arc lamp and reactance in series. It can be seen that this value is much less than the actual sum of $o-b$ and $o-d$.

This figure also shows that the E.M.F. $o-c$ is out of phase with the current $o-a$, by the angle $c-o-a$. This angle is called the lag of the current $o-a$, behind the E.M.F. $o-c$. Inductive circuits cause, as shown, a lag of current flowing into them behind the E.M.F. applied to them. Take the case of the Fig. 219, but first without the ring on the core. Let us assume that there is no loss in the iron of the core or in the copper used around the core. Fig. 234 shows the

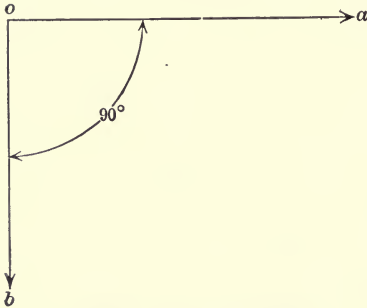

FIG. 234.—Vector Diagram. Coil without Iron.

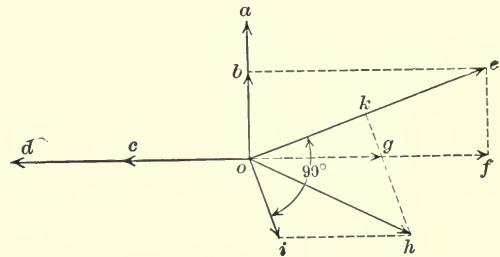

FIG. 235.—Vector Diagram of Transformer.

diagram of E.M.F. current. Here $o-a$ represents the current flowing into the coil and $o-b$, 90 degrees away, as has been shown, the applied E.M.F. Now place the ring upon the core, and it is noticed that the current into coil promptly increases. The current in the ring must be supplied from somewhere; thus, each ampere in it must appear in equivalent amperes (allowance being made for extra turns) in the coil itself, since into it only can energy enter, the wire supplying energy being connected only to the coil.

Consider Fig. 235. Let $o-a$ equal in amplitude and phase the flux. Let $o-b$ in phase with the flux represent the current which, when flowing into the coils of the magnet, produces the flux. We assume no iron loss, so that the magnetizing current proper is only considered. This flux produces, when alternating through the primary, an E.M.F. equal to $o-f$, and through the secondary an E.M.F. equal to $o-c$; for, as has been shown, the E.M.F. from flux is 90 degrees away from it, and the E.M.F. $o-c$ in the secondary or ring appears in

the primary or coil as $o-g$ equal and opposite $o-c$ (allowance being made for the difference of turns between the ring and the coil). Assuming the ring itself to be non-inductive, the current flowing in it is the result of the E.M.F. $o-c$ and in phase with it, that is, $o-d$. This current has its equivalent and just opposite to it in the primary or coil, as has been shown, and hence appears in the diagram as $o-f$. Thus, the ring E.M.F. appears in the coil as $o-g$, and the ring current appears in the coil as $o-f$. Therefore the two currents which must combine as a single current, since only one current can flow in a wire at one time, are $o-b$ and $o-f$, and the two E.M.F.'s which must combine to give the applied E.M.F. are $o-g$ and $o-i$. The latter is the E.M.F. of self-induction of the primary coil. This is at right angles, as has been shown in the case of self-induction E.M.F., to the primary or coil current $o-e$. But the combination of two vector quantities is the resultant of the parallelogram with the two forces as sides; thus, the *vector sum* of $o-b$ and $o-f$ is $o-e$, which gives the phase and amplitude of the current flowing in the coil. And the vector sum of $o-g$ and $o-i$ is $o-h$, which is, therefore, the applied E.M.F. upon the coil. An inspection of the figures shows that the current flowing into the coil $o-e$ lags in phase behind the applied E.M.F. upon the coil $o-h$, by the angle $h-o-e$, which now is less than the lag in Fig. 196*b*, where the ring was not on the core. Thus, the energy given to the ring brought the current and E.M.F. applied to the coil nearer in phase. As a matter of fact, the energy now represented is the product of the current $o-e$, and the proportion of the E.M.F. upon it $o-k$, for energy means the product of current and E.M.F. *when in phase*. Examining the triangle, $k-o-h$, shows the cosine of the angle $k-o-h$ equals $\frac{ok}{oh}$, as has been explained at the first of the chapter. Thus,

$ok \times oe = oh \times \cos koh \times oe$, or energy equals product of E.M.F. and current and cosine of angle of lag. This value *cosine of angle of lag* of a circuit is called the *power factor*. When there is no lag the power factor is unity, for the cosine of 0° , as you know, is 1. With a lag of 90 degrees, the power factor is 0, and the energy is 0, since the cosine of 90° equals 0. This diagram, which has just been explained, is that of the alternating transformer, the ring being the secondary circuit and the coil the primary. It deserves careful study.*

In order to calculate in volts the value of self-induction of any circuit, certain constants of that circuit must be known. In Fig. 235 the line $o-i$ is drawn to show in volts the self-induction of the coil. We will now proceed to show just how to calculate this voltage having the coil. In any circuit there is a coefficient of self-induction denoted by electricians by the letter *L*. It is equal to the maximum of the

* For complete discussion of the design and operation of a transformer treated with no calculus, see Chap. III, Raymond's "Alternating Current Engineering"

flux wave times turns of the circuit divided by ampere times 100,000,000, or $\frac{\text{max. flux} \times \text{turns}}{\text{amp.} \times 100,000,000}$. This is expressed in a unit which has been given the name of *Henry*. When multiplied by $2\pi N$, when π equals 3.14159, and N equals cycles per second of the circuit, ohms are obtained; thus, having L of a circuit, the ohms inductance equals $2\pi NL$ and the volts inductance (*o-i* of Fig. 235) equals $2\pi NLI$, when I equals the current flowing in the circuit. The calculation of L , that is the flux times turns, is the same as the calculation of flux in any circuit and must be done as shown in the first of this book, where it was shown that flux equals $1.258 \times \text{ampere turns per unit length of circuit} \times \mu$, the permeability of the circuit. Consider another problem as follows: What would be the diagram of currents and E.M.F. of a circuit consisting of an inductance in series with a resistance having upon it an E.M.F. applied? The circuit would look like Fig. 236.

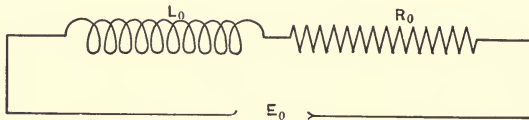

FIG. 236.—Circuit with Inductance and Resistance.

Let the inductance equal L_0 , and the resistance equal R_0 . Let the cycles of the circuit equal N cycles per second and the current equal I_0 . Then the E.M.F. consumed by the reactance L_0 equals $2\pi NL_0 I_0$, and by the resistance equals IR_0 . We will now draw the vector diagram of these voltages and current.

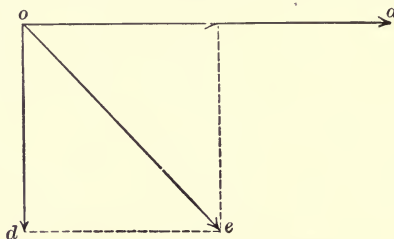

FIG. 237.—Vector Diagram.

Draw $o-a$ equalling in phase and amplitude the value of the current flowing. Then the E.M.F. used up by resistance due to this current is in phase with this current and represented by $o-b$ (thus, $ob \times oa$ equals energy loss due to resistance). The E.M.F. of self-inductance is at right angles to the current and is thus represented by $o-d$. The total E.M.F. necessary to drive this current $o-a$ through the resistance and inductance in series is, therefore, the *vector sum*

of $o-b$ and $o-d$, or $o-e$. Any circuit can thus be analyzed and shown diagrammatically by bearing in mind the laws which have been expressed.

To prove that $2\pi NL$ equals ohms:

It has been shown that $\frac{2\pi N\phi}{\sqrt{2 \times 100,000,000}}$ equals "square root of mean square" voltage of the sine curve of E.M.F. produced by an alternator of one turn on its armature and of two poles. The back E.M.F. of a coil of n turns having threaded through it an alternating flux of maximum value of ϕ and turns n and cycles N (cycles N equal revolutions per second of an alternator of two poles, as has been shown) is

$$\frac{2\pi N\phi \text{ (max.)} \times n}{\sqrt{2 \times 100,000,000}} = E. \dots \dots (1)$$

In this case the flux alters instead of remaining constant and the turns revolving in it. Since motion is relative, the same formula held for the E.M.F. produced by the flux alternation, as cycles equal N , though turns equal n .

In this coil the coefficient of self-inductance, as has been shown, equals

$$L = \frac{\phi \text{ (max.)} n}{\text{amp. (max.)} + 100,000,000} \dots \dots (2)$$

From (1)

$$E = \frac{\phi \text{ (max.)} n \text{ amp. (max.)}}{\text{amp. (max.)} \times 100,000,000} \times \frac{2\pi N}{\sqrt{2}} \dots \dots (3)$$

Substituting (2) in (3) gives

$$E = \frac{L \times \text{amp. (max.)}}{\sqrt{2}} \frac{2\pi N}{1} \dots \dots (4)$$

But $\frac{\text{amp. (max.)}}{\sqrt{2}}$ equals, as has been shown, square root of mean square amperes, as read on an ammeter. Hence, E (square root of mean square) equals $2\pi NLI$, where I equals square root of mean square amperes; since from Ohm's law volts equal current times resistance, it follows from the equation $E = 2\pi NL \times I$ that $2\pi NL$ equals ohms, which was to be proved.

Referring again to Fig. 237, the line $o-e$ represents the opposite of the flow of current by resistance and inductance. It is a fact that in any right angle triangle the long side equals the square root of the sum of the squares of the other two sides; thus, $o-e$ equals the square root of $ob^2 + be^2$. But $b-e$ equals $o-d$. Thus, $o-e = \sqrt{2\pi nL^2 + R^2}$.

This value is called impedance and represents the opposition in ohms to the flow of an alternating current in a circuit containing the resistance R and the inductance $2\pi NL$.

Wattmeter—Power-Factor

For determining the watt consumption of an alternating circuit, it is not sufficient to measure the effective voltage and current. For this purpose it is therefore necessary to employ an instrument which at any moment is influenced by the *simultaneous* values of current

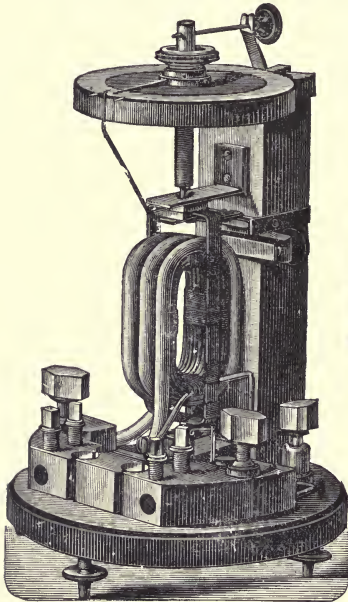

FIG. 238.—Wattmeter.



FIG. 239.—Two-wire Single-phase Integrating Wattmeter.

and voltage, *i.e.* an instrument which directly indicates watts. Such an instrument, the construction of which is shown in Fig. 238, is called a **Wattmeter**. It is similar to the electro-dynamometer mentioned on page 60, with the difference only that it is not, like the electro-dynamometer, wound with wires of equal, but with wires of different diameter. The wattmeter essentially consists of a fixed coil, of few windings made of thick wire, through which (as with an ammeter) the main current passes, and of a movable coil, with a few windings of fine wire, which (like a voltmeter) is in series with a resistance, and is directly connected on the full voltage. To prevent any phase-dif-

ference between the shunt-coil current and the voltage producing it, the movable coil and the series resistance must have small self-induction.

Hence there must (1) be no iron in the apparatus, and (2) the coils of the resistance in series with the coil must be "doubly wound," as is shown in Fig. 240. A winding of this kind prevents self-induction, since to any winding tending to produce a field in a definite direction there is opposed a neighbouring winding tending to produce a magnetic field in an opposite direction, so that no magnetic field results. The shunt coil within the wattmeter itself cannot, of course, be wound in this way, since it then would be unable to exert a directive force. It possesses, therefore, a certain, although small, self-induction, because the coil consists of very few windings. The self-inductionless series resistance has, in addition, an important influence in preventing lag, which depends not only on self-induction, but also on the ohmic resistance of the circuit.

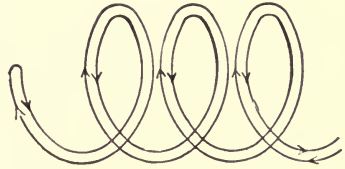

FIG. 240.—Spiral without Self-induction.

To keep the fixed and the movable coils always at the same position at right angles to each other, so that their repelling action cannot be weakened, the movable coil has always to be turned back to its original position. For this purpose in the centre of the dial there is a milled head, with a spiral spring attached to it and to the movable coil. The stronger the repelling force, the greater is the angle we have to twist the spring through by using the milled head in order to turn the movable coil back to its zero position. The head has a pointer attached to it, so that we can read on the dial how much we have turned the head and hence how great is the torsion on the spring. The dial being usually divided into 360 degrees, it is necessary to calibrate the instrument. This may be done with a continuous current, by sending, for instance, a current of 10 amps. through the main coil and connecting the shunt coil with its series resistance to a source of 100 volts. If now, to bring the shunt coil back to its zero position (to help in doing this a small aluminium pointer is fixed to the shunt coil, and is bent up to reach the dial), we had to turn the knob through 30° , we then know that 30° correspond to 1 kilowatt, thus 1° corresponds to $33\frac{1}{3}$ watts.

The force with which the movable coil is repelled or attracted by the fixed coil depends with alternating current at any moment on the instantaneous values of current and voltage. Since, as we know, the product of instantaneous voltage \times instantaneous current really is equal to the instantaneous power in watts, the wattmeter will at any moment indicate in a correct manner the

output of, or the watts taken by, an alternating-current circuit. If current and voltage are exactly in phase, as is, for instance, nearly the case with a glow-lamp circuit, the reading on the wattmeter will be exactly equal to the product of the voltage and current as indicated by suitable instruments, such as a voltmeter and an ammeter of the hot-wire type. If, for instance, in a glow-lamp circuit we read on the voltmeter 100 volts and on the ammeter 10 amps., then the wattmeter will indicate 1000 watts. If we had in circuit a phase-difference of a quarter-period, the wattmeter would stop at zero. The voltmeter would, for instance, show 100 volts, the ammeter 10 amps., and the wattmeter nothing.

The product of volts \times amps. is called the **apparent watts**, that indicated by the wattmeter is the *real* or *effective* watts. From the ratio between the real and apparent watts we are able to calculate the phase-difference. The ratio, that is the number we get by dividing the real by the apparent watts, is called the **power factor**. With an inductionless load the power factor is equal to unity, with an inductive load it is smaller than unity, and with a phase-difference of a quarter-period it is zero. Instead of the expression "power factor," for mathematical reasons the expression $\cos \phi$ is generally preferred (where ϕ is the angle of lag and $\cos \phi$ indicates the cosine of this angle).

If the power factor is known, we can even without a wattmeter determine the real watts used. If, for instance, $\cos \phi = 0.9$, then with a current of 10 amps. and a voltage of 100, the real watts will be $100 \times 10 \times 0.9 = 900$ watts. If with an unloaded transformer, consuming 100 volts and 40 amps. $\cos \phi = 0.3$, then its real consumption $= 100 \times 40 \times 0.3 = 1200$ watts. With a fully loaded transformer, consuming 100 volts and 300 amps., the power factor ($\cos \phi$) might be equal to 0.99, its real consumption being then $100 \times 300 \times 0.99 = 29,700$ watts.

There are instruments for measuring directly the power factor, which are, however, not often in use. They are called **phasemeters**.

Commercial wattmeters which read directly upon their dials the reading of watts, just as ammeters or voltmeters, are sold by leading manufacturers.

CHAPTER IX

ALTERNATORS

THERE are many kinds of alternating-current generators or alternators. The simplest we became acquainted with in the form of the "magneto-electric machine." A Gramme ring may also be employed as an alternator armature. Its construction is then still simpler than that of a continuous-current armature. The commutator can be omitted, and two opposite windings have to be connected by wires with two slip-rings. This is shown diagrammatically in Fig. 241,

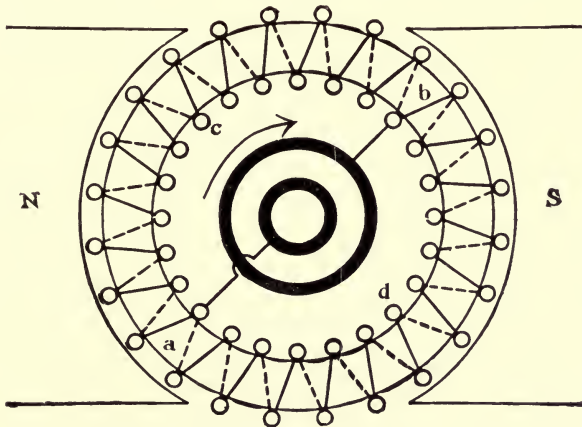

FIG. 241.—Ring Armature with Slip-rings.

in which, for the sake of distinctness, the two slip-rings are indicated by circles of different sizes. If the windings *a* and *b*, with which are connected the slip-rings, are situated just in the neutral zone, then the conductors of the left half are in series, and also those of the right half. The two halves are in parallel, and we get at this moment the largest voltage, the same as would continuously appear

if the armature were built for continuous current. If, however, the windings *a* and *b* leave the neutral zone (as shown in the diagram), then one part of the windings of each half is under the influence of the north, the other part under the influence of the south pole, and the voltage of each half becomes therefore smaller. If the windings *a* and *b* are horizontal, then in each half there are as many wires under the influence of the north as under the influence of the south pole, and the momentary voltage becomes zero, whilst at the next moment the voltage is reversed. As the armature continues to revolve these changes of pressure are repeated, so that a regular alternating-current pressure is produced between the two slip-rings.

Naturally in a four- or multi-polar magnetic frame, ring armatures can also be employed for producing alternating currents, provided that the series or parallel connections of the windings and the connection with the slip-rings are made in a corresponding way.

Multi-polar machines are generally employed, since, to obtain the usual periodicity of 100 per second, or 6000 per minute with a 2-pole machine, a speed of 3000 revolutions per minute would be required, whereas with a 4-pole machine but 1500, with a 6-pole machine 1000, and with an 8-pole machine 750 revolutions per minute are necessary.

For exciting the field of an alternator, continuous current is essential, and is supplied either by an outer source of current or by a special small continuous-current machine, coupled directly to the alternator.

In cases in which a Gramme armature is employed as an alternator armature, besides the slip-rings there is frequently fixed on the armature a commutator, enabling the machine to supply continuous on one, and alternating current on the other side. The continuous current may then be used for exciting the magnetic field. Such a **double-current** machine is shown in Fig. 242.

Ordinary continuous-current drum armatures may also be used in this manner and provided with slip-rings. The latter have then to be connected with two armature wires, which are distant by the width of one pole-shoe.

There are other drum windings, which are quite different from those of continuous-current armatures, and only serve for producing alternating currents. The simplest example of an alternating-current drum armature is the Siemens H armature (see Fig. 64). This armature is provided with a single slot per pole, and the windings are wound as a coil through the two slots, which are opposite to each other. With this armature all the conductors employed in inducing E.M.F. have at any moment equal positions in the magnetic field. All the wires are either in the neutral zone, or in any position between the poles. Thus, with this winding in, all the wires are at any moment either induced equal voltages, or none at all.

We may also express this as follows:—With a drum-winding, which is wound like a continuous-current winding, in the series connected conductors, E.M.F.'s are induced, which are not in the same phase, whereas with the two-slot alternating-current winding

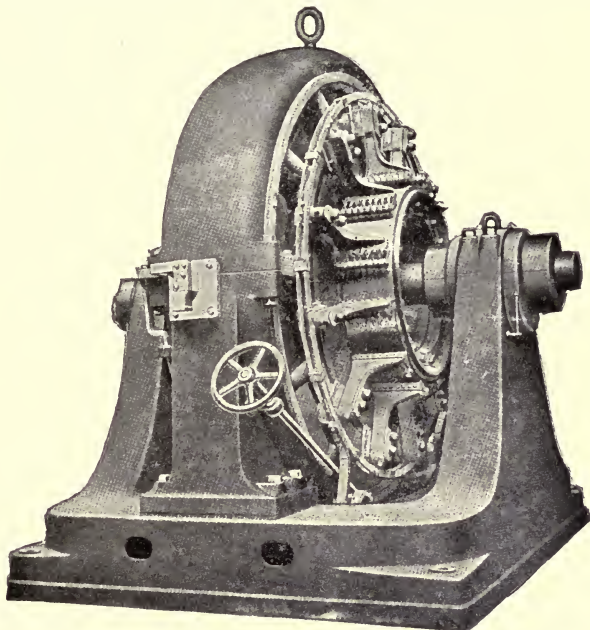

FIG. 242.—Rotary Converter (*British Schuckert Co.*).

the E.M.F.'s of all the conductors are at any time equal in phase. Thus 100 conductors, wound as a continuous-current armature, will not be as effective as 100 wires wound within the slots of a 2-slot alternating-current armature. On the other hand, we can obviously place more conductors on the whole armature circumference than in two slots.

Instead of a single slot per pole there might as well be two or more slots, as shown in Fig. 243. But it is clear that such a winding, even if there are many slots, is very different to a continuous-current winding. With the alternating-current winding the armature is wound so that all the coils, if traversed by a continuous current, would tend to magnetize the armature in the same direction.

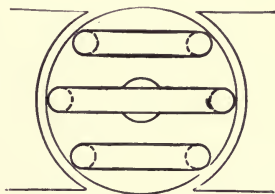

FIG. 243.—Armature with Three Slots per Pole.

The winding diagram of a 4-pole machine, having a single slot per pole, is shown in Fig. 244. Both coils must be connected in series in a suitable manner. The windings shown in Figs. 64, 243,

and 244 are all open windings, whereas the drum and ring armatures have closed windings.

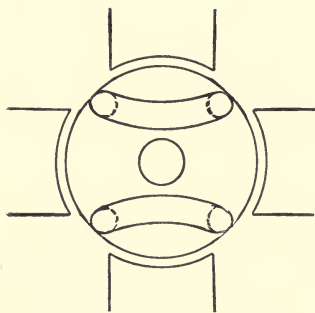

FIG. 244.—Four-pole Armature with Single Slot per Pole.

With high-tension generators brushes and slip-rings must be avoided whenever possible. Now, with alternating-current generators it is quite easy to build the armature as the stationary, and the magnetic frame as the rotating, part.

From the stationary part the alternating current may then be taken without slip-rings or brushes, merely by means of fixed terminals and cables. A scheme of this type is shown in Fig. 245. The Gramme armature is arranged on the outside, and in the interior of it the magnet system rotates. The armature is divided into four quarters, and opposite points are connected with each other, exactly as is the case with an ordinary ring armature. There is naturally no difference in the inducing action whether the armature or the field rotates.

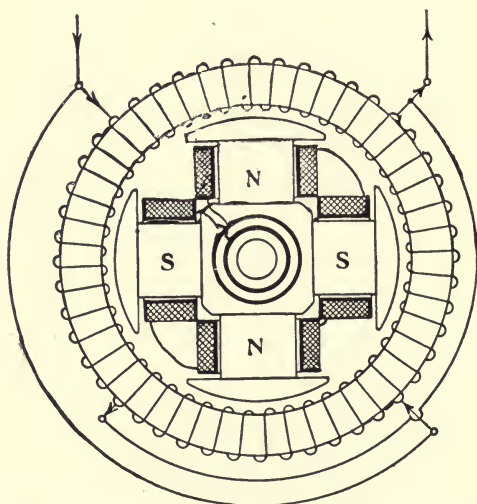

FIG. 245.—Four-pole Inner-pole Generator with Ring-armature.

Very often a drum winding is used instead of a ring winding—for the reason that the fixing of the armature and its building up within the casing is simpler. Fig. 246 shows the general construction of an

8-pole machine, having two slots per pole. All the eight coils of the armature are connected in series, and wound clock and counter-clockwise alternately. Since now the coils are first under the influence of a north and then of a south pole, this winding will give a proper series connection of all the induced electro-motive forces.

Such **inner-pole** machines with stationary armatures are far more reliable than machines with rotating armatures. The armature wires are generally threaded through entirely closed mica or insulating *press-pahn* tubes, which are embedded in the slots. The closed tubes

have a very high insulating power, so that even with high voltages there is no fear of their breakdown and the leakage of electricity from the winding to the iron part. The single wires do not require very good insulation, since the pressure difference between the wires is comparatively small.

The rotating magnetic field must be excited by a continuous current, it is therefore provided with two slip-rings, by means of which the continuous current is supplied. For excitation a low-voltage current of about 65 to 110 volts is generally used. Thus, slip-rings and their brushes do not present any danger.

Shapes of slots generally used with alternating-current machines are shown in Fig. 247. The slots are here generally far larger than those of continuous-current machines. They are either open or, more frequently, nearly closed, and of rectangular, circular, or oval shape. With high-tension generators entirely closed slots and insulating tubes are generally used.

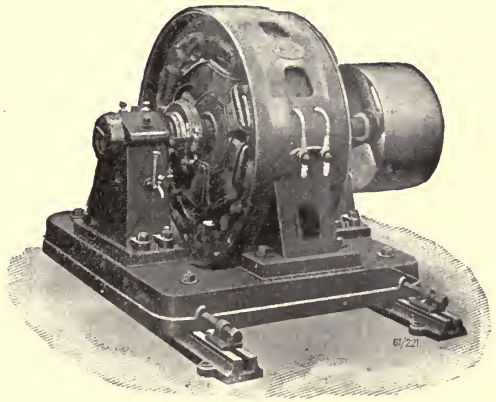

FIG. 246.—Eight-pole Inner-pole Alternator
(Brothers Körting).

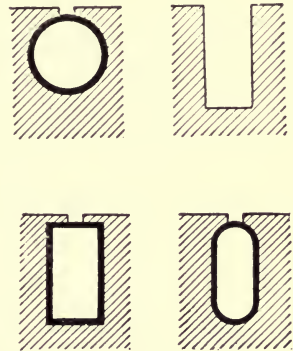

FIG. 247.—Different Shapes of Slots.

Another method of machine construction is shown in cross-section in Fig. 248. The magnet wheel consists of two halves. On the

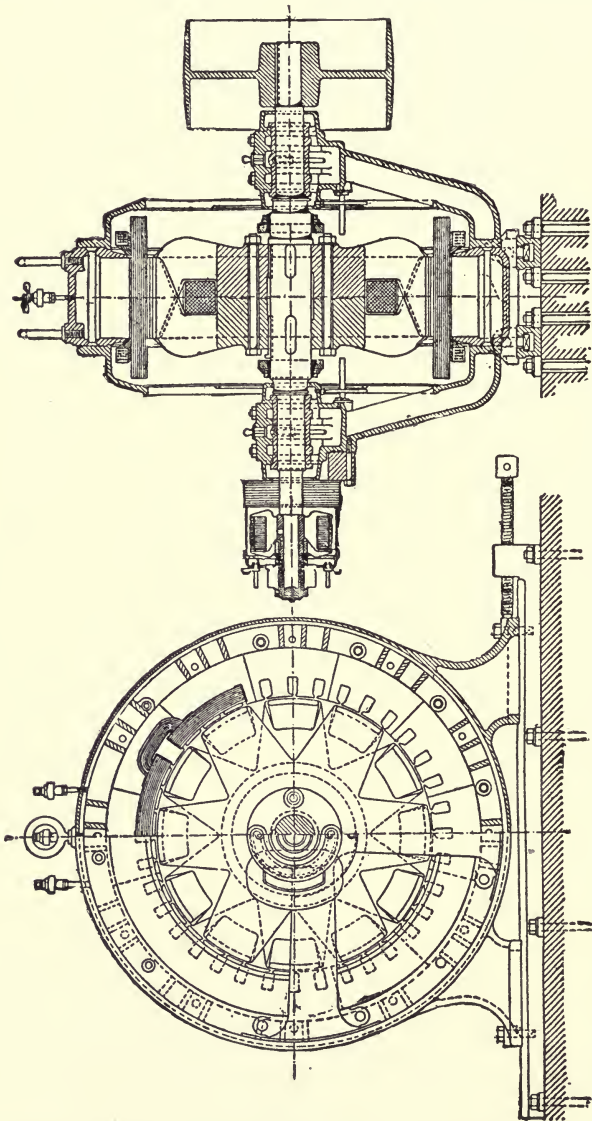

Fig. 248.—Alternator with Single Rotating Magnet Bobbin.

circumference of each half are provided tongue-shaped extensions.

arranged so that in the spaces of the right half the extensions of the left half project, and *vice versa*. These tongue-shaped extensions represent the poles. The *single field coil* is enclosed by the two halves of the magnet, and thus rotates with them. It tends to produce, in the direction of the axis of the magnet wheel, on one side north, and on the other side south, polarity. Thus the tongue-shaped extensions on the left become of north polarity, those on the right of south polarity. Since now the extensions

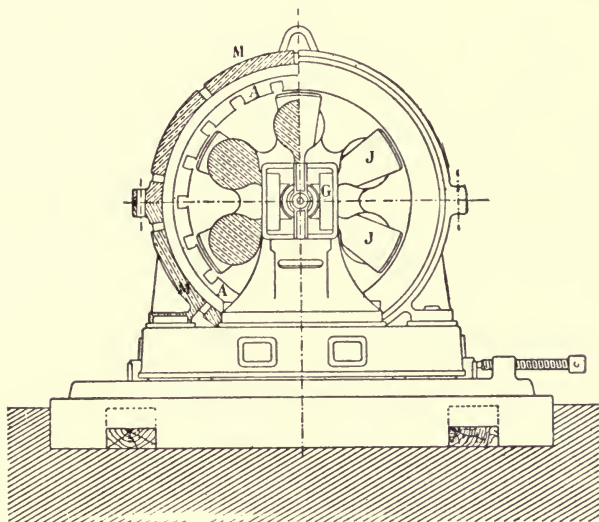

FIG. 249.—Inductor Type of Machine (*Maschinenfabrik Oerlikon*).

belong alternately to one and the other half, we have here a row of alternating north and south poles, like the magnet wheels previously described. Both these types of alternating-current machines belong therefore to the “alternating pole type.”

With both types the exciting current has to be led to the rotating part by means of slip-rings.

The formula for the E.M.F. of an alternator has been shown to be $E.M.F. \text{ (virtual)} = \frac{4.44Nn\phi}{100,000,000}$, where N = cycles per second, n = turns embracing flux ϕ , which are connected in series, where N =

revolutions of alternator per minute multiplied by the number of pairs of poles and divided by 60.

A usual winding of a single-phase alternator armature is shown in Fig. 250.

Each coil may have as many turns as desired to produce, when all are in series, the proper number of n to give the desired E.M.F. There are many forms of windings. Often, between the coils, as shown in Fig. 250, another complete set of coils is inserted using the same armature slots, the extra coils either being placed beside or above in the slot of the other windings. These extra coils have to

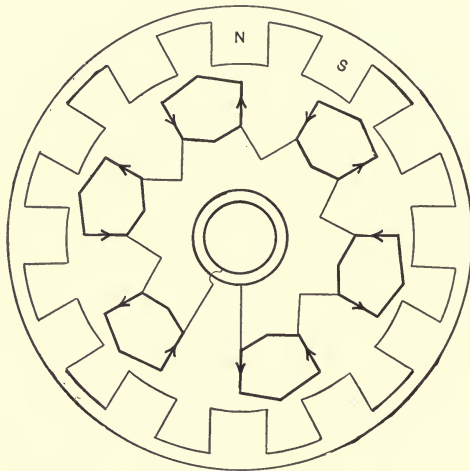

FIG. 250.—Armature Winding.

be wound left-handed, if the first are right, to put the E.M.F. induced in them in series with the other E.M.F. By this means the armature surface is more filled with wires and thus, for certain voltages, the winding is more desirable. The poles, cycles, speed, amperes, and volts regulate what type of winding should be used. Those shown are common. Such a winding as shown in Fig. 250 gives a single-phase alternating E.M.F., as shown in Fig. 217, page 218. The winding of Fig. 241, page 247, also gives the same wave of E.M.F., as do the various alternator windings. Suppose in the alternator as shown in Fig. 241, which from the collector rings as shown a wave of alternating E.M.F. is obtained, taps to the winding are made at c and d , at points at right angles or 180 degrees away from a and b . Suppose these taps are connected to two extra collector rings, what E.M.F. would be obtained from these extra rings? Obviously an

alternating E.M.F. would result independent from the E.M.F. at the rings, as shown in the figures. Obviously this E.M.F. would be alike in value to that at the rings as shown in the figures. But this E.M.F. differs in one important point. That is, it is out of phase 90 degrees with the E.M.F. from the rings as shown. That is, when the E.M.F. for $a-b$ taps is a maximum (which occurs when the taps $a-b$ are vertical in the figure) the E.M.F. from $c-d$ taps is 0 (which occurs when the taps $c-d$ are horizontal). Thus, such an alternator produces what is called a quarter-phase E.M.F. This machine is then of a class called polyphase alternators. The E.M.F.'s are as shown in Fig. 217, one phase producing the E.M.F. shown by the full line and the other the E.M.F. shown by the dotted line, differing in phase from the first by 90 degrees. Fig. 280, page 287, shows also the quarter-phase relation of E.M.F.'s or currents. If the taps on armature shown in Fig. 241 were at points 120 degrees apart instead of at

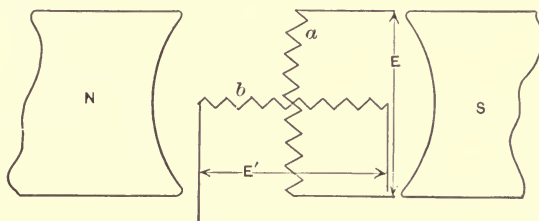

FIG. 252.—Diagram Quarter-phase Alternator.

right angles to each other a three-phase E.M.F. would be produced, the maximums of the three E.M.F.'s being 120 degrees apart in phase. This is shown in Fig. 288, the three phases being represented by a , b , and c , differing at their positive maximums by 120° . A polyphase (in this case a quarter-phase) is shown in Fig. 310.

Fig. 252 shows diagrammatically a quarter-phase alternator, the two windings a and b being shown.

The E.M.F., E and E' are produced equal to each other and reaching their maximum values 90 degrees apart. Fig. 253 shows similarly a three-phase alternator, with coils A , B , and C set 120 degrees apart in phase, that is, to have any coil give the same E.M.F. as the next the armature must turn 120 degrees.

Another way of showing this same thing diagrammatically is as in Fig. 254.

As before, the coils A , B , C are 120 degrees apart, just as in Fig. 253. There is, however, a different connection in the two cases. In Fig. 253 each coil produces the full E.M.F. of the alternator, while in Fig. 254 the E.M.F.'s are the resultants of the E.M.F. of one coil with the next, the resultants being 120 degrees apart, as the coils are. The windings of Fig. 253 are said to be connected *delta*,

from their resemblance to the Greek letter Δ , and in Fig. 254 to be connected Y or star-connected. The resultant of the E.M.F.'s A and B (any two E.M.F.'s give the same result) made by the parallelogram of forces, as has been shown, equals $\sqrt{3}$ times the E.M.F.

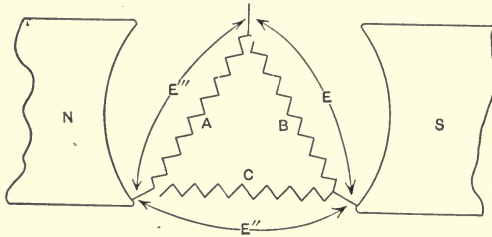

FIG. 253.—Diagram Three-phase Alternator, Delta.

of one of them. Thus, the E.M.F. of a single coil A, of Fig. 253, is $\sqrt{3}$ (equals 1.732) times the E.M.F. of a single coil of Fig. 254 (assuming, of course, the coils to be of equal turns). Thus, to change from Δ voltage to Y voltages divide by $\sqrt{3}$.

In Fig. 254 the current in the coils is the same as the current in

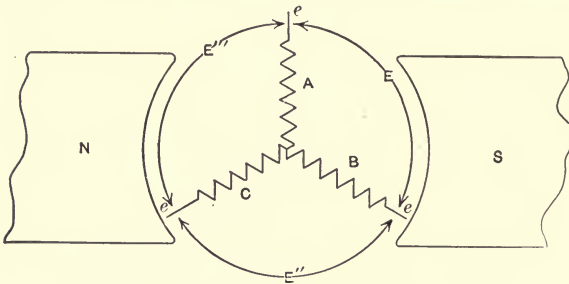

FIG. 254.—Diagram Three-phase Alternator, Star.

the lines eee running to the external circuit. This current is called the Y current. The current in the coils of Fig. 253, however, combines before going into the lines eee . Thus, the current in the coils of Fig. 253 is called the Δ current. The current in the lines is of course as before the Y current; the Y current, being the combination of the Δ currents, is larger. It is $\sqrt{3}$ times Δ current. Thus, we have in the three-phase circuits and machines Y currents and voltages and Δ currents and voltages differing by the factor $\sqrt{3}$. A three-phase winding is shown in Fig. 256.

The regulation of an alternator is influenced as in a direct-current generator by the resistance drop of the armature and by the armature

reactance. The resistance drop is calculated just as in a direct-current machine. The armature reactance, however, is a different matter. In a direct-current machine the current is a constant, and the flux produced by it is a constant, and no self-induction exists. Also a direct-current generator has a commutator upon which the brushes are shifted forward with their demagnetizing influence. With an alternator, however, the armature current is variable (a sine-curve current); hence this current must produce a variable flux and therefore self-induction. Also, the current flowing from an alternator need not necessarily be in phase with the E.M.F. created. Hence, the maximum of the current may occur after the maximum of the E.M.F.

The maximum E.M.F. is produced (see Fig. 241) when the taps $b-a$ are vertical. The current may not, if lagging, be a maximum till later, as shown at $b-a$. When vertical, the demagnetizing action of the armature is vertical between the poles, just as in a direct-current machine with the brushes at neutral point. Thus, one pole tip is strengthened and the other weakened—not constant in value, however, but naturally pulsating, due to the armature current pulsating. When the current lags, however, and the maximum comes as in the position $a-b$, shown in Fig. 241, there is a component actually opposing the flux, this being similar in effect to the shifting of the brushes on a direct-current generator. Thus, we have to lower the voltage of an alternator, the ohmic drop, the self-induction, and the armature reaction. These must be overcome by extra field current. If, instead of lagging current, the current is leading, then the armature reaction tends to help the voltage, and the field current may have to be lowered as the load comes on. Condensers and synchronous motors with strong field excitation produce leading currents.

Due to the pulsating nature of the armature reaction of single-phase alternators, the pole-pieces must be laminated to keep down the eddy currents which would be produced by the alternating flux of the armature currents near them.

To find the efficiency of an alternator, various losses must be determined and added to the output. The ratio of the output to the sum of the output and the losses gives the efficiency; that is, the ratio of the useful output to the total energy generated. The losses are, first, friction; second, core loss; third, I^2R of field; fourth, I^2R of armature. The core loss should be determined exactly as has been described for a dynamo, page 130. The normal core loss corresponding to full load should be taken at a field in the alternator to give the voltage of $E+IR$, when E equals the operating voltage of the alternator and R equals the resistance. At first thought it might be assumed that instead of R equalling the above, the impedance, which is $\sqrt{R^2+2\pi NL^2}$, as has been shown, should be used. But it must be remembered that the flux produced by the armature

ampere turns, called armature reaction, and the flux produced by the induction of the armature proper, combine with the main flux, producing actually, therefore, but one flux. This flux need produce but $E + IR$ to give E at the terminals. The armature reaction and inductance can be regarded as a tendency for pulling down the voltage met by the field ampere turns. Having measured the resistance of armature and field circuits, then I^2R losses are, of course, known, from which the efficiency of the alternator is known, being equal to output in watts divided by output in watts plus core loss, plus I^2R field, plus $I_1^2R_1$ armature.

The curve of voltage with load variation of an alternator is shown in Fig. 257. As the load increases the voltage drops.

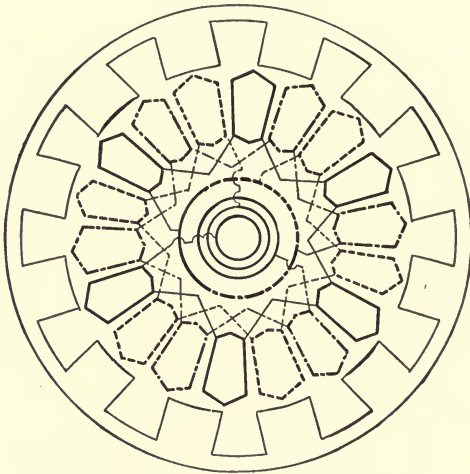

FIG. 256.

If the current of the field is increased to keep the voltage constant, the curve of field current plotted against load appears as in Fig. 258. As may be noted, the current in the field must be increased as the load comes on. The two factors that tend to lower the voltage as the load comes on are resistance and armature inductance. The resistance can easily be measured. How, now, should the inductance be measured? The inductance consists, first, of the demagnetizing effect of the ampere turns of the armature. On a pure inductive load of 90 degrees the armature ampere turns act directly, opposing the field ampere turns and in the same magnetic circuit as act the field ampere turns. Thus on 90 degrees lag the ampere turns of the field spools must have subtracted from them the ampere turns of

the armature current. On no lag the ampere turns of the armature act to produce a flux at right angles to the main flux flow of the poles. Thus, as the lag is increased, the effect of the demagnetizing

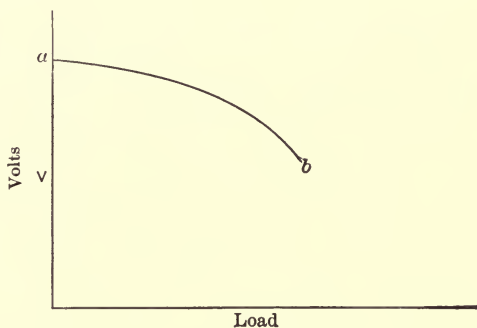

FIG. 257.

ampere turns increases, swinging around until at 90 degrees lag the armature ampere turns are actually opposing. Second, the pure inductance of the armature windings themselves has its separate influence to influence the E.M.F. The flux path of the ampere turns is not the same as that of the main flux produced mainly by the field spools, but it is a leakage circuit around the wires themselves. If the wires of the armature are embedded in slots, this path would be down one tooth, across underneath the slot, up the next tooth, across the gap, across the pole over the slot, across the gap again to the starting-point, completing the circuit. As has been shown in Fig. 237, the self-induction effect is at right angles to the current. If the current from the alternator lags 90 degrees behind the alternator E.M.F., and if the E.M.F. of self-induction lags also 90 degrees behind the current, under such conditions the self-induction E.M.F. would exactly oppose the main alternating E.M.F. in its effect. Thus, just like armature reaction, the self-induction effect swings around into exact opposition with increasing lag of alternator current. Due to this similarity, a test to combine both effects has been suggested by Charles P. Steinmetz, which most engineers now use to obtain regulation. The method consists in short-circuiting the alternator upon itself and increasing its field current until full current is flowing in the armature. Note the ampere turns in the field. Under these conditions these ampere turns are exactly opposing the armature ampere turns as well as overcoming the exactly opposing induction of the armature. This is true since when short-circuited the armature current lags practically 90 degrees behind the small E.M.F. induced to

produce, through the short circuit, full-load current. Thus, we have a direct measure in ampere turns of these values. Mr. Steinmetz gives the name of *synchronous reactance* to this value.

Having now found this value for a given alternator (this holds true for a single-phase or polyphase alternator), it should be used as any value of reactance. Then consider the use of an alternator on a non-inductive load. To calculate the regulation, let, in Fig. 259,

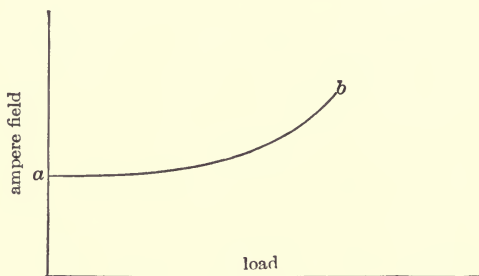

FIG. 258.

$o-b$ equal the ampere turns to produce the normal E.M.F. of the alternator E , plus the IR drop when running at normal speed no load. Let $o-d$ equal the ampere turns of synchronous reactance determined as shown. Then the resultant of them equals $o-c$, which equals the ampere turns necessary to produce normal voltage E at full non-induction load. If, when this load be thrown off, the field ampere turns be kept at $o-c$, the voltage would naturally rise above E , since $o-c$ is greater than $o-b$. The amount, then, the voltage rises divided by E gives the regulation of the alternator. This method, therefore, serves not only to determine the regulation, but gives an opportunity to find out the necessary ampere turns of field to give full load. Since it is not always practical to actually load alternators when making tests of regulation, etc., this method is very convenient and it is at the same time very accurate.

If the current flowing from the alternator be lagging, the diagram of Fig. 259 appears as in Fig. 260, when the current $o-a$ is shown lagging by the angle α and behind the E.M.F. $o-b$. In such case, plot $o-b$ as before equal to the ampere turns necessary to produce the voltage $E+IR$ at no load; plot $o-d$ as before, equal to synchronous reactance ampere turns, but in this case plot them at right angles to the current vector $o-a$, since induction is always 90 degrees away from the current. Thus, in this case the resultant $o-c$ is greater than in Fig. 260, showing that under lagging load the ampere turns required in an alternator are greater than under non-inductive load.

This same method is used to obtain regulation of transformers. It is not practical to read direct the regulation of a transformer, so instead the synchronous reactance is obtained similarly to a generator. In the case of a transformer it is short-circuited upon itself, and the

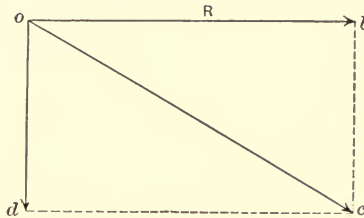

FIG. 259 —Vector Diagram. Regulation on A. C. Generator.

voltage necessary to put field current through the windings is read. This voltage is then a measure of the inductance of both primary and secondary added together. Knowing this and the resistance, and remembering that inductance in vector diagrams must always be plotted at right angles to the current and that resistance drop must be plotted in phase with the current, the diagram under load can be plotted just as has been shown in Figs. 259 and 260.

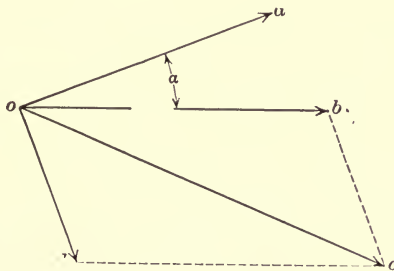

FIG. 260.—Vector Diagram. Regulation on A. C. Generator Inductive Load.

Another type of alternating-current machines is represented by the inductor type shown in Figs. 249, 261, and 262. As may be seen from the illustration (Fig. 262), the magnet wheel has no winding at all. It has on each side five (or with larger machines more) pole pieces. By a stationary coil fixed in the casing

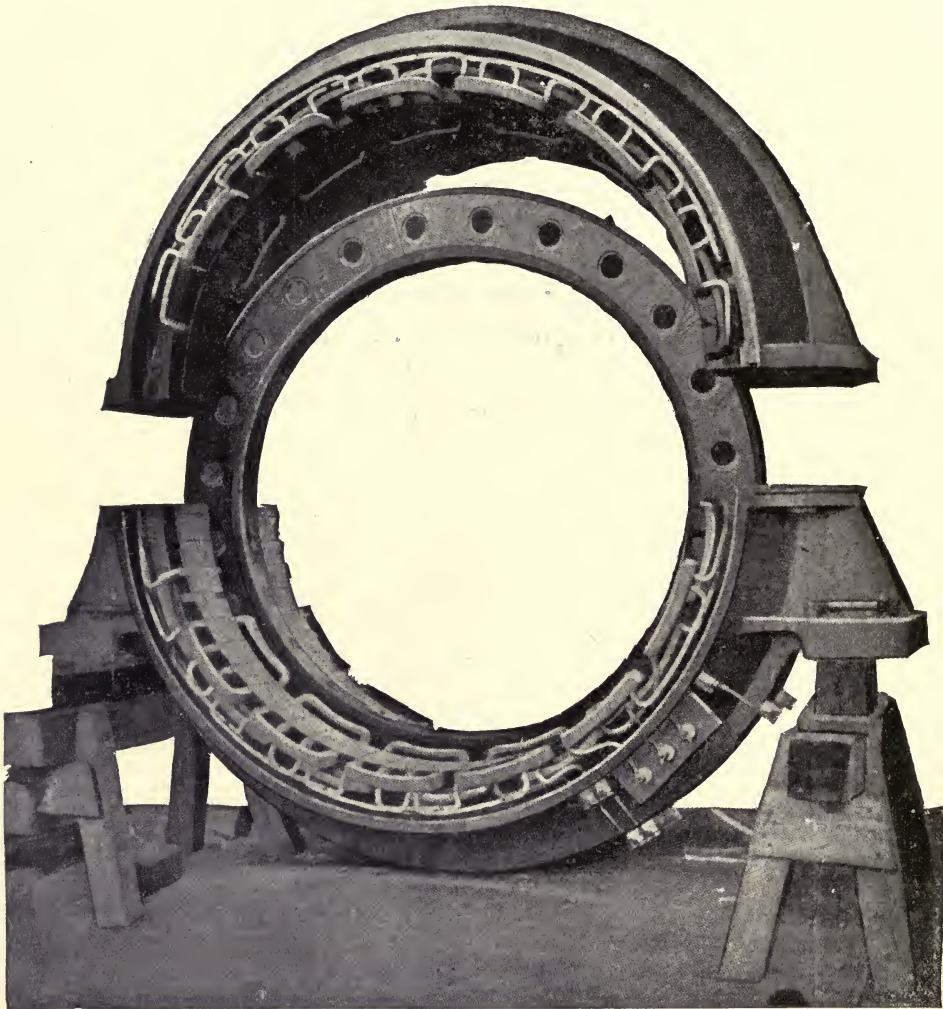

FIG. 261.—Armature and Exciting Bobbin of Inductor Machine (*Maschinenfabrik Oertikon*).

the rotating iron part is magnetized, one side with its pole pieces becoming north, the other side south, magnetic. The stationary casing contains, besides the exciting coil, two armatures, which

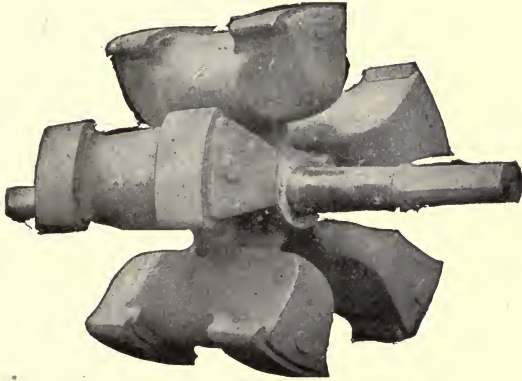

FIG. 262.—Magnet System of an Oerlikon Inductor Alternator.

are built up in the usual way with iron disks, forming rings surrounding the pole pieces of the right and left sides respectively. The two armatures are provided with windings in slots. A small continuous-current dynamo, generally fixed beyond one of the bearings, supplies the necessary exciting current.

The course of the lines of force in this machine is as follows: The lines of force, produced by the stationary exciting coil, leave the pole pieces in one, say the left, side, enter the left armature, and pass through the case—which is generally made of cast steel, sometimes of cast iron,—flow through the right armature, and from there back to the pole pieces of the right-hand side of the magnet wheel. Thus with this machine the wires are not alternately under the influence of a south and a north pole, but the wires of one half, say, for instance, those of the left, are always acted upon by north poles, those of the other half always by south poles. Hence if with this machine we connected the armature wires in the same way as we did with the alternating-pole machines—viz., always two wires which are distant by the width of one pole—the resulting E.M.F. would be nil; the reason being that the two wires connected with each other would be under the influence of a pole of the same name, and thus their E.M.F.'s would act against each other.

To avoid this we must not lead the winding from one pole to the next one, but must complete each coil by passing the winding

through the space between poles of the same name. The separate coils then may be connected in series as usual.

We want, therefore, with such a machine twice as many slots as there are poles, and only half the wires are at any moment effective in producing an E.M.F. From this it will be clear that this machine is heavier, and thus more expensive, than one of the rotating-field type of equal output. It has, on the other hand, the advantage of the absence of any rotating windings, and thus of any slip-rings. Since, however, the rotating windings and the slip-rings of a rotating-field machine do not give any trouble, this advantage is not a very important one.

The right and the left half of a continuous-pole type represent, in a manner, two separate machines, but we may as well connect their windings in series and so get the double voltage.

The most up-to-date type of alternating-current generator is that of the alternating-pole type with radial poles, which revolve. (See Frontispiece.)

Switching in Parallel of Alternating-current Machines—Synchronizer

To run two alternating-current generators in parallel, several conditions have to be fulfilled. The second machine must—as in the case of continuous-current machines,—be brought to the same voltage as the first one; it must run with exactly the same speed; and it must, at the moment of switching in parallel, be equal in phase with the first machine. The exact correspondence of speed and phase is called

“Synchronism.”

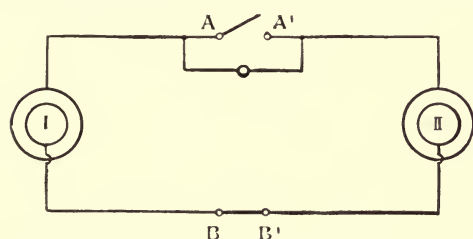

FIG. 263.—Synchronizing Lamp Connections.

With mechanical speed-measuring devices—tachometers and speed-counters—it is impossible to determine the speed as accurately as is necessary for this purpose. There is, however, a very ingenious and simple device which indicates electrically small differences in the speeds.

In Fig. 263 the two double circles represent two single-phase alternators, which can be connected by means of a single-pole switch AA' . In parallel with the latter there is connected a glow lamp which is able to stand double the voltage of either of the alternators. When the switch is open there is a closed circuit, in which the two machines and the lamp are connected in series. If the two machines were continuous-current machines, there would be only two possibilities: either they work in series, so that their voltages are added, or they act in opposition, so that the resulting voltage is zero. If both machines were designed for 110 volts, then in the first case the lamp receives 220 volts, and burns with its normal intensity. In the second case the lamp does not glow at all. On the



FIG. 264.—Westinghouse Synchronoscope.

other hand, with alternating-current machines there are between these two extremes many other possible cases. According to the phase-difference between the two machines, all voltages between double and no voltage may be given to the lamp.

If now we want to switch the two machines in parallel, we have to watch the lamp. Supposing that machine II. is running a very little slower or quicker than machine I., then the lamp will glow for one moment, and be dark the next. At the instant, when the voltages of the two machines are equal in phase, the lamp will remain dark, and at any other period, in which the phases are displaced by half a period, the lamp will burn with its maximum intensity. If two 60-pole machines differ in their speeds by four revolutions per minute, the flickering of the lamp will appear 240 times per minute. In this state the machines must naturally not be switched in parallel, but the steam-engine of the second generator must by some means—say, for instance, by adjusting the governor, be brought to the right speed. The nearer the alternator approaches the right speed, the slower the flickering will become; and when it is very slow, we can use the moment the lamp is dark again to switch the machines in parallel. The machines are then in the same phase, and will remain so, since if one machine tends to slow up it will be driven by the current of the other machine.

Instead of a lamp a voltmeter may be employed. As long as the voltmeter pointer swings quickly backwards and forwards, the machines must not be switched in parallel, but if the vibrations become very slow, the moment when the pointer is at zero may be used for closing the switch.

The arrangement of Fig. 263 has a disadvantage: the machines have to be switched in parallel at that moment when the lamp indicates no pressure. This moment is rather difficult to determine, since a 110-volt lamp becomes dark long before the voltage is nothing, generally at about 15 to 20 volts. Hence it may happen with this arrangement that the machines are switched in parallel, whilst there is still a considerable difference between the two voltages, and a sudden rush of current be caused.

To obviate this an arrangement is often employed, which diagrammatically is shown in Fig.

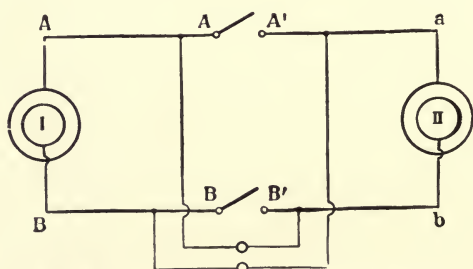

FIG. 265.—Synchronizing Lamps cross-connected.

265. The machines, to be switched in parallel, are first separated

by a 2-pole switch. Two glow lamps, each of the voltage of one of the generators are in cross-connection with the two machines, thus one lamp is connected with A and B', the second with B and A'. The current flows from the terminal A of machine I, through the upper lamp to terminal B' (b) of the other machine, through this machine to terminal a (A'), from there through the lower lamp to the second terminal B of the first machine. If both machines are in phase, A is equivalent in voltage to A', and B to B'; thus the lamp switched on A and B' will glow with the same voltage—that is, with a single generator voltage—as if it were switched on A and B. It is exactly the same with the second lamp. If the machines happen to be exactly opposite in phase, then A is equivalent to B', and B to A'; thus the lamps will remain dark. At any other phase-difference the lamps will glow, but not as brightly as when in phase. Hence the switching in parallel has, with this arrangement, to be done at the moment when the lamps are brightest, which point can be far better observed than when they are dark.

The connections described can only be employed with low voltages. For medium voltages, say 300–500, it will be necessary to use, instead of single lamps, groups of 3–5 series connected lamps.

With still higher voltages this is inadmissible. Hence, with high-tension generators, the lamps are not put in the high-tension

circuit, but small transformers are employed, to the low-tension side of which the lamps are connected. In Fig. 266 the diagram of connections is shown. If A is equal in phase with A', then the low-tension terminals of the transformers, viz. *a* and *a'*, are equal in phase. Since now *a* is connected with *b'*, and *a* and *a'* are in series with the lamp, the voltages of the low-tension coils of the transformers are added,

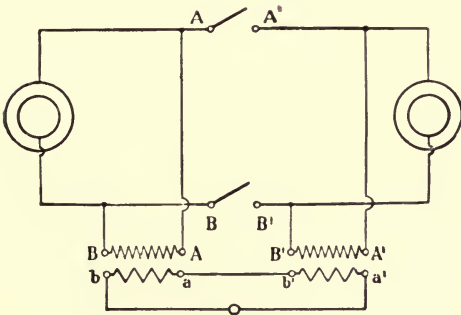

FIG. 266.—Arrangement of Synchronizing Lamps for High-tension Circuits.

and the lamp will glow with its maximum intensity. The transformers are generally designed so as to produce a low-tension voltage of 55. If, then, the machines are equal in phase, so that the low voltages of the transformers are added, a 110-volt lamp will just burn with its normal intensity. The procedure for switching in parallel is exactly the same here as with the previous arrangements.

The action of two alternators in parallel can be shown by Figs. 267 and 268.

In Fig. 267 the lines 1-2 and 1-3 represented the E.M.F.'s of the two alternators in parallel. They are drawn beside each other, but in reality are exactly superimposed. The condition represented by Fig. 267 is when the two alternators have the same wave shape, the same voltage, and the prime movers (engines or water-wheels) run at a constant speed *throughout each revolution*. Under these conditions no cross-current flows between the alternators, but each does its share of the work. Suppose the wave shapes are different. Then, as the wave of one during its generation becomes bigger or smaller than the other, a current will flow from one alternator across to the other, since they are connected directly together, the path of the

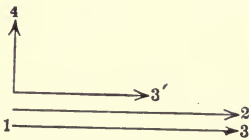

FIG. 267.

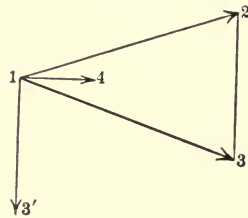

FIG. 268.

current being thus through the armature of one machine across the connecting wires between the two machines and then through the armature of the second. This effect, while it may exist, is usually negligible, and so will not be discussed here. The other, that is variation in speed during a revolution, is more serious and frequent, especially with engine direct-connected units. Under some circumstances the engine and generator may swing apart during a single revolution. This effect is shown in Fig. 268. The two voltages 1-2 and 1-3 are now swung apart as described by the angle 2-1-3. This, then, now equals the resultant voltage 2-3 (completing the triangle), which is free to create current through the windings of the two alternators, circulating around through the cross-connecting or buss wires. The line 1-3' equals 2-3, drawing it as usual in either diagram to a common centre (in this case, point 1). This represents the free voltage. The current from this voltage equals the vector 1-3 divided by the sum of the impedance of the alternator armatures in series. This circuit is inductive, since the induction is much more than the resistance. Thus, the current flowing lags much behind the E.M.F. and the current for 1-3 equals 1-4, lagging behind it by the angle 4-1-3. But this brings, as can be seen, the current 1-4 apparently in phase with the E.M.F.'s 1-2 and 1-3, and thus, since E.M.F.'s and currents in phase represent energy, this exchange of current

represents energy, and thus there is a prompt tendency by the current to pull the alternators together again. This is called synchronizing action and is what keeps alternators in multiple from falling out of step.

Suppose no swing action exists as just described, but one voltage is greater than the other. This may be shown by Fig. 267 again, where the vector 1-3' represents the difference between the two E.M.F.'s in phase with them in this case, since exact synchronism is assumed. Again, the current from these E.M.F.'s, as in Fig. 268, lags about 90 degrees from it and can be shown by the vector 1-4. This, however, is 90 degrees away from the voltage vectors 1-2 and 1-3, and thus does not represent energy, since E.M.F.'s and currents in phase represent energy, and 90 degrees apart represent no energy. Thus, the current does not tend to pull the alternators together, representing no energy. Hence, if alternators in parallel do not take their respective portions of load, altering field will not usually help matters, but the throttle and water (in case of water pans) must be adjusted. Also in removing an alternator from the busses by pulling the main switch, the current flowing cannot be cut down by lowering the alternating field, since this may actually increase the current flowing (being cross-current, not energy current, however). The arc also from breaking such a lagging or leading current is much worse than with an equal energy current, since with energy current the E.M.F. and current pass through 0 together, whereas with lagging or leading current, if one is 0 the other has value and hence gives more sparks at whatever part of the wave the break of current may occur. (With E.M.F. and current in phase, the arc is 0 if the current happens to be broken as the wave passes through 0.)

The way to withdraw one alternator from a group is to lower the driving power until the current commences to lower, keeping the alternators in phase (this takes care of itself) and the E.M.F.'s the same as the other alternators. When due to lowering the driving power by the throttle, the current dies down just as it reaches a very small value, preferably 0, the switch can be pulled and the alternator taken out of circuit. With high-tension machines, such as 10,000 volts, this method is desirable.

CHAPTER X

ALTERNATING-CURRENT MOTORS

Synchronous Motors

ALTERNATING currents have the great advantage over continuous currents that, in the stationary windings of a generator, high voltages may be produced easily and without danger, and this high pressure may be subsequently "stepped down" by stationary transformers to a conveniently low pressure.

There are different kinds of alternating-current motors. Our first thought will naturally be, whether we cannot use an alternating-current generator as a motor, as we are accustomed to do with continuous-current machines. Let us consider this case by the aid of Fig. 269, which represents the simplest type of an alternator, viz. the Siemens armature with a single armature winding rotating in a 2-pole field excited by continuous current. If through this winding we send by means of two slip-rings, a current in the direction marked by a dot and cross respectively, then the armature will tend to rotate clockwise. Now the motor wants a definite time for starting. But before it has started to move, the current has already altered its direction; thus the armature now tends to rotate in the opposite direction. With a current of 100 alternations per second no rotation of the armature will take place, but merely a vibration will be noticed, just as we have seen with a magnetic needle surrounded by an alternating current. This motor cannot, therefore, be made to start by an alternating current.

Assume now that we are able to keep the current in the direction, as marked in Fig. 269 until the armature has started to rotate and

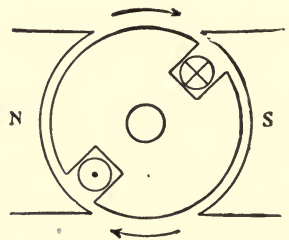

FIG. 269.

has made half a revolution. Whilst the wires are in the neutral zone again, let us reverse the current. The armature now possesses a certain amount of live energy, so that it can pass the dead points which occur when the wires are in the neutral zone. After the reversal of the current the wire which was previously under the influence of the north pole will now be under the influence of the south pole, and *vice versâ*. Since, however, the current has altered its direction, the rotation of the armature in the same direction will continue, and the armature will therefore rotate more rapidly. Obviously we must, just at the moment the wires pass the neutral zone, alter the direction of the current, or the rotation cannot be maintained.

To start a motor in this manner is naturally impossible, since an alternating current supplied for driving a motor has its normal periodicity from the beginning. Nevertheless we have learned from this consideration that, if such a motor be once brought to its full speed, it can be kept in rotation and do work. Thus we must start the motor by some auxiliary power before switching it on the mains, and bring it to its full speed—that is to say, to that speed which corresponds to the number of alternations of the current supplied. If, for instance, the latter makes 6000 alternations per minute, then we have to bring the armature to a speed of 3000 revolutions per minute, and after having made sure that the neutral armature position coincides exactly with the change of direction of the alternating current, *i.e.* that motor and generator are “synchronous,” we can switch the motor on the source of current. To ascertain whether motor and generator are in synchronism we use a synchronizer as described at the end of the last chapter.

This type of motor is called a **synchronous motor**. Any alternating-current generator can run as a synchronous motor. The speed of a synchronous motor is quite a definite one, and may easily be found from the number of alternations of the current and the number of poles of the motor. A 2-pole machine will with a current of 6000 alternations per minute run with 3000 revolutions per minute, and an 8-pole motor with 750 revolutions. If from any reason—say, for instance, a heavy overload of the motor—its speed falls off but as much as half the width of a pole, then the motor is almost instantly stopped. For, while the armature conductors are still under the influence of one pole, there are produced forces, due to the change of the current which tend to drive the motor in an opposite direction. Thus the motor is subjected to a powerful braking action, and stopped in a short time, while consuming a large current.

This type of motor has, therefore, two considerable disadvantages. It requires an auxiliary power for starting, and is stopped if, for any reason, the synchronism is destroyed. It may be compared

to a novice in cycling. He cannot by himself get on a bicycle and set it into motion, but once the machine is brought up to sufficient speed, he is able to keep it from falling. If, however, he is impeded by any obstacle in his run, he falls, and a new start has to be made with the help of an assistant.

Hence, for many purposes, synchronous motors cannot be employed at all—as, for example, for the purpose of driving shafts in small workshops having no other power at liberty for starting the motor. Likewise a synchronous motor cannot be employed in cases where frequent starting, or a strong effort at starting, is necessary, as is the case with cranes, lifts, and railways.

On the other hand, the synchronous motor has certain advantages. First of all, the speed of the motor is very uniform, a property very desirable in many cases. Further, the synchronous motor has a decided advantage over all other alternating-current apparatus, in the fact that no phase-difference between voltage and current is caused by it. We shall later on deal with other alternating-current motors, which do not require a field excited by a continuous current. These motors, on the other hand, take a considerable amount of wattless current. If a motor of this kind consumes 2000 effective watts, its apparent watt consumption might be as much as 3000. The generator has then to be designed for an output of 3000 watts, and likewise the mains have to be calculated for a larger current, much of which is useless for producing power.

Now, with a synchronous motor, the magnetization of which is effected separately by continuous current, there is no phase-difference as long as the excitation is correctly adjusted. Before switching the motor on the mains it is brought to the same periodicity, voltage, and phase as the alternating current with which it is supplied, and therefore, after the motor is switched on the mains, there is no magnetizing or wattless current flowing into the motor, the current thus being in phase with the voltage. If the motor consumes 20 amps. at 100 volts, there are 2000 watts used.

If, on connecting the motor to the mains, the excitation is too weak, so that its voltage is lower than that of the alternating current supplied, then here a wattless current would appear, since the missing magnetization has, as it were, to be supplied from an external source. A wattless current, and therefore a phase-difference, also appears when the magnetization of the motor is too strong.

It is easy to construct a vector diagram of the various values of resistance, induction, and E.M.F.'s of a synchronous motor which will illustrate why varying its field gives varying phase relation to its incoming current. The E.M.F.'s in a synchronous motor are, first, the IR drop; second, the inductance drop, which combine together to give the impedance drop in the armature; third, the E.M.F. applied; and, fourth, the E.M.F. created by the revolution of the armature in

pole-pieces and the field producing these currents. By Lenz's law the armature tends to move in such a direction to prevent the induc-

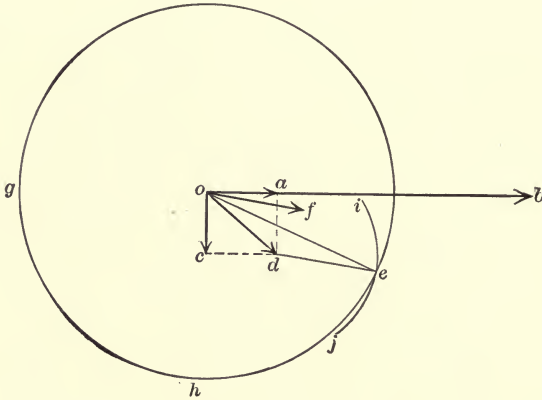

FIG. 271.

tion of the currents causing the motion. To add to this effect, poly-phase synchronous motors have wound into the pole-pieces a regular

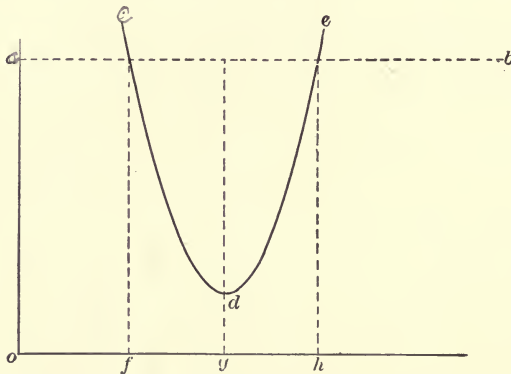

FIG. 272.

winding, which acts just like a "squirrel-cage" winding in the rotor of an induction motor. Single-phase synchronous motors are rarely used. Almost always three-phase motors are used, embodying the advantages of a fair starting torque, less pole-piece losses, and technical designing features better than the single-phase arrangement.

Synchronous motors are particularly useful for large units. The largest alternating motor in the United States to-day is a synchronous motor. It delivers 9000 H.P. This feature of the synchronous motor that at will by simple field control the phase of the incoming current can be controlled sometimes results on transmission circuits in the use of a motor running "light" solely for this purpose. A plot *at no load* of the variation of incoming current with field strength is shown in Fig. 272.

The curve *c-d-e* represents the plot of current. As may be noted, at a field current of value *o-g*, the armature current is a minimum at *d*. If the field current is reduced, the armature current commences to rise until with field current *o-f* it reaches the full-load current value *a-b*. Here the incoming current is lagging. If the field current is now increased, the incoming armature current commences to fall till it reaches its minimum at *d*. Further increase of current causes the armature current to increase till full-load current is again reached, but in this case on the leading side. The current taken at *g* is only that necessary to supply the losses of the synchronous motor running light, and is thus small in value.

The synchronous motor must have its field circuit excited by direct current. For this purpose a small direct-current exciter is belted or direct connected to the main motor. Since on starting there is no field required on the synchronous motor, the exciter need deliver no current to the field of the synchronous motor till it reaches full speed, which therefore makes feasible the method of operating the exciter from the synchronous motor field. Thus, even though direct current is necessary, the unit is self-contained, requiring only itself and the alternating energy to do its work. At starting with the armature stationary, the field spools form a secondary of a transformer of which the armature is the primary, and since the field turns are high as compared with the armature a voltage is induced in them higher than the voltage applied to the armature. Thus, it is dangerous to be near the terminals of the field at the instant of starting. Deaths have occurred from this cause. To avoid trouble, the spools may be split up at starting, or closed on the exciter, which entirely annihilates the voltage. The latter method, however, reduces the ability to start somewhat. Usually the field insulation is so designed that it will stand the high voltage induced. These motors are very generally used for a large variety of purposes in the United States.

The Rotary Converter

For reasons already known to us, alternating currents are very frequently employed for transmission of electrical energy. Now, there are many purposes for which alternating currents are inapplicable. They cannot be used for charging secondary batteries. At alternating-current central stations it is therefore necessary, even when there is a very small load during the daytime, to have one or more generators running. Also the valuable "buffer effect" of secondary batteries cannot be used in alternating-current central stations. To combine the advantages of alternating currents with those of continuous currents, the following scheme is employed in many cases for transmission of energy to long distances:—In the central station alternating current is produced and is led to a number of sub-stations distributed over the area of supply. In these sub-stations the alternating current is transformed into continuous current, and at the sub-station secondary batteries are generally employed. For certain hours the secondary batteries in the sub-stations are charged, thus providing current for the time of small demand when the machines in the central station as well as in the sub-stations are shut down.

At a sub-station, machines are required for transforming alternating into continuous current. For this purpose either two separate machines, viz. one alternating-current motor coupled directly to a continuous-current generator, which combination is generally called a **motor generator**, or a single machine, with a rotating armature, may be employed, having slip-rings on one side and a commutator on the other. A machine of the latter type is generally called a **converter**.

In both cases synchronous motors can be used without any disadvantage, for the secondary battery installed at the sub-stations will serve for exciting the synchronous motors. The procedure is quite simple. In the case of the motor generator the continuous-current generator is started as a motor by means of the secondary battery and its speed regulated until it is that required for synchronism. Then the synchronous motor is excited and the switch closed. The synchronous motor now drives the continuous-current machine, and, by more strongly exciting the latter, its E.M.F. increases above that of the battery, so that the continuous-current machine supplies current to the battery; *i.e.*, it is working as a generator. Each of the two coupled machines may be built for any voltage. For example, the synchronous motor

might be built for a voltage of 2000 or 5000, and the continuous-current dynamo for 110, 220, 500, or any other voltage.

The synchronous motor can also be started by itself, as has been explained. Under these conditions there is a large drawing of current at low-power factor (say double the normal operating current), so that the voltage upon the line is affected considerably. If this is troublesome, the starting from batteries by synchronizing can be done, which cuts out all the trouble. Another method of starting synchronous motor generator sets is to use a compensator, so that just the required amount of current is given to the synchronous motor, the line current being reduced in proportion to the ratio of the compensator. After the motor is well started, throw one switch within the compensator (or without), which gives normal voltage again to the motor. Since the maximum current occurs with the armature at rest, sometimes the motor is given a start by mechanical means provided, such as a rod inserted in holes in the shaft.

With a converter the case is different. It is impossible to use it for direct transformation of high-tension alternating into low-tension continuous current.

Any alternating-current dynamo provided with a commutator and slip-rings like that shown in Fig. 242 can be used as a converter. The armature of the converter can have either a single winding connected with slip-rings *and* commutator or two separate windings. In this latter case one of them has to be connected with slip-rings, the other with the commutator.

Both the motor generator and converter may be used for many different purposes. They can be used as (1) a continuous-current motor, (2) continuous-current generator, (3) a synchronous motor, (4) an alternator, (5) a dynamo for continuous and alternating currents simultaneously, (6) a continuous-current to alternating-current transformer, and (7) finally an alternating-current to continuous-current transformer.

Since in all these cases of the use of a converter continuous and alternating currents are either produced or transformed in *one* armature, it is clear that there must exist a definite proportion between the continuous and alternating voltage, and that, unlike the motor generator, it is impossible with the converter to transform alternating current into continuous current of any voltage. The ratio between the two voltages may be determined by the help of a simple consideration. We shall first of all consider an armature with a single winding.

In dealing with the Gramme ring, as an alternating-current armature (see p. 247), we learned that the maximum alternating voltage is produced if the windings connected with the slip-rings are just in the neutral zone. Now, this is the normal voltage of the continuous current produced by the same ring, since in this case

the brushes are always in the neutral zone. Thus we have the simple equation:—In a single-phase converter maximum alternating-current voltage is equal to the normal continuous-current voltage. We have learned that the measured or effective value of the alternating-current voltage is equal to about 0.7 of its maximum voltage. Hence, if with this converter a continuous voltage of 100 is produced, then the effective voltage of the alternating current taken from the slip-rings will be about 70.

Owing to the ohmic loss in the armature wires, the secondary voltage of a rotary converter will be somewhat smaller than that found by the above calculation. If the machine be used as a continuous- to alternating-current converter, we get, at a continuous voltage of 100, not quite 70 volts on the alternating-current side, but, according to the load of the machine, somewhat less—say 69, perhaps 68, volts only. If, on the other hand, we use the machine as an alternating- to continuous-current converter, we shall for 70 volts alternating current get less than 100 volts continuous current, perhaps only 98 or 97 volts. If there be two separate windings on the armature, the winding connected with the slip-rings having three times as many turns as that of the winding that is connected to the commutator, then to a continuous current of 100 volts an alternating current of $3 \times 70 = 210$ volts would correspond. In any case there exists a definite relation between alternating and continuous voltage which cannot be altered by the regulation of the continuous-current excitation. If for charging cells we want to increase the continuous voltage from 100 to 150, then we must increase the voltage of the alternating current supplied to the slip ring by one-half.

Since to the rotating armature of a converter alternating current has to be supplied, it is impossible to employ machines of this kind for directly converting high-tension alternating into low-tension continuous current. For this purpose a further apparatus, an ordinary or **static transformer**, is required, which first transforms the high-tension alternating current of, say, 2000 volts into a low-tension alternating current of, say, 70 volts. This alternating current may then, by a rotary converter, be converted into a continuous current of about 100 volts.

A converter is started in the same way as a motor generator. The machine is first excited, then started as a continuous-current motor, and, as soon as it is running in synchronism, it is switched on the alternating-current circuit.

Often converters are started from the A.C. end when they are not single-phase. As a matter of fact, single-phase converters are rarely used in the United States. Three-phase converters are almost universally used. Like the polyphase synchronous motor, a three-phase converter will start from its own A.C. current. About 30 to 40 per cent. normal voltage is required. When this is applied the

rotary will quickly come up to speed, drawing from the line about double current. There is practically no sparking at the D.C. brushes under these conditions. Sixty-cycle rotaries, due to their very small armature reaction, draw more current from the line than do 25-cycle. The ratio of A.C. to D.C. voltage in a three-phase rotary is different than that of a single-phase. Consider Fig. 273.

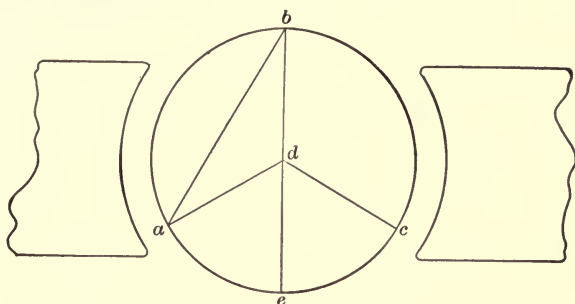

FIG. 273.

Let the letters a , b , c represent the points where the A.C. taps are connected to the winding, for, as has been stated, a three-phase rotary converter consists simply of a D.C. generator (with commutator and brushes) having taps in its winding at three equidistant points which are connected to three collector-rings. Into these collector-rings three-phase current is given, and out of the commutator direct current is taken.

Let the armature be in the position shown. The D.C. brushes, being at b and e , $b-e$ equals the direct-current voltage and the maximum A.C. voltage of a single-phase converter. Thus $b-d$ equals one-half the D.C. voltage. In the triangle $b-d-a$, the value $b-d$ equals $d-a$ is thus known, as well as the angle $b-d-a$, and the angles $a-b-d$ and $d-a-b$ are equal. Thus the line $b-a$ can be found, but $b-a$ represents the three-phase voltage of the converter; *i.e.*, the voltage

between collector-rings. $b-a$ equals $\sqrt{3} \times b-d = \frac{\sqrt{3}}{2} \times b-e$. But $b-e$ equals the maximum of the single-phase voltage. Thus, the virtual E.M.F., or the square root of mean square voltage, $b-a = \frac{\sqrt{3}}{2} \times \frac{b-e}{\sqrt{2}}$,

since the ratio of maximum to virtual equals $\sqrt{2}$, as has been shown. Calling voltage $b-e = E$ the D.C. voltage, we get the A.C. voltage between collector-rings (equal $a-b$, Fig. 273) equals the D.C. voltage

E multiplied by $\frac{\sqrt{3}}{2\sqrt{2}} = 0.612E$. Assuming the converter to be of

100 per cent. efficiency, the input equals the output. In a three-phase circuit the input is, as will be shown later, $E'I\sqrt{3}$. The D.C. output is, as has been shown previously, IE when E' equals the alternating E.M.F. between collector-rings, I' the current in the line to the collector-rings, and E and I the D.C., E.M.F., and current.

Thus, $E'I\sqrt{3}=EI$. But $E'=E\times\frac{\sqrt{3}}{2\sqrt{2}}$. Thus, $\frac{E\sqrt{3}I'\sqrt{3}}{2\sqrt{2}}=EI$, or

$$I'=\frac{2\sqrt{2}}{3}I=0.943I.$$

Since the efficiency is not 100, but nearer 94, the current I' in the A.C. line has not only to supply the output but the losses. This I' is about 6 per cent. more than the above, or about equal to the D.C. current. Thus, in a three-phase converter the A.C. and D.C. currents are about alike. Since both the A.C. currents and the D.C. current flow in the same wires in the armature, and since under such conditions there cannot be two separate currents actually, it follows that they must combine. Since also the A.C. currents act as driving power and the D.C. as energy given out, it follows that these two currents tend to flow opposite in direction and thus tend to neutralize each other. We thus have in the windings of a rotary converter D.C. and A.C. currents in opposition. It can be expected that since one current has a sine wave in shape and the other a steady value that this combination is rather complicated. Without covering the matter in detail, it has been found that the resulting current in a three-phase converter, when squared (this representing the heat produced in the windings) is $58\frac{1}{2}$ per cent. of the square of the D.C. current. This value allows for the efficiency of the converter. From this it can be at once seen that a rotary of a given size will heat less than a D.C. machine of the same size, and thus a rotary is smaller for the same heating and therefore cheaper than a D.C. machine, which is true. In addition to this, it is apparent that since the A.C. current flows in one direction and the D.C. in the other, that there is no armature reaction, and thus no brush shift is required with change of load. Thus, a rotary must be better in commutating characteristics than an ordinary D.C. machine. As a matter of fact, rotaries require no shift of brushes and will carry three times normal load without difficulty. They are thus especially suitable for railway lines when excessive load may momentarily come on.

Since the A.C. end of a rotary acts just like a synchronous motor, it naturally follows that the phase of the entering current can be altered by altering the field strength, a leading current resulting from strengthening the field and a lagging from weakening it. Advantage is taken of this in rotaries to regulate the D.C. voltage. A series field is placed on the rotary, and as the D.C. load comes on the field is strengthened. As it strengthens the A.C. current comes

more and more leading, holding up the voltage. To increase the effect, inductance is inserted in the A.C. lines, and since A.C. current in passing through inductance raises the voltage if the current is leading, a combination of inductance and field strength may be chosen, so that a constant or rising D.C. voltage will result. Thus, rotaries can over-compound on their D.C. ends just as ordinary D.C. machines.

Rotaries are extensively used in the United States for sub-stations to supply lights or power. They are low in cost per kilowatt and capable of large overloads and in general are very important adjuncts in electrical distribution of power.

Commutator Motors

The question may be asked, Is it possible to run a continuous-current motor with alternating current?

We are acquainted with the fact that the direction of rotation of a continuous-current motor remains the same if we change the mains leading to the motor (p. 145), for the reason that both the magnet field and the armature current change their direction. It must hence follow that we are able to get motive power from a continuous-current motor supplied with an alternating current. Naturally the magnet system of the motor must not be solid, but must, like all cores of alternating-current magnets, consist of insulated iron disks. Otherwise its construction is quite similar to an ordinary continuous-current motor. Commutator motors are generally built as series motors.

Let us now consider the starting of the motor. The motor has to be switched on the alternating-current mains. Armature and magnet coils are then traversed by the same current. The armature wires in the magnetic field tend now to turn the armature in a definite direction—say, for instance, clockwise. The armature is therefore turned a little, but before it has turned through one revolution the direction of the armature current is altered. At the same instant the direction of the magnet current is also altered. The effect after the change of the current direction is the same as it was before; *i.e.*, the armature is turned again clockwise, and thus the motor will start. Since, however, the armature windings short-circuited by the brushes are traversed first by a negative, then by a positive current, these motors, on starting, violently spark, and sparkless running is difficult or impossible to obtain.

Alternating D.C. motors have characteristics similar to D.C. motors, differing only in this fact, that the current lags behind the applied E.M.F. to the motor, which condition cannot, of course, apply

to D.C. motors. Thus, the line drop in the transmission is greater than with D.C. motors, since, as has been shown, the line drop is greater the greater the lag of current for a given condition of the line. Also the generator must be large to furnish this lagging current and must be better in regulation. In spite of the sparking tendency, which is excessive at starting, this type of motor has been introduced, and roads are now operating using them. In order to reduce the sparking resulting from the pulsating flux through the armature coil short-circuited by the brushes, the leads to the commutator are made high in resistance, increasing the resistance of the circuit in which the short circuit acts. By this means the motors are made operative. More attention must be given, however, to the commutator to keep it in good running condition. On railway lines a good deal of coasting is done by the cars, during which time no current is flowing into the motor. During this time the commutator gets polished up by the brushes, partly or wholly, depending upon the condition of the injury done by the sparking when current is flowing into the motors.

CHAPTER XI

MULTIPHASE ALTERNATING CURRENT

Induction Motors—Rotating Field

NEITHER of the two alternating-current motors described in the last chapter is so simple in some respects as the continuous-current motor. Whilst the alternating-current generator and transformer are far simpler than the corresponding continuous-current appliances, with the motor the contrary would seem to be the case.

It is important now to point out that we can, with alternating currents, produce motion by availing ourselves of the effects of induction. We have seen this with a metal ring which was repelled by an alternating current flowing through an electromagnet. On switching the coil in circuit the ring was pushed upwards, on stopping the current the ring fell down.

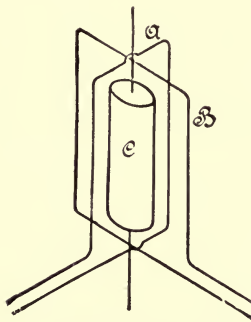

FIG. 274.—Production of Rotating Field.

An up and down motion of this kind is insufficient for a motor. What we want is a means of producing rotating motion.

The Italian electrician *Ferraris* found that by two alternating currents differing in phase a rotating field can be produced. Fig. 274 shows two coils, A and B, whose windings are at right angles to each other. These coils are traversed by alternating currents which differ in phase by 90° .

Either of these coils in itself would produce a pulsating field, but the two coils together produce a rotating field.

A simple experiment with a freely suspended stick, or, still better, a stone suspended by a string, gives us a corresponding example, and will make the matter clear. If we push such a pendulum from its position of rest, then it will swing to and fro. A *complete*

movement from, say, the left to the right and back to the left is called a **period**. If, from its position of rest, we push the stone from us, it will then take up a swinging motion from front to back, which differs from the first vibration in direction only, but not in the kind of motion. If, now, we push the pendulum, firstly, from its position of rest towards the right; and, secondly, after a quarter-period—that is, after it has made half an oscillation, being, therefore, in its extreme position to the right—we push it forwards, we shall observe that the pendulum takes up a rotating motion. It swings no longer in a single plane, but in a circle. The motion in a straight line has been changed into a rotating motion.

It is essential for the second impulse to take place in a direction which is at right angles to the first impulse, and also that the time when the second impulse takes place is a quarter of a period later than that of the first impulse. If, whilst the pendulum is swinging from left to right, we strike it in the direction from front to back just at the instant it passes its lowest position, we do not now get a rotating motion of the pendulum, but it will swing in a direction between the directions of the two impulses.

Similarly the two coils in Fig. 274, each of which alone is capable of producing a pulsating field, are able to set up a rotating field, provided that they are traversed by two alternating currents, the phase-difference between which is a quarter-period. We know that the direction of a field is that indicated by a freely movable north pole. Let us now imagine a north pole under the influence of coil A (in Fig. 275 the coils are shown more distinctly in cross-section). The coil A tends to drive the north pole at right angles to its plane from left to right—that is, in the direction of the single-barbed arrow. Coil B alone will try to drive the pole from front to back in the direction of the arrow with two barbs. If, now, the currents differ by a quarter-period, exactly the same will take place as with the pendulum. The pole will rotate.

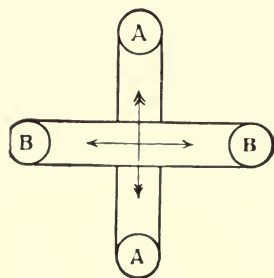

FIG. 275.

What influence will this rotating field exert on a metal cylinder, C, suspended in its interior?

A magnetic field rotating about a conductor produces, as we know, in the latter an E.M.F., and if there is a closed circuit, electric currents result. These currents have their direction so as to resist any motion, following Lenz's law. In the metal cylinder C, in Fig. 274, such currents will be produced. These currents, *first*, tend to weaken the primary field (just as the currents in the secondary coil

of a transformer do), and, *secondly*, they resist the motion of the field, which will rotate as long as the primary currents differ in phase by a quarter-period. The metal cylinder within this field will be acted upon in a certain way. Consider for a moment what happens to any one who tries to stop a heavy and fast-moving carriage by taking hold of it. The attempt will be a failure, for he will be carried along with the vehicle. In the same way, the armature C, which resists the rotating motion of the field without being able to stop it, will be taken with the rotating field, *i.e.*, it will be turned round its axis.

Hence there will be a tendency to turn the armature with the same speed as that with which the field is rotating. This state can, however, never be perfectly reached, for if the armature ran in synchronism with the field, the effect on the armature would be the same as if field and armature were at rest, and no current could be induced in the armature. The result will be that the armature can now no longer exert any force, and it will slow up owing to the frictional resistances. As soon as this happens, the armature is again crossed by lines of force, a current is again induced inside, it exerts a force, and thus is able to overcome the frictional resistances. The greater the load becomes, the slower the armature will run in comparison with the speed of the rotating field. The consequence will be that stronger currents are induced in the armature, enabling it to overcome the heavier load. The armature currents have a further important action—they also tend to weaken the primary field, and this will now, just in the same way as the primary coil of a transformer, take more current when it is connected with a source of constant voltage. Hence we observe that the behaviour of this kind of motor is very similar to that of continuous-current shunt motors.

Motors depending on this principle are called **induction motors**, or **asynchronous motors**. They are called asynchronous because their working principle depends on the fact that they do *not* run synchronously; but their speed is less than the speed of synchronism.

The amount the armature speed of an asynchronous motor is less than the speed of rotation of the field is called the “**slip**.”

We shall now deal with the construction of a 2-phase induction motor. To obtain sufficiently strong magnetic fields, both the outer and inner parts have to be built up from the iron disks, and the windings have to be laid in slots. We have here two circular parts, the cores of which are built up like that of a continuous-current armature. In its simplest form (see Fig. 276) the outer stationary armature, called the “**primary armature**” or “**stator**,” has four slots. Into every two opposite slots, AA and BB, the coils are laid which correspond to the first and second phase respectively. On the circumference of the inner, rotating armature, or so-called **rotor**, there are a number of slots or holes through which wires are drawn.

These wires can be connected with each other in many different ways. One method of connection is shown in Fig. 277, which represents the type called a **squirrel-cage** rotor. At the front and the back of the armature all the wires are connected by copper rings.

If on the stator there were the coil A only, and this coil were traversed by a continuous current in the direction marked in Fig. 278 by a cross and dot respectively, it would produce a magnetic field as shown in this figure. The lines of force leave the left part of the stator and enter the right part, making the former a north and the latter a south pole. If the coil has an alternating current passing through it, then at a certain instant the left part will have the strongest north,

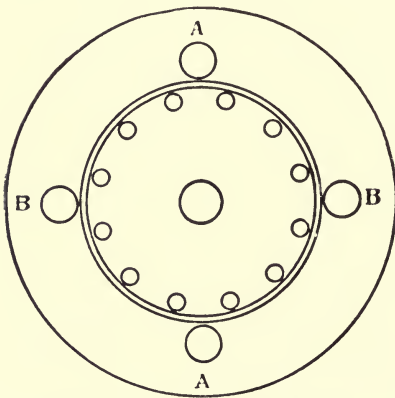

FIG. 276.—Two-phase Motor.

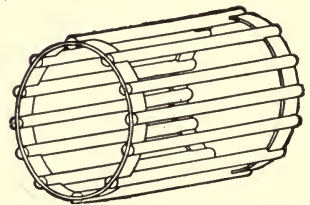

FIG. 277.—Squirrel Cage.

and the right part the strongest south, magnetism. The magnetism will then gradually become weaker, until it is reduced to nothing, then it will be reversed, and so on. Similarly coil B alone, if traversed by a continuous current in the direction marked, would cause the lower part of the outer armature to become a north, and the upper part a south pole (see Fig. 279), whilst with alternating currents the polarity would continually be reversed.

Now coils A and B are simultaneously supplied with alternating currents, which differ in phase by a quarter-period. Hence, if the current in A is a maximum, that in B will be a minimum or nothing. It is as if coil B did not at this moment exist. A only produces magnetism, say, for instance, a north pole on the left. Now, the current in A decreases, whilst that in B increases (see the wave-lines in Fig. 280). Hence A continues to produce a north pole on the left, B tends—firstly in a weak, but later in a stronger manner—to produce a north pole at the bottom. Both actions are therefore combined, and there will appear a north pole at the left

lower quarter, which will be lower in position the stronger the current is in B, and the weaker it is in A. After a quarter-period

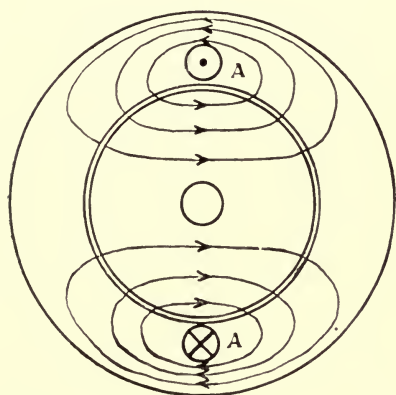

FIG. 278.

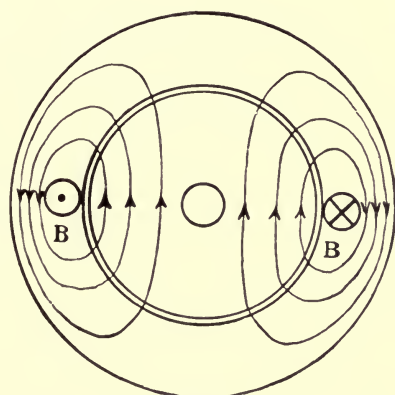

FIG. 279.

the current in A becomes zero, whereas the current in B is now a maximum, and thus the north pole is produced only by the latter. The current in B now decreases, and the current in A has changed its direction, and tends to produce a north pole at the right. By the com-

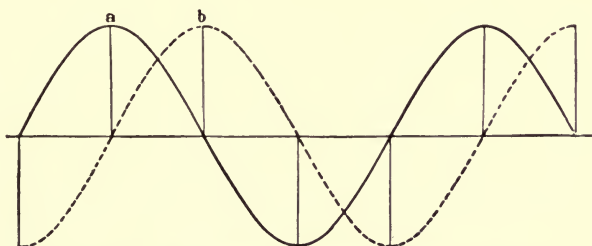

FIG. 280. —Two-phase (or Quarter-phase) Current.

bined action of the coils A and B, the north pole will now travel from the bottom to the right; and again, after a quarter-period, the north pole will be produced on the right-hand side, since at this moment the current in B becomes zero again. We have therefore in the stationary outer armature a rotating magnetic field, which makes a quarter of a revolution during each quarter-period of

the current, and a whole revolution during each complete period. This rotating field produces currents in the conductors of the squirrel-cage, causing it to revolve.

The speed of the rotor differs but little from the theoretical speed of the rotating field. If, for instance, the current flowing in the stator makes 6000 alternations—that is, 3000 periods or cycles per minute, then the rotor will make nearly 3000 revolutions per minute. If the motor is not loaded, and the armature therefore has to overcome only the frictional resistance in the bearings, then even with the most accurate speed-counters no difference between the speed of the field and that of the motor can be measured. On the other hand, if the motor is loaded, its speed will fall down to about 2900, 2800, or even 2700. The motor has then a slip of 100, 200, or 300 revolutions, or expressed as a percentage of 3, 6, or 10 per cent.

The windings considered have 2 poles. Two-pole induction motors are seldom used. Generally the motors are, according to their size, wound with four, six, eight, or more poles. The diagram of a 4-pole 2-phase motor is shown in Fig. 281. The least number of slots required in this case is eight. We may then have two coils in each phase, as shown in Fig. 281, or four coils in each phase, as shown in Fig. 282, the former winding corresponding to a consequent pole winding, as in the case of some direct-current machines. The coils are wound so that each of

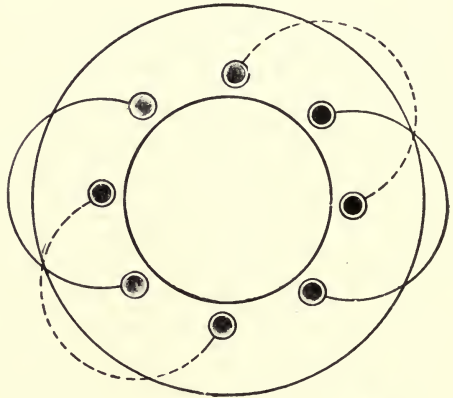

FIG. 281.—Four-pole Two-phase Motor.

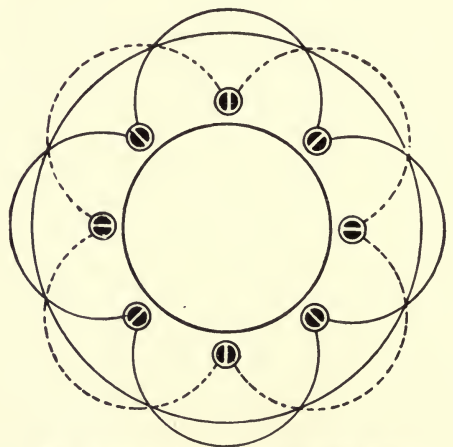

FIG. 282.—Four-pole Two-phase Motor.

them tends to produce in the part it surrounds the same polarity, say, for instance, each a north pole. Then, in the left- and right-hand parts, north poles are produced by the coils, marked by full lines, and therefore, as consecutive poles, south poles will appear in the

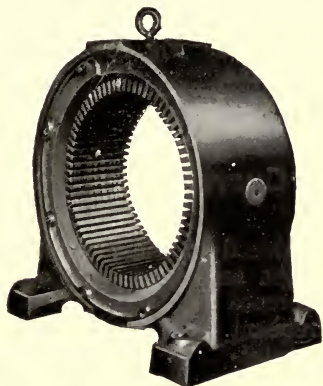

FIG. 283.—Primary Ready for Winding.

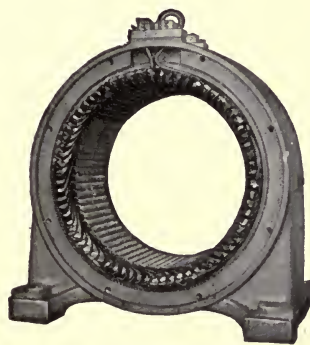

FIG. 284.—Primary Completely Wound.

upper and lower quarters. The second phase (represented by the winding which is marked by dotted lines) produces also a 4-pole field, which here lags behind the first field by an eighth of the whole

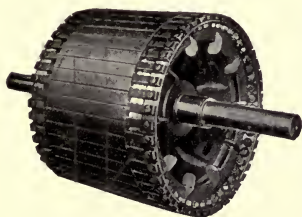

FIG. 285.—Secondary Complete.

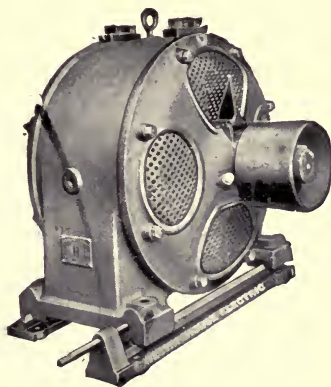

FIG. 286.—Type C Motor Complete.

circumference. Thus, each quarter-period of the current will correspond to $\frac{1}{8}$ revolution of the rotating field. Two periods of the

current correspond to one revolution of the field, and 3000 periods to 1500 revolutions of the field, and nearly 1500 revolutions of the armature. A 6-pole motor will run with a speed of nearly 1000, an 8-pole with nearly 750, and a 12-pole with nearly 500 revolutions per minute.

Fig. 283 shows the field of a 2-phase motor ready for winding. Fig. 284 shows the field completely wound. Fig. 285 is the wound rotor, and Fig. 286 is the complete machine.

Three-phase Current

A rotating field can also be produced in other ways than by the method of two windings at right angles to each other, and traversed by currents with a phase-difference of a quarter-period. The most frequent arrangement employed for producing rotating fields is that with three windings, with an angle of 120° between each other (in a 2-pole field), when through these windings three alternating currents are passed, each of which has a phase-difference of one-third of a period with reference to the two other currents.

In Fig. 287 the three coils A, B, and C, and in Fig. 288 the courses of the three respective currents *a*, *b*, and *c* are shown. The dotted wave-line *b* is one-third of a period behind the full wave-line *a*, but is in advance by one-third of a period of the wave *c*,

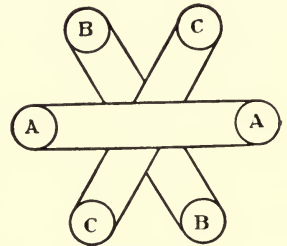

FIG. 287.

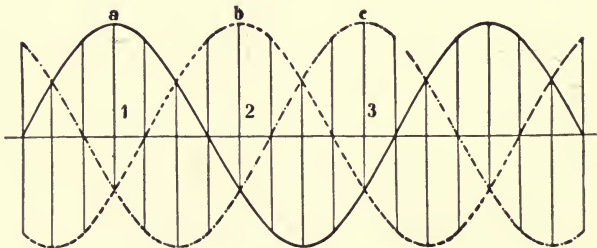

FIG. 288.—Three-phase Current.

represented by a line made of up dots and dashes; hence *a* remains behind *c*, but runs before *b*. At a definite moment 1 (see Fig. 288

the current will be strongest in A (see Fig. 287), thus tending to produce a north pole above (south pole below). In B and C currents are also flowing, but these are not so strong as that in A. These coils are arranged so that, at the same moment, B tends to produce a north pole to the right above, and C also a north pole to the left above. The action of these three coils is represented in Fig. 289 by three arrows of different length.

We may compare this with a coach having three horses, the middle the strongest, which pulls straight forward, whereas the weaker horses also pull forward, but at the same time towards the right and left respectively. The pulling of one horse to the right and the other one to the left does not cause a deviation of the coach at all; yet the vehicle will be drawn with greater force than if the middle horse, although it is the strongest, had alone been in harness. Hence we have at this instant the strongest north pole at the top.

Next, the action of the coil C increases gradually, since, as we see from the wave-line, the current c grows, whilst at the same time the currents in A and B decrease. After a one-third period, when the

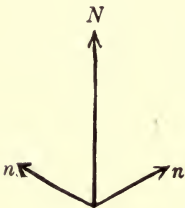

FIG. 289.

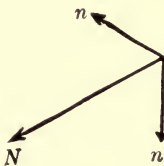

FIG. 290.

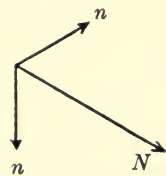

FIG. 291.

currents have the values as indicated in Fig. 288 by the vertical line 2, \bar{o} has reached its maximum value. Since it flows now in an opposite direction, it produces a north pole in the direction to the left, and downwards (see Fig. 290). Also the current in phase A has changed its direction, whereas the current in phase C has kept its direction. Hence B, which now predominates, produces a strong north pole below on the left, whereas A tends to produce a pole of the same name right at the bottom, and, finally, C makes a north pole above on the left side. It again resembles a vehicle with three horses. The north pole will appear on the left below in the same strength as it was previously above.

One-third of a period later (see Fig. 291) the north pole will have wandered towards the right, and again, after one-third of a period, upwards. Hence, in a third part of a period the field makes the third part of a revolution, and in a complete period an entire

revolution, exactly as in the case of the 2-phase rotating field. The effect of a 3-phase field is, therefore, equal to that of a 2-phase field. The combination of three currents, the phases of which differ by a third of a period, is called a **rotary or three-phase current**.

A rotating field may also be produced with six coils, which are arranged so that the angle between any two coils is 60° , and which are traversed by currents displaced by a sixth of a period from each other.

As with 2-phase motors, 2-pole windings are very seldom employed with 3-phase motors. With a 4-pole winding the distance between two coils is naturally not equal to the third, but to the sixth part of the circumference. The winding diagram of a 4-pole 3-phase motor is shown in Fig. 292. The consequent-pole winding, previously described, is also employed here. The two opposite coils AA belonging to one phase are connected with each other in such a way as to produce, for instance, in the part enclosed by the coils north poles, and in the parts not enclosed, consequent south poles.

The squirrel-cage may obviously also be used as a rotor for 3-phase motors. Generally 2- and 3-phase motors do not differ in their mechanical construction, but merely in their winding. Without considering the

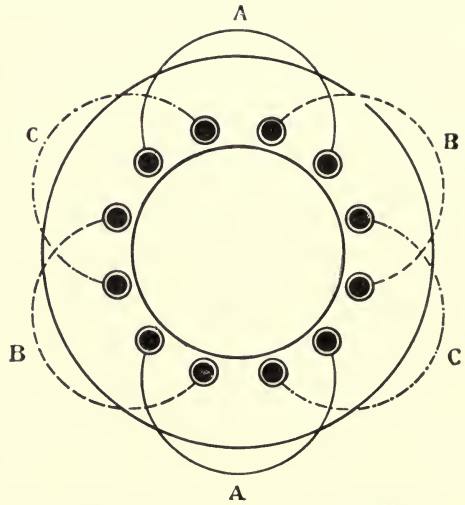

FIG. 292.—Four-pole Three-phase Motor.

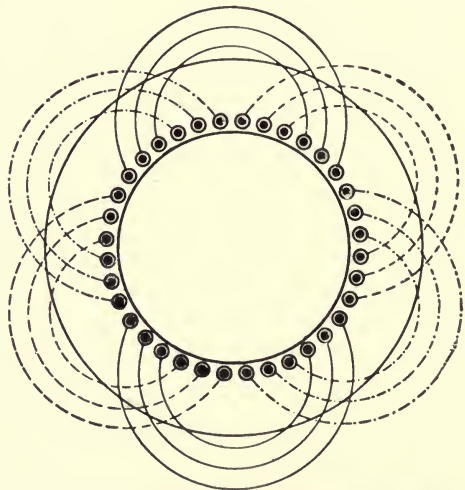

FIG. 293.—Four-pole Three-phase Motor, with Three Slots per Pole and Phase.

Without considering the

winding and slotting of the stator, a 2-phase motor cannot be distinguished from a 3-phase motor.

With regard to slots there is a difference between 2- and 3-phase motors, inasmuch as with a 2-phase motor at least two, and with a 3-phase motor at least three slots per pole are required. The coils may, if desired, be laid into any larger number of slots; say, for instance, 2, 3, 4, or more, as shown in Fig. 293.

Actions in Induction Motors—Squirrel-cage and Slip-ring Armatures

The induction motor armature as hitherto described is distinguished by utmost simplicity. A squirrel-cage rotor is little more than a number of wires short-circuited on themselves. No current has to be led to the rotating part from outside, consequently no slip-rings are required. This is, of course, a great convenience. But this type of armature has one great disadvantage: after it has once been started it is found to work well, but in starting it causes trouble.

If by closing a 3-pole switch we connect the stationary winding of a 3-phase motor with the mains, then the armature, whilst at rest, corresponds to the secondary winding of a transformer, although the actual construction is very different to that of an ordinary transformer. Again, the field does not pulsate like that of a common transformer, but rotates. This rotating field produces electro-motive forces both in the stationary windings (primary windings of the transformer) and in the rotor winding. The back E.M.F. now produced in the stationary winding is, like that of the primary coil of a transformer, nearly equal to the terminal voltage supplied, so that only the magnetizing current flows in the primary winding when the secondary windings are not short-circuited.

It may be remarked that the magnetizing current of a motor must be far larger than that of a transformer. For the lines of force do not here only flow through iron (see Figs. 278 and 279), but have twice to pass air gaps. Now, although the space between rotor and stator is kept as small as possible, a much greater number of magnetizing ampere-turns is required than is the case with a magnetic flux having a path entirely of iron.

On starting the motor the field rotates with full speed round the still stationary armature. Hence, in the short-circuited armature winding an excessive current will be produced, which reacts on the

primary field of the stator with the effect of so weakening it that a large current flows to the stationary windings from the mains. This lasts only a short time, for the current flowing in the rotor winding causes the rotor to start with considerable turning effort, so that it rotates very quickly. The quicker the rotor runs, the nearer it approaches the speed of the rotating field, and the fewer lines of force it will therefore cut. Consequently the E.M.F. and the current induced in the armature decrease, the reaction on the field becomes smaller, and the stator absorbs less current.

To give a numerical example, a motor which is designed for a current of 30 amps. will, if running at full speed unloaded, absorb a current ("no-load current") of about 10 amps. It must not be thought that the motor really requires one-third of the maximum energy for running without load. The phase-difference is (as with the unloaded transformer) great, and the power factor is equal to about 0.2 or 0.3, so that the watts taken by the unloaded motor are about $\frac{1}{10}$ or $\frac{1}{15}$ of the watts taken at full load.

At the moment of starting, the current will be large, perhaps as much as 90 or 100 amps., which is about three times the normal current. This is a great disadvantage in a motor with a squirrel-cage armature. With very small motors up to about 1 H.P., sometimes even with rather larger motors, such a sudden rush of current might be allowable; on the other hand it is clear that if a 20-H.P. motor requires three times the normal current at starting, this would be very objectionable, especially when lamps are also on the motor mains.

To avoid these sudden rushes of current, we must not short-circuit the windings of the rotor, but connect them with slip-rings, so that resistance may be inserted in the rotor circuit.

With slip-ring motors the rotor winding is similar to that of the stator. For a 3-phase motor it may be 2-, 3-, or poly-phase. Supposing it to be 3-phase like the stator winding, then we can connect the phases either in star or in mesh, and lead the ends to the three slip-rings. The slip-rings are provided with brushes, and from them cables lead to the three regulating resistances, which may be connected either in star or mesh, and generally are switched in or out by means of a single lever. If with an open rotor circuit we connect the stator winding with the mains by using a 3-pole switch, then in the rotor winding an E.M.F. is, of course, induced; but since the rotor circuit is not closed, no current can be produced. Hence the rotor does not exert a weakening reaction on the stator. Through the latter, therefore, only the magnetizing current will flow—that is, a current equal to only $\frac{1}{3}$ or $\frac{1}{4}$ of the normal current.

Round the armature a magnetic field—say, for example, a 4-pole one—is rotating with a speed of about 1500 revolutions per minute. The effect is the same as if the rotor were the stationary

armature of a generator about which a 4-pole field rotates. In the armature electro-motive forces, but no currents, are induced until the outer circuit is closed. Immediately we close the switch and connect the external circuit, currents flow through the armature and the resistances, and these currents cause the armature to rotate. The resistances ought, of course, to be so selected that the currents in the armature and in the stator do not exceed the normal currents.

When the armature is set into rotation, the E.M.F. induced in it becomes smaller than that previously induced in the stationary armature, and if the regulating resistance be diminished the armature will gain speed. We can then gradually diminish, and finally short-circuit the resistance when the armature is nearly synchronous with the field. Hence, when actually at work under a load there is no difference between a "short-circuit" and a "slip-ring" armature, since the windings of the slip-ring armature are short-circuited, finally. Different windings of a 3-phase motor armature suitable for use with slip-rings are shown in Figs. 294 and 297.

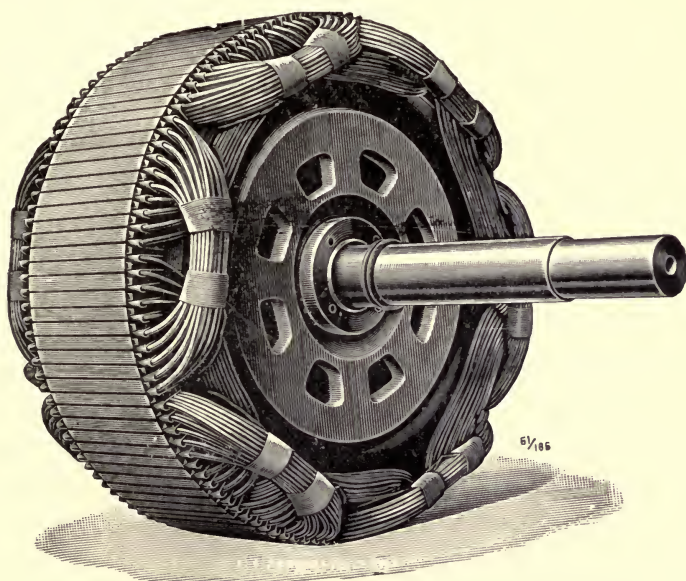

FIG. 294.—Wound Rotor of Three-phase Motor (*Körting Brothers*).

The input of an induction motor can be measured by watt-meters and the output by a prony brake. Thus, the ratio of input to output is easy to obtain. These values can be obtained with the motor

standing still, in which case the output is 0, since there is no motion, but the torque, or tendency to turn, is a specific value which can be measured. Thus, curves of current input, torque (or tendency to turn), and speed can be plotted all the way from rest up to synchronism, as well as efficiency and power factor (*i.e.* cosine of angle of lag of entering current, as has been explained), and maximum output when running at normal speed. The curve of the torque from rest to synchronism is shown in Fig. 295. Curve shown with 0.04 ohm

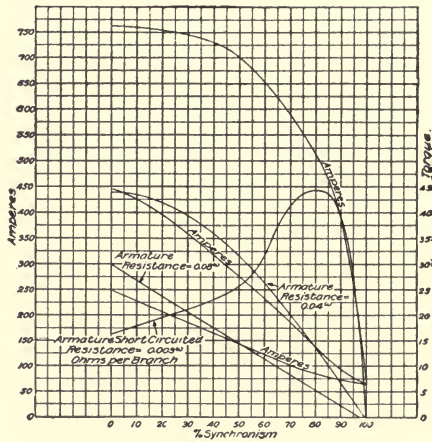

FIG. 295.

resistance in armature is so chosen that the torque at starting is the maximum torque. The formula for torque of an induction motor is

$$\text{Torque in pounds} = \frac{SE_0^2 pbR}{17.04n[(R_1 + SR_0)^2 + S^2(2\pi L_1 + 2\pi nL_0)^2]}$$

when E_0 = the applied E.M.F.;

p = number of field (an armature) circuits (thus 2 for quarter-phase and 3 for three-phase);

s = slip of secondary (at standstill, $s=1$; at synchronism, $s=0$);

R = resistance per circuit of armature in ohms;

n = cycles per second in primary;

R_0 = resistance per circuit of primary in ohms;

L_1 = inductance per circuit of armature in ohms;

L_0 = inductance per circuit of field in ohms.

From this formulæ the resistance for a given type can be calculated.

Curve with 0.005 ohm gives the torque values without resistance in the armature. It can be seen at starting the torque is now less than with resistance. A little farther the two curves cross and have the same torque. At this point the resistance should be cut out and the torque up to synchronism would then be on the curve higher. Thus, under such conditions the complete torque curve would be as in curve with 0.04 ohm resistance, the resistance being cut out at the point where the two curves cross. From an inspection of the formula for torque it can be seen that the applied voltage appears in the numerator as the square. Thus, the torque of an induction motor is proportional to the square of the applied voltage. Hence, low voltage on an induction motor means more than lower starting (or running) torque. The formula for the horse-power of an induction motor is

$$\text{H.P.} = \frac{pR_1E_0^2S(1-S)}{746[(R_1+SR_0)^2+S^2(2\pi nL_1+2\pi nL_0)^2]}$$

In this formula it can be seen that again the applied voltage E_0 appears as the square, so that the output of an induction motor when running on half-voltage is only one-quarter of the value when running on full voltage. The formula for the maximum horse-power obtainable from an induction motor is

$$\text{H.P.} = \frac{pE_0^2}{1492[(R_1+R_0)+\sqrt{(R_1+R_0)^2+(x_1+x_0)^2}]}$$

when $x_1=2\pi nL_1$

and $x_0=2\pi nL_0$.

The formula for maximum torque in pounds at one foot is

$$\text{Maximum torque} = \frac{E_s^2 pb}{34.09[R_s+\sqrt{R_0^2+(x_1+x_0)^2}]}$$

From an inspection of this formula it can be seen that R_1 , the resistance of the secondary, does not appear, from which it may be concluded that the maximum torque of an induction motor is independent of the secondary resistance, the presence of the latter only determining at what per cent. of synchronism the maximum torque will appear.* Curves of amperes and torque without resistance and with armature short-circuited are shown in Fig. 295, as can be seen when the amperes are 0; that is, running at exact synchronism, there

* See Raymond's "Alternating Current Engineering," pages 128-163, for proof of these formulæ without using calculus.

is no torque; when standing still (or 0 per cent. synchronism) the current is a maximum. Thus, an induction motor standing still without resistance in the armature takes its maximum current, usually about ten or fifteen times its normal current.

The curves showing the efficiency, maximum output, etc., are shown in Fig. 296.

It will be noticed that the output reaches a maximum in this case at the line of about 195 per cent. output, beyond which no more load can be put on the motor. If an attempt is made to do so, the motor will slow down and, unless the load is relieved, come to rest. Since under such conditions, that is, at rest, the motor takes, as has

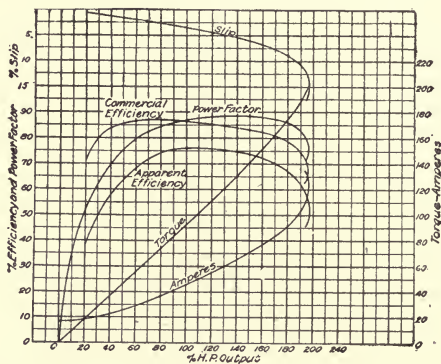

FIG. 296.

been shown, many times normal full-load current, it will soon burn up unless the current be taken off. Thus, in applying loads to induction motors they must be chosen of such values that they are always below the maximum output of the motor.

The power factor of a motor is the cosine of the angle of lag of entering current, or the ratio of the real input to the apparent input, obtained by multiplying volts and amperes together, not allowing for any lag.

The commercial efficiency is the ratio of the actual energy given out to the actual energy taken in.

The apparent efficiency is the ratio of the actual energy output to the apparent input, obtained, as stated, by multiplying volts and amperes input together, not allowing for their phase difference. Thus, it can be seen that the power factor equals the actual input divided by the apparent input. A properly designed induction motor of about 50 H.P. should give from ordinary conditions a maximum output of 100 H.P., a power factor at full load of 95, and efficiency of 92. In spite of this limitation of maximum output, induction motors are

used very extensively indeed in the United States for all sorts of power purposes, and are built in sizes up to 3000 horse-power. They are used in the same application exactly as our direct-current motors. Thus, you will find them on hoists, cranes, street-cars, pumps, driving shafting in mills, driving tools, the design of output and torque being such as to properly meet the conditions imposed. The advantage of the use of an induction motor over that of a direct current is, in the former the commutator is dispensed with. Thus, there are no brushes to attend to, nor any of the commutator troubles which arise with direct-current apparatus. Also since long-distance transmission is always alternating, the induction motor can be used by stepping down from the line voltage to a safe operating voltage, whereas with direct-current motors the A.C. long-distance transmission voltage must be transformed into direct current by rotaries or motor generator sets, with increased cost of first installation and maintenance and attendance during operation. These facts have made the use of induction motors very general.

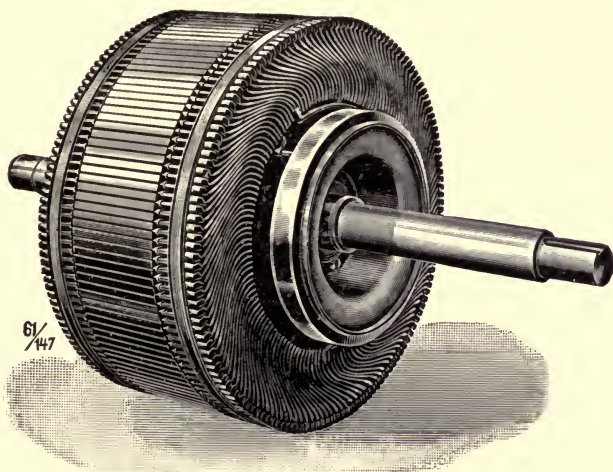

FIG. 297.—Triphase Rotor (*Körting Brothers*).

By means of a voltmeter connected to two brushes, we may observe that, before closing the starting switch, there is a considerable voltage between two slip-rings, which nearly disappears after short-circuiting the resistance. According to the number of wires on the rotor, the voltage between the slip-rings will be smaller or larger, and will be nearly equal to that of the stator, if the number of turns on stator and rotor are alike.

The number of rotor windings will of course be selected so as to avoid a dangerous voltage arising between the slip-rings whilst starting

the motor. Generally the limit for this voltage is 200 to 300 volts. But even this voltage might, under unfavourable circumstances, prove dangerous, and therefore *touching the slip-rings whilst starting the motor should be avoided*. After the motor has reached its full speed, and the starter has been short-circuited, the slip-rings may without hesitation be touched with both hands, since the voltage existing between the slip-rings of a short-circuited rotor is very small.

Alternating-current motors only (both induction and synchronous types) have the important advantage, that the feeding current is led to a stationary winding. Hence these motors can, as well as generators, be built for high tension. Large 3-phase motors for 2000 and even 5000 volts are frequently made. For these high pressures the terminals and windings of the primary have, of course, to be well protected to prevent danger to life, and the windings must be excellently insulated.

Slip

If between a slip-ring and a starter terminal we place an ammeter, we are then able, with a slip-ring induction motor, to make some interesting observations. As long as the motor runs without load, the ammeter indicates a very small current, but a very evident and slow oscillation of the pointer of the instrument will be noticed. If the load on the motor is increased, the deflection of the pointer becomes greater and its oscillations occur more quickly. The number of the swings gives us a direct measure for the slip of the armature. If the armature runs synchronously with the field, then—as we know—no currents at all can be produced in the armature. On the other hand, if the armature of a 4-pole motor (not loaded) remains by two revolutions per second behind the field speed, then this has the same effect as if the 4-pole field rotated twice round the stationary armature. Hence, in the armature an alternating current of eight alternations per minute is produced. The ammeter pointer is then deflected eight times from zero up to a maximum value. If the motor is fully loaded, its slip then being 40 revolutions, we can observe 160 oscillations of the ammeter pointer per minute. Since in this case the oscillations quickly follow each other, the pointer has no time to return to its zero position.

This phenomenon becomes still more distinct if, instead of the usual electro-magnetic or hot-wire instrument, we employ a Deprez ammeter, with a zero in the middle of the scale. Then we see the needle deflected from zero—for instance, to the right, then to the left and back again to zero, and so on. With a 4-pole motor a double

movement of this kind of the pointer corresponds to the slip of one revolution.

The vector diagram of an induction motor is similar to that of a transformer, since the former is really a stationary transformer with a movable secondary, bearings being provided to permit revolution. It may be that a vector diagram for an induction motor cannot be drawn as in the case of a transformer, for in the former case the secondary has the same frequency as the primary, while in the induction motor the frequency in the rotor is the same as in the primary when the rotor is standing, but is 0 when running at synchronism, and about 4 per cent. of full frequency when running at full load. It must be borne in mind, however, that the revolutions of the rotor plus the frequency in the rotor always equal exactly the primary frequency. From the nature of things, thus the rotation brings around the secondary current, so that when they are at a maximum they bear physically to the primary the same relation as if they had full frequency and the rotor were standing still. In vector diagrams and calculations, it is convenient to reduce the induction of secondary to the same number of turns as the primary by multiplying the value of L and R by the square of the number of turns, reducing similarly back again by dividing after the calculation is over. Fig.

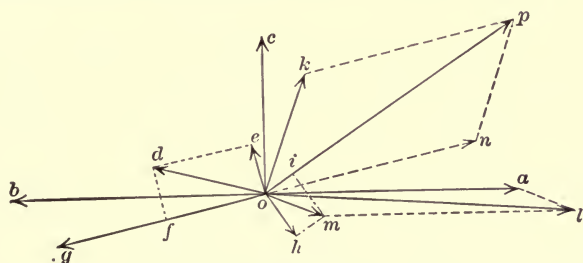

FIG. 298.

293 is so drawn and gives the phase relations between the various currents and the flux in an induction motor.

Let $o-c$ equal in length and phase the flux ϕ . Then the line $o-a$ equals the E.M.F. produced by the flux due to its pulsating in the primary, and $o-b$ the E.M.F. in the secondary when standing still. Draw $o-k$ ahead in phase to $o-c$ an amount such that the product of its projection upon $o-a$, the E.M.F., gives the losses in the motor due to friction, hysteresis, eddy currents, etc. Thus, the product of E.M.F. and current in phase represents energy. Let $o-g$ represent current in the armature. It lags behind the E.M.F. $o-b$ by the angle $b-o-g$. $o-f$ in phase with the current represents the E.M.F. used up in resistance. (The loss in resistance is always in phase with the

current from Ohm's law.) $o-e$ drawn 90 degrees away from the current represents the E.M.F. consumed by induction. (Always 90 degrees away from the current, as has been shown earlier in the book.) Then $o-d$ represents the E.M.F. at this load necessary to force the current $o-g$ through the rotor, since resistance drop and inductance drop combine by the parallelogram of forces, as has been shown. The line $o-n$ equals the secondary current as it appears in the primary, since the currents in the secondary always appear equal and opposite to the primary (assuming, as in this case, a ratio of terms of 1:1). Thus, the total primary current is the combination of the exciting current $o-k$ and this other component $o-n$, since there are no other currents. Thus, $o-p$ equals the primary current; this current flowing through the primary windings consumes the E.M.F. $o-i$ in phase with itself, and the E.M.F. $o-h$ at right angles with itself, or the combination of both, i.e., $o-m$. The primary applied E.M.F., therefore, has to be of such a value and phase as to overcome the combination of the primary impedance drop $o-m$ and the E.M.F. produced in the windings by the flux pulsating through them, or $o-a$. The combination by the parallelogram of force of $o-a$ and $o-m$ equals $o-L$, which represents, therefore, in amplitude and phase the applied E.M.F. Thus, this diagram gives the value and phases of all the currents and E.M.F.'s existing in an induction motor.

Single-phase Induction Motors

After the invention of the three-phase motor its simplicity and its superiority over all other alternating-current motors soon became known. Since then many alternating-current central stations have been designed for the three-phase system, especially when the motor load is important. There are, however, many older central stations which work with single-phase current. For lighting purposes the single-phase system has an advantage over the three-phase system, for with the latter it is rather difficult to distribute the lamps so as to get equal loads on the three phases. Further, with the 3-phase system *three*, but with the single-phase system only *two*, mains are required. Engineers have, therefore, given much attention to the design of single-phase induction motors, having the advantages of 3-phase motors.

If, whilst a 2-phase motor is running lightly loaded, we disconnect one phase from the motor, we observe that the motor still continues to run, and a considerable alteration takes place in the current consumption, both in the connected phase and the armature, but,

what is most essential, the motor continues to do work. From this observation we conclude that it is feasible to build single-phase induction motors.

On stopping the motor, and trying to start it again, with only one phase connected, the armature circuit being closed, a great difference will be observed between this and an ordinary 3-phase motor. *A single-phase motor is not self-starting.*

We can, after continued experiments, find out a position of the lever of the starting resistance, so that, when the rotor is once set in motion, it continues to run, runs quicker and quicker, till finally, if we gradually short-circuit the resistance, the full speed is reached. We may further observe that we can give the motor a start either to the right or to the left, and that in both cases it will continue to run in the direction in which we started the rotor, whereas a 3-phase motor runs when the connections are made in a definite way in one direction only.

With the single-phase motor we have originally not a rotating, but merely a pulsating field. Hence there is no turning effort

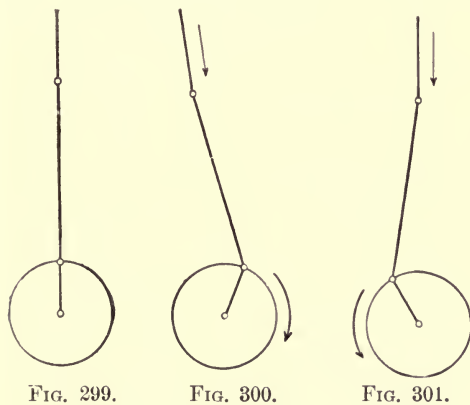

on the stationary armature, but a force which tends to pull the rotor first in one and then in the opposite direction. Similar actions take place in many other machines. A steam-engine furnishes a good example: the piston has a reciprocating motion, and piston-rod, crank, and flywheel are required to transform this kind of motor into a rotating one. The bicycle and swing-

machine are similar instances. If the crank (see Fig. 299) is at the top or bottom, then the piston is unable to produce any motion, neither by pulling nor by pushing. It is absolutely necessary that the crank be turned past these *dead points*. If the crank reaches the position shown in Fig. 300, on pushing the piston a further turning of the crank in the direction indicated by the arrow will result. If, on the other hand, we had turned the flywheel counter-clockwise (see Fig. 301) instead of clockwise, then a thrust on the piston will cause a motion of the crank to the left. Hence, if no other mechanism prevents this, we can really turn as we please the flywheel of a sewing-machine, either to the right or to the left. When the machine

is once started, then we are assisted by the momentum of the flywheel, which carries the crank over the dead points, thus giving us the desired rotatory motion.

In a corresponding way the working of a single-phase motor may be imagined. We have first of all to help the armature over the dead points, in order to produce in the windings of the armature (which, as with the 3-phase motor, might be wound as a squirrel-cage, 2- or 3-phase), by its revolution in a pulsating field, currents of different phases, which latter then produce a rotating field in the armature. The armature wires then act like a flywheel, taking up the reciprocating forces and producing rotating power.

Small motors may be started by hand, but this would be impossible with large motors. Such motors may be started by providing them with a second phase winding, obtaining by its help a self-starting single-phase motor. Through this second phase, during starting, a current is caused to flow which differs in phase from the current in the main phase. We may get a second phase from a single-phase circuit by dividing the main current into two parts and inserting in one branch, called the 'auxiliary phase,' a choking coil. These connections are shown diagrammatically in Fig. 302.

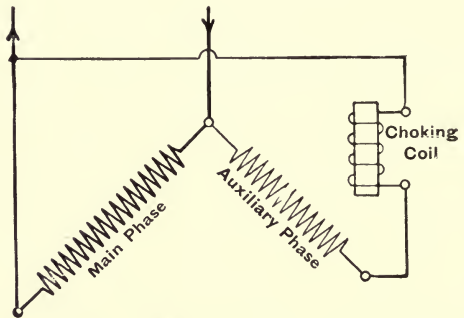

FIG. 302.—Single-phase Motor with Auxiliary Phase with Self-induction.

The main phase is connected to the mains directly, the auxiliary phase is in series with a choking coil. In the latter circuit, due to the large self-induction of the choking coil, a far greater phase-difference between current and voltage is produced than in the main phase. If the phase-difference becomes a quarter-period, then we get a complete rotating field. The phase-difference will, however, here be far smaller than a quarter-period, since in the main phase the current already lags behind the voltage, owing to the main phase not being free from self-induction. In the auxiliary phase the phase-difference is, of course, larger, but in no case as much as a quarter-period. Hence we do not get a true rotating field. The effect may be compared to the swinging pendulum to the bob of which we gave a lateral push before it reached its highest position. Then the pendulum will not get a circular, but an elliptical motion.

Hence the single-phase motor with an auxiliary phase is self-

starting, but the starting power so obtained is far smaller than that of a 3-phase motor. Whilst the latter can start under full load and even double the normal load, an ordinary single-phase motor with auxiliary phase can only start with a part—say about one-third to two-thirds of its normal load. By suitable means the starting power may be increased, but then the current consumption is greatly increased.

Single-phase induction motors are therefore generally provided with a loose pulley. Before starting the motor the belt is placed on the loose pulley, so that, on starting, the motor has to overcome the low frictional resistance of the loose pulley only. After the motor has reached its full speed the auxiliary phase is switched out, and the belt is removed from the loose on to the belt-pulley. Sometimes, instead of a loose pulley, a friction coupling is employed. When a coupling of this kind is fixed the motor starts without any load, and after it has reached full speed the coupling is thrown into gear, either by hand or automatically.

Phase-Difference caused by Capacity

We may now deal with another kind of phase-difference besides that produced by self-induction.

Any cable and generally any conductor which is connected with a single pole of a source of alternating current, causes a so-called "charging-current" to flow. Let, in Fig. 303, the two circles I. and II. represent the slip-rings of an alternating-current generator, the brushes of which are connected with wires. The two wires are not connected with each other. As long as the machine is stopped, all conductors which are considered here—the armature conductors, the brushes, and the two wires—have the same electrical potential. But when the machine is working, in each of the two brushes an alternating potential or pressure appears, sending a current to the end of the wire, which is still at the previous potential. If we had a continuous-current dynamo, then this current would soon cease—the positive brush sending a current through the wire connected with it until the

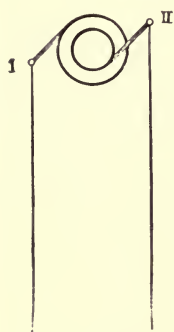

FIG. 303.

whole main had the potential of this part; similarly, the negative brush would take current from the main connected to it till the latter came to the same low potential as the negative brush itself. When this state is reached, the charging current will cease.

If, on the other hand, we have a perpetually alternating potential on the two brushes the case is different. As long as the voltage on the brush increases, it will send a current to the end of the wire. The wire is now charged, and will, when the voltage of the brush after reaching its maximum begins to fall, return to the brush, like an honest debtor, the amount previously borrowed. During the time the voltage of the brush decreases from its maximum through zero to its minimum value, the current comes back from the wire to the brush; whilst during the time in which the voltage of the brush increases, a current flows from the brush to the end of the cable; only at the instant when the voltage has its maximum or minimum value is the current zero. Hence the charging current has, exactly like the magnetizing current, a phase-difference of a quarter-period from the voltage. If the voltage has its maximum value the charging current is zero, and if the charging current has its maximum value the voltage is zero. The charging current is therefore a wattless current, like the magnetizing current. It is a quarter of a period in advance of the voltage, whereas the magnetizing current is a quarter of a period behind the voltage.

The charging current will be greater the larger is the "capacity" of the main connected with the brush. A large capacity may be produced either if the cables are very long or if they lead to very large surfaces which are placed directly opposite to each other, if for instance (see Fig. 304), the wires I. and II. are connected to very large sheets of tinfoil, which are fixed on opposite sides of a glass plate or a sheet of mica. By this means the capacity of the mains is increased considerably. Such an apparatus is called a **condenser**. Instead of using a single large sheet of glass or other material, a number of smaller plates connected in parallel may be employed with the same effect. A type of condenser in ordinary use consists of a large number of sheets of tinfoil, insulated from each other by mica or sheets of paraffined paper; the alternate sheets of foil, say the 1st, 3rd, 5th, etc., are connected to one terminal, whilst the 2nd, 4th, 6th, etc., go to a second terminal. When a condenser is put across the mains supplied with alternating current, a current flows in and out of it, although the two halves of the condenser are insulated from each other. To get large currents from the mains in this way necessitates the use of a very large number of sheets of foil.

The effect of capacity may very well be observed with long, and more especially with concentric, mains. Such cables cause a con-

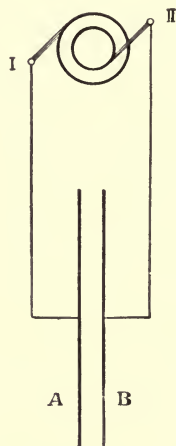

FIG. 304.—Capacity in Circuit.

siderable current to flow from the alternator to the mains, even if not a single lamp or apparatus is switched on. This current is, however, as already mentioned *wattless*.

This capacity effect may be used instead of a choking coil for producing a phase-difference in the auxiliary phase of a single-phase

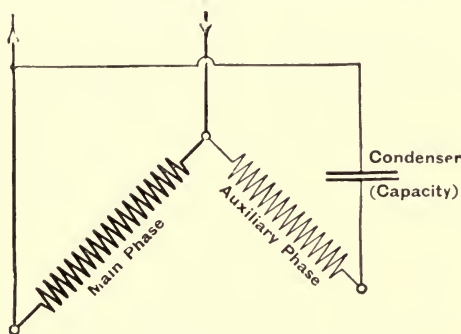

Fig. 305.—Single-phase Motor with Auxiliary Phase having Capacity.

induction motor (see diagram, Fig. 305).

Theoretically with this arrangement it would be quite possible to produce a perfect rotating field; for the main phase has a certain self-induction, and therefore a phase retardation of the current occurs in it, whereas in the auxiliary phase in which a condenser is inserted, a *lead* and not a lag of the current takes place.

With a condenser of the

right capacity a phase-difference of a quarter-period with the same current could be effected, and thus a proper rotating field produced.

To secure that sufficient current passes to the condenser, it is necessary to have much capacity, which means a very large and expensive arrangement. With the usual construction of condensers for these purposes a combined capacity and resistance effect is used. The condenser plates are placed in a tank filled with a conducting liquid, such as a solution of soda. The phase-difference is in this case far less than a quarter of a period. It therefore follows that motors provided with such condensers cannot start under a heavy load.

Sometimes both induction and capacity are employed for starting a single-phase motor, a choking coil being inserted in one, a condenser in the other phase.

A phase-difference of the currents in the two windings may also be produced by inserting in one winding ohmic resistance only. Then in this phase the phase-difference between current and voltage will not be as large as it is in the other phase.

Even without a resistance, choking coil or condenser, the starting of a single-phase motor may be effected by providing the main and the auxiliary phase with a very different number of windings and switching them directly on the mains. Since the self-induction in the two windings will then be different, the two currents will also have different phase-differences against the outer voltage.

All the means that have been described in which capacity or self-induction effects help to create a rotating field, are used only for *starting* single-phase motors. After this has been effected these devices are switched out of the circuit. The motor is then really running on a single phase only, but by the effect of the armature conductors a rotating field is then produced.

How to build single-phase motors with considerable rotary power, and which can be overloaded without stopping, like 3-phase motors, is a problem that has yet to be solved in a satisfactory way. If it were possible to design single-phase motors with the same good working properties as 3-phase motors, then the 3-phase system would probably be soon discarded.

The Reversing of Alternating-current Motors

For reversing single-phase motors *without* an auxiliary phase no change of the connections is required. It has no inherent tendency to rotate in a definite direction, the direction in which it is turned by hand or by any auxiliary means decides the matter. This applies both to single-phase synchronous motors and to single-phase induction motors without an auxiliary phase.

The single-phase induction motor with auxiliary phase behaves exactly like a 2-phase motor, and we shall therefore first of all examine the behaviour of the latter. In considering the working of a 2-phase motor we have assumed (see Figs. 278 and 279) that phase A produces at one moment a north pole on the left; phase B, a quarter of a period afterwards, a north pole below. Hence the field rotates from the left downwards, then to the right, then upwards, *i.e.* in counter-clockwise fashion. We may now reverse the direction of rotation of the field in different ways: *firstly* by reversing the current in phase A. The effect of this will be that phase A will not, at the particular moment considered above, produce a north pole on the left but on the right. Phase B, however, the connections of which have not been altered, produces now, as before, a quarter-period later, the north pole at the bottom. Hence we have now a rotation from the right downwards, to the left, then upwards, *i.e.* a clockwise rotation.

We may, of course, get the same effect by leaving unaltered the current direction in A, and reversing that in B. Reversing the current both in A and B would, of course, be ineffective.

The *third* way to reverse the motor is to interchange the phases, so that then phase B is traversed by that current, which has a lead

of one-fourth of a period. Then B will at first produce a north pole below, and a quarter-period later A will produce a north pole to the left, so that we now get a clockwise rotation. *i.e.* we have reversed the previous direction of rotation.

We may hence alter the direction of rotation of a 2-phase motor having four terminals, simply by changing the two mains of one phase. With a 2-phase motor supplied with three mains (the middle one having about $1\frac{1}{2}$ times the area of the outer mains) it is only necessary to change the positions of the outer mains.

When we wish to reverse the direction of rotation of a

single-phase motor with an auxiliary phase, either the two ends of the main phase or those of the auxiliary phase must be changed. In Fig. 306 the diagram of connections for clockwise rotation is given. One main is connected with end I.' of the main phase and with end II. of

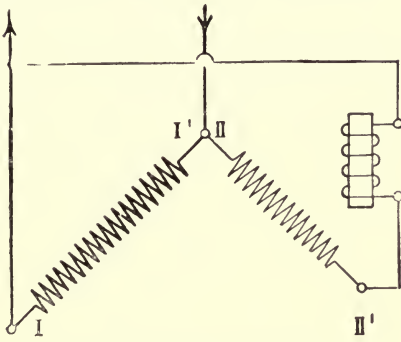

FIG. 306.—Connection of Single-phase Motor for clockwise Rotation.

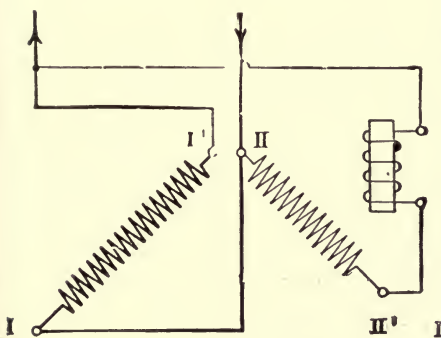

FIG. 307.

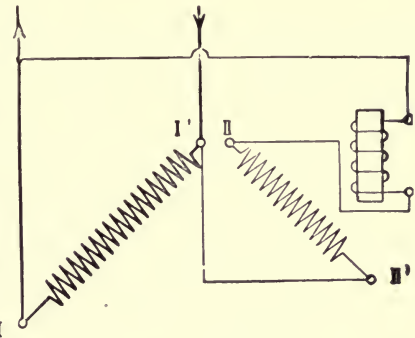

FIG. 308.

Connections of Single-phase Motor for Counter-clockwise Rotation.

the auxiliary phase. The connection for counter-clockwise rotation may then be made either according to Fig. 307 or to Fig. 308. In the former case the direct main is connected with I. and II., whereby the ends of the main phase are changed. In the latter case the direct main is connected with I.' and II.', causing the ends of the auxiliary phase to be changed.

With a 3-phase motor the reversal of rotation may be effected by changing the ends of any two of the three mains, it being a matter of indifference whether the motor has either a star or a mesh connection. Let us consider the motor to be star-connected, and the rotating field to be produced as shown in Figs. 287, 289, 290, and 291. Let us further assume that the currents in the phases B and C are interchanged; then we arrive at the following result: Previously, the strongest north pole was produced first on the top, then below to the left, next below to the right, etc., giving a field rotation in a counter-clockwise direction. When now the change is made, the north pole is produced firstly at the top, then below on the right, next below on the left, and so on; hence the field is rotating clockwise. The same result may be effected by changing the phases A and B or C and A.

These alterations of connections refer of course only to that part of the motor fed by the alternating current. Altering the connections in the rotor of an induction motor or in the magnet system of a synchronous motor are without effect on the direction of rotation, because the armature of an induction motor or the magnet system of a synchronous motor are always made to revolve with the rotating field that is produced by the supplied alternating current.

In the United States slip-rings are used only in special cases. Instead, the resistance is mounted within the armature itself, thus

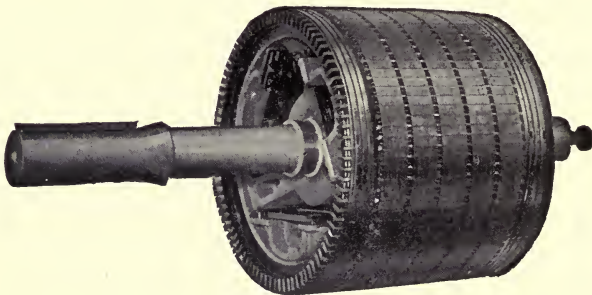

FIG. 309.

revolving with it, and no slip-rings are required, the connection between windings and resistance being direct. The resistance is cut out by sliding contact brushes, which are pushed forward and back on contacts mounted on the resistance (sometimes the contacts rest upon the wire of the resistance itself), by means of a collar mounted upon the shaft. This collar has in it a groove in which the lugs from the starting lever are located. Thus, the collar which revolves

with the shaft only makes contact with the lugs while they are pushing the collar forward or back. The motion imparted to the collar is thus transmitted to the brushes and the resistance altered while the motor comes up to speed, being finally cut out at full speed. This arrangement avoids all troubles from collector-rings. The latter are used when the resistance needs to stay in circuit all the time and when, therefore, the resistance must be so large that there is not enough room within the armature to place it. Fig. 309 shows an induction-motor armature with internal resistance revolving with the armature itself, thus avoiding collector-rings.

Faults with Alternating-current Motors

If we try to reverse the direction of a 3-phase motor by changing the two ends of one phase as we did with the 2-phase and the single-phase motor with auxiliary phase, the result will be of interest. The motor is then no longer a 3-phase motor, and it either does not run at all, or only with a third of its normal speed, consuming at the same time an excessive current, and soon getting very hot. For in this case phase A will, at the moment of its maximum strength, produce a north pole at the bottom; a third period later phase B, which is still connected as before, will produce a north pole below to the left, and again, after a third period, phase C will produce a north pole below to the right.

With a slip-ring motor we may, by observing the armature voltage, perceive exactly whether the motor has a correct rotating-field connection or not. With a properly connected 2- or 3-phase motor a lamp connected with the armature slip-rings will burn regularly as long as the armature circuit is not closed (see p. 295). The position of the armature does not make any difference, since the field rotates with a uniform speed about the stationary armature. With a single-phase motor, however, we have no rotating but merely a pulsating field, and thus, according to the position of the respective armature coil in the pulsating field, the lamp will burn either brightly or with little light or will not burn at all. The same will occur with any irregular rotating field; thus, for instance, with a single-phase motor with auxiliary phase, or with the erroneous connection of a 3-phase motor just mentioned. Hence, if we connect a lamp or a voltmeter with two slip-rings of the armature, and with a slow rotation of the armature we observe that the voltage between the two slip-rings varies considerably, then we infer that there is something wrong with the 3-phase motor. If one of the

3 phases is disconnected, so that the motor is on 2 phases, then the same phenomenon may be observed as with the single-phase motor.

There is another fault sometimes found in the working of induction motors. If one phase of the armature is disconnected—for instance, if one of the brushes is not in contact with its slip-ring—then the motor may run at half speed. If this happens we can easily make sure whether there is a disconnection in the armature itself, in the brushes or in the starter circuit, by examining, with a lamp or a voltmeter, firstly the voltage between each two of the three slip-rings, then the three brush-holders, etc. If the disconnection is within the armature, then, if the brushes are taken off and the stator windings are switched in, no voltage can be observed between one of the slip-rings and either of the two others; hence a lamp connected with this slip-ring does not burn, and a voltmeter is not deflected.

In the case of an induction motor without slip-rings, the fact that one of the phases of a three-phase motor is connected in reversal by mistake can be noted by the fact that the motor will not come up to full speed. Then the three currents entering the motor are not alike, as they should be, but one smaller and the other two considerably larger, and often at starting a considerable humming will be noticed. Another fault with induction motors is a sudden shut-down and resulting blowing of fuses. Investigation may show all circuits to be O.K. In fact, the motor may have been running satisfactorily for some time. Often the cause will be found to be due to the rubbing of the field on the armature. Air-gaps of induction motors must be as small as possible in order to get good power factors for the magnetizing current, which, as has been shown, lags behind the applied E.M.F. and thus lowers the power factor. The magnetizing current is used principally in an induction motor in forcing the lines of force through the air-gap, the iron parts of the circuit not counting much. Thus, the smaller the gap the better. In motors as large as 500 H.P. the gap is only .050 inch, and in small motors, such as 10 H.P., this may be only .015 inch. Thus, in the case of shut-downs and blowing of fuses, the air-gap should be investigated. If rubbing is occurring the H.P. consumed by the rubbing may be such that, added to the regular H.P., the total may be beyond the maximum output of the motor itself, thus causing the shut-down. This touching when it first occurs is not noticeable, since it is slight. As it increases a point may be reached where actual trouble results. This rubbing is also most injurious to the windings; since the energy represented by it is shown as load, it may destroy the insulation, introducing short-circuits, still further complicating matters. In a plant using induction motors an examination of the air-gaps once a month does not consume much time and guards against trouble. Low voltage on the line is another cause of induction-motor trouble,

since, as has been shown, the output of an induction motor is proportional to the square of the voltage. If the latter is low, a large effect on the output results. Hence, if a motor has swings of load carrying it up for a moment to something near its maximum output, it may break down under such load conditions, if the voltage be low. The same holds true in starting a motor; if the voltage is low, a low starting torque results. Another cause of low voltage

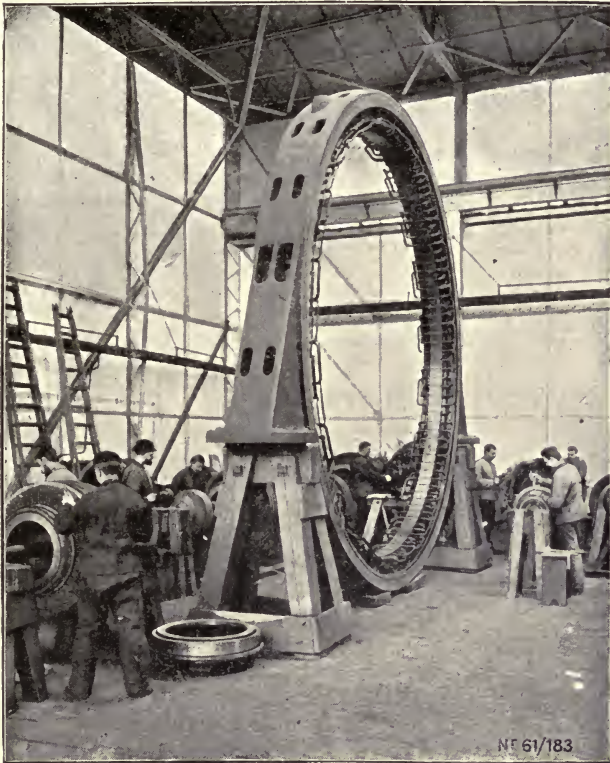

FIG. 310. —Forty-pole Armature of Tri-phaser (*Körting Brothers*).

of a motor is unbalanced voltages, while a motor may give proper output with balanced voltages. If these become much unbalanced, the output is much reduced.

Finally, short-circuits in the fields are a source of considerable bother with poor insulation. Such a short-circuited coil does not burn out at once, since by Lenz's law the current induced in it by the pulsating flux opposes the flux. About three times normal E.M.F. flows, but does not burn up the coil at once, but creates a local heating,

which may affect other coils until finally the motor becomes inoperative. In a plant using motors it is well to measure the insulation resistance of all motors (and lines) once or twice a month to locate such faults soon after they appear.

Transmission of Multiphase Currents

The two currents produced in a 2-phase generator may be separately led through two pairs of wires to a 2-phase motor. In this case four mains are required, each of which has to carry the single current. This is shown schematically in Fig. 311. The zig-

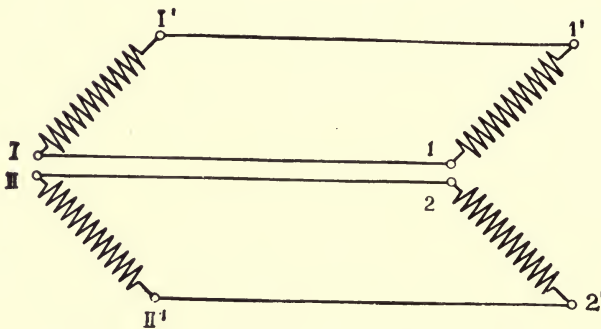

FIG. 311.—Two-phase System with four Mains.

zag lines represent the phase windings of the generator and motor respectively. In order to indicate the 2-phase system, the zigzag lines are at right angles to each other.

It is, however, possible to combine two of these mains. We can join the ends I. and II. of the generator, and 1 and 2 of the motor (see Fig. 312). Then each phase has *one* main for itself, but the middle main is common to both phases, and through this main the currents flowing in the two outer mains, return together. Now one might think that the current flowing in the middle main must be twice as great as that flowing in one of the outer mains. This is not the case, since the two currents are different in phase, and therefore do not arrive at their maxima simultaneously. This may be seen from Fig. 313. On adding the values of the two wave-lines, by first plotting the heights of one wave and above them the heights of the second wave, we get a resultant wave, which is marked in the figure by a thick line. We observe that this resultant wave is, of course, of greater amplitude than either of the single waves, but only $1\frac{1}{2}$ times or, as may be found by an exact calculation, 1.41 times as great. Not only is the maximum value of the combined current

1.41 times as much as the maximum value of the single currents, but this is also true regarding the effective value of the combined current; that is to say, it is 1.41 times as large as the effective value of the

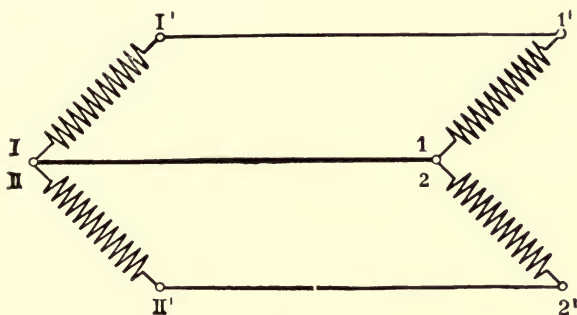

FIG. 312.—Two-phase System with three Mains.

single currents. For this reason the sectional area of the middle wire must be made equal to about $1\frac{1}{2}$ times the area of the single wires.

We have now to consider what will be the voltage between these two *interlinked* phases—that is, between the terminals I' and II''.

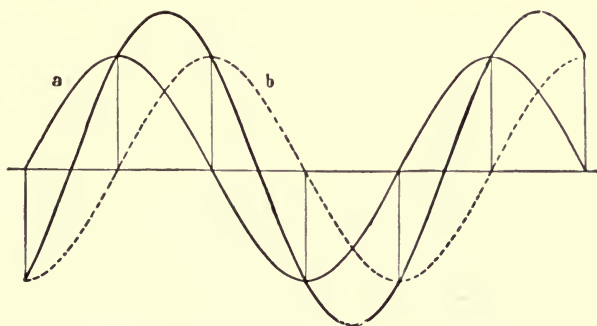

FIG. 313.—Resultant of two Alternating Currents differing in Phase by one-quarter of a period.

As will readily be understood, this voltage will not be twice as great as the separate voltages, but also about 1.41 times as much.

This will be clearer from the following comparison. Suppose a man walks from *a* (Fig. 314) 100 yards in a straight direction, reaching a point *o*. At *o* he makes a quarter of a turn, and then goes 100 yards up to *b*. Although now the man has gone

$2 \times 100 = 200$ yards, he is not at a distance of 200 yards from the starting-point, but, as can be found by measuring exactly the connecting-line ab , a distance of 141 yards only.

This geometrical figure can be used in another way. We can measure on the line ab the resulting voltage between the outer terminals (the interlinked voltage of the system) provided that we make the length of the other two sides of the triangle correspond to the phase voltages. If, for instance, for 100 volts phase voltage we make the sides oa and ob equal to 100 inches, then the length of the line ab will be equal to 141 inches—which means that the interlinked voltage of this 2-phase system is equal to 141.

With 3-phase machines we may lead six mains from the generator to the motor, as shown in Fig. 315. The phases of both machines are indicated by zigzag lines at angles of 120° .

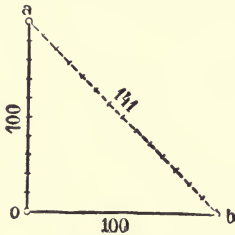

FIG. 314.

Now we may, as we have done before, combine the returns. Thus we have to connect the inner ends of the three phases of motor and generator with each other, getting consequently three single leads and one common return (see Fig. 316).

Next let us consider what will be the voltage between the outer terminals and the current in the common return. The first of these two questions may easily be answered by means of a drawing similar to that shown in Fig. 314. Let us plot three straight lines, distant from each other by 120° (see Fig. 318). The line oa represents

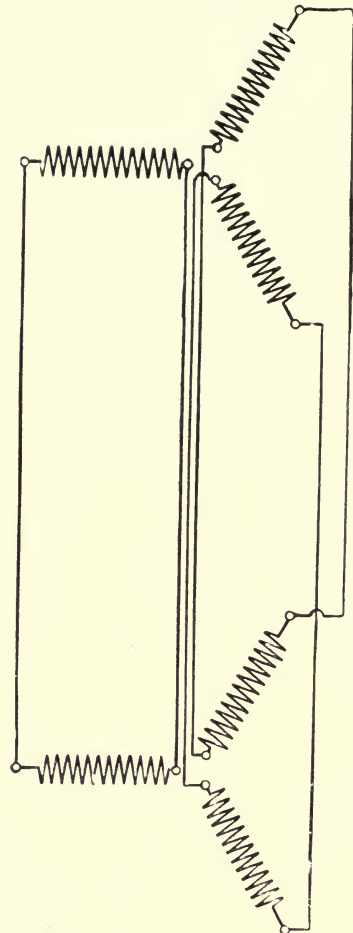

FIG. 315—Three-phase System with six Mains.

the voltage of the first phase, *ob* the voltage of the second, and *oc* that of the third phase. To get the voltage between the outer terminals of the first and second phase, we have only to connect *a*

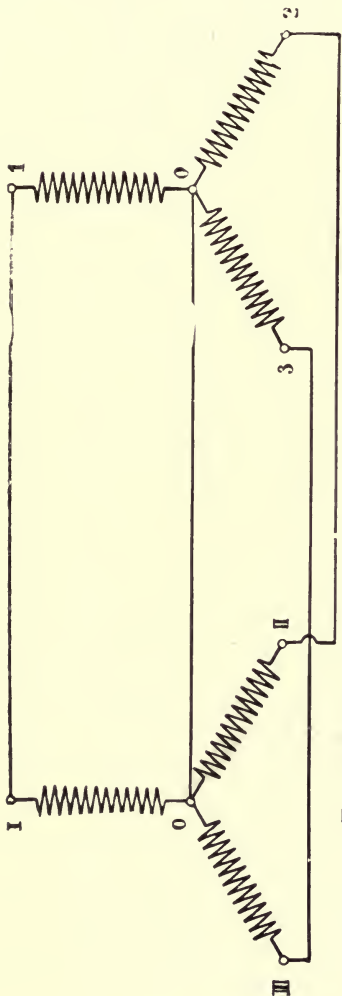

FIG. 316.—Star-connected Three-phase System with four Mains.

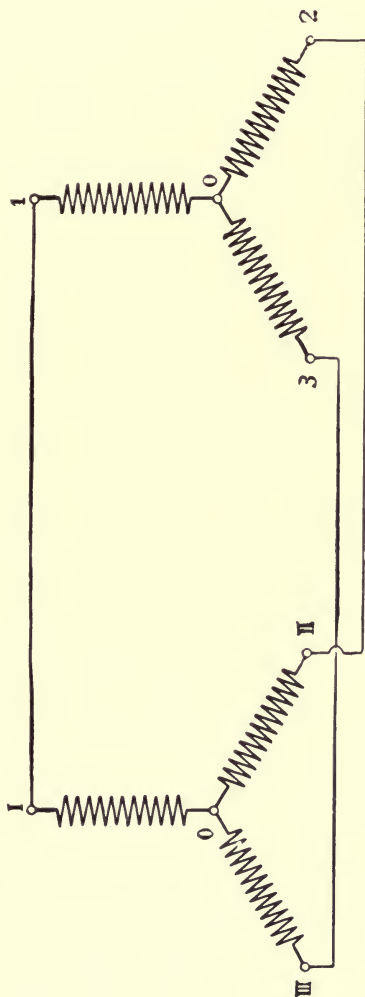

FIG. 317.—Three-phase Star Connection with three Mains.

and *b* by a straight line, and to measure the length of the latter. If the lines *oa* and *ob* have a length of 100 inches, then the dotted lines *ab*, *cb*, and *ca*, will have a length of 173 inches each.

Thus between the outer terminals of a 3-phase generator so connected a voltage of 173 will appear when the phase voltage is 100. *The interlinked voltage is therefore equal to 1.73 times the phase voltage.*

With regard to the current flowing in the common return, we arrive at a curious result. In Fig. 288, the three single currents of a 3-phase system have been represented by three wave-lines,

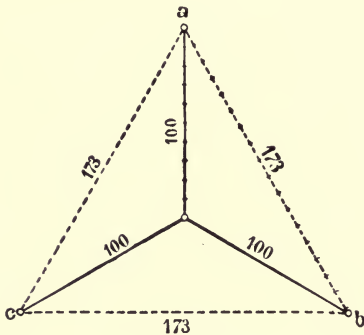

FIG. 318.

a, b, and c respectively. To get the resultant current, we have, as in the case of Fig. 280, to add the three currents. Hence we have to plot on each vertical line, starting from the horizontal, first the height of wave *a* at this point; and shall then—according as the waves *b* and *c* are directed at this point, upwards or downwards—plot their heights above or below the zero line respectively. In doing so, we are surprised to find that we always arrive at the horizontal middle line. If, for instance, *a* reaches its maximum

upwards, then the waves *b* and *c* are directed downwards, each having half the height of the wave directed upwards. It is now obvious that if a person ascends a height of 100 yards, and then descends twice 50 yards, he will come back to the level from which he started; also that at any moment the waves *b* or *c* have their upper- or lower-most position, and in any point between these positions the same will occur. *Thus through the middle wire no current flows at all.*

This seems very strange indeed, and one might ask what has happened with the three currents which are flowing through the three outer mains. The answer is very simple. If the current passing out of the phase OI of the generator (see Fig. 316) is just at a maximum—say, for instance, 100 amps., and is directed outwards, then the currents in the two other phases have, as we have seen from the wave-line in Fig. 288, an opposite direction and only half the strength or 50 amps. Hence from I. to 1 a current of 100 amps. is flowing, which passes through the phase 1—0 of the motor, then branches in two parts, so that 50 amps. are flowing through each of the two other phases, passing then through the two mains 2—II. and 3—III., coming back again along the generator phases II.—0 and III.—0, to the common centre point of the generator. Since now the current which passes outwards through one main comes back again through the two other mains, the return O—0 is useless; it is a neutral main,

and can be left out altogether. In Fig. 317 a 3-phase system with three mains is shown, as is usually employed if the generator is used for feeding motors only. Between any two of the three mains the voltage is of the same value.

The neutral or middle wire is often employed in cases when both motors and lamps are installed on the 3-phase mains (see Fig. 319). The motors are then directly fed by the outer mains, which might, for instance, have a voltage of 173; the lamps are

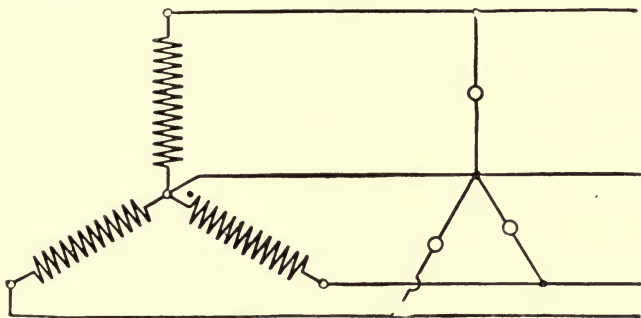

FIG. 319.—Glow Lamps star-connected.

connected between one outer and the neutral wire, which have a voltage of 100.

Very frequently the phase voltage is in such a system 110, the interlinked voltage being then $110 \times 1.73 = 190$.

If one or several lamps are connected across a single phase only (see Fig. 320), then obviously through this phase more current

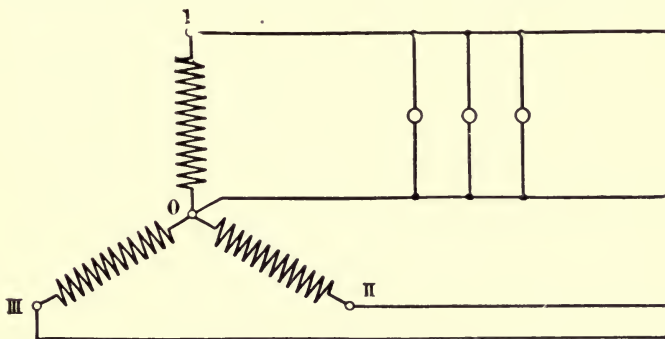

FIG. 320.—Glow Lamps on one Phase.

flows than through the two others. The balance is then disturbed, and the neutral wire has to carry some current. If now this one phase were loaded, and the two other phases were not loaded at all,

then the neutral wire would have to carry the full current of the first phase. This is also the case with currents, the waves of which are irregular, when, even if the mains are equally loaded, current may flow through the neutral wire.

The arrangement of the three phases of a 3-phase system so far described is called the **star** method. It is essential with star connections that the beginnings of the 3-phase windings are connected together at one point. From this point, the **neutral** point, the three phases radiate like the rays of a star.

The phases may also be arranged so that in turn the end of the first is connected with the beginning of the second phase, the end of the second with the beginning of the third, and the end of the third with the beginning of the first phase, as shown in Fig. 321. We get in this way the **mesh** or **delta** connections. Considering Fig. 321,

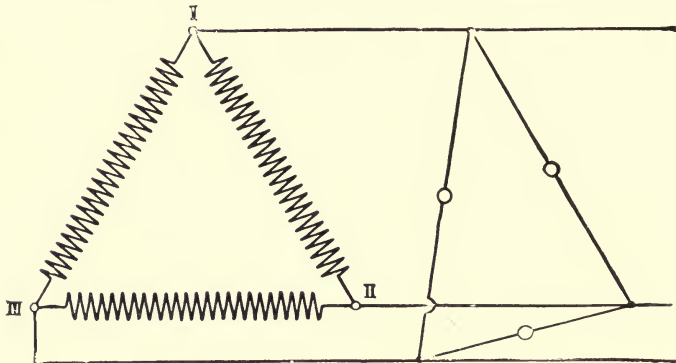

FIG. 321.—Mesh Connection of Machine and Load.

one would expect that through these closed windings a strong current must flow, even if there is no outer load at all. This is not the case. As previously, with the star connections, the three currents added together destroyed each other, so the three voltages added together give no voltage. The matter is somewhat more complicated, but similar to the phenomenon, which we have studied in the case of the Gramme armature (see p. 76), where we have a closed circuit in which electromotive forces are acting. These E.M.F.'s are equal, but opposed to each other, so that their resultant is zero.

Any side of the triangle (Fig. 321), and therefore any phase, has its voltage, and we may take current from the machine by connecting between any two mains a conductor, for instance, a lamp. If the lamps are equally distributed between the mains I. and II., II. and III., III. and I., then through all the mains equal currents flow. The current passing through any one of the mains will then of course be equal to the sum of the currents flowing in the two phases, which

are connected with this main. Let us now suppose that the phase currents are 100 amps. each. It might at first be thought that the main will receive 200 amps. But it must be remembered that between the currents in the single phases there is a considerable lag, causing their resultant to be only 173 amps.

Hence with the *mesh connection* the *voltage* between two outer mains is equal to the *phase voltage*, but the *current* in the outer mains is 1.73 times as great as the *phase current*.

With the *star connection* the *voltage* between the outer mains (the resultant voltage) is 1.73 times the *phase voltage*, but the *current* in the outer mains is equal to the *phase current*.

Let us compare the amount of copper required to transmit a certain amount of energy over a three-phase circuit with the amount of copper for the same percentage loss using a single-phase circuit, the condition of comparison being that the voltage between lines be the same in each case. In the single-phase circuit let the percentage line drop equal S , and the power transmitted equal P . Let L equal length of line both ways, E equal volts between lines, and I the current flowing into the line. Then the resistance of the line equals $\frac{SE}{I}$, and the resistance per foot equals $\frac{SE}{LI}$.

In the three-phase circuit the energy in watts per circuit equals $\frac{P}{3}$. We will imagine for a moment that there are three separate circuits, each having a voltage equal to $\frac{E}{\sqrt{3}}$, that is, the voltage between any outside wire and the neutral. The current per circuit (thus divided into three separate circuits) equals I_1 equals $\frac{P}{3} \div \frac{E}{\sqrt{3}} = \frac{P}{\sqrt{3}E}$. Thus, I_1 equals $\frac{I}{\sqrt{3}}$, when I is the single-phase current for power P .

For the same percentage drop, S , we have a voltage drop of $\frac{SE}{\sqrt{3}}$ or a resistance drop of $\frac{SE}{\sqrt{3}} \div \frac{I}{\sqrt{3}} = \frac{SE}{I}$, and the resistance per foot of $\frac{SE}{I} \div \frac{L}{2} = \frac{2SE}{LI}$. $\frac{L}{2}$ is used instead of L , since, as has been shown, on a three-phase circuit the return wires become unnecessary and can be left out of the calculation. With the single-phase circuit the resistance per foot was shown to be $\frac{SE}{LI}$. Thus, with the three-phase circuit one of the wires has twice the resistance of one of the wires in a single-phase circuit. Hence, since the resistance of w wire is

usually proportional to its area or weight, the weight of the wire in the three-phase circuit is one-half that of the single-phase circuit. But there are three wires in the three-phase and only two in the single-phase. Thus, if the weight of a single wire equals W in the single phase, the total weight single-phase equals $2W$, since there are two wires, and the total weight three-phase equals $\frac{3W}{2}$. Hence, the ratio of weight three-phase to weight single-phase equals $\frac{3W}{2} \div 2W = \frac{3}{4}$. Thus, for a given difference of potential between wires, it takes only three-fourths the weight of copper at a given percentage-line loss to carry the energy three-phase as compared with carrying it single-phase. On this account it is customary in long-distance transmission to carry the energy on three-phase transmission lines. They have a further advantage that the self-induction with unbalanced loads, while unbalancing the various voltages between the various lines somewhat, does not do so to the extent of a quarter-phase transmission with a common return wire. For, in the latter case, as can be shown by plotting the vector diagram and remembering that the induction is at right angles to the current, it is seen that the inductance of the common wire boosts the voltage of one phase and lowers the other.

Power in a Three-phase System

We are now in a position to determine the output of a 3-phase generator, if the voltage and current be given. Assuming the phase voltage to be 100, the phase current 10 amps., and assuming further that the load consists of glow lamps, and is therefore *inductionless*, the calculation becomes very simple. Each phase supplies 100 volts \times 10 amps. = 1000 watts. Hence the generator supplies $3 \times 1000 = 3000$ watts.

The calculation becomes apparently more complicated if there be given not the phase voltage and the phase current, but either (with star connection) the resultant voltage and the phase current, or (with mesh connection) the phase voltage and the resultant current. In this case the calculation is not really difficult. Let the resultant voltage be 173 and the phase current 10 amps., then to get the phase voltage we have to divide the resultant voltage by 1.73. Next we have to multiply the phase voltage by the phase current, thence getting the output of one phase. This we have again to multiply by 3 in order to find the output of the generator.

$$\text{Thus } \frac{1}{1.73} \times 10 \times 3 = 100 \times 10 \times 3 = 3000 \text{ watts.}$$

[It may be remarked here, that the phrases "resultant voltage" and "phase current" are very seldom used. In speaking of the voltage of a star-connected generator the resultant voltage, and in speaking of the current the phase current, is generally understood.]

We might just as well have proceeded in another way, and *firstly* have multiplied the current by the voltage, next by 3, and then have divided the whole by 1.73. On dividing 3 by 1.73 we find that we get 1.73. Hence, instead of first using the multiplier 3, and afterwards the divisor 1.73, we can directly employ the factor 1.73. Our rule is then simply to obtain the product of volts, amperes, and 1.73, getting thus the output of the generator in watts when the load is free from self-induction.

EXAMPLE.—173 volts \times 10 amps. \times 1.73 = 3000 watts. (Exactly 2992.9, but 3000 is quite accurate enough.)

The same calculation applies to a mesh-connected generator. Let the voltage be again 100 and the resultant current 1.73 amps. Then we get the phase current by dividing the resultant current by 1.73. Next we have to multiply the phase current by the phase voltage and again this product by 3. Instead of dividing by 1.73 and multiplying by 3, it is easier to use the factor 1.73 as before, getting then the same result as above. Hence we may say:—With an inductionless load a 3-phase generator has an output in watts given by the formula—

$$1.73 \times E \times C$$

where E is the voltage and C the current of the system. The formula only applies if the three phases are equally loaded, otherwise it is necessary to determine the output of each phase separately.

If the load of the generator is not free from self-induction—if, for example, the generator has to feed asynchronous motors—then we get by the above formula *not the real*, but the *apparent watts*, and we have still to multiply the result by the power factor $\cos \phi$, and the formula becomes—

$$\begin{aligned} \text{Watts} &= 1.73 \times \text{voltage} \times \text{current} \times \text{power factor} \\ &= 1.73 EC \cos \phi. \end{aligned}$$

A 3-phase motor which is supplied at 190 volts, taking a current of 12 amps., and having a power factor of 0.8, consumes *apparently*—

$$1.73 \times 190 \times 12 = 3944 \text{ (volt-amps.)}$$

and *really*—

$$3944 \times 0.8 = 3155 \text{ watts.}$$

Synchronizer for Multiphase Machines

The connections of synchronizing lamps for 3-phase current are similar to those for single-phase current. For low voltages three lamps may be connected between the terminals AA', BB', and CC' (see Fig. 322). If all three lamps become simultaneously dark or bright, then the connections are all right, and at an instant of darkness the switch may be closed. It might, however, happen that, on starting the machines, or after any alteration on the machine or switch-board, the lamps do not

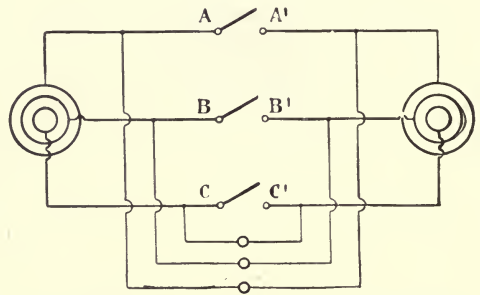

FIG. 322.—Arrangement of Synchronizing Lamps for Three-phase Circuit.

become bright or dark simultaneously, but one after the other. This is a sign that the succession of the cables on the terminals of the one machine does not correspond with the succession of cables on the terminals of the other machine. In this case, any two of the cables may be changed; for instance, that cable which was previously connected with the switch terminal A' might now be connected with B', and that of B' with A'.

In still another way we can assure ourselves before starting that the cables of the two machines are correspondingly connected with the switch, viz., by switching a 3-phase motor first on the terminals A, B, and C, and then in exactly the same way on A'B'C' (that terminal of the motor which was on A before now to be connected with A', B before now with B'). If the direction of rotation is the same in the second case as it was in the first one, then the connections are all right; if the direction of rotation is opposite, then two of these cables must be changed as before.

About the proper connection of the two machines we have to make sure—once for all—before switching them in parallel the first time. In subsequent work it is quite sufficient that one phase of one machine is synchronous with the corresponding phase of the second machine, for in this case it is certain that also the two other phases of the first machine are in synchronism with those of the second one. Hence, for the normal working of the machine, three synchronizing

lamps are not required as is shown in Fig. 322, but two or one respectively, as with a single-phase system.

For high tension likewise, only a single-phase transformer is re-

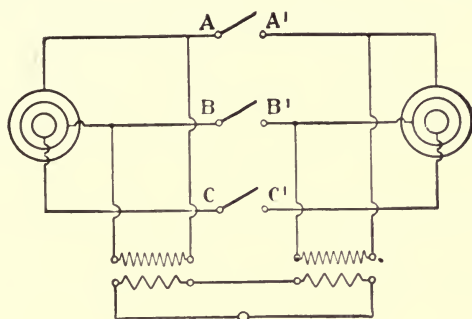

FIG. 323 —Arrangement of Synchronizing Lamps for High-tension Three-phase Circuits.

quired, which then is switched between two mains. This arrangement, shown in Fig. 323, corresponds to that of Fig. 266.

The connections of a 2-phase synchronizer are arranged in exactly the same way.

CHAPTER XII

HIGH TENSION

WITH alternating-current work, very frequently high-tension current has to be considered, and we shall therefore now deal with the safety appliances and arrangements which have to be provided both for protecting human life and machines and apparatus against the dangerous effects of high-voltage currents.

The windings of first-class machines are always insulated with the very best insulating materials. Notwithstanding this, windings may be spoiled if metal or carbon dust or damp is allowed to remain on them. Hence the first condition is to keep the machines always *clean*. To keep them dry is, however, not always possible. Especially during erection or long disuse, dampness of the windings in rooms that are not very dry can hardly be prevented. Before a machine is started, it may therefore be necessary to dry it thoroughly. This refers both to continuous-current and alternating-current machines.

With alternating current generators drying is very easily effected. For this purpose the machine has to be short-circuited, *i.e.* all the terminals are directly and without any outer circuit connected with each other, and an ammeter is inserted in either all or only in one phase. Afterwards the machine is started, and the magnet field feebly excited, so that the current produced by this weak field is equal or somewhat larger than the normal current. The windings get warmed, and if the machine be run for several hours, perfect drying of the windings can be effected.

The voltage obtained with a short-circuited alternating-current generator is negligibly small whenever the ends of each phase are connected directly with each other. This is, for instance, the case with a short-circuited single-phase generator, a 2-phase, a mesh-connected 3-phase generator, and also with a star-connected generator, the star-point of which is short-circuited together with the three outer terminals. In all these cases there is practically no voltage in the short-circuited machines. With a star-connected 3-phase machine, on the other hand, in which the outer terminals only are

connected with each other, there might under certain circumstances be considerable voltages. With such high-tension machines, even when short-circuited, one must avoid touching the windings.

Synchronous motors may be dried in the same way as generators, by short-circuiting the alternating-current terminals, driving the machine as a generator, and exciting the field.

Induction motors may be heated by reducing the generator voltage to a small value, short-circuiting the starting resistances of the motor, and putting a brake on the armature. Then, despite the low voltage, a considerable current will flow both through the stator and the braked rotor.

In a corresponding manner static transformers may be treated by short-circuiting the secondary winding and connecting the primary (high-tension) winding with a voltage far lower than the normal pressure (about 3 to 5 per cent. of the latter). The current flowing through the coils is then about as much as, or a little greater than, that for which they have been designed.

Machines and transformers may easily be manufactured so that with proper management they remain in a proper state for a very long time. But with ammeters and voltmeters and other instruments it is very difficult to provide an insulation which can stand voltages of several thousand volts with certainty. When ammeters are employed in high-tension plants, they must always be mounted on a very good insulating base. Voltmeters, measuring the voltage directly between two high-tension terminals, are seldom employed. Generally measuring transformers are used, the ratio of the number of high- and low-tension windings being definitely fixed as required. If, for instance, the primary winding has 100 times as many turns as the secondary, then at a primary voltage of 5000 on the terminals of the low-voltage coil a voltage of 50 will appear. Generally the scale of the reading instrument is not marked with the secondary, but with the primary voltage, so that, for instance, that point to which the pointer of the instrument is deflected with 50 volts is marked 5000.

There are also measuring transformers for ammeters, the "current transformers." Hence high-tension switchboards may be manufactured without any high-tension apparatus at the front. Voltmeters, ammeters, and wattmeters are inserted in low-tension circuits. The measuring transformers, the high-tension fuses, and the high-tension switches are placed behind the board, and nothing but the long insulated handles of the switches project at the front of the board.

In connection with high-tension switches there are generally employed special devices, so that on opening the switch there are long air gaps between the contacts, hence the arc that is produced on breaking a high-voltage current is destroyed (see Fig. 324).

For the same reason high-tension fuses are of special construction, and frequently of considerable length. Generally the fuse wires are enveloped in insulated safety tubes, by which splashing of the melted fuse wire is prevented (see Fig. 325).

An essential feature with which we have still to deal, is the safety of persons in charge of high-tension plants. It is a matter of course that in no case two terminals of different voltages must be touched, but to touch even a *single* high-tension terminal must also strictly be avoided. This might have fatal consequences for a man standing on an un-insulated place if there existed anywhere an earth connection with the second pole. With alternating-current machines a fatal shock may result, although the whole network may be very well insulated; for, as we have learned from the effect of capacity, there is even in a wire connected to a single pole a current continuously flowing in and out. Hence, if a person in contact with earth touches one pole, he will receive a current flowing to earth, and even this may prove fatal.

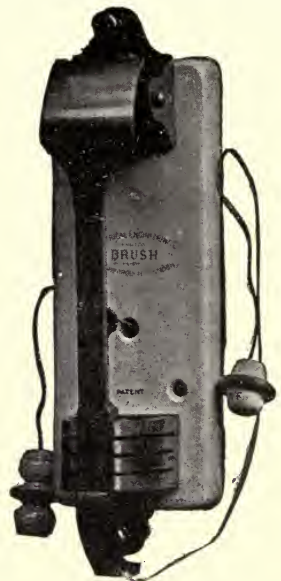

FIG. 324. — High-tension Switch. (*The Brush Company*).

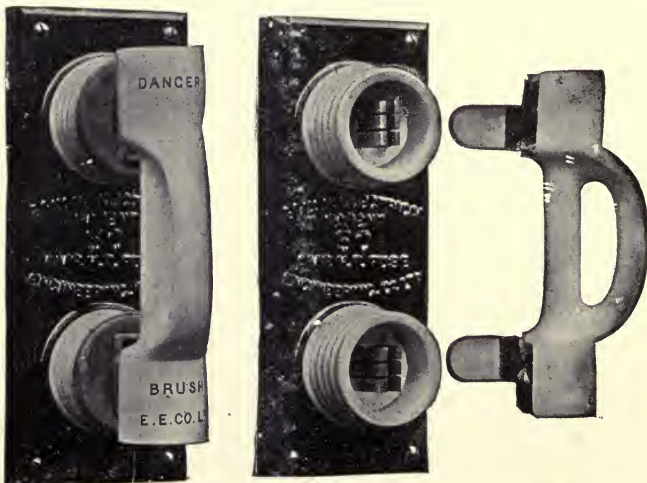

FIG. 325. — High-tension Fuse (*The Brush Company*).

Therefore, if it is necessary to touch working high-tension machines, apparatus, or "live" mains, insulation of the operator is necessary—a position on a good uninjured india-rubber plate or dry wood, the protection of the hands with good rubber gloves, and the wearing of rubber shoes are necessary precautions. With high-tension plants other dangers may arise in addition to those due to touching the mains. Assuming that a high-tension generator or transformer is fixed on an insulated foundation, and that one pole of the machine has *a connection with the frame*. If the insulation of the windings is uninjured, then obviously there can be no short circuit, and hence no interruption of work will happen. But the frame of the machine is now in connection with one pole, so that touching the frame is, for a man standing on the earth, just as dangerous as touching one high-tension terminal. If somewhere in the network there is another pole earthed, then the attendant stands in a manner with his feet on one pole of the high-tension service, touching with the hands the second pole. It is, therefore, generally specified that such insulated machines and transformers must be provided with an insulating platform.

There is still another means of protection against such accidents—*connect all machines and transformer frames with earth*. This might be done, for instance, by fixing a copper wire to a machine bolt, and leading it to an earth plate or to the water pipe. If there is a good connection between earth and the machine frame, then a considerable potential difference cannot appear between them, and the frame may be touched without any danger. If, now, one pole of the machine at any time touches the iron frame, and the other pole has anywhere in the network an earth connection, then, of course, an interruption of the work will follow, due to the short circuit, but without endangering human life. It is, notwithstanding, possible, with a bad earth connection, for a considerable voltage to exist between the iron frame and the earth, and therefore the very best connection between earth and the iron part of the machine is the main requirement with high-tension plants. Where a good earth connection cannot be made, the machine should be insulated from the earth, but in this case an insulated platform round the machine is required.

The same refers also to switchboard apparatus—either an insulated platform in front of the switchboard in cases in which the touching of all parts carrying current cannot be avoided, or earth connection with all places which have to be touched must be made. In the latter case all levers of the high-tension switches, the iron frame of the board, the cores of the measuring transformers, etc., must be connected with earth. If there are high-tension ammeters on the switchboard, they are either enclosed in an insulating box, or covered

with a metal box, which latter is then connected with earth. The metal box has, of course, in the front, a glass window.

The limit at which the voltage becomes dangerous cannot be stated exactly. Generally voltages up to 500 volts are not fatal, whilst under especially unfavourable circumstances shocks of even 200 volts may have fatal results.

Lightning Arresters

With any overhead electric mains, whether they carry either high or low tension, continuous or alternating currents, it is necessary to arrange safety appliances to guard against lightning discharges. Lightning consists of an electric arc which strikes either across two clouds or a cloud and any object on the earth. Its potential is always extremely high, and sometimes amounts to many millions of volts. It is therefore able to break down any insulation, and to cross air gaps in a way that would be impossible in the case of relatively low voltages. Very frequently discharges of atmospheric electricity occur which are invisible to the eyes (so-called dark discharges), but which may damage electrical machines and apparatus.

From many observations it has been found that lightning does not consist of a single discharge, but that, despite the short time of discharge, a frequent alteration of the current direction takes place. Lightning is hence really an alternating current with an extremely high periodicity, many hundred times greater than that of the usual alternating currents. Even if lightning lasts but a fraction of a second, yet it changes its current direction in this short time many thousand times.

Now, the effect of self-induction is far greater with a high than with a low periodicity. With alternating currents of usual periodicity we have observed strong induction effects on coils with iron cores, whilst with currents of such a high periodicity as with lightning, even on coils consisting of very few windings and having no iron cores, we can observe strong self-induction effects. Since a circuit having a large self-induction produces a back E.M.F. which opposes the increase of the current-strength, this is equivalent to adding a very large resistance to the circuit. Hence if we provide for the lightning discharge two paths, one of them leading through a coil, and the other one through an air gap to the earth, then by far the greatest part of the discharge will flow through the air gap to the earth, whereas, on account of the high inductive resistance, but a small part will flow through the coil. This fact has been used to prevent lightning from flowing through sensitive apparatus, and for conducting it in a harmless way to the earth.

The simplest type of lightning arrester is shown in Fig. 326. It consists of two horn-shaped thick copper wires placed opposite each other and fixed on porcelain insulators. One horn is connected with the supply line, from the other one a cable is led to an earth plate. The two horns do not touch each other. The least distance between them varies, according to their position (whether fixed in rooms or outside), between $\frac{1}{8}$ to $\frac{1}{2}$ inch. The usual dynamo voltage cannot bridge over this distance.

Before the aerial line is connected to any machine, or to any transformer, a coil consisting of several windings is interposed. This latter does not offer any obstacle to continuous currents, or for alternating currents of the usual periodicity. If a discharge of atmospheric electricity into the line takes place, then this discharge current will not flow through the induction coil, which offers to it a very high resistance, but will flash over the air-gap to the second horn, where it finds a direct way to the earth.

Since there is now formed an arc between the two horns, the dynamo current could also take this way. But this bridging of the horns by means of the arc lasts only a very short time. By the action of the stream of heated air the arc rises upwards, becoming longer (in this the special shape of the horns assists), till finally, like the arc of an arc lamp, the carbons of which are separated too far from each other, it is extinguished. All this happens during a brief period, and afterwards the plant remains with-

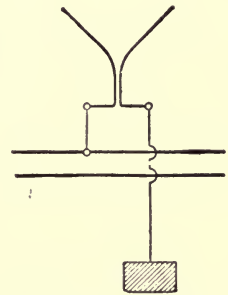

FIG. 326—Lightning Arrester.



FIG. 327.—Westinghouse Lightning Arrester.

out injury.

A type of arrester for alternating current in use at the present time by the General Electric Company consists of multi-air gaps with shunt and series resistance. The air-gaps are carefully spaced between cylinders of non-arcing metal, and part of the gaps shunted by resistance. The whole is then connected in series with resistance. This type of arrester for 2200 volts is illustrated in Fig. 328, which

shows both the multiple and series connection. In Fig. 329 is shown a 35,000-volt three-phase arrester with double-blade disconnecting switches for Y-connected neutral grounded circuits.

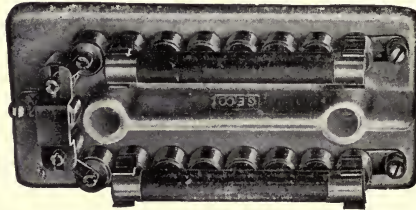

FIG. 328.

The non-arcing character of the alloy used in the cylinders reduces the number of gaps necessary, and aids the resistance in reducing the

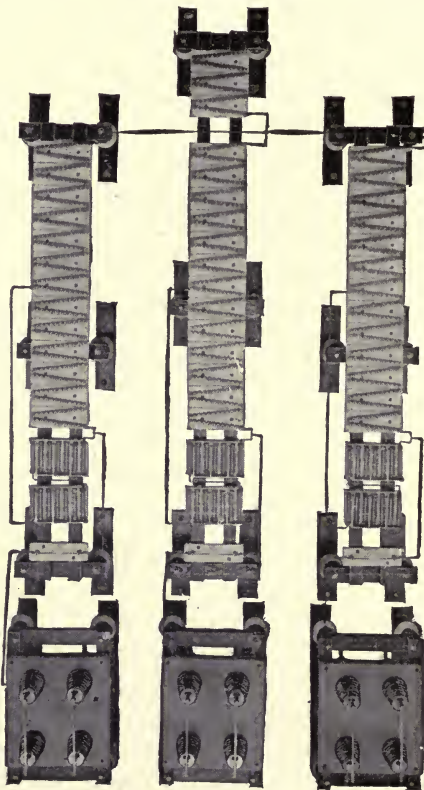

FIG. 329

destructive effects and in opening the resulting arc. Not only the high-potential, high-frequency discharges of lightning, but also the smaller charges within the circuit, are discharged across the gap. These surges within the system are caused by opening or closing of feeder switches, switching in transformers, and sudden variations of load. Records of discharge are made by inserting a small square of paper between two adjacent cylinders in each line, the discharge puncturing the paper. These are renewed regularly.

In theory, the cylinders are charged electrostatically until the voltage is high enough to break down the air-gaps in succession, passing the charge along from cylinder to cylinder, thus discharging the whole system

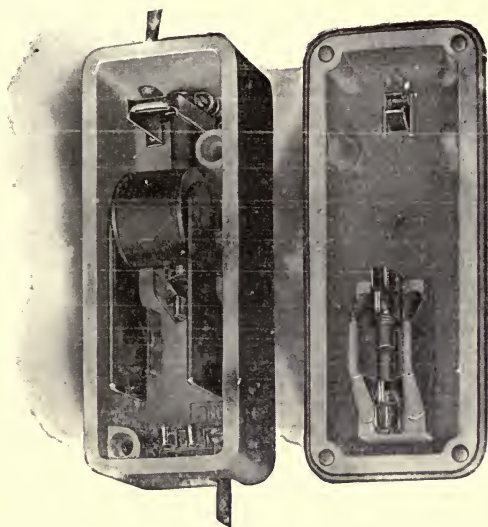

FIG. 330.—Lightning Arrester used on Railway Apparatus.

An arrester used on railway apparatus is shown in Fig. 330. The arrester has an adjustable spark-gap between two electrodes in the field of an electro-magnet. One electrode is connected, through the magnet windings and a small non-inductive resistance, to the ground. The other electrode is connected to the positive side of the circuit. Under normal conditions no current passes through the arrester coil, but any arc established by a lightning discharge which jumps the gap and is followed by current from the generator is blown out by the magnetism induced by the coil of the blow-out magnet.

These arresters are used in connection with kicking or choke coils.

When used on a feeder panel, the panel is equipped with a kicking coil made of bare copper rod coiled and connected between the main switch and the circuit-breaker.

It is desirable to isolate the arresters from the switchboard.

In addition to those just described, there are many other types of lightning arresters. In one type many metal and mica plates are arranged alternately one upon the other. The first metal plate is connected with the line, the last one with the earth. This row is practically an insulator for a low voltage, but a lightning discharge glides over the outer surface of the mica and metal plates.

Every aerial line must be protected by a lightning arrester before it is passed within any building.

Switchboards

The object of a switchboard is to concentrate (or concentrate the means of controlling) all the energy developed or distributed in a station for the purposes of control, distribution, measurement, and protection. It is best located so as to give the operator full view

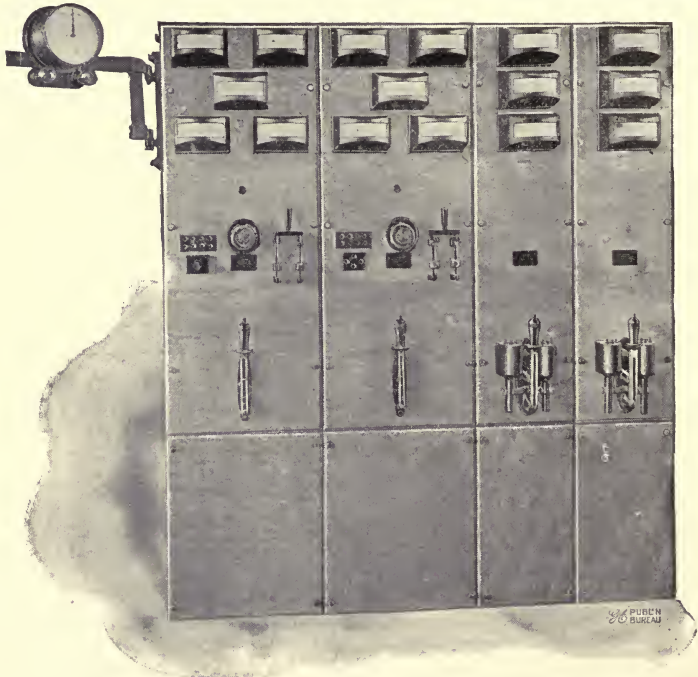

FIG. 331.—A. C. Three-phase Generator and Feeder Panels.

of the machines and so as to keep the cable leads between the board and machines as short as possible. Plenty of room back of the board should also be provided in order that the attendant may safely inspect, repair, or adjust connections.

It is usually built up in sections or panels of a strong insulating fire-proof material, upon which are mounted the various instruments and devices. Marble and slate fulfil these requirements and are most generally used. Slate, however, is not used for circuits above 1000 volts unless the high-potential carrying parts of the circuits are insulated from the panel. This is due to the fact that slate is stratified and is liable to have veins of lower insulating qualities. Slate panels are finished with oil or black enamel. Natural black slate oiled is very substantial, is easily retouched by the attendant in case it becomes marred, and harmonizes with the finish of the devices mounted on it. Black enameled slate gives an excellent polished surface, but is difficult to retouch if scratched through the coating of enamel.

Marble is stronger and a much better insulator than slate. Any kind of marble with a polished surface will show oil stains, which renders it difficult to keep it looking neat. In order to overcome this trouble, marble boards may be black enameled or given a dull black finish. The latter finish is perhaps the more durable and is also more easily repaired.

The panels are supported by bolting them to vertical pieces of $1\frac{1}{4}$ -inch gas-pipe by means of malleable iron clamps. The pipes are held upright by mounting them in a cast-iron flange at the bottom and by bolting to a horizontal brace at the top. This pipe-work permits of many adjustments and is often used in supporting the devices and connections.

In mounting the instruments and devices on a switchboard, nothing should be used which has no other use than ornamentation. Similar instruments and devices on the different panels are located at the same heights, which tends to give the board a symmetrical, uniform, and pleasing appearance. Circuit-breakers and fuses are located near the top of the panel in order that any arc may rise without injury to the adjacent devices or to the attendant. Just beneath the breaker are located the instruments which must be of a type not easily affected by a stray field. About the middle of the panel are placed the rheostat hand-wheel, field switches, etc., with oil switches, large recording wattmeters, and relays at the bottom, depending upon the nature of the panel. In stations of large capacity it is convenient to use electrically operated switches. In this case a controlling board is used in the shape of an inclined table, with the meters and instruments located on vertical panels back of the controlling board. By this means an operator can stand in front of the controlling board, with all of the controlling switches within easy reach and with the various instruments in full view.

The illumination of the board is best when it can be provided for from that of the station. When necessary, however, lamps are mounted at the top of the panel, but this is open to the objection that it does not give uniform illumination and reflects in the attendant's eyes.

The switchboard is a check upon the efficiency and economy of the whole station. The various machines were designed to operate under certain loads, and the board must be laid out with sufficient indicating and recording instruments to determine if the machines are working under proper load, and to obtain a record of the total

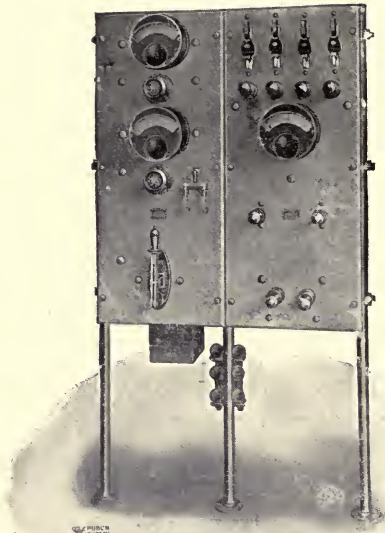

FIG. 332.

output. Sufficient protective devices must be provided in order to protect the system and its various parts. Where these devices are automatic, they should be reliable and kept in good order. Otherwise they are liable to become a source of trouble, resulting in shut-downs.

Switchboards are usually arranged so that similar panels are together. This avoids crossing of leads, with the liability to short-circuit, fire risk, and shut-downs. Usually the generator panels are at one end of the board and the feeder panels at the other. Fig. 331 shows a typical board of two alternating-current three-phase gen-

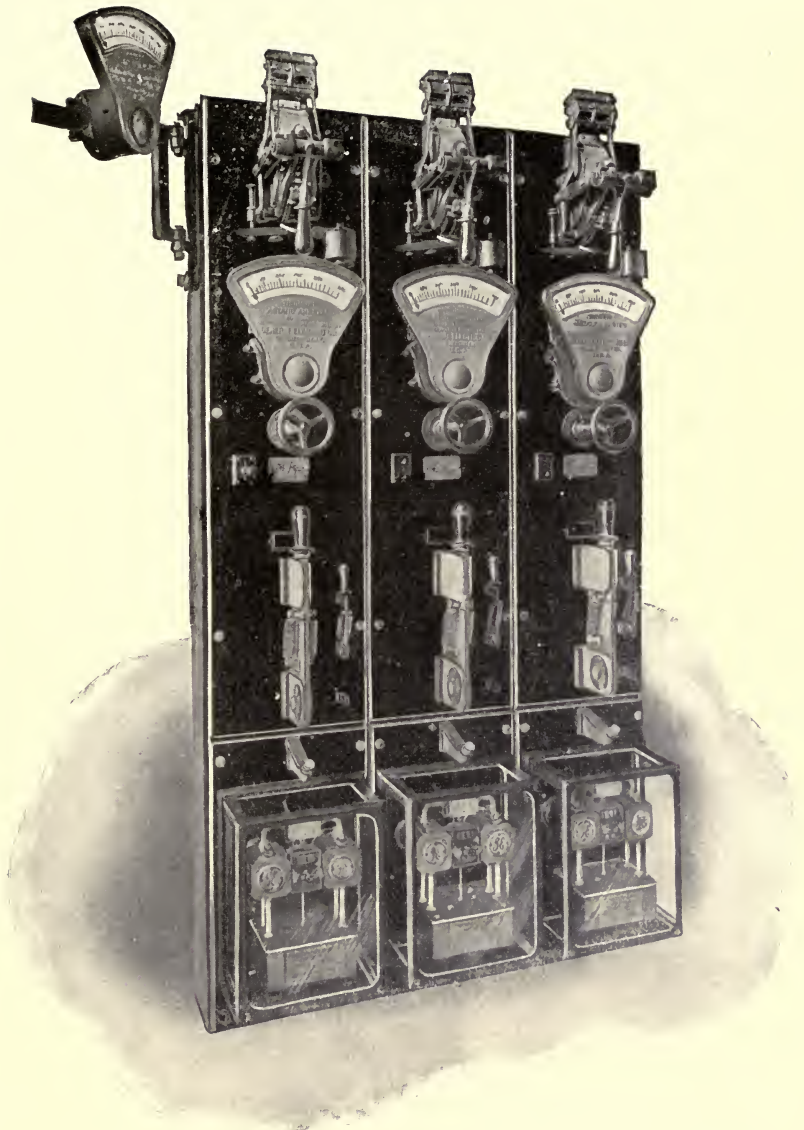

FIG. 333.

erator panels and two feeder panels. Switchboard design and construction has become so standardized that complete boards are made up from standard panels to meet practically all conditions of generation and distribution of energy. Boards such as shown in the above figure may be used on potentials up to and including 13,200 volts and may be of either slate or marble, since no parts carrying high potential are mounted on the panels.

In laying out a station it is necessary to lay out both the board and the cable runs carefully, in order to make proper provision for the protection of the cables and the location of the board with respect to the machines. Direct-current cables between the board and the machines are usually supported on insulator racks under the main floor. High-tension conductors from the alternator should preferably be lead-covered, varnished cambric or paper cable laid in ducts.

Isolated boards are made up for use in small plants where but one or two machines are controlled. In this case the feeder switches, instruments, circuit-breakers, or fuses are mounted on the same panel as shown in Fig. 332. This shows an A. C. isolated board for two machines and feeder circuits. Such boards are also largely used for isolated motor control.

At the present time most sub-stations are used for railway work and hence use railway converters in connection with high-tension transforming apparatus. Such stations differ only in the number and size of the units and use a board such as shown in Fig. 333. Here the breaker is shown at the top of the panel, with the ammeter just beneath. In the middle is located the handle for field rheostat, feeder and field switches just beneath, and recording wattmeter at the bottom. This does not differ materially from the standard railway generator panel, while the feeder panels usually omit the rheostat, field switch, and recording wattmeter.

The panels are connected in the positive side of the circuit, the rotary converters having their series fields connected in the negative side. No negative switches are required, as the negative side of the board is connected directly to the ground.



INDEX

- Accumulator apparatus, 191
Accumulator battery, 185
Accumulator cars, 196
Accumulator cells, 184; end cells, 186
Accumulator plates, 181, 182; negative, 182; positive, 182
Accumulators, 179, 180; Planté, 181; efficiency of, 183; applications of, 195; cars provided with, 196
Action, electro-dynamic, 60
Alternating-current curve, 70, 234
Alternating-current generators, 247
Alternating-current motors, 270; important advantage of, 300; reversing of, 308; faults with, 311
Alternating currents, 71, 217; angles concerned with, 217; experiments with, 221; magnetic, electro-dynamic, and chemical effects obtained with, 223; current strength and voltage of, 224; induction effects of, 225; differing in phase, 315
Alternation, 71
Alternators, 247; double-current, 248; inner-pole, 250, 251; with single rotating magnet bobbin, 252; inductor type, 253, 261-264; alternating-pole type, 253 and frontspiece; electro-motive force of, 253; quarter-phase, 255; three-phase, 255; regulation of, 256; efficiency of, 257; on a non-inductive load, 260; switching in parallel, 265; action of two in parallel, 268; withdrawing one, 269; simplest type of, 270
Ammeter, electro-magnetic, 18, 19; hot-wire, 19, 20, Deprez, 57, 133, 300; Weston, 58; shunt for, 59; with central zero point, 194; measuring transformers for, 327; in high-tension plants, 327
Ampere, 15
Amperes, number of, passing through a circuit, 23
Ampère's Rule, 11
Ampere-turns, 11, 16
Angles concerned with alternating currents, 217
Apparent watts, 246
Applications of accumulators, 195
Arc, 207
Arc lamp, 207; current strength of, 208; series, 209; differential, 210; shunt, 210; general arrangement of parts of, 211; the Křížik or Pilsen, 211, 212; enclosed, 214, 216; more economical than glow lamp, 214; magnetite (General Electric Company), 215, 216; used as a search-light, 215; the Bremer, 216; the Cooper-Hewitt, 216
Arc lamp resistance, without cover, 213; enclosed, 213
Arc lighter, 214
Armature, 68; Siemens, 69; Gramme, 74, 320; closed-coil, 75; toothed, 83; smooth, 83; partially wound, 84; finished, 84; locomotive motor, 85; of multipolar dynamo, 109; former-wound, 115, 117; motor, 133; with three slots per pole, 249; four-pole, with single slot per pole, 250; of inductor machine, 262; primary, 285; slip-ring, 293; squirrel-cage, 293; short-circuit, 295; induction-motor, diagram of, 310. See also *Drum armature* and *Ring armature*

- Armature coil, multiple-formed, 116;
 series-formed, 116
 Armature reaction, 88; with motors,
 149
 Armature resistance loss, 131
 Armature winding, outer and inner
 wires of, 75; of single-phase alter-
 nator, 254; of three-phase alter-
 nator, 258
 Astatic instrument for switchboards,
 59
 Asynchronous motors, 285
 Auer, Dr., of Vienna, 213
 Automatic features of Type M Control,
 175
 Auxiliary phase of single-phase motor,
 304, 307

 Back electro-motive force, 134, 226
 Bar magnet, 5
 Battery, galvanic, 1, 2; storage, 185;
 Edison, 186; buffer, 195
 Battery switch, 189, 190
 Bayonet holder, 204
 Bicycle, diagrams of working of, 303
 Bipolar dynamo, 71
 Blow-out, magnetic, 177
 Boat, moving, action of, 66
 Bobbin, for alternating-current electro-
 magnet, 227; exciting, of inductor
 machine, 262
 Boosters, 97, 189
 Brake, electric, 175; Proney, 295
 Branching of circuits, 29
 Break spark, 222
 Breaks in a circuit, 125
 Bremer arc lamp, 216
 Brushes, 69; sparking and displace-
 ment of, 118; carbon, 120; copper,
 120
 Brush-holder, carbon, 120; copper
 gauze, 121; with metal and carbon
 brushes, 121
 Buffer batteries, 195
 Buffer effect, 276

 C type of dynamo, 100
 Cables, concentric, 43; control, 174
 Calculation of resistance, 23
 Calibration, 18
 Calorie, 39
 Carbon-holder, sliding type, 120;
 swivel type, 120
 Carbonizing, 204
 Carbon lamp, 203
 Cast steel, 103
 Cell, galvanic, 1; storage, 184

 Cell switches, 186
 Cells, in series and parallel, 31; in
 opposition, 32; jointly supplying
 an outer circuit, 32
 Cellulose, 203
 Centigrade, 24
 Centimetre measure, 24
 Charging, 180, 194
 Charging current, 305
 Chemical energy, 197
 Choking coil, 238, 304
 Circuit-breaker, 50-52
 Circuits, magnetic, 15, 63, 86, 106, 163;
 simple, 27; series, 29; in parallel,
 29; branching of, 29; characteristic
 of closed, 88; main, 92; shunt, 92;
 breaks in, 125; motor, 175; control,
 175; with inductance and resistance,
 242
 Cleanliness, 326
 Clockwise rotation, of separately
 excited dynamo, 122; of shunt
 dynamo, 122; of series dynamo, 123;
 of compound dynamo, 123; of
 series motor, 146; of shunt motor,
 146, 147; connection of single-
 phase motor for, 309
 Closed circuit characteristic, 88
 Closed-coil armature, 75
 Coil, 225; primary, 227; secondary,
 227; choking, 238, 304; without
 iron, vector diagram of, 240
 Commercial efficiency of a dynamo, 130
 Commutator, simple, 71
 Commutator motors, 281
 Compound dynamos, 97; connections,
 98, ready for switching in parallel,
 199, 200
 Compound motor, 143
 Concentric cables, 43
 Condenser, 306
 Conductor in a magnetic field, 65
 Conductors of electricity, 21
 Connecting, in parallel, 29; in series,
 29
 Connection, correct and incorrect,
 for braking motor, 176; earth, 329
 Connection box, 174
 Connections, for booster when charg-
 ing, 189; of single-phase motor, 309;
 star, 317; mesh or delta, 320
 Consequent poles, 109
 Constant current, 71
 Contactors, 172, 178
 Continuous current, 71, 72
 Continuous-current dynamo, 75
 Control cable, 174

- Control couplers, 174
 Control cut-out switch, 174
 Control fuses, 174
 Control rheostat, 174
 Controller, street-car, cylinder develop-
 ment of, 168; master, 173, 178
 Converters, rotary, 249, 276
 Cooper-Hewitt lamp, 216
 Copper required to carry energy three-
 phase and single-phase, 321
 Copper wire, data on, 54, 55
 Copper wires and cables, table of
 sizes, resistances, and maximum
 currents of, 53
 Core, 2; iron, 225, 227
 Core loss of a dynamo, 131
 Correct connection for braking motor,
 176
 Coulomb, 15
 Counter-clockwise rotation, of sepa-
 rately excited dynamo, 122; of
 shunt dynamo, 122; of series dy-
 namo, 123; of compound dynamo,
 123; of series motor, 145; of shunt
 motor, 146; connections of single-
 phase motor for, 309
 Counter-electro-motive force, 134
 Couplers, control, 174
 Crater, 208
 Current, electric, 2, 10, 60; measure-
 ment of, 14; unit, 16; maximum,
 47; induced, 66, 67, 226; constant,
 71; rectified or continuous, 71, 72;
 for exciting magnet coils, 86; run-
 ning light, 131; effective or virtual,
 224; inducing or primary, 226; watt-
 less, 237, 307; field, curve of, 258,
 261; at no load, 274, 275; multi-
 phase alternating, 283; quarter-
 phase or two-phase, 287; rotary or
 three-phase, 290, 292; magnetizing,
 293; no-load, 294; charging, 305;
 multiphase, transmission of, 314;
 phase, 323
 Current indicator, 194
 Current strength, 23, 29
 Current transformers, 327
 Currents, Eddy, 77, 78
 Curve of field current plotted against
 load, 258, 260
 Curve of voltage with load variation of
 an alternator, vector diagram of,
 259
 Curves, magnetic, 8; saturation, 87;
 sine, 218
 Cut-out, 47, 48; for large current, 48;
 minimum, 192; maximum, 193
 Cycles of a dynamo, 219
 Cylinder development of street-car
 controller, 168
 Damping, 211
 Dead points in working of bicycle and
 sewing-machine, 303
 Decomposition of water, 3
 Delta connections, 320
 Deprez instrument, 56, 57, 133; used
 as an ammeter, 57; used as a pole-
 finder, 58; used as a voltmeter, 58,
 202
 Diagrams, vector, 239, 259, 260, 261
 Difference of electrical potential, 4
 Differential arc lamp, 210
 Direct-current dynamos in parallel,
 198
 Direct-current motors, operating troub-
 les with, 178
 Direction of rotation, methods for
 changing, 121
 Direction of rotation of a motor, 145
 Discharging, 180, 194
 Discs, toothed, 83
 Double-cell switch, 188, 191
 Double-current alternator, 248
 Double-pole throw-over switch, 150
 Driving-keys, 83
 Drop of potential, 27; to reduce, 28
 Drum armature, 79; connections, 79,
 81, 82, 83; wound, 84; without
 winding, 84; four-pole parallel, 113;
 four-pole series, 114
 Drying, 326
 Dynamo, 68, 133; bipolar, 71; con-
 tinuous-current, 75; shunt, 92;
 self-excitation of, 92; series, 94;
 compound, 97; types of, 98; over-
 compounded, 98; Edison, 99; Kapp,
 99; C type of, 100; Manchester,
 100; Lahmeyer, 101; Gramme, 102;
 multipolar, 105; four-pole, 106;
 six-pole, 107; two-coil four-pole,
 108, 109; non-excitation of, 124;
 commercial efficiency of, 129, 130;
 direct-current, 198; switching, 201;
 cycles of a, 219
 Dynamo armature, 74, 133
 Dynamo-brushes, material for, 120
 Dyne, 9
 Earth connection, 329
 Eddy currents in iron, 77, 78
 Edison, Thomas A., 186; dynamo, 99;
 battery, 186; carbon lamp, 203;
 lamp-holder, 204

- Effective current, 224
 Effective voltage, 225
 Effective watts, 246
 Efficiency, of dynamos, 129; stray power method of getting, 131; of the accumulator, 183; of an alternator, 257
 Electric brake, 175
 Electric current, 2; influence of, on a magnetic needle, 10
 Electric lighting, 203
 Electric mains, 40
 Electric motor, 133
 Electric traction, 164
 Electric units, 14, 38
 Electrical energy, 197; the kilowatt-hour a commercial unit for, 197
 Electrical machines, 68
 Electrical output, 39
 Electrical phenomena, 1
 Electrical potential, difference of, 4
 Electrical power, 34, 197; the watt a convenient unit for, 197
 Electrical pressure, motion essential for maintenance of, 66
 Electrically driven fan, 164
 Electro-dynamic action, 60
 Electro-dynamometers, 60, 61
 Electrolytic polarization, 179
 Electro-magnetic ammeter, 18, 19
 Electro-magnets, 2, 61; horseshoe, 63 64; straight or bar, 63, 64
 Electro-motive force, 3 4, 27; back, 134, 226; of self-induction, 235, 236; of an alternator, 253
 Electro-motor, 133
 Enclosed arc lamp, 214, 216
 Enclosed fuse, 49
 Enclosed motor, 159, 160
 Enclosed regulating resistance, 90
 Energy, transformation of, 129; chemical, 197; electrical, 197
 Engineering, electrical, fundamental principles of, 1
 Equalizing wire, 199
 Equivalence of electrical mechanical and heating effects, 37
 Examples of installation calculations, 46
 Expulsion fuse-block, 49
 Expulsion-tube fuse-block, 49

 Fahrenheit, 24
 Fan, electrically driven, 164
 Faraday, 14
 Faure, 181
 Ferranti transformer, 231, 232
 Ferraris, 283
 Field, magnetic, 9, 234, 235, 286, 287; pulsating, 283, 303; rotating, 283
 Field magnets, material for, 102
 Field of magnetic force, 9
 Field rheostats, 91
 Filaments for incandescent lamps, 205-207
 Filings round current, arrangement of, 13
 Fixed lead, 121
 Foot-pounds, 38
 Force, electro-motive, 3, 4, 27, 235, 236, 253; exerted by a magnetic pole, 6; magnetic, lines and field of, 8, 9; lines of, 12, 13, 56, 60, 75, 104; magnetizing, 15, 17; magneto-motive, 15, 63; back or counter-electro-motive, 134, 226
 Former-wound armature, 114, 115, 117
 Forming, 180
 Four-pole three-phase motors, 292
 Four-pole two-phase motor, 288
 Friction loss of a dynamo, 130, 131
 Fundamental principles of electrical engineering, 1
 Fuse, 47, 48; for large current, 48; enclosed, 49; plug, 52; control, 174; high-tension, 328
 Fuse-block, expulsion, 49; expulsion-tube, 49

 Galvanic battery, 1, 2
 Galvanic cell, 1
 Galvanometer, 73; simple, 11
 Galvanometer coil, 11
 Gas voltameter 18
 Generator, 133, 250; alternating-current, 247; motor, 276, 277, 278
 Glow lamps, 35, 203; brass cap of, 204; star-connected, 319; on one phase, 319
 Gramme, 74
 Gramme armature, 74, 320
 Gramme dynamo, 102
 Gramme ring, 247, 277

 Hand rule, 67
 Heating effect, 35, 37
 Heating of a line 47
 Hefner-Alteneck, 82
 Helix, lines of force of, 13; resultant field of, 13
 Henry, 242
 High tension, 326
 High-tension fuse, 328
 High-tension insulator, 42

- High-tension plants, safety in, 328
 High-tension switch, 328
 High voltages, 46
 Holder, bayonet, 204; Swan, 204
 Horse-power, 38
 Horseshoe magnet, 5
 Hot-wire ammeter, 19, 20
 Hot-wire voltmeter, 34
 Hydraulic analogy, 3
 Hysteresis, 104
 Hysteresis loss, 129, 130
- Incandescent lamp, 35, 203; the Nernst, 205-207
 Incorrect connection for braking motor, 176
 Induced current, law of, 14; direction of, 66, 67, 226; rule for determining, 67
 Inducing or primary current, curve of, 226
 Induction, 65
 Induction motor, 283; two-phase, 285; actions in, 293; input and output of, 295, 298; formulæ for torque of, 296, 297; curve of torque of, 296; formulæ for horse-power of, 297; curves showing efficiency, maximum output, etc., of, 298; power factor of, 298; efficiency of, 298; advantages of, 299; vector diagram of, 301; single-phase, 302
 Inductionless load, 322
 inductor alternator, Oerlikon, 263
 Inductor machine, armature and exciting bobbin of, 262
 Influence of electric currents on each other, 60
 Installation calculations, 46
 installation of type M Control, 175
 Insulation, 327-329
 Insulator, 21; high-tension, 42; porcelain, 42
 Interlinked phases, 315; voltage between, diagram of, 316
 Internal resistance, 27
 Iron core, diagrams of, 225, 227
 Iron loss of a dynamo, 131
- Joule, 39
- Kapp type of dynamo, 99
 Kilowatt-hour, 195, 197
 Křižik arc lamp, 211, 212
- L, use of, 241
 Lag, 237
- Lahmeyer type of dynamo, 101
 Lamp-holder, 204
 Lamps, incandescent, 35, 203; in series and parallel, 45; testing, 126; carbon, 203; new types of, 216; synchronizing, 265
 Law, of induced currents, 14; of Ohm, 23, 26; of change of resistance with temperature, 24; Lenz's, 67, 274, 284
 Lead, fixed, 121; of current, 307
 Lenz's law, 67, 274, 284
 Lighting, electric, 203
 Lightning arresters, 330
 Line, heating of a, 47
 Lines, stray, 64
 Lines of force, 60, 104; round current, 12; of helix, 13; magnetic, 56; through ring armature, 75
 Lines of magnetic force, 8; meanings of, 8, 9
 Load, inductionless, 322
 Locomotive motor armature, 85
 Loop winding, 112
 Loss in field windings, 130
 Losses in transformation of energy, 129
 μ , use of, 17
- Machines, electrical, 68; magneto-electric, 73, 247; for charging accumulators, 187
 Magnet, bar, 5; horseshoe, 5; poles of, 13, 62; influence of a, on an electric current, 56; molecular, 62; field, 102
 Magnet frame, eighteen-pole, 108
 Magnet system, 85; of Oerlikon inductor alternator, 264
 Magnetic blow-out, 177
 Magnetic circuit, 15, 63; of bipolar dynamo, 86; four-pole, 106; four-pole inter-pole, 1.3
 Magnetic curves, 8
 Magnetic field, 9, 286, 287; alteration of, 234, 235
 Magnetic lines of force, 56
 Magnetic needle, 5, 6; pivoted, 5
 Magnetism, unit of, 9; residual, 62; permanent, 63
 Magnetite arc lamp, 215, 216
 Magnetization characteristic, 87
 Magnetizing current of a motor, 293
 Magnetizing force, 15, 17
 Magneto, 73, 127
 Magneto-electric machine, 73, 247
 Magneto-generator, 68
 Magneto-motive force, 15, 63

- Magnets and magnetic lines of force, 56
- Main circuit, 92
- Mains, electric, 40
- Manchester type of dynamo, 100
- Master controller, 173, 178
- Master switch, 173
- Maximum current, 47
- Maximum cut-outs, 193
- Measurement of currents, 14
- Measuring transformers, 327
- Mesh connections, 320, 321
- Metal ring, repulsion of, 225
- Metric system, 24
- Minimum cut-outs, 192
- Minium, 181
- Molecular magnets, 62
- Molecules, 62
- Motor, electric, 133; shunt, 136; speed regulation of, 137; series, 139, 176; compound, 143; for certain purposes, 159; enclosed, 159, 160; connected to machine tool, 160; connected to pump, 161; commutating pole, 161; connected to elevator, 162; connected to mine hoist, 163; street-car, 165; braking, 176; direct-current, 178; alternating-current, 270, 300, 308, 311; synchronous, 270; polyphase synchronous, 273, 274; commutator, 281; asynchronous, 285; two-phase, 288; three-phase, 292, 295; single-phase, 304. See also *Induction motor*
- Motor armature, 133
- Motor generator, 276, 277, 278
- Motor starting switch, 154
- Moving boat, action of, 66
- Moving coil ammeter, construction of, 57
- Multiphase alternating current, 283
- Multiphase currents, transmission of, 314
- Multiple-unit control system, 167
- Multipolar dynamos, 105
- Needle, magnetic, 5, 6
- Negative pole, 3
- Nernst, 205; lamp, 205-207
- Neutral point in three-phase windings, 320
- Neutral zone, 76
- No-load current, 294
- Non-excitation of dynamos, causes of, 124
- North and south poles of magnet, 13, 62
- Number of amperes passing through a circuit, 23
- ω , use of, 22
- Oerlikon inductor alternator, magnet system of, 263; lines of force in, 263
- Ohm, 22
- Ohm's Law, 23, 26; for magnetism, 64
- Operating troubles with direct-current motors, 178
- Osmium as a filament for glow lamps, 216
- Output, electrical, 39
- Output of a dynamo, 103
- Overload, 140
- Oxide of iron, 179
- π , use of, 10
- Paper, pole-finding, 202
- Parallel winding, 112
- Period, 284
- Permanent magnetism, 63
- Permeability, 17
- Phase, quantities out of, 240; main, 304, 307; auxiliary, 304, 307
- Phase current, 323
- Phase-difference, 233; caused by self-induction, 304; caused by capacity, 305; diagrams of capacity, 305, 306
- Phasemeters, 246
- Phases, interlinked, 315
- Phenomena, electrical, 1
- Pilsen lamp, 211
- Pitch, 80
- Pivoted magnetic needle, 5
- Planté, 180; plates, 180; accumulators, 181
- Plates, Planté, 180
- Plot of current at no load, 274, 275
- Plug fuse, 52
- Point, neutral, 320
- Polarity, 6; right, 201, 202
- Polarization, electrolytic, 179
- Pole-finder, 58
- Pole-finding paper, 202
- Poles, negative and positive, 3; north and south, of magnet, 13, 62; consequent, 109
- Pole-shoes, 68
- Polyphase synchronous motor, one phase of, 273, 274
- Porcelain insulator, 42
- Portable storage battery, 185
- Positive pole, 3
- Potential, electrical, 4; drop of, 27

- Power, electrical, 34, 197
 Power factor, 241, 246
 Power loss, 44, 45
 Power transmission, series method of, 141
 Presspahn tubes, 251
 Pressure, electrical, 66
 Pressure losses, 41
 Primary armature, 285; ready for winding, 289; completely wound, 289
 Primary current, 226
 Proney brake, 295
 Properties of angles concerned with alternating currents, 217
 Pulsating field, 283, 303
- Quantities out of phase, 240
 Quarter-phase alternator, 255
 Quarter-phase current, 287
- Raymond, 241, 297
 Reactance, synchronous, 260
 Real watts, 246
 Rectified current, 71, 72
 Regulating resistance, 89; enclosed, 90
 Regulator, shunt, 127, 128, 157
 Remanence, 62
 Residual magnetism, 62
 Resistance, 23, 25, 26; specific, 23; calculation of, 23; internal, 27; resultant, 31; regulating, 89
 Resistance frames, 25
 Resistance of a wire, 24
 Resistances in parallel, 30
 Resultant resistance, 31
 Resultant voltage, 323
 Reverser, 172
 Reversing and starting switch, 152, 157, 158
 Reversing apparatus, 150
 Reversing of alternating - current motors, 308
 Revolutions, 104
 Rheostat, control, 174
 Right polarity, two methods of securing, 201, 202
 Ring, metal, 225; Gramme 247, 277
 Ring armature, 74; lines of force through, 75; with commutator, 76, 77; two-pole, 118; four-pole parallel, 110, 111; four-pole series, 112; motor, 134; with slip-rings, 247
 Ring transformer, 228
 Rotary converters or rotaries, 249, 276
 Rotary or three-phase current, 292
 Rotating field, 283; production of, diagrams, 283, 284, 290, 291; speed of, 288
 Rotation, direction of, methods for changing, 121; of a motor, 145. See also *Clockwise* and *Counter-clockwise*
 Rotor, 285; squirrel-cage, 286; speed of, 288; wound, 289, 295; triphase, 299
 Running light current, 131
 Running position of series motor, 176
- Safety in high-tension plants, 328
 Saturation, condition of, 65
 Saturation curve, 87
 Search-light, 215
 Secondary winding, 226
 Self-excitation, 91; of dynamos, 92
 Self-induction, 153, 226; electro-motive force of, 235, 236
 Series arc lamp, 209
 Series circuit, 29
 Series dynamos, 94; connections, 95; closed circuit characteristic of, 96; working in parallel, 199, 200
 Series method of power transmission, 141
 Series motor, 139; with starting resistance, 139; speed and torque curves of, 142; counter-clockwise rotation, 145; clockwise rotation, 146
 Series winding, 95, 111, 113
 Sewing-machine, diagrams of working of, 303
 Shell transformer, 231
 Short-circuit armature, 295
 Short-circuiting, 326
 Shunt, 58
 Shunt arc lamp, 210
 Shunt circuit, 92
 Shunt dynamos, 92; connections, 92; external characteristic of, 93, 94; ready for switching in parallel, 198, 199, 200
 Shunt for ammeter, 59
 Shunt motor, with starting resistance, 136; with starting resistance and shunt regulator for speed regulation, 138; clockwise rotation, 146, 147; counter-clockwise rotation, 146; with wrong connection, 147, 148; rule for connecting up, 148; with change-over switch, 151
 Shunt regulator, 157; automatic, 127, 128
- Siemens, Werner, 92; armature, 69, 74, 75, 84, 221, 248, 270; lamp-holder, 204

- Simple circuit, 27
 Simple commutator, 71; second position of, 71; third position of, 72
 Simple galvanometer, 11
 Sine curve of electro-motive force and current, 218; 90° apart in phase, 220
 Single-phase induction motor, 302; with auxiliary phase with self-induction, 304; with auxiliary phase having capacity, 307
 Slip, 285, 300
 Slip-ring armatures, 293
 Slip-rings, 70, 310
 Slots, different shapes of, 251
 Smooth armatures, 83
 Solenoid, 12
 Spark, break, 222
 Sparking and displacement of brushes, 118
 Sparking with starters and shunt regulators, 153
 Specific resistance, 23
 Speed and torque curves of series motor, 142
 Speed-measuring devices, mechanical, 265; electrical, 265
 Speed regulation of a motor, 137
 Spiral without self-induction, 245
 Sprague-General Electric Type M Control, 169
 Square, to determine area of, 36
 Squirrel-cage armatures, 293
 Squirrel-cage rotor, 286
 Squirrel-cage winding, 274
 Standard Wire Gauge, 22
 Star connections, 317, 321
 Star method of arrangement of phases of three-phase system, 320
 Starter, 166; with inductionless break, having shunt slip-ring, 154; without slip-ring, 156
 Starting and reversing switch for shunt motor, 152, 157
 Static transformer, 278
 Stationary state, 40
 Stator, 285
 Steel, cast, 103
 Steinmetz, Charles P., 104, 259, 260
 Storage cells, 184
 Stray lines, 64
 Stray power method of getting efficiency, 131
 Street-car controller, 166-168
 Street-car motor, closed, 165; open, 165
 Sum, vector, 240
 Swan, 203; holder, 204
 S. W. G., 22
 Switch, double-pole throw-over or two-pole change-over, 150, 151; reversing and starting, 152, 157, 158; motor starting, 154; master, 173; control cut-out, 174; cell, 186; double-cell, 188, 191; battery, 189, 190; high-tension, 328
 Switchboards, 334; astatic instrument for, 59; high-tension, 327; insulation of, 329
 Switching dynamos in parallel, 201
 Switching in parallel of alternating-current machines, 265
 Synchronism, 265
 Synchronizer, 265; for multiphase machines, 324
 Synchronizing action, 269
 Synchronizing lamps, connections, 265; cross-connected, 266; for high-tension circuits, 267; arrangement of, for three-phase circuit, 324; for high-tension three-phase circuits, 325
 Synchronous motors, 270; disadvantages of, 271; advantages of, 272; electro-motive forces of, 272; field insulation of, 275; use of, 276; starting, 277
 Synchronous reactance, 260
 Synchroscope, Westinghouse, 265
 System, metric, 24; Ward-Leonard, 158; multiple-unit control, 167; train control, 171; two-phase, 314; three-phase, 316
 Temperature, change of resistance with, 24
 Tension, high, 326
 Testing lamp, 126
 Three-phase alternator, 256, 334
 Three-phase current, 290
 Three-phase motor, wound rotor of, 295
 Three-phase system, with six mains, 316; voltage between outer terminals, 316; with four mains, 317; with three mains, 317; current in common return, 318; power in, 322
 Toothed armatures, 83
 Toothed discs, open slots, 83; nearly closed slots, 83
 Traction, electric, 164
 Train control system, 171
 Transformation of energy, 129
 Transformers, 227; ring, 228; shape of, 229; with horseshoe-shaped

- iron core, 230; with coils subdivided, 230; with coils wound one on the other, 231; shell, 231; Ferranti type, 231, 232; applications of, 232; vector diagram of, 240; regulation of, 262; static, 278; measuring, 327
- Triphase rotor, 299
- Tri-phaser, forty-pole armature of, 313
- Trolley, 165
- Tubes, Presspahn, 251
- Two-phase current, 287; motor, 286
- Two-phase induction motor, 285, 286; ready for winding, 289; wound, 289
- Two-phase system, with four mains, 314; with three mains, 315
- Two-pole change-over switch, 150, 151
- Two-pole dynamo, 71
- Type C motor complete, 289
- Type M Control, 169; automatic features of, 175
- Types of dynamos, 98
- Unit, of magnetism, 9; of electric pressure, 14
- Unit current, 16
- Units, 24; electric, 14, 38
- Value of resistances in parallel, 30
- Vector diagram method, 221
- Vector diagrams, 239, 259, 260, 261
- Vector sum, 240
- Virtual current, 224
- Virtual voltage, 225
- Volta, 18
- Voltage, 14; high, 46; effective or virtual, 225; square root of mean square, 243; curve of, 259; in three-phase rotary, 279; resultant, 323
- Voltage drop, 44
- Voltmeter, 18
- Volt-ampere, 35
- Voltmeter, electro-magnetic type, 33, 202; hot-wire, 34; for cell testing, 194; switch, 202
- Ward-Leonard system of control for shunt or series motors, 158
- Water, decomposition of, 3
- Water current, production of, 4
- Watt, 35, 197
- Watt, James, 38
- Wattless current, 237, 307
- Wattmeter, 60, 244
- Watts, apparent, 246; effective or real, 246
- Wave winding, 113
- Westinghouse lightning arrester, 331
- Westinghouse synchroscope, 265
- Weston ammeter, 58
- Winding, series, 95, 111, 113; loop, 112; parallel, 112; wave, 113; field, 130; secondary, 226; squirrel-cage, 274; three-phase, 320
- Wire, resistance of a, 24; equalizing, 199
- Working of direct-current dynamos in parallel, 198
- Zone, neutral, 76

SHORT-TITLE CATALOGUE

OF THE

PUBLICATIONS

OF

JOHN WILEY & SONS,

NEW YORK.

LONDON: CHAPMAN & HALL, LIMITED.

UNDER SUBJECTS.

Books marked with an asterisk (*) are sold in cloth unless otherwise stated.

CULTURE.

Philadelphia Book Co.	12mo, \$1 75
Philadelphia, Pa.	8vo, 4 00
al Manual:	
Improvement.....	12mo, 1 50
.....	12mo, 1 50
ca	8vo, 5 00
.....	12mo, 1 50
.....	12mo, 1 00
Graves's Forest Mensuration.....	8vo, 4 00
Green's Principles of American Forestry.....	12mo, 1 50
Grottenfelt's Principles of Modern Dairy Practice. (Woll).....	12mo, 2 00
Kemp's Landscape Gardening.....	12mo, 2 50
Maynard's Landscape Gardening as Applied to Home Decoration.....	12mo, 1 50
* McKay and Larsen's Principles and Practice of Butter-making.....	8vo, 1 50
Sanderson's Insects Injurious to Staple Crops.....	12mo, 1 50
Insects Injurious to Garden Crops. (In preparation.)	
Insects Injuring Fruits. (In preparation.)	
Stockbridge's Rocks and Soils.....	8vo, 2 50
Winton's Microscopy of Vegetable Foods.....	8vo, 7 50
Woll's Handbook for Farmers and Dairymen.....	16mo, 1 50

ARCHITECTURE.

Baldwin's Steam Heating for Buildings.....	12mo, 2 50
Bashore's Sanitation of a Country House.....	12mo, 1 00
Berg's Buildings and Structures of American Railroads.....	4to, 5 00
Birkmire's Planning and Construction of American Theatres.....	8vo, 3 00
Architectural Iron and Steel.....	8vo, 3 50
Compound Riveted Girders as Applied in Buildings.....	8vo, 2 00
Planning and Construction of High Office Buildings.....	8vo, 3 50
Skeleton Construction in Buildings.....	8vo, 3 00
Brigg's Modern American School Buildings.....	8vo, 4 00

in the
on the
the
POSTAGE
Book to
of the

SHORT-TITLE CATALOGUE

OF THE

PUBLICATIONS

OF

JOHN WILEY & SONS,

NEW YORK.

LONDON: CHAPMAN & HALL, LIMITED.

ARRANGED UNDER SUBJECTS.

Descriptive circulars sent on application. Books marked with an asterisk (*) are sold at *net* prices only. All books are bound in cloth unless otherwise stated.

AGRICULTURE.

Armsby's Manual of Cattle-feeding.	12mo,	\$1 75
Principles of Animal Nutrition.	8vo,	4 00
Budd and Hansen's American Horticultural Manual:		
Part I. Propagation, Culture, and Improvement.	12mo,	1 50
Part II. Systematic Pomology.	12mo,	1 50
Downing's Fruits and Fruit-trees of America	8vo,	5 00
Elliott's Engineering for Land Drainage.	12mo,	1 50
Practical Farm Drainage.	12mo,	1 00
Graves's Forest Mensuration.	8vo,	4 00
Green's Principles of American Forestry.	12mo,	1 50
Grotenfelt's Principles of Modern Dairy Practice. (Woll.)	12mo,	2 00
Kemp's Landscape Gardening.	12mo,	2 50
Maynard's Landscape Gardening as Applied to Home Decoration.	12mo,	1 50
* McKay and Larsen's Principles and Practice of Butter-making	8vo,	1 50
Sarderson's Insects Injurious to Staple Crops.	12mo,	1 50
Insects Injurious to Garden Crops. (In preparation.)		
Insects Injuring Fruits. (In preparation.)		
Stockbridge's Rocks and Soils.	8vo,	2 50
Winton's Microscopy of Vegetable Foods.	8vo,	7 50
Woll's Handbook for Farmers and Dairymen.	16mo,	1 50

ARCHITECTURE.

Baldwin's Steam Heating for Buildings.	12mo,	2 50
Bashore's Sanitation of a Country House.	12mo,	1 00
Berg's Buildings and Structures of American Railroads.	4to,	5 00
Birkmire's Planning and Construction of American Theatres.	8vo,	3 00
Architectural Iron and Steel.	8vo,	3 50
Compound Riveted Girders as Applied in Buildings.	8vo,	2 00
Planning and Construction of High Office Buildings.	8vo,	3 50
Skeleton Construction in Buildings.	8vo,	3 00
Brigg's Modern American School Buildings.	8vo,	4 00

Carpenter's Heating and Ventilating of Buildings.	8vo,	4 00
Freitag's Architectural Engineering.	8vo,	3 50
Fireproofing of Steel Buildings.	8vo,	2 50
French and Ives's Stereotomy.	8vo,	2 50
Gerhard's Guide to Sanitary House-inspection.	16mo,	1 00
Theatre Fires and Panics.	12mo,	1 50
*Greene's Structural Mechanics.	8vo,	2 50
Holly's Carpenters' and Joiners' Handbook.	18mo,	75
Johnson's Statics by Algebraic and Graphic Methods.	8vo,	2 00
Kidder's Architects' and Builders' Pocket-book. Rewritten Edition. 16mo, mor.,		5 00
Merrill's Stones for Building and Decoration.	8vo,	5 00
Non-metallic Minerals: Their Occurrence and Uses.	8vo,	4 00
Monckton's Stair-building.	4to,	4 00
Patton's Practical Treatise on Foundations.	8vo,	5 00
Peabody's Naval Architecture.	8vo,	7 50
Rice's Concrete-block Manufacture	8vo,	2 00
Richey's Handbook for Superintendents of Construction.	16mo, mor.,	4 00
* Building Mechanics' Ready Reference Book. Carpenters' and Wood-		
workers' Edition.	16mo, morocco,	1 50
Sabin's Industrial and Artistic Technology of Paints and Varnish.	8vo,	3 00
Siebert and Biggin's Modern Stone-cutting and Masonry.	8vo,	1 50
Snow's Principal Species of Wood.	8vo,	3 50
Sondericker's Graphic Statics with Applications to Trusses, Beams, and Arches.		
	8vo,	2 00
Towne's Locks and Builders' Hardware.	18mo, morocco,	3 00
Wait's Engineering and Architectural Jurisprudence	8vo,	6 00
	Sheep,	6 50
Law of Operations Preliminary to Construction in Engineering and Archi-		
tecture.	8vo,	5 00
	Sheep,	5 50
Law of Contracts.	8vo,	3 00
Wood's Rustless Coatings: Corrosion and Electrolysis of Iron and Steel. 8vo,		4 00
Worcester and Atkinson's Small Hospitals, Establishment and Maintenance,		
Suggestions for Hospital Architecture, with Plans for a Small Hospital.		
	12mo,	1 25
The World's Columbian Exposition of 1893.	Large 4to,	1 00

ARMY AND NAVY.

Bernadou's Smokeless Powder, Nitro-cellulose, and the Theory of the Cellulose		
Molecule.	12mo,	2 50
* Bruff's Text-book Ordnance and Gunnery.	8vo,	6 00
Chase's Screw Propellers and Marine Propulsion.	8vo,	3 00
Cloke's Gunner's Examiner.	8vo,	1 50
Craig's Azimuth.	4to,	3 50
Crehore and Squier's Polarizing Photo-chronograph.	8vo,	3 00
* Davis's Elements of Law.	8vo,	2 50
* Treatise on the Military Law of United States.	8vo,	7 00
	Sheep,	7 50
De Brack's Cavalry Outposts Duties. (Carr.)	24mo, morocco,	2 00
Dietz's Soldier's First Aid Handbook.	16mo, morocco,	1 25
* Dudley's Military Law and the Procedure of Courts-martial.	Large 12mo,	2 50
Durand's Resistance and Propulsion of Ships.	8vo,	5 00
* Dyer's Handbook of Light Artillery.	12mo,	3 00
Eissler's Modern High Explosives.	8vo,	4 00
* Fieberger's Text-book on Field Fortification.	Small 8vo,	2 00
Hamilton's The Gunner's Catechism	18mo,	1 00
* Hoff's Elementary Naval Tactics.	8vo,	1 50

Ingalls's Handbook of Problems in Direct Fire.	8vo,	4 00
* Ballistic Tables.	8vo,	1 50
* Lyons's Treatise on Electromagnetic Phenomena. Vols. I. and II. 8vo, each		6 00
* Mahan's Permanent Fortifications. (Mercur.)	8vo, half morocco,	7 50
Manual for Courts-martial.	16mo, morocco,	1 50
* Mercur's Attack of Fortified Places.	12mo,	2 00
* Elements of the Art of War.	8vo,	4 00
Metcalf's Cost of Manufactures—And the Administration of Workshops.	8vo,	5 00
* Ordnance and Gunnery. 2 vols.	12mo,	5 00
Murray's Infantry Drill Regulations.	18mo, paper,	10
Nixon's Adjutants' Manual.	24mo,	1 00
Peabody's Naval Architecture.	8vo,	7 50
* Phelps's Practical Marine Surveying.	8vo,	2 50
Powell's Army Officer's Examiner.	12mo,	4 00
Sharpe's Art of Subsisting Armies in War.	18mo, morocco,	1 50
* Tupes and Poole's Manual of Bayonet Exercises and Musketry Fencing.	24mo, leather,	50
* Walke's Lectures on Explosives.	8vo,	4 00
Weaver's Military Explosives.	8vo,	3 00
* Wheeler's Siege Operations and Military Mining.	8vo,	2 00
Winthrop's Abridgment of Military Law.	12mo,	2 50
Woodhull's Notes on Military Hygiene.	16mo,	1 50
Young's Simple Elements of Navigation.	16mo, morocco,	2 00

ASSAYING.

Fletcher's Practical Instructions in Quantitative Assaying with the Blowpipe.	12mo, morocco,	1 50
Furman's Manual of Practical Assaying.	8vo,	3 00
Lodge's Notes on Assaying and Metallurgical Laboratory Experiments.	8vo,	3 00
Low's Technical Methods of Ore Analysis.	8vo,	3 00
Miller's Manual of Assaying.	12mo,	1 00
Cyanide Process.	12mo,	1 00
Minet's Production of Aluminum and its Industrial Use. (Waldo.)	12mo,	2 50
O'Driscoll's Notes on the Treatment of Gold Ores.	8vo,	2 00
Ricketts and Miller's Notes on Assaying.	8vo,	3 00
Robine and Lenglen's Cyanide Industry. (Le Clerc.)	8vo,	4 00
Ulke's Modern Electrolytic Copper Refining.	8vo,	3 00
Wilson's Cyanide Processes.	12mo,	1 50
Chlorination Process.	12mo,	1 50

ASTRONOMY.

Comstock's Field Astronomy for Engineers.	8vo,	2 50
Craig's Azimuth.	4to,	3 50
Crandall's Text-book on Geodesy and Least Squares.	8vo,	3 00
Doolittle's Treatise on Practical Astronomy.	8vo,	4 00
Gore's Elements of Geodesy.	8vo,	2 50
Hayford's Text-book of Geodetic Astronomy.	8vo,	3 00
Merriman's Elements of Precise Surveying and Geodesy.	8vo,	2 50
* Michie and Harlow's Practical Astronomy.	8vo,	3 00
* White's Elements of Theoretical and Descriptive Astronomy	12mo	00

BOTANY.

Davenport's Statistical Methods, with Special Reference to Biological Variation.	16mo, morocco,	1 25
Thomé and Bennett's Structural and Physiological Botany.	16mo,	2 25
Westermaier's Compendium of General Botany. (Schneider.)	8vo,	2 00

CHEMISTRY.

* Abegg's Theory of Electrolytic Dissociation. (Von Ende.)	12mo,	1 25
Adriance's Laboratory Calculations and Specific Gravity Tables.	12mo,	1 25
Alexeyeff's General Principles of Organic Synthesis. (Matthews.)	8vo,	3 00
Allen's Tables for Iron Analysis.	8vo,	3 00
Arnold's Compendium of Chemistry. (Mandel.)	Small 8vo,	3 50
Austen's Notes for Chemical Students	12mo,	1 50
Bernadou's Smokeless Powder.—Nitro-cellulose, and Theory of the Cellulose Molecule.	12mo,	2 50
* Browning's Introduction to the Rarer Elements.	8vo,	1 50
Brush and Penfield's Manual of Determinative Mineralogy.	8vo,	4 00
* Claassen's Beet-sugar Manufacture. (Hall and Rolfe.)	8vo,	3 00
Classen's Quantitative Chemical Analysis by Electrolysis. (Boltwood.)	8vo,	3 00
Cohn's Indicators and Test-papers.	12mo,	2 00
Tests and Reagents.	8vo,	3 00
Crafts's Short Course in Qualitative Chemical Analysis. (Schaeffer.)	12mo,	1 50
* Danneel's Electrochemistry. (Merriam.)	12mo,	1 25
Dolezalek's Theory of the Lead Accumulator (Storage Battery). (Von Ende.)	12mo,	2 50
Drechsel's Chemical Reactions. (Merrill.)	12mo,	1 25
Duhem's Thermodynamics and Chemistry. (Burgess.)	8vo,	4 00
Eissler's Modern High Explosives.	8vo,	4 00
Effront's Enzymes and their Applications. (Prescott.)	8vo,	3 00
Erdmann's Introduction to Chemical Preparations. (Dunlap.)	12mo,	1 25
Fletcher's Practical Instructions in Quantitative Assaying with the Blowpipe.	12mo, morocco,	1 50
Fowler's Sewage Works Analyses.	12mo,	2 00
Fresenius's Manual of Qualitative Chemical Analysis. (Wells.)	8vo,	5 00
Manual of Qualitative Chemical Analysis. Part I. Descriptive. (Wells.)	8vo,	3 00
System of Instruction in Quantitative Chemical Analysis. (Cohn.)	2 vols.,	8vo, 12 50
Fuertes's Water and Public Health.	12mo,	1 50
Furman's Manual of Practical Assaying.	8vo,	3 00
* Getman's Exercises in Physical Chemistry.	12mo,	2 00
Gill's Gas and Fuel Analysis for Engineers.	12mo,	1 25
* Gooch and Browning's Outlines of Qualitative Chemical Analysis. Small 8vo,	1 25	
Grotenfelt's Principles of Modern Dairy Practice. (Woll.)	12mo,	2 00
Groth's Introduction to Chemical Crystallography (Marshall)	12mo,	1 25
Hammarsten's Text-book of Physiological Chemistry. (Mandel.)	8vo,	4 00
Helm's Principles of Mathematical Chemistry. (Morgan.)	12mo,	1 50
Hering's Ready Reference Tables (Conversion Factors).	16mo, morocco,	2 50
Hind's Inorganic Chemistry.	8vo,	3 00
Laboratory Manual for Students	12mo,	1 00
Holleman's Text-book of Inorganic Chemistry. (Cooper.)	8vo,	2 50
Text-book of Organic Chemistry. (Walker and Mott.)	8vo,	2 50
Laboratory Manual of Organic Chemistry. (Walker.)	12mo,	1 00
Hopkins's Oil-chemists' Handbook.	8vo,	3 00
Iddings's Rock Minerals.	8vo,	5 00
Jackson's Directions for Laboratory Work in Physiological Chemistry.	8vo,	1 25
Keep's Cast Iron.	8vo,	2 50
Ladd's Manual of Quantitative Chemical Analysis.	12mo,	1 00
Landauer's Spectrum Analysis. (Tingle.)	8vo,	3 00
* Langworthy and Austen. The Occurrence of Aluminium in Vegetable Products, Animal Products, and Natural Waters.	8vo,	2 00
Lassar-Cohn's Application of Some General Reactions to Investigations in Organic Chemistry. (Tingle.)	12mo,	1 00
Leach's The Inspection and Analysis of Food with Special Reference to State Control.	8vo,	7 50
Löb's Electrochemistry of Organic Compounds. (Lorenz.)	8vo,	3 00

Lodge's Notes on Assaying and Metallurgical Laboratory Experiments.	8vo,	3 00
Low's Technical Method of Ore Analysis.	8vo,	3 00
Lunge's Techno-chemical Analysis. (Cohn.)	12mo,	1 00
* McKay and Larsen's Principles and Practice of Butter-making	8vo,	1 50
Mandel's Handbook for Bio-chemical Laboratory	12mo,	1 50
* Martin's Laboratory Guide to Qualitative Analysis with the Blowpipe.	12mo,	60
Mason's Water-supply. (Considered Principally from a Sanitary Standpoint.) 3d Edition, Rewritten.	8vo,	4 00
Examination of Water. (Chemical and Bacteriological.)	12mo,	1 25
Matthew's The Textile Fibres.	8vo,	3 50
Meyer's Determination of Radicles in Carbon Compounds. (Tingle.)	12mo,	1 00
Miller's Manual of Assaying.	12mo,	1 00
Cyanide Process	12mo,	1 00
Minet's Production of Aluminum and its Industrial Use. (Waldo.)	12mo,	2 50
Mixer's Elementary Text-book of Chemistry.	12mo,	1 50
Morgan's An Outline of the Theory of Solutions and its Results	12mo,	1 00
Elements of Physical Chemistry.	12mo,	3 00
* Physical Chemistry for Electrical Engineers.	12mo,	5 00
Morse's Calculations used in Cane-sugar Factories.	16mo, morocco,	1 50
* Muir's History of Chemical Theories and Laws	8vo,	4 00
Mulliken's General Method for the Identification of Pure Organic Compounds. Vol. I.	Large 8vo,	5 00
O'Brine's Laboratory Guide in Chemical Analysis.	8vo,	2 00
O'Driscoll's Notes on the Treatment of Gold Ores.	8vo,	2 00
Ostwald's Conversations on Chemistry. Part One. (Ramsey.)	12mo,	1 50
" " " " Part Two. (Turnbull.)	12mo,	2 00
* Pauli's Physical Chemistry in the Service of Medicine. (Fischer.)	12mo,	1 25
* Penfield's Notes on Determinative Mineralogy and Record of Mineral Tests. 8vo, paper,		50
Pictet's The Alkaloids and their Chemical Constitution. (Biddle.)	8vo,	5 00
Pinner's Introduction to Organic Chemistry. (Austen.)	12mo,	1 50
Poole's Calorific Power of Fuels.	8vo,	3 00
Prescott and Winslow's Elements of Water Bacteriology, with Special Refer- ence to Sanitary Water Analysis.	12mo,	1 25
* Reisig's Guide to Piece-dyeing.	8vo,	25 00
Richards and Woodman's Air, Water, and Food from a Sanitary Standpoint.	8vo,	2 00
Ricketts and Russell's Skeleton Notes upon Inorganic Chemistry. (Part I. Non-metallic Elements.)	8vo, morocco,	75
Ricketts and Miller's Notes on Assaying.	8vo,	3 00
Rideal's Sewage and the Bacterial Purification of Sewage.	8vo,	4 00
Disinfection and the Preservation of Food.	8vo,	4 00
Riggs's Elementary Manual for the Chemical Laboratory.	8vo,	1 25
Robine and Lenglen's Cyanide Industry. (Le Clerc.)	8vo,	4 00
Ruddiman's Incompatibilities in Prescriptions.	8vo,	2 00
* Whys in Pharmacy	12mo,	1 00
Sabin's Industrial and Artistic Technology of Paints and Varnish.	8vo,	3 00
Salkowski's Physiological and Pathological Chemistry. (Orndörff.)	8vo,	2 50
Schimpf's Text-book of Volumetric Analysis.	12mo,	2 50
Essentials of Volumetric Analysis.	12mo,	1 25
* Qualitative Chemical Analysis.	8vo,	1 25
Smith's Lecture Notes on Chemistry for Dental Students.	8vo,	2 50
Spencer's Handbook for Chemists of Beet-sugar Houses.	16mo, morocco,	3 00
Handbook for Cane Sugar Manufacturers.	16mo, morocco,	3 00
Stockbridge's Rocks and Soils.	8vo,	2 50
* Tillman's Elementary Lessons in Heat.	8vo,	1 50
* Descriptive General Chemistry.	8vo,	3 00
Treadwell's Qualitative Analysis. (Hall.)	8vo,	3 00
Quantitative Analysis. (Hall.)	8vo,	4 00
Turneure and Russell's Public Water-supplies.	3vo,	5 00

Van Deventer's Physical Chemistry for Beginners. (Boltwood.)	12mo,	1 50
* Walke's Lectures on Explosives.	8vo,	4 00
Ware's Beet-sugar Manufacture and Refining.	Small 8vo, cloth,	4 00
Washington's Manual of the Chemical Analysis of Rocks.	8vo,	2 00
Weaver's Military Explosives.	8vo,	3 00
Wehrenfennig's Analysis and Softening of Boiler Feed-Water	8vo,	4 00
Wells's Laboratory Guide in Qualitative Chemical Analysis.	8vo,	1 50
Short Course in Inorganic Qualitative Chemical Analysis for Engineering Students.	12mo,	1 50
Text-book of Chemical Arithmetic	12mo,	1 25
Whipple's Microscopy of Drinking-water.	8vo,	3 50
Wilson's Cyanide Processes	12mo,	1 50
Chlorination Process.	12mo,	1 50
Winton's Microscopy of Vegetable Foods	8vo,	7 50
Wulling's Elementary Course in Inorganic, Pharmaceutical, and Medical Chemistry.	12mo,	2 00

CIVIL ENGINEERING.

BRIDGES AND ROOFS. HYDRAULICS. MATERIALS OF ENGINEERING. RAILWAY ENGINEERING.

Baker's Engineers' Surveying Instruments.	12mo,	3 00
Bixby's Graphical Computing Table.	Paper 19½ × 24½ inches.	25
Breed and Hosmer's Principles and Practice of Surveying.	8vo,	3 00
* Burr's Ancient and Modern Engineering and the Isthmian Canal	8vo,	3 50
Comstock's Field Astronomy for Engineers.	8vo,	2 50
Crandall's Text-book on Geodesy and Least Squares	8vo,	3 00
Davis's Elevation and Stadia Tables.	8vo,	1 00
Elliott's Engineering for Land Drainage.	12mo,	1 50
Practical Farm Drainage.	12mo,	1 00
* Fiebigger's Treatise on Civil Engineering.	8vo,	5 00
Flemer's Phototopographic Methods and Instruments.	8vo,	5 00
Folwell's Sewerage. (Designing and Maintenance.)	8vo,	3 00
Freitag's Architectural Engineering. 2d Edition, Rewritten	8vo,	3 50
French and Ives's Stereotomy.	8vo,	2 50
Goodhue's Municipal Improvements.	12mo,	1 75
Gore's Elements of Geodesy.	8vo,	2 50
Hayford's Text-book of Geodetic Astronomy.	8vo,	3 00
Hering's Ready Reference Tables (Conversion Factors).	16mo, morocco,	2 50
Howe's Retaining Walls for Earth.	12mo,	1 25
* Ives's Adjustments of the Engineer's Transit and Level.	16mo, Bds.	25
Ives and Hilts's Problems in Surveying	16mo, morocco,	1 50
Johnson's (J. B.) Theory and Practice of Surveying.	Small 8vo,	4 00
Johnson's (L. J.) Statics by Algebraic and Graphic Methods.	8vo,	2 00
Laplace's Philosophical Essay on Probabilities. (Truscott and Emory.)	12mo,	2 00
Mahan's Treatise on Civil Engineering. (1873.) (Wood.)	8vo,	5 00
* Descriptive Geometry.	8vo,	1 50
Merriman's Elements of Precise Surveying and Geodesy.	8vo,	2 50
Merriman and Brooks's Handbook for Surveyors.	16mo, morocco,	2 00
Nugent's Plane Surveying.	8vo,	3 50
Ogden's Sewer Design.	12mo,	2 00
Parsons's Disposal of Municipal Refuse.	8vo,	2 00
Patton's Treatise on Civil Engineering.	8vo half leather,	7 50
Reed's Topographical Drawing and Sketching	4to,	5 00
Rideal's Sewage and the Bacterial Purification of Sewage.	8vo,	4 00
Siebert and Biggin's Modern Stone-cutting and Masonry.	8vo,	1 50

Smith's Manual of Topographical Drawing. (McMillan.)	8vo,	2 50
Sondericker's Graphic Statics, with Applications to Trusses, Beams, and Arches.	8vo,	2 00
Taylor and Thompson's Treatise on Concrete, Plain and Reinforced.	8vo,	5 00
* Trautwine's Civil Engineer's Pocket-book.	16mo, morocco,	5 00
Venable's Garbage Crematories in America.	8vo,	2 00
Wait's Engineering and Architectural Jurisprudence.	8vo,	6 00
	Sheep,	6 50
Law of Operations Preliminary to Construction in Engineering and Architecture.	8vo,	5 00
	Sheep,	5 50
Law of Contracts.	8vo,	3 00
Warren's Stereotomy—Problems in Stone-cutting.	8vo,	2 50
Webb's Problems in the Use and Adjustment of Engineering Instruments.	16mo, morocco,	1 25
Wilson's Topographic Surveying.	8vo,	3 50

BRIDGES AND ROOFS.

Boller's Practical Treatise on the Construction of Iron Highway Bridges.	8vo,	2 00
* Thames River Bridge.	4to, paper,	5 00
Burr's Course on the Stresses in Bridges and Roof Trusses, Arched Ribs, and Suspension Bridges.	8vo,	3 50
Burr and Falk's Influence Lines for Bridge and Roof Computations.	8vo,	3 00
Design and Construction of Metallic Bridges.	8vo,	5 00
Du Bois's Mechanics of Engineering. Vol. II.	Small 4to,	10 00
Foster's Treatise on Wooden Trestle Bridges.	4to,	5 00
Fowler's Ordinary Foundations.	8vo,	3 50
Greene's Roof Trusses.	8vo,	1 25
Bridge Trusses.	8vo,	2 50
Arches in Wood, Iron, and Stone.	8vo,	2 50
Howe's Treatise on Arches.	8vo,	4 00
Design of Simple Roof-trusses in Wood and Steel.	8vo,	2 00
Symmetrical Masonry Arches.	8vo,	2 50
Johnson, Bryan, and Turneure's Theory and Practice in the Designing of Modern Framed Structures.	Small 4to,	10 00
Merriman and Jacoby's Text-book on Roofs and Bridges:		
Part I. Stresses in Simple Trusses.	8vo,	2 50
Part II. Graphic Statics.	8vo,	2 50
Part III. Bridge Design.	8vo,	2 50
Part IV. Higher Structures.	8vo,	2 50
Morison's Memphis Bridge.	4to,	10 00
Waddell's De Pontibus, a Pocket-book for Bridge Engineers.	16mo, morocco,	2 00
* Specifications for Steel Bridges.	12mo,	50
Wright's Designing of Draw-spans. Two parts in one volume.	8vo,	3 50

HYDRAULICS.

Barnes's Ice Formation.	8vo,	3 00
Bazin's Experiments upon the Contraction of the Liquid Vein Issuing from an Orifice. (Trautwine.)	8vo,	2 00
Bovey's Treatise on Hydraulics.	8vo,	5 00
Church's Mechanics of Engineering.	8vo,	6 00
Diagrams of Mean Velocity of Water in Open Channels.	paper,	1 50
Hydraulic Motors.	8vo,	2 00
Coffin's Graphical Solution of Hydraulic Problems.	16mo, morocco,	2 50
Fletcher's Dynamometers, and the Measurement of Power.	12mo,	3 00

Folwell's Water-supply Engineering.	8vo,	4 00
Frizell's Water-power.	8vo,	5 00
Fuertes's Water and Public Health.	12mo,	1 50
Water-filtration Works.	12mo,	2 50
Ganguillet and Kutter's General Formula for the Uniform Flow of Water in Rivers and Other Channels. (Hering and Trautwine.)	8vo,	4 00
Hazen's Filtration of Public Water-supply.	8vo,	3 00
Hazlehurst's Towers and Tanks for Water-works.	8vo,	2 50
Herschel's 115 Experiments on the Carrying Capacity of Large, Riveted, Metal Conduits.	8vo,	2 00
Mason's Water-supply. (Considered Principally from a Sanitary Standpoint.)	8vo,	4 00
Merriman's Treatise on Hydraulics.	8vo,	5 00
* Michie's Elements of Analytical Mechanics.	8vo,	4 00
Schuyler's Reservoirs for Irrigation, Water-power, and Domestic Water-supply.	Large 8vo,	5 00
* Thomas and Watt's Improvement of Rivers.	4to,	6 00
Turneure and Russell's Public Water-supplies	8vo,	5 00
Wegmann's Design and Construction of Dams.	4to,	5 00
Water-supply of the City of New York from 1653 to 1895.	4to,	10 00
Whipple's Value of Pure Water.	Large 12mo,	1 00
Williams and Hazen's Hydraulic Tables.	8vo,	1 50
Wilson's Irrigation Engineering.	Small 8vo,	4 00
Wolff's Windmill as a Prime Mover.	8vo,	3 00
Wood's Turbines.	8vo,	2 50
Elements of Analytical Mechanics.	8vo,	3 00

MATERIALS OF ENGINEERING.

Baker's Treatise on Masonry Construction.	8vo,	5 00
Roads and Pavements.	8vo,	5 00
Black's United States Public Works	Oblong 4to,	5 00
* Bovey's Strength of Materials and Theory of Structures.	8vo,	7 50
Burr's Elasticity and Resistance of the Materials of Engineering.	8vo,	7 50
Byrne's Highway Construction.	8vo,	5 00
Inspection of the Materials and Workmanship Employed in Construction.	16mo,	3 00
Church's Mechanics of Engineering.	8vo,	6 00
Du Bois's Mechanics of Engineering. Vol. I.	Small 4to,	7 50
* Ecker's Cements, Limes, and Plasters.	8vo,	6 00
Johnson's Materials of Construction.	Large 8vo,	6 00
Fowler's Ordinary Foundations.	8vo,	3 50
Graves's Forest Mensuration.	8vo,	4 00
* Greene's Structural Mechanics.	8vo,	2 50
Keep's Cast Iron.	8vo,	2 50
Lanza's Applied Mechanics.	8vo,	7 50
Marten's Handbook on Testing Materials. (Henning.) 2 vols.	8vo,	7 50
Maurer's Technical Mechanics.	8vo,	4 00
Merrill's Stones for Building and Decoration.	8vo,	5 00
Merriman's Mechanics of Materials.	8vo,	5 00
* Strength of Materials	12mo,	1 00
Metcalf's Steel. A Manual for Steel-users.	12mo,	2 00
Patton's Practical Treatise on Foundations.	8vo,	5 00
Richardson's Modern Asphalt Pavements.	8vo,	3 00
Richey's Handbook for Superintendents of Construction.	16mo, mor.,	4 00
* Ries's Clays: Their Occurrence, Properties, and Uses.	8vo,	5 00
Rockwell's Roads and Pavements in France.	12mo,	1 25

Sabin's Industrial and Artistic Technology of Paints and Varnish.....	8vo,	3 00
Smith's Materials of Machines.....	12mo,	1 00
Snow's Principal Species of Wood.....	8vo,	3 50
Spalding's Hydraulic Cement.....	12mo,	2 00
Text-book on Roads and Pavements.....	12mo,	2 00
Taylor and Thompson's Treatise on Concrete, Plain and Reinforced.....	8vo,	5 00
Thurston's Materials of Engineering. 3 Parts.....	8vo,	8 00
Part I. Non-metallic Materials of Engineering and Metallurgy.....	8vo,	2 00
Part II. Iron and Steel.....	8vo,	3 50
Part III. A Treatise on Brasses, Bronzes, and Other Alloys and their Constituents.....	8vo,	2 50
Tillson's Street Pavements and Paving Materials.....	8vo,	4 00
Waddell's De Pontibus. (A Pocket-book for Bridge Engineers.)..	16mo, mor.,	2 00
* Specifications for Steel Bridges.....	12mo,	50
Wood's (De V.) Treatise on the Resistance of Materials, and an Appendix on the Preservation of Timber.....	8vo,	2 00
Wood's (De V.) Elements of Analytical Mechanics.....	8vo,	3 00
Wood's (M. P.) Rustless Coatings: Corrosion and Electrolysis of Iron and Steel.....	8vo,	4 00

RAILWAY ENGINEERING.

Andrew's Handbook for Street Railway Engineers.....	3x5 inches, morocco,	1 25
Berg's Buildings and Structures of American Railroads.....	4to,	5 00
Brook's Handbook of Street Railroad Location.....	16mo, morocco,	1 50
Butt's Civil Engineer's Field-book.....	16mo, morocco,	2 50
Crandall's Transition Curve.....	16mo, morocco,	1 50
Railway and Other Earthwork Tables.....	8vo,	1 50
Dawson's "Engineering" and Electric Traction Pocket-book..	16mo, morocco,	5 00
Dredge's History of the Pennsylvania Railroad: (1879).....	Paper,	5 00
Fisher's Table of Cubic Yards.....	Cardboard,	25
Godwin's Railroad Engineers' Field-book and Explorers' Guide...	16mo, mor.,	2 50
Hudson's Tables for Calculating the Cubic Contents of Excavations and Em- bankments.....	8vo,	1 00
Molitor and Beard's Manual for Resident Engineers.....	16mo,	1 00
Nagle's Field Manual for Railroad Engineers.....	16mo, morocco,	3 00
Philbrick's Field Manual for Engineers.....	16mo, morocco,	3 00
Searles's Field Engineering.....	16mo, morocco,	3 00
Railroad Spiral.....	16mo, morocco,	1 50
Taylor's Prismoidal Formulæ and Earthwork.....	8vo,	1 50
* Trautwine's Method of Calculating the Cube Contents of Excavations and Embankments by the Aid of Diagrams.....	8vo,	2 00
The Field Practice of Laying Out Circular Curves for Railroads.....	12mo, morocco,	2 50
Cross-section Sheet.....	Paper,	25
Webb's Railroad Construction.....	16mo, morocco,	5 00
Economics of Railroad Construction.....	Large 12mo,	2 50
Wellington's Economic Theory of the Location of Railways.....	Small 8vo,	5 00

DRAWING.

Barr's Kinematics of Machinery.....	8vo,	2 50
* Bartlett's Mechanical Drawing.....	8vo,	3 00
* " " " " Abridged Ed.....	8vo,	1 50
Coolidge's Manual of Drawing.....	8vo, paper,	1 00

Coolidge and Freeman's Elements of General Drafting for Mechanical Engineers.....	Oblong 4to,	2 50
Durley's Kinematics of Machines.....	8vo,	4 00
Emch's Introduction to Projective Geometry and its Applications.....	8vo,	2 50
Hill's Text-book on Shades and Shadows, and Perspective.....	8vo,	2 00
Jamison's Elements of Mechanical Drawing.....	8vo,	2 50
Advanced Mechanical Drawing.....	8vo,	2 00
Jones's Machine Design:		
Part I. Kinematics of Machinery.....	8vo,	1 50
Part II. Form, Strength, and Proportions of Parts.....	8vo,	3 00
MacCord's Elements of Descriptive Geometry.....	8vo,	3 00
Kinematics; or, Practical Mechanism.....	8vo,	5 00
Mechanical Drawing.....	4to,	4 00
Velocity Diagrams.....	8vo,	1 50
MacLeod's Descriptive Geometry.....	Small 8vo,	1 50
* Mahan's Descriptive Geometry and Stone-cutting.....	8vo,	1 50
Industrial Drawing. (Thompson.).....	8vo,	3 50
Moyer's Descriptive Geometry.....	8vo,	2 00
Reed's Topographical Drawing and Sketching.....	4to,	5 00
Reid's Course in Mechanical Drawing.....	8vo,	2 00
Text-book of Mechanical Drawing and Elementary Machine Design.....	8vo,	3 00
Robinson's Principles of Mechanism.....	8vo,	3 00
Schwamb and Merrill's Elements of Mechanism.....	8vo,	3 00
Smith's (R. S.) Manual of Topographical Drawing. (McMillan.).....	8vo,	2 50
Smith (A. W.) and Marx's Machine Design.....	8vo,	3 00
* Tittsworth's Elements of Mechanical Drawing.....	Oblong 8vo,	1 25
Warren's Elements of Plane and Solid Free-hand Geometrical Drawing.....	12mo,	1 00
Drafting Instruments and Operations.....	12mo,	1 25
Manual of Elementary Projection Drawing.....	12mo,	1 50
Manual of Elementary Problems in the Linear Perspective of Form and Shadow.....	12mo,	1 00
Plane Problems in Elementary Geometry.....	12mo,	1 25
Primary Geometry.....	12mo,	75
Elements of Descriptive Geometry, Shadows, and Perspective.....	8vo,	3 50
General Problems of Shades and Shadows.....	8vo,	3 00
Elements of Machine Construction and Drawing.....	8vo,	7 50
Problems, Theorems, and Examples in Descriptive Geometry.....	8vo,	2 50
Weisbach's Kinematics and Power of Transmission. (Hermann and Klein.).....	8vo,	5 00
Whelpley's Practical Instruction in the Art of Letter Engraving.....	12mo,	2 00
Wilson's (H. M.) Topographic Surveying.....	8vo,	3 50
Wilson's (V. T.) Free-hand Perspective.....	8vo,	2 50
Wilson's (V. T.) Free-hand Lettering.....	8vo,	1 00
Woolf's Elementary Course in Descriptive Geometry.....	Large 8vo,	3 00

ELECTRICITY AND PHYSICS.

* Abegg's Theory of Electrolytic Dissociation. (Von Ende.).....	12mo,	1 25
Anthony and Brackett's Text-book of Physics. (Magie.).....	Small 8vo	3 00
Anthony's Lecture-notes on the Theory of Electrical Measurements.....	12mo,	1 00
Benjamin's History of Electricity.....	8vo,	3 00
Voltaic Cell.....	8vo,	3 00
Classen's Quantitative Chemical Analysis by Electrolysis. (Boltwood.).....	8vo,	3 00
* Collins's Manual of Wireless Telegraphy.....	12mo,	1 50
Morocco.....		2 00
Crehore and Squier's Polarizing Photo-chronograph.....	8vo,	3 00
* Danneel's Electrochemistry. (Merriam.).....	12mo,	1 25
Dawson's "Engineering" and Electric Traction Pocket-book.....	16mo, morocco,	5 00

Dolezalek's Theory of the Lead Accumulator (Storage Battery). (Von Ende.)	12mo,	2 50
Duhem's Thermodynamics and Chemistry. (Burgess.)	8vo,	4 00
Flather's Dynamometers, and the Measurement of Power.	12mo,	3 00
Gilbert's De Magnete. (Mottelay.)	8vo,	2 50
Hanchett's Alternating Currents Explained.	12mo,	1 00
Hering's Ready Reference Tables (Conversion Factors)	16mo morocco,	2 50
Holman's Precision of Measurements.	8vo,	2 00
Telescopic Mirror-scale Method, Adjustments, and Tests.	Large 8vo,	75
Kinzbrunner's Testing of Continuous-current Machines.	8vo,	2 00
Landauer's Spectrum Analysis. (Tingle.)	8vo,	3 00
Le Chatelier's High-temperature Measurements. (Boudouard—Burgess.)	12mo,	3 00
Löb's Electrochemistry of Organic Compounds. (Lorenz.)	8vo,	3 00
* Lyons's Treatise on Electromagnetic Phenomena. Vols. I. and II. 8vo, each,	8vo,	6 00
* Michie's Elements of Wave Motion Relating to Sound and Light.	8vo,	4 00
Niaudet's Elementary Treatise on Electric Batteries. (Fishback.)	12mo,	2 50
* Parshall and Hobart's Electric Machine Design.	4to, half morocco,	12 50
Reagan's Locomotives: Simple, Compound, and Electric. (New Edition.	Large 12mo,	3 50
* Rosenberg's Electrical Engineering. (Haldane Gee—Kinzbrunner.)	8vo,	2 00
Ryan, Norris, and Hoxie's Electrical Machinery. Vol. I.	8vo,	2 50
Thurston's Stationary Steam-engines.	8vo,	2 50
* Tillman's Elementary Lessons in Heat.	8vo,	1 50
Tory and Pitcher's Manual of Laboratory Physics.	Small 8vo,	2 00
Ulke's Modern Electrolytic Copper Refining.	8vo,	3 00

LAW.

* Davis's Elements of Law.	8vo,	2 50
* Treatise on the Military Law of United States.	8vo,	7 00
*	Sheep,	7 50
* Dudley's Military Law and the Procedure of Courts-martial	Large 12mo,	2 50
Manual for Courts-martial.	16mo, morocco,	1 50
Wait's Engineering and Architectural Jurisprudence.	8vo,	6 00
.	Sheep,	6 50
Law of Operations Preliminary to Construction in Engineering and Architecture.	8vo	5 00
.	Sheep,	5 50
Law of Contracts.	8vo,	3 00
Winthrop's Abridgment of Military Law.	12mo,	2 50

MANUFACTURES.

Bernadou's Smokeless Powder—Nitro-cellulose and Theory of the Cellulose Molecule.	12mo,	2 50
Bolland's Iron Founder.	12mo,	2 50
The Iron Founder," Supplement.	12mo,	2 50
Encyclopedia of Founding and Dictionary of Foundry Terms Used in the Practice of Moulding.	12mo,	3 00
* Claassen's Beet-sugar Manufacture. (Hall and Rolfe.)	8vo,	3 00
* Eckel's Cements, Limes, and Plasters.	8vo,	6 00
Eissler's Modern High Explosives.	8vo,	4 00
Effront's Enzymes and their Applications. (Prescott.)	8vo,	3 00
Fitzgerald's Boston Machinist.	12mo,	1 00
Ford's Boiler Making for Boiler Makers.	18mo,	1 00
Hopkin's Oil-chemists' Handbook.	8vo,	3 00
Keep's Cast Iron.	8vo,	2 50

Leach's The Inspection and Analysis of Food with Special Reference to State Control.....	Large 8vo,	7 50
* McKay and Larsen's Principles and Practice of Butter-making.....	8vo,	1 50
Matthews's The Textile Fibres.....	8vo,	3 50
Metcalf's Steel. A Manual for Steel-users'.....	12mo,	2 00
Metcalf's Cost of Manufactures—And the Administration of Workshops.....	8vo,	5 00
Meyer's Modern Locomotive Construction.....	4to,	10 06
Morse's Calculations used in Cane-sugar Factories.....	16mo, morocco,	1 50
* Reising's Guide to Piece-dyeing.....	8vo,	25 00
Rice's Concrete-block Manufacture.....	8vo,	2 00
Sabin's Industrial and Artistic Technology of Paints and Varnish.....	8vo,	3 00
Smith's Press-working of Metals.....	8vo,	3 00
Spalding's Hydraulic Cement.....	12mo,	2 00
Spencer's Handbook for Chemists of Beet-sugar Houses.....	16mo morocco,	3 00
Handbook for Cane Sugar Manufacturers.....	16mo morocco,	3 00
Taylor and Thompson's Treatise on Concrete, Plain and Reinforced.....	8vo,	5 00
Thurston's Manual of Steam-boilers, their Designs, Construction and Operation.....	8vo,	5 00
* Walke's Lectures on Explosives.....	8vo,	4 00
Ware's Beet-sugar Manufacture and Refining.....	Small 8vo,	4 00
Weaver's Military Explosives.....	8vo,	3 00
West's American Foundry Practice.....	12mo,	2 50
Moulder's Text-book.....	12mo,	2 50
Wolff's Windmill as a Prime Mover.....	8vo,	3 00
Wood's Rustless Coatings: Corrosion and Electrolysis of Iron and Steel.....	8vo,	4 00

MATHEMATICS.

Baker's Elliptic Functions.....	8vo,	1 50
* Bass's Elements of Differential Calculus.....	12mo,	4 00
Briggs's Elements of Plane Analytic Geometry.....	12mo,	1 00
Compton's Manual of Logarithmic Computations.....	12mo	1 50
Davis's Introduction to the Logic of Algebra.....	8vo,	1 50
* Dickson's College Algebra.....	Large 12mo,	1 50
* Introduction to the Theory of Algebraic Equations.....	Large 12mo,	1 25
Emch's Introduction to Projective Geometry and its Applications.....	8vo	2 50
Halsted's Elements of Geometry.....	8vo,	1 75
Elementary Synthetic Geometry.....	8vo,	1 50
Rational Geometry.....	12mo,	1 75
* Johnson's (J. B.) Three-place Logarithmic Tables: Vest-pocket size, paper,	100 copies for	5 00
* Mounted on heavy cardboard, 8×10 inches,	10 copies for	2 00
Johnson's (W. W.) Elementary Treatise on Differential Calculus.....	Small 8vo,	3 00
Elementary Treatise on the Integral Calculus.....	Small 8vo,	1 50
Johnson's (W. W.) Curve Tracing in Cartesian Co-ordinates.....	12mo,	1 00
Johnson's (W. W.) Treatise on Ordinary and Partial Differential Equations.	Small 8vo,	3 50
Johnson's (W. W.) Theory of Errors and the Method of Least Squares.....	12mo,	1 50
* Johnson's (W. W.) Theoretical Mechanics.....	12mo,	3 00
Laplace's Philosophical Essay on Probabilities. (Truscott and Emory.).....	12mo,	2 00
* Ludlow and Bass. Elements of Trigonometry and Logarithmic and Other Tables.....	8vo,	3 00
Trigonometry and Tables published separately.....	Each,	2 00
* Ludlow's Logarithmic and Trigonometric Tables.....	8vo	1 00
Manning's Irrational Numbers and their Representation by Sequences and Series	12mo,	1 25

Mathematical Monographs. Edited by Mansfield Merriman and Robert S. Woodward.	Octavo, each	1 00
No. 1. History of Modern Mathematics, by David Eugene Smith.		
No. 2. Synthetic Projective Geometry, by George Bruce Halsted.		
No. 3. Determinants, by Laenas Gifford Weld. No. 4. Hyperbolic Functions, by James McMahon. No. 5. Harmonic Functions, by William E. Byerly. No. 6. Grassmann's Space Analysis, by Edward W. Hyde. No. 7. Probability and Theory of Errors, by Robert S. Woodward. No. 8. Vector Analysis and Quaternions, by Alexander Macfarlane. No. 9. Differential Equations, by William Woolsey Johnson. No. 10. The Solution of Equations, by Mansfield Merriman. No. 11. Functions of a Complex Variable, by Thomas S. Fiske.		
Maurer's Technical Mechanics.	8vo,	4 00
Merriman's Method of Least Squares.	8vo,	2 00
Rice and Johnson's Elementary Treatise on the Differential Calculus. .Sm.	8vo,	3 00
Differential and Integral Calculus. 2 vols. in one.	Small 8vo,	2 50
* Veblen and Lennes's Introduction to the Real Infinitesimal Analysis of One Variable	8vo,	2 00
Wood's Elements of Co-ordinate Geometry.	8vo,	2 00
Trigonometry: Analytical, Plane, and Spherical	12mo,	1 00

MECHANICAL ENGINEERING.

MATERIALS OF ENGINEERING, STEAM-ENGINES AND BOILERS.

Bacon's Forge Practice.	12mo,	1 50
Baldwin's Steam Heating for Buildings.	12mo,	2 50
Barr's Kinematics of Machinery.	8vo,	2 50
* Bartlett's Mechanical Drawing.	8vo,	3 00
* " " " " Abridged Ed.	8vo,	1 50
Benjamin's Wrinkles and Recipes.	12mo,	2 00
Carpenter's Experimental Engineering.	8vo,	6 00
Heating and Ventilating Buildings.	8vo,	4 00
Clerk's Gas and Oil Engine.	Small 8vo,	4 00
Coolidge's Manual of Drawing.	8vo, paper,	1 00
Coolidge and Freeman's Elements of General Drafting for Mechanical Engineers.	Oblong 4to,	2 50
Cromwell's Treatise on Toothed Gearing	12mo,	1 50
Treatise on Belts and Pulleys.	12mo,	1 50
Durley's Kinematics of Machines.	8vo,	4 00
Flather's Dynamometers and the Measurement of Power.	12mo,	3 00
Rope Driving.	12mo,	2 00
Gill's Gas and Fuel Analysis for Engineers.	12mo,	1 25
Hall's Car Lubrication.	12mo,	1 00
Hering's Ready Reference Tables (Conversion Factors).	16mo, morocco,	2 50
Hutton's The Gas Engine.	8vo,	5 60
Jamison's Mechanical Drawing.	8vo,	2 50
Jones's Machine Design:		
Part I. Kinematics of Machinery.	8vo,	1 50
Part II. Form, Strength, and Proportions of Parts.	8vo,	3 00
Kent's Mechanical Engineers' Pocket-book.	16mo, morocco,	5 00
Kerr's Power and Power Transmission.	8vo,	2 00
Leonard's Machine Shop, Tools, and Methods.	8vo,	4 00
* Lorenz's Modern Refrigerating Machinery. (Pope, Haven, and Dean.)	8vo,	4 00
MacCord's Kinematics; or, Practical Mechanism.	8vo,	5 00
Mechanical Drawing.	4to,	4 00
Velocity Diagrams.	8vo,	1 50

MacFarland's Standard Reduction Factors for Gases.	8vo,	1 50
Mahan's Industrial Drawing. (Thompson).	8vo	3 50
Poole's Calorific Power of Fuels.	8vo,	3 00
Reid's Course in Mechanical Drawing.	8vo,	2 00
Text-book of Mechanical Drawing and Elementary Machine Design.	8vo,	3 00
Richard's Compressed Air.	12mo,	1 50
Robinson's Principles of Mechanism.	8vo,	3 00
Schwarz and Merrill's Elements of Mechanism.	8vo,	3 00
Smith's (O.) Press-working of Metals.	8vo	3 00
Smith (A. W.) and Marx's Machine Design.	8vo,	3 00
Thurston's Treatise on Friction and Lost Work in Machinery and Mill Work.	8vo,	3 00
Animal as a Machine and Prime Motor, and the Laws of Energetics.	12mo,	1 00
Tillson's Complete Automobile Instructor.	16mo,	1 50
	Morocco,	2 00
Warren's Elements of Machine Construction and Drawing.	8vo,	7 50
Weisbach's Kinematics and the Power of Transmission. (Herrmann—Klein).	8vo,	5 00
Machinery of Transmission and Governors. (Herrmann—Klein).	8vo,	5 00
Wolff's Windmill as a Prime Mover.	8vo,	3 00
Wood's Turbines.	8vo,	2 50

MATERIALS OF ENGINEERING.

* Bovey's Strength of Materials and Theory of Structures.	8vo,	7 50
Burr's Elasticity and Resistance of the Materials of Engineering. 6th Edition.	8vo,	7 50
Reset.	8vo,	6 00
Church's Mechanics of Engineering.	8vo,	6 00
* Greene's Structural Mechanics.	2vo,	2 50
Johnson's Materials of Construction.	8vo,	6 00
Keep's Cast Iron.	8vo,	2 50
Lanza's Applied Mechanics.	8vo,	7 50
Martens's Handbook on Testing Materials. (Henning).	8vo,	7 50
Maurer's Technical Mechanics.	8vo,	4 00
Merriman's Mechanics of Materials.	8vo,	5 00
* Strength of Materials.	12mo,	1 00
Metcalf's Steel. A Manual for Steel-users.	12mo,	2 00
Sabin's Industrial and Artistic Technology of Paints and Varnish.	8vo,	3 00
Smith's Materials of Machines.	12mo,	1 00
Thurston's Materials of Engineering.	3 vols., 8vo,	8 00
Part II. Iron and Steel.	8vo,	3 50
Part III. A Treatise on Brasses, Bronzes, and Other Alloys and their Constituents.	8vo,	2 50
Wood's (De V.) Treatise on the Resistance of Materials and an Appendix on the Preservation of Timber.	8vo,	2 00
Elements of Analytical Mechanics.	8vo,	3 00
Wood's (M. P.) Rustless Coatings: Corrosion and Electrolysis of Iron and Steel.	8vo,	4 00

STEAM-ENGINES AND BOILERS.

Berry's Temperature-entropy Diagram.	12mo,	1 25
Carnot's Reflections on the Motive Power of Heat. (Thurston).	12mo,	1 50
Dawson's "Engineering" and Electric Traction Pocket-book.	16mo, mor.,	5 00
Ford's Boiler Making for Boiler Makers.	18mo,	1 00
Goss's Locomotive Sparks.	8vo,	2 00
Locomotive Performance.	8vo,	5 00
Hemenway's Indicator Practice and Steam-engine Economy.	12mo,	2 00

Hutton's Mechanical Engineering of Power Plants.	8vo,	5 00
Heat and Heat-engines.	8vo.	5 00
Kent's Steam boiler Economy.	8vo,	4 00
Kneass's Practice and Theory of the Injector.	8vo,	1 50
MacCord's Slide-valves.	8vo,	2 00
Meyer's Modern Locomotive Construction.	4to,	10 00
Peabody's Manual of the Steam-engine Indicator.	12mo,	1 50
Tables of the Properties of Saturated Steam and Other Vapors	8vo,	1 00
Thermodynamics of the Steam-engine and Other Heat-engines.	8vo,	5 00
Valve-gears for Steam-engines.	8vo,	2 50
Peabody and Miller's Steam-boilers.	8vo,	4 00
Pray's Twenty Years with the Indicator.	Large 8vo,	2 50
Pupin's Thermodynamics of Reversible Cycles in Gases and Saturated Vapors. (Osterberg.)	12mo,	1 25
Reagan's Locomotives: Simple, Compound, and Electric. New Edition. Large	12mo,	3 50
Rontgen's Principles of Thermodynamics. (Du Bois.)	8vo,	5 00
Sinclair's Locomotive Engine Running and Management.	12mo,	2 00
Smart's Handbook of Engineering Laboratory Practice.	12mo,	2 50
Snow's Steam-boiler Practice.	8vo,	3 00
Spangler's Valve-gears.	8vo,	2 50
Notes on Thermodynamics.	12mo,	1 00
Spangler, Greene, and Marshall's Elements of Steam-engineering	8vo,	3 00
Thomas's Steam-turbines.	8vo,	3 50
Thurston's Handy Tables.	8vo,	1 50
Manual of the Steam-engine.	2 vols., 8vo,	10 00
Part I. History, Structure, and Theory.	8vo,	6 00
Part II. Design, Construction, and Operation.	8vo,	6 00
Handbook of Engine and Boiler Trials, and the Use of the Indicator and the Prony Brake.	8vo,	5 00
Stationary Steam-engines.	8vo,	2 50
Steam-boiler Explosions in Theory and in Practice	12mo,	1 50
Manual of Steam-boilers, their Designs, Construction, and Operation	8vo,	5 00
Wehrenfenning's Analysis and Softening of Boiler Feed-water (Patterson)	8vo,	4 00
Weisbach's Heat, Steam, and Steam-engines. (Du Bois.)	8vo,	5 00
Whitham's Steam-engine Design.	8vo,	5 00
Wood's Thermodynamics, Heat Motors, and Refrigerating Machines.	8vo,	4 00

MECHANICS AND MACHINERY.

Barr's Kinematics of Machinery.	8vo,	2 50
* Bovey's Strength of Materials and Theory of Structures	8vo,	7 50
Chase's The Art of Pattern-making.	12mo,	2 50
Church's Mechanics of Engineering.	8vo,	6 00
Notes and Examples in Mechanics.	8vo,	2 00
Compton's First Lessons in Metal-working.	12mo,	1 50
Compton and De Groot's The Speed Lathe	12mo,	1 50
Cromwell's Treatise on Toothed Gearing.	12mo,	1 50
Treatise on Belts and Pulleys.	12mo,	1 50
Dana's Text-book of Elementary Mechanics for Colleges and Schools.	12mo,	1 50
Dingey's Machinery Pattern Making	12mo,	2 00
Dredge's Record of the Transportation Exhibits Building of the World's Columbian Exposition of 1893.	4to half morocco,	5 00
Du Bois's Elementary Principles of Mechanics:		
Vol. I. Kinematics.	8vo,	3 50
Vol. II. Statics.	8vo,	4 00
Mechanics of Engineering. Vol. I.	Small 4to,	7 50
Vol. II.	Small 4to,	10 00
Durley's Kinematics of Machines.	8vo,	4 00

Fitzgerald's Boston Machinist.	16mo,	1 00
Flather's Dynamometers, and the Measurement of Power.	12mo,	3 00
Rope Driving.	12mo,	2 00
Goss's Locomotive Sparks.	8vo,	2 00
Locomotive Performance.	8vo,	5 00
* Greene's Structural Mechanics.	8vo,	2 50
Hall's Car Lubrication.	12mo,	1 00
Holly's Art of Saw Filing.	18mo,	75
James's Kinematics of a Point and the Rational Mechanics of a Particle.	Small 8vo,	2 00
* Johnson's (W. W.) Theoretical Mechanics.	12mo,	3 00
Johnson's (L. J.) Statics by Graphic and Algebraic Methods.	8vo,	2 00
Jones's Machine Design:		
Part I. Kinematics of Machinery.	8vo,	1 50
Part II. Form, Strength, and Proportions of Parts.	8vo,	3 00
Kerr's Power and Power Transmission.	8vo,	2 00
Lanza's Applied Mechanics.	8vo,	7 50
Leonard's Machine Shop, Tools, and Methods.	8vo,	4 00
* Lorenz's Modern Refrigerating Machinery. (Pope, Haven, and Dean.) 8vo,	4 00	
MacCord's Kinematics; or, Practical Mechanism.	8vo,	5 00
Velocity Diagrams.	8vo,	1 50
* Martin's Text Book on Mechanics, Vol. I, Statics.	12mo,	1 25
Maurer's Technical Mechanics.	8vo,	4 00
Merriman's Mechanics of Materials.	8vo,	5 00
* Elements of Mechanics.	12mo,	1 00
* Michie's Elements of Analytical Mechanics.	8vo,	4 00
* Parshall and Hobart's Electric Machine Design.	4to, half morocco,	12 50
Reagan's Locomotives: Simple, Compound, and Electric. New Edition.	Large 12mo,	3 00
Reld's Course in Mechanical Drawing.	8vo,	2 00
Text-book of Mechanical Drawing and Elementary Machine Design. 8vo,	3 00	
Richards's Compressed Air.	12mo,	1 50
Robinson's Principles of Mechanism.	8vo,	3 00
Ryan, Norris, and Hoxie's Electrical Machinery. Vol. I.	8vo,	2 50
Sanborn's Mechanics: Problems.	Large 12mo,	1 50
Schwamb and Merrill's Elements of Mechanism.	8vo,	3 00
Sinclair's Locomotive-engine Running and Management.	12mo,	2 00
Smith's (O.) Press-working of Metals.	8vo,	3 00
Smith's (A. W.) Materials of Machines.	12mo,	1 00
Smith (A. W.) and Marx's Machine Design.	8vo,	3 00
Spangler, Greene, and Marshall's Elements of Steam-engineering.	8vo,	3 00
Thurston's Treatise on Friction and Lost Work in Machinery and Mill Work.	8vo,	3 00
Animal as a Machine and Prime Motor, and the Laws of Energetics. 12mo,	1 00	
Tillson's Complete Automobile Instructor.	16mo,	1 50
	Morocco,	2 00
Warren's Elements of Machine Construction and Drawing.	8vo,	7 50
Weisbach's Kinematics and Power of Transmission. (Herrmann—Klein.) 8vo,	5 00	
Machinery of Transmission and Governors. (Herrmann—Klein.) 8vo,	5 00	
Wood's Elements of Analytical Mechanics.	8vo,	3 00
Principles of Elementary Mechanics.	12mo,	1 25
Turbines.	8vo,	2 50
The World's Columbian Exposition of 1893.	4to,	1 00

MEDICAL.

De Fursac's Manual of Psychiatry. (Rosanoff and Collins.)	Large 12mo,	2 50
Ehrlich's Collected Studies on Immunity. (Bolduan.)	8vo,	6 00
Hammarsten's Text-book on Physiological Chemistry. (Mandel.)	8vo,	4 00

Lassar-Cohn's Practical Urinary Analysis. (Lorenz.)	12mo,	1 00
* Pauli's Physical Chemistry in the Service of Medicine. (Fischer.)	12mo,	1 25
* Pozzi-Escot's The Toxins and Venoms and their Antibodies. (Cohn.)	12mo,	1 00
Rostoski's Serum Diagnosis. (Bolduan.)	12mo,	1 00
Salkowski's Physiological and Pathological Chemistry. (Orndorff.)	8vo,	2 50
* Satterlee's Outlines of Human Embryology	12mo,	1 25
Steel's Treatise on the Diseases of the Dog.	8vo,	3 50
Von Behring's Suppression of Tuberculosis. (Bolduan.)	12mo,	1 00
Wassermann's Immune Sera. Hæmolysis, Cytotoxins, and Precipitins. (Bolduan.)	12mo, cloth,	1 00
Woodhull's Notes on Military Hygiene	16mo,	1 50
* Personal Hygiene.	12mo,	1 00
Wulling's An Elementary Course in Inorganic Pharmaceutical and Medical Chemistry	12mo,	2 00

METALLURGY.

Egleston's Metallurgy of Silver, Gold, and Mercury:		
Vol. I. Silver.	8vo,	7 50
Vol. II. Gold and Mercury.	8vo,	7 50
Goessel's Minerals and Metals: A Reference Book.	16mo, mor.	3 00
* Iles's Lead-smelting.	12mo,	2 50
Keep's Cast Iron.	8vo,	2 50
Kunhardt's Practice of Ore Dressing in Europe.	8vo,	1 50
Le Chatelier's High-temperature Measurements. (Boudouard—Burgess.)	12mo,	3 00
Metcalf's Steel. A Manual for Steel-users.	12mo,	2 00
Miller's Cyanide Process.	12mo,	1 00
Minet's Production of Aluminum and its Industrial Use. (Waldo.)	12mo,	2 50
Robine and Lenglen's Cyanide Industry. (Le Clerc.)	8vo,	4 00
Smith's Materials of Machines.	12mo,	1 00
Thurston's Materials of Engineering. In Three Parts.	8vo,	8 00
Part II. Iron and Steel.	8vo,	3 50
Part III. A Treatise on Brasses, Bronzes, and Other Alloys and their Constituents.	8vo,	2 50
Ulke's Modern Electrolytic Copper Refining.	8vo,	3 00

MINERALOGY.

Barringer's Description of Minerals of Commercial Value. Oblong, morocco.	2 50
Boyd's Resources of Southwest Virginia.	8vo, 3 00
Map of Southwest Virginia.	Pocket-book form, 2 00
Brush's Manual of Determinative Mineralogy. (Penfield.)	8vo, 4 00
Chester's Catalogue of Minerals.	8vo, paper, 1 00
	Cloth, 1 25
Dictionary of the Names of Minerals.	8vo, 3 50
Dana's System of Mineralogy.	Large 8vo, half leather, 12 50
First Appendix to Dana's New "System of Mineralogy."	Large 8vo, 1 00
Text-book of Mineralogy.	8vo, 4 00
Minerals and How to Study Them	12mo, 1 50
Catalogue of American Localities of Minerals.	Large 8vo, 1 00
Manual of Mineralogy and Petrography.	12mo, 2 00
Douglas's Untechnical Addresses on Technical Subjects.	12mo, 1 00
Eakle's Mineral Tables.	8vo, 1 25
Egleston's Catalogue of Minerals and Synonyms.	8vo, 2 50
Goessel's Minerals and Metals: A Reference Book.	16mo, mor. 3 00
Groth's Introduction to Chemical Crystallography (Marshall)	12mo, 1 25

Iddings's Rock Minerals.	8vo,	5 00
Merrill's Non-metallic Minerals: Their Occurrence and Uses.	8vo,	4 00
* Penfield's Notes on Determinative Mineralogy and Record of Mineral Tests.	8vo, paper,	50
* Richards's Synopsis of Mineral Characters.	12mo, morocco,	1 25
* Ries's Clays: Their Occurrence, Properties, and Uses.	8vo,	5 00
Rosenbusch's Microscopical Physiography of the Rock-making Minerals. (Iddings.)	8vo,	5 00
* Tillman's Text-book of Important Minerals and Rocks.	8vo,	2 00

MINING.

Boyd's Resources of Southwest Virginia.	8vo,	3 00
Map of Southwest Virginia.	Pocket-book form	2 00
Douglas's Untechnical Addresses on Technical Subjects.	12mo,	1 00
Eissler's Modern High Explosives.	8vo,	4 00
Goesel's Minerals and Metals: A Reference Book.	16mo, mor.	3 00
Goodyear's Coal-mines of the Western Coast of the United States.	12mo,	2 50
Ihlseng's Manual of Mining.	8vo,	5 00
* Iles's Lead-smelting.	12mo,	2 50
Kunhardt's Practice of Ore Dressing in Europe.	8vo,	1 50
Miller's Cyanide Process.	12mo,	1 00
O'Driscoll's Notes on the Treatment of Gold Ores.	8vo,	2 00
Robine and Lenglen's Cyanide Industry. (Le Clerc.)	8vo,	4 00
* Walke's Lectures on Explosives.	8vo,	4 00
Weaver's Military Explosives.	8vo,	3 00
Wilson's Cyanide Processes.	12mo,	1 50
Chlorination Process.	12mo,	1 50
Hydraulic and Placer Mining.	12mo,	2 00
Treatise on Practical and Theoretical Mine Ventilation.	12mo,	1 25

SANITARY SCIENCE.

Bashore's Sanitation of a Country House.	12mo,	1 00
* Outlines of Practical Sanitation.	12mo,	1 25
Folwell's Sewerage. (Designing, Construction, and Maintenance.)	8vo,	3 00
Water-supply Engineering.	8vo,	4 00
Fowler's Sewage Works Analyses.	12mo,	2 00
Fuertes's Water and Public Health.	12mo,	1 50
Water-filtration Works.	12mo,	2 50
Gerhard's Guide to Sanitary House-inspection	16mo,	1 50
Hazen's Filtration of Public Water-supplies.	8vo,	3 00
Leach's The Inspection and Analysis of Food with Special Reference to State Control.	8vo,	7 50
Mason's Water-supply. (Considered principally from a Sanitary Standpoint) 8vo,		4 00
Examination of Water. (Chemical and Bacteriological.)	12mo,	1 25
* Merriman's Elements of Sanitary Engineering.	8vo,	2 00
Ogden's Sewer Design.	12mo,	2 00
Prescott and Winslow's Elements of Water Bacteriology, with Special Refer- ence to Sanitary Water Analysis.	12mo,	1 25
* Price's Handbook on Sanitation.	12mo,	1 50
Richards's Cost of Food. A Study in Dietarics.	12mo,	1 00
Cost of Living as Modified by Sanitary Science.	12mo,	1 00
Cost of Shelter.	12mo,	1 00

Richards and Woodman's Air, Water, and Food from a Sanitary Stand-point.	8vo,	2 00
* Richards and Williams's The Dietary Computer.	8vo,	1 50
Rideal's Sewage and Bacterial Purification of Sewage.	8vo,	4 00
Turneure and Russell's Public Water-supplies.	8vo,	5 00
Von Behring's Suppression of Tuberculosis. (Bolduan.).	12mo,	1 00
Whipple's Microscopy of Drinking-water.	8vo,	3 50
Winton's Microscopy of Vegetable Foods.	8vo,	7 50
Woodhull's Notes on Military Hygiene.	16mo,	1 50
* Personal Hygiene.	12mo,	1 00

MISCELLANEOUS.

Emmons's Geological Guide-book of the Rocky Mountain Excursion of the International Congress of Geologists.	Large 8vo,	1 50
Ferrel's Popular Treatise on the Winds.	8vo,	4 00
Gannett's Statistical Abstract of the World.	24mo,	75
Haines's American Railway Management.	12mo,	2 50
Ricketts's History of Rensselaer Polytechnic Institute, 1824-1894. Small	8vo,	3 00
Rotherham's Emphasized New Testament.	Large 8vo,	2 00
The World's Columbian Exposition of 1893.	4to,	1 00
Winslow's Elements of Applied Microscopy.	12mo,	1 50

HEBREW AND CHALDEE TEXT-BOOKS.

Green's Elementary Hebrew Grammar.	12mo,	1 25
Hebrew Chrestomathy.	8vo,	2 00
Gesenius's Hebrew and Chaldee Lexicon to the Old Testament Scriptures. (Tregelles.).	Small 4to, half morocco,	5 00
Letteris's Hebrew Bible.	8vo,	2 25



THIS BOOK IS DUE ON THE LAST DATE
STAMPED BELOW

AN INITIAL FINE OF 25 CENTS
WILL BE ASSESSED FOR FAILURE TO RETURN
THIS BOOK ON THE DATE DUE. THE PENALTY
WILL INCREASE TO 50 CENTS ON THE FOURTH
DAY AND TO \$1.00 ON THE SEVENTH DAY
OVERDUE.

SEP 29 1937

OCT 13 1937

MAY 11 1938

MAR 13 1940

OCT 5 1940

FEB 22 1941M

MAY 5 1941M

APR 10 1948

MAR 02 1989

AUTO DISC MAR 02 1989

TC 19578

U.C. BERKELEY LIBRARIES

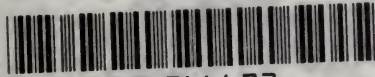

C006766672

287104

Rosenberg

TK145

R8

UNIVERSITY OF CALIFORNIA LIBRARY

