

**1001
WONDERFUL
THINGS**

A PLANETARIUM

[Courtesy, Carl Zeiss, Jena]

The most amazing machine ever invented, the planetarium is like some futurist's vision, conquering both time and space. Operating in the middle of a lecture theatre, its lights gleaming upon a blue dome to represent the heavens, it throws an accurate image of every star in the heavens—and makes them move. The turn of the Earth, the individual motions of planets and comets, are all given at relative but vastly quickened speeds. And, to cross the heavens may be seen from any point on the Earth as they were or will be at dates thousands of years

1001 WONDERFUL THINGS

Edited by

WALTER HUTCHINSON, M.A., F.R.G.S., F.R.S.A., F.R.A.I.,
F.Z.S., Barrister-at-Law (Editor of "Story of the Nations",
"The Wonders of the World", "Britain Beautiful", "Hutchin-
son's Dog Encyclopædia", "Marvels of the Universe",
"Animals of all Countries", "Marvels of Insect Life",
etc., etc.

HUTCHINSON & Co.
(PUBLISHERS) LTD.
LONDON

INTRODUCTION

HU

SURELY, the age we live in must be the most interesting ever known to mankind.

In every field giant strides of discovery and invention have been made. Knowledge of this, that and the other has increased by leaps and bounds—and still we know so little ; there is more and more to come.

Consequently, the field of general knowledge has been considerably widened. Every man and woman who wishes to enjoy life to the full and make headway in it, needs to enlarge his or her fund of general knowledge to the maximum. At the same time, men and women of to-day are so busy, so fully occupied that, so the publishers of this volume feel, some ways and means must be contrived of bringing the wonders of the universe within easy reach of all, in a minimum of time.

Seeing is believing.

It would take volumes to describe and conjure up an adequate word picture of some of the wonders described and shown in the pages of this book, and even the most vivid and detailed description would still throw the reader on his own imagination to visualize in his mind's eye what he has read.

The House of Hutchinson have realized the want of a new form of publication — pictorial presentation of knowledge and information, of presenting in pictures, accompanied, not by lengthy letterpress, but by brief lucid legends, interesting items of general knowledge which every educated man and woman should know.

In these days of stress and strain, this type of publication should also prove a boon and a blessing for wet Sunday afternoons, when one wants to relax and yet be interested without too much effort.

It also has its educational value for those who have to look after the welfare of the youngest generation, who, like ourselves, find it much easier to believe what they have seen, than what they have merely heard about.

THE EDITOR.

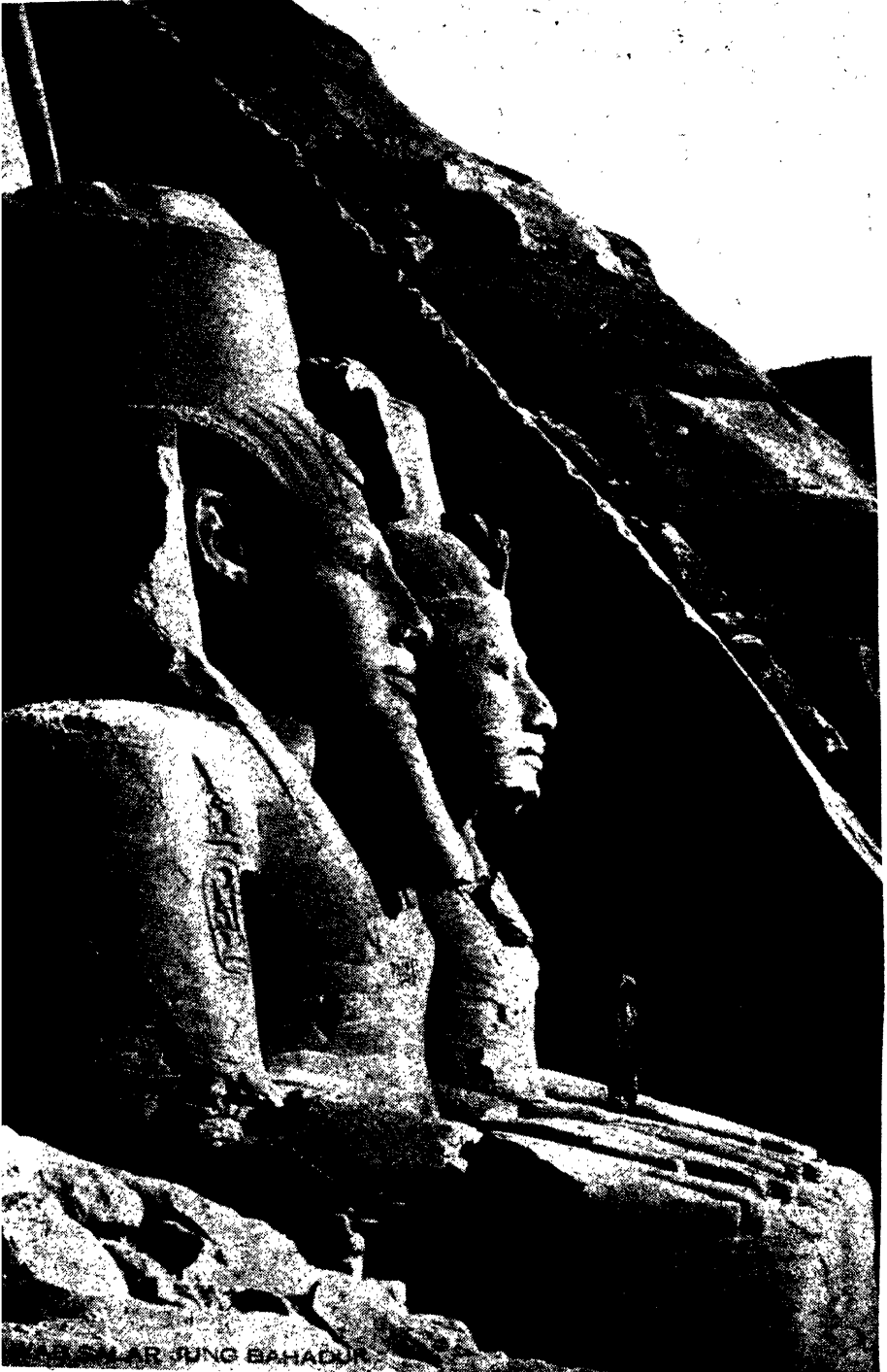

TEMPLE OF ABU SIMBEL

[Underwood Press Service

ty temple in the Sudan was built in the reign of Rameses II, and the two statues shown, each sixty-five

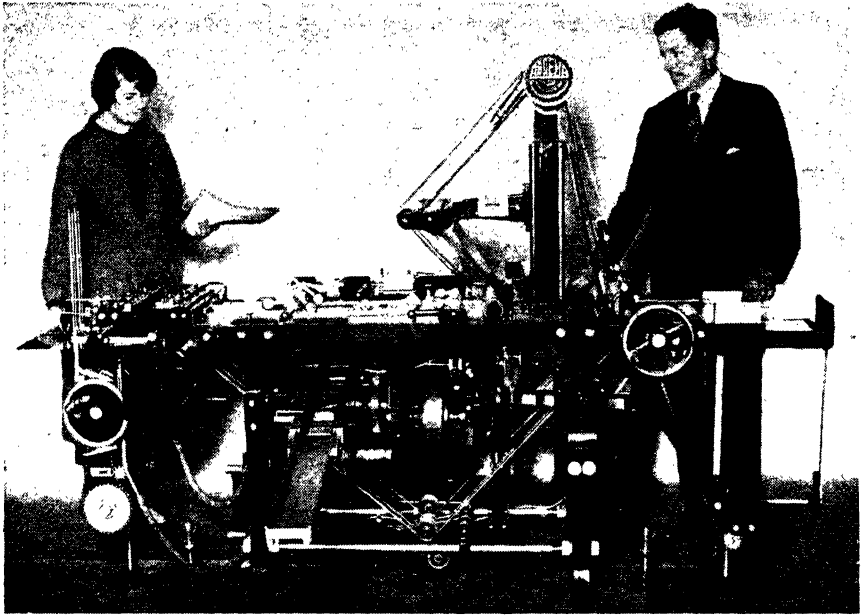

FASTEST ADDRESSING MACHINE

[Carthew & Kinnaird

With th
none so



AERIAL FLASHLIGHT CAMERA

[Dorien Leigh

When the art of photography was combined with the new science of flying, there opened up a new field of activity for makers of maps and surveys. Soon aerial mapping cameras came on the market, but not until comparatively recently was an instrument invented which would take preliminary "snapshots" by flashlight. The new flashlight mechanism is fitted beneath the wing of the aeroplane

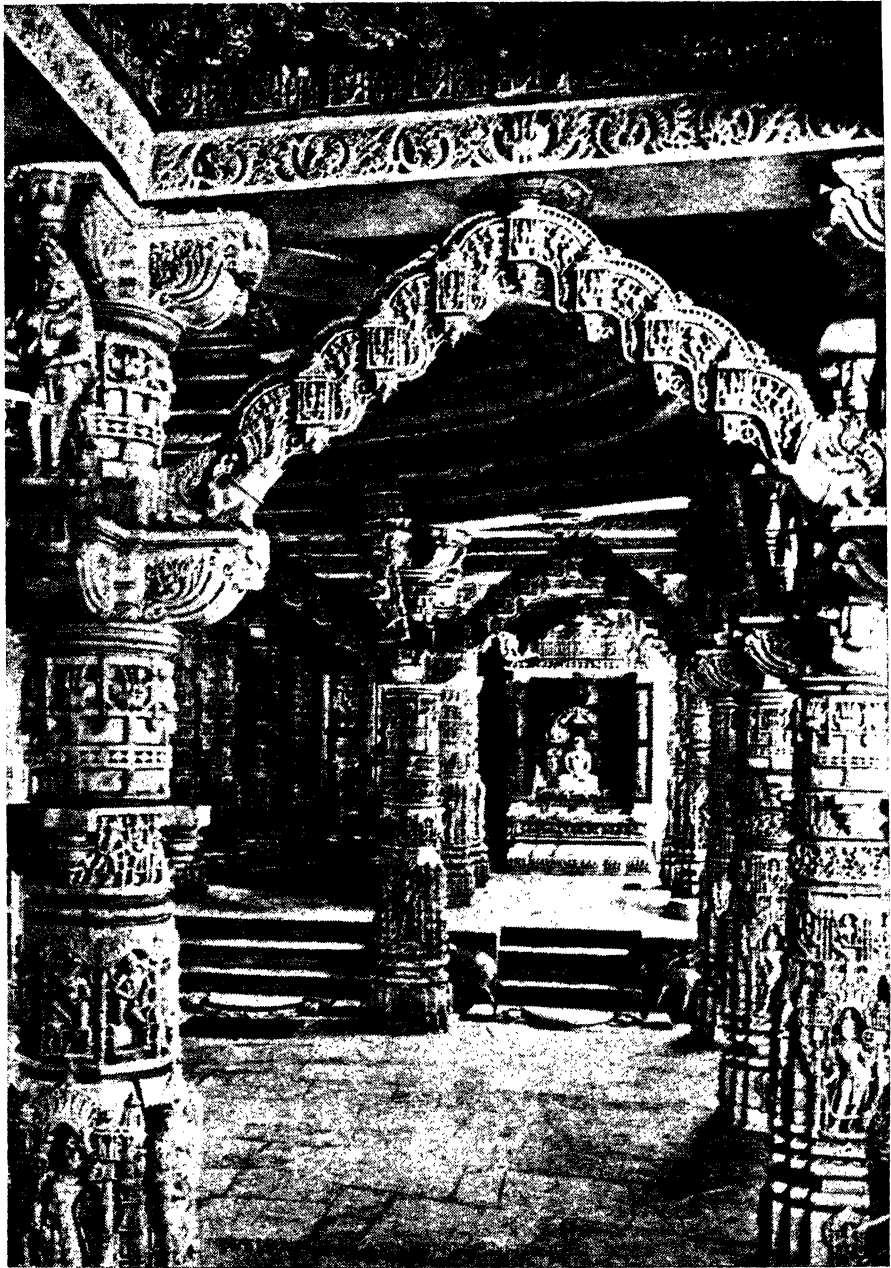

[From "Wonders of the World"

A JAIN TEMPLE ON MOUNT ABU

Of recent years Mount Abu in North-West India has become a popular hot-weather resort for Europeans. The Jains, however, who built this magnificent Temple, are a religious sect who claim to be as old as the Buddhists. The exquisite traceries were worked about 800 years ago and are wrought in pure white marble; they rank easily amongst the finest and most remarkable in the world. Fortunately, neither the climate nor the hand of man has harmed their original freshness

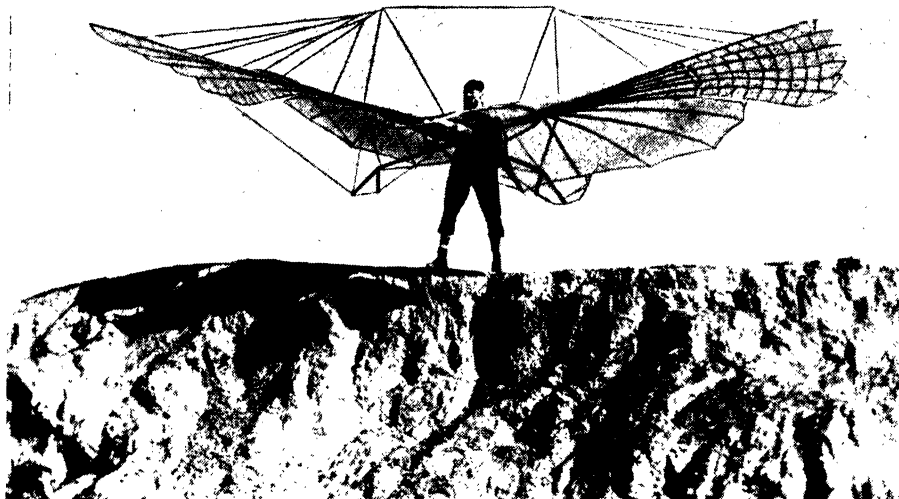

[Carthew & Kinnaid

THE PROGRESS OF FLIGHT

The above photograph of Lilienthal was taken during the latter part of the nineteenth century, and him tenaciously adhering to the old idea of bird-like wings which had fascinated so many inventors from Daedalus to Leonardo da Vinci

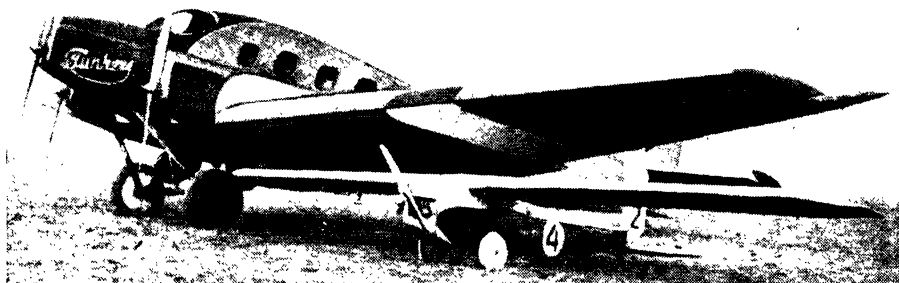

[Carthew & Kinnaid

but the all-metal transport of the type depicted above had become a familiar sight, and the invention of one of the outstanding marvels of the twentieth century—flying in heavier-than-air craft

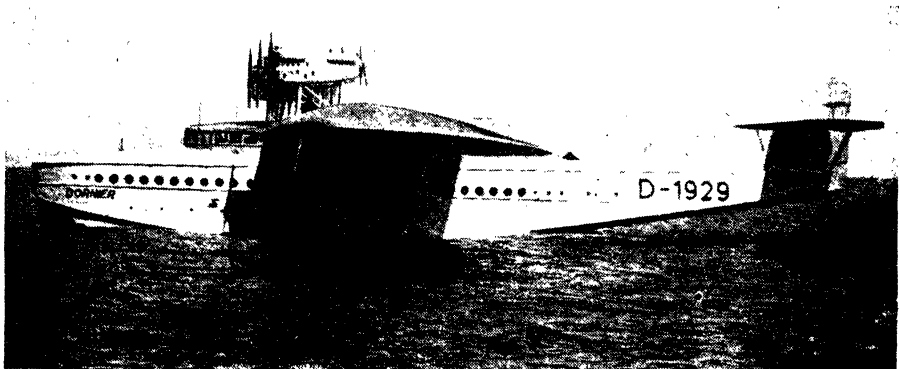

[Keystone

Another version of the modern wonder of the sky—a giant flying boat, built in Germany

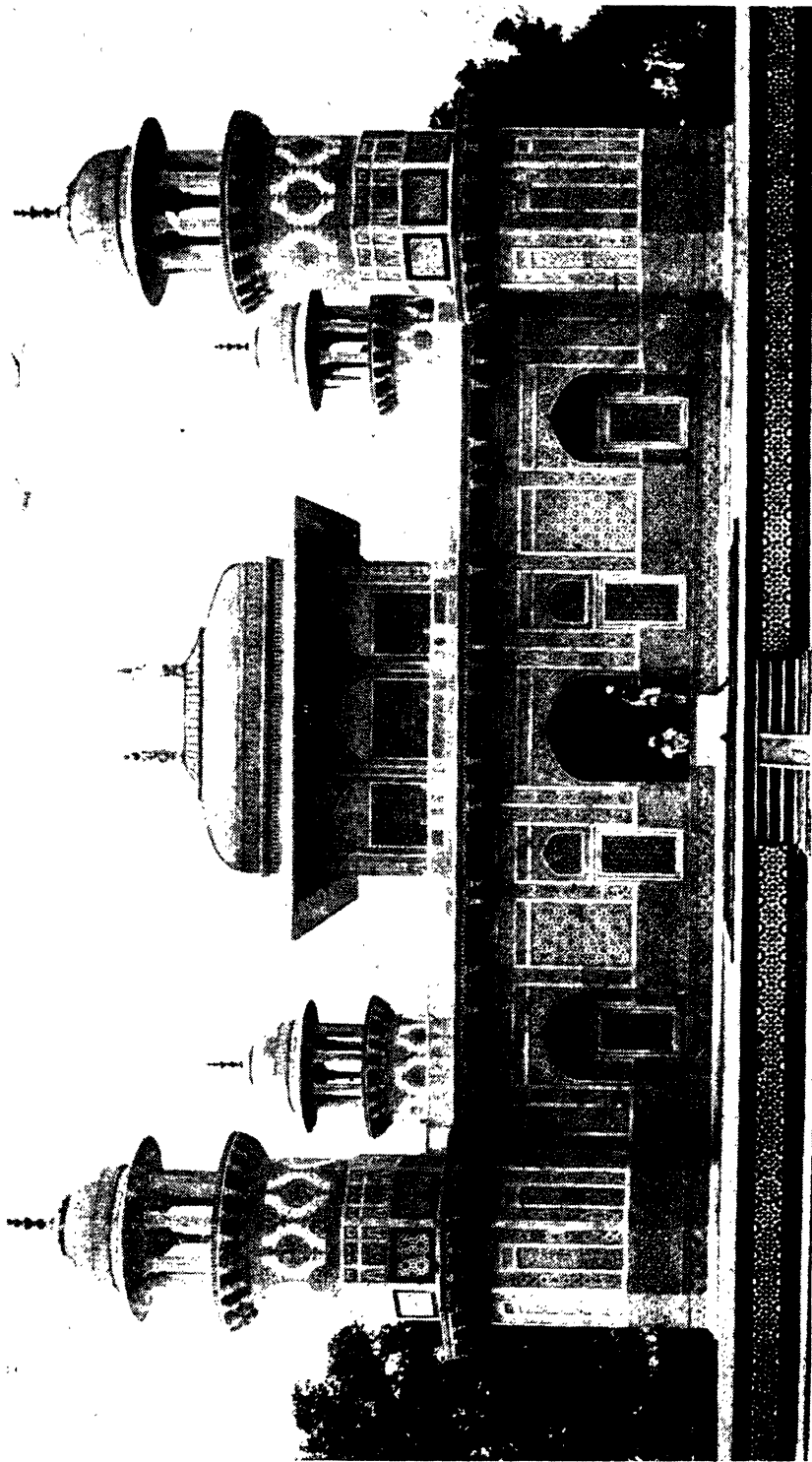

AGRA: TOMB OF I'TIMAD-UD-DAULAH

Frequently called one of the finest mausoleums of the world, this tomb was erected to a noted Persian refugee by his daughter. In his own land I'timad-ud-Daulah's name was Ghiyas Beg; in India he was treasurer to Jehangir, and, incidentally, grandfather to the lady of the Taj Mahal. The marble inlay dates from 1628; and is not only the most perfect, but also the earliest example of its kind in India.

[The late H. G. Ponting, F.R.G.S.]

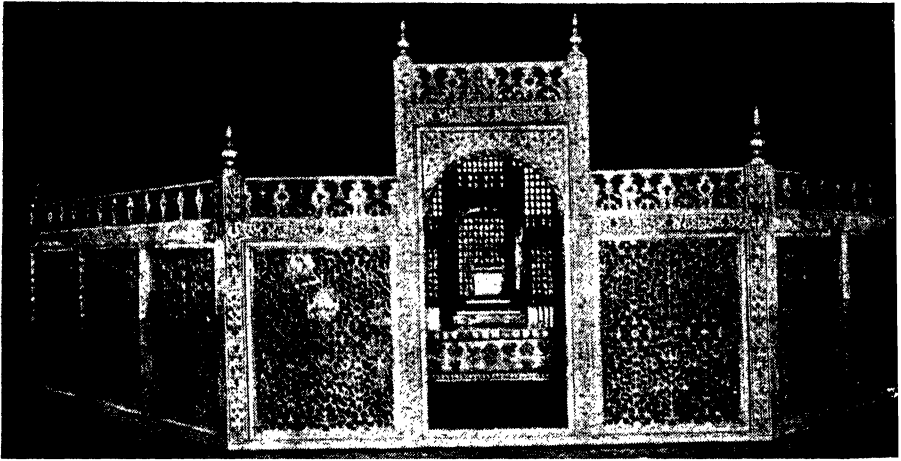

[The late H. G. Ponting, F.R.C.S.]

AGRA: A MARBLE SCREEN IN THE TAJ MAHAL

Easily the most renowned resting-place on the face of the earth, the Taj Mahal is as beautiful within as without. The marble trellis shown, which is heavily encrusted with gems, surrounds the actual tombs of Shah Jehan and Mumtaz-i-Mahal.

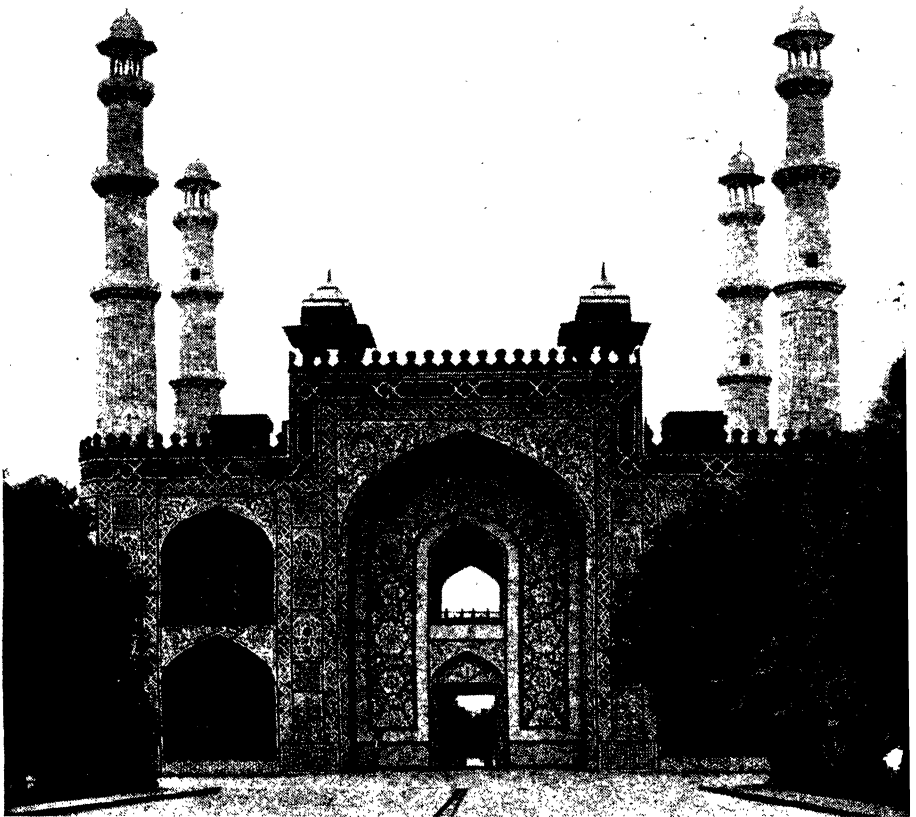

[The late H. G. Ponting, F.R.C.S.]

THE GATE OF AKBAR'S TOMB, SIKANDRA

Sikandra is a suburb of Agra, and one of its chief attractions is the garden which shelters the Tomb of Akbar, the great Mogul Emperor who died in 1605. The gate to the Tomb is of red sandstone marble.



THE TAJ MAHAL

[The Late H. G. Ponting, F.R.G.S.]

Hardly less attractive than the Taj Mahal itself is the love story which it symbolizes. Shah Jehan built the tomb for his favourite wife, Mumtaz-i-Mahal, and when he died, his mourners knew that nothing would content his soul but to be buried beside her. It took seventeen years to build the Taj and £600,000 was spent in wages for the masons alone

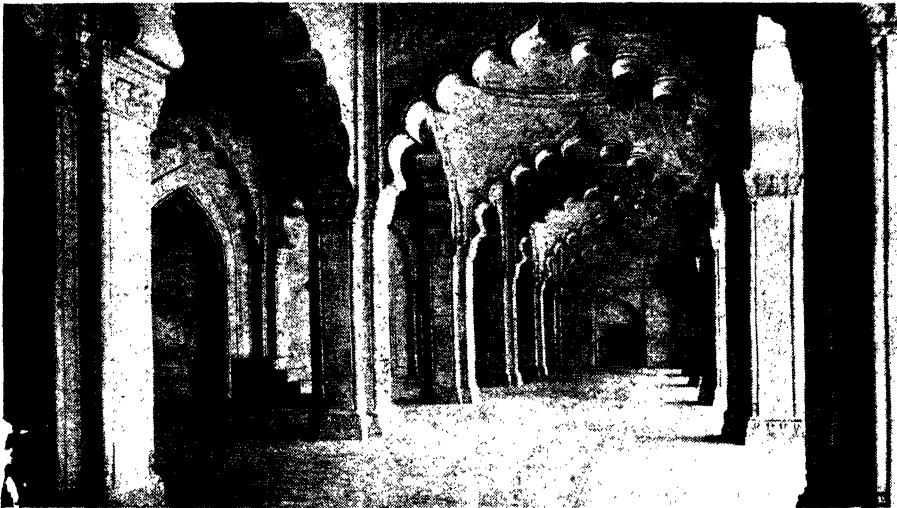

AGRA: INTERIOR OF THE PEARL MOSQUE [From "Wonders of the World"]

The Pearl Mosque, one of the world's loveliest buildings, is yet another of Agra's many splendours. Shah Jehan again was the builder. The Mosque is not large, but the dazzling whiteness of its marble is almost blinding in the fierce Indian sunlight



Sauba, Coushie and Leaf-cutting Ants, these
 Their practice is to cut
 ts as manure to aid th
 their young



Painted by Theo. Carreras]

AGRICULTURAL ANTS "PLANTING"

On the forcing-bed of leaves collected by the Sauba Ants, fungi quickly appear and later develop into little knobs; if the ants did not bite these off, they would soon grow into fairly large mushrooms. The white "spawn" threads of the fungus, also serve to bind the carpet of leaves together and to increase fermentation

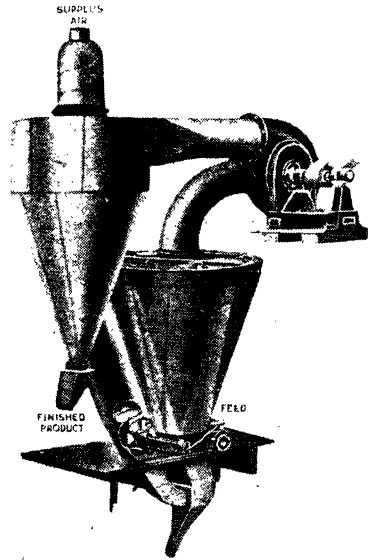

[International Combustion Ltd.

AIR SEPARATOR

This device is used to rid the atmosphere of solid impurities or to separate particles of different substances. The matter for separation is drawn by a high-speed fan into a device causing rapid changes of direction and motion, thus provoking a slackening in the momentum of the particles and their consequent fall by gravity



THE WALLS OF AIGUES MORTES

[Dorien Leigh

Aigues Mortes is near the Camargue, at the mouth of the Rhône. The city is now three miles from the Mediterranean coast, but in the 13th century Louis IX used it as his port of departure for the Crusades

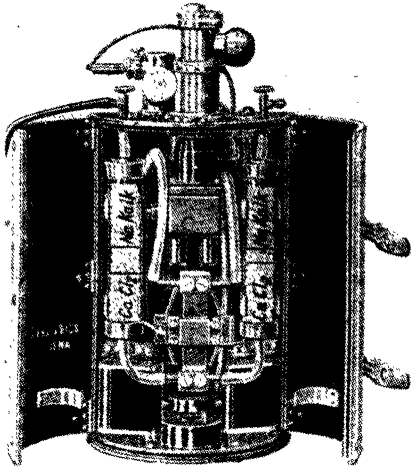

Courtesy Carl Zeiss, London]

AIR-TESTER

The Firedamp Interferometer is used to examine the air in mines, tunnels, well-workings, etc.; strapped on to the body of its operator, it sucks in the air through a rubber tube and gives readings on a dial. With slight additions it can also be used for testing the purity of water supplies

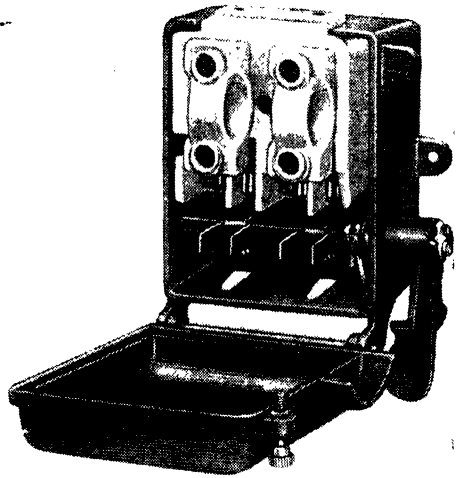

[Courtesy G.E.C.]

AIR BREAK SWITCH

A circuit-breaker's purpose is to cause a disconnection automatically as soon as the electric current passing through it threatens to exceed a specified safety limit. The current then jumps across the break in the form of a spark, which is cooled either by air or by immersion in oil

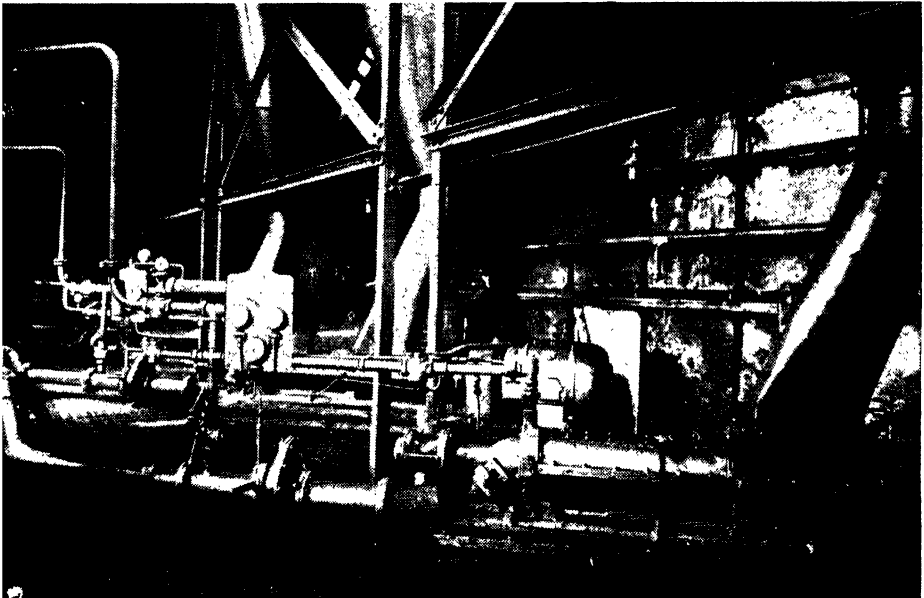

[Courtesy Babcock & Wilcox, Ltd.]

AIR-CONDITIONING

Air-conditioning may take the form either of supplying breathable air to tube-railways, mines, etc., or of rendering purer the atmosphere of factories, offices, and public buildings. Though still a new field of endeavour, it is an extremely important science. The illustration shows part of the ventilating plant used for the Dutch State Mines

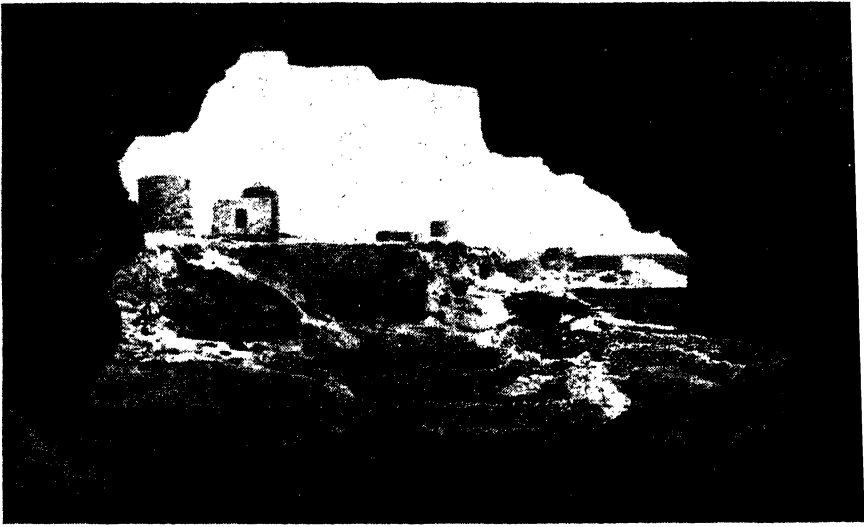

THE CATACOMBS OF ALEXANDRIA

[Photochrom Co.,

These catacombs, one of the few relics of the great city's ancient splendours, are not the work of mankind, were probably hollowed out by underground springs long since dry. Their extent is enormous, and in earliest times they were used as dwellings and refuges in war before becoming the burial-place of the Rom



DANCE OF THE CUPIDS, BY ALBANI

[Dorien Leigh

Francesco Albani was a Bolognese who lived from 1578 to 1660. As a painter he belonged to the Carracci school, and his works, most of which are now at Rome, Dresden, and in the Louvre, are fairly evenly divided between religious and mythological subjects. His favourite task was to paint children, using his own twelve beautiful offspring as models

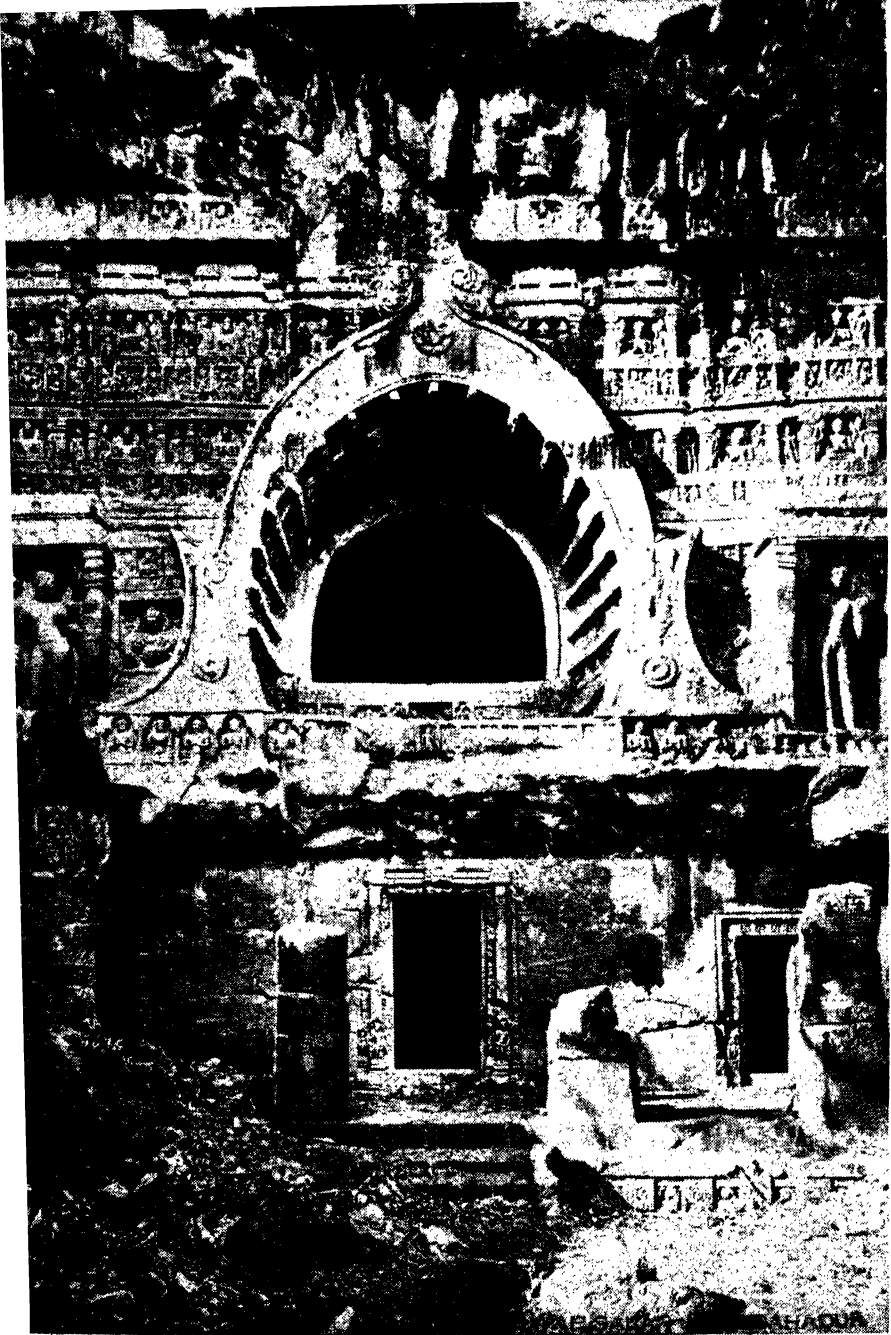

ourtesy]

["Wonders of the World"]

AJANTA, THE ROCK TEMPLES

It is an unimportant town in Hyderabad State, India; but near it, in the face of a cliff, five temples and twenty-four monasteries are hewn from the solid rock, representing eight hundred years of Buddhist toil. The external carvings, typical examples of which are shown on the above façade, the interiors of these man-made caves are lavishly decorated with skilful paintings.

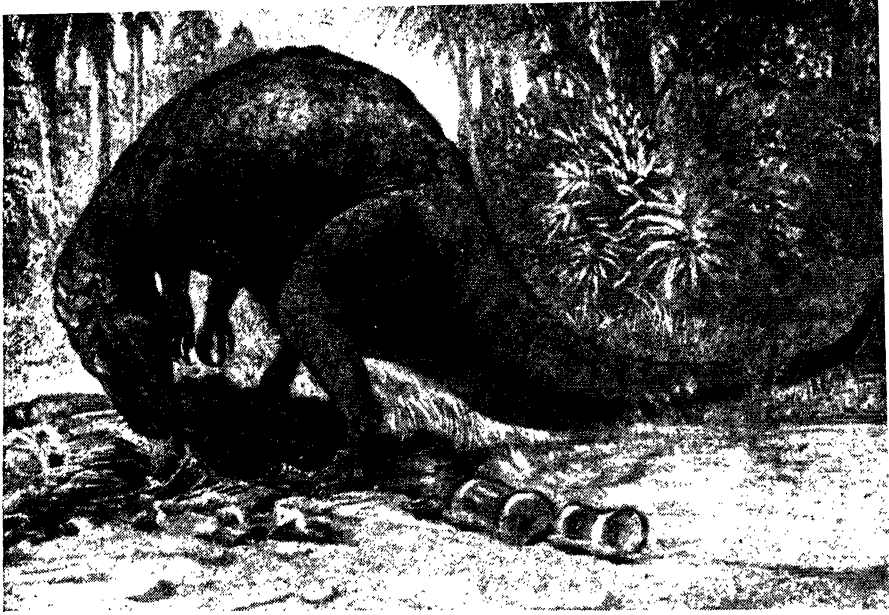

THE ALLOSAUR

[H. J. Shepstone

Strong, swift, and light, the Allosaur was one of the most terrible of all the now extinct Dinosaurs, for, unlike many of them, he fed on flesh. Some idea of his size may be gathered from the fact that in the skeleton on which the above restoration was based, the skull alone measured over three feet

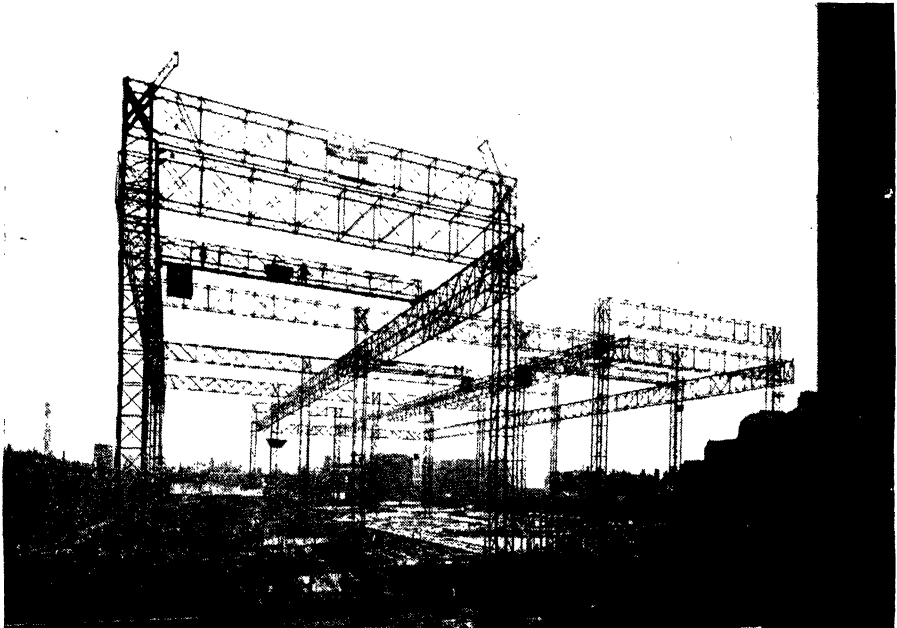

ALL-STEEL BUILDING SKELETON

[C. G. & Kinnear & Co.]

Looking like the runway of some huge travelling-crane, this mass of girders is actually the framework of a building to be made entirely of steel. Such methods of construction are more popular in Germany and America than in Great Britain; at Essen, in Germany, there is actually an all-steel church

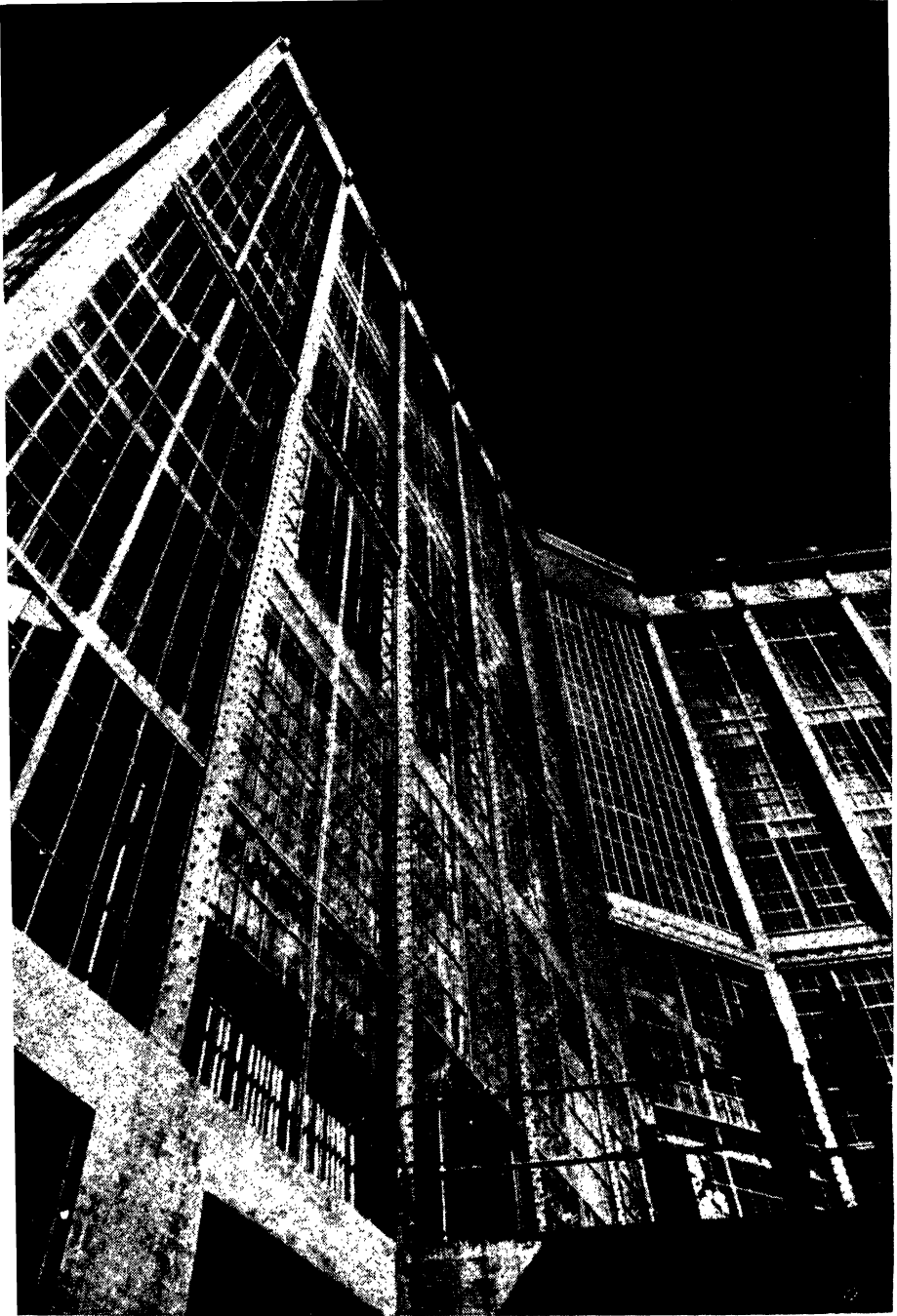

FINISHED ALL-STEEL BUILDING

[Keystone

This photograph of the all-steel and glass factory of an American steel company strikingly shows one of the chief advantages of this type of building—the maximum amount of light that can be admitted. Other advantages are the cheapness and amazing speed of erection possible, and the ease with which alterations and extensions can be made

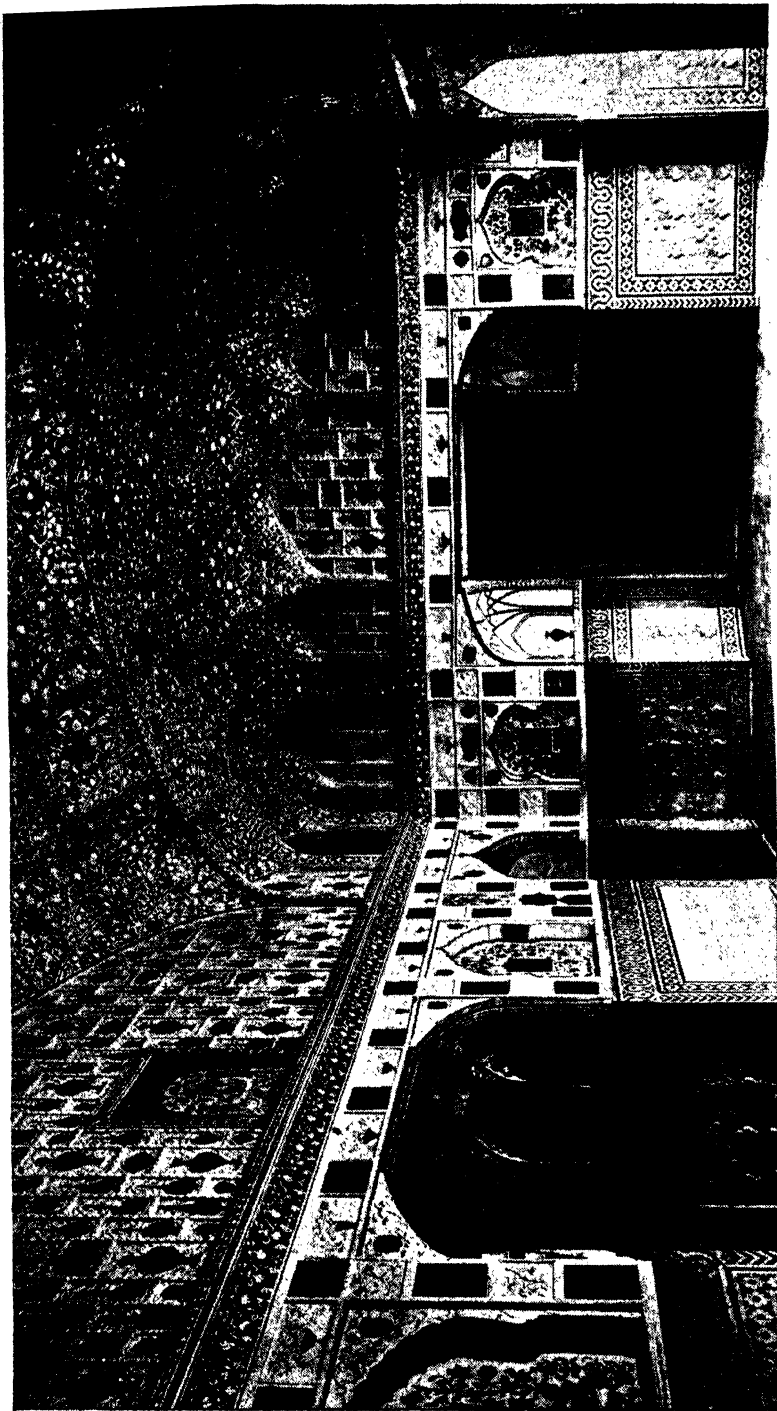

[The late H. G. Ponting, F.R.G.S.

THE SHISH MAHAL, AMBER

A "wizened old city," as one traveller called it, Amber stands at the end of a lonely gorge in the hills of Rajputana. Long since deserted, it was once one of the proudest capitals of India, and its old palace ranks among the highest examples of Rajput art. The aortic view of the Rajah's apartments shows the intricate, although always intricate, is never overdone.

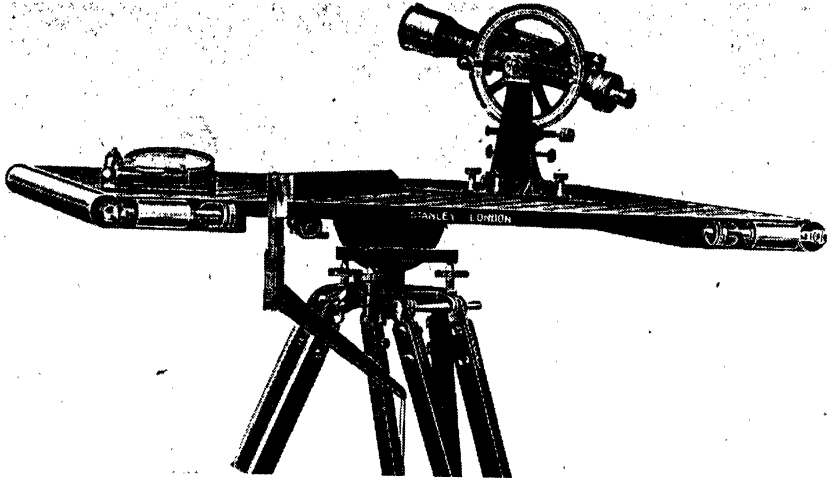

ALIDADE AND PLANE TABLE

[Carnew & Kinnaird]

One of the commonest instruments in surveying is the plane table. When this is adjusted into an exactly horizontal position, the surveyor looks through the telescope surmounting it, and by measuring on the alidade (the circular disc shown at the telescope's side) the angles of various objects in the landscape, is able to form an accurate idea of their distances and relative positions



[Dorion Leigh]

ALOE TO CURE X-RAY BURNS

For many years the Indians of Florida and Brazil cured fire-burns by applying aloe-leaves; now American experiments have shown this old remedy to be the cure for one of the newest and deadliest maladies—X-ray dermatitis

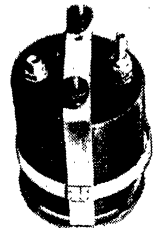
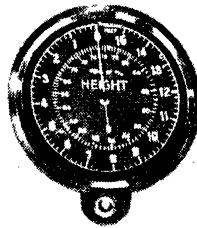

[Smiths' Aircraft Instruments]
THE ALTIMETER

This is the important instrument by which airmen tell their height above ground. It works on the principle that the higher one climbs, the smaller becomes the atmospheric pressure; there is an adjustment to cope with the variations of pressure at sea-level



THE ALETSCHE GLACIER

[From "Marvels of the Universe"]

Largest glacier in the Alps, the Aletsch is one of many great rivers of ice surrounding the Aletsch peak like tidal trains. The dark streak in the centre of the picture is a moraine of rock-debris which has flowed down from the mountains. The whole face of the glacier is covered with

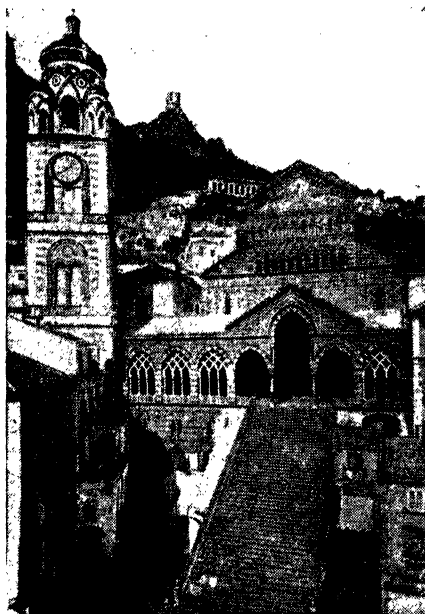

W. F. Mansell]

AMALFI CATHEDRAL

Amalfi, a seaport some two dozen miles south of Naples, is one of the most picturesquely situated towns in Italy. It is now of little importance, but was a place of much note in the Middle Ages. The splendid Romanesque cathedral dates from as early as the eleventh century



[G. K. Ballance

THE ALPS: THE DREI ZINNEN

The Drei Zinnen in the Southern Tyrol form one of the most conspicuous landmarks in Europe's mountain-range. They are at one end of the Dolomitic Rienz Valley, and their peculiar multi-peak formation is an outstanding feature of the Dolomites



[Lorien Leigh

AMBOISE, THE CHATEAU

Amboise is one of the most celebrated châteaux of Touraine. Originally a feudal fortress, it was altered to its present Renaissance form by Charles VIII. Besides being beautiful, it is very rich in historical associations, most of which centre round the Huguenots; but perhaps its greatest claim to fame is that in its chapel lie the remains of Leonardo da Vinci

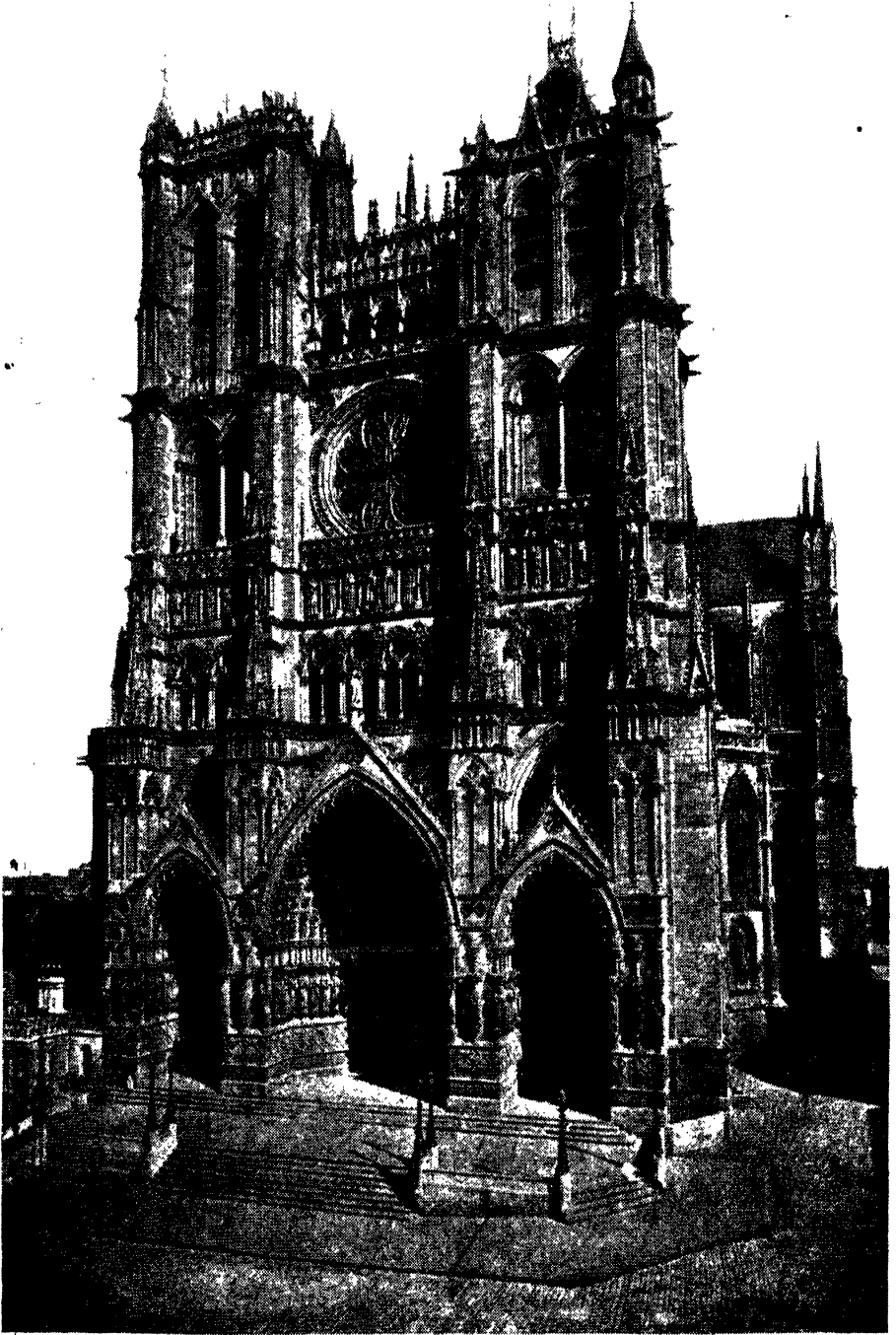

AMIENS CATHEDRAL

[F. Frith & Co.]

It is sixteen hundred years since Amiens became a bishopric, and seven hundred since the first stones of the present Cathedral were laid. Though restored in the nineteenth century by Viollet-le-Duc, it still dates mainly from the thirteenth century, and is generally called the finest piece of Gothic architecture in France. Almost miraculously, it escaped serious damage during the Great War



[The late H. G. Ponting, F.R.G.S.]

THE GOLDEN TEMPLE AT AMRITSAR

Amritsar is to the Sikh religion what Rome is to the Catholics and Mecca to Moslems. In the Golden Temple lies the Holy Book of the faith, and every true Sikh is expected to lay his tribute here at some time. The building, surrounded by water, is fashioned of white marble, the upper part of which is clothed in plates of gilded copper



From "Marvels of Insect Life"

INSECTS IN AMBER

AMBER is a resin of pine trees of the ancient world. Then, as now, small insects would become trapped by the stickiness, and some of them have thus been preserved for our inspection. The insect shown is related to the ant, and is mu

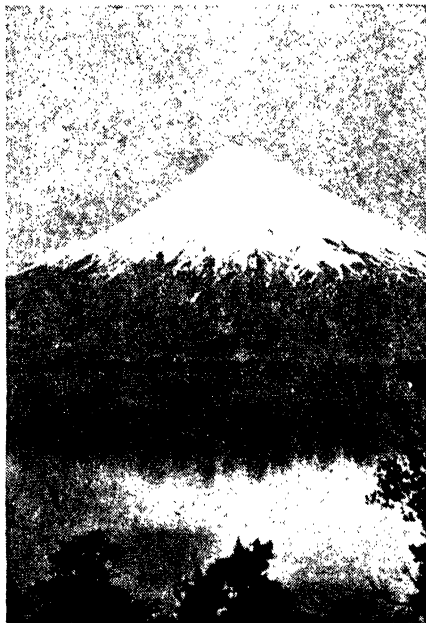

[Courtesy

THE ANDES

4,400 miles long, the Andes are easily the greatest mountain chain in the world. Their scenery is always wild. Much of the chain is volcanic, the active volcanoes extending the whole length of South America

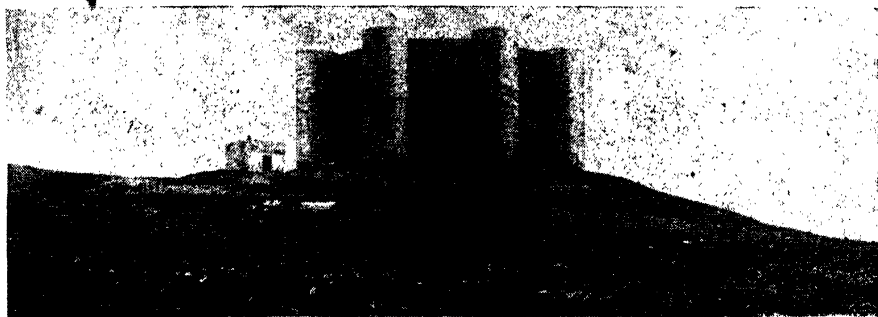

CASTEL DEL MONTE. ANDRIA

[W. F. Mansell

On a lonely hill near Andria, South-eastern Italy, stands this giant octagonal castle, an impressive reminder of the great medieval emperors. Frederick II, "the Wonder of the World," made it his favourite hunting seat, and on the downfall of his cause after his death, his son's wife and children were imprisoned in it



[Dorcen Leigh

"THE ANNUNCIATION," BY ANDREA DEL SARTO

Andrea del Sarto, one of the greatest of the sixteenth-century Florentine painters, based most of his work on the study of Michael Angelo and Leonardo da Vinci. Besides original paintings, he executed many copies of old masters, often excelling the quality of the originals. Perhaps Englishmen know him best by Browning's famous poem, written round an incident in Del Sarto's visit to Francis I of France

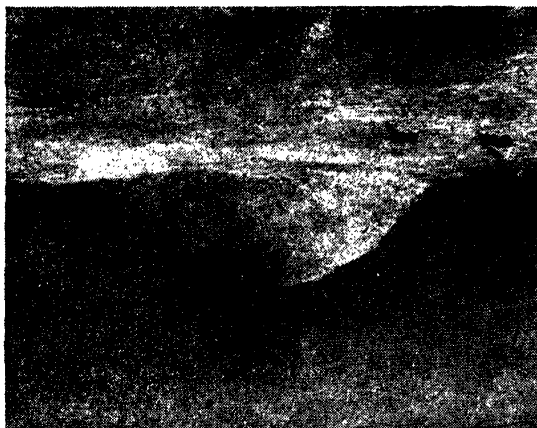

By Theo. Carreras

CROSS SECTION OF ANT-LION PIT

The ant-lion is so named because of its habit to trap ants and eat them. It hollows out a circular pit in loose, dry sand, and buries itself at the bottom. Approaching ants fall into the pit, and eventually slide into the ant-lion's jaws

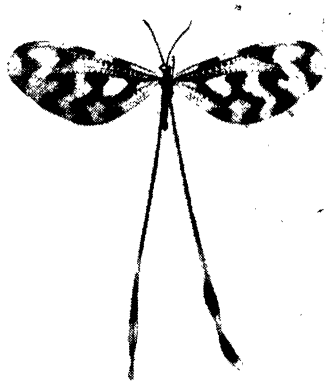

[From "Marvels of Insect Life"
THE ANT-LION FLY

Not all ant-lions dig pits, but some are equally remarkable owing to the enormous length and thinness of their hind wings when they reach the adult fly stage

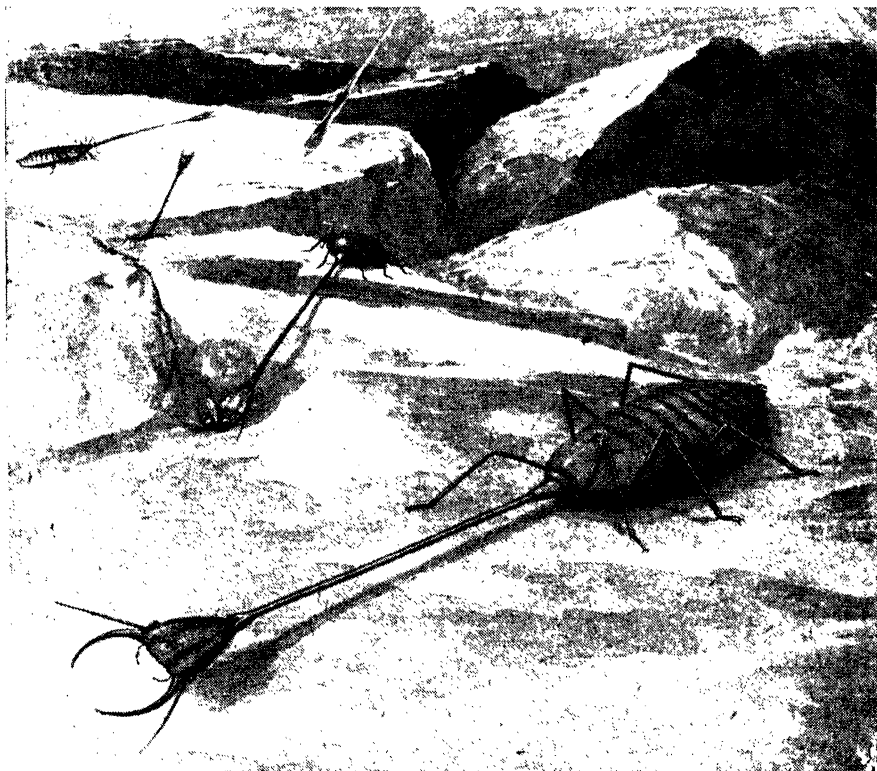

[By Theo. C.]

THE LONG-NECKED ANT-LION

This remarkable insect is believed to be the larva of the long-winged fly at top of the page. It lives at the tombs and pyramids of Egypt, and the long neck is probably for reaching into the crevices of their :
In real life the insect is only half an inch long

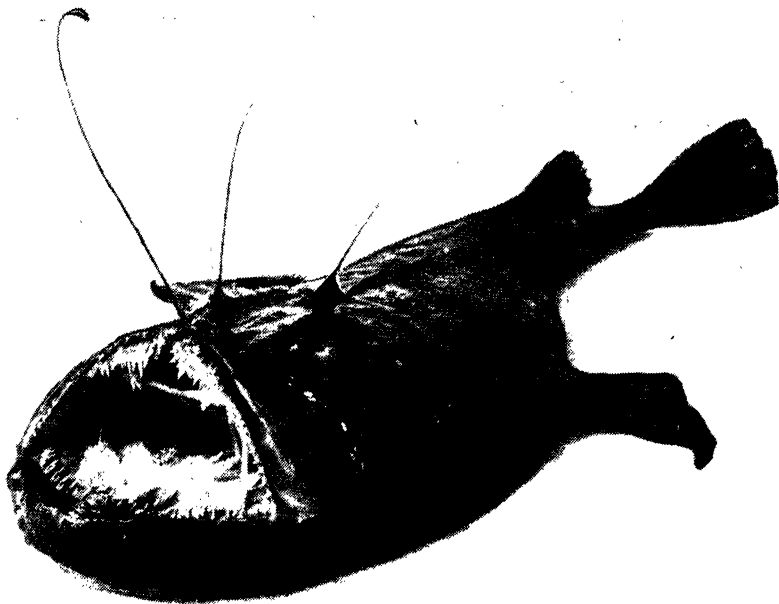

THE ANGLER FISH

[R. Thiele & Co.]

There are several types of Angler Fish, but all share the same chief trait—the lazy habit of lying sluggishly amid weeds or mud and attracting prey by the "fishing rod" suspended over the mouth. The latter is enormous—about half the size of the fish—and in all types the teeth are very formidable



ANTRIM: THE GIANT'S CAUSEWAY

[From "Wonders of the World"]

The North-west coasts of the British Isles are rich in these strange, organ-like basalt formations, originally created by volcanoes. This causeway is the best known of all, famed since remote antiquity in countless Celtic songs and legends. The Giant of the title is one Fin MacCoul, a great Celtic hero

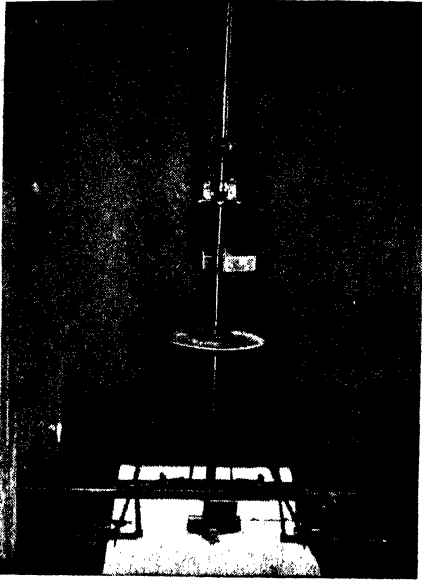

[Cartney & Kinnard]

AN ANEMOMETER

This is an instrument for measuring the flow of gases. Generally a light wheel with special blades is set turning, like a windmill, by the gas current, and operates a counting mechanism, which, from the number of revolutions, automatically determines the gas speed.

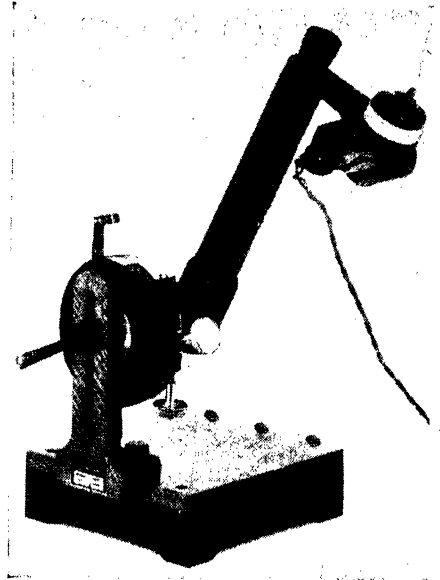

[Cartney & Kinnard]

AN ANGLE GAUGE

Ever since the Pyramids were built architects and engineers have had to obtain accurate angle-measurements. To-day the accuracy has to extend to minute fractions of a degree. The instrument shown is used in engineering and mechanical products.

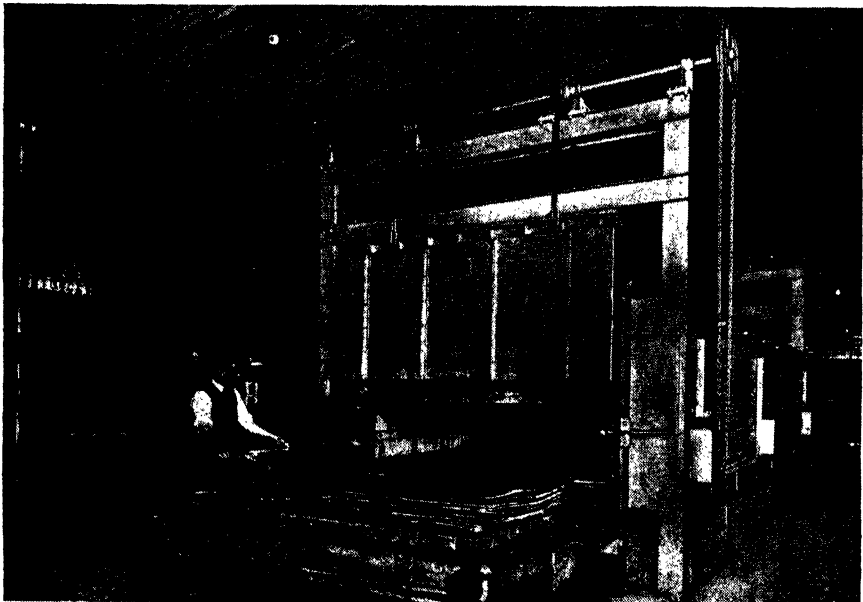

[Courtesy G.E.C.]

ALUMINIUM ANNEALING FURNACE

Annealing is the process of heating a metal or alloy to a certain temperature, keeping it there for a time, and then cooling it at a specific rate. The purpose may be to soften hardened and embrittled metals, to remove inner stresses from castings, or to "melt" the constituents of alloys. The furnace shown is electric, and the aluminium sheets are run in and out of it on a huge trolley.



ANTS AND APHIDS

(By Ineu. Carreras

Of the manifold activities of ants, none is so striking to the human imagination as their "cow-milking." Not only do the ants obtain the milk (a sweet colourless liquid) by the actual milking process of stroking with their feelers, but they actually breed the aphids in herds, build sheds and walls for their comfort, and drive off their enemies. These aphids are a well-known insect, being none other than the "Greenfly"



VIRGIN AND CHILD, BY FRA ANGELICO

[Dorien Leigh

Angelico was one of the early Renaissance painters; he died in 1455. Born in Vecchio, nearly all his life was spent in Florence, and he is somewhat of an exception among the great masters in that he was a Dominican monk. Apart from his holy portraits, he painted a number of remarkable frescoes, of which those in San Marco, Florence, are the best known. The above painting is in the Uffizi Gallery

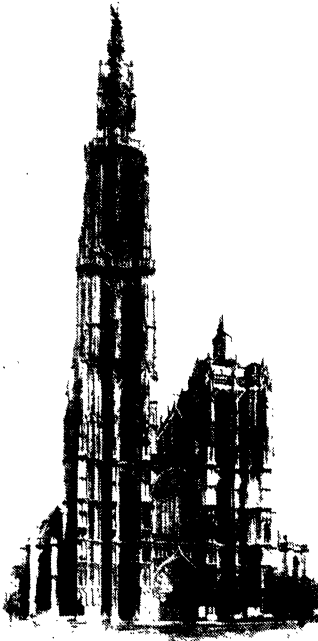

Dorien Leigh]

ANTWERP CATHEDRAL

This edifice took over 160 years to build, and is famous for its Gothic spire, its chimes, its six aisles, and the masterpieces by Rubens which adorn it



[Underwood Press Service

THE INCA BRIDGE, ARGENTINA

This bridge was nature's own work, yet the cleverest engineer could hardly have improved on the symmetry of the colossal rock. The river flowing beneath is the Mendoza, and the mountains are an offshoot of the giant Andes



[Curthw & Kinnaird

ARGENTINA, THE TANDIL ROCKING STONE

In the Tandil Mountains, south of the Rio Plata, this 700-ton mass of granite has lain for centuries on the brink of a precipice. A man can rock it easily with one hand, and control its swing sufficiently to crack a nut; but a team of a thousand horses which was once yoked to it failed to displace it by a single inch!



THE HEAD OF ARTEMIS

[Dorson Leigh

This famous head is part of a classical group by an unknown sculptor, representing Artemis (whom the Romans called Diana) and her lover Endymion; the group is in the Vatican. Though not so well known as the statue of the goddess now in the Louvre, the chiselling of these features is hardly surpassed by the finest works of Melos and Pheidias

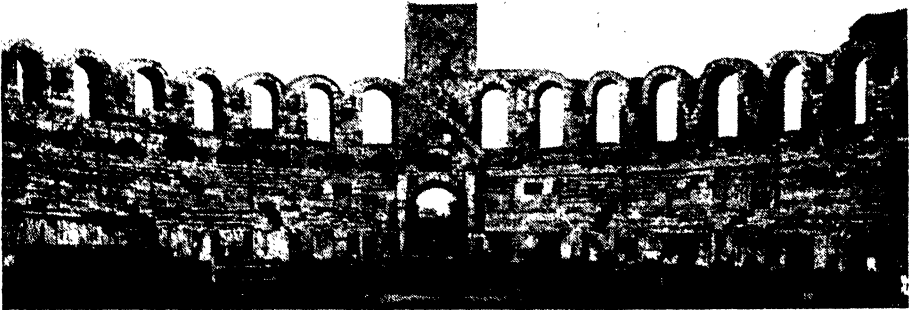

ARLES. THE ROMAN ARENA

[Photochrom Co., Ltd.

For pride of place as the best in France, the Arena at Arles is a close rival to that at Nîmes. Arles also has baths, an aqueduct, a theatre and a palace dating from Roman days. Bull-fights are still held in the arena where the gladiators used to fight



[H. Bastin

THE ARRINDI CATERPILLAR

ct, the larva of the American silk-moth, has an extraordinary method of cocoon-building. It begins the oper by weaving a silken sheath round the stem and part of the branch. The photo on left shows the completion of this sheath: the one on right the caterpillar almost hidden in its covering



[Courtesy Sir H. H. Johnson, G.C.M.G.]

ARCHAEOPTERYX

Or, the first bird. A restoration showing clearly how this pioneer of winged life retained many terrestrial characteristics, such as fingers beyond the wings and a long vertebral tail instead of a mere stump

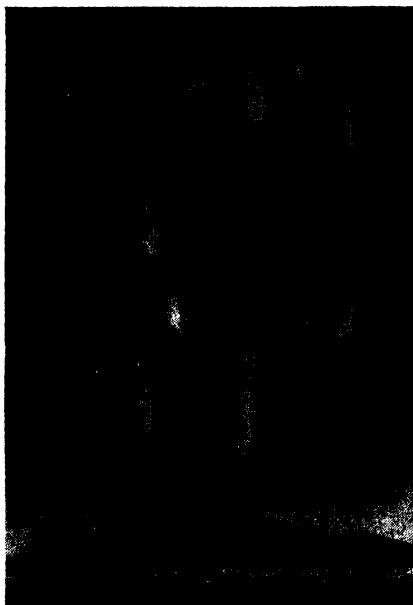

[Courtesy The Royal Astronomical Society

ARCTIC LIGHTS

A picture of the Antarctic Lights, taken during Capt. Scott's last expedition, which shows that, North or South, the Aurora displays the same curtain-like formations of strange design and colour



By courtesy]

Nobody knows exactly what caused this forest to petrify. It is supposed that a tornado having uprooted a large number of trees and deposited them where they are to-day, the wood fibres gradually became charged with mineral deposits. The trees are mostly broken into short lengths, but the total area of the forest is more than ten square miles. The fossils are many millions of years old.

THE PETRIFIED FOREST, ARIZONA

[Santa Fe Passenger Ry.]

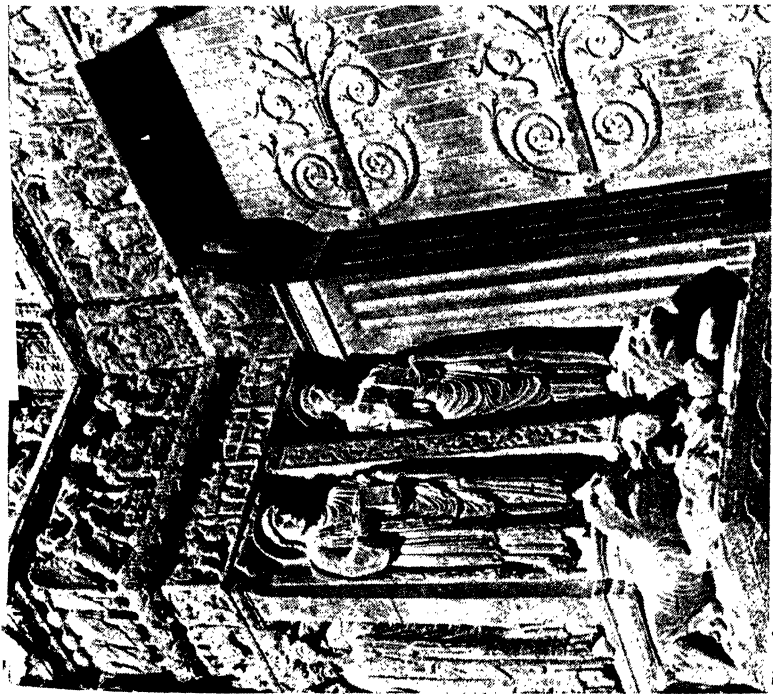

Photos]

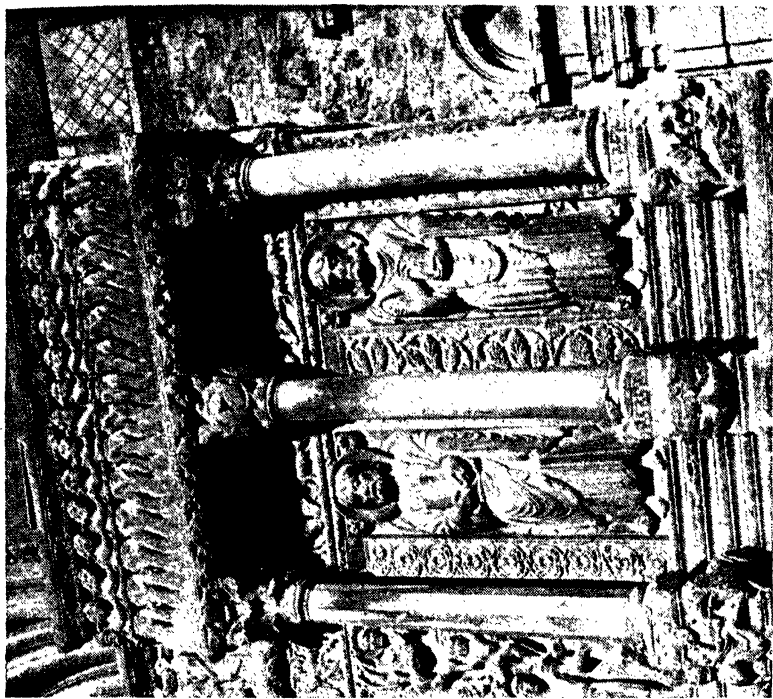

[Dorrien Leigh

ARLES: THE PORCH OF SAINT TROPHIME

The little Cathedral of St. Trophime is the finest in Provence, and the sculptures round its western doorway are equal to anything of the kind in France. They date from the twelfth century, but are newer by some five centuries than the Church itself. A certain amount of restoration was effected in 1870, but the West Porch escaped the Revolution and is largely untouched.



From "Britain Beautiful"

ASTRONOMICAL CLOCK—OLD STYLE

This instrument might be called the parent of all timekeepers, for its job was to measure star-time, and the solar clocks which give the basis of our own system are regulated on its principles. That the astronomical clock is not new is shown by this medieval example in Wimborne Minster.

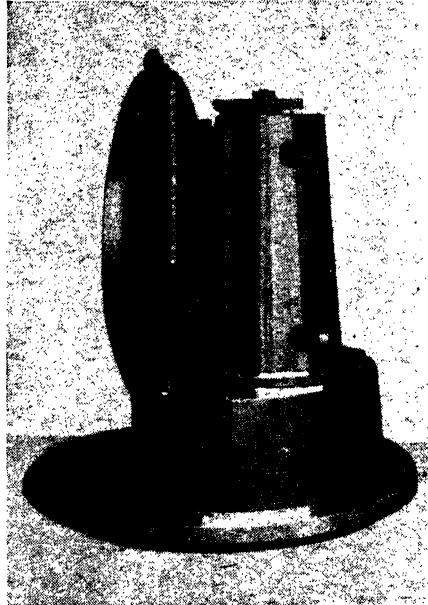

[Thomas Mercer

ASTRONOMICAL CLOCK—NEW STYLE

The modern astronomical, or sidereal, clock is an important feature of every observatory. The above is a lateral view of the "works," the appearance of which differs from that of ordinary clocks chiefly by the thermometer running up the side. These modern instruments are capable of greater regularity than the rotating Earth itself!

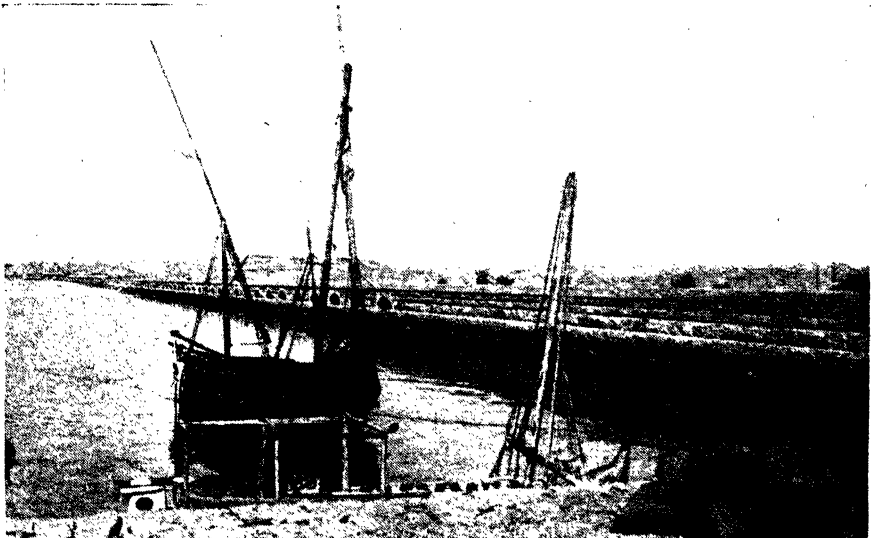

THE ASSOUAN DAM

[Carruth & Kinnaird

The famous Nile barrage is here seen from its upstream, or southern, side. A mile and a quarter long, with forty sluice-gates, each measuring seventy-five feet square, it has brought thousands of acres of fertility to Upper and Lower Egypt. Designed by Sir William Willcocks, it was the first of the great Nile dams. It has recently been heightened

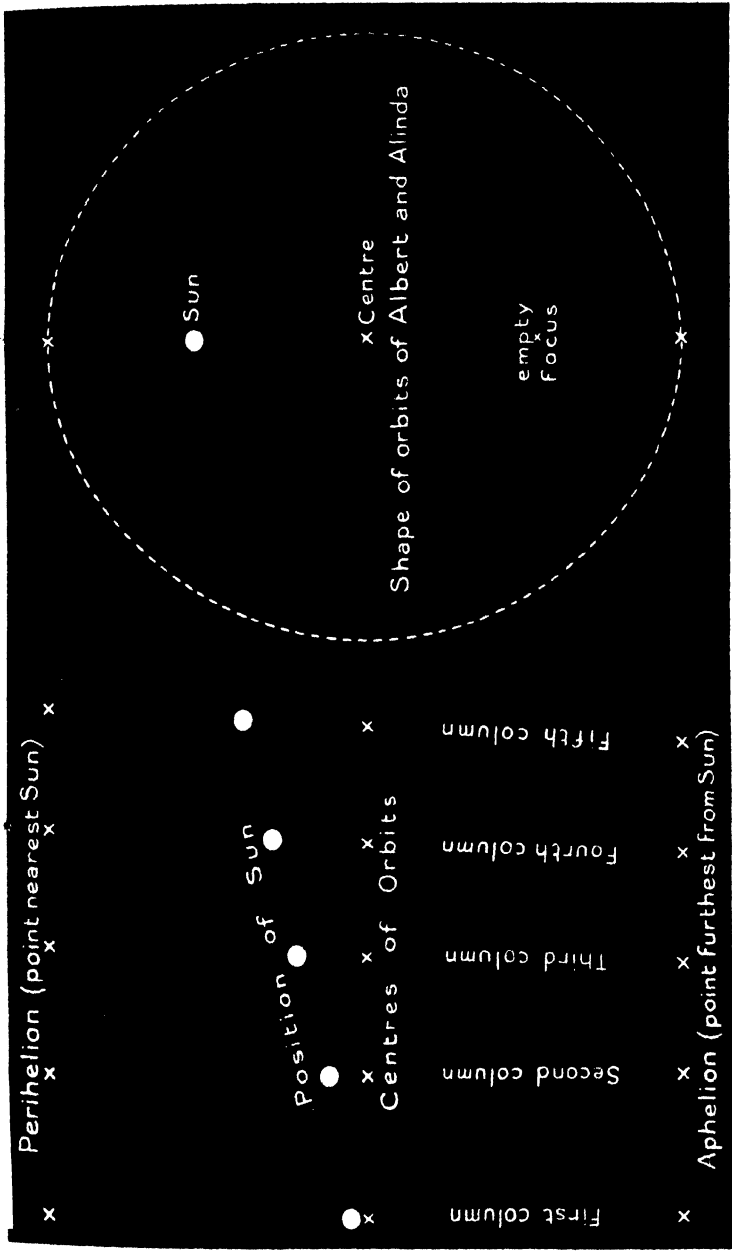

The Asteroids

['Splendours of the Heavens']

ASTEROIDS

The asteroids are thousands of minute planets (the biggest one-fifth the diameter of our moon) circling round the Sun between the orbits of Mars and Jupiter. There is an interesting theory that all the great planets, including our Earth, have evolved from similar collections of tiny particles. The diagram shows how some of the asteroid orbits—especially that shared by Albert and Alinda—are not round but oval. Only the last named has been sketched in full, but the "columns" on the left show in the same way the degree of eccentricity of the other chief asteroids.

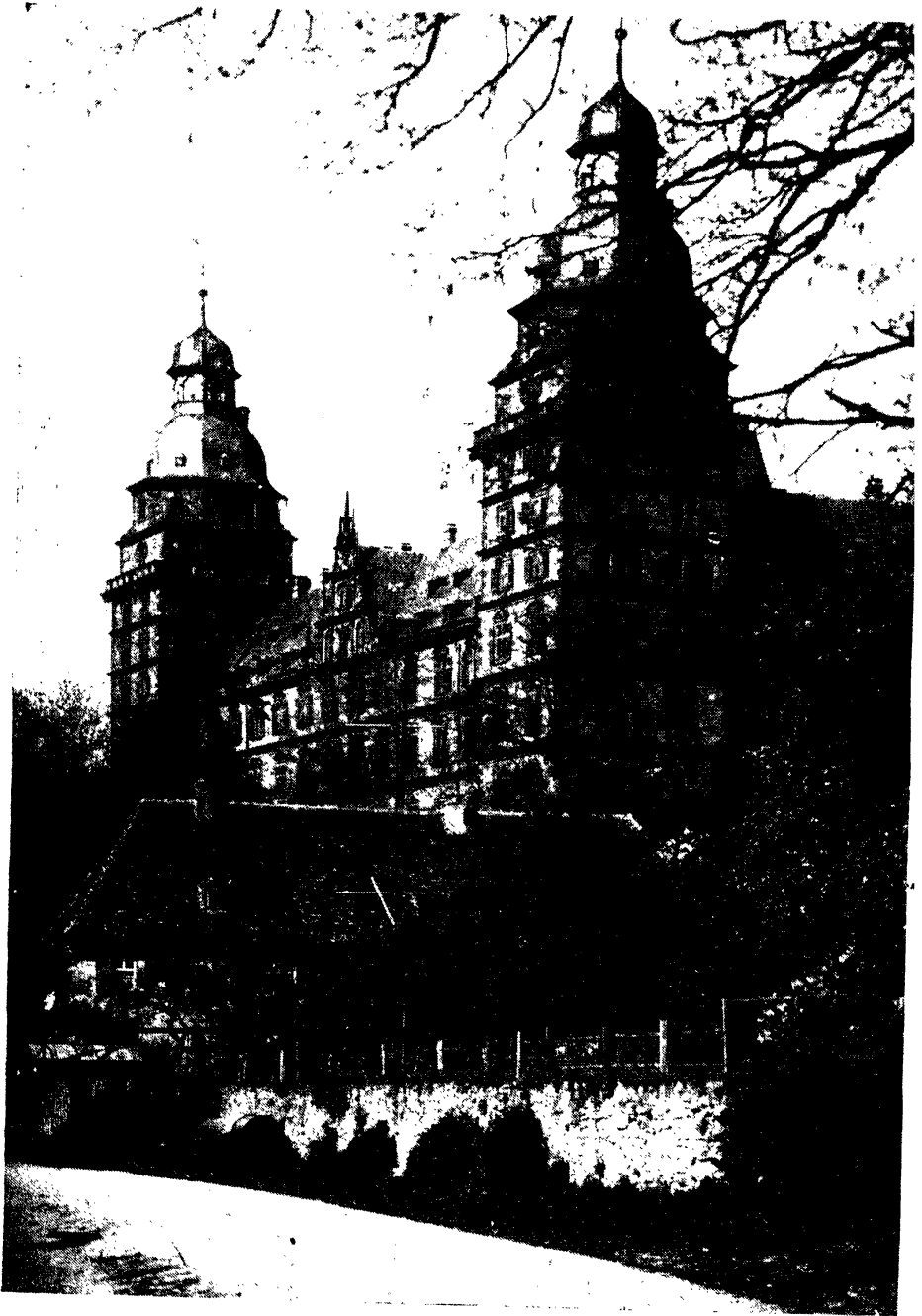

ASCHAFFENBURG CASTLE

[Dorien Leigh's

The mighty Castle of Johannisburg, overlooking the town of Aschaffenburg, is one of the largest of the great Bavarian strongholds which played such a conspicuous part in the grim Thirty Years War. Once a Roman fortress stood on the site, but the present building was erected during the Renaissance. It stands some twenty-five miles south-east of Frankfurt, facing the River Ufer.

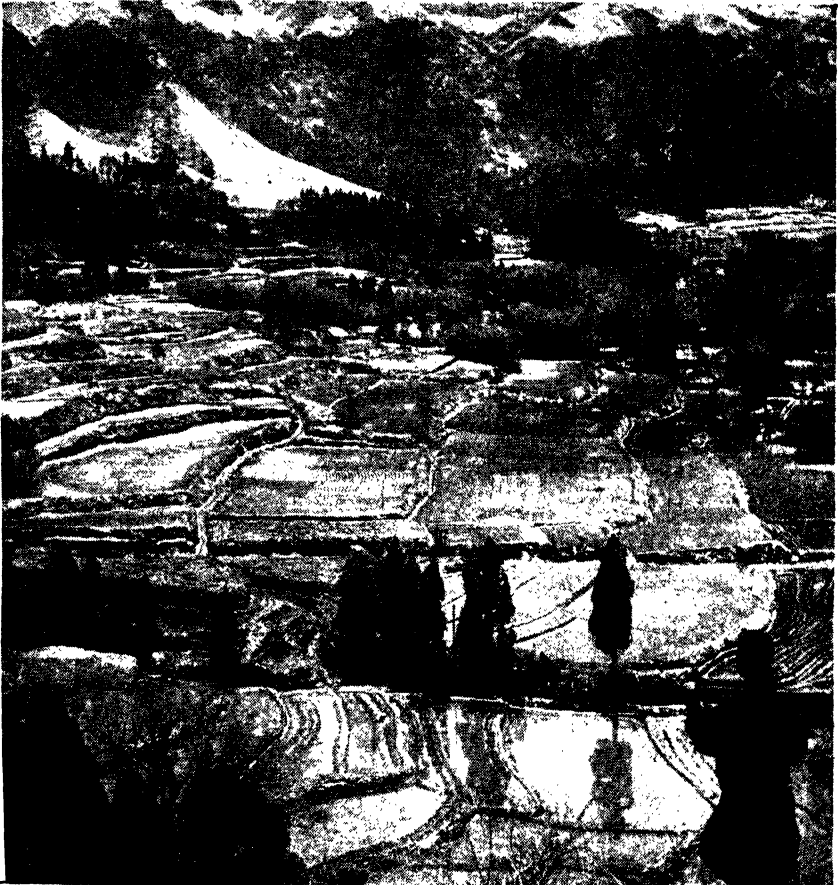

[Keystone

ASO-SAN

The Vale of Aso-San is the crater of an extinct volcano, the largest in the world. At present, with its fields, trees and villages, it is one of Japan's beauty spots; but there is a terror underlying its beauty, for no man can be certain that the most slumberous of volcanoes will not suddenly awaken. The re-awakening of Aso-San would mean untold devastation



[Dorien Leigh

ATHENS: THE ACROPOLIS

Literally, "acropolis" means "highest city", and there are several in Greece. None, however, can boast a tenth of the fame of the great rock dominating Athens, whose temples represent the highest standard ever attained in architecture. The celebrated Parthenon stands out boldly in the above photo.



Underwood Press Service]

THE TEMPLE OF APTEROS NIKE

The most renowned portion of this exquisite little temple on the walls of the Acropolis is the sculptured frieze round the top. Four panels of the original were brought to England by Lord Elgin, and have been replaced by terra-cotta duplicates

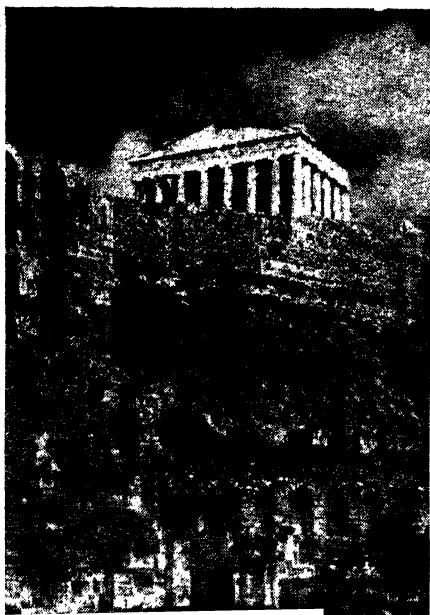

[Dorrien Leigh WALLS]

THE ODEON AND ACROPOLIS

The Odeon or Theatre of Herod, a few of whose arches are seen to the left, was built by a wealthy Athenian for his wife. The stout rock on which the Acropolis walls are built is well shown. At the top is the portico of Eumenes

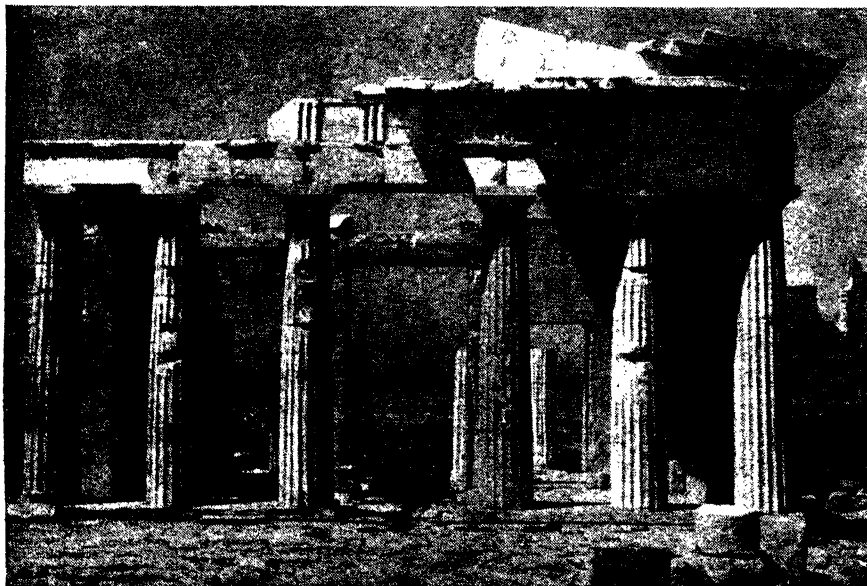

[Dorrien Leigh

THE PROPYLÆA

This is the most important secular ruin of Ancient Athens. It was originally a magnificent gateway, and in proof that its beauty was appreciated from the start, the splendid marble steps which lead to it were the Romans soon after the Grecian decline

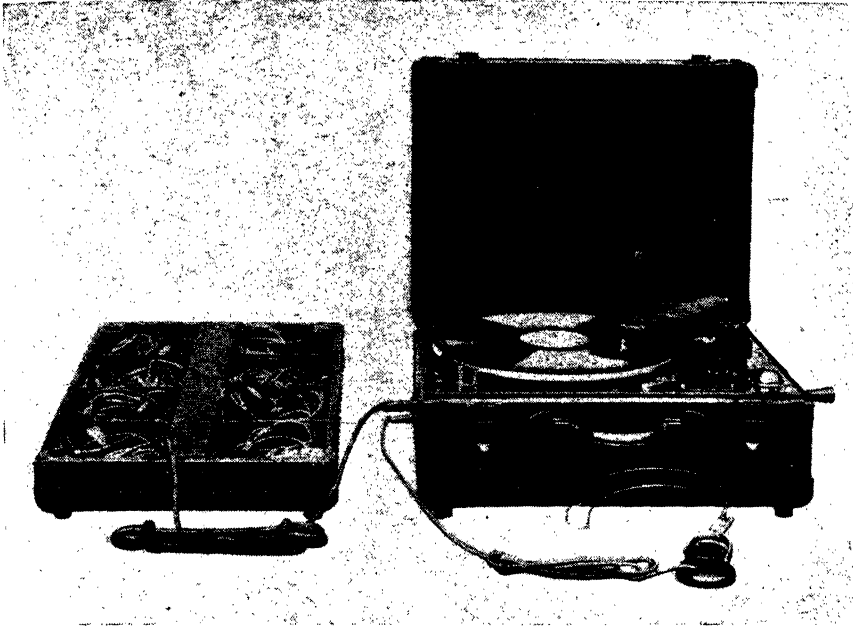

AN AUDIOMETER

This is an electrical equipment for testing the acuteness of hearing. The type shown comprises a gramophone outfit, on which are 'played' a series of three-figure numbers of varying and known relative loudness. The subjects to be tested listen through a special set of earphones and record as many numbers as they can hear.



[Photos]

THE AUTOGYRO

[Carthew & Kinnaird]

The Autogyro, or Windmill Plane, has already attracted world-wide notice on account of its extreme safety. The four horizontal blades do not, as is often supposed, obtain their motive power from the engine, but from the air alone. It is this that renders the machine nearly crash-proof, for the faster it falls, the greater becomes the blades' braking-power.

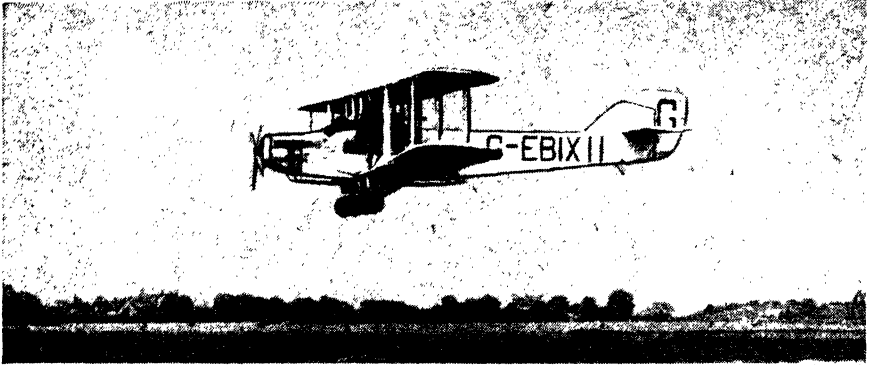

[Carthew & Kinnaird]

AUTOMATICALLY PILOTED AEROPLANE

imental stage, the automatic piloting of an aeroplane has attained considerable emiciency. Its chief uses are in case of mishap to the pilot, and, in war-planes, to relieve the pilot's attention from the controls

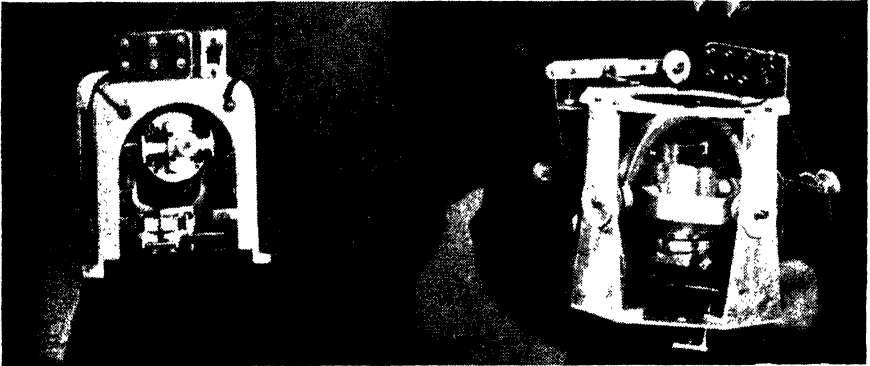

[Dorien Leigh]

AUTO-PILOT MECHANISM

During recent American Air-Corps manœuvres, a giant 'plane was piloted throughout by these two small gyro-compasses. Their accuracy excelled that of the most skilful human pilots



[Carthew & Kinnaird]

THE AUTOCRYPTOGRAPH

This is one of several names applied to machines which automatically codify messages struck on an ordinary typewriter-keyboard, and also decode them. The above is a decoding apparatus

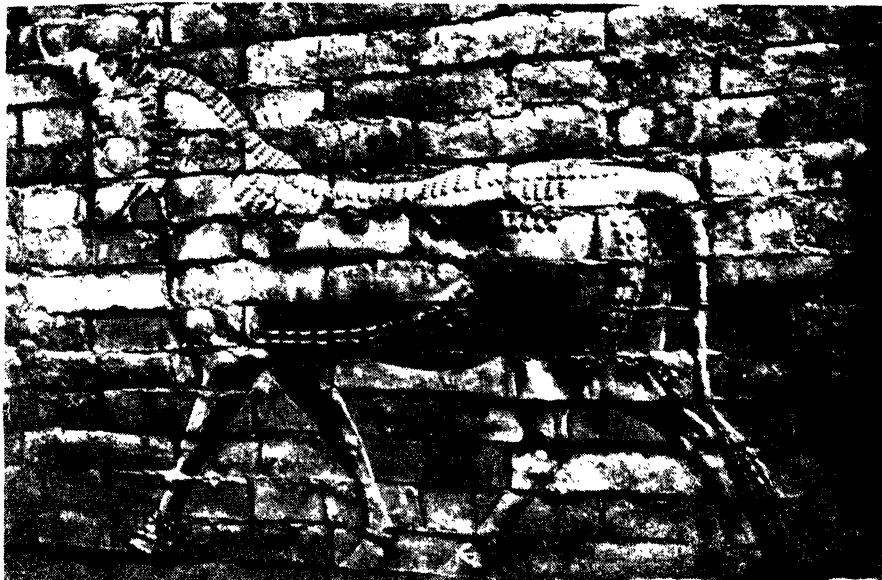

A BAS-RELIEF IN BABYLON

[From "Monarchs of the World"]

Of all the relics of Nebuchadnezzar, none has been preserved so well as the splendid Gate of Ishtar which he built. The tiles of its walls, which are fitted together to form such life-like studies as the one above, are enamelled by a process of which no one to-day knows the secret.



THE RUINS OF BABYLON

[Underwood Press Service]

Nothing can bring the Old Testament so vividly before us as the rediscovery of its cities. The man to the left of this picture is standing upon a piece of brick pavement which not only must have often borne the feet of Daniel, but which is the fragment of a long street actually named after him.

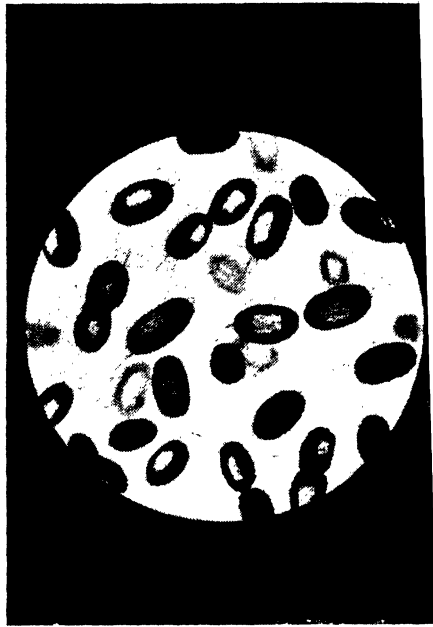

[Carthew & Kinnear]

TWO KINDS OF BACTERIA

Bacteria are a simple form of plant organism, not dissimilar to fungi, but so small that 2,500 of the larger sorts, placed end to end, would hardly measure one-tenth of an inch, and so quick to multiply that more than 16,000,000 may be produced in a day. Some are too small to be seen at all, though their effects are not. On the left is the bacillus causing sleeping-sickness, on the right that of bubonic plague

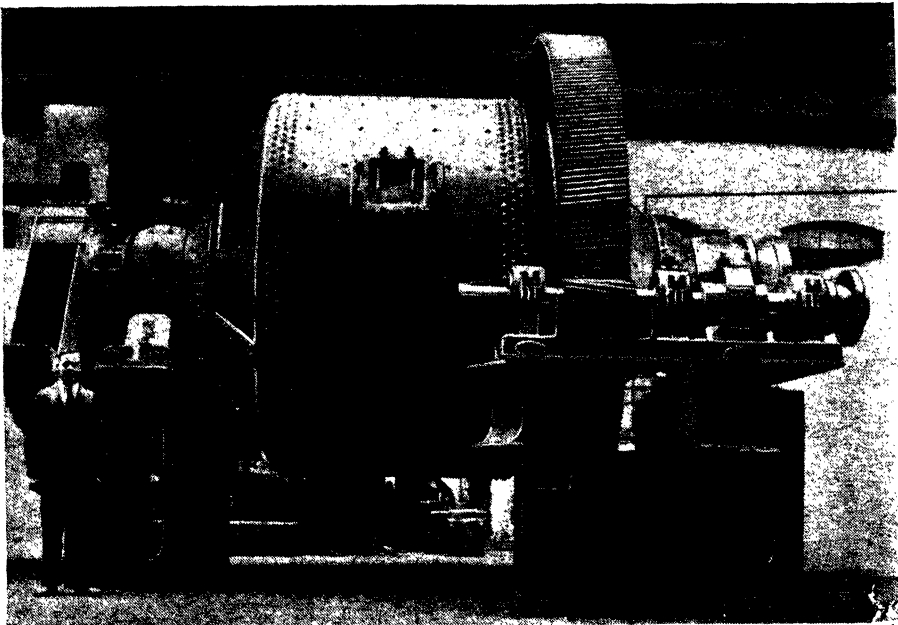

[International Combustion, Ltd.]

A BALL MILL

When manufactured in 1931 this mill was the largest of its kind in the world. Its purpose is the grinding of copper ore in South Africa. The unground ore is inserted in the huge drum, which is then revolved until a series of heavy metal balls within the drum have pounded the ore to dust



[L.E.A.]

AYUTHIA

Once the capital of Siam, Ayuthia has lain in ruins since 1767, when it was almost destroyed by the Burmese. During the brief period—only four centuries—of its active life, the wealth it acquired was almost fabulous. The colossal Buddha, who still watches over the desolation, is built of bricks and coated with thick bronze, and in spite of its dilapidation, betokens no little skill on the part of his unknown architect

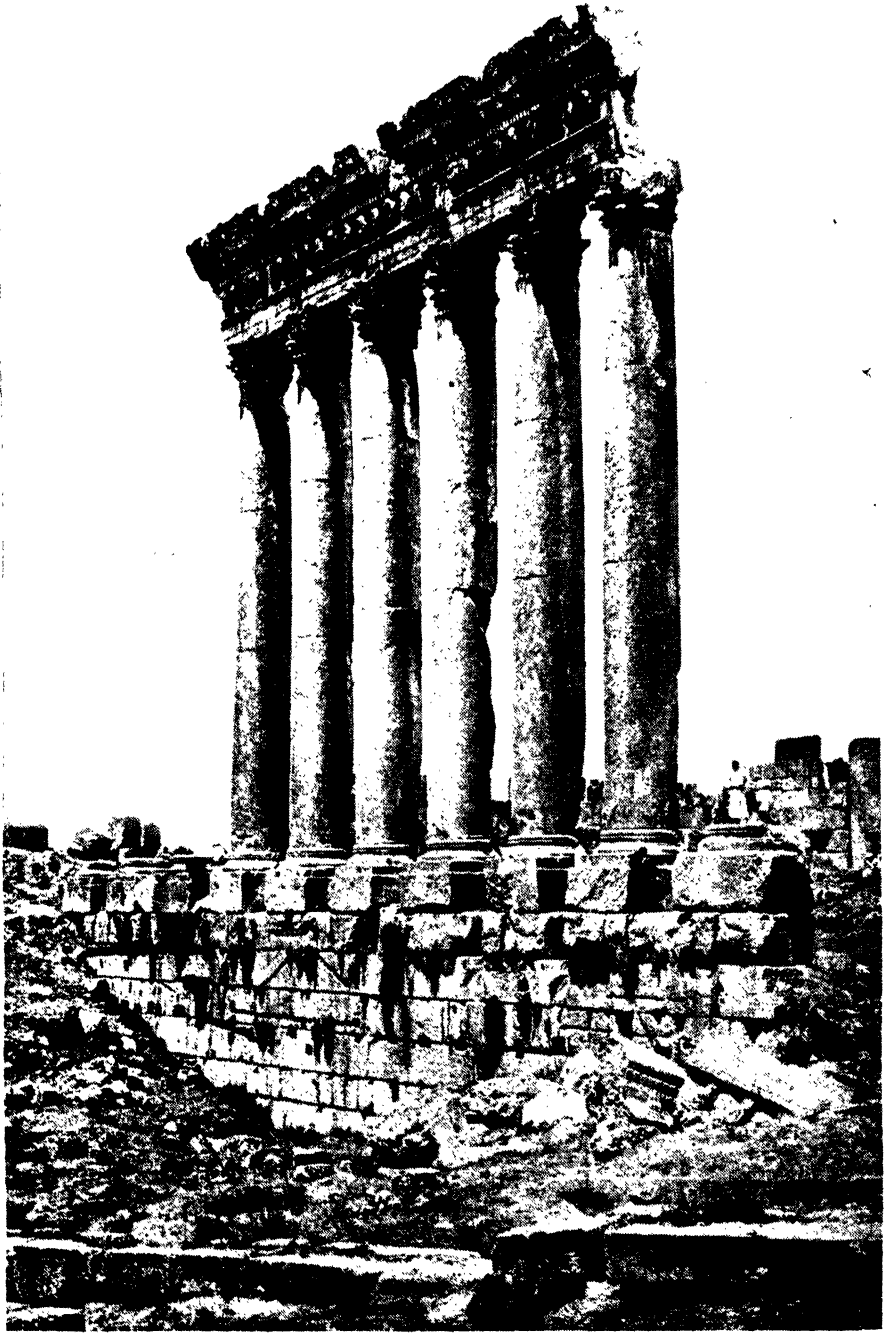

[Photochrom Co., L.S.]

THE TEMPLE OF THE SUN, BAALBEK

Six lonely columns are all that remain of the great Sun Temple in Syria's most famous dead city. The Heliopolis of the ancients, Baalbek is something of a mystery to us, for though it is known to be very old, it is practically unmentioned in Greek, Jewish, or Latin writings until early Christian days. How big the Temple of the Sun must once have been can be gauged from the man standing near the right-hand pillar

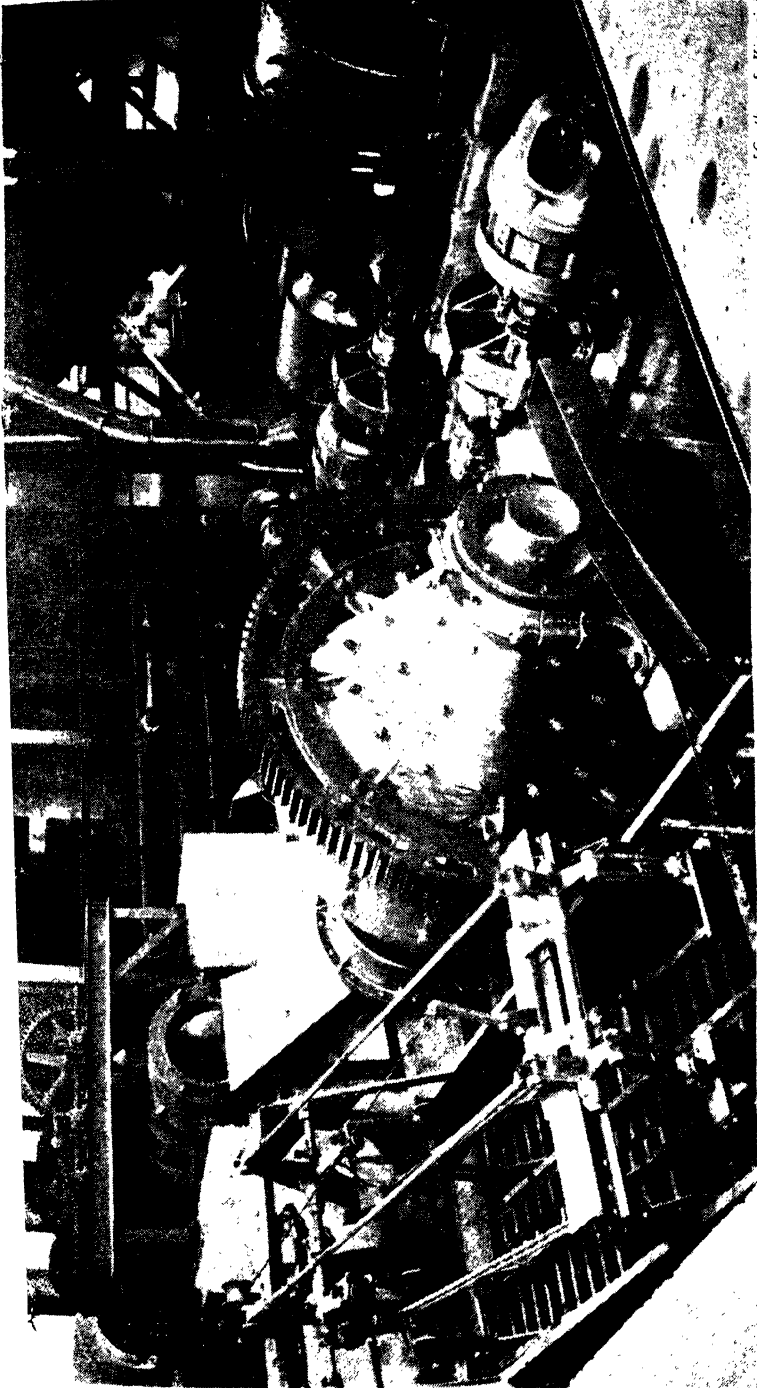

A BALL MILL PLANT

This picture gives a good idea of the complicated machinery which goes to complete a Ball-mill unit. The actual grinding drum is seen in the middle, complete with chait. On the left, a multiple-lever system controls the speed and direction of the revolutions. On the right is an electric motor, and in the right background is seen the drum of another mill (see also page 42)

[Carlisco & Kinnaird]

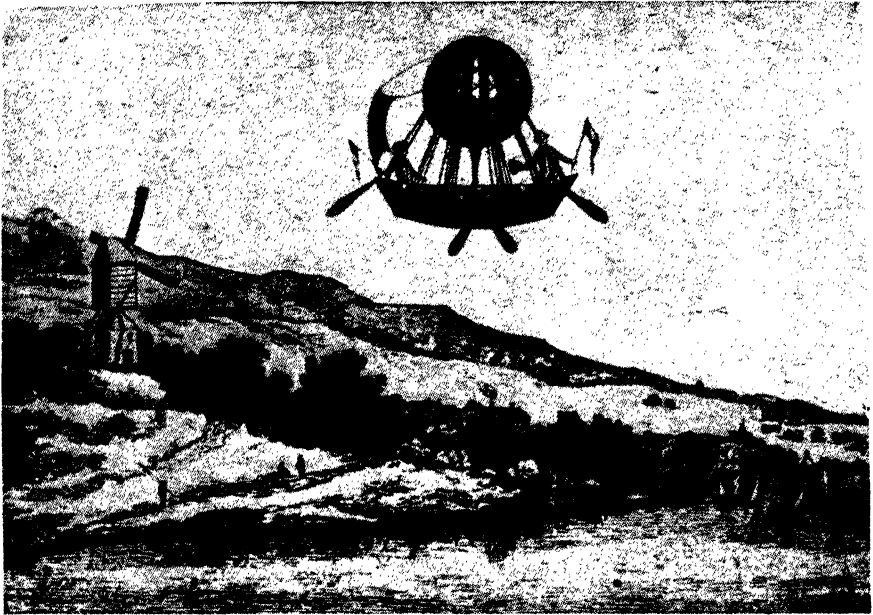

THE BALLOON AND THE AIRSHIP

Long before the coming of the aeroplane, men in different parts of the world were experimenting with balloons. The above quaint contrivance was the first flying craft ever to cross the Channel, piloted by Blanchard and Jeffries in 1785

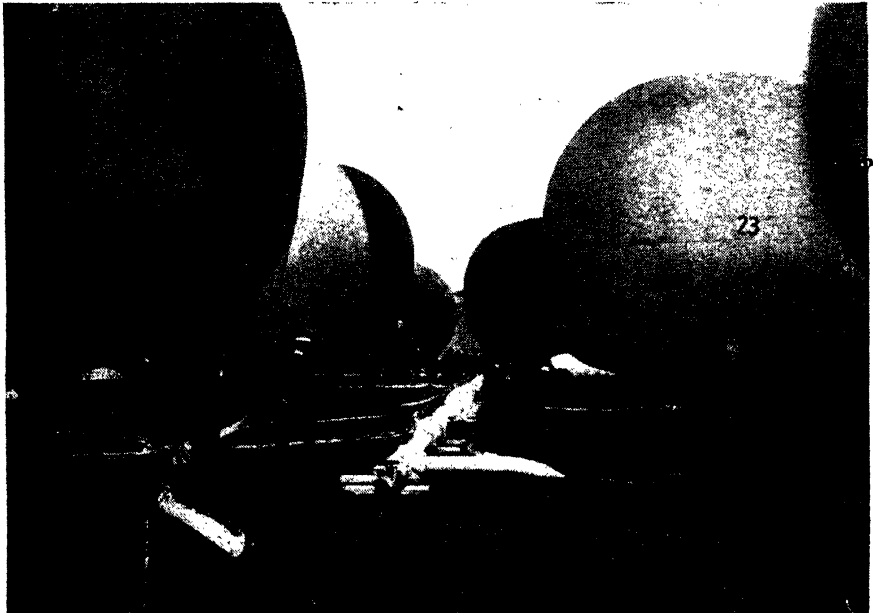

Photos]

BALLOONS IN THE GREAT WAR

[Carthew & Kinnaid

It is a far cry from the hot air balloons of the brothers Montgolfier in the eighteenth century to the modern product. Probably the greatest use which has ever been made of the invention was for observation purposes during the Great War. Above is a group of British Army balloons being filled with gas



[Courtesy Government of Western Australia]

AUSTRALIA'S GIANT CAVES

Both in the East and in the West, Australia possesses large groups of caves whose stalactite formations are the strangest on earth. Sparkling and colourful with all the hues of the rainbow, they take the likeness of trees, animals and buildings, and sometimes, as here in the Yallingong Caves of Western Australia, of hanging draperies



[Courtesy Government of New South Wales

STALACTITES IN AN AUSTRALIAN CAVE

In New South Wales there are three principal cave-groups—the Jenolan, the Wollondilly and Yarrangobilly. The picture shows a stalactite formation in the Jenolan Caves. Originally formed by the action of water on calcareous rock, these stalactites are composed of limestone.

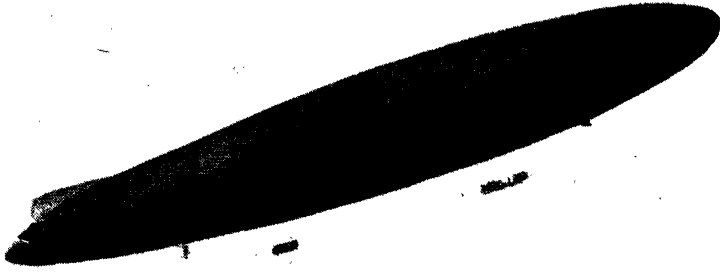

THE PROGRESS OF THE AIRSHIP

As soon as balloon-flying became established, men turned their attention to the question of dirigibility, and from the globular gas-bag evolved the finned and ruddered airship. The above is an early type by Shutto Lang



The two greatest figures in the history of dirigibles are Santos Dumont, a Brazilian, and the German, Count Zeppelin. The zeppelin shown is one of the inventor's early pre-War types

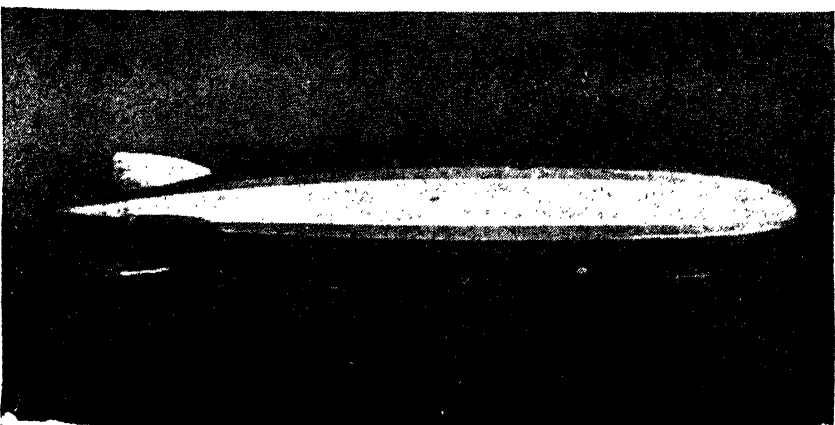

[Photos]

The modern airship's immense range and large carrying power make it in many ways an excellent form of transport, especially for trans-oceanic work. Compare this graceful machine with the clumsy "sausage" at top of page

[Carthew & Kinnaird]



[Dorien

BAMBERG-AM-SAALE: THE SCHLOSS
 Bamberg, in Upper Franconia, is a thousand-year-old town famous for two fine castles and a magnificent Byzantine cathedral. The vast size of Bavarian palaces is apparent in this courtyard view. The high towers with their many dormer windows are also typical of the locality

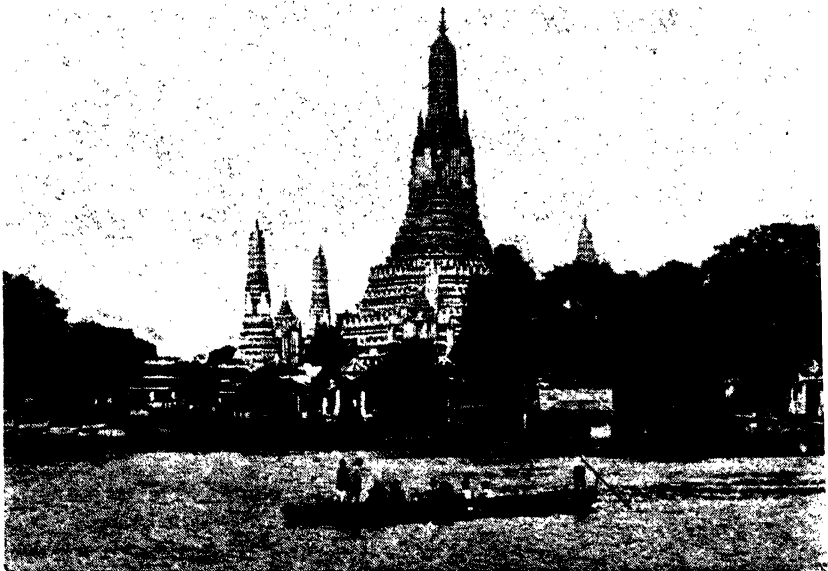

[L.]

THE WATS OF BANGKOK

A "wat" is simply a pagoda or temple. Those at Bangkok, the capital of Siam, represent the highest form of their particular art. Wat Chang, here shown, stands in ornamental gardens nineteen acres in extent. It is lavishly adorned with faience and porcelain, and also with multitudes of figures and elephants

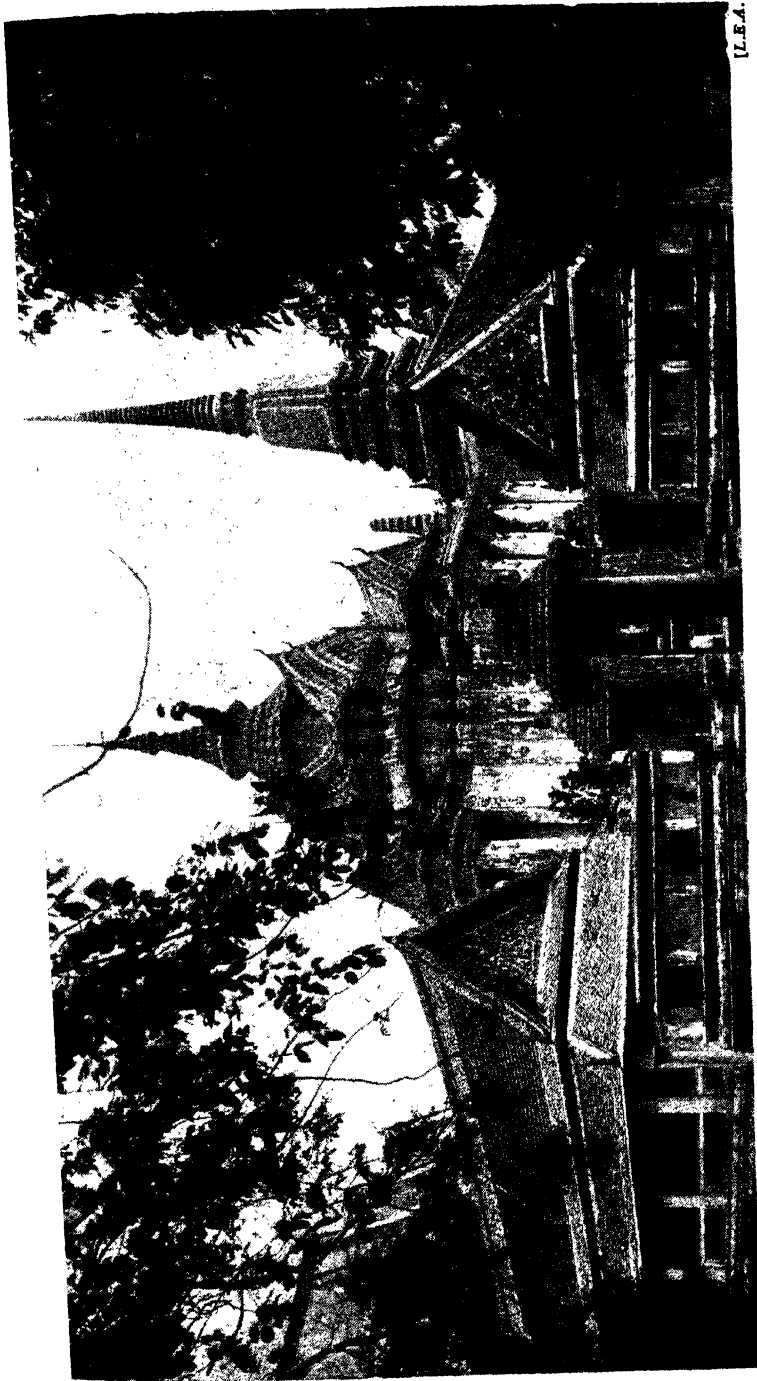

[L.E.A.]

INTERIOR OF WAT PO, BANGKOK

Owing to the high surrounding wall, it is impossible to obtain a general view of this, the largest temple-monastery in Siam. The photograph shows some of the inner buildings. The Wat is most famous for an 175-foot-long figure of the Dying Buddha, so thickly coated with gold that early European visitors believed it to be of solid gold

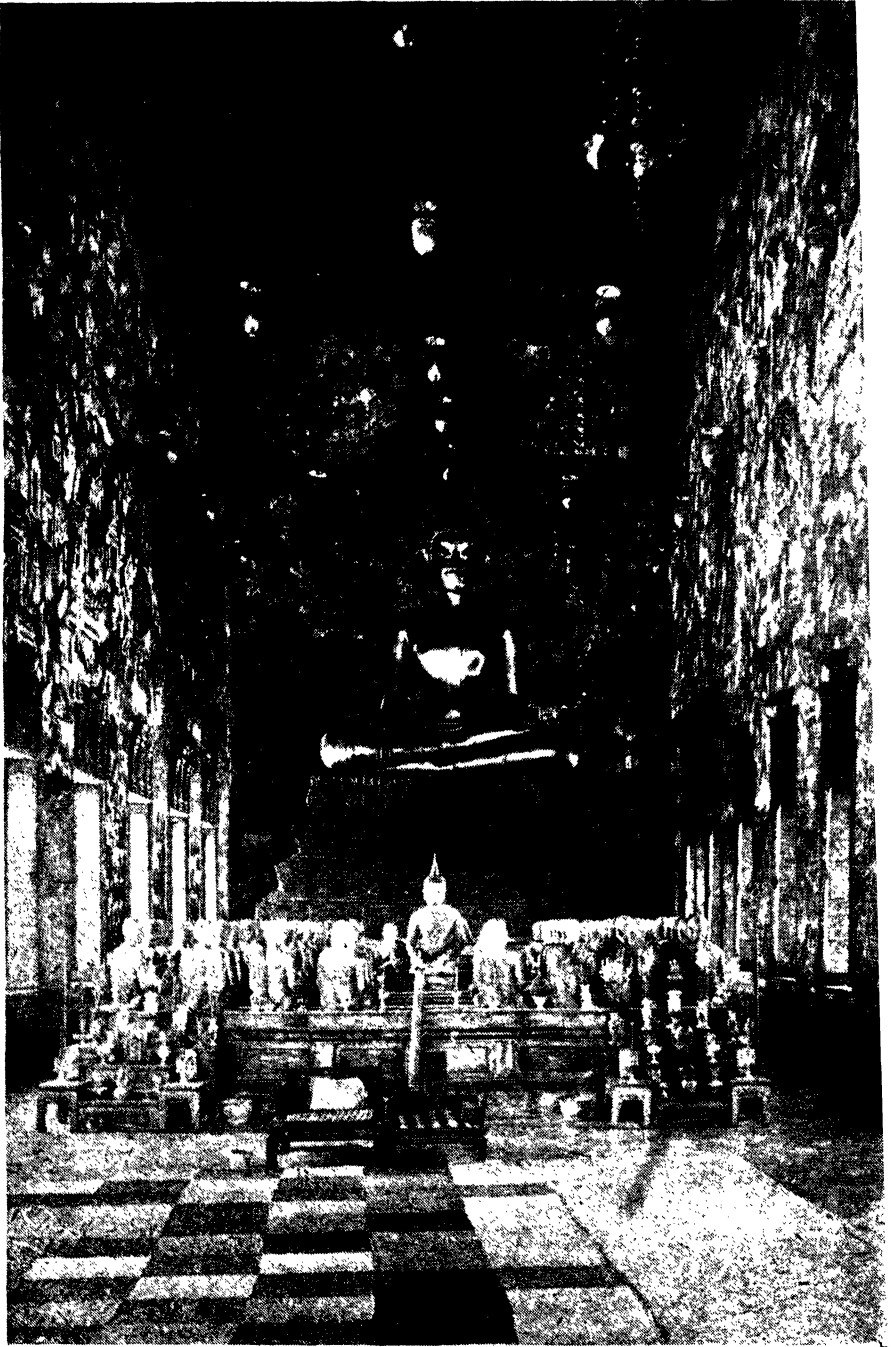

[L F 7

INTERIOR OF WAT SUTHAT

Yet another of the great Bangkok temples, Wat Suthat differs from the rest in having an inside as interesting as its outside. The giant Buddha is as usual seated in an attitude of meditation—i.e., cross-legged, right hand on shin, left palm upward in his lap. Below is a smaller Buddha with his two chief disciples.

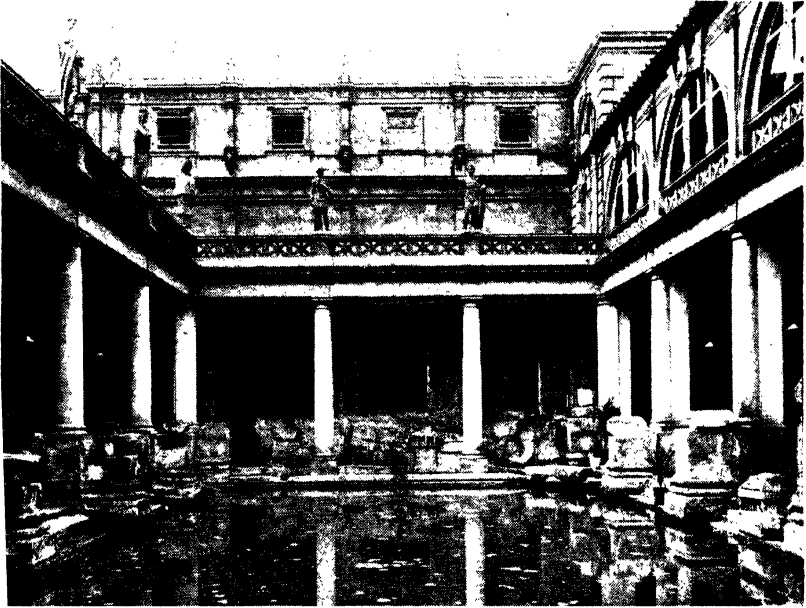

BATH: THE ROMAN BATHS

[Courtesy G. W. R.]

associate Roman remains of primary importance with Great Britain, the Baths are the best preserved of their type in the world. They were built in the fourth century, and their largest hall measured 110 ft. by 68 ft.



THE BANYAN TREE

[E. N. A.]

The plant illustrated here is known as Trimen's banyan, but it shares with the common banyan the extraordinary habit of sending down innumerable roots from the horizontal branches. In the above picture the trunk is almost hidden by the roots which have become part of it.

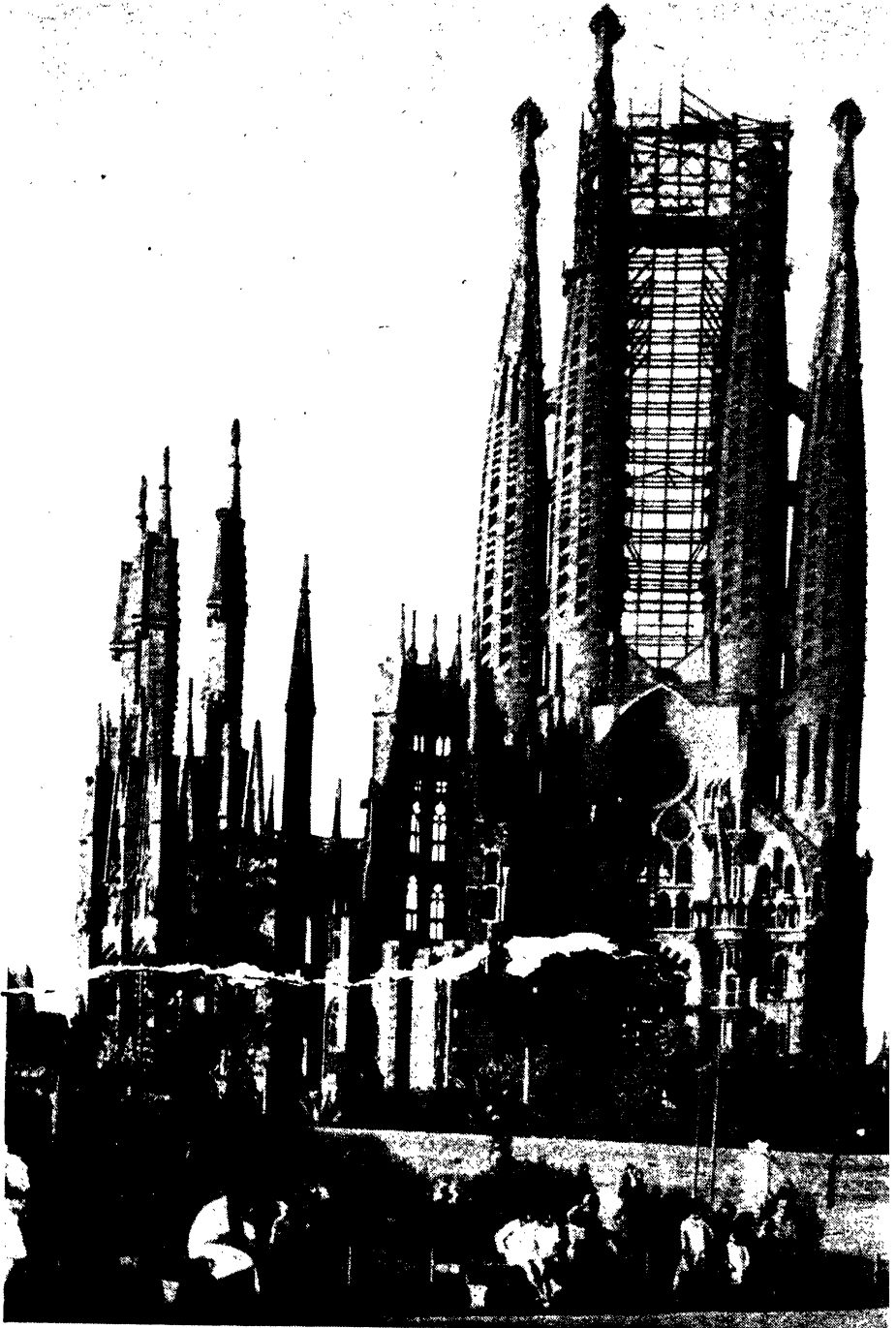

[Dorien Leigh]

BARCELONA'S NEW CATHEDRAL

The Cathedral of La Familia Sagrada at Barcelona may well claim to be one of the most striking Christian churches in existence. Raised by public subscription, it was begun quite early in the twentieth century, but by 1935 was still, as the scaffolding shows, incomplete. Notice the huge doorway extending right up to the rock

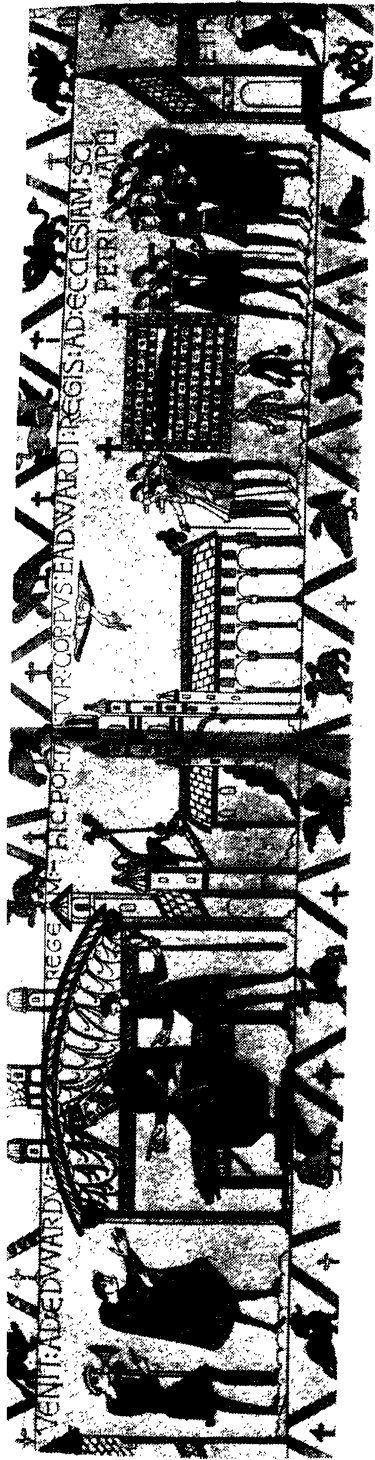

THE BAYEUX TAPESTRY

The remarkable piece of needlework known by the above title is not only a decoration, but a vivid and almost cinematographic record of the events which led to the Norman Conquest. It was probably worked for a half-brother of William the Conqueror in about 1068. It is 231 feet long and divided into 72 separate scenes, each with a legend in Latin

[Dorrien Leigh



[Dorrien Leigh

On the left, top, Edward the Confessor is receiving Harold—who looks a little depressed about it. On the right is Edward's funeral. Below, the left-hand panel shows preparation for, and eating of, a banquet, complete with episcopal blessing; whilst to the right, William and his family hold a council of war

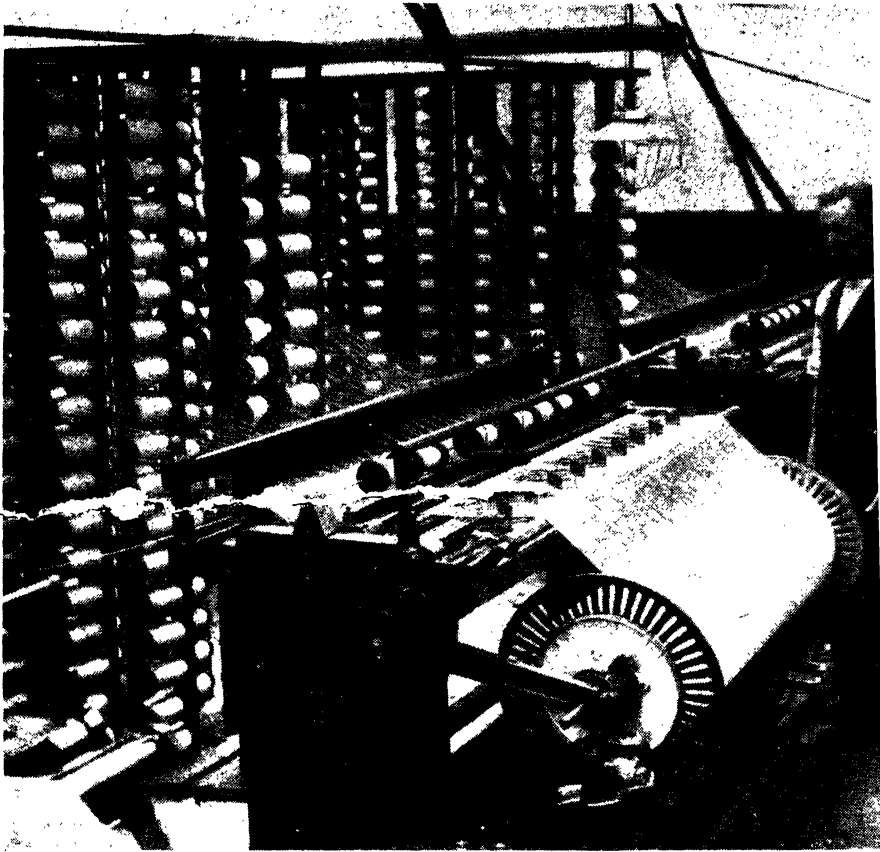

[Keyst

A BEAMING MACHINE

g. or beam warping, is one of the early processes of cotton-weaving. From 200 to 400 ends of cotton bobbins, are fixed in a frame called a "creel", and thence are drawn through a special comb mechanism and wound side by side on to a warper's beam or drum.

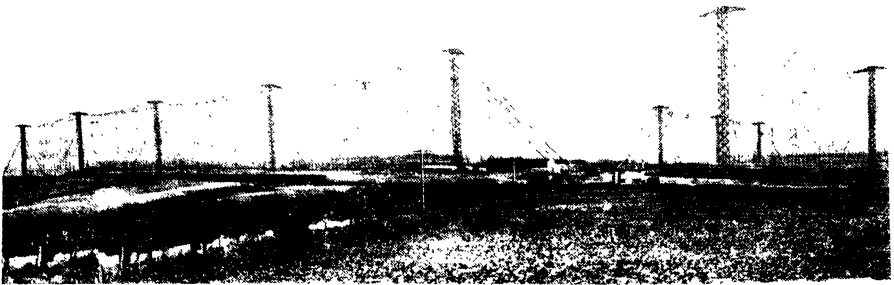

[Cartnew & Kinnay

BEAM WIRELESS

The beam system of wireless makes use of a special antenna array to concentrate the radiated electric wave into a beam, much as a searchlight beam is produced by a lamp within a specially designed projector. The picture shows the vertical aerial of the Dorchester Beam Station. In the wireless transmitter most of the radiated energy is concentrated within an arc of 10 to 15 degrees; this beam is then directed toward the receiving station where a similar antenna array is adjusted to the appropriate direction for receiving.

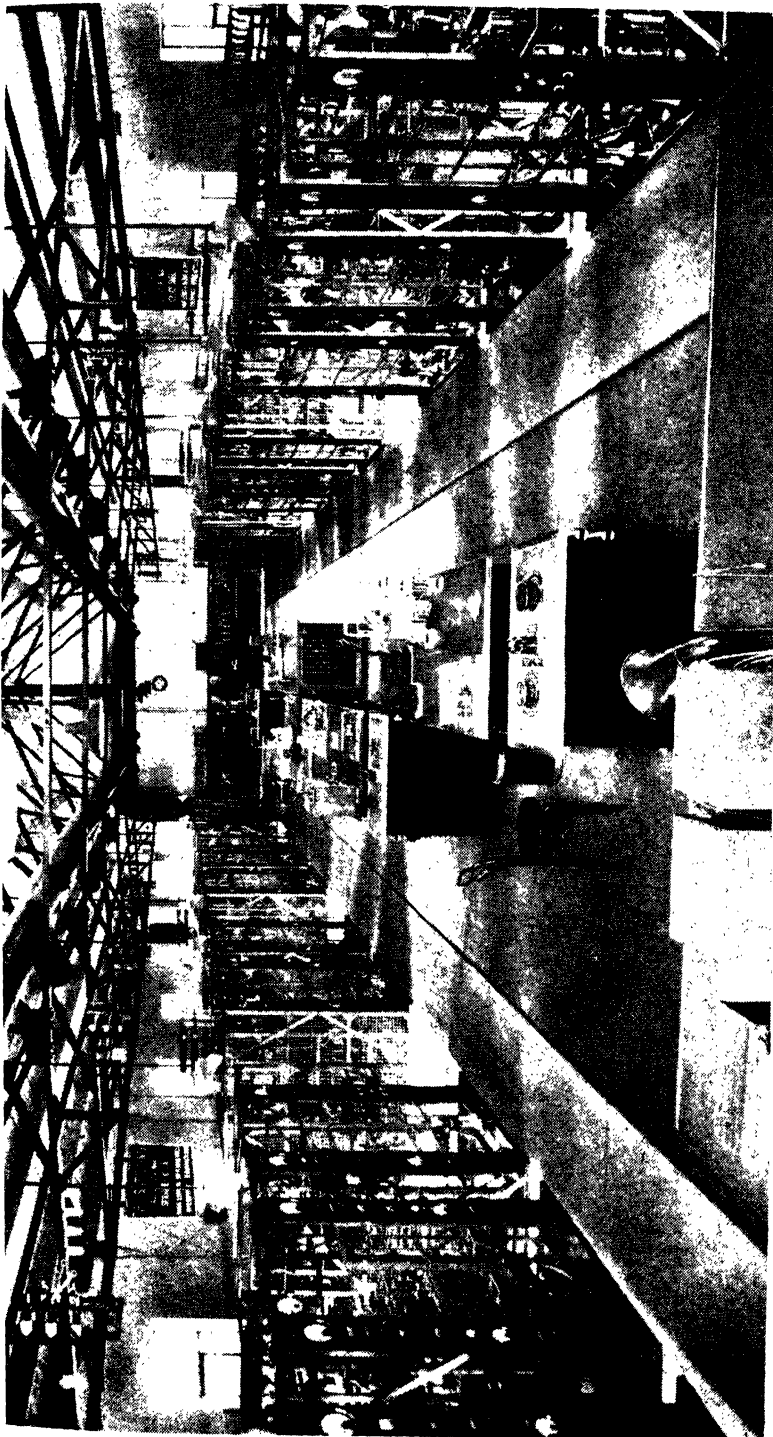

[Carlow & Kinnard]

BEAM WIRELESS: A TRANSMITTING STATION

This is the transmitting room of the Dorchester Station, which operates on the Marconi system. From here high-speed wireless telegraph services are operated to North and South America, Egypt, Japan, and many other lands. The wireless beam is directed toward the particular station meant to receive it, which in turn "tunes in," by directing its own antenna towards the sender



From "Marvels of the Universe"

BEAVERS AT WORK

Canadian beavers live in what are called "lodges" by streams, and in order to ensure a sufficiency of water they build large wooden dams, cemented with mud and stones. To do this they fell with their teeth quite large trees

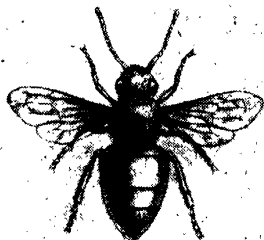
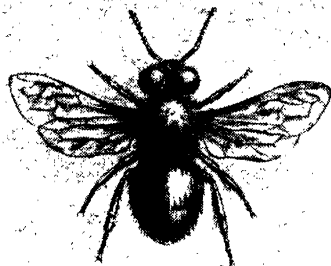

THE HONEY BEE [Carthew & Kinnaird]

Here we have two types of this amazing insect: drone (top), the languid male who does no work; the worker, who does it all, from the making of for the comb to the feeding of the young which queen has put within it



[Carthew & Kinnaird]

THE BEE'S TONGUE

In this photomicrograph the "furry" condition of the tongue which facilitates the extraction of honey is well seen, as is also the slender shape which enables the tongue to be pushed into the most recalcitrant flowers



[Carthew & Kinnaird]

THE BEE'S STING

The grim-looking barbs are only to hold the sting in the victim, and it is the poison which the bee carries that actually makes stinging so painful. Both this and the tongue photograph are of ordinary honey-bees



[Tickner Edwards

This remarkable photograph shows drone and worker combs being constructed side by side by the same party builders. Note the chain being formed for wax-generating. Nearly all this complicated work is done in total darkness, it being very rare indeed for comb-making to proceed other than at night



[H. Bastin]

A COMB IN EMBRYO

Combs are nearly always built downwards. A number of the wax-makers deposit their products in a small lump, wherein a cell-maker then begins to hollow out the bases from which the cell walls are built up. The hollows can be seen in the photograph

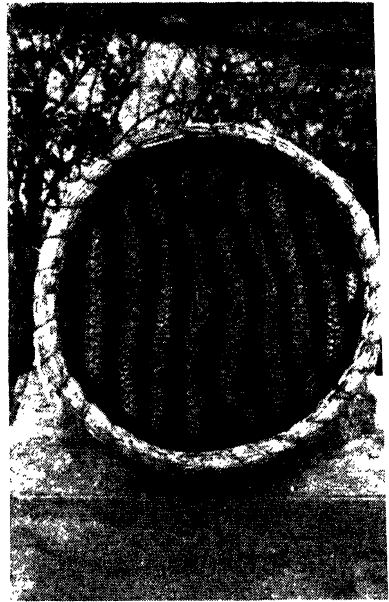

[Tickner Edwards]

A HIVE UPTURNED

This shows the natural arrangement of combs in a skep-hive. On being hived, the bees once gather within the hive roof, and stay there in dense cluster while the wax—a secretion from their own bodies—is forming



[Tickner Edwards]

THE FANNING ARMY

Perhaps the most amazing thing about bees is the way they ventilate the hive. All through the not weather and periodically during the cooler season, a gang of worker bees is stationed in open formation at the hive entrance, their wings vibrating to circulate the air. At regular intervals the gangs are relieved. The draught is often strong enough to extinguish a candle held level with the board



MADONNA AND CHILD BY GENTILE BELLINI

[Dorien Leigh

There were three famous Bellini artists—Jacopo, one of the first painters in oils, who died in 1470; Gentile, the elder son, and Giovanni, the younger—all three born at Venice. Some of Gentile's paintings reached the Sultan Muhammad II at Constantinople, and later the artist himself accepted an invitation to work there—a rare occurrence in those days of religious intolerance.



Photos]

THE APOLLO DEL BELVEDERE
This renowned statue is an imitation of an early bronze. Originally a bow was held in the left hand, the figure being intended to represent the god driving back the



[Dorick Leigh

APOLLO AND DAPHNE: BY BERNINI
Bernini was an Italian sculptor, painter and architect of the seventeenth century



Courtesy Cyprus Trade Commission

BELLA PAÏSE: THE ABBEY

Probably only Sicily, of all the islands in the Mediterranean, can claim a more varied history than that of Cyprus. In medieval days Cyprus was a "stopping-off place" for Crusaders of every nation, and the magnificent ruins of Bella Païse Abbey are not the only relics of Gothic architecture as fine as any in the West



THE STAR CHURCH, BERLIN

[Underwood Press 5

Shaped within and without in the form of a star, this is one of the most curious churches in a country where queer modern churches. It is by no means ungraceful, is very light, and, as the photograph shows, possesses seating accommodation considerably roomier than in many a fine old Gothic structure

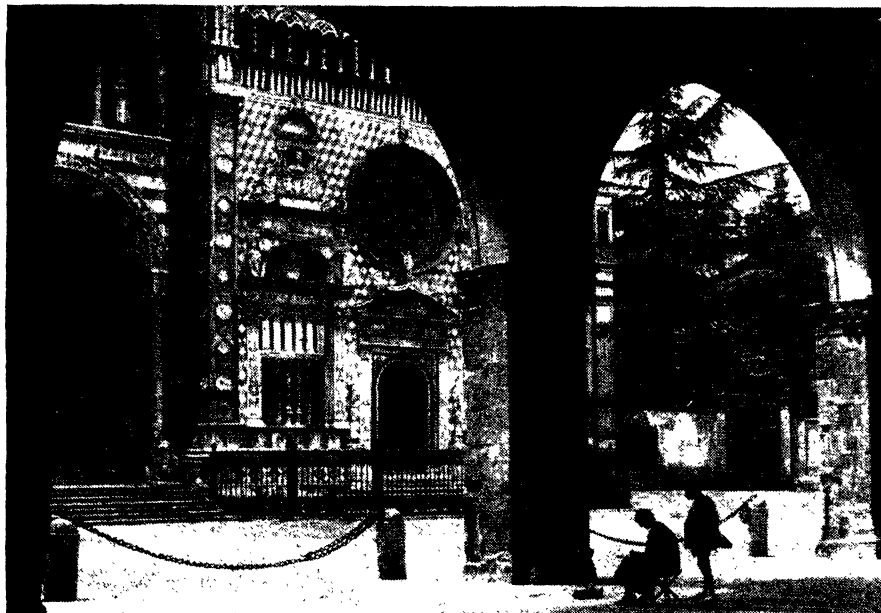

BERGAMO: THE CAPELLA COLLEONI

[Doris

A picturesque old Lombard town at the junction of two rivers, Bergamo belonged during most of its history first to Milan and then to Venice. Its quaint streets are filled with exquisite Romanesque and Renaissance buildings, in the latter category of which the Capella Colleoni stands easily first

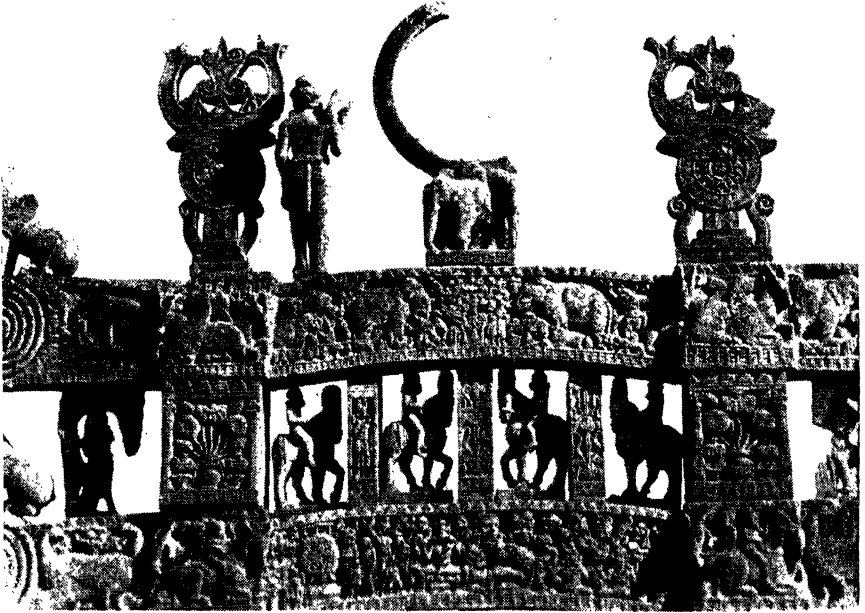

GATES OF THE SANCHI TOPE, BHILSA

The Sanchi Stupa is a brick mound like an upturned pudding-basin, is the oldest ruin in India, its surrounding wall unbroken. At the four cardinal points of the wall encircling it are arched gateways whose ornamentations are unsurpassed anywhere in the land. The photo shows a



EDIBLE BIRDS' NESTS

The tern builds its nest on the rocks. These are wont to be a delicacy in the East

[H. Grönvold



[H. G.]

NEST OF THE LITTLE TITMICE



H. Grönrold]

A HAMMOCK NEST

The bird which builds this remarkable home is the Titmouse.



[H. Grönvold

FOUR WONDERFUL BIRDS' NESTS

The Philippine Sunbird and the Blood-breasted Flower Pecker—1 and 4 respectively—both build their nests of vegetable fibre held together with spiders' webs and hang them from small branches. The Cape Penduline Tit suspends a structure of cleverly-felted cotton or wool between cactus shoots. The Tailor Bird (3) actually stitches together two leaves with caterpillar silk to form his nesting-place.

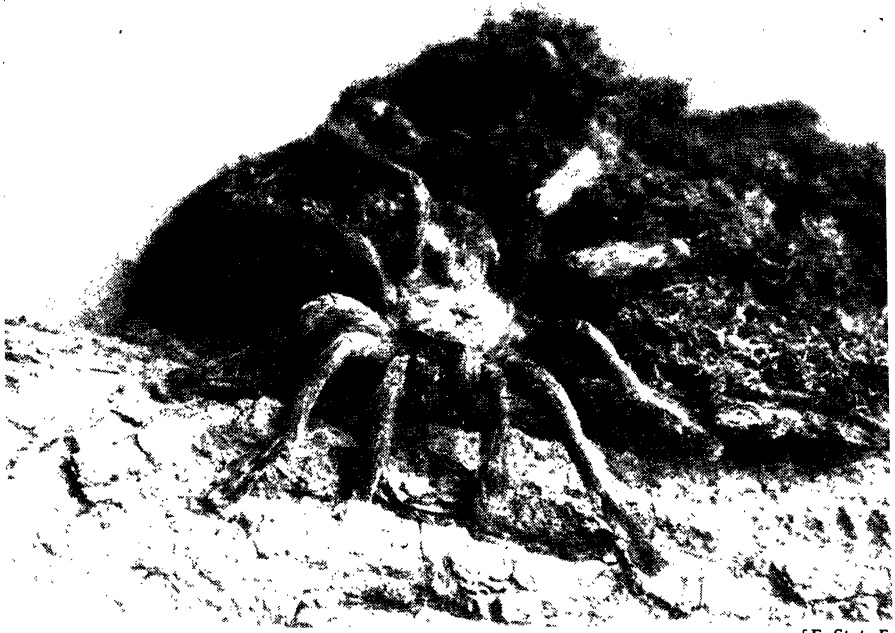

[E. Step, F.]

A BIRD-EATING SPIDER

These huge, repulsive creatures are found in various tropical countries. The species shown is West Indian. They have long, thick legs covered with dense hair, and move by night. Despite their name, their chief prey is insects, though they are known to catch mice and even lizards.

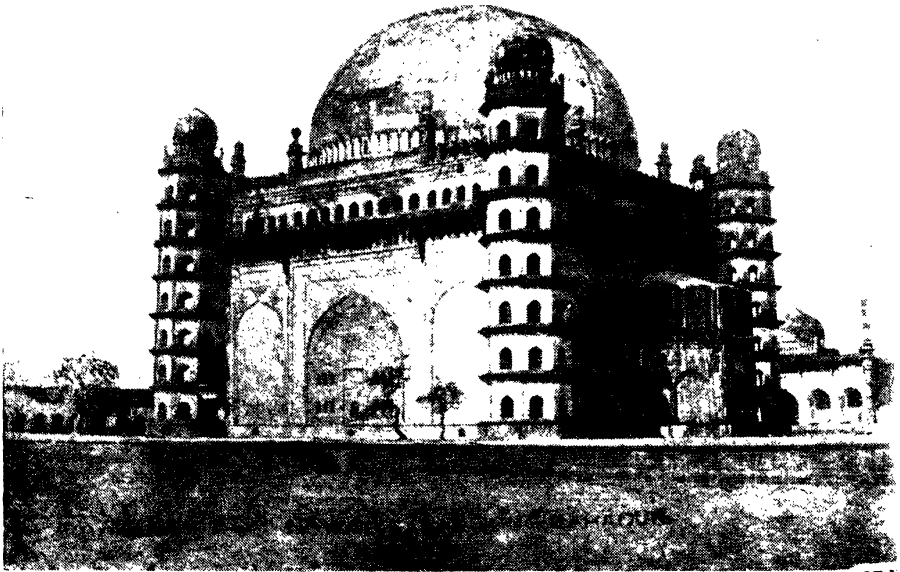

[E.A.]

BIJAPUR: THE GOL GUMBAZ

This, the tomb of one Mahmoud, is the largest domed space in the world, its dome measuring 135 feet across. The manner in which the various heavy thrusts are counteracted is a masterpiece of architecture—so masterly indeed, that even to-day it is one of the world's mysteries.



[F. Frith & Co.

ENTRANCE TO THE CHATEAU DE BLOIS

Finest of all Touraine's fine châteaux, Blois owes its most beautiful portions to Francis I; the figure over the main door, however, is not of him, but of Louis XII, who was born here. The initials and porcupine crest are those of Louis and his Queen. Blois was for many centuries in possession of the Orleans family

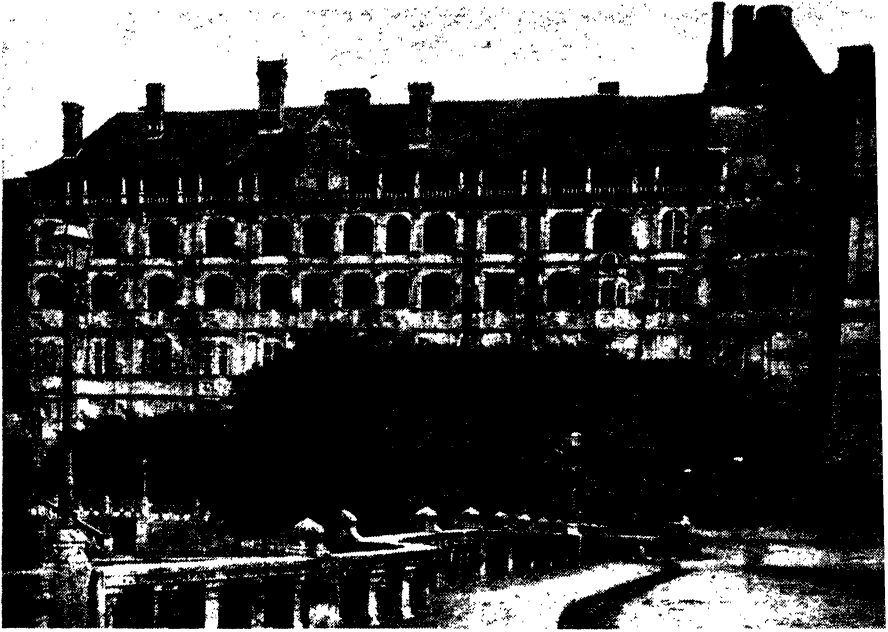

CHATEAU DE BLOIS: THE FRANCIS I WING

[F. Frith & Co.]

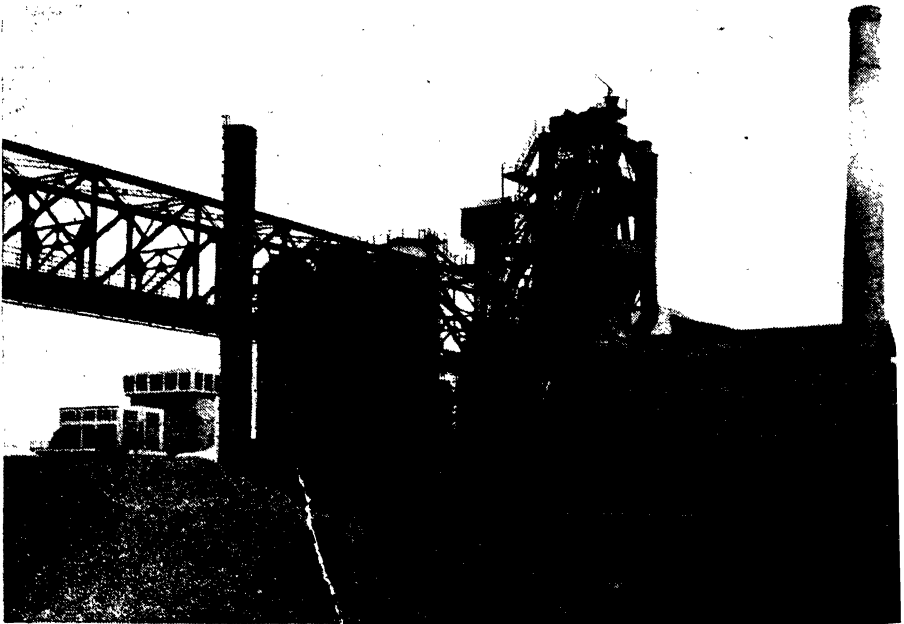

A BLAST FURNACE

[Courtesy Ford Motor Co.]

Used largely in the smelting of metallic ores, especially iron, copper and lead, this type of furnace, so called because the air for combustion is supplied as a blast from blowing-engines. Once started, work is usually continuous, the ore, flux and fuel being charged in rotation, and the metal and slag tapped at intervals.



[*Theo Carreras*]

THE BLISTER BEETLE

In its earliest stages the grub of the blister beetle contrives to get on the back of a solitary bee (left centre); on arrival at the bee's nest in the stem of a bramble, the grub enters a cell where a bee's egg floats on honey; using the shell as a raft, it eats the egg; next, changing its form so that it can abandon the shell and float on the honey, it eats that; then the full-grown grub walks down the bramble, digs its own cell in the earth, and becomes a chrysalis (bottom); from hence the mature beetle emerges and flies away.



Courtesy New South Wales Government]

THE BLUE MOUNTAINS

The Blue Mountains of New South Wales form the loveliest region of Australia and one of the finest ranges in the Australasian continent. Verdant, majestic and colourful, they abound in such graceful cascades as these, the Lodic Falls

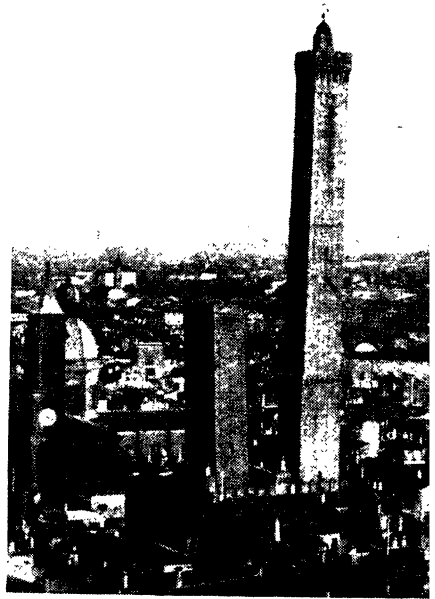

[From "Wonders of the Wo.

THE LEANING TOWERS OF BOLOGNA

Far older than their famous rival at Pisa, the Leaning Tower of Bologna dates from the twelfth century. The finished tower, 320 feet high, is four feet out of plumb and its companion—which has not collapsed, but never completed—is eight feet out



By courtesy]

THE BONDHUS GLACIER

["Picturesque Europe

About 2,000 square miles of Norway are glacier-covered, and the Bondhus Glacier is one of the biggest. It is situated by the Bondhus Lake, not far from Sundal, in the south-west of the country—though most of the glaciers are in the north. Note the size of the human beings at the extreme foot of the photograph



Page 24

BORDONE: THE CONSIGNMENT OF THE RING

[*Dorien Leigh*]

is Bordone (1500-1571), a pupil of Titian, was a painter of the Venetian school. He travelled more than most of his contemporary artists, working in Venice, Treviso, Augsburg and France. He was chiefly known his lifetime as a fashionable portrait-painter, but by far his most celebrated painting to-day is the one shown here, which depicts "The Fisherman giving St. Mark's Ring to the Doge". It hangs in the Venice Academy





By courtesy]

["Wonders of the World"]

A RIVER BORE

A bore is the phenomenon produced in the estuary of a river, generally during spring tides, by the incoming tidal flow pushing against the river current. The bore of the Severn is the one illustrated.

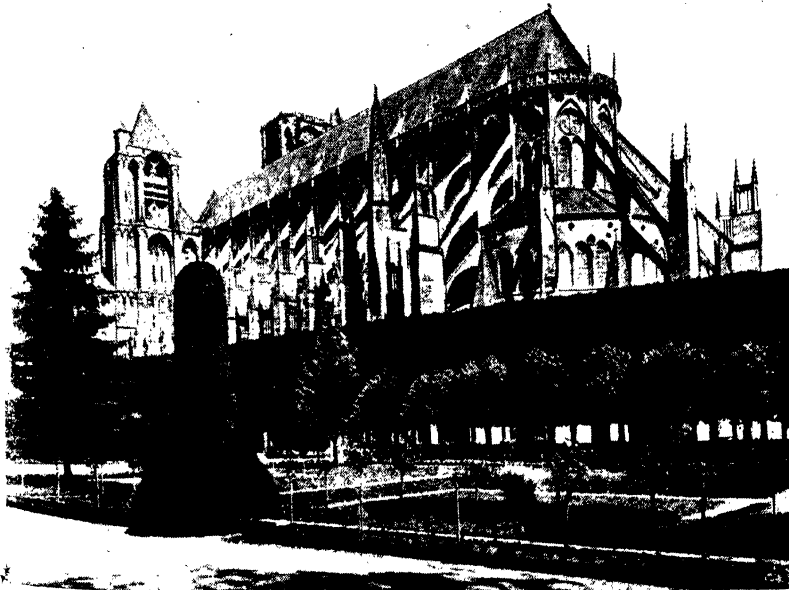

[Dorien Leigh

BOURGES CATHEDRAL

The Cathedral of St. Etienne, Bourges, in central France, is one of the finest churches in Europe, in general appearance it is not unlike Notre Dame at Paris. It was begun in the thirteenth century, and over the main entrance it contains some exquisite sculptures of the

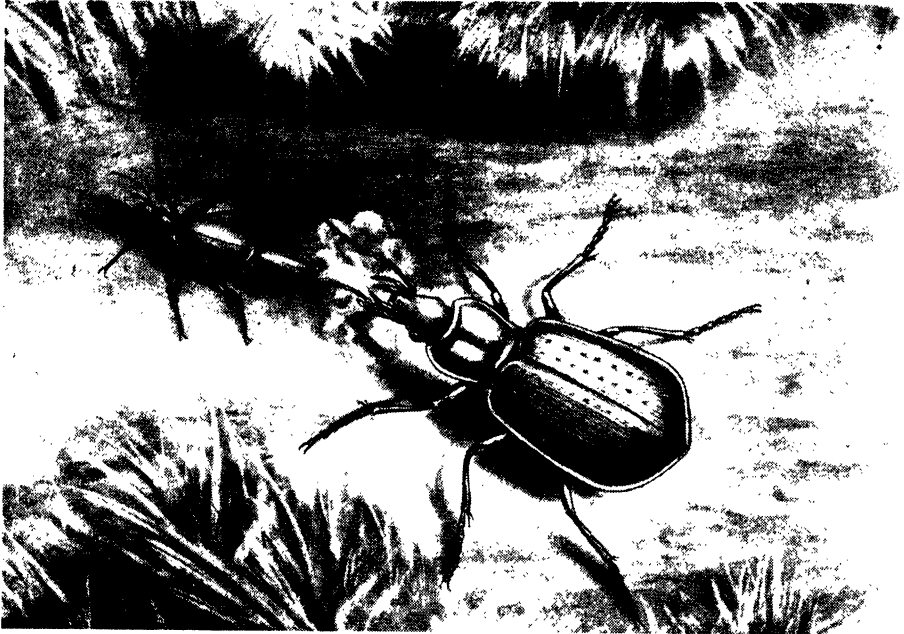

A BOMBARDIER BEETLE IN ACTION

[*Carthew & Kinnaird*]

The bombardier is the smaller insect in the picture. On being pursued by an enemy, the bombardier emits from its stern a (relatively) loud report, accompanied by a bluish cloud of vapour. The vapour is due to a fluid which rapidly volatilizes on contact with the air. The above is about three times natural size.

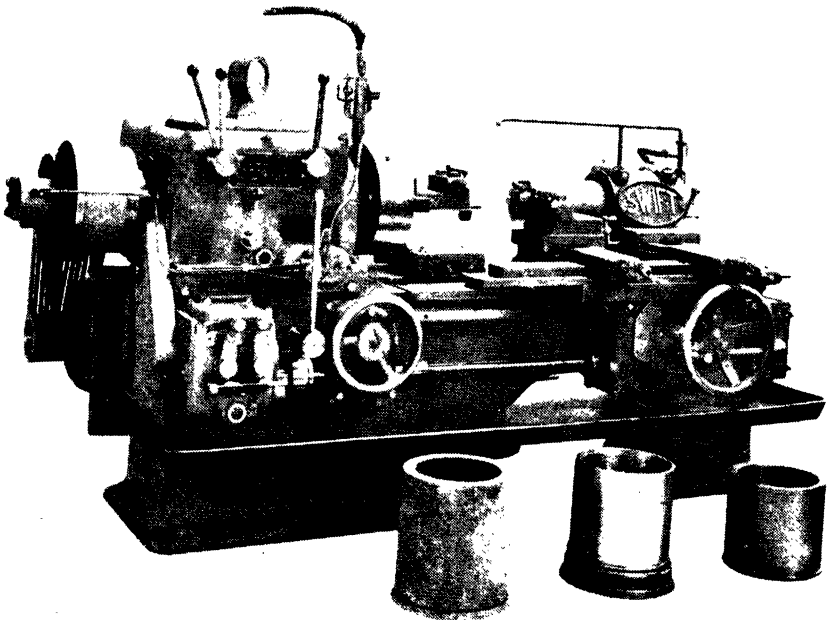

A BORING AND TURNING MACHINE

[*Courtesy G. Swift & Son*]

This may be termed a machine for making machines. Its business is to bore, turn and profile locomotive cylinder linings and similar parts. It is semi-automatic, works at a very high speed, and can shape and cut hard steel easily and accurately as though it were wood. It is worked by a 10 h.p. electric motor.

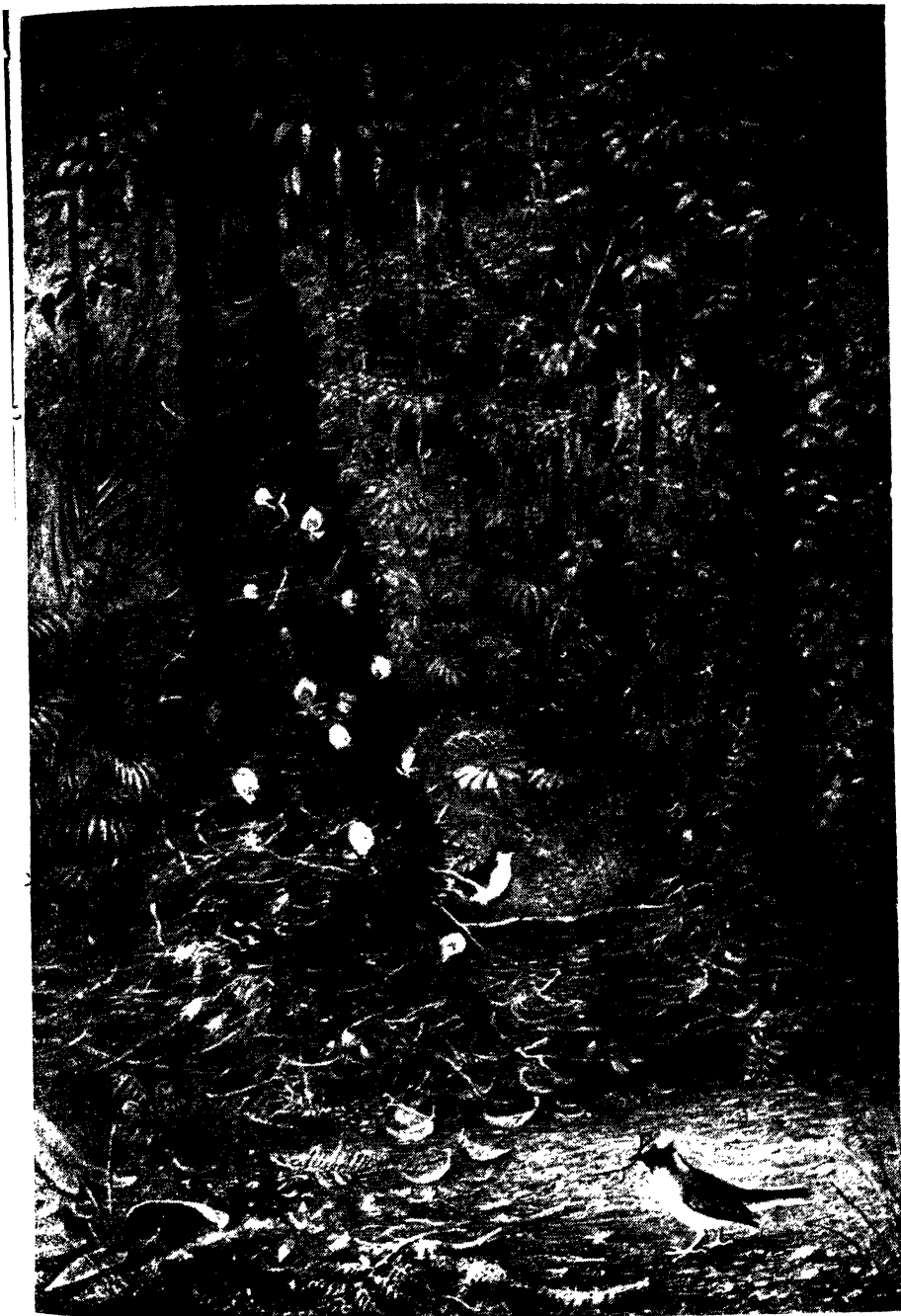

[H. Grönvold

A BOWER BIRD'S NEST

There are several types of bower birds found in Australia, of which Newton's Bower Bird of Queensland is the most remarkable. Though no larger than a thrush, this bird will pile up sticks against two neighbouring trees as shown, to a height of as much as ten feet on one side. It will then decorate the larger pile with flowers, especially orchids and rock lilies! This is perhaps the only example in Nature, outside the realms of men and monkeys, of the purely æsthetic instinct



[Dorien Le

THE SUNSET: BY BOUCHER

There is a sentimental charm about this picture which is very characteristic of eighteenth-century French art. Though "Sunset" shows undoubted genius, Francois Boucher is more remarkable for the number than for the excellence of his works. In a life of sixty-seven years (1703-70) he executed—it is said—10,000 paintings and 10,000 drawings, besides engravings! He was for a long time painter to Louis XV and a director of the French Academy. The original of "Sunset" hangs in the Wallace Collection.

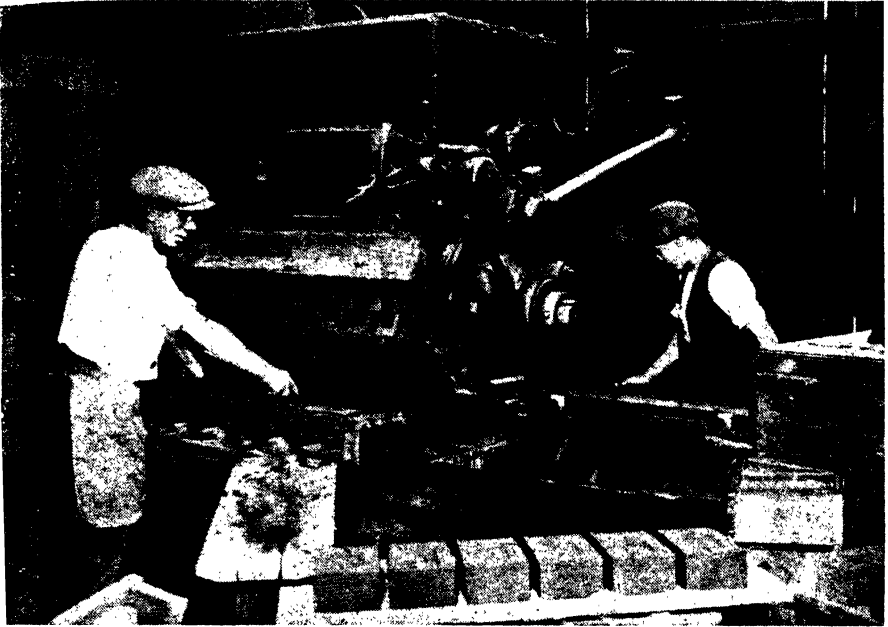

BRICK-MAKING

[Carthew & Kinnaird]

... compare how many millions of bricks are made in the civilized world in one year. The third stage in the customary British process. After the clay has been mixed, it is moulded and cut into the required size by the above apparatus

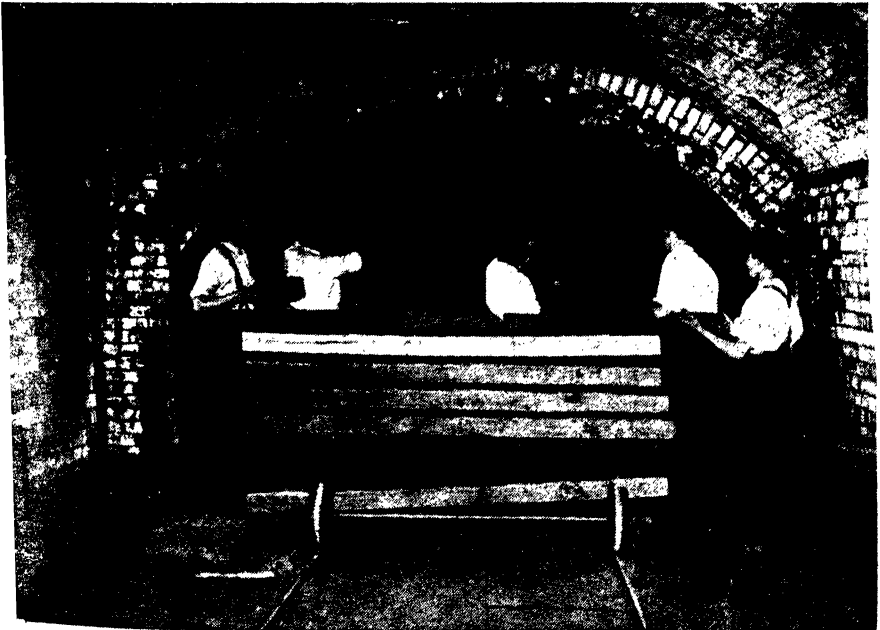

FILLING A BRICK-KILN

[Carthew & Kinnaird]

... is the sixth stage in brick-making. The bricks are placed in a kiln, sealed up, and left there for about two weeks whilst they undergo the process known as burning. They are then ready to be drawn. There are over a dozen different types of brick, including concrete

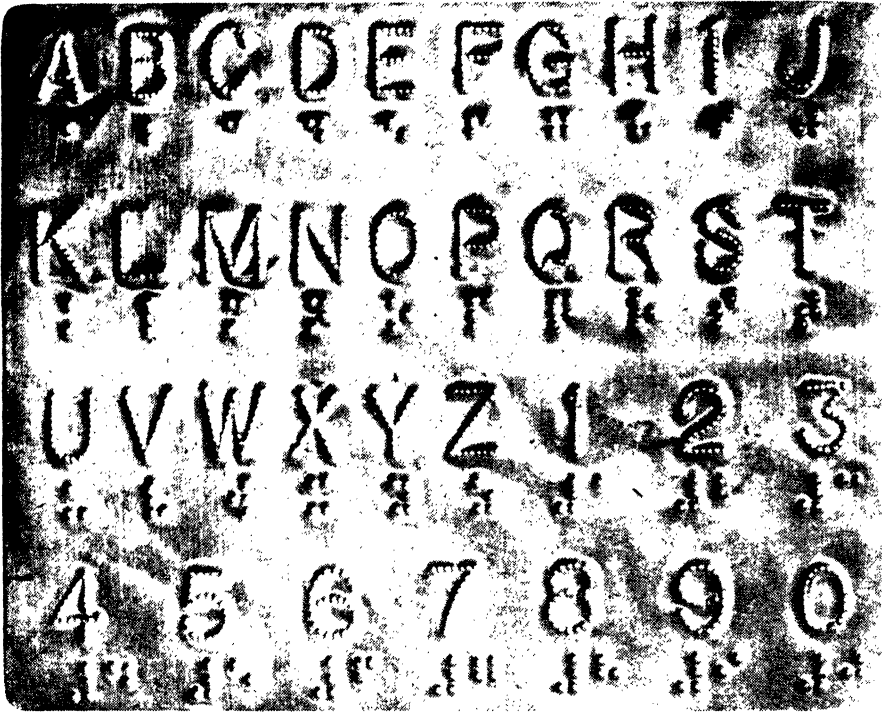

[Carthew & Kinna

THE BRAILLE ALPHABET

M. Braille was a Frenchman who first brought out his famous system in 1834. Since then, despite many other attempts both before and after to discover even easier ways for the blind to read, his simple alphabet of dots has become, with modifications, the world-wide system of the day. Braille typewriters have been invented in America and Germany, also Braille watches



XDorien L

A BRAILLE ALGEBRA OUTFIT

The idea of enabling the blind to read by touch is not new, but the idea of combining Braille symbols with the slide-rule principle to enable blind persons to work at mathematics is very recent. The above photograph comes from Germany

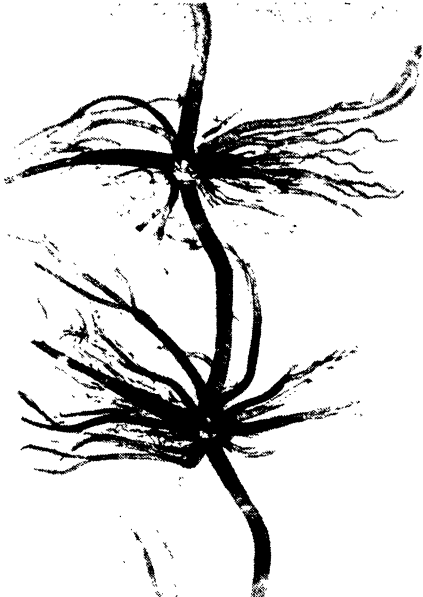

From "Marvels of Insect Life"

INSECTS' BREATHING

An insect breathes through a complex system of air-tubes, the air being taken in through many mouths. The photograph shows a small section of a silkworm's breathing apparatus, which extends all down the caterpillar's sides. The radiating tubes convey air to parts distant from the sides.



[Courtesy Booth Steamship Line

BRAZIL: THE AMAZON

The size of the world's mightiest river is strikingly shown in this moonlight photograph taken nearly a thousand miles from the mouth! The shores in the background are not cliffs, but a solid mass of jungle which extends back for hundreds of miles. The men in the boats are fishermen from Manaos.



[Courtesy Booth Steamship Line

A BRAZILIAN JUNGLE

For thousands of miles the Brazilian jungles stretch, the richest domain of Nature on the earth. Alligators, rattlesnakes, brilliant birds, monkeys, uncouth sloths, insects like gems—all are to be found there, amid a wilderness of plant growth so luxuriant that in parts it is literally impenetrable.



THE HUMAN BRAIN

[Carthew & Kinnaird

The human brain, the fount of our intelligence, the driving-power of every action, conscious and unconscious, which we make, is also the part of our anatomy which most differentiates us from animals and our own primitive ancestors. This picture shows a plaster cast of the brain of the Piltdown Man, one of the earliest human types known



[Courtesy South African Railway

BRANDVLEI: THE HOT SPRINGS

Hot springs and geysers are common to countries as far apart as Iceland and New Zealand. In South Africa, however, there are not many, and the boiling pool at Brandvlei, near Worcester, is celebrated. Its waters are so hot that animals jumping in are instantly scalded to death



[Dorion Leigh

ALLEGORY OF HEARING: BY BREUGHEL

There were four distinguished Breughels, two Pieters and two Jans. They were Flemings, who took their name from the small village near Brecht, where Pieter Breughel the Elder was born (1510). Pieter the Elder was a humorous painter; Pieter the Younger, his son, chiefly religious. One of the Jans is noted for his landscapes, and for having lent a hand in the landscape parts of some of Rubens' works; the second Jan is best known for the remarkable picture here shown. It will be noticed that practically everything in the crowded scene is connected with sound

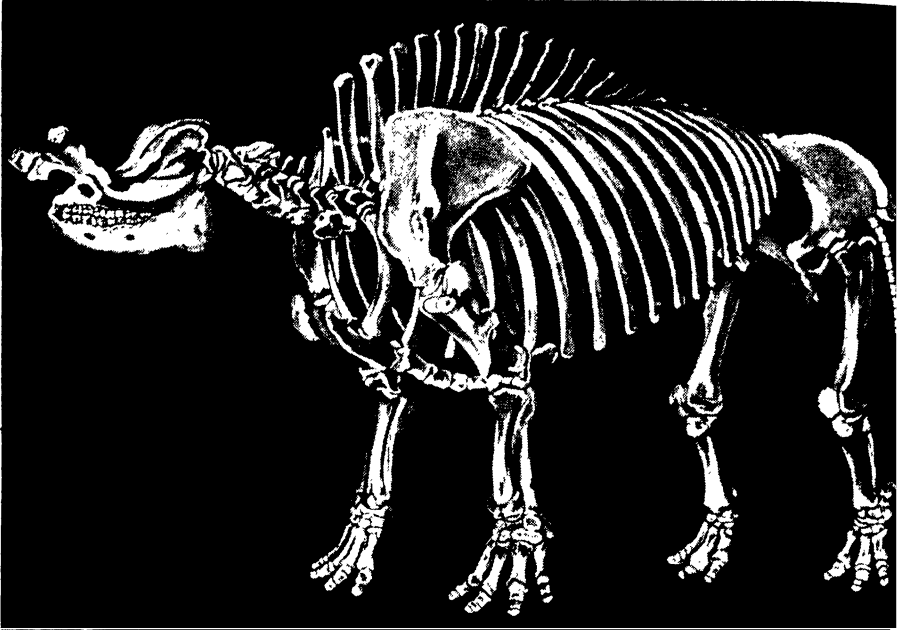

By courtesy]

SKELETON OF A BRONTOPS

[*"Marvels of the Universe"*

The chief features, apart from the extraordinary skull, are the enormous rib development and the ridge of "spikes" projecting from the vertebræ. Remains of the Brontops are found in North America, and so old is he that when he lived the Rocky Mountains were just beginning to rise!

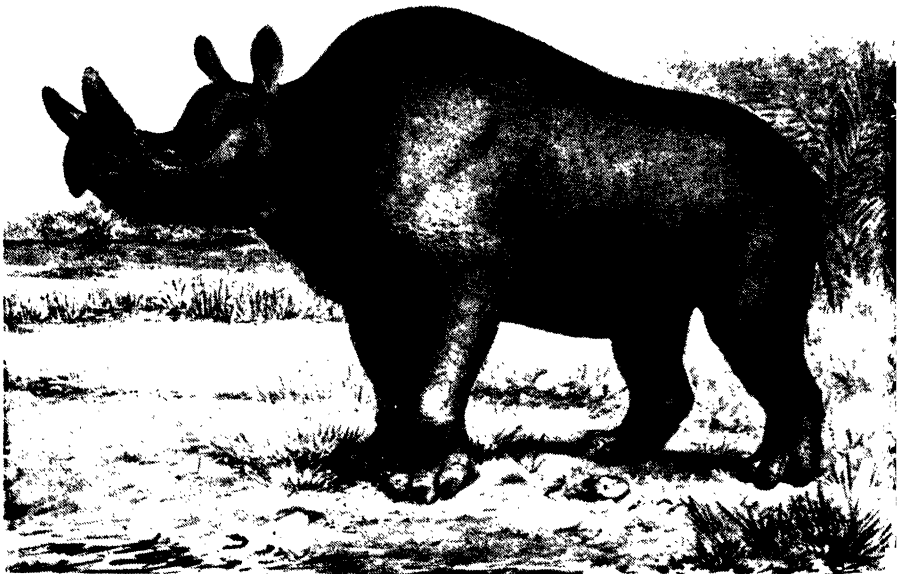

By courtesy]

THE BRONTOPS

[*"Marvels of the Universe"*

This restoration-drawing shows, if not one of the most formidable, at any rate one of the most curious of the beasts of prehistoric days. A forerunner of the Rhinoceros, the Brontops—also called the Great Tit—was some 15 feet long and 10 feet high at the withers



[Dorien Leigh

A PORTRAIT BY BRONZINO ANGILOLO

y as Angelo Bronzino, this artist was one of the post-Renaissance Florentine school, who Though he painted certain religious works, his paintings were mostly portraiture, in which ased not only his contemporaries but most of his predecessors, except the very great masters. above portrait, one of his most charming, is of Lucrezia Panciatichi, and hangs in Florence

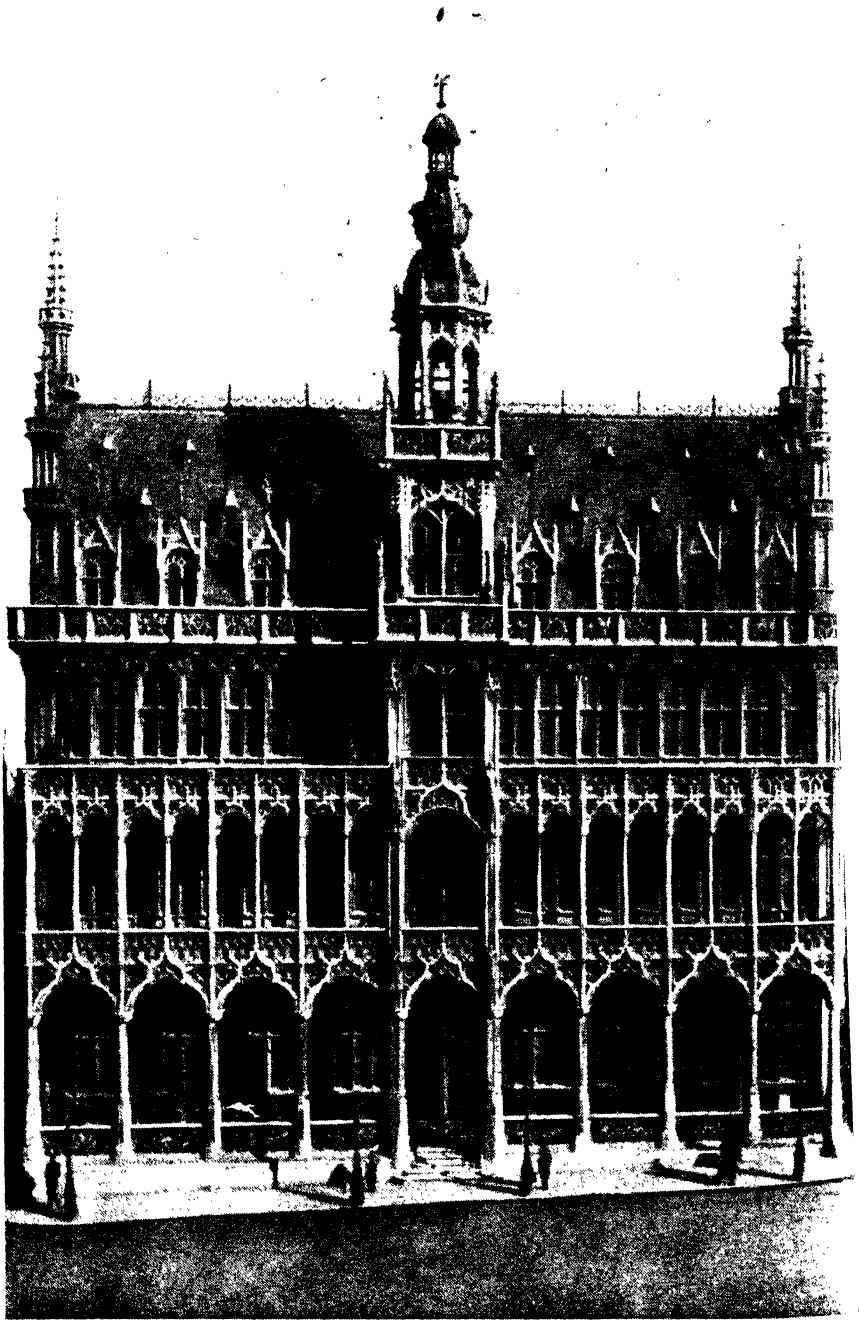

[Keystone]

THE MAISON DU ROI, BRUSSELS

Rather paradoxically, this exquisite Belgian building is one of the most famous in the history of Holland for it was here that the Princes of Orange, Holland's liberators, dwelt during the Spanish dominion. Previous to being the "Maison du Roi", where the Spanish governing councils met, it was the "Maison du Pain", the bakery inspectors. Begun in 1514, it repeatedly suffered damage, and was entirely reconstructed in the nineteenth century

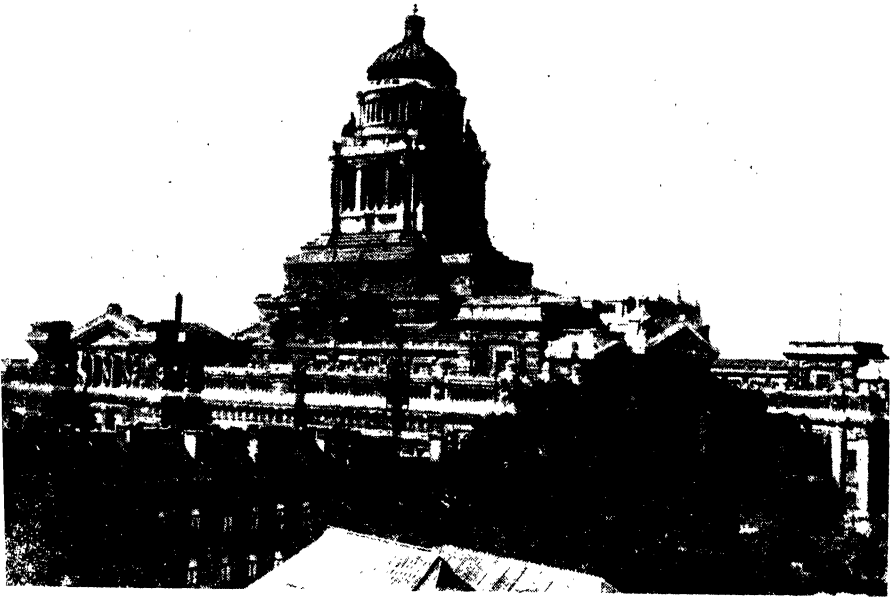

BRUSSELS: THE PALAIS DE JUSTICE

[Keystone

One of the most remarkable pieces of modern architecture in Europe, the Palais de Justice was begun in 1866, and took seventeen years to complete at a cost of £2,000,000. The fine cupola is 400 feet high, and surrounded by gigantic statues representing abstract subjects.



stone]

COLUMNS IN THE PALAIS DE JUSTICE
 and a half acres are covered by this building. It contains 27 law courts and nearly 250 other rooms, and is considerably larger than St. Peter's dome. The gigantic scale of the architecture is shown by this view of an interior colonnade.

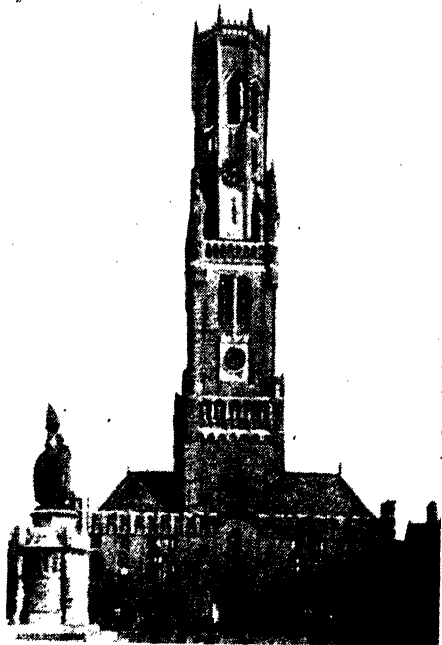

[From "Wonders of the World"

BRUGES: THE BELFRY

The most famous tower in Belgium, and the possessor of the finest peal of bells in Europe, the Belfry is attached to the Bruges "Halles", or market building. It was erected in the sixteenth century, and is 208 feet high.



[Underwood Press Service]

THE WORLD'S LARGEST BUILDING STONE

At Baalbek, Syria, there lies half-buried in debris the mightiest building stone ever hewn by man. Baalbek (q.v.) is renowned for its ancient temples—the pillars of one of which can be seen in the background—but this 60 ft. block, perfectly squared, is perhaps the mightiest triumph of the ancient masons

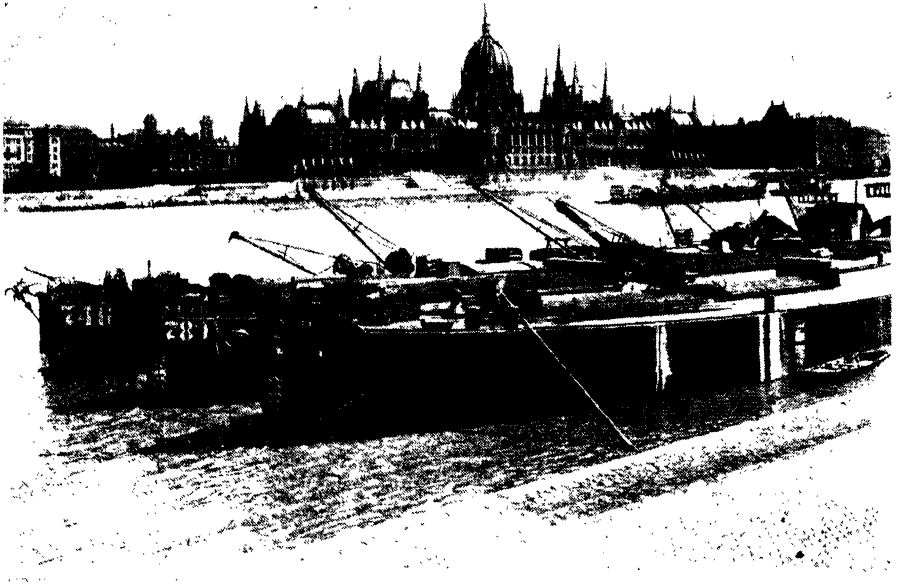

[Keystone]

BUDAPEST: THE PARLIAMENT BUILDINGS

One of Europe's finest Government buildings, the Budapest Houses of Parliament were not built until 1903. They face the Danube on the Pest side. The two rival towns of Buda and Pest were united in 1873, and though Buda is the older, Pest is now the larger and more important

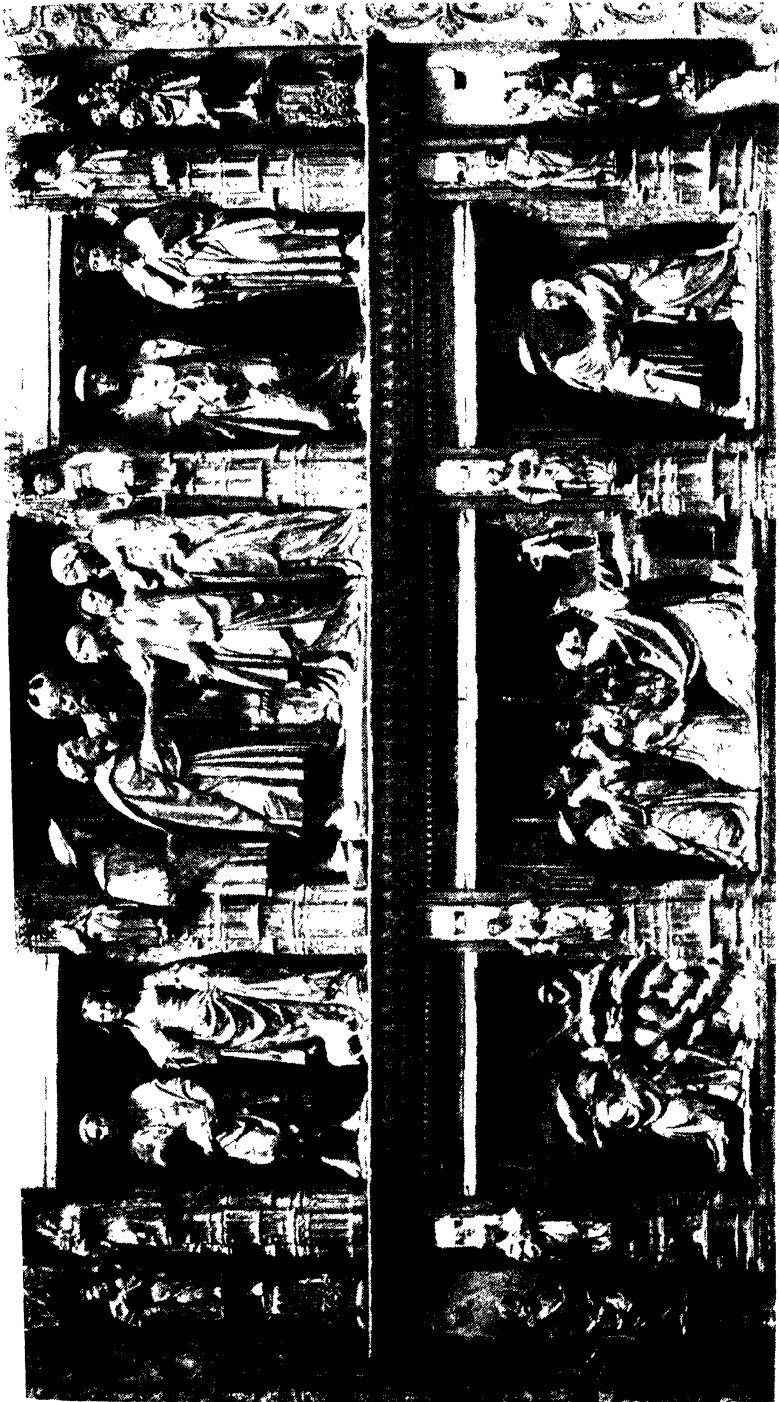

By courtesy]

A RETABLE IN THE IGLESIA SAN GIL, BURGOS

The fourteenth-century Church of San Gil in Burgos is a fine example of the Spanish love for ornate decoration. Though it is not large, paintings, sculptures and carvings abound in the interior, while there are also a beautiful and elaborate wrought-iron pulpit, and curious black-and-white marble pictures on the floor. The above retable, or back-screen to an altar, is an instance of medieval sculpture in its highest form

[*"Picturesque Europe"*]

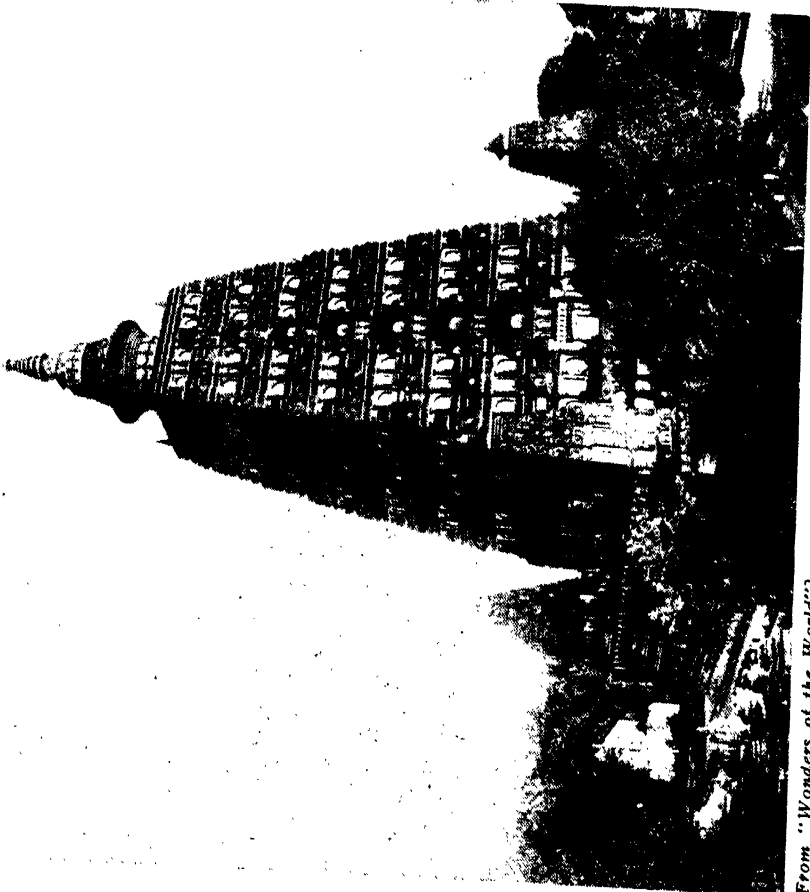

From "Wonders of the World"

THE TEMPLE OF BUDDHGAYA

This temple marks what is the holiest place on earth to the largest number of human beings. It is erected on the spot where Buddha received his enlightenment under the Sacred Fig-tree. A descendant of the original tree still springs from beneath the great Temple's western wall. The temple itself is built in the style of the great



MIGRATION OF BUTTERFLIES

[*Theo Carreras*]

The Painted Lady Butterfly of Africa thrives so well that there is often too little food for its vast numbers in the home district. Therefore enormous swarms periodically leave Africa and visit various countries, often crossing wide tracts of ocean. Were it not for these foreign visitors, the Painted Lady would be extremely rare in Britain

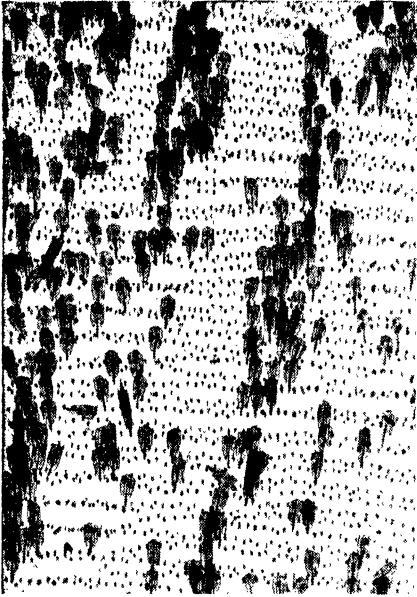

By courtesy]



["Marvels of the Universe"

BUTTERFLIES' AND MOTHS' WINGS

Two microphotographs showing the wonderful structure of these insects' wings. On the left is a section of a Currant Moth's wing, partly denuded of its tiny scales to show the method of arrangement and the sockets (seen as dots) of the scales which are missing. On the right are loose scales from the wing of a butterfly. Note the perfect symmetry, whatever the shape, of each fragment

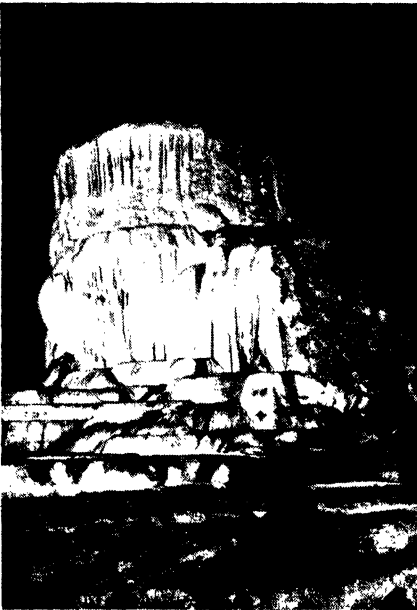

Courtesy Mexican Legation]

THE CAVES OF CACAHUAMILPA

Though less known than their brethren of Australia, Burma and Europe, the Cacahuamilpa caves of Garrero Province, Mexico, possess some of the largest stalactite formations in existence. The picture shows a giant stalagmite

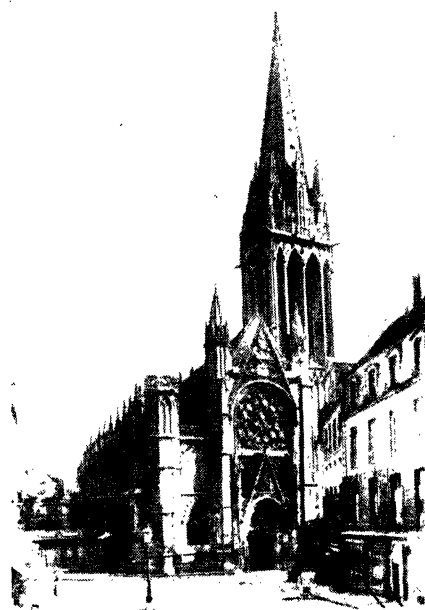

[Dorien Leigh

EGLISE ST. PIERRE, CAEN

The Church of St. Pierre is included here for its exquisite spire, one of the loveliest in France. The whole church, though quite small, is an admirable Renaissance production. Caen is best known to Englishmen as the burial place of William the Conqueror

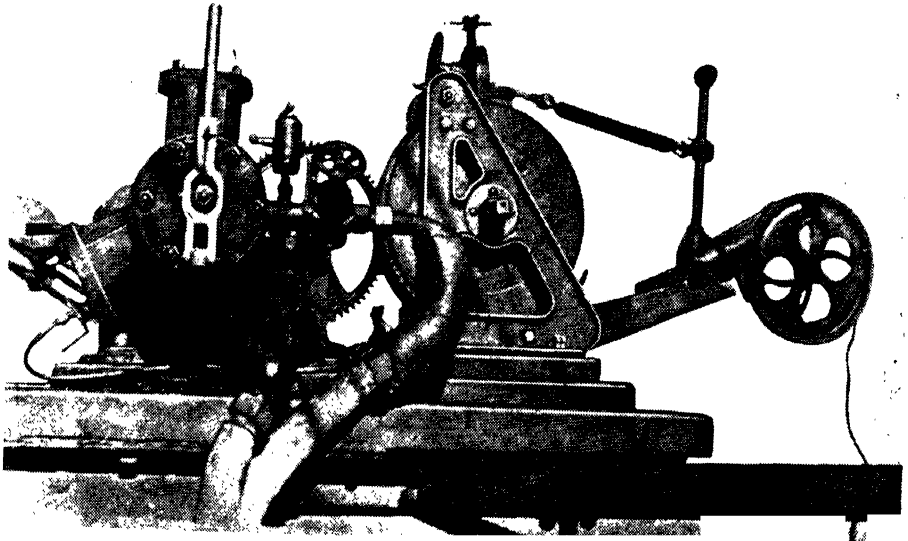

CABLES AND THEIR LAYING

[Carthew & Kinnaird

There are few better romances in engineering than that attendant on the laying of the first cables across the Atlantic in 1859-66. Since then cables have linked up practically every civilized country in the world. The above machine serves to indicate the difficulties which beset cable-laying; it is a deep-sea sounding machine, its sole purpose being to show how deep the cable lies

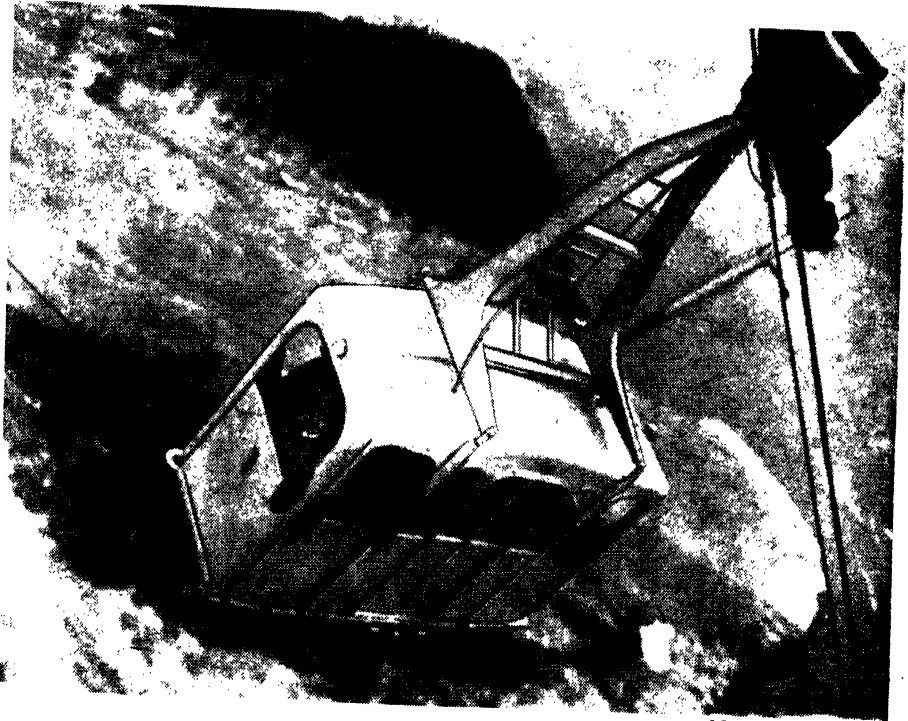

A CABLE RAILWAY

[Carthew & Kinnaird

To the uninitiated there is something very dangerous in the notion of swinging across dizzy voids in a car running on only a single wire rope. Cable railways, however, are becoming increasingly popular, especially in mountainous areas. This picture shows an electrical line on the Zugspitz, in the Bavarian Alps—9,721 feet up)



CAERWENT

Venta Silurum was the name of the Roman city where Caerwent now stands. This picture shows the foundations of a Temple, characteristically built with a layer of earth between the outer and inner layers of stone. Serious excavation of this south-east Monmouthshire site did not begin until 1902, since when it has been revealed as one of the most interesting Roman towns in Britain, quite on a par with its famous neighbour Caerleon



The Roman city seems to have been of a fair size. It is still possible to pick out the various public buildings and chief mansions of the place, and the more noteworthy remains may be summed up as the foundations of a large basilica, an amphitheatre, a temple, a potter's kiln, and a bathing-house. An interesting minor find, unique in the British Isles, is the sandstone figure of a British goddess. Here are shown the remains of a typical house and courtyard



The above photograph shows a corner of the Roman city wall of Caerwent. The place was originally a military encampment, but as the legions fought further west to Caerleon, it gradually became a fashionable residential town



[The Photochrom Co.]

KING'S COLLEGE CHAPEL, CAMBRIDGE

Considered one of the most perfect pieces of Late Perpendicular architecture in existence, King's College Chapel was erected during the years 1446-1515. Apart from the magnificent fan-tracery roof, the building is renowned for its twenty-five stained-glass windows dating from the time of Henry VIII. The stalls are seventeenth century



CALCUTTA: A JAIN TEMPLE

[Underwood Press Service.]

The Jains form a religious sect which has flourished in Upper India for some twenty-five centuries. The precepts of their faith are very high, and that they early developed very cultivated aesthetic tastes is shown by this delicate and graceful Temple, with its garden of quaint statues. Compare this shrine with the Temple on Mt. Abu, illustrated on page 7



[E.N.A.]

CAIRO: THE MOSQUE OF MUHAMMED ALI

The size of this mosque, and its splendid glass lanterns, make of it one of the minor wonders of the world. The photograph shows the beautiful fountain for ablutions within the courtyard. Washing and general cleanliness are essential features of the Islamic faith.

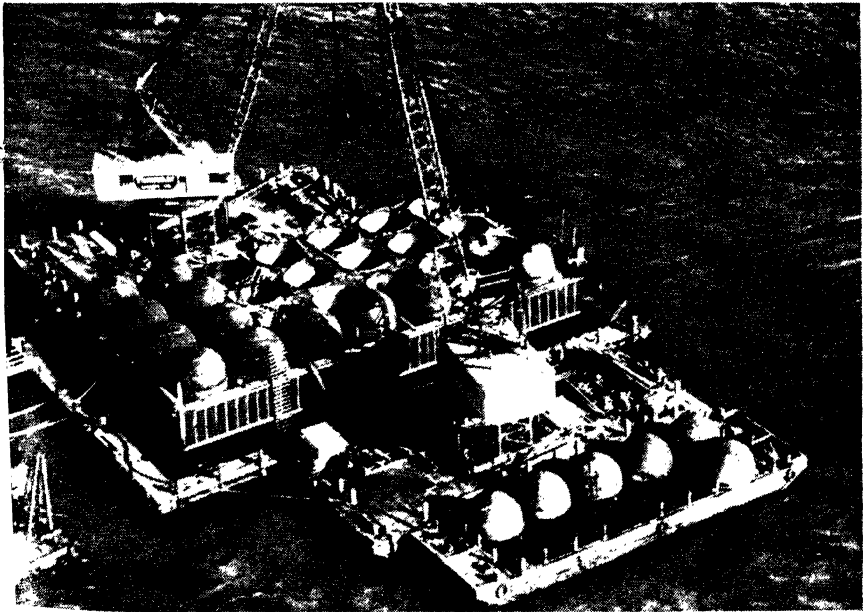

[Keystone]

CAISSONS

Caissons of the type shown here are cylindrical steel shells, open at the bottom, which enable men to work in river beds, etc., at the making of foundations for bridges. The bottom edge of the caisson is sharpened to cause it to sink as excavation proceeds. In this photograph the tops of some caissons have been removed.

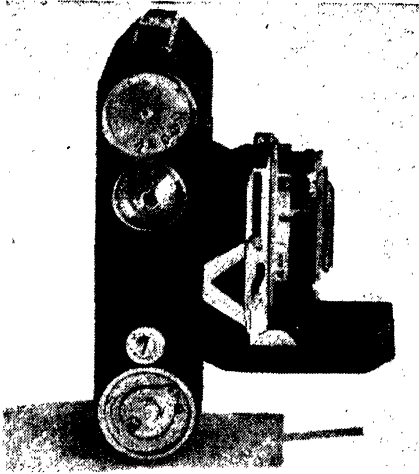

Courtesy Kodak, Ltd.]

A MODERN CAMERA

The camera as a practical instrument was first evolved by Daguerre in the early nineteenth century. Above is shown one of the latest developments.

want of the photographer

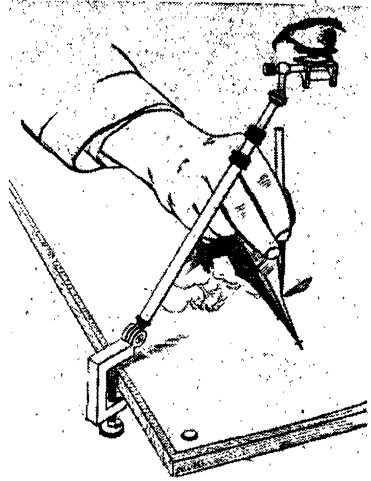

[Carthew & Kinnaird]

THE CAMERA LUCIDA

This apparatus eliminates error in drawing from life. The image of the object to be drawn is projected

on the piece of paper, so that all the artist has to do is to trace lines over what he sees.

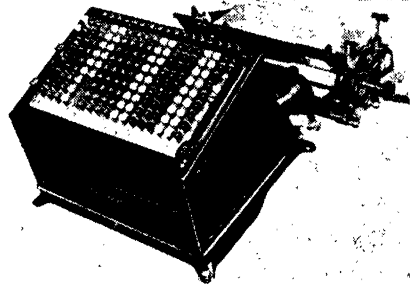
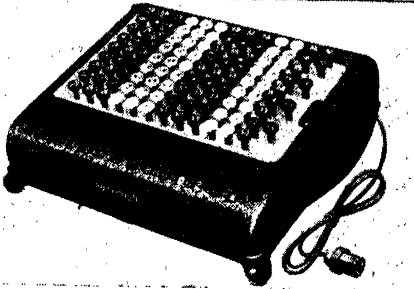

[Courtesy Burroughs Adding Machine]

CALCULATING MACHINES

speed in business has caused numerous attempts to eliminate the human factor. Above are two typical "mechanical mathematicians"—an electric adding, subtracting and dividing machine (left), and an automatic ledger-posting machine.

A MASTER CALCULATOR

is the invention of R. R. M. Mallock, M.A., may claim to be the most wonderful calculating machine devised. Besides other things, it can solve as many as ten equations, with ten unknowns, simultaneously. A detailed view of one end of the device is shown on the opposite page.

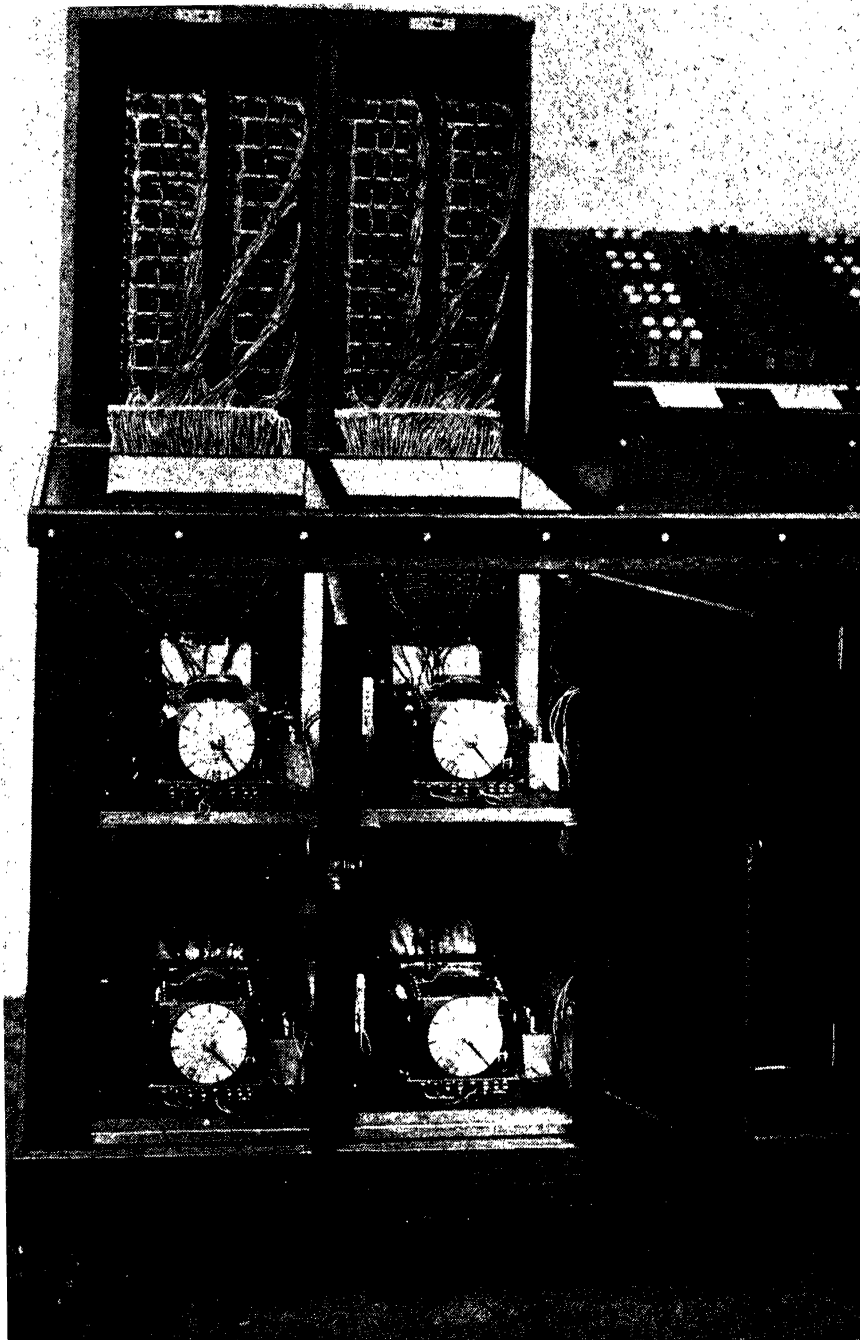

SECTION OF MALLOCK'S CALCULATOR

[Courtesy Cambridge Instrument Co.]

This is a view of the left-hand end of the instrument shown on the preceding page. Below, within the cupboards, are the electrical transformers and compensators, and above, beneath the "counter", is shown the wiring of the first four columns of switches. This machine solves equations and also determines square roots. It is designed chiefly to meet the requirements of physicists; its accuracy extends to the fourth decimal figure

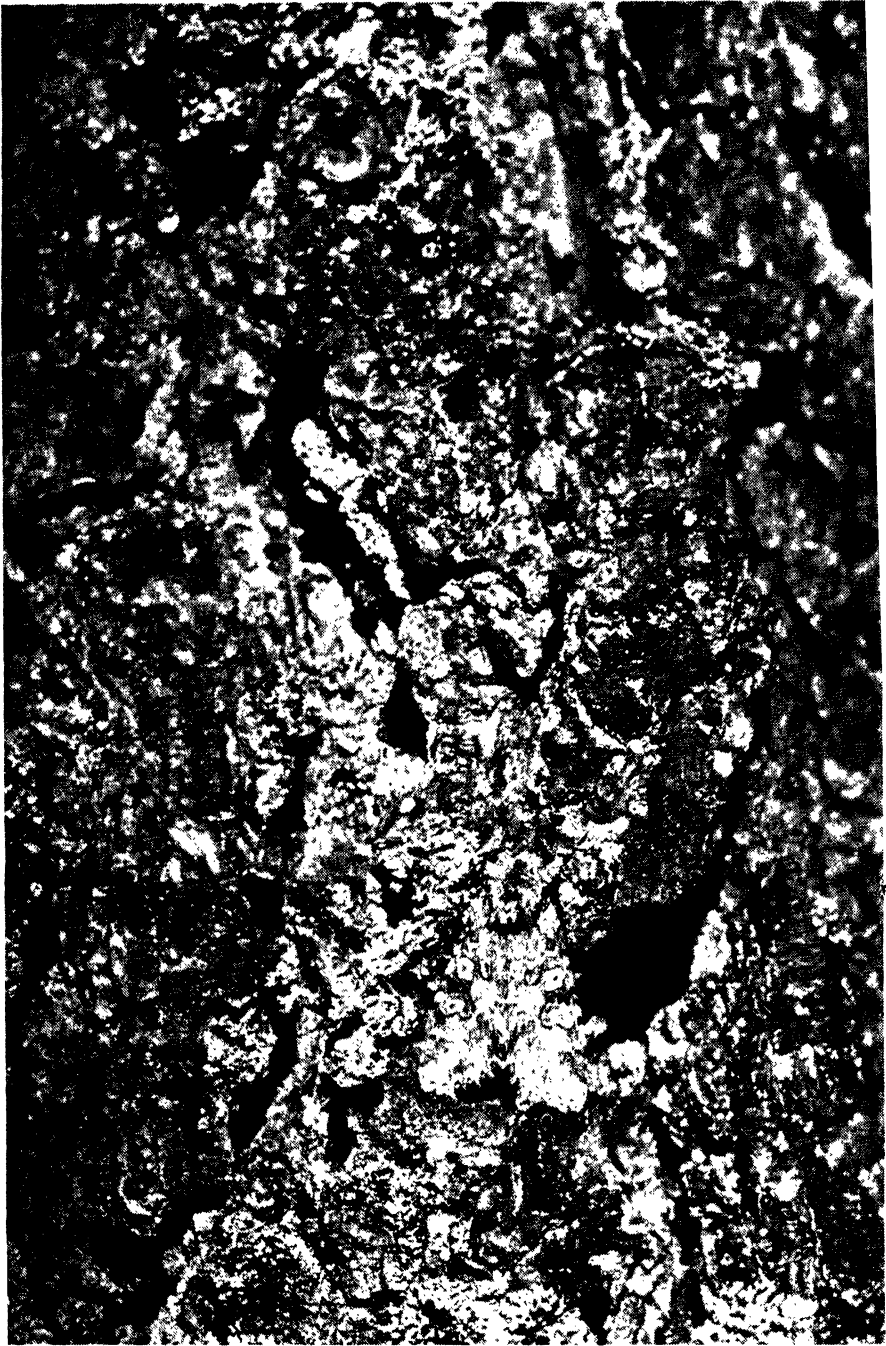

[E. Step, F.L.S.]

THE CAMOUFLAGE OF INSECTS

A striking illustration of Nature's power to protect otherwise defenceless insects from their foes by likening their colouring to that of their haunts. The picture shows a Grey Arches Moth on the lichen-covered bark of an old tree. The camouflage principle is, of course, not confined to the insect world, as witness such mammals as the zebra, leopard and polar bear, and such fishes as the plaice, which can vary its colouring as it moves



E. Step, F.L.S.

A CAMOUFLAGED GRASSHOPPER

A more perfect simulation of a collection of leaves than this insect has achieved would be hard to find. It is the best-known of the various walking-leaf insects, and lives in India. The photograph shows a female



[J. J. Ward

TWIG-LIKE CATERpillARS

This is not a picture of stick insects proper, which are fully-grown creatures built to resemble stalks, but of the larval stage of the Swallow-Tail Moth. It would be difficult to count the caterpillars on the branch



By courtesy]

BUTTERFLIES IN DISGUISE

["Marvels of the Universe"

Perhaps the most striking example of "insect camouflage". At first sight this picture shows nothing but a collection of dried leaves. Actually, however, for every leaf there is an Indian Leaf Butterfly with folded wings. The wings when open display gorgeous upper sides, but beneath they are veined and brown

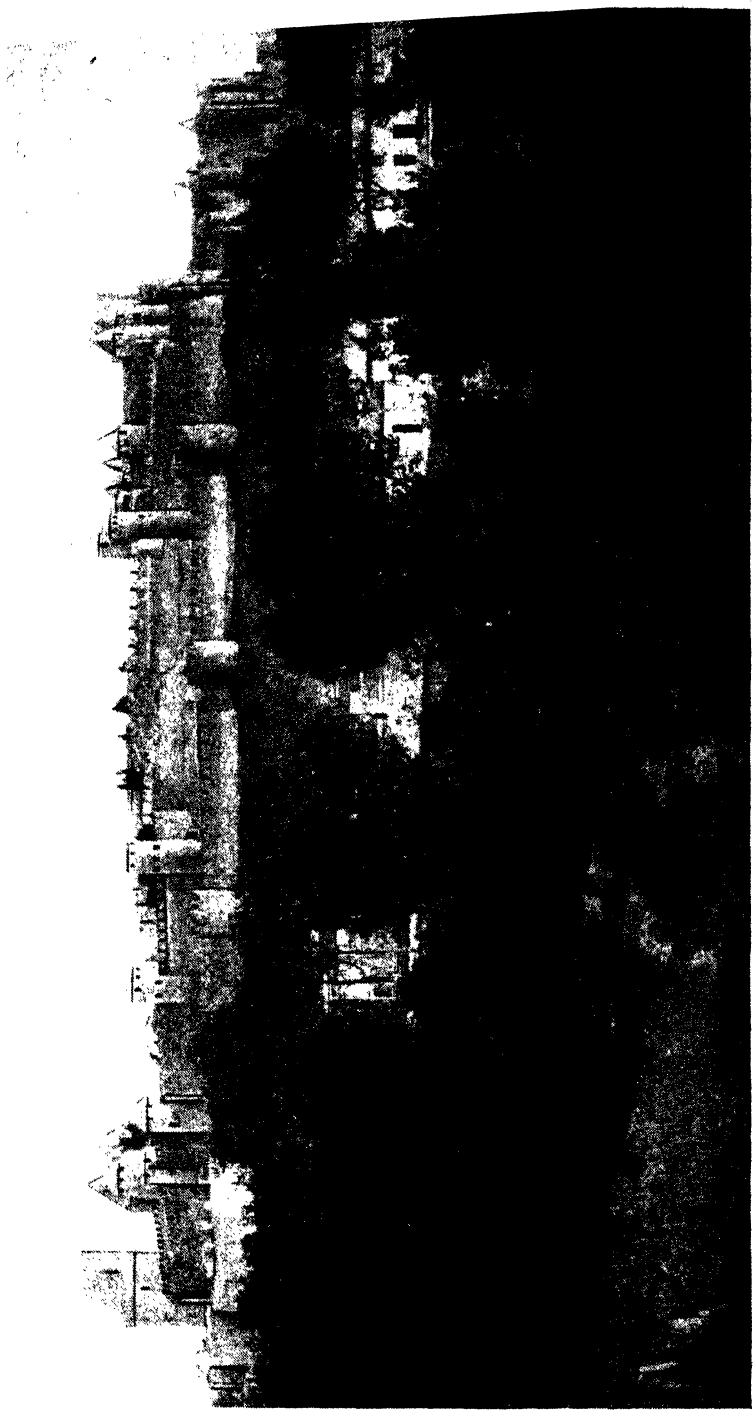

[E.N.A.]

THE CITY OF CARCASSONNE

The modern town of Carcassonne lies at the foot of the hill on which the old citadel is built, so that once within the ramparts, every trace of modernity disappears, though the place is fully inhabited. Viollet le Duc restored Carcassonne in the nineteenth century, but much medieval and even Roman work remains.



[*Dorien Leigh*

THE PIAZZETTA AT VENICE: BY CANALETTO

Destined ultimately to become the finest landscape painter of Italy, Antonio Canale, or Canaletto, first distinguished himself by decorating theatres. A Venetian by birth, he visited Rome and also London, where he painted several views. His Venetian pictures, however, are much his best-known. He was born in 1697 and died in 1768



[*From*

CANTERBURY CATHEDRAL FROM THE AIR

This picture shows how the famous Cathedral dominates the ancient town. Canterbury was important as a junction of coastal roads even in Roman days, and St. Augustine was the first to erect holy buildings there



By Courtesy]

["Britain Beautiful"]

A GLIMPSE OF CANTERBURY CLOISTERS

These cloisters are amongst the oldest structures of the present Cathedral, and are a relic of the monastery which St. Augustine founded. In the background of the picture is the passage known as the "Dark Entry", which has been immortalized in the Ingoldsby legends

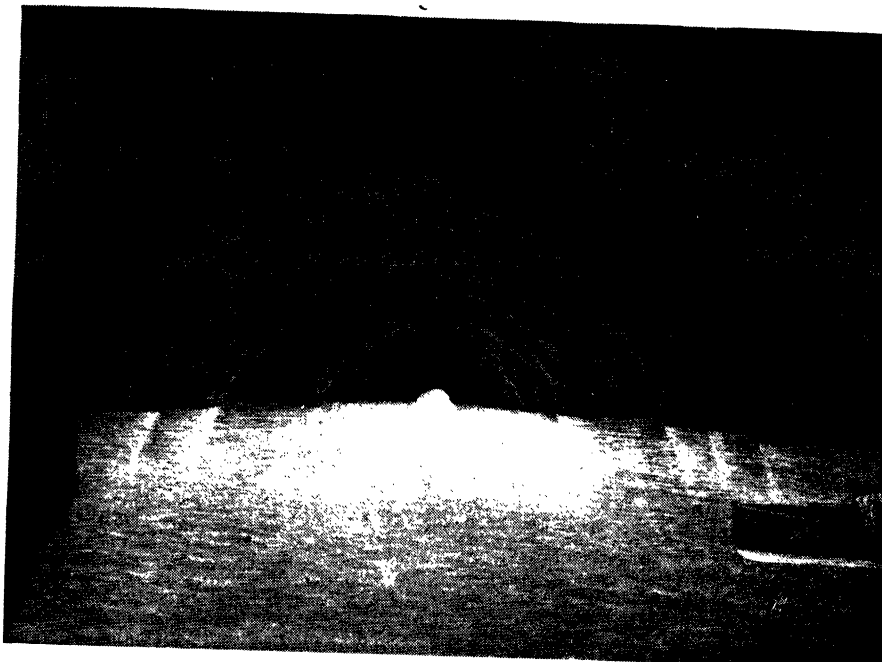

CAPRI: THE BLUE GROTTTO

[The Photochrom C.

The loveliest of the island's celebrated caves. The visible mouth, though large enough for a boat to enter, is tiny, and nearly all the cave's light is derived from its underwater portions, thus producing the glorious colour effect, like that of a celestial limelight, which gives the grotto its name.

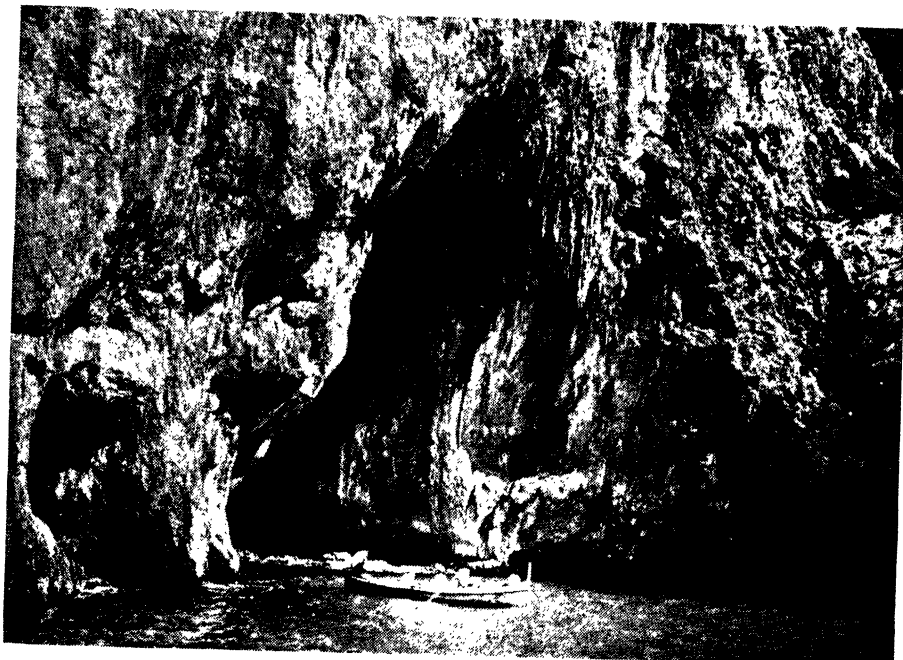

CAPRI: THE WHITE GROTTTO

[E.N.A.

These caves were made by the action of the waves on the island's limestone cliffs, and some of them stretch far underground. They abound in stalactites, and the play of light on these, especially in the White Grotto, is very beautiful indeed and attracts many sightseers.



THE "MENHIRS" OF CARNAC

[From "Wonders of the World"]

A "menhir" is a Druidical monolith, and the "menhirs" of Carnac form the most extensive Druidical remains anywhere to be found. It is computed from the patterns in which they are set out that originally they must have numbered no less than 15,000. Above is a general view down the ranks



THE TABLE ROCK, CAROLINA

[E.N.A.]

In South Carolina there rears a gaunt precipice which caused several bygone explorers, in the first flush of their enthusiasm, to name it as a new wonder of the world. If not quite that, it is at least very striking, for in the middle of a wooded and not very tall range, it presents a sheer drop of 900 feet



VERGINE IN GLORIA: BY CARRACCI

[Dorien Leigh

Carracci is the surname of three famous painters of the sixteenth century who founded the "eclectic" school of art at Bologna. Ludovico, the son of a butcher, was the uncle of the two others and the real master of the school. Called a dunce by Tintoretto, his master, he soon proved the untruth of that judgment. The above picture shows the Madonna standing on the moon, with St. Francis and St. Jerome before her and a retinue of angels behind

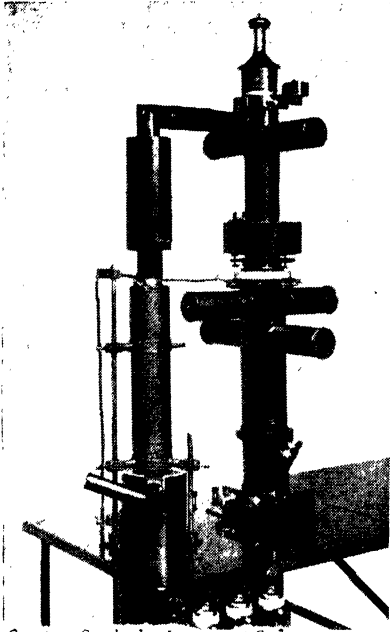

Courtesy Cambridge Instrument Co.]

A CATHODE RAY OSCILLOGRAPH

Its uses are numerous; the best-known is in connection with television. Though invented in 1897, this oscillograph has only recently entered commerce. Its principle is the harnessing by magnetic means of the electron-streams (Cathode Rays) given off by rarefied gases.

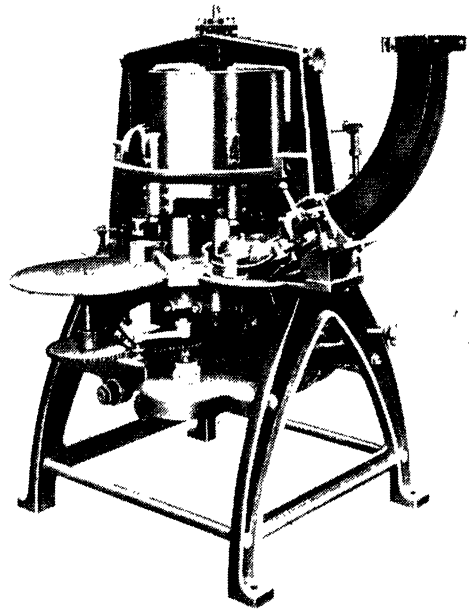

[Carthew & Kinnaird

A CAN-FILLING MACHINE

Several of the ingenious and little-known machines used in the canning industry are shown in different parts of this book. Above is a Universal Filler, which can fill cans of all sizes with fruit or syrup at a remarkable rate. The secret of preserving food, which baffled experimenters for so long, lies in the necessity for excluding not only air, but bacteria

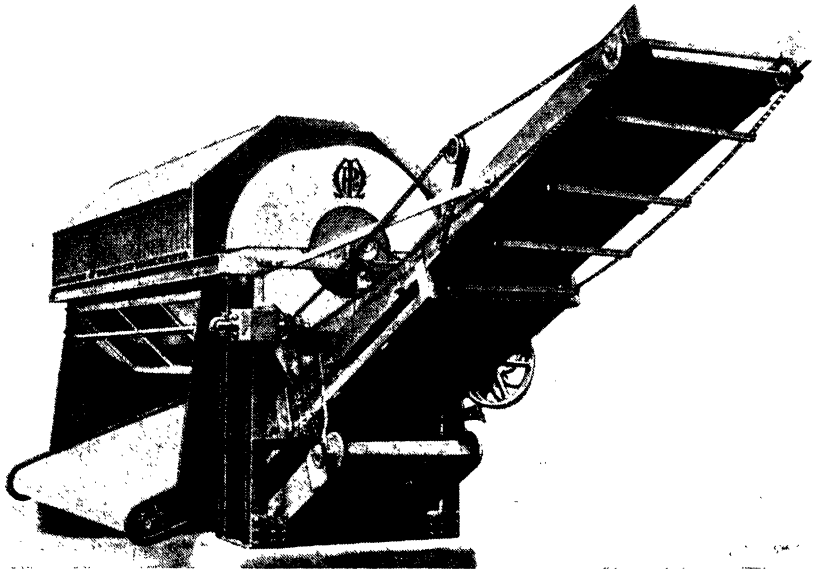

[Carthew & Kinnaird

FOR PREPARING CANNED PEAS

Some years ago the range of canned foods was limited to a few fruits and fish. To-day, so much has the industry improved it, it is possible to obtain in preserved state almost everything edible—fish, meat or vegetable. The above machine is used for "vining" green peas before canning and cooking

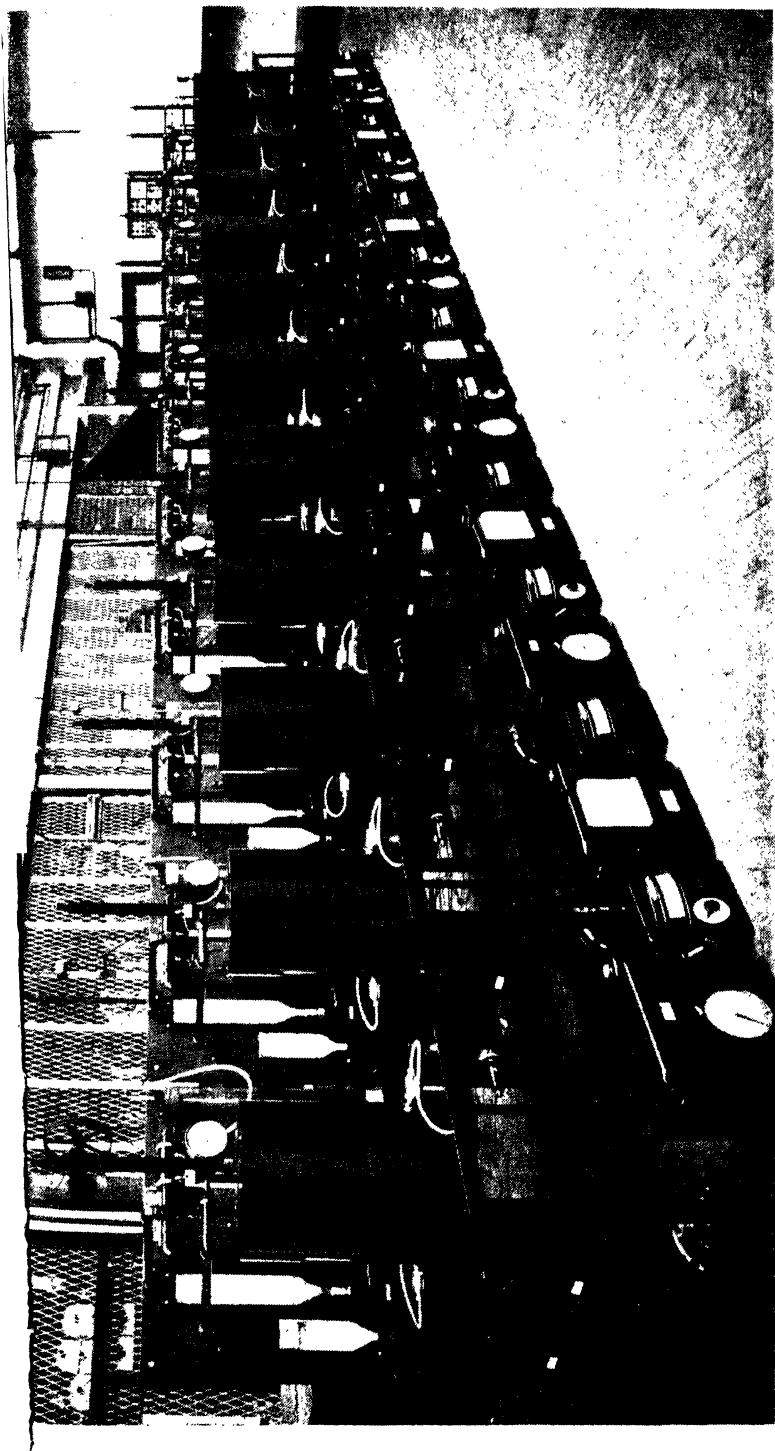

[Cambridge Instrument Co.

CARBON MONOXIDE ANALYSERS

The analysers depicted here are a set in operation in the new Mersey Tunnel. Carbon monoxide is a deadly gas contained in the exhaust fumes of motor vehicles; it can be neither seen nor smelt, yet is sufficiently powerful to cause injury if present even to the small extent of one part in 2,000. The above instruments, which are part of an elaborate ventilating and purifying apparatus, detect the gas and disintegrate it



[*Theo Carreras*]

THE CARPENTER BEE

Carpenter Bees are of several species, all large; that shown here is the violet variety found in Europe. It bores tunnels in wooden posts, divides them into chambers, and lays one egg with provisions in each. In the picture the bees are seen at work. In the bottom right-hand cell is an egg with pollen; on the left, from top to bottom, are a vacated cell, a grub feeding, and back and front views of the chrysalis

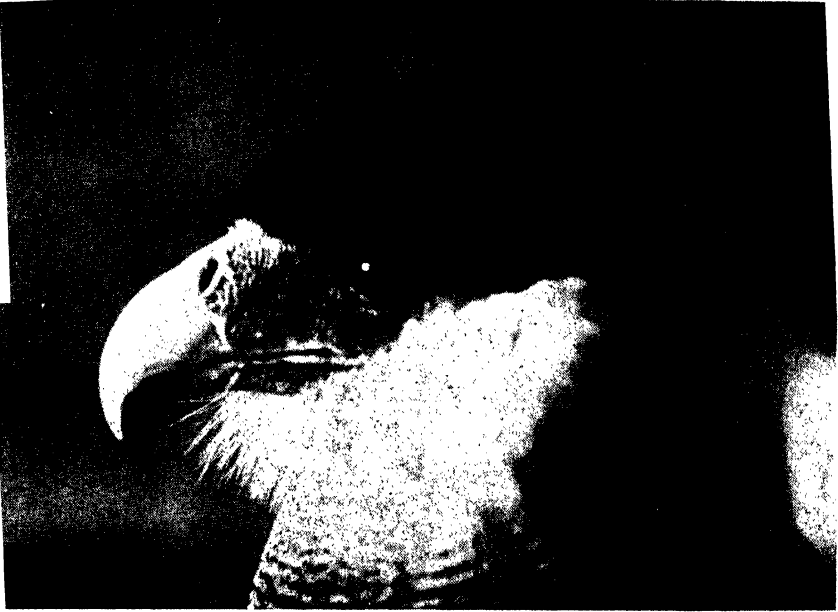

A CARRION HAWK

[Carnew & Kinnard

The Brazilian Carrion Hawk is one of the handsomest of this unpleasant tribe. The wonder of vultures, crows, etc., is not that they eat what seems to us the most repulsive nutriment of decaying flesh, but that they know where to find it. A carrion hawk or vulture will "sense" a corpse tens of miles away



CARNARVON CASTLE

[From "Britain Beautiful"

the greatest castle in Wales and one of the best preserved of its period in Western Europe, Edward I's grand building is picturesquely set despite its low level. Edward II finished it, and in much later days it was a good deal restored, but substantially it still remains as Edward I conceived it



THE CANTILEVER BRIDGE

[Carlow & Assn.]

The cantilever, as applied to bridges, means simply a pair of gallows-shaped brackets rooted in a pier and set back to back, the tips of their arms meeting similar cantilevers set in other piers. In modern engineering the world's finest example is the Forth Bridge, illustrated here



CATERPILLAR TRACTION

[Carlow & Assn.]

Though originally invented for the sinister purpose of tank warfare, caterpillar traction in various forms has since the Great War developed enormous commercial advantages. The caterpillar-car here shown is particularly interesting, as it was the first vehicle to cross the Sahara. No ground, however rough, is too much for these vehicles

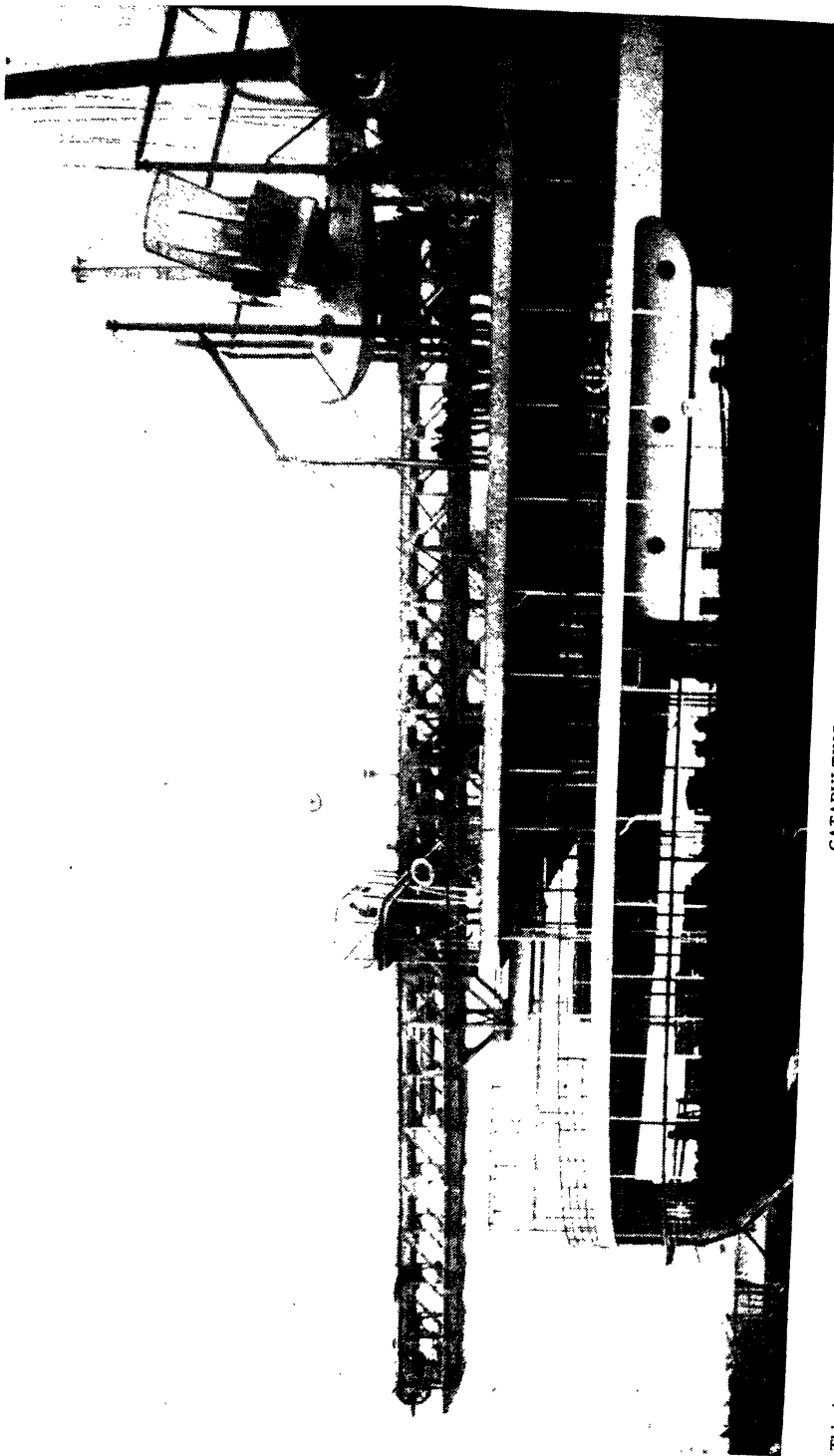

CATAPULTING AIRCRAFT

This is a means by which an aeroplane carried on the deck of a ship may be set flying without the usual "run". The planes are generally fitted with floats to land on the sea, and a primary use of them is to take mails off a liner whilst still a distance from port. The picture shows a mail-plane and catapult on board the *Hé de France*

[Keystone

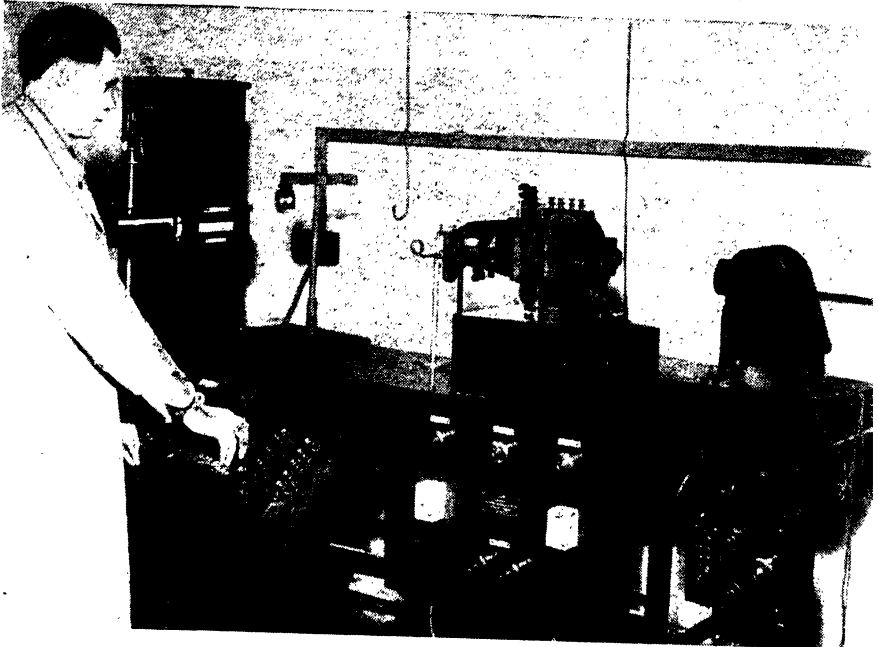

THE CARDIOGRAPH

[Carthew & Kinnaird]

There are two types: that which records by the ordinary method; and the one illustrated here, which records by the use of films. The latter is used for study.

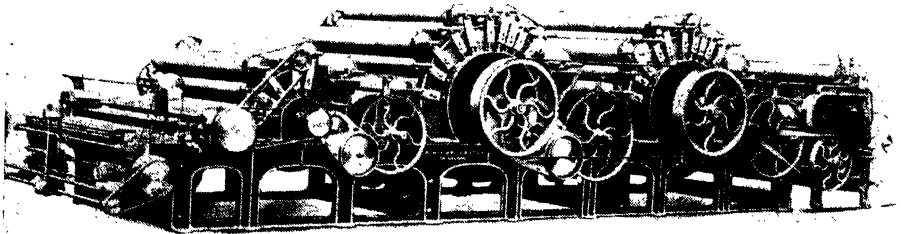

A WOOL-CARDING MACHINE

[Carthew & Kinnaird]

Carding is one of the earliest processes in the manufacture of wool, cotton or linen. In the case of wool, its purpose is to finish the disentangling, opening-out and mixing which two earlier processes have already begun. As shown here, the machine consists mainly of a variety of rollers which revolve at different speeds.

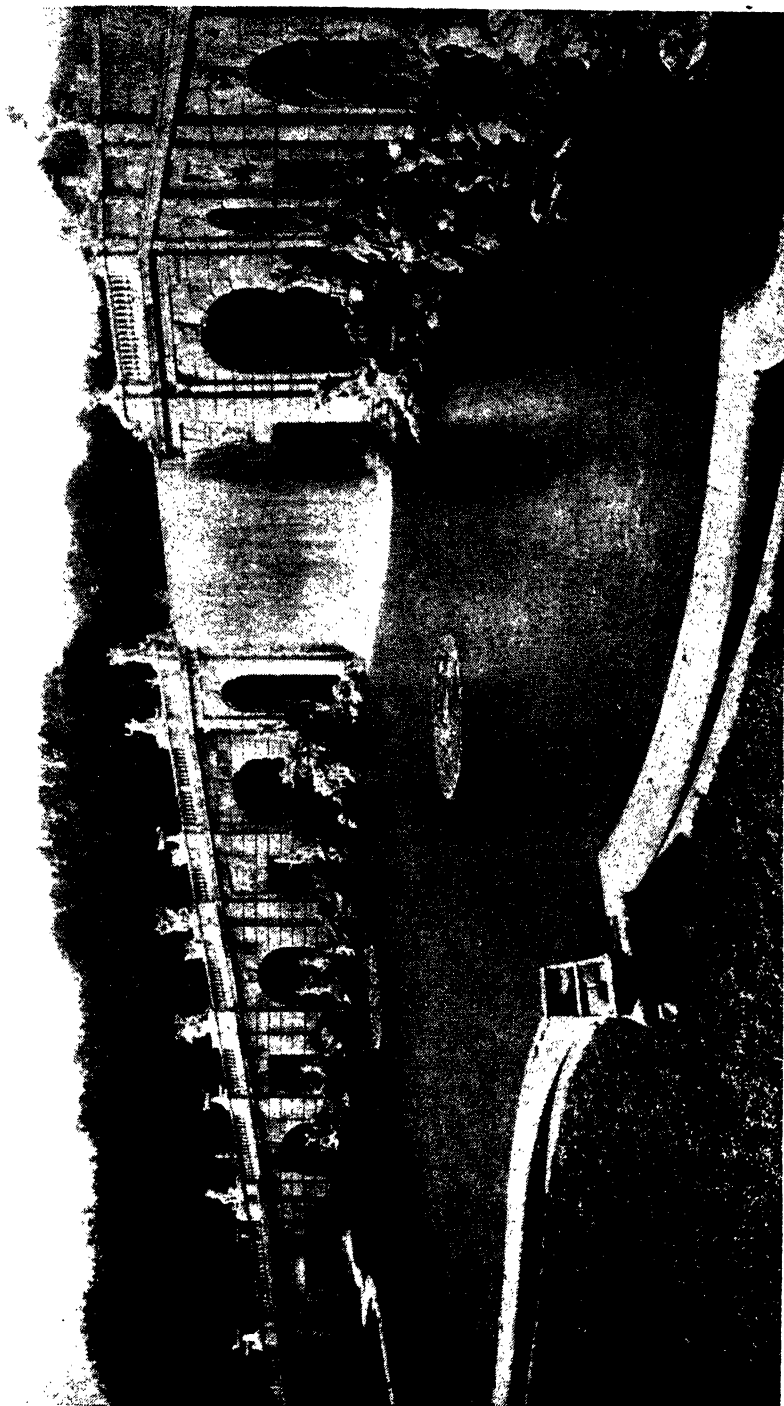

[W. F. Mensch]

CASERTA: THE MARBLE CASCADES

The Royal Palace at Caserta, Southern Italy, was designed by Vanvitelli in the mid-eighteenth century for Charles III of Naples. Its lovely grounds are filled with terraces, statues, cascades and fountains representing a high degree of art. The Grand Cascade, pictured above, is magnificently adorned

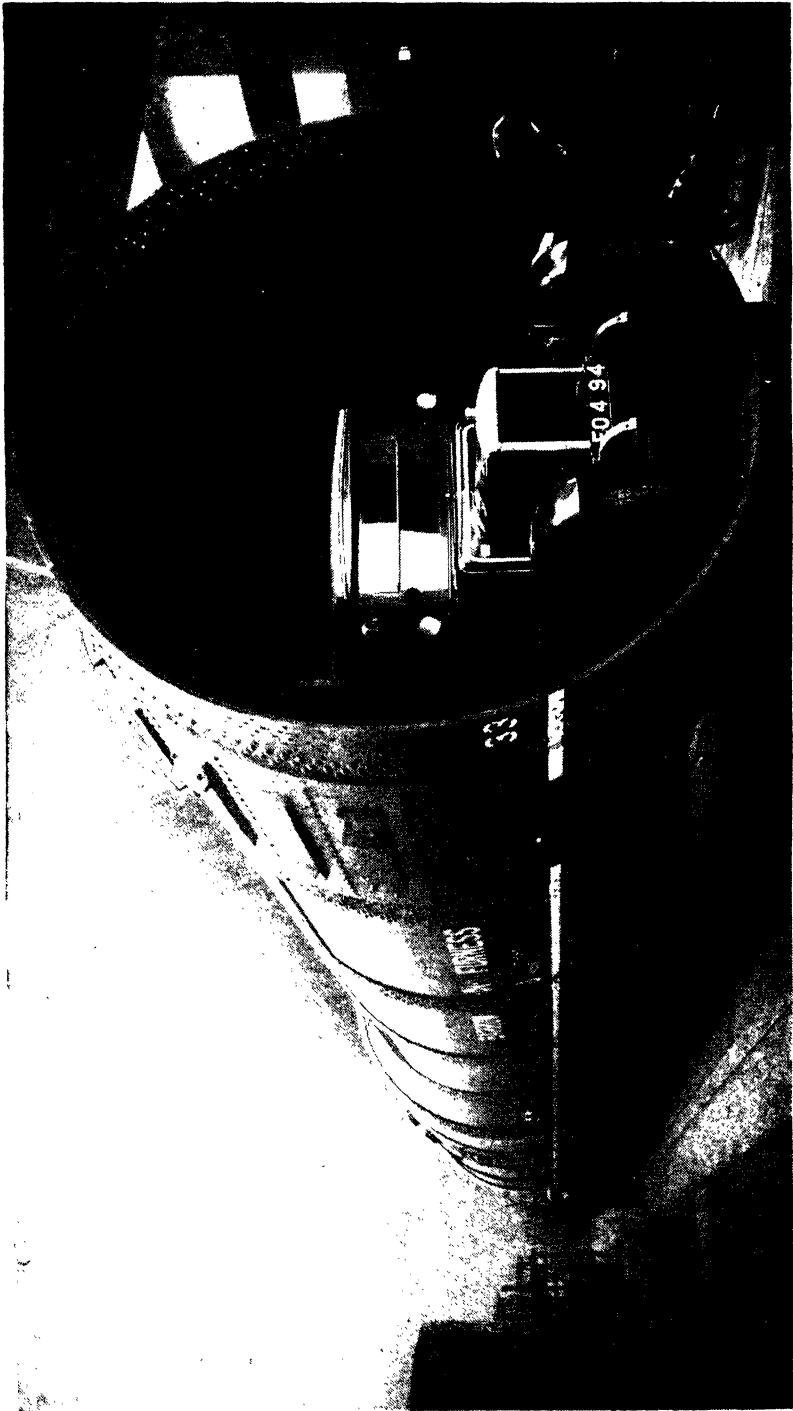

(Courtesy Pickers, Ltd.)

A GIANT CEMENT KILN

Cements, as distinct from plasters, which are based on gypsum, may be of four different kinds, each having a basis of chalk and clay. Portland cement, the most generally used variety, is made by mixing certain proportions of chalk and clay well ground into a mixture called "sherry", which is then burnt into clinker in long rotary kilns, cooled, and granulated into the familiar grey-green powder. Above, an enormous kiln is seen about to leave the factory.



from "Marvels of the Universe"]

THE CHAMELEON

his famous lizard, which can change its colour at will to suit its surroundings, is a native of Africa, though now widely distributed elsewhere. The photograph shows one of the largest species, nearly two feet long. The smallest measures less than three inches. The range of colours includes green, black, yellow, grey and brown



[Dorien Leigh

A WORK BY BENVENUTO CELLINI

Cellini (1500-71), who wrote his own memoirs, lived a life worthy of a character of Dumas. Sculptor, musician, author, engraver, and friend of kings, he was also murderer, libertine and scapegrace adventurer. The above statue of Perseus and Medusa is one of the greatest sculptures of the Renaissance

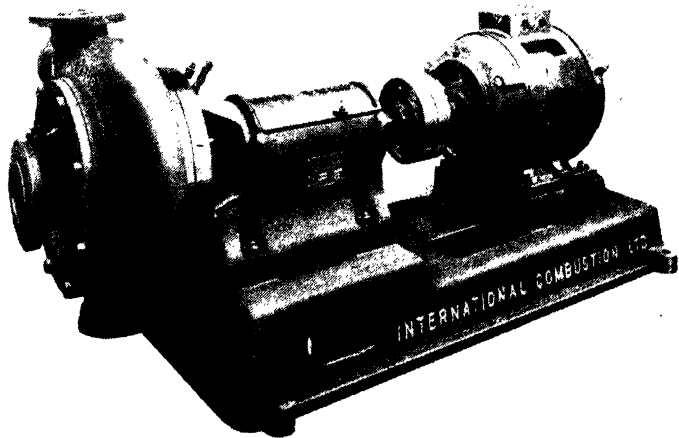

A CENTRIFUGAL PUMP

the
A



THE CHATEAU DE CHAMBORD

[Keyston]

The mightiest of the palaces of Touraine. Francis I began its construction, after which nearly every monarch down to Louis XV inhabited it, as well as an exiled King of Poland and Napoleon's Marshal, Berthier. It now belongs to France, after having seventeen claimants in 1933.

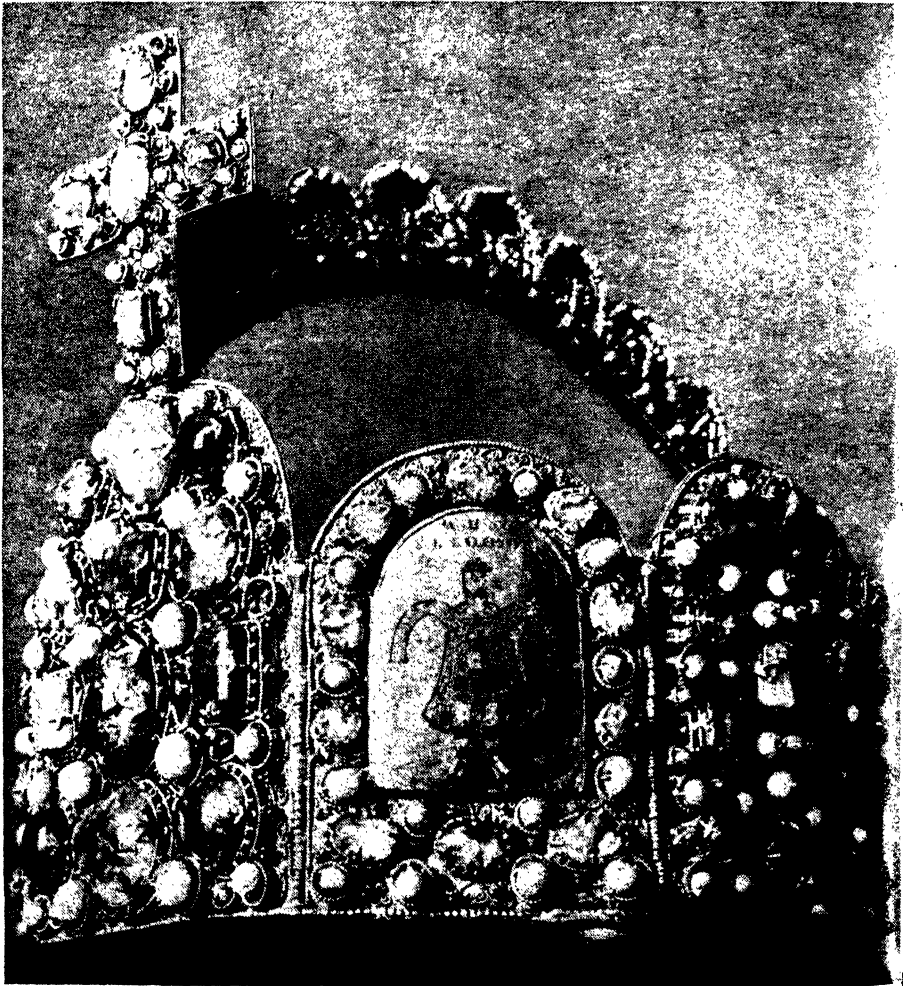

CHARLEMAGNE'S CROWN

[Dorien Leijer]

On Christmas Day, 800 A.D., Charles I of France was crowned by the Pope as "Caesar Augustus, Emperor of the West". Above is the actual crown used for that historic ceremony more than eleven hundred years ago. The last Holy Roman Emperor changed his title to Emperor of Austria in 1804.



BENEDICITE: BY CHARDIN

[Dorien Leigh

Jean-Baptiste Chardin is notable not so much for his winsome and slightly sentimental style as for his having been the first artist in France to depict middle-class life. He lived from 1699-1779, a period wherein it required no little courage to break away from the almost universal vogue for classical artificiality



THE WEST END OF CHARTRES CATHEDRAL

[Dorien Leigh

Reckoned by some the finest facade in France, the Cathedral of Notre Dame at Chartres was founded by Bishop Fulbertin in the eleventh century. Its towers and Western facade are especially noted for their beauty of proportion. The older tower, 351 feet high, dates from the twelfth century, and appears in this photograph; the other, 377 feet high, is more ornate and was not finished until the



SCULPTURES ON CHARTRES CATHEDRAL

[Dorien Leigh

Two close-ups of the decorations on the renowned Western façade. The work is almost entirely twelfth-century, and is as fine as any which the Middle Ages produced. The South portico, though smaller, was similarly ornamented a century later, the sculptures here being devoted exclusively to the glorification of Christ

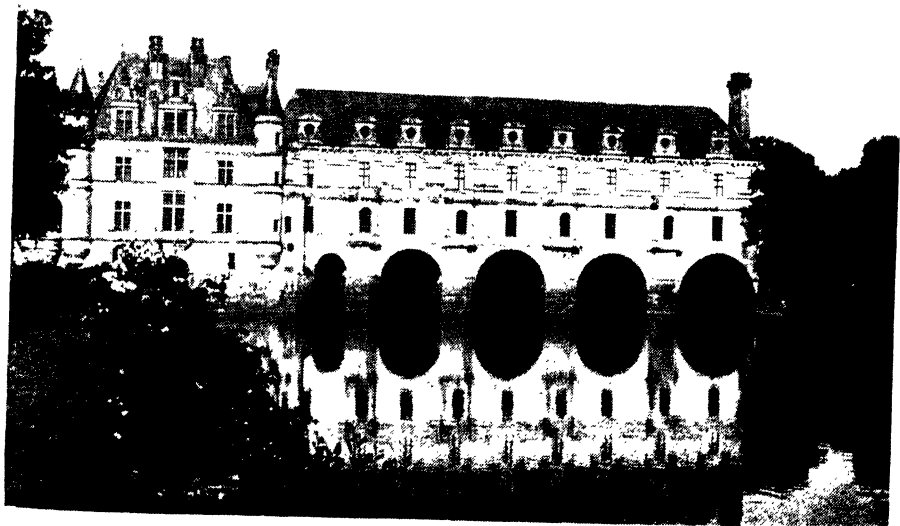

THE CHATEAU DE CHENONCEAUX

[From "Picturesque Europe"

side of this ...
le on the ...
The old ...
ent her



[Keystone

CHILLON CASTLE

The most famous castle in Switzerland, Chillon, for all its pleasant thirteenth-century architecture and picturesque setting in the Lake of Geneva, has had sombre history. For centuries after the decline of feudalism it was a State prison, and even to-day preserves its grimness as an arsenal. Byron wrote a well-known poem called *The Prisoner of Chillon*.



[The late H. G. Ponting, F.R.G.S.

THE GREAT WALL OF CHINA

The Great Wall, 2,500 miles long and boasting 25,000 watch towers, was built by Che-Hwang-te, the first Chinese Emperor, more than 2,000 years ago. This photograph shows a section of the wall crossing the top of the Nankow Pass. In the centre, down in the dip, is the Pa-ta-ling Gate.

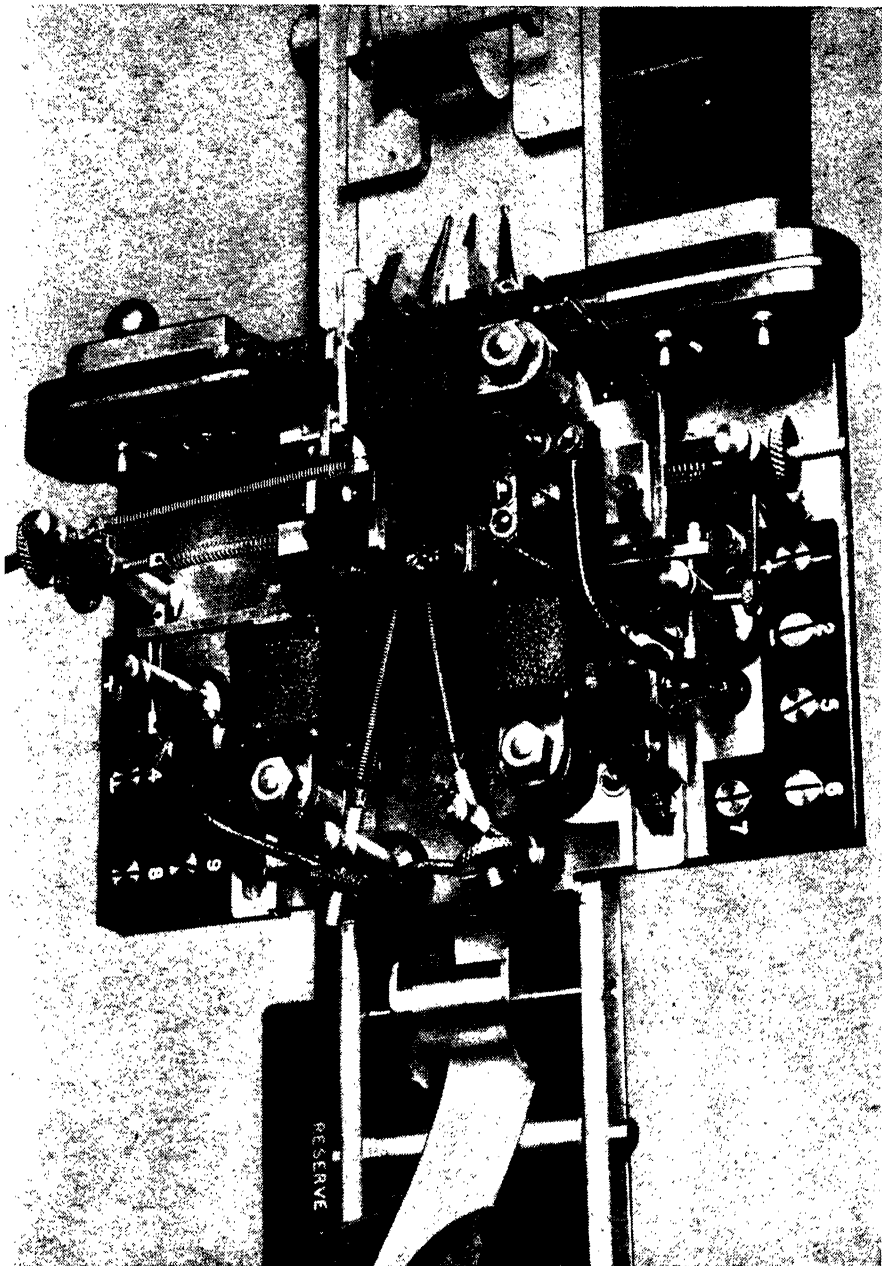

A THREE-PEN CHRONOGRAPH

[T. Mercer

The recording chronograph is an instrument for making permanent time-records on a strip of paper. The pen or pens (seen at the top of the picture) are attached to electro-magnets, and normally each traces a

If, however, the circuit to the electro-magnets be closed, the pens will deviate to one side. lock or chronometer to interrupt the current at fixed intervals, these intervals become recorded in the form of niches in the lines of ink. Further, by connecting only two pens to the clock and the third to a switch, a person may switch on and off, and read the exact period between these operations by comparing the third pen's niches with the two others. The apparatus may be arranged to record automatically over a period. The simplest of all chronographs is the familiar "stop-watch"

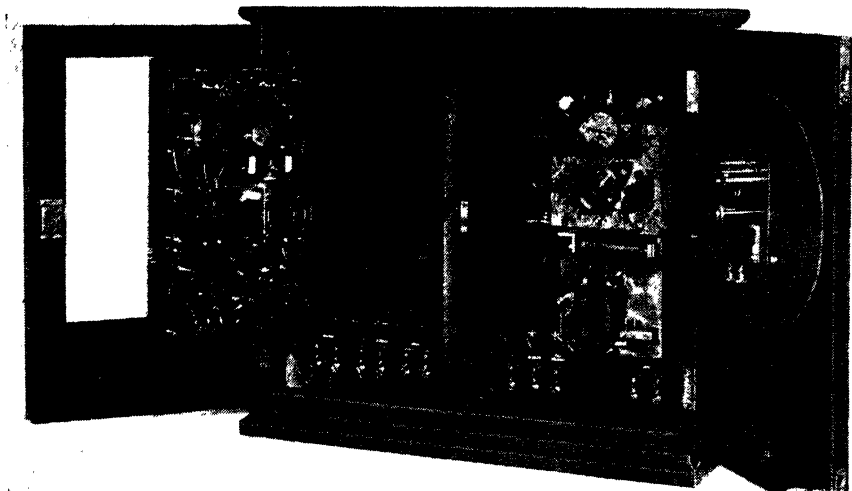

A CHRONOMETER

[J. Mercer]

Chronometers, which may be called hyper-accurate clocks, have lost some of their use since the invention of wireless telegraphy, but are still bound by law to be carried in ships for navigation. The picture shows the internals of an automatic, electrically-run control panel for governing a big vessel's chronometer system

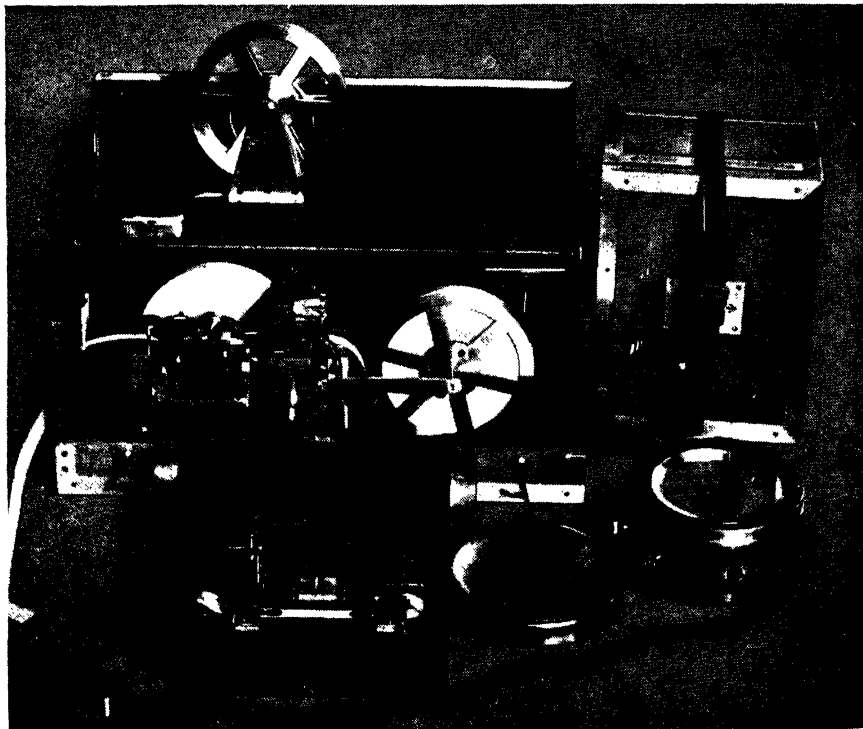

A COMPLETE CHRONOGRAPH INSTALLATION

[J. Mercer]

er and incidence measure. The chronograph is previous page. The incidence measurer is in the ray of light and the surface on which it falls

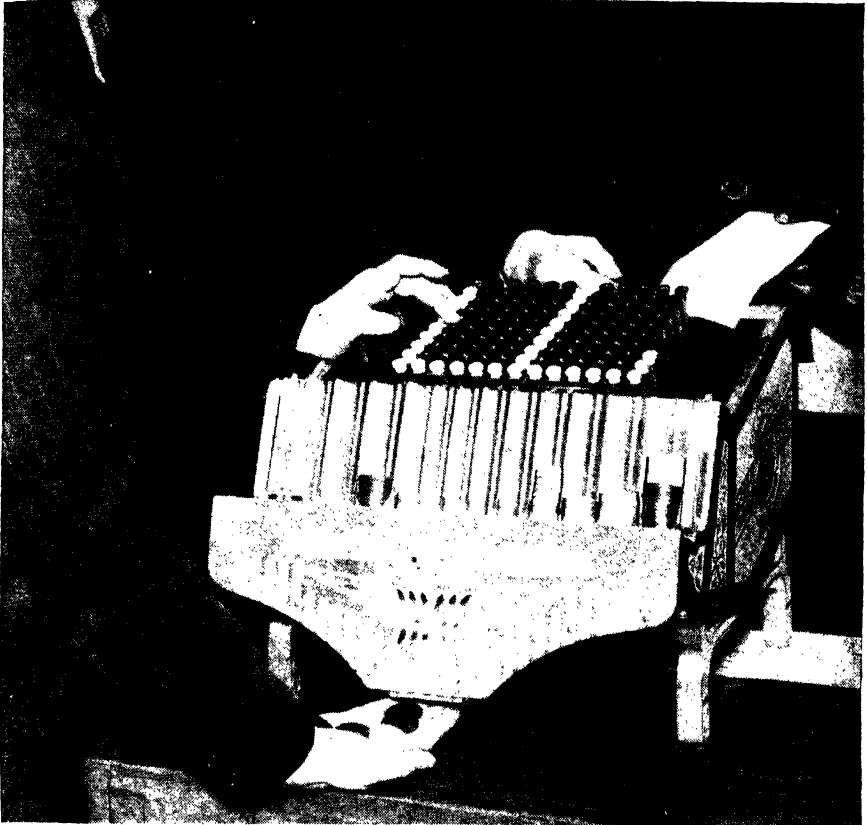

CHANGE-GIVING MACHINE

[Carthew & Kinnaird]

This in comparison with the devices to be seen nowadays in certain tube railway-stations, is a fairly simple change-giver. It is however, sufficiently ingenious as a pioneer of the invention, for it releases always the correct amount even if containing worn or bent coins.

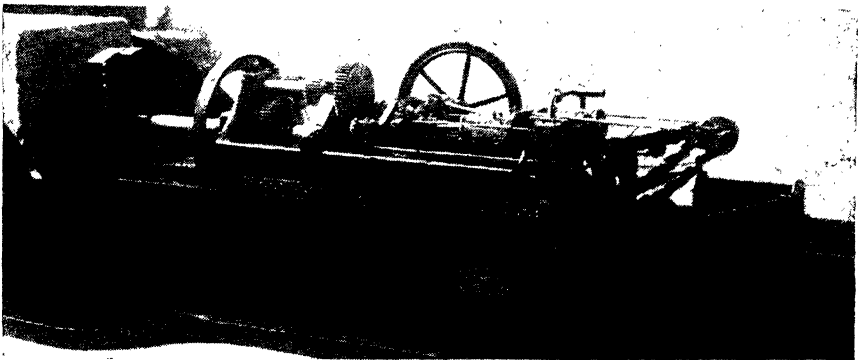

A CHANNELLING MACHINE

[Carthew & Kinnaird]

This photograph was taken from a scale model of one of the machines most commonly used for tunnelling, especially in mines. The cutting or digging mechanism is seen on the right of the picture. Such machines are tremendously powerful and can make rapid progress through any substance other than hard rock.



H. Bastin]

THE CICADA'S DRUM

The cicada's musical apparatus is much more complicated than the grasshopper's. In this view the right side of the male has been removed to show the "drum". This, however, is not struck or rubbed, but set vibrating, and the vibrations are then taken up by other parts of the apparatus. The sound, proportionately to the creature's size, is one of the loudest in nature.



[From "Marvels of the Universe"

A CICADA EMERGING

The cicada's song from the tree-tops in summer sunshine has been commemorated on since the days of ancient Greece. Here the insect is seen emerging from his chrysalis skin. In the tropics the cicada sings only by night, and in all countries the song is confined to the male.

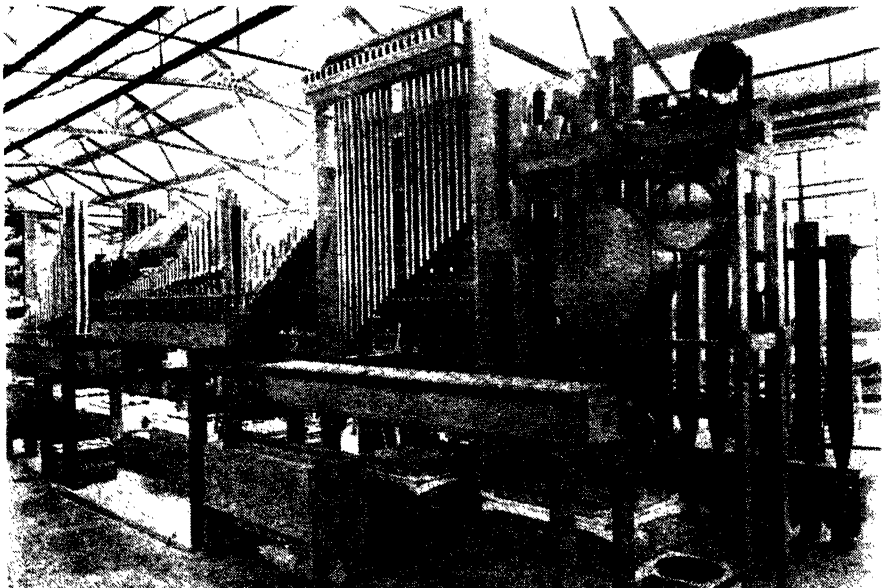

THE COMPONENTS OF A CINEMA ORGAN

[Courtesy Compton Organ Co.

in calling itself a "music cabinet" in this picture of components in the factory some of the organ pipes can be seen bass and side drums, an angelus, a cymbal, castanets, xylophone, Chinese box, etc. The cinema organ was invented in America based on the suggestions of an



The Photogram Co.

CINTRA: THE CASTELLO DA PENA

Cintra, Portugal's loveliest and healthiest town, is built round two hills each crowned by a castle. One of these castles, built by the Moors, lies in ruins; the other, seen here, was founded by Ferdinand II of Coburg, in the nineteenth century, on the site of an ancient convent, whose cloister and tiny church are incorporated in the new building. The views from the Castello da Pena are scarcely rivalled in the world.



[Carthew & Kinnaird]

ANCESTOR OF THE CINEMATOGRAPH

This picture shows one of the earliest moving-picture appliances—the Zoopraxiscope. An ordinary magic lantern does the projection, and the moving effect is obtained by revolving discs with drawings on them before an arrangement of shutters

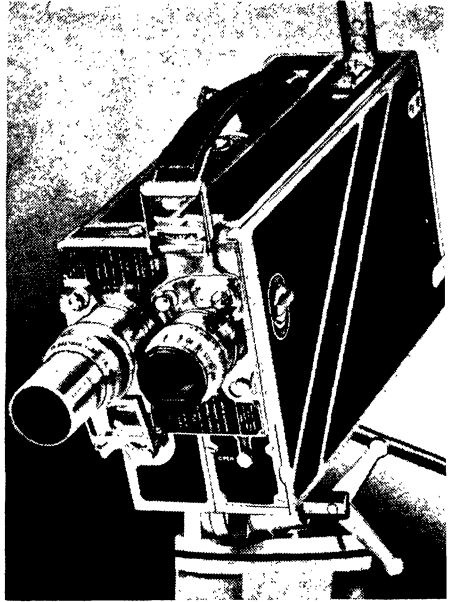

[Courtesy Kodak, Ltd]

A MODERN CINÉ-CAMERA

In contrast to the Zoopraxiscope, here is one of the latest developments of the film camera. An instrument such as is shown is capable of practically every requirement of the cinematographer under a wide variety of conditions, and is fitted with innumerable ingenious gadgets

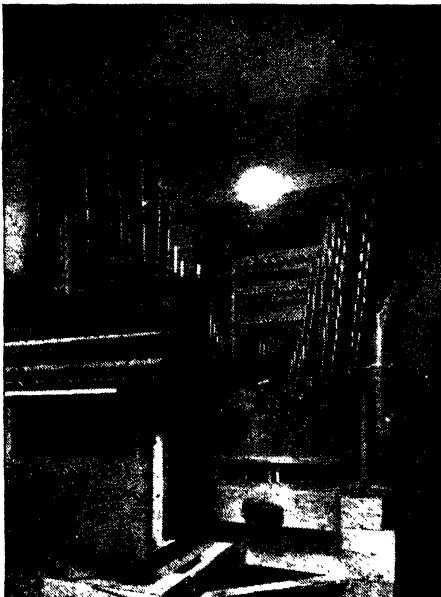

[Courtesy Compagnie Organ Co.]

A CINEMA ORGAN'S PIANO

The piano-like notes which are often to be heard in cinema organ music come genuinely from a piano, which is operated by the organist from the console. In the background of this picture may be seen the xylophone, similarly operated



[Dorren Leigh]

A CIRCUIT TESTER

This instrument is similar in function to the Earth Tester illustrated on page 182, with the important difference that this tests the earth-resisting power of circuits which are already "alive". Its mechanism differs substantially from the other



[Dorien Leigh

"TOBIAS AND THE ARCHANGEL," BY CIMA

Giovanni Battista Cima, called Cima da Conegliano, was an Italian Renaissance painter whose work resembles closest that of Giovanni Bellini. His varied works are now distributed at Venice, Milan, Rome, Dresden, Paris, London, and elsewhere. The above painting is at Rome. Cima lived from 1460-1518.



[Dorien Leigh

"THE LANDING OF CLEOPATRA," BY CLAUDE LORRAINE

One of the most famous of French landscape painters, Claude Lorraine (properly Claude Gellée) was born in Lorraine in 1600. Early in life he went to Italy, and executed two pictures for Pope Urban VIII. His fame rose so high that for one of his works a later Pope offered as much gold as would cover the canvas.



From "Marvels of the Universe"

A GIANT CLAM

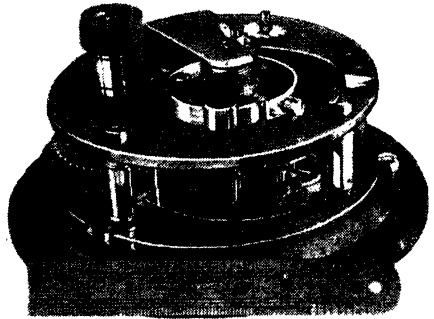

Driven marine chronometer



[From "Wonders of the World"

THE CLOUDS

This remarkable cloud photograph was taken from the summit of Pike's Peak, in the Rocky Mountains, at sunrise. At that hour a white fleecy formation appears below the level of the topmost peak, blotting out the others. As the day progresses it dissolves. The picture shows the great difference in altitude between what may be termed "earthly" and "heavenly" clouds



Dorien Leigh

TAKING THE TEMPERATURE OF COAL

Grading coal into different qualities is a delicate task. The above photograph shows the complicated apparatus used for temperature tests. Besides heat value, coal is tested for moisture, ash, and volatile matter, for coking power, and for sulphur, arsenic, etc., and in the ultimate analysis for the percentage of each element present.



COAL CUTTING

[Carthel & Kinnand

This photograph shows a gallery only three feet high. The cutter, which is electrically driven, is pressed against the run and cuts horizontally by means of the revolving band of teeth. Vertical cuts are made either by hand or with a different type of machine.

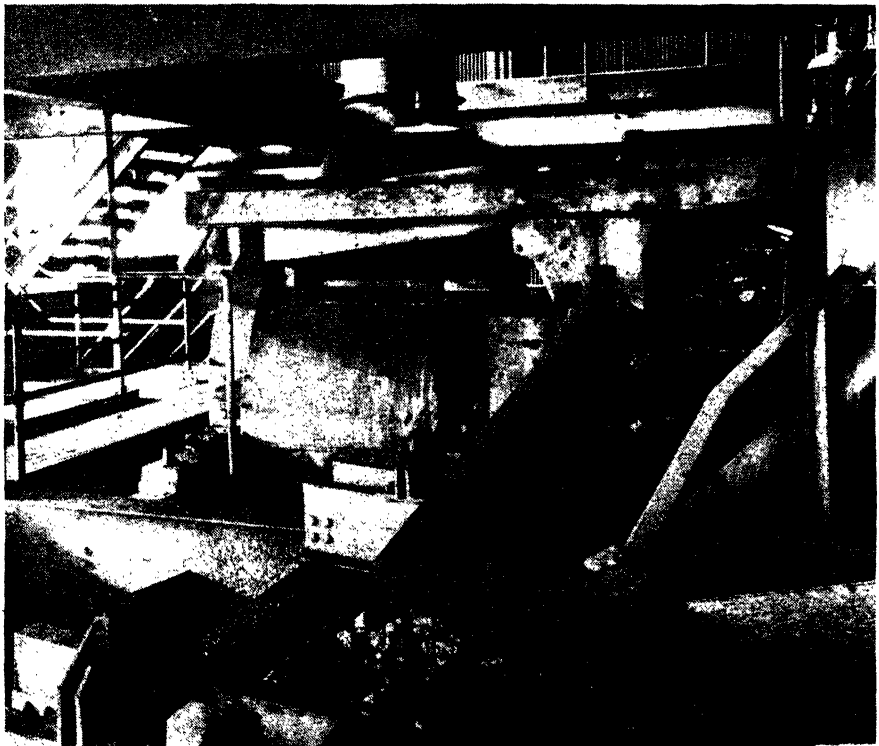

COAL SORTING

[Keystone

On other pages are illustrated methods of cleaning and analysing coal. Here is a detail of the machinery used for grading it into sizes. The general system for sizing is for the coal to pass down long slides perforated with increasingly large holes. The end of such a slide is seen in the background, with a further perforated tray below.

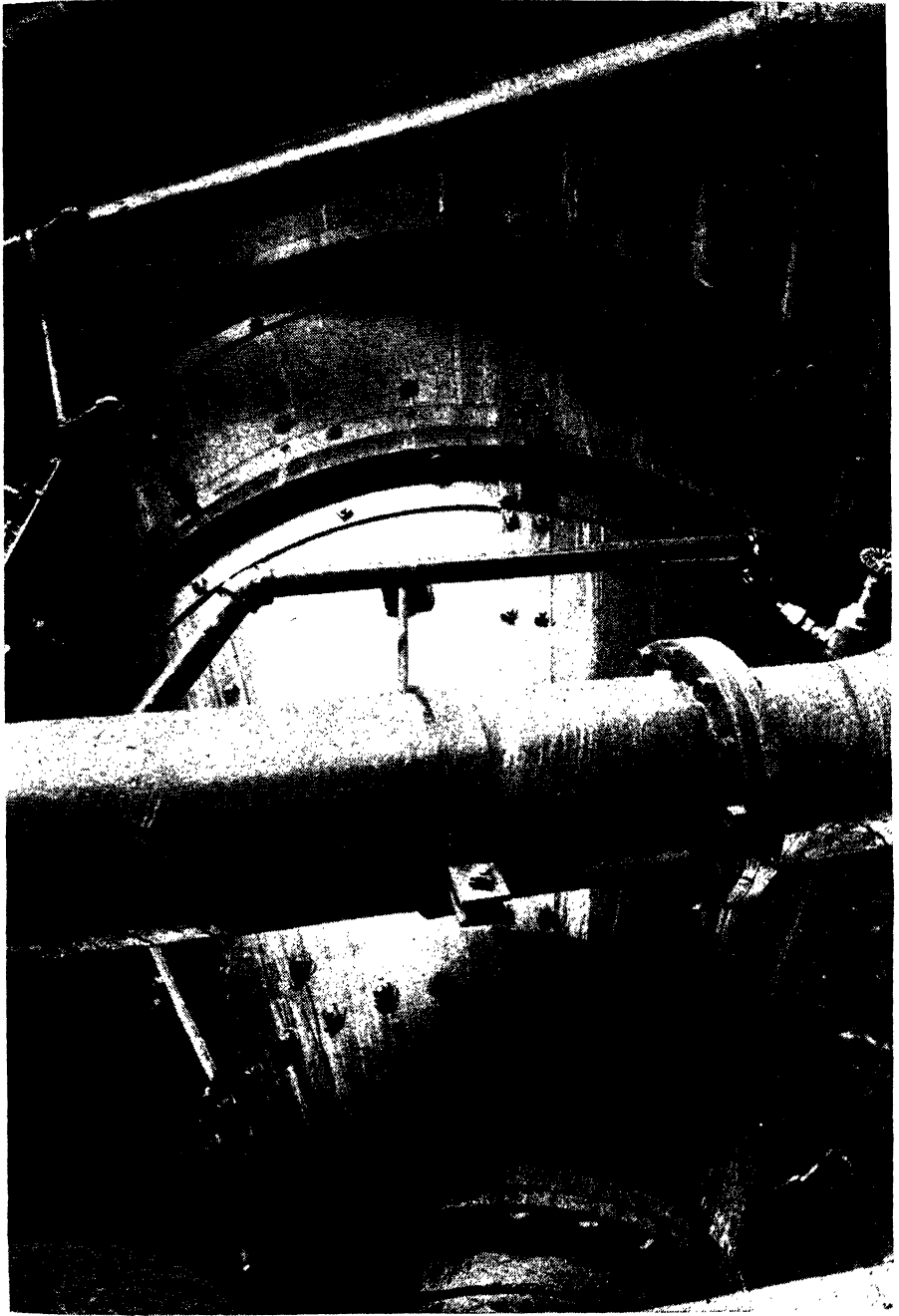

[Keystone]

WASHING COAL

The coal or anthracite to be washed is shot into this huge conical tank, where it is automatically cleaned of all impurities. Another process, not alternative but supplementary to this, is to immerse the coal in chemical baths which separate it from other minerals; instead of washing, a pneumatic process is sometimes employed

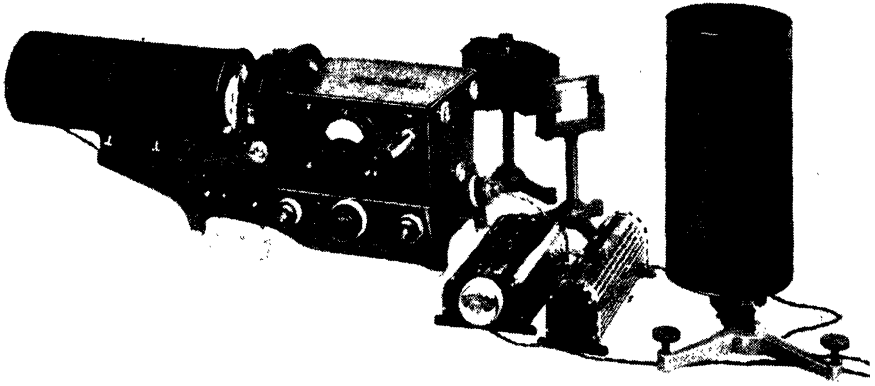

A COLORIMETER

[Carther & Kinnear]

This is an apparatus for measuring the precise hue, purity, and brightness of colour. The principle of the type of instrument shown involves the prismatic focussing on to a single area of three separate beams of light passing through slits from a continuous spectrum. The resulting patch of pure spectral colour may be matched with the colour for test by manipulating the slits.

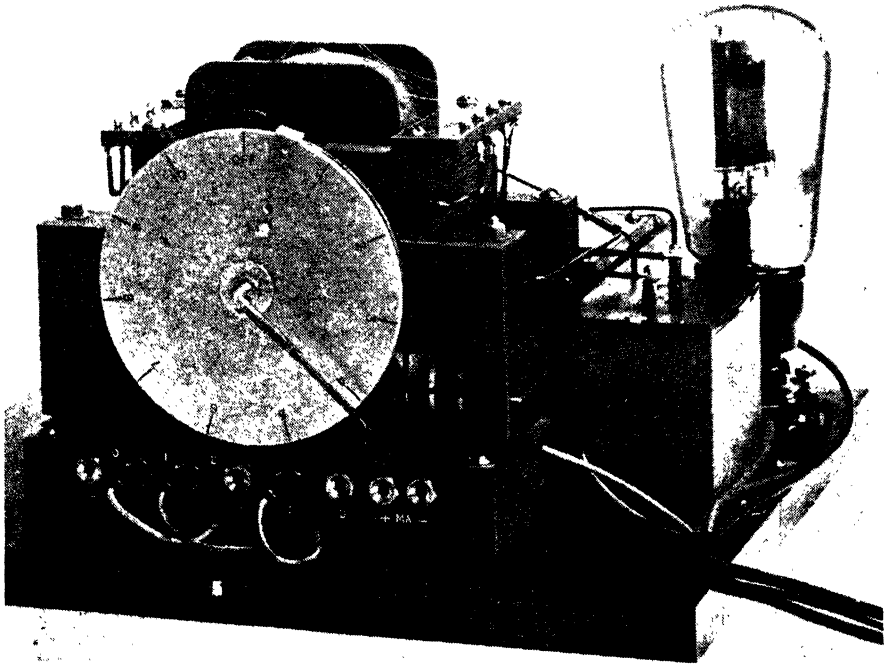

A COMPENSATOR

Courtesy Cambridge Instrument Co

The function of a compensator is to correct disturbing action in appliances worked by electricity. For example, one of the commonest uses is to raise gradually the voltage of a high-powered electric motor on starting, so that too much current is not immediately imparted to a stationary machine. Compensators are a type of auto-transformer.



By courtesy;

THE GRAND CANYON OF THE COLORADO

This colossal chasm in Arizona is not the narrow, close-walled rift we are apt to associate with the word, but a mighty split in the earth's crust, which at the summit is now here less than twelve miles wide! Its depth varies between a mile and a half. The whole of it has been carved by the river from a granitic mass of rock, which at the present time is a

"Marricis of the Universe"

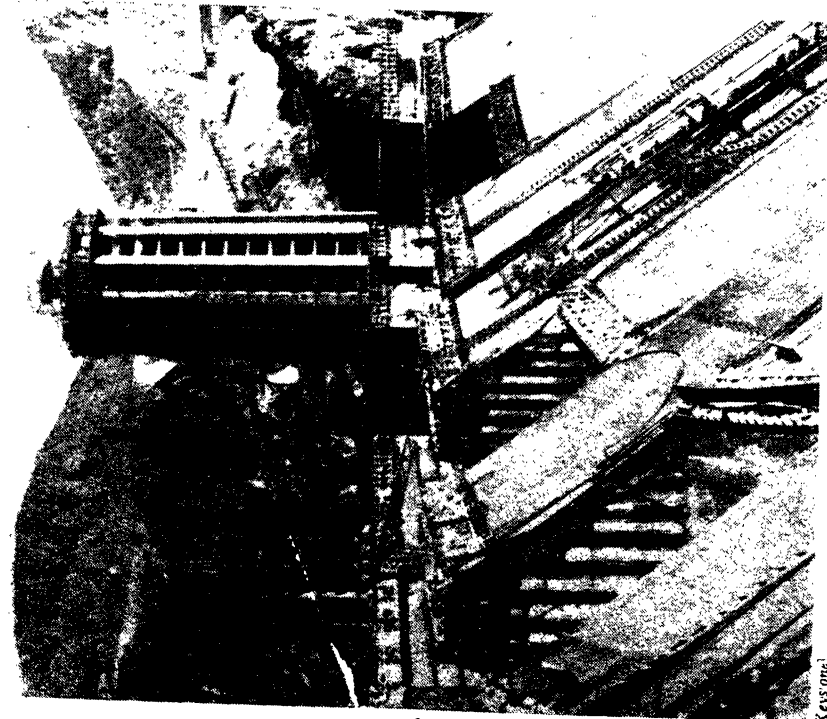

Keystone

BUILDING THE COLORADO DAM
 The gigantic Boulder Dam is 554 feet high, and this picture shows its half-completed downstream face from the Nevada abutments. Two intakes for the huge power-plant at the base of the dam are shown towering above the mass of concrete. With the help of Hoop-lighting, construction work was carried on all night as well as all day.

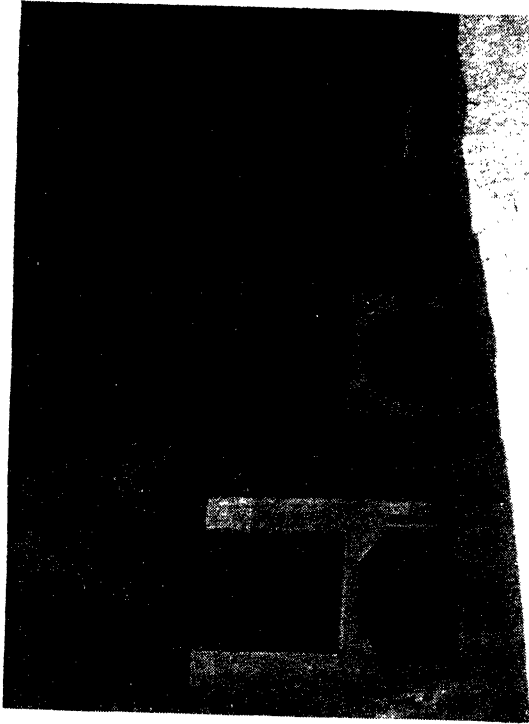

Keystone

THE COLORADO RIVER AQUEDUCT

In connection with the gigantic Boulder Dam, the waters of the Colorado have been diverted for a short section and directed in tunnels through the heart of a mountain. The photograph shows one end of this subterranean aqueduct, which represents one of the largest diversions ever made.



(Theo. Carreras)

THE COCKROACH-WASP AT WORK

This beautiful, shining green wasp should be popular with cockroach haters, for its whole business in life is the destruction of these pests. First stinging them to render them inert, it then drags them away to its nesting holes in cracks and crevices of buildings to provide food for its grubs. The cockroach-wasp is commonest in India



Theo Carreras

INSECTS OF THE COAL AGE

The chief characteristic of Coal Age insects was their enormous size. The dragon-fly at the top of this picture was found in France and measured more than two feet across. The other insects shown, proportionately huge, are a mayfly, an earwig, and a cockroach, a rather terrifying and impressive group.

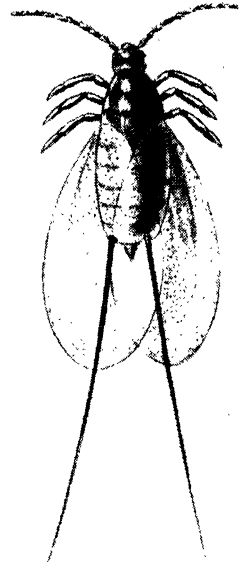

[Cartier & Ki]

THE COCHINEAL INSECT

Cochineal may be used as a carmine, yellow, or purple dye, and is much employed in cooking and preserving. It consists of the fecundated females, dried, of the tiny insect here shown, which is a native of Mexico and Central America.



[Chapman & Hall 111]

ANIMAL LIFE IN THE COAL AGE

A restoration drawing of five members of the new tribe (amphibians) whose remains have been found in the coal measures and deposits of the Permian Period. The conspicuous feature is the eyes, which in each case are right on top of the flat head. The large creature in the centre is an archegosaur.



SOME NOTABLE COMETS

Comets are believed to consist of dense swarms of meteors, containing much gas which is driven out and repelled by light-pressure when they approach the sun. In the centre is the six-tailed comet of 1744; top left, Donati's comet of 1858, passing the star Arcturus; below that, Coggia's comet of 1874; in the bottom right corner, the head of Halley's, the most renowned of all comets, in 1835

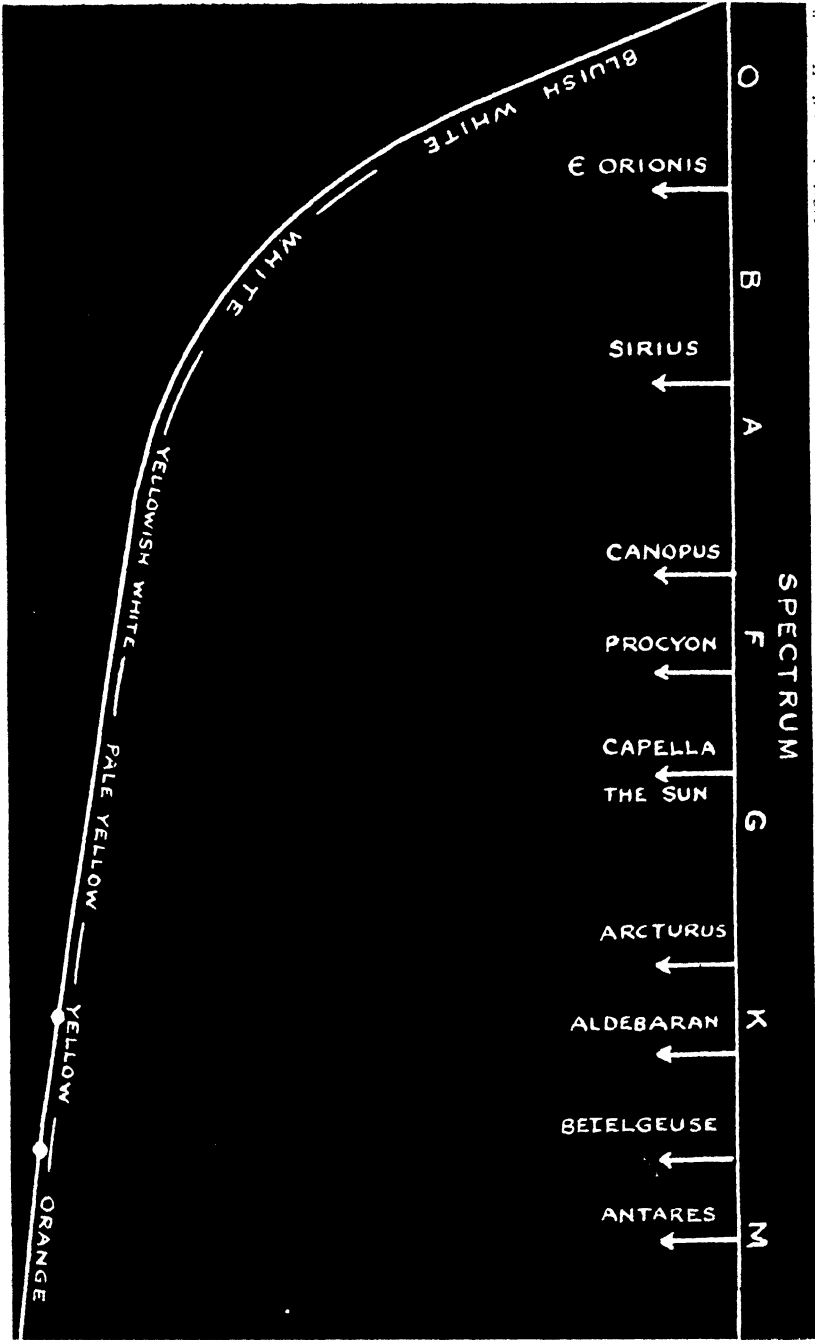

["Splendour of the Heavens"]

THE COLOURS OF THE STARS

This is a chart showing the relation between the colours of certain prominent stars, their spectra, and the temperatures of their atmospheres.

By courtesy]

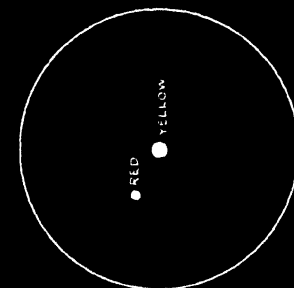

α CASSIOPEIAE

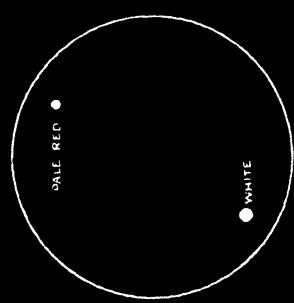

β CYGNI

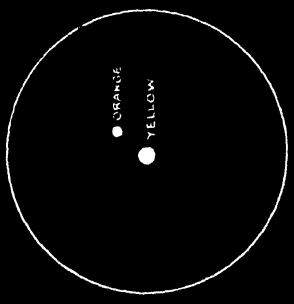

ϵ BÖÖTIS



α HERCULIS

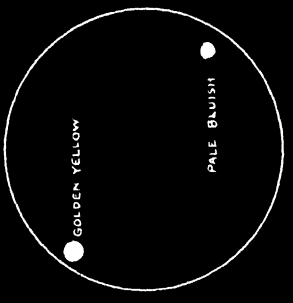

β LEONIS

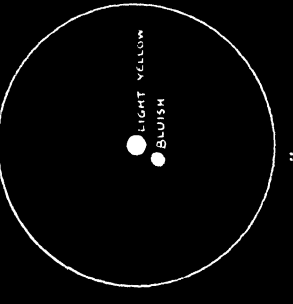

ϵ HERCULIS

By courtesy:

THE COLOUR OF DOUBLE STARS

Double stars (see p. 176) are star-couples whose existences proceed in definite relation to one another. The colours of such couples are always different, the actual shades greatly helping astronomers to determine heat and other characteristics. Seen through a telescope, these colour contrasts are very beautiful

"Splendour of the Heavens"

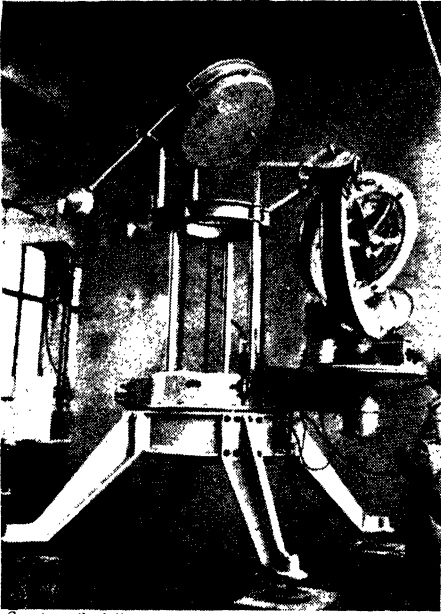

Courtesy Carl Zeiss

A COELOSTAT

The purpose of this instrument is to reflect the light of a star in a constant direction despite the earth's rotation on its own axis. It is found that if a mirror rotates half as fast as the Earth on an axis parallel to the Earth's, the reflected beam will be constant.

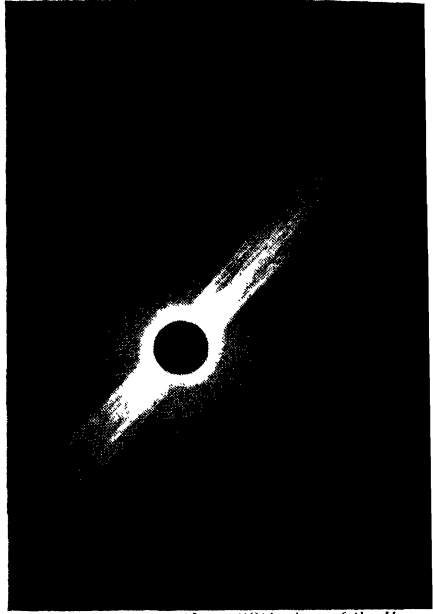

[From "Splendour of the Heavens"

A SOLAR CORONA

The corona is the halo of light seen round the sun during total eclipse. It is actually a solar atmosphere, and extends outwards for millions of miles. Normally it is circular but its shape depends on the prevalence of sunspots, which at their minimum, produce the elongated effect shown here.

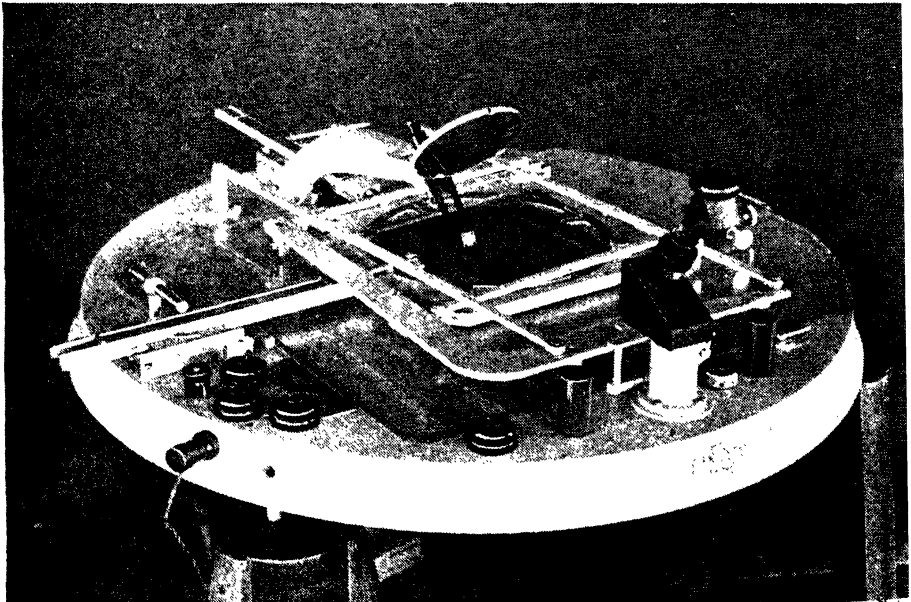

CO-ORDINATE MEASURING MACHINE

(Courtesy Carl Zeiss)

This is an instrument, used chiefly in astronomy but applicable elsewhere, for simultaneously measuring photographic plates in two directions. The principle is an extension of that of the comparator and the apparatus is so designed that the two scales may be read and the plate adjusted by means of a single eye-piece.

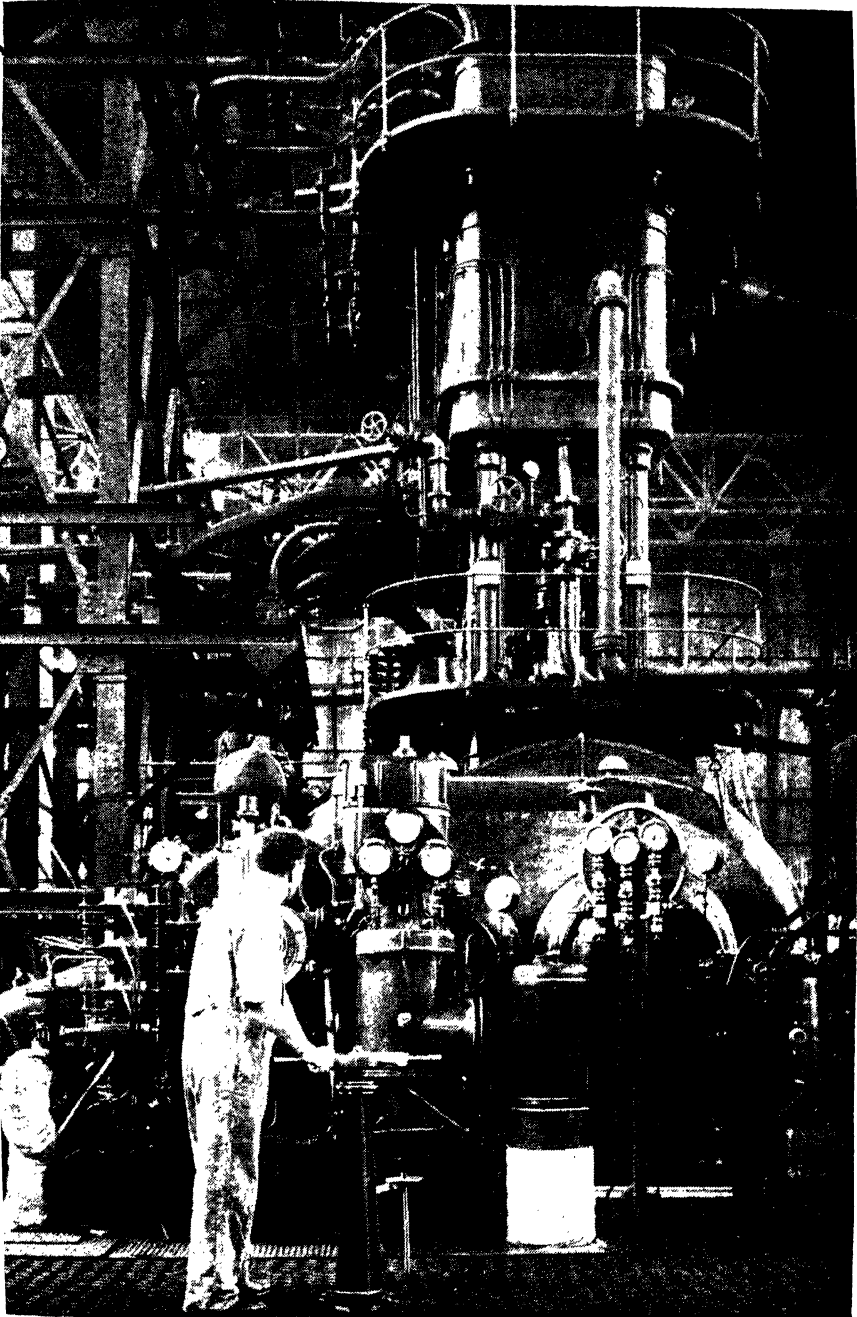

[Courtesy I.C.I.]

A GIANT GAS COMPRESSOR

This enormous plant is used for compressing gas to 250 times the pressure of the atmosphere - i.e. to 3750 lbs. per sq. inch - in connection with ammonia manufacture. Ammonia is formed by certain bacterial decompositions, and is mainly obtained nowadays by compressing the gases hydrogen and nitrogen together until they liquefy.

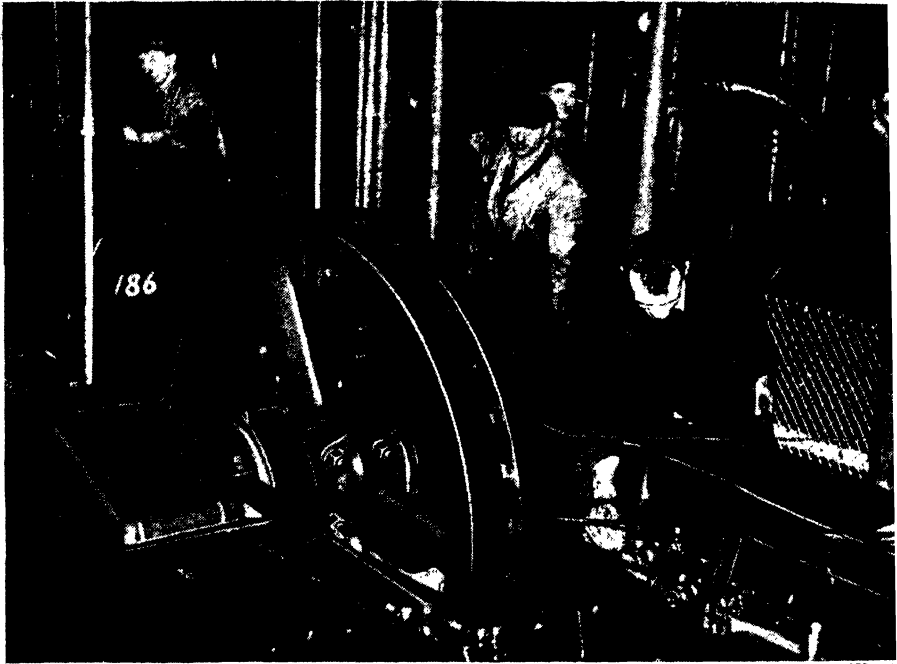

AN AIR COMPRESSOR

[Kevst]

Compressed-air engines are a well-known form of power, but an equally important form of compressed air is to raise sunken ships in salvage work. This picture shows one of the largest compressors ever carried on a ship, which is one of four on board the chief vessel employed to raise the German Fleet at Scapa Flow

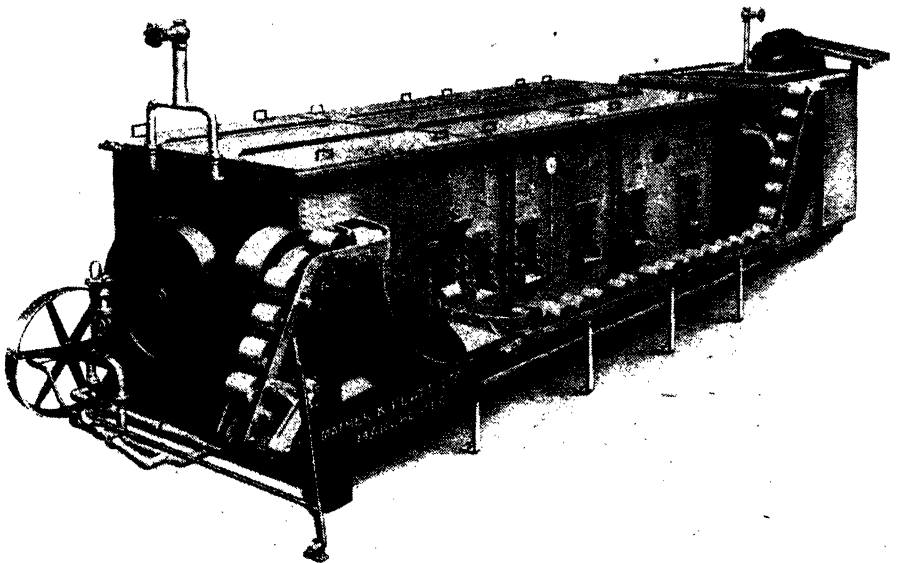

COOKING BY MACHINERY

[Cartlew & Kinnu]

This shows a machine for the partial cooking of foods necessary in the canning industry. The usual process is to put the unsealed cans on an endless belt through a shallow bath of hot water, to lid them automatically on the other side, and then to put them through a cooler. The cooler is at the far end of this picture



Dorothy Leigh

"THE HAY WAIN", BY JOHN CONSTABLE

One of the most celebrated of Constable's landscapes. The artist (1776-1837), born in Suffolk, was the son of a mill-owner, and began his painting in his schooldays. He was elected an R.A. in 1819, and two years later "The Hay Wain" gained him a gold medal at the Paris Salon. Much of his later life was spent in London and his death was due mainly to grief at the loss of his young wife, whom he had married in 1816 only after some of his...



(Dorien Leitch)

"MERCURY, CUPID, AND VENUS", BY CORREGGIO

Antonio Allegri da Correggio (1494-1534) was born in Correggio, near Modena. Despite his immense fame as an artist, next to nothing is known of his life. His painting is renowned for its soft merging of colours, and for his depiction of children. An alternative title to the above picture, which is in the National Gallery, London, is "Mercury teaching Cupid to read".



Dorien Leigh

COCHEM CASTLE

Standing on an isolated hill whose symmetry the hand of man could hardly have improved, Cochem is one of the most striking of the Rhineland castles. It is a few miles from Coblenz, and dominates the beautiful valley of the Moselle, an impressive monument to history, a delight to the eye



[From "Picturesque Europe"]

CORFU: THE ACHILLEION

On the beautiful island of Corfu, near the western shore of Greece, stands the Achilleion, a magnificent palace which once belonged to Kaiser William II. Most striking of all are the grounds, in which terraces and graceful statuary abound—the more effectively for the loneliness of the setting



[Photochrom]

THE MESQUITA, CORDOVA

Originally the largest mosque in the world, the Mesquita became Cordova Cathedral at the reconquest. It is often said that the forest of pillars is bizarre rather than beautiful; but this is partly due to Catholic vandalism, which has not only built walls where before daylight streamed in, but has raised the floor to hide the pillar-bases and destroy the whole proportion

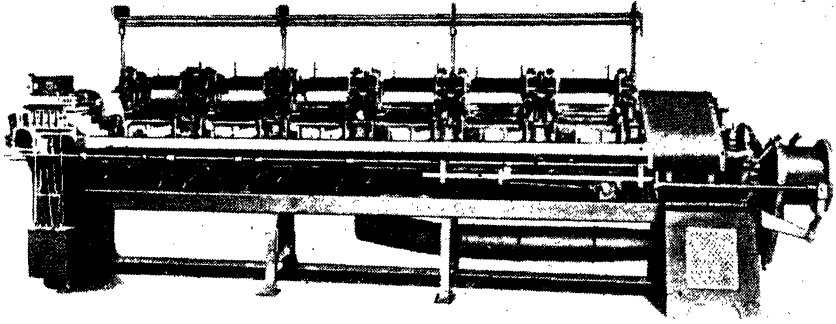

[Carthew & Kinnaird]

COMBING MACHINE

Combing, in worsted manufacture, is the chief process in the production of a worsted "top". The wool fibres, already carded, are straightened out by the machine and arranged in parallel order, or cast out altogether if they are too short. There are four types of comber; the one shown above is the latest

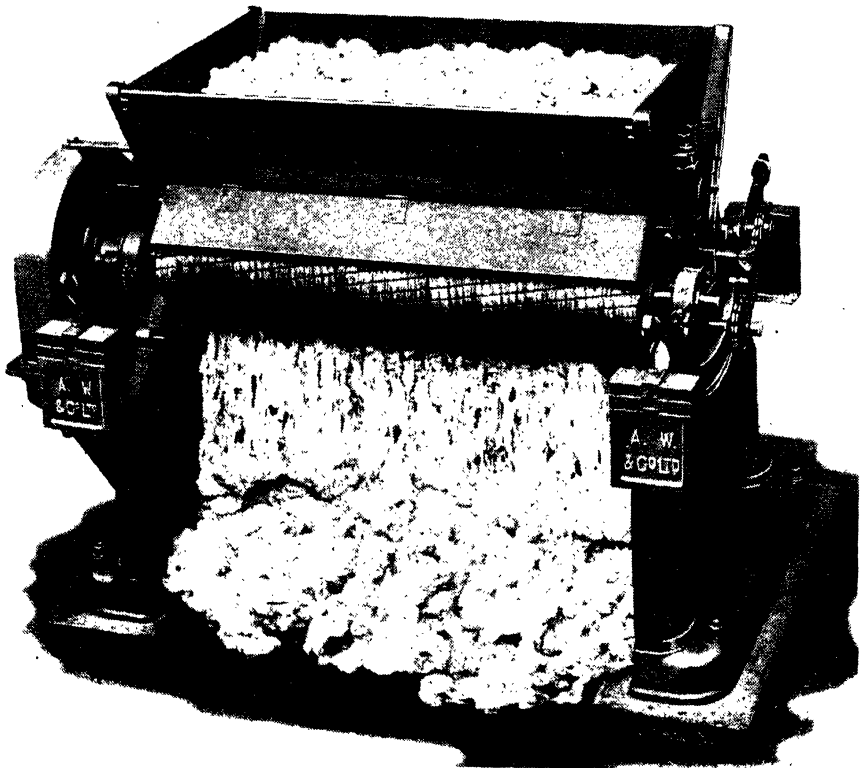

[Carthew & Kinnaird]

A COTTON GIN

The word "gin" usually means a hoisting machine in which mechanical aids human labour, but as applied to the cotton industry it signifies a machine for separating cotton fibres from the seed to which they are attached when grown. There are many types, as it was found that those which act best on American cotton do not do so on Egyptian, and *vice versa*

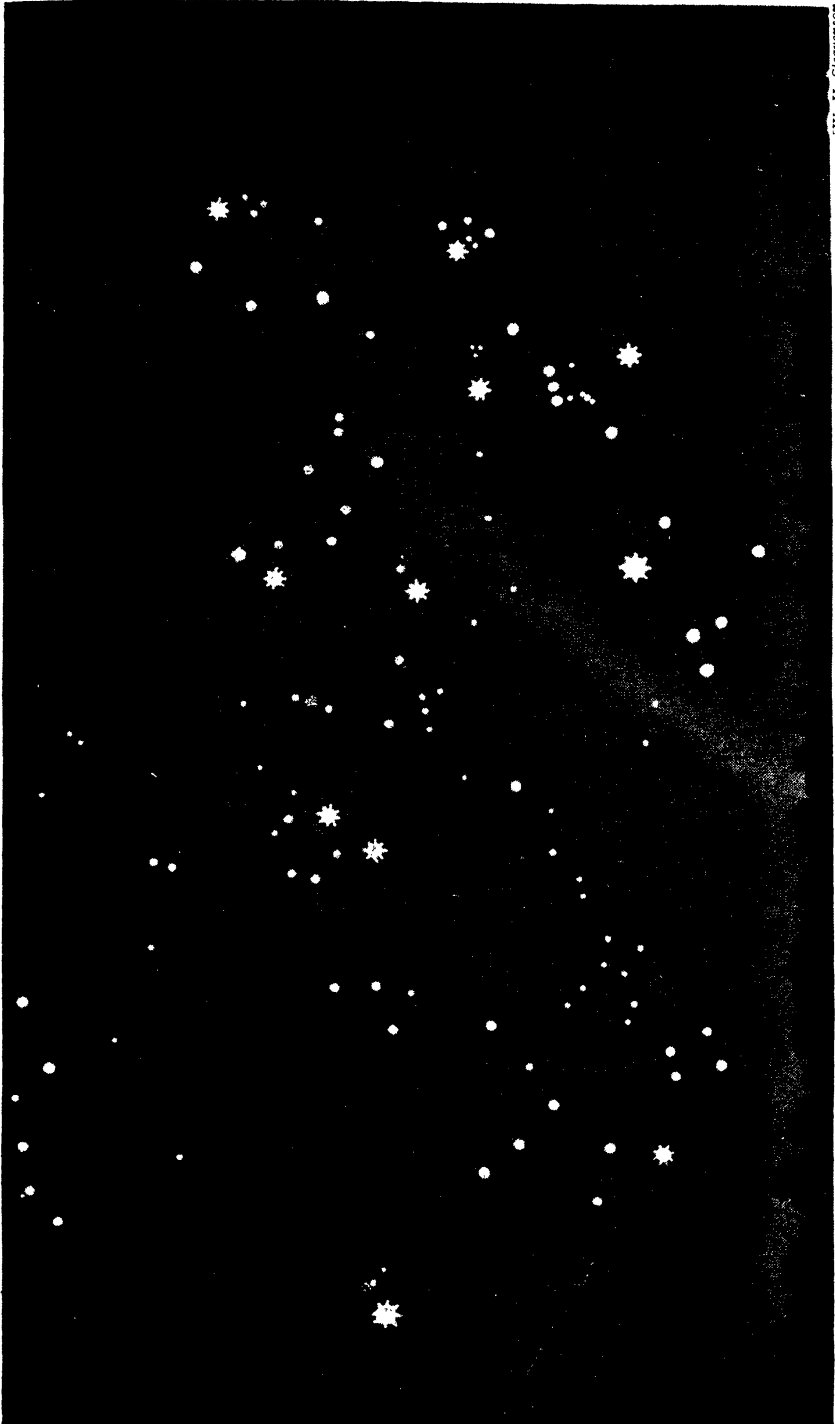

W. H. Stevenson

COUNTER-GLOW

The large, rainbow-shaped patch of light is the Zodiacal Light : the Counter-Glow is the small oval patch almost in the centre of the picture The two are thought to be connected but at

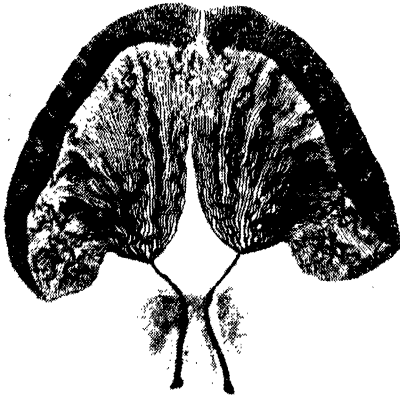

A CRICKET'S TONGUE

Strangely enough, it is not known in what manner a Cricket uses its tongue. Seen here, highly magnified, the organ is a fan-like structure of the suctional tubes such as are found on the proboscis of blow-flies and other sucking insect.

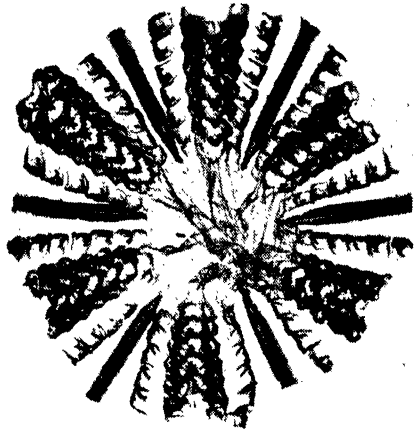

A CRICKET'S GIZZARD

The gizzard is an insect's equivalent for our biting and masticating organs. It consists of a bag-like organ surrounded by powerful horn teeth which grind and break down the food before it is passed to the stomach. Much magnified.

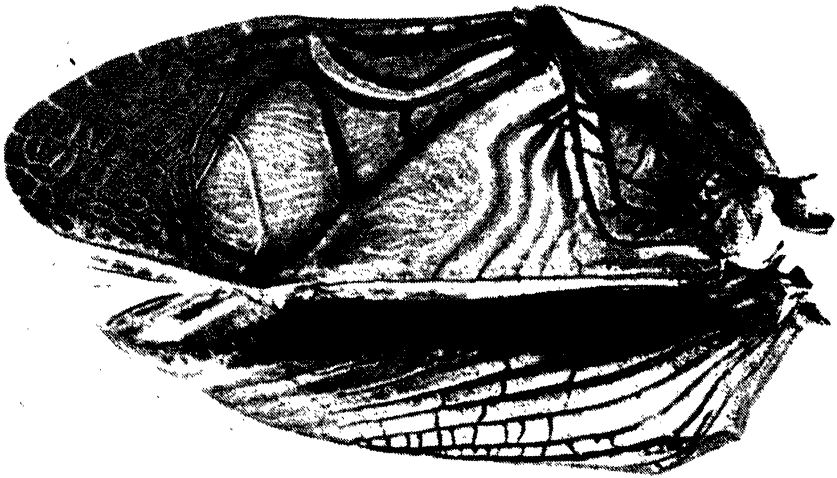

All by courtesy

THE CRICKET'S DRUM

["Marvels of the Universe"]

It is the friction of the "bow" on the drum that produces the cricket's well-known chirping. In this enlarged photograph of the insect's side the drum is visible as a light patch to the left of the wing-case. It is literally a drum, for it consists of an area of tense membrane over a hollow.



[*Dorien Leigh*]

CRANACH THE ELDER'S "MADONNA WITH THE GRAPES"

There were two Lucas Cranachs, father and son, the latter the devoted helper of the former. So much are the works in resemblance that sometimes it is very hard to tell by which a certain painting may be. The family name was really Sunder, the elder artist being born at Cranach, Bavaria, in 1472. Most of his work was done at the Wittenberg Electoral Palace, and he was an intimate friend of both Luther and Melancthon. He died in 1553.



[Arthur Twiddle

AN AUSTRALIAN CYCLONE

Properly this should be called a cyclonic storm, a cyclone being simply an area of low-pressure in meteorology. The cyclone, in the sense of a tempest, is closely allied to the tornado (the terms being interchangeable in some parts), and is one of the most destructive weather phenomena known



THE CATHEDRAL OF CURTEA D'ARGESH

[Dorrien Le

Curtea d'Argesh is now an unimportant Roumanian village, but at one time it was the capital of Wallachia. The gorgeous cathedral has been called the Eighth Wonder of the World; outside it is of white and gold, and the interior is rich with mosaics, marble monuments, paintings, wood-carving and gilding.



MEDIEVAL CARVING IN DANZIG

[Danziger 1

This picture has been chosen as typical of medieval wood-carving, which reached an especially high and elaborate standard in the great Hansa towns. Danzig alone abounds in such excellent work as the above oaken staircase, the balustrade of which represents the artist of the Middle Ages at his best.



[Keystone

THE DAVIS ESCAPE APPARATUS

Until long after the Great War there was no device at all by which men trapped in a submarine which had failed to rise could with reasonable safety reach the surface. The Davis apparatus enables a man not only to rise easily to the surface but, if need be, to breathe for two hours under water. The picture shows a demonstration tank

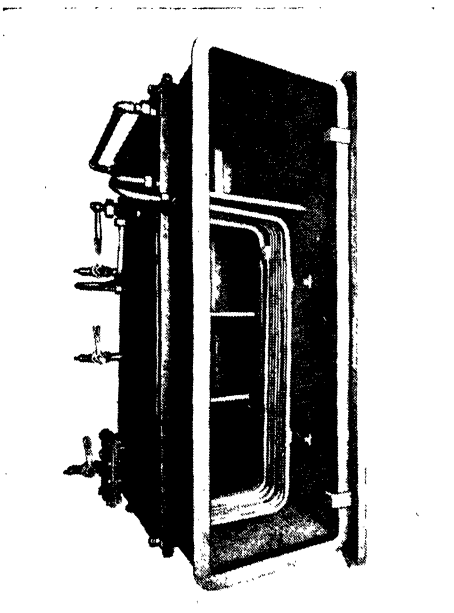

[Courtesy I.C.I.]

A DE-GREASER

Engineering parts which are steeped in thick lubricant need at times some special form of bath. The bath shown instantly removes by means of chemicals all grease or dirt, solid or liquid, from any type of metal, leaving the metal unharmed



[Courtesy International Combustion, Ltd.]

A DE-SLIMER

An apparatus used in the mining industry for the surface treatment of ores. With many types of ore it is necessary to extract as much moisture as possible before baking in the furnace. In mining, the term "ore" is applied only to minerals containing combined metals

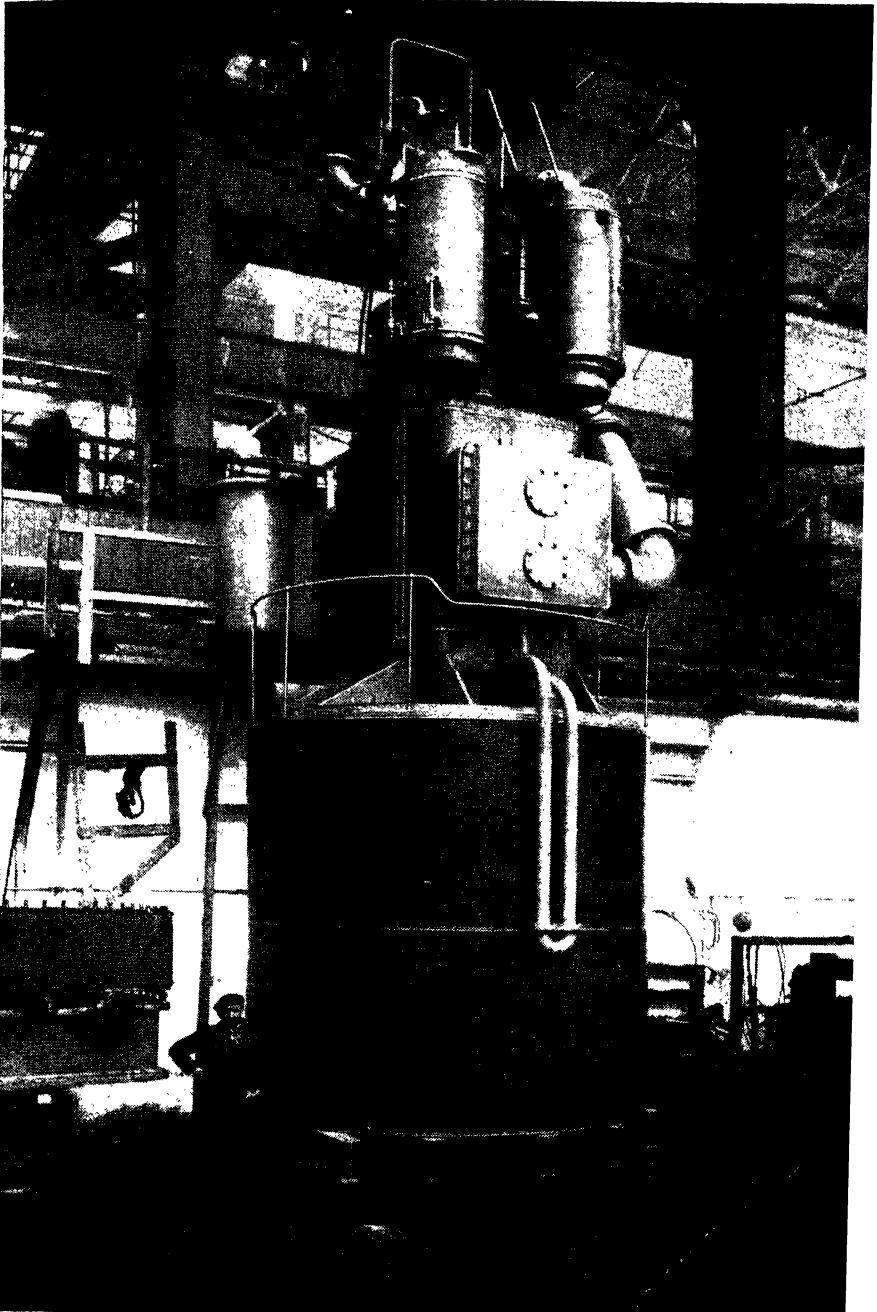

A LARGE DE-AERATOR

[Courtesy Vicker

This appliance is symbolical of the high standard demanded everywhere in modern engineering, for its sole purpose is to remove dissolved air from boiler-feed water to enhance the boiler's efficiency. The general principle involves heating of water at low pressure, increase of temperature and reduction of pressure both assisting in the liberation of the dissolved air. The low pressure is maintained by extracting the freed air through an ejector.

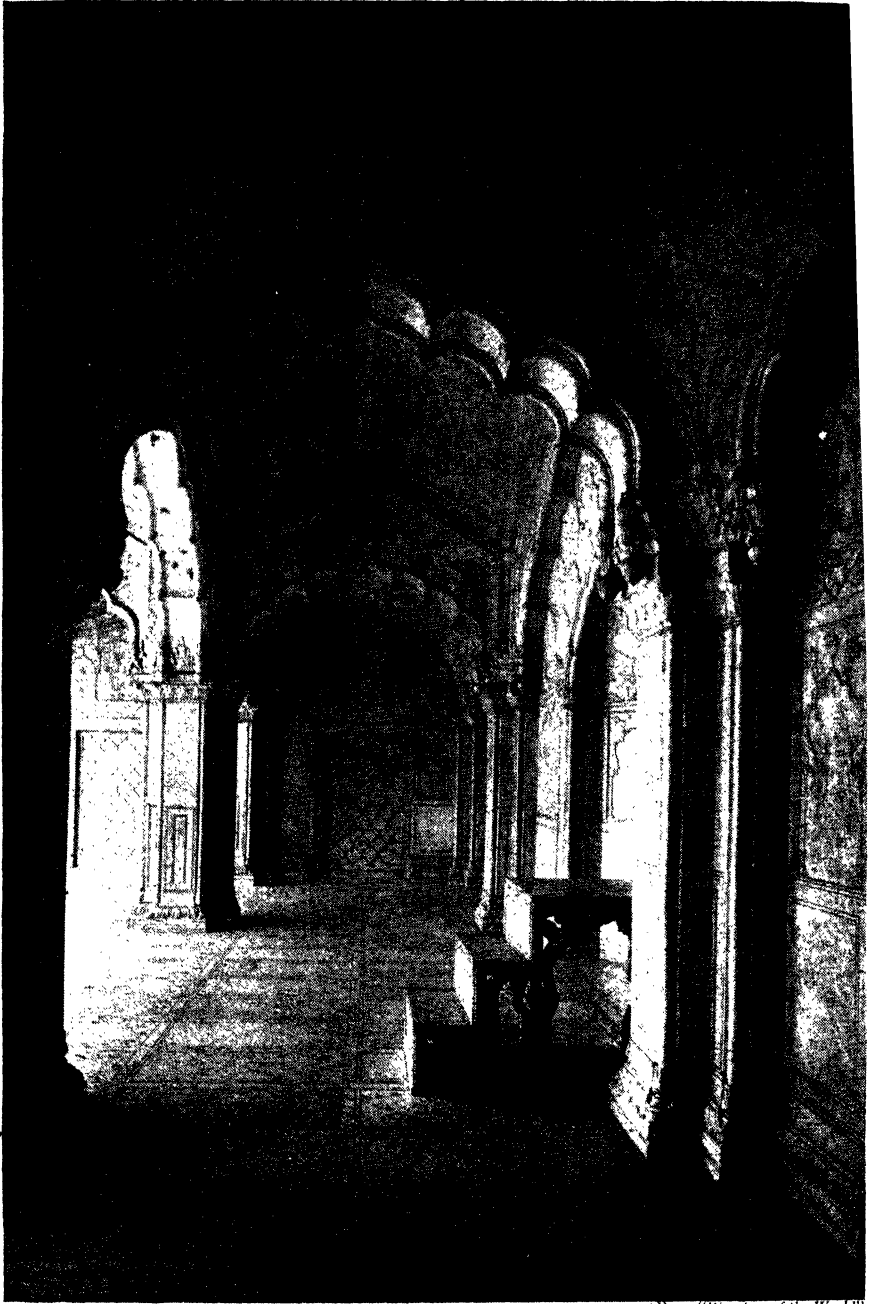

[From "Wonders of the World"]

THE PEARL MOSQUE, DELHI

This delightful little private mosque was built by Aurungzeb, son of that Shah Jehan who erected the Taj Mahal at Agra. The decorations, in their restraint, are more effective than many of India's vastly elaborate monuments. The mosque is built throughout of white marble

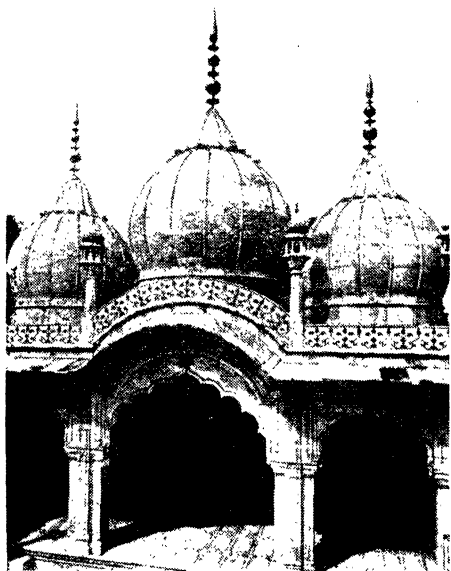

[Carthew & Kinnaird]

EXTERIOR OF THE PEARL MOSQUE

Aurangzeb's little mosque at Delhi is as beautiful without as within. Though only sixty feet square, it is perfectly proportioned, and has all the dignity of a much larger building. It is a fine example of the inspiration afforded by a great religion.

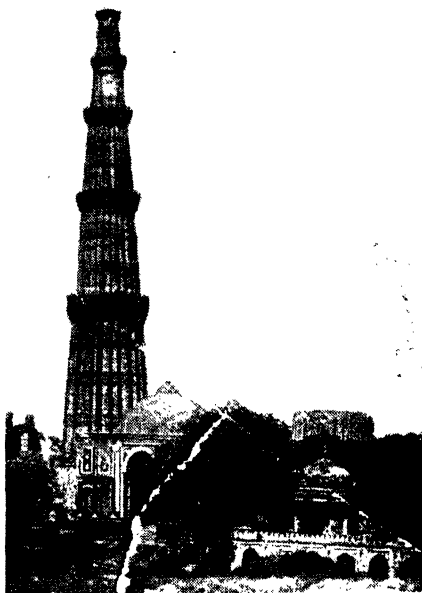

[Carthew & Kinnaird]

DELHI: THE KUTAB MINAR

The great Victory Tower, known as the Kutab Minar rises perfect amid ancient ruins eleven miles south modern Delhi. It was begun in the year 1200, and gradually attained a height of 238 feet. Texts from the Koran encircle it.



[By courtesy]



[“Wonders of the World”]

THE DIWAN-I-KHAS, DELHI

Above some of the arches in the Diwan-i-Khas the words are written “Here is Heaven on Earth”. Never has a superlative expression been less exaggerated. The Audience Chamber is made of white, translucent alabaster inlaid with gems. On the left is a magnificent screen which is of alabaster also.



KeyStone

NEW DELHI

A fine aerial view of the grounds- and chief buildings of the new city. In the foreground is the magnificent approach with its avenues of trees and elongated lakes. To the right is the famous circular Council Chamber designed by Sir Herbert Baker, R.A. New Delhi is still little more than half finished. Sir Edwin Lutyens, R.A., is the other architect responsible for the layout; the site was chosen by King George V in 1911.

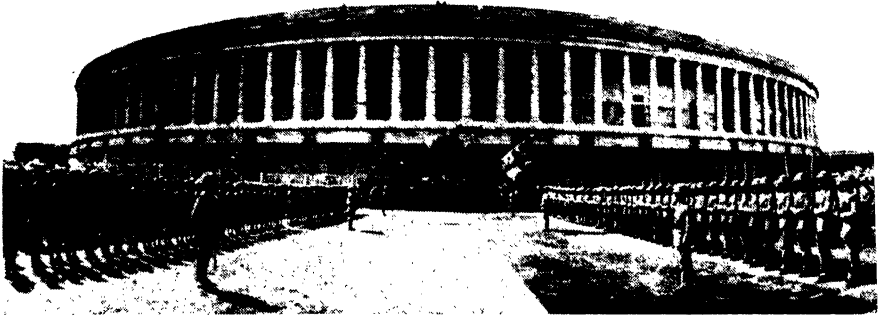

NEW DELHI: THE PARLIAMENT HOUSE

[Kevston

The photograph shows a military review in progress outside the imposing circular building. All the buildings of New Delhi are built of red and white sandstone, quarried locally. There are more than eighty columns round the Parliament House



THE DANCING BOYS: BY LUCA DELLA ROBBIA

[Dorien Leigh

Della Robbia (1399-1482), like so many artists of his time, was brought up as a goldsmith, but early turned to sculpture. He is best known for his works in enamelled terra-cotta and for his bas-reliefs in the cathedral of Florence. A valuable collection of his terra-cotta works is now in the Victoria and Albert Museum, London



[Dorion Leigh]
A CHILD-STUDY BY A. DELLA ROBBIA
 Andrea Della Robbia, nephew of Luca, greatly fostered

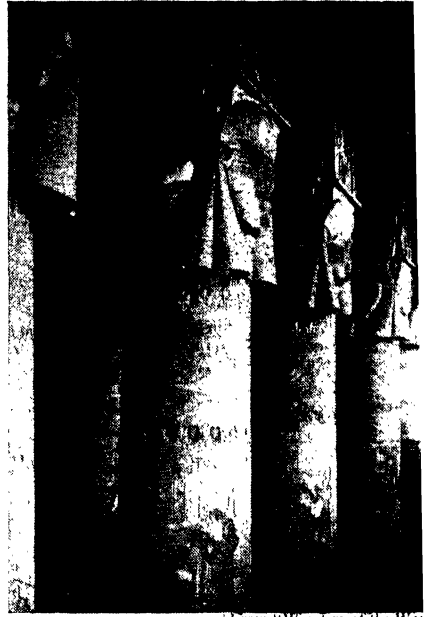

[From "Wonders of the World"]
DENDERA: THE GREAT COLUMNS
 At Dendera stand the remains of one of the principal temples in Egypt of the goddess Hathor. The massive pillars here illustrated are in the form of totems. They are brilliantly painted.

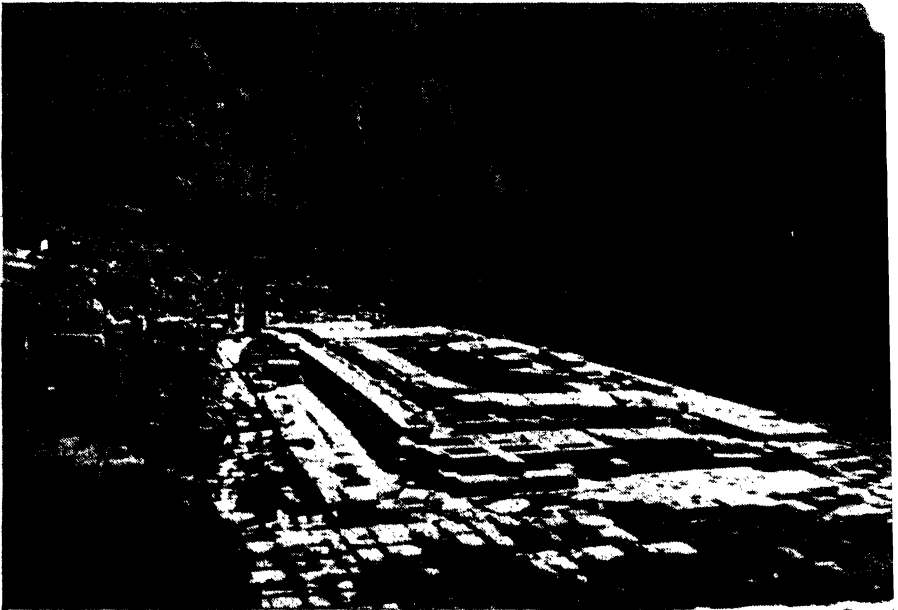

THE RUINS OF DELPHI *[From "Picturesque Europe"]*
 The Delphic Oracle was consulted in ancient times by many barbarians as well as the Greeks, and its responses carried great weight. This weight, however, was mainly due to their remarkable ambiguity, which enabled the priestess Pythia who "worked" the oracle, to prove her prophecies right either way. The picture shows what was formerly the precinct Temple of Apollo in Greece.



THE DEAD SEA

[American Colony at Jerusalem]

This salt lake between Palestine and Transjordan receives the waters of no less than seven rivers, including the Jordan yet it has no outlet and does not overflow! The secret lies in the intense salty evaporation. No fish can live in the lake nor does the body of a man sink. The surrounding neighbourhood, however, is healthy.



HOW DESERTS ARE MADE

[Valentine & Sons]

The picture gives a striking illustration of the immense power of sand. The bleak Scottish waste now known as Culbir Sands was but a few centuries ago famed as the Garden of Moray, a fertile 3,600-acre pleasure. Mediaeval relics are constantly being dug up to prove the former habitability of the now useless desert.



(A. Trindle)

A MONSTER OF THE DEEP SEA

Sarrophagus flagellum is the Latin name of this fish. Its entire length is over six feet. This is one of the many monsters living out their lives in eternal darkness, at huge pressures, and below zero temperatures, of which few types are still known.



[Carthew & Kinnaird]

THE FACE OF A DEVIL FISH

The Devil Fish is an inhabitant of Australian waters. Weighing from 1 to 2 tons, black in colour, and flat in shape like a skate, it has a whip-like tail possessed of tremendous strength.



THE DEVIL'S HORN

This terrible African seed pod lies in the grass with its curved upward. Grazing animals catch it in their mouths which makes them career madly about, thus scattering seeds from the half-opened case.

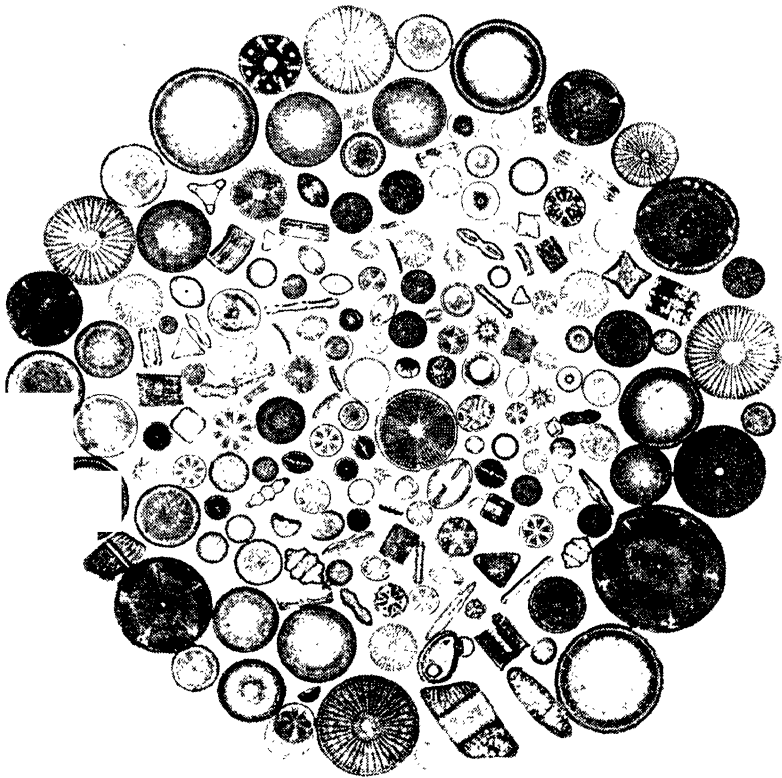

DIATOMS

What at first glance appears a collection of tiny shell-fish, is in reality a group of minute plants of the seaweed family magnified here thirty times. Their plant matter is built around a hard, flinty base, which is impervious to flame. Each diatom is of complex and perfectly symmetrical construction.

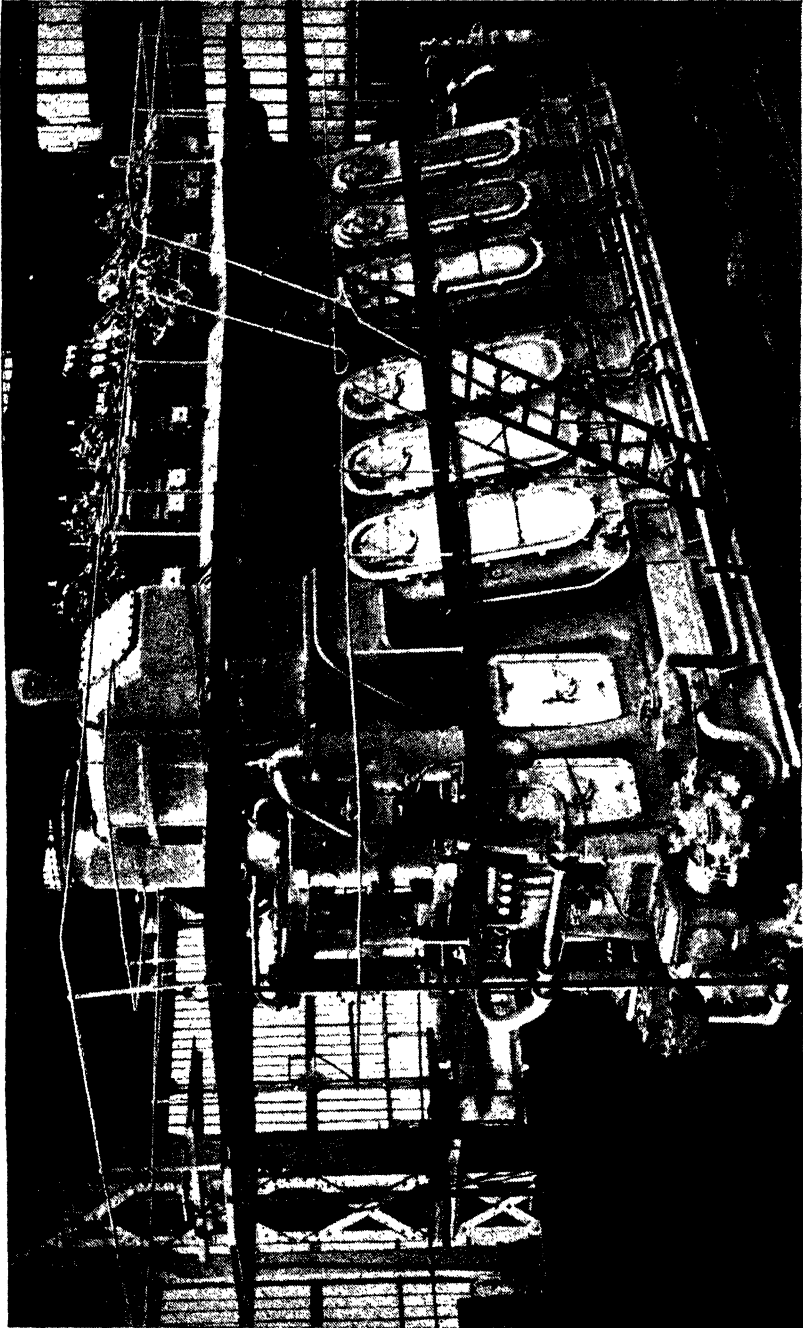

Carlier & Ammaud

A MARINE DIESEL ENGINE

The essential difference between a Diesel and an ordinary internal combustion engine is that the former, instead of drawing the fuel into the cylinder during the suction stroke as a mixture of gas and air, injects the fuel separately at the end of the compression stroke. The advantage of Diesel is that

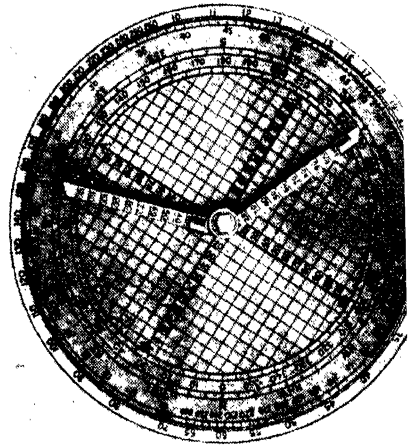
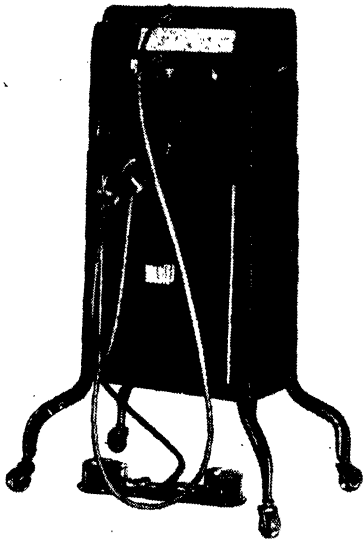

Carthew & Kinnaid]

THE DICTAPHONE

The standard dictaphone for recording speech is well known.

COURSE AND DISTANCE

Officially called the Vector Compass.

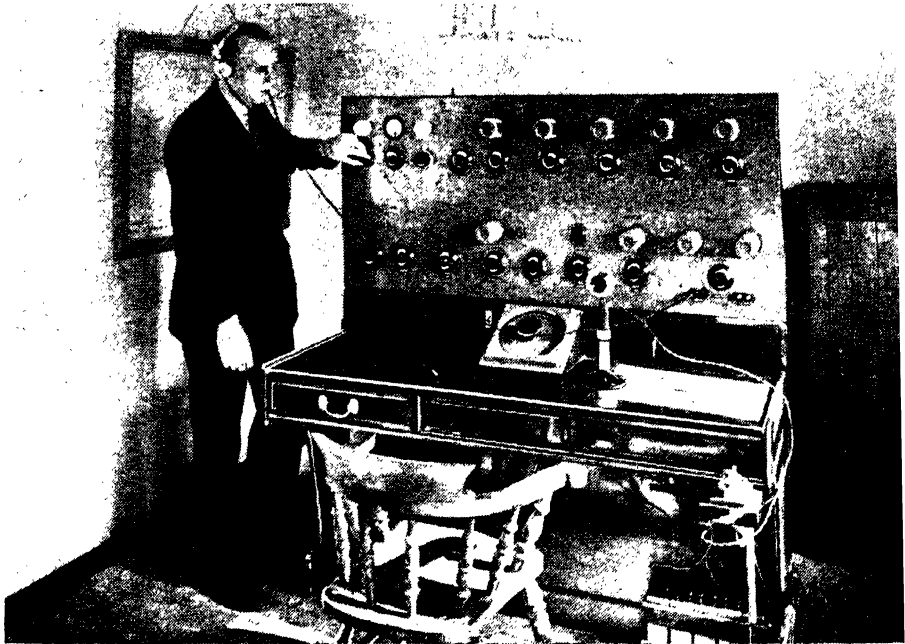

DIRECTION FINDING BY WIRELESS

[Marconi L]

More than eight types of wireless direction-finders, ranging from a simple frame aerial to a cathode-ray type, is almost universally employed nowadays for guiding aircraft, and very largely for ships. The apparatus is based on the principle of vertical aeri- als rotating about a centre, and is set up at an Air Ministry ground station.

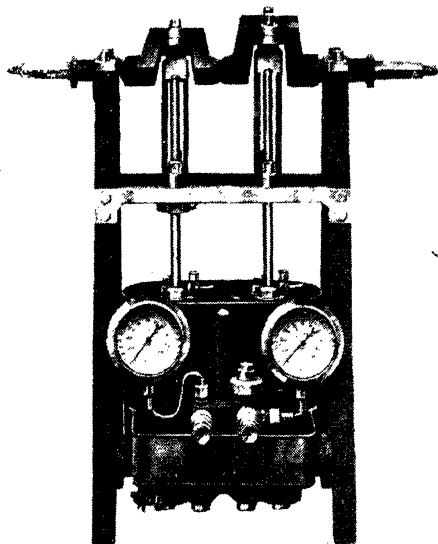

Courtesy

DIVING APPARATUS

Beside the appliances actually worn by the diver it is necessary to have an ultra reliable apparatus at the surface for pumping down air. Above is shown an air pump of the type used by the British Admiralty.

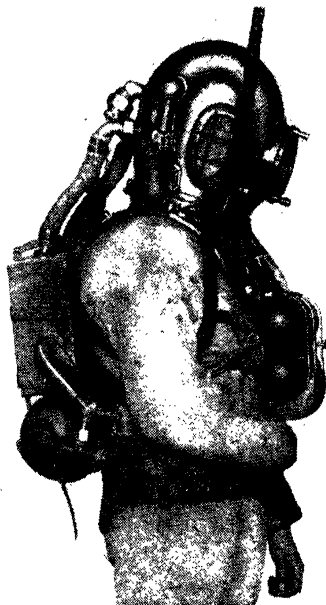

[Sicbe Gorman & Co

A MODERN DIVER

This diving-suit differs from most in that it is entirely self-contained except for the rope which pulls the diver up. Oxygen is carried, and also an apparatus for regenerating the breathed air.

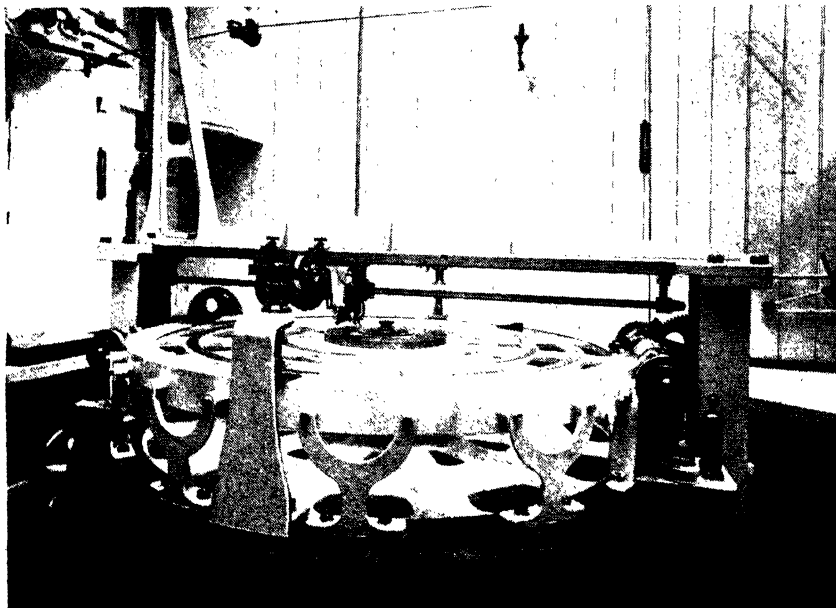

[Carline & Smith]

THE DIVIDING ENGINE

An instrument for marking the divisions on accurate scales, e.g. in the making of mathematical instruments. The scale is supported on a movable carriage, and the marker is fixed above it on the dividing head which controls the tool when it makes a mark. The dividing engine is sufficiently accurate to make rulings $1/1000$ th of a millimetre apart.

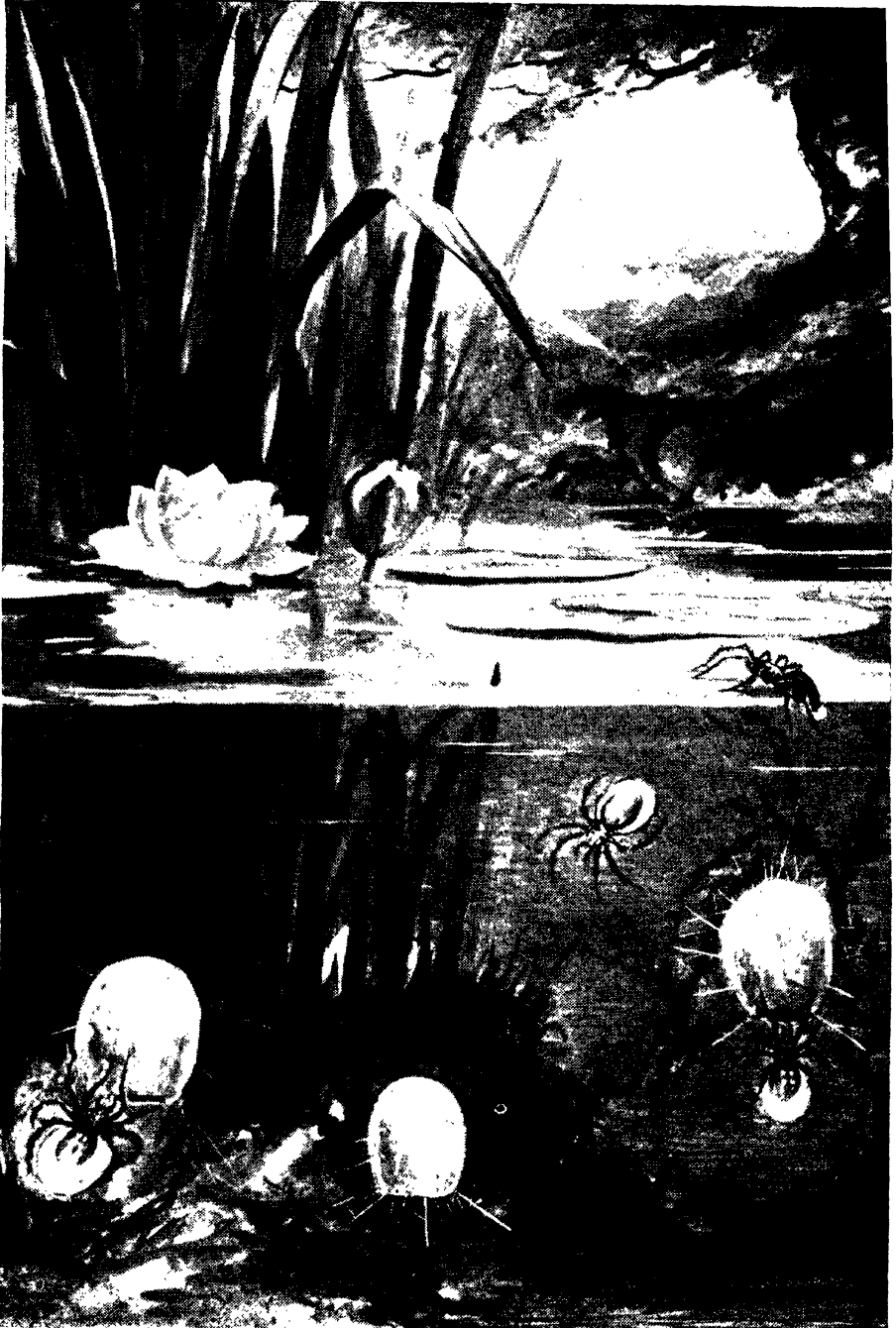

By courtesy[

DIVING-BELL SPIDERS

["Marvels of Insect Life"]

A scene below the waters of a quiet pool. The finished water-spider's nest consists of an inverted cup from which water is excluded by the pressure of air. This cup is finely spun by the spider, and moored securely by threads. Then, to fill it with air, the spider makes repeated journeys to the surface; the rough hairs on her body are such that each time she dives a bubble is carried down and this she puts in the nest.



THE DIGGER WASP

[*"Marvels of Insect Life"*

When this large and fierce wasp desires to lay eggs she first stings a cicada. Carrying this, as shown, to the underground cell which she has dug, she lays on it a single egg. When this egg hatches, the grub has the cicada to feed on. This is happening in the centre of the illustration: in the lower part, the grub is enclosing itself in a cocoon prior to becoming a chrysalis.



A DINOSAUR'S NEST

(Carnew & Kinnaird)

Dinosaurs were a class of reptiles of the Mesozoic Age; sometimes their size would be as much as 10 feet tall and 80 ft long. For many years it was uncertain how these creatures reproduced, but shortly after the War an expedition to the Gobi Desert found a nest of eggs which were indisputably Dinosaurs'. This photograph shows the nest and eggs near intact after 100,000 years!

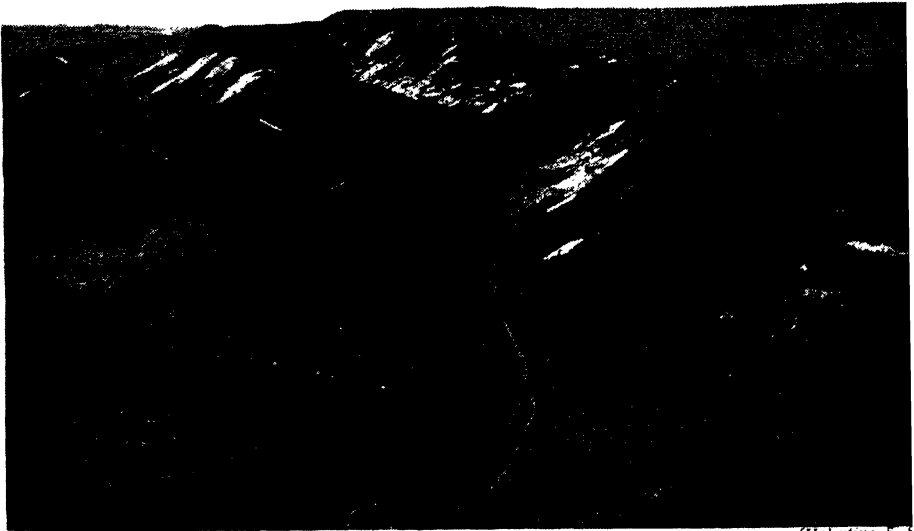

MAIDEN CASTLE, DORCHESTER

(Valentine & S)

Two miles from Dorchester, on the top of Fordington Hill, stands one of the finest prehistoric fortresses in Britain. Maiden Castle is more than a mile in circumference, and on one side the defence lines number no less than eight. No one knows who built the fort, for it was of venerable age even when the Romans found it.

SIRIUS'S
ORBIT ↘

COMPANION
ORBIT ↘

EARTH'S ORBIT
○
ON SAME SCALE

DOUBLE STARS

[From "Splendour of the I

One of the strangest phenomena of the heavens is the manner in which stars sometimes "work" in pairs, generally a big star with a little one. Sirius, one of the brightest lights in the sky, has a small companion whose existence was not discovered until 1862. The diagram shows their respective orbits. The cross marks the centre of gravity of the dual system.

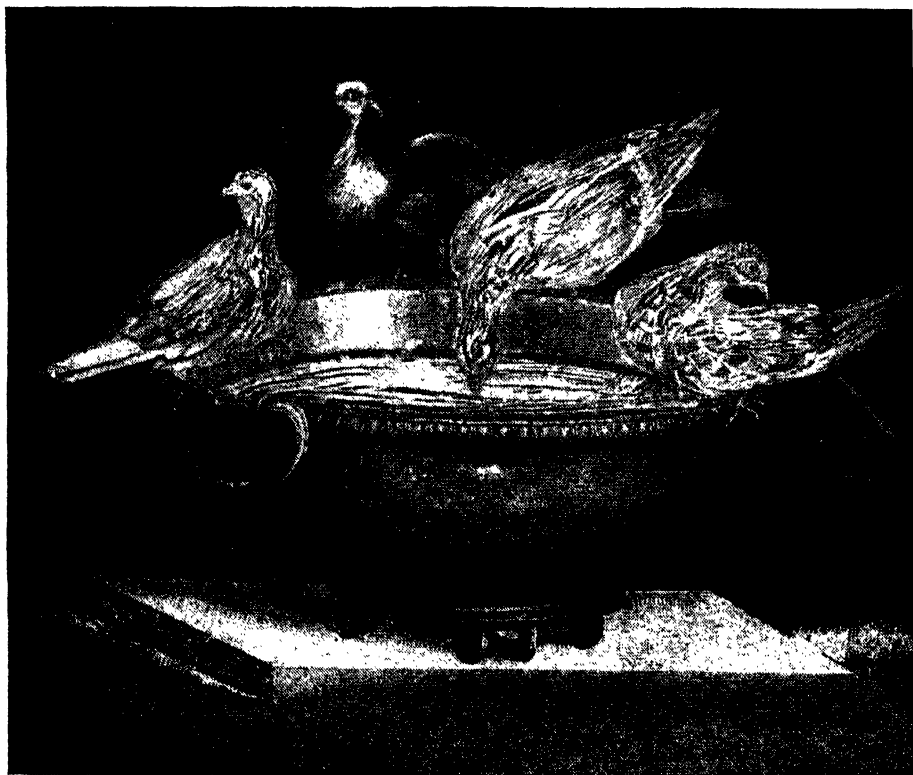

THE MOSAIC OF THE DOVES

[Dorien Leigh

One of the most remarkable mosaics ever known, this exquisite piece of work was discovered in Hadrian's Villa, and is now in the Capitoline Museum. There is none of the stiffness about the birds which characterizes the Byzantine works, and it is reported that to gain this free effect the artists used no less than 160 pieces of stone to the square inch.



[Dorien Leigh

THE LAST COMMUNION OF ST. JEROME: BY DOMENICHINO

Domenico Zampieri Domenichino (1581-1641) belonged to the Bolognese school, and ranks as one of the finest painters of frescoes. His fame aroused fierce jealousy amongst his rivals, and it is believed that his death, which occurred in Naples, was due to poisoning by one of them. The above is his most famous work

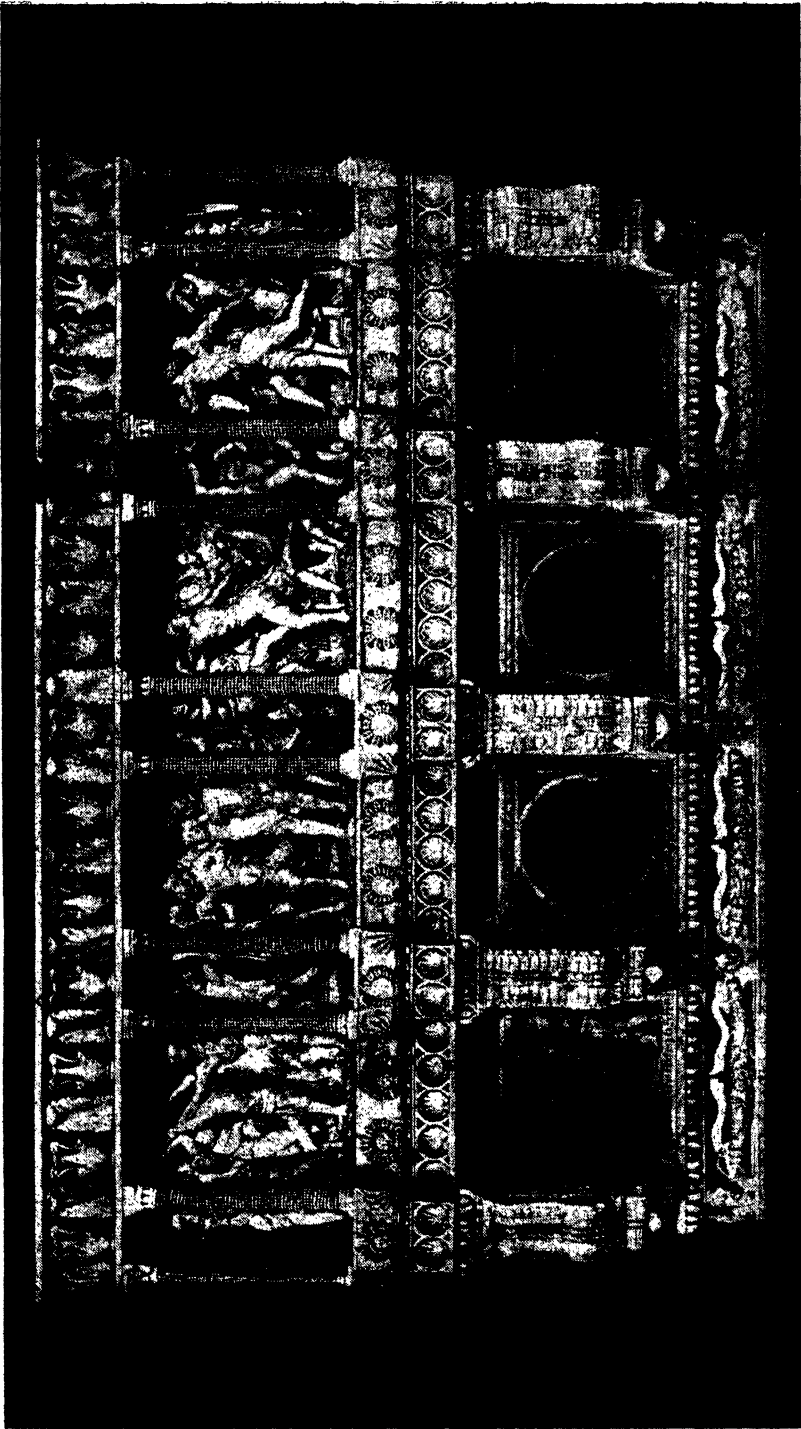

Dorinda Leigh

CANTORIA : BY DONATELLO

Like many Renaissance artists, the famous sculptor Donatello was in early life a goldsmith. He was born in Florence in 1386, and after studying in Rome, returned to his birthplace to begin a dazzling series of works in marble and bronze.

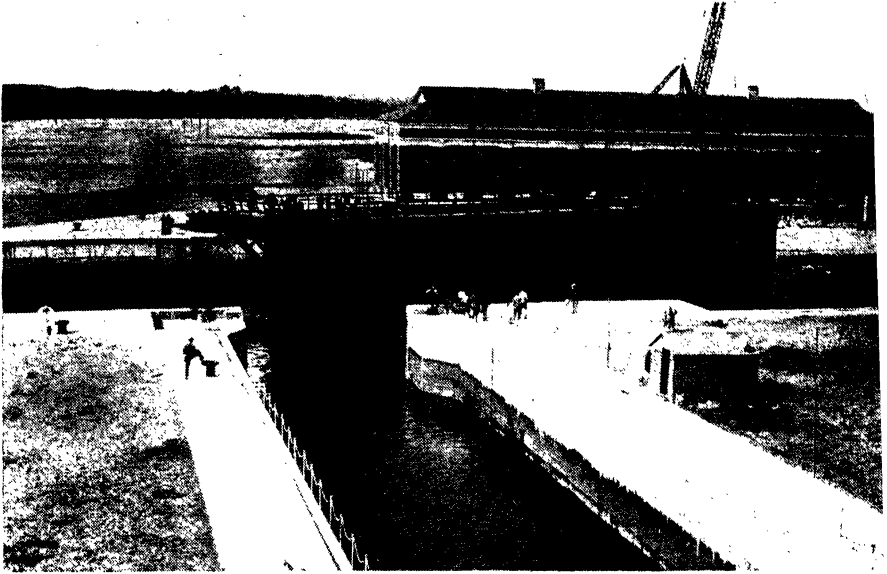

THE GATE OF A DOCK AT SOUTHAMPTON

[Keysto

Southampton is the third busiest port in the United Kingdom, and its docks probably surpass those of its rivals, London and Liverpool. Docks large enough to take the biggest liners necessitate enormous gates to stand the pressure of water. The above picture of a new gate being floated to its place gives some idea of the actual size.

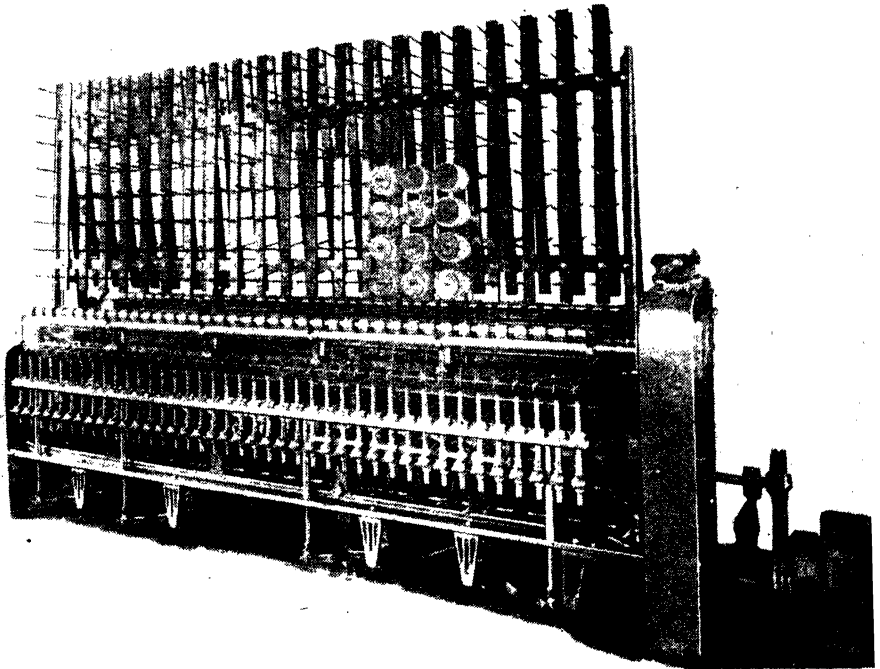

A RING DOUBLING FRAME

[Carthw & Kinnaird

A machine used in the manufacture of worsted, its purpose being to fold or twist together yarns. The materials to be twisted are wound in bobbins, which are placed on the rack at the top of the frame, and the threads are then drawn through the twisting mechanism on to the spindles near the base. Twelve bobbins are here shown in position.



Courtesy G.E.C.]

WORKING AN ELECTRIC DRILL.

The power to drill holes in hard metals with less effort than it takes to bore wood with a gimlet is one of the greatest assets of modern engineering, and a valuable time-saver. For small work, especially inside buildings, the electric drill is preferable to the pneumatic and other types.



Courtesy I.C.I.

"DRY ICE"

This is the name given to solid carbon dioxide, one of the coldest refrigerating mediums known. It is extensively used in America, even for household purposes, but the above English picture shows it put to the novel use of shrinking brass. Its temperature in ordinary air is -78° centigrad.

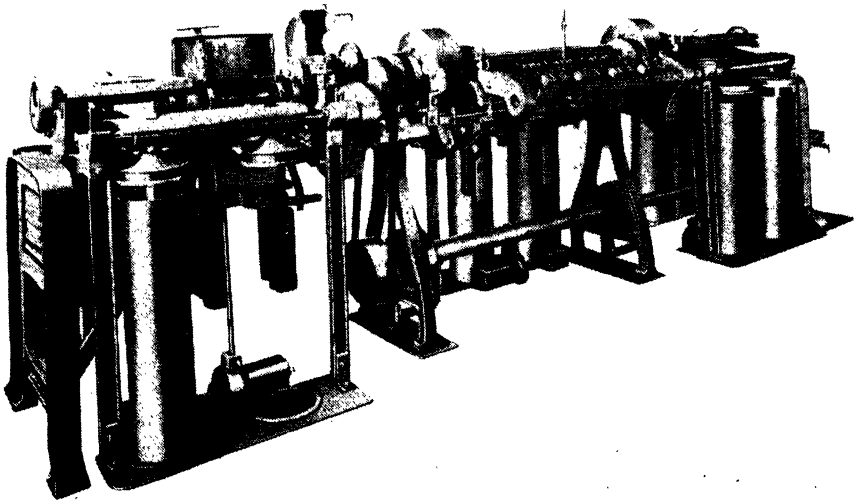

A DRAWING FRAME

[Carthew & Kinnaird

Drawing, in cotton manufacture, is the fourth of the five to seven processes involved. Its object is to make the carded fibres parallel and to even out their weight. The drawing frame does its work by several pairs of rollers revolving at different speeds, which "iron out" the fibres.

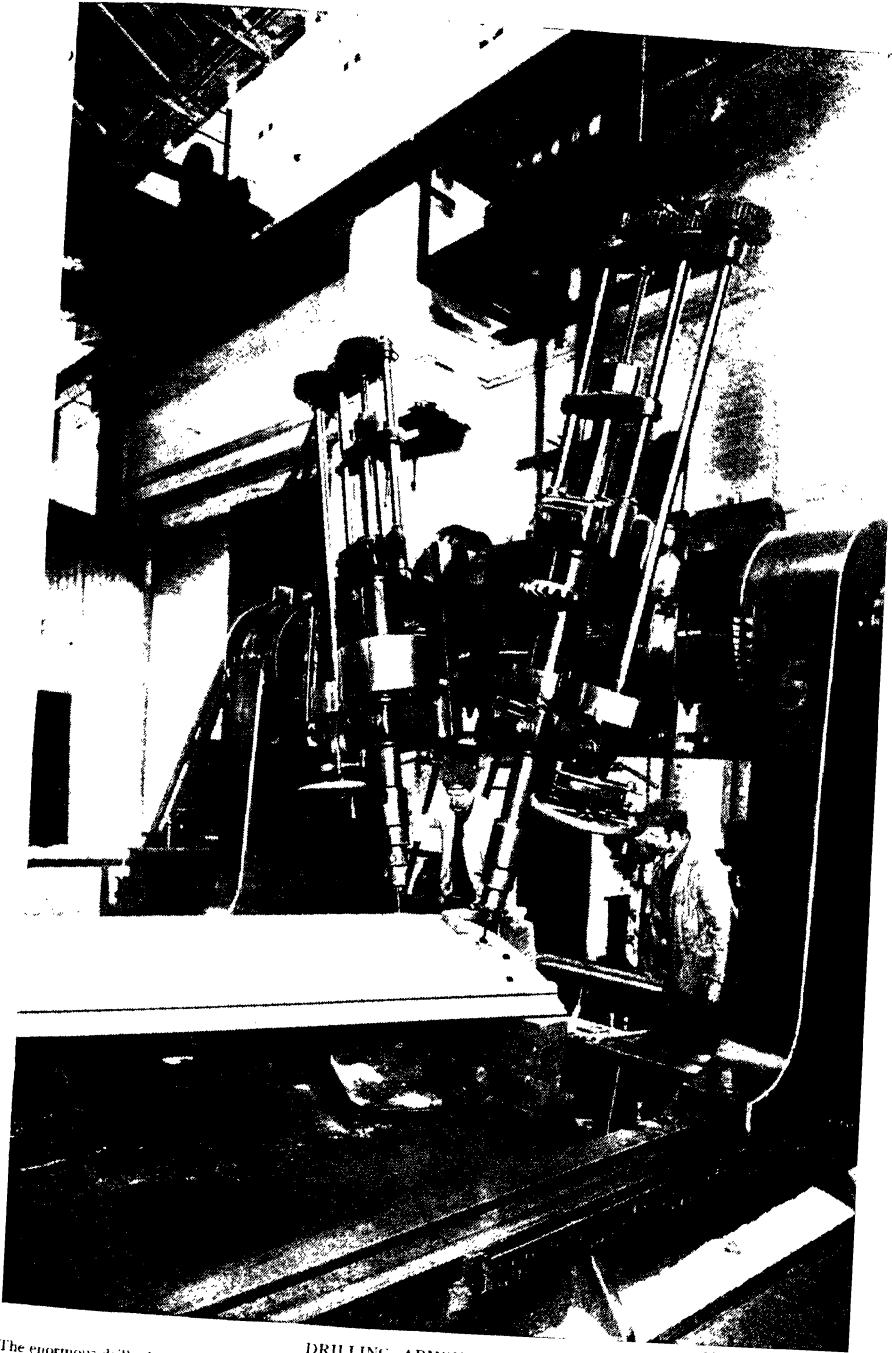

DRILLING ARMOUR PLATE

(Carthew & Kinnaird)

The enormous drills shown in this picture should be contrasted with the small hand-drill on page 174. The armour plate of the kind used in battleship construction is several inches thick, and extremely hard. The drills used are again electric, and are so adjusted that they may be moved from the perpendicular to bore curved surfaces at an angle as they are doing here.

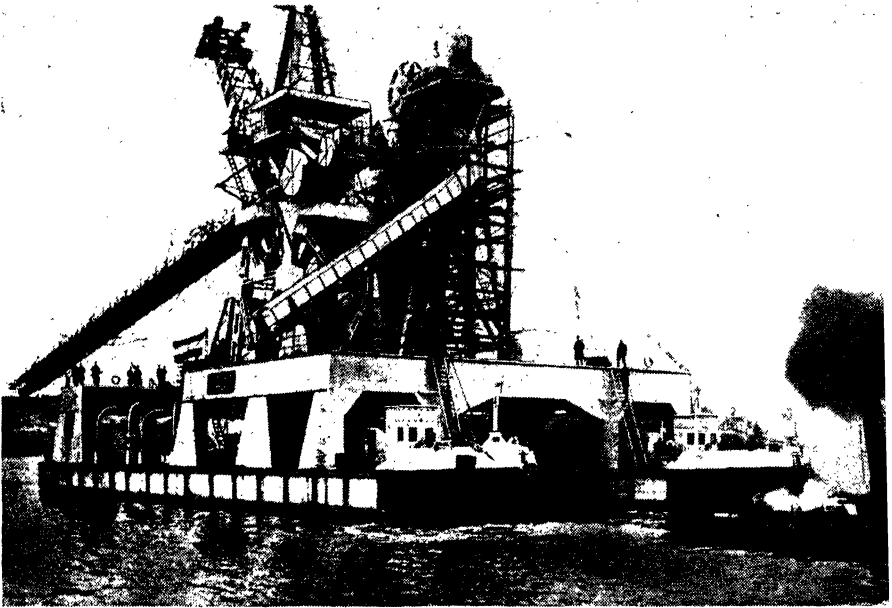

THE WORLD'S LARGEST DREDGER

[Keyston

This mighty contraption was built in 1930 at Lubeck, Germany, for the harbour of Rouen, France, and was delivered as part of the Reparations account. It weighs 2100 tons, is driven by engines of 1040 h.p., can haul 450 cubic metres per hour, and has 47 shovels of 500 litres capacity each

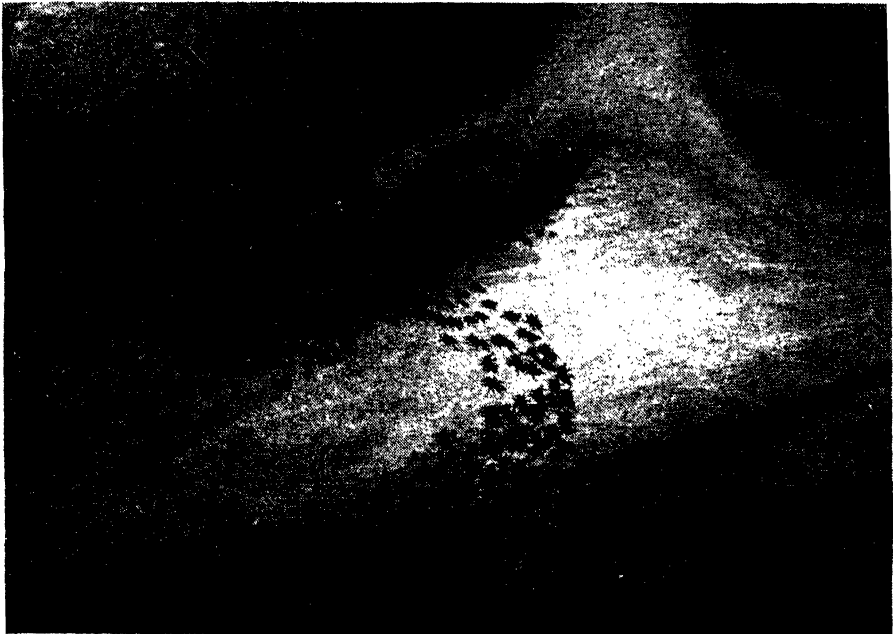

DRIVER ANTS ON THE WAR PATH

[By Theo Carreras

There are grounds for calling these African ants the most remarkable creatures in the realm of nature. Their marching columns are irresistible, and even the mighty elephant makes haste to get out of their way. The above sketch, made from an authentic incident, shows Driver Ants attacking a Horned Viper. Eventually they killed this snake and completely ate it



[*Theo Carreras*]

THE DEVELOPMENT OF THE DRAGONFLY

In its early or nymph stage the Dragonfly lives under water. It then has a remarkable mouth, capable of being thrust far out to catch prey, as shown in the centre of the picture. Later the nymph emerges from the water and, crawling up a stem, splits its skin to emit the imago or mature insect; this is happening at the top. The nymph on the extreme right is devouring a worm.

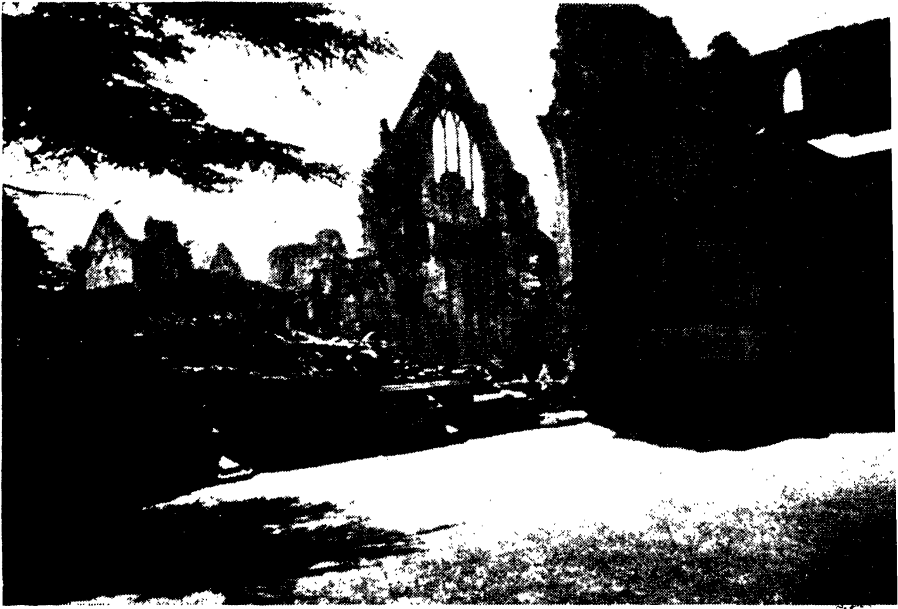

DRYBURGH ABBEY

[Dorrien

One of the most beautiful ruins in Scotland, Dryburgh, in south-west Berwickshire, was founded in 1150 by Hug Moreville. Partially restored by Robert the Bruce after Edward II had burned it in 1322, it was again desolated by Earl of Hertford in 1545, and has not been rebuilt since.



[Valentine & Sons]

A GATEWAY AT DRYBURGH

This, the entrance to the cloisters, is an exquisite piece of Norman work. The Abbey is chiefly built in the Transitional Norman and Early English styles. In September 1832, long after it had fallen into ruin, it became the burial-place of Sir Walter Scott.

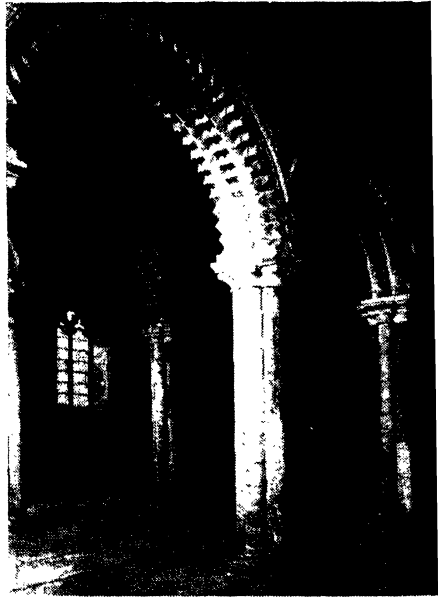

[W. F. May

DURHAM CATHEDRAL: THE GALILEE

This charming piece of architecture owes its name to the medieval belief in Durham that women occupied the same position as the ancient Galileans had done toward the Jews. The Galilee was built in 1154 for the receipt of female penitents.

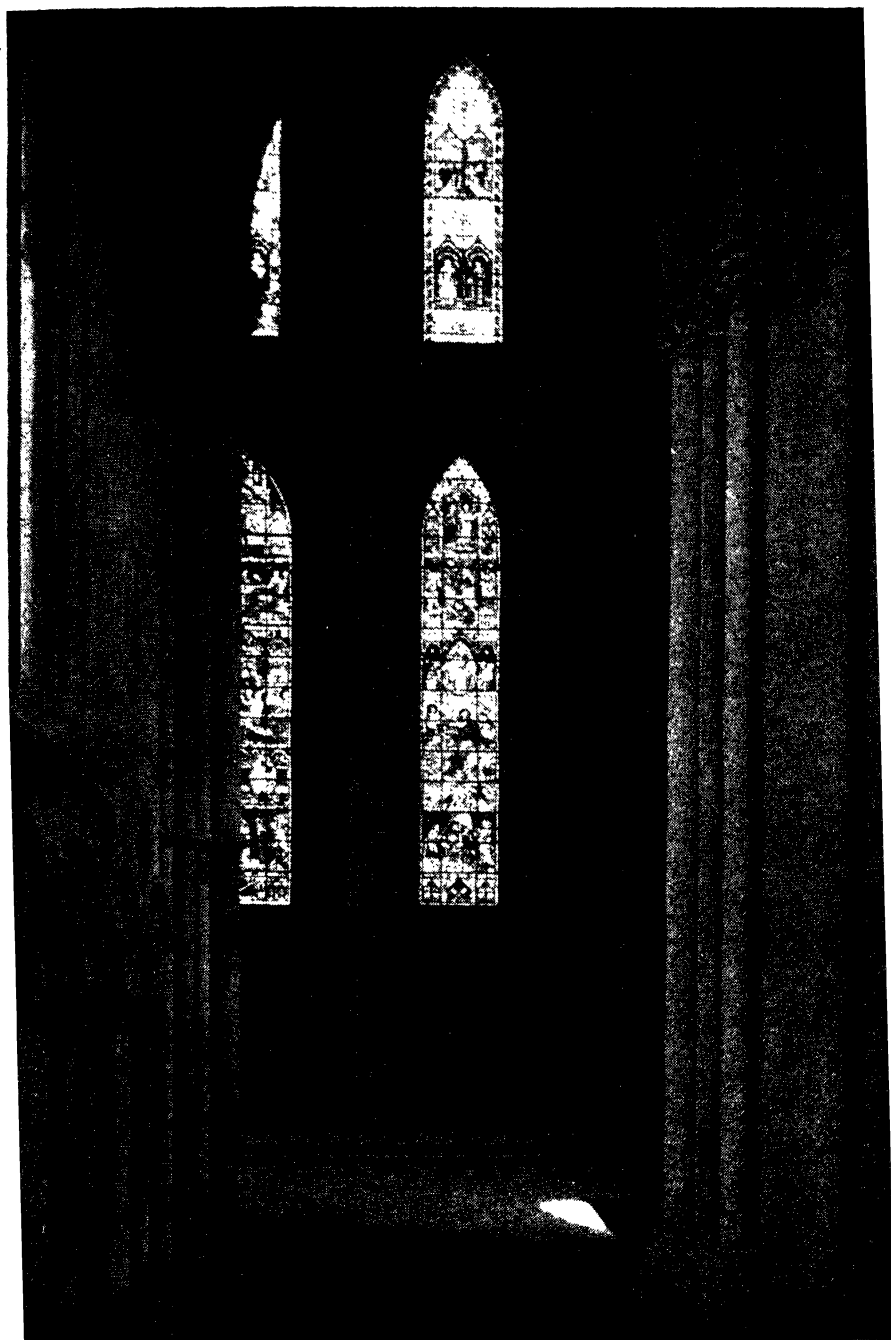

[Underwood Press]

DURHAM CATHEDRAL : THE NAVE FROM THE CHOIR

gigantic Norman building, is unusual in that it is built of the local redstone. Its construction dates largely from the twelfth century. The Nave, of which a glimpse is shown here, is said to be the finest piece of Norman architecture existing. except for the roof, it is almost entirely twelfth-century work, and was completed by Bishop Flambard

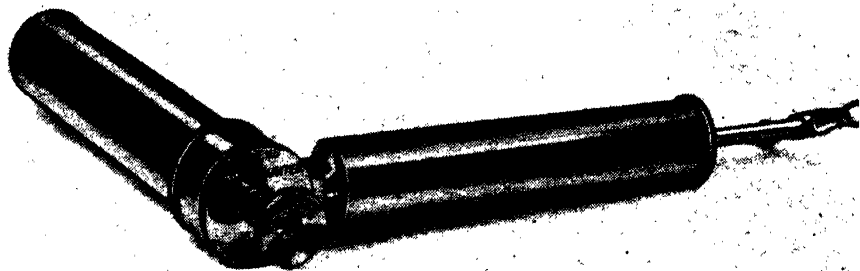

A DUST COUNTER

[Carthwaite]

This is one of the several meteorological instruments designed to ascertain the purity of the air. Simply by means of a light, for its particular task is to number accurately the particles of dust in a given volume of air.

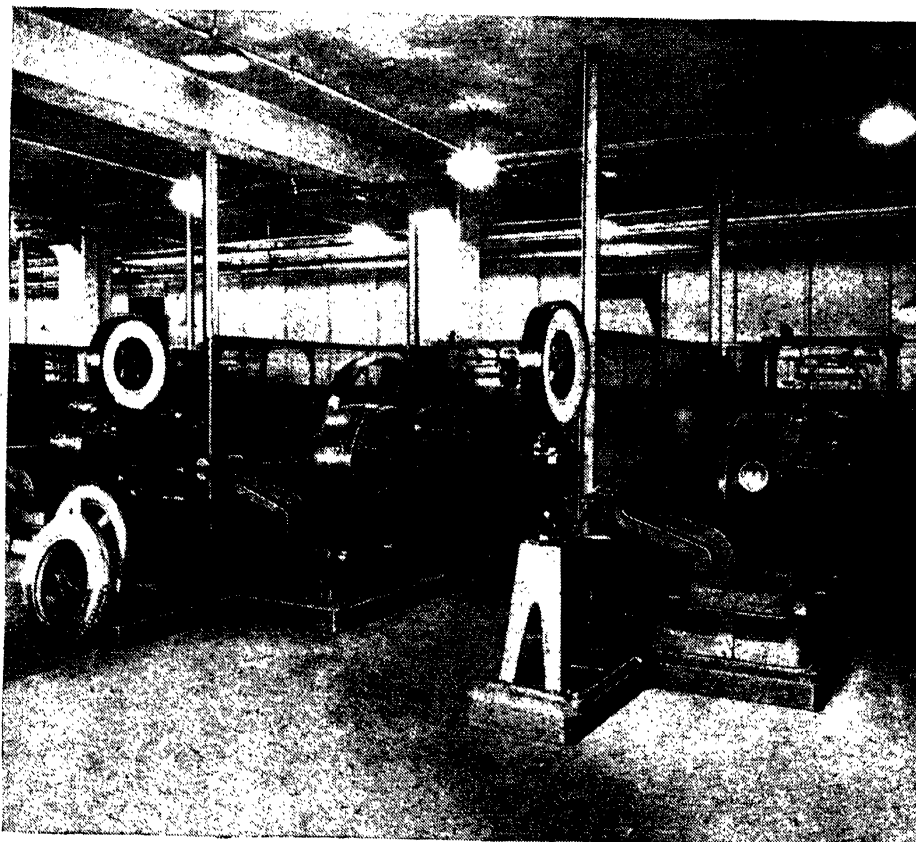

DYNAMOMETERS

[Keyston]

The dictionary definition of a dynamometer is "an instrument for measuring the power of an engine". In application, however, other things besides engines may be measured, and the above photograph shows a battery of dynamometers used for testing the toughness, durability and other characteristics of pneumatic tyres.



W. F. Marsell

THE DYING GLADIATOR

The Gladiators, or professional swordsmen, who in ancient times fought to amuse the public, were generally slaves, criminals, or very low-caste freedmen. Sometimes, however, noble-born youths of aristocratic families were made to fight in the arena.



[Carthew & Kinnaird]

THE HUMAN EAR

The human ear controls not only hearing, but to a large extent the sense of balance. There are three portions to it — outer, middle and inner. The above picture shows a section across the 'pinna' of the ear, or the external portion which acts as a cup to catch sound.

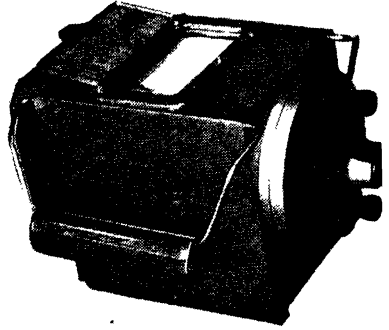

[Carthew & Kinnaird]

AN EARTH TESTER

Earth or resistance testers are electrical instruments for ascertaining how many volts a circuit can stand before current becomes too much for the wires and takes a short cut to earth. Though very small, the instruments are expensive and intricate.



[By courtesy]

AFTER AN EARTHQUAKE

Severe earthquakes play havoc with life and property, but slight tremors, as this photograph shows, are comparatively harmless. These three ruined columns in Palestine merely had their stones displaced, but remained upright.



[Wonders of the World]

EASTER ISLAND SCULPTURES

Until April, 1935, scientists puzzled in vain over the origin of the above strange carvings. A Belgian investigator now believes that they were fashioned by the Maori ancestors of the present islanders as headstones to large communal graves.



By courtesy

AN ECLIPSE OF THE MOON

The Moon is seen entering the Earth's shadow. Note the dark band across the Moon which is due to the red rays of sunlight being refracted into the geometrical shadow by the Earth's atmosphere



["Marvels of the Universe

AN ECLIPSE OF THE SUN

A view of the partial eclipse of August 30, 1905. The thin veil of clouds which was drifting across the sky act like a dark-glass and made the sun's outline clearly visible. The shadow crosses from right to left

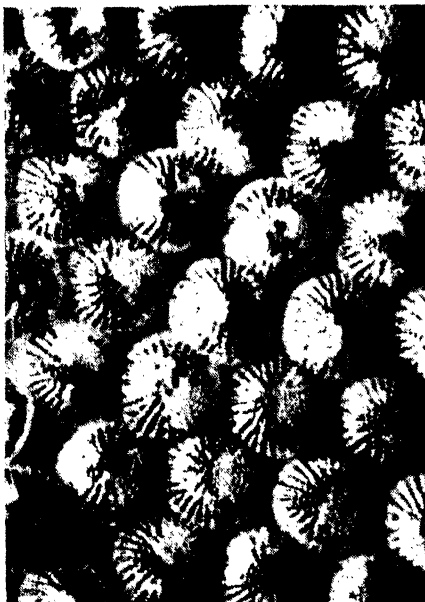

By courtesy F. N. Clarke]

THE EGGS OF A MOTH

A small portion, magnified thirty times, of a cluster of eggs laid by a Light Brocade Moth. Note the symmetrical arrangement and the "ribbed" design of the eggs, a feature common to many moths and butterflies



["Marvels of Insect Life

THE EGGS OF A SNAKE-FLY

Insect-eggs vary greatly in shape, size and texture. Compare the above with the eggs of a house fly. The snake-fly is the parent's full title

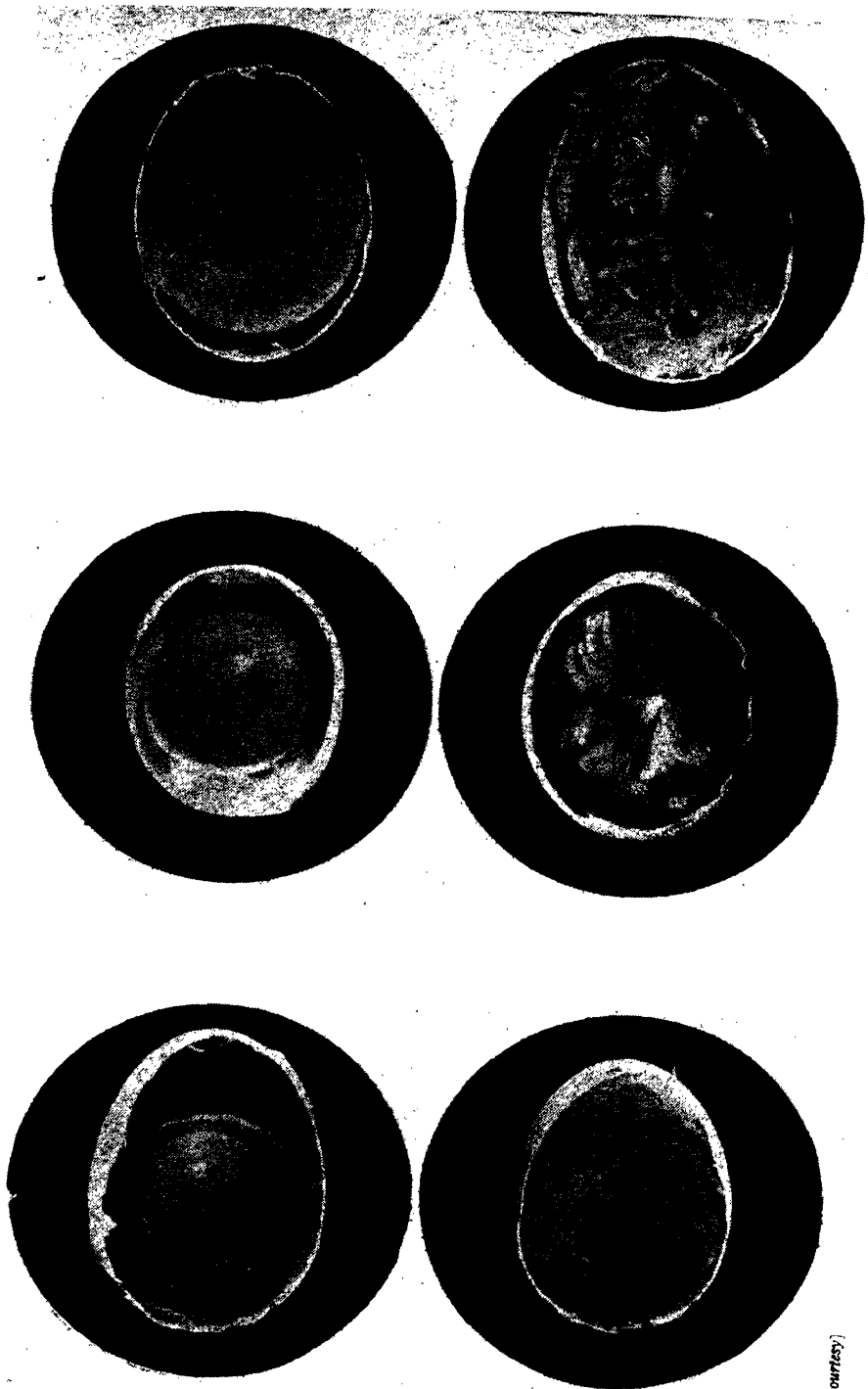

[Marnolds of the Universe]

THE TRANSFORMATION OF AN EGG

By courtesy]

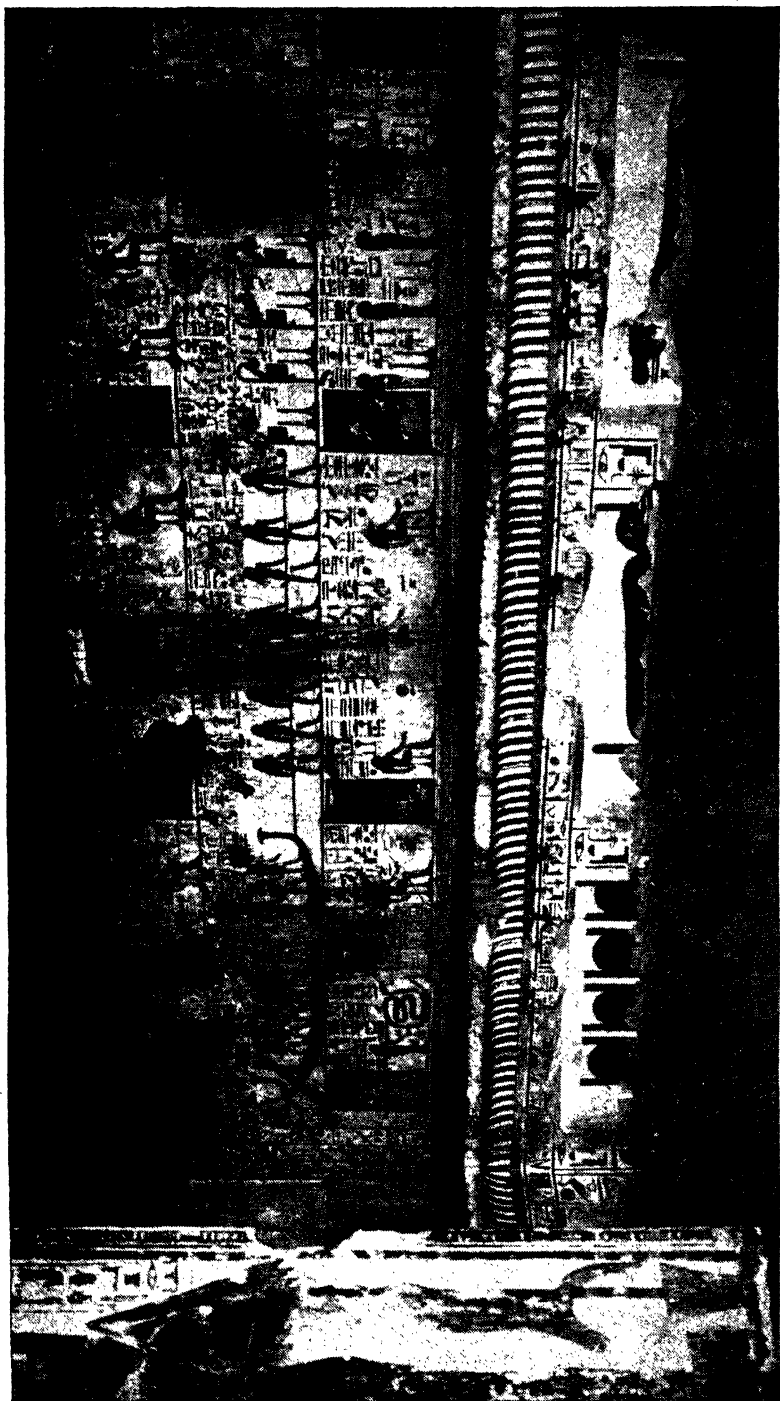

By courtesy

THE ART OF PAINTING IN ANCIENT EGYPT

Though they knew nothing of perspective, and generally executed their pictures to convey messages rather than for the sake of art, the ancient Egyptians mastered the art of the brush to a surprising degree. The above paintings are worked upon the wall of the tomb of King Seti I, in the Valley of the Kings near Thebes. The immense amount of hieroglyphic explanation of the larger figures should be noticed.

Wonders of the World



EGYPTIAN POTTERY

[Dorian]

The aesthetic qualities of the ancient Egyptians are revealed at their highest in the art of pottery. The three alabaster vases shown above, though several thousand years old, are the equal in design to their counterparts in almost any late



ELEPHANTA: THE TEMPLE OF SHIVA

[From "Wonders of the World"]

The island of Elephanta is six miles from Bombay, and contains a remarkable series of temples chiselled from solid rock in the tenth century. The subterranean hall of the Temple shown above is 130 feet square, its roof being supported by 26 massive pillars. The walls are highly ornamental throughout.



Frith & Co., Reigate

IN THE CAVES OF EILORA

The rock-hewn temples of Ellora are the most famous in India. Nearly every Indian religion has contributed to their lavish decoration. This sculpture represents Shiva, one of the manifestations of the Hindu Trinity

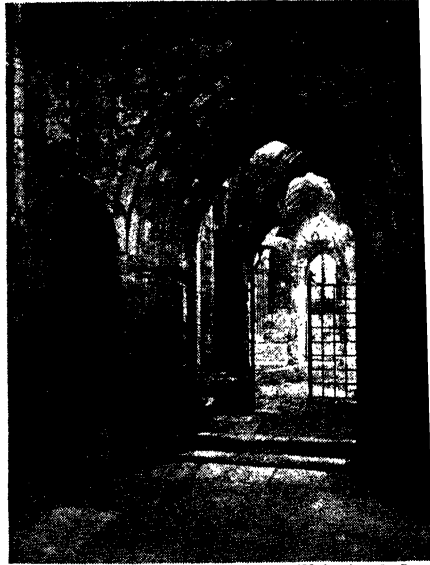

Valentine & Sons

A CORNER OF ELGIN CATHEDRAL

Elgin Cathedral, "The Lantern of the North", is the finest ecclesiastic ruin in Scotland. It was built first in 1224, and rebuilt later. This view shows the porch of the Chapter House



Underwood Press Service

ELGIN CATHEDRAL: THE CHOIR

The Cathedral was founded by the Bishops of Moray, and is mostly in the Pointed Style, having been rebuilt several times during the fourteenth and fifteenth centuries. It was eventually abandoned during the seventeenth century, when, after a succession of minor disasters, the central tower fell through the roof on Easter Sunday 1731.



[Underwood Press Service

ELY: THE PRIOR'S DOOR

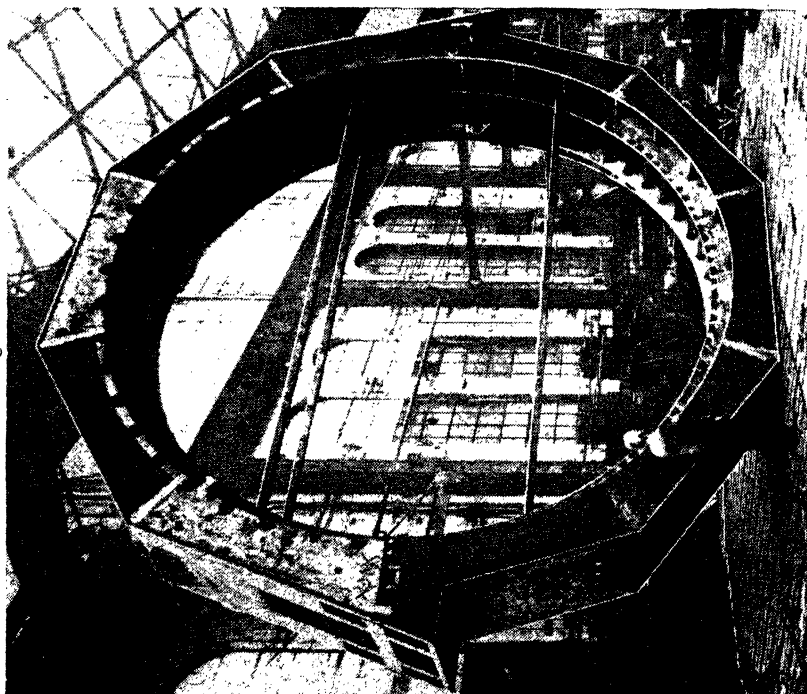

Courtesy B.T.H.]

THE STATOR FRAME OF AN ELECTRIC MOTOR

Part of one of the largest electric motors ever built; made in England for an Indian steel

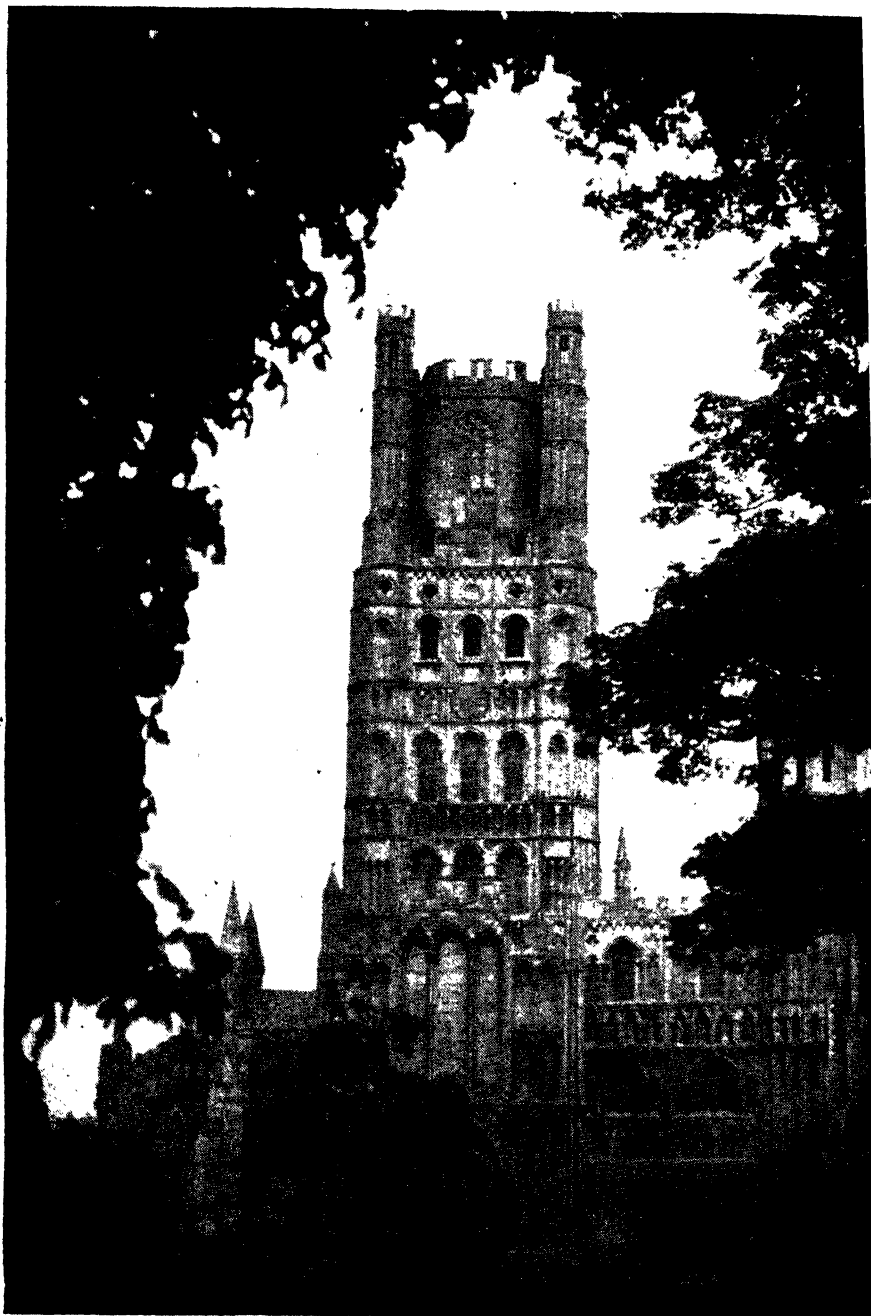

[Dorien Leigh]

ELY TOWER

The tower of Ely's famous Cathedral is 266 feet high, and was built between 1174 and 1189; the turrets and lantern were added two centuries later. The castellated top is unusual for so high a structure, and the interior consists of arcaded galleries with a modern roof painted by LeStrange.

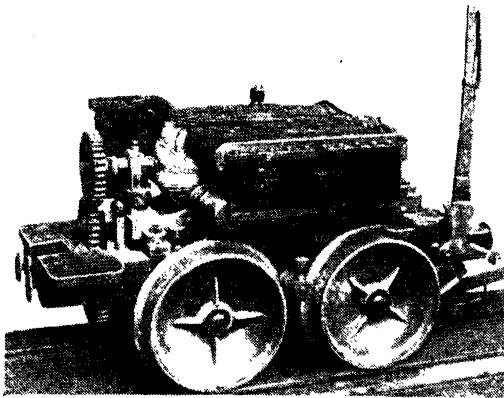

Courtesy Siemens-Schuckert

THE FIRST ELECTRIC LOCOMOTIVE

The locomotive is one of the most important adaptations of electrical power, and it is still a matter of speculation whether it will presently supersede all other forms of rail transport. The first electric locomotive was designed by Werner Siemens, the great inventor and pioneer, in 1879.

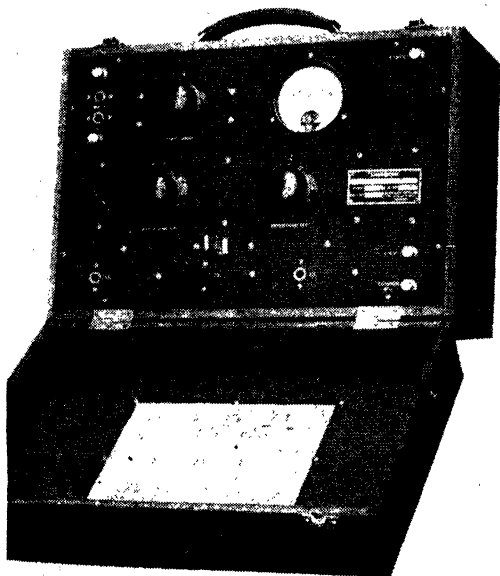

Marconi, Ltd.

AN ELECTRIC VALVE VOLTMETER

One of the very newest of the many forms of electric meter. The purpose of a voltmeter is to test the number of volts (i.e. the strength of current) passing through an electrical circuit; only recently, however, have wireless valves (whose accuracy is extremely high) been adopted for use in the testing apparatus

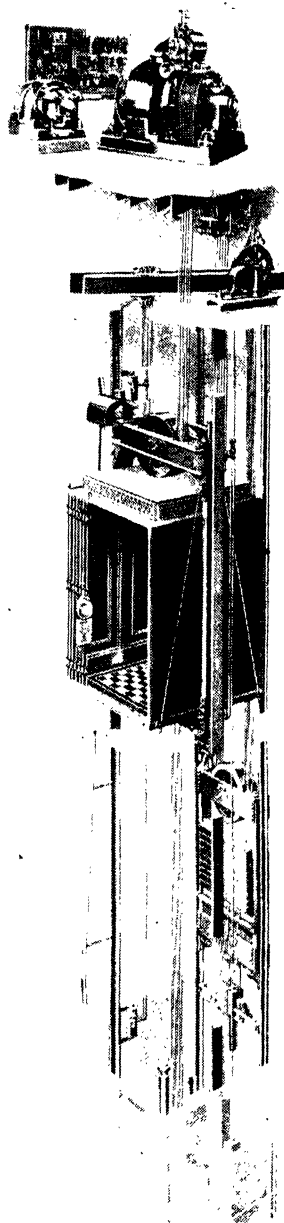

Carlow & Kinnaire

AN ELECTRIC LIFT

Diagram shows one of the latest developments in electric-lift making—a lift without gears. Electric haulage was given a great fillip by the invention of the self-operating push-button lift now in use in most up-to-date buildings

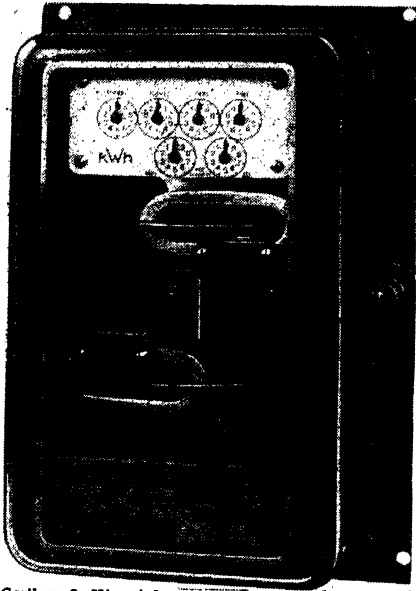

Carthw & Kinnaird

A DOMESTIC ELECTRIC METER

Here is a polyphase meter of the type seen in nearly every home using electricity. Wherever electricity is employed the meter is an indispensable adjunct

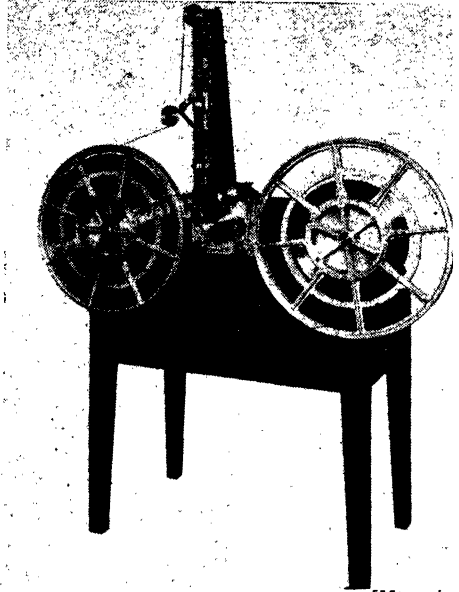

Marconi

ELECTRIC RECORDER AND REPRODUCER

The Marconi-Stille is not used for sound-film making, but recording speeches, ceremonies, etc. The principle is based the passing of a metal thread between magnets

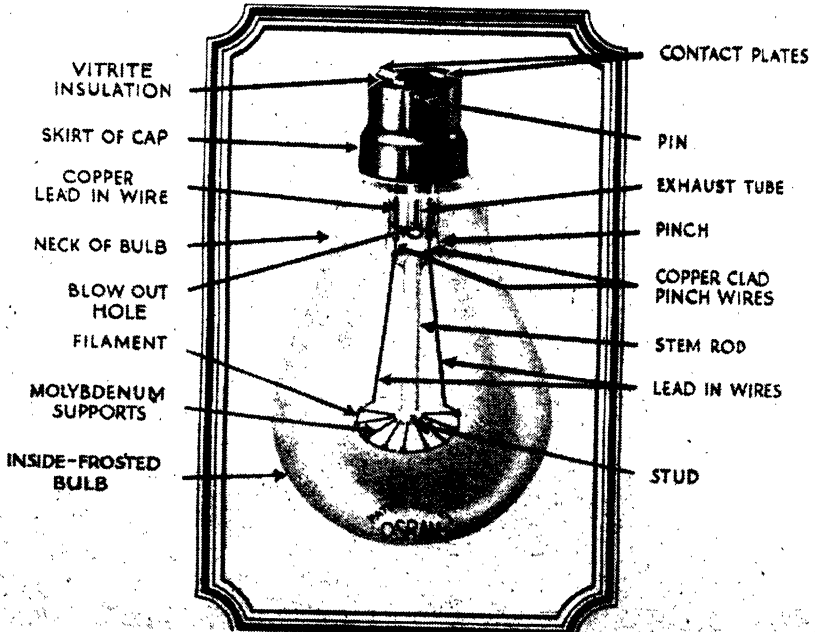

THE PARTS OF AN ELECTRIC LAMP

[Courtesy G.E.]

Who has not at some time wondered what the various parts of an electric bulb signify? This diagram shows all the names, most of which are self-explanatory, as applied to the latest gas-filled type. The principle of electric (arc) lighting was discovered as long ago as 1810, but many years elapsed before practical developments were made



By courtesy]

THE SNAKE-NECKED BLAMOSAU

Of all the fearsome monsters of bygone ages this surely was one of the most terrible. Its relics are found amongst the fossils of the Upper Cretaceous system in Kansas, and it is believed to have been sometimes 45 feet long. Its name means "neck like a snake" and in the above illustration is shown in its natural position.

(American Museum of Natural History)



By courtesy]

THE ELECTRIC EEL

[*Marvels of the Un*

The most formidable of the electric fishes. The "battery" extends along four-fifths of the body, and consists of huge masses of cells filled with jelly and nerves. The discharge from an electric eel is sufficient seriously to incapacitate an animal as large as the horse. Scarcely less formidable is the Electric Catfish; here the battery envelopes the body between the skin and the muscles, and is itself a transformation of the skin

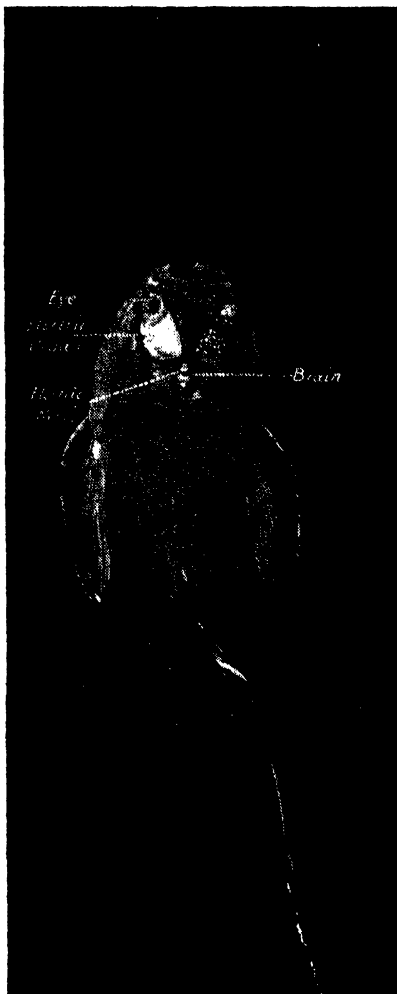

From "*Marvels of the Universe*"
ELECTRIC STAR-GAZER

A diagram photograph, with the outer skin of the fish removed, to show the connection between the electric and other organs of the head. Note the very small size of the brain



[*E. Step, F.I*
COCCOON OF THE EMPEROR MOTH

This cocoon is built on the principle of a reversed lobster-trap. The narrow end consists of straight threads, which converge, making it easy for the inmate to get out, difficult for enemies to get in

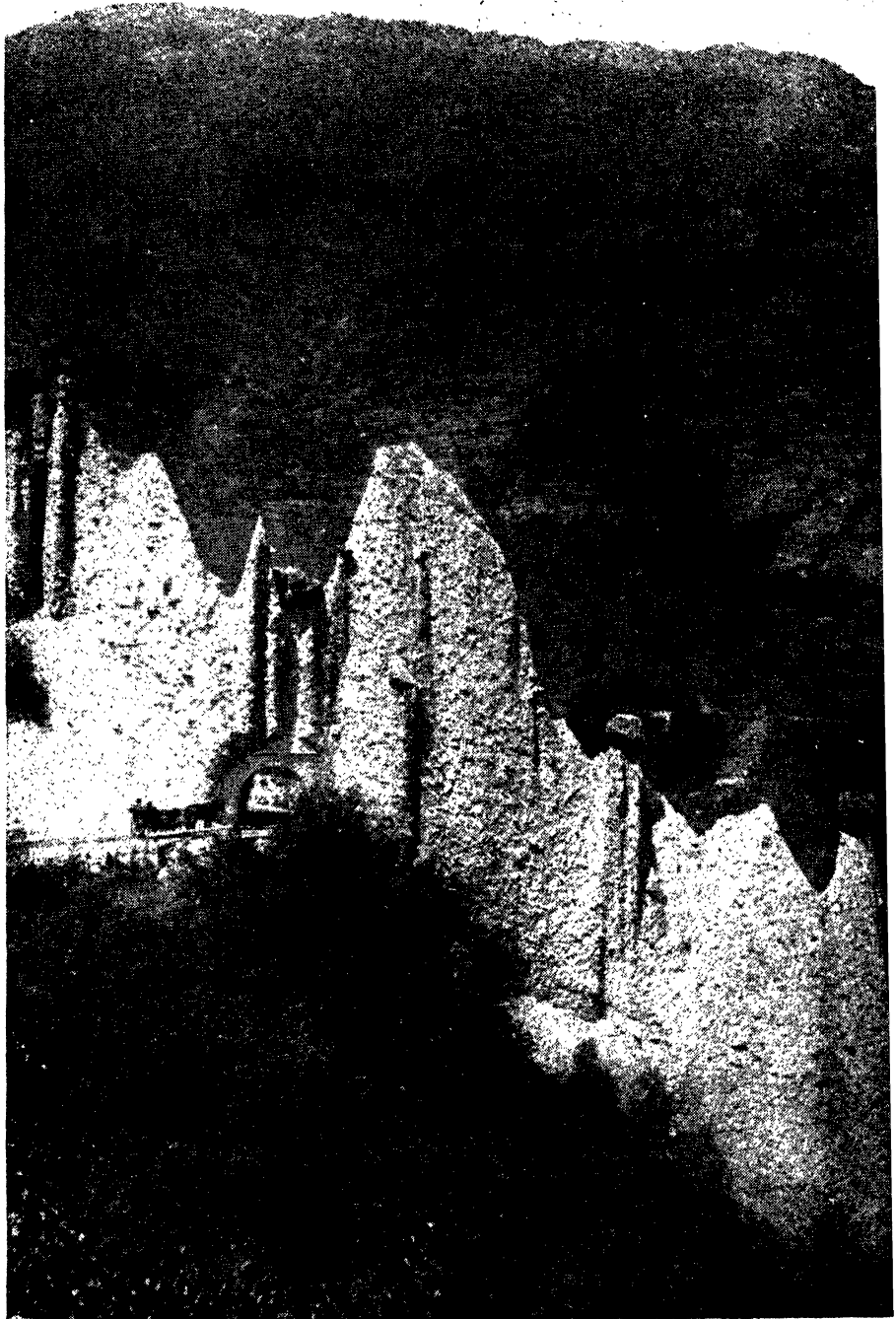

THE EARTH-PYRAMIDS OF ENSEIGNE

[G. P. Abrahams]

The origin of these peculiar formations is as follows: in some past era granite rocks fell on soft clay soil; the clay then became washed away by heavy rains, but the parts sheltered beneath the rocks were protected, with the result that the rocks gradually found themselves on pillars high above the surrounding level. Enseigne is in the French Alps.

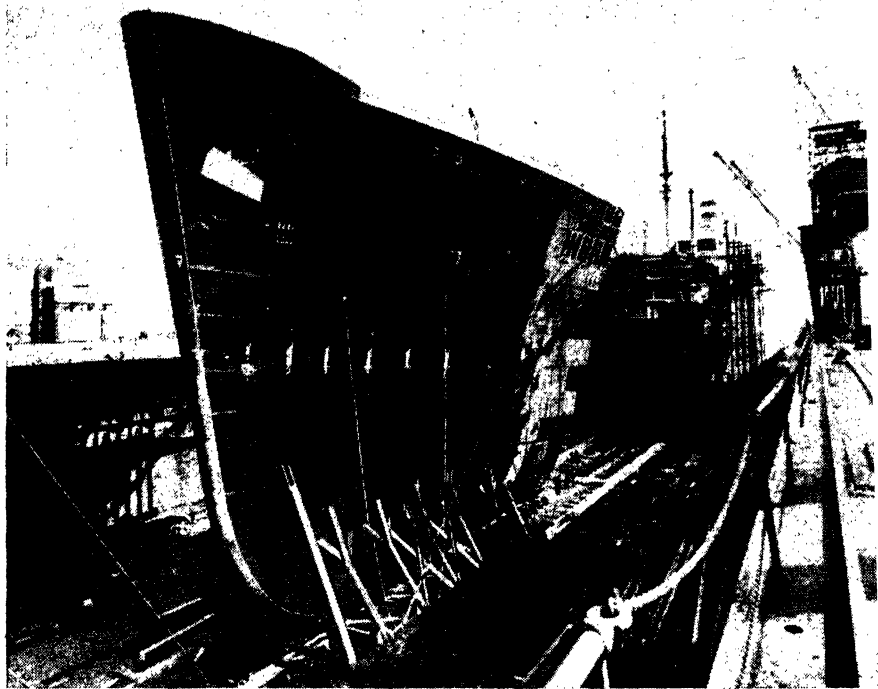

ENLARGING A SHIP

(Kyst)

It sometimes happens that ships—both naval and civil—become too small for the purposes for which they were built, though still in sound condition. Until lately the only solution would have been the expensive one of build additional vessels, but in the twentieth century it has become possible to give a ship new and longer bows, or even to insert a larger waist, without affecting the "balance". The picture shows a new bow about to be fitted to Hamburg-America liner



By courtesy)

THE PLESIOSAUR

(*"Marvels of the Universe"*)

Relatively little is known about this prehistoric monster, nor are naturalists agreed as to what position it occupied in the scale of creation. It is believed, however, from sundry affinities, to have been an aquatic burrower; it is in some respects not unlike the still extant duck-billed platypus



[Dorset Leigh

COASTAL EROSION

One of the least conspicuous and most irresistible forces of nature is that which is continually but imperceptibly altering the maps of many coast-lines—in England as elsewhere. Recession in some parts (as at Kye, Sussex) transcients former settlements and ruins.

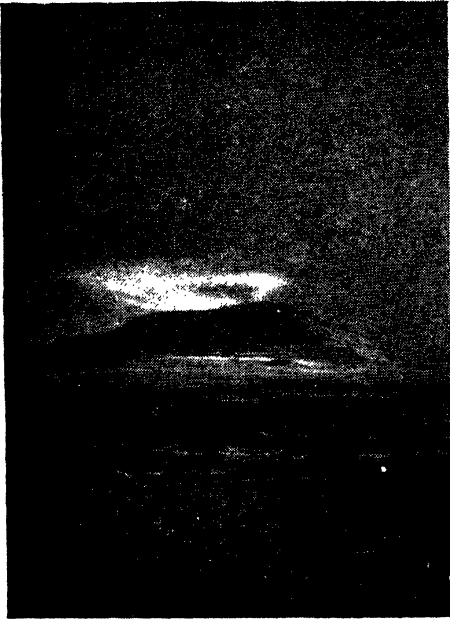

From "Wonders of the World"

MOUNT EREBUS IN ERUPTION

Mounts Erebus and Terror are the two greatest volcanoes of the Antarctic. The late Sir Ernest Shackleton, who took the above photograph, said that few sights are grander than Mount Erebus by moonlight, its huge clouds of steam rising 3000 feet above the crater



[Courtesy L.P.]

BENEATH AN ESCALATOR

Beneath every escalator in the London tube stations an ordinary stone stairway, so that engineers may have access to every part of the "works." The longest escalator in the world has recently been built in reconstruction of Leicester Square station

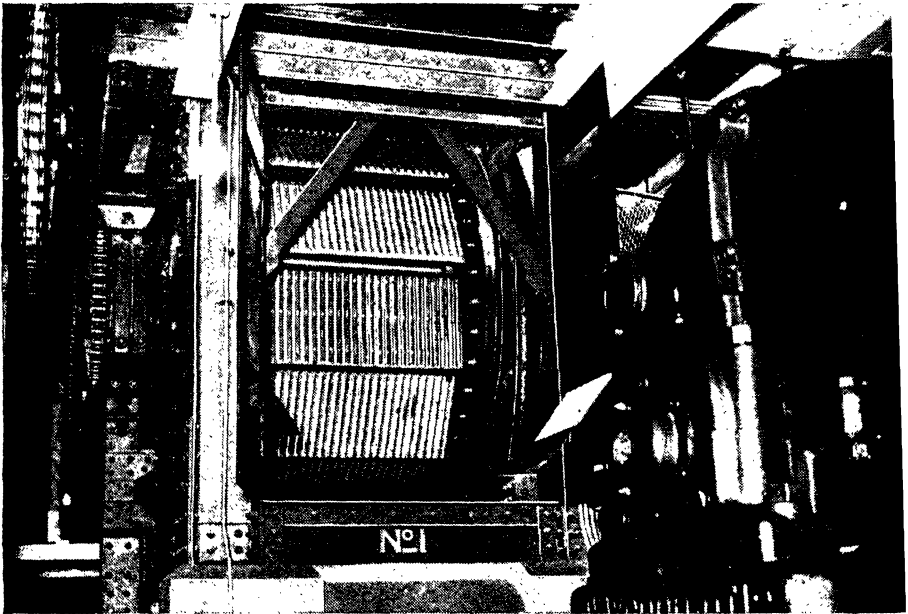

[Courtesy L.P.]

AN ESCALATOR'S TURNING-POINT

A picture of the turning place of the treads at the upper end of an escalator at Wood Green. The machinery like everything to do with the tube railways, is electrically operated, and, once started, is entirely automatic



[Underwood Press Service

MOUNT ETNA

Looking at this photograph, it is not difficult to believe that the great Sicilian volcano played a conspicuous part in the history of the Ancient World. There are over 200 craters, of which the one shown is the largest; the base of the mountain measures 86 miles round. — The Great Pastoralist, *Journal of the Royal Geographical Society*, 1901.



From "Marvels of Insect Life")

THE EYE OF AN INSECT

This is a much enlarged cross-section of the eye of a gnat. Insects' eyes are compound, consisting of many (sometimes 27,000) entirely separate lenses, each of which reflects, or sees, one small portion of the object looked at. That the resultant image appears as one whole was recently proved by photographing through a glow-worm's eye

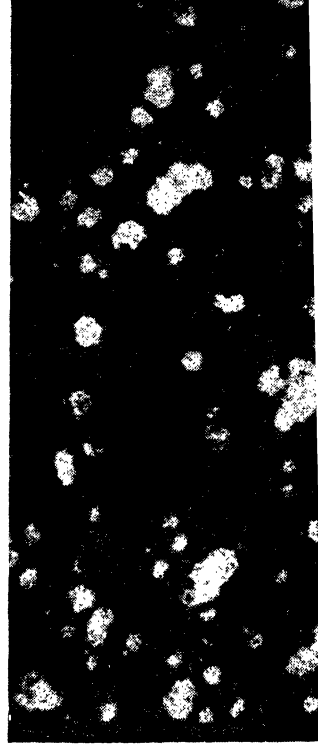

[Carlson & Kinna]

THE HUMAN EYE

This photograph shows a highly magnified view of pigment cells from the retina, the "sensing" part of the human eye, which covers the back of the interior and acts as a mirror

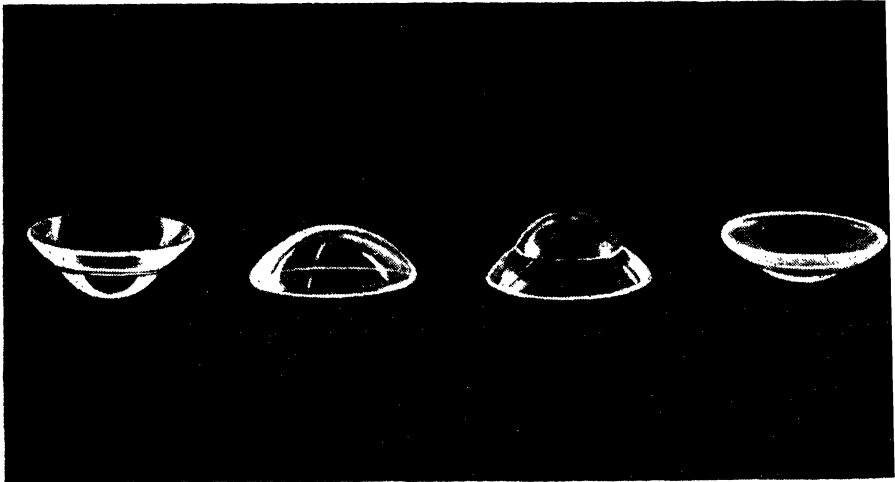

INVISIBLE EYEGLASSES

[Courtesy Carl Zeiss]

The eyeglass, as a means for assisting defective sight, has been known for several centuries, and throughout that time "spectacles" have hardly altered. Now, however, it is possible to fit lenses inside the eyelids, which not only makes them invisible but enables the wearers to swim or face rain without inconvenience. Above are different patterns of lenses

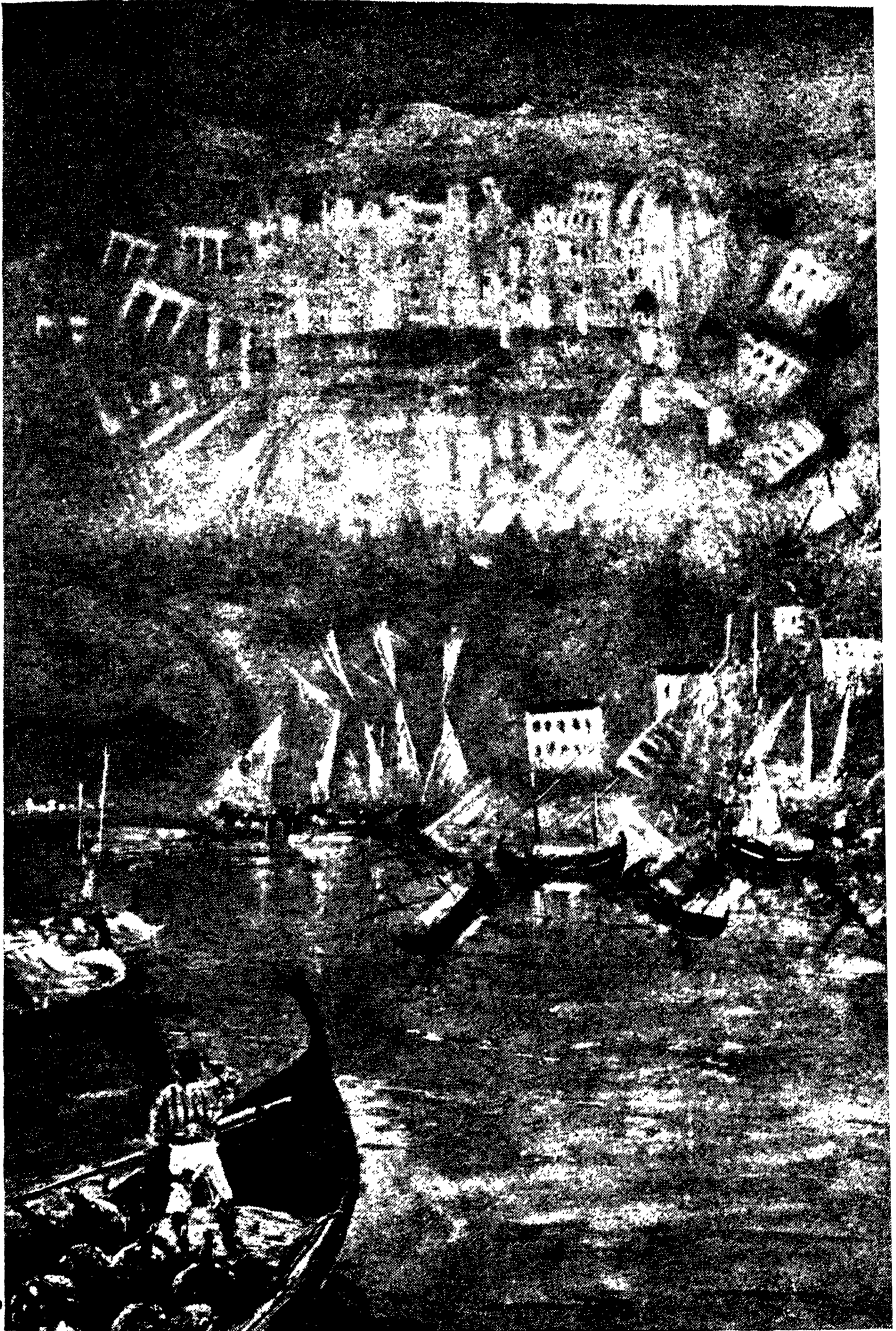

By courtesy]

FATA MORGANA

[“Marvels of the Universe”]

This is a peculiar kind of mirage confined to the Straits of Messina. Buildings and moving objects are seen on surface of the water or even suspended in the air above it, and boats appear in chaotic positions which suggest wildest of storms. The cause is believed to be due to refraction caused by diverse currents of air.



(Dorrien Leigh)

FATHER NILE

This symbolical rendering of the great river, its people, its monuments, and its fertility, is the only outstanding relic left to prove the former greatness of Carthage. Founded in the ninth century B.C. by the Phoenicians, the Carthaginian Empire successfully resisted first the Greeks and then the Romans, until utterly devastated by Rome in 146 B.C. Carthage was then said to hold 700,000 people and to be a treasure-house of art and literature

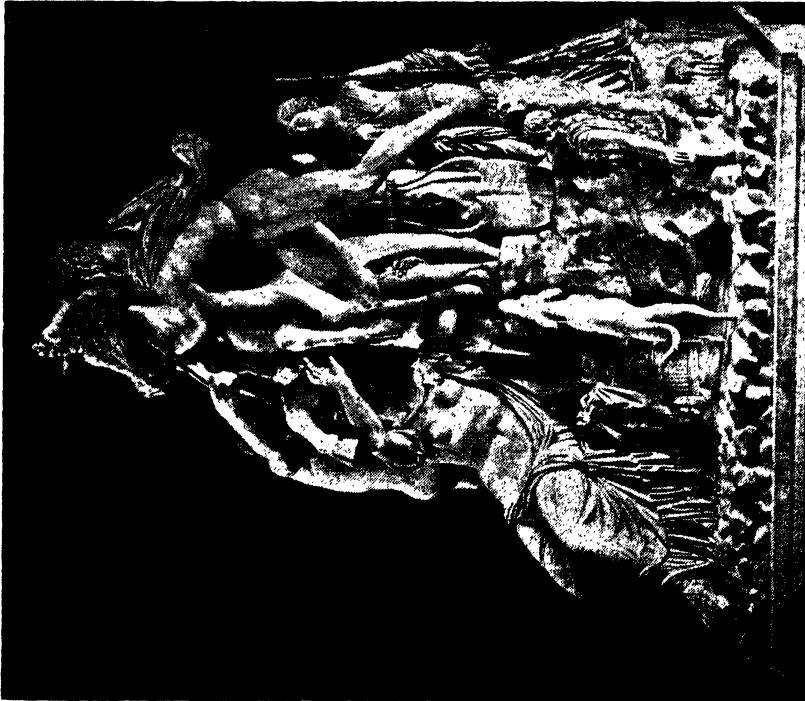

Photos]

THE FARNESE BULL

This colossal and striking group is one of the finest action studies ever produced by the sculptors of the Ancient World. It represents the Punishment of Dirce, a Queen of Thebes who was bound to the horns of a bull by the two sons of her divorced predecessor, and dragged to death. Apollonius of Trales was the sculptor, and the group is now at Naples

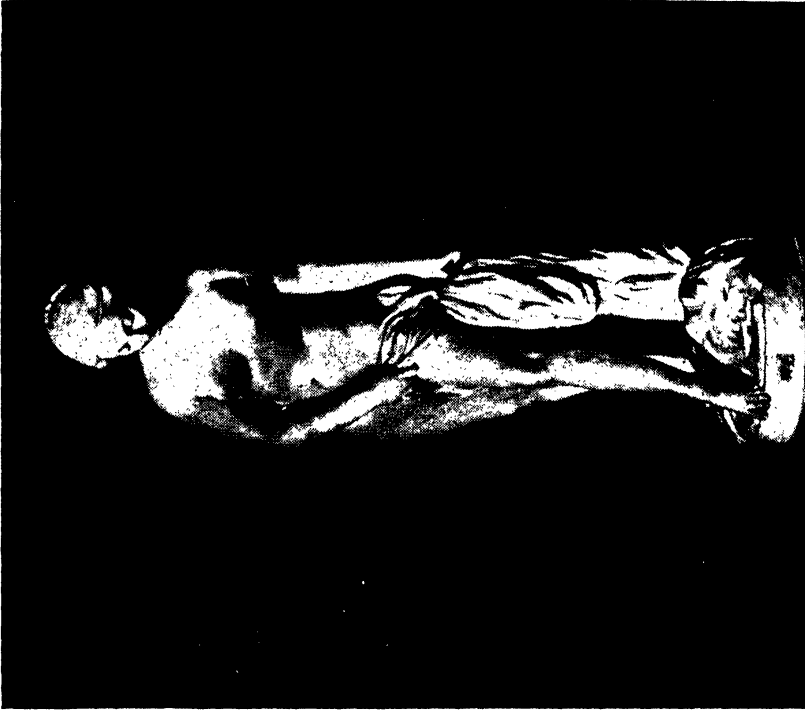

[Dorinda Leigh

FALCONET'S "LA BAIGNEUSE"

Etienne Marie Falconet (1716-1779) is famous for his colossal statue of Peter the Great, executed by order of Catherine II, and in St. Petersburg's chief square. Apart from his twelve years in Russia, however, he spent his life in France as a typical sculptor of the ancien régime. The marble statue shown here is in the Louvre



From "Wonders of the World"

A GATE AT FATTEHPUR-SIKRI

"The most beautiful gate on earth" has been claimed as the title for this arch built by Akbar before the courtyard of the Fattēhpur-Sikri Mosque near Agra. The tolerance of Islam towards Christianity is exemplified by an inscription over the door reading, "Jesus, on whom be peace!"

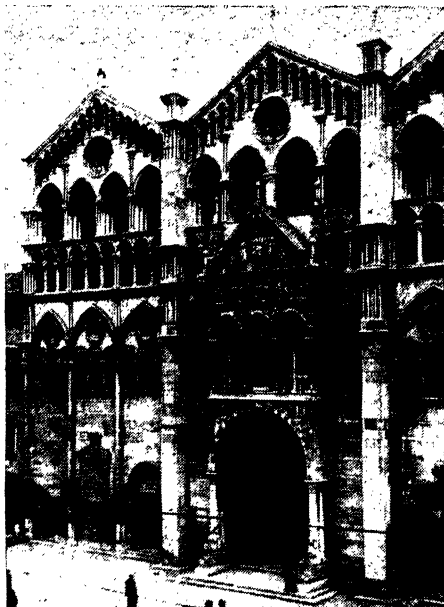

[Dorien Leigh

FERRARA CATHEDRAL

Ferrara is noted for its Renaissance School of painting, its sixteenth-century literary centre, the refuge it afforded to Calvin, and the birth within its walls of Savonarola; but its greatest claim to fame lies in its glorious cathedral, which is the finest of its epoch in Europe



W. Saville, Kent]

THE FIERASFER

This is a name given to a tiny fish which lives as a parasite within the shelter of jellyfish and pearl oysters. The photograph shows how one specimen of the race happened to enter an oyster shell and irritate the occupant, whereupon it was converted into mother-of-pearl!



[Prague Observatory

FIREBALL AND NEBULA

For the nature of fireballs see next page. This remarkable photograph came about more or less by accident. A camera study was being made of the nebula in the centre of the picture, and during the exposure the fireball unexpectedly flashed across the plate



By courtesy

A FIREBALL.

("Splendours of the Heavens")

Fireballs are large masses of stone or iron, probably at one time attached to a comet, which enter the earth's atmosphere at very high speed and are caused to glow by the friction. Many of them are consumed before reaching earth, but analysis of other fragments proves them to contain much hydrogen. This implies that they once formed parts of a giant planet, or even the sun, since it is only in these that free hydrogen is found.

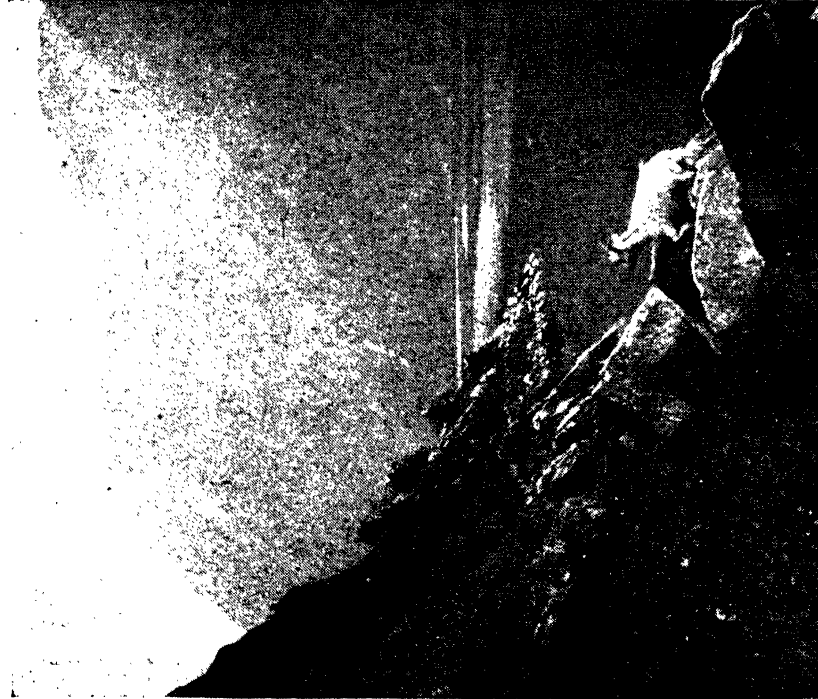

Donald McLeish

THE FJORDS OF NORWAY

Only in New Zealand are there to be found coasts comparable with those of Norway. For hundreds of miles the mountainous Norwegian seaboard is indented with these long, infinitely beautiful sea-filled valleys. Naero Fjord, seen here, is the greatest of all; mountains 4000 feet high fall practically sheer into waters equally deep

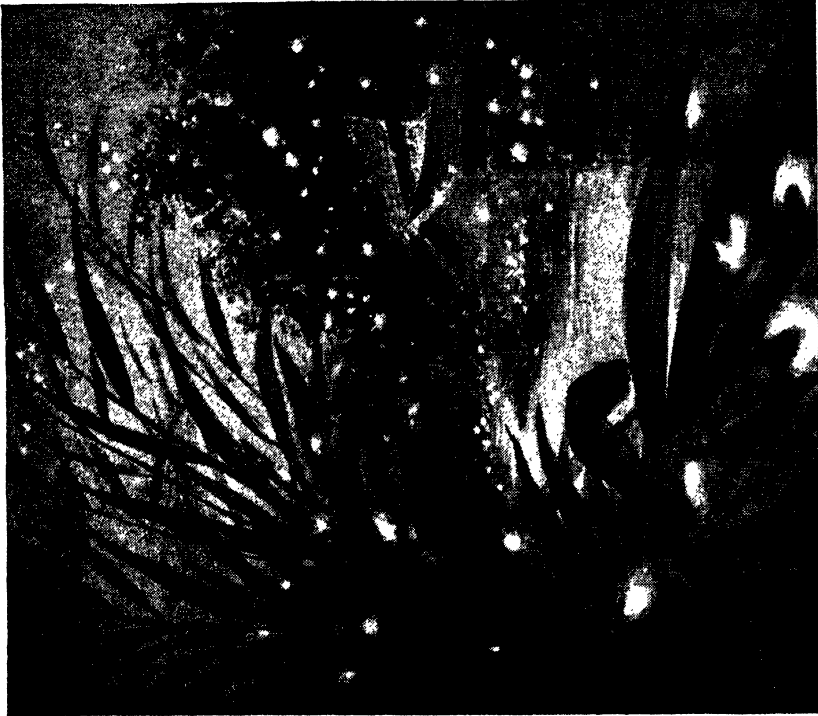

[By Theo Carreras

FIREFLIES

The firefly is no more a fly than the glow-worm is a worm; it is a species of fairly large beetle which abounds in parts of tropical America. Ladies there often use it for adornment, and inventors have made experiments with collected numbers of it for illumination purposes. The fireflies' light is used to attract the opposite sex

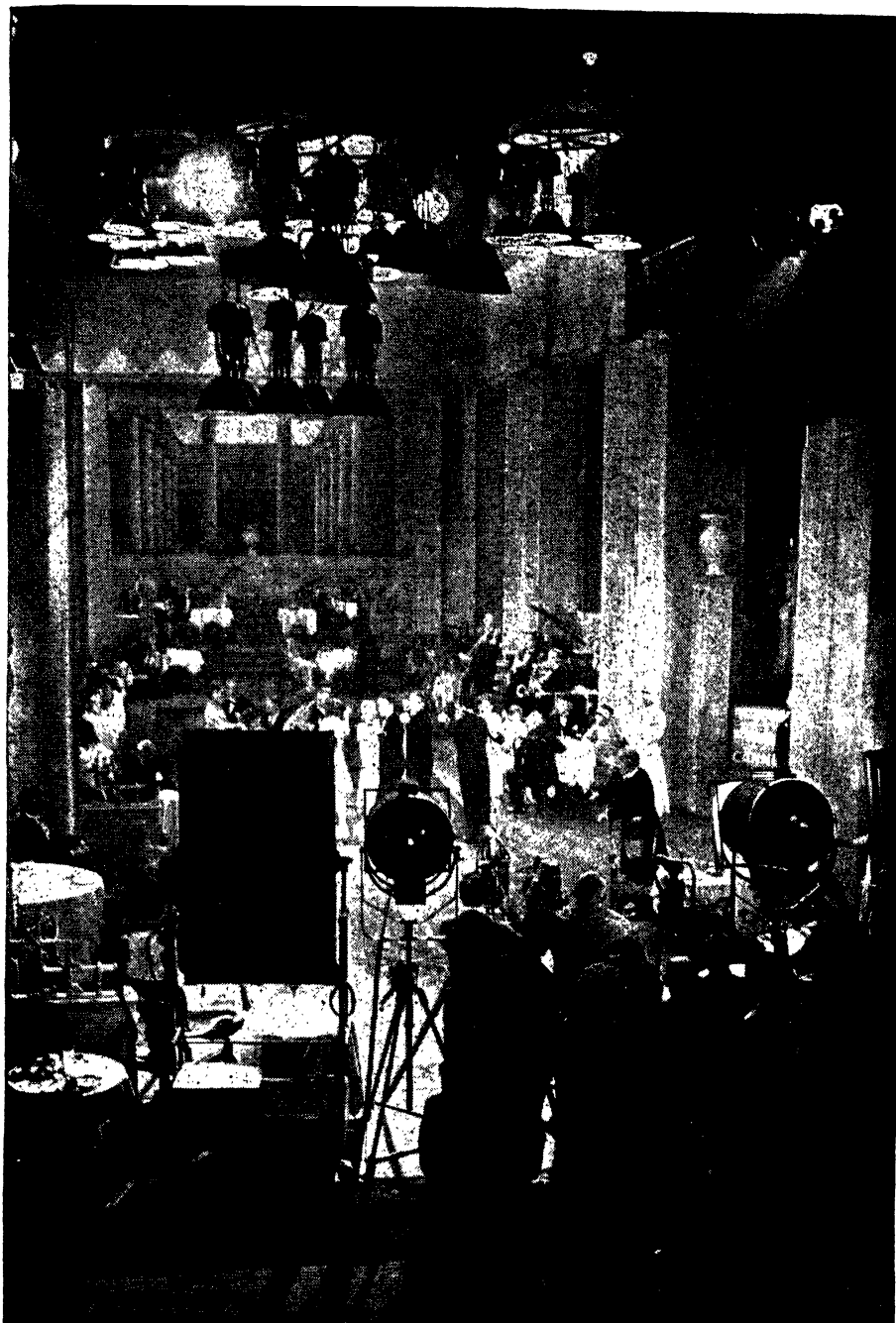

FILM-MAKING

[Keystone

A typical scene in a film studio. The scene of the film here being "shot" is laid in a restaurant; above the tables and cardboard walls dozens of fierce arc-lights beat down, whilst searchlights and a battery of cameras are set in the front. Generally there are other cameras at various points overhead, and views of mass dancing, etc., are often taken vertically by cameramen at the ends of long arms like fire-escape ladders

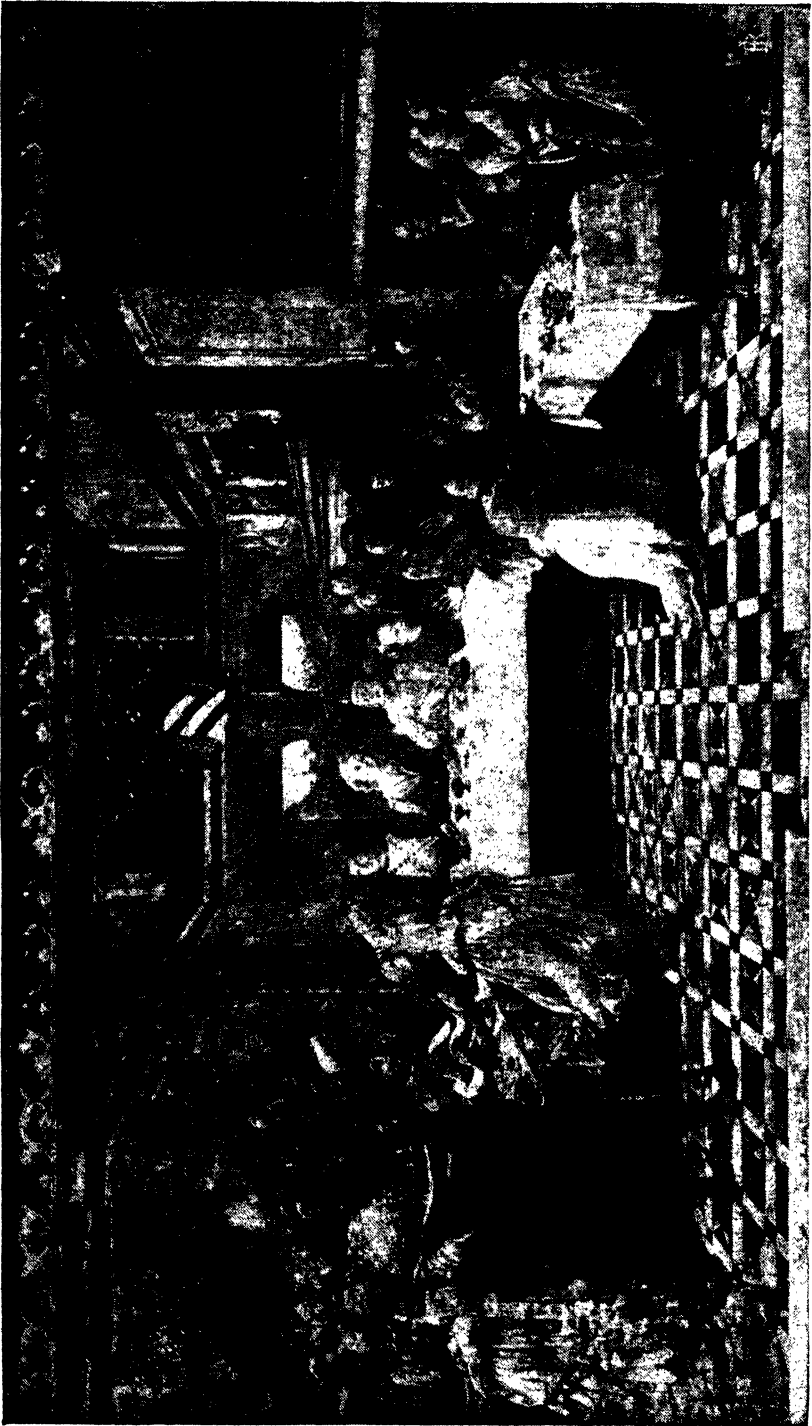

[Dorrien Leigh

"THE DANCE OF SALOME," BY FILIPPO LIPPI

Fra Filippo Lippi was a Florentine of the fifteenth century, and, being a monk, painted little but religious subjects. Though he executed at Spoleto some fine frescoes of the life of the Virgin, his greatest achievement is the collection of frescoes in Prato Cathedral. These are virtually pictorial biographies of St. Stephen and St. John the Baptist. "Salome" is generally reckoned the finest individual painting. Filippo's son, Filippino Lippi, was also a great painter



FRA FILIPPO LIPPI'S "THE ANNUNCIATION"

[Dorien Leigh

This is an earlier work of the artist's, but extremely well known and much better preserved than the "Dance of Salome." It is very similar to the type of work done by Filippino Lippi, who did not, however, study directly under his father, but under one of his father's pupils.



[From "Wonders of the World"

FLORENCE CATHEDRAL

The Cathedral, or Duomo of Florence, is the resultant labour of an architect who in 1296 was ordered "loftiest, most sumptuous edifice that human invention could devise or human toil execute." Art was this architect, and Giotto and a certain Francesco Talenti were his successors.

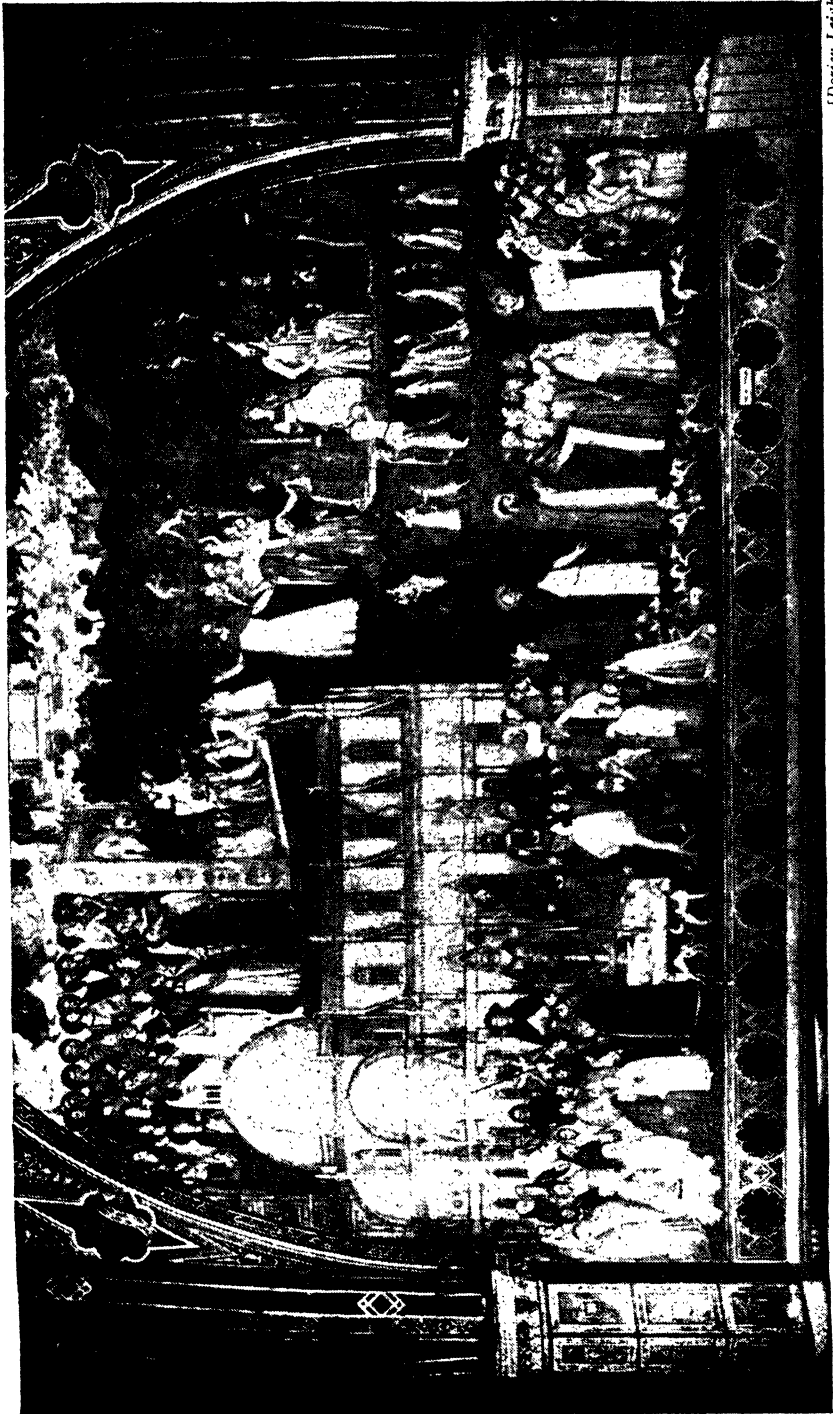

Dorcin Leigh

FRESCO OF CHURCH MILITANT AND TRIUMPHANT, FLORENCE

Though Arnolfo, Talenti, Giotto, Brunelleschi (who built the dome) and many other great artists made the outside of Florence Cathedral one of the most splendid in Europe, the inside was left practically bare, and it is in the city's other churches that famous frescoes are found. The above is in S. Maria Novella, and is a remarkable piece of work. Curiously enough, the painter is unknown.

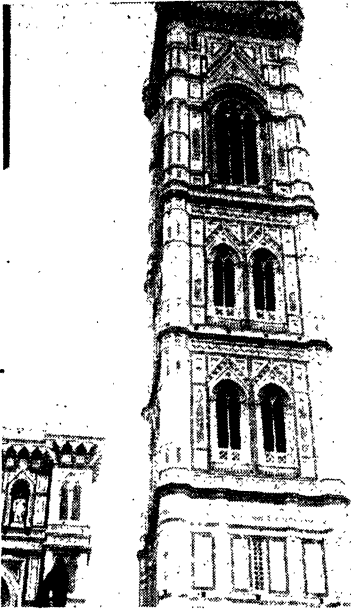

(Dorson Leigh)

FLORENCE: GIOTTO'S CAMPANILE

Giotto di Bondone, painter, architect, and sculptor, was a contemporary of the great Dante. The Campanile is a masterpiece of design, adorned with sculptures which are themselves masterpieces



FLORENCE: THE PALAZZO VECCHIO

A picture showing the central courtyard of this delightful building, which was begun in 1298 to the designs of Arnolfo di Cambio, the architect of Florence Cathedral. The porphyry fountain and statue were fashioned by Bernini for Lorenzo de Medici



THE FLYING SHUTTLE

[Keystone]

The shuttle of a loom is the moving part which threads the weft to and fro across the warp, and in older days it had to be thrown back and forth by hand. In 1711 John Kay invented a mechanical means of propulsion which is now in universal use. Not only are speed and ease increased, but the width of the material is no longer limited to the "throwing span" of two human arms

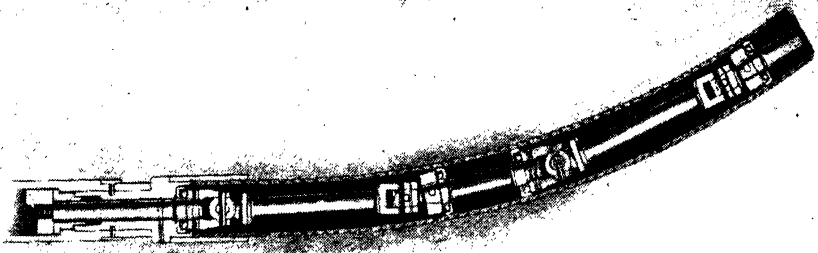

FLEXIBLE DRIVING-SHAFTS

[Courtesy C. Wickstead & Co.]

The advantages of being able to use flexible shafts for connecting the source of power with the machine driven is obvious, since it does not matter at what relative angle the two are set. This picture shows a cross-section of such a shaft, with the ingenious arrangement of universal joints within the casing. The clearest conception of what such a flexible axle-rod is like externally may be had by imagining it like a short hose.

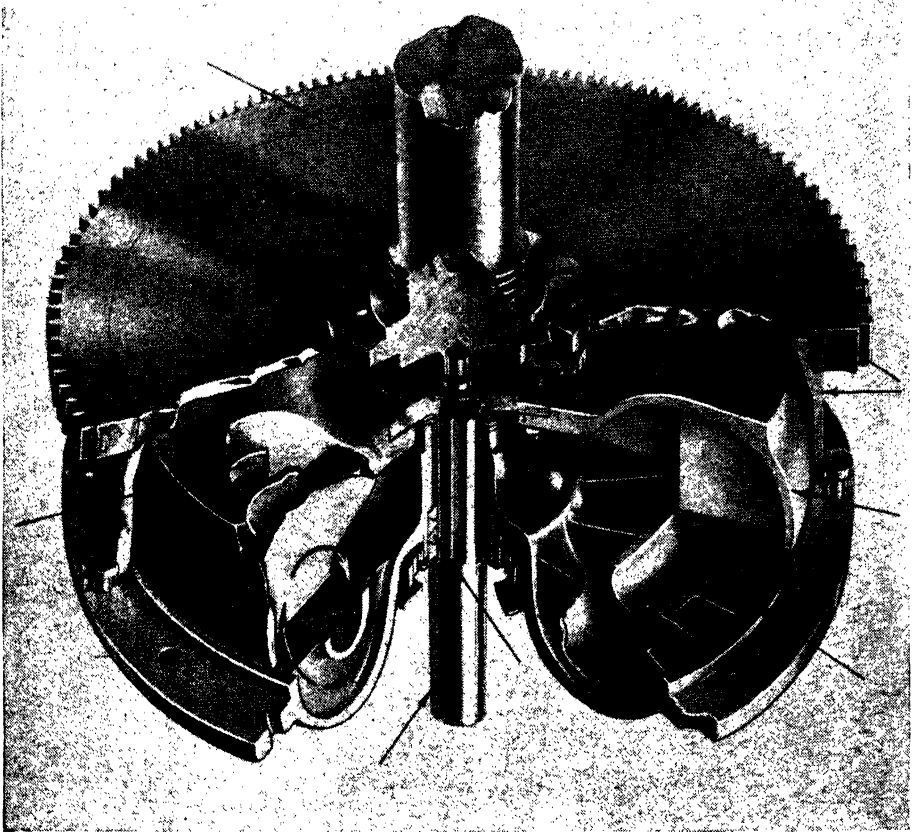

THE FLUID FLYWHEEL

[Courtesy Daimler Ltd.]

The flywheel or clutch of a motor-car is the part which connects the running engine with the driving shaft and road wheels. Recently the ordinary mechanical clutch has been improved upon by a hydraulic form. In the above diagram, the lower (driving) plate is seen to be hollowed out. These hollows are filled with oil, and vanes on the driving plate are pressed upon by the revolving oil in such a way that the drive is actually imparted through the fluid.

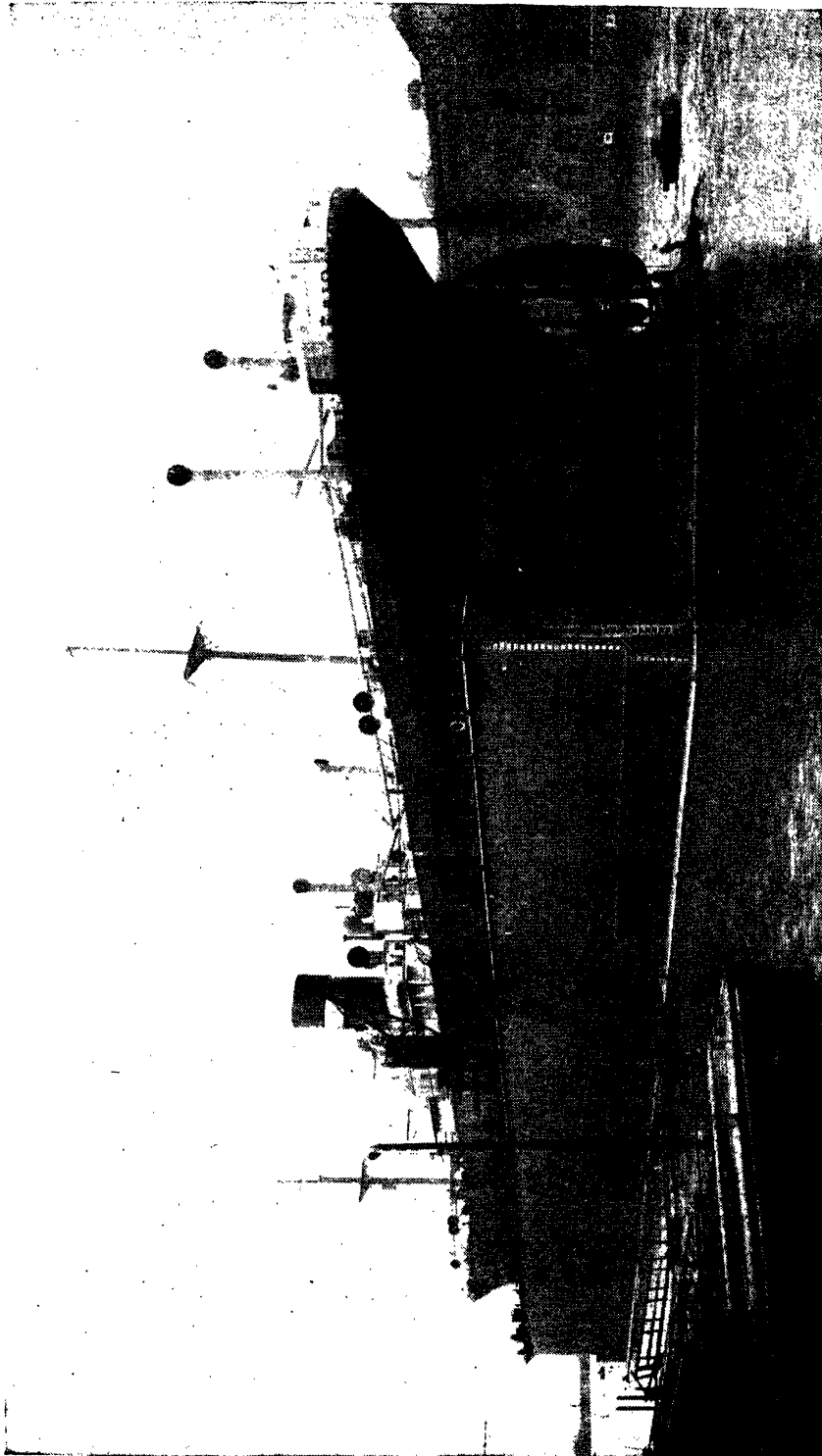

Cornwall Vickers Ltd.

A FLOATING DOCK

A floating dock is a hollow structure of iron, open at the ends and fitted with air-chambers. Sinking to the required depth to allow the ship to enter is effected by filling these chambers with water, and when the vessel is safely berthed the dock rises again as the water is pumped out. Recently one of the largest floating docks in existence was built at Southampton and towed round the Cape of Good Hope to Singapore.



THE FLOWERLIKE MANTIS

[By Theo Carreras

In this sketch four kinds of the "praying" insect are shown. The reverent attitude which it adopts when hunting is really a ploy for pouncing on prey. The Flowerlike, or Diabolical, Mantis is seen on the right, a large insect with its terrible claspers enormously developed and coloured to resemble a flower, thus helping to attract unsuspecting victims

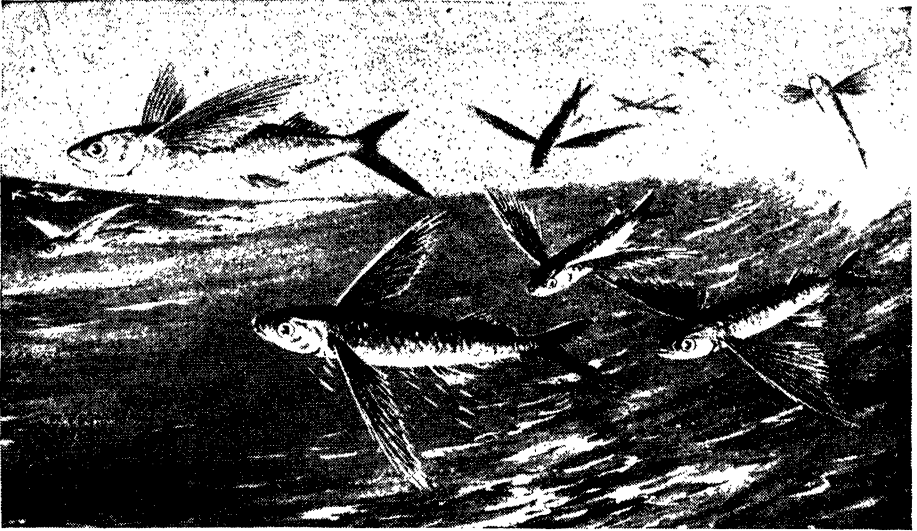

By courtesy]

FLYING FISH

["Marvels of the Universe"]

Save for the enormously developed fins, the flying fishes of California and elsewhere are very like herrings. Their skimming flight as they rise from the crests of the waves is very beautiful; their scales glisten like silver, and the rapid wing vibration creates the illusion of a glittering aura of film. They invariably inhabit tropical seas, and move in the large shoals suggested by the illustration

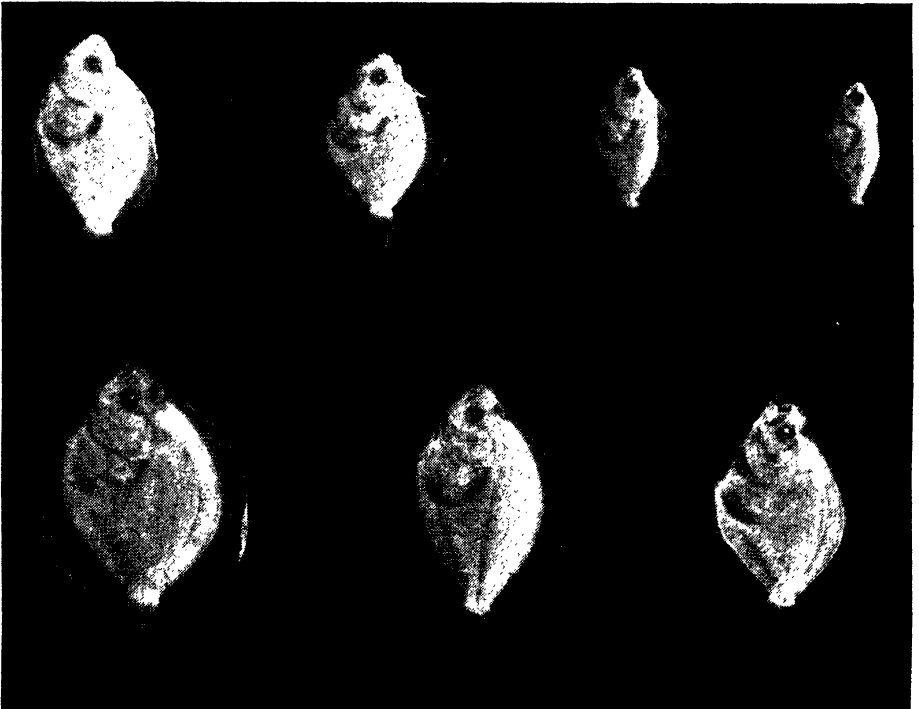

THE MOVING EYE OF A FLAT FISH

[Cuthew & Kinnaird]

Most of the flat-fishes such as plaice, sole, and brill, which in adult life maintain a horizontal position, in youth swim about vertically. To allow for this change, nature has provided that the right eye, as the fish matures, shall gradually travel completely across the forehead until both eyes are on the left. This series of photographs shows the transition

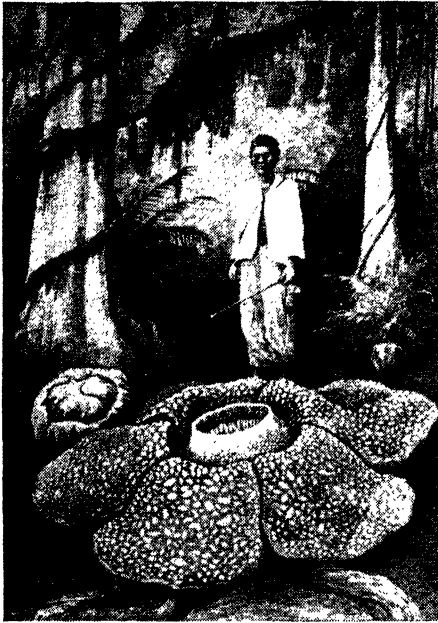

By Theo Carreras

THE WORLD'S LARGEST FLOWER

This flower is a parasite which grows upon the roots of stumpling plants in Sumatra. It weighs about fifteen pounds, and the central cavity would hold a gallon and a half of water. It has neither stem nor leaves; its petals give off a very offensive smell

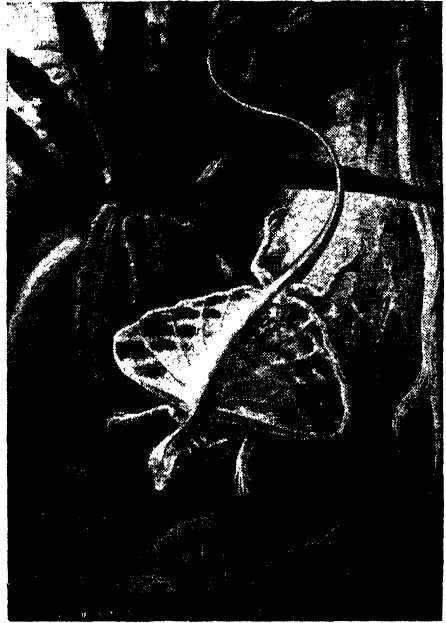

By Theo Carreras

THE FLYING DRAGON

The Flying Dragon is a brilliant blue- or orange-coloured lizard found in Malaya. It lives entirely in tree tops and by a wonderful adaptation of its ribs it can take long flying leaps from tree to tree. The long tail serves as balancer and rudder



FOSSIL PLANTS

The fragments of Banksia fern-leaves can just be distinguished in this lump of Australian ironstone. The fossil plants found in coal are millions of years old, but those shown date back to long before the coming of animal life

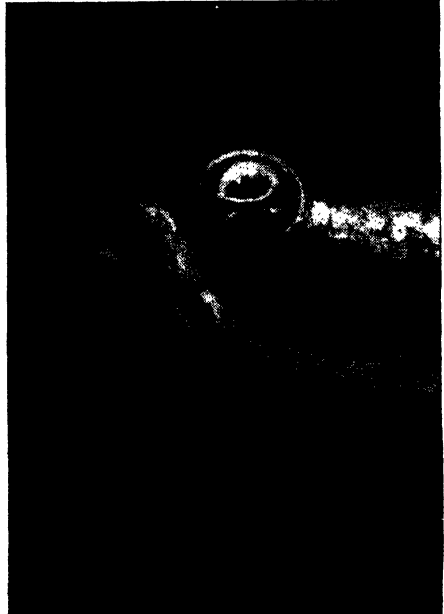

By Theo Carreras

THE FOUR-EYED FISH

An extraordinary fish, with each eye divided horizontally into two parts. It is the creature's habit to swim with its head half above the water; the two upper eyes then look into the open air, and the two lower into the water

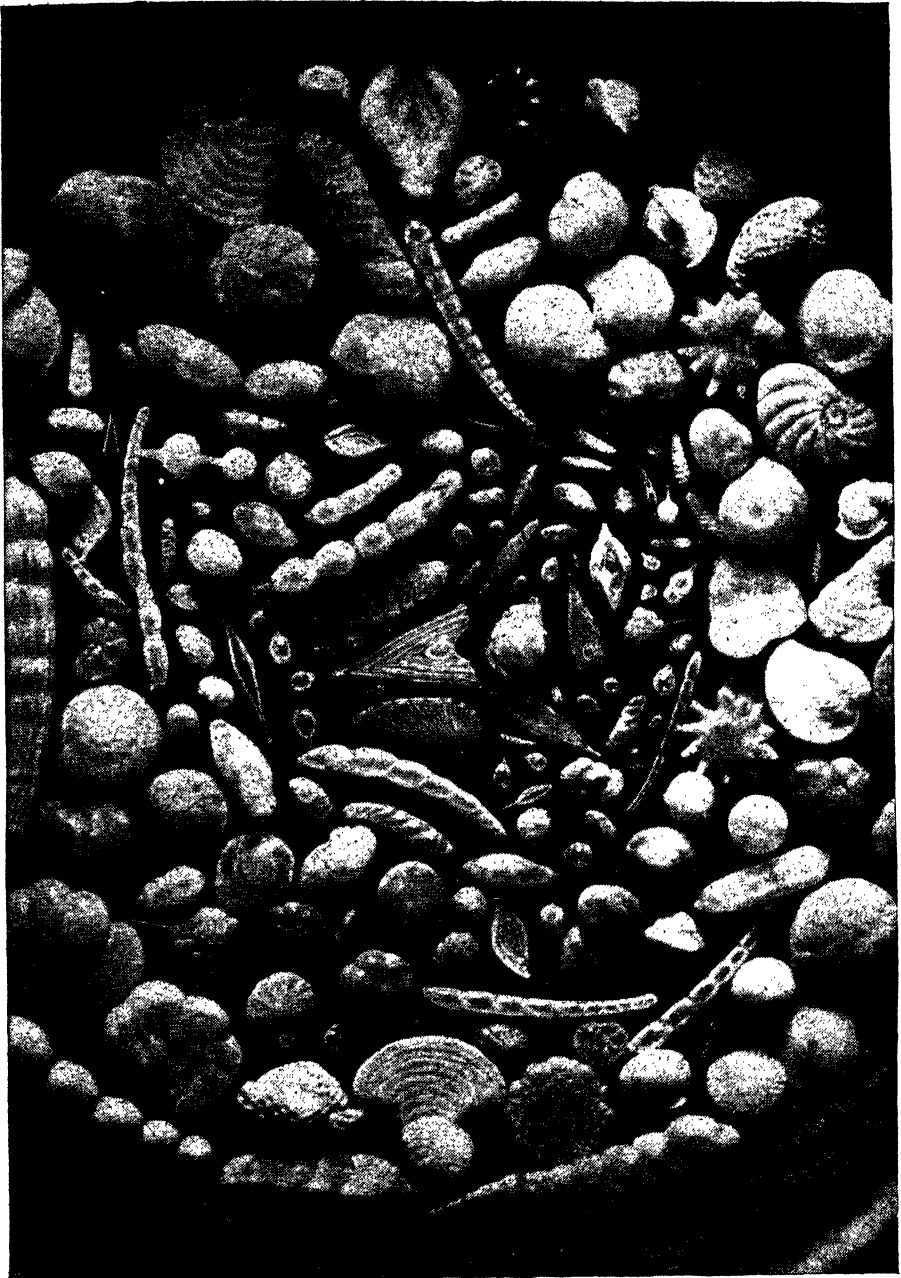

[A. E. Smith

FORAMINIFERA

This group contains the smallest forms of shellfish. The shells are made of carbonate of lime, and are perforated to allow the protrusion of minute feelers for feeding and locomotion. There are, however, large as well as small forms, and the fossilized shells of the larger compose much of the stone of which the Pyramids are built. The entire group illustrated here measures one-fifth of an inch from top to bottom.

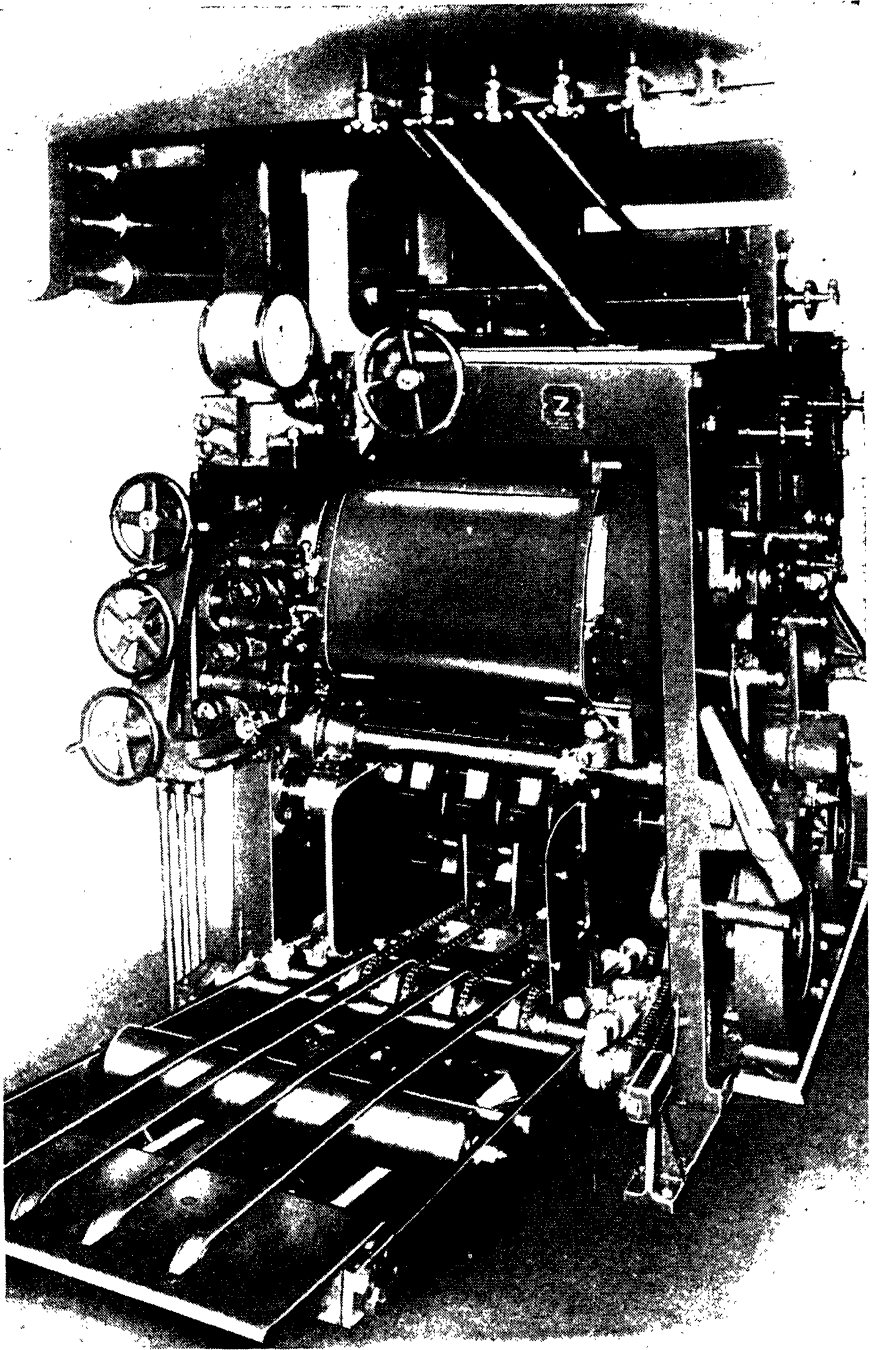

A NEWSPAPER FOLDER

[Courtesy R. Hoe Ltd.]

The modern daily newspaper being printed on five-mile-long rolls of paper, it is necessary to have a quick, accurate, and trustworthy apparatus to cut and fold the printed pages. This photograph shows such a machine. It is entirely automatic, and besides cutting and folding, counts the quires. It can handle many thousands of copies per hour



THE CLOISTERS OF FOUNTAINS ABBEY

[The Photochrom Co.]

Fountains Abbey, a Cistercian foundation dating from 1132, is a magnificent pile of ruins in West Yorkshire containing every style of architecture from Norman to Perpendicular. The famous cloisters date from 1147-1170, are 300 feet in length, and include a remarkable Dormitory of the Lay Brothers (seen here) which was formerly divided into cells



[Underwood Press Service]

THE LEANING TOWER OF FOO-CHOW

Foo-Chow (a corruption of Soo-Chow) is reckoned one of the two loveliest cities in China. The Leaning Tower, or Tiger Hill Pagoda, is acknowledged to be at least 1,300 years old, and has been well out of the perpendicular from time immemorial

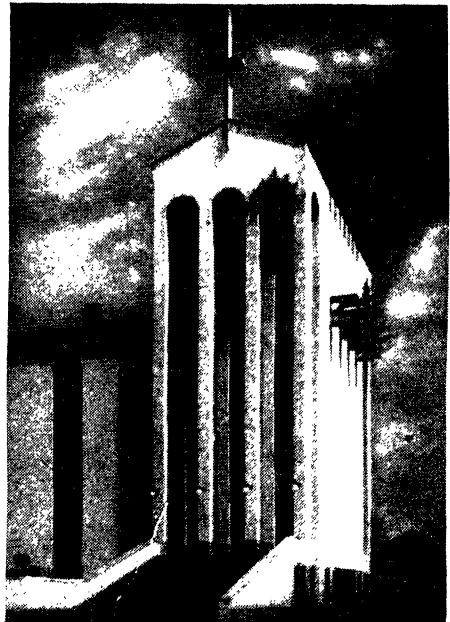

[Dorrien]

A CHURCH IN FRANKFURT

The Heiligkreuzkirche is a remarkable modern building typical of a very large number of twentieth-century temples in Germany and Scandinavia. There is something very effective about the enormous archways, and additional dignity is lent by the steps

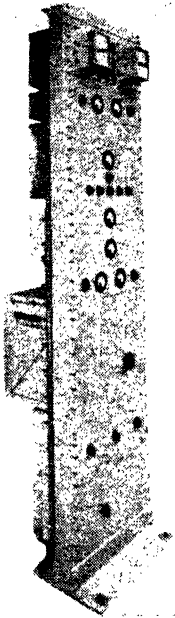

Macmillan Ltd.

A FREQUENCY CONTROL PANEL

Frequency in wireless means the number of radio waves given out per second, and the purpose of a control panel is to keep the frequency of a transmitter constant. The control panel shown here is crystal-driven, and has an accuracy of one part in a million.

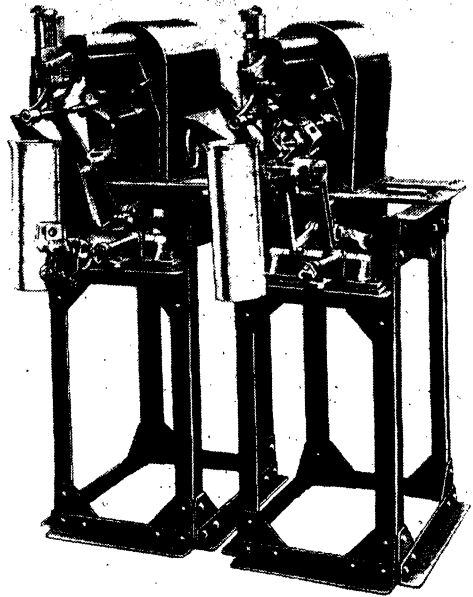

Carlisle & Kinnaird

FRUIT PARING MACHINERY

The preparation of fruit and vegetables, not only for canning, but for consumption in large quantities in restaurants, hotels, etc., entails much peeling, stoning and coring, which is nowadays done almost entirely by machinery. The apparatus shown here is a two-fold peeler and corer of apples, capable of handling several hundreds of apples an hour.

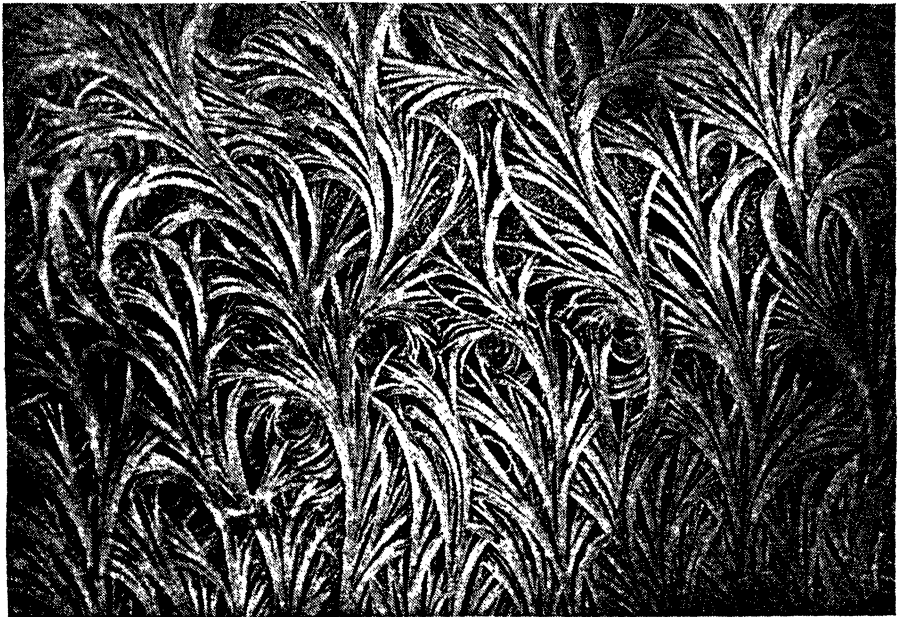

FROST CRYSTALS

[From "Marvels of the Universe"]

The marvellous symmetry of frost upon a window-pane may be detected to some extent with the naked eye, but a microphotograph such as the above is needed to show its true glories. It is still an unsolved question whether the plant-like shapes are really coincidental or due to a common underlying principle of nature.



FREIBURG SPIRE

(Dorien Leigh)

Freiburg Cathedral, one of the most glorious examples of Gothic architecture, was begun by the combined efforts of Freiburg citizens and the House of Hahringen in the twelfth century. The truly wonderful lacework spire was added 200 years after. Its imposing shape is striking, and even at a distance the open texture of its build is conspicuous.

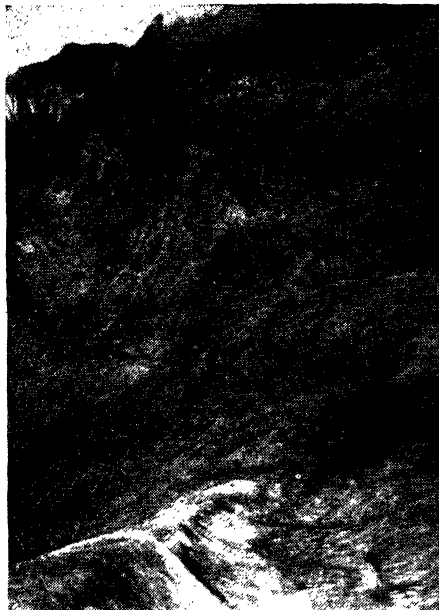

Courtesy of New Zealand Govt.]
THE FRANZ JOSEF GLACIER

This and the Tasman are the mightiest glaciers in New Zealand, or, indeed, in the Australasian continent. In the Southern Alps these ice-rivers descend much lower than in the northern hemisphere. Note the four men in this picture



[The late H. G. Ponting, F.R.G.S.]
FUJI-YAMA

Japan's sacred mountain, Fuji-Yama, rises in lonely majesty to a height of over 12,000 feet. The last eruption occurred in 1707, and the volcanic cone may now be climbed to the summit. The low surrounding hills abound in thread-like waterfalls



Courtesy G.E.C.]
AN ELECTRIC FURNACE

Elsewhere an annealing furnace is shown. Above is an electric furnace for vitreous enamelling, which necessitates extreme cleanliness. The furnace has an automatic temperature control and a motor-driven door

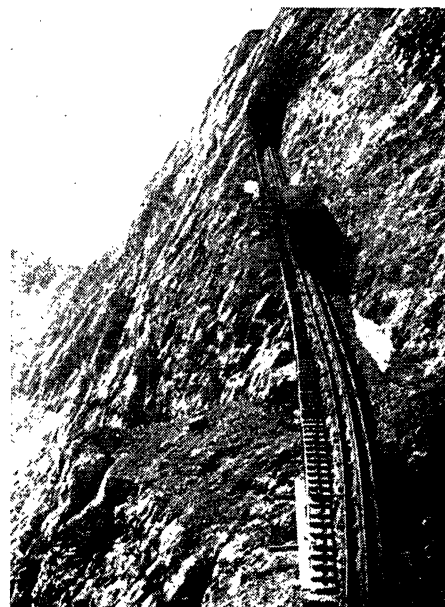

[Carthew & Kinnaird]
FUNICULAR AND MOUNTAIN RAILWAYS

Some of the devices used to conquer the mighty Alps by railway train show great engineering genius. On longer routes than those of funiculars a centre ratchet-rail is used, as shown above

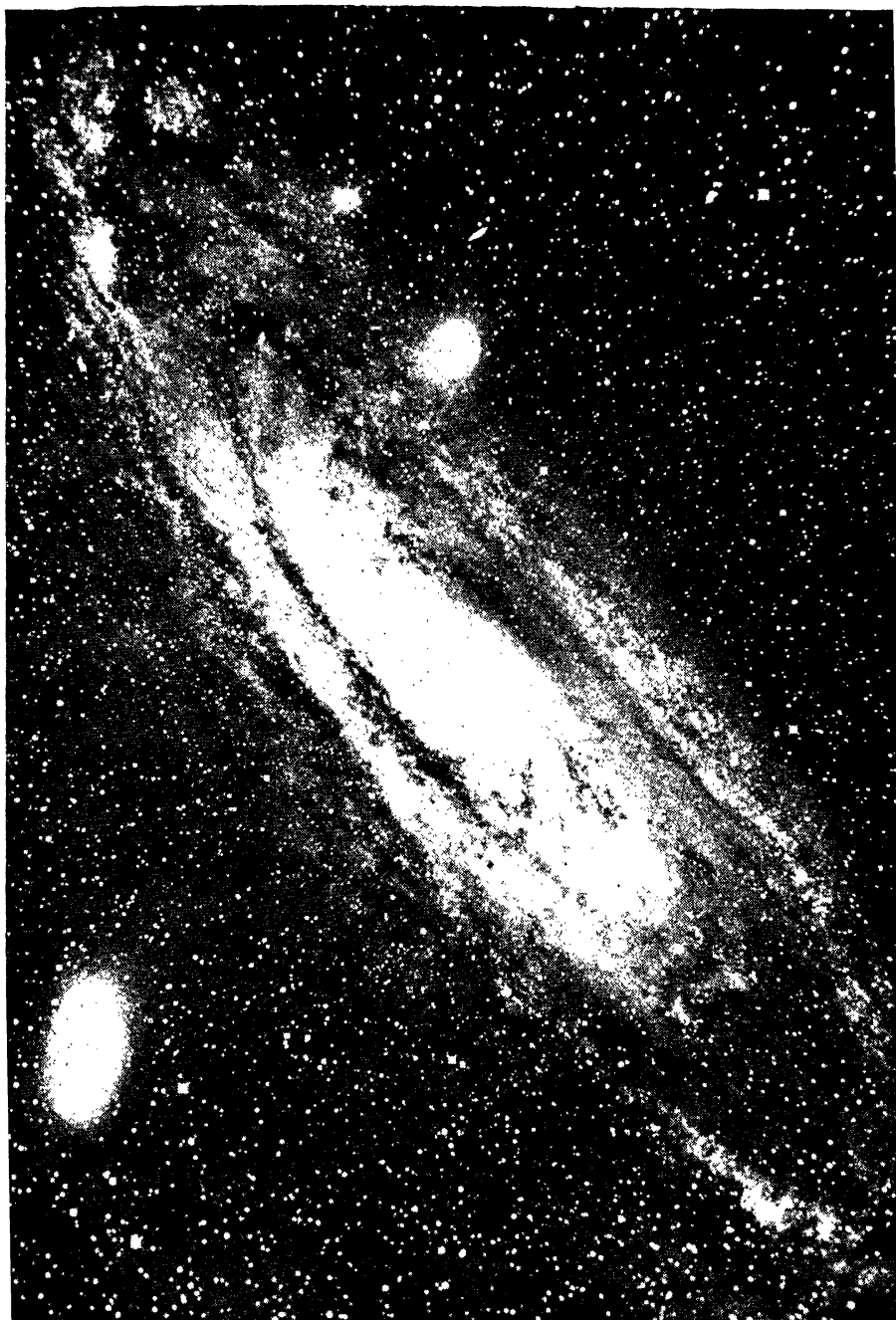

By courtesy]

THE GALACTIC NEBULA IN ANDROMEDA ["Splendours of the Heavens"]

Galactic nebulae are those which rotate upon an axis and form each an entire universe like our own, whirling round and round in space. Not only our tiny system of planets, but the whole of the stars which we see in our own heaven are parts of just such a galaxy, revolving like a cart-wheel of which the Milky Way represents the rim.

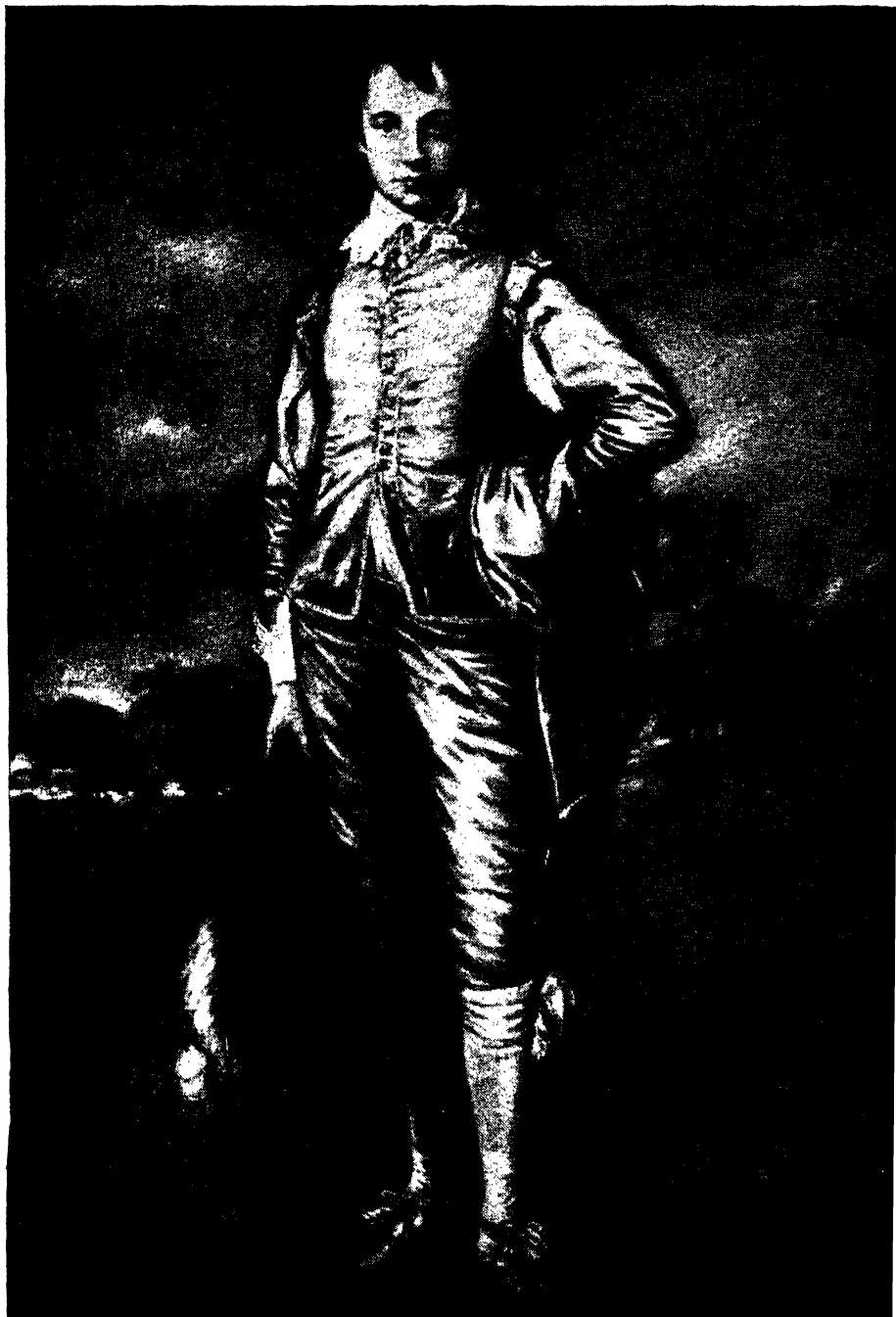

GAINSBOROUGH'S BLUE BOY

[Dorion Leigh]

Thomas Gainsborough was born at Sudbury, Suffolk, in 1727. At fourteen he went to London to study, at nineteen he married. He was a Foundation Member of the Royal Academy. His world-renowned "Blue Boy" was a lightning sketch of Master Buttall



MRS. SIDDONS, BY GAINSBOROUGH

[*Dorien Leigh*]

During his lifetime Gainsborough was most famous for his landscapes—a judgment which posterity has reversed. He painted Clive, Franklin, Sheridan, Dr. Johnson, Canning, Burke, the Duchess of Devonshire, and the great actress, Mrs. Sarah Siddons, whose portrait hangs in the National Gallery



Carthew & Kinnaird

GAS-MASKS

Though gas masks first came into sinister prominence during the War, they have great civil use in protecting the workers in mines, sewers, and many industrial tasks involving danger to the lungs. The picture shows gas-masks as worn by firemen

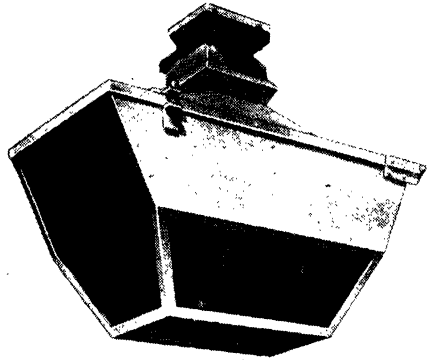

[Courtesy B.T.H.]

A GAS DISCHARGE LAMP

The light from such lamps is due to the incandescence, by electric current, of a certain gas within the bulb. The above is a street lamp, but the widest use of this device is for advertising, different gases producing different colours. (See Vapour-tube lighting)

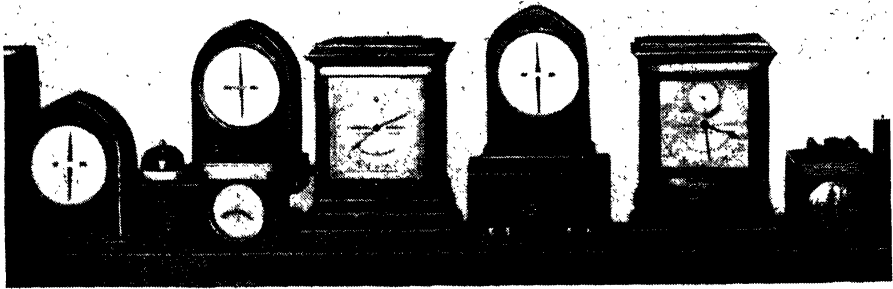

A SET OF GALVANOMETERS

[Carthew & Kinnaird]

Galvanometers are instruments for measuring very small currents, and most of them depend upon the force between a magnet and the conductor which carries the current to be measured. There are two subdivisions - those illustrated here, which employ a moving magnetic needle, and a moving-coil type in which the conductor is in the form of a light coil suspended in a fixed magnetic field

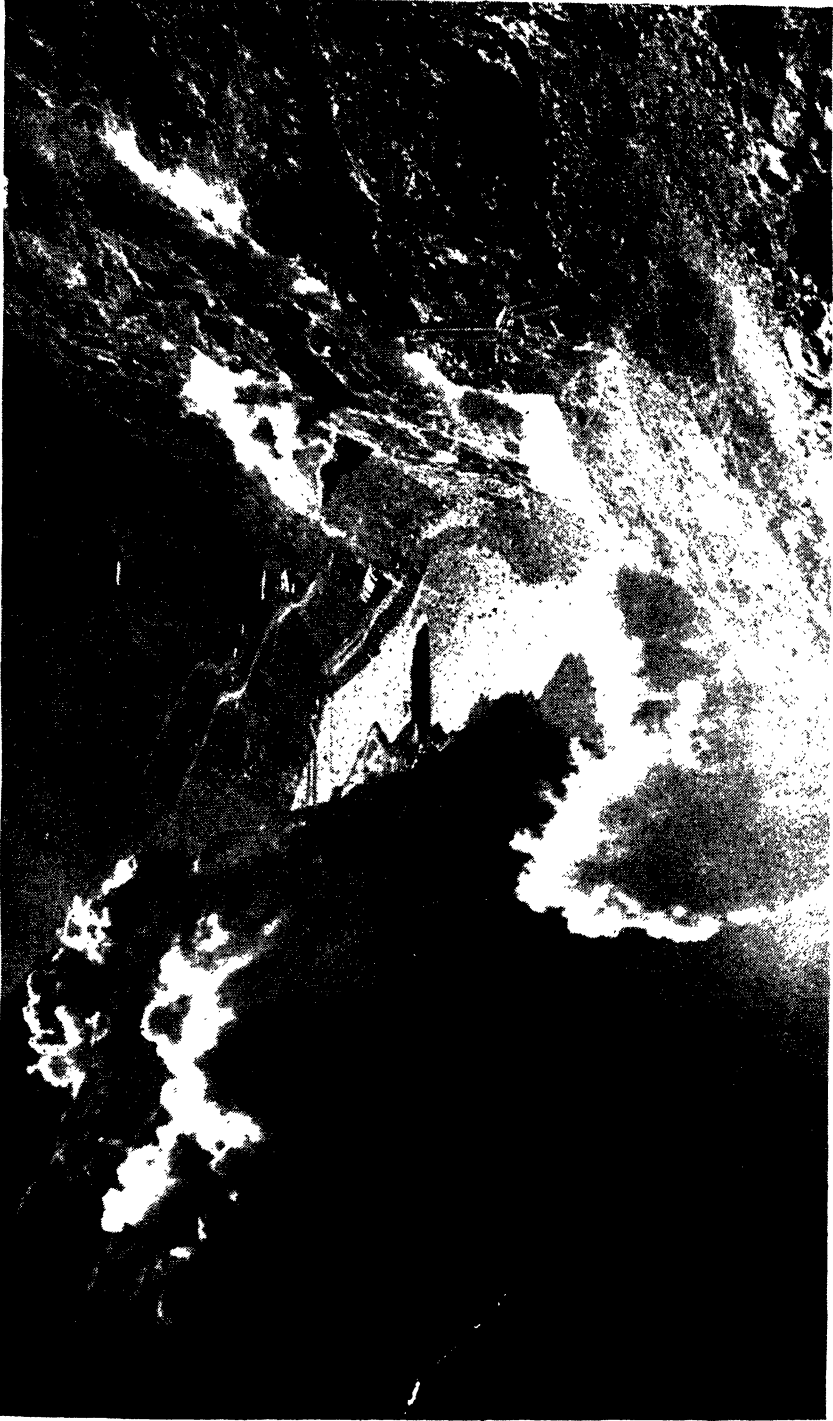

[Keytoms]

BLASTING WITH GELATINE EXPLOSIVES

In metal mining, sinking, tunnelling, and railway levelling, where massive rock has to be shifted in large quantities with accuracy and safety, three explosives based on nitro-glycerine are adopted: dynamite, blasting gelatine, and gelignite. The above photograph shows tunnel blasting in connection with the Boulder Dam on the River Colorado (q.v.)

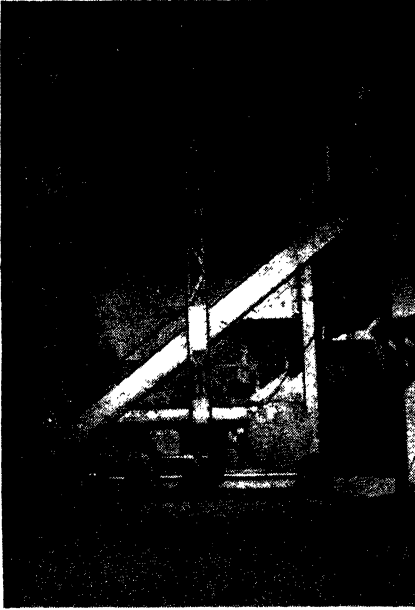

[Carthw & Kinnaird & Keystone

THE MANUFACTURE OF GAS

by heating coal in a closed chamber so that volatile matter is driven off, leaving a solid residue of coke. The matter is then cooled to condense watery and tarry liquid constituents. The above photographs show a hydraulic machine for drawing the coke after the gas has been extracted. (Right) a new type of cooling plant

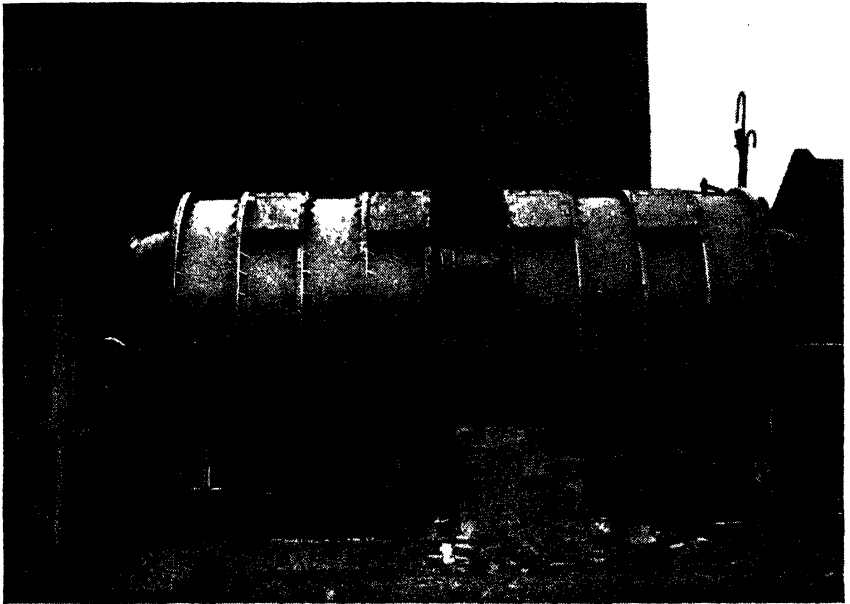

[Carthw & Kinnaird,

A GAS-"BRUSHING" PLANT

During carbonization a proportion of the nitrogen of coal is evolved as ammonia, which is found in the water condensate. It is recovered by distillation or "brushing" with steam, and the ammonia is fed with sulphuric acid to form sulphate of ammonia. The process has declined since the advent of synthetic ammonia

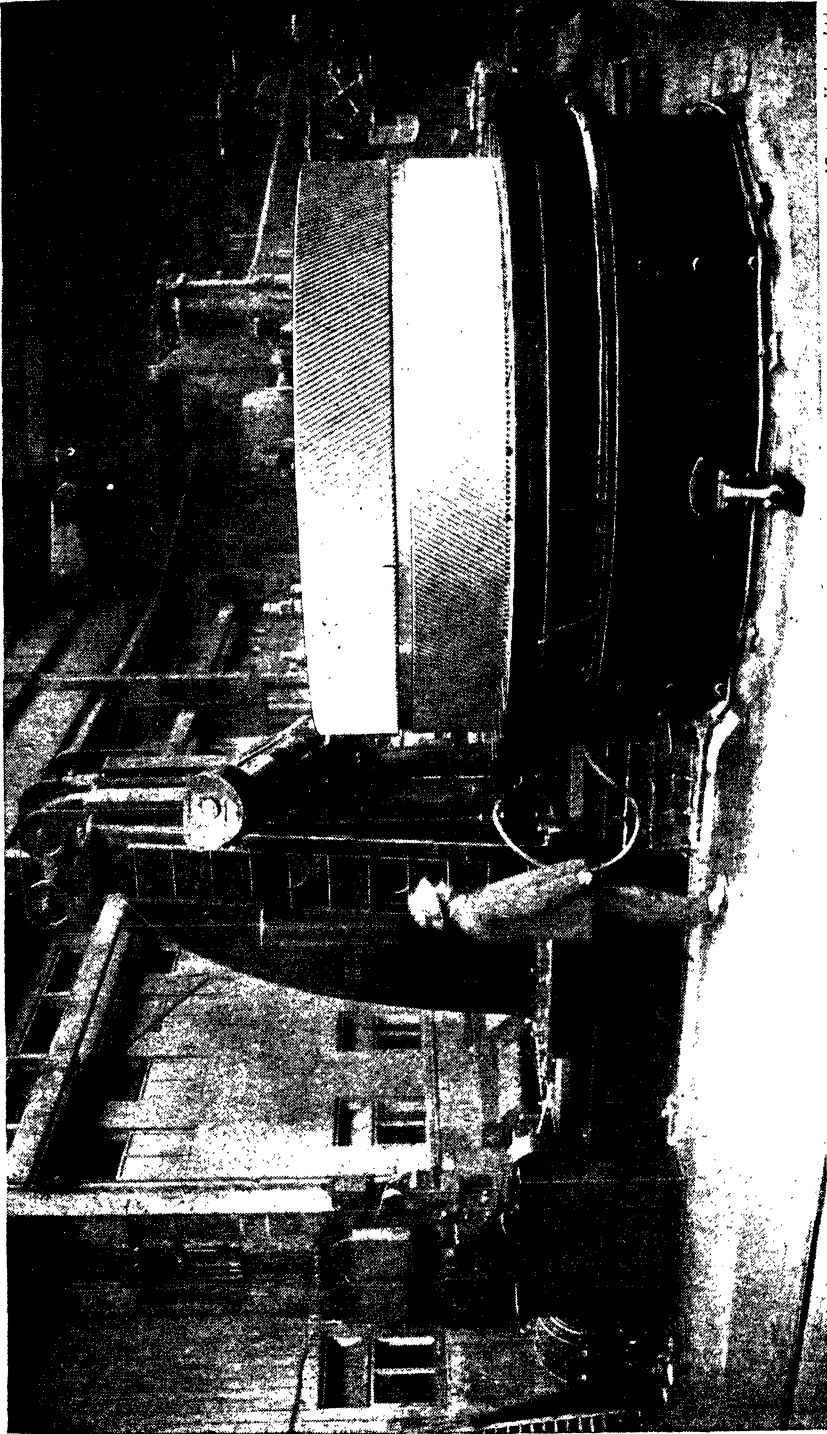

[Courtesy Vickers Ltd.]

A GEAR-HOBGING MACHINE

A machine on which gear-wheels are cut. The work necessitates much accuracy, as the slightest deviation in the teeth would render the wheel useless. It would be too costly to provide a different apparatus for each purpose, so the hobber has to be provided with variations for cutting spiral, single or double helical, bevel and worm gears. The machine shown is capable of handling wheels up to 15 feet in diameter

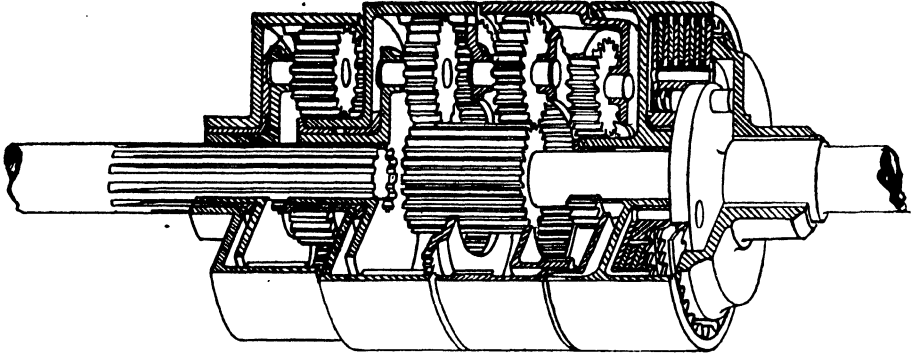

SELF-CHANGING GEARS

[Courtesy Daimlers Ltd.]

The gear box of any mechanical apparatus is designed to multiply the driving-power when the greatest effort is required, and to multiply the speed, at the cost of power, as the need for effort diminishes. Thus on a motor car, a small pinion rotating a large is needed for the initial push at starting, and vice versa when the momentum has made possible a reduction of force in order to gain rapidly. This diagram shows an automobile gear box where the stages change automatically.

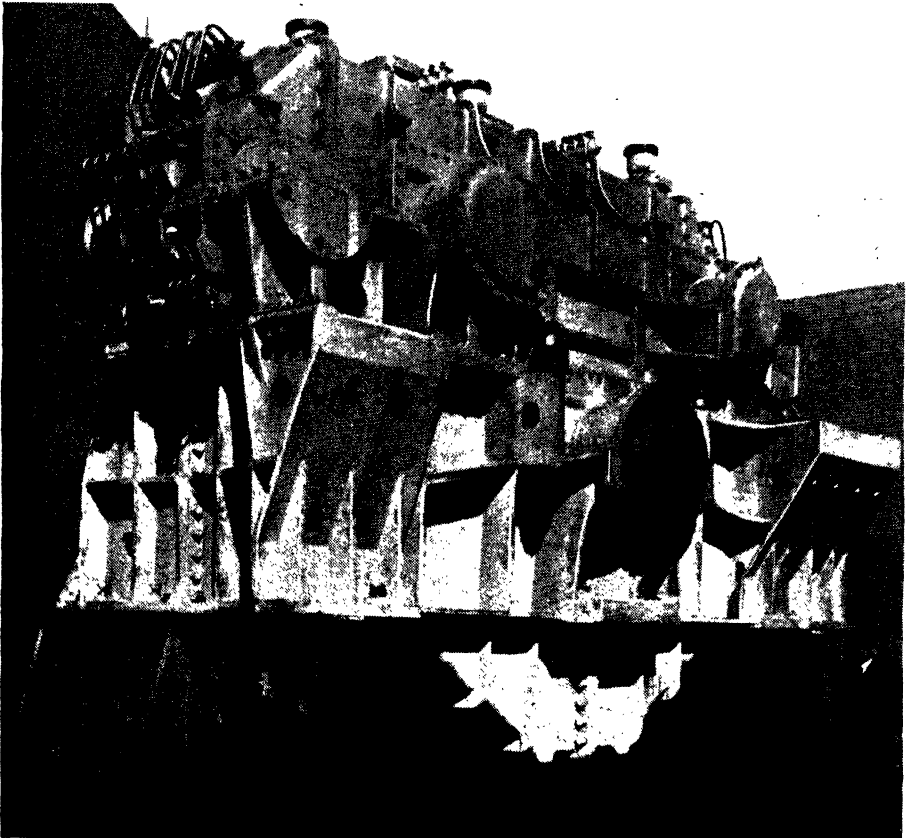

THE GEAR-CASE OF A LINER

[Courtesy Vickers Ltd.]

For the reasons set out above, a ship requires gears as much as a land vehicle, and of course on a much larger scale. The resistance of water to a stationary vessel requires infinitely more effort to master than that when the vessel is under way. The gear-case illustrated is for the Cunard liner *Scythia*.



[Dorion Laigh

"THE RAFT OF THE MEDUSA," BY GÉRICAUT

Jean Louis Géricault (b. 1791) was the leader of the Romantic school of painting in France. By far his most celebrated picture, that reproduced here. The *Medusa* was a vessel which sank in 1816; fifty-nine people, unable to find places in the boats, took refuge on a raft, which drifted for twelve days, when it was found there were only fifteen survivors.

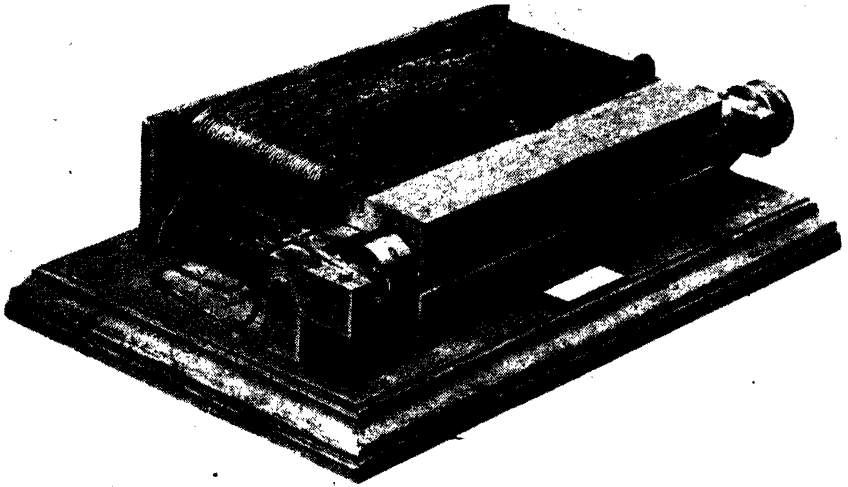

[Courtesy Siemens Bros.]

GENERATING ELECTRICITY: THE FIRST DYNAMO

Few achievements of science could be more startlingly shown in two pictures than the progress of electricity as portrayed on this page. Above is the first dynamo ever built; it was constructed by Werner Siemens in 1862

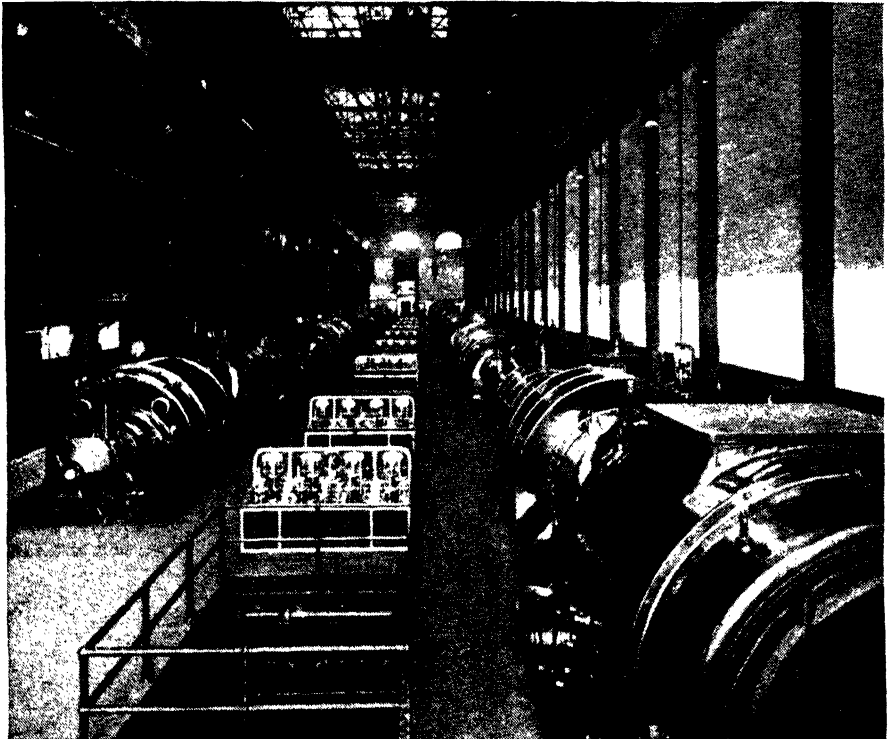

[Courtesy London Transport]

GENERATING ELECTRICITY: A MODERN POWER-STATION

ators at the Lots Road power-station, one of the chief on the Underground Its are produced hourly. The impetus for dynamos is mostly derived in countries by steam-power, but wherever there are waterfalls hydro-electric stations are a great source of economy

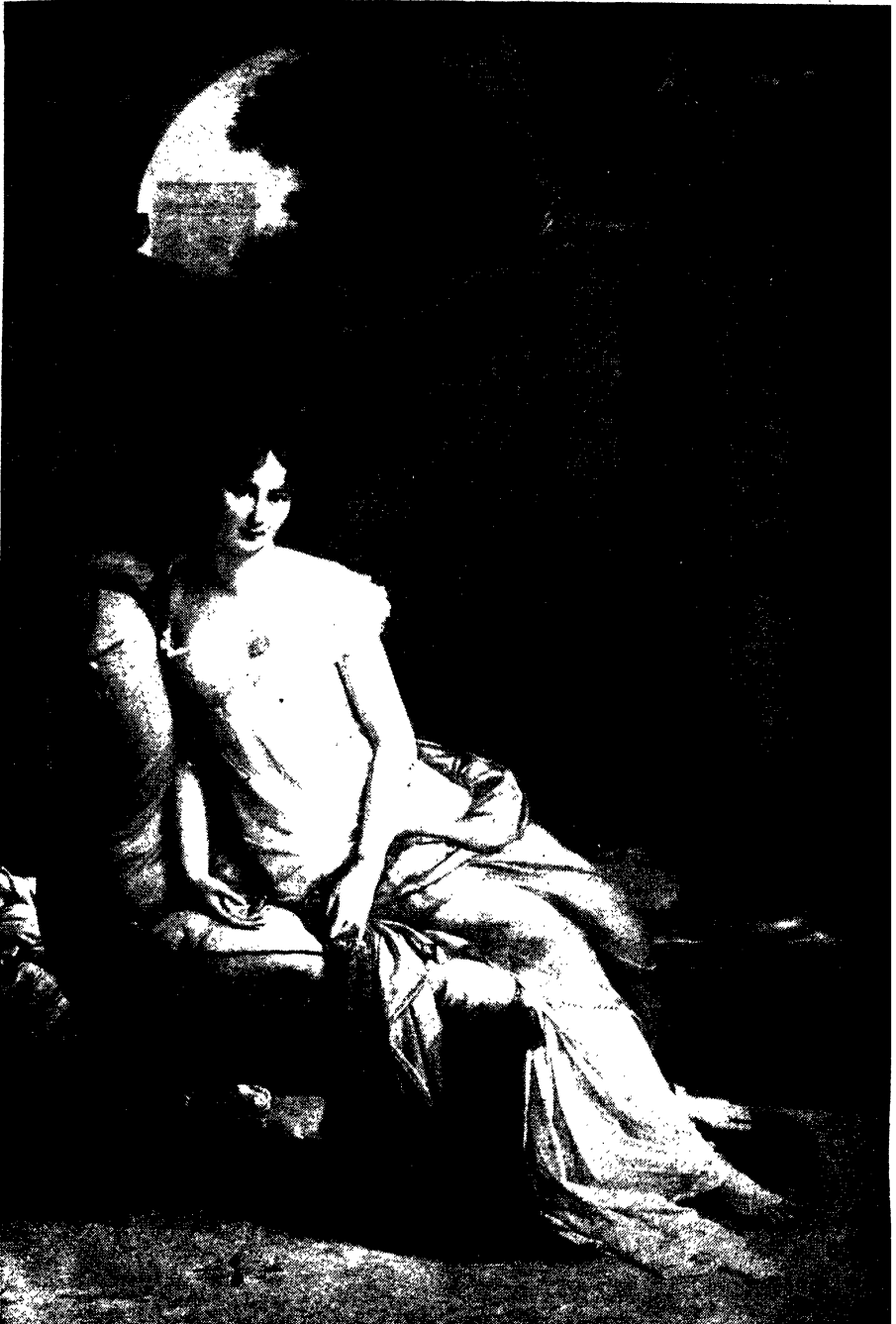

"MME RÉCAMIER," BY GÉRARD

[Dorien Leigh

François Pascal, Baron Gérard (1770-1837), was a Frenchman born at Rome. His parents soon took him to France, where, with one brief interval, he lived throughout the Revolutionary and Napoleonic eras. He studied painting under Brenet and David, and in 1796 created a sensation in Paris with his first important work, "Bélisaire." To-day, however, he is best known for his portraits, which include, besides Mme Récamier, Napoleon, Talleyrand and Mme de Staël



From "Marvels of the Universe"

THE GEOSAUR

Jurassic period. It shows a transition stage in the evolution, for the limbs are merely paddles and there are no scales on the back



[Dorrien Leigh]

STONE MOUNTAIN, GEORGIA

an ordinary formation, the origin of which is volcanic, is a conspicuous feature in the flattish country in which it lies. Practically no plants grow on its rounded sides, which are several hundred feet high



[from "Wonders of the World"

GERMANY'S EXTINCT CRATER LAKES

What in very ancient times were volcanic craters in Northern Germany are now deep lakes. Some of the lakes are of quite recent formation. Beneath the above, the Weinfeldermaar, a mediæval village and castle lie buried, the only surviving feature, the church, may be just distinguished on the further shore. Only one of these volcanic lakes has a natural outlet. The aspect of all is very sinister



[W. F. Mansell

GHIBERTI'S DOORS TO THE FLORENTINE BAPTISTRY

These doors are the masterpiece of one of the greatest sculptors of all time. Lorenzo Ghiberti (1378-1455) was twenty-nine when he began this work and seventy-four when he finished it. The panels, which are executed in bronze, represent scenes from the Old Testament. Ghiberti also executed some fine bas reliefs and statues of the Apostles



W. F. Mansell]

A CHURCH IN GENOA

One of the world's chief ports during the Middle Ages, Genoa abounds in glorious churches and palaces. For sheer architectural beauty the above church of S. Maria di Carignano is unrivalled, being one of the finest small churches in Europe.



[Underwood]

INSIDE A PYRAMID

In the heart of each pyramid is the tomb of the king for whom it was built. The long passage, shown here, leading to the hall of the Pyramid of Cheops, is one of the hottest and sombrest corridors in existence. The hall is 157 feet long and 28 feet high.



E.N.A.]

THE GREAT PYRAMID

A close-up of the Great Pyramid of Cheops at Ghizeh, showing the large size of the individual stones. This pyramid is 451 feet high, and contains 85,000,000 cubic feet of stone. It was built about 5650 years ago.



[Keystone]

THE SPHINX, GHIZEH

This unusual view of the age-old Sphinx was taken after the final clearing away of sand. Between the forepaws is a tablet in hieroglyphics describing the why and wherefore of the monument's erection.



[Dorsten Leigh]

"ADORATION OF THE SHEPHERDS," BY GHIRLANDAIO
"Ghirlandajo" (garland-maker) (1449-1494), in reality Domenico Bogardi, or Corradi, was the founder of a famous school of painting and the first Florentine to attain skill in aerial perspective. Michelangelo was one of his pupils. Ghirlandaio's pictures are all religious, and the above, which is now in the Florence Academy, is a typical example



THE OUDEBURG, GHENT

[Donald McLeish]

Count Philip of Alsace built this massive chateau in the twelfth century. Since then it has played a conspicuous part in Flemish history, but is mainly interesting to the English in that here, in 1330, Jacques Van Artevelde entertained Edward III, and in the Oudeburg in 1340 was born Edward's son, John of Gaunt.



AGRIGENTO: THE TEMPLE OF CONCORD

[Photochrom Co.]

This is one of those cosmopolitan Sicilian towns which have been dominated in turn by Phœnician, Greek, Byzantine, Saracen, Norman and Spanish Dynasties. The Greeks left the greatest memorial in the shape of the magnificent Temple here seen—one of the best of its kind outside Greece.

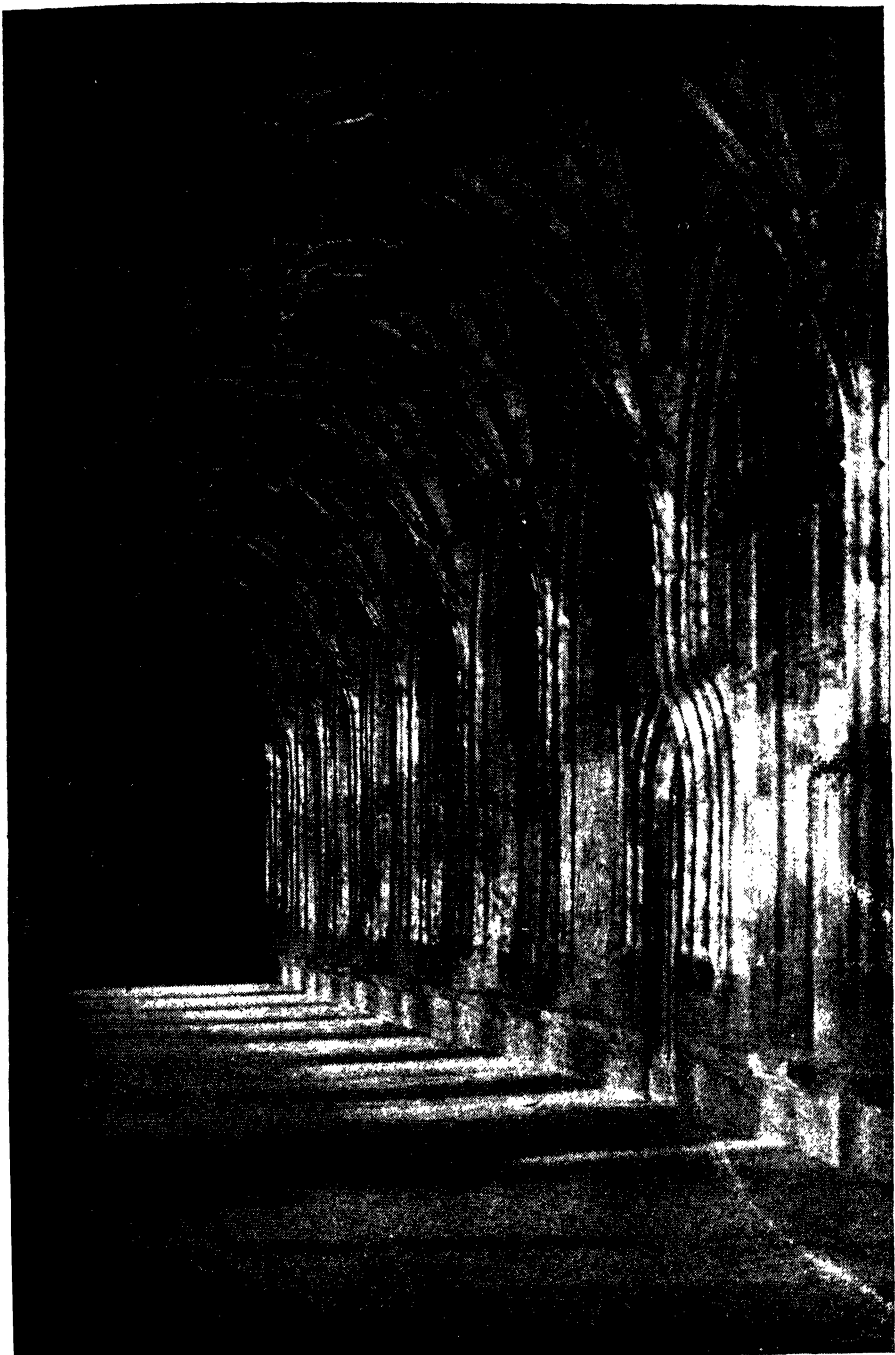

[Dorion Leigh]

GLOUCESTER CATHEDRAL CLOISTERS

The idea of putting fan-tracery in open cloisters is believed to have been original to the Gloucestershire masons. The result is one of the most graceful cloister-walks in West-European architecture. The work dates from 1351-1412, and together with the rest of the Cathedral, the cloisters were restored in the nineteenth century by Gilbert Scott. On one side there are sculptured recesses for manuscript-writing

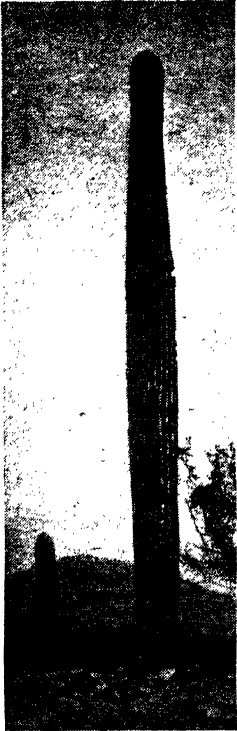

[Dorien Leigh]
A GIANT CACTUS

Mexico abounds in queer examples of cactus. Some are very picturesque, others are useful in that they contain water which may be tapped by travellers. The photograph shows one of the tallest species—nearly 50 feet high



[Courtesy Southern Pacific Railway

CALIFORNIA'S GIANT TREES

The giant trees of California are of two varieties, neither of which is found elsewhere. Most of them grow in Mariposa Grove, and the above specimen in the Grove measures 94 feet round. It is estimated to be 8000 years old



[Dorien Leigh]
"MERCURY," BY GIAN BOLOGNA

Gian Bologna (1521-1603) is still known in France as Jean de Douai after his birthplace. His sculpture however, were executed in Ron Florence, and Bologna. His celebrated bronze Mercury is depicted here, a famous version of the Go



THE THYROID GLAND

[Catharine S. Kinnsitt

Briefly a gland may be described as a collection of cells which secrete into a common cavity. The influence of gland on health has been startlingly shown by thyroid grafting for "rejuvenation." Above is a photomicrograph of thyroid gland cells

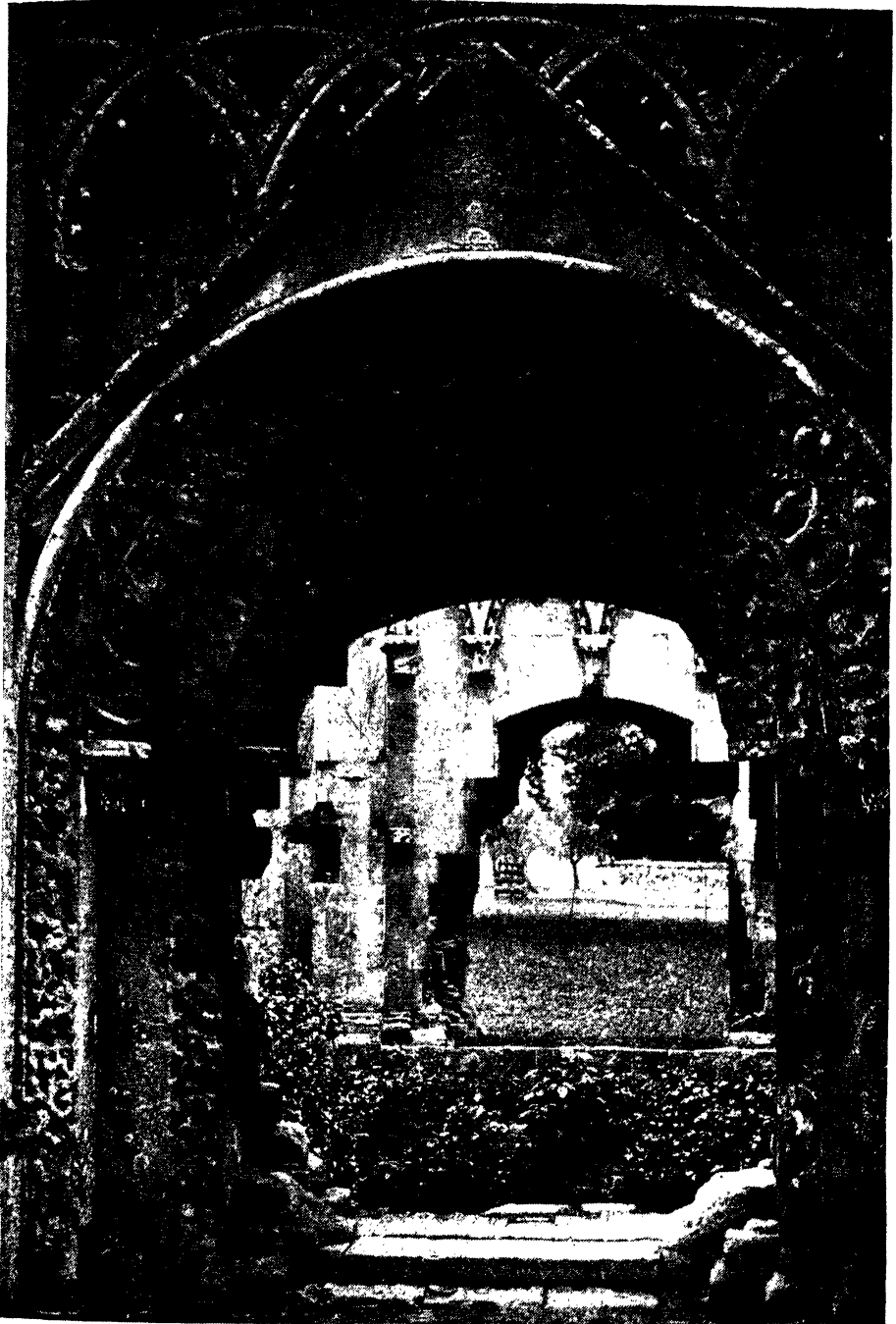

A DOORWAY IN GLASTONBURY ABBEY

[Rev. W. Mann, M.A.]

The monastery of Glastonbury is the earliest Christian foundation in all Britain. A.D. 601 is the date of the first authentic record, but tradition connects the site with Joseph of Arimathea. The various extant buildings date from many periods, but the noblest, the Chapel, is Transitional Norman. The magnificent doorway to this is shown above.



ST. JOSEPH'S CHAPEL, GLASTONBURY

[*F. Frith & Co.*]

St. Joseph's, or St. Mary's, Chapel was built by Henry II in 1186. It takes the form of a Galilee at the western entrance of the main church, and originally each of the four corners was surmounted by a little tower. The chapel is supposed to stand on the site of St. Joseph's shrine

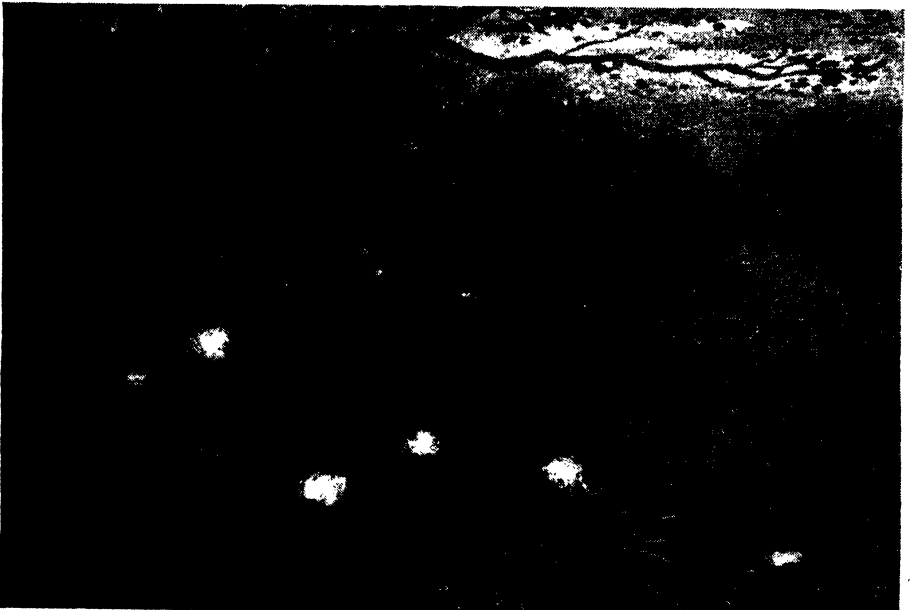

GLOW-WORMS IN A 'SURREY LANE

[*By Theo Carreras*]

Well known though the glow-worm is, naturalists to this day are uncertain of the reason for its mystic light. It is believed to enable the winged male to find the wingless female. Nor is it fully known what causes the glow. The insects are beetles, not worms

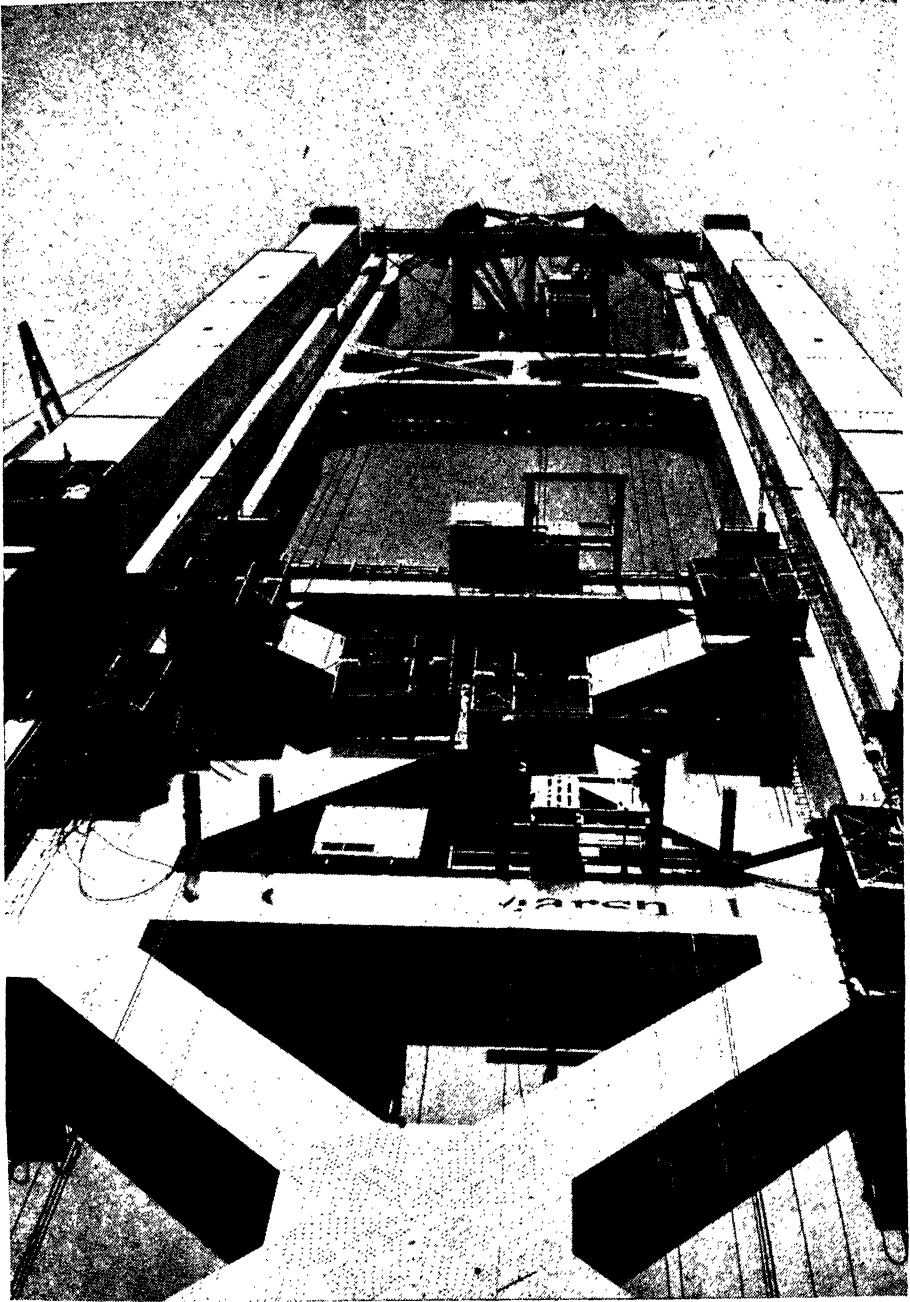

Keystone

BUILDING THE GOLDEN GATE BRIDGE, CALIFORNIA

One of the most remarkable engineering feats the world has known was launched by the decision to build two gigantic bridges across the harbour of San Francisco. Of these the Golden Gate Bridge, though the shorter, is in many ways the more spectacular. This photograph shows a ground view of one of the mammoth steel towers at the bridge's in course of erection. These towers are 632 feet high

[Courtesy Messrs. Chapman & Hall]

THE GLYPTODON

This tank-like and heavily-armed beast was a remote ancestor of the modern armadillo. However, the armadillo's armour consists of movable bands, while the glyptodon's was made of fixed plates, like a turtle's shell. Notice the curious bony cap protecting the head, and the hard scales protecting even the tail

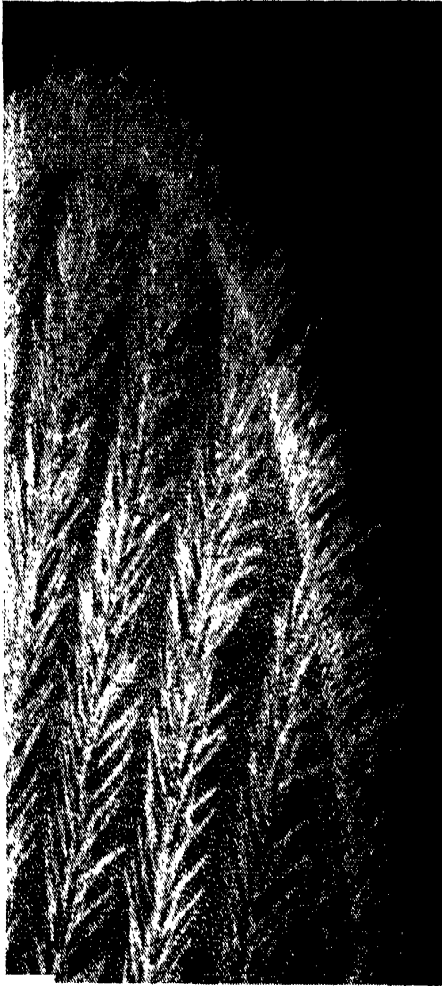

170 "Marvels of the Universe"
A GNAT'S WING

A portion of a gnat's wing, sufficiently magnified, looks not unlike a lace tray-cloth. The border is seen to be heavily fringed, as are also the nervures, which cross the membrane in parallel lines



[From "Marvels of Insect Life"
HEAD ORGANS OF A GNAT

This shows, highly magnified, the head of a male gnat. The tiny hairs which branch out from the antennae are the organs of hearing, and respond to the 512 vibrations per second given out by the hum of the female's wings

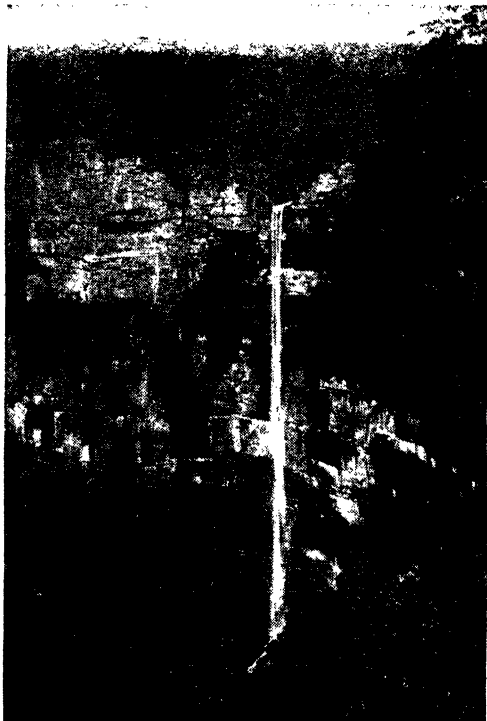

[Courtesy N.S. Wales Govett.]

GOVETT'S LEAP FALLS

The Blue Mountains of South-eastern Australia form that continent's finest scenery, majestic, thickly forested, and of glorious colouring. Above is one of the many graceful cascades which adorn them.



[Dorson 1898]

A PORTRAIT BY GOYA

Francisco Jose de Goya y Lucientes (1746-1828), one of the foremost Spanish painters, lived a stormy and varied life. He was at his best at portrait painting, and was for a time attached to the court of Charles IV, whose picture is seen here.

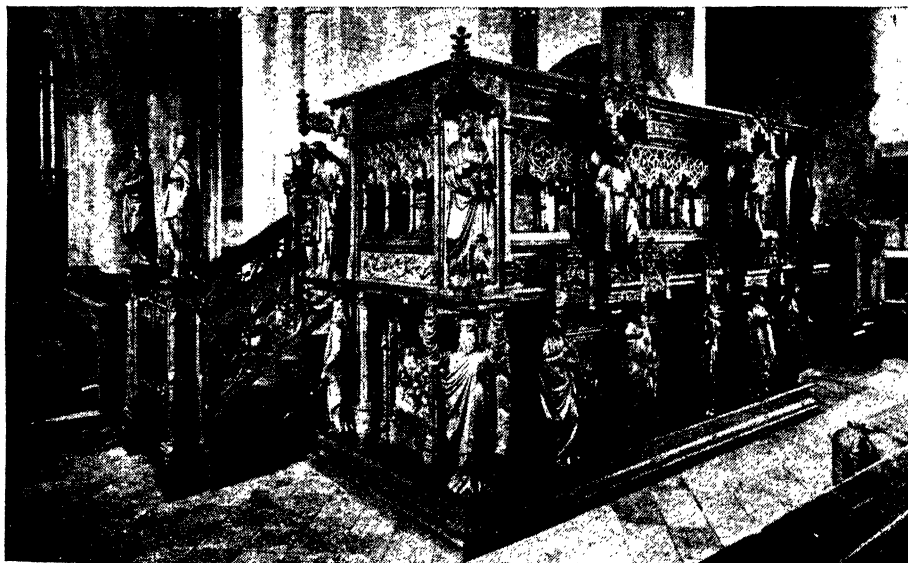

THE PULPIT OF ST. NICHOLAS, GREAT YARMOUTH

[P. Froth & Co.]

St. Nicholas's Church, Yarmouth, is almost the largest parish church in England and dates from 1101, though little of the original building. The pulpit here illustrated is a magnificent piece of work, and both for size and manner of decoration is more German than English.



JOURNEY OF THE WISE KINGS, BY GOZZOLI

[Dorson Leigh

Bennozo Gozzoli, one of the Florentine School, was an assistant of Fra Angelico, whose work is illustrated elsewhere in this book. Gozzoli is chiefly renowned as a fresco-painter, and his best-known work, which took him sixteen years to complete, is a fresco in Pisa consisting of twenty-four Biblical scenes. An equally fine series, however, is in Florence, one scene from it being reproduced here. Gozzoli lived from 1420-1498

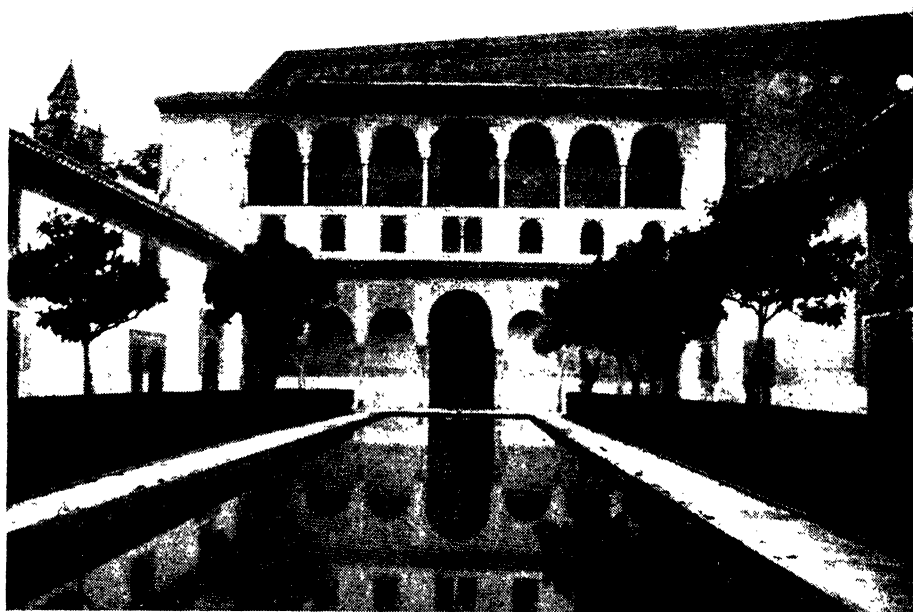

[Photochrom Co.]

THE COURT OF THE MYRTLES, ALHAMBRA

Granada was the last city to be held by the Moors, before the Spanish, whom they had been civilizing for 777 years ungratefully turned them out. In every room of the Alhambra there is an unearthly stillness in which spirits still seem to protest against Christian

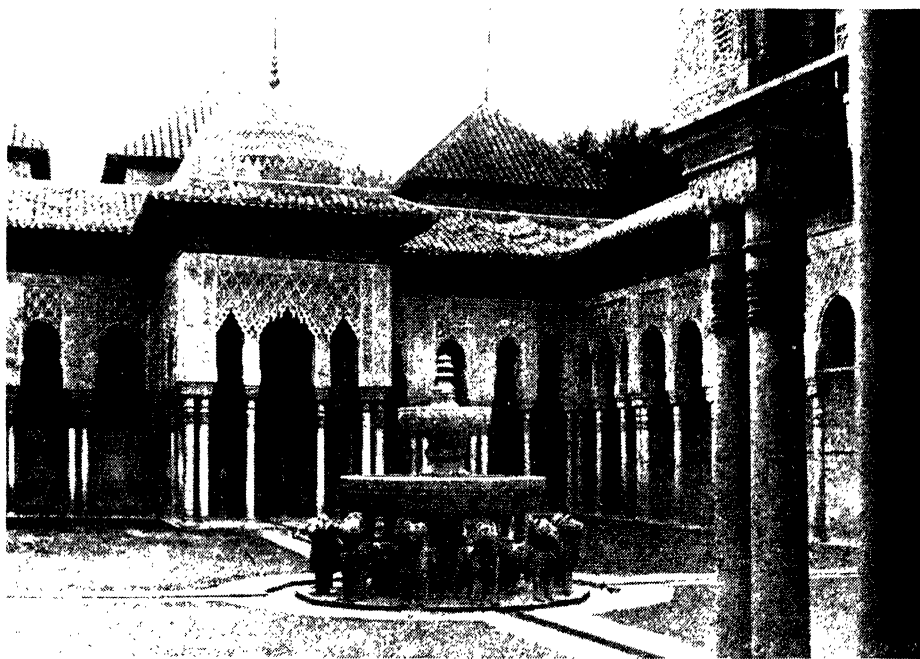

[Photochrom Co.]

GRANADA, A SCENE IN THE ALHAMBRA

Though lacking the simplicity of earlier Moorish structures such as the Giralda and Alcazar at Seville, the famous palace in the Alhambra fortress is held by many to be the loveliest building in Europe. Most of it, including the Court of Lions shown here, is fourteenth century work.



[Dorion Leigh]

GREEK POTTERY

The pottery of Ancient Greece reached an aesthetic level which has never been surpassed before or since. The two vases shown are Attic, and are remarkable for their perfect shape and the decorations on them. The vase on the left shows a battle; the other, Amphorite. Both are well over 2000 years old.



GRANTHAM SPIRE

One of the finest steeples in Britain. It is over 280 feet high. The church itself is mainly thirteenth century, but shows some excellent Perpendicular work.



GREUZE'S "LA CRUCHE CASSÉE"

[Dorion Leigh]

Not often is an artist's first picture so good that his teachers doubt whether it is entirely his own work. This, however, happened to Jean Baptiste Greuze (1725-1805). His speciality was portraits of young girls, of which the above is a celebrated example.



[Dorson Leigh]

A PAGE FROM THE GRIMANI BREVIARY

The illumination of manuscripts was a high art in practically all European countries before the advent of printing. In England and France its golden period was the fourteenth century, in Flanders the fifteenth, in Italy most of both.

The Grimani Breviary, above, is now in St. Mark's Library, Venice.

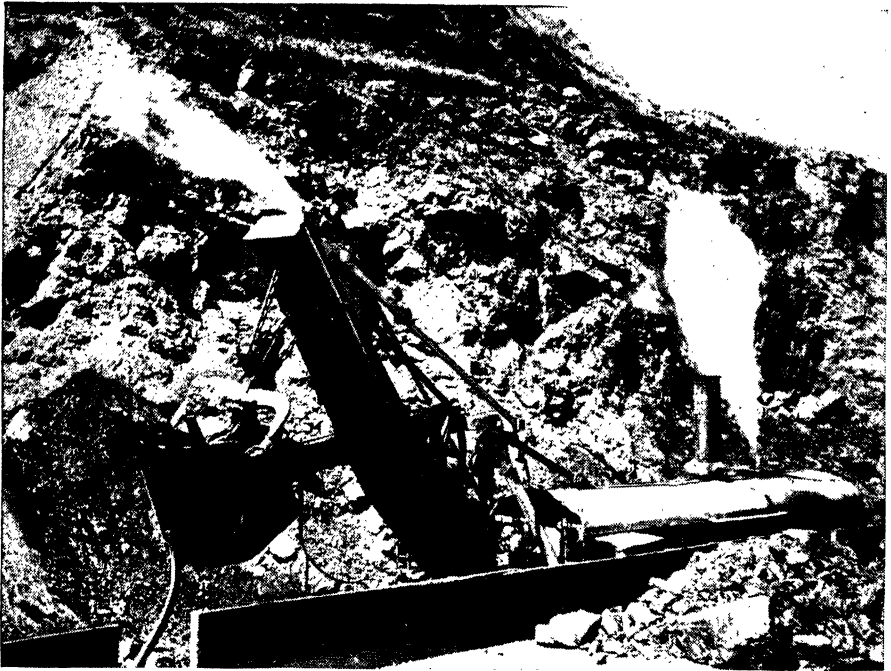

AN AUTOMATIC GRAB

[Carlew & Kinnaird

The machine illustrated is a special type of grab, akin to a digger, which is used in canal and railway cutting work. The more usual type replaces the shovel with a gigantic pair of steel jaws, which may be shut and opened to take up and release the debris rather as a dog moves things with its mouth.

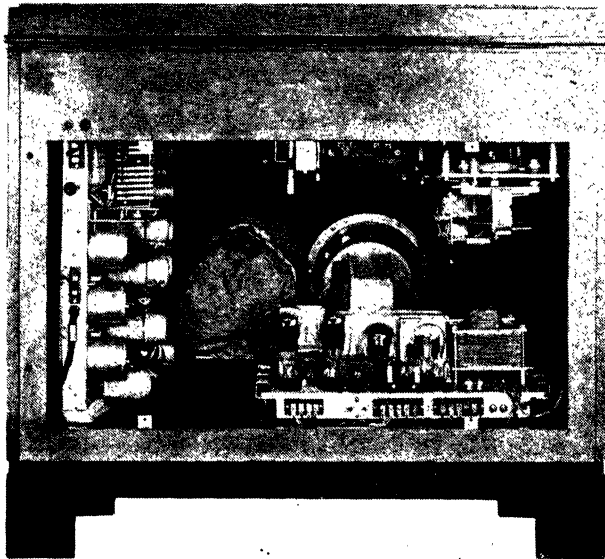

THE GRAMOPHONE

[Courtesy The Gramophone Co.

This is a view into the back of a modern self-changing radio-gramophone. Note the two moving-coil loud-speakers, the electric motor (top), the record-changing mechanism (top right), the gold-plated cans containing the I. F. coils (left), and the two chassis containing in all fifteen valves. Edison invented the phonograph in 1877.

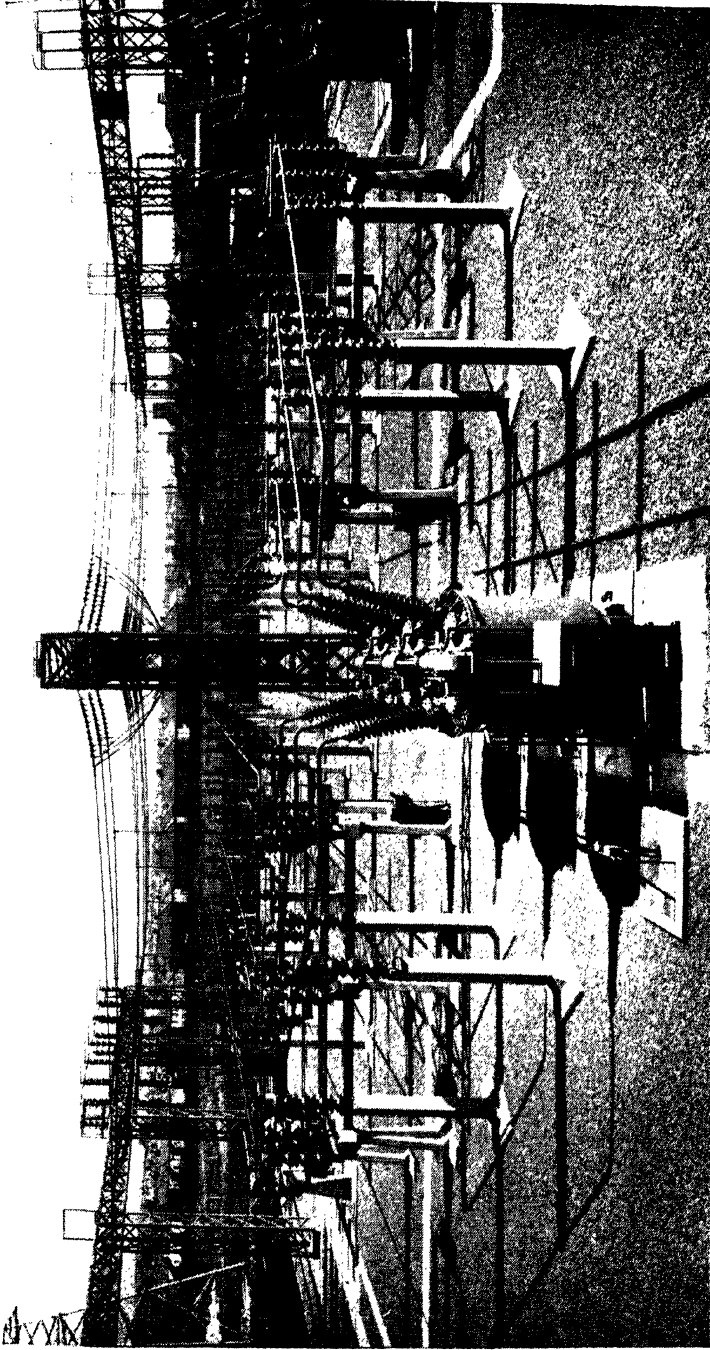

Courtesy Central Electricity Board

A GRID TRANSFORMING STATION

The network of pylons and overhead lines which is now covering Britain is part of a scheme for co-ordinating and improving the national electricity supply. There are altogether 4000 miles of these cables, and 273 switching and transforming stations. The system is now complete except for the North Scottish area, and the cost including standardization of plants, has been nearly 150,000,000.

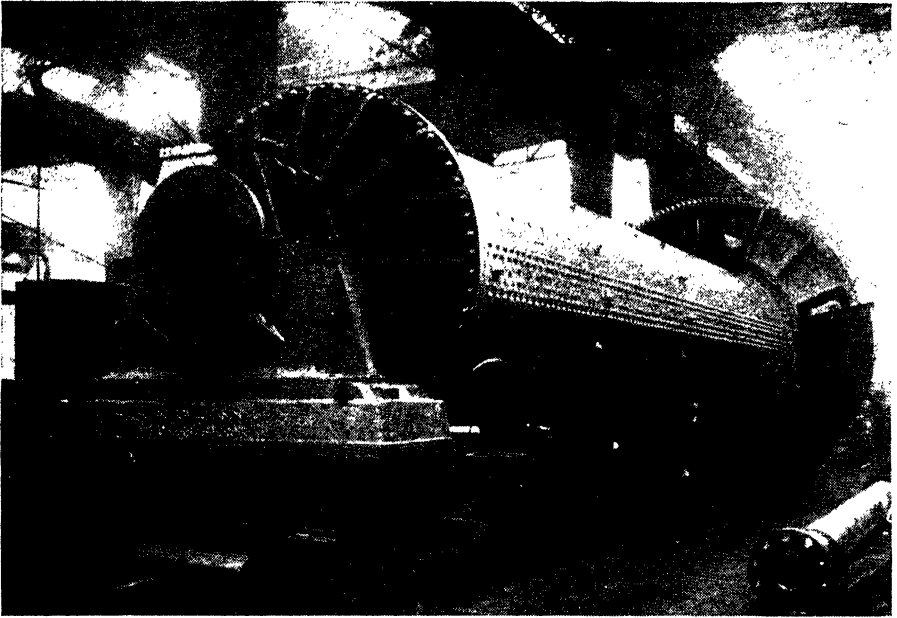

A MAMMOTH GRINDING MILL

[Courtesy T. & L. Ltd.]

The process of making cement has been outlined under the illustration of a Cement Kiln. Above is a gigantic mill assembled for the grinding process, and about to leave the factory. It is 7 feet in diameter and 36 feet long.

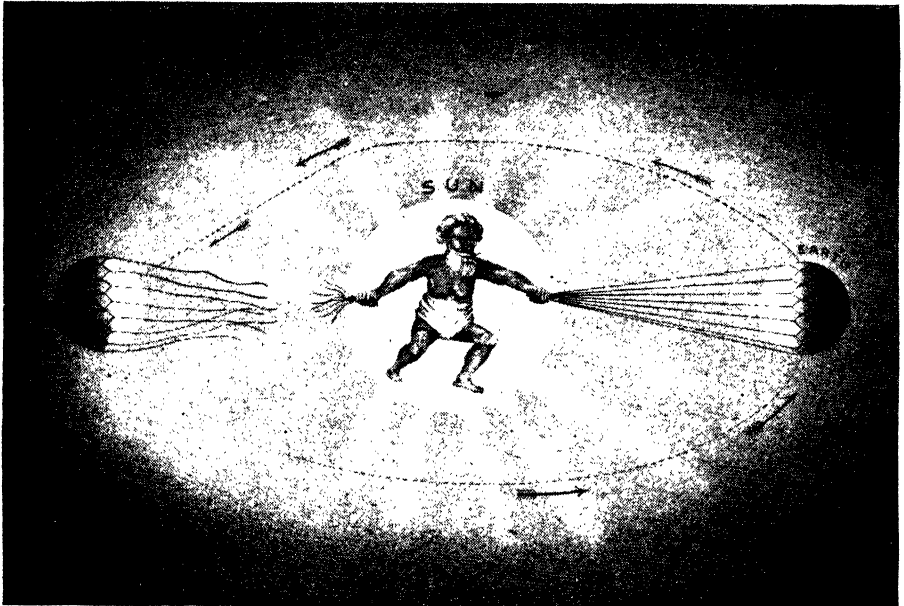

THE POWER OF GRAVITATION

[From "Splendours of the Heavens"]

It is doubtful whether Newton, on seeing the falling apple, realized at once that the force which drew the fruit to the earth also drew the earth to the sun. The above diagram represents allegorically the gravitational pull of the sun which causes the planets to revolve round it, and the disastrous effect if that pull could cease.

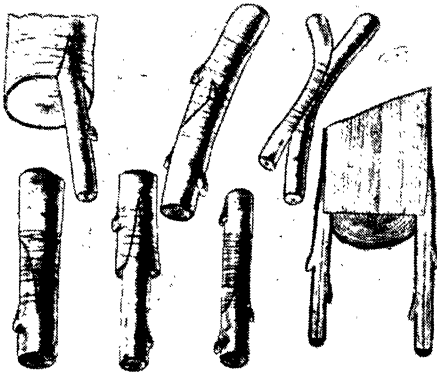

Carthew & Kinnaird

METHODS OF GRAFTING

A diagram showing seven different methods of grafting. The purpose of this science is either to induce a wild tree to nourish a cultivated shoot (e.g. a choice plum or rose) with its more vigorous sap, or to blend two varieties of fruit or flower together. Bulbs may also be so blended to form new types.



[From "Marvels of the Universe"
THE POWER OF GROWTH

The power latent in growing plants is frequently seen by the effects of ivy upon ruins, etc. In tropical countries creepers are often stronger still. The picture shows the roots of a sacred fig holding together a heavy statue after first breaking it



THE GREAT LAKES

[Dorion Leigh

The Great Lakes of Canada and the United States are the largest freshwater stretches in the world. Two hundred rivers drain into Lake Superior alone. This picture shows the beautiful Thousand Islands district, where Lake Ontario meets the St. Lawrence



A. P. Maudslay]
RUINS AT MENCHE, GUATEMALA

Less well-known than the Aztec ruins of Mexico, the impressive remains of another bygone civilization which are found half-buried in the forests of Guatemala are very impressive



[Dorien Leigh
THE COLOSSI OF GWALIOR

Gwalior Fort, India, illustrated opposite, boasts among other remarkable features several colossal statues of gods, carved of yore from solid rock by the Jains. Each of these gigantic figures is 70 feet high



[Carthew & Kinnaird]
A GYRO-COMPASS

The large masses of steel in modern ships render navigation by magnetic compass almost impossible. The first gyro-compass was tried in 1911, and all in use to-day follow the principle then adopted

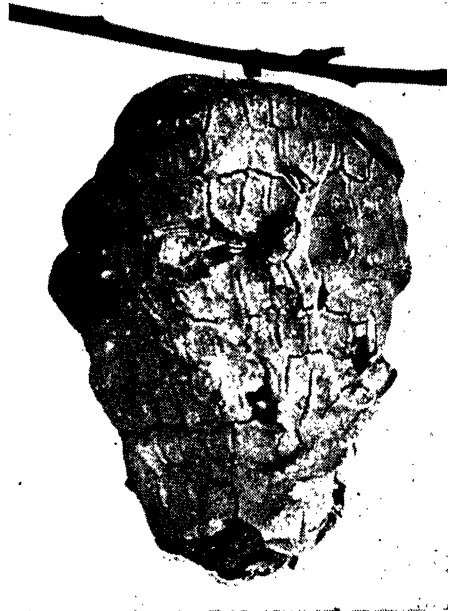

[Harold Bastin
A HANGING-TERMITE'S NEST

The ordinary termite builds its pyramid nests on the ground; the above variety builds downwards from the branches of trees. These hanging nests consist of finely chewed wood fibres, cemented by the insect's juices

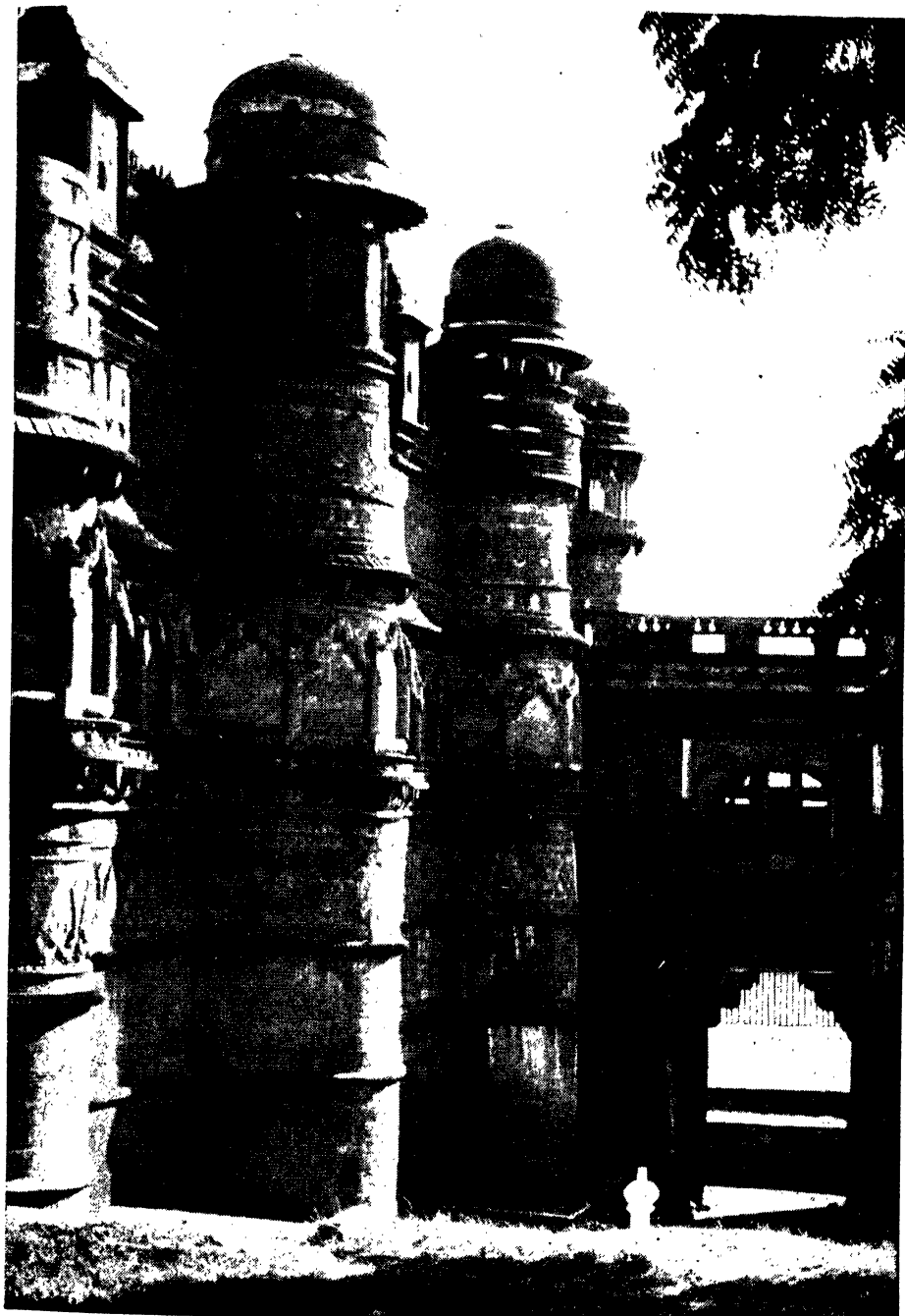

THE FORTRESS OF GWALIOR

[Dorien Leigh

The mighty castle of Gwalior, of which this photograph shows the gateway and one end of the main façade, stands some miles to the south of Agra, India. Long deserted, it is somewhat dilapidated to-day, but at one time it must have been nearly impregnable.

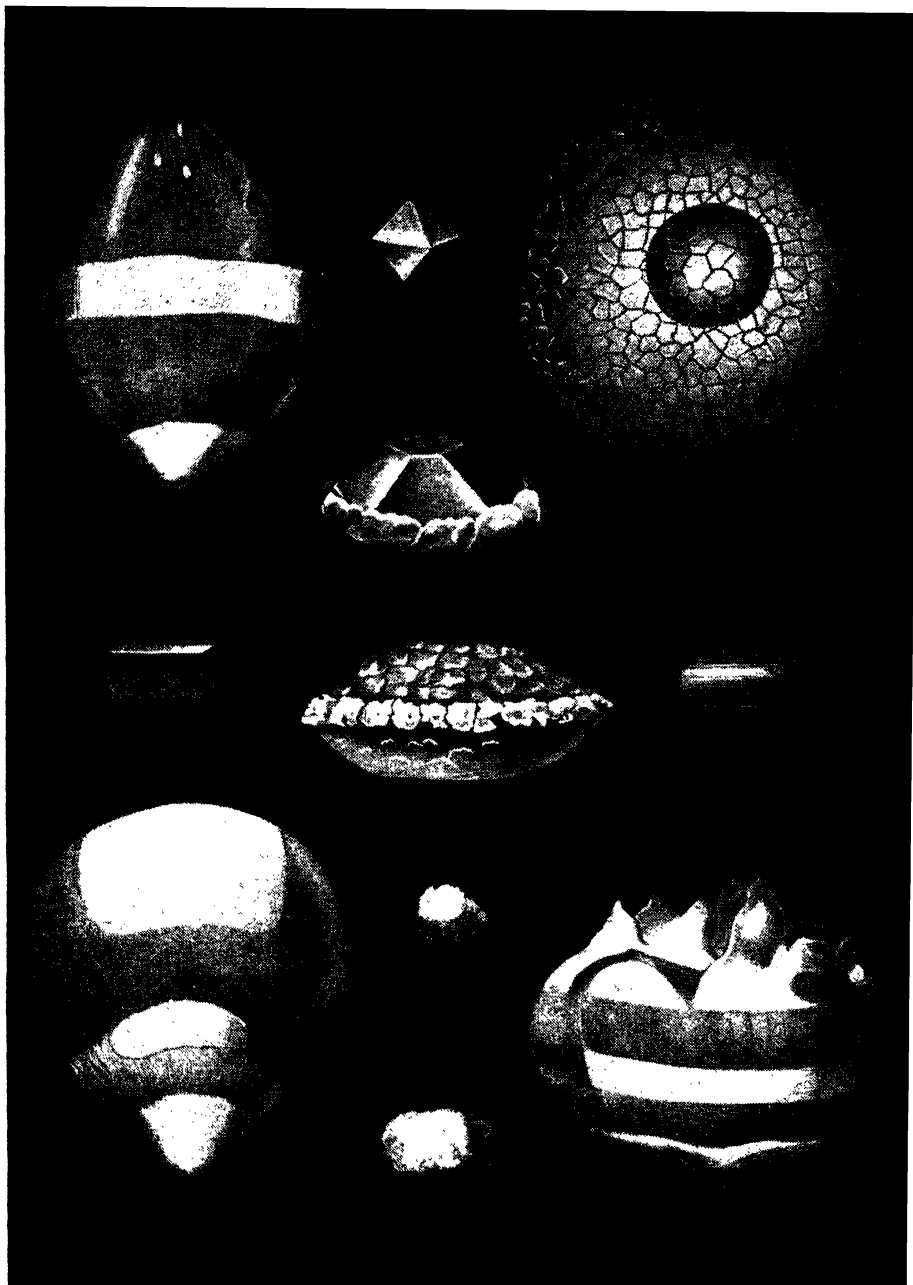

By courtesy]

[of Miracles of the Univ.

TYPES OF HAILSTONES

The four largest of these hailstones were picked up after a severe storm at Auxerre, France; the two central ones fell at TMs in 1863. The first four are remarkable for the presence of both transparent and opaque ice, the central pair for their similarity to badly-cut diamonds. A transverse section of the central stone showed it to consist of perfect hexagons like a honeycomb



Dorley Langley

"THE LAUGHING CAVALIER", BY HALS

One of the world's best known portraits. Franz Hals (1580-1666), a Fleming, was reputed second only to Van Dyck as a portrait painter. Original is in the Wallace Collection, London. Hals did most of his work at Haarlem and Delft.

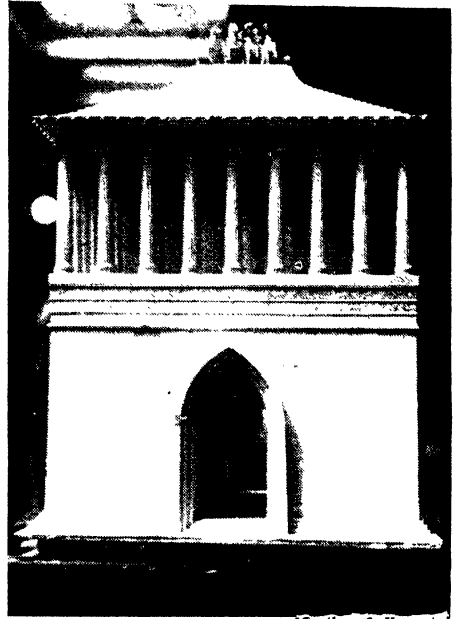

Carlisle & Kinnaird

THE MAUSOLEUM, HALICARNASSUS

Reconstruction of the famous tomb which was one of the Seven Wonders of the Ancient World. Artemisia raised it over her husband, King Mausolus of Caria, in 353 B.C. The few remaining fragments of the original monument are in the British Museum.



Photochrom Co.

HAWKESBURY RIVER BRIDGE, N.S.W.

Until 1889, this bridge, 9,000 feet long, is still the longest in Australia and remains the deepest-set bridge in the world its piers descend to 162 feet below the bed of the river.

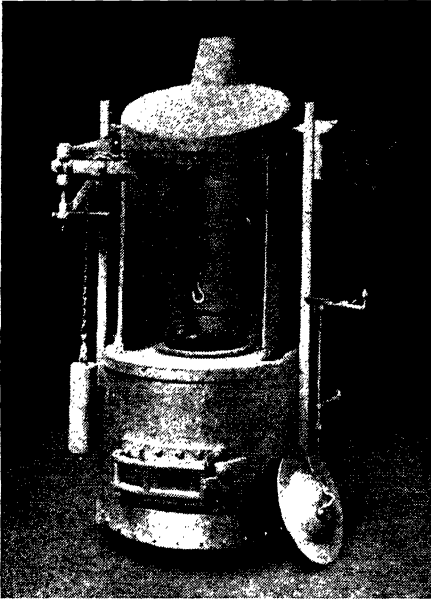

Courtesy I.C.I.]

HARDENING METALS

Case-hardening, as it is called, is a method of surface-hardening iron or mild steel objects by carburization at a very high temperature, followed by quenching. Above is a small case-hardening furnace capable of heating to 1000° Centigrade, though its interior is only 10½ by 15 inches



[Courtesy Vickers, Ltd.]

A HARDNESS-TESTING MACHINE

This is a recent invention for measuring accurately and reliably the hardness of every kind of metal, no matter what its shape. The principle involves the indentation of the metal with a diamond, and then the measuring of the resultant impression



Carthew & Kinnaird]

THE MUSCLES OF THE HEART

The function of the heart is to pump the blood continuously round the system, which it does by means of valves. It follows that the organ must be very strong, and the above section of a photomicrograph gives an idea of the heart's muscular structure



[Courtesy Carl Zeiss,

THE HEMIKINESIMETER

An apparatus for examining the pupil of the eye for hemianopia, or paralysis of certain fibres of the optic nerve. The purpose of such an examination is not merely to correct the eyesight but to assist in the location of diseases in the interior of the brain



THE HEBRIDES : FINGAL'S CAVE

[*Photochrom Co.*

The fluted manner in which this cave is built is akin to that of the Giant's Causeway in Northern Ireland, of most of the Faroe Islands, and of many other regions of the Scottish coast. The substance is basalt : its origin dates from a remote period and is volcanic. Fingal's Cave, on the Island of Staffa in the Outer Hebrides, inspired Mendelssohn's well-known musical overture

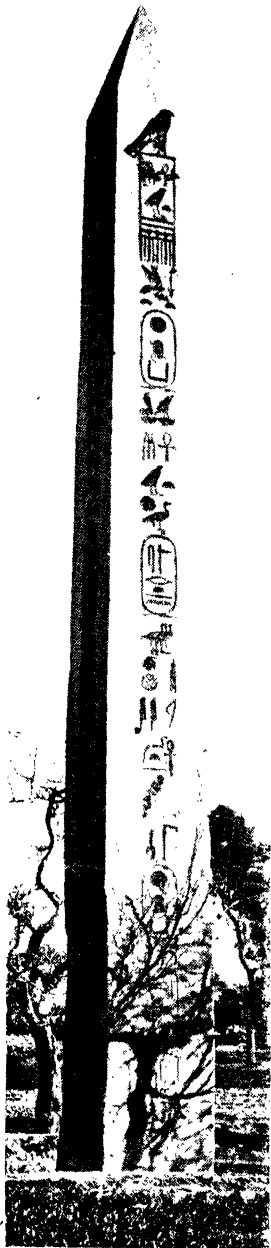
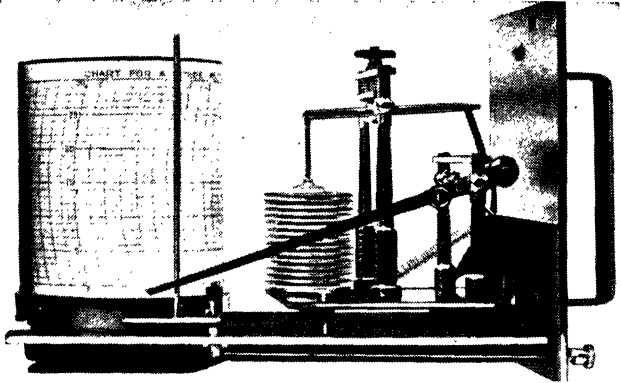

Photo from Co.]

HELIOPOLIS

Helopolis was once the centre of Egyptian sun-worship, and famous for its school of philosophy and astronomy. To-day this solitary granite column, the Obelisk, is the ancient city's only vestige



[Smith's Aircraft Instruments

A HEIGHT RECORDER

The recorder shown is an altigraph, and is an application of the altimeter (q.v.). In place of readings on a dial, permanent record of the height above ground is obtained by a pen attached to the mechanism, which writes on a measured, revolving drum



[Cartier & Kinnaid

ARTIFICIAL HEARING

The photograph shows the apparatus used in the vibratory method of artificial hearing, by which nerve impulses akin to those of sound are transmitted to the brain by vibrations applied to the skull

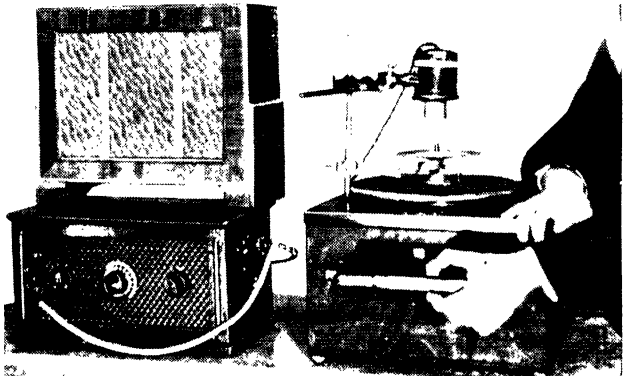

[Dorien Leigh

ARTIFICIAL HEARTBEATS

The purpose of this invention is to provide an accurate representation of the beating heart for lectures and experiments. The foundation of the apparatus is a theoretical calculation drawn on a sound track similar to that of a "talkie". Reproduction then follows in the customary way



Houston-Everest Flight

THE HIMALAYAS FROM THE AIR

This photograph was taken during the Houston-Mount Everest Flight of 1933, and shows that famous peak, the world's highest mountain, on the right of the picture, shrouded by cloud. The eastern (Tibetan) end of the Himalayas is a vast mass of peaks and plateaux, spreading over hundreds of square miles. It is the highest region on the earth, and the Himalayas themselves are the Highest Range.

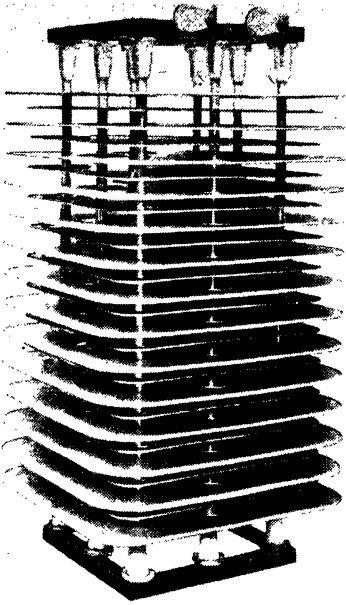

Carthew & Kinnaird

HIGH CAPACITY CONDENSER

An electrical condenser consists of pairs of conducting plates separated from one another by insulating material, and its purpose is roughly the artificial increase of the capacity of a conductor. In radio it is an important feature of both transmitting and receiving

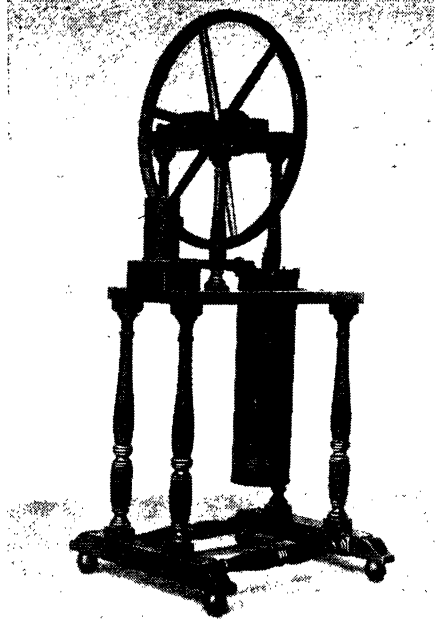

Carthew & Kinnaird

AN EARLY HOT-AIR ENGINE

Hot-air engines are external combustion engines in which the piston derives its force from the expansion of air when heated. They are little used to-day, but have the advantage of safety, simplicity, and quietness. Above is the original engine patented by Stirling over a century ago



From "Marvels of Insect Life"

FUNGUS OF THE HOUSE FLY

This photograph, magnified about forty times, shows the fungus of the house fly upon a windowpane. Such fungus grows very rapidly wherever the fly's sucking tongue has passed



Carthew & Kinnaird

A HORNETS' NEST

The hornet builds not unlike the common wasp. It is the fiercest of all the stinging insects, and in the depths of jungles, it is said, only the jaguar dare pull a hornets' nest apart



[Theo Carreras

HONEY ANTS

Honey Ants live in Mexico and the south-western United States. Certain members of the nest are set aside from "youth" to act as storage-barrels. They never leave the hive, and are fed on honey by the workers : this is stored for an indefinite time in special sacs, relatively enormous compared with the insects. Whenever another ant requires food one of its honey-companions disgorges a drop of the fluid



Carlson & Kinnaird

THE HORNBILL

The extraordinary casque of the hornbill is hollow but strong. When nesting in a hollow tree-trunk, the female allows the male to wall up all the opening except a tiny portion for his beak. There she stays, he feeding her, until the eggs hatch. The Black African Hornbill is shown here.



Dorien Leigh

HOGARTH'S "SHRIMP GIRL"

William Hogarth (1697-1764) was a Londoner, and first won fame by his series of pictures entitled "A Harlot's Progress", after which he turned out a long succession of brilliant and bitter satires. "Marriage à la Mode" proved his masterpiece, closely followed by the "Shrimp Girl".



Dorien Leigh

"THE AVENUE", BY HOBBEEMA

One of the best-known landscape paintings in existence. Meindert Hobbema (1638-1733) was a Dutchman, an Ensaye that he died in poverty. Little is known of his life and character. His manipulation of cloud and lighting effects in his scenes has rarely been surpassed. "The Avenue" is a road at Middelbarnus; the original picture is in the National Gallery, London.



Dorcen Leigh

HOLBEIN'S "MADONNA OF THE MEYER FAMILY"

Hans Holbein the Younger is best remembered by Englishmen for his portrait of Henry VIII. He led, however, a varied life, and during his lifetime (1497-1543) he painted in Germany, Switzerland, and England. He also did a remarkable series of woodcuts called the "Dance of Death". His work can hardly be over-estimated, as he was the first great portrait painter. The above famous work takes its name from Burgomaster Meyer of Waseu, who is portrayed

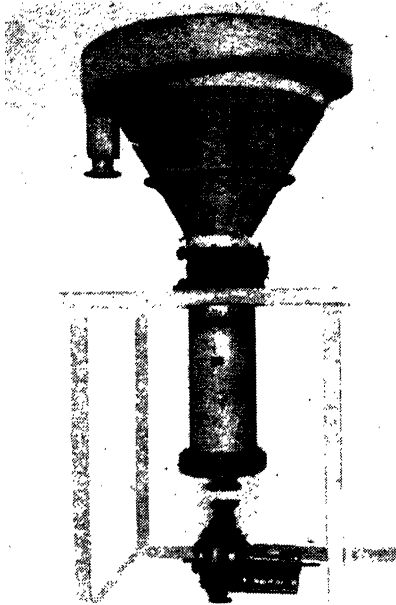

Courtesy International Combustion, Ltd.

A HYDRAULIC CLASSIFIER

A machine used in the mining industry for separating and classifying ores. The material is washed by water into special troughs, and whilst it is in motion, the different specific gravities cause the heavier particles to fall to the bottom, leaving the others in layers above.



(Dorien Leigh)

A HYDRAULIC PRESS

Hydraulic presses are used in many industries: the above shows one employed for the testing of briquettes of coal. The invention was made as long ago as 1785, by Joseph Bramah, and employs the principle of forcing up the plunger by pumping water into a tank below it.

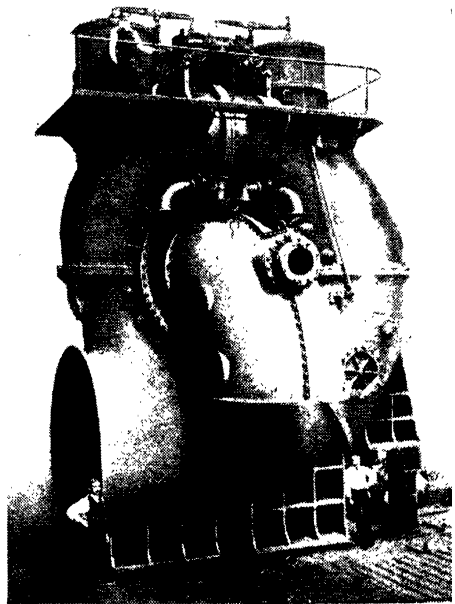

(Carthew & Kinnaird)

HYDRO-ELECTRIC POWER

The generation of electricity entails initial motive power of some sort to turn the generators. This has largely to be done by steam, but in mountainous regions a great saving of cost results from utilizing the pressure of water in cascades or even swift rivers. On the left is a general view of the Rjukan Station in Norway; on the right a giant water turbine.

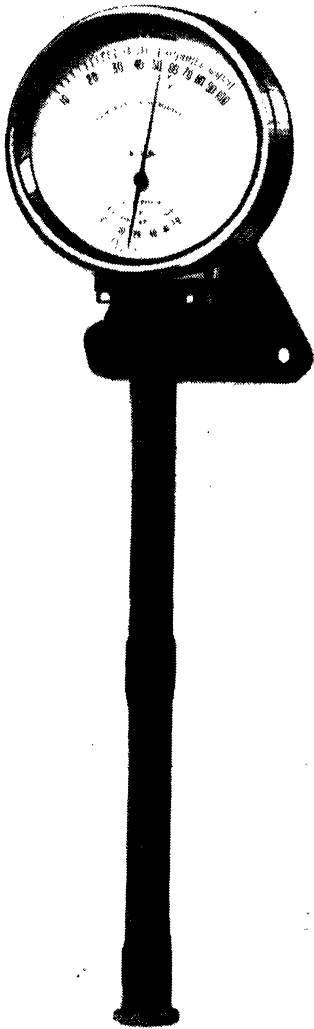

[Negretti & Zambra]

A HAIR HYGROMETER

The hygrometer is an instrument used for measuring the relative humidity of the atmosphere. The hair hygrometer, which is one of several kinds, is controlled by the variation in length, according to humidity, of a single human hair. It can be made self-recording, and has the advantage of working at temperatures below freezing-point. It is calibrated by a standard hygrometer.

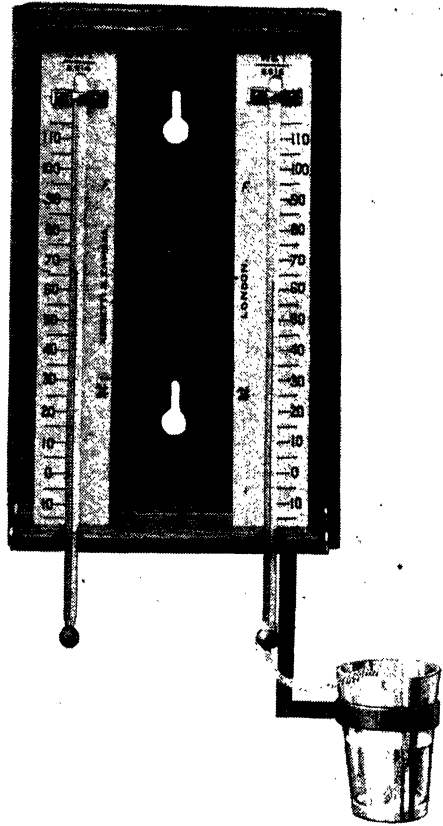

A BULB HYGROMETER

[Negretti & Zambra]

Another type of hygrometer, consisting of two thermometers mounted side by side, the bulb of one being surrounded by a wet wick. Evaporation from this last cools the bulb, and by the amount of cooling, as read against the other thermometer, the relative humidity is found.

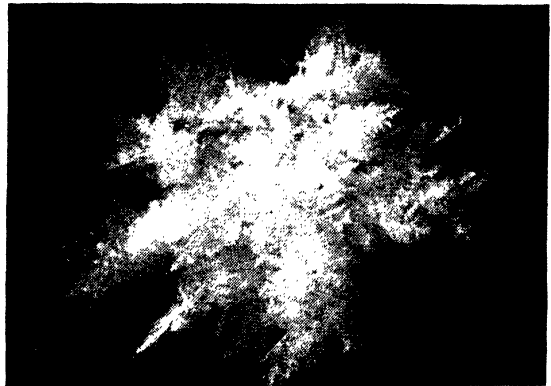

[Carthew & Kinnaird]

AN ICE FLOWER

These beautiful frost formations are seen at their best amongst the smaller lakes of the Alps. They are very delicate and form only under certain atmospheric conditions and in very still air. They measure as a rule about two inches, but have been known to be a foot in diameter.



A FIELD OF ICE FLOWERS

(Carter & Kinnaird)

This view was taken on one of the smaller Swiss lakes (see previous page). A thin coating of black ice forms over the water, above which hangs a mist composed of ice crystals. Some of the tiny crystals fall, and then, by a kind of magnetic attraction, others are caught and successively added to them until these beautiful formations result, presenting an unusual spectacle.



AN ICEBERG

(L.E.A.)

The size of icebergs may be gathered from the fact that although they rise sometimes to a height of nearly 300 feet above the water, their visible mass is barely one-eighth of the whole. They are caused by the breaking away, during thaws, of large masses of polar ice which drift into temperate and warmer zones of ocean currents



THREE ICHNEUMON WASPS

Each of these specimens is magnified about two and a half times. At the top is one of the largest British Ichneumons, which is very destructive to puss-moth caterpillars. Below, to the left, is a small example of the same family emerging from its cocoon, spun in the empty skin of its victim. To the right are two cocoons, spun by grubs, which have destroyed a saw-fly caterpillar; also a newly emerged wasp.

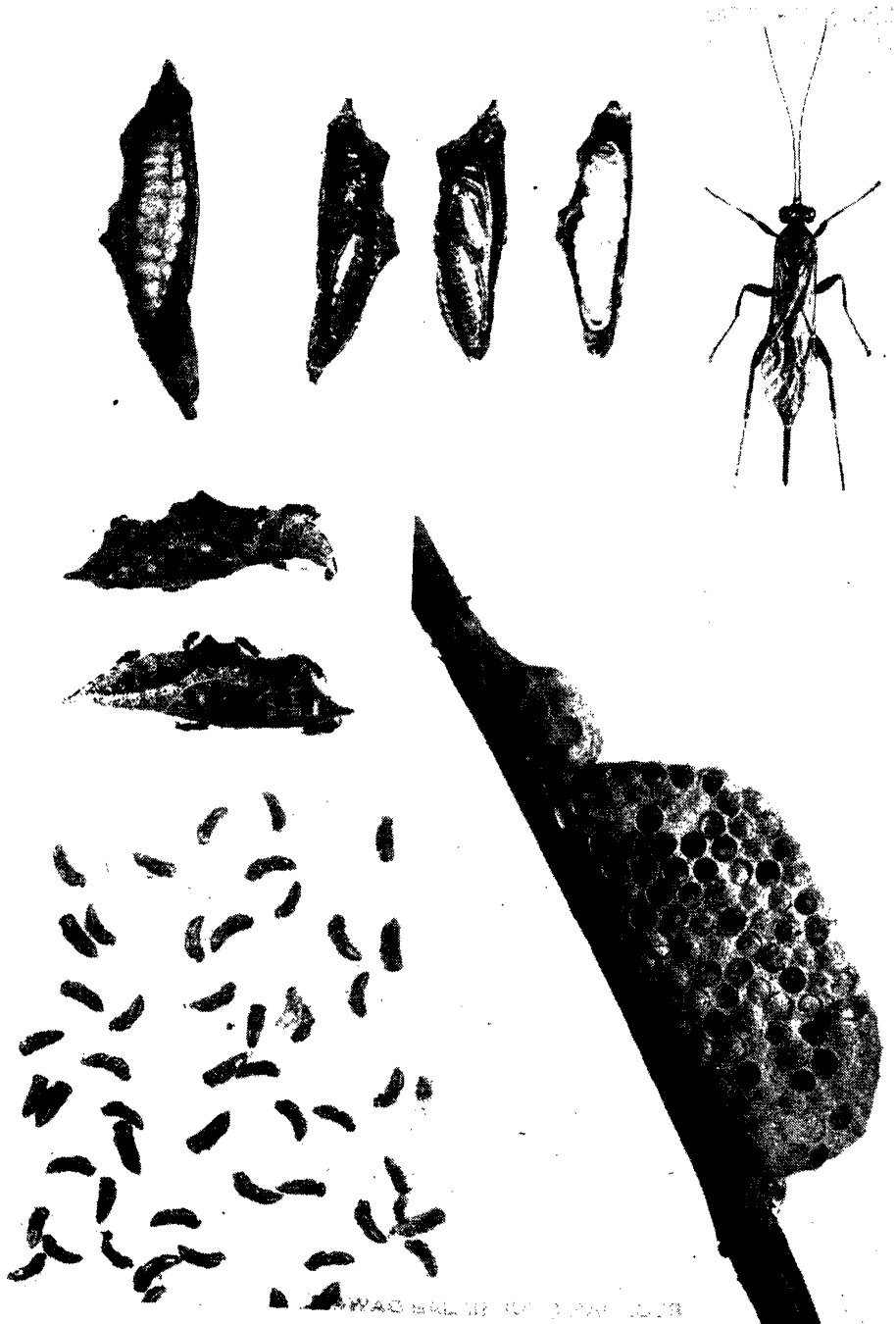

ICHNEUMONS

(H. Main, F.E.S., and E. Slep, F.I.S.)

At the top, stage of the *Pimpla Ichneumon*, which keeps the white "cabbage" butterfly in check: on the right, a fully developed female; centre, *Ichneumon* chrysalids inside the butterfly chrysalids; left, an *Ichneumon* grub having consumed the butterfly pupa's interior (the two last sectional views). Centre, below, shows mature *Ichneumon*s escaping from victims. Bottom left, section of over sixty chrysalids taken from a "cabbage" butterfly pupa. Above is, full and empty, of a variety which leaves the victim during grub stage and builds for itself



AN ICHTHYOSAURUS AND YOUNG

Remains of this prehistoric porpoise-like reptile are distributed over all five continents, and many occur in England, where the creature became extinct on the deposition of the chalk layers. The Ichthyosaurus is believed to be descended from land or marsh animals; the earliest types were very small, but all were conspicuous for the large number of teeth



THE IDOLINO

One of the most graceful statues in existence, the original of this remarkable figure is in the Archaeological Museum at Florence. It is exquisitely fashioned in bronze, and dates from so remote a period that the artist is unknown. Its alternative title is "Mercury"



ICELAND: HOT-WATER SPRINGS

The whole of this large island is of volcanic formation. Mount Hekla, a still active volcano, is one of the largest in Europe, and the hot springs and geysers are comparable with those of New Zealand. The largest geyser has a diameter of 100 feet, and erupts once a day; other non-eruptive springs are used for washing clothes, as here shown

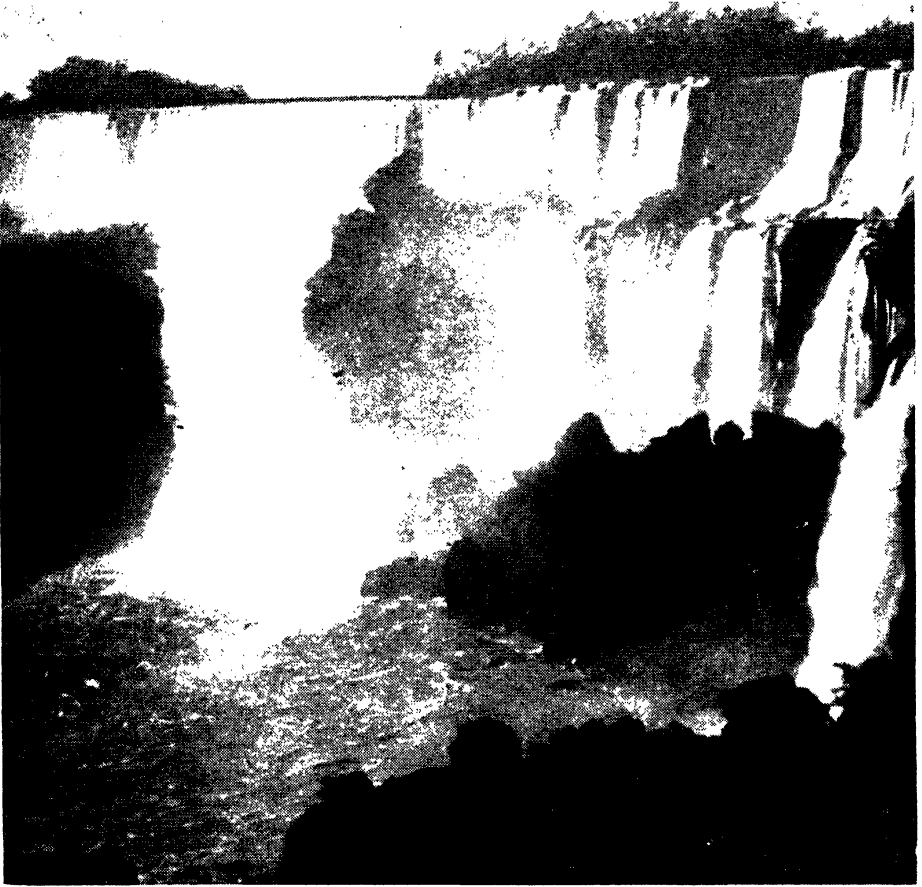

THE IGUAZU FALLS, BRAZIL

Though they are next in magnitude to Niagara, relatively few people have seen these magnificent cascades on the borders of Brazil and Argentina. Their effect is the more startling in that they are surrounded by dense jungle. The various falls extend over several miles.



Photos from]

A NEIGHBOUR OF THE IGUAZU FALLS

[“Wonders of the World”

These are the Alto Parana Falls in Argentina, some miles above the Iguazu. Seven major and numerous minor cascades grace this stretch of the river, whose turbulence and speed are truly stupendous: their thunder can be heard for two miles



FINLAND. THE IMATRA FALLS.

[Keystone

These famous cascades are the most powerful in Europe. The rapids are 1000 yards long, and have a fall of 62 feet; about 111,000 gallons of water per second is precipitated through the granite channel. The Imatra Falls are part of the River Vuoksen, which has its outlet in Lake Saima, in the south-east of Finland. The whole of southern Finland is a gigantic mass of lakes and islands

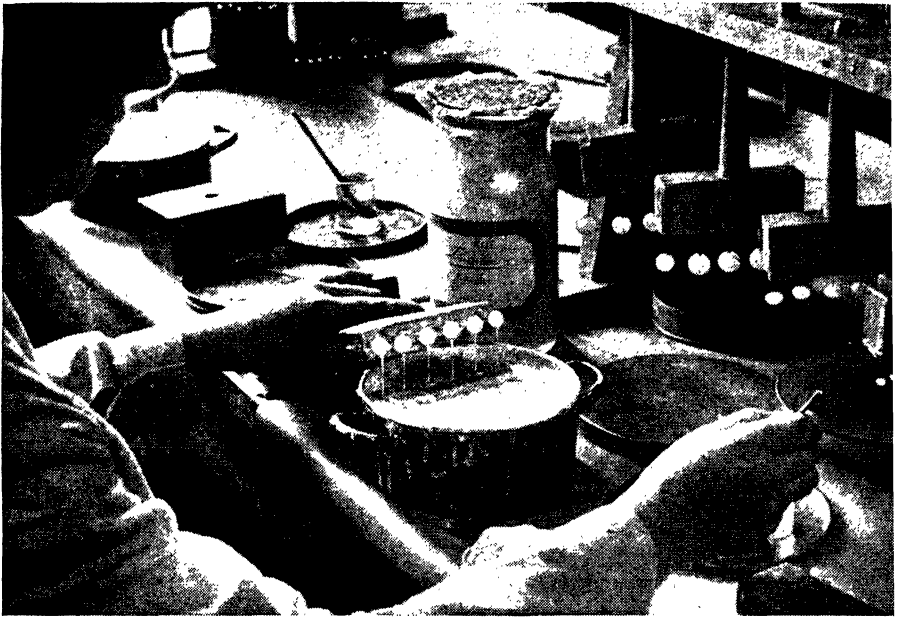

[Keystone

IMITATION-PEARL-MAKING

There are three kinds of pearl: the genuine variety, produced by oysters for their own reasons; the cultured type, produced by oysters kept for the purpose and specially "trained"; and the purely synthetic or imitation variety. The views here shown were taken in an imitation pearl factory at Zurich. The process—



[Keystone

SORTING IMITATION PEARLS

involves first of all the digesting in ammonia of the scales of fresh-water fish. This mixture is injected into thin glass balls until a film forms on the inner surface. Wax or gum is then injected to fill up and render solid the interior; finally the glass is removed by hydrofluoric acid

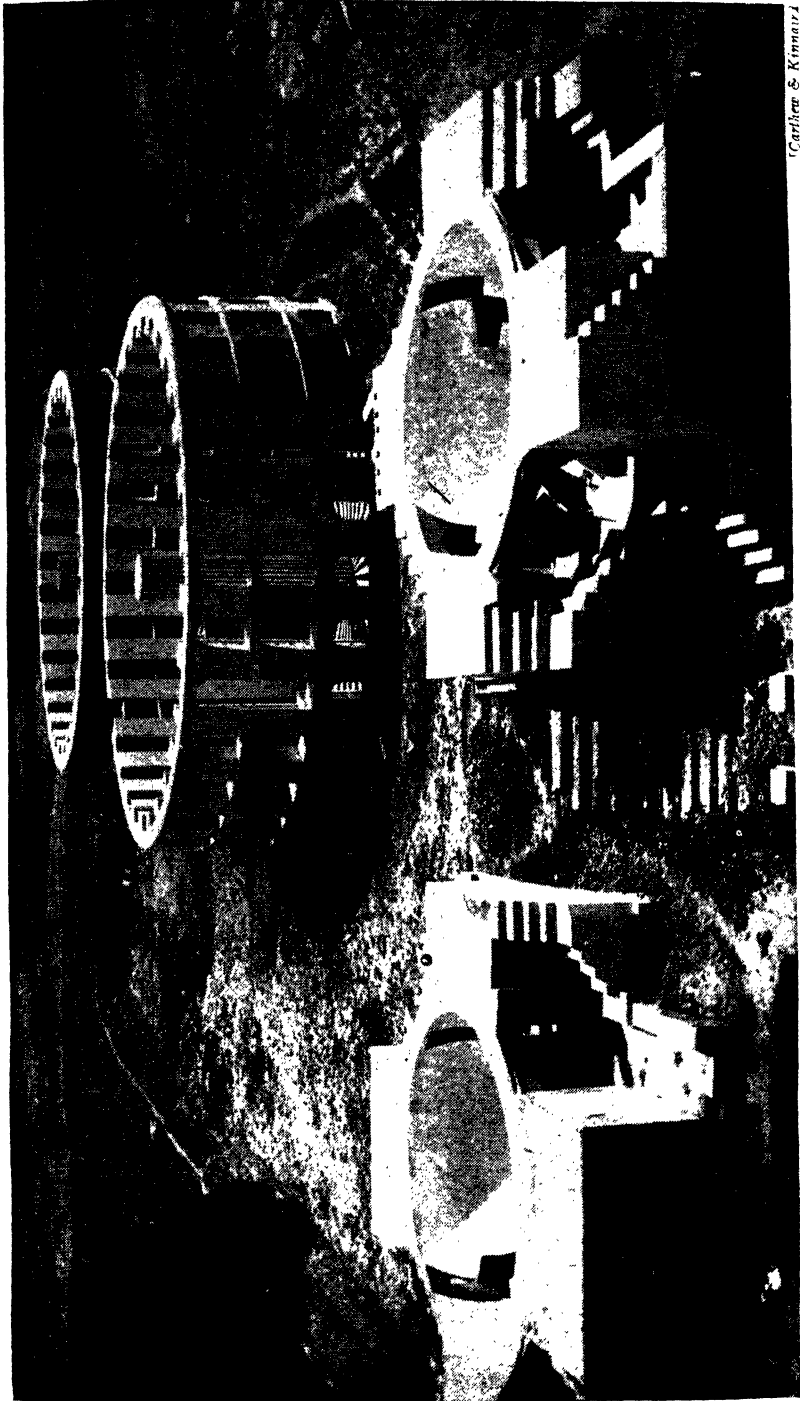

Carlier & Kinnear

INDIAN OBSERVATORIES

The Oriental religions, especially Islam, have always encouraged astronomy from the earliest times. In the eighteenth century Rava Jai Singh began an elaborate system of observatory construction throughout his domains in India. One of his erections at Benares survives undamaged to this day.

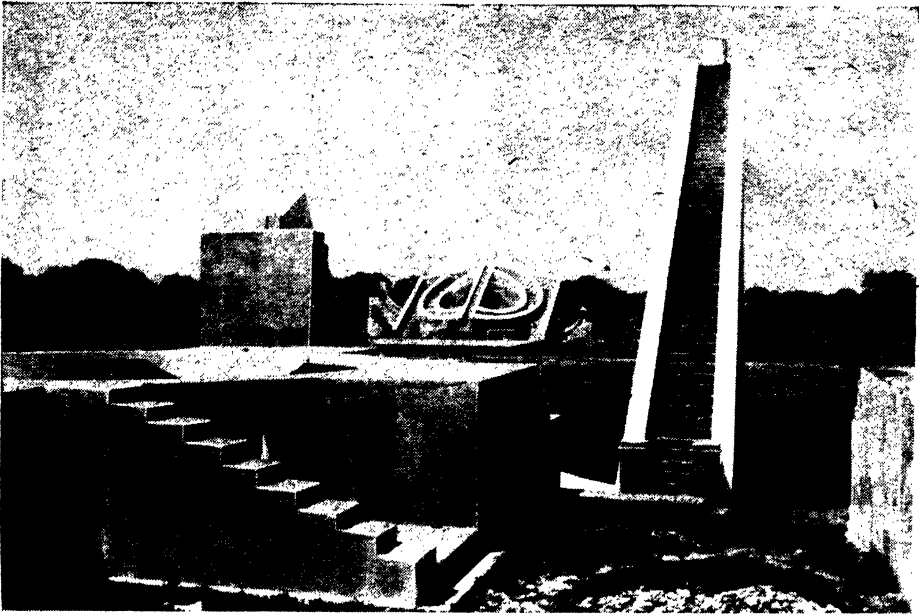

[Carthew & Kinnaird]

ASTRONOMICAL BUILDINGS AT DELHI

Jaipur, Jai Singh's capital, was adorned with the most ambitious buildings, but the observatories at Delhi, Benares, Muttre, and Ujjain were all on a vast scale. This picture of the Delhi group shows the instruments for measuring time and for studying the paths of the heavenly bodies

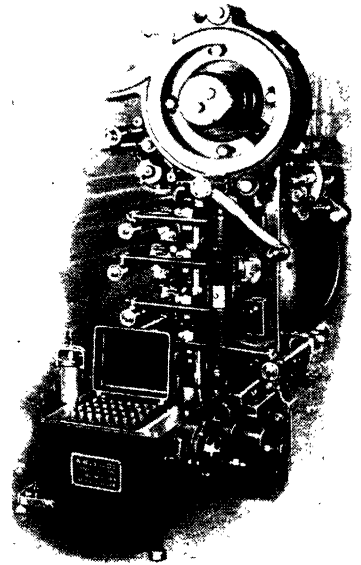
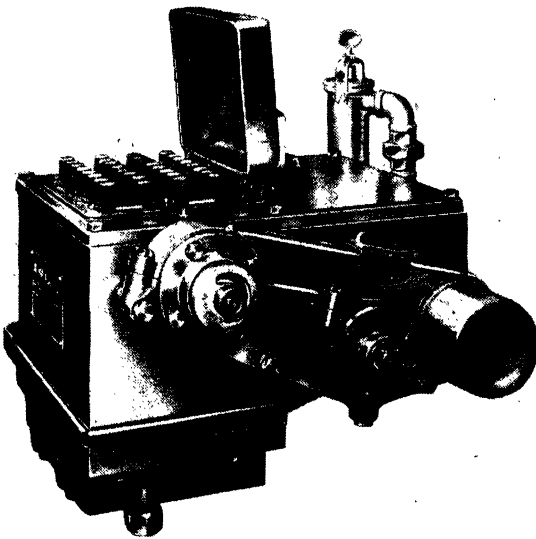

[Courtesy R. Hoe & Co.]

AUTOMATIC INKING MACHINERY

Elsewhere an automatic folder for newspaper work has been illustrated. For printing in such quantity and at such speeds it is equally needful to have special inking apparatus. The smaller photograph above shows an automatic ink-pump. The ink enters the box in the foreground through a brass filter, and is pumped on to the distributing drum by a mechanism in the ink. The other picture shows a close-up of the box

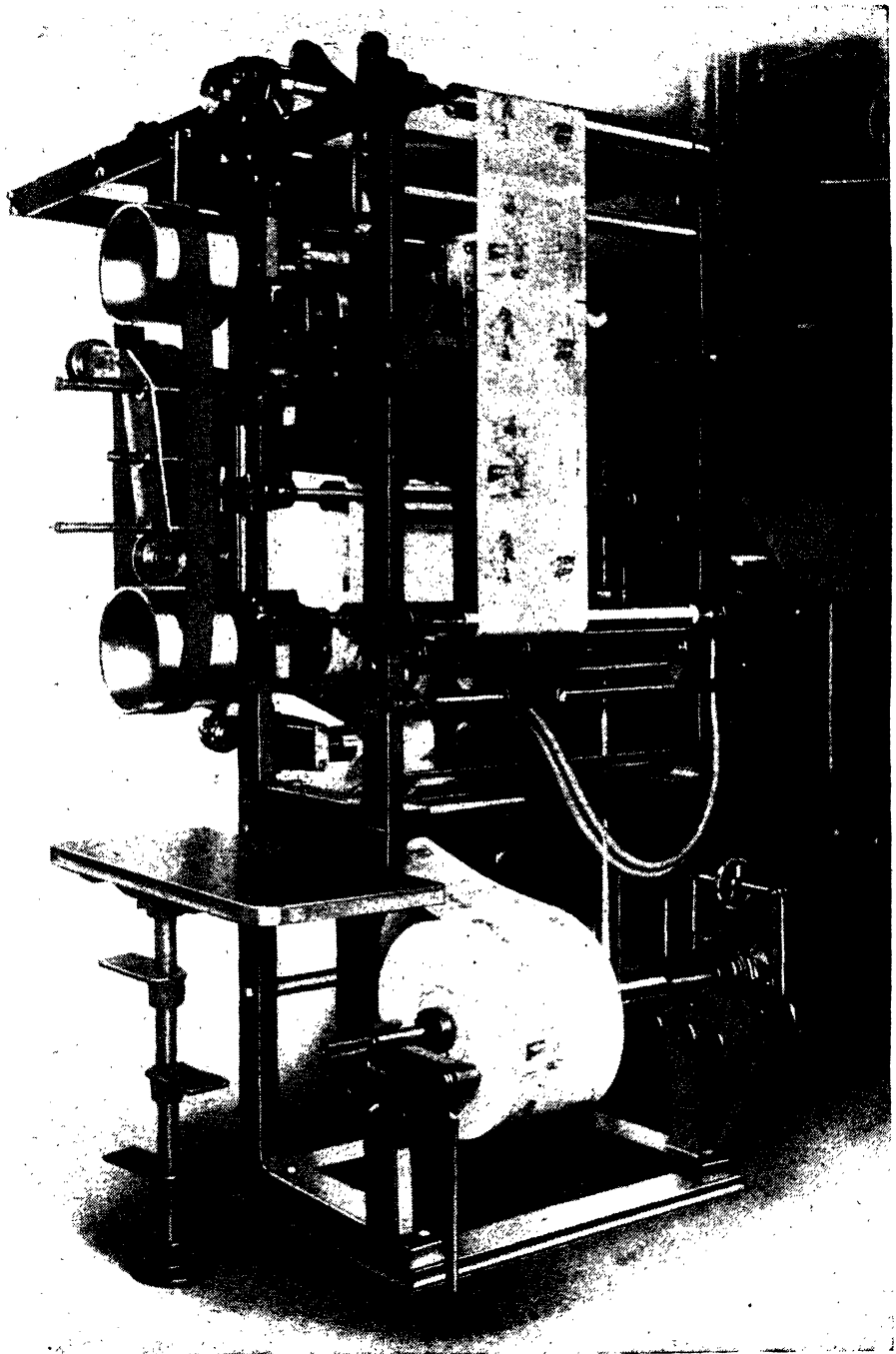

A PHOTO-ELECTRIC INSETTER

[Courtesy R. Hoe & Co.]

Insetting means the fixing into a magazine of pages (usually pictures in photogravure) printed by a different process from the bulk of the publication. Above is shown a machine which unwinds the photogravure pages from the continuous roll on which they are printed, cuts them, folds them, and inserts them in the main product. The photo-electric cells govern the plant's electric current and consequent operation by its reactions to the light and shade of the printed surface



INTERIOR OF THE ANGKOR WAT

The interior of this temple (which is also known as Nakhon Wat) consists largely of these majestic colonnades, on whose walls elaborate bas-reliefs are sculptured. The Cingalese influence is very apparent here. A replica of the Angkor Wat was built at Paris for the Colonial Exhibition of 1931.



[Photos from]

INTHAPATAPURI. THE ANGKOR WAT

["Wonders of the World"]

This gigantic Buddhist temple, in what is now French Indo-China and was once the Kingdom of Cambodia, owes its origin indirectly to the influence of Ceylon, whence Buddhism was spread. The exact date of the Wat is unknown. The above view shows three terraces and five towers of the principal building.

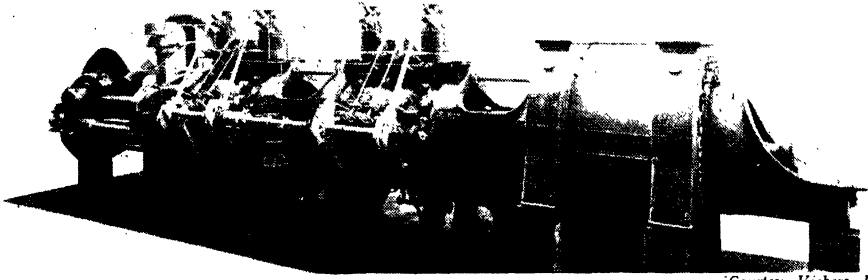

[Courtesy Vickers, Ltd.]

INTERNAL COMBUSTION: A GAS ENGINE

The gas engine is a type of internal combustion plant which preceded the petrol engine by some years. The first practical example was built by Lenoir in 1859. The modern gas engine, including the one shown here, frequently uses the otherwise waste gas from a blast furnace for its motive power. (For internal combustion as applied to the motor car see p. 281)

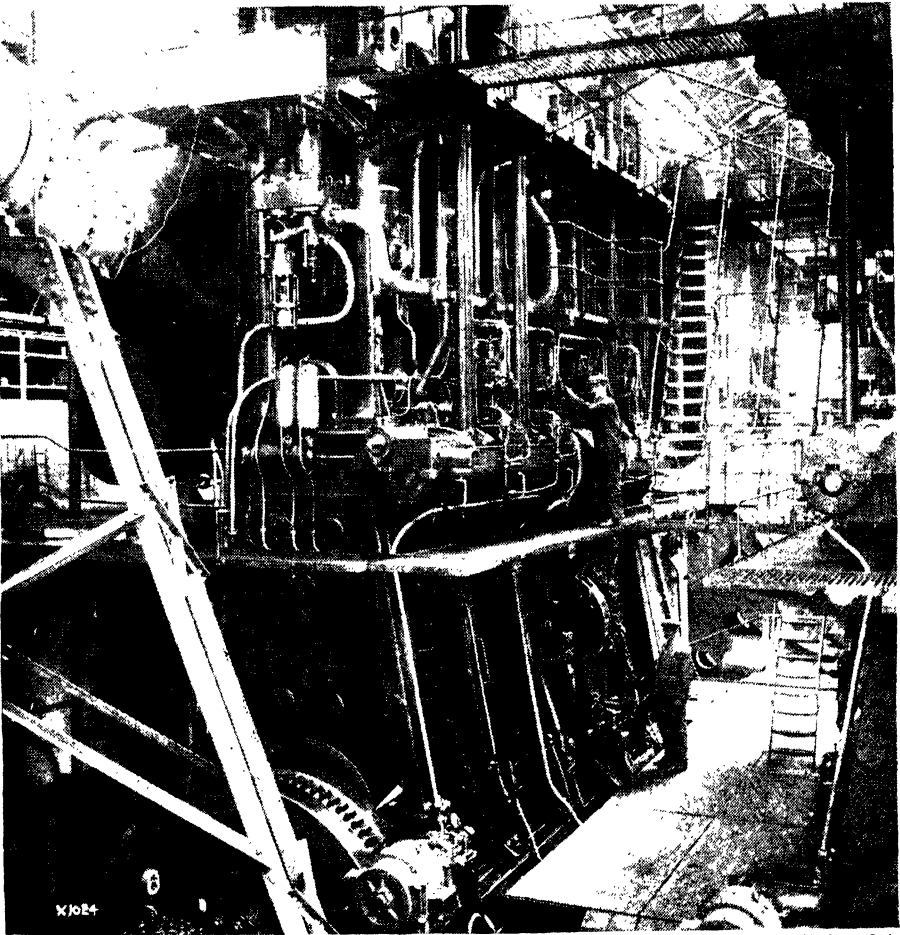

[Courtesy Vickers, Ltd.]

AN INTERNAL COMBUSTION MARINE ENGINE

Of the various types of internal combustion engine, the petrol-using sort is in widest use. Applied experimentally to road vehicles in the late nineteenth century, oil-fuel engines had already been tested on ships. Above is a two-stroke, double-acting marine oil engine, as used in a medium-sized modern craft



INTERIOR OF THE ANGKOR WAT

The interior of this temple (which is also known as Nakhon Wat) consists largely of these majestic colonnades, on whose walls elaborate bas-reliefs are sculptured. The Gingalese influence is very apparent here. A replica of the Angkor Wat was built at Paris for the Colonial Exhibition of 1931

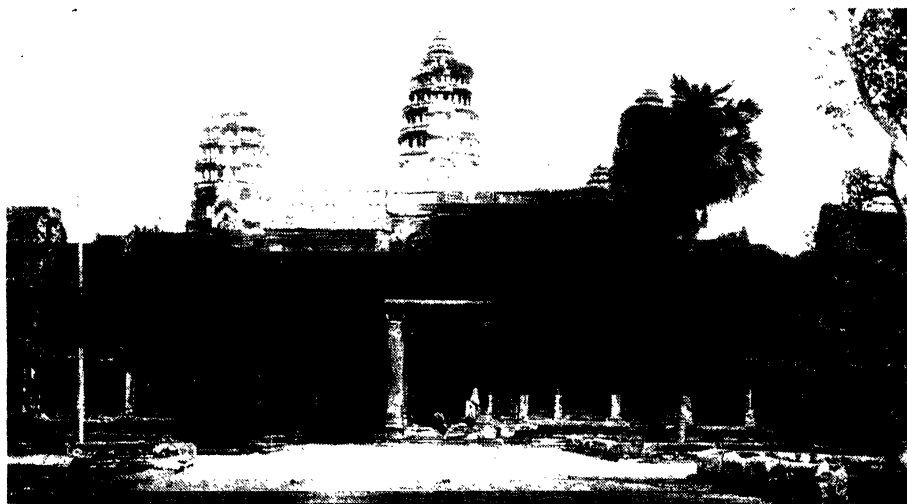

[Photos from]

INTHAPATAPURI- THE ANGKOR WAT

[*"Wonders of the World"*]

This gigantic Buddhist temple, in what is now French Indo-China and was once the Kingdom of Cambodia, owes its origin indirectly to the influence of Ceylon, whence Buddhism was spread. The exact date of the Wat is unknown. The above view shows three terraces and five towers of the principal building

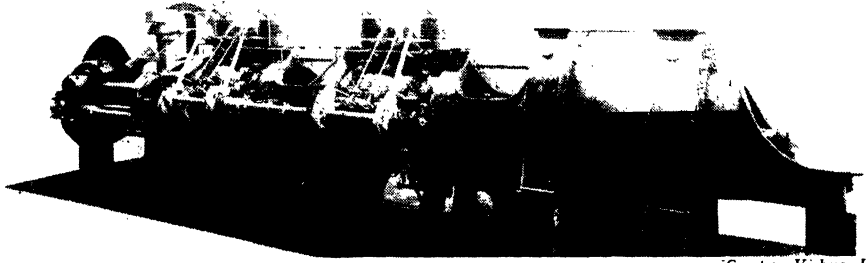

[Courtesy Vickers, Ltd.]

INTERNAL COMBUSTION: A GAS ENGINE

The gas engine is a type of internal combustion plant which preceded the petrol engine by some years. The first practical example was built by Lenoir in 1850. The modern gas engine, including the one shown here, frequently uses the otherwise waste gas from a blast furnace for its motive power. (For internal combustion as applied to the motor car see p. 281)



[Courtesy Vickers, Ltd.]

AN INTERNAL COMBUSTION MARINE ENGINE

Of the various types of internal combustion engine, the petrol-using sort is in widest use. Applied experimentally to road vehicles in the late nineteenth century, oil fuel engines had already been tested on ships. Above is a two-stroke, double-acting marine oil engine, as used in a medium-sized modern craft.

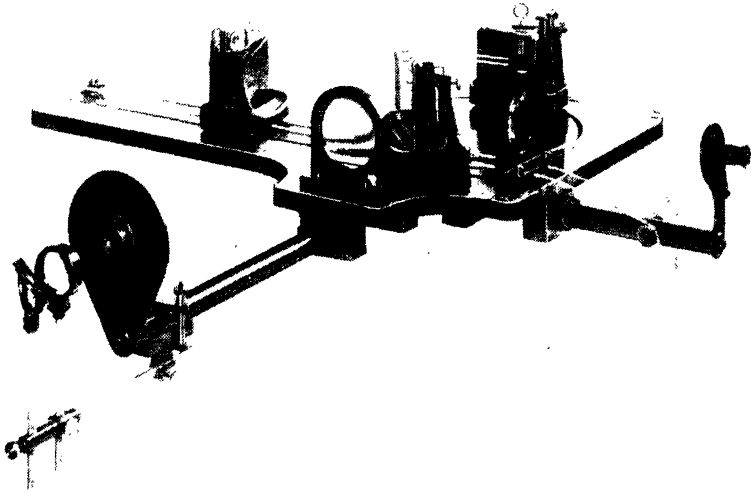

[Carthew & Kinnaird.]

AN INTERFEROMETER

The Interferometer is an accurate instrument for measuring the wave-lengths of light. Its method is to cause the superimposition of two beams of light radiating from the same source. Its capacity varies from the measurement of the diameters of stars to that of small differences in the refractive indices of gases

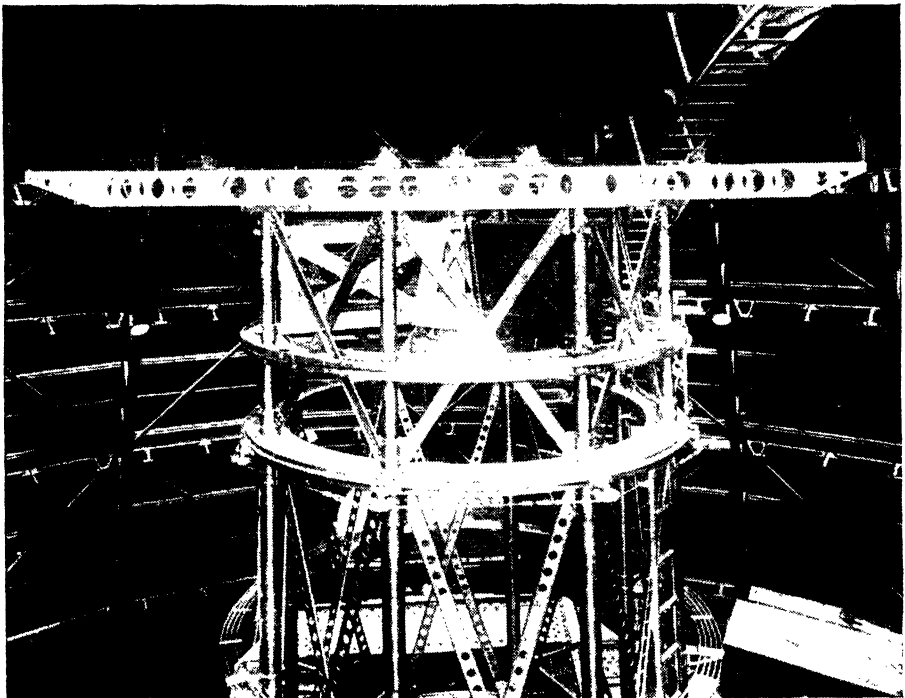

[Mount Wilson Observatory]

THE MOUNT WILSON TWENTY-FOOT INTERFEROMETER

This is the type of Interferometer used for measuring the diameters of stars. To a steel girder, horizontally fastened to the top of the 100-inch reflector, two pairs of mirrors are attached. The inner pair reflects starlight direct to the mirror - the outer pair can be manipulated to produce interference effects, by which the measurements are obtained

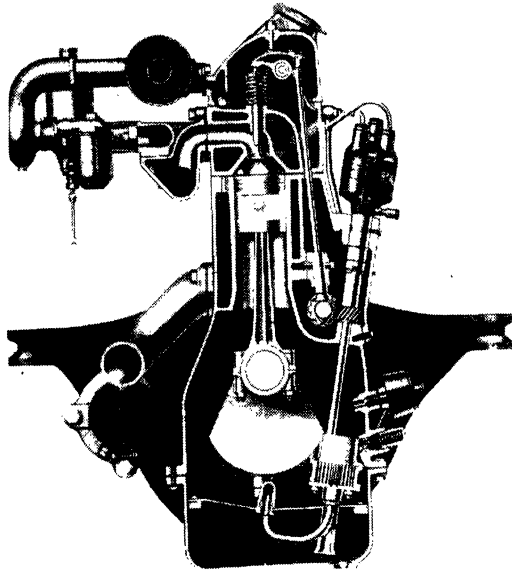

Courtesy Daimler, Ltd.

INTERNAL COMBUSTION: A SECTIONAL VIEW

A sectional view of the internal combustion engine as applied to the motor-car. The engine is of the poppet-valve type, as opposed to the sleeve valve; i.e. the valve is a circular disc on the end of a stem, moving in the line of its axis, and admitting the fuel to the cylinder for ignition. This example is of the overhead-valve push-rod operated type, one of several used

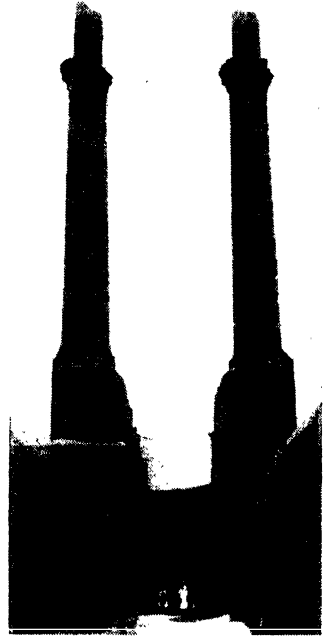

[A. Upham Pope]

ISFAHAN: THE TWO MINARS

Two fine old columns typical of the Muhammadan art which is Isfahan's glory. The Muslims conquered Persia soon after the foundation of their faith, and, causing the Zoroastrians to flee to India, where they are now called Parsees, made Persia for evermore an Islamic country



[Courtesy Prince Abdullah Mirza]

ISFAHAN: THE ZENDEH RUD BRIDGE

In former times Isfahan was Persia's capital, and it was during this era that in 1604, Ali Verdi Khan, a field marshal of Shah Abbas, built the great bridge over the Zende Rud which connects Isfahan with Hulfa. 386 yards long and 10 yards wide it has been described as the finest bridge in the world



[Carthew & Kinnaird]

THE GIANT IRISH ELK

The antler-spread of this magnificent animal often exceeded twelve feet. Though extinct to-day, and graced by naturalists with the name *Megaceros*, the Giant Irish Elk was by no means rare as late as the thirteenth century, and was a favourite quarry for medieval huntsmen; it was not confined to Ireland, but roamed in Britain and on the Continent. Other versions of its history make it of much earlier extinction.



[Courtesy E. Pollard & Co.]

INVISIBLE WINDOWS

Though only placed on the market in 1933, the so-called "invisible" plate-glass windows for shops have already become popular. Actually the secret lies in the curved shape of the glass rather than in any intrinsic properties. The excellence of the new effect may be judged by comparing the upper (ordinary) and lower (invisible) panes of glass.

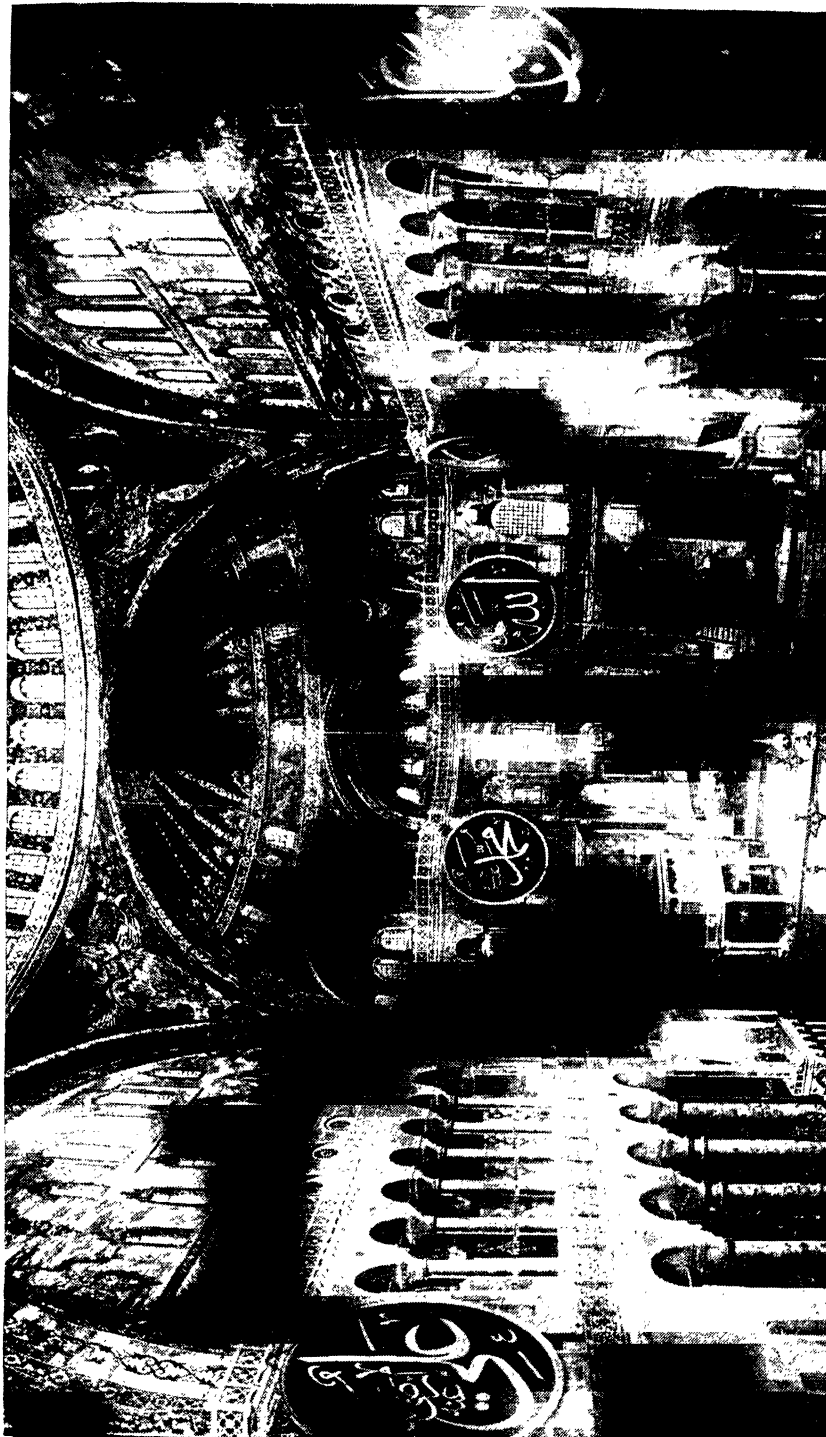

19.1.1

INTERIOR OF SAN SOPHIA, ISTANBUL

This world-famous temple has suffered exactly the reverse fate of the Grand Mosque at Cordova: the latter, built as a great shrine of Islam, at the Reconquest became a Christian cathedral; San Sophia, which the Byzantines erected as a temple of Christianity, is now a mosque. The Turks, however, have been more tolerant than the Spaniards, for, though Moslem pulpits, carpets, and inscriptions have been added, the glorious architecture remains unobscured and Christian emblems have not been defaced.

THE HALL OF 1003 COLUMNS, ISTANBUL

Built by the East Roman Emperor Justinian, this forest of pillars is not a hall at all, but a huge tank to improve Byzantine's then very inadequate water supply. The whole city is honeycombed with mysterious subterranean conduits connecting with this and other tanks. The "Hall" is as large as Notre Dame, and many of the pillars bear inscriptions and monograms showing that the water was hardly perpetual

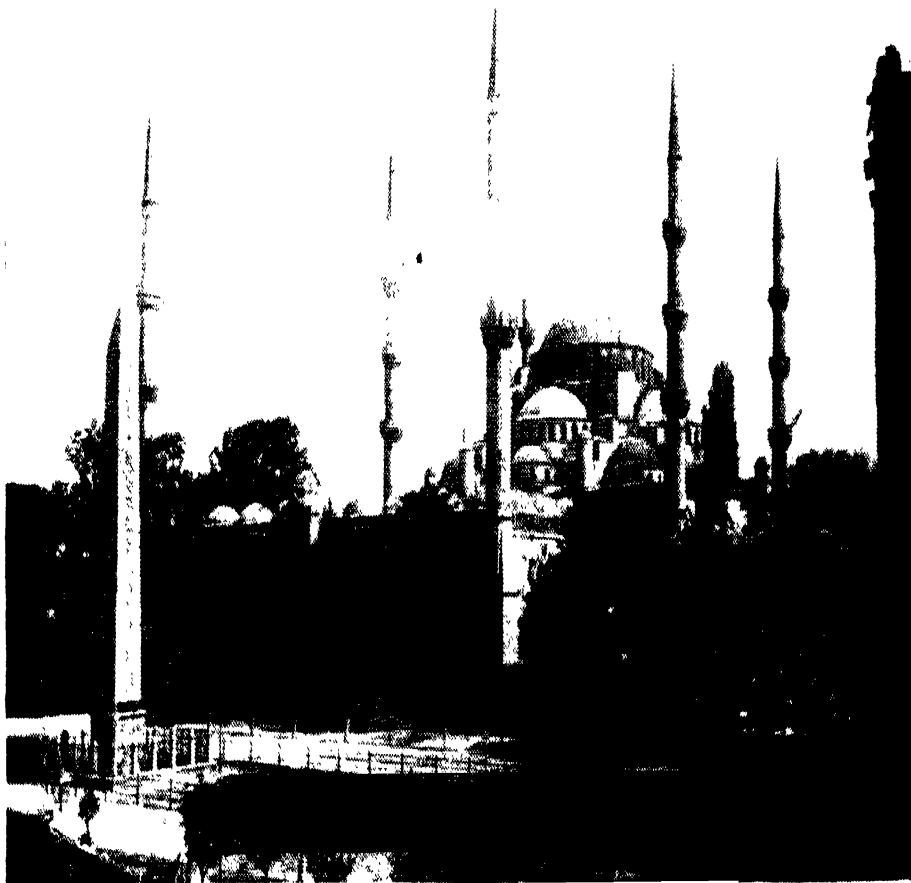

[Carthew & Kinnaird]

THE MOSQUE OF SULTAN AHMED, ISTANBUL

Ahmed was a contemporary of James I of England, and was the last Sultan to build a mosque as memorial to himself. Despite its great size, the Mosque of Ahmed is light, airy, and graceful. The dome is supported by great marble pillars, and is surrounded by six stately minarets

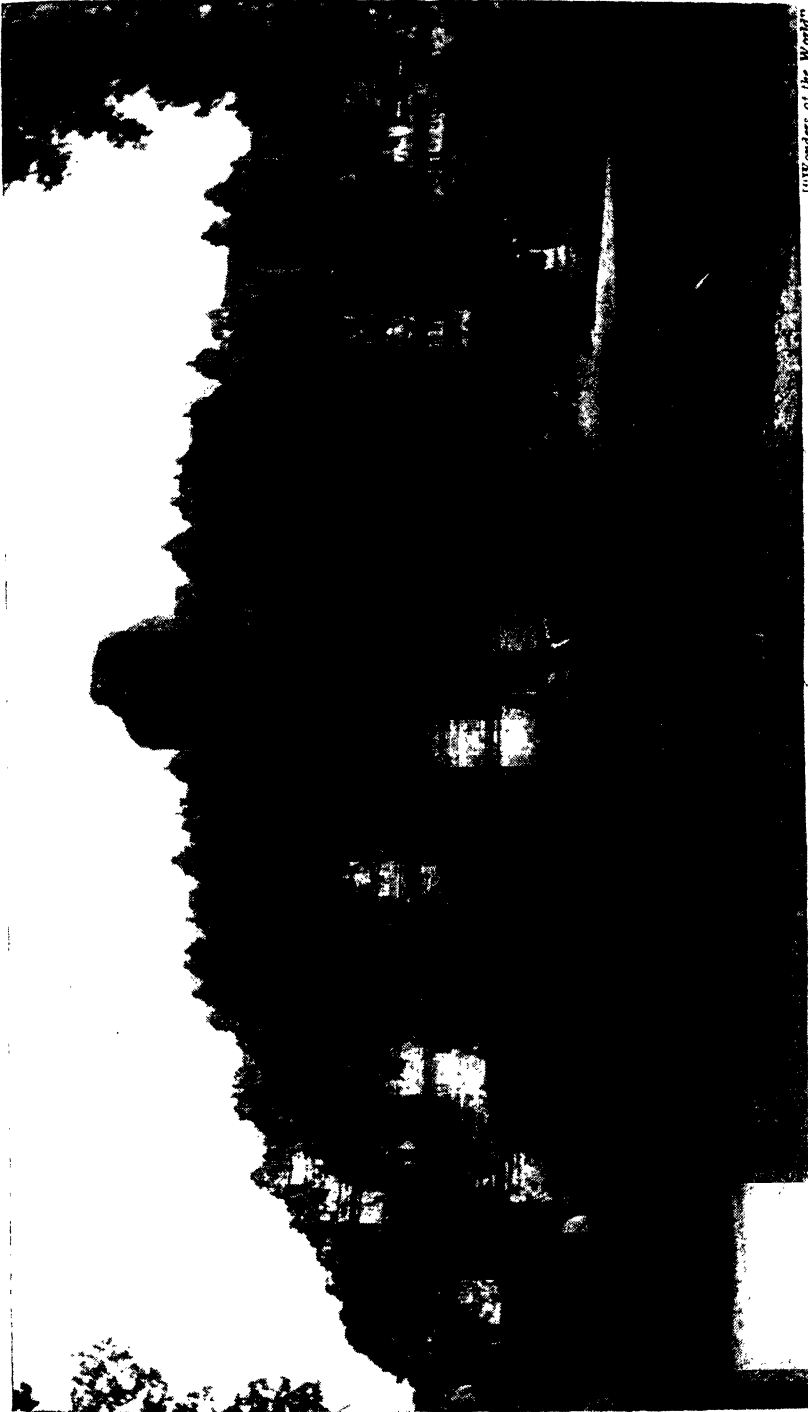

"Wonders of the World"

THE TEMPLE OF BORO-BODOER, JAVA

By 10

For a short period during the Napoleonic wars Java was a British possession, and during that time Sir Stamford Raffles, the Governor, discovered this mighty temple. So deeply had it been overgrown that even the local natives thought it was just a hill! The building is most ornately carved—three miles of sculpture surround it—so much so that for sheer labour involved even the Pyramids pale beside it. It is believed to have been built from the seventh century



of the World")

JABALPUR THE MARBLE ROCKS

The gorge of marble rocks, twelve miles from Jabalpur, India, through which the River Nerbudda flows, is a mile of glistening beauty. The rocks tower to a height of 120 feet, and the magnesian limestone composing them gleams snowy white.



(From "Marvels of the Universe")

THE AFRICAN JACANA

There are two varieties of this bird: the one illustrated, which in life is about the size of a plover, is the commoner as well as the larger type. The Jacana is remarkable for its huge feet, which are so shaped as to enable it to walk on water-lily leaves.

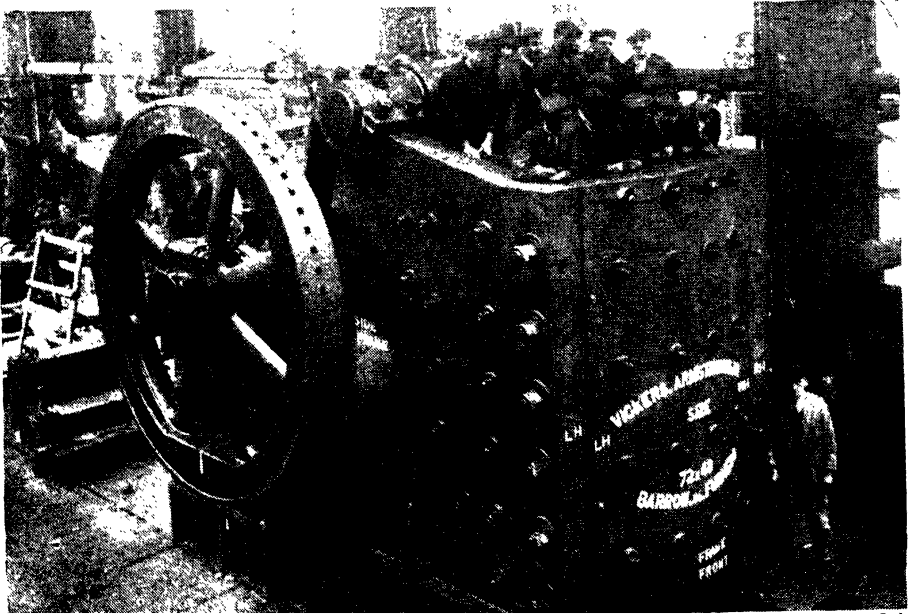

[Courtesy Vickers, Ltd.]

A SWING JAW-CRUSHER

The rather ominous title of this massive machine is due to its method of operation by large internal jaws. It is used in the cement industry to break up cubes of limestone. The specimen illustrated, believed to be the largest in Europe, can reduce 4-foot (5-ton) cubes to 6-inch lumps at the rate of 250-300 tons an hour.



[Courtesy Brit. School of Arch. in Jerusalem]

THE SITE OF A MIRACLE, JERASH

The photograph shows Fountain Court, Jerash, and in the background a former cathedral. The Court owes its name to a legend that once a year, at the Epiphany, the water of a fountain here was miraculously turned to wine. The floors of some of the Jerash buildings are paved with fine mosaics

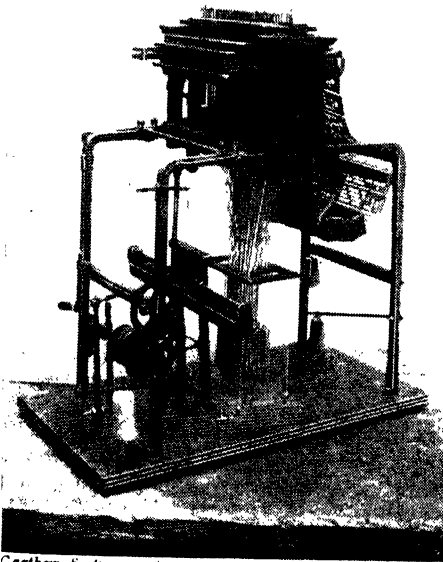

Cartier & Kinnsaw

JACQUARD'S LOOM

Joseph Jacquard was a Lyonnais, born in 1752. His silk-weaving loom, of which the above is a pioneer example, did away with guidance by hand, and caused furious opposition at first. He lived, however, to see it in almost universal use, and was pensioned by Napoleon



[Courtesy Brit. School of Arch. in Jerusalem]

RUINED JERASH

Serious excavation of Jerash, Palestine, began in 1927, since when many fourth-century Christian buildings have been unearthed. This handsome stairway, which was once roofed, used to lead to a shrine dedicated to the Virgin Mary and the Archangels Gabriel and Michael



[Underwood Press Service]

JERUSALEM: CHURCH OF THE HOLY SEPULCHRE

The only Christian church in the world which, as a place of pilgrimage, stands above the difference of sect and faction. The photograph shows the façade of the Chapel of the Angel, hung with innumerable lamps placed there on behalf of Christian bodies all over the earth. The little altar in the background marks the spot where, according to legend, the angel stood on Easter morning to tell the women that Christ had risen.

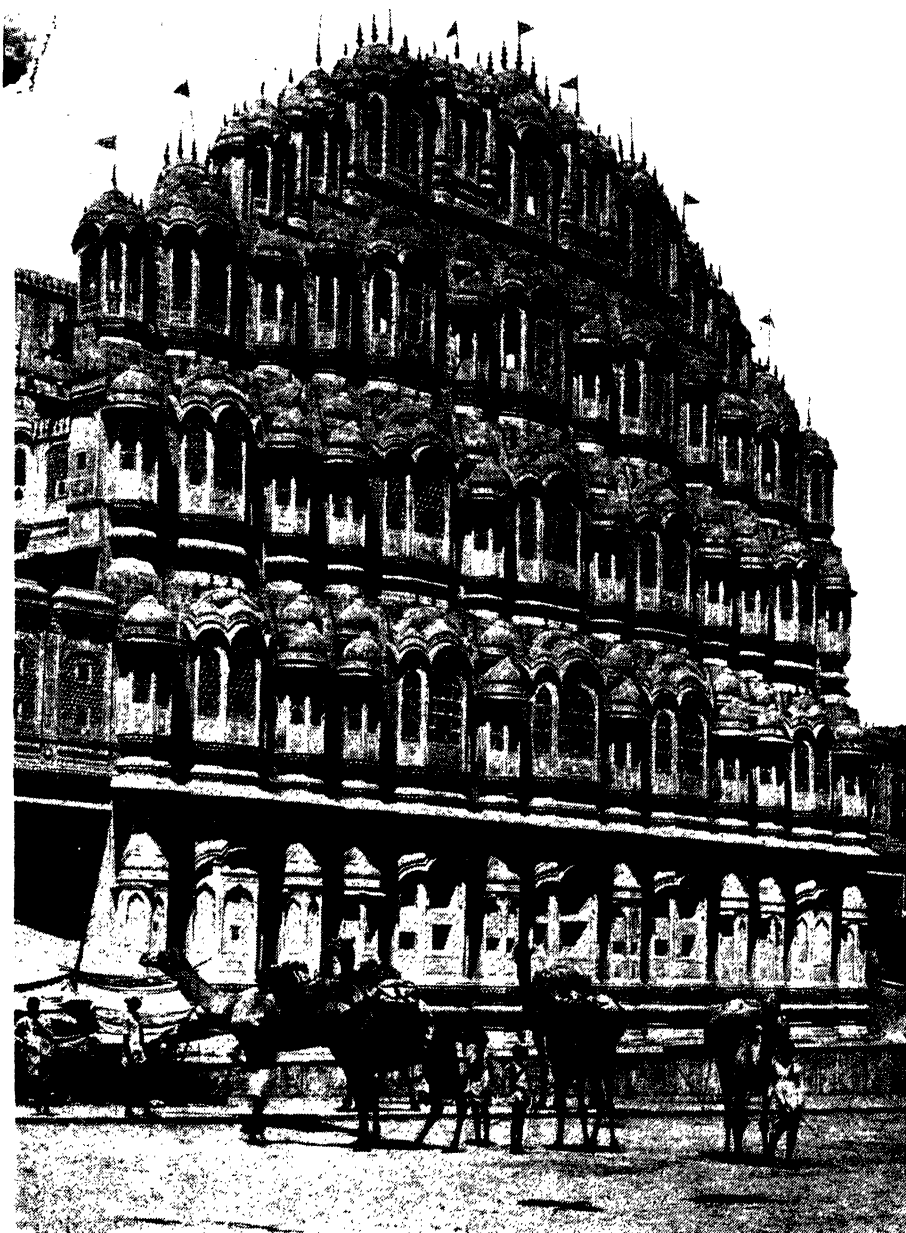

By courtesy]

[“Wonders of the World”

THE HAWA MAHAL, JEYPORE

The Hawa Mahal, or Hall of the Winds, was built as part of the palace of the Maharajas of this Indian city. It was built by Jeyapore's founder, Jey Singh, in 1728. Its composition is entirely of pink and white stucco, so that it presents as curious and bewildering a whole as is to be found in Indian architecture. There is, however, much grace about it, despite its intricate and crowded design

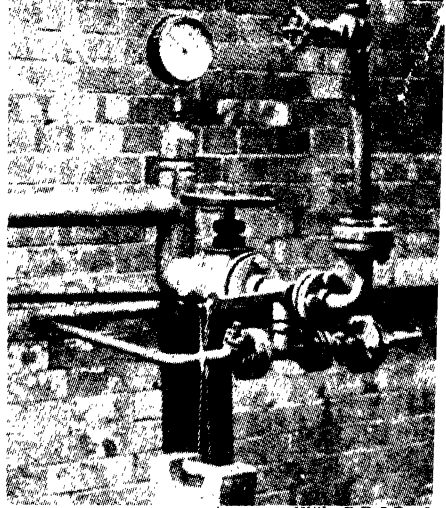
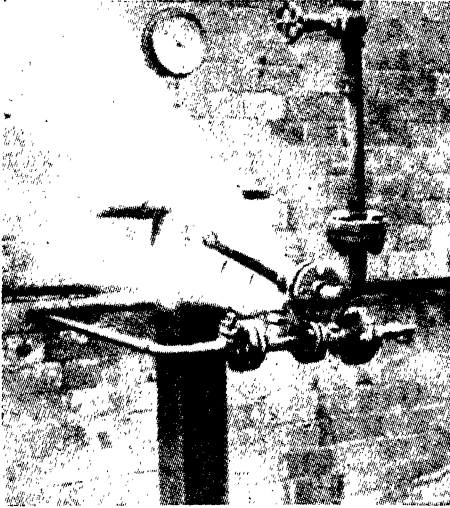

[Courtesy Wills P.F.I.R., L.]

JOINT-RINGS FILLED WITH GAS

Perfect sealing of joints in pipes carrying a high pressure of water or steam is often difficult to obtain without great strain on the bolts. A joint ring, or washer, has been evolved which is resilient, like a tyre. The above pictures show (left) slackened bolts allowing steam to escape; (right) a weight of 28 lb. hung from a spanner completely sealing the joint.

GAS FILLED

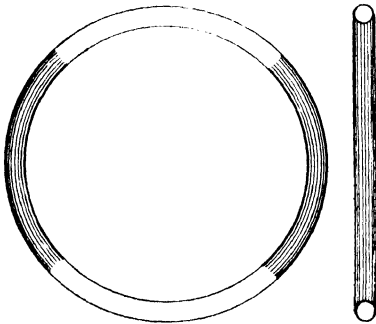

[Courtesy Wills P.F.I.R., L.]

THE GAS-FILLED JOINT-RING.

A section across both dimensions of the ring. The transverse section shows clearly the cavity which provides the resilience. It is filled with a non-explosive gas under pressure. The ring itself, of copper or other soft metal, may be of any shape.

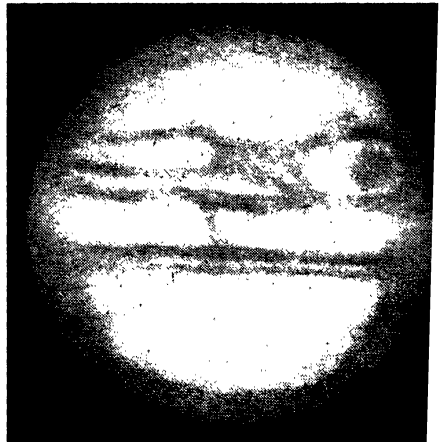

[M. Anton]

JUPITER, SHOWING THE RED SPOT

The red spot on the planet (seen on the right) first became noticeable in 1875, and after being the most conspicuous region for 25 years, it is now barely visible again. Two thousand miles long, the spot is believed to be due to a vast volcanic eruption.

[By courtesy]

JUPITER IN RELATION TO OTHER PLANETS

An imaginary view of the mighty Jupiter and the nearer planets revolving round the Sun. The relative distance approximately to scale, but Jupiter in reality is 1300 times as big as the Earth.

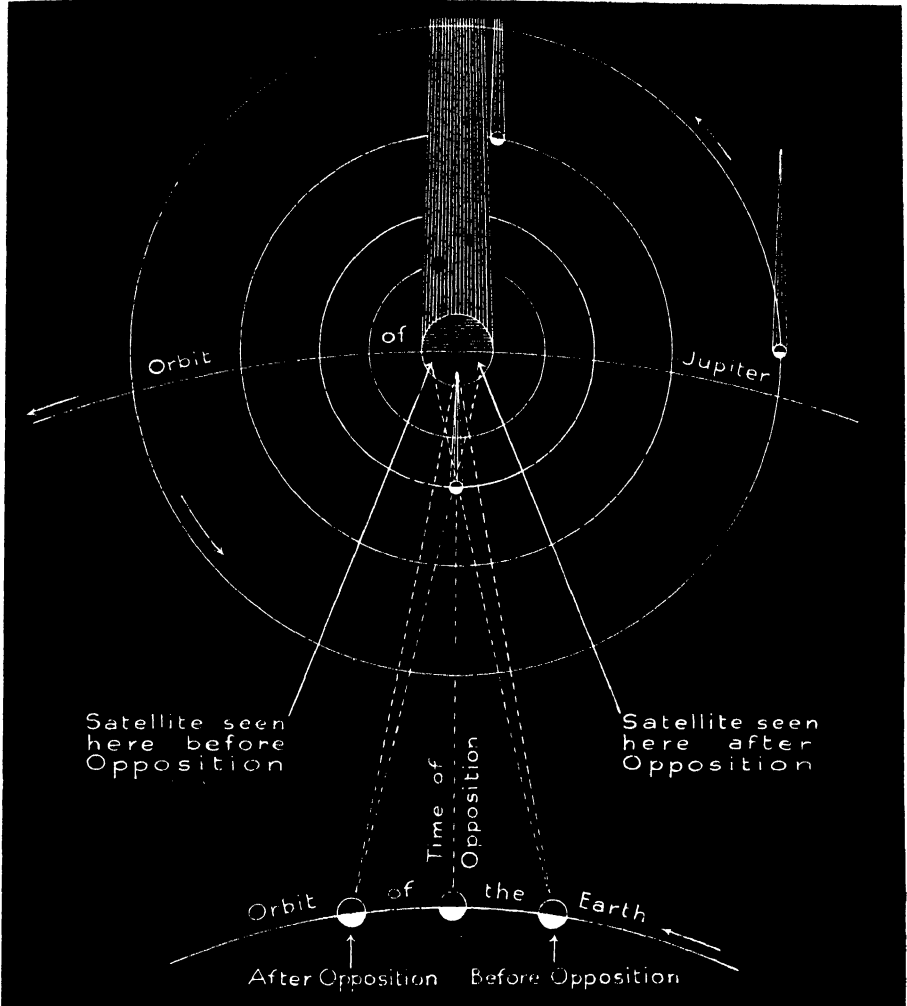

[From "Splendour of the Heavens"]

ECLIPSES AND TRANSITS OF JUPITER'S SATELLITES

The orbits of Jupiter's larger satellites lie so nearly in the same plane as the Earth's path round the Sun that most (and often all) of them pass at each revolution in front of and behind their primary. This diagram shows how they may become invisible by eclipse, or how, when in "transit", i.e. in front of their primary each throws a little round black shadow on the bright surface of the planet.

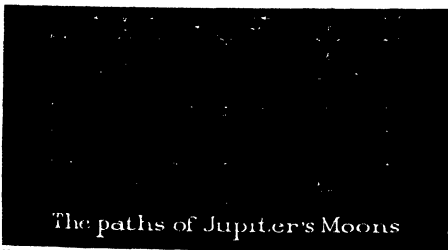

The paths of Jupiter's Moons

[From "Kometenlehre", vol. 277.]

THE PATHS OF JUPITER'S MOONS

Movements of Jupiter's satellites differ considerably from our Moon's. The latter's course is always concave to the Sun; but the courses of Jupiter's five moons are convex to the Sun at New Moon.



[From "Splendour of the Heavens"]

JUPITER AND THE EARTH

Jupiter is the largest of the planets--so much larger that its bulk is greater than that of all the others combined! The Earth in comparison with it shows as a small dot, actually one 1300th of the bulk.

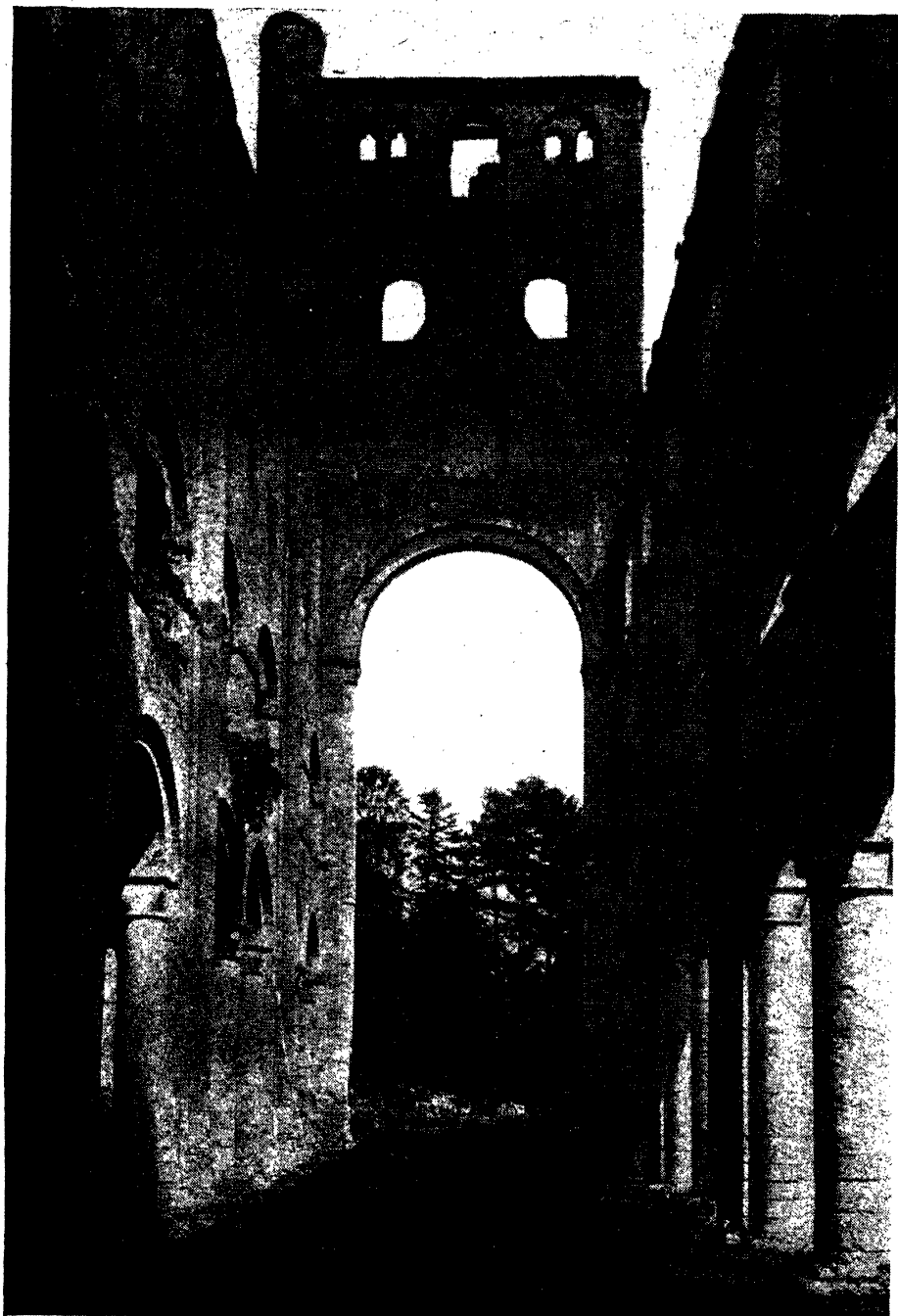

THE ABBEY OF JUMIÈGES

(W. F. Mansell)

Jumièges, seventeen miles from Rouen, was formerly one of the most important Benedictine abbeys. Most of its remains, including the nave and mighty arch here shown, date from the eleventh century; other fragments date from the twelfth to fifteenth centuries, and one from the time of Charlemagne. Charles VII and Agnes Sorel often resided here, the stone once covering the latter's grave still existing. Robert of Jumièges was made Archbishop of Canterbury in 1031.



THE AMIDA OF KAMAKURA

[Underwood Press Service

The word "Amida" means one of the five Buddhas of the present world in Japan. The gigantic statue at Kamakura is easily the most famous representation. Nearly 50 feet high and 100 feet in girth, the image, which is of pure bronze, dates from A.D. 1252. The boss in the forehead is of solid silver weighing 30 lb., and the eyes, each four feet long, are of pure gold

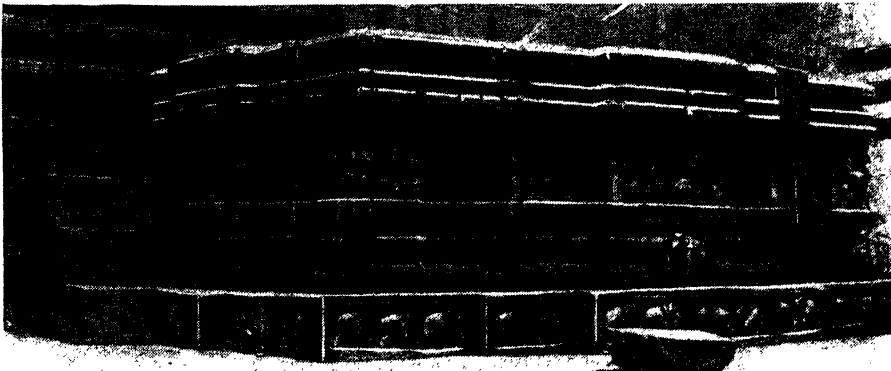

By courtesy]

KANARAK: THE BLACK TEMPLE

[*"Wonders of the World"*

This temple, though now deserted, is probably the finest example of pure Hindu art. The walls, roofs, and platforms are minutely carved, and, as this photograph of the great central altar shows, the carving is of a very high order. Note especially the elephant frieze at the foot



THE PALACE OF KANO

Kano was the capital of the Emir of Hausaland before its capture in 1903 led to incorporation with Nigeria. The palace is built of clay on a framework of wood. The central dome covers the audience chamber



THE WOMEN'S QUARTERS AT KANO

This exterior view of the feminine regions of the Emir's palace shows the type of decoration with which some of the clay buildings are adorned

Photos from]

PART OF KANO'S WALLS

The walls of Kano, like the rest of the city, are made of clay, with a stout inner framework of wood. They are 50 feet high, and 40 feet thick at the base

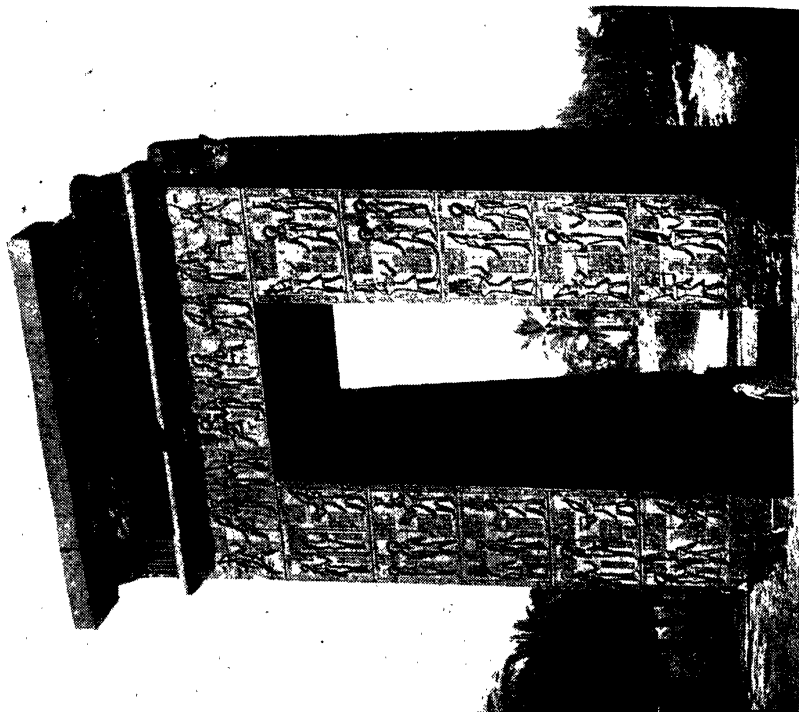
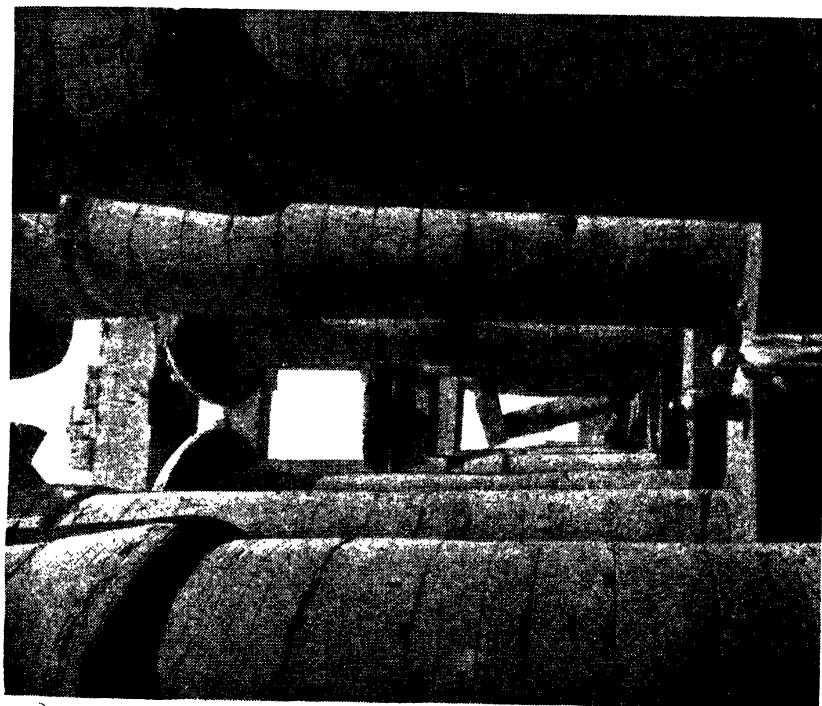

Photochrome Co.

A MIGHTY TEMPLE AT KARNAK

Karnak, adjoining Egyptian Thebes, was an important sacred city in olden times. Each of the above photographs shows a massive relic of the former Temple of the Sun. The colonnade, with its prodigious pillars elaborately ornamented, is, except for the Pyramids and the Sphinx, the best known relic in Egypt. **Rameses II** built most of Karnak though several Pharaohs made their contributions later.

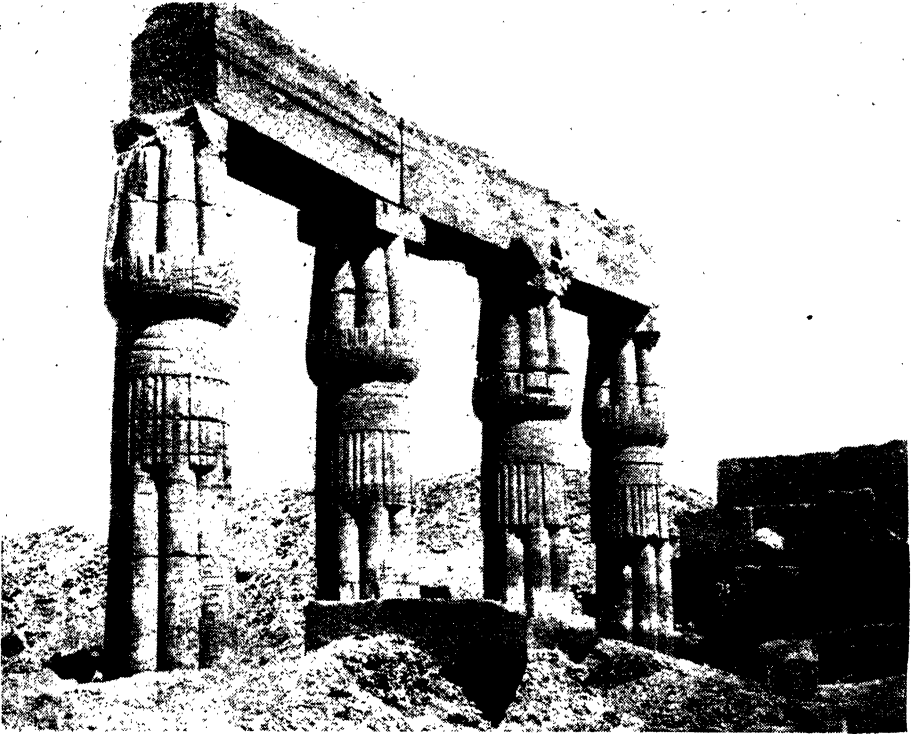

[E.N.A.]

ANOTHER TEMPLE AT KARNAK

In quite a different style of architecture from the Temple of the Sun is the fragment of the Temple built by Tehutimes III. This king, who reigned some 3500 years ago, was the successor to the extraordinary Queen Hatshopsitu, the story of whose conception and birth exactly resembles that of the Christian Nativity.

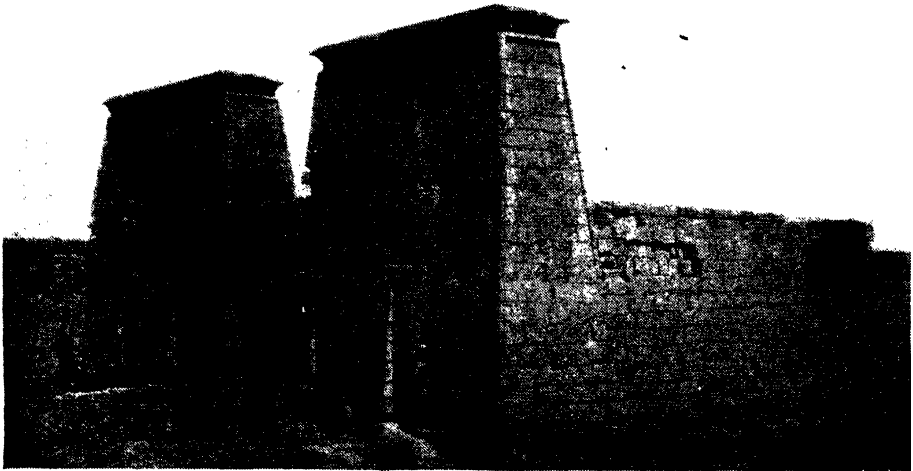

[E.N.A.]

TEMPLE OF RAMESES IV, KARNAK

It was under the Kings of the nineteenth dynasty, who followed some years after Tehutimes and Hatshopsitu, that Karnak rose from a mere Egyptian town to be a wonder of the world for all time. Ramesses IV, of the twentieth dynasty was almost the last of the great Theban line to embellish the city.



Dorien Leigh

THE GOTHIC ALTAR AT KEFFERNARKT

As a triumph of wood-carving this altar would be hard to match except by a very few contemporary pieces. The work is so fine as to resemble bronze or stone, and it must be remembered that the grain in all woods is normally a great limitation on the carver's art. There are two great periods of European woodwork: the Gothic and the Renaissance. The Keffernarkt altar is an example of the former.



[Dorien Leigh

DETAIL OF A HEAD ON THE KEFERMARKT ALTAR

In Gothic days the woodcarver was a master craftsman travelling with his assistants from church to church: for the most part he was actuated by high religious and social ideals. Skillful blend of colours often enhanced (as well as preserved) his work, but that this aid was not essential for the full display of his almost superhuman powers is shown by this photograph. The patience lavished upon minutest details is astounding

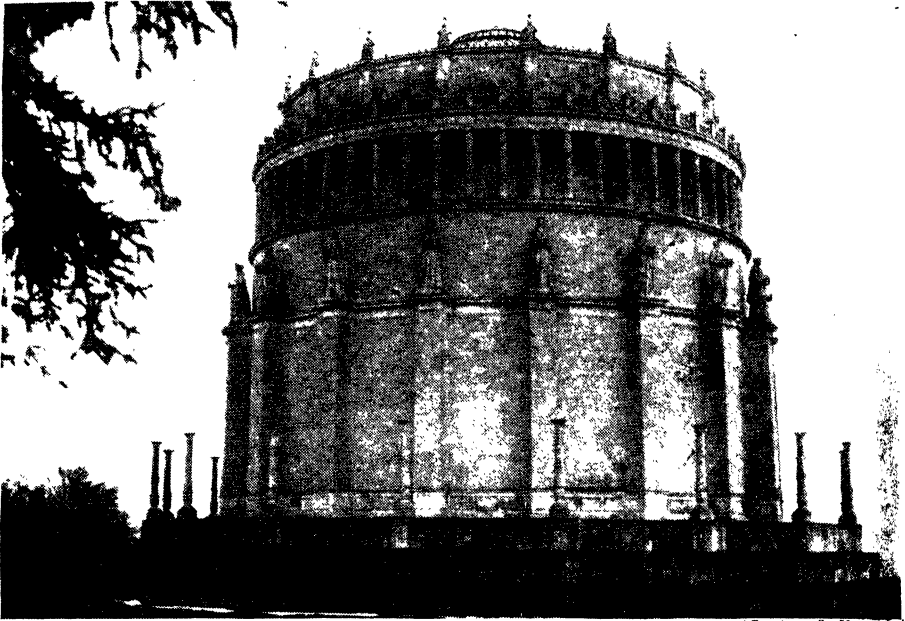

THE HALL OF DELIVERANCE, KEILHEIM

(Carthew & Kinnara)

This Hall was erected between 1842 and 1843 by Ludwig I of Bavaria as a memorial of the deliverance of his country from Napoleon. 1500 feet round and 100 feet high, the monument stands on the top of a high mountain. Gaertner and Klenze were its architects, adopting the classical style.



KENILWORTH CASTLE

(G.W. Railway)

Geoffrey de Clinton, Treasurer of England, founded this great fortress in the twelfth century, and the present Great Keep is of his or his son's day. Most of the other ruins, as the windows indicate, are of Tudor conversion if not origin. Kenilworth is better remembered as the scene of Scott's great novel than for its historical associations.



THE MAMMOTH CAVE, KENTUCKY

[Underwood Press Service]

The actual point of the cave at which this picture was taken is the head of Echo River. Nobody knows how far the river flows, for only rough estimates have so far been formed of the Mammoth Cave's extent. It is known, however, to pursue its subterranean course for at least 100 miles



THE PILLARS OF HERCULES, MAMMOTH CAVE

[Underwood Press Service]

The stalactites found along the immeasurable Mammoth Cave are of great beauty. They are not abundant, as in the caves of Mexico, Australia, and Europe, which perhaps adds to their effect. Above is one of two giant stalactite formations whose title is appropriate



[W. S. Berridge, I. Z. S.]

THE KING CRAB

In reality this creature is not a crab at all, and, in so far as its strongly individual type resembles anything, it is related to the scorpion. The most interesting part about the King Crab is its remarkable resemblance to the Trilobite, which became extinct no one knows how many millions of years ago.

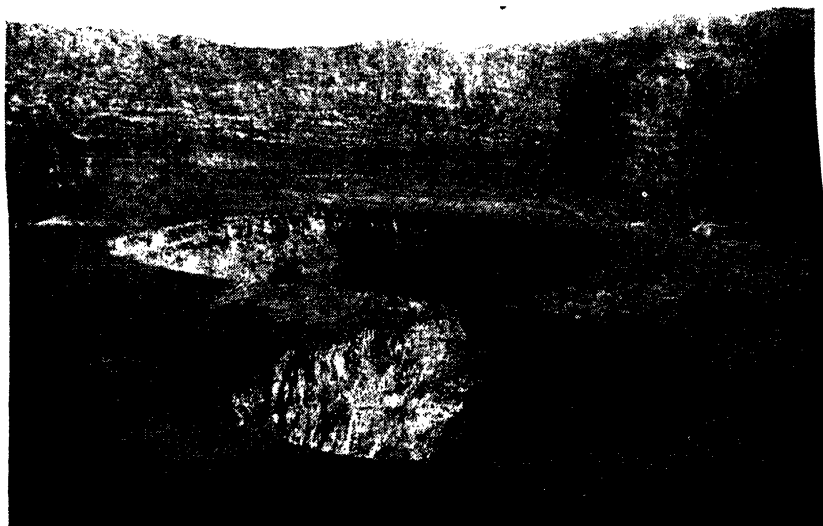

1 "Wonders of the World"

KIRUNGA-CHA-GONGO

This, or Nina Gongo as it is also called, is one of a group of formidable volcanoes on the borders of the Belgian Congo and Uganda. They rise to a height of nearly 10,000 feet, and at night light up the neighbourhood for miles with golden and crimson vapours. The above shows the curious crater



(Carthew & Kinnear)

THE NAVAL CATHEDRAL, KRONSTADT

Peter the Great founded and fortified Kronstadt in 1703. It occupies an island in Neva Bay, on the Gulf of Finland, and is the seaport for Leningrad. The Cathedral is a splendid example of modern, as opposed to post-war modern, work, having been begun in 1903 and completed in 1913

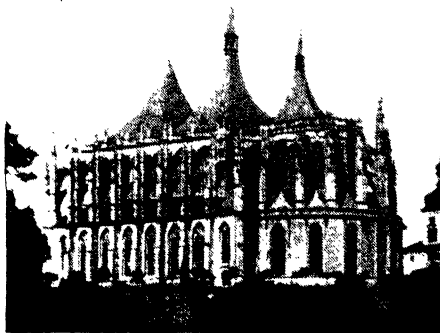

From "Picturesque Europe"

A CHURCH AT KUTNA HORA

Kutna Hora, or Kuttenberg, in the Bohemian division of Czechoslovakia, was famous of yore for its silver mines, but to-day for its unfinished fourteenth-century Church of Santa Barbara, a brilliant example of Czech-Gothic architecture. Peter of Gmünd was the architect

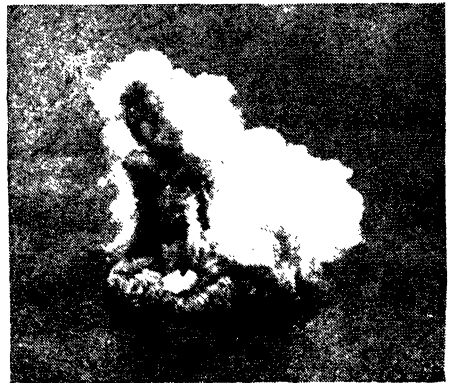

(Dorien Leigh)

KRAKATOA, NEAR JAVA

When Krakatoa erupted in 1883, a hill 1400 feet high became a cavity 1000 feet deep; the ash darkened the sky 150 miles away; stones were thrown 17 miles high; the atmospheric oscillations encircled the earth three times. Above is shown where the vanished island stood

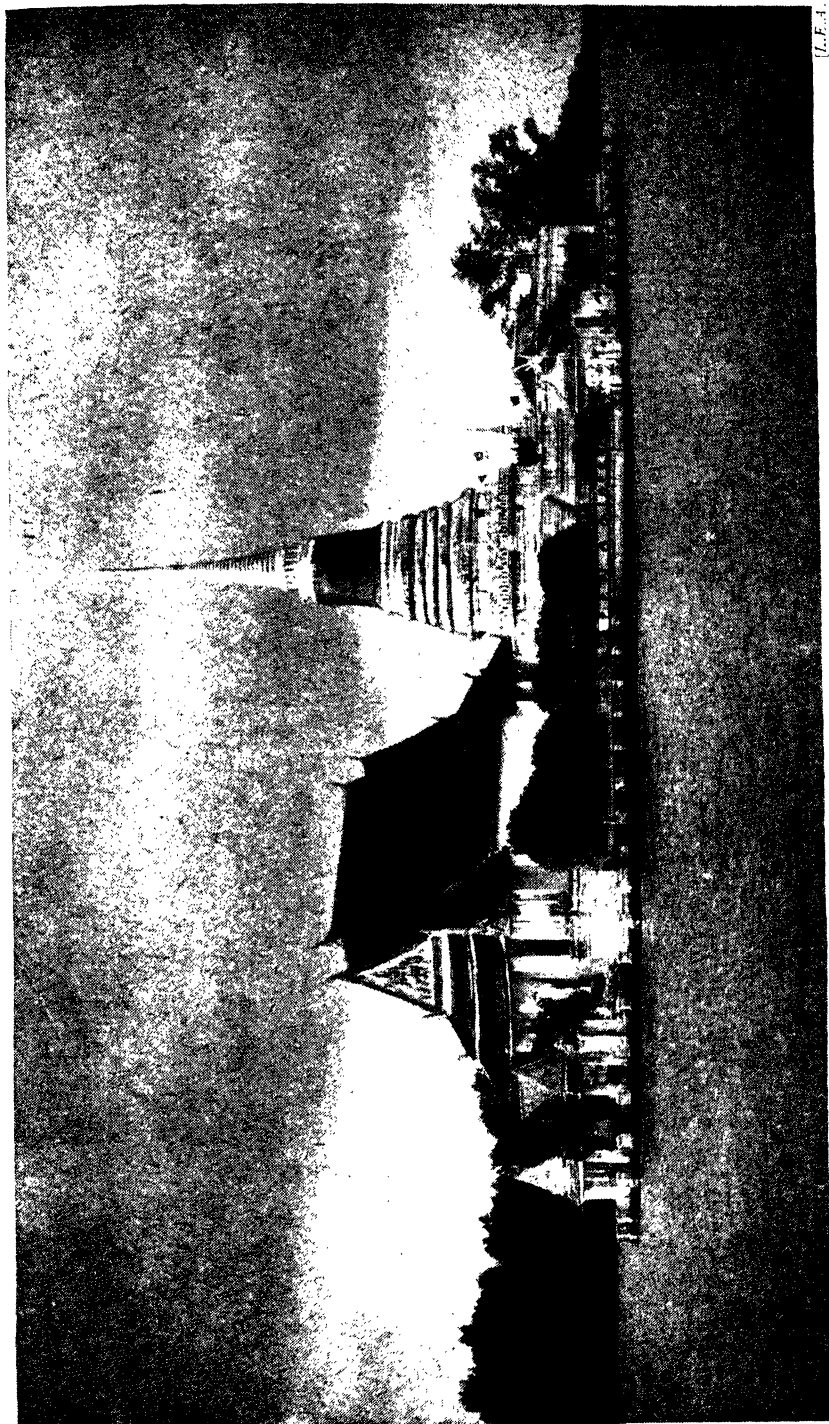

[L.F. 1.]

THE PAGODA IN THE RIVER KIANG-NAM

This graceful temple is situated on an island in the River Menam, not very far from Bangkok, and is one of the best sights seen by visitors to Siam. It is of the same style and period as most of the Wats in Bangkok itself, which for an Oriental city, is comparatively new, having been founded in 1782 by the head of the still ruling dynasty.



[Carthar & Kinnaird]

THE FALSE-HEADED LANTERN FLY

This insect, a native of Brazil, is illustrated here considerably smaller than the natural size. It is remarkable not only for the light emitted, but for the grotesque false head, complete with apparent eyes and teeth, which projects beyond the real head to scare enemies.



[Llano Carrera]

THE LATTICE FUNGUS AND ORANGE ELF-CUP

The Lattice Fungus is one of the most remarkable of the fungoid tribe. Starting much like a puff-ball, it bursts its wrappers and rises to a height of four inches, covered with slime. Gradually this thins away, leaving the plant like a network of pink coral, but very evil-smelling. The Orange Elf-cup, seen in the left-hand picture, is a beautiful fungus to be seen in many woods.



(Dorien Leigh.)

"THE LAOCOÖN"

The most celebrated "action group" produced by the ancient world. According to legend, Laocöon was a priest of Apollo and incurred the anger of that deity by his warning against admitting the Wooden Horse to Troy. Apollo therefore drove two serpents from the sea to consume Laocöon and his two sons. The death agony was vividly depicted in stone by the three Rhodian sculptors of this group, which was found in 1506 and is now in the Vatican.



Lorton Leigh

LARGILLIÈRE'S PORTRAIT OF HIMSELF, WIFE, AND DAUGHTER

Though Nicolas de Largillière (1656-1716), by comparison with most, was not a particularly great artist, his contemporaries certainly thought he was, for they called him the French Van Dyck. He painted very much in the precise and classical style demanded by public taste in that period. His work is fairly evenly divided between portraits and historical tableaux. The above

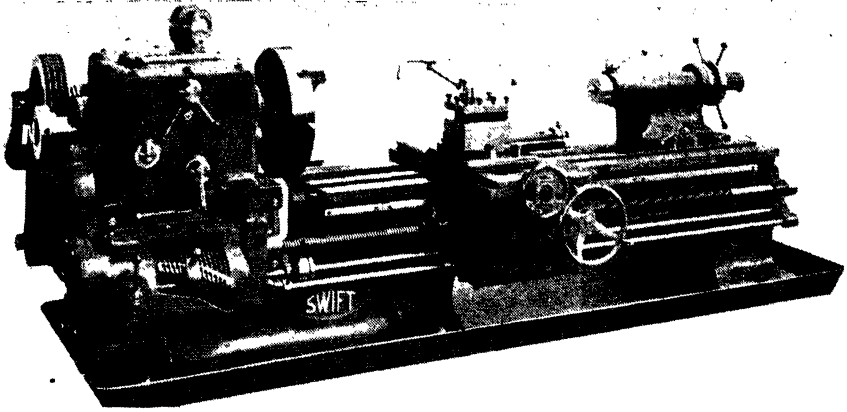

(Courtesy Geo. Swift & Sons)

Lathes may range in size from mammoth erections weighing many tons to delicate instruments used for cutting various parts of watches. In this picture is a medium-sized modern lathe suitable for heavy cutting of engineering parts. The speed of such lathes has doubled in a decade. The various types are: bench lathes (small size); "engine" lathes (automatic feed); capstan and turret lathes; vertical lathes (or turning and boring mills); and special purpose lathes.

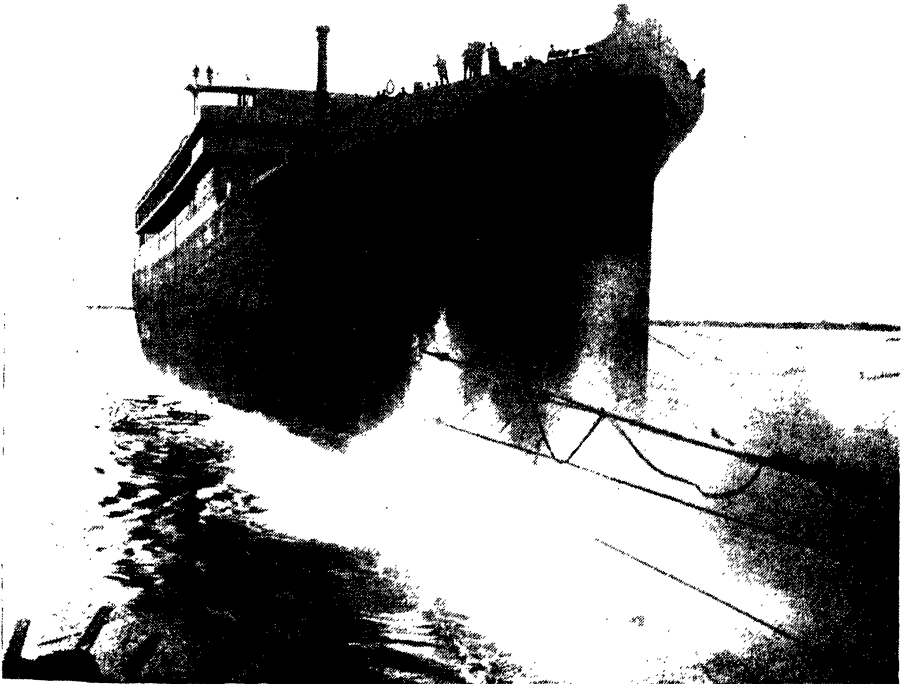

(Courtesy Vickers Ltd.)

LAUNCHING A LINER

As ships grow larger the business of getting them from the building stocks to the water demands increasing accuracy. Modern launching machinery arranged to operate electrically on the pressing of a single button is complicated and ingenious. Note that the ship enters the water stern first; also why



By courtesy

["Picturesque Europe"]

THE VOLKERSCHLACHT-DENKMAL, LEIPSIC

This striking memorial commemorates the great Battle of Leipsic, which really marked the end of Napoleon. Begun in 1898, it was finished in 1913—100 years after the battle. It is 300 feet high, and stands on a high mound with a lake in front. The inside consists of a domed hall and crypt, and the flight of steps on one side leads up to a platform whence a magnificent view may be obtained of the flat, fertile countryside round the city.



[Dorien Leigh]

"MME LEBRUN AND HER DAUGHTER", BY HERSELF

The charming Mme Marie Louise Elizabeth Lebrun (*née Vigée*) is one of the few great women portrait painters. Her first success was a portrait of Marie Antoinette in 1779, and four years later she was admitted to the Academy. She travelled much, and her portraits include Lady Hamilton, Lord Byron, Mme de Staël, and the Prince Regent.



"LA GIOCONDE", BY LEONARDO DA VINCI

Dorren Leigh

The most celebrated portrait in the world, by one of the greatest men of all time. Leonardo da Vinci (1452-1519) was not only painter, sculptor, architect, engineer, and mechanical inventor, but author, poet, musician, philosopher, and natural historian. In addition he was handsome of person and of generous and fascinating personality. "La Gioconde" is not allegorical, but a portrait of Monna Lisa, wife of Zanobi del Gioconde

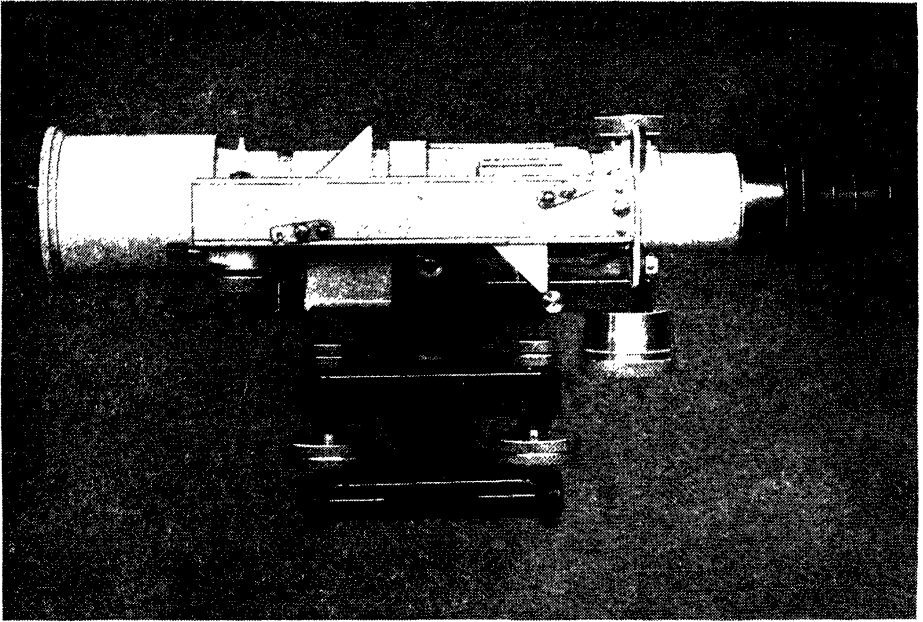

A PRECISION LEVEL—SIDE VIEW

(Carthew & Kinnaird)

This is a surveying instrument for ascertaining levels with a high degree of accuracy. To obtain the difference in level between two points the precision level is placed at a third point between them. The difference is then the same as the difference between the two points on a scaled leveling staff at which the line of sight is cut off.

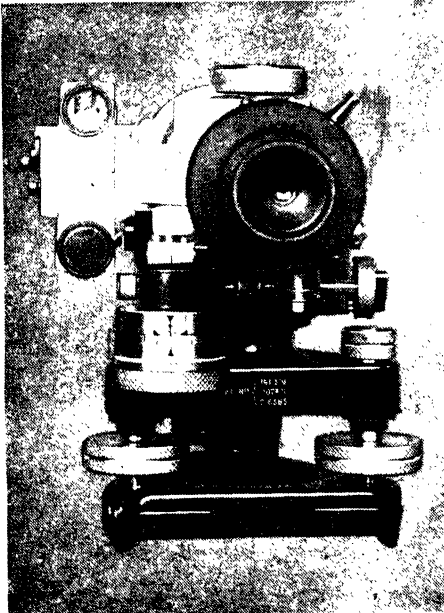

(Carthew & Kinnaird)

A PRECISION LEVEL

The instrument consists of a telescope bearing an ordinary spirit level and mounted horizontally. The construction is similar to that of a theodolite, and a description of the working will be found under the lateral view above.



(From "Picturesque Europe")

ST. MICHAEL'S CHAPEL, LE PUY

Le Puy, the capital of the department of Haute Loire, is little known to tourists. The town has a famous cathedral, but its *pièce de résistance* is the little tenth-century Chapel of St. Michael d' Aiguilhe, reached by 300 steps.

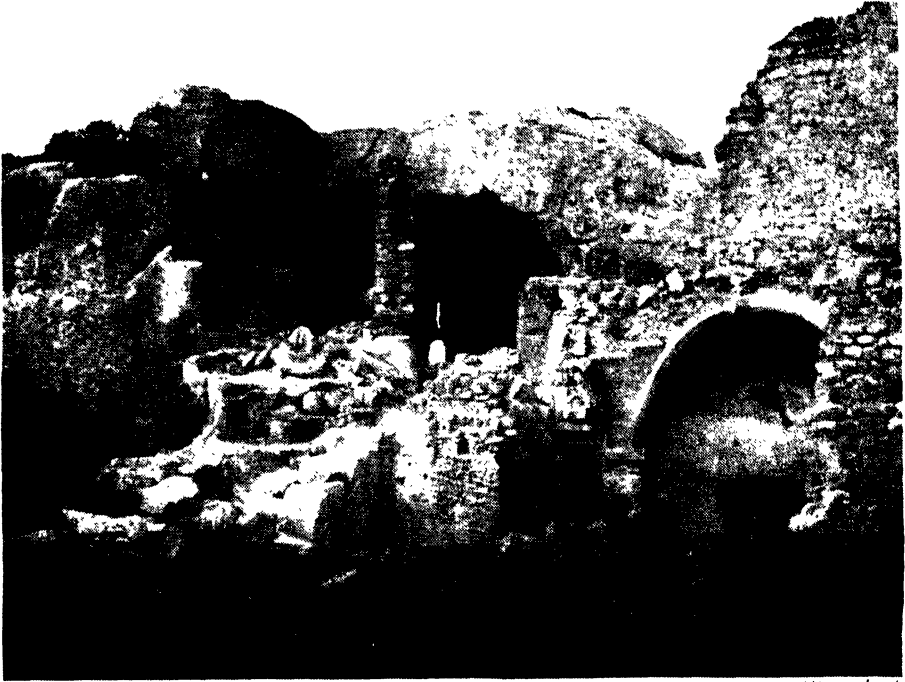

[Dorrien Leigh

THE DEAD CITY OF LES BAUX

Les Baux to-day is a sleepy little village, dominated by its gigantic ruined castle, amongst the olives and vineyards of the sub-Alpine hills of Provence, near Arles -but mediaeval Les Baux was a thriving town ruled by powerful Counts. This is difficult to realize in these days, when all is dead and silent there, except for the tinkling of sheep bells.



[By courtesy]

"Wonders of the World"

THE POTALA, LHASA

A good view of the famous palace of the Grand Lama of Tibet. It is about 900 feet in length, and its gilded roofs are 400 feet above the plain. Prior to 1904, only one white man had ever penetrated to the Forbidden City, but otherwise as the Mecca of Lamaism, it is filled with cosmopolitan pilgrims.

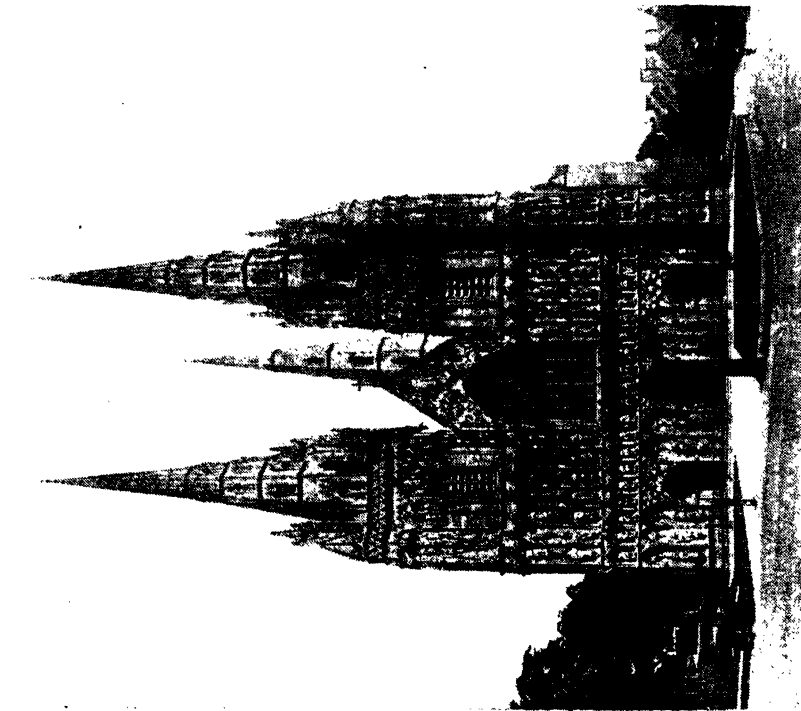

Lichfield Cathedral's delicate triple spires are known in Staffordshire as the Ladies of the Vale. Because of their and because of the rich and tasteful decoration of the façades, the building equals any in England for elegance and grace. The interior is equally fine, here again the decorative treatment being prominent. The date of the edifice is roughly 1200-1310

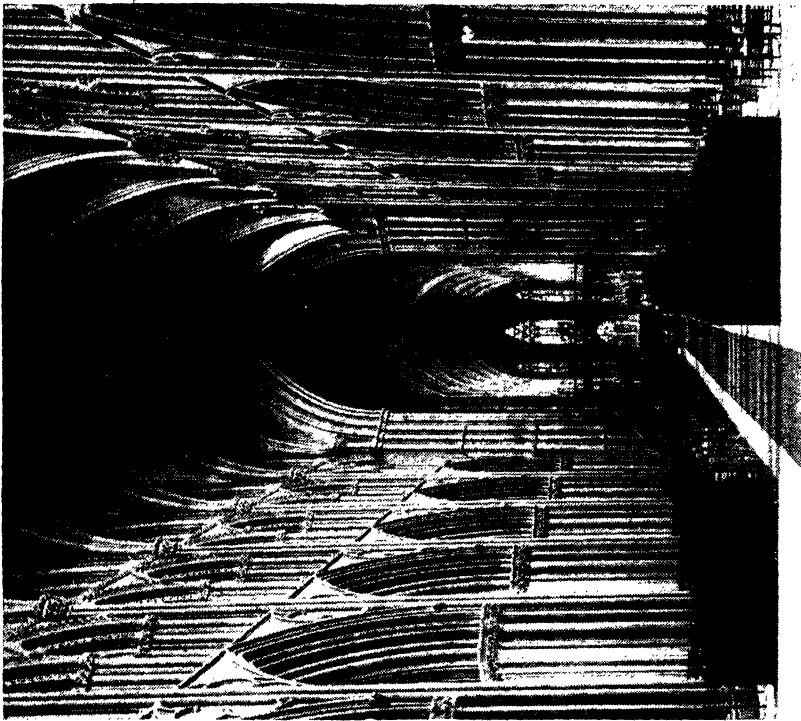

W. F. Mansell

LICHFIELD CATHEDRAL

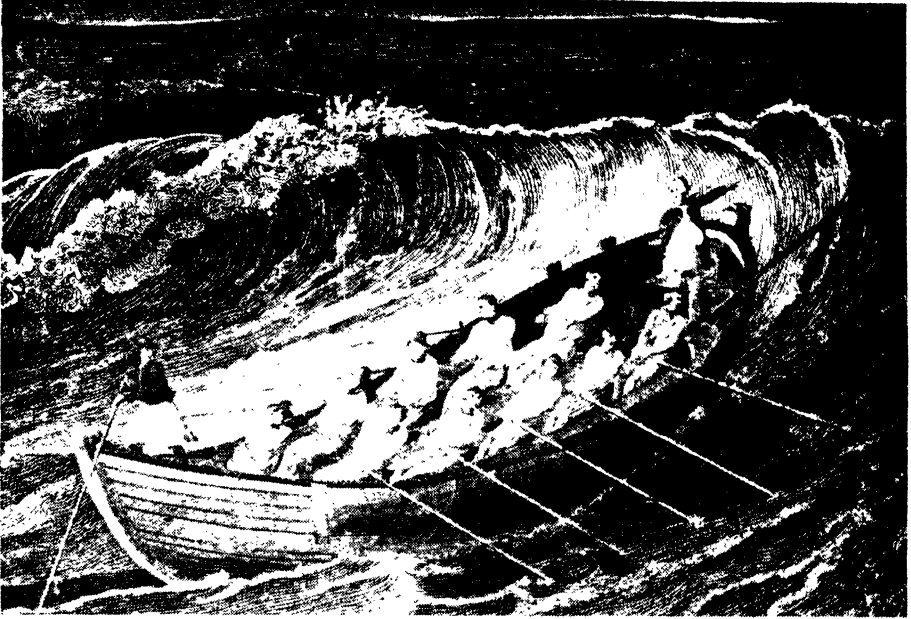

Carthee & Kinnaird

A LIFEBOAT—OLD STYLE

The first insubmersible lifeboat was built in 1785, but a notorious wreck in 1789 gave the first real impetus to public support. A prize was offered for the best boat, and was jointly won by Greathead and Wouldhave. The old print reproduced here shows Greathead's boat going out to assist a wreck.



[Keystone]

A LIFEBOAT—NEW STYLE

The first self-righting lifeboat was not built until 1849, after another disaster had rekindled public opinion. The self-righting apparatus consists of an arrangement of air-chambers, assisted by a very heavy keel. The above photograph shows what, in 1929, was the largest lifeboat in the world, stationed in Cornwall.

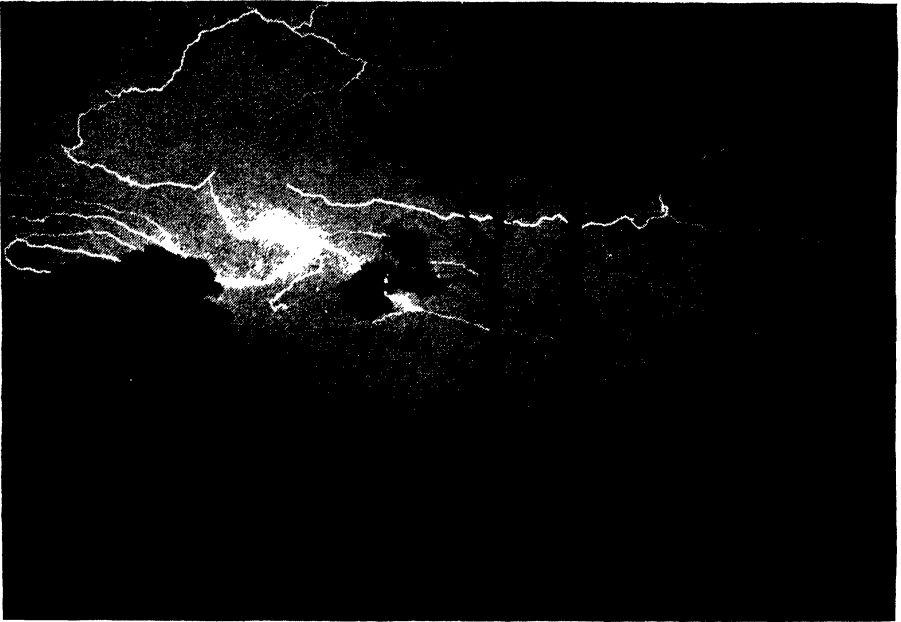

THE BEAUTY OF LIGHTNING

J. J. Shepstone

There are three commonly distinguishable forms of lightning: (1) forked or zigzag lightning; (2) sheet lightning; (3) ball, or globular lightning. This wonderful photograph of an electrical storm reveals flashes which last no longer than one hundred thousandth part of a second.

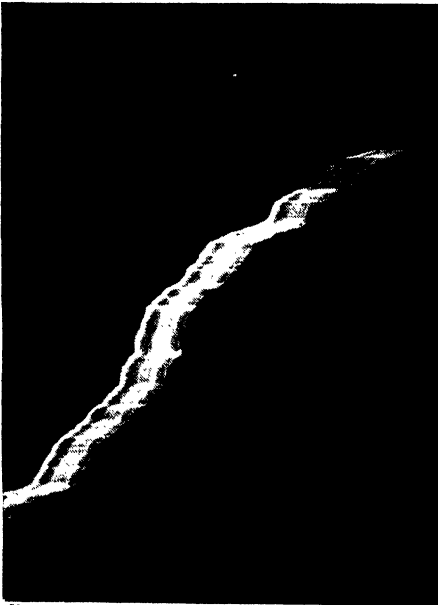

Harvard Observatory

SPECTRUM OF A FLASH

This unique photograph shows the spectrum of a lightning flash, by which means the electric light is broken up into its component colours as indicated by the lines of different intensities.



Valentine & Sons, Ltd.

LINCOLN CATHEDRAL

The nave of Lincoln Cathedral is one of the most beautiful in England. It was completed in 1250 by Robert Grosseteste, though extensive restoration work has recently been in progress.

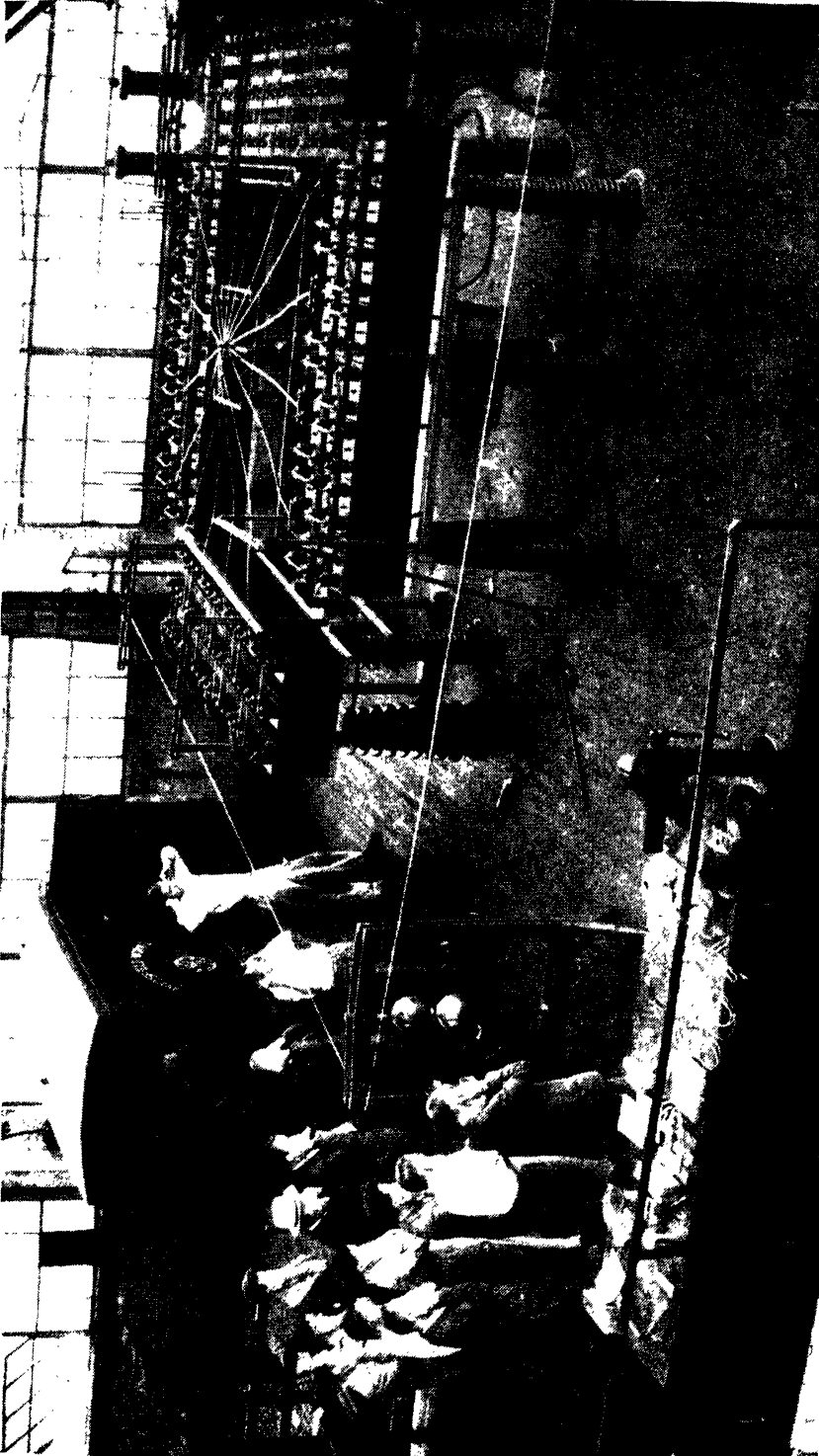

Keystone

ARTIFICIAL LIGHTNING

The photograph depicts the scene in an American laboratory just before the discharge of a quarter of a million amperes in 81,000,000ths of a second. At a pressure of 100,000 volts, more than 30,000,000 kilowatts were here reproduced. The amperage is far higher than that available with any equipment before devised as it is more than would be contained in the most powerful stroke of lightning.



ON THE LINCOLNSHIRE FENS

[From "Britain Beautiful"]

These curious fens were originally formed by the gradual silting up by the rivers of a large area of the coast into swamps. At various times since the days of the Romans efforts to reclaim them have been made, but it was not until the nineteenth century that the task was accomplished. This photograph shows one of the huge ditches cut to drain the fens



THE INTERIOR OF A LINER

[Keystone]

The modern liner has achieved a pitch of internal luxury which far exceeds that of all but a very few hotels. The mode of decoration, with its mock fireplaces and make-believe windows, removes every sign that the traveller is not on land. The view given here shows a writing room in the celebrated *Empress of Britain*

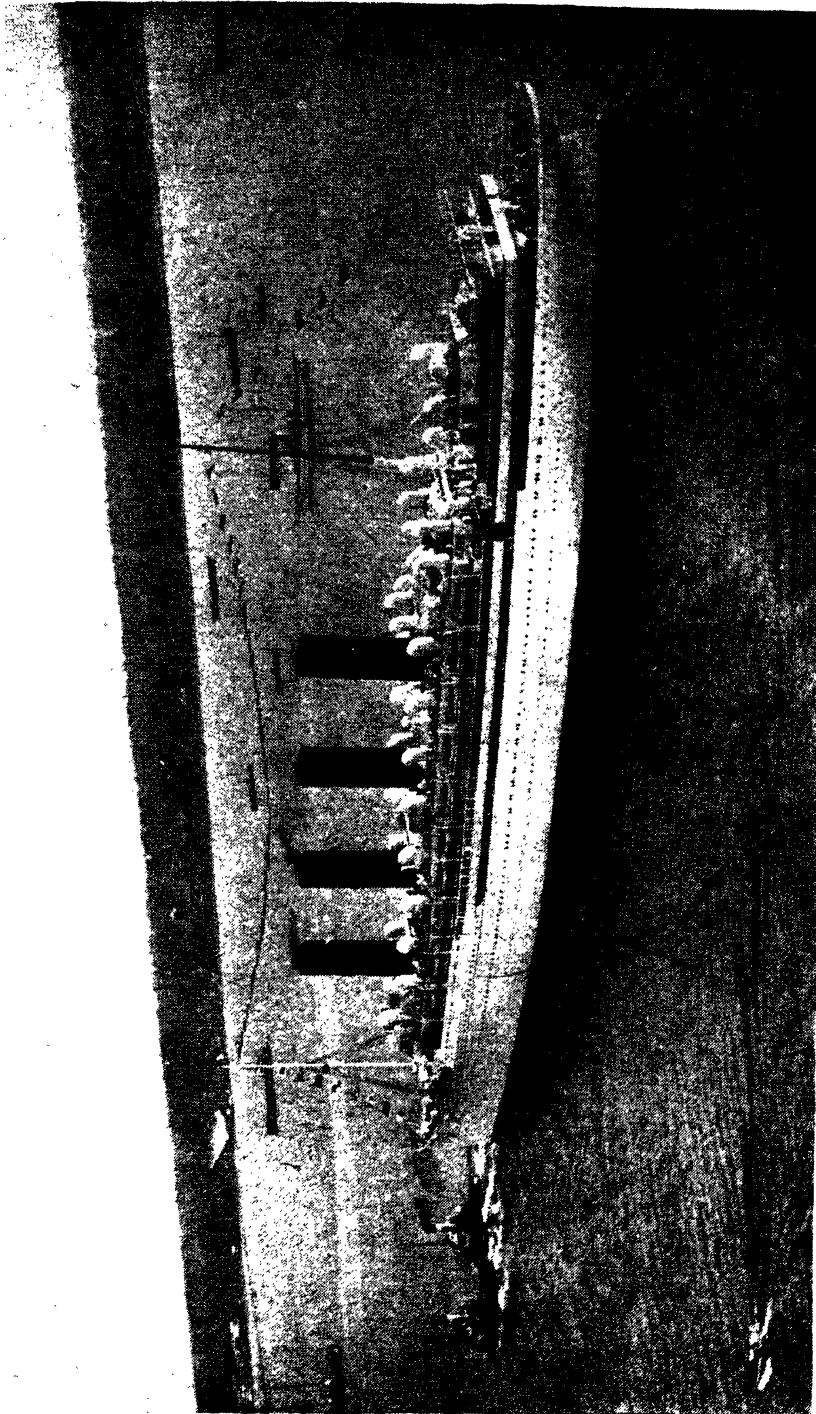

Keystone

A WORLD-FAMOUS LINER

It would perhaps be no exaggeration to call this, the *Maudslayi*, the most famous liner modern civilization has yet known. Relegated to the scrapheap in 1915, this great vessel held the "Bye-Bye Kuba," for the Atlantic crossing during the astonishing period of 22 years. Besides her peacetime activities, the *Maudslayi* did wartime service in many areas

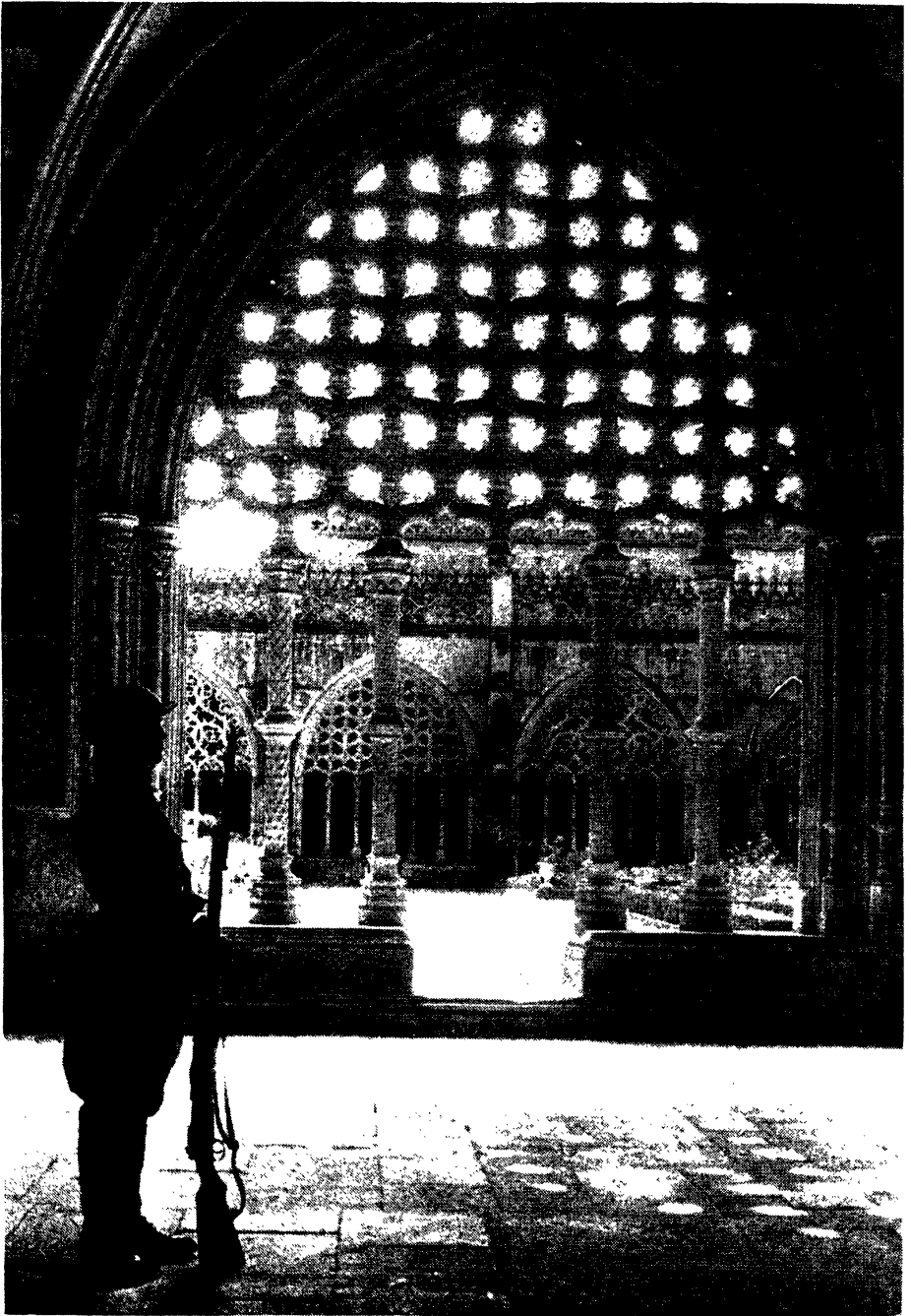

[Keystone

SAO JERONYMO MONASTERY, BELEM, NEAR LISBON

Few English people are aware of the delightful and often brilliant architecture of Portugal. At Belem is a monastery as fine as anything in Italy. Sao Jeronymo was built to commemorate Vasco da Gama's discovery of the seaway to India, and is now additionally famous as containing the tomb of Portugal's Unknown Warrior. The blend of Gothic arch and Moorish tracery in the cloisters is a triumph of harmony.

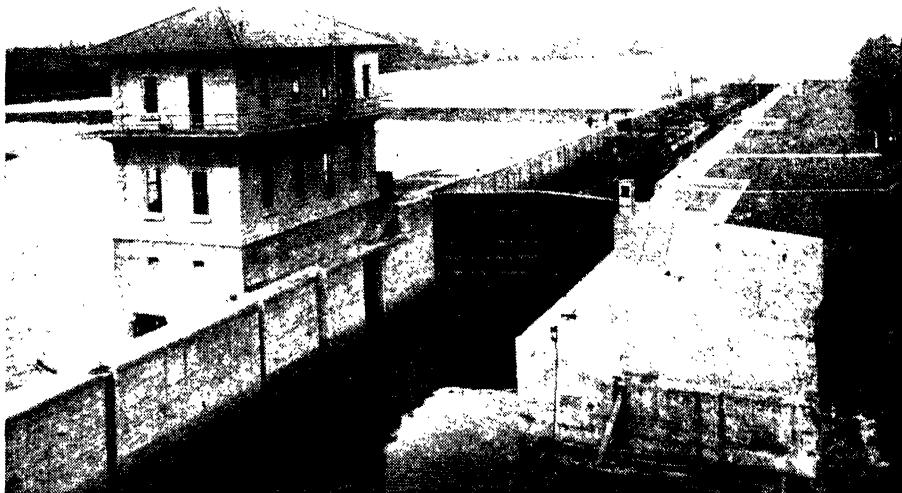

Keystone

A LOCK

A lock is a section of a river or canal, enclosed by gates at either end, which by the lowering or raising of its content of water can transfer ships to different levels. Modern locks, which have to admit the largest liners, have gates weighing many tons. They always open against the current.

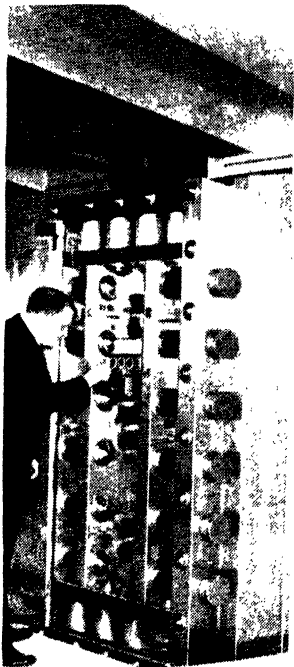

Carlier & Kinnaird

THE SAFEST LOCK -

...on the largest safe in the world, built at New York, to hold 3,000,000,000 dollars. The illustration gives a good idea of the type of mechanism

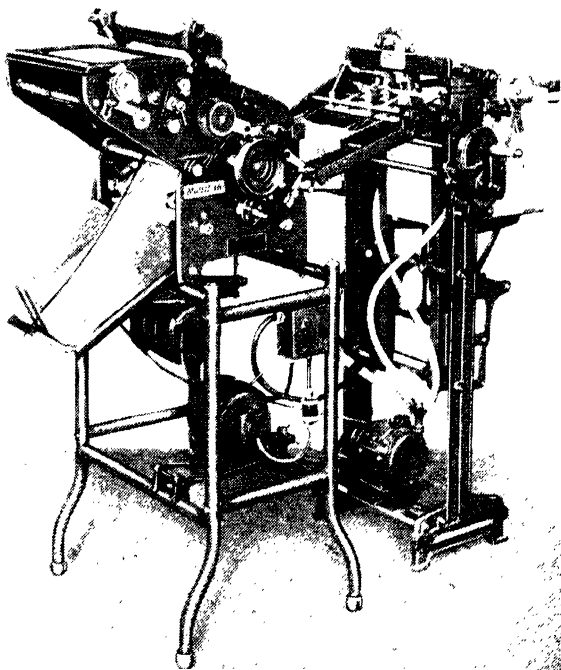

[Courtesy Addressograph-Multigraph, Ltd.]

A LITHOGRAPHING MACHINE

Lithography as a means of reproduction has attained a very high level. The machine illustrated is simple and small enough to be installed in any office, yet it can automatically reproduce any type, lettering, drawing, or half-tone block at the rate of 5000 sheets an hour.

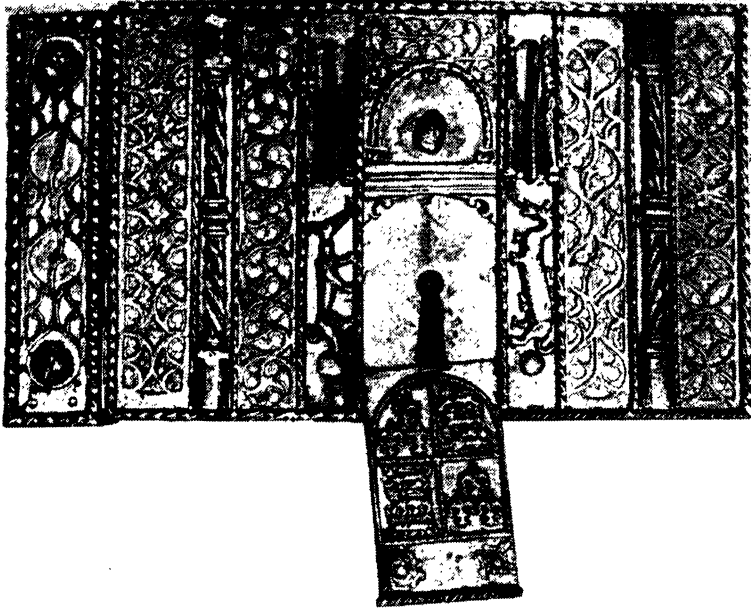

[Underwood Press

THE LOCK OF A FAMOUS DOOR

The above lock is that of Henry VIII's bedroom. Besides its decoration, note the secret catch: it is necessary to turn the ape's head upside down to release the panel covering the keyhole.



[E. Step, F.L.S.]

LOCUSTS

Few insects are more destructive than locusts. Nevertheless, as the photograph on the right shows, there is much beauty of mechanism in their construction. This enlargement reveals how the body is built up of ring-like segments: it also shows the openings to the air tubes along the side, the ear above the base of the leaping leg, and the antennae or feelers. The lower wing has been removed to reveal the side of the body. On the left is a typical picture of locusts on the wing.

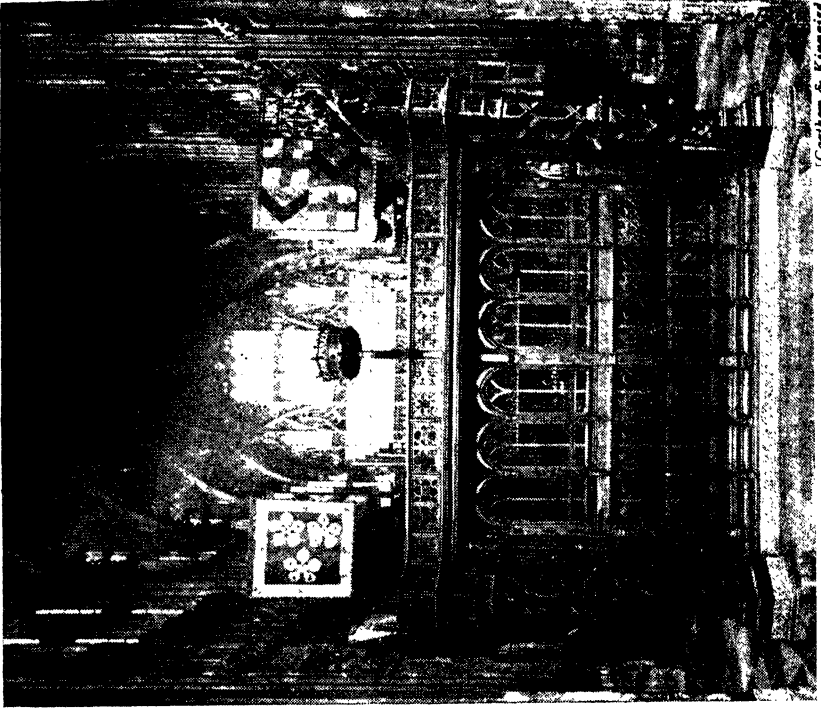
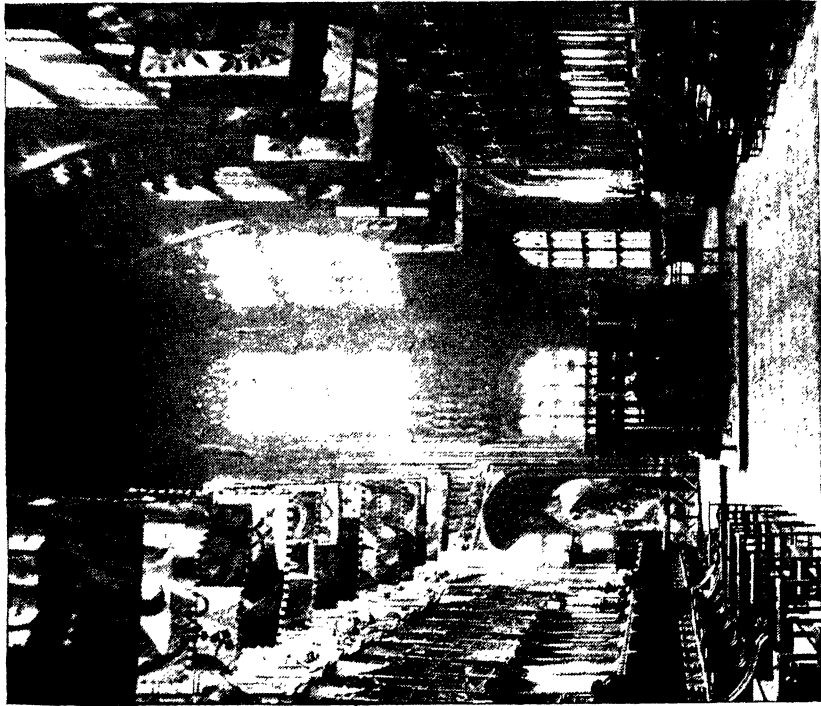

[Carlson & Kinnasir]

HENRY VII CHAPEL, WESTMINSTER ABBEY, LONDON

Henry VIII's Chapel, one of the most beautiful examples of its period, was built on the site of a Lady Chapel erected by Henry III, and represents the last addition to the Abbey except for the rebuilding of the western towers under Sir Christopher Wren. Sebert erected the first church to St. Peter at Westminster in about A.D. 600, after which St. Dunstan, Edward the Confessor and Henry III carried out successive renewals



LOUVAIN: THE TOWN HALL

[Dorien Léig]

Prior to the Great War Louvain had many historic and beautiful buildings, of which the Hôtel de Ville alone managed to survive partially. Most of the city, including the university, famous library, and Church of St. Peter, were razed by the Germans. The Hôtel de Ville, now restored, dates originally from 1447-63, and is a good example of the Flemish Renaissance



[B.B.C.]

LONDON BROADCASTING HOUSE

The home of British broadcasting is one of the most fortunate examples of twentieth-century architecture to be found in England. Though it has been likened to a battleship, it is well proportioned and in no wise grotesque. The balconies of flowers greatly enhance it.



[Cartier & Kinnaird]

LUMBER-FLOATING

In 1930 the forest area of Canada was estimated at over a million square miles; since then extensive reforestation schemes have been afoot. For transport of the timber from the remote areas where it is cut to the mills and towns, rivers are mainly used. Above is a vast mass of logs in tow.

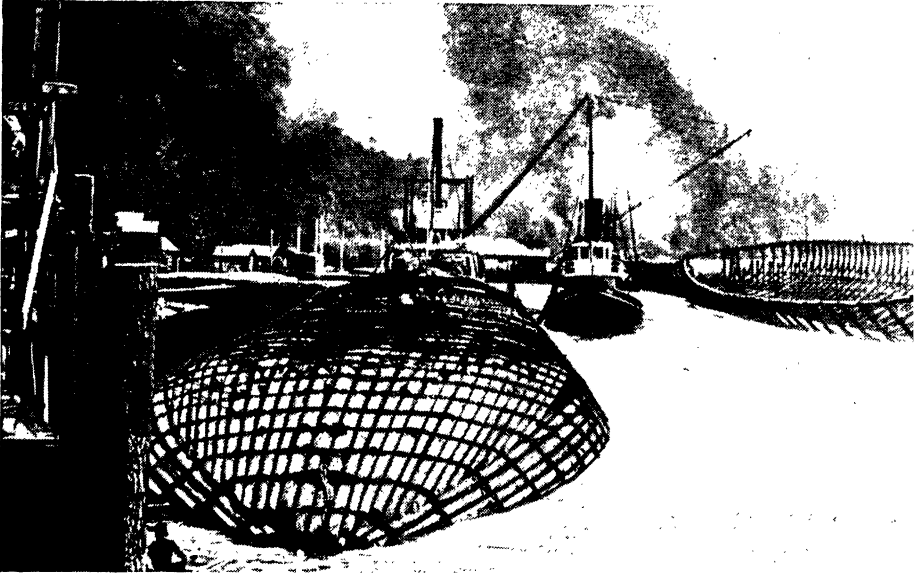

ANOTHER METHOD OF LUMBER-FLOATING

[Carthew & Kinnaird]

The timber is not always transported by floating it with the current, or by the ramshackle grouping together shown on page 323. Sometimes, as illustrated here, vast numbers of logs are bound together by iron chains into a gigantic raft; in this way one tug can manipulate thousands of feet of wood

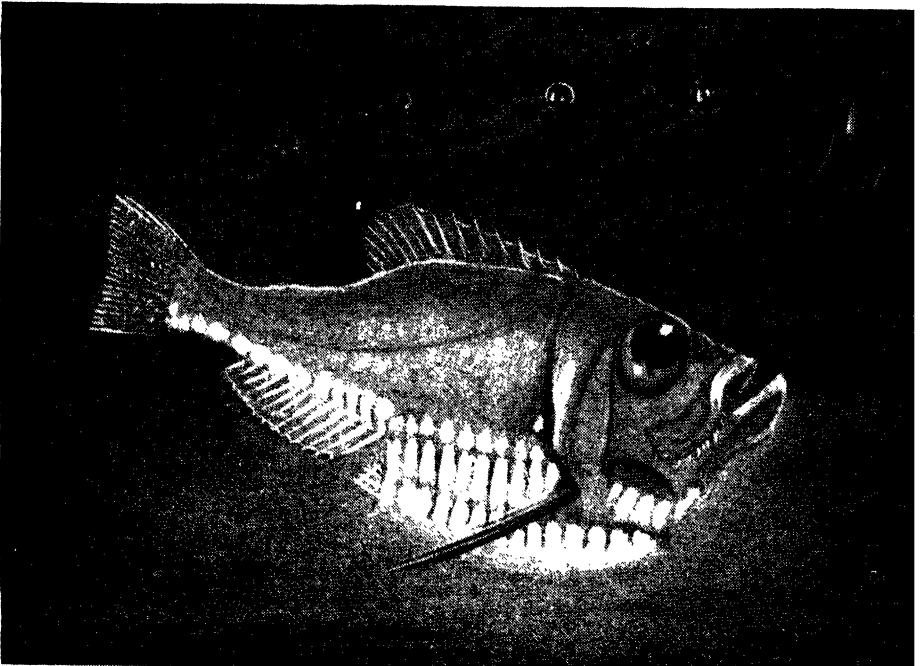

SELF-LUMINANT FISH

[Arthur Twidle]

glow which is noticeable in many surface fish has nothing in common with the extraordinary system of animal which illuminates this fish thousands of feet below the surface. This particular specimen is apparently able to live equally happily near the surface or at a depth of four to five thousand feet

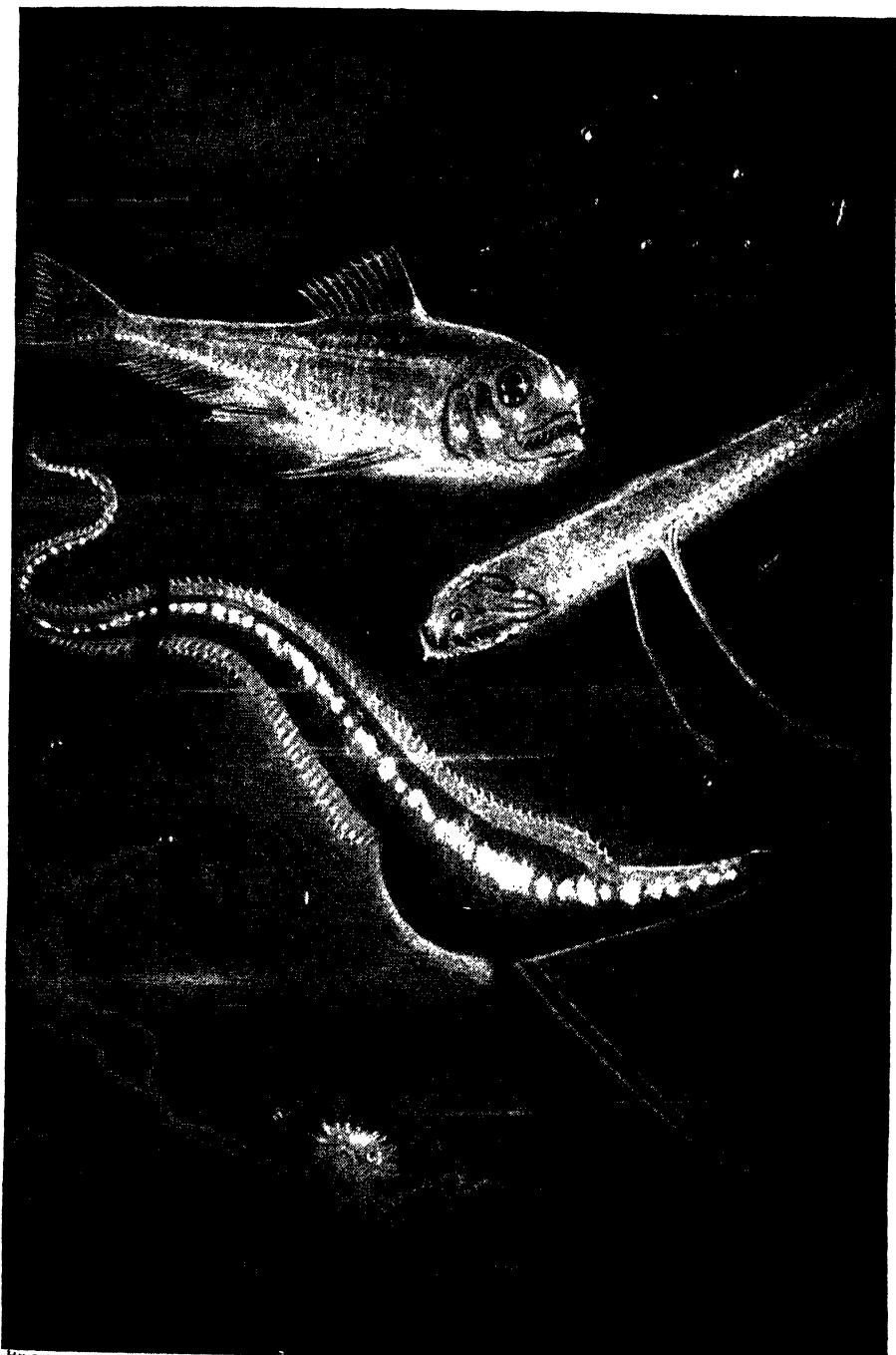

[*by courtesy*]

MORE "FLOOD-LIT" FISH

[*"Marvellous of Insect Life"*]

The top fish in this picture is generally found in immense depths; the centre form is a brilliant specimen of sluggish movement, with two antennae depending from the middle of its body for the purpose of feeling the bottom. The lower fish is the most paradoxical of all the deep-sea denizens. It is sluggish, blind and brilliantly lit

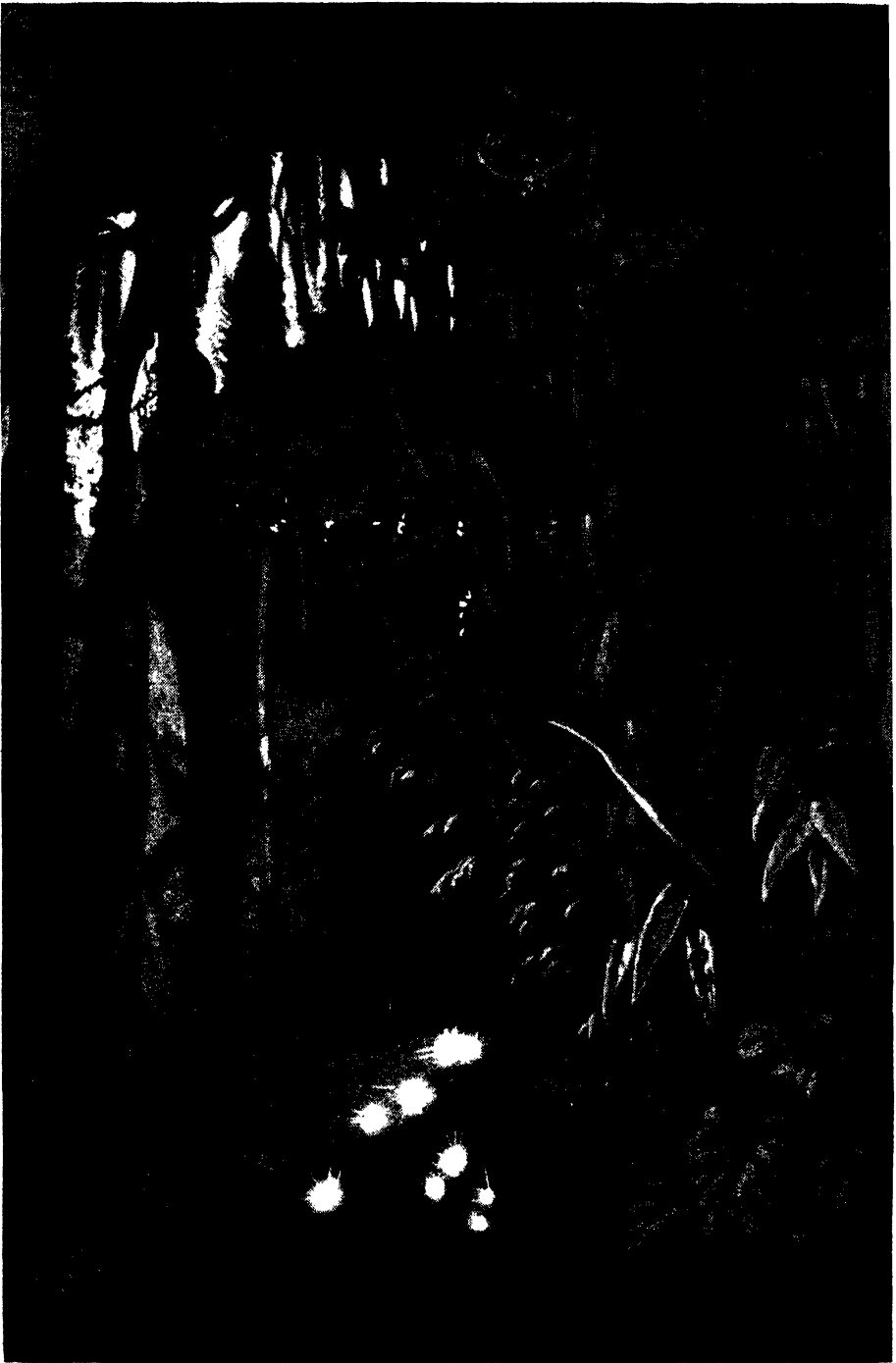

[By courtesy]

LUMINOUS FUNGI IN A BRAZILIAN FOREST

[*"Marvels of the Universe"*]

Not Fairyland, but a picture showing the strange phenomenon of certain toadstools which give out a soft but brilliant light. It has been thought that this is a device to attract certain insects who may be instrumental in the disposal of their spores.



A LUMINOUS SHRIMP

[Carthew & Kinnaird

Luminous shrimps, like luminous fish, live mainly at very great depths, where but for their own light they would be in complete darkness. The phosphorescence proceeds in most species from the base of the antennæ, but in some, as here, additionally from "portholes" along the flanks

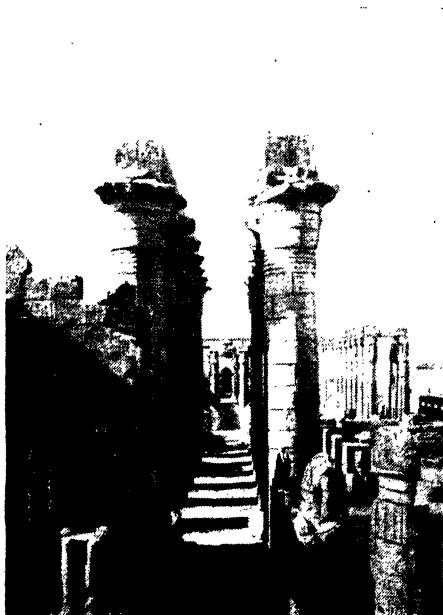

By courtesy)

IN THE TEMPLE OF LUXOR

This imposing colonnade is the most impressive part of the Luxor Temple. The fourteen colunas, in two rows, supported the roof. Amenhotep III commenced the erection of this colonnade, but it was finished by Horemheb in about 1350 B.C.

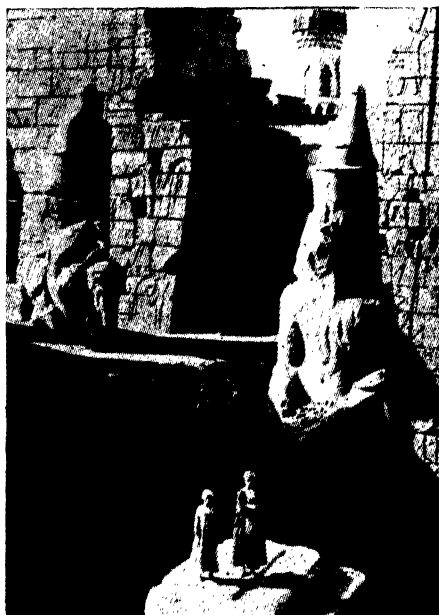

["Wonders of the World"

ENTRANCE TO LUXOR TEMPLE

The colossal seated statues one of which is partially buried, are those of Ramses II, and through this northern entrance one passes to the great forecourt of the temple which was built in the reign of that monarch. On the pylons are depicted incidents of wars

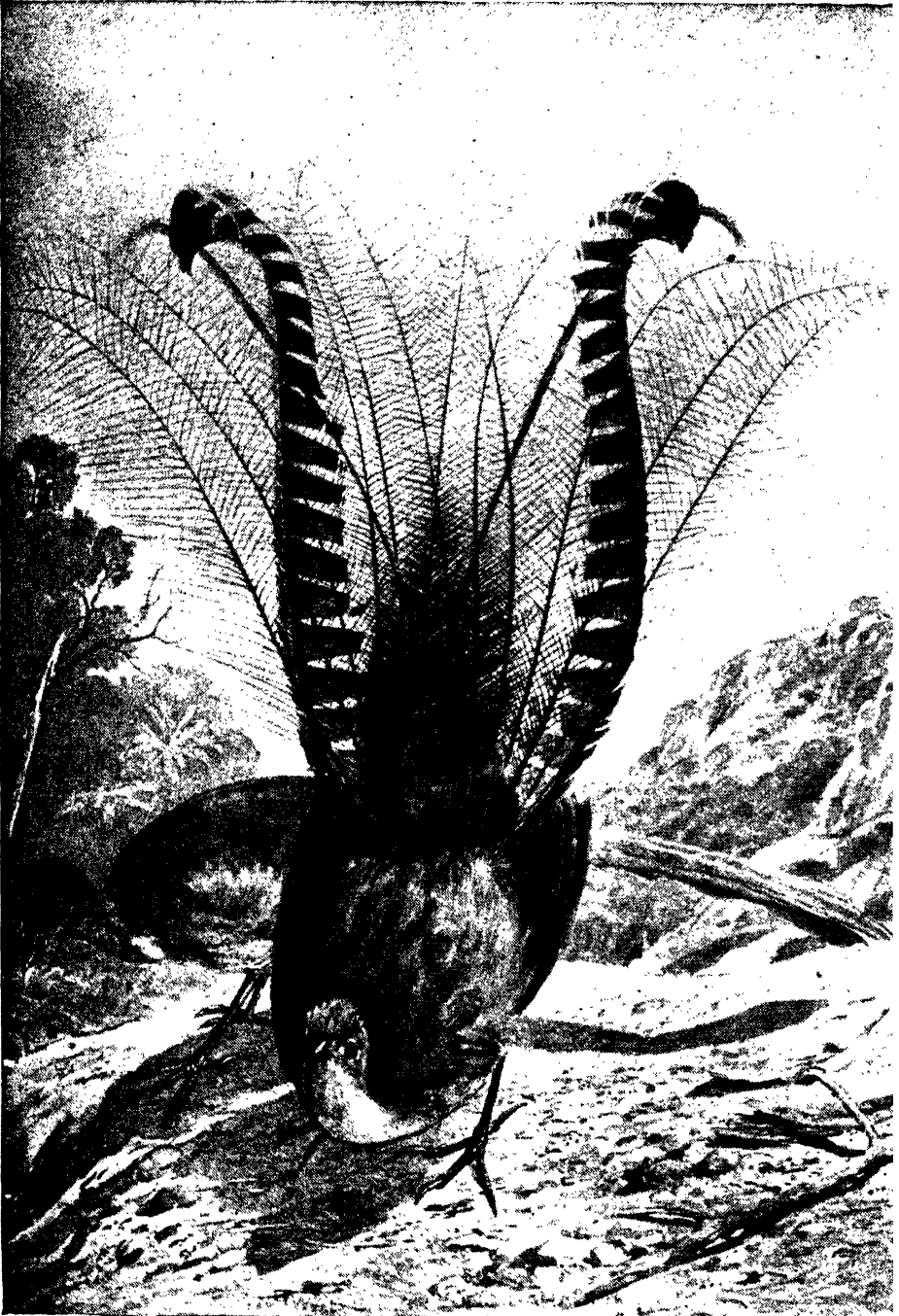

By courtesy]

THE LYRE BIRD

[" Marvels of the Universe "

are natives of Australia. Both male and female are represented, and it will be seen that only the male is characterized with the beautiful development of the tail-feathers, whose distinct curves have given the bird its name. It is solitary, or almost so, in its habits, rarely more than a pair being seen in company



MACADAMISED ROADS

[Keystone]

John Macadam (1756-1836) was a Scotsman. The first roads to be treated by his now world wide process of breaking up granite or other hard stone into very small pieces and covering the top with tar. Above are shown the various layers of a modern road.



GIANT-TAILED MOTH OF MADAGASCAR

[By A. Twiddle]

This gigantic moth is one of the biggest winged insects known. From wing to wing it measures eight inches, and from antennae to the tips of the tails nine and a half inches. The long, slender and brittle appendages are believed to be a foil for pursuing enemies.



ADORATION OF THE MAGI, BY MABUSE

[Dorien Irish

John Mabuse (1470-1532) took his name from his Flemish birthplace—Maubeuge. Philip of Burgundy, his patron, took him to Italy for a period, but otherwise all his work was done in Flanders. "The Adoration of the Magi," now in the National Gallery, and painted before he met with Italian influences, is a masterpiece in pure Flemish

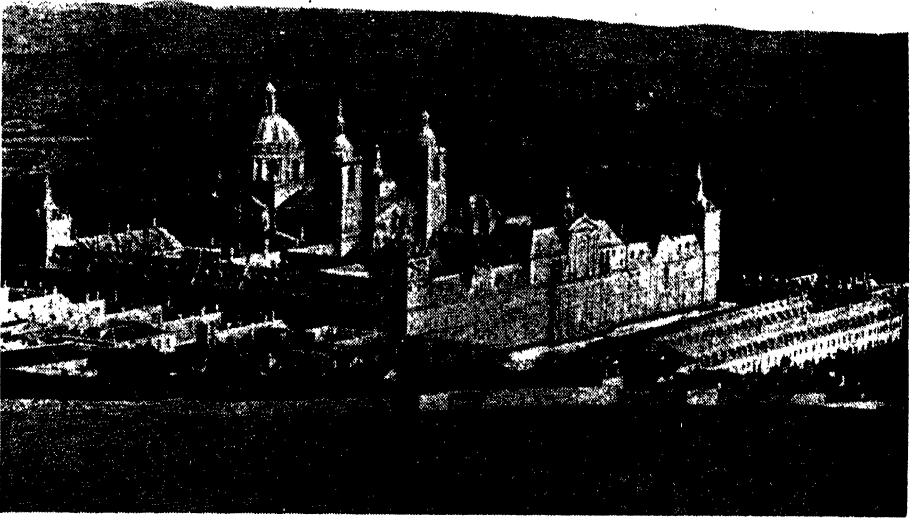

THE ESCURIAL IN 1581 & 4

About thirty miles from Madrid Philip II erected this splendid monastic palace, which contains the burial vault of the kings of Spain. It is an enormous building with, tradition tells, sixteen courts, forty altars, and one hundred miles of corridors



[Photos from]

THE GOLDEN LILY TANK, MADURA

[“Wonders of the World”]

The Great Temple at Madura, Madras Presidency, is guarded from European eyes, but the brilliant Golden Lily Tank is a source of great admiration. Here by the waterside elephants and sacred cows wander at will, and parrots constantly fly above the green water

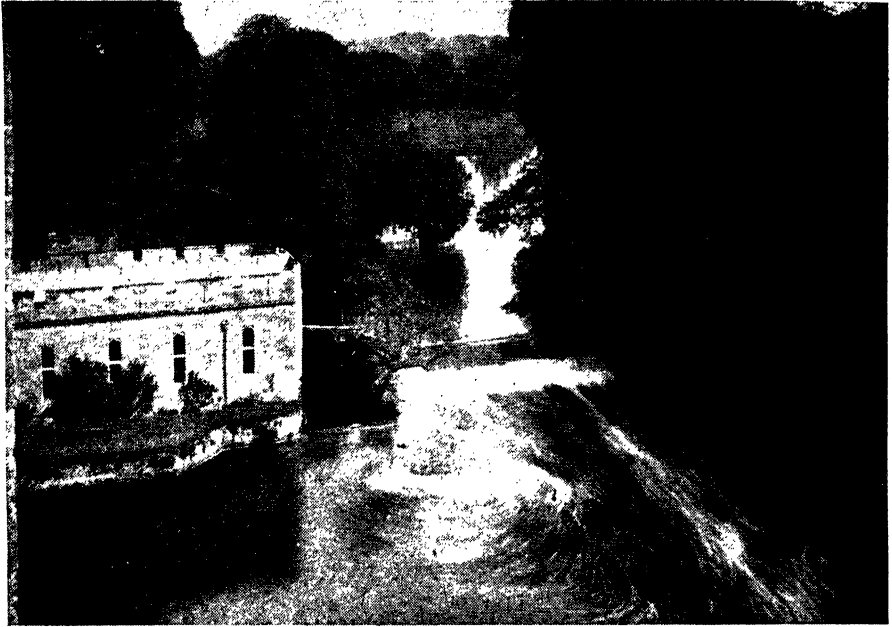

[From "Britain Beautiful"]

A MINIATURE MAELSTROM

The original maelstrom (the word in Danish means a great whirlpool) is a celebrated phenomenon arising occasionally, and with much danger to shipping, off the island of Moskoe on the west coast of Norway

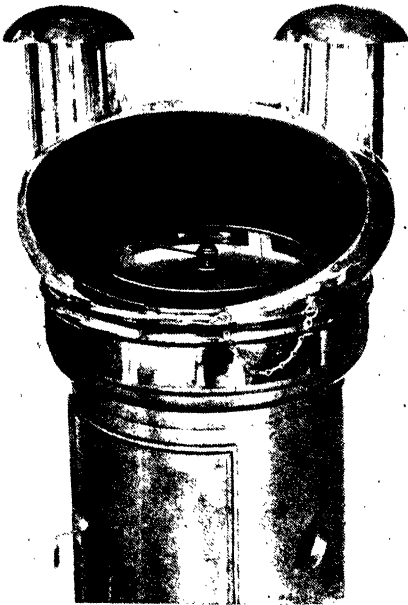

[Carthew & Kinnaird]

THE MAGNETIC COMPASS

Navigators of ships were the first to discover the magnetic properties of the earth. By a series of observations in different localities, it has been made possible to check compasses to the true meridian

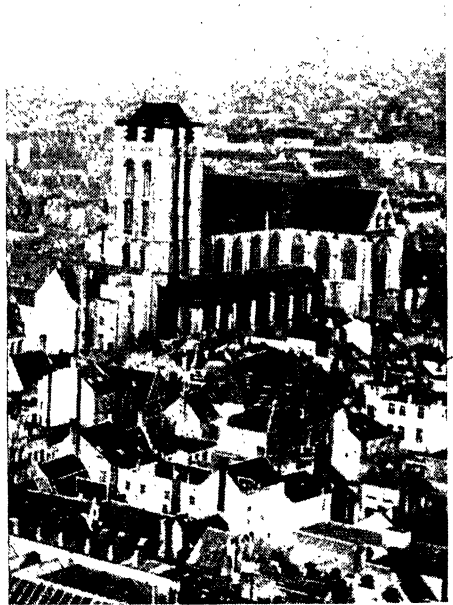

[Dorian Leigh]

ST. RUMBOLD'S CATHEDRAL, MALINES

St. Rumbold was an Irishman who converted the Malinois to Christianity, but was afterwards martyred there. The Cathedral, named after him, dates from the fifteenth century and is exceedingly fine both within and without



THE HYPOGEUM, MALTA

Here is a view of Malta's amazing underground buildings. The circular decorations seen on the ceiling are done in red paint on scrolls, and still show quite clear evidence of their very ancient origin.



THE HYPOGEUM

[By courtesy "Wonders of the World"]

Photos from The Hypogeum at Malta is the most important monument belonging to the neolithic period, which scientists reckon dates back three thousand years before the dawn of history. This astounding honeycomb of galleries and rooms, covering an approximate area of fifty-four thousand square feet, was discovered by chance by a workman in 1902.

[From "Wonders of the World"]

THE KUTHODAW, OR THE 729 PAGODAS

A remarkable group of miniature pagodas built by a religious uncle of King Theebaw, who wished to set up a record of the words contained in the holy books of Buddhism. Written slabs were erected and domes built over them



[Lafont Dupire]

THE PRAYING MANTIS

Head, thorax and fore-limbs of a Rose-leaf Mantis are portrayed. The awesome spines which grip the prey are clearly illustrated



[Carter & Kinnear]

THE SIBERIAN MAMMOTH

A perfectly preserved Mammoth, or Woolly Elephant, that formerly roamed over Europe. Its preservation is due to its having lain in the ice for thousands of years



[From "Marvels of the Universe"]

THE MANTIS LEAVING HER EGG-CASE

It would be difficult to find a more saintly looking insect than the Praying Mantis, so called on account of the way in which it raises its forelegs, as though in supplication. Actually it is one of the most rapacious of insects. The female is here seen depositing her egg-capsule on the twig of a tree

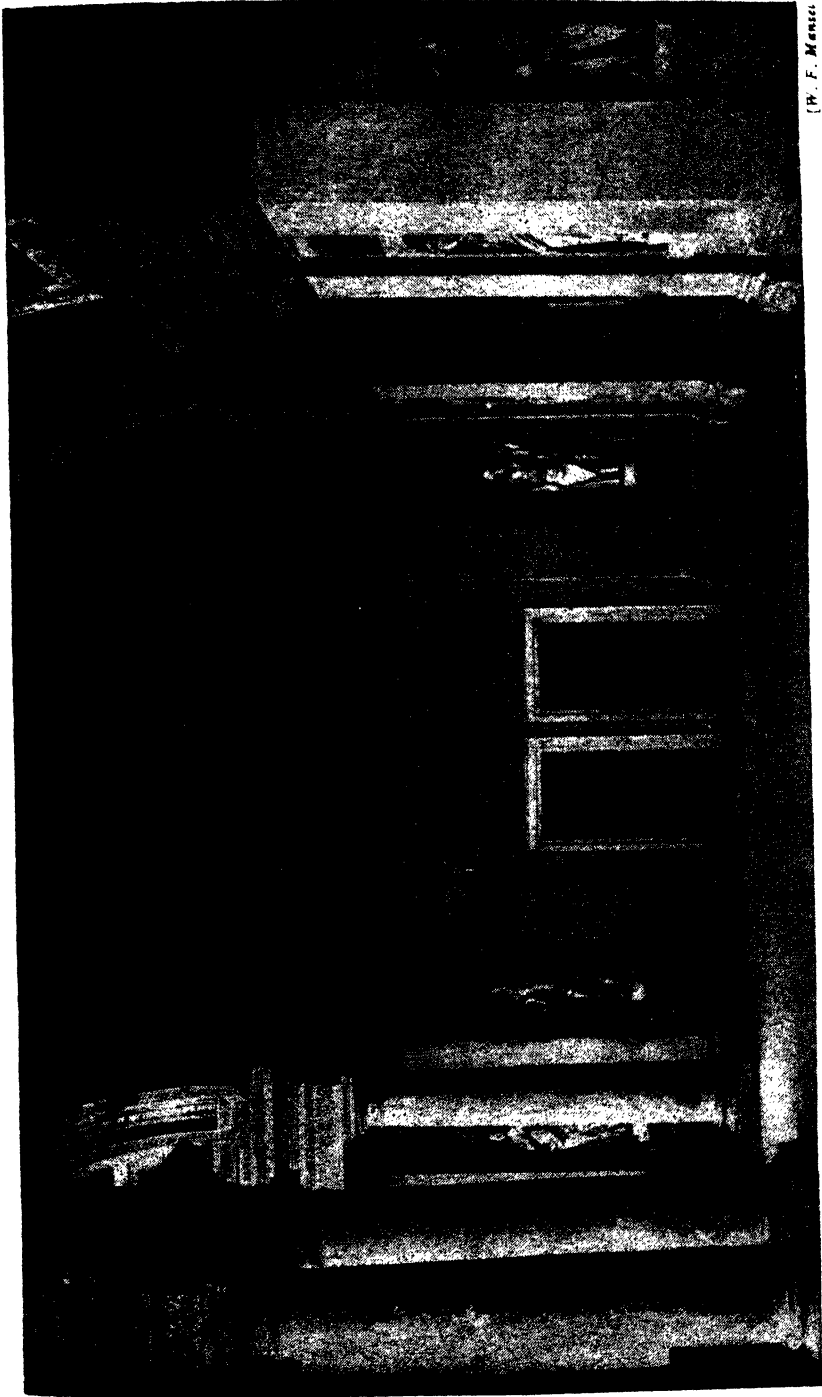

[P. F. Mancini]

MANTUA: THE PALAZZO DEL TE

Mantua is one of Italy's most picturesque cities: it stands on an island in the middle of a lagoon formed by the River Mincio. It abounds in magnificent churches and palaces. The great artist of the place in Renaissance times was Giulio Romano, who is responsible for the present form of the Palazzo del Te—the old ducal palace—which he decorated in 1525-35

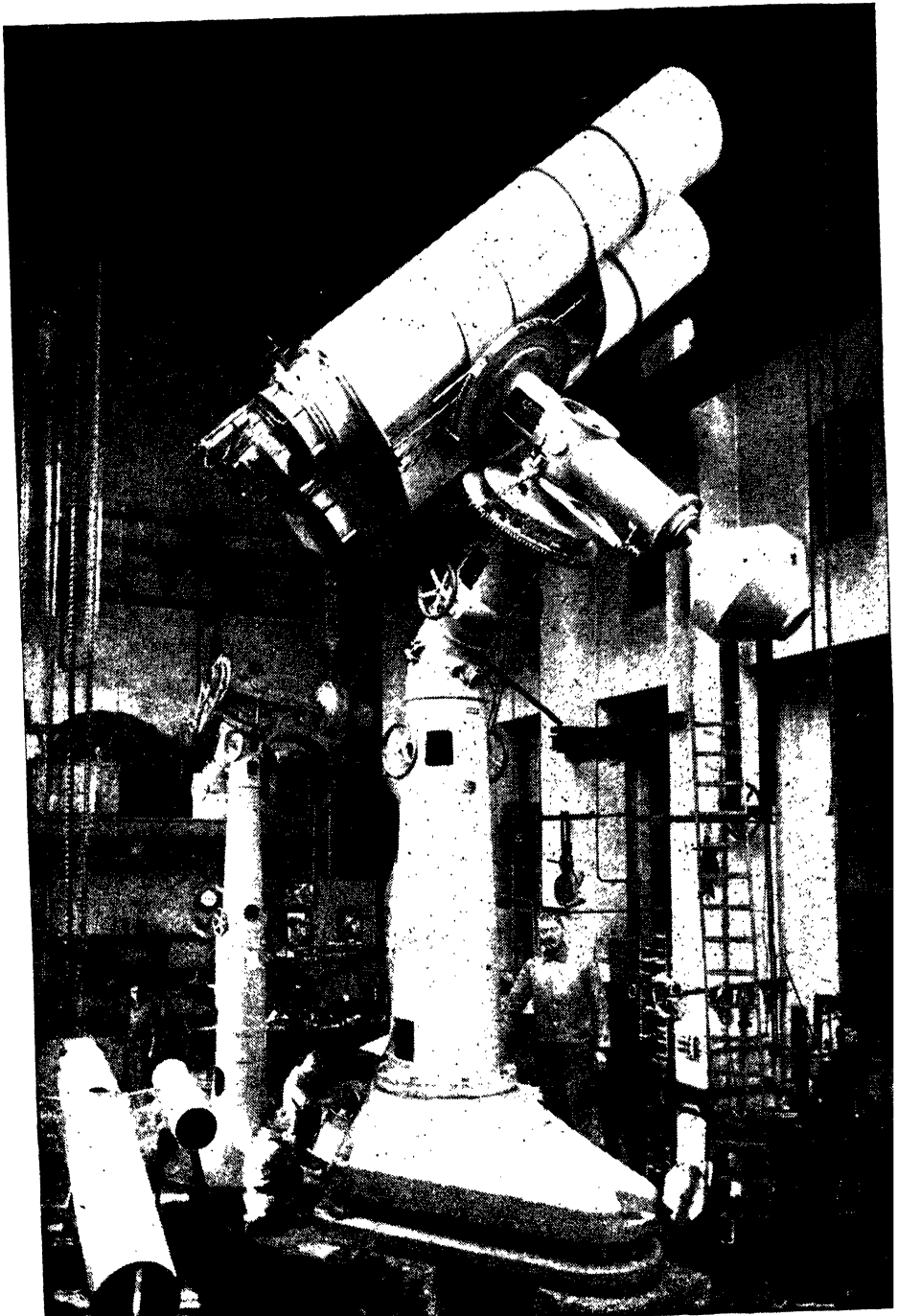

[By courtesy Carl Zeiss, Leond

MAPPING THE HEAVENS

[The photograph shows a 400 mm. twin astrograph in the Observatory at Nice, France. Astrographs are the principal instruments used in the mapping of the stars. The type shown consists of two four-lens objectives of 6 feet 6 inch length, a 7'9-inch guide telescope, and twin cameras for 04 by 12-inch plates. The method of mounting enables tubes to move fre



[*Step, F.L.S.*]

AN INSECT NECKLACE

These necklaces, worn by ladies in South Africa, are really a species of scale-insect which attacks the roots of certain trees. At a particular stage in their career, the females cover themselves with a secretion which hardens into a horny shell, varying in hue from clear yellow to brown



MARIENBURG CASTLE

[*Dorien Leigh*]

Marienburg, in Western Prussia, used to be the seat of the Grand Masters of the Teutonic Knights, an order founded in Palestine during the Crusades and later opposed to the Slavs. The gigantic Castle at Marienburg is enormous even for Germany



[*E. M. Antoniadi*]

MARS

Forty-eight million miles! This is approximately the nearest distance of the planet Mars from the earth. It is therefore impossible to make definite statements as to the possibility of organic life on the planet, though this is to-day thought much less likely than it used to be

AN IMAGINARY LANDSCAPE ON MARS

Some astronomers believe that the straight intersectorary streaks in the photograph are artificial canals, built for the purpose of making the best use of the scanty water supply on Mars. Three-fifths of Mars' surface is covered by bright orange regions, probably deserts, and this imaginary picture illustrates a sandstorm



[*From " Splendours of the Heavens "*]



(H. Main, F.L.S.)

THE MASON-BEE

An amazing example of insect industry and ingenuity. The Mason Bee is able to construct a dome-shaped home in the form of several cells which she builds with grains of sand cemented with a viscid secretion from her mouth. She builds in spring, and on completion of this exquisite and sturdy home lays her eggs in it.



[Theo Carrot]

THE NEST OF A MASON-WASP

The Mason or Solitary Wasps are smaller and dark coloured than the ordinary kind and all the males are females are perfect; for this species will not tolerate evil imperfect workers or imperfect females. In this picture they are seen storing up food for the young grubs, which consist of a multitude of little green caterpillars.



MASS PRODUCTION

[By courtesy Ford Motor Works]

Mass production is more or less a modern American invention, though in parts of Europe, as in the Bata shoe-factory of Czechoslovakia, the idea has been developed to a degree far surpassing the original American conception. Above is a scene in the English works of one of the most famous mass-products in the world—the Ford Car.



A PAINTING BY QUENTIN MASSYS

(Dorien Leigh)

Quentin Massys or Matsys (1466-1530), a Fleming of Louvain, is believed to have started life as a blacksmith. His works are mainly religious, but he executed portraits and a number of extremely sensitive studies in character. "The Banker and His Wife," illustrated here, is one of the best examples. Note the reflection in the convex mirror



IN THE CRATER OF KILAUEA, HAWAII

[Underwood Press Service

The massive peak of Mauna Loa is still an active volcano ; he and his companions have built the island, layer by layer. This picture of the crater shows part of the vast wall of volcanic rock, nine miles in circumference, enclosing the narrower circle of lead-coloured walls of the " House of Everlasting Burning "

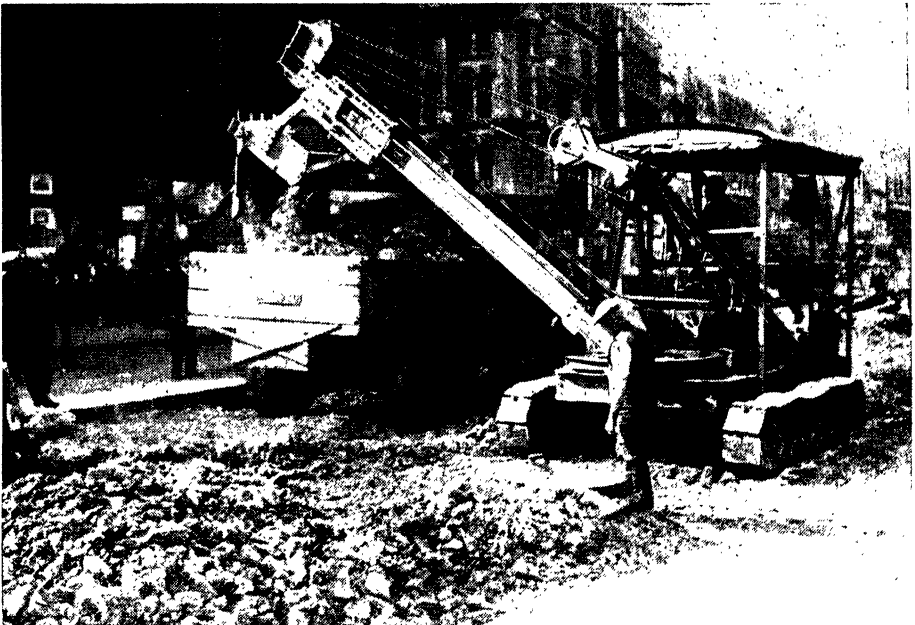

TWO PHASES OF THE MECHANICAL NAVVY

[Carthw & Kinnaird

Machines of this type are capable of doing in a few hours work which would take a number of men several days. Their two commonest uses are to remove the debris of buildings after house-breaking, and to dig away loose earth

of modern engineering have upon industry. The immense economy both in time and money enables such projects as slum-clearance to progress at ten times their otherwise rate

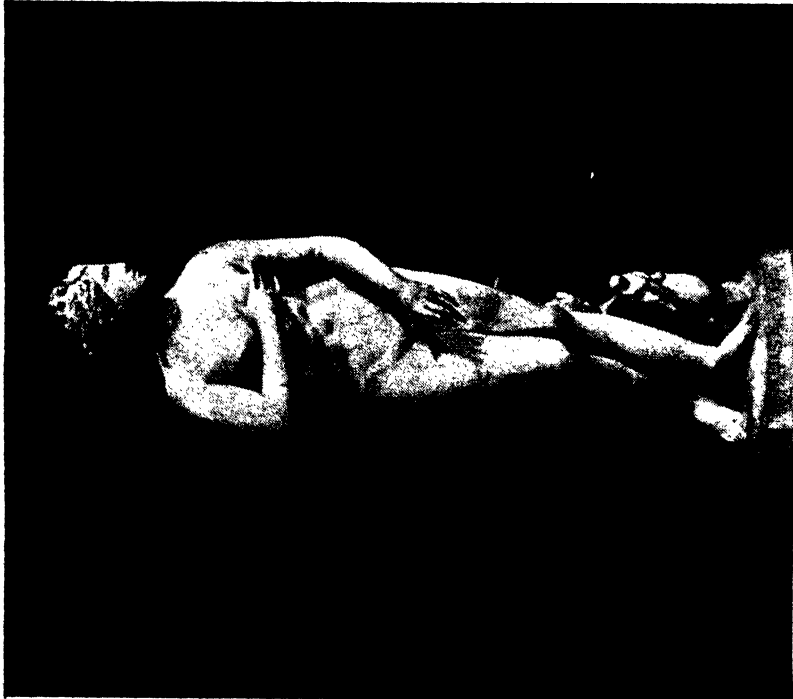

[Notes]

THE MEDICI VENUS
This is one of the four most famous representations of the goddess. Her Greek name—*Apbrodite*—means "sprung from the foam," a phrase on which several artists, notably Botticelli, have based paintings. The sculptor of the Medici Venus is unknown; the name is due to it having been discovered during the time of Medici rule in Florence

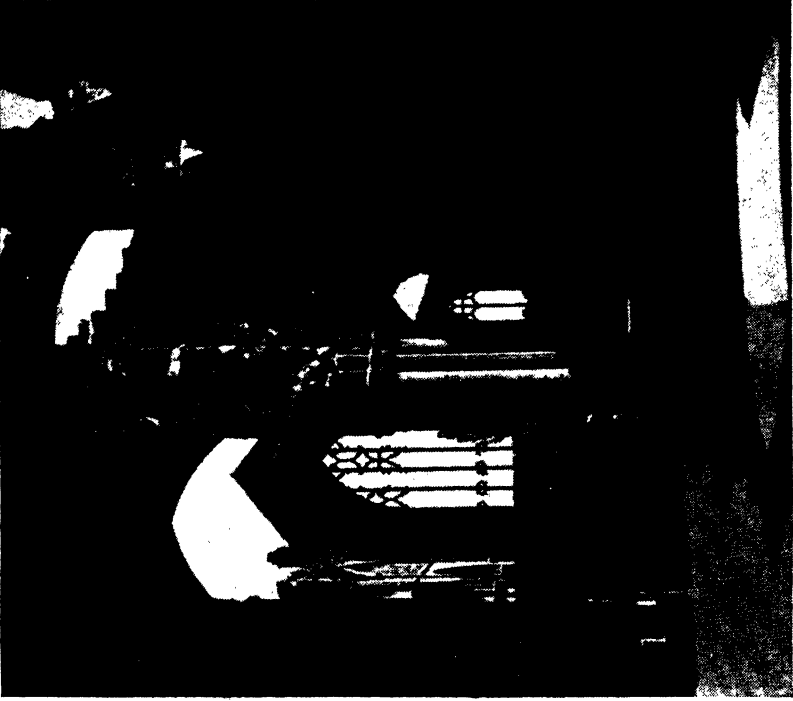

[Lorien Leigh]

MELROSE ABBEY

The beautiful Perpendicular windows are the most striking feature of the ruins of Melrose Abbey. Founded by David I in about 1136, it was partially destroyed twice by English kings before being finally wrecked by Lord Herford in 1545. The heart of Robert the Bruce lies buried here, and Scott's home, "Abbotsford," is three miles distant



(Dorsten Loga)

"THE MYSTICAL MARRIAGE OF ST. CATHERINE," BY MEMLING

Hans Memling's life is shrouded in obscurity, he is believed to have been born in 1430 and is supposed to have settled in Bruges about 1478. He died in 1484. As a painter he attained a fame, even in his lifetime, of being greater than any Fleming who had yet lived save the brothers Van Eyck. He finished much beautiful work on the hospital at Bruges, of which St. Ursula's Shrine and the above triptych are the gems

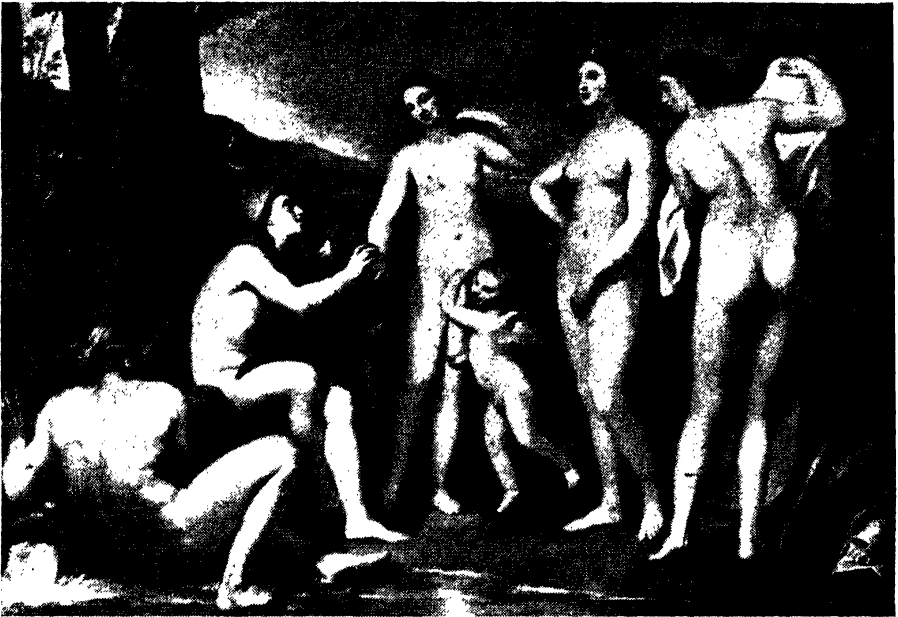

"THE JUDGMENT OF PARIS," BY MENGS

Dorien Leigh

Less renowned than the "Judgment of Paris" by Rubens, this is nevertheless a great painting. Anton Rafael Mengs (1728-1779) was a Bohemian. He travelled much, being at various times Court painter at Dresden, decorator of the Spanish royal palaces for Charles III, and painter of the holy pictures in Rome. The above work is now at Leningrad

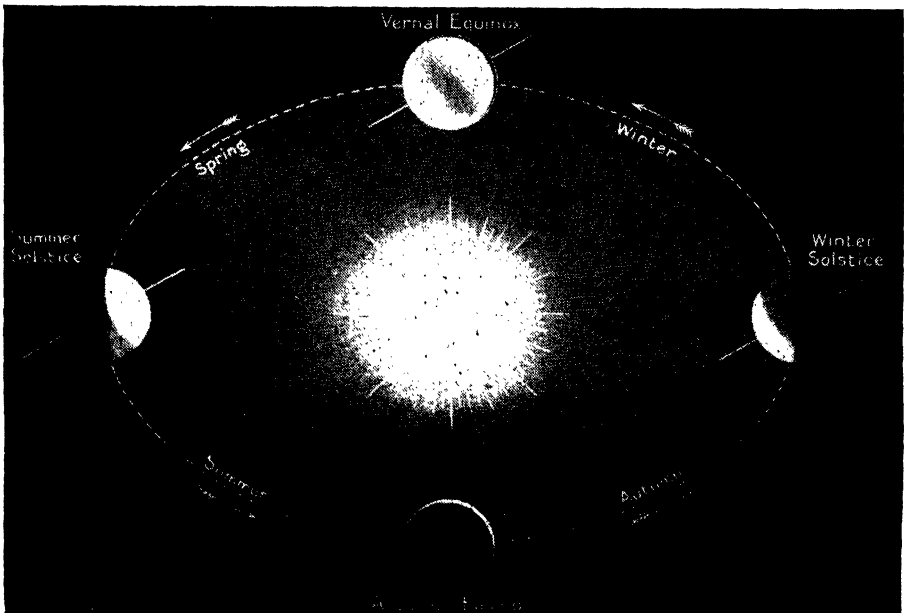

By courtesy]

THE MYSTERY OF MERCURY'S AXIS

[" Splendours of the Heavens "]

The exact inclination of Mercury's axis is not known but Schroter, in the eighteenth century, suggested that the axis of the "swift-winged messenger" was inclined considerably to its path round the sun, as is the case with the earth. The effect of this would be to produce seasons. Their presumed rotation can be seen from the above picture

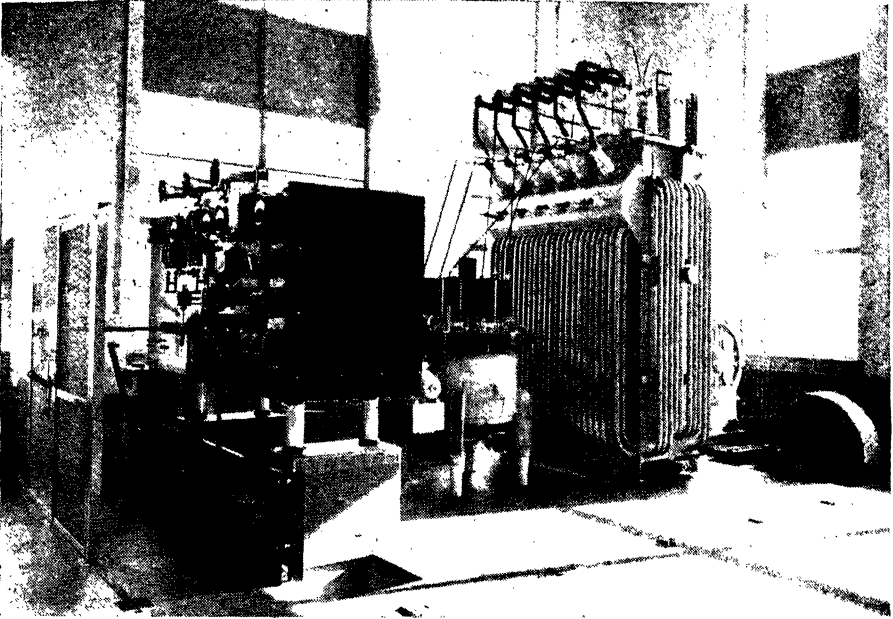

A LARGE MERCURY ARC RECTIFIER

[Courtesy B.T.H.]

This might be described as a short-cut method of converting alternating to direct current. These rectifiers supersede costly and clumsy rotary converters. Our picture shows the first high-voltage (20,000 volt-) rectifiers to be built in England. They are at the new Droitwich station of the B.B.C.

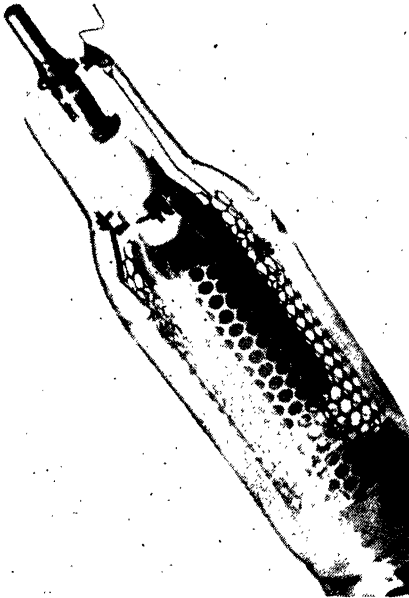

[Courtesy Siemens-Schuckert]

DETAIL OF A MERCURY ARC RECTIFIER

This photograph shows the anode-arm of a grid-controlled mercury arc glass bulb rectifier. The apparatus of which this is a part, is considerably smaller than the one on the Ploccadilly line sub-station, being only of 600 volts, 300 amperes capacity

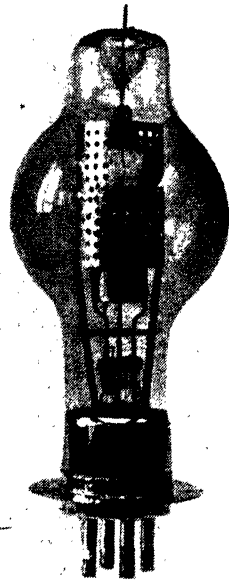

[Courtesy B.T.H.]

A MERCURY VAPOUR DISCHARGE VALVE

This is a particular type of the gas-discharge valve by which, with the aid of a grid control electrode, it is possible not only to rectify currents of hundreds of amperes, but to start or stop them or control their force. The valve shown is used in high-speed welding

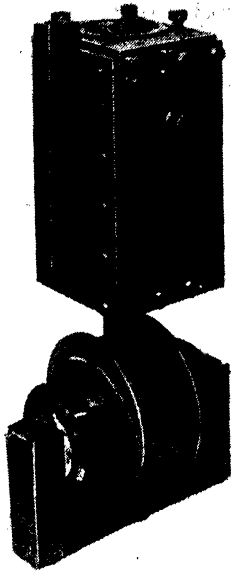

Courtesy: B.T.H.

A MERCURY VAPOUR VACUUM PUMP

The pump illustrated is part of the mercury arc rectifier equipment on the Piccadilly Railway. The mercury pump has exceedingly high speed, and is heated by induction, so that at no point does the temperature exceed 700° centigrade



[Keystone

METAL SPRAYING

The spraying of metal enables it to be coated with ease on to previously impossible surfaces. It is melted by passing through a fierce oxy-acetylene flame, and then blown on to the surface by compressed air. It solidifies again almost as soon as deposited

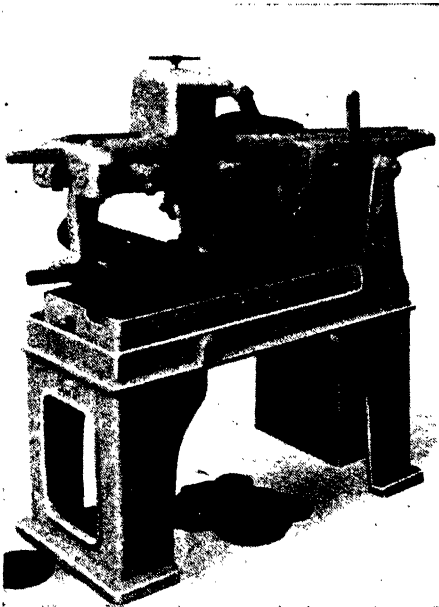

Courtesy: Chas. Wickstead Ltd.

A METAL-SAWING MACHINE

The function of this machine is yet another instance of the amazing mastery which twentieth-century man has acquired over materials. As the picture implies, it is now possible to saw the hardest metals as efficiently and quickly as slabs of wood

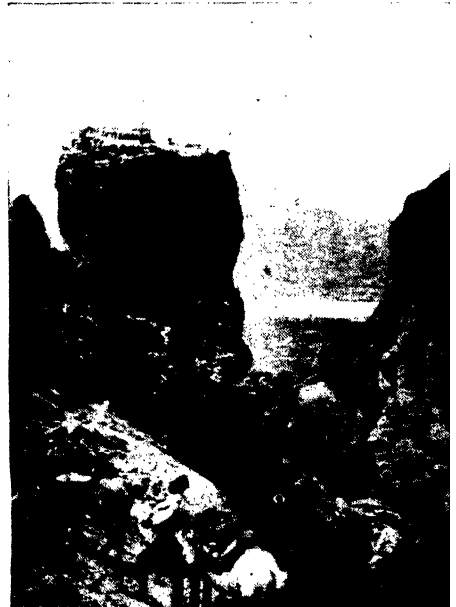

[Underwood Press Service

HOLY TRINITY MONASTERY, GREECE

The Monasteries of Meteora, or "Monasteries in the Air," in the north-west of Greece, were founded in the fourteenth century on a number of precipitous, pillar-like rocks. There were originally twenty-four, but only seven now remain. The River Peneios can be seen in the distance

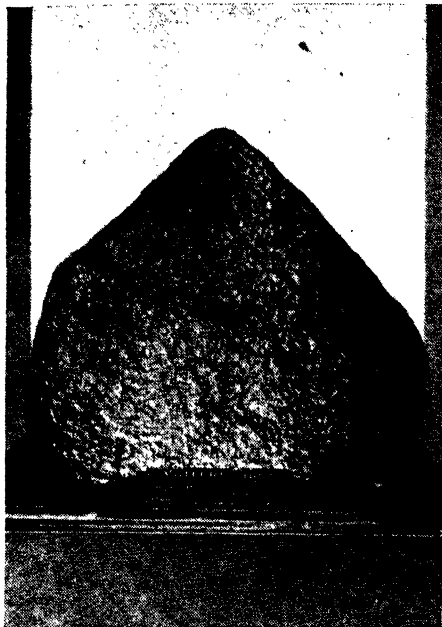

By courtesy

METEORIC IRON

Meteors frequently reach the earth from outer space, and in many cases it is possible to collect quite large fragments. This photograph shows a fragment of Meteoric Iron found in 1877 at Inulac, in South America

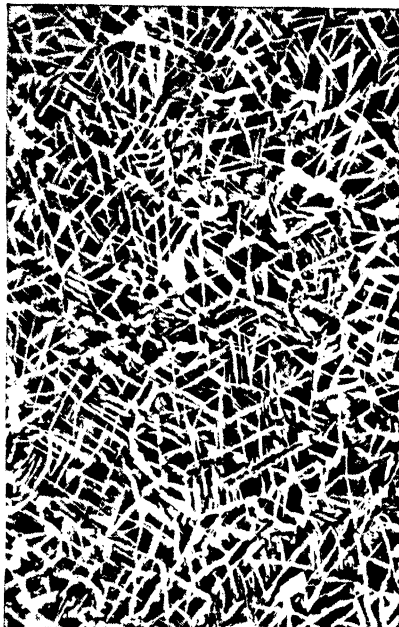

"Marvels of the Universe"

METEORIC METAL

This sectional photograph clearly illustrates the structure of a Meteorite. This particular portion is nickel iron metalolite, magnified a hundred and thirty times

30 Camelopardalus

Cassiopeia

Andromeda

A METEOR'S TRACK EXPLAINED

[From "Splendours of the Heavens"]

The members of a stream of meteors move in parallel paths, but the Earth, during its weeks of passage through a broad stream, constantly alters the direction of its motion as it progresses round the Sun. The effect of this is to make the meteors appear to come from a slightly different point each night



RUINS IN YUCATAN, MEXICO

Savil is one of the marvels of Central America. It is an ancient city inhabited by the Mayas long before the Spaniards arrived. This palace is one of the very rare examples of a three-storied Mayan building, and contains even to-day no less than eighty-seven rooms



All photos]

RUINS IN YUCATAN

Here is a fine example of ancient art in the state of Yucatan. It looks like a carving in stone, but in reality the weird decorations have been moulded in plaster. In some of the cities this has been a common form of decoration



["Wonders of the World"]

RUINS IN YUCATAN

This colossal head, which formed part of a figure over an entrance, was found at Cancun Island, in the Yucatan Channel: another testimonial to the art of ancient Central America and the high degree of civilization of the former races inhabiting it



[Dorien Leigh]

"THE LAST JUDGMENT," BY MICHELANGELO

Sculptor, painter, architect, and poet, Michelangelo Buonarroti stands head and shoulders above even his great contemporaries, save Leonardo da Vinci. Born at Caprese in 1475, he studied under Ghirlandajo and entered the household of Lorenzo the Magnificent. After the fall of the Medici Michelangelo went to Rome, and from then onward his life was spent between Rome, Florence and Bologna. He died in 1564.



[David]



[Dorian Leigh]

TWO STATUES BY MICHELANGELO

Above are two of Michelangelo's chief works in stone. "David," on the left, is a colossal figure carved at Florence, in 1504, from a block of marble rejected by some builders. "Notes," an almost terrifying example of the artist's dynamic force, was chiseled twenty-five years later and is in the Church of S. Rocco in Vicenza, Italy.

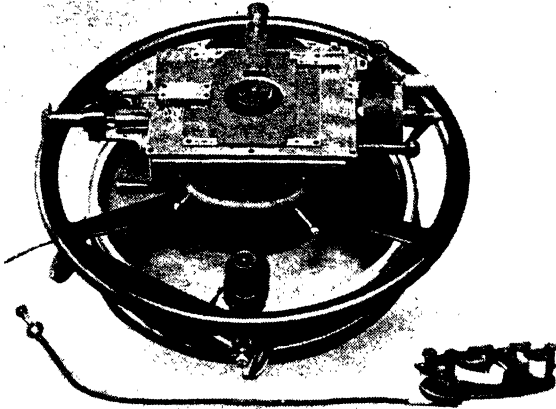

[Courtesy Carl Zeiss]

ASTRONOMICAL MICROMETER

There are three types of micrometer. The one shown uses the method of moving two fine wires by a turn-screw across the lens of a telescope, and calculating the number of turns. The accuracy is to 1/100th of a mm. A micrometer's purpose is to measure small quantities—in the case of astronomy, small angles. The instrument here depicted is astronomical.

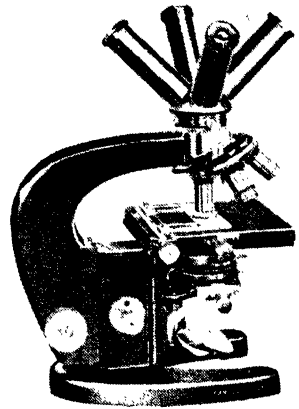

[Courtesy Carl Zeiss]

THE MICROSCOPE

The microscope, besides its obvious uses to biologists and geologists, is of the highest importance in engineering for the examination of the structure of metal castings. Above is a four-eyepiece biologist's instrument.

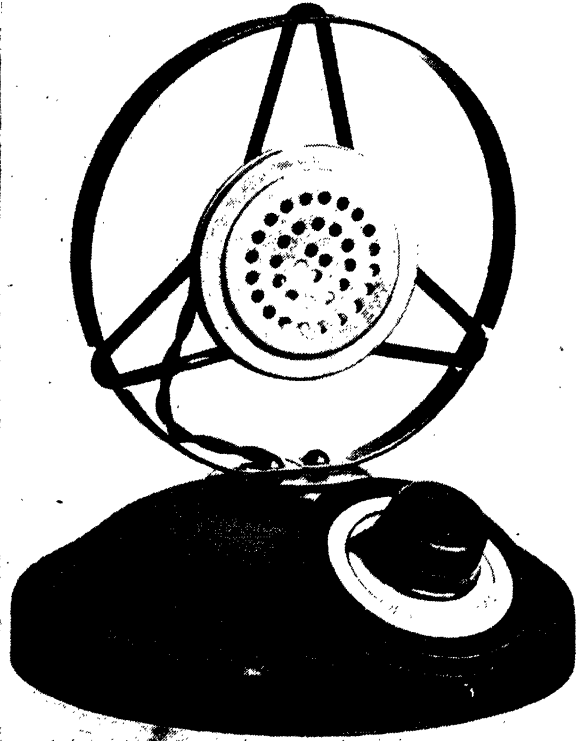
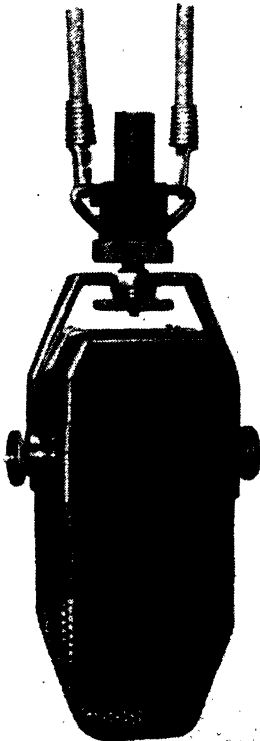

TWO TYPES OF MICROPHONE

[By courtesy Marconi & G.E.C.]

There are five types of microphone—carbon, electro-dynamic, electro-static, thermal, and piezo. The cheapest is that in use with a telephone; the dearest, that used in sound film recording and broadcasting, where freedom of action must be allowed to the people or objects creating the sound. Above are two types used in broadcasting.

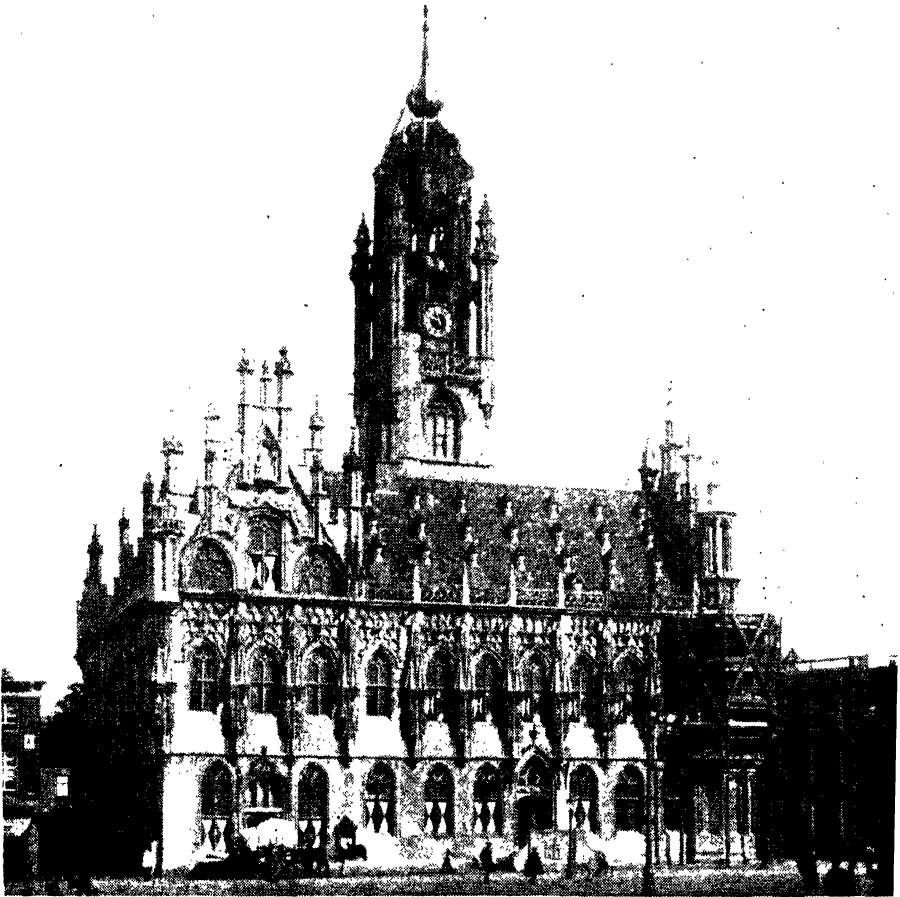

TOWN HALL, MIDDELBURG

[D. McLess

The Stadhaus, or Town Hall, of Middelburg is considered to be one of the finest in Holland. It was built at the beginning of the sixteenth century by Kelseman of Malmes. The elaborately ornamented façade is adorned with twenty-five statues of the Counts of Holland and Zeeland, and there is an imposing tower in the centre which rises to a height of 180 feet.

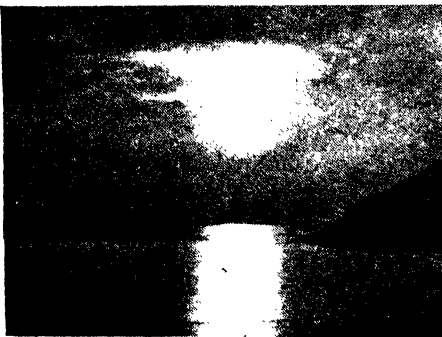

H. J. Shepstone

THE MIDNIGHT SUN

In certain parts of the Arctic there is perpetual day between the end of May and the end of July on account of the non-setting of the sun. It is here seen approaching the horizon on one of its complete circles above that level.

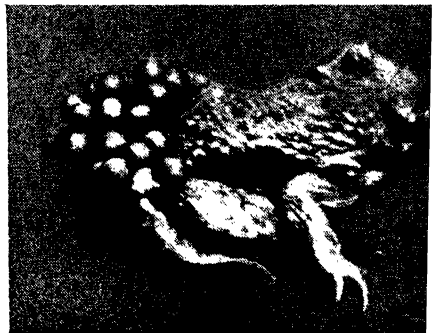

[W. S. Berridge, F.R.S.

THE MIDWIFE TOAD

This toad waits until his mate has laid the eggs and then girds himself up with the whole lot. With the true forethought of a parent, he confines his search for food to night, to safeguard the eggs.

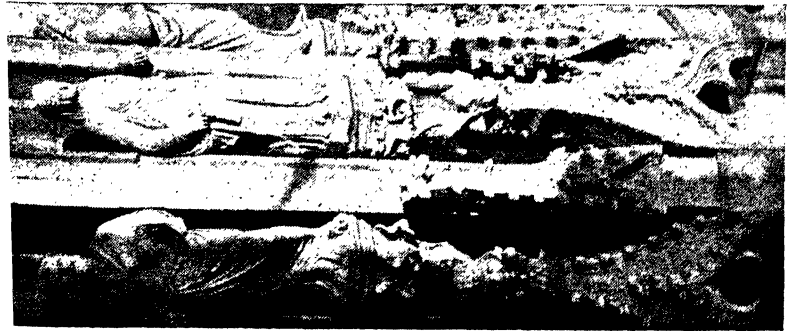
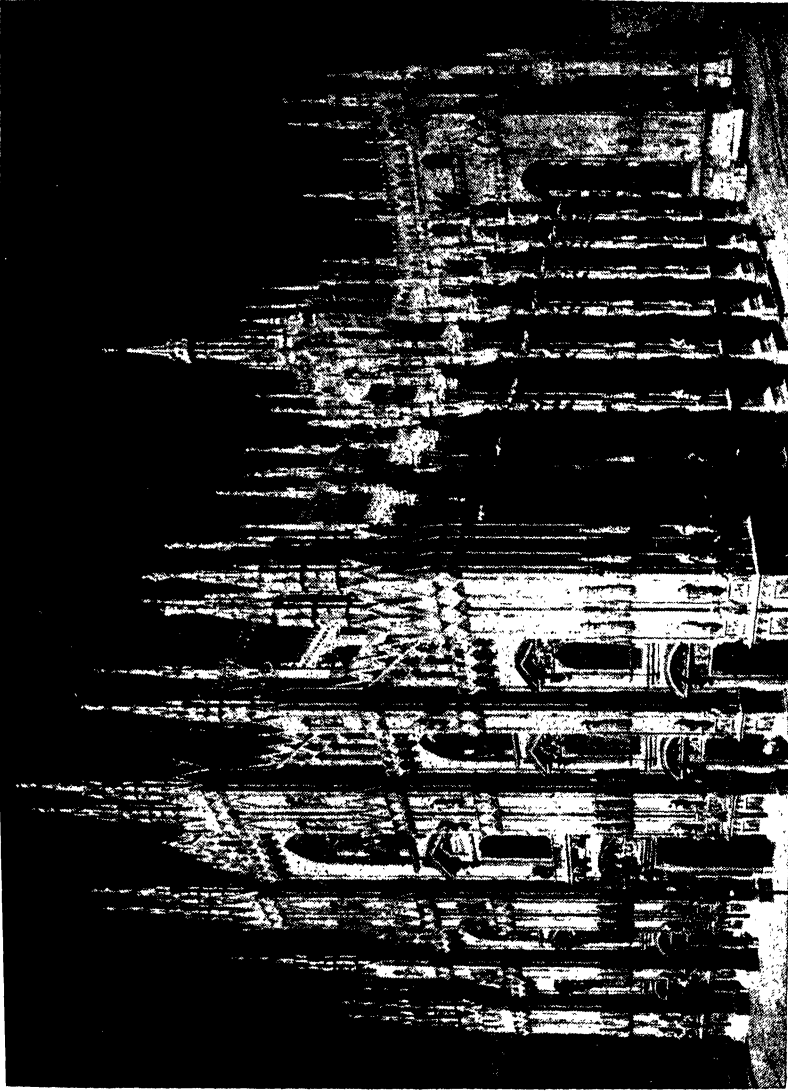

[E.N.A.]

MILAN CATHEDRAL

The great Napoleon's name is indissolubly connected with this noble building, for in 1805 he commanded it to be completed after a delay of nearly four and a half centuries. Despite its over-ornate and lavish design, the great white temple, with its forest of spires, cusps and pinnacles, fascinates the eye by its extravagant beauty. It is quite unique among the Cathedrals of Europe



[The Agent-C era] jo

MILFORD SOUND, NEW ZEALAND

In Milford Sound the scenery of South New Zealand reaches its culminating beauty. Under the shadow of the rock glacial steep the deep water becomes blue black in shade, while the feathery palm-tree ferns clothe the cliffs, and at the back the snow white peaks sparkle in the sun. It is a magnificent and majestic sight.

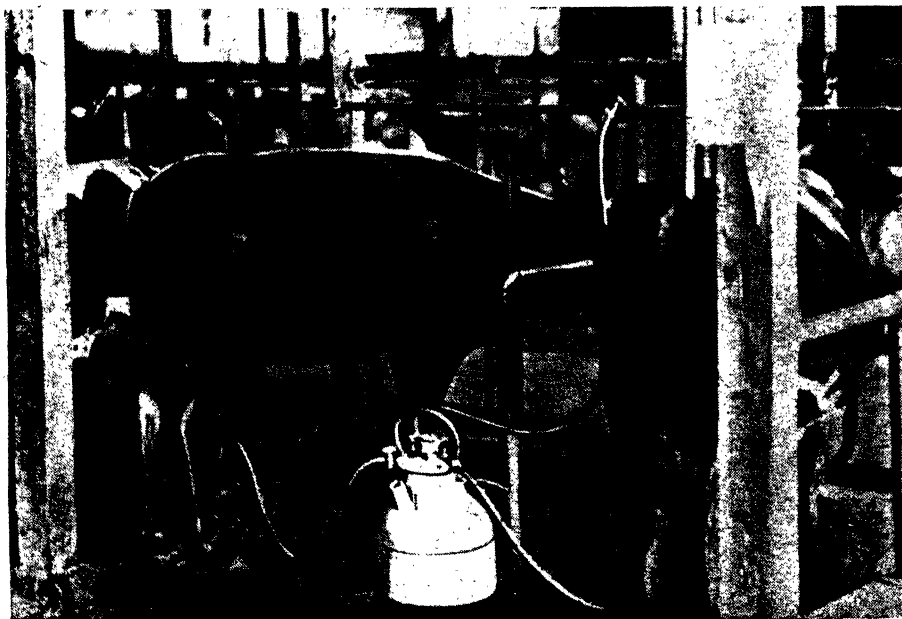

[Carlhuw & Kinnai

MILKING COWS ARTIFICIALLY

The electric milkmaid is time-saving, efficient and clean. A vacuum pump, acting through the milk pipe, produces a sucking effect on the cow's udder, which is rendered intermittent by a pulsator; this is a valve which places the pipe alternately in communication with the vacuum and the outside air.

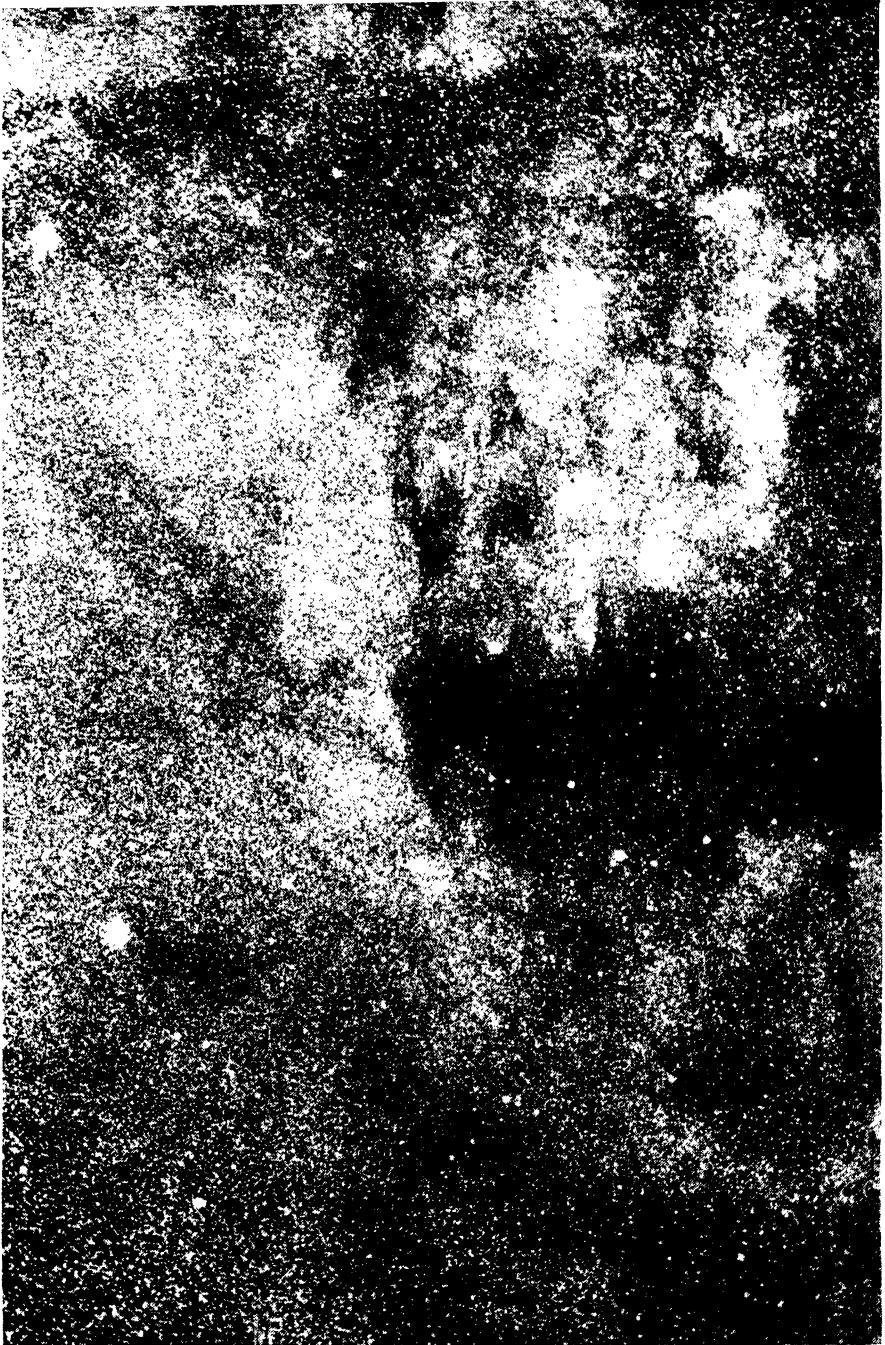

A RIFT IN THE MILKY WAY

[H. J. Stepstone

The Milky Way, the outer rim of our huge cartwheel-like universe, composed of millions of stars, is figured in certain parts, as are some of the nebulae, with unaccountable black rifts (see Orion). The photograph reproduced here shows one of the greatest of these rifts, occurring in the Milky Way's thickest part



THE VENUS OF MILO

[Dorien Leigh]

The most celebrated statue in the world. Seeing that most of the chief gems of antique sculpture were re-discovered during Byzantine or Renaissance times, it is surprising that this Venus was not unearthed until 1820. It is now in the Louvre. Melos, or Milo, is a Greek island in the A'gean Sea.



INSECT MIMICRY

[*Theo Carreras*]

Apart from those which are camouflaged to resemble leaves, sticks and flowers, insects of many species bear a resemblance to others on which their enemies do not prey. Wasps, for example, have many imitators. Above is an amusing example of a small membracid (right) built by nature as a replica of the Leaf-cutter Ant carrying its burden



[*F. Halbherr*]

MINOAN POTTERY

Before the Bronze Age Crete possessed a high civilization, but until recently even the later kingdom of Minos, of which the Greeks wrote, was thought to be entirely legendary. Recent excavation has proved its reality, and laid bare some remarkable pottery and statuettes of a
ent days



A MIRAGE

[*Theo Carreras*]

The phenomenon of refraction of light rays by layers of air, which we call a mirage, is common to all five continents. Sometimes the phantom scene will appear without embellishment or distortion; at others with an inverted double, as in this sketch; at others again, the whole thing will be inverted



[E.N.I.T.]

A CORNER OF THE CLOISTERS, MONREALE

The Benedictine Monastery which adjoins Monreale Cathedral is a modern building, but its beautiful cloisters, which are in an almost perfect state of preservation, date from the twelfth century. This view of one of the angles suggests a resemblance to the Alhambra in Spain.



From "Britain Beautiful"

CLIFFS OF MOHER

Here is County Clare's unrivalled possession. At the highest these majestic cliffs are over 600 feet and extend for about five miles. They form, probably, the most magnificent rock wall on the whole Irish coast. The tower at the crest was built by Cornelius O'Brien in 1835 for the convenience of visitors, but has since become a ruin

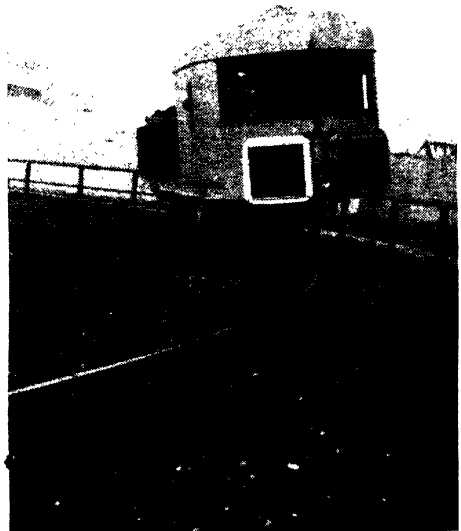

[Carlow & Kinnarda]

THE MONORAIL

This type of transport, with gyroscopic balance, was invented by Louis Brennan, an Irishman, who died in 1934. He also invented the dirigible torpedo, and was for years adviser on munitions to the British Government. The Brennan monorail-car was produced early in the century, and the picture shows it on a successful run

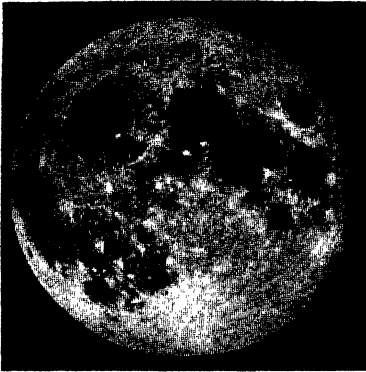

[Lick Observatory]

A PHOTOGRAPH OF THE FULL MOON

This photograph of the nearest of all Celestial objects, and the only one, with the exception of Mars, of which we see the actual solid surface, was taken just after Full. It shows the various "seas" as dark areas.



[Underwood Press Service]

MONT PÉLÉE IN ERUPTION

This view of Mont Pélée was taken within 800 feet of its riven crest. The terrible eruption of 1902 devastated one-tenth of the island of Martinique and buried between thirty and forty thousand inhabitants. Great clouds of smoke and a mass of fire appeared, whilst molten lava and ashes swept down on the doomed city of St. Pierre.

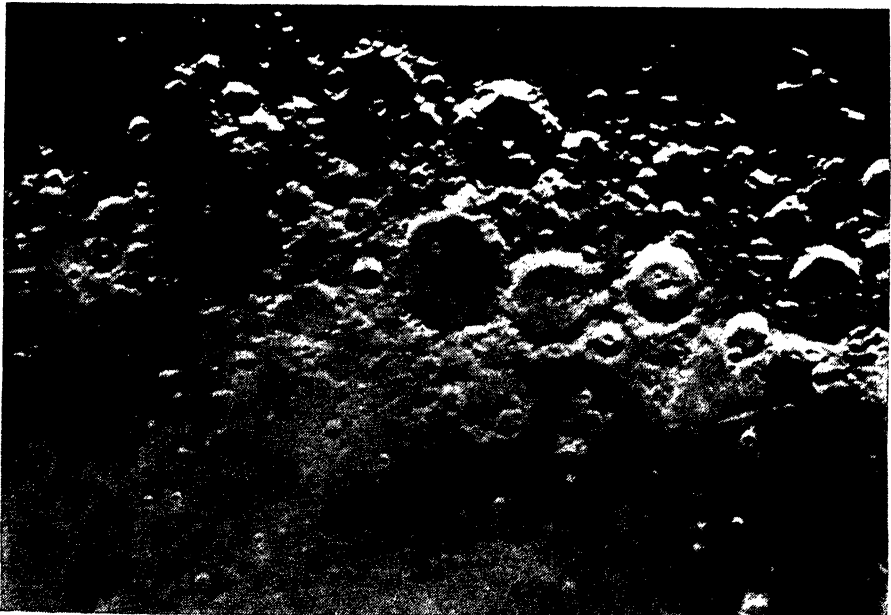

[Lick Observatory]

REGION OF THE LUNAR CRATERS

This photograph gives a good idea of the lunar landscape, and has an advantage over direct observation in that it is invaluable in fixing the outlines and positions of the various features. Larger telescopic instruments will give more detail but not such a good general idea.



QUEEN MARY I, BY SIR ANTHONY MORE

[*Dorien Leigh*]

Anthony More, or Anthonis Mor, was a Dutchman of Utrecht, born about 1512. After visits to Brussels and Rome he became Court painter to Philip II of Spain. When Philip came to England to marry Mary Tudor, More came too and was knighted for painting this portrait. Later he returned to the Netherlands and died at Antwerp in 1577.



"VIRGIN AND CHILD" BY MORALES

[Dorian Leigh

The pictures of Luis Morales have been much criticised, but exhibit remarkable skill in depicting devout emotions, especially that of Christian suffering.



CATHEDRAL OF THE ASSUMPTION

[From "Picturesque Europe"]

This Cathedral was the Westminster Abbey of Russia, for all the Tsars were crowned there. It has been described as being so "fraught with recollection, so teeming with worshippers, so bursting with tombs and pictures, from the pavement to the cupola, that its small area of space is forgotten in the fullness of its contents." A contemporary description would sound very different.

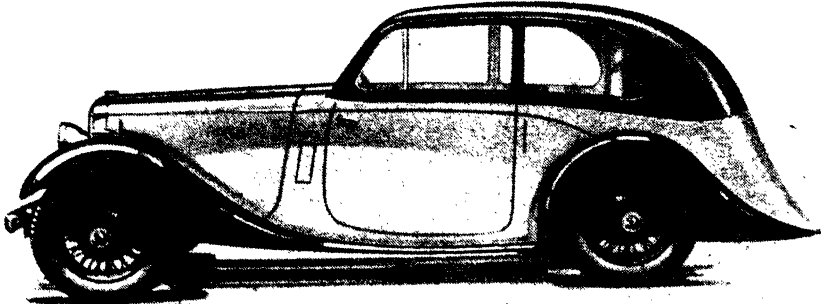
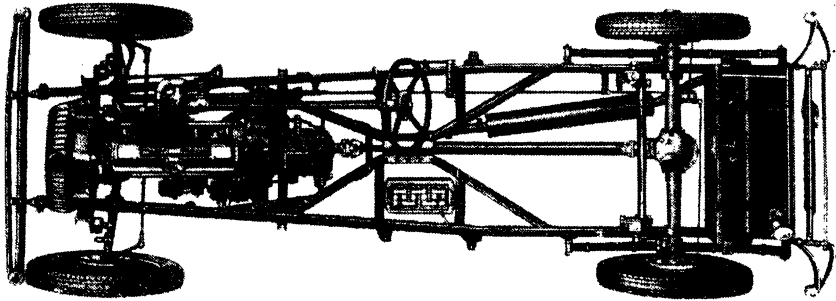

THE MOTOR CAR—INSIDE AND OUT

[Courtesy Daimler Ltd.]

The lower illustration shows a typical modern example of this type of transport, which sixty years ago was unknown. Otto patented the first gas engine vehicle in 1876, Daimler and Benz followed in 1885; Daimler in 1886 used the first carburettor. To-day there are 30 million cars in the U.S.A. alone. Above is a modern Daimler chassis



[Courtesy A. J. C.]

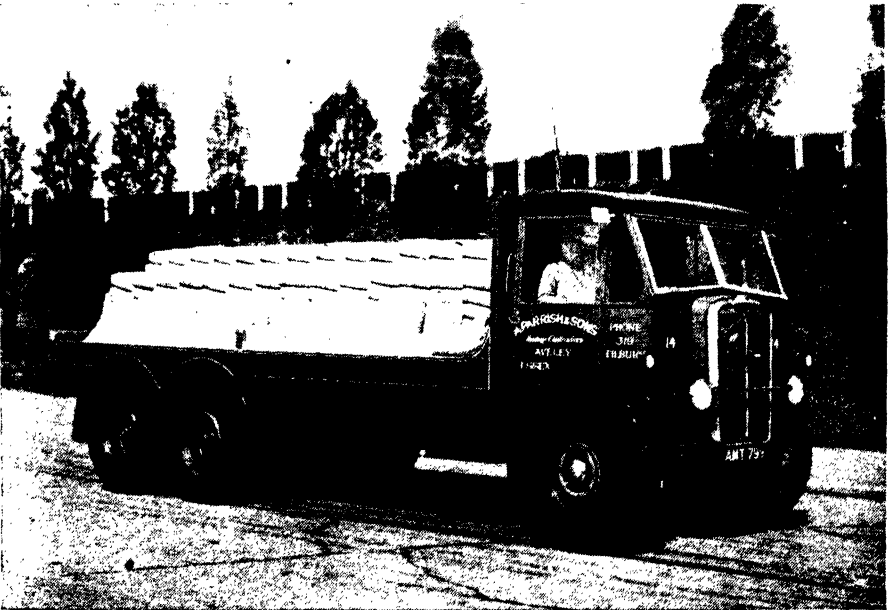

[Courtesy A. J. C.]

THE MOTOR CAR IN COMMERCE

The modern large-size commercial motor is in many ways an entirely separate invention from the modern private car. The engine burns crude oil instead of standard petrol, and is in reality a road application of the Diesel; the drive is frequently imparted to the front as well as rear wheels; the extra pair of wheels often added necessitates special independent mounting. The omnibus in the upper picture shows a bonnetless development of coachwork symbolical of the continual efforts which have to be made to cope with an ever-growing road passenger traffic without adding more than necessary to the number of vehicles congesting the roads

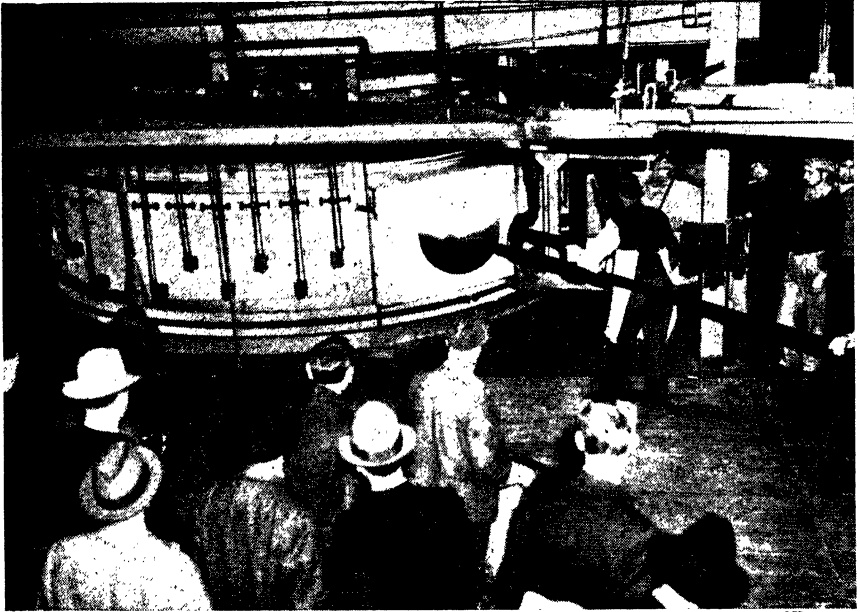

MAKING A MAMMOTH MIRROR

[Keystone]

In 1934, after a first attempt had failed, one of the largest mirrors ever cast was successfully made at the Corning Glass Works, U.S.A., for the world's largest telescope at Mount Wilson Observatory. The mirror is 200 inches across, and has to be without the smallest defect. Above, scientists are watching the glass being poured into the mould



MOULD FOR THE MOUNT WILSON MIRROR

[Keystone]

Twenty tons of molten glass were poured into this curious ribbed mould for the great 17-foot "eye" which is to see four times further into space than any before. Over three years of experiment were needed before a suitable compound for the glass could be found

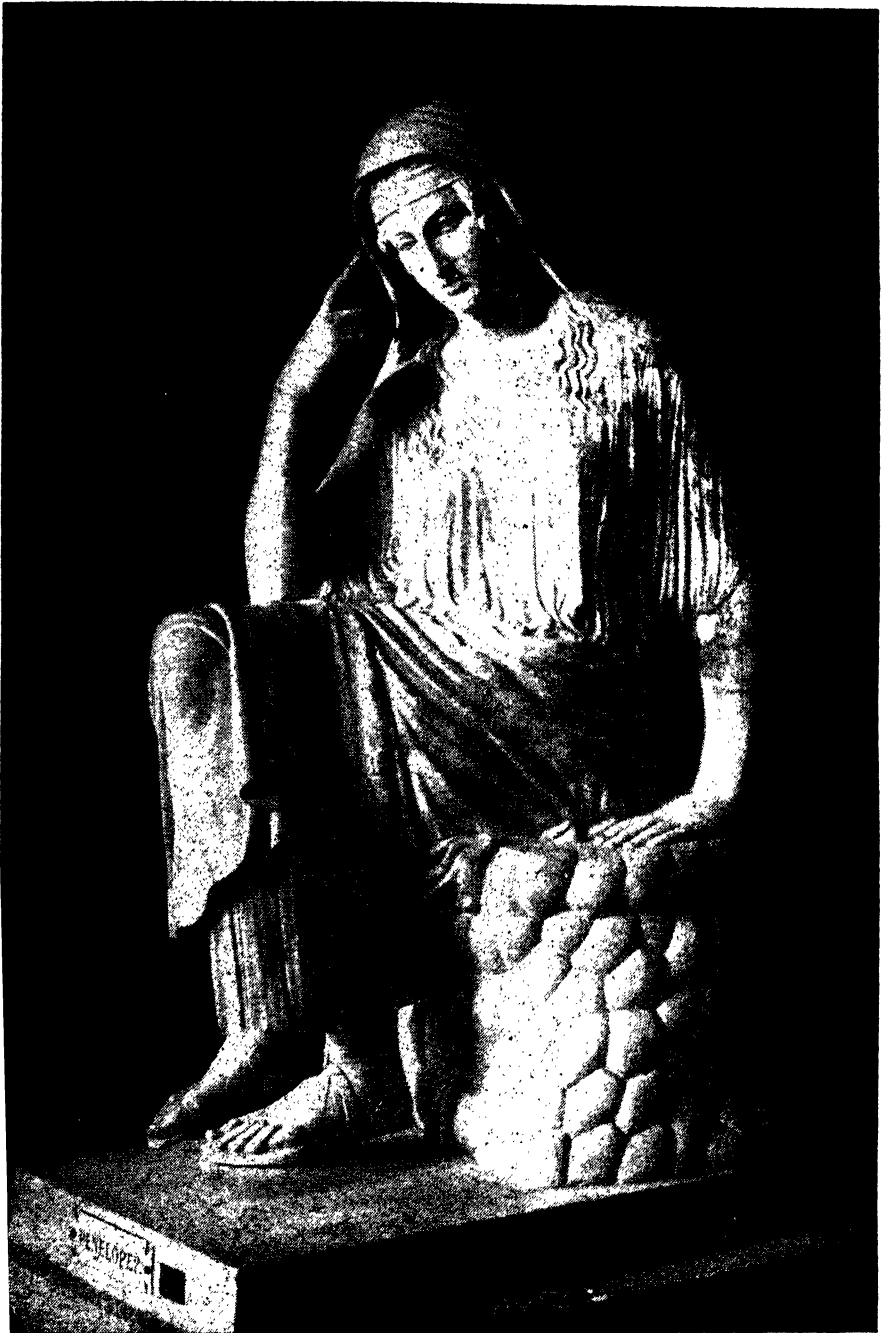

THE MOURNING PENELOPE

[Dorien Leigh]

The above is the popular title of this exquisite sculpture, which is one of the treasures of the Vatican. Actually it is not definitely established whether the figure represents Penelope at all, and the charming pose may imply thought as much as grief. Penelope in Greek lore was the wife of Odysseus.



MOUSE-CATCHING LOCUST

[*Theo Carrer*]

These powerful insects are here shown hunting for their animal food. One has caught a mouse, another a large bi-
spider. This spiny-legged grasshopper from the Congo affords probably the only example of an insect killing a four-
footed animal



[Keystone]

A MOVING MOUNTAIN

Creeping mountains, which are either crumbling away or settling down into the earth, are noticed from time to time in many parts of the earth, including the British Isles. This strange picture shows a moving mountain near Cochem Castle, Germany

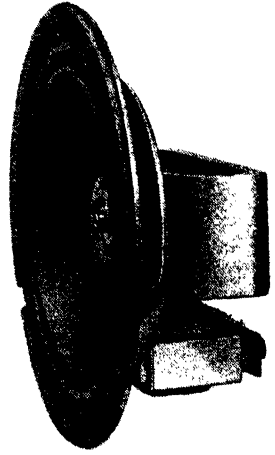

A MOVING COIL LOUDSPEAKER

The moving coil type of loudspeaker is so much truer than all others that it is now more or less universal. A movable coil is suspended in the uniform magnetic field of a horseshoe magnet, whenever the current changes the magnet attracts or repels the coil.



[Cuthbert A. Kinnaird]

MUD SKIPPERS

These extraordinary creatures are remarkable for their eyes, which are placed on the tops of their heads exactly like those of certain prehistoric reptiles of the Coal Age (q.v.)



[Dorrien Leigh
"THE DREAM OF A ROMAN PATRICIAN," BY MURILLO
Bartolomé Estéban Murillo was born at Seville in 1617. After a visit to Madrid, during which he attracted the interest of Velasquez, he returned to Seville, married, became acknowledged head of the Seville School of Painting, and founded the Seville Academy. In late life he met with a serious fall, the effects of which lasted until his death in 1682. His paintings were nearly all religious, and are now mainly in Spain, France and England. Murillo is generally considered the greatest Spanish painter after Velasquez.



MUSIC FOR THE BLIND

[Dorion Leigh]

Not only is this clever wire notation for the blind, but has been made by blind people. It is the invention of a Fraulein Mahler of Germany. Except for the few stamped words at the bottom, every symbol consists of thin wire easily fashioned with the fingers. The notes are stuck into a base covered board.

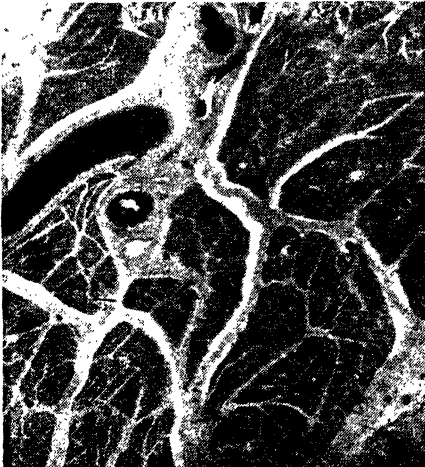

[Carthou & Kinnaird]

THE MUSCLES

, the parts of the body which cause motion and are an " of meat. consist of elongated cells or fibres, in response to nerve impulses, and l by tendons to a bone or bones. h shows veins, arteries and nerves



[Underwood Press Service]

THE LION GATE, MYCENAE

But for a small postern there was only one gateway to the almost impregnable walled citadel of Mycenae—the Lion Gate. Noble lions guard the gate to the prehistoric Acropolis. It forms the most ancient piece of sculpture extant and was created in the seventeenth century B.C.

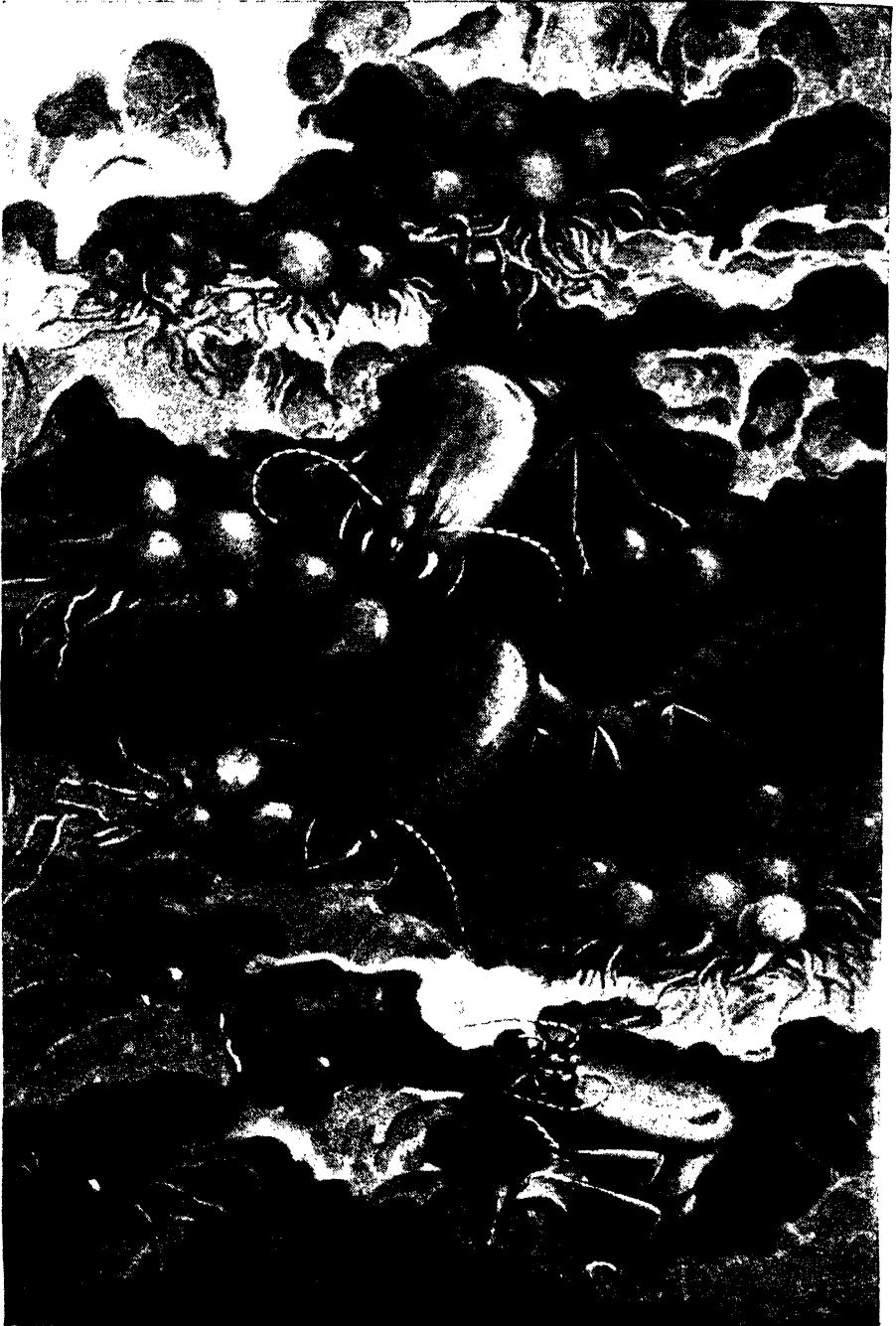

[Thao Carrera]

"WHITE ANTS" AS MUSHROOM GROWERS

The almost human ingenuity of Termites, erroneously known as "White Ants," is indeed wonderful. They not only hoard food, but actually cultivate their own, by cutting and storing grain and leaves, upon which, when fermented, the Termites grow mushrooms! In this enlarged representation they are seen gathering the mushrooms in the chambers allotted to their culture



J. Thomson, F.R.G.S.

A TEMPLE IN NAKHON THOM

Nakhon Thom is more or less another name for Inthepatanuri, French Indo-China, where stands the Angkor Wat. The Temple shown here, however, has nothing to do with the Wat. Its 37 towers show in all 146 of the sphinx-like faces of Buddha such as are seen above.



[From "Wonders of the World"]

MYSORE: THE SACRED BULL

The Hindus revere many animals, and chief among them the cow. This Sacred Bull, or Nandi, the especial emblem of Shiva, is carved from a single block of stone, and stands on a low bill close to Mysore. The Nandi is always shown in the same recumbent position



H. J. Shepstone

THE NAOSAUR

Though not much larger than a large dog, this animal of the Permian era owned the most remarkable spine Nature has ever produced

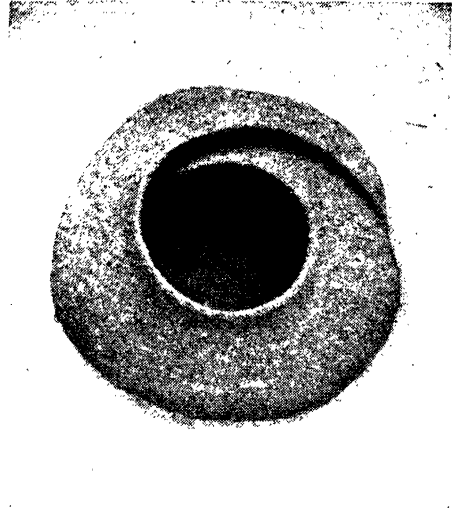

From "Archeology of the Universe"
A SAND SAUCER

This is the egg ribbon of the Necklace Shell, and is composed of sand and mucus: in this the eggs are laid. In time the sand hardens and protects the eggs



THE NEEDLE FISH

[W. Saville Kent, F.Z.S.]

In lateral aspect there is nothing very remarkable about this fish, which is here reproduced at about three-quarters of its natural size. It is when seen "end on" that its wonder becomes apparent, for the creature is less than one-tenth of an inch thick.

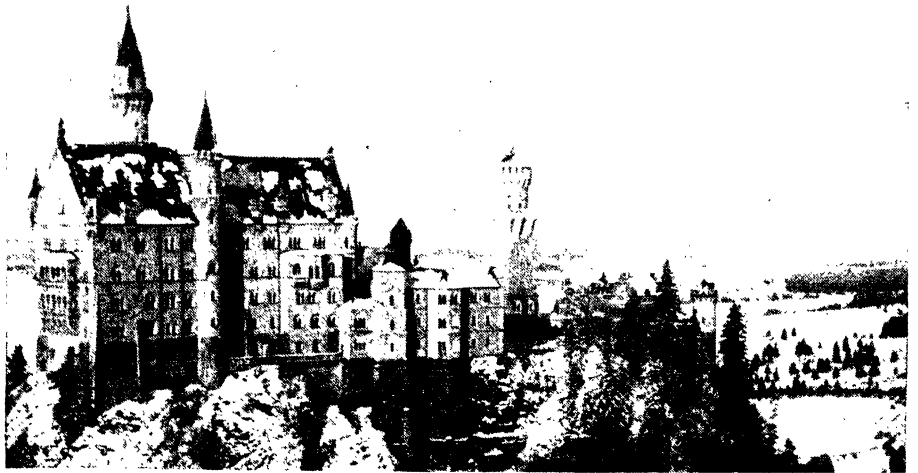

NEUSCHWANSTEIN CASTLE

[Carthen & Kinnaird]

This gigantic castle, from its building in 1869 by Ludwig II until 1918, was the home of the notorious Ludwigs of Bavaria. It was built to the plan of another and smaller castle in the valley of the Neckar, and itself stands on precipitous rock overlooking Hohenschwanggen and the Alpsee



Keystone

NEON ADVERTISING SIGNS
 The old bulb type of electric sign, such as is seen on the extreme left of this picture, has been in use for many years, but the type wherein long glass tubes are filled with neon and other gases rendered incandescent is less than a decade old. The colour of the lighting depends on the gas used. This view was taken on Broadway, New York.

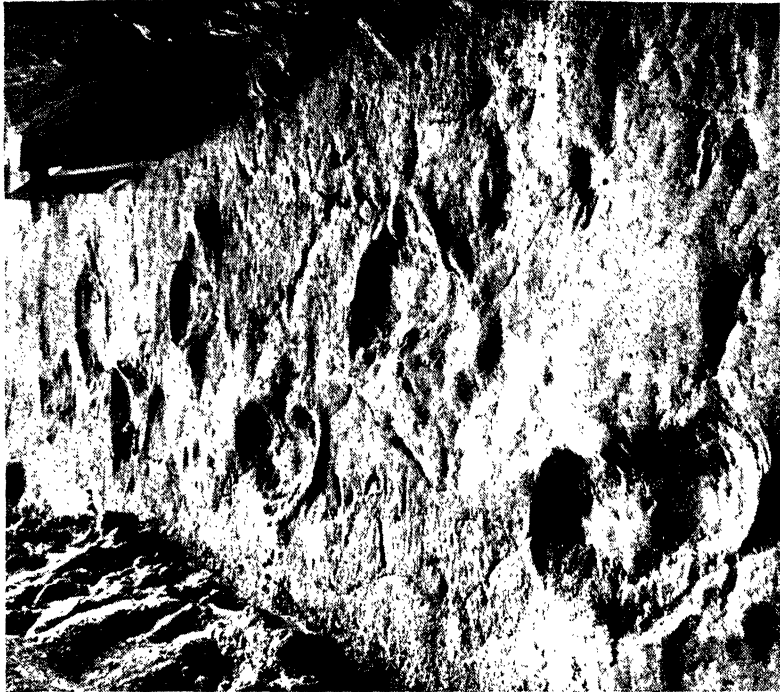

U.S. Southern Pacific Railway

FOSIL FOOTPRINTS, NEVADA
 In the early sixties of the last century the authorities of the Nevada State Prison set its convicts to work at quarrying on the prison ridge. All sorts of animal remains were unearthed. Finally tracks of gigantic ground sloths of the Pliocene period were discovered, and proved to be the clearest prehistoric footprints ever laid bare.

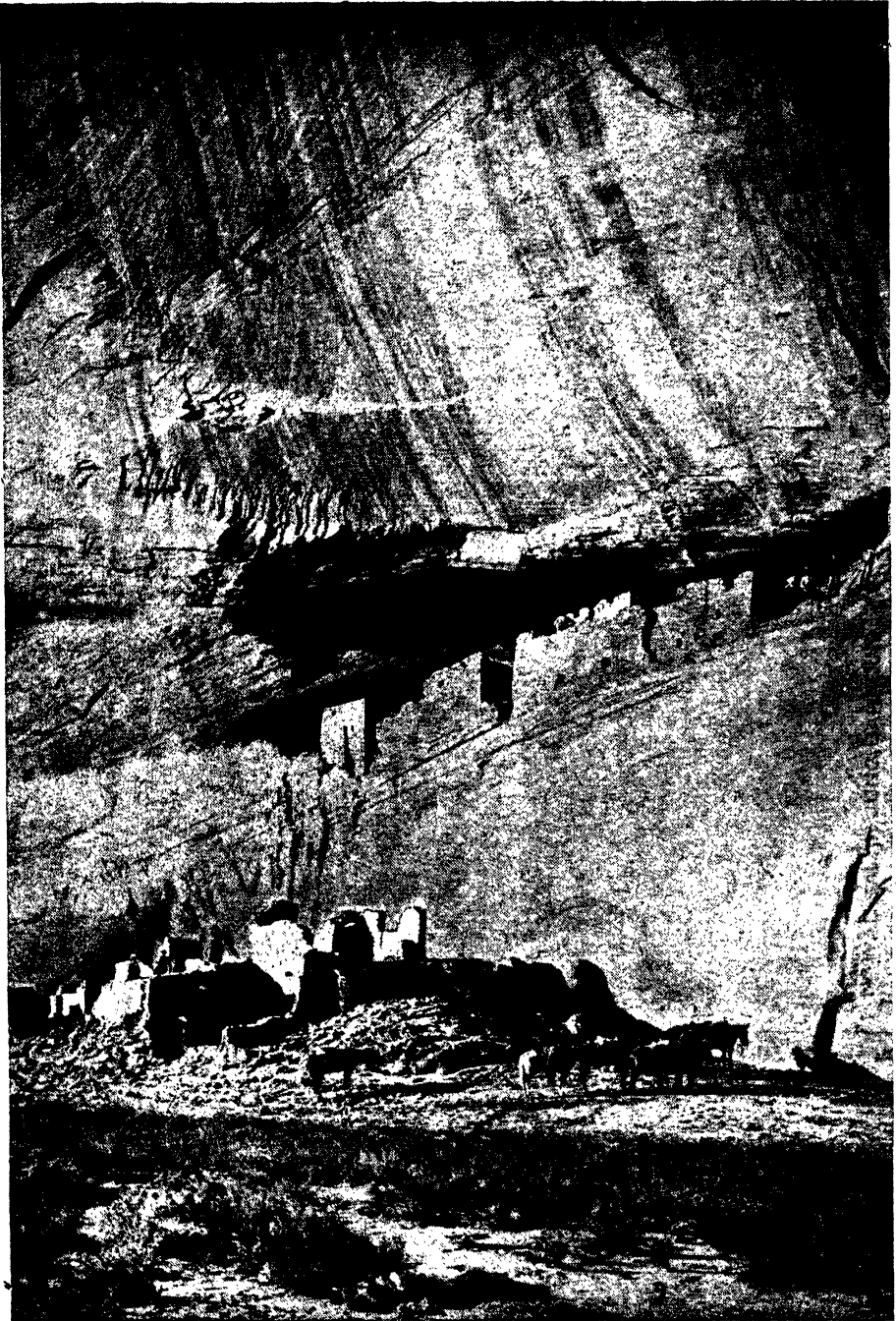

(Courtesy Bureau of American Ethnology)
NEW MEXICO: CLIFF DWELLINGS

The cliff and rock dwellings of North America are not confined to New Mexico, but are plentiful in Mexico Republic and in Arizona. There are three kinds: simple caves, excavated caves with porches, and built-up houses such as are here illustrated. They were inhabited originally by tribes of Indians, who resorted to the cliffs mainly for protection

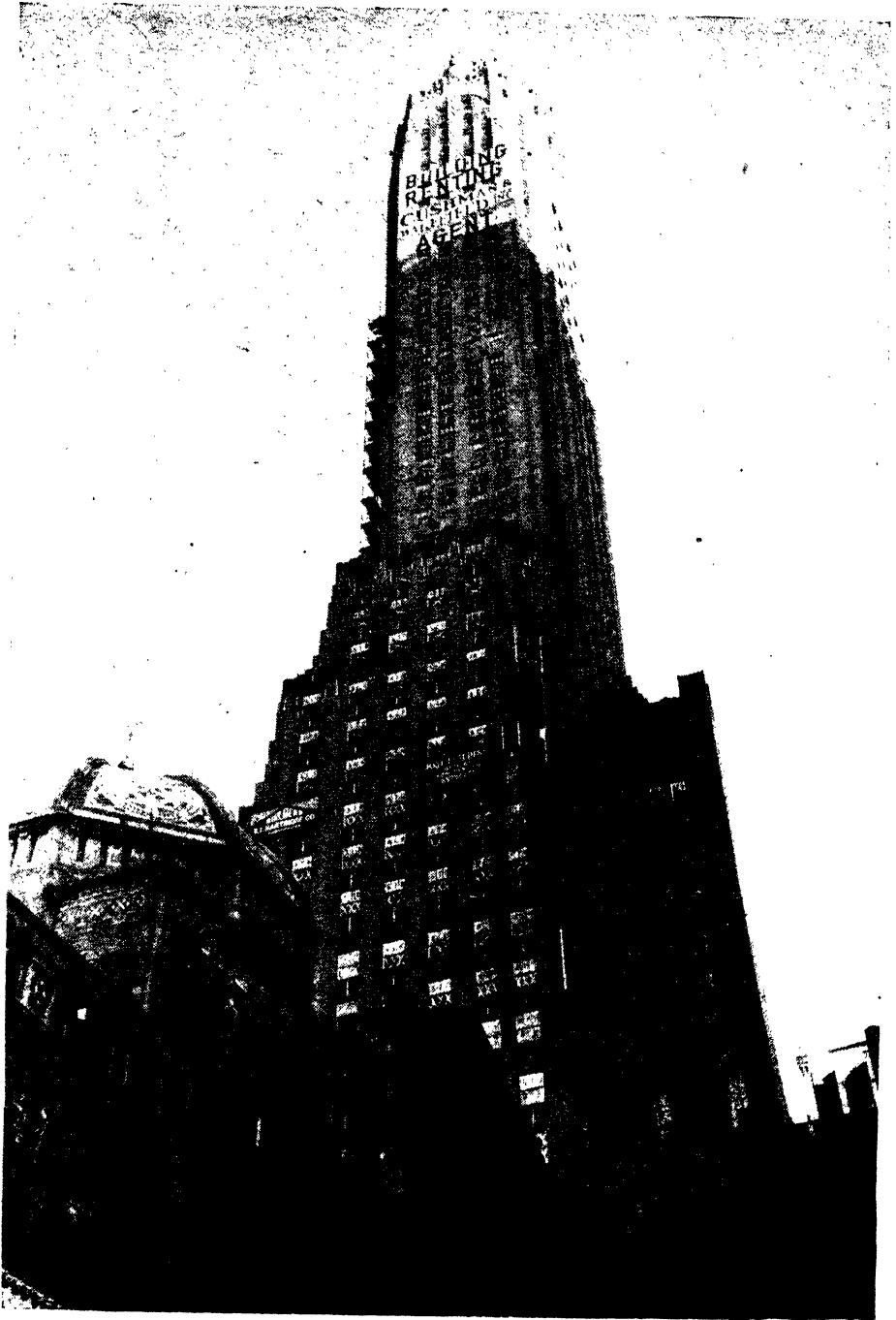

NEW YORK: A SKYSCRAPER

[Keystone.

This is one of the newest of the city's cloud-scratchers, being the Radio Corporation of America Building in which Radio City (see overleaf) is housed. It is a good example of the new effort to impart a little variety of decoration to these and monotonous piles. In the foreground, by way of contrast, is the "old" Church

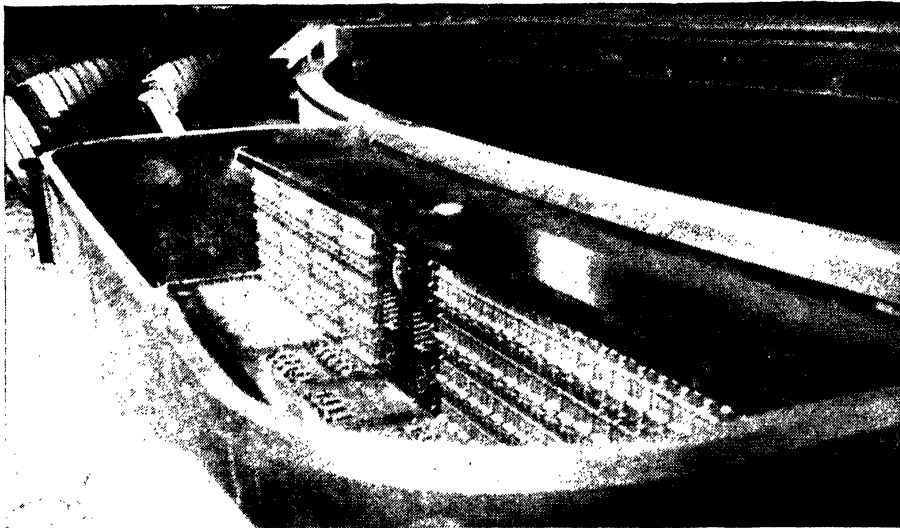

[Keystone

NEW YORK: TWO VIEWS IN RADIO CITY

Radio City is the name of New York's broadcasting headquarters. An amazing theatre has been constructed, which is not likely to have a parallel in the world for many years to come. Above is shown machinery for controlling the "effects," altering the stage, and moving the orchestra.

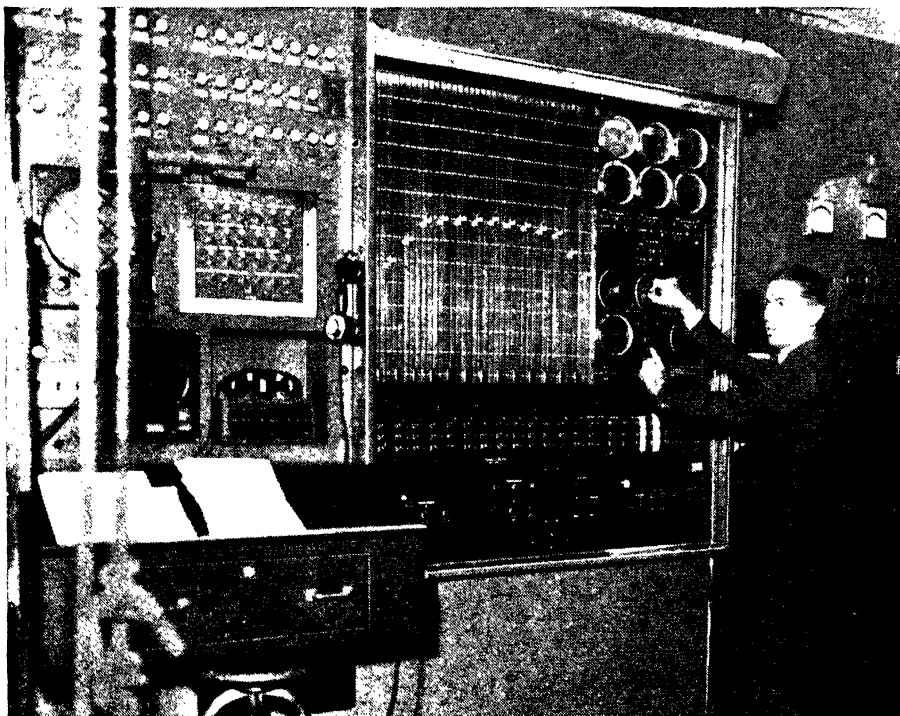

[Dorien Leigh

This is the switchboard controlling the curtain. It causes the curtain to be enlarged or diminished, to be raised or lowered at any speed to any height, and even to take on different shapes as shown by the studs on the board



NEW YORK: A PANORAMA

[Keystone

shown four different styles of really tall skyscrapers, and though neither the Empire State Building nor the 40th Building is visible, they may be taken as representative of the city's most striking erections. On the left is No. 300 Fifth Avenue; next, the Chrysler Building; then the Lincoln and Chanin Buildings



Courtesy New Zealand Government)

NEW ZEALAND: A GEYSER

The geysers of New Zealand are as varied as they are many. Some are merely boiling springs; others are foaming cauldrons of mud. Most majestic of all, there are geysers which erupt high into the air at regular intervals. One of the best of this last type, Wairoa, is shown here



(The Agent-General for New Zealand
NEW ZEALAND

KERERA GEYSER, NEW ZEALAND
We are not perhaps accustomed to connect geysers with the beautiful, but Kerera is indeed a wonderfully beautiful sight. The water, heavily charged with silica from the geyser cores, gradually forms marvellously lined terraces round the geyser cones, and in the bright sunlight they make a vivid picture

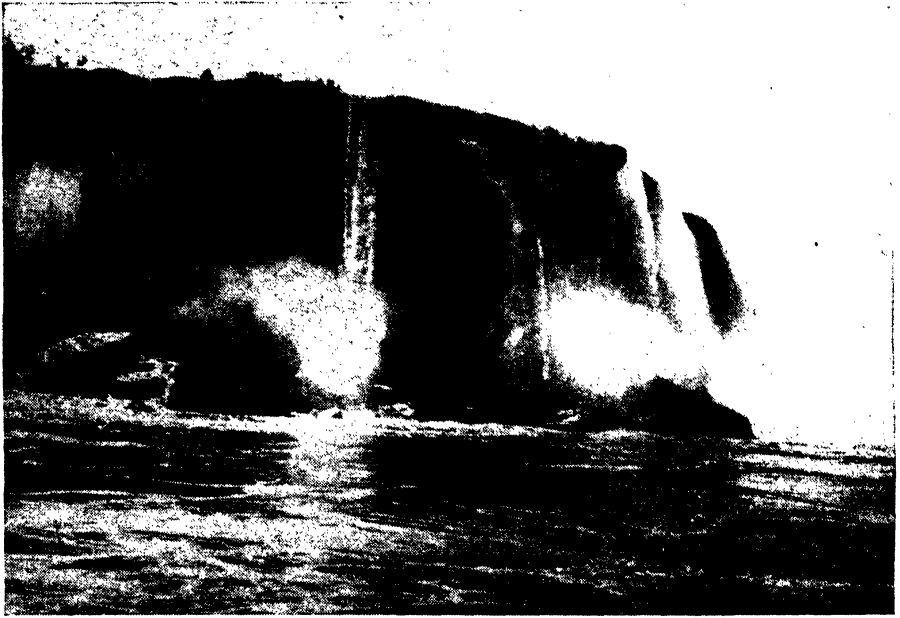

NIAGARA FALLS

[Carlow & Kinnaird

Though not by any means the highest, Niagara is the world's greatest fall for volume of water. There are two cascades: the American, and the Canadian or Horseshoe. The edge of the latter is receding, so great is the pressure of water, at the rate of 3 feet per year. The falls were discovered in 1678

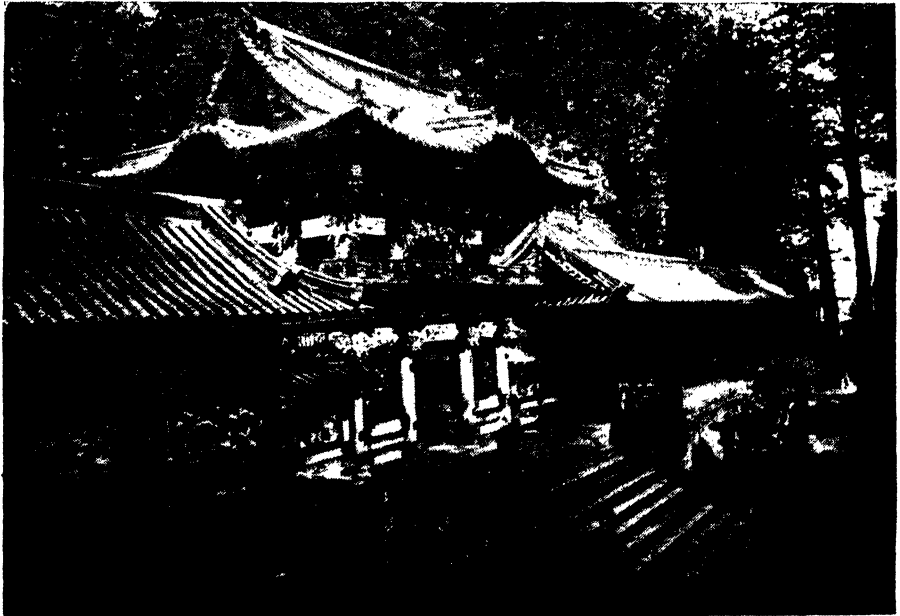

THE YOMEI GATE, NIKKO, JAPAN

[Courtesy "Wonders of the World"

The city of Nikko is approached by two avenues, 50 and 30 miles long, of gigantic cryptomeria trees. The Yomei Gate leads to one of the many temples. Over another is carved the original trio of monkeys illustrating the legend, "see not, hear not, speak not evil"

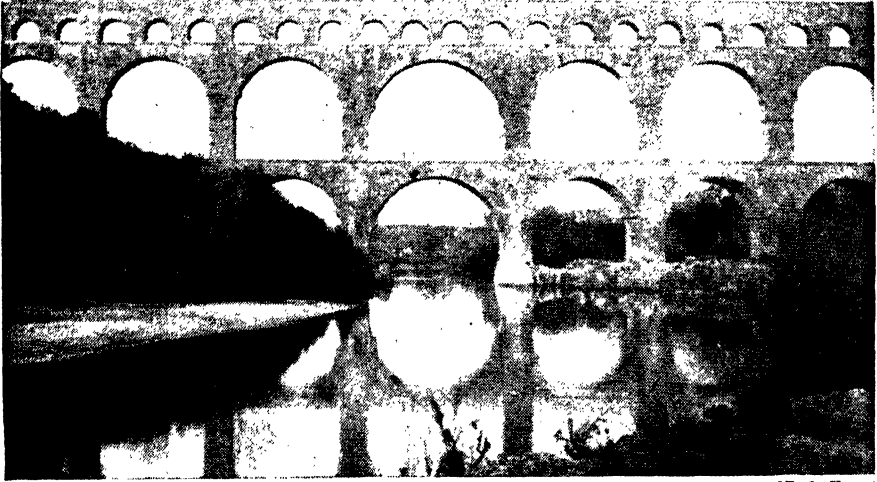

LE PONT DU GARD, NIMES

[E. O. Hoppe

This famous Roman aqueduct, just outside the city, was built by Agrippa, who also founded the baths nearby. Under the Romans Nîmes was very prosperous, but declined considerably after the fall of the Empire

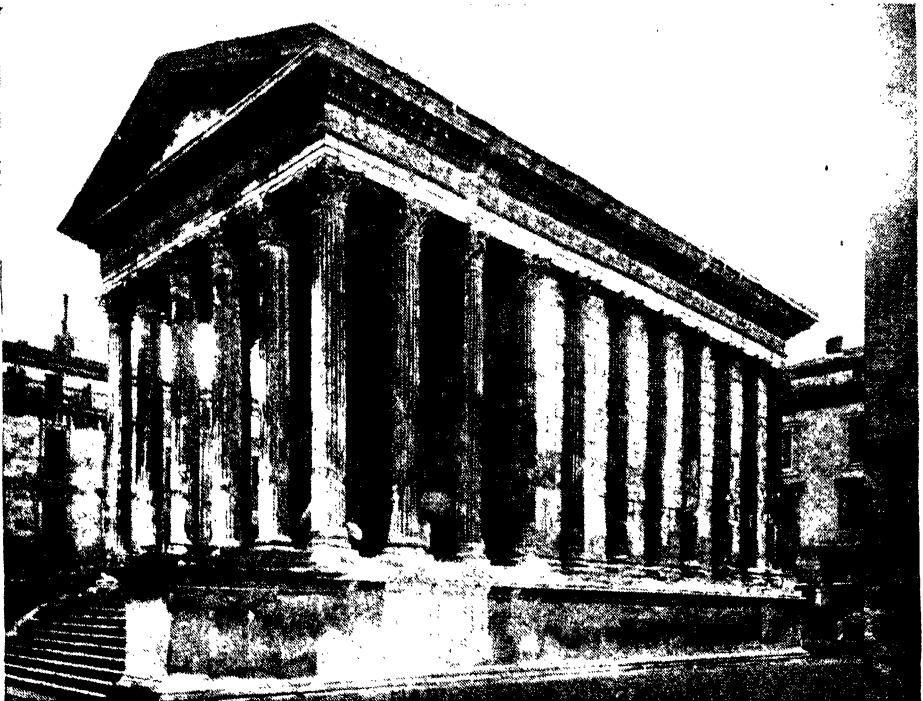

LA MAISON CARRÉE, NIMES

[The Photochrom Co.

[Nîmes, one of the loveliest, cleanest, and healthiest towns in France, possesses more extensive Roman remains than anywhere else in the country. Of these the Maison Carrée, once a temple, now a museum, is the gem. Its preservation is excellent, and it is often referred to as "the finest Greek temple outside Greece"



NÎMES: LA TOUR MAGNE

[Carthew & Kinnaird]

This grand old watch-tower, 92 feet high, crowns a high hill flanking the town. It is easily the oldest relic in the place, having been built in the early days of Roman occupation. It commands an almost unparalleled view of a wide area of Provence. Other notable ruins at Nîmes are Roman baths and a large amphitheatre in which bull-fights are still held—where once the gladiators fought.

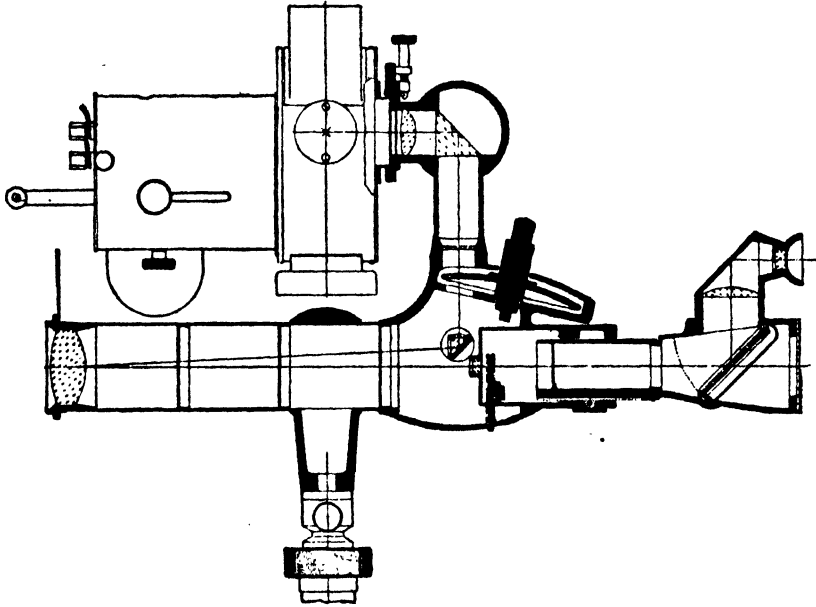
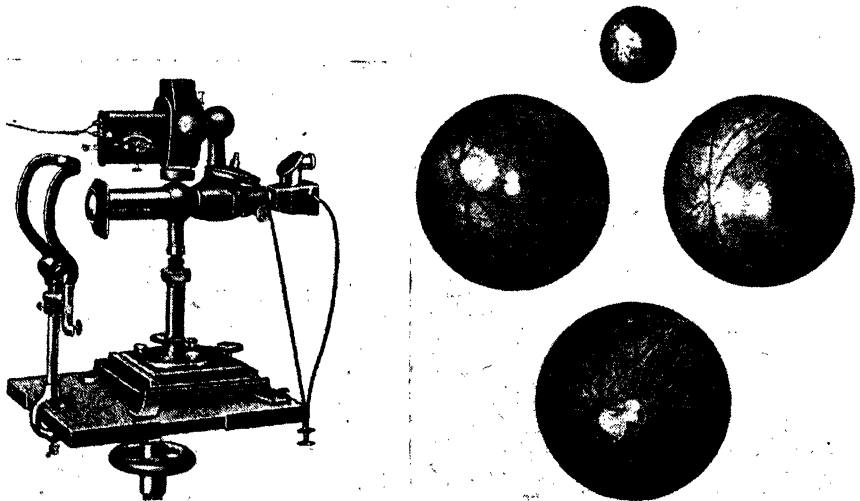

DIAGRAM OF A NORDENSON CAMERA

The first pioneers of retinal photography were Noyes in America (1862) and G. Bagnieres in Nancy, France (1889). But one problem was to make the photography "flare-free," and not until 1891 did one Gerhoff take the first relatively successful picture. Professor Nordenson evolved his camera at Uprala, Sweden, from an earlier type by Dimmer



THE NORDENSON RETINAL CAMERA

[Courtesy Carl Zeiss, London

This remarkable instrument is in reality no more than a camera attached to an ophthalmoscope, but its outstanding photographic achievement may be judged from the above pictures, taken by it, of the interior of the human eye. Hitherto no satisfactory permanent record of what the ophthalmoscope revealed had been obtained, but with the Nordenson camera it is possible to make an accurate study of pathological changes

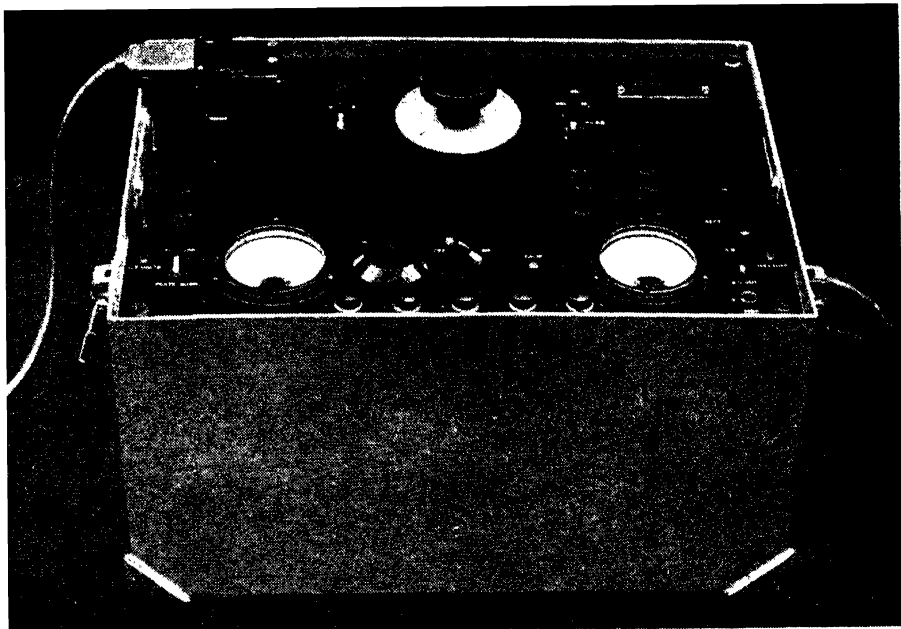

[Carlow & Kinnaird]

A NOISE METER

Noise-meters are instruments for measuring in units called decibels any sound from an aero-engine to a whisper; they are of immense value in planning for noise-abatement in cities. The noise meter consists of a microphone and an amplifier, a weighing filter which attenuates frequencies like the human ear and a further amplifier to make the faintest sound mechanically measurable.

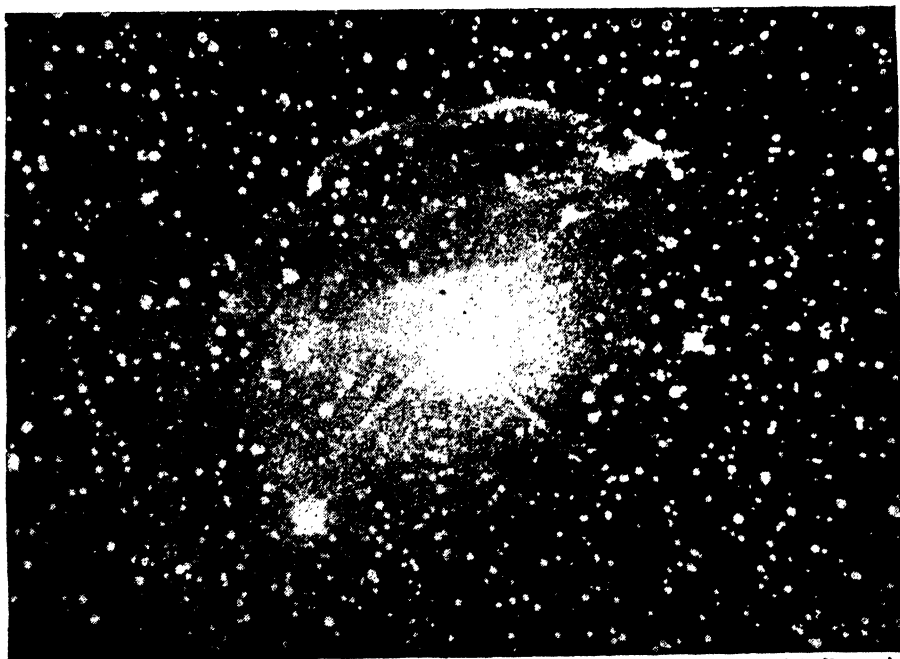

[From "Splendours of the Heavens"

NEBULOSITY SURROUNDING NOVA PERSEI, 1901

Nova Persei is the name of one of the most conspicuous "new" or temporary stars ever observed. To-day only faintly visible in the most powerful telescopes, the star was in 1901 easily discernible with the naked eye; this long-exposure photograph shows the nebula which surrounded it soon after the original outburst.

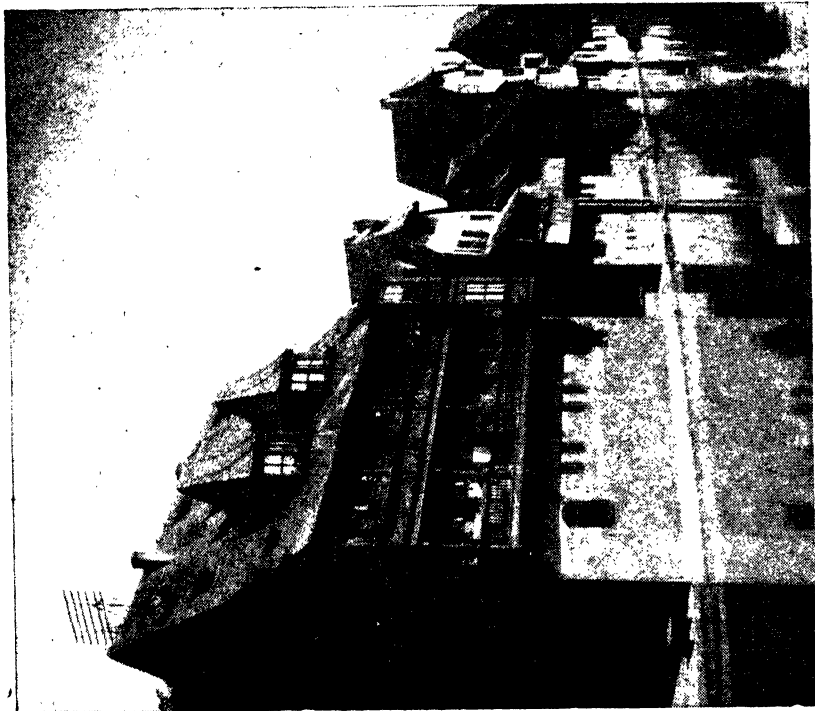

[Dorrien Leigh

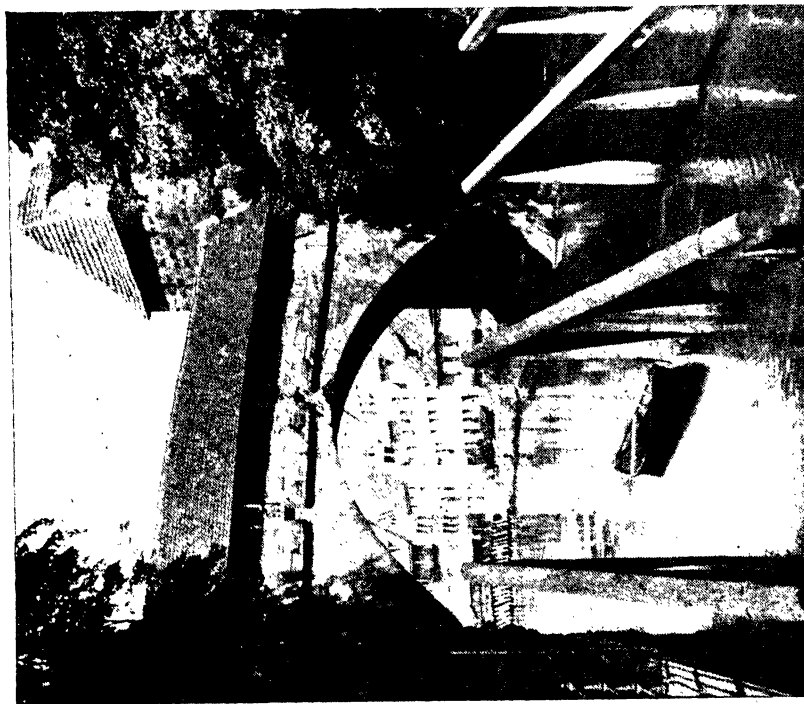

Rev. M. Mann, M.A.]

TWO VIEWS OF NUREMBERG

Nuremberg is one of the most perfect relics of mediævalism to be found in Europe. There seems hardly a house in it built later than the fifteenth century, and the *Nibelungenland*, Nuremberg was once the richest Free Town in the Holy Roman Empire, the story of Hamelin's Pied Piper, seem not legends but realities in these surroundings. Nuremberg was once the richest Free Town in the Holy Roman Empire, its eleventh-century castle a favourite resort of the Emperors. Above are two typical views on the small River Pegnitz.

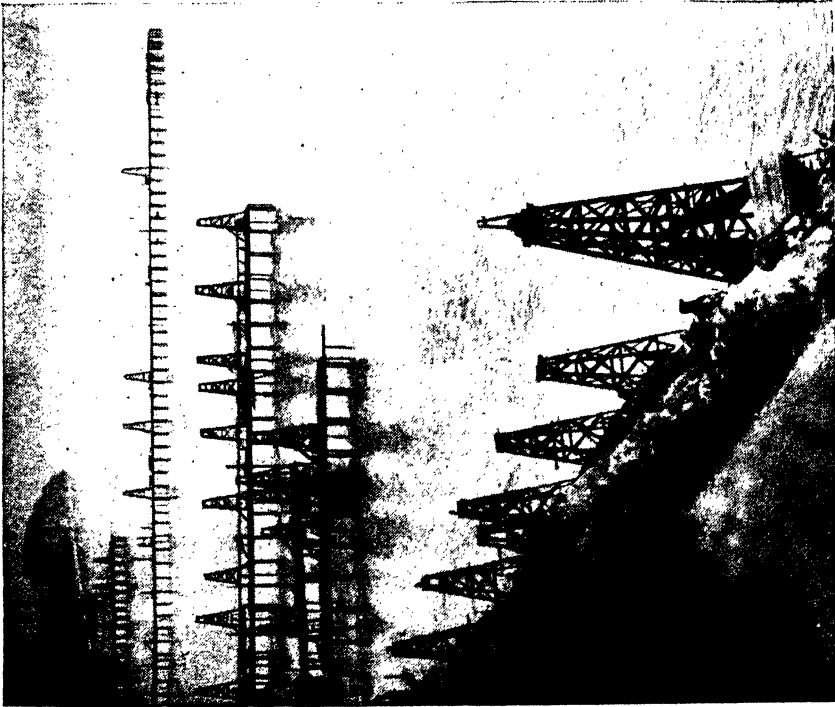

E. O. Hooppé

Oil is found in many areas of the world—Rumania, Persia, the U.S.A. and Venezuela being among the most important. The above photographs show (left) oil wells sunk beneath the sea off Santa Barbara, Cal. and (right) one of the chief dangers in the industry—an oil-well fire

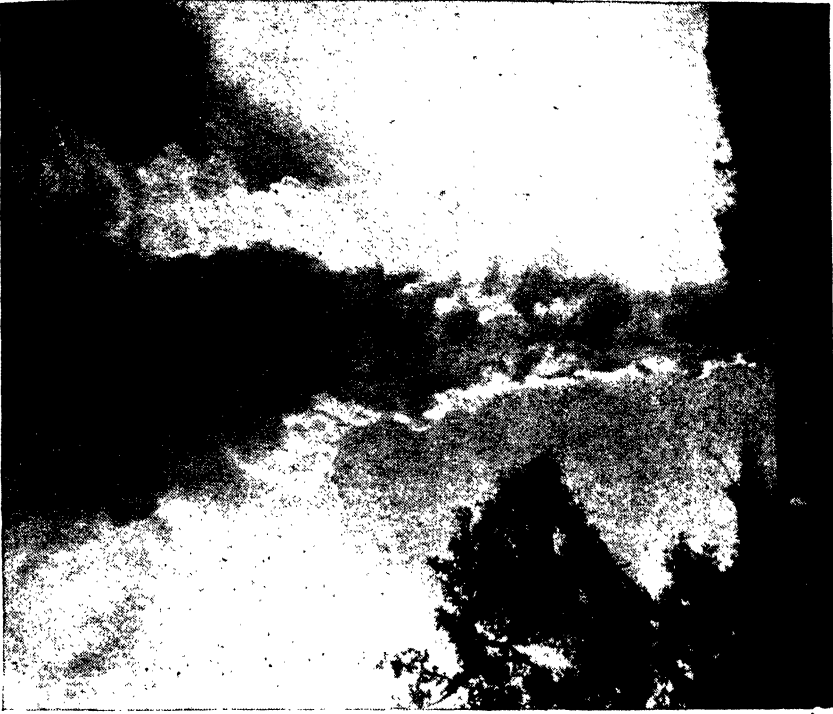

OIL-FIELDS

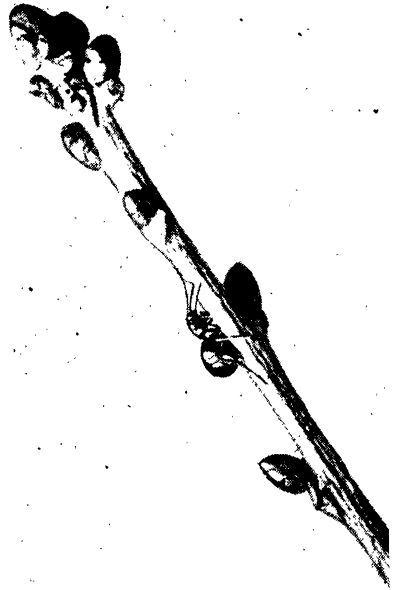

[H. Bastin

Oak-apples are always formed at the end of shoots. The right-hand photograph shows the wingless female crawling up to deposit her eggs in the bud, which will then grow into the "apple" seen on the left. A remarkable thing is that the wasps produced in the galls are winged, and lay their own eggs down among the roots. The wasps born here are again wingless, and crawl up to form oak-apples.

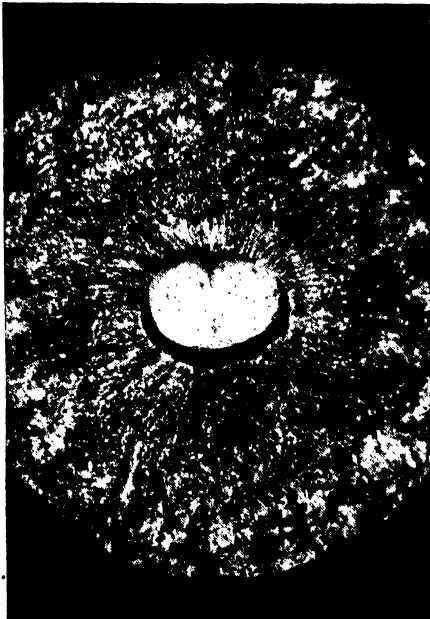

[H. Bastin

OAK-APPLES AND THE GALL-WASP

On the left an oak gall or oak-apple is cut open to show the wasp-grub in the interior. On the right the young mature wasp has bored its way out of the gall by the hole seen just beneath it. The galls are formed as sustenance for the grub, which feeds on the pulpy interior.

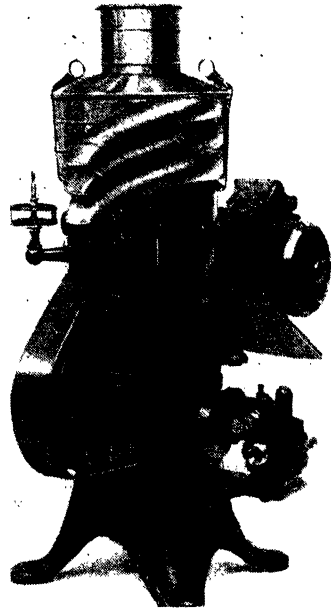
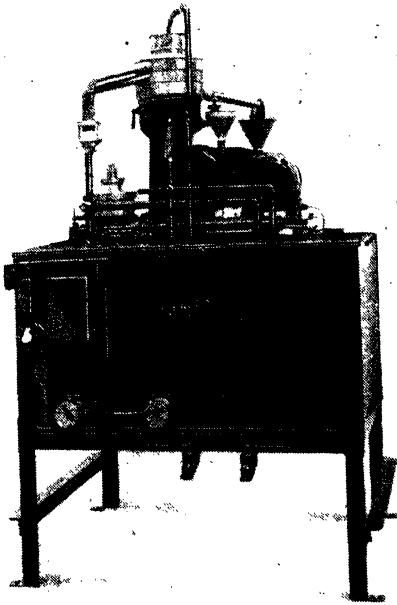

OIL SEPARATION

[Carthew & Kinnaird

There are two types of oil separator: that which separates one oil from another, or purifies it; and that which recovers lost oil from waste. Two models of the latter type are here illustrated. Their particular use is to recover oil from bilge and ballast water on ships, and they are so built as to be impervious to sea motion.

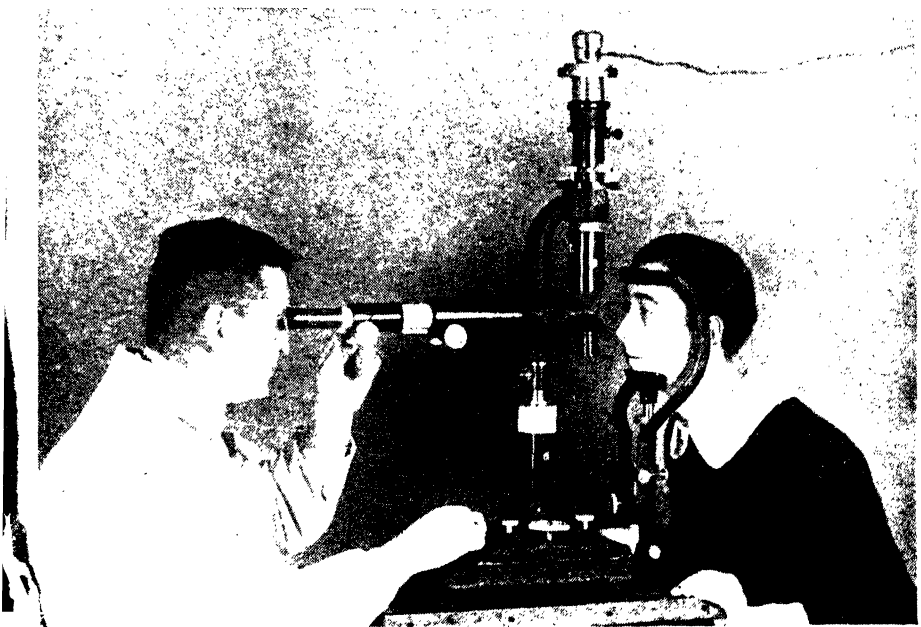

AN OPHTHALMOSCOPE

[Courtesy Carl Zeiss, London

This is an instrument for examining the surface of the retina in the human eye, and for examining the refractive properties of defective eyes. The principle involves ordinary microscopic magnification plus the addition of a concave (and therefore magnifying) mirror with a hole in its centre. Ophthalmoscopes are also used by neurologists and physiologists.



THE ROMAN THEATRE, ORANGE



Mt. Wilson Observatory
ORION: THE DARK PATCH

This delicate strand of nebulous tissue near Orion's belt is invisible save to the camera. Scientists have yet to solve the nature of the mysterious dark patch in the centre

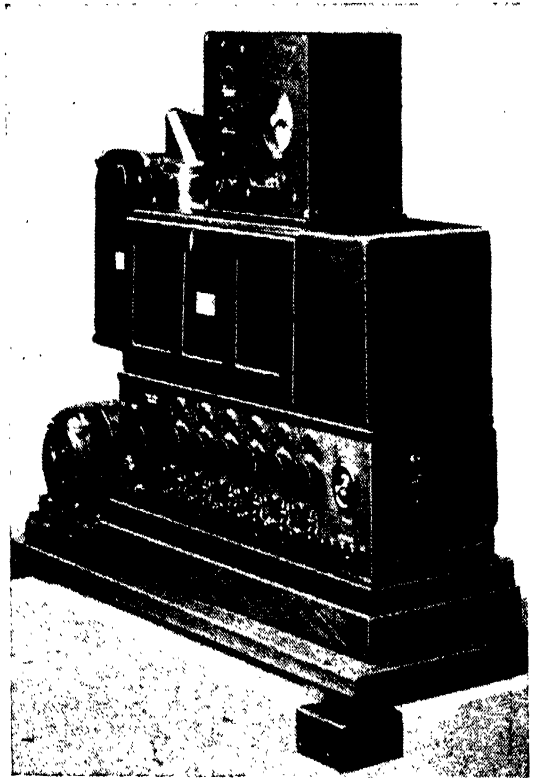

[Courtesy Cambridge Instrument Co]
AN OSCILLOGRAPH

The oscillograph's purpose is to record the wave-forms of an electric current. The instrument shown here is doubly interesting in that it incorporates a cinematograph camera, with three speeds and provision for two widths of film (see also Cathode Ray Oscillograph)



ORCAGNA'S "THE GLORY OF PARADISE"

[*Dorien Leigh*]

"Orcagna" ("the archangel") was the nickname of one Andrea di Cione, a Florentine painter, sculptor, and architect of the early Renaissance (1308-68). The above and similar frescoes in the Church of St. Maria Novella, Florence, are considered his best work, though other famous examples are to be found at Pisa and in the National Gallery, London

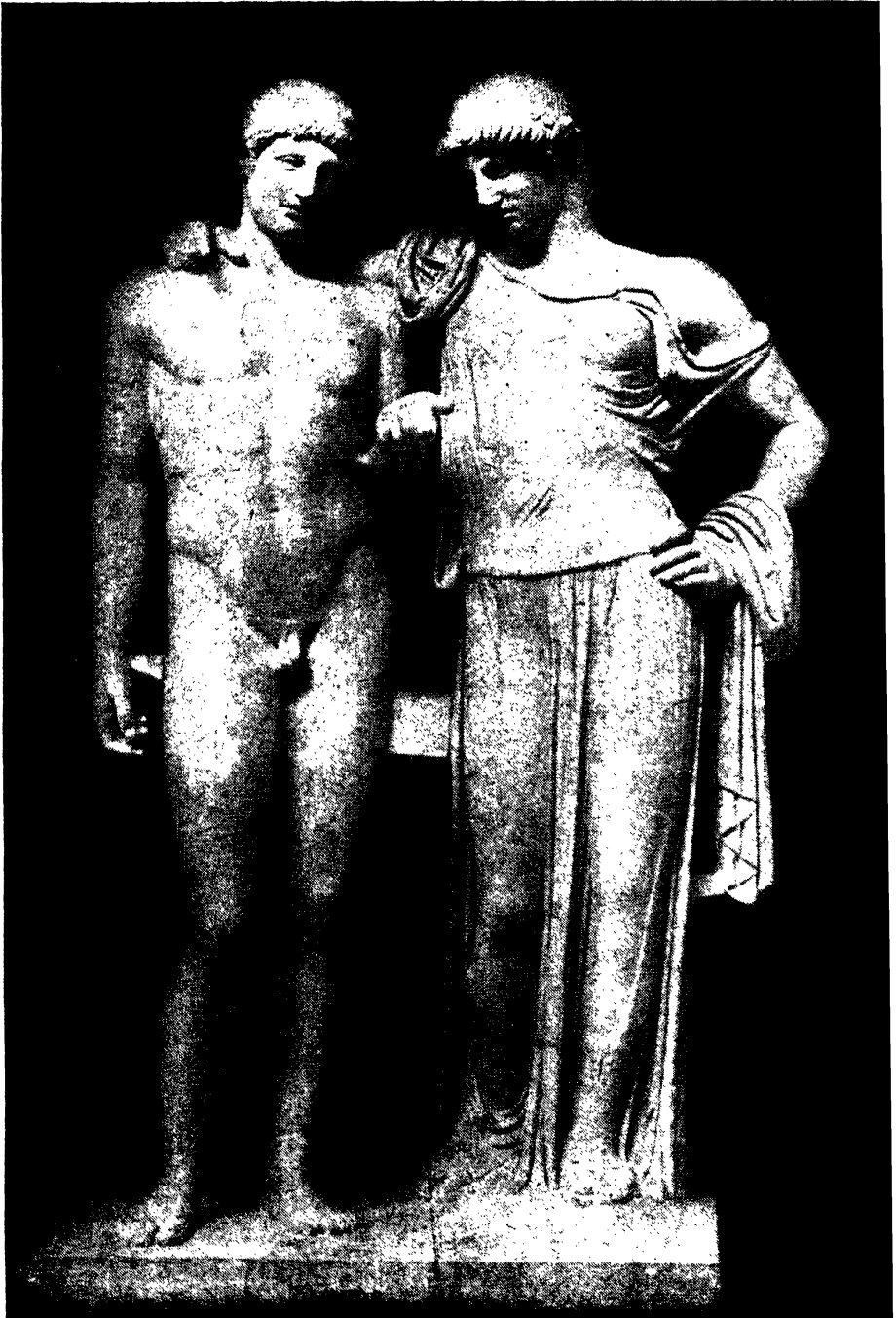

ORRESTES AND ELECTRA

(Dorsen Leish)

Orestes was the son of Agamemnon and Clytemnestra, Clytemnestra a lover murdered Agamemnon. Electra, Orestes' sister, then took her brother to their uncle, where he became friendly with a male cousin. The two young men eventually killed Clytemnestra and her paramour, but the deed drove Orestes mad. The tragic brother and sister have never been so finely depicted as in the above group, now at Naples, by an unknown sculptor.



[Dorien Leigh

THE FORTUNA OF OSTIA

Ostia was in olden days the port of Rome; it declined on the fall of the Empire, and though rebuilt during the middle ages it again lapsed into nonentity and is now conspicuous only for its mediæval and Roman ruins. Among the last-named nothing has been found to equal this splendid and Amazonian depiction of the Goddess of Chance, carrying her horn of Plenty. Fortuna was extensively worshipped in the ancient world.

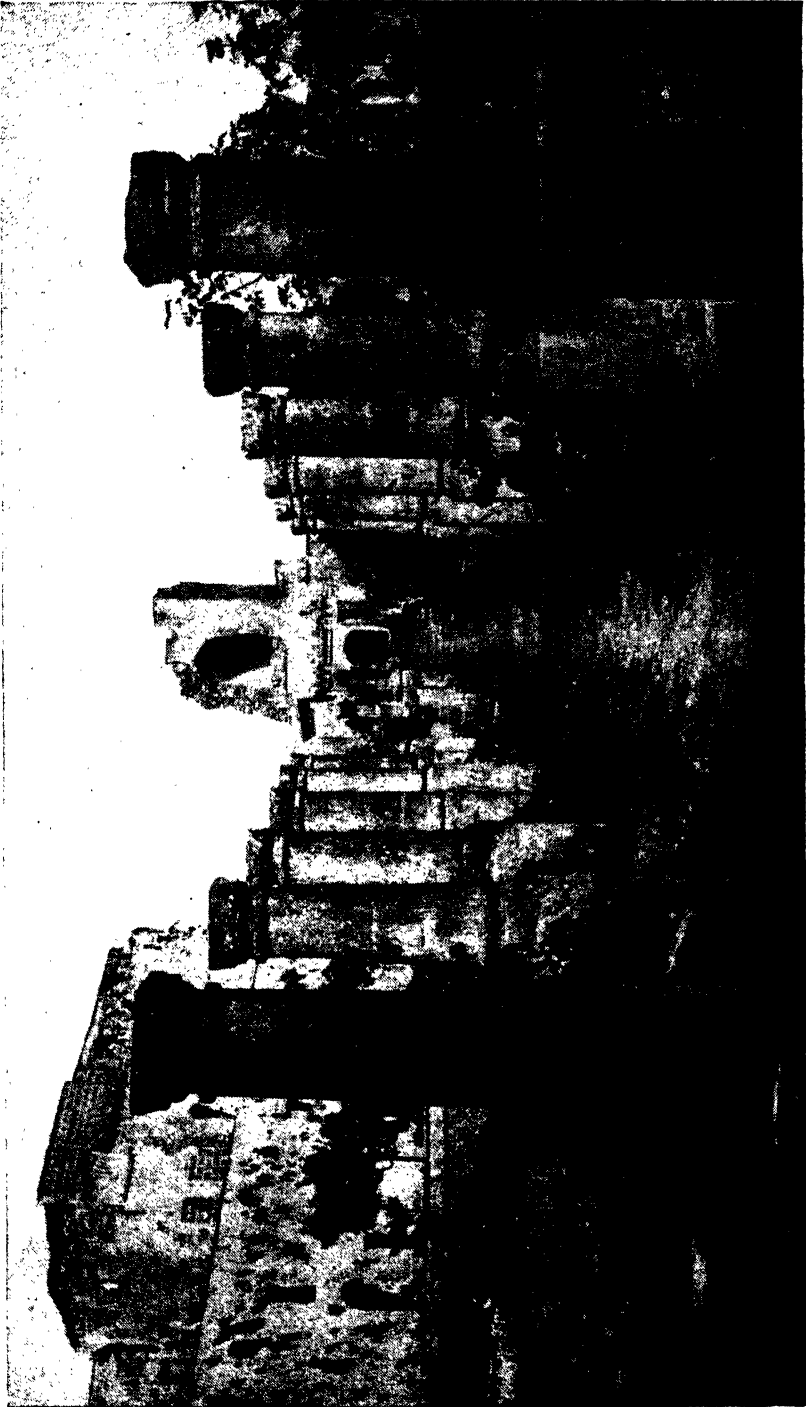

[Courtesy "Wonders of the World"]

ORTA : THE RUINED CASTLE

The old town of Orta, known in ancient times as Uria, is situated to the west of Brindisi, in the very centre of the heel of Italy. There are several palaces in the town, but its most interesting feature is the old ruined castle. This view shows the remains of its magnificent colonnade and one of the towers

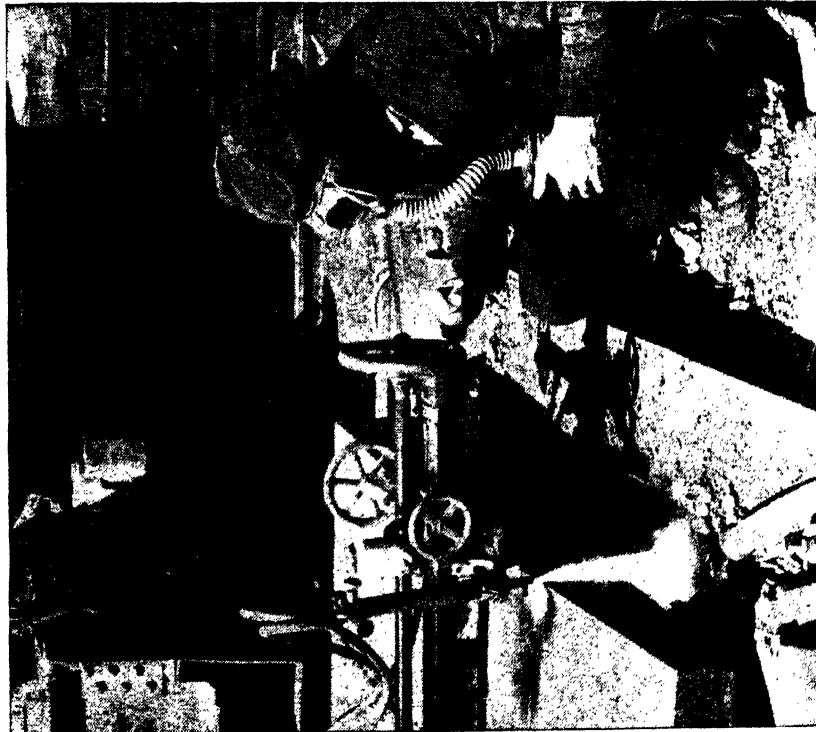

Carshaw & Kinneaird,

OXY-ACETYLENE CUTTING

The apparatus consists simply of a torch burning a mixture of air under pressure and acetylene; the temperature produced, however, is as high as 3,400° centigrade, which enables the flame to cut like a knife through the hardest metals. Note the screw-rack for guiding the torch straight, and the operator's mask

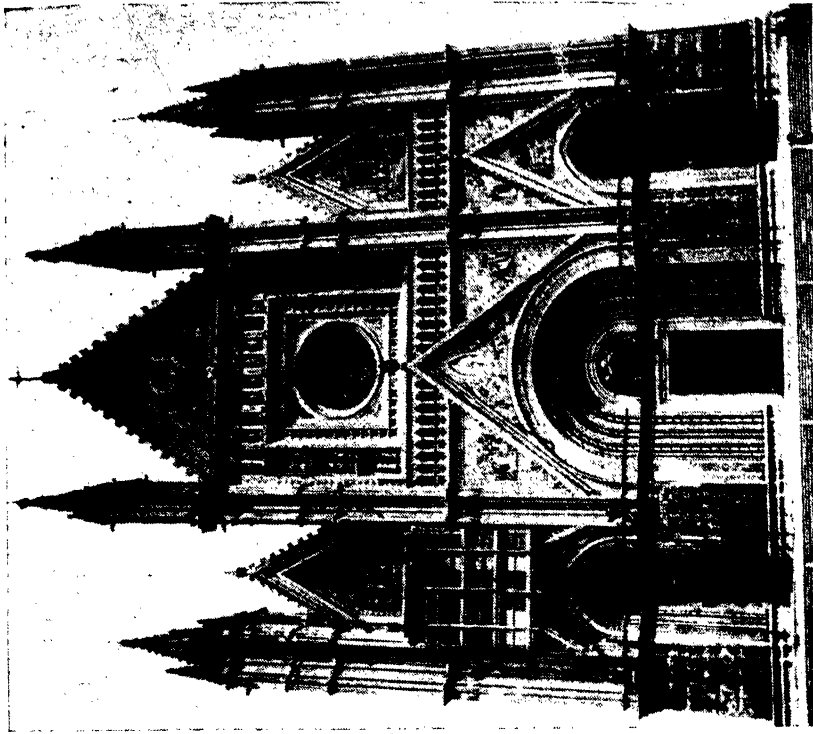

ORVIEO CATHEDRAL

Orvieto is a walled city in Perugia, 60 miles north of Rome. Though not so rich in architecture as many Italian towns, its Gothic Cathedral is hardly surpassed throughout the country. Built of black and white marbles in the thirteenth century, its western façade was later adorned with exquisite paintings

(E.N.T.)

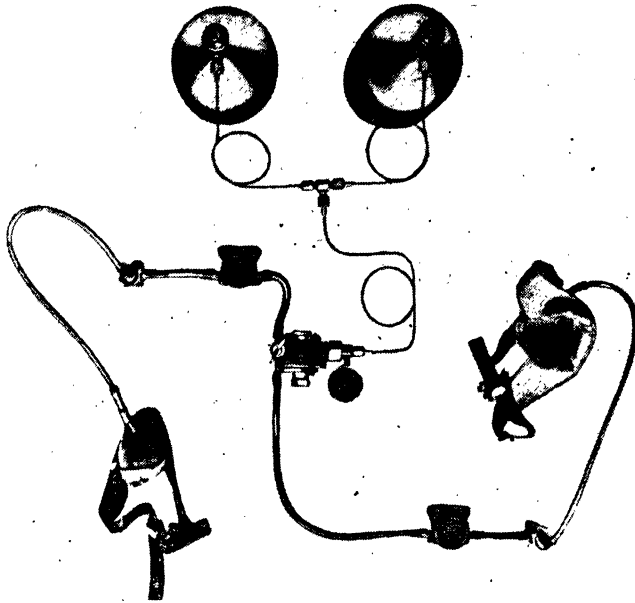

OXYGEN APPARATUS

[Smith's Aircraft Instrumen



THE OTOPHONE

[Carthaw & Kinnaird

This, like the instrument illustrated under "Deafness," depends for its function on the possibility of transmitting sound to the brain by means of vibrations imparted to the bones of the skull. This particular device, however, is so constructed that the earpiece can be held to any part of the head or face with undiminished efficiency

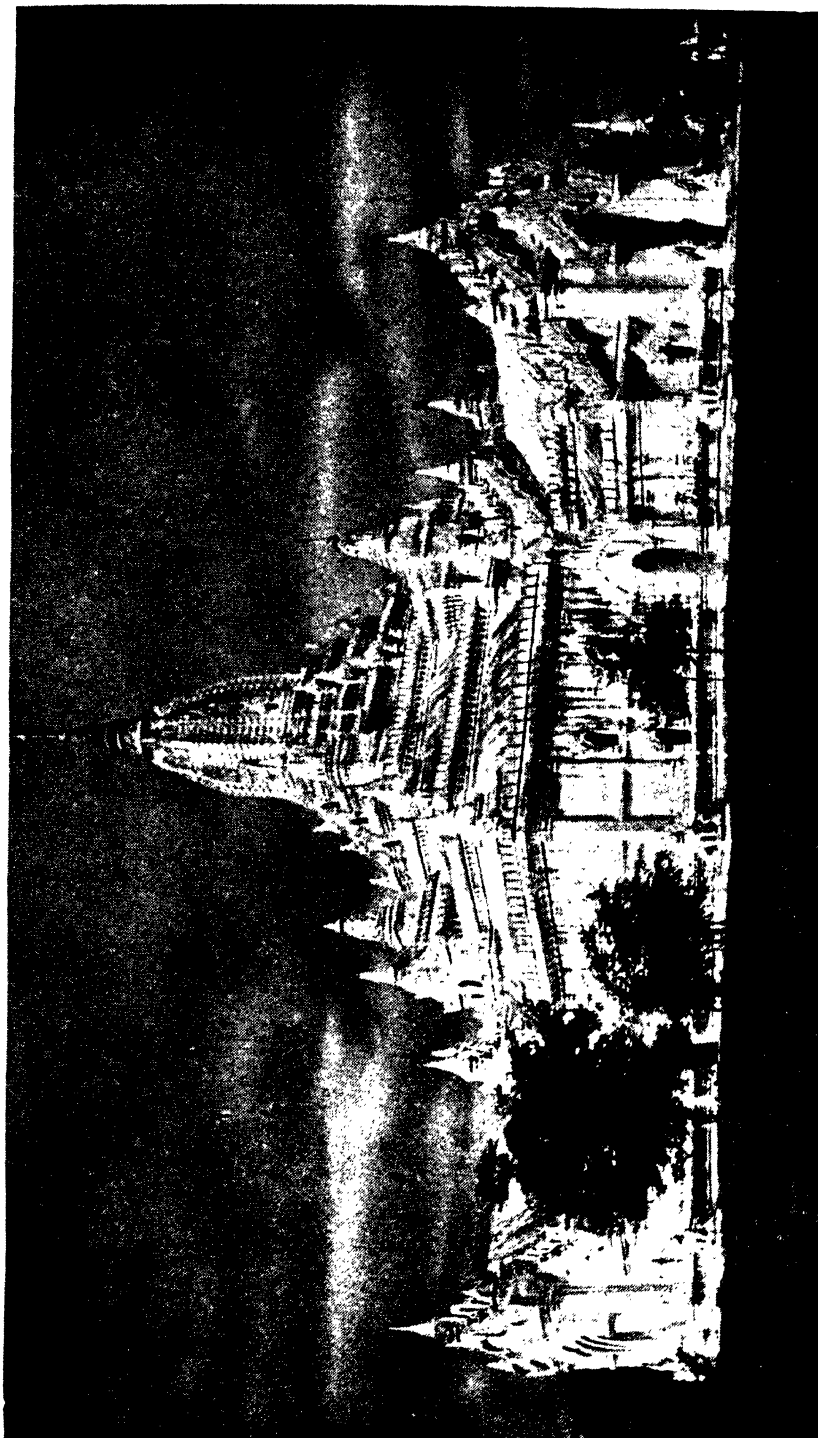

The late H. G. Posting, F.R.G.S

THE ANANDA PAGODA, PAGAN

Pagan is one of the most extraordinary ruined cities even in that continent of ruins, Asia, for its buildings, in various stages of repair, number no less than a thousand. Strictly speaking the Ananda building is not a pagoda, but rather a temple. It is very ornate, and by far the most conspicuous object in Burma's former capital.



PAESTUM: THE TEMPLE OF NEPTUNE (Courtesy "Wonders of the World")

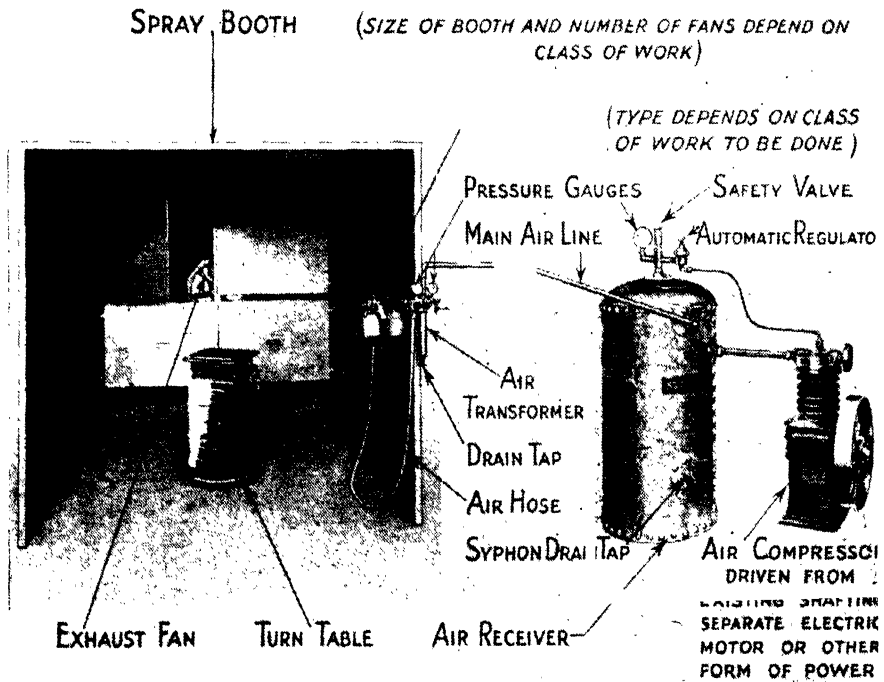

PAINT-SPRAYING

(Courtesy Aerograph Li)

Paint-spraying, time saving, bu



From "Picturesque Europe"
A ROSE WINDOW IN PALERMO

This fine rose window is in the Church of St. Francis of Assisi, one of the most celebrated of the old churches of Palermo



[From "Picturesque Europe"
PALERMO: S. GIOVANNI DEGLI EBREI

This mosque-like "church of the five domes" was founded in 1132 on the site of a church built by Gregory the Great. Note the Saracen style of architecture



THE CATHEDRAL, PALERMO

[Courtesy "Picturesque Europe"

The Cathedral of Palermo was built by an Englishman, Archbishop Walter, in the twelfth century; it contains the tombs of many bishops, and the massive silver sarcophagus of St. Rosalia. The west front is a fine example of Sicilian pointed architecture, and the south porch is very richly ornamented



THE CLOISTERS OF S. GIOVANNI DEGLI EREMITI

[E.N.I.T.]

The cloisters again show marked oriental influence, and are reckoned as one of the "high spots" in this city of glorious buildings. Palermo reached its greatest glory in the thirteenth century, when it was the capital city of the Emperor Frederick II. Intermingling with the mediæval architecture is the most luxuriant and exquisite foliage

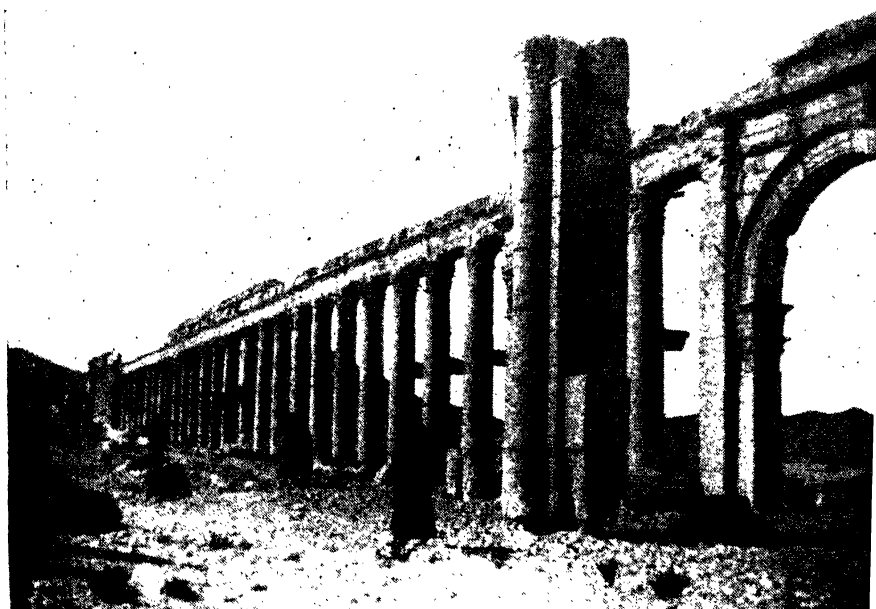

THE GRAND COLONNADE, PALMYRA

[American Colony, Jerusalem]

The Roman capture of Palmyra (A. D. 273) was the result of an attempt by its notorious Queen, Zenobia, to just her epithet of "Queen of the East" by including all-Syria, Asia Minor, and Egypt in her sway. The Grand Colonnade ran down the main street of the proud capital and was thronged all the year with merchant caravans

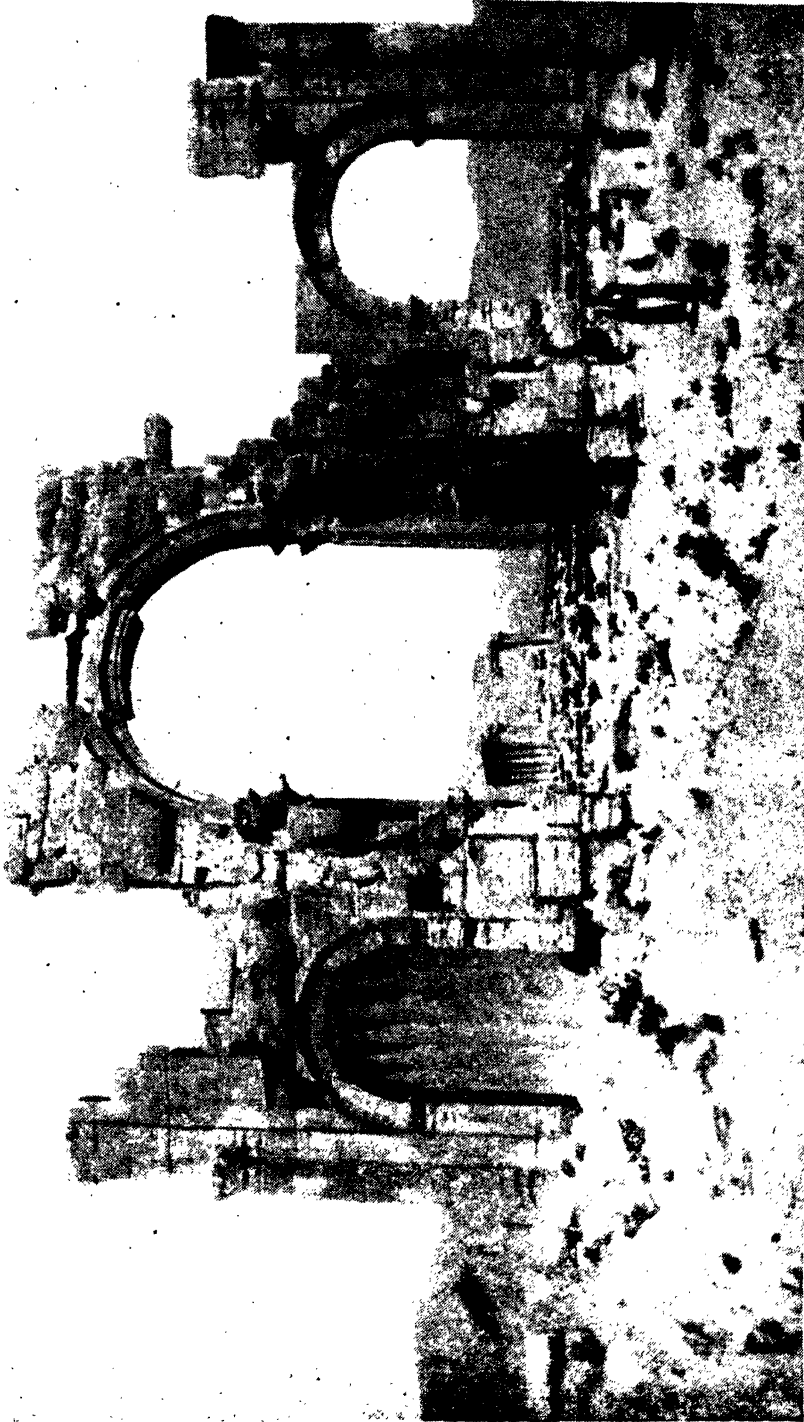

—American Colony, Jerusalem

THE TRIUMPHAL ARCH, PALMYRA

Palmyra, sometimes identified with Solomon's "Tadmor in the Wilderness," remains the largest group of ruins in Syria. Originally the city walls were 12 miles in circumference. The Triumphal Arch whose remains are shown here dates from Roman times, when, under Hadrian, the city's fame reached its highest

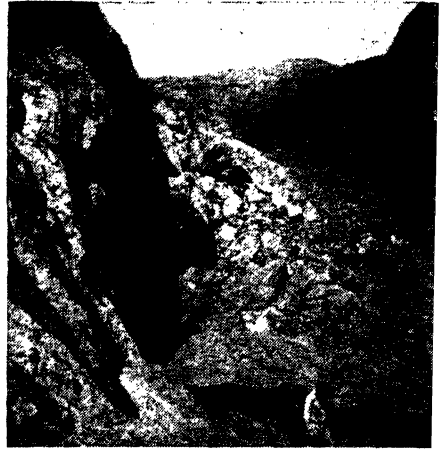

Courtesy

A GIGANTIC ENTERPRISE

The Culbra Cut represented one of the most intensive dredging and rock-blasting schemes of the Panama Canal construction. The difficulties encountered can be appreciated from this photograph

CULBRA CUT, PANAMA *["Wonders of the World"]*

Another picture showing the almost insuperable difficulties encountered in the construction of famous cut in the Panama Canal. The rock is blasted out at Contractor's Mill

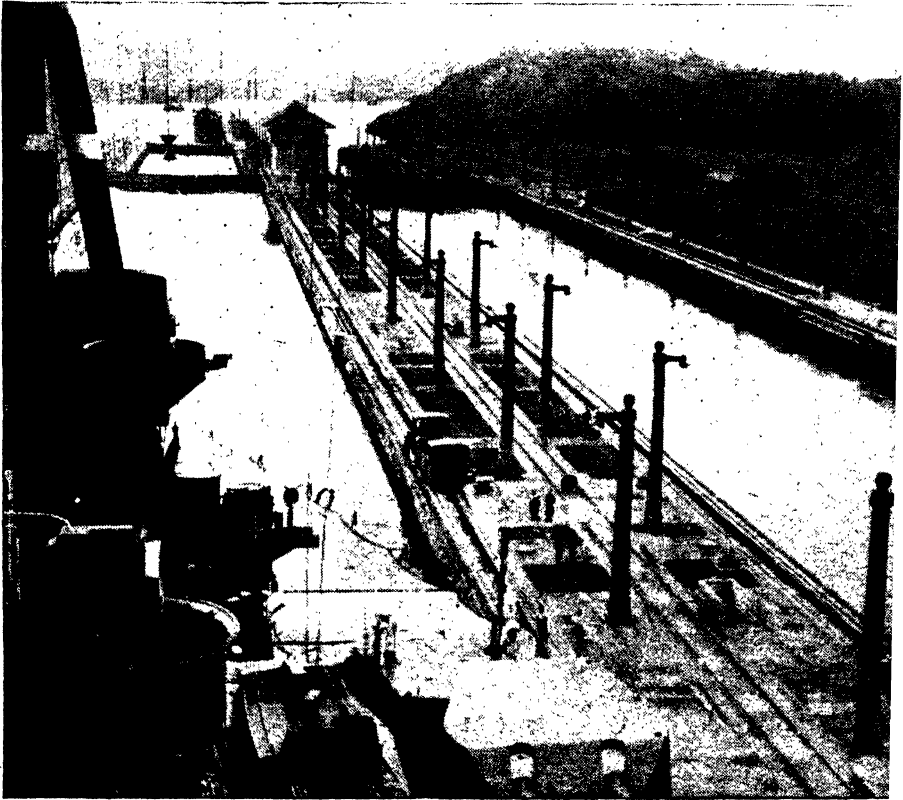

THE PANAMA CANAL

The Panama Canal represents the biggest triumph of maritime engineering that has ever taken place. Be de Lessep's original planning of the scheme in 1879 and the formal completion in 1920, approximately £130,000,000 were spent. The above photograph shows a warship passing through one of the locks

[K6]

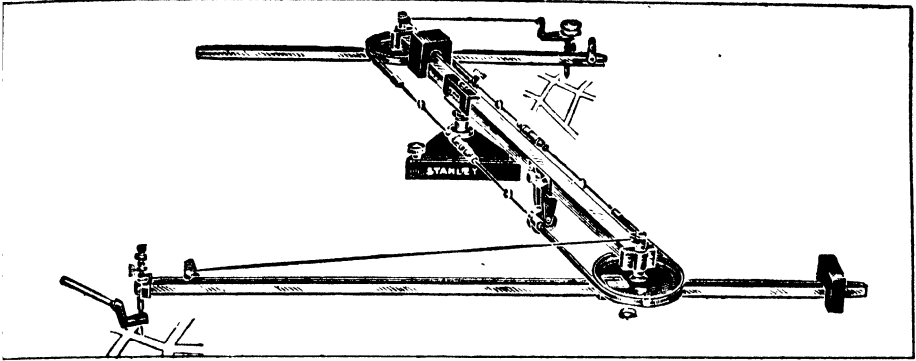

[Cathes & Knauer]

THE PANTOGRAPH AND EIDOGRAPH

Both these instruments fulfil the same function—the accurate copying of drawings on a larger or smaller scale; they are therefore of use mainly to architects and surveyors. The principle, though difficult to explain in a few words, should become fairly apparent by a study of the above sketch of an eidograph.

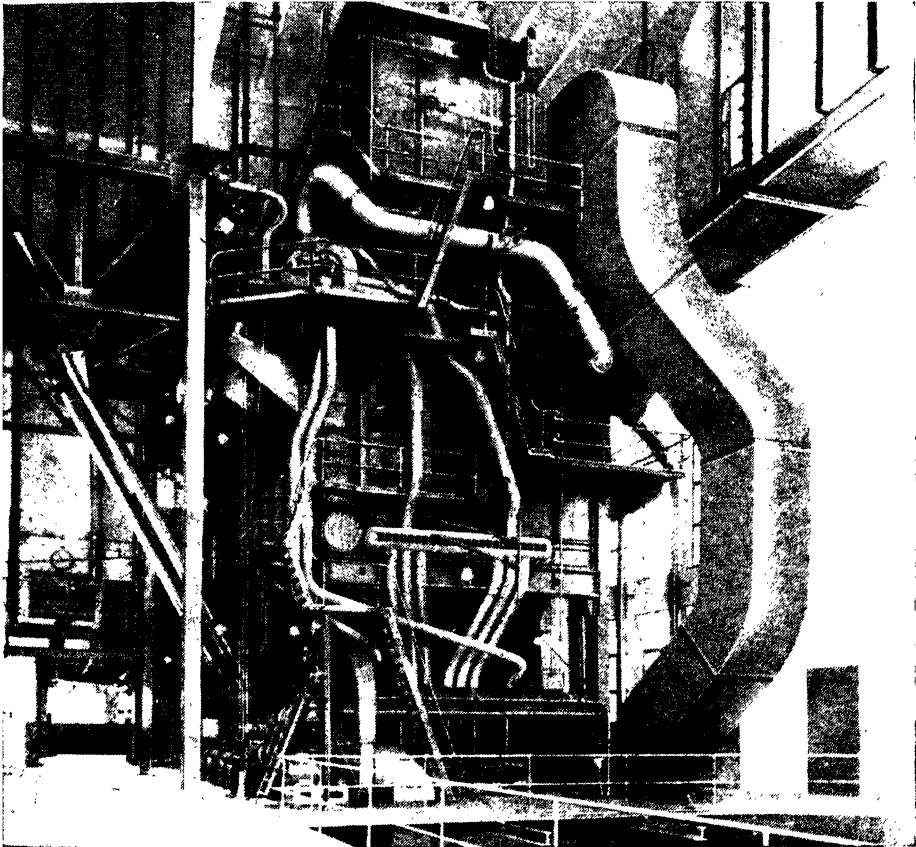

[Babcock, Wilcox Ltd.]

PAPER-MAKING

A Frenchman, Nicolas Robert, was the inventor of the first machine to make paper in bulk, at the end of the eighteenth century. Most papers nowadays are made of a combination of rag, esparto grass, and wood-fibre. Above are seen the furnaces and boilers used for steam-heating the cylinders which dry the pulp.

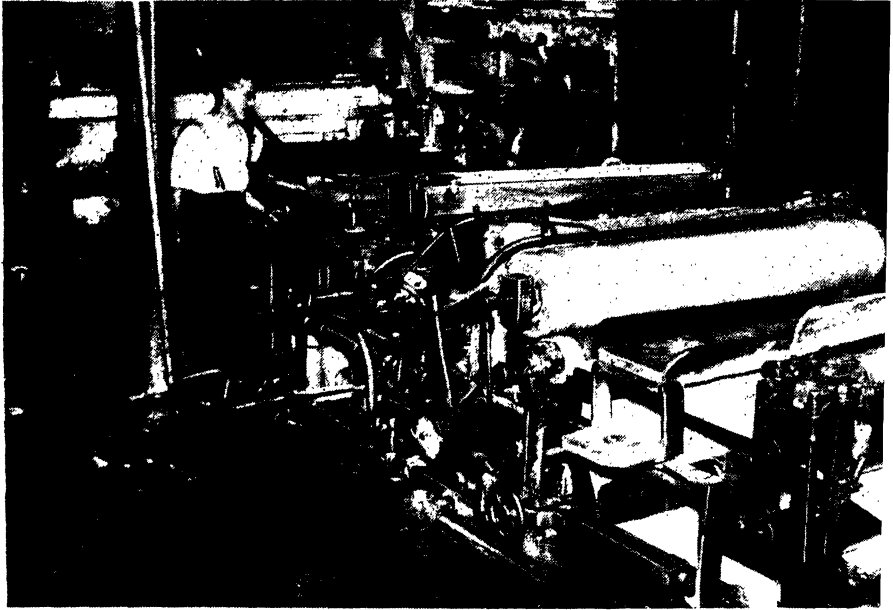

ANOTHER STAGE IN PAPER-MAKING

[Carlow & Kinn

After being mixed and beaten, turned on to an enormous wire mould which is "joggled" from side to side to cut interlocking of the fibres, and then steam-dried, the paper finally passes to the glazing rolls and is chopped into sheets. Hand made paper is, however, by no means obsolete

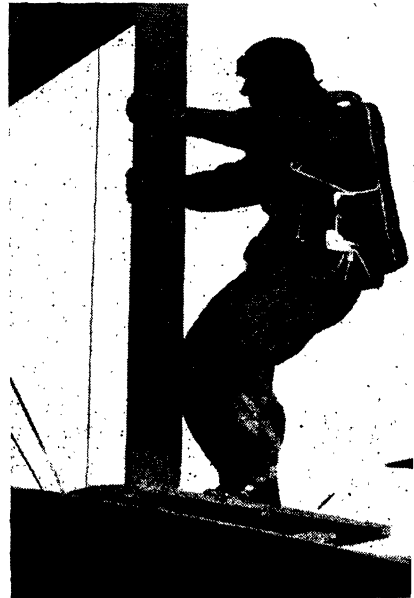
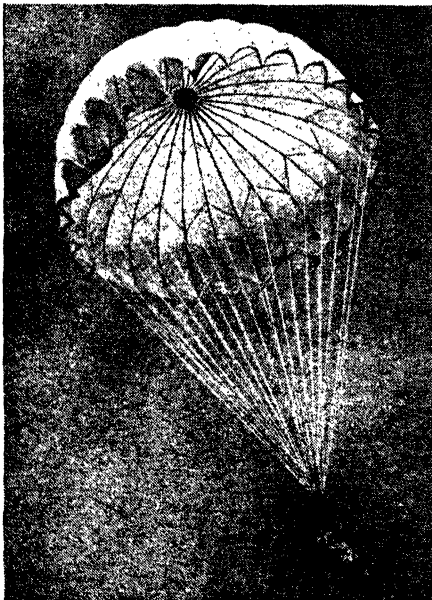

PARACHUTES

[Kev

The parachute's origin is attributed to Leonardo da Vinci, but not until the late eighteenth century did one / Garnerin make the first successful parachute descent from a balloon. The modern parachute owes its success to a boy, who suggested the hole in the top to prevent oscillation. The parachutist illustrated above, about to jump training for an R.A.F. display



BIRDS OF PARADISE

[Courtesy "Marvels of the Universe"]

The plumes which grow from the back of the Paradise Bird's head are the most extraordinary to be found in the whole bird world. Divided into enamelled lobes of pale glistening blue, they are twice as long as the bird's body. Birds of Paradise live in New Guinea and Northern Australia. There are several varieties.



THE PARADOX FROG

[Courtesy "Marvels of the Universe"]

The tadpole of this South American frog attains in real life to about four times the size of its portrait here, yet the mature frog seldom measures more than two and a half inches. Cases of "growing backwards" are not uncommon in nature, especially among eels, but few examples are quite so exaggerated as here.



[Courtesy "Marvels of the Universe"]

THE PARIASAUR

The alligator and crocodile of to-day seem already to be envisaged in this bygone reptile. Pariasaur's chief merit however, is that he is believed to be an intermediate link between mammals and the toad class of reptile. Though only 9 feet long, he is one of the earliest known creatures.

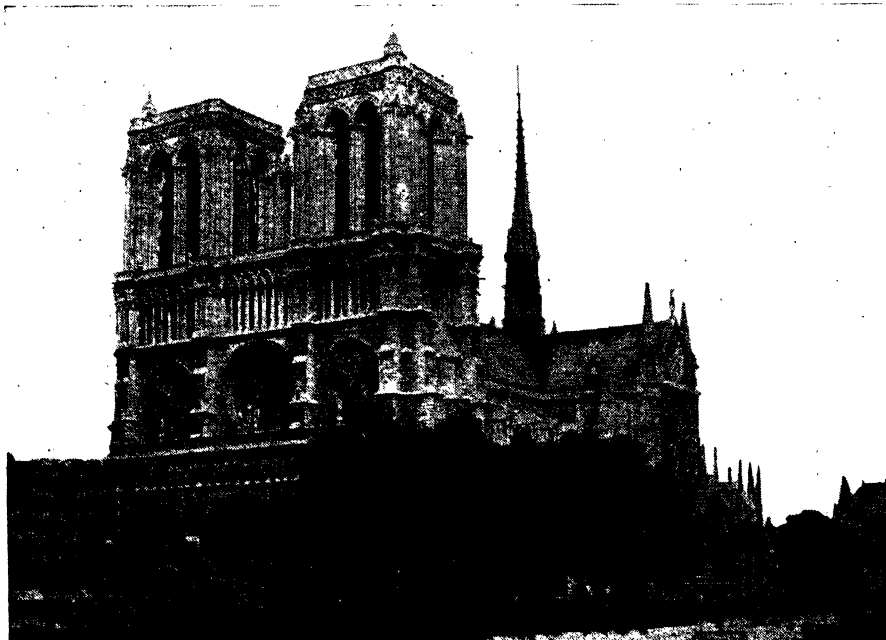

[The Photokrom]

PARIS: NOTRE DAME

The Cathedral, famous for its flying buttresses and its gargoyles, stands on the old Ile de la Cité, which was the nucleus of ancient Paris. The present building was begun in 1163, and is a fine example of the first two Gothic periods. Note the resemblance to the Cathedral at Bourges.

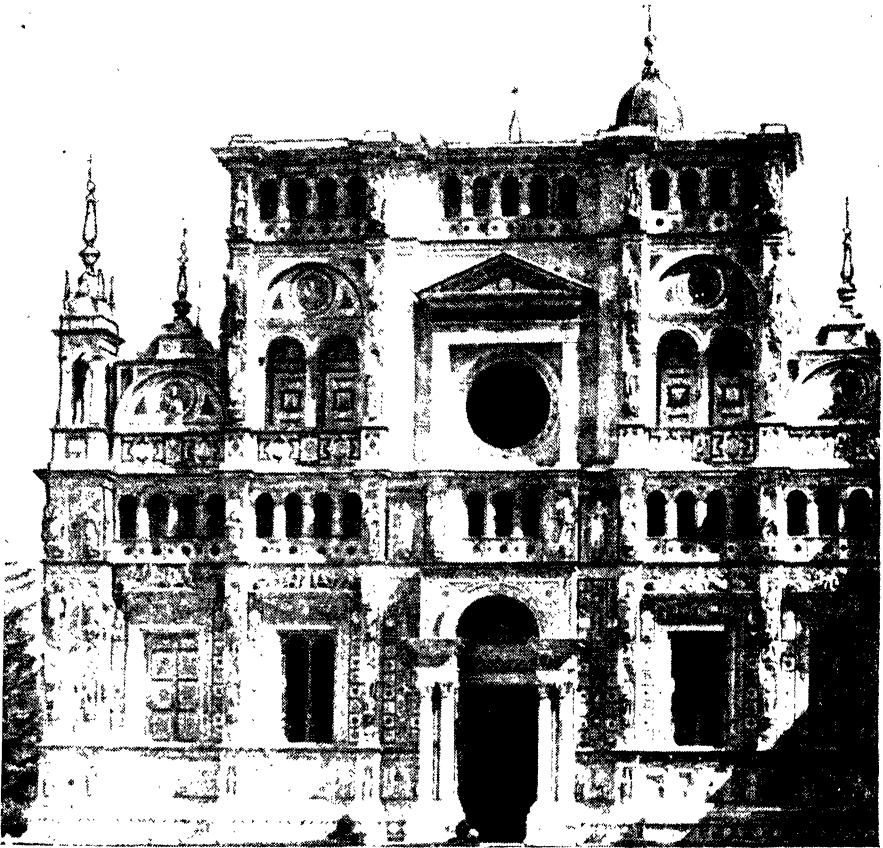

THE CHARTERHOUSE OF PAVIA

[Dorian

Pavia, on the River Ticino in Lombardy, is one of those ancient towns still surrounded by mediæval walls, its still crossed by a covered-in bridge. The Cortosa or Charterhouse is five miles north of the town. It was founded in 1396, it is curiously Spanish in style; within are cloisters no less lovely than the beautiful façade

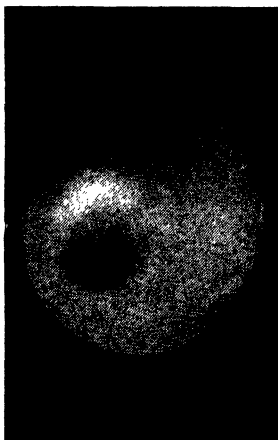
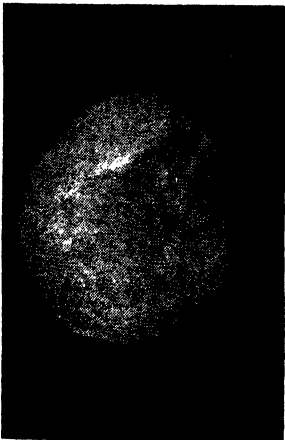

THE PEA WEEVIL

(Hugh Main, F.E.S., and Harold Ba

The first two photographs show the resemblance between a pea which is merely dimpled by the pressure of its fellows, and one in which the weevil grub already lurks, but betrays its presence by nothing except a faint discoloration. The third photograph is a cross section of a pea from which the mature beetle is about to cut its way out



PEARLS

(Key:)

Pearls are due to the attempt of an oyster to rid itself of a minute worm, and occasionally of other irritants; secretion of nacre (mother of pearl). Pearl-fishing is popularly associated with the South Pacific, but the best fisheries in the world are in the Persian Gulf. The above pictures show *(left)* pearl blisters forming; *(right)* famous "Southern Cross," one of the most extraordinary natural formations hitherto discovered since the beginning of the industry.



THE GREAT BUDDHA OF PEGU

[Underwood Press Service]

The accidental discovery of this huge figure in a Burmese forest is one of the great modern romances of the East. The Buddha is 180 feet long and 147 feet high. The photograph shows it soon after its finding at the beginning of the 20th century.

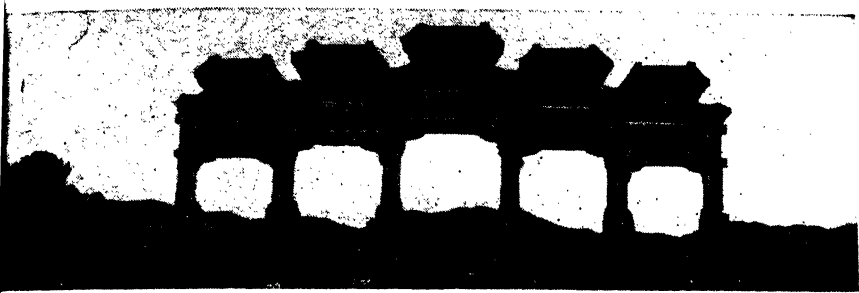

ENTRANCE TO THE MING TOMBS, PEKIN *[From "Wonders of the World"]*

The Ming Emperors' tombs at Pekin (Peiping) and Nankin are characterised in the main by gigantic statues of men and animals, but at Pekin the most beautiful object is the graceful five-arched entrance gate. It is of white marble, roofed with dark red tiles

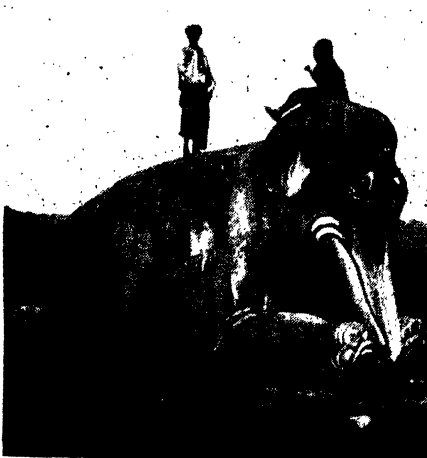

PEKIN: THE MING TOMBS

[Courtesy "Wonders of the World"]

There are Ming cemeteries at both Pekin and Nankin, and in either case a long avenue of stone figures and animals forms the approach. At Pekin these beasts number 32, of which a representative quartet is here seen



PENGUINS

[From "Wonders of the Wo

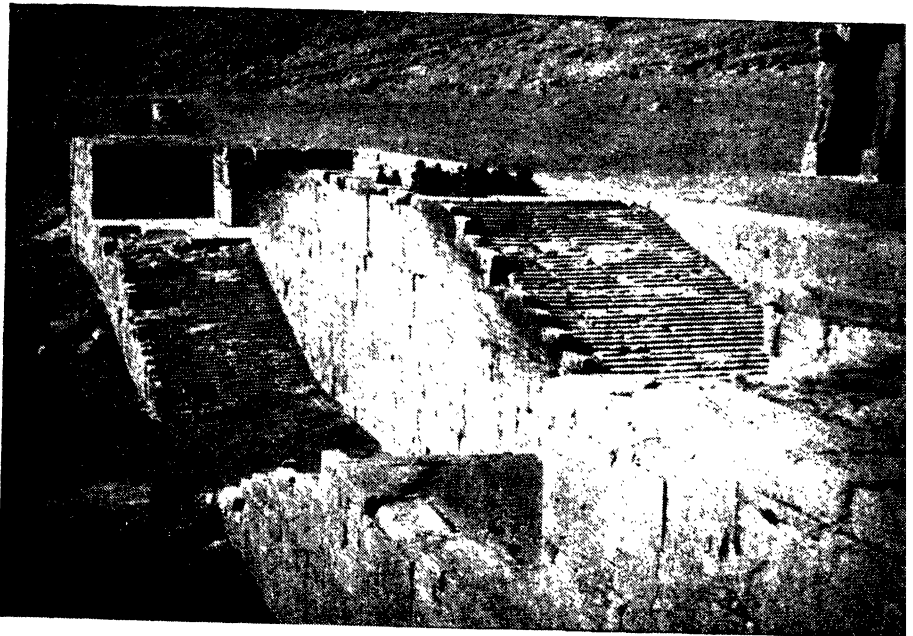

[Courtesy "Wonders of the

THE GREAT STAIRCASE AT PERSEPOLIS

Persepolis, ancient capital of the Persian Empire, though by no means of the practical importance of Babylon or Susa, was the burial place of the kings, and, as Alexander found on conquering it in 331 B.C., was immensely wealthy. Though burnt by Alexander, it continued to play a prominent part until the Middle Ages. The great staircase once led to the palace of Xerxes and Darius.



(Courtesy: Wonders of the World ...)

PERU: AN INCA FORTRESS

The Inca civilization of what is now called Peru was much more advanced than that of the Aztecs of Mexico, and is advantageously comparable, even in regard on, with most contemporary civilizations in the Old World. The illustration shows a corner of one of the largest Inca forts—that of Pisac



PETERBOROUGH CATHEDRAL

[A. H. Robinson

The west front of this cathedral is generally held to be the noblest example of Early English exterior work in Britain. In the niches above the huge arches there are in all thirty figures—an odd mixture, ranging from the Apostles to early English Kings! The building was founded in the twelfth century on the site of a seventh century monastery. It became a Cathedral in 1541.



From "Picturesque Europe"

PETRA: THE TREASURY OF PHARAOH

Petra, Arabia, once capital of the Idumaeans, stands in a gorge between the Dead and Red Seas. It is remarkable for its temples and palaces hewn from the solid rock. This Temple of El Khasneh, believed by the Arabs to hold Pharaoh's treasure, was built by Hadrian in A.D. 131.



[The Photochrom (

PETRIFYING WATERS

Petrification, which has the effect of turning to stone almost any animal or vegetable matter, is caused by the chance solution in streams and springs of silica, lime and iron pyrites. The Dropping Well at Knaresborough, Yorkshire, here illustrated, is a famous petrifying stream.



[Dorien Leigh

THE SCULPTURES OF PHEIDIAS

Pheidias (500-432 B.C.) is universally acknowledged as the greatest sculptor of all time, without exception. He was born an Athenian, and his opportunity came when Pericles ordered him to adorn Athens; above is one of the resulting ornaments, on the frieze of the Parthenon. Pheidias worked in bronze, gold and ivory as well as stone. He died in prison—an ironical close to one of the greatest lives ever lived.



[Dorien Leigh

"TWO HORSEMEN," BY PHEIDIAS

Here are two more figures from the frieze of the Parthenon. Pheidias also decorated with a huge figure of Athena in bronze, the Lemnian Athena, a gilt Athena in ivory and gold. An accusation of stealing the gold for the latter brought him to prison.

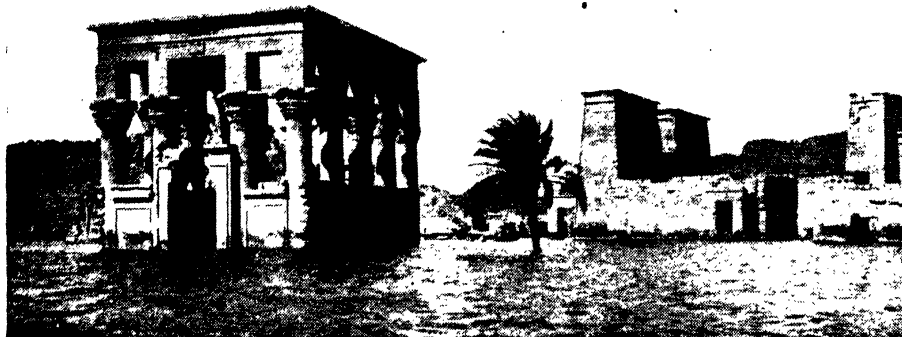

ANOTHER VIEW OF PHILAE

[Courtesy "African World"]

This modern photograph shows the island at what is now almost its lowest water level. The Temple of Isis is in the background, and in the foreground is the next most famous ruin, the *Hyraethrum*, or Pharaoh's Bed. There is a slight grace about the latter which is suggestive of Greece rather than Egypt.



THE TEMPLE OF ISIS, PHILAE

[E. N. A.]

Philae is an islet in the Nile 5 miles south of Assouan, and contains as fine a selection of temples as any spot in Egypt. Unfortunately for picturesqueness, the waters of the river have of late been so much raised by the Assouan dam that the buildings are often wholly submerged. This photograph and that on the next page were taken prior to the dam's construction.

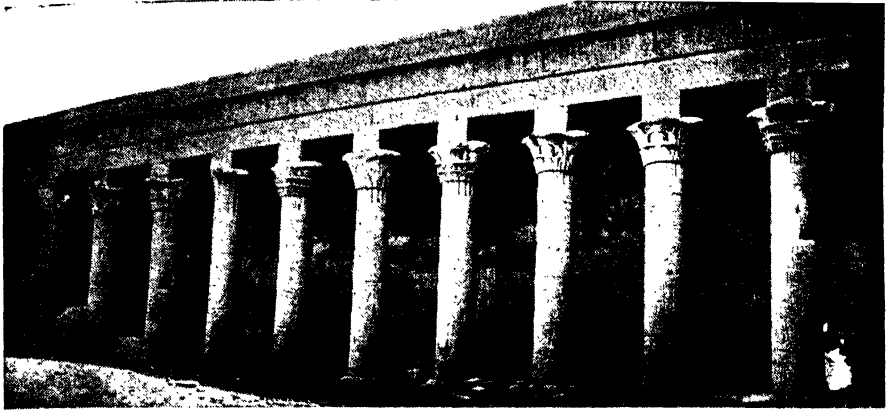

ANOTHER VIEW OF THE TEMPLE OF ISIS

[E N A

This temple is the most important of Philae's ruins. On the previous page the Second Gateway is shown; here the Great Peristyle, or Hall of Pillars. There are paintings of Christ in the Hall and it is interesting to note that the similarity between Isis and her baby and Mary and hers often led early Christians to worship the wrong goddess. It is, indeed, more than probable that the modern conception of the Virgin is directly derived from this Egyptian deity. Philae (or Elephantine) Island first came into prominence as a rendezvous, for commercial purposes, between the Egyptians and the black Nubians of the south. It stands just below the First Cataract.

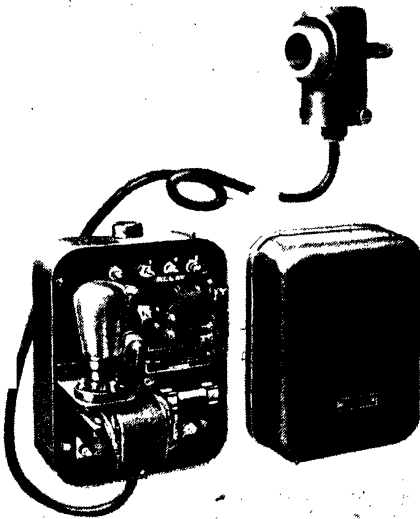

(Courtesy B.T.H.)

A PHOTO ELECTRIC CELL AND RELAY

It is doubtful whether any scientific discovery of modern times has so quickly found so many applications as photoelectricity. The principle is simply that of operating an electrical relay the emission of electrons from a metal plate when a beam of light falls on it. Above, the source of light is seen at the upper end of the flex

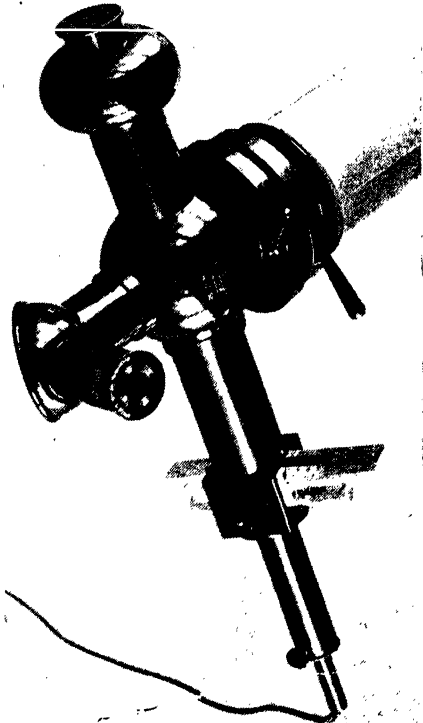

(Courtesy Carl Zeiss, Jena)

A PHOTOMETER

Photometry is a comparison of the illuminating power of different sources of light. The photometer illustrated is an astronomical type used for measuring the brightness of stars against that of an artificial star within the instrument, whose brilliance can be varied and ascertained by means of the scaled wedge below.

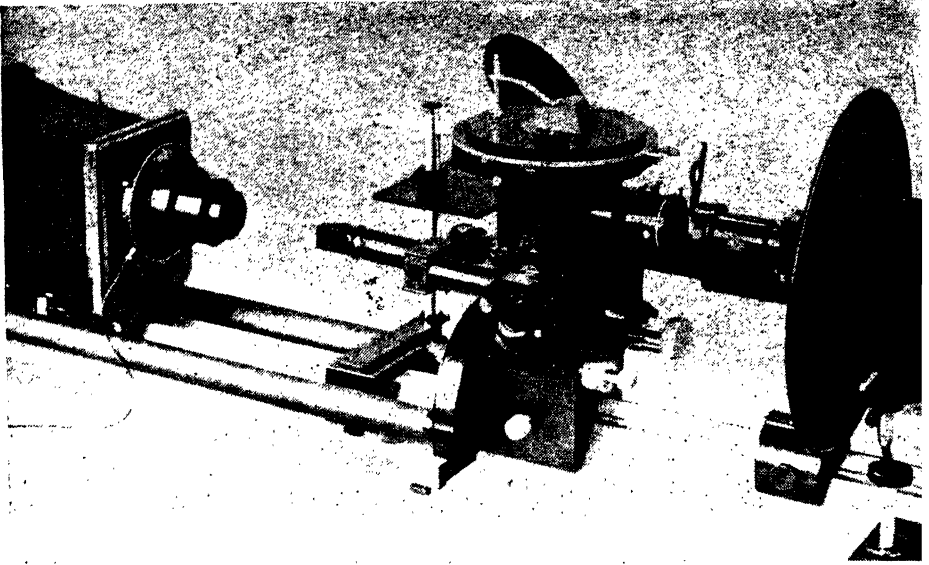

[Courtesy Carl Zeiss, London]

PHOTOMICROGRAPHY

The photograph shows a highly developed form of microscope and camera which can be used for microscopic observation and photography (photomicrography), low power survey photography, or macro-photography of large objects. The instrument works with incident light and magnifies from 50 to 2000 times.

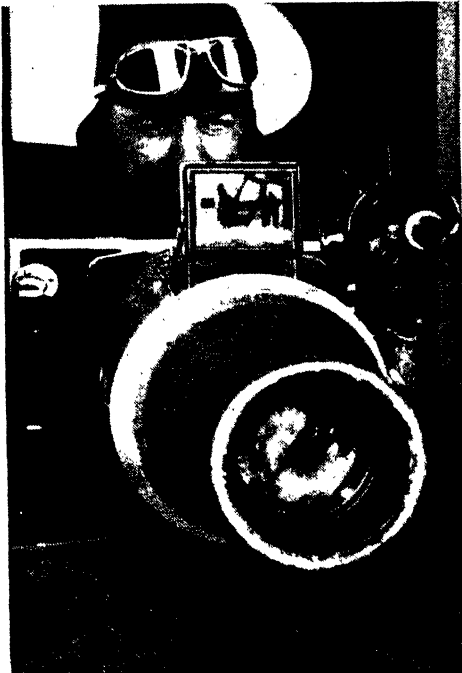

[Dorrien Leigh]

THE NIGHT CAMERA

Here is the aerial instrument by which the flashlight picture of Manhattan at night (p. 413) was obtained. It is shown mounted in its normal position on the aeroplane. Though first used by the U.S.A. Army Photographic Service, the invention originated in Germany.

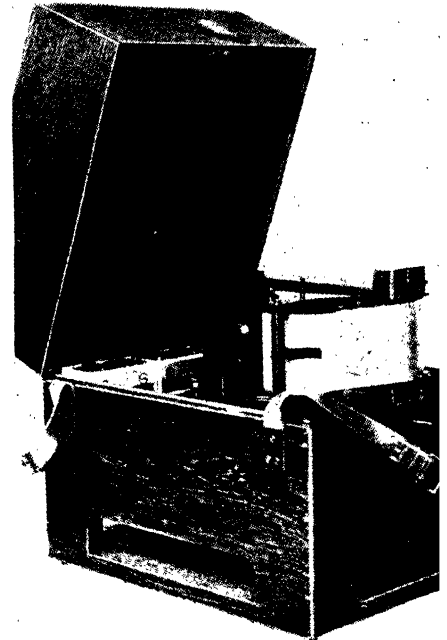

[Necretti & Zamboni]

PHOTOGRAPHIC TEMPERATURE RECORDS

An ingenious variation on the ordinary recording thermometer. Instead of a pen tracing a line upon a revolving drum, a camera is arranged to take photographs, at regular intervals, of the thermometer. The film thus accumulates an accurate record.

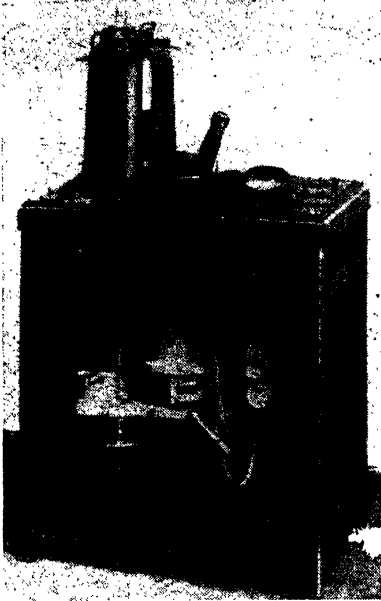

Courtesy Siemens-Schuckert

PHOTO-TELEGRAPHY

This term, which is loosely applied to several different processes, is here intended to mean the transmitting of pictures by telegraph. The illustration shows the transmitter of a German system. The process, which is in wide use, should not be confused with wireless picture-telegraphy

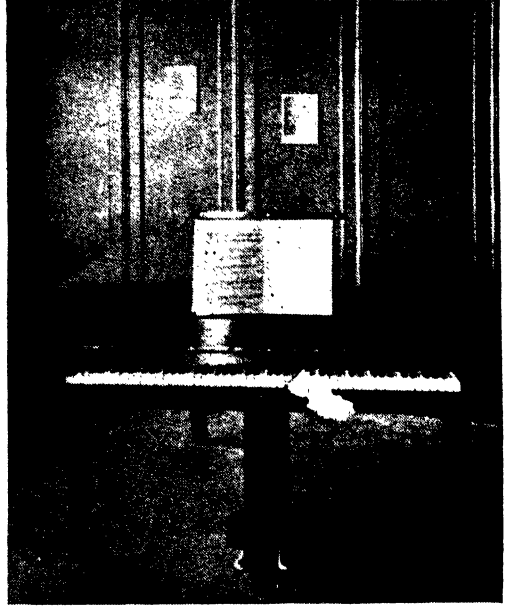

[Courtesy Siemens-Schuckert]

AN ELECTRIC PIANO

This instrument is a result of the combined genius of the Bechstein piano-makers and the Siemens electrical experts. The piano is "real" and is played in the ordinary way, but the vibrations of the piano-wires are electrically transmitted to a loudspeaker; the result is that the piano can be heard any distance from where it is played



PHOTOGRAPHY IN THE DARK

[Dorien Leigh]

His arresting photograph was one of the first ever to be taken in the dark from an aeroplane. It shows Manhattan Island, New York, by aerial flashlight. The achievement of illuminating so clearly a scene so far away is a remarkable scientific triumph, only obtained after years of patient research

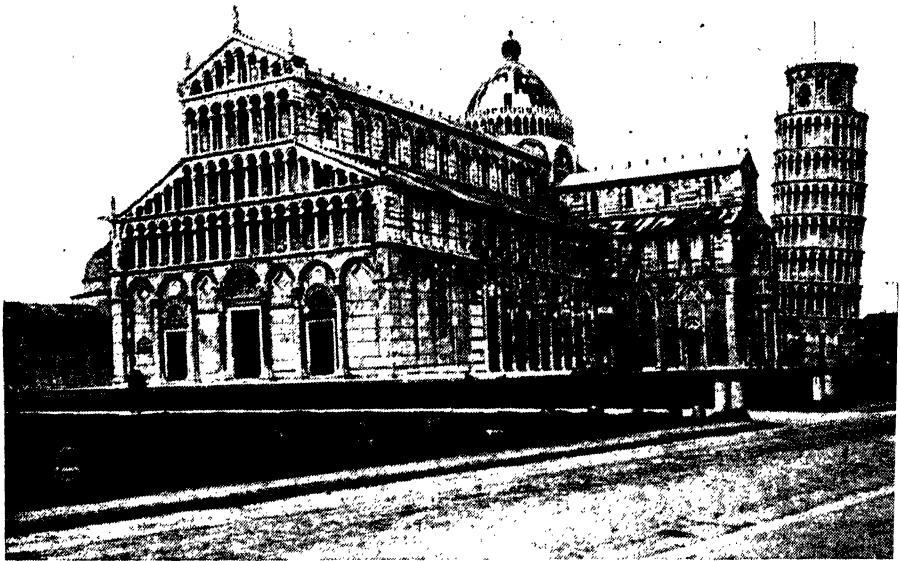

PISA - THE CATHEDRAL AND LEANING TOWER

[Carlton & Kinna

Pisa, capital of Tuscany, was in olden days the maritime rival of Genoa and Venice, but has to-day ceded pride of place to Leghorn. Few cities, even in Italy, are so rich in fine buildings. Amongst these, the marble Gothic cathedral dates from 1063-1118, and the celebrated Campanile, or Leaning Tower—14 feet out of true—from A. D. 1174-1350. Tower was, of course, not intended to lean, but suffered a sinkage of the foundations during construction.

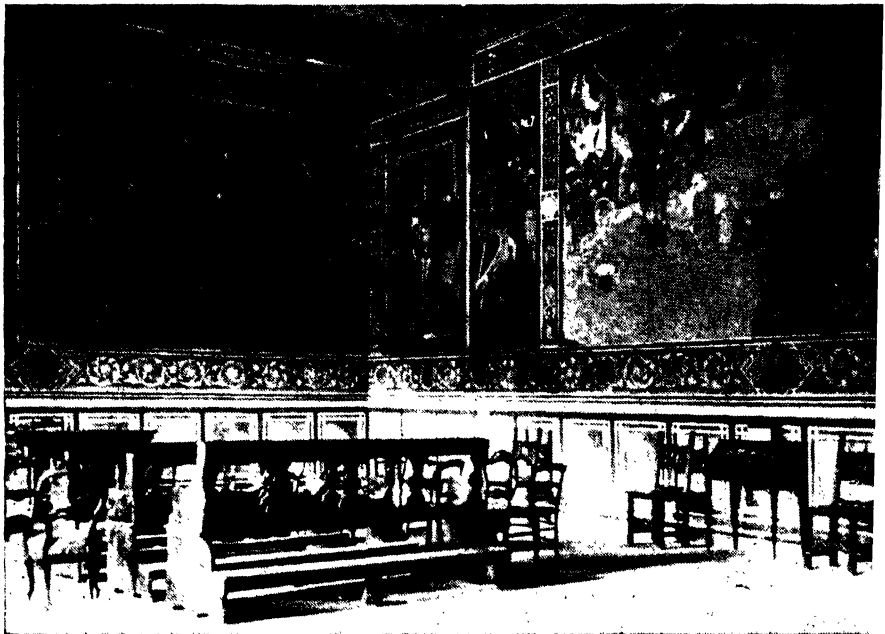

FRESCOES IN THE CHURCH OF ST. FRANCIS, PISA

[E. N.

The Church of St. Francis is less famous than that of St. John, but the frescoes which cover many of its inner are amongst the greatest treasures of Tuscany. This photograph gives a glimpse into the Capitolo di S. Bonave

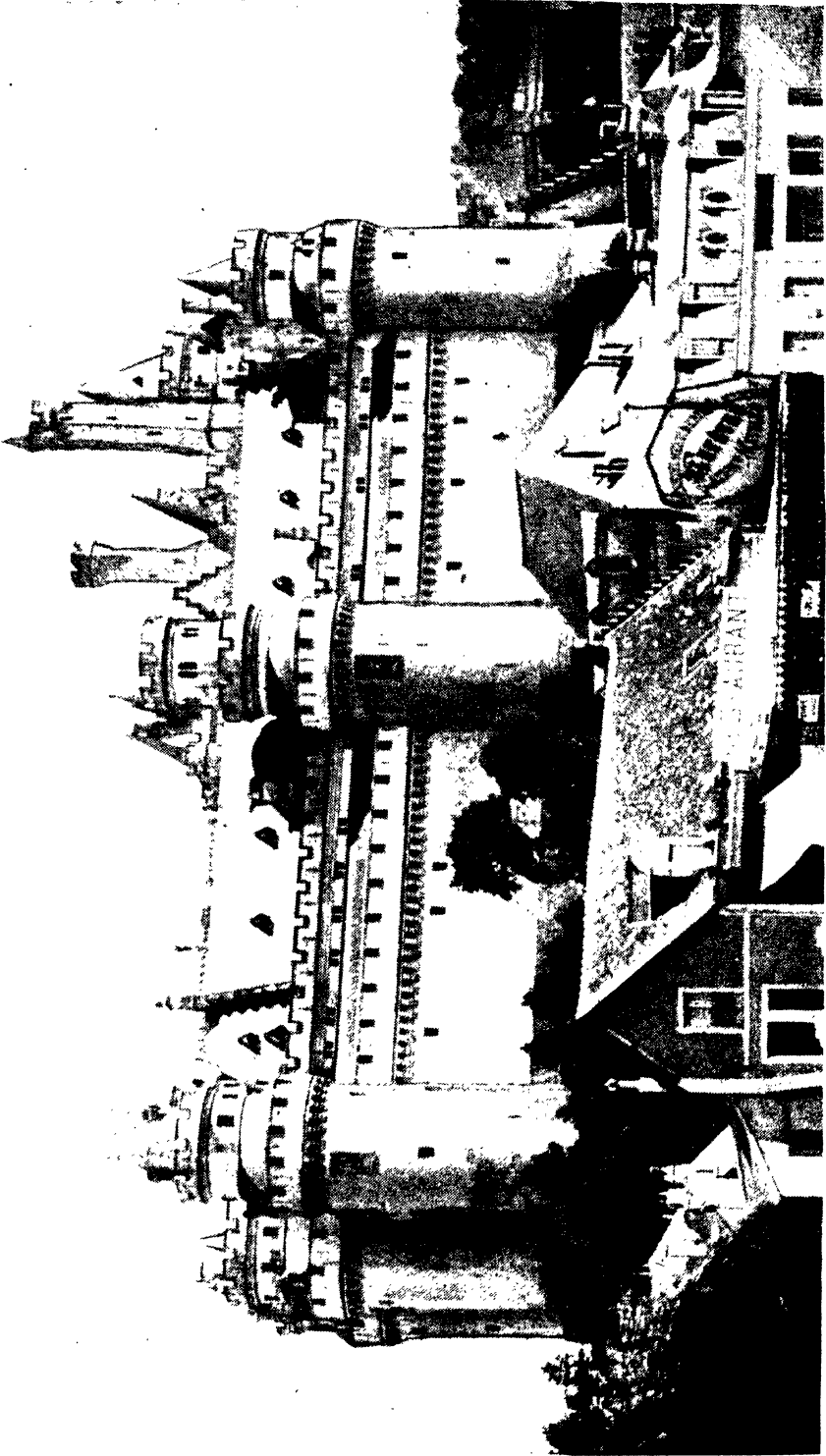

[Dorsten Leigh

THE CHATEAU DE PIERREFONDS

In many ways Pierrefonds is the finest feudal castle in Europe. It was erected by Louis de Coligny in 1566, at a time when feudal architecture had begun to take on artistic embellishments without losing its purposes of defence. Though restored by Napoleon III, much of the old structure remains. The walls are 15 to 20 feet thick.

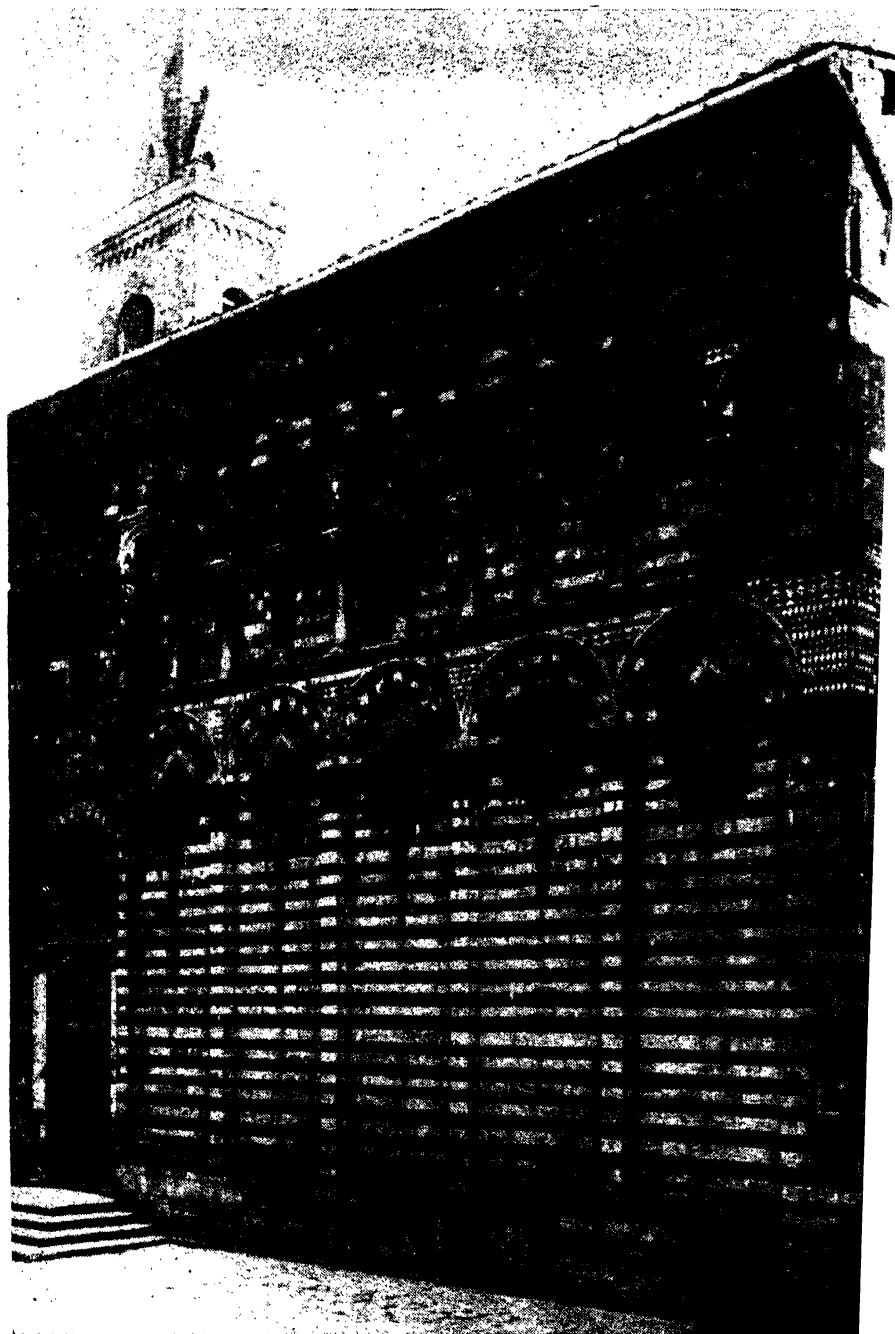

S. GIOVANNI FUORCIVITAS, PISTOJA

[W. F.]

Pistoja is an old walled town on a spur of the Appenines, 30 miles north-west of Florence. It is a healthy pl partly owing to its having been a favourite summer resort from immemorial times, it is full of fine buildin Church of S. Giovanni was founded in the eighth century, the façade added in the fourteenth. It is a fine s of the Middle Ages when they were at their best

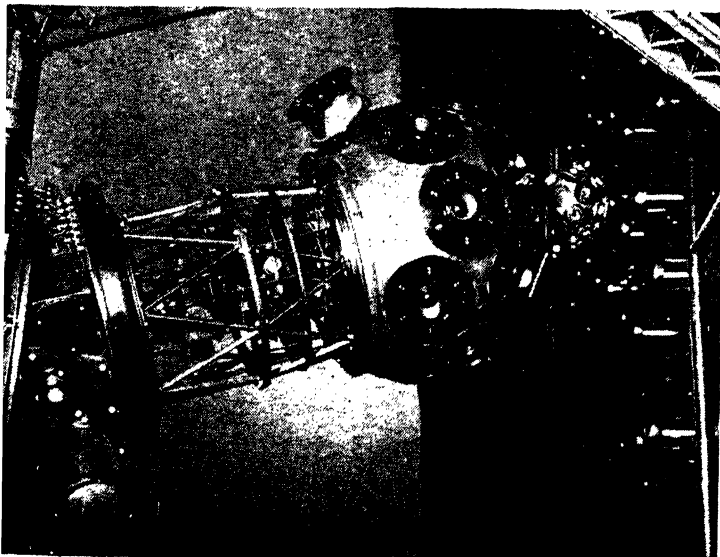

Courtesy Carl Zeiss, London

THE PLANETARIUM

A close-up of this most amazing of all man's scientific achievements, of which a full description will be found beneath the microscope. Altogether there are 104 projectors and 7 driving motors. The audience travel through space at sixty miles a minute, and through time to the extent of 24,000 years. Planetaria cost from £20,000 upward

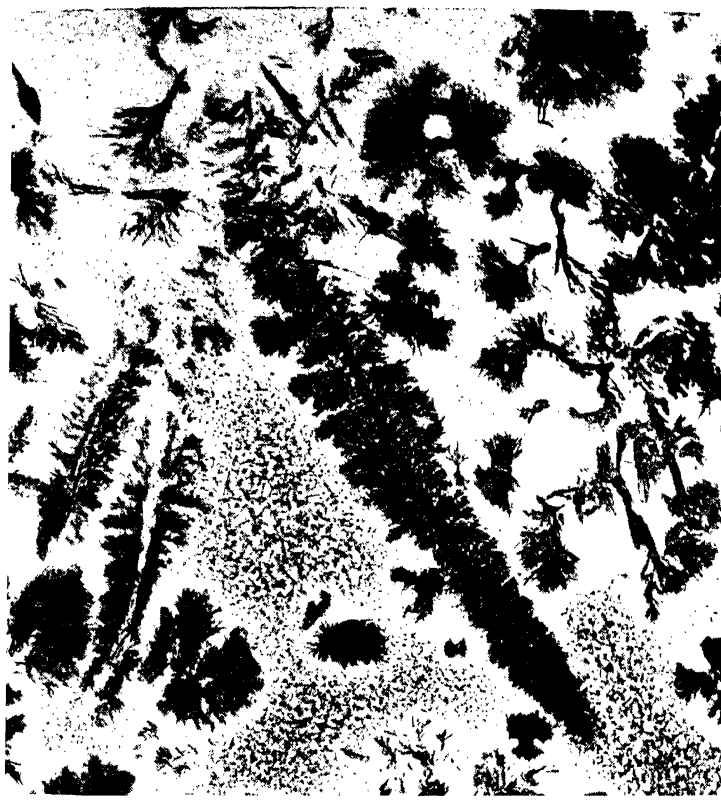

[From "Marvels of the Universe"

MAGNIFIED PITCHSTONE

Pitchstones are glassy rocks, black or dark green in colour, and found mainly in the Isle of Arran, Scotland. A cross section through the microscope reveals a mass of fern-like embryo crystals of hornblende, which are similar to those found in the Scottish Scaur of Eigg, they occur in stones are discovered as intensive dikes, but in another part of Scotland, they occur in contemporaneous sheets. They are characterised by a resinous luster, and break with a splintery fracture

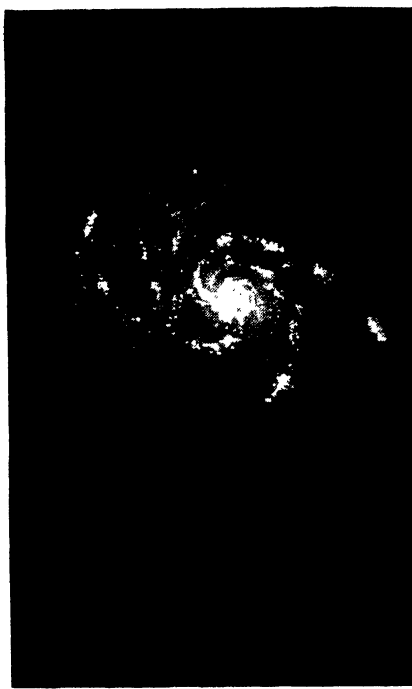
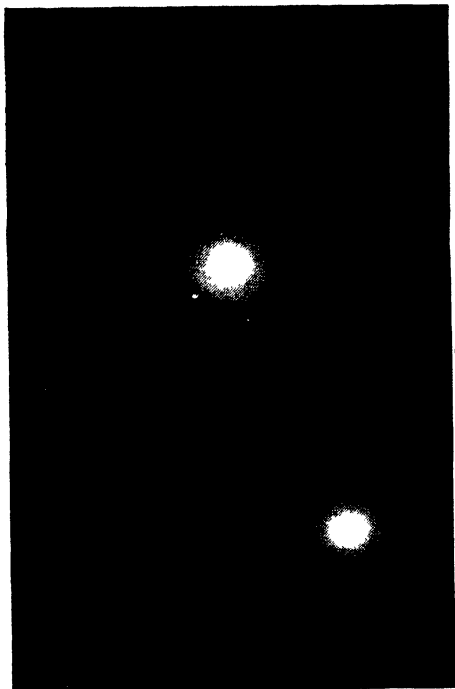

[Courtesy "Splendours of the Heavens"]

THE FORMATION OF THE PLANETS

problem. On the left, Laplace's theory was that a ball of gas, rotating and contracting, increased its speed until it burst apart at the condensation of an earlier ring. The other theory was that another ball of gas, which left our sun in spirals. These, condensing, became the planets. The first of these theories is by no means proved.

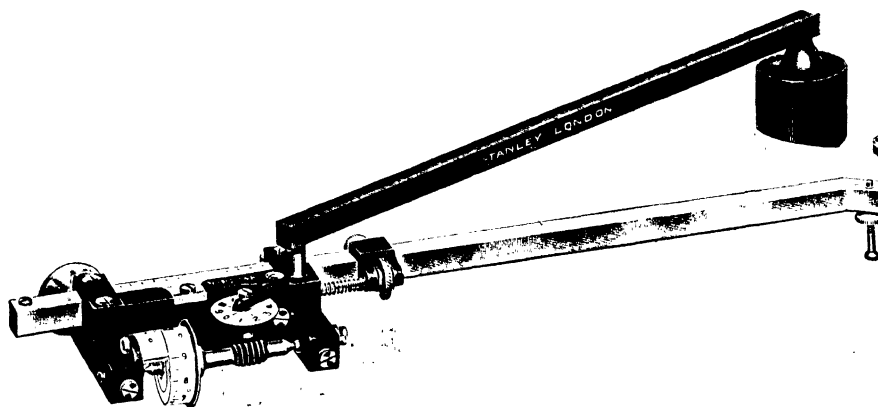

[Courtesy G. & K.]

THE PLANIMETER

A planimeter is an instrument for determining the area of any figure, regardless of shape. The tracing point on the right is guided round the boundary of the figure, thereby causing the arm supporting it to roll upon the surface seen in the left foreground. The figure's area is ascertained from the scales operated by this

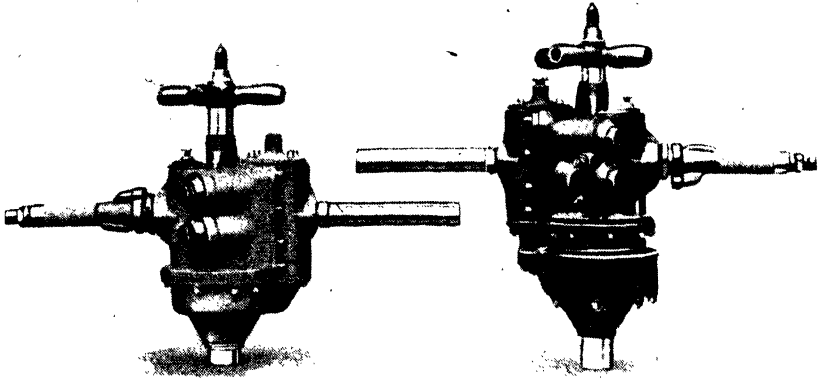

PNEUMATIC DRILLS

[Carrick & Kinnaird]

Pneumatic tools—drills, riveters, hammers—are worked directly by compressed air, which they obtain from a machine (generally on wheels) to which they are attached by a flexible tube. In the case of drills, the air works pistons in form of more horizontal cylinders, exactly as a steam cylinder is worked. These pistons turn a central vertical shaft on whose point is the drill head.



[Wallis]

A LIPPED PITCHER PLANT

This is a different kind of insect-trapping pitcher—different from the Venus's horn of which a section is shown on the right. The pitcher's horn grows straight up out of the ground, but the type depicted above hangs its pitchers out at the ends of its leaves.

Note the movable lids

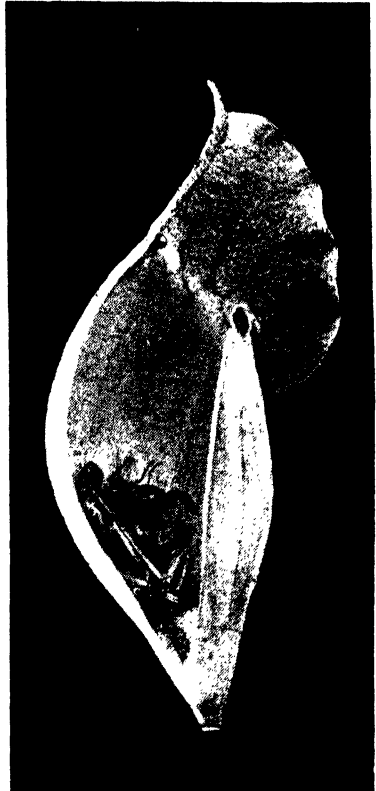

[From "Marvels of the Universe"]

PLANTS WHICH EAT INSECTS

Insect-eating plants are of numerous varieties; some, as the sundew and butterwort, are sticky; others, as the "Venus's Flytrap," close their half-folded leaves like jaws when touched; others again, as the American pitcher plant here shown in section, entice the insect to tumble in

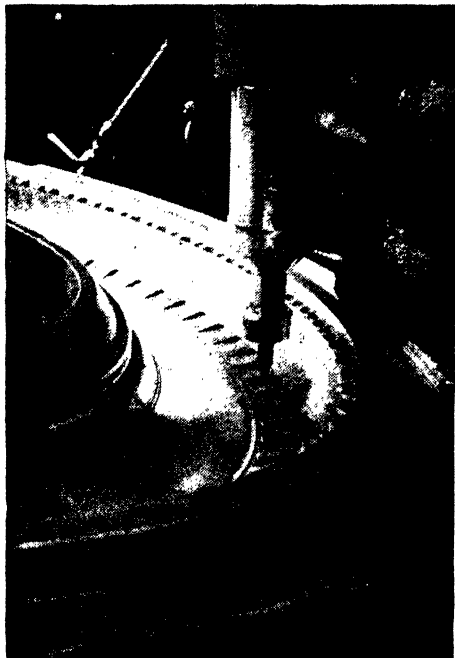

Courtesy Dunlop Rubber Co.]

A PNEUMATIC-TYRE MOULD

Tyres are cast, like jellies or ingots of metal, in a shaped mould, into which the rubber is poured while in a glutinous state. The mould is of steel and is made in two halves which are eventually clamped together. Here one half is seen being engraved

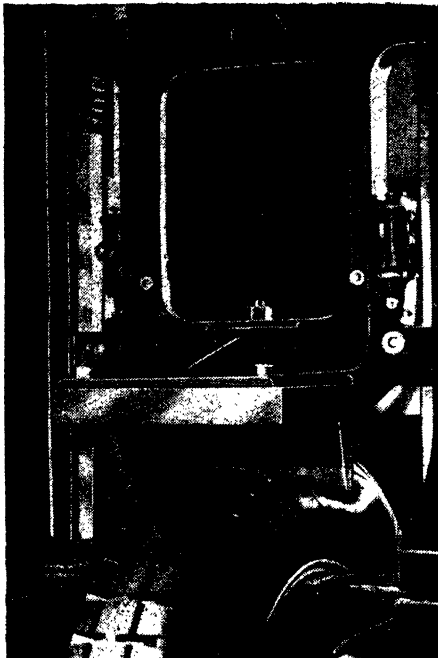

[Courtesy Dunlop Rubber

PNEUMATIC-TYRE TESTING

Such a great deal of safety depends on the reliability of a modern tyre that the most stringent tests are applied before it leaves the factory. A heavy weight, with a knife-edged spike underneath, is dropped on the inflated tyre from heights up to 200 feet to test the casing



PNEUMATIC-TYRE MAKING

[Courtesy Dunlop Rubber

Though the processes of manufacture are many, the processes of testing are almost as numerous before the tyre leaves the factory. Here is shown the wear- and tear-testing machinery. The metal flywheel against which the tyre pressure can be made to revolve at speeds up to 50 m.p.h., and to the arm holding the tyre the equivalent of 10 tons load be imparted

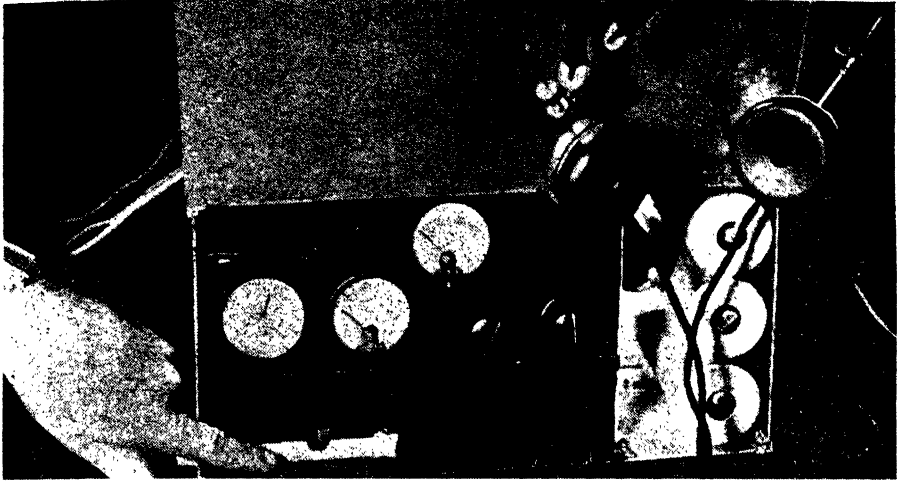

POLAR ICE: HOW ITS DEPTH IS FOUND

[Dorien Leigh

The heavy pack ice, interlarded with icebergs, of a polar winter, or the serried ice of a glacier, cannot be measured by actual penetration. The method is to radiate a sound-wave through the ice, and to time by special instruments the interval before the wave reaches the earth or water; this is possible because sound travels at different and known speeds through different substances



A. E. Smith]

MALLOW POLLEN

The transparency and globular form of this pollen gives a strong resemblance to insects' eggs. Even here, however, the roughness of the exterior can be discerned. The mallow is a plant related to and closely resembling the hollyhock

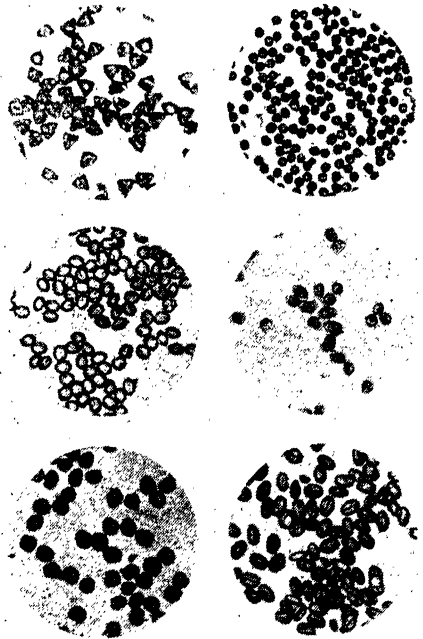

[From "Marvels of the Universe"
POLLEN

Here are shown six kinds of pollen as seen in the microscope. In the left-hand row are Mimosa, Lesser Bindweed, and Rosebay Willow-herb; on the right are Sage, Cedar of Lebanon, and a species of Thistle

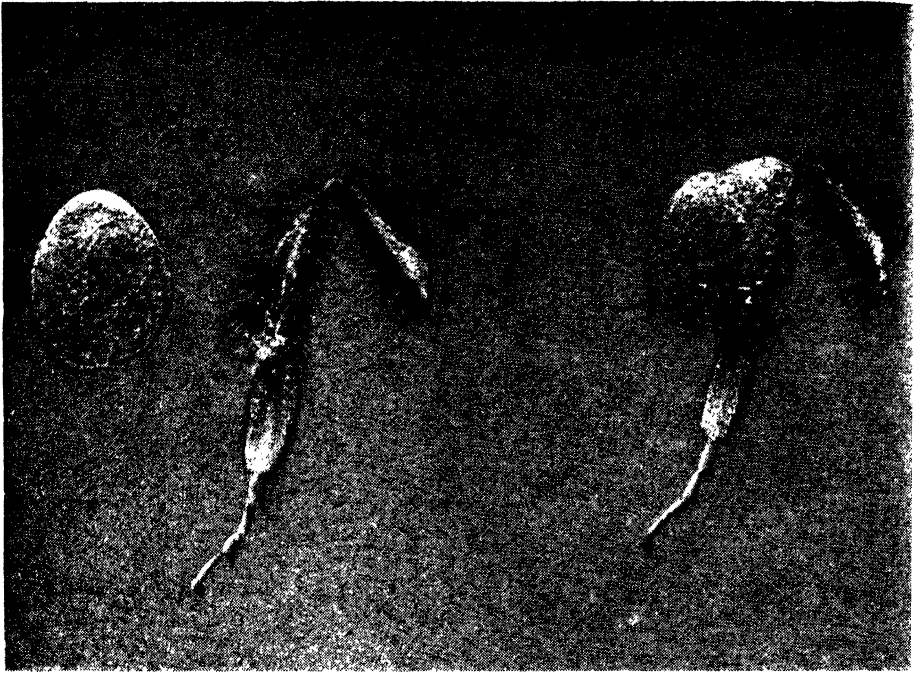

HOW POLLEN IS CARRIED

[H. Ba

The photograph shows, highly magnified, a single pollen grain and the hind leg of that greatest of pollen carriers, the humble bee. The grains are picked up by the hairy coat as the bee gathers the nectar, and are then transferred by the insect to a special "pollen bag" on one of the hind legs.



A HUMBLE BEE REMOVING POLLEN

[Carthea & Kinn

Here the bee's method of removing the pollen from its coat for eventual transference to the "bag" is easily seen. The hairy hind leg is long enough, and so pointed, that it can cover the whole of the appropriate flank in one sweep. Humble bees, as common bees, are divided into females, workers and drones.

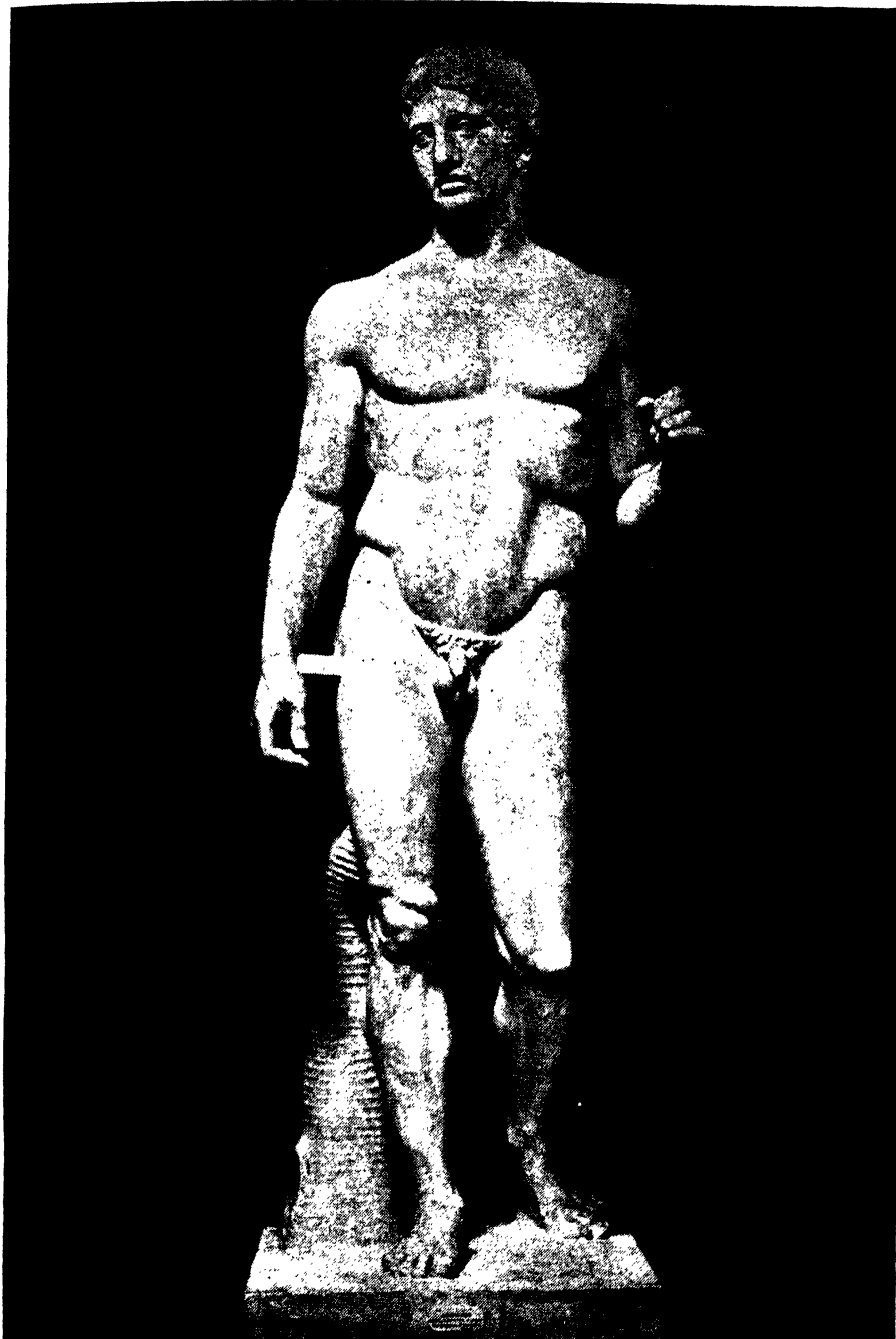

"THE SPEAR BEARER," BY POLYCLETUS

[Dotien Leich

Polyclethus of Argos was a contemporary of Pheidias and Myron, in the fifth century b. c. As Pheidias was head of the Athenian School, so Polyclethus was head of the Schools of Argos and Sicyon. The *Spear Bearer* or *Doryphoros* (whose spear was held in the left hand) became known as the *Criterion*, or perfect example of the proportions of man. Polyclethus's dignified work is only surpassed by that of Pheidias.

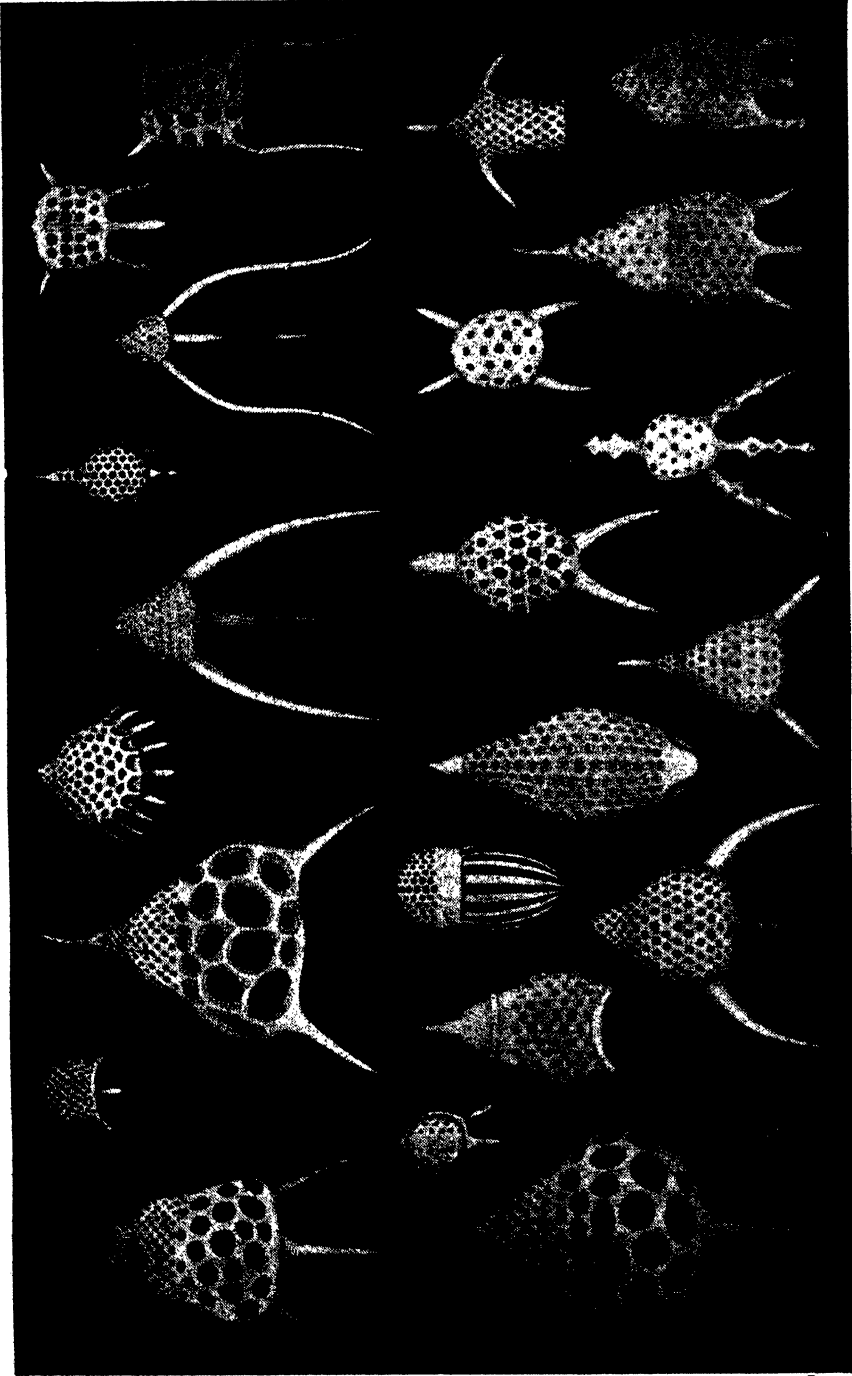

A GROUP OF POLYCYSTINA

Polycystina are a subdivision of Radiolarians. The picture shows the skeletons of what were once minute living creatures, not unlike diatoms, ranging from $1/1000$ to $1/1500$ th part of an inch in diameter; and though classed amongst the lowest forms of life, it will be seen that their structure is not simple. The skeletons consist of



A BAKER'S SHOP, POMPEII

When the great eruption of Vesuvius in A. D. 79 buried Pompeii, the burial was so complete that during the Middle Ages the very site was lost. This was re-identified in 1594, but not until 1763 did excavations begin. They are still continuing. In this picture note the oven on the left and the grinding-mills in the centre. In the road leading to this bakery the marks of chariot-wheels are still visible



[Photos from "Wonders of the World"]

HOUSE OF THE VETII, POMPEII

So swift was Pompeii's destruction and so preservative its covering of lava that the very forms of the fleeing people have been preserved. The House of the Vetii has been restored as far as possible to its original state—even the plants being only such as are known to have grown there of old

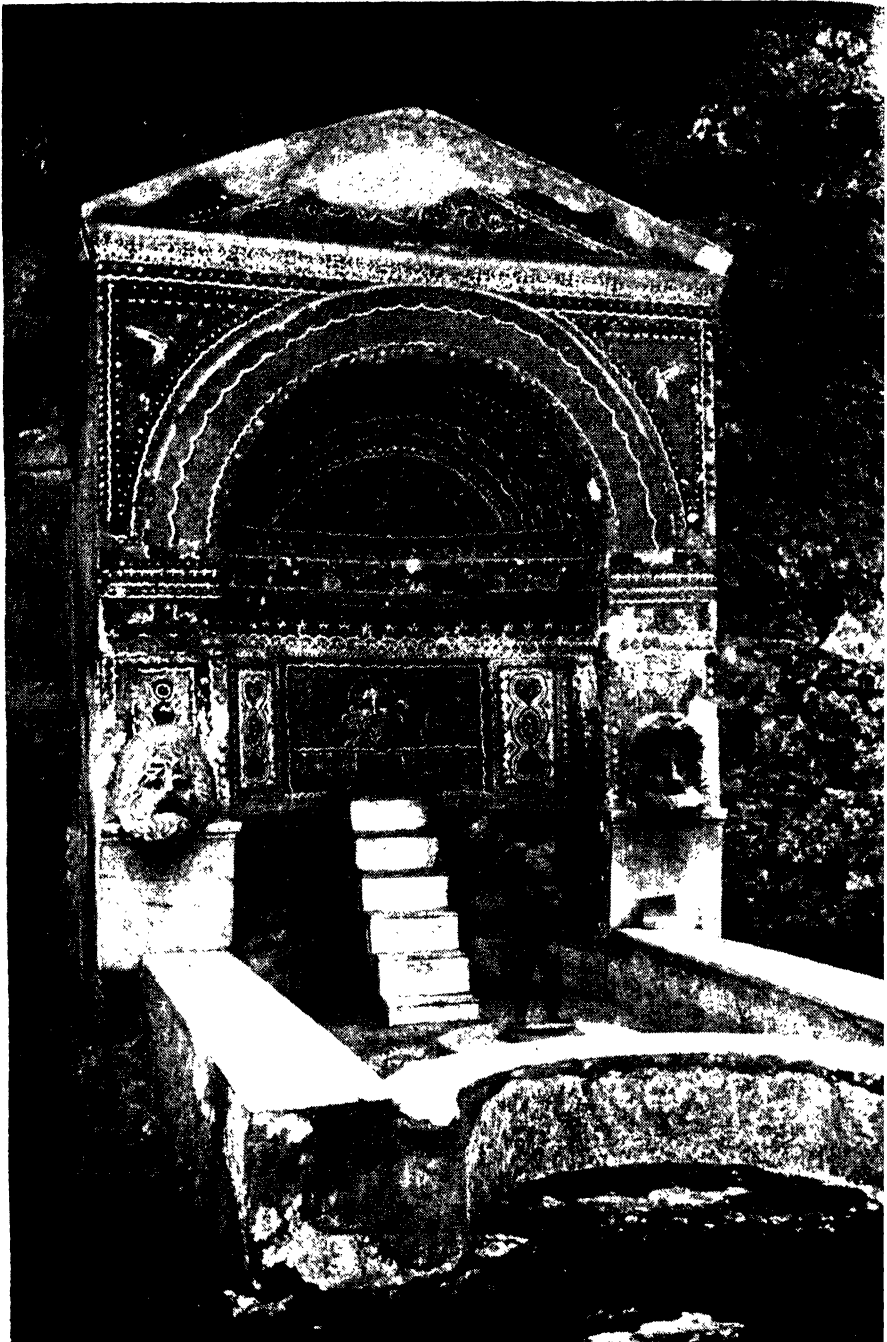

ROMAN MOSAIC FOUNTAIN AT POMPEII

[Donald McLeis

Pompeii is remarkable not only for its buildings and relics of commerce, but for its art. On some of the walls are paintings whose range of colour, conception and treatment of the human form make them unrivalled by anything until the work of the later Renaissance artists. In the kindred art, mosaic, the high standard of the Byzantines equalled if not surpassed

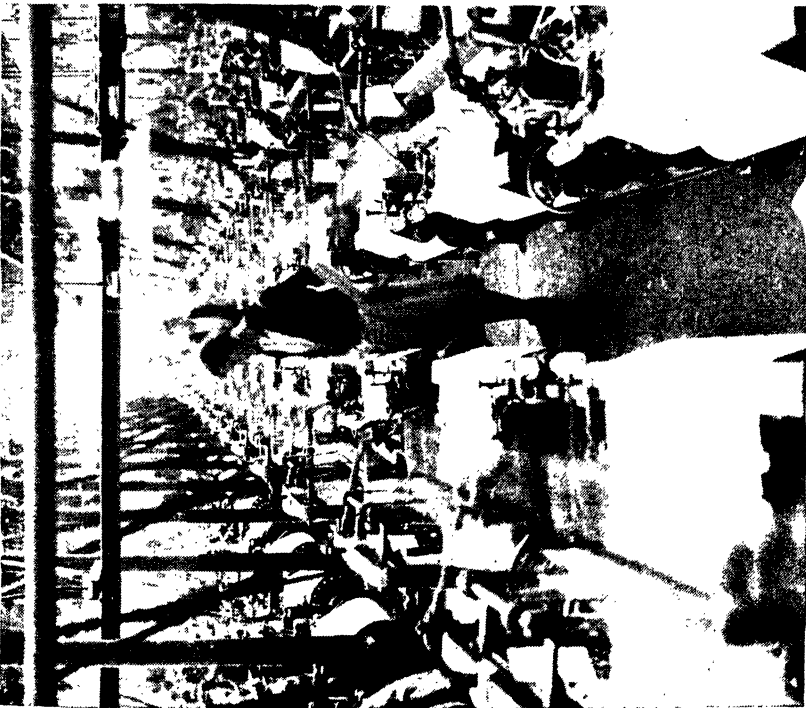

Keystone

POWER-LOOMS

This is a typical scene in a cotton mill. The power loom was patented by Dr. Cartwright in 1783. He like many of the inventors of the Industrial Revolution suffered bitter opposition from workers fearing displacement, but the invention spread rapidly. In 1817 there were 2,400 power looms in Britain. A century later there were 805,700.

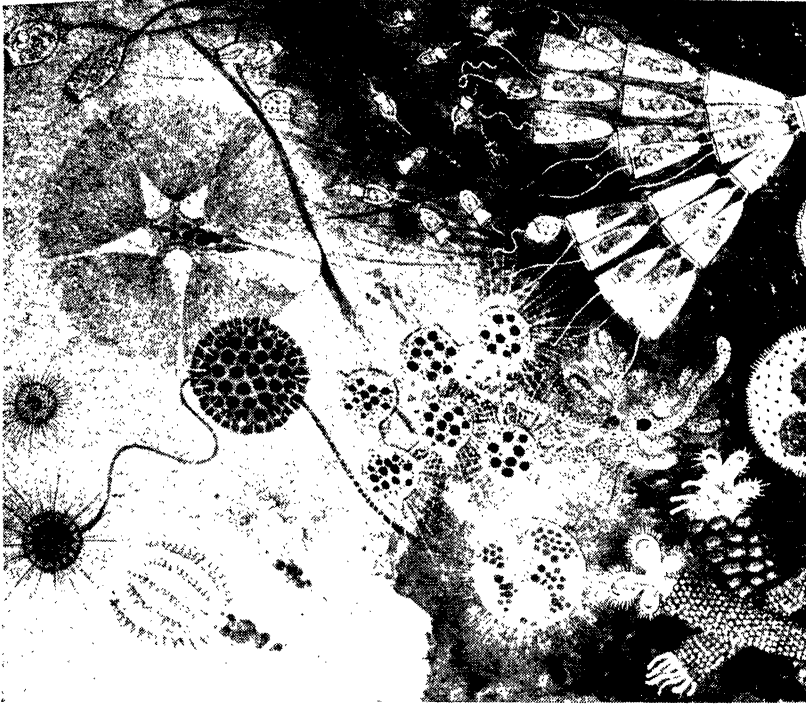

From "Miracle of the Universe"

POND LIFE

This is a highly magnified conception of a small fraction of the multitudinous life existing in streams and ponds. Some of these minute entities are plants, others animals, and yet others exhibit the characteristics of both at different stages of existence. The scales of magnification here range between 100 and 200 times.



Dorrien Leigh

"THE APHRODITE OF KNIDOS," BY PRAXITELES

This exquisite statue is almost unique for work of such early date in that not only the artist, but the model, can be identified. The poser for this Aphrodite was Phryne, a famous Athenian courtesan, who numbered Praxiteles among her lovers. The sculptor himse-



Dorrien Leigh

THE "POMPEIAN BACCHUS"

This Bacchus is but one of the many delightful statues unearthed at Pompeii which together with the paintings and mosaics, reveal the city to have been to the Roman world what Florence was to the Renaissance. The statue is of marble, and though compared with the finest and most perfect Roman work, the feature may lack in shapeliness the artistic



From "Marvels of the Universe."
PRECIOUS STONES

A sketch of some typical gems in their natural state. Dividing the picture in half is a long crystal of Tourmaline; the others are, from top to bottom: (left half) Cornelian, S. American Diamond, Turquoise, Emerald, Rose Topaz, Opal, Chrysolite, Hyacinth, Onyx; (right half) Lapis Lazuli, Tourmaline (another kind), Ruby, Yellow Topaz, Sapphire and Amethysts.



[Carleton & Kennard]

PREHISTORIC MAN

The ultimate origin of man is still a mystery bound up with the problem of organic life as a whole, for since the definite abandonment of the theory that separate species were spontaneously created, man's pedigree is of the same length as all others. Great help in tracing ancestors is afforded by early skulls; a plaster cast from the famous Pittdown skull is shown here.

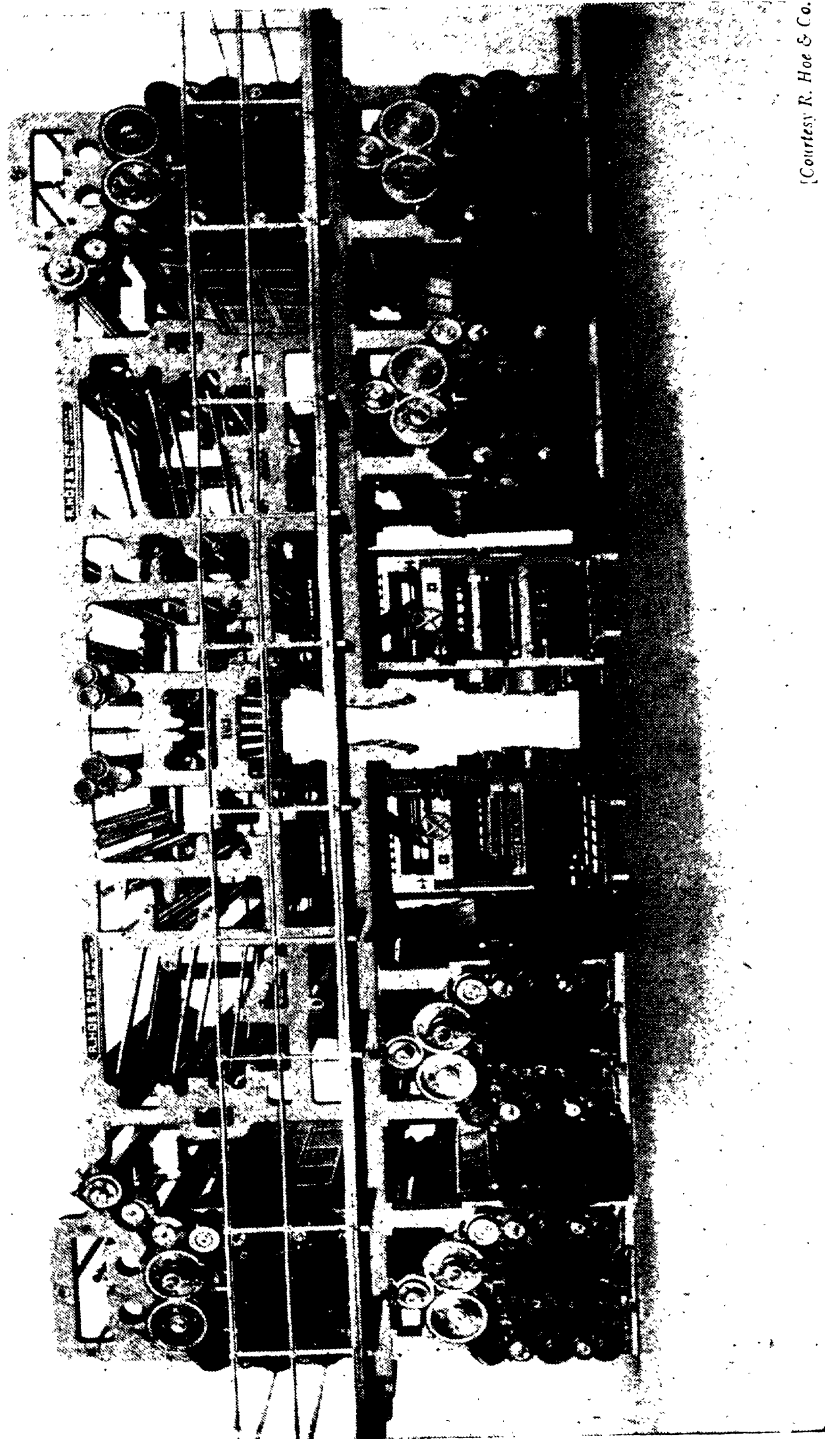

[Courtesy R. Hoe & Co.]

PRINTING

No more striking illustration of the progress of printing since the distant days of its invention in China could be furnished than this photograph of a giant modern newspaper press. The date of this press is from two 85-h.p. motors. Its capacity is 100,000-24 page newspapers per hour. It is fitted with automatic folders, latr news devices, and innumerable mechanical attachments.



THE PRIONUS BEETLE

[T. Stepien]

This photograph, about 24 times natural size, shows the head of the beetle walking toward the left. It is one of the most conspicuous of so-called "horned" beetles, the horns being in reality enormously powerful jaws. The mystery of the various horned beetles is that in hardly any cases have naturalists discovered why they should be horned. In some varieties the horns are not part of the jaws, but project from the top of the head.



[Dorien Leigh]

"JUSTICE AND VENGEANCE PURSUING CRIME," BY PRUD'HON

Pierre Paul Prud'hon (1758-1823) is chiefly known for his famous portrait of the Empress Josephine which now hangs in the Louvre, but from an artistic point of view the above is probably his best work. Prud'hon spent much of his life in Rome, where he won the Grand Prix in 1782 and later became a close friend of Canova.

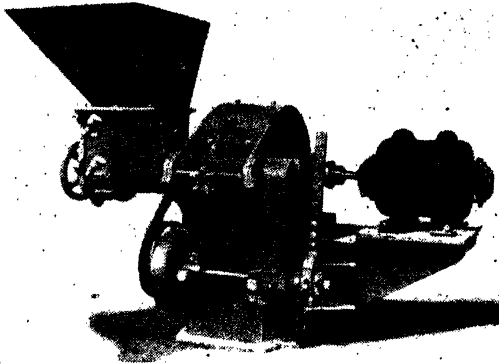

[Courtesy Ind. Combustion Ltd

A SCREEN PULVERISER

This is yet another device used for the surface work upon ores in the mining industry. The rotating screen in the centre portion is driven by the electric motor on the right, and the material is fed through the chute on the left.

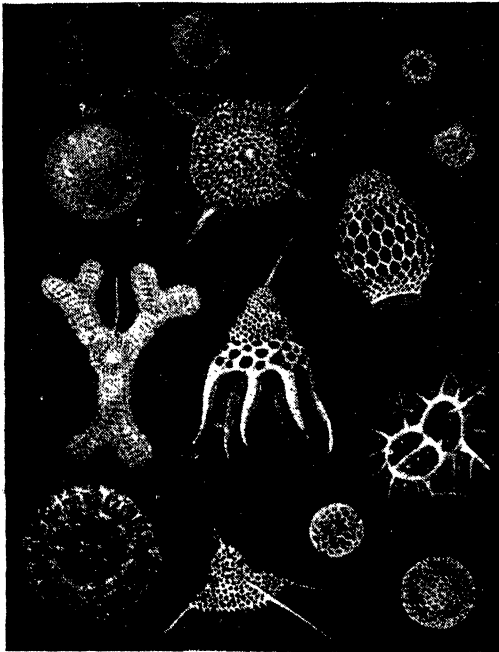

From "Marvels of the Universe")

RADIOLARIANS

Some skeletons of a class of radiolarians called polycystina were illustrated under that title. Here a mixed group of the microscopic organisms is shown as in life. Nearly all radiolarians are phosphorescent. The feelers collect food, the tiny internal globes store food and cause locomotion. The creatures mostly live far from land in the tropical oceans; as they die, they collect in vast deposits of radiolarial ooze, which, when cemented into rock, forms beds of chert. In simpler species the skeleton is merely a series of needles embedded in protoplasm. Radiolaria can live at 500 fathoms.

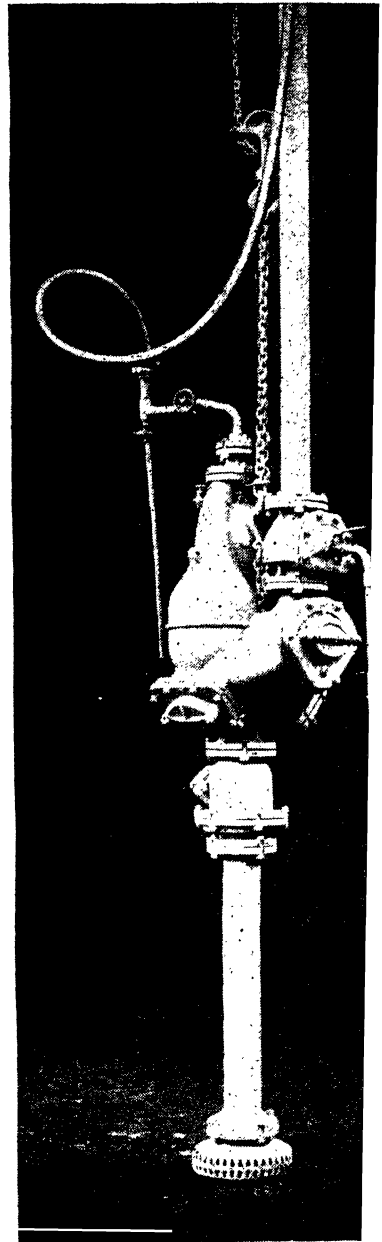

[Pulsometer Engine

A PULSOMETER STEAM PUMP

At the widest part of the pump are two chambers separated vertically, but having a common tube below and outlet above. Through the pipe steam is admitted, and the pressure exerted by it on various valves raises the wa



Catherine Kinnaird

MEASURING RAINFALL

The picture shows a standard rain-gauge such as is still used, despite the unassuming construction, in most meteorological stations. The cylinder is made of copper and the measuring glass graduated to show half-inches. Many precautions are necessary in selecting the site for a rain-gauge

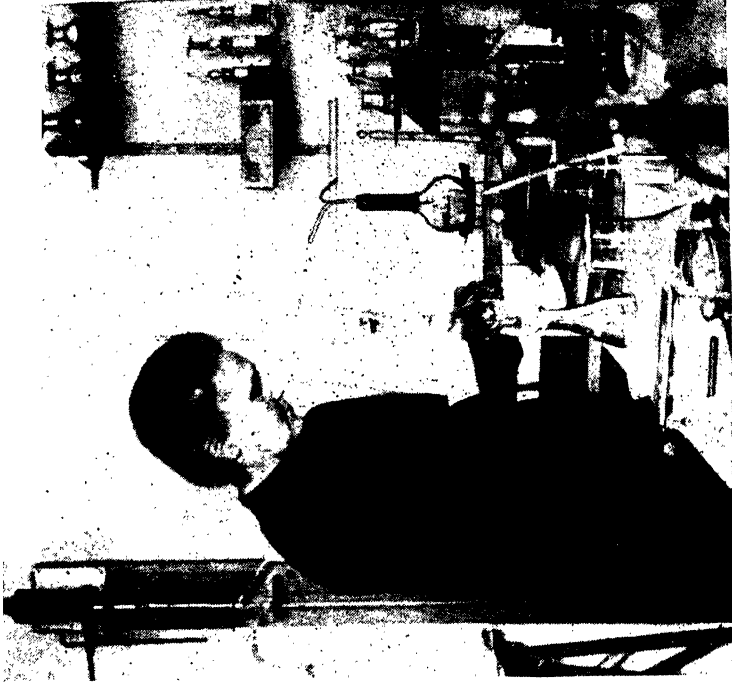

[Devlin Lough]

RADIUM: MME CURIE

The photograph shows radium's celebrated discoverer, Mme Curie, in the laboratory where she and her husband were working when the find was made. Of the rare metal's various therapeutic qualities, none is so great as its use in curing that hitherto incurable disease, cancer



[Dorrien Leigh

DR. ALEXANDER ADAM BY MARRING



F. Frith & Co.]

RAGLAN CASTLE

Though not by any means as renowned as certain others, for instance



RANGOON: THE SHWAY DAGON

[Courtesy "Wonders of the World"]

This huge cone, 368 feet high, is the central point of one of the most extraordinary buildings in Asia. From pinnacle to base, though taller than St. Paul's Cathedral, it is covered with gold, and the vane at the top is set with over 4,600 diamonds, emeralds and rubies. Buried in the foundations of the great Burmese temple is a golden reliquary said to contain four hairs from the head of Buddha.



RAPHAEL'S "LA BELLE JARDINIÈRE" (IN THE LOUVRE)

[Dorien Leigh

Raphael Sanzio (1483-1520) was born at Urbino, Tuscany, in 1483. Trained at first under his father, he finished his art education at Perugia under Perugino. Without being a copyist, he had an amazing faculty of assimilating the best qualities of other masters, and he benefited much from his friendship with Leonardo da Vinci and Michelangelo. His works, though exclusively religious, were versatile, and he left no fewer than 1,400 of them

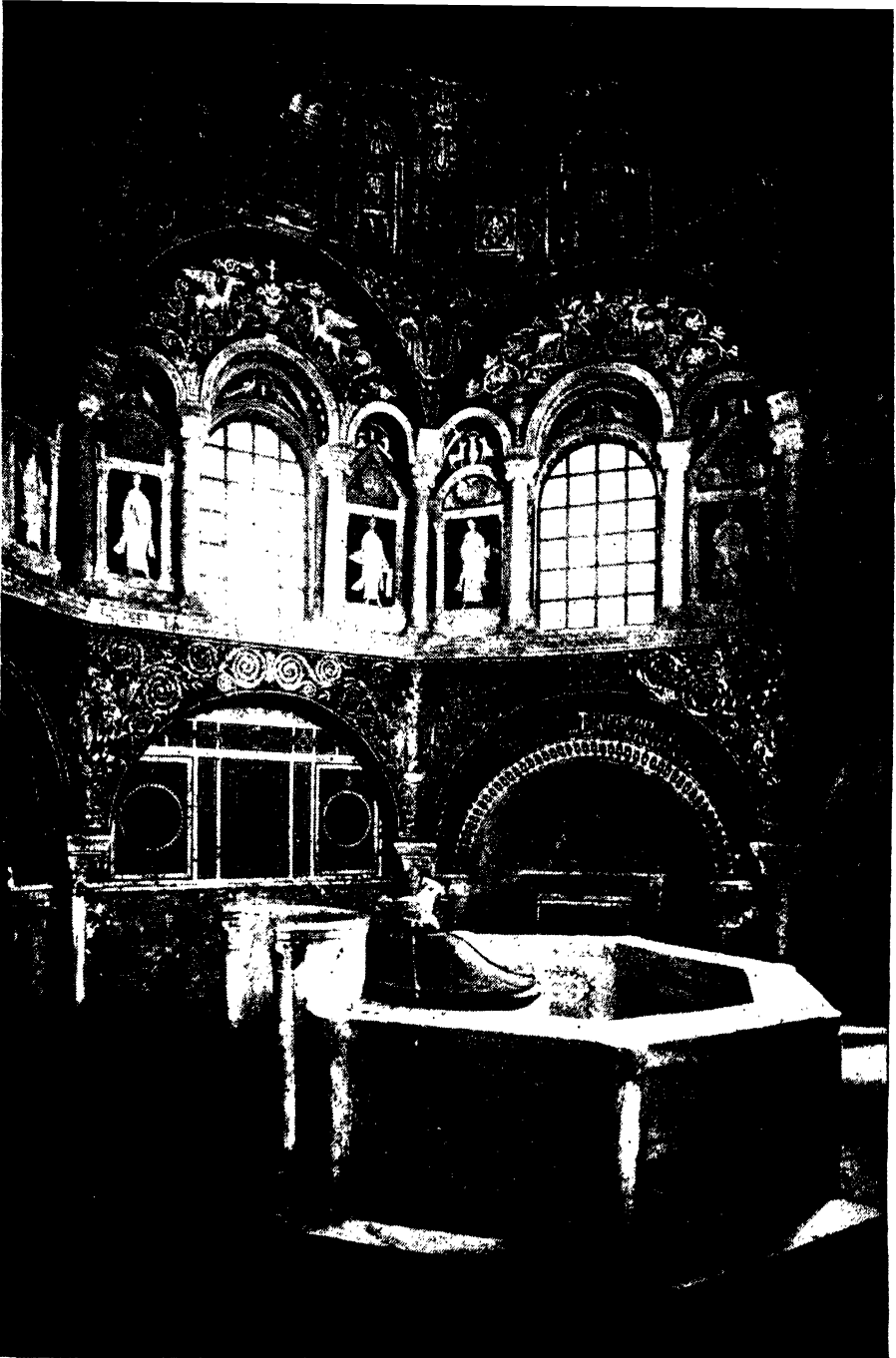

RAVENNA: THE BAPTISTERY

(W. F. Maxwell)

Some of the churches and monasteries of Ravenna are of great antiquity. S. Vittore dates from the fourth and Santa Agata from the fifth century. In most of these ancient fanes are to be seen exquisite mosaics, relics mainly of the era of Ostrogothic domination in Italy. The mosaics shown above are sixth-century work, and characteristic of the far-off days of Ravenna's glory. (See also overleaf)

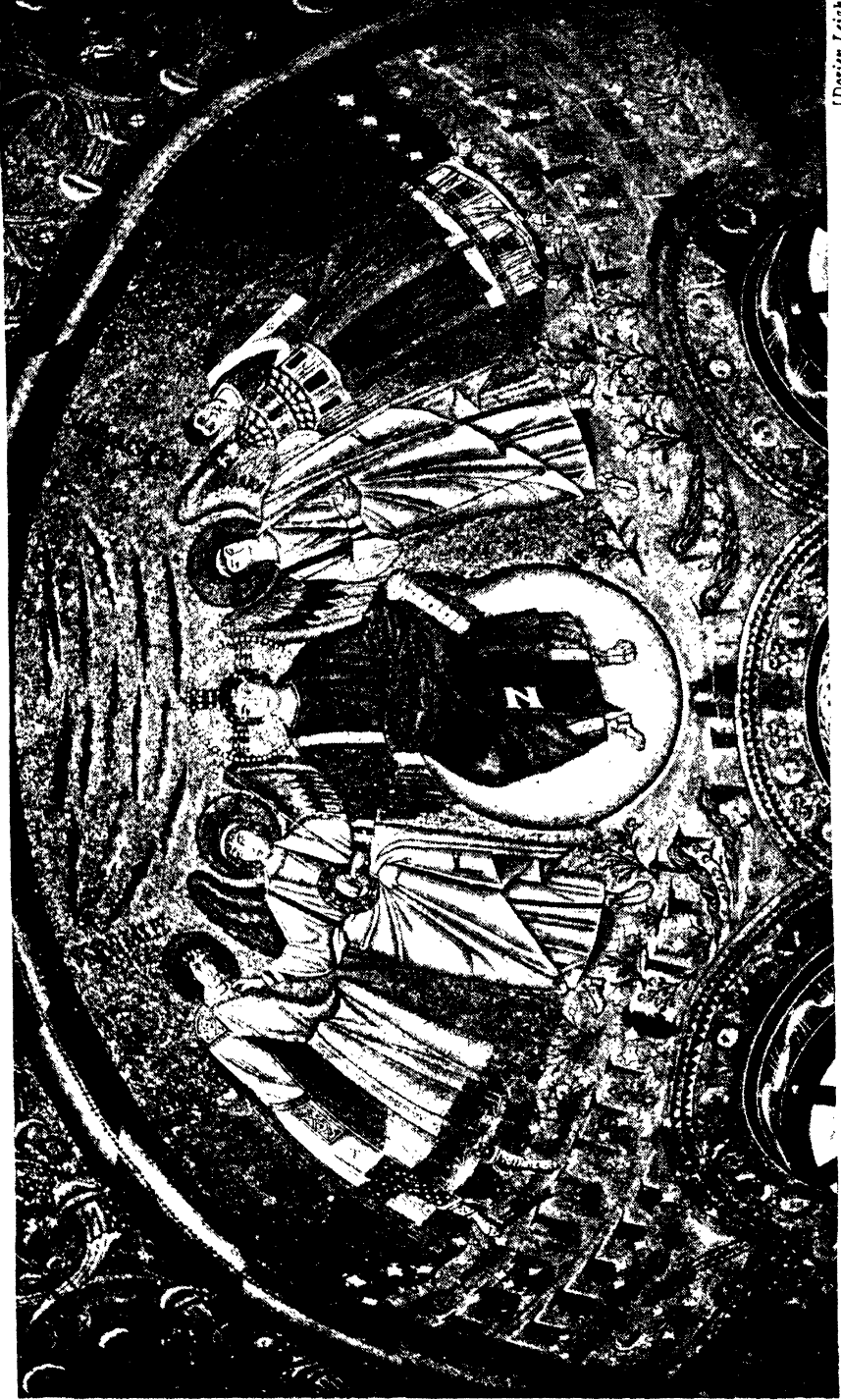

[Dorrien Leigh

RAVENNA: THE MOSAICS OF S. VITALE

The mosaics of the church of S. Vitale are the finest Byzantine work in the Western Empire. From the fifth to the eighth centuries Ravenna was the capital of Italy, and a thriving city. It was during the sixth century that the fine mosaics were added, when the city was at its peak of glory. In the

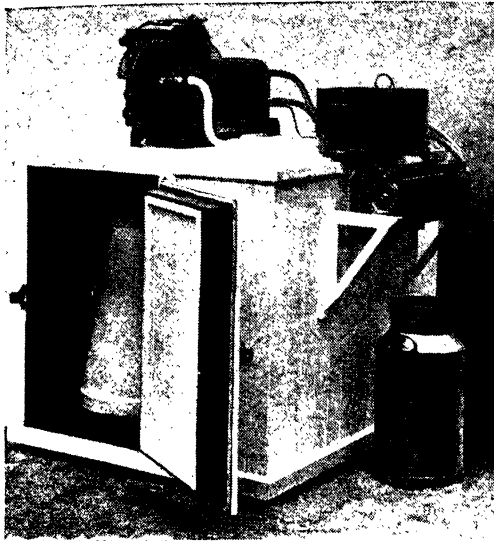

Carthew & Kinnaird

REFRIGERATION

The photograph shows, not a domestic refrigerator, but one used by a dairy to cool fifty gallons of milk per hour. The principle is the same whether milk or cooling air is circulated, and depends on the fact that a liquid or gas, when compressed and then allowed rapidly to expand, cools greatly in the process of expansion. The earliest refrigerator was the ice cream brine freezer.

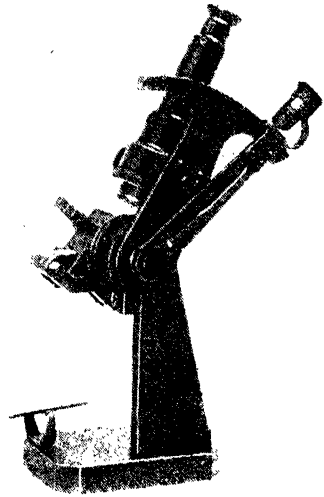

A REFRACTOMETER

Broadly speaking, a refractometer is any instrument for measuring the indices of refraction—but one of the commonest forms, which measures the refractive index of a substance by the deflection of a ray of light, is also an accurate gauge for very minute quantities, e.g. an

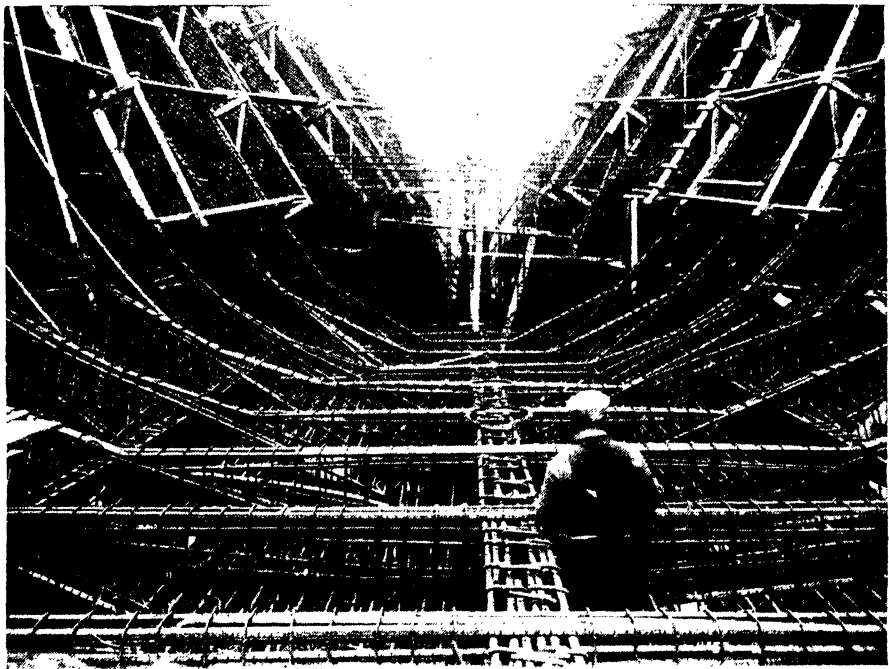

REINFORCED CONCRETE

Carthew & Kinnaird

Reinforced concrete is concrete strengthened with iron or steel rods in the parts liable to greatest stress. Though to-day the chief use of the invention is for tanks, floors, bridges, and buildings, it is also applied occasionally to ship construction, as illustrated.



RIO DE JANEIRO HARBOUR

[From "Wonders of the World"]

Rio Harbour is generally acclaimed as the most beautiful in the world. The mouth of the bay is only a mile wide but the water, deep enough for large vessels, extends back for nearly fifteen miles. The scenery is extremely lovely.

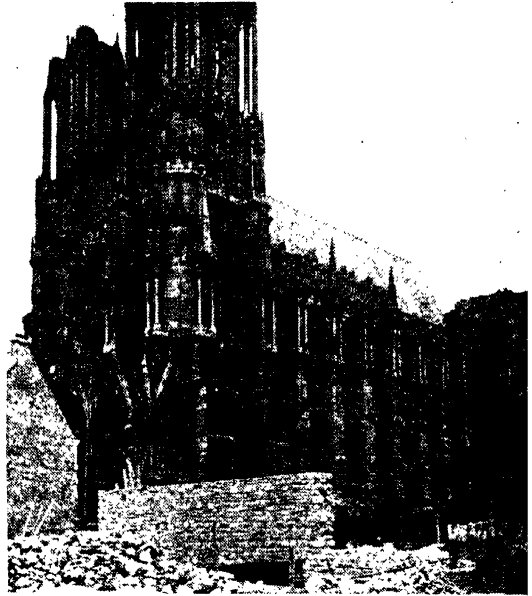

RHEIMS CATHEDRAL

[Dorien Lei]

The Cathedral of Notre Dame at Rheims is said to possess in its western façade one of the most perfect masterpieces of the Middle Ages. Completed in 1241, and for a long time the crowning glory of the French kings, the Cathedral has changed much, and was severely damaged during the Great War.



THE RIBBON FISH

The adult Ribbon Fish, sometimes cast up on the shores of Scotland is an elongated, flattened creature whose fins are its least conspicuous feature. The amazingly contrasted fins of the young fish are shown here. The arrow-head effect is due to little tabs of skin.

[From "Marvels of the Universe"]



"THE ANATOMY LESSON" BY REMBRANDT
Harmens van Rijn Rembrandt, perhaps the finest of all Dutch painters, was born of humble parents at Leiden in 1606. After training under Swansenburgh he settled down in Leyden to paint the life he saw around him, though often metamorphosing his subjects into Biblical guise. In later life (he died 1669) he moved to Amsterdam. Rembrandt was pre-eminently the painter of old age, but as a study in expression the example reproduced here could scarcely be bettered. The original of this picture is at The Hague

(Dorlon Leigh)



"LOUIS XIV.," BY RIGAUD

[Dorien Leigh]

Though this portrait of the "Grand Monarque," owing to the illustriousness of the sitter, is the widest known of Rigaud's works, it is somewhat touching to note that the artist's masterpiece, from an artistic standpoint, was not one of the many notabilities who sat for him, but his own mother. After early study in Paris, Hyacinthe Rigaud in 1681 went to Rome, and acting on advice, modelled his style on that of Van Dyck. He was a respected member of Louis' court, and painted, amongst others, Charles XII of Sweden, Boileau and Bossuet.

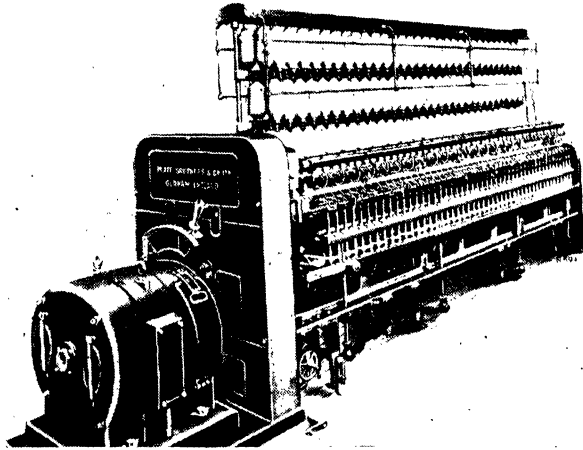

A RING SPINNING FRAME

[Carthoe & Kinnaird

Spinning is the final process in cotton manufacture, and can be performed on either a ring spinning frame or a mule. In the former the processes of attenuating, twisting and winding are carried on continuously and simultaneously. This photograph shows the machine with a full load of bobbins.



Theo Carreras]

ROCK SHELLS

These are shell-fish which burrow their way into fairly soft rock for protection. In this sectional illustration three varieties are shown: at back, the Magilus, which has prolonged its spiral shell to escape burial alive in the growing coral; on left, the common Piddock, showing the curious hinges; on right, the Date Mussel



[Carthoe & Kinnaird
A ROBOT

While admittedly more 'scientific than utilitarian, the robot as devised in different countries is a great triumph of invention. The word is of Czechoslovakian origin, and came gradually into English use

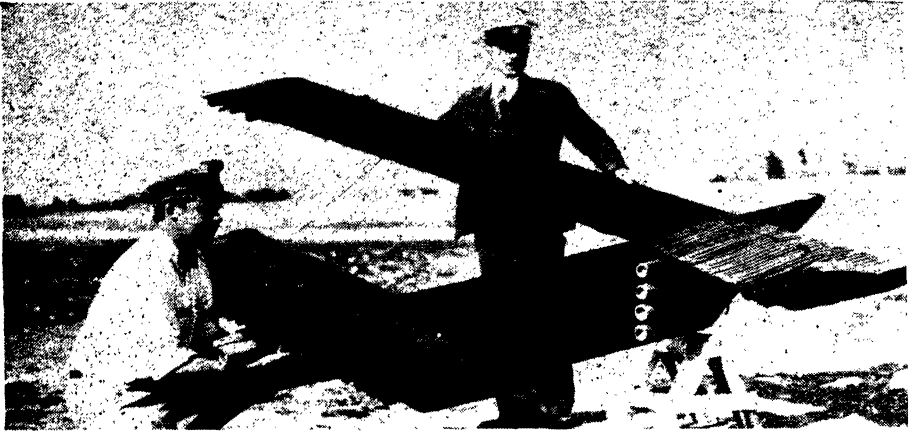

A ROCKET AEROPLANE

[Kevst

The inventor (seen standing) of this rocket aeroplane is American. The model plane is equipped with a series of rockets in the broad tail, the sides of the fuselage, and the extremities of the wings, and is otherwise without engine of any kind.

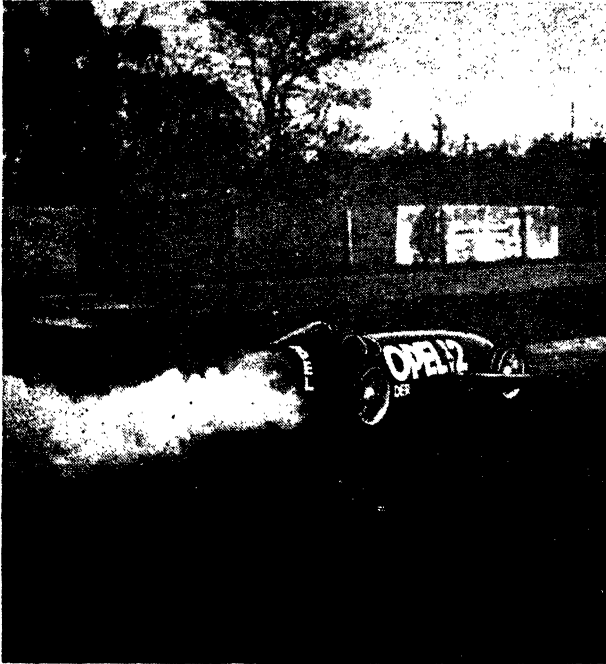

Photos]

THE OPEL ROCKET CAR

[Kevstanc

This photograph shows the rocket driven car, invented by Herr von Opel, during tests on the Berlin race track. With thunderous noise and a streaking trail of flame and smoke the car attained a speed of 60 miles per hour in 8 seconds. Though hardly commendable in present form, this mode of propulsion is not without possibilities.

ROCKET MAIL-CARRYING

The greatest possibilities of the rocket seem to lie in uses which do not concern the transport of man. Although an experiment in 1934 to "rocket" letters from Kent to the Isle of Wight proved a failure, a similar but smaller enterprise in Germany proved a conspicuous success.

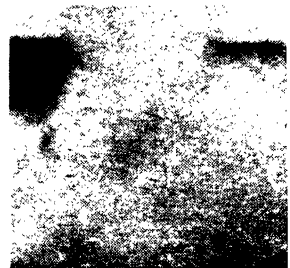

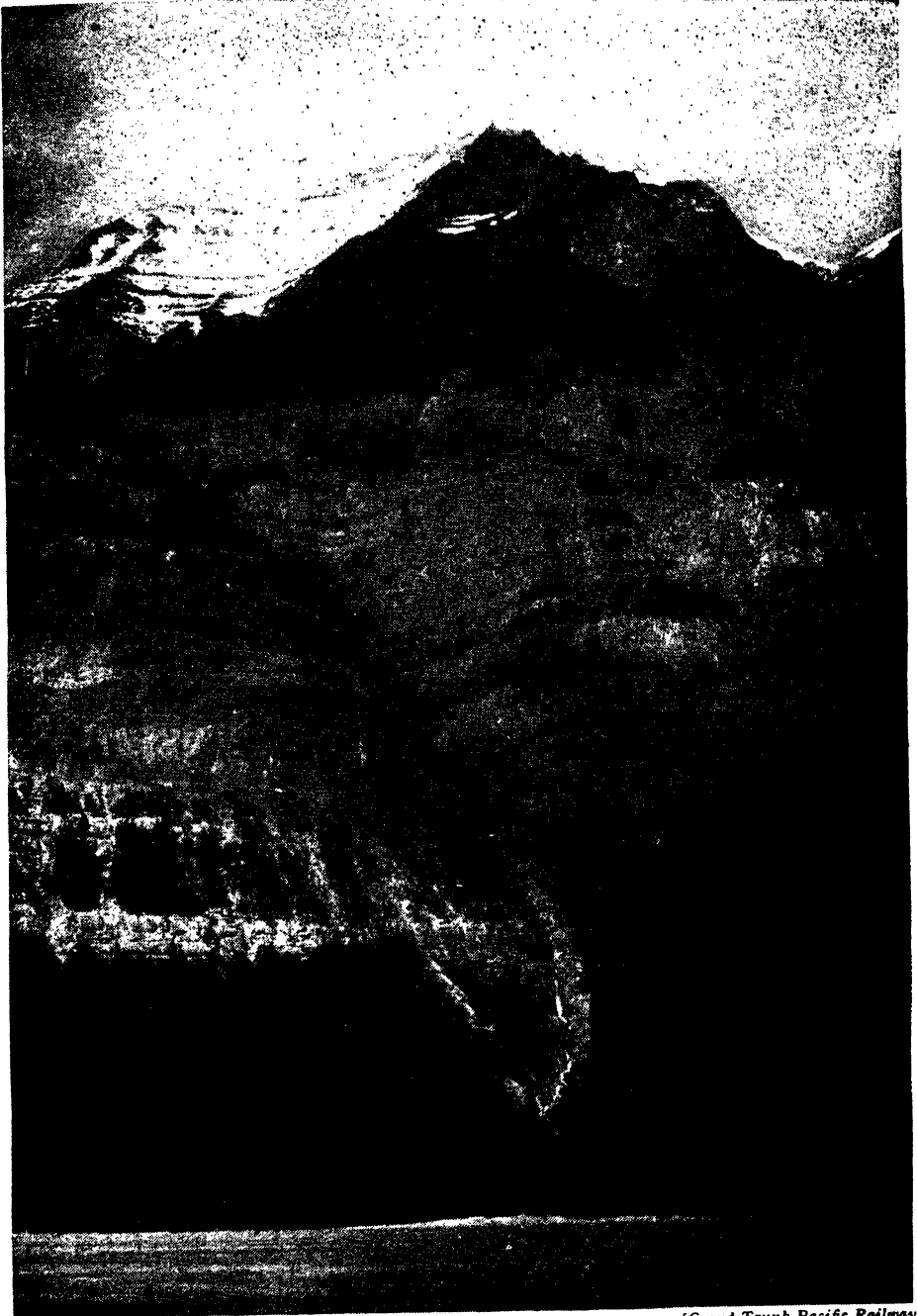

[Grand Trunk Pacific Railway]

THE ROCKIES: MT. ROBSON

There is still some controversy whether the Rockies are directly linked to the Andes, but even regarded severally the two systems are the greatest mountain ranges in the world. The Rockies stretch from Alaska to Mexico, and contain volcanoes at both ends. The highest peak, 20,000 feet, is in Alaska. Mt. Robson is in Canada.

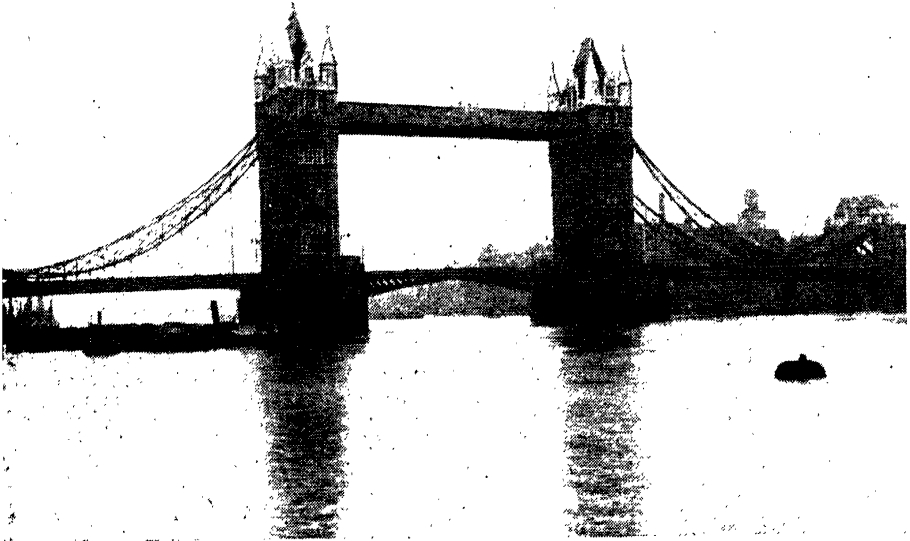

THE PRINCIPLE OF THE ROLLER LIFT BRIDGE

[Carthew & Kinnaird

Also known as a bascule bridge, this type is distinguished by the centre span being formed in two leaves which pivot vertically on the horizontal rollers, to admit the passage of shipping. A counterweight keeps each leaf in poise, and the movement is generally hydraulically controlled. The picture shows a well known example, the world-famous Tower Bridge of London

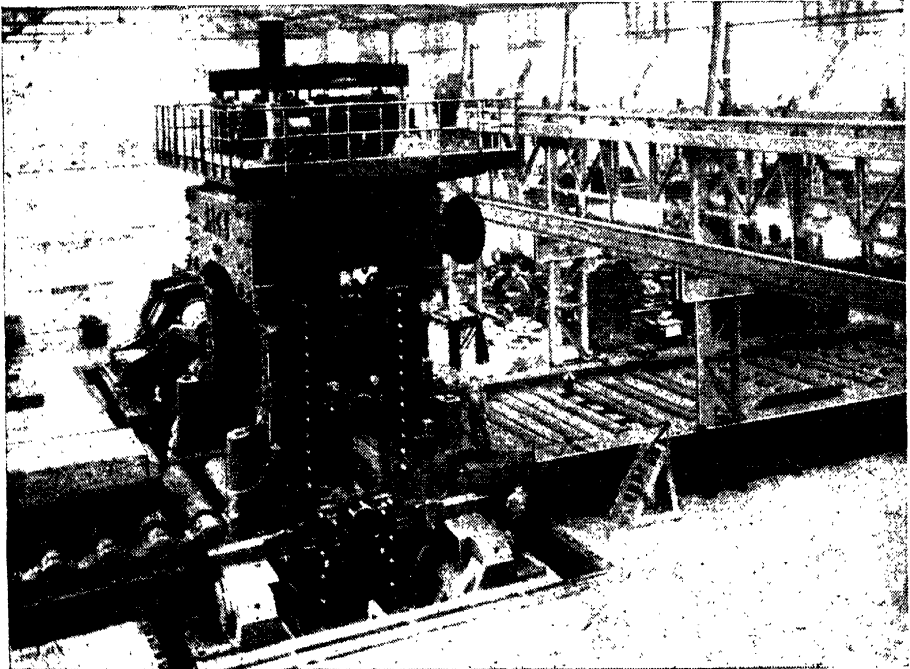

A ROLLING MILL

[Keystone

The mill here illustrated was at the time of construction the largest of its type in the world. It was built in a Düsseldorf steel works, and weighs in all 2,500 tons. Driven by a 15,000 h.p. motor, the machine is capable of rolling blocks of 90 tons



7



THE REMAINS OF A ROMAN GALLEY

[Carthew & Kinnaird]

Roman galleys, the luxury liners of the Ancient World, were not only large vessels for their time, but if anyone of importance was to travel in them, often of unimaginable magnificence. Not much, except the suggestion of size, left of the galley shown here, the interestingly in the site, for the old timbers were unearthed during the foundation-laying of the present County Mall, Westminster.

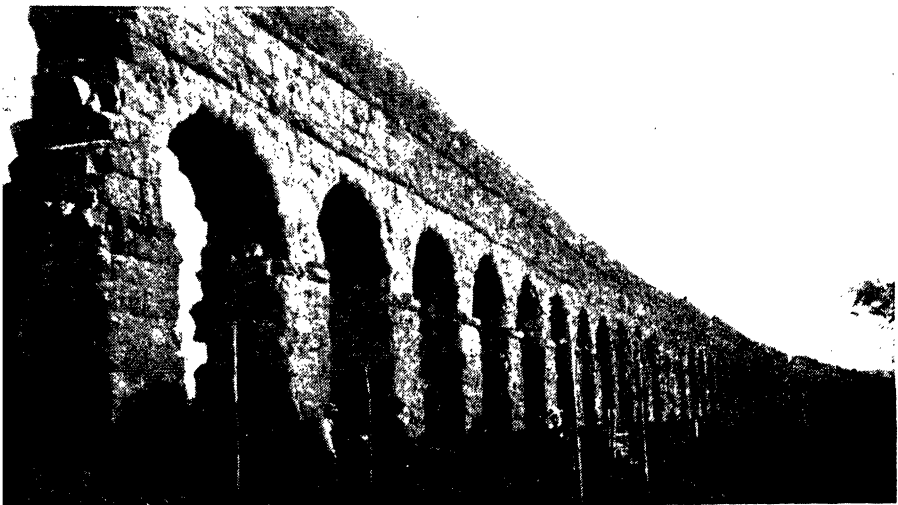

[From "Wonders of the World"]

ROME: THE AQUEDUCT OF CLAUDIUS

Rome was in olden days supplied with water by means of these gigantic aqueducts. The Claudian Aqueduct, which brought water from the Subiaco neighbourhood, was no less than 42 miles long. Curiously, another aqueduct, the Anio Novus, was built on top of it. The remains are exceedingly impressive.

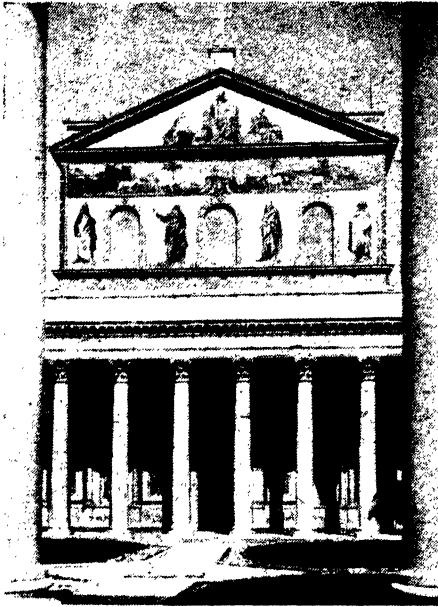

Dorrien Leigh

ROME S. PAOLO FUORI LE MURA

This church stands about a mile beyond the S. Paolo gate. The original building, founded by Theodosius I in 386, was said to be the finest in Rome. A disastrous fire in 1823 necessitated entire rebuilding, and the opportunity was taken to add the richest possible decorations. The mosaics on the façade are typical of the whole.



**ROMAN FORUM [From "Wonders of the World"]
HOUSE OF THE VESTAL VIRGINS**

The Vestal Virgins were the six priestesses of the goddess Vesta. Their term of office lasted at least thirty years, during which any violation of chastity was punishable with death. Vesta herself was the goddess of the hearth, and the Vestals' chief duty was to keep alight the sacred fires.

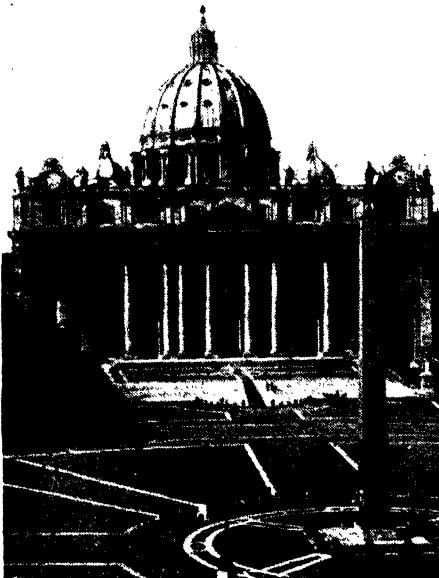

From "Wonders of the World"

ROME: ST. PETER'S

For St. Peter's great dome Michelangelo is said to have made a close study of the dome of the cathedral at Florence. Seeing that St. Peter's is the chief temple of the oldest and most international sect, it is



From "Wonders of the World"

ROME: THE ARCH OF TITUS

Titus, in the reign of his father, Vespasian, performed the famous capture of Jerusalem (A.D. 70). It was to commemorate this that the Arch was erected; the inside face is decorated with bas-reliefs showing the

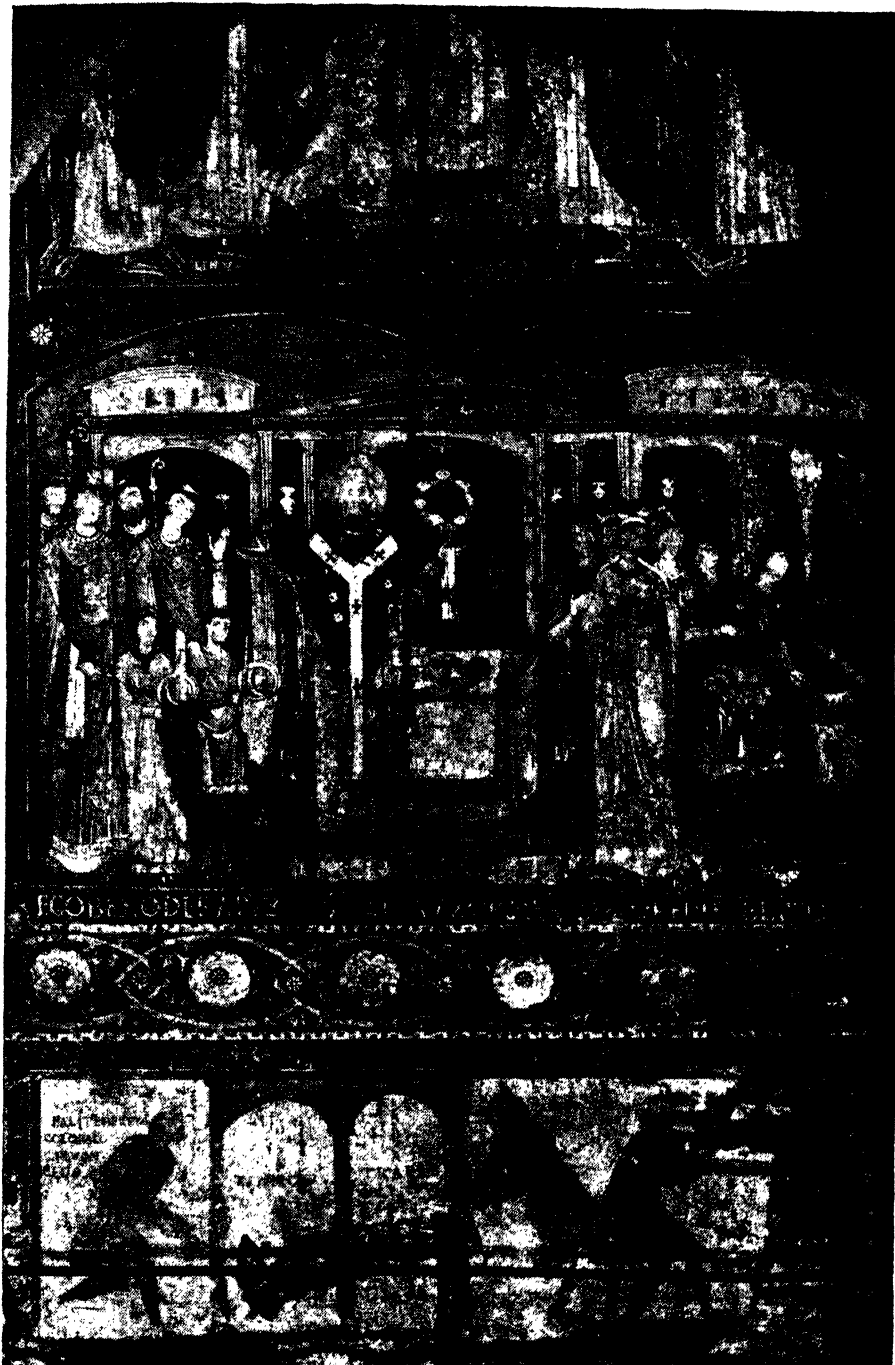

[Dorien Leigh

ROME. MOSAICS IN THE CHURCH OF S. CLEMENTE

S. Clemente is one of the oldest and best preserved churches in Rome. Below the present building is an old basilica used by the very earliest Christians; beneath that again, the house where Clemente received St. Peter and St. Paul. In the basilica are some wonderful mosaics and frescoes of the ninth and tenth centuries. One of these, representing S. Clemente officiating at the altar, is reproduced here



[Donald McLeish]

ROME. THE "TEMPLE OF VESTA"

The title of this little round temple is entirely erroneous, and dates only from the sixteenth century. The small church of S. Maria del Sole is now contained within the building. The roof is a tasteless Catholic addition, very much out of keeping with the beautiful Roman columns.



[From "Wonders of the World"]

ROME FROM THE ROOF OF ST. PETER'S

The famous Piazza, containing Caligula's obelisk brought from Heliopolis, is in the foreground, and on the extreme right are some of the buildings of the Vatican city. Bernini designed the colonnades of the Piazza; St. Peter's itself, the largest cathedral in the world, is the work of Bramante, Raphael, and Michelangelo.



ROME: THE TRIBUNE AND ALTAR OF IL GESU

[W. F. Mansell

The Church of Gesù is the chief church of the Jesuits, and contains the tomb of Ignatius Loyola, their founder. As with all other Jesuit buildings, the decoration is in the main over-ornate; but the shrine of Loyola, here illustrated, is not without majesty, and at least is remarkable for the wonderful variety of marbles used. Andrea Pozzo was the architect.

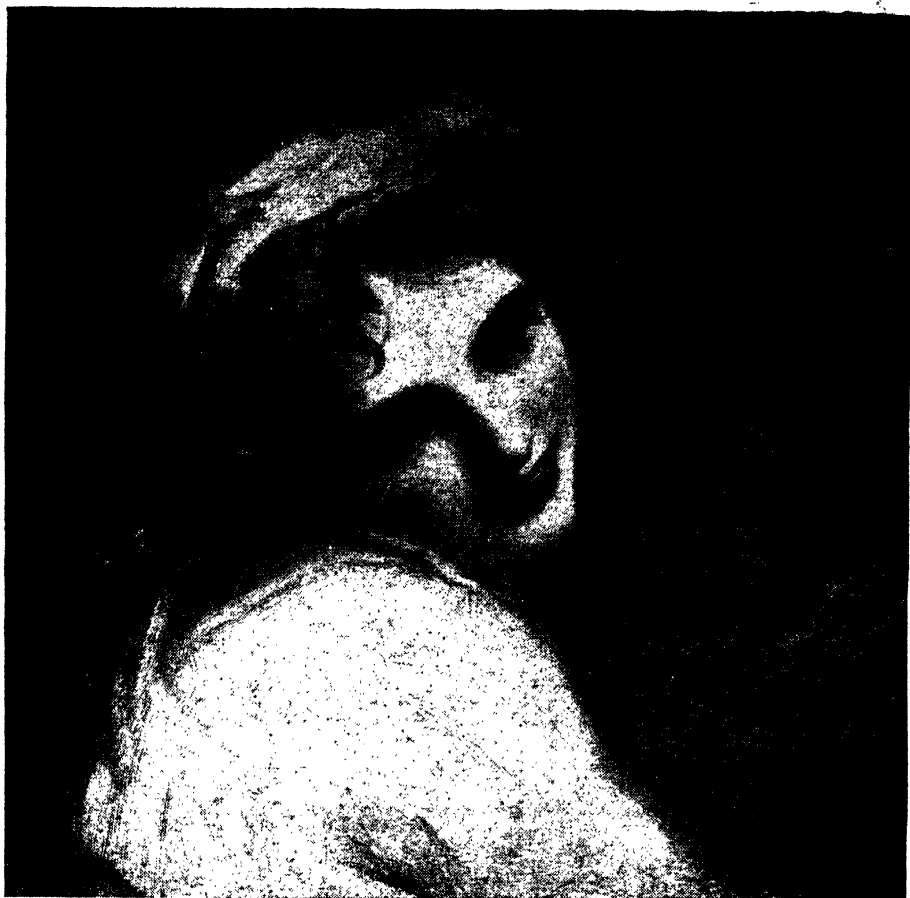

"LADY HAMILTON AS A BACCHANTE," BY ROMNEY

[Dorien Leigh]

George Romney (1734-1802) was the son of a builder of Dalton-in-Furness, and went to London in 1762. He became the professional rival of Reynolds, but his most famous and frequent sitter was Emma Hart, Nelson's Lady Hamilton. Romney died rather obscurely, and for a century after his death his beautiful work was unaccountably neglected.



[From "Wonders of the World"]

LAKE ROTOMAHANA

The most remarkable feature of this New Zealand lake is not that its waters are hot and steaming, but that until 1886 it was only one-thirtieth of its present size! Itself originally a volcanic crater, it stands close to the volcano Tarawera, which fifty years ago erupted violently.



ROTHENBURG AM TAUBER
 Almost every street of this small Bavarian town is crowded with medieval buildings, making the place a serious rival to the larger Nuremberg. This particular view shows the curious Punishment Tower at the North-west corner of the old city walls. These towers in various sizes and shapes are a common feature of Rothenburg, which is one of the most romantic towns in all Bavaria.



RONDA - THE TAJO
 The Andalusian town of Ronda is, perhaps the most uniquely situated in the world. Many of its magnificent houses are built on the tops of cliffs, but the pinnacle on which Ronda stands is cleft in two, and, for a long time, it was considered impossible until the seventeenth century did anybody dare to build a bridge across—and then the architect fell headlong from the top!



Cartlew & Kennasra

A ROTOR SHIP

This type of vessel depends on the discovery, made in 1922, that the driving pressure of wind on a rotating cylinder, especially one fitted with discs, is nearly five times greater than on an ordinary sail. The rotor is turned by an electric motor, and has the added advantage of great stability

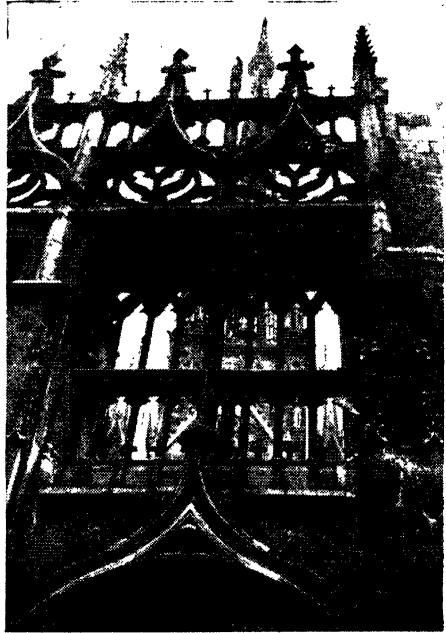

Durson Lyle

ROUEN CATHEDRAL

Rouen Cathedral took three centuries (thirteenth to sixteenth) in building, the earliest church on the site having been burnt down in 1200. There are three spires, all of different dates, the tallest (400 feet high) being modern. The photograph here shown is typical of the views from the town's narrow streets



ST. OUBN, ROUEN

[Keystone

Rouen is unique in possessing three churches unsurpassed anywhere else in France. St. Ouen, built in the fourteenth and fifteenth centuries, stands on the site of a Roman basilica, and is in some ways finer than the Cathedral. The octagonal Fontaine and the rose-window seen beneath it are outstandingly lovely

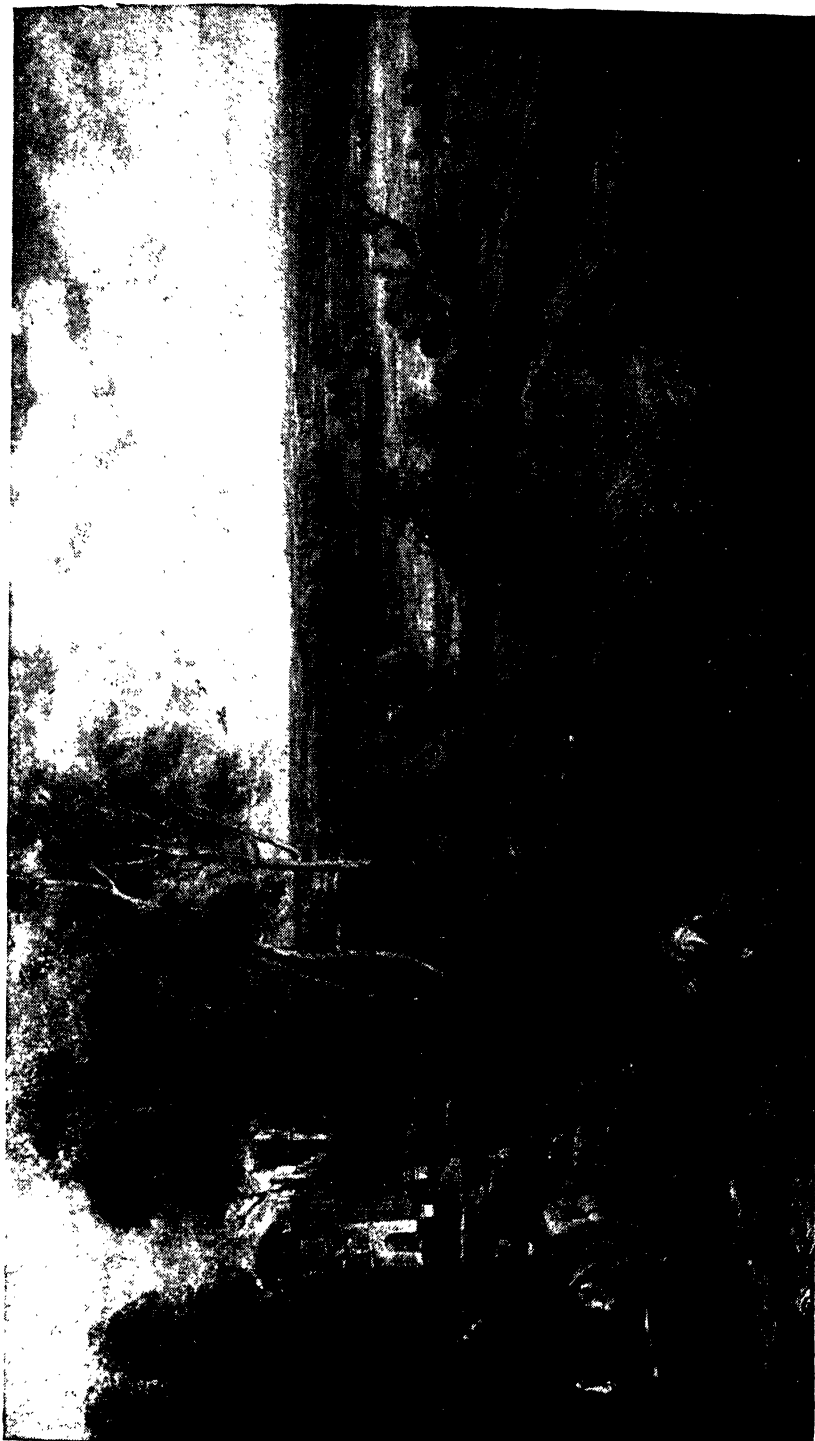

(Doris Leigh)

RUBENS' "LE CHATEAU DE STEEN"

Though a Fleming, Peter Paul Rubens (1577-1640) was born in Westphalia, where his father was temporarily a prisoner. He studied art first under various Flemings, and then at Mantua and Venice. He returned to Antwerp, where he remained, except for a short visit to England, working prodigiously until his death. His paintings include landscapes (of which the above is a fine example), religious works and portraits. His forte, apart from landscapes, was the depiction of tumultuous action and stirring emotions

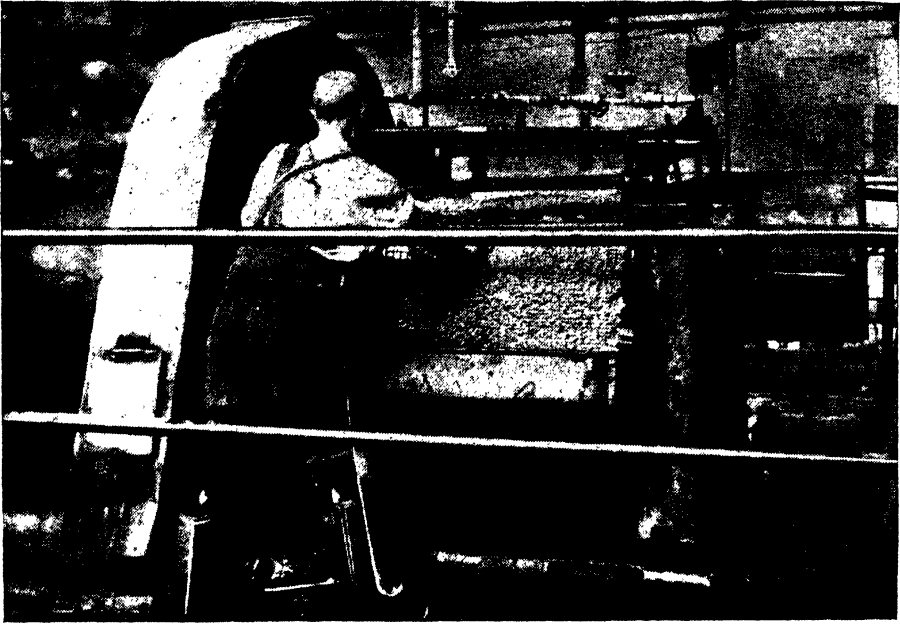

WASHING RAW RUBBER

[Courtesy Dunlop Rubber Co.]

The milky juice, which in coagulated form is known as rubber, is entirely different from the sap of the rubber trees; it lies chiefly in small sacs between the outer bark and the wood. The first cultivated rubber plantation was laid out in Ceylon in 1876, though some use had already been made of wild rubber grown in the Amazon area.



BUILDING THE CASING OF A RUBBER TYRE

[Courtesy Dunlop Rubber Co.]

The uses of rubber run into unnumerable divisions, but probably the most important, and certainly the largest of all, is the tyre industry. The first pneumatic rubber tyre was patented in 1845 by Robert Thompson, an Englishman; used exclusively for bicycles before the invention of the motor car, tyres were first fitted to the latter by Michelin.



A GROUP BY RUDE

[Dorson Lough

François Rude (1784-1855), the son of a Dijon potter, rose to be one of the greatest sculptors of nineteenth-century France. After a youth spent in the pottery business, he studied sculpture in Paris under Cartellier, and in 1817 won the Prix de Rome. Many of his early commissions he owed to his friend David, the painter, and his crowning success came when Napoleon commissioned him to decorate many public places of the "new" Paris. The above group, typical of Rude's stirring style, is on one of the two Arcs de Triomphe, and is called *La Marseillaise*. Other notable works of the sculptor are *Napoleon awakens to immortality* (in the Louvre) and the tomb of General Cavagnac in Montmartre cemetery.



THE GIANT SABRE-TOOTHED TIGER

[From "Marvels of the Universe"]

Except for the terrible tusks which gave it its name, this prehistoric beast is much nearer to the likeness of present-day animals than almost any other creature long since extinct. The Sabre-tooth was widely distributed, remains being found in Europe, India and both Americas; it was much heavier and less agile than the modern tiger, and probably owes its extinction to inability to cope with changing environment

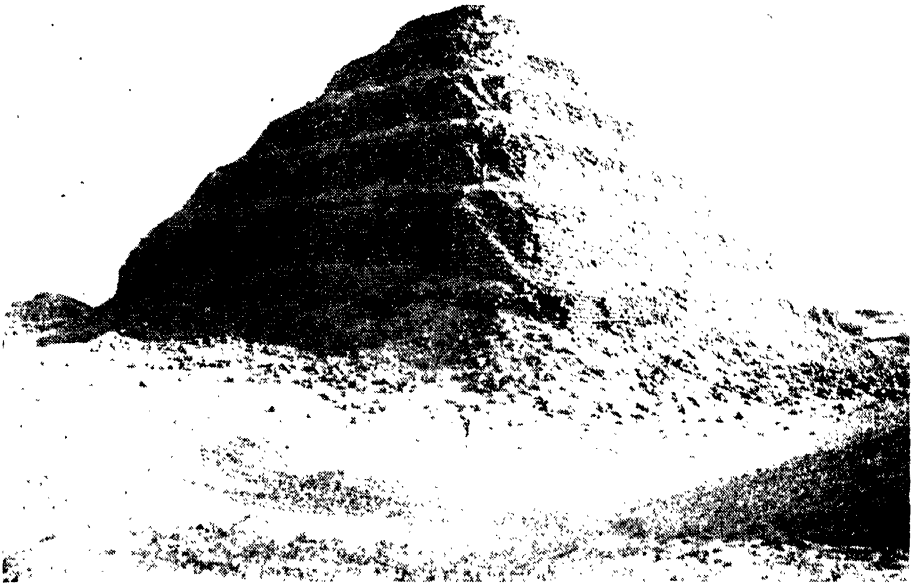

THE STEP PYRAMID, SAKKARA

[E.N.A.]

This is reputed to be one of the oldest monuments in Egypt, and is an illustration of how the Egyptians are believed to have learnt "step" pyramid building as a stage to the better-known sort. The Sakkara Pyramid covers the tomb of a First Dynasty king. The shape is not square, but oblong.

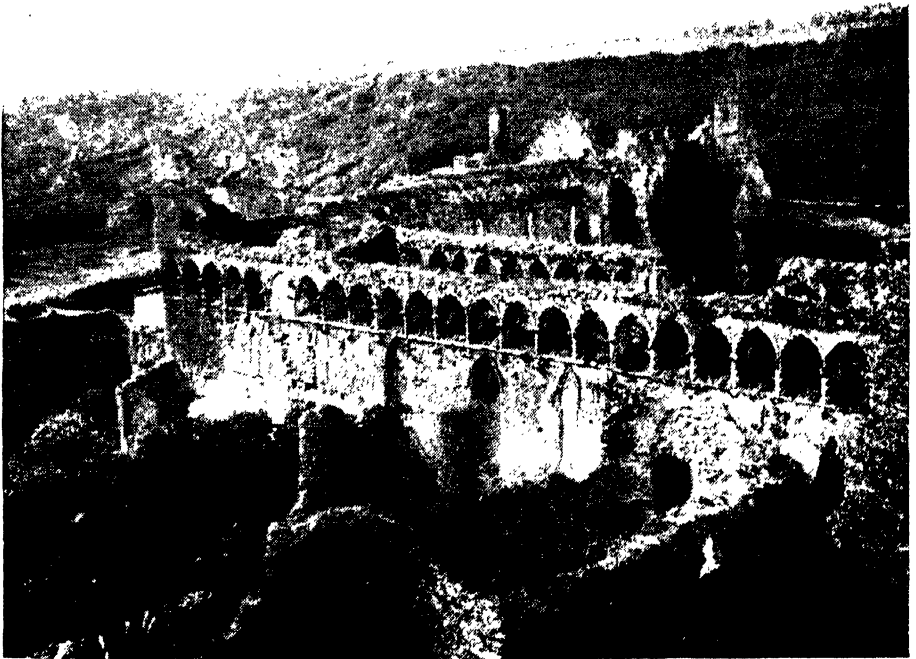

THE BISHOP'S PALACE, ST. DAVID'S

[Sport & General]

St. David's, Pembrokeshire, is the smallest and loneliest cathedral city in the United Kingdom. The first church founded here by St. David himself; the Bishop's Palace, which to judge from its ruins must once have been a minor wonder of Europe, was built by Bishop Gower in 1142.



[Dorsten Leish.]

SAN GIMIGNANO

San Gimignano has been called the Carcassonne of Italy. It stands in Tuscany, 17 miles north-west of Siena. Though not entirely walled about, such walls as remain are singularly free from restoration. In addition there are thirteen tall square towers and a cathedral of early medieval date.



Donald M. Leish.

LA ROCCA, SAN MARINO

San Marino, 48 square miles in extent, prides itself on being the smallest and oldest republic in the world. Most of its area is taken up by Monte Titano, a three-peaked mountain whose highest peak, Gaiata, is crowned by the fifteenth-century castle of La Rocca. The amazing situation of this fortress is clearly shown here—the drop to the right being 1,000



SAND-BLASTING BELLS

[Keystone]

Probably not one person in a thousand has ever heard of this difficult and dangerous job. Sand-blasting is one of the last processes at a bell foundry and consists in blowing sand at high speed on to the inner surface. The operator, despite his heavy protective garb, must not remain in the cabinet for more than half an hour, and is served with milk at intervals.



[Photos]

BACCHUS: BY SANSOVINO

Andrea Sansovino (1460-1529) (real name Contucci) was a great Italian sculptor and architect, the son of a peasant, whose most individual characteristic is his close study of the theoretical side of art.



[Dorion Leigh]

A PAINTING BY SASSOFERRATO

Giambattista Salvi, better known as Sassoferrato, was an Italian artist of the seventeenth century. Though not one of the greatest masters, he occasionally produced a work of outstanding excellence. The painting reproduced here—probably his best—shows the "Madonna del Rosario" with SS. Dominic and Catherine of Siena.

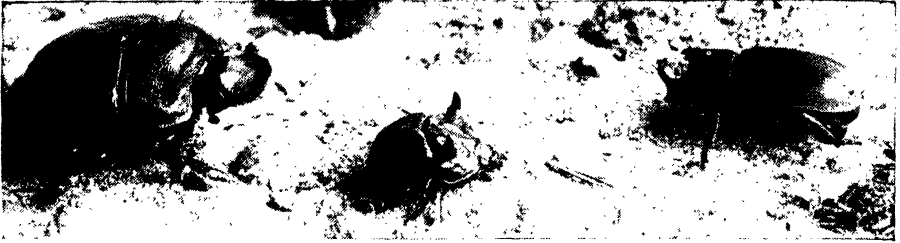

SCARABS

[L. STIMP, F.L.S.]

A group of three scarab varieties is shown here. The scarab's chief claim to renown is that one of its varieties was the famous sacred beetle of the Egyptians

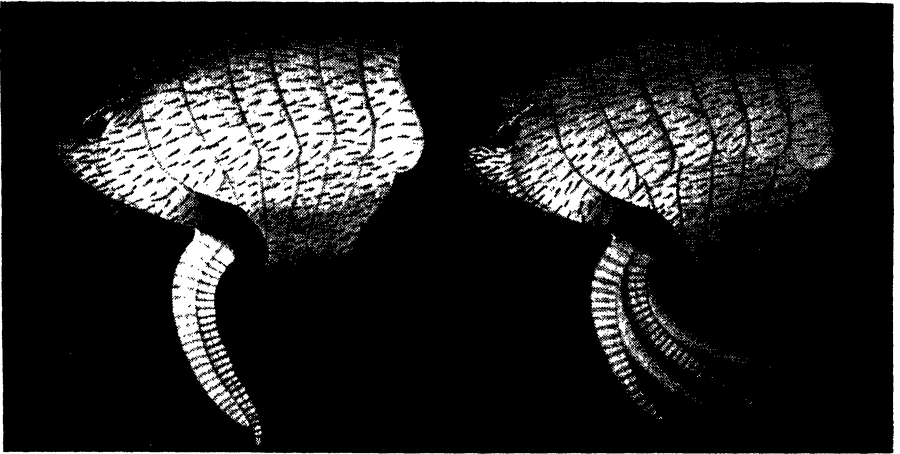

THE SAW-FLY'S SAW

[FROM "MIRACLES OF THE UNIVERSE"]

The saw-fly's habit is to cut a minute slit in a willow-leaf, therein place an egg, and hermetically seal the slit with saliva. This diagram gives a much enlarged view of the delicate instrument which not only does the cutting but lays the eggs. On the left the "saw" is in its natural state, on the right pulled apart to show its quadruple form

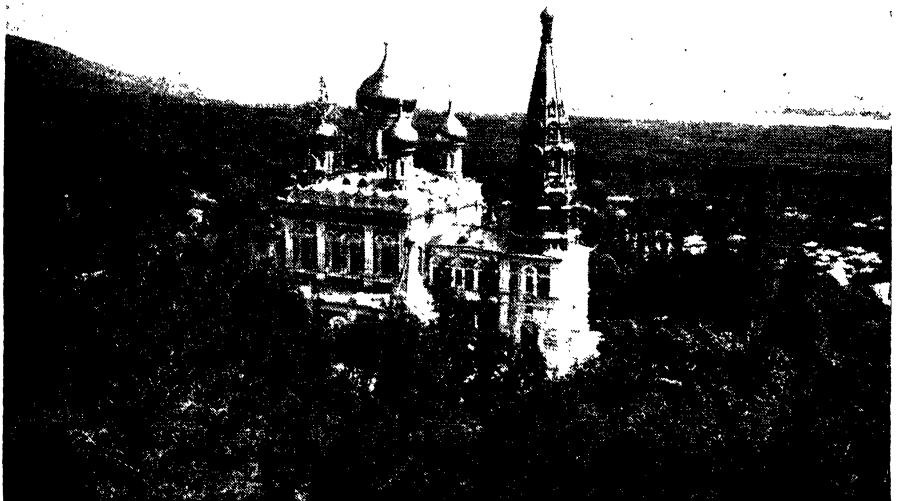

THE MONASTERY OF SHIPKA

This edifice, situated in the famous Shipka, or Schipka, Pass, Bulgaria, 47 miles north-east of Philipopolis, is one of the most artistic monastic buildings in Europe. The Pass itself is known as the "Wild Rose" Pass, because in the Toundja valley, adjoining, thousands of roses are grown for attar



SEA DRAGONS AND SEA HORSES

These extraordinary appetitions are fish, despite their unfishlike form. The liberal streamers of loose skin, in life coloured vivid red or brown, closely resemble the seaweeds among which the creatures dwell. The Dragons are shown in the centre—the lower specimen showing the affinity with the Pipe-fishes—the Horses in the upper corners

[From "Marvels of the Universe"]

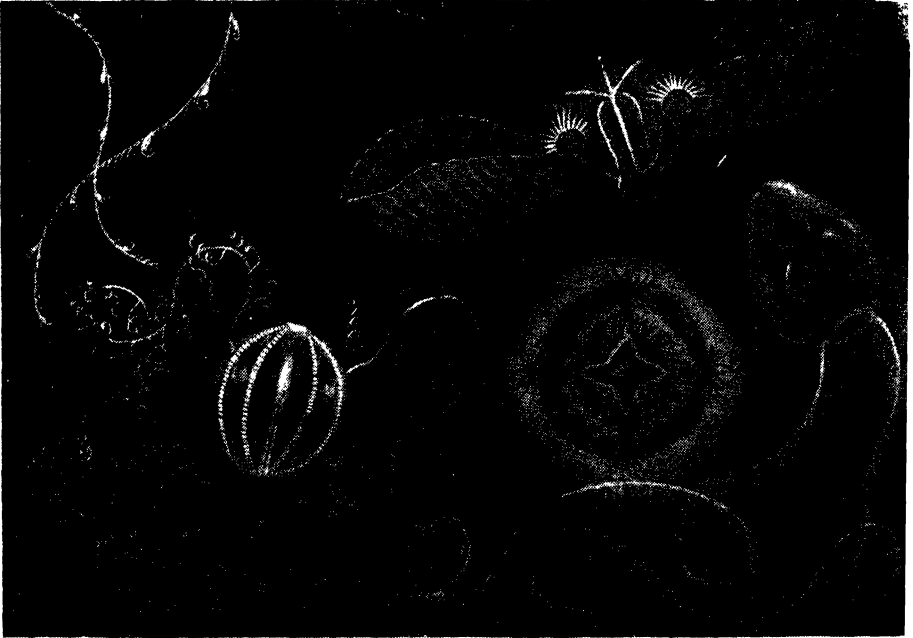

SEA-GOOSEBERRIES

[Theo Carreras

This peculiar class of Jellyfish is very abundant on the surface of the open sea 98 per cent water, the delicate tissues forming the other 2 per cent consist of muscle and nerve; the creatures prey greedily on little crustaceans and other marine life. The illustrations are slightly below life size

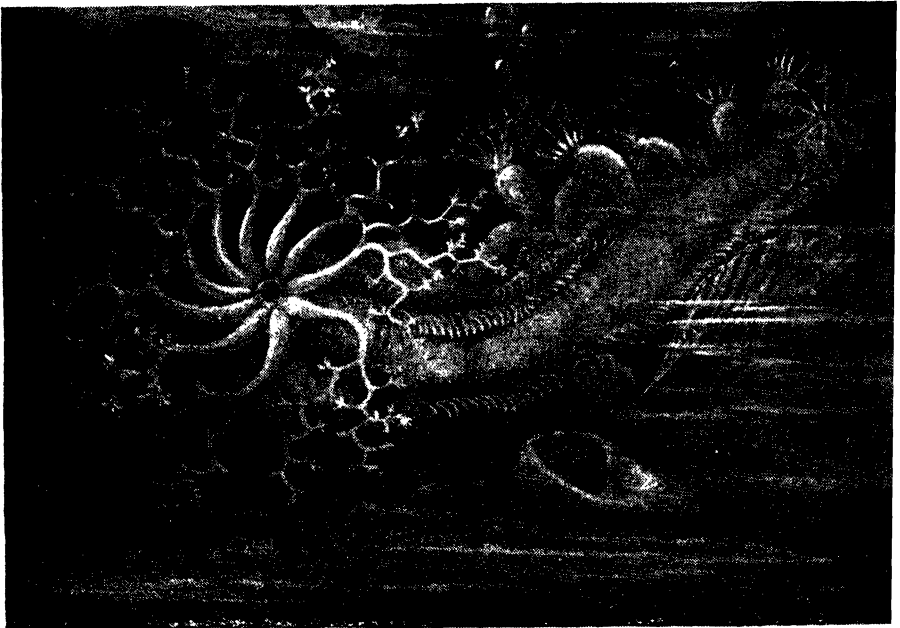

SEA-CUCUMBERS AND THEIR YOUNG

[Theo C

The saffron-coloured Sea Cucumber shown here is most abundant off the Falkland Islands, where it adheres to its suckers to big seaweeds. The branching expansions round the mouth are feelers for catching food. The young attach themselves to their mother's back, causing a bizarre effect



FOSSIL SEA MATS

[A. E. Smith

Sea Mats are colonies of polyzoa somewhat resembling, but organically superior to, the familiar Sea Firs. The skeletons of Sea Mat colonies are also not rare, though often mistaken for seaweed. The fossil type illustrated are so abundant in certain strata that beds are named after them.

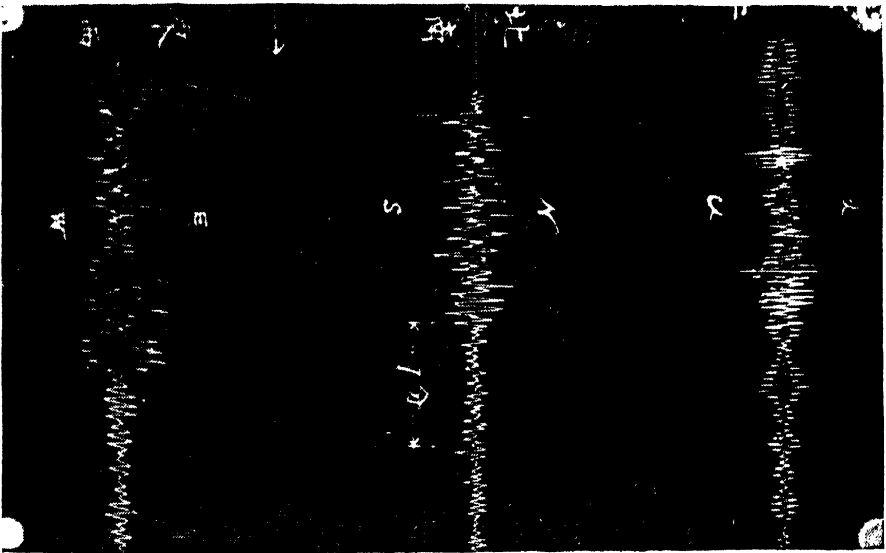

[Cartham & Kinnaird

A SEISMOGRAPH RECORD

This instrument for detecting earthquakes is the invention of Milne, a great pioneer in seismology. At least two seismographs are necessary for each detection, in order to determine direction. The record illustrated here is especially interesting, being that of the great Tokyo earthquake of 1923 which caused 150,000 deaths.

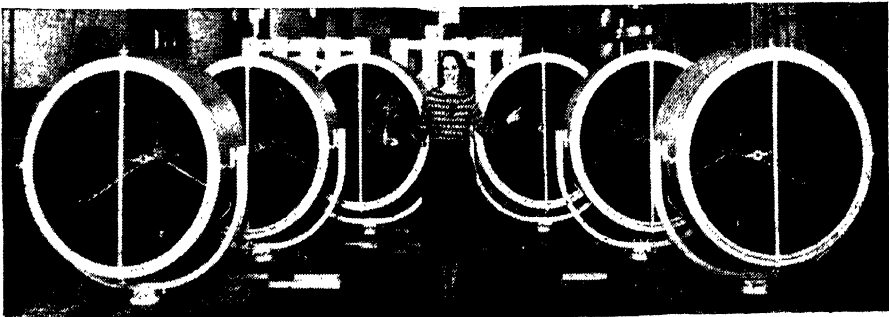

[Dorien Leig

SEARCHLIGHTS

The modern searchlight is the product of a chain of developments which have been made since the Great War. This photograph shows a batch of American searchlights, each 36 inches across, and in all capable of producing 1,500,000 candle-power.

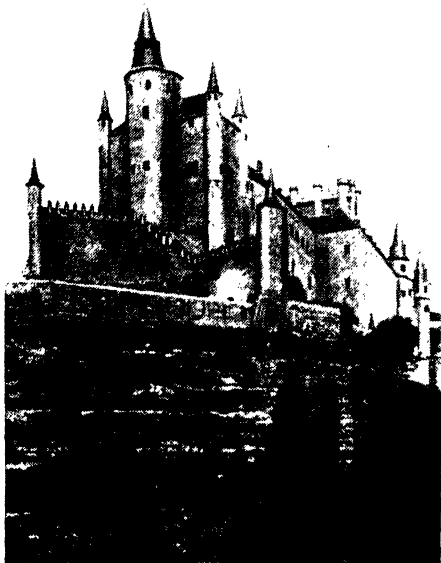

C. H. E. West, F.S.A., F.R.G.S.

SEGOVIA ALCAZAR

Alfonso VI founded this charming and fairylike castle in the eleventh century, since when it has been enlarged and remodelled. Its situation is very fine, for it stands at an apex of the long, diamond-shaped hill on which the old city is built.

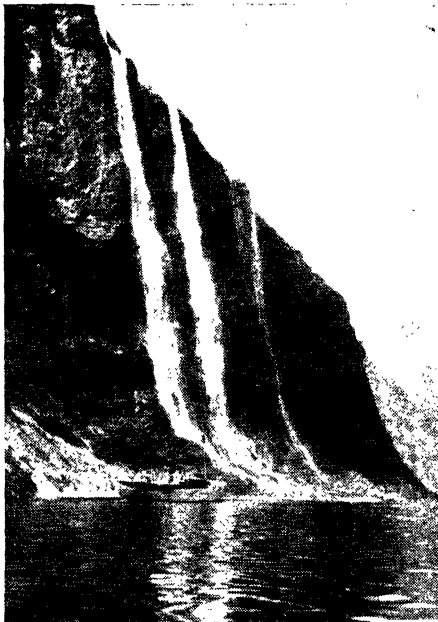

[Curtho & ...]

SEVEN SISTERS FALLS

The Seven Sisters drop into Geiranger Fjord, Norway. All around are mountains 5000 to 6000 feet high, among which tiny green valleys hang, seemingly inaccessible. The Falls are greatly enlarged during the season of avalanches.

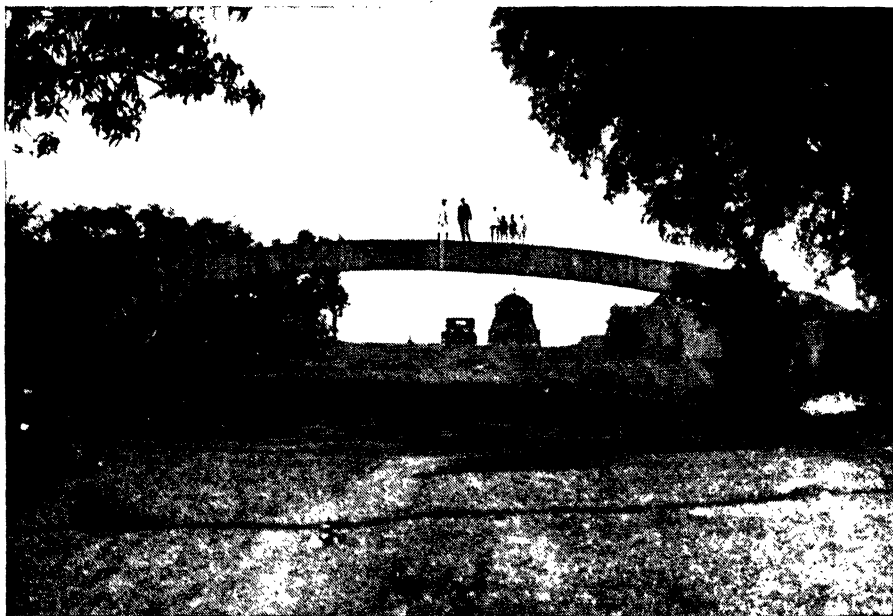

SERINGAPATAM: DE HAVILAND'S ARCH

[Dorion Leigh]

De Haviland's bridge, within the fort compound of this Mysore town, is a fine illustration of a mechanical principle pushed to its utmost. The bridge consists of a single span of ordinary bricks and mortar; yet so perfect is the construction that the arch actually springs up and down beneath the feet.

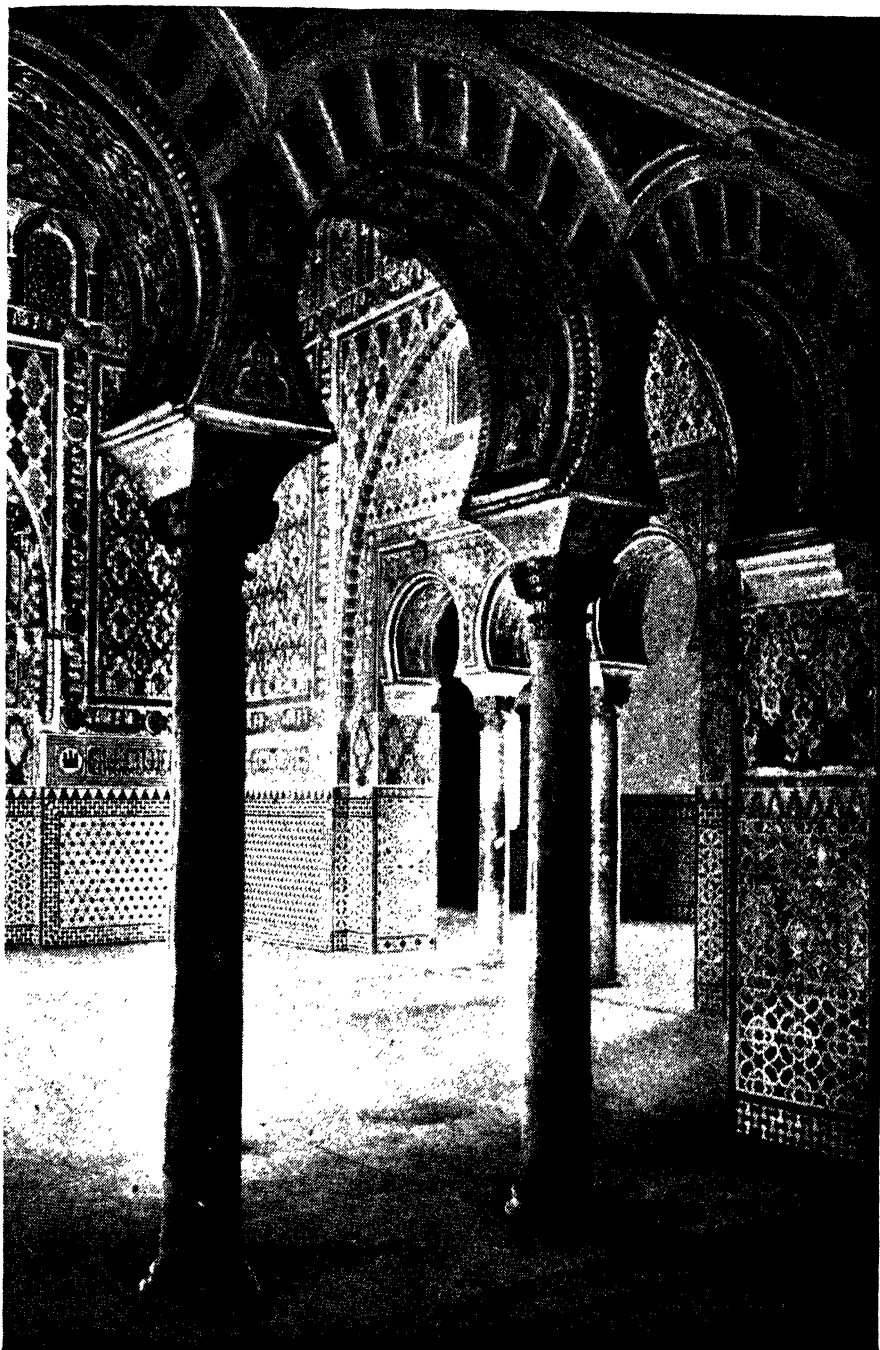

A GLIMPSE OF THE ALCAZAR, SEVILLE

[Photokrom Co. Ltd.]

With the Mesquita at Cordoba and the Alhambra at Granada, this constitutes the trio of Spain's most celebrated Moorish buildings, and in many ways it is the loveliest. Seville was regained for Catholicism long before Granada; one of its earliest Christian inhabitants was Pedro the Cruel. The Hall of Ambassadors shown above was his throne-room and at a later date it witnessed the wedding of the Emperor Charles V.

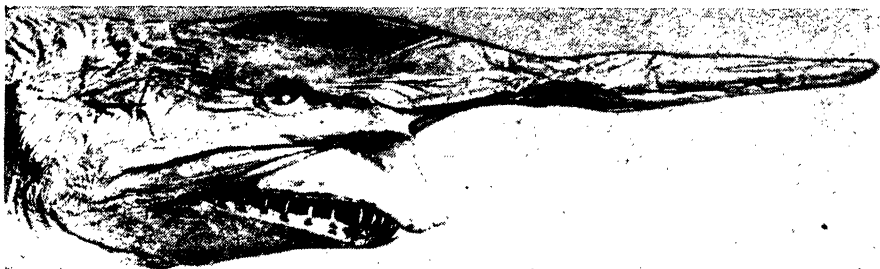

THE JAWS OF A SHARK

[From "Marvels of the Universe"]

This shows the head of a Goblin Shark, and anything at the same time so hideous and so formidable it would be difficult to find. The largest shark living, the Whale Shark, attains to a length of 60 feet. It is confined to the Indian and Pacific Oceans, but other types are found as far north as Britain. One variety lives almost entirely on shellfish, masticating the hard shells easily.



SIENA: THE CATHEDRAL BAPTISTERY

[W. F. Mansell]

In mediæval days the architectural magnificence of Siena rivalled that of Florence, and though it declined from the sixteenth century onwards, its beauties were carefully restored. The glorious Baptistery of the Cathedral, the apse of which is shown here, originally took 100 years to decorate. Latterly it was restored by Socini.



PUNKTAL SIGHT-TESTING APPARATUS

[Courtesy Carl Zeiss, London]

This instrument should not be confused with an ophthalmoscope, as it fills several different additional operations. By it defects of sight and angles of squints of every kind and degree may be ascertained, either for one or for both eyes, as well as accurate measurements made for the fitting of spectacles. The apparatus is a product of the great Zeiss works at Jena.

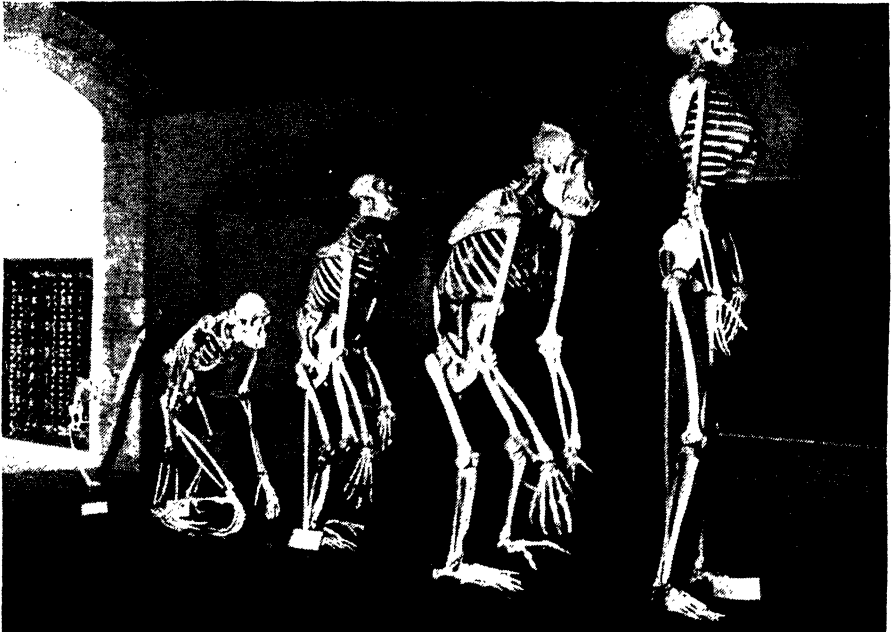

THE SKELETON

[Carthew & Kinnaird]

The human skeleton is of great interest not only intrinsically, but in comparison with those of animals which do not walk upright. Man was in his early stages probably something between biped and quadruped (as the modern monkey), and lived in trees. This series of skeletons in an American museum shows his transition to a vertical posture.

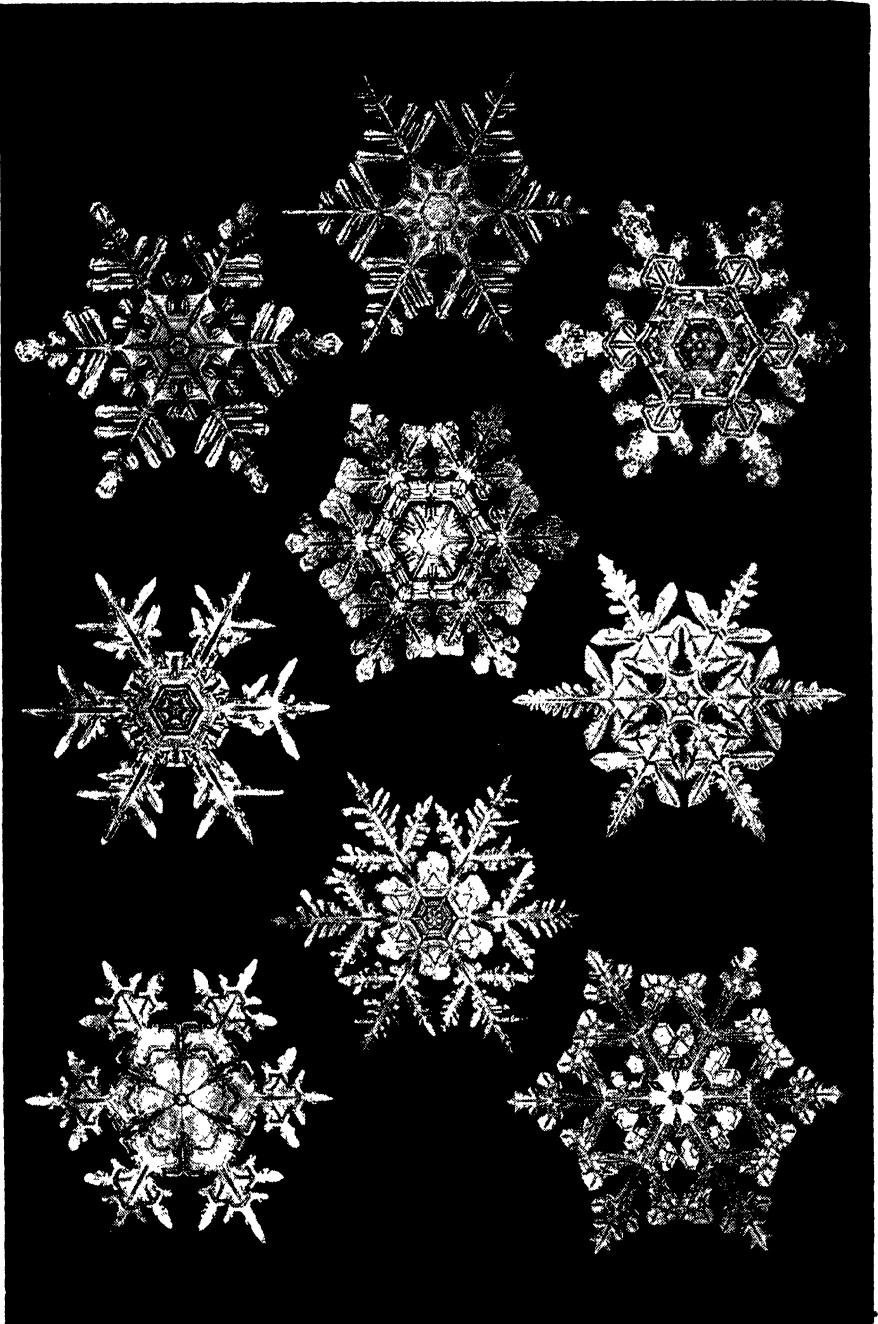

SNOW CRYSTALS

[From "Marvels of the Universe"]

It is said that no two snow flakes in a thousand are exactly alike ; on the other hand, notice from these pictures (which are enlarged photographs, not drawings) how the same fundamental principle is always kept—that of six straight rods radiating from a centre. Sometimes the interstices are barely decorated, leaving the rods like the spokes of a wheel, at others the spaces are filled in solid, transforming the star to an elaborate and decorative hexagon

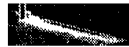

(Courtesy Western Electric Ltd.)

A SOUND FILM STUDIO AMPLIFICATION RACK

This view, though showing a very small fraction of the mass of scientific equipment at a modern film studio, gives a fair notion of its complexity. The picture was taken at the British and Dominion's premises at Ealing. To see how a film is "shot," turn to page 207.

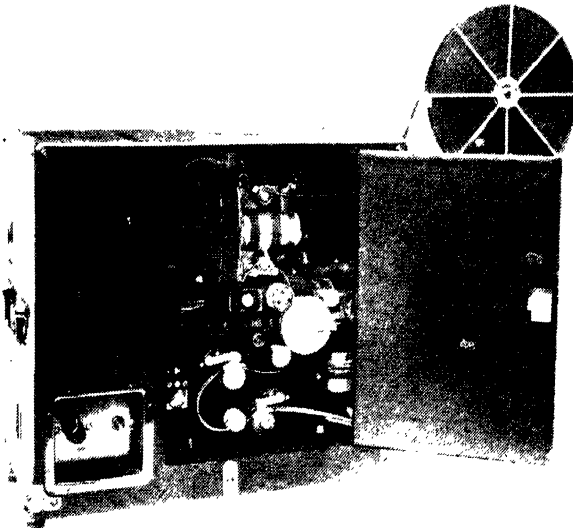

A SOUND FILM CAMERA

Here is shown a particularly remarkable form of sound-film camera, of the type which records the sound on the edge of the film. This machine takes a film only 16 mm. wide (the normal is 35 mm.) and is easily portable, yet fills a 12-foot screen and incorporates all the amenities of full-size cameras.



"SPANISH MOSS"

[Underwood Press Service]

This beautiful plant suspends its long silvery trails from the boughs of various trees; yet it is not a parasite, having the very remarkable propensity of drawing its nourishment entirely from the air. Actually the plant is not a moss but a true flowering species allied to the pineapple. Its fibrous core is used as a substitute for horsehair. The grove here shown is in Florida. Spanish Moss does not grow in the Old World.

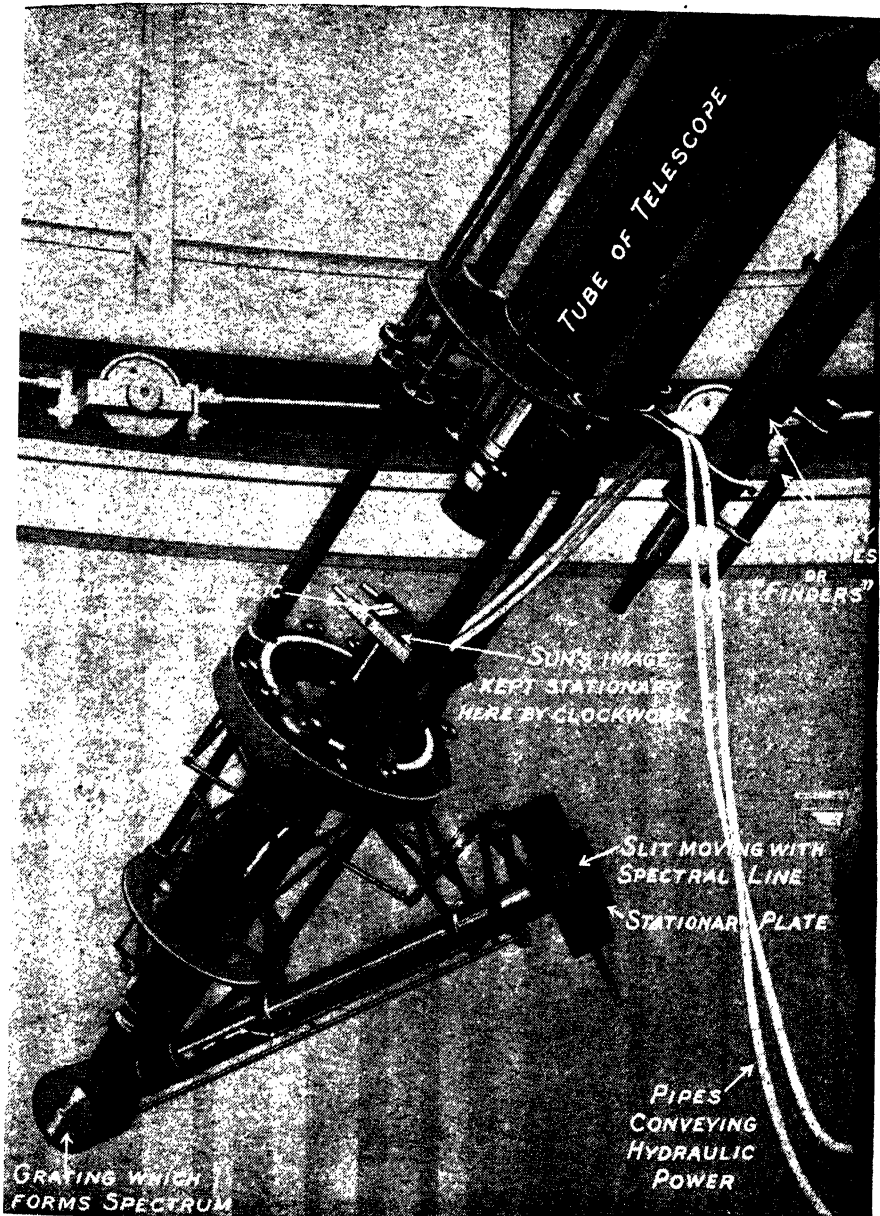

[From "Splendon"]

A SPECTROHELIOGRAPH

The use of this instrument, the invention of Hale and Deslandres, is to make possible individual study of normally invisible gases present in the upper atmosphere of the sun. A spectrum is formed in the slit and grating, and by placing a second slit over one of the dark lines (e.g. of hydrogen) all light is blocked except a single ray from that element. Then, by moving both slits in the same direction, a composite picture is built up showing the whole of the sun's hydrogen layer. Though the instrument was invented in 1890, work with it has not yet progressed very far, as the field of research opened up by it is entirely new. The finest spectroheliograph so far constructed is at the Mount Wilson Observatory.

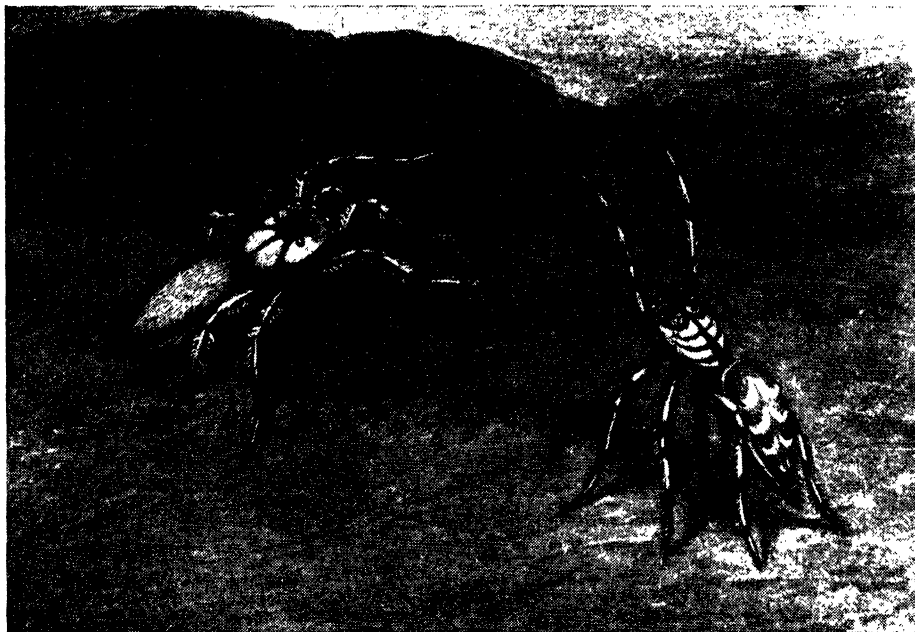

[By Theo Carver]

SPIDER'S COURTSHIP

The natural instinct for the male to display his charm before the female is as common in the insect world as in that of the mammals. In this sketch the male of the *Ascia* variety of spider is dancing and posturing to display "physique" and ornamentation to the less brilliantly marked female.



[By Theo Carver]

THE SPINNING ANT

A peculiarity of this race is that only the grubs can spin. For constructing their shelters, therefore, the ad workers draw together the edges of several leaves, and one of their number, seizing a grub in her jaws, applies mouth to the edges and presses out the liquid silk, which draws out into threads. Below other ants are attacking beetle for food

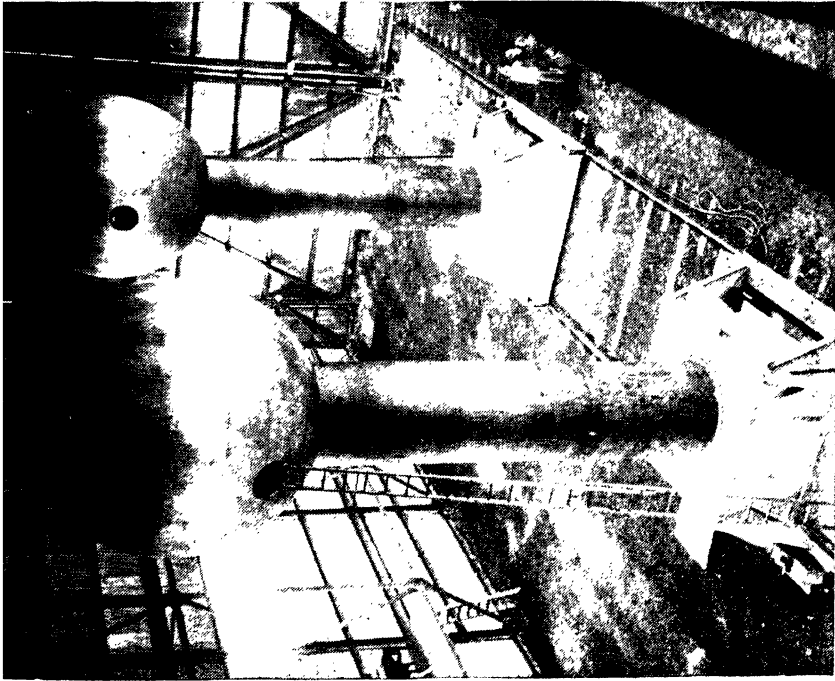

[Kystone

SPLITTING THE ATOM

Actually, since the atom was split elsewhere and by an entirely different process, the curious apparatus shown here is led in one of its purposes. It is, nevertheless, one of the most amazing electric generators ever built. Erected after six years of experiment by Massachusetts scientists, J. Van de Graaf, the two fifteen-foot-diameter electrodes sparked under a current of no less than 7,000,000 volts in their bang, and 10,000,000 volts outside.



[From "Picturesque Eurot

STALACTITES AND STALAGMITES

These formations occur as follows: in certain caves water saturated with limestone held in solution by carbon dioxide drips from the roof; as each drop gathers, it partly evaporates, losing carbon dioxide; the excess of carbon which it can no longer hold is deposited in solid state. Thus, in time, drop after drop builds up a stalactite. Stalagmites form similarly from the water which reaches the floor.

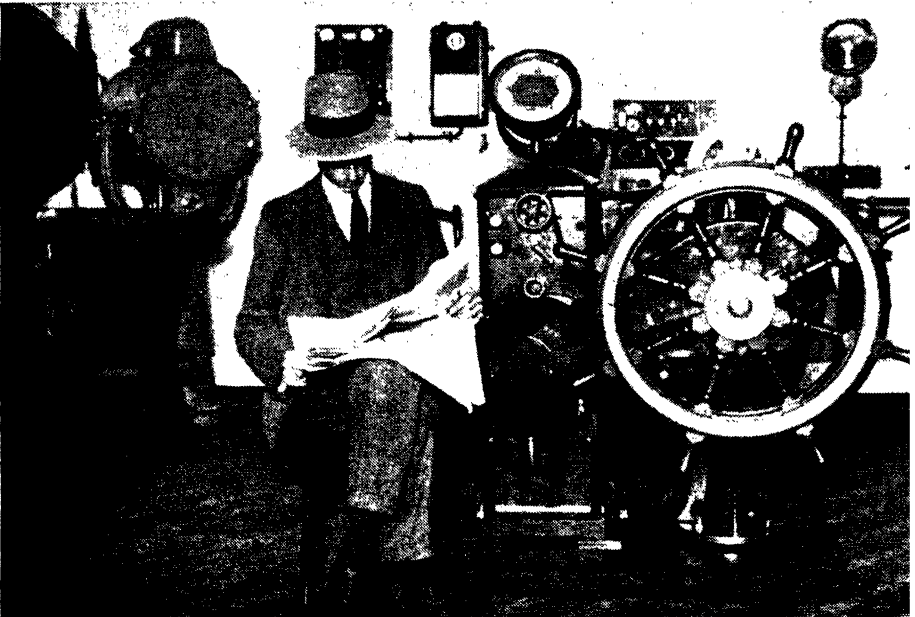

AUTOMATIC MARINE STEERING

[Cathew & Kinn

This form of steering is yet another application of the gyroscope. By linking the steering mechanism to a gyroscope containing a gyroscopic apparatus and compass, it has been found possible, through careful graduations of necessary pressure, to keep a large ship accurately guided in accordance with the gyroscope's direction.

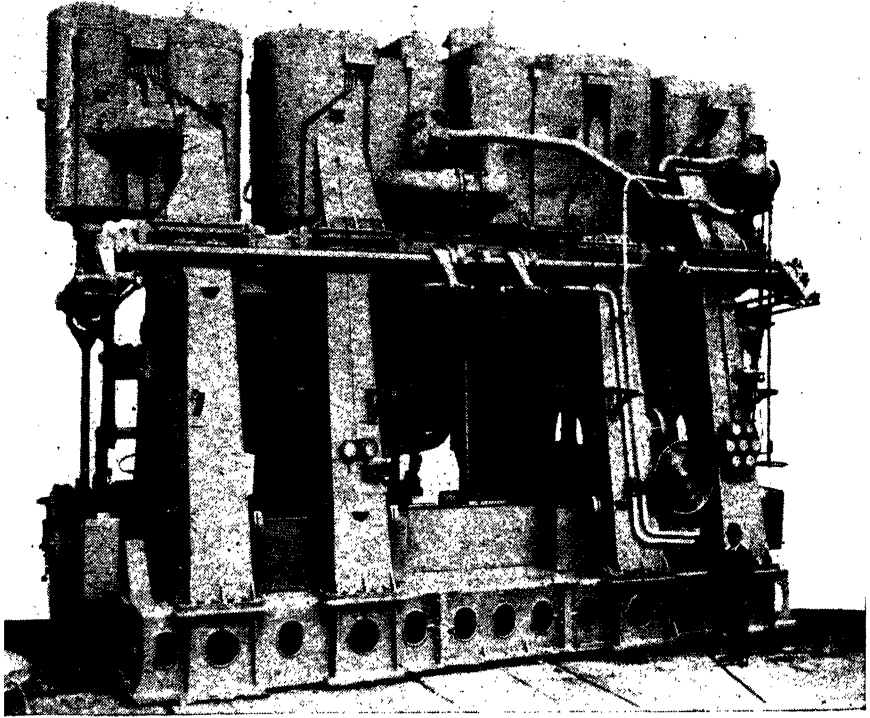

[Courtesy Vickers Ltd.]

STEAM POWER

story of steam power has been often told, and extends in our times into infinite ramifications. The above illustration perhaps symbolizes as well as any words the huge part occupied by steam power in modern life—the machine (quadruple expansion engine for a single screw steamer); its imposing size may be gauged by comparison with the man on the right of the photograph.



[Courtesy Vickers Ltd.]

A STEEL FOUNDRY

part from steels of plastic origin, there are four different processes for making steel by liquefying the iron: these are the crucible, basic, acid, and electric-furnace methods—the last named being very recent. Above is a typical scene in the steel foundry of one of the largest British engineering firms.

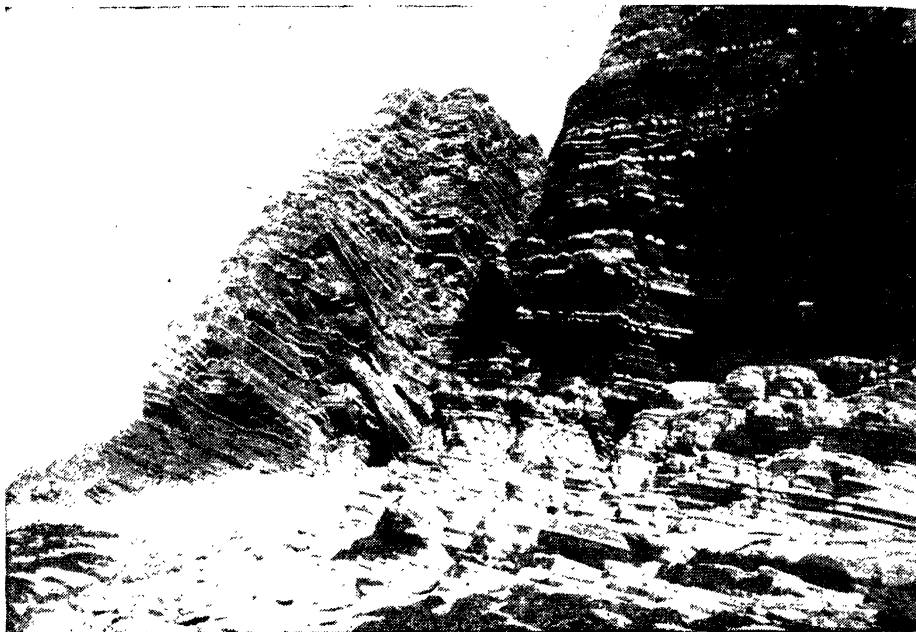

[From "Marvels of the Universe"]

THE STRATA OF THE EARTH

The Earth consists of three layers: an outer layer of gas, the atmosphere; a middle layer of water, the hydrosphere (confined to the hollows); and the solid core, the lithosphere. The last is subdivided into twenty-one layers of different solid substances, the strata. Shrinkage of the Earth's crust and the action of weather often make the uppermost strata very noticeable, as in this picture of rocks at Aberystwyth



[From "Marvels of the Universe"]

STONE-COPYING PLANTS

The commonest form of plant-mimicry, as with insect mimicry, is for a harmless species to imitate a harmful one. Above, however, the South African Mesembryanthemum is seen adopting the novel protection of copying the pebbles amongst which it grows



[Dionysius' Ear]

SYRACUSE: THE EAR OF DIONYSIUS

This vast Sicilian cave is so named because here the tyrant Dionysius was supposed to have listened to his prisoner's whispered secrets. If he did, he chose well for the extraordinary acoustics are such that the smallest sound is deepened into a loud roar



Jorien Leigh

THE TASMAN GLACIER

The Tasman glacier, the most famous in the Southern Alps (New Zealand), is a colossal river of ice 2 miles wide and over 11,000 feet high. The glaring expanses of white are offset by banks abloom with luxuriant flowers.

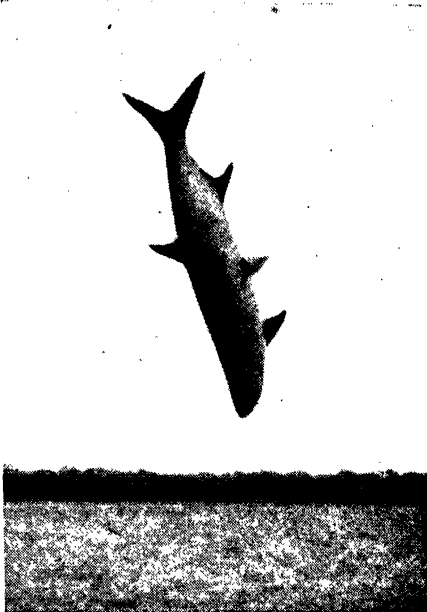

[From "Marvels of the Universe"]

THE LEAPING TARPON

The tarpon, a native of the West Indian and Florida coast, is noted for its huge bulk and prodigious agility. In appearance like a 7-foot herring, it can project itself high into the air to rid itself of a fisherman's hook.

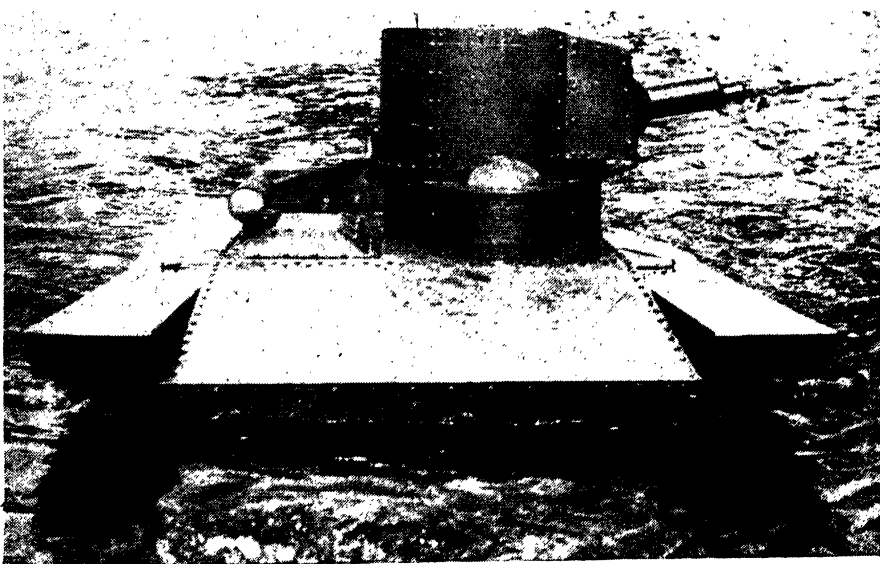

AN AMPHIBIOUS TANK

[Keystone]

This extraordinary amphibian, a British invention, is able to travel at 40 m.p.h. on land, to cruise at 6 m.p.h. in water, to climb a 30-degree slope continuously, and a 40-degree slope for a short period. The tank can therefore cross large rivers or be launched from a ship. It is here shown cruising upstream in the Thames.

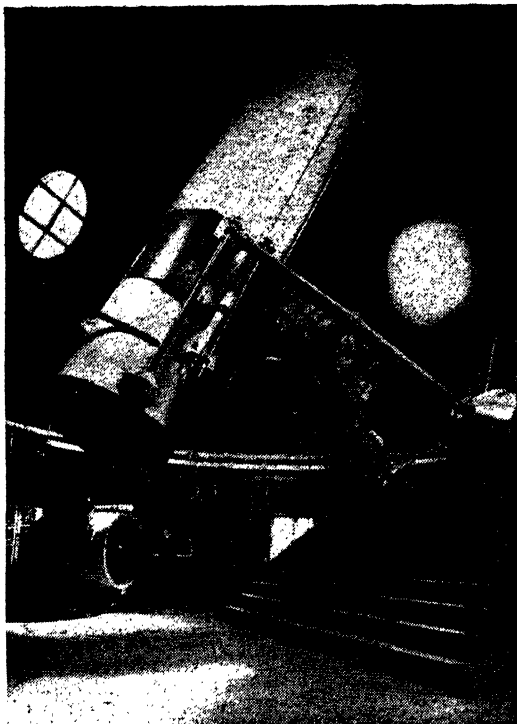

Courtesy Carl Zeiss, London]



[Courtesy Siemens Br
THE NEEDLE TELEGRAPH

This valuable invention dates back to the discovery by Oersted in 1819 of the magnetic field produced by an electric current. Wheatstone and Cooke then devised the first practical system. The telegraph shown is an improved Siemens model

A REFLECTING TELESCOPE

The first telescope was probably made by Lippershey, a Dutchman, in 1608, though Galileo began his work in 1609. The first reflecting (as opposed to refracting) telescope was made by Newton, the latest of this type being the giant 200-inch instrument at Mt. Wilson

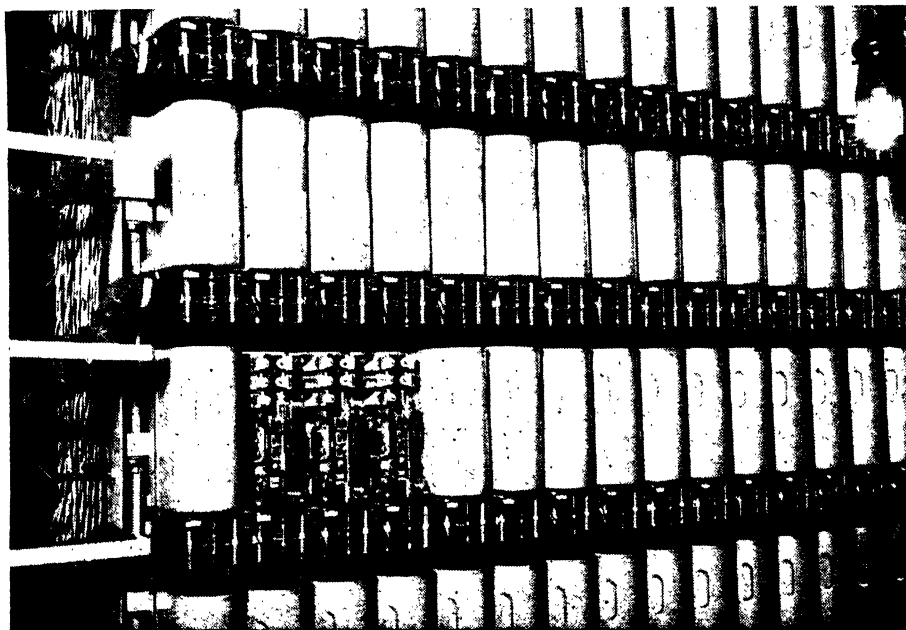

THE AUTOMATIC TELEPHONE

[Carthew & Kinnaird

Alexander Graham Bell and Thomas Edison both invented practical systems of electrical telephony. The modern telephone is adapted from a third modification by Blake, but at least three more inventors had a share in it. The automatic system is of post-war origin; the illustration shows a bank of selector-switches in a London automatic telephone exchange



TELEVISION

(*Marconi Ltd.*)

Television is one of the chief applications of the photo-electric discovery, and the first demonstration (by Baird) was as recent as in 1926. In the short interval since, tremendous development has taken place; this is symbolized by the picture, which shows the motor mechanism of an apparatus for televising between London, New York and Melbourne.

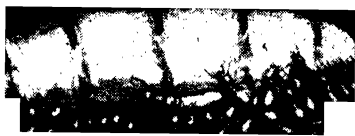

[*Theo Carreras*]

THE TERMITE QUEEN

The Royal Cell is in the very heart of the termite cairn. Its narrow opening allows passage for workers and soldiers, but not for King or Queen. A soldier-guard surrounds the queen, and corps of workers continually bears off the eggs to the nurseries. The queen lays one egg per second for five years

A HUGE TERMITES' NEST (Right)

A striking illustration of the height attained by the nests of these small insects. Termites, often called "white ants," are not of the ant family at all, but live in communities like ants

[*Dorien Leigh*]



[Dorien Leitch

SIGNING OF THE PEACE OF MÜNSTER BY TER BORCH

Gerard Ter Borch (1617-81), a Dutchman of Zwolle, studied art in Haarlem, Italy and France, and later visited England, Germany and Spain. His technique and ability to depict emotion were very fine; the above painting is a remarkable study in faces. The original is in the National Gallery, London.



[Dorien Leitch

THE TEMPTATION OF ST. ANTHONY: BY TENIERS

There were two David Teniers, father and son. The father, a pupil of Rubens, painted scenes from Flemish life. The son (1610-91), a master in the Antwerp Guild, became court painter to Archduke Leopold of Austria, and many of his works are still at Vienna. The above, perhaps his masterpiece, hangs in the Prado Madrid.

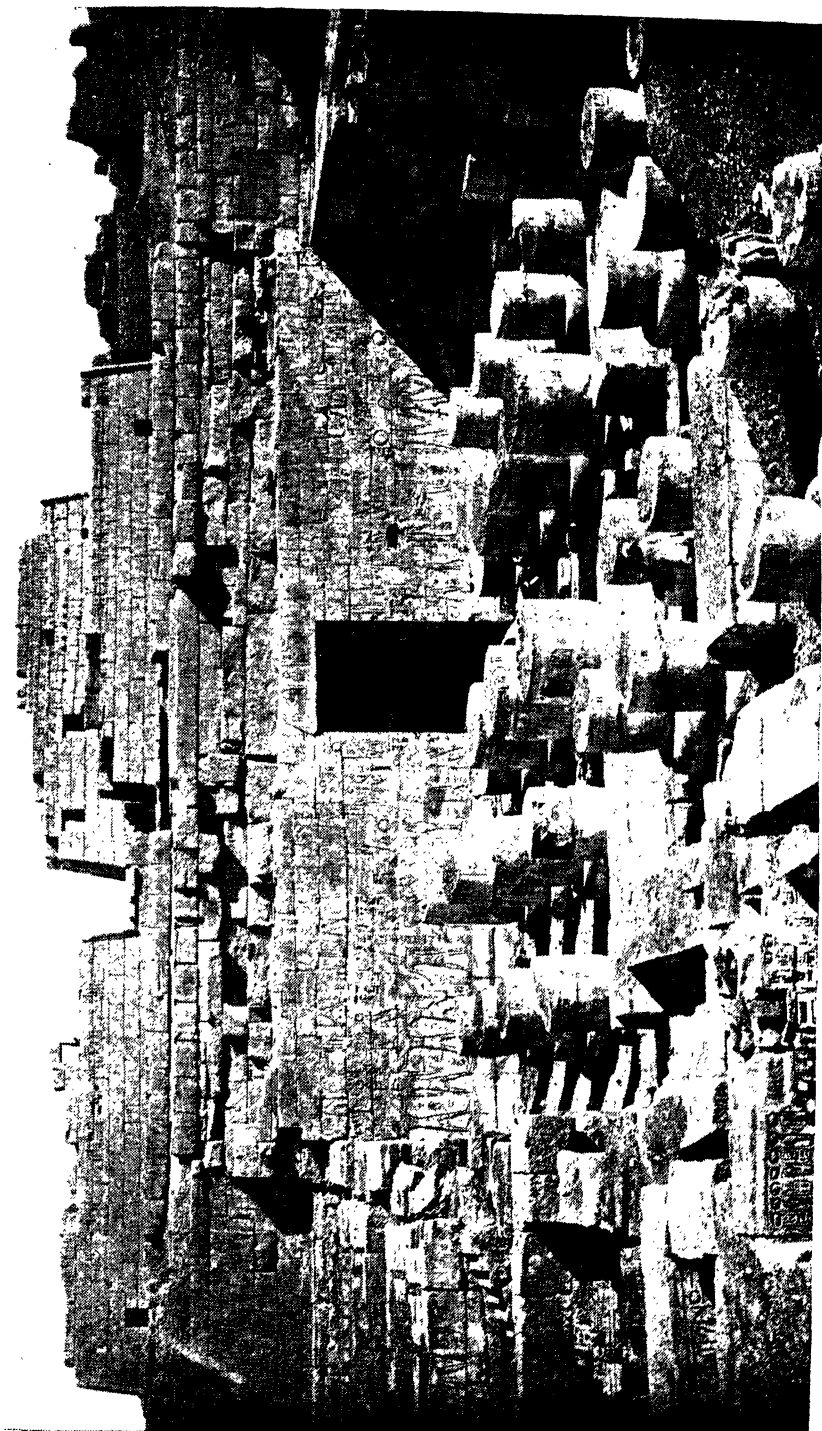

[E.N.A.]

THE GREAT TEMPLE OF RAMSES III, THEBES

There were two celebrated cities of Thebes in the Ancient World, one in Egypt, one in Greece; the above is from the great metropolis of the Pharaohs adjoining Kamak and Luxor. All the ruins are very fine and many very old, Thebes having been founded probably during the First Dynasty. By contrast with this age, Ramesses III, builder of the vast and multi-floored Mortuary Temple, was the last of Egypt's great Pharaohs.

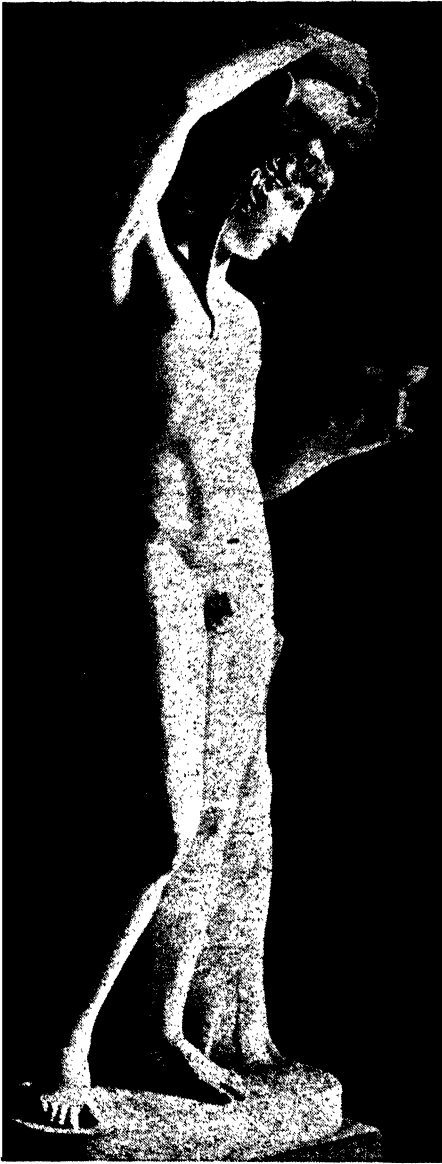

Dorrien Leigh

THORWALDSEN'S "GANYMEDE"

The most famous statue ever made in Scandinavia. Bertel Thorwaldsen (1770-1844), the son of a woodcarver, was born in Copenhagen, and after early training there, came under the influence of Canova in Italy. Amongst his works is a statue of Byron, now at Trinity College, Cambridge

A THERMO-ELECTRIC PHOTOMETER (Right)

The photometer has been dealt with under that heading. The thermo-electric variety is an ingenious combination of the photometric and thermo-electric principles, which enables the magnitudes of stars to be accurately determined from photographic records

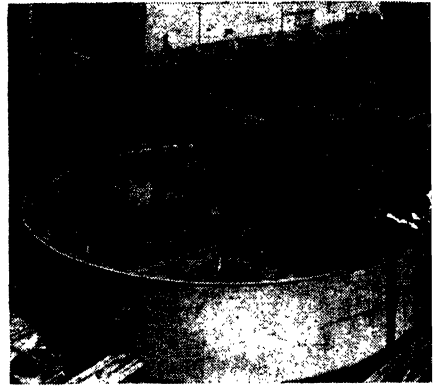

[Carthaw & Kinnair]

A GIANT THICKENER

This great tank with the revolving stirrer is used for ore reduction, its particular task being to thicken slurries, or the washy mixture containing the ores

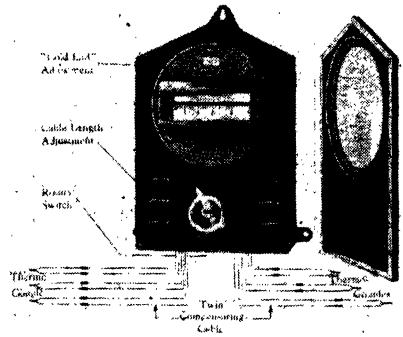

[Carthaw & Kinnair]

A THERMOCOUPLE PYROMETER

Pyrometers are for the measurement of high temperatures. The thermocouple type depends on the principle that when two dissimilar metals are heated, a small electro-motive force is generated in the circuit including the junction. The type is used for temperatures up to 1,000° C.



[Courtesy Carl Zeiss]

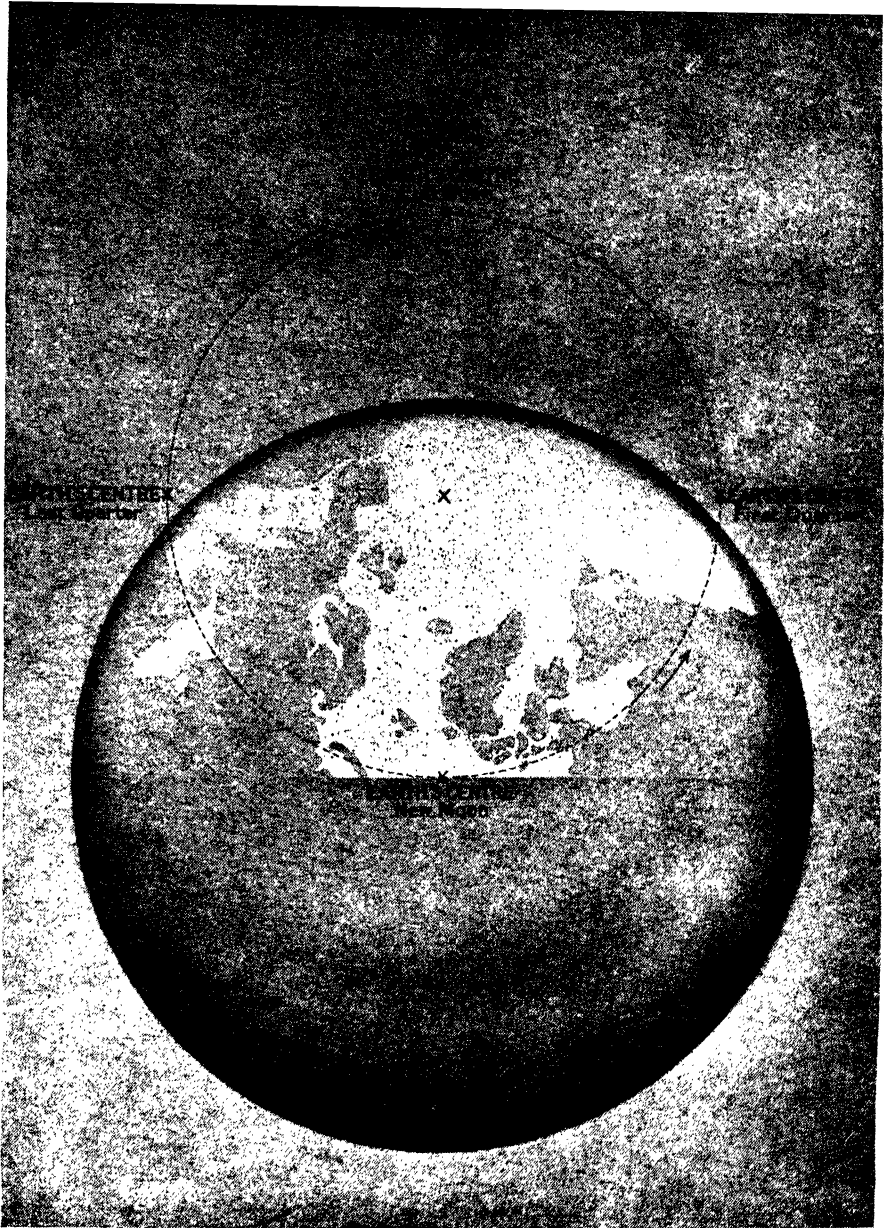

[From "Splendours of the Heavens"]

TIDES AND THE MOON

The movement of the tides is produced by a combination of the gravitational effects of the moon and the sun, and of these the moon's is by far the greater. Some idea of why the tides vary may be obtained from this sketch, showing how the moon does *not*, strictly speaking, revolve round the earth under gravitation, but that they both circumvent a common centre of gravity. At full moon the earth is on the sunward side of the centre, and at new moon on the opposite side. When the moon and sun are both on the same side of the earth, the result is a period of spring tides, for the two pulls are united. Neap tides, it follows, are a result of opposing pulls. The diagram also explains why spring tides are contemporaneous with full moons.



U. Leo Carreras

THE TIMBERMAN

These wood boring insects are conspicuous for the long antenna, which may be four times the length of the body. When, as in the middle part of this picture, two males engage in combat for the favours of a female, these are often disfigured seriously. In the lower part of the sketch a larva is seen in its tunnel, and in a neighbouring tunnel a chrysalis of the male shows the method of storing the antenna. The above sketch depicts the insects about twice the natural size.



TRIUMPHAL ARCH, TIMGAD

[L.N. 1.]

Timgad, Algeria, is of Roman origin; the Emperor Trajan was its founder. It is the most complete of the several extensive ruined African towns, testifying to the thoroughness of Rome's occupation overseas. A basilica, a theatre, a forum, two arches, and numerous streets and houses survive in varying stages of decay.

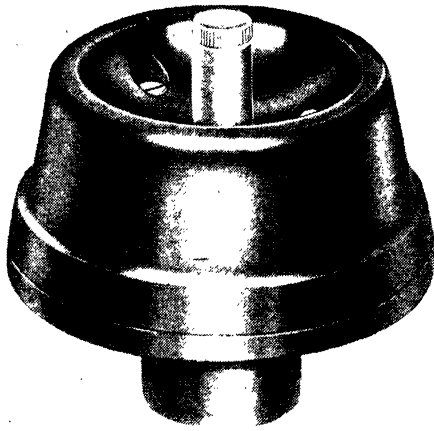

Fig. 1. A TIME LAG SWITCH

This type of switch is often used in small heating institutions where the electric light is switched off at a certain hour; the light is turned on again during the



Standing on the Wye in Monmouthshire, this abbey dates from 1131, the present beautiful ruins being of the thirteenth century. Both a famous painting and a famous poem have been inspired by Tintern Abbey.

[Great Western Rly.]

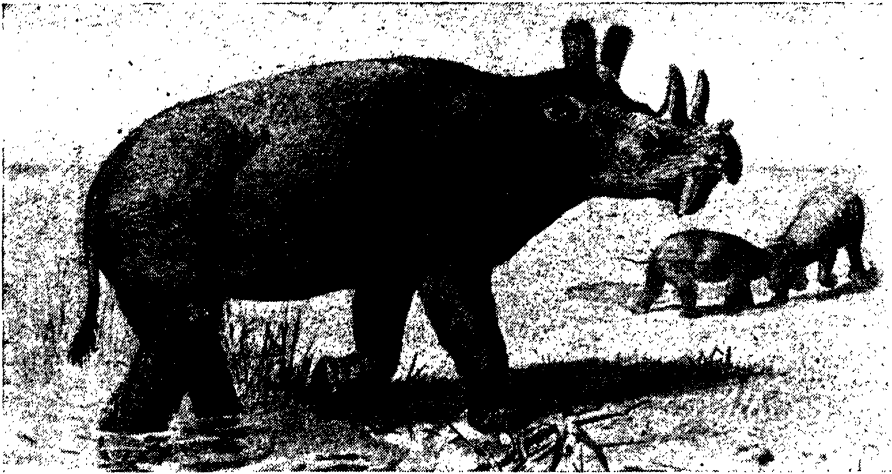

THE TINOCERAS

[Courtesy Chapman & Ha

This animal flourished in the Eocene period. Though its six-horned head and the phonetics of its name suggest relationship with the Rhinoceros, the limbs are actually nearer to those of an elephant, and the tusks bear relation to neither



"BACCHUS AND ARIADNE," BY TITIAN

[Dorien Leic

itian, or Tiziano Vecelli (1477-1576), the greatest painter of the Venetian school and one of the foremost in the world, studied at Venice under Bellini and Giorgione. He travelled much in Italy and Germany, and was a frequent companion of the Emperor Charles V. His works range from Holy Families to "himself and his mistress." The above masterpiece was painted at Ferrara

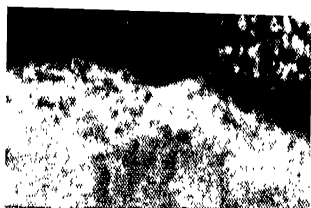

TIVOLI: THE CASCADES OF THE ANIO

Tivoli, ancient Tibur, standing on a river now renamed the Teverone, was a flourishing Latin city even before the building of Rome. In Horace's day it was a favourite resort, and abounds in the remains of elegant villas. Capping all, however, is the Renaissance Villa d'Este, through whose grounds the Anio falls in the exquisite cascades here shown. It is one of Europe's loveliest beauty spots, and the Villa d'Este occupies an important niche in the Continent's history and fiction



[Dorien Leigh

TITIAN'S "SACRED AND PROFANE LOVE"

Probably the great master's most famous work, this was one of his earliest efforts, painted when he was house-decorating in Venice. Photographs do scant justice to Titian's pictures, for his power lies in the glory of his colour.

In spite of his great age he died only as a victim of the plague



TRAFFIC SIGNALS

[Courtesy Automatic Electric Co.]

The view shows a section of Trafalgar Square, London, where the most complicated system of lights yet erected controlled entirely by the pressure of traffic over the "pads" in the roadway. A decade ago traffic signalling by three-coloured lights was almost unknown; to day it has spread all over Europe and far beyond.

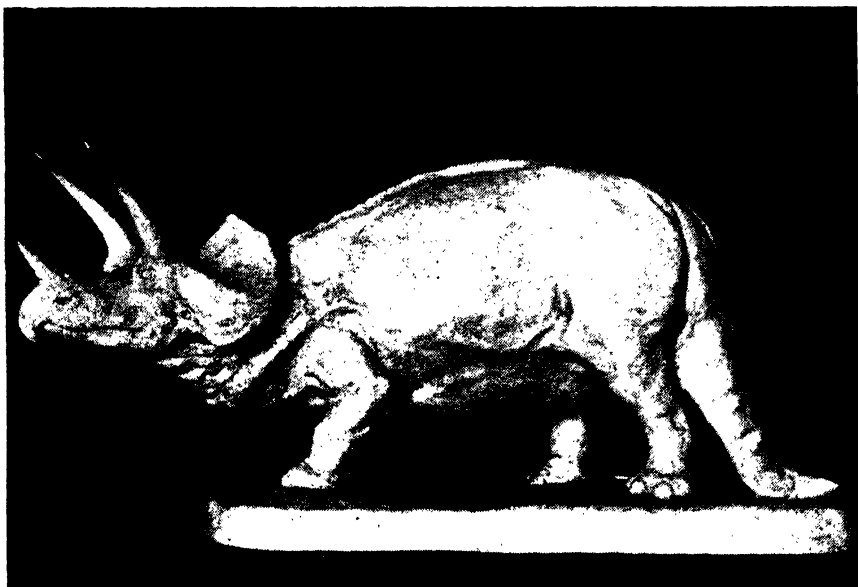

THE TRICERATOPS

[Carthen & Kinnaird]

Besides the three horns from which it derives its name, this Dinosaur, as indicated in the model, possessed a formidable hooked beak on the upper jaw. Nevertheless, the animal was a vegetarian, and is noteworthy as having reintroduce the four-toed posture after its ancestors had for some ages hopped like kangaroos.

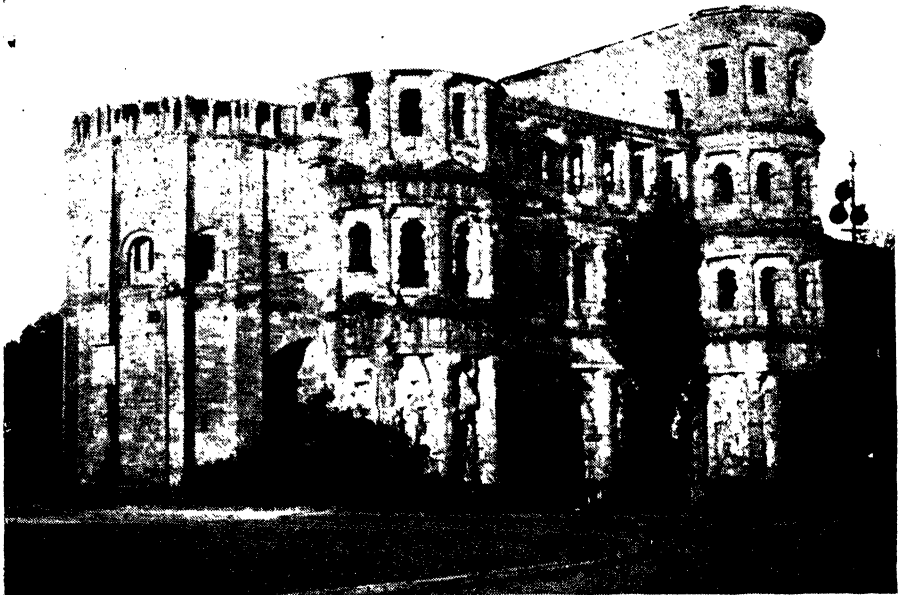

TRIER: THE PORTA NIGRA

(Doreen Leigh)

Trier, called Treveris in Latin tongue, is an ancient and historic city in the fertile Moselle country of Western Prussia. It contains more important Roman remains than anywhere else in Northern Europe, and claims to be the oldest German town. Paramount among the Roman relics is the splendid gateway illustrated.



(Arthur E. Kinnard)

THE RENOBORG TRAVELLING BRIDGE

These bridges represent what is probably the most useful form of overhead railway. A very high structure—so built either for geographical reasons or to clear ships—carries passengers to and fro at lower levels by a trolley hung from a rail-car attached to the bridge's under-part



(From "Marvels of the Universe")

TROPICAL FISH

The chief wonder of this group lies in its wondrous tropical colouring. The fish at the bottom is covered with a velvet pile instead of scales, and is orange-yellow. The little fish on the right above is a brilliant blue; that at the top deep red with green and blue



H. Bastin]

THE TSETSE FLY

Not until the nineteenth century did the Tsetse fly become identified as the carrier of sleeping sickness and other germs. Above is a magnified head, showing the blood-sucking proboscis

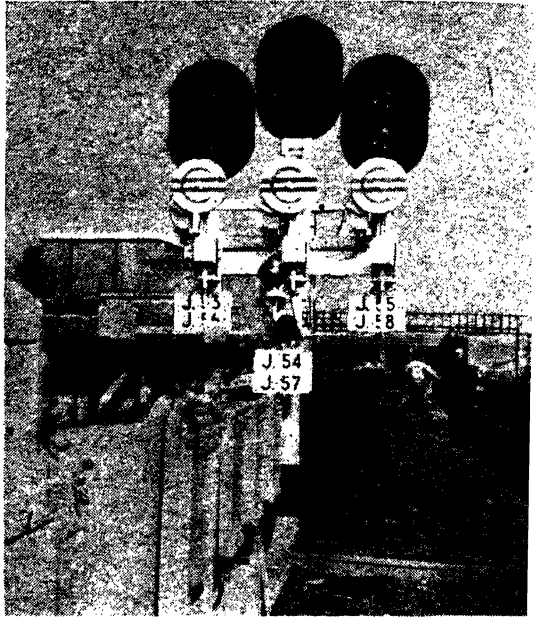

Courtesy L.

TUBE RAILWAY CONTROL

A typical signal-group on an open-air stretch of the London underground system. The fact that this system is the safest railway in the world, though carrying immeasurably more passengers in proportion to mileage than any other, is chiefly owing to its automatic proof control

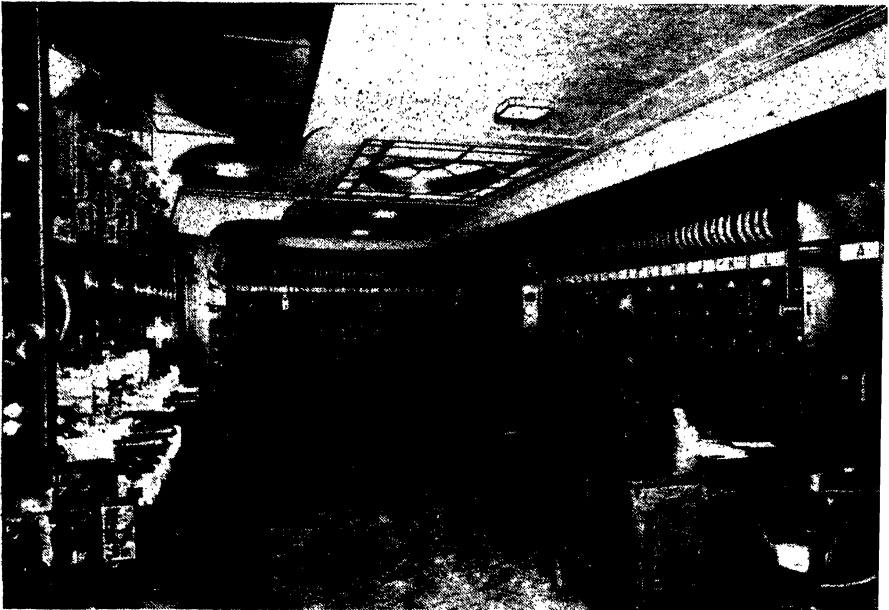

A CONTROL ROOM AT LOT'S ROAD

[Courtesy I

Lot's Road Power Station supplies the current for the London Underground Railways, and something of the vastness of the system is estimable from the aspect of this control-room. The principle on which all the present London Underground Railways were built is the invention of one J. H. Greathead



"CROSSING THE BROOK," BY TURNER

[Dorrien Leigh

Joseph M. W. Turner, the son of a barber, was born in London in 1775. He became an R. A. at the age of 27, and though in later life he visited Scotland, France and Venice, most of his years were spent in his native town. He died in 1851 and was buried in St. Paul's. The majority of his works are in the National Gallery, London. Turner must be held largely responsible for the general idea that landscape painting is the *forte* of English artists.



THE WHITE PALACE, UDAIPUR

[The late H. G. Ponting, F.R.C.]

Udaipur is the capital of the Indian State of Mewar, and is built beside the beautiful lake seen in the photograph. Two palaces are built on this lake's islands, one at least of which is like a dream residence out of fairyland, its gleaming white traceries in the midst of the clear water making an unforgettable sight.



THE RAINBOW BRIDGE, UTAH

[Dorien Leis]

There is a charming legend attached to this striking natural formation. The Utah Indians believe it to be a rainbow turned to stone, and that over it every brave soul passes on its way to eternal happiness. The bridge is one of the most striking of the numerous similar arches in North America.

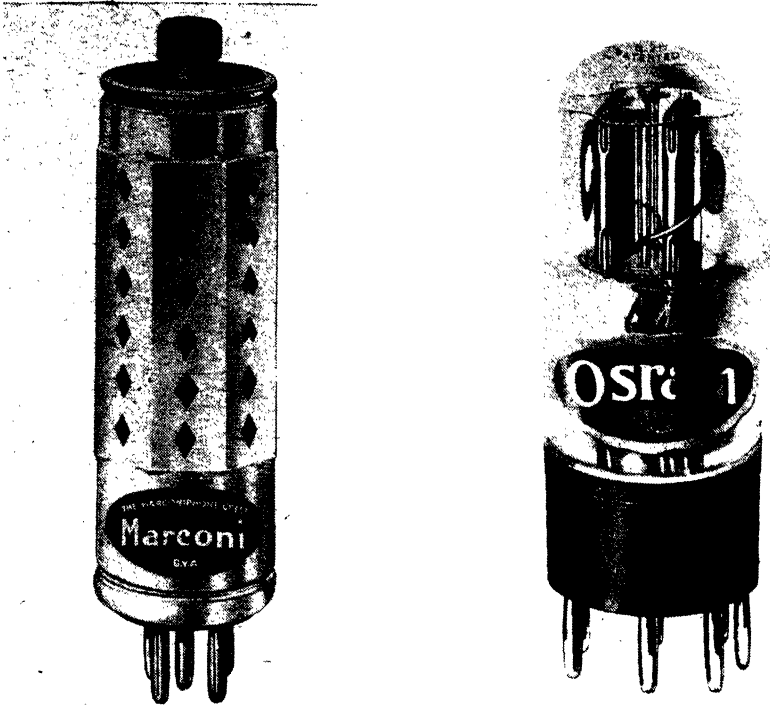

TWO TYPES OF WIRELESS VALVE

The origin of wireless is traceable to certain theories published by Clerk Maxwell in 1873. The inventor of the all important valve was Fleming, who in 1904 produced a valve as the result of O. W. Richardson's discovery of thermionic currents. Above are two typical receiving valves—on the left the all metal "catkin" variety



ADORATION OF THE LAMB: BY THE BROTHERS VAN EYCK

[Dorton Leigh

an, Hubert, and their sister Margaret Van Eyck were all painters and pioneers of the Flemish school. Though modern criticism is sceptical, they are reputed to have been the inventors of painting in oils. The brothers (born 1370 and 1390) worked much together, the masterpiece here shown being their joint effort. Until 1918 four of its panels were at Ghent and six in Berlin



Photos]

VAN OSTADE: "THE FIDDLER"

Adriaan Van Ostade (1610-88) was a native of Haarlem, where he spent most of his life. Sir Anthony Van Dyck (1599-1641), a native of Antwerp, was invited to England in 1620. His paintings of Dutch peasant life are hardly rivalled for colour and get-to-ouch. He when he was employed by James I. (going to Italy in 1621, he had again settled in



"Dertien Leijck

VAN DYCK: "LA VIERGE AUX DONATEURS"

when he was employed by James I. (going to Italy in 1621, he had again settled in

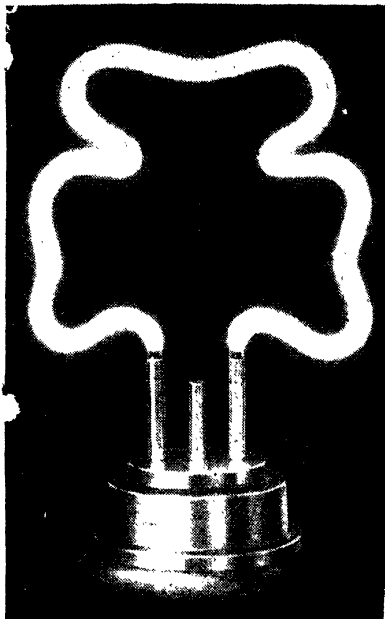

Courtesy Brilliant Neon Ltd.]

VAPOUR TUBE LIGHTING

The tubular lighting used for modern advertising utilizes many gases beside neon and mercury; since each gas produces a different colour, the dearer gases are the rarer colours.



[From "Wonders of the World"]

THE VATICAN LIBRARY

This building is comparable with the Sistine Chapel in 1440, and decorated during succeeding centuries. It is now a treasure house of thousands of rare books. A 100' part of the ceiling is a superb model.

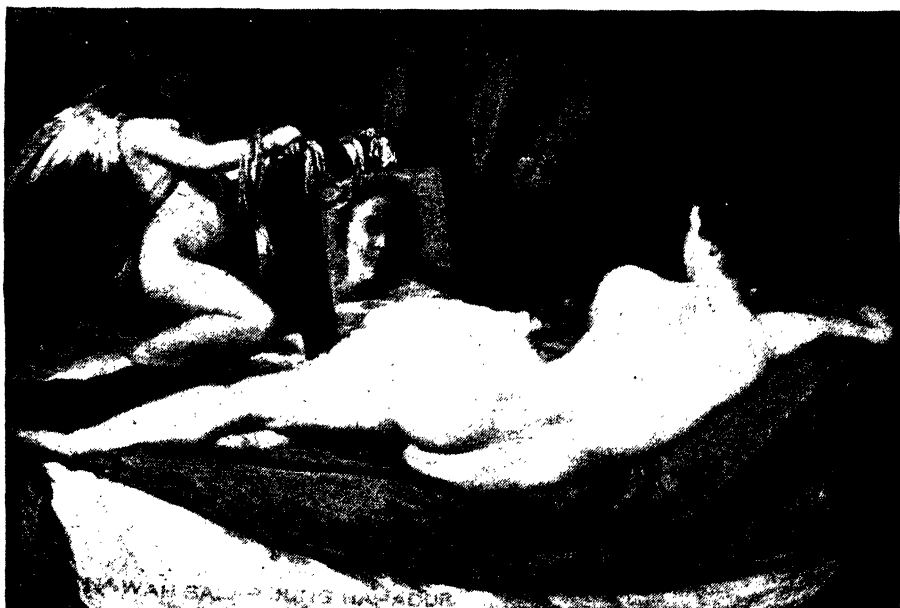

THE RUBY VENUS: BY VELASQUEZ

[Dorren Leigh]

Velasquez, "the King of Spanish Art," was a native of Seville who lived from 1599-1660. His career is one long improvement of fortune, and he enjoyed high titles under Philip IV. He visited Rome for some period, and knew Rubens and Tiberia intimately. Though his best work was portraiture, his very little produced much else. The above masterpiece is in the National Gallery, London.

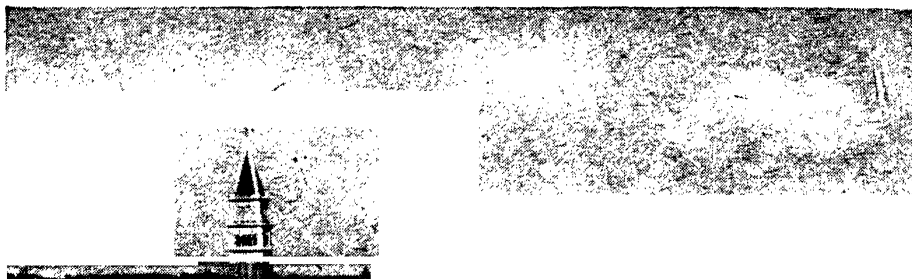

[Keysto

VENICE : A PANORAMA
Venice, the city of canals, is built mainly on piles, on 122 small islands. In historical and artistic importance on Rome and Florence can vie with her, and in glamour Venice surpasses both of these. In this view, St. Mark's dome appear behind the Doge's Palace, on the left of which are the Piazzetta, Old Library and Campanile



[W. F. Mausel

VENICE, ST. MARK'S : THE PALA D'ORO
St. Mark's Cathedral is in itself the most renowned church in Italy after St. Peter's; but even were it not so, the treasure housed in it would ensure perpetual fame. The Pala d'Oro is the finest artistic relic of the Byzantine epoch known to the world; the richness of design and glory of colouring are almost unique



E.N.I.T.]

MOUNT VESUVIUS

The best-known volcano in the western world, the destroyer of Pompeii owes its twenty-five centuries of close association with mankind to the amazing fertility of its slopes. Since the terrible outbreak of A. D. 79, described so graphically by Pliny, at least ten serious eruptions have occurred—but men continue to live there



[Courtesy S. African Govt.]

THE VICTORIA FALLS

Though only half the width of Niagara, the Victoria Falls on the Zambesi are twice as deep, and the force of their drop sends up mist-clouds visible for 20 miles. Livingstone discovered the Falls in 1855. Their native name means "smoke sounds there." They lie on the boundary of Southern and Northern Rhodesia

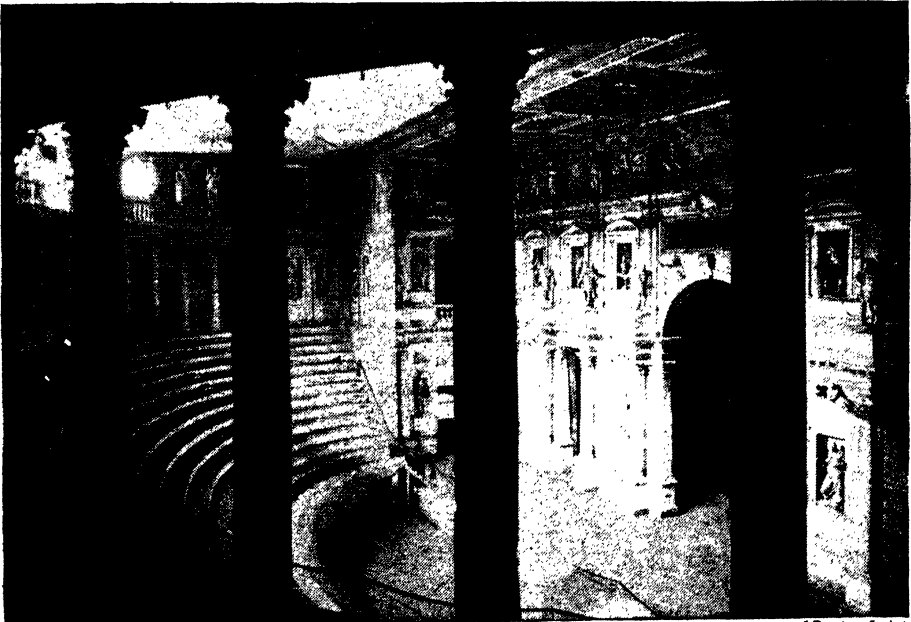

THE TEATRO OLYMPICO, VICENZA

[Dorson Leigh

Vicenza, a comely town at the junction of two rivers 40 miles north west of Venice, owes many of its architectural beauties to Andrea Palladio, born there in 1518, who was the greatest Italian architect of the late Renaissance. The Teatro Olimpico is a masterpiece of pseudo classical design



CHURCH OF THE ARCHANGEL MICHAEL, WARSAW

[D. M. Lee]

is an attractive city, noted for the number of its fine buildings, which are erected on terraces rising from the sea. It abounds in churches—Catholic, Greek, and Lutheran—of which the finest is the one illustrated. The church was patterned on St. Basil's, Moscow, during the Russian domination of Poland.

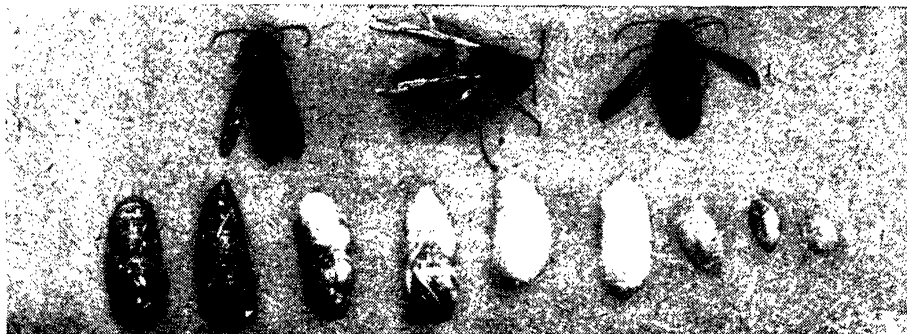

[From "Marvels of Insect Life"]

DEVELOPMENT OF THE COMMON WASP

There is an enormous number of wasp varieties, but in all the development is approximately the same. On the right is a newly hatched grub; the next four are grub stages; then a newly formed chrysalis, all white but for the eyes and on the left the upper and under sides of a chrysalis whence the wasp is about to emerge.



[From "Britain Beautiful"]

THE FONT OF ST. MARY AND ALL SAINTS, WALSINGHAM

This font is one of the finest examples of its kind in the Perpendicular Style to be found. Its faces are carved with pictures of the Seven Sacraments. Before the Reformation the shrine of "Our Lady of Walsingham" was visited in all over Europe, as it was said to contain a flask of Mary's milk. At the Disolution this questionable theory was proved to be a fiction, and the Virgin's image was taken to Southfield and burnt.



Keystone]

WATER-DIVINING

This science is so remarkable that many people are still disinclined to believe that it is not a "fake." Yet in its crudest form it has been practised from the earliest times. Above is a water-divining apparatus recently invented for use in the City of London



WATER-FLEAS

[By Theo Carrer

Water-fleas are relatives of the lobster and crab, and like them are entirely armour-clad. There are numerous varieties, especially in salt water. A group of many types, all greatly magnified, is shown here. Note especially the Butterfly flea at the bottom

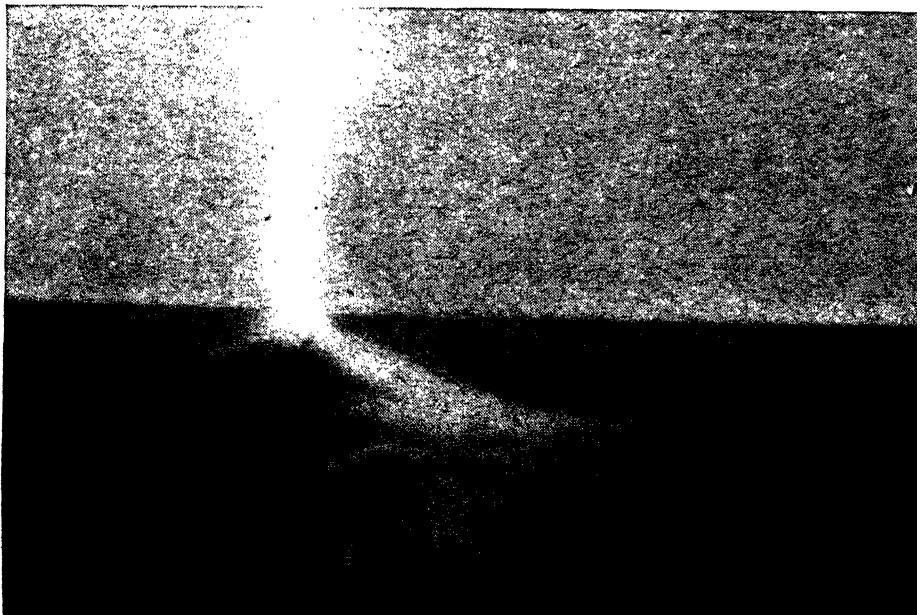

A WATER-SPOUT

[From "Marvels of the Universe"

many tropical seas this phenomenon is quite common. A dark column, actually a whirlwind, descends toward the ground from a cloud. Into this a white column of sea-water is drawn up by the suction, until the whole resembles two cones point to point, with a cylinder between them. The moisture carried up has been known to deposit fish inland



[Dorion Leigh

THE EMBARKATION FOR CYTHERA : BY WATTEAU

Antoine Watteau has probably come in for greater diversity of reception than any artist prior to the twentieth century. Whether his works be called fine or poor, his influence on French art was profound and lasting. Born at Valenciennes in 1684, he went to Paris in 1702, but endured bitter privation before attaining recognition. Fame and wealth then came too late, for he had already contracted consumption, and died prematurely in 1721—three years after being made painter to Louis XV.



WINDING-GEAR OF A MINE

[Courtesy Vickers, Ltd.]

One of the most important parts of a mine is the pithead winding-gear, which operates the cages between the surface and the subterranean galleries. The huge size of the drums on which the cage cables are wound becomes apparent from this picture of one in course of manufacture. Its eventual position will, of course, be vertical.



Dorien Leigh]

X-RAYS

X-Rays were discovered by Wilhelm von Rontgen in 1895, and immediately the whole aspect of physics and surgery became revolutionised. The above picture shows a newly-invented chair to enable doctors to take X-Ray photographs at any angle.



[From "Britain Beautiful"
YORK MINSTER

The walls of York form one of Europe's most perfect enclosures, and the Minster is one of the most perfect Cathedrals. Founded in 626, its choir, shown here was built between 1361 and 1405. The great fifteenth century east window is one of the largest in the world.

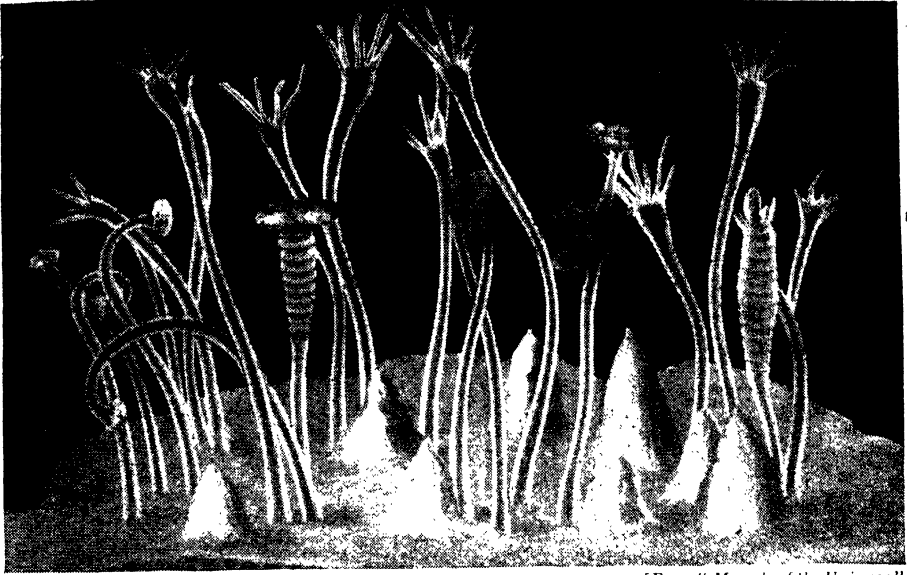

[From "Marvels of the Universe"]

ZOOPHYTES

Zoophytes in general are invertebrate animals whose appearance and mode of growth resemble a plant's—e.g. sea-anemones, corals and sponges. The variety here shown, highly magnified, is a curious type whose method is to line the mouths of shells occupied by hermit crabs. Zoophytes always live in colonies.

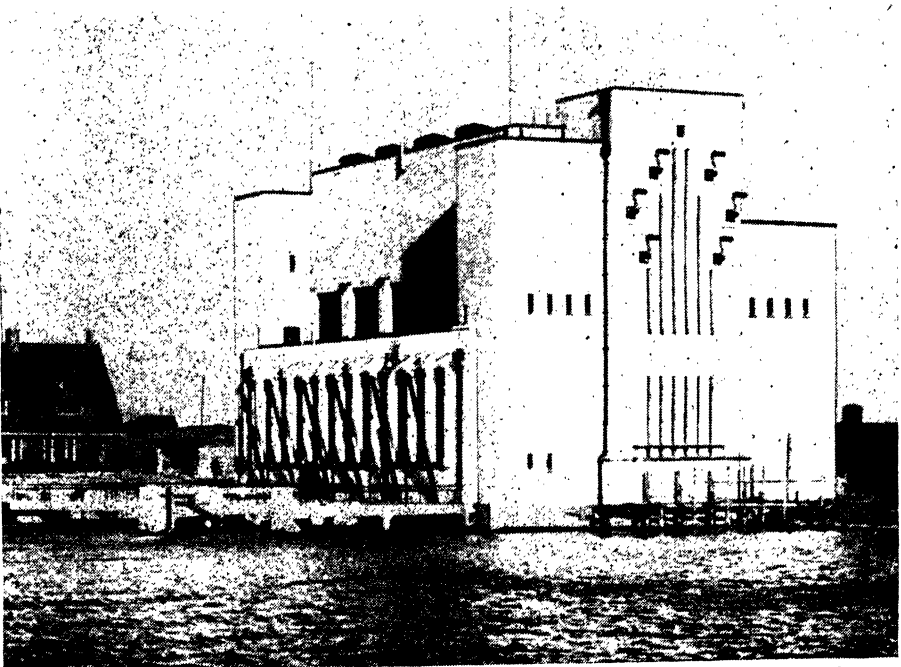

[Keystone

DRAINING THE ZUYDER ZEE

Before the thirteenth century there was no Zuyder Zee, but a vast marshy expanse intersected by rivers and containing a lake. Then tremendous floods swallowed hundreds of square miles of land. Now, in the twentieth century, the land is being slowly but surely won back again. This picture shows the draining plant house, a prominent feature of the great reclamation scheme.

INDEX

WONDERS OF ANIMAL, INSECT, BIRD AND MARINE LIFE	PAGE	PA
Agricultural Ants	11, 12	
Angler Fish	25	
Ant-lion Fly	24	
Ant-lion, Long-necked	24	
Ant-lion Pit : Cross section	24	
Ants and Aphids	27	
Arrindi Caterpillar	31	
Beavers at Work	58	
Bees	58, 59, 60	
Bird-eating Spider	68	
Birds' Nests	65, 66, 67	
Blister Beetle	71	
Bombardier Beetle	76	
Bower Bird's Nest	77	
Breathing of Insects	81	
Butterflies	91, 92	
Camouflage of Insects	100	
Camouflaged Butterflies	101	
Camouflaged Grasshopper	101	
Carpenter Bee	110	
Carrion Hawk	111	
Caterpillars, Twig-like	101	
Chameleon	117	
Cicada, The	126	
Clam, A giant	130	
Coal-age Insects and Animals	138	
Cochineal Insect	138	
Cockroach Wasp	137	
Cricket, The	150	
Deep-sea Fish	162	
Devil Fish	163	
Devil's Horn	167	
Digger Wasp	168	
Diving-bell Spiders	167	
Dragonfly	177	
Driver Ants	176	
Egg, The, transformation of	185	
Eggs of a Moth	184	
Eggs of a Snake-fly	184	
Electric Eel	194	
Electric Star-gazer	194	
Emperor Moth, The, cocoon of	194	
Eye of an Insect, The	200	
Fierasfer, The	204	
Fireflies	206	
Flatfish, The moving eye of a	215	
Flower-like Mantis	214	
Flying-dragon	216	
Flying-fish	215	
Four-eyed Fish, A	216	
Glow-worms	241	
Gnats	242	
Hanging Termite's Nest	254	
Honey Ants	263	
Hornbill	264	
Hornet's Nest	262	
House-fly, The, fungus of	262	
Ichneumon Wasps	269	
Ichneumons, Various	270	
Insect Necklace	337	
Jacana, The African	286	
King Crab, The	301	
Lantern Fly, The	304	
Locusts	320	
Luminous Fish	324, 325	
Luminous Shrimp	327	
Lyre Bird	328	
Madagascar Moth, The	329	
Mantis, The Praying	334	
Mason Bees	338	
Mason Wasps	338	
Midwife Toad	352	
Mimicry, Insect	357	
Mouse-catching Locust	366	
Mud Skippers	367	
Mushroom growers, Termites as	370	
Needle Fish	372	
Paradise Bird	4	
Paradox Frog	4	
Penguins	4	
Polycystina	4	
Prionus Beetle	4	
Radio-larians	4	
Ribbon Fish	4	
Saw Fly	4	
Scarabs	4	
Sea Dragons	4	
Shark	4	
Spider Courtship	4	
Spinning Ant	4	
Tarpon	4	
Termites	4	
Timberman Beetle	4	
Tropical Fish	4	
Tsetse Fly	4	
Wasp, The common	5	
Water-fleas	5	
Zoophytes	5	
WONDERS OF ANTIQUITY AND ARCHITECTURE		
Abu, A Jain Temple		
Abu Simbel, The Temple of		
Agra :		
Tomb of I'timad-ud-Daulah		
Taj Mahal	10,	
Akbar's Tomb		
The Pearl Mosque		
Aigu s Mortes, The Walls of		
Ajanta		
Alexandria, The Catacombs of		
Amalfi Cathedral		
Amber : The Shish Mahal		
Amboise, The Château		
Amiens Cathedral		
Amritsar : The Golden Temple		
Andria : Castel del Monte		
Antwerp Cathedral		
Arles :		
The Roman Arena		
The Perch of St. Trophime		
Aschaffenburg Castle		
Athens	37,	
Ayuthia		
Baalbek : Temple of the Sun		
Babylon		
Bamberg am-Saale : The Schloss		
Bangkok :		
Wat Chang		
Wat Po		
Wat Suthat		
Barcelona, The New Cathedral		
Bath : The Roman Baths		
Bayeux Tapestry, The		
Bella Païse Abbey		
Bergamo : The Capella Colleoni		
Berlin : The Star Church		
Bhilsa		
Bijapur : The Gol Gumbaz		
Blois Château	69,	
Bologna : The Leaning Towers		
Bourges Cathedral		
Bruges, The Belfry of		
Brussels :		
Maison de Roi		
Palais de Justice		
Budapest : Parliament		
Buddhgaya, The Temple of		
Building Stone, The Largest		
Durgos Cathedral		
Caen : The Eglise St. Pierre		
Cairo : The Mosque of Muhammed Ali		
Calcutta : The Jain Temple		
Cambridge : King's College Chapel		

INDEX

	PAGE		PAGE
Canterbury Cathedral	103, 104	Milan Cathedral	353
Carnac, The Menhirs of	106	Minoan Pottery	357
Carnarvon Castle	111	Monreale Cathedral	358
Caserta	115	Mycenæ: The Lion Gate	366
Chambord, The Château	118	Mysore: The Sacred Bull	371
Charlemagne's Crown	118	Nakhon Thom	371
Chartres Cathedral	120	Neuschwanstein Castle	372
Chenonceaux, The Château de	121	New Mexico: Cliff Dwellings	374
Chillon Castle	122	New York: Skyscrapers	375
China, The Great Wall of	122	Nikko, Japan	379
Cintra: The Castello da Pena	127	Nimes:	
Cochem Castle	147	La Maison Carrée	380
Cordova: The Mesquita	147	Le Pont du Gard	380
Curtea D'Argesh Cathedral	153	La Tour Magne	381
Delhi	156, 157	Nuremberg	384
Delhi, New	158, 159	Orange: The Roman Theatre	388
Delphi, The Ruins of	160	Oria	392
Dendera, The Great Column of	160	Orvieto Cathedral	393
Dryburgh Abbey	178	Paestrum	396
Durham Cathedral	178, 179	Pagan: Ananda Pagoda	395
Egyptian Art, Ancient	186	Palermo	397, 398
Egyptian Pottery	187	Palmyra	398, 399
Elephanta	187	Paris: Notre Dame	405
Elgin Cathedral	188	Pavia Charterhouse	404
Ellora, The Caves of	188	Pegu: The Great Buddha	406
Ely Cathedral	189, 190	Peking: The Ming Tombs	407
Fattehpur-Sikri Gate	204	Persepolis	408
Ferrara Cathedral	209	Peru	409
Florence	209, 211	Peterborough Cathedral	410
Foo Chow, The Leaning Tower of	219	Petra	410
Fountains Abbey	219	Philæ	412, 413
Frankfurt, A Modern Church in	219	Pierrefonds, The Château de	417
Freiburg Spire	221	Pisa	416
Genoa	236	Pistoja	418
Ghent: The Oudeburg	238	Pompeii	427, 428
Ghizeh	236	Raglan Castle	436
Girgenti: The Temple of Concord	238	Rangoon	437
Glastonbury Abbey	240, 241	Ravenna: The Baptistery	439
Gloucester Cathedral	239	Rheims Cathedral	442
Granada, The Alhambra	247	Roman Galley, The remains of a	449
Grantham Spire	248	Rome:	
Greek Pottery	248	The Aqueduct of Claudius	449
Guatemala: The Ruins at Menche	254	The Arch of Titus	450
Gwalior	254, 255	House of the Vestal Virgins	450
Helicarnassus, The Mausoleum	257	S. Paolo Fuori Le Mura	450
Heliopolis	260	Mosaics in Church of S. Clemente	451
Indian Observatories	275, 276	St. Peter's	450
Inthapatapuri	278	View from St. Peter's	452
Isfahan	281	Temple of Vesta	452
Istanbul	283, 284	Ronda: The Tajo	455
Jabalpur: The Marble Rocks	286	Rothenburg-am-Tauber	455
Java: The Temple of Boro-Bodoro	285	Rouen Cathedral	456
Jerash	287	St. Ouen	456
Jerusalem	288	St. David's: The Bishop's Palace	461
Jeypore	289	Sakkara: the Pyramid	461
Jumièges Abbey	292	San Gimignano	462
Kamakura, The Amida of	293	San Marino	462
Kanarak	293	Schipka Monastery	464
Karnak	295, 296	Segovia Alcazar	468
Kelheim: Hall of Deliverance	299	Seringatam	468
Kenilworth Castle	299	Seville	469
Kitna Hora	302	Siena	470
Klang-Nam Pagoda	303	Thebes	485
Kronstadt: The Naval Cathedral	302	Timgad	489
Kuthodaw, The	334	Tintern Abbey	489
Leipzig	308	Tivoli	491
Le Puy	310	Trèves	493
Les Baux	311	Udaipur Palace	496
Lhasa: The Potala	311	Vatican Library	499
Lichfield Cathedral	312	Venice	500
Lincoln Cathedral	314	Vicenza	501
Lisbon: Sao Jeronymo Monastery	318	Warsaw	502
Lock of Henry VIII's Bedroom	320	Walsingham	503
London:		York Minster	506
Westminster Abbey	321		
Broadcasting House	323		
Louvain: Town Hall	322		
Luxor	327		
Madrid: The Escorial	331		
Malièzes: St. Rumbold's Cathedral	332		
Malta: The Hypogeum	333		
Mantua: The Palazzo del Te	335		
Marienburg Castle	337		
Mayan Ruins	348		
Melrose Abbey	342		
Meteora Monasteries	346		
Middelburg Town Hall	352		

WONDERS OF ENGINEERING AND INVENTION

Addressing Machine			6
Aerial Flashlight Camera			6
Aeroplanes			8
Air-break Switch			13
Air Conditioning			13
Air Separator			12
Airships			49
Air-Tester			13
Alidade and Plane Table			19
All-Steel Buildings			16, 17

INDEX

	PAGE	
Altimeter	19	Film-making
Aluminium Annealing Furnace	26	Flexible Driving-shafts
Anemometer	26	Floating Dock
Angle Gauge	26	Fluid Flywheel
Assouan Dam	31	Flying Shuttle
Astronomical Clocks	34	Folder, A Newspaper
Audiometer	39	Frequency Control Panel
Autocryptograph	40	Fruit-paring Machinery
Autogyro	39	Funicular and Mountain Railw.
Automatically-piloted Aeroplane	40	Furnace, An Electric
Autopilot Mechanism	40	Galvanometers
Ball Mill	45	Gas-"brushing" Plant
Balloons	46	Gas Discharge Lamp
Beaming Machine	56	Gas, The Manufacture of
Beam Wireless	50, 57	Gas Masks
Blast Furnace	70	Gear-case of a Liner
Boring and Turning Machine	76	Gear-hobbing Machine
Braille	80	Gears, Self-changing
Brick-making	79	Gelatine Explosives
Cable-laying	93	Generating Electricity
Cable Railway	93	Golden Gate Bridge, California
Caissons	97	Grab, An Automatic
Calculating Machines	98, 99	Gramophone, Electric
Camera	98	Grid Transmitting Station
Camera Lucida, The	98	Grinding Mill
Can-filling Machine	108	Gyro Compass
Canned Peas Preparer	108	Hair Hygrometer
Cantilever Bridge	112	Hardening Metals
Carbon Monoxide Analyser	109	Hardness Testing Machine
Carding Machine, Wool	114	Hawkesbury River Bridge
Cardiograph	114	Hearing, Art. ficial
Catapulting Aircraft	113	Heartbeats, Artificial
Caterpillar Traction	112	Height Recorder
Cathode Ray Oscillograph	108	Hemikinesimeter
Cement Kiln	116	High Capacity Condenser
Centrifugal Pump	117	Hot-air Engine
Change-giving Machine	125	Hydraulic Classifier
Channelling Machine	125	Hydraulic Press
Chronograph, Three-pen	123, 124	Hydro-electric Power
Chronometer	124	Hygrometer
Cinema Organ, Components of a	126, 128	Installation Pearls
Cinematograph	128	inking Machinery, Automatic
Circuit Tester	128	nssetter, A Photo-electric
Clockwork	130	nterferometers
Coal cutting	132	nternal Combustion Engines
Coal sorting	132	nvisible Glass
Coal, Taking the temperature of	131	acquard's Loom
Coal washing	133	aw Crusher, A Swing
Coelostat	142	out Rings filled with Gas
Colorimeter	134	Lathe, A
Combing Machine	148	Launching a Liner
Compensator	134	Level, A Precision
Compressors	143, 144	Lightning, Artificial
Cooking Machinery	144	Liners
Co-ordinate Measuring Machine	142	Lithographing Machine
Cotton Gin	148	Locks
Davis Escape Apparatus	154	Lock, A Safe
De-Aerator, A	155	Macadamised Roads
De-Greaser, A	154	Magnetic Compass
De-Slimer, A	154	Mapping the Heavens
Dictaphone	165	Mass Production
Diesel Engine, A Marine	161	Mechanical Navy
Direction-finding by Wireless	165	Mercury Arc Rectifier
Distance and Course Calculator	165	Mercury Vapour Discharge Valve
Diver, A Modern	166	Mercury Vapour Vacuum Pump
Dividing Machine	166	Metal-sawing Machine
Diving Apparatus	166	Metal-spraying
Dock Gate	173	Micrometer, A Pillar
Doubling Frame	173	Microphone
Drawing Frame	174	Microscope
Dredger	176	Milking Cows Artificially
Drill, Electric	174	Mirror, Making a Mammoth
Drilling Armour Plate	175	Monorail, The
"Dry Ice"	174	Motor Cars
Dust Counter	180	Motor Cars in Commerce
Dynamometers	180	Mould for Mt. Wilson Mirror
Earth Tester, An	182	Moving-Coil Loudspeaker
Electric Lamp, Parts of	192	Music for the Blind
Electric Lift	191	Neon Advertising Signs
Electric Locomotive, The First	191	New York: Radio City
Electric Meter	192	Noise Meter
Electric Motor	189	Non-Ionson Retinal Camera
Electric Recorder and Reproducer	192	Oil Fields
Electric Valve Voltmeter	191	Oil Separation
Enlarging a Ship	196	Ophthalmoscope
Escalators	198	Oscillograph
Eyeglasses, Invisible	200	Otophone

INDEX

	PAGE		PAGE
Oxy-acetylene Cutting	393	Nebulosity surrounding Nova Persei	383
Oxygen Apparatus	394	Orion	388
Paint-Spraying	396	Planets, The Formation of	420
Panama Canal	400	Tides and the Moon	487
	401, 402		
	402	WONDERS OF NATURE	
Parachutes	403	Alatsch Glacier	19
Photo-electric Cell and Relay	413	Aloes	19
Photometer	413	Alps, The Drei Zinnen	20
Photomicrography	414	Andes, The	22
Photography by Night	(11), 415	Antrim: The Giant's Causeway	25
Photo-Telegraphy	415	Argentina	25
Photographic Temperature Recorder	414	The Inca Bridge	29
Piano, An Electric	415	The Tandil Rocking Stone	29
Planetarium	(10), 416	Arizona: Petrified Forest	32
Planimeter	420	Aso-san	37
Pneumatic Drills	421	Australian Caves	47, 48
Pneumatic Tyres	422	Banyan Tree	53
Polar Ice: Finding the Depth of	423	Blue Mountains, The	72
Power Looms	426	Bondhus Glacier, The	72
Printing	432	Bore, A River	75
Pulsometer Steam-Pump	431	Brain, The Human	82
Pulveriser, A Screen	434	Brandvlei: Hot Springs	82
Radium	435	Brazil:	
Rainfall, Measuring	443	The Amazon	81
Refractometer	441	The Jungle	81
Refrigeration	44	Cacahuamilpo, The Caves of	92
Reinforced Concrete	441	Capri:	
Ring Spinning Frame	445	The Blue Grotto	105
Robot	445	The White Grotto	105
Rocket Aeroplane	446	Carolina, The Table Rock of	106
Rocket Car	446	Colorado, The Grand Canyon of	135
Rocket Mail Carrier	446	Cyclone, An Australian	152
Roller Lift Bridge	448	Dead Sea, The	161
Rolling Mill	448	Deserts	161
Rotor Ship	456	Diatoms	163
Rubber	458	Ear, The Human	182
Sand-blasting Bells	463	Earthquakes	182
Searchlights	467	Enseigne, The Earth Pyramids at	196
Seismograph Record	467	Erebus in Eruption	198
Sight-testing Apparatus	471	Erosion, Coastal	197
Sound Films	473	Etna	199
Spectroheliograph	475	Eye, The Human	200
Splitting the Atom	477	Fata Morgana	201
Steam Power	479	Fjords of Norway	206
Steel Foundry	479	Flower, The World's Largest	215
Steering, Automatic Marine	478	Franz Josef Glacier	222
Tank, An Amphibious	481	Frost Crystals	220
Telegraph, A Needle	482	Fuji-Yama	222
Telephone, The Automatic	482	Georgia, The Stone Mountain	234
Telescope, A Reflecting	482	Germany's Extinct Crater Lakes	234
Television	483	Giant Cactus	240
Thermocouple Pyrometer	486	Giant Trees in California	240
Thermo-electric Photometer	486	Gland, The Thyroid	240
Thickener, A Giant	486	Govet's Leap Falls	246
Time Lag Switch	489	Great Lakes of America	253
Traffic Signals	492	Growth, The Power of	253
Travelling Bridge	493	Hailstones	256
Tube Railway Control	494	Heart, Muscles of the	258
Valves, Wireless	497	Hebrides: Fingal's Cave	259
Vapour Tube Lighting	499	Himalayas, The	216
Water-Divining	504	Icebergs	268
Winding-gear of a Mine	506	Iceflowers	267, 268
X-Rays	506	Iceland: The Hot Springs	271
Zuyder-Zee Draining Plant	507	Iguazu Falls	272
		Imatra Falls	273
		Irish Elk, The Giant	282
WONDERS OF THE HEAVENS		Kentucky, The Mammoth Cave of	300
Arctic Lights	31	Kirunga-cha Congo	301
Asteroids	35	Krakatoa	302
Clouds	130	Lattice Fungus	304
Colours of Double Stars	141	Luminous Fungi	326
Colours of Stars	140	Maelstrom, A	332
Corona, A Solar	142	Mauna Loa: The Crater of Kilauea	340
Counter-glow	149	Milford Sound	350
Double Stars	170	Moher Cliffs	358
Eclipses	183, 184	Mont Pelée in Eruption	359
Fireball, A	205	Moving Mountain in Germany	367
Fireball and Nebula	204	Muscles, The Human	369
Galactic Nebula in Andromeda	223	New Zealand Geysers	378
Gravitation	252	Niagara Falls	386
Jupiter	290, 291	Oak Apple	304
Lightning	314	Orange Elf Cup	405
Mars	337	Pea Weevil	410
Mercury's Axis	344	Petrifying Waters	419
Meteor's Track, A	347	Pitchstone	419
Milky Way, The	355	Plants, Insect eating	421
Moon, The	359		

INDEX

		PAGE
	Pollen	423, 424
Alt	Pond Life	429
Alt	Precious Stones	431
An	Rock Shells	445
An	Rocky Mountains, The	447
As	Rotomahana Lake	454
As	Sea Cucumbers	466
Au	Sea Gooseberries	466
Au	Seven Sisters Falls, The	468
Au	Spanish Moss	474
Au	Stalactites and Stalagmites	478
Au	Stone-copying Plants	480
Ba	Strata of the Earth	480
Ba	Syracuse: The Ear of Dionysius	480
Be	Tasman Glacier, The	481
Be	Utah, The Rainbow Bridge	496
Bl	Vesuvius	501
Bo	Victoria Falls	501
Br	Waterspout	504
Ca	WONDERFUL PAINTINGS AND SCULPTURES	
Ca	Albani: Dance of the Cupids	14
Ca	Andrea del Sarto: The Annunciation	23
Ca	Angelico: Virgin and Child	28
Ca	Artemis, Head of	30
Ca	Bellini, Gentile: Madonna and Child	61
Ca	Belvedere, The Apollo del	62
Ca	Bernini: Apollo and Daphne	62
Ca	Bordone: The Consignment of the Ring	73
Ca	Botticelli: Primavera	74
Ca	Boucher: The Sunset	78
Ca	Breughel: Allegory of Hearing	83
Ca	Bronzino Angiolo: A Portrait	85
Ca	Burgos, A Retable in the Iglesia San Gil	89
Ca	Canaletto: The Piazzetta at Venice	103
Ca	Carracci: Vergine in Gloria	107
Ca	Cellini: Perseus and Medusa	117
Ca	Chardin: Benedicite	119
Ca	Chartres Cathedral Sculptures	121
Ca	Cima: Tobias and the Archangel	129
Ca	Claude Lorraine: The Landing of Cleopatra	129
Ca	Constable: The Hay Wain	145
Ca	Correggio: Mercury, Cupid and Venus	146
Ca	Cranach the Elder: Madonna and the Grapes	151
Ca	Danzig, Medieval Carving in	153
Ca	Della Robbia, L.: The Dancing Boys	159
Ca	Della Robbia, A.: A Child Study	160
Ca	Domenichino: St. Jerome's Last Communion	171
Ca	Donatello: Cantoria	172
Ca	Doves, The Mosaic of the	170
Ca	Dying Gladiator, The	181
Ca	Easter Island Sculptures	182
Ca	Falconet: La Baigneuse	203
Ca	Farnese Bull, The	203
Ca	Father Nile	202
Ca	Filippo Lippi:	
D	The Dance of Salome	208
D	The Annunciation	209
D	Florence: Fresco of Church Militant	210
D	Gainsborough:	
D	The Blue Boy	224
D	Mrs. Siddons	225
D	Gérard: Mme Récamier	233
D	Géricault: the Raft of Medusa	231
D	Ghiberti: The Doors of the Florentine Baptistery	235
D	Ghirlandaio: Adoration of the Shepherds	237
D	Gian Bologna: Mercury	240
D	Goya: A portrait	246
D	Gozzoli: The Journey of the Wise Kings	245
D	Great Yarmouth, Sculptures on St. Nicholas'	
D	pulpit	216
D	Greuze: La Cruche Cassée	248
D	Hals: The Laughing Cavalier	257
D	Hobbema: The Avenue	264
D	Hogarth: The Shrimp Girl	264
D	Holbein: Madonna of the Meyer Family	265
E	Idolino, The	271
E	Kefermarkt, the altar	297, 298
E	Laocoon, The	305
E	Largillière: Himself, Wife and Daughter	306
E	Lebrun: Himself and Daughter	308
E	Leonardo da Vinci: La Gioconda	309
E	Mabuse: Adoration of the Magi	336
E	Matsys: The Banker and His Wife	339
E	Medici Venus, The	342
E	Memlinc: The Mystical Marriage of St. Catherine	343
	Mengs: The Judgment of Paris	
	Michelangelo:	
	The Last Judgment	431
	David	445
	Moses	447
	Milo: Venus of	454
	Morales: Virgin and Child	466
	More: Queen Mary I	466
	Mourning Penelope	468
	Murillo: The Dream of a Roman Patrician	474
	Orcagna: The Glory of Paradise	478
	Orestes and Electra	480
	Ostia: The Fortuna of Ostia	480
	Pheidias: The Sculptures of	481
	Pisa: Frescoes in Church of St. Francis	481
	Polyclctus: The Spear Bearer	480
	Pompeian Bacchus	501
	Pompeii: The Roman Mosaic Fountain at	501
	Praxiteles: The Aphrodite of Knidos	504
	Prud'hou: Justice and Vengeance pursuing C	
	Rabbin: Dr. Alexander Adam	
	Raphael: La Belle Jardinière	14
	Ravenna: Mosaics in S. Vitale	14
	Rembrandt: The Anatomy Lesson	28
	Rigaud: Louis XIV	28
	Rome: Mosaics in the Church of S. Clemente	14
	Romney: Lady Hamilton as a Bacchante	28
	Rubens: Le Château de Steen	62
	Rude: A Group by	62
	Sansovino: Bacchus	73
	Sassoferrato	74
	Teniers: The Temptation of St. Anthony	78
	Ter Borch: The Signing of the Peace of Mu	83
	Thorwaldsen: Ganymede	85
	Titian:	
	Bacchus and Adriane	89
	Sacred and Profane Love	103
	Turner: Crossing the Brook	107
	Van Dyck: La Vierge aux Donateurs	117
	Van Eyck: Adoration of the Lamb	119
	Van Ostade: The Fiddler	121
	Velasquez: The Rokeby Venus	129
	Watteau: Embarkation of Cythera	129
	PREHISTORIC WONDERS	
	Allosaur, The	159
	Amber, Insects in	159
	Archæopteryx	171
	Brontops, The	172
	Dinosaur's Nest	170
	Dorchester, Maiden Castle	181
	Elasmosaur, The Snake-necked	182
	Eryops, The	203
	Foraminifera	203
	Fossil Plants	202
	Geosaur, The	203
	Glyptodon, The	202
	Ichthyosaurus and young	208
	Mammoth, The Siberian	209
	Naosaur, The	210
	Nevada: Fossil Footprints	224
	Pariasaur	225
	Prehistoric Man	233
	Sabre-toothed Tiger	231
	Sea Mats, Fossil	235
	Tinocerans	237
	Triacrotops	240
	MISCELLANEOUS WONDERS	
	Bacteria	248
	Caerwent	248
	Carcassonne	257
	Grafting	264
	Kano	264
	Lifeboats	265
	Lincoln Pens	271
	Lumber-floating	297, 298
	Madura	305
	Meteorite:	
	Iron	306
	Midnight Sun	308
	Mirage	309
	Rio de Janeiro	336
	Skeletons	339
	Snow Crystals	342

