

UNIVERSITY OF TORONTO



3 1761 00360591 2



Digitized by the Internet Archive
in 2013

<http://archive.org/details/archaeologicals16egyp>

300

(34) 1752

ARCHAEOLOGICAL SURVEY OF EGYPT

EDITED BY F. LL. GRIFFITH

SIXTEENTH MEMOIR

THE ROCK TOMBS

OF

E L A M A R N A

PART IV.—TOMBS OF PENTHU, MAHU, AND OTHERS

BY

N. DE G. DAVIES

FORTY-FIVE PLATES

LONDON

SOLD AT

THE OFFICES OF THE EGYPT EXPLORATION FUND, 37, GREAT RUSSELL STREET, W.C.

AND PIERCE BUILDING, COPLEY SQUARE, BOSTON, MASS., U.S.A.

AND BY KEGAN PAUL, TRENCH, TRÜBNER & CO., DRYDEN HOUSE, 43, GERRARD STREET, SOHO, W.

B. QUARITCH, 15, PICCADILLY, W.; ASHER & Co., 13, BEDFORD STREET, COVENT GARDEN, W.C.

AND HENRY FROWDE, AMEN CORNER, E.C.

1906

102741
23/6/10.

DT
57
E326
no. 16

LONDON:
PRINTED BY GILBERT AND RIVINGTON LTD.,
ST. JOHN'S HOUSE, CLERKENWELL, E.C.

EGYPT EXPLORATION FUND

President

F. G. HILTON PRICE, Esq., Dir.S.A.

Vice-Presidents

| | |
|---|---------------------------------------|
| THE RT. HON. THE EARL OF CROMER, G.C.B., G.C.M.G., K.C.S.I. (Egypt) | |
| SIR JOHN EVANS, K.C.B., D.C.L., LL.D., F.R.S., F.S.A. | THE HON. CHAS. L. HUTCHINSON (U.S.A.) |
| SIR E. MAUNDE-THOMPSON, K.C.B., D.C.L., LL.D. | PROF. T. DAY SEYMOUR (U.S.A.) |
| THE REV. PROF. A. H. SAYCE, M.A., LL.D. | PROF. AD. ERMAN, Ph.D. (Germany) |
| PROF. W. W. GOODWIN (U.S.A.) | PROF. G. MASPERO, D.C.L. (France) |
| | JOSIAH MULLENS, Esq. (Australia) |

Hon. Treasurers

H. A. GRUEBER, Esq., F.S.A. EDWARD R. WARREN, Esq. (U.S.A.)

Hon. Secretary

J. S. COTTON, Esq., M.A.

Members of Committee

| | |
|--|--|
| T. H. BAYLIS, Esq., M.A., K.C., V.D. | PROF. ALEXANDER MACALISTER, M.D. |
| C. F. MOBERLY BELL, Esq. | MRS. McCLURE. |
| THE HON. J. R. CARTER (U.S.A.) | THE REV. W. MACGREGOR, M.A. |
| SOMERS CLARKE, Esq., F.S.A. | ROBERT MOND, Esq., F.R.S.E. |
| NEWTON CRANE, Esq. (U.S.A.) | THE MARQUESS OF NORTHAMPTON. |
| W. E. CRUM, Esq., M.A. | FRANCIS WM. PERCIVAL, Esq., M.A., F.S.A. |
| LOUIS DYER, Esq., M.A. (U.S.A.) | SIR HERBERT THOMPSON, BART. |
| ARTHUR JOHN EVANS, Esq., M.A., D. Litt., F.R.S. | MRS. TIRARD. |
| PROF. ERNEST A. GARDNER, M.A. | EMANUEL M. UNDERDOWN, Esq., K.C. |
| F. LL. GRIFFITH, Esq., M.A., F.S.A. | JOHN WARD, Esq., F.S.A. |
| F. G. KENYON, Esq., M.A., D.Litt. | T. HERBERT WARREN, Esq., M.A. |
| | E. TOWRY WHYTE, Esq., M.A., F.S.A. |



CONTENTS

| | PAGE |
|---|------|
| LIST OF PLATES | vii |
| CHAPTER I. THE TOMB OF PENTHU. | |
| A. Architectural Features. | |
| The exterior | 1 |
| The wall-thicknesses | 1 |
| The interior | 1 |
| The condition of the tomb | 2 |
| B. The Sculptured Scenes. | |
| North Wall—Upper Part | 2 |
| " " Lower Part | 3 |
| South Wall—Lower Part | 5 |
| " " Upper Part | 5 |
| Titles of Penthu | 6 |
| CHAPTER II. THE SITE OF THE SOUTHERN TOMBS. | |
| Situation | 7 |
| Number | 7 |
| Previous records | 7 |
| Change of Necropolis | 8 |
| Architecture | 8 |
| Tomb-forms | 9 |
| Sequence | 9 |
| Methods of construction | 9 |
| Later burials | 10 |
| Roads | 11 |
| CHAPTER III. THE TOMB OF MAHU. | |
| A. Site and condition | |
| B. Architectural Features | |
| C. Scenes and inscriptions. | |
| The wall-thicknesses | 13 |
| The rewards of Mahu | 14 |
| An inspection of the defences | 15 |
| Policing the capital | 16 |

| | PAGE |
|--|------|
| CHAPTER IV. THE TOMB OF APY | 19 |
| CHAPTER V. THE TOMB OF RAMES | 21 |
| CHAPTER VI. THE TOMB OF NEFER-KHEPERU-HER-SEKHEPER | 23 |
| CHAPTER VII. THE TOMB OF SUTI | 25 |
| CHAPTER VIII. THE RELIGIOUS TEXTS. | |
| A. Their character | 26 |
| B. Longer prayers | 27 |
| C. Shorter prayers | 30 |
| D. Burial petitions | 30 |
| APPENDIX. DECORATIVE TECHNIQUE AT EL AMARNA | 32 |
| INDEX | 34 |

LIST OF PLATES

WITH REFERENCES TO THE PAGES ON WHICH THEY ARE DESCRIBED.

| PLATE | Tomb of Penthu. | PAGE |
|---------|---|------------------|
| I. | Plan and Sections | 1, 2 |
| II. | Façade | 1, 2, 6, 30 |
| III. | N. thickness | 1, 29 |
| IV. | S. thickness | 1, 29, 30 |
| V. | N. wall: Upper Scene. A visit to the Temple | 2 |
| VI. | „ „ The Temple Court | 2, 3 |
| VII. | „ „ The Lesser Sanctuary | 3 |
| VIII. | N. and S. walls. Lower scenes | 3, 4, 5 |
| IX. | „ „ Fragments | 4, 5 |
| X. | S. wall. The King and Queen at meat | 5, 6 |
| XI. | Tombs of Penthu and Rames. Photographs | 2, 22, 32 |
| XII. | Tombs of Penthu and Mahu. Photographs | 2, 3, 16, 17, 32 |
| XIII. | Southern tombs. General Plan | 7—11 |
| | Tomb of Mahu. | |
| XIV. | Plans and Sections | 12, 13 |
| XV. | N. thickness. The Royal Family | 13, 14 |
| XVI. | N. end wall. The Stela | 12, 13, 28 |
| XVII. | Back wall: N. side. Mahu and his train | 14 |
| XVIII. | „ „ Mahu visits the Temple | 15 |
| XIX. | „ „ (<i>continuation</i>) | 15 |
| XX. | Back wall: S. side. The Royal Chariot | 15, 16 |
| XXI. | S. end wall: Left side | 16 |
| XXII. | Back wall: S. side. Passing the sentries | 16 |
| XXIII. | S. end wall. The false door | 12, 13, 28 |
| XXIV. | Front wall. Mahu exercising office | 16, 17 |
| XXV. | S. end wall. Right side | 17 |
| XXVI. | Front wall. Mahu brings prisoners | 17, 18 |
| XXVII. | Back wall. Doorway | 13, 31 |
| XXVIII. | Exterior. Door-jambs | 13, 30, 31 |
| XXIX. | Fragments | 13, 14, 28, 29 |
| | Smaller Tombs. | |
| XXX. | Tombs 10 (Apy), 9A, 9C. Plans | 11, 19 |

| PLATE | | PAGE |
|----------|---|---------------|
| XXXI. | Tomb of Apy. Entrance | 19, 20 |
| XXXII. | Hymn to the Aten. Collation of texts | 20, 26—29, 31 |
| XXXIII. | <i>(The same continued.)</i> | 28, 29 |
| XXXIV. | Tombs 7A, 7B, 9B, 11 (Rames). Plans | 11, 21 |
| XXXV. | Tomb of Rames. Entrance | 22, 30 |
| XXXVI. | Tomb 13. Plan and section | 23, 24 |
| XXXVII. | „ Sections and inscription | 23, 24, 31 |
| XXXVIII. | Tomb of Suti. Plan and sections | 25 |
| XXXIX. | Tombs of Suti and Apy. Inscriptions | 19, 25, 31 |
| | Photographic Plates. | |
| XL. | Tomb of Mahu. Entrance | 13, 14, 28 |
| | The sentries | 16 |
| XLI. | Mahu and the city officials | 17, 32 |
| | The Royal Family driving out | 15, 16 |
| XLII. | Mahu's Chariot. (<i>Ink design</i>) | 15 |
| | Mahu. Nefertiti | 13, 15, 22 |
| XLIII. | Tomb 13. Exterior. Interior | 23, 24 |
| | Tomb of Apy. Hymn to Aten | 27 |
| XLIV. | „ „ Votive pieces | 19 |
| | „ „ The Royal Family | 19, 20 |
| XLV. | Rames at prayer | 22, 30 |
| | Rames and his wife | 21 |

THE ROCK TOMBS OF EL AMARNA.

PART IV.

CHAPTER I.

THE TOMB OF PENTHU ().¹

A. ARCHITECTURAL FEATURES.

EXTERIOR. (Plates i., ii.)—This tomb is hewn in the cliff, 60 yards or thereabouts to the South of No: 4 (Meryra). The rock here forms an overhanging face about 30 ft. high, and by cutting back the foot-slope on the left hand a vertical wall 70 ft. long and 15 ft. high was gained for a façade with but little labour. Perhaps because by chance the rock above took the exact shape of the usual roll and cornice, though in gigantic dimensions, the portal was furnished with no other. The excavation left a protected court on the North side of the door, and dwellers in the desert at a later period formed this into a snug abode by adding thick walls of piled stone.

The framing of the doorway stands out in slight relief from the wall, and is decorated in the usual way (Plate ii.). The lintel has the usual device of royal and divine cartouches, flanked on each side by the figure of the deceased and his prayer. It is the exact counterpart of that of Ahmes (III. xxvii.).²

¹ No. 5. (No. 2 of Lepsius and L'Hôte.)

² A complete drawing of the doorway was lost in transit, in England, and had to be replaced by a less careful record. The figures on the lintel are only approximately correct.

The jambs (much broken and time-worn) contain *dy hetep seten* prayers in four columns each. (Translations on p. 30.)

THE WALL-THICKNESSES.—Here the usual figures and prayers of the deceased are again found, facing outward. They have suffered great injury, but the texts can be restored from parallels in the tomb of Huya. The hieroglyphs were carefully formed, but retain shape and colour only on the upper part of the walls. Several Greek graffiti are scratched over the figure on Plate iii., one of which reads *Ερμαιος*.³ Penthu wears the long gown, waist-sash and sandals, and has the shaven head of the priest. Translations of the prayers will be found on p. 29.

INTERIOR.—The tomb is in nearly every respect similar to that of Ahmes (III. xxvi.), being T-shaped, with the cross-corridor at the further end from the door. The inner room served as the burial-chamber, the actual place of interment being provided by a shaft, which is protected by a parapet of rock and goes down nearly 40 ft. I descended this and found a regularly-formed chamber, 17 ft. long, opening out of it on the South side. It was partially

³ Cf. Part III., pp. 35, 36.

filled with loose stones, and had evidently been thoroughly ransacked.

Beyond the cross-corridor was the Shrine. It had contained a statue or the block out of which one was to be hewn, but this has been entirely removed. The roof of the outer corridor is vaulted. For the trench in the floor, see Part II., p. 2.

CONDITION OF THE TOMB.—The tomb had, no doubt, been used as a dwelling-place, and to this are due two rounded niches in the South wall and a square niche in the North wall, which have removed a large part of the scenes. In order to give more light to the back room, an attempt was made to break away the whole of the framing of the inner doorway, but it was only partially carried out. The wall-surface of the long hall is in a deplorable condition. The further half on both sides is almost entirely destroyed, owing, apparently, to the poor nature of the rock; and the parts which have not so suffered are almost equally unsightly. The whole tomb was decorated in a peculiar way, each figure or group being moulded in an inset of plaster. This adhered so indifferently that it has nearly all fallen away, and has left simply the roughly-shaped mould which it occupied. (Pls. xi., xii.) The plates therefore give, for the most part, merely the depression which the figure was to occupy. As this sometimes closely resembles, sometimes only roughly approximates to the final picture, a suggested restoration of the outline has generally been added within.¹

Despite present appearances and the aspect of the plates, the few fragments of plaster that remain in place show that the reliefs were executed with the greatest care and delicacy. The decoration of the tomb, however, remained incomplete. The lower scene on the South wall finished abruptly half way along, and of the upper design only fragments of the preliminary coloured sketch remain.

¹ A more detailed description of the methods followed by the sculptors is given in an appendix, p. 32.

B. THE SCULPTURED SCENES.

1.—A ROYAL VISIT TO THE SANCTUARY.

North Wall. Upper Part. Plates v., vi., vii., xi., xii.

Though this subject as a whole has no counterpart in other tombs, it has resemblances. As a representation of the Smaller Sanctuary it is most akin to that in III. xxx., and to two pictures in the Royal Tomb.² But in each of those scenes, the visit of the King, which is its ostensible motive, is very differently portrayed; while here there is added as a second motive, with a second appearance of the Royal party, the bestowal of rewards on Penthu. It has already been explained (Vol. III., p. 29) in dealing with a similar picture of the temple, that the first double-gated pylon represents the outer gate of the Temple of the Aten; the furniture which is seen behind it indicates the intervening courts or sanctuary; and the second pylon, with the building attached to it, is the Smaller Sanctuary.

The Royal party stand outside the temple, the King holding up his hands in a reverential attitude. The Princesses Merytaten, Meketaten and another, with the usual attendants, accompany their parents.³ Five chariots, one of them with royal plumes, wait outside.

The furniture, by which the intervening places of offering are symbolized, corresponds most closely to that of the last courts of the larger temple or to that of the dependent building at the rear of the smaller. It is only in the latter that the tables with curved legs, which crowd the space here, occur again (I. xi., xxxiii.). This picture of the temple, however, finds its closest parallel in the Royal Tomb, where the rays strike through the building in the same way,

² *Mon. du Culte d'Atonou*, I. i.

³ Lepsius took away with him a piece of falling plaster, showing two heads of female fan-bearers. (LEPSIUS, *D. Text*, ii., p. 133.) They must be from this group (Pl. xi.). Dr. Schaefer kindly sent me an excellent drawing of the fragment (No. 521 in the Berlin Museum) which is reproduced on Plate ii.

and the joints of meat stacked on tables and in shrines are a similar feature; but where the Smaller Sanctuary, like the Greater, is indicated only by furniture and gates.¹

Penthu and one or two fellow-priests meet the King at the gates, and the picture suggests that the King presently took the opportunity to show his favour to this worthy by substantial rewards. Possibly the similar scene below (Pl. viii.) records the reward of Penthu's industry as Chancellor, that on the South wall the honour done him as Chief Physician, or Privy Councillor, and this his recompense for true discharge of his duties as Chief Servitor of Aten, the scene of his exertions being in each case chosen as the scene of his reward. The occasion is described as "Rewarding² the Intimate of the King, the Chief Servitor of Aten." Over Penthu's head is the stereotyped acknowledgment by the lucky courtier—"Abounding in wealth and knowing who bestows it." ³ A longer inscription, which, no doubt, gave the reason for the ceremony, has fallen from its setting.

The faces of the royal pair, too, have perished, with the exception of the chin and neck of the Queen, a fragment which, being moulded with extreme care, makes us regret the loss of the remainder. The mannerism of the earliest period is indeed not entirely kept under. The chin, however, is unexaggerated, and the neck, though lean, is such as Rossetti might have drawn. The muscles are strongly indicated; the cheeks are hollow, giving prominence to the cheek-bones, and suggest a hard, masculine aspect. It thus conveys a different impression from the painted profile on the opposite wall (Pl. x.),

¹ The inference would be that this part of the Royal Tomb was decorated at the period of the change from the South to the North necropolis. But this seems impossible unless the one wall of the room which represents mourning for Meketaten were decorated later.

² Emending to 

³ Cf. I., viii.; III., p. 13, where the rendering is incorrect.

and from other portraits of the Queen (cf. Pls. xv., xxxi.) and is not convincing. The figure does not extend below the collar-bones; for, by some inexplicable slovenliness, the cutting out of the matrix for the figure had gone no further, and the modeller in plaster, finding his basis fail, had to round off his work as best he could (Pl. xii. *d*).

Behind the Royal party is seen the familiar columned pylon, the entrance gate to the Smaller Sanctuary. The appearance of this building has already been described from better representations (III. pp. 21-25). The walls screening the entrance inside are shown, but the only furniture of the interior now visible consists of numerous shrines stacked with bread and meat.⁴ The sun's rays penetrate the building, and the sky extends overhead till it reaches the supporting mountains.

2.—THE REWARD OF PENTHU.

North Wall. Lower Part. Plates viii., ix.

Sufficient remains of this greatly injured design to show that it was the fellow and perhaps the original of one in the tomb of Meryra, which it resembles in all essentials (I. xxix.-xxxi.). It has been suggested already that the same subject once had a place in the hall of Panehesy (II. p. 29),⁵ and this warns us forcibly how little there may be in these pictures that is personal to the owner of the tomb. As the selection of verses on the grave-

⁴ Possibly at the time of these early designs the great temple of the Aten was, in fact, little more than a series of courts entered by pylons, and the furniture still of the simplest. Cf. Pl. xx. The sun's rays entering the building everywhere would then be even more noticeable than at later periods.

⁵ Panehesy, as Superintendent of the Granaries and Cattle of Aten, would seem to have the best claim to the design, and possibly it originated with him; for his tomb might be contemporary with Penthu's. Whether his fellow-officials adopted it with equal justice, or any justice, we cannot determine.

stones of an English churchyard are determined much more by the limited *repertoire* of the local sculptor than by any applicability to the deceased, originality being extremely rare; so also was it in Akhetaten. So small was the number of stock designs that their connection with the personal history of the deceased might be very remote. The personality of these officials of Akhenaten becomes very attenuated when we observe that the tombs of Ahmes, Penthu, Panehesy and Meryra are illustrated with much the same subjects, whether the owner is a High Priest, a Chief Physician, or a Superintendent of the Court-house. The prayers and biographical statements put into the mouth of the deceased are also largely professional compositions; and even the short legends and docketts, in which we might hope to find a personal note, generally at El Amarna show signs of being stereotyped, too. There is, however, a certain degree of liberty. There are, nearly always, differences of treatment and expression; the artist then, as now, despised the ignoble rôle of a mere copyist, and it is in these variations that we shall find, if anywhere, signs of individual fortune and character.

The inscription accompanying the picture of Meryra sets forth that he was rewarded for filling the temple with all kinds of provisions for offerings. The fragments of the corresponding but shorter notice here make it probable that its tenour, and even its wording, were very similar. But the reference to Penthu is lost. Apparently similar services and rewards were claimed in both cases.

As in the later picture,¹ the opening scene shows the freight ships drawn up side by side at the river bank, with their prows moored to the shore. There are nineteen single-masted vessels. Fragments of plaster with detail (mooring-stakes, landing planks, cartouche-headed steering

¹ The full description given in Part I., pp. 33-36, allows me to be more brief here.

paddles, figures standing by piles of produce, &c.) show that the copy of Meryra followed this closely. The cattle-yards, however, are not in this tomb placed on the river-bank, but at the end of the picture, and in their place we have here a glimpse of the gardens and villas which lay along the quay. Between these and the ships is a broad band, which may represent either the quay or the river. It is impossible to see whether the two strips of garden are simply such or contain colonnades.² There is a strip of sky over each, indicating perhaps that they lie side by side, not one beyond the other. The rest of the line of buildings and gardens is lost, except for a small fragment (on a larger scale in ix. A.) The rest of the wall-space up to the store-yard was occupied apparently by numerous chariots and their attendants.

The enclosing wall of the store-yard is shown running round on all sides. In its outer court the King and Queen, accompanied by three princesses, their nurses (recognizable by their bending attitude, Pl. ix. E.), and a numerous suite, receive Penthu. He, on his side, has with him a considerable company of shade-bearers, scribes, officials and attendant priests; for it is presumably in his capacity of Chief Servitor of Aten that he has earned the distinction of the golden insignia.³ The response of Penthu to the King's generosity is on a strictly official model "Give health to Pharaoh (life, prosperity and health to him!), thy fair child, O Aten. Grant that he may complete [thy duration; grant it for ever.]"

Behind the royal party is the granary, filled with heaps of grain (cf. I. xxxi.) From here onward the wall-surface is destroyed, partly by

² Cf. the picture of the river bank in the tomb of Maÿ (V. v.). *Mon. du Culte d'Atonou*, I. xxxv.

³ See Plate ix c. Also L'Hôte, *Lettres Écrites*, p. 61. Enough details of this group and its text remain to justify their restoration on the exact lines of the replica in I. xxx.

outline with the flesh in solid red, but blue is also used on the collar: the cup is left white.

This group lies about six feet from the right end of the wall. It shows the King and Queen (with a princess beside her?) seated on chairs, each before a pile of viands. A hand on the left suggests that a figure of equal size and importance sat facing the King, and the picture in Huya's tomb leads us to ask if it can be Tyi. Conceivably, however, it might be the hand of Penthu or some other official in attendance.¹

5.—TITLES OF PENTHU.

Penthu is entitled (Plates iii. and iv.) :—
Royal Scribe.
Intimate of the King.

¹ The hand is at its true level in the Plate, but it should be some distance further to the left, as if it were helping itself from the same table.

Chief Servitor of Aten in the temple of Aten in Akhetaten.

Chief Physician.

Privy Councillor (*ami khent*).

The following epithets are also applied to him (Plate ii.) :—²

Royal Chancellor.

Sole Companion.

Attendant on the feet of the King.

Favourite of the Good God.

Beloved of his lord.

He who approaches the person of the God.

Chief of Chiefs.

Companion, chief of the Companions.

Though we know little of the special duties which these varied offices and honours entailed, it is plain that Penthu's rank was high and brought him into close relations with the Court.

² All these are borrowed by or from Ahmes (III. xxvii.), along with the device on the lintel, showing that they were honorary titles only, applicable to any high official.

CHAPTER II.

THE SITE OF THE SOUTHERN TOMBS.

1. SITUATION.—It is curious that the bold cliffs themselves were not selected as a site for the earliest tombs at Akhetaten, but a low bank which marks the rise from the level of the plain to that of the great wady running southward through the mountains. The rock is of the worst possible nature; the site was limited in area and lay an hour's ride south-east of the city. Hence after a few years it was abandoned for the northern cliffs. These unattractive hills are bounded on the East and West by two *Khors* (drainage valleys) and are cut into three parts by dry water-courses, descending from the level of the wady.

2. NUMBER.—Of the tombs excavated here, nineteen are usually open and have been numbered;¹ but there are others in a greater or less state of completion, of which eight appear on the accompanying map (Plate xiii.). All the tombs are liable to become sanded-up, so that many of the numbered tombs had to be excavated in order to secure plans. The eight lettered tombs were completely hidden and were cleared of sand by me. Most of them had been unearthed before by MM. Bouriant and Barsanti, but no records or plans seem to have been made. The tombs are betrayed at once by the piles of stone fragments thrown out; so that it is almost impossible that any large chamber remains undiscovered, though there might be many of the type 9B., 9C. There are also many small cuttings where a tomb was

planned or whence stone was taken for inset (patchings, cornices, etc.), and these no doubt have caused disappointment to others besides myself. Of the tombs which I opened only 7c was of any size, and none showed any traces of inscription except 25A.²

3. PREVIOUS RECORDS.—The buried state of these tombs, consequent on their low position, kept them unknown or uncopied long after their first discovery. They seem to have been unvisited by Wilkinson, as HAY, who shared with him the knowledge of the tombs of Et Til, refers to the conspicuous tomb of Aÿ as “the tomb opened by me.”³ Tomb 13 also was opened by him and his companion Laver in 1830, as he records on its ceiling; and tombs 7 and 8 were entered, and such copying and planning done as were possible under the circumstances. L'HÔTE did very little work here. The great advance which LEPSIUS made on Hay was more in the publication than in the extent of his copies; for though the entrances of most of the other tombs were plain to him, he made no attempt to penetrate into them. The work done by French Egyptologists on the site between 1883 and 1902 has already been noted (Part I., p. 5). The result of their combined labours, long delayed owing to the illness and death of M. Bouriant,

¹ 7 to 25 in continuation of the northern tombs. They are often called the Tombs of Hagg Qandil after the nearest village on the river-bank.

² The evident excitement under which M. Bouriant worked can alone account for the statement that the South group contains more than fifty tombs, and that all the valleys are full of them. *Deux jours de fouilles*, pp. 1, 15.

³ HAY, MSS. 29847, fol. 65.

has now appeared, so far as the south group is concerned.¹

4. CHANGE OF NECROPOLIS.—The transference of the Necropolis to the northern hills presents us with an unsolved problem: for the material changes that coincided with it suggest that it had real significance. The new and stricter name of the Aten comes into use; the form of tombs undergoes considerable alteration; the Queen's sister disappears; detailed pictures of the temple are shown and those of the palace are altered; the figure of the deceased takes the place of the King in the doorways. None of these changes is startling; none perhaps was sudden; yet, taken together, they show that the 8th or 9th year of the reign marked a turning-point. Probably it exhibited in some definite way the success of the revolution: only a very partial and short-lived success, no doubt; yet not to be a failure was already much.

It may well be supposed that up to this point all had been in doubt. Now (surely by a compromise) civil peace was assured. The city had been solidly founded; the temple and the palace erected;² the boundaries of the sacred district solemnly confirmed; the Queen's sister married

¹ *Monuments pour servir à l'étude du Culte d'Atonou en Égypte*. Tome I. *Les Tombes de Khouitatonou*. Par MM. U. BOURIANT, G. LEGRAIN et G. JÉQUIER. 1905. The previous publications of texts, &c., by M. BOURIANT (*Deux jours de fouilles à Tell el Amarna*) and M. DARESSY (*Recueil*, xv., p. 36) being superseded by and referred to in that work, I shall not cite them in addition.

As far as possible I have worked on the site with previous copies before me; so that where I differ from my predecessors I must be understood to have fully convinced myself that they were in error. I may add that, except for deliberate mutilations, and inscriptions in ink on the façade or in the entrance of tombs, the records, with rare exceptions, do not appear to have deteriorated since the days of Hay.

² Perhaps temporarily the court had settled further to the south (in the mansion with the smaller painted pavement?), but now moved northward to the newly-built quarter of the city; the necropolis, naturally, shifting with it.

off, in a way, perhaps, that had political results³; a new influx from Thebes was changing somewhat the first fashions in which the King's influence and local mannerisms had been unchallenged. All this is hypothetical; but some such change, important yet not radical, seems indicated.

5. ARCHITECTURE.—The originality so marked at this epoch in other directions is not less prominent in tomb architecture. There was a complete break from the traditions of Theban tombs both in form and in mode of decoration. The ordinary T-shaped chamber is unknown at El Amarna, and so also is decoration in colour on plaster. Papyrus columns everywhere replace the square pillar of rock where support is needed for the roof. If Akhenaten fails to win our admiration away from the bright colour and rich detail of the Theban tomb, his architecture at least is in the highest degree imposing, especially in the Southern Group, where the larger tombs almost reach the dignity of rock-temples. There is no other necropolis like this in Egypt. Beside the solid masonry of Saqqareh, the magnificent simplicity of Beni-Hasan, the rich colouring of Thebes, must be set the graceful architecture of the tombs of Hagg-Qandil. The row of complex columns finishing at the wall in pilasters with cavetto-cornice, and carrying either a simple or a corniced architrave, is an architectural element which, by its harmonious blending of straight lines with curves and of the plain with the broken surface, may bear comparison with features of classical architecture that have become imperishable models. The breaking of the plain wall-surface by double corniced portals, or by the door and lattice, also shows admirable decorative taste, and we can only regret that no free-standing building remains in Akhetaten. Unfortunately the period was so short and the work so hurried that we have to

³ But not, it would seem, to Horemheb, the future King of Egypt. See SETHE, *A.Z.* 1905, p. 134.

complete the tombs in imagination. One and all they remain sketches which show the restless genius of the artist; and if there seems no great variety of type, no more indeed than indicates that the type was variable, we must remember that the tombs of the group appear to be the product of two or three years at most.

6. **TOMB-FORMS.**—The most natural impulse in tomb-quarrying is to gain wall-space with least labour. To this the corridor answers best. It might lie athwart the entrance or in line with it, and though the latter arrangement had the advantage of taking small frontage space, the cross corridor was generally adopted, as it secured room for expansion. In the South group only tombs 18, 19 and 23 adopted the direct corridor. It was imitated in tombs 3 and 5, but there the cross-corridor (with false doors) was added at the *further* end, thus forming an exact T.

The smallest tombs are all of the cross-corridor type, with a false door (shrine) at each end and another opposite the entrance (tombs 7, 11, 17). If time and means permitted, the breadth of the corridor was doubled, the back wall becoming a row of columns down the centre (commenced in Nos. 10, 12, 20; nearly completed in 7c, 13). Or it might be trebled or quadrupled by having two rows of columns (Nos. 8, 14, 16) or three (No. 25). Two false doors to right and left on entering still bore witness to the embryo-form, though these might be repeated in the new cross-aisle (Nos. 8, 16). Not that the development actually took place in successive strips. After the cross-corridor was finished the central aisle might be run out to its limit, and the excavation begun to right and left (Nos. 21, 22).

The simple cross-corridor tomb was, however, not really complete. It had no place for burial (only a shaft in the chamber in tomb 11), and it was intended that the door in the back wall should lead to a further room, in which or through which the burial place should be reached. In the tomb of Mahu (No. 9) this

room was left quite simple and small. In Nos. 8 and 15 this inner room was meant to become a many-columned chamber.¹ Where the cross-corridor had become a columned hall, it was felt advisable to begin the burial place at once, placing it at the end of a flight of steps leading down from the floor (in the left-hand back corner, Nos. 8, 13, 14, 16, 25). If the stairway was extensive, it was made to turn on itself so as to keep within the area of the tomb. The stairway, when in the second chamber, was on the right (Nos. 6, 9, 15).²

7. **SEQUENCE.**—It is difficult to determine the order of succession of the tombs in this group. The Princesses are always three in number, except in tombs 9 and 11 where Merytaten alone appears. Reasons will be given for doubting if these two tombs can really date as early as Akhenaten's fifth or sixth year. All the tombs therefore seem to be practically of one period, and I am unable to suggest with confidence any sequence among them. Tombs 8 and 23 show examples of the later form of the name of the Aten, and tomb 9 uses no other. These, then, we should expect to be latest in date.

8. **METHODS OF CONSTRUCTION.**—As will be seen in dealing with separate tombs, they are all more or less unfinished, and the decoration of all is seriously incomplete. Evidently the work was done in the utmost haste. The shrewd king seems to have seen that the best way to bind his courtiers to Akhetaten and to his enterprise there was to let them see their future halls of burial already planned on an elaborate scale and actually begun. A tomb was invariably quarried from

¹ It is from this type that the larger tombs of the North group are developed, but with considerable changes of dimensions and arrangement. The two false doors are still seen in the first chamber of Meryra (No. 4) and of Panehesy (No. 6). In the latter they are transferred to the back wall.

² When the inner room was added in No. 6, the provisional burial place in the outer hall was abandoned for a more elaborate one in its true place, the second chamber.

the roof downwards, and to the last the ceiling remained the most finished and accurate portion; so that the modern surveyor is obliged to adopt the laborious and inverted method of taking the ceiling as the basis of his plans. The reason for this is not far to seek. When one tomb was begun before its neighbour had been completed, it was advisable that the latter should have marked out its claim to frontage by excavating the whole breadth within. This is in fact always found to have been done, even if the tomb was left unfinished in the rear (cf. Nos. 14, 22, 25, etc.).

A further peculiarity of these tombs is that they were evidently finished piecemeal as the work went on; the last smoothness and detail were given to the ceilings, architraves, cornices of doors, and capitals of columns, while the other half of the tomb, the column, the doorway, was still a mass of rock. The explanation, however, is not that, owing to a childish impatience to reach pleasing results or in order to avoid the use of scaffolding, the tomb was completed in sections: this feature is the direct result of the conditions under which the work was done. So hasty was it, so insecure the supply of labour, so remote the chance of completion, that the most expeditious method was the only method. Quarriers, finishers, plasterers and decorators were employed upon the tomb simultaneously, one following upon the other's heels; and when, as was feared, the quarriers were called away from the half-excavated tomb, the finishers employed the interval that must elapse before new work was prepared for them in completing the chamber to the limit that their forerunners had set them. The plasterers moulded and whitewashed the capitals of columns regardless of the fact that the shaft was still unformed and that their work would be seriously impaired, if not destroyed, should the excavation ever be proceeded with. The decorators and sculptors, who found a properly smoothed wall, sketched out, sculptured and

painted their scenes, though half the chamber, or all save the doorway, was still virgin rock. This procedure has been justified. But for this unmethodical haste there could have been no architectural beauty and no texts or scenes in the necropolis; for not a single tomb reached completion, and only in two cases are even the interiors perfectly ready for decoration. This must be remembered in appreciating architectural features, and not less in drawing conclusions from the scenes. No evidence can be gathered from the absence of certain representations, for the subjects which would have occupied the remaining walls are unknown to us. As a matter of fact all the pictures we have in this group, with the exception of those in the tomb of Mahu and one in the tomb of Maÿ, are three separate versions of the same design, showing the reward of the official from the window of the palace (Tombs 7, 8, 25).

The tombs and their sculptures lie open also to the charge of being "jerry-built"; for the material in which they are excavated is quite unsuited to their ambitious designs. The admirable lines of cornice and column and the fine detail of sculpture are all executed in plaster. The stone basis for both is often of the roughest description. Many of the columns, owing to faults and fissures in the rock, are largely made up of plaster. No doubt a great deal of bad work, due to haste, has also been covered up in this way. But the Egyptian work in plaster was so excellent, and the insecure basis for this rock-architecture is so little to be suspected even now, that the passing centuries must be considered to have sufficiently vindicated the ancient architect.

9. LATER BURIALS.—Most, if not all, of the tombs have been re-used for later burials, bones and great mounds of sherds outside the principal tombs witnessing eloquently to the fact. Large numbers of coffins were, I believe, found by the first excavators, many being burnt and others

removed to Cairo. No notes of this Departmental undertaking have been published.¹

10. ROADS.—As in the North group, broad tracks, swept clear of stones, lead from the vicinity of the ancient town to many of the chief tombs. They are marked on Plate xiii. for a certain distance, but after three or four hundred yards from the tombs they visibly swerve from the straight line and often bend considerably, perhaps because several ran into one.² Their full mapping remains to be done.

¹ I hope to be able later to obtain a little evidence on the subject from the heaps of *débris* and from the *fellahin* who did the work.

² For their further course, consult PETRIE, *T. A.*, pl. xxxv. Their number and direction is given in LEPSIUS, *D. Text*, ii. p. 148.

The following notes on this subject may be added:—

From Tomb 25.—Two roads; one leaving at 319° , one at 322° , and seeming to strike the river bank at points $317^\circ 30'$ and $333^\circ 30'$ from the tomb. Twenty and twenty-two feet broad.

From Tomb 23.—Thirty-four feet broad.

From Tomb 22.—Very straight. Twenty-five feet broad.

From Tomb 8.—Appears to strike the bank 303° from the door of the tomb. Twenty-nine feet broad.

The uninscribed tombs, of which some plans are given on Plates xxx., xxxiv., will be noticed in Part V.

CHAPTER III.

THE TOMB OF MAHU .¹

A. SITE AND CONDITION OF THE TOMB.

THIS tomb was opened by M. Bouriant in 1883² for the first time.

Mahu, Chief of Police, was better aware than any one of the risk, or rather the certainty, that his tomb would be plundered after his death. Instead, therefore, of hewing his chambers conspicuously in the face of the hills overlooking the plain, he chose a retired spot where the ground was almost flat. Driving a narrow stairway to a sufficient depth he formed his "eternal home" cellar-wise there, where the whirling sands would quickly conceal it. Though his aim was not permanently secured, the ruse was partially successful. The little tomb remained immune, not only during the religious reaction that soon occurred, but from the assaults of modern thieves. If his little chamber is now the most attractive of the Southern tombs, it is owing not only to the peculiar interest of the scenes but also to the unsullied whiteness of a large part of the walls.

B. ARCHITECTURAL FEATURES.

The tomb is of the simple cross-corridor type, with a second chamber in the axis of entrance

through which the place of burial is reached. This inner chamber is roughly hewn and askew, and the shrine at the back of it remains an unfinished doorway. From this chamber a winding stairway of 47 steps leads down to the burial-place, making more than a complete turn before the owner was satisfied. Two flights bring one to a small chamber, and from the floor of this two flights more descend to a room at double the depth of the first. This contains a burial-pit with a rough chamber at one end for the actual interment. The pit had been filled up with round boulders and loose stones. A niche in the wall at the foot of the first flight of steps may be a later *loculus* for burial.

The intermediate chamber seems to reflect the uncertainty of life and fortune in Egypt. Had Mahu died or fallen from favour just then, this provisional chamber must have formed his place of sepulture. The prospect of sudden arrest, or of possible elaboration of the work, seems to have often affected the plans of the Egyptian architect, as it not infrequently does those of his modern successors. Sometimes, perhaps, the stoppage was deliberate, the coveted achievement being so far beyond the immediate resources of the official that it was impossible to execute the whole plan at one outlay.

The inscribed chamber in all finished tombs of this group has a doorway at each end. In this tomb, however, this feature is replaced at the North end by a round-topped stela; while the other, though of the usual form, has its inner part inscribed, thus obviating the possibility of hewing a chamber or statue-shrine there. These doorways, plainly, have been interpreted as door-

¹ Tomb 9. The name is spelt (or misspelt) in four other ways in the tomb by the slovenly scribe. By error a *b* (?) precedes the name on the right jamb outside (Plate xxviii.). Can it be this blunder that has induced the editors of the French publication to transliterate the name by Mabhou? It was correctly given in the first instance by M. Bouriant.

² BOURIANT, *Deux jours de fouilles*, p. 16. As might be expected from this title, the excavation seems to have been of the most summary sort. The tomb was published last year in *Mon. du Culte d'Atonou*, I., ch. xv.

shaped stelae and decoratively treated as such: the North stela being just a repetition of the inner design of its fellow, omitting the door-framing. A single step leads up to the latter; two steps to the former. The sculpture in each case shows acts of worship by the royal family. The profile of the Queen is repeated in line on Plate xxix., and in photograph on Plate xlii.

The façade of the tomb occupies only the breadth of the narrow stairway, and hardly admits even of the door-framing. The cornice and the scene on the lintel are almost weathered away. The inscriptions on the jambs, as well as those on the corresponding doorway to the inner chamber, are translated on pp. 30, 31.

The walls of the outer hall were to have been fully occupied by scenes in two series, an upper and a lower; but, as is invariably the case in these tombs, the work is unfinished. As a consequence the walls afford a most interesting exhibition of the technical methods employed; for they remain in almost every stage from the ink sketch to the finished relief. In most cases the paint seems not yet to have been applied. The scene on Plate xv., however, has received part, if not all, of its colouring, and the hieroglyphs on the door-jambs, instead of being as elsewhere in simple blue, are in varied colours. Attention is called to the technique later on (p. 32).

C. THE SCENES AND INSCRIPTIONS.

1.—THE WALL-THICKNESSES.

Plates xv., xxix., xl.

The sides of the short entrance-passage to the tomb (representing the thicknesses of the wall) are ornamented in the way almost universal in the Southern tombs. On the left, namely, the Royal family are shown sacrificing at the altar of the Aten (Plates xv., xl.), and, in a lower panel, the figure and liturgy of the deceased (Pl. xxix.). On the other side the latter subject occupies the

whole wall.¹ The prayer, which is a duplicate of that on the opposite wall with one or two variants in spelling, occurs four times in this tomb alone,² as well as in those of Apy, Any, Tutu, and of Meryra in the North Group. (A collation of these texts will be found on Plates xxxii., xxxiii., and a translation on p. 28.)

The texts in this tomb contain the most extraordinary errors and are often unreadable as they stand, the decorator being plainly incapable of reading a word of that which he copied and having besides a corrupt or illegible exemplar.

The portraits of Mahu which so often recur in the tomb agree fairly well with one another; but as they also differ little, if at all, from the typical Egyptian official, they cannot be taken as a serious attempt at portraiture.

The faces of the royal pair in the tomb are well preserved and confirm the most pleasing and least bizarre examples elsewhere. The King's profile in Plate xv., where the work is on the largest scale and most carefully executed, strikingly resembles the plaster head found by Professor Petrie in the ruined town.³ The proportions of the figures are bad, erring above all in the excessive size of the head and shortness of the thighs. Yet they do not show the anatomical enormities which, though rarely perpetrated in tomb-sculpture, are often considered characteristic of the period,⁴ and are even supposed to reproduce similar physical peculiarities of the unhappy pair.

The scene in Pl. xv., in which the King pours incense or oil⁵ on the flaming bowls, while the

¹ The figure is shown on Plate xxix.; the whole in *Mon. du Culte d'Atonou*, I., p. 97 (with some inaccuracies and omissions).

² For variants in the four texts of this tomb consult Part I., pp. 50, 51, where the text of Plate xxix. = Mahu *a*, that of Pl. xvi. = Mahu *b*, that of the S. thickness = Mahu *c*, and that of Plate xxiii. = Mahu *d*.

³ PETRIE, *T. A.*, Frontispiece.

⁴ Characteristic perhaps of work of the first few years of the reign, (boundary stelae, stelae in the palace, trial pieces, etc.).

⁵ Cf. II. xxxii. for the shape of the vessel.

Queen offers the sceptre and a lamp (?) such as already burns on the sacrifice, calls for little comment. Ribbons secure the uraei to the Queen's headgear or *coiffure*.¹ The King's sporran (in faint red ink) seems to have been sewn with ornaments of inlaid enamel and fringed with glaze pendants.

Here and elsewhere in the tomb only the first-born daughter, Merytaten, is shown;² but against the inference that the work belongs to the earliest years of the reign is to be set the fact that in this tomb the cartouches of the Aten take their later form.³

It scarcely seems possible that the tomb should have been decorated before the birth of Meketaten. For we find the hymn to the Aten already composed, plagiarized and corrupted; the town guarded by forts; its police and government organized; the peculiar artistic style and methods of decoration fully developed. It seems more likely that the artist had no place in the pictures except for the heiress, who was now old enough to appear with her parents in public.

2.—THE REWARDS OF MAHU.

Front Wall, N. half. Back Wall, N. half. Plates xvii., xviii., xix., xxix., xlii.

The scenes in the hall itself have two subjects, the duties and the rewards of Mahu. The former subject occupies the South, the latter the North half of the chamber. In every case the scenes on each side of the stelae on the end walls form a part of the larger picture on the adjacent wall.

The design on the North half of the front wall is gone, but a fragment in ink which survives (Pl. xxix.) shows that on the upper part Mahu was seen receiving the customary honours at

the hands of the King from the window of the palace.

On the North half of the back wall we have as the upper picture the ink fragment shown in Pl. xvii.; the parts on the extreme left (end wall) and on the extreme right are completely effaced. The former probably contained additional attendants and soldiery; the latter evidently showed the loggia of the palace from which the collars were being handed to Mahu by the King. What is left shows us the waiting chariots, the crowd, the close attendants of Mahu, and a second figure of that official, "Mahu, commandant of the Mazau of Akhetaten."⁴ By virtue of his office he appears to have been entitled to have a standard carried before him. Unfortunately the design on the panel cannot any longer be deciphered with certainty; it appears to present the execution of an enemy by the King. Mahu's men are ranged behind him unarmed. He himself is lifting his hands in excited salutation and says, "Thou makest great by troops and troops; thou, the ruler of Aten (?), thou shalt live for ever."⁵

The lower scenes (Pls. xviii., xix.) differ little from the last, except that the temple is substituted for the palace, indicating another occasion and place for the reward of this important public official. The completion of the palace and temple would be great public events in Akhetaten, and Mahu might well receive tokens of court favour on both occasions. Or perhaps the artist in decorating the tomb rather had it in mind to indicate Mahu's responsibilities: the temple and the palace which he had to protect, and the system of defences round the city which he had to maintain. In all this, of course, Mahu did excellently and reaped generous recognition.

The whole of this picture, being also merely

¹ Cf. STEINDORFF, *Blütezeit*, pp. 156, 157.

² One also in the tomb of Rames (Pl. xxxv.); two on most stelae; not less than three elsewhere.

³ As in the tomb of Any and once in that of Tutu.

⁴ The Mazau formed the police force in important centres, being recruited principally from a Nubian tribe of that name. Their Commandant was responsible to the Vizier or Governor.

⁵ Cf. III. xii.

sketched out in black ink,¹ not only affords an example of the skill and method of the ancient draughtsman and of the basis which was given to the sculptor for his subsequent work; but, owing to its provisional character and to the manual dexterity which it betrays, it brings the day of its execution singularly near to us. The man whose brush traced these clever sketches seems to have but left his task for a moment and to be still in our midst. We can see the sculptor, too, who had looked forward to this task, when pressure of work elsewhere called him away from the tomb, deferring his departure for half-an-hour while his deft tool modelled a head of Mahu, which was to remain for all time the only advance on the ink design (Photograph, Pl. xlii.) Or perhaps Mahu himself, intensely chagrined at the stoppage of the work, would not release the craftsman until he had at least seen his own portrait elaborated.

Mahu, wearing the festal cap, and with his neck laden with collars, kneels in prayer or homage before the great gate of the temple. The whole scene is the familiar one of the reward of the faithful official by the King, and the inscriptions confirm it. The King, however, is not present, unless the scene on the other side of the door (Pl. xxii.) is to be brought into connection with it. Otherwise we must suppose that Mahu, after being honoured as shown in the scene above, presented a thankoffering at the gate of the temple, and this prayer for his royal master, "Health to [Pharaoh]! Life, prosperity and health to him! O Aten, vouchsafe him for ever, (namely) Ua-en-ra, who forms by (his) *Ka*."

Mahu is followed by fifteen of his men, "the Mazau of Akhetaten," led by their officer and a standard-bearer, who all praise their God or their King with upraised arms and cry, "The good ruler (?) who makes monuments to the

Father! He does it again and again, for ever and ever. The good master!"

In the row above, Mahu is seen again at the head of his force. It is led as before, but is now ranged in six ranks of five.² A formal review of the police of Akhetaten may have preceded the honour shown to their Commandant, or it represents the orderly march to the temple. Above them is written, "the police of Akhetaten sing and shout the refrain³ (lit. 'so as to say.') 'He promotes [in masses, in masses. So long as Aten dawns] he will endure eternally.'"⁴



Mahu's charioteer and saises outside the crowd join in a similar cry, "He promotes by (?) numberless masses. He shall live eternally like Aten." Women and children (of Mahu's harem?) join in the general jubilation. (Photograph, Pl. xlii.)

3.—A ROYAL INSPECTION OF THE DEFENCES.

Back Wall. South end. Plates xii., xx., xxi., xxii., xl.

This picture has such evident reference to Mahu's calling that it must have been designed for this tomb. Nothing similar occurs elsewhere, though the chariot and the occupants were reproduced by Ahmes (III. xxxii., xxxii. A). In Pl. xx. the royal chariot is seen leaving the temple. This building is represented, as in Pl. xviii., simply by the front elevation, a mode which is not elsewhere employed. A peculiarity is the terrace, reached

² In both cases those with the pointed flaps to their tunics are to those with a squarely-ending cloth as two to one; whether as indicating a difference of race or function, or merely for diversity's sake, is not clear. Five men seem to form a unit.

³  or , omitting , must be meant. This scribe is capable of any error.

⁴ Reading  Cf. I. viii.; III. xii., xvi., xvii.

¹ Facsimiled here from tracings.

by an ascent, on which it is set: an explanation of this has been previously suggested.¹

The Queen and Princess are in the King's chariot, instead of each driving her own, as in later representations. The Queen, regardless of the situation, seems to pester the King with talk, though his whole thought is given to the management of his steeds. These are not the more easily controlled because little Merytaten is playfully poking their haunches with a stick! (Pl. xii. c.) It will be noticed how exceptionally human and unrestrained the pictures are in this tomb, and in consideration of this we may well pardon Mahu and his artist their illiterate texts.

The officials have an even more difficult task than the King. Not only Mahu and his fifteen police (Pl. xxi.), but also the plump vizier and his deputy, feel obliged to run before the chariot. The gait of these two is suggestively constrained in comparison with that of the active policemen. The objective of the excursion is the little blockhouse shown on Pl. xxi. above the door.² It is merely a windowless tower entered by a door on the ground floor, with provision for defence from the roof by means of crenellated and overhanging ramparts. A protection is afforded against night attack by a quadruple line of posts round it, connected by rails or ropes. Probably they are rather in the nature of entanglements, set a short height from the ground, and may easily have been arranged so as to give an alarm within when displaced.³

¹ Part III., p. 24. For the façade with masts see I. xii., xxvii., II. xviii. In Plate xviii. here the terrace is emphasized, and there are shown to right and left of the columns those pilasters in which each row of columns terminates, and which are such a feature of the local tomb-architecture. See also *Mon. du Culte d'Atonou*, I. i.

² For the arrangement of this wall see the Key on Plate xxviii.

³ This device is shown again in Pl. xxii., where truly one would have expected the posts to have appeared in elevation rather than in plan. It is a little more easy to explain if the obstruction was set low down. It may be added that the sentries in Pl. xxviii. are not *holding* the rope or rail, as has been stated.

LOWER SCENES (Pls. xii., xxi., xxii., xli.).—The round of inspection seems still to be the subject. The King is on the point of setting out again, and is turning in his chariot to take leave of the deputy-mayor (Pl. xli.). The artist represents Mahu's activity and ubiquity in a striking way. He is there behind the vizier of Akhetaten to raise a loyal cry in farewell—"O Ua-en-ra, thou livest for ever; thou who hast built Akhetaten, acting as Ra himself (?)." He is seen again at the head of the police that remain behind, yet kneels in front of the detachment that prepares to run behind the chariot; none the less, when the chariot approaches its destination, he is foremost in greeting it.

The chariot, as it passes from the guard-house to the city (?), takes a road flanked with sentry-houses to right and left. These, too, like the block-house, are linked together by post and rail, for better defence against surprise (Pl. xl.). Each sentry has his prescribed beat, and as the royal chariot passes each inclines in respectful salute, or lifts his hands in acclaim, according as he perceives his master act. The unarmed escort of police seems to witness still more powerfully to the popularity of the King and the law-abiding character of the city.

4.—POLICING THE CAPITAL.

Front Wall. South end. Plates xxiv., xxv., xxvi., xli.

UPPER SCENES.—No written clue being given, the scenes upon this wall are a dumb show which might admit of more than one interpretation. The picture has been thought to represent the taking of *octroi* dues at the outposts from caravans or peasants coming into the city with produce. It must be remembered, however, that almost the whole of the supplies of Akhetaten would be likely to reach it by river, cultivable land on the east bank being scanty and the roads to North and to South mountainous. We have already seen the im-

posts which were laid upon the surrounding country for the support of the temple arriving in this way.¹ Probably, too, the scribe who is ever to the fore on such occasions, would be more noticeable.

I would rather suggest that the scenes show Mahu superintending the periodical revictualing of the guard-houses. Above the door in Pl. xxv. Mahu, with a detachment of ten men, is seen coming, as I assume, to take what is requisite from the Government stores in the city, where wine, furniture, vessels, cloth, sacks, &c., are to be had. An employé there seems to be forbidding him to take anything without a signed warrant. On the right therefore (Pl. xxiv.) we see Mahu having a colloquy with the vizier of Akhetaten² and a lesser official, “. of the Lord of the Two Lands, praised by him, Heqanefer.”

They are gathered round a brazier of burning coal or logs, which is always welcome early in the day during the Egyptian winter. The result is satisfactory, and when Mahu³ returns to the store with his authorization he meets with a very different reception from the authority in charge. Everything and everybody is now at his disposal.

Mahu draws his supply of weapons, etc., from the stores, but the daily tale of fresh provisions is brought by the villagers to the guard-house. This scene is shown in the lower division of Plate xxiv. There, women and children are seen bringing fish, bread, water-jars, and even flowers, on asses, or on their shoulders. They are received at the guard-house, and when the quota is complete the scribe reports to Mahu, who, attended by his dog, inspects the array of food (Plate xxv.). The block-house is similar

to that already seen, but here the inner arrangement is shown. It is apparently three-storied, the ground-floor being used for storage of food; the room above as a guard-room, for here a fully armed sentry keeps his watch; while the topmost storey forms an armoury (Pl. xxiv.).

LOWER SCENES.—The meaning of the picture below is somewhat more obvious. In the early morning Mahu is called out of his house to hear a report of his subordinates.⁴ A brazier of burning embers is brought outside and blown or stirred into a bright blaze by a house-servant (Pls. xii., xxvi.). There Mahu, leaning on his staff, listens to the news. The whereabouts of some malefactors has been discovered. At once every one is alert and brisk. The chariot already awaits its master, and a posse of six men is running at the summons, armed with batons, curious forked sticks, and a javelin (?). Mahu, escorted by four of his men, drives off, and the capture is effected. It is his duty to bring offenders before the vizier for judgment, and this final episode is also represented. The vizier stands outside the porch of a gateway, attended by “the chief princes of Pharaoh (Life, Prosperity and Health to him!) and the commanders of soldiery who stand in the presence of His Majesty” (Pl. xli.). Mahu dismounts and brings forward his prisoners with the words, “Examine ye, O princes, (these) men whom the foreigners have instigated” (?). The three hand-cuffed wretches, who seem to be spies or assassins, are of different nationalities; one may be an Egyptian, the others perhaps Bedawin. The exclamation of the vizier, “As the Aten endureth! As the ruler endureth!” probably evinces his admiration at the importance of the capture.⁵

It is a scene which, in reference to a smaller

¹ Pl. viii., and I. xxix.

² His title is scarcely legible, but his dress is distinctive.

³ The hieroglyphs overhead only gave his name and rank once more.

⁴ What remains of the ink-sketch of his home is shown on Pl. xxv. Note especially the figure of the servant warming his hands over the fire.

⁵ I am indebted to Mr. Griffith for the precise significance of the final scene as given above.

matter, might be enacted in any Egyptian village to-day.¹ As to the jars, etc., which

¹ Curiously enough, while engaged upon the scenes, I had a striking proof that life in Egypt is little more mutable than the art which represents it. Being called out of the tomb one day by the sound of voices, I found that the police of the excise had lain in wait in the early dawn and had captured two miserable salt-diggers, whom they were driving off to the village, bent double as in the picture ;

appear above the chariots, it is hard to say whether they connect this scene with that above, merely fill up space, or represent stolen property recovered by the activity of the Mazau.

no doubt to go through a similar examination from the village dignitaries in the midst of the ruins of Akhetaten. And yet the world moves ! This contemptible salt-monopoly was abolished a few months later.

CHAPTER IV.

THE TOMB OF APY (𓂏𓂏𓂏𓂏𓂏).¹

A. ARCHITECTURAL FEATURES.

Plate xxx.

THIS tomb as it stands is small, simple, and rude. Only the door and entrance-way are completed and decorated. The passage to it through the rock slope has not yet been cut down to the floor-level, so that one descends by rough steps into the tomb. The framing of the doorway had the customary form and decoration, but only the inscription in coloured hieroglyphs on the right jamb is now worth reproduction (Pl. xxxix. Translation on p. 31). That on the left-hand had similar cartouches and apparently the same text, but the personal name had not been cut. The lintel showed the familiar design of the King, Queen and three princesses worshipping the sun, but it is almost erased. The tomb was probably sanded-up when the religious reaction took place, and did not suffer outrage. Hence the two sides of the entrance provide us on the one hand with the best-preserved portraits of the King and Queen, and on the other with the best-preserved text of the shorter hymn to the Aten.

The interior is very rough. The narrow cross-corridor was to be enlarged into a hall, with a row of four columns and two pilasters down the centre. These features, however, are only roughly blocked out, a slanting fissure in the rock which traverses the chamber having discouraged the quarriers.

B. THE SCENES AND INSCRIPTIONS.

The panel which represents the royal family at worship is executed in the best style of the period and is still excellently preserved (Plates xxxi., xlv.). The scene was painted, and the blue of the sky, the hieroglyphs and the helmets is still of startling brightness. The zeal with which the artists of Akhetaten sought anatomical correctness, generally with the most unhappy results, is seen in the modelling of the collar-bone and the neck-muscles. The figures are but little exaggerated. The King's profile, which is perfectly preserved, shows a considerable variation from that in the tomb of Mahu (Pl. xv.), the lips being more sharply cut and the angle of the nose different. This of Apy strikes one as more conventional, but the impossible angle given to the skull, and especially to the occiput, in the heads of the period throws out the whole face.

The only other feature of interest in the conventional scene is the offering made by the King and Queen, votive pieces, namely, of happy device, wherein in the one case the Queen, in the other two of her daughters, support the cartouches of the Aten. The King offers for his family, the Queen for herself;² and it seems to be a visible pledge that the members of the Royal family are one in loyalty to Aten and deserve the royal epithet "upholding the name of Aten."

¹ Tomb 10. Published in *Mon. du Culte d'Atonou*, I. pp. 87-92. Pls. xxxviii., xxxix., xl.

² So also in PETRIE, *T.A.*, pl. xii., and STEINDORFF, *Blütezeit*, p. 155. In the former the Queen wears four feathers, as the princesses here wear three, perhaps in impersonation of Maat.

As elsewhere,¹ the name of the Queen is caressed with pretty phrases; she is "the hereditary princess, great in favour, lady of grace, dowered with gladness; the Aten rises to shed favour on her and sets to multiply her love; the great and beloved wife of the King, Mistress of South and North, Lady of the Two Lands, Nefertiti, who lives always and for ever."

She is followed by her three daughters with *sistra*.

The space below this was filled with a figure (?) of Apy and his prayer, but only in ink.² The figure has completely disappeared and the text nearly so. The latter was only another and abbreviated copy of the hymn on the opposite wall. It added, however, at the end the personal note, which is wanting in the other, "for the *ka* of the Royal Scribe and Steward, Apy, who lives again."

The text on the right hand side of the en-

¹ II., p. 14; III., pp. 7, 15.

² Reproduced in *Mon. du Culte d'Atonou*, I., pp. 90, 91, but the figure appears to be fictitious. It is plain that the reading of the text was already very uncertain.

trance will be found on Plates xxxii., xxxiii., in collation with others, and a translation on p. 28. The text, like those in a corresponding situation in the tombs of Mahu, Rames, Tutu and Ay, does not occupy the whole of the wall-space. A kneeling figure would have been added below, and the space to the right, here and elsewhere, is left blank, in order that the text might be read when the door was thrown back against this wall. Perhaps the space was sometimes coloured in horizontal bands to represent this plank-door, as in the tomb of Ahmes (III. xxviii.).

The ceiling of the entrance-way was marked off into two panels for colouring by three columns of hieroglyphs. Of the latter only that on the left (East) side is cut (Plate xxxii.: translation on p. 31). Traces of ink show that the right column also began with the same formula. Apy is given no other titles than those of Royal Scribe and Steward. We are not informed what household it was which he controlled, so that he may have been past active service.

CHAPTER V.

TOMB OF RAMES (☉ 𓂏 𓂏).¹

A. ARCHITECTURAL FEATURES.

Plate xxxiv.

THIS tomb is a small one, and of the simplest cross-corridor type. There was indeed little encouragement to anything ambitious, for a broad vein of gravel intersects the chamber. The hope of enlarging or fully decorating the chamber was abandoned, and the walls were not even smoothed.

A door, however, was fashioned in the back wall, and its entrance formed into a niche, where seated statues of the deceased and of his wife (?) were hewn. These figures were finished off in plaster, as the coarse nature of the rock demanded, and hence they have suffered considerably. They were evidently thoroughly pleasing and carefully worked, the wigs receiving elaborate treatment. The woman sits on the right side of the man and embraces him with her arm. Her name, which does not occur elsewhere, has been written on her lap. Apparently it is Nebtant, a known name of the period. The inscriptions on the door-framing are in faded ink, and are practically illegible. On the lintel there was a single set of the five cartouches, with a figure (?) and a short prayer at each end. The jambs appear to have con-

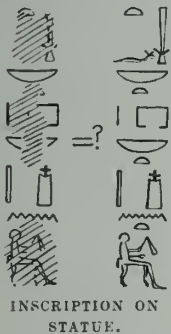

¹ The name is spelt ☉ 𓂏 𓂏 on the outer lintel.

The tomb (No. 11) is published in *Mon. du Culte d'Atonou*, I., xxxvii. and pp. 83-85.

tained texts of the usual form, and a repetition of the titles given to Rames elsewhere.

The inscriptions on the framing of the outer door are in much the same state. The lintel showed figures of Rames adoring cartouches. The columns on the jambs began with a *dy-hetep-seten* formula; proceeded with requests for such favours as "the loaves which are set out in the Presence, bread, beer, birds," &c.; and ended, "for the *ku* of the Royal Scribe, Commandant of the soldiery of the Lord of the Two Lands, Rames, *maakheru*."

There is a pit in the East corner of the chamber; but I did not re-excavate it. The chamber now contains part of a stone door-jamb (?) of Rames, which is said to have been found near the tomb by M. Barsanti;² but which, as a matter of fact, was found in the town-ruins by Professor Petrie and conveyed there. The identity of name is, however, small proof of identity of person in the case of so common a name. While there is no place in a tomb for such a stone, its inscription would well suit the door-jamb of a house; for it reads, "provisions (*zefa.u*) within the house of entertainment every day, (his) belly having joy may his name (?) not be lost (*nen nehy [r]en.f*), the scribe Rames, born of the house-mistress, Huy."³ It thus appears that the inscriptions on the doors of the tomb may be such as were also written on the doorposts of the living, *mutatis mutandis*. It need hardly

² *Mon. du Culte d'Atonou*, I., p. 85. The copy there has two or three inaccuracies.

³ "For the *ka* of" is omitted, be it noted.

be said that there is still less ground to identify this Rames with that namesake whose great tomb at Abd-el-Gurneh shows the transformation of Amenhetep IV. into Akhenaten. He would hardly have narrowed his ambitions to so poor a burial-place as this, and his offices as well as the name of his wife ("sister") are different. The title, "Steward of the House of Neb-maat-ra" given to Rames on Plate xxxv. seems indeed to show that Rames had held that important office under the late king, but it might possibly refer to some present appointment.

B. SCENES AND INSCRIPTIONS.

Entrance. Plates xi., xxxv., xl.

The scene on the left hand in the entrance

presents a very different aspect from that in the tomb of Apy.¹ It is much more simple in design, and the plaster in which it is moulded is rapidly crumbling away. The King offers incense, the Queen a cruse of ointment (?). As in the tomb of Mahu, Merytaten alone of the daughters is present. The cartouches of Aten are illegible, and their form therefore is not known; one would expect them to be the same as in the neighbouring tomb of Apy.

The figure and face of Rames on the opposite wall are well preserved and pleasing. A translation of the prayer is given on p. 30.

¹ This picture has been drawn for me by Mr. Harold Jones.

CHAPTER VI.

TOMB OF NEFER-KHEPERU-HER-SEKHEPER († ♂ | ♀ | ♂)¹

(Plates xxxvi., xxxvii., xliii.)

THE tomb of this official, who in his zeal out-did Kings in taking an epigram for a name,² was opened by M. Bouriant in 1883,³ and cleared completely by M. Daressy in 1893,⁴ but not for the first time; for they found written on the ceiling in smoke, "R. Hay opened this tomb 1830," and "C. Laver 1830 measured this tomb."⁵

Tomb 13 is interesting only for its architectural features. Not that these differ from those employed elsewhere in this necropolis; for there are several tombs where the same forms have been used on a larger scale, and carried nearer to completion. Yet owing to its admirable proportions, to its spotless whiteness and good preservation, this tomb, even in its half-finished state, is one of the most pleasing examples of rock-architecture in Egypt. It is the only instance here where the cross-chamber, supported on a single row of columns, has been carried so far towards completion as to convey any idea of the ultimate effect; and no one can see it without being struck by the fatal loss of beauty in larger tombs, such as Nos. 16 or 25, where the columns are crowded together,

mutually blotting one another out, and forming mazes rather than buildings.

The chamber is divided down the centre by a row of six columns. The two central ones are set wider apart to afford an aisle in the axis of entrance, and, in conformity with this, their abaci carry architraves parallel with the axis as well as the ends of the longitudinal architraves. The latter rest, or are feigned to rest, at both ends on pilasters, which, according to custom, are furnished with a roll-moulding at the corners, and are surmounted by a cavetto-cornice and abacus. The columns (Pl. xxxvii.) are of the 8-stemmed type already described in Part ii., p. 33; but, like all those in this necropolis, they have much more graceful proportions than their successors in the Northern group. As they stand, they are without bases and spring from the rough floor. They are pure white, for the columns of this group do not seem to have been meant to receive colour.

A portal is set in the back wall, which might have led to a second chamber or shrine, had the enterprise been carried to a finish. The chamber retains traces of its embryo form, the narrow cross-corridor tomb, in the portals in which the front half of the chamber terminates to right and to left. These are double in form, showing a doorway within a doorway, a handsome decorative feature which we shall meet with frequently in these tombs. The chamber is not well laid out, being askew with the axis, and the transverse architraves are still more seriously out of the square. The heightening of the room towards the back, however, may

¹ Three times out of four the name is written without the strokes of the plural. The tomb (No. 13) has a chapter devoted to it in *Mon. du Culte d'Atonou*, I., p. 79. The sketch-plan and the description, however, will be found on p. 65, assigned to a 12-columned tomb.

² " ' Beautiful of forms ' (a name for the King) fosters."

³ *Deux jours de fouilles*, p. 9.

⁴ *Recueil*, xv., p. 38, where the inscription on the jamb is given.

⁵ Laver's plans are given in HAY, *MSS.* 29,847, fol. 43.

be an architectural means of increasing its apparent size.

As is plain from the plates, the chamber is only half finished, and this in a curious manner, the upper part being in a final state down to the last detail, save inscription and colour, while the lower part is untouched; so that the slim columns seem to be emerging slowly and without injury from a subsiding bank of rock. This feature, though very marked in this tomb, is noticeable in nearly every other, and has already been commented upon (p. 10).

BURIAL-PLACE.—It is evident that there was no longer any hope of completing the tomb when the burial was made. As soon as the central aisle was finished to the foot of the columns and the whole area was cleared well down below the capitals, the quarriers confined their labours to the North-East corner, where the stairway to the sepulchre was usually placed. Disengaging the columns first, they then sunk a well at the spot without staying to remove the intervening rock, and, forming a stairway in it, burrowed into the Eastern wall without paying any heed to the original plan of the tomb. The stairway was carried little further than was absolutely

necessary, and from the level landing at the foot a rough and slightly descending gallery was driven at right angles to it, of size sufficient to receive a coffin. The two galleries to right and left immediately on entering the stairway may, or may not, be contemporary in date.

EXTERIOR.—The entrance to the tomb was neatly finished, but no traces of any designs are now apparent. The jambs and lintel outside were similarly prepared, and here a hasty attempt was made to commemorate the deceased, and to secure for him some measure of preternatural grace. Inscriptions were, no doubt, duly sketched out on both jambs. All that is now visible is, on the right, the lower half of a column cut in the plaster, and, on the left, the lower third of all four columns similarly cut, and fragments of the upper part decipherable through the mordant power of the ink on the surface (Plate xxxvii.: translation on p. 31). The abandonment of the work was so unforeseen that the royal *prenomen* on the right jamb has not received its cartouche. We here learn that the owner was "Governor of Akhetaten," and by holding this responsible post took rank as "head of the notables."

CHAPTER VII.

THE TOMB OF SUTI (↓ ).¹

(Plates xxxviii., xxxix.)

THIS tomb (No. 15) is of the cross-corridor type, but with the addition behind of a large columnar hall, or at least the rough commencement of one. The exterior door-framing, the entrance, and the corridor are executed with care and well-finished; but no part has received decoration, except the façade. Here the prayers on the jamb are still extant, though much weather-worn (Pl. xxxix.: translation on p. 31).

A beginning has been made of excavating the interior of the portals at each end of the corridor, no doubt with the intention of forming shrines containing statues, as in the larger tombs. These portals are of the double form met with in the last tomb. The chamber

behind was to have been square in shape, and divided into three aisles by two rows of four columns each. On the left, only the capitals of three columns have been separated from the mass. On the right, a little more has been achieved, less in the hope of completing the tomb than in order to secure a makeshift resting-place for the dead. A well (which I did not empty) and a little gallery to the South were hewn out for this purpose.

Suti was standard-bearer of "the guild of Nefer-kheperu-ra." We have already met with guilds such as these, which were wont to take some royal epithet as a designation, Huya, the steward of Tyi, having become at a later date the marshal, or perhaps even the standard-bearer of one such.²

¹ Published in *Mon. du Culte d'Atonou*, I., pp. 67-69. DARESSY, *Recueil*, xv., p. 42.

² Part III., Pl. xii. and p. 8.

CHAPTER VIII.

THE RELIGIOUS TEXTS¹

A. THEIR CHARACTER.

THE hymns to the Aten with which every grave at El Amarna is provided show manifest signs of addition and subtraction, and are put together with so little literary skill that they often scarcely make sense, the pronouns changing from one person to another in a single sentence. They exhibit no instinct for true composition, nor even for the faithful reproduction of well-known liturgies. A multitude of short phrases culled from the Royal Hymn or echoing its thoughts, or else lingering in the memory from some "teaching of the King," seems to have formed the stock-in-trade of the professional scribe. His longer texts were made up of a number of these liturgical expressions, strung together with little regard for literary form. If tediously alike in sentiment and phraseology, most of the hymns are, in a sense, original compositions, and afford us some insight into the mind of the ordinary Egyptian and his comprehension of the new faith. It is somewhat surprising that there should be even so much originality, if, as it appears, most of the tombs were made to the order of the King; but the orthodoxy of the pious phrases and the long adulations of Akhenaten might counterbalance this latitude in his eyes. Yet this propensity to compilation was not everywhere apparent. Huya, who perhaps was a Theban and less instructed in the new piety, simply went to the tombs of Ahmes and Penthu, and borrowed word for word the four longest prayers which he

needed. Earlier, this poverty of feeling was still more marked. The worthy Mahu, who could only repeat for the fifth and sixth time the little official prayer which had been written down for him, may have been specially dull. But Apy's more capable scribe can do nothing better with his second wall-space than repeat the same composition; while the Royal Hymn, though incomparably superior, was plagiarized and mutilated, but never recopied. Perhaps this Royal Hymn and that feeble echo of it, which, in distinction, I have called the Shorter Hymn to the Aten, were the only two compositions that were committed to writing, and of these the shorter and less poetic compilation seems speedily to have gained popular favour.

It might have been thought that here, where we have a freshly-composed and local hymn, containing the creed of a new and victorious propaganda, with the King himself as author and preacher, we should have a stereotyped text free from all the corruption and variance that years and repeated transmission bring. Nothing is farther from the truth. The great hymn is only known in one copy, and that not exempt from suspicion. As to this Shorter Hymn, no one reading it in its complete version can feel that it represents an original composition; for it contains no progression of thought and no unity. It separates, indeed, on consideration, into two distinct hymns. The first ends, perhaps, with the sentence, "thy son is pure, doing what is well-pleasing to thee, O living Aten, whenever he appears"; and the second begins with the words, "The son of the Sun." What lies between the two seems an

¹ I must again acknowledge substantial help from the Editor in matters of translation.

interpolation, perhaps itself taken bodily from some third source. The addition may have been due to a misunderstanding of the phrase, "when-ever he appears," which was thought to refer to the rising of the Aten, and to need expansion.

The first hymn, which roughly corresponds to the text in Meryra,¹ has unity and development. Eulogizing first the appearance of the visible god, it goes on to notice his creative and life-giving power, and then his ability to bestow happiness. With the day comes joy, and this finds its fit expression in the temple worship. This leads to mention of the King as chief celebrant in the Aten worship, and so to a concluding word in his praise. The interpolated passage repeats the picture of all creation, the King, and the god rejoicing in unison; its grammatical disconnection and the variant texts, however, suggest an alien origin. The second hymn is a laudation of the Aten by the King. The words "he says" have been dropped out, or are represented by a sentence "by the King, &c.," which is often added near the outset in the complete text. This second part also has a certain unity. Beginning with an expression of the King's loyalty to the Aten, it goes on to show how the Aten passes from his lonely eternity to be a creator and a sustainer of a grateful creation from the plants upward. Perhaps we have not the end of it, for finish is lacking. It borrows its thought wholly, and often its very words, from the Royal Hymn.

Which of the texts collated on Pls. xxxii., xxxiii., then, is to be relied upon? Study soon shows us that we are far from the original, though we have apparently all the tomb-copies, through which corruption and alteration might have crept in. The texts plainly fall into two groups: Any and Meryra on the one side; on the other Apy and Tutu, with Mahu (too corrupt to be considered in detail). The differences between the two groups are largely in vocabulary;

if anything, the former is further from the original. Capricious alterations seem the chief ground of variance, and in Tutu these have gone to a great length and not with advantage or insight.

Meryra seems plainly to have curtailed from Any; or perhaps from his source, since he omits an error of Any's, though elsewhere verbally alike. His long omission, too, though apparently due to lack of space, is precisely that passage which seems interpolated. He seems, therefore, to be aware of the original elements of the hymn. He even adds to it, "Meryra saith it," as if he were himself the composer. And, as the hymn smacks a little of the priest, this may possibly have been the case; but only if we suppose that his scribe was using the extended version, and that to fill up space, or to secure the phrase "without ceasing" as a fitting conclusion, he borrowed some incongruous passages from the supplement. It had also the advantage of adding a short laudation of the King to the very curt reference of the original.²

Apart altogether from the intrinsic merit of the hymn, the appearance of variants of this character and number when the peculiar circumstances ought to have eliminated all the causes of variation, presents a problem, the study of which may have much value for textual criticism. I hope others will reach a clearer perception of the process by which the original hymn has taken the forms before us. At present it is plain that both oral and written transmission played a part here, but it is not clear what their mutual relations were.

B. LONGER PRAYERS.

1. THE SHORTER HYMN TO THE ATEN.

Tomb of Apy. Both entrance-walls (Plate xliii.).
Tomb of Any. Left entrance-wall.

¹ I. xxxvii.: translation *ib.*, p. 50.

² This probably was the reason for the otherwise invariable addition of the second part.

Tomb of Mahu. Four texts (Plates xvi., xxiii., xxix., xl.).¹

Tomb of Tutu. Left entrance-wall.

Tomb of Meryra. Right inner entrance-wall (I., xxxvii.).

A collation of all the texts on Plates xxxii., xxxiii.²

Previous copies or publications are:—

Mon. du Culte d'Atonou, I., plate xxxviii.; pp. 88-91 (Apy): plate xxviii.; p. 52 (Any): plates xlii., xlvi.; pp. 96, 97, 98, 102 (Mahu): plate liv.; p. 112 (Tutu). DARESSY, *Recueil*, xv. p. 43 (Any). PIEHL, *Inscriptions*, i. pls. exei., exei. (Apy). LEPSIUS, *D.*, iii. 106b. (Tutu). HAY, *MSS.* 29,814, fol. 36 (Meryra): 29,847, fol. 15 (Tutu). L'HÔTE, *Papiers*, xi. 27 (Meryra).

"An adoration of (the living Hawk of the two horizons, who exults on the horizon) (under his name of 'The Light which is in the Sun-disk'), who gives life for ever and ever, by the King who lives in Truth, Lord of the Two Lands, Nefer-kheperu-ra-Ua-en-ra, the Son of the Sun, who lives in Truth, Lord of Diadems, Akhenaten, great in his duration, who gives life for ever and ever."³

"Thy rising is beautiful, ⁴O living Aten, Lord of Eternity! ⁴Thou art radiant, fair and ⁵strong: ⁵thy love is great and large: thy rays ⁶strike (?) upon all mankind. ⁶⁷Thy surface gleams, giving life to hearts,⁷

¹ The text given in the collation is that on the left entrance-wall (Plate xxix.). For the others see Part I., pp. 50, 51.

² I rely on my own copies entirely, except in the following cases:—(1) The text on the left entrance-wall of Apy (Apy A), very unreliable in the days of Bouriant, is now nearly invisible. (2) The text in the tomb of Any, also in ink, has deteriorated, and Bouriant's copy sometimes adds a sign or two to the top and bottom of the columns. (3) A great part of the text of Tutu is now destroyed, and I use in these places the texts of Hay, Lepsius, and Bouriant, the last-named having preference.

³ This sentence in italics has probably been added, in order to justify the use of the first person singular in the second part, or when the text was accompanied by a picture of the King at worship (Apy A, Tutu, Mahu a, b, d). To judge from the prayers, *an* ("by") only implies recital, but *zedef* ("he saith") implies or feigns composition. Apy A (*Mon. du Culte d'Atonou*, p. 90) may have used the latter form, but I cannot verify this.

⁴ Tutu reads, "O divine and sovereign father, the Aten, whose life is ever fresh!"

⁵ Any and Meryra have, "gleaming" (or "white").

⁶ Any and Meryra have, "Shall (?) make eyes for all that thou hast created."

⁷ Tutu has perhaps "thy surface (lit. "colour"; spelt as in L. D., iii. 107a, col. 2) gleams (or "is white") with love."

and thou fillest the Two Lands with thy love. ⁸O reverend god,⁸ who himself formed himself, who made every land, and created what is on it; both mankind and all herds and flocks, and the trees which grow on the ground. They live when ⁹thou dawnest on them.⁹ Thou art mother and ¹⁰father¹⁰ for ¹¹those whose eyes thou hast made. When thou dawnest they see by means of thee.¹¹ ¹²Thy rays illumine the entire land. Every heart exults ¹²at seeing thee (when) thou risest as their lord.

"(But when) thou settest on the western horizon of heaven, they lie down after the manner of those who die. Their heads are wrapped up, their nostrils are stopped; until thou dawnest in the morning on the Eastern horizon of heaven.

"(Then) their arms are (outstretched) in praise to thy *ka*. Thou givest life to hearts by thy beauty, and there is life.

"(When) thou sendest thy rays every land is in festival;¹³ the singers, musicians, and criers (?) are joyful in the Court of the House of the *Benben* (and in ¹⁴every temple in Akhetaten,¹⁴ that ¹⁵perfect place¹⁵ with which thou art well pleased, and in which food and fat things are offered.

"Thy son is pure, doing what is well pleasing ¹⁶to thee, O living Aten,¹⁶ in his festal appearances.¹⁷

¹⁸"All that thou hast made leaps before thee; thy revered son exults,¹⁸ his heart is in joy. ¹⁹O living Aten, rejoicing in heaven every day!¹⁹

⁸ Meryra has, "O good ruler."

⁹ Tutu has, "when thy rays shine"

¹⁰ Tutu seems to omit "father."

¹¹ Meryra has, "all that thou hast made. As for their eyes, when thou dawnest they see by means of thee." The texts of Mahu break off here without regard to the sense.

¹² Any has, "when thy rays give light the entire land has joy, and every heart exults." (*Ab neb* has been omitted by me after *reshut* in the Plate). This seems an error. Tutu omits the whole passage.

¹³ Tutu adds, "(thou) feedest and illumineest it." A bad reading.

¹⁴ Tutu has, "thy (?) temple," and Meryra, "every shade of Ra on the horizon" (*sic*, perhaps for "in Akhetaten.")

¹⁵ Any and Meryra have "every shrine."

¹⁶ Tutu has "to the living Aten."

¹⁷ I regard what follows (from *ary-ek* to *mesy-ef* at least) as an interpolation in the original, owing to *khay-ef* being taken to refer to the dawning of Aten (hence Tutu's more grammatical *ary-ef*). *Khay-ef* would then belong to the original, though not occurring in Meryra, perhaps for lack of space.

¹⁸ Tutu has "all that he has made leaps before him. Thy son exults."

¹⁹ Tutu has "The Aten is born in heaven every day."

“He hath given birth to ¹his revered son Ua-en-ra,¹ like unto him without ceasing.² The Son of the Sun, upholding his beauty, Nefer-kheperu-ra-Ua-en-ra [says] ‘I am thy son, serviceable to thee, upholding thy name. Thy might and power are firmly ³fixed³ in my heart. Thou art the living Aten, and eternity is thy portion. ⁴Thou hast made the far-off heaven that thou mightest dawn therein, that thou mightest see all that thou hast made. Thou art alone,⁴ but infinite vitalities are in thee to give them life. ⁵It is a breath of life to (their) nostrils to see thy rays.⁵

“All flowers blow (?); that which grows on the soil (?) thrives at thy dawning; they drink draughts before thy face.⁶ All cattle leap⁷ upon their feet. The birds that were in the nest fly with joy; their wings that were closed move quickly with praise to the living Aten, flying (?) to do”⁸

2. Penthu. North thickness (Plate iii.).

A previous copy is L'HÔTE, *Papiers*, iii. 294.⁹

¹ Tutu has “his son who hath come forth from his body.” I consider that a second hymn in which the King speaks is here appended to the first. If the word “says,” supplied after the King’s name, occurred in the original text, it probably implied authorship, as what follows is largely derived from the Royal Hymn.

² Meryra adds “for ever,” and ends. Apy A ends with “his beauty.”

³ Any has “rooted.”



⁴ Word for word from the Royal Hymn.



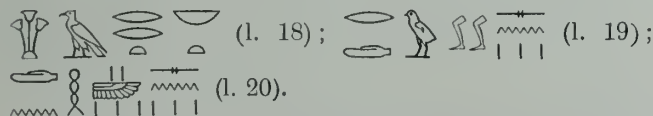

⁵ Tutu has “Breath enters (their) nostrils when thou givest thyself to them.”

⁶ The text of Any may well have continued above the figure of Any, but all is now completely effaced.

⁷ The text of Apy ends here, for lack of room apparently.

⁸ Cf. the Royal Hymn, “The birds flutter in their nests; their wings are (outstretched) in praise to thy *ka*. The cattle are leaping on their feet.” The space above the figure of Tutu admits of very few more signs, if any; perhaps *en ka en*. The text of Tutu in the last column of the plate should be emended (from Hay) as follows:—

 (l. 18);  (l. 19);  (l. 20).

⁹ From this the text has been restored in the Plate. Asterisks indicate a slight change in the hieroglyph, the true reading being obvious. In the first column  should be starred, as L'Hôte reads . The initial sign is probably , not . A parallel text (bracketed here) occurs in the tomb of Huya (III. ii.). Cf. also II. vii. for the opening phrases.

“An adoration of Horakhti-Aten¹⁰ [who gives life for ever] and ever. Homage to thee, [dawning] in the sky and shining early on the horizon of heaven, coming in peace, the Lord of Peace! The entire land assembles at thy rising; [their] hands (are outstretched) in praise at thy dawning. They prostrate themselves on the ground when thou shinest on them. They shout to the height of heaven; they receive joy and gladness; [they] exult (when) they see Thy Majesty. Thou sendest thy rays on all men. They go forth when thou attainest heaven, when thou takest the goodly road. Thou settest me eternally in a place of favour, in my [mansion] of bliss. My spirit goes forth to see thy rays, to feed on its offerings. I am called by my name, and one cometh at the summons. I enjoy the things which are offered. I consume *shens* and *bat* and *pesen* bread and *des* beer, hot roast meat and cold water, wine and milk, that are offered in the sanctuary of the Aten in Akhetaten.

“The royal scribe, the Intimate of the King, the Chief Servitor of Aten in the sanctuary of Aten in Akhetaten, the Chief Physician Penthu, *maakheru*, says (this).”

3. Penthu. South thickness (Plate iv.).

A previous copy is L'HÔTE, *Papiers*, iii. 293.¹¹

“An ascription of praise to ¹²Horakhti-Aten who gives life for ever and ever, coming [each day eternally].³ Praise to thee, O Ra, Lord of the horizon! When thou traversest heaven all mankind (depends?) on thee¹⁴ without ceasing in night as in daytime. Thou dawnest on the Eastern horizon and settest¹⁵ on the Western horizon. Thou settest in life and gladness, every eye¹⁶ rejoices; (but) they are in darkness after thou settest. When thou arrivest from (?) the sky,¹⁷ eye sees not its fellow; ¹⁸

¹⁰ I use this and “Ra-Aten” as abbreviations of the two forms of the names of Aten.

¹¹ The text of the Plate is restored from this. A duplicate text, badly preserved, exists in the tomb of Huya (III. xxxvii.), and from this the additions in square brackets are taken. A good copy of this text (with a few errors) will be found in *Mon. du Culte d'Atonou*, I., p. 60, ascribed to Tomb 21 of the South group!

¹² Huya has, “Thy setting is beautiful.”

¹³ Huya has  from Huya, and I. xli. Something

seems to have been lost, and the latter text supports this view by giving “all men welcome. . . .”

¹⁵  in Huya.

¹⁶ Clearly  in L'Hôte and Huya.

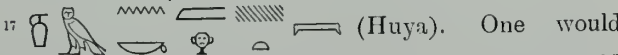
¹⁷  (Huya). One would have expected “in Duat,” but mention of the Underworld seems purposely avoided.

¹⁸ Reading . So Huya.

who lives on Truth, Lord of Diadems, Akhenaten, great in his duration. For the *ka* of the Commandant of the police of Akhetaten, Mahu."¹

3. Mahu. Inner Jambs (Plate xxvii.).²

The first columns (*a*, *e*) contain salutations of Ra-Aten ("Long life to the divine and sovereign Father"), the King, and the Queen.

"Praise to thy *ka*!"

(*b*) (Right side). "Thy rising is beautiful, O living Aten, Lord of Eternity. Do thou give to me fair burial after old age."

(*c*) Repeats 2 *c*.

(*d*) "O [Ua-en-ra, the King (?)] who lives on Truth, Lord of the Two Lands, Nefer-kheperu-ra, who gives life. May he give favours [every] day (?).

(*f*) "O living Aten, Lord of Rays, thou who illuminest the Two Lands with thy rays, for all the land (*sic*). When thou settest on the Western horizon, they lie down.

(*g*) ". Nefer-kheperu-ra, the god who hears the of the King. He does what is well-pleasing to his father, the Aten.

(*h*) "Lord of Rays!(?) When thou risest on the Eastern horizon of heaven their hands are (outstretched) in praise to thy *ka*. Hearts live at (*sic*).³

"For the *ka* of the Commandant of the police of Akhetaten, Mahu, *maakheru*."

4. Apy. Right Jamb (Pl. xxxix).⁴

(*a*) Salutation of the three Powers (the Aten, the King, and the Queen).

(*b*) ". Bestow (thy) duration as Aten in heaven on the King of South and North (etc.). May he grant a good name in Akhetaten."

(*c*) "They (thy rays?) embrace thy son, the Son of the Sun (etc.). May he grant a reception of loaves in the temple of Aten."

(*d*) ". . . Grant to her eternity as her life, to the great wife of the King (etc.). May [she] grant a sight of Aten in the necropolis(?) of Akhetaten."

"For the *ka* (of) the Steward Apy."

5. Nefer-kheperu-her-sekheper. Left jamb (Pl. xxxvii.).⁵

¹ The sign of the deceased man is followed by the papyrus-flower and buds, which at a later period was in frequent use after names of deceased women in place of "*maatkheru*." It rarely occurs after men's names. Its use here is probably one more solecism of this ignorant scribe.

² *Mon. du Culte d'Atonou*, I., li.

³ All these petitions of Mahu consist of snatches, often incomplete and bungled, from the hymn which already occurs four times in the tomb. The hieroglyphs, strictly followed, would often make nonsense.

⁴ *Mon. du Culte d'Atonou*, pl. xxxviii.

⁵ *Ib.*, p. 79.

(*a*) Salutation of the three Powers.

(*b*) ". . . . beloved of the Lord of the Two Lands for his talent, possessor of favour before the Lord of the Two Lands, the Governor of Akhetaten, N., *maakheru*."

(*c*) ". . . . Akhenaten, great in his duration. May he grant . . . the way of Truth for him. He was called at the head of the notables, Governor of Akhetaten, N., *maakheru*."

(*d*) ". . . the great wife of the King, beloved of him, Lady of the Two Lands, Nefertiti, living for ever and ever. May [she] give (?) . . . entering the Presence in the reserved part of the Palace, the Governor of Akhetaten, N., *maakheru*."

6. Suti. Jambs (Pl. xxxix).⁶

The first columns (*a*, *e*) contain salutations of the three Powers.

"A *dy hetep seten* of the living Aten,"

(*b*) (Right jamb) ". . . . May he grant that which is offered in the Presence."

(*c*) ". . . . [like?] the Light, lord of food, great in Niles, by food of whose giving the land liveth. May he send the pleasant breezes of the north wind."

(*d*) ". . . of lofty plumes, gleaming with the diadem(?), beloved (?) of the Lord of the Two Lands. Mayest thou (fem.?) grant a sight of Aten May he grant"

(*f*) ". . . . who illumines all the land by his *ka*. May he give a fair burial after old age, and my rest in the necropolis (?) of Akhetaten (?), a fitting seat."

(*g*) "who illumines (?) all the land by his rising. May he grant the bounty of the good god, the daily offering in the Presence, that which is set out on the a reception of that which he giveth and his food (?)."

(*h*) ". . . Do thou grant departure in the morning from the Underworld to see Aten as he rises daily without ceasing."

"For the *ka* of the standard-bearer of the guild of Nefer-kheperu-ra, Suti, *maakheru*, possessor of the good guerdon."

7. Apy. Ceiling (Pl. xxxii.).⁷

"A *dy hetep seten* of the living Hawk of the two horizons (Horakhti),⁸ a god noble and beloved, living in Truth every day. May he grant the smell of incense, the reception of ointment, a draught of water at the swirl of the stream,⁹ and that my soul be not debarred from that which it desires."

⁶ *Ib.*, p. 68.

⁷ *Ib.*, p. 92.

⁸ This occurrence, without qualification, of the name of the ancient deity whom Akhenaten gradually transformed into the Aten is unparalleled, but not surprising. It was this tendency to revert to old ideas that caused the King about this time to abandon the use of the name entirely.

⁹ "Banks of the pool," in the parallel passage, Plate iv.

APPENDIX.

DECORATIVE TECHNIQUE AT EL AMARNA.¹

THE first process after the rock-walls of the chamber had been dressed with the chisel as smoothly as the nature of the stone allowed, was to cover the whole with a coating of hard plaster. This was done in order that by filling up the holes and fissures with which the local rock abounds, a perfectly plane surface might be secured, rather than with the idea of being able to work in a softer medium; for where the wall was already plane the plaster becomes a mere smear, little thicker than paper.

On this dry plaster the design was sketched out in ink in all detail, often in greater detail than was likely to be reproduced by the chisel. The ink might be yellow, red, or black; if the design needed corrections they were made in red or in black. This picture was generally in somewhat thick outline (Plates xvii., xviii., xix.; III. xxx., xxxii.), but occasionally in solid colour (Pl. x.).

The pictures were always executed in sunk relief for the sake of the protection afforded to the figures by the surrounding surface. The depth to which they were cut varied greatly, large figures being cut very deep, while small work was sometimes only faintly impressed on the plaster (I. xi., xii.; III. x., xi., xiv.).² The sculptor, working on the ink outlines, sank them to the required extent, leaving the figures in rounded relief within. If the plaster happened to be thick, the smaller work might be entirely within it; but if it were a mere wash, even the small inscriptions would be cut into the stone below. The larger figures, owing to their deep cutting, were always mainly formed in stone. Generally speaking, even where all the plaster has fallen away, the main outlines of the picture and much of the detail can still be recovered from the stone alone.

At this stage the small work had reproduced the ink-design in all or most of its detail, and was complete, except for a lack of finish and precision of line. It needed no more than a wash of fine plaster to make the

surface smooth, and to enable the fine detail to be elaborated.³ But in large work, where the stone had been deeply cut into, and the relief stood out boldly, the figures were often rough, and the greater part of the detail had been lost with the surface; so that it was necessary to build them up more or less afresh with new plaster of a fine quality. No doubt at this stage the fresh plaster might be modelled while still soft. Whether the sculptor used memory and judgment in adding the outlines which the chisel had removed, or had a copy of the design for reference, is not determinable; but the latter is not probable.

The procedure in the tombs of Penthu and Ahmes was somewhat different, owing to the soft and crumbling nature of the stone. There the sculptor set to work on his figures either by cutting the wall-surface within the outlines down to the same depth all over, as if for inlay, or gave them only the roughest blocking-out in relief within the mould so formed. By so doing he left nearly all the work to be done afresh; for he had already removed even the outline of his figures. Nothing of the original design was preserved except a depression roughly corresponding to the original outline, and sometimes rough work in relief within it indicating inner detail (see Pl. xi.).

The result was that the modeller was provided only with a rough mould to guide him and had to build up the required figure within this in fresh plaster. The medium, in short, is largely or entirely plaster inlaid in stone, and the results, if correspondingly delicate, were also correspondingly frail. The new plaster made a poor join with the old (see the helmets of the King and Queen in Pl. xi.); the mould was cut out so roughly that its walls were more plaster than stone; the inserted figure proved a dead weight of plaster, without the grip upon the wall which it had when it was a thin overlay on a stone matrix. In addition, the stone itself was friable. It is no wonder then that practically the whole of the decoration in the tomb of Penthu has fallen away, and that the inscriptions

¹ See also Part I., p. 18.

² In these cases the work gives the impression of having been done with a blunt modelling tool while the plaster was soft, as it is so slightly depressed that it scarcely has a definite outline, and often fades into the general surface. Possibly, however, the final coating or wash has given it this smooth appearance, and nearly blotted out the indistinct outline.

³ Cf. Plate xlii., where the head of Mahu is finely chiselled in plaster, but without smoothness. Also Pl. xli., where only the head of the vizier is perfectly finished off. Those of the elders there need further working up, and the faces and figures of the prisoners are very roughly cut.

APPENDIX.

which were cut in inlaid tablets of plaster have been lost. In the entrance the rock was of better quality, and the figures and texts on both sides, being cut in stone in the old way, were fairly well preserved till recent years.

This method of inlay was partially adopted also in the tomb of Ahmes; probably in imitation, for the stone here appears to be good. Some of the figures (altars, slaughtered oxen, etc.) have been cut out bodily in the plaster and merely form moulds to be filled in afterwards (III. xxx.). In general, however, the work was on the old lines, and, thanks to this, the representation of the soldiery there has not only withstood the lapse of time, but even the process of casting.

The general technique of the later tombs of Meryra II. and Huya is poorer, the figures in the smaller work being often but slightly sunk and without distinctness of outline.

The final process was that of painting, which was for

the most part in flat primary colours. In the Southern tombs this stage has rarely advanced far. Alike the sculptures and the architecture remain in general a pure white. The painted ceiling of Ay, the coloured inscriptions on the beams and columns, the bright cornice of Any, and the fully-coloured scene in tomb 7,¹ show that this was not deliberate, but that with greater leisure a full scheme of colour would have been carried out. The wall-surfaces of the entrance passages, which were the first parts to be completed, are generally coloured.² A great deal of fine detail was added or restored in the process of painting, and sometimes the smaller work was re-outlined in red (especially on the North Wall of the tomb of Meryra).

¹ See Frontispiece, Part V.

² This is applicable also to the tombs of Ahmes and Penthu, which are so closely allied to the S. group.

INDEX.

- AHMES, tomb of 1, 4, 5, 6, 9, 15, 20, 26, 32, 33
 AKHENATEN depicted 2, 3, 4, 5, 6, 13, 14, 16, 19, 22, 28
 ,, policy of 9, 26, 31
 ,, prayers to 30, 31
 AKHETATEN 4, 7, 8, 16
 ,, ruins of. 11, 13, 18, 21
 Amenhetep III. 22, 30
Ami khent 6, 30
 Anatomy 3, 5, 13, 19
 ANY, tomb of 13, 14, 27, 28, 29, 33
 APY, tomb of 13, 19, 20, 22, 26, 27, 28, 29, 31
 Architecture, tomb- 1, 8, 9, 10, 12, 13, 16, 19, 21, 23, 33
 ,, ,, styles compared 8
 Armoury 17
 Art, quality of 2, 3, 5, 10, 15, 19, 23, 31, 33
 Artists 3, 4, 15
 ,, methods of 5, 10, 14, 16, 32, 33
 Asses 17
 ATEN, names of 1, 8, 9, 14, 19, 22, 29, 30, 31
 ,, temple of 2, 3, 8, 14, 15, 17, 28, 29
 ,, hymns to 13, 14, 19, 20, 26-31
 Authorship of hymns 27, 28, 29
 Aÿ, tomb of 7, 20, 33

 Barsanti, M. 7, 21
Benben, House of the 28
 Bouriant, M. 7, 12, 23, 28, 30
 Brazier 17
 Buildings depicted 4, 5, 14, 15, 16, 17
 Burials 9, 10
 Burial-chamber 1, 9, 12, 22, 24
 Burial-shaft 1, 9, 21, 25, 30

 Cartouches 1, 4, 14, 19, 21, 22, 24
 Cattle 3, 4, 5
 Ceilings 2, 10, 20, 31, 33
 "Chancellor," 3, 6, 30
 Chariots 2, 4, 5, 15, 16, 17, 18
 "Chief of Chiefs" 6, 30
 "Chief of Companions" 6, 30
 "Chief Physician" 3, 4, 6, 29, 30

 "Chief Servitor of Aten" 3, 4, 6, 29, 30
 Chronology, data for 3, 8, 9, 14, 22, 31
 Clothing 1, 14, 15, 17, 19
 Coffins 10, 24
 Collars, golden 4, 5, 14, 15
 Colour 1, 2, 5, 6, 8, 13, 19, 20, 23, 32, 33
 Columns 4, 5, 8, 9, 10, 19, 23, 24, 25, 33
 "Commandant of Police" 14, 31
 "Commandant of Soldiery" 17, 21, 30
 "Companion" 6, 30
 Conventions, artistic 4, 5, 16
 Cornices 1, 7, 8, 10, 13, 23, 33
 Corridor, cross- 2, 9, 12, 19, 21, 23, 25
 ,, direct 9
 Cow-keeper 5
 Creation, hymns of 27, 28, 29
 Cup 5, 6

 Daressy, M. 8, 23
 Decoration of tombs 2, 8, 10, 13, 15, 19, 24, 25, 32, 33
 Defences of city 14, 16
 Deputy-mayor 16
 Deterioration of records 8, 20, 22, 28, 30, 32
 Door-framings inscribed 1, 12, 19, 21, 24, 25
 Door with lattice 8
 ,, plank- 20
 ,, double 8, 23, 25
 Dog 17
Dy hetep seten prayers 1, 21, 30, 31

 Editor, assistance by 17, 26
 Egypt, ancient and modern 18
 Enamel 14
 Entanglements, military 16

 False-doors 9, 13
 Fashions, changes in 8, 13, 16, 22, 31
 "Favourite of the good God" 6, 30
 Feathers as head-dress 19
 Figures of deceased 1, 8, 13, 20, 21
 Fish 17

- Flowers 17
 "Follower of the feet of the King" 6, 30
 Food 3, 4, 6, 17, 28, 29, 30, 31
 Foreigners 17
 Forts 14, 16, 17
 Furniture 2, 3
- Galleries for burial 24, 25
 Gardens depicted 4
 "Governor of Akhetaten" 14, 24, 31
 Graffiti 1
 Granary 4
 Guilds 25
- Hagg Qandil, village of 7, 8
 Handcuffs 17
 Haste apparent in work 3, 8, 9, 10, 15, 24, 25
 Hay, Robert 7, 8, 23, 28, 29
 Head-dress 14, 15, 19
 Historical veracity of scenes 4
 Horakhti 31
 Horemheb 8
 Horses (see also "Chariots") 16
 Human touches in scenes 16, 17
 HUY 21
 HUYA, tomb of 1, 6, 25, 26, 29, 30, 33
 Hymn to Aten 14, 26, 27, 29, 30
 " " " Shorter 13, 19, 20, 26-29, 31
- Illiteracy 12, 13, 15, 16, 26, 31
 Incense 13, 22
 Ink, records in 8, 13, 14, 15, 20, 21, 24, 32
 Inlay, plaster 2, 32, 33
 Inspection of stores 17
 Interpolated texts 26, 27, 28
 "Intimate of the King" 3, 29, 30
- Jars 5, 17, 18
 Jecquier, M. 8
 Jones, Mr. Harold 22
- King (see "Royal," "Akhenaten," "Amenhetep").
 " " smiting enemy 14
- Laver, C. 7, 23
 Lamp 14
 Legrain, M. 8
 Lepsius, Richard 1, 2, 7, 11, 28
 L'Hôte, Nestor 1, 4, 7, 29
 Lintel, scenes on 1, 13, 19, 21
 Literary quality of hymns 26, 31
 Loggia of palace 5, 14
- Maat 19
 MABHOU 12
 MAHU 9, 10, 12-18, 20, 22, 26, 27, 28, 30, 31, 32
 Mannerisms in art 3, 5, 8, 13, 14
 Masts 16
 MAY 4, 10
 MEKETATEN 2, 3, 14
 MERYRA, tomb of 3, 4, 9, 13, 27, 28, 29, 33
 MERYTATEN 2, 9, 14, 16, 22
 Methods of craftsmen 10, 15, 24
 Motives estimated 2, 8, 9, 10, 12, 15, 16
 MAZAU. (See also "Police") 14, 15
 Mutilation of tombs 1, 2, 5, 8, 12, 19, 28
- NEB-MAAT-RA 22, 30
 NEBT-ANT 21
 Necropolis, Northern 3, 7, 9, 11
 " " Southern 3, 5, 7-11, 12, 13, 29, 33
 " " change of 3, 7, 8
 NEFER-KHEPERU-HER-SEKHEPER 23, 31
 NEFERTITI (see "Queen").
 Nurses 4
- Octroi* 16
 Offerings 2, 13, 14, 19, 22
 Ointment 22, 31
 Originality 4, 26
 Ornaments, personal 4, 6, 14, 15, 19
- Palace 5, 8, 10, 14
 PANEHESY, tomb of 3, 4, 9
 Papyrus-flower sign 31
 Patching-stones 5, 7
 PENTHU 2-6, 29, 30
 " " titles of 3, 4, 5, 29, 30
 " " tomb of 1-6, 9, 26, 32, 33
 Petrie, Professor 11, 13, 21
 Pharaoh 4, 17
 Pilasters 8, 16, 19, 23
 Plagiarism 3, 4, 14, 26
 Plaster, use of 2, 3, 5, 10, 21, 22, 24, 32, 33
 Portals 8, 23, 25
 Portraiture 3, 5, 13, 19, 22, 32
 Priests 1, 3, 4, 27
 Princesses (see "Royal Family").
 Princes 17
 Police 14, 15, 16, 17, 18
 Prisoners 17, 18, 32
 "Privy Councillor" 3, 30
- Quality of art 2, 3, 5, 10, 15, 19, 23, 32, 33
 Quay shown 4

- Queen depicted 2, 3, 4, 5, 6, 13, 19, 22
 „ laudation of 20, 31
 „ prayers to 30, 31
 „ sister of 8
- RAMES 14, 20, 21, 22, 30
 „ of Abd-el-Qurneh 22
- Records of tombs, previous 7, 8, 11, 23, 28
- Rewards of officials 2, 3, 4, 5, 10, 14
- Roads to tombs 11
- Rock, nature of 1, 2, 7, 10, 19, 21, 32, 33
- Rossetti 3
- “Royal Chancellor” 6, 30
- “Royal Scribe” 6, 20, 21, 29, 30
- Royal family 2, 3, 4, 6, 13, 14, 16, 19, 22
 „ hymn 14, 26, 27, 29, 30
 „ tomb 2, 3
- Sanctuary, Smaller 2, 3
- Sceptre 14
- Schaefer, Dr. 2
- Screens 3
- Scribes 4, 6, 17, 20, 21, 26, 29, 30, 31
- Sentries 16, 17
- Sentry-houses 17
- Shipping 4
- Shrines 2, 9, 12, 21, 23, 25
- “Sister” as wife 21, 22
- Sistra 20
- “Sole Companion” 6, 30
- Soldiery 5, 14, 33
- “Standard-bearer” 25
- Standards, military 14, 15
- Statues 1, 21, 25
- Stela in tomb 12, 13
 „ boundary 8, 13, 14
- Stairs 9, 12, 13, 24
- “Steward” 20
- “Steward of the house of Nebmaatra” 22, 30
- Stores, Government 4, 17
- SUTI 25, 31
- Technique 2, 10, 13, 15, 32, 33
- Temple represented 2, 3, 8, 14, 15
- Terrace, raised 15, 16
- Texts, corruption of 26
- Textual criticism 26, 27
- Theban fashions 8, 26
- Titles 6, 17, 20, 21, 22, 24, 25, 30, 31
- Tombs, late occupation of 1, 2, 10
 „ uninscribed 7, 9, 10, 11, 29
- Trench in floor 2
- TUTU, tomb of 13, 14, 20, 27, 28, 29
- TYI 6, 25
- UA-EN-RA 15, 16, 29, 30, 31
- Underworld 29, 31
- Unfinished designs 2, 3, 5, 9, 10, 13, 14, 17, 19, 20, 21,
 24, 32, 33
 „ tombs 2, 9, 10, 12, 19, 21, 23, 24, 25
- Variants in hymns 26, 27
- Vessels 5, 6, 13, 17, 22
- Victualling guard-houses 17
- Vizier 14, 16, 17, 32
- Weapons 17
- Whitewashed tombs 10, 12, 23, 33
- Wigs 21
- Women 15, 17, 21, 31
- Worship, scenes of 1, 2, 13, 15, 19, 22

PLATES.

NOTE.

An index to the passages in the text which are explanatory of the several plates will be found on pages vii., viii.

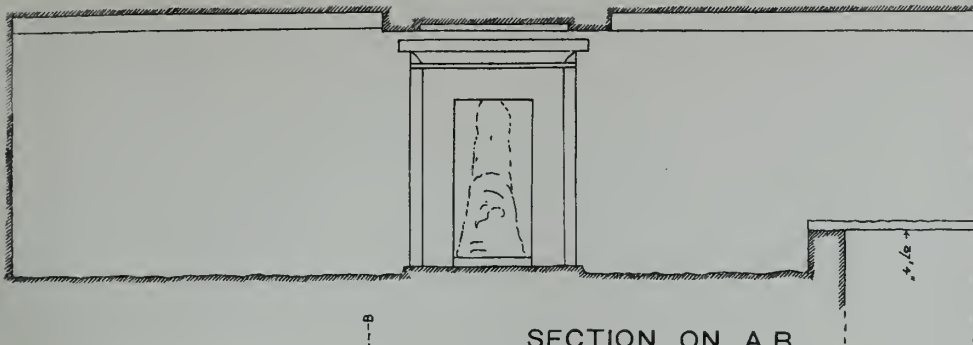

SECTION ON A.B.

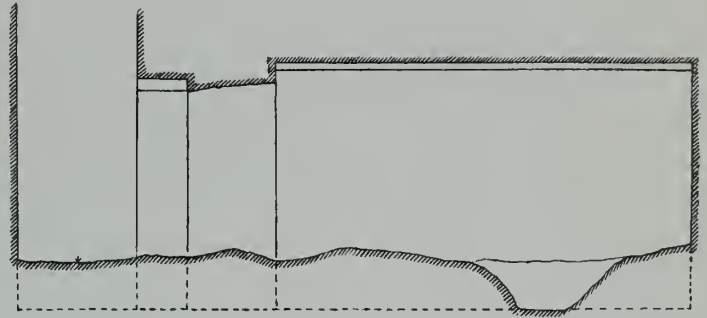

Shaft

Scale

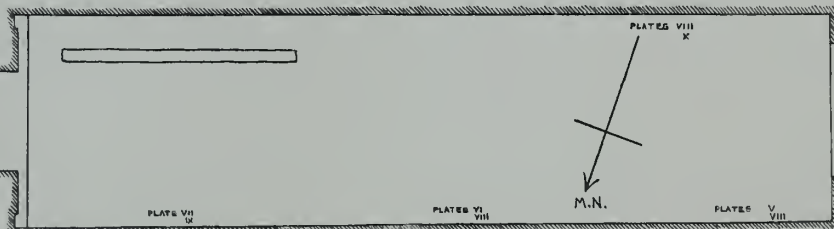
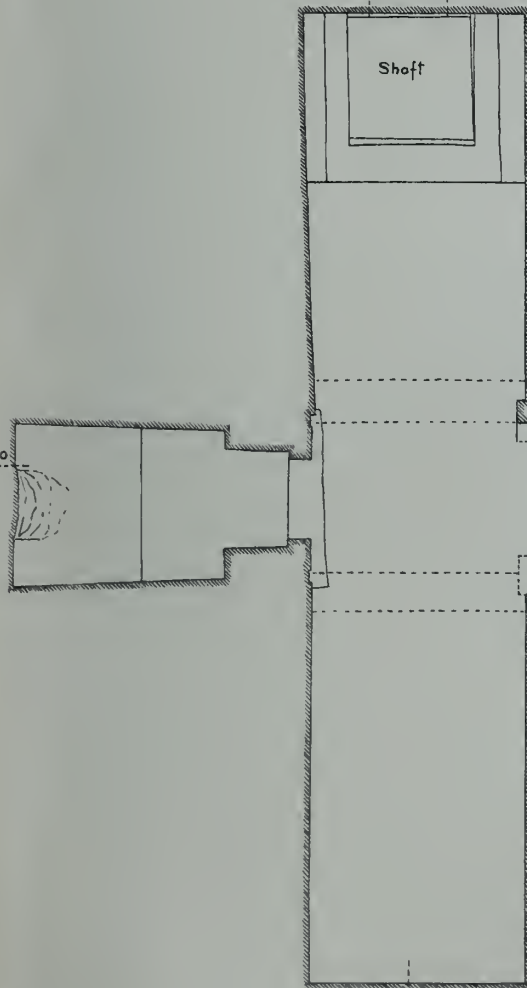
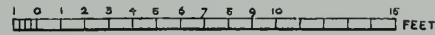

PLAN.

Vertical wall for 29 ft. +
 Vertical wall for 37 ft. +

SECTION ON C.D.

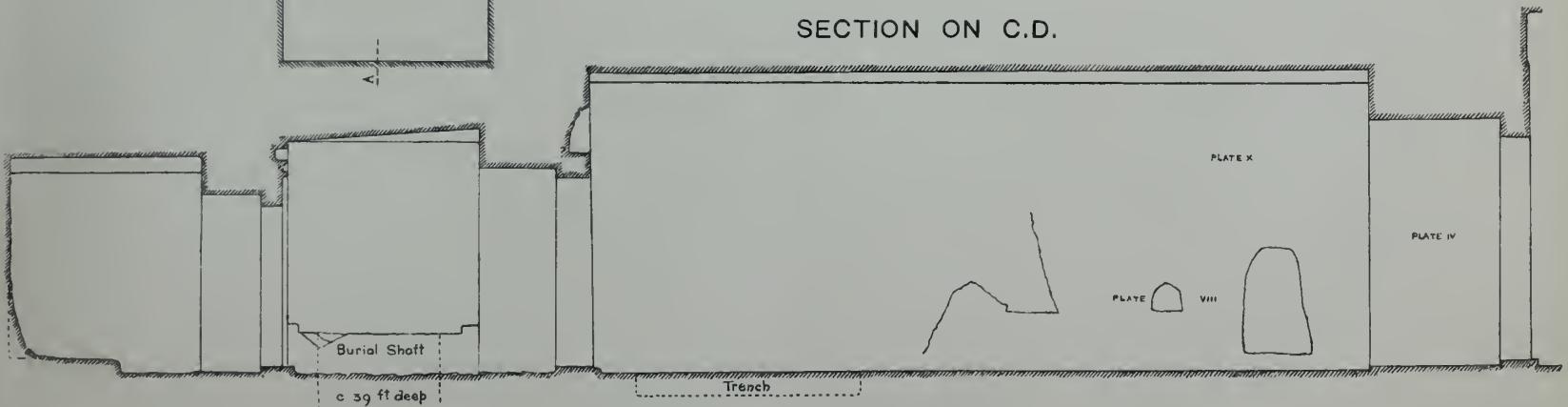

Burial Shaft

c 39 ft deep

Trench

Scale 1/32

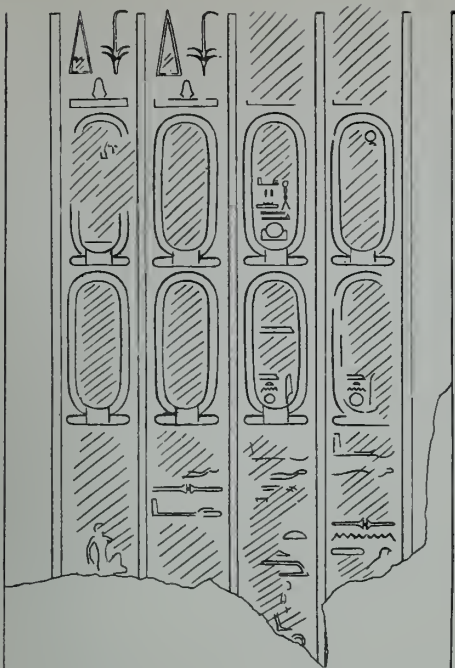

LEFT END OF LINTEL.

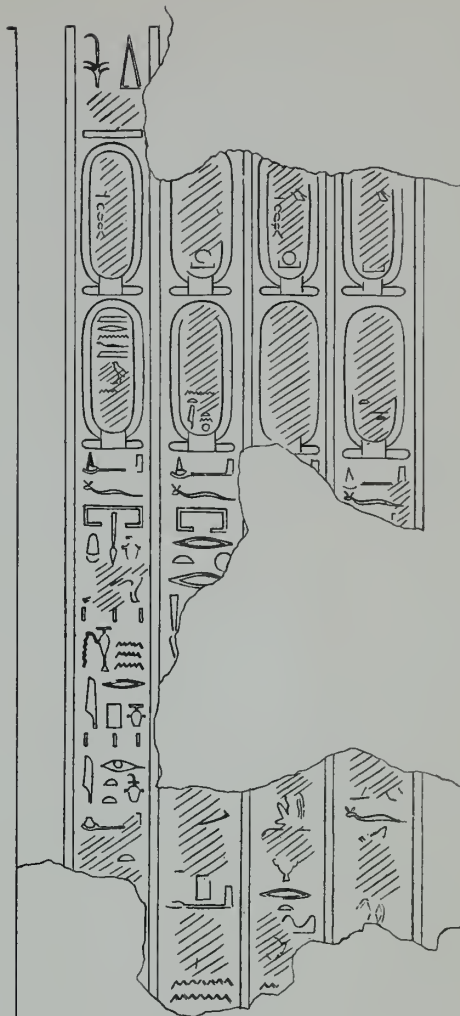

PLASTER FRAGMENT.

(Now in Berlin.)

Scale $\frac{2}{3}$



LEFT JAMB.



RIGHT END OF LINTEL.

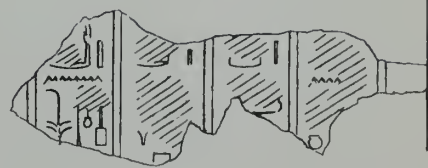

RIGHT JAMB.

Scale $\frac{1}{10}$

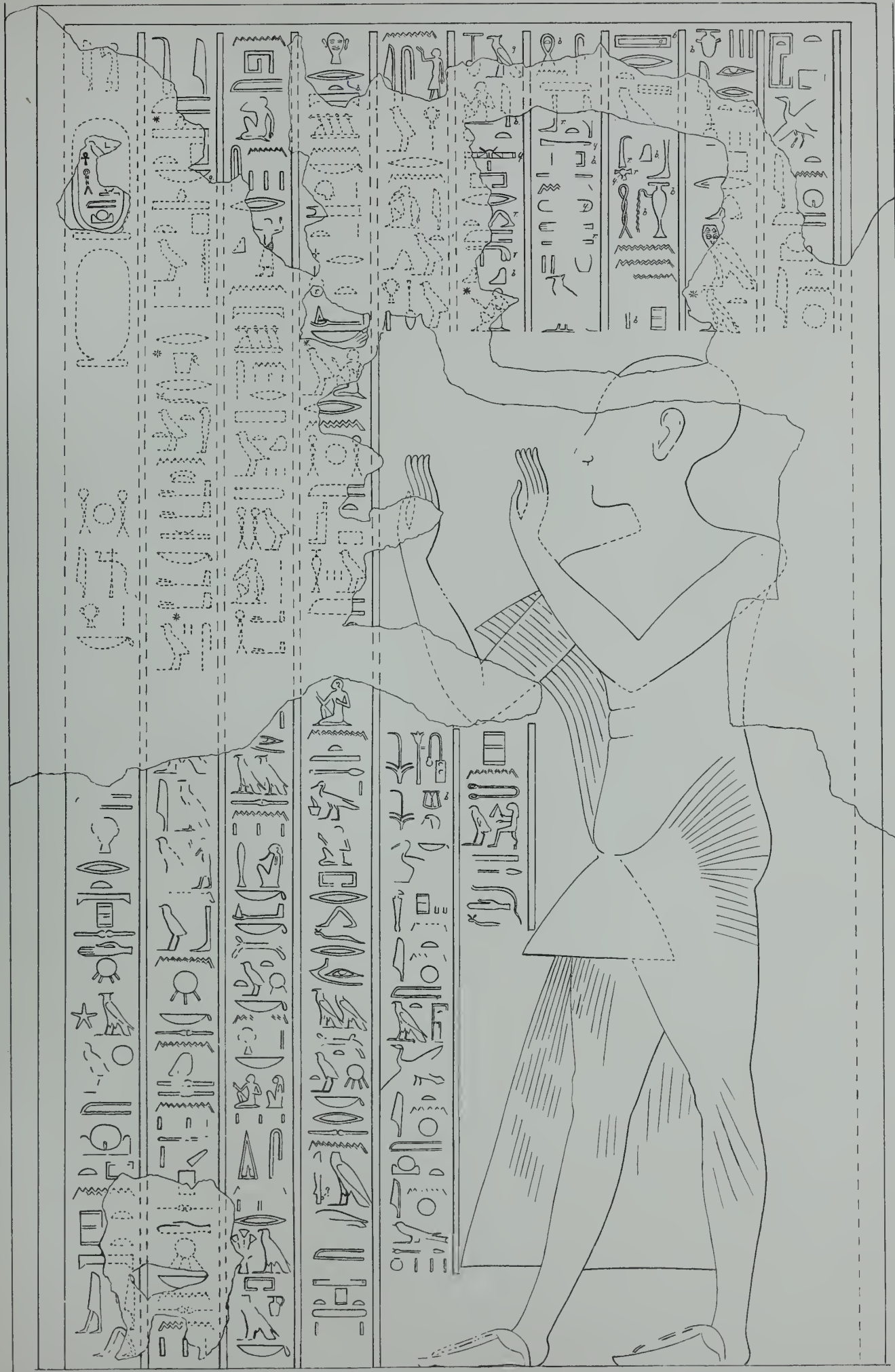

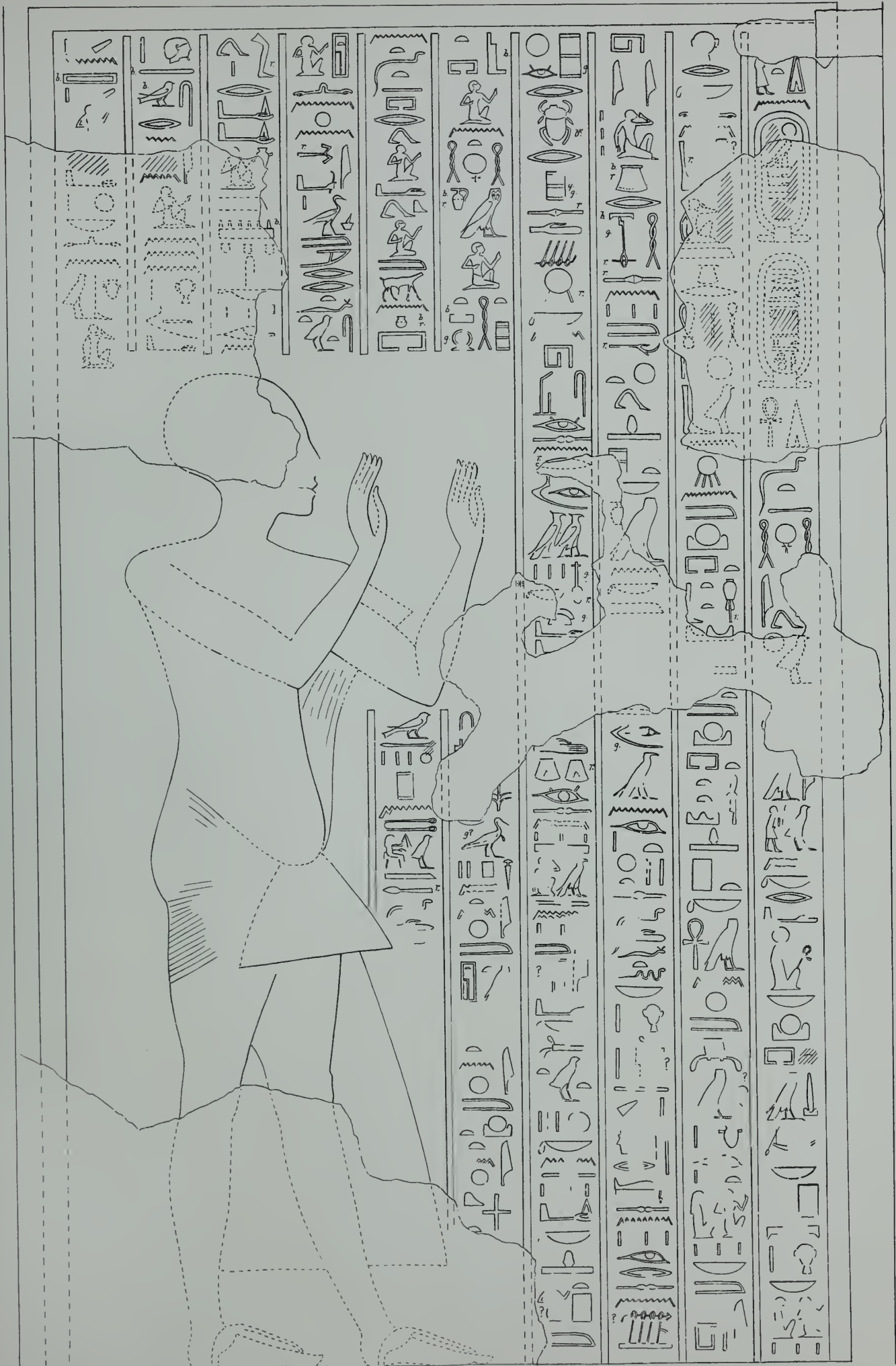

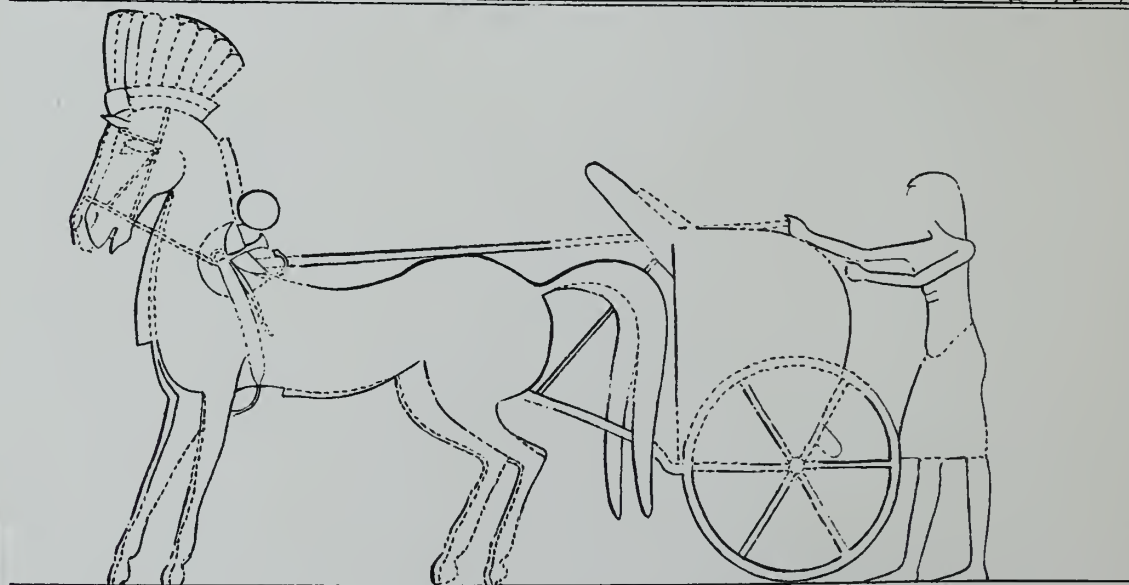
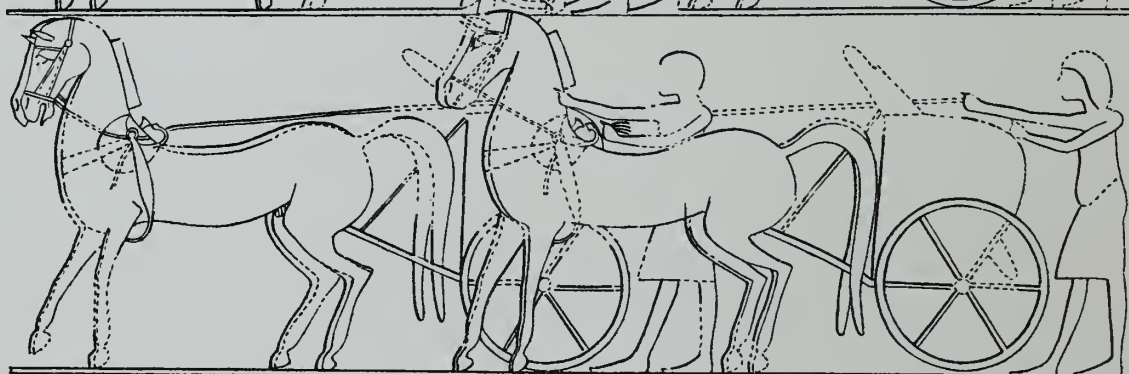
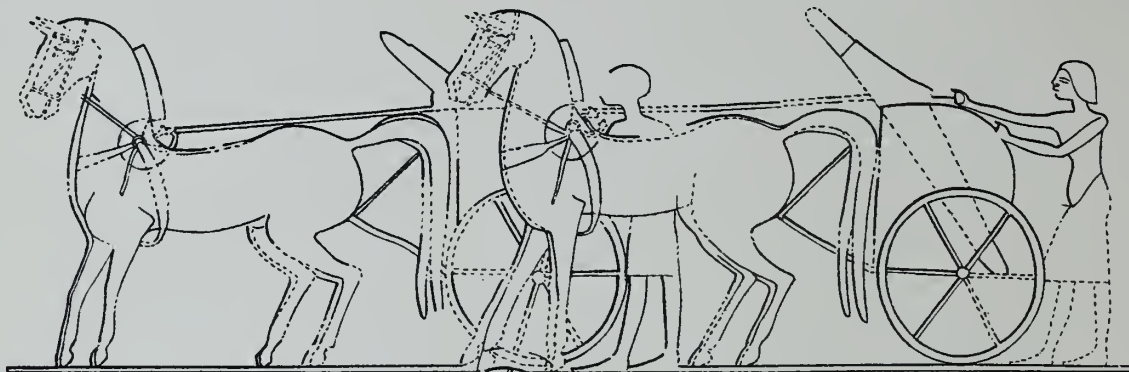

Scale $\frac{1}{9}$

THE ROYAL FAMILY

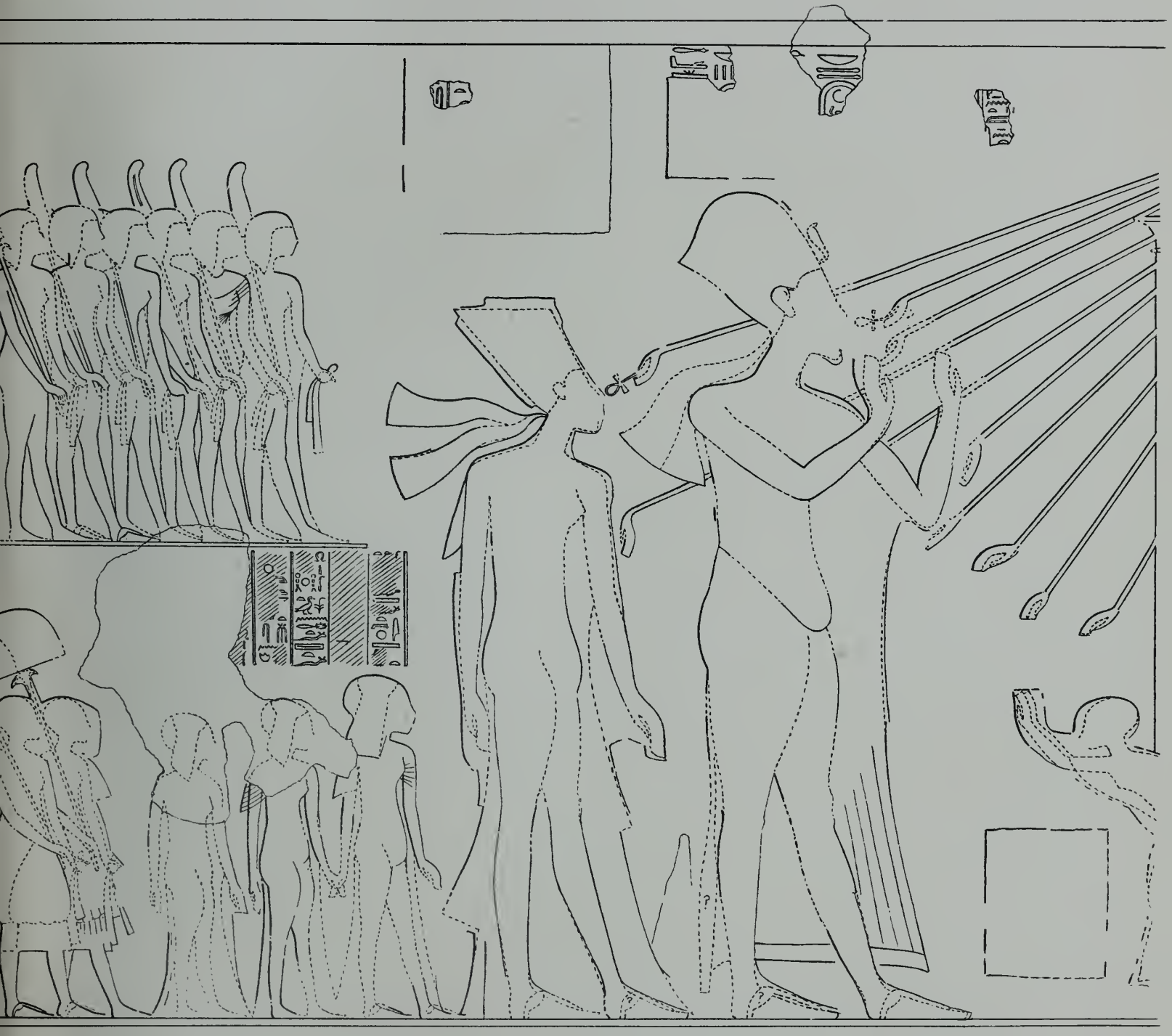
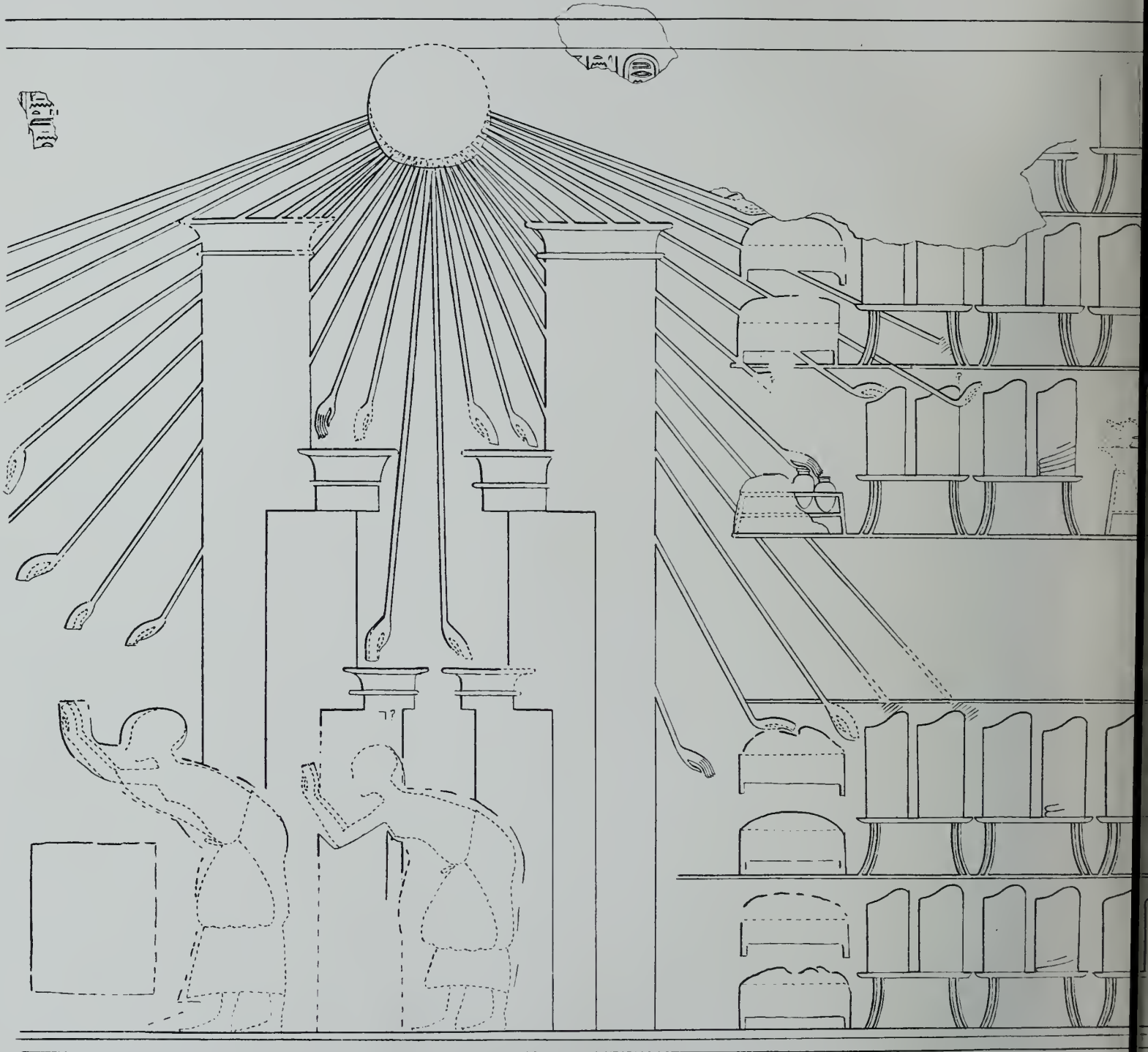

Plate VI.

Plate V.



THE COURT OF

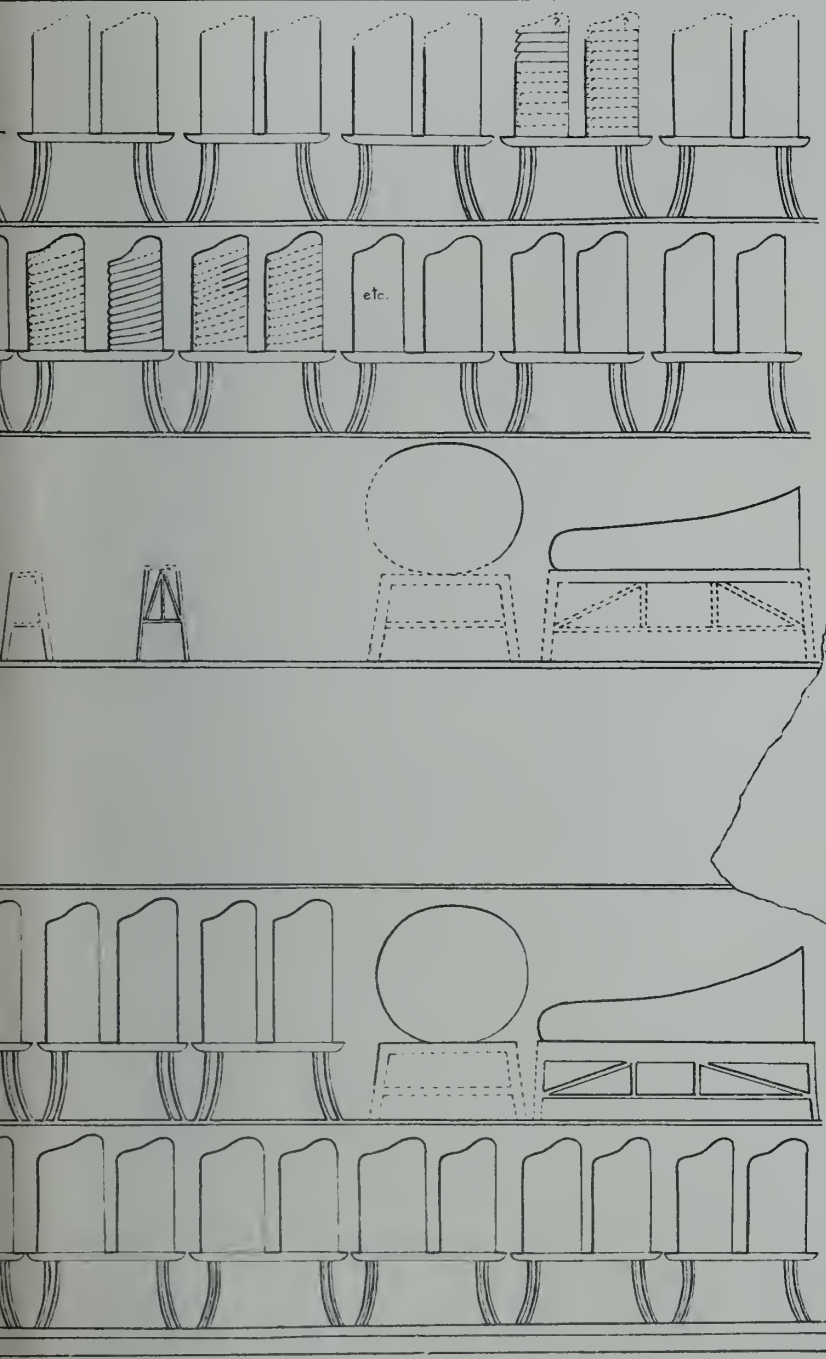
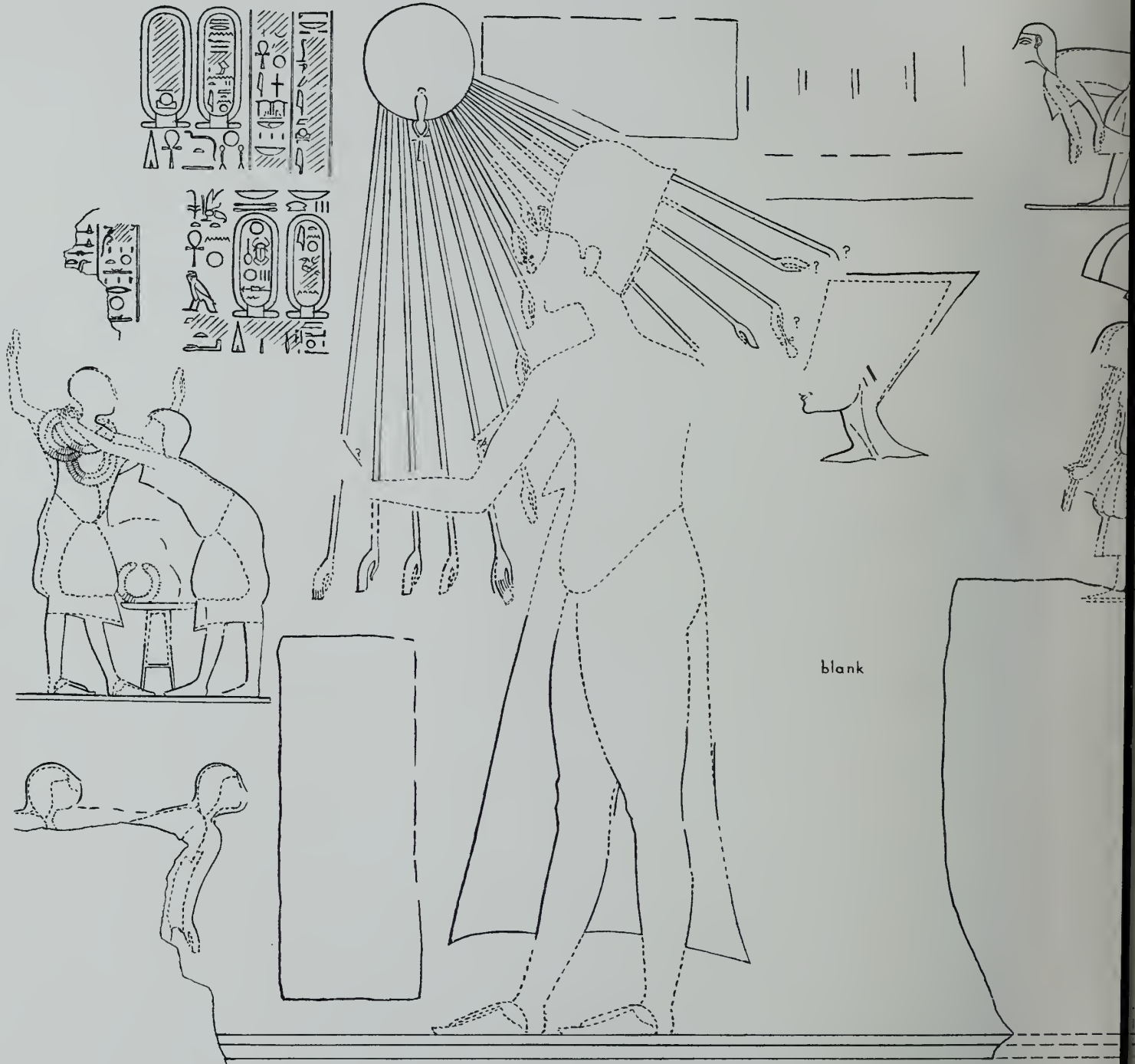
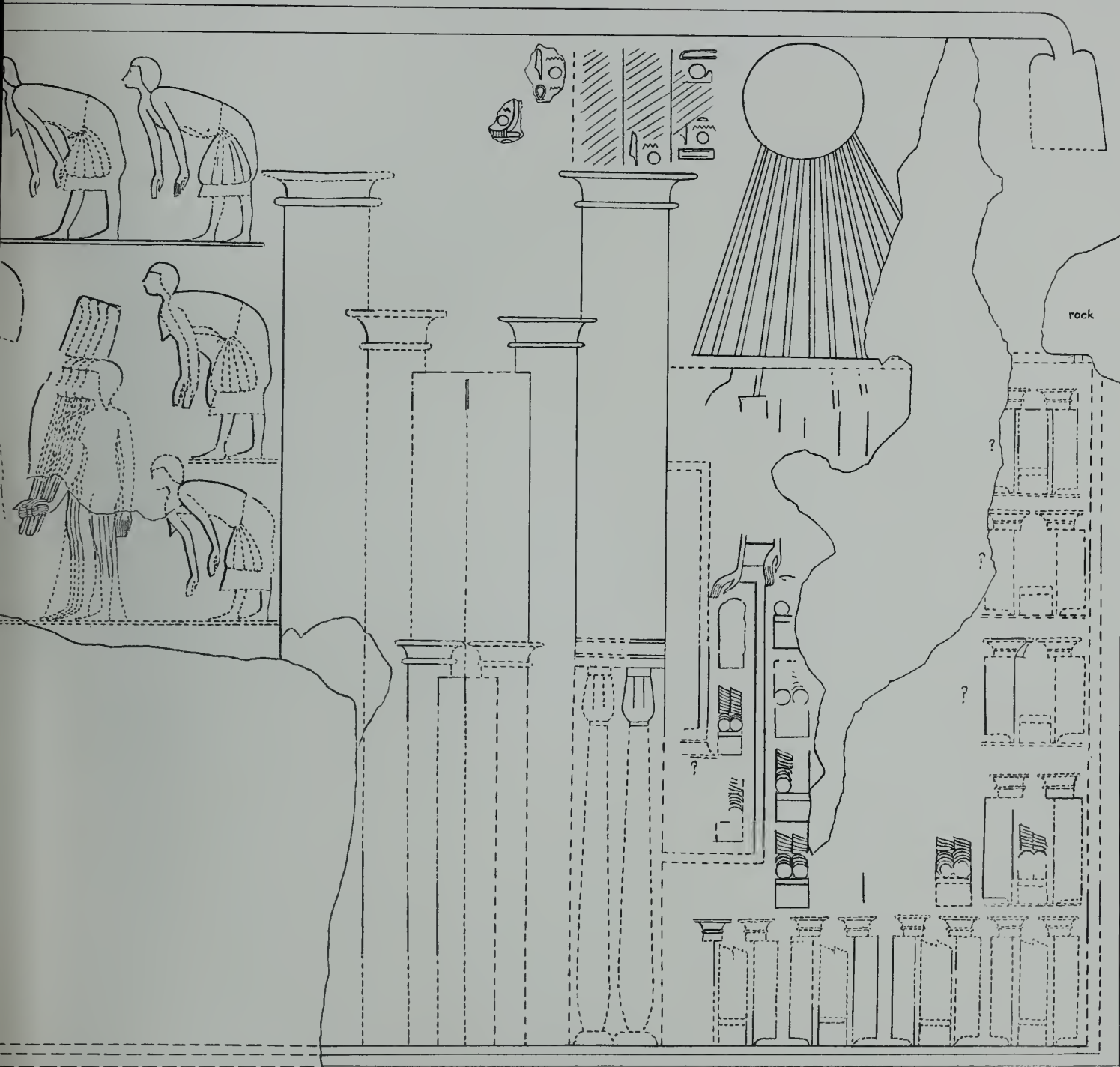

Plate VII.

Plate VI.



PENTU DECORATED.



THE LESSER SANCTUARY.

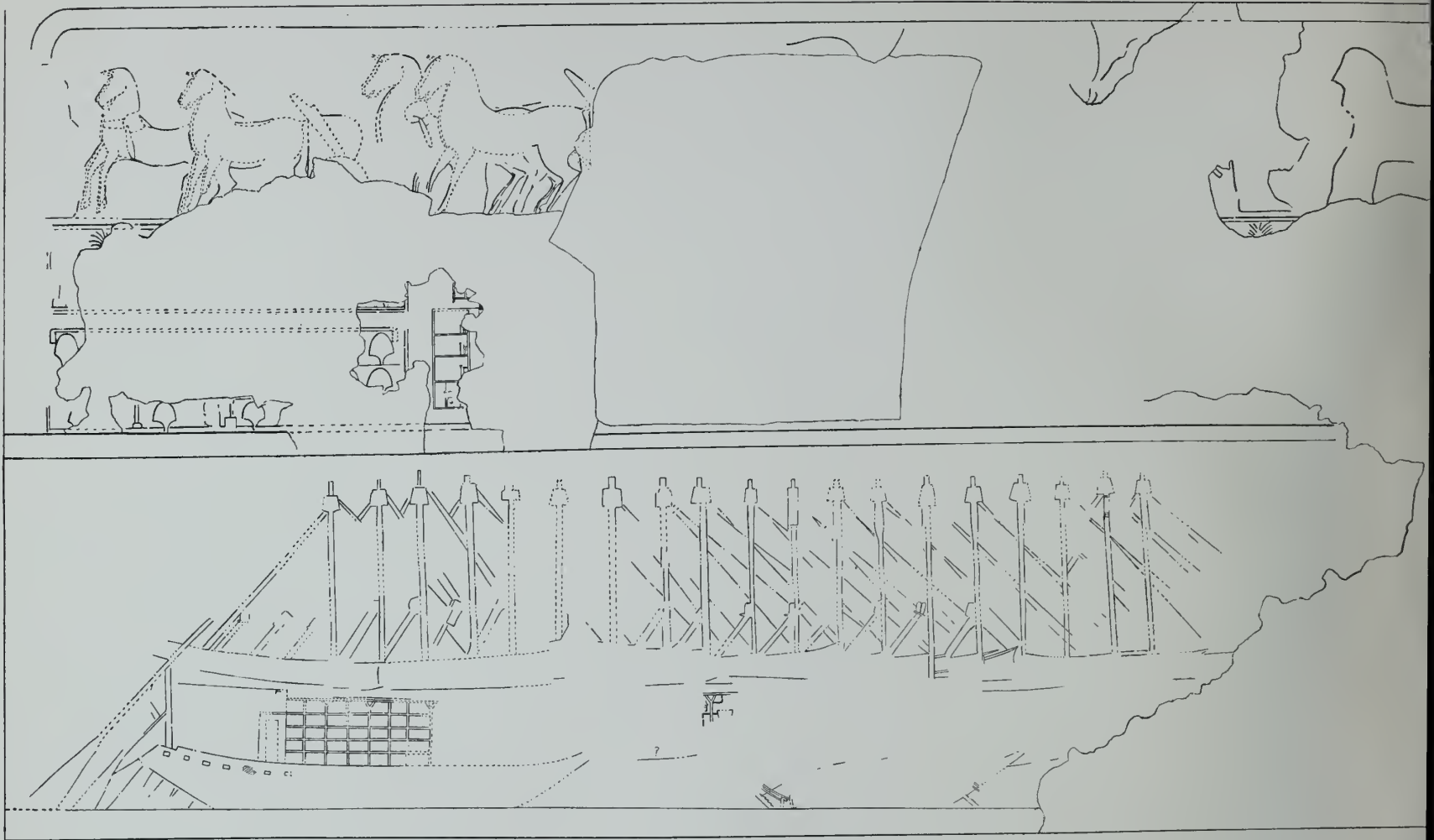

NORT

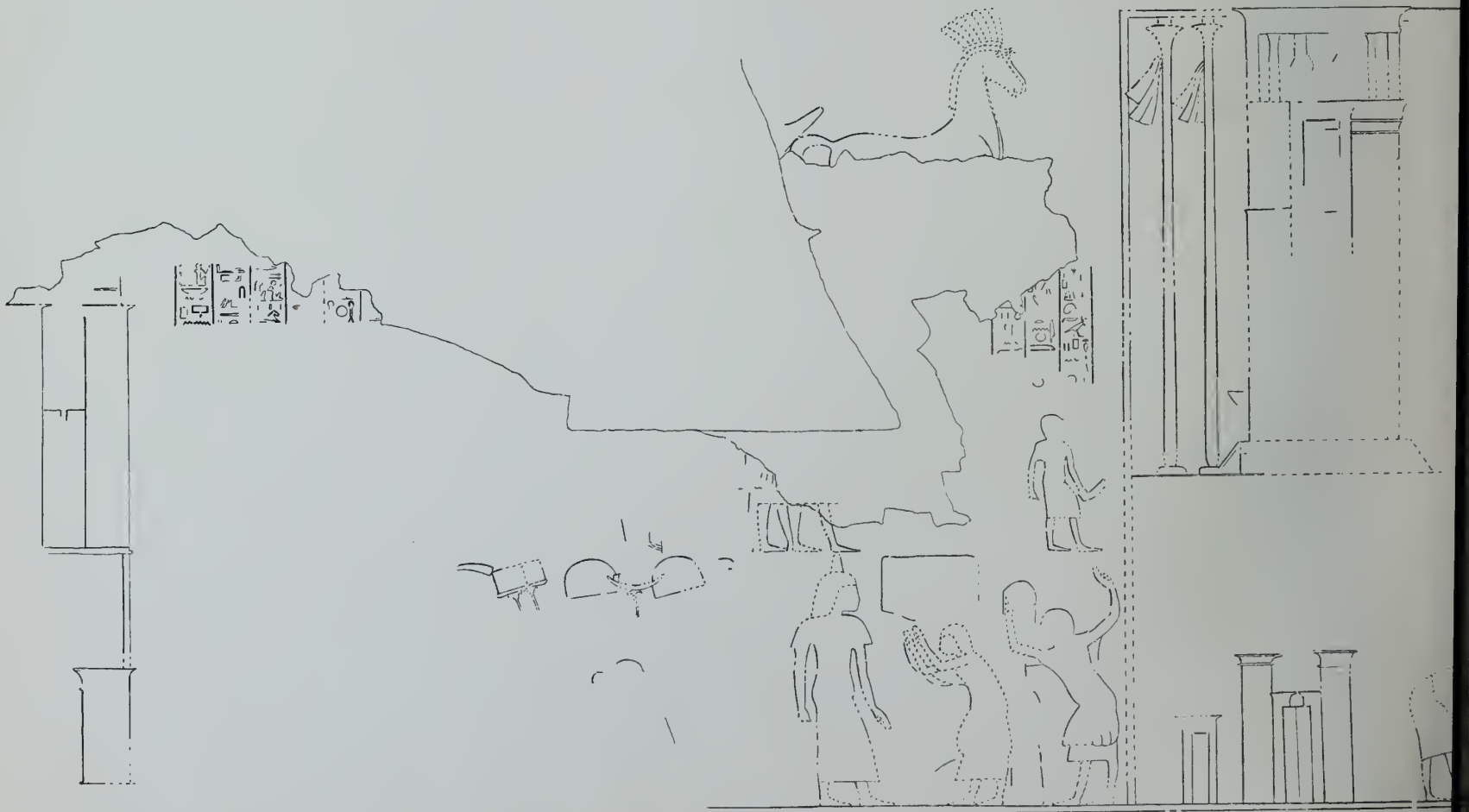

Scale $\frac{1}{13}$

SOUT

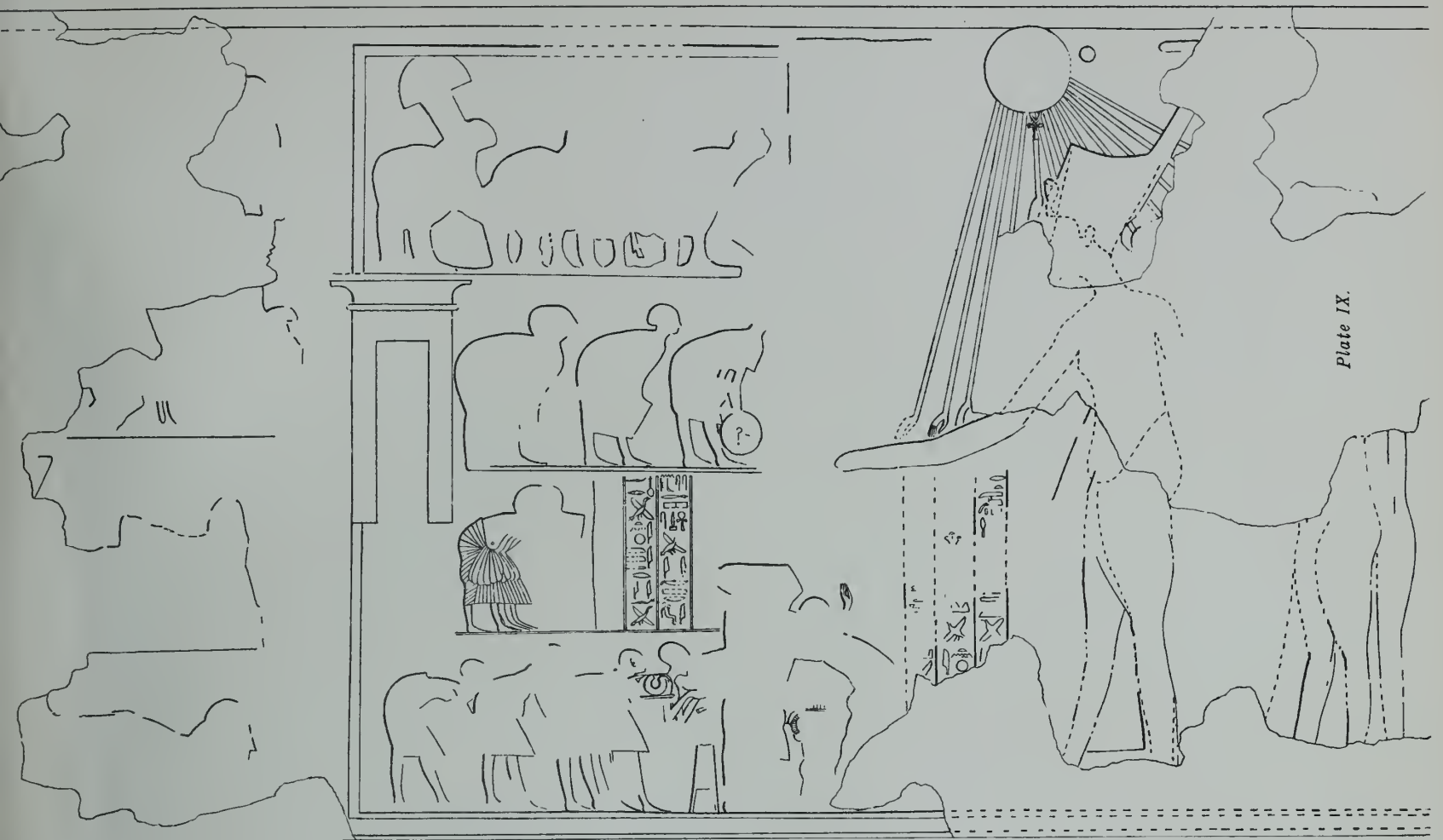
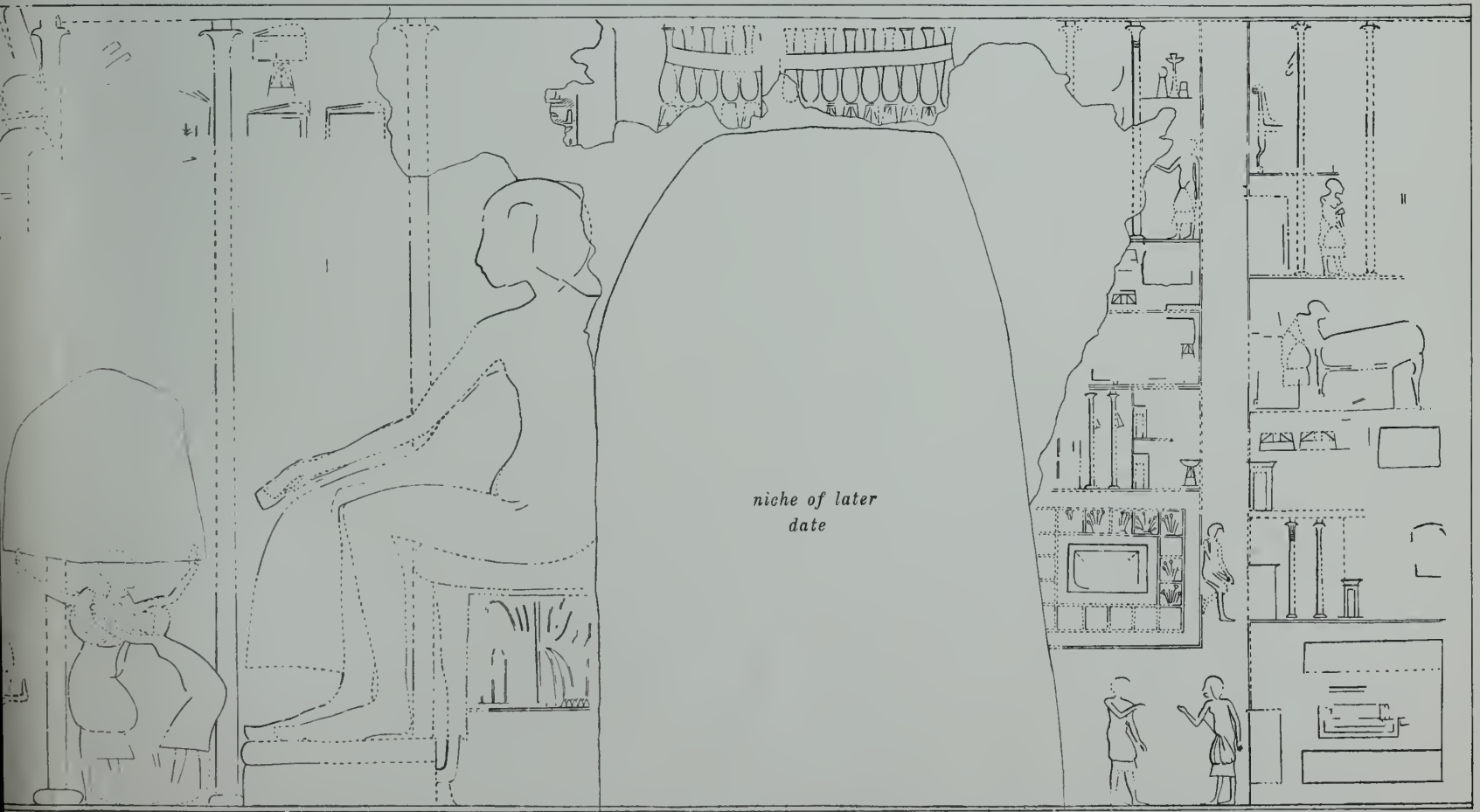

Plate IX.

VALL



niche of later date

VALL

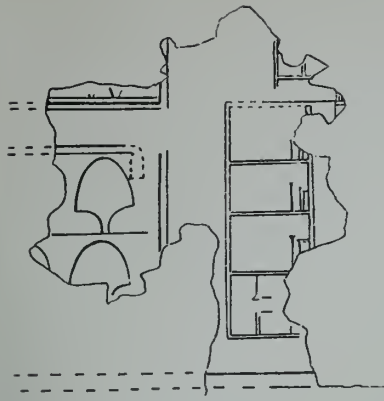

A (See Plate VIII)



B (See Plate VIII)

C (See Plate VIII)

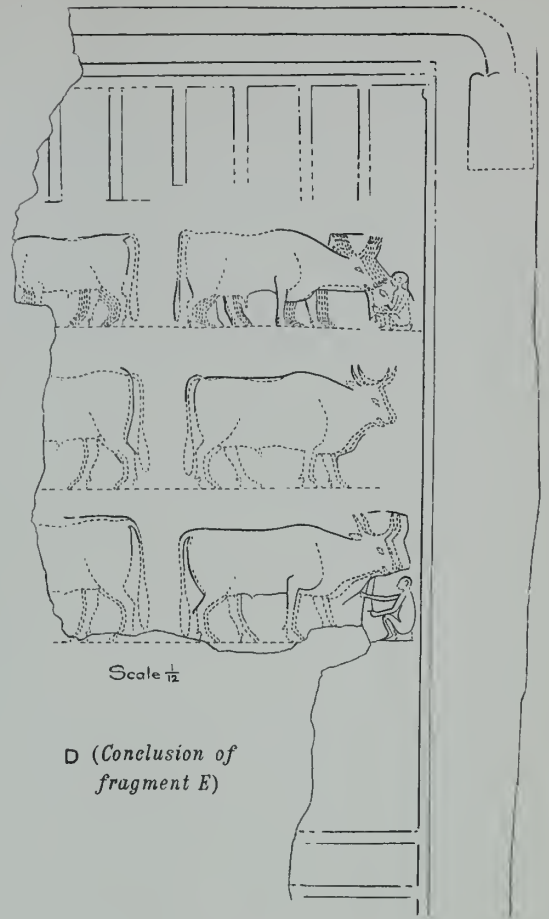

D (Conclusion of fragment E)

E (Continuation of Plate VIII, N. Wall)



A long gap between this and fragment D



THE KING AND QUEEN AT MEAT.

Scale $\frac{1}{6}$



RAMES — THICKNESS



PENTU — N. WALL

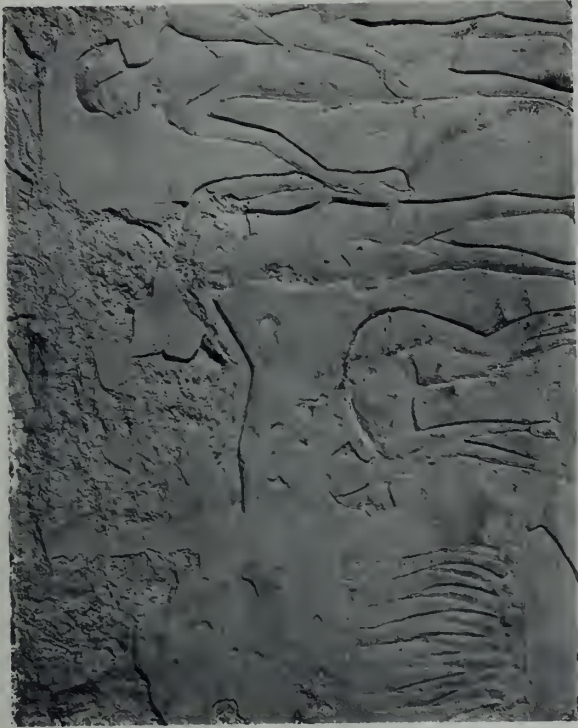

B. (Plate XXVI)



D. (Plate VII)

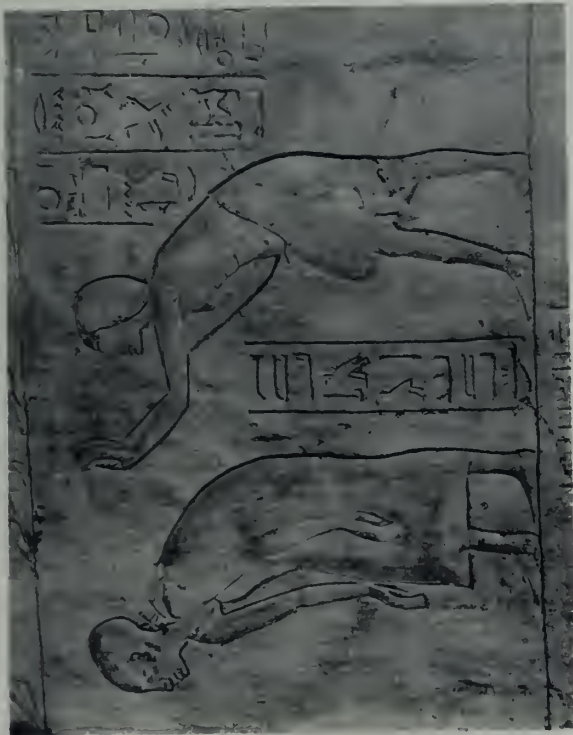

A. (Plate XXI)



C. (Plate XX)

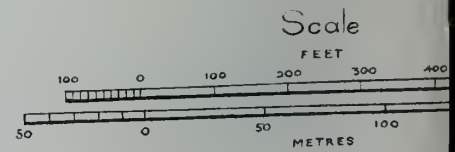
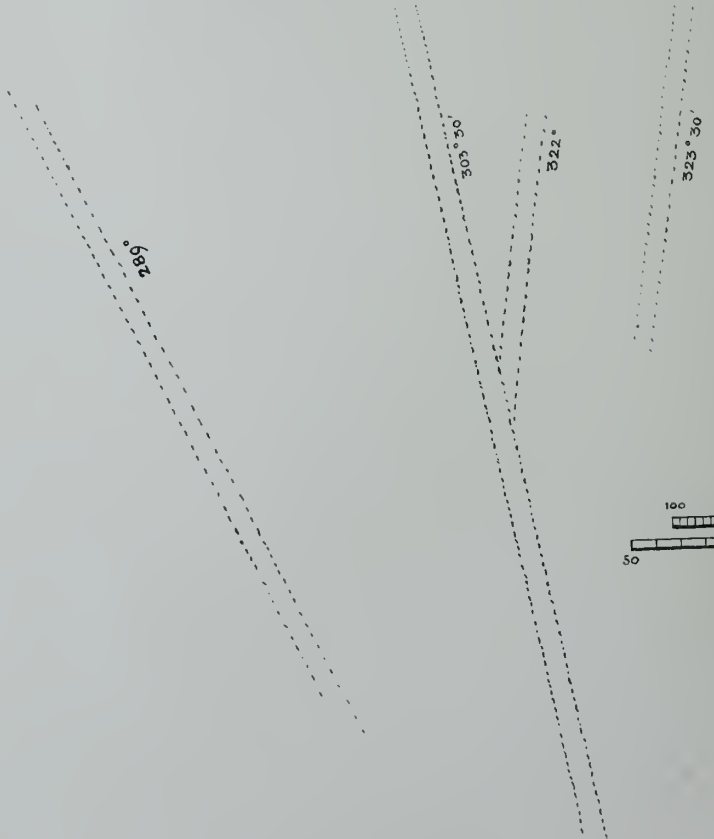
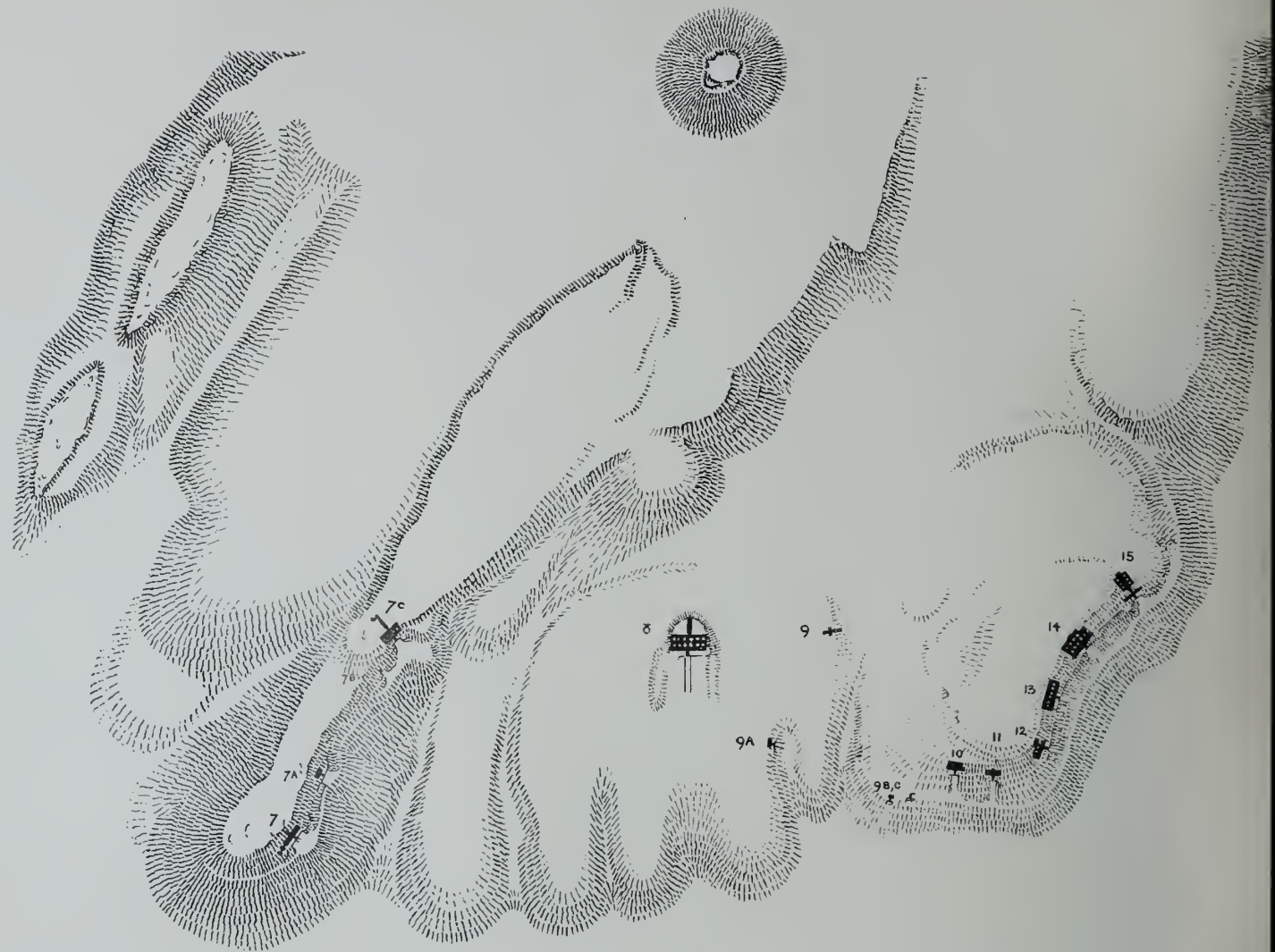

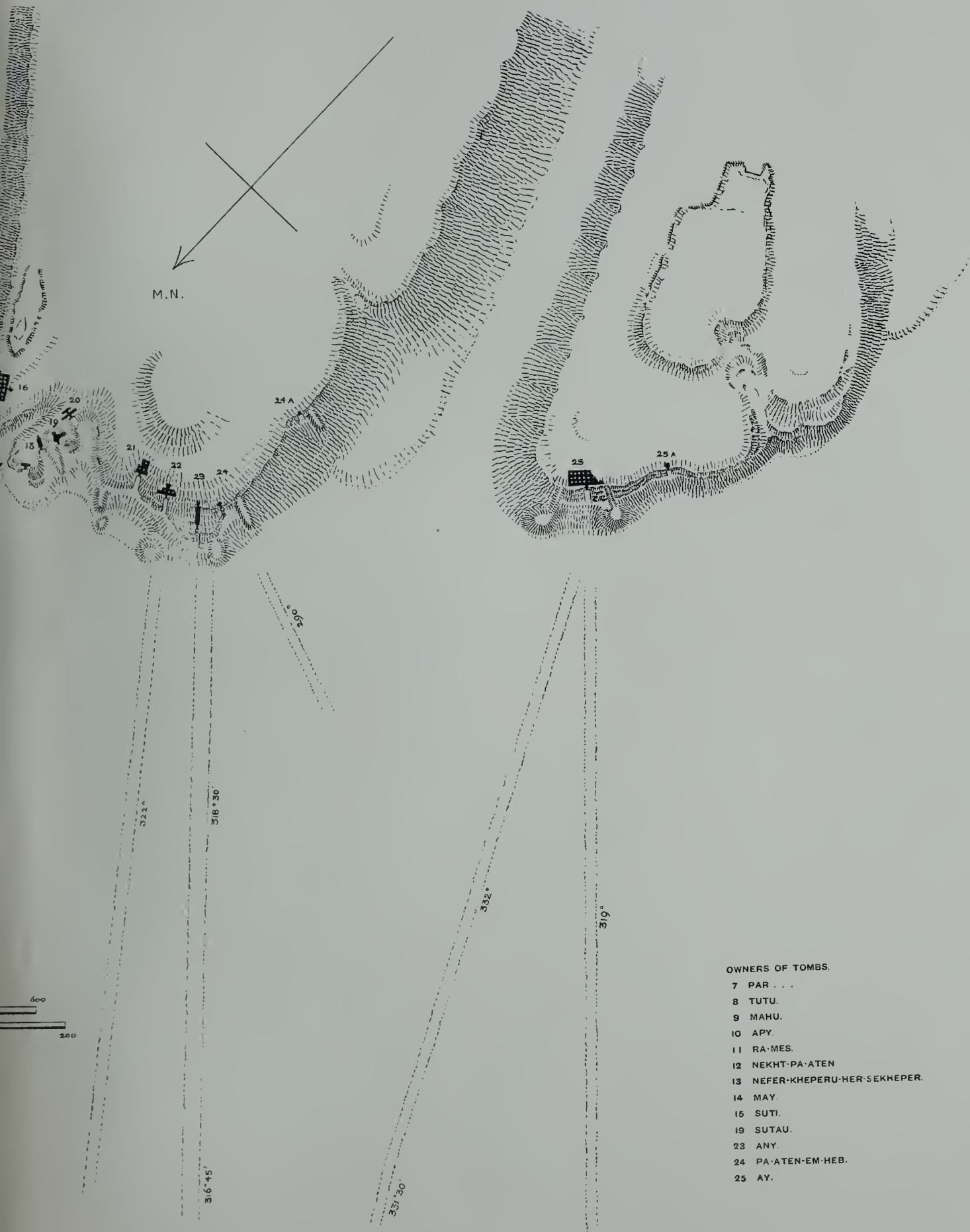

OWNERS OF TOMBS.

- 7 PAR . . .
- 8 TUTU.
- 9 MAHU.
- 10 APY.
- 11 RA-MES.
- 12 NEKHT-PA-ATEN
- 13 NEFER-KHEPERU-HER-SEKHEPER.
- 14 MAY.
- 15 SUTI.
- 19 SUTAU.
- 23 ANY.
- 24 PA-ATEN-EM-HEB.
- 25 AY.





THE ROYAL FAMILY WORSHIPPING ATEN.

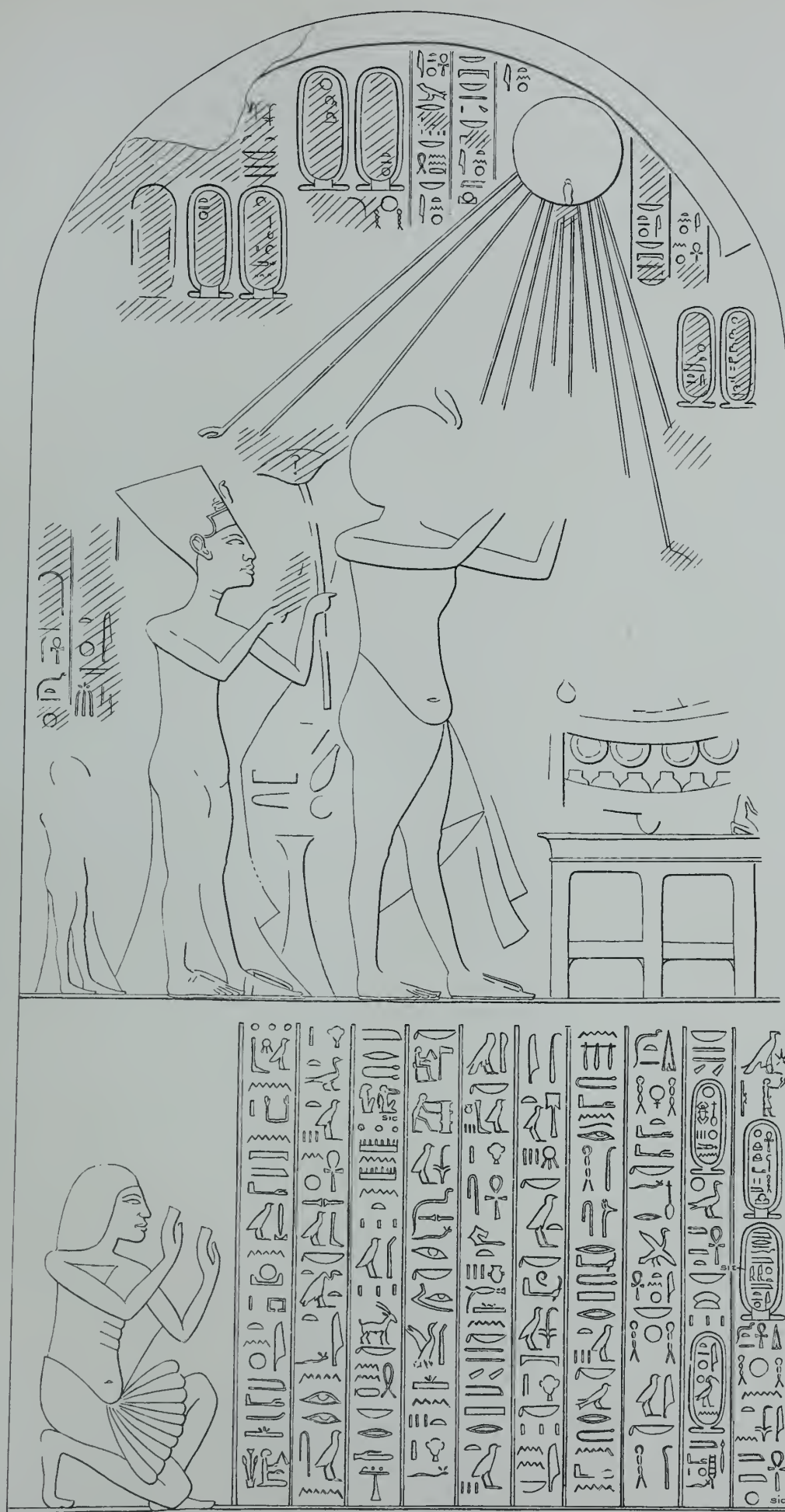

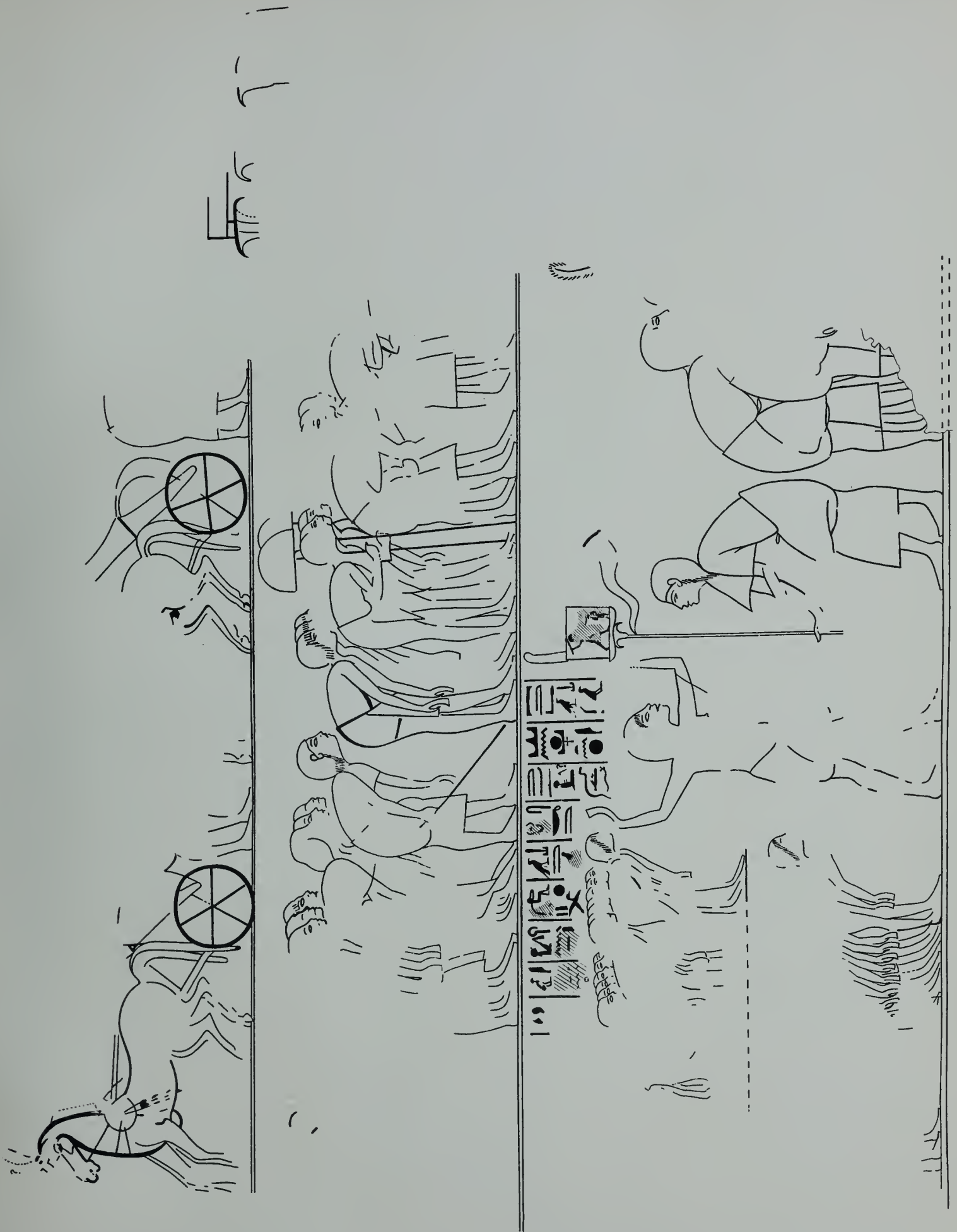

MAHU AND HIS TRAIN BEFORE THE PALACE.

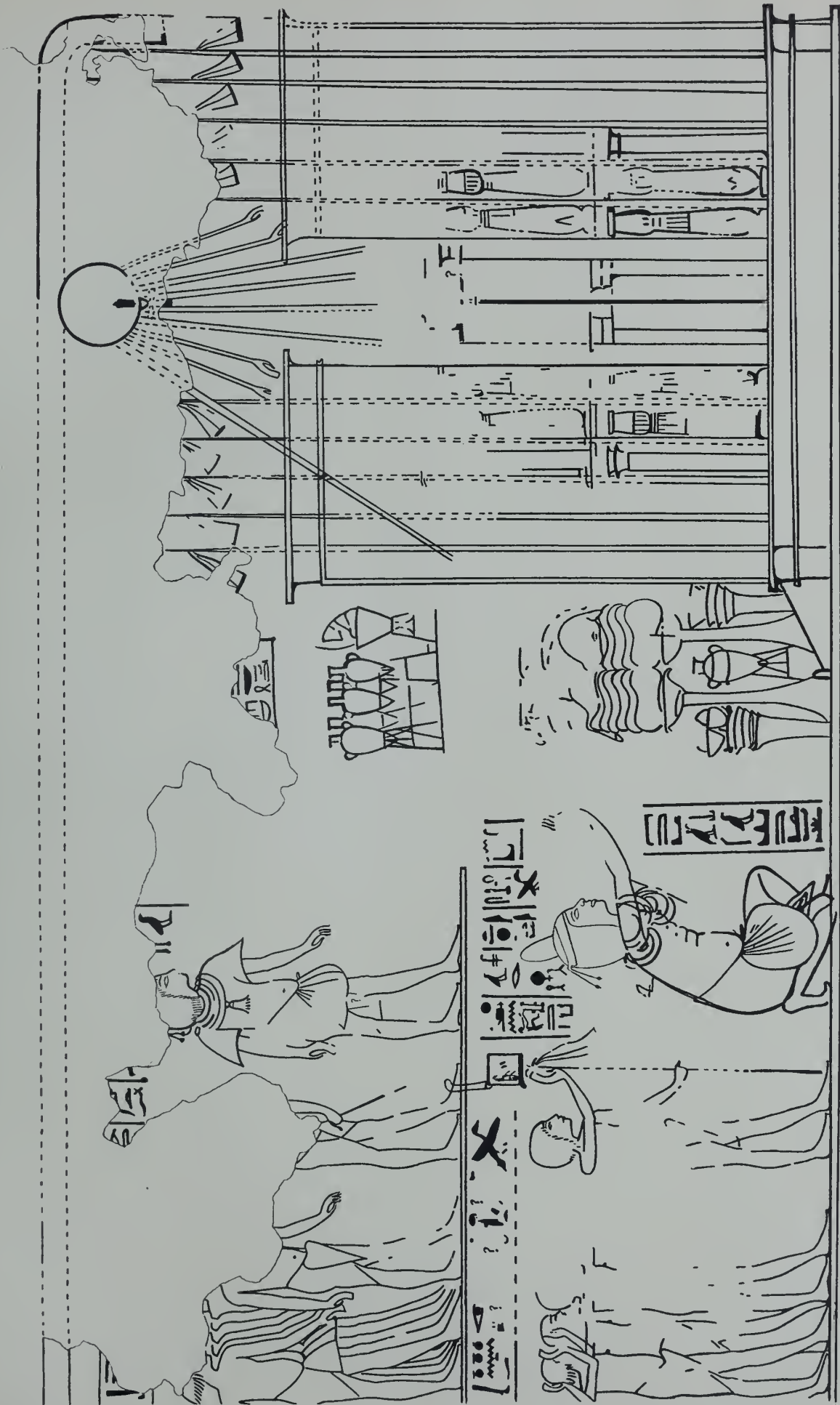

MAHU VISITS THE TEMPLE.

(Completed on Plate XIX.)

N. End Wall

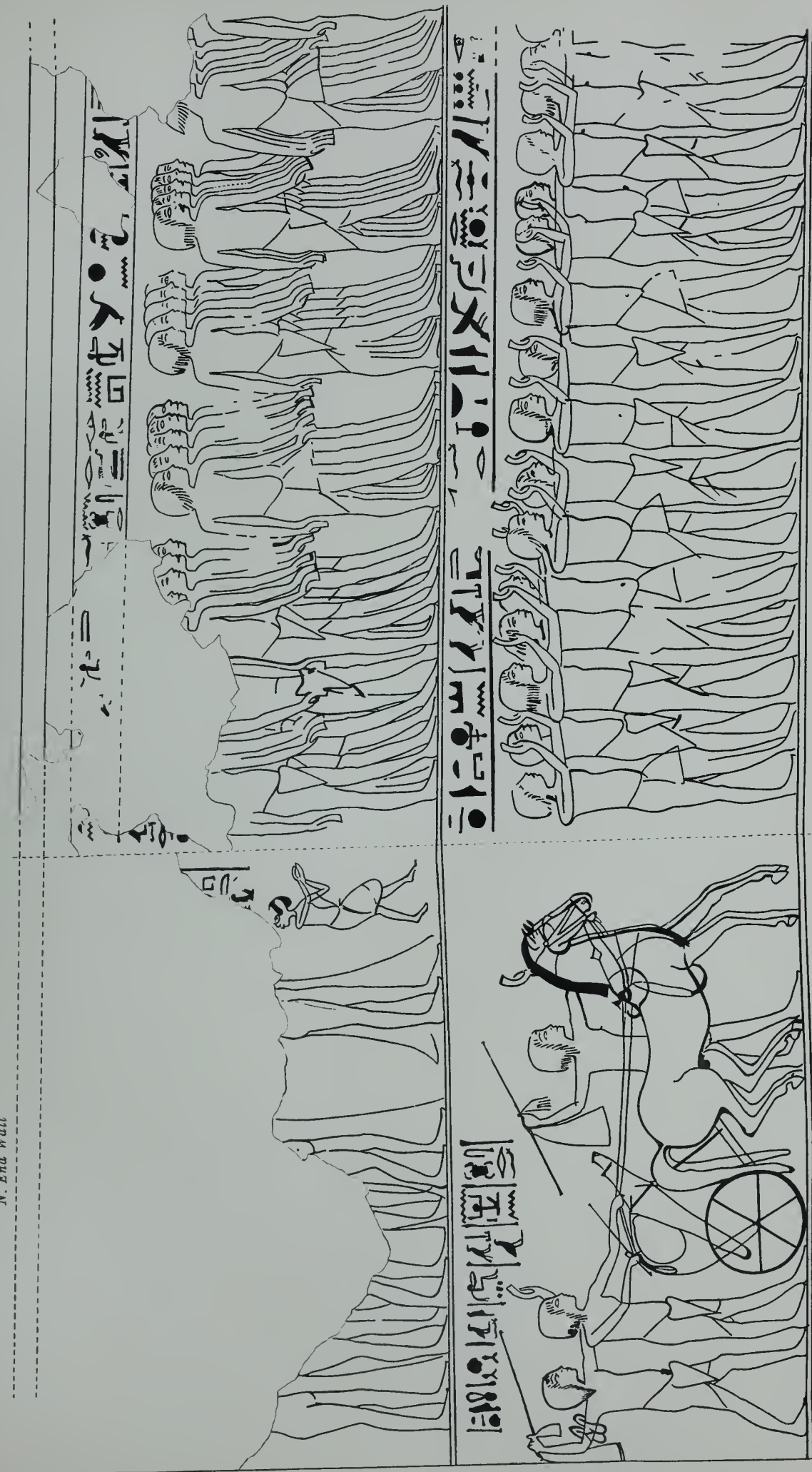

MAHU VISITS THE TEMPLE (Continuation).

Scale 1/2

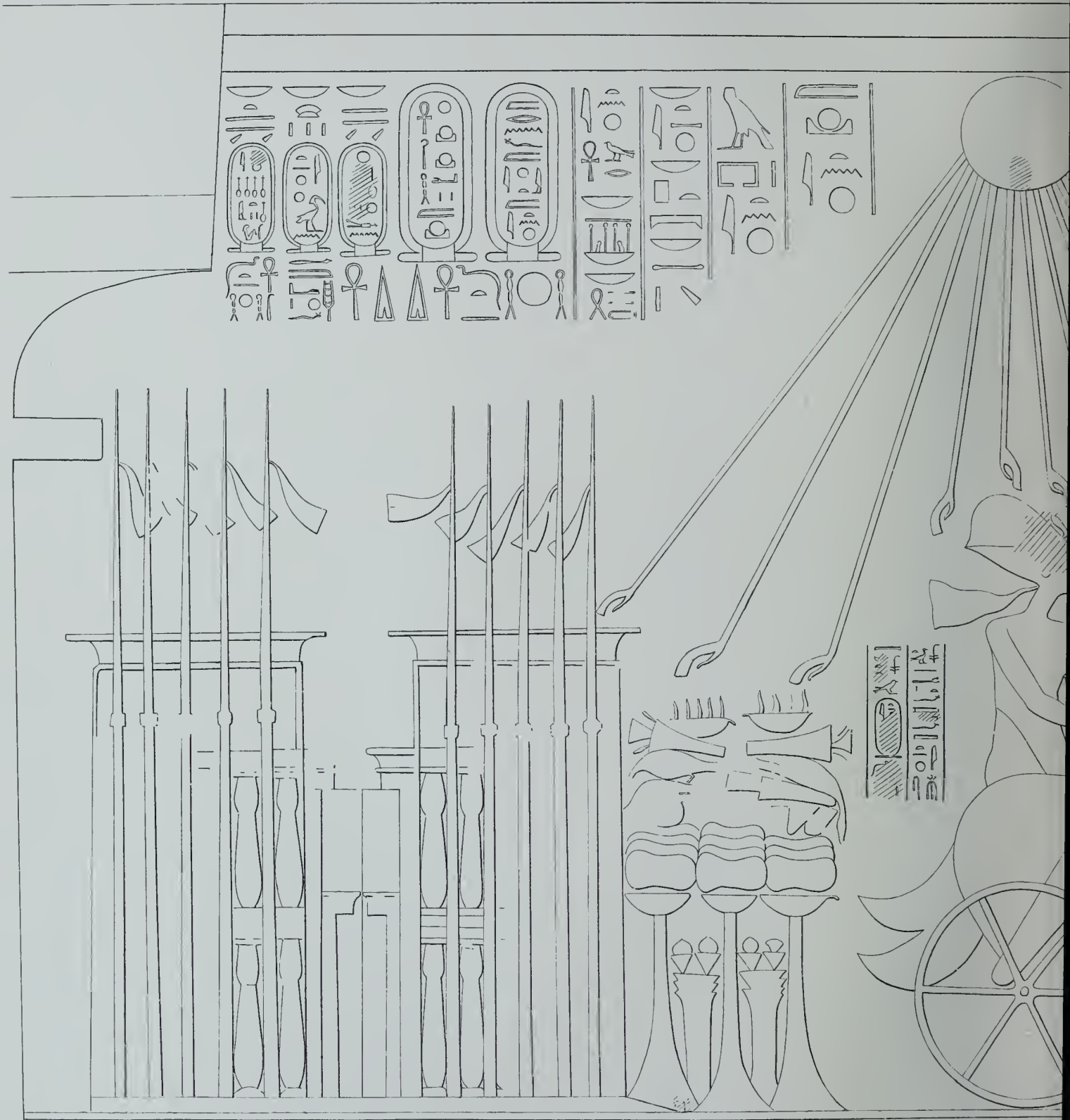

THE ROYAL CHARIOT

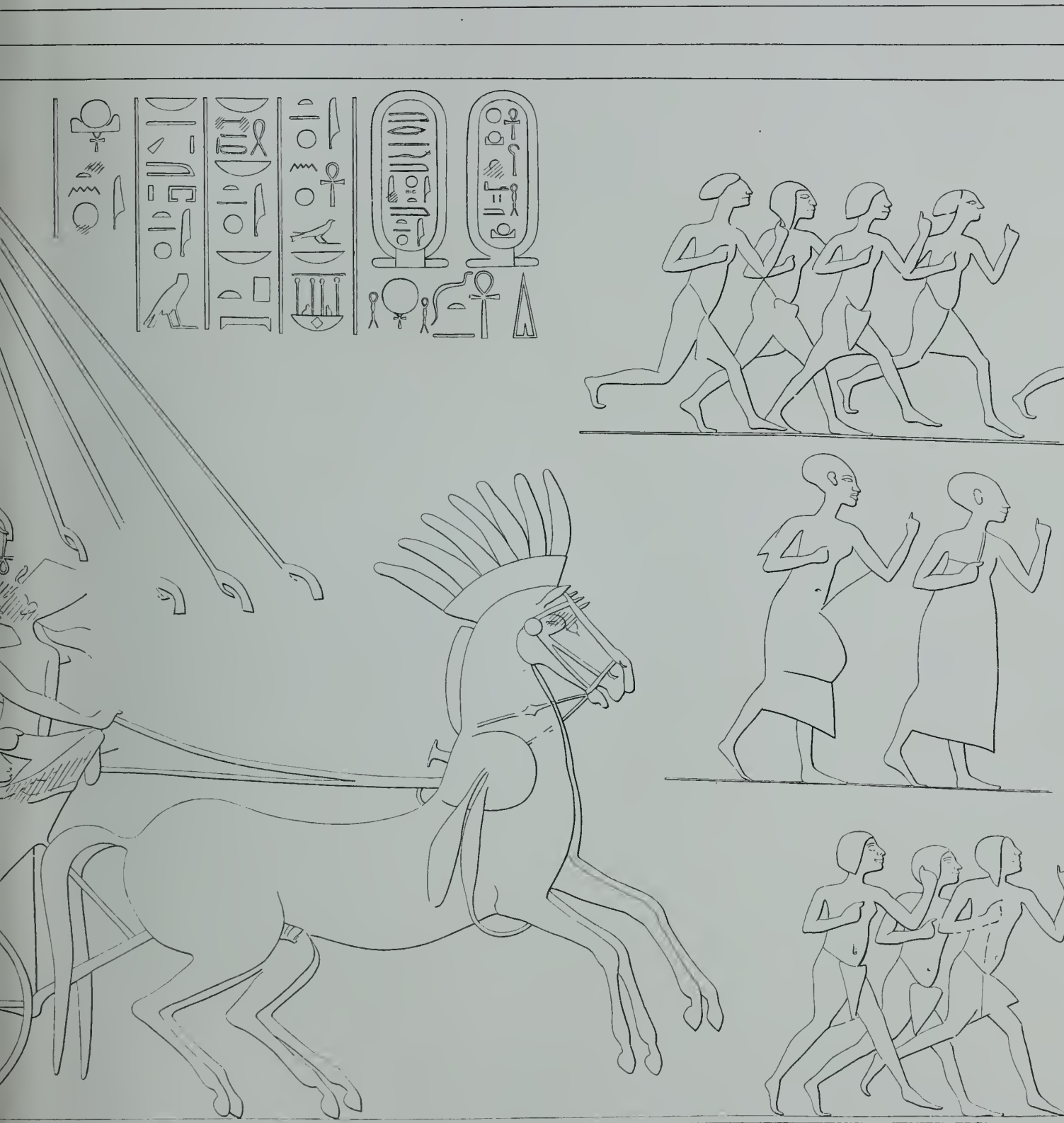

Plate XXI

c

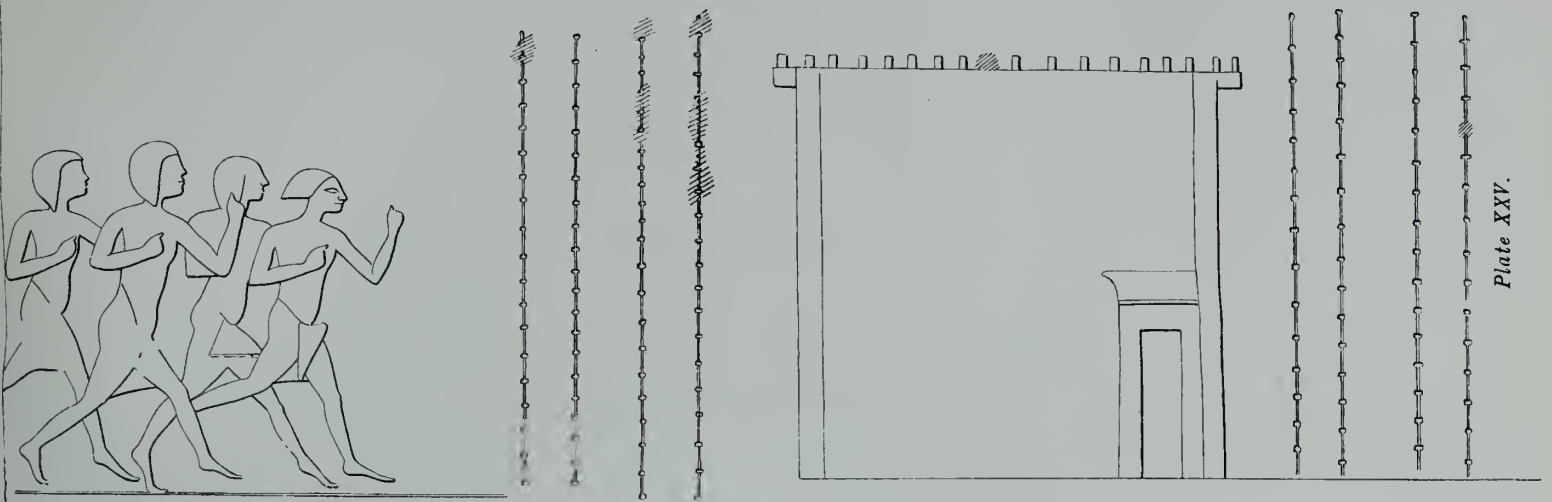
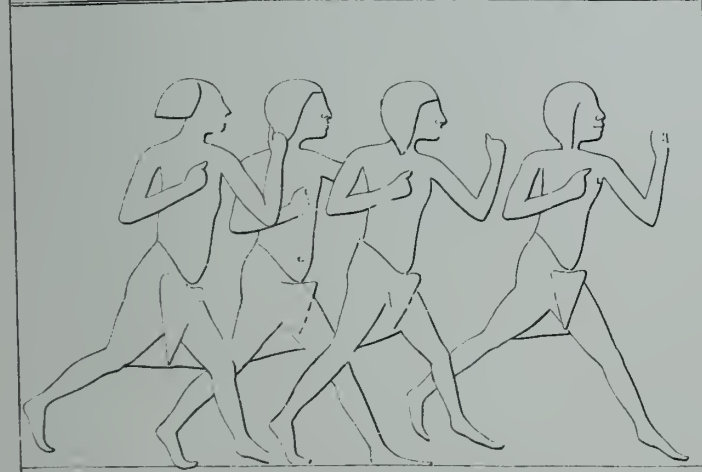
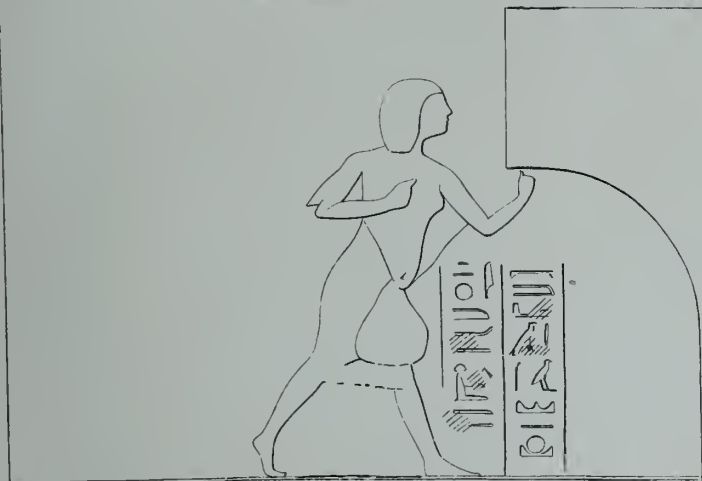

Plate XXV.

d

Completion of Plate XX.



a

b

Completion of Plate XXII.

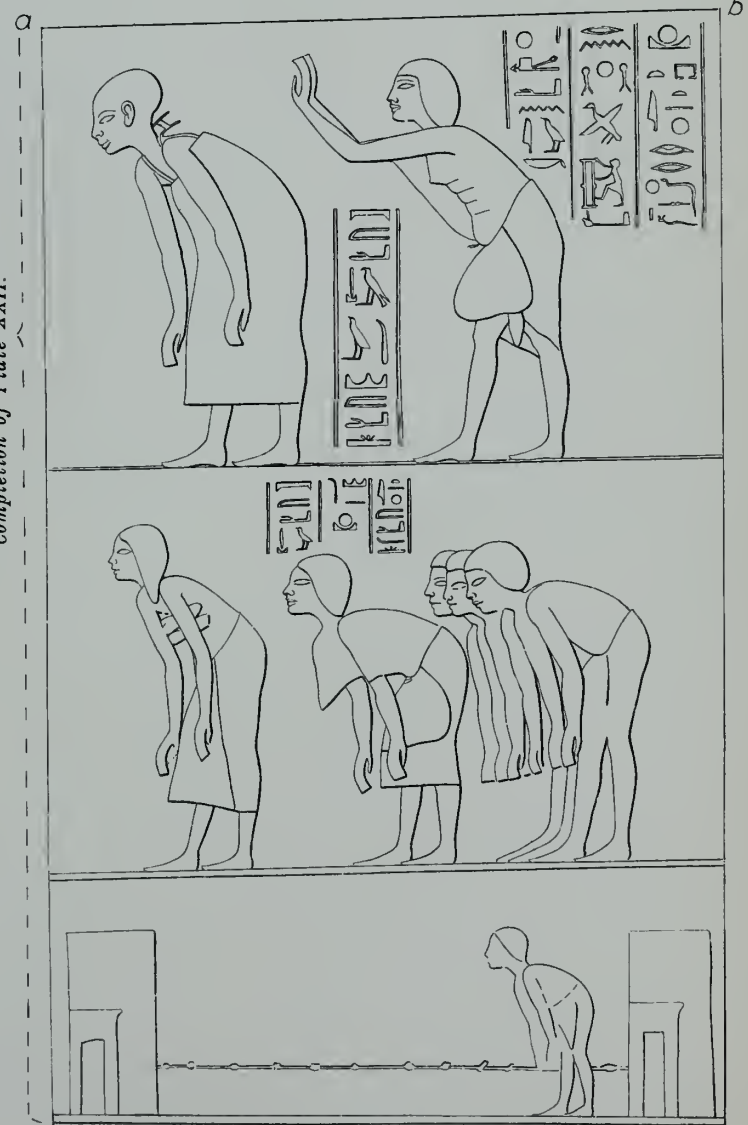

b

Scale $\frac{1}{6}$

(Completion of Scenes on Pls. XX, XXII).

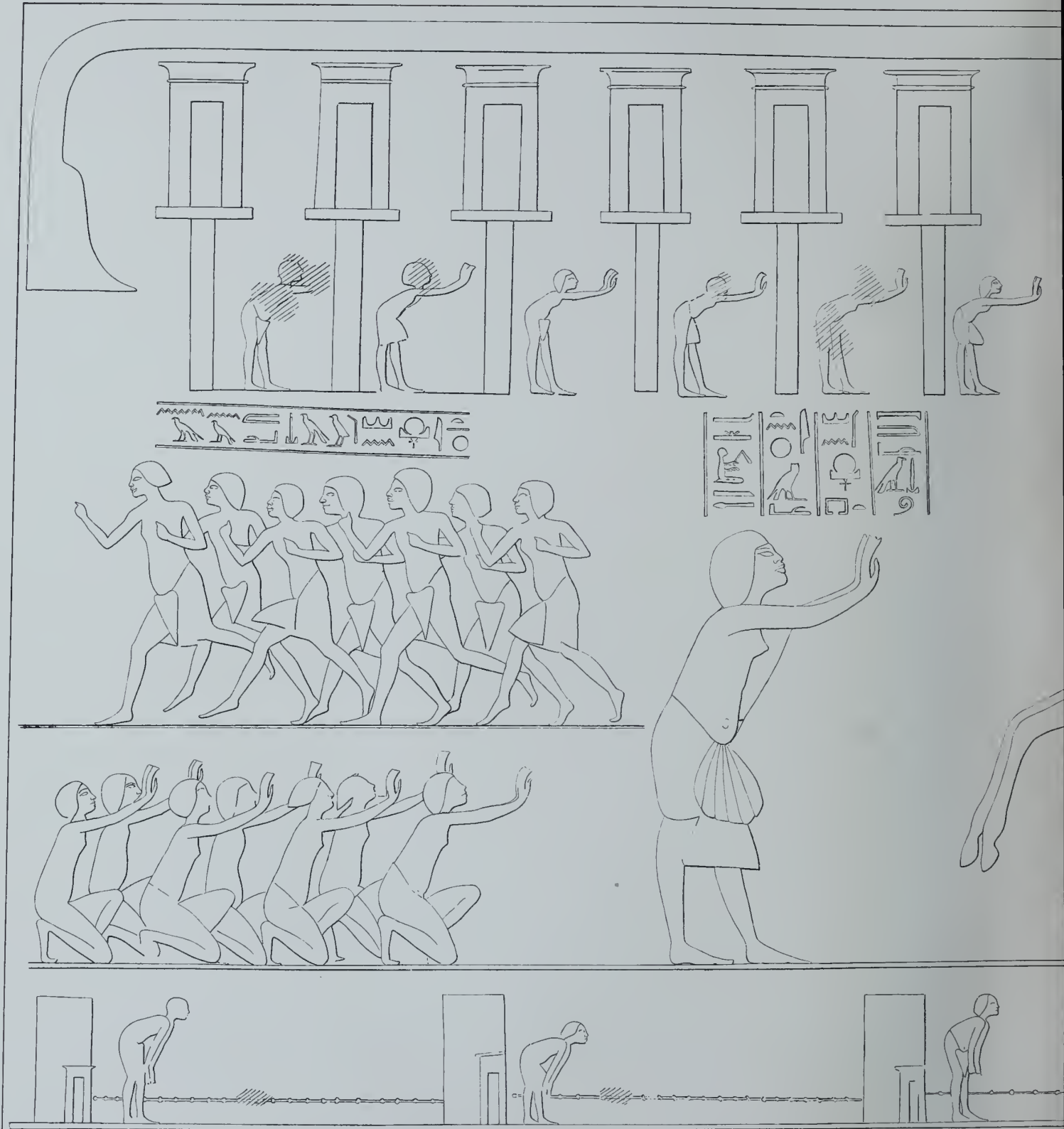

Scale $\frac{1}{6}$

THE ROYAL CHARIOT

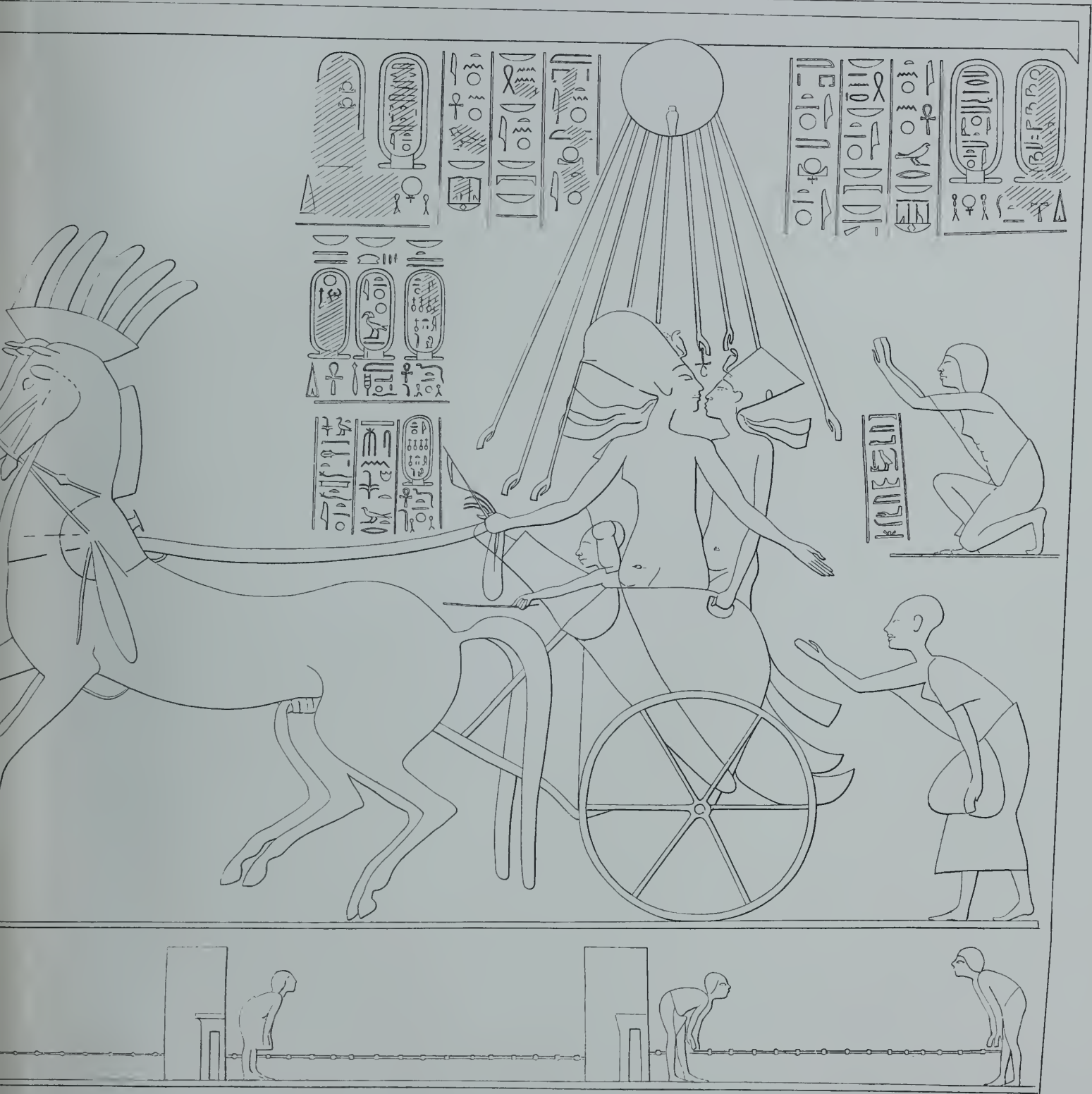

SSING THE SENTRIES.

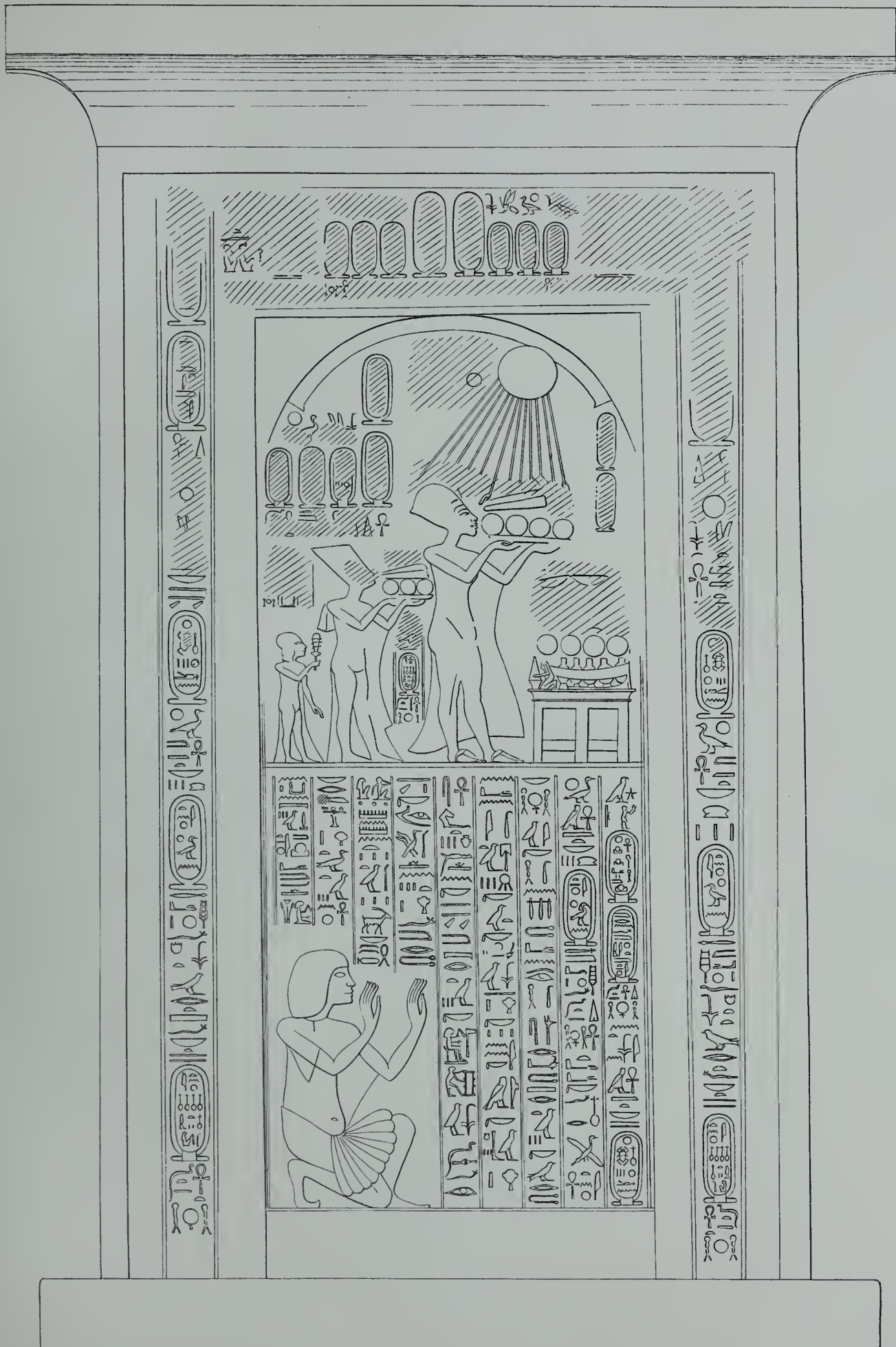

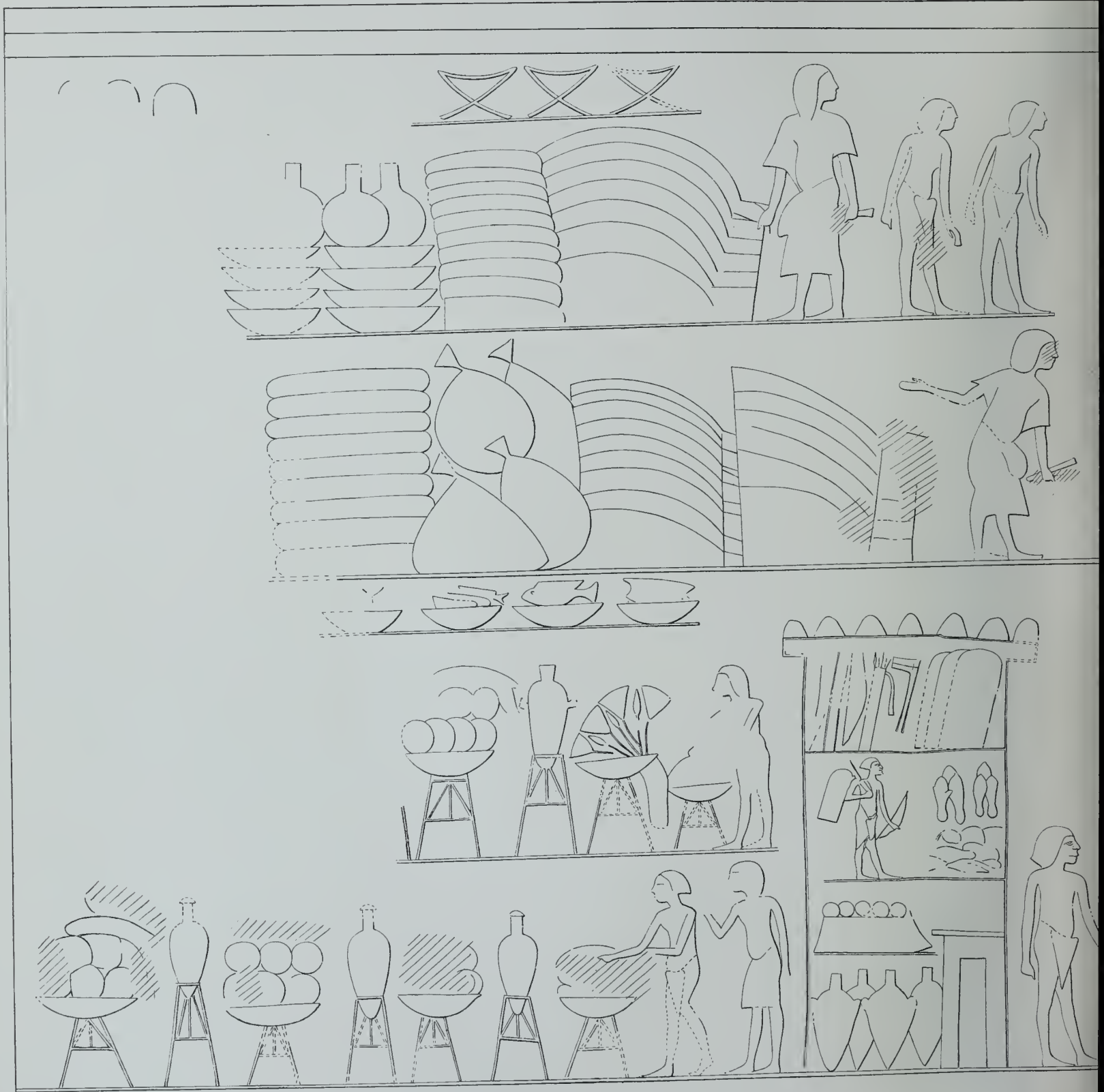

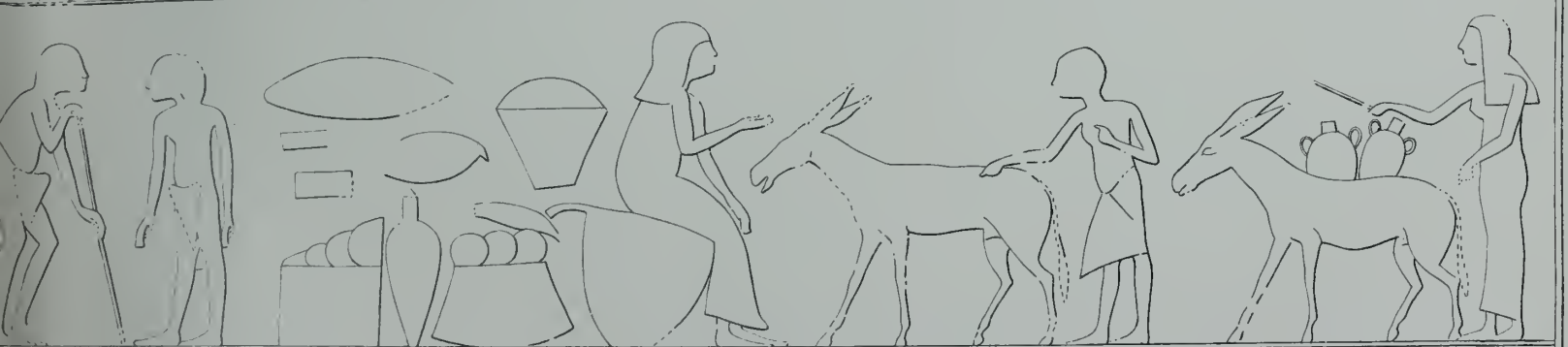
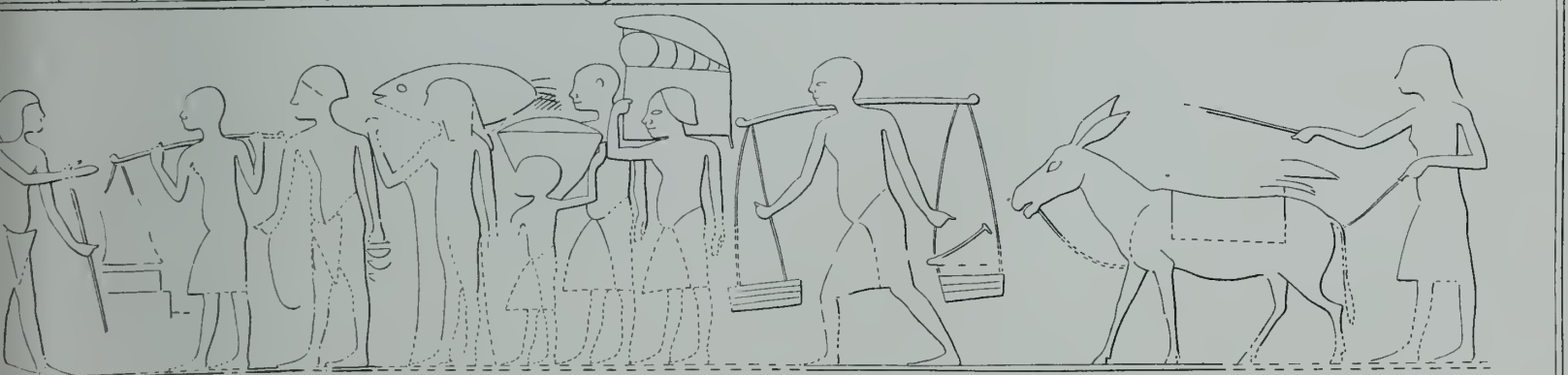

c

Plate XXI.)

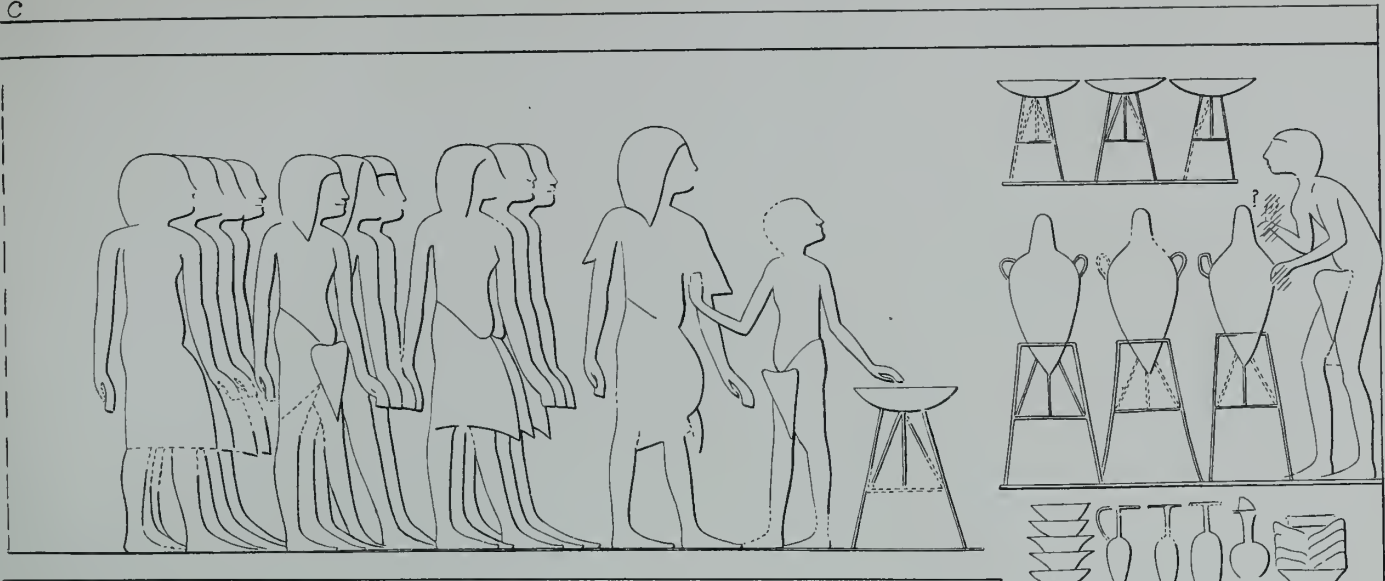

d

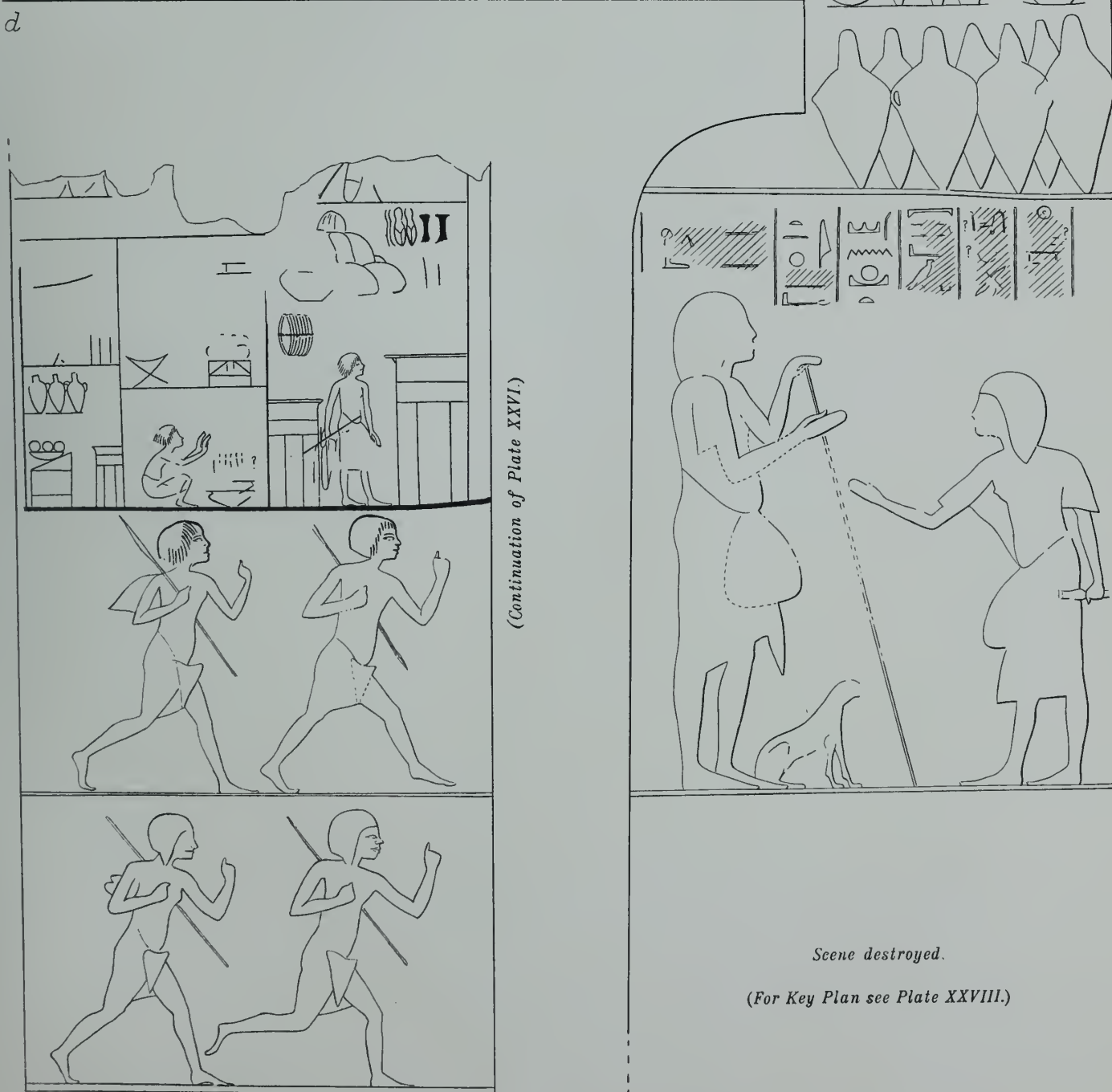

(Continuation of Plate XXVI.)

(Continuation of Plate XXIV.)

Scene destroyed.

(For Key Plan see Plate XXVIII.)

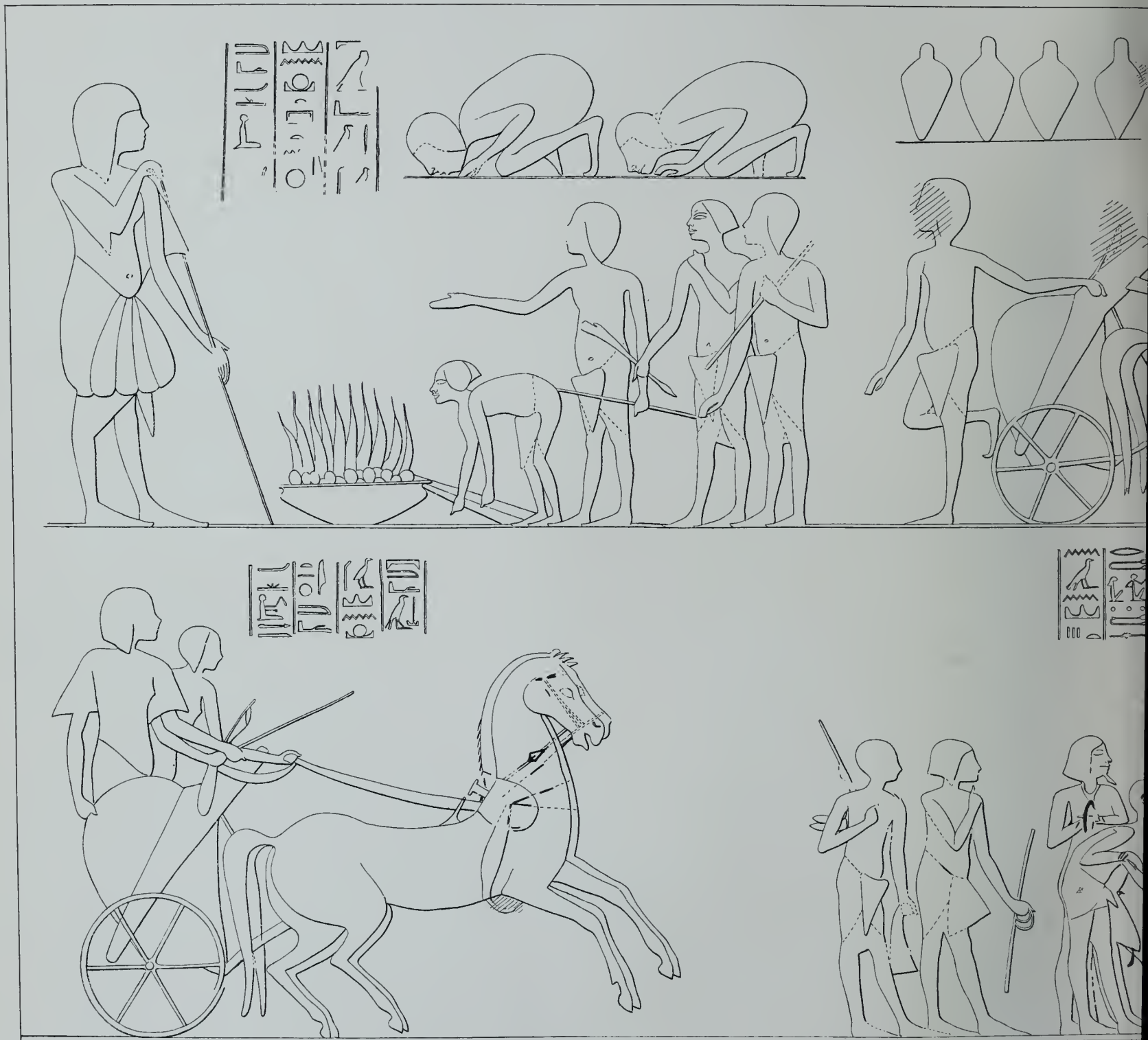

MAHU BRINGS PRISONERS

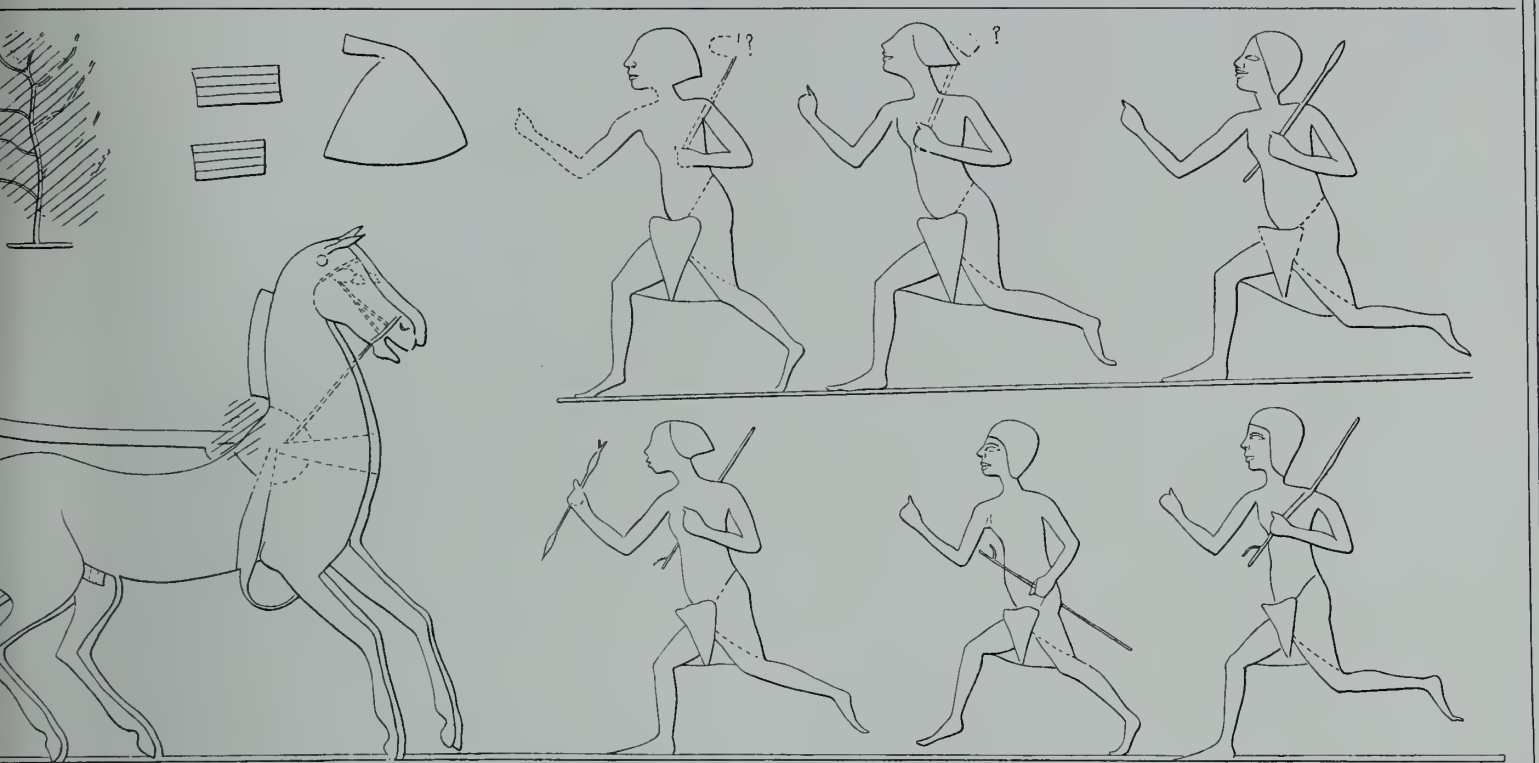

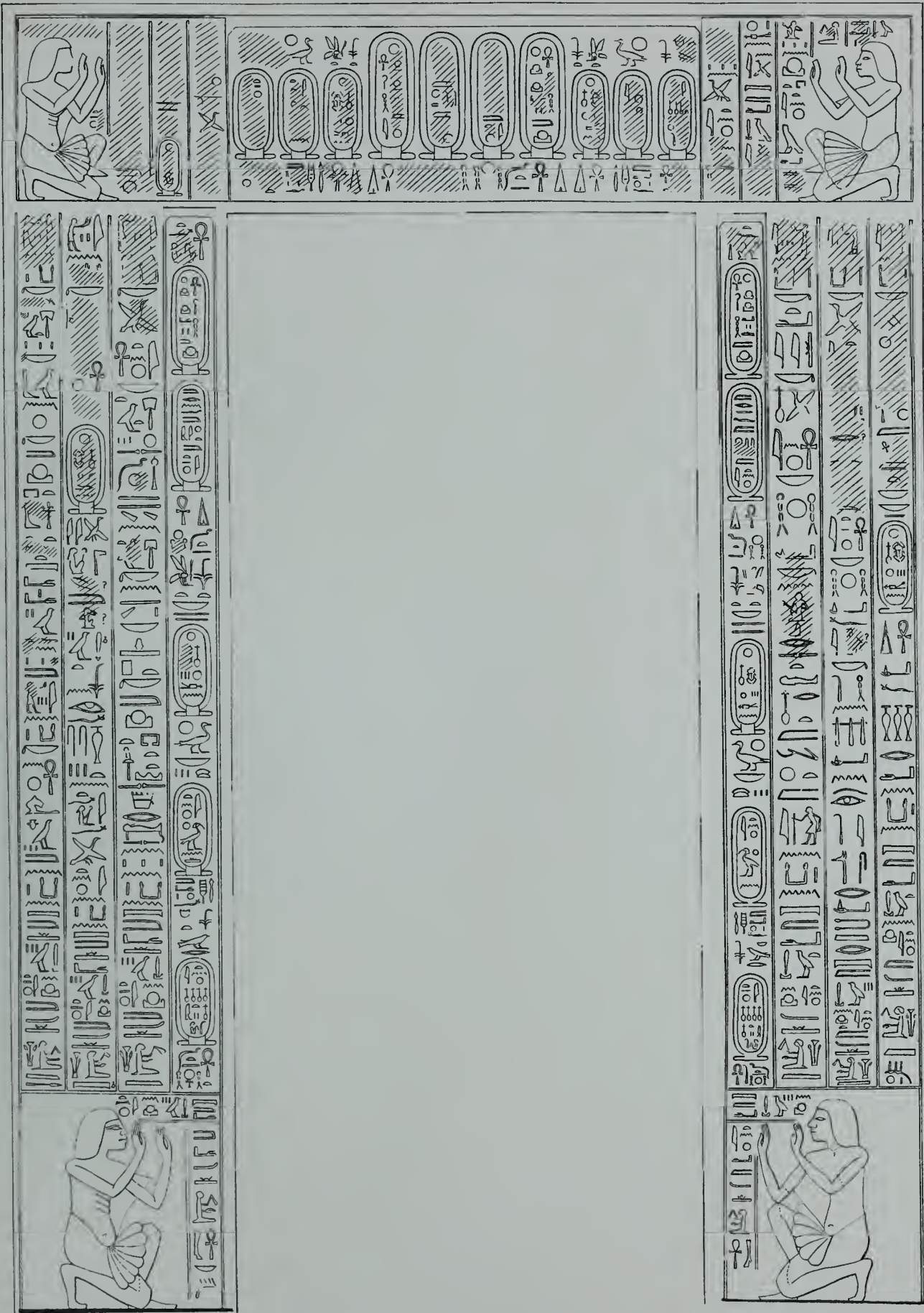

DOORWAY TO INNER ROOM.

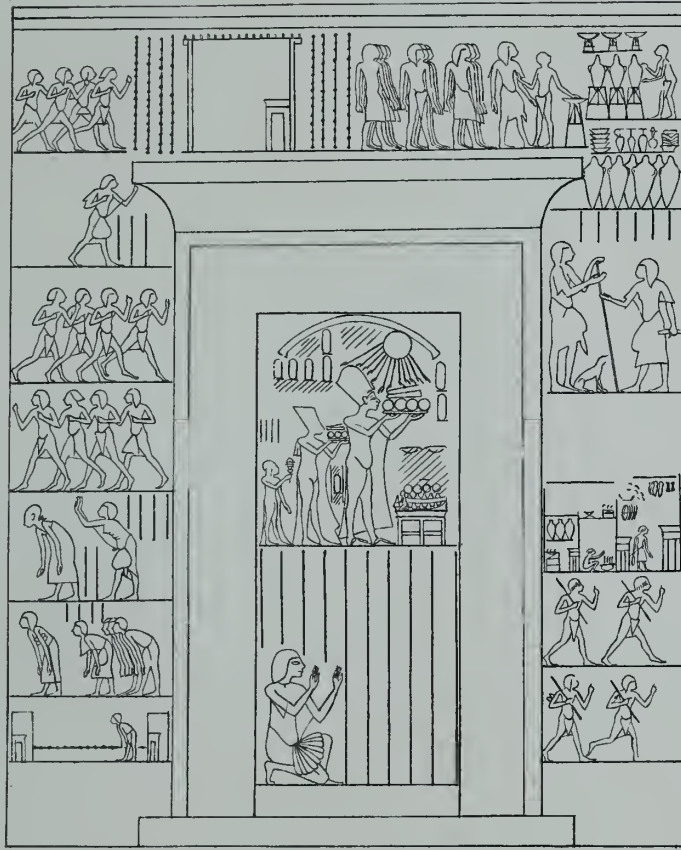
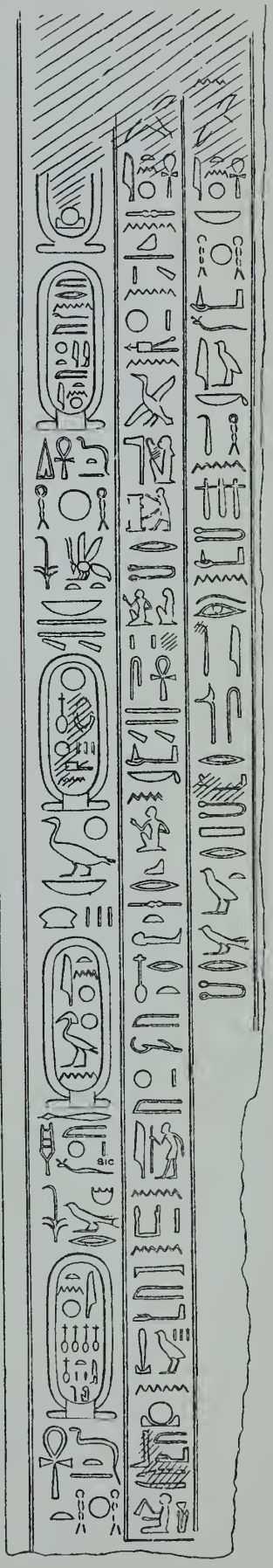
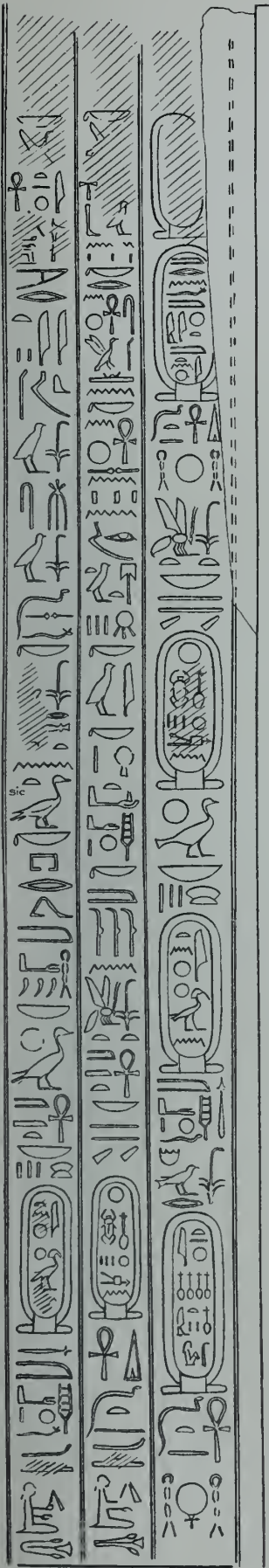

Scale $\frac{1}{25}$

KEY TO SOUTH END WALL.

Scale $\frac{1}{8}$



Scale $\frac{1}{8}$ FIGURE OF MAHU (S. Thickness)

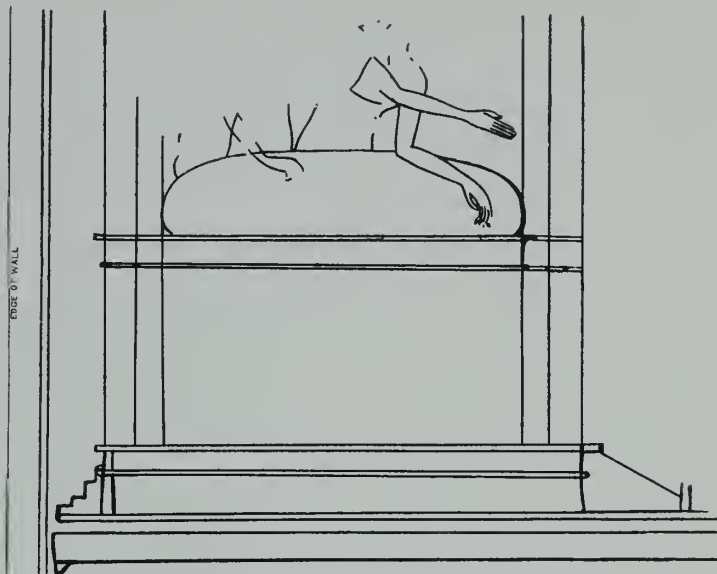

Scale $\frac{1}{8}$ THE PALACE BALCONY (Front Wall, N. Side)



Scale $\frac{1}{4}$ HEAD OF QUEEN (See Plate XVI.)

PLATE XV



Scale $\frac{1}{8}$ THE PRAYER OF MAHU (North Thickness)

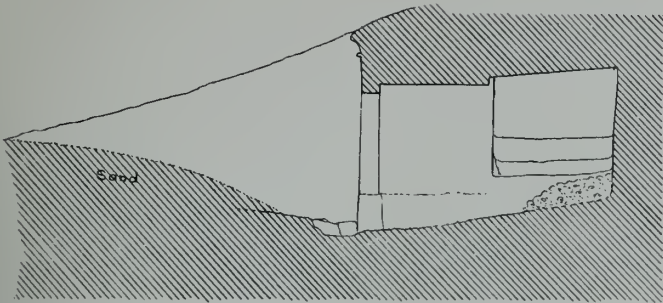

TOMB 9A—SECTION.

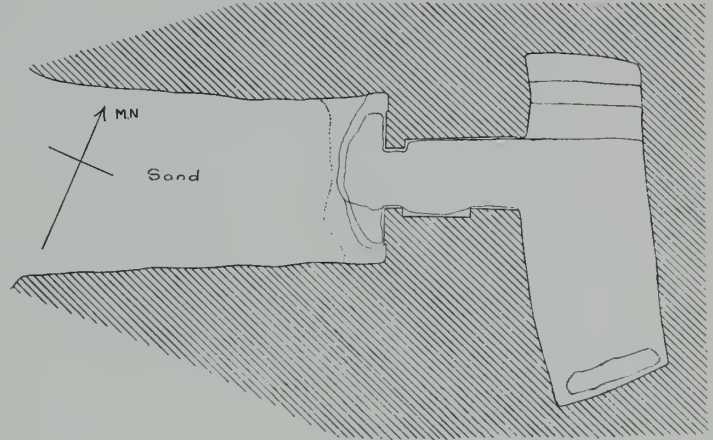

TOMB 9A—PLAN.

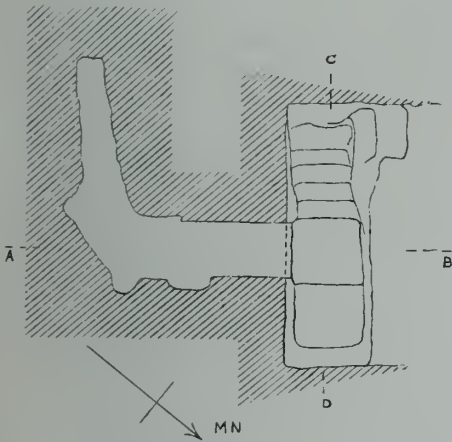

TOMB 9c—PLAN.

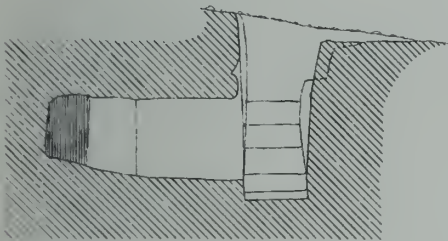

TOMB 9c—SECTION ON A.B.

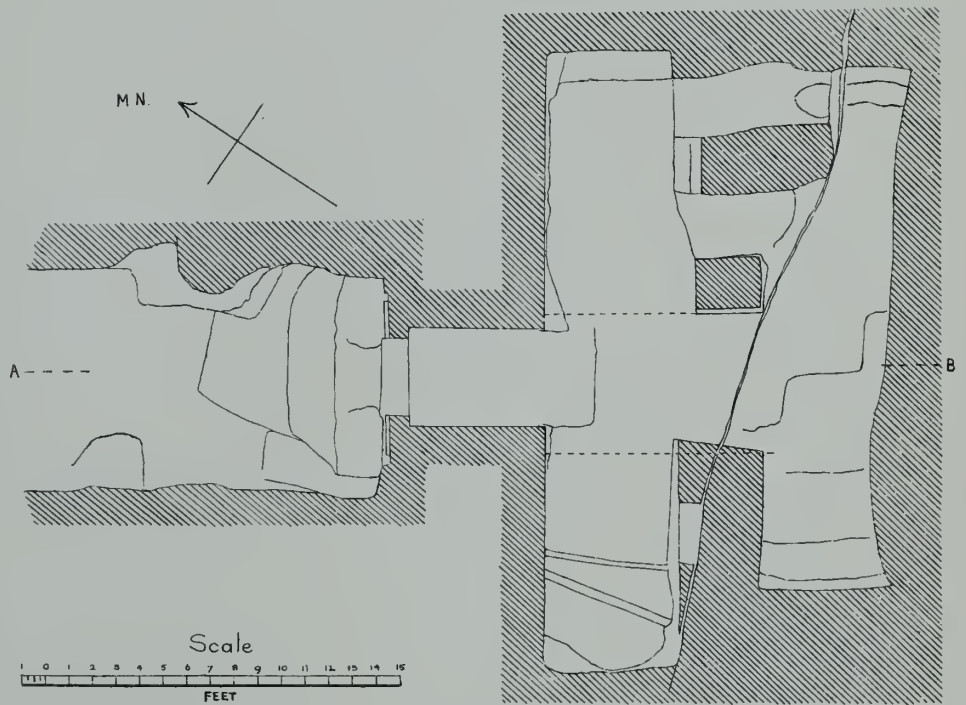

TOMB 10—PLAN.

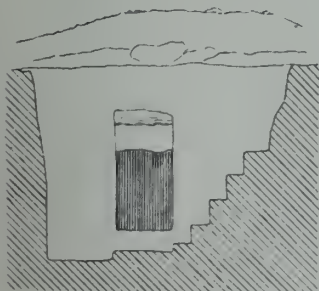

TOMB 9c—SECTION ON C.D.

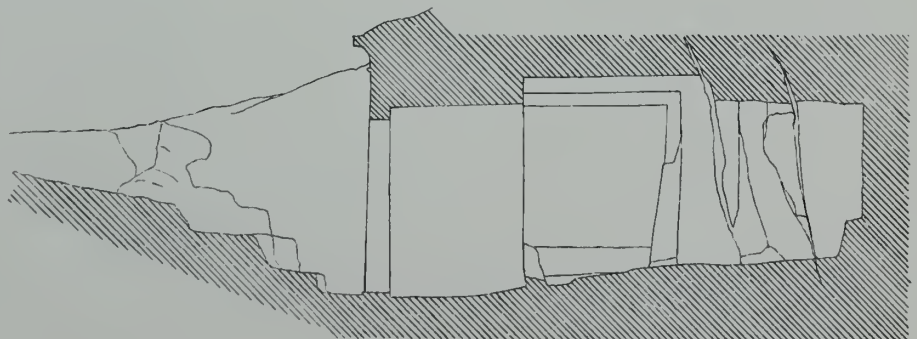

TOMB 10 (APY)—SECTION ON A.B.

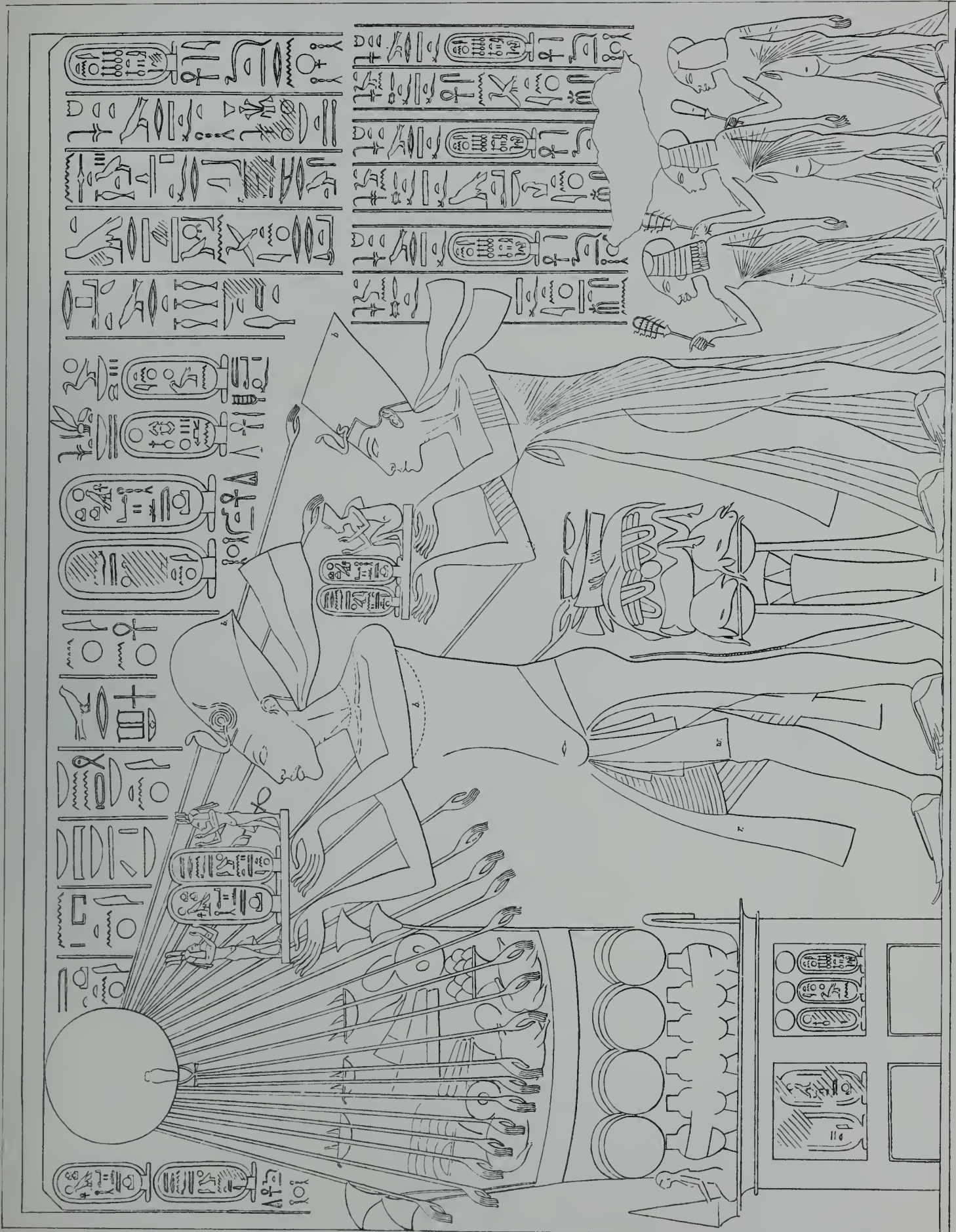

THE ROYAL FAMILY MAKE VOTIVE OFFERINGS TO THE SUN.

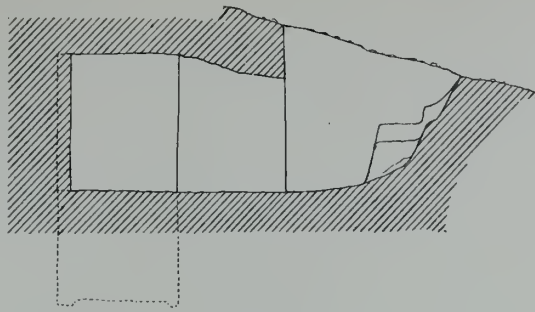

TOMB 9B-SECTION.

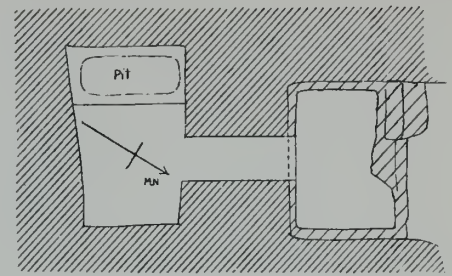

TOMB 9B-PLAN.

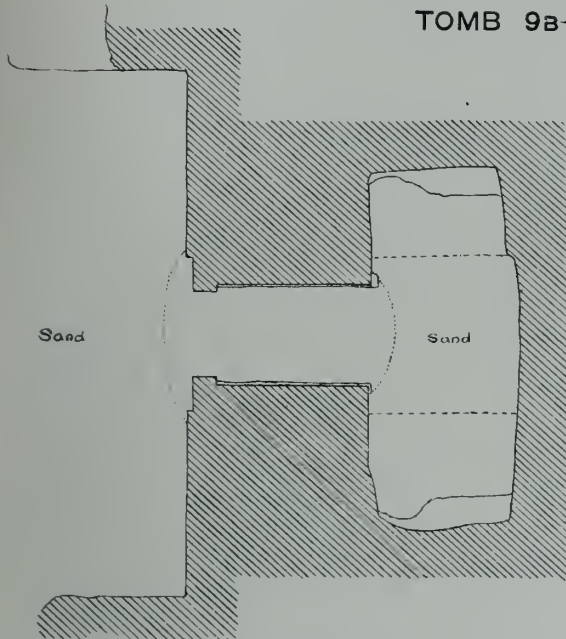

TOMB 7A-PLAN.

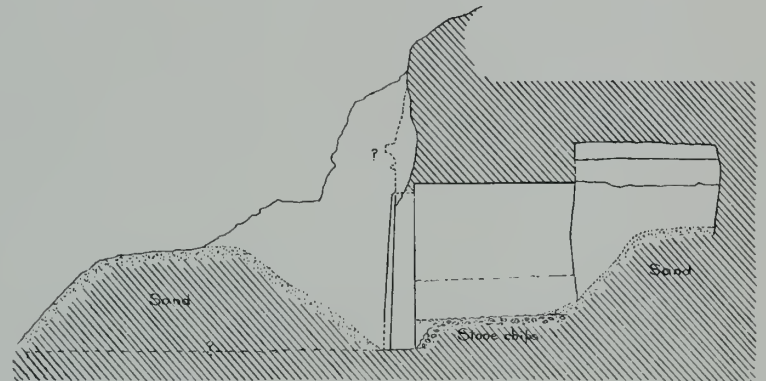

TOMB 7A-SECTION.

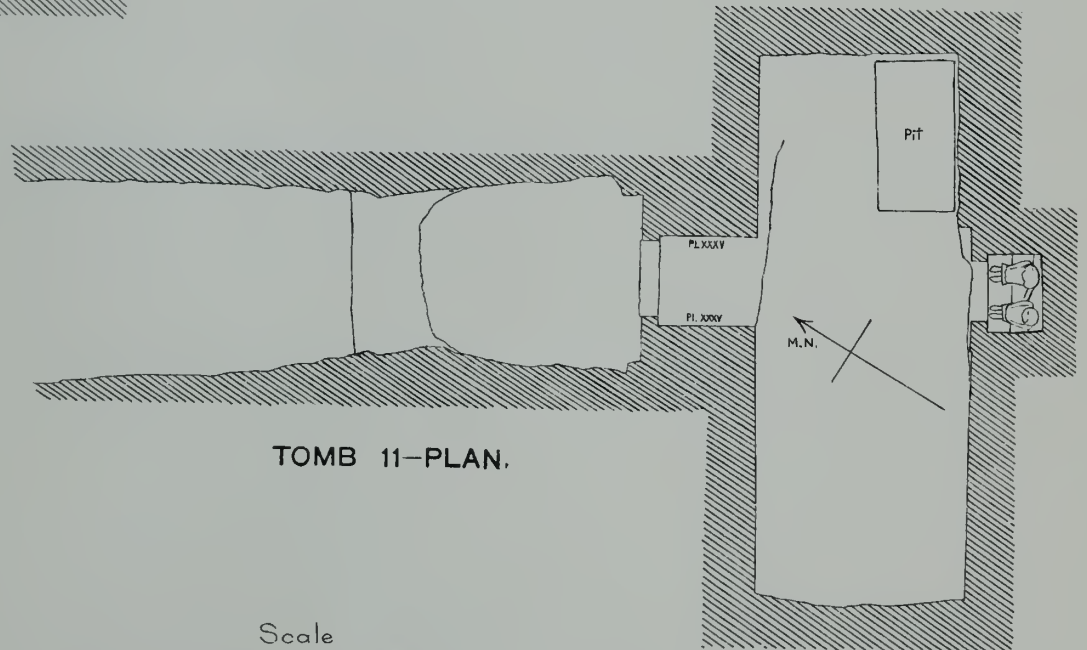

TOMB 11-PLAN.

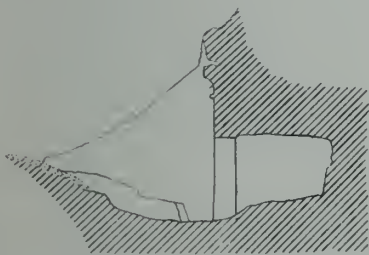

TOMB 7B-SECTION.

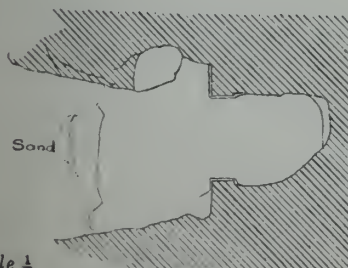
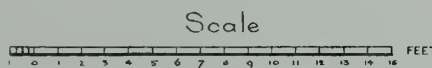

Scale $\frac{1}{96}$

TOMB 7B-PLAN.

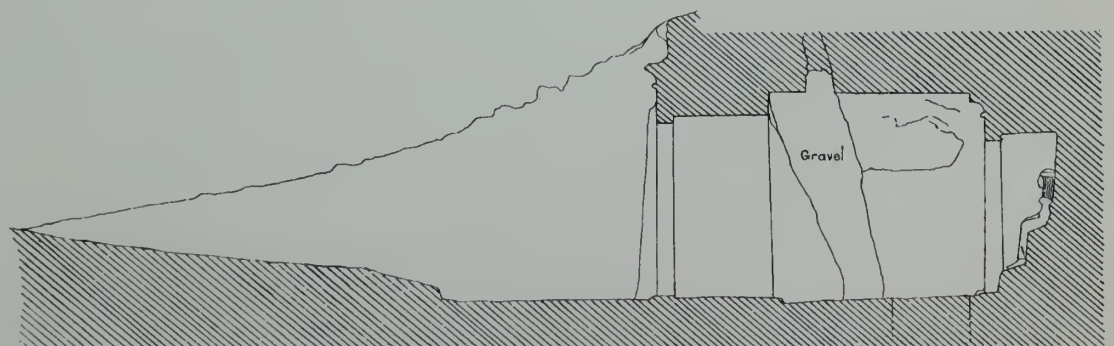

TOMB 11-SECTION.

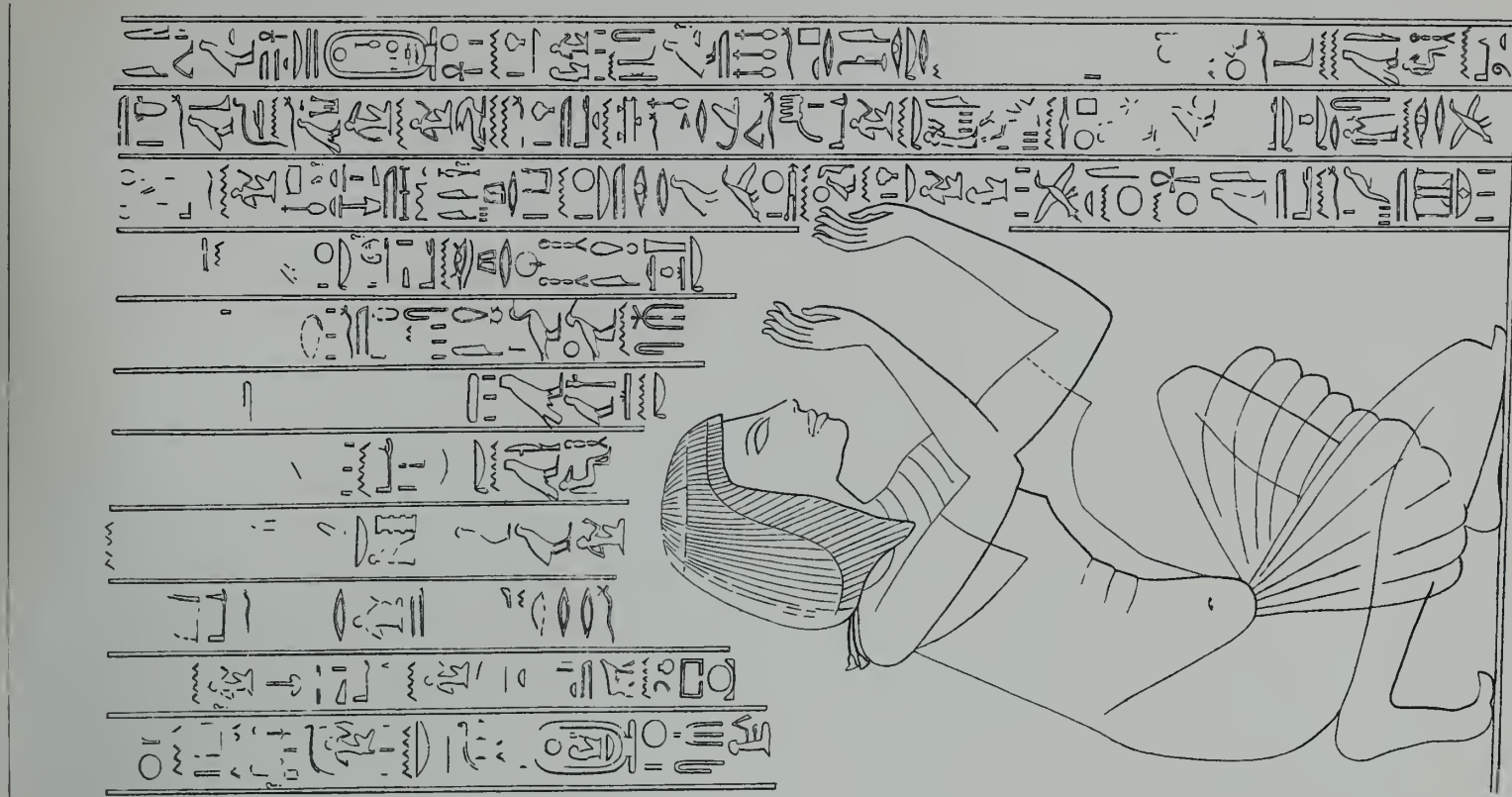

THE PRAYER OF RAMES.

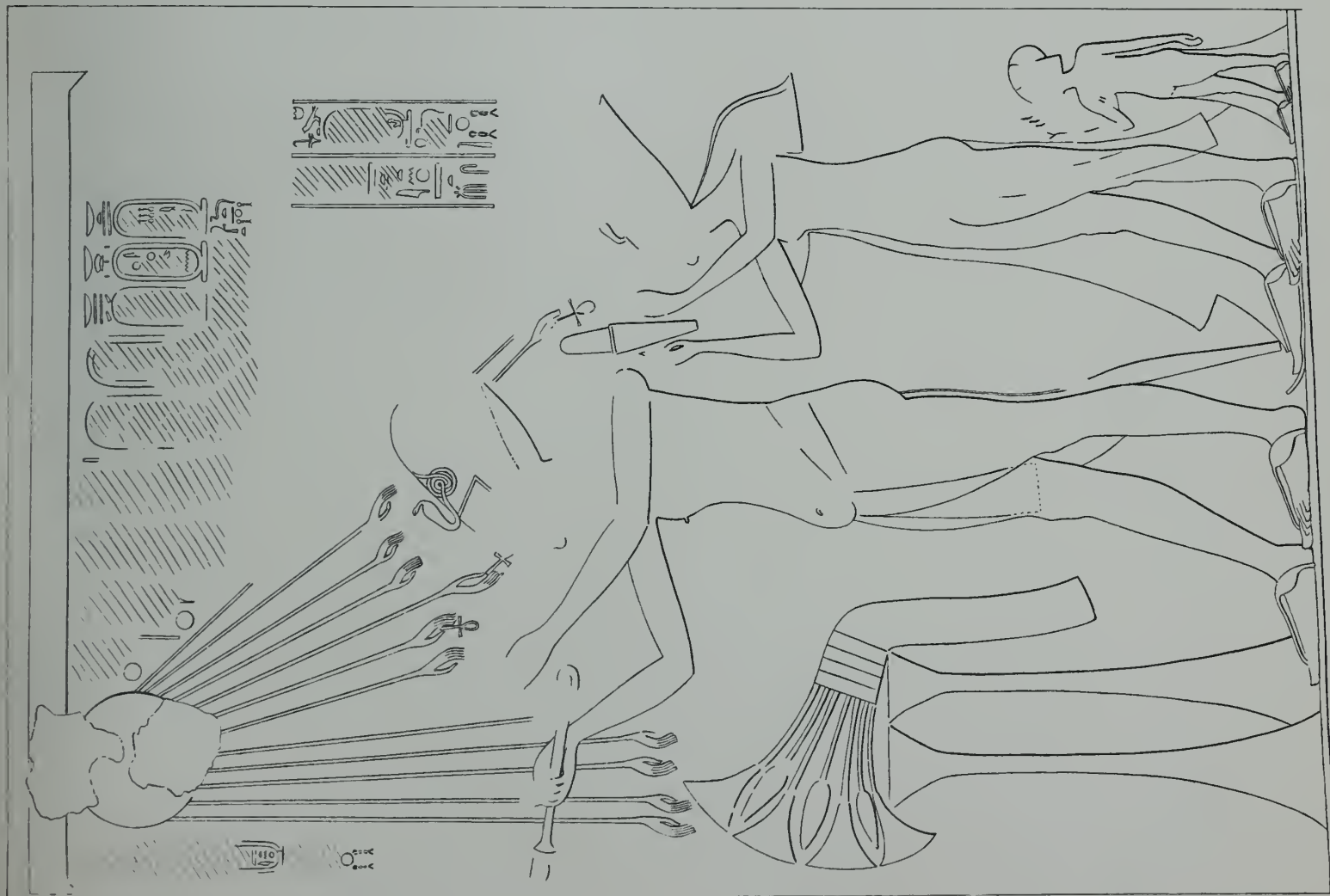

THE ROYAL FAMILY.

Scale 1/3

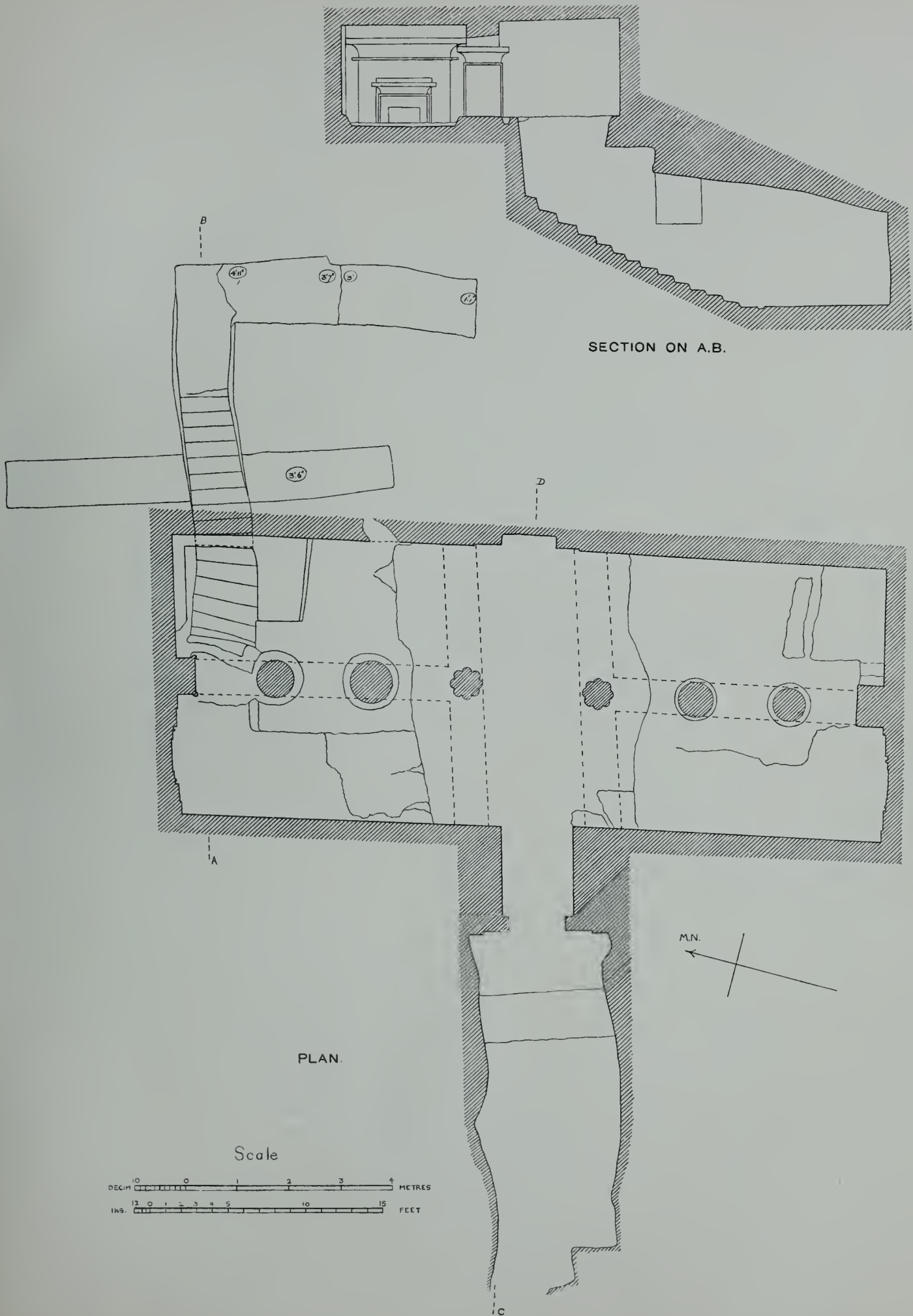

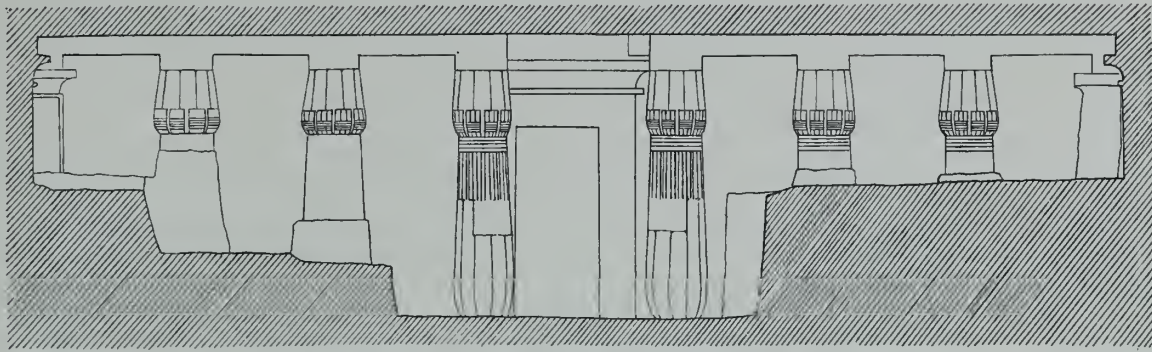

LONGITUDINAL SECTION
(looking East).

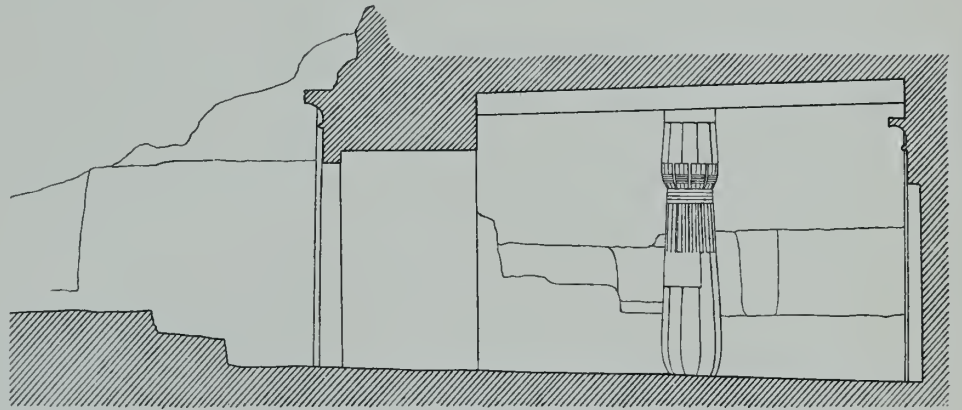

Scale $\frac{1}{96}$

SECTION ON C.D.

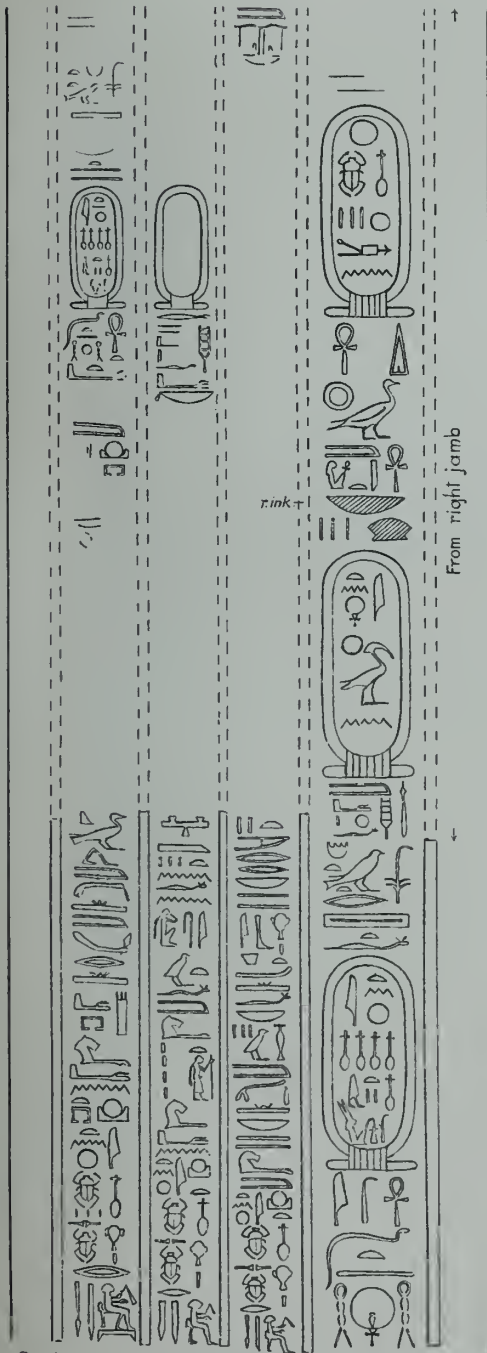

Scale $\frac{1}{8}$

EXTERIOR, LEFT JAMB.

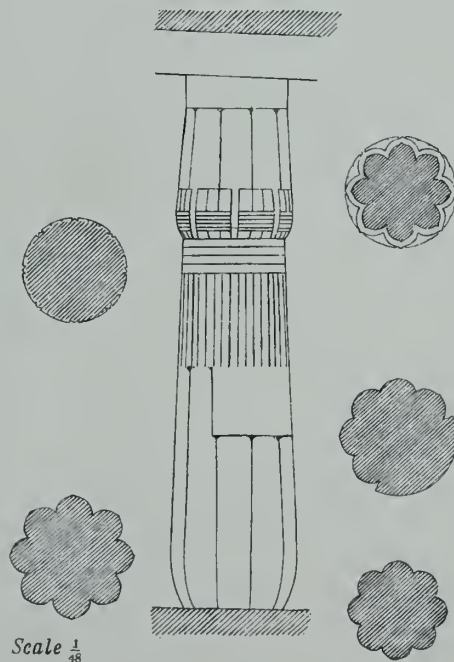

Scale $\frac{1}{48}$

S. COLUMN, N. SIDE.

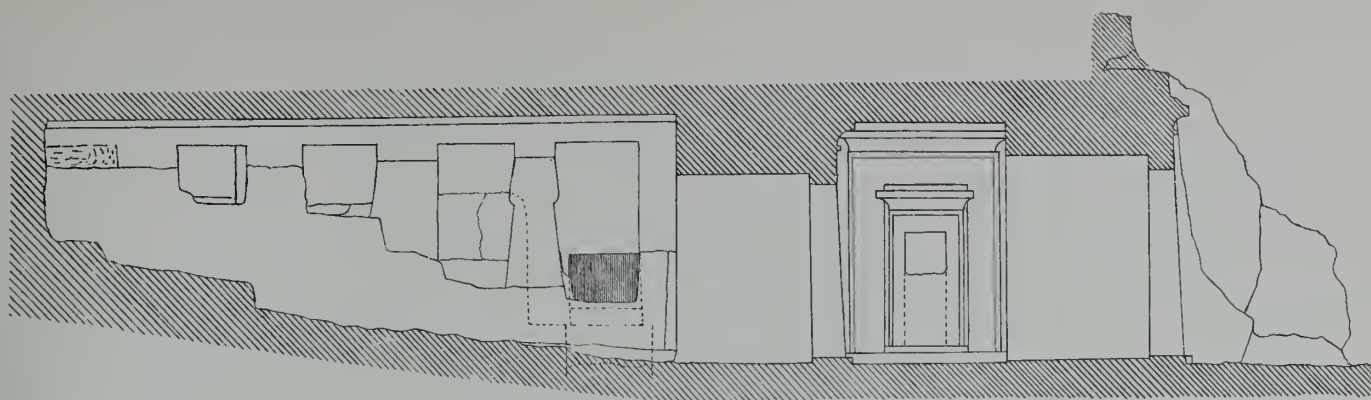

LONGITUDINAL SECTION.

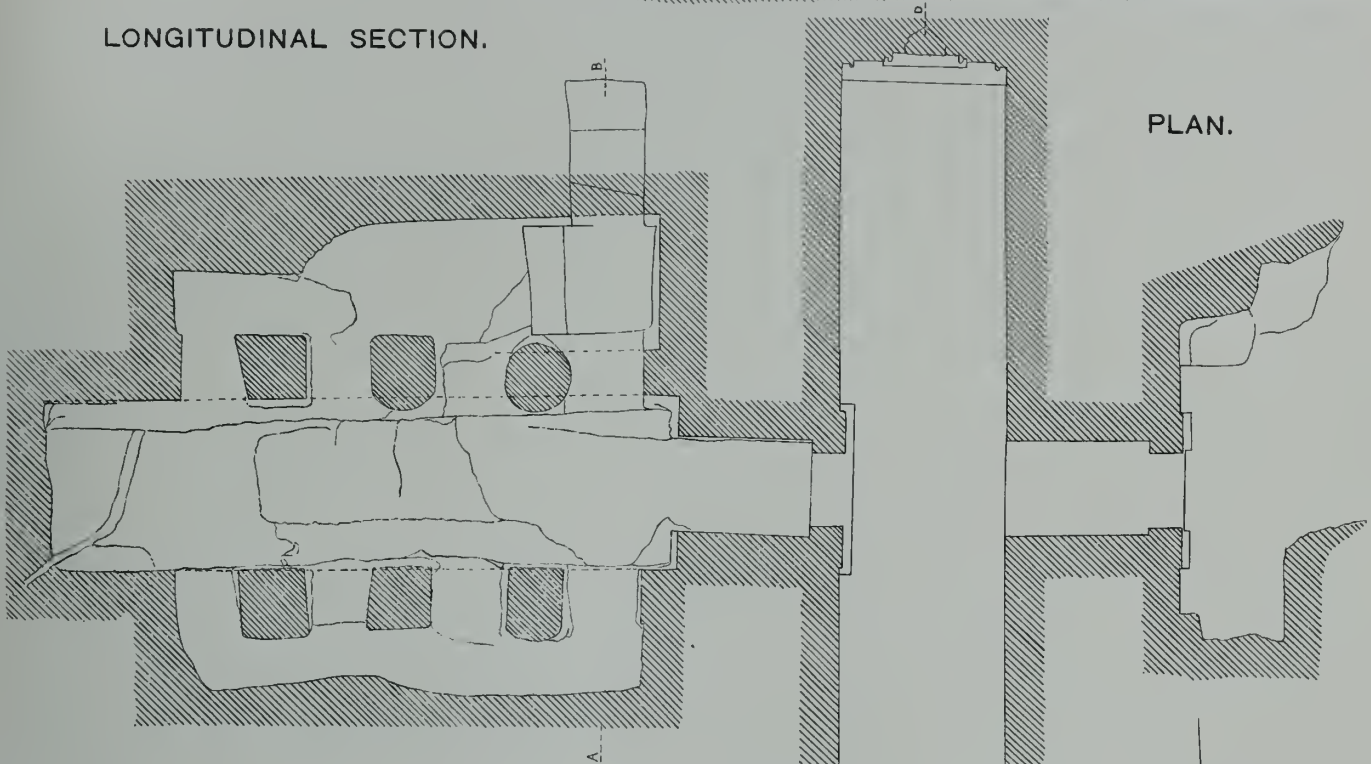

PLAN.

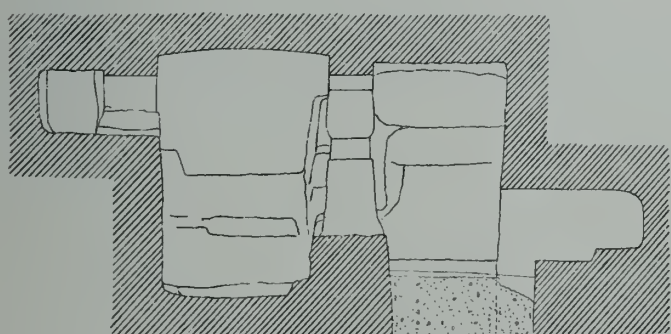

SECTION ON A.B.

SECTION ON C.D.

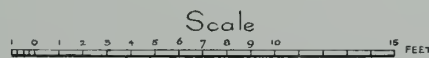
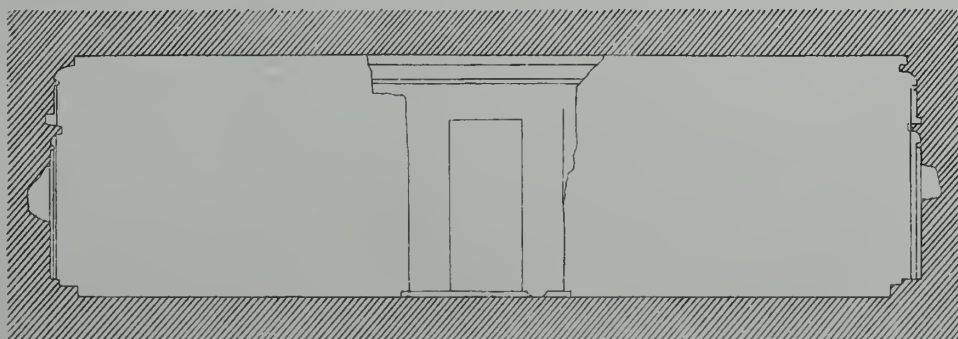



THE SENTRIES



ENTRANCE — LEFT WALL



MAHU AND THE CITY OFFICIALS



THE ROYAL FAMILY DRIVING OUT



CHARIOT (Ink design)

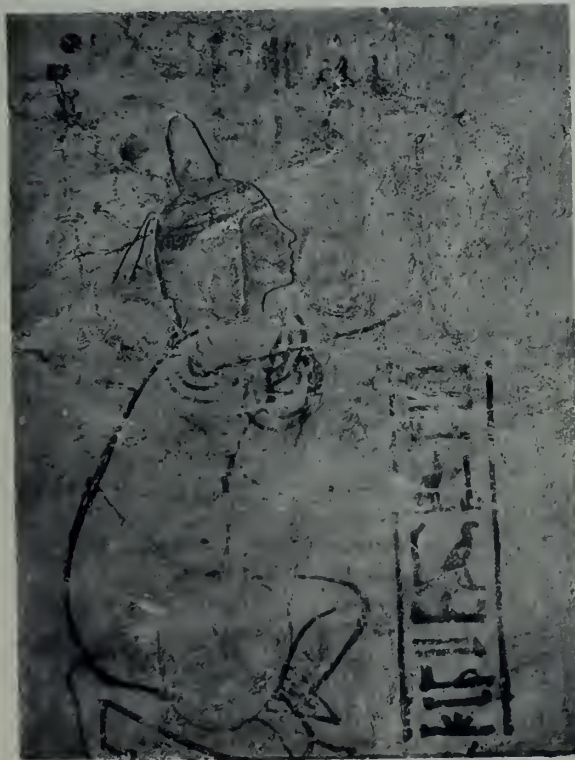

MAHU (Plate XVIII)



NEFERTITI (Plate XVI)



TOMB 13 — INTERIOR

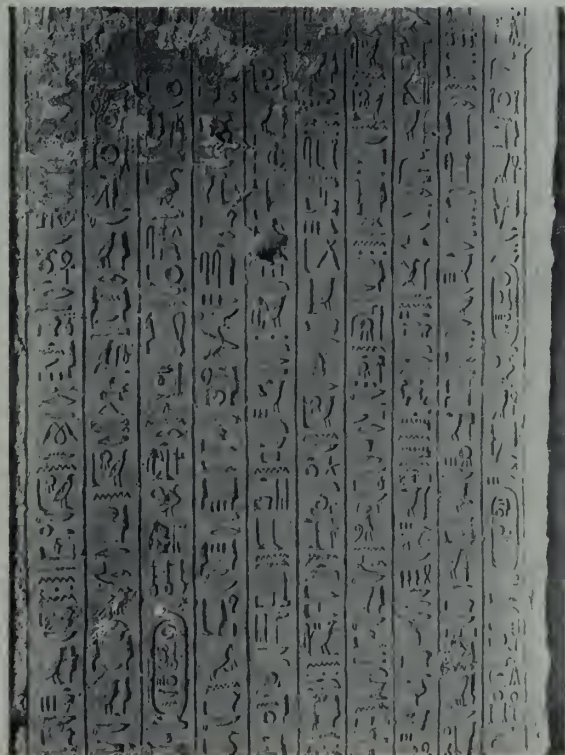

APY — HYMN TO ATEN



TOMB 13 — EXTERIOR

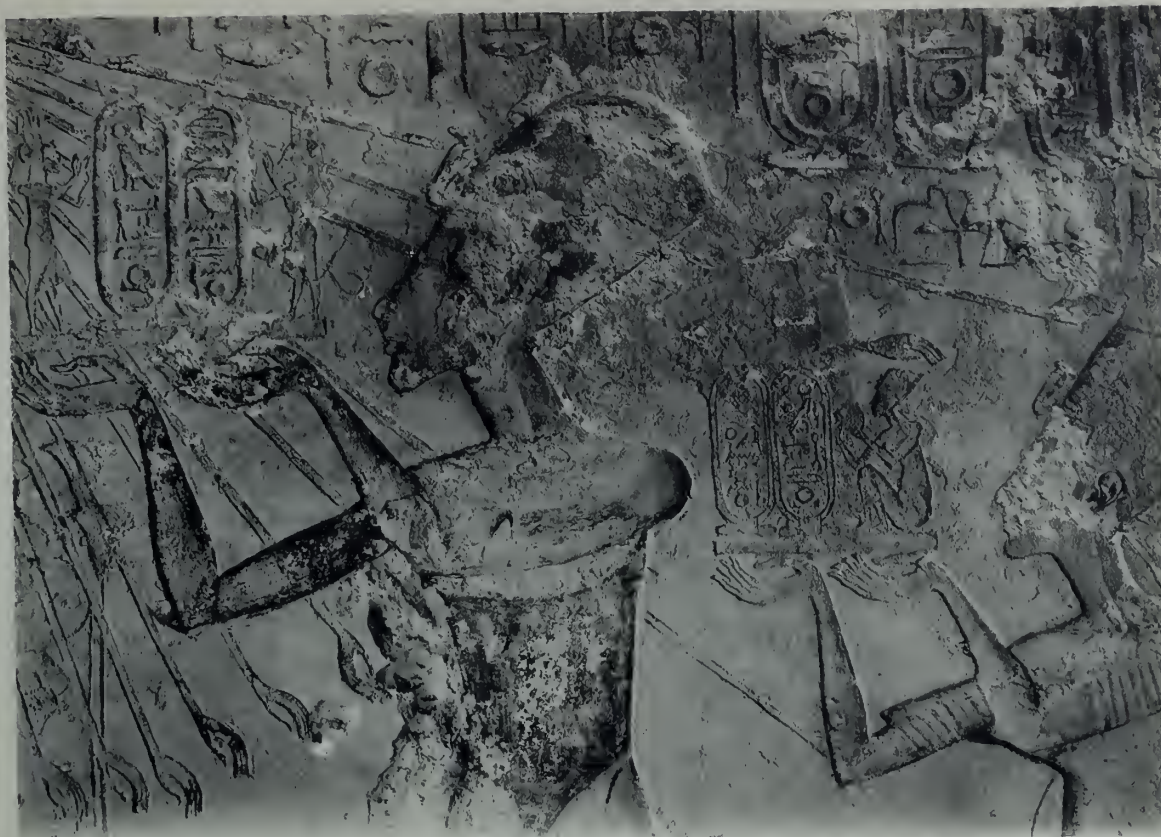

THE VOTIVE PIECES



THE ROYAL FAMILY

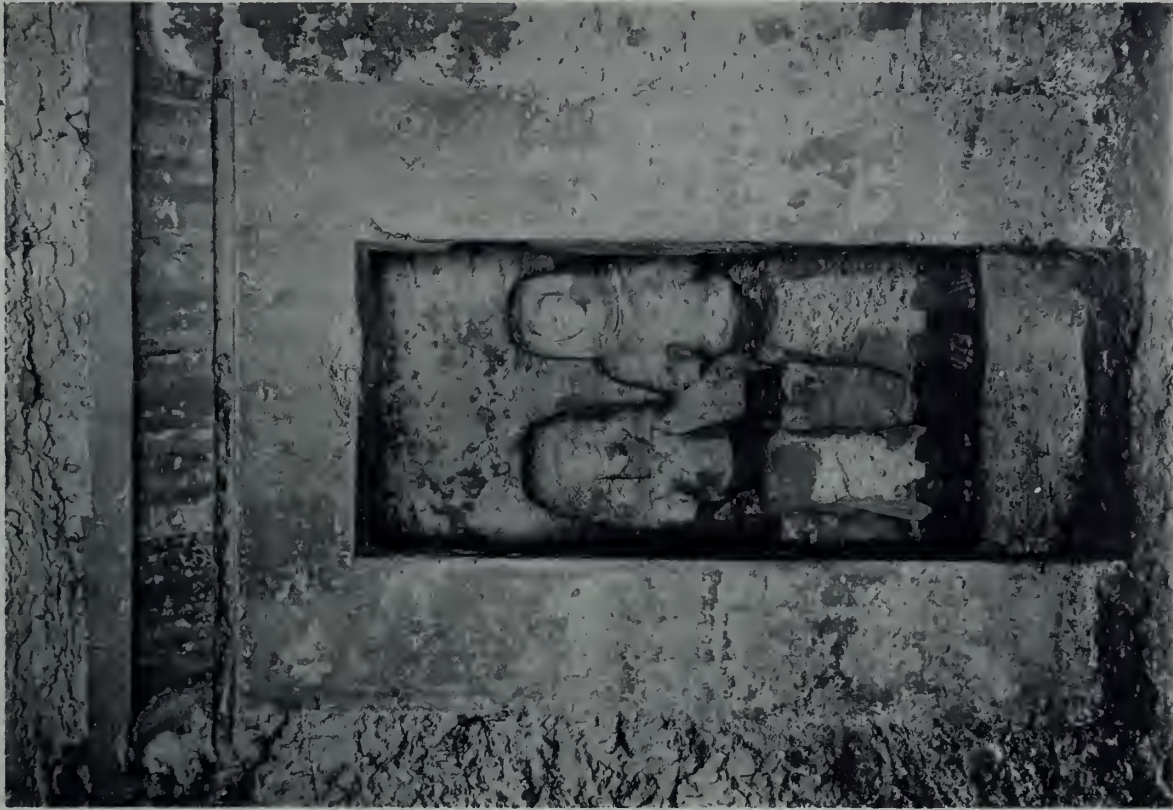

RAMES AND HIS WIFE



RAMES AT PRAYER

CIRCULATE AS MONOGRAPH

DT Egypt Exploration Society.
57 Archaeological Survey of
E326 Egypt
no.16 Memoir

34

CIRCULATE AS MONOGRAPH

**PLEASE DO NOT REMOVE
CARDS OR SLIPS FROM THIS POCKET**

UNIVERSITY OF TORONTO LIBRARY
