

Historic, Archive Document

Do not assume content reflects current scientific knowledge, policies, or practices.



CONTENTS

MAY, 1918

Honey Markets.....	260
Editorials.....	267-269
How to Unite—Spring and Fall.....	C. C. Greiner 270
Not All Italian Queens Good.....	Earl C. Walker 272
Importance of May Work.....	Editor 273
Conversations With Doolittle.....	G. M. Doolittle 276
Succeeds With Comb Foundation.....	Harry T. Huff 277
Good Italian Stock Will Do It.....	E. S. Miller 277
Package Bee Experience.....	F. W. Redfield 278
Beekeepers' Bookkeeping.....	C. R. Parks 278
Nuclei—Not Pound Packages.....	N. T. Spangler 280
Stray Straws.....	Dr. C. C. Miller 281
Siftings.....	J. E. Crane 283
Our Food Page.....	Stancy Puerton 284
Beekeeping as a Side Line.....	Grace Allen 286
From North, East, West, and South.....	Department Editors 288
Heads of Grain from Different Fields.....	293
Bees, Men and Things.....	298
Gleaned by Asking.....	E. R. Root 300
Talks to Beginners.....	Editor 303
Our Homes.....	A. I. Root 306

SUBSCRIPTION RATES.—One year, \$1.00; two years, \$1.75; three years, \$2.50; five years, \$4.00. Canadian subscription, 30 cents additional per year, and foreign subscription, 60 cents additional. **DISCONTINUANCES.**—On and after March 1, 1917, all subscriptions, not paid in advance, or specifically ordered by the subscriber to be continued, will be stopped on expiration. No subscriber will be run into debt by us for this journal. **CHANGE OF ADDRESS.**—Give your old address as well as the new and write the name that appears on the paper. **REMITTANCE.**—Should be sent by postoffice money order, bank draft, express money order or check. **CONTRIBUTIONS TO GLEANINGS** columns solicited; stamps should be enclosed to insure return to author of manuscript if not printed. **ADVERTISING RATES.**—Advertising rates and conditions will be sent on request. Results from advertising in this journal are remarkably satisfactory. **ADVERTISERS' RELIABILITY.**—The publishers use utmost diligence to establish in advance the reliability of every advertiser using space in this journal.

Entered as second class mail matter at the Postoffice at Medina, Ohio. Published monthly.

THE A. I. ROOT COMPANY, Publishers, Medina, Ohio

Editorial Staff		
E. R. ROOT	A. I. ROOT	H. G. ROWE
Editor	Editor Home Dept.	Managing Editor

We offer you even better service than ever before at our new location.

Come in and see us.

Have you received our new catalog?

Write for our 1918 Bee Catalog now.

BIG MONEY?

YES. READ HOW

If your banker said to you, "Mr. Brown, buy that piece of land next to you at \$100.00 per acre, it will be worth \$2,000.00 per acre this coming summer." Would you buy it to-day or wait—well, until later on? We are sure you would not delay one moment.

We offer you the same kind of buy—that is, make \$20.00 on each \$1.00 invested. Buy your sections and bee-supplies NOW for the sections cost less than \$1.00 per hundred and next summer when they are filled with honey, they will be worth \$20.00—think of it, those same sections that you bought for \$1.00. The same holds good on other supplies, ORDER NOW and tell your neighbors to do the same or Mr. Railroad Embargo "will buy that piece of land next to you and you'll be left."

Old Comb

Ship your old comb and cappings to us for rendering. We charge you 5c per pound for the wax rendered and pay you the highest market price.

Wax and Honey

We always buy Comb and Extracted Honey as well as Beeswax, so when you have the above to offer, write us and you will be well pleased.

FOUR REASONS FOR OUR SUCCESS

HONESTY
QUALITY

Lewis' Beeware

If you have used LEWIS' BEEWARE, you know the quality, if not this is just the time to invest your money where the results are lasting.

"Made Like Furniture"

PRICE
SERVICE

DADANT'S
FAMOUS
FOUNDATION

ROOT'S
SMOKERS and
EXTRACTORS

The Fred W. Muth Co.

Pearl & Walnut Sts.
Cincinnati, Ohio

"Quality Counts With Us."

GLEANINGS IN BEE CULTURE

MAY, 1918



EDITORIAL

YOU, MR. BEEKEEPER, are a soldier in this world's great army. Didn't you know



**Your Part
in the
Great Struggle.**

it? If you did not, it's time you woke up. You will find it out before this war is over, and the

quicker you realize it now and become accustomed to doing your share, the more efficient you will be when the crucial test comes that will later show us all what we must do, whether we wish to or not.

Your duty, Mr. Beekeeper, in this great world's crisis, is the duty of the soldier at home—to do most efficiently and intelligently everything that concerns food production. Don't leave a thing undone that may produce an additional ounce of honey. Get your brains and your hands to work. Neglect nothing. Do better than you have ever done before. And don't forget to speak a patriotic word wherever you can. Cheer for Uncle Sam. Lend him your money. Get others to do so. While our boys in khaki are dying for us and for this country and for humanity's cause "over there," let us "over here" do to the utmost what we can—and every man, woman, and child of us can help.

Do it.



YEARS AGO W. Z. Hutchinson in his journal, the Beekeepers' Review, sounded the slogan, "keep more bees." He kept this up until he made it a general propaganda. His

idea was that the necessary, fixed expenses in the case of a small number of colonies would eat up all the profits, while the same expenses would be but little more when two or three times the number of colonies were kept. He continued urging his readers to "keep more bees," until finally many of them followed his advice.

The propaganda, "keep more bees," would not apply in the case of the backlotter nor in that of the farmer who keeps only a few bees for pleasure and a little profit. But the man who makes beekeeping his sole means of livelihood can well afford to consider whether his locality will stand more bees, and whether he himself has sufficient

experience and skill to handle a larger number of colonies.

During these strenuous war times the question is of special importance. The Government thru its various bulletins has been urging beekeepers to "speed up on honey production." The general shortage of sugar and the difficulty of transportation have brought into the limelight the necessity of raising sugar (honey) right in one's back yard. This the bees can do and save much transportation.

The past severe winter, during which many bees could raise no brood or died outright, has brought to the beekeeper the problem of spring dwindling. Wherever winter or spring losses prevail, thousands of beekeepers will need more bees. If they are to "speed up on honey production," they must have more. There are two ways of getting them. One plan, and perhaps the more feasible, is to buy or rent bees in one's own neighborhood. The other plan is to buy bees from the South in package form. The former method, perhaps, should be tried first, as there are many farmer beekeepers and backlotters who will give their bees scant, if any, attention. The good beekeepers should get in touch with these people and, if possible, enter into an agreement to take care of their bees on shares, or, better still, buy outright. Every colony of bees in the country should be made to turn out its maximum output; but it will not do so unless the best beekeepers in the locality (and that means usually those who have the largest investment in bees) either buy or rent the bees of their neighbors. The farmers and backlotters would do much better to get a professional to take care of the bees for them. It then behooves you, Mr. Professional Beekeeper, and you, Mr. Backlotter, if you are up to date, to make arrangements so that every colony in your locality will yield its maximum of honey. You should also see that the entrances of all hives in your locality containing dead colonies are closed, as such a hive, with plenty of honey in it, is always a menace on account of bee disease.

In some cases it would be impossible to buy many bees in the neighborhood. One professional beekeeper writes us that he has been all around the country within 10 miles of home, and he finds that the bees are all dead. His own loss, however, thanks to pack-

ing and his practical knowledge of the requirements of wintering, will not be above the normal. But he wants more bees, he says. The only thing we can suggest is to buy bees in the package form.

This brings up the very, very serious question of transportation. Both freight and express are fearfully congested. Much of the express matter that ordinarily takes a week for delivery may now take three weeks. Delays like this in shipping bees would be fatal. On the other hand, all such shipments might be made by parcel post, resulting in very slight delay simply because Uncle Sam is the carrier. The question has been raised, in view of the fact that day-old chicks are now being sent by parcel post, whether bees could not be sent the same way. There is no reason why they should not be so sent. There are many more postoffices than express offices; and, if bees could be sent by mail, it would help out the war situation. All over the land are weak colonies that, without assistance, will not be able to produce any surplus honey; but if a pound of bees can be given to each, they might do as well as fair colonies wintered over. With express matter congested as it is, there is danger that bees by express may be delayed long enough to kill all the bees in shipment. Of all the exasperating and vexatious things in beedom, if we except foul brood and bad wintering, there is nothing worse than a lot of dead bees by express. The receiver blames the shipper, and the shipper blames the express company; and during the general controversy the consignee is left high and dry with no satisfaction. While it is not presumed that Uncle Sam will assume any responsibility in shipping bees by mail, yet it is probable that all packages will go thru without unnecessary delay.

Beekeepers are urged to write to the Third Assistant Postmaster-General and make clear that the general congestion in freight and express renders it absolutely necessary to have bees go by parcel post.

THE PAST WINTER was a severe one on bees in many localities; but, as a rule, it was not serious to



**Fundamentals
of Wintering
Confirmed.**

the professional beekeeper nor to those who put their bees up according to the

latest methods that are accepted by Government experts and by nearly all our best authorities.

Three or four facts stand out very clear. First, the loss last winter in the case of fair-to-good colonies well packed or in cellars was only slightly above normal. In practically all the Northern States the loss of colonies in single-walled hives outdoors was somewhere around 90 per cent. In other localities in New England and in the States immediately south of the Ohio River, where winter packing is not generally practiced, the losses were the heaviest ever known. In

our opinion had the beekeepers of the section covered by Missouri, Tennessee, Kentucky, and West Virginia packed their bees, the mortality probably would have been only normal. As it was, there were several million dollars' worth of bees lost when the small expenditure of only 50 cents or a dollar per colony in the way of winter packing or cases last fall would have saved \$5.00 worth of bees. The same proposition is exactly true in the New England States, where winter packing is the exception rather than the rule. The case of Mrs. Allen as reported in this issue is the exception that proves the rule.

Fact 2. It is often argued that winter packing is not necessary when bees are wintered outdoors. If there ever was a winter that proved the fallacy of this statement, it was the past one in our locality. While there were occasional instances of colonies in single-walled hives that wintered better than those in double-walled, with some exceptions the evidence in other localities as well as in our own, this year, is so strong and convincing that never again should a beekeeper in any State, except in the extreme South, try to winter without at least some packing.

Fact 3. It has been shown conclusively again this year, in our locality at least, that large entrances, such as are used in summer, either in double-walled or single-walled hives, means a 90 per cent loss of bees. Dr. E. F. Phillips of the Bureau of Entomology is exactly right, not only in advocating packing but the use of constricted entrances.

Fact 4. It has been made very clear from reports as well as by our own observation that the use of doorsteps or ledges just beneath the opening or entrance to a colony during winter is not only unnecessary but many times fatal. These attachments allow the snow or water to lodge and in many cases to close the entrance hermetically by freezing.

Fact 5. This was a winter that was not only cold, but it was accompanied by exceptionally heavy winds. The experience of the winter just past shows unquestionably the value of windbreaks. While colonies out in the open exposed to winds from all directions, and in single-walled hives, may winter successfully, yet these cases are so few and far between that we must conclude that they are the exception that proves the rule.

IT IS NOT too early, at least in California and the Southern States, for honey-producers to consider what



**Before You
Sell Your
Honey.**

price they should receive for their product and how to place a right value

on it. Government officials interested in the welfare of honey-producers estimate that California beekeepers last year lost a sum somewhere between a half million and a million dollars by selling their honey too low

as a result of a lack of market information on the part of the producer and misrepresentation on the part of some buyers in the field. Of course, last spring and summer no one could forecast where prices would go. Quite likely some of those buyers may be in the field again.

We are not here to try to condemn the foolish policy of producers in contracting to sell their crop before it is produced nor are we trying to effect a reform in the morals of honey-buyers. Buyers are going to continue to buy as low as they can, taking advantage of lack of information on the part of sellers; and some of these buyers will continue to "bear" prices for the future as they have done in the past in order that they may cover future crops at low prices for future delivery. This is the human nature of all too many buyers in every line, we are sorry to say, and the trait has existed before and since as good a man as Jacob "skinned" his poor old father-in-law Laban. Let's not blame altogether the buyer for the producer's getting too low a price for his honey. That will do the producer no good, and will not work a reform in the buyer.

Let us, rather, lay a part of the fault at the door of the producer himself. He can accept or reject any offer for his honey; and if he accepts too low a price it is simply his own fault, resulting from lack of correct information as to market conditions which he might have known. It is just as possible for him today to secure information about the honey market as it is for the stock raiser or the wheat grower to know about the market for beef and wheat. This has not always been so, it is true. But today the Government issues twice-monthly bulletins from the Bureau of Markets giving honey market quotations thruout the country, and a half dozen bee journals in the country give their readers the most correct information that they have concerning honey market prices. If the honey-producer does not take a bee journal, he can have for the asking by applying to Office of Markets, U. S. Department of Agriculture, Washington, D. C., these honey-market bulletins sent to his address regularly. If the honey-producer does not take advantage of these various sources of market information, the fault is solely his own if he gets "skinned" in the sale of his honey. We are tempted to add that he is not entitled to any sympathy whatever if he today sells his honey at less than a just and fair price.

In this connection, Gleanings wishes to advise honey-producers not to put themselves at a disadvantage by letting anybody interested in the purchase of honey finance them. Do not buy supplies on credit, if in any way possible to do otherwise. Do not, without fullest information, take an advance payment from the honey-buyer. If the honey-producer must have money to carry on his business, let him make the greatest endeavor to finance himself without becoming obligated to the honey-purchaser either directly

or indirectly. Any advance help that the honey-buyer may extend to the honey-producer is advanced in the buyer's interest and not in the interest of the beekeeper.

All that the honey-producer needs to get the right price for his honey is to make himself as well informed concerning the honey market as successful men in other lines of agriculture are informed regarding the markets in their lines of production. The cure for low honey prices is better-informed honey-producers.



IN SOME localities beekeepers have reported to us that they have lost heavily on ac-



**To Prevent
Killing of Bees
By Spraying.**

count of their neighbors spraying their fruit trees with arsenate of lead or other poisonous mixtures while the trees were in full bloom, notwithstanding that experiment stations all over the United States, practically with one accord, have advised against it. In view of the fact that this spraying in most cases is done thru ignorance and not because of any malice toward the bees or the beekeeper, we shall have ready for distribution post cards which local beekeepers can send out telling when and how to spray.

These directions will show that lime sulphur mixtures will do no harm. They are not poisonous and moreover must be applied on the trees in the dormant state before either the blossoms or the leaves come out. Arsenate of lead, on the contrary, under many circumstances as used in spraying, is poisonous to bees and a direct damage to the blossoms themselves. The directions that go out from the experiment stations are to spray before the trees are in bloom and after the petals of the blossoms have fallen. Such practice is entirely effective in preventing the development of the codling moth in the embryo fruit and at the same time does absolutely no harm to the bees which are the fruit growers' best friends.

We will furnish these cards at 1c a piece in small amounts and cheaper in large amounts—at cost to us. All that will be necessary will be for the local beekeeper to put on a 1c postage stamp and mail them to local fruit growers. He can sign the postal cards, or not, just as he sees fit.

The mailing of these cards in a fruit-growing locality before the trees come into bloom, will save a lot of bees and brood. If there ever was a time when we needed to save both, it is this spring.

Probably most beekeepers whose bees are in danger from spraying, will not require more than a very few cards, and we will accept stamps in payment for these cards, whether few or many. We shall furnish them at bare cost, postage paid, seeking only to serve the beekeepers needing them and to promote a larger production of honey.

TIME and again we have been told by good bee authorities that an abundance of young bees in the fall is necessary to insure good wintering.

We have accepted this assertion as logically correct, and have managed our bees accordingly.

Fall Dividing Condemned.

In a recent number of one of our bee journals a prominent beekeeper tells of his plan of making increase in September, by dividing his colonies, I suppose. According to my experience that is the greatest mistake a beekeeper can make, if good wintering and a large honey crop are the objects. In this locality it would be much more profitable to winter a colony full strength and divide it in the spring early enough to nip all swarming notions in the bud. When treated in this way it will produce at least twice as much surplus honey as the combined effort of both swarms made in September. Besides, we have fewer colonies to winter. Dividing a colony in September cuts its stock of young bees in halves. Having little chance to recuperate before winter sets in, both halves are liable to come out only half-strength in the spring. The theory of this plan seems to run in the opposite direction to the advice first given.

Which are we to follow!

Fall Uniting.

Bees in a locality that is favored with a fall honey flow will generally produce plenty of young bees to go into winter safely. If the honey flow extends all thru the latter part of September, we should find hatching brood in October. If we don't, it is the fault of the queen, and the sooner she is replaced by a new one the better.

But to replace a queen in October is for various reasons not always practical. In such cases I resort to doubling up. Every colony that fails to come up to the standard mark of populousness for profitable wintering is united with a similar one before winter sets in. I make my selections for this purpose during the forepart of October.

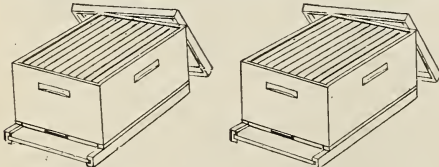

(1) Weak colony with queen and sufficient stores for itself and weak colony (2) to be united with it. (2) Weak colony, either with or without queen, to be united by placing above colony (1).

Those colonies that fill five spaces or more on a cool morning, when closely clustered, are considered safe for wintering. Those that occupy four spaces or less are doubled up.

HOW TO UNITE--SPRING and FALL

Two Colonies United, with Both Queens Retained, Working Peaceably. Other Uniting Plans

By G. C. Greiner

At the same time that I make these selections I prepare the hives for the final uniting operation by unhooking or otherwise loosening the bottom-boards of

such hives as are to be placed on top, and providing the colonies intended for lower stories with winter stores sufficient for both colonies. This is the proper time for supplying any shortage of stores as later, when one hive is placed on top of the other, the bees should be disturbed as little as possible.

Any queens that are known to be in any way deficient are removed before their colonies are united, and they are the ones that take the upper place. If I have no choice in queens, I pay no attention to them—simply set the hives one on top of the other and let them fight it out on their own battleground. I do this uniting on a cool day when the bees are closely clustered. Thus there is no necessity of using a newspaper which is always a hindrance to good rapid work. The cool temperature seems to fulfill the mission of the newspaper, as the bees are disturbed but little and get acquainted only gradually.



Having everything ready for the operation, it is done so smoothly that the bees hardly know anything has happened; and before they spread out again, which may take several days, the two colonies are so well acquainted with one another that they unite without any trouble.

This has reference to the two colonies of which the upper one is queenless. If both have queens, they are not likely to unite without assistance. Therefore a little different management is necessary. After they have been sitting in pairs (one on top of the other) for a number of days, they are made to unite the first time the weather is favorable for handling bees. Beginning on the opposite side from where the lower colony is clustered, the bees from one comb after another are swept off into the frames below, and having no alternative they readily accept as their home the empty spaces between the combs below. When all combs are thus taken care of, the empty hive-body is taken off and the hive with its two sets of inmates covered up. This operation may require a little smoke, both to make the upper bees retreat more readily down below and to keep the lower ones from coming up.

Fall and Spring Uniting Differ.

While it is an advantage to have strong colonies in the fall, it is no less so in the

spring. Doubling up weak colonies at this time, altho in principle the same as when done in the fall, its immediate purpose is somewhat different. In the fall we prepare our bees for good wintering, while in the spring our aim is to prepare them for gathering our surplus honey crop. Having no need of taking the winter-store problem into consideration at this time, the mechanical execution of the operation is also managed in a little different way.

Spring Uniting of Weak Colonies.

All colonies set aside for this purpose are crowded by division-boards onto the least number of combs they can well cover. This

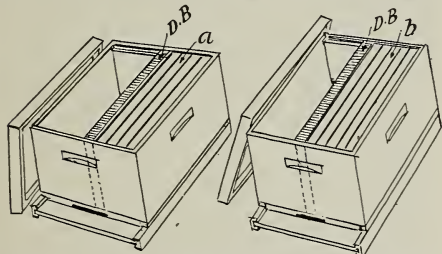

Colonies a and b crowded onto as few frames as possible.

is done several days before they are to be united that they may have a chance to congregate again on the reduced number of combs. When ready for the operation (which may be on some cool day, the same as in the fall) one colony after another is hung into the hive of its intended partner into the space vacated by the reduction of its combs until all are treated in like manner. After a few days the division-board is removed and the hive otherwise arranged as may seem necessary for future super work.

Colonies a and b in the same hive, separated by an ordinary division-board D B, which is removed in a few days.

Having been connected over the tops and under the frames and compelled to use the same entrance, they have gradually become sufficiently acquainted to unite in peace and harmony. If the doubled-up colony should still be too weak to promise any surplus returns, the same operation may be repeated a second or even a third time. Better have one good colony than a dozen poor ones.

Spring Uniting of Medium Colonies.

Occasionally one has a few medium colonies, too strong to be treated as the above and yet too weak to produce much surplus honey. Such colonies are too promising for one to lose their use entirely for the season and may be made to produce a fair yield by hanging two of them into a 10-frame hive with a tight-fitting division-board between, this honey-board being left throuth the entire season. Each colony should have its own passageway to its respective corner of the

front entrance at which corner it was previously (while still in its original hive) trained to enter. It is an advantage to have such colonies sitting beside one another for

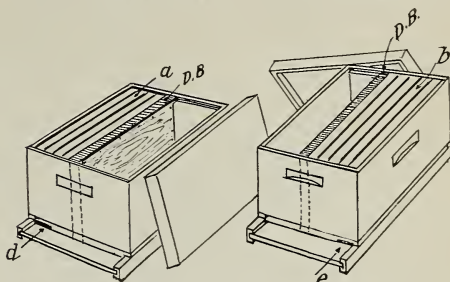

Two medium colonies, a and b, each crowded onto a few frames and left a few days. Notice the entrances d and e at opposite corners of the respective hives. The two colonies should be placed beside each other a few days before uniting.

a time before they are placed in one hive. This arrangement for medium colonies keeps the queens separate while the bees have free communication in the supers, the latter being managed like all others in one-queen

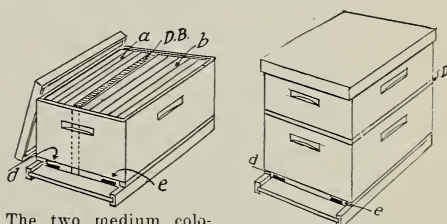

The two medium colonies are next placed in the same hive, separated by a tight-fitting division-board (D B), each having its own entrance, d and e, respectively. The division-board is left on the entire season.

Colonies a and b in the lower story, separated by a tight-fitting division-board. Above this queen-excluder D and super. Thus there are two queens in the lower story.

colonies. We have two queens in one hive and practically two queens in one colony. Above the excluder, it is actually in one colony. I have run such for comb honey without the excluder with fairly good results, but they will do better when run for extracted.

La Salle, N. Y.

[At first thought it might seem that in the spring uniting of medium colonies, the two queens being compelled to occupy the same story, would perhaps be rather crowded for room. (In the above drawings we have represented 10-frame standard hives instead of the eight Jumbo frames which we understand Mr. Greiner uses, but in either case the square inches of comb would be about the same.) If four or five combs should not prove a large enough brood-chamber for either colony, doubtless sufficient room could be given and the bees kept contented by exchanging some of the frames of brood with those above. Later, if the colonies should become large enough to warrant it, they could be placed in separate hives.—Editor.]

WHILE most beekeepers recognize the fact that there is a difference in bees and consider the Italians superior to other races, yet I feel safe in saying that most apiarists do not recognize the fact that there is a vast difference in Italians of different strains, and hence pay little or no attention to selection in breeding or in purchasing queens for requeening. It is common practice for many beekeepers to save queen cells with no regard to the merits of the stock from which they are taken. And, in buying queens, they order from the breeder who sells the cheapest, or perhaps from a breeder who is supposed to have good stock and they are satisfied that such stock is as good as any. Such beekeepers are apt to consider it too much trouble to keep a record of their colonies and of the pedigree of their queens.

Stocks That Deteriorate.

While I regret to say it, I am convinced that some commercial queen-breeders either pay no attention to the selection or have thru years of line-breeding or inbreeding allowed their original stock which gave them their reputation as breeders to deteriorate. I have in mind one breeder who is reputed to have very superior stock and from whom I have purchased queens off and on for the last 25 years. The stock originally was, without doubt, most excellent, but the queens received during the last few years have proved poor indeed and in my opinion are degenerate. This conclusion is drawn from my own observations as well as from reports from other beekeepers who have recently tried this same stock. Now this breeder is honest and really thinks he is offering high-class stock as he formerly did, but he has, I believe, practiced inbreeding so long that his stock has degenerated and he is depending on his past reputation as a queen-breeder.

I believe however that most queen-breeders by careful selection are constantly improving their stock, but what is needed is a general awakening among the rank and file of beekeepers to the importance of selection and improvement of their own stock. This can be done only by keeping a record of the performance of each colony and a record of the pedigree of each queen and then breeding from the best. Likewise careful attention must be paid to rearing drones from stock that has been thoroly tested. Every beekeeper who is striving for stock improvement, should read in the August, 1916, number of the American Bee Journal, Dr. C. C. Miller's article on this subject of drone selection, in which is emphasized the importance of rearing good drones for breeding. Contrary to general practice and belief it is conclusively shown that there is more to the

NOT ALL ITALIAN QUEENS GOOD

*Eternal Vigilance Necessary. Where-
in Some Queen-breeders Fail. A
Show-down of Best Strains.*

By Earl C. Walker

the queen but also upon the drone with which the queen was mated. In other words these workers have the composite character of their mother and their father, that is the drone with which the mother mated. But the drones of this same queen, since they spring from unimpregnated eggs, are not influenced by the mating of their mother. These drones are sons of their mother alone and depend for their character entirely upon her own blood without regard to her mating. Now since this queen is the product of the combined blood of her mother and father, she transmits to her sons the character of her dual parentage. In other words a drone gets its character from its grandparents. Hence it is clear that in choosing drones for breeding, we must estimate their value not by their mother or her colony of workers but must know the record of their grandmother and her colony.

I conducted the following experiment which to me is conclusive evidence that blood tells. In 1914 queens were purchased from three prominent queen-breeders in this country and also from one breeder in Italy, so that four distinct strains of Italians were used. During the first season the best queen of each strain was selected to be used the following season (1915) as a breeder. From each of these breeders, daughters were raised and mated with the best drones of my own stock. That is, an abundance of select drones were raised with a view of mating them with these queens. Ten of the best queens of each of these strains were used to head the colonies. This last season a careful record of each of these colonies was kept and the difference in pounds of honey stored by each strain is conclusive evidence that it is a mistake to think that "bees is bees." All these colonies were kept in the same yard and all were managed in the same way and given an equal chance. Extracted and bulk comb honey were produced by all but two colonies which were run for comb honey.

In setting forth the results, the three domestic strains of Italians are designated as A, B, and C, while the imported strain is designated by the letter I.

Strain A. Produced an average yield of 122 lbs. per colony. All were run for extracted except one which produced 97 sections of fancy comb. The best individual colony yield was 191 lbs. extracted, the lowest 90 lbs. extracted.

Strain B: All run for extracted. Average yield 86 lbs. Best individual colony yield 134 lbs, lowest 55 lbs.

Strain C. All run for extracted. Average

problem than simply rearing drones from a queen whose workers have a record as honey-gatherers. Such workers depend for their character not only upon

yield 58 lbs. Best individual yield 93 lbs., lowest 35 lbs.

Strain I. Imported. All run for extracted except one. Average 95 lbs. Best individual yield 152 lbs., lowest 39 lbs. The comb-honey colony gave 87 sections.

The best domestic strain A with an average yield of 122 lbs. contrasts strongly with Strain C, also domestic, with its average of only 58 lbs.; and as this latter strain C was bred from stock secured from the breeder referred to above as selling degenerate stock, it seems that my conclusion that such stock has deteriorated is well founded, for this stock once had the reputation of being superior as a honey-gathering strain and is still advertised as such. The leather-colored imported stock ranked next to the best domestic strain but fell short an average of 27 lbs. per colony, which if figured at 8c made a difference of \$2.16 per colony—more than the price of two good queens. The poorest domestic strain tested fell short of the best an average of 64 lbs. per colony, which in money meant a difference of \$5.12 per colony.

Now doesn't it pay to keep records? Isn't it worth the trouble to know what your stock is? Won't it pay to breed from the best; or, if you buy all your queens, is it not well to know by actual test the most desirable stock to purchase? Isn't there a vast difference in the strains of bees? Whether you raise your own queens or buy them, selection is important and you must keep everlastingly at it.

What percentage of the readers of this and other bee journals practice the most approved methods of management and use the best appliances obtainable and yet pay little attention to the selection and breeding of the best stock? Should not more emphasis be given this subject?

A Honey-Producing Contest.

Why not have a honey-producing contest similar to the egg-laying contests conducted annually by poultry breeders? Appoint some fair-minded honey-producer whose locality will support say 200 or more colonies in one apiary and invite queen-breeders to enter a contest such as suggested, each breeder to send free to said apiarist say ten queens

for competition in honey-producing. The honey-producer should handle all colonies in the same way and keep an accurate record of the yield of each colony. Would not a report of the performance of the bees of the different strains competing be of interest and value both to the breeders themselves and to the beekeeping fraternity in general? Why not make this an annual event?

The honey-producer conducting the contest should be impartial and should not himself be interested in breeding queens for sale. To eliminate any suspicion of partiality, it could be arranged so that the one conducting the contest would not know from what breeders the various strains of bees came. The queens from the breeders competing could be forwarded thru some disinterested party of recognized integrity who could designate the various strains by fictitious names or numbers or letters.

A prize might be offered to the breeder winning the contest, altho it would seem that any breeder would be glad to enter without other reward than the advertising he would get out of winning such a competition. The honey-producer's reward would be the ownership of the queens entered.

Now my only objection to contests of this kind is the chance of unfairness. Could such a competition as suggested be conducted in such a way that it would be absolutely fair and void of any suspicion of partiality? If so why not have it? Would queen-breeders sanction and support such a competition and would they be willing to have the results published? It might be well to publish the names of the three breeders whose bees made the best record and simply tabulate the result of the other strains by letter without giving the names of their breeders.

I am not breeding queens for sale, but for the last 26 years I have been interested in bees and their improvement. The test of the four strains as reported was made with the direct object of ascertaining their relative merits so that we might select the best to cross with our own stock, which has been improved by selection for a number of years.

Earl C. Walker.

New Albany, Ind.



IMPORTANCE OF MAY WORK

*Between Neglect and First-class Care
at this Time Lies the Possibility of
Getting a Half or a 100 per cent Crop*

By the Editor

EVERY so often, when our consciences become too active, we say to ourselves, "After all, the war must be fought in two places." Well,

our boys are fighting it out in one place and no bluffing about it. How many of us honey-producers can say as much? Are we doing our work in the same humdrum fash-

ion we have in years past, or is our every plan and every bit of work with the bees actuated by a definite vital purpose to produce every pound of honey

of which we are capable?

Unless our actions are to belie our words, the month of May this year will see more thoughtful, thoro work done in the apiary

than ever before; for, in many instances this is the month which will determine whether we shall obtain a 50 or a 100 per cent crop.

At the beginning of the honey flow our hives should be overflowing with bees. The amount actually present will depend entirely upon our manipulations begun some six or eight weeks previously.

Give More Stores Than Needed.

Thruout the entire month, and until the honey flow, the colonies should be kept supplied with plenty of stores. At all times there should be at least from three to six pounds of honey in the hive—more if possible; for during spring breeding great quantities of stores are needed, full colonies some times needing three or more pounds each week. It is the stores in excess of their actual needs that stimulate the bees to increased brood-rearing. Therefore close watch should be kept in order that the stores may not run low and thus curtail brood-rearing.

If some colonies are short of honey, it is generally possible to find others in the apiary which can easily spare a few combs, and stores may thus be equalized. Otherwise it will be necessary to feed syrup or candy, which may be placed immediately over the brood-chamber and covered snugly.

Feeding Just Before Honey Flow.

If it should happen that the bees must be fed syrup or candy a week or so before the honey flow and after the supers are put on, it is preferable to feed candy; for as soon as the flowers begin yielding nectar, the bees will desert the candy. In case of syrup many would continue taking the syrup and neglect the nectar in the fields. One need have no fear that the bees will store the candy in the supers; for, as fast as taken, it will be used in brood-rearing. To feed candy when the supers are on, just preceding the honey flow, the feed may be placed on the bottom-board at the back of the hive; or, if desired, it may be put inside of a two-inch rim inserted between the two stories. Since bees are more liable to rob during the spring, the hives should not be open for any length of time. The entrances should be left contracted, and the feeding done toward night unless candy is given above the brood-chamber, when no special precautions need be taken.

Clipping and Re-queening.

Unless the laying queens have already been clipped, the work should be done during apple-blossom, while the weather is warm and some honey coming in. (See page 305.) Good queens usually begin laying toward the center of a comb and gradually work outward, leaving the eggs placed regularly, one in each cell, and almost no cells skipped. If an undersized queen with short abdomen is found, and the eggs are irregularly placed, such a queen is defective and should be replaced by a queen-cell from another colony or by a queen purchased from

a breeder. In case a queen is sent for, the defective queen should not be removed until the arrival of the new one. Rather than await the arrival of another queen, some would prefer to kill the undesirable queen and in a couple of days unite with an undersized colony. This may be done toward night by placing the queenless colony with some brood over the queen-excluder and the queen-right colony to be united, or they may be united by the newspaper plan, or by contracting each colony to five combs and then placing in one hive by alternating the combs with adhering bees. When uniting colonies that are far apart, they should be gradually moved a few feet each day until they stand side by side, facing in the same direction.

Expanding and Removing Packing.

Those brood-nests that were contracted last fall should be expanded as soon as the colonies become strong enough to cover more frames. As these combs are added, they should be placed at the sides in order not to divide the brood-nest. When expanding, it will be necessary to remove some of the side packing which fills the space made by removal of the combs last fall—all such packing may be removed if double-walled hives are used. It does not pay to be in too big a hurry about removing the top packing. In the northern states, probably the middle of May will be soon enough, and some seasons it may be well to leave it on until the first of June. Weak colonies that are in danger of being robbed or of having their brood chilled should have contracted entrances; but strong colonies may be given a full entrance a few weeks before the honey flow.

Equalizing Brood—When and How.

The inexperienced should be cautious not to equalize the brood too early in the season nor to give a colony more brood than it can care for. Every good comb of brood that becomes chilled means the loss of about a pound of bees that would have been at their best during the honey flow. However, as soon as the colonies have from five to eight frames of brood, it will be safe to take a comb or two of sealed (and preferably hatching) brood from the strongest and give two broods to each of the medium colonies, and one brood to those a little weaker. No colony should be given more brood than it can certainly keep warm. After the brood has hatched, the process may be repeated if necessary. This "equalizing of brood" should not be confused with "spreading of brood," by which plan empty combs are inserted in the middle of the brood-nest. In regard to the latter plan we have already given a word of warning.

In order to equalize the brood without danger of chilling it, it should be borne in mind that the cluster has somewhat the form of an irregular ball, often egg-shaped; and since the cluster is arranged so as to cover the entire brood, the brood itself has more or less the same form. Therefore

when looking straight down into the top of the hive, a cross-section of the brood-chamber would show the brood arranged in the frames in the form of an oblong circle or ellipse, as in diagrams 1, 2, and 3.

When equalizing, sealed or hatching brood is preferred; and at this time of the season such combs are apt to be found near the center of the ball or sphere, and therefore contain the largest patches of the brood, some extending perhaps 11 inches in the longest diameter. Such a comb might safely be inserted in a brood-nest beside patches of brood of about the same diameter, or even at the center of such a brood-nest as shown in Fig. 2; but to insert it in a brood-nest

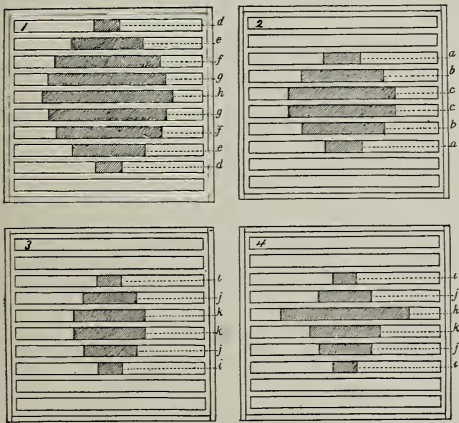

The above figures represent horizontal cross-sections of brood-chambers, the shaded portions showing the location of the brood in the frames. In figures 1, 2, and 3, it will be noted that the cross-sections of brood have more or less the outline of circles. The longest diameters of the patches of brood a, b, c, d, e, f, g, h, i, j, and k are 3, 7, 9, 2, 6, 9, 10, 11, 2, 4½, and 6 inches respectively. If it is desired to equalize the brood of the brood-chambers 1 and 3, brood h should not be inserted between k and k, which would give such a brood-chamber as that represented in 4, which is not circular in outline. Instead of this the third hive 2 should be opened, h exchanged with c, and c inserted between k and k.

similar to that shown in Fig. 3 would be quite foolhardy, as it would result in the bees spreading out to such an extent as to cause the chilling of patches (i) and (i) or the outer parts of (h). In such a case it would therefore be a good plan to go to a third hive and exchange frame (h) with frame (c) and then place frame (c) between frames (k) and (k), at the same time removing one of the outside broodless frames if necessary.

Cutting Out Drone Comb.

During the fruit-bloom, after the bees are in the best possible condition, queens clipped, colonies strong, stores and brood equalized, and brood-chamber expanded, there is still a very profitable piece of work that one can hardly afford to omit. In the lower corners of the brood-frames, along the bottom-bar, and at various other parts of the combs, will be found patches of drone-comb.

This excess of drones should on no account be tolerated (during the present year especially), and the warm spring days of apple-bloom is the ideal time for cutting it out and replacing with worker brood.

After cutting out the undesirable comb, that from which portions have been cut, should be used as a pattern and placed over the worker comb which is to be used for patches. With a knife the shape of holes may be marked on the under comb. Then removing the upper comb the pieces may be cut out, after which they are inserted in the comb to be patched. If they are small and fit in tightly, it may not be necessary to fasten them. Otherwise they can be held securely by means of wires wrapped around the frames, or if honey is coming in, the patches may be tied in with strings which will be removed by the bees as soon as they have attached the patches to the rest of the comb.

Giving Room Below and Above.

To move brood above too early in the season would be attended with danger of chilling the brood, since so much of the heat of the lower story would rise to the upper one. But two or three weeks before the opening of the main honey flow, if the strongest colonies become crowded with brood and bees and little particles of new wax appear along the tops of the combs, a super should be given immediately above the lower story; and if the crowded condition seems to warrant it, it may be advisable to place one or two frames of eggs and larvæ in the upper story, replacing with frames of empty combs or foundation. If the latter is used, it will be necessary to feed syrup in order to get the foundation drawn out. When some brood is thus kept in the second story, the bees become so accustomed to occupying the second story that when the honey flow comes they start to work in the super with energy and enthusiasm. A week or so after the opening of the honey flow, a queen-excluder should be placed between the two stories and the queen placed below.

Increase—Prevented or Made.

By tearing down queen-cells as fast as they appear, placing a few brood, or all but one, above, and filling the remainder of the lower story with drawn combs, it will doubtless be possible to prevent all increase during this month. Or, if increase is desired, the above plan may be used, only inserting a queen-excluder between the two stories and tearing down all capped cells. About eight days later the upper story may be moved to a new location and its entrance contracted to prevent the brood from chilling.

If these suggestions are conscientiously carried out in the northern states to which they apply, we believe that each beekeeper will be richly repaid for the extra time and trouble expended, and that many tons of honey will be added to our annual output.

Well, how about it? Of what does our patriotism consist—of words or deeds?



FROM THE FIELD OF EXPERIENCE

CONVERSATIONS with DOOLITTLE

He Carefully Tells an Inquirer About Producing Extracted Honey

"The tide in beekeeping seems to be changing from that of section to extracted honey. Be kind enough to give us something in the May number of Gleanings about working for extracted honey, so that even the novice can make a success of it."

The work in early spring is little if any different when working for extracted honey than for section. All hives should be kept as tight as possible to economize the heat generated by the bees. Then each colony should have stores enough to last the colony without scripping till the first flowers yield nectar. This last is where many beekeepers "fall down." Fifteen to 20 pounds is none too much to allow from the time of the first flight in March or April to the time of fruit bloom, as rapid brood-rearing calls for much honey.

With apple bloom, all fairly populous colonies should have a queen-excluder put on the live, and on this a hive of combs. If these combs contain 10 to 15 pounds of stores, so much the better, for, should this bloom fail to give the bees more than a living (as is often the case), the honey given will carry them over in good condition till the clover bloom. As soon as the lower hive is pretty well filled with brood, two combs from the same may be set in the upper one, taking from the upper hive two nearly empty combs to replace those removed from below. A week later three or four frames of brood may be exchanged in the same way. Thus rousing colonies may be obtained by the time the clover begins to bloom, without many of the colonies having any desire to swarm.

Colonies that have not yet arrived at sufficient strength to warrant one's putting a hive of combs on top, may safely be united at this season of the year by smoking and jarring in the dark of the evening, and then placing one of the hives on top of the other, with nothing between. The smoking and jarring cause them to mark their location anew in the morning. If one queen is superior, kill the other; if not, let the bees manage the matter.

If increase is wanted, this is easily made by setting off one of the upper hives in which we have set four or five frames of brood a week or two previous, giving each a queen cell nearly ripe about 6 P. M. and doing the setting off on a new stand in the twilight of the same day.

It is best to have plenty of extracting combs, and not let the bees run short of room; otherwise swarming may be the result. Queen-excluding honey-boards simplify the necessary work. If we want to secure the greatest number of pounds, we can extract when the honey in the frames is about

three-fourths capped over, as it is usually ripe enough at that stage to extract; but it is better to tier up and leave it on the hives until the end of the season.

In localities where there are two crops or more in a year, a light-colored, an amber, and a dark, with a dearth between, it is better to keep the two crops separate, by removing the light honey just before the other flow is beginning. In the hot weather usually prevailing in July and August, honey will soon ripen in the hive, and may be extracted when the combs are not more than half sealed over. At the end of the dark or fall flow it is usually cool to cold weather, and only the capped-over combs should be extracted unless we have a cheap home trade or can sell for manufacturing purposes.

Sell none but well-ripened honey of any color or flavor for table use, if you would build up and hold a profitable trade. In this way you will get a trade that pays. It is not necessary that honey be mild in flavor and white in color to be good. Many customers prefer good, thick, well-ripened buckwheat or goldenrod honey to that from clover or basswood. Some 35 years ago an old aunt came to see us and I took special pains to have some exceedingly thick basswood extracted honey on the table, as we had pronounced it the "very best ever." I noted that she ate sparingly of it. Presently she said, "Haven't you got some of that good, old, black, buckwheat honey? This white honey hasn't got any taste to it but sweet."

In taking honey from the hives, it pays well to have some bee-escape boards. I have tried most of the many kinds of escapes as they have been brought before the public, but so far consider the Porter the best. Put them in at any time when you wish to remove an upper story, and if there is no brood or queen above them, the upper stories will usually be practically free of bees in from 24 to 48 hours. Do not leave these boards on very long after the upper stories have been removed. Otherwise the bees are liable to plaster the inside of the escapes with propolis which makes the escape useless till the same is removed.

Extracting from the brood-chamber is seldom necessary or advisable, if good management is used in supplying upper stories of combs before those already on are crowded with honey. A small room made tight and warm by lining with heavy building-paper, lapping the paper well, and tacking lath over the joints makes a good place for extracting, either in summer or winter. If the weather is cool or cold, pile the supers of honey on a scaffolding, about head-height if possible, and heat the room to a temperature of 90 to 95 degrees from 18 to 24 hours, according to the length of time the honey has been exposed to the low temperature. Most honey rarely candies in the comb, and

FROM THE FIELD OF EXPERIENCE

where the demand is for liquid honey, it is better to leave it there until wanted for sale or use. The 5-gallon screw-cap tin cans are good for storing in where it is to be handled for retail trade. Produce only a good, well-ripened article and sell it direct to the customer yourself at a reasonable price.

G. M. Doolittle.

Maricetta, N. Y.

SUCCEEDS with COMB FOUNDATION

How One Beekeeper Gets Bees to Draw Out Comb for Extracted Honey Production

In the March issue of *Gleanings*, a statement is made that "It is not an easy matter to face the season running for extracted honey without drawn combs," and "The swarming impulse would be much greater when the bees had to draw out sheets of comb foundation in the supers instead of having combs."

I wish to take exception to both of those statements. A good beekeeper can take medium colonies of bees and by right management have at the opening of the clover-flow from six to ten frames of comb foundation drawn by each colony. Also the drawing of this foundation will help to keep down swarming.

According to my method, as soon as a colony gets the hive well filled with bees and brood, the second story is added. Two frames of bees and brood are raised from the lower story into the top one and two full sheets of foundation placed in the lower hive, with one or two frames of brood between them. The two frames of brood in the top hive should be together so there will be no danger of chilling the brood. In both stories the bees that are taking care of the brood will soon begin work on the adjacent foundation. In fact, they will draw out such foundation when they would not touch foundation in a super by itself. If one wishes to hurry things, he can go thru his hives in a week or ten days and raise more brood from below, substituting comb foundation.

This plan keeps the bees busy and gives them a place to store their surplus wax, also the queen is constantly provided with plenty of room for egg-laying, and, as a general rule, when a queen is busy laying, her colony does not swarm.

The past year I had about 80 colonies that I ran for extracted honey and they had no drawn combs, but drew all their extracting combs from full sheets of foundation. They averaged a little over 50 pounds to the colony. During the same season, 160 colonies that had drawn combs and did almost no drawing of foundation only averaged a little over 25 pounds to the colony.

Chapman, Kan.

Harry T. Huff.

[In the plan given above, we especially

caution the beginner that when foundation is given, there should be either a natural or an artificial flow of honey. Otherwise holes will be gnawed in the foundation and these spaces later filled with drone-comb.—Editor.]

GOOD ITALIAN STOCK WILL DO IT

Don't Get Scared, Don't Get Worried About European Foul Brood

It is somewhat amusing to read of the fears and lamentations of certain beemen over the advent of European foul brood. It reminds me of the time, several years ago, when the disease arrived in this locality and practically wiped out for me two yards of 100 colonies each. I surely was alarmed, to use a mild term, for it looked as if the end was in sight. Of course, I tried all the modes of treatment advocated by writers in the bee journals, and many others of my own invention. I tried the McEvoy treatment, the Alexander plan, stacking up brood over diseased colonies, and dozens of other plans with varying success; but still for a number of years there were many cases of the disease cropping out. I destroyed hundreds of dollars worth of brood combs, rendering them into wax, and, in one case upon the advice of an old beekeeper, even went so far as to attempt to burn a colony of bees, but nevermore.

However, the proverbial cloud had its silver lining. The bees recovered and so have I. In 1915 there was not a single case of foul brood in any of our five yards of about 400 colonies, and in two of these yards there has been none for three years. It came about in this way: the best Italian queens obtainable were carefully tested out in comparison with former stock with respect to vitality, prolificness, color, and honey-gathering qualities, only the best being reserved for breeders, and those of low vitality discarded. Furthermore, it happened that in the various manipulations of the bees I had acquired the habit of killing all queens whose complexion did not suit me or whose performance was unsatisfactory. The result seems to be that thru a process of selection and by the elimination of degenerate stock, a strain of bees has been secured which is practically immune to European foul brood. It is probable that if the remains of diseased larvæ were fed directly to these bees, they might again acquire the infection, but under ordinary circumstances, it is believed that there is little or no danger. In fact I would not hesitate to purchase diseased colonies and bring them home for treatment.

Now as to the actual treatment of European foul brood. Don't get scared. Don't worry. Don't destroy combs. Don't burn or kill colonies of bees. Don't do that other



FROM THE FIELD OF EXPERIENCE



fool thing—burn out the inside of your hives, for it does no good and it spoils the hive. Do this: (1) As fast as possible work into a good strain of Italian stock, getting rid of your blacks; (2) Dispose of your poor queens; (3) Examine all colonies frequently and do not permit any to become badly affected; (4) If you find a colony with European foul brood, nip off the queen's head and contract the hive entrance. In 10 days destroy the cells, and a week later set the hive and bees on top of another colony, preferably a strong one of Italian stock, with a sheet of paper between to prevent fighting. That is all, the bees will do the rest.

Of course, if your bees are nearly all diseased, as mine were once, the thing to do is to stack them up and keep them strong while you get in some Italian stock. Remember that the germs of this disease may be anywhere, but Italian bees of a good strain are not likely to become infected unless the larvæ are fed from the remains of diseased larvæ, those that have died recently; for it is probable that the decomposed or the dried up matter could not be so utilized, and it will in most cases be cleaned out by the bees within a few days. After an interval of two weeks there will be little or no danger of infection.

You cannot get rid of European foul brood by any known method and keep black or degenerate bees. Don't try it.

Valparaiso, Ind.

E. S. Miller.



PACKAGE BEE EXPERIENCE

Water or Liquid Feed Very Necessary for Long Shipments if Bees Are to Live

Having received perhaps more package bees at our Utah and Idaho apiaries during the season of 1917 than were handled by any other buyer in the United States during the same period, our experience may be of value to those who are now preparing bees for shipment in this manner.

First we would advise shipments before the hot summer weather is at hand, as our early packages were received in better condition than our late packages. If properly prepared for shipment, deliveries up to the middle of June ought to be in good condition. The risk increases during the hot days of July.

At no time during 1917 did bees reach us in good condition when shipped with feed candy only. Where candy is used it is of the utmost importance that water cans be used also, especially where packages require four to seven days for delivery to distant points. Sugar syrup, however, may prove to be the ideal feed, replacing candy and water. We received a few such shipments and in very satisfactory condition, considering the warm

weather prevailing at that time. At this particular time packages containing candy, without any water supply, were arriving in very poor condition, many such shipments being entirely dead on arrival. Shipments with the syrup cans showed a decided contrast, as did also those with water cans, which proves to us that either water or liquid feed is absolutely necessary, except on shipments moving only a short distance. For experimental purposes we have shipped a carload of bees to California this year, where they will breed up earlier than in Utah. We propose to draw package bees heavily from them about the last of May, shipping them back to Utah with sugar syrup as feed.

Tags with printed instructions would be of considerable value. These should be of good size, with such wording thereon as follows:

DO NOT COVER WITH PACKAGES IN CAR.
DO NOT ALLOW BEES TO STAND IN SUN.
DO NOT DELAY EN ROUTE; RUSH DELIVERY.
SPRINKLE FREQUENTLY WITH WATER.
BEES MUST HAVE VENTILATION AND MUST
BE KEPT AS COOL AS POSSIBLE.

If the above suggestions are followed out, we are satisfied losses on express shipments will be largely overcome. Such losses should at least be cut in half, if not almost entirely eliminated. The construction of the package itself is of far less importance than the food supply given the bees during the journey. If properly provisioned to stand the trip, the bees should arrive in good condition in almost any kind of a package, so long as it is well ventilated.

Our receipts during 1917 were several thousand packages, to help offset a severe winter loss of about 60 per cent the previous winter. Packages to help replace this loss were received from such points as Texas, Georgia, Mississippi, Tennessee, California, etc., so that we have had ample opportunity to observe results. We have decided that the vital point hinges on the water supply, either in syrup form, or separate from the feed. Do not overlook the placing of proper handling instructions on the express shipments. The express employees should be educated as to the proper care that the bees should receive enroute to destination.

Ogden, Utah.

F. W. Redfield.



BEEKEEPERS' BOOKKEEPING

Directions as to How Keep Account of the Income, Outgo, and Capital Involved

Now that the Government demands a statement of the finances of every citizen with an income above \$1,000 for a single person and \$2,000 if married, every beekeeper should keep an accurate account of



FROM THE FIELD OF EXPERIENCE



money or its equivalent received and the amounts expended.

The beekeepers' fiscal year should start and end at the time of year when spring and winter losses of bees have practically ended and swarming begins. Thru the central part of the United States, I believe May 1 to be the proper date. On that day take pencil and paper or book, and start the invoice. Count all live colonies of bees. If producing comb honey, let two supers be considered as part of a colony of bees. Figure the value of your bees at prices for which bees are selling in your neighborhood. Count all extra hives and supers and place their value opposite the number. List your extractor, tanks, gas engine, wax press, tools of all kinds pertaining to the bee industry; also cans, shipping cases, wax and honey left over, placing their value on the left-hand side of paper.

Every thing you possess of value in connection with the bee industry should be listed in this invoice and its present value set down. These things are not taxed under the income law, but only the income derived from the sale of the bees or the sale of what they produce. This invoice furnishes a foundation on which to start a simple set of books in which to keep accurate account of your bee industry.

The books needed can be obtained at 89¢ per dozen. They have pasteboard backs or covers and are listed as "Bookkeeping Blanks." Those marked "Day Book" will answer for all purposes. Write on the outside of one, "Ledger," and use it for a ledger. On about the third page of this ledger, write above the top line "Bees." On the first line intended for accounts, write "May 1, 1918. By invoice, 100 colonies of bees @ \$6.00, \$600.00." Charge the \$600.00 in the first column intended for figures. The top of this first column should be marked Debit (Dr.); and the top of the next column, on the same page, should be marked Credit. (Cr.) If you buy any bees during the year, charge "Bees" with the number of colonies purchased at the price paid for them. But do not make any entry of the swarms you have during the season: they will be counted and entered at invoice next May, 1919. If you sell any bees or queens, credit "Bees" with the amount you sold.

Turn over a leaf and write at the top "Supplies and Tools." Charge or debit "Supplies and Tools" with extra hives, extractor, hive tools, smokers, every thing used for keeping and working with bees, and for securing the honey and the wax.

Turn over another page and write "Honey and Cans." Charge "Honey and Cans" with cans on hand; also with all salable honey left over, at the price for which it can be sold. The cans or cases purchased this year must be charged to this account. Also

charge this account with freight paid on cans or cases, as it is a part of the cost of the cans or cases. All the honey sold during the year must be credited to this account, and the freight or postage paid to ship the honey must be charged to this account.

Turn over another leaf and write "Wax." Look on your invoice and, if you had any foundation on hand, charge it to "Wax." If any wax is left over, charge it to "Wax" at market price. All the foundation you buy charge to "Wax." All the wax you sell, or have made into foundation, or trade for other goods, credit "wax" with the value of it.

Turn over another leaf and write "Expense." Charge "Expense" with hired labor, gasoline, cost of fixing broken tools, etc.

If you peddle your honey or sell it in small amounts, mark one of the day books "Honey Sales," and set down in this book every sale you make; and at the end of the year, transfer the total amount of the sales to the ledger to the credit of "Honey and Cans."

Mark one book "Day Book" and set down each day the things you pay out money for and the things you sell, exclusive of the honey sales, which are set down in the book marked "Honey Sales." At a convenient time, transfer these entries in the day book to their proper place in the ledger. Always set down the date in the day book and the ledger.

If you sell honey on credit to some of your customers, enter the sale in your "Honey Sales Book" in this manner: July 30, 1918. John Doe, Dr., 4 10-lb. cans honey @ \$1.25, \$5.00. When he pays you, mark somewhere in the above account in large letters, "Paid." The sale of honey is on record in your "Honey Sales" book and you can readily see if it is or is not paid for. If paid, you need not have any account in your ledger with John Doe.

Use one of the books for your invoice.

Use one in which to keep addresses of your customers, and also of firms with whom you wish to do business.

Do not mix farm accounts and bee accounts.

At the end of the year, ask some friend who is a bookkeeper to carry your accounts to "Profit and Loss," and to close your books for you. Then you will know just what your bee industry is worth. The same friend will tell you what expense to subtract from your income, and whether or not you owe any income tax. C. R. Parks.

Ft. Duchesne, Utah.

[In the ledger, instead of the account "Honey and Cans," some might prefer the two separate accounts "Honey" and "Cans and Cases"; and then at the end of the year charge the "Cans and Cases" to the account of the honey.—Editor.]

FROM THE FIELD OF EXPERIENCE

NUCLEI—NOT POUND PACKAGES

Experience of this Beekeeper is all Against Pound-Package Shipping

After having had the experience of working with over a thousand one-pound packages of bees shipped from different breeders of the South to a company operating in Ogden, I have decided to tell you why I prefer the nuclei to the pound packages of bees.

I find that, owing to high express charges, most Southern shippers try to ship in too small packages. The result is a heavy loss on their part and dissatisfaction on the part of the receiver. One-third to one-half came dead. Some were supplied with sweetened water, some with candy, others with chunk honey. The last had pounded all around in the cage until the larger part of the bees were killed and the residue were so smeared as to be worthless. What does an express agent care whether they stand on end, upside down, or any old way? In the cases in which water was used, the cans had sprung a leak or become clogged, and the bees were dead.

Of all the methods employed, those shipped with a can containing water sweetened with honey came out best. But that is no guarantee that they will arrive in good condition. Besides this loss of bees, it was found later that the queens were more or less damaged, as they were almost immediately superseded.

In my own yards I used the one-frame nuclei purchased from a distance of 800 miles. They were shipped in a redwood box 12

inches wide, 18 long, 9 deep, with a partition in the center, and one-frame nuclei in each side. The express on each box was 50 cents; but there was no loss whatever. Bees, honey, and all, were on one Hoffman frame—no leaking of combs, no suffocation.

The oldest head of beedom will tell you that bees in nucleus form with queen is the only way to ship; and when a receiver would tell us that pound packages are cheaper than nuclei, we feel certain he has not had the experience in handling both that I have had. This year I am sending to the same company again. They are the only ones I have found who advertise pound packages and then send one-frame nuclei with a smile. Why. He knows—satisfaction. N. T. Spangler.

Tremonton, Utah.

[There can be no question but that a pound of bees will travel better on a frame of brood and honey than in any combless wire-cloth cage that was ever invented, whether it has a water-bottle, bottle containing syrup, or a compartment for bee-cage candy. Our experience is that a nucleus will travel safely many hundreds of miles with a loss of less than one per cent, while bees in cages without combs will have a mortality of from 33 to 50 per cent. Why then should combless bees be the prevailing method of shipping? For the reason that bee disease is so prevalent that it is unsafe to ship combs from one locality into another. The consignee always takes a risk when he takes bees in nucleus form.—Editor.]



Altho blind, Chas. Kirk of Embro, Ont., (at the demonstrator's left) is running from fifty to sixty colonies of bees and is making good in spite of his handicap.

THE Swiss Bee Journal says that scientific authorities reckon the value of the bees' labors in fertilizing blossoms at five times as much as their value in gathering honey. In this country it's reckoned at twice as much, isn't it? Probably it isn't an easy thing to have any very definite figures in the matter, but it would hardly seem that there's anything extravagant in saying that the fertilization of flowers is twice as important as the honey. [We have seen no estimate in this country of the relative value of bees' pollination work and the amount of honey they gather. From the little we know of the subject, we should be inclined to favor the estimate as quoted from the Swiss Bee Journal. We do know that the presence of bees in some orchards and in some localities makes an astonishing gain in the amount of fruit produced. We have seen that right in the vicinity of Medina.—Editor.]

* * *

Dr. H. W. Wiley says in *March Good Housekeeping*, page 44: "Another thing which should be fully understood is that there is no common sweetening agent except sugar which is of any value whatever. When we are officially advised to eat 'corn syrup' and save sugar, this fact ought to be known: there is no such thing as 'corn syrup' on the market at retail. This term is applied sometimes to the commercial commodity known as glucose. When I went into the stores and asked for 'corn syrup' I was uniformly handed a can of 'karo.' I sought in vain for the term 'corn syrup' on the label. Karo is glucose which has been sweetened with sugar to make it edible. Bees will not eat glucose by itself. If glucose is mixed with 50 per cent of sugar, bees will eat it. If the Government knows these facts, it should publish them."

Of course Dr. Wiley knows about the value of honey as a sweetening agent, but probably does not consider it a common sweetening agent. Which is true, and "pity 'tis 'tis true." Our bit is to make it more common.

* * *

"The European foul brood is not nearly so prevalent as the American. It is always found in unsealed cells and is a light-yellow color, instead of the dark, dirty, brownish color. While the American foul brood is found at all times of the year, the European is found only at the first of the season before the honey flow."—The Beekeepers Item for March. It is perhaps a common belief that in European foul brood no diseased brood is to be found in sealed cells, for a superficial examination shows nothing wrong with them, but dig away the cappings and you will find a goodly proportion of diseased

STRAY STRAWS

Dr. C. C. Miller

brood in cells that are nicely sealed over. Neither is it correct in this region to say that European foul brood is found only before the honey flow. Does

the warmer climate of Texas make a difference? [It is a little too strong a statement to say that European foul brood does not appear in sealed cells. There is too much testimony that proves to the contrary. Another thing, it should be noted that European foul brood in a few cases takes on the appearance of American in that it ropes almost as much.—Editor.]

* * *

You never know what Allen Latham will be up to next. Now it's honey in a form not commonly found. He has sent me a pound bottle put up in attractive style, a blend of clover, sumac, and goldenrod. The flavor is excellent, yet I've eaten honey of equally good flavor. The thing about it that I'm not sure I ever met before is its texture, and in that it seems to me he has struck something big. He says: "I cannot bear the sandy, coarse-grained candied honey that one often meets. I much prefer liquid honey, or honey in the comb; but I am very fond of this velvety consistency. I get this by seeing that my honey is well ripened, and by giving the honey two or three stirrings as it candies. When it has acquired the appearance of new soft soap—you know like what our mothers used to make in the back yard—I pour it into the receptacles, for after that it will stiffen up in a very few hours. It generally takes from one to two weeks to candy the honey if conditions are favorable."

The even, soft texture, what he well calls "velvety consistency," it seems likely should remove the objection any one could have to granulated honey. At the ordinary temperature of the dining room it spreads perhaps more readily than butter, without the nuisance of dripping as comb honey does when spread. The question is whether the same result can be obtained with honey in general. I don't know. He calls it "honey-butter." I don't altogether like the name. Across the water "honey-butter" is made by adding an ounce of honey to each pound of butter. [Mr. Latham's idea, we believe, is all right as we have done something similar.—Editor.]

* * *

That very practical beekeeper, E. D. Townsend, says, *Domestic Beekeeper*, page 83: "Several colonies were wintered during the winter of 1916-17 with queen-excluders on. Some were left on the same as during summer, others were turned the other side up, throwing two bee-spaces together. On top of the excluders quilts of factory were placed to keep the chaff packing from trickling into the hive. This year likely three or four

hundred colonies are wintering with excluders on the same as summer. With this free passage of bees over the top of the frame, less bees are cut off from the cluster by changes of temperature and lost. We shall pack more colonies with queen-excluders on another fall." [This is only another way of providing space over the tops of the frames during winter. Practically all authorities agree that this is essential and necessary. The kind described by Mr. Townsend, however, may be very simple and easy to apply, because one already has excluders on hand if he is running for extracted honey.—Editor.]

* * *

Old Smithers had to hiccough,
When extracting honey,
At each frame he'd piccough;
Wasn't that too foney?

* * *

"It does not do much good to take two weak colonies from remote parts of the same apiary and put them together."—April Gleanings, page 206. That's because the bees will return to their old location. But you will partly or entirely overcome that, if you put a newspaper over the colony with the best queen and set the other over it, especially if you make this last queenless two or three days in advance. The bees being imprisoned until they gnaw a hole in the paper, will, upon releasing themselves, mark their new location and stay put. [But can you recommend putting two weak colonies together with a newspaper between in early spring? Is it not true that the cluster may be so weak that they will not work thru the paper? We have never tried it in the spring and therefore do not know.—Editor.]

* * *

That discussion as to elimination of drones by the location of the entrance (April Gleanings, page 211) is very interesting. It raises some questions. When bees build drone-comb at the lower corners, are you dead sure it's because those corners are near the entrance? When the warm system is used, with side entrance, do the bees have drone-comb just as certainly and just as much at the middle of the bottom-bars-as at the end? According to the entrance theory, shouldn't there be more at the middle than at the ends? After all, do the bees generally build drone-comb at the lower corners? When I got that far I thot I'd let the combs answer for themselves. So I went down cellar and examined the first 16 combs I came to. They were old, black combs, and here's what I found: Five of them had a decidedly objectionable amount of drone-comb at the lower corners; two of them had a little at both ends; five of them had a little at one end; and four of them had none at either end. That is, of the 32 lower corners of the 16 frames, 10 were bad with drone-comb, 9 had a little, and 13 had none. These combs had been in use pretty certainly 20 years or more, and it is hardly possible that in that time none of the 13 corners without drone-comb had ever

been at the entrances, so it does not seem that corners at the entrances are so universally furnished with drone-comb as the inexperienced would be inclined to believe from reading the discussion.

Perhaps I may be pardoned for saying how the thing looks to me. Nowadays bees are limited as to drone-comb, and are anxious to build it wherever they have a chance, and they'll build just as well in the middle of the brood-nest as at the entrance, if they have the same chance. They prefer to have a space left between comb and bottom-bar, and when given foundation clear to the bottom-bar in a slack time they will dig away the foundation to leave that space, and will dig away more at the lower corners than elsewhere because that's more out of the sphere to which they tend. Then when flush times come, and they hunt every spot to build drone-comb, that open corner is very inviting. But once that corner is filled with comb, will the bees dig away the solid comb to replace it with drone-comb? I don't know, but I doubt. If they don't, then the remedy is easy! just plug the corners with old worker-comb. [It will be remembered that in our April issue we did not offer an opinion as to the effect of the position of the entrance upon the building of drone-comb in the corners of the frames. What you say in this last paragraph seems very reasonable and possible. We hope, however, that our readers will test this out because it is a very important matter. If drone-comb can be eliminated by the A. C. Miller plan it is important to know it. If it can not be eliminated by his plan, then we should know that.—Editor.]

* * *

DeWarren B. Davis, you wonder, page 230, at my not painting hives, and query whether it's locality. Likely. If I were in your locality where "an unpainted hive is fit only for kindling-wood after two years of use," I'd surely paint. But here an unpainted hive is good for 25 years, or until the inside of the hive gives out, so painting is hardly economy. And when a painted hive is the only one to have moldy combs in the cellar, the economy seems still less.

* * *

Stancy Puerden refuses to pronounce the word "vitamine" until some dictionary lists it. We'd be in a pretty fix if every one should be of the same mind, for dictionaries list words only after they have been pronounced. If she thinks she can write so interestingly that what she says must be read aloud to the whole family, and then sprinkles a word all over the page expecting that word to be skipped each time, she's mistaken. "In this locality," rather than to skip the word, we call it vi'ta-min.

* * *

Jas. Bachler, page 234, I don't have rheumatism, and I think it's somewhat due to the honey I eat, and also to some of the other things I don't eat.

WE have lost in wintering up to Apr. 1 about five per cent of our bees—somewhat more than usual. The intense cold of the past winter has caused

a larger consumption of stores which has resulted in a good many cases of starvation; but April is here at last, the snow is gone, and the bees once more filling the air with their gentle hum. I wonder if there is any one so unresponsive to their environment as not to feel the thrill of a new life when all about us is throbbing with the fresh new life that April brings to us.



I am glad Mr. Latham has pricked the bubble of a "let-alone hive," page 216. The inspector sees so many "let-alone hives" in his rounds that they possess no charm for him. "Let-alone hives" and "fool-proof hives" should both be relegated to the rear in these days of bee diseases.

We have recently purchased a small yard of 26 hives. Seventy per cent were dead and those left were in poor condition, as the result of attempting to winter in large brood-chambers and without sufficient packing or stores. We always find something to learn in looking over our neighbors' yards that have met with misfortune or neglect.

As restful as robin songs in spring time, after the long, bleak, snowy winter, are the warm colors of the cover page of Gleanings for April. Again and again have I turned to it to rest and refresh myself and assure myself that the winter is over, the snow melted and gone, that green fields and opening flowers are before us. [You, Mr. Crane, have caught the exact idea and have experienced the exact feelings the Editors had in mind when selecting that April cover design.]

Dr. Miller quotes A. I. Root as saying, "There is no easier, quicker, and safer way of feeding bees that are short of stores than to give them sealed stores of honey," page 218. This is quite true; but how are we to proceed when we have no sealed stores, as often happens in spring time? Where quilts or cushions are used over brood-chambers we sometimes use granulated honey on top of frames very satisfactorily or fill combs with inferior honey or sugar syrup and feed same as sealed stores, but sealed stores are the best.

There is doubtless a tendency in building new combs for bees to draw in the lower corners, especially near a large entrance, as suggested by A. C. Miller, page 212, and

later filling in with drone-comb. If the space is small, it seems to satisfy the instinct of the bees for drones, and does little harm; but if the patch of drone-

comb is large, we have been in the habit of cutting out a triangular piece and inserting a piece of worker-comb in its place resting on the bottom-bar. Such insertions are rarely gnawed out, and the drone-comb removed is rich in wax and pays well for the work.

I have a great deal of respect for Mrs. S. Wilbur Frey, page 214, if she can accomplish all she claims on pages 214 and 215 in "a poor season." "During the entire season," she says, "there were only a few good days that the bees were able to gather honey, and the farmers had plowed up their lands for cultivated crops, . . . there is a little basswood, a few red raspberries, and here and there a buckwheat field, that yielded very little last year." She also assures us that she secured but little from fall flowers as compared with ordinary years, as her combs were full of brood, and yet she secured from colonies run for section honey an average of 50 lbs. surplus per colony and enough to winter them, and an average profit of over \$7.00 per colony. Is not there some mistake about this that is likely to deceive young beekeepers? A season when a yard of bees gives a profit of more than \$7.00 per colony can hardly be called a poor year.

I am surely grateful to Dr. Miller for his more complete method of the treatment of European foul brood on page 218. I had supposed that to make the caging treatment successful it was necessary that all foul brood cells must be cleaned out and polished before brood-rearing was begun. But now we are given to understand that it is only those that have died at a certain age and turned yellow that spread disease. There appear to be a good many mysteries connected with the spread of this disease that it would be a comfort to have cleared up. How long does the virus live under different conditions? What conditions are most favorable for its development or its death? Some years ago a teacher in our graded school asked for a single-comb observation hive. I selected a suitable comb, and while getting things ready dropped the comb for a little time into a hive that proved to be infected with European foul brood. I expected this comb of brood would soon develop disease, but I found no indication of disease that season. However, the next spring it came down with a virulent form of European foul brood, so bad that we did not attempt to cure it but destroyed it—combs and all.

"GIVE us this day our daily bread." I wonder how many readers of Gleanings have ever attached any particular significance to the above line in our Lord's Prayer. I for one have always repeated that part in the most perfunctory manner. To me it was somewhat like "grace" at the table. It seemed like a graceful acknowledgment to the Creator that we are indebted to Him for our food and daily comforts, a reminder that in olden times there was sometimes a scarcity of food. That people in civilized countries should ever regard it in the light of an earnest petition did not occur to me.

You may have noticed that the Food Administration has recently sent out speakers to every part of the country to tell of the urgent need of food conservation. A commission of six has recently returned from France where it was sent to see conditions and report what it actually saw. The members of this Commission together with other speakers have been making this speaking tour.

The speaker assigned to our town was a woman, and the address was well advertised for weeks in advance. It was at the courthouse, and on our way there we had to pass our local picture theater. Now I have no objection to a good picture show. The children and I go occasionally and we enjoy it, too. But I did not enjoy seeing crowds of people around the entrance to that picture theater, waiting a chance to get seats, while at the courthouse a few people at a time were drifting in to hear a speaker sent out by our government to talk on a most important phase of war work.

Now I wish to tell you a few points that this speaker made. If people in other towns turned out in the proportion that they did here, there is little chance that I shall be repeating anything you have heard before.

A Hero of France.

Let me begin by telling you a little story. The members of this Commission were invited to witness an unusual occurrence "somewhere in France." A private soldier was to receive a decoration. Previous to this he had received all the decorations for bravery which France had to bestow, and so the authorities had to get together and decide on a new decoration. The deed which called for this last decoration was this: There had been a sharp engagement and when the soldiers returned to their trenches their colonel was missing. This man, Henri Andre, volunteered to go back out in "No Man's land" in search of him. He finally found him in a shell hole, paralyzed by a shell wound in his spine. Henri managed to get

OUR FOOD PAGE

Stancy Puerden



his helpless colonel on his back and started crawling back to the French trenches. When they had gone but a short distance, the slowly moving figures were discovered and the boches opened fire on them. Henri's hand was shot off, later his leg was broken in two places by shots, and, if I remember the story correctly, he received some other wound. But in spite of his terrible wounds and the burden of his helpless colonel on his back, he crawled back three hundred yards and saved his officer's life and his own.

When Henri Andre came to receive his decoration he was dressed in an old civilian uniform, one arm hung limp, and he was on crutches. France cannot supply new uniforms even to the soldiers she decorates for bravery. When he went home a little woman in a sunbonnet and several little children were with him. His home was a little hut, which had been built after his house had been destroyed by enemy shells. Later on in the evening when the members of the Commission were talking to the commandant, a messenger came to see if he could get a bread card. The commandant told him he was sorry, but it would be irregular to issue a card at that time. On inquiry it was found that the card was wanted for the family of Henri Andre, that when their ration of bread was issued the day before the children were so ravenous with hunger that they had found and eaten it all, and now the family of the hero whom France had decorated with all the medals she had to bestow and for whom she had then devised a new decoration, was hungry. One of the Commission immediately put his hand in his pocket and suggested that they go out and buy bread for the family. The commandant told him that bread could not be bought in France without cards.

Hungry Children.

May I tell you one more story? The members of the Commission were present when a line of little children came up to receive their bread ration. By the way, that bread was twenty per cent wheat flour and eighty per cent substitutes. An inspector stood by the line and occasionally he bent over and scrutinized some child sharply, felt of his flesh, and then pushed him out of the line. The children who were treated in this way went away crying bitterly. A member of the Commission asked why this was and was told that these children looked strong enough to endure twenty-four hours longer without bread, and so were sent away without it. And yet we find people in this country who are unwilling to substitute grains just as high in food value for part of the

wheat, that we may send it to the hungry children of France.

The speaker further told us that the allied world is on the verge of the greatest famine ever known. Remember famine does not begin when the last ship is sunk by the submarine. It begins when the food supply falls below normal, and it has been below normal for months in France and England.

The pity of it is that you who read such an article as this are not the ones who need it. You are already trying to carry out the wishes of the Food Administration. But there is something you can all do to help. Won't you make it your business to see that the terrible need of conserving wheat is carried to every part of your community? Self-interest, if nothing higher, should dictate that we implicitly obey the directions of the Food Administration. Our Allies must be fed. "We must go on or go under."

Money Versus Food.

Don't, please don't, confuse the saving of money with the saving of food. It is food of which our allies are in such dire need. It probably costs you a little more to use the substitutes than to use the wheat flour. That is one of the sacrifices you and I must make to win this war. When men are dying at the rate of 100,000 a day, when their blood flows in the trenches like water, are we going to shirk our part?

The stories which come to me of late of people who are defeating the purpose of the Food Administration by purchasing the wheat substitutes and then throwing them away, make my heart sick. We have no right even to feed them to chickens. It is up to us as patriots to eat those substitutes and buy more feed for the chickens.

A certain Hungarian, who has not lived in this country many years, is a better American than many who were born here. His wife had been making her bread largely of cornmeal. One day she said, "I am becoming so tired of cornmeal in bread that I don't believe I can eat any more of it." "Yes, you can," said her husband, "it is our duty to eat the wheat substitutes, and we are going to do it whether we like them or not; and we should be thankful we are living in a country where we have enough to eat, even if it is not just what we like best."

The Food Administration is now asking us to get along with 1½ pounds of wheat products per person a week. Possibly by the time this is in print the amount will be even less. We must send the most concentrated foods to our Allies when there is such a ship shortage and their need so great. Corn cannot be shipped at all at this time of year, as it is the germinating season and it would spoil in transit.

Try weighing out wheat flour enough to make 1½ pounds per person in your family, and then make up your mind to use as much less as possible in one week. For weeks back we have not been using that much in the Puerden family, and we are in the best of health. During the Civil War

the Southern States managed to get along without wheat for three years, and we can do the same if we have to. Wheat bread is not a necessity but a luxury.

For the sake of the health and well-being of your family you should make what bread you use at home. Many of the bakers, in deference to the wish of the public for perfectly white bread, are using corn flour as the wheat substitute. Don't feel your children corn-flour bread if you can help it. They need bread made from the tissue-building parts of the grain. Cornmeal is good, but corn flour has been robbed of the best parts of the corn in the milling. It is little better than cornstarch.

If you become very hungry for white bread, try the recipe for oatmeal bread which I am giving this month. It tastes very much like ordinary white bread and yet uses about one-third part oatmeal. The rolled oats also may be added to an ordinary white bread recipe without the preliminary scalding, but in that case it is well to put it thru a food chopper first.

Make your muffins and quick breads wheatless, if possible, in order to save what little wheat flour you use for your yeast bread. It is not hard to make all desserts wheatless if you use your ingenuity. Last winter we were asked to make our cakes sugarless and eggless, and now we may use plenty of eggs during the spring season and a moderate amount of sugar, but no wheat.

Don't be afraid to try those barley-flour cakes. The recipes were worked out by an expert of the Food Administration and they are delicious. I have tested them, and let me tell you something—I am the sort of woman who needs fool-proof cake recipes. The one for drop cakes I changed slightly in order to use honey instead of sugar.

OATMEAL BREAD.

3 pints rolled oats	1 cake dry yeast soaked
2 tablespoons honey	in
1½ tablespoons salt	1 cup warm water
3 pints boiling potato water	white flour

When preparing the evening meal pour the boiling potato water over the oatmeal, honey, and salt. When lukewarm add the yeast softened in the cup of warm water. Beat well and set to rise in a warm place. At bed time mix in enough flour to make a rather stiff dough, and knead well. Flour as now milled has not the absorbing power that it formerly had and therefore all bread should be mixed stiffer. Cover the bread raiser and leave over night. In the morning divide into loaves, let rise again until doubled in bulk, brush the loaves with melted shortening, and bake. This should make four large loaves. The sponge may be started late in the evening and the flour added in the morning, if preferred.

APRICOT OATMEAL BETTY.

2 cups cooked oatmeal	½ cup honey
1 cup cooked apricots	½ teaspoon cinnamon
½ cup raisins	½ teaspoon salt

Mix the above ingredients lightly and
(Continued on Page 313.)

ONE day at the very end of March, I went a few miles out of Nashville to examine some bees for the widow of a late side-line member of our

association. It was a perfect day in apple-blossom time. On my way out it was borne in upon me once again that beekeeping is one of the few side lines that are utterly at one with the beauty of the earth. It takes us, of necessity, out into the suns of spring and summer, and makes us eager watchers of the procession of the flowers. Talking shop with beekeepers means always some mention of budding maples and apple-bloom, of clover fields or sweet singing locust or the golden-rod and wild asters of the autumn.

It is partly because of this natural connection of bees with the beautiful things of earth, and partly just because it is spring again, that I come renewing my plea for beautifying our beeyards. Of course this means side-line yards chiefly. Extensive commercial beekeepers must concern themselves (poor things!) with outyards and trucks and labor and doing things on so big a scale that nasturtiums and daffodils and gay hollyhocks must be left quite out of their plans. But it is different with those who keep a few stands of bees at their own homes. Neat, well-painted hives really add of themselves to the attractiveness of any yard. Put them under your fruit trees, near the young grapevines; set out syringa or bridal wreath or lilac near; put in some narcissus bulbs or iris; let honeysuckle climb over the fences and have roses all around. Then will your apiary be a thing of beauty, a lovely spot where the very work is rest. If your real labor lies amid the glare and roar of the city, here you will find healing for your soul.

Then on my way back that day another thing came to me forcibly. Better have two colonies and give them good care and attention than have 22 partly neglected. In this particular case, the sad and sudden death in July had naturally left the bees without any fall attention—in fact, with supers piled almost to my shoulder. But this side-liner was a very busy man (and a very good man) and last summer he had frankly admitted not having examined some of his brood-chambers for two or three years. It wasn't strange I found them so difficult to get into. Strength and ingenuity were sorely taxed in prying off supers and almost exhausted in pulling out brood-frames. Outside combs clung to the hives—and broke—and almost spoiled the party. Queen-excluders were nearly solid with propolis. A good many colonies had died. Roaches were plentiful in others. Bees were cross.

Let us be very careful, we side-line beekeepers, to increase our yards only to the ex-

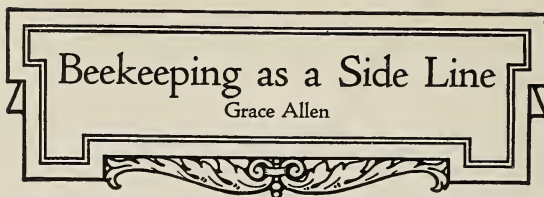

tent that we can continue to give them good care. If we have time to give good care to five colonies or slipshod to ten, five is our logical limit.

Because we may have made a success of 20 colonies, it does not follow that we will make a success of 30. If we are wise, we will inventory our hours carefully, and not increase to the number that compels carelessness or neglect.

Undoubtedly side-line beekeepers as a whole are inclined to spend more time with their bees, per colony, than is required, or even advisable. That is partly because of love of the work, and largely because of a lack of efficient methods—a regular worked-out system. It is not good for the bees to be constantly opening their hives and interfering with their own schedule. Neither is it good to leave them too much to their own devices, not knowing oneself what they are about. Hives do get hard to open and frames difficult to manipulate. Bees are more resentful of inspection when they don't get it often. Hives may become crowded. Unexpected swarms issue, weakening the colony. Disease may get a start. Truly, better two colonies well cared for than 22 half-neglected.

* * *

Oh! the blossoming trees, the blossoming trees,
That waft all the scent of their souls on the breeze,
And blend the spring rapture with beauty sublime
And sweetness that haunts us like music and rhyme!

* * *

For Dixie Side-liners.

The rest of this concerns Dixie side-liners. Did you notice how M.-A.-O. squealed on page 256, April, just because he was 'squeoze'? And did you happen further to notice that in that same issue the Dixie Bee just quietly died, without even a squeal? She didn't know she was going to die, she doesn't quite know why she did die, but die she did. The Editor says so. Hereafter if any Dixie bee wants to go humming thru a page of Gleanings, it has to be in this side-line department. So, if nobody minds, we'll start in right now. [No—Dixie Bee isn't dead, nor shall she die. This queen has merely been "transferred."—Editor.]

We are all intensely interested in this Southeast in whatever experiments have been made with winter packing, and are asking one another how it turned out. There have been letters as well as personal inquiries about the results here in our own yard. Last month I had high hopes for our one quadruple packing case. Our county association met last week, on Apr. 6, and, as I had been asked to give a report on this winter packing, I opened the big case the day before. Today I looked into one hive that snuggled a'l winter by itself in the center of a big box, with inches and inches

of dry leaves above and under and around. So far I am disappointed. One colony in the big case died, neither from cold nor starvation—probably lost its queen. The others are fairly strong with bees and have plenty of stores. They are not, however, any stronger in bees than some of the colonies that were not packed. I think they average somewhat more stores than the others.

But what is most discouraging is that brood-rearing is behind. At this time of the year, the most satisfactory colony is the one that is rearing the most brood, as the honey flow is almost upon us. (In fact, white clover is already coming into bloom, incredibly early as it may seem. I picked my first white clover bloom on Easter Sunday, March 31.) The packed hives are certainly behind the unpacked hives in brood-rearing.

Now I know this question isn't settled yet, and I intend to try out this very case again. I really had hoped big things for it and haven't given them up yet. To date, however, they have not materialized.

But the little experiment with upward ventilation did all I hoped for it. There was not a moldy comb in a hive where the sealed cover was replaced by burlap, over which was a super of leaves. There were six of these and another fall there will be more. All moldy combs in the yard were under sealed covers. Yet this experiment is not conclusive, as there were colonies under sealed covers where no moldy combs showed up.

Comparing colonies in brood-chamber only with those wintered in two stories, I see very little difference, tho the latter average a trifle ahead in brood-rearing. Last month I mentioned a strong colony that starved in February. That one was wintered in the brood-chamber only, which was contracted to eight combs and had the sides packed.

Mr. L. E. Webb, of Morganton, N. C., maintains that the standard hive, even 10-frame, does not make a brood-chamber large enough for wintering without protection in this part of the country. Moreover, he would rather risk a colony in a large unpacked hive than in a single standard brood-chamber in any amount of packing. He wintered every one of his colonies this past hard winter, all in Jumbo hives and story-and-a-half standards. His recent letter is so interesting I am tempted to quote extracts.

"Didn't lose a single colony, didn't have to feed any in spring and haven't a weak colony; having looked thru all, find I will have all ready to swarm before April is out . . . Within a few blocks a number of good Italian colonies starved in standard hives. I didn't pack any, except to place an inch of newspaper between the metal and inner covers, leaving sealed covers on, entrance $\frac{3}{8}$ by 2 inches, and during the zero weather piled the loose dry snow around the hives until it showed signs of thawing. . . I am pleased to the extent of being "Dee-lighted" with my wintering arrangements.

After such a winter as we have had, am satisfied my time is worth more elsewhere than in packing bees (and there's the expense of packing), so I am going to run my yard unpacked, with sealed covers and small entrances, and large brood-chambers thru-out the year. It is such a satisfaction to be free of the worry of feeding, and know they are safe from starvation regardless of the weather; but still greater is the satisfaction of such immense colonies."

One thing is sure—for myself, I shall never again use loose packing. It's too mussy. Being a mere side-liner, I can easily get enough sacks to stuff the packing in. Don't most side-liners buy chicken feed? There are the sacks, and it saves a lot of muss at both packing and unpacking times. Moreover, one can thus look into the hives before ready to unpack, if desired, and replace the packing easily.

* * *

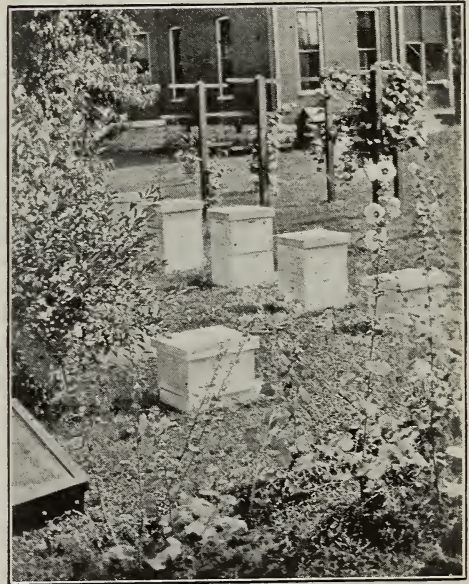

Hives on green grass near fruit trees and young grape vines. "A lovely spot where the very work is rest. Here you will find healing for your soul."

* * *

POLLENIZATION

Like Spanish galleons in from the seas
 With onyx and gold from rich Peru,
 Heavy with treasure, and singing, my bees
 Float in from the blue.

Powdery plunder of green and gold,
 Gay little gems of purple and red—
 The bees have not begged them nor bought
 them nor sold—
 They steal them instead!

Laden with delicate dust from a flower
 To the heart of another a pillager slips—
 And a wonder is done in the plundering
 hour
 Of these my ships!



FROM NORTH, EAST, WEST AND SOUTH



In Northern California—Copious rains visited this section during March and the weather on the whole was not favorable for bee activity. There were comparatively few bee days during almond bloom. Nevertheless both beekeeper and almond grower have been benefited considerably. On the other hand, conditions in the orange groves are exceptionally favorable. The trees are now (Apr. 5) in bloom and many beekeepers with colonies in fair condition are taking advantage of this excellent source of nectar. Filaree and mustard are yielding, but they have not the rank growth of normal years. April showers will prolong their blooming periods and beekeepers may yet secure considerable increase. The condition of the bees generally is backward. Very few colonies are strong enough to swarm and many are still weak owing to disease and the mild winter which has resulted in an unusually high death rate among the old bees. Some Fresno County beekeepers report 20 per cent of their colonies queenless this spring. This trouble in a less degree is prevalent elsewhere.

The Monterey Beekeepers' Club held their second meeting at Salinas on March 16. The principal topic of discussion was that of organizing a honey producers' co-operative exchange, as outlined previously in Gleanings. The consensus of opinion was heartily in favor of such action and it was held that at least 6,000 colonies without much effort could be subscribed. A local promotion committee of prominent beemen was named in order to carry on the campaign work. The officers of the club are: M. G. Lee of Pacific Grove, president; Geo. Sill of Watsonville, vice-president; and H. J. Hemriken of Salinas, secretary-treasurer. Crop prospects in Monterey are good, with the black sage in bloom at the time of the meeting. A. Norton of Watsonville, the inspector of the county, reported the results of a unique and successful experiment, namely, the sowing of a hillside with the seed of white sage. This honey plant, which is not indigenous to the locality, according to Mr. Norton, made a thrifty growth and yielded a surplus at a time when there always existed a dearth. Mr. Norton urged beekeepers to sow not only white sage but white sweet clover seed as well. The two types of brood diseases in the county are not only prevalent, but are also seriously interfering with increase and honey production.

The series of meetings held in the San Joaquin and Sacramento valleys at Bakersfield, Visalia, Hanford, Fresno, Modesto, and Sacramento, during the first week in April, were decidedly helpful and instructive. The outstanding features at these meetings were as follows: The desire for organization, the general prevalence of disease, and the lack

of an efficient state law relative to bee diseases. Pertaining to organization work the results were highly satisfactory. Many thousand colonies were signed up and the interest in the subject was very keen. It is expected that a large part of the beekeepers in our valleys will become members of exchanges in record time. The Central Valley Honey Producers Co-operative Exchange has already applied for articles of incorporation, and it will not be long before this exchange is in operation.

The disease situation is serious, and it may be stated that the production of honey will be curtailed considerably in northern California. In many of the sections where meetings were held Geo. S. Demuth, of the Bureau of Entomology at Washington, found that both American and European foul brood not only existed in the same apiary and colony but also the the same comb. In not a few cases it was extremely difficult to diagnose samples, as in some instances a colony would have considerable European and a few cells of American foul brood. In one case in particular, a short honey flow resulted in healthy unsealed brood, a considerable amount of sealed European with a few cells of unmistakable American. In the same apiary, the next few colonies examined were infected mildly by European, only to be followed by another colony showing a few cells infected with American. Such conditions are not rare and are becoming increasingly common. Your correspondent in several of his apiaries has a sprinkling of American scattered thruout a large part of colonies infected by European. Is it any wonder that so many beekeepers become confused in their diagnosis? This condition exists today thruout our entire section. Not only this spring, but in some years past, many colonies with traces of American, but covered up and apparently lost sight of by the more discernible symptoms of European, have been treated for European and the destruction of combs was not practiced. It must be seen that American is spreading widely and undetected. So we are grateful to our Agricultural Department at Washington for their help in impressing upon us the importance of careful diagnosis. Colonies predominately affected by European, yet containing some American, should unquestionably be treated for American. Let every beekeeper make a thoro study of the symptoms of the two diseases, and, when in doubt as to diagnosis, treat the trouble as if it were American foul brood. No reports of sacbrood have been received this spring. Many of our counties have secured new ordinances this spring as a protection against infected material thru migratory beekeeping. There is increasing dissatisfaction over our antiquated state foul brood law, and one of the first things that our California Honey Pro-



FROM NORTH, EAST, WEST AND SOUTH



ducers Co-operative Exchange hopes to accomplish is the drafting of a new law, and, by means of the Exchange's united representation of the beekeepers of the state, to secure its passage.

M. C. Richter.
Modesto, Calif.

* * *

In Southern California—Perhaps never in all the years since bees were first brought to southern California has there been a season like the present. During one whole year, or until Feb. 17, scarcely enough rain fell to lay the dust. From Feb. 17 to date (Apr. 3) from 8 to 16 inches have fallen over the honey-producing sections of the State. Even tho the ground is getting dry and rain is again needed, crops of all kinds promise well, and honey is no exception. Even the orange, that is always irrigated, will yield much better when thoroly wet by nature's rainfall. Sages and wild buckwheat are looking better every day. Some difference of opinion exists as to the probability of the black sage in this section yielding a full crop owing to the lateness of the rainfall. Usually this plant starts growing in January and during some of our good years, I have seen six inches of new growth in February. At present the new growth measures only three or four inches. A great deal will depend upon the weather during April, May, and June as these are our principal honey-producing months. With warm, balmy weather and not too hot, we may expect great growth from all wild vegetation, and growth means blossoms, and blossoms mean honey.

The series of meetings held in different parts of southern California, with Federal and State bee-experts present, have been of great benefit to beekeepers. I do not think any of us could listen to the splendid addresses of such men as Demuth, Atwater, Coleman, Weinstock or Massey and not get many good ideas. Much interest in the California Honey Producers' Co-operative Exchange was manifested, but where there are strong beekeepers' clubs, working satisfactorily, the members are inclined to think that they are not much in need of this organization and are slower in taking up the plan. Consequently, educational work along co-operative lines is quite necessary to properly instruct beekeepers in the advantages of state-wide organizations.

To get the real practical side, some of the beekeepers of Riverside County spent a day with the bee-experts visiting apiaries. Here is where the heart-to-heart talks seem to be at their best. Nor do we get all of the good ideas from the experts. In visiting one man's apiary, we found neatness personified. More than 300 10-frame hives were located on a piece of ground just 100 feet square and did not seem crowded. The hives have a 7/8-inch entrance, when clear, and an en-

trance-closer that is ahead of anything I ever saw or heard of. A change of position gave an entrance of 1/4 by 5, or 3/8 by 12, or full size, or closed the entrance entirely.

Bees in the orange districts in most cases are in good condition. The honey flow coming at least a month later than usual will be of great benefit to many beekeepers. Colonies that were weak and light in stores have had time to build up and should make a good surplus. The oranges are just about ready to blossom and in a week or 10 days we can look for the honey to begin to come in.

Buyers have been around since Mar. 15 ready to contract for our 1918 crop. How to know what is our just due as to price is our great question. Coming, as our orange honey does, almost two months earlier than most other kinds, it is hard to set a price.

L. L. Andrews.

* * *

In Idaho—Additional reports continue to indicate that winter losses in southern Idaho will be extremely light. Several honey producers with 150 to 350 colonies report losses of less than 5 per cent. Another states he lost only one colony out of about 500, but this is unusual and credit should be given this man for his thoro winter preparation and attention to detail. It is probable that the average loss will range from 5 to 10 per cent, this not taking into consideration spring dwindling.

A number of commercial producers state that in their districts ranchers are planting up alfalfa and seeding this acreage to wheat. These men are attracted by the high price of wheat, and, no doubt, the difficulty experienced in marketing alfalfa hay in certain parts of this State last fall and winter has some bearing in the matter. Several producers are now seeking new range for bees at present located near the plowed acreage.

The above comment on range brings to mind the fact that repeated inquiry has been made in this immediate territory the past few years by Eastern beekeepers searching for new locations. Letters of information have been forwarded to inquirers saying this range is now overstocked with bees and no open range is available; further, that a change of location might be made by purchasing an outfit already located here. The Boise Valley is badly congested at the present time. Beekeepers of towns located in that valley are continually working over into range of neighboring towns in all directions. The Payette Valley is also heavily overstocked, with apiarists of various towns working into neighboring range—not only in the valley but in other near-by territory. Some inclination is shown by the larger apiarists to ignore the smaller beekeeper, and instances are known where out-yards



FROM NORTH, EAST, WEST AND SOUTH



have been established within a very short distance of small yards on the home grounds of owners.

We have had cold weather and high winds for over a week, the latter being especially disliked by apiarists. However, our bees are coming along in good shape, and conditions up to this time have not been particularly adverse.

A few honey producers in this vicinity are inclined to ignore our State law governing the inspection of bees before moving. One or two have barely escaped arrest for moving out-yards without a permit from local inspectors, and our State Horticultural Inspector, who is also ex-officio State Bee Inspector, feels that beekeepers should cooperate more fully with him. An effort will be made during the next session of our State Legislature to provide heavier penalties for violation of our bee laws.

Demand for both comb and extracted honey for fall delivery is increasing. Buyers both east and west are trying to place orders subject to approval of price later in the season, but up to this time no record is had of contracts being made. The usual influx of Coast buyers looking for cheap honey is anticipated later.

P. S. Farrell.

Caldwell, Ida.,

* * *

In Iowa—The beemen are quite enthusiastic over the prospects for a good honey crop this season. The beautiful sunshine of the past few weeks would produce a smile of anticipation on the countenance of the sourest Iowa beekeeper. This State has been blessed with one of the mildest and most agreeable of March months. While it was warm enough almost every day for bees to fly, the nights were quite cold. Vegetation did not advance fast enough to be in danger of being harmed by a freeze at any time. April, so far, has started off rather cold, the temperature already ranging as low as 20° F. We are short on moisture, so far, this spring. With no fall rains and the ground very dry, it may yet prove to be a menace. There have been two light rain-falls the past two weeks. This section needs copious rains.

Many bees are still in the cellars. There has been nothing of consequence in Iowa that bees could use; and, unless the bees are suffering for the need of a flight, they are much better off in the cellar.

With few exceptions, section honey sold in Iowa at present, is imported from the more favored states. In Marshall county, the home of the writer, honey production was a failure last year. Section honey retails in Marshalltown at 25c to 30c per section—when it is to be had; and then some of it presents a very unmarketable appearance.

Hamlin B. Miller.

In Ontario—Since sending in report for April Gleanings, many have written me regarding winter losses. Summing up these reports, it would seem that the winter loss has been much heavier than it was thought to be a month ago. The heaviest losses seem to have occurred in localities where they generally have a fall flow. Owing to the cool weather here in Ontario during the last half of August and early September, this expected flow failed to materialize. The result was that bees were not as heavy as usual, and, with an exceptionally severe winter, the bees perished largely thru starvation. Many colonies died leaving honey on the side of the hive opposite from where the cluster was formed. The bees consumed all the honey on the combs on which they were clustered and then were unable to move over to combs of honey on account of severe weather. In other words, they had too much "winter nest." A number have reported a loss of all their bees—these reports coming from amateurs, as a rule. But some older beekeepers have had a terrible loss as well. One friend, who had 150 colonies within 10 miles of one of my apiaries, stated that his bees were heavy enough for winter and needed no sugar feeding—crop was a failure there last year and honey would not have been available even if wanted. As my large apiary, located in the same kind of locality as my friends, most assuredly did need feeding, I was puzzled as to why there should be such a difference. I have just returned from a first visit to this apiary in question, and found perfect wintering, as out of 190 colonies put in cases in the fall, 175 are in fine shape and most of the balance were queenless last fall. On the other hand, I am told that my friend's apiary of 150 colonies has not 50 colonies left alive.

While on this question of winter stores, it would not be fair for me to stop without making a confession as to failure on my own part. As I have already stated more than once, owing to having a lot of buckwheat in sealed combs last fall, I used these full combs in place of feeding sugar syrup as I usually do other falls and as I should have done last fall. Now I felt sure that all had enough as I had combs of honey left over after giving all that I thought necessary. But for some reason my judgment was either wrong or else the consumption of stores was heavier than usual, for at one yard there were half a dozen colonies starved before their condition was noted, and at another apiary half a dozen or more would have starved in a few days if I had not found out their needs early in April. Such a condition is deplorable, for if there is anything we dislike in connection with the bee business, it is to be forced to feed in the spring



FROM NORTH, EAST, WEST AND SOUTH



to avoid starvation, and I have to do that very thing this spring.

Sugar is scarce just now, but the wholesaler sent me some "Jamaica crystals." This sugar is put up in large sacks of over 200 pounds and is designated as a "raw" sugar. Can any one tell me as to whether this sugar would do for winter stores or not, as it might be available this fall when granulated would be hard to secure?

Clover is looking well, and, altho we have had freezing nights for the last 10 days, danger from heaving should soon be over. I had thought that owing to very high prices of all kinds of grains clover growing would decrease in favor of grain growing. But clover seed is also very high, and farmers recognize the need of rotation of crops and are not to any great extent, at least, cutting down on the clover crop. Careful inquiry from seedsmen shows that the clover seed sales this spring are on an average with other years, and that is about the best way of gauging a question of this kind.

No change in the honey markets except that honey is still scarcer than it was and most of the dealers have none to offer.

Regarding the heavy losses among many beekeepers, it is unfortunate that Southern breeders are not able to supply the demand for queens and packages. A few that lost all their bees have been unable to get promise of delivery from Southern breeders, and some are trying to buy a colony or two for the purpose of making increase again and caring for the combs they have on hand. Winter losses are always bad enough, but under present conditions are exceptionally regrettable. [But the Southern breeders are to be highly commended for not promising deliveries of which they themselves are uncertain.—Editor.]

Surprising what bees will stand in a very severe climate providing they have lots of good stores in a position available for the bees' needs, no matter how cold it may be. The strongest colony of bees that I have seen this spring is in a basswood log standing in a neighbor's apiary. The tree was cut in February and when the bees were discovered, the log was cut thru just above the combs and a board nailed on to keep out rain. The entrance was about five feet further down the tree and consisted of a hole about four inches in diameter. The log was brought to my friend's place, and, altho he has a lot of strong colonies in regular hives, this colony in the log will be flying when not a bee is stirring in his other colonies. I have had other reports this spring of bees having wintered well in trees, so it can be safely said that cold does not necessarily mean injury to bees, if stores are abundant and of good quality and in the right place.

Markham, Ont.

J. L. Byer.

In Texas—On March 31, Frank C. Pellett left for his home, having completed a seven weeks' tour of the State. This was perhaps the most comprehensive trip ever undertaken by any specialist in apiculture in any State. The trip included almost every important beekeeping section from the extreme southern to the northern border of the State. Mr. Pellett came primarily to observe Texas beekeeping conditions and he found much of interest and some features that were very unique. Taking the attitude of a visitor, Mr. Pellett could readily see many problems in Texas beekeeping that must be solved. In most of the counties that Mr. Pellett visited, the County Beekeepers' Association held a meeting so that most of the beekeepers might avail themselves of the opportunity of meeting with Mr. Pellett. W. E. Jackson of the State Entomologist's office accompanied Mr. Pellett on the entire trip. E. G. LeSturgeon, manager of the Texas Honey Producers' Association, was present during a portion of the trip. Much good will come to the beekeepers of this State as a result of this trip of study by Mr. Pellett.

At the annual meeting of the County Apiary Inspectors the need of an experimental apiary was discussed. In order to get one in operation at the earliest possible date, each inspector agreed to donate one colony of bees to form the nucleus of an apiary for experimental purposes located at College Station. This public-spirited move on the part of the inspectors to advance the beekeeping industry of this State is worthy of much commendation. Texas needs much investigational work in apiculture and it is expected that the present gifts will prove to be a start of much good effort for the industry.

Over the eastern half of the State quite general rains have occurred in the last two weeks, but the western half is still very dry. In some localities of the mesquite area, light showers have occurred and these will help greatly. Much more rain is badly needed over the entire State to insure satisfactory honey yields.

Several of the larger shippers of pound packages of bees have received orders for all they can supply. There are still a few who are well prepared to handle late orders. An effort is being made by the State Entomologist's office to determine who can handle more orders so as to direct purchasers properly. There is an increasing demand for package bees from beekeepers in the North and it is the desire to put buyers at once in touch with those who may have bees for sale.

More interest is being manifested in bees by a greater number of people this year than ever before. It is a well-directed desire to produce as much honey as possible so as to



FROM NORTH, EAST, WEST AND SOUTH



release more sugar for our army. And why do we not produce more honey? It can be used in so many ways and is a healthful sweet. There are some beekeepers in the State who feel that beginners should be given every encouragement in their new endeavors. One has even gone so far as to give detailed information on the production of section honey. Such ill-advised information can only do harm to the industry.

In one county it has been estimated that 30 per cent of the bees in trees have died. It seems that nature takes care of what belongs to it wonderfully well. In this same county, the average loss of the beekeepers was higher.

We notice with much interest an advertisement of an enterprising queen-breeder offering for sale "medelian" bred queens. This is a big term full of meaning which will baffle the majority of the beekeepers.

College Station, Tex. F. B. Paddock.

* * *

In Florida—The orange bloom has been somewhat of a disappointment this year. Altho we have all secured fair crops, the flow was of such short duration that only the best of colonies were able to make a good showing in the supers. From all reports available, the crop will be about 45 lbs. per colony. There will be some reports of very much larger yields, the kind of reports that give a false impression of Florida beekeeping. But the object of this department is not to exploit the doings of individual colonies or small apiaries in especially favored locations. There are always some colonies that give results out of all proportion to the rest, but these exceptions should not be taken account of when forming an average. I have one colony of Carni-Italians that have given me over 200 lbs., and several others that have given over 100 lbs., but such colonies can only be looked upon as freaks.

Altho our crop is not so good as in 1914, the advanced prices will more than make up for the shortage. We are offered 15 cents per lb., f. o. b. shipping point, and, while this is a good price, it is doubtful if we ought to accept it. Cuba is offered the same price for campanilla honey, the low-grade West Indian honeys bring the same, and I have one report of a crop of cabbage palmetto that sold for 16 cents. Why should Florida beekeepers sell their best honey at the price of inferior grades? It is seldom that we make a crop from the orange, and to sell at the price of palmetto and fall honeys is not reasonable.

The practice of selling to the consumer and small retailer at the same price we are offered by the wholesale houses should be discontinued. When we are offered \$1.80 a gallon by, let us say, the A. I. Root Co., is

it fair that we should sell locally at \$2.00 per gallon when "Airline" honey is being sold in our retail groceries at a very much higher rate? It is the wholesale buyer on whom we depend for the disposal of our crops, and we cannot expect the best prices when we do not give a square deal ourselves.

Prospects of a good crop from gallberry and saw palmetto are excellent, and this bloom is coming nearly a month earlier than usual in this section. Already the gallberry is in bloom (Apr. 4), and a few sprays of palmetto are flowered out. There has been comparatively little swarming where the bees had plenty of drawn combs, and colonies are in fine shape to care for the coming palmetto bloom, which will undoubtedly be the heaviest we have had for years.

Many new apiaries will be started in Florida this year, if all those who are trying to buy bees succeed. Many will do well, but a great many who are locating near the orange groves will fail because they have nothing with which to back up their orange flow. If those who start with bees would look first to their summer pasturage, there would be fewer failures in Florida beekeeping.



A Florida Apiary.

The picture of the apiary printed above doesn't show anything in particular, but it does show in general what a Florida apiary looks like and Florida apiaries are doing pretty well this season, thank you.

Apopka, Fla.

Harry Hewitt.

HEADS OF GRAIN FROM DIFFERENT FIELDS

Better Treatment for American Foul Brood.

Recently Gleanings has received several requests for a plan of treating American foul brood which would be less expensive, less exhausting on the bees and more certain in its results than the usual shaking plan. We here give a simple method by making use of a bee-escape which we believe will answer the requirements, but at the same time call attention to the fact that the recurrence of American foul brood is not necessarily a reflection upon the shaking method as it may be due to some neighboring source of infection. However, it is true that in shaking there is the possibility that some honey might be shaken out or that some diseased bees might enter neighboring hives. Therefore, we believe the following a better plan:

In order that the bees may become accustomed to the changed appearance of their surroundings, a few days before applying the treatment, it is well to place an empty hive with its entrance parallel to the left side of the hive containing the diseased bees and extending a few inches in front of the other entrance. A few days later, the queen should be found, caged, and placed in the entrance. After the bees have recovered from this disturbance, and during the time of day when they are still flying strongly, the caged queen is removed and a bee-escape which is fastened to the end of a tin tube is inserted at the left end of the entrance, the rest of the entrance being securely stopped up so there is no room for the escape of any bees except thru the bee-escape. This hive is now placed in the position formerly occupied by the empty hive, the latter being placed on the old stand and filled with frames containing

turning in great numbers to what they believe to be their old home.

The tin tube holding the bee-escape extends out in front of the new entrance so that bees leaving the old hive leave from the same relative position as before, and therefore do not realize that the hives have changed places, and consequently will not attempt to return to the old hive but will unhesitatingly enter the hive with the queen. After a large number of bees have returned

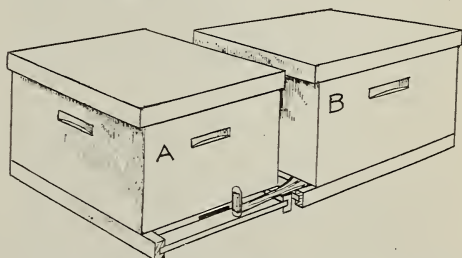

Arrangement after the exchange of hives has been made. (A) is new hive on old stand and contains frames of foundation and the caged queen which is soon released. (B) is the diseased colony, the bees of which leave thru the tube and bee-escape. On returning they enter the hive (A) not knowing the hives have changed positions.

the queen should be liberated. Altho there is no brood or larvæ present, it is very seldom that the colony will swarm out. If this is feared, however, a queen-excluder may be placed under the hive. Within two or three days it sometimes happens that dead bees clog the escape, in which case the cage should be detached from its groove in the end of the tube, and the bees removed.

Just before dark, two or three weeks later, when most of the brood has hatched, the few straggling bees that may be left in the old hive may be sulphured thru a small opening at the entrance, care being taken not to allow the escape of a single bee. The combs may then be rendered, the frames and the few dead bees burned, and the inside of the hive, the entrance, and the alighting-board, scorched by means of gasoline and straw, charring to a light brown.

In very hot climates it may be advisable to provide special ventilation for the old hive in order to prevent the combs from melting down. But ordinarily this is not necessary, for it should be remembered that nearly all of the bees are in the new hive and a mere handful are left taking care of the brood in the old one.

This method is a very safe one, since there is no disturbance at the time of the treatment and no chance for spreading disease by means of the honey or bees. The bees entering the new hive are not bees that have been smoked, and are therefore not gorged with diseased honey, but are field bees bringing in uncontaminated stores, straight from

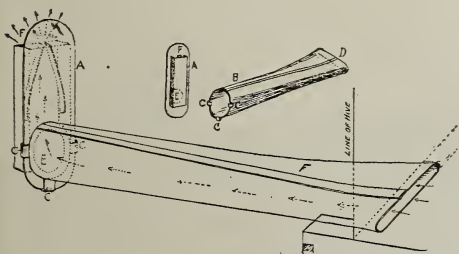

The upper figure represents the tin tube (B) with three lugs (C) into which the bee-escape (A) is inserted. The end (D) of the tube is somewhat flattened to make possible its insertion in the entrance. The lower figure shows the tube and escape connected and attached to the hive. The bees in leaving the hive follow the line of arrows thru the tube and thru round opening (E) of the escape, then up the length of the escape and finally leave thru the opening between the two springs at (F).

full sheets of foundation. The caged queen is also left in this new hive, where she is soon joined by the field bees who are re-

HEADS OF GRAIN FROM DIFFERENT FIELDS

the flowers. At first thought it might seem possible that the young bees from the old hive might carry the disease to the new hive; but apparently they carry no honey with them, for we have yet to learn of their spreading the disease in this way.

boiling down the syrup described in the Bulletin referred to would result in a tarry product, which would be unusable."

It may readily be seen that if the beet syrup contains gums, this would preclude its extensive use as a bee feed. Moreover, we have always felt that the place for the beekeeper to raise sweets is right in his beehives. Let us concentrate our energies where they will bring most paying results.

Sugar Beets for Producing Bee Feed.

Having recently received quite a number of inquiries concerning the advisability

of beekeepers raising beets to obtain syrup for feeding the bees, we referred the matter to the Ohio Agricultural Experiment Station. From the reply by Chas. E. Thorne, we quote the following:

"The information we have respecting the making of syrup from the sugar beet leaves us in doubt as to whether it is practicable to make an acceptable syrup in a small way. It is true that Farmers' Bulletin 823 of the U. S. Department of Agriculture, claims that this may be done, but I doubt whether the author of that Bulletin has had practical experience in the matter. The literature on this subject in our library indicates that the syrup will have an objectionable flavor which cannot be avoided without some chemical treatment.

"Our chemist, Mr. Ames, has had considerable experience in the testing of beets for sugar, in which the juice was extracted and evaporated in a small way, and he has found this disagreeable flavor very persistent. I am quite sure that the method of

Defends Comb-Honey Production.

Perhaps you will remember that not long ago the Government was advocating the production of comb honey. In 1909 I changed and have been producing extracted honey ever since.

I don't think you have looked ahead or you would not be quite so emphatic. I happen to be acquainted with all these men, members of the Jefferson and St. Lawrence County (N. Y.) Beekeepers' Association, quoted by Mr. Holtermann in March Gleanings, and I know that if they changed from comb honey to extracted, it would not be very long before they would not have a colony of bees. Do you ask the reason? Because they would take all the honey and not feed the bees. I find it is more work than anything else to see that the colonies run for extracted honey do not starve. As a rule we do not have much of a fall flow; and if they are not fed with combs of honey or sugar syrup, they will starve before January.

Wrong again. At the present price of



Apiary of Geo. B. Howe, Black River, N. Y.

HEADS OF GRAIN FROM DIFFERENT FIELDS

honey there is more dollars and cents in the production of extracted honey. What I wish to emphasize is this: That the expert will feed and care for his bees; but the let-



Product from one colony (numbered 25), secured by Geo. B. Howe, Black River, N. Y.

alone beekeeper will not. Thus we shall have a mighty sight more bees, if we let this class run for comb honey.

Nor is that all. There is a class that will not eat extracted honey. "Let them go without," I hear you say. If they do not get the comb honey they will have their sugar, even if a few do starve over in Europe. What do they care? I should like to see this class starve a little. But they won't. They are the last to suffer.

There are locations where they can produce as much comb honey as extracted, and all you and I might say would not prove the contrary. I have retailed tons of honey, as you know, so I am not guessing in regard to that class that will not eat extracted honey.

Black River, N. Y.

[That a large per cent of the beekeepers of New York or any other State will be so un-

patriotic as to take the honey away from the bees and allow them to starve, we refuse to believe. If there should chance to be a few such slackers, we and Government officials feel convinced that such a loss of honey will be small in comparison with the increased crop which the extracted-honey producers will obtain as a result of less swarming and less work on the part of bees and beekeepers. It is just because the Government has looked ahead—that is why it is urging this change. As for the people who "will have their sugar even if a few do starve over in Europe," we certainly shall not cater to them in the smallest degree and we believe we may trust our Government to deal with them quite summarily and effectively when the time comes. However, we feel that Mr. Howe had on his dark glasses the day he wrote that article. Really the people of our country are not as bad as that. Since the war began, the old careless selfishness has been gradually disappearing. Now the people are waking up, each one alert and eager to do his bit in production, work, money, or any other way that he possibly can. As soon as the beekeepers understand that their bees must be fed, and as soon as the public is shown that extracted rather than comb honey should be eaten, just so soon will Mr. Howe's objections be repudiated.—Editor.]

Device for Wiring Brood-Frames.

I had so much trouble in holding the brood-frames steady while wiring them that I thought I needed a frame to hold them plumb. Happening to see the end of a Florida-orange box which was mortised, I said, "There are the pieces already

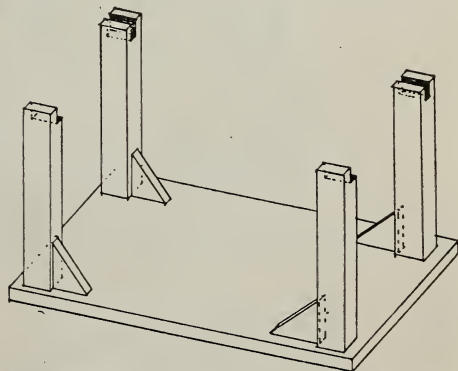

made for me." So I took an old hive-top, mortised four holes in it, drove in the box ends, and cut four braces to support them. For the top-bar I cut off the inside lip, stuck in the frame, and I tell you it is fine and it cost nothing. I nail the top onto the top of my workbench.

Ashland, Va.

Parkin Scott.

HEADS OF GRAIN FROM DIFFERENT FIELDS

Two Young Queens Winter Together.

Recently I ran across something that I think is new. I found two queens that had wintered over in the same hive. The circumstances are as follows: Last fall I was re-queening a certain yard by removing the old queens and introducing cells. I had more cells than there were colonies to be re-queened, and put a plurality of cells in certain colonies. In this case it appears that two cells hatched and both queens were accepted; that they mated and layed side by side last fall and finally wintered over together. Is it something new, or is it ordinary occurrence?

The only similar occurrence that ever came under my own observation happened in the summer time. I had two young queens hatch in the same hive, and they layed side by side for a month or more. As soon as I discovered that there were two queens, I removed one of them. Of course, I have no means of knowing whether they would have shared the hive peaceably all winter or not. But, in this last case, I am sure that both queens occupied the same hive all winter. Now, please, don't let anybody call me a liar. I have a witness to the fact that they were discovered on the same comb.

Roxton, Texas.

H. D. Murry.

[In commenting on Mr. Murry's observation, our queen-rearer, Mr. Pritchard, says:

"A year ago last fall I had what I think were two young queens in a hive when I packed it away for winter, but one was gone when spring came. I have had two young queens living peaceably together in the nucleus-boxes several times. But all kinds of strange things happen in these little swarms. I think Mr. Murry's report is rather unusual."]

Paraffine for Fastening Foundation.

Referring to the item on page 238, April Gleanings, "Can I use paraffine for fastening foundation in frames?" I would say yes. I cannot afford to put foundation into the wooden groove as generally done; besides, it narrows the foundation in the frame. I use a glass tube with a rubber bulb; have a board—or, rather, six boards—on a layer upon which the sheet of foundation is laid, and the frame slipped over. I used 100 pounds of paraffine mixed with rosin, melted. Very little is required. The rosin added does the trick. Not a sheet was melted down.

R. F. Holtermann.

Brantford, Ont., Canada.

[This seems to be a valuable suggestion. The rosin would, of course, raise the melting-point. We know many beekeepers who use wax, mixing it with about one-third part rosin to cut down the cost, and also to attach the foundation more securely.—Editor.]



THE BACK LOT BUZZER.

Ma says Miss Annie Applefing wants to do all she can in these days of conservation but she just can't find out what to use for a bee-bread substitute.

R E P O R T S
Coming to
Gleanings
during the last
month do not
lead us to
change material-
ly our estimate
of winter losses
and the condi-

tions of bees prevailing thruout the country, as told in the April number of this journal. The northeastern part of the country was generally hard hit by winter losses. The Southern States, excepting Kentucky and Tennessee, seem to have experienced normal wintering conditions, with the bees in North Carolina, Georgia, and Florida having done exceptionally well. Varying reports, good and bad, come from the middle North and the northern Mississippi Valley. The good reports coming from the Rocky Mountain and Pacific Coast regions early in the season are not contradicted by later word from those sections.

The National Food Administration, thru the deputy state administrators thruout the Nation, has made it easy for beekeepers to secure sugar for their bees—wherever any sugar at all can be secured. Some States still report a serious shortage of sugar, but generally thruout the country the sugar conditions have much improved during the last month.

As before noted in this department, beekeeping is coming on more and more in Montana. The fourth annual meeting of the beekeepers' association of that State was held at Billings on March 7, when a number of very enthusiastic beekeepers were in attendance. The new officers of this association are: President, B. F. Smith, Jr., of Fromberg; secretary-treasurer, Frank E. Clift of Huntley. An executive committee, consisting of the officers of the association and several members, was instructed to formulate and issue from time to time during the season recommendations to the members of the Association as to the prices at which their honey crop should be sold. A very interesting program was carried out at the meeting.

Nebraska is another State that is taking a decidedly larger interest in beekeeping, and the county agents there are generally giving every encouragement to the work. H. C. Cook of Omaha, an enthusiastic and successful beekeeper, is giving much of his time and experience to the promotion of good beekeeping in his state. The Nebraska Beekeepers' Association is also lending aid to better beekeeping and a more general interest in the craft thruout the State.

An important gathering of the beekeepers of Massachusetts was held March 23 at Worcester where there was a wide and representative attendance, among them the presidents of each of the five local beekeepers' societies of the State together with sec-



retaries. Absolute unity, enthusiasm, and earnestness prevailed, having in view the formation of a "Federated Massachusetts Beekeepers' Association,"

for which bylaws were formulated and adopted. It was voted to incorporate this association. O. N. Smith of Florence is president, and Miss Dorothy Quincy Wright of Chelmsford is the secretary-treasurer of the new organization. This movement looks to a bigger and better day for the beekeepers of the old Bay State.

Texas now claims to have the most comprehensive foul-brood eradication system in the United States, and the factor of co-operative county organizations plays a large role in it. F. B. Paddock, State Entomologist of Texas, speaking of the efficiency of the work done there, says: "When we discover foul brood we try our best to get the beekeepers themselves sufficiently interested to form county associations. Each inspector is chosen jointly by the county association and this office. He is not, therefore, a foreign element in the county. He is nominated by the beekeepers and is as much responsible to them as to us. It is a frequent occurrence for the president of an association to get behind an inspector and see that he does things properly. On the other hand, the association is an ever-present help to the inspector in enforcing the regulations. If a beekeeper is ordered to clean up and fails to do so, the association, by its influence, sees that directions are carried out."

The second annual beekeeping short course of Iowa State College will be held at Ames, May 13 to 18. The course will be made very practical, several successful commercial apiarists assisting in instruction. Programs can be obtained from F. Eric Millen, Ames. No fees will be charged.

The Panhandle Beekeepers' Association held its annual winter meet at the Market House auditorium, Wheeling, W. Va., on March 27. About 50 enthusiastic beekeepers were in attendance, and an excellent program was carried out. The officers are one of the livest lot of beekeepers anywhere, and they purpose to build up a large membership. They are in a fair way to do it. Charles A. Reese of the Department of Agriculture, Charleston, is one of the big helpers in advancing beekeeping in the Panhandle region.

The beekeepers of Western Pennsylvania will meet at the home of F. J. Lillie, 336 E. Pleasant St., Corry, Pa., on May 15. Geo. Rea, State Bee Inspector of Pennsylvania, will be present to demonstrate.

Francis Jager, former president of the National Beekeepers' Association, left America on Apr. 16, in charge of another Red Cross expedition to Serbia.

"OUR honey season is just about closing here for the winter and has been very good around these parts. I have taken about 60 pounds average per hive."—Wm. Barnes, Garrah Willah, N. S. W., Australia, Mar. 4.

"I harvested and marketed a good eucalyptus crop of honey during January."—S. J. Paul, Los Angeles County, Calif., Mar. 30.

"The honey outlook in the Ozarks of Missouri is A No. 1."—Frank McMurray, Lawrence County, Mo., Mar. 30.

"I had 37 colonies packed on the summer stands last fall, and all alive now."—D. A. Harnon, Crawford County, Pa., Mar. 18.

"The honey harvest was quite fair and the prices just doubled. The demand was enormous."—Anna Sommer, Ronne Bornholm, Denmark, Jan. 14.

"I had a fine swarm of bees on Mar. 14. Is this early? I put them to work on some starters O. K."—W. W. Bayles, Washington County, La., Mar. 20.

"D. D. Turner, Ancon, Canal Zone, is the first and original beekeeper on the Isthmus Canal to my knowledge."—A. H. Clagg, Gatun, Canal Zone, Panama, Mar. 6.

"I have 14 colonies. One died this winter. I packed them. My neighbor lost 9 out of 12 colonies—no packing."—Collis R. Bower, Columbia County, Pa., Apr. 2.

"I am trying to get my three uncles into the bee business. I am 15 years old and have been in the bee business myself for two years now."—Bert C. Elkin, Indiana County, Pa., Mar. 15.

"We had two very dry seasons and have lost most of our bees. People in this part of the country have had very poor crops the past two years."—G. G. Miller, Nueces County, Texas, Mar. 18.

"I am a beginner who has hopes of better things. I have purchased A. M. Applegate's goat and perhaps shall have milk and honey—if wheatless and meatless."—Mrs. M. S. Oliphant, Sussex County, Del.

"On March 19 bees gathered their first natural pollen, and today (March 20) 24 bees loaded with pollen entered one hive in one minute's time."—L. A. Ressler, Elkhart County, Ind., Mar. 20.

"My bees wintered perfectly in my closed-entrance cases, while I lost 66 per cent of those wintered the old way. I keep the entrances to the packed cases closed except when the bees can fly. It is 100 per cent perfection with me."—Clyde Cordrey, Logan County, Ohio, Mar. 18.

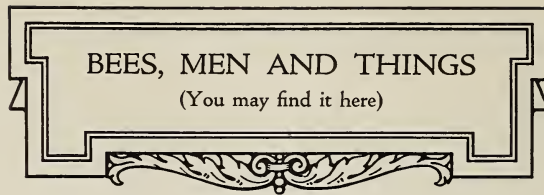

"Not many bees alive in this section now. I don't think pound packages of bees from the South turn out to be much. They are on the road too long and are

all fretted out."—F. Alderman, Livingston County, Mich, Mar. 18.

"I enjoy having a few colonies in the back yard where I can see somebody work besides father, and also have a supply of honey to run to, while the food profiteers are having things about their own way."—John H. Ream, Dakota County, Nebr., Mar. 7.

"We are giving a correspondence course in beekeeping here in Oklahoma. At present we have about 500 enrolled and expect a maximum enrollment of something like 1,000."—C. E. Sanborn, Entomologist, Oklahoma Agricultural and Mechanical College.

"As the extremely cold winter killed all the peaches, which is my main crop, I'll have little to do but work with the bees the coming summer, and expect to make the 30 colonies I now have equal to about 60 guns against the Kaiser."—S. H. Burton, Daviess County, Mar. 28.

"Our winter was rather short. I ditched some on Dec. 2, and harrowed today. My bees also flew Mar. 2. We have not had more than six inches of snow at any time this winter. I keep my bees in packed hives out of doors."—H. O. Barlow, Sargent County, N. D., Mar. 22.

"Up to Feb. 1, 1918, we had the driest year since 1861. So I sold all my bees. But in March we had as much rain as in the flood year of 1884, and now we have had about our natural rainfall of 20 inches and expect a fair crop here this year yet."—J. G. Harman, San Diego County, Calif., Mar. 1.

"Don't send Gleanings next year unless you can send a cure for the disappearing disease as I have lost all my bees thru it. It was lamentable looking at them and unable to do anything for them. So I have no bees. Hoping you will have a cure by next year."—Thomas Finegan, Drogheda, Ireland, Mar. 13.

"The drones of the best colonies should never be trapped as they will improve any virgin queen that may fly. It is a common belief that the presence of drones causes swarming, but it never has been proved to my knowledge, and seems only an inference from the fact that only strong vigorous colonies rear many drones and only they swarm."—L. W. J. Deuss, Blantyre, Nyasaland, So. Africa.

"Weather here ideal. Fishing hilarious. Meatless days are no barriers to us. With a large king fish fried or baked and a liberal

supply of good johnnycake and honey to go with it, kings and emperors should envy. One man here alone yesterday caught 525 pounds of fish."—M. L. Brewer, Manatee County, Fla., Mar. 11.

"This man, ————, set the price locally for all our comb honey last year because he did not take any bee journal and did not know what honey was worth. He sold at five cents less than he might have obtained, as well as the rest of us, had he known conditions."—Eugene Secor, Winnebago County, Iowa, Mar. 25.

"I am not at all surprised that you so easily made a contract for all the honey you could supply. I never have seen honey so pure gold a hue, nor so rich, and the perfume—from which scents a room so that it is as full of sweet odors as a flower garden."—From a letter of Marian Moffet, 144 E. 17th St., New York City, to J. Jensen of Guatemala, Mexico.

"The bees have gathered more honey in Florida this year from orange bloom than I have even known them to do before. I understand that the bees get a lot of honey, too, from a plant that the various bee men term wicker, greasewood, wild huckleberry, myrtle, and some other names for the same thing. Wm. A. Selser, transient at New Smyrna, Fla., Mar. 18.

"The outlook for beekeeping this season in Nebraska is just grand, and judging from what Mr. Tubbs of Beatrice said, the bees are starting off early to do their part in putting Nebraska to the front. He says he hived a swarm for a neighbor on Feb. 24. I lost only one swarm this last winter and keep them outdoors."—O. E. Timm, Douglas County, Neb., March 23.

"I am on the retired list in our West Wisconsin Conference, being in my 80th year. One son has been in the army ten years and two other younger boys are in the draft. So my work is to feed the stoves, bees, and poultry. My bees are all in the cellar, and I buy my sugar, a dollar's worth at a time, for the feeding I have to do."—J. N. Mills, Barron County, Wis., Mar. 4.

"I have just been reading in March Gleanings what J. H. B. Hall says as to 'all bees in this country are in boxes and logs—bees ain't no good here.' I beg to say that I have been living in Shelby County, Ala., for more than a year and while I must admit that up-to-date beekeepers are scarce, yet I know of eight or ten beekeepers within as many miles who have more or less bees in movable-frame hives and are producing section honey."—H. A. Lynd, Shelby County, Ala., Mar. 11.

"For a watering-place for bees, get a keg or small barrel, bore a number of one-inch holes with an auger near the bottom; put a corn-cob in each hole but don't fit the cob too tight; put a tight cover on the barrel,

and it is ready for use. The water soaks thru the cobs and in a short time they become thoroly saturated. Fresh cobs should be put in every month or six weeks. The water does not require changing very often and none is wasted. It is impossible for any bees to get drowned at this watering-place."—M. L. Dodson, Deatur County, Kans., Mar. 20.

"While in Detroit some weeks ago, I found several restaurants serving honey instead of sugar in tea and coffee. Altho a great many beekeepers are known to use honey for that and other table purposes, this is the first instance I have known where honey was used in this way in restaurants. Proprietors of these establishments stated that customers seemed to like honey in beverages, and some would ask for it specially after it was put into use."—P. S. Farrel, Canyon County, Idaho.

"I have nine bee yards fully equipped, 25 to 300 colonies in each. Six yards are along fine stone road, and two more can be reached most of the year by auto or motor cycle. I move two or three of my yards in the spring to the coast, and in the fall back to the mountains. My central location is in the largest and most progressive American colony. We have a school, church, large American hotel, town waterworks, ladies' club and several associations. It is very healthy here, especially good for asthma."—M. C. Engle, Herradura, Cuba, Mar. 27.

"Sweet clover will be a factor in honey production in the future in the great Gallatin Valley as it is getting a stronghold along the irrigating ditches and along the highways. The main sources are alfalfa, alsike clover, white clover, and certain wild mints along the streams. There are a great many fine swarms of Italian bees in the hollow cottonwoods along the river. I found a piece of wild honeycomb among some rocks in a stream away up in the mountains last summer, 20 miles from nowhere."—C. A. Kinsey, Gallatin County, Mont., Apr. 4.

"I have harvested from two colonies in a season 1,000 pounds of honey. The box-tree is the best yielder here. This season in Australia is an exceptionally good one for honey. Thousands of tons are being produced. I and my brother have 40 colonies and up to the present have secured 5,500 pounds and expect 3,000 pounds more. A good average, don't you think? In regard to prices, at present it is worth 9 cents for extra prime. I am more than pleased to see American buyers here buying our honey and in fairly big consignments. Our seasons here are very irregular. One in four will be grand, two will be good, and one will be almost a failure. Beekeepers are becoming more modern in their methods here and working their apiaries on a good American system. So beekeeping is becoming a big industry in Australia."—Percy Sweetman, Dennis Island, George's Plains, N. S. W., Australia, Feb. 15.

QUESTIONS.—
 (1) Does about one quart of bees weigh a pound or more? (2) Does one get more bees in a one-pound package than in a one-frame nucleus? (3) Beginning in June, if one should put one pound of bees in an old-fashioned box hive and have a section fastened in the top, would the bees be apt to stay and begin working and do fairly well without a queen?

New York.

Leeman Ferris.

Answers.—(1) One quart of bees contains about 3,200 bees, and one pound contains 5,000. (2) A one-pound package of bees contains more bees than a one-frame nucleus. (3) No, you could obtain no honey whatever by this method, for the nucleus would constantly dwindle and finally die outright. They should be given a queen, and by slow stimulative feeding allowed to build up their colony to a suitable size for honey-gathering. In the March issue of *Gleanings* you will notice among the editorials a good description of the method of treating these pound packages on their arrival.

Questions.—(1) When all the Hoffman self-spacing frames in a ten-frame hive are pushed together to one side there remains a space of $\frac{3}{8}$ inch. For what is this space? (2) Should the Hoffman frames in the brood-nest of a ten-frame hive be pushed close together or should they be spread slightly apart to take up the $\frac{3}{8}$ -inch space left on one side?

Missouri.

H. J. Pelikan.

Answers.—(1) After the frames have been used a while, the projections at the sides of the frames become more or less covered with wax and propolis, so that less space will be left. There should be some extra space, however, to facilitate the removal of frames. If there were no space, then, in order to remove a frame, it would be necessary to pry straight up on the top-bar; and, if the frames were stuck down as securely as they often are, this would result in a crack in the comb near the top-bar, and sometimes the top-bar would even break or be pulled away from the end-bar. If there is some extra space, then, instead of prying upward, one may first insert the tool between the ends of the frames, and by prying sidewise loosen each end of each frame from that of its neighbor. Then by an upward lift the frames may be easily removed. In this connection we wish to call attention to the fact that a frame should never be pryed near the middle since at that place there is so much spring to the top-bar that the prying is very apt to pull the top-bar away from the comb. The tool should always be used near the ends of the frames as above stated. (2) A space of $\frac{7}{16}$ inch should be left at each side. If all the space were left at one side of the hive, the bees would build brace-combs—that is, irregular combs connecting the outside comb with the hive wall.

Question.—I have ordered from the South 75 pound packages of bees with queens to be delivered



early in May. I intend to put them in Jumbo brood-chambers and to feed for comb-drawing and brood-rearing. As I have only two or three drawn combs for each colony, I must, therefore, fill in with

sheets of foundation in wired frames. Now, should I start the bees in extracting supers of standard frames, and then during the honey flow, when the combs are filled with brood, move the queen and one brood below onto Jumbo frames under a queen-excluder, leaving drawn combs above to be filled with honey as soon as the brood hatches, or should I start the queen to rearing brood in the Jumbo frames?

M. A. Shepard.

River Falls, Wis.

Answer.—If you could be perfectly certain that each nucleus would increase sufficiently to build out the foundation in the Jumbo body and brood-chamber as well as store sufficient honey for wintering, and also some in the super, then they might be started in the super, as you suggest. However, if you wish to winter in the Jumbo hives, we believe the best plan would be first of all to get the Jumbo combs properly drawn out so that the approach of winter will not find you with only frames of foundation for wintering. Moreover, if these Jumbo combs are used for breeding during the summer, the extra cocoons added to the cells will make the frames warmer for wintering. The nuclei should not be given the entire hive at first; but by means of division-boards they should be kept crowded onto only as many combs as they will conveniently cover. Then as the nucleus gradually increases in size, more frames may from time to time be added.

Question.—What is the best way to feed bees honey in the comb?

C. F. Oliver.

Indiana.

Answer.—The best way to feed honey that is in the comb is to put the comb right in the hive. If it is liquid honey, it should be thinned with about 10 per cent of warm water, and, on account of the danger of transmitting diseases, it would be preferable to boil the honey, if it comes from a source unknown.

Question.—Would it not be better to use full sheets of drone foundation in place of worker foundation in the sections? I find that bees fill out with drone comb when starters of worker foundation are used.

G. A. Sheppard.

Minnesota.

Answer.—It is true that, when given starters, the bees show a decided inclination to build drone comb rather than worker comb; but this would in no way warrant the use of drone foundation in sections; for the worker foundation results in comb of such superior grade that this more than offsets the apparent preference of the bees.

Question.—Please give a good method for preventing swarming.

Maud Hulbert.

Kirkville, N. Y.

Answer.—The queen should be clipped, the colonies examined at least every week to be

certain that no queen-cells are built; and should they appear all capped ones should be torn out and a hive of combs, containing one comb with young larvæ and the queen, should be placed on the old stand and covered with a queen excluder. Above this should be placed the supers, if any are in use at the time, and, at the very top, the hive of brood. At the end of eight days this upper story may be moved to a new location and the bees allowed to raise a queen if increase is desired. If not, the cells may be torn out and the bees allowed to hatch just where they are, or the brood distributed to other colonies that are in need of it.

Question.—Will a queen leave her hive and go to another and remain there? Last summer I hived a swarm, and two days later saw a fine yellow queen alight and go in. Later I examined them and found her quite different in appearance from the others.

Virginia, A. A. Campbell.

Answer.—It would be very unusual for a queen to leave her own hive and go into another and remain there. If she did so at all, it would be purely by accident, and, unless the other colony was queenless, this new queen would probably be balled and killed. But if the colony were queenless, her chances of being favorably accepted would be rather good. The fact that the queen you saw was of a more yellow color than the bees proves nothing. Many times a queen is of better color than her own bees.

Question.—In the Townsend bee book I have read that, as soon as the swarm begins to cluster, a new hive should be set on the old stand and the supers from the old hive put on it whether they are partly filled or not. Now, what becomes of the old hive? Should I put a super on it also?

Richmond, Va. F. E. Ingroff.

Answer.—Since the old colony is in a very weak condition, having lost most of the bees, and since there will not be another laying queen for at least one or two weeks, it is evident that they will be unable to store any surplus honey for some time. Therefore no super should be put on until the colony has built up sufficiently to warrant such a step. If the swarm occurs early in the season, it may be possible to obtain several supers of honey from this old stand, but, if late, not much can be expected from them in the line of surplus.

Question.—In a neighborhood containing hybrid stock, how may one raise pure queens?

R. L. Wilby.

Answer.—The question of obtaining pure mating is a vexing one frequently. You can not hope to attain the highest percentage of pure mating until you have done all you possibly can toward Italianizing your locality. For a temporary emergency, drone-excluding entrance-guards can be put on the entrances of colonies in the locality that have undesirable drones. At the same time you should insure plenty of young vigorous Italian drones that will be flying at the time your young queens would go out to mate. In order to improve the locality permanently it often pays for a queen-breeder to furnish young laying queens to neighboring beekeep-

ers at a low price, say about half the usual amount charged. If this is done in July, or August, when queens are cheapest, the expense is not great, and for the next season the drones flying will be largely Italians. Of course, if there are a large number of colonies of bees living in trees, or in old box hives, about all one can do is to make sure of plenty of young vigorous drones flying in his own yard.

Questions.—Does a temperature of 16 degrees above zero kill wax-moth eggs, or do they survive the winter and hatch out in the spring to start a crop of moths? Do the larvæ become dormant with low temperature, survive the winter and hatch out in the spring? Can you tell me whether at this time of the year, combs may be stacked moth proof and be safe without further notice until they are needed?

Texas. T. P. Robinson.

Answers.—We believe there has been no scientific determination of the exact temperature required to kill the wax moth, pupa, larvæ and eggs, respectively. However, F. B. Paddock of the Texas Agricultural Experiment Station in bulletin No. 158, June, 1913, states that wax moths sometimes stand a freezing temperature for as long as three days, and in well protected places can stand an outside temperature of 26 degrees Fahr. for five days. In general, a freezing temperature is considered sufficient to kill all moth eggs and larvæ. During the winter about one-third are in the pupal stage. These being better protected are able to withstand greater extremes of temperature, and at the advent of warm weather will hatch out and begin their work of destruction. The best way to treat the combs is to pile them in moth-proof piles and then examine them often, giving them a carbon bisulphide treatment as soon as evidence of moths occurs.

Questions.—(1) What is the easiest way to find the old queen when re-queening black bees and one's sight is not good? (2) Suppose one-day-old virgins or young laying queens were properly introduced without de-queening, about what percent would survive?

California. L. T. Ayers.

Answers.—(1) The hive should be opened during the middle of the day and the bees smoked as little as possible. As black bees run so rapidly, it is a good plan to have a person at each side of the hive, only one handling the frames. Beginning at the edge of the brood nest, carefully examine one frame after another. When a frame is pulled out, the queen will probably be frightened and run to the side of the comb furthest from the manipulator. So the chances are that the queen will be first seen by the one not handling the frames. As fast as the frames are examined, they should be placed in an empty hive body, for after the frames are removed the queen may be found running about wildly on the bottom board or further side of the hive. When working alone, begin taking out the frames from the further side of the brood nest, for when a frame is removed, a black queen often runs

to the unexposed side of the adjacent frame, which is the side that first comes in view on removal of the next frame. If one's sight is not good and he has no helper, perhaps the easier method would be to attach a queen trap to the entrance, lift out all the frames and place them in an empty hive, carefully examine the old hive to be certain she is not among the few adhering bees and then after shaking each frame at the entrance replace it in the old hive. When the bees have run in, the queen will be found at the entrance.

(2) It is difficult to state what per cent would survive. Probably for an expert 50 per cent might be killed and for a beginner as many as 95 per cent. Young laying queens are much easier to introduce than virgins. Three- and four-day-old virgin queens may sometimes be introduced without even de-queening, by the Miller smoke method as given in the A B C and X Y Z of Bee Culture under "Introducing." But we would caution that one-day-old virgins are too weak to be introduced without de-queening.

Questions.—(1) Which are the better frames: Langstroth or Danzenbaker? Why? (2) How many extra supers for each hive should one have for safety? (3) Should all the hives be uniform, that is, the same make and size?

Michigan.

Wm. C. Leonard.

Answers.—(1) Most of the leading beekeepers greatly prefer the Langstroth frame. It is much better for wintering, as it leaves the cluster in a higher, warmer place, further from entrance drafts. Moreover, the additional space in the Langstroth frame gives a better chance for contracting the brood chamber in winter and still leaving the bees with plenty of stores. Our experience has been that the Danzenbaker frame is a big nuisance in handling, and the colonies with these frames need more frequent attention, as they are more inclined to swarm and also are not as apt to provide themselves with winter stores. (2) That depends upon whether one leaves all of the extracting to be done after the season. If so, five or six shallow supers or three deep ones would probably be plenty for your locality. (3) Yes, it will save much time, trouble, and expense.

Questions.—(1) I like the dimensions of the eight-frame hive; but for a divisible brood-chamber hive which do you think is preferable—an eight- or ten-frame hive? Why? (2) Do you consider the divisible brood-chamber hive as good as or better than the ordinary style?

Minnesota.

J. N. Johnson.

Answers.—(1) Many use the divisible brood-chamber idea for only a short time before and after the opening of the honey flow. In that case the deep ten-frame chambers are generally used. Most of those who use the plan thruout the year prefer the shallow ten-frame or the deep eight-frame brood-chambers. (2) For ourselves we prefer the ordinary standard ten-frame hive, giving the queen two stories when necessary.

ANSWERS BY C. C. MILLER.

Question.—I am having a terrible scourge of European foul brood. Probably 200 out of my 300

colonies are badly afflicted. I have been caging my queens for about 20 days until the bees clean up. A friend, who is visiting me, says I should disinfect my hive tool, hands, etc., in going from an affected colony to a healthy colony, also I must melt my combs, boil my frames, and scald or burn my hives. What do you say? I have not taken the precautions mentioned, as I believed European foul brood to be a disease of the queens and brood only.

California.

A. E.

Answer.—In a severe case of European foul brood, I wouldn't cage the queen, but kill her. Even in a mild case it may pay to kill the queen, if she is below par and you can replace her with an Italian of good stock. In a mild case, with a good queen, I would cage. But I don't believe it's advisable to cage more than ten days, nor in any case to have the colony go longer than ten days without egg-laying. You say they clean up in about 20 days. Yes, there may be dead brood present up to the end of 20 days, or even longer. But it's very dead and so dried up that it is not likely to do any harm. The kind that does harm is that which has been dead only a short time, and not yet too disagreeable to be still eatable. And you'll find none of that kind left, if you stop the queen's laying for ten days. Be sure to make your colonies strong.

As to disinfection, upon my first acquaintance with European foul brood I melted combs and boiled frames, but gave it up and afterward got along just as well, if not better. Altho combs that are affected with American foul brood must be melted up, it seems an unpardonable waste to destroy a single comb on account of European foul brood. Hives need no disinfection, and indeed some hold that no disinfection of hives is needed with American foul brood. Yet when all that is said, it remains very important to guard against carrying the disease from an infected colony to a healthy one. If a hive tool should be thrust into a diseased larva at the right stage, it would be easy to infect the next colony. So I am careful about my tool and hands. The quickest way to disinfect the tool is to thrust it into the ground a few times. If the hands do not become daubed, merely handling the dry frames needs no disinfection. Whether the disease can be carried by the honey or not, I take no chances, and if the hands are the least daubed, I always clean them.

Question.—I have read about swarm prevention in your book "Fifty Years Among the Bees." Do you think that following your plans closely will actually prevent any from swarming when they are in good stores and strong in spring?

Answer.—Yes, any of the plans there given involving the cessation of egg-laying for ten days have proved effective with me, no matter how strong or well provisioned the colony.

Question.—I have read about clipping; do you think that would be best for one with 15 or 20 colonies?

Answer.—If I had only one colony, I should want the queen clipped, and I should clip if I had 500 colonies or more.

C. C. Miller.

SINCE we have our outfit in readiness and have learned a little concerning the interior of the hive, we are now ready to get our bees and to begin the actual business of beekeeping.

Where and How to Get Bees.

Altho one might obtain a start by getting bees from the bee-trees or by purchasing colonies in old box hives, we do not recommend either plan for the beginner. The first is interesting, but entails considerable work, and is hardly advisable unless one has some knowledge of bees. The second is undesirable because it is impossible to remove the combs and learn the condition of the bees one is buying. Still, since many beginners will purchase their bees in box hives, we shall in this same talk describe the method of transferring to modern hives.

Another common plan of getting bees is to send to some breeder for nuclei (small colonies) on combs, or for combless packages of bees, a queen being ordered with each. Of these two plans the combless package is much the cheaper and safer investment, since there is no danger of acquiring foul brood as in the case of a nucleus sent on combs. If two-pound or three-pound packages are obtained early in May, and given a little brood, they may, by stimulative feeding, be built up into good colonies six or eight weeks later, and in many localities might, therefore, be in time for part of the main honey flow. But even a two-pound package obtained the last of May or June, could by fall be increased to one full-sized colony all ready for the fall flow. However, unless one can obtain an entire colony to supply the desired brood, we would be inclined to discourage the beginner from buying the combless packages.

A two-pound package (and we advise buying no smaller package) should be hived on four or five drawn combs, one containing some young larvæ. More combs may be added later as the colony increases in size. These three combs are shoved over against the side of the hive and a division-board placed at the inside. Also the entrance of the hive should be contracted to but a small opening in order to prevent robbers from entering. Upon the arrival of the bees they should be placed in the new hive in accordance with the directions that accompany them.

Two cups of syrup consisting of two parts of sugar to one of water should be given the bees every other day. It may be fed in Mason fruit jars or friction-top pails with lids pierced with only one or two holes to insure slow feeding, which is conducive to rapid breeding. Snugly covering the tops of the frames, and the feeders inverted over the brood-chamber, should be a

TALKS TO BEGINNERS

By the Editor

warm cover for retaining the heat of the cluster.

By far the best plan is to buy entire colonies of bees from some reliable breeder or

from a beekeeper in one's own vicinity. These may be purchased in the hives just as they stand; or, better still, an agreement may be made by which the buyer provides the beekeeper with new hives in which to hive the new swarms. These new colonies are taken care of by the purchaser, but not removed until the end of the season. Even tho obliged to pay a little more for the sake of having the bees hived, it would certainly be cheaper than to buy bees in a swarm hanging from a limb thus necessitating the dropping of one's work at a minute's notice.

How to Know the Value of a Colony.

If bees are to be purchased in the hives, it is a good plan to take along an experienced beekeeper to determine whether or not the stock is diseased. If in healthy condition, their value will depend entirely upon the size of the colony; the age, prolificness, and strain of the queen; the condition of the combs, whether crooked, full of drone cells, etc.; the amount of stores contained in the combs; and the condition and style of the hive. Bees that are purchased in old hives should be transferred to modern ones if one expects to get a good crop the first season.

Moving the Bees.

After the colonies are purchased there arises the problem of moving them to their new home. When bees first fly in the spring they circle about the hive, noting its exact location in regard to its surroundings. Later, if the hive is moved, the bees return to this same spot, and, being unable to find the hive, become lost. With the exception of bees in a swarming condition, those colonies moved a distance less than a mile will thus lose many of their bees. For this reason if one wishes to move a colony only a short distance, it should first be moved to a place two or three miles away. Then a few weeks later it may be moved to the desired spot with no loss of bees; for by that time the original location will have been forgotten. If one wants to move but a few feet, this may be done with less trouble. The hive may be moved a foot or so the first day, and each successive day the distance increased until they are moved a yard or more at a time. The bees appear to get into the habit of expecting their hive to be removed a little further each day.

About the quickest and easiest way of moving bees is by auto. Any sudden lurching or jerking of the combs sidewise might cause them to break, especially if heavy with honey. Therefore if the road is very rough, so that one is obliged to drive slowly, the

hives should be placed with the frames crosswise of the car. If the road is smooth, perhaps the frames should be lengthwise of the car; but in this case it would make but little difference.

To prepare bees for moving, the night before (or early in the morning, before any bees are stirring), screens should be tacked over the full-sized entrances, and over the top should be placed a screen attached to a rim about two inches in depth. This allows a nice, cool clustering place; for during joltings of the journey they will become so active that the temperature of the hive will be increased considerably. This is the reason for providing all this extra ventilation. If the weather is cool, of course they will need less ventilation, and in that case the screens may be partly covered. The upper screens and the hive bottoms may be attached to the hives proper by means of a long staple at each corner. If moving some distance, however, it might be safer to fasten the bottom-boards to the hives by means of a screw driven thru the bottom-board and up into the middle of each side wall of the hives. Two screws to each hive hold them very securely.

Of course, when buying bees the chances are that the hives will be old-fashioned, and the bottom-boards attached; also there may be large bee-spaces in various places; but the main idea is to shut in the bees securely and to have plenty of ventilation at the entrance and top of the hive.

Where to Place the Bees.

An ideal location for the bees would be a southeast slope having a little scattered shade and somewhat open woods on the north and west. Still, almost any well-drained spot not too near passersby can be made

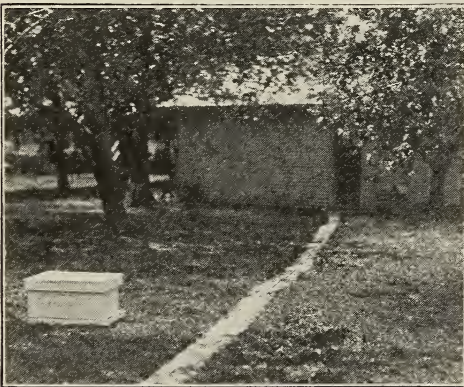

A poor location for a hive, near to and facing a walk, where the bees will be annoyed by passers-by.

a suitable location if a windbreak is provided on the north and west. The small beekeeper need look for no better location than right under the apple trees of his own back yard; or, lacking the back yard, he may place the hives in the attic or on a flat city

roof, altho the latter place would be rather hot during the summer. Colonies kept in the attic should be placed near the wall and pro-

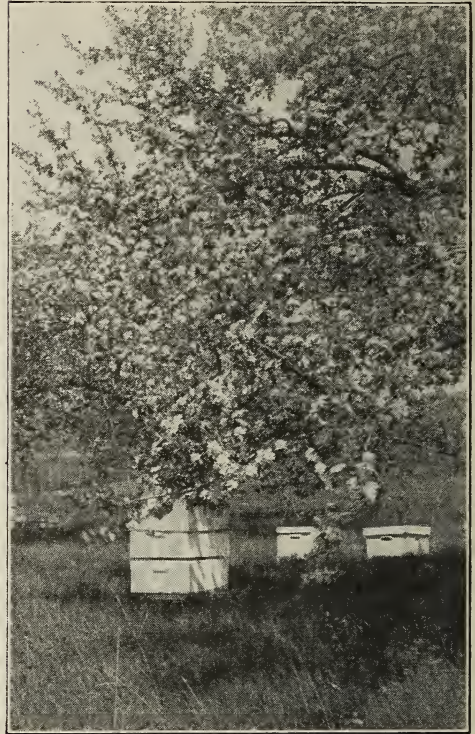

No better location for the hives than right under the apple trees.

vided with an outside entrance. There should also be a window that could be opened to allow the escape of bees that will collect on it whenever the hive is opened.

Transferring to New Hives.

Soon after being moved and placed on the new stands, preferably during the middle of a warm day in fruit bloom, the colonies in old, undesirable hives should be transferred to new ones of standard dimensions. The following is an easy way of transferring: Place on the stand a new hive filled with drawn combs, if possible having in one of the combs a patch of young larvæ (unhatched bees which look like little white worms). After smoking the colony a little, remove the bottom-board and place the old live over the new, tacking on strips if necessary, so that there will be no open cracks between the two hives. Then blow smoke down thru the old story, gradually driving the bees and queen below, after which insert a queen-excluder between the two hives. In three weeks' time the worker brood will all be hatched from the old hive, when it may be removed and the combs saved to be rendered into wax. (See Transferring, as described on page 172 of the March issue.)

When no combs are obtainable, colonies

may be transferred into the new hives onto frames of foundation and then fed continuously until the foundation is drawn out into comb; but it gives the bees a much nicer start to give them drawn combs. This spring

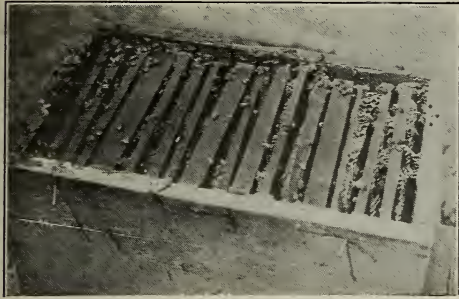

A look into an old-fashioned box hive.

there ought to be little difficulty in obtaining such combs from beekeepers in the vicinity whose bees have died during the winter; but one should make sure that such combs do not come from diseased colonies.

Feeding the Bees.

Unless there happens to be plenty of stores in the combs, the colonies will need to be fed after transferring. It is always safer for the beginner to feed candy or combs of honey rather than syrup, as there is less danger of starting robbing. During a dearth of honey there is always a chance that bees

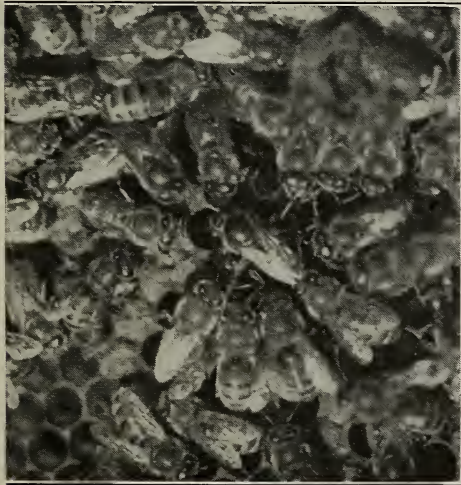

A queen laying and her attendants.

may get a taste of stolen sweets, and soon be in a regular turmoil of excitement. Whenever the bees begin robbing, the entrances should be contracted and loosely covered with dampened grass. This subject will be discussed at greater length in a succeeding "talk."

Re-queening.

In all probability the bees purchased will

not have the distinguishing marks of Italians—three yellow bands on the abdomen—but will be either blacks or hybrids which are a cross between any two strains. Since the Italians are the best strain, being very good-natured, excellent honey-gatherers, and quite resistant to disease, it will be advisable to re-queen the poor stock with good Italian queens, which may be purchased from any reliable breeder, and each introduced according to the directions which accompany her, the old queen being removed at the time of introduction.

Clipping the Queen's Wings.

During the middle of a warm day in fruit bloom all laying queens should have their wings clipped in order to prevent the bees from swarming later and decamping to the woods; for with clipped wings the queen cannot fly, and the bees will not leave without her. Any warm day in May, when most of the field bees are out gathering nectar,



How to hold queen when clipping wings.

the queen may be easily found. She will probably be on one of the central frames of brood, and may readily be distinguished by her marked dignity, larger size, and surrounding circle of worshippers, as described in our last lesson. On no account should a queen be held by the abdomen, as it is very easy to injure her in this way. She should be picked up by the wings, transferred to the left hand, and with thumb and fore finger held securely by the thorax, as shown in the illustration. About two-thirds the length of one pair of wings should be clipped, care being taken not to render her useless by clipping a leg at the same time. Those feeling a little timid about clipping valuable queens might first practice on drones until the trick is learned. (Neither drone nor queen can sting you.)

In general we may say that the ordinary May work consists in keeping the colonies sufficiently warm, well supplied with good queens and plenty of stores, and, along toward the end of the month, provided with supers if indications seem to warrant them. This subject is more fully treated in the article on page 273, this same number.

I SUPPOSE that at least most of you have read what I have had to say during the past few months about windmills and electricity. On page 939 of the December issue of GLEANINGS some mention was made of George Manikowske, the inventor of the electric windmill, or, at least, one of the inventors. Well, on page 12 of the January issue I informed you that he expected to come down here to my Florida home and install the plant. Of course I had to mention my undertaking in our week-day prayer meeting. I also promised to bring the young inventor to our prayer meeting if I could get him to come. Our good pastor, Dr. Hallock, warmly seconded my undertaking. Now, I knew almost nothing of this young man whom I had never seen, and I recognized that he *might* be one of the prayer-meeting kind, and he might also be far away from it. I watched anxiously for him, and I might confess I *prayed* for him. I had gathered that his lifework (and I might say his life passion) had been windmills and electricity, and, as a matter of course, I expected it to be one of the events of my life to meet him. It was. He came to prayer meeting, and, at the request of our pastor, gave us a talk of ten minutes, mostly in regard to the Y. M. C. A. work in his State of North Dakota. I am going to have quite a little to say about him, because I think it may be helpful to the thousands of other young men who read GLEANINGS. He neither drinks, smokes, nor uses tobacco in any form, and uses tea and coffee only when it might look singular not to use them as others do. His appearance shows the result of his pure, clean life. He is 29 years old, weighs over 200, and has a wife and two fine children whose pictures I have seen.

I have owned for nearly ten years a Sears automobile. Until recently I have been able to make all repairs with but little trouble. Just before George came I had about decided to put it on the scrap-heap. I couldn't think of selling it, nor even giving it away, for that matter, to have some one else have a like experience. It made me think of the woman (Mark 5:26)

OUR HOMES

A. I. ROOT

Behold an Israelite indeed, in whom is no guile.—JOHN 1:47.

Know ye not that your body is the temple of the Holy Ghost?—I. COR. 6:19.

But Daniel purposed in his heart that he would not defile himself.—DANIEL 1:8.

who "spent all she had and was nothing bettered but rather worse." I was told that expensive new parts were needed, but still the old trouble remained.

Well, after the mill was up and running, George got his eye on my unfortunate

"Sears," asked a few questions, and suggested he might fix it for me. It is now running as well as, perhaps better than when new, and runs on the magneto without any help from the batteries—something it has not done for years. His keen, bright way of going at once right to the spot where



This is the windmill that turned the dynamo, that stored the batteries, of the electric auto (as it stands in its garage), that carried the potatoes to market.

the trouble lies is in sharp contrast to some of the young men in repair shops who have to puff at a cigarette before diagnosing the seat of trouble. I have had for years a pumping windmill that starts before the tank is empty. George fixed it in a few

minutes so that if you draw from a hydrant only a single pailful, it will start at once and replace the pailful. Several of my friends had automobiles with peculiar troubles that seemed to defy ordinary skill. It seemed just fun for George to "chase down" and "make good" all these, while waiting for some delayed part of our electric outfit.

He is the very model of a strong, healthy physique. Even his 200 pounds or more seems no impediment to his climbing windmill towers like a squirrel. Perhaps never before in the world's history was there such a demand for clean, vigorous manhood, and a bright, clear mind comes only with a clean, healthy body.

There are many evidences just now to show that wind is soon to receive more attention than ever before. Below is a clipping from the *Practical Farmer*:

While looking around for extra labor on the farm this year, let's not overlook our two greatest helpers—wind and water. These two forces are often only thought of as being destructive, altho they have of late years been put to various kinds of work thru the agency of modern equipment. It is no uncommon thing now to find a farm illuminated and much of the light labor done by electricity generated by the creek which has always been running down hill. Washing, ironing, cleanings, separating, churning, and a host of men's chores are done by water power at practically no expense after the first installation.

Wind, which is just as free as water as a source of power, has in many cases saved work and time in doing some of the necessary farm labor. This year its possibilities can be appreciated more than ever before, since it will take a working in unison of all forces to see us successfully thru a war which we are fighting for our very existence.

Here is another, clipped from an advertisement of a pumping windmill:

You still get the wind free. With prices of everything soaring skyward, wind is free. We hope it will stay so. Utilize it and pump your water for nothing.

In regard to running automobiles by wind power, at present (April 2) it would seem that, to store the batteries to full capacity* (which must be done at least occasionally), a pretty strong wind for quite a considerable time is needed—very much stronger than is required for lighting the house and outbuildings and doing other similar work. Of course we have a device that throws the current on and off, so we can utilize the breeze that springs up in the night, as I have explained on former pages; but if one expects to run his car several miles a day, and do it every day, it would probably require a windier locality (say North or South

*I have succeeded in getting 62 miles on one full charge here in Florida, where we have no hills. Unless, however, you have paved roads, the Florida sand is even worse than hills.

Dakota) than those we have here in Florida, or else a bigger windmill. Our is only 14 feet.

Permit me to quote a single sentence from a letter just at hand from H. H. Root:

Dear Father:—I wish I could see you this morning delivering your potatoes by a power derived from the sky. I imagine that the new scheme of transportation is giving you a greater thrill than the finest railroad train or automobile ride ever gave you in the past, and well it may.

Huber has hit it exactly in the above, and the picture below shows the auto and myself with one of the loads of potatoes that I have been carrying to town daily for the past two weeks.



Some of the potatoes that were hauled to market on the auto propelled by the windmill-made electricity.

Just a word in closing about lighting our homes by wind power. A very gentle breeze indeed will light one or more electric globes, especially if you use the 32-volt globes generally used in the home-lighting plants. While the mill was standing still I placed one of these in our dining-room. Mrs. Root awakened in the night and saw such a blaze of brilliant light that she first thought the house was on fire. You see a breeze had started up. Without a battery the light dances up and down, from nothing at all, and just now the expense (and upkeep) of the battery is the great obstacle in the way of home-lighting outfits. It is true the electricity goes straight from the windmill to the work; but the battery serves to take and store, whenever there is a surplus, and also to give out when there is not enough current or when the mill stops entirely. The same batteries that run the automobile will answer for lighting and for other purposes providing you have wind enough for both.

THE ELECTRIC WINDMILL DURING A THUNDER
STORM.

Yesterday (Apr. 7) we had a thunder storm with quite a gale of wind. The new windmill did its work beautifully. It took the whole battery of 28 cells, and at times gave 25 amperes of current. As a sample of the electric current, a screw began to work out in the "cut-out" device. Without taking the trouble to cut off the current, I started to turn up the screw. A blinding light followed and the tempered steel of the screwdriver began melting and dropping off as if it was sealing wax. The mill took the gale very quietly, with only about 25 revolutions per minute during the biggest squalls.

"ON THE WINGS OF THE WIND;" WIND IN-
STEAD OF CORN, OATS, AND HAY
FOR HORSE FEED.

It is now April 9, and we have had a pretty good wind for several days. The result is, that after using the electric auto all I wish during the day the windmill stands ready to replace promptly the amount of current used. Let us consider a moment what this really amounts to as an achievement in scientific invention. I ride in the easiest-running carriage (the electric automobile) that has ever been made, and the most easily managed of any vehicle that has ever been constructed. I can go thru a crowd so slowly and so still that no one knows I am near until I gently press against him; or with the six different speeds I can go as fast as any one should go; and when I get home I drive into a garage that can be made as nice as a lady's parlor—no harness to remove and no stable to clean. Neither is there any corn, oats, or hay to be provided for this modern steed, for he feeds on wind instead of corn, oats, and hay which cost *money*, as many of us know to our sorrow. You simply drive in, press a button, and your horse will be both fed and watered (with wind) while you do something else, or, stranger still, *while you sleep*. You may suggest a gasoline car. But, my good friend, *gasoline* costs money: but not so with wind. Another thing, gasoline smells; and the burnt gases have cost the lives of several where they have been so thoughtless as to run the auto in a close room, say in cold weather. The modern windmill, running on ball bearings, can almost as well be left running as to stand still. I tell Mrs. Root, if she wishes to go anywhere, that now is the time, for it costs no more to travel than to let the auto stand still.

I have dear friends, received during my busy life many kind words, as most of you know; but a kind word or two that pleased

me most was reported to me by my young friend Manikowske. It came from Rear Admiral Garst, of the Navy (now retired), who has a fine residence here, when some one remarked in his hearing:

"Is it likely that Mr. Root will ever get his money back for such an investment?"

He replied, as reported to me, as nearly as I can recall, "If I understand Mr. Root, he does not expect to get his *money* back. His pay will come in the knowledge that future generations (perhaps unborn) will be benefited by his experiments."

WILL THE WAR RESULT IN A BETTER MAN-
KIND, THE WORLD OVER?

Dear Mr. Root:—I am not an atheist, socialist, anarchist, nihilist, Republican or Democrat—am not what may or might be called religious, but have been a reader of your GLEANINGS off and on for years, but have been a subscriber for only two years. There are so many papers, etc., that one cannot get them all. What use I have for your magazine is your innocent, simple way that you do your writings. Do I believe them? Not all, but you put out some good advice. I cannot quote exactly, but in one of your papers you said something like this: "God is letting this war go on to create a better feeling in mankind." Do you believe it?

There are lots of things I would like to say but just this one more, was: I have read in your writing of the harmony that there is in your family; altho I am not Irish, will say more power to you. I have preached the bundle of sticks for years but have never got a convert. It's all for themselves and the devil for the crowd.

Cleveland, O.

W. B. Kitteringham.

Dear Friend:—I may have said, and I say again, we have many evidences that might indicate that God is letting the war go on that the *final outcome* may be a better *mankind*, the world over. I cannot name a tenth part of them here. The death of the liquor traffic, saving of food, the study of the best and most nourishing foods, gambling on wheat, extortion in food prices, better care of the babies, saving the money that has been wasted in folly, doing away with gambling, etc.

Now, a word about yourself, dear brother. Go down on your knees, and ask God to direct you and give you light. Go to church *regularly*. Go to Sunday school. Be on hand in the Bible class every Sunday. Accept "the Lamb of God, who taketh away the sins of the world," as your helper and your guide. I am praying for you as I write this letter.

God permits wickedness to go on at times, that indifferent people like you and I, may wake up and do something. Some of our best laws have been enacted, just because of indignities perpetrated on helpless women and children. May God guide you and give you faith.

Our Food Page—Continued from page 285.

bake about half an hour. It may be served hot or cold. Any other fruits may be substituted for the apricots and raisins. Serve with the juice of the apricots made into a sauce.

JOHNNYCAKE.

- 2 eggs well beaten
- 3 cups sour milk
- 3 level teaspoons soda
- 3 cups cornmeal
- ½ cup rye flour
- 1 teaspoon salt
- 2 tablespoons melted shortening

Beat the eggs in the mixing bowl and add sour milk. Sift together the cornmeal, salt, rye flour, and soda, and add to eggs-and-milk mixture. Beat in the melted shortening and bake in shallow pans.

CORN RICE MUFFINS.

- 1 cup cornmeal
- 1 cup boiled rice
- 1 cup milk
- 1 tablespoon fat
- 1 teaspoon salt
- 2 teaspoons baking powder
- 2 eggs

Mix cornmeal, rice, milk, and melted shortening together; beat five minutes, add well-beaten egg yolks, beat two minutes and sift in the baking powder. Fold in the stiffly beaten whites of the eggs, and bake in hot well-oiled muffin pans.

BEAN PORRIDGE.

- Cooked white beans
- Cornmeal
- Beef broth
- Salt

Make a thin mush of the seasoned beef broth and meal; cook about two hours and
(Continued on page 314.)

PATENTS Practice in Patent Office and Courts
Patent Counsel of The A. I. Root Co.
Chas. J. Williamson, McLachlan Building,
WASHINGTON, D. C.

SWARMING CONTROLLED

No additional fixtures needed; unnecessary to clip queens; done solely by manipulation. Successfully used for eight years. For particulars address

Trimble & Thompson, Marion, Iowa.

The BEST LIGHT

Positively the cheapest and strongest light on earth. Used in every country on the globe. Makes and burns its own gas. Casts no shadows. Clean and odorless. Absolutely safe. Over 200 styles. 100 to 2000 Candle Power. Fully Guaranteed. Write for catalog. AGENTS WANTED EVERYWHERE.

THE BEST LIGHT CO.
306 E. 5th St., Canton, O.

Mott's Northern-bred Italian Queens

are hardy, prolific, gentle, and hustlers, therefore resist well disease.

- Untested, \$1.00 each; \$9.00 for 12.
- Select Tested, \$1.50 each.
- Virgins, 50c each; or three for \$1.00.
- Bees by pound.
- Plans "How to Introduce Queens," and "Increase," 25c. List free.

E. E. Mott, Glenwood, Mich.

FLOUR IS HIGH

Why not live better and save money, too? Grind your wheat into Best Whole Wheat or Graham Flour. Your doctor knows how healthy these are. Make the BEST Corn Meal, the old-fashioned sort you can't buy at any price nowadays.

Do all sorts of fine and coarse grinding with an

APACHE MILL

Wt. 35 lbs.

BALL

B
E
A
R
I
N
G

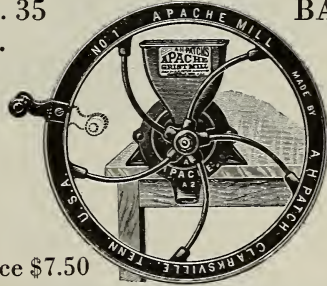

Price \$7.50

This Mill Makes Best Corn Meal, Graham Flour, Rye Flour, Chops, Hominy, Cracks Peas, Grinds Coffee, Spices, etc. Perfect adjustment for coarse or fine work. Will send Mill prepaid by Express \$7.50
APACHE CRIST MILL—Largest capacity, fastest grinding, easiest turning handmill. Does more, lasts longer.

A. H. Patch, Inc., Clarksville, Tenn.
The Blackhawk Corn Sheller Inventor
Invented 1885

\$30,000 WORTH OF Bee Supplies



All boxed, ready to ship at once; 275,000 Hoffman frames, also Jumbo and Shallow frames of all kinds, 100 and 200 in a box. Big stock of Sections, and fine polished Dovetailed Hives and Supers. I can give you big bargains. Send for a new price-list. I can save you money.

Will Take Beeswax in Trade at Highest Market Price.

Charles Mondeng

146 Newton Ave., N. Minneapolis, Minn.

BEES Tested Italian queens . . . \$1.50
Silk faced veils80

We furnish a full colony of Italian bees in a new 8-frame chaff hive, complete with super, for \$15.00. Three-frame nucleus with Italian queen in May, \$5.50.

I. J. Stringham, Glen Cove, L. I., N. Y.

Queens Rhode Island Queens

Italian Northern Bred Queens. Very gentle and hardy. Great workers. Un-
tested, \$1; 6 for \$5. Circular on applica-
tion. Queens delivered after June 1.

O. E. TULIP, ARLINGTON, RHODE ISLAND,
56 Lawrence Street.

**Forehand's Three Bands
THE THRIFTY KIND**

have been placed on the market for
over a quarter of a century. We guar-
antee that they will please you. One,
\$1; 6, \$5; 12, \$9. Write for circular.

W. J. Forehand & Sons, Fort Deposit, Ala.

When Ordering Supplies

remember we carry a full stock and sell at the
lowest catalog price. Two lines of railroad—
Maine Central and Grand Trunk.
Prompt service and no trucking bills.

THE A. I. ROOT CO., Mechanic Falls, Maine.
J. B. MASON, Manager.

QUEENS

Quirin's Improved Superior Italian Bees
and Queens. They are Northern Bred
and Hardy. . . 25 Years a Queen-breeder

PRICES	Before July 1st			After July 1st		
	1	6	12	1	6	12
Select untested....	1.50	8.00	15.00	1.00	5.50	10.00
Tested	2.00	10.00	18.00	1.50	8.00	14.00
Select tested	2.50	14.00	25.00	2.00	10.00	18.00
2-comb nuclei	4.00	22.00	42.00	3.50	18.00	35.00
3-comb nuclei	6.00	35.00	60.00	4.50	25.00	45.00
8-frame colonies . .	10.00	55.00		8.00	45.00	
10-frame colonies . .	12.00	68.00		10.00	55.00	
1-lb pkg. bees	3.00	16.00		2.50	14.00	
2-lb. pkg. bees	5.00	28.00		4.50	25.00	

BREEDERS.—The cream selected from our en-
tire stock of outyards; nothing better. These
breeders, \$5.00 each.

Can furnish bees on Danzenbaker and L. or
Hoffman frames.

Above price on bees by pound, nuclei, and
colonies does not include queen. You are to
select such queen as you wish with the bees,
and add the price.

No bees by pound sent out till first of June.

Breeders, select tested, and tested queens can
be sent out as early as weather will permit.

Send for testimonials. Orders booked now.
Reference—any large supply dealer or any
bank having Dunn's reference book.

H. G. Quirin, Bellevue, Ohio

Our Food Page—Continued from page 213.

then stir in about 2/3 of its bulk of the hot
beans. Mix well, cook a few minutes, and
serve hot with a little milk or butter.

Miss Abbie A. French.

BARLEY SPONGE CAKE.

- 4 eggs
- 1 cup sugar
- 1 1/3 cups barley flour
- 1 tablespoon lemon juice
- 1/4 teaspoon salt

Measure the flour after once sifting, also
sift the granulated sugar. Separate the
whites and yolks of the eggs and beat the
yolks until light and thick. Add the sugar
and the lemon juice and fold in alternately
the flour and the stiffly beaten egg whites,
a little at a time.

HONEY BARLEY DROP CAKES.

- 1/2 cup melted fat
- 3/4 cup honey
- 1 egg
- 1/4 cup milk
- 2 cups barley flour
- 3 teaspoons baking pow-
der
- 1/4 teaspoon salt
- 3/4 cup chopped nuts
- 1 teaspoon vanilla or
other flavor

Cream the melted fat and honey together,
beat in the egg, and add the milk. Sift the
barley flour, baking powder, and salt to-
gether and add to the first mixture. Stir in
the chopped nuts. Drop on well-oiled cooky
sheet and bake in a moderate oven.

CODFISH CAKES.

- 1 cup salt codfish
- 1 pint raw potatoes cut
in thick slices
- paprika
- 1 tablespoon melted fat
- 1 egg

Shred the fish in small pieces, lay it on
(Continued on page 316.)

**ROOT'S
Bee Supplies**

**AT ROOT'S PRICES
PROMPT SERVICE**



BEEKEEPERS' SUPPLIES

A Good Stock of the
Lewis Beeware
 and
Comb Foundation
 Is at your command at
 factory prices.

Western Honey Producers
 Sioux City, Iowa
 We have a market for your honey and
 beeswax.

"Griggs Saves You Freight"
TOLEDO

We are now well supplied with a big stock of **NEW ROOT HIVES, SUPERS, SECTIONS, and FOUNDATION**, besides everything you may wish for the season. But don't delay ordering your wants, as goods are going out fast.

FINEST ITALIAN BEES and QUEENS. We make a specialty of these and send the best stock money can buy.

POULTRY FEEDS. Dickinson's Globe Feeds are the best. Get our prices of one bag or twenty.

HONEY and BEESWAX always wanted, cash or in trade.
 Send postal for Free Catalog.

S. J. GRIGGS & CO.,
 Dept. No 25. Toledo, Ohio
 "Griggs Saves You Freight"

WITTE

Kero-Oil Engines

Twice the Power at Half the Cost
 Sizes 2 to 22 H.P.--Select Your Own
 Terms -- Direct-from-Factory prices. Write
 your own order--Save \$15 to \$200. Prompt
 Shipment. Big new catalog, "How to Judge
 Engines" FREE--by return mail, Postpaid.

Write **WITTE ENGINE WORKS**
 Today 1932 Oakland Ave., Kansas City, Mo.
 1932 Empire Bldg., Pittsburgh, Pa.

**Save \$15
 to \$200**

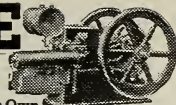
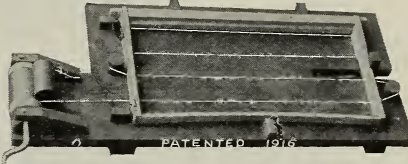
WRIGHT'S FRAME-WIRING DEVICE
 Most rapid in use. Saves cost of machine in one day. Tighter wires; no kinks; no sore hands.
 Price, \$2.50, postpaid in U. S. A.
 G. W. Wright Gompany - Azusa, California

"Best" Hand Lantern



A powerful portable lamp, giving a 300 candle power pure white light. Just what the farmer, dairyman, stockman, etc. needs. Safe--Reliable--Economical--Absolutely Rain, Storm and Bug proof. Burns either gasoline or kerosene. Light in weight. Agents wanted. **Big Profits.** Write for Catalog. **THE BEST LIGHT CO.**
 306 E. 5th St., Canton, O.

For Potato Bugs And Blight use **SULFOCID** and **CAL-ARSENATE**

—a new combination which bids fair to replace the old Lime Sul-Arsenate of Lead and Bordeaux-Lead mixtures, in both orchard and garden.
 It is more powerful and much less expensive. 1 gallon and 4 1/2 lbs. makes 150 gallons of spray.

Send for circular
B. G. PRATT CO., Mfg. Chemists
 50 Church St. Dept 6 New York

30 DAYS FREE TRIAL

and freight prepaid on a new 1918 "RANGER" bicycle. Write at once for our big catalog and special offers. Take your choice from 44 styles, colors and sizes in the famous "RANGER" line.



Marvelous Improvements. Extraordinary values in our 1918 price offers. You cannot afford to buy without getting our latest propositions and Factory-to-Rider prices.

Boys, be a "Rider Agent" and make big money taking orders for bicycles and supplies. Get our liberal terms on a sample to introduce the new "RANGER".

TIRES, equipment, sundries and everything in the bicycle line at half usual prices. Write Today.

MEAD CYCLE COMPANY
 Dept. F153, Chicago

Ranger Electric Lighted Motorbike

BARNES' Hand and Foot Power Machinery

This cut represents our combined circular saw, which is made for beekeepers' use in the construction of their hives, sections, etc.

Machines on Trial

Send for illustrated catalog and prices

W. F. & JOHN BARNES CO
545 Ruby St
ROCKFORD, ILLINOIS

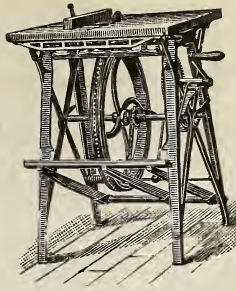

Our Food Page—Continued from page 314.

the potatoes, and pour over boiling water to cover and cook until potatoes are done. Drain thoroly in a strainer, return to the kettle in which they were cooked, and mash, making sure there are no lumps of potato left. Add the melted fat, the well-beaten egg, and beat smooth. Take up by spoonfuls, place on well-oiled pan, sprinkle with paprika, and bake until brown.

HASHED BROWN POTATOES.

3 cups chopped cooked potatoes	1/2 onion sliced
1 teaspoon salt	1/3 cup milk
1/2 teaspoon pepper	2 tablespoons drippings

Combine the potatoes, seasonings, and milk; melt the drippings in frying pan and cook the onion until yellow and soft. Add the potato mixture and press down smoothly. Cook over a hot fire for a moment, and then slip a stove mat under and cook very slowly until brown on the bottom, about twenty minutes. Fold over like an omelet and serve on a hot platter garnished with parsley.

All measurements level.

BANKING BY MAIL AT 4%

Where Do You Live?

No matter WHERE you live you can take advantage of the banking facilities which this bank offers. The people of the United States have at their disposal the strength and service of this safe and strong bank and they can transact their financial business through it with the greatest safety, ease and confidence when they

Bank by Mail

Deposits may be sent in the form of check, draft, money order or the currency by registered mail.

Write for detailed information concerning this plan which assures absolute safety and 4 per cent interest.

**THE SAVINGS
DEPOSIT BANK CO.**
MEDINA, OHIO

A. T. SPITZER, Pres.
E. R. ROOT, Vice-Pres.
E. B. SPITZER, Cashier

ASSETS OVER ONE MILLION DOLLARS

BOOKS AND BULLETINS

MRS. ALLEN'S COOKBOOK.

Ida C. Bailey Allen, editor "Housewives' Forum" in *Pictorial Review*; formerly editor "Three Meals a Day" in *Good Housekeeping*; lecturer for Chautauqua and Westfield Domestic Science Schools. Small, Maynard & Co., Boston. Price, \$2.00 net.

This is not only a complete cookbook, but an all-around help for the housekeeper in her kitchen. In Part I Mrs. Allen treats of the chemistry of food and cookery, the diet for the different seasons, children's meals, the problem of the dinner pail, the art of combining foods, seasonings and on thru the equipment of the kitchen, short-cut preparation of meals, the serving of home and company meals and the chafing dish.

Part II gives methods of preparing and recipes for practically every thing one may wish to cook. There are good cooks who are not scientific; there are dietitians who understand the science of cooking, but are not especially good cooks. Mrs. Allen happily combines the sciences with the art, for good cooking is an art. One feels that she is a born cook who has availed herself of every help that science can give in the selection and preparation of foods for the family. And she has set it forth in a most attractive way. Her enthusiasm for her subject is apparent in every chapter of the book. The book is invaluable as a reference work, but a housekeeper who opens it will be sure to read on and on until she is seized with an uncontrollable desire to go to her kitchen and try some of the delectable dishes described. While not strictly a war cookbook, it is emphatically a thrift cookbook. One can find plenty of wheat substitute dishes, meat substitute dishes, and, best of all,

attractive ways of using left-overs and portions of food commonly discarded.

Her talk on bread-making and flours is especially good and up to date, and she gives many recipes for using home-ground flours and meals in both yeast breads and quick breads.

Of especial interest to beekeepers is the casual way in which many of the recipes call for half a cup of honey here and one-fourth of a section of honey there. While there are not many honey recipes labeled as such, there are many containing honey.

The book is enriched by 45 illustrations of kitchen equipment, foods prepared according to the recipes, and daintily arranged trays and tables.

PRICES ADVANCED AGAIN.

Increasing costs of material and labor makes imperative a further readjustment of prices effective this date. This decision was reached too late to make an extended announcement of the various advances adopted. A circular is being prepared which will be mailed on application. The advances will average ten per cent; more on some items and none on others. No change on price of comb foundation. Copper smokers advanced 35c each. Honey extractors and most other metal goods 10 to 20 per cent advance.

THE A. I. ROOT CO., Medina, O.

BEEKEEPER'S SUPPLIES

HIVES . FRAMES
FOUNDATION . ETC.

The Tillson Company, Ltd.
Tillsonburg, Ontario, Canada

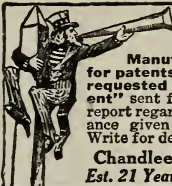

Inventions Wanted!

Manufacturers constantly writing us for patents. List of inventions actually requested and book "How to Obtain a Patent" sent free. Send rough sketch for free report regarding patentability. Special assistance given our clients in selling patents. Write for details of interest to every inventor.

Chandlee & Chandlee, Patent Attorneys
Est. 21 Years 427 7th St., Washington, D. C.

Beeswax Wanted

In big and small shipments, to keep Buck's Weed-process foundation factory going. We have greatly increased the capacity of our plant for 1918. We are paying higher prices than ever for wax. . We work wax for cash or on shares.

Root's Bee-supplies

Big stock, wholesale and retail. . . Big catalog free.

Carl F. Buck

The Comb-foundation Specialist

Augusta, Kansas

Established 1899

Full Values in

"Falcon" Beekeepers' Supplies

For the last forty years during our manufacture of "FALCON" supplies it has been our endeavor to place upon the market the best possible line of supplies. And we pride ourselves in having accomplished this. "FALCON" supplies have not only been recognized as the best in this country, but also a leader in other countries. Nothing expresses the superiority of the "FALCON" wares better than the many kind and pleasing words we receive from our satisfied customers, and the ever-increasing demand for "FALCON" supplies.

The season is drawing nearer and beekeepers should endeavor to order early. By making up your wants now you will be better fitted to go into the season with a view of not only obtaining a bigger crop but to facilitate matters thruout the season. If you will make up a list of requirements for quotation we shall be glad to quote.

Red Catalog, postpaid

Dealers everywhere

"Simplified Beekeeping," postpaid

W. T. FALCONER MFG. COMPPANY, FALCONER, NEW YORK

where the good beehives come from.

New England Beekeepers

will find a complete line of supplies here. Order early and avoid delays. Write for catalog.

H. H. JEPSON

182 Friend Street Boston, Mass.

Complete Line of

Beekeepers' Supplies

Catalog on Request

F. Coombs & Sons, Brattleboro, Vt.

Order Your Bee Supplies Early

We want you to have our catalog. . . Send for one.

August Lotz Company, Boyd, Wis

New England Beekeepers

EVERY THING IN SUPPLIES

New Goods Factory Prices Save Freight

Cull & Williams Co., Providence, R. I.

QUEENS QUEENS QUEENS

Three-banded and Golden Italians. The best of either. They are hustlers—gentle to handle, cap their honey white, are very resistant to European foul brood. We have added B. M. Caraway's queen-rearing outfit to ours; also have with us one of his assistants, so we hope to fill devised shipping-cage, a number of shipments going as far as Idaho and Wyoming. Mr. R. B. all orders promptly. We had fine success last season shipping bees by the pound in our newly Millis, Corinth, N. Y., wrote, "Bees arrived in fine shape; not 50 dead bees to the cage." 2-lb. size, Satisfaction and safe arrival guaranteed. Reference: The Guaranty State Bank, Robstown, Texas, or The City Nat. Bank, Corpus Christi, Texas.

	1	6	12	50	100
Untested Queens	\$1.15	\$ 6.35	\$11.50	\$ 43.70	\$ 85.00
Select Tested	2.50	11.50	20.70	74.75	138.00
Bees, 1-lb. package.	1.75	9.80	18.40	74.75	138.00
Bees, 2-lb. package.	2.90	17.25	33.95	132.25	240.00

When ordering pound packages add price of queen wanted. Get our prices on empty bee-cages. *Circular Free.* Satisfaction and safe arrival guaranteed *within six days of Calallen, Tex.*

NUECES VALLEY APIARIES, Calallen, Texas, hereafter will be known as Nueces County Apiaries, Calallen, Texas

E. B. AULT, Proprietor

QUEENS THAT WILL PLEASE

OVER 20 YEARS OF CAREFUL SELECTING AND BREEDING

GUARANTEE.

You take no risk in buying my queens, for I guarantee every queen to reach you in first class condition, to be purely mated, and to give perfect satisfaction.

They are bred from IMPORTED stock. The very best for honey gathering and gentleness. They are not given to swarming and are highly resistant to diseases. Give me your order and if after you have given my queens a fair trial, you are not satisfied in every way that they are as good as you have ever used, just return them and I will send you queens to take their places or return your money with any postage you have paid out on returning the queens.

PRICES APRIL 1 TO JUNE 15th.

	1	6	12
Untested.	\$1.00	\$ 5.00	\$ 9.00
Select Untested.	1.15	6.00	10.00
Tested.	1.50	8.00	17.00
Select Tested.	2.00	11.00	20.00

L. L. FOREHAND - - FORT DEPOSIT, ALABAMA