

Scientific American.

THE ADVOCATE OF INDUSTRY, AND JOURNAL OF SCIENTIFIC, MECHANICAL AND OTHER IMPROVEMENTS.

VOLUME VIII.]

NEW-YORK, JULY 30, 1853.

[NUMBER 46.

THE Scientific American,

PUBLISHED WEEKLY

At 123 Fulton street, N. Y., (Sun Building),

BY MUNN & COMPANY.

Hutchkiss & Co., Boston.
Dexter & Bro., New York City.
Stokes & Bro., Philadelphia.
LeCount & Strong, San Francisco, Cal.
Cooke, Kinney & Co., ditto.
B. Dawson, Montreal, C. E.
M. Boulemet, Mobile, Ala.
E. W. Wiley, New Orleans, La.
E. G. Fuller, Halifax, N. S.
M. M. Gardissal & Co., Paris.

Responsible Agents may also be found in all the principal cities and towns in the United States.
Terms—\$2 a year—\$1 in advance and the remainder in 6 months.

USEFUL RECEIPTS.

Solid Plating Process by Heat.

After having well cleaned and polished the metal to be plated, moisten its surface with salt water, by means of a camel-hair pencil, and spread over it very uniformly some of the powder No. 1, (the composition of which is given below), so that, on turning over the metal, a layer of the powder remains adhering to its surface. This done, place the metal in a clear charcoal fire, and heat it to redness, immerse it in pure boiling water, or water containing a small quantity of salt or tartrate of potash dissolved in it; then rub it, with a stiff brush, over every part. In this state it will appear to be already entirely silvered, and this first operation is the most important, inasmuch as it is in this way, the silver in a state of fusion by penetrating the object to be plated, serves as a basis for the following additional operations:—Cover again, very evenly the article to be plated by means of a pencil, with the paste, the composition of which is given in No. 2; heat to a cherry-red, plunge it into boiling water, and rub well when cold. Repeat this four or five times, after which the object is sufficiently silvered, and becomes fit to receive the lustre of the burnisher.

No. 1. Powder for the first operation—Dissolve silver in nitric acid, and precipitate in the usual manner, by means of a slip of copper, wash, and dry the silver precipitate. Take one part of this silver powder, one part of chloride of silver, two parts of calcined purified borax. Mix these ingredients with great care in a porcelain mortar, and afterwards pass through a fine silk sieve.

No. 2 Paste for the subsequent operations—Mix, very carefully equal parts of silver powder, purified sal ammoniac, pure salt, sulphate of zinc, and clear pure gall; grind these together very fine, adding distilled water containing a very little gum dissolved in it, and make a paste of a convenient consistence to apply by means of a pencil.

Articles silvered or plated in this way, show, when broken, that the silver has evidently penetrated into the copper, thereby ensuring the most solid and durable plating. The points and edges of plated goods, from which, by use, the silver has worn off, may be restored by this means, and to effect this, it will be necessary only to apply the process to those parts which may require a renewal of the silvering. Articles which have been blackened or tarnished may readily be restored to their original beauty by means of this simple and easy process.

Deaths at Niagara.

Three men were drawn into the rapids in a boat, at Niagara Falls last week, and were dashed down into the fearful abyss of boiling waters. One clung for 20 hours on a rock, in view of hundreds of people on the shore many were the efforts made to save his life; but all failed; faint and weak he was at last drawn over the awful verge of the cataract; he gave one loud shriek, and his voice was drowned forever amid the roar of waters.

DENTON'S REAPER AND SELF-RAKER...-Fig. 1.

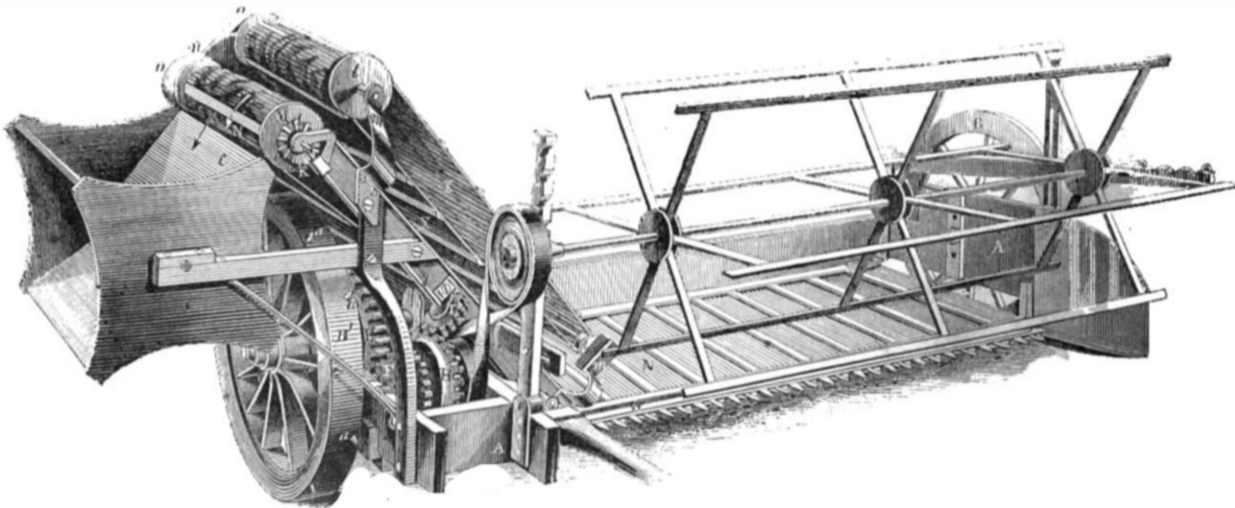

The annexed engravings are views of an improved harvesting machine—reaper,—invented by Charles Denton, of Peoria, Ill., who has taken measures to secure a patent for the same.

Figure 1 is a perspective view of the machine; figure 2 is a plan or top view, showing how the sheaf hopper is acted on by the dog, spur, and wiper wheel, and fig. 3 is a perspective view of the dog spur and wiper wheel. The same letters refer to like parts.

The nature of the improvements consist in having a rotary sheaf hopper attached to the machine, and operated by the machinery, so as to receive and deposit the cut grain in sheaves or bunches at the side of the machine;

the grain, when cut, is received on a platform behind the reel and cutters, and deposited in the boxes of the hopper (there are four of them), which rotate with an intermittent motion to receive and deposit the cut bunches of grain at regular intervals as the machine is drawn forward.

A represents the frame of the machine; B B' are the wheels on which the frame is suspended; B' is the driving wheel, or the one from which motion is communicated to the working parts; it has pins, *a*, on its periphery which penetrate the earth as it revolves, and prevent it slipping. This wheel is placed loosely on a shaft, C, and is connected to said shaft when it turns forward by a spring

Figure 2.

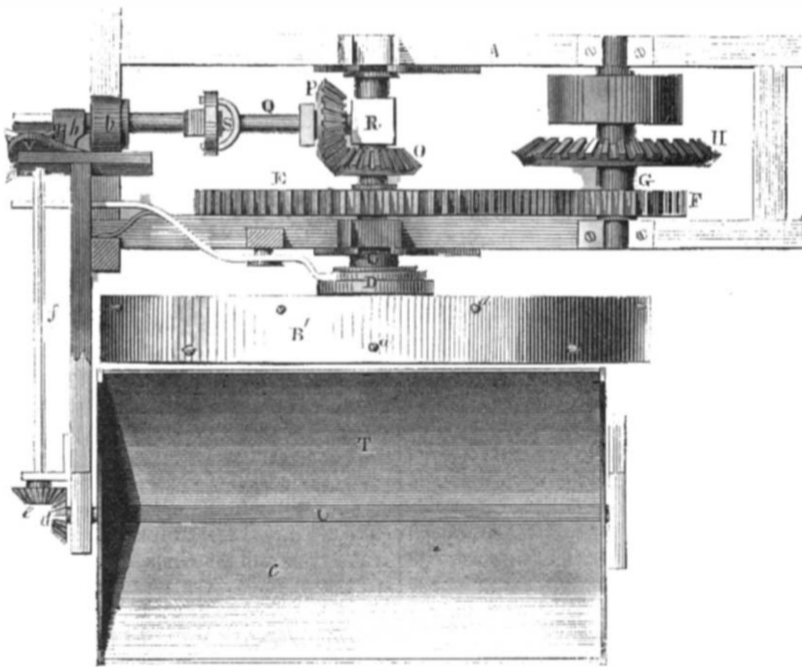

clutch, D (see figs. 1 and 2), this clutch does not connect the wheel with the shaft when the wheel is turned backward. E (figs. 1 and 2) is a toothed wheel permanently attached to the shaft, C. This toothed wheel gears into a pinion, F, on a shaft, G, on which is hung a bevel wheel, H. This bevel wheel gears into a bevel pinion, I, at the lower end of an inclined shaft, J, on the upper end of which there is a small bevel wheel, K (fig. 1), which gears into a bevel wheel, L, on one end of a roller, M. This is the driving roller of an endless apron. O is a bevel wheel on the shaft, C (fig. 2), said bevel wheel gears into another bevel wheel, P, on a shaft, Q; one end of this shaft runs or has its bearing in a roller, R, which encompasses loosely the shaft, C. The opposite end of the shaft, Q, has its bearing at *b*, on a portion of the frame A. The

shaft, Q, is provided with a universal joint, S. T is a rotary hopper divided into four compartments, the partitions, *e*, which radiate from the shaft, U, on which the hopper is hung. On one end of the shaft, U, there is a small bevel wheel, *d*, which gears into a bevel wheel, *e*, on the upper end of an inclined shaft, *f*; on the lower end of this shaft there is a wiper wheel, *g* (fig. 2 and 3), against which a spur, *h*, on the outer end of the shaft, Q, operates. V is a dog, which fits over a square on the shaft, *f*, and adjoining the wiper wheel, *g*. The spur, *h* operates upon the dog as well as upon the wiper wheel.

The endless apron, N, previously alluded to, passes over the roller, M, and downward to the platform, W, where it passes under clamps and then around a roller at one end of the platform. X is an endless apron placed pa-

rallel, or nearly so, with the inclined portion of the endless apron, N, as shown in fig. 1. The upper and lower rollers, *l l*, of the apron, X, run in suitable bearings, *m m*, attached to the frame of the machine. Motion is commu-

Fig. 3.

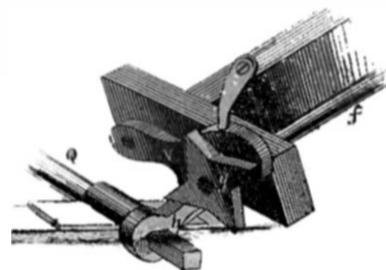

nicated to the apron, X, by means of a cross belt, *n*, which passes around pulleys, *o o*, at the ends of the rollers, M. Any suitable form of cutters may be used, and motion may be given them in any manner. The cutters of course would be placed in front of the platform, W, as in other harvesting machines.

OPERATION—As the machine is drawn along the grain is cut by the cutters and falls upon the endless apron, N, on the platform, W. The two endless aprons, N and X, move in the direction indicated by the arrows in fig. 1. Motion being given the aprons by means of the bevel wheels, H I K L, previously described. As the aprons move, the grain is carried upward between them and thrown into the compartments of the hopper, T. The arrows in fig. 1 indicate the direction of the grain. The shaft, Q, has a rotary motion given it by the bevel wheels, O P, and an intermittently rotating motion is given the hopper, T, by the spur, *h*, operating against the wiper wheel, *g*. The spur, *h*, once in every revolution, acts against a projection of the wiper wheel, and turns it one quarter of a revolution, owing to the action of bevel wheels, *e d*, and as there are four compartments in the hopper, an empty compartment is placed underneath the driving rollers, M, of the endless apron, N, at every movement of the hopper, the compartments that are filled being emptied or thrown out as the hopper rotates.

Thus, it will be seen that the grain is thrown out of the hopper upon the ground in sheaves or bundles, ready for binding, and the grain is carried up and deposited in the hopper by means of the two endless aprons, N and X. The universal joint, S, in the shaft, Q, is for the purpose of compensating for the elevating or depressing of the machine. This machine, like most others, is raised or lowered, the shafts of the wheels being made, by any proper contrivance, adjustable. The object in raising and lowering the machine is to cut the grain close to the ground or otherwise.

The first experimental machine of this kind

was constructed in the summer of 1851, and thoroughly tested in the field with great satisfaction. The advantages claimed for it are as follows:—

Each end of the machine is supported by a wheel four feet high and three to six inches wide, to diminish the motive power necessary to propel it; the width and height of the wheels prevent their sinking into the soil, and also lessens the number of revolutions necessary to propel the machinery at the required speed. The width of the cutting part is eight and a half feet, being two and a half feet wider than most other reapers, consequently enabling it to cut more acres with less travel. The sickle can be adjusted to any required height in a few minutes. It requires but the attendance of one person, and can be guided with ease and precision. It deposits the grain in bundles of an appropriate size, ready to bind, thus saving the labor of an active man, whose constant attendance is required by other machines.

This machine is on exhibition at the Crystal Palace, and agriculturists are invited to give it special attention.

More information respecting this invention may be obtained by letter addressed to the inventor at Peoria, Illinois.

THE CRYSTAL PALACE

During the past week, the Exhibition has greatly improved in every respect. Great activity has been displayed in the opening up of new packages, and the arrangement of new articles. The average daily attendance of visitors has been about 4,000. As machinery is capable of doing almost everything now-a-days, a machine counts the number of persons who enter the building. It is an instrument like that employed at some Toll Bars to register the number of tax payers. Every person entering passes through a turn-stile which records each admission; and all that is necessary, therefore, at the end of the day to ascertain the aggregate number of visitors, is to add up the record of each turn-stile.

New cases are being opened every day, and the daily visitor is greeted in each department with many novelties of which he catches glimpses on the various counters, without, however gaining more information of the articles than a mere view affords him.

JAPAN WORK.—The Japanese collection is now arranged, and from the many quaint articles which it displays, attracts the attention of those curious in carvings, fans, shell, embroidery, and other ingenious trifles. This collection is small, but coming as it does from a country whose customs and native manufactures are a mystery to the traveller. It is of more interest on that account.

This collection is in the German Department, near the West entrance in the North West wing, and unless specially examined, may be overlooked by many. The articles of real Japan workmanship to which we wish to direct attention, are some large tablets, which will bear close inspection before their merits can be fully appreciated. No such piece of Japan work has ever been seen in our country before, and it is a great curiosity. The figures are out of proportion, and as for perspective, the Japanese do not seem to have discovered any such laws as those which regulate the operations of our artistic designers; the mechanical workmanship, however, surpasses everything that we have seen in this kind of ware.

MACHINERY.—The working machinery of the Exhibition, under the Superintendence of Joseph E. Holmes, is to be erected in a separate building at the side of the Crystal Palace. The structure is now in the course of erection, the severe hurricane, mentioned by us two weeks ago, having much delayed its advancement. It may be about three weeks before it is complete for receiving and working the machines to be exhibited. The iron work upon it is done;—The upper floor is wholly, and the lower floor nearly laid; the engines for driving the machinery are being introduced. This Department will be of the most interest to us and our readers; the delay in its erection tries our patience, but we have no doubt of eventually witnessing a display

of American machinery, which will make us proud of the genius and skill of our countrymen. Two printing presses have been introduced into the Palace, and are kept at work on the Illustrated Catalogue. We have been informed that Messrs. Hoe are not going to have one of their large lightning presses on exhibition. The reason given is, they could not get the requisite quantity of room to erect and work it. We regret this, because we are sure that this press would command the admiration of all. It would especially arrest and rivet the attention of all our foreign brethren. Applegarth's great press was at the London Exhibition; why should not Hoe's be at the American? A working model of Wilkinson's new press is to be on exhibition, but that is not enough, in justice to our country, we want to see the biggest and fastest press in America at the Exhibition.

We also want to see some of the largest and finest locomotives, and other engines in our country, at the exhibition, for we know that we can make a show in useful machinery equal to any nation—England not excepted—in the world, and had New York been as near to London as Paris is, there would have been a different story to tell about American machines at the World's Fair in 1851.

In the Palace some excellent English cotton machinery from Manchester has been put up; it does credit to the makers, but we will be able to say more about it when it is in full operation, at present little can be said about any of the machines in the building.

PUMPS, FIRE ENGINES, &c.—A very large centrifugal pump, of J. Stuart Gwynne's patent, is placed in the east wing, and will astonish the on-lookers when it gets into operation; it is intended as a fire engine if required, and it will throw a stream of great power and volume, as it is to be driven by steam. Will Aphold's be here to risk its reputation on a second trial under different auspices from that under which it was tried in competition with Gwynne's in London? We believe it will not. Carey has also a fine rotary pump on exhibition. Both of these pumps have been illustrated in our columns; they are the best extant; those who have good machines know where to have them brought before the public for just criticism, and to spread a knowledge of their qualities among those who are the most competent judges of their merits. An efficient Fire Brigade has been organized for the protection of the building and goods against the dangers of fire. It will be on duty day and night. E. F. Randolph is Chief Superintendent of the Brigade, composed, principally, of the Police. During the day the Superintendent of machinery, with his engines and centrifugal pumps, will be a powerful reserve force, enough to drown Vesuvius. A very fine engine built by William Jeffers, of Pawtucket, R. I., whose engines have been frequently noticed in our columns, has been placed at the disposal of the fire brigade. This engine can now be seen by visitors, and is well worthy of their attention.

This engine stands in the open space, in the north nave, near the dome, and is capable of throwing water to any part of the Palace. Each section of the building is supplied with four large hydrants, with two lines of hose to each hydrant, and an extra hose for the engine, on the lower floor. The galleries are supplied with three small hydrants, and fifty buckets of water in each of the four divisions. There are also twelve small hydrants on the lower floor. For the further and more complete protection of the edifice from fire, there will be tanks in the higher portions of the two eastern towers, capable of containing 1,300 gallons each, which will be supplied with water by a steam force pump, from pipes connected with the main pipe on Fortieth street. These tanks connect by four inch pipes with all the lines of hose and hydrants in the main building, giving a constant head about twenty-five feet higher than the average level of the water in the Reservoir. In the machine arcade there will be one large hydrant in the centre of the building, with eight smaller ones, four on the lower floor, and four in the picture gallery; on the upper floor, each will be supplied with hose, as in the main building. Exhibitors need not place their

trust in Fire Annihilators of doubtful merit, while they have such an efficient Fire Brigade.

SILVER WARE.—In the British Department there is already a display of silver ware which is worth travelling some distance to see. There are some cases filled with the most gorgeous specimens of table ornaments. There is a group named "The Halt in the Desert," which is a superb piece of workmanship. It is about twenty-two inches across the base, and about thirty-six inches in height, and is valued at \$2,000. Upon a heavy massive ground-work stands a palm tree, about two feet three inches in height, elegantly wrought, and heavy with flowing leaves. Around the foot of the tree are gathered three Arabs with their steeds, so grouped as to be expressive of fatigue from a weary journey. One of the horses is lying upon the ground, the others are yet standing, the rider of one is still in the saddle with lance in hand. Near this group is placed another of very exquisite workmanship, and possessing great interest for the lovers of English literature; it is named "Sir Roger De Coverly and the Gipseys." Upon a green sward, around the trunk of an old tree, despoiled of its branches, are gathered a group of six figures—Sir Roger, his companion, two gipseys, Sir Roger's horse, and a dog. Sir Roger has just alighted from his horse, which he holds by the bridle with one hand, and presents the palm of the other to one of the gipseys, who is reading his fortune, while the other gipsy, a perfect Meg Merrilies in countenance, is looking over the shoulders of her companion at De Coverly. The companion of Sir Roger stands in the back-ground, surveying the fortune tellers with apparent distrust. This work is frosted, excepting in some places in the folds of the garments, which, being burnished, turn their silver linings to the view, and render the work beautiful and chaste.

The most curious piece, however, is one named "Æsop's Tea Set." It consists of four pieces—a coffee and tea-pot, sugar bowl, and milk cup. Upon these are richly carved eight fables of Æsop in style both artistic and beautiful. We made a distinct examination of each piece of the set, which is superior to any thing of the kind we have ever before seen. Upon the coffee pot is wrought the two fables, "The Dog and the Shadow," and the "Wolf and the Lamb," and under the former is written the moral, "Be not over greedy," and under the latter, "A tyrant never wants a plea." The figures are all raised work, presenting a beautiful picture upon the burnished surface of the piece. In connection with these illustrations are wrought, in the same style, the coffee plant and large palm trees, indicative as to the pot, of its use, and as to the beverage, of its clime.

The teapot has upon one side (it also has relief) the fable of the "Fox and the Crane," and under it the moral, "True charity needs no return." Upon the other side is the "Lion and the Mouse," and under it reads, "Return a favor." Upon this is carved tea plants and tropical trees.

The sugar-bowl is in keeping with the pieces already described; upon it are most magnificently carved the two well-known fables of the "Fox and the Grapes," and the "Fox and the Storks." The morals read, "Be not envious," and "Do as you would be done by." The vine hanging with clusters, and anxious Reynard seated upon a bank, consoling himself with the reflection that they are all sour, is a triumph of the artist in this kind of work. The sugar cane grows in abundance on the surface of the bowl. The remaining piece of this magnificent set is the milk cup. This, though a small article, is nevertheless heavy with rich carving and massive figures, "The Fox and the Crow," with the moral of the fable, "Learn to resist flattery," is fully pictured upon one side of this cup. The crow, sitting upon the limb of a tree, and the fox resting upon the flowery bank of a little rivulet, fully illustrate the fable. Upon the other side of this cup is the "Crow and the Pitcher," with the moral inscribed, "Science prevails over strength." The ornaments of which we have spoken compose a separate net-work, and are so neatly crossed around the pieces that all suppose them to be carved upon their surface. They are fastened firmly

on the pieces with small screws, and at pleasure can be taken off, leaving a plain modest tea set. The inside of each piece is plated with gold.

There are various other pieces, of which we shall speak in future.

A correspondent in the "Tribune" advocates the opening of the Crystal Palace on Sunday. By his style and remarks he evidently belongs to some of the continental cities of Europe, where the Sabbath is kept as a day of amusement. He asserts that the keeping open of the Exhibition on this day would have a tendency to elevate the thoughts and feelings of the working people, keep them from the grog shop, and prove of general benefit to them, as they cannot afford to lose their daily labor during other days of the week, for viewing such sights. The managers of the Exhibition will not pay the least attention to such suggestions—not solely because they are wrong in a moral sense, but because such a course would receive, as it would deserve, the severest condemnation from the public. In those countries where the Sabbath is most devoted to amusement, we find the working people—those for whose benefit so many talk and write—in the most depressed condition.

We hope that every exhibitor will place a label on every article he exhibits, so as to explain something about its manufacture, who made it, where it came from, what is its price, &c. This will directly benefit the exhibitors, and make the Exhibition far more interesting to visitors, and we hope the superintendents will issue and enforce an order to have this done at once.

Important to Manufacturers and Railway Companies.

We had the pleasure, yesterday morning of examining, at the works of Messrs. Lorenz & Sterling, an exceedingly ingenious double machine for making railway chairs, recently patented by Mr. Robert Griffiths, of Newport, Kentucky.

Simple as what are technically termed chairs for the reception of the rails appear to be, they have, nevertheless, hitherto required great labor in the construction; and when made, they were liable to many defects, which are all removed by the use of the machine in question. The eminent firm, who purchased the patent right for Allegheny county from Mr. Griffiths, found that, by the old mode, the process of making them was a tedious and expensive one, involving a great deal of trouble and labor; and, learning that Mr. Griffiths had invented a new machine for the purpose of forming chairs, which obviated all the former difficulties, they purchased the right to use it; Mr. G., [who is now in this city, has superintended the construction of a machine, at present in operation, to the merits of which too high praise cannot be awarded. The double machine will turn out, at a moderate rate of speed, the enormous quantity of four thousand chairs, or fourteen tons per day, and if required, the quantity can be increased to five or six thousand.

Eight men will attend to it in all its departments, whereas, by the old machines, thirty two would be required. The quantity of coal consumed in the furnace is, besides, not half as much as before.

Another great advantage which it has over all others, is that it will work on a plate of any size, since it is so arranged that by the simple movement of a few screws, the bed, into which the rough plate of wrought iron is put, can be either enlarged or contracted.—The lips too, by a similar arrangement of screws, are bent to any required angle, and the whole operation is performed with mathematical precision, thus causing the chair to fit the rail accurately, and requiring none of the hammering, which has hitherto caused so great an expenditure of labor, on our railroads. These advantages must be obvious to all, for not only are the track layers of a railroad saved a great deal of trouble, but the rails, when placed in the chairs, unite together firmly, and form a straight line, thus removing a fruitful cause of accidents, besides saving a great deal of wear and tear on the rails.

We congratulate Messrs. Lorenz & Sterling on the addition they have made to their extensive works.—[Pittsburgh Com. Jour.

[For the Scientific American.]
Telegraph Batteries.

Having had some acquaintance with telegraphing and telegraphers, I desire to call your attention to a point of practice, in the use of the battery, and its explanation by science.

Some telegraphers (I know not how many) have laid aside Grove's battery and substituted a modification of Daniell's, asserting, after considerable experience, that it is cheaper—they have rejected the use of the mercury, and the sulphuric acid; they say that the former is useless—a dead loss—while the latter, in any quantity, eats up the zincs. They place a cylinder of sheet copper in a glazed earthen jar, within this a porous cup, and still within this a Grove's zinc, unamalgamated. The jar is poured two-thirds or three-fourths full of water, and more than enough to saturate it, is added, of sulph. copper. The porous cup is filled to a level with the fluid outside, simply with water. Now, a person who had taken his ideas of a battery solely from scientific works, would not suppose this would 'go off'; but it does, and practice has demonstrated that it is far superior in length and constancy of action to that in which mercury and sulphuric acid are used—showing, beyond the possibility of a doubt, that they are not only not needed, but positively injurious.

Now what is the chemistry of this battery? In consequence of the conjugal union of the copper and zinc in the fluids of the battery, there is developed a force producing constantly a disruption of previously existing affinities. This force is emphatically a "disorganizer;" it absolves the oxygen and hydrogen in the porous cup, from their marital vows, and a divorce at once takes place—an atom of oxygen unites with an atom of zinc, leaving the atom of hydrogen to seek a more congenial element. Disregarding all natural barriers, she traverses the walls of the porous cup, and instantly unites with an atom of oxygen already divorced from the sulphate of copper, leaving the copper uncombined adhering to the copper cylinder. Here all electrical traverses the porous cup traverses the porous which the freed sulphuric acid has for the oxide of zinc. But a strong affinity does exist here, and an instantaneous combination is effected in the porous cup. Or, on the simpler binary theory, the sulphatoxide of copper, $S.O^4$. Cu., is decomposed, pure copper is deposited on the copper electrode, while the sulphatoxygen ($S.O^4$) traverses the porous cup, and unites with the zinc, forming sulphatoxide of zinc, ($S.O^4$, Zn.) I have described but one series of changes—they succeed one another continually while the battery is in action.

There being no superfluous acid in contact with the zinc cylinder, there is and can be no cross-play of affinities, as in the usual form of battery, producing 'local action.' If the impurities are active at all they must produce a circuit in the same direction as the zinc. It seems to me this very battery, got up by practical men—telegraphers—at once illustrates and proves, in a beautiful and forcible manner, Faraday's law of "definite electro-chemical action." For every nine grains of water decomposed, there are eight grains of oxygen eliminated to combine with thirty-three of zinc; one grain of hydrogen, to combine with eight grains of oxygen of oxide of sulphate of copper; forty of sulphuric acid (real), with forty-one of oxide of zinc, and thirty-two grains of pure copper deposited. Nothing is wanting and nothing is left. The decomposition and re-composition are complete, and the forces are equal. The iron, as impurity in the zinc, has no sulphuric acid to combine with it, unless it decomposes an atom of water; in which case sulphate of copper is decomposed, and the acid is obtained from the copper side of the battery, and the current of electricity generated travels the common highway. The cost of an equivalent of quantity, generated by this battery, taking Mathiot's data (Sci. Am., Vol. 6, page 43), is about 87; and of power with which telegraphers have principally to do, 43 or 44. But when we take into the account the fact that this battery will hold good for a month without renewing, merely adding water and blue vitriol from time to time, while, on the other hand, the Grove's—well amalgamated—only for a

few days, together with the fact that in the hands of operators, generally there is not that scientific precision requisite for the economical working of so complicated a battery—the zincs imperfectly amalgamated or not at all—the quicksilver wasted, and the refuse amalgam thrown away—no one will be disposed to question the cheapness of this telegraph battery.

I think the mechanical arrangement of this battery may be very materially improved, and I intend to devote some study and experiment to it soon. In the description of Farmer's battery, in your paper, reference was made to a certain law laid down by Ohm, which I am very anxious to see elucidated and illustrated. It may not be new, but that is the only time I recollect to have seen any reference to it. * * *

Ottawa, Ill., July 11, 1853.

[For the Scientific American.]
Turning of the Ericsson's Wheels.

I have noticed with much interest the progress of Capt. Ericsson's "Hot-Air Engines." In an article copied by you from "Appleton's Mechanic's Magazine," in the Scientific American of the 18th ult., Capt. Ericsson alludes to the turning of the wheels of the "Ericsson," at the dock, $4\frac{1}{2}$ times per minute, and compares this with the revolutions when under way, at nine turns. I was in the city of New York at the time the Ericsson was fastened at the dock in Williamsburgh, and making these great turns of " $4\frac{1}{2}$ times per minute," and had the curiosity to go over and witness the performance. I was not allowed to go on board, and had to make my examinations at a distance—but I made an important discovery, which I believe has not been made public, and that was, that all the buckets but one, in the water at a time, had been removed from the wheel, and this seemed to be a very narrow one—hence the reason of her ability to make even $4\frac{1}{2}$ turns. I made inquiry of the guard (who, by-the-by, informed me "I could not go on board even if I were Capt. Ericsson's own brother,") who gave as a reason for those off the buckets, "that the engine was too strong to put them all on at once, for fear of breaking all to pieces."

Some of the papers in your city were very free to give the performance of the wheels at the dock, but, as I thought at the time, overlooked the little item that most of the buckets had been removed, and that those which were on were very narrow—if there had been none on the wheel I think the revolutions might have been increased.

I wish to say that, in my opinion, you have done yourself and your paper much credit by an exposure of the defects of the Hot-Air Engine. A. G.

Chicago, Ill., 1853.

Interesting about Oxygen.

Prof. Faraday recently delivered a lecture at the Royal Society, in explanation of the late experiments and researches of Boussingault, Fremy, Becquerel, and other continental chemists, respecting the generation and the nature of oxygen. As that element constitutes at least one-half of the substances on the surface of the earth, and is an active agent in most chemical decompositions, the determination of its properties is extremely interesting and important; the importance of such investigations having been increased by the recently-discovered magnetism of oxygen gas, which has become very interesting by the new theory based upon it by Lieut. Maury, U. S. N., as the cause of the circulation of the winds, and by other qualities that point out its agency in various operations of nature that are at present but imperfectly understood. The researches of Boussingault have been principally directed to the means of obtaining a supply of oxygen on a large scale for its application to practical purposes. His principal aim was to separate the oxygen from the nitrogen with which it is mixed in the atmosphere, and from that exhaustless source to procure it in an economical manner. The combinations of oxygen with mercury by means of heat, and their separation by the application of a higher temperature, suggested the principle on which the experiments were conducted. When, for example,

mercury is subjected to a temperature just above its boiling point, the vapor combines with the oxygen of the atmosphere, and forms a peroxide; and that substance when exposed to a higher degree of heat, is decomposed, and one-half of the oxygen is liberated. In this manner by variations of the temperature alone, oxygen is first abstracted from the atmosphere, and solidified in mercury, from which it is afterwards expelled in a gaseous state. Boussingault found that baryta could be made to act in a similar way, and much more economically. After innumerable experiments, in which he had to encounter and overcome various practical difficulties, he succeeded in contriving a mode of operating from which he expects to obtain important results. He encloses the baryta in a retort open at each end, through which a current of steam is transmitted. The retort is placed in a furnace that can be heated to any required degree. The baryta when operated on in this manner, at a certain temperature, doubles its former quantity of oxygen, and is converted into a peroxide. The supply of steam is then cut off, the heat of the furnace is raised, and a communication by a separate tube having been made with a gasometer, the oxygen absorbed during the former process is expelled in a gaseous state and collected.—The same baryta may be operated on any number of times, without requiring change or addition, and the oxygen gas thus obtained is of the purest kind. It is estimated that with an apparatus of this kind, containing only 2½ lbs. of baryta, about 200 pints of pure oxygen gas may be generated in 24 hours, and, by enlarging the size of the apparatus, that a sufficient supply of oxygen gas may be procured to allow of its being applied practically to many useful purposes. Professor Faraday expressed doubts whether the plan proposed would be sufficiently economical for general application, but he said it was, at all events, an important step towards the accomplishment of so desirable an object. Several experiments were made to show the uses to which oxygen gas might be advantageously applied if it could be procured in abundance at a cheap rate, especially as a means of increasing the illuminating power of coal gas. In noticing the difficulties that Boussingault had to overcome, Professor Faraday mentioned that in the first experiments with baryta he had carefully excluded water from the apparatus, conceiving according to previously received opinions, that its presence would be detrimental to the absorption of the oxygen from the air. Under these circumstances, it was found that the baryta after having been once operated on, did not absorb oxygen freely a second time until it had been exposed to the atmosphere. Boussingault was for a long time at a loss to account for this perplexing occurrence, when he at last discovered that aqueous vapor, which he had been so careful to exclude, was necessary to restore the absorbing power. The researches of Fremy and Becquerel relate principally to the identification of ozone with oxygen, which they have very satisfactorily proved. The change oxygen undergoes in its conversion into ozone, and the peculiar bleaching properties it acquires, has given rise to interesting speculations respecting the mode of action of that body, and even thrown a doubt on its elementary character.

American Inventions and Sir Charles Lyell.

In the last number of the Scientific American we alluded to an excellent speech made by Sir Charles Lyell, at the dinner given by the Crystal Palace Association, to President Pierce, his Cabinet, and the foreign Commissioners. We had no room to publish his remarks then, and we consider them of too much importance to pass over with a mere notice. He said:—

"Gentlemen, the President of the United States has spoken of me in such terms that I say most sincerely, with every disposition to believe him—for your first magistrate like our own, can do no wrong—that he has not measured carefully enough the terms of his eulogy. I receive gratefully the expressions, as intended at least to convey his kind feelings towards me for the little part which I have played whether in the sciences or in making your country better known, as I

think it deserves to be, to my own countrymer. (Applause.) Your President has also alluded to the observations of one of my colleagues, Mr. Whitworth, which he made after his return from a visit to the Lowell factories, and I may say that during their tour—and my colleagues have said the same thing to me—they were struck with the wonderful labor-saving inventions in the machinery of this country, to which far more than its soil or any other cause, they ascribed the great wealth which has accumulated there, (Applause.) I trust this commission will be the means of making sooner known some of these inventions and machines which it is most desirable our countrymen should understand the benefits of. This is the fourth visit I have made to your country, and it is only by observing the wonderful progress which this people are making in knowledge, power, and general prosperity, that we can arrive at a true estimate of the greatness of the country. It is indeed a most cheering sight for any foreigner to witness. I say a foreigner, but whenever I have travelled in your country, whether pursuing science or with others engaged in the same pursuit, or travelling as a stranger I have never been allowed to feel myself a foreigner; and yet, strange to say, this is the first time I have visited the United States without finding the press, and sometimes Congress, engaged in the discussion of questions that seemed to endanger the amicable relations between this country and my own. Sir Charles Lyell here alluded to the McLoud difficulty in 1841, and the Oregon question in 1845, when he said the walls of our city were placarded with 'fifty-four forty or fight.' (Great laughter.) He then expressed the hope that nothing more serious should occur to disturb the present peaceful relations of the two countries. After alluding to the New York Crystal Palace in appropriate terms, he concluded as follows:—The Exhibition of England in 1851, created a unity of all the nations of the world, however different their tendencies and systems of government. Let us therefore hope that these other being so much greater than all others, may be sustained, and these industrial exhibitions may be insured. And I believe that the tendency is to insure their perpetuity, provided they are so arranged as not to interfere with other great questions; and let us hope they may last, not only eleven centuries, but eleven times eleven centuries."

Mammoth Remains.

The "Niles (Mich.) Republican" of the 9th inst., relates that during an afternoon of last week they were shown a fragment from an enormous jaw which had just been found about five feet from the surface of the ground by a man residing in Wayne Township, Cass County (about 14 miles east of this). In the jaw was a grinder which measures seven inches in length, and four inches across the top. The portion found—which is evidently but a small portion of the whole jaw—weighs 14½ pounds. The point of a large tusk was also found, some 18 in. long, partly petrified, the balance showing most beautiful ivory. Some five years since, a portion of the jaw of the same animal was found near the same place, which weighed upward of 80 pounds; also, a rib as long as a common scythe, which grew in the animal edgewise.

The Iron Trade.

According to calculation in the "Pittsburg Post," the iron manufacturers of this country have a sure demand before them of nearly \$300,000,000 for fabrics to be turned out from their manufactories—a demand that will require all, and more than all their capacity to supply fast enough. The calculations upon which the statements are based, is the extent of railroad now in course of construction—With one hundred tons per mile, single track, it will require 1,300,000 tons of iron rail to complete the thirteen thousand miles of railroad, either in progress, or which will be in progress ere long, including the Pacific railroad. At \$50 per ton this would require an outlay of \$65,000,000 for single tracks alone. But many of these roads will be double tracks, besides turnouts, &c. Then follows a vast outlay for cars, locomotives, and other iron works about such roads.

NEW INVENTIONS.

Improved Artificial Leg.

There is the famous Anglesey leg, the redoubted Palmer leg, and the Yerger leg,—but that is not to say that no improvement can yet be made; we are certain that a good improvement has just been made in artificial legs by David B. Marks, of New York City, who has taken measures to secure a patent for it. This artificial leg is intended to perform all the movements of the natural leg in walking. In taking a step, the foot is brought flat to the ground, with the perfect rigidity of the knee-joint, which is maintained until the ankle is bent by bringing the body forward, as the opposite leg takes the next step. This bending of the ankle leaves the knee free to make the slight bend which is necessary to raise the heel from the ground, and when the knee is thus bent, the ankle becomes stiff, with the toe slightly raised to prevent its dragging during the early portion of the movement of the leg in taking the succeeding step, and it remains stiff until it is necessary for the straightening of the knee and the depression of the toe to bring the foot flat to the ground, both of which latter movements are effected simultaneously. The improvement relates to the means or devices by which the movements of the knee and ankle-joints are controlled, and the necessary rigidity maintained during the cessation of these movements.

Manufacture of Friction Matches.

Anthony Sohn, of Monroeville, O., has taken measures to secure a patent for useful improvements in machines for filling match frames preparatory to the dipping operation. In the manufacture of friction matches, the dipping of a large number is always effected at the same time, by securing them in a frame in such a manner that their ends are all even. They require to be held in the frame—each match by itself, to prevent their adhering together by the melted sulphur or the igniting compound; the manner of placing them in the frame has always been difficult to perform aright, and has been nearly all done by hand. This improvement is intended to perform and repeat the operation of taking a suitable number, for one row, from a box or hopper, and depositing them separately in the frame, so that all the hand labor necessary to be performed will simply consist in placing a piece of pasteboard or a thin slab of any suitable material between the successive rows. The improvements which have been made in the manufacture of friction matches, within the past fifteen years, have been of the greatest benefit to the human race—friction matches are now one of the most useful and necessary articles of civilized life. For further particulars address the assignee, Wm. Gates, Jr., Frankfort, N. Y.

Screw Compression Cocks.

Geo. H. Dodge, of Phila., has taken measures to secure a patent for a useful improvement in screw compression cocks, the nature of which improvement consists in making the valve detached from the screw, and furnishing it with a stem passing entirely through the screw to the outside of the cock. The principal object of this improvement is to allow of the valve being ground when it gets loose, and this can be effected while the cock is in place by simply relieving it from the pressure of the screw, and turning it in its seat by the part of the stem protruding through the screw. The valve being detached from the screw makes it fit correctly to the seat, as it is not subject to a racking action, consequent upon any want of accuracy in the screw.

Improved Horse or Sleigh Bells.

An improvement in bells for horses has been made by Jason Barton, of Middle Haddam, Ct., who has taken measures to secure a patent for the same. The invention relates to a peculiar manner of suspending the tongues within the bells, whereby the positions of the tongues may be varied according to the inclination of the sides of the pad to which the bells are attached. The positions of the sides of the pad vary according to the transverse form of the body of the animal, and by this improvement the tongues of the bells may be adjusted so as to act upon the bells, whatever position the pad or belt and bells may have when attached to the animal.

Reaction Water Wheels.

J. W. Martin, of Taladega, Ala., has invented an improvement in reaction water wheels, to relieve the lower gudgeon of the shaft from undue friction and load by weight of water after it has acted upon the buckets. The improvement is to prevent up-lift by under

pressure of water, and also down pressure on the shaft. The wheel is open at top and bottom, and the periphery is connected to the shaft by arms, so that no water can lodge in the wheel, whether it may be let in at top or bottom. Measures have been taken to secure a patent.

MACHINERY FOR SAWING BEVELLED WORK.—Fig. 1.

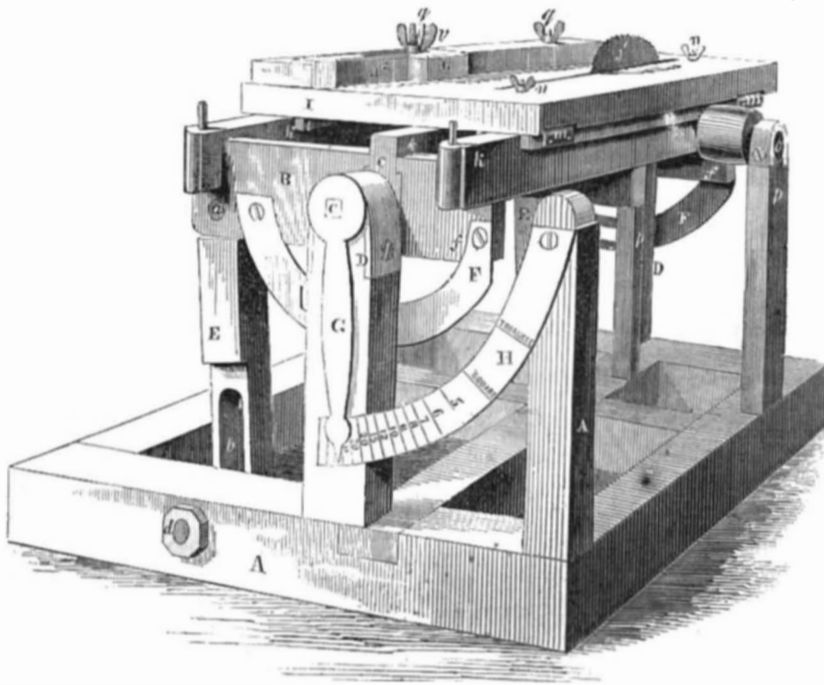

The annexed engravings represent an improvement made in machinery, named "the adjustable bevel gauging and indicating bench, for sawing bevelled work." It is the invention of Alfred C. Cook, of Russellville, Ky., who has taken measures to secure a patent for it.

Figure 1 is a perspective view of the machine, and fig. 2 is an end view. The same letters refer to like parts.

The nature of the improvement consists in an adjustable bevel gauging bench, having a travelling feed carriage on the top to feed

in the lumber to the saw, so as to cut the stuff to any desired bevel, according to the way the frame is set and gauged. A circular saw is represented on the figures, but it is equally adapted to work with a reciprocating one. A is the main frame, which sustains the swinging bench; B is the swinging adjustable bench, it is secured upon and turns on a shaft, C, which extends the length of the frame, and is supported in posts, D D. This bench is attached by each of its ends, on one side, to standards, E E, by a pin, a, at each end, which serve as the fulcra for the bench to turn

Figure 2.

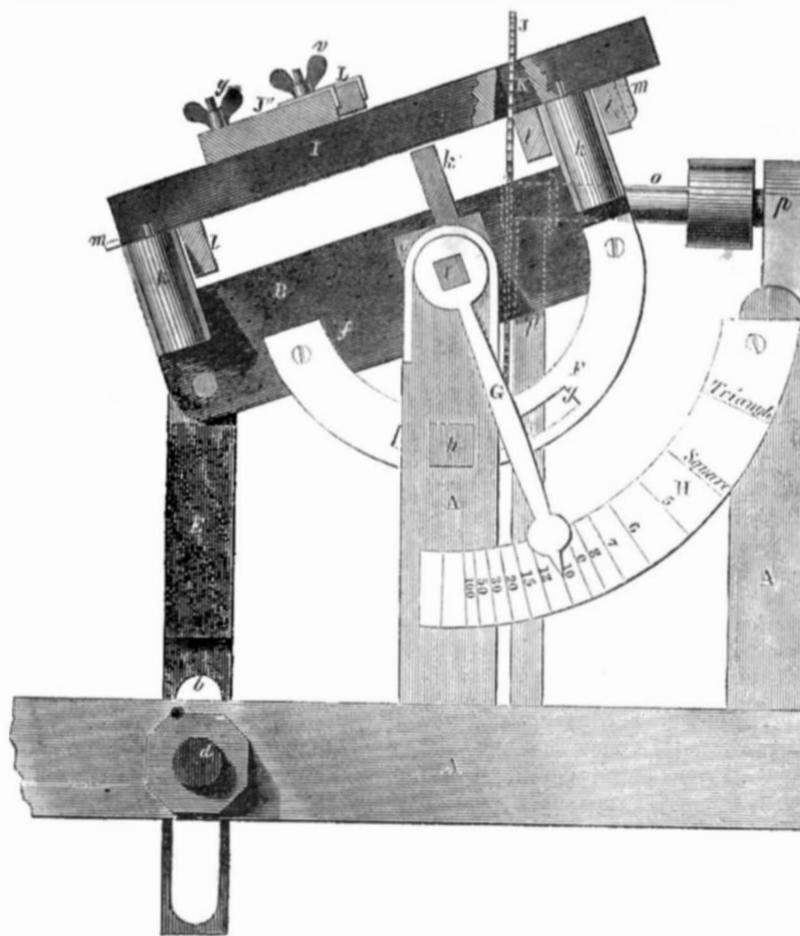

upon; these standards have slots, b b, for screws, d d, to raise or elevate them (the standards) and bench. These set screws, d d retain the standards at such an elevation at one side as will fix the position, inclined or horizontal, of the bench, for the stuff to be fed to the saw. F F are segmental braces let into the two end pieces, f f, of bench B; each curved brace, F, has a slot, g, cut in it for a set screw, h, to work in, as the bench, B, moves in a vertical circle. These braces keep

the swinging bench firm and steady in its position when at work. G is a pointer hand secured on the end of shaft, C; it moves with said shaft, as the bench, B, is raised or lowered at one side, and points to the numerals and words on the index plate, H, to indicate the position of the gauging bevel bench; it points to the exact angle of the bench, and tells at once what bevel will be cut upon the stuff fed into the saw.

I is the feed carriage; it slides on the top

and is guided on the ways, k k, by the flange pieces, l l. These flange strips are adjustable by plates of metal, m m, which are secured transversely on the underside of the carriage, and to which the flanges are attached; the set screws, n n, secure the plates, m m, as they work in slots in said plates. These flanges are made adjustable to allow the bench, B, to be set at the greatest possible angle to which it is capable of being set. J' J' is the side rest, against which the stuff lays while being sawed; this rest is made adjustable by the set screws, q q, which work in slots: by the use of this rest, in connection with the adjustable bench, the "flare" and bevel of staves may be cut at the same time, as this rest can be set at any angle desired by the set screws, q, and by a pivot axis working in a slot near the distant end of the carriage. L is a heel rest or dog, for the end of the board or stuff to rest against; it is attached to the side of the rest and is adjustable by the set screw, r, in a slot. J', fig. 1, and J, fig. 2, is a circular saw; it is secured on a horizontal shaft, O, driven by any power, and works through a flaring opening, K, in the bench and carriage. The shaft of the saw is supported in bearing standards, p p.

From the description given of the engravings, our readers will have obtained a correct understanding of the nature, action, and use of the adjustable bench, feed carriage, and their adjuncts, whereby stuff may be mitred and sawed to any bevel and angle, from 0 to 90°. The machine is equally adapted for common straight slitting, and sawing work of all kinds. The improvement can be applied to all saw frames, and the extra expense cannot be much; nothing at least in comparison to the advantages obtained.

More information may be obtained by letter addressed to the inventor.

Scientific Memoranda.

NIAGARA FALLS AND LAKE ERIE.—Prof. Silliman, the eminent geologist, discredits the opinion advanced by some that information wearing away of the rocks of hard limestone may possibly result in draining Lake Erie. In recent lecture he remarked—"They will not halt at their present thought but point slowly and surely about two miles torrent when they will stop again for an unknown period, and probably forever, since at this place the hard limestone will form both base and top of the falls, and thus stop the destruction of the rock. Some have thought that they would finally reach Lake Erie, and that then the lake would be completely drained. Such an event is impossible. At the point already mentioned, the torrent will gradually wear away the surface of the limestone, forming a rapid, and thenceforth Niagara will be one of the lost wonders of the world."

BED OF THE MISSISSIPPI.—The "Alton Telegraph" says, it has generally been the received opinion of geologists that the Mississippi and tributaries traversed a valley, with a strata dipping towards the bed on each side. Recent observations prove, very conclusively, that this is all a mistake. Dr. Norwood's survey, as well as the excavation of the artesian well at Belcher's refinery, at St. Louis, show that the line of the Mississippi traverses a ridge, and not a valley, and that the strata dips from the river east and west. In other words, that the bed of the Mississippi traverses a line of anti-clinal axis or upheavals.—This theory is applied by Mr. Phillips, to explain the structure of lead veins in the West.

LOCOMOTIVE BUILDING.—The business of building locomotive engines has become an important branch of domestic industry, and is steadily growing in magnitude. According to an estimate made by the "Railroad Journal," there are probably no less than one thousand locomotives built yearly by the shops now in operation, sufficient to stock from three to four thousand miles of road. From ten to fifteen thousand tons of cast-iron, and the same amount of wrought-iron, and a large amount of other stock are used by these establishments for this yearly production.

San Francisco.

The population of San Francisco, is now 50,000. Six years ago, the "California Star" announced its population as being 321 males and 138 females. This increase is unprecedented.

Scientific American

NEW-YORK, JULY 30, 1853.

Truth in Journalism.

One of the daily papers of this city, while descanting recently on the Newspaper Press, placed its influence far above that of the pulpit, and its usefulness far above that of general book literature. The influence of the newspaper press, at the present day, is indeed very great, either for good or evil. Its influence is great for good, according to its truthfulness; for evil, according to its disregard of truth. The promulgation of truth in discreet and prudent language never can do evil, but good, and the influence for good of a newspaper which makes truth its aim and object, is in proportion to its circulation. On the other hand, the influence for evil of a newspaper which does not respect truth, is evil only and that continually. Editors should therefore be exceedingly careful of what they say in order that they may not mislead and deceive, and thereby avoid doing injury to the community. Truth should be their idol, their first and last consideration always, for unless truth is the leading characteristic of the newspaper press, it cannot be morally useful and beneficial, but pernicious and hurtful. Yet when we read the various papers belonging to our own, or any other country, and witness the various views expressed on almost every subject of general importance, also the contradictory statements in them respecting many events in which the papers themselves have peculiar interests—party or personal—we cannot but conclude that truth is not yet the idol of the newspaper press, and that there is still great room for improvement. No editor is perfect, and no paper can be utterly free from error and mistakes; but where truth is the rule of conduct, although every essential error must do evil, the evil done will be greatly mollified by a stern anxiety always to be right.

The propagation of wrong statements and erroneous opinions under the influence and through the instrumentality of the press, cannot be otherwise than prolific with evil. The most absurd and dangerous views upon any subject will find believers; no limit can be assigned to the credulity of man, nor the evil to be apprehended from the propagation of falsehood and error. "Error of opinion may indeed be safely tolerated while reason is left free to combat against it," because any other course of conduct towards errorists, would be injurious to society, still neither errors of opinion, nor erroneous statements are safe in themselves, they are dangerous and should be guarded against with the most sleepless vigilance, especially by the newspaper press. The poet Editor, W. C. Bryant, than whom there is no better judge, asserted that the literature of the Daily Press was, in many respects, superficial, and the reason of this is obvious. Readers of daily papers expect editors to present their views on the subjects of the day—passing events of the moment—hence there is often much inconsiderate haste displayed, on the very questions which require the most research and caution, viz., those of deep and exciting general importance. Much evil is done by taking up a position—sides—hastily upon any new question, and in expressing opinions favorable or unfavorable, which future developments may prove to be wrong. There is a natural vanity in man which tempts him, after he has committed himself to wrong views, ignorantly though it may be, to confess an error, even after he becomes perfectly convinced of the same. This is the reason why so many errors, by the influence of the press, roll on through space and time, accumulating and propagating evil. Every editor should therefore be exceedingly cautious of what he says, for the evil that men do, especially through the influence of the press, is not confined to our own day and generation.

These remarks have been elicited by those in the paper referred to; also, in consequence of seeing in another of our daily papers, a few days ago, statements respecting a certain inventor known to us, which were the very opposite of truth, and of this the author of the statements could not have been ignorant. The press is indeed a mighty engine for good or

evil; but it has not yet, we believe, reached its climax of influence, dignity, and usefulness; and will not, until truth in journalism becomes its guide and its glory.

Caloric Air Engines Again.

By reference to our list of patent claims, on the succeeding page, our readers will perceive that a patent has been granted for some new improvements on hot air engines. In a number of our exchanges we have also noticed that improvements in this class of engines have likewise been made by mechanics in Boston, Cincinnati, and New York. What those improvements are, except in one case, we know not, but their authors would have shown more prudence had they investigated the matter more profoundly before they added superfluities to existing defects. In its very nature, hot air can never supersede steam as the moving power of machinery. Why it should, not one of its advocates have given nor can give a reason. The advocates of the Ericsson call it the "caloric engine;" this is for effect; the steam engine has a better title to this name, as there is more caloric in steam than in the hot air of the Ericsson. They say it economizes fuel by using a definite proportion of heat over and over and over again, to produce repeated effects upon new quantities of matter. This is a fallacy, a piece of nonsense; if it were true we could say the same of the heat in steam, it surely could be used the same way. We have said much on this subject, and have more arguments left, but those we have produced have not yet been answered. On page 317, we quoted a letter from Capt. Ericsson, which was an answer to one by Brevet Major J. G. Barnard, Engineer U. S. A., who assailed the fallacies of the caloric engine. Major Barnard has answered Capt. Ericsson, and on every point that could be raised, has shown that he was wrong in his information, and consequently wrong in all his conclusions; it is a complete settler.

All those who have advocated the use of hot air as a superior motive agent to steam, have blindly seen some grand multiplier of power in the Ericsson regenerator—a few packages of wire gauze—whereby 491 degs of heat, in a cylinder full of hot air, could be made to drive a vessel from Cape Cod to Cape Horn and back again in amazing quick time. They have talked the greatest nonsense about "the transfer of heat," its condensation in the pores of metal," and such stuff, as it such arguments could not all be used in favor of the steam as well as the hot air engine. Capt. Ericsson and all those who have talked about using the same heat over and over again, do not seem to have ever asked the question, "what is heat and what is its nature as applied to water or hot air, &c.?" They have in every instance spoken of it as a ponderable body, the least minutia of which could produce (by transfer) infinite mechanical effects. Heat as applied to hot air or steam, is merely according to its quantity, a force—a repellant force the opposite of gravity, consequently its effects are only in proportion to its quantity. One quantity cannot produce two effects, no more than the one effort of a man who gives one revolution to large main wheel could multiply its effects, by transferring it to the resisting point through a multitude of other wheels; the power is transferred through the gearing of wheels, but not multiplied. Had the advocates of the hot air transfer legerdemain been more deeply versed in mechanical philosophy, they never would have committed such blunders; as it is, they have reasoned as profoundly as the old schoolmen on the question of two spirits occupying the same space at the same time. In all its essential and important principles, it is easy to show that the steam engine is as superior to the caloric engine, as a locomotive is to a donkey.

The Ericsson has at last been moved from her dock at Williamsburgh, and is now, we believe, getting in her new machinery; we hope it may yet be the means of earning as much as will save the proprietors from losing the large amounts they have invested in her. If her owners have confidence in her abilities, we would suggest to them a fair trial of speed with some of our steamships during the period the Crystal Palace is open; this would be a proper way of testing its qualities.

Events of the Week.

PERILOUS BALLOON ASCENSION.—On the afternoon of the 13th inst., John Wise, the celebrated aerial navigator, while repairing his mammoth balloon named the "Hercules," in an open lot in the city of Lancaster, Pa., was taken up in a very unceremonious manner, which nearly proved disastrous. While it was partly inflated with atmospheric air, and the workmen were engaged in giving it a fresh coat of varnish, it became necessary to turn the balloon for the purpose of coating the other side. It had been kept in its place by heavy sand bags, and during that time the air in it became extremely rarified. In order to turn it over, it required a person to go inside for an instant to see that all was right there, and for this purpose Mr. Wise entered it. When he entered, the weights outside were taken off too quickly, allowing a sudden expansion of air inside, and in an instant the balloon was up and off, Mr. Wise entangled in it. The workmen were so confounded as to be perfectly at a loss what to do, and the balloon gradually rising, went across the field until it turned with its mouth downward, and spilled Mr. Wise out at the bottom, giving him a severer fall and bruises than he ever received at any regular ascension.

PROF. AGASSIZ; ZOOLOGY.—This eminent naturalist has been making a tour of some of the south and western States, studying, lecturing, and observing. With his usual diligence and penetration he has discovered many unclassified species of fish in southern waters. In a letter to Prof. Dana, of Cambridge, he states that he has collected about sixty new species, one is like the blind fish of the Mammoth Cave, though provided with eyes. He has been among the rice fields, and has obtained new specimens from the ditches; the waters of the Gulf, the Mississippi and other rivers have furnished him with an excellent collection, and he will probably present a paper on the subject at the meeting of the Association for the Advancement of Science, at Cleveland.

Wonderful Geological Calculation.

In a paper read by Sir Charles Lyell, a short time previous to his arrival in this city, before the Royal Society in London, on the coal fields of Nova Scotia, he entered into speculations respecting the solid matter contained in the carboniferous formation of that country. He believes that it was once a delta like that of the Mississippi, and that the formations were produced by river inundation dritts. The average thickness of the whole of the coal measures is three miles, and the area, including the fields of New Brunswick, &c., may comprise 36,000 square miles, or 108,000 cubic miles, but taking the half of this, it would be 54,000 cubic miles of solid matter. It would take more than two millions of years for the Mississippi River to convey to the Gulf of Mexico an equal amount of solid matter at the rate of 450,000 cubic feet per second, as calculated by Mr. Forshey.—This is a subject for deep reflection and examination by all Biblical geologists especially. Sir Charles Lyell found fossil reptilian remains, and a land-shell in the interior of a fossil tree in a Nova Scotia coal field.

Parker's Water Wheel.

We have received a letter from J. W. Myers, of Kewaskum, Wis., in which he says, "having frequent claims presented to us for using and building Parker's re-action water wheels, and being at a loss what course to take, or what situation the patent is in, any information you can give us on the subject will confer a favor."

We do not know what claims have been presented, nor by whom, consequently we can say nothing about them. If any person were to present a claim against us for the use of the Parker Wheel, we would ask, before witnesses, for the authority on which the claims were based, and decide accordingly. Some agents for Parker's wheel—we do not say all—have neither acted honorably to Mr. Parker, nor to those from whom they sought to collect money for alleged infringements. Zebulon Parker is a poor man, and from his nature, the very reverse of a driving, money making one, and has never derived sufficient compensation for his water wheel improvements. To those who wish for more information res-

pecting his patents—the first and principal one has expired—it may be an advantage to know where Mr. Parker lives; his residence is at La Harpe, Hancock, Co., Ill.

Steamboat Inspectors.

We understand that the Steamboat Inspectors for this District, of which R. L. Stevens is Chief Superintendent, and H. B. Renwick, formerly of the Patent Office, Engineering Inspector, have not been so strict in making the owners of steamboats come up to the requirements of the New Act, as they should have been. The law should have gone into full force in this District on the first or last March, and all the steamboats had plenty of time to be fully prepared in every respect to meet those requirements, and yet the majority of them, we are positive are not yet prepared to meet them. The Inspectors have complained of an inadequacy of force, this evil should be remedied, but we humbly believe, they have been too free and easy with the proprietors of many steamboats. There never was a fault committed, nor a duty left unperformed, for which some excuse was not offered. In cases of life and death on steamboats, let the Inspectors remember, that they are now held as responsible—the most responsible of all—for accidents connected with carelessness of Engineers, worm-eaten hulls, defective boilers, want of life boats, preservers, &c.

Improvements in the Patent Office.

As many inventors who have made applications for Patents, feel anxious respecting the results, especially as they have experienced the feelings of "hope delayed, maketh the heart sick," we would state, that the reason why there has been so much delay in examinations, was owing to an inadequate examining force, and the many changes which have taken place in the Office during the past year. Not less than a thousand cases, unexamined, were on the files of the Office last week, but as six additional Assistant Examiners have been appointed recently by the New Commissioner, Judge Mason, we expect that all the delayed cases will soon be decided, and that in future, we shall have no such accumulations of unexamined applications in the Patent Office. No application should remain in the Patent Office longer than one month before it is examined. We have known Examiners to give themselves, and the Office, much unnecessary trouble and labor, by too hasty rejections—this they should be exceedingly careful to avoid for their own sakes, and that of Inventors.

Pumps—Bursting of Suction Pipes.

We have received a letter from Joseph Bailiff, Allegheny City, Pa., stating that he has been much troubled with the suction pipes of pumps bursting at about two of three feet below the valves—the pipes are about 27 feet in depth. The bursting of the pipe has usually taken place in iron pumps that have only five feet of water above the lower valves—the valve being nearly 1½ inches in diameter, and pipe about the same, stroke of piston 8 inches, diameter of chamber, 3 inches. Pumps at Pittsburgh do not work well with more than 27 feet of suction pipe.

The fault in all likelihood is in the suction pipe—a defect in the iron. There is no less a pressure than 15 lbs. on the square inch of the suction pipe, and it must be well cast to stand this pressure. An air chamber should be attached behind the lower valve to every suction pipe over 12 feet in depth.

Daguerreotypes of the Moon.

We have in our possession a photograph likeness of the Moon, painted by herself in the reflecting telescope at Cambridge, Mass. The artist was Mr. Whipple of Boston, whose fame is co-extensive with our country. He has lately made great improvements in taking lunar photograph pictures, by daguerreotyping them on glass prepared for that purpose.

Alex. Humboldt has written a letter, in which he advocates the construction of an oceanic canal, without locks, across the Isthmus of Darien, having reference to points on the Gulf of San Miguel, and Cupica.

Next week the "Scientific American" will be illustrated with a large interior and ground-plan view of the Crystal Palace.

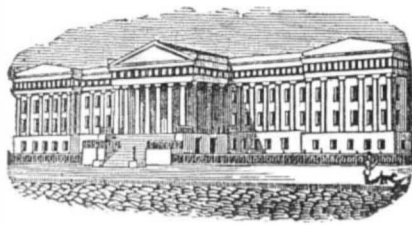

Reported Officially for the Scientific American

LIST OF PATENT CLAIMS

Issued from the United States Patent Office

FOR THE WEEK ENDING JULY 19, 1853

PRESS MOULD CANDLETICKS—By S. T. Barnes, of Columbus, Ohio: I claim the wick tube to guide and retain the wick in the center of the candle, in combination with the wick, so arranged on a spool as to supply a continuous wick, as the tallow is forced out to form the candle, as described.

PROCESSES FOR OBTAINING CHROMATES—By J. C. Booth, of Philadelphia, Pa. Patented in England Nov. 9, 1852: I do not desire to claim separately such portion of the process described, as I have stated to be similar to that now in use for manufacturing chromate and bichromate of potash.

But I claim, first, the reduction of chrome ore by the carbonaceous materials, as described, as a stage in the manufacture of potash.

Second, the art or process of manufacturing chromate and bichromate of potash from chromic iron ore by means of the reduction of the oxide of iron and the removal of the reduced iron by the several substances and modes set forth.

Third, I claim the process of reduction and removal described, in connection with the process of reduction described, or in combination with the equivalent therefor.

FEATHERING PADDLE WHEELS FOR STEAMERS—By A. H. Brown, of Washington City, D. C. Patented in England March 5, 1853: I claim the combination of the pinion, rack cam, and steering drum, with the eccentric, for the purpose of adjusting the paddles and converting them into a powerful steering apparatus.

I also claim the combination of the curved paddle with any apparatus for adjusting and feathering the same.

DRIVING SAWS—By Isaac Brown, of Baltimore, Md.: I claim the mode described of applying the power of the engine to the saw gate or frame, without being permanently connected therewith, so that the piston shall, in a great measure, be relieved from any lateral motion which the gate may have, which causes it to bind or cut in the cylinders, as described.

HANGING SAWS—By N. T. Coffin, of Knightsdown, Ind.: I claim the combination of the stirrup hung upon a knife edge, with the adjusting screws, for the purpose of regulating the rake of the saw in the manner described.

LAMPS—By C. J. Conway, of New York City: I do not claim the peculiar property of small tubes preventing the passage of flame; neither do I claim the making the base of the lamp serve as a reservoir for the fluid used. Nor do I claim the construction by which no part is made movable, but the cap of the feeding tube.

But I do claim that peculiar construction by which two chambers or reservoirs are combined in the same lamp, one containing the wicks and the fluid which saturates them, and the other forming the receptacle into which the fluid is poured, and the two chambers communicating by means of two pipes or tubes, the whole arranged and operating as described, by which means the wick chamber is filled, and may at any time be replenished from the larger reservoir by simply changing the position of the lamp from a vertical to a horizontal direction; and the larger reservoir may be supplied without bringing the can or filler near the burners.

SPINNING JACKS—By John Jackson, of Lawrence, Mass.: I do not claim stripping the bobbins preparatory to winding on. Neither do I claim raising the "former" by a horizontal screw, giving motion to an inclined plane beneath it.

But I claim the stop, in combination with the tappet or gear, for the purpose of arresting the motion of the latter at the instant the belt is shipped upon the pulley, that the gear may be left in the precise position necessary for the performance of another duty, the instant it is again set in motion, without being carried past this position by momentum or otherwise, when the brake is so arranged in connection with the lever, or otherwise, that it shall be withdrawn by the mechanism which shifts the belt at the instant the gear is again set in motion, the operating the winding on mechanism, raising the stripping wire, and depressing the building wire, in the proper order, and then shifting the belt on to the fast pulley at the close of these operations, by means of a single cogged gear in combination with the tappet placed upon its side, the whole arranged as set forth.

EYES FOR MILL STONES—By Edmund Munson, of Utica, N. Y.: I do not claim the conical form of a portion of the eye; nor do I claim a metallic eye; but I claim the spiral wings arranged in such manner as to perform the double office of feeding the grain and supporting the stone.

MACHINES FOR DITCHING—By R. C. Pratt, of Canandaigua, N. Y.: I claim the ditching machine, consisting of a beam and casing, or their equivalents, in one or more parts, with a cutting and scraping point, hung on the shaft of a revolving wheel, with shovels attached to the outer circle of the wheel which self-act by turning the wheel and forming a bucket in connection with the casing, so as to carry up the earth to the inclined slides, the whole being operated as described.

LINING FOR FIRE-PROOF SAFES—By John Farrel, of Philadelphia, Pa.: I claim the application and use of flour, grain, maize, starch, or other vegetable substance of a like nature, either alone or in combination with lime, cement, or similar substances, in the construction of fire-proof chests or safes, as described.

GRIPES FOR HOLDING LEATHER—By Bradford Rowe, of Albany, N. Y.: I claim the construction of a gripe composed of a key within a socket or chamber, the key being a solid cylinder, with a portion of its surface cut away, in two faces parallel with its axis, and at an angle with each other, one face being grooved lengthwise, and the chamber being a hollow cylinder, with a portion of its space filled up parallel with its axis, and having a longitudinal slit through it for nearly its whole length, corresponding with the cut away part of the key, so that when the key is in the chamber a strap of leather or other material can pass through the chamber and under the key, as described.

GRAIN WINNERS—By Geo. B. Salmon, of Elmira, N. Y. Ante-dated July 6, 1853: I do not claim the blast head or the blast spout separately; neither do I claim the screen nor the trough and spouts separately.

But I claim, first, the expansion of the upper part of the blast spout, into the circular irregular enlarged head with an opening or mouth at the lower extremity, partly covered with the sieve, for the purpose of allowing the force of the blast to be exhausted, the screenings immediately falling through the opening or mouth of the head while the blast and dust escape through the screen, the blast being governed by a slide, as set forth.

Second, I claim the arrangement and construction of the graduated sieve of unequal fineness, the portion being protected from the action of the fan blast, so that the small substances, such as cockle, &c., passing through and falling on the bottom board of the sieve, passing off at the trough and spouts, and when the grain arrives at the coarser part of the sieve, it passes through and is acted upon by the fan blast, while larger substances than wheat pass over the end of the sieve, and fall on the floor, as set forth.

[We may be mistaken; but the first claim reads as if it were a similar improvement to that of Benj. D. Sanders, to whom a patent (No. 6,545) was granted in 1849.]

OVENS—By Ephraim Treadwell, of New York City: I claim the use of a preheated oven having side doors in it, for charging and discharging it at intermediate points between the ends of the oven, in combination with upper and lower independent heating flues and furnaces for directing the entire heat from one set of furnaces through flues on the upper side of the article to be baked, and the entire heat from the other independent set of furnaces through flues on the under side of the article to be baked, as set forth.

COMPRESSORS FOR FLYERS—By Wm. H. Thompson & Wm. H. Plummer, of Biddeford, Me.: We claim the combination of the guard rib with the hole and the passage, and the opening, for the purpose specified.

SPIKE MACHINES—By P. P. Trayser, of Baltimore, Md.: I claim the combination with the knife which severs the blank from the rod, of two stumps either or both moving, whereby, while one blank is being headed and pointed in the dies, the end of the rod for the next blank is cut off and bent preparatory to forming a head, as described.

I also claim the method of heading spikes by bending the end of the rod preparatory to upsetting before placing it in contact with the heading dies, instead of giving it the preparatory bending while in contact with the dies, whereby the heated rod is kept a shorter time in contact with the dies, and therefore heat them less, while at the same time it is not detained longer than usual out of the dies, so that by this method the dies are better protected from excessive heating, the rod from cooling, and the whole operation expedited and improved, as set forth.

MOUNTING SPIRIT LEVELS—By S. J. Sherman, of New York City: I claim the spring catch to hold the level in place upon the square or ruler, in combination with the bearers, the latter being so formed in respect to the level, that when they are placed upon a horizontal line, the bubble will be in the middle of the glass, and thus a horizontal or a vertical line may be ascertained from a ruler or from a square, which said level is attached as set forth.

MANUFACTURE OF WIGS—By T. C. Weiland, of Hartford, Conn.: I claim the method of fastening and attaching the hair to wigs, toupees, or any other kind of hair work, by means of any kind of glutinous substance, as set forth.

BRISTLES FOR BRUSHES—By Chas. Williams, of Philadelphia, Pa.: I claim, in the manufacture of that class of brushes known as "drove-work," preparing the bristles by the application of heat to the roots, as set forth.

GUTTA PERCHA STEREOTYPE COMPOSITIONS—By Leonardo Westbrook, of New York City: I claim an improvement on the patent of Josiah Warren, dated April 25, 1846, first, the compound described, of shellac, plumbago or graphite, asphaltum and gutta percha, treated by sulphate of copper and water, as described, as a substitute for type metal.

CALORIC AIR ENGINES—By A. O. Wilcox, of Philadelphia, Pa.: I claim the interchanging circulators situated within and occupying one half of the capacity of each heat reversing vessel, and so arranged as to alternately transfer the air or other fluid to the heating and cooling divisions of said vessels in the same movement to cause the air to pass through renovating plates or their equivalent, whether placed within the circulators and transmitting the air, or placed without the circulators and the air forced through them, as described.

I also claim placing an inwardly pressing packing in the open end of each working cylinder, and in combination therewith the construction of the working piston (being of the requisite length) of a little less diameter than the interior of the cylinders, whereby the friction surface is confined to the periphery of the piston, in order to sufficiently exclude its lubricating fluid from the contact of the hot-air within the cylinders, as set forth.

I claim the barrel and stationary hollow piston, with its supply tube, aperture, valves, in combination with the working piston and its valves, for the purpose of supplying air or other fluid to the cylinders, when desired, as described.

PAPER CUTTING MACHINE—By Frederik Hesse (assignor to H. J. Oster), of Bethlehem, Pa.: I do not claim a stock provided with a knife or cutter, working on a bed-piece, irrespective of the employment and arrangement of the rack bar and pinion, as that has been previously used.

But I claim cutting paper, pasteboard, or other articles, by means of a knife or cutter, attached to a rack bar, which meshes into a pinion, said pinion being hung or attached to a spindle or shaft, to the ends of which the handles of the sliding stock are secured, the above parts being attached to the sliding stock, by which device the knife or cutter may be elevated or depressed, as desired, while working the sliding stock upon the bed piece, as set forth.

DESIGN.

COOK STOVE—By J. J. Dudley, of Troy, N. Y. (assignor to Johnson, Cox & Fuller).

COOKING STOVE—By John Mason (assignor to I. H. Holden, as Agent of the "High Street Furnace Co.") of Providence, R. I.

The Best Toast of the Season.

OUR TOAST.—"The Scientific American: The best publication of the kind in the world. May its patrons increase until it takes one of Hoe's last fast a week to work its edition.—[Lewistown (Pa.) Gazette.]

Crystal Palace Receipts.

The following table shows the number of visitors and the cash receipts for the week ending July 23:—

Season	Transient	Received at	
Tickets.	Visitors.	the Door.	
Monday	3,506	2,721	\$1,360 50
Tuesday	1,800	2,686	1,265 00
Wednesday	1,200	3,009	1,479 00
Thursday	1,000	2,810	1,389 50
Friday	1,100	2,898	1,429 00
Saturday	900	2,484	1,224 00
Total	9,506	16,608	\$8,147 00

This gives the gross number of visitors during the week as 26,114, and the daily average at 4,352. The cash receipts, from transient visitors, are over and above the amount received from the sale of season tickets.

Preparing and Crystallizing Gold.

The following is the specification of a patent granted to Alfred J. Watts, of Utica, N. Y., on the 18th, of last April, and as it is a very important invention, we publish it entire.

The nature of the invention consists in dissolving gold (which has been previously purified by any of the well known methods in mercury, and after treatment by heat or otherwise, dissolving out the mercury by nitric acid, and then subjecting the new conditioned but as yet unfinished gold to the action of a particular heat, whereby it is rendered coherent, soft and malleable, and admirably fitted for filling teeth.

I take gold, either pure or alloyed, dissolve it in nitro-muriatic acid, and precipitate by proto-sulphate of iron; I wash the precipitated gold with diluted hydrochloric acid, to remove any per-oxide of iron or other impurities; edulcorate with hot water, and dry it thoroughly. I now amalgamate it with from 4 to 12 times, its own weight of mercury, triturate it thoroughly and set it aside and allow it to stand from about 1 to 24 hours, according to circumstances. If I wish the gold to be in a highly crystalline condition, I make a pretty fluid amalgam, and after thorough trituration, put it in a flat bottomed vessel, and heat it gradually till it is quite hot and painful to the touch (about from 180° to 240° Fah.) I keep it at this heat for a few minutes, and then allowing it to cool gradually, let it remain some hours, as before stated, to condition itself. I then pour over it pure nitric acid diluted with about its own bulk of water. I apply heat very gently at first, and as the action progresses I increase it. Towards the end of the operation, when the mercury appears to be all dissolved out, and the gold presents the appearance of a mass of crystals, or semi-crystals, or sponge, I pour off the acid solution of mercury and pour pure undiluted nitric acid into the vessel containing the gold and then apply heat. This dissolves out the mercury, or any other metals which may have escaped the action of the diluted acid, and also any of the salts of mercury remaining in the pores of the gold, and after washing with hot water and drying, the gold is left in a perfectly pure condition. In this state, however, it is very friable, and so easily broken, that it will not bear the slightest handling without breaking it up into fine powder; it must be very tenderly treated while getting it into position for the next process. When this is thoroughly dry, I raise the heat to a cherry red, or to a heat just short of the melting point of gold. This is a particular part of the process and requires care and skill. The heat must be raised to just that point which will partially liquify without actually melting the gold and when properly managed, the gold will be left in the condition of a soft malleable and extremely ductile mass of crystals, which will be either close and spongy, or loose, and in a mass of brilliant needle-shaped crystals, radiating from centres, and crossing each other in every direction, and will bear handling without crumbling to pieces, and upon pressure will readily weld into a solid mass eminently fitting it for the purpose set forth.

I take gold, either pure or alloyed (I prefer pure), roll it out into thin strips, heat them to a red heat, cut them up into small pieces put them in a glass, a matress, or any convenient vessel to answer the purpose hereafter mentioned. I pour over it from 6 to 10 times its weight of mercury, and apply heat just short of

the boiling point of mercury. The vessel is closed and kept close at the top, so as to condense any mercurial vapors, and the gold dissolves. I then pour it into a glass mortar and afterwards add more mercury, according to circumstances, and triturate it thoroughly till cold, when it is poured into a flat bottom glass vessel convenient for applying nitric acid; I then, according to the condition I wish to bring the gold into, either apply heat and set it aside to cool gradually or quickly, as required, or set it aside without applying heat, to remain an hour, or a day, according to circumstances, and then apply acid, as in the other case before mentioned.

The herein mentioned processes of preparing and crystallizing gold, are claimed for preparing gold to fill teeth.

Imprisoned Reptiles.

Not long since, a number of specimens of mineral and animal products were received at the Smithsonian Institute, Washington, from New Mexico, and among other things was a horned lizard, accompanied by a letter from Judge Houghton, of that Territory, stating that the animal was taken alive from a block of stone, so solid as to preclude the entrance of the smallest insect; the lizard lived forty-eight hours after it was released from its long imprisonment. The letter states that this lizard must have been in the position in which it was found since the commencement of the formation of the rocks, and which, if true must make it a very old animal indeed. Many stories have been reported of toads and lizards having been liberated alive from solid rocks, and it is a prevalent opinion that they were enclosed while alive by the rock forming over them. We have seen a stone ourselves from which a toad was liberated of this antediluvian type, but not different in any respect from the present species. The place from which the animal was taken was somewhat hollow, and appeared to be a snug, strong nest, but as part of the rock was broken up before we saw it, we could not tell whether there was or was not some entrance into it. Geologists have no faith in toads or lizards being enclosed alive in solid rocks—the rocks forming over them. On this subject, Dean Buckland, the celebrated zoologist, remarks:—

"There is," he says, "a want of sufficiently minute and accurate observation in those so frequently recorded cases, where toads are said to be found alive within blocks of stone and wood, in cavities that had no communication whatever with the external air. The first effort of the young toad, as soon as it has left its tadpole state and emerged from the water, is to seek shelter in holes and crevices of rocks and trees. An individual, which, when young, may have thus entered a cavity by some very narrow aperture, would find abundance of food by catching insects, which, like itself, seek shelter within such cavities, and may have increased so much in bulk as to render it impossible to go out again through the narrow aperture at which it entered. A small hole of this kind is very likely to be overlooked by common workman; who are the only people whose operations on stone and wood disclose cavities in the interior of such substances. In the case of toads, snakes, and lizards, that occasionally issue from stones that are broken in a quarry, or in sinking wells, and sometimes even from strata at the bottom of a coal mine, the evidence is never perfect to show that the reptiles were entirely enclosed in a solid rock; no examination is ever made, until the reptile is first discovered by the breaking of the mass in which it was contained, and then it is too late to ascertain, without carefully replacing every fragment (and in no case that I have seen reported, has this ever been done), whether or not there was any hole or crevice by which the animal may have entered the cavity from which it was extracted. Without previous examination, it is almost impossible to prove that there was no such communication. In the case of rocks near the surface of the earth, and in stone quarries, reptiles find ready admission to holes and fissures."

By the last news from Europe, there was still great talk of war, but not a blow had been struck.

TO CORRESPONDENTS.

J. McC., of N. Y.—We have in our possession a fountain pen which was imported from England in 1846, which operates and is constructed on precisely the same plan as the one you describe.

R. H. S., of O.—Your corn planter is not new. We have had several models sent to us which contain the identical principles of your machine.

E. C., of Mass.—Your diagram of a water gauge represents no new invention.

E. A. D., of N. Y.—The application of an india rubber spring, adapted in any like manner to your drawing, would not be patentable, nor practicable in use.

D. D., of Ill.—As we understand your description, you merely duplicate the implements used; a mere multiplication of parts does not make a patentable subject, any more than it would make a patentable combination to work several different machines from one shaft.

P. McS., of Md.—The Dublin Crystal Palace is an affair highly creditable to the spirit of old Ireland; the beneficence of one man, once poor, raised the structure.

G. C., of Me.—The Wheeling Bridge is permitted to stand; the road which the bridge accommodates has been made a post road since the litigation was had, therefore the structure will not be molested. The only effectual remedy we ever knew for sea sickness was to remain on land.

J. M. M., of Michigan.—We think your anvil for straightening and repairing the T-rail would be patentable, but the forge refrigerator we think would not, unless a legitimate combination could be made by making one part of the invention strictly dependent on the other, in that case they might both be probably patented under one application.

C. B., of Pa.—Your plan for balancing window sash is certainly novel, and we see no objection to its operating well. We are of the opinion that it is patentable, and would recommend you to send us a model.

E. G. B., of N. C.—The engine and boiler, with every thing complete, is offered for \$500, to close a concern. We think the property would be cheap at \$350; the engine is entirely new, and the boiler is in good condition. The information about the pump we cannot give.

J. M. C., of Ct.—We made an application for a patent on a Meat Cutter, about nine months ago, which we believe is precisely like yours.

J. A. P., of Ohio.—We do not know of a single good and practical work on the manufacture of woolen goods.

G. B., of Ohio.—An endless chain water motor (not a wheel) is old and well known, it consists of a series of buckets on an endless belt reaching from the top to the bottom of a fall, taking in the water on one side only; no such motor, to our knowledge, is now in use.

G. J., of Ohio.—Yours has been received. Seek wisdom with a different spirit and you may find it.

J. M., of N. Y.—If you could give us the name of the Englishman you speak of, we could soon give you positive information; at present we have no recollection of his patent. We have a receipt for the enamel you speak of.

G. H., of Va.—You can find the plan described for making horse-shoe magnets in any good work on the subject; it would be too long for us to describe. Your plan of a railroad double car is plausible, we can see no objection to its success in populous localities.

C. H. F., of R. I.—We publish the claims of all the patents that issue, and if a patent was granted to the party to whom you allude, his claim must be found in the Sci. Am. We are often requested by inventors to suppress the publication of their claims, but it is only by that class of inventors whose patents are rehinged upon useless or invalid claims.

H. J. O., of Pa.—When you get your machine in the city we shall be happy to take drawings of it for publication. We have no drawings from which to get up engravings at present. Your claim you will find in another column. See the back volumes of the Sci. Am., for receipts on tempering.

Money received on account of Patent Office business for the week ending Saturday, July 23:—

I. M. H., of R. I., \$30; G. N. S., of N. Y., \$30; E. F., of Ill., \$37; W. W., of N. Y., \$30; S. B. & Co., of Mass., \$9; W. D. C., of —, \$30; W. M. S., of N. Y., \$325; W. T. M., of N. Y., \$30; H. A., of N. Y., \$70; N. & G., of N. Y., \$25.

Specifications and drawings belonging to parties with the following initials have been forwarded to the Patent Office during the week ending Saturday July 23:—

H. A., of N. Y.; W. K. P., of Mass.; G. N. S., of N. Y.; A. T. C., of Pa.; G. B., of N. Y.; G. H. D., of Pa.; J. B. W., of N. J.; A. S., of O.; E. P., of Ill.

A Chapter of Suggestions, &c.

BACK NUMBERS AND VOLUMES.—In reply to many interrogatories as to what back numbers and volumes of the Scientific American can be furnished, we make the following statement:—Of Volumes 1, 2 and 3—none. Of Vol. 5, all but six numbers, price, in sheets, \$1; bound, \$1.75. Of Volume 6, all; price in sheets, \$2; bound, \$2.75. Of Vol. 7 all; price in sheets, \$2; bound, \$2.75. Of Vol. 8, all the back numbers subsequent to No. 27, but none previous.

PATENT CLAIMS.—Persons desiring the claims of any invention which has been patented within fourteen years, can obtain a copy by addressing a letter to this office—stating the name of the patentee, and enclosing one dollar as fee for copying.

ADVERTISEMENTS.

IN CONSEQUENCE OF A NOTICE of a graduating engine, which was inserted in the Scientific American, of the 18th of June last, we (my father and myself), are perfectly deluged with letters from every part of the country, inquiring the price of the machine, and for a description of it; its mode of operation, of its applicability to various purposes, etc., etc. Now my father, Lemuel Hedge (not Samuel Hedge), of Paterson, N. J., who is the inventor and sole proprietor of the machine, wishes the public, and all interested, to be informed through the medium of your paper, that the machine is not for sale, and that no description of it or its mode of operation will be given either publicly or otherwise.

MORTIMER HEDGE, Westport, Mass., July 14 1853. SELF-SHARPENING REAPING AND MOWING Machine.—Patented June 15, 1853. The subscriber wishes to inform manufacturers that he will sell the patent rights for all the States of the Union but Pennsylvania, and also the right to obtain patents on the above machine in Europe. It is to a great degree self-sharpening, and both sets of knives vibrating adjust themselves to each other, the only principle that will continue to keep a sharp cutting edge; it is adapted to cutting all kinds of grain, grass, harvesting seed, hemp, flax, &c. A machine will be exhibited at the Pennsylvania State Fair, to be held at Pittsburg in September next. Further information may be had of the patentee, Wm. G. HUYETT, Williamsburg, Blair Co., Pa 46 2*

THE RIDER WATER WHEEL.—Is extensively made by G. T. McLAUTHLIN & CO., sole assignees, at Plymouth, Mass. office in Boston, at 108 State st. We know of no wheel so admirably combining simplicity, power, durability and true economy in the use of water; it is adapted to all descriptions of work, and to high or low falls, with or without backwater. Local and travelling agents wanted. 46 2*

MIDDLEBOROUGH, Mass., Aug. 22, 1851. This may certify that I have sawed with Rider's Improved Combination Water Wheel, in my box-board mill, 2350 feet of boards in five hours, stopping twice to file, and once to file and set the saw in the time, with from three and a half to four feet head, and the wheel discharging 312 inches of water. The wheel has been running nearly three years, and thus far operates to my perfect satisfaction. 46 2* SENeca THOMAS

FOR SALE.—An interest in Irwin's Hydrostatic Camels, or Air Floats, for raising and supporting sunken vessels, is now offered for sale, in consequence of the death of the patentee. An explanation of the working of the machine may be had on inquiry of OLIVER BYRNE, Esq., Civil, Military and Mechanical Engineer, 854 North Fourth street, Philadelphia. 1*

WANTED.—Immediately, a quantity of old flat Railroad Iron. Address T. D. & M. M. MANLY, South Dorset, Vt. 46 2*

ALDEN'S PATENT FAN BLOWER, and Robinson's Patent Improved Hydraulic Ram, New York office is removed to 555 Broadway, opposite the Metropolitan Hotel. J. B. CHICHESTER, Agent. 46 2*

COTTON MACHINERY.—For sale, very low, viz. 1 3/4 inch batt card, 1 warper, dresser fans, and 1 iron boiler. Apply to E. WHITNEY, New Haven, Ct. 45 6

LAWRENCE SCIENTIFIC SCHOOL, Harvard University, Cambridge, Mass. The next term of this institution will open on the first day of Sept., 1853, and continue 20 weeks. Instruction by recitations, lectures and practical exercises, according to the nature of the study, will be given in Astronomy, by Messrs. Bond; Botany, by Prof. Gray; Chemistry, Analytical and Practical, by Prof. Horsford; Comparative Anatomy and Physiology, by Prof. Wyman; Engineering, by Prof. Eustis; Mathematics, by Prof. Pierce; Mineralogy, by Prof. Cooke; Physics, by Prof. Lovering; Zoology and Geology, by Prof. Agassiz. For further information concerning the School, application may be made to Prof. E. N. Horsford, Dean of the Faculty. Cambridge, Mass., July 15, 1853. 44 8*

A GOOD CHANCE FOR MANUFACTURING.—A Water Privilege of ten feet fall, on a never-failing stream, with four acres of choice land, in the town of Cornwall, Orange Co., N. Y., 5 miles from the North River, and three miles from the railroad depot, and on the line of survey of the Albany and Hoboken RR. For particulars inquire of John J. Vanduzer, 184 Canal st, N. Y., or John Orr, on the premises. 40 13*

McALLISTER & BROTHER.—Opticians and dealers in mathematical instruments, 48 Chestnut st, Philadelphia Pa. Mathematical instruments separate and in cases, Protractors, Spacing Dividers, Drawing Pens, Ivory Scales, Tape Measures, Salometers, Bourdon Steam Gauge, Spy Glasses, Microscopes, Hydrometers, &c., &c. An illustrated and priced catalogue will be sent by mail free of charge. 39 6m*

IMPROVED CHUCK.—We, the undersigned, being engaged in the manufacture of an Improved Universal Screw Chuck, so arranged as to work the jaws together or separately with other conveniences, are now prepared to attend to orders at short notice. The securing of a patent is anticipated. E. B. WHITE & CO., Nashua, N. H. 43 6*

EXCELSIOR SAND PAPER, GLUE.—Premium "Excelsior" Sand and Emery Papers; these papers practical mechanics have decided to be the best the market affords; also "Abbott's" Manila Sand, and Match Papers, Emery Cloth, Emery of the "Prospect Mills" brand, Corundrum, Pumice Stone ground and in lump, of very superior quality; also Glue of Upton's, Cooper's, and all other brands, in quantities to suit, at the manufacturers' lowest prices, for sale by WILLIAM B. PARSONS, 290 Pearl street, (corner Beekman) N. Y. 40 8*

JAMES D. JOHNSON, Bridgeport, Ct., Proprietor of Wood's Patent Shingle Machine. Persons wishing to purchase rights or machines, can address as above. This is unquestionably the best machine in use for cutting shingles. 33tf

UPTON'S GLUE.—This celebrated brand is noted for its great strength and durability, having been proved by Chickering and Gilbert, the great piano makers of Boston, to be the only glue that will stand in all climates. For sale in barrels and cases by WM. B. PARSONS, Sole Agent, 290 Pearl st, cor. Beekman, N. Y. 40 8*

NOTICE TO IRON MASTERS.—We hereby caution iron masters against purchasing the right to use any furnace for the manufacture of malleable iron directly from the ore, having a "down blast" therein, and we believe, those are the only kind now in successful operation, as any use of said down blast will be an infringement upon the patent granted to G. A. Whipple, 10th May, 1853. The proprietors of said patent will sell the right to use said invention in furnace or territorial rights, by which iron can be made from \$8 to \$12 per ton cheaper than in any other way. They will also guarantee the free use of all necessary apparatus for manufacturing malleable iron directly from the ore without infringing on any other patent right. Application for further information can be made to J. J. GREENOUGH, Attorney for the Proprietors, No. 6 Wall street, New York. 45 3

NORRIS WORKS, Norristown, Pa. The subscribers build and send to any part of the United States, Pumping, Hoisting, Stamping, and Portable Engines, and Mining Machinery of every description. THOMAS, CORSON & WEST. 40 1y.

AMERICAN PIG IRON.—Of the brands Wm. Penn, Swede, Amenia, Durham, Allentown, Sterling, Crane, and Mount Hope—also Scotch Pig Iron of favorite brands constantly on hand and for sale by G. O. ROBERTSON, 135 Water street, cor. of Pine. 43 8*

NORCROSS ROTARY PLANING MACHINE, N.—Decided by the Circuit Court not to infringe the Woodworth Machine—I now offer my Planing Machines at a low price; they are not surpassed by any machines as to amount or quality of work. Tongueing and grooving machines also for sale, doing one or both edges as desired; 80 machines now in operation. Address me at Lowell, Mass. 39 20* N. G. NORCROSS

ANDREWS & JESSUP.—No. 70, Pine street New York, Commission Merchants for the sale of all kinds of Cotton and Woollen Machinery, Machinists' Tools, Belling, &c. Importers and dealers in every variety of manufacturers' articles. 43tf

GARDINER'S PATENT MAGNETIC GOLD Washer, Amalgamator and Separator.—This is the most perfect machine for Gold Mining that has been invented; it performs the operation of washing the earth or pulverized quartz rock, amalgamating and magnetic separation of black sand or oxide of iron, all at one movement, saving every particle of gold dust, however minute. With this machine two men can perform as much work per day as ten by any other process, and save all the gold. A full explanation of its operation will be given by the manufacturer. The public are invited to examine Price \$250. Iron Returns at wholesale and retail. NORTON & GARDINER, 47 Deu street, N. Y. 40tf

ENGINEERING.—The undersigned is prepared to furnish specifications, estimates, plans in general or detail of steamships, steamboats, propellers, high and low pressure engines, boilers, and machinery of every description. Broker in steam vessels, machinery, boilers, &c. General Agent for Ashcroft's Steam and Vacuum Gauges, Allen & Noyes' Metallic Self-adjusting Conical Packing, Faber's Water Gauge, Sewall's Salinometers, Dudgeon's Hydraulic Lifting Press, Roebling's Patent Wire Rope for hoisting and steering purposes, &c. &c. CHARLES W. COPELAND, Consulting Engineer, 64 Broadway. 39 26*

PORTABLE STEAM ENGINES.—The subscriber is now prepared to supply excellent Portable Engines, with Boilers, Pumps, Heaters, etc., all complete, and very compact, say 1, 2, 2 1/2, 3, 4, 6, 8, and 10 horse-power, suitable for printers, carpenters, farmers, planters, &c. they can be used with wood, bituminous, or hard coal; a 2 1/2 horse engine can be seen in store, it occupies a space 5 feet by 3 feet, weighs 1500 lbs., price \$240; other sizes in proportion. S. C. HILLS, Machinery Agent, 12 Platt st, N. Y. 27eotf

PATENT LAWS OF THE UNITED STATES, and information to inventors and patentees; for sale at the Scientific American office. Price 12 1-2 cents.

WHEELER, WILSON, & Co.—Watertown, Ct., proprietors and manufacturers of Allen B. Wilson's Patent Stitching Machine. Patented June 15, 1852, it can be seen at the Company's Office, 265 Broadway, New York. 30 20*

ATMOSPHERIC TELEGRAPH.—The English patent (just issued) is now offered for sale at the Company's office, 24 Merchant's Exchange, Boston, Mass. I. S. RICHARDSON, Agent A. T. Company. 35tf

KRUPP'S (London Council Medal 1851) CELEBRATED CAST STEEL.—Of any dimensions, warranted superior to any other for Platers and other Rollers requiring hardening; also for hydraulic and other pistons, railway axles, and shafts for steam engines, &c. &c. This cast steel admits of welding without borax with the same facility as iron. THOS. PROSSER & SON, 28 Platt street, New York. 39tf

NEW WORKS ON CIVIL ENGINEERING.—The Field Practice of Laying out Circular Curves for Railroads: by John C. Trautwine, C. E.; second edition, in pocket-book form. A New and Rapid Method of Calculating the Cubic Contents of Excavations and embankments, by the aid of Diagrams: by John C. Trautwine, C. E., with 10 copper-plates. Price \$1 each; postage on the Curves, 5 cents, and on the Excavations and Embankments, 8 cents. The postage may be remitted or not, as the Post Office does not require pre-payment. For sale by Wm. HAMILTON, Hall of the Franklin Institute, Phila. 35 3m

PROSPECT MILLS EMERY.—This article has been thoroughly tested by many of our practical machinists, and proved equal to the best "London Extra" Emery; for sale in lots to suit by WM. B. PARSONS, 290 Pearl st, N. Y. 40 8*

STEAM ENGINE FOR SALE.—7 horse-power, new, and in good order: also a cylinder boiler for the engine; it has been used but is in good condition; price \$500; the engine is worth the money. Address MUNN & CO., Scientific American Office.

CIRCULAR SAW MILLS.—The undersigned are manufacturing, and keep constantly on hand, "Child's Premium Double and Single Circular Sawing Machines." The best machines in use for sawing lumber from logs of all sizes, and warranted capable of cutting more lumber in a given time than any other mill. Shafting, gearing, and all other mill work, made to order, with dispatch and in a workmanlike manner. H. WELLS & Co., Florence, Hampshire Co., Mass. 44 6*

NEW METHOD FOR MAKING WROUGHT-IRON direct from the Ore.—The proprietors of James Renton's Patent, who have purchased Alex. Dickerson's patent for the above purpose, are desirous of introducing the invention into general use, and invite parties who may wish to negotiate for rights for States and counties, or for furnaces, to make immediate application, and to examine the furnace which is in successful operation at the American Iron Company's Works, Newark, N. J. The invention is exciting considerable interest; gentlemen from all parts of the country, who are engaged in the manufacture of iron, have examined the furnace in its workings, and give it their decided commendation. A circular, giving more minute information, will be sent to those desiring it. The rights for several States and counties have already been disposed of. Applications for rights in the State of New Jersey may address the Hon. J. M. Quinby, President of the American Iron Company. Inquiries or applications for other States may be made to A. H. BROWN, Newark, N. J., Office 107 Market st. 34tf

BEARDSLEE'S PATENT PLANING Tongueing and Grooving Machine.—These celebrated machines have now been generally introduced in various portions of the United States. More than thirty are now in successful practical operation in the State of New York alone. As an illustration of the extent of work which they are capable of performing, with unrivalled perfection, it is sufficient to state that, within the last six months and a half, over five millions of feet of spruce flooring have been planed, tongued and grooved by one of these machines at Plattsburgh, N. Y., never running to exceed ten hours a day. The claim that the Beardslee machine was an infringement upon the Woodworth patent, has been finally abandoned; and after the proofs had been taken, the suit instituted by the owners of that patent was discontinued, and the whole controversy terminated on the first of November last. Applications for machines or rights may be made to the subscriber, GEO. W. BEARDSLEE, 57 State street, or No. 764 Broadway, Albany. 15tf

THE NEW HAVEN MANUFACTURING Company, New Haven, Conn., having purchased the entire right of E. Harrison's Flour and Grain Mill, for the United States and Territories, for the term of five years, are now prepared to furnish said mills at short notice. These mills are unequalled by any other mill in use, and will grind from 20 to 30 bushels per hour of fine meal, and will run 24 hours per day, without heating, as the mills are self-cooling. They weigh from 1400 to 1500 lbs., of the best French burr stone, 30 inches in diameter: snugly packed in a cast-iron frame, price of mill \$200, packing \$5. Terms cash. Further particulars can be had by addressing as above, post-paid, or to S. C. Hills agent N. H. M. Co., 12 Platt st, N. Y. 28tf

MACHINERY.—S. C. HILLS, No. 12 Platt-st. N. Y. dealer in Steam Engines, Boilers, Iron Planers, Lathes, Universal Chucks, Drills, Kase's, Von Schmidt's and other Pumps; Johnson's Shingle Machines; Woodworth's, Daniel's and Law's Planing machines; Dick's Presses, Punches and Shears; Morticing and Tennoning machines; Belting; machinery oil, Beal's patent Cob and Corn mills; Burr mill and Grindstones; Lead and Iron Pipe &c. Letters to be noticed must be post-paid. 40tf

A. B. ELY, Counsellor at Law, 52 Washington st., Boston, will give particular attention to Patent Cases. Refers to Munn & Co., Scientific American. 16tf

LEONARD'S MACHINERY DEPOT, 109 Pearl-st. and 60 Beaver, N. Y.—Leather Banding Machinery, N. Y.—Machinists' Tools, a large assortment from the "Lowell Machine Shop," and other celebrated makers. Also a general supply of mechanics' and manufacturers' articles, and a superior quality of oak-tanned Leather Belting. P. A. LEONARD. 40tf

PAINTS, &c. &c.—American Atomic Drier, Graining Colors, Anti-friction Paste, Gold Size, Zinc Drier, and Stove Polish. QUARTERMAN & SON, 114 John st., Painters and Chemists. 27tf

LOGAN VAIL & CO., No. 9 Gold st, New York Agency for Geo. Vail & Co., Speedwell Iron Works, Norristown, N. J., furnish and keep on hand Portable Steam Engines of various sizes, Saw and Grist Mill Irons, Hotchkiss's Water Wheels, Iron Water Wheels of any size, Portable Saw Mills, complete; Bogardus's celebrated Planetary Horse Powers; heating forgings and castings for steamboats and rolling mills, Ratchet Drills of superior quality for machinists, Saw Gummers, Hand drills, Tyre Benders, and shafting and machinery generally. 38 1y

E. A. BOURRY & H. E. ROEDER—Consulting and Mechanical Engineers; Office No. 333 Broadway, New York City. 43 9*

C. B. HUTCHINSON'S PATENT STAVE Cutting Machines, the best in use, and applicable alike to thick or thin staves; also his Head Cutting and Turning, and Stave Jointing Machines. For machines or territorial rights, apply to C. B. HUTCHINSON & CO., Syracuse, N. Y. 38tf

J. B. WHITE'S PATENT CARAXLE LATHES J.—also Patent Engine Screw Lathes, for boring and turning tapers, cutting screws, &c. We manufacture and keep constantly on hand the above lathes; also double slide Chuck and common Band Lathes, Iron Planers, S. Ingersoll's Patent Universal Ratchet Drill, &c. Weight of Axle Lathe, 5,500 lbs. price \$600; Engine Screw Lathe, 1400 to 7,000 lbs., price \$225 to \$675. BROWN & WHITE, Windsor Locks, Conn. 27tf

COCHRAN'S CRUSHING MACHINE.—Can be seen in daily operation in Thirteenth street, between 9th and 10th avenues. Parties in want of a machine for crushing and pulverizing quickly and cheaply Quartz Rock, Iron, Lead, Copper, and Silver Ores, and other mineral substances equally hard, are invited to witness the operation of these powerful and simple, but yet effective machines. For further particulars apply to E. & J. BUSSING & CO., No. 32 Cliff st., N. Y. 35tf

THE NEW HAVEN MANUFACTURING CO. No. 2 Howard st, New Haven, Ct., are now finishing 6 large Lathes, for turning driving wheels, and all kinds of large work; these lathes weigh 9 tons, and swing 7 1-3 feet, shears about 16 feet long. Cuts and further particulars can be had by addressing as above, post-paid, or to S. C. Hills, agent N. H. M. Co., 12 Platt st, N. Y. 28tf

LEE & LEAVITT—Manufacturers of every description of Cast Steel Saws, No. 53 Water street, between Walnut and Vine, Cincinnati, O. 27 6m*

SCIENTIFIC MUSEUM.

New Method of Analyses for Organic Poisons,
by C. Flandin.

The author commences by laying down the principles on which he supposes the action of poisons may be explained:—1. Poisons are unassimilable substances. 2. They pass into the organism by absorption. 3. Their action is that of presence.

If these principles be correct, it follows that all poisonous substances, whatever they may be, must be found in the organs with which they have been brought into contact, or to which they have been transported by absorption. In the case of the inorganic poisons, experience has shown that there is no exception to the rule. It still remains to be shown that the same rule applies to the organic poisons.

Christison states, with regard to opium, that as a general rule the medical jurist can scarcely obtain satisfactory proof of the existence of this substance by the best methods of analysis at present known. Now the best methods of analysis known at present for ascertaining the presence of opium, and of the organic proximate principles in general, consist in treating the suspected substances either with acetic acid or alcohol, filtering the liquid, and evaporating it to the consistence of an extract. This extract is then re-dissolved in water, either pure or acidified, and decolorized by animal charcoal, or the animal matters are precipitated as far as possible by various reagents (such as subacetate of lead, sulphuretted hydrogen, nitrate of silver, &c.). Lastly, the extractive matter thus obtained is tested by different re-agents, such as nitric acid and perchloride of iron, when it is desired to ascertain the presence of morphine, the active principle of opium. In this way, however, no satisfactory result can be obtained. The poison is not isolated; it is not directly acted upon by the re-agents; its characteristic properties consequently cannot be ascertained.

The author considers that animal substances may be divided as follows:—1. Proteine or albuminous substances. 2. Coloring matter. 3. Fatty substances.

The proteine substances are readily coagulable, and in this state they become insoluble in water, alcohol, acids, &c.

The colored or coloring matters are easily changed by various acids and alkaline agents, anhydrous lime and baryta for instance, without mentioning heat.

The fatty substances are separated with ease from all the other matters by alcohol and ether.

Now, if an inorganic substance be mixed with organic substances, there is nothing more easy than to discover it. The organic substance is burnt, the inorganic principle is brought to the state of a soluble compound within the cinder, and then extracted with water. The process of carbonization or incineration by means of sulphuric acid for the discovery of the mineral poisons is founded on these very simple data.

But if the substance which it is necessary to separate from animal matters be combustible, or capable of essential modification by heat, the course is not so clear. The following is the process proposed:—

To 100 parts of the substance to be examined, 12 parts of anhydrous lime or baryta are to be added, and the whole pounded together in a mortar. The mixture is then to be heated to 212° Fah., then pulverized, either with a pestle, or with a special apparatus appropriated to this operation, which is very essential; the powder is to be treated with boiling anhydrous alcohol three times, filtering the liquid after cooling. This liquid as it leaves the filter is scarcely colored; it only contains the proximate principle or principles sought for with the fatty or resinous matters.

The alcohol is now slowly evaporated, and the dry residue treated with ether to remove the fatty matters. If the principle be insoluble in ether (morphine, strychnine, brucine,) it will be separated in the fluid, and may be obtained by filtration or simple decantation. If it be soluble in ether, the alcoholic residue

or the etherial fluid must be treated with a special solvent of the organic bases, such as the acetic acid, precipitating the base afterwards by ammonia.

To 100 grms. of animal matter the author added a single grain or 0.05 grm. of morphine, strychnine, and brucine; and by operating in the manner just described, succeeded in obtaining, in a state of absolute purity, a ponderable quantity of each of those principles.—Instead of strychnine, morphine, and brucine, the author applied crude opium, laudanum, decoction of nux vomica, and of false angostura bark; and in these cases also he was able to isolate the poisonous principles. He also, in order to assure himself that his process was applicable to medico-legal purposes, poisoned animals with the smallest effective doses of the above-mentioned substances, when he was able to detect the poisons in the matters contained in the stomach and intestines, and sometimes even in organs to which they had been carried by absorption.

In one experiment, he mixed 2 grs. (or 10 centigrams.) of morphine with 100 grms. of flesh, leaving the substances to undergo putrefaction for two months. At the end of this period he discovered several centigrammes of morphine in the mass.—[Comptes Rendus.

[The above is very important information. A few weeks ago a young man named Hendricksor, was found guilty of murder at Albany, N. Y., for poisoning his wife by aconitic acid, principally upon the testimony of Dr. Salisbury, of Albany, who analyzed the stomach, and Dr. Swinburne, who made the post-mortem examination—both young physicians. Rebutting testimony by Dr. L. Reid, a distinguished chemist of New York City, Dr. Emmons, of Albany, an experienced chemist, and Dr. B. P. Staats, of Albany, an experienced physician. These testified that no reliance could be placed in the experiments of Dr. Salisbury, to prove that aconitine was administered, yet, the jury found the man guilty. All the information that can be gathered on the means of detecting organic poisons, is of great importance, as it has been held hitherto almost impossible to do so in the majority of cases.

Improved Vise Attachment.

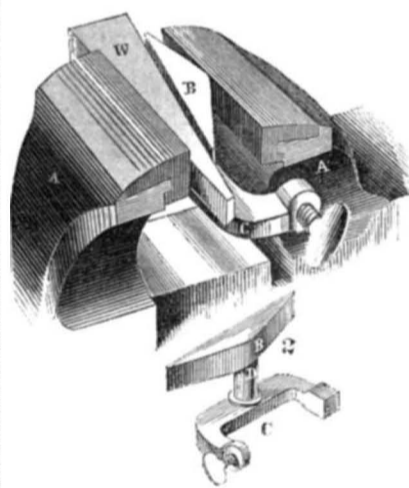

The annexed engravings are two views of an improvement in vises, whereby the ordinary is converted into a taper vise by an adjustable attachment to be applied for that purpose. The improvement is exceedingly simple, and requires but few words to explain its construction and use, so as to render its operation clear to any person.

Figure 1 is a perspective view of a common vise, with attachment applied to it, and a taper piece of metal to be operated upon between the jaws. Fig. 2 is a perspective view of the attachment. The same letters refer to like parts.

A A are the jaws of an ordinary vise (the other parts of it need not be described.) The attachment, fig. 2, is screwed to one of the jaws, A, by the clamp, C. This attachment has a taper jaw, B, secured on a vertical axis, D, and when it is screwed to one jaw of the vise, as shown in fig. 1, it can be turned so as to embrace a taper piece of metal, like W, to be filed or otherwise operated on, which could not be done in a common vise with parallel jaws, as the piece, B, has its apex placed close to the inside of jaw A, so as to alter the taper of the jaws to suit the

taper of the article to be embraced between them.

This improvement was patented on the 30th of last November; the inventor is J. W. Bliss: the manufacturers are Roys & Wilcox, of East Berlin, Conn., to whom all letters about it should be addressed. These gentlemen manufacture all sizes, from the small jeweller's, up to the largest size of machinist's vise. The claim of the patent for this improvement will be found by our readers on page 102, this volume of the "Scientific American."

Diseases of Cattle—Innoculation.

Within the past ten years disastrous losses have been met with in some parts of Europe, by dealers in cattle, from a comparatively modern disease named pleuro-pneumonia; it is most prevalent in the marshy districts of Holland, but is not confined to them. The symptoms of it are like inflammation of the lungs, but remedies ordinarily used for that disease have failed to be of any use in this. How this disease came to be first introduced is difficult to tell, but from what we have read upon the subject we are of the opinion that it was first caused by bad ventilated stables, and feeding a great number of animals in a small space, for fattening, on the refuse grains, &c., obtained from German and Dutch distilleries. The hot-beds of the disease are the distillery and beer districts of those countries. No less than 10 per cent. of the cattle bought to be fattened for market, in some parts of Holland and Belgium, die of this disease. We have heard no word of it attacking cattle in our country, still such a disease may not be unprevalent among stall-fed cattle in some districts; it should be looked after with zeal by those whose duties require of them a watchful care for the public health. Innoculation has been resorted to in Holland to try and arrest it. The virus for this purpose is taken from the lungs of a diseased animal, and innoculation is performed on the tails of live animals to prevent them taking it. The operation is said to be somewhat successful, and the practice is about to be introduced into England as a preventive.

Tortoise Shell.

Tortoise shell, or rather scales, is a horny substance that covers the hard strong covering of a bony cotexture, which covers the Testudinibricata, Linn. The lamellæ or plates of this tortoise are 13 in number, and may be readily separated from the bony parts by placing fire beneath the shell, thereby they start asunder. They vary in thickness from one-eighth to a quarter of an inch, according to the age and size of the animal, and weigh from 5 to 25 pounds. The larger the animal the better is the shell. This substance may be softened by the heat of boiling water; and if compressed in this state by screws in iron or brass moulds, it may be bent into any shape. The moulds being then plunged in cold water, the shell becomes fixed in the form imparted by the mould. If the turnings or filings of tortoise-shell be subjected skillfully to gradually increased compression between moulds immersed in boiling water, compact objects of any desired ornamental figure or device may be produced. The soldering of two pieces of scale is easily effected by placing their edges together, after they are nicely filed to one bevel, and then squeezing them between the long flat jaws of hot iron pinchers, made somewhat like a hair dresser's curling tongues. The pinchers should be strong, thick, and just hot enough to brown paper slightly without burning it. They may be soldered also by the heat of boiling water, applied along with skillful pressure. But in whatever way this process is attempted, the surfaces to be united should be made very smooth, level, and clean; the least foulness, even the touch of the finger, or breathing upon them, would prevent their coalescence.

American Clippers in England.

The American clipper ship "Sovereign of the Seas," built by Donald McKay, and commanded by his brother, made the passage from this City, which she left on the 18th of June last, to Liverpool, in 14 days and 19 hours, having arrived there on the 2nd of July, the fastest passage on record, between New

York and Liverpool. Her average time of running was 12.73 knots per hour. A correspondent in the "London Daily News," asserts, that this time was beaten 12 years ago by the British Frigate "Resistance" in a voyage from Quebec to Cork, which she made in 12½ days. He does not present data, but we have no doubt, if the "Resistance" and "Sovereign of the Seas," were placed alongside of one another for a race, in a sailing breeze, the latter would run her out of sight in a few hours. This Clipper Ship has created quite a sensation in Liverpool, and in all probability, Mr. McKay will sell her for a good round sum, to some of the Liverpool China Companies.

Capt. E. Nye, of the steamship "Pacific," in a letter to the "New York Herald," says that he made the passage from New York to Liverpool in 14 days 5 hours, in the packet ship "Independence," of only 733 tons, built by Messrs. Smith & Dimon, of this city.

Boiler Explosions.

On Tuesday last week (19th) a steam boiler exploded at the foundry of J. A. Pratt, Attorney street, this city, by which one man, Thomas Reilly, was killed. On the 22d, the coroner's jury returned the following verdict:—

"That Thomas Reilly came to his death by fracture of the skull, from a stone or brick, thrown by the explosion of the steam boiler in the foundry of John R. Pratt, July 19 1853. That said explosion was the result of said boiler not being sufficiently braced by its builder, said builder being to the Jury unknown, but believed to be in Canada."

[This we assert is an outrageous decision, and the very reverse of creditable to the Jury that rendered it, and the coroner who gave them the charge.

LITERARY NOTICES.

PRACTICAL DRAUGHTSMAN'S BOOK.—The second number of this superior work, from the French of Armengaud, by Wm. Johnson, of the "Glasgow Practical Mechanic's Journal," is just issued by Stringer & Townsend, 222 Broadway, this city; it is a work without a superior for architects, machinists and engineers. We commend it without any reserve.

THE STRUGGLE AMONG THE NATIONS OF THE EARTH.—This is the title of a pamphlet published by E. D. Fletcher, 141 Nassau st, this city: it explains prophecy, and describes terrible events which are to take place during the next fifteen years.

LITTELL'S LIVING AGE.—No. 17, new series, of this unrivalled weekly magazine, published by Littell, Son & Co., Boston, contains 14 strong and useful articles, selected from the best magazines of English literature.

WILSON'S BUSINESS DIRECTORY for 1853-54, published by John F. Trow, of 51 Ann street, N. Y. This is one of the most useful books for citizens and strangers who wish to find the store, office, or place of business of any man or company in our city. It contains 37,312 names of persons and firms doing business in this city. The classification is excellent.

MECHANICS

Manufacturers and Inventors.

A new Volume of the SCIENTIFIC AMERICAN commences about the middle of September in each year. It is a journal of Scientific, Mechanical, and other improvements; the advocate of industry in all its various branches. It is published weekly in a form suitable for binding, and constitutes, at the end of each year, a splendid volume of over 400 pages, with a copious index, and from five to six hundred original engravings, together with a great amount of practical information concerning the progress of invention and discovery throughout the world.

The Scientific American is the most widely circulated and popular journal of the kind now published. Its Editors, Contributors, and Correspondents are among the ablest practical scientific men in the world.

The Patent Claims are published weekly and are invaluable to Inventors and Patentees.

We particularly warn the public against paying money to Travelling Agents, as we are not in the habit of furnishing certificates of agency to any one.

Letters should be directed (post-paid) to
MUNN & CO.,
128 Fulton street, New York.

Terms! Terms! Terms!

One copy, for One Year	\$2
" " Six Months	\$1
Five copies, for Six Months	\$4
Ten Copies for Six Months for	\$8
Ten Copies for Twelve Months,	\$15
Fifteen Copies for Twelve Months,	\$22
Twenty Copies for Twelve Months,	\$28

Southern and Western Money taken at par for subscriptions, or Post Office Stamps taken at their full value.