

TM 1-4920-444-13&P

TECHNICAL MANUAL

OPERATOR'S AND AVIATION INTERMEDIATE
MAINTENANCE (AVIM) MANUAL INCLUDING
REPAIR PARTS AND SPECIAL TOOLS LIST (RPSTL)

FOR

NON-DESTRUCTIVE INSPECTION SHOP

P/N CL4920-99-B71

NSN 4920-01-509-5989

EIC: N/A

DISTRIBUTION STATEMENT: Approved for public release; distribution is unlimited.

HEADQUARTERS, DEPARTMENT OF THE ARMY
28 February 2007

WARNING SUMMARY

Personnel performing operations, procedures and practices which are included or implied in this Technical Manual shall observe the following warnings. Disregard of these warnings and precautionary information can cause **SERIOUS INJURY or DEATH** or destruction of materiel.

WARNINGS

- Four people are needed when moving or lifting the Environmental Control Units (ECUs). Each unit weighs approximately 270 pounds. Trying to move or lift an ECU without sufficient help can cause **SERIOUS INJURY** to personnel.
- When all equipment and materiel is stored on the stationary side of the shelter, the limited floor space presents a safety hazard to operating personnel. This is most critical during the raising and lowering of the roof panel. Failure to observe supplemental instructions could result in **SERIOUS INJURY** to personnel. Personnel inside the shelter could become trapped between the roof panel and equipment bolted to the floor.
- The two upper lockout pins must be installed at the cable housing prior to raising the shelter floor from its lower position to its level position. If the lockout pins are not in place, the counterbalance cable will remain under tension. **DO NOT** attempt to remove these cables if the upper lockout pins are not installed. Removing cable while under tension could cause **SERIOUS INJURY** to personnel.
- **HIGH VOLTAGE** exists in the electrical system of the shop. All electrical inspections, repairs or replacement will be performed with the power **OFF** and only by qualified electricians. Serious shock hazards exist which could result in **INJURY OR EVEN DEATH** to personnel.
- Make sure compressed air supply is disconnected before attempting any work on the water/oil separator. Do not direct compressed air near eyes or directly against skin. Wear goggles; high pressure air against eyes can cause **BLINDNESS**.

TM 1-4920-444-13&P

LIST OF EFFECTIVE PAGES/WORK PACKAGES

NOTE: The portion of text affected by the changes is indicated by a vertical line in the outer margins of the page. Changes to illustrations are indicated by miniature pointing hands. Changes to wiring diagrams are indicated by shaded areas.

Date of issue for the original manual is:

Original 28 February 2007

TOTAL NUMBER OF PAGES FOR FRONT AND REAR MATTER IS 19 AND TOTAL NUMBER OF WORK PACKAGES IS 37 CONSISTING OF THE FOLLOWING:

PAGE/WP NO.	*CHANGE NO.	PAGE/WP NO.	*CHANGE NO.
Title	0	Chp 5 title page	
Warning Summary i thru vi	0	WP 0029 (2 pgs)	0
	0	WP 0030 (6 pgs)	0
		WP 0031 (2 pgs)	0
Chp 1 title page		WP 0032 (6 pgs)	0
WP 0001 (6 pgs)	0	WP 0033 (28 pgs)	0
WP 0002 (4 pgs)	0	WP 0034 (2 pgs)	0
WP 0003 (2 pgs)	0	WP 0035 (2 pgs)	0
		WP 0036 (8 pgs)	0
Chp 2 title page		WP 0037 (2 pgs)	0
WP 0004 (2 pgs)	0		
WP 0005 (18 pgs)	0		
WP 0006 (6 pgs)	0		
WP 0007 (10 pgs)	0		
WP 0008 (4 pgs)	0		
WP 0009 (2 pgs)	0		
WP 0010 (2 pgs)	0		
WP 0011 (2 pgs)	0		
WP 0012 (4 pgs)	0		
WP 0013 (6 pgs)	0		
WP 0014 (6 pgs)	0		
WP 0015 (12 pgs)	0		
WP 0016 (6 pgs)	0		
Chp 3 title page			
Chp 4 title page			
WP 0017 (2 pgs)	0		
WP 0018 (18 pgs)	0		
WP 0019 (4 pgs)	0		
WP 0020 (2 pgs)	0		
WP 0021 (10 pgs)	0		
WP 0022 (10 pgs)	0		
WP 0023 (8 pgs)	0		
WP 0024 (2 pgs)	0		
WP 0025 (6 pgs)	0		
WP 0026 (2 pgs)	0		
WP 0027 (16 pgs)	0		
WP 0028 (2 pgs)	0		

**OPERATOR'S AND AVIATION INTERMEDIATE MAINTENANCE
MANUAL INCLUDING REPAIR PARTS
AND SPECIAL TOOLS LIST**

**FOR
NON-DESTRUCTIVE INSPECTION SHOP**

**P/N CL4920-99-B71
NSN 4920-01-509-5989**

EIC: N/A

REPORTING ERRORS AND RECOMMENDING IMPROVEMENTS

You can improve this manual. If you find any mistakes or if you know of a way to improve these procedures, please let us know. Mail your letter or DA Form 2028 (Recommended Changes to Publications and Blank Forms) located in the back of this manual, directly to: Commander, U.S. Army Aviation and Missile Command, ATTN: AMSAM-MMC-MA-NP, Redstone Arsenal, AL 35898-5000. A reply will be furnished to you. You may also provide DA Form 2028 information to AMCOM via e-mail, fax, or the World Wide Web. Our fax number is: DSN 788-6546 or Commercial 256-842-6546. Our e-mail address is: 2028@redstone.army.mil. Instructions for sending an electronic 2028 may be found at the back of this manual immediately preceding the hard copy 2028. For the World Wide Web use: <https://amcom2028.redstone.army.mil>.

DISTRIBUTION STATEMENT A: Approved for public release; distribution is unlimited.

TABLE OF CONTENTS

Page No. WP Sequence No.

WARNING SUMMARY

HOW TO USE THIS MANUAL

CHAPTER 1 – GENERAL INFORMATION, EQUIPMENT DESCRIPTION, AND THEORY OF OPERATION

General Information		WP 0001 00
Scope	0001 00-1	
Maintenance Forms, Records, and Reports	0001 00-1	
Reporting Equipment Improvement Recommendations (EIRs).....	0001 00-1	
Corrosion Prevention and Control (CPC).....	0001 00-1	
Destruction of Army Material to Prevent Enemy Use	0001 00-1	
Preparation for Storage or Shipment	0001 00-1	
Warranty Information.....	0001 00-1	
List of Abbreviations/Acronyms.....	0001 00-2	
Quality of Material	0001 00-3	
Safety, Care, and Handling	0001 00-4	
Supporting Information for Repair Parts, Special Tools, TMDE, and Support Equipment.....	0001 00-5	
Equipment Description and Data.....		WP 0002 00
Equipment Characteristics, Capabilities, and Features	0002 00-1	
Location and Description of Major Components for Transport Mode	0002 00-2	
Location and Description of Major Components for Operational Mode	0002 00-3	
Equipment Data	0002 00-4	
Theory of Operation.....		WP 0003 00

TM 1-4920-444-13&P

TABLE OF CONTENTS (Continued)

	<u>Page No.</u>	<u>WP Sequence No.</u>
CHAPTER 2 – OPERATOR INSTRUCTIONS		
Description and Use of Operator Controls and Indicators.....		WP 0004 00
Shelter Opening Sequence		WP 0005 00
Security Measures for Electronic Data.....	0005 00-1	
Siting Requirements.....	0005 00-1	
Assembly and Preparation for Use	0005 00-1	
Initial Leveling	0005 00-2	
Shelter Expansion.....	0005 00-3	
Positioning Hinged Sidewall.....	0005 00-6	
Positioning Hinged Jacks for Leveling	0005 00-7	
Positioning Roof and Hinged End Walls	0005 00-9	
Securing Shelter.....	0005 00-13	
Installing Ceiling Lights	0005 00-14	
Installing Cable and Receptacle Assembly.....	0005 00-16	
Installing Area Light.....	0005 00-17	
Connecting Electricity		WP 0006 00
Connecting Power Distribution Box (PDB) to Generator	0006 00-1	
External Grounding of Shelter.....	0006 00-2	
Connecting Main Power Cable.....	0006 00-3	
Positioning ECUs.....		WP 0007 00
Counterbalance Cable Retaining Block Removal.....	0007 00-1	
Opening ECU Fold-down Panels	0007 00-3	
Positioning ECUs	0007 00-6	
Connecting Power to ECUs	0007 00-9	
Positioning Shop Equipment		WP 0008 00
Safeguarding Bolts, Washers, and Nuts	0008 00-1	
Eyewash Station	0008 00-1	
Cabinet E.....	0008 00-3	
Stools	0008 00-4	
Connecting Compressed Air and Water.....		WP 0009 00
Compressed Air	0009 00-1	
Water Supply.....	0009 00-2	
Checking Shelter Level.....		WP 0010 00
Disconnecting Compressed Air and Water		WP 0011 00
Compressed Air	0011 00-1	
Water Supply.....	0011 00-2	
Repositioning Shop Equipment		WP 0012 00
Obtaining Correct Bolts, Washers, and Nuts	0012 00-1	
Stools	0012 00-1	
Cabinet E.....	0012 00-2	
Eyewash Station	0012 00-3	
Repositioning ECUs.....		WP 0013 00
Disconnecting Power From ECUs	0013 00-1	
Repositioning ECUs.....	0013 00-2	
Closing ECU Fold-down Panel	0013 00-4	
Counterbalance Cable Retaining Block Installation.....	0013 00-6	
Disconnecting Electricity.....		WP 0014 00
Disconnecting Main Power Cable	0014 00-1	
Disconnecting PDB from Generator.....	0014 00-4	
Removing External Ground Rod	0014 00-5	

TM 1-4920-444-13&P

TABLE OF CONTENTS (Continued)

	<u>Page No.</u>	<u>WP Sequence No.</u>
Shelter Closing Sequence		WP 0015 00
Removing Area Light.....	0015 00-1	
Removing Cable and Receptacle Assembly.....	0015 00-2	
Removing Ceiling Lights from Hinged Roof.....	0015 00-3	
Releasing Shelter Latches	0015 00-4	
Releasing Shelter Walls	0015 00-4	
Lowering Shelter Roof.....	0015 00-6	
Raising Hinged Roof	0015 00-8	
Lowering Shelter	0015 00-10	
Securing the Shelter.....	0015 00-11	
Operation Under Unusual Conditions.....		WP 0016 00
Security Measures for Electronic Data (Not Applicable).....	0016 00-1	
Unusual Environment/Weather	0016 00-1	
Operation in Rain and/or Mud.....	0016 00-1	
Operation in Snow, Ice, or Extreme Cold.....	0016 00-1	
Operation in High Winds	0016 00-2	
Operation During Blackout Conditions.....	0016 00-5	
CHAPTER 3 TROUBLESHOOTING PROCEDURES		
NOT APPLICABLE		
CHAPTER 4 MAINTENANCE INSTRUCTIONS		
Service Upon Receipt.....		WP 0017 00
Basic Shop Equipment		WP 0018 00
First Aid Kit Bracket.....	0018 00-2	
Bayonet Neil Concelman (BNC) Cable Assembly	0018 00-3	
Grounding Rod.....	0018 00-5	
Door Hasp	0018 00-7	
54 Degree Angle Adapter	0018 00-9	
60A Receptacle.....	0018 00-13	
100A Circuit Breaker.....	0018 00-16	
Fire Extinguisher Bracket		WP 0019 00
ECU Large Closeout Panel		WP 0020 00
ECU Electrical Components		WP 0021 00
Services Utility Panel.....		WP 0022 00
Water/Oil Separator.....		WP 0023 00
Cabinet Brackets		WP 0024 00
Equipment and Brackets		WP 0025 00
Wall/Floor Inserts, Bolts, and Plugs.....		WP 0026 00
Illustrated List of Manufactured Items.....		WP 0027 00
Torque Limits		WP 0028 00
CHAPTER 5 SUPPORTING INFORMATION		
References		WP 0029 00
Maintenance Allocation Chart (MAC) Introduction		WP 0030 00
MAC.....		WP 0031 00
Repair Parts and Special Tools List (RPSTL) Introduction		WP 0032 00
RPSTL		WP 0033 00
National Stock Number (NSN) Index.....		WP 0034 00
Part Number (P/N) Index		WP 0035 00
Components of End Item (COEI) and Basic Issue Items (BII) Lists.....		WP 0036 00
Expendable and Durable Items List.....		WP 0037 00

TM 1-4920-444-13&P

LIST OF ILLUSTRATIONS

	<u>WP/Page No.</u>
Figure 1. NDI Shop	0002 00-1
Figure 2. Transport Mode Component View	0002 00-2
Figure 3. Operational Mode Component View	0002 00-3
Figure 1. Cabinet Bracket, Part No. 17A6X0007	0027 00-3
Figure 2. Processing Tank Bracket, Part No. 17AXX1002	0027 00-4
Figure 3. Film Dryer Bracket, Part No. 17AXX1003.....	0027 00-5
Figure 4. End Shelf Brackets, Part No. 17AXX1005.....	0027 00-6
Figure 5. Illuminator Shelf, Part No. 17AXX1006.....	0027 00-8
Figure 6. Bar, Part No. 17AXX1007	0027 00-10
Figure 7. First Aid Kit Bracket, Part No. 20089721	0027 00-14
Figure 1. Equipment and Brackets.....	0033 00-1
Figure 2. Basic Shop Installation.....	0033 00-5
Figure 3. ECU Large Closeout Panel.....	0033 00-8
Figure 4. ECU Electrical Installation	0033 00-12
Figure 5. Water/Oil Separator	0033 00-14
Figure 6. Services Utility Panel	0033 00-16
Figure 7. Fire Extinguisher Bracket.....	0033 00-18
Figure 8. Cabinet Brackets.....	0033 00-20
Figure 9. Wall and Floor Inserts	0033 00-22
Figure 10. Illuminator Shelf and Brackets	0033 00-24

LIST OF TABLES

	<u>WP/Page No.</u>
Table 1. Torque Limits	0028 00-1
Table 1. MAC for Non-Destructive Inspection Shop	0031 00-1
Table 2. Tool and Test Equipment for Non-Destructive Inspection Shop.....	0031 00-2
Table 3. Remarks for Non-Destructive Inspection Shop.....	0031 00-2
Table 1. Components of End Items (COEI) List.....	0036 00-5
Table 1. Expendable and Durable Items List.....	0037 00-2

HOW TO USE THIS MANUAL

Purpose and Scope

This technical manual provides Aviation Unit (AVUM) and Aviation Intermediate (AVIM) usage and maintenance information for the Non-Destructive Inspection Shop. The information includes component and assembly description, usage instructions, maintenance and supporting data including a Repair Parts and Special Tools List (RPSTL) for identifying and ordering components, assemblies, and repair parts.

Arrangement, Identification, and Location of Front Matter, Chapters and Work Packages, and Rear Matter

This manual is composed of front matter, chapters containing work packages (WP's) and rear matter.

Front Matter

The front matter includes such items as the Warning Summary, List of Effective Pages, Table of Contents and How to Use This Manual.

Chapters and Work Packages

The WP's contain information pertinent to the performance of specific tasks. Each WP is maintained as a separate entity. The WP's are grouped into Chapters based on overall content. WP's are arranged in numerical sequence regardless of chapter division. The chapter divisions and the WP's contained within the chapters are listed in the Table of Contents.

Locating a Work Package in the Table of Contents

First determine the category of the WP subject and then find the appropriate chapter in the Table of Contents. Scan the WP titles in that chapter until you find the WP subject matter. In the example below, it is desired to locate the Siting Requirements for the Non-Destructive Inspection Shop. The procedures fall into Chapter 2 Operator Instructions. Go to the Table of Contents and find the chapter titled "Operator Instructions". Scan the WP titles within that chapter until you find the WP's titled "Shelter Opening Sequence", now scan these WP's for the "Siting Requirements" statement and then follow the leader line to find the WP number.

WARNING SUMMARY

HOW TO USE THIS MANUAL

CHAPTER 1 – GENERAL INFORMATION, EQUIPMENT DESCRIPTION, AND THEORY OF OPERATION

General Information	WP 0001 00
Scope	0001 00-1
Maintenance Forms, Records, and Reports	0001 00-1
Corrosion Prevention and Control (CPC).....	0001 00-1

CHAPTER 2 – OPERATOR INSTRUCTIONS

Description and Use of Operator Controls and Indicators.....	WP 0004 00
Shelter Opening Sequence	WP 0005 00
Security Measures for Electronic Data.....	0005 00-1
Siting Requirements.....	0005 00-1
Assembly and Preparation for Use	0005 00-1
Initial Leveling	0005 00-2
Shelter Expansion.....	0005 00-3

Work Package Content and Presentation

The content and the presentation techniques used in the WP's vary according to the material content. The TM number and WP number are placed at the top of the page and are set off by a horizontal line as shown below.

TM 1-4920-444-13&P	0001 00
-------------------------------	----------------

The page number is placed at the bottom of the page and consists of the WP number and a sequential number denoting the page within the WP as shown below.

0001 00-1

Finding Instructions You Need

Primary paragraph title heads in bolded upper case letters.

Secondary level paragraphs are denoted by bolded headings set in Upper and Lower Case Type. These paragraphs always relate to and are subordinate to the most recent primary paragraph heading.

Tables are titled, numbered, and listed in the table of contents under the chapter and WP they appear and if you follow the leader line the last digit is the page number of the WP where the table is shown.

Warnings, Cautions, and Notes

WARNING

A warning denotes a condition or procedure, which when not complied with can result in injury or death to personnel and damage to equipment.

CAUTION

A caution denotes a condition or procedure, which when not complied with can result in damage to equipment.

NOTE

A note highlights a condition or statement, which aids the reader.

CHAPTER 1
GENERAL INFORMATION, EQUIPMENT DESCRIPTION, AND
THEORY OF OPERATION
FOR
NON-DESTRUCTIVE INSPECTION SHOP

NON-DESTRUCTIVE INSPECTION SHOP GENERAL INFORMATION

SCOPE

Type of Manual: Operator and Intermediate Level Equipment

Name: Non-Destructive Inspection Shop, NSN 4920-01-509-5989

Purpose of Equipment: To provide Non-Destructive Inspection fabrication support for divisional and non-divisional aviation units. This shop is utilized in conjunction with other maintenance shops in the AVIM support unit.

MAINTENANCE FORMS, RECORDS, AND REPORTS

Department of the Army forms and procedures used for equipment maintenance will be those prescribed by (as applicable) DA PAM 750-8, The Army Maintenance Management System (TAMMS) Users Manual; DA PAM 738-751, Functional Users Manual for the Army Maintenance Management Systems - Aviation (TAMMS-A); or AR 700-138, Army Logistics Readiness and Sustainability.

REPORTING EQUIPMENT IMPROVEMENT RECOMMENDATIONS (EIRs)

If your Non-Destructive Inspection Shop needs improvement, let us know. Send us an EIR. You, the user, are the only one who can tell us what you do not like about your equipment. Let us know why you do not like the design or performance. If you have Internet access, the easiest and fastest way to report problems or suggestions is to go to <https://aeps.ria.army.mil/aepspublic.cfm> (scroll down and choose the "Submit Quality Deficiency Report" bar). The Internet form lets you choose to submit an EIR, a Product Quality Deficiency Report (PDQR) or a Warranty Claim Action (WCA). You may also submit your information using an SF 368 (PQDR). You can send your SF 368 via e-mail, regular mail or facsimile using the addresses/facsimile numbers specified in DA PAM 750-8, The Army Maintenance Management System (TAMMS) Users Manual. We will send you a reply.

CORROSION PREVENTION AND CONTROL (CPC)

CPC of Army material is a continuing concern. It is important that any corrosion problems with this item be reported so that the problem can be corrected and improvements can be made to prevent the problem in future items. Corrosion specifically occurs with metals. It is an electrochemical process that causes the degradation of metals. It is commonly caused by exposure to moisture, acids, bases, or salts. An example is the rusting of iron. Corrosion damage in metals can be seen, depending on the metal, as tarnishing, pitting, fogging, surface residue, and/or cracking. Plastics, composites, and rubbers can also degrade. Degradation is caused by thermal (heat), oxidation (oxygen), salivation (solvents), or photolytic (light, typically UV) processes. The most common exposures are excessive heat or light. Damage from these processes will appear as cracking, softening, swelling, and/or breaking. SF Form 368 (PQDR) should be submitted to the address specified in DA PAM 750-8, The Army Maintenance Management System (TAMMS) Users Manual.

DESTRUCTION OF ARMY MATERIEL TO PREVENT ENEMY USE

Instructions for destruction of this equipment are contained in TM 750-244-1-4, Procedures for Destruction of Aviation Ground Support Equipment (FSC 4920), to Prevent Enemy Use.

PREPARATION FOR STORAGE OR SHIPMENT

In the event the Pneudraulic Shop is to be placed in storage, refer to TM 10-5411-201-14 and applicable shop equipment TMs or manufacturer-supplied operating manuals.

WARRANTY INFORMATION

For warranty information, please e-mail inquiries to: avim.shopsetplus@amrdec.army.mil.

LIST OF ABBREVIATIONS/ACRONYMS

BNC.....	Bayonet Neil Concelman
BII.....	Basic Issue Items
CPC.....	Corrosion Prevention and Control
COEI.....	Components of End Item
EIR.....	Equipment Improvement Recommendations
IAW.....	In Accordance With
MTOE.....	Modified Table of Organization and Equipment
PDB.....	Power Distribution Box
PM.....	Preventive Maintenance
AVIM.....	Aviation Intermediate Maintenance
AVUM.....	Aviation Unit Maintenance
DA.....	Department of the Army
ea.....	each
FM.....	Field Manual
gl.....	gallon
hd.....	hundred
kt.....	kit
lb.....	pound
MAC.....	Maintenance Allocation Chart
NDI.....	Non-Destructive Inspection
NSN.....	National Stock Number
P/N.....	Part Number
pt.....	pint
PQDR.....	Product Quality Deficiency Report
RPSTL.....	Repair Parts and Special Tools List
rl.....	Roll
SDR.....	Supply Discrepancy Report
TB.....	Technical Bulletin
TM.....	Technical Manual
TMDE.....	Test, Measurement, and Diagnostic Equipment
UOC.....	Usable on Code
U/I.....	Unit of Issue
WCA.....	Warranty Claim Action
yd.....	yard

**NON-DESTRUCTIVE INSPECTION SHOP
QUALITY OF MATERIAL**

Material used for replacement, repair, or modification must meet the requirements of this TM 1-4920-444-13&P, Non-Destructive Inspection Shop. If qualities of material requirements are not stated in this TM 1-4920-444-13&P, Non-Destructive Inspection Shop, the material must meet the requirements of the drawings, standards, specifications, or approved engineering change proposals applicable to the subject equipment.

**NON-DESTRUCTIVE INSPECTION SHOP
SAFETY, CARE, AND HANDLING**

The following precautions should be exercised:

1. Use extreme caution when performing procedures that involve the electrical system of this equipment. High voltage exists and death on contact may result if personnel fail to observe safety precautions.
2. Before performing continuity checks or replacing electrical components, ensure electrical power is disconnected completely from the circuit involved.
3. In the event of a fluorescent lamp breakage, care must be taken in the removal of broken glass fragments and white phosphorous dust. Inhalation of phosphorous dust could cause serious injury.
4. Do not use handling equipment with capacity of less than gross weight of shelter system. Do not allow the shelter to swing back and forth when it is suspended. Failure to observe this warning may result in damage to equipment or severe injury or death to personnel.
5. Lock stop plate on load balancer with quick release pin before disconnecting support cable from hinged floor.
6. Expandable section (hinged floor and hinged sidewall together) weighs 700 pounds (318 kg). Do not stand directly in front of hinged section.
7. Prior to removing load balancer from fixed roof, the hinged floor must be near stowed position to remove tension from support cable. The support cable bracket on hinged floor must then be removed to permit disconnecting support cable from hinged floor. Secure hinged floor to prevent accidental release.
8. Do not attempt to disassemble or repair load balancer. This equipment contains powerful torsion springs and serious injury or death to personnel could result if disassembled.
9. In extreme cold, do not touch metal parts with bare hands because severe skin damage may result.
10. Safety glasses shall be worn by personnel when installing ground anchors.

**NON-DESTRUCTIVE INSPECTION SHOP
SUPPORTING INFORMATION FOR REPAIR PARTS, SPECIAL TOOLS,
TMDE, AND SUPPORT EQUIPMENT**

COMMON TOOLS AND EQUIPMENT

For authorized common tools and equipment, refer to the Modified Table of Organization and Equipment (MTOE) applicable to the AVIM unit.

CONSUMABLE MATERIAL

For information relating to consumable materials, refer to the Expendable and Durable Items List (WP 0037 00).

REPAIR PARTS

For information relating to repair parts, hardware, and bulk stock, refer to Repair Parts and Special Tools List Introduction (WP 0032 00) and Repair Parts and Special Tools List (WP 0033 00).

TORQUE VALUES

All equipment or tools secured to the floor or walls of the shelter must be carefully tightened to specific torque limits. These torque limits are contained in WP 0028 00 of this manual.

End of Work Package

**NON-DESTRUCTIVE INSPECTION SHOP
EQUIPMENT DESCRIPTION AND DATA**

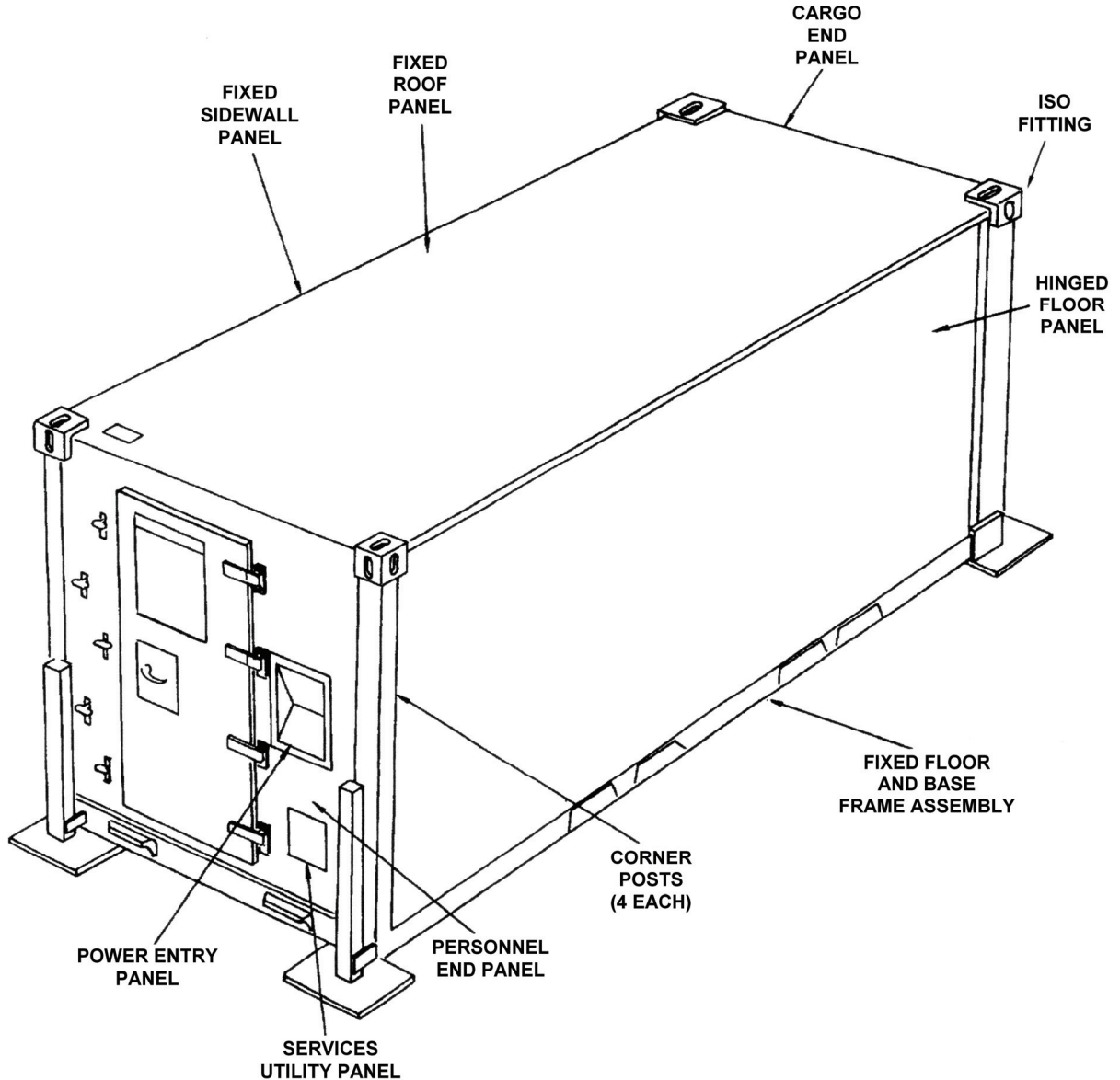
EQUIPMENT CHARACTERISTICS, CAPABILITIES, AND FEATURES**Figure 1. NDI Shop.**

- Shop is housed in a tactical, one-sided expandable, 100 amp shelter
- Additional floor space provides a work area necessary for the shop to perform its maintenance function
- Shop is equipped with tools, machines, and equipment necessary to provide non-destructive inspection for the AVIM unit
- Shelter can be transported by highway, rail, marine, or air (C-130, C-141, or C-5 aircraft, Army CH-47 helicopter)
- Shop can be operated in any geographic area and under any climatic condition in support of Army divisional and non-divisional units

LOCATION AND DESCRIPTION OF MAJOR COMPONENTS FOR TRANSPORT MODE

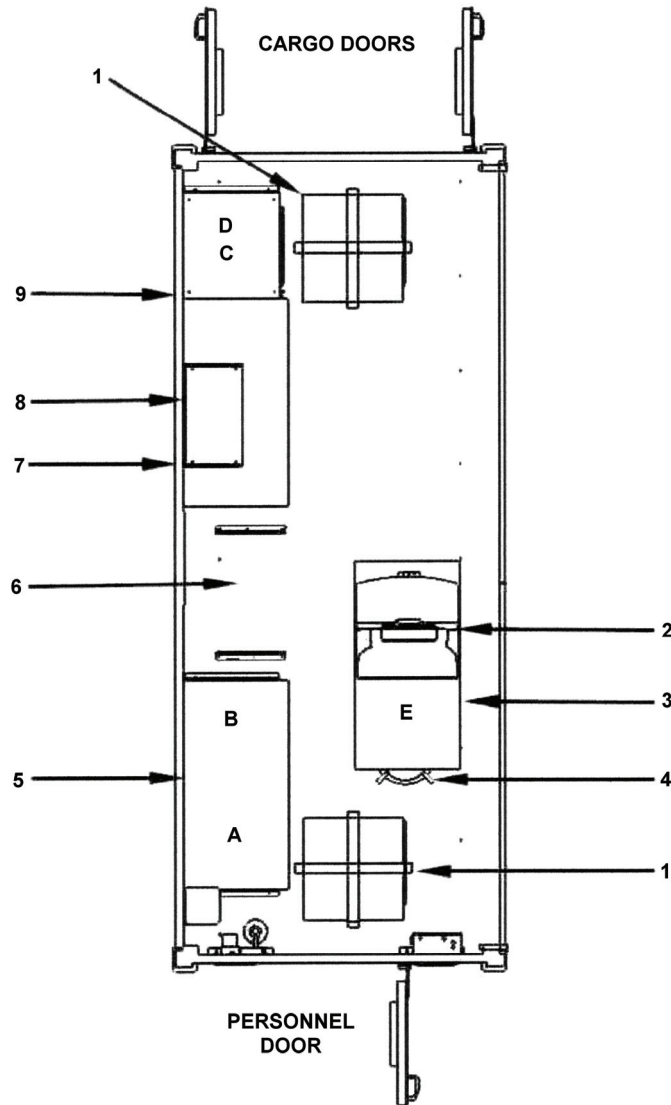

Figure 2. Transport Mode Component View.

- | <u>Item No. and Name</u> | <u>Item No. and Name</u> |
|-----------------------------------|------------------------------|
| 1. ECUs (furnished by unit) | 6. Processing Tank |
| 2. Eyewash Station | 7. Film Dryer |
| 3. Cabinet, Shelf (E) | 8. Illuminator Shelf |
| 4. Stools | 9. Cabinet, Shelf – Top (D); |
| 5. 2 Cabinets with Drawers (A, B) | 2 Cabinets with Drawers – |
| | Bottom (C, D) |

LOCATION AND DESCRIPTION OF MAJOR COMPONENTS FOR OPERATIONAL MODE

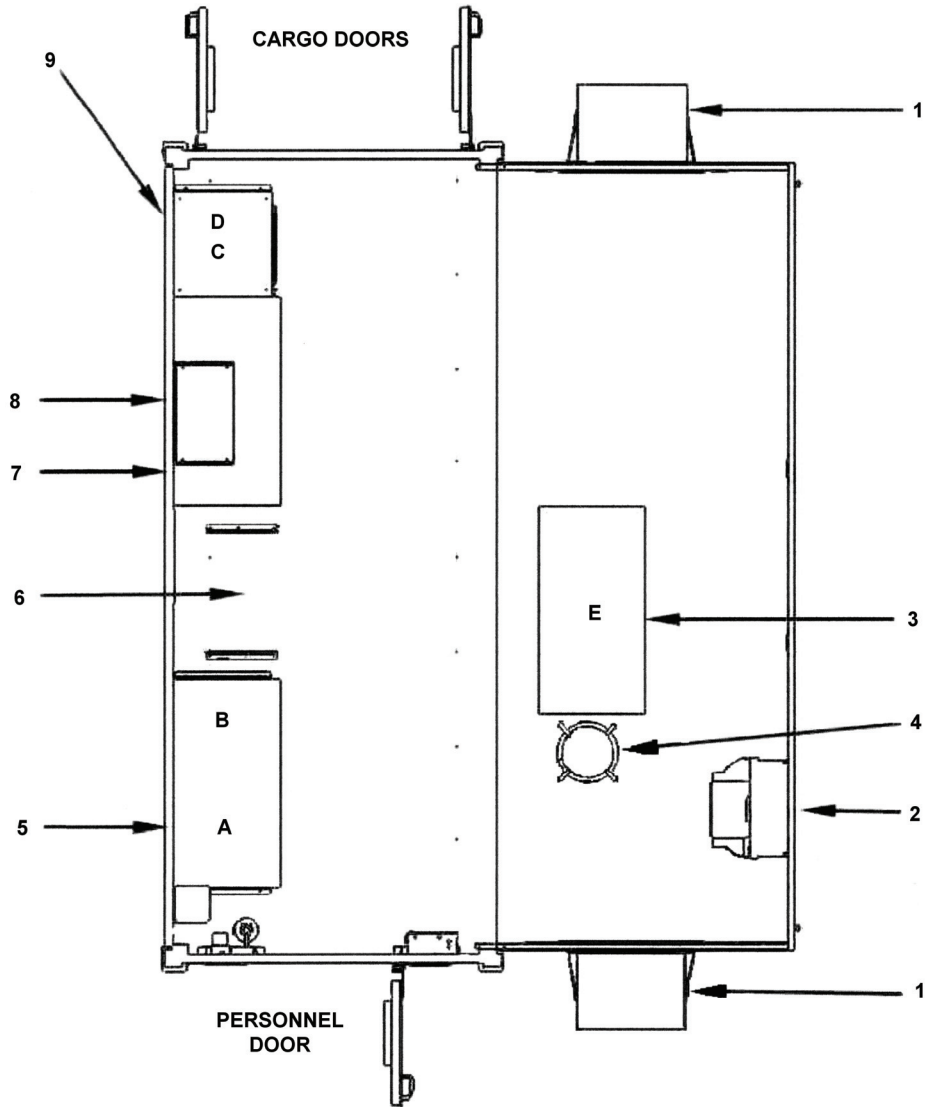

Figure 3. Operational Mode Component View.

- | <u>Item No. and Name</u> | <u>Item No. and Name</u> |
|-----------------------------------|------------------------------|
| 1. ECUs (furnished by unit) | 6. Processing Tank |
| 2. Eyewash Station | 7. Film Dryer |
| 3. Cabinet, Shelf (E) | 8. Illuminator Shelf |
| 4. Stools | 9. Cabinet, Shelf – Top (D); |
| 5. 2 Cabinets with Drawers (A, B) | 2 Cabinets with Drawers – |
| | Bottom (C, D) |

EQUIPMENT DATA

- Shelter weight: 7560 lbs.
- Shelter cubic feet: 1274
- Shelter dimensions: 239 x 96 x 96

End of Work Package

NON-DESTRUCTIVE INSPECTION SHOP THEORY OF OPERATION

After the shelter has been erected, the operator personnel will unbolt selected items of equipment. (See WP 0002 00, Figure 2). These items will be relocated to pre-selected positions on the expanded side of the shelter. (See WP 0002 00, Figure 3). The selected items, when moved, will not be secured (bolted) in place. This allows the shop personnel a certain flexibility in the event long or bulky materiel must be repaired within the shelter. The recommended locations were selected for proper utilization of floor space and maximum safety for the operating personnel.

WARNING

Four people are needed when moving or lifting the ECUs. Each unit weighs approximately 270 pounds. Trying to move or lift an ECU without sufficient help can cause **SERIOUS INJURY** to personnel.

Detailed instructions for unbolting equipment and the recommended sequence for relocating equipment are contained in WP 0008 00. The procedures for striking the shelter and preparing the Non-Destructive Inspection Shop for transport or storage are contained in WP 0011 00 through WP 0015 00.

Permanently installed equipment or components should not be removed. If hardware is damaged and it is necessary to remove, reinstall, or replace fixed equipment or shop components within shelter, care must be taken to remove all bolts, nuts, and other fasteners. All cabinets and racks are bolted to floor and unless isolated, are normally bolted to adjacent cabinets and/or to wall and ceiling.

The ECUs are supplied by the unit. Procedures for positioning the ECUs for operation are in WP 0007 00. The two ECUs are positioned on special fold-down panels when the shop is in the operational mode. Power is provided by a 208V, 3 phase cable located inside the shelter next to each panel. Both ECUs can be easily removed for service or repair. Procedures for repositioning the ECUs for transport or storage are in WP 0013 00.

Electrical power to operate the Non-Destructive Inspection Shop is provided by an auxiliary generator or a commercial power source. A Power Distribution Box (PDB) is used between the power source and the power entry panel of the shelter. The generator, PDB, and the pigtail used to connect the PDB to the generator are supplied by the unit. Overload protection is provided by circuit breakers. The circuit breaker panel is located inside the shelter next to the personnel entrance door. Procedures for connecting electrical power to the shop are in WP 0006 00. Procedures for disconnecting electrical power from the shop are in WP 0014 00.

End of Work Package

CHAPTER 2

OPERATOR INSTRUCTIONS
FOR
NON-DESTRUCTIVE INSPECTION SHOP

**NON-DESTRUCTIVE INSPECTION SHOP
DESCRIPTION AND USE OF OPERATOR CONTROLS AND INDICATORS**

Operator's manuals are provided with all equipment that is located in the Non-Destructive Inspection Shop. For operator instructions or equipment information consult the manual that coincides with the equipment.

End of Work Package

**NON-DESTRUCTIVE INSPECTION SHOP
SHELTER OPENING SEQUENCE**

SECURITY MEASURES FOR ELECTRONIC DATA

Not Applicable

SITING REQUIREMENTS

The Non-Destructive Inspection Shop should be set up with power cable length, tactical deployment, exhaust/inlet of ECUs, and phasing between related shops kept in mind. The shop's power entry panel, next to personnel entrance door, should be facing toward the power source and PDB (see WP 0002 00, Figure 1).

ASSEMBLY AND PREPARATION FOR USE**NOTES**

- Four personnel are required to perform all of the following procedures.
- Each shelter is equipped with six container jacks. Four are ISO jack assemblies and two are hinged jack assemblies. Four ISO jack assemblies are used to lift and level shelter. Two hinged jack assemblies are used on the expanded side to level floor after expansion.
- If ground is soft, place wood planks or boards on ground under each shelter corner before detaching lifting equipment.

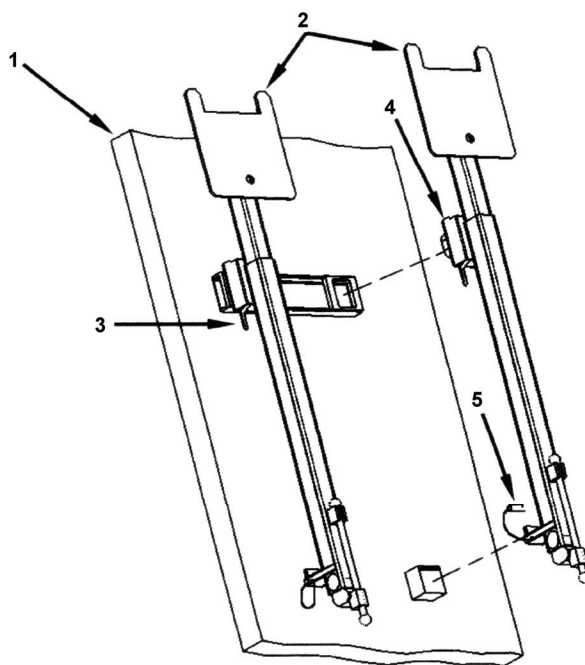

1. Remove four ISO jacks (2) from inside of personnel and right cargo doors (1) by turning locking handle (3) to loosen jack attachment insert (4) and removing safety pin (5).
2. Position ISO jacks at each corner of shelter.

NOTE

Stencil on ISO jack indicates handle rotation to raise or lower jack.

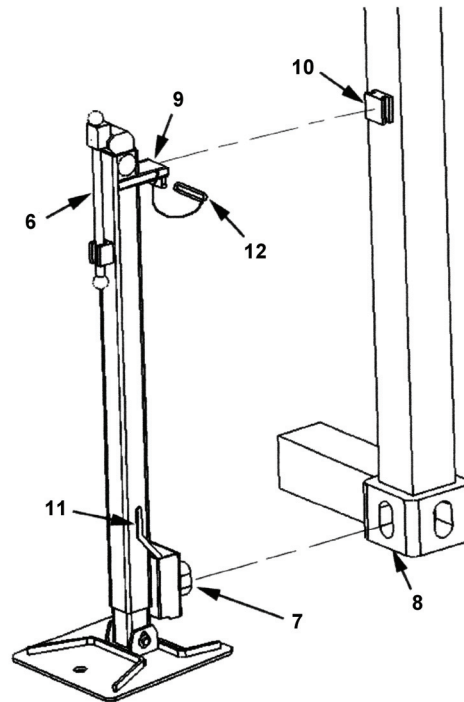

3. Ensure ISO jack is lowered completely.
4. Place upper jack attachment insert (9) on upper jack support bracket (10) on corner post.
5. Insert ISO jack attachment (7) into lower ISO fitting (8) of shelter.
6. Turn locking handle (11) to rotate ISO jack attachment on jack to lock.
7. Rotate handle (6) on ISO jack to raise until safety pin (12) can be installed.
8. Install safety pin (12).
9. Repeat steps 3 through 8 at three remaining corner posts.

NOTE

Shelter shall be raised a minimum of 3 inches (7.6 cm) off ground.

10. Raise all ISO jacks simultaneously, at each corner of shelter, to prevent excessive strain on ISO jacks or shelter.

INITIAL LEVELING**NOTE**

Four personnel are required to perform all of the following procedures.

1. Remove level from Shelter Basic Issue Items (BII) Box.
2. Level both cargo and personnel end from side to side, and middle of shelter from end to end by adjusting ISO jacks accordingly.

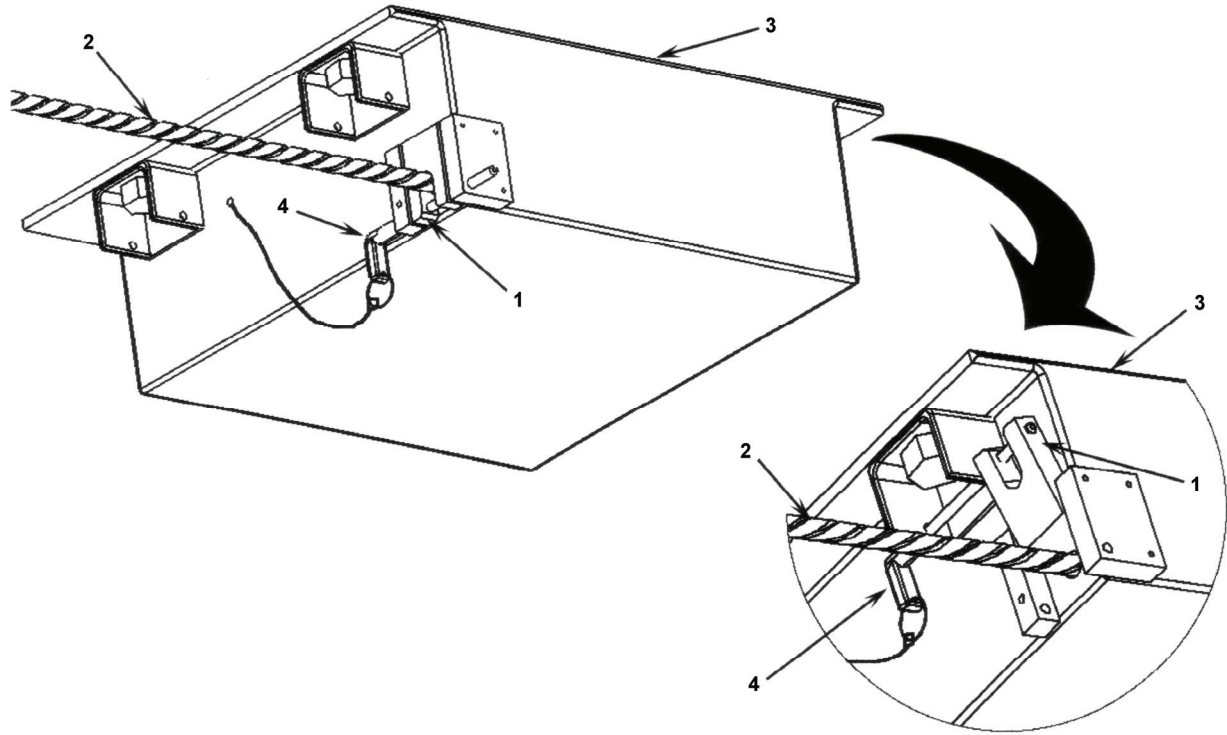
SHELTER EXPANSION

1. Remove lockout pins (4) from lower position on both cable reels (3).
2. Open slide stops (1) against counterbalance cables (2) on both cable reels (3).
3. Replace lockout pins (4) in upper position on both cable reels (3).

WARNINGS

- Stop plate cable assembly is a spring powered mechanism. Personal **INJURY OR DEATH** may result if two quick release pins are not installed in stop plates.
- Fold-out floor counterbalance cables must be secured in cable housings prior to raising shelter floor from its lowered position to its level position. If counterbalance cables are not secured, counterbalance cables will remain under tension. **DO NOT** attempt to remove cables if counterbalance cables are not secured. Removing cables while under tension could cause **SERIOUS INJURY** to personnel.

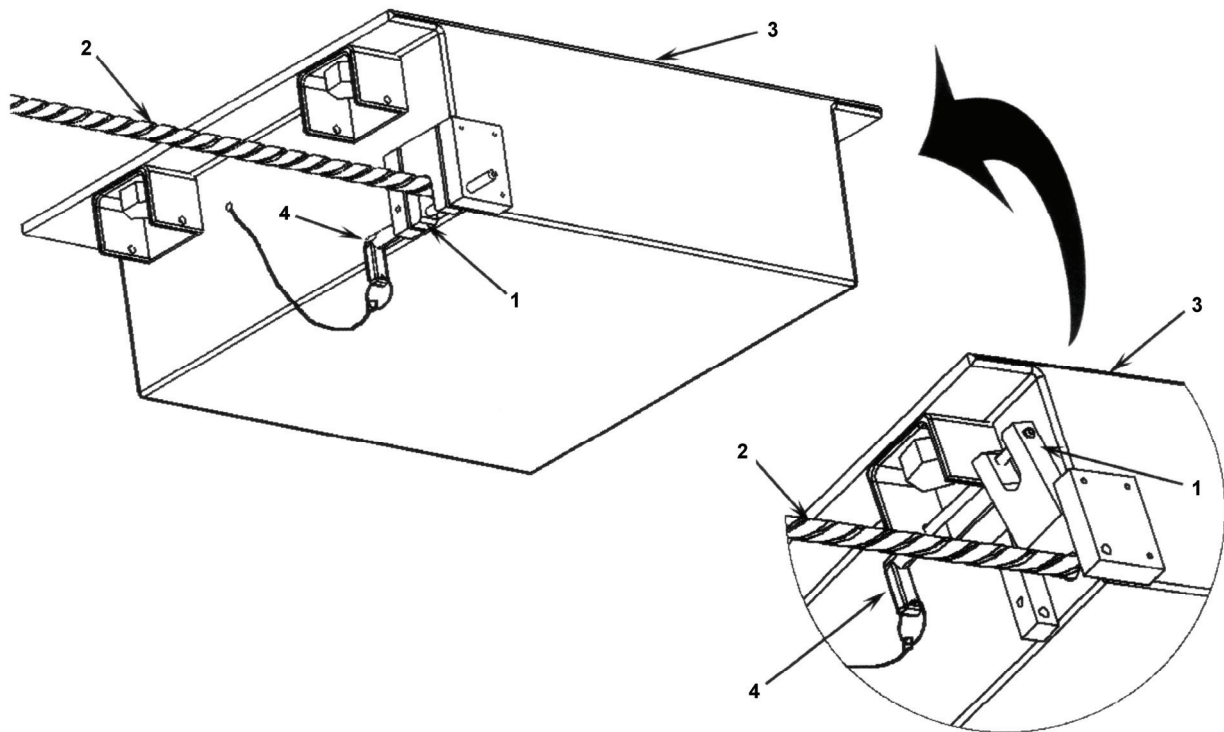

6. Remove lockout pins (4) from upper position on both cable reels (3).
7. Close slide stops (1) against counterbalance cables (2) on both cable reels (3).
8. Replace lockout pins (4) in lower position on both cable reels (3).

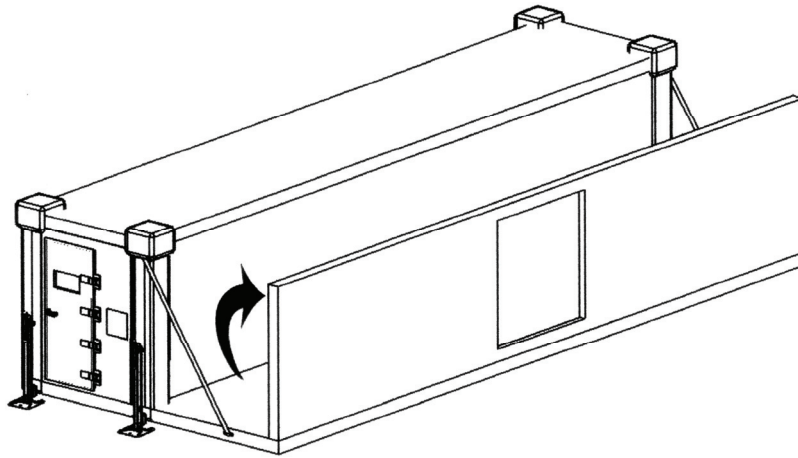
POSITIONING HINGED SIDEWALL

1. Remove two sidewall support braces from Shelter BII Box.
2. Raise hinged sidewall and hold in position.

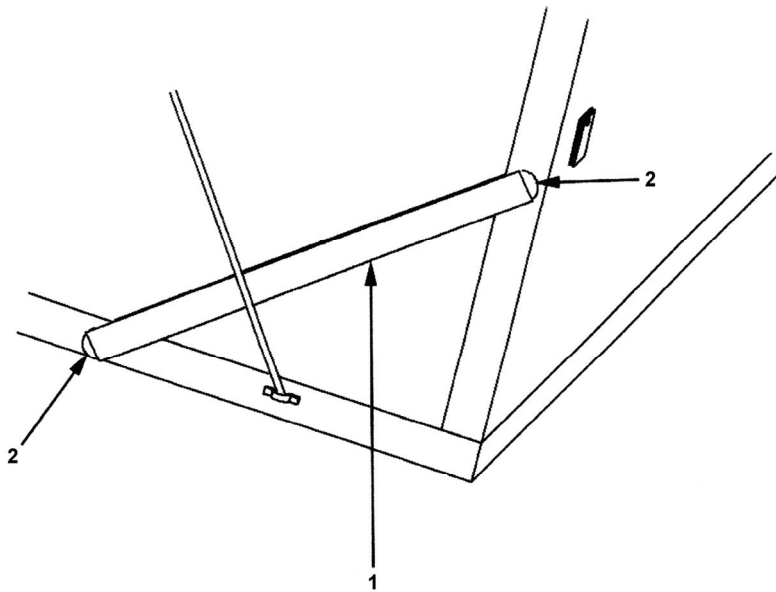

3. Install two sidewall support braces (1) in brace cups marked "A" (2) on hinged floor and sidewall behind support cable.

POSITIONING HINGED JACKS FOR LEVELING

1. Remove two hinged jacks from inside of left cargo door.
2. Position hinged jacks at each corner of expanded side.

NOTES

- If step 3 cannot be successfully completed, perform Step 4 and then return to step 3. When step 3 is successfully completed, go to Step 5.
- Stencil on hinged jack indicates handle rotation to raise or lower jack.

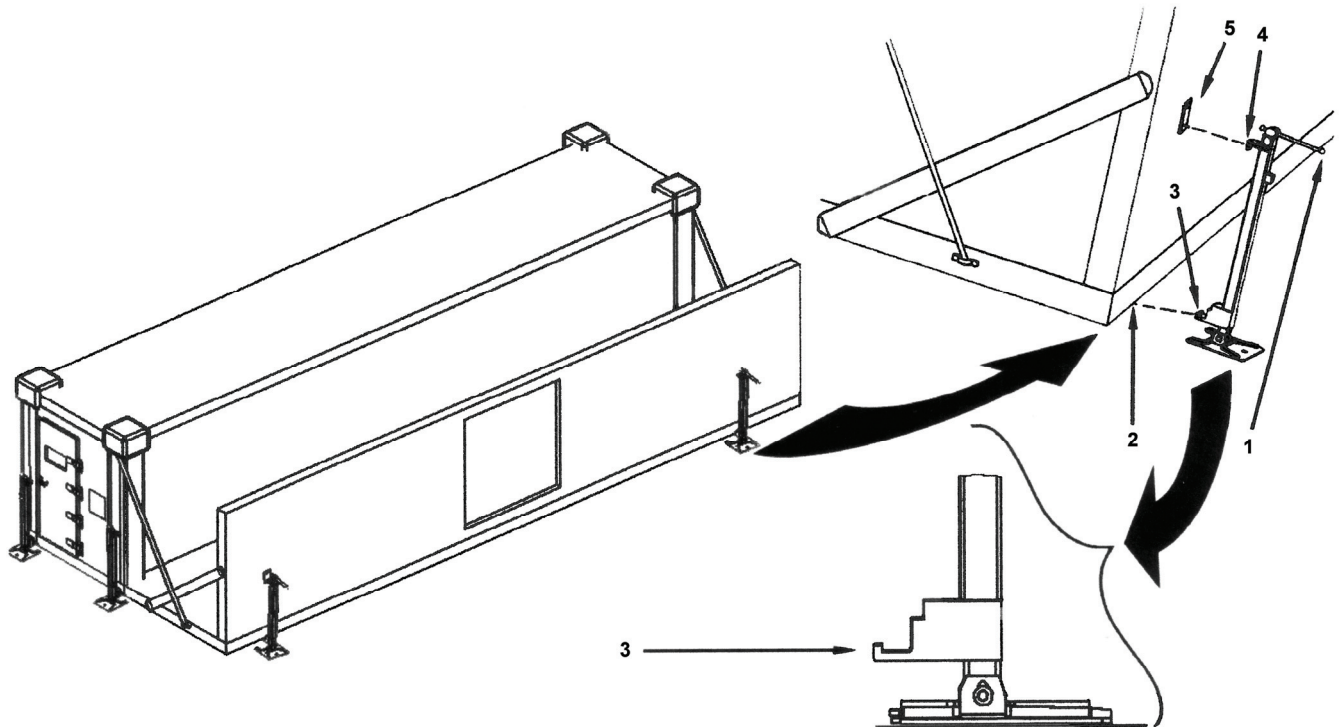

3. Rotate handle (1) to raise hinged jack until jack lift pin (3) engages hinged floor socket (2) and jack hook (4) engages jack support bracket (5) on hinged sidewall.

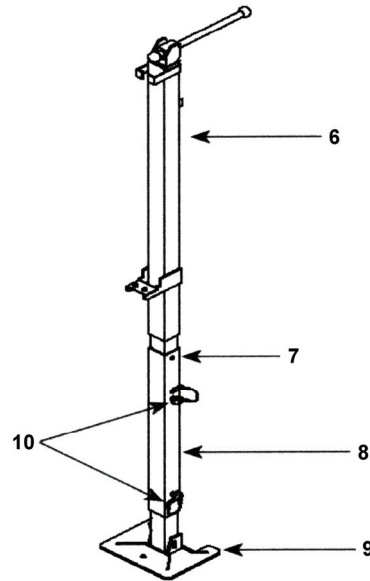

4. Install jack extensions (if necessary).
 - a. Remove two jack extensions (8) from Shelter BII Box and install between jack base (9) and upper section of hinged jack assembly (6).
 - b. Position jack extension (8) in jack base (9) and secure by installing pin (7).
 - c. Position hinged jack assembly (6) on jack extension (8) and secure by installing two quick-disconnect pins (10) through tubes of jack extension and hinged jack assembly.

CAUTION

Do not attempt to level or raise floor at this time.

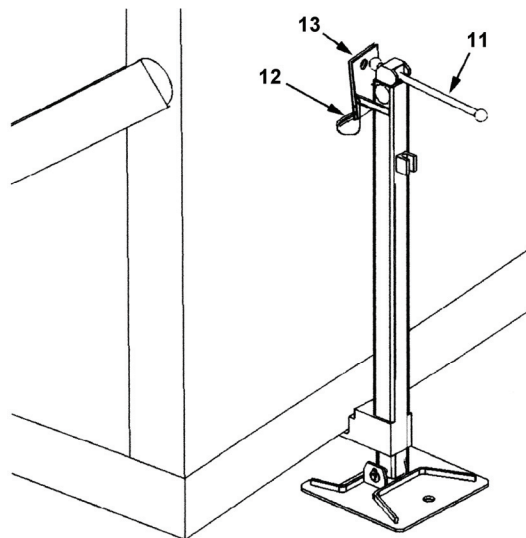

5. Rotate handle (11) to raise hinged jack until safety pin (12) can be installed in jack support bracket (13).

POSITIONING ROOF AND HINGED END WALLS**NOTE**

Solar bars are located at each end of shelter, on inside of fixed roof.

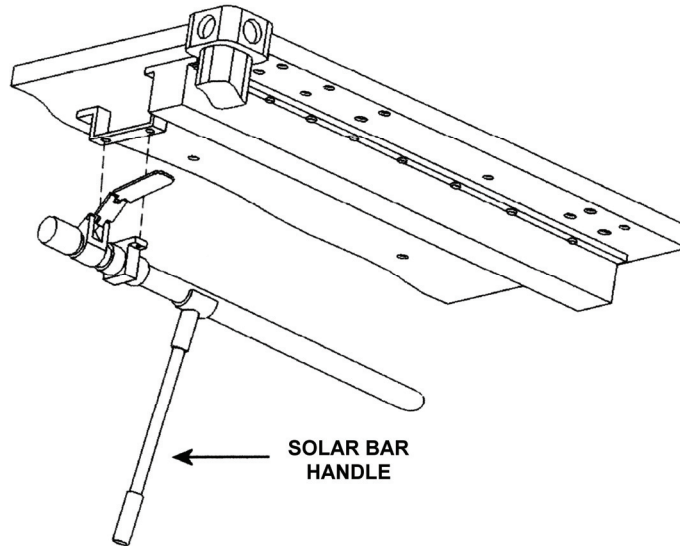

1. Rotate two solar bar handles simultaneously to their full extent. This will slide hinged roof outward.

WARNING

When all equipment and materiel is stored on stationary side of shelter, limited floor space presents a safety hazard to operating personnel. This is most critical during raising and lowering of roof panel. Failure to observe supplemental instructions could result in **SERIOUS INJURY** to personnel. Personnel inside shelter could become trapped between roof panel and equipment bolted to floor.

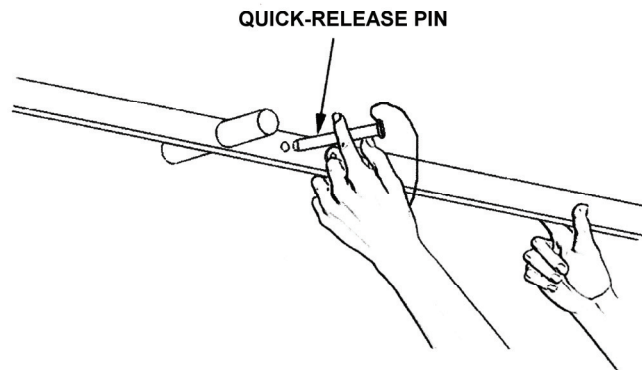
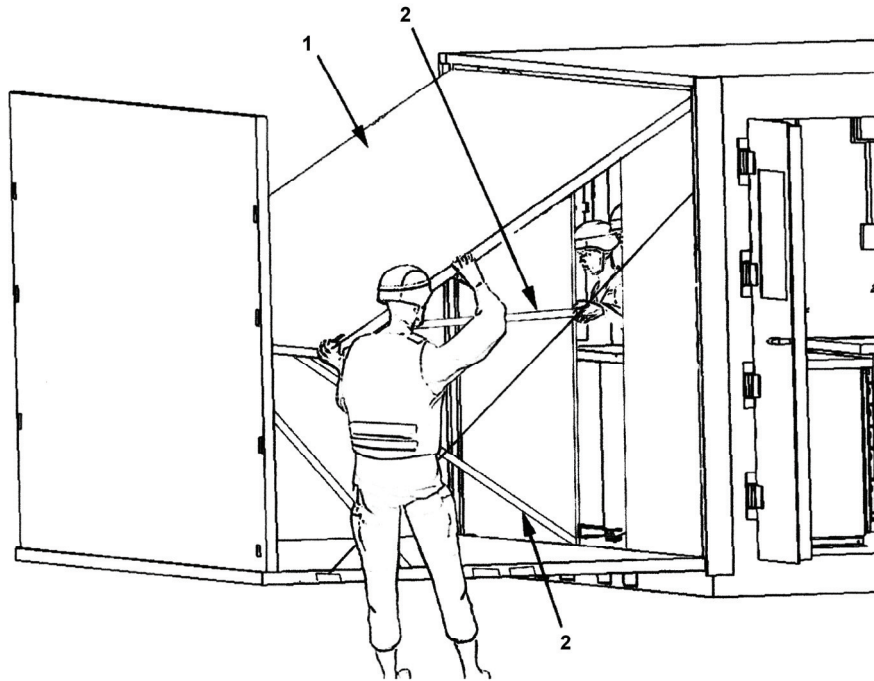

2. Two personnel outside shelter must lift roof panel (1) far enough to allow two people inside to release two support struts (2), extend them to full length, and insert quick-release pin.

CAUTION

Do not force hinged roof to full height. This could cause damage to roof and sidewall seal. Ensure that hinged roof will clear hinged sidewall prior to lifting.

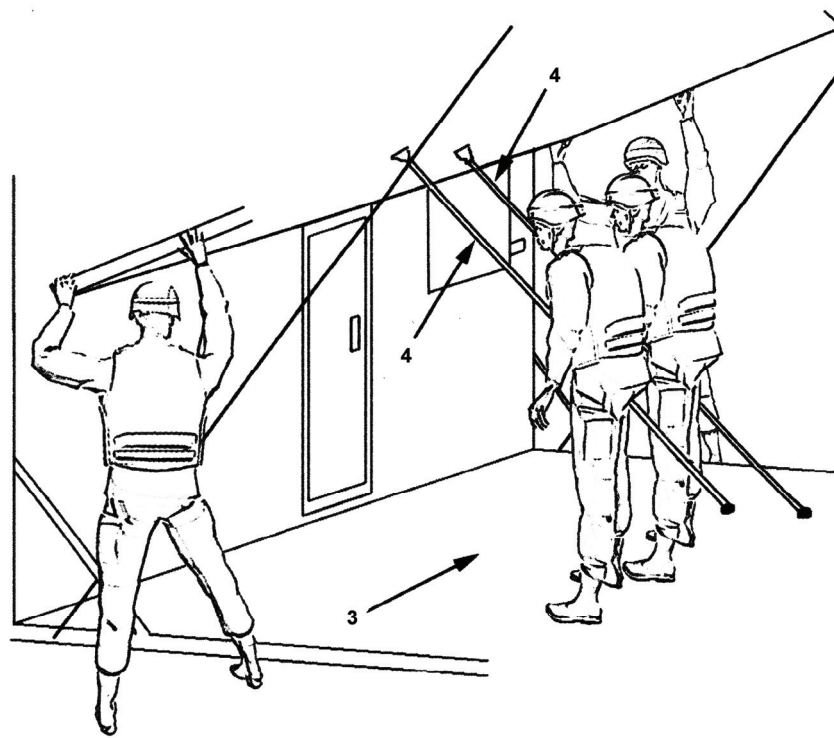

3. As soon as there is enough floor area (3), personnel inside, along with personnel outside, will move to expanded side of shelter, raising roof with two extended support struts (4).

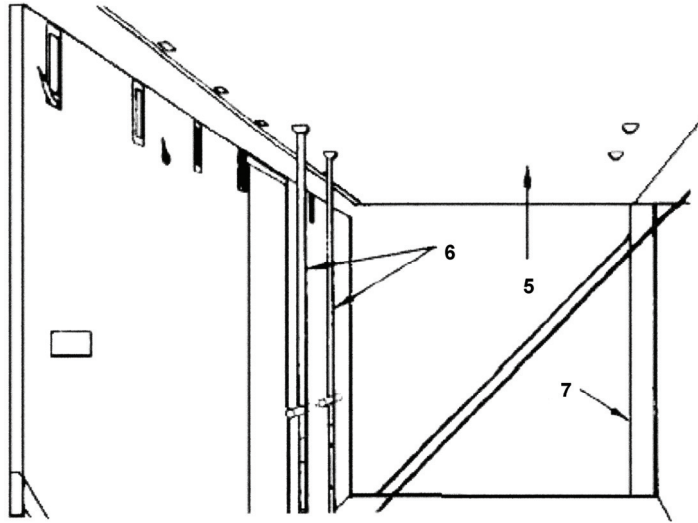

4. After two struts (6) are totally supporting roof panel (5), end walls (7) are swung open and ECU support cables are placed outside of shelter.

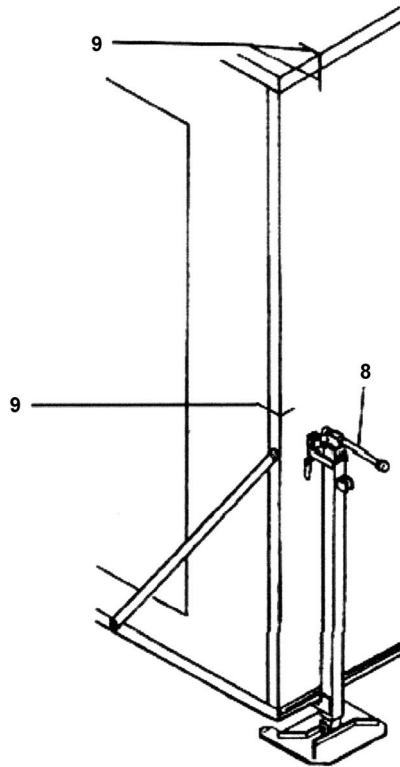

5. Rotate hinged jack handles (8) simultaneously to raise both hinged jacks until positioning marks (9) on hinged end walls and hinged sidewall are in alignment.
6. Use support struts to lower hinged roof to rest on hinged end walls and sidewall.
7. Remove lock pins from support struts.
8. Retract support struts and secure in support brackets on hinged roof with lock pins.
9. Adjust hinged jacks to make sure positioning marks on hinged roof and hinged sidewall are properly aligned.

SECURING SHELTER

1. Obtain four removable latches from Shelter BII Box.
2. Install two latches on hinged sidewall and one latch on each hinged end wall. Do not engage at this point.
3. Compress seals by first engaging all non-removable latches between hinged sidewall, end wall, roof, and floor.
4. Engage four removable latches.
5. Visually check to make sure all seals are properly compressed.
6. Remove sidewall support braces and store in Shelter BII Box.

INSTALLING CEILING LIGHTS**WARNING**

In an event of lamp breakage, care must be taken in removal of broken glass fragments and white phosphorous dust that may be dispersed within fixture. Inhalation of phosphorous dust could cause **SERIOUS INJURY** to personnel.

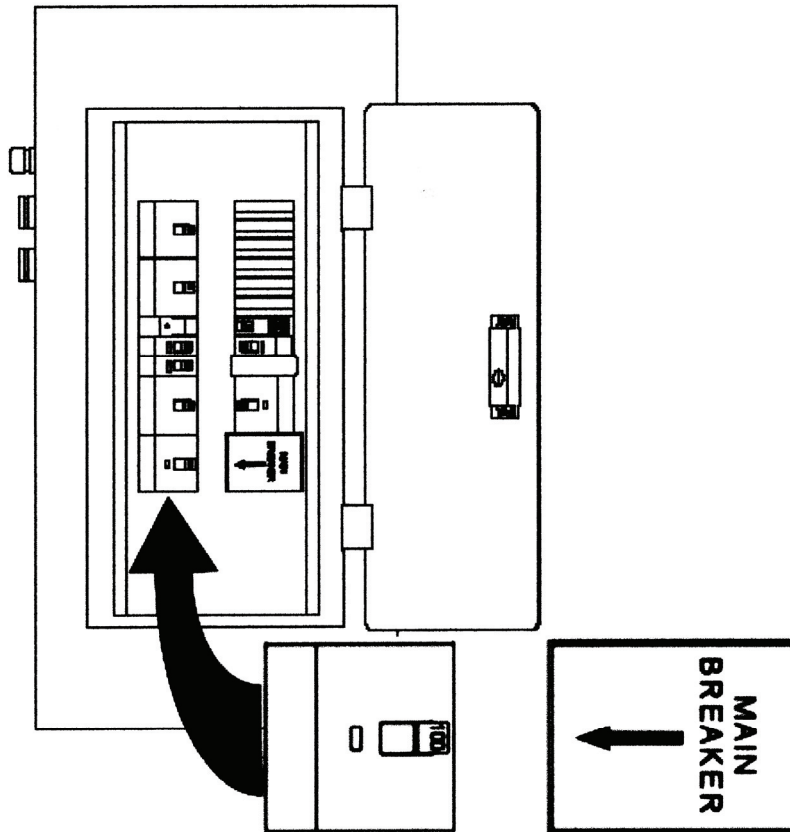

1. Set main circuit breaker and all other circuit breakers in breaker panel to the **OFF** position.

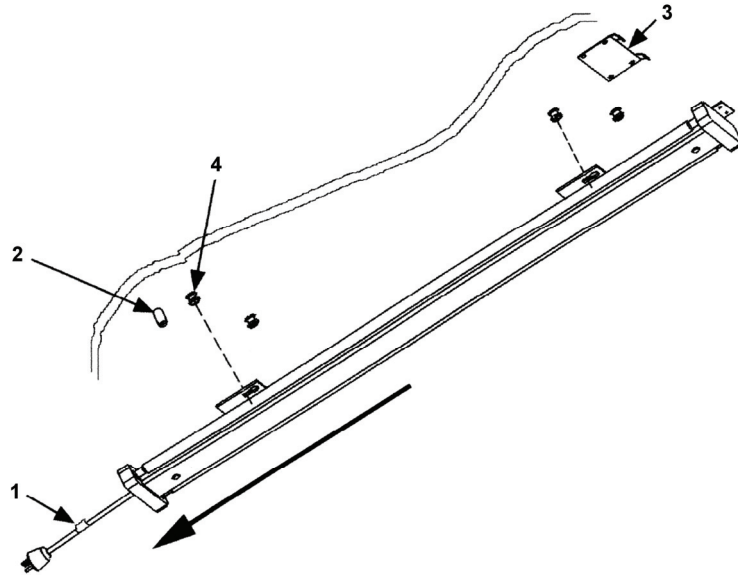

2. Remove power cable from storage clip (1) on ceiling.
3. Press and hold plunger lock (2) in fixed roof light storage bracket (3).
4. Move entire light fixture lengthwise toward power cable end to disengage light from four captive studs (4) in fixed roof.
5. Move light fixture into expandable section and rotate 180 degrees. Mate with four captive studs (4) in hinged roof.

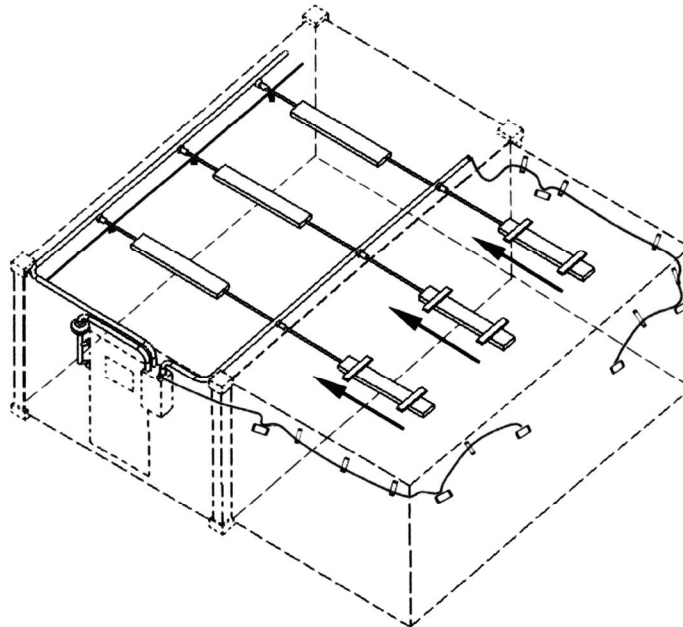

6. Secure fixture by moving until spring loaded plunger engages.
7. Plug power cable into connector, and twist one-quarter turn clockwise to lock in.
8. Repeat these procedures for two remaining ceiling lights.

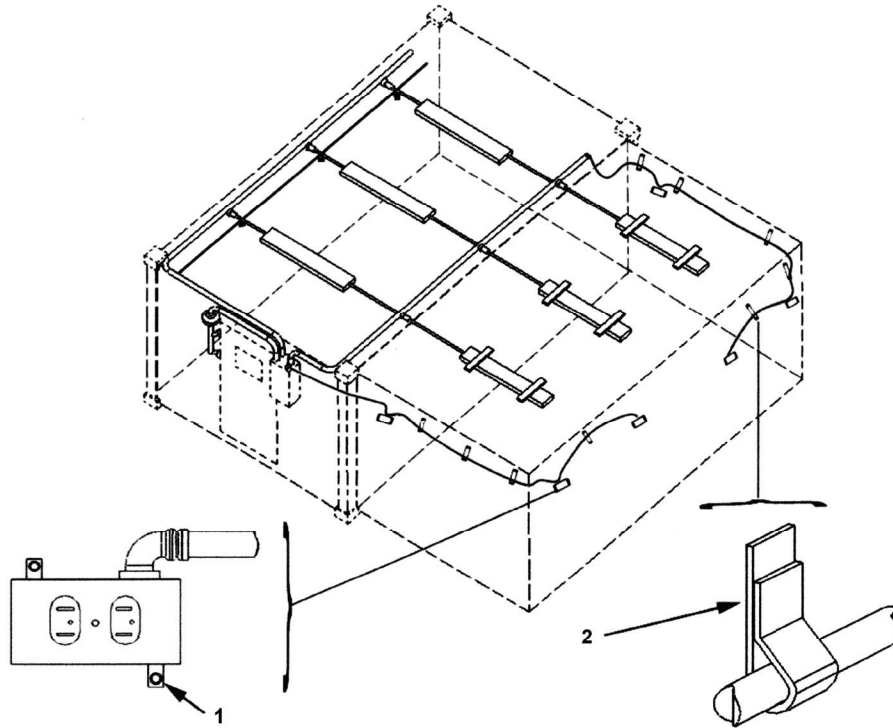
INSTALLING CABLE AND RECEPTACLE ASSEMBLY

1. Release captive fasteners (1) from receptacles on one end of shelter.
2. Reposition receptacles from stored position on hinged end wall to operating position on hinged sidewall.
3. Position receptacles with power cables facing up and secure captive fasteners (1).
4. Secure power cable with Velcro straps (2).
5. Repeat these procedures for receptacles at other end of shelter.

INSTALLING AREA LIGHT

NOTES

- Do not remove wing nuts from screws.
- When area light is installed at cargo end of shelter, cable is routed over top of shelter. Excess cable slack should be neatly coiled on area light post so that it does not present a hazard to personnel.

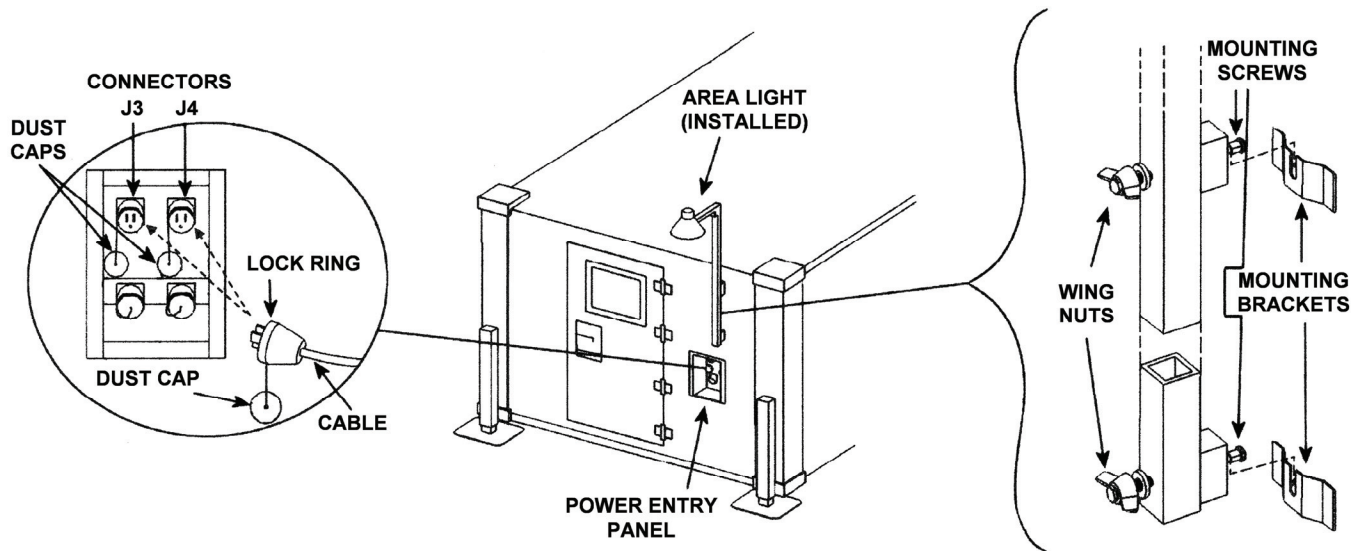

1. Remove area light from inside fixed personnel end wall by loosening two wing nuts and sliding mounting screws out of mounting brackets.
2. Remove bulb from Shelter BII Box and twist into light socket.
3. Unroll area light cable.
4. Install area light on outside of fixed personnel or cargo end wall by sliding mounting screws into mounting brackets.
5. Secure area light to mounting brackets by tightening two wing nuts.
6. Remove protective dust cap from either "J3" or "J4" connector on power entry panel.
7. Remove protective dust cap from area light cable.
8. Connect area light cable into "J3" or "J4" connector on power entry panel and secure with lock ring.

End of Work Package

**NON-DESTRUCTIVE INSPECTION SHOP
CONNECTING ELECTRICITY**

WARNING

HIGH VOLTAGE exists in electrical system of shop. All electrical inspections, repairs, or replacements will be performed with power **OFF** and only by a qualified electrician. Serious shock hazards exist which could result in **INJURY OR EVEN DEATH** to personnel.

CONNECTING PDB TO GENERATOR (IF NECESSARY)

WARNING

This procedure is required only if power is not available. Only a qualified electrician should attempt to connect PDB to generator.

NOTE

PDB and Pigtail are supplied by unit. Refer to TM 9-6150-226-13 and/or TM 9-6150-226-23P for additional information.

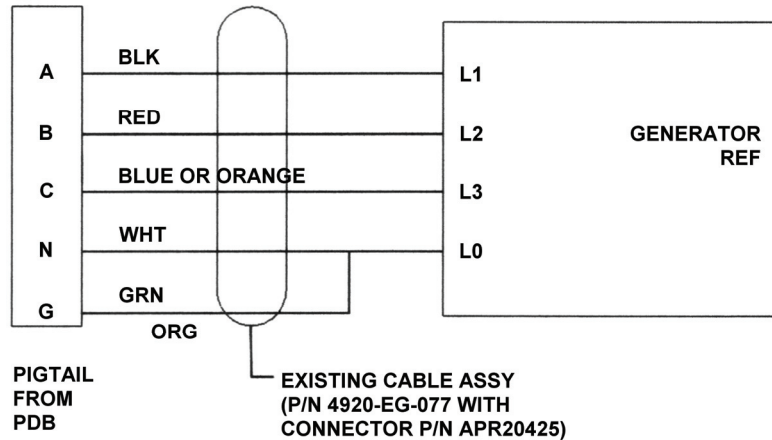

1. Ensure all circuit breakers on PDB are in the **OFF** position.
2. Ensure pigtail is connected to PDB.
3. Connect pigtail wires to generator lugs by connecting black wire to lug L1, red wire to lug L2, blue or orange wire to lug L3, and white and green wires to lug L0 on generator.

EXTERNAL GROUNDING OF SHELTER

NOTE

Shelter is grounded through an externally connected power supply. Consult a qualified electrician for proper grounding procedures required for surrounding soil conditions.

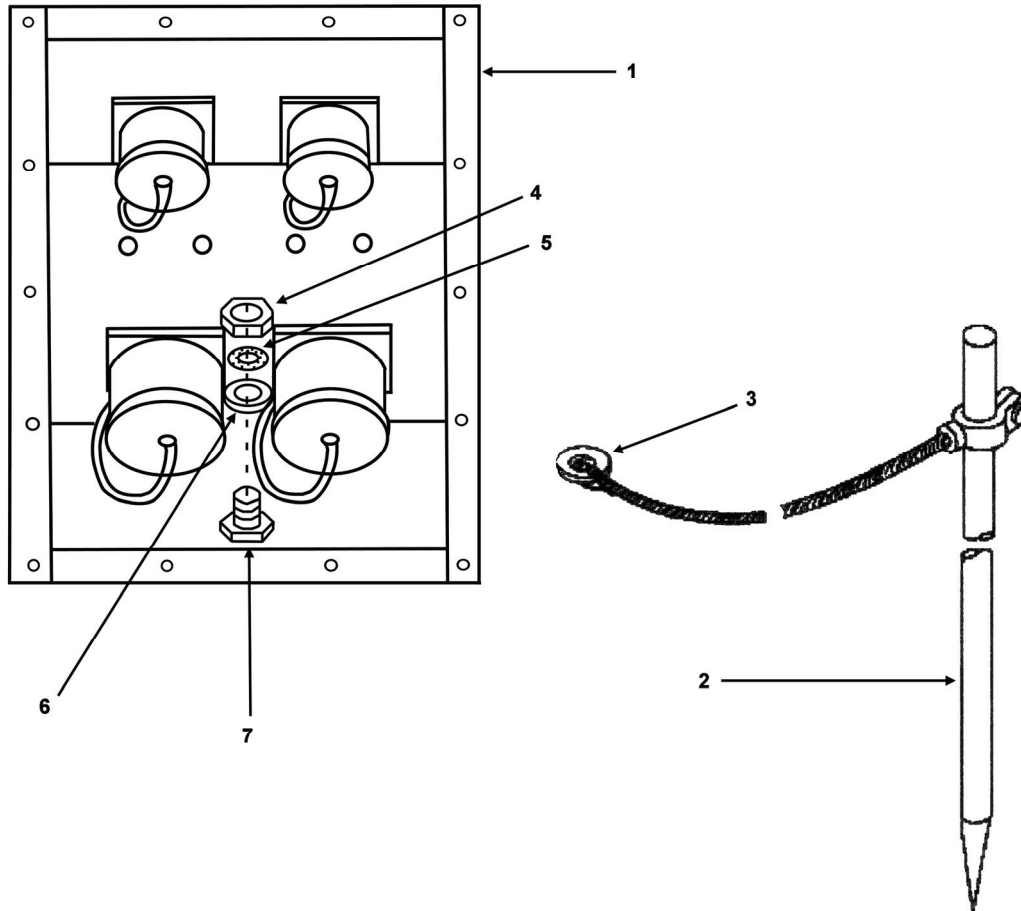

1. Remove ground rod assembly from appropriate storage location.
2. Drive ground rod (2) into earth at a suitable location that permits ground cable lug (3) to reach ground stud (7) on power entry panel (1).
3. Remove nut (4), lock washer (5), and flat washer (6) from ground stud (7) on power entry panel (1).
4. Connect ground cable lug (3) to ground stud (7) and secure with flat washer (6), lock washer (5), and nut (4).
5. Ensure all connections are tight.

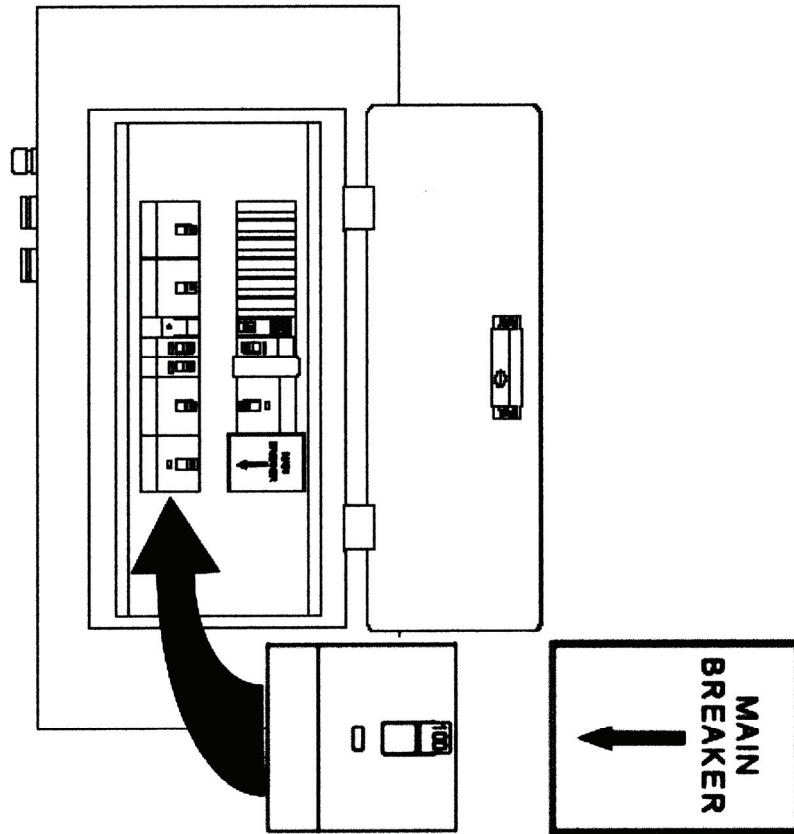
CONNECTING MAIN POWER CABLE

1. Before connecting main 100 amp power cable, ensure that all circuit breakers (including main circuit breaker) in circuit breaker panel are in the **OFF** position.
2. Ensure the circuit breaker from PDB is in the **OFF** position.
3. Remove rolled up power cable from appropriate storage location.

CAUTION

Ensure that power cable is not twisted, kinked, or placed over sharp rocks or projections. Where possible, cable should not be routed through any deep ground depressions where water may accumulate.

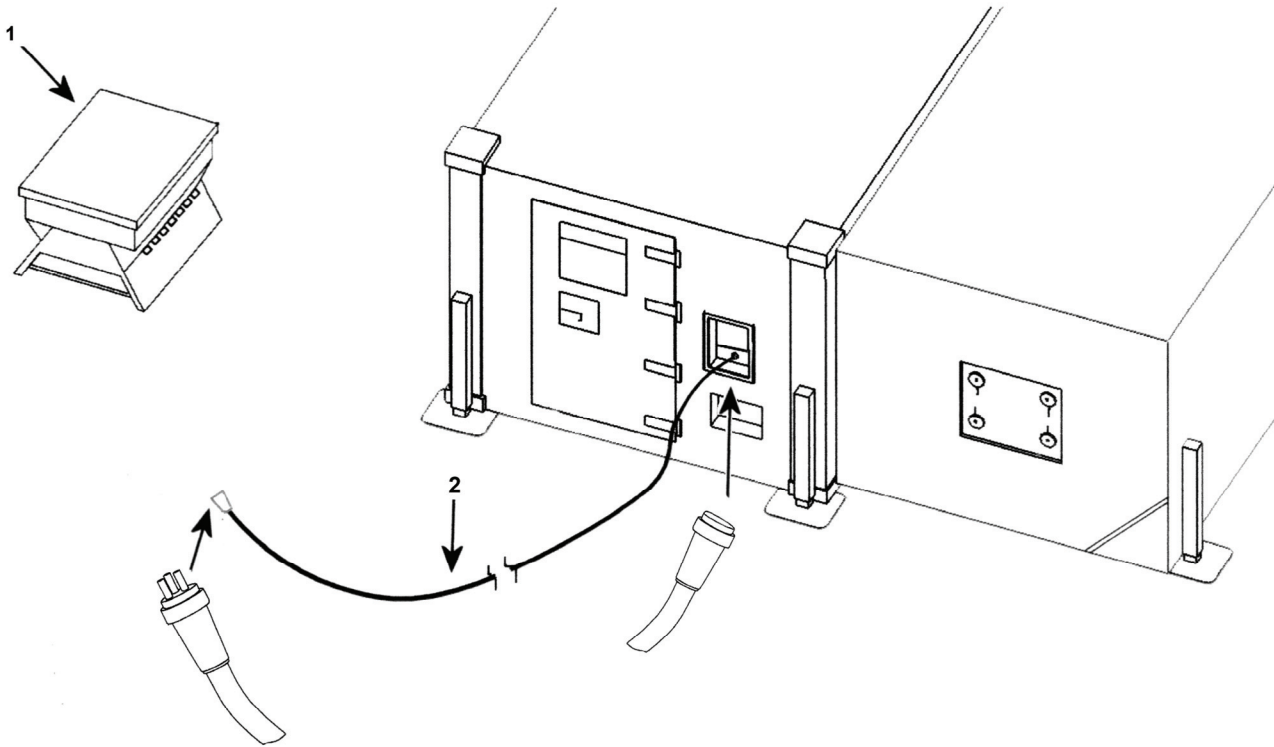

4. Unroll power cable (2) and extend it between shop and PDB (1).

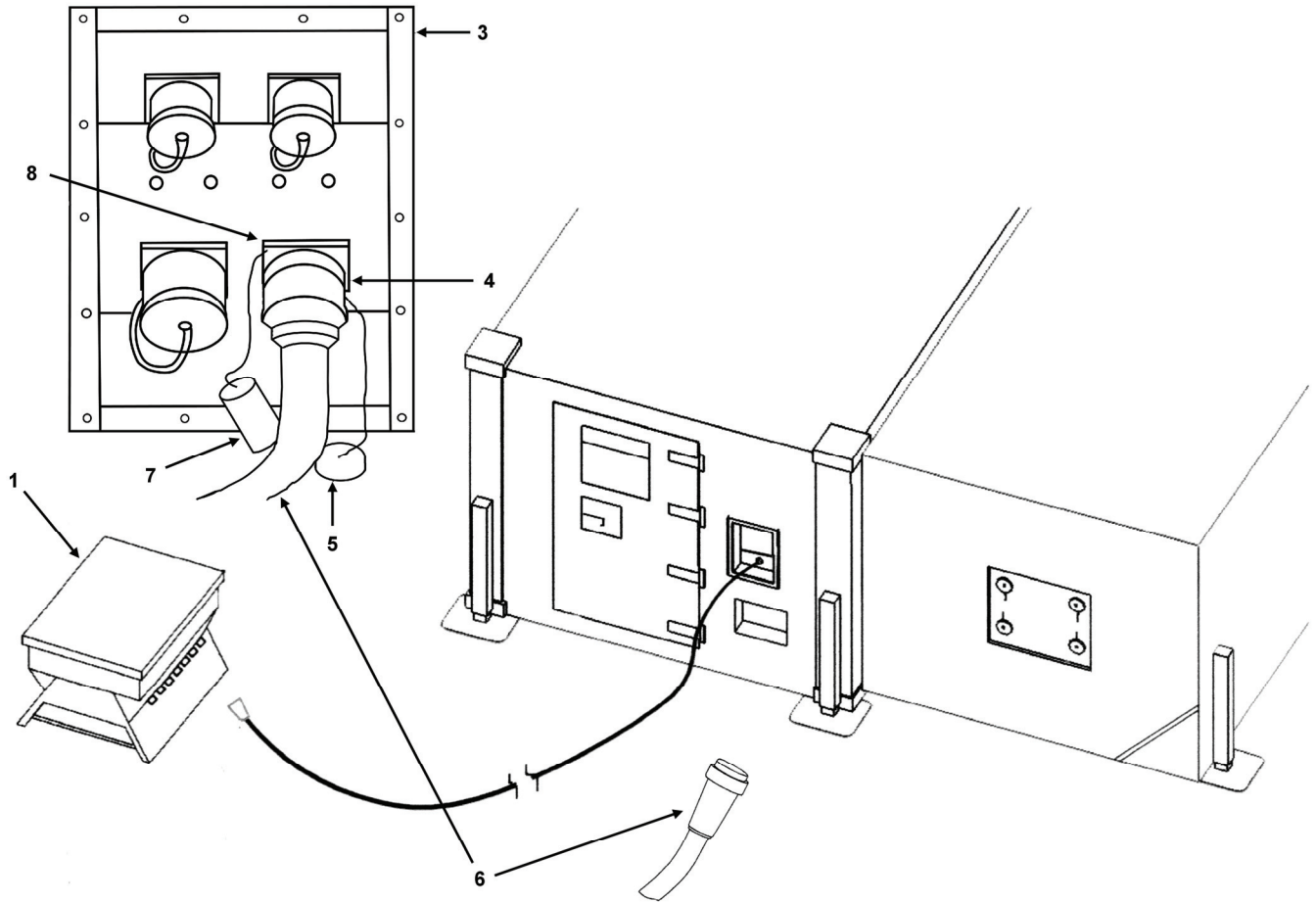

5. Remove protective dust cap (7) from "J1" receptacle (8) at power entry panel (3).
6. Remove protective dust cap (5) from female power connector (6).
7. Insert female power connector (6) into "J1" receptacle (8) and secure with lock ring (4).

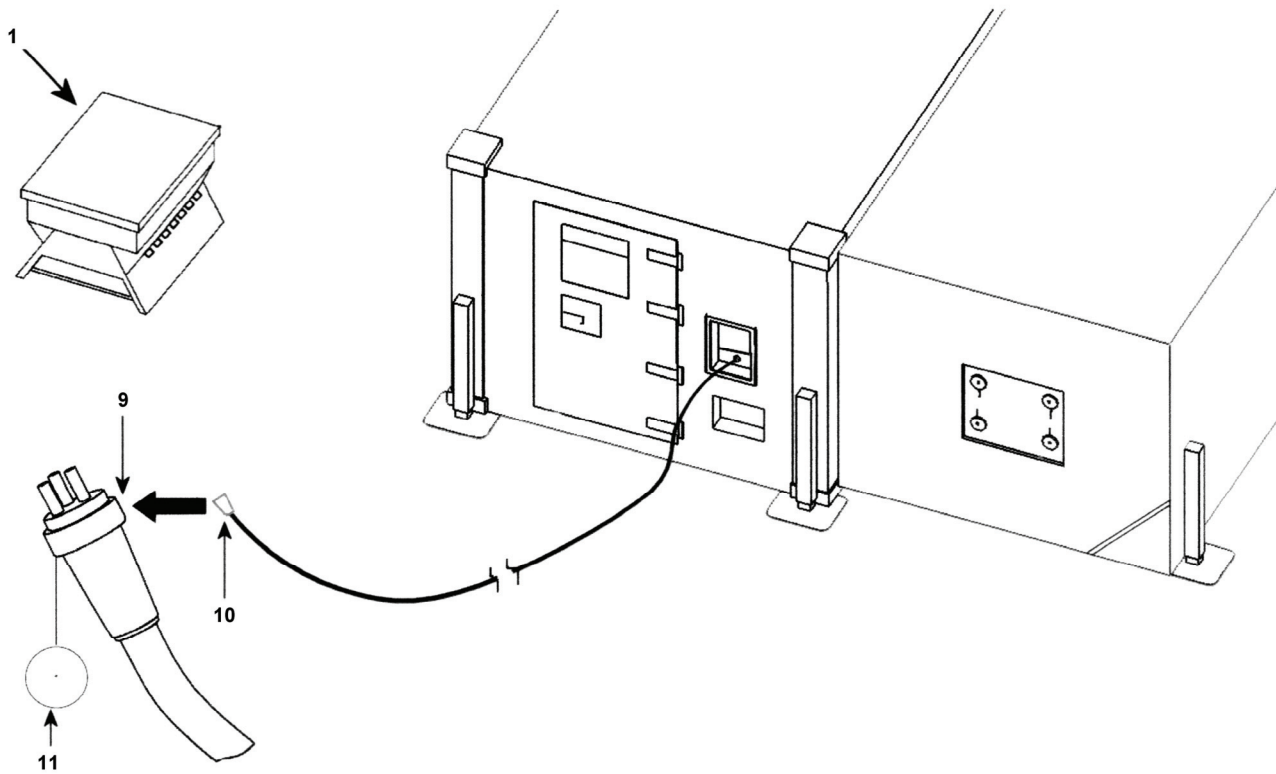

8. Remove protective dust cap from receptacle at PDB (1).
9. Remove protective dust cap (11) from male power connector (10).
10. Insert male power connector (10) into receptacle at PDB (1) and secure with lock ring (9).
11. Move circuit breaker from the PDB (1) from **OFF** to **ON**.
12. Move main and other circuit breakers in circuit breaker panel from **OFF** to **ON**.

End of Work Package

**NON-DESTRUCTIVE INSPECTION SHOP
POSITIONING ECUs**

NOTES

- Skip this Work Package if ECUs are not going to be installed.
- ECUs are supplied by unit.

COUNTERBALANCE CABLE RETAINING BLOCK REMOVAL**WARNING**

Before installing ECUs, shelter expansion must be complete (see WP 0005 00), electrical power supplied to shop (see WP 0006 00), and **COUNTERBALANCE CABLES MUST BE SECURED** (see WP 0005 00).

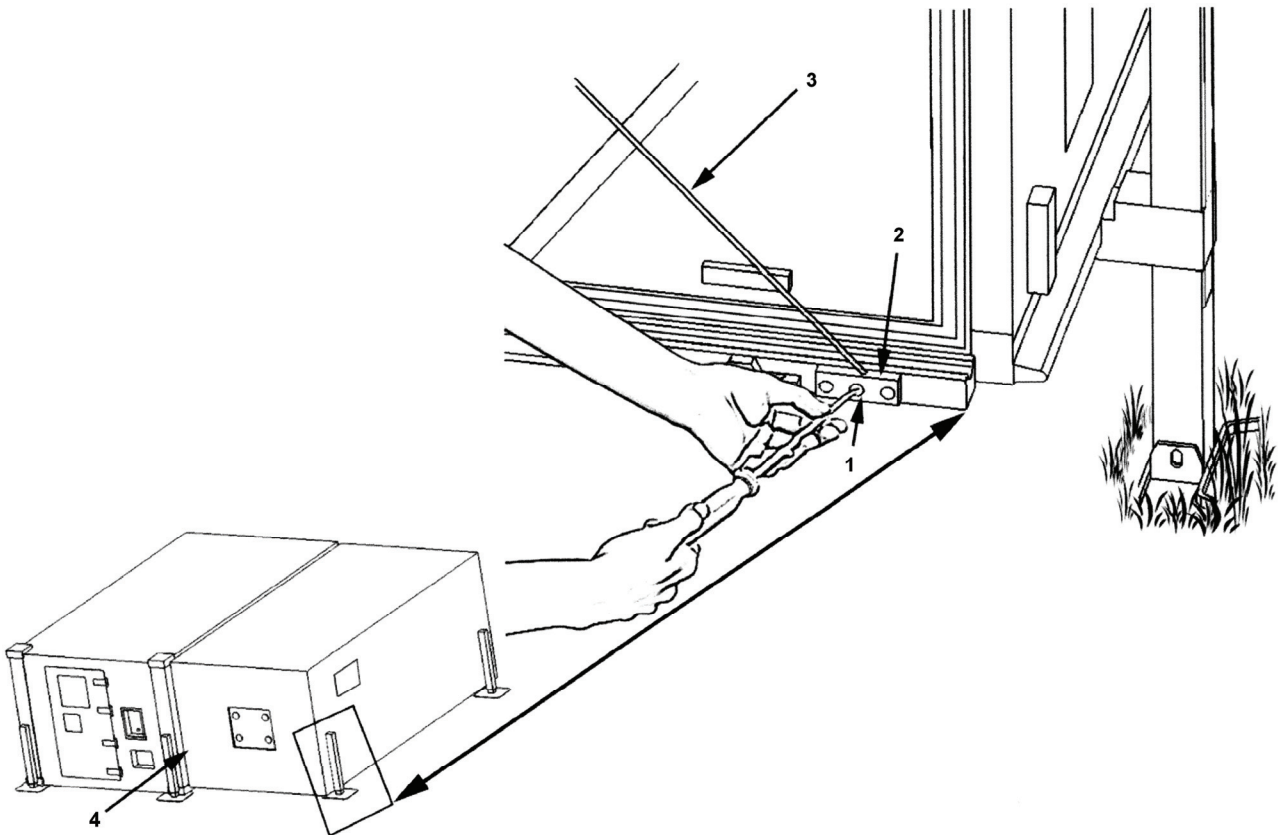

1. Remove three screws (1) from counterbalance cable retainer block (2) located at corner of fold-out floor.
2. Let cable (3) and cable retainer block (2) hang loose next to shelter (4).

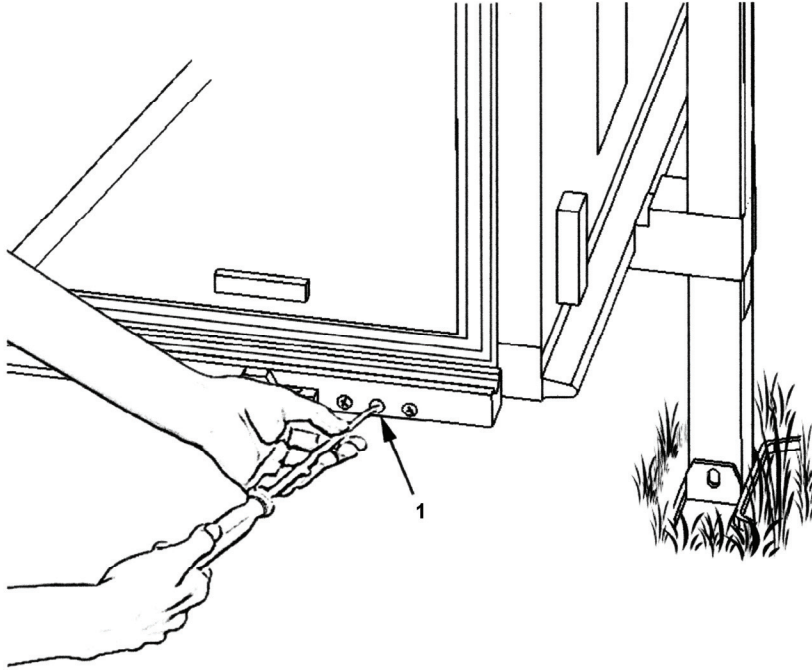

3. Reinstall three counterbalance cable retainer block screws (1) on corner of fold-out floor and secure.
4. Repeat these procedures for counterbalance cable retainer block on other side of shelter.

OPENING ECU FOLD-DOWN PANELS

CAUTION

Prior to lowering ECU panel, ensure one person is outside shelter to catch panel as it is unlatched from inside.

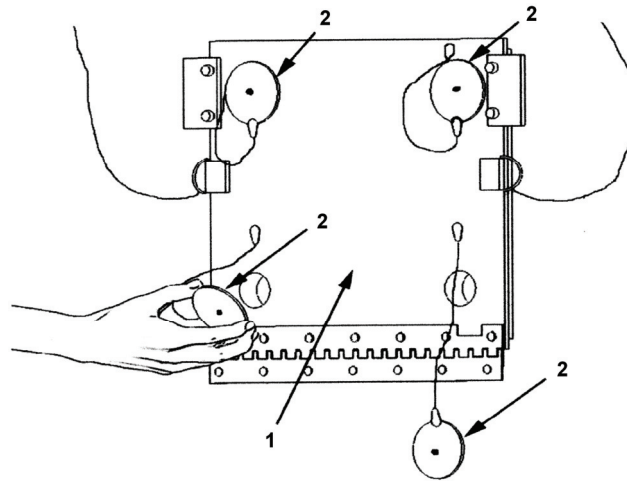

1. Remove four plugs (2) on outside of fold-down panel (1).

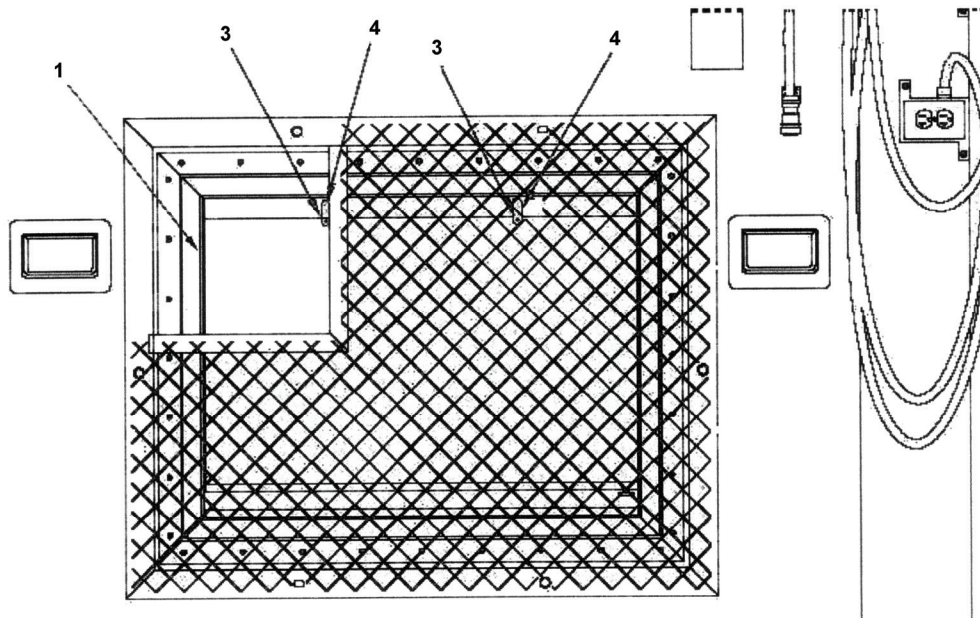

2. Loosen two latch bolts (3) on end wall from inside shelter.
3. Turn latches (4) counterclockwise a quarter turn to release fold-down panel (1).

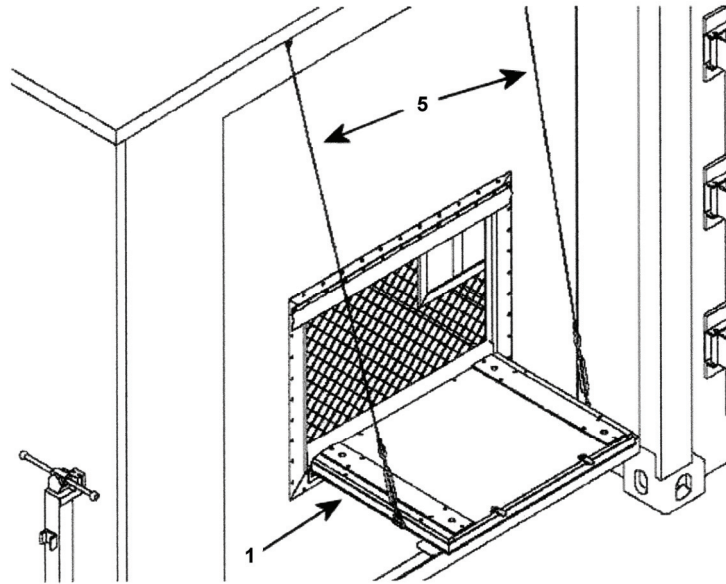

4. Lower fold-down panel (1) using D-rings, to limit of support cables (5) and hook support cables (5) on end wall from outside shelter.

NOTE

Fold-down panel must be at an angle of approximately 91 degrees in order for water to drain.

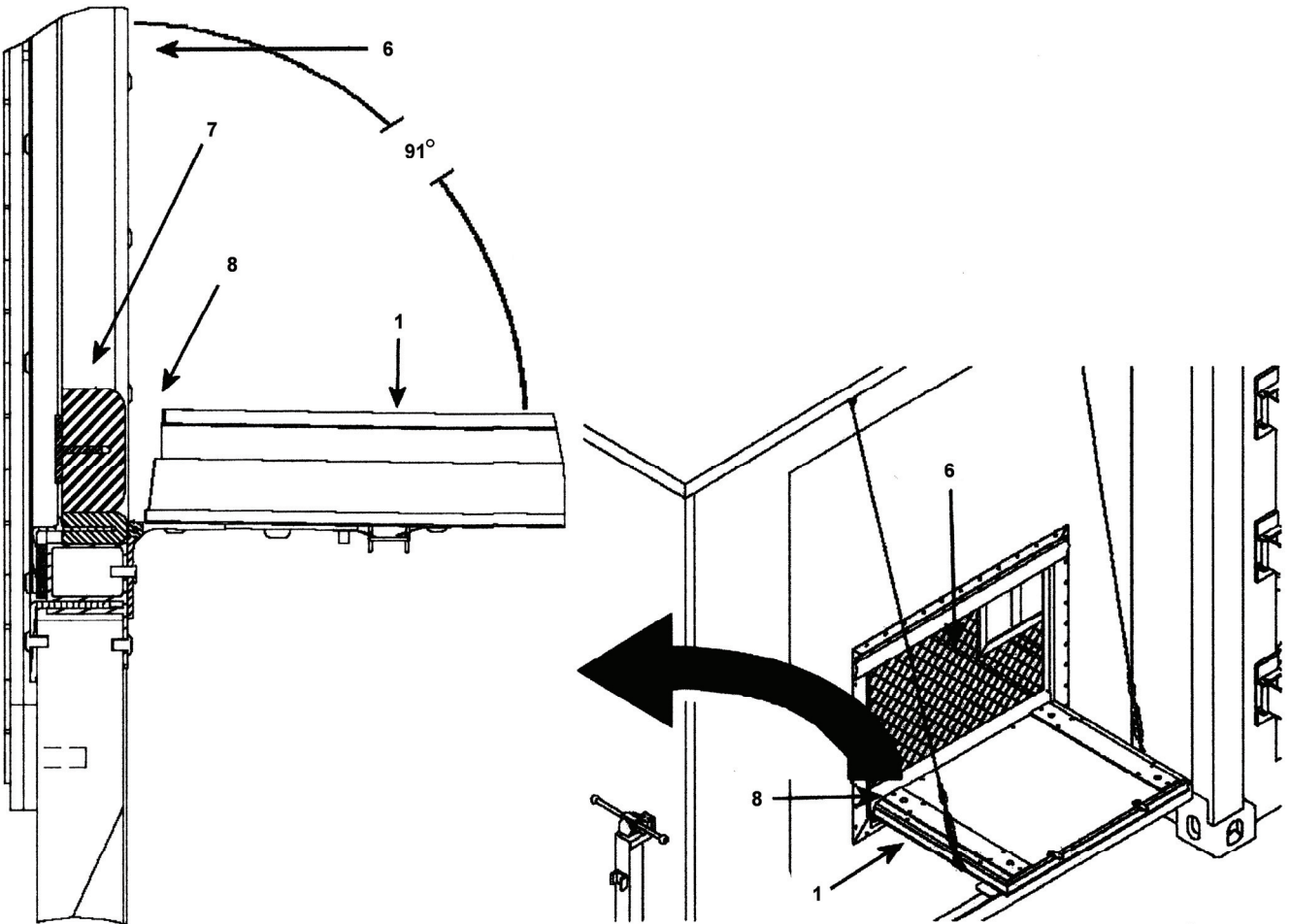

5. Obtain T-seal (7) from appropriate storage location and insert it into gap (8) located between fold-down panel (1) and ECU screen (6) while positioning T-seal (7) with metal strip against metal ECU screen (6).
6. Repeat these procedures for other fold-down panel.

POSITIONING ECUs**WARNING**

Four people are needed when moving or lifting ECUs. Each unit weighs approximately 270 pounds. Trying to move or lift an ECU without sufficient help can cause **SERIOUS INJURY** to personnel.

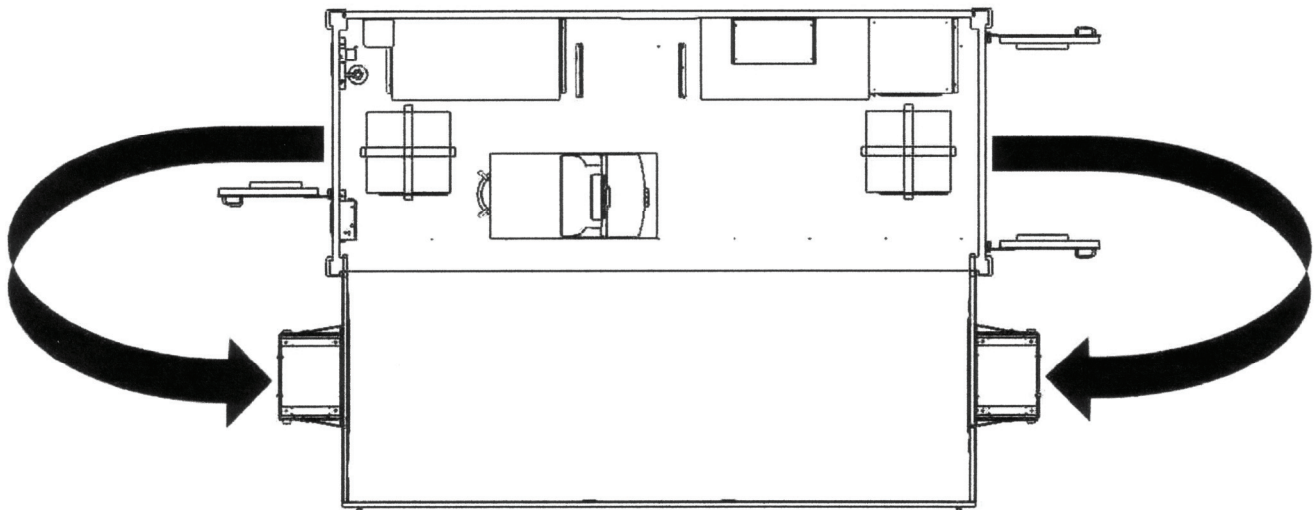
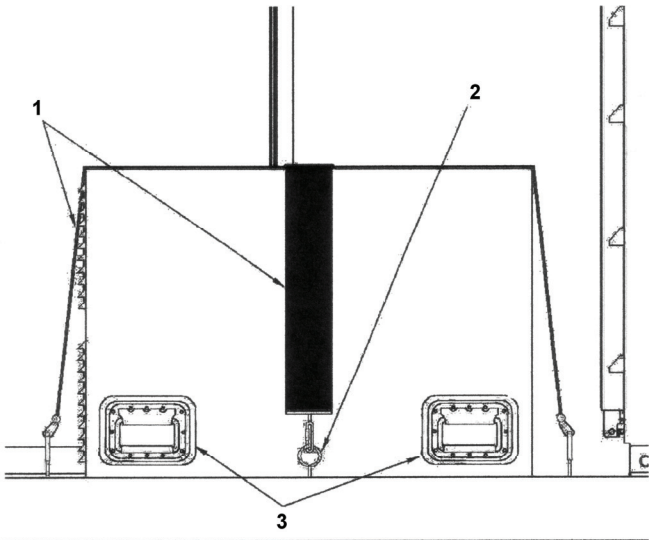

1. Loosen cargo straps (1) on ECU and unhook from ring bolts (2).
2. Remove cargo straps and store in appropriate storage location.
3. Use lift handles (3) to raise ECU and carry through shelter door to fold-down panel.

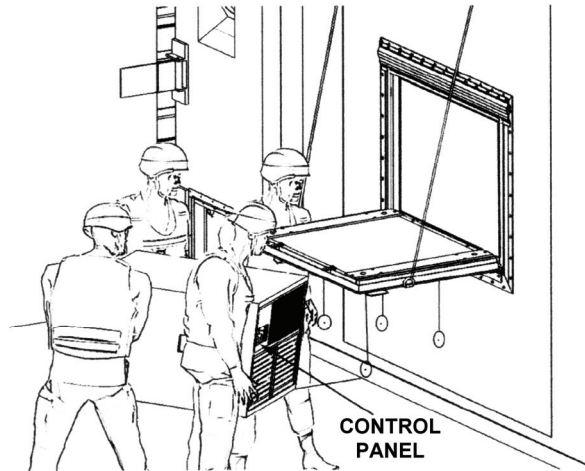

4. Lift ECU onto fold-down panel and position with control panel facing toward inside of shop.

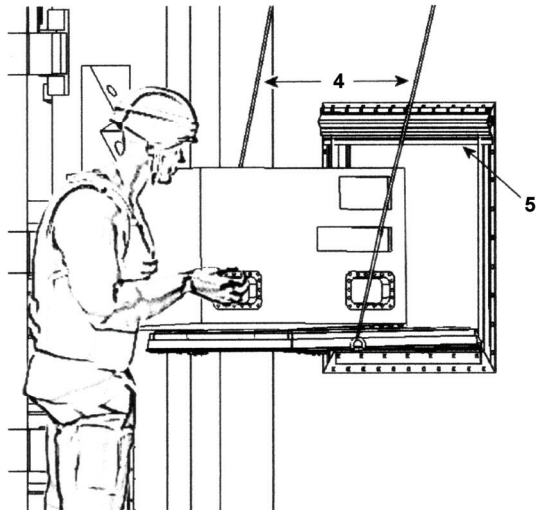

5. Slide ECU forward between support cables (4) while holding up outside seal (5).

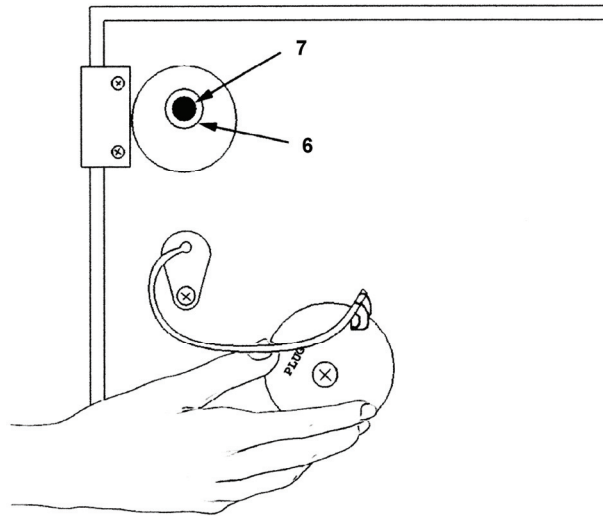

6. Align bolt holes (7) in base of ECU with fold-down panel holes (6).

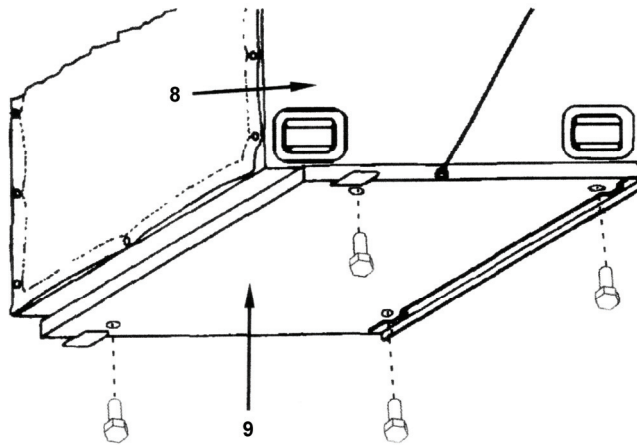

NOTE

Mounting hardware is supplied with ECU.

7. Mount ECU (8) to fold-down panel (9) using hardware supplied with ECU. Install IAW TM 5-4120-369-14.
8. Remove four ring bolts from ECU transport location inside shelter and store in Shelter BII Box.
9. Obtain four set screw floor plugs from appropriate storage location and insert into empty ring bolt holes.
10. Repeat these procedures for other ECU.

CONNECTING POWER TO ECUs**CAUTION**

For specific grounding instructions of ECU, refer to TM 5-4120-369-14.

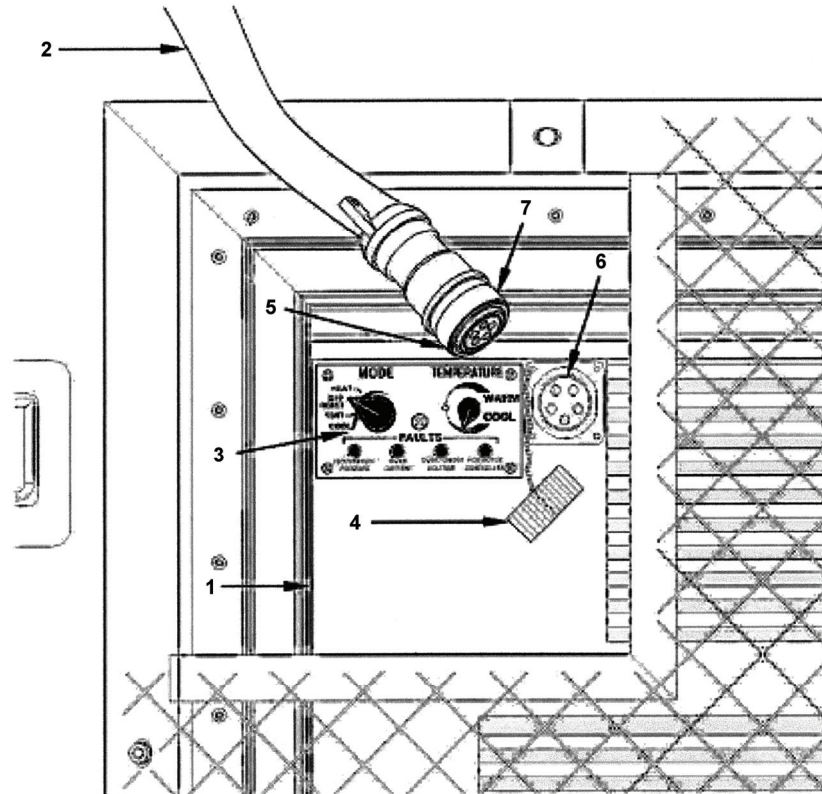

1. Inspect installation of ECU (1) and power cable (2).
2. Position **MODE** switch (3) to **OFF** position.
3. Remove protective dust cap (4) from power input receptacle (6).
4. Push end of connector (5) into power input receptacle (6) until seated.
5. Screw connector lock ring (7) on power input receptacle (6).
6. Repeat these procedures for other ECU.

End of Work Package

**NON-DESTRUCTIVE INSPECTION SHOP
POSITIONING SHOP EQUIPMENT**

SAFEGUARDING BOLTS, WASHERS, AND NUTS

The following procedures and recommended sequence for moving equipment shall be observed. New positions in which equipment will be located on expanded half of shelter are identified.

CAUTION

Ensure that proper bolts, washers, and nuts are available to secure equipment when shop is to be transported. Lack of correct hardware could cause extensive damage to equipment or shelter when shop is moved. All bolts, washers, and nuts removed from equipment will be collected and placed in cotton mailing bag. Cotton mailing bag is kept in Shelter BII box for safekeeping until shelter is to be moved and equipment bolted to floor.

EYEWASH STATION**NOTE**

Bolts, washers, and nuts used during installation of eyewash station are in cotton mailing bag.

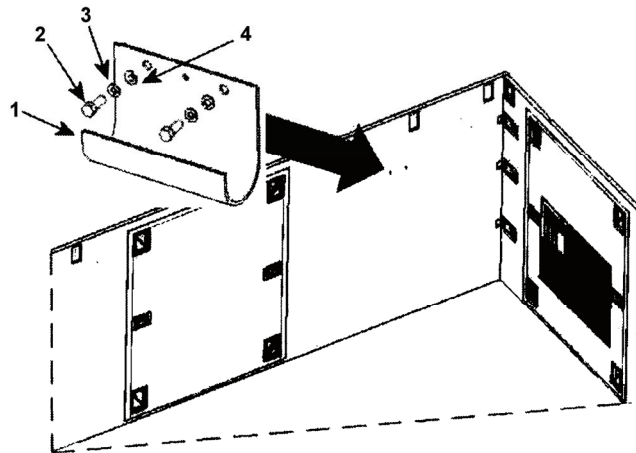

1. Obtain eyewash station wall bracket, two bolts (2), two lock washers (3), and two flat washers (4) from appropriate storage location.
2. On expanded wall, align holes in wall with bracket (1) and install bolts (2), lock washers (3), and flat washers (4).
3. Torque bolts 160-190 in. lbs.

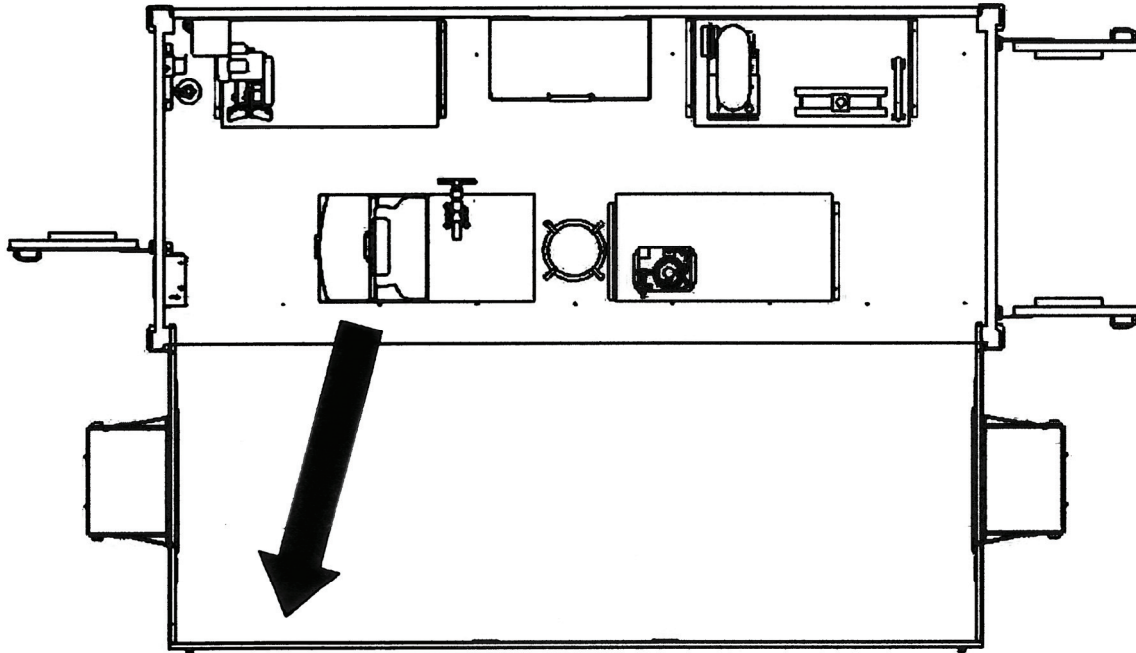

4. Loosen and remove cargo strap from eyewash station located on top of Cabinet E (see WP 0002 00, Figure 2).
5. Store cargo strap in appropriate storage location.
6. Position eyewash station by lifting from top of Cabinet E and carrying to new location.

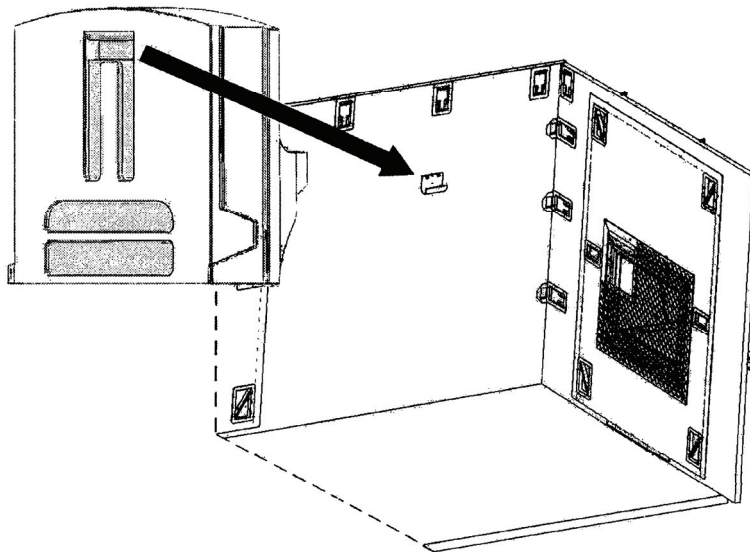

7. Remove cover from eyewash station.
8. Position handle on back of eyewash station over bracket on wall.
9. Replace cover on eyewash station.
10. Refer to eyewash station manual for additional instructions.

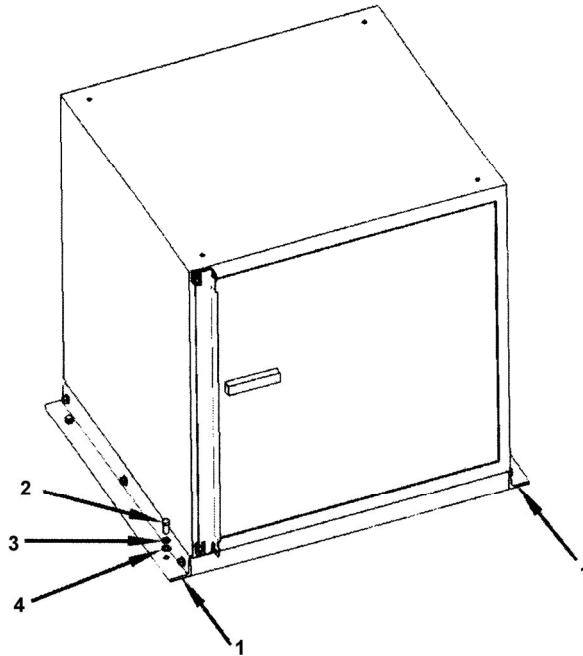
CABINET E

1. Remove four bolts (2), four lock washers (3), and four flat washers (4) from brackets (1) located on both sides of cabinet.
2. Store hardware in appropriate storage location.

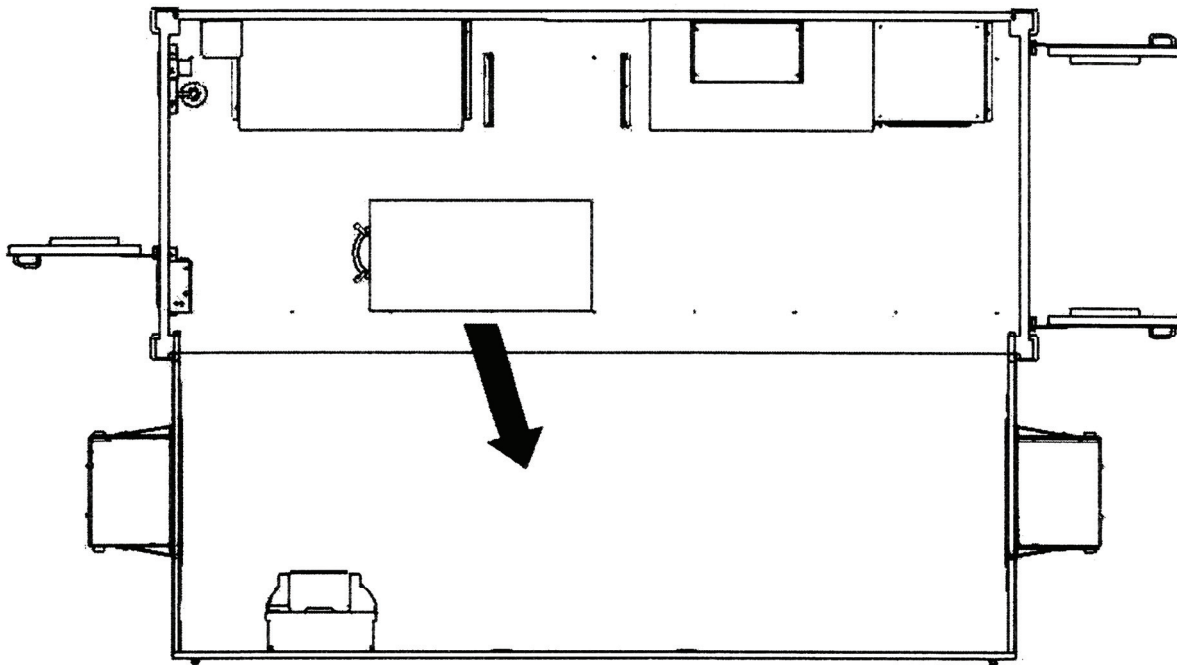

3. Position cabinet by sliding along floor to new location.
4. Obtain four set screw floor plugs from appropriate storage location and insert into empty bolt holes.

STOOLS

1. Loosen and remove cargo strap from stools.
2. Move stools to locations within shop as needed.
3. Remove two ring bolts from stool transport location.
4. Store cargo strap in appropriate storage location and ring bolts in Shelter BII Box.
5. Obtain two set screw floor plugs from appropriate storage location and insert into empty bolt holes.

End of Work Package

**NON-DESTRUCTIVE INSPECTION SHOP
CONNECTING COMPRESSED AIR AND WATER**

In addition to electrical power, shop is provided with connections for compressed air and water. These connections are located on the Services Utility Panel (see WP 0002 00, Figure 1).

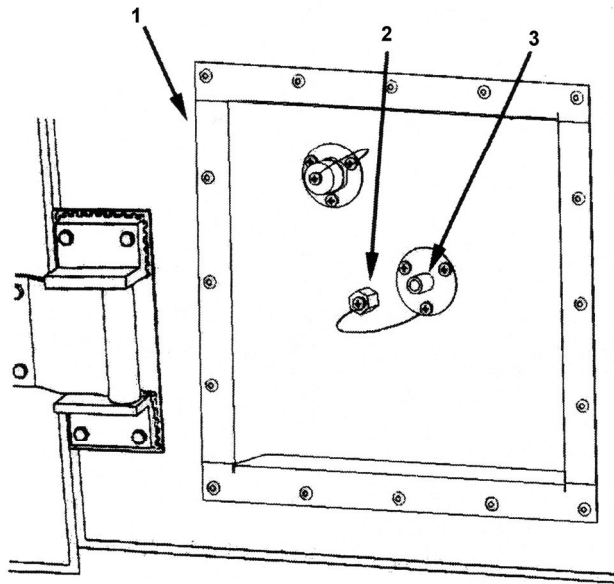
COMPRESSED AIR

1. Remove protective dust cap (2) from air inlet nipple (3) at services utility panel (1).

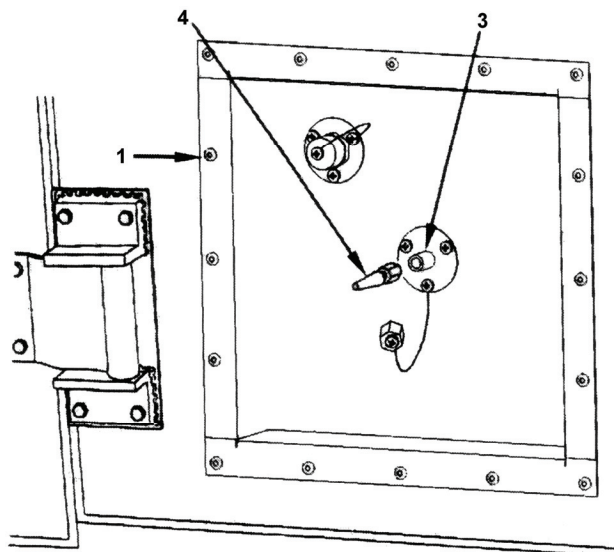

2. Obtain a quick disconnect coupling (4) from appropriate storage location.
3. Install the quick disconnect coupling (4) on air inlet nipple (3) located on service utility panel and tighten securely.

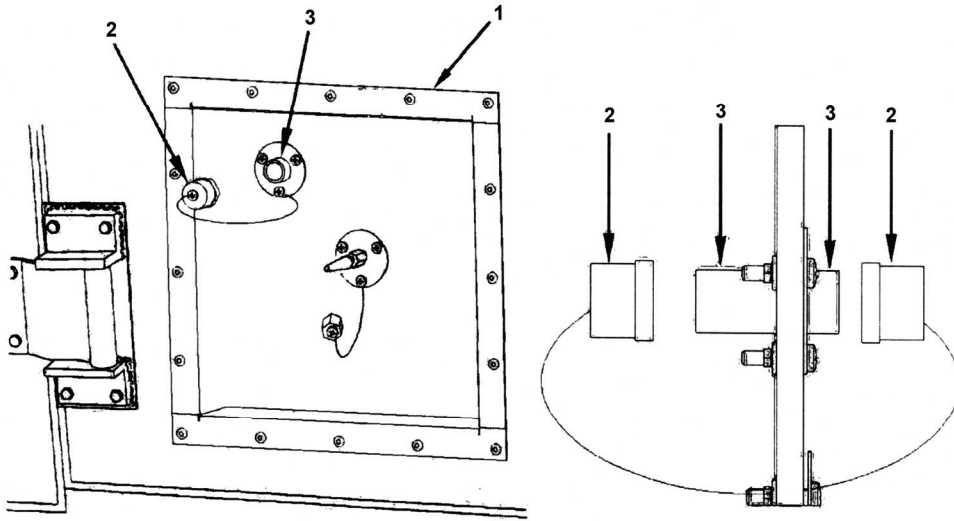
WATER SUPPLY

1. Remove protective dust cap (2) from each end of water feed-thru connector (3) at services utility panel (1).
2. Install adapters and fittings as required.

End of Work Package

**NON-DESTRUCTIVE INSPECTION SHOP
CHECKING SHELTER LEVEL**

After all equipment is in recommended operational position, recheck leveling of shelter. See WP 0005 00-2, Initial Leveling, to verify and adjust level. Correct leveling adjustments are essential to ensure proper operation of machine tools, doors, and access panels.

The Non-Destructive Inspection Shop is now operational.

End of Work Package

**NON-DESTRUCTIVE INSPECTION SHOP
DISCONNECTING COMPRESSED AIR AND WATER**

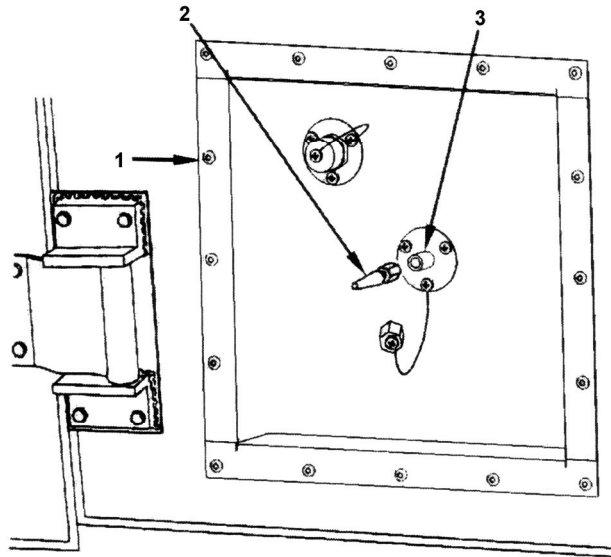
COMPRESSED AIR

1. Remove quick disconnect coupling (2) from air inlet nipple (3) located on service utility panel (1) and store in appropriate storage location.

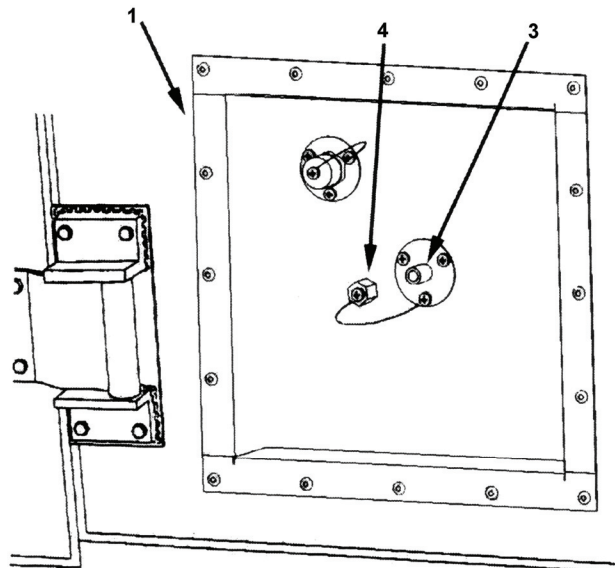

2. Install protective dust cap (4) on air inlet nipple (3) at services utility panel and tighten securely.

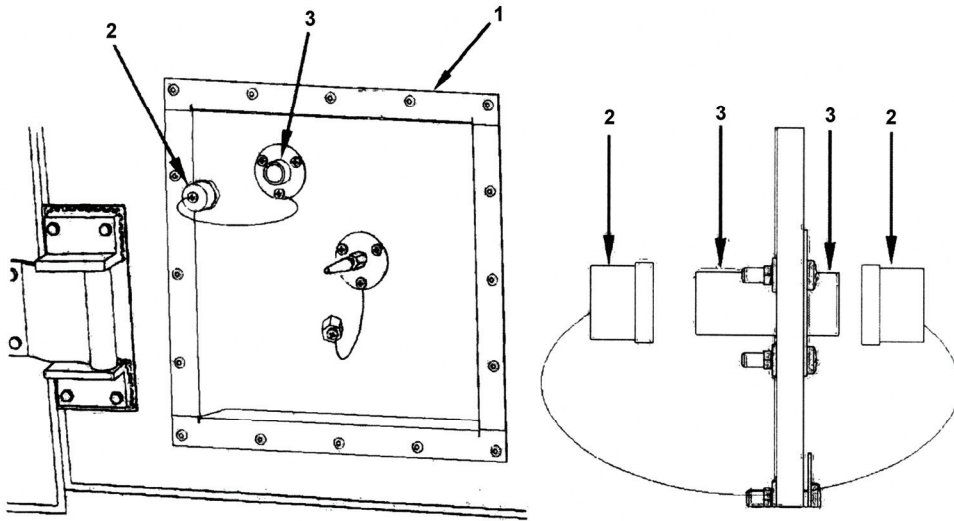
WATER SUPPLY

1. Remove adapters and fittings from services utility panel (1).
2. Install protective dust cap (2) on each end of feed-thru connector (3) and tighten securely.

End of Work Package

**NON-DESTRUCTIVE INSPECTION SHOP
REPOSITIONING SHOP EQUIPMENT**

OBTAINING CORRECT BOLTS, WASHERS, AND NUTS

The following procedures and recommended sequence for moving equipment shall be observed. Transport positions in which equipment will be located are identified.

CAUTIONS

- Care must be taken to ensure that proper bolts, washers, and nuts are used to secure equipment when shop is transported. Lack of correct hardware could cause extensive damage to equipment or shelter.
 - Torque values are provided and must be respected to prevent possible damage to equipment or shelter. Improper procedures could result in extensive damage to government property.
1. Remove cotton mailing bag with bolts, washers, and nuts from appropriate storage location.
 2. Inspect hardware for damage or missing parts.
 3. Check out a torque wrench from tool crib.

STOOLS

1. Remove two set screw floor plugs from floor inserts at transport location (see WP 0002 00, Figure 2).
2. Store plugs in appropriate storage location.
3. Obtain cargo strap from appropriate storage location and two ring bolts from Shelter BII Box.
4. Insert ring bolts into floor inserts and tighten.
5. Stack stools at transport location.
6. Attach one end of cargo strap to first ring bolt, slide cargo strap through legs of top stool and attach other end of cargo strap to second ring bolt.

CABINET E

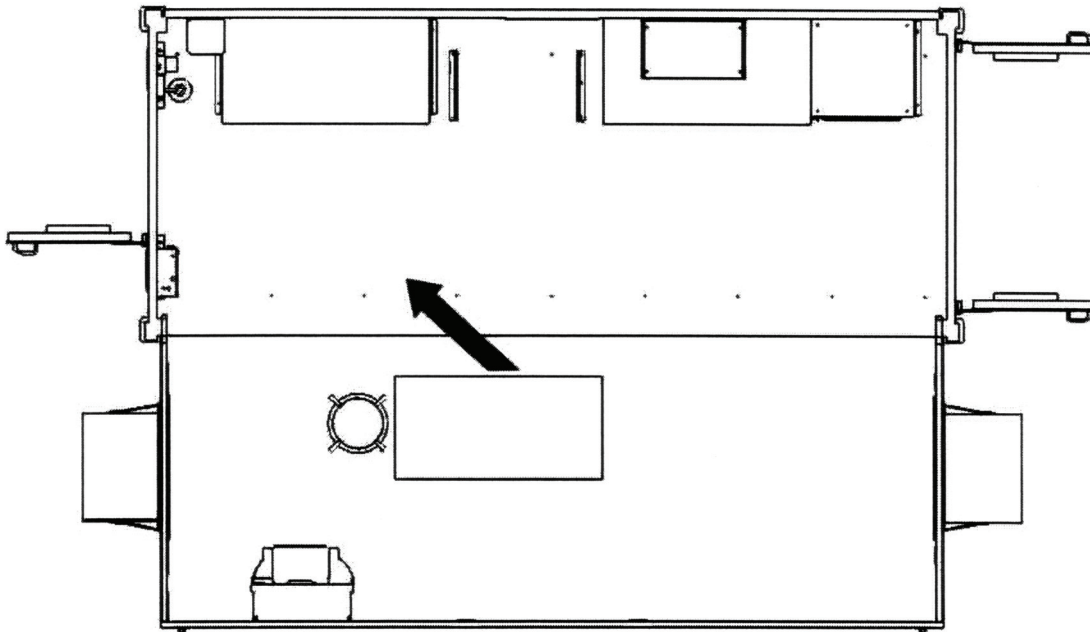

1. Remove four set screw floor plugs from inserts at transport location (see WP 0002 00, Figure 2).
2. Store plugs in appropriate storage location.
3. Reposition cabinet by sliding along floor to transport location.

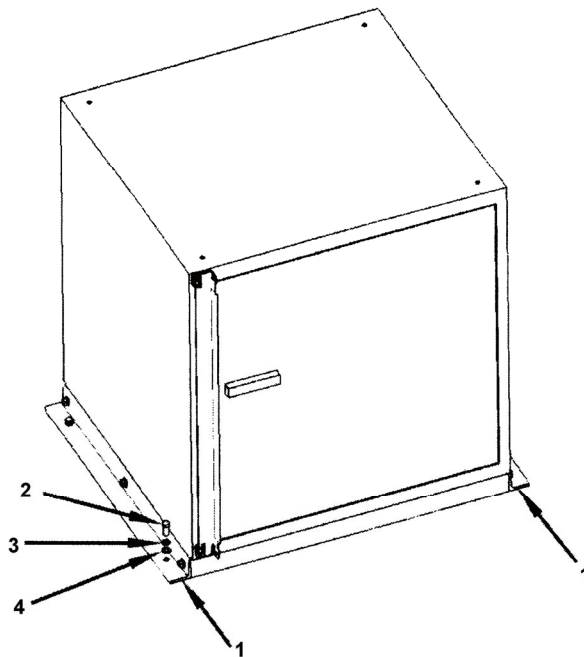

4. Obtain four bolts (2), four lock washers (3), and four flat washers (4) from appropriate storage location.
5. Align holes in cabinet brackets (1) with inserts and install bolts (2) with lock washers (3) and flat washers (4).
6. Torque bolts 160-190 in. lbs.

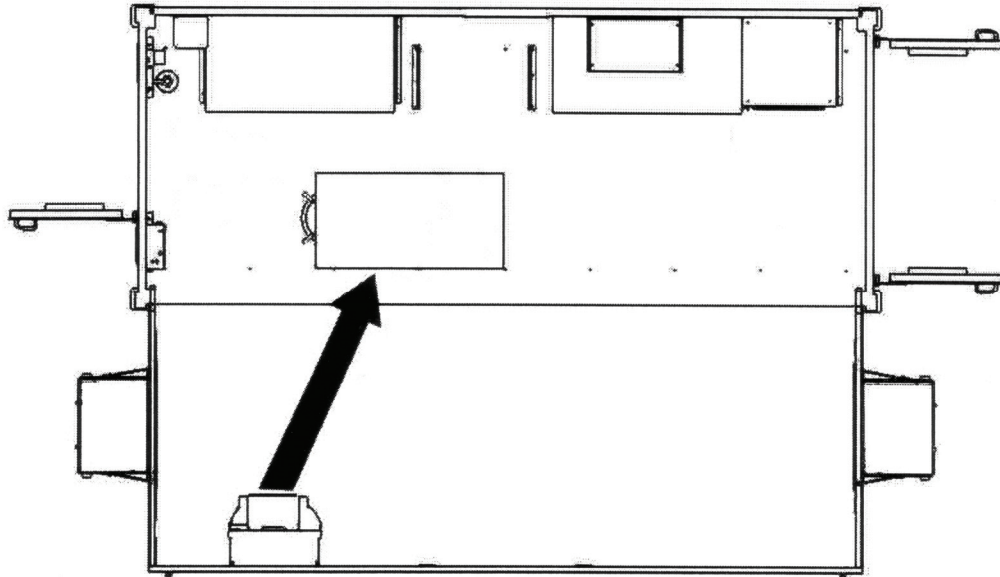
EYEWASH STATION

1. Drain saline into appropriate container IAW eyewash station instruction manual.
2. Remove cover from eyewash station.
3. Detach eyewash station from wall bracket.
4. Replace cover on eyewash station.
5. Place the eyewash station on top of Cabinet E (see WP 0002 00, Figure 2).

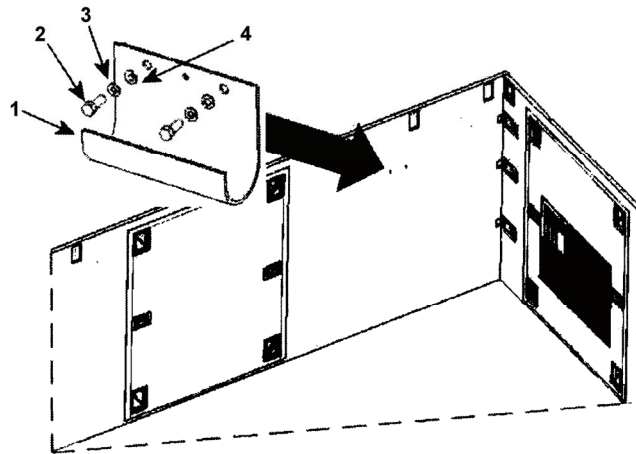

6. Obtain cargo strap from appropriate storage location.
7. Position cargo strap around eyewash station and attach to Cabinet E.
8. Remove two bolts (2), two lock washers (3), and two flat washers (4) from wall bracket (1) and store in cotton mailing bag.
9. Store cotton mailing bag and wall bracket in appropriate storage location.

End of Work Package

NON-DESTRUCTIVE INSPECTION SHOP REPOSITIONING ECUs

NOTE

Skip this Work Package if ECUs are not installed.

DISCONNECTING POWER FROM ECUs

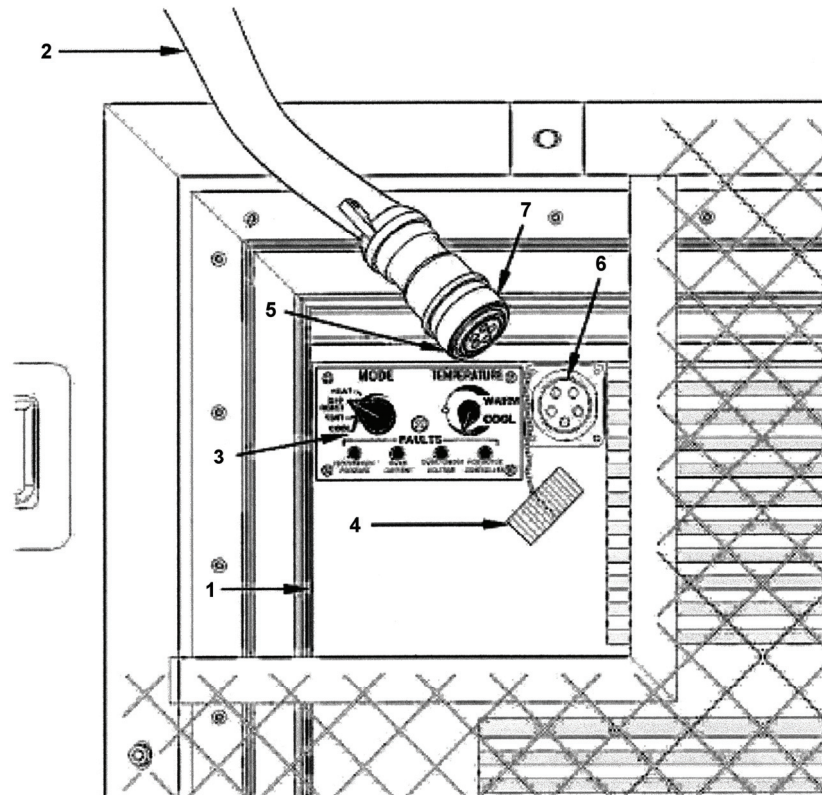

1. Set **MODE** switch (3) on ECU (1) to **OFF** position.
2. Unscrew connector lock ring (7) from power input receptacle (6).
3. Pull end of connector (5) from power input receptacle (6).
4. Store cable (2) in appropriate storage location.
5. Install protective dust cap (4) on power input receptacle (6).
6. Repeat these procedures for other ECU.

REPOSITIONING ECUs

1. Remove four set screw floor plugs from inserts at transport location (see WP 0002 00, Figure 2).
2. Store plugs in appropriate storage location.
3. Retrieve cargo straps from appropriate storage location and ring bolts from the Shelter BII Box.
4. Install four ring bolts and tighten securely.
5. Repeat these procedures for other ECU.

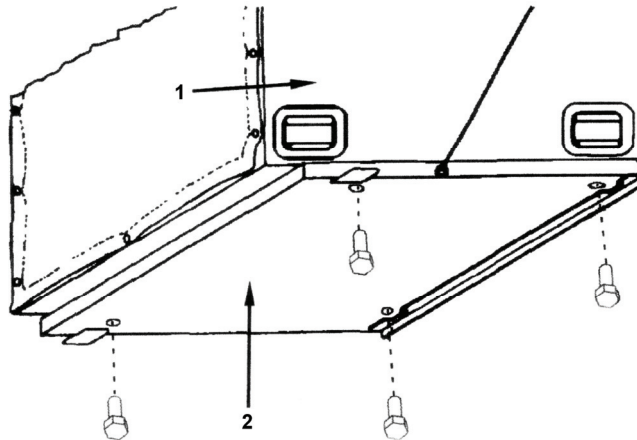

6. Remove mounting hardware securing ECU (1) to fold-down panel (2).
7. Store hardware in appropriate storage location.

WARNING

Four people are needed when moving or lifting the ECUs. Each unit weighs approximately 270 pounds. Trying to move or lift an ECU without sufficient help can cause **SERIOUS INJURY** to personnel.

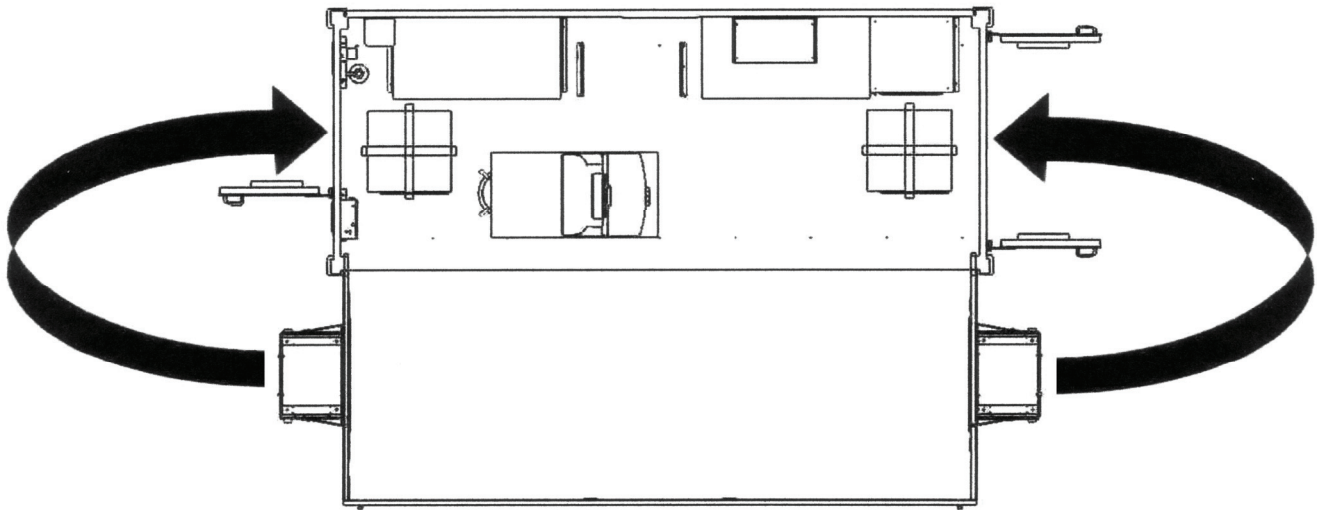
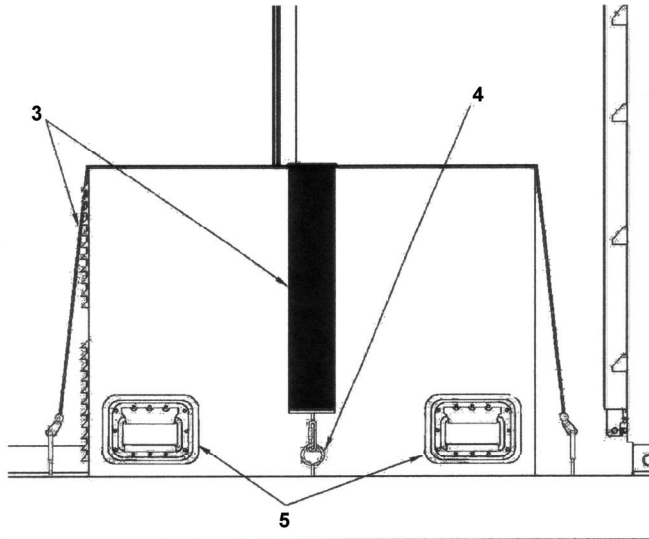

8. Using lift handles (5), slide ECU off fold-down panel, carry through shelter door and position it on floor.
9. Position two cargo straps (3) on ECU and hook to ring bolts (4).
10. Tighten cargo straps (3) to secure ECU in place.
11. Repeat these procedures for other ECU.

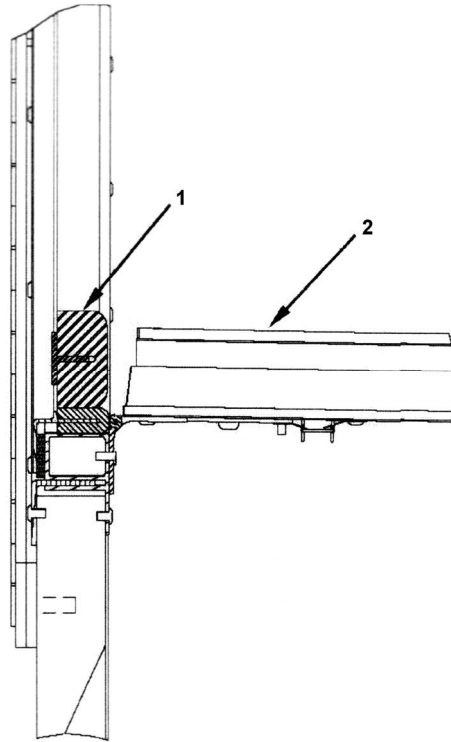
CLOSING ECU FOLD-DOWN PANEL

1. Remove T-seal (1) from gap located between ECU fold-down panel (2) and ECU screen.
2. Store T-seal (1) in appropriate storage location.

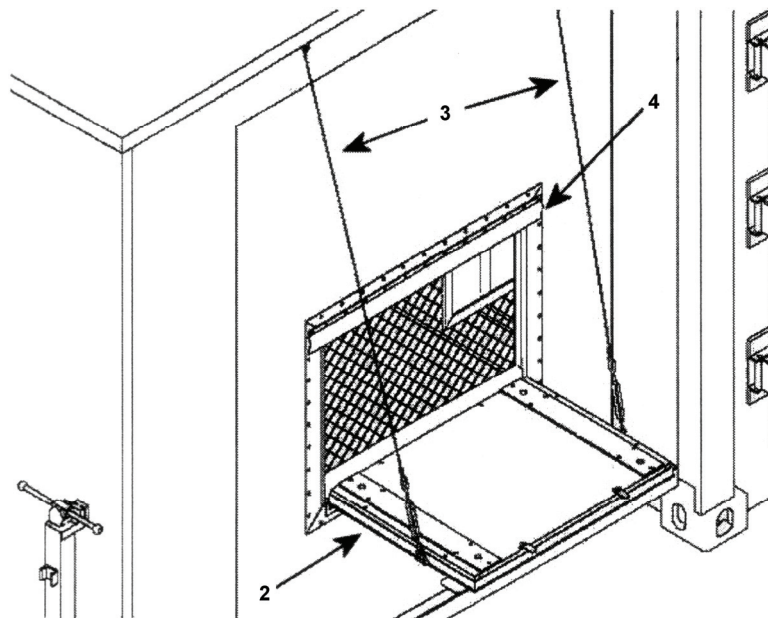

3. Remove two ECU support cables (3) from ECU fold-down panel (2).
4. Lift outside seal (4) and close ECU fold-down panel (2).

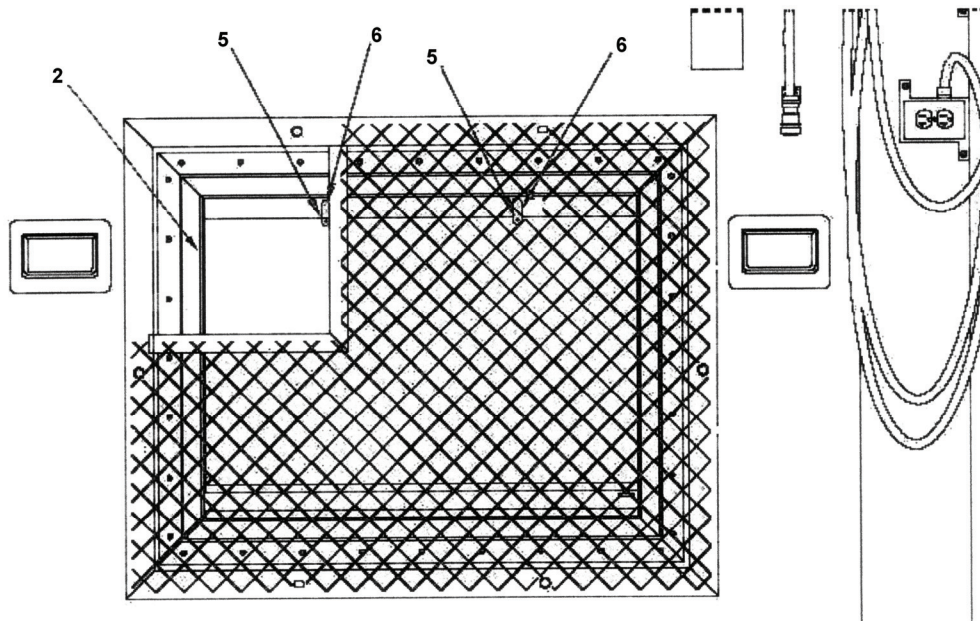

5. Turn latches (6) clockwise, to hold ECU panel (2) in place, and tighten latch bolts (5).

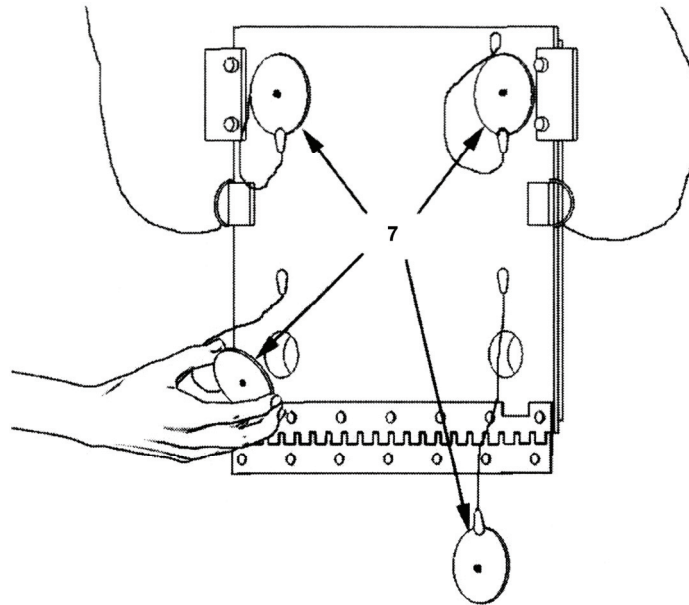

6. Insert four plugs (7) in ECU panel.
7. Repeat these procedures for other ECU fold-down panel.

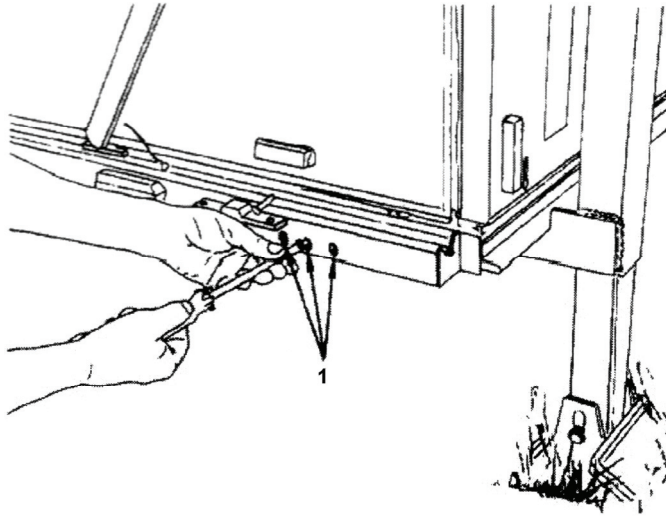
COUNTERBALANCE CABLE RETAINING BLOCK INSTALLATION

1. Remove three counterbalance cable retainer block screws (1) from corner of fold-out floor.

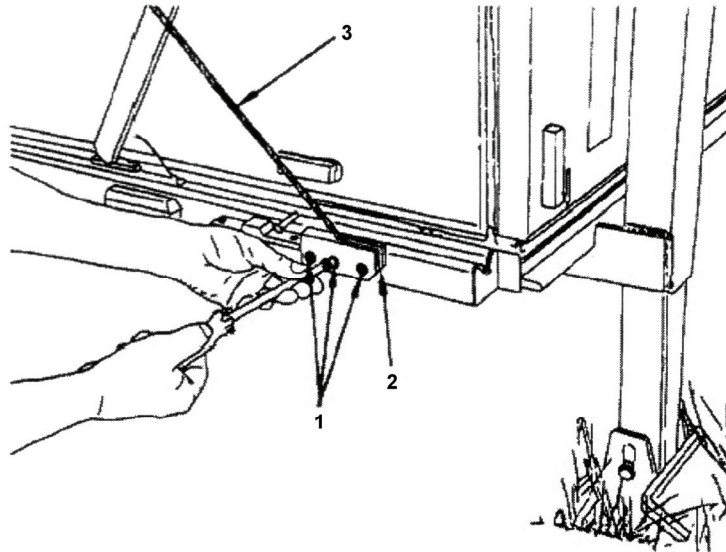

2. Install counterbalance cable (3).
3. Replace counterbalance cable retainer block (2) with three screws (1) and tighten securely.

End of Work Package

**NON-DESTRUCTIVE INSPECTION SHOP
DISCONNECTING ELECTRICITY**

WARNING

HIGH VOLTAGE exists in electrical system of shop. All electrical inspections, repairs, or replacements will be performed with power **OFF** and only by qualified electricians. Serious shock hazards exist which could result in **INJURY OR EVEN DEATH** to personnel.

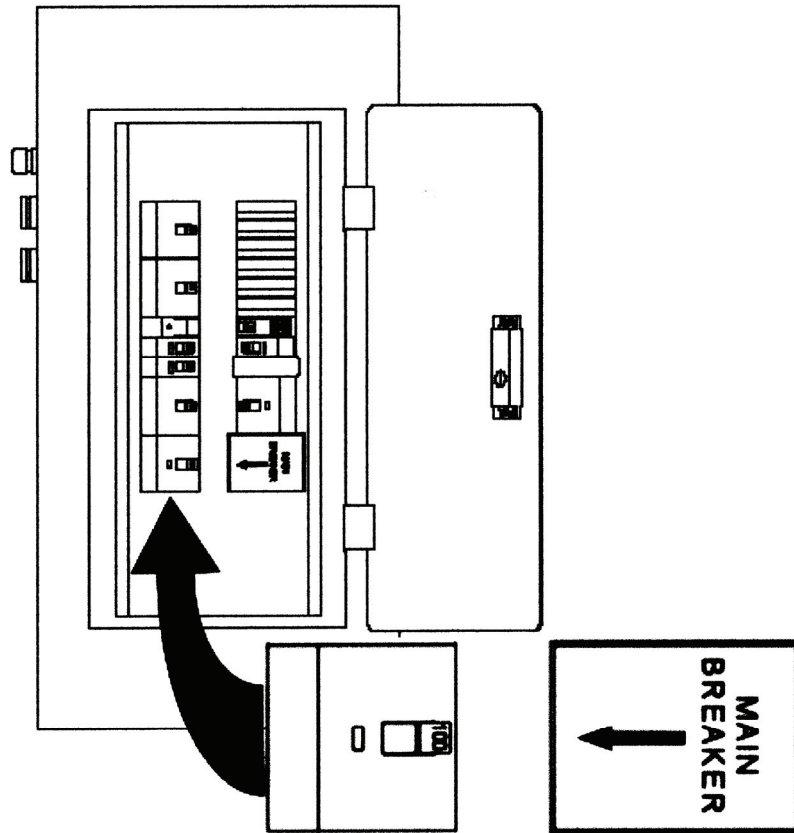
DISCONNECTING MAIN POWER CABLE

1. Ensure that all electrical tools and shop equipment are **OFF**.
2. Before disconnecting main 100 amp power cable, ensure that all circuit breakers (including main circuit breaker) in circuit breaker panel are in the **OFF** position.

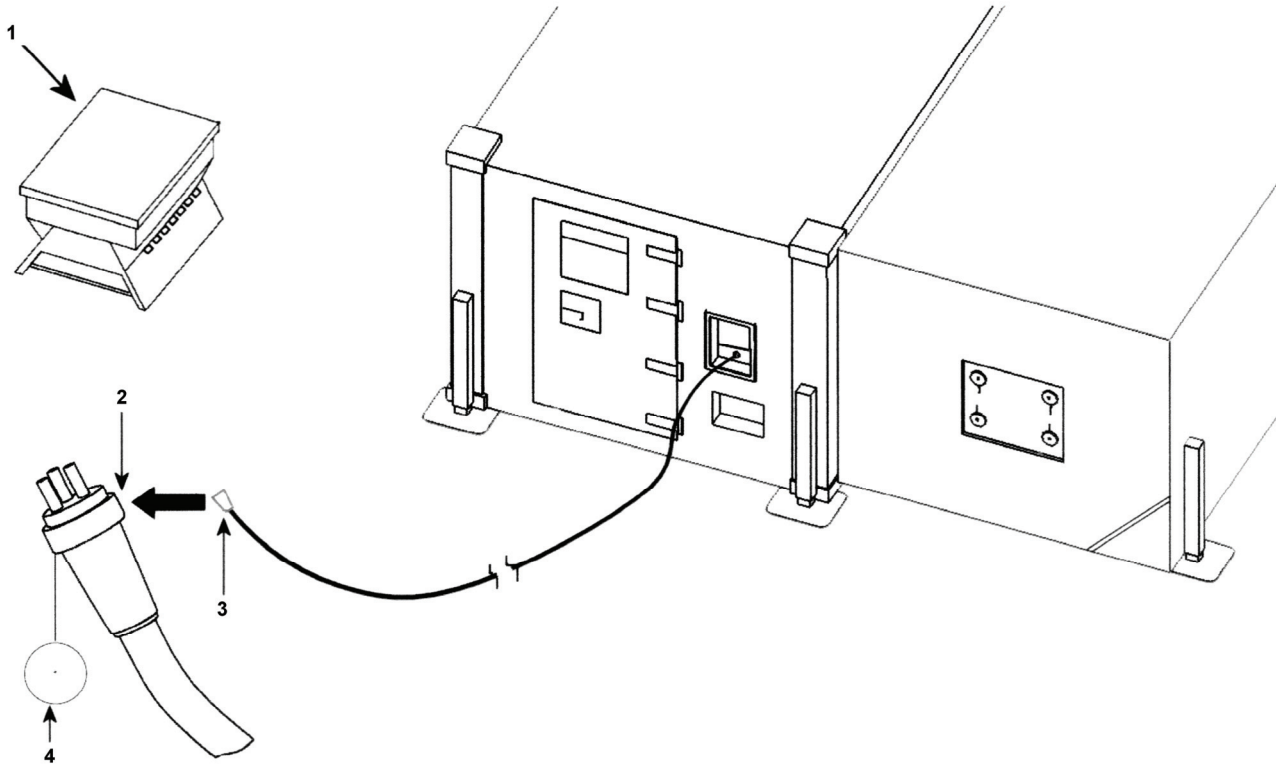

3. Ensure circuit breaker from PDB (1) is **OFF**.
4. Unscrew lock ring (2) and disconnect male power connector (3) from PDB (1).
5. Install protective dust cap (4) on male power connector (3) and PDB receptacle (1).

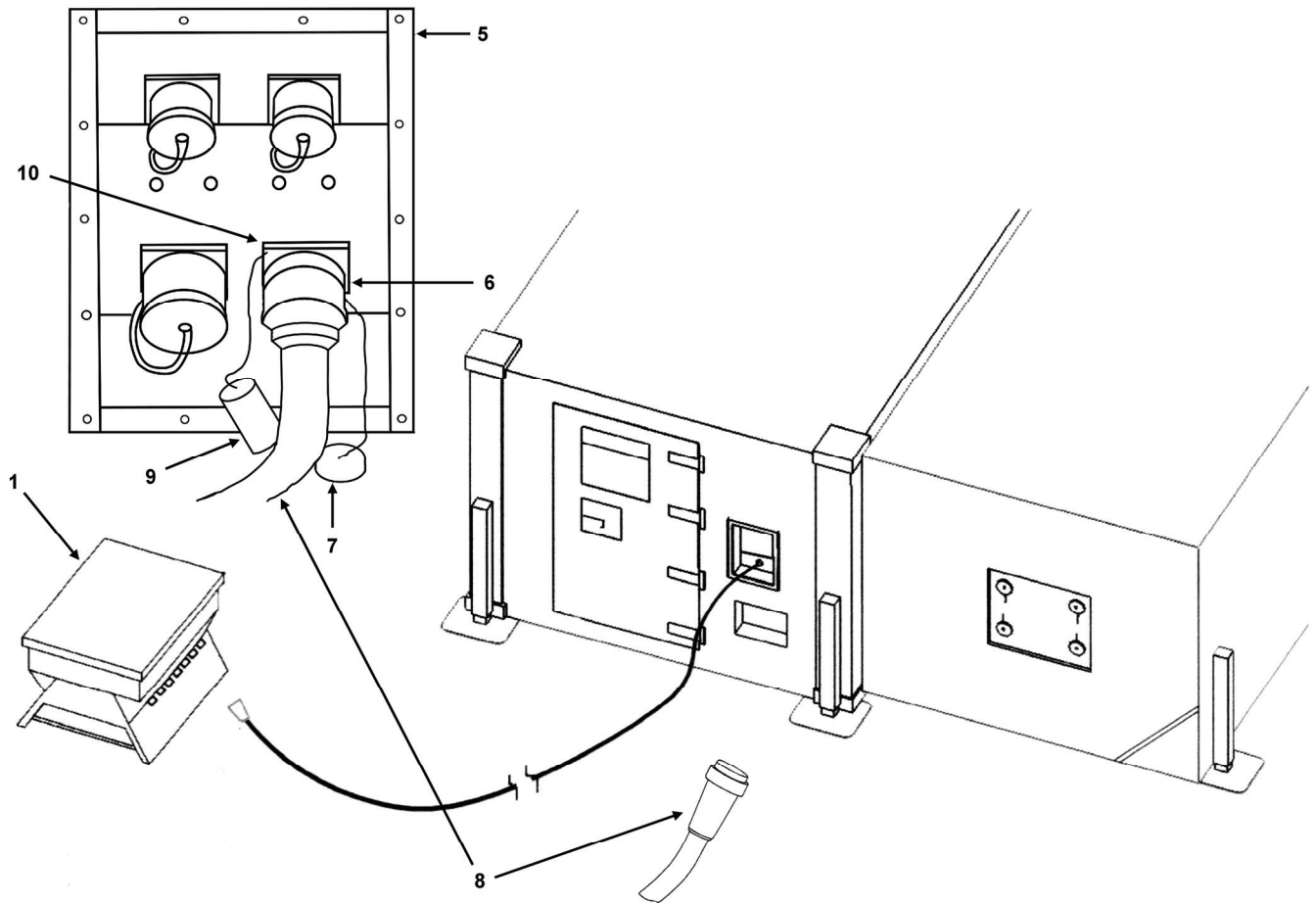

6. Unscrew lock ring (6) and disconnect female power connector (8) from "J1" receptacle (10) at power entry panel (5).
7. Install protective dust cap (9) on the "J1" receptacle (10).
8. Install protective dust cap (7) on the female power connector (8).
9. Clean cable with rag. Roll cable and store in appropriate storage location.

DISCONNECTING PDB FROM GENERATOR (IF NECESSARY)

WARNING

This procedure is required only if a complete power shutdown is necessary. Only a qualified electrician should attempt to disconnect PDB from generator.

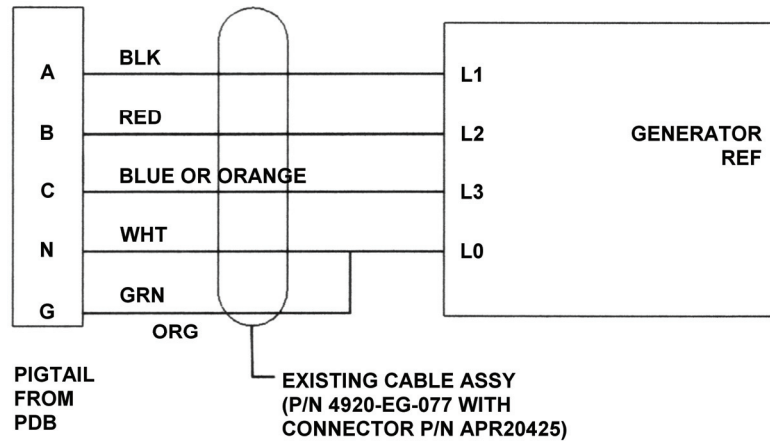

1. Ensure all circuit breakers on PDB are in the **OFF** position.
2. A qualified electrician will disconnect pigtail wires from generator lugs. Disconnect black wire from lug L1, red wire from lug L2, blue or orange wire from lug L3, and white and green wires from lug L0.
3. Disconnect pigtail from PDB.

REMOVING EXTERNAL GROUND ROD**NOTE**

Shelter is grounded through externally connected power supply. Consult a qualified electrician for proper grounding procedures required for surrounding soil conditions.

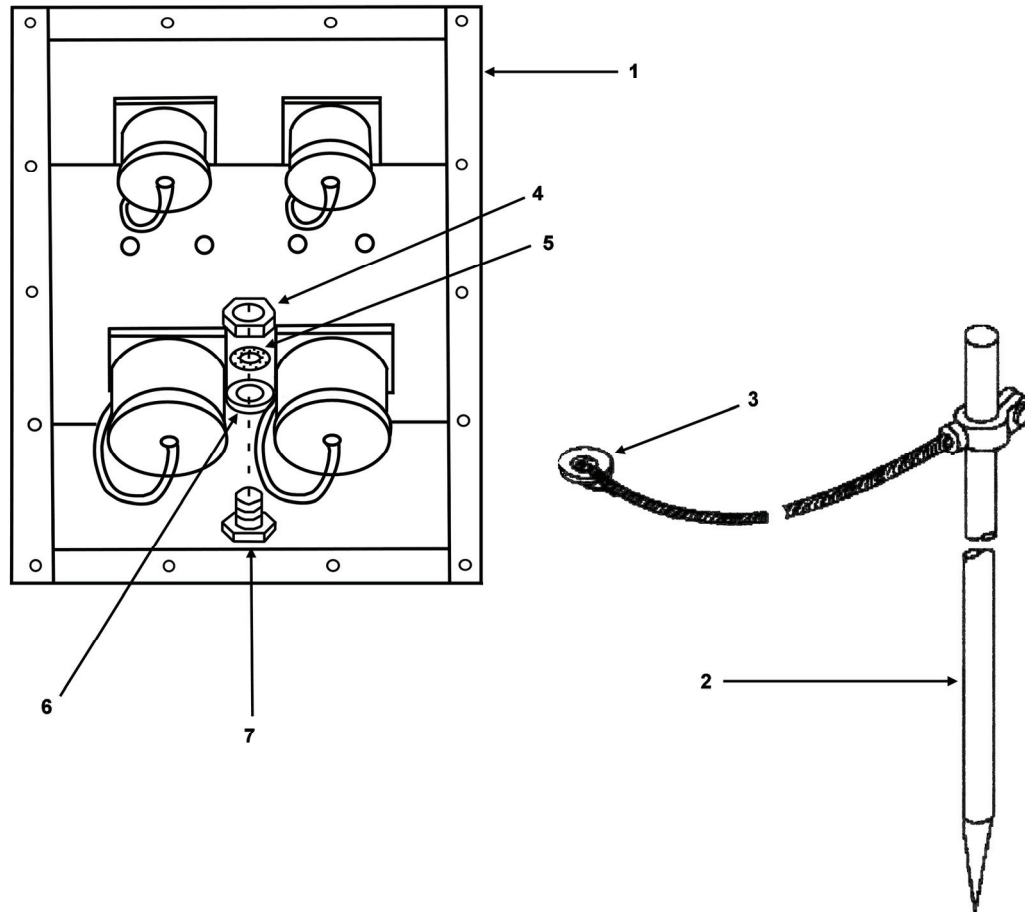

1. On power entry panel (1) remove nut (4), lock washer (5), and flat washer (6) from ground stud (7).
2. Disconnect ground cable lug (3) from ground stud (7).
3. Replace flat washer (6), lock washer (5), and nut (4) on ground stud (7).
4. Remove grounding rod (2) from earth.
5. Store grounding rod assembly in appropriate storage location.

End of Work Package

NON-DESTRUCTIVE INSPECTION SHOP SHELTER CLOSING SEQUENCE

NOTES

- Four personnel are required to perform the following procedures.
- Make sure hinged floor is clear of items or debris and floor hinges are clean of sand or dirt.
- Make sure top of hinged roof is clear of items, debris, snow, or ice and hinged floor extension is clear of foreign matter, snow, or ice.
- Do not attempt to remove ISO jacks until after shelter has been lowered.
- When floor is lowered, (to allow roof clearance for folding) devices securing fold-out floor counterbalance cables can be disengaged.

REMOVING AREA LIGHT

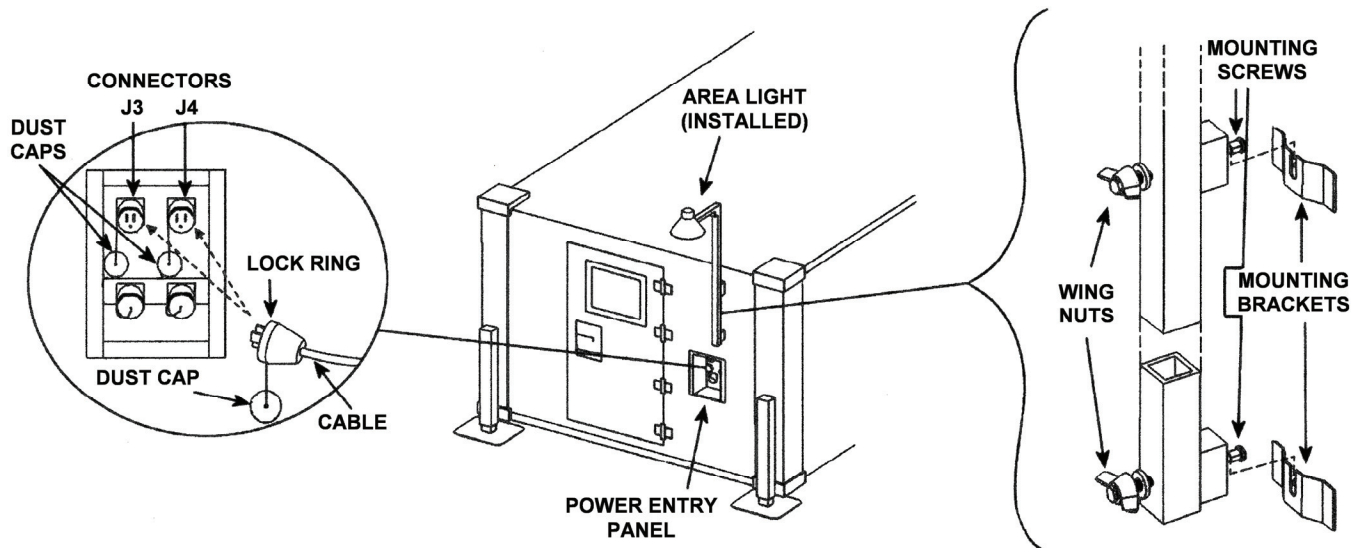

1. Disconnect area light cable from either "J3" or "J4" connector on power entry panel.
2. Replace protective dust cap on "J3" or "J4" connector on power entry panel.
3. Replace protective dust cap on area light cable.

NOTE

Do not remove wing nuts from screws.

4. Loosen wing nuts and remove area light from location outside shelter.
5. Roll up area light cable.
6. Remove bulb and store in Shelter BII Box.
7. Install area light on inside fixed personnel end wall by securing area light to mounting brackets and tightening wing nuts.

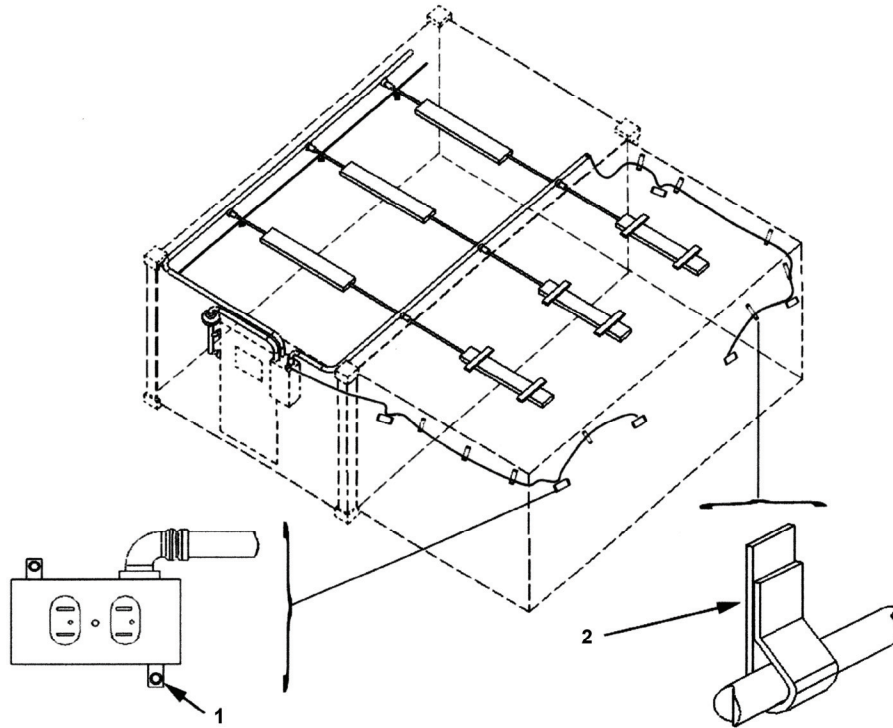
REMOVING CABLE AND RECEPTACLE ASSEMBLY

1. Release power cables from Velcro straps (2).
2. Release captive fasteners (1) and reposition receptacles from operating position on hinged sidewall to stored position on hinged end walls.
3. Position receptacles with power cables facing up and secure with captive fasteners (1).
4. Repeat these procedures at other end of shelter.

REMOVING CEILING LIGHTS FROM HINGED ROOF

WARNINGS

- Ensure main circuit breaker and all other circuit breakers in breaker panel are in the **OFF** position.
- In the event of lamp breakage, care must be taken in removal of broken glass fragments and white phosphorous dust that may be dispersed within fixture. Inhalation of phosphorous dust could cause **SERIOUS INJURY** to personnel.

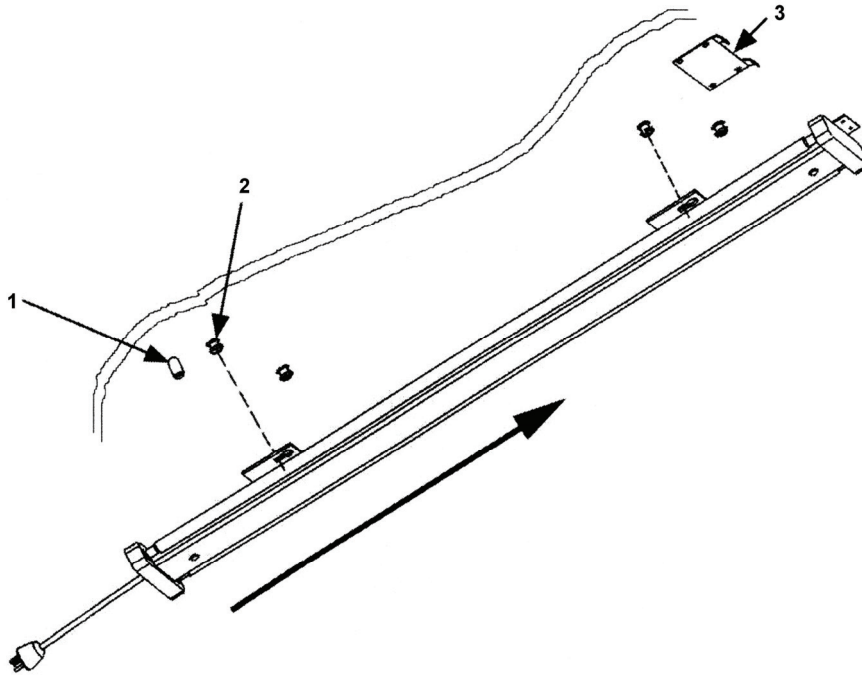

1. Twist power cable plug one-quarter turn counterclockwise to unlock and then remove from connector.
2. Press and hold plunger lock (1) in hinged roof light bracket (3).
3. Move entire light fixture lengthwise away from power cable end to disengage light from four captive studs (2) in hinged roof.
4. Move light fixture into fixed roof section and rotate 180 degrees. Mate with four captive studs (2) in fixed roof.
5. Secure fixture by moving until spring loaded plunger engages.
6. Place power cable into storage clip on ceiling.
7. Repeat these procedures for each of two remaining ceiling lights.

RELEASING SHELTER LATCHES

1. Remove four removable latches and place in Shelter BII Box.

WARNING

It is essential that non-removable latches are pressed flat into pans.

2. Release all non-removable latches between hinged sidewall, end wall, roof, and floor and press flat in pans.

RELEASING SHELTER WALLS

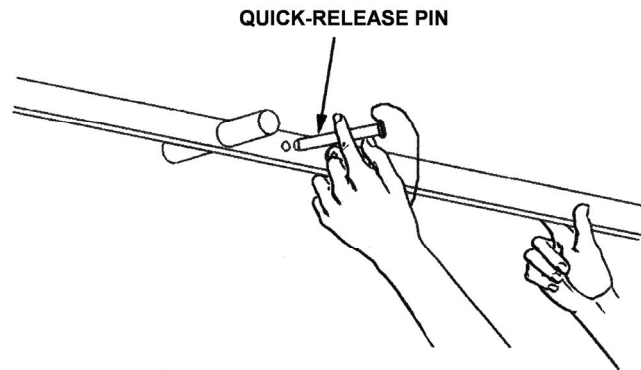

1. Lower two support struts from hinged roof by removing quick-release pin.
2. Extend support struts to their full length and insert quick-release pin.
3. Using two personnel raise roof with struts and set struts in place.

CAUTION

Prevent hinged end walls from hitting Velcro straps, walls can tear straps.

NOTE

Stencil on jack indicates handle rotation to raise or lower jack.

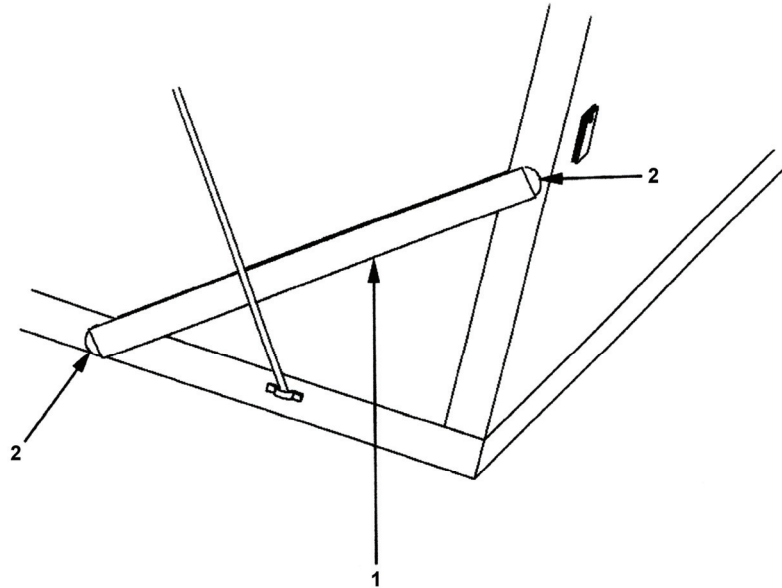

4. Simultaneously lower hinged floor with hinged jacks until hinged end walls can swing free.
5. Remove two sidewall support braces from Shelter BII Box.
6. Install two sidewall support braces (1) in brace cups marked "A" (2) on hinged floor and sidewall behind support cable.
7. Place two ECU support cables over each hinged end wall and secure cable ends to ECU screen.
8. Fold in each hinged end wall to roof beam and hold in place with Velcro straps.

LOWERING SHELTER ROOF**WARNING**

When all equipment and materiel is stored on stationary side of shelter, limited floor space presents a safety hazard to operating personnel. This is most critical during raising and lowering of roof panel. Failure to observe supplemental instructions could result in **SERIOUS INJURY** to personnel. Personnel inside shelter could become trapped between roof panel and equipment bolted to floor.

CAUTION

When swinging end wall closed, D-rings on ECU panel should be pressed flat against panel to prevent damage to hinged roof.

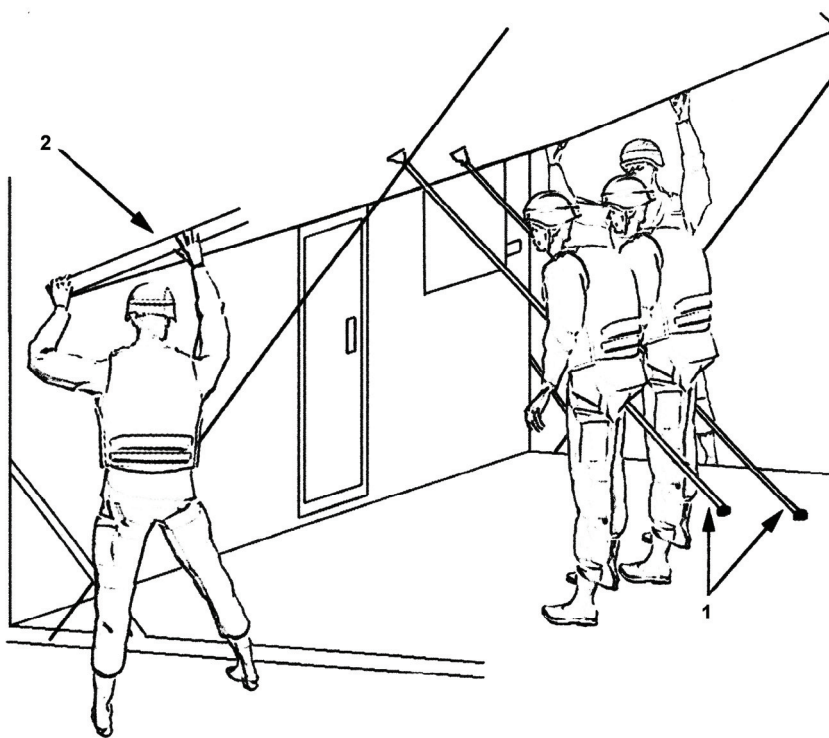

1. Two personnel inside shelter, using support struts (1), will lower roof panel (2) until two personnel outside can reach and hold weight of roof.

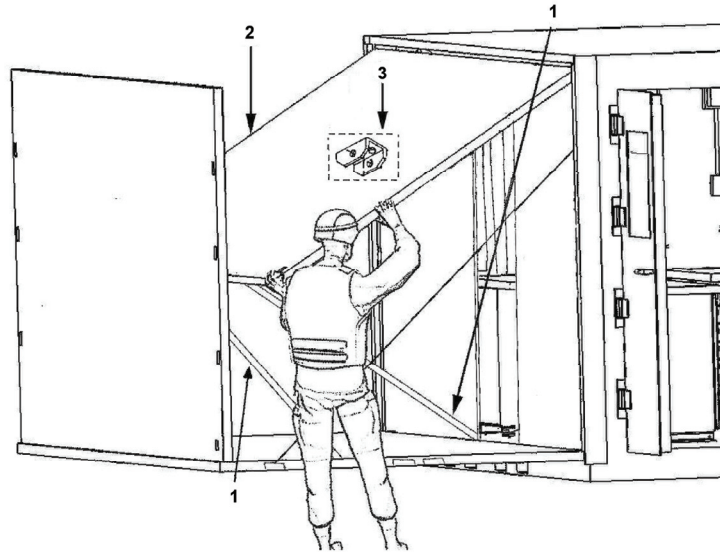

2. Inside personnel will shorten two struts (1) and secure to ceiling brackets (3). They will then move outside shelter to assist outside personnel.
3. After all inside personnel are clear, allow the roof panel (2) to close to vertical position.

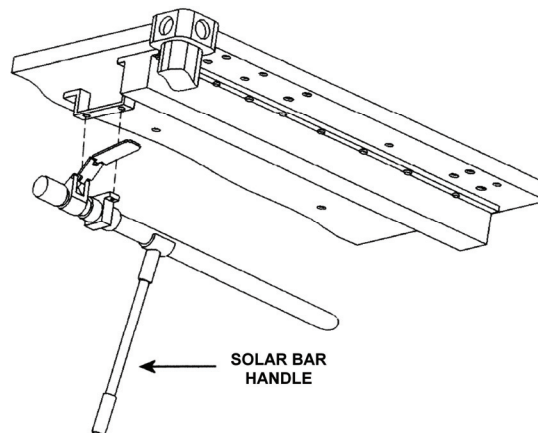

4. Slide hinged roof inward to storage position by rotating the solar bar handles up.
5. Remove safety pin from hinged jacks.
6. Lower and remove hinged jacks (and extensions, if used) supporting hinged floor.
7. Store hinged jacks on left cargo door and secure safety pins. For more information on jack extensions, refer to WP 0005 00-7, Positioning Hinged Jacks for Leveling.
8. While holding hinged sidewall, remove two sidewall support braces and store in Shelter BII Box.

WARNING

To avoid injury, be careful not to get caught between cable and sidewall panel. Do not attempt to control panel if it is accidentally dropped, trapped air acts as a cushion.

9. Fold down hinged sidewall onto hinged floor. Allow wall to free fall before it comes to same plane as cables.

RAISING HINGED FLOOR

WARNING

Fold-out floor counterbalance cables must be secured in cable housings prior to raising shelter floor from its lowered position to its level position. If counterbalance cables are not secured, counterbalance cables will remain under tension. **DO NOT** attempt to remove cables if counterbalance cables are not secured. Removing cables while under tension could cause **SERIOUS INJURY** to personnel.

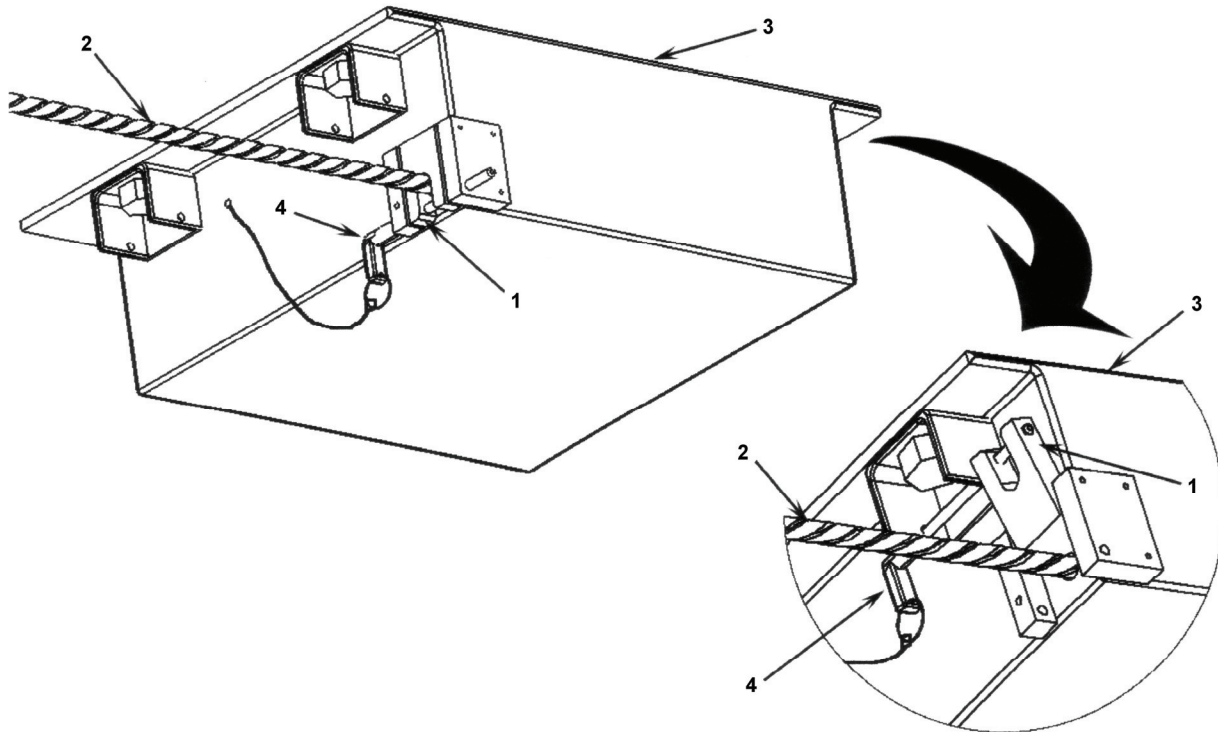

1. Remove lockout pins (4) from lower position on both cable reels (3).
2. Open slide stops (1) against counterbalance cables (2) on both cable reels (3).
3. Replace lockout pins (4) in upper position on both cable reels (3).
4. Position cam locks so handles are vertical and down for cargo end and vertical and up on personnel end of shop.

WARNING

Expandable section (hinged floor and hinged sidewall together) weighs 700 pounds (318 kg). **DO NOT** stand directly under hinged section.

NOTE

If hinged floor and corner post bind, re-level shelter.

**ENGAGE
HINGED FLOOR LOCKS**

**PERSONNEL
END OF SHELTER**

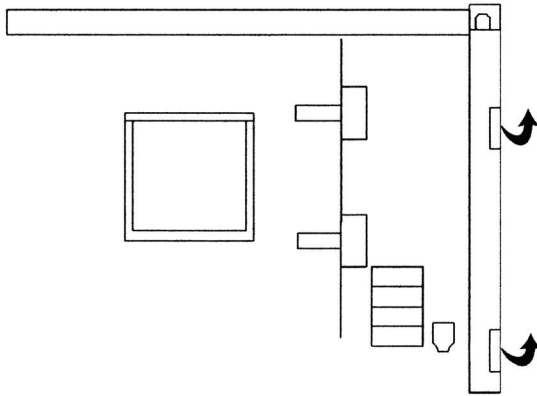

**CARGO
END OF SHELTER**

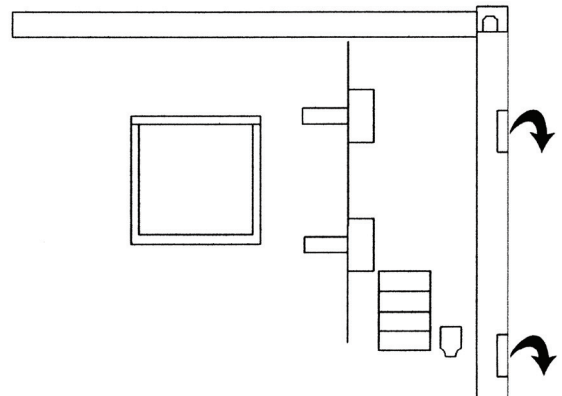

5. Raise hinged floor and secure to corner post with cam locks. Rotate cam lock handles as indicated and engage lower locks first. Make sure pins are in holes.

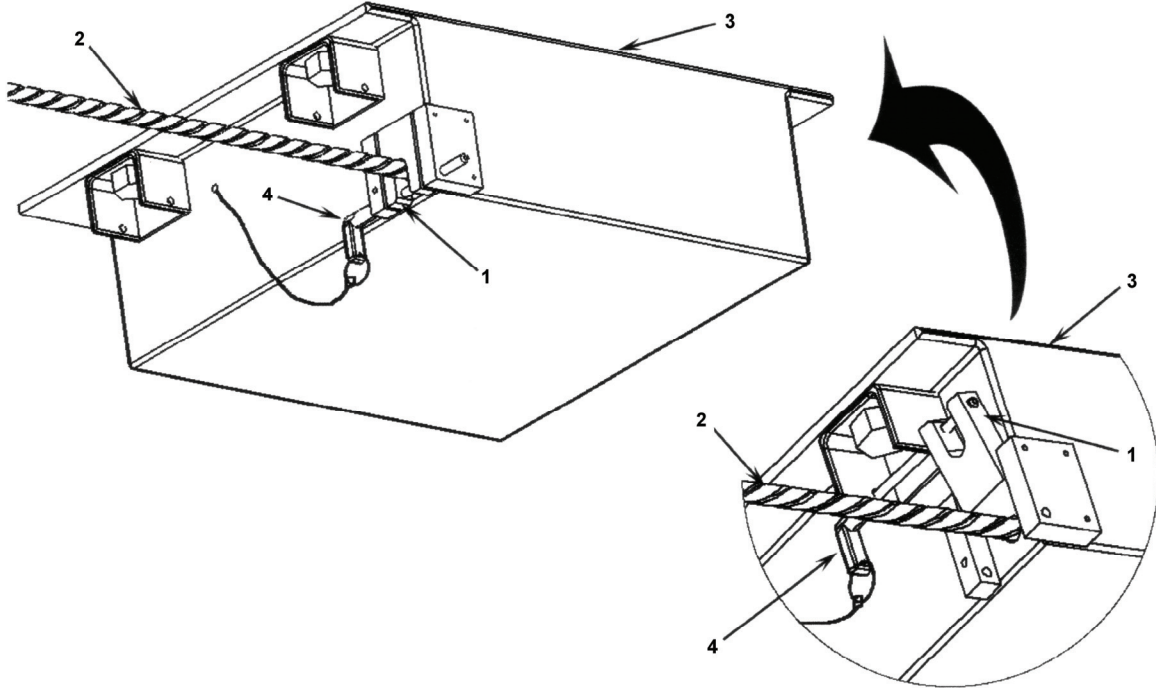

6. Remove lockout pins (4) from upper position on both cable reels (3).
7. Close slide stops (1) against counterbalance cables (2) on both cable reels (3).
8. Replace lockout pins (4) in lower position on both cable reels (3).

LOWERING SHELTER**NOTE**

If it is intended to use a dolly set to move shelter, place pieces of 4x4 lumber under frame and clear of ISO fittings to facilitate mounting of dolly set.

1. Remove safety pins on four ISO jacks.

NOTE

Stencil on ISO jack indicates handle rotation to raise or lower jack.

2. Lower all ISO jacks simultaneously until shelter is completely lowered.
3. Turn locking handle clockwise thus lowering jack attachment insert in ISO fitting.
4. Remove ISO jacks from four corners of shelter.

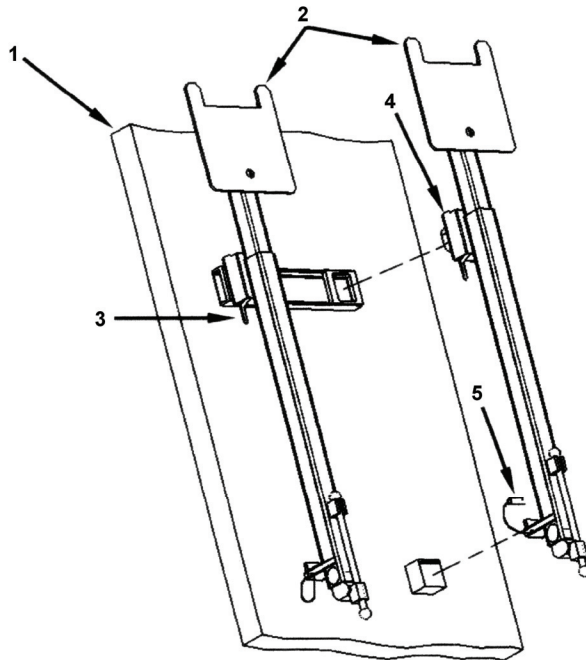

5. Replace four ISO jacks (2) inside of personnel and right cargo doors (1) by turning locking handle (3) to secure jack attachment insert (4) and insert safety pin (5).

SECURING THE SHELTER**CAUTION**

Left cargo door has a chain latch and a spring latch. These latches must be properly engaged or door is not secure.

1. Close shelter doors.

WARNING

Door handle must be padlocked at 12 o'clock position for shipping mode and 3 o'clock position for storage mode. Correct locking positions ensure that doors are secure and remain closed.

2. Check security of shelter. Place padlocks on outside door handles.
3. The Non-Destructive Inspection Shop is ready for transport or storage.

End of Work Package

**NON-DESTRUCTIVE INSPECTION SHOP
OPERATION UNDER UNUSUAL CONDITIONS**

SECURITY MEASURES FOR ELECTRONIC DATA

Not Applicable

UNUSUAL ENVIRONMENT/WEATHER

This section provides instructions for operation of the shelter in unusual weather conditions. Operation during blackout conditions is also provided.

OPERATION IN RAIN AND/OR MUD

1. When setting up shelter, place wood planks or boards under each jack pad to increase bearing area.
2. Provide adequate drainage ditch to prevent standing water around shelter area.
3. Check leveling jacks frequently for sinking; level shelter as required by adjusting lift jacks.
4. Close and secure all doors in shelter.
5. Check seals for proper placement and compression.

OPERATION IN SNOW, ICE, OR EXTREME COLD**WARNING**

In extreme cold, do not touch metal parts with bare hands. Severe skin damage may result.

NOTE

Fluorescent lights have a delay time in coming on at temperatures of 0°F and below.

1. Remove snow routinely and prior to holding roof with a soft bristle brush, broom, or equivalent.
2. Remove ice from shelter before lowering hinged panels.
3. Ensure ECU is properly connected to shelter.
4. Keep all doors and vents closed.

OPERATION IN HIGH WINDS**WARNING**

To avoid injury when expanding or closing hinged sidewall in high winds, use six personnel.

NOTE

Two personnel are required to perform the following procedure.

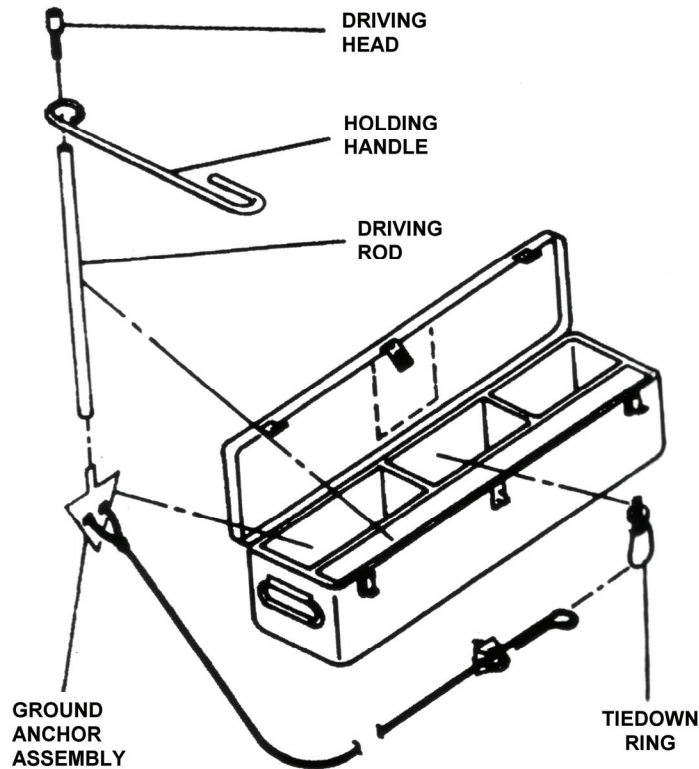

1. To install storm configuration (tie-down installation) kit, use the following items.
 - a. Ground anchor assembly
 - b. Driving rod
 - c. Holding handle
 - d. Driving head
 - e. Tiedown ring

WARNING

Safety goggles must be worn by personnel when installing ground anchors.



2. One person shall support driving rod with holding handle, while second person drives ground anchor into ground using a 12-pound sledge hammer.
3. Drive each of six loop and clamp ground anchors into ground approximately 3 feet (91.5 cm) deep, and as close as possible to shelter attaching points, at locations indicated.

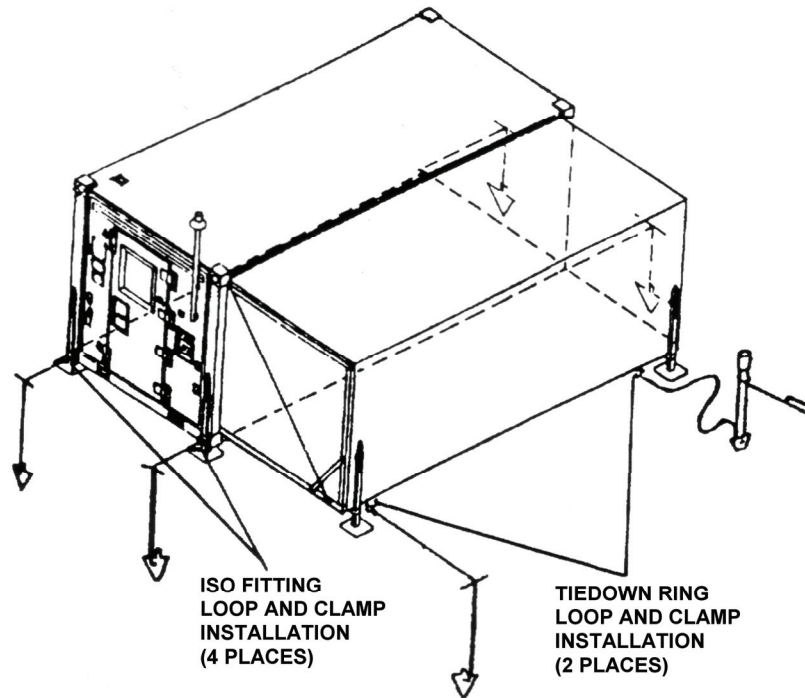

4. Set each ground anchor by forming a loop in cable end and secure loop with clamp.

NOTE

This setting of the anchor is required to turn the anchor in the ground so that it develops maximum holding power.

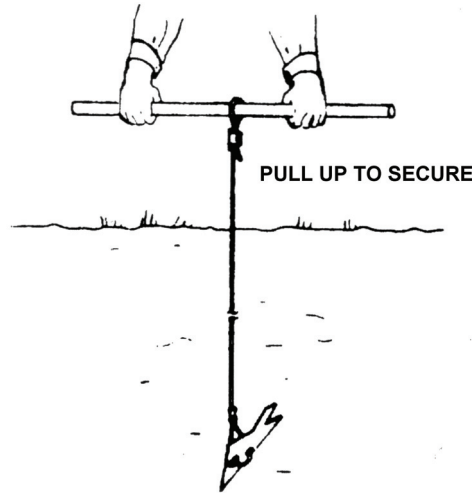

5. Insert driving rod through loop and pull up sharply to ensure anchor is set into ground.

NOTE

When moving shelter, disassemble storm configuration kit and cut cable as close to ground as possible. Discard cable components. Retain the two tiedown rings and store in appropriate storage location.

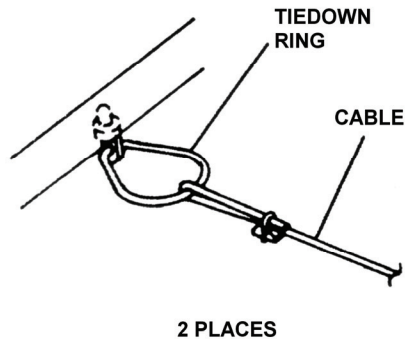
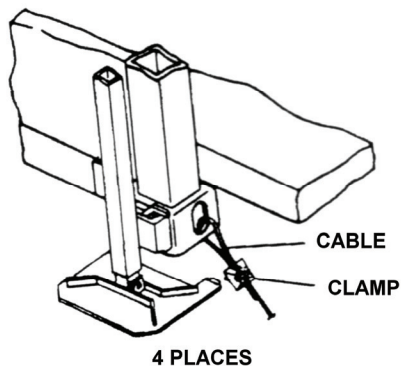

6. Remove clamp, loop cable at six places (two with tiedown rings) as shown.
7. Replace clamp and tighten clamp nuts.

OPERATION DURING BLACKOUT CONDITIONS**NOTES**

- During blackout condition, enter and leave shelter through personnel door only. Do not operate exterior area light.
 - Blackout override switch must remain in **OFF** position for duration.
1. Activate all interior lights and check from 25 feet (7.6 m) away to ensure no light is visible.
 2. Place blackout override switch to **OFF** position.

End of Work Package

**CHAPTER 3
TROUBLESHOOTING PROCEDURES
FOR
NON-DESTRUCTIVE INSPECTION SHOP
(Not Applicable)**

**CHAPTER 4
MAINTENANCE INSTRUCTIONS
FOR
NON-DESTRUCTIVE INSPECTION SHOP**

**NON-DESTRUCTIVE INSPECTION SHOP
SERVICE UPON RECEIPT**

INITIAL SETUP**Tools And Special Tools:**

Tool Kit, Power Plant
(WP 0031 00, Table 2, Item 102)

References:

N/A

Personnel Required: (1)

CMF 15 Series

CHECKING EQUIPMENT

1. Inventory for completeness of shop once shelter has been erected.
2. Inspect equipment to ensure that all items are still firmly secured to floor and wall mounts.
3. After equipment has been positioned to recommended operational floor plan, check all items requiring service. Preventive Maintenance (PM) and preoperational services will be performed IAW applicable shop equipment TMs or manufacturer-supplied operating manuals.

End of Work Package

**NON-DESTRUCTIVE INSPECTION SHOP
BASIC SHOP EQUIPMENT**

INITIAL SETUP**Tools And Special Tools:**

Tool Kit, Power Plant
(WP 0031 00, Table 2, Item 102)
Tool Kit, Electrical Repairer
(WP 0031 00, Table 2, Item 104)
Torque Wrench 0-600 in. lbs. (5120-01-530-2311)
Multimeter (6625-01-265-6000)
Portable Disc Grinder (5130-01-358-5262)
Rivet Puller (5120-00-391-0116)
Electrical Drill (5130-00-889-9004)
3/16" Drill Bit (5133-01-399-0721)
1/8" Drill Bit (5133-00-980-3423)
Welding Machine (3431-01-507-1712)
Spoolmatic (3431-01-024-1681)
Control (3431-04-429-9607)
Regulating Flow Meter (4820-01-086-4310)
Argon Bottle (8120-00-282-8077)
Paint Brush (8020-00-245-4519)

References:

MIL-STD-2219
TC 11-6
TM 43-0139
WP 0026 00

Equipment Conditions:

Functional

Materials/Parts:

Paint (WP 0037 00, Table 1, Item 2)
Paint (WP 0037 00, Table 1, Item 3)
Primer (WP 0037 00, Table 1, Item 4)
Paint (WP 0037 00, Table 1, Item 13)
Sealing Compound (WP 0037 00, Table 1, Item 8)
Rivets (WP 0037 00, Table 1, Item 9)
Rivets (WP 0037 00, Table 1, Item 10)
Paint (WP 0037 00, Table 1, Item 13)
First Aid Bracket (WP 0033 00, Figure 2, Item 1)
BNC Cable Assembly
(WP 0033 00, Figure 2, Item 2)
Grounding Rod (WP 0033 00, Figure 2, Item 3)
Door Hasp (WP 0033 00, Figure 2, Item 4)
Hexagon Head Cap Screw
(WP 0033 00, Figure 2, Item 5)
Lock Washer (WP 0033 00, Figure 2, Item 6)
Flat Washer (WP 0033 00, Figure 2, Item 7)

Personnel Required:

44E, Machinist
15F, Electrical Repairer
CMF 15 Series

NOTE

During installation of components the same hardware should be used so as to maintain the original integrity of the shop sets.

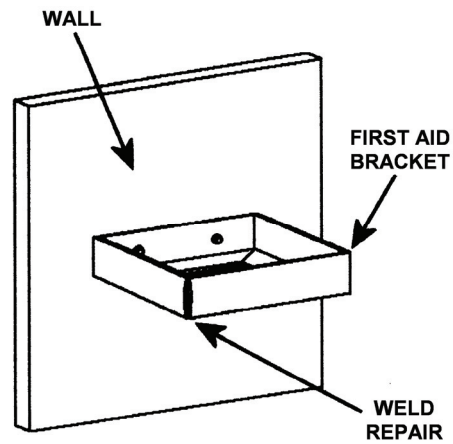
FIRST AID KIT BRACKET**Inspect**

Visually inspect first aid kit bracket for damage and for loose bolts. If bracket is loose, follow procedures in WP 0026 00. If bracket is damaged, replace it with a new one.

Remove

Remove two bolts, two lock washers, and two flat washers attaching first aid kit bracket to wall.

Repair

1. If first aid kit bracket has a broken weld and can be repaired by welding, repair it by welding damaged area IAW MIL-STD-2219. The welding repair must not interfere with form, fit, or function of bracket.
2. Paint repaired first aid kit bracket with specified primer and paint per TM 43-0139.

Install

1. Install two bolts with two lock washers and two flat washers.
2. Torque bolts 160-190 in. lbs.

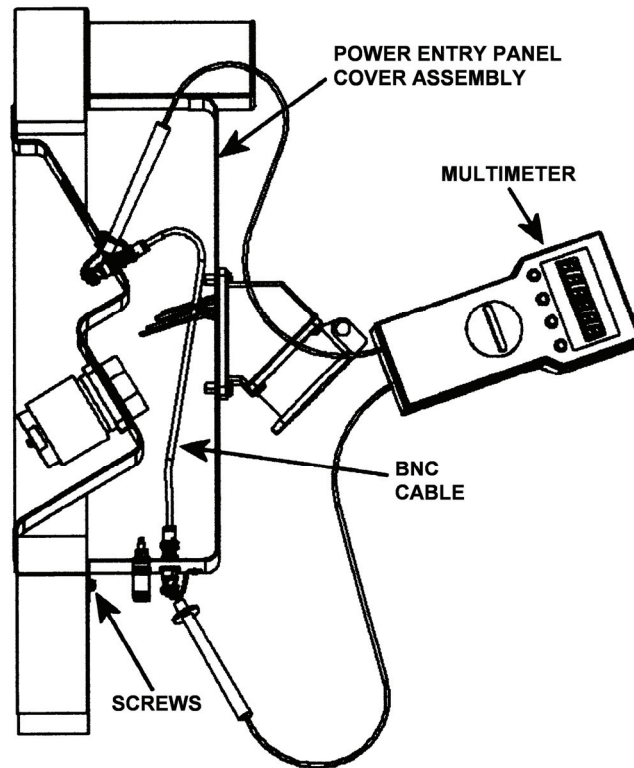
BAYONET NEIL CONCELMAN (BNC) CABLE ASSEMBLY**Inspect**

Visually inspect BNC connectors and cable for damage.

WARNING

Turn **OFF** all power to shelter before proceeding with any electrical tests or repairs.

CAUTION

This work should be performed by a qualified electrician.

Test

1. Move main circuit breaker to the **OFF** position.
2. Test BNC cable for continuity. If test indicates a break in BNC cable, replace BNC cable assembly.

Remove

1. Move main circuit breaker to the **OFF** position.
2. Remove four screws attaching power entry panel cover assembly to personnel end wall, located below circuit breaker panel.
3. Carefully remove cover from wall.
4. Remove nut and lock washer from BNC connector attaching cable to power entry panel.
5. Remove nut and lock washer from BNC connector attaching cable to cover assembly for power entry panel.
6. Remove damaged cable.

Install

1. Install new BNC cable connector in cover assembly by installing lock washer and nut.
2. Install new BNC connector into power entry panel and install lock washer and nut.
3. Attach BNC cable to both BNC connector ends.
4. Install cover assembly back on interior wall of shelter using four screws.
5. Reconnect power to shelter.

GROUNDING ROD**WARNING**

HIGH VOLTAGE exists in electrical system of shop. All electrical inspections, repairs, or replacements shall be performed with power **OFF** and only by qualified electricians. Serious shock hazards exist which could result in **SERIOUS INJURY OR DEATH** to personnel.

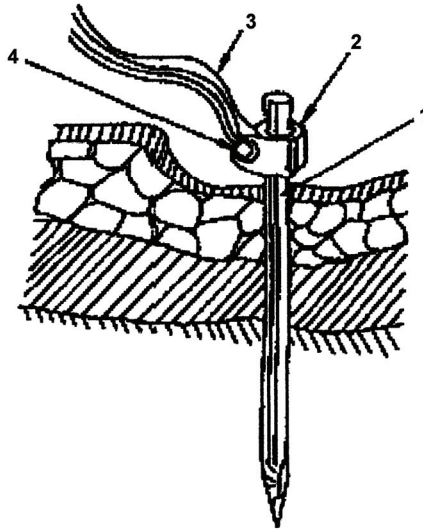
**Inspect**

1. Move main circuit breaker to the **OFF** position.
2. Ensure grounding rod (1) is firmly driven into ground.
3. Ensure BNC clamp (2) and screw (4) are securely fastened.
4. Ensure there is no sign of oxidation around clamp (2) or screw (4).
5. Check that grounding cable (3) is not frayed or broken.

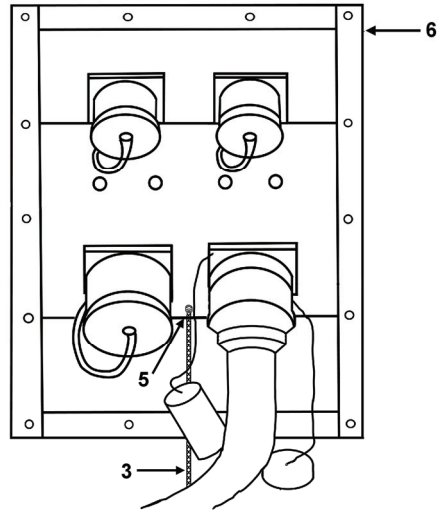

6. Check grounding cable (3) connection at terminal lug (5) on shelter power entry panel (6).

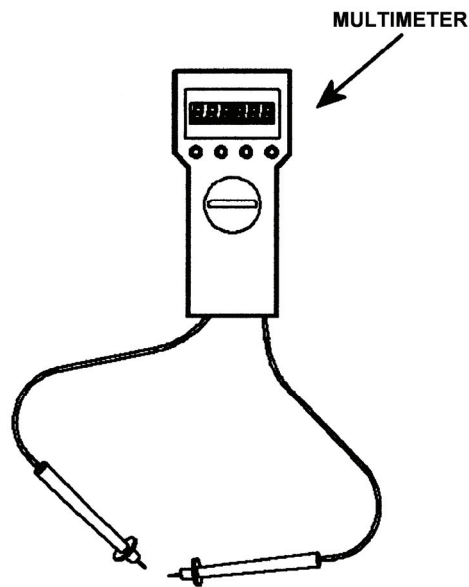

7. Check condition of ground. (Use TC 11-6)
 - a. Set for ohms
 - b. Red lead on shelter
 - c. Black lead on ground cable
 - d. 0-5 ohms - adequate ground
 - e. Over 5 ohms - poor ground

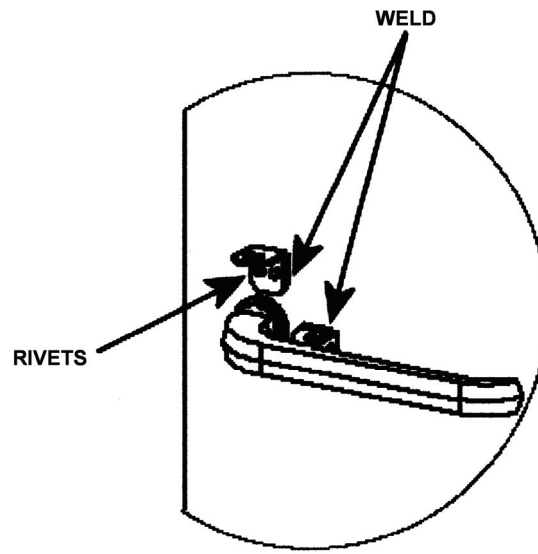
DOOR HASP**Inspect**

1. Visually inspect door hasps.
2. Replace if damaged is present.

Remove**CAUTION**

Use extreme care not to grind or cut through the shelter skin.

1. Grind welds from damaged door hasp.
2. Drill out two rivets attaching door hasp.
3. Remove hasp.
4. Clean skin surface of paint and epoxy down to bare metal.

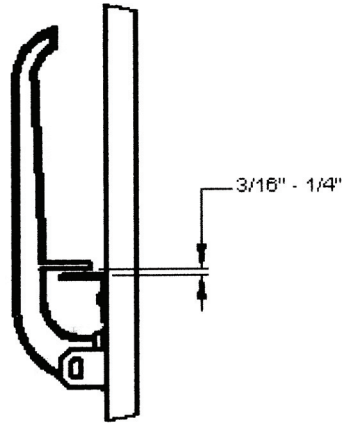
Install

1. Install door hasp by using latch handle as a guide to position.
2. Mark position of door hasp.

NOTE

There should be adequate clearance for latch handle to swing around door hasp without interference.

3. Rotate latch handle out of way and match drill door hasp to door in two places.
4. Deburr all holes and clean off all metal shavings.
5. Position latch and insert two rivets into two holes.

NOTE

Rivets should be dipped or coated in sealing compound before inserting into drilled holes.

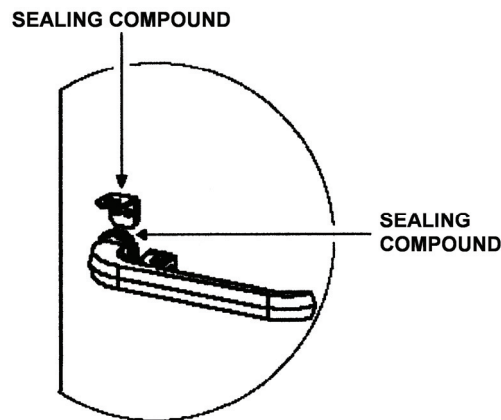

6. Pull rivets to secure door hasp to door.
7. Weld door hasp to door in two places.
8. Prime surface.
9. Apply a bead of sealing compound along remaining two sides of door hasp as well as coating rivet heads with sealing compound.
10. Paint per specifications located on CARC plate on personnel end, outside of shelter.

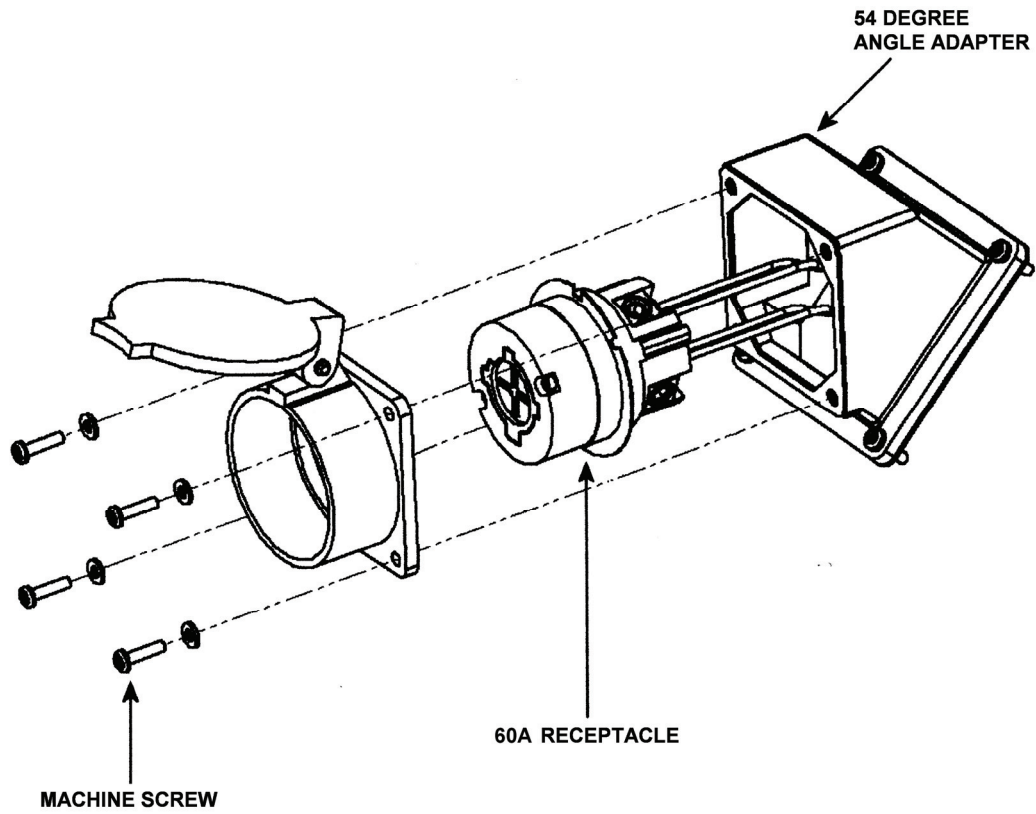
54 DEGREE ANGLE ADAPTER**Inspect**

Visually inspect 54 degree 60A receptacle adapter housing for any damage that will prevent intended use of 60A receptacle or present a safety hazard.

WARNING

Turn **OFF** all power to shelter before proceeding with any electrical repairs.

CAUTION

This work should be performed by a qualified electrician.

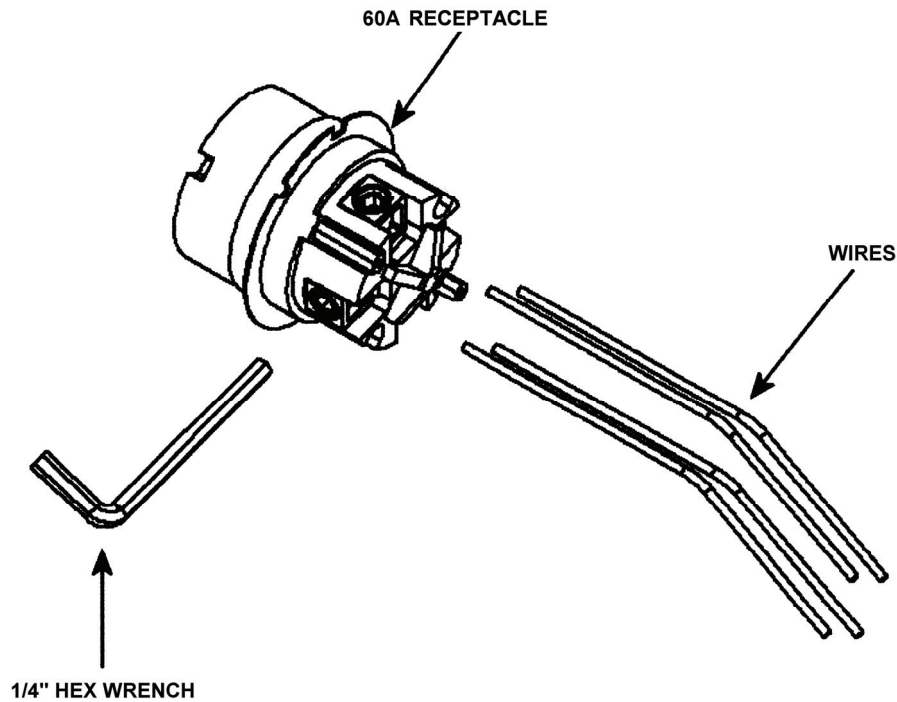
Remove

1. Remove four machine screws attaching 60A receptacle to 54 degree adapter housing.
2. With machine screws removed, pull 60A receptacle out of housing until wire lug terminals are exposed.

NOTE

Receptacle lugs are identified by letters "X", "Y", and "Z" with ground connection being identified by color green. Black wire will be attached to "X", red wire will be attached to "Y", and blue wire will be attached to "Z".

3. Loosen all lugs on 60A receptacle and remove wires.

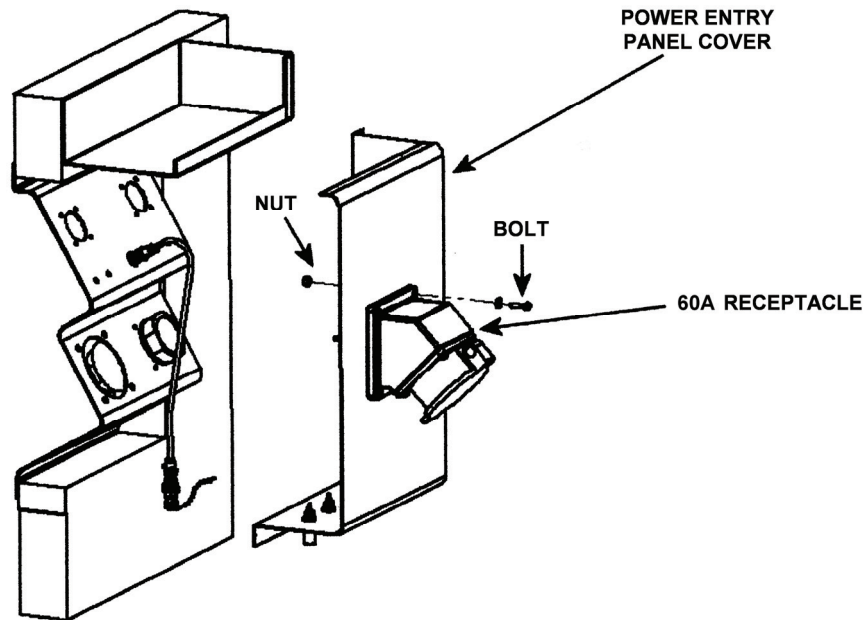

4. Remove four machine screws from power entry panel cover located inside shelter below circuit breaker panel. Carefully remove cover from shelter wall.
5. Remove four nuts, lock washers, and bolts that attach 54 degree angle 60A receptacle adapter housing from power entry panel cover.

Install

1. Install four nuts, lock washers, and bolts to attach 54 degree angle 60A receptacle adapter housing from power entry panel cover.
2. Install four machine screws on power entry panel cover located inside shelter below circuit breaker panel. Carefully replace cover on shelter wall.

NOTE

Receptacle lugs are identified by letters "X", "Y", and "Z" with ground connection being identified by color green. Black wire will be attached to "X", red wire will be attached to "Y", and blue wire will be attached to "Z".

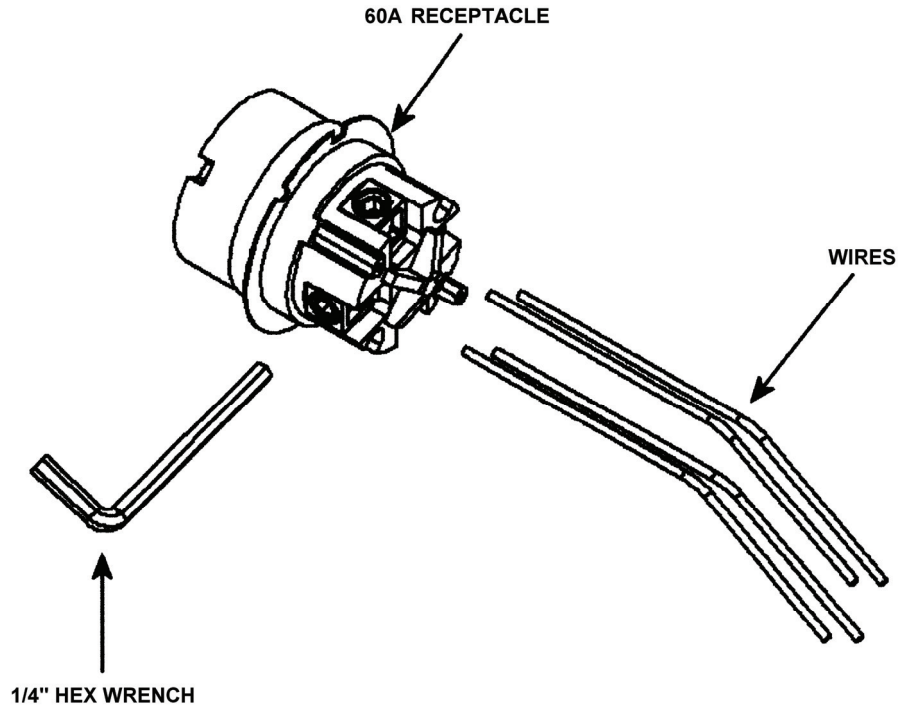

3. Replace wires and tighten all lugs on 60A receptacle.
4. Replace 60A receptacle.
5. Install four machine screws to attach 60A receptacle to 54 degree adapter housing.

60A RECEPTACLE**Inspect**

Visually inspect 60A receptacle connections for looseness or damage.

WARNING

Turn **OFF** all power to shelter before proceeding with any electrical tests or repairs.

CAUTION

This work should be performed by a qualified electrician.

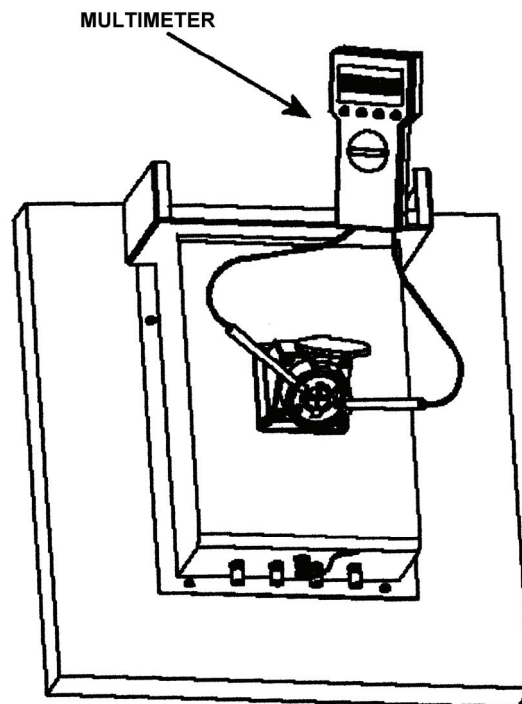
Test

Check 60A receptacle and wires for continuity. If problems are found with 60A receptacle, replace.

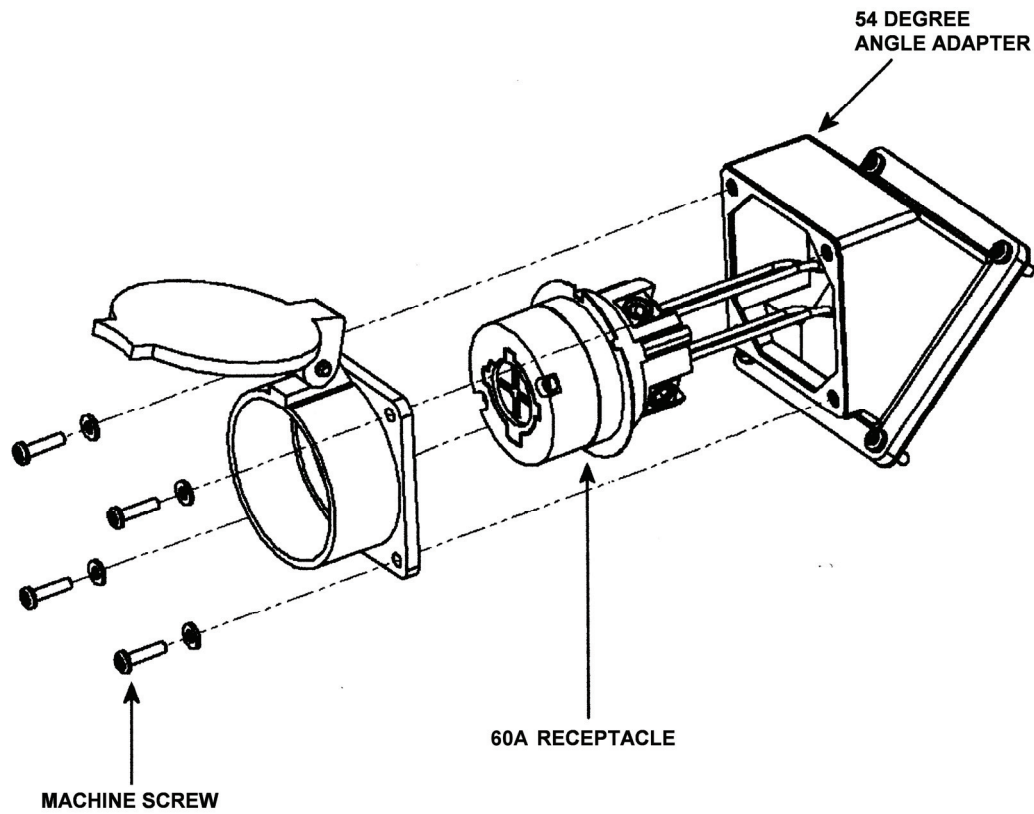
Remove

1. Remove four machine screws attaching 60A receptacle to 54 degree adapter housing.
2. Pull 60A receptacle out of housing until wire lug terminals are exposed.

NOTE

Receptacle lugs are identified by letters "X", "Y", and "Z" with ground connection being identified by color green. Black wire will be attached to "X", red wire will be attached to "Y", and blue wire will be attached to "Z".

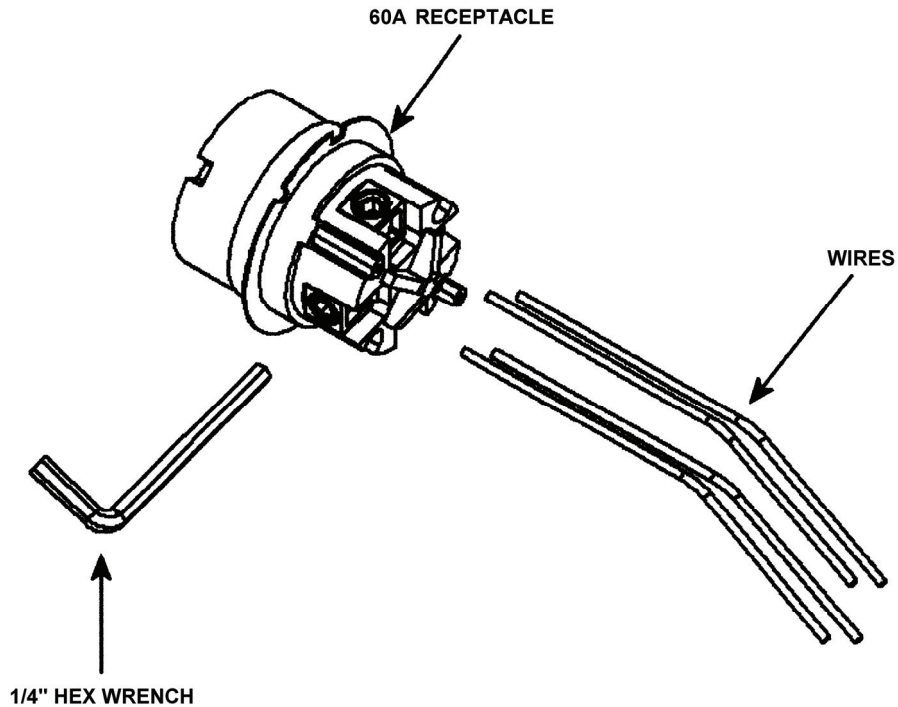

3. Loosen all lugs on 60A receptacle and remove wires.

Install

1. Attach wires to new 60A receptacle with black wire connected to "X" lug, red wire to "Y" lug, and blue wire connected to "Z" lug.
2. Attach ground wire to "green" terminal.
3. Reinstall 60A receptacle into 54 degree adapter housing using four machine screws that were removed.
4. Restore power to shelter.

100A CIRCUIT BREAKER

Inspect

Visually inspect 100A circuit breaker for any apparent damage.

WARNING

All power to shelter must be turned **OFF** before proceeding with any electrical tests or repairs.

CAUTION

This work should be performed by a qualified electrician.

Remove

1. Tag and disconnect shelter electrical power.
2. Set all circuit breaker switches to **OFF** position.

NOTE

This procedure covers obsolete NQOB circuit breaker panel and new NQOD circuit breaker panel. These units are distinguishable by nameplates attached to panel boards.

3. Open circuit breaker panel door on both models.
4. Loosen four captive screws and move clamp fingers to **OPEN** position on model NQOB.
5. Lift circuit breaker panel cover from panel board on model NQOB.
6. Remove four screws and washers and lift panel board from circuit breaker box on both models.

NOTE

Once panel boards are removed, all further procedures are identical for both models.

7. Reconnect site power.

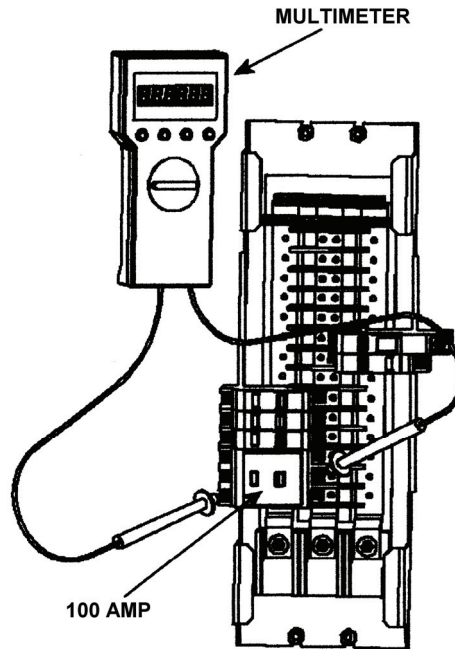
Test

1. Set 100A circuit breaker to **ON** position.
2. Set branch circuit breakers to **ON** position and observe if any breakers pop to **OFF** position.
3. Disconnect site power.
4. Using a multimeter, check 100A circuit breaker for continuity.
5. If there is no continuity, 100A circuit breaker is defective and must be replaced.

WARNING

Disconnect electrical power from shelter before removing components. Failure to observe this warning may cause **DEATH OR SERIOUS INJURY** to personnel.

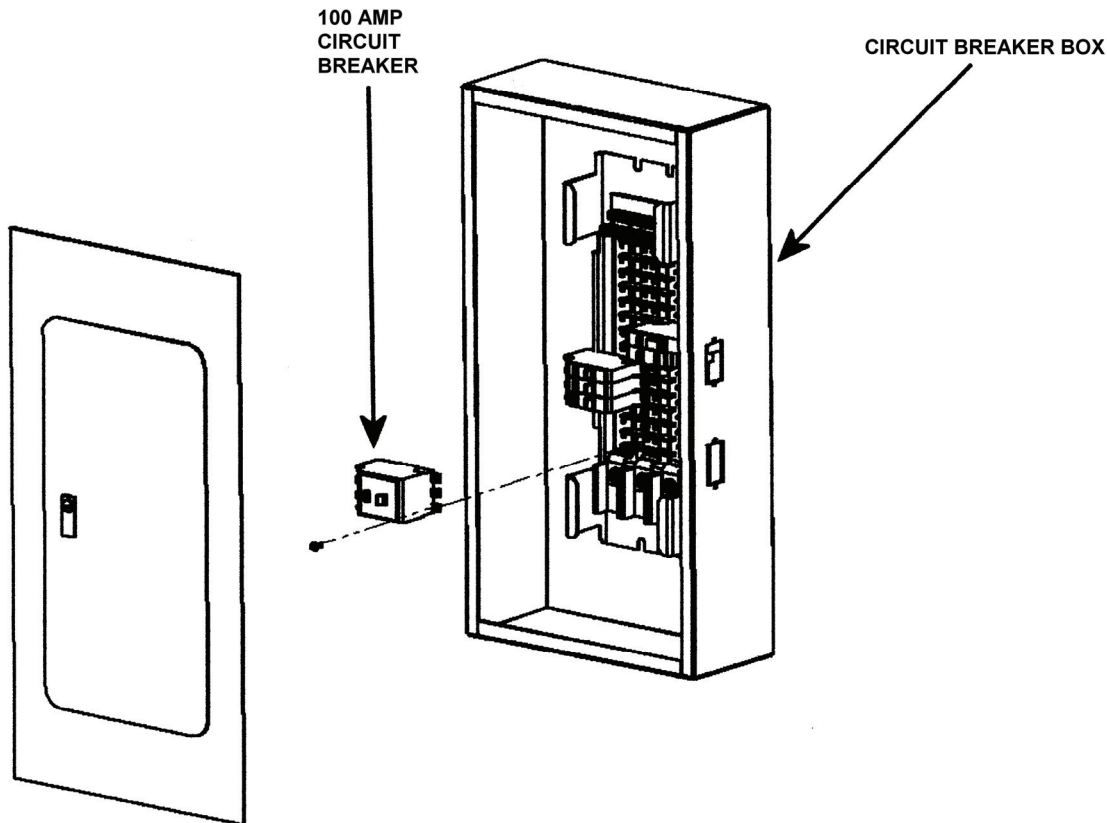
Remove

1. Mark and disconnect wires from 100A circuit breaker that will be removed.

NOTE

Do not completely remove screw; loosen only enough to allow removal of 100A circuit breaker.

2. Loosen screw holding 100A circuit breaker in place. Pull the 100A circuit breaker from the bus bar and remove from the circuit breaker box.

Install

1. Place new 100A circuit breaker in place and tighten screw.
2. Connect wires.
3. Attach panel board to circuit breaker box with screws and washers.
4. Place panel cover on model NQOB panel board, move clamp fingers to **LOCK** position and tighten captive screws.
5. Close circuit breaker panel door.

End of Work Package

**NON-DESTRUCTIVE INSPECTION SHOP
FIRE EXTINGUISHER BRACKET**

INITIAL SETUP**Tools And Special Tools:**

Tool Kit, Power Plant
(WP 0031 00, Table 2, Item 102)
Torque Wrench 0-600 in. lbs. (5120-01-530-2311)

References:

WP 0026 00

Equipment Conditions:

Functional

Materials/Parts:

Hexagon Head Cap Screw
(WP 0033 00, Figure 7, Item 1)
Lock Washer (WP 0033 00, Figure 7, Item 2)
Flat Washer (WP 0033 00, Figure 7, Item 3)

Personnel Required: (1)

CMF 15 Series

NOTE

During installation of components the same hardware should be used so as to maintain the original integrity of the shop sets.

REMOVE

Release clamp (1) securing fire extinguisher (2) in bracket (3) and remove fire extinguisher.

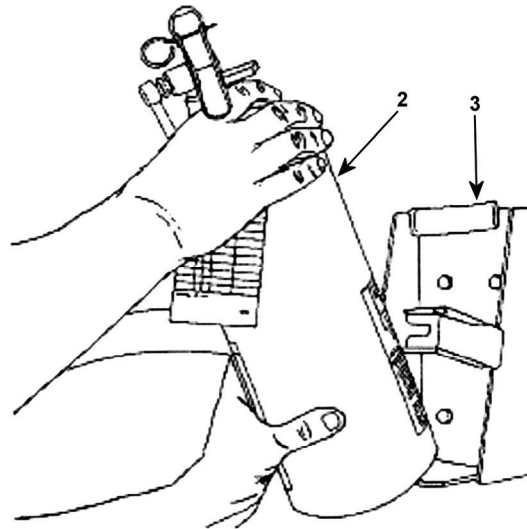
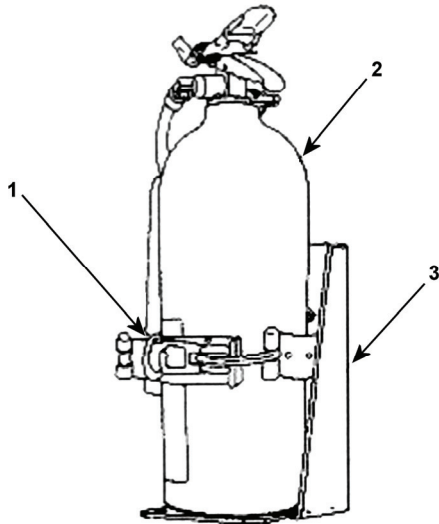

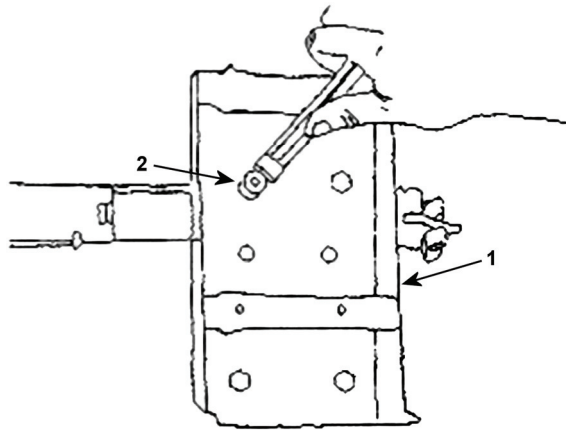
INSPECT

1. Check fire extinguisher bracket (1) for looseness.
2. Torque mounting bolts (2), when loose, 160-190 in. lbs.

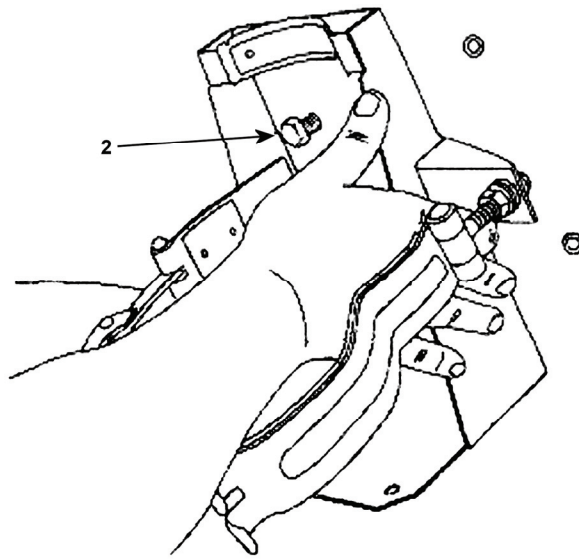

3. If bolts (2) will not tighten to specified torque (see WP 0026 00).

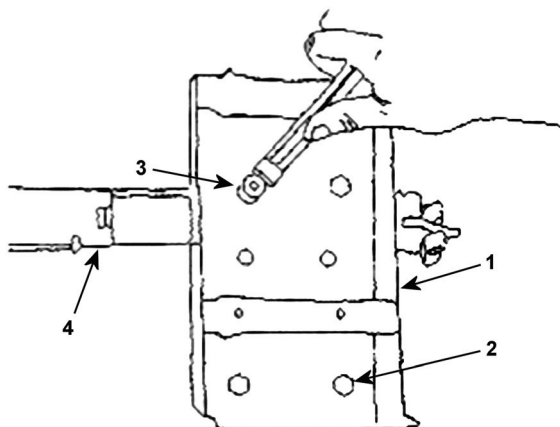
INSTALL

1. Position fire extinguisher bracket (1) and align bolt holes (2) with wall inserts.
2. Install bolts (3) with flat washers and lock washers.
3. Torque bolts 160-190 in. lbs.
4. Install fire extinguisher, and clamp (4) securing fire extinguisher.

End of Work Package

**NON-DESTRUCTIVE INSPECTION SHOP
ECU LARGE CLOSEOUT PANEL**

INITIAL SETUP**Tools And Special Tools:**

N/A

References:

N/A

Materials/Parts:

N/A

Equipment Conditions:

Functional

Personnel Required: (1)

CMF 15 Series

Inspect

Visually inspect large closeout panel modifications on each hinged end wall for any damage that will prevent proper installation of ECU and/or sealing against water intrusion into inside of shelter.

End of Work Package

**NON-DESTRUCTIVE INSPECTION SHOP
ECU ELECTRICAL COMPONENTS**

INITIAL SETUP**Tools And Special Tools:**

Tool Kit, Electrical Repairer
(WP 0031 00, Table 2, Item 104)
Multimeter (6625-01-265-6000)

References:

TM 10-5411-201-14

Equipment Conditions:

Functional

Materials/Parts:

Electrical Tape (WP 0037 00, Table 1, Item 14)
Twine/Rope (WP 0037 00, Table 1, Item 15)
Box Connector (WP 0033 00, Figure 4, Item 2)
30A Circuit Breaker
(WP 0033 00, Figure 4, Item 3)

Personnel Required: (1)

15F, Electrical Repairer

NOTE

During installation of components the same hardware should be used so as to maintain the original integrity of the shop sets.

ECU POWER CABLE ASSEMBLIES**Inspect**

Visually inspect ECU cable connectors and ECU cable for any type of damage.

WARNING

Turn **OFF** all power to shelter before proceeding with any electrical test or repairs.

CAUTION

This work should be performed by a qualified electrician.

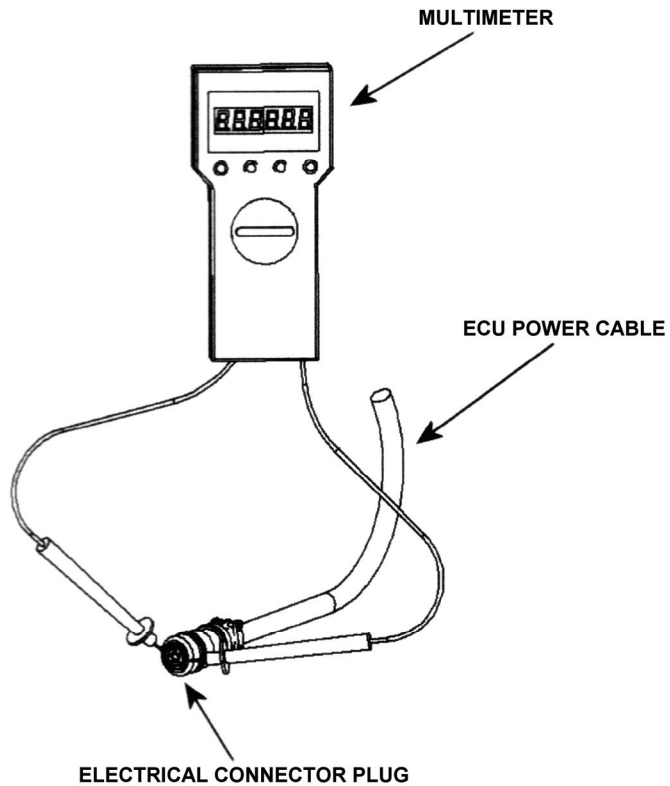
Test

Test ECU connectors, cables, and circuit breaker for any electrical problems. If any electrical problems are found, replace ECU power cable.

Replace

NOTE

This procedure covers obsolete NQOB circuit breaker panel and new NQOD circuit breaker panel. These units are distinguishable by nameplates attached to panel boards.

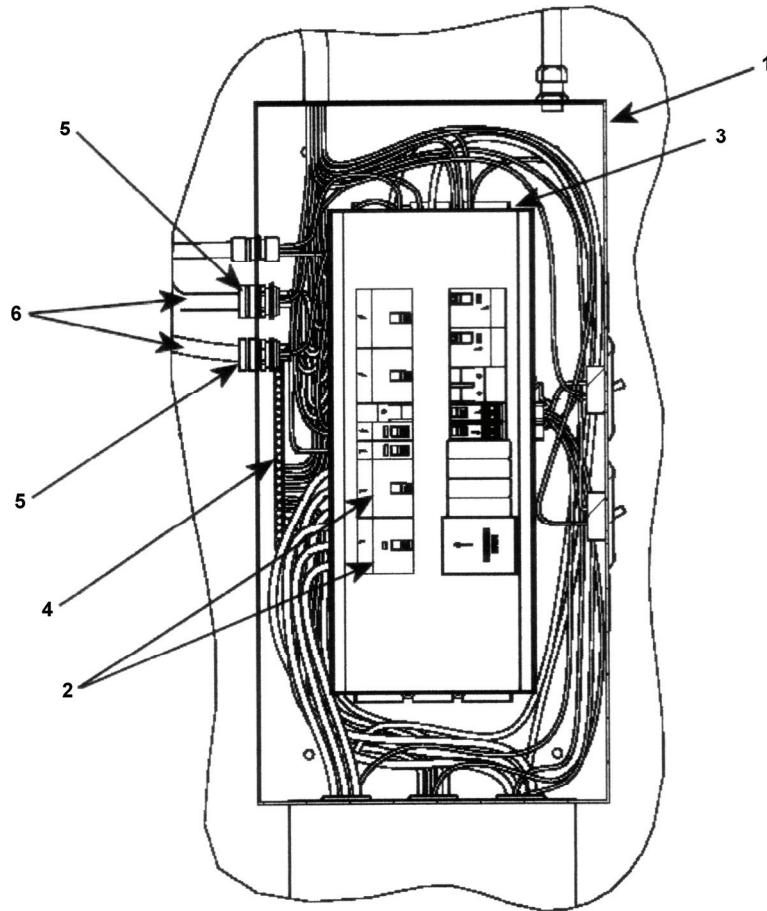

Personnel End

1. Tag and disconnect shelter electrical power.
2. Set all circuit breaker switches to the **OFF** position.
3. Remove panel cover from circuit breaker box (1).
4. Open circuit breaker panel door.
5. To remove panel cover and board:
 - a. NQOD - Remove four screws and washers and lift circuit breaker panel cover from panel board.
 - b. NQOB - Move clamp fingers to **OPEN** position and lift circuit breaker panel cover from panel board.
 - c. Remove four screws and washers and lift panel board from circuit breaker box.
6. Disconnect ECU power cable (6) from 30A, 240V, 3 pole circuit breaker (2).
7. Disconnect neutral from circuit breaker box terminal strip (3).
8. Disconnect ground wire from ground terminal strip (4).

9. Loosen compression nut (5) on box connector at circuit breaker box (1) and pull ECU power cable (6) through and out of box connector.

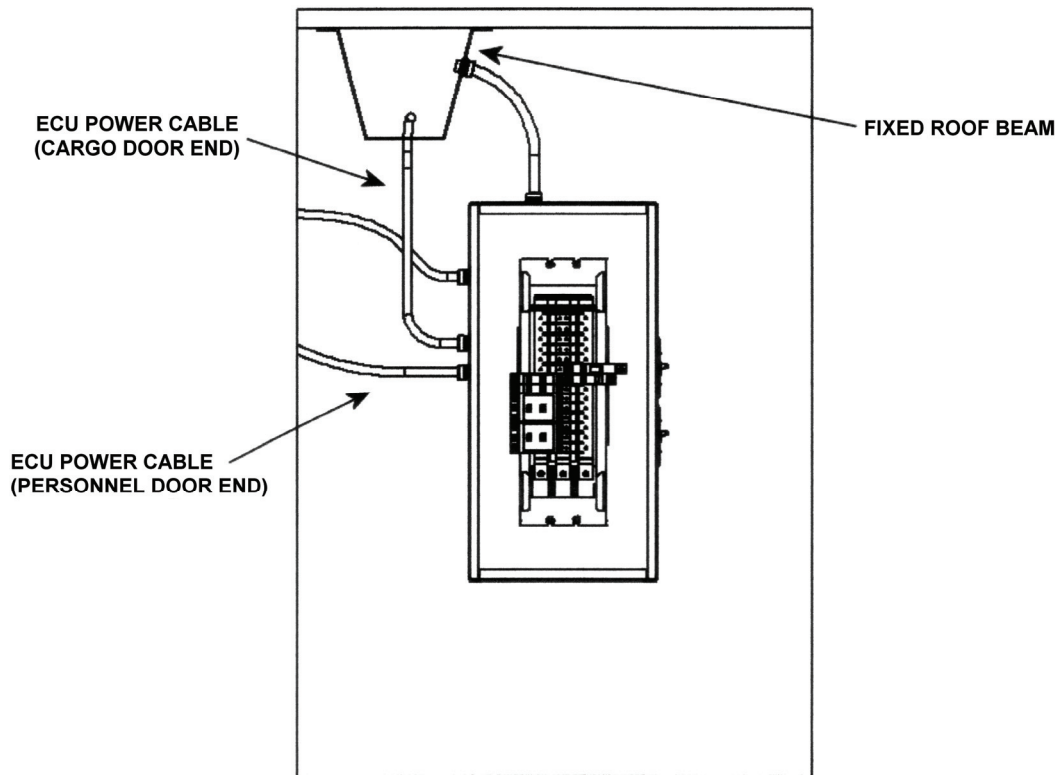

10. Pull ECU power cable through box connector and tighten connector compression nut after cable has been positioned with length of wire, approximately 36 inches, needed inside circuit breaker box.
11. Attach ECU power cable wires to circuit breaker with neutral and ground wires to corresponding terminal strip.
12. Replace circuit breaker panel board and cover onto circuit breaker box.
13. Move main circuit breaker to the **ON** position.

Cargo End

1. Following steps 1 thru 9 of Personnel End. Once those steps are complete, continue with step 2 of Cargo End.
2. Using electrical tape, attach a length of package twine or 1/4" rope approximately 25-30 feet long to end of ECU power cable. This will be end just removed from circuit breaker box.
3. At electrical connector end of ECU power cable, pull ECU power cable through fixed roof beam. When ECU power cable has been pulled completely out of fixed roof beam, there should be an adequate amount of twine/rope left at circuit breaker box end to allow for pulling rope back through with new ECU power cable attached.
4. After old ECU power cable has been pulled through, remove twine/rope and attach to new ECU power cable.
5. At circuit breaker box end, pull twine/rope through fixed roof beam until correct amount of ECU power cable is extending beyond end of fixed roof beam. (A second person at cargo door end guiding and feeding cable into fixed roof beam will make this procedure easier).
6. Remove twine/rope.

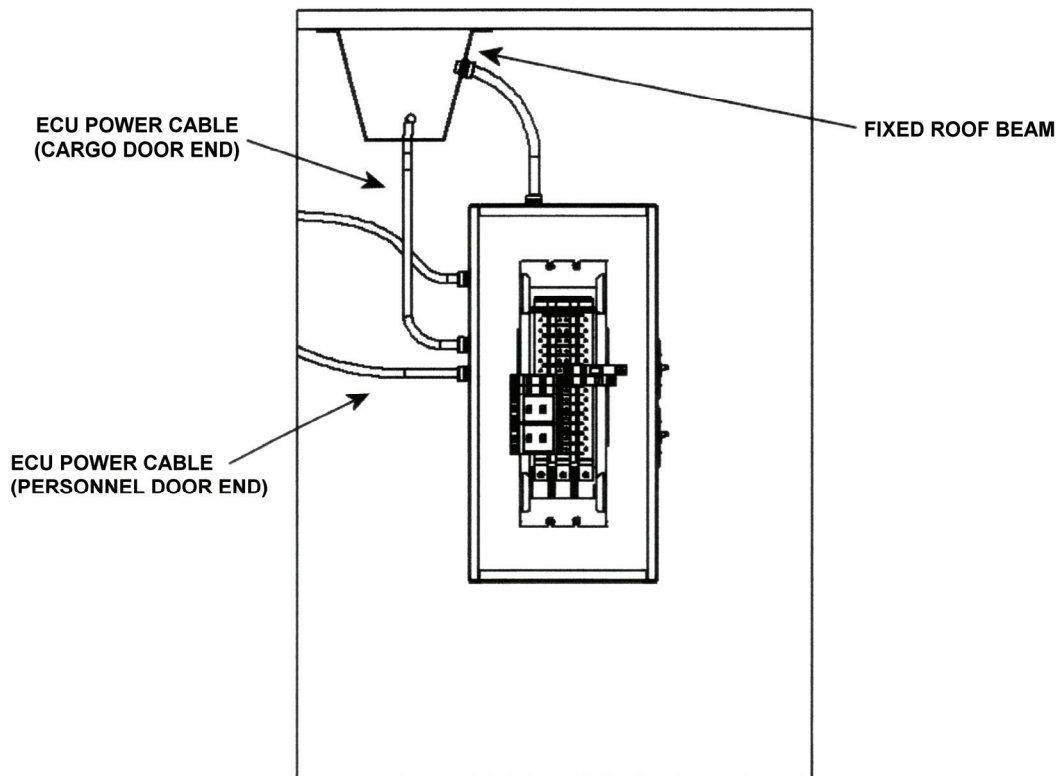

7. Pull ECU power cable through box connector and tighten connector compression nut after cable has been positioned with length of wire, approximately 36 inches, needed inside circuit breaker box.
8. Attach ECU power cable wires to circuit breaker with neutral and ground wires to corresponding terminal strip.
9. Replace circuit breaker panel board and cover onto circuit breaker box.
10. Move main circuit breaker to the **ON** position.

BOX CONNECTOR FOR ECU POWER CABLE**Inspect**

Visually inspect for damage. If damage is present, remove and replace ECU box connector.

WARNING

Turn off all power to shelter before proceeding to any tests or repairs.

CAUTION

Work should be performed by a qualified electrician.

Remove

1. Tag and disconnect shelter electrical power.
2. Set all circuit breaker switches to **OFF** position.

NOTE

This procedure covers obsolete NQOB circuit breaker panel and new NQOD circuit breaker panel. These units are distinguishable by nameplates attached to panel boards.

3. Open circuit breaker panel door.
4. To remove panel cover and board:
 - a. NQOD - Remove four screws and washers and lift circuit breaker panel cover from panel board.
 - b. NQOB - Move clamp fingers to **OPEN** position and lift circuit breaker panel cover from panel board.
 - c. Remove four screws and washers and lift panel board from circuit breaker box.

NOTE

Once panel boards are removed, all further procedures are identical for both models.

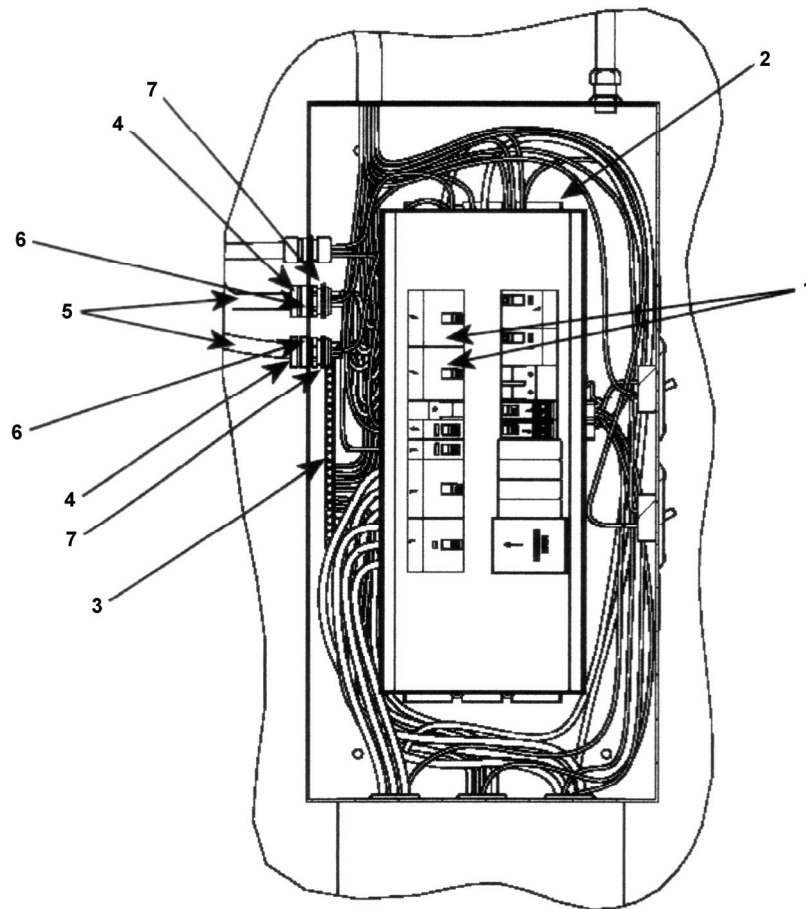

5. With 30A circuit breaker box door and panel cover removed, disconnect wires from 30A circuit breakers (1), neutral bar (2), and ground bar (3).
6. Loosen compression nut (4) on outside of circuit breaker box that is securing ECU power cable (5) in box connector (6).
7. Pull ECU power cable through and out of box connector (6).
8. Remove box connector lock nut (7) from inside circuit breaker box wall.
9. Remove damaged box connector (6) and discard.

Install

1. Insert new box connector (6) into hole in side of circuit breaker panel, place compression nut (4) on box connector (6) and tighten.
2. Push cable through box connector (6) and locate at original position.
3. Tighten compression nut (4).
4. Connect wires to 30A, 240V circuit breaker (1).
5. Replace panel board and cover.
6. Move main circuit breaker to the **ON** position.

30A CIRCUIT BREAKER

Inspect

Visually inspect 30A circuit breaker for any apparent damage.

WARNING

All power to shelter must be turned **OFF** before proceeding with any electrical tests or repairs.

CAUTION

Work should be performed by a qualified electrician.

Remove

1. Tag and disconnect shelter electrical power.
2. Set all circuit breaker switches to **OFF** position.

NOTE

This procedure covers obsolete NQOB circuit breaker panel and new NQOD circuit breaker panel. These units are distinguishable by nameplates attached to panel boards.

3. To remove panel cover and board:
 - a. NQOD - Remove four screws and washers and lift circuit breaker panel cover from panel board.
 - b. NQOB - Move clamp fingers to OPEN position and lift circuit breaker panel cover from panel board.
 - c. Remove four screws and washers and lift panel board from circuit breaker box.

NOTE

Once panel boards are removed, all further procedures are identical for both models.

4. Move main circuit breaker to the **ON** position.

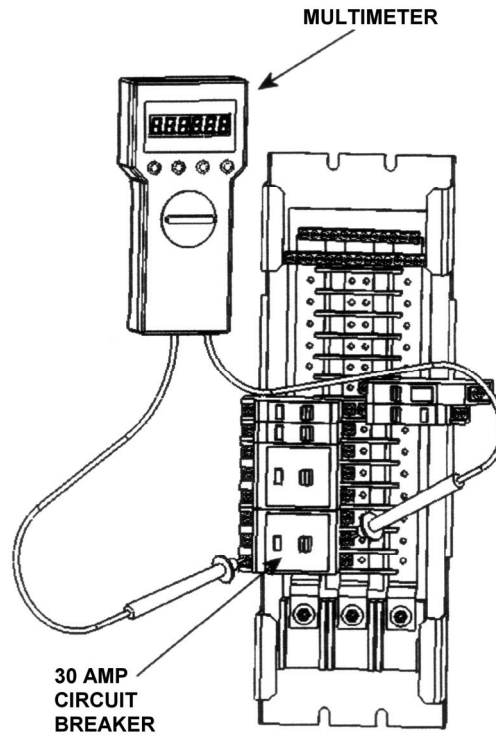
Test

1. Set 30A, 240V circuit breaker to **ON** position.
2. Set branch circuit breakers to **ON** position and observe if 30A breakers pop to **OFF** position. If other breakers pop, refer to TM 10-5411-201-14.
3. Move main circuit breaker to the **OFF** position.
4. Check the 30A, 240V circuit breaker for continuity.
5. If there is no continuity, 30A, 240V circuit breaker is defective and must be replaced.

WARNING

Disconnect electrical power from shelter before removing components. Failure to observe this warning may cause **DEATH OR SERIOUS INJURY** to personnel.

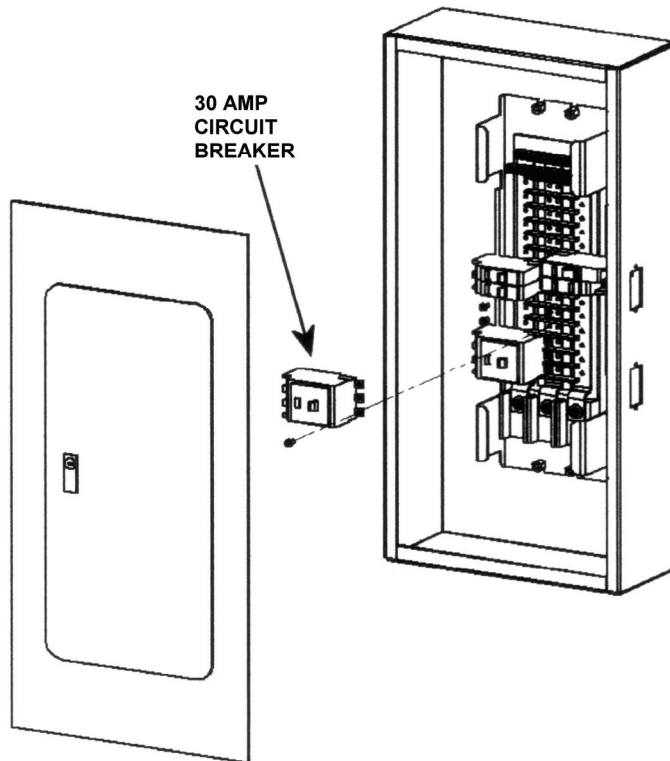
Remove

1. Mark and disconnect wires from 30A, 240V circuit breaker that will be removed.
2. Loosen screw holding 30A, 240V circuit breaker in place. Do not completely remove screw; loosen only enough to allow removal of 30A circuit breaker.
3. Pull 30A, 240V circuit breaker from bus bar and remove from circuit breaker box.

Install

1. Place new 30A circuit breaker in place and tighten screw.
2. Connect wires.
3. Move main circuit breaker to the **ON** position to test.
4. Move main circuit breaker to the **OFF** position.
5. Replace panel cover and door and close circuit breaker panel door.

End of Work Package

**NON-DESTRUCTIVE INSPECTION SHOP
SERVICES UTILITY PANEL**

INITIAL SETUP**Tools And Special Tools:**

Tool Kit, Power Plant
(WP 0031 00, Table 2, Item 102)
Utility Knife (5110-00-293-1585)

References:

N/A

Equipment Conditions:

Functional

Materials/Parts:

RTV (WP 0037 00, Table 1, Item 7)
Sealing Compound
(WP 0037 00, Table 1, Item 8)
Pan Head Machine Screw
(WP 0033 00, Figure 6, Item 1)
Socket Head Shoulder Screw
(WP 0033 00, Figure 6, Item 2)
Pipe Cap 1/2" (WP 0033 00, Figure 6, Item 3)
Water Feed-Thru Connector Assembly
(WP 0033 00, Figure 6, Item 4)
Flat Washer (WP 0033 00, Figure 6, Item 5)
Lock Washer (WP 0033 00, Figure 6, Item 6)
Plain Nut (WP 0033 00, Figure 6, Item 7)
Air Feed-Thru Connector Assembly
(WP 0033 00, Figure 6, Item 8)
Lanyard (WP 0033 00, Figure 6, Item 9)
Pipe Cap 1/4" (WP 0033 00, Figure 6, Item 10)

Personnel Required: (2)

CMF 15 Series

NOTE

During installation of components the same hardware should be used so as to maintain the original integrity of the shop sets.

INSPECT

Visually inspect utility pan assembly. If there is any visible damage that renders utility pan assembly unusable, it must be replaced.

REPLACE

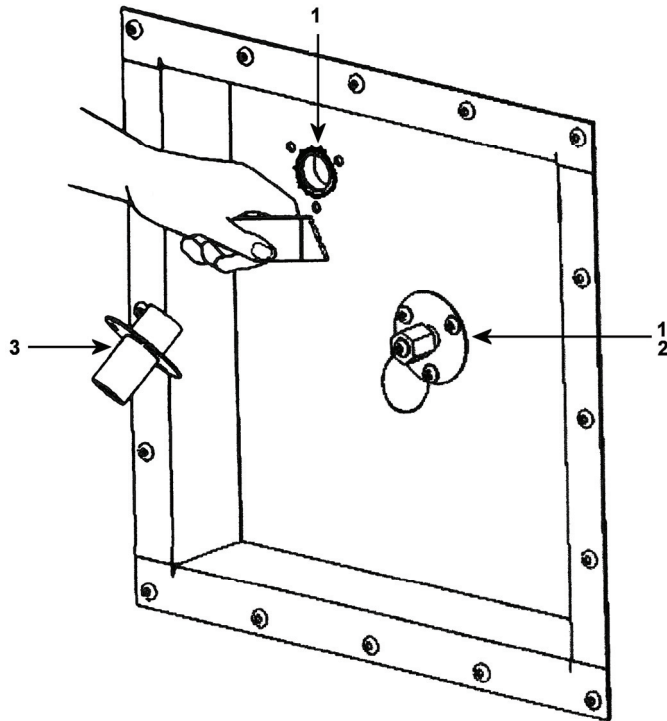

1. Match drill center hole (1) into utility pan for water feed-thru fitting (3).
2. Match drill center hole (1) into utility pan for air feed-thru fitting (2).
3. Apply a bead of paintable RTV to water/air feed-thru flanges before installing from outside.
4. Use existing or new hardware to attach water/air feed-thru connector assemblies to utility pan.

WATER FEED-THRU CONNECTOR ASSEMBLY

Inspect

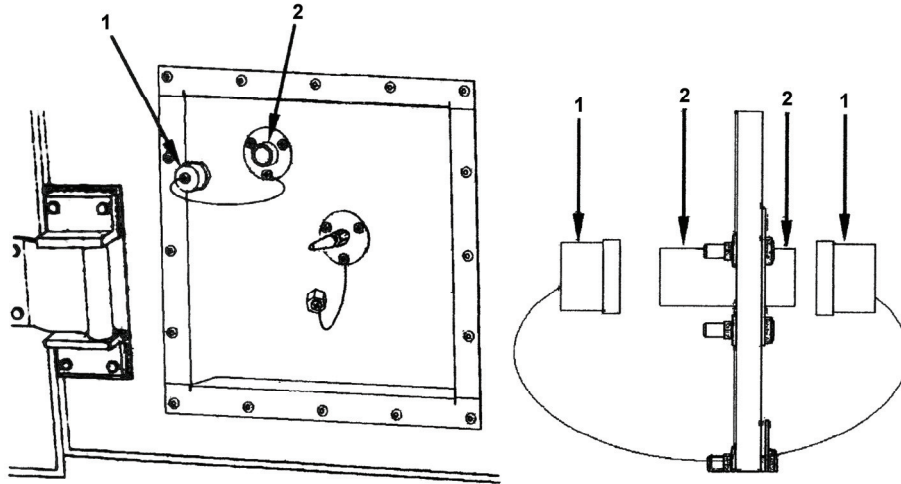

1. Check condition of threads on both ends of water feed-thru connector (2).
2. See that protective dust caps (1) are attached and used as required.

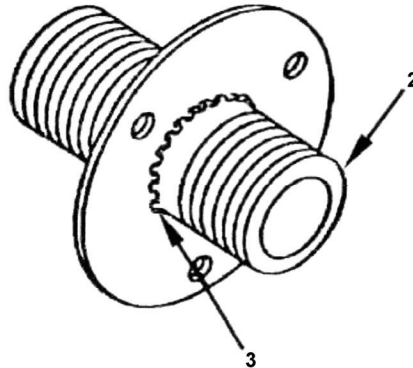

3. Ensure that weld (3) on connector (2) is not cracked or broken. If defective, replace.

Remove

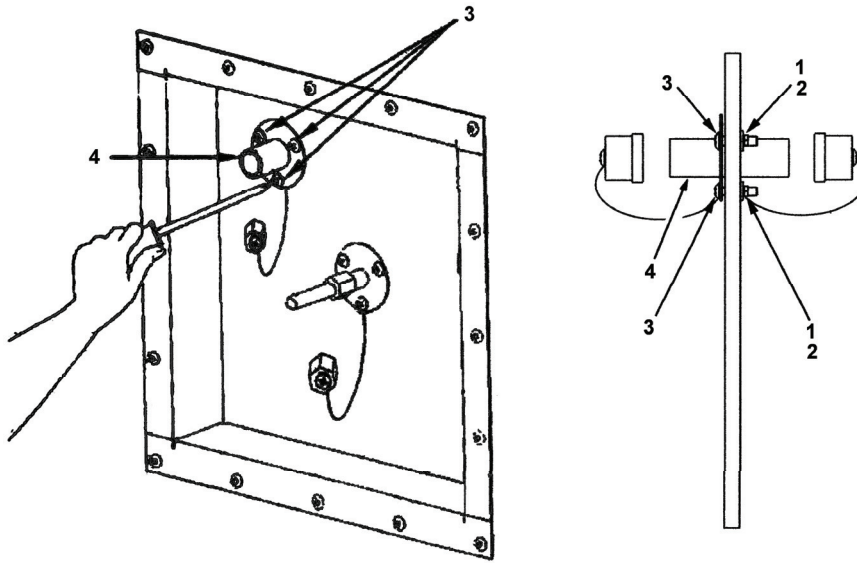

1. Have helper hold washers (1) and nuts (2) inside shelter.
2. Remove screws (3), releasing connector (4).

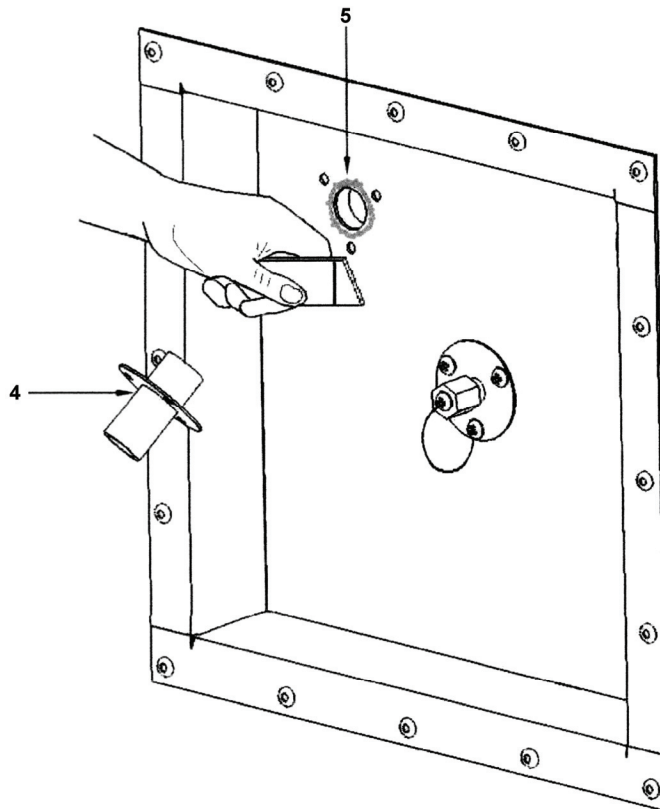

3. Remove connector (4) from service utility panel, and scrape off old sealant (5).

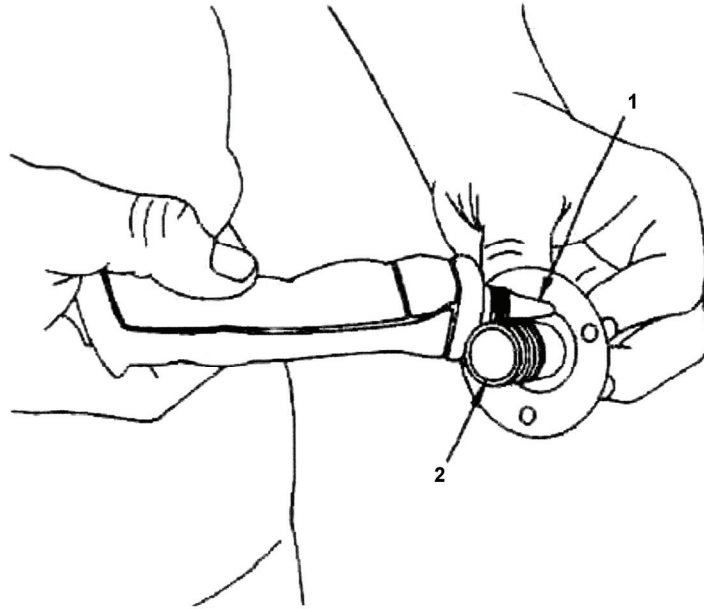
Install

1. Apply adhesive on side of connector flange (1) toward long end of connector (2).

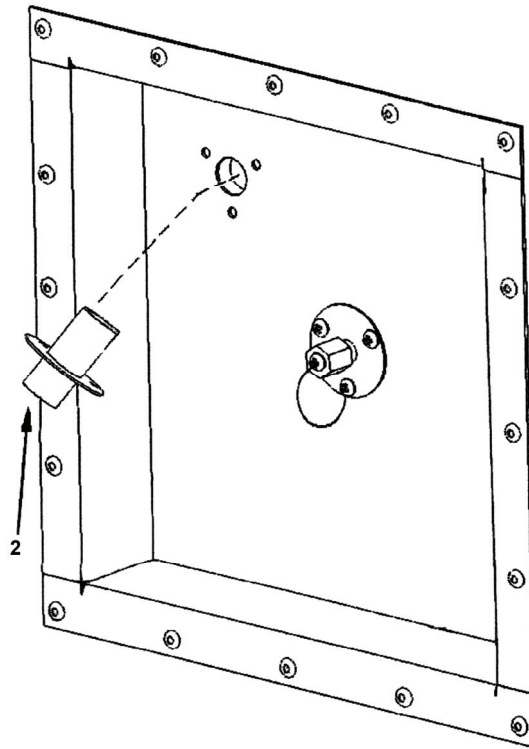

2. Install new connector (2) from outside of shelter; long end of connector through hole.

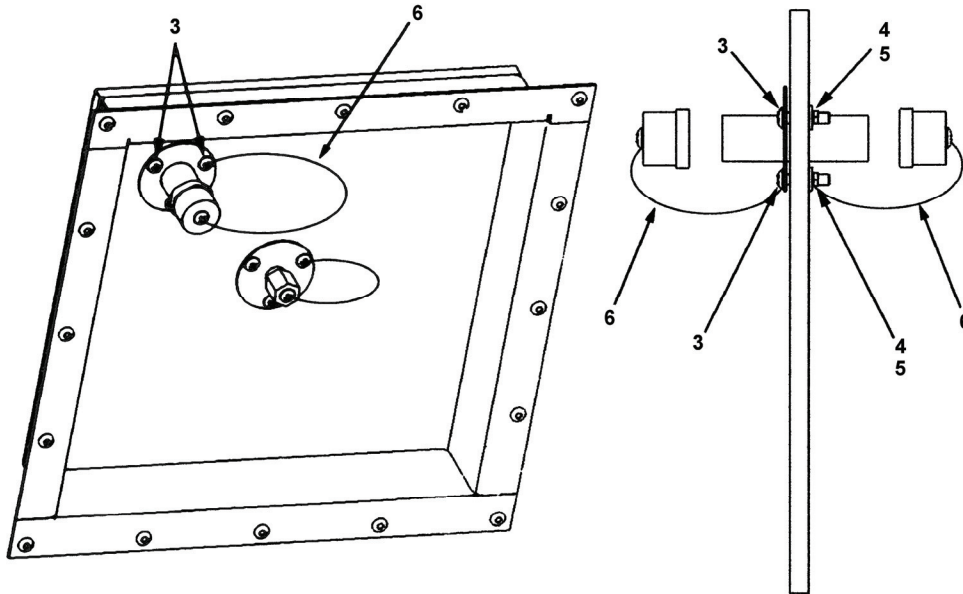

3. Install all but one screw (3), have helper install flat washers (4) and nuts (5) inside shelter and secure.
4. Replace one lanyard (6) on outside of shelter and put in screw (3).
5. Have helper install flat washer (4), second lanyard (6), and nut (5), inside shelter.
6. Tighten screws (3).

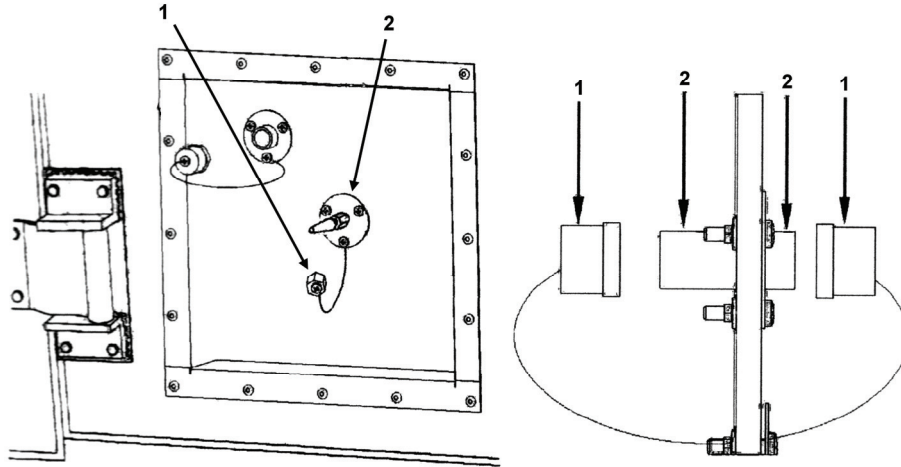
AIR FEED-THRU CONNECTOR ASSEMBLY**Inspect**

1. Check condition of threads on both ends of air feed-thru connector (2).
2. See that protective dust caps (1) are available and used as required.

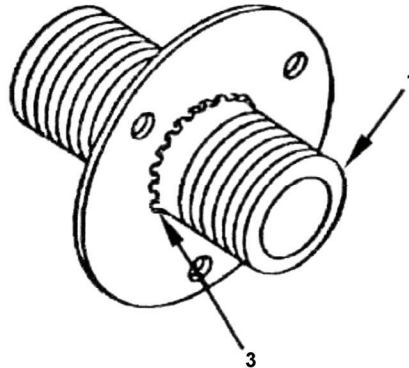

3. Ensure that weld (3) on connector (1) is not cracked or broken. If defective, replace.

Remove

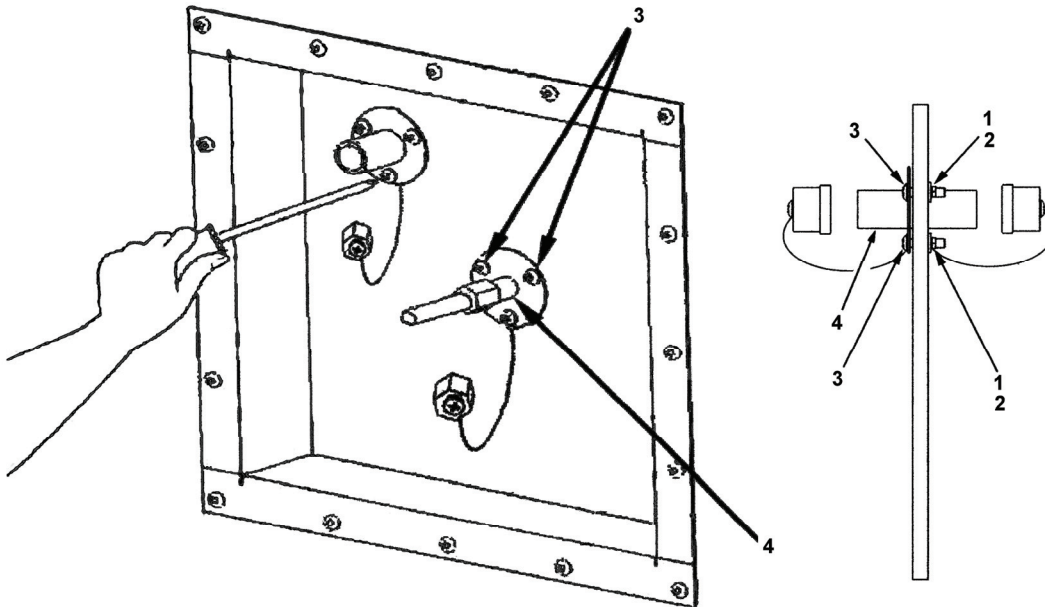

1. Have a helper hold washers (1) and nut (2) inside shelter.
2. Remove screws (3), securing connector (4) in place.

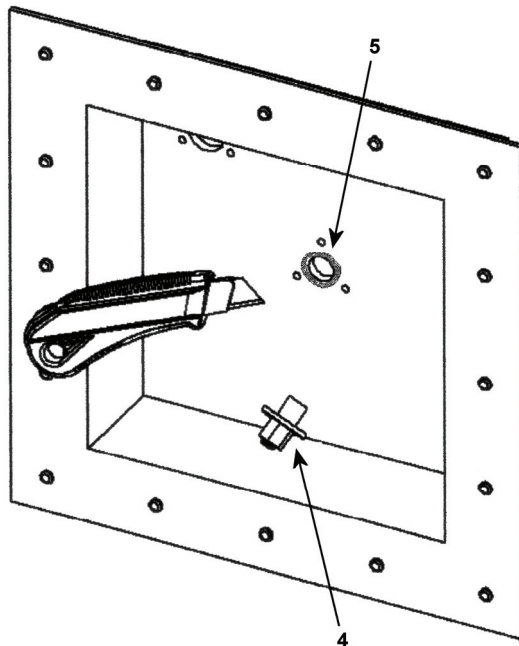

3. Remove connector (4) from service utility panel and scrape off old sealant (5).

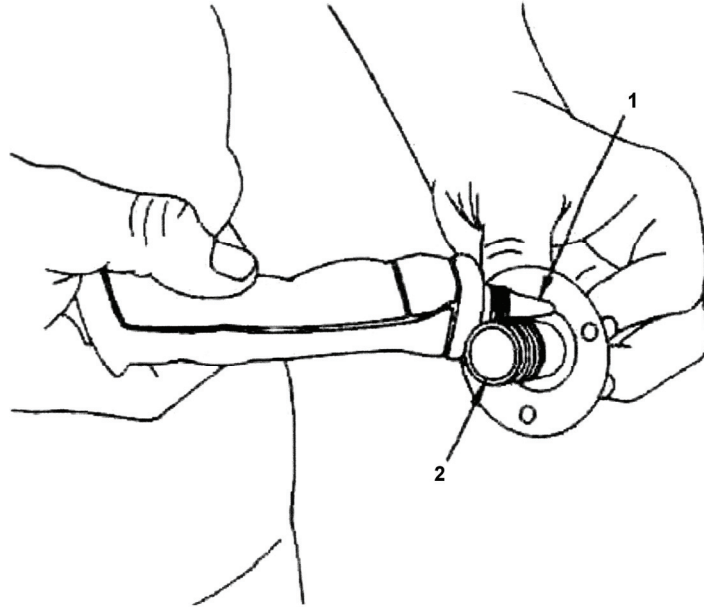
Install

1. Apply adhesive on side of connector flange (1) toward long end of connector (2).

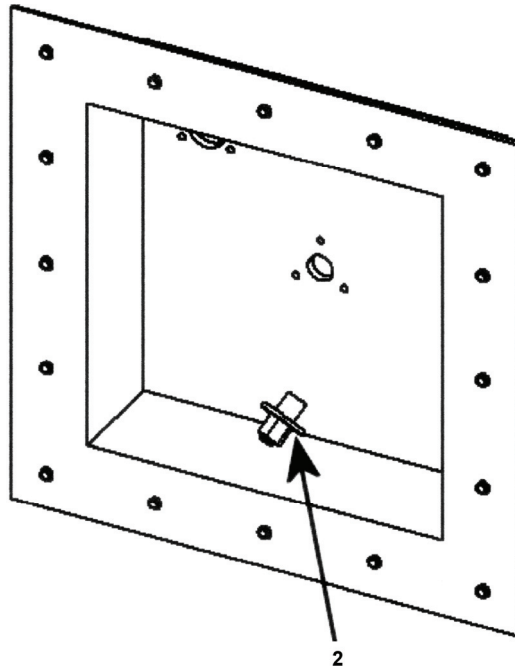

2. Install new connector (2) from outside of shelter; long end of connector (2) through hole.

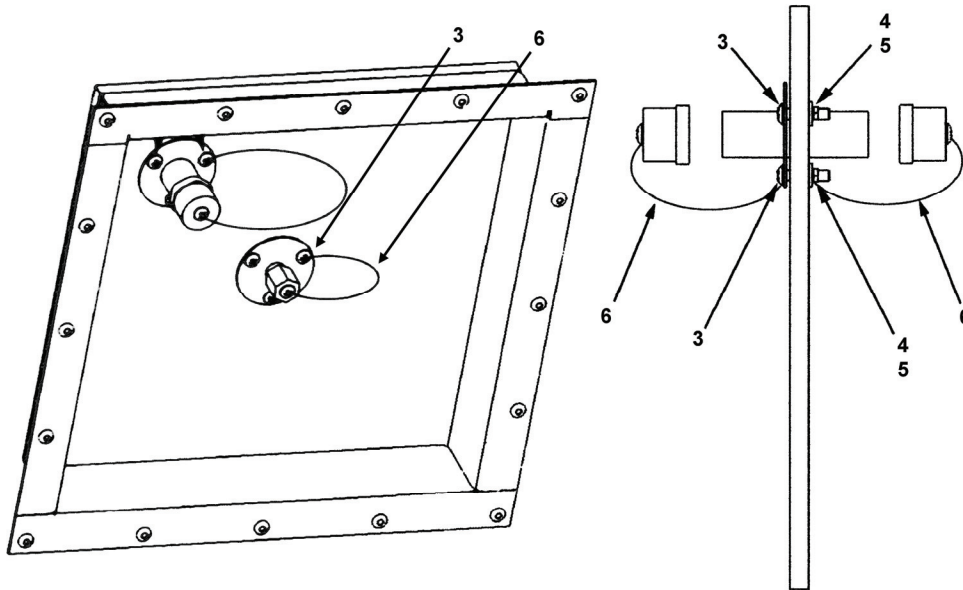

3. Install all but one screw (3), have helper install flat washers (4) and nuts (5) inside shelter and secure.
4. Replace one lanyard (6) on outside of shelter and put in screw (3).
5. Have helper install flat washer (4), second lanyard (6), and nut (5), inside shelter.
6. Tighten screws (3).

End of Work Package

**NON-DESTRUCTIVE INSPECTION SHOP
WATER/OIL SEPARATOR**

INITIAL SETUP**Tools And Special Tools:**

Tool Kit, Power Plant
(WP 0031 00, Table 2, Item 102)
Utility Knife (5110-00-293-1585)

References:

WP 0026 00

Equipment Conditions:

Functional

Materials/Parts:

Hexagon Head Cap Screw
(WP 0033 00, Figure 5, Item 1)
Lock Washer (WP 0033 00, Figure 5, Item 2)
Flat Washer (WP 0033 00, Figure 5, Item 3)
Pipe Bushing (WP 0033 00, Figure 5, Item 4)
Pipe Nipple (WP 0033 00, Figure 5, Item 5)
Pipe Coupling (WP 0033 00, Figure 5, Item 6)
Pipe Elbow (WP 0033 00, Figure 5, Item 7)
Non-Metallic Hose (WP 0033 00, Figure 5, Item 9)
Loop Clamp (WP 0033 00, Figure 5, Item 10)

Personnel Required: (1)

CMF 15 Series

WARNING

Make sure compressed air supply is disconnected before attempting any work on water/oil separator. Do not direct compressed air near eyes or directly against skin. Wear goggles; high pressure air against eyes can cause **BLINDNESS**.

NOTE

During installation of components the same hardware should be used so as to maintain the original integrity of the shop sets.

INSPECT

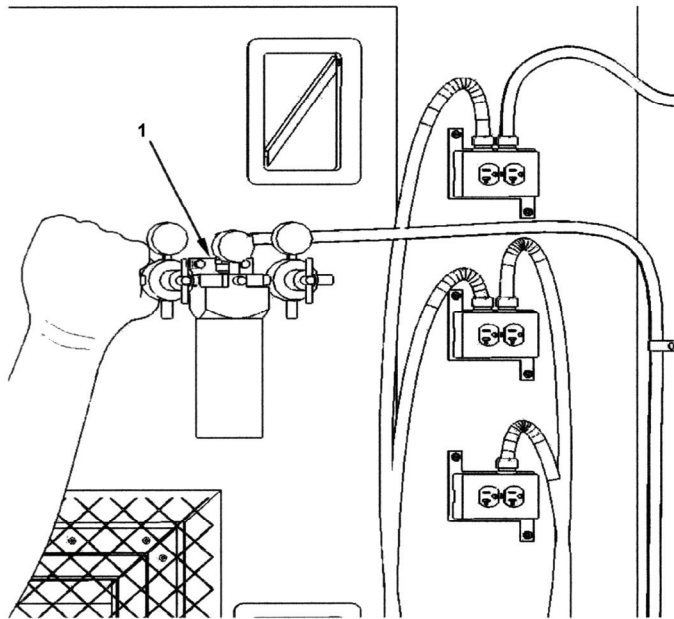

1. Check water/oil separator bracket (1) for looseness.

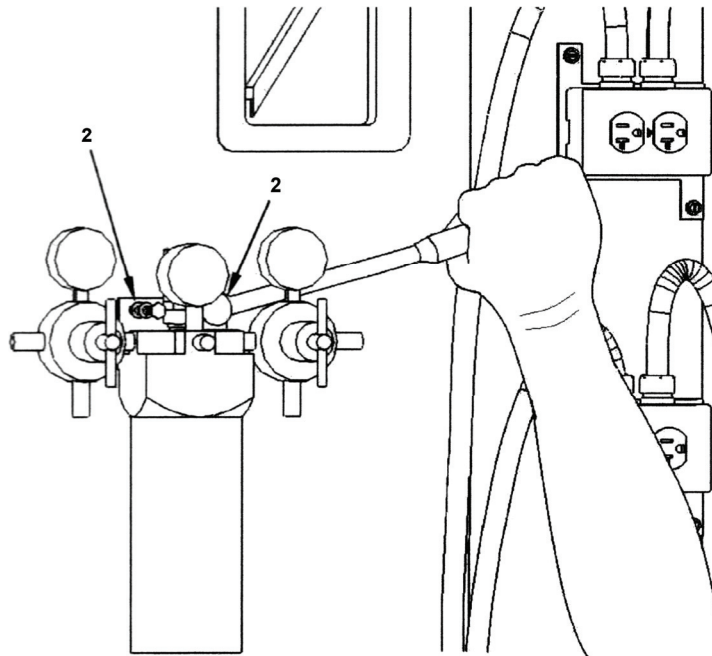

2. Tighten mounting bolts (2) when loose.

NOTE

Graphic depicts the center gauge removed for clarity.

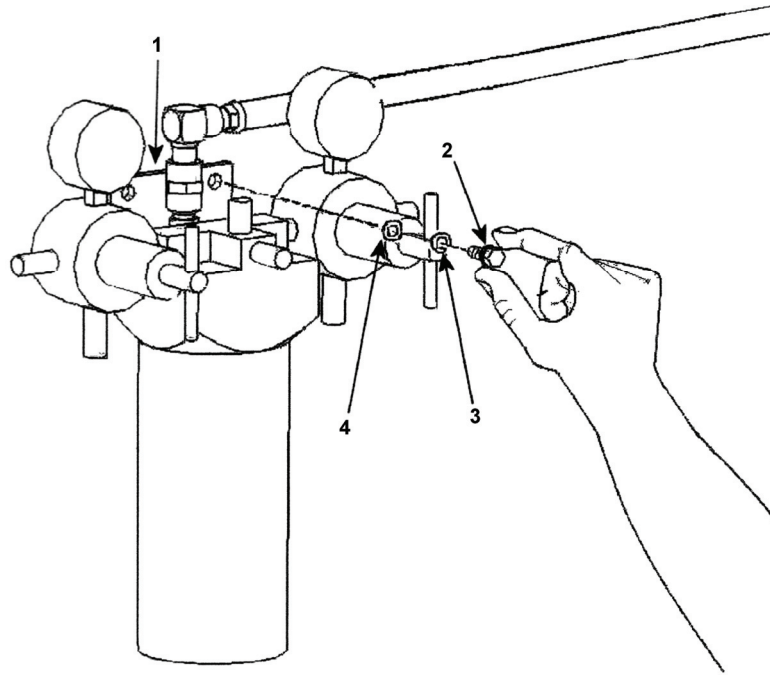

3. If bolts (2) will not tighten, remove bolts (2), lock washers (3), flat washers (4), and water/oil separator (1) and follow procedures in WP 0026 00.

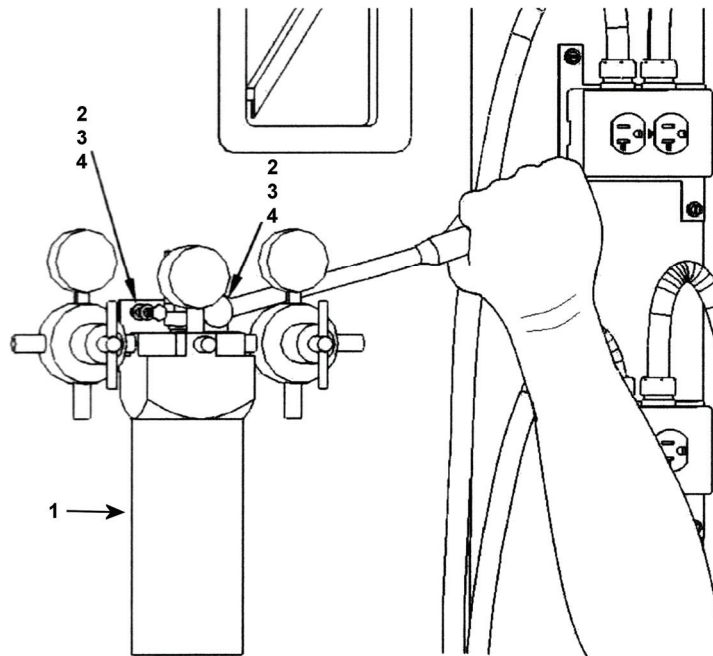

4. Position water/oil separator (1) over wall inserts and install bolts (2) with lock washers (3) and flat washers (4) and tighten.

NON-METALLIC HOSE AND FITTINGS**WARNING**

Make sure compressed air supply is disconnected before attempting any work on water/oil separator. Do not direct compressed air near eyes or directly against skin. Wear goggles; high pressure air against eyes can cause **BLINDNESS**.

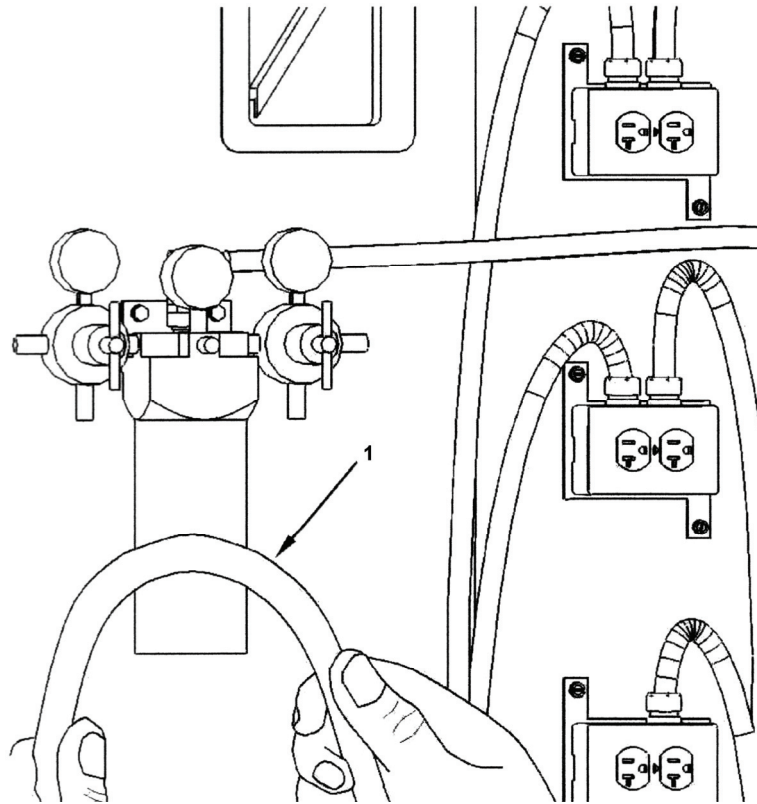
Inspect

Inspect non-metallic hose (1) for visible damage. Replace if damaged.

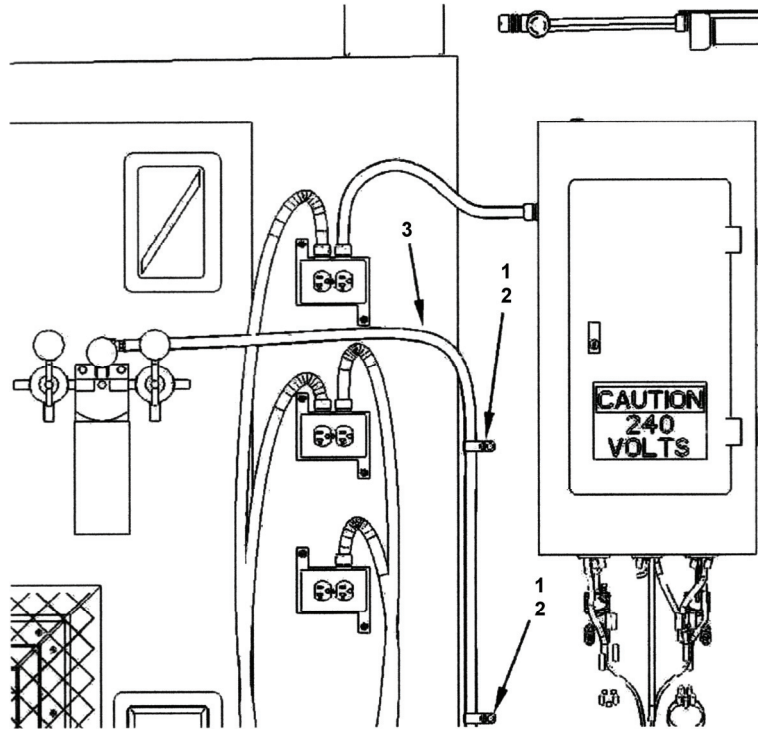
Remove

1. Remove bolts (1) and loop clamps (2) from damaged non-metallic hose (3).

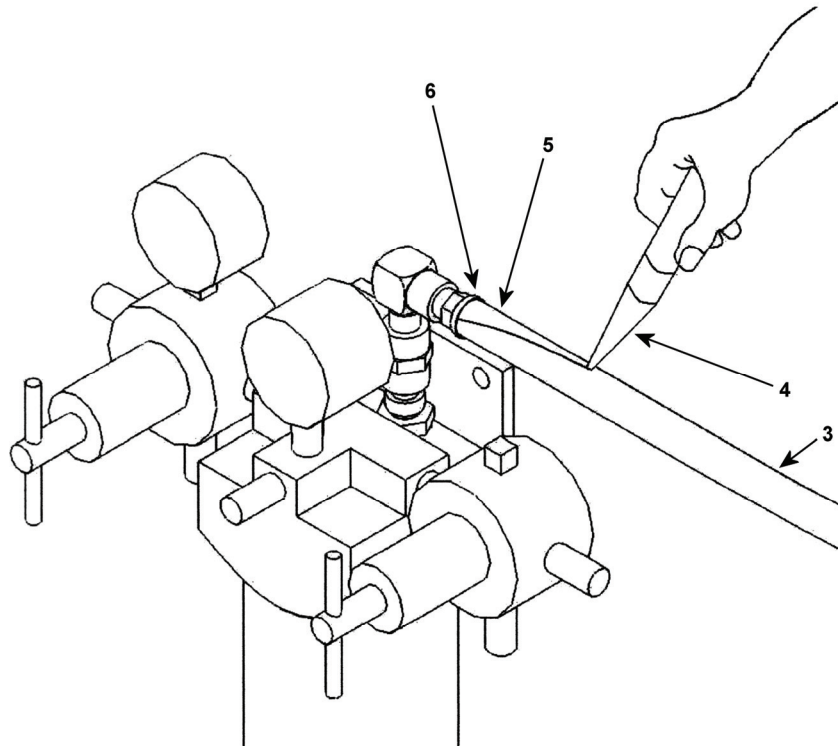

2. Slit non-metallic hose (3) lengthwise, with utility knife (4), from protective cap (5) to end of fitting (6); approximately 1 1/2 inches.

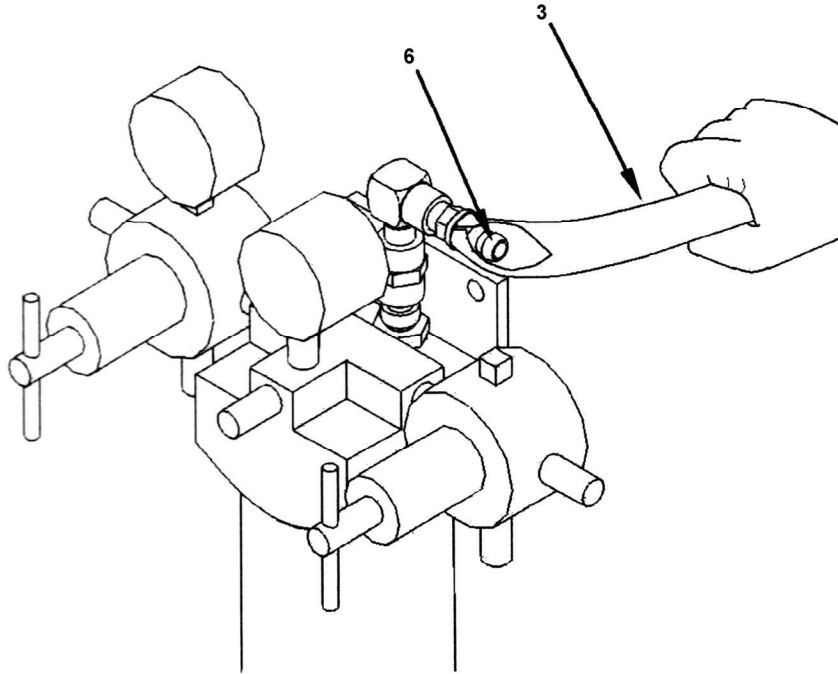

3. Bend non-metallic hose (3) back over fitting (6) to remove.
4. Repeat steps 2 and 3 for other end of hose.

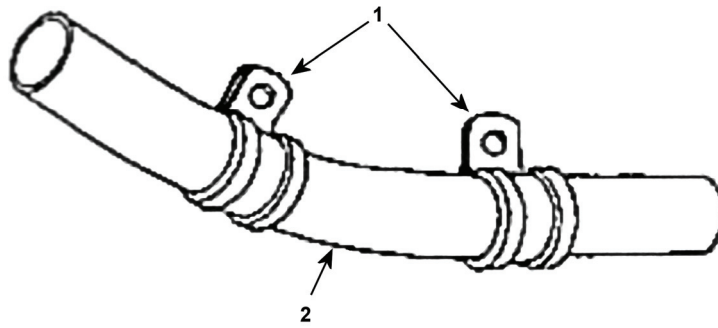
Install

1. Slide loop clamps (1) over new non-metallic hose (2).

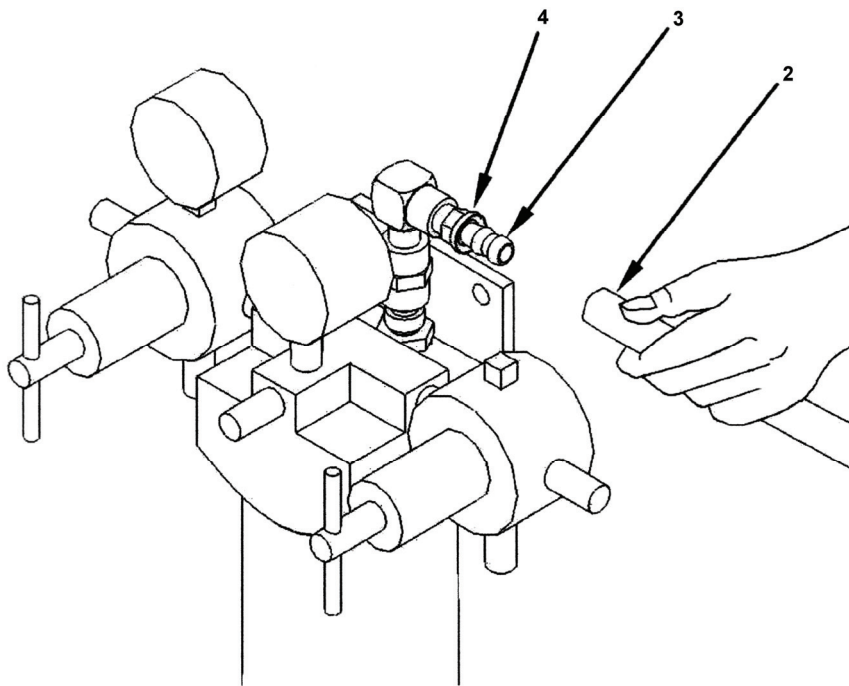

2. Push non-metallic hose (2) on fitting (3) until end seats against protective cap (4).

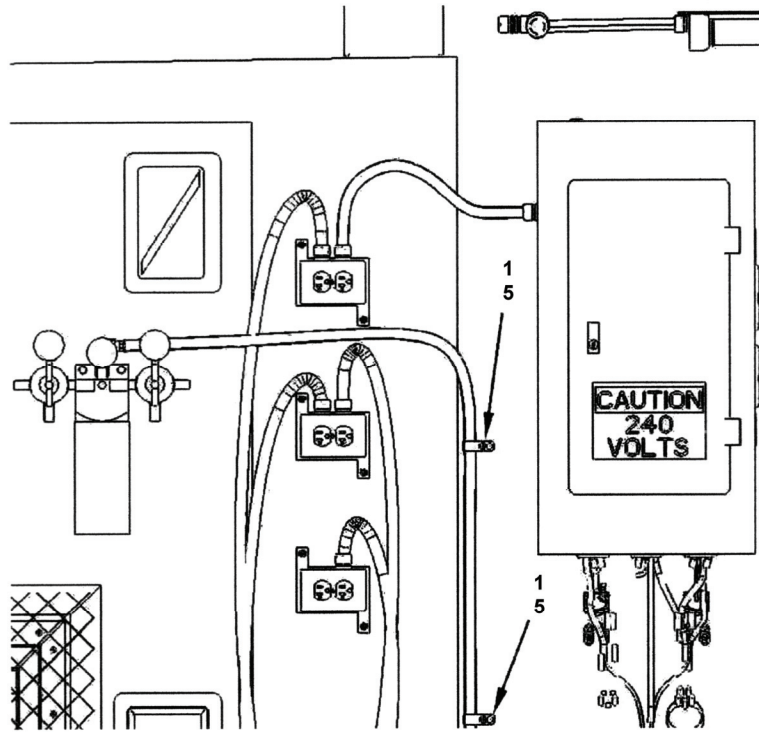

3. Reinstall loop clamps (1) with bolts (5) in original position and secure.

End of Work Package

**NON-DESTRUCTIVE INSPECTION SHOP
CABINET BRACKETS**

INITIAL SETUP**Tools And Special Tools:**

Tool Kit, Power Plant
(WP 0031 00, Table 2, Item 102)
Torque Wrench 0-600 in. lbs. (5120-01-530-2311)

References:

MIL-STD-2219
TM 43-0139
WP 0026 00

Materials/Parts:

Paint (WP 0037 00, Table 1, Item 2)
Primer (WP 0037 00, Table 1, Item 4)
Cabinet Bracket (WP 0033 00, Figure 8, Item 1)
Hexagon Head Cap Screw
(WP 0033 00, Figure 8, Item 2)
Flat Washer (WP 0033 00, Figure 8, Item 3)
Lock Washer (WP 0033 00, Figure 8, Item 4)
Nut (WP 0033 00, Figure 8, Item 5)

Equipment Conditions:

Functional

Personnel Required: (1)

CMF 15 Series

NOTE

During installation of components the same hardware should be used so as to maintain the original integrity of the shop sets.

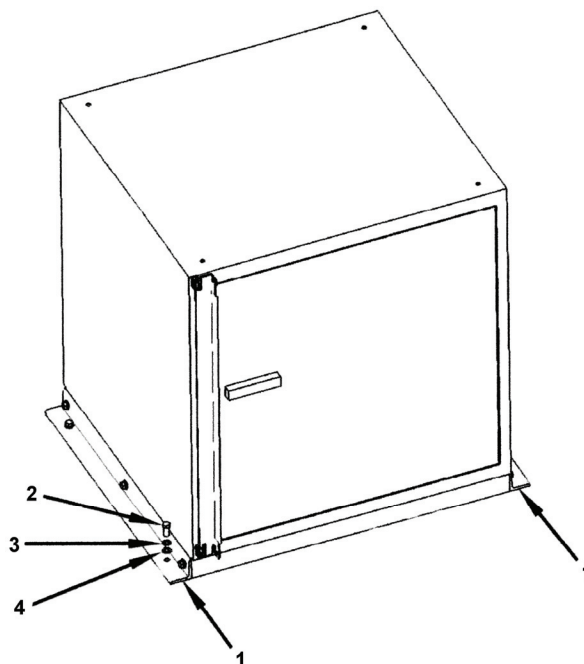
**INSPECT**

Visually inspect all brackets for looseness or damage. If bracket is loose, follow procedures in WP 0026 00. If bracket is damaged, replace it with a new one.

REMOVE

Remove bolts (2), lock washers (3), and flat washers (4) attaching bracket (1) to floor or cabinet.

REPAIR

1. If bracket is a weldment and can be repaired by welding, have bracket repaired by welding broken areas back together IAW MIL-STD-2219. Welding repair must not interfere with form, fit, or function of bracket.
2. Paint repaired bracket with specified primer and paint per TM 43-0139.

INSTALL

1. Install new or repaired bracket with bolts (2), lock washers (3), and flat washers (4).
2. Torque bolts to 160-190 in. lbs.

End of Work Package

**NON-DESTRUCTIVE INSPECTION SHOP
PROCESSING TANK AND BRACKETS**

INITIAL SETUP**Tools And Special Tools:**

Tool Kit, Power Plant
(WP 0031 00, Table 2, Item 102)
Torque Wrench 0-600 in. lbs. (5120-01-530-2311)

References:

WP 0026 00
WP 0027 00

Materials/Parts:

Processing Tank Bracket
(WP 0033 00, Figure 1, Item 1)
Hexagon Head Cap Screw
(WP 0033 00, Figure 1, Item 3)
Lock Washer (WP 0033 00, Figure 1, Item 4)
Flat Washer (WP 0033 00, Figure 1, Item 5)

Equipment Conditions:

Functional

Personnel Required: (1)

44E, Machinist
CMF 15 Series

NOTE

During installation of components the same hardware should be used so as to maintain the original integrity of the shop sets.

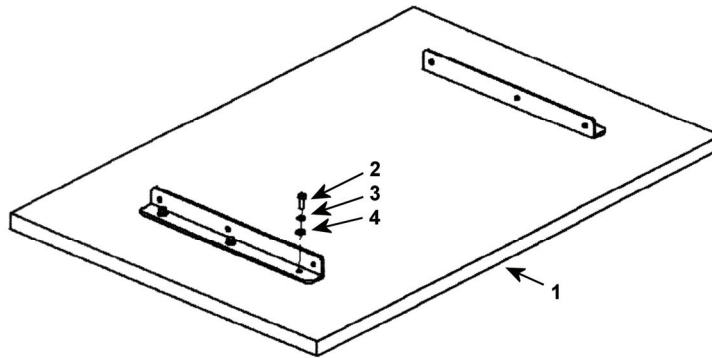
**INSPECT**

Visually inspect processing tank brackets for looseness or damage. If bracket is loose, follow procedures in WP 0026 00. If bracket is damaged, replace it with a new one. A drawing for manufacturing a new bracket can be found in WP 0027 00.

REMOVE

1. Remove bolts (2), lock washers (3), and flat washers (4) from bracket (1) attaching it to floor.
2. Remove bolts, lock washers, and flat washers from bracket attaching it to processing tank.
3. Store hardware in cotton mailing bag.

INSTALL

1. Install bracket on processing tank with bolts, lock washers, and flat washers.
2. Mount bracket to floor with bolts (2), lock washers (3) and flat washers (4).
3. Torque bolts to 160-190 in. lbs.

**NON-DESTRUCTIVE INSPECTION SHOP
FILM DRYER AND BRACKETS**

INITIAL SETUP**Tools And Special Tools:**

Tool Kit, Power Plant
 (WP 0031 00, Table 2, Item 102)
 Torque Wrench 0-600 in. lbs. (5120-01-530-2311)

References:

WP 0026 00
 WP 0027 00

Materials/Parts:

Film Dryer Bracket
 (WP 0033 00, Figure 1, Item 2)
 Hexagon Head Cap Screw
 (WP 0033 00, Figure 1, Item 3)
 Lock Washer (WP 0033 00, Figure 1, Item 4)
 Flat Washer (WP 0033 00, Figure 1, Item 5)

Equipment Conditions:

Functional

Personnel Required: (1)

44E, Machinist
 CMF 15 Series

NOTE

During installation of components the same hardware should be used so as to maintain the original integrity of the shop sets.

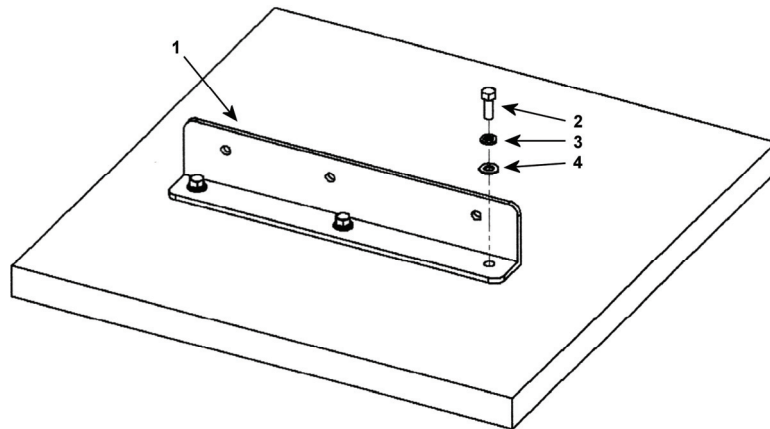
**INSPECT**

Visually inspect film dryer bracket for looseness or damage. If bracket is loose, follow the procedures in WP 0026 00. If bracket is damaged, replace it with a new one. A drawing for manufacturing a new bracket will be found in WP 0026 00.

REMOVE

1. Remove bolts (2), lock washers (3), and flat washers (4) from bracket (1) attaching it to floor.
2. Remove bolts, lock washers, and flat washers from bracket attaching it to film dryer.
3. Store hardware in cotton mailing bag.

INSTALL

1. Install bracket on film dryer with bolts, lock washers, and flat washers.
2. Mount bracket to floor by using bolts (2), lock washers (3), and flat washers (4).
3. Torque bolts 160-190 in. lbs.

**NON-DESTRUCTIVE INSPECTION SHOP
ILLUMINATOR SHELF AND BRACKETS**

INITIAL SETUP**Tools And Special Tools:**

Tool Kit, Power Plant
(WP 0031 00, Table 2, Item 102)
Torque Wrench 0-600 in. lbs. (5120-01-530-2311)
Welding Machine (3431-01-507-1712)
Spoolmatic (3431-01-024-1681)
Control (3431-01-429-9607)
Regulating Flow Meter (4820-01-086-4310)
Argon Bottle (8120-00-282-8077)

References:

MIL-STD-2219
WP 0026 00
WP 0027 00

Equipment Conditions:

Functional

Materials/Parts:

End Shelf Bracket
(WP 0033 00, Figure 10, Item 1)
End Shelf Bracket
(WP 0033 00, Figure 10, Item 2)
Plate (WP 0033 00, Figure 10, Item 3)
Hexagon Head Cap Screw
(WP 0033 00, Figure 1, Item 4)
Lock Washer (WP 0033 00, Figure 1, Item 5)
Flat Washer (WP 0033 00, Figure 1, Item 6)
Hexagon Head Cap Screw
(WP 0033 00, Figure 10, Item 7)
Lock Washer (WP 0033 00, Figure 10, Item 8)
Flat Washer (WP 0033 00, Figure 10, Item 9)
Plain Hex Nut (WP 0033 00, Figure 10, Item 10)

Personnel Required: (1)

44E, Machinist
CMF 15 Series

NOTE

During installation of components the same hardware should be used so as to maintain the original integrity of the shop sets.

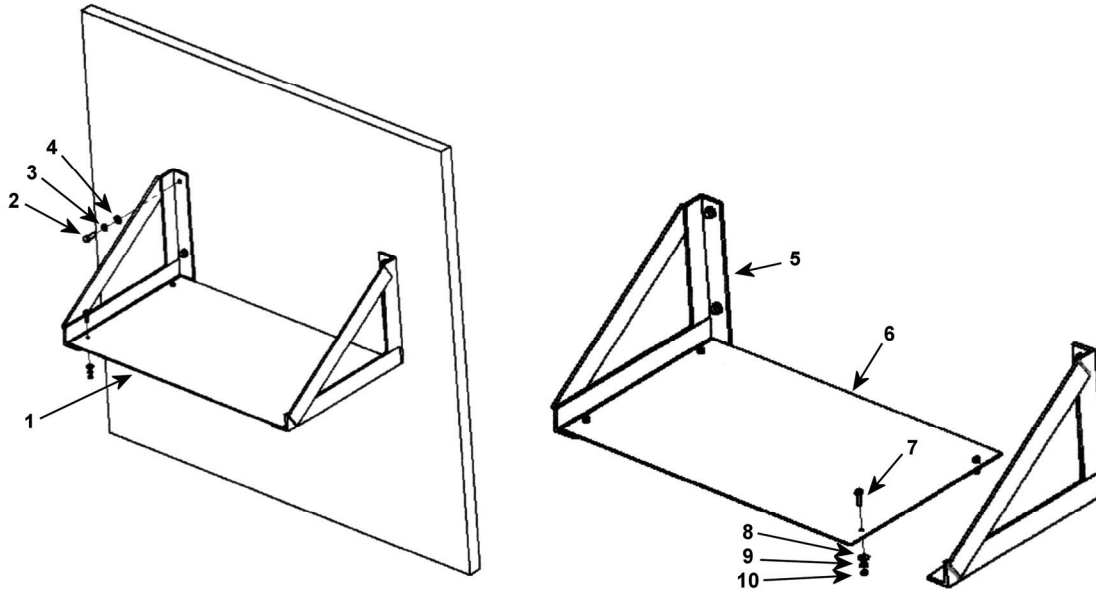

INSPECT

Check illuminator shelf for looseness or damage. If shelf is loose, follow procedures in WP 0026 00. If shelf has cracked or broken welds it must be repaired or replaced.

REMOVE

1. Remove bolts (2), lock washers (3), and flat washers (4) attaching shelf (1) to wall.
2. Remove shelf bracket (5) from plate (6) by removing bolts (7), lock washers (8), flat washers (9), and nuts (10).
3. Store hardware in cotton mailing bag.

REPAIR

1. If illuminator shelf bracket has a cracked or broken weld and can be repaired, repair shelf by welding damaged area in accordance with MIL-STD-2219. The welding repair must not interfere with form, fit, or function of shelf.
2. Prepare and paint per finish requirements given on drawing found in work package WP 0027 00.

INSTALL

1. Install new or repaired shelf bracket (5) to plate (6) with bolts (7), lock washers (8), flat washers (9), and nuts (10).
2. Torque bolts 50-70 in. lbs.
3. Mount shelf (1) on wall using bolts (2) with lock washers, (3), and flat washers (4).
4. Torque bolts to 160-190 in. lbs.

End of Work Package

**NON-DESTRUCTIVE INSPECTION SHOP
WALL/FLOOR INSERTS, BOLTS, AND PLUGS**

INITIAL SETUP

Tools And Special Tools:

Tool Kit, Power Plant
(WP 0031 00, Table 2, Item 102)

References:

TM 10-5411-201-14
WP 0028 00

Materials/Parts:

Wall Inserts (WP 0033 00, Figure 9, Item 1)
Floor Inserts (WP 0033 00, Figure 9, Item 2)
Hexagon Head Cap Screws
(WP 0033 00, Figure 9, Item 3)
Floor Plugs (5305-00-728-6350)

Equipment Conditions:

Functional

Personnel Required: (1)

CMF 15 Series

BOLTS AND INSERTS

NOTES

Quantity of mounting hardware may vary.

Inspect

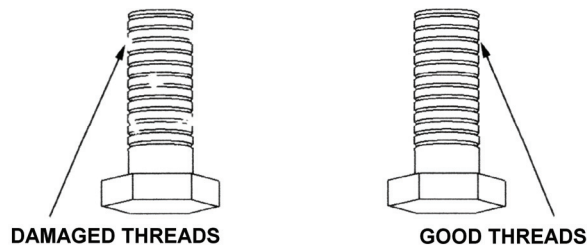

1. Inspect bolt for thread damage or rounded head.
2. Replace if bolt is damaged.
3. Torque bolt to its required torque limit specified in WP 0028 00.

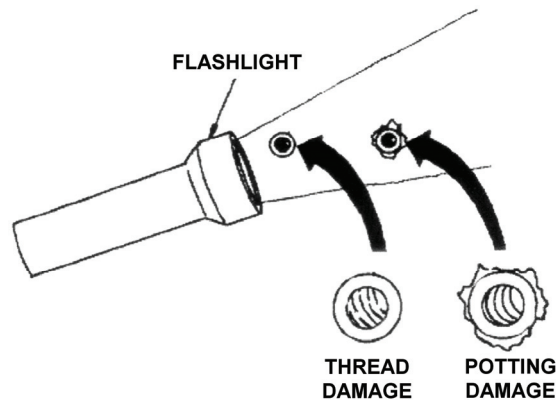

4. If bolt damage is present, visually inspect insert with flashlight.
5. If insert thread is damaged or insert has broken loose in adhesive potting, replace. For replacement information see TM 10-5411-201-14, Threaded Inserts Replacement.

FLOOR PLUGS

Inspect

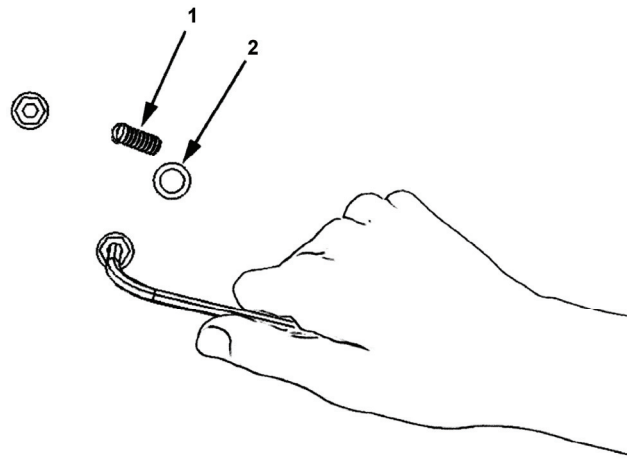

1. Remove any floor plug (1) that will not screw into floor insert (2).
2. Inspect floor plug (1) and insert (2) for damaged threads.
3. Install new floor plug (1) as required.

End of Work Package

**NON-DESTRUCTIVE INSPECTION SHOP
ILLUSTRATED LIST OF MANUFACTURED ITEMS**

INTRODUCTION**Scope**

This work package includes complete instructions for making items authorized to be manufactured.

How to Use the Index of Manufactured Items

A part number index in alphanumeric order is provided for cross-referencing the part number of the item to be manufactured to the page that covers fabrication criteria.

Explanation of the Illustrations of Manufactured Items

All instructions needed by maintenance personnel to manufacture the item are included on the illustrations. All bulk materials needed for manufacture of an item are listed by part number or specification number in a tabular list on the illustration.

REFERENCE INDEX

PART NUMBER	NOMENCLATURE	FIGURE NO.
17A6X0007	Cabinet Bracket	1
17AXX1002	Processing Tank Bracket	2
17AXX1003	Film Dryer Bracket	3
17AXX1005	End Shelf Brackets	4
17AXX1006	Illuminator Shelf	5
17AXX1007	Bar	6
20089721	First Aid Kit Bracket	7

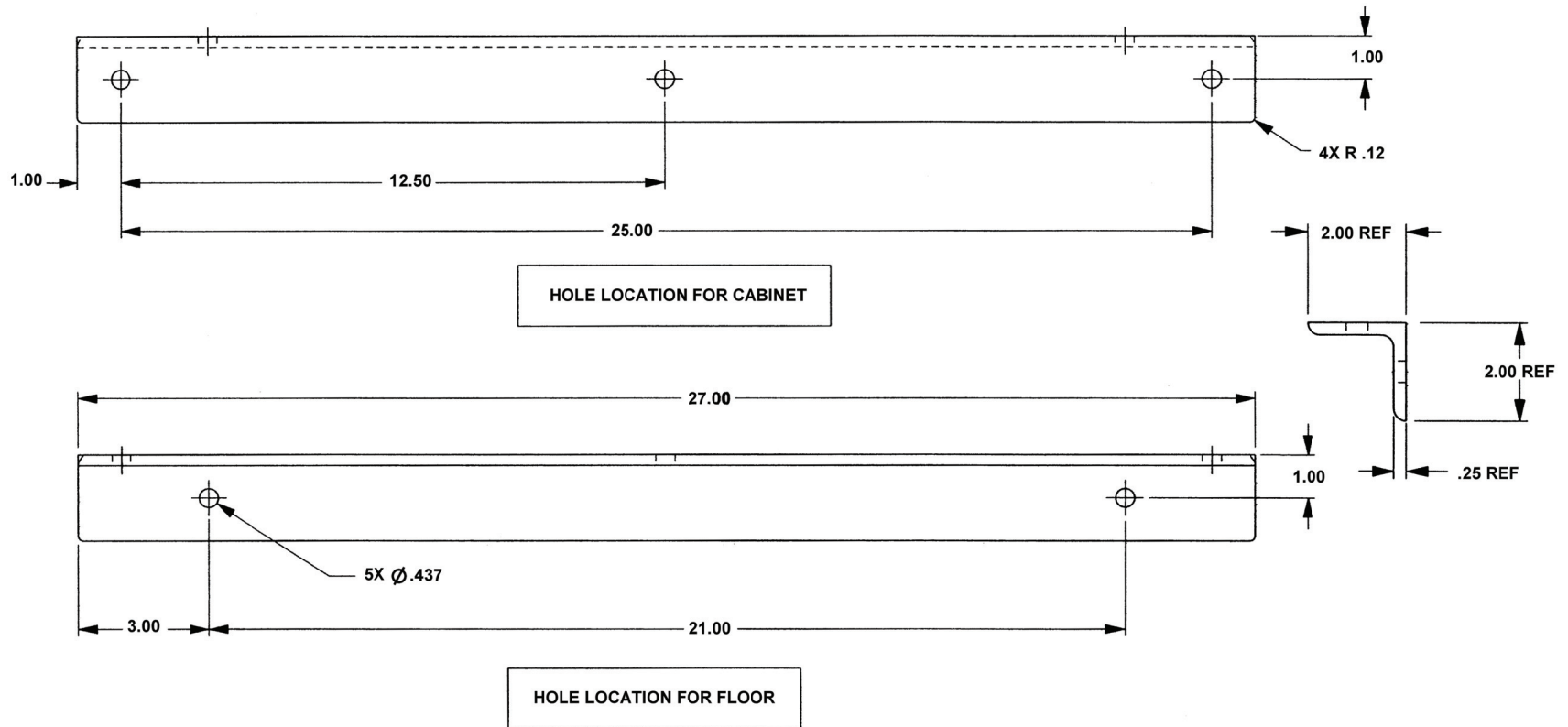

NOTES:

1. APPLICABLE STANDARDS/SPECIFICATIONS:
 - a. ASME Y14.100
 - b. ASME Y14.5M
2. MATERIAL: AL ALY 6061-T6, PER SAE AMS-QQ-A-200/8, ASTM B221, ASTM B308
3. REMOVE ALL BURRS AND SHARP EDGES
4. FINISH: 4.10 PLUS 7.3.1 PLUS 22.2 OF MIL-STD-171, COLOR GRAY NO. 16187 PER FED-STD-195

Figure 1. Cabinet Bracket, Part No. 17A6X0007.

0027 00-4

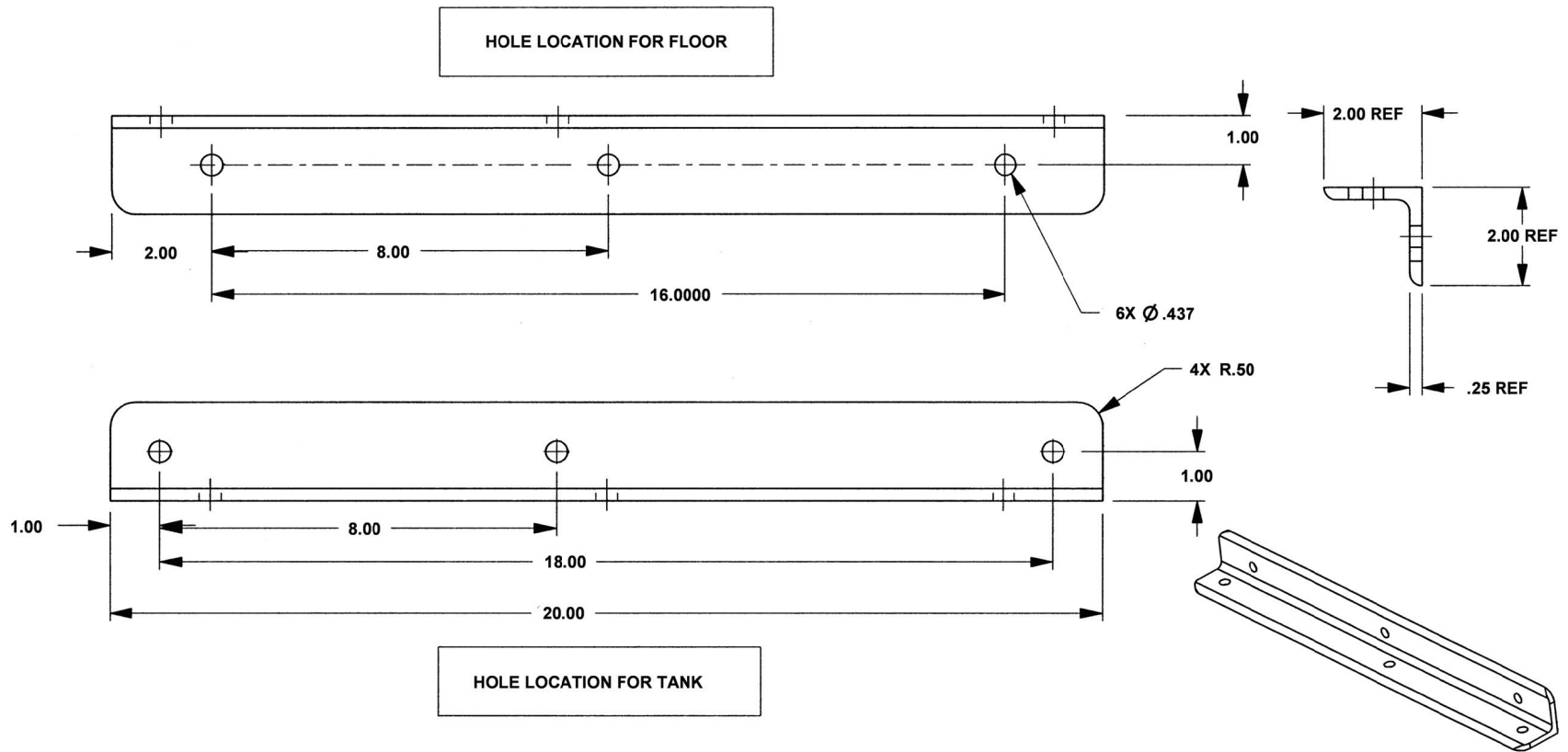

NOTES:

1. APPLICABLE STANDARDS/SPECIFICATIONS:
 - a. MIL-STD-100
 - b. ASME Y14.5M-1994
2. MATERIAL: 6061-T6 ALUMINUM ANGLE, 2.00 x 2.00 x .250 AL ANGLE PER SAE AMS-QQ-A-200/8
3. FINISH: 4.10 PLUS 7.3.1 PLUS 22.2 OF MIL-STD-171
COLOR GRAY NO. 16187 PER FED-STD-195

Figure 2. Processing Tank Bracket, Part No. 17AXX1002.

TM 1-4920-444-138P

0027 00

HOLE LOCATION FOR FLOOR

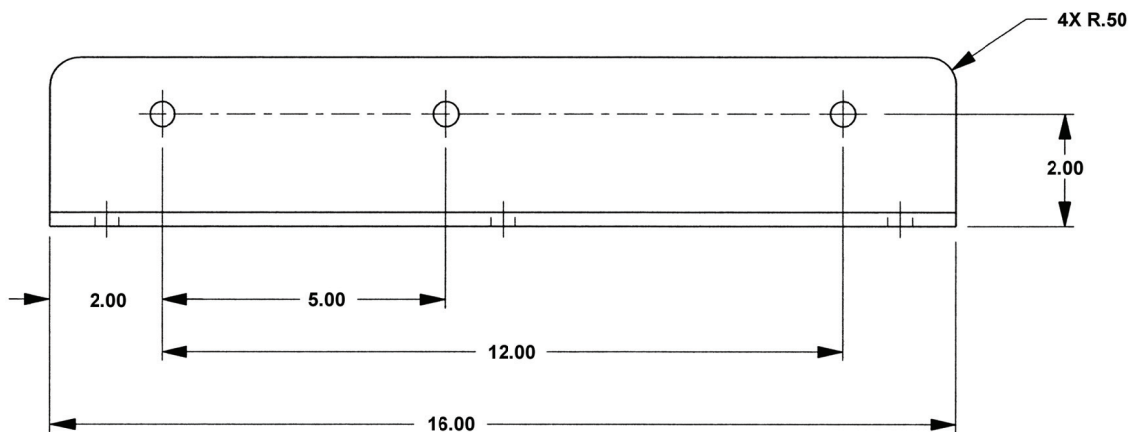
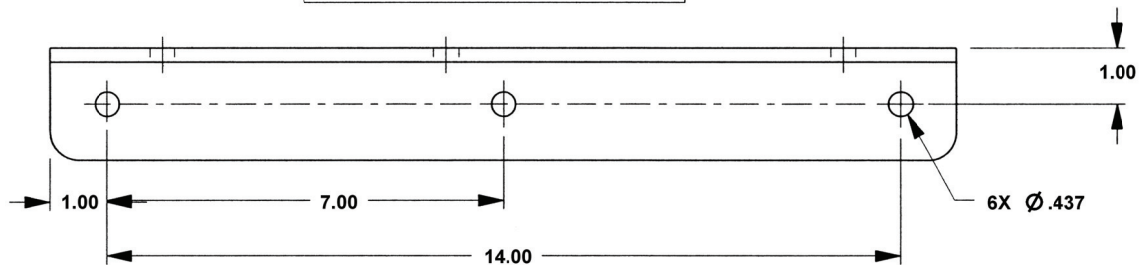

HOLE LOCATION FOR DRYER

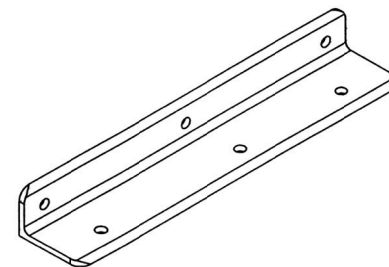
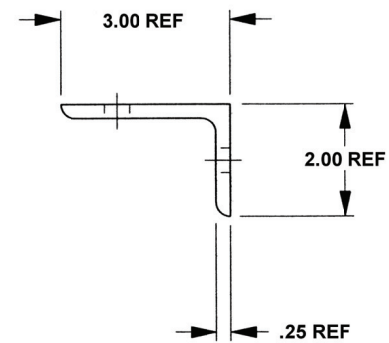

NOTES:

1. APPLICABLE STANDARDS/SPECIFICATIONS:
 - a. MIL-STD-100
 - b. ASME Y14.5M-1994
2. MATERIAL: 6061-T6 ALUMINUM ANGLE, 3.00 x 2.00 x .250 AL ANGLE PER SAE AMS-QQ-A-200/8
3. FINISH: 4.10 PLUS 7.3.1 PLUS 22.2 OF MIL-STD-171
COLOR GRAY NO. 16187 PER FED-STD-195

Figure 3. Film Dryer Bracket, Part No. 17AXX1003.

0027 00-6

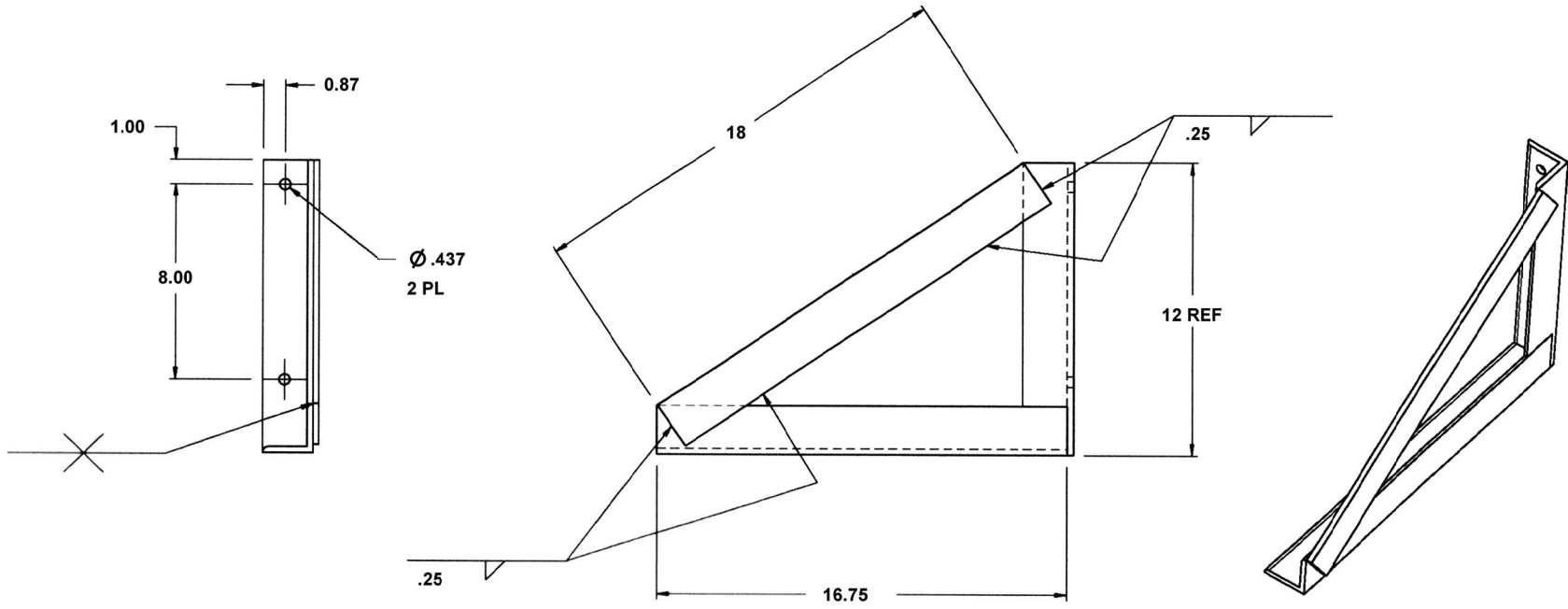
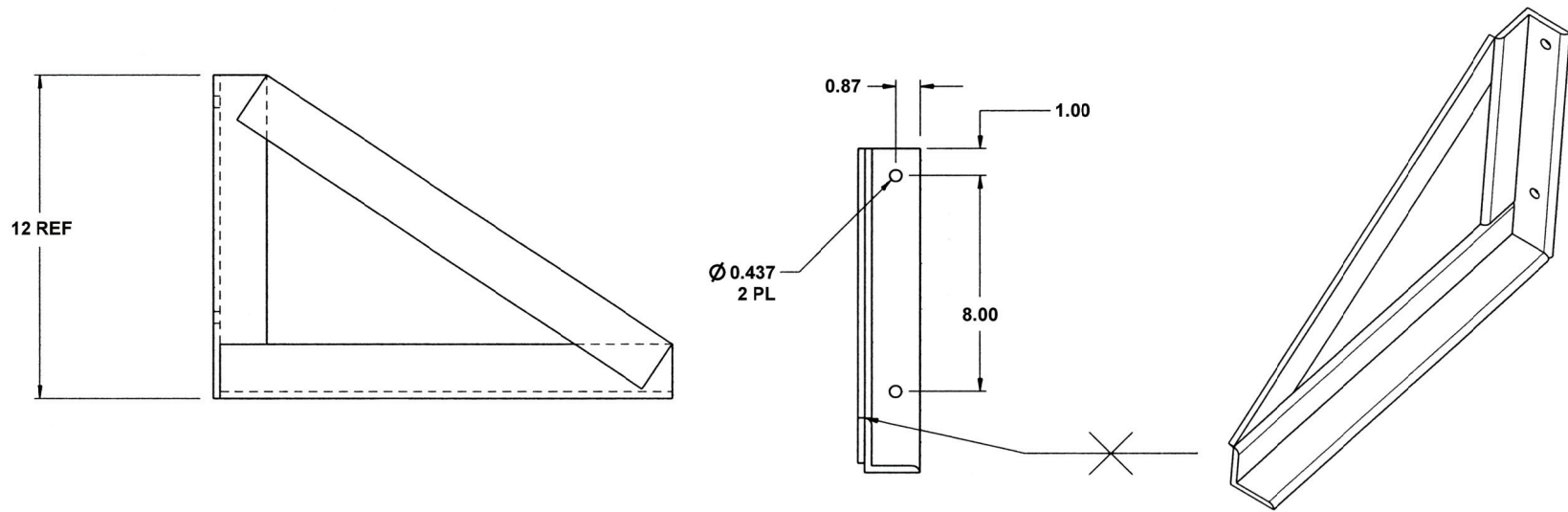

Figure 4. End Shelf Brackets, Part No. 17AXX1005. (Sheet 1 of 2)

TM 1-4920-444-138P

0027 00



NOTES:

1. APPLICABLE STANDARDS/SPECIFICATIONS:
 - a. ASME Y14.100
 - b. ASME Y14.5M
2. WELD IAW S9074-AQ-G1B-010/248 AND 13214E8326 TYPE II, CLASS 2

Figure 4. End Shelf Brackets, Part No. 17AXX1005. (Sheet 2 of 2)

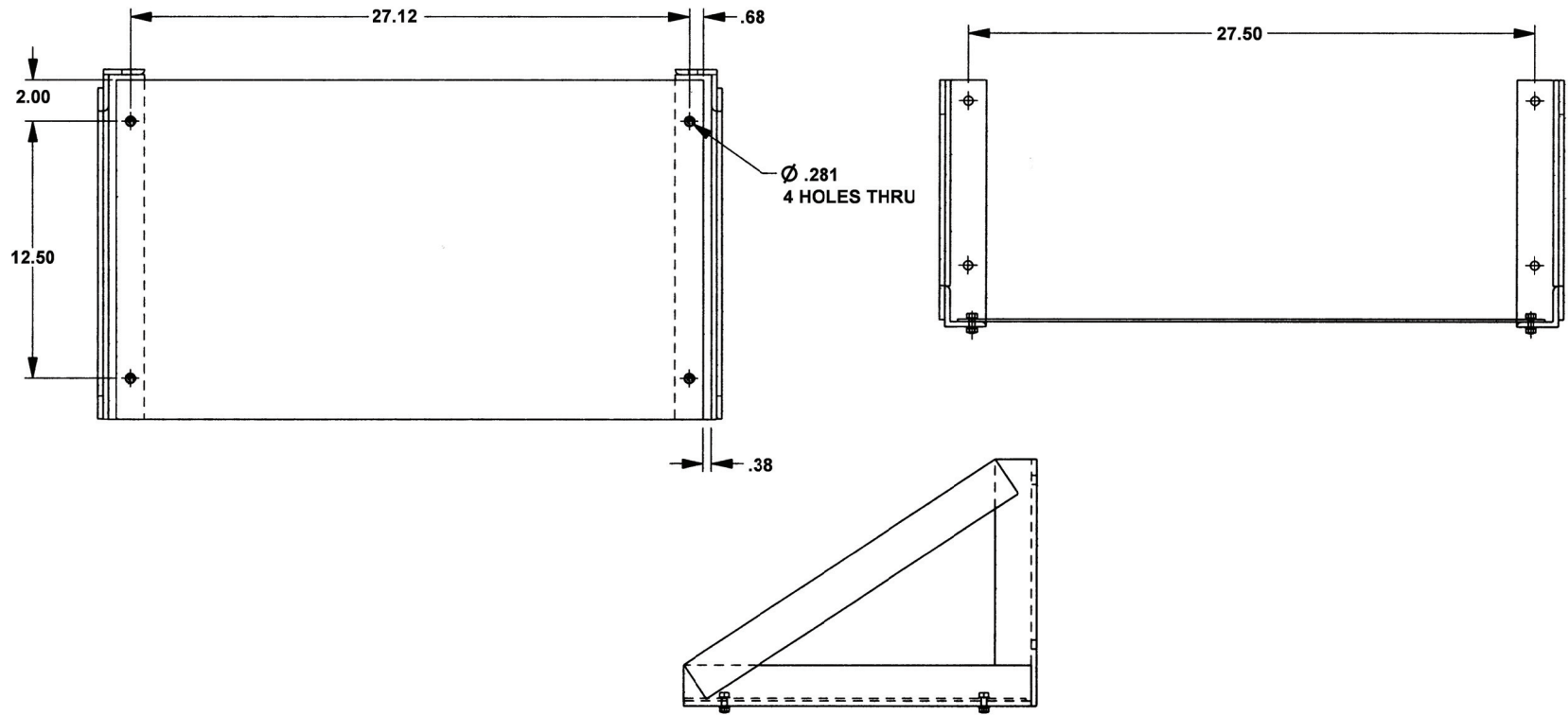
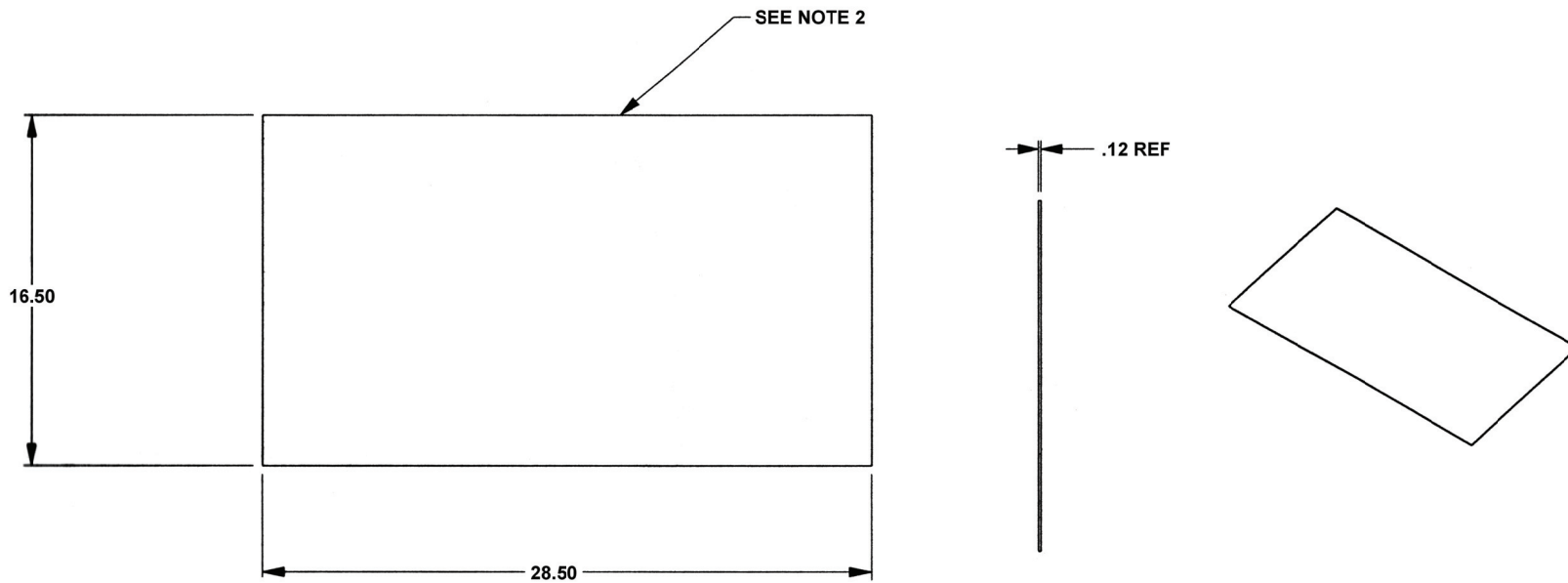

Figure 5. Illuminator Shelf, Part No. 17AXX1006. (Sheet 1 of 2)



NOTES:

1. APPLICABLE STANDARDS/SPECIFICATIONS:

- a. ASME Y14.100
- b. ASME Y14.5M

2. MATERIAL: ALUMINUM PLATE, 5052 AL, .12 INCH THICK

3. FINISH: 4.10 PLUS 7.3.1 PLUS 22.2 OF MIL-STD-171, COLOR WHITE NO. 17773 PER FED-STD-595

Figure 5. Illuminator Shelf, Part No. 17AXX1006. (Sheet 2 of 2)

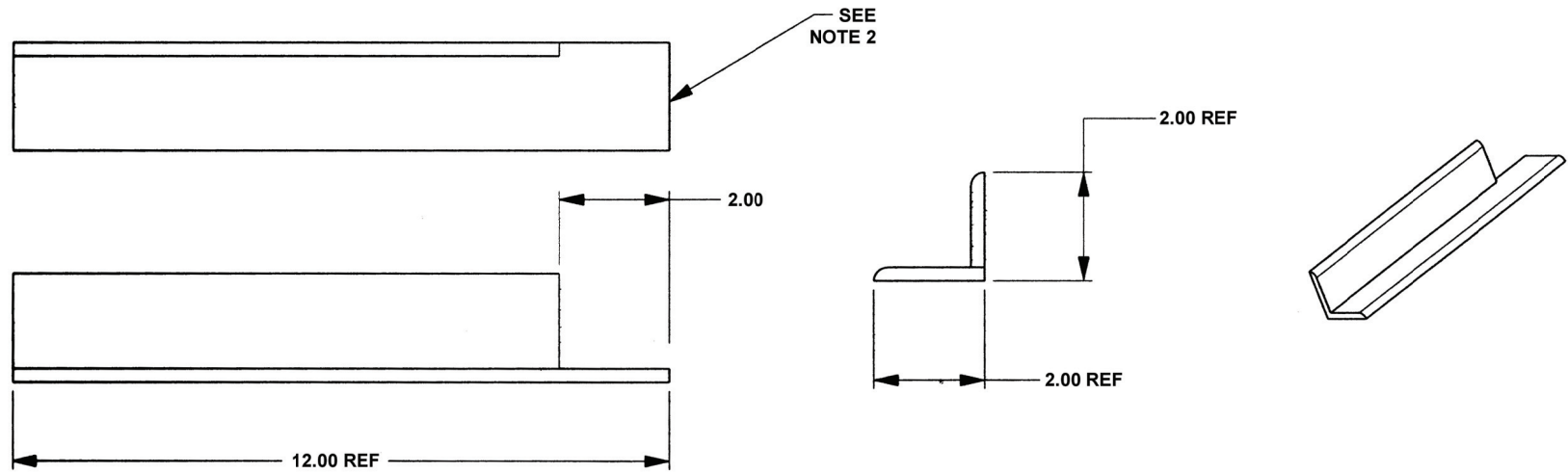

Figure 6. Bar, Part No. 17AXX1007. (Sheet 1 of 4)

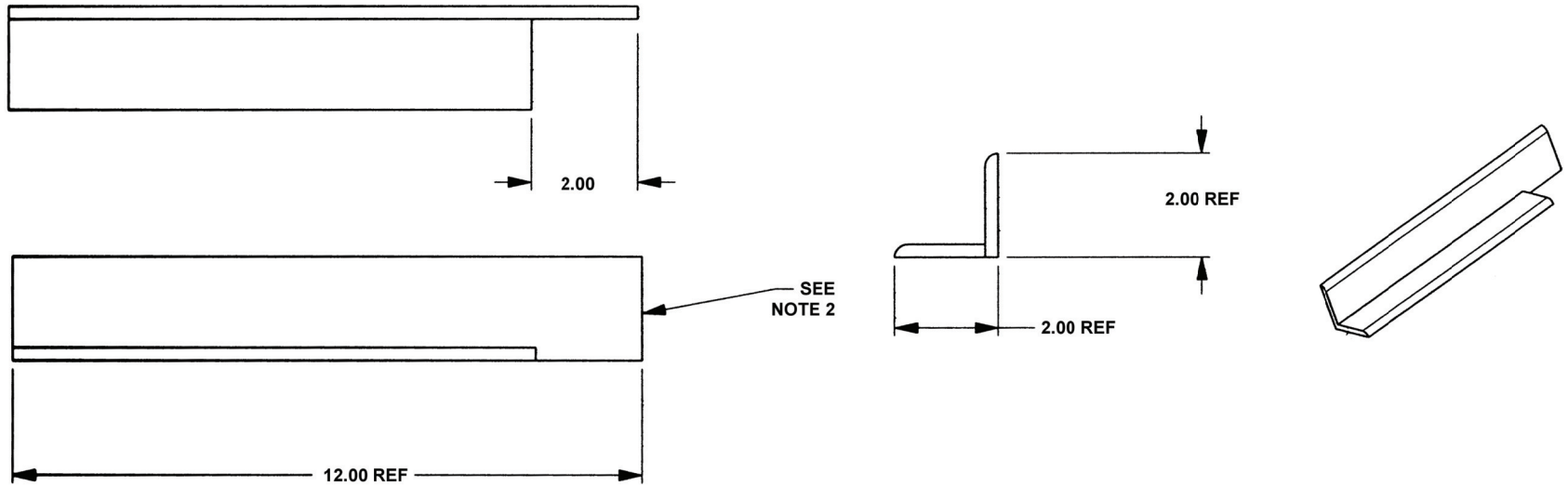

Figure 6. Bar, Part No. 17AXX1007. (Sheet 2 of 4)

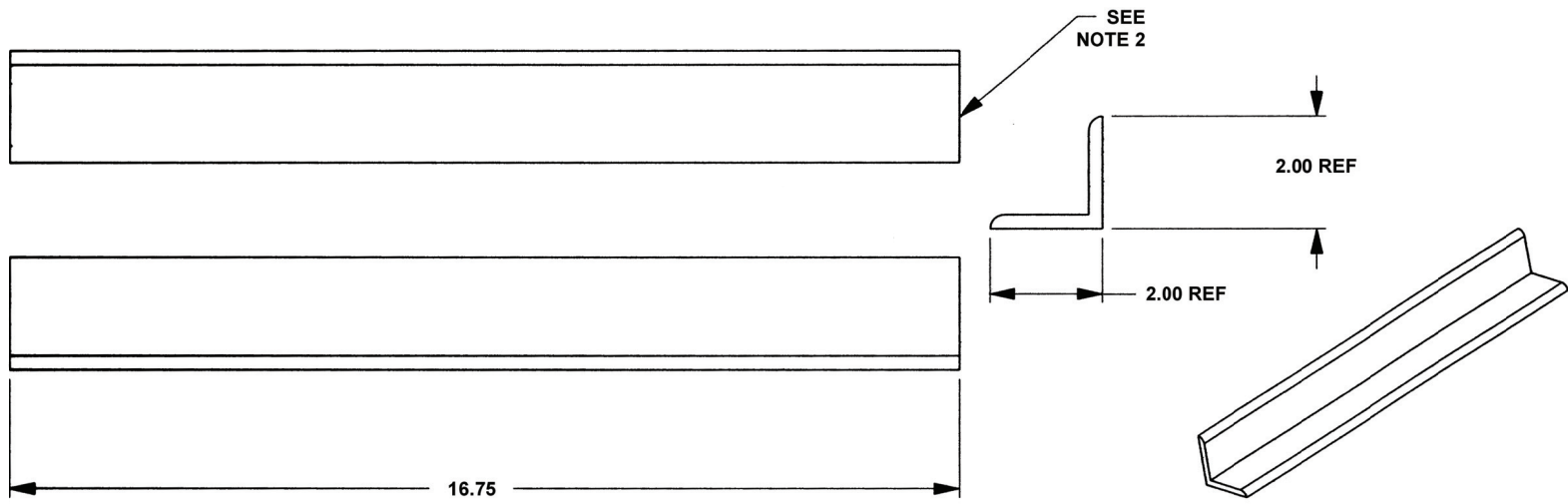
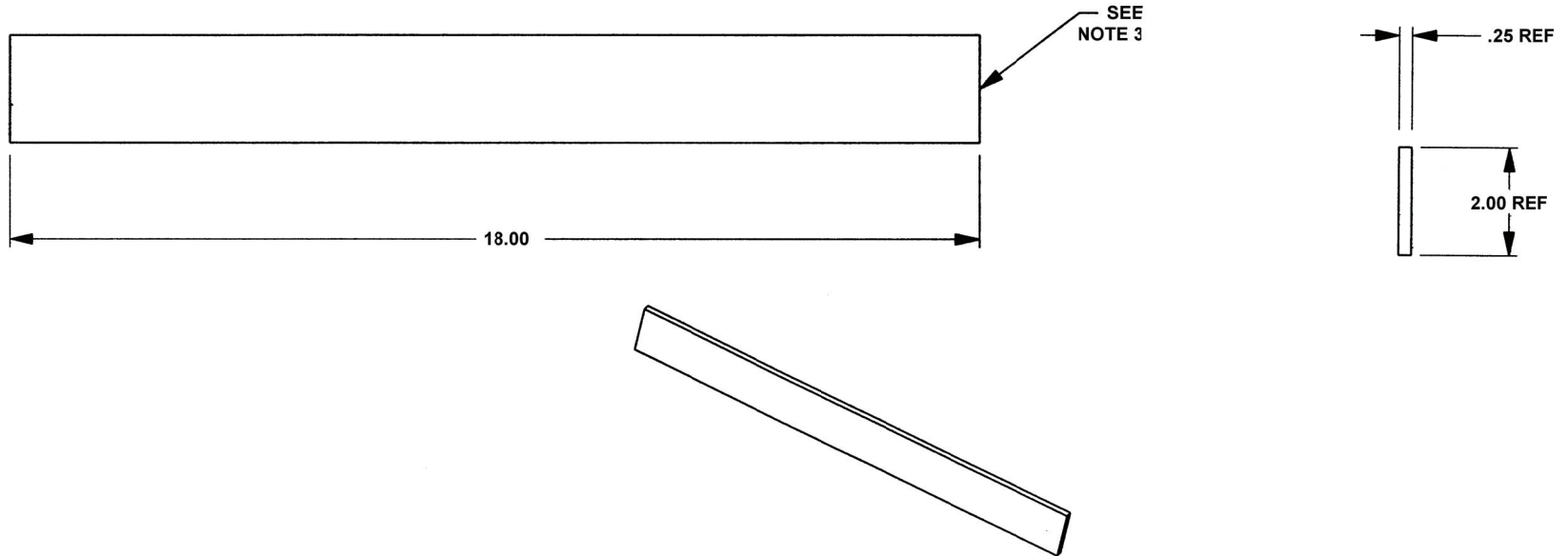

Figure 6. Bar, Part No. 17AXX1007. (Sheet 3 of 4)



NOTES:

1. APPLICABLE STANDARDS/SPECIFICATIONS:
 - a. ASME Y14.5 1994
 - b. MIL-STD-100
2. MATERIAL: 6061-T6 ALUMINUM ANGLE, 2.00 X 2.00 X .25 THICK PER ASTM B308
MATERIAL: ALY ALY 6061-T6, PER SAE AMS-QQ-A-200/11, ASTM B209

Figure 6. Bar, Part No. 17AXX1007. (Sheet 4 of 4)

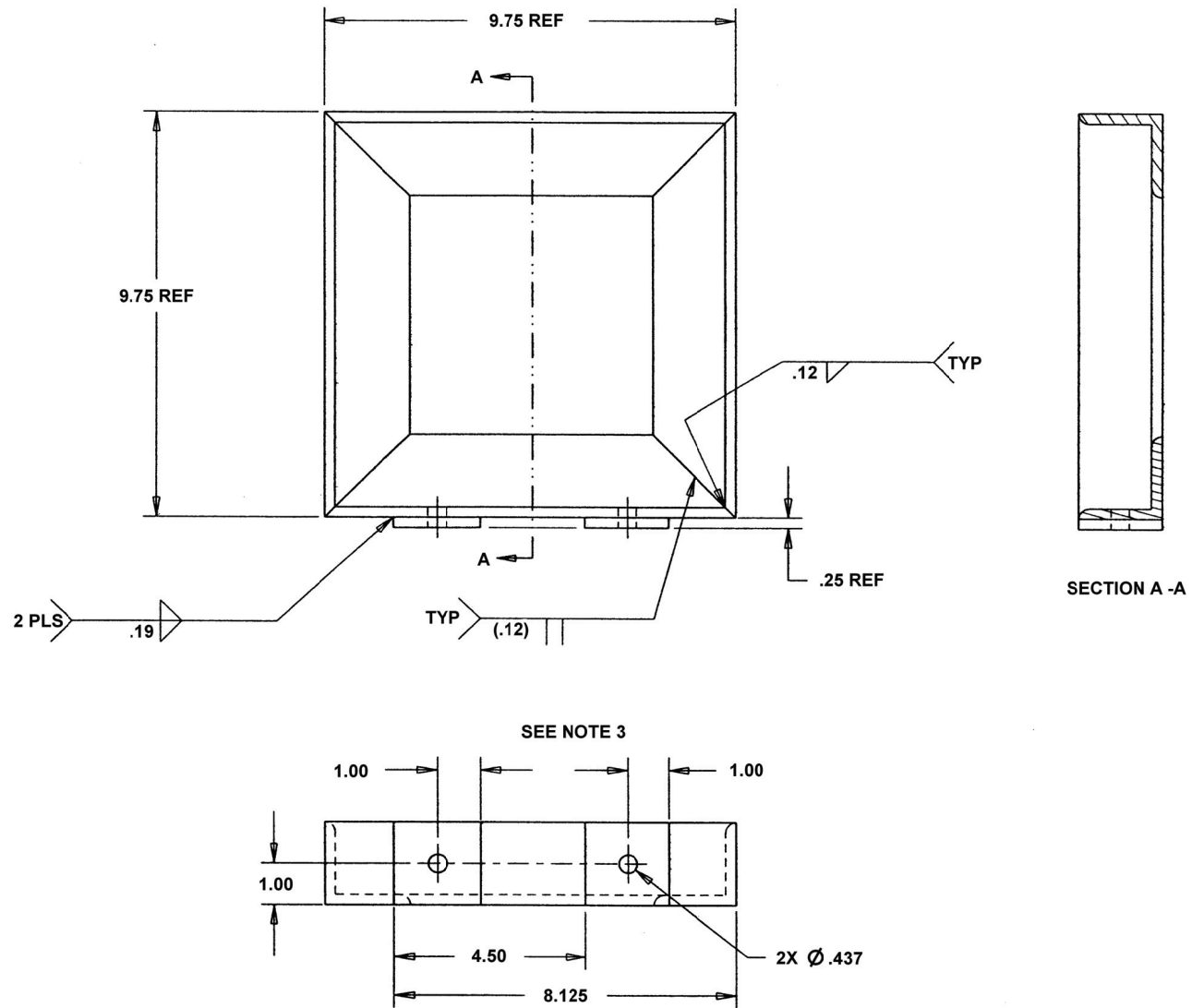

Figure 7. First Aid Kit Bracket, Part No. 20089721. (Sheet 1 of 3)

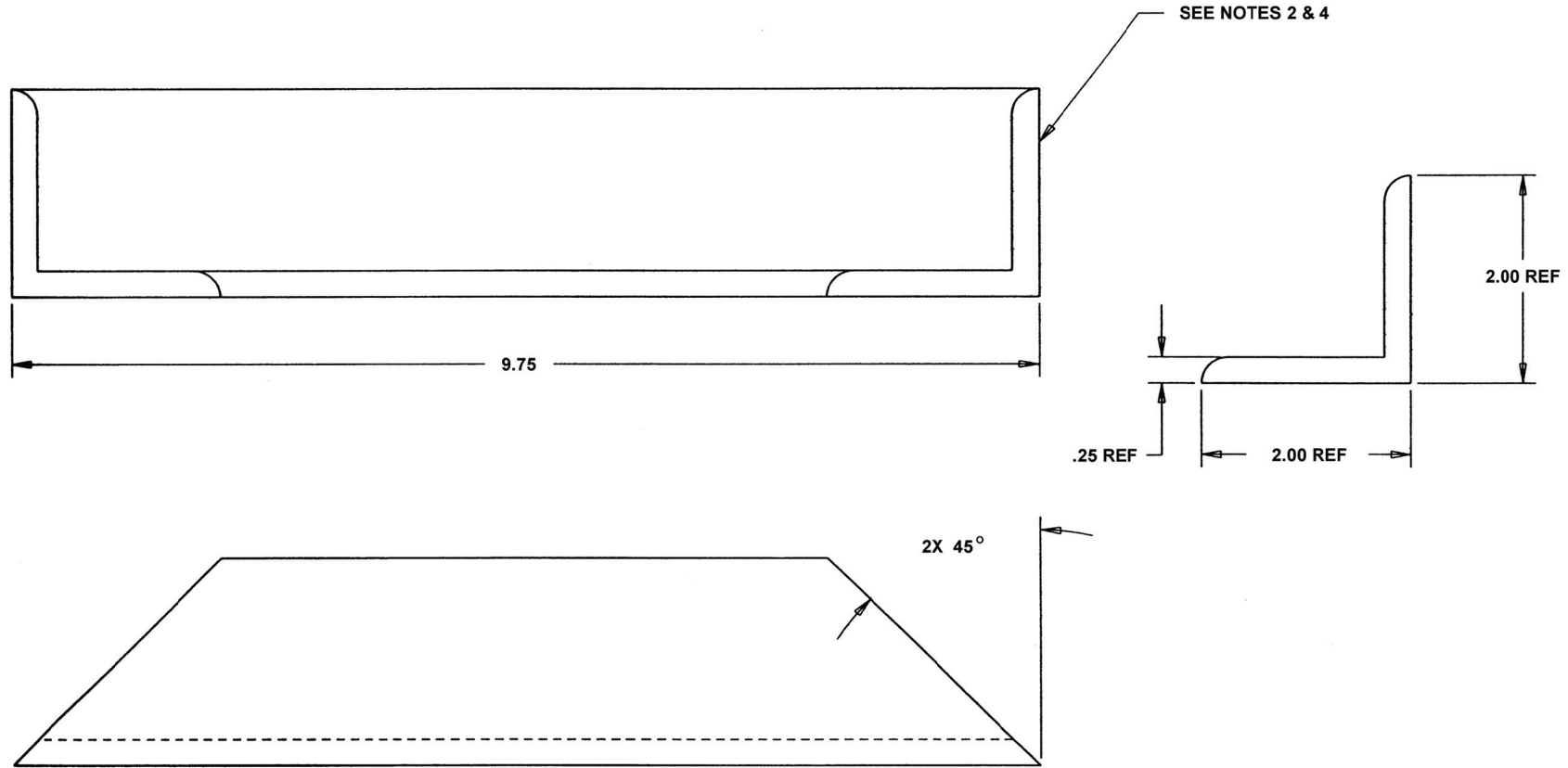
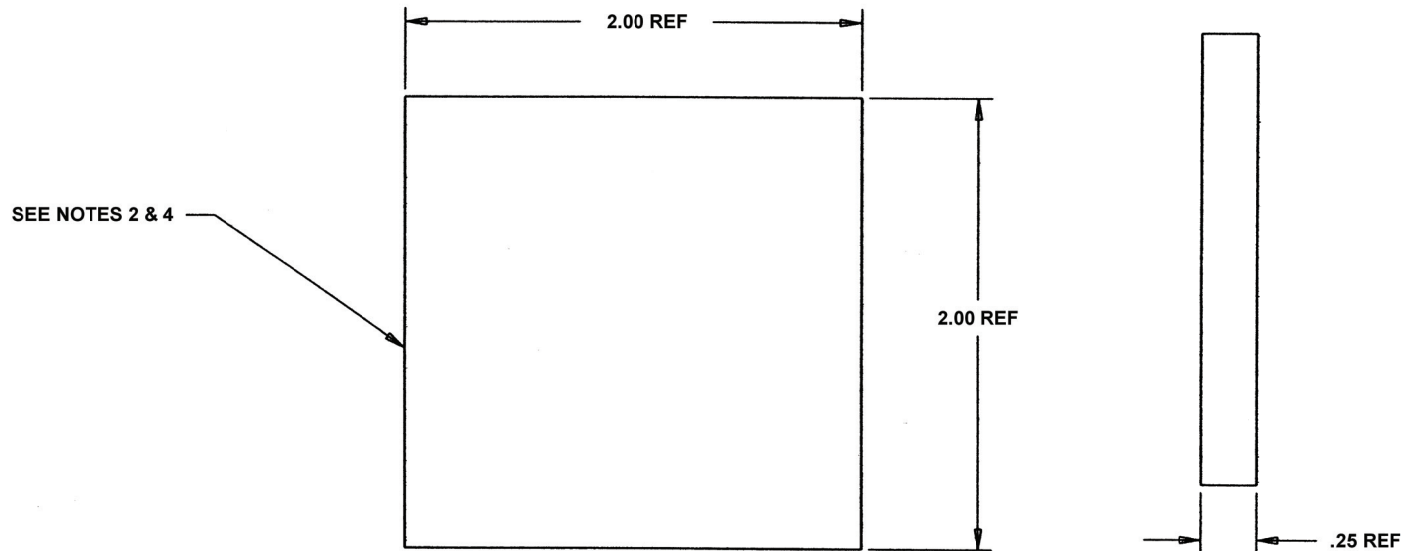

Figure 7. First Aid Kit Bracket, Part No. 20089721. (Sheet 2 of 3)



NOTES:

1. APPLICABLE STANDARDS/ SPECIFICATIONS:
 - a. ASME Y14.100
 - b. ASME Y14.5M
2. MATERIAL: AL ALY 6061-T6, PER SAE AMS-QQ-A-200/8
3. WELDING IAW S9074-AQ-G1B-010/248 AND 13214E8326 TYPE II, CLASS 2
4. FINISH: 4.10 PLUS 7.3.1 PLUS 22.2 OF MIL-STD-171, COLOR WHITE NO. 17773 PER FED-STD-595
5. REMOVE ALL BURRS AND SHARP EDGES

Figure 7. First Aid Kit Bracket, Part No. 20089721. (Sheet 3 of 3)

**NON-DESTRUCTIVE INSPECTION SHOP
TORQUE LIMITS**

Table 1. Torque Limits.

Bolt Size	Tension Loading
1/4-28	50-70 inch pounds
5/16-24	100-140 inch pounds
3/8-24	160-190 inch pounds
7/16-20	290-360 inch pounds
1/2-20	430-540 inch pounds
9/16-18	640-790 inch pounds

End of Work Package

CHAPTER 5
SUPPORTING INFORMATION
FOR
NON-DESTRUCTIVE INSPECTION SHOP

NON-DESTRUCTIVE INSPECTION SHOP REFERENCES

SCOPE

This work package lists all field manuals, forms, technical manuals, and miscellaneous publications referenced in this manual.

FORMS

SF 368 Product Quality Deficiency Report (PQDR)

TECHNICAL MANUALS

TM 5-4120-369-14 Air Conditioner, Horizontal, Compact, 18,000 BTU
 TM 9-6150-226-13 Operator, Unit, and Direct Support Maintenance Manual for Distribution Illumination
 Systems, Electrical (DISE) and Power Distribution Illumination Systems, Electrical
 (PDISE)
 TM 9-6150-226-23P Unit and Direct Support Maintenance Repair Parts and Special Tools List for Distribution
 Systems, Electrical (DISE) and Power Distribution Illumination Systems, Electrical
 (PDISE)
 TM 10-5411-201-14 Shelter, Tactical, Expandable, One Side NSN 5411-01-124-1377
 TM 43-0139 Painting Instructions for Army Material
 TM 750-244-1-4 Procedures for the Destruction of Aviation Ground Support Equipment
 (FSC 4920) to Prevent Enemy Use

OTHER PUBLICATIONS

AR 420-90 Fire and Emergency Services
 AR 700-138 Army Logistics Readiness and Sustainability
 AR 735-11-2 Reporting of Supply Discrepancies
 AR 750-1 Army Materiel Maintenance Policy
 DA PAM 25-30 Consolidated Index of Army Publications and Blank Forms
 DA PAM 25-40 Army Publishing: Action Officers Guide
 DA PAM 738-751 Functional Users Manual for the Army Maintenance Management System –
 Aviation (TAMMS-A)
 DA PAM 750-8 The Army Maintenance Management System (TAMMS) Users Manual
 MIL-STD-2219 Fusion Welding for Aerospace Applications
 TC 11-6

End of Work Package

**NON-DESTRUCTIVE INSPECTION SHOP
MAINTENANCE ALLOCATION CHART (MAC)**

INTRODUCTION**Aviation Maintenance Allocation Chart**

This MAC designates overall authority and responsibility for the performance of maintenance functions on the identified end item or component. The application of the maintenance of the maintenance functions to the end item or component shall be consistent with the capacities and capabilities of the designated maintenance level which are shown on the MAC as:

Field – includes two columns, “O” which corresponds to Aviation Maintenance Company (AMC) and “F” which corresponds to Aviation Support Battalion (ASB)

Sustainment – includes two columns, “L” which corresponds to Theater Aviation Sustainment Maintenance Group (TASMG) and other organizations that have National Maintenance Program certification and “D” which corresponds to Depot.

DEPOT - Corresponds to a “D” Code in the RPSTL.

The maintenance to be performed below depot and in the field is described as follows:

Aviation Unit Maintenance (AMC)

1. Aviation Maintenance Company (AMC). The primary purpose of the Aviation Maintenance Company is to support the momentum of offensive operations. Composition of the AMC will be based on type of operations being supported, nature of the battlefield, and the need for flexibility. AMCs will provide forward positioning of essential maintenance repair parts and supplies, maximum use of support teams, use of airlift/air drops for resupply, for maintenance that does not interfere with the tactical plans and operations. AMCs are agile, mobile, and well equipped. They will carry limited stockpiles of demand supported, essential parts, and supplies. The AMC performs battle damage assessment and repair (BDAR) and unit level repairs on Aviation Life Support Systems (ALSS). The AMC performs production control, quality control, and Maintenance Management/Maintenance Test Pilot functions. AMCs will rig aircraft for recovery operations. The AMC manages the battalion maintenance program and operates a central tool room. The AMC conducts forward arming and refueling. AMCs will be comprised of 3 to 4 modular platoons, which are configured to maintain unit level operational readiness and aircraft availability:

Headquarters Platoon – Establishes standard operating procedures, receives, and processes work requests, schedules maintenance, maintains status of aircraft, coordinates inspections and test flights and return to repaired aircraft, enforces quality standards, responsible for safety. Also, obtains, stores, and issues Classes II, III, IV, and IX, prescribed load list shop stock and authorized stockage list items.

Airframe Repair Platoon – Tailored to battalion it supports. Performs scheduled and unscheduled maintenance, troubleshoots faulty components, and removes and replaces aircraft components. Provides mission capable aircraft to support flight company operations.

Component Repair Platoon – Performs scheduled and unscheduled maintenance, troubleshoots faulty components, and removes and replaces aircraft components. Performs BDAR and manages Class IX spare/shop stock. This platoon uses Shop Equipment Contact Maintenance (SECM) trucks which are multi-capable and self-contained and are used to perform on-site maintenance using enhanced power tools, test, measurement, and diagnostic equipment, welding and cutting equipment, and an air compressor. The SECM truck is highly mobile.

-
2. Aviation Support Company (ASC) in the Aviation Support Battalion (ASB). Comprised of Headquarters, Airframe, and Component Repair Platoons. Provides maintenance assistance to aviation units helping them maintain operational readiness and aircraft availability. Utilizes SECM trucks. Capable of supporting split based operations in two separate and distinct locations. Performs the following types of maintenance:
 - a. Intermediate maintenance and logistics support operations.
 - b. Maintenance actions which require more than 3 days to correct.
 - c. Phased maintenance and preventive maintenance services.
 - d. In-depth troubleshooting and diagnosis of airframe and component malfunctions.
 - e. Repairs airframes and LRU component.
 - f. Fixes night vision systems, aviation life support systems, aviation electrical and hydraulic components.
 - g. Limited capability to fabricate hydraulic lines.
 - h. Repairs engines, prop and rotors, armament, and armament subsystems.
 - i. Fixes and fuels organic battalion equipment, ground aviation vehicles, and aviation ground support equipment.
 - j. Operates and performs field maintenance on aviation ground power units, generator, and ground support equipment.
 - k. Battle damage assessment and repair (BDAR).
 - l. Production control and quality control.
 - m. Test Pilot functions.
 3. Theater Aviation Sustainment Maintenance Group (TASMG) – Assists in deployment and redeployment, provides technical assistance, supports increased operational tempo, sustains Army aviation across the entire spectrum of operations. The TASMG:
 - a. Provides support to CONUS deploying forces.
 - b. Provides support to OCONUS deployed forces.
 - c. OCONUS aviation maintenance support for contingency and stability and/or support operations.
 - d. Expands aviation maintenance capabilities of CONUS depots.
 - e. Classifies and inspects aviation stocks and components.
 - f. Repairs engines, airframes, armament, composite materials, electrical systems, avionics, hydraulics.
 - g. Fabricates hydraulic lines.
 - h. Backup ASB and AMC maintenance functions.

Use of the MAC

NOTE

Approved item names are used throughout this MAC. Generic terms/nomenclature (if any) are expressed in parentheses and are not to be considered as official terminology.

This MAC assigns maintenance functions to the lowest level of maintenance, based on past experience and following considerations:

Skills available.

Work time required.

Tools and test equipment required and/or available.

Only the lowest level of maintenance authorized to perform a maintenance function is indicated. If the lowest maintenance level cannot perform all tasks of any single maintenance function (e.g., test, repair), then the higher maintenance level(s) that can accomplish additional tasks will also be indicated.

A maintenance function assigned to a maintenance level will automatically be authorized to be performed at any higher maintenance level.

A maintenance function that cannot be performed at the assigned level of maintenance for any reason may be evacuated to the next higher maintenance level. Higher maintenance levels will perform the maintenance functions of lower maintenance levels when required by the commander who has the authority to direct such tasking.

The assignment of a maintenance function will be construed as authorization to carry the related repair parts or spares in stock. Information to requisition or otherwise secure the necessary repair parts will be as specified in the associated RPSTL.

Normally there will be no deviation from the assigned level of maintenance. In cases of operational necessity, at the request of a lower maintenance level and on a one-time basis, transfer of maintenance functions to the lower level may be accomplished by specific authorization of the maintenance officer of the higher level of maintenance to which the function is assigned. The special tools, equipment, etc., required by the lower level of maintenance to perform this function will be furnished by the maintenance level to which the function is assigned. This transfer of a maintenance function to a lower maintenance level does not relieve the higher maintenance level of the responsibility for the function. The higher level of maintenance will provide technical supervision and inspection of the function being performed at the lower level.

Maintenance Functions

Maintenance functions will be limited to and defined as follows:

1. Inspect. To determine the serviceability of an item by comparing its physical, mechanical and/or electrical characteristics with established standards through examination (e.g., by sight, sound, or feel).
2. Test. To verify serviceability by measuring the mechanical, pneumatic, hydraulic, or electrical characteristics of an item and comparing those characteristics with prescribed standards.
3. Service. Operations required periodically to keep an item in proper operating condition, i.e., to clean (includes decontaminate, when required), to preserve, to drain, to paint, or to replenish fuel, lubricants, chemical fluids, or gases.
 - a. Unpack. To remove from packing box for after service when required for the performance of maintenance operations.
 - b. Repack. To return item to packing box after service and other maintenance operations.
 - c. Clean. To rid the item of contamination.
 - d. Touch up. To spot paint scratched or blistered surfaces.
 - e. Mark. To restore obliterated identification.

4. **Adjust.** To maintain or regulate, within prescribed limits, by bringing into proper position, or exact position, or by setting the operating characteristics to specified parameters.
5. **Align.** To adjust specified variable elements of an item to bring about optimum or desired performance.
6. **Calibrate.** To determine and cause corrections to be made or to be adjusted on instruments or test, measuring and diagnostic equipment used in precision measurement. Consists of comparisons of two instruments, one of which is a certified standard of known accuracy, to detect and adjust any discrepancy in the accuracy of the instrument being compared.
7. **Remove/Install.** To remove and install the same item when required to perform service or other maintenance functions. Install may be the act of emplacing, seating, or fixing into position a spare, repair part, or module (component or assembly) in a manner to allow the proper functioning of an equipment or system.
8. **Paint.** To prepare and spray color coats of paint so that the ammunition can be identified and protected. The color indicating primary use is applied, preferably, to the entire exterior surface as the background color of the item. Other markings are to be painted as original so as to retain proper ammunition identification.
9. **Replace.** To remove an unserviceable item and install a serviceable counterpart in its place. "Replace" is authorized by the MAC and assigned maintenance level is shown as the third position code of the Source, Maintenance and Recoverability (SMR) code.
10. **Repair.** The application of maintenance services, including fault location/troubleshooting, removal installation, disassembly/assembly procedures and maintenance actions to identify troubles and restore serviceability to an item by correcting specific damage, fault, malfunction, or failure in a part, subassembly, module (component or assembly), end item or system.

NOTE

The following definitions are applicable to the "repair" maintenance function:

Services - Inspect, test, service, adjust, align, calibrate and/or replace.

Fault location/troubleshooting - The process of investigating and detecting the cause of equipment malfunctioning; the act of isolating a fault within a system or Unit Under Test (UUT).

Disassembly/Assembly - The step-by-step taking apart (or breakdown) of a spare/functional group coded item to the level of its least component identified as maintenance significant (i.e., assigned an SMR code) for the level of maintenance under consideration.

Actions - Welding, grinding, riveting, straightening, facing, machining, and/or resurfacing.

11. **Overhaul.** That maintenance effort (service/action) prescribed to restore an item to a completely serviceable/operational condition as required by maintenance standards in appropriate technical publications. Overhaul is normally the highest degree of maintenance performed by the Army. Overhaul does not normally return an item to like new condition.
12. **Rebuild.** Those service/actions necessary for the restoration of unserviceable equipment to a like new condition in accordance with original manufacturing standards. Rebuild is the highest degree of material maintenance applied to Army equipment. The rebuild operation includes the act of returning to zero those age measurements (e.g., hours/miles) considered in classifying Army equipment/components.

Explanation of Entries in the MAC

Group Number and Component/Assembly. The functional groupings in the sample below identify maintenance significant components, assemblies, subassemblies, and modules with the next higher assembly.

Columns (1) and (2) - Functional Groups. The functional groupings in the sample below identify maintenance significant components, assemblies, subassemblies, and modules with the next higher assembly.

Group Number	Component/Assembly Description
04	POWER PLANT
0401	ENGINE, GENERAL Servicing, handling inspection requirements, overhaul and retirement schedules. External lines and hoses. (As applicable)
0402	COMPRESSOR SECTION (COLD SECTION MODULE) Rotor, blades, vanes, impeller, stators, inlet guide vanes, mainframe, particle separator, bleed valve, bearings, seals, external lines, and hoses.
0403	COMBUSTION SECTION (HOT SECTION MODULE) Liners, nozzles, stators, rotor, seals, couplings, and blades.
0404	POWER-TURBINE (POWER TURBINE MODULE) Nozzles, rotors, blades, exit guide vanes, exhaust frame, drive shaft, bearings, seals, external lines, and hoses.
0405	ACCESSORY GEAR BOX (ACCESSORY SECTION MODULE) Input and output gears, seals, chip detector, housings, drive shaft, and bearings.
0406	FUEL SYSTEM Fuel control, fuel boost pump, governors, fuel filter assembly, sequence valve, fuel manifold, fuel nozzle, external lines, and hoses.
0407	ELECTRICAL SYSTEM Electrical control units, exciters, thermocouples, ignition harness, electrical cables, history record, torque over speed sensor, Np sensor, external lines, and hoses.
0408	OIL SYSTEM Tanks, oil filter, oil cooler, lube and scavenger pumps, oil filter bypass sensor, external lines, and hoses.

Maintenance Function. Entry lists the functions to be performed on the items listed in Component/Assembly.

Maintenance Level. The maintenance levels field and sustainment are listed on the MAC with individual columns for AMC, ASB, TASM, and Depot that include the work times for maintenance functions at each maintenance level. Work time presentations such as "0.1" indicate the average time (expressed in manhours in whole hours or decimals) it requires a maintenance level to perform a specified maintenance function. If a work time has not been established, the columnar presentation will indicate "--". Maintenance levels higher than the level of maintenance indicated are authorized to perform the indicated function.

Tools and Equipment Reference Code. Entry specifies, by code, those common tool sets (not individual tools), common TMDE, and special tools, special TMDE, and special support equipment required to perform the designated function.

Remarks Code. When applicable, this column contains a letter code, in alphabetical order, which is keyed to the remarks.

Explanation of Columns in the Tools and Test Equipment Requirements

Tool or Test Equipment Reference Code. The tool or test equipment reference code correlates with a code used in tasks and equipment reference code entry of the MAC.

Maintenance Level. The lowest level of maintenance authorized to use the tool or test equipment.

Nomenclature. Name or identification of the tool or test equipment.

National Stock Number (NSN). The NSN of the tool or test equipment.

Tool Number. The manufacturer's part number.

Explanation of Entries in the Remarks

Remarks Code. The code recorded in remarks code entry of the MAC.

Remarks. This entry lists information pertinent to the maintenance function being performed as indicated in the MAC.

End of Work Package

**NON-DESTRUCTIVE INSPECTION SHOP
MAINTENANCE ALLOCATION CHART**

Table 1. MAC for Non-Destructive Inspection Shop.

(1) GROUP NUMBER	(2) COMPONENT or ASSEMBLY	(3) MAINTENANCE FUNCTION	(4) MAINTENANCE LEVEL				(5) TOOLS AND EQUIPMENT REF CODE	(6) REMARKS CODE
			FIELD		SUSTAINMENT			
			AMC	ASB	TASMG	DEPOT		
			(O)	(F)	(L)	(D)		
00	Equipment and Brackets	Inspect Remove Install		0.2 0.8 0.8			101, 102	C
01	Basic Shop Equipment	Inspect Test Remove Repair Install		0.8 0.6 1.3 1.0 1.9			101, 102, 103, 104	C, E
0101	ECU Large Closeout Panel	Inspect Remove Repair Install		0.6		4.5 1.0 4.7	101, 102, 103	C
0102	ECU Electrical Installation	Inspect Test Remove Repair Replace/Install		0.5 0.5 1.0 1.0			104	E
0103	Oil/Water Separator	Inspect		0.1			101, 102	C
0104	Services Utility Panel	Inspect Remove Replace/Install		0.6		5.0 5.2	102	
02	Fire Extinguisher Bracket	Inspect Remove Install		0.1 0.2 0.2			101, 102, 103	
03	Cabinet Brackets	Inspect Remove Repair Install		0.1 0.2 1.0 0.2			101, 102, 103	C
04	Wall and Floor Inserts	Inspect Remove Install		0.1 0.2 0.2			102	
05	Illuminator Shelf and Brackets	Inspect Remove Repair Install		0.1 0.3 1.0 0.5			101, 102, 103	C

Table 2. Tool and Test Equipment for Non-Destructive Inspection Shop.

TOOL OR TEST EQUIPMENT REFERENCE CODE	MAINTENANCE CATEGORY	NOMENCLATURE	NATIONAL STOCK NUMBER
101	F	Tool Crib Shop	4920-01-139-4548
102	F	Tool Kit, Power Plant	5180-01-375-6927
103	F	Machine Welding Shop	4920-01-139-4533
104	F	Tool Kit, Electrical Repairer	5180-01-375-6926

Table 3. Remarks for Non-Destructive Inspection Shop.

REMARKS REFERENCE CODE	REMARKS
A	Torque value on 5/16" inserts not to exceed 100-140 inch pounds.
B	Torque value on 1/4" inserts not to exceed 50-70 inch pounds.
C	Torque value on 3/8" inserts not to exceed 160-190 inch pounds.
D	Follow procedures in TM 10-5411-201-14.
E	Electrical and ground checks to be made by qualified electrician.

End of Work Package

**NON-DESTRUCTIVE INSPECTION SHOP
REPAIR PARTS AND SPECIAL TOOLS LIST (RPSTL)**

INTRODUCTION

Scope

This RPSTL lists and authorizes spares and repair parts, special tools, special test measurement and diagnostic equipment (TMDE), and other special support equipment required for performance of the Non-Destructive Inspection Shop. It authorizes the requisitioning, issue, and disposition of spares, repair parts, and special tools as indicated by the Source, Maintenance, and Recoverability (SMR) codes.

General

In addition to the Introduction work packages; this RPSTL is divided into the following work packages:

1. Repair Parts List Work Packages. Work packages containing lists of spares and repair parts authorized by this RPSTL for use in the performance of maintenance. These work packages also include parts which must be removed for replacement of the authorized parts. Parts lists are composed of functional groups in ascending alphanumeric sequence, with the parts in each group listed in ascending figure and item number sequence. Sending units, brackets, filters and bolts are listed with the component they mount on. Repair parts for repairable special tools are also listed in a separate work package. Items listed are shown on the associated illustrations.
2. Special Tools List Work Packages. Work packages containing lists of special tools, special TMDE, and special support equipment authorized by this RPSTL (as indicated by Basis of Issue (BOI) information in the DESCRIPTION AND USABLE ON CODE (UOC) column). Tools that are components of common tool sets and/or Class VII are not listed.
3. Cross-Reference Indexes Work Packages. There are two cross-reference indexes work packages in this RPSTL: the National Stock Number (NSN) Index work package and the Part Number (P/N) Index work package. The National Stock Number Index and the Part Number Index work package refer you to the figure and item number.

Explanation of Columns in the Repair Parts List and Special Tools List Work Packages

ITEM NO. (Column (1)). Indicates the number used to identify items called out in the illustration.

SMR CODE (Column (2)). The SMR code containing supply/requisitioning information, maintenance level authorization criteria and disposition instruction, as shown in the following breakout:

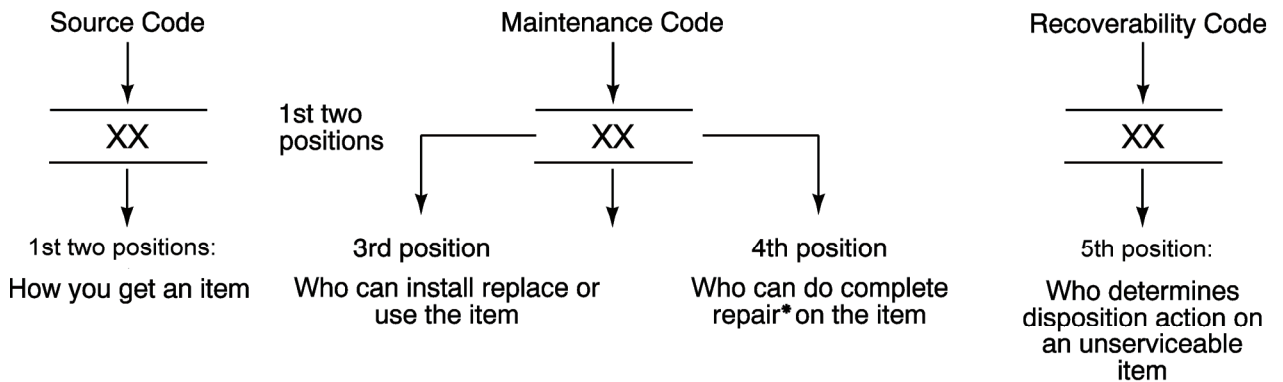

*Complete Repair: Maintenance capacity, capability, and authority to perform all corrective maintenance tasks of the "Repair" function in a use/user environment in order to restore serviceability to a failed item.

Source Code. The source code tells you how you get an item needed for maintenance, repair, or overhaul of an end item/equipment. Explanations of source codes follow:

SOURCE CODE:	APPLICATION/EXPLANATION
PA	
PB	NOTE
PC	Items coded PC are subject to deterioration.
PD	
PE	Stock items; use the applicable NSN to requisition/request items with these source codes. They are authorized to the level indicated by the code entered in the 3 rd position of the SMR code.
PF	
PG	
PH	
PR	
PZ	
KD	
KF	Items with these codes are not to be requested/requisitioned individually. They are part of a kit, which is authorized to the maintenance level indicated in the 3 rd position of the SMR code. The complete kit must be requisitioned and applied.
KB	
MO-Made at unit/ AVUM level	
MF-Made at DS/ AVIM level	Items with these codes are not to be requisitioned/requested individually. They must be made from bulk material which is identified by the P/N in the DESCRIPTION AND USABLE ON CODE (UOC) column and listed in the bulk material group work package of the RPSTL. If the item is authorized to you by the 3 rd position code of the SMR code, but the source code indicates it is made at higher level, order the item from the higher level of maintenance.
MH-Made at GS level	
ML-Made at SRA	
MD-Made at depot	
MG- Navy only	
AO-Assembled by unit/AVUM level	
AF-Assembled by DS/AVIM level	Items with these codes are not to be requested/requisitioned individually. The parts that make up the assembled item must be requisitioned or fabricated and assembled at the level of maintenance indicated by the source code. If the 3 rd position of the SMR code authorizes you to replace the item, but the source code indicates the item is assembled at a higher level, order the item from the higher level of maintenance.
AH-Assembled by GS level	
AL-Assembled by SRA	
AD-Assembled by depot	
AG-Navy only	
XA	Do not requisition an "XA" coded item. Order the next higher assembly. (Refer to NOTE below.)
XB	If an item is not available from salvage, order it using the CAGEC and P/N.
XC	Installation drawings, diagrams, instruction sheets, field service drawings; identified by manufacturer's P/N.
XD	Item is not stocked. Order an XD-coded item through normal supply channels using the CAGEC and P/N given, if no NSN is available.

NOTE

Cannibalization or controlled exchange, when authorized, may be used as a source of supply for items with the above source codes except for those items source coded "XA" or those aircraft support items restricted by requirements of AR 750-1.

Maintenance Code. Maintenance codes tell you the level(s) of maintenance authorized to use and repair support items. The maintenance codes are entered in the third and fourth positions of the SMR code as follows:

Third Position. The maintenance code entered in the third position tells you the lowest maintenance level authorized to remove, replace, and use an item. The maintenance code entered in the third position will indicate authorization to the following levels of maintenance:

<u>Maintenance Code</u>	<u>Application/Explanation</u>
O*	Unit level/AVUM maintenance can remove, replace, and use the item.
F	Direct support/AVIM maintenance can remove, replace, and use the item.
H	General Support maintenance can remove, replace, and use the item.
L	Specialized repair activity can remove, replace, and use the item.
G	Afloat and ashore intermediate maintenance can remove, replace, and use the item (Navy only).
K	Contractor facility can remove, replace, and use the item.
Z	Item is not authorized to be removed, replaced, or used at any maintenance level.
D	Depot can remove, replace, and use the item.

*NOTE – Army may use C in the third position. However, for joint service publications, Army will use O.

Fourth Position. The maintenance code entered in the fourth position tells you whether or not the item is to be repaired and identifies the lowest maintenance level with the capability to do complete repair (perform all authorized repair functions).

NOTE

Some limited repair may be done on the item at a lower level of maintenance, if authorized by the Maintenance Allocation Chart (MAC) and SMR codes.

<u>Maintenance Code</u>	<u>Application/Explanation</u>
O	Unit/AVUM is the lowest level that can do complete repair of the item.
F	Direct support/AVIM is the lowest level that can do complete repair of the item.
H	General Support is the lowest level that can do complete repair of the item.
L	Specialized repair activity XXXX is the lowest level that can do complete repair of the item.
D	Depot is the lowest level that can do complete repair of the item.
G	Both afloat and ashore intermediate levels are capable of complete repair of item. (Navy only)
K	Complete repair is done at contractor facility.
Z	Non-reparable. No repair is authorized.
B	No repair is authorized. No parts or special tools are authorized for maintenance of "B" coded item. However, the item may be reconditioned by adjusting, lubricating, etc., at the user level.

Recoverability Code. Recoverability codes are assigned to items to indicate the disposition action on unserviceable items. The recoverability code is shown in the fifth position of the SMR code as follows:

Recoverability Code	Application/Explanation
Z	Non-reparable item. When unserviceable, condemn, and dispose of the item at the level of maintenance shown in the third position of the SMR code.
O	Reparable item. When uneconomically reparable, condemn, and dispose of the item at the unit level.
F	Reparable item. When uneconomically reparable, condemn, and dispose of the item at the direct support level.
H	Reparable item. When uneconomically reparable, condemn, and dispose of the item at the General Support level.
D	Reparable item. When beyond lower level repair capability, return to depot. Condemnation and disposal of item are not authorized below depot level.
L	Reparable item. Condemnation and disposal not authorized below Specialized Repair Activity (SRA).
A	Item requires special handling or condemnation procedures because of specific reasons (such as precious metal content, high dollar value, critical material or hazardous material). Refer to appropriate manuals/directives for specific instructions.
G	Field level reparable item. Condemn and dispose at either afloat or ashore intermediate levels. (Navy only)
K	Reparable item. Condemnation and disposal to be performed at contractor facility.

NSN (Column (3)). The NSN for the item is listed in this column.

CAGEC (Column (4)). The Commercial and Government Entity Code (CAGEC) is a five-digit code which is used to identify the manufacturer, distributor or Government agency/activity that supplies the item.

PART NUMBER (Column (5)). Indicates the primary number used by the manufacturer (individual, company, firm, corporation, or Government activity), which controls the design and characteristics of the item by means of its engineering drawings, specifications, standards, and inspection requirements to identify an item or range of items.

NOTE

When you use an NSN to requisition an item, the item you receive may have a different P/N from the number listed.

DESCRIPTION AND USABLE ON CODE (UOC) (Column (6)). This column includes the following information:

1. The federal item name, and when required, a minimum description to identify the item.
2. P/Ns of bulk materials are referenced in this column in the line entry to be manufactured or fabricated.
3. Hardness Critical Item (HCI). A support item that provides the equipment with special protection from electromagnetic pulse (EMP) damage during a nuclear attack.
4. The statement END OF FIGURE appears just below the last item description in column (6) for a given figure in both the repair parts list and special tools list work packages.

QTY (Column (7)). The QTY (quantity per figure) column indicates the quantity of the item used in the breakout shown on the illustration/figure, which is prepared for a functional group, subfunctional group, or an assembly. A "V" appearing in this column instead of a quantity indicates that the quantity is variable and quantity may change from application to application.

Explanation of Cross-Reference Indexes Work Packages Format and Columns

1. National Stock Number (NSN) Index Work Package.

STOCK NUMBER Column. This column lists the NSN in National item identification number (NIIN) sequence. The NIIN consists of the last nine digits of the NSN.

*For example, if the NSN is 5385-01-574-1476, the NIIN is 01-574-1476.

FIG. Column. This column lists the number of the figure where the item is identified/located. The figures are in numerical order in the repair parts list and special tools list work packages.

ITEM Column. The item number identifies the item associated with the figure listed in the adjacent FIG. column. This item is also identified by the NSN listed on the same line.

2. Part Number (P/N) Index Work Package. P/Ns in this index are listed in ascending alphanumeric sequence (vertical arrangement of letter and number combinations which places the first letter or digit of each group in order A through Z, followed by the numbers 0 through 9 and each following letter or digit in like order).

PART NUMBER Column. Indicates the P/N assigned to the item.

FIG. Column. This column lists the number of the figure where the item is identified/located in the repair parts list and special tools list work packages.

ITEM Column. The item number is the number assigned to the item as it appears in the figure referenced in the adjacent figure number column.

Special Information

UOC. The UOC appears in the lower left corner of the Description Column heading. Usable on codes are shown as "UOC:..." in the Description Column (justified left) on the first line under the applicable item/nomenclature. Uncoded items are applicable to all models. Identification of the UOCs used in the RPSTL are:

<u>Code</u>	<u>Used On</u>
PAA	Model M114
PAB	Model M114A
PAC	Model M114B"

Fabrication Instructions. Bulk materials required to manufacture items are listed in the bulk material functional group of this RPSTL. Part numbers for bulk material are also referenced in the Description Column of the line item entry for the item to be manufactured/fabricated. Detailed fabrication instructions for items source coded to be manufactured or fabricated are found in TM 1-1500-204-23-10.

Index Numbers. Items, which have the word BULK in the figure column, will have an index number shown in the item number column. This index number is a cross-reference between the NSN / P/N index work packages and the bulk material list in the repair parts list work package.

How to Locate Repair Parts

1. When NSNs or P/Ns Are Not Known.

First. Using the table of contents, determine the assembly group to which the item belongs. This is necessary since figures are prepared for assembly groups and subassembly groups, and lists are divided into the same groups.

Second. Find the figure covering the functional group or the subfunctional group to which the item belongs.

Third. Identify the item on the figure and note the number(s).

Fourth. Look in the repair parts list work packages for the figure and item numbers. The NSNs and part numbers are on the same line as the associated item numbers.

2. When NSN Is Known.

First. If you have the NSN, look in the STOCK NUMBER column of the NSN index work package. The NSN is arranged in NIIN sequence. Note the figure and item number next to the NSN.

Second. Turn to the figure and locate the item number. Verify the item is the one you are looking for.

3. When P/N Is Known.

First. If you have the P/N and not the NSN, look in the PART NUMBER column of the P/N index work package. Identify the figure and item number.

Second. Look up the item on the figure in the applicable repair parts list work package.

End of Work Package

NON-DESTRUCTIVE INSPECTION SHOP
REPAIR PARTS LIST

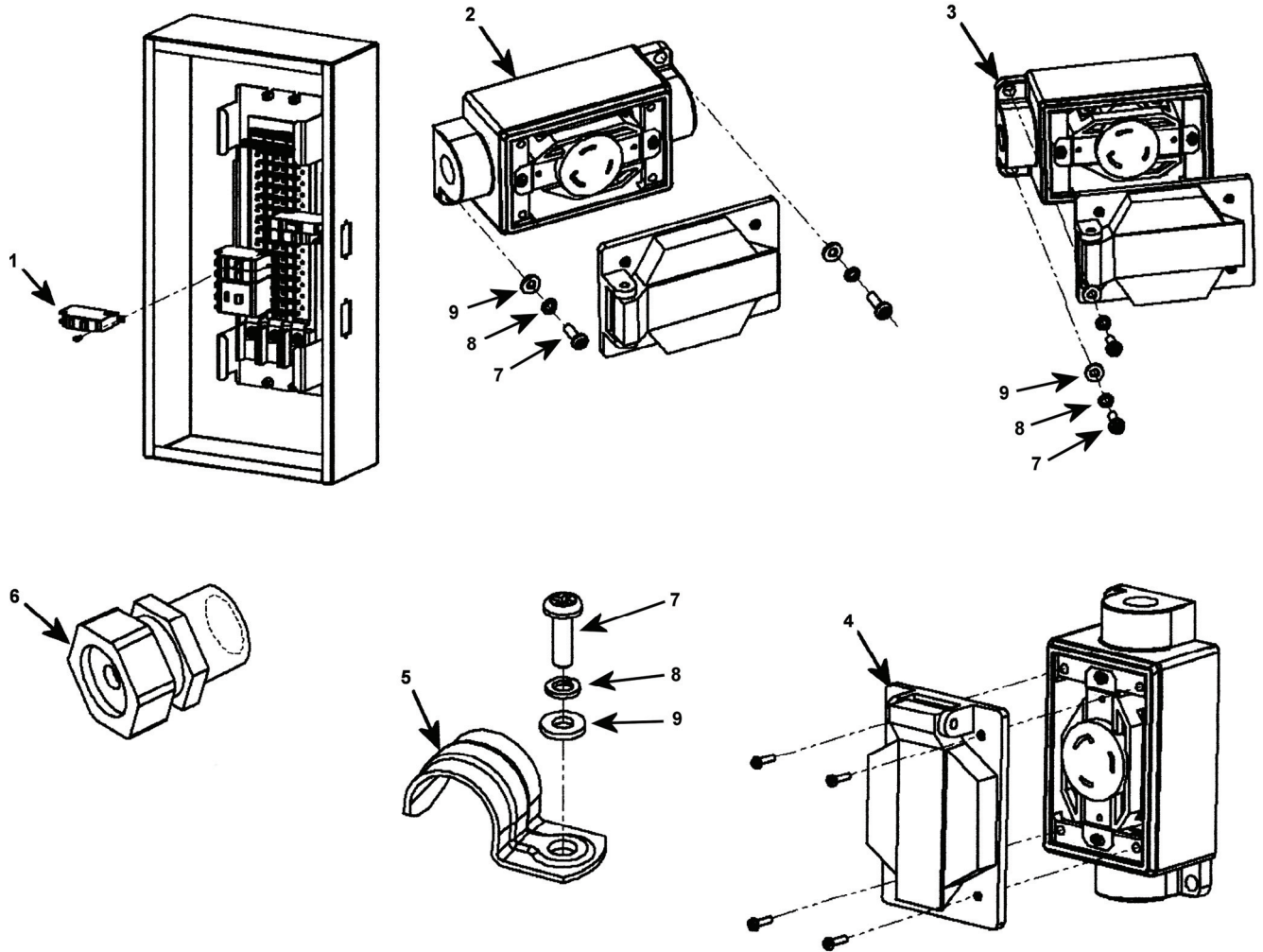

Figure 1. Equipment and Brackets. (Sheet 1 of 2)

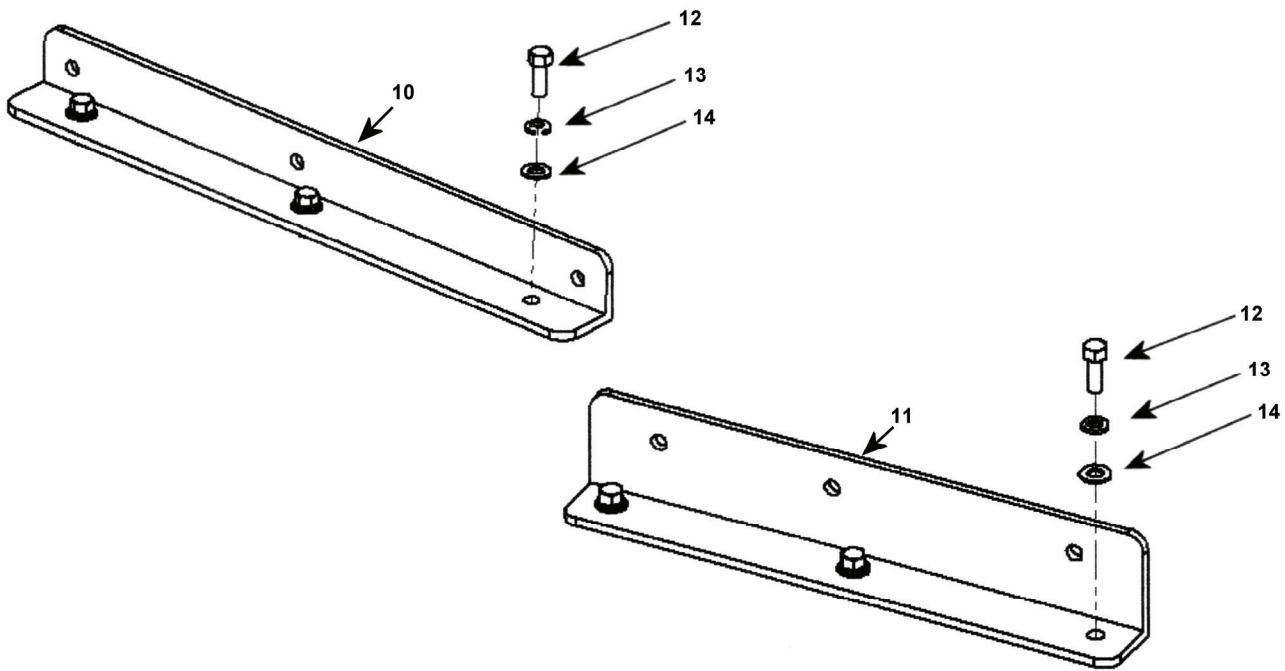

Figure 1. Equipment and Brackets. (Sheet 2 of 2)

(1)	(2)	(3)	(4)	(5)	(6)	(7)
ITEM NO.	SMR CODE	NSN	CAGEC	PART NUMBER	DESCRIPTION AND USABLE ON CODE (UOC)	QTY
					GROUP 00 EQUIPMENT AND BRACKETS	
					FIG 1. EQUIPMENT AND BRACKETS	
1	PAFZZ	5925-00-967-9874	14280	QOB220	CIRCUIT BREAKER, 20A	2
2	XDFZZ		4R280	FSC2-SC	BOX, OUTLET	1
3	XDFZZ		4R280	FSC1-1C	BOX, OUTLET	1
4	XDFZZ		03743	FSK-WR2	COVER	2
5	PAFZZ	5340-01-221-0272	05500	920S	STRAP, RETAINING	4
6	PAFZZ	5975-00-179-0098	56501	TC111A	BOX CONNECTOR	4
7	PAFZZ	5305-00-432-4205	80205	MS51861-49	MACHINE SCREW, PAN HEAD	9
8	PAFZZ	5310-00-045-3296	80205	MS35338-43	WASHER, LOCK	9
9	PAFZZ	5310-01-352-2752	80205	NAS1149C0332R	WASHER, FLAT	9
10	MFFZZ		81996	17AXX1002	BRACKET , PROCESSING TANK	2
11	MFFZZ		81996	17AXX1003	BRACKET , FILM DRYER	1
12	PAFZZ	5305-00-269-2803	80205	MS90726-60	CAP SCREW, HEXAGON HEAD	9
13	PAFZZ	5310-00-637-9541	80205	MS35338-46	WASHER, LOCK	9
14	PAFZZ	5310-01-236-6203	80205	NAS301-6	WASHER, FLAT	9
					END OF FIGURE	

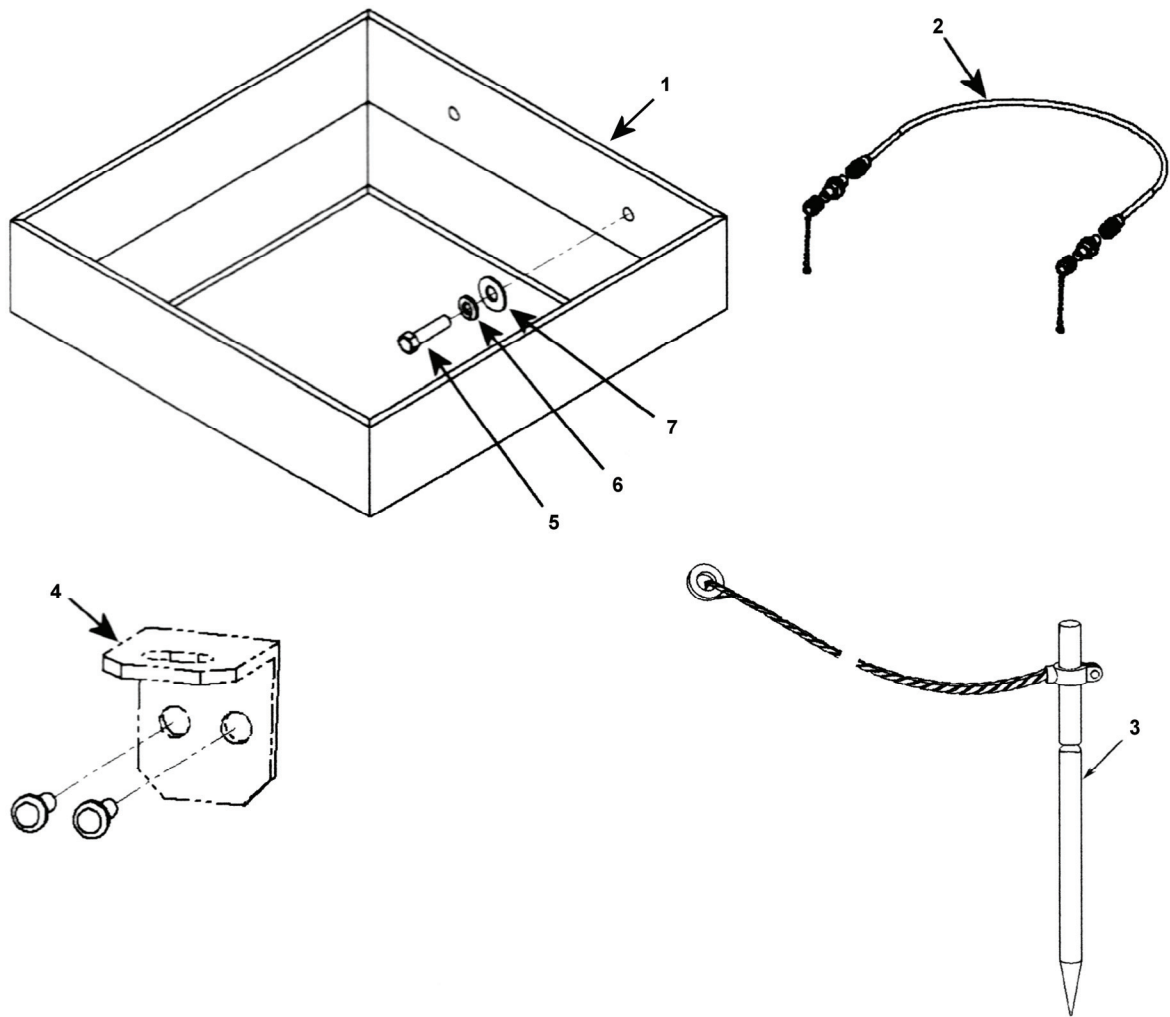

Figure 2. Basic Shop Equipment. (Sheet 1 of 2)

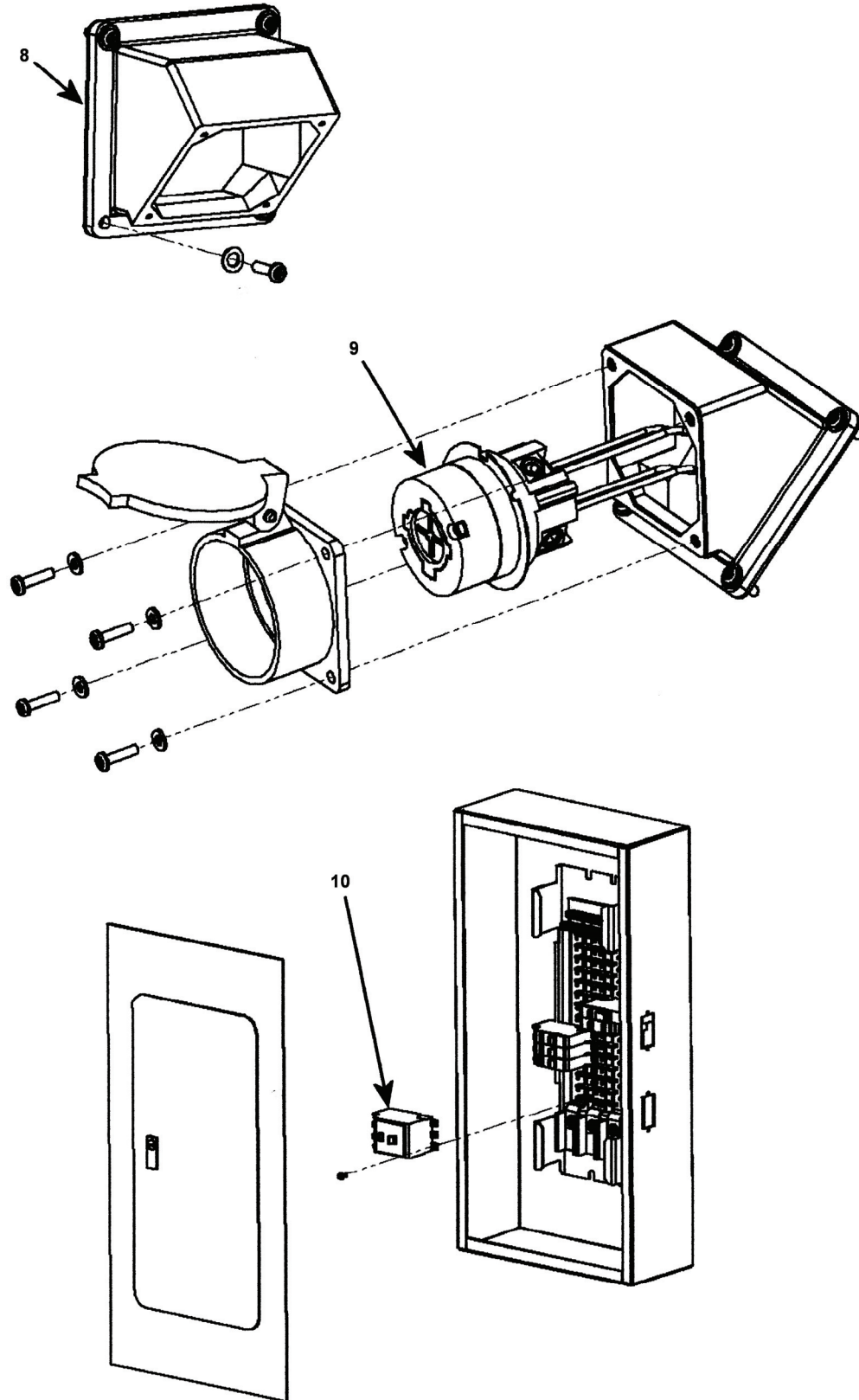

Figure 2. Basic Shop Equipment. (Sheet 2 of 2)

(1)	(2)	(3)	(4)	(5)	(6)	(7)
ITEM NO.	SMR CODE	NSN	CAGEC	PART NUMBER	DESCRIPTION AND USABLE ON CODE (UOC)	QTY
					GROUP 01 BASIC SHOP EQUIPMENT	
					FIG 2. BASIC SHOP EQUIPMENT	
1	MFFZZ		81996	20089721	BRACKET , FIRST AID	1
2	XDFZZ		81996	17A6X0019	BNC CONNECTOR ASSEMBLY	1
3	PAFZZ	5975-00-878-3791	58536	A-A-55804	ROD, GROUNDING	1
4	XDFZZ		81996	17A6X1001	HASP, DOOR	2
5	PAFZZ	5305-00-269-2803	80205	MS90726-60	CAP SCREW, HEXAGON HEAD	4
6	PAFZZ	5310-00-637-9541	80205	MS35338-46	WASHER, LOCK	4
7	PAFZZ	5310-01-236-6203	80205	NAS301-6	WASHER, FLAT	4
8	XDFZZ		81996	17A631001	ADAPTER	1
9	PAFZZ	5935-01-105-1378	81348	WC596/64-1	RECEPTACLE	1
10	PAFZZ	5925-01-252-7781	63637	QOB3100	CIRCUIT BREAKER, 100A	1
					END OF FIGURE	

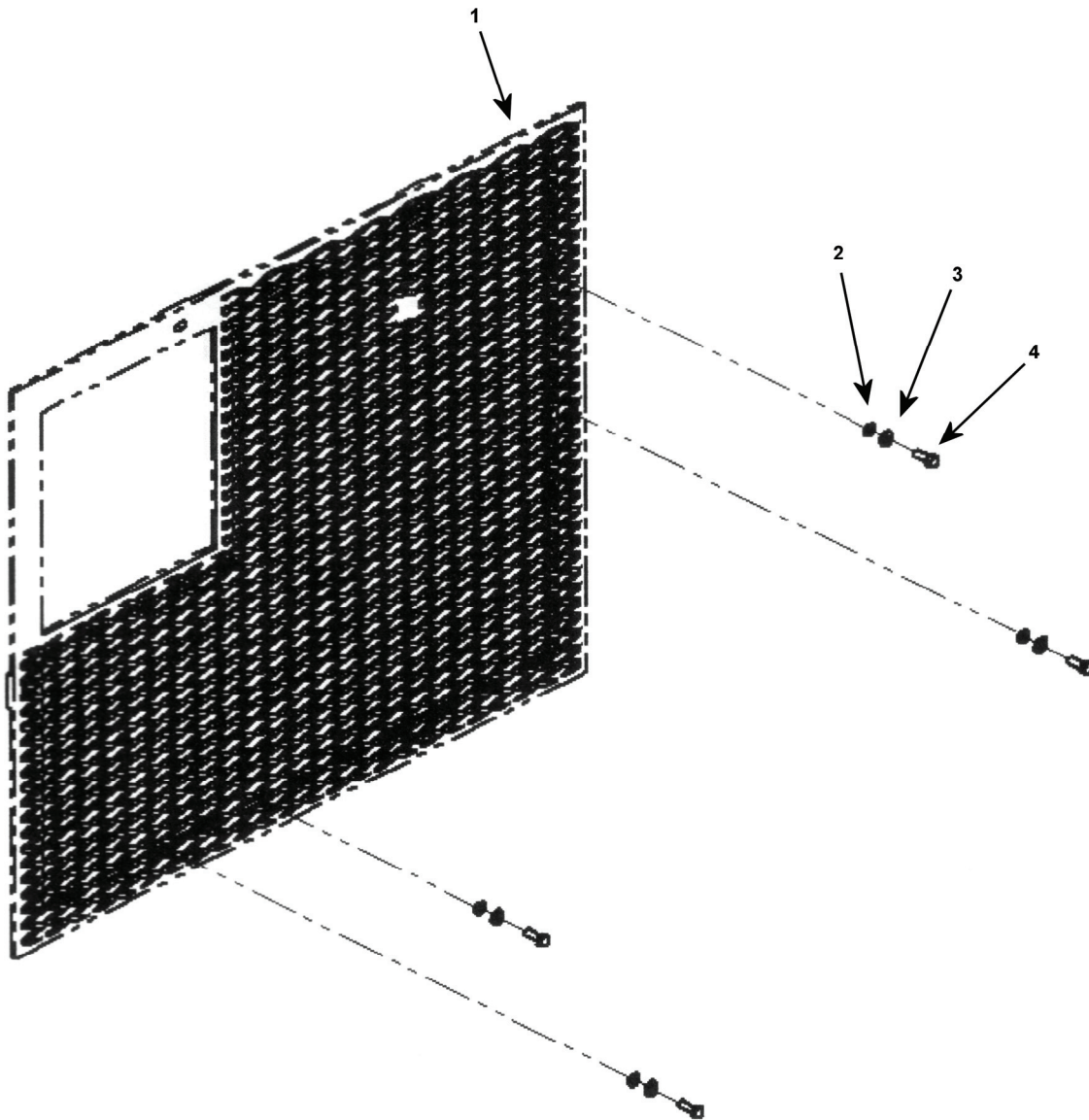

Figure 3. ECU Large Closeout Panel. (Sheet 1 of 3)

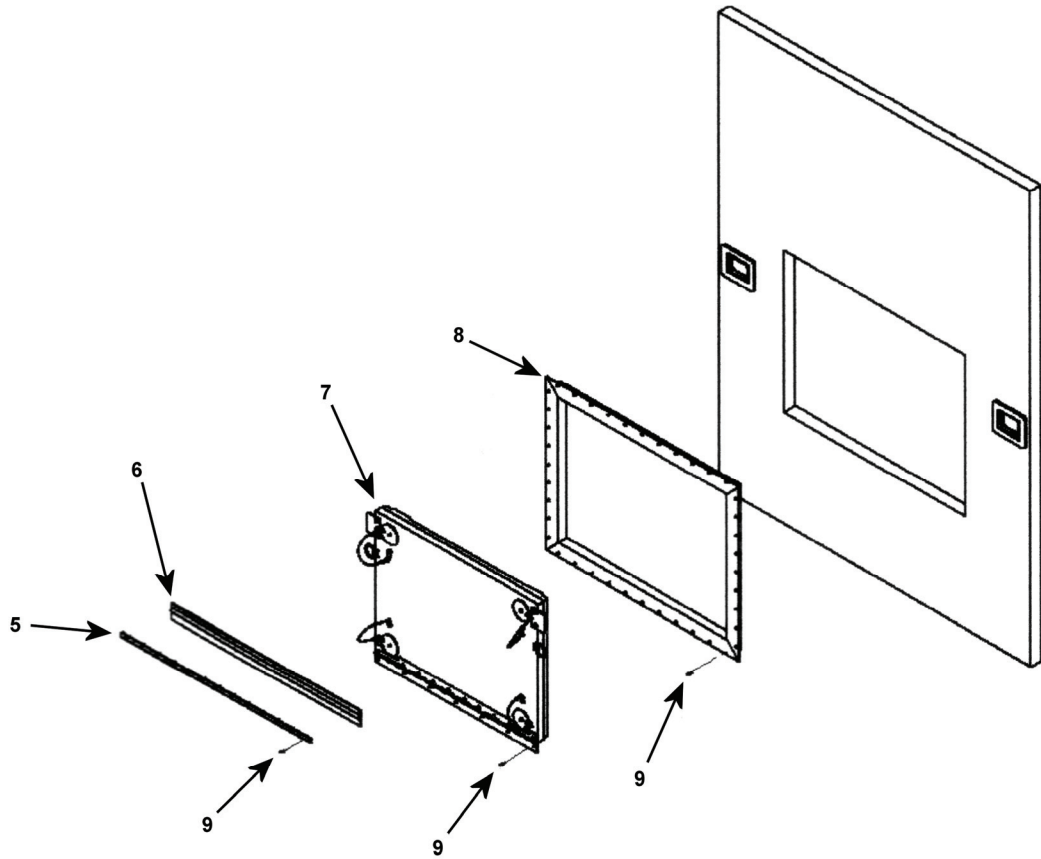

Figure 3. ECU Large Closeout Panel. (Sheet 2 of 3)

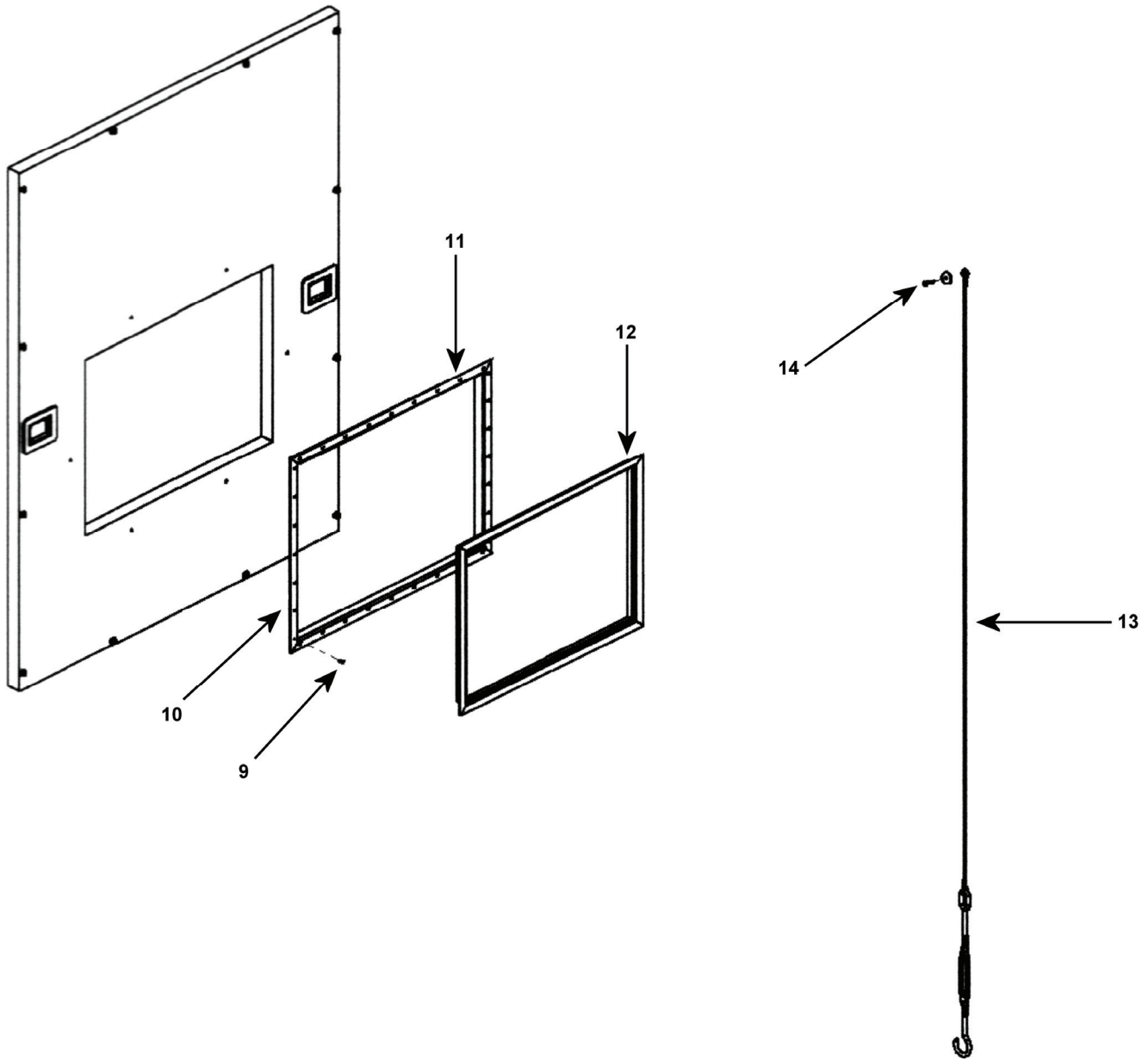

Figure 3. ECU Large Closeout Panel. (Sheet 3 of 3)

(1)	(2)	(3)	(4)	(5)	(6)	(7)
ITEM NO.	SMR CODE	NSN	CAGEC	PART NUMBER	DESCRIPTION AND USABLE ON CODE (UOC)	QTY
					GROUP 0101 ECU LARGE CLOSEOUT PANEL	
					FIG 3. ECU LARGE CLOSEOUT PANEL	
1	XDDZZ		81996	17A6X0021	ECU SECURITY SCREEN ASSEMBLY	2
2	PAFZZ	5310-00-637-9541	80205	MS35338-46	WASHER, LOCK	4
3	PAFZZ	5310-01-236-6203	80205	NAS301-6	WASHER, FLAT	4
4	PAFZZ	5305-00-269-2805	80205	MS90726-62	CAP SCREW, HEXAGON HEAD	4
5	XDFZZ		81996	20085233	STRIP, RETAINER	1
6	XDFZZ		81996	20085287	SEAL, OUTSIDE	1
7	XDFZZ		81996	20085244	ECU PANEL ASSEMBLY	1
8	XDFZZ		81996	20085289	FRAME INSTALLATION, ECU	1
9	PADZZ	5420-00-957-5819	80205	MS20604B6W4	RIVET	20
10	XDFZZ		81996	20085269-1	ANGLE, RETAINER	2
11	XDFZZ		81996	20085269-2	ANGLE, RETAINER	2
12	XDFZZ		81996	20085261	SEAL FRAME ASSEMBLY	1
13	XDFZZ		81996	20085285	ECU CABLE ASSEMBLY	4
14	PAFZZ	5305-00-054-9246	80205	MS24694C107	SCREW, MACHINE	4
					END OF FIGURE	

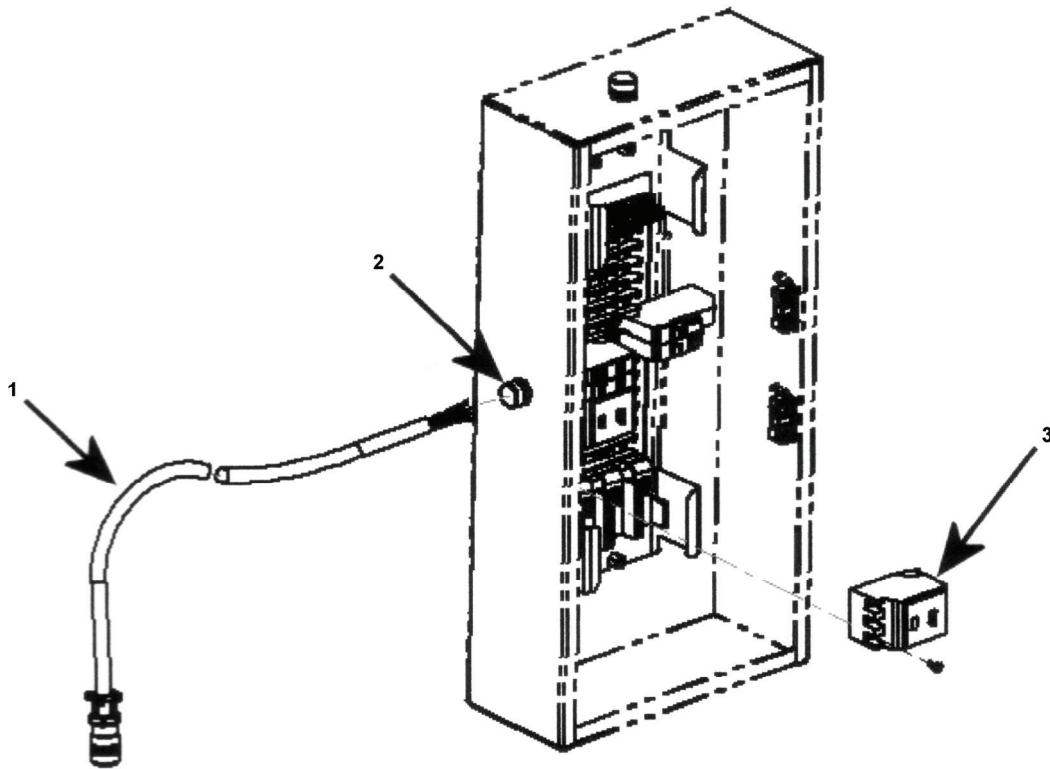

Figure 4. ECU Electrical Installation.

(1)	(2)	(3)	(4)	(5)	(6)	(7)
ITEM NO.	SMR CODE	NSN	CAGEC	PART NUMBER	DESCRIPTION AND USABLE ON CODE (UOC)	QTY
					GROUP 0102 ECU ELECTRICAL INSTALLATION	
					FIG 4. ECU ELECTRICAL INSTALLATION	
1	XDFZZ		81996	17A6X1013-1	ECU CABLE ASSEMBLY	1
	XDFZZ		81996	17A6X1013-2	ECU CABLE ASSEMBLY	1
2	XDFZZ	5975-00-916-4923	03743	CG-5075	BOX CONNECTOR	2
3	PAFZZ	5925-00-728-1969	56365	QOB330	CIRCUIT BREAKER, 30A, 240V	2
					END OF FIGURE	

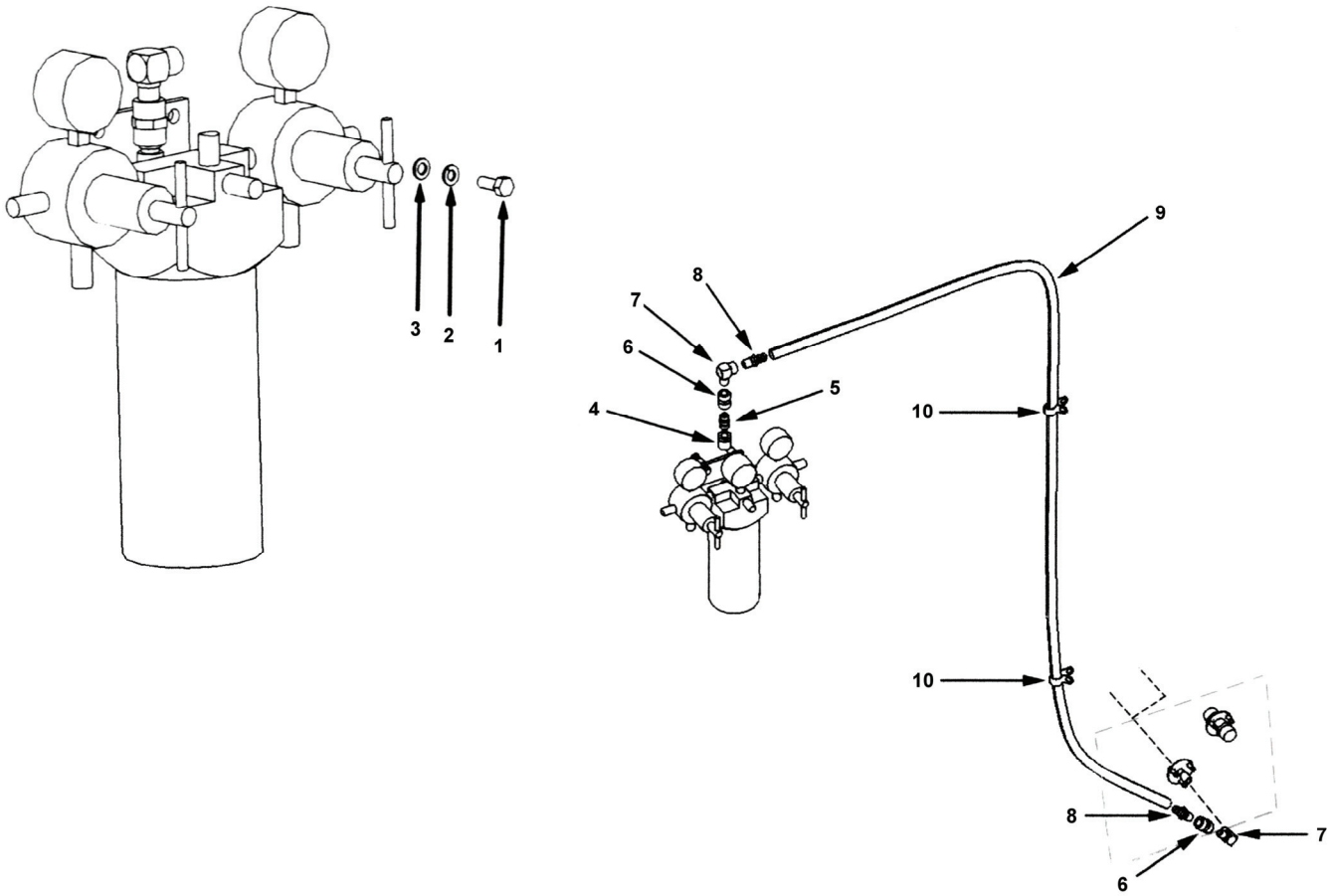

Figure 5. Water/Oil Separator.

(1)	(2)	(3)	(4)	(5)	(6)	(7)
ITEM NO.	SMR CODE	NSN	CAGEC	PART NUMBER	DESCRIPTION AND USABLE ON CODE (UOC)	QTY
					GROUP 0103 WATER/OIL SEPARATOR	
					FIG 5. WATER/OIL SEPARATOR	
1	PAFZZ	5305-00-269-2803	80205	MS90726-60	CAP SCREW, HEXAGON HEAD	2
2	PAFZZ	5310-00-637-9541	80205	MS35338-46	WASHER, LOCK	2
3	PAFZZ	5310-01-236-6203	80205	NAS301-6	WASHER, FLAT	2
4	XDFZZ		96906	209P-4	BUSHING, PIPE	1
5	PAFZZ	4730-00-287-1589	13174	896WM	NIPPLE, PIPE	1
6	PAFZZ	4730-00-277-5736	81343	4-4130138B	COUPLING, PIPE	2
7	PAFZZ	4730-01-515-4774	93061	1202P-4-4	ELBOW, PIPE	2
8	PAFZZ	4730-00-932-7511	87373	30182-4-6	FITTING, HOSE	2
9	PAFZZ	4720-00-402-9511	05415	134MKC1	HOSE, NON-METALLIC	1
10	PAFZZ	5340-00-584-6556	81343	AS21919WDG10	CLAMP, LOOP	2
					END OF FIGURE	

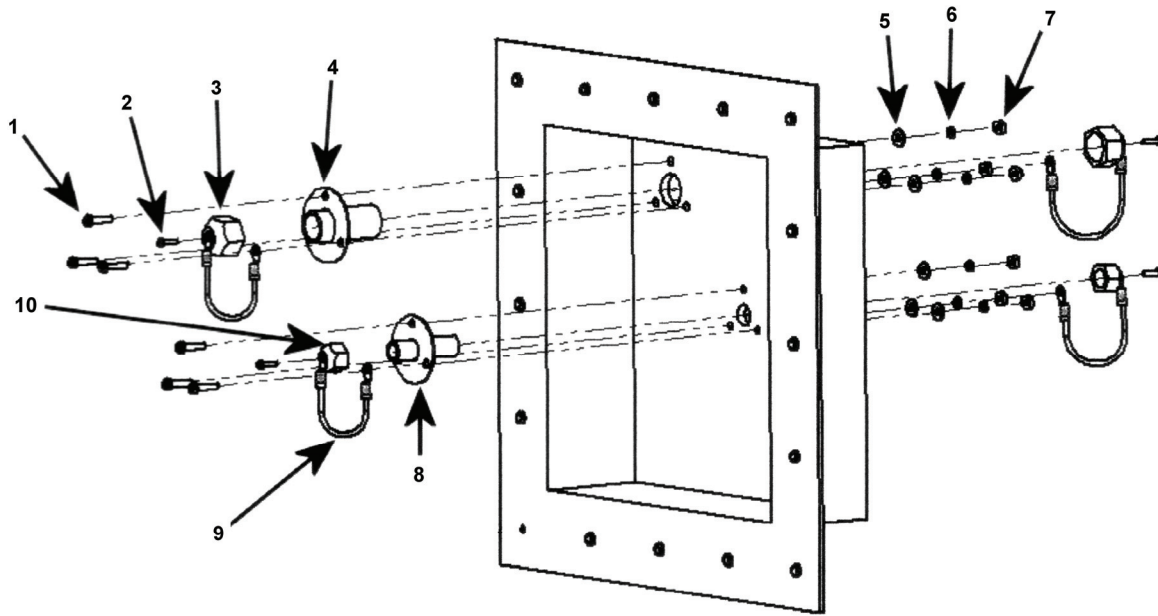

Figure 6. Services Utility Panel.

(1)	(2)	(3)	(4)	(5)	(6)	(7)
ITEM NO.	SMR CODE	NSN	CAGEC	PART NUMBER	DESCRIPTION AND USABLE ON CODE (UOC)	QTY
					GROUP 0104 SERVICES UTILITY PANEL	
					FIG 6. SERVICES UTILITY PANEL	
	MDDZZ		81996	20085191	UTILITY PAN ASSEMBLY	1
	PADZZ	5320-00-616-4353	80205	MS20600B6W2	RIVET	16
1	PAFZZ	5305-00-912-7308	80205	MS27039-1-14	MACHINE SCREW , PAN HEAD	6
2	PAFZZ	5305-01-340-9057	96906	MS51576-6	SHOULDER SCREW, SOCKET HEAD	3
3	XDFZZ		39428	50785K164	CAP 1/2", PIPE	2
4	XDFZZ		81996	20083250	WATER FEED-THRU CONNECTOR ASSEMBLY	1
5	PAFZZ	5310-01-385-4624	80205	NAS1149D0363K	WASHER, FLAT	6
6	PAFZZ	5310-00-045-3296	80205	MS35338-43	WASHER, LOCK	6
7	PAFZZ	5310-00-934-9751	80205	MS35650-302	NUT, PLAIN	6
8	XDFZZ		81996	20087058	AIR FEED-THRU CONNECTOR ASSEMBLY	1
9	PAFZZ	4010-01-476-2507	39428	30345T2	LANYARD 7.65"	4
10	XDFZZ		39428	50785K162	CAP 1/4" IPE	2
					END OF FIGURE	

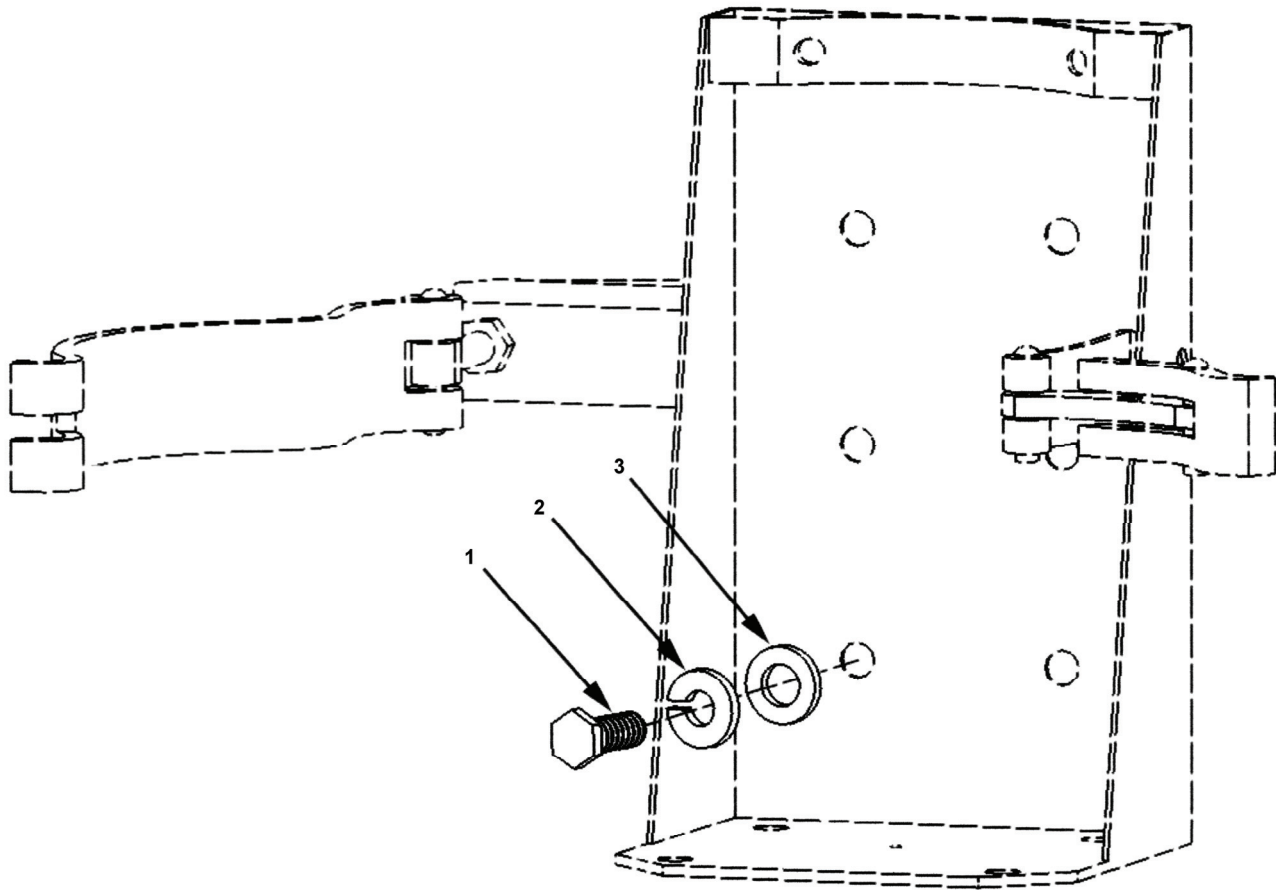

Figure 7. Fire Extinguisher Bracket.

(1)	(2)	(3)	(4)	(5)	(6)	(7)
ITEM NO.	SMR CODE	NSN	CAGEC	PART NUMBER	DESCRIPTION AND USABLE ON CODE (UOC)	QTY
					GROUP 02 FIRE EXTINGUISHER BRACKET	
					FIG 7. FIRE EXTINGUISHER BRACKET	
1	PAFZZ	5305-00-269-2803	80205	MS90726-60	CAP SCREW, HEXAGON HEAD	4
2	PAFZZ	5310-00-637-9541	80205	MS35338-46	WASHER, LOCK	4
3	PAFZZ	5310-01-236-6203	80205	NAS301-6	WASHER, FLAT	4
					END OF FIGURE	

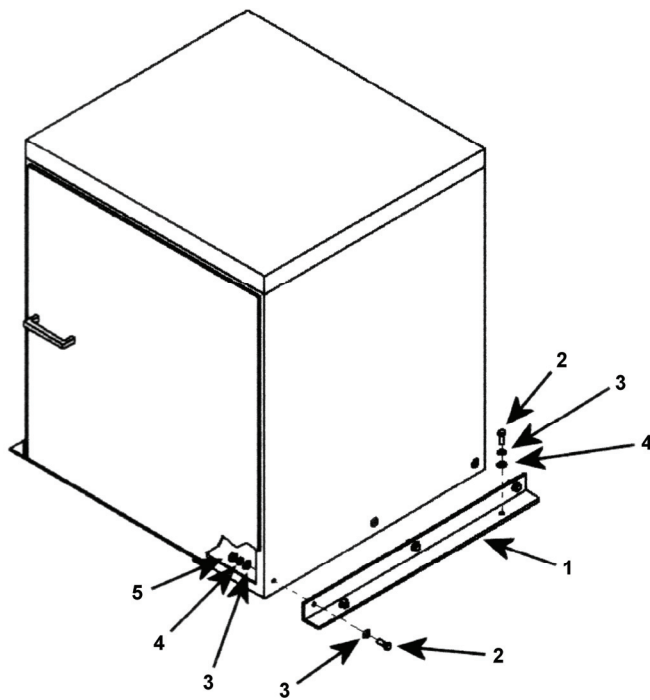

Figure 8. Cabinet Brackets.

(1)	(2)	(3)	(4)	(5)	(6)	(7)
ITEM NO.	SMR CODE	NSN	CAGEC	PART NUMBER	DESCRIPTION AND USABLE ON CODE (UOC)	QTY
					GROUP 03 CABINET BRACKETS FIG 8. CABINET BRACKETS	
	XCFFF		81996	17A6X0012-11	CABINET ASSEMBLY	1
	XCFFF		81996	17A6X0012-18	CABINET ASSEMBLY	2
	XCFFF		81996	17A6X0012-19	CABINET ASSEMBLY	1
1	MFFZZ		81996	17A6X0007	BRACKET, CABINET	6
2	PAFZZ	5305-00-269-2803	80205	MS90726-60	CAP SCREW, HEXAGON HEAD	30
3	PAFZZ	5310-01-236-6203	80205	NAS301-6	WASHER, FLAT	30
4	PAFZZ	5310-00-637-9541	80205	MS35338-46	WASHER, LOCK	30
5	PAFZZ	5310-00-732-0559	96906	MS51968-8	NUT, PLAIN HEX	30
					END OF FIGURE	

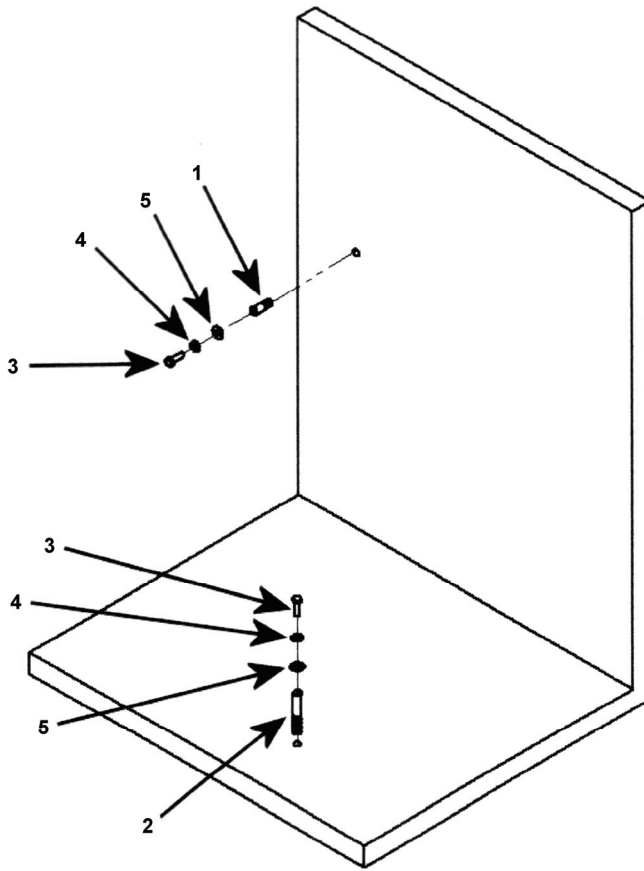

Figure 9. Wall and Floor Inserts.

(1)	(2)	(3)	(4)	(5)	(6)	(7)
ITEM NO.	SMR CODE	NSN	CAGEC	PART NUMBER	DESCRIPTION AND USABLE ON CODE (UOC)	QTY
					GROUP 04 WALL AND FLOOR INSERTS	
					FIG 9. WALL AND FLOOR INSERTS	
1	PAFZZ		81996	17A6X0003	SCREW THREAD INSERT, WALL/CEILING	21
2	PAFZZ		81996	17AGX0004	SCREW THREAD INSERT, FLOOR	36
3	PAFZZ	5305-00-269-2803	80205	MS90726-60	CAP SCREW, HEXAGON HEAD	47
4	PAFZZ	5310-00-637-9541	80205	MS35338-46	WASHER, LOCK	57
5	PAFZZ	5310-01-236-6203	80205	NAS301-6	WASHER, FLAT	41
					END OF FIGURE	

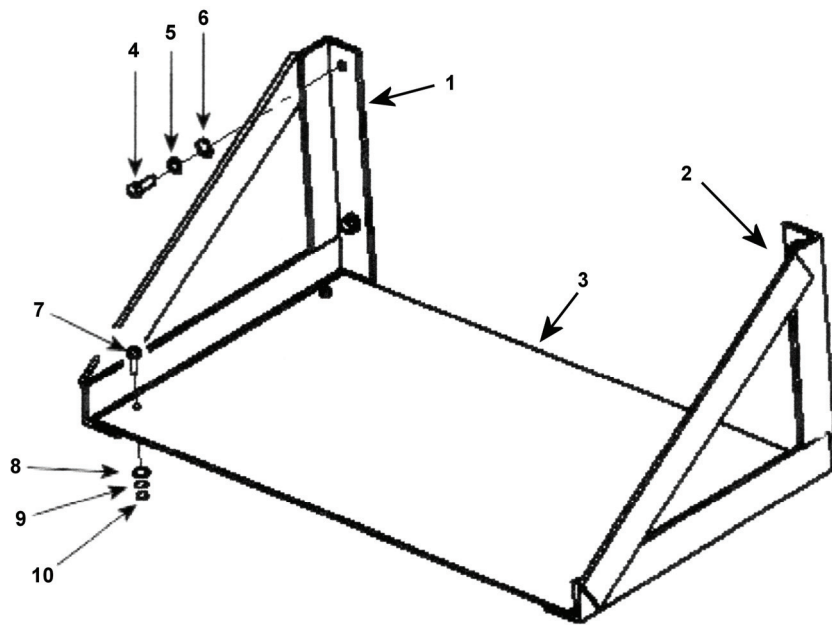

Figure 10. Illuminator Shelf and Brackets.

(1)	(2)	(3)	(4)	(5)	(6)	(7)
ITEM NO.	SMR CODE	NSN	FSCM	PART NUMBER	DESCRIPTION AND USABLE ON CODE (UOC)	QTY
					GROUP 05 ILLUMINATOR SHELF AND BRACKETS FIG 10. ILLUMINATOR SHELF AND BRACKETS	
1	MFFZZ		81996	17AXX1005-2	BRACKET, END SHELF	1
2	MFFZZ		81996	17AXX1005-1	BRACKET, END SHELF	1
3	MFFZZ		81996	17AXX1006-2	PLATE	1
4	PAFZZ	5305-00-269-2803	80205	MS90726-60	CAP SCREW, HEXAGON HEAD	4
5	PAFZZ	5310-00-637-9541	80205	MS35338-46	WASHER, LOCK	4
6	PAFZZ	5310-01-236-6203	80205	NAS301-6	WASHER, FLAT	4
7	PAFZZ	5305-00-068-0506	80205	MS90726-6	CAP SCREW HEXAGON HEAD	4
8	PAFZZ	5310-00-582-5965	80205	MS35338-44	WASHER, LOCK	4
9	PAFZZ	5310-00-656-0110	80205	MS15795-711	WASHER, FLAT	4
10	PAFZZ	5310-00-768-0319	96906	MS51968-2	NUT, PLAIN HEX	4
					END OF FIGURE	

**NON-DESTRUCTIVE INSPECTION SHOP
SPECIAL TOOLS LIST**

NOT APPLICABLE

End of Work Package

**NON-DESTRUCTIVE INSPECTION SHOP
NATIONAL STOCK NUMBER (NSN) INDEX**

STOCK NUMBER	FIG.	ITEM	STOCK NUMBER	FIG.	ITEM
4010-01-476-2507	6	9	5310-00-656-0110	10	9
4720-00-402-9511	5	9	5310-00-732-0559	8	5
4730-00-277-5736	5	6	5310-00-768-0319	10	10
4730-00-287-1589	5	5	5310-00-934-9751	6	7
4730-00-932-7511	5	8	5310-01-236-6203	1	14
4730-01-515-4774	5	7		2	7
5305-00-432-4205	1	7		3	3
5305-00-054-9246	3	14		5	3
5305-00-068-0506	10	7		7	3
5305-00-269-2803	1	12		8	3
	2	5		9	5
	5	1		10	6
	7	1	5310-01-352-2752	1	9
	8	2	5310-01-385-4624	6	5
	9	3	5320-00-616-4353	6	
	10	4	5340-00-584-6556	5	10
5305-00-269-2805	3	4	5340-01-221-0272	1	5
5305-00-912-7308	6	1	5420-00-957-5819	3	9
5305-01-340-9057	6	2	5925-00-728-1969	4	3
5310-00-045-3296	1	8	5925-00-967-9874	1	1
	6	6	5975-00-179-0098	1	6
5310-00-582-5965	10	8	5975-00-878-3791	2	3
5310-00-637-9541	1	13	5975-00-916-4923	4	2
	2	6			
	3	2			
	5	2			
	7	2			
	8	4			
	9	4			
	10	5			

End of Work Package

0034 00-1/(0034 00-2 blank)

**NON-DESTRUCTIVE INSPECTION SHOP
PART NUMBER (P/N) INDEX**

PART NUMBER	FIG.	ITEM	PART NUMBER	FIG.	ITEM
1202P-4-4	5	7	MS15975-711	10	9
134MKC1	5	9	MS20600B6W2	6	
17A6X0003	9	1	MS20604B6W4	3	9
17A6X0004	9	2	MS24694C107	3	14
17A6X0007	8	1	MS27039-1-14	6	1
17A6X0012-11	8		MS35338-43	1	8
17A6X0012-18	8			6	6
17A6X0012-19	8		MS35338-44	10	8
17A6X0019	2	2	MS35338-46	1	13
17A6X0021	3	1		2	6
17A6X1001	2	4		3	2
17A6X1013-1	4	1		5	2
17A6X1013-2	4	1		7	2
17AXX1002	1	10		8	4
17AXX1003	1	11		9	4
17AXX1005-1	10	2		10	5
17AXX1005-2	10	1	MS35650-302	6	7
17AXX1006-2	10	3	MS51576-6	6	2
20083250	6	4	MS51861-49	1	7
20085191	6		MS51968-2	10	10
20085233	3	5	MS51968-8	8	5
20085244	3	7	MS90726-6	10	7
20085261	3	12	MS90726-60	1	12
20085285	3	13		2	5
20085287	3	6		5	1
20085289	3	8		7	1
20087058	6	8		8	2
20089721	2	1		9	3
20085269-1	3	10		10	4
20085269-2	3	11	MS90726-64	3	4
209P-4	5	4	NAS1149C0332R	1	9
30182-4-6	5	8	NAS1149D0363K	6	5
30345T2	6	9	NAS301-6	1	14
4-4130138B	5	6		2	7
50785K162	6	10		3	3
50785K164	6	3		5	3
896WM	5	5		7	3
920S	1	5		8	3
A-A-55804	2	3		9	5
AS21919WDG10	5	10		10	6
CG-5075	4	2	QOB220	1	1
FSC1-1C	1	3	QOB330	4	3
FSC2-SC	1	2	TC111A	1	6
FSK-WR2	1	4			

End of Work Package

**NON-DESTRUCTIVE INSPECTION SHOP
COMPONENTS OF END ITEM (COEI) AND BASIC ISSUE ITEMS (BII) LISTS**

INTRODUCTION

Scope

This work package lists COEI and BII for the Non-Destructive Inspection Shop to help you inventory items for safe and efficient operation of the equipment.

General

The COEI and BII information is divided into the following lists:

Components of End Item (COEI). This list is for information purposes only and is not authority to requisition replacements. These items are part of the Non-Destructive Inspection Shop. As part of the end item, these items must be with the end item whenever it is issued or transferred between property accounts. Items of COEI are removed and separately packaged for transportation or shipment only when necessary. Illustrations are furnished to help you find and identify the items.

Basic Issue Items (BII). These essential items are required to place the Non-Destructive Inspection Shop in operation, operate it, and to do emergency repairs. Although shipped separately packaged, BII must be with the Non-Destructive Inspection Shop during operation and when it is transferred between property accounts. Listing these items is your authority to request/requisition them for replacement based on authorization of the end item by the TOE/MTOE. Illustrations are furnished to help you find and identify the items.

Explanation of Columns in the COEI List and BII List

Column (1) Illus Number. Gives you the number of the item illustrated.

Column (2) National Stock Number (NSN). Identifies the stock number of the item to be used for requisitioning purposes.

Column (3) Description, CAGEC, and Part Number. Identifies the Federal item name (in all capital letters) followed by a minimum description when needed. The stowage location of COEI and BII is also included in this column. The last line below the description is the CAGEC (Commercial and Government Entity Code) (in parentheses) and the part number.

Column (4) Usable On Code (UOC). When applicable, gives you a code if the item you need is not the same for different models of equipment.

Column (5) Unit of Issue (U/I). Indicates the physical measurement or count of the item as issued per the National Stock Number shown in column (2).

Column (6) Qty Rqr. Indicates the quantity required.

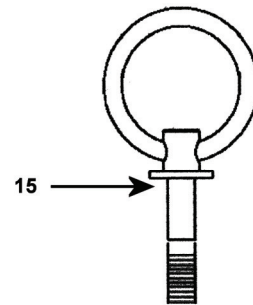
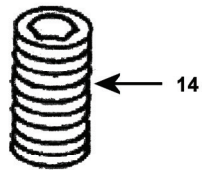
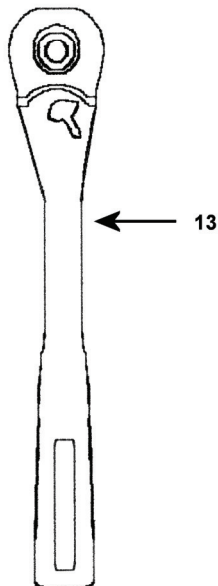
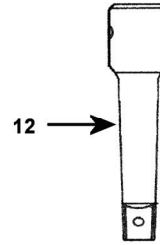
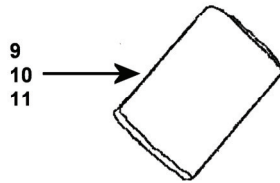
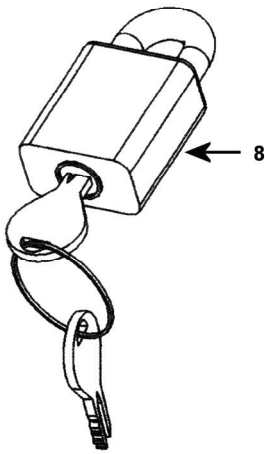
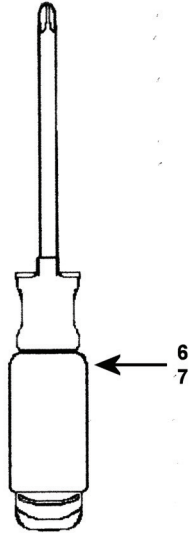
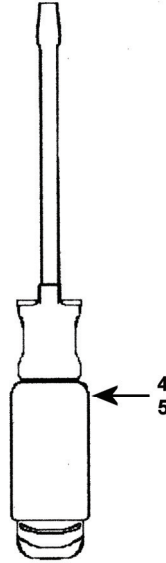
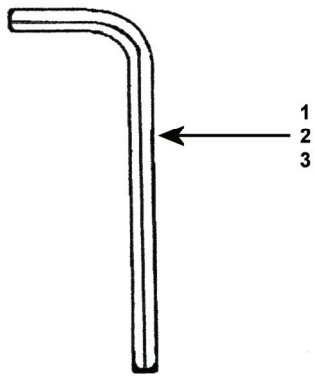

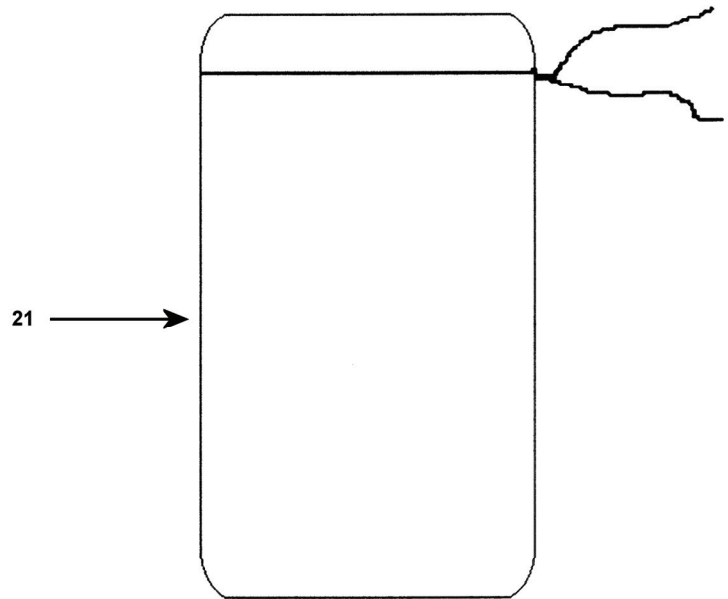
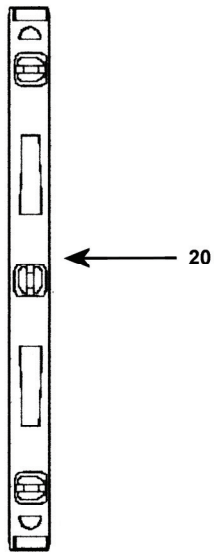
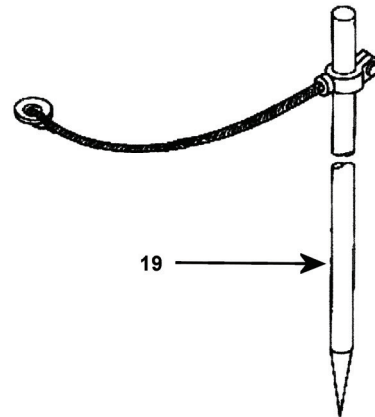
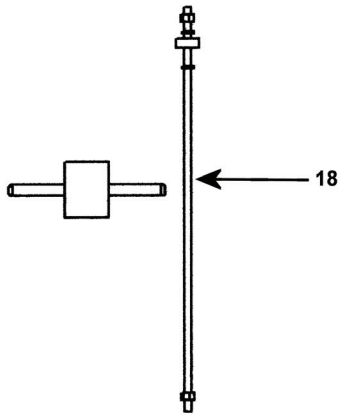
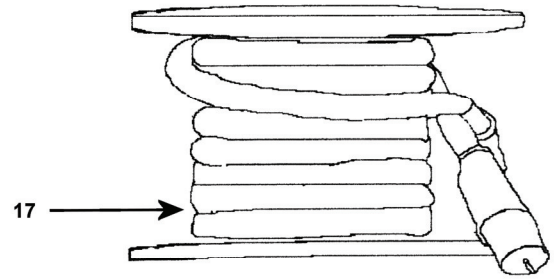
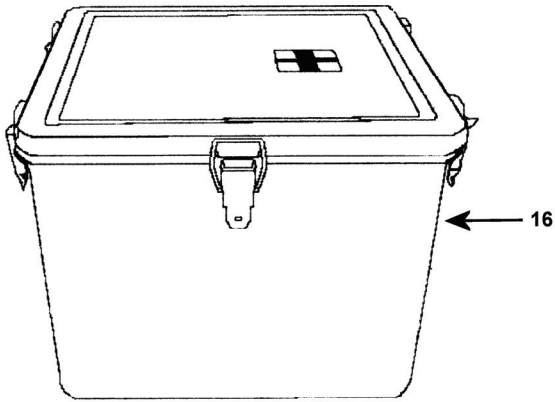

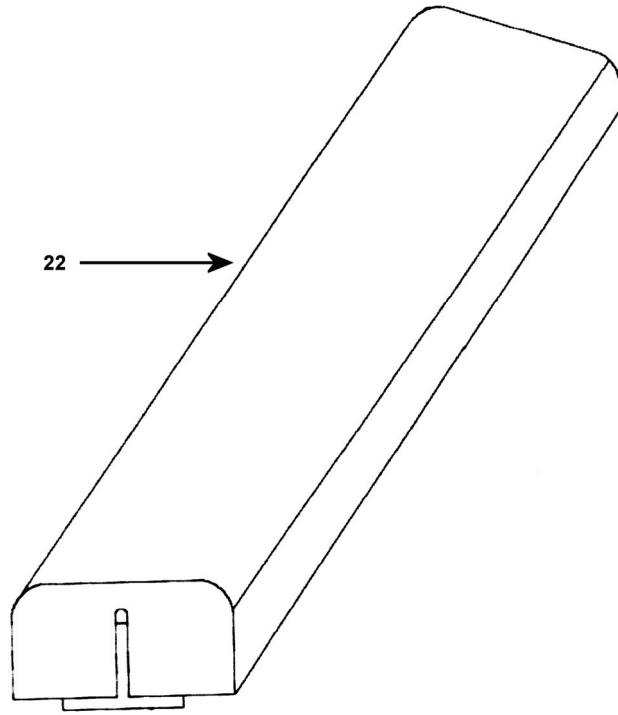

Table 1. Components of End Items (COEI) List.

(1) ILLUS NO.	(2) NATIONAL STOCK NUMBER	(3) DESCRIPTION, CAGEC, AND PART NUMBER	(4) UOC	(5) U/I	(6) QTY RQR
1	5120-01-335-2115	KEY, SOCKET HEAD SCREW: LONG ARM LENGTH 2.25" NOMINAL, MATERIAL STEEL OVERALL, SHORT ARM LENGTH .75" NOMINAL, DESIGN L-HANDLE, WRENCHING SURFACE SIZE .125" NOMINAL SINGLE END BII ENVELOPE (5014) 08292	NA	EA	1
2	5120-01-335-2117	KEY, SOCKET HEAD SCREW: LONG ARM LENGTH 2.5" NOMINAL, MATERIAL STEEL OVERALL, SHORT ARM LENGTH .844" NOMINAL, DESIGN L-HANDLE, WRENCHING SURFACE SIZE .156" NOMINAL SINGLE END BII ENVELOPE (57020) 08292	NA	EA	1
3	5120-01-335-2118	KEY, SOCKET HEAD SCREW: LONG ARM LENGTH 2.75" NOMINAL, MATERIAL STEEL OVERALL, SHORT ARM LENGTH .938" NOMINAL, DESIGN L-HANDLE, WRENCHING SURFACE SIZE .188" NOMINAL SINGLE END BII ENVELOPE (57022) 08292	NA	EA	1
4	5120-01-398-7989	SCREWDRIVER, FLAT TIP: BLADE LENGTH 8" NOMINAL, FLARED TIP SIDE, STRAIGHT FLUTED HANDLE, STEEL BLADE, PLASTIC HANDLE, OVERALL LENGTH 12.5" NOMINAL, TIP WIDTH .375" NOMINAL BII ENVELOPE (2343-8) 96508	NA	EA	1
5	5120-01-398-7960	SCREWDRIVER, FLAT TIP: BLADE LENGTH 6" NOMINAL STRAIGHT FLUTED HANDLE, STEEL BLADE, PLASTIC HANDLE, SHANK SHAPE ROUND, ELECTRICIAN'S TYPE, TIP WIDTH .188" NOMINAL BII ENVELOPE (2243-6) 96508	NA	EA	1
6	5120-01-399-9019	SCREWDRIVER, CROSS TIP: BLADE LENGTH 4" NOMINAL, CUSHION GRIP, STEEL BLADE, PLASTIC HANDLE, OVERALL LENGTH 8.344" NOMINAL, SHANK SHAPE ROUND, TIP SIZE DESIGN 2, TIP TYPE PHILLIPS CROSS BII ENVELOPE (3R991) 25795	NA	EA	1
7	5120-01-399-9031	SCREWDRIVER, CROSS TIP: BLADE LENGTH 6" NOMINAL, CUSHION GRIP, STEEL BLADE, PLASTIC HANDLE, OVERALL LENGTH 10.344" NOMINAL, SHANK SHAPE ROUND, TIP SIZE DESIGN 2, TIP TYPE PHILLIPS CROSS BII ENVELOPE (65-903) 1CV05	NA	EA	1
8	5340-00-158-3805	PADLOCK: CONSTRUCTION SOLID OR LAMINATED, MATERIAL STEEL OVERALL, OVERALL HEIGHT 3.125" NOMINAL, OVERALL THICKNESS .688" NOMINAL, OVERALL WIDTH 1.75", SURFACE TREATMENT CHROMIUM OVERALL OR ZINC BII DOOR (A-A-59487A) 58536	NA	EA	2

(1) ILLUS NO.	(2) NATIONAL STOCK NUMBER	(3) DESCRIPTION, CAGEC, AND PART NUMBER	(4) UOC	(5) U/I	(6) QTY RQR
9	5120-01-399-9534	SOCKET, SOCKET WRENCH: DRIVE SURFACE SIZE .375" NOMINAL SINGLE END, MATERIAL STEEL OVERALL, OVERALL LENGTH 1.125" NOMINAL, SURFACE TREATMENT CHROMIUM OVERALL, WRENCHING SURFACE SHAPE 12 POINT, WRENCHING SURFACE SIZE .5" NOMINAL SINGLE END BII ENVELOPE (J5216) 1CV05	NA	EA	1
10	5120-01-399-9535	SOCKET, SOCKET WRENCH: DRIVE SURFACE SIZE .375" NOMINAL SINGLE END, MATERIAL STEEL OVERALL, OVERALL LENGTH 1.125" NOMINAL, SURFACE TREATMENT CHROMIUM OVERALL, WRENCHING SURFACE SHAPE 12 POINT, WRENCHING SURFACE SIZE .562" NOMINAL SINGLE END BII ENVELOPE (5218) 1CV05	NA	EA	1
11	5120-01-399-9538	SOCKET, SOCKET WRENCH: DRIVE SURFACE SIZE .375" NOMINAL SINGLE END, MATERIAL STEEL OVERALL, OVERALL LENGTH 1.062" NOMINAL, SURFACE TREATMENT CHROMIUM OVERALL, WRENCHING SURFACE SHAPE 12 POINT, WRENCHING SURFACE SIZE .438" NOMINAL SINGLE END BII ENVELOPE (J5214) 1CV05	NA	EA	1
12	5120-01-430-7919	EXTENSION, SOCKET WRENCH: DRIVE SURFACE SIZE .375" NOMINAL BOTH ENDS, MATERIAL STEEL OVERALL, OVERALL LENGTH 3" NOMINAL, SURFACE TREATMENT CHROMIUM OVERALL BII ENVELOPE (11905) 08292	NA	EA	1
13	5120-01-430-7929	HANDLE, RATCHET SOCKET WRENCH: DRIVE SURFACE SIZE .375" NOMINAL SINGLE END, MATERIAL STEEL OVERALL, OVERALL LENGTH 7.625" NOMINAL, SURFACE TREATMENT CHROMIUM OVERALL BII ENVELOPE (11901) 08292	NA	EA	1
14	5305-00-728-6350	SETSCREW: FASTENER LENGTH .735" MINIMUM AND .765" MAXIMUM, HEAD STYLE HEXAGON, MATERIAL STEEL COMP 4032/4037/4137/4140/8630/8740 OVERALL, NOMINAL THREAD DIAMETER .375", SURFACE TREATMENT CADMIUM OVERALL AND CHROMATE, THREAD LENGTH .735" MINIMUM AND .765" MAXIMUM, THREAD QUANTITY PER INCH 24-UNF BII ENVELOPE (MS51966-90) 96906	NA	EA	25
15	5306-00-624-9317	BOLT, RING: MATERIAL STEEL COMP 4130 OVERALL, NOMINAL THREAD DIAMETER .375", RING INSIDE DIAMETER 1.625" NOMINAL, RING STOCK DIAMETER .25" NOMINAL, SURFACE TREATMENT CADMIUM OVERALL BII ENVELOPE (FDA1658-3) 98313	NA	EA	20
16	6545-00-116-1410	FIRST AID KIT, GENERAL PURPOSE: GENERAL PURPOSE RIGID CASE BII MTD ON BRKT A (UA-68-1371) 06416	NA	EA	1
17	6150-00-255-8332	CABLE ASSEMBLY, POWER, ELECTRICAL BII MTD ON FLOOR (07878) 72289-100	NA	EA	1

(1) ILLUS NO.	(2) NATIONAL STOCK NUMBER	(3) DESCRIPTION, CAGEC, AND PART NUMBER	(4) UOC	(5) U/I	(6) QTY RQR
18	5120-01-013-1676	SLIDE HAMMER, GROUND ROD: STEEL, 36" LENGTH, 5/8" DIA, 5/8"-11 UNC X 3 1/4", THREADED BOTH END BLACK OXIDE FINISH, NUT 5/8-11 UNC EACH END, STRICKER PLATE 4" OD X 1" ID THICK CENTER HOLE 5/8-11 UNC THREADED STEEL BLACK OXIDE FINISH, STRIKER 4" OD x 3/4" ID X 5" HIGH W/ 3/4" OD X 8" LONG HANDLES CENTERED BII MTD ON TABLE D (P74-144) 45225	NA	EA	1
19	5975-00-878-3791	ROD, GROUND: 3 SECTIONS, DIM 9' LG, 5/8" DIA, CONE POINT, MALE THD END, W/SEPARABLE CLAMP, CABLE AND TERMINAL CLAMP WILL BE ATTACHED ON EACH ROD IN A MANNER SO AS NOT TO COME OFF IN HANDLING BII MTD ON TABLE D (A-A-55804) 58536	NA	EA	1
20	5210-01-509-2259	LEVEL AND PLUMB: STANDARD EXTRUDED ALUMINUM I-BEAM LEVEL, 24" LENGTH, 1 LEVEL VIAL, 2 PLUMB VIALS BII TOOL BOX (22675A22) 39428	NA	EA	1
21	8015-00-271-1511	BAG, COTTON MAILING BII TOOL BOX (8015-00-271-1511) 83421	NA	EA	1
22		T-SEAL BII TOOL BOX (20085241) 81996	NA	EA	2

End of Work Package

**NON-DESTRUCTIVE INSPECTION SHOP
EXPENDABLE AND DURABLE ITEMS LIST**

INTRODUCTION**Scope**

This work package lists expendable and durable items that you will need to operate and maintain the Non-Destructive Inspection Shop. This list is for information only and is not authority to requisition the listed items. These items are authorized to you by CTA 50-970, Expendable/Durable Items (Except Medical, Class V Repair Parts, and Heraldic Items), CTA 50-909, Field and Garrison Furnishings and Equipment or CTA 8-100, Army Medical Department Expendable/Durable Items.

Explanation of Columns in the Expendable/Durable Items List

Column (1) Item Number. This number is assigned to the entry in the list and is referenced in the narrative instructions to identify the item (e.g., "Use brake fluid (WP 0098, item 5)").

Column (2) Level. This column identifies the lowest level of maintenance that requires the listed item (O = Unit/AVUM, F = Direct Support/AVIM, D = Depot).

Column (3) National Stock Number (NSN). This is the NSN assigned to the item, which you can use to requisition it.

Column (4) Item Name, Description, Part Number/(CAGEC). This column provides the other information you need to identify the item. The last line below the description is the part number and the Commercial and Government Entity Code (CAGEC) (in parentheses).

Column (5) Unit of Issue (U/I) code shows the physical measurement or count of an item, such as gallon, dozen, gross, etc.

Table 1. Expendable and Durable Items List

(1) ITEM NO.	(2) LEVEL	(3) NATIONAL STOCK NUMBER	(4) ITEM NAME, DESCRIPTION, CAGEC, AND PART NUMBER	(5) U/I
1	F	8040-00-877-9872	ADHESIVE, SEALANT (81349) MIL-A-46106	kt
2	F	8010-00-852-9034	ENAMEL, GRAY (81348) 16187	pt
3	F	8010-00-159-4520	ENAMEL, WHITE (81348) 17773	pt
4	F	8010-00-297-0593	PRIMER, COATING (81348) TT-P-1757	pt
5	F	3439-00-063-5200	ROD, WELDING (81348) 5356	lb
6	F	6810-00-201-0907	ALCOHOL, DENATURED (81348) MIL-A-6091	gl
7	F	9160-01-517-5484	RTV, SEALANT (45152) 3119525	ea
8	F	8030-00-753-4599	SEALING COMPOUND (1DWR5) AC-236	kt
9	F	5320-00-962-4693	RIVET, BLIND (10054) AB6-6	hd
10	F		RIVET AD45BS200	hd
11	F	8030-01-451-0284	CORROSION RESISTANT (81349) MIL-C-5541	gal
12	F	8040-00-900-6296	ADHESIVE (92528) FE 6026	kt
13	F	8010-01-492-6639	GREEN 383 (81349) MIL-DTL-64159	kt
14	F		TAPE, ELECTRICAL	rl
15	F		TWINE/ROPE	rl

End of Work Package

TM 1-4920-444-13&P

By Order of the Secretary of the Army:

Official:

JOYCE E. MORROW
*Administrative Assistant to the
Secretary of the Army*
0701827

PETER J. SCHOOMAKER
*General, United States Army
Chief of Staff*

DISTRIBUTION:

To be distributed in accordance with Initial Distribution Number (IDN) 314188, requirements for TM 1-4920-444-13&P.

These are the instructions for sending an electronic 2028

The following format must be used if submitting an electronic 2028. The subject line must be exactly the same and all fields must be included; however only the following fields are mandatory: 1, 3, 4, 5, 6, 7, 8, 9, 10, 13, 15, 16, 17, and 27.

From: "Whomever" <whomever@wherever.army.mil>

To: 2028@redstone.army.mil

Subject: DA Form 2028

1. From: Joe Smith
2. Unit: home
3. Address: 4300 Park
4. City: Hometown
5. St: MO
6. Zip: 77777
7. Date Sent: 19-OCT-93
8. Pub no: 55-2840-229-23
9. Pub Title: TM
10. Publication Date: 04-JUL-85
11. Change Number: 7
12. Submitter Rank: MSG
13. Submitter FName: Joe
14. Submitter MName: T
15. Submitter LName: Smith
16. Submitter Phone: 123-123-1234
17. Problem: 1
18. Page: 2
19. Paragraph: 3
20. Line: 4
21. NSN: 5
22. Reference: 6
23. Figure: 7
24. Table: 8
25. Item: 9
26. Total: 123
27. Text:

This is the text for the problem below line 27.

RECOMMENDED CHANGES TO PUBLICATIONS AND BLANK FORMS For use of this form, see AR 25-30; the proponent agency is ODISC4.						Use Part II (reverse) for Repair Parts and Special Tool Lists (RPSTL) and Supply Catalogs/Supply Manuals (SC/SM)	DATE 8/30/02
TO: (Forward to proponent of publication or form)(Include ZIP Code) Commander, U.S. Army Aviation and Missile Command ATTN: AMSAM-MMC-MA-NP Redstone Arsenal, AL. 35898						FROM: (Activity and location)(Include ZIP Code) MSG, Jane Q. Doe 1234 Any Street Nowhere Town, AL 34565	
PART 1 - ALL PUBLICATIONS (EXCEPT RPSTL AND SC/SM) AND BLANK FORMS							
PUBLICATION/FORM NUMBER TM 9-1005-433-24						DATE 16 Sep 2002	TITLE Organizational, Direct Support, And General Support Maintenance Manual for Machine Gun, .50 Caliber M3P and M3P Machine Gun Electrical Test Set Used On Avenger Air Defense Weapon System
ITEM NO.	PAGE NO.	PARA-GRAPH	LINE NO. *	FIGURE NO.	TABLE NO.	RECOMMENDED CHANGES AND REASON	
1	WP0005 PG 3		2			Test or Corrective Action column should identify a different WP number.	
<i>* Reference to line numbers within the paragraph or subparagraph.</i>							
TYPED NAME, GRADE OR TITLE MSG, Jane Q. Doe, SFC						TELEPHONE EXCHANGE/AUTOVON, PLUS EXTENSION 788-1234	SIGNATURE

EXAMPLE

TO: (Forward direct to addressee listed in publication) Commander, U.S. Army Aviation and Missile Command ATTN: AMSAM-MMC-MA-NP Redstone Arsenal, AL. 35898	FROM: (Activity and location) (Include ZIP Code) MSG, Jane Q. Doe 1234 Any Street Nowhere Town, AL 34565	DATE 8/30/02
---	--	------------------------

PART II - REPAIR PARTS AND SPECIAL TOOL LISTS AND SUPPLY CATALOGS/SUPPLY MANUALS

PUBLICATION NUMBER			DATE	TITLE				
PAGE NO.	COLM NO.	LINE NO.	NATIONAL STOCK NUMBER	REFERENCE NO.	FIGURE NO.	ITEM NO.	TOTAL NO. OF MAJOR ITEMS SUPPORTED	RECOMMENDED ACTION

PART III - REMARKS (Any general remarks, recommendations, or suggestions for improvement of publications and blank forms. Additional blank sheets may be used if more space is needed.)

EXAMPLE

TYPED NAME, GRADE OR TITLE MSG, Jane Q. Doe, SFC	TELEPHONE EXCHANGE/AUTOVON, PLUS EXTENSION 788-1234	SIGNATURE
---	--	-----------

RECOMMENDED CHANGES TO PUBLICATIONS AND BLANK FORMS <small>For use of this form, see AR 25-30; the proponent agency is ODISC4.</small>						Use Part II (reverse) for Repair Parts and Special Tool Lists (RPSTL) and Supply Catalogs/Supply Manuals (SC/SM)	DATE
TO: (Forward to proponent of publication or form)(Include ZIP Code) Commander, U.S. Army Aviation and Missile Command ATTN: AMSAM-MMC-MA-NP Redstone Arsenal, AL 35898						FROM: (Activity and location)(Include ZIP Code)	
PART 1 - ALL PUBLICATIONS (EXCEPT RPSTL AND SC/SM) AND BLANK FORMS							
PUBLICATION/FORM NUMBER						DATE	TITLE
ITEM NO.	PAGE NO.	PARA-GRAPH	LINE NO. *	FIGURE NO.	TABLE NO.	RECOMMENDED CHANGES AND REASON	
<small>* Reference to line numbers within the paragraph or subparagraph.</small>							
TYPED NAME, GRADE OR TITLE						TELEPHONE EXCHANGE/ AUTOVON, PLUS EXTENSION	SIGNATURE

TO: (Forward direct to addressee listed in publication) Commander, U.S. Army Aviation and Missile Command ATTN: AMSAM-MMC-MA-NP Redstone Arsenal, AL 35898	FROM: (Activity and location) (Include ZIP Code)	DATE
--	---	-------------

PART II - REPAIR PARTS AND SPECIAL TOOL LISTS AND SUPPLY CATALOGS/SUPPLY MANUALS

PUBLICATION NUMBER			DATE	TITLE				
PAGE NO.	COLM NO.	LINE NO.	NATIONAL STOCK NUMBER	REFERENCE NO.	FIGURE NO.	ITEM NO.	TOTAL NO. OF MAJOR ITEMS SUPPORTED	RECOMMENDED ACTION

PART III - REMARKS (Any general remarks or recommendations, or suggestions for improvement of publications and blank forms. Additional blank sheets may be used if more space is needed.)

--

TYPED NAME, GRADE OR TITLE	TELEPHONE EXCHANGE/AUTOVON, PLUS EXTENSION	SIGNATURE
----------------------------	--	-----------

The Metric System and Equivalents

Linear Measure

1 centimeter = 10 millimeters = .39 inch
 1 decimeter = 10 centimeters = 3.94 inches
 1 meter = 10 decimeters = 39.37 inches
 1 dekameter = 10 meters = 32.8 feet
 1 hectometer = 10 dekameters = 328.08 feet
 1 kilometer = 10 hectometers = 3,280.8 feet

Weights

1 centigram = 10 milligrams = .15 grain
 1 decigram = 10 centigrams = 1.54 grains
 1 gram = 10 decigrams = .035 ounce
 1 decagram = 10 grams = .35 ounce
 1 hectogram = 10 decagrams = 3.52 ounces
 1 kilogram = 10 hectograms = 2.2 pounds
 1 quintal = 100 kilograms = 220.46 pounds
 1 metric ton = 10 quintals = 1.1 short tons

Liquid Measure

1 centiliter = 10 milliliters = .34 fl. ounce
 1 deciliter = 10 centiliters = 3.38 fl. ounces
 1 liter = 10 deciliters = 33.81 fl. ounces
 1 dekaliter = 10 liters = 2.64 gallons
 1 hectoliter = 10 dekaliters = 26.42 gallons
 1 kiloliter = 10 hectoliters = 264.18 gallons

Square Measure

1 sq. centimeter = 100 sq. millimeters = .155 sq. inch
 1 sq. decimeter = 100 sq. centimeters = 15.5 sq. inches
 1 sq. meter (centare) = 100 sq. decimeters = 10.76 sq. feet
 1 sq. dekameter (are) = 100 sq. meters = 1,076.4 sq. feet
 1 sq. hectometer (hectare) = 100 sq. dekameters = 2.47 acres
 1 sq. kilometer = 100 sq. hectometers = .386 sq. mile

Cubic Measure

1 cu. centimeter = 1000 cu. millimeters = .06 cu. inch
 1 cu. decimeter = 1000 cu. centimeters = 61.02 cu. inches
 1 cu. meter = 1000 cu. decimeters = 35.31 cu. feet

Approximate Conversion Factors

<i>To change</i>	<i>To</i>	<i>Multiply by</i>	<i>To change</i>	<i>To</i>	<i>Multiply by</i>
inches	centimeters	2.540	ounce-inches	Newton-meters	.007062
feet	meters	.305	centimeters	inches	.394
yards	meters	.914	meters	feet	3.280
miles	kilometers	1.609	meters	yards	1.094
square inches	square centimeters	6.451	kilometers	miles	.621
square feet	square meters	.093	square centimeters	square inches	.155
square yards	square meters	.836	square meters	square feet	10.764
square miles	square kilometers	2.590	square meters	square yards	1.196
acres	square hectometers	.405	square kilometers	square miles	.386
cubic feet	cubic meters	.028	square hectometers	acres	2.471
cubic yards	cubic meters	.765	cubic meters	cubic feet	35.315
fluid ounces	milliliters	29.573	cubic meters	cubic yards	1.308
pints	liters	.473	milliliters	fluid ounces	.034
quarts	liters	.946	liters	pints	2.113
gallons	liters	3.785	liters	quarts	1.057
ounces	grams	28.349	liters	gallons	.264
pounds	kilograms	.454	grams	ounces	.035
short tons	metric tons	.907	kilograms	pounds	2.205
pound-feet	Newton-meters	1.356	metric tons	short tons	1.102
pound-inches	Newton-meters	.11296			

Temperature (Exact)

°F	Fahrenheit temperature	5/9 (after subtracting 32)	Celsius temperature	°C
----	---------------------------	-------------------------------	------------------------	----

PIN: 083817-000

This fine document...

Was brought to you by me:



[Liberated Manuals -- free army and government manuals](#)

Why do I do it? I am tired of sleazy CD-ROM sellers, who take publicly available information, slap “watermarks” and other junk on it, and sell it. Those masters of search engine manipulation make sure that their sites that sell free information, come up first in search engines. They did not create it... They did not even scan it... Why should they get your money? Why are not letting you give those free manuals to your friends?

I am setting this document FREE. This document was made by the US Government and is NOT protected by Copyright. Feel free to share, republish, sell and so on.

I am not asking you for donations, fees or handouts. If you can, please provide a link to liberatedmanuals.com, so that free manuals come up first in search engines:

<A HREF=<http://www.liberatedmanuals.com/>>Free Military and Government Manuals

– Sincerely
Igor Chudov
<http://igor.chudov.com/>