

THE ENGINEERING AND MINING JOURNAL



(Published Every Saturday at 253 Broadway, New York.)

Entered at the Post-Office of New York, N. Y., as Second Class Mail Matter.

VOL. LXXI. JUNE 1, 1901. No. 22.

THE SCIENTIFIC PUBLISHING CO., Publishers. ROSSITER W. RAYMOND, Ph. D., M. E., Special Contributor. FREDERICK HOBART, Associate Editor.

Copyright, 1901, by the Scientific Publishing Company.

SUBSCRIPTIONS ARE PAYABLE IN ADVANCE. For the United States, Mexico and Canada, \$5 per annum; all other countries in the Postal Union, \$7.

REMITTANCES should be made by bank drafts, post-office orders or express money orders on New York, payable to the Scientific Publishing Co.

When change of address is desired, both old and new address should be sent.

NOTICE OF DISCONTINUANCE. The JOURNAL is not discontinued at expiration of subscription, but is sent until an explicit order to stop is received by us.

Main Office: 253 Broadway (P. O. Box 1833), NEW YORK.

Telephone Number, 3,095 Cortlandt.

New York Cable Address: "ROTHWELL." (Use McNeill's or A B O 4th Edition Code. London Cable Address: "PULCINETTO.")

Branch Offices: Chicago, Ill 737 Monadnock Building, Phone 73 Harrison. Denver, Colo., Boston Building, Room 206. Salt Lake City, Utah, Atlas Building. San Francisco, Cal., Third Floor, Mills Building.

Vancouver, B. C., Office, Molson's Bank Bldg. Wm. M. Brewer, Manager. London, Eng., Office, 20 Bucklersbury, 368. E. Walker, Manager.

English subscriptions to the JOURNAL may be paid at the London Office at the rate of \$7 = £1 8s. 3d.; the publications of the Scientific Publishing Company may be bought at the rate of 4s. 2d. to the dollar, net.

CONTENTS.

Table listing contents with page numbers: Editorial Notes 685, The International Miners' Conference 686, Consumption of Coal in Zinc Smelting 686, United States Steel Production 686, New Publications 686, Books Received 687, The American Phosphate Export Trade 688, Open-Hearth Steel in the United States 688, \*Spring in the San Juan Country in Colorado 689, An Electric Plant for a Mountain Mine 689, \*Benjamin Thomas Lacy 690, \*The Elmore Concentration Process 691, \*Horizons of Arkansas and Indian Territory Coals Compared With Those of Other Trans-Mississippians 692, Michigan Limestones and Their Uses 693, \*The "Crown" Dry Concentrating System 694, Mining Among the Moros in the Philippines 695, Abstracts of Official Reports 695, \*A New Coal Conveyor Plant 696, Recent Decisions Affecting the Mining Industries 696, Mineral Collectors' and Prospectors' Column 697, Questions and Answers 697, \*Patents Relating to Mining and Metallurgy 697

\* ILLUSTRATED.

Table listing various sections and their page numbers: Personal 699, Obituary 699, Societies and Technical Schools 699, Industrial Notes 699, Trade Catalogues 700, Machinery and Supplies 700, Mining News 700, United States: Alabama 700, Arizona 700, California 700, Colorado 701, Idaho 702, Illinois 702, Michigan 702, Missouri 702, Montana 702, Nevada 703, New Jersey 703, New Mexico 703, Oregon 703, Foreign: Africa 704, Canada 704, Cuba 704, Europe 704, Ontario 704, Markets: Coal: New York 704, Birmingham 705, Chicago 705, Cleveland 705, Pittsburg 705, Foreign Coal Trade 705, Chemicals and Minerals: New York 705, Metals: Iron: Pigg Iron Production 706, Gold and Silver Prices, Statistics, Imports and Exports 707, Foreign Coins 707, Copper 708, Tin 708, Lead 708, Spelter 708, Antimony 708, Nickel 708, Platinum 708, Quicksilver 708, Minor Metals 708, Slate: New York 709, Mining Stocks: New York 709, Boston 709, Denver 709, San Francisco 709, Market Reviews: New York 709, Boston 709, Denver 709, San Francisco 709, Paris 710, Meeting 710, Dividends 710, Assessments 710, Stock Quotations: New York 710, San Francisco 710, St. Louis 710, Boston 711, Philadelphia 711, Salt Lake City 711, Toronto 711, Colo. Springs 711, Montreal 711, Mexico 711, London 712, Denver 712, Spokane 712, Paris 712, Mining Co.'s: List of 713, Current Prices: Minerals, Chemicals, etc. 714

Notes and memoranda of results obtained in practical work and of difficulties encountered and overcome are the most valuable information which the miner and metallurgist can receive. We do not doubt that many of our readers could furnish such information from their past experience or their present work, and we should be much pleased to receive from them any accounts or records which they may be able to send us for publication.

The Texas oil-field, which is now exciting so much interest, is undoubtedly an important one. New discoveries are constantly extending its known limits, and it seems quite possible that it may be found to cover a large part of Eastern Texas and Western Louisiana. It is not wise, however, to attempt to exaggerate its importance, and to state—as some of our contemporaries have done—that its production will soon exceed that of all the other oil-fields in the United States combined.

In his presidential address at the recent meeting of the Iron and Steel Institute in London, Mr. William Whitwell devoted some time to the consideration of by-products in iron making. He touched here upon a point which has been considered much less in Great Britain than in Germany and Belgium; and which, we may say, has hardly been taken up in this country at all. The changing conditions of the iron trade and the increasing competition of other nations have made it necessary for British iron-masters to consider every possible method of reducing costs.

The shipments of silver to the East for the four months ending April 30th have shown some notable changes this year, as compared with 1900. The value of these shipments as far as reports have been received—and these cover by far the greater part of the export—have been as follows:

Table showing silver shipment values for 1900 and 1901 from London, San Francisco, and India, including changes and percentages.

The total exports to China this year have amounted only to \$3,167,708, showing a decrease of \$5,000,121 as compared with last year.

The increase in Indian shipments of silver was due almost entirely to the purchases which the India Council was compelled to make to maintain the circulation of the rupee. The attempt to force gold coinage has been practically abandoned, and the coinage of a large amount in silver rupees was found necessary to maintain the circulation in India and avoid grave currency difficulties.

The report of the Robinson Mining Company of the Transvaal states that during the time when the mine and mill at Johannesburg were operated by officers of the South African Republic, the books kept show

that 119,335 ounces of fine gold were obtained from the ore worked. The gold on hand, which was taken by the British troops when they captured Johannesburg, was 11,901 ounces. This shows a difference of 107,434 ounces of fine gold which have disappeared, at least so far as the Robinson Company is concerned. Presumably the gold was appropriated to the uses of the Transvaal Government.

Not much has been said about this question yet; the report now before us simply gives the figures without comment. It is probable, however, that some or all of the Witwatersrand companies will make some move for compensation, though it is not easy to see what they can do. The South African Republic no longer exists, and when a colonial government is established in its place it is not at all likely to assume claims for war damages resulting from the acts of a government over which it had no control.

Presumably the companies which suffered losses similar to those of the Robinson will keep quiet for a time, since the present is not a propitious time to bring their claims forward. It will be interesting to see how those claims will be submitted and how they will be met.

#### THE INTERNATIONAL MINERS' CONFERENCE.

The International Miners' Conference, a body in which the coal miners of all the European countries are represented, has just concluded its annual session, which was this year held in London. Whether it was the local influence, or because the questions chiefly discussed were less disturbing than usual, the friction which has in previous years been apparent between the British and the Continental delegations, was not in evidence this year. The main point under discussion was the establishment of an eight-hour day for miners, and this was approved by all the delegates. The British members expressed a belief that the passage of an eight-hour law could be secured from Parliament next year, while the French delegation asserted that a general strike of the coal miners in that country would almost certainly follow a refusal to grant the shorter hours.

There was less of the socialistic element in evidence in the discussions this year than usual. The French and German delegations, in which this element is usually strong, were either somewhat changed in composition, or else kept that element in the background. The German delegates, especially, had comparatively little to say.

The conference recognized the importance of the American competition, which troubles Europe so much just now. In the closing discussions several delegates pointed out the possibility that imports of American coal might be used to keep down prices of coal, or to make up deficiencies in case of strikes in European countries. In this way the American miners might be used to the disadvantage of their European brethren. Accordingly resolutions were passed, inviting the miners' associations in the United States to send delegates to the next International Conference.

Very possibly this invitation will be accepted. In view of the great diversity of conditions and interests here and in Europe, however, it is very doubtful whether the presence of American delegates will have much influence in the Conference.

#### CONSUMPTION OF COAL IN ZINC SMELTING.

In a recent issue we referred to the present high value of coal in Europe and the serious manner in which it has affected the zinc smelters of Belgium, France and Germany. There is probably no other industry which is so much dependent upon cheap coal as zinc smelting, inasmuch as the proportion of coal per ton of ore and per ton of product which is required therein is so high. In the very best practice the distillation of a ton of roasted ore containing 50 per cent. zinc requires 1.4 to 1.9 tons of superior coal (including both heating coal and reduction material) which is equivalent to 3 to 4 tons of coal per ton of spelter produced. In distilling the low-grade ore of Upper Silesia and in inferior practice with high-grade ore the consumption of coal per ton of spelter is much higher.

A little thermo-chemical calculation will show how wasteful of fuel the process of zinc smelting is at its best and what great room for improvement there is when it is at its worst. The reduction of zinc oxide may be effected either by carbon monoxide or solid carbon; probably both reactions take place in the retort. Assuming for the present purpose that it is effected solely by the reaction  $ZnO + C = Zn + CO$  there are required theoretically 56,000 calories of heat for the production of 65 kilograms of zinc, or 860 per kilogram, corresponding to 0.124 kilogram of pure carbon and 0.143 kilogram of coal of 7,000 calories heat value. This refers only to the heating coal from which the extraneous energy required to effect the reaction must be derived. If the highest grade of ore that can be produced commercially (assaying 75 per cent. zinc after roasting) were to be distilled with a consumption of one ton of heating coal per ton of ore and a yield of 90 per cent.

of its zinc, which are the maximum results that can be expected from the present best practice, the consumption of coal would be about 1.5 kilogram per kilogram of spelter produced, or more than 10 times the theoretical quantity. Theoretically 1 kilogram of roasted ore containing 75 per cent. zinc should require only 0.2 kilogram of coal as reduction material (reckoning on the basis of crude coal before conversion into cinder or coke); in practice at least 0.5 kilogram would be used for an ore so rich.

When we consider the large consumption of coal in zinc smelting even in the best European practice and the extremely high cost which it has now attained, we begin to appreciate the extraordinary advantage which is possessed by the smelters of Kansas with their all but costless natural gas and the importance of preserving the supply of that marvellous but exhaustible fuel as long as possible; an importance which we fear has not yet been fully perceived by those who are now draining the resources.

#### UNITED STATES STEEL PRODUCTION.

Somewhat to the contrary of the general impression, the total production of steel in the United States in 1900 showed a considerable decrease as compared with that of 1900. The output of pig iron showed a small increase, but in steel there was a total falling off of 443,598 tons, or 4.2 per cent. This result, if considered with the fact that the unsold stocks of iron increased considerably during the year, indicates that the consumption of foundry and forge irons about held its own, while the falling off in production and consumption was entirely in steel. It is not a large decrease; and it was entirely in the second half of the year, when nearly all production was on the decline, and people began to anticipate dull times. With the close of the year the demand began to increase, and production was at once enlarged, until at the present date it is on the greatest scale ever reported.

We have heretofore given separately the production of bessemer and of open-hearth steel, as collected and reported by the American Iron and Steel Association. In the table below we have brought these together and added the estimated output of crucible and other special steels. The figures are in long tons, and include ingots and also castings made direct from the furnace, the quantity of the latter being comparatively very small. The production was as follows:

	1899		1900		Changes. Tons.
	Tons.	Per Ct.	Tons.	Per Ct.	
Bessemer.....	7,586,354	71.2	6,684,770	65.4	D. 901,584
Open-hearth, Acid.....	866,890	8.1	855,529	8.4	D. 11,361
Open-hearth, Basic.....	2,080,420	19.5	2,547,023	24.9	I. 466,597
Crucible and special.....	128,500	1.2	131,250	1.3	I. 2,750
Totals.....	10,662,170	100.0	10,218,572	100.0	D. 443,598

The total decrease in 1900 was 4.2 per cent. It was entirely due to the falling off in bessemer steel, which was only partially offset by the increase in open-hearth metal. In the latter also it is to be noted that the gain was in basic steel, which showed an advance of 22.4 per cent., its proportion of the total output rising from 19.5 to 24.9 per cent. The gain was very generally distributed. Part of it was due to the establishment of the large plant at Ensley, in Alabama; but other plants in different parts of the country contributed also. The gain is likely to continue, as other plants are being started in the South, following the example set at Ensley.

The basic bessemer process has never been extensively in use in this country, and practically all the bessemer steel is made by the acid process. It will be seen, therefore, that in 1900 a total of 75.1 per cent. of the steel made was acid steel, and 24.9 per cent. basic. The basic process, as we have already noted, is the growing branch of the manufacture.

Over three-quarters of our pig iron production was converted into steel in 1900. Making the usual allowances, we find that the steel makers used 77.8 per cent. of all pig iron made. Our steel production exceeded in quantity the pig iron output of Great Britain or of Germany, and probably approached one-third of the world's supply.

#### NEW PUBLICATIONS.

"A Hand-book of Trade, Industries and Production." By Oscar Halvorsen. Madison, Wis.; published by the Author. Pages, 66; with map and diagrams. Price, 35 cents.

The attempt to compress a statement of the industries of the United States and the trade of the world into a pamphlet of 66 small pages could hardly be successful, even if undertaken by the skilled statistician. In this case it has resulted only in a jumble of figures and facts, which necessarily contains some information, but it is of very little value. The time given to compiling this pamphlet might have been better employed, though the compiler has doubtless tried honestly to make it of service to its readers.

"State of Michigan. Eighteenth Annual Report of the Bureau of Labor and Industrial Statistics." Joseph L. Cox, Commissioner of Labor. Lansing, Mich.; State Printers. Pages, 416.

This report contains much valuable information about the varied industries of Michigan, its towns and city organizations, and its public

institutions. It does not refer to the great iron and copper mines of the State—which are covered by a separate report, made by another officer—but it includes the report of the coal mine inspector. Coal mining is a growing industry in Michigan, and from this report it appears that in 1900 there were 2,038 men employed in 31 mines, the output reaching a total of 843,476 tons. Michigan coal miners appear to be exceptionally well paid, for the average wages reported—including all labor—were \$2.34 per day, while the average working period was 21.5 days per month. The statistics given in the report are well arranged and appear to have been carefully and thoroughly collected.

"Induction Coils: How to Make, Use and Repair Them." By H. S. Norrie (Norman H. Schneider). New York; Spon & Chamberlain. London; E. & F. N. Spon, Limited. Pages, 270; illustrated. Price, \$1.

The first edition of this book was issued some time ago. The second edition has been considerably enlarged and in large part rewritten, to bring it up to date. This was necessary in order to make it conform to the rapid progress of electrical science. Perhaps the most important addition is a chapter on Wireless Telegraphy. The object of the book is not to give specific directions and full dimensions for all the apparatus described, but rather to lay down such general rules and principles as will be sufficient to enable one possessing ordinary constructive ability to make his own apparatus. Such modifications as are necessary to adapt the work to special purposes can readily be made. Induction coils have many applications in electrical work, and this book will be found very useful.

"Practical Coal Mining." By George L. Kerr. London; Charles Griffin & Company, Limited. Philadelphia; the J. B. Lippincott Company. Pages, 462; illustrated. Price, \$4.

The author of this book has had long experience in coal mining in Scotland, and his work is based chiefly on Scotch practice and Scotch methods. This is his main defect, for it is carefully written and contains much that the mine foreman or manager ought to know. While it is written largely from the practical side, a number of examples and the mathematical calculations required to solve them are given.

For American use it would be well if some additions had been made. The subject of coal cutting by machine is too briefly treated, though several machines—chiefly of American make—are mentioned. The subject of electricity is passed over in a rather brief and unsatisfactory way. Mechanical haulage is also too briefly treated, it seems to us. While, as we have said, there is much in the book that is useful, it would have been much better had it been revised by a practical American mining engineer before offering it to the American public.

"Ausgewählte Methoden der Analytischen Chemie." By A. Classen. Vol. I. Braunschweig, Friedrich Vieweg & Son 1900. Pp. 940. Illustrated. Price in New York, \$7.

Books bearing on analytical chemistry appear every year in astonishing numbers, yet those that are at once comprehensive and exact enough to fulfil the requirements of general reference are very few. There is the well-known work of Fresenius; also those of Balley and Post, and recently Carnot's excellent treatise. Classen's work, however, differs from the manuals of Fresenius and Carnot in that, being intended for advanced students or those having a knowledge of general analytical operations, it contains no lengthy descriptions of apparatus, laboratory equipment, etc., but starts in with the determination of silver. The author, who is director of the laboratory for inorganic and electro chemistry at the Royal High School at Aachen, states that he has either tested the methods given himself or knows that they have been tested. He has not sought to give all methods known, but rather to give those methods best suited for industrial work or for the advanced student. Especial attention is given to the chemistry of many of the rare elements, which now have both scientific and industrial importance but are touched on but lightly in elementary works.

Possibly the author might have omitted some of the methods he gives to advantage and doubtless there will be criticism of an arrangement which devotes 41 pages to beryllium and only 23 to copper; but this prominence given to rare elements the author states is because of the increasing industrial importance of these elements and the fact that most laboratory manuals have so little to say on the subject. The analysis of monazite sand and the materials used in the manufacture of mantles for incandescent lamps, for instance, is here given, with the methods of separating the rare earths by fractional precipitation. This matter alone adds greatly to the value of the book. In another direction Classen's work is strong, as might be expected from the author's experience, and that is in the space given to the description of electrolytic methods. Three different electrolytic methods for the determination of copper are given and mention is made of various approved modifications of these methods. This is a refreshing contrast to some laboratory manuals, and the author's judgment is to be praised.

The volume treats of the metals and metalloids only. It gives methods for the qualitative determination of each element, following with quantitative determinations by gravimetric, volumetric, colorimetric or electrolytic methods, and is strong in short methods or methods of proximate analysis. The book will also be valuable to the industrial chemist because of the special schemes given for analyzing substances of industrial importance as iron and steel, clays, cements, glasses, zinc, chromium, uranium and platinum ores, glass, ammoniates, etc. The author is to be commended also for the pains he takes to indicate the methods of procedure in stoichiometrical calculations, in all cases where these calculations are at all complicated.

The author states that the methods given are selected as the result of thorough tests by himself or his assistants and pupils. Still, American chemists will criticize some features. Thus the analysis of iron and steel is well summarized and the author mentions with approval details of iron ore analysis used in the Lake Superior country, yet the author favors German rather than American practice. In other parts of the book some excellent methods are omitted. Still, if some methods

given are different from the best American practice, they are none the less interesting and some will be found very instructive, as, for instance, those for the determination of different kinds of glass.

The author and his assistant have evidently ranged the whole field of technical literature with results that leave little to be desired. Thus we find references in the text to articles that appeared in 1900. It is not often that a German professor brings a publication so well up to date.

The general arrangement of the work is admirable. The methods given are clearly described. The book is well printed and has a good index. It will undoubtedly find a place in many a laboratory. A second volume dealing with organic work will presumably be issued later. It will be awaited with interest.

#### BOOKS RECEIVED.

In sending books for notices, will publishers, for their own sake and for that of book buyers, give the retail price? These notices do not supersede review on another page of the Journal.

"The Ready Reference Book of the Oil Companies of California." San Francisco; Joseph B. Topf. Pamphlet, pages 18. Price, 10 cents.

"Water Filtration Works." By James H. Fuertes. New York; John Wiley & Sons. London; Chapman & Hall, Limited. Pages, 284; illustrated. Price, \$2.50.

"Annals of South Africa." First Series. Reprinted from "South Africa." London, England; "South Africa" Pamphlet, pages 28. Price (in New York), 20 cents.

"Treatise on an Improved Extraction of Gold Ores, by Means of KCN, BaO and Time." By Eugen Schilz. King William's Town, South Africa; published by the author. Pamphlet, pages 12.

"Commercial Relations of the United States with Foreign Countries During the Year 1900." Volume I. Prepared by the Bureau of Foreign Commerce, Department of State. Washington; Government Printing Office. Pages, 1242.

#### CORRESPONDENCE.

We invite correspondence upon matters of interest to the industries of mining and metallurgy. Communications should invariably be accompanied with the name and address of the writer. Initials will only be published when so requested.

Letters should be addressed to the MANAGING EDITOR. We do not hold ourselves responsible for the opinions expressed by correspondents.

#### Gas Explosions in Metal Mines.

Sir: An explosion of gas under conditions similar to those which have already been described in your columns, occurred in the Gould & Curry Mine in the Comstock Lode, Virginia City, Nev., in the late sixties. It was desired to tap and drain a winze about 200 ft. in depth in the upper workings; and to do this safely, as the winze was full of water, a long drill hole was kept well in advance of the working face of the tapping drift. This drill hole had not yet reached the reservoir, when one of the workmen noticed a movement of the rock in the face of the drift, but although they took to flight instantly, they were caught by the rush of water and mud, nearly waist deep, but luckily without loss of life. When the flow had ceased, the foreman (Mr. W. Welch) with several men entered the drift to ascertain its condition. One of the party, to get a better view ahead, raised his candle nearer the roof, when the explosion occurred. The result was more or less singeing, but nothing worse; and unless my memory is defective, there was no repetition of the flash. Investigation showed, that the bottom of the winze (about 8 by 4 ft. and tightly boarded) was badly caved, and the gas had been under such pressure, aided by the weight of the water, that more than 12 ft. of rock had been broken down and forced into the drift. It is evident in this case, as in those previously described, that the gas resulted from the decomposition of the timbering of the winze, although it is probable that the rocks in the neighborhood were also badly decayed, to allow of so great a thickness being broken down.

West Seattle, Wash., May 14, 1901.

R. H. Stretch.

#### Petroleum in Texas and Mexico.

Sir: Owing to the interest now being taken in the development of oil in certain parts of the State of Texas, I have thought that the following statement might be of benefit to parties seeking new fields. In the year 1894, while employed as mine engineer by the Minera Coal Company, then operating the Santo Tomas Coal Mines on the Rio Grande, between Laredo and Eagle Pass, I became very much interested in the matter of the existence of oil in Southwest Texas and Northeast Mexico, and through the courtesy of Capt. Wm. Anderson, then manager of the company, was given access to data derived from about 400 diamond drill borings through the Eocene Tertiary formation, by means of which, together with detailed exploration of portions of the territory involved, I was enabled to make the following deductions:

1st. That the oil belt or zone is continuous through the State of Texas.

2d. That the oil belt of Texas is closely associated with those of Indiana, Kentucky, Ohio and Pennsylvania.

3d. That the same belt continues to the southwest, and southward into the State of Tamaulipas in Mexico, crossing the Rio Grande in the vicinity of Camargo, and thence traversing the State of Tamaulipas throughout its entire length, passing into the State of Vera Cruz, beyond which point I have no data concerning it.

4th. That proceeding southward the oil becomes heavier.

Regarding this matter, I will further add that I prepared a chart of a portion of the belt, involving a part of Northern Mexico and South-west Texas, for Mr. Thomas O'Conner, of Nuevo Laredo, who, I under-

stand, still has the same in his possession. Some months after it was prepared he informed me that he had caused a well to be sunk within the limits of the belt as defined on the chart, and showed me a sample of a good grade of what I would class as lubricating oil, which he informed me had been taken from said test-well.

As the above work was all done at my own expense, through my interest in the matter, merely as a geological study, I feel entirely at liberty to give this information to the public for what it may be worth.

G. A. Burr.

Avino, Durango, Mexico, May 20, 1901.

THE AMERICAN PHOSPHATE EXPORT TRADE.

While foreign producers' agents are pushing their phosphates in the consuming markets of Europe, American exporters are planning to meet competition. In Florida the high grade rock people contemplate a consolidation, while in Tennessee options have already been taken on certain mines in the Mt. Pleasant District. It is claimed by exporters that an amalgamation of mining interests will afford them a better opportunity to regulate prices and freight rates. Florida and Tennessee are the two principal sources of the supply of high grade phosphate rock for the manufacture of marketable superphosphate. We

OPEN-HEARTH STEEL IN THE UNITED STATES.

We stated briefly last week the total production of open-hearth steel in the United States, and now add the details of that production, as collected and reported by the American Iron and Steel Association. The following table shows the production of open-hearth steel ingots and direct castings by States during the past four years, in tons:

States.	1897.	1898.	1899.	1900.
New England .....	51,402	47,381	57,124	74,522
New York and New Jersey.....	39,521	47,957	61,461	67,361
Pennsylvania .....	1,271,751	1,817,521	2,393,811	2,703,919
Ohio .....	73,357	79,886	117,458	130,191
Illinois .....	120,909	182,103	246,133	285,551
Other States .....	47,031	54,444	71,279	141,008
Total .....	1,608,671	2,230,292	2,947,316	3,402,552

The open-hearth steel made in 1900 was produced by 92 works in 17 States—Massachusetts, Connecticut, New York, New Jersey, Pennsylvania, Delaware, Maryland, Kentucky, Tennessee, Alabama, Ohio, Indiana, Illinois, Michigan, Wisconsin, Minnesota and Missouri. Only 76 works and 14 States made open-hearth steel in 1899; the new States to enter the list in 1900 being Delaware, Kentucky, and Tennessee. In 1899 the production of open-hearth steel by the basic process



1. TURKEY CREEK MINE AND MILL.



2. ENTRANCE TO TURKEY CREEK TUNNEL.

SPRING IN THE SAN JUAN COUNTRY, COLORADO.

give below a detailed statement of the exports for the three months ending March 31st:

Destination.	—Florida.—		Tennessee.	Total Tons.
	High grade	Pebble.	High grade.	
Austria .....	.....	2,200	.....	2,200
Belgium .....	11,256	.....	3,000	14,256
England .....	4,400	2,420	1,782	8,602
France .....	2,300	8,378	17,657	28,335
Germany .....	57,583	4,300	915	62,798
Holland .....	16,337	.....	.....	16,337
Italy .....	.....	4,200	16,096	20,296
Norway and Sweden.....	2,910	5,098	.....	8,008
Total, tons .....	94,786	26,596	39,450	160,832

It will be seen by this table that the foreign trade in Florida high grade rock constitutes nearly 59 per cent. of the total, while Tennessee furnished about 25 per cent., the remaining 16 per cent. being Florida land pebble. Comparing the total movement with the corresponding period last year, there was an increase of 32,146 tons, or 20 per cent. in 1901, owing principally to the heavier demand for Florida high grade rock. In addition to the above South Carolina exported about 7,241 tons of rock, which is a large falling off from last year.

Our leading customer abroad is Germany, which received 39 per cent of the total exports. This amount would probably be increased were it possible to give the quantity sent through Holland ports. In France and Italy, Tennessee rocks finds a larger sale than does the Florida.

Foreign prices for American phosphates we note are less than last year. To a degree this is due to the lower freight rates to these ports, although it is understood that the demand there is very quiet. The average c. i. f. prices for Florida phosphates during the quarter ended March 31st, this year, were as follows, per ton of 2,240 lbs.: High grade rock, 77 to 80 per cent., \$12.18; land pebble, 68 to 73 per cent., \$9.35; Peace River, 58 to 63 per cent., \$7.75. Tennessee rock, 78 per cent., \$11. Ocean freight rates from Florida to Continental ports ruled at \$3.18 to \$3.85 per ton; to Baltic and Mediterranean, \$4.80 to \$5.28, and to United Kingdom, \$3.50 to \$3.75. These rates were booked chiefly on time charters, and since April 1st, lower figures have been named. In fact, the present freight rates are the lowest for a long time.

amounted to 2,080,426 tons and by the acid process to 866,890 tons. Of the total production last year 2,547,023 tons were made by the basic process and 855,529 tons were made by the acid process, as follows:

	Basic.	Acid.	Total.
New England .....	23,550	45,972	74,522
New York and New Jersey.....	32,129	35,232	67,361
Pennsylvania .....	2,063,077	640,842	2,703,919
Ohio .....	76,615	53,576	130,191
Illinois .....	244,935	40,616	285,551
Other States .....	101,717	39,291	141,008
Total .....	2,547,023	855,529	3,402,552

The total production of open-hearth direct steel castings in 1900, included above, amounted to 179,326 gross tons, of which 41,094 tons were made by the basic process and 138,232 tons were made by the acid process. In 1899 the production amounted to 169,729 tons, of which 39,689 tons were made by the basic process and 130,040 tons by the acid process. The following table gives the production of open-hearth steel castings by the acid and basic processes in 1900, by States.

	Acid.	Basic.	Total.
Massachusetts, Connecticut, New York and N. J. . . . .	21,833	.....	21,833
Pennsylvania .....	76,629	3,752	80,381
Other States .....	39,720	37,342	77,062
Total .....	138,232	41,094	179,326

In 1900 our open-hearth production probably exceeded that of Great Britain, which amounted to 3,030,251 tons in 1899. Great Britain's production in 1900 has not yet been published.

MANGANESE ORE IN QUEBEC.—Important deposits of manganese ore of good grade have been discovered in the islands of the Madelaine group, in the Gulf of St. Lawrence. The fact has been known a long time, but a prospect made last summer has shown a considerable extent of this ore. The mining right is under the control of Mr. W. G. Tait, of Pictou, N. S. This discovery is an important one, at a time when the metallurgical industry is taking such a development in Canada.

SPRING IN THE SAN JUAN COUNTRY IN COLORADO.

The accompanying views, which are reproduced from photographs kindly sent us by Mr. J. H. Shockley, of Telluride, Colo., are given here because they are thoroughly typical and characteristic views, illustrating the conditions in the San Juan country in Colorado during the late winter and early spring.

No. 1 shows a view of the Turkey Creek mine and mill. It was taken April 25th, 1901, and shows the heavy snow still covering the region at that date, and in great part submerging the mill building. We may add that for a snow picture it is one of the finest kodak prints we have seen. No. 2 shows the entrance to the Turkey Creek tunnel, taken at the same date. This illustrates in a still more striking way the great depth of snow covering the region at that date. This tunnel is expected to cut the East Virginia Vein at about 2,500 ft. from the surface.

No. 3 is a view taken at the Palmyra Mine of the Four Metals Mining Company on the same date, April 25th, 1901. The altitude at the point shown is 12,000 ft. above sea level. It will be observed that all that can be seen of the Palmyra building is the smoke-stack which projects from the snow at the right of the picture.

No. 4 is an extremely interesting view, showing a thoroughly typical amphitheater in the San Juan Mountains. On this view the course of the Palmyra and St. Louis veins of the Four Metals Mining Company can be traced on the summit shown in the center of the picture, while

1,400 ft. long and 30 in. in diameter and made of No. 14 steel. These plates as received were 36 by 96 in., and weighed from 65 to 70 lbs. each. These were punched, rolled and riveted and six sheets put together, the horizontal seams being double, and the vertical ones single riveted and making sections 17½ ft. long. These sections were then dipped in a hot bath of maltha and coal tar and thoroughly coated inside and out. Ten barrels of the compound were required for the job. After drying they were hauled to the grade and put together as follows: Beginning at the wheel end, the sections were united by a 6-in. telescope joint. The larger ends of the sections were expanded by sprinkling with gasoline oil and firing. This process also softened the compound and aided in making a tight joint. The sections were forced together by using a set of triple blocks on each side, having two men operating each set of blocks and a fifth man to guide the end of the pipe and at the same time jar it to a tight fit by using a sledge against a block of wood on the end of the pipe. As the line was straight, and the fall not over 75 ft., this style of joint proved very effective. The wheel opening being 24 in., a reducing section was necessary at this end. A 14-in. manhole and a hose connection was also placed in this section. The connection at the penstock was enlarged from 30 to 36 in. to allow an easy entrance for the water.

A 3-in. air valve was inserted in the pipe on the highest vertical bend. Most of the pipe was laid on an elevated grade. It crossed the stream from which the water was taken, and required two special bridges for

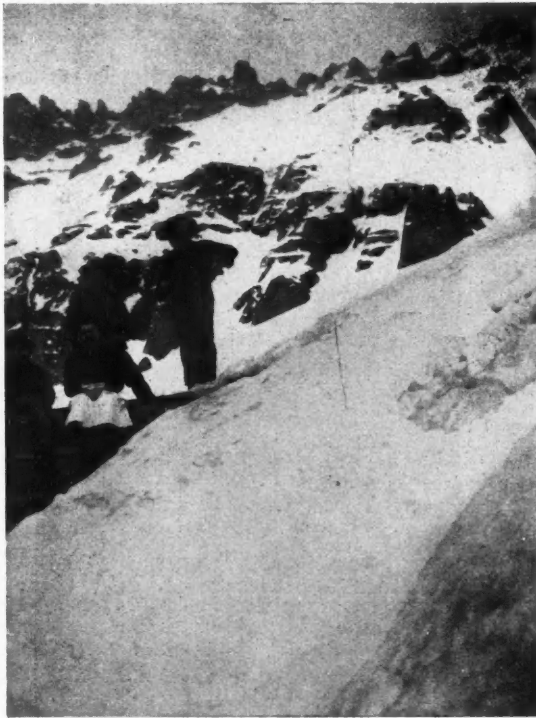

3. BUILDINGS AT PALMYRA MINE.



4. PALMYRA AND ST. LOUIS VEINS AT THE SUMMIT.

SPRING IN THE SAN JUAN COUNTRY, COLORADO.

the middle ground is deeply covered with snow. The figure 1 marks the location of the Palmyra Vein, and 2 that of the St. Louis Vein, while the cross in the snow shows the location of the mine building. The figure in the foreground is the mine foreman traveling on "skees," which are necessary in the San Juan even as late as the end of April.

AN ELECTRIC PLANT FOR A MOUNTAIN MINE.\*

By F. W. Brady.

The plant of the American Nettie Gold Mine, of Ouray, Colo., is a good example of an installation in which all the mine machinery and most of the materials for the transmission line were transported from the railway over a burro trail. The source of power for the plant is the Uncompahgre River, a dashing mountain stream fed by springs and heavy snows from a very large area of an intensely rugged range. There is a considerable variation in the volume of the flow of the stream, the lowest being in February and March, when there is the least thaw and the streams are frozen. The flow at this time was found to be 960 cu. ft. per minute. The river also has a daily variation, being lowest about 3 o'clock a.m., and highest in the evening. The flow is also cut off temporarily at times by big snow slides which close the stream until it can melt through.

The highest water is in early July, when the first hot days in this region bring down all the snow from the immediate foothills. No measure was secured of this flood stage. A 30-ft. log dam, a penstock 18 ft. high by 6 ft. square, and 400 ft. of 4 by 5-ft. flume with sandbox and screens were erected in the winter during the lowest stage of water. Ten feet of the penstock was built of 2 by 6-in. plank laid flatwise in tar and spiked together; upper 8 ft. of 2 by 4-in. Four 1-in. anchor bolts extended through the entire height. The pipe line was

this transfer. Practically the whole of the pipe was therefore subject to the extreme changes of temperature. Such a pipe should be kept full of water to prevent undue expansion and contraction. If not, there will be excessive leakage.

The building erected to house the machinery was a two-story frame structure 30 by 32 ft., the second story being used as a residence for the operator. The plan was made to accommodate duplicate generators to be operated by a 20-in. double discharge Lefell turbine with horizontal shaft and friction clutch pulleys, 28 in. diameter by 13 in. face, one for each unit. The turbine with its two 12-in. by 4-ft. draft tubes was set on foundations as directed by the makers.

The foundations for machinery and building were made of rock and cement. However, the I-beams composing the longitudinal part of the frame were deflected sidewise by the water pressure, and it became necessary to bring them into line again by the use of jack-screws, and then to extend the concrete foundation to the top of the beams. The wheel was fitted with a Wood governor, which worked very well for small variations of load; but for large ones like that caused by the starting of a compressor, it was of no value in this plant. When such changes were to be made, the operator was notified by telephone, and hand regulation was applied to the wheel. Without this hand regulation, the incandescent lights would be destroyed when a heavy load was thrown off. The plant was operated continuously. The switch-board was made of kiln-dried maple, and arranged for the duplicate 60-Kw. 500-volt compound generators.

The line extended over a very rough section of country, and was rather difficult both to locate and to construct. There were several zigzags so as to cross the cliffs where it was possible for men to approach the route. Trees were used for poles wherever possible. Other poles were cut from the nearest timber, and rolled or dragged into position, and set in holes blasted from the rock by the use of dynamite. Heavy guys and double cross-arms were frequently used along the line. The wire, 000 bare copper, was received on wooden spools in lengths of 1,000 ft. (500 lbs.). It was desired to take about one-third of these

\*Abstract from paper read before the American Institute of Electrical Engineers, April, 1901.

coils to the mine and run them out from that end. As 500 lbs. was too heavy for one mule to carry, and as it was preferable not to cut the wire, they were transported as follows: The wooden spools were removed from the wire, and the coils separated into four parts with connecting links. Two of these were placed on the pack saddle of one mule, one on each side, so as to balance. The other two were similarly placed on a second mule, the animals being connected by the 10 or 15 ft. of wire between the two loads. The outfit could then move single file up the trail. At the mine the four sections were replaced on the spools, which served as reels when placed on a spindle anchored to a tree. The end of the wire was passed through a friction clutch made of two pieces of plank bolted together, and then guided down the route of the poles by several men. A second section was then spliced and soldered to the first, and the operation continued until 3,000 ft. of wire was drawn out, 1,500 ft. on each side. Other sections were then drawn out by men and horses from various locations along the route, which could be most easily reached, for the total length of 4,400 ft. The completed joints were made Western Union style and soldered by pouring the molten solder over them. The wire was laid up and drawn into position in the usual manner. Special railway insulators were used to anchor the wire on the tops of high bluffs. Care should be taken in such rough country to set the cross-arms on the poles so that the grooves of the insulators will be in line with the wire, also that such construction be made extra good and strong.

The mine consisted of a series of tunnels opening in the face of quartzite ledges on the mountain side at an elevation of about 9,500 ft. These tunnels were connected by a network of excavations from which ore had been taken. The tunnels were of irregular size, varying from that of a rectangle less than 4 by 6 ft. to very large rooms or cavities. The mine was practically dry, though some water accumulated in two or three places.

The mine equipment besides incandescent lights in the tunnels and buildings was as follows: one 12 by 12-in. high altitude type of Norwalk compressor, a No. 4½ Baker blower, and a Lidgerwood hoist. The machines were housed in good-sized rooms made of boards and corrugated iron. It is necessary to cover such machines with a tight and strong roof to prevent small pieces of rock from dropping into the working parts. A substantial room for each machine is advisable, which can be locked to prevent meddling by employes other than the ones directly in charge.

The compressor was set in an offset from the main tunnel about 1,000 ft. from the entrance, and near the work to be done. This method of location is important, as it saves power, cost of installation, and avoids loss by leakage of pipes. No. 0 insulated wire was used in this tunnel. The compressor was operated by a 35-Kw. shunt motor geared on the same bed-plate. The air receiver 30 in. in diameter by 10 ft., was located about 20 ft. from the compressor. The jackets of the air cylinders and the intercooler were supplied with water from two 735-gallon tanks located about 100 ft. from the compressor. A centrifugal pump was driven by belt from the intermediate shaft of the machine, and forced the circulation of the water through suitable piping. From 10 to 18 gallons of water per minute were passed through the compressor, and kept it in fair condition. The speed of the compressor varied from 150 to 200 revolutions per minute, and when operating two Ingersoll-Sergeant drills and furnishing blast for one forge at a pressure from 60 to 80 lbs., the motor required from 65 to 80 amperes at 450 to 475 volts.

The No. 4½ Baker blower was located about 200 ft. in the tunnel in the Y formed by a branch. A 15-in. galvanized iron pipe extended from the blower to near the head workings. The blower was operated by a 6-Kw. shunt motor arranged with a reversing switch so that the smoke could be exhausted directly from the head of the mine without scattering it through the other tunnels. Also by this method fresh air could be sent directly to the miners, and the work carried on with the least interruption possible. The blower required 7 to 10 amperes at 475 volts.

The hoist was set up in a branch from the extreme inner end of the main tunnel some 300 ft. from the compressor. It was of the Lidgerwood style, operated by a 25-Kw. series street car motor controlled in the same manner. It was arranged with a drum for 600 ft. of ¾-in. wire rope in one layer. The shop test of the motor showed 1,300 lbs. raised 600 ft. per minute. The normal load was 700 lbs. at 600 ft. per minute.

The wire in the tunnels was of heavy weather proof insulation tied to heavy porcelain insulators bolted to wooden pins which were driven into holes drilled in the quartzite roof and walls. The location of the holes for the insulator supports so as to have the wire clear all obstructions was done by two men, each with a lighted candle. By holding a candle at one pin and the other a few feet ahead at such points as allowed the lights to be seen by both men, the proper places for the pins were rapidly located. There was a heavy condensation of moisture on the insulators and wire. This was effectively prevented by coating them with P. & B. paint.

One of the greatest troubles experienced in the operation of high altitude electrical plants is from lightning. Electrical storms are of very frequent occurrence, heavy discharges from the lines occurring sometimes during clear weather. The arresters used on this plant were of the General Electric Company magnetic blow-out type. Four were placed at the mine, and two at the station. As the mine was a dry one, it was difficult to get a suitable ground at that end. A good-sized basin was blasted out of the quartzite near the mouth of the tunnel, and this was filled with charcoal, the arresters grounded to a copper plate placed in it. The basin was kept damp by water occasionally thrown in it.

The transportation of the station materials and machinery was done by wagons in the usual manner. But that for the mine had to be taken over a very steep, crooked and more or less dangerous trail. All apparatus had to be entirely dismantled. The small parts and attachments were packed in ore sacks and carried on burros. The next larger sizes, such as bearings, small gears, pulleys, etc., were wrapped in sacks and loaded on mules. All pieces too heavy for mules or of such shape that they could not be balanced on the pack saddles, were

moved on sleds. These sleds were made of 2 by 3-in. pine, from 3 to 8 ft. long, and having a width of 20 in. A sled was used for each of the pieces such as armatures, fields, pole pieces, sections of bed-plates, gears, cylinders, air receiver, etc. Some of these pieces required the use of four horses in tandem to move them on the trail. In passing the zigzags, blocks and ropes with two horses pulling down hill, was found to be the most secure and rapid method. Several of the parts of the equipment required the use of 4 horses, 3 men and a good supply of tackle, crowbars, etc., about 5 days to move each one to the mine from the railway station, a distance of about 2½ miles. Only a few pieces received scratches and bruises, and only one piece jumped the trail, and this fortunately did not receive serious damage.

#### BENJAMIN THOMAS LACY.

Benjamin Thomas Lacy, who was widely known on the Pacific Coast as an engineer and a designer and constructor of mining machinery, died at his home in San Francisco, May 21st, aged 55 years. The cause of his death was Bright's disease. His loss will be regretted by the many mining men with whom he had been brought in contact, and by his associates in San Francisco, who had learned to appreciate his business enterprise and uprightness.

Mr. Lacy was born in 1846 in Wexford, Ireland, from where the family moved to Liverpool. There he was educated and later learned the business of machinist at the R. J. Rankins machine shops. In 1867 he came to the United States and settled for a time in Fitchburg, Mass., where, with Charles Burleigh, he became engaged in perfecting the Burleigh rock drill and air compressor.

He was in charge while these machines were being installed in the

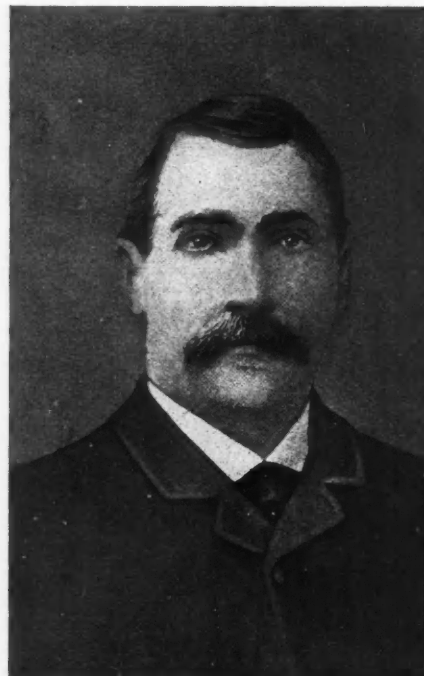

BENJAMIN T. LACY.

Hoosac Tunnel in Massachusetts, and later in New York, where he was engaged in removing the rocks at Hellgate, under the direction of General Newton.

Subsequently he was sent to Europe in charge of the drills operated at the Mount Cenis tunnel, where he remained 3½ years, returning to America to install the same machinery at the Sutro Tunnel to drain the Comstock Lode at Virginia, Nev.

There he met the late Lyman C. Parke, with the result that upon his arrival in San Francisco the firm of Parke & Lacy was formed to deal in machinery and mining tools of all descriptions. The firm grew and prospered until it has established a very large and profitable trade through all the mining sections of the Pacific Coast. It has also placed branches in Australia, where it has introduced American mining machinery into the leading camps throughout the colonies. It has also done much business in Mexico.

Mr. Lacy thoroughly understood his business; he was of a kindly and charitable disposition, and made many friends, who will sincerely regret his loss. He leaves a widow, two sons and two daughters.

**A GERMAN ELECTRIC HOIST.**—The London "Colliery Guardian" says that in an electric hoisting engine, made by Schmidt, Kranz & Company, of Nordhausen, in Prussian Saxony, the electromotors are keyed directly on the drum shaft, so that there is no necessity for spur or other gear; and a strong hollow cast-iron frame, on which the field magnets are placed, carries two long bearings (provided with ring lubrication) in which revolves the single shaft. The ordinary brake is worked by compressed air or water under pressure, and the emergency brake by the release of a weight, effected automatically by electricity or by the engineman with a pedal. The engine, which can be regulated for winding speeds of 30 mm. to 7 m. per second, is fitted with a retarding appliance, two lift indicators and an arrangement for eventually putting on the emergency brake.

THE ELMORE CONCENTRATION PROCESS.

References to this process have been made in our columns from time to time, and in view of the interest taken generally in concentration, a fuller description, with illustrations of the apparatus used, will be of interest. The special feature of the Elmore process, as has been heretofore explained, is the use of oil to assist in the separation and classification of the materials treated.

The process, as it is now being worked at the Glasdir Copper Mine at Dolgelly, North Wales, may be shortly described as follows: The rock from the mine, after passing through the usual stonebreakers, is crushed in a pair of Cornish rolls, and run thence to two Huntington mills, wherein it is reduced to pass through a 30-hole screen, and issues therefrom with just sufficient water to make it into a freely flowing pulp. From the Huntington mills the pulp passes directly into the open end of a horizontal rotating drum, inside of which is fixed a helix with cross blades or buckets, which lift up the pulp to a certain height and drop it again, at the same time propelling it forward to the opposite end of the drum, thus keeping the pulp in constant agitation for the few seconds which are occupied in its progress through the drum. With the pulp is also admitted a small quantity of a thick, sticky oil—the residue left in the stills in the refining of paraffine oil. This oil is, of course, subjected to the same agitation as the pulp, and is consequently tumbled about with it, and exercises the remarkable property of sticking to and buoying up the particles of mineral that are floating about or suspended in the pulp; but it does not stick to or have any effect whatever upon the particles of rock which are present in much greater number. The oil and pulp automatically discharge from the opposite end of the drum into a pointed box or spitzkasten, in which the tailings or rock at once settle down and flow off with the water at the bottom, while the oil, by reason of its buoyancy, floats to the top and carries up with it practically all the values which the ore contained. From the pointed box the oil with its load of mineral flows off continuously

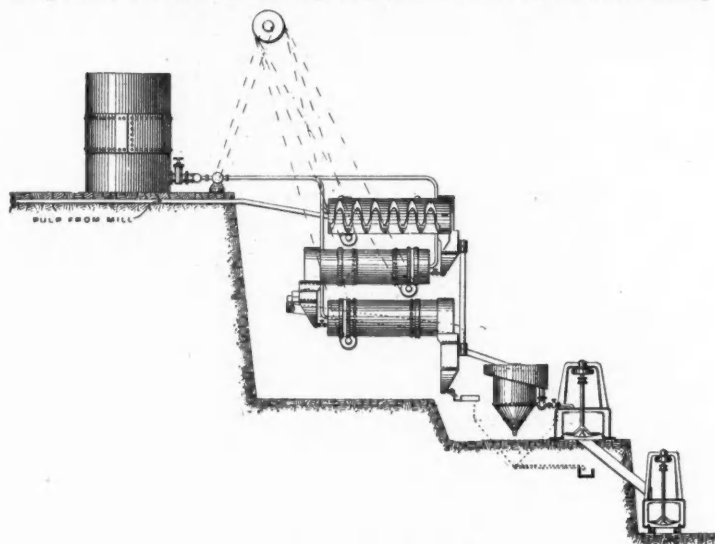

FIG. 1.—ELEVATION.

ELMORE CONCENTRATING PLANT AT GLASDIR, WALES.

for over four months night and day, and arrangements are in progress for making extensive additions thereto. The recovery of over 80 per cent. of the metallic values from the Glasdir ore by the new process having been fully demonstrated, the whole of the original jig and Luhrig table plant has been abandoned in favor of the new plant.

The advantages for this process which are claimed by the inventor are stated by him as follows:

1. The process saves the finest slime or float mineral, which is the chief source of loss in concentration plants, and will separate such mineral even when the same is of less specific gravity than the gangue it occurs in.
2. It can be used after any system of wet crushing without classification on material finer than 20-mesh (400 holes to square inch), or can be added to existing concentration mills for the treatment of the slimes which carry off value.
3. The pulp flows automatically and continuously through the mixers without attention; and the oil passes continuously from the surface of the spitzkastens below mixers into the centrifugal machines, and thence—freed from concentrates—is pumped back into circulation again through tanks feeding the mixers. The discharge of concentrates from the centrifugal machines involves extremely little labor. The power required is very small, being simply that to revolve the mixers and to run two centrifugal machines for several sets of mixers.
4. The cost of installation is not relatively high for a plant in which the capacity is at least 50 tons per day. The floor space occupied is very small.
5. The cost of operating is very low and wear and tear as little as any running machinery will admit of. It may be taken for estimating purposes at the same cost as running a Frue vanner plant, with the addition of cost of oil lost per ton and cost of royalty.
6. The quantity of water necessary per ton of ore is small, and by settling this can be to a great extent used over again, except, perhaps, where amalgamation is used before concentration.
7. Clean concentrates can be produced almost free from rocky particles, but containing a small percentage of oil, which is no disadvantage for smelting, and assists in briquetting if this be desirable.

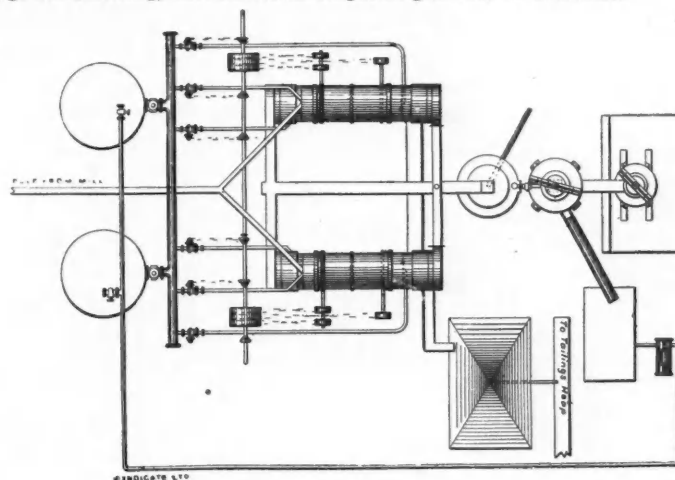

FIG. 2.—PLAN.

to a specially constructed centrifugal machine, where the oil is extracted from the mineral (which is left in the machine), the oil being at once ready for re-use. For close extraction three mixing cylinders are used, the pulp passing from one to another after floating off the oil and collected mineral and receiving a fresh stream of oil in the next mixer. A second centrifugal machine is also found desirable below the first, to separate the oil and water from the concentrates more closely. The concentrates are left in the machine, dry and almost free from oil.

The Glasdir Mine was originally equipped with one of the most modern concentrating mills obtainable, which was worked in the best possible manner under the direct personal supervision of able experts. Over 52,000 tons of ore from the Glasdir Mine were treated by the jig and Luhrig table plant referred to, with a result that only 14.5 per cent. average value recovery could be obtained from the ore. The Glasdir Company secured the services of expert managers from Germany and Cornwall, as well as from America, and gave the mill every chance to show its best performance. During the time the various experts sought to remedy the defects in the dressing and concentrating process which had been established at so great an expense, almost every known mechanical appliance was tried in turn to see if a reasonable recovery could be got from this ore, but without success, owing to the large proportion of float and slime material produced. Magnetic separation was considered and tried, but with negative results; several chemical processes were tested, and in turn abandoned, owing to great cost or poor recovery. It was found that the disastrous loss arose largely from the very friable nature of the pyrites. Various experiments have resulted, after nearly three years' constant work, in the complete and novel process which is now working at Glasdir.

The process was first tried in the laboratory, then on a small working scale, and then with a plant erected at the Glasdir Mine, capable of treating about 50 tons of ore per week. After a lengthened trial of this plant a larger one was erected which gave satisfactory results when treating 100 tons per week. From the experience gained from working this last-named installation, the existing plant was designed, which is a thoroughly practical working equipment in every respect, treating 250 tons of ore weekly; this has been in operation continuously

8. Certain minerals can be separated from others of similar or greater specific gravity. For instance, copper pyrites can be taken from magnetite, which is impossible by water concentration, and very imperfectly accomplished by magnetic separation, however slowly and carefully conducted.

9. Although oil is used freely in the process, the whole plant and building can be kept absolutely clean and neat, owing to the perfection of the mechanical appliances as now developed. The total loss of oil depends in part on percentage of concentrates, and may be taken at from 1 to 3 gallons per ton of ore.

10. The plant is constructed in very convenient units of about 25 tons daily capacity, but depending on character of ore; and can easily be added to when installed.

11. The concentration depends on the surface condition of the material; and generally it may be said that metallic surfaces are attachable to the oil, and earthy surfaces not. Nevertheless, sulphur, earthy-looking cinnabar, graphite, molybdenite and some other minerals, which in advance might not seem to possess promising surfaces, are most successfully taken up by the oil. Tellurides which are difficult to concentrate, and from their gold and silver values need close saving, are easily concentrated. Some oxidized gold ores in which the metal is so fine as to defy amalgamation have given good results. Average basket gold ore from the Rand mines without any previous amalgamation has yielded a high extraction and rich concentrate. These last three classes would seem to promise a field for the process in direct competition with cyaniding. As it is desirable to extend the knowledge of its application, correspondence is invited, and samples will be gladly received for laboratory testing by the process, in all cases where difficulty or loss occurs in existing methods of concentration or cyaniding.

PIG IRON IMPORTS INTO GREAT BRITAIN.—Imports of pig iron into Great Britain for the four months ending April 30th were 43,075 long tons, of which 25,411 tons were from the United States. In the corresponding period of 1900 the imports were 29,472 tons, 14,639 tons being from the United States.

HORIZONS OF ARKANSAS AND INDIAN TERRITORY COALS COMPARED WITH THOSE OF OTHER TRANS-MISSISSIPPIAN COALS.

Written for the Engineering and Mining Journal by Charles R. Keyes.

The Western Interior coal basin has long been regarded as formed of two entirely disconnected parts. In the north, in Iowa, Missouri and Kansas, the stratigraphic relations of the various coal seams have been more or less carefully paralleled. In the south, in western Arkansas and Indian Territory, is another productive region which, geologically, has never been accurately correlated with the coal-bearing horizons of other districts. The recent exact parallelism of the productive horizons in all parts of the Trans-Mississippian field is not without special significance.

In the many attempts to correlate the coal-bearing beds of Arkansas and those nearest to them in Kansas and Missouri, it has been the endeavor to show that the first mentioned deposits are stratigraphically equivalent to certain other coal-bearing horizons high up in the coal measures of the Kansas River Region. The data upon which these assumptions were based are entirely paleontological in nature. How discordant these conclusions really have been compared with the results later derived from stratigraphical evidence and direct tracing in the field, is now quite manifest.

As now understood, the terranes or geological formations of the Trans-Mississippian Carboniferous are as follows:

Series.	Terranes.	Thickness.	
Carboniferous.	Oklahoman .....	So-called Permian, not here differentiated.	1,500
		Cottonwood limestone.	10
		Atchison shales.	500
	Missourian .....	Forbes limestones.	25
		Platte shales.	105
		Plattsmouth limestones.	30
		Lawrence shales.	265
		Stanton limestones.	35
		Parkville shales.	75
		Iola limestones.	50
Des Moines.....	Thayer shales.	50	
	Bethany limestones.	75	
	Marais des Cygnes shales.	250	
Arkansan .....	Henrietta limestones.	50	
	Cherokee shales	200	
Arkansan .....	Not here differentiated.	20,000	
Mississippian .....	Not here differentiated.	1,000	

The thicknesses given are the measurements at the more typical localities of the several formations. The standard thicknesses of the different series in the north and the south may be advantageously contrasted.

Series.	Northern Section.	Southern Section.
Oklahoman .....	1,000	1,000
Missourian .....	2,000	1,000
Des Moines .....	500	3,500
Arkansan .....	Wanting	20,000
Mississippian .....	1,000	1,500

Of these formations, the second and third constitute the Coal Measures in the northern district; the third and the fourth the Coal Measures of the southern area. In both regions the Des Moines series forms the principal coal-bearing deposits. As recently shown in this "Journal," over 96 per cent. of the total coal output of the Trans-Mississippian Region in the north comes from the Des Moines series alone.

The most notable feature connected with the coal-bearing horizons of the south is that they do not lie near the base of the coal measures, or immediately above the Carboniferous limestones (Mississippian), as in the case in the north, but 15,000 to 20,000 ft. above. In western Arkansas, this productive terrane appears to include the Lower and Eastern Coal-bearing Division, the Intermediate Barren Division, of indefinite delimitation, and the chief coals of the Upper or Western Coal-bearing Division. The position of the highest coals of the State were apparently unknown at the time these subdivisions were made.

While some thin seams are known at other levels, the entire coal supply of Arkansas and Indian Territory south of the Arkansas River comes from a terrane higher above the Kaskaskia limestones of the Mississippian than the entire Carboniferous section of Missouri and Kansas. In both Missouri and Arkansas the correlation of the Kaskaskia beds has been determined with accuracy, so that their exact position is known.

The general section of the Carboniferous in Indian Territory presents some unusually instructive features. There is a rapid increase in thickness to the south. The three cross-sections of the coal measures as given by Noah Drake, in his recent reconnaissance of the Arkansas River Region, also indicate a very great thickening to the southward. In his subdivision of the Carboniferous above the Mississippian he recognizes (1) the Lower Coal Measures, (2) the Upper Coal Measures, composed of the Cavanaugh and Poteau groups, and (3) the Permian. From his notes alone, it would be difficult to compare these sections with the Kansas section. Personal observations in the field enable the two districts to be paralleled, so that if Drake's tracings in the field are correct we are able to tell quite closely the relationship that the southeastern sections bear to those north of the Territory.

Drake's correlation is that the Lower Coal Measures of Indian Territory are (presumably) equivalent to the formation of the same title farther north. The Cavanaugh (Kavanaugh) is paralleled with the Missourian up to the Atchison (Waubunsee) shales; while the Poteau is made the representative of the latter and the Cottonwood terrane. The exact grounds for this correlation are not clear, though it is inferred to be chiefly the fossils.

There are cogent reasons for believing that all of the Indian Territory beds are much lower in the stratigraphic scale than Drake has supposed. It has already been shown that J. P. Smith's conclusions that the Poteau Mountain beds were "high up in the Coal Measures," probably in part Permian, was not necessarily correct. It was farther stated that his detailed evidence indicated rather that the beds in question were much lower, possibly as far down as the horizon of the Des Moines series. The data presented by Drake, and partly corroborated by personal examination, point to the correctness of the suggestion.

Where the Cavanaugh Group, as indicated on Drake's map, is extended into Kansas it falls wholly within the boundaries of the Des Moines series. The eastern limits are the same, if the basal sandstone is considered by itself. The upper or western boundary coincides with the lowermost of the Bethany limestones. If the Poteau is rightly traced, it corresponds, in Indian Territory, to the Missourian series of Kansas, up as far as, possibly, the Plattsmouth (Oread) limestone, but certainly not higher. The details of the northern extension of Drake's Poteau are obscure; and it is just possible that the upper limit is more nearly that of the Iola limestone.

If this be the correct interpretation, and it appears that it is, Drake's Cavanaugh Group is almost the exact equivalent of the Des Moines series, minus the basal sandstone of the more northern localities; while his Poteau Group is to be paralleled with the Missourian series below the Plattsmouth limestone. The basal sandstone placed by Drake in his Lower Coal Measures would appear to belong, toward the north, to the Des Moines series, and to the south to a lower horizon than any of that series north of the Kansas line.

In the eastern part of the Territory, south of the Arkansas River, and also in the adjoining parts of Arkansas, the coal-fields have been extensively developed and coal-seams traced for long distances. On account of the wide extent of the coal beds, the various sections in this part of the Territory are readily compared with one another and with those of the neighboring State on the east. There are three notable seams in the Choctaw field—the Grady (Huntington of Arkansas), the McAlester and the Mayberry. Drake's Cavanaugh Group embraces the strata between the Grady and Mayberry coals. The maximum distance between these two horizons is estimated by Drake to be 5,000 ft., though in his general section it is placed at only about 1,700 ft.

When we come to compare H. M. Chance's section with that made by Drake, we find that he places the distance between the two coals at a little over 8,000 ft., which is certainly excessive, as has already been suggested. With the exception of the 1,200 ft. of shale above the Mayberry, or Kavanaugh, coal, and 200 ft. beneath the Grady coal, the whole of the Chance section would belong to the Cavanaugh Group.

J. J. Stevenson has paralleled the section made by Chance with Winslow's section of the coal measures of western Arkansas in his yet unprinted report. It seems impossible to reconcile this attempt with the known facts. A. Winslow states clearly that the Huntington (Grady) coal is near the base of his Poteau stage. This being the case, his six other stages are all below the base of Chance's section.

In this connection it may be said that Drake's Poteau Group is not the Poteau of the Arkansas geologists. Winslow's Poteau stage, and presumably also Branner's, extends upward from the Grady coal horizon to the beds at the top of Poteau Mountain, an horizon near the Mayberry coal. The Poteau formation of Arkansas is therefore practically the exact equivalent of Drake's Cavanaugh Group; while the latter's Poteau lies wholly above the Poteau of Arkansas.

In regard to the lower part of the section it may be stated that what Drake calls the Lower Coal Measures are below the Lower Coal Measures of Missouri and Kansas. The Lower Coal Measures of Indian Territory are very thin at the north and are there merged with the basal sandstone of the Des Moines series. Southward they rapidly increase in thickness, until beyond the Arkansas River they have an ascribed measurement of more than 2,000 ft. In Chance's section of the Choctaw coal-field only the lower 200 ft., out of the entire 10,000 ft., appear to belong to the Lower Coal Measures as given by Drake.

The most complete section of the coal measures of Arkansas is that constructed by Winslow for his unpublished report on the coal of the State. The section has been, however, published by Stevenson. Comparing his earlier section with this one, it is assumed that the Lower or Eastern coal-bearing division corresponds to the Spadra stage, the Intermediate or Barren division to the Sebastian stage, and the Upper or Western coal-bearing division essentially to the Poteau. As the positions of the higher coals in the Poteau were not well understood in Arkansas, it seems probable that the Grady or Huntington coal at the base of the Poteau and the lower coals occurring in the Spadra stage were included in Branner's Productive beds.

The detailed stratigraphic work done during the past decade in various parts of the Trans-Mississippian coal-fields has enabled satisfac-

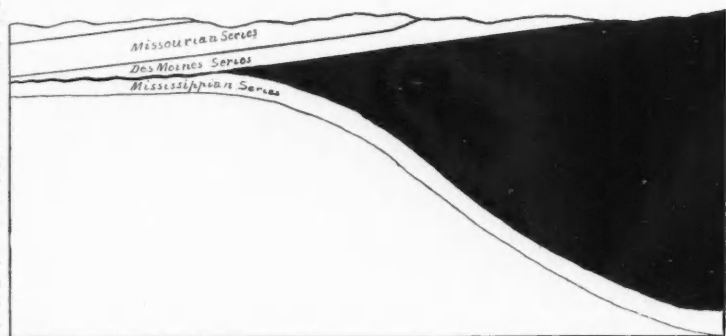

FIG. 1.

tory correlations to be made, without falling back upon the fossils. Various horizons have been traced in the field, so that every portion of the area occupied by the coal measures may now be considered as being very closely connected. From these correlations it would appear that, taking the section of the Missouri River as the standard, the serial subdivisions are readily followed around the great dome occupying southern Missouri and northern Arkansas.



According to the accumulated stratigraphic evidence, there begins south of the Kansas boundary a formation having no representative terrane in the north. This formation rapidly gets thicker and thicker southward and eastward, until it attains the enormous vertical measurement of 20,000 ft. This great terrane, composed almost entirely of shales and sandstones, lies entirely below the basal horizon of the Des Moines series (Lower Coal Measures) of Missouri, but is above the Mississippian limestones.

The Des Moines series of Missouri appears to have its almost exact equivalent in Indian Territory in the Cavanioi Group, and in Arkansas in the Poteau Division. The Missourian series up to perhaps the horizon of the Plattsmouth limestone may correspond to the Poteau Division of Indian Territory (not Poteau of Arkansas).

The great Arkansan series, with its enormous thickness of strata, is represented in the north by the hiatus at the base of the coal measures of that region, marked by an unconformity that is well displayed in many points. The development of the several series of the Carboniferous of the Trans-Mississippian Region are perhaps more clearly represented by the accompanying diagram (Fig. 1):

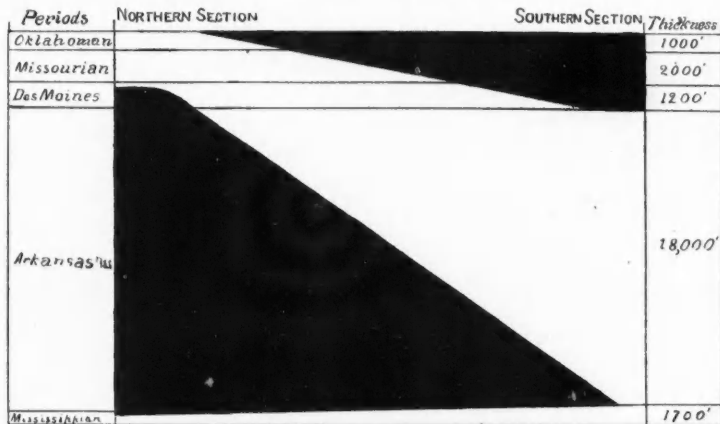

FIG. 2.

In Fig. 2 the relative development of the two regions as compared with the general section is shown:

The Des Moines series is therefore pre-eminently the coal-producing formation throughout the entire Trans-Mississippian field, notwithstanding the fact that it is in the south so many thousands of feet higher, apparently, in the geological scale.

MICHIGAN LIMESTONES AND THEIR USES.

Written for the Engineering and Mining Journal by A. C. Lane.

(Continued from page 663.)

Next above these beds come beds which contain more calcium carbonate; in fact, I have drawn the line between the upper and lower Helderberg so as to make it coincide with the division between the limestones of the upper Helderberg and the dolomite of the lower Helderberg. This difference in chemical character appears quite uniform throughout the State, as is shown by very numerous qualitative tests on drill borings as well as the analyses given. The upper Helderberg or Corniferous limestones are one of the important horizons of the State, which I think will be even more developed in the future. The most extensive quarry is that of the Sibley Quarry Company, of Detroit River, in the south part of Wayne County. These are controlled by the Churches, soda ash people, who originally planned to manufacture soda ash here, but who have probably got a better thing in their limestone quarry than the manufacture of soda. The drillings here show clearly and sharply by the sudden rise in magnesia, the line between the lower Helderberg, and the very best beds run over 98 per cent. of lime. A section of the quarry will be about as follows:

- A. 6-ft. bed of limestone, thin layered, very fossiliferous and a very high grade limestone.
- B. 7-ft. bed, 2 to 11 in. thick, more coarsely crystalline, somewhat pyritic, not so conspicuously fossiliferous.
- C. 2-ft. bed of limestone with much cystiphyllium.
- D. 5-ft. bed of limestone with a deposit of black carboniferous material full of crinoids and bryozoa.
- E. 6 ft. limestone, almost a solid mass of crinoids, joints, bryozoa, corals and brachiopods. Between D and E there is also a carbonaceous deposit.
- F. 14-in. bed, mainly of chert, which contains only 3 per cent. or so of Ca CO<sub>3</sub>. Analysis of a number of chert beds gives as an average analysis the result below.
- G. 6 ft. limestone, light gray and full of crinoids.
- H. 2-ft. bed of chert about 30 in. thick, very friable, of a hard, ringing, impure matrix, sent to the crushers.
- I. 9 ft. pure limestone supposed to be the best bed of the quarry and frequently runs over 98 per cent. of calcium carbonate.
- J. 6-ft. "magnesium" bed. It is "magnesium" only as compared with I, for it is really a fairly pure limestone, but not so pure as I.
- K. 8-ft. bed of limestone, full of the usual fossils. A thin bed as exposed and good for lime or building purposes.

Prospect holes sunk from bed I show limestone and for 40 ft. down calcium carbonate runs from 81 to 93 per cent., magnesia from 2½ to 16 per cent. and silica from 0.73 to 7.24 per cent. Below this we find a sudden drop in the per cent. of calcium carbonate, which runs from 54.27

to 70.54, while the magnesia carbonate runs from 23.49 to 43. The silica is generally less, from 0.29 to 1.05.

All through this region we find the distinction between the upper Helderberg of high per cent. Ca CO<sub>3</sub> and the lower Helderberg or Monroe beds, with low per cent. I may say that in general at Monroe there is about 50 per cent. of calcium carbonate, at Gibraltar and Grosse Isle 62 per cent., at Newport and Brest somewhat higher, about 80 to 84 per cent., and at Amherstburg, 92 per cent., while the Sibley quarry probably runs best of all with 94 to 98 per cent. of calcium carbonate. The 9-ft. blue bed can, it is said, be so picked as to give 98 per cent. guaranteed at each shipment. The beds lower in calcium carbonate are useful for macadam, lime, building stone and other purposes, while the beds high in calcium carbonate are reserved for chemical purposes.

These high-grade limestones are widely in use in the State. In the process of manufacture of soda ash from salt we have practically the fundamental equation 2 Na Cl + Ca CO<sub>3</sub> = Na<sub>2</sub> CO<sub>3</sub> + Ca Cl<sub>2</sub>. This reaction is not one that will take place spontaneously and the several methods by which it is performed have been treated in "The Mineral Industry" in discussing the alkali industry. More than \$10,000,000 capital has been invested in the alkali business in this State of late years. The region along the Detroit River is very well suited for this industry, for it is on the water, has ample railroad facilities, has the high-grade limestone of the Sibley quarry and by boring 800 ft. or more down an indefinite supply of rock-salt can be obtained. Some of the beds are of great thickness, as is shown by the well record of the well at Royal Oak, given in Volume 5 of the Michigan reports. The only well of which we have an accurate record, which has passed clear through the salt, is that at Wyandotte, which is reported in the same volume. Suffice it to say, that between 800 and 1,500 ft. down there is a very large supply of rock-salt.

The above use of the limestone is so extensive that the calcium chloride becomes a waste product which is manufactured faster than it can be used. Instead of calcium chloride the Fords at Wyandotte—the Michigan Alkali Company—produce cement as a by-product. The Solvay Process people, who are manufacturing soda at the old Exposition grounds in Detroit, are using the chloride of lime to make land and redeem a marsh, known as Zug Island, into good property. Calcium chloride will harden after some months and it is the base of a number of artificial stones. It is also employed in refrigeration, as calcium chloride can be circulated through pipes at a very low temperature with no danger of freezing.

But this is not the only use for this limestone. Michigan has within two or three years leaped into prominence as a producer of beet sugar. It has just the right climate, and many of the hard lake-clay soils with a light coating of sand on top have just the right character for the growth of sugar beets. There is also a good German population who are not afraid of hard work and make good growers of the beets. Consequently we have a number of factories established at Kalamazoo, Rochester, Alma, Bay City and elsewhere, and they have very largely depended on the Sibley quarry for their supply of calcium carbonate, which is separated into the constituents, quicklime and carbon dioxide, and used in clarifying the beet juice. Michigan is also a large producer of calcium bromide and this also requires a high-grade limestone.

For this purpose, magnesia, silica, alumina are less injurious than iron, which should not be over 0.25 per cent. if possible.

Very much the same limestone beds as those of the Sibley quarry are exposed on the Macon River, and have been quite fully described by Rominger and Sherzer. The drainage and transportation facilities of these quarries are not as good as at the Sibley quarry.

When we pass to the northern part of the State we find indications of the same contrast of limestone and dolomite between the upper and lower Helderberg. But in this northern part a group of rocks, not conspicuous in Wayne and Monroe counties, are important. They correspond to the Hamilton group of New York. Normally, this is a group of blue calcareous and argillaceous limestones, but between Alpena and Petoskey it is very much thicker than elsewhere and has considerable variety in its layers, some of them being extremely high-grade limestone, others dolomitic, while others are more shaly. It is probable that in this series one could find beds suited to almost all purposes to which limestone is put. The Bolton limestone from this group appears to be dolomitic and Rominger gives two analyses of dolomitic beds.

Analyses show some beds which are extremely high in calcium carbonate, and over on the other side of the peninsula, 7 miles west of Petoskey, the limestone made by E. R. Sly, the Petoskey Lime Company, as the Petoskey standard lime, is said to have the following analysis: Calcium carbonate, 91.25; magnesium carbonate, 4; alumina, 4.74. Other specimens which I took around Alpena gave the following results: Calcium carbonate, 95.4; magnesium carbonate, 1.76; insoluble, 1.1; loss (organic, etc.), 1.74; total, 100. The Dow Chemical Company report from three samples:

	I.	II.	III.
Silica .....	3.18	4.01	2.51
Ferric oxide and alumina.....	1.43	2.20	1.90

I have also seen analyses of limestone for use in the sulphite wood fiber process, from around Alpena, which ran up to 94 per cent. of calcium carbonate. So that there can be no doubt but that high-grade limestone exists in this region. Many good beds, like the Encinal limestone of New York, are full of fragments of crinoids and other echinoderms which show the cleavage facets of calcite. At Alpena at 1,200 ft. depth, rock salt is said to have been found, and so we have reproduced here the conditions for soda manufacture which exist on the Detroit River. On the west side of the peninsula, from St. Ignace south, rock salt does not seem to be so abundant. The Alpena Portland Company proposes to grind the better and softer grades of limestone and mix them with the proper proportions of clay or shale to give the correct proportions for Portland cement. The better and purer beds resemble the Encinal limestone, being made up of crinoids.

Above the limestones of the Traverse series, there are no more limestones of commercial importance until near the top of the geological column. There are, to be sure, nodules of lime in the Devonian black

shales which are quite pure carbonate of lime, with some organic matter, and in the shales of the Marshall or lower carboniferous, we find nodules of carbonates, which are mainly carbonates of iron. They have been suggested for use from time to time, in the manufacture of iron, but it is very doubtful if they are anything commercial.

When we get up higher into the Michigan series, in which the famous gypsum beds occur, at the level of the Burlington and Keokuk of the Mississippi Valley, we find limestone again. This time it appears very much like the rock cement of Milwaukee, and although it has never been developed for this purpose, we do not doubt that a fair quality of rock cement could be made from it, though it has too much magnesia; Portland cement will probably replace rock cement in Michigan. The most promising places to investigate this limestone are in the neighborhood of Grand Rapids, in the gypsum quarries, and along Saginaw Bay, in Iosco, Arenac and Huron counties, and in the valley of the Cass near Cass City.

(To be Concluded.)

#### THE "CROWN" DRY CONCENTRATING SYSTEM.

The accompanying illustration is a sectional view of a concentrator of a type which is now manufactured by the Crown Gold Milling Company, of San Francisco. The system introduced by this company is one of dry crushing and concentrating, which may be briefly described as follows:

In the Crown dry ore milling process the ore is first passed through the rock breaker; thence it passes through a series of rolls carefully gauged to give pulp of the desired fineness and without grinding or crushing the sulphides to a sliming powder. The pulped ore is conveyed by a carrier belt to the sizer, which consists of a dust-tight box containing screens of from 40 to 180 mesh; the mesh sizes can be varied to suit particular ores. By a simple mechanism, and a small expenditure of power, the sizer is given a rapid oscillatory motion, and each screen discharges its special sized grains into a separate bin. An automatic attachment takes assay samples from the separate discharges at regular intervals. In the sizer the ore particles have been rearranged and classified from: (1) Bodies having unequal sizes but

The sulphides saved, it is claimed, will be from 85 to 95 per cent. of the total quantity contained in the ore, even though such sulphides should be those having the greatest tendency to slime. In purity, or freedom from worthless matter, the concentrates will reach 90 to 95 per cent. The most perfect rolling or crushing will leave some grains of matrix with adherent particles of sulphides or free gold; these will pass over into the concentrates, and, to this extent, debase the product. Every millman will readily understand what this high degree of purity means in the saving of freight and reduction of charges.

Numerous assays have established the fact that in very many cases the major portion of the valuable contents of ores, or sands, will be found in a well-defined series of the classified particles. In some ores these values will be in the coarser series; in other ores they will be found in the finer series and in still other ores in the intermediate series. As assay tests are taken at the sizer, only those sizes carrying value are put through the concentrator. The worthless sizes are consigned to the waste dump; thus there is usually a large amount of material upon which no further expense is incurred.

Among the sizes showing values it will be found that one or more of these carry the bulk of the sulphides, while the other sizes will carry the larger percentage of free gold in ores. Those sizes carrying free gold will give much better results when treated after concentration,

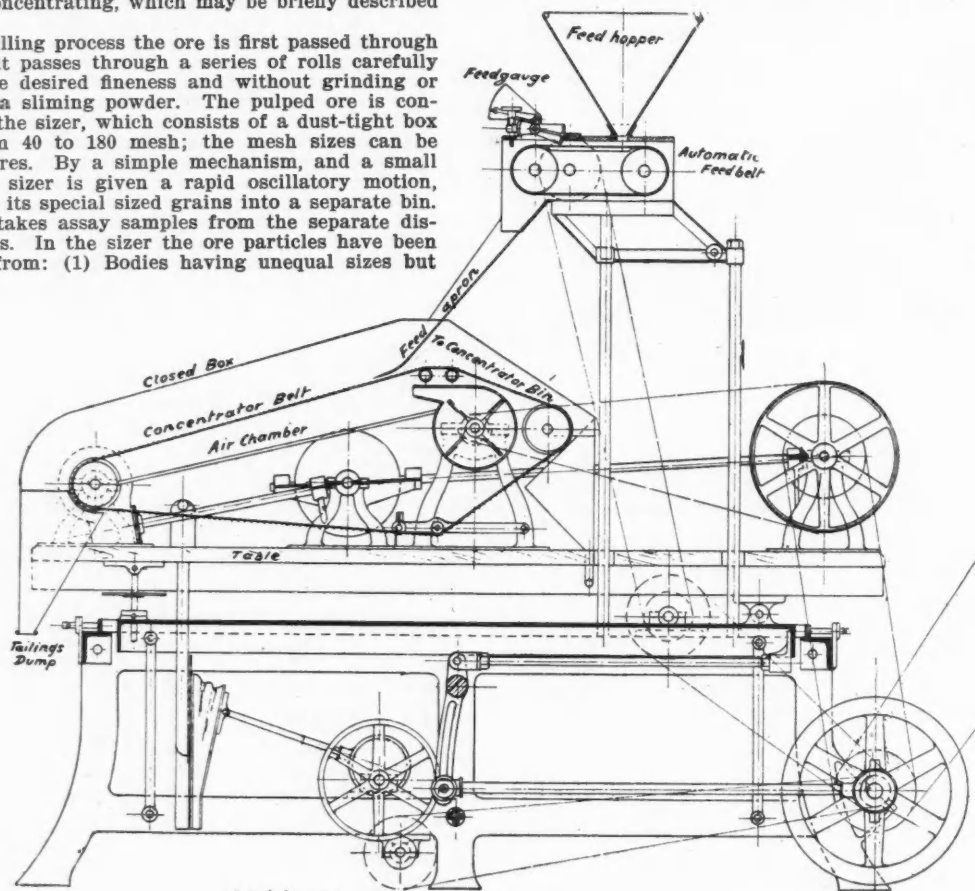

Skeleton view of Concentrator.  
CROWN DRY ORE CONCENTRATOR.

equal falling weights, into (2) bodies having equal sizes but unequal falling weights.

From the sizer bins the assorted particles are taken to the concentrators by carrier belts, each size grains being concentrated separately, but all of the concentrates are delivered into one receptacle and all of the waste is discharged into one dump, unless for any reason it is desired to keep the sizes segregated.

The concentrator consists of a woven corrugated belt travelling through a closed box, having an air chamber under the superior portion of the belt. The concentrator box is fastened to a shaking table to which is given a vibratory motion sufficient to keep the ore particles actively vibrating on the belt and insure perfect concentration. The concentrator belt travels equal distances in equal times and a very perfect device eliminates all slippage. The travel of the belt can be quickly varied and the table elevated or depressed as may be best suited to obtain the most profitable results from the different sized ore grains being concentrated. At the head, or elevated end, of the concentrator is placed a blower which discharges the air horizontally into a chamber under the corrugated belt. This air pressure may be regulated from an ounce to the smallest fraction of an ounce to each square inch of belt surface, as may be found most suitable to the gravity and size of ore grains. The air pressure can relieve itself only through the interstices of the woven belt; as this belt is running at an angle of 15°, more or less, the horizontal air column strikes it at an acute angle and passing through the belt deflects the slower moving light and worthless grains from the perpendicular, causing them to travel toward the lower or waste discharge, while the heavier and valuable particles being unaffected by the air current are carried by the belt to the upper or concentrate discharge.

and a larger value recovered than if treated while associated with the sulphides; and the loss of free gold floated away by the slimes, or the loss of mercury and amalgam by being scoured, sickened or floured, and carried off in the tailings is reduced almost to zero.

The ores are handled automatically from breaker to waste dumps. A limited personal supervision is necessary, to attend to such details as stopping, starting, and regulating machinery and air currents, feeds, elevation and action. The feeds are so adjusted that absolute precision and uniformity are assured. When the machines are in action, the floating dust particles are absorbed by a dust collector, much to the comfort of the millman and the increased longevity and cleanliness of the machinery.

It is claimed that the cost of the Crown plant is moderate and the space occupied much less than that required for a stamp mill and wet concentrators.

A plant having a capacity of 100 tons a day is now in course of erection at the Mayday Mine in the Tintic District in Utah. The system will be submitted there to a thorough practical trial.

BRITISH IRON AND STEEL EXPORTS.—The exports of iron and steel from Great Britain for the four months ending April 30th were valued by the Board of Trade returns as below:

	1900.	1901.	Changes.
Iron and steel.....	£11,148,013	£8,132,816	D. £3,015,197
Machinery .....	6,490,221	5,802,823	D. 687,398
New ships .....	1,735,289	4,072,928	I. 2,337,639
Totals .....	£19,373,523	£18,008,567	D. £1,364,956

The large decrease this year was partly in quantities but to a greater degree in values.

## MINING AMONG THE MOROS IN THE PHILIPPINES.

Written for the Engineering and Mining Journal by "Manila."

Your correspondent has been down among the people of the Moros country and visited a number of mining enterprises which are paying exceedingly well. The Moros have always had a sort of piratical record and this has prevented many miners from going to this section of the Philippine Archipelago. I did not observe that the people were any more dangerous or uncivilized than the majority of people in the islands. The average Moro does not as a rule wear even as much clothing as the Tagalog or Bisayan, and he appears to be better equipped with weapons of war. Nearly every inhabitant of the Moros country carried some sort of a large knife or dagger-spear. The women seemed to be working at the various industries in the fields, shops and hills and the country flourishes. As to the mining interests, these may be developed in the course of a few years to large proportions, for all of the American and other foreign prospectors agree that there are numerous rich deposits of metals to be had and at present quite a number of Filipino miners as well as others are securing good returns from the mines now in operation. The native inhabitants have always been satisfied to work the mines in the crude, old-fashioned way and such mines as have been opened have proven limited in supply of ores for this reason. With the introduction of new methods and machinery, wonderful changes would be brought about.

Probably the most interesting mining now in progress on this portion of the Philippine Archipelago is that of copper. The copper mines are being worked wherever outcrops of copper are found for the reason that copper is most wanted. There are many persons in the country looking for samples of copper, and these will buy up any copper ores for shipment to America. The Filipino and Chinese miners have crude ways of getting the copper. At one place I saw that they were pounding large pieces of the copper-bearing rock into crumbs on anvil-shaped metals. Then they ran the smaller pieces through iron rolls, reducing the quartz to finer proportions. These rolls were stone in some places, arranged in disk form at times, and turned by means of water buffalo. At another place they had erected large furnaces for creating intense heat for ovens in which the copper-bearing rock was placed, and when the rock became reduced to a condition which made it soft and crumbly, the natives removed it and pulverized it. The copper deposits could then be separated. Smelting furnaces were erected in some places and used with good results in getting copper. The Americans have not made much headway in this section, and the writer saw only a few at work. The English have been operating among the Moros for some years, but have not as yet established any mines. The Germans are here and some of them are running paying mines. One German concern is interested in the development of one of the native towns, in which its mining operatives live, and this town has been graded, drained and put into very good order. The German concern gets hundreds of competent native miners at the rate of a few cents per day each.

The Moros have mined for gold for years. The old chiefs have an abundance of the yellow metal. I saw large ornaments in the nipa shacks of some of the chiefs. Idols for purposes of worship, large spear heads, bolo handles, and the like, are frequently of gold. One chief gave me a gold device which I found to be worth \$60. The Moros do not know the value of the gold and often exchange large nuggets for ordinary articles of merchandise. I have seen pieces of gold worth \$5 and \$10 exchanged for a campaign hat worth less than \$1 or a garment. Stationery, beads, ribbons, colognes, brushes, etc., are readily exchangeable for gold. The profits to the persons effecting the bargains are often much greater than could be made by actual mining. Therefore when one meets a party of so-called miners, they often prove to be merely traders with the natives for the valuable metal. I went to the interior with a party of prospecting engineers, and although we were told that we were taking our lives in our hands, I observed only peaceful natives in some places, while in others the natives fled upon seeing us. I recollect seeing a whole town taking flight, including police force and many armed and full grown natives. They returned later. We visited one gold mine which had been operated with success for 40 years by the Moros and the owners had made money. They told us that the Spanish had driven them from the mines many times and that the losses had been heavy as a result. The Spanish would secure some of the products at each raid. We prospected for many days and found color in many pits in the interior. Gold evidently exists in paying quantities. We secured good specimens without going down to bed rock. Some of our samples are in flakes, and very nearly pure. I saw some mines in which the work had been suspended for years and large trees were growing in the works, although the remains of the mining outfit could be seen. The military officials and the soldiers are in position to secure good samples of gold product from among the mines in the Moros country. Some of these men showed me excellent specimens. At the Bay of Illana and east of there, many mines are reported in paying condition.

There are silver mines in the Moros country, this having been proven by the quantities of silver ores which have been brought to the coast by the natives and by foreigners engaged in the mining enterprises. A number of prospecting parties have canvassed the country with a view of determining the precise conditions and chances for the development of silver mines. The Philippines are a great country for the use of silver ornaments and most of the silver produced in the mines finds ready sale. The silversmiths do a good trade in all the cities and towns. The native smith has a very poor outfit with which to work, but he manages to produce some very fine pieces of silver ware both for personal wear, the church, and for utensils for home use.

The Church consumes considerable of the silver output in ornaments. In some of the Filipino churches I noticed that the trimmings about the altar were of silver, the value being enormous. In the Moros the natives lack entirely the mechanical equipments for mining and even use their hands for removing the earth, stooping down and scooping it out. A plain stick with a sharpened point is the pick. A heavy stone

slugged to the end of a hemp handle of twisted strands forms the rock-breaking instrument in mines where they have no metal sledge hammers. Yet, in spite of all of these difficulties, the natives take things coolly and manage to procure considerable silver.

It is well known that iron ore exists in paying quantities in some of the islands of the Philippines, but the writer understands that the iron mines of the Moros have not received much notice from the world outside. He was much surprised upon arriving in the Moros section to be shown some very good specimens of the iron ores secured by the Filipino, Chinese and foreign miners. The specimens he saw contained from 60 to 70 per cent. iron. So far as he could find out, none of the iron mines are worked steadily. Most of the mines have not been worked for nearly a century, but quite recently certain individuals have opened a shaft and worked it long enough to procure a quantity of ore for home use. There are not many iron foundries in the islands, still there are enough to keep a number of mines in operation. There is a great shortage of iron all through the Philippines, and once an iron producing mine is started the owners will derive rich returns. I know of many concerns in Manila and Iloilo who make a business of buying up old iron and steel tires, building trimmings, and rejected machinery solely for the purpose of furnishing metal to the foundries. The foundries make plow points, vehicle fixings, castings for house and bridge building purposes, pipes for drainage and the like. Molding sand is found in the islands. The need of iron is greatly felt all through, increasing with American occupation and the development of industries. There are machine builders arriving here for the purpose of putting in shops for building machinery, and the first thing that these men ask about is the supply of pig iron. The commanding officers of the military posts which have been established throughout the islands are looking into this question of developing the iron mines.

Mining in the Moros can be continued steadily throughout the year if desired. There are some portions of the islands in which the rains are excessive for mining operations during certain periods, but in the Moros section the rainfall is usually moderate. Old miners tell me that the climatic conditions in the Moros are good for mining and that the mines can be run constantly.

Labor in the Moros section is very like that of the other portions of the archipelago. I saw numbers of the natives working in the mines and most of them appeared to be doing well. The natives are well built, strong and adapted to rough work. The Chinese coolies are in all of the mines, mixed in with the Filipinos. I also saw a few Americans, the majority being discharged soldiers or teamsters, acting as foremen or mechanical engineers. There is a good field for mining engineers here in starting up, directing and managing mines for rich natives. I know of several men who were mining or mechanical engineers when they enlisted in the army, and after serving their enlistment, engaged with the owners of mines and are now doing well. Any American with mechanical or engineering knowledge can do well here among the Filipino or Spanish mine owners, for the Spanish have great faith in the management of the Americans. The Filipinos are bungling machinists themselves and do not know much, as a rule, about steam power plants or mining machinery. I have, however, seen Filipino engineers and machinists doing well under the eye of an American who trained them. After they are gotten into line in the right way, the Filipinos are capable so long as they are held to that special work. If changed to a new machine or duty, a new start in instruction under the personal direction of the foreman or superintendent must take place.

Finally we have the transportation in the Moros section to consider. Like other sections of the country, the roads have all been in very bad shape for many years, but are now rendered passable for light and heavy transportation by grading the low places, bridging the rivers and streams and putting into shape portions of the road-bed which for years have hindered the development of the country and the movement of freights. The present miners in the Moros country find but little trouble in securing transportation of their products to the sea coast cities and towns for shipment. The water buffalo are commonly employed in carts or sleds for hauling purposes. In some places they use pack horses. I have seen the little trotting bulls of the country used for pack animals and they do good work, getting over the ground with good speed and seldom giving out during the journey. I have also observed that the natives themselves often do the packing of ores, and it is remarkable what loads they can carry. They make the load into two packs, in split bamboo plaited mattings, and suspend a mat at either end of a stick carried across the shoulders. They travel 14 and 15 miles per day with these loads, usually moving at a trot.

## ABSTRACTS OF OFFICIAL REPORTS.

## Isle Royale Copper Company, Michigan.

The report covers the year ending December 31st, 1900. The financial statement shows: Balance on hand January 1st, \$1,486,449; interest receipts, \$24,104; total, \$1,510,553. The total expenses during 1900 were \$677,811, leaving a balance on hand December 31st of \$832,742. Of this amount \$299,570 is due from the receiver of the Globe National Bank. Since December 31st, 1900, \$59,914 of this has been paid by the receiver.

The superintendent's report shows that the total drifting done during the year was 12,920 ft. The total length of drifts completed at the close of the year was 22,194 ft. During the year No. 1 shaft was sunk 206 ft. and No. 2 was sunk 235 ft., entirely on the lode. At No. 1 shaft a steel rock-house 44 by 64 ft. was erected, and two rock-breakers put up; also one 12 by 24 Corliss engine to drive rock breakers, etc. A coal trestle and storage platform with capacity of 4,000 tons was built in connection with No. 1 boiler house. A tunnel under entire length of storage platform will help the economical handling of coal to boiler house. At No. 2 shaft, work done at No. 1 shaft has been duplicated. The steel rock house on masonry foundation is completed, and breakers and engine, same as No. 1, in place. The main hoist for No. 2 shaft, a direct 32 by 72 hoisting engine with steam reverse, steam brake and

turned conical and cylindrical drum, was erected complete and placed in commission. It was built by Nordberg Manufacturing Company of Milwaukee, and is a duplicate of No. 1 hoist. A cross-compound two-stage air compressor 20 by 40 by 44 in. and 35 by 22 by 44 in. was also installed in No. 2 engine house. This machine is capable of supplying air easily to forty drills. A dam was built to hold condensing water for this compressor. No. 2 boiler house, duplicate of No. 1, was completed, and three 84-in. boilers, feed pump and fire pump installed.

A new machine shop, 40 by 60 ft. was built at mine. A steel mill building 210 by 135 ft. for three heads of stamps was erected complete, and installation of machinery is now under way. The dock and railroad were completed ready for work.

#### Mason & Barry, Limited, Portugal.

This company owns and works the San Domingos Mine in Portugal, a large deposit of copper-bearing pyrites. The report is for the year ending December 31st, 1900. The mine assets and appurtenances at the close of the year were valued at £47,011; supplies and cash assets, £14,041; stocks of ore, etc., £80,943; total assets, £141,995. The ore stocks were made up as follows: Cost of ore at cementation works, £42,880; ore ready for shipment, £26,893; copper precipitate, £11,170; stocks in England and the Continent, £18,167; total £99,110.

The directors' report says: "The total quantity of ore broken and raised at the mine during the year 1900 was 117,714 tons, as against 126,841 tons in 1899, and the shipments during the same period (in-

#### A NEW COAL CONVEYOR PLANT.

The accompanying illustration shows a coal conveyor designed to meet somewhat difficult conditions. It was recently installed by the Robins Conveying Belt Company, of New York, at the works of Jones & Laughlins, Limited, in Pittsburg, to carry coal from the river front to the coke ovens. The amount of coal conveyed daily varies from 2,500 to 3,000 tons and as the elevator and conveyor can easily handle 500 tons per hour, the daily consumption of the 1,000 coke ovens dependent on the system can be cared for in a single shift, including the time lost in shifting boats and other similar delays. The quantity of coal handled daily is very large and the cost of the work done very low.

The elevator consists of a double row of steel buckets each measuring approximately 4 ft. long by 2 ft. wide and 2 ft. deep and these buckets, 70 in number, are attached to a steel chain. The elevator is supported at its head and foot on a boom which is moved in an inclined plane by an electric motor and in this way its position can be adjusted to any stage of water. Another motor drives the chain and a third warps the coal barges into position and moves them along under the elevator as fast as the coal is removed. Through these three motors one man operates the entire system, controlling the working of the elevator and shifting the boats with perfect ease. This elevator was designed by Jones & Laughlins, Limited, and built at their works.

At the head end of the elevator the coal is delivered to a Robins

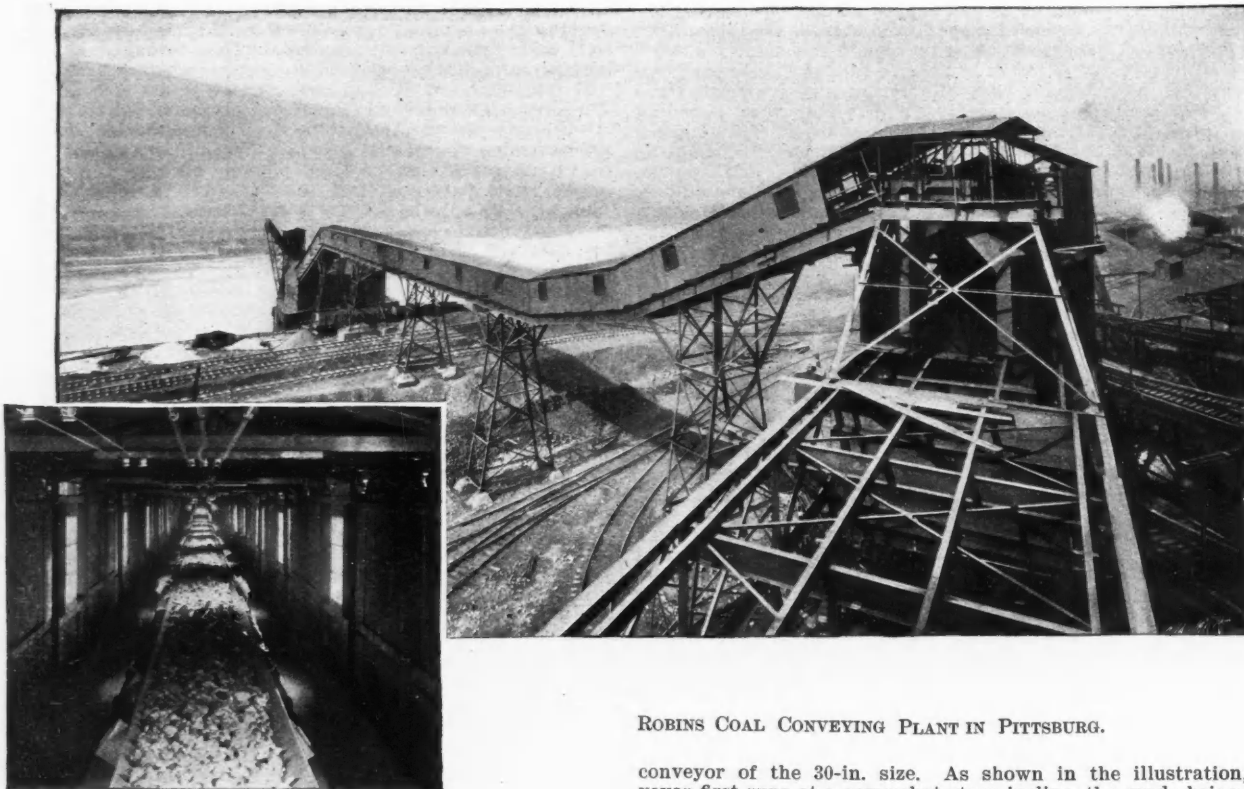

ROBINS COAL CONVEYING PLANT IN PITTSBURG.

conveyor of the 30-in. size. As shown in the illustration, the conveyor first runs at a somewhat steep incline, the grade being 20°. After reaching a sufficient height the conveyor runs horizontally, crossing several railroad tracks, including the main line of the Baltimore & Ohio Railroad, over which it passes at a height of 24 ft. Near its inshore end it takes an upward curve and on reaching a height of 63 ft. delivers its load to another similar conveyor running nearly at a right angle to the first. This conveyor is 250 ft. between centers. The second conveyor delivers the coal into three hoppers distributing it equally between them and automatically ceasing to deliver into a hopper as soon as it is filled. This is accomplished by means of trippers and an arrangement of chutes designed by the builders, the Robins Company. Both conveyors are driven at the end where they receive the load and not at their head ends as one would expect. By this arrangement the motor of the long conveyor is located in the house, which also contains the elevator motors, and this concentration of the power plant is of undoubted convenience.

#### RECENT DECISIONS AFFECTING THE MINING INDUSTRIES.

Specially Reported for the Engineering and Mining Journal.

clusive of ore from the cementation works) amounted to 394,740 tons, as against 339,298 tons in the previous year. The quantity of ore sold and invoiced for its sulphur value during 1900 amounted to 392,813 tons, as against 332,452 tons in 1899. The average price of standard copper during 1900 was £73 12s. 6d. as against £73 13s. 8d. in 1899, and £51 16s. 6d. in 1898. After writing off in the mine books for depreciation of works, plant, etc., the sum of £15,746 and allowing for the variation in the estimated value of the stocks on hand in Great Britain, on the Continent, and in Portugal on December 31st, 1900, and after deducting management expenses and income tax, the net profits on working account have amounted to the sum of £106,250, to which has to be added the sum of £8,310 received as dividend on La Sabina shares, and the sum of £5,665 from sundries, making together a total profit for the year of £120,225. To this has to be added the balance, £6,300, brought forward from the year 1899, making together the sum of £126,525, and the directors having written the sum of £2,500 off La Sabina shares, there remains a balance for appropriation of £124,025. From this balance the directors recommend the payment of a dividend of 12s. 6d. per share, the appropriation of £1,000 to the staff pension fund, and to carry forward the sum of £7,292 to account of 1901."

**CASPIAN-BLACK SEA CANAL.**—United States Consul Hughes, of Cobourg, April 12th, 1901, informs the State Department that a canal to unite the Caspian and Black seas is under consideration. The projected waterway will be 22 ft. deep and about 150 ft. broad; will begin at Astrakhan, on the Caspian, and end at the harbor of Taganrog, on the Sea of Azof. It is estimated that the cost will be about 40,000,000 rubles (\$20,600,000). The center of Russian trade and manufacture, adds the consul, is gradually shifting southward, where the production of iron, coal and petroleum is rapidly increasing. The metallurgical industries and the trade in cotton from middle Asia are also being largely developed. The railroads at times prove insufficient carriers, and the construction of other roads and the digging of this canal will be necessary in the near future to meet the growing demands of commerce.

**PAID-UP STOCK IN MISSOURI.**—A note from Jefferson City, Mo., says that the Trinidad Mining and Development Company, of St. Louis, was ousted of its franchise in an opinion by Chief Justice Burgess of the Missouri Supreme Court May 21st. This opinion is of importance to corporations. The writ of ouster against the company was asked by Attorney-General Crow on the ground that the company made false representations when it secured its articles of incorporation from the Secretary of State. In the application for a charter it alleged that the company had a capital stock of \$90,000, all paid up. In its answer to the suit for ouster it admitted that the amount was not in cash, but was in an option in mining lands in Mexico valued at \$90,000. The lower court gave the judgment for the defendant, which the Supreme Court reversed. Orders were given the Circuit Court to enter a judgment of ouster.

MINERAL COLLECTORS' AND PROSPECTORS' COLUMN.

(We shall be pleased to receive specimens of ores and minerals, and to describe and classify them, as far as possible. We shall be pleased to receive descriptions of minerals, and correspondence relating to them. Photographs of unusual specimens, crystals, nuggets and the like, will be reproduced whenever possible. Specimens should be of moderate size, and should be sent prepaid. We cannot undertake to return them. If analyses are wanted, we will turn specimens over to a competent assayer, should our correspondent instruct us to do so, and send the necessary money.—Editor E. & M. J.)

351.—Some Blowpipe Tests.—In the "Journal" of the American Chemical Society, Joseph W. Richards says that the closed tube tests may be made quantitative for approximate determination of water, volatile sulphur, etc. A weighed amount of material is put into the tube, tapped down and heated regularly. The upper part of the tube, containing the sublimate, is then nicked with a file and broken off. In determining water a small cork in each end of the piece will prevent evaporation. The piece and the sublimate are weighed, the tube heated until the sublimate is driven off and then heated again. Results on pyritic ores have proved satisfactory. A piece of goethite gave 10.28 per cent. water; theoretically required, 10.11 per cent. Time, 5 minutes.

In open tube tests the behavior of the antimony coat is uncertain. Sometimes the entirely volatile oxide  $Sb_2O_3$  is the only product without a trace of the non-volatile  $Sb_2O_5$ . This has been observed with allemonite, dyscrasite and ullmanite. It takes nearly a red heat to volatilize this coating and if the upper end of the tube from which the vapors are escaping be held in the flame, the latter is colored pale yellowish green, while arsenic gives a pale blue. In making open tube tests any substance not giving a sublimate from lumps should be powdered and be heated from the outside with the blowpipe flame as hot as the glass will stand. Some sulphides, as argentite and sphalerite, do not roast until thus heated.

An excellent flame test for phosphoric acid is to touch the assay on the platinum wire while hot to concentrated sulphuric acid and bring it into the outside edge of the Bunsen flame as slowly and as low down as possible. The flame is slightly bluish green close to the wire, grayish green a short way off and yellowish green farther off. Phosphorus can thus be infallibly detected in any combination.

When testing similarly for boron the assay should be held slightly higher, in a hotter part of the flame. When testing for boron with Turner's mixture it is an advantage to moisten the mass to a paste with a drop of concentrated sulphuric acid and put it moist into the edge of the flame.

QUESTIONS AND ANSWERS.

(Queries should relate to matters within our special province, such as mining, metallurgy, chemistry, geology, etc.; preference will be given to topics which seem to be of interest to others besides the inquirer. We cannot give professional advice, which should be obtained from a consulting expert. Nor can we give advice about mining companies or mining stock. Brief replies to questions will be welcomed from correspondents. While names will not be published, all inquirers must send their names and addresses. Preference will, of course, always be given to questions submitted by subscribers.—Editor E. & M. J.)

The Herbertz Furnace.—Can you inform me if any practical results have been obtained with the furnace for treating various metals invented by F. A. Herbertz, of Cologne, Germany, and what the capacity of the furnace is?—A. M. N.

Answer.—We have not recently received any information about the furnace you refer to. Perhaps some of our readers may be able to answer the question.

Antimony Ores.—Will you kindly give me some information regarding the market for antimony ores and the price paid for same.—E. J. M.

Answers.—The only concerns in the United States which treat antimony ores are Matheson & Company, of New York, and the Chapman Smelting Company, of San Francisco. Both of these are under the same control. The market for antimony ores is therefore closely limited, and it is impossible to quote prices.

Cadmium.—What is the value of cadmium ore which assays 10 to 40 per cent. cadmium? Where is cadmium ore treated?—H. T.

Answer.—There is no demand for cadmium ore at present. The production of the metal has exceeded the demand for some time. The cadmium produced is made chiefly in Silesia (Germany) where the metal is found in connection with zinc. The Silesian smelters could increase their production very largely if there was any demand for the metal.

See the "Engineering and Mining Journal," May 4th, 1900; also "The Mineral Industry," Volume VIII.

Diamond Drill Prospecting on Claim.—Does prospecting work done by diamond drill count as labor expended either for purposes of assessment work or for patent?—C. T. R.

Answer.—Judging by analogy, diamond drill work ought to count just as much as any other exploration work, either for assessment work or for patent. The question might depend somewhat on local custom or State laws. We believe that the General Land Office has never passed upon this question definitely. Diamond drilling, however, would seem to come under the definition of "work done or improvements made."

The safest course would be to make up a case and present it to the General Land Office for decision.

Separating Wolframite from Cassiterite.—Can you tell me whether there is any plant in existence for separating tungsten ore (under the form of wolframite) from tin ore (under the form of cassiterite)? If there is such a plant, does it employ wet concentration, dry concentration or the electric (magnetic) method? I would like to know if any such plant is obtaining practical working results.—F.

Answer.—A separator of the Wetherill type, made by the Wetherill Separating Company, of New York, is used by the Metallurgische Ge-

sellschaft, of Frankfurt-a-M., Germany, for the purpose named. The plant is at the works of the company in Hoboken, near Antwerp, Belgium, and is in regular use. We are informed that the company treats the ores in this plant, returning the wolframite and cassiterite products to the owners, and making a moderate charge for the work. Practically, no complaint seems to be made of the completeness of the separation.

Clay for Cement Making.—A clay is found in this county in large quantities of which an average analysis is as follows: Moisture, 3.09; carbon dioxide,  $CO_2$ , 10.05; phosphoric acid,  $P_2O_5$ , 2.16; silica,  $SiO_2$ , 32.41; iron oxide,  $Fe_2O_3$ , 0.75; alumina,  $Al_2O_3$ , 6.37; lime,  $CaO$ , 17.40; magnesia,  $MgO$ , 12.11; alkali, 1.33; combined water, 15.36. The silica is nearly all in combination. The clay is fusible before the blowpipe. Would this clay be suitable for use in making cement of any class.—H. K. M.

Answer.—The clay analysis approaches in many respects those of clays used in making Portland cement in some parts of the country; but it is difficult to give a positive opinion on the analysis alone, without some further tests. Your best plan would be to submit samples to several cement makers for their opinion.

See articles on "Cement," in Volume I, and "Clay" in Volume II of "The Mineral Industry." You will find some information also in "Clays of New York," by Dr. H. Ries.

IRON AND STEEL EXPORTS.—The total value of iron and steel exports from the United States in March is reported by the Bureau of Statistics at \$8,571,320, against \$11,858,387 in March, 1900. The decrease of \$3,287,067 was more in values than in quantities. All of the more important items show an increase in quantities, except pig iron, wire rods and wire.

ELECTRICITY AT AN AUSTRIAN COKE PLANT.—The new coking plant at the Orlan-Lazy Colliery in Austrian Silesia uses electric power altogether. All the machines in use are driven by electric motors. The power is generated at a central station by steam engines. The boilers which supply the steam are fired entirely by the waste gas from the coke ovens.

PATENTS RELATING TO MINING AND METALLURGY.

UNITED STATES.

The following is a list of the patents relating to mining and metallurgy and kindred subjects, issued by the United States Patent Office. A copy of the specifications of any of these will be mailed by the Scientific Publishing Company upon receipt of 25 cents.

Week Ending May 14th, 1901.

- 673,896. BRICK KILN. John C. Boss, Elkhart, Ind. In combination in a kiln, an air-blast box at the bottom of the arch thereof, said box having a cover with a plurality of upwardly-directed openings, a blower, and a pipe leading from the blower to the air box.
- 673,920. EXCAVATING MACHINE. James H. McKee, Chicago, Ill., assignor to Frederick C. Austin, same place. An excavator comprising a series of traveling diggers arranged to dig up or loosen and carry the dirt upward and forward to a point of discharge, and an extensible guard arranged and adapted to prevent a premature discharge of the dirt.
- 673,928. REGENERATIVE COKE OVEN. Frederic W. C. Schniewind, New York, N. Y., assignor to the United Coke & Gas Company, Charleston, W. Va., and Philadelphia, Pa. A series of coke ovens with heating flues situated between adjacent ovens built up of masonry

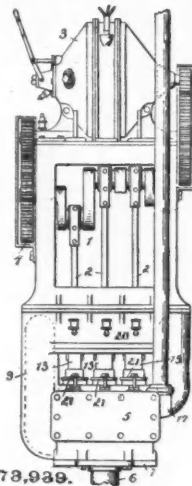
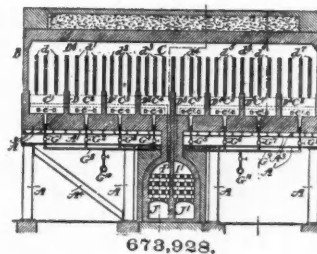

- 673,939. SINKING PUMP. Roscoe H. Aldrich, Jeanesville, Pa., assignor to Jeanesville Iron Works Company, same place. A pump consisting of a working barrel and a power end, a framework connecting the power end with the working barrel, a storage tank located in said framework on one side of the working barrel, an air chamber located in the framework on the opposite side of the working barrel, a cross-section connecting the parts of the framework containing the air chamber and the storage tank together, said cross-section serving as a guide for the pump plungers.
- 673,962. METHOD OF MAKING ALKALI CYANIDES. Carl Moldenhauer, Frankfurt-on-the-Main, Germany, assignor to Deutsche Gold & Silber-Scheide-Anstalt vorm. Roessler, same place. The process of manufacturing alkali cyanide by first melting in a crucible carbonate of alkali together with a flux and then adding to the molten mass the suitable quantity of ferro-cyanide or alkali.
- 673,974. PROCESS OF REDUCING METALLIC SULPHIDES. Louis M. Buller, Paris, France. The process consists in heating the compounds to a high temperature and to a state of fluidity, and acting

upon the same while thus fluid with calcium carbide, thereby causing the said calcium carbide to react upon the said compounds and to effect their reduction.

- 674,011. CONTINUOUS ROD MILL. John B. Nau and Thomas Battersby, Astoria, N. Y. The combination of the twisting guide, a guide box upon which it is mounted and the separate guide or channel placed between the delivery rolls and twisting guide proper and composed of upper and lower parts independently held in the guide box.
- 674,031. PROCESS OF MAKING LEAD OXIDE. Ambrose G. Fell, New York, N. Y. The process of treating lead ore or similar lead compounds, which consists in first converting the lead into a lead salt decomposable with an alkali, then treating the mass with an alkali to convert the lead into oxide, then dissolving out the soluble salts of the alkali, then heating the residue containing lead oxide with a solution of alkali to dissolve the lead oxide, and then cooling said solution to allow the oxide to crystallize out.
- 674,057. GRINDING OR CRUSHING ROLLS. Thomas A. Edison, Llewellyn Park, N. J. The combination of the two side frames, each made in two parts with essentially parallel abutting edges, connecting bolts passing through sleeves cast integrally with the sections of the side frames to permit relative movement of said sections, a compression plate connected to one section of each side frame, a second compression plate connected to the connecting bolts on each

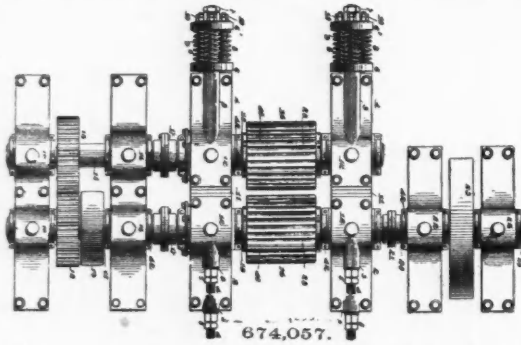

side, compression springs between said plates tending by their elasticity to hold the sections of each side frame together, two shafts carried in bearings in corresponding sections of the side frames, grinding or crushing rolls carried by said shafts, two driving shafts mounted approximately in line with the shafts of said rolls but in stationary bearings, gearing between said driving shafts, and wabbling connections between the driving shafts and the corresponding shafts of the grinding or crushing rolls.

- 674,079. FURNACE. Frederick Danner, Springdale, Pa. A furnace having in combination a heating or melting chamber, two gas-regenerating chambers, two pairs of air-regenerating chambers arranged on opposite sides of the gas chambers, and valves controlling the flow of air and gases.
- 674,095. SAMPLER. Gustave A. Overstrom, Anaconda, Mont. The combination of a main shaft, a cam thereon, a rock shaft, a rock arm movable with said rock shaft and actuated by said cam, a deflector movable with said rock shaft, a chute above said deflector, main and sample chutes beneath said first-named chute and divided by said deflector, a suitably-journaled ratchet wheel, a pawl actuated by said main shaft and engaging said ratchet wheel, a latch-engaging arm movable with said rock shaft, a latch engaged therewith, and means carried by said ratchet wheel for disengaging said latch at intervals to permit movement of said rock shaft.
- 674,104. GAS PRODUCER. William Swindell, Allegheny, Pa. The combination of a gas-discharge chamber, generating chambers located on opposite sides thereof, and having separate fuel openings, a fuel support below and open to each of said chambers, valve-controlled ports establishing communication between the generating chambers and gas-discharge chamber, and a discharge passage leading out of the gas-discharge chamber.
- 674,112. STOCK INDICATOR FOR BLAST FURNACES. David Baker, Chicago, Ill. In a blast furnace the combination with the movable bell adapted to open and close the mouth of the furnace, of the meas-

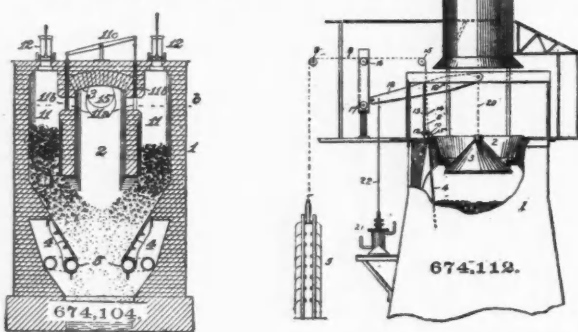

uring rod adapted to rest on the stock, and suitable connections between the bell and rod, formed to cause the rod to be lifted off the stock when the bell is moved to open the furnace mouth.

- 674,159. EXPLOSIVE AND METHOD OF MAKING SAME. Jonas E. Blomen and Henry C. Aspinwall, Pompton Township, N. J. An explosive consisting of a colloided comminuted friable mass containing the following co-nitrated substances, viz.: cellulose and a hydroxyl derivative of a hydrocarbon.
- 674,169. ORE CLASSIFIER. John Klein, Desloge, Mo., assignor of one-half to Paul A. Fusz, Granite, Mont., and Charles D. McLure, St. Louis, Mo. An ore classifier, consisting of a chamber or hopper adapted to receive the mixture containing the ore and the sides and bottom of which are integral, rendering it devoid of cracks or joints at the corners, and having openings through the sides thereof to permit the passage of the ore, classified ore chambers at the sides of the chamber or hopper to receive the ore which passes through the openings, air pipes leading through the sides and bottom of the hopper, and water pipes leading into the chamber or hopper and directed toward the openings in the sides thereof so that when water is admitted through said pipes the ore will be driven through the openings into the classified-ore chambers.
- 674,214. CONCENTRATING JIG. Samuel Orr, Leadville, Colo. A concentrating jig, comprising a water tank, a jig pan having a perforated bottom, held submerged in the water in said tank, slotted links connected with said pan, a jig beam provided at one end with

means for engaging the slots in the links and fulcrumed near said end, a toothed wheel engaging the longer member of the jig beam at its free end to impart a downward movement to the same, and means for swinging the beam upward when released from the toothed wheel.

- 674,222. ROLLS FOR THE MANUFACTURE OF RAILS. Joseph S. Seaman, Pittsburg, Pa. In a mill for finishing rails rolls provided with passes for the progressive reduction of an article toward a rail shape in combination with the rolls having a boxing pass for the further reduction of the article, and a universal mill having a rail-finishing pass.
- 674,269. JIG. John Klein, Desloge, Mo., assignor of one-half to Paul A. Fusz, Granite, Mont., and Charles D. McLure, St. Louis, Mo. In a jig a screen compartment, a plunger compartment adapted to contain water, a hollow air-charged plunger having a sloping top, within the said plunger compartment, suitable guides for said plunger, and means for operating the said plunger.
- 674,291 and 674,292. EXPLOSIVE AND METHOD OF MAKING SAME. Jonas E. Blomen and Henry C. Aspinwall, Pompton Township, N. J. An explosive consisting of a colloided, comminuted, friable mass containing the following co-nitrated substances: Cellulose and a hydrocarbon.
- 674,295. PROCESS OF MAKING ALKALINE AMIDES. Thomas Ewan, Birmingham, England, and Johannes Pfleger, Frankfort-on-the-Main, Germany. A process consisting in passing a rapid current of ammonia gas into the interior of melted alkali metal, so that the ammonia gas is caused to rise through the alkali metal in a finely divided condition.
- 674,296. METHOD OF AND APPARATUS FOR THE MANUFACTURE OF CEMENT PIPES. Carl J. Kielberg, Hillerod, Denmark. A device comprising inner molding case and outer molding case, both of cylindrical form; a rotatable cylindrical compressor inclosing said inner molding case, with suitable driving mechanism fixed on the upper extremity of said compressor.
- 674,299. AMALGAMATING AND CONCENTRATING APPARATUS. James H. Lancaster, New York, N. Y. The combination with a tank having a lower discharge, of a number of alternating and horizontally-separated triangularly-arranged amalgamating plates.
- 674,321. HOOK PLATE FOR LAMP HOLDERS OF MINERS' CAPS. Audley H. Stow, Matewan, W. Va. A hook plate for the lamp holders of miners' caps, consisting of the combination of a horizontal portion or body, and a perforation in same for the miner's lamp hook, the said perforation being adjacent to one or more ridges.
- 674,322. BASE PLATE FOR LAMP HOLDERS OF MINERS' CAPS. Audley H. Stow, Matewan, W. Va. A holder for a miner's lamp adapted to be attached to a cap, the same comprising a back plate, a base plate having a horizontal top part, a body portion which is provided with a longitudinal concavity to receive the lamp and having side ribs as specified, a spring clasp, and a head plate arranged behind the body and attached to the back plate, and having its outer side portions bent forward and inward at an angle to meet the said ribs.
- 674,341. APPARATUS FOR CASTING INGOTS. Adolphus J. Lustig, Newark, N. J., assignor of two-fifths to Isaac Lehman, same place, and Louis Kahn, New York, N. Y. The combination with an ingot mold, of a mold support, consisting essentially of a chambered base plate or foundation, means for conducting a reducing gas into said base or foundation.
- 674,346. CONVEYING APPARATUS. Edward N. Trump, Syracuse, N. Y., assignor to the Solvay Process Company, same place. A conveying apparatus comprising a rotary conveyor element for feeding

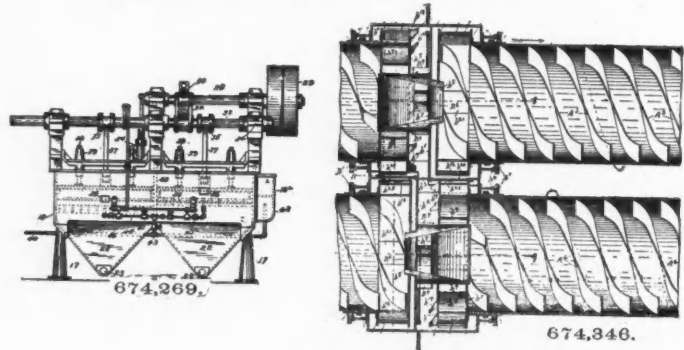

material, a casing communicating with the conveyor element, and mechanism within the casing for feeding material to the conveyor element, said mechanism being connected to the conveyor element with the casing and being actuated by said conveyor element.

- 674,353. CONVEYOR. Frederick C. Durant, Colorado Springs, Colo., assignor by mesne assignments of one-half to the Colorado-Philadelphia Reduction Company of Colorado. The combination of a cylinder provided with flanged openings at each end adapted to prevent the access of water; a series of transferring scoops mounted within the interior of the cylinder and arranged with relation to each other; a discharging scoop arranged in relation to the last scoop of the transferring series; a supply spout extending into one end of the cylinder.
- 674,354. ORE-COOLING DEVICE. Frederick C. Durant, Philadelphia, Pa., assignor of one-half to Spencer Penrose, Charles L. Tutt and Charles M. MacNeill, Colorado Springs, Colo. In combination with an ore chamber, having a series of air inlets in its sides, a series of

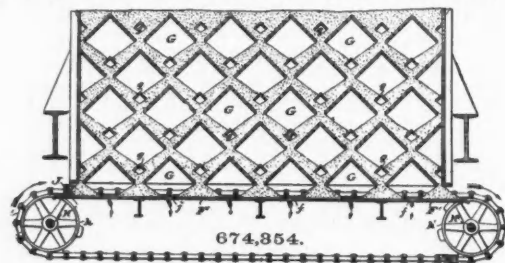

sheds or inverted trough-like conduits connecting said air inlets, and discharge openings in the bottom of the chamber, and directly under, and covered by each shed of the lower series of sheds, of a discharge device movable along the bottom of the chamber, and means for actuating the same, said discharge device being so constructed and arranged as to intermittently discharge the material.

## PERSONAL.

Messrs. P. L. Kimberly, J. H. James and Henry M. Ryan are looking over mining operations in Utah.

Mr. Percy B. McCoy, of Kempton & McCoy, New York City, has gone to Nome, Alaska, on mining business.

Mr. R. Maitland Brereton, mining engineer, of London, Eng., is examining the mines and geology of Republic, Wash.

Mr. Martin J. Heller, one of Capt. De La Mar's experts, is examining the Escudra Mine, near Ocotlan, Oaxaca, Mexico.

Mr. John E. DuBois, of DuBois, Pa., recently inspected the Yankee Consolidated and Humbug mines at Tintic, Utah.

Mr. Louis Will, of New York, accompanied by Mr. G. H. Evans, of Colorado, is examining mining properties in Nevada County, Cal.

Mr. J. A. Ede, mining engineer, of La Salle, Ill., recently has returned from Mexico, where he examined copper properties for Eastern men.

Dr. Jay Backus Woodworth, for several years instructor in geology at Harvard University, has been promoted to an assistant professorship of geology.

Mr. R. J. Cory, manager of the Denver office of the Edward P. Allis Company, has recently returned to Denver from an extended trip through Mexico and Arizona.

Mr. Leon M. Hall, consulting engineer of the Comstock Pumping Association, is in Virginia City arranging for the installation of the new electric hoisting machinery at the C. & C. shaft.

Messrs. B. B. Gage, president of the Congress Gold Mining Company, of Arizona; F. M. Murphy and J. H. Emert, of the Santa Fe, Prescott & Phoenix Railroad, have been visiting Youngstown, O.

Mr. W. M. Brewer, traveling correspondent of the "Engineering and Mining Journal," who formerly dwelt in Birmingham, Ala., but is now located at Victoria and Vancouver, B. C., was in Birmingham last week.

Mr. N. Corwith, sales agent of the American Smelting and Refining Company, Chicago, has resigned, to take effect June 1st. The general offices of the company are to be consolidated in New York, and Mr. Corwith preferred to remain in Chicago.

Mr. J. B. Gibson, secretary of the Birmingham, Ala., Commercial Club, is assisting in the preparation of the Alabama mineral display for the Pan-American Exposition. It is intended to make a small but thorough exhibit of minerals, especially those from the Birmingham District.

Mr. Robert Green, of Springfield, Ill., formerly mine manager at the Jones & Adams Company's mine north of Springfield, it is reported, is organizing a stock company for the purpose of shafting for coal at Shennan on the Chicago & Alton Railway, about 6 miles north of Springfield. The coal there is about 6 ft. thick and about 150 ft. below the surface.

Mr. Joseph Giroux, vice-president and general manager of the United Verde Copper property at Jerome, Ariz., with Messrs. J. A. Snedaker and E. L. Giroux, of Denver, Colo., mining experts representing Senator Clark and associates, have lately been making an examination of the Pilot Knob group of copper mines near Ely, Nev., which are being developed by Senator Clark, who has a bond on them.

Mr. A. Schwarz, chief constructor of the German navy, and Prof. Ernest Von Halle are visiting this country for the purpose of studying industrial methods on behalf of their government. They will visit the Cramp and Newport News shipbuilding yards, also the Baldwin Locomotive Works, besides making an inspection of various important manufacturing undertakings in the Pittsburg, Cleveland and other industrial centers.

Governor Tyler, of Virginia, has appointed the following delegates to the International Mining Congress at Boise City, Idaho: Thomas L. West, Dr. Froehling, Robert F. Morris, John F. Fleming, of Richmond; P. D. Camp, J. D. Fretlow, Franklin; R. L. Parrish, Jr., J. W. Wallace, Covington; John W. Eshman, George M. Holstein, Pulaski; T. C. Jones, Iron Gate; C. R. Boyd, Wytcheville; H. M. Engle, Roanoke; L. M. Johnson, Longdale; C. A. Catlett, Staunton; T. H. Lewis, Craigsville; W. M. Fontaine, Charlottesville; C. F. Z. Carachristi, Granite; B. M. Bibb, Roanoke; G. L. Carter, Bristol; J. J. Johnson, Windsor; H. C. Clive, Front Royal.

Governor Geer, of Oregon, recently commissioned the following persons to represent the State at the International Mining Congress in Boise, Idaho: Colonel F. V. Drake, Portland; Arthur Conklin, Grant's Pass; J. O. Booth,

Grant's Pass; R. G. Smith, Grant's Pass; J. W. Virtue, Leland; J. W. Cook, Portland; W. B. Dennis, Cottage Grove; George A. Dyson, Blue River; W. B. Hawley, Eugene; Geo. W. Lloyd, Eugene; W. J. D'Arcy, Salem; W. T. Wright, Union; Dunham Wright, Union; E. J. Godfrey, Portland; W. A. Thatcher, Geiser; F. S. Balle, Bourne; Alme Case, Cornucopia; George Barin, Granite; Albert Geiser, Baker City; William Smith, Baker City; H. V. McCallum, Sumpter; H. A. Himes, Canyon City; Ira Spraul, Canyon City; J. W. Larkin, Granite.

Governor Stanley, of Kansas, has appointed the following delegates to the International Mining Congress at Boise City, Idaho: C. J. Devlin, Topeka; J. H. Durkee, Weir City; A. E. Winter, Blue Rapids; W. H. Mahan, Coffeyville; J. Ainsworth, Lyons; Louis Matignon, Scranton; W. F. Brinkman, Dillon; John R. Morrison, Midway; John R. Braidwood, Weir City; George Richardson, Weir City; Robert Gilmore, Pittsburg; Edward Keegan, Pittsburg; John T. Stewart, Weir City; Thomas McManus, Weir City; Erasmus Haworth, Lawrence; A. M. Schermerhorn, Galena; E. C. Welpe, Galena; S. J. Crawford, Topeka; Charles K. Holliday, Topeka; James W. Orr, Atchison.

Prof. Haworth, of Lawrence, is to present a paper on the geology of Kansas.

Governor Richards, of Wyoming, has appointed the following delegates to the International Mining Congress at Boise, Idaho: I. C. Miller, Rawlins; J. B. Hassett, Saratoga; J. M. Thomas, Jr., Battle; J. A. Godshall, Encampment; Malachi Dillon, Rawlins; Charles Kuster, Jr., W. B. Roberts, I. R. Swigert, Fred A. Miller, Laramie; T. G. Smith, Hazelton; R. M. Kennedy, Buffalo; C. Frank McLaughlin, Sheridan; Felix Kennedy, Dietz; William Carrard, Wolf; J. Boardman Cann, Lewiston; Charles L. Tewsbury, Kirwin; George T. Beck, Cody; W. H. Kilpatrick, Newcastle; Augustine Kendall, Rock Springs; Matt Muir, Rock Springs; C. H. King, Casper; H. J. Wells, Glenrock; John Foxton, Spring Hill; Frank A. Hoyt, Cheyenne; William Sturgis, Jr., Cheyenne; John Charles Thompson, Cheyenne; Theophilus Grout, Hecla; Thomas Snedden, Diamondville; F. M. Foote, Evanston.

Alfred Stansfield, J. A. Mathews and Julius Goldberg have each been awarded an Andrew Carnegie Research Scholarship of £100 by the Council of the Iron and Steel Institute. Alfred Stansfield was born in England, March 18th, 1871. He graduated from the Royal School of Mines, where he was awarded in 1893 the first Honors Associateship in Metallurgy. In 1898 he was appointed instructor in assaying at the Royal College of Science. From 1891 to 1898 he made a number of researches for the Alloys Research Committee of the Institution of Mechanical Engineers. He has read before the Iron and Steel Institute, of which society he is a member, 2 papers on the solution theory of carburized iron. He is the author of a paper on thermo-electric pyrometry in the "Philosophical Magazine," and joint author of a report on alloys presented to the International Physical Congress in Paris last year. John Alexander Mathews, of Brooklyn, was born on May 20th, 1872. He was educated at Washington & Jefferson College, and at the Columbia School of Mines. He is the author of some 10 papers in the "Journal" of the American Chemical Society, and in the "School of Mines Quarterly." Julius Goldberg, of Leoben, Austria, was born on April 15th, 1876, and was educated at Kalish, in Russia, at the University of Warsaw, and the Leoben School of Mines. He has had experience of practical metallurgy at Kertsch in Russia, and at Wissen in Germany. He is the author of a paper in Russian.

## OBITUARY.

H. W. Tangerman, formerly superintendent of the Consolidated California & Virginia and Hale & Norcross mines at Virginia City, Nev., died recently at Clinton, Amador County, Cal., aged 65 years.

Waverly Shetler, a young mining engineer who graduated from the State School of Mines at Golden, Colo., in 1895, died at El Paso, Tex., recently after a short illness. During the past 5 years he had held several positions in Mexico and had just been appointed general superintendent of the Mexico Copper Company. He was 30 years old.

Weston Howland, who is said to have been the first American to discover a method of refining petroleum, died at his home in Fair Haven, Mass., May 24th, aged 85 years. In 1860, when secretary of the New Bedford Coal Oil Company, Schieffelin Brothers, of New York City, who had about 2,000 bbls. of the crude oil on hand, suggested to him the immense profits to be made in refining petroleum. A barrel of oil was shipped to Mr. Howland's home in New Bedford, where he hit upon a successful method. He purchased oil works at Fish Island, procured stills, and began the manufacture of petroleum on a large scale.

## SOCIETIES AND TECHNICAL SCHOOLS.

Harvard University.—Elwood Mead, expert in charge of irrigation experiments, United States Department of Agriculture, has been in Cambridge for the month of May giving a course of lectures on irrigation to the engineering students of the Lawrence Scientific School.

Mining and Mechanical Institute of the Anthracite Coal Regions of Pennsylvania.—The graduating exercises of this institution will be held at Freeland, Pa., on May 25th. The speaker of the evening will be John Field, of Philadelphia, and Geo. D. McCreary, of Philadelphia, will act as chairman of the exercises.

Engineers' Club of Philadelphia.—At the meeting on May 18th 67 members and visitors were present. Mr. Edwin F. Bertolett presented the first paper of the evening, on "Fireproof Construction in Philadelphia," in which he described the progress made during the past 20 years in the use of fire-proof materials in the construction of large buildings, especially in the neighborhood of Philadelphia. He gave particular attention to the various methods of floor and partition construction, and illustrated his remarks with a large series of views.

James S. Merritt presented the second paper, on "Expanded Metal in Fireproof Construction," in which he described the original and improved methods of cutting and spreading steel sheets to form the so-called expanded metal, and the methods of applying it in connection with cement, plaster, etc., in the forming of floors, partitions and exterior walls, and for the protection of iron members in buildings and bridges. His remarks were illustrated by a large number of lantern views.

## INDUSTRIAL NOTES.

The Vulcan Iron Works, of Toledo, O., recently obtained an order from the De Beers Consolidated Diamond Mines, Kimberly, South Africa, for a 26-ton steam shovel.

The Ford Automatic Boiler Cleaner Company, of St. Louis, Mo., is already talking of increasing its capacity, as its business from the mining industries has increased much during the past few months.

The coal mining department of the Lackawanna Iron and Steel Company is inviting proposals for sinking 4 shafts and 2 rock slopes at its new collieries at Vintondale, Pa., and wishes to have this known among contractors.

The Herzler & Henninger Machine Works, of Belleville, Ill., has recently erected a new factory where it will manufacture its specialty, the "Tornado" coal drill. The company will also manufacture ventilating fans and mine cars.

The new plant of the Wilmington Railway Spring and Manufacturing Company, at Washington, Pa., was designed by Wm. B. Scaife & Sons, Pittsburg, Pa., who will also manufacture and erect the buildings. These will have steel frames with slate roofs and corrugated iron sides.

The Clayton Air Compressor Works, of Brooklyn, N. Y., is about to ship air compressor equipments to Aberdeen, Scotland, and Paris, France, for use with pneumatic tools. The Clayton Company is understood to be figuring on some important inquiries from both the German and Japanese Governments.

A large amount of modern machinery has lately been added to the plant of the Denver Engineering Works, of Denver, Colo. The company has completed and shipped 8 large smelting furnaces for the new smelter being constructed by the American Smelting and Refining Company at Salt Lake City.

The General Incandescent Arc Light Company, of New York City, manufacturers of arc lamps, switches, switchboards, power motors, flush switches, etc., has arranged with its employees to run its factory 54 hours per week and pay the same wages as were paid when the factory was running on a 60-hour basis.

The Edward P. Allis Company has just closed a contract with Compañia Minera de Peñoles, Durango, Mex., for additions to the company's present lead-silver smelting plant. The new work will consist in part of 6 new blast furnaces, 8 Holthoff-Wethey roasting furnaces, cooling and conveying furnaces, crushing rolls and also 2 cross-compound direct connected generating Corliss engines.

The Baldwin Locomotive Works, of Philadelphia, Pa., have secured a contract from the New Zealand Government for 6 locomotives. J. B. Baro, of the Central Conchita, A. S. Mendoza, of the Central Santa Gertrudes, and Miguel Diaz, of the Central Perseverencia, Cuba, have each ordered Baldwin locomotives for their plantation railways. The engines intended for Cuba will have 12 by 16-in. cylinders and 36-in. driving wheels.

A contract for a complete central air compressing plant has been awarded the McKiernan Drill Company, of New York City, by Messrs. Shanahan, Woolfolk & Company, of So. Framingham, Mass., who have secured a large contract from the Metropolitan Water Board of Boston, Mass., for an aqueduct consisting of 2 tunnels, etc. The value of the contract secured by the McKiernan Drill Company is in the neighborhood of \$25,000.

The Niagara Falls Power Company, of Niagara Falls, N. Y., will begin at once to develop power on the Canadian side of the river, under the charter of the Canadian Niagara Power Company, which it controls. The plans call for a first development of 25,000 electric horse-power. The contract for the shaft has been let to A. C. Douglas, of Niagara Falls, who will begin work at once. Of the new power 10,000 horse-power is to be transmitted in Toronto.

The Lukens Iron and Steel Company is to build at Coatesville, Pa., a plate mill which will be the second largest in the United States. It will be completed in 1902, will employ 500 men and give the Lukens Company a capacity of from 200,000 to 215,000 tons of plate yearly. The new mill building will be 590 by 125 ft., the main building for furnaces and mill trains being 330 by 54 ft. with a lean-to 24 ft. wide along one side. The coaling, shearing, and shipping floors are to be equipped with electric cranes and all the machinery will be of the latest type. The rolls will be 116 in. long, with arrangements for installing rolls 140 in. long.

Ernest Kilburn Scott has taken the position of engineer and manager for the United Kingdom, Colonies and Egypt to the International Electric Company, of Liege, with London offices at Shin House, Surrey Street, Strand. Besides the ordinary run of electric lighting work, Mr. Scott proposes to give special attention to the application of continuous and multiphase motors, to machine driving in factories, iron and steel works, etc.; also to mining work, electric traction for tramways and railways and to long-distance power transmission. The International Electric Company has supplied machinery to the Dowlais Iron Works, South Wales, and many other prominent industrial concerns in Great Britain.

Messrs. S. Drescher & Sons, of Pittsburg, Pa., have completed plans and awarded contracts for building a large zinc rolling mill plant for the Kenyon Zinc Company, which is to be built either at Iola or La Harpe, Kan. The contract for the buildings has been given to the American Bridge Company. The boilers will be furnished by C. H. Bradley, Jr., & Company, and will be of the Geary type, amounting to 600 H. P.; the heater will be of the Crookson type and will be furnished by the same firm. The rolling mill machinery will consist of a 3-stand, one roughing and 2 finishing, 24-in. sheet mill for rolling sheets of zinc. This machinery, together with a 1,200-H. P. Corliss engine will be furnished by the Mesta Machine Company, of Pittsburg.

The Sullivan Machinery Company, of Chicago, which recently became successor to the M. C. Bullock Manufacturing Company, in future will manufacture the complete line of diamond drills, rock drills and mining machinery formerly put on the market by the 2 concerns. Since this change in management the Sullivan Company has transferred its Western works into the larger and more commodious building formerly occupied by the Bullock Company. A line of Corliss air compressors and Corliss hoists of all sizes is now being built, which has necessitated the complete overhauling and enlarging of this plant. Two new buildings have lately been erected and are now almost ready for use. The Sullivan Company has recently extended its Western agencies, and in addition to the Denver office, in charge of R. D. Hunter, has opened a branch office in Spokane, Wash., under the management of M. J. Ready.

#### TRADE CATALOGUES.

"Thirty Days After," a little pamphlet issued by the B. F. Sturtevant Company, of Boston, Mass., is a remarkably neat bit of work. By a few well chosen illustrations it shows the damage done to the company's plant by the fire of April 14th, and also how the company contrived to have work going on just as usual 30 days after the fire.

The St. Louis & San Francisco Railroad, otherwise known as the Frisco Line, which recently completed the Blackwell, Enid & Southwestern Railway between Blackwell and Enid, Oklahoma, a distance of 48 miles, has issued circulars calling attention to this fact; also other printed matter setting forth the mineral and agricultural resources of the Ozark Country and the way of reaching important points there.

American steam stamps are described in a 24-page pamphlet sent out by the American En-

gineering Works, of Chicago, Ill. The pamphlet gives general dimensions besides information in regard to this device, which the company recommends to the owners of claims, prospects and small mines and claims for its small cost of installation, large capacity for size and cost, facility of erection, minimum cost of operation and large screen surface.

The Joseph Dixon Crucible Company, of Jersey City, N. J., has published a very artistic catalogue of its graphite productions. In the 70 pages of the pamphlet will be found descriptions of graphite, crucibles and retorts, stirrers, phosphorizers, graphite facings, graphited lubricants, silica-graphite paints, graphite products for electricians and the celebrated American graphite lead pencils. The pamphlet is of artistic appearance and well printed.

No. 23 of the Baldwin Locomotive Works' "Record of Recent Construction" is likely to be read by a large number of people who would not look over an ordinary catalogue. It contains a paper read by Cornelius Vanderbilt before a recent meeting of the junior members of the American Society of Mechanical Engineers. The daily press has had much to say about the Vanderbilt boiler with corrugated firebox. This pamphlet gives the views of the designer with diagrams of the device as used in various locomotives, and the results of comparative tests as regards economy, etc.

Section 1 of the mining machinery catalogue published by the Edward P. Allis Company, of Milwaukee, Wis., treats of gold and silver amalgamating mills and appliances. It contains descriptions of the "Reliance," "New Reliance," Dodge and Gates crushers, "Reliance" ore feeders, stamp batteries and parts, amalgamating pans, mercury traps, hydraulic classifiers, "Reliance" vanners and concentrators, 3-stamp prospecting batteries, amalgam barrels, presses and safes, silver and gold retorts, perforated screens, wooden tanks, elevators and conveyors and other mill accessories.

The W. E. Caldwell Company, of Louisville, Ky., shows its faith in the excellence of the tanks and tubs it manufactures by issuing a 1901 edition of its catalogue. This is a 38-page pamphlet calling attention to the value of cypress wood as a material for tanks, with tables showing the capacity, weight and price. The company makes both circular and rectangular tanks for use in mines, mills, chemical factories, breweries, etc. The company states that cypress lumber is very durable, is impervious to acids, is not injuriously affected by hot water and shrinks, swells or warps less than other woods.

The Stanley Electric Manufacturing Company, of Pittsfield, Mass., has issued its Bulletin No. 117, descriptive of the S. K. C. indicating wattmeter and S. K. C. phase indicator. These instruments depend upon the dynamometer principle and are of the spherical coil type. No allowances, it is said, have to be made in the reading of the wattmeter, as it is not affected by a leading or a lagging load of any power factor and indicates power directly. The company states that the S. K. C. phase indicator facilitates counteracting leading or lagging load disturbances on a line by indicating the proper variation of the excitation of the synchronous motors connected thereto. Where motors and lights are supplied by the same machine this instrument is said to be of great value. By its indications the regulation of the whole system may be materially increased.

The Chicago House Wrecking Company, of Chicago, Ill., which makes a specialty of buying and dismantling manufacturing plants and all kinds of machinery, issues a 260-page pamphlet calling attention to the wares it carries in stock. The company states that it is the largest house of its kind in the world. It dismantled many of the buildings at the Chicago Exposition and those at Omaha. The company sells roofing felt, steel roofing and siding, wrought iron pipe, pipe fittings and tools, brass valves and fittings, blacksmith's supplies, nails, picks, jack screws, pulleys and shafting, belting, hemp and wire rope, emery wheels, locks and other hardware articles, axes and sledges, circular saws, safes, plumbers' supplies, doors and sashes, electrical supplies, steam and gasoline engines, hoists, boilers, steam pumps, fans and blowers, air compressors, water wheels, scales, sheaves, and tackles, etc. The company sends a copy of this catalogue on application.

#### MACHINERY AND SUPPLIES WANTED.

If any one wanting machinery or supplies of any kind will notify the "Engineering and Mining Journal" what he needs he will be put in communication with the best manufacturers of the same.

We also offer our services to foreign correspondents who desire to purchase American goods of any kind, and shall be pleased to furnish them information, catalogues, etc.

All these services are rendered gratuitously in the interest of our subscribers and advertisers; the proprietors of the "Engineering and Mining Journal"

are not brokers or exporters, and have no pecuniary interest in buying and selling goods of any kind.

#### GENERAL MINING NEWS.

##### ALABAMA.

###### Clebourne County.

Anniston Gold Mining Company.—This company has filed a deed to 320 acres of land, in the Arbachoochee gold district, and active operation of the mines will begin at once with a large force of men. Samuel Wallace, of Anniston, is at the head of the new company, along with a number of New Yorkers.

##### ARIZONA.

###### Pima County.

United Globe.—At the Grey Mine near Globe the 3-compartment shaft is down 365 ft. and stations are completed at the 4th and 6th levels. On the surface a 50 by 36-ft. boiler is erected with 3 boilers set. Sinking will continue to 1,000 ft. possibly, and the waste taken out will be raised through the old Grey shaft, 420 ft. distant. The ore will be hoisted through the new shaft and trammed by mules half a mile to the Buffalo ore house, at the head of the cable tramway. N. S. Berray is superintendent.

##### CALIFORNIA.

State Mining Bureau.—State Mineralogist Aubury has instructed Frank M. Anderson, field assistant, to make an examination of the copper mines and deposits of Shasta, Siskiyou, Trinity and Del Norte counties for the forthcoming bulletin of "Copper Mining in California." The State will be districted and field assistants appointed shortly who will visit every county where copper is known to exist, examine the various deposits and report on them. This bulletin will probably be in demand, as little pertaining to this subject has been published, and the industry has been making great strides during the past year.

Mr. Aubury has also instructed Field Assistant S. W. Bowers to investigate that section of San Diego County tributary to Carisso Creek in regard to oil possibilities.

There are now ready for distribution at the Bureau maps and registers of the following counties: Calaveras, Siskiyou, Trinity and Plumas. The maps of Mariposa and Tuolumne counties are now being prepared. There is also ready for distribution a bulletin giving a description of the Mother Lode Region.

Bulletin No. 19, "Oil and Gas Yielding Formations in California," and Bulletin No. 16, "Genesis of Petroleum and Asphalt in California," have been exhausted.

##### El Dorado County.

(From Our Special Correspondent.)

Messrs. Dingee & Company, of Oakland, are reported to have purchased a large tract of land south of Darlington's Ranch, said to contain all the material necessary for the manufacture of Portland cement.

##### Kern County.

(From Our Special Correspondent.)

Piute Chief.—This mine in the Piute Mountains, being developed by R. E. Doan and associates, is said to be looking well. The 4-stamp mill is crushing high-grade ore. The concentrates are shipped to the smelter.

Yellow Aster.—The deepest workings in this mine at Randsburg are 1,100 ft. Sinking still continues and drifts are being run while about one-half of the force of 200 men is engaged in stoping, hoisting and milling the ore.

##### Mariposa County.

(From Our Special Correspondent.)

Stockton & Buffum.—These claims, leased by Dr. I. R. Hamilton, are showing up well. A force of men is at work sinking a shaft, which is now down 100 ft.

##### San Diego County.

(From Our Special Correspondent.)

Advance Dredging Company.—The large Urlic gold dredge belonging to this company located at the Pot Holes on the Colorado River, which has been aground for several months, has been floated by the recent rise in the river and will now work on the bars and banks of the river.

##### Shasta County.

(From Our Special Correspondent.)

French Gulch District.—Active work is going on in this district. At the Gladstone 35 men are employed, at the Milkmaid 20 and smaller forces at the Scorpion, American and other mines. The general outlook is very promising.

Hiatt.—This mine at Quartz Hill, in Buckeye District, has started up with a force of 15 men under the superintendency of D. G. Hunt. The shaft is now clear of water.

Mount Shasta.—Work has been resumed at this mine on Clear Creek. Ten men are employed.

South Fork Mining and Development Company.—Work has started preparatory to running a long tunnel to intersect several high-



grade ore veins in this property near Igo. The superintendent, B. F. Rodgers, purchased a Cummings air compressor and 2 power drills machines at San Francisco, the entire plant to be constructed by L. F. Barlow. The enterprise will test the depth of the rich ores in the locality.

Stowell Group.—These copper claims 7 miles southwest from Copley, part of the estate of the late John H. Stowell, appraised at \$65,000, will probably be sold under an order given by Judge Sweeney.

#### Siskiyou County.

(From Our Special Correspondent.)

Chloride-Bailey.—This group of mines at head of Canon Creek, 2½ miles northeast from Dedrick, is being developed by Homer Wilson and associates. The tunnel run from Canyon Creek has opened up the ore body 1,000 ft. below the surface. A shaft has been sunk from this level and rifts run from the 50-ft. and 120-ft. stations. The vein is said to carry good milling ore. The 10-stamp mill is running steadily and the concentrates are being shipped to the smelter. The tailings will be cyanided.

Quigley Ranch.—On the lower part of this property on the Klammath River a company is putting in a wing dam. The river is about 2 ft. higher than usual.

#### Trinity County.

Lawrence.—H. Z. Osborne of Los Angeles informs us that this mine is no longer worked by Mr. and Mrs. Lawrence, but is now worked by the Union Consolidated Gold Mines Company, of which Mr. Lawrence is president. The mine is somewhat remarkable for the amount of tellurides which accompany its ores.

#### Tuolumne County.

(From Our Special Correspondent.)

Ajax.—The mill on this property on the Major Ranch is being repaired and 2 concentrators put in. A pipe line 1,100 ft. long is being laid from the ditch. The shaft is down 120 ft. and 3 drifts have been run, all in ore.

Dreisam.—On the 400 ft. the old Yellow Jacket vein has been cut by 2 cross-cuts, the vein being about 2 ft. wide, showing free gold and carrying high-grade sulphurets. A mill test is to be made. The property is located at Arrastraville.

Dutch.—In the north drift on the 500-ft. and 600-ft. levels of this mine at Quartz Mountain rich ore continues to be stoped and the ore bodies have been proven for 250 ft. On the 1,100 ft. south of the shaft the ore is also found to be high grade. The mill is crushing steadily. Oil is used for fuel for hoisting and electric power to run the mill and concentrators.

Golden West Mining and Milling Company.—A complete plant with capacity to sink to a depth of 1,000 ft. or more has been contracted for by this company and sinking will start about July 1st. A mill is to be erected at once. F. R. Restano is superintendent.

Mack.—At this mine on the north side of Big Oak Flat 20 men are employed on the mill, which will soon be ready for crushing.

#### COLORADO.

##### Boulder County.

Enterprise.—A rich streak of telluride ore is reported in both of the 100 and 200 ft. levels in this mine at Eldora.

Gold Lode.—This claim at Gold Hill is reported to show good ore in the 200 ft. level. George Blaisdell is owner and Mark Dully superintendent. The Ramona, under the same management, is to be developed and a shaft house is being erected.

Ingraham.—This mine near Salina is shipping in a small way. H. P. Walker is in charge.

Lucky Star.—This mine near Gold Hill employs 10 or 12 men, and is shipping 4 or 5 cars per month.

Richmond.—This group at Salida, idle for many years, is now shipping regularly a good gold ore. Twelve men are busy under Steve Hoyle, superintendent. Dr. Cook, of Denver, president of the company, has recently purchased the Sitting Bull Claim adjoining on which it is proposed to sink a new shaft. The shaft on the Richmond is down 270 ft.

Senator Tillman.—Machinery for this claim at Eldora is on the ground this week and will be installed under the inspection of George F. Armitage of Philadelphia, who is one of the owners. The work of sinking will be resumed as soon as the water is removed.

##### Clear Creek County.

Alunde Consolidated Mining Company.—Solomon Turck, president, and H. M. Cohn, treasurer, of New York, recently spent several days making a thorough examination of this property at Georgetown.

Pay Rock.—Hendrie & Bolthoff, of Denver, have been formally given possession of this mine at Georgetown under the tax titles which they recently secured. Receiver J. M. Copeland has been discharged by the court after administering the company's affairs for about 5 years.

Pelican-Dives.—The Georgetown company keeps up its usual run of shipments from the large number of good leases that are in operation. Many of the stopes are being carried from 12 to 20 ft. wide, the ore broken with power drills and shipped without sorting, the values in large lots sometimes ranging from 200 to 250 oz. silver per ton. About 250 men are at work on the property.

#### Gunnison County.

Maid of Athens.—At this Pitkin mine, the new shaft is down 160 ft. W. Friend and T. Huxtable, of Pitkin, and J. H. Frambough, of Denver, are the owners.

Wallace Mining Company.—This company owns the Citizens group of 7 claims, at Pitkin. The production is said to be 60 tons per week. The 2-compartment shaft is down 130 ft. The vein is said to be 5 ft. wide, carrying good silver values and a little gold.

#### Gilpin County.

(From Our Special Correspondent.)

Mining Deeds and transfers.—C. M. Smith to H. R. Burk, the Howard R. Lode; W. Colby to Ed. Kinzy, the M. K. and T. group of 6 claims in Pine District; S. E. Fraser to Sam Mellor, 1/3 interest Blythe, Ground Hogg and Columbus lodes in Gregory District; F. S. Burton to Kokomo-Pioneer Mining and Milling Company, the George T. Day and Boston lodes, Russell District; G. W. Blethen to N. W. Blethen, portion West Pewabic Lode in Russell District; W. Wentworth to J. Short et al., the Lottie Lode in Gregory District; C. F. and R. L. Hill to J. P. Speer, 1/10 interest east 700 ft. of Wautauga Lode in Russell District; J. F. Shoemaker to F. Swallow, ¼ interest in Penobscot Group, 6 claims, in Independence District.

Barnes.—Milwaukee men have purchased this group on Quartz Hill for the reported price of \$100,000, making a payment down of \$15,000 to Byron Lake. They have everything in readiness for production. Nic. H. Scheuer, Central City, is manager.

Carroll.—F. Neumeyer & Company, who are working the Boodle, have placed an order for machinery and will arrange for early work.

Cui Bono.—Dr. Brown, of Nevada, the owner, is having the shaft retimbered and will sink to 200 ft. at once.

Golden Star.—This property in Hawkeye District is to be reopened again by E. C. Lindemann, of Leadville.

Kokomo Pioneer Mining and Milling Company.—This company is going to reopen the Kokomo property in Russell District, as well as do work on its Pioneer Group at Dumont in Clear Creek County. E. H. Wilson has been appointed superintendent.

Lillian.—The operators have decided to jig their talc ores, carrying a heavy proportion of iron, which when cleaned show high values. R. Hughes, Russell Gulch, is manager.

Old Town.—An 80-H. P. high-pressure boiler will be put in. The shaft is down 560 ft. and a 6-ft. crevice of concentrating ore is showing. Regular shipments average 25 tons per day. George Kimball, Russell Gulch, is manager.

Patch Mining Company.—Some fair-grade ore is being opened in the 1,400-ft. of the Hidden Treasure and a car of mill ore per day is shipped. The 2,000-ft. level of California is being cleaned out and a dam put in before unwatering shaft to its depth of 2,230 ft. Pat McCann, Central City, is manager.

Pewabic.—This property owned by J. Stanton, of New York, will, it is said, be reopened by a strong company. E. W. Williams, of Denver, is agent.

Phoenix.—Iowa parties are going to put up a new shaft building, machinery and boarding house at this property, 2 miles west of Rollinsville. W. A. Parrish, Rollinsville, is in charge.

Yankee Consolidated Mining, Milling and Tunnel Company.—Manager H. I. Sennaun, of Denver, has ordered machinery to be placed on a shaft of this property near Yankee Hill.

#### Lake County—Leadville.

(From Our Special Correspondent.)

Brian Boru.—This territory lies on the north slope of Iowa Gulch and the 4 ft. of ore recently opened is attracting considerable attention to the territory adjoining where there is a large amount of undeveloped ground.

California Gulch Mill.—This plant has been experimenting on the low-grade ores from Brece Hill, but has closed down temporarily. Tests included wet and dry crushing, concentration and cyaniding, but nothing definite has been decided on.

Capitol Hill Mining Company.—This new 250-ft. shaft on undeveloped territory on Capitol Hill, which has been idle for some months, is to be drained and a churn drill installed at the bottom to test the formation. C. F. Dennison is at the head of the project.

Carbonate Mining Company.—The company has 20 acres of good territory on Carbonate Hill

and is after the P. O. S. ore shoot. The shaft is down 520 ft. and a drift has been run 260 ft.

Catalpa-Crescent.—This combination has been for years one of the heaviest manganese producers in the camp, but of late has encountered such a good grade of iron ore that manganese shipments have ceased and the combination is shipping daily 50 tons of ore to the smelter.

Chippewa Mining and Leasing Company.—This 40-acre tract on Brece Hill is under a long lease to the Esteys, who have resumed work. A small quantity of good ore can be shipped.

Chrysolite.—The only important work is through the Fairview shaft, where 30 tons a day of manganese ore are taken out.

Evelyn Mining Company.—This new shaft is 800 ft. deep. It will go at least 1,000 ft., where it will tap the rich ore shoots of the Graham Park section. Additional machinery is being put in in case of extra water flow.

Fanchon Placer.—This 65 acres of Sugar Loaf territory has been sublet by lessee Boyd to different sets of lessees who will work separately. The Dinero, Gunnison, Orinoco and a number of other celebrated veins extend through this territory.

Four Per Cent.—This group includes the Four Per Cent. and Cady Mines and lessee Germon is sinking his new shaft down 350 ft. to contact.

Golden Basin Mining Company.—The new machinery has started and the shaft will be sunk to the ore horizon.

Highland Chief Mining Company.—The new shaft is 550 ft. deep and will be sunk 100 ft. more.

Ibex Mining Company.—Shipments are 200 tons a day. Nearly 400 men are employed. The Ibex No. 4 shaft is draining an immense amount of surrounding territory. For over a year one of the 3 immense plants at the Ibex has been lifting steadily 1,000 to 1,200 gal. per minute direct to surface from 1,040 ft., a performance not duplicated by any other property in the camp.

Leadville Zinc Production.—The output is about 250 tons per day. R. J. Davis, representing Jacobson & Company, of New York City, has just returned from Europe with representatives of the Vielle Montagne Company and made a careful examination of the local conditions.

Morocco Mining Company.—This new shaft at the foot of Harrison Avenue, put down by the Sheedy-Kountz combination, of Denver, and known as the A. V., is running a prospect drift at 414 ft.

New Elkhorn Mining Company.—The management will be ready to go ahead with exploration work as soon as the old workings are cleaned out.

New Leadville Home Mining Company.—Shipments have increased to 350 tons a day. The directors have made a proposition to begin sinking the Penrose shaft another 110 ft. if the Cloud City and Home Extension companies lying below them pay a part of the pumping expenses.

Penn Mining Company.—Shipments from 2 shafts average 100 tons of good-grade ore daily.

Rialto Leasing and Mining Company.—Upon request of some of the Denver stockholders W. G. Brown, of Denver, has been appointed receiver. The request was made on the charge of mismanagement and is the result of trouble among the stockholders. W. G. Reed and other Boston people are largely interested. The Rialto embraces 4 good claims on Iron Hill and is a promising new mine. The shaft is down 1,237 ft. and the workings look encouraging. The receiver will soon make a report and some interesting developments are expected.

Tarshish Mining Company.—An effort will be made to resume work by selling 300,000 shares of preferred stock. The stockholders have already agreed to subscribe for 150,000 shares. The report of the directors shows that the 8 original stockholders subscribed \$10,500 and afterward loaned the company \$7,300. Cash received from sale of stock amounted to \$10,000 and cash received from sale of ores amounted to \$4,243. The total sum of \$32,043, the directors state, has been spent in development.

#### San Miguel County.

Peck.—This cyanide plant of 200 tons daily capacity has started for the season. It has 20 years' accumulation of tailings from the Smuggler-Union and Marshall Basin mills to work over. The seasons will not permit of more than 6 months' work yearly. W. E. Gill, of Telluride, is resident manager.

Smuggler-Union.—All mining operations are at a standstill by means of the strike, with no indication of an immediate settlement. Meanwhile the company is proceeding with additions to its equipment. The new cyanide plant of 400 tons daily capacity is under way, as is the work of enlarging one of its two 60-stamp mills. A tramway between 13,000 and 14,000 ft. long from the Contention Group, recently purchased by the company, has been ordered.

## Summit County.

American Gold Dredging Company.—This company has started its Bucyrus dredge near Breckenridge on the Swan River. The dredge has a capacity of 2,500 cu. yds. of gravel in 24 hours. Repairs on the ditch are about completed, and the big Evans hydraulic elevators will be put in action the first of the month, thus doubling the output of gold. B. Stanley Revett is here personally managing affairs.

Gold Pan Company.—This company now employs 75 men busy at its plant near Breckenridge. The company has completed a large quantity of pipe and is reported to have contracted for digging a large amount of ditch.

Excelsior.—This mine at Frisco, E. Miller, manager, is shut down indefinitely.

Rio Grande.—This placer company has been repairing its 11 miles of ditch and is digging 2 miles more.

Wapiti.—Boyce Brothers are putting in a flume and sluice on Farncomb Hill, near Breckenridge, to run through the old dump of this property.

## IDAHO.

## Ada County.

Homestake.—A strike of good gold ore is reported in this mine at Neal. The vein was cut at a depth of 200 ft. in a crosscut from the Daisy Tunnel.

## Boise County.

Boston & Idaho Gold Dredging Company.—This company has just completed remodeling dredge No. 2, at Idaho City, and it is now running smoothly.

Little Sammie.—At this mine, 12 miles from Idaho City, a crew of men has started work. E. F. Fitzhugh is owner.

## Washington County.

Blue Jacket Consolidated Mining Company.—This company, recently formed in New York City, controls the Blue Jacket Mine in Seven Devils District. J. H. Swift, of New York, is president, C. F. Frothingham, treasurer, and F. J. French, of Cuprum, secretary and general manager. About 15 men are now employed on the property. A larger sinking plant is to be installed, when the force will be increased and the 200-ft. shaft sunk to the 500-ft. level. There will be no shipments this summer, it is said, owing to the high cost, \$12 to \$20 per ton on the wagon haul, and because of the projected smelter at Weiser and the anticipated completion of the Pacific & Idaho Northern Railroad to the vicinity of the mine.

Bodie.—Lewis Hall, of the Pacific & Idaho Northern Railway, is developing this claim in Heath District. The shaft is down 300 ft.

Boston & Seven Devils Company.—This company is pushing development. A diamond drill has been used in prospecting on the Peacock with encouraging results and a deep shaft is to be sunk. The Helena Claim of the same company is to be equipped with suitable machinery this summer.

Mineral City Smelter.—This smelter, near Huntington, recently suspended operations. The Mineral City fast freight line has stopped hauling coke, and the camp at Nagle has been let out. The rate by wagon is said to be too high to justify the operation of the smelter, and it is thought that the operators, a Portland company, headed by Charles M. Ladd, will suspend operations until rail transportation is secured.

Pocahontas.—On this claim, owned by John Ross and Weiser men, a strike of high-grade ore is reported.

Salzer-Ford Company.—This company is developing a group of claims at Pollock. The new wagon road from Bear to the mines is nearly completed and the cyanide plant now lying at Council will soon be brought to the mines. It is thought that the machinery may be in place by July. About 100 men are employed. E. D. Ford is manager and Detroit men are interested.

Stemwinder.—A Philadelphia, Pa., company has taken hold of this property in Heath District and has 15 men at work.

Weiser Smelter.—It is stated that work is to start at once on this plant to be built by Lewis Hall. The smelter will be on the line of the Pacific & Idaho Northern Railroad, 10 miles above Weiser, and is expected to be completed this fall.

## ILLINOIS.

## Sangamon County.

(From Our Special Correspondent.)

Republic Iron Company.—This company is equipping its coal mine north of Springfield with tail rope haulage. The haul is about 1½ miles. There will be 2 branches from the main line, making 3 gathering switches.

## Vermillion County.

(From Our Special Correspondent.)

Consolidated Coal Company.—This company, of St. Louis, is considering closing down its mine at Fairmont. Since the recent settlement of the strike there and the resumption of work the men have been gradually leaving, so that

the mine is now producing less than 100 tons daily instead of about 400, the regular output. The Catlin Coal Company may suffer in the same way, though it is now getting 750 tons per day, as against 1,050 daily a couple of months ago.

## MICHIGAN.

## Copper—Houghton County.

Osceola.—Work on the new 3-head mill, 176 by 210 ft., is well along and the structural work will be complete by September 1st. The foundation for a large boiler house, 45 by 150 ft., is now being laid.

(From Our Special Correspondent.)

Isle Royale.—The second head at the stamp mill has gone into commission.

Tecumseh.—The water is now about out of the shaft on the Osceola amygdaloid and sinking will begin at once.

## Iron—Gogebic Range.

Ashland.—This mine, near Ironwood, has been sub-leased by the Hayes Mining Company to the Cleveland-Cliffs Iron Mining Company. The lease runs for the time of the lease held by the Hayes Company from the fee owners, or about 18 years. By its terms the lessees are to receive a royalty on the ore mined, which must not be less than 200,000 tons annually. The Ashland is the most westerly property of the Michigan portion of the Gogebic Range and was opened in 1885. Its largest output was in 1890, when 435,949 tons were shipped. The lease of the property was surrendered in the fall of 1899 by the Penokee & Gogebic Development Company to J. O. and E. A. Hayes, the original owners, principally because it was believed that there was but little ore in sight.

## Copper—Keweenaw County.

(From Our Special Correspondent.)

Manhattan.—This property, which is owned by William Warden, is likely to be purchased by Western men.

Mohawk.—McCurdy Brothers, of Houghton, have secured a contract for the construction of a 30 by 300-ft. dock at the stamp mill site on Traverse Bay. It will be built of 3 30 by 100-ft. cribs, starting in 14 ft. of water and extending out into 21 ft. This will permit fair-sized boats to take freight from the dock, which will be built jointly by the Mohawk and Wolverine companies.

## Copper—Ontonagon County.

(From Our Special Correspondent.)

Michigan.—The old Minnesota workings have been encountered by a drift at the 5th level of a shaft.

## Iron—Menominee Range.

Thomas J. Spencer has taken an option on 12 40's northwest of Norway. The lands are owned by the Lake Superior Canal Company and W. E. Rees, of Cleveland, O., and are thought to carry the Aragon formation. Capt. W. A. Dunn, of Houghton, Mich., is exploring 2 40's south of the Aragon by a diamond drill.

Armenia.—This old Crystal Falls mine is being equipped by the new operators, Corrigan, McKinney & Company. The shaft house is to be 70 ft. Shipments are to be made over the Chicago, Milwaukee & St. Paul Railroad.

Bird Iron Company.—The shaft is down 125 ft. A level is being started at 75 ft. and another at the bottom. The ore is said to average 50% iron and .022% phosphorus. The property is north of Crystal Falls and was formerly known as the Voos. Houghton County owns the fee.

Groveland.—Corrigan, McKinney & Company, of Cleveland, O., have taken an option on this mine, 6 miles east of Randville, which was opened in 1889, and worked a few years. Rails are being laid from the Chicago, Milwaukee & St. Paul Railway at Randville, along the old right-of-ways, and machinery is to be installed and the mine unwatered. About 8,000 tons of ore are on the stockpile. The ore is bessemer, but low-grade, and when the mine was first worked an attempt was made to concentrate it by jigging.

Hope.—At this exploration in the Crystal Falls district the shaft is down 225 ft. and cross-cutting is going on. Some good iron ore has been exposed in test pits.

## MISSOURI.

## Jasper County.

(From Our Special Correspondent.)

Zinc Exports.—A large meeting of producers was held at the rooms of the Joplin Club on May 23d. Telegrams were read from the Eastern managers of a number of large companies favoring the export movement and pledging their companies to sign the contract with the Missouri-Kansas Zinc Miners' Association. There was an immediate advance in the price of ore after the first shipment in April, but the gradual decline as soon as it appeared that the export movement was weakening has aroused producers.

Joplin Ore Market.—There was no change in the price of either zinc or lead ore last week. The first reported sale of the week was the ore from the King Jack Mine on the ground of the

United Zinc Company in Chitwood Hollow at Joplin at \$27.50 per ton, but later offers of \$28 per ton were made and accepted. The shipments were larger than the previous week and in the corresponding week last year.

Lead was settled for at \$23.25 per 1,000 lbs. the same as last week. Following is the turn-in by camps of the Joplin District for the week ending May 25th:

	Zinc lbs.	Lead lbs.	Value.
Joplin	2,982,860	491,780	\$51,703
Galena-Empire	1,929,510	244,060	28,808
Cartersville	1,827,230	369,570	29,696
Oronogo	735,410	59,450	10,994
Webb City	590,820	52,440	8,013
Aurora	600,510	20,990	7,195
Zincite	507,240	.....	6,848
Duenweg	308,230	44,260	4,727
Granby	367,000	41,000	4,100
Wentworth	308,000	.....	4,150
Spurgeon	206,700	68,170	3,859
Carl Junction	295,770	.....	3,702
Central City	203,490	35,420	3,367
Neck City	188,350	.....	2,543
Cave Springs	150,680	8,320	2,152
Peacock City	152,840	4,330	2,012
Stotts City	101,810	.....	1,375
Carthage	65,860	.....	790

Total ..... 11,572,310 1,439,780 \$175,944  
Total, 21 weeks..... 213,434,960 26,502,880 \$3,175,324  
Zinc value for week, \$142,500; lead, \$33,444; zinc value 21 weeks, \$2,579,590; lead, \$595,634.

During the corresponding week last year best grade zinc ore sold at \$30 per ton and lead at \$22.50 per 1,000 lbs. The output was less than last week by 1,263,080 lbs. of zinc and 380,210 lbs. of lead and the value less by \$12,570. For the first 21 weeks last year the sales were less by 8,570,940 lbs. of zinc and 2,519,540 lbs. of lead, but the value was greater by \$513,918. Compared with the previous week the sales were greater by 1,903,370 lbs. of zinc and 324,620 lbs. of lead and the value was greater by 31,984.

Poster-Jackson Lease.—This property 7½ miles southeast of Joplin in Newton County, being a little out of the run of mining developments, received no attention until recently, when a phenomenally rich pile of mill dirt attracted shrewd operators and drew a swarm of visitors. Numerous attempts were made to get an option on the property, but it was found that an option had been secured by New York men just before the ground began to attract attention. Drill developments by sub-lessees have been so remarkable that a third more than the option price has been offered the owners for the property and they have endeavored to secure a re-lease from the holders of the option.

International Zinc Company.—Gov. A. M. Dockery has issued requisition papers for Dr. J. Grant Lyman and Charles S. Hartwell, of New York, who floated and promoted this company. There is a strong desire among the people of this district to see Dr. Grant brought to the locality which was made the base of his operations and where proofs are more easily accessible. Should Gov. Odell honor the requisition of Gov. Dockery, both men will be vigorously prosecuted by the Jasper County officials.

Natural Gas.—On the Monitor lease at Roaring Springs, about 3 miles southwest of the city limits of Joplin, a small flow of natural gas has followed sinking a drill hole to 1,250 ft. The hole was first drilled for water to 900 ft. and an ample supply was at first obtained which eventually failed and the hole was drilled deeper. At about 1,000 ft. a light flow of gas resulted which increased in strength as the hole was put down deeper until the flow became so strong that the gas would burn for an hour or two at intervals. The pressure of the gas became stronger as the lower strata was reached, but at 1,250 ft. the water rushed into the drill.

## MONTANA.

## Carbon County.

Montana Coal and Coke Company.—This company is employing 150 men at its coal mines at Aldrich, 2 miles from the coke oven plant at Horr. The seam worked is 4½ ft. thick and is opened to a depth of 700 ft. by an incline shaft. The coal as it comes from the mine is passed through 2 sets of rolls and from them to 6 large 2-compartment jigs, and from these jigs, each of which has a product capacity of 60 tons per 10 hours, it goes to a flume in which it drops to the bunkers at the coke ovens at Horr. Here it dries for 3½ days, after which it is conveyed to the individual ovens for treatment by a steam motor traveling over the 128 ovens. This product is loaded directly into cars and finds a market in the smelters and foundries of Butte, Helena, Anaconda, and shipped to Salt Lake. A steam drying plant and more rolls will soon be installed at the lower works. The present capacity of the plant is 4,000 tons per month. W. G. Morse is manager.

## Deer Lodge County.

Emery Mining Company.—This company, 9 miles northeast of Deer Lodge, is shipping ore steadily that gives good returns in gold and silver, and 7 or 8% lead per ton. About 60 men are working under W. J. Higgins, manager. The mine is developed by an incline 850 ft. and has a steam hoist and an air compressor. Im-

improvements contemplated include sinking of a vertical shaft that will give 1,500 ft. of stoping ground along the lead. The property was discovered in 1888 by W. P. Emery and worked intermittently by leasers till 5 years ago, since which it has been a steady producer.

#### Fergus County.

Central Montana Mines Company.—This company's mill in the Judith Range is experiencing a favorable season. The water supply is adequate for all demands and development work is said to be exposing ore in large quantities. The daily mill run for some time has exceeded 125 tons.

Kendall.—The last shipment of bullion from the mill in the North Moccasin Range while under the ownership of H. T. Kendall was brought to Lewistown May 18th. The shipment consisted of 5 bars of gold bullion valued at about \$5,000. Finch & Campbell, of Spokane, who recently purchased the properties, will, about June 1st, begin replacing the 100-ton cyanide mill now in operation with a mill having a daily capacity of 300 tons.

Mammoth.—Jones, Matthews & Miller have given an option for a bond on this group of 8 claims in the Gilt Edge District to W. L. Lawrence, of Rossland, B. C., who is reported to represent New York men. The option, which is for 60 days, and the bond when given will be for one year. The group lies immediately north of and joining the mines of the Great Northern Mining and Development Company about 1½ miles west of Gilt Edge. On the Mammoth Claim a large body of cyaniding ore, carrying an average value of about \$8 per ton, is reported exposed. Two shifts of miners are at work.

#### Jefferson County.

Mountain Chief & Blackwell Consolidated Mining Company.—This company is sinking a new shaft near its 10-stamp mill at Homestake and will run a cross-cut about 200 ft. to tap the lead which has been opened up on top of the hill. The property is owned entirely by Mrs. L. K. Von Horn, of Chicago. About 20 men are employed. The ore carries gold and silver.

Victor.—Charles Bertholf is working this claim at Homestake and recently struck a good body of gold ore. The shaft is down 105 ft. (From Our Special Correspondent.)

Baltimore.—This property 3 miles from Boulder, belonging to Sam G. Mackey, is being worked under bond and lease by Owsley & Pritchett, who contemplate sinking 200 ft. below the tunnel level. The quartz is from 5 to 9 ft. wide and will average about \$8 crude.

Minneapolis Copper Mining and Milling Company.—This company, headed by ex-Gov. John Lind, of Minnesota, is working the Gray Eagle property 8 miles from Basin. The bond on the mine is for \$100,000, the first payment of which has been made. J. J. Holmes, of Boulder, and Mrs. L. Sponheim, of Basin, are the owners.

Princess.—This property 3 miles from Pipe Stone Springs, owned by H. J. Blume, of Butte, and W. J. Headley, of Los Angeles, Cal., is under bond and lease to Butte parties for \$40,000. Some years ago about \$25,000 worth of ore was shipped. It has been idle for 5 years.

#### Madison County.

Broadway.—This mine was patented as the Bowery, operated under lease by the Glass Brothers, but the owner, F. E. Merks, of Two Bridges, took possession, and has since been operating it himself. The mine is opened to a depth of 450 ft., showing an average ore body of about 5 ft. The ore is free-milling and is treated by both cyanide and amalgamation. The mill is equipped with stamps, also 2 Tremain stamps, and the present capacity is about 22 tons.

Gold Dredging.—The "Maggie A. Gibson" dredge boat which was formerly in operation at Bannack was purchased by the company and is now in operation near Laurin. This boat cost about \$45,000 and can handle 2,500 cu. yd. of dirt each day. One of the other dredges is being remodeled and will be in commission about July 1st. This boat will have a capacity of nearly 5,000 cu. yd. a day. Another dredge of large capacity is being constructed at a point a few hundred feet below the "Maggie A. Gibson" and will be in operation early next spring. It is estimated that it will take 50 years to exhaust all the pay ground at the mouth of Alder Gulch. Bedrock is from 18 to 35 ft. A new town has sprung up between Laurin and Virginia City, where the dredgers are located. The chief concern now is the outlook for fuel. At present wood is used, but the company has guaranteed the Northern Pacific railroad to take 5 cars of coal each day if the line is extended from Twin Bridges. A corps of surveyors is now at work between Twin Bridges and Laurin.

Watseka.—Work on this mine has been going on under the direction of Carl Hand, manager, for some months. A strike of oxidized ore below the old workings on the 100 ft. is reported to have developed into a sulphide body, which by fine crushing and concentration is giving

good returns. The ore is said to go \$20 per ton and upward in gold.

The mill uses a combination process; about 70% of the values is saved by a coarse cyanide treatment. The tailings go through a Huntington, over plates, to amalgamate the coarse gold not dissolved, and thence over 2 Wilfleys, making a total saving, it is claimed, of 98%. The present capacity is about 40 tons.

#### Park County.

Red Bluff Mining Company.—No effort is being made to unwater the mine recently flooded, but a concentrator will be built, work upon which will be started soon. It is likely that it will be run by electric power, as the new power plant on the Madison River will be in operation shortly.

Robinson Mining Company.—This new company is to work the property formerly the Revenue Mining Company at Jardine. The 40-stamp mill is to be run by water power. The mine is being put in shape for operation. Alexander Livingston, of Livingston, is manager, and John Monahan, formerly of Spokane, is superintendent.

#### Silver Bow County.

Butte & Boston Smelter.—The closing of this smelter has had the effect of shutting down the Berkeley and Silver Bow No. 1 and No. 2 mines. The ore was sent to Anaconda, but the entire output of the Butte & Boston mines could not be put through. The shutdown throws 250 men out of work, making nearly 550 idle on account of the smelter closing down.

Minnie Healey.—The suit brought by F. Aug. Heinze to prevent Miles Finlen from further prosecuting an action in the United States Court that involved issues similar to the Minnie Healey case has been dismissed by Judge Clancy without prejudice.

Parrot Mining Company.—A petition for the removal to the United States Court of the case of Daniel Lamm and John MacGinnis against this company and the Amalgamated to prevent the absorption of the Parrot by the Amalgamated has been granted.

Snohomish and Tramway.—Judge Knowles recently affirmed the finding of Henry N. Blake, special master appointed to hear the testimony in the Larkin insanity case, instituted by F. Augustus Heinze in favor of the Butte & Boston Company and against Heinze. The effect of the decision is that these mines will be sold at public sale to the highest bidder should the circuit court of appeals affirm the decision of Judge Knowles. Notice of appeal has been given by Judge McHatton of counsel for Heinze and the order for entering the decree was stayed until June 25th, in order to give the intervenor time to prepare an appeal.

#### (From Our Special Correspondent.)

Butte & Boston.—Most of the producing mines of this company are idle temporarily until some arrangement can be made for reducing the ore, its own smelter being closed owing to the late labor trouble. The probabilities are that the employees will recede from their demands for an 8-hour day for all employees, and that the works will soon be running full blast.

Smokehouse.—Sinking on this property is suspended, it is hoped only temporarily. The trouble seems to be in acquiring all the title to the mineral rights. When the surface was sold off as city lots the mineral rights along with the surface reached the hands of some 250 different owners, all of whom had to be dealt with by the Smokehouse Company. The title to about 7% of the mineral is found to be vested in minor heirs. It looks as if the only way to adjust the matter will be by bringing a suit in partition and having the property sold.

Speculator.—This property has closed on account of not having any market for its ore, owing to the closing of the Colorado Smelter.

#### NEVADA.

Mining Claim Regulations.—According to the State law as amended before the expiration of 90 days from the posting of his notice upon his claim, the locator must sink a discovery shaft upon the claim to the depth of 10 ft. A cut or crosscut or tunnel cutting the vein at a depth of 10 ft., or an open cut along the ledge or lode equivalent in size to a shaft 4 ft. by 6 ft. by 10 deep is equivalent to a discovery shaft. The boundaries of the claim must be plainly marked by posts or stone monuments. The act prescribes the site of the posts or monuments and where they must be placed.

#### Lyon County.

Excelsior Copper Mining Company.—This company is developing the so-called Bluestone Mine 5 miles southwest of Yerington. The company is a Montana corporation and composed mostly of Montana men with C. S. Batterman as general manager; C. McHenry, general superintendent, and J. C. Smolt, superintendent of smelter. The company has sunk a shaft 100 ft. on the ledge, which is cut by a 300-ft. tunnel. In the tunnel a station has been cut and 12 H. P. gasoline engine installed to hoist ore from the 200 ft. The ore is said to be black oxide mixed

with carbonate and assaying in places 25% copper in 2 shoots, while a third shoot carries sulphides. The general average of the ore is said to be 10%. The formation is limestone. A 150-ton smelter has been erected about ½ mile down the canyon. Cars holding 5 tons each carry the ore. The ore is dumped from the cars, after being weighed, into large bins. The coke bins are also arranged alongside of the ore bins, so that very little handling of material has to be done. Just below the smelter is the power house which contains 2 large boilers, a 150-H. P. Corliss engine and a large blower.

The water for the jacket is used over and over, being passed through a cooler. The pumping plant is about 2 miles below the smelter. An incline has been sunk 90 ft., a pump installed and a 4-in. pipe line carries the water 11,000 ft. and to an elevation of 850 ft. into a 50,000-gal. tank. During the last 3 or 4 months from 75 to 150 men have been at work, and it is said that nearly \$200,000 has been expended on the property.

#### NEW JERSEY.

##### Sussex County.

New Jersey Slate Company.—This company, says the "New Jersey Herald," has been engaged in making extensive improvements at the Newton slate quarry. An additional boiler has been added and other machinery is being placed in position for advancing the work and filling with promptness the numerous orders for slate that are being daily received by the company from all parts of the country. This slate is of a superior quality, and one of its prominent as well as important features is its fastness of color. A large force of men are employed in the old and new quarries removing large slabs of slate, which are carried to the workhouses and manufactured into the various sizes of roofing slate, and material for other purposes. The company is developing new plans for placing goods on the market, and has secured a force of expert workmen.

#### NEW MEXICO.

##### Colfax County.

Black Copper.—This mine near Elizabethtown is keeping its 5-stamp mill busy. Good results are reported.

Clarkville Coal Mines.—The miners at these coal mines, property of W. A. Clark, struck recently because the superintendent discharged a few men. The mines have since resumed work and the local miners' union has disorganized. The miners of the Colorado Fuel and Iron Company at Gallup are also running with non-union employees. The only union mines now in operation near Gallup are the Thatcher and Otero mines, operated by the Caledonian Coal Company, employing about 150 men.

June Bug Company.—This company has its new mill at Elizabethtown about ready for work.

Relling Dredger.—The dam for this plant near Elizabethtown is nearing completion and the machinery is expected soon. The company hopes to have the dredge at work by September.

#### Taos County.

Pennsylvania Mining and Milling Company.—This company, with principal place of business at Tres Piedras, has completed its organization by the election of F. A. Elliott as president and manager and W. J. A. Kennedy secretary. The company owns a group of 8 claims on Cow Creek, about 7 miles west of Tres Piedras. Development work is now in progress with 12 men including day and night shifts. Up to the present time the workings consist of 70 ft. of tunnel and 2 shafts, each about 40 ft. deep.

#### OREGON.

##### Jackson County.

Braden.—G. H. McDonald, formerly of the Ashland Mine, is now foreman of this mine at Gold Hill. Dr. C. R. Ray, the owner, is having lumber hauled on the ground for an additional 5 stamps to be added to his 10-stamp quartz mill and concentrators, and has also ordered a 60-ton cyanide plant.

Placer Mines at Woodville.—According to a local paper among some of the prominent placer mines tributary to Woodville are: The J. H. McKee Placer, 6 miles from Woodville, 200 acres, with 1 giant under 70 ft. pressure; Hillis Brothers Placer, at mouth of Saxe Creek 9 miles from Woodville, 200 acres, with 1 giant under about 40 ft. pressure; M. L. Jones, of Brooks, has 800 acres of placer on Saxe Creek, with 2 pipe lines, the giant being under 75 ft. pressure and the other under 162 ft. for operating an elevator, raising the gravel 16 ft. into the sluice boxes; Watts & Carter have 40 acres on Dixie Gulch, a tributary of Pleasant Creek, with 1 giant under 80 ft. pressure; Cameron & Haymond have 600 acres on Pleasant Creek, with 1 giant under low pressure; C. E. Wickstrom has 275 acres on Pleasant Creek, with 3 giants under 160 ft. pressure.

#### PENNSYLVANIA.

##### Anthracite Coal.

Philadelphia & Reading Coal and Iron Company.—This company's statement for April and

for the 10 months of the fiscal year from July 1st to April 30th is as follows:

	April.	Ten months.
Earnings .....	\$2,345,039	\$23,474,721
Expenses .....	2,329,943	21,794,697
Net earnings .....	\$15,096	\$1,680,024

For the 10 months the earnings showed a decrease of \$281,369, or 1.2%, and the expenses a decrease of \$201,754, or 0.9%; leaving a decrease of \$79,615, or 4.5%, in net earnings.

#### Bituminous Coal.

**Midland Coal Company.**—This company recently bought 2,000 acres of land adjoining the tract it is now opening 4 miles west of Hustonville. It is the intention of the company to open 2 mines on the new tract at a cost of about \$80,000 each and erect fine steel tipples and modern appliances. Seven miles of the Western Washington railroad, which gives an outlet for the coal, will be built, and contractors have already been on the ground to make rough estimates. Contracts have been awarded for the machinery for the new mines. The Norwalk Machinery Company, of Norwalk, Conn., has been given the order for the air compressors, and the Erie Boiler Company will make all the boilers. The work of installing the equipment will be rushed. The Midland Company has awarded a contract for 160 miners' dwelling houses. These houses will cost about \$75,000. The 2 new towns will probably be known as Taylor and Salsbury. It is the intention of the Midland also to erect a brick-making plant near the new mines at a cost of \$20,000, having a capacity of 30,000 rough bricks a day. George Albertson, manager of Booth & Flinn, Ltd., will manage the plant. The company opened its first mine on November 17th, and already it is shipping about 1,400 tons daily. It is the purpose to bring this daily capacity up to 2,500 tons.

(From Our Special Correspondent.)

**Bessemer Coke Company.**—This company has enlarged its holdings in the Masontown District by purchasing the plants of the Columbia Coke Company, amounting to about 100 ovens, and large tracts of valuable coal land. The Bessemer Company is one of the most flourishing independent coke concerns in the Connellsville Region. It owns about 1,000 ovens and has a yearly output of 600,000 tons of coke.

**Donohoe Coke Company.**—This company has begun the erection of a string of 61 bee-hive coke ovens at its Crabtree plant. The company began work in January, 1900 with 119 ovens. Now 275 men are employed at the plant.

**Indiana Steel Company.**—This company has bought from J. V. Thompson, of Uniontown, a tract of 1,000 acres of coal land in the Masontown District. The price was about \$400 an acre. Thompson, Barnes & Hibbs sold another 1,000 acre tract of coal land in Menallen Township to H. H. Stambaugh and other Youngstown, O., men. The price was \$400 an acre.

**Merchants' Coal Company.**—A new branch of the Baltimore & Ohio Railroad, about 12 miles long, will leave the Somerset & Cambria Railroad near Freidens and run through Quemahoning Township to tap the rich coal-fields near Janer's, which are being developed by the Merchants' Coal Company.

**Mt. Pleasant Coke Company.**—The last tract of Connellsville coking coal held by the original owners in Westmoreland County was sold last week to this company for \$22,000. The incorporators of the new company are William A. Wilson, Jacob B. Kuhns, Edward B. McCormick, William M. Hudson and Thomas N. Barnhart, all of Greensburg. The tract includes 132 acres under the Ebers farm. The fact that the coal sold for considerably less than \$1,000 an acre contradicts the recent remark of Charles M. Schwab, president of the United States Steel Corporation, that not another acre of Connellsville coal could be bought for less than \$60,000 an acre.

**Neff Coal and Coke Company.**—This company has been chartered at Harrisburg with a capital of \$12,000. The directors are: John C. Neff, Masontown; John P. Brennan, Scottdale; Alfred E. Harper, Chicago; J. G. Van Swearingen, Uniontown.

#### TENNESSEE.

##### Rhea County.

**Dayton Coal and Iron Company.**—A gas or dust explosion in this company's Richland Mine at Dayton on May 27th killed 21 men. The explosion is thought to have been caused by a miner carrying a naked lamp. The mine was considerably damaged and many of the gangways were blocked by falls of roof, thus hindering attempts at rescue. The mine is situated on a spur of Walden's Ridge and has been worked for many years. It is a companion of the Nelson Mine, belonging to the same company, in which 32 miners lost their lives by an explosion in 1895.

#### UTAH.

##### Beaver County.

**Carbonate & Rattler Mining Company.**—This

company has been organized in Salt Lake with \$200,000 capital in \$1 shares to develop the Homestake group of 3 mining claims, situated in San Francisco District. M. P. Gilbert is president and treasurer; W. H. Bramel, vice-president; George W. Parks, secretary, and John A. Street and T. R. Higgins are the other directors.

The property was recently acquired by Mr. Gilbert from Messrs. Lawrence and Hampton under bond for 18 months. A new 400-ft. shaft is to be sunk.

#### Juab County.

**Joe Bowers.**—The directors recently paid \$12,500 on the judgment against the company. The insurance company is expected to pay the balance.

**May Day.**—Salt Lake papers report a strike of rich silver ore carrying chlorides in this mine at Tintic. The discovery is said to be 40 ft. from any known ore shoot.

#### Salt Lake County.

**Germania Smelter.**—The building covering the 10 Bruckner roasters of this plant at Murray was destroyed by fire recently. The loss is estimated at about \$8,000.

**Mingo Smelter.**—This plant of the American Smelting and Refining Company at Sandy is again producing matte.

**Neptune.**—The tunnel on this mine at Bingham was recently blown up by outside parties, leaving the men in the mine to get out as best they could through the upper workings. The damage is not great. The trouble is said to be the result of orders issued by Managing Director Holden of the United States Company for the miners to vacate the property. The owners of the ground are New York and New Jersey men. The United States Company claims the ground.

**Winnemuck.**—This group of 11 locations on the silver-lead belt at Bingham is reported to be now in the possession of F. H. Lathrop and M. L. Effinger, who represent a Detroit company. A force of miners under Henry Crowther has started work. It is said the same Detroit men have an option on the Trewaukee and on a ½ interest in the Dixon Group.

#### Summit County.

**Burlington Extension Mining Company.**—This company, with \$50,000 capital in 25c. shares, has been formed in Salt Lake to develop the Burlington group of 4 claims in West Tintic District. M. J. Kennedy is president; Richard Whitaker, vice-president; C. E. Kennedy, secretary and treasurer. Besides the president and vice-president, the other directors are R. F. Nelsen, Mary R. Stanton and John J. Woodring.

#### WASHINGTON.

##### Ferry County—Republic.

(From Our Special Correspondent.)

The Great Northern Railway Company has surveyors in the field here. The Grand Forks & Republic Railroad Company also has surveyors in the field who have nearly completed their locating survey. This company must begin the construction of its road by June 6th.

The report of rich placers on Granite Creek, 2½ miles northwest of Republic, has caused some excitement. It had been known for 4 years that there is placer gold in the stream, but no one ever found enough to pay. Some woodchoppers recently found coarse gold and located a claim. Hundreds of men, women and children rushed to the spot with shovels and pans of every description. About \$200 was taken out in a few hours, including fine gold and small nuggets, the heaviest of which weighed 237 grains. About 200 ft. of flume has been built and the first day's clean-up was estimated at about \$100. Every creek bottom within 15 to 20 miles has since been located.

**California.**—The shaft is down 300 ft. and a station has been cut 30 ft. above the bottom. Sloping continues on the No. 2 level. About 200 tons of low-grade ore remain on the dump. The last shipment ran \$187 per ton. About 24 men are employed.

**Morning Glory.**—The upraise from the 280-ft. level is up 70 ft., and the width of the vein has more than doubled. Samples show native gold.

**Trade Dollar.**—The new shaft is down 110 ft., but has not struck the lead.

#### WISCONSIN.

##### Sauk County.

A find of good iron ore at North Freedom near Baraboo in a diamond drill hole is to be investigated by a shaft. Chicago parties, said to be connected with the Illinois Steel Company, are interested, and C. T. Roberts is in charge of the work.

#### FOREIGN MINING NEWS.

##### AFRICA.

##### Natal.

The commissioner of mines reports for March that from 11 collieries working 46,285 tons were produced and shipped. The men employed in

the mines included 148 white men, 2,103 negroes and 1,051 East Indians. Of these 986 were employed above ground; 2,316 under ground; a total of 3,302. The coal exported was 2,903 tons, while that sold for use of ships was 17,986 tons.

#### CANADA.

##### British Columbia—West Kootenay District.

**Noble Five.**—At the annual meeting in Victoria of this company, operating at Sandon, George B. McDonald, general manager, presented a very full report of the work undertaken. He reported that it was now for the first time since its incorporation upon a self-supporting basis, and also held out the hope that before the year closed the mine would be a large shipper. The following officers were elected for the ensuing year: President, James Dunsmuir; vice-president, C. E. Pooley.

##### British Columbia—East Kootenay District.

**St. Eugene.**—This mine at Moyie, which has been partly closed down for several weeks, is to start up again, giving employment to 200 men. James Cronin is manager.

##### British Columbia—West Kootenay District.

**Giant.**—This company at Rossland is being reorganized by C. H. McIntosh. The purchase price is on the basis of about \$175,000 for the mine. Stockholders in the present Giant Company will get stock in a new company at a rate of a little less than 7c. a share. Mr. Mackintosh undertakes to form a London company, to be known as the Giant Mining Company, Limited, with a capital of £200,000. The Giant is one of the old locations at Rossland, and lies on Red Mountain to the west of the Le Roi. The largest shareholders were A. D. Coplen, M. S. Bentley and C. O'Brien Reddin, of Spokane.

#### CUBA.

The question whether there is gold in Cuba is answered in the official report of Mr. Charles M. Dobson, the mining expert employed by Gen. Wood to examine the metalliferous deposits of the province of Santiago, says the New York "Post." The report shows that there is not enough gold to cause any excitement, though some samples of copper ore carry a little, and there are some 7 gold mines denounced at El Cobre and at Holguin. There are, however, large deposits of manganese to the northward of Santiago, and also deposits of lead, copper, zinc, and other minerals.

The production of bessemer ore, however, promises particularly rich rewards to skillful and economical management. Within the last 10 years from the properties at Juragua and Daiquiri alone there has been mined and shipped iron ore representing a value of \$21,000,000. For more than 130 miles in the foothills on each side of the Sierra Maestra Mountains, the south coast range, there are deposits of iron ore of varying quality and volume, beginning 35 miles east of Santiago, and stretching westward. The indications, according to Mr. Dobson's report, are that workable deposits of bessemer ore can be opened in many places. But only the strongest financial organizations can expect to cope successfully with the preliminary expense necessary to open the ore deposits, build railroads, and import equipment for the transportation of the ore to the seaboard.

#### EUROPE.

##### Wales.

**Universal.**—At this colliery at Senghenydd in the Rhondda Valley an explosion on May 24th of gas wrecked the mine and entombed 78 miners, all of whom perished. The Rhondda Valley is a populous coal mining district and many accidents have occurred, though the Government regulations regarding the ventilation of mines, etc., are now strict. In 1867 out of 170 men and boys in the Ferndale Mine 167 were killed. At another explosion in 1885 75 men out of 400 were killed.

#### ONTARIO.

##### Lake of the Woods District.

**Golden Star.**—Development work has started with a force of 15 men.

#### COAL TRADE REVIEW.

##### Anthracite.

##### New York.

May 31.

Though in past years the anthracite trade has usually begun to show "mid-summer" dullness by June 1st, this year a new condition prevails. The demand for coal is remarkably strong, particularly from lower lake and Eastern points, and prices are as firm as a rock.

There are rumors of impending changes in the control of the Delaware, Lackawanna & Western Railroad, changes which may have considerable effect if not on the coal trade, then on the present "community of interest" which controls that trade. Some of the rumors are merely Wall Street gossip, but it really looks as though part of the present activity in the stock had a better basis than rumor. It may be that the Gould-Harriman-Standard Oil interests are at

work. Remembering what has happened in Union Pacific and Northern Pacific and desirous of getting an Eastern outlet for the Missouri Pacific by way of the Wabash, these interests may be seeking control of the Lackawanna. Lackawanna stock is widely held, still with the aid of Standard Oil interests in the City Bank, the Moses Taylor estate and by purchase of the First National Bank stock with what small lots that may be picked up in the present flurry, the acquiring of a controlling interest would not be as difficult as it looks at first sight. With Gould-Standard Oil interests in control of the Lackawanna the "community of interest" idea might not be in jeopardy, but Mr. Morgan and his associates would probably find the "interests" somewhat larger than they expected.

Trade at the head of the lakes and in Chicago territory shows little change. Buying for immediate needs is naturally light. Buying for storage would be much brisker if the coal could be had. The movement of coal up the lakes is not heavy as yet, owing partly to the demand at other points. Demand at lower lake ports and in Canadian territory is excellent for this season of the year. The present freight rate up to the lakes from Buffalo is 40c. Along the seaboard anthracite is in demand. Receipts at Boston are 55% ahead of the figures to this date last year and are probably the largest on record. At New York the steam sizes are reported in better supply, but stories of low prices for these sizes are generally found to apply only to coal of inferior quality. Bad weather is interfering with coastwise shipments.

The June prices for free-burning anthracite f. o. b. New York will be: Broken, \$3.70; egg, \$3.95; stove and nut, \$4.20.

**Bituminous.**

The Atlantic seaboard soft coal trade continues quiet and there is not much strength to the market. Abundant water supply for those manufacturing establishments using water power, the attention given by dealers to the anthracite trade and the slackening of industrial activity from threatened labor troubles are all given as reasons for the quiet market. Coastwise shipments are hampered by bad weather and there is as yet but little improvement in the congested condition of tidewater shipping ports.

In the far East coal is in good supply. The better grades are held at schedule prices, but the poorer grades can be had at discounts. There are still vessels discharging at points beyond Cape Cod, but new arrivals are few. Along Long Island there is, if anything, a little improvement. Demand at New York ports remains quiet. All-rail trade continues to take a fair tonnage.

Transportation from mines to tide is still slow and irregular, while car supply at the collieries is regulated by the despatch shown by individual producers in unloading cars at the shipping ports. In the coastwise vessel market, owing to bad weather and also to the demand from anthracite shippers, vessels continue in poor supply, while rates are firm. We quote current rates from Philadelphia as follows: Providence, New Bedford and the Sound, 60c.; Boston, Salem and Portland, 70@75c.; Portsmouth, Wareham and Bath, 75c.; Lynn, 80@85c.; Newburyport, 90c.; Dover, \$1.25 and towages; Saco, 90c.@\$1 and towages; Bangor, 85c. Rates from the further lower ports are about 10c. higher.

**Birmingham, Ala.**

May 27.

(From Our Special Correspondent.)

There is not a great demand for coal in Alabama, and as a consequence work at a number of the mines is rather slack. Four days a week is considered good work at a large number, while in some places three days is the most. The free miners at Coalburg, in Jefferson County, 96 in number, went out on a strike last week because the company allowed two non-union men to work in the mines at that place. The Sloss-Sheffield Steel and Iron Company operate the mines at Coalburg, but as there is no special need for the coal no effort is being made to settle the strike.

The coming conventions of the miners in this State for the adoption of a wage scale for the ensuing year, commencing July 1st, is the absorbing topic. The miners of Walker, Winston and Marion counties who have formed a sub-district, will meet in Jasper, Walker County, on June 3d for the purpose of forming a wage scale. Inasmuch as very little coal mined in the counties named enters into the manufacture of pig iron, an effort will be made to divorce the coal mining wages from the selling price of pig iron, the basis at present. The convention of the miners in Jefferson, Bibb, Tuscaloosa and other counties in which coal is mined, other than those previously mentioned, will be held in Birmingham on June 17th. A conference with the operators of the mines has been set for June 24th. The Coal Operators' Association, formed last year among the coal operators of Alabama, will meet in Birmingham on June 10th for the purpose of discussing what will be done at the conference with the miners.

**Chicago.** May 27.

(From Our Special Correspondent.)

Anthracite Coal.—But little change is observed in the trade at this point, sales having increased but slightly and inquiry having been no larger. Though the actual business done here is small, yet it is understood that some companies have refused further orders for May delivery, because the supply of hard coal is small, with no present prospect of enlargement. Prices as per circular are \$5.75 for grate; \$6 for egg, stove and chestnut.

Bituminous Coal.—Sales are yet very modest, actual business being almost wholly in small quantities. There is a large supply of soft coal here and prices are quoted away below supposed circular; but even with such an inducement the market drags.

Coke is in but limited demand, with prices weak. The supply is abundant.

**Cleveland, O.** May 28.

(From Our Special Correspondent.)

Contrary to all expectations, about the time the coal shippers were getting down to business for a heavy movement up the lakes during the next six weeks, a car famine has set in which is having a serious result upon the lake shipping. Yesterday and to-day it has been almost impossible to get enough coal at the Ohio coal docks to give waiting boats their cargoes. The lack of cargoes has sent some boats back to the head of the lakes light and is having a retarding effect upon business generally. During the week the shippers made concerted effort to break both the wild and contract rates. Some blocks of coal were covered to the head of the lakes at 35c. which, it was hoped, could be made the regular rate, but a combination of Cleveland owners prevented this from meeting with success. The wild rates also have held firm at 40c., although a few cargoes have been placed at 35c. In these instances, however, the docks are the best and dispatch assured. Sales are being made more freely on old prices, some of the dealers in the Northwest covering for most of the season's coal within the last few weeks.

**Pittsburg.** May 29.

(From Our Special Correspondent.)

Coal.—The independent coal companies are becoming stronger and as a result the two big coal combinations are not attempting to advance prices, but it is said that considerable shading is being done. The rates to the northwestern markets are fixed at \$2 f. o. b. at the Cleveland docks and will not be changed this season. Shipments are going forward promptly and there is no complaint this week of a shortage of railroad cars. The Monongahela River Consolidated Coal and Coke Company, the river combination, will have shipped all the coal loaded before the close of the week. The river operators never before have been so favored by navigable rivers as they have since March 1st. Last Saturday 2,000,000 bus. went out to Southern ports and this week the balance that is loaded, fully 7,000,000 bus. will go down. All returning tow boats bring back empty coal boats and barges and there will be no idleness among the miners at the river pits this summer.

Connellsville Coke.—There was a slight falling off in the production of Connellsville coke, but the shipments were increased. The production last week amounted to 230,017 tons, a decrease compared with the previous week of 3,251 tons. Of the 21,447 ovens in the region 19,802 were active and 1,645 were idle. The shipments for the week aggregated 10,828 cars, distributed as follows: To Pittsburg and river tipples, 3,561; to points west of Pittsburg, 5,084 cars; to points east of Connellsville, 2,183 cars. This is an increase of 353 cars compared with the shipments of the previous week. Prices remain unchanged at \$2 for furnace and \$2.50 for foundry.

**Foreign Coal Trade.** May 31.

No new contracts are reported. The trade to the West Indies and South America is about as usual. For Mediterranean ports there is considerable inquiry.

Several French steamers have been chartered to carry coal from Virginia, Baltimore or Philadelphia to the Mediterranean, especially to Marseilles, at 15 6d. (\$3.72), June sailing. Other charters were from Newport News, Va., to Malta at 12s. 6d. (\$3), or to Trieste, Austria, at 13s. 6d. (\$3.25), June sailing.

The German coal trade is suffering from the depression prevailing in metallurgical industry. The symptoms are becoming more marked as the season advances. Among these may be mentioned a diminution in the deliveries made by the three principal German coal-producing districts, the movement from the Ruhr, the Saar, and Silesia in the first half of April having been 2,540,940 tons, as compared with 2,670,390 tons in the corresponding period of 1900, showing a falling off of 129,450 tons. The daily deliveries of coke made by the German coke syndicate in March were 25,340 tons, as compared with 23,740 tons in March, 1900. The daily deliveries in the first quarter of this year were 25,730 tons, as compared with 24,340 tons in the corresponding three months of 1900. The imports of coal into Germany in the first quarter

of this year were 1,023,903, as compared with 1,265,439 tons in the corresponding period of 1900; of lignite, 1,718,191 tons, as compared with 811,180 tons; and of coke, 104,200 tons, as compared with 120,660 tons. The exports of coal from Germany in the first quarter of this year were 3,628,129 tons, as compared with 4,045,550 tons in the corresponding period of 1900; of lignite, 5,681 tons, as compared with 28,350 tons; and of coke, 559,422 tons, as compared with 505,987 tons.

Messrs. Hull, Blyth & Company, of London and Cardiff, report as below, under date of May 18th: The sharp decline in coal experienced last week has not continued. Prices in view of the Whitsuntide holidays are fairly steady, and are nominally as follows: Best Welsh steam coal, \$4.56@4.68; seconds, \$4.32; thirds, \$4.08; dry coals, \$3.96; best Monmouthshire, \$4.08@4.20; seconds, \$3.72@3.84; best small steam coal, \$2.28; seconds, \$2.04; other sorts, \$1.68.

The above prices for Cardiff coals are all f. o. b. Cardiff, Penarth or Barry, while those for Monmouthshire descriptions are f. o. b. Newport, exclusive of wharfage, and are for cash in 30 days, less 2½% discount.

Toward the close of the week freight rates firmed somewhat, especially toward the Mediterranean. Some rates gave from Cardiff: Marseilles, \$2; Genoa, \$1.98; Naples, \$2.04; Port Said, \$2.10; Singapore, \$3.36; St. Vincent, \$1.98; Rio Janeiro, \$3.60; Buenos Aires, \$3.24.

**CHEMICALS AND MINERALS.**

(For further prices of chemicals, minerals and rare elements, see page 702.)

**New York.** May 31.

Heavy Chemicals.—There continues a good forward business in alkali and caustic soda at quotations below. Sal soda meets with an improved export demand. Bleaching powder strengthened after selling at \$1.60@1.75 per 100 lbs., as spot supplies are moderate. Domestic soda ash in bulk is worth 2½c. per 100 lbs. less than quotations below:

Articles.	Domestic.		Foreign.
	F.o.b. Works.	In New York.	In New York.
Alkali, 58% " 48%	77½@85 85@90	.....	85@87½
Caustic Soda, high test.... powd. 60% 70@74% 98%	\$1.85@1.90 ..... ..... .....	..... 2.75 2.85 3.25	1.85@1.87½ ..... ..... 3.75@4.00
Sal Soda..... " conc. Bicarb. Soda.. " extra	50 1.25@1.50 1.05@1.10 3.25@3.50	60 ..... ..... .....	67½ 1.75 1.37½@3.00 .....
Bleach Pdr., Eng. prime, other brands.	..... ..... .....	..... ..... 8.00@8.25	2.00@2.16 1.90@1.95 9.50@9.75
Chl. Pot. cryst. " powd.	..... .....	8.25@8.50	9.75@10.00

Bichromates.—Abroad makers report trade quiet, and quote f. o. b. Glasgow, Scotland, 3¼d. (6½c.) per lb. for potash, and 2½d. (5c.) per lb. for soda. In New York importers ask 8½c. per lb. for potash, and 6¼c. for soda. American makers' prices are fractionally lower.

Arsenic.—Unsteady, owing to limited demand. White is worth 4c. per lb. on spot, while shipments are held at 3½c. Red is obtainable at 7@7½c. per lb.

Acids.—Export business in muriatic and sulphuric acids is improving. Domestic trade is quiet. Blue vitriol competition among sellers has disturbed the market and prices are irregular.

Quotations as below are for large lots delivered in New York and vicinity, per 100 lbs. unless otherwise specified.

Acetic, No. 8.....	\$1.62½	Nitric, 38°.....	\$3.57½
Blue Vitriol.....	4.25@4.50	Nitric, 38°.....	4.12½
Aqua Fortis, 38°	3.62½	Nitric, 40°.....	4.37
Aqua Fortis, 38°	3.87½	Nitric, 42°.....	4.75
Aqua Fortis, 40°	4.12½	Oxalic.....	5.60@5.75
Aqua Fortis, 42°	4.50	Sulphuric, 66°	1.30
Muriatic, 15°	1.20	" bulk 50° ton	14.00
Muriatic, 20°	1.35		
Muriatic 22°	1.50		

Pyrites.—This week we imported at New York 691 metric tons Spanish iron pyrites. Acid makers are calling more regularly on contract, and prices are pretty well maintained.

We quote per ton as follows: Mineral City, Va., lump ore, \$4.90 per long ton, and fines \$4.20. Charlemon, Mass., lump, \$5, and fines, \$4.75. Spanish pyrites, 12c. per unit delivered ex-ship New York and other Atlantic ports. Spanish pyrites contain from 46@51% of sulphur; American, from 42@44%.

Brimstone.—Practically no change at \$21.75@22 per ton for spot best unmixed seconds and \$21.25@21.50 for shipments. Best thirds are \$2 less. During this month spot sales of best unmixed seconds were made at an average of \$21.63, which is the lowest this year. On the other hand, shipments were booked at \$21.33, which compares favorably with previous months, owing to the efforts in the primary market to bolster up prices.

The exports of brimstone from Sicily in April

are reported to us by Emil Fog & Sons, as below, in long tons:

Destination.	1900.	1901.	Changes.
America	10,560	11,510	I. 950
Austria	3,225	2,740	D. 485
France	11,071	9,005	D. 2,066
Germany	2,241	840	D. 1,401
Greece and Turkey	3,394	5,770	I. 2,376
Holland	673	1,435	I. 762
Italy	16,584	15,873	D. 711
Portugal	955	873	D. 82
Russia	2,536	3,945	I. 1,409
Spain	123	879	I. 756
Sweden and Norway	5,663	10,906	I. 4,243
United Kingdom	1,612	681	D. 1,131
All other countries	867	2,319	I. 1,432
Total	59,504	66,776	I. 7,272

The increase in April this year, equals 11%, owing principally to the larger movement to Norway and Sweden.

Stocks in Sicily amounted to 171,935 tons on May 1st, this year, showing a decrease of 43,012 tons as compared with the corresponding date last year. This falling off was due chiefly to the very small stocks at Catania, amounting to 19,073 tons, against 55,824 tons on May 1st, 1900.

Sulphate of Ammonia.—Gas liquor is stronger at \$2.80@2.82½ per 100 lbs.

Phosphates.—With easier freight rates the export movement has improved. But there is still some indispotion manifest among foreign consumers to place any large contracts for phosphate rock. It is clearly evident to exporters though that the Continental superphosphate makers will be obliged to buy raw material in the near future, as the stocks abroad are much depleted. In the United Kingdom, on the other hand, competition between the lower grade American and Algerian phosphates is so keen that buyers have things pretty much their own way, and some rather low prices have been heard. Agents for the Algerian stuff quote 5¼d. per unit, but buyers will not pay more than 5d.; consequently there is a deadlock which prevents business. While this year's business may be ruled by unsatisfactory prices, miners in Algeria are loath to book contracts for 1902, as there is talk of a higher export duty being imposed on phosphates by the government. Until this question is settled we cannot look for much improvement in business.

High grade Florida and Tennessee rock are also quoted lower in foreign markets.

Mining operations in South Carolina have been favorably influenced by the reduction in stocks, and three of the largest concerns—the Coosaw, Beaufort and Central—are working actively. As yet comparatively little rock has been exported, owing to keen competition with foreign stuff.

In the other producing fields miners are preparing for a larger foreign trade in the near future.

We quote, per ton, as follows:

Phosphates.	Per Ton F. o. b.	C. i. f. Un'd Kingdom or European Ports.	
		Unit.	Long ton.
*Fla. hard rock (77@80%)	\$6.50@7.00	6¼@7d	\$10.53@10.87
*Fla. land pebble (68@73%)	3.85@4.00	6¼@7d	8.58@8.75
*Fla. Peace River (58@63%)	2.50@2.75	6@6¼d	7.20@7.35
†Tenn. rock 78% export.	3.25@3.50	6¼@6¾d	10.14@10.53
†Tenn. .... 78% domestic.	3.00	.....	.....
†Tenn. .... 75%	2.75	.....	.....
†Tenn. .... 70@72%	2.00@2.25	.....	.....
‡So. Car. rock, crude	2.50@2.75	.....	.....
‡So. Car. rock, dried	3.25	5¼@5½d	6.90@7.25
Algerian, rock, (63@70%)	.....	5¾@6¼d	7.70@8.71
Algerian, rock, (58@63%)	.....	5¼@6d	6.30@7.20
Tunis, Gafsa	.....	5¼@6d	6.30@7.20

\* Fernandina, † Mt Pleasant. ‡ At mines. § On vessels, Ashley River.

Nitrate of Soda.—Firmer, owing to advancing prices on the coast. New York quotations are \$1.90@1.95 per 100 lbs. for all positions. Some business has been done at these figures, but consumers are still inclined to hold off buying for lower prices. The "Nellie Troop" arrived with 16,352 bags. Expected cargoes in June are the "Bijorgvin" with 28,000 bags; "Belmont," 16,000 bags; "Helen Brewer," 18,000 bags; "Cumbal," 14,400 bags; "Coya," 14,950 bags, and the "Vidette," with 9,187 bags, making a total of 100,537 bags.

Concerning the primary market, Messrs. Jackson Brothers, of Valparaiso, Chile, write us under date of April 20th as follows: Although cable advices from Europe state that the market is weak, due to heavy arrivals of cargoes of nitrate, producers have been very firm, owing to the increased consumption of the world in March and first fortnight of April. There has been considerable demand for prompt 95% nitrate at 5s. 11½d. alongside, at which price 600,000 qtls., more or less, have changed hands, with little disposable at 6s. alongside. Sales for July delivery have been effected at 6s.@6s. 0½d. alongside. But although no transactions of importance have taken place for season's shipment, producers who were willing to accept 6s. 1d. alongside at the close are holding for higher prices. Refined nitrate has been disregarded entirely, and we have no transactions to report. The production during March amounted to 2,018,000

qtls., making a total of 5,939,000 qtls. for the first quarter, as against 7,520,000 qtls. in 1900. We quote 95% May-June, 5s. 11½d.; July, 6s., August, 6s. 0½d.; September-December, 6s. 1d., all ordinary terms sellers. The price of 5s. 11½d. with an all-round freight of 21s. 3d. stands in ¾s. ¼d. per cwt, net cost and freight without purchasing commission. Reported sales for the fortnight ended April 20th were 662,000 qtls., and re-sales, 100,000 qtls.

IRON MARKET REVIEW.

NEW YORK, May 31, 1901.

Pig Iron Production and Furnaces in Blast.

Fuel used	Week ending		From Jan., '00.	From Jan., '01
	June 1, 1900.	May 31, 1901.		
An'racite & Coke.	266	288,525	233	294,125
Charcoal.	24	6,250	23	7,225
Totals..	290	294,775	256	301,350
				6,401,655
				6,139,600

The waiting period continues and we have continued hesitation about placing contracts for the second half of the year. For the next two or three weeks we shall have this sort of a market, with the usual talk about concessions to secure orders, decreasing trade, and the rest of it. At present makers of pig iron, billets and other material do not seem disposed to make any concessions. While new work is temporarily held back and orders are few, it is generally believed that another good harvest is secure, and consequently another year of active trade and good demand for construction materials. This is the important point, and sellers are generally firm in refusing the concessions which buyers are inclined to press.

Birmingham, Ala. May 27.

(From Our Special Correspondent.)

There is considerable pig iron being shipped from Alabama, but the demand is not as satisfactory as it might be, although a number of inquiries are being received. The production will be increased in the State in the next fortnight or so and perhaps sooner. It is stated that three furnaces will resume operation before the end of three weeks, two in Anniston, belonging to the Woodstock Iron Company, and one at Sheffield belonging to the Sloss-Sheffield Steel and Iron Company. The work on the big new furnace of the Republic Iron and Steel Company at Thomas is being rushed to completion. The furnaces of the Tennessee Coal, Iron and Railroad Company at Oxmoor, Bessemer and Ensley undergoing repairs are nearing completion also, while the Sloss-Sheffield Company has increased the force on its North Birmingham furnace relining in order to finish it as quickly as possible.

The following prices are given for the commodity: No. 1 foundry, \$11.50@12.25; No. 2 foundry, \$11@11.50; No. 3 foundry, \$10.50@11; No. 4 foundry, \$9.75@10.25; gray forge, \$9.50@10; No. 1 soft, \$11.50@12.25; No. 2 soft, \$11@11.50.

There is a good demand for finished iron and steel and the rolling mills have been kept busy. The Birmingham mills are purchasing their steel from the Ensley plant and are rolling a good quantity of the product. The machine and foundry trade is in good shape. There was no strike among the machinists in Birmingham or in the Birmingham District. Caldwell & Watson have purchased a lot on Fourteenth Street and are considering the erection of a large and modern foundry and machine shop. The Hardie-Tynes Foundry and Machine Company will put the new shops in operation June 1st. In the steel line there is much activity. The steel rail mill is nearing completion rapidly. During the past week a large engine was placed in this plant and other machinery is being placed.

Chicago. May 27.

(From Our Special Correspondent.)

Pig Iron.—The pig iron market remains quiet and few transactions of note have been made. There continues a good demand from foundries for small lots, the weekly aggregate of such sales footing up a considerable tonnage. Southern furnaces are doubtless anxious for business as a reduction of about 50c. per ton is noted. Northern furnaces are mostly sold up for months ahead and in consequence there is no loosening up in prices from this quarter. Quotations are as follows: Lake Superior charcoal, \$17.50@18; local coke foundry, No. 1, \$16@16.50; No. 2, \$15.50@16; No. 3, \$15@15.50; local Scotch, No. 1, \$16.25@16.50; Ohio strong softeners, No. 1, \$16.50@16.75; Southern silvery, according to silicon, \$15.65@16.15; Southern Coke, No. 1, \$15.40@15.90; No. 2, \$14.90@15.40; No. 3, \$14.40@14.90; Southern, No. 1 soft, \$15.40@15.90; No. 2 soft, \$14.90@15.40.

Cleveland, O. May 28.

(From Our Special Correspondent.)

Iron Ore.—The movement of iron ore appears now to have struck its pace for the summer and the business is beginning to be very active. About all of the tonnage that will be applicable during the season is now afloat and actively en-

gaged, hence if there has been any backwardness to this time it will disappear before the flood of tonnage. So far the rates have held firm at 80c. on going charters, but unless the grain trade livens up some, drawing boats away from the ore trade, this rate is likely to slump off a little. Short season contracts are now made at 75c. quite freely, with full season contracts 5c. higher.

Pig Iron.—A little business has been done during the week just closed in basic at \$14.25, which is a sharp reduction from prices heretofore obtained. Most of the sales made for the third quarter, and a number of them have been recorded, are now made on the basis of \$15 at the Valley furnace. Foundry No. 1 is now bringing \$14.50, both for immediate delivery and also to cover during the second half of the year. Foundry No. 2 is quoted at \$14. No bessemer is being sold now or likely to be sold soon, as the market is a little backward.

Finished Material.—The mills producing almost every grade of finished steel are now content to receive specifications on former orders and some of them receive these gladly. The occasion for this feeling is the absence of any new business and a tendency, with some who have placed large contracts, to recall them. The business this week has been rather light, when considered in the light of new orders, but upon the basis of applications on former orders it is satisfactory. Some of the mills, however, are losing business heavily because those who made contracts cannot be persuaded to place specifications to cover their orders. The capacity of the mills upon plates has been very well taken up for some time to come, which is considered fortunate in view of the light demand which the future presents in which the car companies are the only prominent figures. The sales of structural material have been very light, but little, if any, new business making its appearance. Rail sales are moderate, the electric lines taking all that is being sold. Billets are in good demand and such mills as have them are able to make immediate disposition of the product. Bars are moving at an uncertain gait, with but little new business appearing. The following prices are quoted: Bars, 1.55c.; plates, beams and channels, angles, 1.70c.; rails, \$28; billets, \$24.

Old Iron.—Those who have scrap are holding on to it until the market shall change and those who use the iron have bought up ahead and are now waiting the change also. Many of the dealers have sold short and are now compelled to make deliveries. They will not lose heavily because they sold at prices recently prevailing and are compelled to buy now upon the same basis. The result of this agitation has been a deadlock which is completely blockading business.

Philadelphia. May 29.

(From Our Special Correspondent.)

Pig Iron.—There is scarcely any difference of opinion among those who speak for pig iron in eastern and middle Pennsylvania as to probable conditions for the next three months. The fact that very little iron is being bought or sold makes no impression among the owners of modern plants, but the difference in cost of production between the best plants and some of the older ones has been figured out very closely. A good many big iron buyers firmly believe that they will pay less for iron in July than they could buy it for now. The only present reason for this notion is that certain makers have allowed certain buyers to understand that they will be favored if they place autumn orders. The forge and foundry buyers are not impressed; in fact, it is a question whether an actual cut at this time would induce large ordering. This statement is based on personal interviews. But when it comes to basic pig or bessemer the condition is a little different, although even here buying is limited. People are waiting to see whether \$15 for bessemer is to stand. Unless some new strengthening factor appears forward buying will be entered upon more cautiously than last spring. Prices may be fairly quoted at \$16 for No. 1 X foundry; \$15.50 for No. 2 X; \$15 for No. 2 plain; \$14.50 for forge; ordinary, \$14; basic, \$14.50.

Billets.—As manufacturers are acting on the defensive, nothing can be said. Users are indifferent, but two or three parties would buy at \$25.50. The only business since last week is in early delivery lots of special steel to cover new work.

Bars.—There is no evidence that the recently agreed upon bar iron prices are being disregarded. The Eastern bar iron users are very busy. Steel bars are strong at 1.60@1.70c.

Sheets.—This week's business has been mainly in cheaper grades of iron. There are reasons for knowing that, good as business is, big autumn orders could secure fractional concessions. The usual quotations are from 2½ for No. 10 to 3.80 for No. 28 for best sheets.

Pipes and Tubes.—The report from this branch is like all recent ones. Tubular goods cannot be turned out fast enough.

Skep.—Inquiries this week from Western

sources show that prompt deliveries can command their own terms.

Plates.—Capacity in eastern Pennsylvania will be materially increased. Our local requirements are growing. Shops using boiler, tank and other forms of plates have their hands full. Manufacturers are busy and for prompt deliveries of fire-box steel an exceptionally high price was agreed to this week. Steel for marine purposes will soon be contracted for to cover recent business taken.

Structural Material.—Among new enterprises is a 24-story building, but the contract is as good as placed. Other buildings, five or six in number, from 8 to 10 stories, are soon to be provided for. The bridge building requirements are likely to be heavy in June if inquiries are reliable. Angles are 1.75@1.85c.; beams and channels the same price.

Steel Rails.—Actual news on rails is not to be had.

Scrap.—The heavier scrap dealers are scouring around like they were two or three months ago, but the kind of scrap they are after is hard to get and commands very good figures. Choice railroad brings \$20 when it can be had.

**Pittsburg.** May 29.  
(From Our Special Correspondent.)

The pig iron market is somewhat weaker than it has been for some time. It is due to the fact that consumers have their wants covered for the first half of the year and have not commenced buying for the second half. Furnaces not having their entire output sold for the first half are offering iron at lower prices than prevailed for several months. Bessemer pig iron is being offered in the Valleys at \$15.50@15.75. The sales of the past week amounted to about 10,000 tons at that price, which is \$16.25@16.50 delivered in Pittsburg. Foundry iron is selling somewhat lower this week and forge iron is also lower than it has been for several weeks. The demand for finished material continues strong and a number of new contracts have been taken. All the mills are busy and if there are no labor complications will continue in steady operation for several months. Steel billets are scarce for prompt shipment. Sheets continue firm and prices are unchanged. Zug & Company, Limited, have put their three new sheet mills in operation. This firm is sold up to July 1st.

There is considerable interest here in the deliberation of the delegates attending the 26th annual convention of the Amalgamated Association of Iron, Steel and Tin Workers now in session in Milwaukee. Reports from the convention city received to-day are to the effect that but few changes are to be made in the sheet and tin scale. The wage committee has recommended a new scale for iron workers. It fixes the puddling rate at \$5 based on bar iron selling at 1c. with an advance for each 1/10c. advance in bar iron. The present rate is \$4.75 a ton on a 1c. bar iron rate. The changes recommended in the sheet scale are trifling. The base remains unchanged, being 3c. for Nos. 26, 27 and 28 gauges. The tin-plate workers are urging an advance, but the committee has not recommended any material changes. The conservative element seems to be in charge of the convention and it seems likely now that a fair scale will be prepared. The proposition of the Republic Iron and Steel Company for a continuous scale or one with a non-interruptive clause does not appear to be meeting with much favor. If a satisfactory base can be agreed upon it is admitted that there will be no difficulty in securing a scale that will run for several years at least.

Pig Iron.—Sales of bessemer pig iron amounted to about 10,000 tons. The market is weak, however, and the price was \$15.50@15.75, Valley furnaces. Foundry No. 2 is low this week, being quoted at \$14.75, Pittsburg. Gray forge is offered at \$14.25 delivered in Pittsburg.

Steel.—Bessemer steel billets are scarce for prompt shipment. The pool price of \$24 is still being quoted for future delivery. Open-hearth billets are quoted at \$27@28. There is no change in the price of steel bars and plates.

Sheets.—The sheet market is firm and prices remain at 3.30@3.35c. for No. 28 gauge and galvanized at 70 and 5% off. The mills are all busy and considerable new business was taken this week.

Ferro-manganese.—There is no change in the market. The leading producer continues to quote 80% domestic at \$58.50.

**New York.** May 31.

Pig Iron.—The local market is quiet and prices are not strong. We quote as follows: Northern irons, tidewater delivery: No. 1 X foundry, \$15.65@16; No. 2 X, \$15@15.25; No. 2, plain, \$14.65@15; gray forge, \$14.15@14.50. For Southern irons on dock, New York, No. 1 foundry, \$15.50@15.75; No. 2, \$15@15.25; No. 3, \$14.25@14.50; No. 4, \$13.75@14.25; No. 1 soft, \$15.50@15.75; No. 2, \$15@15.25.

Plates.—The market for plate is steady, with a good demand for small lots. Eastern mills quote for large lots at tidewater: Tank, 1/4-in.

and heavier, 1.78c.; flange, 1.88c.; marine, 1.98c.; universals, 1.78c.

Bar Iron and Steel.—The market is quieter than it has been, though there is a fair amount of buying. We quote common bars at 1.50c. for large lots on dock; refined bars, 1.58c.; soft steel bars, 1.60c.

Steel Rails and Rail Fastenings.—Mills are reported very busy, but locally the market continues decidedly quiet. Standard sections are quoted at \$28 at Eastern mills; light rails at \$28 @ \$30 according to weight. Spikes are 1.60c.; splice bars, 1.40c.; bolts, 2.10@2.25c.

Structural Material.—There is a good demand. Building continues active. Large lots are taken right along, while buying of small lots is active. We quote for large lots at tidewater as follows: Beams, 1.75c.; channels, 1.75c.; tees, 1.80c.; angles, 1.75c.

**METAL MARKET.**

**New York.** May 31.

**Gold and Silver.**

**Gold and Silver Exports and Imports**  
At all United States ports in April and year.

Metal.	April.		Year.	
	1900.	1901.	1900.	1901.
<b>GOLD.</b>				
Exports	\$1,961,580	\$4,916,965	\$10,137,808	\$14,046,005
Imports	3,388,813	2,222,606	9,213,657	10,700,911
<b>EXCESS</b>	<b>E. \$1,427,233</b>	<b>\$2,694,359</b>	<b>E. \$924,151</b>	<b>E. \$3,345,094</b>
<b>SILVER.</b>				
Exports	4,112,043	4,959,047	19,116,508	19,479,971
Imports	3,323,808	2,346,061	11,488,560	11,077,355
<b>EXCESS</b>	<b>E. \$788,235</b>	<b>E. \$2,612,986</b>	<b>E. \$7,627,948</b>	<b>E. \$8,402,616</b>

These figures include the exports and imports at all United States ports, and are furnished by the Bureau of Statistics of the Treasury Department.

**Gold and Silver Exports and Imports, New York**  
For the week ending May 30th, 1901, and for years from January 1st, 1901, 1900, 1899 and 1898.

Period.	Gold.		Silver.		Total Excess, Exp. or Imp.
	Exports.	Imports.	Exports.	Imports.	
Week	\$1,522,993	\$29,955	\$333,700	\$64,334	E. \$1,762,404
1901..	20,411,990	1,125,503	14,366,435	1,697,632	E. 31,955,290
1900..	14,370,265	1,394,088	16,354,211	1,856,081	E. 27,474,337
1899..	2,913,298	6,230,248	11,442,488	1,292,907	E. 6,832,681
1898..	4,441,939	68,910,978	14,415,662	1,749,066	I. 51,802,243

Exports of gold were chiefly to France; of silver to London. Imports, both of gold and silver, were from the West Indies and Mexico.

The United States Assay Office in New York reports the total receipts of silver at 31,000 oz. for the week. This makes a total of 1,489,000 oz. from January 1st.

**Average Prices of Silver per oz. Troy.**

Month.	1901.		1900.		1899.	
	London Pence.	N. Y. Cents.	London Pence.	N. Y. Cents.	London Pence.	N. Y. Cents.
January..	28.97	62.82	27.90	59.30	27.42	59.36
February..	28.13	61.06	27.49	59.76	27.44	59.42
March....	27.94	60.63	27.59	59.81	27.48	59.64
April....	27.30	59.29	27.41	59.59	27.65	60.10
May.....	.....	.....	27.56	59.96	28.15	61.23
June.....	.....	.....	27.81	60.42	27.77	60.43
July.....	.....	.....	28.23	61.25	27.71	60.26
August....	.....	.....	28.13	61.14	27.62	60.00
September	.....	.....	28.85	62.63	27.15	58.89
October..	.....	.....	29.58	63.83	26.70	57.98
November	.....	.....	29.66	64.04	27.02	58.87
December.	.....	.....	29.68	64.14	27.21	58.99
Year.....	.....	.....	28.27	61.33	27.44	59.58

The New York prices are per fine ounce; the London quotation is per standard ounce, .925 fine.

**Average Prices of Metals per lb., New York**

Month.	COPPER.		TIN.		LEAD.		SPELTER.	
	1901.	1900.	1901.	1900.	1901.	1900.	1901.	1900.
Jan.....	16.25	15.58	26.51	27.07	4.35	4.68	4.13	4.65
Feb.....	16.38	15.78	26.68	30.58	4.35	4.675	4.01	4.64
March....	16.42	16.29	26.03	32.90	4.35	4.675	3.92	4.60
April....	16.43	16.76	25.93	30.90	4.35	4.675	3.98	4.71
May.....	16.41	16.34	27.12	29.37	4.35	4.181	4.04	4.53
June.....	.....	15.75	.....	30.50	.....	3.901	.....	4.29
July.....	.....	15.97	.....	33.10	.....	4.030	.....	4.28
August....	.....	16.35	.....	31.28	.....	4.250	.....	4.17
Sept.....	.....	16.44	.....	29.42	.....	4.350	.....	4.11
October..	.....	16.37	.....	28.54	.....	4.350	.....	4.15
Nov.....	.....	16.40	.....	28.25	.....	4.350	.....	4.29
Dec.....	.....	16.31	.....	26.94	.....	4.350	.....	4.25
Year.....	.....	16.19	.....	29.90	.....	4.37	.....	4.39

The prices given in the table for copper are the averages for electrolytic copper. The average price for Lake copper for the year 1900 was 16.52c.; for the month of January, 1901, it was 16.77c.; for February, 16.90c.; for March, 16.94c.; for April, 16.94c.; for May, 16.94c.

**Prices of Foreign Coins.**

	Bid.	Asked.
Mexican dollars.....	\$ .48 1/2	\$ .50 1/4
Peruvian soles and Chilean pesos....	.43 1/2	.46 1/4
Victoria sovereigns.....	4.86	4.88
Twenty francs.....	3.86	3.88
Twenty marks.....	4.75	4.80
Spanish 25 pesetas.....	4.78	4.82

**Financial Notes of the Week.**

Business continues generally steady, while the speculative markets are very quiet, under the

**Imports and Exports of Metals.**

Port.	Week, May 29.		Year 1901.	
	Expts.	Impts.	Expt.	Impts.
<b>New York.</b>				
(N. Y. Metal Exchange.)				
Aluminum.....long tons			43	50
Antimony ore.....			263	263
" regulus.....			33	19
Copper, fine.....	1,482	590	25,389	7,175
" matte.....	132		2,733	
" ore.....				17,340
" ash.....				75
Iron ore.....			10,404	1,034
" pig, bar, rod			153	570
" plates, sheets			1,215	31,989
Lead.....		1,100	100	6,799
" ore.....			49	1,211
Manganese, ore.....			8	3,657
Metals, old, scrap			141	4,619
Composition.....			17	908
Nails.....				40
Nickel.....				22,249
" ore, matte			176	8,171
Pipe, iron & steel			869	10,392
Railroad material			40	1,017
Rails, old.....			195	27,578
Steel bars, plates			3,112	43,917
" rails.....			669	14,287
" wire.....			185	230
Tin.....			25	12,414
" and black plates			85	12,231
" dross.....			5	537
Zinc.....			10	226
" dross.....			20	336
" ashes, skim				8,160
" ore.....				
<b>Baltimore.</b>				
(Special Correspondence.)				
Antimony..... long tons				10
Chrome Ore.....				4,036
Copper, fine.....	539	361	10,925	3,237
Iron pig, bar, etc.			10	2,504
" ore.....			7,880	157,104
Manganese ore.....			3,765	35,571
Nails.....				306
Pipe, iron & steel				905
Spiegel Eisen.....				2,541
Steel, bars, etc.		45	33,683	148
" wire.....		6	676	114
" rails.....		2,458	54,452	175
Tin.....				241
" and blackplates				
<b>Philadelphia.</b>				
Chrome ore..... long tons				195
Copper, fine.....			623	20,043
" ore.....			135	3,275
Iron, pig, bar.....			3,776	103,463
" ore.....			46	1,926
" pipe.....				200
Lead.....				5,419
Manganese ore.....			2,144	1,101
Metals, old.....				29
Nails.....				87
Pipe, iron & steel				3,758
Railroad material				175
Steel, bars, etc.				4,372
" rails.....			86	3,776
" wire.....				380
Tin.....			10	331
" and black plates			75	421
Zinc ore.....				2,064
" dross.....				106
" ash.....				32
<b>Total United States.</b>				
Articles.	March.		Year, 1901.	
	Expts.	Impts.	Expts.	Impts.
Antimony..... long tons		69		399
" ore.....			21	119
Copper, in all forms.....	6,818	25,539	23,274	38,029
Iron, pig & bar.....	6,215	3,196	42,247	8,564
" ore.....	805	47,379	1,647	120,107
Iron & steel plates	6,357	121	15,570	429
Iron & steel rails	35,451		84,848	117
" wire.....	6,915	1,251	18,533	2,205
Lead, in all forms	8,840	9,495	27,046	32,916
Manganese ore			13,447	22,728
" and oxide.....			165	539
Nickel & matte.....			5,029	4,456
Nails, cut.....			41	106
" wire.....				
Quicksilver.....				
Steel, billets,				
" rods, etc.....	4,397	2,022	25,174	5,403
Tin.....	24	2,885	40	8,662
" and black plates	49	2,121	410	12,972
Zinc.....	624	1	1,315	131
" ore.....	1,308		8,479	

**Import Duties on Metals.**

The duties on metals under the present tariff law are as follows: Antimony, metal or regulus, 3/4c. a lb. Lead, 1 1/2c. a lb. on lead in ores; 2 1/2c. a lb. on pigs, bars, etc.; 2 1/2c. on sheet, pipe and manufactured forms. Nickel, 6c. a lb. Quicksilver, 7c. a lb. Spelter or zinc, 1 1/2c. a lb. on pigs and bars, 2c. on sheets, etc. Copper, tin and platinum are free of duty.

reaction from the recent overturn. Small shipments of gold to Europe—chiefly to France—continue.

The silver market is without special features. Demand is fair and supplies are disposed of at current rates without any particular effort. Mexico has recently been a purchaser of supplies, presumably for coinage.

A demand for gold for Paris is reported, somewhat unexpectedly, and on Wednesday gold to the amount of \$4,500,000 was taken in New York for shipment to France. The demand is thought to be in connection with the Russian loan. It is said that this shipment represents a share in the loan taken by New York parties. In some quarters this is doubted and it is said to be simply a banking loan.

The statement of the United States Treasury on Wednesday, May 29th, shows balances in excess of outstanding certificates as below, compared with the corresponding day last week:

	May 22.	May 29.	Changes.
Gold.....	\$95,560,297	\$92,867,281	D. \$2,693,016
Silver.....	19,739,677	20,139,540	I. 419,863
Legal tenders.....	10,928,737	12,267,904	I. 1,339,167
Treas. notes, etc....	75,049	123,364	I. 48,315
<b>Totals.....</b>	<b>\$126,306,820</b>	<b>\$125,418,089</b>	<b>D. \$888,731</b>

Treasury deposits with national banks amounted to \$102,587,794, showing an increase of \$1,369,131, as compared with the corresponding day last week.

The statement of the New York banks—including the 63 banks represented on the Clearing House—for the week ending May 25th give the following total, comparison being made with the corresponding week in 1900 and 1899:

	1899.	1900.	1901.
Loans and discounts.....	\$745,923,400	\$792,921,000	\$858,872,600
Deposits.....	889,705,100	876,610,300	941,116,900
Circulation.....	13,765,700	21,959,300	31,014,700
Reserve:			
Specie.....	206,876,500	166,172,400	180,067,200
Legal tenders.....	59,483,500	71,252,500	76,501,900
<b>Total reserve.....</b>	<b>\$266,360,000</b>	<b>\$237,424,900</b>	<b>\$256,569,200</b>
<b>Legal requirements.....</b>	<b>222,426,275</b>	<b>219,152,575</b>	<b>235,279,225</b>
<b>Balance, surplus....</b>	<b>\$43,933,725</b>	<b>\$18,272,325</b>	<b>\$21,289,975</b>

Changes for the week, this year, were increases of \$3,178,100 in specie, \$2,183,500 in legal tenders, and \$7,989,050 in surplus reserve; decreases were \$14,639,500 in loans and discounts, \$10,509,800 in deposits, and \$4,300 in circulation.

The following table shows the specie holdings of the leading banks of the world at the latest dates covered by their reports. The amounts are reduced to dollars and comparison is made with the holdings at the corresponding date last year:

Banks.	1900.		1901.	
	Gold.	Silver.	Gold.	Silver.
N.Y. Ass'n.....	\$166,172,400	.....	\$180,067,200	.....
England.....	167,553,316	.....	176,450,040	.....
France.....	400,713,365	\$228,962,290	489,655,220	\$222,165,345
Germany.....	142,410,000	73,360,000	156,750,000	80,745,000
Spain.....	68,445,000	79,180,000	70,010,000	83,400,000
Neth'lds.....	24,375,000	29,770,000	26,244,000	28,610,500
Belgium.....	14,535,000	7,270,000	14,675,000	7,355,000
Italy.....	77,240,000	8,215,000	75,620,000	9,552,000
Russia.....	419,340,000	39,670,000	353,415,000	36,645,000

The returns of the Associated Banks of New York are of date of May 25th and the others are of date of May 23d, as reported by the "Commercial and Financial Chronicle" cable. The New York banks do not report silver separately, but the specie carried is chiefly gold. The Bank of England reports gold only.

Shipments of silver from London to the East for the year up to May 16th, 1901, are reported by Messrs. Pixley & Abell's circular as follows:

	1900.	1901.	Changes.
India.....	£2,108,362	£3,108,210	I. £999,848
China.....	265,324	339,125	I. 73,801
The Straits.....	148,752	79,976	D. 68,776
<b>Totals.....</b>	<b>£2,522,438</b>	<b>£3,527,311</b>	<b>I. £1,004,873</b>

Arrivals for the week, this year, were £180,000 in bar silver from New York, £6,000 from the West Indies and £3,000 from Australia; total, £189,000. Shipments were £130,000 in bar silver to Bombay and £5,000 to Calcutta; total, £135,000.

Indian exchange has been somewhat less firm, and Council bills were in lighter demand in London, the average price being 15.91d. per rupee. The weakness in demand was due chiefly to some large shipments of gold to India, which have lately been made.

Other Metals.

Daily Prices of Metals in New York.

May.	Sterling Exchange.	Silver.		Copper.				Spelter.	
		Fine oz. Cts.	London. Pence.	Lake. cts. @ lb.	Electrolytic @ lb.	London. @ lb.	Tin. cts. @ lb.	Lead. cts. @ lb.	N. Y. cts. @ lb.
25	4.88 1/4	59 1/2	27 1/2	16 1/2 @ 17	16.35 @ 16.45	28 1/2 @ 29	4.32 1/2 @ 4.37 1/2	4.00 @ 4.05	3.85 @ 3.87 1/2
27	4.88 1/4	59 1/2	27 1/2	16 1/2 @ 17	16.35 @ 16.45	28 1/2 @ 29	4.32 1/2 @ 4.37 1/2	4.00 @ 4.05	3.85 @ 3.87 1/2
28	4.88 1/4	59 1/2	27 1/2	16 1/2 @ 17	16.35 @ 16.45	28 1/2 @ 29	4.32 1/2 @ 4.37 1/2	4.00 @ 4.05	3.85 @ 3.87 1/2
29	4.88 1/4	59 1/2	27 1/2	16 1/2 @ 17	16.35 @ 16.45	28 1/2 @ 29	4.32 1/2 @ 4.37 1/2	4.00 @ 4.05	3.85 @ 3.87 1/2
30	.....	.....	.....	.....	.....	.....	.....	.....	.....
31	4.88 1/4	59 1/2	27 1/2	16 1/2 @ 17	16.35 @ 16.45	28 1/2 @ 29	4.32 1/2 @ 4.37 1/2	4.00 @ 4.05	3.85 @ 3.87 1/2

London quotations are per long ton (2,240 lbs.) standard copper, which is now the equivalent of the former g. m. b. s. The New York quotations for electrolytic copper are for cakes, ingots or wirebars; the price of electrolytic cathodes is usually 0.25c. lower than these figures.

The average price of silver in New York for the month of May was 59.64c. per fine ounce; in London, 27.43d. per standard ounce.

Copper has again ruled very quiet. Owing to the recent holidays, there was hardly any inquiry from abroad, and the business transacted for home consumption was also nothing out of the ordinary. Quotations are unchanged and rather nominal at 16 1/2 @ 17c. for Lake copper; 16.35 @ 16.45c. for electrolytic copper in cakes, wirebars and ingots, 16.10 @ 16.20c. for cathodes; 16.25 @ 16.35c. for casting copper.

The market for standard copper in London, which closed last week at £69 5s., opened on Tuesday at £69, and the closing quotations are cabled as £69 7s. 6d. @ £69 10s. for spot, £70 @ £70 2s. 6d. for three months.

Refined and manufactured sorts we quote: English tough, £73 15s. @ £74 5s.; best selected, £75 10s. @ £76; strong sheets, £84 @ £84 5s.; India sheets, £80 @ £80 5s.; yellow metal, 7d.

A Western dispatch on May 29th announced the incorporation under South Dakota laws of the United Copper Company, of Montana, with \$80,000,000 authorized capital and stated that the company, according to report, had arranged to acquire all the properties of the Montana Ore Purchasing Company, the Heinzes and other mines outside of those controlled by the Amalgamated Copper Company. The company is organized for the purpose of carrying on a copper business and the purchase of mines, machinery, lands and everything pertaining thereto. Under its charter it also has the right to purchase stocks and bonds of other mining companies in exchange for its own or for cash. Among the corporators and directors are Arthur P. Heinze, Stanley Gifford and Franklin Bein. Under the arrangements made, it is stated, F. Augustus Heinze will be elected president of the new company.

Tin has been rather irregular and the buying has again been mostly of a speculative nature. The close is firm at 28 1/2 c. for spot, 28 1/2 c. for futures.

The foreign market opened on Tuesday at £128 15s., and the closing quotations are cabled as £130 5s. for spot.

Lead continues firm, with the demand better than it has been for a long time past. We quote St. Louis at 4.27 1/2 @ 4.32 1/2 c.; New York at 4.32 1/2 @ 4.37 1/2 c.

The foreign market has again advanced, the closing quotations being cabled as £12 6s. 3d. @ £12 8s. 9d. for Spanish lead, £12 8s. 9d. @ £12 11s. 3d. for English lead.

Spelter.—A very good demand from both galvanizers and brass manufacturers is reported, and prices are well maintained. The ruling quotations are 3.85 @ 3.87 1/2 c. St. Louis, 4 @ 4.05c. New York.

The foreign market is also firm, the quotations being cabled as £17 15s. @ £18 for good ordinaries, £18 @ £18 5s. for specials.

Antimony is without change. We quote Cookson's at 10 @ 10 1/4 c.; Hallett's at 8 1/4 c.; Italian, Hungarian, Japanese and U. S. Star at 8 1/2 c.

Nickel.—The price continues firm at 50 @ 60c. per lb., according to size and terms of orders.

Platinum.—Consumption continues good and prices are strong. Ingot platinum in large lots now commands \$20.50 per ounce in New York. In London prices are about on a parity with the New York rate.

Chemical ware (crucibles and dishes), best hammered metal from store in large quantities, is worth 80c. per gram.

Quicksilver.—While the nominal quotation is still \$51 in New York, the metal can be had for \$48.75 @ \$50 per flask in large quantities, with a slightly higher rate named for small orders. San Francisco prices are a shade lower than last week, \$46 @ \$47 per flask being named for domes-

tic orders and \$42 @ \$43 for export. The London price continues nominally £9 2s. 6d. per flask.

Minor Metals and Alloys.—Wholesale prices, f. o. b. works, are as follows:

Aluminum.	Per lb.	Ferro-Titanium (20%)	Per lb.
No. 1, 99% ingots.....	33 @ 37c.	Ferro-Tungsten (37%)	52c.
No. 2, 90% ingots.....	31 @ 34c.	Magnesium.....	\$2.75 @ \$3
Roller sheets.....	42c. up	Manganese (over 99%)	\$1.00
Alum.-bronzes.....	20 @ 23c.	Manganese Cop. (20% Mn)	32c.
Nickel-alum.....	33 @ 35c.	Manganese Cop. (30% Mn)	38c.
Bismuth.....	\$2.05	Molybdenum.....	\$1.75
Chromium (over 99%)	1.00	Phosphorus.....	50c.
Copper, red oxide.....	50c.	American.....	70c.
Ferro-Molyb'dum (50%)	\$1.25	Tungsten (Best).....	.69c.
Ferro-Titanium (10%)	90c.		

Variations in prices depend chiefly on the size of the order.

LATE NEWS

Mr. Alexander McKenzie, who has been in prison at San Francisco under a sentence for contempt of court in certain cases involving mining claims at Cape Nome for which he was receiver, has been pardoned by President McKinley.

Summit County, Utah.

(From Our Special Correspondent.)

During the week ending May 25th there was marketed through the Mackintosh Sampler at Park City, 3,256,170 lbs. of ore and concentrates, which represents the output of the camp. Following are the several contributors: Daly-West, concentrates 419,810 lbs., crude ore, 910,120 lbs.; Silver King, concentrates 480,050 lbs., crude ore 358,520 lbs.; Ontario, crude ore 632,350 lbs.; Daly, crude ore, 206,000 lbs.; Anchor, crude ore 249,320 lbs.

Juab County, Utah.

(From Our Special Correspondent.)

There was sent forward from the three rail points of the Tintic District during the week ending May 25th 117 cars of ore, two cars of concentrates and one bar of bullion, the concentrates and bullion being from the Mammoth Mill. Following are the several contributors of ore: Centennial-Eureka, 44; Bullion-Beck, \$5; Gemini, 22; Godiva, 4; May Day, 2; Carissa, 14; Tesora, 3; Mammoth, 12; Grand Central, 6; Lower Mammoth, 5; total, 117 cars.

(Special Report of Rogers, Brown & Co.)

Buffalo, N. Y., May 29th.—The market conditions remain about as they have been for several weeks past, quiet as to new business and active as to deliveries on orders already booked. A canvass of the blast furnaces tributary to this market, made during the past week, developed a more heavily sold-up condition than was expected, order books being filled to a period ranging from August to October, including the absorption of stocks on hand. Prices remain substantially as stated below, but concessions from these would probably be made on large forward delivery contracts. We quote below on the cash basis, f. o. b. cars Buffalo: No. 1 strong foundry coke iron, Lake Superior ore, \$15.50; No. 2, \$15; Southern soft, No. 1, \$16; No. 2, \$15.50; Lake Superior charcoal, \$17.50; coke malleable, \$15.

Teller County, Colorado—Cripple Creek.

(From Our Special Correspondent.)

A decision in regard to the mining tax case has been rendered in the District Court. The decision upheld the action of the County Commissioners and the assessor, and the petition presented by the Moon Anchor Gold Mining Company, the Hart Gold Mining Company and the Pilgrim Consolidated Company was dismissed. The main complaint was that non-producing mining property is assessed too high compared with producing property in the same locality.

Ajax.—The shaft is now down 1,000 ft. and will be continued to the 1,200-ft., giving 400 ft. of stoping ground on the shoot. Much rich ore is being taken on the 8th level. The output from the mine is said to be about 60 tons per day.

Doctor-Jack Pot.—The April production was 1,353,134 tons of ore valued at \$99,167; \$10,000 were expended in taking out ore and \$11,000 in development work, the net profit for the month being \$55,559.

Elkton.—Work has been resumed in the 7th level and it is thought that in a few days the 8th level will be unwatered. The cost of unwatering the lower levels, aside from the 2 weeks' delay caused by concentrating all work on pumping, is estimated to be about \$15,000. The ore in these levels is said to be the richest in the mine.

Union Gold Extraction Company.—This company's mill at Florence is being enlarged to a capacity of 10,000 tons per month. Its present capacity being about 8,000 tons. The mill is controlled by men who own some of the largest producing mines in the district. The Victorator owns \$50,000 worth of stock.



SLATE TRADE REVIEW.

New York. May 31.

The list of prices per square for No. 1 slate standard brand f. o. b. at quarries in car-load lots, is given below:

Size, inches	Monarch or Br'n. ville.	Bangor.	Bangor Ribbon.	Alb'n. or Jackson Bangor.	Chap'n Key's ne	Peach Bottom.	Sea Gr'n.	Unfed'g Green.	Red
24 x 14	6.50	3.50	3.00	3.00	3.50	5.10	3.00	3.75	.....
24 x 12	6.60	3.50	3.00	3.00	3.50	5.25	3.00	3.75	.....
22 x 12	6.60	3.50	3.25	3.00	3.50	5.25	3.00	3.75	.....
22 x 11	6.50	3.75	3.25	3.00	4.00	5.25	3.00	4.00	.....
20 x 12	6.90	3.75	3.00	3.00	4.00	5.25	3.00	3.75	.....
20 x 11	6.80	4.25	3.50	3.25	4.00	5.35	3.00	4.25	10.50
20 x 10	6.80	3.75	3.00	3.00	4.00	5.25	3.00	3.50	.....
18 x 11	7.00	4.25	3.50	3.25	4.00	5.35	3.00	4.00	10.50
18 x 10	7.00	4.50	3.50	3.25	4.00	5.35	3.00	4.25	10.50
16 x 12	6.80	3.75	3.00	3.00	4.00	5.25	2.90	3.50	.....
16 x 10	7.00	4.00	3.50	3.25	4.00	5.35	2.90	4.25	10.50
16 x 9	7.00	4.25	3.50	3.25	4.00	5.35	2.90	4.25	10.50
16 x 8	7.00	4.50	3.50	3.25	4.00	5.35	2.90	4.25	10.50
14 x 10	6.60	3.75	3.25	3.00	4.00	5.25	2.70	3.75	10.50
14 x 9	6.50	3.75	3.25	3.00	4.00	5.25	2.70	3.75	10.50
14 x 8	6.60	3.75	3.25	3.00	4.00	5.10	2.70	4.25	10.50
14 x 7	6.40	3.75	3.25	3.00	3.75	5.10	2.50	4.25	10.50
12 x 10	5.75	3.00	2.50	2.50	3.50	4.75	2.50	3.25	.....
12 x 9	5.60	3.00	2.50	2.50	3.50	4.75	2.50	3.50	9.00
12 x 8	5.50	3.25	2.85	2.85	3.25	4.85	2.50	3.50	9.00
12 x 7	5.00	3.50	2.85	2.85	3.25	4.85	2.00	3.50	9.00
12 x 6	4.80	3.25	2.85	2.85	3.25	4.75	2.00	3.50	8.50

A square of slate is 100 sq. ft. as laid on the roof.

The improved demand for ribbon roofing slate has caused some sellers to ask 15c. per square more than the schedule herewith. There is a good movement of most sizes of roofing slate and statistics for May are expected to show an increase over any previous month, this year. Manufactured slate, on the other hand, has not been moving so satisfactorily.

Abroad the quarrymen of Carnarvon, Wales, report shipments for the quarter ended March 31st at 19,721 long tons, showing an increase of 3,016 tons as compared with the corresponding period last year. At Bethesda the strike at Lord Penrhyn's quarries is still on, and an early settlement looks doubtful. Some of the men have gone to other industrial centers for work, but there are still many about the quarries expecting to return to their former duties. Demand for slate from builders in the Kingdom just now is rather quiet and is conveniently satisfied. Speculators have bought moderate quantities from foreign producers, believing the fall trade will be more promising. American exporters, on the other hand, show more interest in Continental business since ocean freights became easier. Denmark has been an active buyer of our roofing slate, the shipments from New York alone so far this year amounting to fully 45 carloads, showing an increase of 20 car-loads as compared with the same time last year.

MINING STOCKS.

Complete quotations will be found on page 710 711 and 712 of mining stocks listed and dealt in at:

Boston.	Salt Lake.	Montreal.
Colo. Springs.	San Francisco.	London.
Denver.	Spokane.	Mexico.
New York.	St. Louis.	Paris.
Philadelphia.	Toronto.	

New York. May 31.

Owing to the mid-week holiday comparatively little interest was shown in mining shares. In the copper group fluctuations were pretty regular, Amalgamated selling at \$113@116, Anaconda at \$48@50, British Columbia at \$17@18, Tennessee at \$19@21 and Union, of North Carolina, at \$6@6 1/2.

Sales of Ontario Silver, of Utah, were made at \$8, a drop of 50c. since last week.

Quicksilver, of California, owing to the strong metal market, rose in value, sales being made of the common shares at \$4@4 1/2, and of the preferred at \$11 1/2@12 1/2. A transaction in Standard Consolidated is reported at \$3.57—the first sale since April 16th, when the price was 58c. higher, or \$4.15. This fall is purely speculative.

Cripple Creek, Colo., gold shares were in moderate request. Portland made a sale at \$3 and Isabella at 63c. We hear that certain "expansionist" brokers in Colorado Springs are urging the Mining Stock Association there to open a branch office in New York. By daily posting quotations and information of Colorado mines and mining stocks it is thought the Colorado Springs Exchange would be materially benefited. As an advertising scheme, the idea seems a good one. Of course, it will have to be managed on the same business-like principles as

the Colorado Springs Mining Stock Association has always followed at home.

Boston. May 29.

(From Our Special Correspondent.)

The market has been rather dull and narrow. The effect of the recent collapse is still felt very severely, while the holiday on Thursday has some quieting effect. To-day there is the best business of the week, Amalgamated and the allied stocks taking quite a spurt. It was chiefly inside business, however, for the public is taking very little interest. The lambs have been pretty well shorn and will keep under what cover they can find for some time to come.

We hear, of course, reports that the market will revive soon, another boom will come, and the like. It is, I fear, rather too late for another boom before the summer holiday season.

The Tamarack dividend of \$10 had no effect, since it was generally expected, and the amount is the same as that paid a year ago.

Reports continue to be circulated that Mr. Heinze is getting ready to settle with the Amalgamated Company. Similar rumors have been heard too often to make much impression now.

Messrs. Kidder, Peabody & Company, who were the depositaries for stock of the Boston & Montana and the Butte & Boston companies under the somewhat peculiar agreement made some weeks ago, have issued circulars to the owners of the stocks, in which the Boston & Montana stockholders are offered four shares of Amalgamated for each share of Boston & Montana, subject to the acceptance of the offer by the Amalgamated Company. Butte & Boston shareholders are offered share for share. All of the large stockholders of both companies have consented to an exchange at the above ratio. It is stated that as there has already been considerable delay owing to litigation in New Jersey, it is desirable that the stockholders signify their intention with respect to accepting Amalgamated shares on or before June 6, when Amalgamated stockholders will pass on the offer. If Boston & Montana stockholders do not desire to make the exchange, stock will be returned to depositors unless giving notice on or before June 6 of their desire to sell at \$375 per share, and in the case of Butte & Boston at \$92.50 per share. In case of an exchange for Amalgamated stock, all dividends declared upon the Boston & Montana and the Butte & Boston companies, pending the delivery of new Amalgamated, will be paid to stockholders.

The agreement is thus brought forward in a characteristic way. So far as the public or the shareholders are informed the holders of Boston & Montana sell their stock for Amalgamated shares, with no guarantee whatever that the latter represent in part their former property—or any other. The Amalgamated Company might, if its directors saw fit, sell the purchased stock at any time. I do not say that they are likely to, but it is possible. Of course, for Butte & Boston stockholders, any trade which brings them into a concern owning appreciable assets is a gain.

The litigation is not at an end yet, and there may be some delay in the completion of the deal. There is no doubt that it will go through.

Denver, Colo. May 25.

(From Our Special Correspondent.)

Eben Smith, president, and Frank L. Smith, treasurer, have resigned as officers of the Mine and Smelter Supply Company, of this city. At a recent meeting of the stockholders John S. Cary was elected president and general manager; Robert J. Cary, vice-president; William J. Seep, treasurer; Herbert E. Fiske, secretary, and Albert H. Seep a director. The interest of Messrs. Eben and Frank L. Smith have been acquired by Messrs. Joseph Seep, Albert H. Seep, William J. Seep, John S. Cary and Robert J. Cary, and the company states that its business will be conducted under the same liberal management as heretofore. Joseph Seep has been at the head of the Crude Oil Department of the Standard Oil Company, and A. H. Seep for 7 years has been connected with the Snow Pump Works, of Buffalo, N. Y. John S. Cary has been general manager of the Mine and Smelter Supply Company since its organization.

Regarding mining rights to city streets, misleading telegrams have been sent out about the Supreme Court decision in the case of the City against the Coronado Mining Company to give the City of Leadville the right to its mineral rights under the streets and alleys. The decision really only remanded the case back to the Leadville District Court for trial. The decision only affects that part of the territory, Stevens & Leiter addition, which is as yet but little explored. If a similar verdict is rendered in the local courts it will simply lead to another local entanglement, as companies like the Coronado claim to have a previous right from deed from the Stevens & Leiter people, who afterward deeded to the city. There is no doubt but that the city has a strong case against the mining companies, but it will be a long time before there is a definite decision. It is therefore mis-

leading to read dispatches sent broadcast to the effect that Leadville would at once receive \$2,000,000 a year in royalties, etc., etc. The case has been in the courts since 1895, but really has never been to trial on evidence. The real importance of the decision lies in the fact that it affects the Stevens & Leiter additions, the largest in the city, and taking in the heart of the residence and business portion of the camp. The large properties that will be affected by it are the Home Extension, Coronado, Cloud City, Sixth Street and Starr Placer. The Cloud City Company, which is simply sinking a new shaft, has an immense portion that would be affected, but the first trouble to be met is a lawsuit with the Leadville Tunnel, Mining and Drainage Company. Of the properties sinking or operating in the limits embraced the Home Extension and Cloud City companies have already a lease from the city.

San Francisco. May 25.

(From Our Special Correspondent.)

The market has been rather dull and heavy this week, with no special reason. News and reports from the Comstock were about as usual, with nothing to affect the market either way. Business done was on a very small scale.

Some quotations noted are: Consolidated California & Virginia, \$2.25; Ophir, 98c.; Caledonia, 48c.; Silver Hill, 33c.; Best & Belcher, 42c.; Hale & Norcross, 18c.; Sierra Nevada, 13c. For Standard Consolidated \$3.80 was bid and \$3.90 asked, with no sales.

On the Producers' Oil Exchange sales were larger than last week, but there was little or no advance in prices. Kern River sold at \$11; San Joaquin Oil and Development, \$9; Sterling, \$1.65; Twenty-eight, \$1.25; Caribou, 70c.; Monarch, of Arizona, 43c.; California Standard, 33c.; Lion, 14c. California Standard and Caribou were special favorites with buyers.

On the San Francisco Oil Exchange business showed an increase. Peerless sold for \$8; Monte Cristo, \$2.20; Independence, 16c.; Petroleum Center, 5c. There were large dealings in Independence and Petroleum Center.

The Amador Phoenix Gold Mining Company has been organized with the following officers and directors: R. C. Rust, president; S. G. Spagnoli, treasurer; John Ross, Jr., vice-president; L. J. Fontenrose, secretary; A. M. Gall, J. E. Dye and W. J. Nettle. The company will work the old Toscano Claim near Clinton. J. E. Dye will act as superintendent. There is a 5-stamp mill on the property.

The Black Bear Gold Mining Company, of Siskiyou County, has been organized with a capital stock of \$1,000,000. Men are now at work preparing to sink the new 2-compartment shaft now down 600 ft. and connect with the old works. The work laid out by the superintendent, John Dagget, will occupy at least 12 months. A good plant is on the property. The property is located on Black Creek, 8 miles south of Sawyer's Bar.

Paris. May 19.

(From Our Special Correspondent.)

The mining stock market has again been quiet, with no notable fluctuations. Our Bourse was not affected by the overturn in Wall Street, as was that of London. Recently there have been few dealings in American securities, at least in those of a speculative class. Our investments are confined to boards, which do not fluctuate greatly and which are held by people of means.

There are no new developments in Malfidano and the stock shows a slight recovery. The other zinc and lead stocks are quiet.

It now seems to be past doubt that a large interest in Rio Tinto has been bought on American account. It follows naturally that the company will act with—at least not against—the American consolidation in all points relating to the market.

The metallurgical shares have shown few fluctuations and nothing has occurred to disturb their course or to produce important fluctuations. New contracts are not coming in freely, but there is still a fair amount of business.

The stocks of the Russian group, on the other hand, have been very irregular. The business of the Empire recovers from depression very slowly. It appears also that the orders for the Government railroads are lighter than for several years. The Empire is growing, however, and there is little doubt that these companies have an important future before them.

The Bank of France continues to pay out gold, which is a contrast to its usual course. This is the more surprising also in view of the large Russian loan which is to be floated here shortly. It is to be considered, however, that this loan will be used in large part to meet interest and other accounts accruing here, and probably very little gold will be taken away. It was hoped that New York would take some of the loan, but under present conditions this does not seem likely. Of course, your people have as much money as ever, but confidence is broken for the time.

The foreign merchandise trade of France for

the four months ending April 30th is reported by the Ministry of Commerce as follows:

Table with 3 columns: Item, 1900 Francs, 1901 Francs. Rows include Imports, Exports, and Excess imports.

This shows a decrease of 120,144,000 fr. in imports; an increase of 44,353,000 fr. in exports; and a resulting decrease of 164,497,000 fr. in the balance of imports.

Recently in France a crusade has been begun against the use of white lead in painting. This is in accordance with a resolution passed by the Superior Council of Hygiene, which ranks white lead among the deadly poisons.

It is said also that a certain prominent company—which I cannot name here—is supporting the crusade. Of course, it is acting purely from sympathy with the painters; the fact that it manufactures zinc white cannot affect its course in such a public matter.

At last a beginning is to be made in the work of developing our great colony of Madagascar. It is, however, to be carried out in a sufficiently slow and cautious way.

surveys have been made and the plan of construction is laid out. The road will be 290 kms. long and the construction is to extend over a period of seven years.

Seven years to build a light railroad of 290 kms! About 41 kms. a year! No wonder your people and the English laugh at our work in the colonies.

ASSESSMENTS.

Table with columns: NAME OF COMPANY, Location, No, Delinq., Sale, Amt. Lists various companies and their assessment details.

ANNUAL MEETINGS.

Table with columns: Name of Co., Location, Date, Place of Meeting. Lists annual meetings for various companies.

\* Special meeting.

DIVIDENDS.

Table with columns: NAME OF COMPANY, Latest Dividend (Date, Per share, Total), Total to date. Lists dividends for various companies.

\* Monthly. † Quarterly. § Semi-Annual.

STOCK QUOTATIONS.

Table titled 'NEW YORK.' with columns for company names, locations, and stock prices for various dates in May.

COAL AND INDUSTRIAL STOCKS.

Table with columns for company names, share prices, and other financial data for coal and industrial stocks.

\* On Pittsburg, Pa., Exchange. Total sales, 358,909 † Ex-Dividend

SAN FRANCISCO, CAL.

Table with columns for company names, locations, and stock prices for San Francisco, California.

CALIFORNIA OIL STOCKS.

Table with columns for company names, share prices, and other financial data for California oil stocks.

\* Producers' Oil Exchange, San Francisco. Total sales, 72,633 shares.

ST. LOUIS, MO.\*

Table with columns for company names, share prices, and other financial data for St. Louis, Missouri.

\* From our special correspondent.

STOCK QUOTATIONS.

BOSTON, MASS.†

Table of stock quotations for Boston, Mass. listing companies like Adventure Con., Acta, Allouez, Amal. Copper, etc., with columns for Par. val., Shares issued, and prices for various dates in May.

COLORADO SPRINGS, COLO. §

Table of stock quotations for Colorado Springs, Colo. listing companies like Acacia, Alamo, Am. Con., Anaconda, etc., with columns for Par. val., prices for various dates in May, and Sales.

† Official quotations Boston Stock Exchange. Total sales, 63,588 shares. \* Ex-Dividend.

PHILADELPHIA, PA. §

Table of stock quotations for Philadelphia, Pa. listing companies like Am. Alkali, Am. Cement, Bethlehem Iron, etc., with columns for Par. val., prices for various dates in May, and Sales.

Total shares sold, 19,254. § Reported by Townsend, Whelen & Co., 809 Walnut St., Philadelphia.

SALT LAKE CITY, UTAH. May 18.

Table of stock quotations for Salt Lake City, Utah listing companies like Ajax, Albion, Anchor, Ben Butler, etc., with columns for Shares, Par. val., Bid., Asked., and Sales.

Colorado Springs Mining Stock Exchange. Total sales, 1,434,224 shares.

MONTREAL, CANADA. \*

Table of stock quotations for Montreal, Canada listing companies like Big Three, California, Can. Gold Fields, etc., with columns for Par. val., prices for Week May 24, and Sales.

\* Montreal Stock Exchange. Total sales, 10,000 shares.

TORONTO, ONT.

Table of stock quotations for Toronto, Ont. listing companies like Ontario, Golden Star, Ham Reef, etc., with columns for Par. val., prices for various dates in May, and Sales.

Total shares sold, 89,950.

MEXICO. May 16.

Table of stock quotations for Mexico listing companies like Durango, Barradon y Cab., Canalarria de Par., etc., with columns for No. of shares, Last div'd, Prices, and Sales.

STOCK QUOTATIONS.

LONDON. May 17. Table with columns: NAME OF COMPANY, Country, Authorized capital, Par value, Last dividend, Quotations (Buyers, Sellers).

DENVER, COLO. Table with columns: NAME OF COMPANY, Par val., May 20, May 21, May 22, May 23, May 24, May 25, Sales.

† Official Quotations Denver Stock Exchange. Total sales, 33,905 shares.

SPOKANE, WASH. Week May 23. Table with columns: NAME OF COMPANY, Par val., B., A., Sales, and another set of columns for another company.

PARIS. May 9. Table with columns: NAME OF COMPANY, Country, Product, Capital Stock, Par value, Latest divs., Prices (Opening, Closing).

DIVIDENDS.

COAL, IRON, OIL, AND INDUSTRIAL COMPANIES.

Large table with columns: Number, Name and Location of Company, Authorized Capital Stock, Shares (Issued, Par Val), Dividends (Paid, Total to Date, Latest), and another set of columns for another company.

This table is corrected up to May 1st. Correspondents are requested to forward changes or additions.

DIVIDENDS. GOLD, SILVER, COPPER, ZINC, LEAD AND QUICKSILVER COMPANIES.

Table with columns: Number, Name and Location of Company, Authorized Capital Stock, Shares Issued, Par Val, Dividends Paid 1901, Total to Date, Latest Date, Amt., and similar columns for the second half of the table.

This table is corrected up to May 1st. Correspondents are requested to forward changes or additions.

