

PHILOSOPHICAL
TRANSACTIONS

OF THE

ROYAL SOCIETY

OF

LONDON.

FOR THE YEAR MDCCCL.

PART I.

LONDON:

PRINTED BY RICHARD AND JOHN E. TAYLOR, RED LION COURT, FLEET STREET.

MDCCCL.

A D V E R T I S E M E N T.

THE Committee appointed by the *Royal Society* to direct the publication of the *Philosophical Transactions*, take this opportunity to acquaint the Public, that it fully appears, as well from the Council-books and Journals of the Society, as from repeated declarations which have been made in several former *Transactions*, that the printing of them was always, from time to time, the single act of the respective Secretaries till the Forty-seventh Volume; the Society, as a Body, never interesting themselves any further in their publication, than by occasionally recommending the revival of them to some of their Secretaries, when, from the particular circumstances of their affairs, the *Transactions* had happened for any length of time to be intermitted. And this seems principally to have been done with a view to satisfy the Public, that their usual meetings were then continued, for the improvement of knowledge, and benefit of mankind, the great ends of their first institution by the Royal Charters, and which they have ever since steadily pursued.

But the Society being of late years greatly enlarged, and their communications more numerous, it was thought advisable that a Committee of their members should be appointed, to reconsider the papers read before them, and select out of them such as they should judge most proper for publication in the future *Transactions*; which was accordingly done upon the 26th of March 1752. And the grounds of their choice are, and will continue to be, the importance and singularity of the subjects, or the advantageous manner of treating them; without pretending to answer for the certainty of the facts, or propriety of the reasonings, contained in the several papers so published, which must still rest on the credit or judgement of their respective authors.

It is likewise necessary on this occasion to remark, that it is an established rule of the Society, to which they will always adhere, never to give their opinion, as a Body,

upon any subject, either of Nature or Art, that comes before them. And therefore the thanks, which are frequently proposed from the Chair, to be given to the authors of such papers as are read at their accustomed meetings, or to the persons through whose hands they received them, are to be considered in no other light than as a matter of civility, in return for the respect shown to the Society by those communications. The like also is to be said with regard to the several projects, inventions, and curiosities of various kinds, which are often exhibited to the Society; the authors whereof, or those who exhibit them, frequently take the liberty to report and even to certify in the public newspapers, that they have met with the highest applause and approbation. And therefore it is hoped that no regard will hereafter be paid to such reports and public notices; which in some instances have been too lightly credited, to the dishonour of the Society.

The Meteorological Journal hitherto kept by the Assistant Secretary at the Apartments of the Royal Society, by order of the President and Council, and published in the Philosophical Transactions, has been discontinued. The Government, on the recommendation of the President and Council, has established at the Royal Observatory at Greenwich, under the superintendence of the Astronomer Royal, a Magnetical and Meteorological Observatory, where observations are made on an extended scale, which are regularly published. These, which correspond with the grand scheme of observations now carrying out in different parts of the globe, supersede the necessity of a continuance of the observations made at the Apartments of the Royal Society, which could not be rendered so perfect as was desirable, on account of the imperfections of the locality and the multiplied duties of the observer.

A List of Public Institutions and Individuals, entitled to receive a copy of the Philosophical Transactions of each year, on making application for the same directly or through their respective agents, within five years of the date of publication.

In the British Dominions.

The Queen's Library.
The Admiralty Library.
The Ashmolean Society, Oxford.
The Radcliffe Library, Oxford.
The Royal Geographical Society.
The United Service Museum.
The Royal College of Physicians.
The Society of Antiquaries.
The Linnean Society.
The Royal Institution of Great Britain.
The Society for the Encouragement of Arts.
The Geological Society.
The Geological Survey of Great Britain.
The Horticultural Society.
The Chemical Society.
The Royal Astronomical Society.
The Royal Asiatic Society.
The Royal Society of Literature.
The Medical and Chirurgical Society.
The London Institution.
The Entomological Society of London.
The Zoological Society of London.
The Institute of British Architects.
The Institution of Civil Engineers.
The Cambridge University Philosophical Society.
The Literary and Philosophical Society, Manchester.
The Royal Society of Edinburgh.
The Royal Irish Academy.
The Royal Dublin Society.
The Royal Institution, Swansea.
The Asiatic Society at Calcutta.
The Royal Artillery Library at Woolwich.
The Royal Observatory at Greenwich.
The Observatory at Dublin.
The Observatory at Armagh.
The Library and Museum, Barbadoes.
The Observatory at the Cape of Good Hope.
The Observatory at Madras.
The Observatory at Paramatta.
The Observatory at Edinburgh.

Denmark.

The Royal Society of Sciences at Copenhagen.
The Royal Observatory at Altona.

France

The Royal Academy of Sciences at Paris.
The Royal Academy of Sciences at Toulouse.
The Ecole des Mines at Paris.

The Geographical Society at Paris.
The Entomological Society of France.
The Dépôt de la Marine, Paris.
The Geological Society of France.
The Jardin des Plantes, Paris.

Germany.

The University at Göttingen.
The Cæsarean Academy of Naturalists at Bonn.
The Observatory at Mannheim.
The Royal Academy of Sciences at Munich.

Italy.

The Institute of Sciences at Naples.
The Institute of Sciences, Letters and Arts, at Milan.
The Italian Society of Sciences at Modena.
The Royal Academy of Sciences at Turin.

Switzerland.

The Société de Phys. et d'Hist. Nat. at Geneva.

Belgium.

The Royal Academy of Sciences at Brussels.

Netherlands.

The Royal Institute of Amsterdam.
The Batavian Society of Experimental Philosophy at Rotterdam.

Spain.

The Royal Observatory at Cadiz.

Portugal.

The Royal Academy of Sciences at Lisbon.

Prussia.

The Royal Academy of Sciences at Berlin.
The Society of Experimental Philosophy, Berlin.

Russia.

The Imperial Academy of Sciences at St. Petersburg.
The Imperial Observatory at Pulkowa.

Sweden and Norway.

The Royal Academy of Sciences at Stockholm.
The Royal Society of Sciences at Drontheim.

United States.

The American Philosophical Society at Philadelphia.
The American Academy of Sciences at Boston.
The Library of Harvard College.
Smithsonian Institution, Washington.
The Observatory at Washington.
The fifty Foreign Members of the Royal Society.

A List of Public Institutions and Individuals, entitled to receive a copy of the Astronomical Observations made at the Royal Observatory at Greenwich, on making application for the same directly or through their respective agents, within two years of the date of publication.

In the British Dominions.

The Queen's Library.
The Board of Ordnance.
The Royal Society.
The Savilian Library, Oxford.
The Library of Trinity College, Cambridge.
The University of Aberdeen.
The University of St. Andrews.
The University of Dublin.
The University of Edinburgh.
The Observatory, Edinburgh.
The University of Glasgow.
The Observatory at Oxford.
The Observatory at Cambridge.
The Observatory at Dublin.
The Observatory at Armagh.
The Observatory at the Cape of Good Hope.
The Observatory at Paramatta.
The Observatory at Madras.
The Royal Institution of Great Britain.
The Royal Society, Edinburgh.
The Observatory, Trevandrum, East Indies.
The President of the Royal Society.
S. H. Christie, Esq., Woolwich.
The Lowndes Professor of Astronomy, Cambridge.
The Plumian Professor of Astronomy, Cambridge.
L. Holland, Esq., London.
Sir John William Lubbock, Bart.
Captain W. H. Smyth, R.N., Chelsea.
Sir James South, Observatory, Kensington.

In Foreign Countries.

The Royal Academy of Sciences at Berlin.
The Royal Academy of Sciences at Paris.
The Imperial Academy of Sciences at St. Petersburg.
The Royal Academy of Sciences at Stockholm.
The Royal Society of Sciences at Upsal.
The Board of Longitude of France.
The University of Göttingen.
The University of Leyden.
The Academy of Bologna.
The American Academy of Sciences at Boston.
The American Philosophical Society at Philadelphia.
The Observatory at Altona.
The Observatory at Berlin.
The Observatory at Breslau.
The Observatory at Brussels.
The Observatory at Cadiz.
The Observatory at Coimbra.
The Observatory at Copenhagen.
The Observatory at Dorpat.
The Observatory at Helsingfors.
The Observatory at Königsberg.
The Observatory at Mannheim.
The Observatory at Marseilles.
The Observatory at Milan.
The Observatory at Munich.
The Observatory at Palermo.
The Observatory at Paris.
The Observatory at Seeberg.
The Observatory at Vienna.
The Observatory at Tubingen.
The Observatory at Turin.
The Observatory at Wilna.
The Dépôt de la Marine, Paris.
The Bowdoin College, United States.
The Library of Harvard College.
The Waterville College, United States.

List of Observatories, Institutions and Individuals, entitled to receive a Copy of the
Magnetical and Meteorological Observations made at the Royal Observatory, Green-
wich.

Observatories.

| | |
|------------------------------------|--------------------------------|
| Altona | M. Schumacher. |
| Armagh | Rev. Dr. Robinson. |
| Berlin | J. F. Encke. |
| Bombay | Dr. Buist. |
| Barnaoul | M. Prang, 1st. |
| Breslau | Prof. Boguslawski. |
| Brussels | A. Quetelet. |
| Cadiz | M. Cerquero. |
| Cairo | M. Lambert. |
| Cambridge | Prof. Challis. |
| Cambridge, United States | Prof. Lovering. |
| Cape of Good Hope | T. Maclear, Esq. |
| Catherineburgh | M. Rochkoff. |
| Christiania | M. Hansteen. |
| Cincinnati | Dr. Locke. |
| Copenhagen | M. Oersted. |
| Dublin | Sir W. R. Hamilton. |
| Gotha | |
| Hammerfest | |
| Heidelberg | M. Tiedemann. |
| Helsingfors | M. Nervander. |
| Hobarton | Lieut. Kay, R.N. |
| Kasan | M. Simonoff. |
| Kew | F. Ronalds, Esq. |
| Königsberg | |
| Kremsmünster | Prof. Koller. |
| Leipsic | Prof. Weber. |
| Madras | Major Jacob. |
| Mannheim | |
| Marburg | Prof. Gerling. |
| Milan | M. Carlini. |
| Munich | Dr. Lamont. |
| Nertchinsk | M. Prang, 2nd. |
| Nikolaieff | Dr. Knorre. |
| Oxford | M. J. Johnson, Esq. |
| Paris | M. Arago. |
| Pekin | M. Gachkévitché. |
| Prague | M. Kreil. |
| Pulkowa | M. Struve. |
| St. Petersburg | M. Kupffer. |
| Seeberg | M. Hansen. |
| Sitka | Messrs. Homann and Ivanoff. |
| Stockholm | Prof. Selander. |
| Teflis | M. Philadelphine. |

| | |
|----------------------|--------------------------------------|
| Toronto | Captain Lefroy, R.A. |
| Trevandrum | |
| Tubingen | |
| Upsal | Prof. Svanberg. |
| Vienna | C. L. von Littrow. |
| Warsaw | Col. G. Du Plat (British Consul). |
| Washington | Lt. Maury, U.S. Navy. |
| Wilna | |

Institutions.

| | |
|-------------------------------------|------------------------------------|
| Aberdeen | University. |
| Berlin | Academy of Sciences. |
| Bologna | Academy. |
| Bombay | Geographical Society. |
| Bonn | University. |
| Boston | Academy of Sciences. |
| Bowdoin College | United States. |
| Bowditch Library | United States. |
| Cambridge | Trinity College Library. |
| ————— | Library, Philosophical Society. |
| Cherkow | University. |
| Dorpat | University. |
| Dublin | University. |
| Edinburgh. | Observatory. |
| Edinburgh. | Royal Society. |
| Edinburgh. | University. |
| Glasgow | University. |
| Göttingen | University. |
| Harvard, U.S. | College. |
| Kiew | University. |
| Leyden. | University. |
| House of Lords, Library | London. |
| House of Commons, Library | „ „ |
| London | King's College. |
| ————— | Royal Institution. |
| ————— | Royal Society. |
| ————— | University. |
| Moscow | University. |
| Oxford | Savilian Library. |
| Paris | Academy of Sciences. |
| Paris | Board of Longitude. |
| Paris | Dépôt de la Marine. |
| Philadelphia | Philosophical Society. |

| | |
|---|---|
| Queen's Library | London. |
| Royal Cornwall Polytechnic Society | Falmouth. |
| St. Andrew's | University. |
| St. Bernard | Convent. |
| St. Petersburg | Academy of Sciences. |
| St. Petersburg | Geographical Society. |
| Stockholm | Academy of Sciences. |
| Upsal | Society of Sciences. |
| Washington | Smithsonian Institution. |
| Waterville, U.S. | College Library. |
| Woolwich | Office of Mag. and Met. Publication. |

Individuals.

| | |
|-------------------------------|-------------|
| Bache, Dr. A. D. | Washington. |
| Barlow, P. W., Esq. | Woolwich. |
| Birt, W. H., Esq. | London. |
| Christie, S. H., Esq. | Woolwich. |
| Colebrooke, Sir W. | Guiana. |
| Demidoff, Prince Anatole de | Florence. |
| Dove, Prof. | Berlin. |
| Capt. C. M. Elliot | |
| Erman, Dr. Adolph | Berlin. |
| Fox, R. W., Esq. | Falmouth. |
| Gauss, Prof. | Göttingen. |
| Gilliss, Lt. J. M., U.S. Navy | Washington. |
| Harris, Sir W. Snow | Plymouth. |

| | |
|------------------------------------|-------------------|
| Holland, L., Esq. | London. |
| Howard, Luke, Esq. | Tottenham. |
| Humboldt, Baron von | Berlin. |
| Kaemtz, M. | Halle. |
| Kupffer, A. T. | St. Petersburg. |
| Lawson, Henry G., Esq. | Bath. |
| Lloyd, Rev. Dr. | Dublin. |
| Loomis, Prof. | Princeton, N.I. |
| Lowndes Prof. of Astronomy | Cambridge. |
| Lubbock, Sir John W., Bart. | London. |
| Lütke, Vice-Admiral | St. Petersburg. |
| Melvill, J. C., Esq. | East India House. |
| Mentchikoff, Prince | St. Petersburg. |
| Phillips, John, Esq. | York. |
| Plumian Prof. of Astronomy | Cambridge. |
| President of the Royal Society | London. |
| Quetelet, A. | Brussels. |
| Redfield, W. C., Esq. | New York. |
| Reid, Lieutenant-Colonel | London. |
| Riddell, Capt., R.A. | Edinburgh. |
| Roget, P. M., M.D. | London. |
| Sabine, Lieut.-Col., R.A. | Woolwich. |
| Senftenberg, Baron von | Prague. |
| Smyth, W. H., Captain R.N. | London. |
| South, Sir James | „ „ |
| Wartmann, Prof. Elie | Lausanne. |
| Wrangell, Vice-Admiral | St. Petersburg. |
| Younghusband, Capt., R.A. | Woolwich. |

R O Y A L M E D A L S.

HER MAJESTY QUEEN VICTORIA, in restoring the Foundation of the Royal Medals, has been graciously pleased to approve the following regulations for the award of them :

That the Royal Medals be given for such papers only as have been presented to the Royal Society, and inserted in their Transactions.

That the triennial Cycle of subjects be the same as that hitherto in operation : viz.

1. Astronomy ; Physiology, including the Natural History of Organized Beings.
2. Physics ; Geology or Mineralogy.
3. Mathematics ; Chemistry.

That, in case no paper, coming within these stipulations, should be considered deserving of the Royal Medal, in any given year, the Council have the power of awarding such Medal to the author of any other paper on either of the several subjects forming the Cycle, that may have been presented to the Society and inserted in their Transactions ; preference being given to the subjects of the year immediately preceding : the award being, in such case, subject to the approbation of Her Majesty.

The Council propose to give one of the Royal Medals in the year 1849 for the most important paper in Physics, communicated to the Royal Society after the termination of the Session in June 1845, and prior to the termination of the Session in June 1848, and printed in the Philosophical Transactions.

The Council propose also to give one of the Royal Medals in the year 1849 for the most important paper in Geology or Mineralogy, communicated to the Royal Society after the termination of the Session in June 1845, and prior to the termination of the Session in June 1848, and printed in the Philosophical Transactions.

The Council propose to give one of the Royal Medals in the year 1850 for the most important paper in Mathematics, communicated to the Royal Society after the termination of the Session in June 1846, and prior to the termination of the Session in June 1849, and printed in the Philosophical Transactions.

The Council propose also to give one of the Royal Medals in the year 1850 for the most important paper in Chemistry, communicated to the Royal Society after the termination of the Session in June 1846, and prior to the termination of the Session in June 1849, and printed in the Philosophical Transactions.

The Council propose to give one of the Royal Medals in the year 1851 for the most important paper in Astronomy, communicated to the Royal Society after the termination of the Session in June 1847, and prior to the termination of the Session in June 1850, and printed in the Philosophical Transactions.

The Council propose also to give one of the Royal Medals in the year 1851 for the most important paper in Physiology, including the Natural History of Organized Beings, communicated to the Royal Society after the termination of the Session in June 1847, and prior to the termination of the Session in June 1850, and printed in the Philosophical Transactions.

The Council propose to give one of the Royal Medals in the year 1852 for the most important paper in Physics, communicated to the Royal Society after the termination of the Session in June 1848, and prior to the termination of the Session in June 1851, and printed in the Philosophical Transactions.

The Council propose also to give one of the Royal Medals in the year 1852 for the most important paper in Geology or Mineralogy, communicated to the Royal Society after the termination of the Session in June 1848, and prior to the termination of the Session in June 1851, and printed in the Philosophical Transactions.

C O N T E N T S.



- I. THE BAKERIAN LECTURE.—*On the Diffusion of Liquids.* By THOMAS GRAHAM, F.R.S., F.C.S. page 1
- II. *On the Nitrogenated Principles of Vegetables as the Sources of Artificial Alkaloids.* By Dr. JOHN STENHOUSE, F.R.S. 47
- III. *On the Mechanical Equivalent of Heat.* By JAMES PRESCOTT JOULE, F.C.S., Sec. Lit. and Phil. Society, Manchester, Cor. Mem. R.A., Turin, &c. Communicated by MICHAEL FARADAY, D.C.L., F.R.S., Foreign Associate of the Academy of Sciences, Paris, &c. &c. &c. 61
- IV. *On the Automatic Registration of Magnetometers, and Meteorological Instruments, by Photography.—No. III.* By CHARLES BROOKE, M.B., F.R.S. 83
- V. *Researches regarding the Molecular Constitution of the Volatile Organic Bases.* By Dr. A. W. HOFMANN, F.C.S., Professor of the Royal College of Chemistry of London. Communicated by Sir JAMES CLARK, Bart., F.R.S. 93
- VI. *On the Development of the Great Anterior Veins in Man and Mammalia; including an Account of certain remnants of Fœtal Structure found in the Adult, a Comparative View of these Great Veins in the different Mammalia, and an Analysis of their occasional peculiarities in the Human Subject.* By JOHN MARSHALL, F.R.C.S., late Demonstrator of Anatomy in University College, London; Assistant Surgeon to the University College Hospital. Communicated by Professor SHARPEY, F.R.S. 133
- VII. *Experimental Researches in Electricity.—Twenty-third Series.* By MICHAEL FARADAY, Esq., D.C.L., F.R.S., Fullerian Prof. Chem. Royal Institution, Foreign Associate of the Acad. Sciences, Paris, Ord. Boruss. Pour le Mérite, Eq., Memb. Royal and Imp. Acadd. of Sciences, Petersburgh, Florence, Copenhagen, Berlin, Göttingen, Modena, Stockholm, Munich, Bruxelles, Vienna, Bologna, &c. &c. 171
- VIII. *On the Development of the Retina and Optic Nerve, and of the Membranous Labyrinth and Auditory Nerve.* By HENRY GRAY, M.R.C.S. Communicated by W. BOWMAN, F.R.S., Professor of Physiology and of General and Morbid Anatomy in King's College, London 189

- IX. *On the means adopted in the British Colonial Magnetic Observatories for determining the absolute Values, Secular Change, and Annual Variation of the Magnetic Force.* By Lieut.-Colonel EDWARD SABINE, R.A., For. Sec. R.S. page 201
- X. *Observations on the Freezing of the Albumen of Eggs.* By JAMES PAGET, Esq., Professor of Anatomy and Surgery to the Royal College of Surgeons of England. Communicated by THOMAS BELL, Sec. R.S. 221
- XI. *Researches on the Tides.—Fourteenth Series. On the Results of continued Tide Observations at several places on the British Coasts.* By the Rev. W. WHEWELL, D.D., F.R.S. 227
- XII. *Experiments and Observations upon the Properties of Light.* By LORD BROUGHAM, F.R.S., Member of the National Institute, and of the Royal Academy of Naples 235
- XIII. *General Methods in Analysis for the resolution of Linear Equations in Finite Differences and Linear Differential Equations.* By CHARLES JAMES HARGREAVE, Esq., LL.B., F.R.S., Professor of Jurisprudence in University College, London 261
- XIV. *Electro-Physiological Researches.—Eighth Series.* By Signor CARLO MATTEUCCI. Communicated by W. R. GROVE, Esq., F.R.S. 287

ERRATA.

The plant mentioned by Professor MACAIRE in his paper, published in the Philosophical Transactions for 1848, p. 253, as *Tamus communis*, is not *Smilax aspera*, as suggested in the note at that page, but *Bryonia dioica*.

Page 243, line 9, for E read F.

— 257, line 25, for light read night.

— 257, line 29, for polarity read polarization.

PHILOSOPHICAL
TRANSACTIONS

OF THE

ROYAL SOCIETY

OF

LONDON.

FOR THE YEAR MDCCCL.

PART II.

LONDON:

PRINTED BY RICHARD AND JOHN E. TAYLOR, RED LION COURT, FLEET STREET.

MDCCCL.

C O N T E N T S.

- XV. *Discussion of Meteorological Observations taken in India, at various heights, embracing those at Dodabetta on the Neelgherry Mountains, at 8640 feet above the level of the sea. By Lieutenant-Colonel W. H. SYKES, F.R.S.* page 297
- XVI. *On the PELOROSAURUS; an undescribed gigantic terrestrial reptile whose remains are associated with those of the Iguanodon and other Saurians in the Strata of Tilgate Forest, in Sussex. By GIDEON ALGERNON MANTELL, Esq., LL.D., F.R.S., F.L.S., Vice-President of the Geological Society, &c.* 379
- XVII. *On a Dorsal dermal Spine of the Hylæosaurus, recently discovered in the Strata of Tilgate Forest. By GIDEON ALGERNON MANTELL, Esq., LL.D., F.R.S., F.L.S., Vice-President of the Geological Society, &c.* 391
- XVIII. *Supplementary Observations on the Structure of the BELEMNITE and BELEMNO-TEUTHIS. By GIDEON ALGERNON MANTELL, Esq., LL.D., F.R.S., F.L.S., Vice-President of the Geological Society, &c.* 393
- XIX. *On the Algebraic Expression of the number of Partitions of which a given number is susceptible. By Sir J. F. W. HERSCHEL, Bart., K.H., F.R.S.* 399
- XX. *Experiments on the Section of the Glossopharyngeal and Hypoglossal Nerves of the Frog, and observations of the alterations produced thereby in the Structure of their Primitive Fibres. By AUGUSTUS WALLER, M.D. Communicated by Professor OWEN, F.R.S.* 423
- XXI. *Influence of Physical Agents on the development of the Tadpole of the Triton and the Frog. By JOHN HIGGINBOTTOM, Hon. Fellow of the Royal College of Surgeons of England. Communicated by THOMAS BELL, Esq., Sec. R.S.* 431

- XXII. *On the Temperature of Man within the Tropics.* By JOHN DAVY, M.D., F.R.S., L. & E., Inspector-General of Army Hospitals 437
- XXIII. *On the Oils produced by the Action of Sulphuric Acid upon various Classes of Vegetables.* By JOHN STENHOUSE, Esq., Ph.D., F.R.S. 467
- XXIV. *On the Development and Homologies of the Molar Teeth of the Wart-Hogs (Phacochoerus), with Illustrations of a System of Notation for the Teeth in the Class MAMMALIA.* By Professor OWEN, F.R.S. &c. 481
- XXV. *Observations on the Nebulæ.* By The Earl of ROSSE, Pres. R.S. &c. &c. 499
- XXVI. *On the Structure and Use of the Ligamentum Rotundum Uteri, with some observations upon the change which takes place in the Structure of the Uterus during Utero-gestation.* By G. RAINEY, M.R.C.S., Demonstrator of Anatomy at St. Thomas's Hospital. Communicated by JOSEPH HENRY GREEN, Esq., F.R.S. 515
- XXVII. *On the Communications between the Cavity of the Tympanum and the Palate in the Crocodilia (Gavials, Alligators and Crocodiles).* By Professor OWEN, F.R.S. &c. 521
- XXVIII. *On the Structure of the Dental Tissues of the Order Rodentia.* By JOHN TOMES, Surgeon-Dentist to the Middlesex Hospital. Communicated by WILLIAM BOWMAN, Esq., F.R.S. 529
- XXIX. *Sequel to a paper on the Reduction of the Thermometrical Observations made at the Apartments of the Royal Society.* By JAMES GLAISHER, Esq., F.R.S., of the Royal Observatory, Greenwich 569
- XXX. *On the Dynamical Stability and on the Oscillations of Floating Bodies.* By the Rev. HENRY MOSELEY, M.A., F.R.S., Corresponding Member of the Institute of France 609
- XXXI. *Electro-Physiological Researches. On Induced Contraction.—Ninth Series.* By Signor CARLO MATTEUCCI, Professor in the University of Pisa, &c. &c. Communicated by W. R. GROVE, Esq., F.R.S. 645
- XXXII. *Contributions to the Chemistry of the Urine.—Paper IV. On the so-called Chylous Urine.* By HENRY BENICE JONES, M.D., M.A. Cantab., F.R.S., Physician to St. George's Hospital 651
- XXXIII. *Contributions to the Chemistry of the Urine.—Paper III. PART IV. On the Variations of the Sulphates and Phosphates in Disease.* By HENRY BENICE JONES, M.D., M.A. Cantab., F.R.S., Physician to St. George's Hospital . 661
- XXXIV. *Second Appendix to a paper on the Variations of the Acidity of the Urine in*

the state of Health. By HENRY BENICE JONES, M.D., M.A. Cantab., F.R.S.,
Physician to St. George's Hospital 669

XXXV. *An Experimental Inquiry into the Strength of Wrought-Iron Plates and their
Riveted Joints as applied to Ship-building and Vessels exposed to severe strains.*
By WILLIAM FAIRBAIRN, Esq. Communicated by the Rev. HENRY MOSELEY,
F.R.S. 677

XXXVI. *On the Mutual Relations of the Vital and Physical Forces.* By WILLIAM
B. CARPENTER, M.D., F.R.S., F.G.S., Examiner in Physiology and Compara-
tive Anatomy in the University of London 727

XXXVII. *On the Condition of certain Elements at the moment of Chemical Change.*
By BENJAMIN COLLINS BRODIE, Esq., F.R.S. 759

XXXVIII. *Supplementary Observations on the Diffusion of Liquids.* By THOMAS
GRAHAM, F.R.S., F.C.S. 805

Index 837

APPENDIX.

Presents [1]

PHILOSOPHICAL TRANSACTIONS, PART I. 1850.

ERRATA.

Page 245, line 13, *after placed insert parallel to it.*

— 246, line 1, *for VI. read XV.*

— 246, line 1, *for one, A, read one, B.*

— 246, line 2, *for B read A.*

— 246, line 17, *after result insert in.*

— 246, line 19, *for fringe read force.*

— 252, line 13, *erase $b=DE$, and for $\frac{1}{\sqrt{a^2+(x-b)^2}-\sqrt{c^2+x^2}}$ read $\frac{1}{\sqrt{a^2+x^2}-\sqrt{b^2+x^2}}$.*

— 253, line 16, *for being read between.*

— 254, line 19, *for XI. read XII.*

— 254, line 21, *for e, c read c, c.*

— 257, line 13, *for 19 read 21.*

— 257, line 25, *for light read night.*

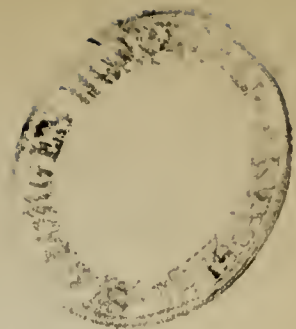
— 257, line 29, *for polarity read polarization.*

— 258, line 4, *for ss read z.*

— 258, line 6, *for $\sqrt{v^2+Zdz}$ read $\sqrt{v^2+2fZdz}$.*

In figs. 6 and 7, R R' should be a straight line.

In fig. 9, P should be opposite to q.



PRESENTS

RECEIVED BY

THE ROYAL SOCIETY,

WITH THE

NAMES OF THE DONORS.

From November 1849 to June 1850.

| PRESENTS. | DONORS. |
|--|----------------|
| ACADEMIES and SOCIETIES. | |
| Abbeville :— | |
| Mémoires de la Société d'Émulation. 8vo. <i>Abbeville</i> 1849. | The Society. |
| Amsterdam :— | |
| Verhandelingen der eerste Klasse van het Koninklijk-Nederlandsche Instituut van Wetenschappen, Letterkunde en Schoone Kunsten te Amsterdam. Vol. II. Part 1. 1848. Derde Reeks. Eerste Deel. 4to. <i>Amsterdam</i> 1849. | The Institute. |
| Jaarboek van het Koninklijk-Nederlandsche Instituut voor 1847-9. 8vo. <i>Amsterdam</i> 1847-9. | ————— |
| Tijdschrift voor de Wis- en Natuurkundige Wetenschappen van het Koninklijk-Nederlandsche Instituut. Vol. II. Parts 3, 4. Vol. III. Parts 1, 2. 8vo. <i>Amsterdam</i> 1849. | ————— |
| Berlin :— | |
| Abhandlungen der Akademie der Wissenschaften zu Berlin für 1847. 4to. <i>Berlin</i> 1849. | The Academy. |
| Monatsbericht. Jan. to Dec. 1849. 8vo. | ————— |
| Bologna :— | |
| Novi Commentarii Academiæ Scientiarum Instituti Bononiensis. Tomus IX. 4to. <i>Bononiæ</i> 1849. | The Academy. |
| Bombay :— | |
| Transactions of the Bombay Geographical Society from October 1848 to May 1849. 8vo. <i>Bombay</i> 1849. | The Society. |
| Breslau :— | |
| Uebersicht der Arbeiten und Veränderungen der Schlesischen Gesellschaft für vaterländische Kultur im Jahre 1848. 4to. <i>Breslau</i> 1849. | The Society. |
| Brussels :— | |
| Mémoires de l'Académie Royale des Sciences de Belgique. Tome XXIII. 4to. <i>Bruxelles</i> 1849. | The Academy. |
| Bulletins. Tome XV. Part 2. Tome XVI. Part 1. 8vo. <i>Bruxelles</i> 1848-9. | ————— |

| PRESENTS. | DONORS. |
|--|------------------|
| ACADEMIES and SOCIETIES (<i>continued</i>). | |
| Brussels:— | |
| Annuaire de l'Académie Royale des Sciences de Belgique. 8vo. <i>Bruxelles</i> 1849. | The Academy. |
| Calcutta:— | |
| Journal of the Asiatic Society of Bengal. Nos. 203 to 207. 8vo. <i>Calcutta</i> . | The Society. |
| Cambridge:— | |
| Transactions of the Cambridge Philosophical Society. Vol. VIII. 4to. <i>Cambridge</i> 1849. | The Society. |
| Cambridge (United States):— | |
| Memoirs of the American Academy of Arts and Sciences. Vol. IV. Part 1. 4to. <i>Cambridge</i> 1849. | The Academy. |
| Connecticut:— | |
| Memoirs of the Connecticut Academy of Arts and Sciences. Vol. I. Parts 1 to 4. 8vo. <i>New Haven</i> 1810–16. | H. Stevens, Esq. |
| Cornwall:— | |
| Transactions of the Royal Geological Society of Cornwall. Vol. I. 8vo. <i>London</i> 1818. | The Society. |
| Annual Reports. 1845–46 and 1849. 8vo. <i>Penzance</i> 1845–46–49. | ————— |
| Dublin:— | |
| Transactions of the Royal Irish Academy. Vol. XXII. Parts 1 and 2. 4to. <i>Dublin</i> 1849–50. | The Academy. |
| Proceedings. Vol. IV. Part 2. 8vo. <i>Dublin</i> 1849. | ————— |
| Journal of the Geological Society of Dublin. Vol. IV. Parts 1 and 2. 8vo. | The Society. |
| Edinburgh:— | |
| Transactions of the Royal Society of Edinburgh. Vol. XVI. Part 5, and Vol. XIX. Part 1, being Observations in Magnetism and Meteorology made at Makerstoun in Scotland in 1845–46. Edited by J. A. Broun, Esq. 4to. <i>Edinburgh</i> 1849. | The Society. |
| Proceedings. Vol. II. Nos. 33 and 34. | ————— |
| Transactions of the Royal Scottish Society of Arts. Vol. III. Part 4. | The Society. |
| Geneva:— | |
| Mémoires de la Société de Physique et d'Histoire Naturelle de Genève. Tome XII. Part 1. 4to. <i>Genève</i> 1849. | The Society. |
| Glasgow:—Proceedings of the Philosophical Society. Vol. III. No. 1. | The Society. |
| Göttingen:—Nachrichten von der Georg-Augusts Universität und der K. Gesellschaft der Wissenschaften von 1849. Nos. 1 to 14. | The Society. |
| Hobarton:— | |
| Papers and Proceedings of the Royal Society of Van Diemen's Land. Vol. I. Part 1. | The Society. |
| Leeds:—Annual Reports of the Leeds Philosophical and Literary Society for 1847–48–49. 8vo. <i>Leeds</i> 1848–49. | The Society. |
| Liverpool:—Proceedings of the Literary and Philosophical Society of Liverpool. No. 5. 8vo. <i>London</i> 1849. | The Society. |
| London:— | |
| The Journal of the British Archæological Association. Nos. 16 to 20. | The Association. |
| British Association. Reports of the Eighteenth and Nineteenth Meetings. 8vo. <i>London</i> 1849–50. | The Association. |

| PRESENTS. | DONORS. |
|---|------------------------------------|
| ACADEMIES and SOCIETIES (<i>continued</i>). | |
| London:— | |
| Chemical Society. Quarterly Journal. Nos. 6 to 9. 8vo. <i>London</i> . | The Society. |
| Geographical Society. Journal. Vol. XIX. 8vo. <i>London</i> 1849. | The Society. |
| Geological Society. Quarterly Journal. Nos. 19, 20, 21. 8vo. <i>London</i> 1849–50. | The Society. |
| Horticultural Society. Transactions. Second Series. 4to. Vol. III. Parts 2, 3. | The Society. |
| ————— Journal. Vol. III. Parts 2, 3. Vol. IV. Parts 1 to 4. | ————— |
| Vol. V. Parts 1, 2. 8vo. <i>London</i> 1848–50. | |
| Linnean Society. Charter and Bye-Laws. 8vo. <i>London</i> 1848. | The Society. |
| ————— List of Fellows. 1849. | ————— |
| Royal Agricultural Society. Journal. Vol. X. 8vo. <i>London</i> 1849. | The Society. |
| Royal Asiatic Society. Journal. Vol. XI. Part 1, and Vol. XII. 8vo. <i>London</i> 1849. | The Society. |
| Royal Astronomical Society. Memoirs. Vol. XVIII. 4to. <i>London</i> 1850. | The Society. |
| ————— Monthly Notices. Vol. IX. 8vo. <i>London</i> 1849. | ————— |
| Royal Medical and Chirurgical Society. Transactions. Second Series. Vol. XIV. 8vo. <i>London</i> 1849. | The Society. |
| Statistical Society. Journal. Vol. XII. 8vo. <i>London</i> 1850. | The Society. |
| Zoological Society. Reports of the Council and Auditors for 1849. | The Society. |
| Mauritius:—Transactions of the Royal Society of Arts and Sciences for 1847–48. 8vo. <i>Mauritius</i> 1849. | The Society. |
| Milan:— | |
| Effemeridi Astronomiche di Milano, per l'anni 1834–36, 1837–38, 1842–48, 1849–50, and Four Supplements. | The Institute. |
| Giornale dell Istituto Lombardo di Scienze. Parts 1 to 6. 4to. <i>Milano</i> 1847–48. | ————— |
| ————— 8vo. <i>Milano</i> 1846–47. | ————— |
| Memoria del F. Meguscher in risposta al quesito additare la migliore e più facile maniera per rimettere i Boschi nelle montagne diboschite dell' alta Lombardia. 8vo. <i>Milano</i> 1847. | ————— |
| Munich:— | |
| Abhandlungen der Philosophisch-Philologischen Classe der König. Bayerischen Akademie der Wissenschaften. Vol. V. Part 3. 4to. <i>München</i> 1849. | The Academy of Sciences at Munich. |
| Abhandlungen der Mathematisch-Physikalischen Classe. Vol. V. Part 3. 4to. <i>München</i> 1849. | ————— |
| Abhandlungen der Historischen Classe. Vol. V. Parts 2, 3. 4to. <i>München</i> 1849. | ————— |
| Almanach für 1849. | ————— |
| Gelehrte Anzeigen. Nos. 28–29. | ————— |
| Bulletin. Nos. 1 to 37. | ————— |
| Naples:— | |
| Escercitazioni Accademiche degli Aspiranti Naturalisti. 8vo. <i>Napoli</i> 1839. | The Academy. |
| Atlante della Statistica Fisica ed Economica dell' Isola di Capri. 4to. <i>Napoli</i> 1840. | ————— |
| Rendiconto della Reale Accademia delle Scienze. Nos. 39 to 45. 4to. <i>Napoli</i> 1849. | ————— |

| PRESENTS. | DONORS. |
|--|--|
| ACADEMIES and SOCIETIES (<i>continued</i>). | |
| New York:—Annals of the Lyceum of Natural History. Vol. IV. No. 12. Vol. V. No. 1. 8vo. <i>New York</i> 1849. | The Lyceum. |
| Paris:— | |
| Comptes Rendus de l'Académie des Sciences. Tome XXX. 1849. Nos. 1 to 21, 1850. 4to. <i>Paris</i> . | The Academy. |
| Bulletin de la Société de Géographie. Tomes X. XI. 8vo. <i>Paris</i> 1849. | The Society. |
| Mémoires de la Société Géologique de France. Vol. III. Part 2. 4to. <i>Paris</i> 1850. | The Society. |
| Bulletin. Vol. VII. Nos. 1 to 13. 8vo. | ————— |
| Journal de l'École Polytechnique. Vols. XVIII. XIX. 4to. <i>Paris</i> 1847–48. | The French Minister of War. |
| Philadelphia:— | |
| Journal of the Academy of Natural Sciences. New Series. Vol. I. Parts 3 and 4. 4to. <i>Philadelphia</i> 1849–50. | The Academy. |
| Proceedings. Vol. IV. Nos. 11 and 12, Vol. V. No. 1. 8vo. | ————— |
| Proceedings of the American Philosophical Society. Nos. 42 to 44. Vol. V. 8vo. | The Society. |
| Journal of the Franklin Institute. Vols. XV. XVI. XVII. 8vo. <i>Philadel- phia</i> 1848–49. | The Institute. |
| Stockholm:— | |
| Årsberättelser om Botaniska Arbeten och Upptackter för ären 1843 och 1844, till Kongl. Vetenskaps-Akademien, af J. E. Wikström. Förra & sednare Delen. 8vo. <i>Stockholm</i> 1849. | Royal Academy of Sciences at Stockholm. |
| Årsberättelse om Technologiens Framsteg, till Kongl. Vetenskaps-Akade- mien, afgifven den 31 Mars 1842–44, 1846, af G. E. Pasch. 8vo. <i>Stock- holm</i> 1849. | ————— |
| Öfversigt af Kongl. Vetenskaps-Akademiens Förhandlingar. Arg. 5. Nos. 7 to 10, 1848. | ————— |
| Kongl. Vetenskaps-Akademiens Handlingar för år 1847–48. 8vo. <i>Stock- holm</i> 1849. | ————— |
| Några reflexioner i anledning af kemins studium och om denna vetenskaps ställning i staten. Tal: af L. F. Svanberg. 8vo. <i>Stockholm</i> 1849. | ————— |
| Årsberättelse om Framstegen i Kemi under år 1847 afgifven till Kongl. Vetenskaps-Akademien, af L. F. Svanberg. 8vo. <i>Stockholm</i> 1849. | ————— |
| Toulouse:—Mémoires de l'Académie de Toulouse. Tomes IV. V. VI. and Tome I. 3rd Series. 8vo. <i>Toulouse</i> 1837–39, 1843–44. | The Academy. |
| Turin:—Memorie della Reale Accademia delle Scienze di Torino. Tomo X. 4to. <i>Torino</i> 1849. | The Academy. |
| Utrecht:— | |
| Scheikundige Onderzoekingen Gedaan in het Laboratorium der Utrechtsche Hoogeschool. 5 ^{de} Deel. 6 & 7 ^{de} Stuk. 8vo. <i>Rotterdam</i> 1850. | The High School of Utrecht. |
| AIRY (G. B.) Astronomical Observations made at Greenwich in 1847. 4to. <i>London</i> 1849. | The Admiralty. |
| ————— Catalogue of 2156 Stars, formed from the Observations made during Twelve Years, from 1836 to 1847, at the Royal Observatory, Green- wich. 4to. <i>London</i> 1849. | ————— |
| ————— Magnetical and Meteorological Observations made at the Royal Observatory, Greenwich, in 1847. 4to. <i>London</i> 1849. | ————— |

PRESENTS.

DONORS.

ANONYMOUS:—

- A Congratulatory Address to Mr. Robert Brown, from the Royal Botanical Society of Ratisbon, on that gentleman being elected President of the Linnean Society.
- Anatomical Drawings selected from the Collection of Morbid Anatomy in the Army Medical Museum at Chatham. 5th Fasciculus. fol. *London* 1850.
- A Natural Scale of Heights, constructed by Miss Colthurst. A sheet.
- Annales des Mines. Tomes XIII. to XVI. 8vo. *Paris* 1848-49.
- Annales Hydrographiques, Années 1848-49. Tome I. 8vo. *Paris* 1849.
- Annuaire des Marées des Côtes de France pour 1848-49. 12mo. *Paris* 1848-49.
- Arctic Papers, published by the Admiralty.
- Buildings and Monuments, edited by G. Godwin, F.R.S. Parts 3 to 6. fol. *London* 1849.
- Catalogue of the Calcutta Public Library, and Report thereon. 8vo. *Calcutta* 1846.
- Die Fortschritte der Physik im Jahre 1847. Redigirt von Professor Karsten. 8vo. *Berlin* 1849.
- Flora Batava. Nos. 150, 151, 159, 161, 162. 4to.
- Further Report on the proposed Great Exhibition of Industry, by the Executive Committee. fol. *London* 1849.
- Index to the Additional Manuscripts in the British Museum. fol. *London* 1849.
- Letter to Lord John Russell on the Constitutional Defects of the University and Colleges of Oxford. By a Member of the Oxford Convocation. 8vo. *London* 1850.
- List of the Fellows and Members of the Royal College of Surgeons for 1849. 8vo. *London* 1849.
- Magnetic and Meteorological Observations made under the direction of A.D. Bache, 1840-1845. 3 vols. and Atlas. 8vo. *Washington* 1847.
- Observations Météorologiques faites à Nijne Taguilsk en 1846-47. 8vo. *Paris* 1846-47.
- Quarterly Reports of the Registrar-General. Nos. 2 to 5. 8vo. *London* 1849-50.
- Report of the Commissioners appointed to inquire into the application of Iron to Railway Structures. fol. *London* 1849.
- Plans accompanying the Report.
- Report of the Commissioner of Patents for the United States. 8vo. *Washington* 1848.
- Report of the Eleventh French Exposition of the Products of Industry. fol. *London* 1849.
- Report of the General Board of Health on the Supply of Water to the Metropolis. 8vo. *London* 1850.
- Report on a General Scheme for Extramural Sepulture. 8vo. *London* 1850.
- Report on the Nature and Import of certain Microscopic Bodies found in the Intestinal Discharges of Cholera. Presented to the Cholera Committee of the Royal College of Physicians of London, by their Sub-Committee, on Oct. 17, 1849. 8vo. *London* 1849.
- Dr. Wallich, F.R.S.
- Sir James MacGrigor, Bart.
- G.B.Greenough, Esq., F.R.S.
Bureau des Mines, Paris.
Bureau des Longitudes.
-
- The Admiralty.
The Editor.
- The Library.
- Dr. Du Bois-Reymond.
- The King of the Netherlands.
The Committee.
- The Trustees of the British Museum.
The Author.
- The College.
- Dr. Forbes, F.R.S.
- Prince Demidoff.
- The Registrar-General.
The Commissioners.
-
- The Commissioner.
- D. Wyatt, Esq.
- The Commissioners of the General Board of Health.
-
- The College of Physicians.

PRESENTS.

DONORS.

ANONYMOUS (*continued*).

- Tableau général des Phares et Fañaux des Côtes de Hollande et de Belgique. 8vo. *Paris* 1849. Dépôt de la Marine.
- The Helix considered as a Propeller of Steam Vessels. 8vo. *New York* 1849. The Author.
- The Sanitary Movement. 8vo. *Edinburgh* 1850. The Author.
- The Zoology of the Voyage of H.M.S. Samarang. Nos. 4, 5. 4to. *London* 1849. The Editors.
- Weekly and Quarterly Reports of the Registrar-General for 1849. The Registrar-General.
- ANSTED (D. T.) An Elementary Course of Geology, Mineralogy and Physical Geography. 8vo. *London* 1850. The Author.
- ART (Works of, &c.).
- A Wire which vibrates in a Parabolic Curve. Mr. Perigal.
- Original Drawing of Sir Isaac Newton, made for Roubilliac's Statue of that Philosopher at Cambridge. Rev. C. Turnor, F.R.S.
- ATKINS (Mrs.) The British Algæ. Parts 11 and 12. 4to. The Author.
- BARBIER (J. B. G.) Quelques Réflexions sur la Psychologie. 8vo. *Paris* 1849. The Author.
- BEAUTEMPS-BEAUPRÉ (C. F.) Rapports sur les Rades, Ports et Mouillages de la Côte Orientale du Golfe de Venise. 8vo. *Paris* 1849. Bureau de la Marine.
- BEKE (C. T.) On the Geographical Distribution of the Languages of Abessinians and the neighbouring Countries. 8vo. *Edinburgh* 1849. The Author.
- On the Sources of the Nile. 8vo. *London* 1849. —————
- Ueber die geographische Verbreitung der Sprachen von Abessinien und der Nachbarländer. —————
- BEROABLO (N. de.) L'Armonia Universale in sesta Rima. 4to. *Vienna* 1846. The Author.
- Repulsione Centrale, Opera a complimento del Poema 'l'Armonia Universale.' 4to. *Vienna* 1849. —————
- BIBO (H.) Erfindung und Bearbeitung einer neuen, durch die 2 gleichmässig ohne Brüche theilbaren Decimal-Rechnung, aus einem neuen Zahlensysteme hergeleitet. 8vo. *Berlin* 1850. The Author.
- BILLING (Dr.) Principles of Medicine. 5th edit. 8vo. *London* 1850. The Author.
- BIOT (J. B.) Une Anecdote relative à M. Laplace. 4to. The Author.
- BLAIR (Daniel.) Some Account of the last Yellow Fever Epidemic of British Guiana. 8vo. *London* 1850. The Author.
- BOURNE (John.) A Report on Indian River Navigation. 8vo. *London* 1849. The Author.
- A Catechism of the Steam Engine. 8vo. *London* 1850. —————
- BRODIE (Sir B. C.) Lectures on the Diseases of the Urinary Organs. 8vo. *London* 1849. The Author.
- Pathological and Surgical Observations on the Diseases of the Joints. 8vo. *London* 1850. —————
- BRYSON (Dr.) Statistical Reports of the Health of the Royal Navy. fol. *London* 1850. Sir W. Burnett, M.D.
- BUCHNER (L. A.) Ueber den Antheil der Pharmacie an der Entwicklung der Chemie. 4to. *München* 1849. Acad. of Sciences, Munich.
- BUSCH (A. L.) Verzeichniss sämmtlicher Werke, Abhandlungen, Aufsätze und Bemerkungen von F. W. Bessel. 4to. *Königsberg* 1849. The Author.
- Astronomische Beobachtungen auf der Königlichen Universitäts-Sternwarte in Königsberg im 1843-8. fol. *Königsberg* 1848. —————

| PRESENTS. | DONORS. |
|--|----------------------------|
| CARAMAN (Le Duc de.) Histoire des Révolutions de la Philosophie en France pendant le moyen âge, jusqu'au 16 ^m e siècle. Vol. III. 8vo. <i>Paris</i> 1848. | The Author. |
| COX (C. J.) On the Ravages committed by the <i>Scolitus Destructor</i> and Larva of the <i>Cossus Ligniperda</i> . 4to. <i>London</i> 1848. | The Author. |
| CURLING (T. B.) Article TESTICLE, from the Cyclopædia of Anatomy and Physiology. 8vo. | The Author. |
| DANA (J. D.) On the Isomorphism and Atomic Volume of some Minerals. | The Author. |
| DARONDEAU (B.) Mélanges Hydrographiques. Tomes I. II. III. 8vo. <i>Paris</i> 1846-7-8. | Bureau de la Marine. |
| DELESSE (A.) Recherches sur le Porphyre Quartzifère. | Bureau des Mines. |
| ————— Recherches sur l'Euphotide. | ————— |
| ————— Sur le Pouvoir Magnétique des Roches. | ————— |
| ————— Sur la Constitution Minéralogique et Chimique des Roches des Vosges. | ————— |
| DEMIDOFF (Prince.) Voyage dans la Russie Méridionale et la Crimée. Livraisons 13 to the end. fol. | The Author. |
| DE MORGAN (A.) Method of Integrating Partial Differential Equations. 4to. <i>Cambridge</i> 1848. | Cambridge Phil. Society. |
| DIXON (R. V.) A Treatise on Heat. Part 1. 8vo. <i>Dublin</i> 1849. | The Author. |
| DOLLEN (W.) Neue Reduction der Königsberger Declinationen für 1820. 4to. <i>St. Petersburg</i> 1849. | The Author. |
| EENENS (M.) Mémoire sur la Fertilisation des Landes. 8vo. <i>Bruxelles</i> 1849. | The Author. |
| EMIL DU BOIS-REYMOND. Untersuchungen über Thierische Electricität. 2 vols. 8vo. <i>Berlin</i> 1848. | The Author. |
| ENCKE (J. F.) Astronomisches Jahrbuch für 1852. 8vo. <i>Berlin</i> 1849. | The Observatory of Berlin. |
| FALCONER (H.) and CAUTLEY (P. T.) Fauna Antiqua Sivalensis. Parts 1 to 9. fol. Text, Part 1. <i>London</i> 1845-9. | The Ordnance Survey. |
| FALLOWS (F.) Cape Observations, 1829-31. 4to. <i>London</i> 1850. | The Astronomer Royal. |
| FARREN (Edwin James.) Life Contingency Tables. Part 1. | The Author. |
| FELLOCKER (S.) Verzeichniss der von Bradley, Piazzzi, Lalande und Bessel beobachteten Sterne in dem Theile des Himmels zwischen 6 ^h 56' bis 8 ^h 4' gerader Aufsteigung und 15° sudlicher bis 15° nordlicher Abweichung berechnet. With a sheet. fol. <i>Berlin</i> 1848. | The Author. |
| FOURCAULT (A.) Causes générales des Maladies chroniques. 8vo. <i>Paris</i> 1844. | The Author. |
| FROST (James.) Description of the Causes of the Explosion of Steam-Boilers. 8vo. <i>New York</i> 1848. | The Author. |
| FUSINIERI (Dr.) Memorie sopra la Luce, il Calorico, l' Elettricità, il Magnetismo, l' Elettro-Magnetismo ed altri Oggetti. 4to. <i>Padova</i> 1846. | The Author. |
| ————— Memorie di Meteorologia. 4to. <i>Padova</i> 1847. | ————— |
| FUSS (P. H.) Ueber L. Euleri Commentationes Arithmeticae Collectae. 8vo. <i>Petrop.</i> 1848. | The Author. |
| GALTON (F.) The Telotype, a Printing Electric Telegraph. 8vo. <i>London</i> 1850. | The Author. |
| GARNER (R.) Natural History of the County of Stafford. 8vo. <i>London</i> 1844. | The Author. |
| GILBART (J. W.) Practical Treatise on Banking. 2 vols. 8vo. <i>London</i> 1849. | The Author. |
| ————— A Lecture on the Philosophy of Language. 8vo. <i>London</i> 1850. | ————— |

| PRESENTS. | DONORS. |
|---|-------------------------|
| GILLISS (J. M.) The Longitude of Washington, computed from the Moon's Culminations, observed during the years 1839 to 1842, inclusive. 4to. <i>Philadelphia</i> 1849. | The Author. |
| GLYNN (Joseph.) Rudimentary Treatise on the Construction of Cranes. 8vo. <i>London</i> 1849. | The Author. |
| GUEST (Edwin.) On the Early English Settlements in South Britain. 8vo. <i>London</i> 1850. | The Author. |
| HALDAT (M.) Traité d'Optique Oculaire. 8vo. <i>Paris</i> 1849. | The Author. |
| ————— Essai historique sur le Magnétisme. 8vo. <i>Nancy</i> 1849. | ————— |
| HAUGHTON (S.) On the Rotation of a Solid Body round a fixed point. 4to. <i>Dublin</i> 1849. | The Author. |
| ————— On a Classification of Elastic Media, and the Laws of Plane Waves propagated through them. 4to. <i>Dublin</i> 1849. | ————— |
| HOGG (John.) Remarks and Additional Views on Dr. Lepsius' Proofs that Mount Serbal is the true Mount Sinai. Map to ditto. 8vo. <i>London</i> 1849. | The Author. |
| HOWARD (Luke.) Essay on the Modifications of Clouds. 8vo. <i>London</i> 1832. | The Author. |
| ————— Papers on Meteorology. 4to. <i>London</i> 1850. | ————— |
| JACUBOWITSCH (N.) De Saliva. 8vo. <i>Dorpat</i> 1848. | The Author. |
| JAMES (C.) Voyage scientifique à Naples, avec M. Majendie en 1843. 8vo. <i>Paris</i> 1844. | The Author. |
| ————— Études sur l'Hydrothérapie. 8vo. <i>Paris</i> 1846. | ————— |
| ————— De l'Emploi de l'Électricité Galvanique dans le traitement de certaines Paralysies des Membres inférieures. 8vo. <i>Paris</i> 1849. | ————— |
| JELINCK (C.) Bahnbestimmung des von de Vico am 24 Jänner 1846 entdeckten Cometen. 4to. <i>Wien</i> . | The Author. |
| ————— Meteorologische Beobachtungen an der Wiener Sternwarte im Jahre 1839. | The Observatory. |
| JELINCK (C.) und HORNSTEIN (C.) Cometen-Beobachtungen an der Wiener Sternwarte 1835-6 und 1843-6. 4to. <i>Wien</i> . | The Authors. |
| JOHNSON (M. J.) Astronomical Observations made at the Radcliffe Observatory, Oxford, in 1847. 8vo. <i>Oxford</i> 1849. | The Radcliffe Trustees. |
| Ditto in 1848. 8vo. 1850. | ————— |
| JOHNSTON (J. F. W.) Contributions to Scientific Agriculture. 8vo. <i>London</i> 1849. | The Author. |
| JOURNALS:— | |
| The American Journal of Science and Arts. Vol. IX. Nos. 25 to 27. 8vo. <i>Newhaven</i> . | Messrs. Silliman. |
| The Astronomical Journal. Nos. 1 to 4. 4to. <i>Washington</i> 1850. | The Editor. |
| The Athenæum. | The Editor. |
| The Builder. Vol. VIII. Parts 1 to 6. | The Editor. |
| The Journal of the Indian Archipelago and Eastern Asia. Nos. 1 and 4, Vol. IV. Nos. 3 to 9, Vol. III. 8vo. | The Editor. |
| The Literary Gazette. | The Editor. |
| The Philosophical Magazine, from Jan. 1846 to June 1850. | Richard Taylor, Esq. |
| KELLER (A. F.) Des Typhons de 1848. 8vo. <i>Paris</i> 1849. | Dépôt de la Marine. |
| KENNEDY (R. H.) De Clifford, a Romance of the Red Rose. A Poem, in 12 books. 8vo. <i>London</i> 1824. | The Author. |
| ————— Narrative of the Campaign of the Army of the Indus in Sind and Kaubool in 1838-9. 2 vols. 8vo. <i>London</i> 1840. | ————— |

| PRESENTS. | DONORS. |
|--|---------------------|
| KENNEDY (R. H.) Notes on the Epidemic Cholera. 8vo. <i>London</i> 1846. | The Author. |
| KERHALLET (C. P. de.) Description Nautique de la Côte Occidentale d'Afrique. 8vo. <i>Paris</i> 1849. | Dépôt de la Marine. |
| KOKSCHAROW (N. v.) Ueber Brookit-Krystalle vom Ural. 8vo. <i>St. Petersburg</i> 1849. | The Author. |
| KRECKE (F. W. C.) Description de l'Observatoire Météorologique et Magnétique à Utrecht. 8vo. <i>Utrecht</i> 1850. | The Author. |
| KREIL (K.) Magnetische und Geographische Ortsbestimmungen im Österreichischen Kaiserstaate für 1847 und 1848. 4to. <i>Prag</i> 1849-50. | The Author. |
| ————— Magnetische und Meteorologische Beobachtungen zu Prag 1848. 4to. <i>Prag</i> 1850. | ————— |
| ————— Ueber den Einfluss der Alpen auf die Aeusserungen der magnetischen Erdkraft. fol. <i>Wien</i> 1849. | ————— |
| KUPFFER (A.) Annuaire Magnétique et Météorologique du corps des Ingénieurs des Mines. Année 1846. 4to. <i>St. Pétersbourg</i> 1849. | The Author. |
| LAMONT (J.) Annalen der Königlichen Sternwarte bei München. 8vo. <i>München</i> 1849. | The Observatory. |
| LASSELL (W.) Description of a Machine for Polishing Specula. 4to. <i>London</i> 1849. | The Author. |
| LEE (Robert.) Memoirs on the Ganglia and Nerves of the Uterus. 4to. <i>London</i> 1849. | The Author. |
| LE VERRIER (U. J. J.) Rapport sur l'établissement de nouvelles Lignes de Télégraphie Électrique. | The Author. |
| LINDHAGEN (Dr.) Ueber die Genauigkeit der in Lalandes Catalog. 8vo. <i>St. Petersburg</i> 1849. | The Author. |
| LITTRON (C. L. von.) Annalen der Sternwarte in Wien. Tomes V.—IX. 4to. | The Observatory. |
| LOVELACE (Earl of.) On the Construction of a Collar Roof. 8vo. <i>London</i> 1849. | The Author. |
| LUBBOCK (Sir J. W., Bart.) On the Theory of the Moon. Part 8. 8vo. <i>London</i> 1849. | The Author. |
| LYELL (Sir Charles.) Address delivered at the Anniversary Meeting of the Geological Society of London, on the 15th February 1850. 8vo. <i>London</i> 1850. | The Author. |
| MANTELL (G. A.) Thoughts on a Pebble. 8vo. <i>London</i> 1849. | The Author. |
| MAPS, CHARTS, &c.:— | |
| The Charts and Sailing Directions published by the Admiralty during 1850. | The Admiralty. |
| Thirty-seven Maps and Charts from French Surveys. | Dépôt de la Marine. |
| Two Maps of Isothermal Lines. | H. W. Dove. |
| MARCET (F.) Cours de Physique Expérimentale. 8vo. <i>Paris</i> 1850. | The Author. |
| MARTIN (F.) Mémoire sur l'Étiologie du Pied-Bot, et Atlas. 8vo. <i>Paris</i> 1839. | The Author. |
| ————— Mémoire sur l'Amputation sus-Malléolaire. 4to. <i>Paris</i> 1842. | ————— |
| ————— Essai sur les Appareils Prothétiques. 8vo. <i>Paris</i> 1850. | ————— |
| MARTIN (J.) Outline of a Comprehensive Plan for diverting the Sewage of London and Westminster from the Thames, and applying it to Agricultural Purposes. 8vo. <i>London</i> 1850. | The Author. |
| MATTEUCCI (C.) Mémoire sur la Propagation de l'Électricité dans les Corps Solides Isolants. | The Author. |

| PRESENTS. | DONORS. |
|--|--|
| MATZKA (W.) Versuch einer richtigen Lehre von der Realitaet der vor- geblich imaginären Grössen der Algebra, oder einer Grundlehre von der Ablenkung algebraischer Grossenbeziehungen unternommen. 4to. <i>Prag</i> 1850. | The Author. |
| MAURY (Lieut.) Circular prepared by direction of the Hon. W. B. Preston, in relation to the Astronomical Expedition to Chile. 4to. <i>Washington</i> 1849. | Lieut. Gilliss. |
| MAYO (T.) Outlines of Medical Proof, revised and corrected. 8vo. <i>London</i> 1850. | The Author. |
| MIERS (John.) Illustrations of South American Plants. Parts 1—4. 4to. <i>London</i> 1846. | The Author. |
| MINERVINI (G.) Dell' Epilessia. 8vo. <i>Napoli</i> 1847. | The Author. |
| MINERVINI (R.) Soluzione di un Problema Geometrico Piano della Classe de' Problemi detta da' Geometri Greci <i>νευστων</i> delle Inclinationi. 8vo. <i>Napoli</i> 1849. | The Author. |
| MISCELLANEOUS:— | |
| The original Model of the Safety Lamp made by Sir Humphry Davy's own hands, and given by him to James Prince Lee, D.D., Lord Bishop of Man- chester. | Joseph Hodgson, Esq., F.R.S. |
| MOON (R.) The New Equation in Hydrodynamics. 8vo. <i>Cambridge</i> 1850. | The Author. |
| MORTON (S. G.) Catalogue of Skulls of Man and the Inferior Animals. 8vo. <i>Philadelphia</i> 1849. | The Author. |
| ————— Observations on the Size of the Brain in various races and families of Man. 8vo. <i>Philadelphia</i> 1849. | ————— |
| ————— Additional Observations on a new living species of Hip- popotamus. 4to. <i>Philadelphia</i> 1849. | ————— |
| MÜLLER (Dr.) (Editor.) Rig-Veda-Sanhita. The Sacred Hymns of the Brahmans. Vol. I. 4to. <i>London</i> 1849. | The East India Company. |
| NICOL (James.) Manual of Mineralogy. 8vo. <i>Edinburgh</i> 1849. | The Author. |
| OHM (G. S.) Elemente der Analytischen-Geometrie im Raume am schief- winkeligen Coordinatensysteme. 4to. <i>Nürnberg</i> 1849. | The Author. |
| ORLEBAR (A. B.) Observations made at the Magnetical and Meteorolo- gical Observatory at Bombay in 1846. 4to. <i>Bombay</i> 1849. | The Hon. Directors of the East India Company. |
| OVEREND (G.) Extraordinary New Steam-Engines. 8vo. | The Author. |
| PARAVEY (C. de.) Réfutation de l'Opinion émise par M. Jomard, que les Peuples de l'Amérique n'ont jamais eu aucun rapport avec ceux de l'Asie. 8vo. <i>Paris</i> 1848. | The Author. |
| ————— Mémoire sur la Découverte très-ancienne en Asie et dans l'Indo-Perse de la Poudre à Canon et des Armes à Feu. 8vo. <i>Paris</i> 1850. | ————— |
| PARKER (W.) The Physiological and Scientific Treatment of Cholera. 8vo. <i>London</i> 1849. | The Author. |
| PARLATORE (Filippo.) Viaggio alla Catena del Monte Bianco e al Gran San Bernardo. 8vo. <i>Firenze</i> 1850. | The Author. |
| ————— Flora Italiana. Fasc. 1. 8vo. <i>Firenze</i> 1848. | ————— |
| PERIGAL (H.) Notes on Revolution and Rotation with reference to the Motions of the Moon and of the Earth. 8vo. <i>London</i> 1846—9. | The Author. |
| ————— Contributions to Kinematics. | ————— |
| PETERS (C. A. F.) Über Professor Mädler's Untersuchungen über die Eigenen Bewegungen der Fixsterne. 4to. <i>St. Petersburg</i> 1848. | The Author. |

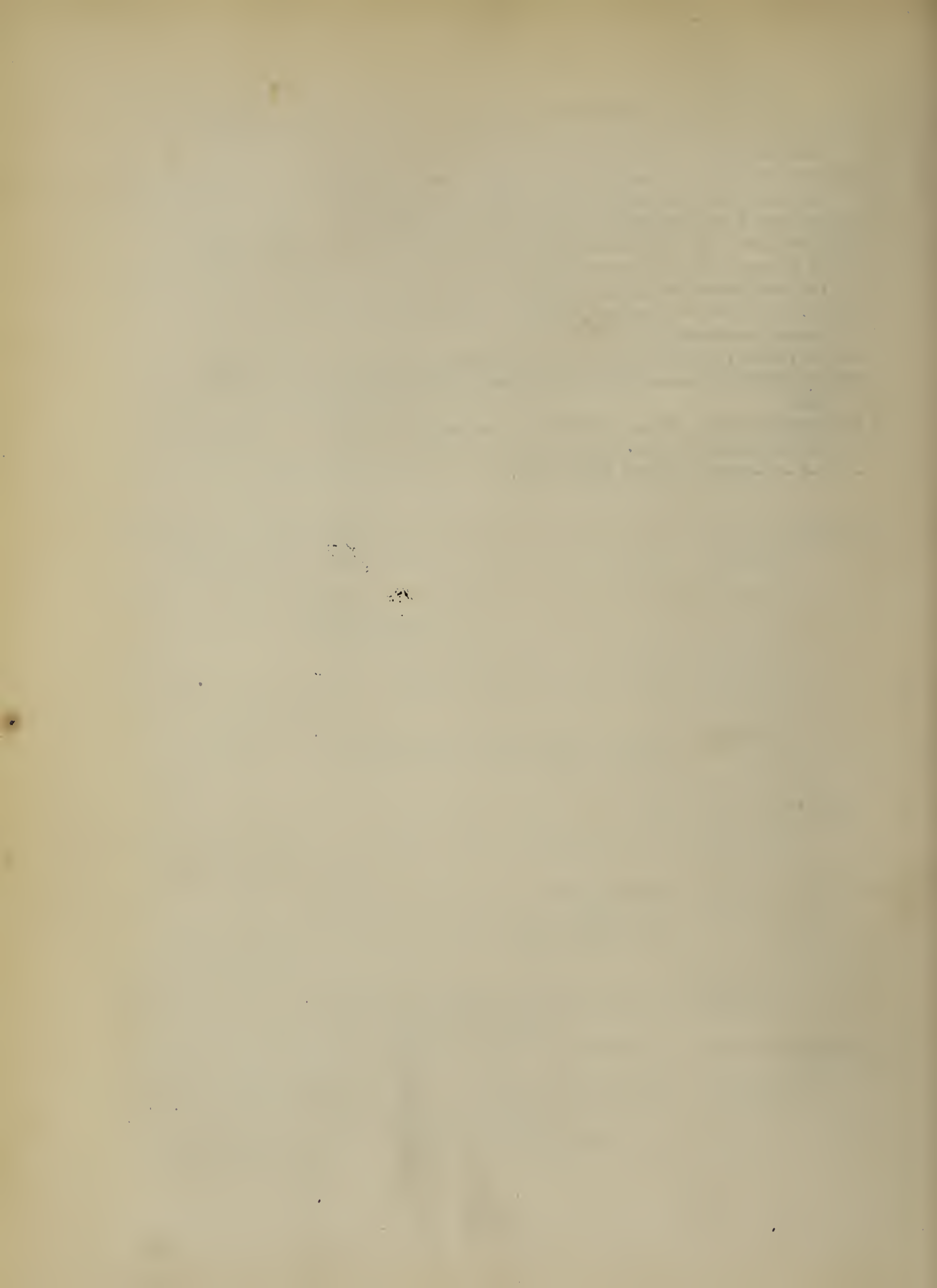
| PRESENTS. | DONORS. |
|--|--------------------------|
| PIROGOFF (N.) Anatomie Pathologique du Choléra Morbus. fol. <i>St. Pétersbourg</i> 1849. | The Author. |
| PLANTAMOUR (E.) Observations Astronomiques faites à l'Observatoire de Genève dans l'année 1847. 4to. <i>Genève</i> 1849. | The Author. |
| ————— Résumé Météorologique de l'année 1847-8 pour Genève et le Grand St. Bernard. 8vo. <i>Genève</i> 1848-9. | ————— |
| PLATEAU (J.) Note sur une nouvelle Application curieuse de la Persistance des Impressions de la Rétine. | The Author. |
| ————— Recherches sur les Figures d'Équilibre d'une Masse liquide sans pesanteur. 4to. <i>Bruxelles</i> 1849. | ————— |
| PORTA (L.) Delle Malattie e delle Operazioni della Ghiandola Tiroidea. 4to. <i>Milano</i> 1849. | The Author. |
| PORTER (G. R.) The Nature and Properties of the Sugar Cane. 8vo. <i>London</i> 1843. | The Author. |
| PORTRAITS:— | |
| Portrait in Lithograph of Sir J. P. Boileau, F.R.S. | George Ransome, Esq. |
| Prince Lucien Bonaparte. | ————— |
| J. S. Bowerbank, Esq., F.R.S. | ————— |
| Marquis of Bristol. | ————— |
| Edward Forster, Esq., F.R.S. | ————— |
| The Rev. Wm. Kirby, F.R.S. | ————— |
| Sir R. I. Murchison, F.R.S. | ————— |
| Robert Patterson, Esq. | ————— |
| Rev. Edwin Sidney. | ————— |
| William Spence, Esq., F.R.S. | ————— |
| William Thompson, Esq. | ————— |
| Portrait in Oil of John Hunter, F.R.S., by Edward Home. | Sir Everard Home, F.R.S. |
| J. Ramsden, F.R.S. | ————— |
| POWELL (B.) On Irradiation. | The Author. |
| QUETELET (A.) Rapport sur l'État et les Travaux de l'Observatoire Royal pendant l'année 1848. 8vo. <i>Bruxelles</i> 1848. | The Author. |
| ————— Annales de l'Observatoire Royal de Bruxelles. Tome VII. 4to. <i>Bruxelles</i> 1849. | The Observatory. |
| ————— Sur le Climat de la Belgique. Tome I. 4to. <i>Bruxelles</i> 1849. | The Author. |
| ————— Observations des Phénomènes Périodiques. 4to. <i>Bruxelles</i> 1849. | ————— |
| RATHKE (H.) Ueber die Entwicklung der Schildkröten. 4to. <i>Braunschweig</i> 1848. | The Author. |
| REEVE (Lovell.) Conchologia Iconica. Monographs of the Genus Achatina—Chama—Dolium—Cassis—Voluta—Eburna—Buccinum—Bulimus—Conus—Bullia—Chitonellus—Cassidaria—Chiton—Isocardia—Mitra—Ficula—Pectunculus—Oniscia—Fusus—Fasciolaria—Mangelia—Hemipecten—Monoceros—Eglisia—Mesalia—Haliotis—Purpura—Turbo—Ranella—Ricinula—Pyrula—Turbinella—Turritella—Paludomus. | The Author. |
| REGNAULT (V.) Cours Élémentaire de Chimie. 4 vols. 8vo. <i>Paris</i> 1849-50. | The Author. |

| PRESENTS. | DONORS. |
|--|--------------------------------------|
| REGNAULT (V.) et REISET (J.) Recherches Chimiques sur la Respiration des Animaux des diverses Classes. 8vo. <i>Paris</i> 1849. | The Authors. |
| REID (Lieut.-Col.) The Progress of the Development of the Law of Storms. 8vo. <i>London</i> 1849. | The Author. |
| REMAK (R.) Neurologische Erläuterungen. 8vo. <i>Berlin</i> . | The Author. |
| RICHARDSON (James.) The Cruisers; being a Letter to the Marquis of Lansdowne, in defence of Armed Coereion for the Extinction of the Slave Trade. 8vo. <i>London</i> 1849. | The Author. |
| ROBERTS (Henry.) The Dwellings of the Labouring Classes; their Arrangement and Construction. 8vo. <i>London</i> 1850. | The Author. |
| ROYLE (J. F.) Report on the Progress of the Culture of the China Tea Plant in the Himalayas from 1835 to 1847. 8vo. <i>London</i> 1849. | The Author. |
| SABINE (Lieut.-Col.) Directions for the use of a small Apparatus to be employed with a Ship's Standard Compass. 8vo. <i>London</i> 1849. | The Author. |
| SCHMIDT (C.) Der Diagnostik Verdächtiger Flecke in Criminalfällen. 8vo. <i>Leipzig</i> 1848. | The Author. |
| SMEE (Alfred.) Principles of the Human Mind. 8vo. <i>London</i> 1849. | The Author. |
| ————— Instinct and Reason: deduced from Electro-Biology. 8vo. <i>London</i> 1850. | ————— |
| SMYTH (C. P.) Astronomical Observations made at the Royal Observatory, Edinburgh, by the late Thomas Henderson, Esq. Vol. VIII. 1842. 4to. <i>Edinburgh</i> 1849. | The Royal Observatory, Edinburgh. |
| SPINOLA (J. y) and CHALUZ DE VERNEVIL (F. T. A.) The Gen- euphonie Grammar. 8vo. <i>London</i> 1850. | The Author. |
| STANNIUS (H.) Das peripherische Nervensystem der Fische. 4to. <i>Rostock</i> 1849. | The Author. |
| STAUNTON (Sir George, Bart.) Miscellaneous Notices relating to China. 8vo. <i>London</i> 1822-50. | The Author. |
| STEVENSON (W. F.) The Composition of Hydrogen and the Non-Decom- position of Water incontrovertibly established. Second Edition. 8vo. <i>Dub- lin</i> 1849. | The Author. |
| STRATFORD (Lieut.) The Nautical Almanac for 1853. 8vo. <i>London</i> 1850. | Lieut. Stratford, F.R.S. |
| STRUVE (W.) Rapport fait à l'Académie Impériale des Sciences, sur une Mission Scientifique en 1847. | The Author. |
| ————— Sur la Dilatation de la Glæe. 4to. <i>St. Pétersbourg</i> 1848. | ————— |
| ————— Beschreibung der zur Ermittlung des Hohenunter- scheides zwischen dem Schwarzen und dem Caspischen Meere. 4to. <i>St. Petersburg</i> 1849. | ————— |
| SYKES (Lieut.-Col.) Contributions to the Statistics of Sugar. | The Author. |
| SYMONDS (J. A.) Some Account of the Life, Writings and Character of the late J. C. Pritchard, M.D., F.R.S. 8vo. <i>Bristol</i> 1849. | The Author. |
| TAYLOR (T. G.) Astronomical Observations made at the East India Com- pany's Observatory, Madras, in 1843-7. | The East India Company. |
| TEMMINCK (C. J.) Coup-d'œil général sur les Possessions Néerlandaises dans l'Inde Archipelagique. Tome III. 8vo. <i>Leide</i> 1849. | J. E. Gray, Esq. |
| THURMANN (Jules.) Essai de Phytostatique appliqué à la Chaîne du Jura. 2 vols. 8vo. <i>Berne</i> 1849. | The Author. |

PRESENTS.

DONORS:

| | |
|---|--------------------------|
| TOYNBEE (J.) Pathological Researches into the Diseases of the Ear. 8vo. <i>London</i> 1849. | The Author. |
| TWINING (Elizabeth.) Illustrations of the Natural Orders of Plants, arranged in Groups, with Descriptions. Parts 1 to 6. fol. <i>London</i> 1849. | R. Twining, Esq., F.R.S. |
| WALKER (C. V.) Electric Telegraph Manipulation. 8vo. <i>London</i> 1850. | The Author. |
| WATERSTON (J. J.) An Account of a Mathematical Theory of Gases. | The Author. |
| WELD (Charles Richard.) Arctic Expeditions: a Lecture delivered at the London Institution, Feb. 6, 1850, with a Map. 8vo. <i>London</i> 1850. | The Author. |
| ————— Auvergne, Piedmont, and Savoy: a Summer Ramble. 8vo. <i>London</i> 1850. | ————— |
| WHITE (Walter.) Arctic Explorations. 8vo. <i>Edinburgh</i> 1850. | The Author. |
| WILLICH (C. W.) Annual Supplement to Tithe Commutation Tables for 1850. | The Author. |
| ZANTEDESCHI (F.) Risposta ai Signori E. Knoblauch sulla Esistenza delle linee longitudinali nello Spettro Solare. 8vo. <i>Roma</i> 1849. | The Author. |
| ————— Annali di Fisica. Part 4. | ————— |



PHILOSOPHICAL TRANSACTIONS.

I. THE BAKERIAN LECTURE.—*On the Diffusion of Liquids.*

By THOMAS GRAHAM, F.R.S., F.C.S.

Received November 16,—Read December 20, 1849.

ANY saline or other soluble substance, once liquefied and in a state of solution, is evidently spread or diffused uniformly through the mass of the solvent by a spontaneous process.

It has often been asked whether this process is of the nature of the diffusion of gases, but no satisfactory answer to the question appears to be obtained, owing, I believe, to the subject having been studied chiefly in the operations of endosmose, where the action of diffusion is complicated and obscured by the imbibing power of the membrane, which is peculiar for each soluble substance, but no way connected with the diffusibility of the substance in water. Hence also it was not the diffusion of the salt, but rather the diffusion of the solution, which was generally regarded. A diffusibility like that of gases, if it exists in liquids, should afford means for the separation and decomposition even of unequally diffusible substances, and being of a purely physical character, the necessary consequence and index of *density*, should present a scale of densities for substances in the state of solution, analogous to vapour densities, which would be new to molecular theory.

M. GAY-LUSSAC proceeds upon the assumed analogy of liquid to gaseous diffusion in the remarkable explanation which he suggests of the cold produced on diluting certain saline solutions, namely, that the molecules of the salt expand into the water like a compressed gas admitted into additional space.

The phenomena of solubility are at the same time considered by that acute philosopher as radically different from those of chemical affinity, and as the result of an attraction which is of a physical or mechanical kind. The characters indeed of these two attractions are strongly contrasted. Chemical combination is uniformly attended

with the evolution of heat, while solution is marked with equal constancy by the production of cold. The substances which combine chemically are the dissimilar, while the soluble substance and its solvent are the like or analogous in composition and properties.

In the consideration of solubility, attention is generally engrossed entirely by the quantity of salt dissolved. But it is necessary to apprehend clearly another character of solution, namely, the degree of force with which the salt is held in solution, or the intensity of the solvent attraction, quite irrespective of quantity dissolved. In the two solid crystalline hydrates, pyrophosphate of soda and sulphate of soda, we see the same ten equivalents of water associated with both salts, but obviously united with unequal degrees of force, the one hydrate being persistent in dry air and the other highly efflorescent. So also in the solutions of two salts which are equally soluble in point of quantity, the intensity of the attraction between the salt and the water may be very different, as exemplified in the large but feeble solubility in water of such bodies as the iodide of starch or the sulphindylate of potash, compared with the solubility of hydrochloric acid or of the acetate of potash, which last two substances are capable of precipitating the two former, by displacing them in solution. Witness also the unequal action of animal charcoal in withdrawing different salts from solution, although the salts are equally soluble; and the unequal effect upon the boiling-point of water produced by dissolving in it the same weight of various salts. Besides being said to be small or great, the solubility of a substance has also therefore to be described as weak or strong.

The gradations of intensity observed in the solvent force are particularly referred to, because the inquiry may arise how far these gradations are dependent upon unequal diffusibility; whether indeed rapidity of diffusion is not a measure of the force in question.

I have only further to premise, that two views may be taken of the physical agency by which gaseous diffusion itself is effected, which are equally tenable, being both entirely sufficient to explain the phenomena.

On one theory, that of Dr. DALTON, the diffusibility of a gas is referred immediately to its elasticity. The same spring or self-repulsion of its particles which sends a gas into a vacuum, is supposed to propel it through and among the particles of a different gas.

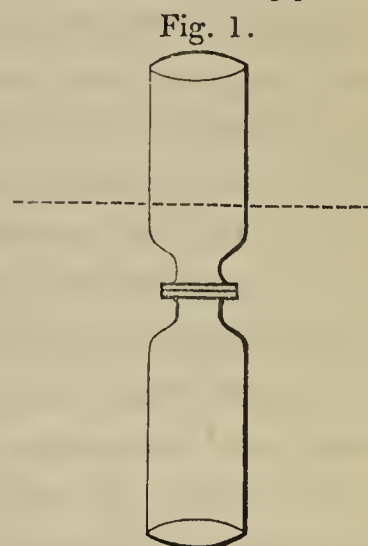
The existence of an attraction of the particles of one gas for the particles of all other gases is assumed in the other theory. This attraction does not occasion any diminution of volume of gases on mixing, because it is an attraction residing on the surfaces of the gaseous molecules. It is of the same intensity for all gases, hence its effect in bringing about intermixture is dependent upon the weight of the molecules of the gases to be moved by it; and the velocity of diffusion of a gas comes to have the same relation to its density on this hypothesis as upon the other*.

* Both of the molecular theories of the diffusion of gases were first publicly explained, and at the same time ably discussed, with the reference to the law of diffusion which had been drawn from observation, by my late

The surface attraction of molecules assumed will recall the surface attraction of liquids, which is found necessary to account for the elevation of liquids in tubes and other phenomena of capillary attraction.

(1.) An early preliminary experiment was made upon the liquid diffusion of a body, with whose diffusion as a gas we are already well acquainted, namely, carbonic acid dissolved in water.

Two half-pound stoppered glass bottles were selected, of which the mouths were 1.2 inch in diameter, and the lips were ground flat so as to close tight when applied together (fig. 1). One of them, placed firmly in an upright position, was filled to the base of the neck with carbonic acid water. Over this distilled water was poured, care being taken to disturb the liquid below as little as possible, in filling up the neck. The second bottle, filled with distilled water and inverted upon a glass plate, was slipped over the first at the water-trough. The solution of carbonic acid in the lower bottle was thus placed in free communication by an aperture of 1.2 inch, with an equal volume of pure water in the upper bottle. It was expected that the carbonic acid would be found, in time, equally diffused through both bottles.



After forty-eight hours, the upper inverted bottle was again slipped off from the lower one, upon a glass plate, and the ratio of the gas found in the upper to that in the lower bottle determined by the weight of carbonate of baryta which the liquids of the two bottles afforded respectively. It was as 1.18 to 12.80 (about 1 to 11), instead of the ratio of equality, which would undoubtedly be the ultimate result of diffusion, were sufficient time allowed.

After five days, in a second experiment with a weaker solution of carbonic acid, the gas was found to be distributed—

| | | |
|-----------------|---------|------|
| In upper bottle | | 1.63 |
| In lower bottle | | 8.44 |

or in the proportion of 1 to 5 nearly.

In other experiments where the liquid in the upper bottle was a solution in water of nitrous oxide gas, instead of pure water, the carbonic acid of the lower bottle was also observed to diffuse into the liquid above it, as freely as it did into pure water in a comparative experiment; the ultimate ratios being 1 to 0.12 in the nitrous oxide liquid, and 1 to 0.10 in the water experiment.

With the necks of the pair of bottles occupied by sponge charged with distilled water, the diffusion of the carbonic acid of the lower bottle proceeded with little

friend Mr. T. S. THOMSON of Clitheroe. A decided preference was given by Mr. THOMSON, and also by the late Mr. IVORY, to the last, or the attraction theory of diffusion, over that of gases being *vacua* to each other. See Phil. Mag., 3rd series, vol. xxv. pp. 51, 282.

change in its rapidity, or in the result when nitrous oxide was placed above it. The carbonic acid found in the upper bottle, and which had diffused into it from the lower, was 0·231 when the upper bottle contained water alone, and 0·229 when it was water charged with three-fourths of its volume of nitrous oxide gas,—to 1 carbonic acid remaining undiffused in the lower bottle in both cases.

It appeared, then, that the liquid diffusion of carbonic acid was a slow process compared with its gaseous diffusion, quite as much as days are to minutes.

That this diffusion of the liquid carbonic acid takes place with undiminished vigour into water already saturated with nitrous oxide, the substance of all others most resembling carbonic acid in solubility and the whole range of its physical qualities. The diffusion of the liquid carbonic acid appears no more repressed by the liquid nitrous oxide, than the diffusion of gaseous carbonic acid is by gaseous nitrous oxide.

But the chief interest of these observations was the practical solution which they give to the question, whether, in conducting experiments on liquid diffusion, accidental causes of disturbance and intermixture of two liquids, communicating freely with each other, can be avoided. It was made evident that little is to be feared from accidental dispersion when ordinary precautions are taken.

An excess of density in the lower liquid of not more than $\frac{1}{1000}$ th part is found adequate to prevent any considerable change of place of the latter,—from expansion by heat, accidental tremors and such disturbing causes, which must exist,—for days together.

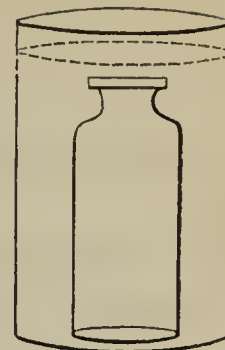
(2.) Another early inquiry was, how far is the diffusion of various salts governed or modified by the density of their solutions.

Solutions of eight hydrated acids and salts were prepared, having the common density of 1·200, and were set to diffuse into water in the following manner:—

Eighteen or twenty six-ounce phials were made use of to contain the solutions, and to form what I shall call the Solution phials or cells. They were of the same make and selected from a large stock, of the common aperture of 1·175 inch. Both the mouths and bottoms of these phials were ground flat. The mode of making an experiment was first to fill the phial to the base of the neck, or rather to a constant distance of 0·6 inch below the ground surface of the lip. A little disc of cork, provided with a slight upright peg of wood, was then floated upon the solution in the neck, after having been first dipt in water. The neck itself was now filled up with pure water by means of a pointed sponge, the drop suspended from the sponge being made to touch the peg of the float, and water caused to flow in the gentlest manner, by slightly pressing the sponge. The only other part of the apparatus, the Water-jar, was a plain cylindrical glass jar, of which the inner surface of the bottom was flat or slightly concave, to give a firm support to the phial. The phial, with its solution only, was first placed in this jar partly filled with distilled water, and the neck of the former was then filled up with distilled water in this position, as before described, to avoid any subsequent movement. The phial was ultimately entirely covered to the

depth of an inch with water, which required about 30 ounces of the latter, fig. 2. The saline solution in the diffusion cell or phial thus communicated freely with about 5 times its volume of pure water, the liquid atmosphere which invites diffusion. Another modification of this procedure was the substitution of phials cast in a mould, of the capacity of 4 ounces, or more nearly 2080 grs., which were ground down to a uniform height of 3·8 inches. The neck was 1·25 inch in diameter and 0·5 inch in depth; and the phial was filled up with the solution to be diffused to that point. The solution cell or phial and the water-jar form together a Diffusion cell.

Fig. 2.



The diffusion was stopt, after twenty-seven days in the present experiments, by closing the mouth of the phial with a plate of glass, and then raising it out of the water-jar. The quantity of salt or of acid which had found its way into the water-jar,—the diffusion product as it may be called,—was then determined by evaporating to dryness for the salts, and by neutralizing the same liquid with a normal alkaline solution for the acids. The quantities of the acids diffused are estimated at present as protohydrates for the sake of comparison with the salts.

TABLE I.—Diffusion of Solutions of Density 1·200. Temp. 66° FAHR.

| | Placed in solution cell. | | Found in water-jar. | |
|--|---|----------------|---------------------|--------|
| | Proportion of anhydrous salt, or of acid protohydrate, to 100 of water. | Boiling-point. | Diffusion product. | |
| | | | In grains. | Ratio. |
| Chloride of sodium | 34·21 | 225·5 | 269·80 | 100 |
| Nitric acid | 37·93 | 227 | 581·20 | 215·42 |
| Sulphuric acid | 29·03 | 223 | 455·10 | 168·68 |
| Chloride of potassium (density 1·178)... | 34·86 | 221 | 320·30 | 118·71 |
| Bisulphate of potash | 31·85 | 216 | 319·00 | 118·23 |
| Nitrate of soda | 32·42 | 220 | 260·20 | 96·44 |
| Sulphate of magnesia..... | 22·38 | 214 | 95·87 | 35·53 |
| Sulphate of copper..... | 21·56 | 213½ | 77·47 | 28·71 |

It appears that the diffusion from solutions of the same density is not equal but highly variable, ranging from 1 to 0·1333.

The results also favour the existence of a relation between large or rapid diffusibility and a high boiling-point. The latter property may be taken to indicate of itself a high degree of attraction between the salt and water.

I. CHARACTERS OF LIQUID DIFFUSION.

1. *Diffusion of Chloride of Sodium.*

The characters of liquid diffusion were first examined in detail in the case of this salt.

(1.) Do different proportions of chloride of sodium in solution give corresponding amounts of diffusion?

Solutions were prepared of chloride of sodium in the proportion of 100 water with 1, 2, 3 and 4 parts of the salt.

The diffusion of all the solutions was continued for the same time, eight days, at the mean temperature of $52^{\circ}5$ FAHR.

| Proportion of salt to 100 water. | Diffusion product. | |
|----------------------------------|--------------------|--------|
| | In grains. | Ratio. |
| 1 | 2.78 | 1. |
| 2 | 5.54 | 1.99 |
| 3 | 8.37 | 3.01 |
| 4 | 11.11 | 4.00 |

The quantities diffused appear therefore to be closely in proportion (for this salt) to the quantity of salt in the diffusing solution. The density of the solutions containing 1, 2, 3 and 4 parts of chloride of sodium, was at 60° , 1.0067, 1.0142, 1.0213, 1.0285. The increase of density corresponds very nearly with the proportion of chloride of sodium in solution. A close approach to this direct relation is indeed observable in most salts, when dissolved in proportions not exceeding 4 or 5 per cent.

The relation which appears in these results is also favourable to the accuracy of the method of experimenting pursued. The variation from the speculative result does not in any observation exceed 1 per cent.

(2.) Is the quantity of salt diffused affected by temperature?

The diffusion of similar solutions of chloride of sodium was repeated at two new temperatures, $39^{\circ}6$ and 67° , the one being above and the other below the preceding temperature. It was necessary to use artificial means to obtain the low temperature owing to the period of the season. A close box of double walls, namely, the ice-safe of the Wenham Ice Company, was employed, masses of ice being laid on the floor of the box, and the water-jars supported on a shelf above. The water and solution were first cooled separately for twenty-four hours in the ice-box, before the diffusion was commenced. It was found that the temperature could be maintained within a range of 2° or 3° for eight days. It was doubtful however whether the temperature was constantly the same to a degree or two in all the jars; and the results obtained at an artificial temperature were always less concordant and sensibly inferior in precision to observations made at the atmospheric temperature.

Diffusion of Chloride of Sodium.

| Proportion of salt to 100 water. | | Diffusion product. | |
|----------------------------------|----------|--------------------|--------|
| | | In grains. | Ratio. |
| 1 | At 39°·6 | 2·63 | 1· |
| 2 | At 39°·6 | 5·27 | 2·00 |
| 3 | At 39°·6 | 7·69 | 2·92 |
| 4 | At 39°·6 | 10·00 | 3·80 |
| 1 | At 67° | 3·50 | 1· |
| 2 | At 67° | 6·89 | 1·97 |
| 3 | At 67° | 9·90 | 2·83 |
| 4 | At 67° | 13·60 | 3·89 |

The proportionality in the diffusion is still well-preserved at the different temperatures. The deviations are indeed little, if at all, greater than might be occasioned by errors of observation. The ratio of diffusion, for instance, from the solutions containing 4 parts of salt, is 3·80 and 3·89 for the two temperatures, which numbers fall little short of 4.

The diffusion manifestly increases with the temperature, and as far as can be determined by three observations, in direct proportion to the temperature. The diffusion-product from the 4 per cent. solution increases from 10 grs. to 13·60, with a rise of temperature of 27°·4, or rather more than one-third. Supposing the same progression continued, the diffusibility of chloride of sodium would be doubled by a rise of 84 or 85 degrees.

(3.) The progress of the diffusion of chloride of sodium in such experiments as have been narrated, was further studied by intercepting the operation after it had proceeded for different periods of 2, 4, 6 and 8 days. The solution employed was that containing 4 parts of salt to 100 water. Two of the six-ounce phials were diffused at the same time for each period. The temperature given is the mean of the temperatures of a water-jar observed each day of the period. The daily fluctuation was not more than two or three-tenths of a degree FAHR.

In 2 days, temperature 63°·7; the salt diffused was 4·04 and 3·86 grs.; mean 3·95 grs.

In 4 days, temperature 63°·7; the salt diffused was 6·78 and 7·12 grs.; mean 6·95 grs.

In 6 days, temperature 63°·8; the salt diffused was 10·02 and 9·70 grs.; mean 9·86 grs.

In 8 days, temperature 64°; the salt diffused was 13·00 and 13·25 grs.; mean 13·12 grs.

The proportion diffused in the first period of two days is given directly in the first experiments. The proper diffusion for each of the three latter periods of two days is obtained by deducting from the result of each period the result of the period which precedes it:—

| | |
|------------------------------------|-----------|
| Diffused in 1st two days | 3·95 grs. |
| Diffused in 2nd two days | 3·00 grs. |
| Diffused in 3rd two days | 2·91 grs. |
| Diffused in 4th two days | 3·26 grs. |

The diffusion appears to proceed pretty uniformly, if the amount diffused in the first period of two days be excepted. Each of the phials contained at first about 108 grs. of salt, of which the maximum quantity diffused is 13·12 grs. in eight days, or $\frac{1}{8\cdot24}$ of the whole salt. Still the diffusion must necessarily follow a diminishing progression, which would be brought out by continuing the process for longer time, and appear at the earliest period in the salt of most rapid diffusion.

All the experiments which follow being made like the preceding on comparatively large volumes of solution in the phial, and for equally short periods of seven or eight days, may be looked upon as exhibiting pretty accurately the initial diffusion of such solutions, the influence of the diminishing progression being still small. The volume of water in the water-jar is also relatively so large, that the experiment approaches to the condition of diffusion into an Unlimited Atmosphere.

2. Diffusion of various Salts and other Substances.

With these notions regarding the influence of temperature and proportion of salt on the amount of diffusion, an examination was next undertaken of the relative diffusibility of a variety of salts and other substances. The results of this first survey I shall state as shortly as possible, as I consider these, as well as the experiments which preceded, as of a preliminary character. The experiments were all made by means of the diffusion phials already described, namely, the six-ounce phials, and with similar manipulations.

In the following experiments, the diffusion took place at a temperature ranging from 62° to 59°, mean 60°·5, and was continued for a period of eight days; the proportion of salt in solution to be diffused being always 20 salt to 100 water, or 1 to 5. I add as usual the density of the solutions.

TABLE II.—Diffusion of solutions of 20 salt to 100 water, at 60°·5, for eight days.

| Name of salt. | Density of solution at 60°. | Anhydrous salt diffused. | |
|-------------------------------|-----------------------------|--------------------------|--------|
| | | In grains. | Means. |
| Chloride of sodium | 1·1265 | 58·5 | |
| Chloride of sodium | 1·1265 | 58·87 | 58·68 |
| Sulphate of magnesia..... | 1·185 | 27·42 | 27·42 |
| Nitrate of soda | 1·120 | 52·1 | |
| Nitrate of soda | 1·120 | 51·02 | 51·56 |
| Sulphate of water | 1·108 | 68·79 | |
| Sulphate of water | 1·108 | 69·86 | 69·32 |
| Crystallized cane-sugar | 1·070 | 26·74 | 26·74 |
| Fused cane-sugar | 1·066 | 26·21 | 26·21 |
| Starch-sugar (glucose) | 1·061 | 26·94 | 26·94 |
| Treacle of cane-sugar | 1·069 | 32·55 | 32·55 |
| Gum-arabic | 1·060 | 13·24 | 13·24 |
| Albumen | 1·053 | 3·08 | 3·08 |

The following additional ratios of diffusion were obtained from similar solutions at a somewhat lower temperature, namely 48° ;—chloride of sodium 100, hydrate of potash 151.93, ammonia (from a 10 per cent. solution, saturated with chloride of sodium to increase its density) 70, alcohol (saturated with chloride of sodium) 75.74, chloride of calcium 71.23, acetate of lead 45.46.

Where two experiments upon the same salt are recorded in the table they are seen to correspond to within 1 part in 40, which may be considered as the limit of error in the present observations. It will be remarked that the diffusion of cane- and starch-sugar is sensibly equal, and double that of gum-arabic. On the other hand, the sugars have less than half the diffusibility of chloride of sodium. It is remarkable that the specifically lightest and densest solutions, those of the sugars and of sulphate of magnesia, approach each other closely in diffusibility. On comparing together, however, two substances of similar constitution, such as the two salts, chloride of sodium and sulphate of magnesia, that salt appears to be least diffusive of which the solution is densest.

But the most remarkable result is the diffusion of albumen, which is low out of all proportion when compared with saline bodies. The solution employed was the albumen of the egg, without dilution, but strained through calico and deprived of all vesicular matter. As this liquid, with a density of 1.041, contained only 14.69 parts of dry matter to 100 of water, the proportion diffused is increased in the table to that for 20 parts, to correspond with the other substances. In its natural alkaline state the albumen is least diffusive, but when neutralized by acetic acid, a slight precipitation takes place and the liquid filters more easily. The albumen is now sensibly more diffusive than before. Chloride of sodium appears 20 times more diffusible than albumen in the table, but the disparity is really greater; for nearly one-half of the matter which diffused consisted of inorganic salts. Indeed the experiment appears to promise a delicate method of proximate analysis peculiarly adapted for animal fluids. The value of this low diffusibility in retaining the serous or albuminous fluids within the blood-vessels at once suggests itself.

Similar results were obtained with egg albumen diluted and well-beaten with 1 and 2 volumes of water. The solution diluted with an equal bulk of water, and made slightly acid with acetic acid, contained $7\frac{1}{2}$ dry matter to 100 water. Diffused from two four-ounce bottles of 1.25 inch aperture, for seven days, at a mean temperature of $43^{\circ}.5$ FAHR., it gave products of 1.73 and 1.48 gr., from the evaporation of two water-jars, in which cubic crystals of common salt were abundant. The whole matter thus diffused in two cells was found to consist of—

| | |
|------------------------------|-----------|
| Coagulable albumen | 0.94 gr. |
| Soluble salts | 2.27 grs. |
| | 3.21 grs. |

The diffusion product of the same solution of albumen left alkaline, or without the

addition of acetic acid, in the same circumstances, was 1·41 and 1·20 grs. in two cells; and consisted of—

| | |
|------------------------------|-----------|
| Coagulable albumen | 0·63 gr. |
| Soluble salts | 1·98 gr. |
| | 2·61 grs. |

The diffusion product of a solution of $7\frac{1}{2}$ parts of chloride of sodium to 100 water, from similar cells and for the same time and temperature, would amount to about 30 grs. of salt. It is to be remarked also that 5·53 grs. of the ignited salt diffused from albumen contained 1·32 gr. of potash or 23·9 per cent., which is a high proportion, and indicates that salts of potash diffuse out more freely from albumen than salts of soda.

Nor does albumen impair the diffusion of salts dissolved together with it in the same solution, although the liquid retains its viscosity. Three other substances, added separately in the proportion 5 parts to 100 of the undiluted solution of egg albumen, were found to diffuse out quite as freely from that liquid as they did from an equal volume of pure water: these were chloride of sodium, urea and sugar. Urea proved to be a highly diffusible substance. It nearly coincided in rate with chloride of sodium.

A second series of salts were diffused containing 1 part of salt to 10 of water; a smaller proportion of salt which admits of the comparison of a greater variety of salts. The temperature during the period of eight days was remarkably uniform, 60°—59°.

TABLE III.—Diffusion of solutions of 10 salt to 100 water at 59°·5.

| Name of salt. | Density of solution at 60°. | Anhydrous salt diffused. | |
|-----------------------------|-----------------------------|--------------------------|--------|
| | | In grains. | Means. |
| Chloride of sodium..... | 1·0668 | 32·3 | |
| Chloride of sodium..... | 1·0668 | 32·2 | 32·25 |
| Nitrate of soda | 1·0622 | 30·7 | 30·7 |
| Chloride of potassium | 1·0596 | 40·15 | 40·15 |
| Chloride of ammonium | 1·0280 | 40·20 | 40·20 |
| Nitrate of potash | 1·0589 | 35·1 | |
| Nitrate of potash | 1·0589 | 36·0 | 35·55 |
| Nitrate of ammonia | 1·0382 | 35·3 | 35·3 |
| Iodide of potassium | 1·0673 | 37·0 | 37·0 |
| Chloride of barium | 1·0858 | 27·0 | 27·0 |
| Sulphate of water | 1·0576 | 37·18 | |
| Sulphate of water | 1·0576 | 36·53 | 36·85 |
| Sulphate of magnesia..... | 1·0965 | 15·3 | |
| Sulphate of magnesia..... | 1·0965 | 15·6 | 15·45 |
| Sulphate of zinc..... | 1·0984 | 15·6 | |
| Sulphate of zinc..... | 1·0984 | 16·0 | 15·80 |

Before adverting to the relations in diffusibility which appear to exist between certain salts in the preceding table, I may state the results of the diffusion of the same solutions at a lower temperature.

TABLE IV.—Diffusion of solutions of 10 salt to 100 water at 37°·5.

| Name of salt. | Anhydrous salt diffused. | |
|----------------------------|--------------------------|--------|
| | In grains. | Means. |
| Chloride of sodium | 22·21 | |
| Chloride of sodium | 22·74 | 22·47 |
| Nitrate of soda | 22·53 | |
| Nitrate of soda | 23·05 | 22·79 |
| Chloride of ammonium | 31·14 | 31·14 |
| Nitrate of potash | 28·84 | |
| Nitrate of potash | 28·56 | 28·70 |
| Nitrate of ammonia | 29·19 | 29·19 |
| Iodide of potassium | 28·10 | 28·10 |
| Chloride of barium | 21·42 | 21·42 |
| Sulphate of water | 31·11 | |
| Sulphate of water | 28·60 | 29·85 |
| Sulphate of magnesia | 13·03 | |
| Sulphate of magnesia | 13·11 | 13·07 |
| Sulphate of zinc..... | 11·87 | |
| Sulphate of zinc..... | 13·33 | 12·60 |

The near equality of the quantities diffused of certain isomorphous salts is striking at both temperatures. Chloride of potassium and chloride of ammonium give 40·15 and 40·20 grs. respectively in the first table. Nitrate of potash and nitrate of ammonia 35·55 (mean) and 35·3 grs. respectively in the first table, and 28·70 and 29·19 grs. in the second table. Sulphate of magnesia and sulphate of zinc 15·45 and 15·8 grs. (means) in the first table, with 13·07 and 12·60 grs. in the second. The relation observed is the more remarkable, that it is that of equal weights of the salts diffused, and not of atomically equivalent weights. In the salts of ammonia and potash, this equality of diffusion is exhibited also, notwithstanding considerable differences in density between their solutions; the density of the solution of chloride of ammonium, for instance, being 1·0280 and that of chloride of potassium 1·0596. It may have some relation however, but not a simple one, to the density of the solutions; sulphate of magnesia, of which the solution is most dense, being most slowly diffusive; and salts of soda being slower, as they are generally denser in solution, than the corresponding salts of potash. Nor does it depend upon equal solubility, for in none of the pairs is there any approach to equality in that respect.

A comparison was now made of the diffusibility of several acids. They were diffused from the same six-ounce phials, and for eight days. Solutions were prepared in the proportion of 4 parts of the anhydrous acid to 100 parts of water. The quantity of acid which diffused into the water-jar was estimated by the proportion of carbonate of soda which it neutralized.

TABLE V.—Diffusion of acid solutions (4 acid to 100 water) at 59°·3.

| Name of acid. | Density of solution at 60°. | Anhydrous acid diffused. | |
|---------------------------------|-----------------------------|--------------------------|--------|
| | | In grains. | Means. |
| Nitric acid | 1·0243 | 29·21 | 28·7 |
| | | 28·19 | |
| Hydrochloric acid | 1·0225 | 34·22 | 34·1 |
| | | 33·99 | |
| Sulphuric acid | 1·0317 | 18·71 | 18·48 |
| | | 18·26 | |
| Acetic acid..... | 1·0094 | 19·13 | 18·16 |
| | | 17·19 | |
| Oxalic acid | 1·0235 | 12·38 | 12·38 |
| | | 12·38 | |
| Arsenic acid | 1·0320 | 12·16 | 12·16 |
| | | 12·16 | |
| Tartaric acid | 1·0194 | 9·90 | 9·79 |
| | | 9·69 | |
| Phosphoric acid..... | 1·0284 | 9·09 | 9·09 |
| | | 9·09 | |
| <i>Chloride of sodium</i> | 1·0285 | 12·32 | 12·32 |

Considerable latitude thus appears to exist in the diffusibility of the different acids. To make the result for nitric acid fairly comparable with that for hydrochloric acid, the former should be increased in the proportion of 54 to 63, that is estimated as nitrate of water. This calculation gives 33·5 grs. of nitrate of water diffused, which approaches closely to 34·1 grs., the quantity for chloride of hydrogen or hydrochloric acid. The quantity of soda neutralized by the sulphuric and hydrochloric acids diffused was as 14·32 to 28·97, or nearly as 1 to 2. Sulphuric and acetic acids, on the other hand, appear to be equally diffusible. Phosphoric acid is the least diffusible acid in the series, presenting only about half the diffusion product of the two last-mentioned acids. The solution of phosphoric acid had been boiled for half an hour before diffusion, and was therefore in the tribasic state. The same precaution was not thought of for arsenic acid, although it is possibly required by this acid also. These two acids do not exhibit the equality of diffusion anticipated from their recognized isomorphism, but it is to be stated that the acidimetical method of analysis followed is not so properly applicable to these two acids as it is to all the others.

3. *Diffusion of Ammoniated Salts of Copper.*

It was interesting to compare together such related salts as sulphate of copper, the ammoniated sulphate of copper or soluble compound of sulphate of copper with 2 equivs. of ammonia and the sulphate of ammonia. It is well known that metallic oxides, or subsalts of metallic oxides, when dissolved in ammonia or the fixed alkalies, are easily taken down by animal charcoal. This does not happen with the ordinary neutral salts of the same acids, which are held in solution by a strong attraction. Supposing the existence of a scale of the solvent attraction of water, the preponderance of the charcoal attraction will mark a term in that scale. And if the solvent

force is nothing more than the diffusive tendency, it will follow that salts which can be taken down by charcoal must be less diffusible than those which cannot.

Of sulphate of ammonia and sulphate of copper, solutions were prepared, consisting of 4 anhydrous salt to 100 water, the sulphate of ammonia being of course taken as $\text{NH}_4\text{O} \cdot \text{SO}_3$. The solution of the copper salt was divided into two portions, one of which had caustic ammonia added to it in slight excess, so as to produce the azure blue solution of ammonio-sulphate of copper.

The solutions were diffused for eight days, at a mean temperature of $64^\circ\cdot9$ for the sulphates and nitrates, and $67^\circ\cdot7$ for the chlorides.

TABLE VI.—Diffusion of solutions, 4 salt to 100 water.

| Name of salt. | Density of solution at temperature of experiment. | Anhydrous salt diffused in grains. |
|----------------------------------|---|------------------------------------|
| Sulphate of ammonia..... | 1·0235 | 12·13 |
| Sulphate of ammonia..... | 1·0235 | 11·96 |
| Sulphate of copper | 1·0369 | 6·19 |
| Sulphate of copper | 1·0369 | 6·51 |
| Ammonio-sulphate of copper | 1·0308 | 1·45 |
| Ammonio-sulphate of copper | 1·0308 | 1·43 |
| Nitrate of ammonia | 1·0136 | 16·15 |
| Nitrate of ammonia | 1·0136 | 15·44 |
| Nitrate of copper | 1·0323 | 9·77 |
| Nitrate of copper | 1·0323 | 9·77 |
| Ammonio-nitrate of copper | 1·0228 | 1·77 |
| Ammonio-nitrate of copper | 1·0228 | 1·36 |
| Chloride of ammonium..... | 1·0100 | 16·18 |
| Chloride of ammonium..... | 1·0100 | 17·00 |
| Chloride of copper | 1·0328 | 10·83 |
| Chloride of copper | 1·0328 | 10·48 |
| Ammonio-chloride of copper | 1·0209 | 4·54 |
| Ammonio-chloride of copper | 1·0209 | 3·94 |

It is to be observed, that in preparing the ammoniated salts, the solutions of the neutral salts of copper were slightly diluted by the water of the solution of ammonia added to them, so that the proportion of salt of copper which they possessed was sensibly reduced below 4 per cent. On the other hand, the copper salt which diffused out is estimated, not as ammoniated, but as neutral salt. It will be observed that the quantity of sulphate of copper diffused out in the experiments falls from 6·35 in the neutral salt to 1·44 gr. in the ammoniated salt; of nitrate of copper from 9·77 to 1·56, and of chloride of copper from 10·65 to 4·24. These numbers are to be taken only as approximations; they are sufficient however to prove a much reduced diffusibility in the ammoniated salts of copper.

It will be remarked that the nitrate of ammonia and chloride of ammonium approximate, 15·80 and 16·59 grs.; as do also the nitrate and chloride of copper, 9·77 and 10·65 grs.; the chlorides, which were diffused at the higher temperature by $2^\circ\cdot8$, exceeding the nitrates in both cases.

4. *Diffusion of Mixed Salts.*

When two salts can be mixed without combining, it is to be expected that they will diffuse separately and independently of each other, each salt following its special rate of diffusion.

(1.) Anhydrous sulphate of magnesia and sulphate of water (oil of vitriol), one part of each, were dissolved together in 10 parts of water, and the solution allowed to diffuse for four days at $61^{\circ}5$.

The water-jar was found to have acquired—

| | |
|------------------------------|------------|
| Sulphate of magnesia | 5.60 grs. |
| Sulphate of water | 21.92 grs. |
| | 27.52 grs. |

The experiment with the same diffusion cell and liquid being continued for a second period, this time of eight days, there was found to be simultaneously diffused, of—

| | |
|------------------------------|------------|
| Sulphate of magnesia | 9.46 grs. |
| Sulphate of water | 29.32 grs. |
| | 38.78 grs. |

It is obvious that the inequality should be greatest in the first period of diffusion, or with the initial diffusion, as it actually appears above, and become less and less sensible as the proportion of the low diffusive salt comes to be increased in the solution phial.

In former experiments upon the solution of sulphate of magnesia alone in water, as 1 salt to 10 water, compared with sulphate of water, also as 1 to 10, the disparity in the diffusion of these two salts was less considerable, being only as 1 to 2.385, instead of 1 to 3 or 4.

(2.) A solution was also diffused of 1 part of anhydrous sulphate of soda and 1 part of chloride of sodium in 10 parts of water, for four days at $61^{\circ}5$. The salt which diffused out in that time consisted of—

| | |
|----------------------------|------------|
| Sulphate of soda | 9.48 grs. |
| Chloride of sodium | 17.80 grs. |
| | 27.28 grs. |

The sulphate of soda in the last experiment had begun to crystallize in the solution phial, from a slight fall of temperature, before the diffusion was interrupted, a circumstance which may have contributed to increase the inequality of the proportions diffused of these two salts.

(3.) A solution of equal weights of anhydrous carbonate of soda and chloride of sodium, namely, of 4 parts of the one salt and 4 parts of the other, to 100 water, was diffused from 3 four-ounce phials of 1.25 inch aperture, at a mean temperature of $57^{\circ}9$ and for seven days. The diffusion product amounted to 17.10, 17.58 and 18.13 grs.

of mixed salt in the three experiments. The analysis of the last product of 18·13 grs. gave—

| | | |
|------------------------------|-------|--------|
| Carbonate of soda | 5·68 | 31·33 |
| Chloride of sodium | 12·45 | 68·67 |
| | 18·13 | 100·00 |

Here the carbonate of soda presents a diffusion less than one-half of that of chloride of sodium. The difference is again greater than the peculiar diffusibilities of the same salts as they appear when the salts are separately diffused. For in experiments made in the same phials with solutions of 4 parts of each salt singly to 100 water, but with a lower temperature by 3°·6, namely, at 54°·3, the diffusion product of the carbonate of soda was 7·17 and 7·34 grs. in two experiments, of which the mean is 7·25 grs.; while the diffusion product of the chloride of sodium was 11·18 and 10·73 grs. in two experiments, of which the mean is 10·95 grs. The quantity of chloride of sodium diffused being taken at 100 in both sets of experiments, we have diffused—

Of carbonate of soda 66·18, when diffused singly.

Of carbonate of soda 45·64, when diffused with chloride of sodium.

The least soluble of the two salts appears in all cases to have its diffusibility lessened in the mixed state. The tendency to crystallization of the least soluble salt must evidently be increased by the admixture. Now it is this tendency, or perhaps more generally the increased attraction of the particles of a salt for each other, when approximated by concentration, which most resists the diffusion of a salt, and appears to weaken the diffusive force in mixtures, as it is also found to do so in a strong solution of a single salt.

(4.) Equal weights of nitrates of potash and ammonia dissolved, as in certain preceding experiments, in five times the weight of the mixed salts of water, and diffused for eight days, gave in two experiments—

| | At 59°·4. | At 52°·6. |
|------------------------------|-----------|-----------|
| Nitrate of potash | 28·39 | 25·88 |
| Nitrate of ammonia | 36·16 | 30·36 |
| | 64·55 | 56·24 |

The inequality in the diffusion of these two nitrates is singular, considering that in solutions of 1 salt to 10 water, they appeared before to be equally diffusive. But on now comparing the diffusion of solutions of 1 salt to 5 water, at 52°·6, the salts no longer diffused in equal proportions:—

| | |
|-----------------------------------|------------|
| Nitrate of potash gave | 57·93 grs. |
| Nitrate of ammonia gave | 82·08 grs. |

The solution of nitrate of potash last diffused was nearly a saturated one, while that of nitrate of ammonia is far from being so. The first has its diffusibility, in consequence, impaired, and falls considerably below the second.

The relatively diminished diffusibility of sulphate of magnesia, when associated with sulphate of water, is probably connected with a similar circumstance; sulphate of magnesia being less soluble in dilute sulphuric acid than in pure water.

(5.) The salt which diffused from a strong solution of sulphates of zinc and magnesia, consisting of 1 part of each of these salts in the anhydrous state and 6 parts of water, did not consist of the two salts in exactly equal proportions. The mixture of salts, diffused for eight days, as in the late experiments, gave the following results:—

| | Exp. I. | II. | III. |
|--------------------------------|---------|-------|-------|
| Sulphate of zinc | 8·12 | 7·49 | 8·12 |
| Sulphate of magnesia | 8·68 | 8·60 | 8·75 |
| | <hr/> | <hr/> | <hr/> |
| | 16·80 | 16·09 | 16·87 |

There is therefore always a slight but decided preponderance of sulphate of magnesia, the more soluble salt, in the diffusion product. These last experiments were made at an early period with another object in view, namely, to ascertain whether in closely related salts, such as the present sulphates of magnesia and zinc, the two salts might be elastic to each other, like the particles of one and the same salt, so that one salt might possibly suppress the diffusion of the other, and diffuse alone for both. The experiments lend no support to such an idea.

It appears from all the preceding experiments, that the inequality of diffusion which existed, is not diminished but exaggerated in mixtures, a curious circumstance, which has also been observed of mixed gases.

5. *Separation of Salts of different Bases by Diffusion.*

It was now evident that inequality of diffusion supplies a method for the separation, to a certain extent, of some salts from each other, analogous in principle to the separation of unequally volatile substances by the process of distillation. The potash salts appearing to be always more diffusive than the corresponding soda salts, it follows, that if a mixed solution of two such salts be placed in the solution phial, the potash salt should escape into the water atmosphere in largest proportion, and the soda salt be relatively concentrated in the phial. This anticipation was fully verified.

(1.) A solution was prepared of equal parts of the anhydrous carbonates of potash and soda in 5 times the weight of the mixture of water. Diffused from a small thousand-grain phial of 1·1 inch aperture, into 6 ounces of water, for nineteen days, at a temperature above 60°, it gave a liquid of density 1·0350, containing a considerable quantity of the salts. Of these mixed salts, converted into chlorides by the addition of hydrochloric acid, 9·39 grs., being treated with bichloride of platinum in the usual manner, gave 19·39 grs. of the double chloride of platinum and potassium, equivalent to 5·91 grs. of chloride of potassium; and left in solution 3·44 grs. of chloride of sodium: loss 0·04 gr. These chlorides represent 5·46 grs. of carbonate of potash and

3·12 grs. of carbonate of soda. The salts actually diffused out were therefore in the proportion of—

| | |
|-------------------------------|--------|
| Carbonate of soda | 36·37 |
| Carbonate of potash | 63·63 |
| | 100·00 |

(2.) In another similar experiment from a six-ounce phial into $8\frac{1}{2}$ ounces of water, the liquid of the water-jar, after twenty-five days' diffusion, contained the two carbonates in nearly the same proportions as before, namely—

| | |
|-------------------------------|-------|
| Carbonate of soda | 35·2 |
| Carbonate of potash | 64·8 |
| | 100·0 |

(3.) A partial separation of the salts of sea-water was effected in a similar manner.

The sea-water (from Brighton) was of density 1·0265. One thousand grs. of the liquid yielded 35·50 grs. of dry salts, of which 2·165 grs. were magnesia. The dry salts contain therefore 6·10 per cent. of that earth.

Six thousand-grain phials, of 1·1 inch aperture, were properly filled with the sea-water and placed in six tumblers, each of the last containing 6 ounces of water. Temperature about 50°. The diffusion was interrupted after eight days. The salts of the sea-water were now found to be divided as follows:—

| | | |
|--------------------------------------|----------------|-----------------|
| Diffused into the tumblers | 92·9 grs., or | 36·57 per cent. |
| Remaining in the phials | 161·1 grs., or | 63·43 per cent. |
| | 254·0 | 100·00 |

Rather more than one-third of the salts has therefore been transferred from the solution phials to the water-jars by diffusion.

Of the diffused salts in the tumblers, 46·5 grs. were found to contain 1·90 gr. magnesia, or 4·09 per cent. Hence we have the following result:—

| | |
|---|----------------|
| Magnesia originally in salts of sea-water | 6·01 per cent. |
| Magnesia in salts diffused from sea-water | 4·09 per cent. |

The magnesia, also, must in consequence be relatively concentrated in the liquid remaining behind in the diffusion cells.

A probable explanation may be drawn from the last results of the remarkable discordance in the analysis of the waters of the Dead Sea, made by different chemists of eminence. I refer to the relative proportion of the salts, and not their absolute quantity, the last necessarily varying with the state of dilution of the saline water when taken up. The lake in question falls in level 10 or 12 feet every year, by evaporation. A sheet of fresh water of that depth is thrown over the lake in the wet season, which water may be supposed to flow over a fluid nearly 1·2 in density, without greatly disturbing it. The salts rise from below into the superior stratum

by the diffusive process, which will bring up salts of the alkalis with more rapidity than salts of the earth, and chlorides, of either class, more rapidly than sulphates. The composition of water near the surface must therefore vary greatly, as this process is more or less advanced.

(4.) I may be allowed to add another experiment which is curious for the protracted immobility of a column of water which it exhibits, as well as for the separation occurring, which last may be interesting also in a geological point of view. A plain glass cylinder with a foot, 11 inches in height, and of which the capacity was 64 cubic inches, had 8 cubic inches poured into it of a saturated solution of carbonate of lime in carbonic acid water, containing also 200 grs. of chloride of sodium dissolved. Distilled water was then carefully poured over the saline solution, so as to fill up the jar, a float being used and the liquid disturbed as little as possible in the operation. The mouth of the jar was lastly closed by a ground glass plate, and it was left undisturbed upon the mantelpiece of a room without a fire, from March 20 to September 24 of the present year, or for six months and four days. Afterwards, on removing the cover, the fluid was observed not to have evaporated sensibly, and it exhibited no visible deposit. This I was not surprised at, as no deposit appeared in a similar experiment with the jar uncovered, after the lapse of six weeks. The liquid in the former jar was now carefully drawn off by a small siphon with the extremity of both its limbs recurved so as to open upwards, in four equal portions, which may be numbered from above downwards. Equal quantities of the four strata of liquids gave the following proportions of chloride of sodium and carbonate of lime:—

| | Chloride of sodium. | Carbonate of lime. |
|--------|---------------------|--------------------|
| No. 1. | 21·91 | 0·10 |
| No. 2. | 23·41 | 0·22 |
| No. 3. | 23·55 | 0·38 |
| No. 4. | 23·99 | 0·42 |

The diffusion of the chloride of sodium has therefore not yet reached complete uniformity, although approaching it, the proportion of that salt obtained from the top and bottom strata being as 11 to 12. But the diffusion of the carbonate of lime appears much less advanced, the proportion of that substance being as 1 to 4 at the top and bottom of the liquid column. The slight difference in density of the strata, it may be further remarked, must have been sufficient to preserve such a column of liquid entirely quiescent, as shown by the distribution of the carbonate of lime, during the considerable changes of temperature of the season.

Chemical analysis, which gives with accuracy the proportions of acids and bases in a solution, furnishes no means of deciding how these acids and bases are combined, or what salts exist in solution. But it is possible that light may be thrown on the constitution of mixed salts, at least when they are of unequal diffusibility, by means of a diffusion experiment. With reference to sea-water, for instance, it has been a question in what form the magnesia exists, as chloride or as sulphate; or how much

exists in the one form and how much in the other. Knowing however the different rates of diffusibility of these two salts, which is nearly chloride 2 and sulphate 1, and their relation to the diffusibility of chloride of sodium, we should be able to judge from the proportion in which the magnesia travels in company with chloride of sodium, whether it is travelling in the large proportion of chloride of magnesium, in the small proportion of sulphate of magnesia, or in the intermediate proportion of a certain mixture of chloride and sulphate of magnesia. But here we are met by a difficulty. Do the chloride of magnesium and sulphate of magnesia necessarily pre-exist in sea-water in the proportions in which they are found to diffuse? May not the more easy diffusion of chlorides determine their formation in the diffusive act, just as evaporation determines the formation of a volatile salt—producing carbonate of ammonia, for instance, from hydrochlorate of ammonia with carbonate of lime in the same solution? We shall see immediately that liquid diffusion, as well as gaseous evaporation, can produce chemical decompositions.

6. *Decomposition of Salts by Diffusion.*

(1.) At an early period of the inquiry, a solution was diffused of bisulphate of potash, saturated at 68° and of density 1·280, from the six-ounce phial of 1·175 inch aperture, into 20 ounces of water. The period of diffusion extended to fifty days. About the middle of that period, a few small crystals of sulphate of potash, amounting probably to 3 or 4 hundredths of a grain, appeared in the diffusion cell and never afterwards dissolved away. When terminated, the liquid remaining in the solution cell was found of density 1·154; that in the water-jar 1·0326. A portion of the latter liquid gave by analysis—

| | | | |
|------------------------------|-------|---|-----------------------|
| Sulphate of potash | 20·37 | } | Bisulphate of potash. |
| Sulphate of water | 11·47 | | |
| Sulphate of water | 12·77 | | |
| | 44·61 | | |

It thus appears that the bisulphate of potash undergoes decomposition in diffusing, and that the acid diffuses away to about double the extent, in equivalents, of the sulphate of potash. This greater escape of the acid will also account for the deposition of crystals of the neutral sulphate in the solution cell.

(2.) A similar experiment was made with another double sulphate of greater stability, common potash-alum. The solution of 4 anhydrous alum in 100 water, was diffused from the six-ounce phial into 24 ounces of water, at 64°·2, for eight days. The quantity of salt diffused in that time amounted only to 7·48 grs. It contained 1·06 gr. alumina, which is equivalent to 5·33 grs. of alum. The diffused salt gave off no acid vapours at 600°. We may therefore suppose the excess of salt which is diffused to be sulphate of potash. The diffusion product of alum, at 64°, appears to be—

| | | |
|------------------------------|------|--------|
| Alum | 5·33 | 71·26 |
| Sulphate of potash | 2·15 | 28·74 |
| | 7·48 | 100·00 |

In a second experiment, the diffusion product amounted to 6.39 grs., of which 0.95 gr. was alumina; and it is represented by 4.77 alum and 1.52 sulphate of potash.

In connexion with the low diffusibility of the sulphate of alumina of alum, it was found that the addition of caustic potash to the alum solution, so as to convert it into an aluminate of potash, increased the diffusibility of the alumina. The diffusion product from the 4 per cent. solution of alum so treated contained 1.62 gr. of alumina in one experiment and 1.54 in another.

As alum is a salt of great stability, it presents a severe test of the influence in question. The decomposition of this double salt by diffusion was further confirmed therefore in experiments made by means of the four-ounce diffusion phials of 1.25 inch aperture, and the alteration which the salt undergoes in the process more exactly ascertained. The experiments were made at a mean temperature of $57^{\circ}9$, and lasted seven days; the solution employed being of 4 anhydrous alum to 100 water, as before.

In three experiments, the salt diffused out amounted to 5.73, 5.80 and 5.65 grs.; of which the mean is 5.73 grs. The latter quantity gave 0.82 alumina and 3.22 sulphuric acid, which correspond to 4.11 anhydrous alum and 1.62 neutral sulphate of potash. Or, we have as the diffusion product of alum, in 100 parts—

| | |
|------------------------------|---|
| Alum | 71.73 |
| Sulphate of potash | 28.27 |
| | <hr style="width: 50%; margin: 0 auto;"/> |
| | 100.00 |

This analysis corresponds closely with the diffusion product of the former experiments, which gave 71.26 per cent. of alum. The solution of alum which remains behind in the solution phials must of course acquire an excess of sulphate of alumina.

The salt, sulphate of alumina, did not appear to be decomposed when diffused alone. A four per cent. solution of the hydrated sulphate of alumina, which is manufactured at Newcastle, when diffused in the same circumstances as the preceding solutions of alum, gave 3.40 grs. of anhydrous sulphate of alumina, in which the acid was to the alumina as 2.95 equivalents of the former to 1 equivalent of the latter, or as nearly as possible in the proportion of 3 equivalents of acid to 1 of base. As the Newcastle salt contained almost exactly half its weight of water, the 3.40 grs. of anhydrous salt diffused out are equivalent to 6.80 grs. of hydrated sulphate of alumina. The sulphate of alumina appears thus to be more diffusive than the double sulphate of alumina and potash, in the proportion of 6.80 to 5.73.

(3.) It was interesting to observe what really diffuses from the ammoniated sulphate of copper ($\text{CuO}, \text{SO}_3, 2\text{NH}_3 + \text{HO}$), and to find if the low diffusibility of that salt is attended with decomposition. The diffusion of the ammoniated sulphate of copper was therefore repeated from a 4 per cent. solution in the six-ounce solution phial, for eight days, at $64^{\circ}2$. In evaporating the water of the jar afterwards, the ammoniated sulphate of copper present was necessarily decomposed, by the escape of ammonia, and a subsulphate of copper precipitated. The copper found, however, was

estimated as neutral sulphate of copper. The diffusion product of two experiments may be represented as follows, in grains :—

| | I. | II. |
|-------------------------------|-------|-------|
| Sulphate of copper | 0·81 | 0·97 |
| Sulphate of ammonia | 5·46 | 5·53 |
| | <hr/> | <hr/> |
| | 6·27 | 6·50 |

The abundant formation and separation of sulphate of ammonia in these experiments, prove that the ammoniated sulphate of copper is largely decomposed in diffusion.

(4.) Perhaps the most interesting result of this kind is a solution which is given of the problem of the decomposition of the alkaline sulphates by means of lime.

Solutions were prepared of $\frac{1}{2}$ per cent. of sulphate of potash and of chlorides of potassium and sodium in lime-water. Two solution phials were filled with each of these solutions, and placed for diffusion in water-jars filled with lime-water, at 49° , for seven days.

In the sulphate no deposition of crystallized sulphate of lime took place within the solution phial, while the water-jar acquired an alkaline reaction, which remained after precipitating the lime entirely by carbonic acid gas and evaporating twice to dryness. Hydrate of potash, it will afterwards appear, is an eminently diffusive salt, having double the diffusibility of sulphate of potash. The tendency of the former to diffuse enables the affinity of the lime for sulphuric acid to prevail, and the alkali is liberated and diffused away into the external atmosphere of lime-water. By the latter, hydrate of lime is returned to the solution cell and the decomposition continued. The salt diffused in the two cells amounted to 2·60 grs., of which 0·62 gr., or 23·85 per cent., was hydrate of potash. The chlorides of potassium and sodium, on the contrary, were not sensibly decomposed.

It is known that a precipitation of sulphate of lime may occur, with a larger proportion of sulphate of potash in lime-water, in a close phial without external diffusion. As the decomposition of the sulphate of potash, in the latter case, has been referred to the insolubility of the sulphate of lime, so the decomposition in the former circumstances is referred, in a similar sense, to the high diffusibility of hydrate of potash.

7. *Diffusion of Double Salts.*

How is the diffusion of two salts affected by their condition of combination as a double salt? A solution of the double sulphate of magnesia and potash, in the proportion of 100 water to 4 anhydrous salt, was operated upon in the four-ounce diffusion phials of 1·25 inch aperture, with a period of diffusion of seven days, at $57^{\circ}\cdot 9$ FAHR. The diffusion product of the double salt was 8·09 and 7·81 grs. in two experiments: mean, 7·95 grs.

The constituent salts, sulphate of magnesia and sulphate of potash, were now dis-

solved separately, in the proportions in which they existed in the double salt, namely, 1.65 gr. anhydrous sulphate of magnesia in 100 water, and 2.35 grs. sulphate of potash in 100 water, making up together 4 parts of salts. The two solutions thus contain equivalent quantities of the different sulphates.

The separate diffusion of the sulphate of magnesia was 2.09, 2.11 and 2.40 grs. in three cells; and of the sulphate of potash, 5.83, 5.97 and 5.54 grs. in three cells; the circumstances of the experiments being the same as those of the double salt. The means of the two salts are 2.20 and 5.78 grs.; and the sum of the two means 7.98 grs. The result is, that the separate diffusion of the constituent salts is almost identical with their diffusion when combined as a double salt:—

| | |
|--|-----------|
| Diffusion of the double sulphate of magnesia and potash | 7.95 grs. |
| Diffusion of equivalents of sulphate of magnesia and sulphate of } potash in separate cells | 7.98 grs. |

It would thus appear that the diffusibility of this double salt is the sum of the separate diffusions of its constituent salts.

It has been a question whether a double salt is formed at once when its constituent salts are dissolved together, or not till the act of crystallization of the compound salt. Equivalents of the same two sulphates, making up 4 parts, were dissolved together without heat in 100 water. Now the diffusion from this mixture, which has the composition of the preceding solution of the double salt, exhibited notwithstanding a sensibly different result of diffusion, giving 7.28, 7.37 and 7.26 grs. in three cells mean, 7.30 grs. The diffusion of the double salt was greater, namely, 7.95 grs. Hence a strong presumption that the mixed salts last diffused were not combined, and that the double sulphate of magnesia and potash is not necessarily formed immediately upon dissolving together its constituent salts.

In early experiments of a similar nature made upon the double salt, sulphate of copper and potash, and upon a mixture of the two sulphates newly dissolved together, a similar result was obtained. While the diffusion of the mixed salts was 25.6 grs., that of the same weight of the combined salts (the double sulphate) was 30 grs. The double salt appears more diffusible, in both cases, than its mixed constituents.

These double salts appear to dissolve in water without decomposition, although the single salts may meet in solution without combining. Hence in a mixture of salts we may have more than one state of equilibrium possible. And when a salt, like alum, happens to be dissolved in such a way as to decompose it, the constituents are not necessarily reunited by subsequent mixing. Many practices in the chemical arts, which seem empirical, have their foundation possibly in facts of this kind.

8. Diffusion of one Salt into the Solution of another Salt.

It was curious and peculiarly important, in reference to the relation of liquid to gaseous diffusion, to find whether one salt A would diffuse into water already charged

with an equal or greater quantity of another salt B, as a gas *a* freely diffuses into the space already occupied by another gas *b*; the gas *b* in return diffusing at the same time into the space occupied by *a*. Or whether, on the contrary, the diffusion of the salt A is resisted by B. The latter result would indicate a neutralization of the water's attraction, and a kind of equivalency or equality of power and exchangeability of different salts, in respect of that effect, which would divide entirely the phenomena of liquid from those of gaseous diffusion.

(1.) A solution of 4 parts of carbonate of soda to 100 water, of density 1·0406, was placed in the six-ounce diffusion phial of 1·175 inch aperture, and allowed to communicate with 24 ounces of water.

Two similar diffusion phials, equally charged, were immersed in 24 ounces of a solution of 4 parts of chloride of sodium to 100 water, having the density 1·0282. The diffusion proceeded for eight days, in all cases, at 64°. The proportion of carbonate of soda found without in the water-jar afterwards, was ascertained by an alkalimetric process, the neutralization being effected at the boiling-point. The following are the results:—

| | |
|--|---------------------------------|
| Experiment I. Diffusion product into water | 9·06 grs. of carbonate of soda. |
| Experiment II. Diffusion product into solution of } chloride of sodium | 8·82 grs. of carbonate of soda. |
| Experiment III. Diffusion product into solution of } chloride of sodium | |

It thus appears that 4 per cent. of chloride of sodium present in the water atmosphere of the jar has no sensible effect in retarding the diffusion into it, from the solution cell, of carbonate of soda from a solution containing also 4 per cent. of the latter.

(2.) The experiment was varied by allowing the solution of carbonate of soda to diffuse into a solution of sulphate of soda, a salt more similar to the former in solubility and composition. The solution of the latter, containing 4 per cent., was of density 1·0352. The temperature and period of diffusion were the same as before:—

| | |
|---|---------------------------------|
| Experiment IV. Diffusion product into solution of } sulphate of soda | 7·84 grs. of carbonate of soda. |
| Experiment V. Diffusion product into solution of } sulphate of soda | |

Here we find a small reduction in the quantity of carbonate of soda diffused, amounting to one-eighth of the whole. The sulphate of soda has therefore exercised a positive interference in checking the diffusion of the carbonate to that extent. So small and disproportionate an effect however is scarcely sufficient to establish the existence of a mutual elasticity and resistance between these two salts.

Still it might be said, may not the diffusion of one salt be resisted by another salt which is strictly isomorphous with the first?

(3.) A solution of 4 parts of nitrate of potash to 100 of water, of density 1.0241, placed in the solution phial, was allowed to communicate with water containing 4 per cent. of nitrate of ammonia in the water-jar, which last solution was of density 1.0136; with all other circumstances as before. With one solution phial having the usual aperture, 1.175 inch, the diffusion product was 15.32 grs. of nitrate of potash. With a second phial, having a larger aperture of 1.190 inch, the diffusion product was 18.03 grs. of nitrate of potash. No comparative experiment, on the diffusion of nitrate of potash into water, was made at the same time. But nitrate of ammonia, which appeared before to coincide in diffusibility with nitrate of potash, gave on a former occasion, in similar circumstances, and at $64^{\circ}9$, nearly the same temperature, a diffusion product of 15.80 grs. The quantity of nitrate of potash (15.32 grs.) which diffused into the solution of nitrate of ammonia approaches so closely to the number quoted, that we may safely conclude that the diffusion of nitrate of potash is not sensibly resisted by nitrate of ammonia, although these two salts are closely isomorphous. They are still therefore inelastic to each other, like two different gases.

These experiments have been made upon dilute solutions, and it is not at all impossible that the result may be greatly modified in concentrated solutions of the same salts, or when the solutions approach to saturation. But there is reason to apprehend that the phenomena of liquid diffusion are exhibited in the simplest form by dilute solutions, and that concentration of the dissolved salt, like compression of a gas, is attended often with a departure from the normal character.

On approaching the degree of pressure which occasions the liquefaction of a gas, an attraction appears to be brought into play, which impairs the elasticity of the gas; so on approaching the point of saturation of a salt, an attraction of the salt molecules for each other, tending to produce crystallization, comes into action, which will interfere with and diminish that elasticity or dispersive tendency of the dissolved salt which occasions its diffusion.

We are perhaps justified in extending the analogy a step further between the characters of a gas near its point of liquefaction and the conditions which we may assign to solutions. The theoretical density of a liquefiable gas may be completely disguised under great pressure. Thus, under a reduction by pressure of 20 volumes into 1, while the elasticity of air is 19.72 atmospheres, that of carbonic acid is only 16.70 atmospheres, and the deviation from their normal densities is in the inverse proportion. Of salts in solution the densities may be affected by similar causes, so that although different salts in solution really admit of certain normal relations in density, these relations may be concealed and not directly observable.

The analogy of liquid diffusion to gaseous diffusion and vaporization is borne out in every character of the former which has been examined. Mixed salts appear to diffuse independently of each other, like mixed gases, and into a water atmosphere already charged with another salt as into pure water. Salts also are unequally diffusible, like the gases, and separations, both mechanical and chemical (decompositions), are

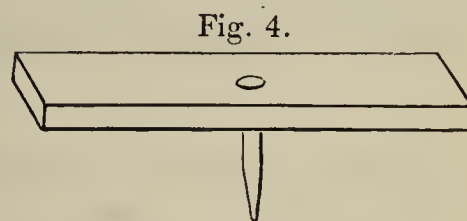
produced by liquid as well as by gaseous diffusion. But it still remains to be found whether the diffusibilities of different salts are in any fixed proportion to each other, as simple numerical relations are known to prevail in the diffusion velocities of the gases, from which their densities are deducible.

It was desirable to make numerous simultaneous observations on the salts compared, in order to secure uniformity of conditions, particularly of temperature. The means of greatly multiplying the experiments were obtained by having the solution phial cast in a mould, so that any number of solution cells could be procured of the same form and dimensions. The phials were of the form represented (fig. 3), holding about 4 ounces, or more nearly 2080 grs. of water to the base of the neck, and the mouths of all were ground down, so as to give the phial a uniform height of 3·8 inches. The mouth or neck was also ground to fit a gauge-stopper of wood, which was 0·5 inch deep and slightly conical, being 1·24 inch in diameter on the upper, and 1·20 inch on the lower surface. These are therefore the dimensions of the diffusion aperture of the new solution cells.



A little contrivance to be used in filling the phials to a constant distance of half an inch from the surface of the lip, proved useful. It was a narrow slip of brass plate, having a descending pin of exactly half an inch in length

fixed on one side of it (fig. 4). This being laid across the mouth of the phial with the pin downwards in the neck, the solution was poured into the phial till it reached the point of the pin. The brass plate and pin being removed,



the neck was then filled up with distilled water, with the aid of the little float as before described. The water-jar, in which the solution phial stood, was filled up with water also as formerly, so as to cover the phial entirely to the depth of 1 inch. This water atmosphere amounted to 8750 grs., or about 20 ounces. A glass plate was placed upon the mouth of the water-jar itself to prevent evaporation. Sometimes 80 or 100 diffusion cells were put in action at the same time. The period of diffusion chosen was now always exactly seven days, unless otherwise mentioned.

II. DIFFUSION OF SALTS OF POTASH AND AMMONIA.

Solutions were prepared of the various salts, in a pure state, in certain fixed proportions, namely, 2, 4, $6\frac{2}{3}$ and 10 parts of salt to 100 parts of water by weight. The density of these solutions was observed by the weighing-bottle, at 60°. The solutions were frequently diffused at two different temperatures; one, the temperature of the atmosphere, which was fortunately remarkably constant during most of the experiments to be recorded at present, and the other, a lower temperature, obtained in a close box of large dimensions, containing masses of ice. The results at the artificial temperature were obviously less accurate than those of the natural temperature, but have still considerable value. Three experiments were generally made upon the diffusion of each solution at the higher, with two experiments at the lower temperature.

(1.) The carbonate and sulphate of potash and sulphate of ammonia were first diffused during a period of seven days, of which the temperatures observed by a thermometer placed near the water-jars were $64^{\circ}5$, 65° , $63^{\circ}5$, 63° , 63° , $63^{\circ}5$, 65° and 66° ; mean temperature $64^{\circ}2$.

TABLE VII.—Diffusion of Carbonate of Potash, Sulphate of Potash and Sulphate of Ammonia.

| Parts of anhydrous salt to 100 water. | Density of solution at 60° . | At $64^{\circ}2$. | | At $37^{\circ}6$. | |
|---|---------------------------------------|--------------------|-------|--------------------|-------|
| | | Experiments. | Mean. | Experiments. | Mean. |
| Carbonate of potash. 2 4 $6\frac{2}{3}$ 10 | 1.0178 | 5.36 | 5.45 | 3.80 | 3.85 |
| | | 5.55 | | 3.91 | |
| | 1.0347 | 10.39 | 10.25 | 6.99 | 7.09 |
| | | 10.11 | | 7.19 | |
| | 1.0572 | 16.50 | 16.67 | 11.42 | 11.25 |
| | | 16.46 | | 11.08 | |
| | | 17.05 | | | |
| | 1.0824 | 24.42 | 24.69 | | |
| | | 24.94 | | | |
| | | 24.70 | | | |
| | | | | | |
| Sulphate of potash. 2 4 $6\frac{2}{3}$ 10 | 1.0155 | 5.62 | 5.52 | 3.93 | 3.95 |
| | | 5.42 | | 3.98 | |
| | 1.0318 | 10.49 | 10.57 | 7.50 | 7.40 |
| | | 10.65 | | 7.31 | |
| | 1.0512 | 17.07 | 17.17 | 11.62 | 11.66 |
| | | 16.89 | | 11.71 | |
| | | 17.54 | | | |
| | 1.0742 | 23.40 | 23.62 | | |
| | | 23.59 | | | |
| | | 23.88 | | | |
| | | | | | |
| Sulphate of ammonia, $\text{NH}_4 \text{O} \cdot \text{SO}_5$. 2 4 $6\frac{2}{3}$ 10 | 1.0117 | 5.71 | 5.58 | 3.73 | 3.76 |
| | | 5.45 | | 3.79 | |
| | 1.0229 | 10.72 | 10.51 | 7.54 | 7.70 |
| | | 10.30 | | 7.86 | |
| | 1.0369 | 17.28 | 16.79 | 10.94 | 10.96 |
| | | 16.28 | | 10.98 | |
| | | 16.80 | | | |
| | 1.0529 | 21.86 | 22.20 | | |
| | | 22.49 | | | |
| | | 22.25 | | | |
| | | | | | |

The diffusion product was obtained by evaporating the water of each jar separately as before, and the result is expressed in grains.

It will be observed at once, on comparing the means of the experiments, that the three salts under consideration are remarkably similar in their diffusion, particularly with the smaller proportions of salt. Thus the mean diffusion of the 2, 4, $6\frac{2}{3}$ and 10 parts of the salts is as follows:—

Diffusion at 64°·2.

| | 2. | 4. | 6 $\frac{2}{3}$. | 10. |
|---------------------------|------|-------|-------------------|-------|
| Carbonate of potash | 5·45 | 10·25 | 16·67 | 24·69 |
| Sulphate of potash | 5·52 | 10·57 | 17·17 | 23·62 |
| Sulphate of ammonia..... | 5·58 | 10·51 | 16·79 | 22·20 |

Diffusion at 37°·6.

| | 2. | 4. | 6 $\frac{2}{3}$. |
|---------------------------|------|------|-------------------|
| Carbonate of potash | 3·85 | 7·09 | 11·25 |
| Sulphate of potash..... | 3·95 | 7·40 | 11·66 |
| Sulphate of ammonia..... | 3·76 | 7·70 | 10·96 |

The proportions diffused are sensibly equal, of the different salts, at the higher temperature, with the exception of the largest proportion of salt, 10 per cent., when a certain divergence occurs. This last fact is consistent with our expectations, that the diffusion of salts would prove most highly normal in dilute solutions. Some of the irregularities at the lower temperature are evidently of an accidental kind.

(2.) The neutral chromate and acetate of potash were diffused at a temperature ranging from 63° to 65°, or at a mean temperature of 64°·1, which almost coincides with the higher temperature of the last experiments.

TABLE VIII.—Diffusion of Chromate of Potash and Acetate of Potash, at 64°·1.

| Parts of anhydrous salt to 100 water. | Density of solution at 60°. | Experiments. | Mean. |
|---------------------------------------|-----------------------------|--------------|-------|
| Chromate of potash. | 2 | 5·79 | 5·77 |
| | | 5·66 | |
| | | 5·86 | |
| | 4 | 11·10 | 11·19 |
| | | 11·35 | |
| | | 11·13 | |
| | 6 $\frac{2}{3}$ | 17·76 | 17·60 |
| | | 17·72 | |
| | | 17·32 | |
| | 10 | 24·49 | 24·75 |
| | | 24·92 | |
| | | 24·85 | |
| Acetate of potash. | 2 | 5·93 | 5·85 |
| | | 5·75 | |
| | | 5·88 | |
| | 4 | 10·55 | 10·70 |
| | | 10·56 | |
| | | 10·98 | |
| | 6 $\frac{2}{3}$ | 16·53 | 16·48 |
| | | 16·06 | |
| | | 16·84 | |
| | 10 | 24·27 | 24·85 |
| | | 24·82 | |
| | | 25·46 | |

We have the same close correspondence in the diffusion products of these two salts as in the preceding group, and here the correspondence extends to the 10 per cent. solution.

Diffusion at $64^{\circ}1$.

| | 2. | 4. | $6\frac{2}{3}$. | 10. |
|--------------------------|------|-------|------------------|-------|
| Chromate of potash | 5.77 | 11.19 | 17.60 | 24.75 |
| Acetate of potash | 5.85 | 10.70 | 16.48 | 24.85 |

The 10 per cent. solution of these two salts also agrees with the same solution of carbonate of potash, which was 24.69 grs. Nor do the lower proportions diverge greatly from the preceding group of salts.

(3). Another pair of salts were simultaneously diffused, but with an accidental difference of $0^{\circ}4$ of temperature.

TABLE IX.—Diffusion of Bicarbonate of Potash, $KO \cdot CO_2 + HO \cdot CO_2$, at $64^{\circ}1$, and Bichromate of Potash, $KO \cdot 2CrO_3$, at $64^{\circ}5$.

| Parts of anhydrous salt to 100 water. | Density of solution at 60° . | At $64^{\circ}1$ and $64^{\circ}5$. | |
|---------------------------------------|---------------------------------------|--------------------------------------|-------|
| | | Experiments. | Mean. |
| Bicarbonate of potash. 2 | 1.0129 | 5.74 5.77 5.91 | 5.81 |
| 4 | 1.0252 | 10.75 11.16 11.13 | |
| Bichromate of potash. 2 | 1.0139 | 5.64 5.73 5.59 | 5.65 |
| 4 | 1.0273 | 11.55 11.54 11.39 | |

Here again the two salts approach closely in diffusion, and also correspond well with the two preceding series.

Mean Diffusion at $64^{\circ}1$ and $64^{\circ}5$.

| | 2. | 4. |
|-----------------------------|------|-------|
| Bicarbonate of potash | 5.81 | 11.01 |
| Bichromate of potash | 5.65 | 11.49 |

It is singular to find that salts differing so much in constitution and atomic weight as the chromate and bichromate of potash, may be confounded in diffusibility. The diffusion products of these two salts are, for the 2 per cent. solutions, 5.77 and 5.65

grs., and for the 4 per cent. solution, 11·19 and 11·49 grs. The bicarbonate of potash also exhibits a considerable analogy to the carbonate, but resembles still more closely the acetate. It is thus obvious that equality, or similarity, of diffusion is not confined to the isomorphous groups of salts.

(4.) The nitrates of potash and ammonia have already appeared to be equidiffusive at two different temperatures. They were diffused again in the same proportions as the last salts, at a temperature varying from 63° to 67°·5.

TABLE X.—Diffusion of Nitrate of Potash and Nitrate of Ammonia at 65°·9.

| Parts of anhydrous salt to 100 water. | Density of solution at 60°. | Experiments. | Mean. |
|--|-----------------------------|--------------|-------|
| Nitrate of potash. | 2 | 7·34 | 7·47 |
| | | 7·58 | |
| | | 7·49 | |
| | 4 | 13·66 | 13·97 |
| | | 14·24 | |
| | | 14·02 | |
| | 6 $\frac{2}{3}$ | 22·11 | 22·37 |
| | | 22·94 | |
| | | 22·05 | |
| | 10 | 32·06 | 32·49 |
| | | 32·90 | |
| | | 32·50 | |
| Nitrate of ammonia, NH ₄ O, NO ₅ . | 2 | 7·85 | 7·73 |
| | | 7·71 | |
| | | 7·64 | |
| | 4 | 14·20 | 14·48 |
| | | 14·79 | |
| | | 14·45 | |
| | 6 $\frac{2}{3}$ | 23·66 | 22·74 |
| | | 23·35 | |
| | | 22·22 | |
| | 10 | 34·94 | 34·22 |
| | | 33·49 | |
| | | 34·23 | |

The solution of nitrate of ammonia of the water-jars was evaporated carefully at a temperature not exceeding 120° FAHR., to prevent loss of the salt by sublimation or decomposition.

Diffusion at 65°·9.

| | 2. | 4. | 6 $\frac{2}{3}$. | 10. |
|--------------------------|------|-------|-------------------|-------|
| Nitrate of potash | 7·47 | 13·97 | 22·37 | 32·49 |
| Nitrate of ammonia | 7·73 | 14·48 | 22·74 | 34·22 |

Although these salts correspond closely, it is probable that neither the diffusion of these nor the diffusion of any others is absolutely identical. The nitrate of ammonia appears to possess a slight superiority in diffusion over the nitrate of potash, which

increases with the large proportions of salt in solution. They are both considerably more diffusible than the seven preceding salts.

(5.) A second pair of isomorphous salts were compared, the chlorides of potassium and ammonium.

TABLE XI.—Diffusion of Chloride of Potassium and Chloride of Ammonium.

| Parts of anhydrous salt to 100 water. | Density of solution at 60°. | At 66°·2. | | At 64°·7. | |
|---------------------------------------|-----------------------------|-------------------------|-------|----------------|-------|
| | | Experiments. | Mean. | Experiments. | Mean. |
| Chloride of potassium. | | | | | |
| 2 | 1·0127 | 7·83 7·72 7·55 | 7·70 | 8·03 7·89 | 7·96 |
| 4 | 1·0248 | 15·22 15·59 15·07 | 15·29 | 15·21 14·82 | 15·01 |
| 6 $\frac{2}{3}$ | 1·0401 | 24·88 24·64 25·09 | 24·87 | 24·83 24·62 | 24·72 |
| 10 | 1·0592 | 36·23 37·63 | 36·93 | | |
| Chloride of ammonium. | | | | | |
| 2 | 1·0061 | 7·10 8·52 | 7·81 | 7·10 7·24 | 7·17 |
| 4 | 1·0118 | 14·55 14·64 | 14·60 | 13·91 14·91 | 14·41 |
| 6 $\frac{2}{3}$ | 1·0190 | 24·30 | 24·30 | 24·12 24·13 | 24·12 |
| 10 | 1·0272 | 36·53 | 36·53 | | |

These two salts agree well in diffusibility, and are also evidently related to the preceding nitrates. The quantity of chloride of ammonium diffused was determined by evaporation, which is troublesome and may lead to small errors, from the volatility and efflorescent tendency of this salt. It would be easier and more accurate to determine this and other chlorides by the use of a normal solution of nitrate of silver, and so avoid evaporation.

Diffusion at 66°·2.

| | 2. | 4. | 6 $\frac{2}{3}$. | 10. |
|-----------------------------|------|-------|-------------------|-------|
| Chloride of potassium | 7·70 | 15·29 | 24·87 | 36·93 |
| Chloride of ammonium | 7·81 | 14·60 | 24·30 | 36·53 |

The quantities diffused of these two chlorides are more closely in proportion to the strength of the original solution, than with any of the preceding salts of potash. Thus the quantities diffused from the 2 and 10 per cent. solutions of chloride of potassium are 7·70 and 36·93 grs., which are as 2 to 9·6, which is nearly as 2 to 10. Chloride of sodium was observed before to be nearly uniform in this respect; but other salts appear to lose considerably in diffusibility with the higher proportions of

salt. It is possibly a consequence of the crystallizing attraction, to which reference was lately made, coming into action in strong solutions and resisting diffusion.

(6.) The diffusion of chlorate of potash was observed at a temperature ranging from 63° to 65° , of which the mean was $64^{\circ}\cdot 1$.

TABLE XII.—Diffusion of Chlorate of Potash.

| Parts of salt to 100 water. | Density of solution at 60° . | At $64^{\circ}\cdot 1$. | |
|-----------------------------|---------------------------------------|--------------------------|-------|
| | | Experiments. | Mean. |
| 2 | 1.0129 | 6.97 | 7.22 |
| | | 7.54 | |
| | | 7.16 | |
| 4 | 1.0246 | 13.03 | 13.31 |
| | | 13.64 | |
| | | 13.27 | |
| 6.5 (saturated solution). | 1.0395 | 21.30 | 20.78 |
| | | 20.29 | |
| | | 20.76 | |

The solutions of chlorate of potash must be evaporated and the residuary salt dried at a temperature not exceeding 212° , otherwise a very sensible quantity of chloride of potassium may be formed. The chlorate appears to be sensibly inferior in diffusibility to the nitrate of potash. From the 4 per cent. solution of the chlorate we have a diffusion product of 13.27 grs., and from the corresponding solution of the nitrate 13.97 grs.; but the latter was obtained at a temperature $1^{\circ}\cdot 8$ higher than the former. It remains a question whether chlorate of potash does not really belong to the nitre group of salts, but has its diffusion interfered with by some secondary agency, such as its sparing solubility and consequent nearer approach to the saturating proportion.

It is certainly true that the uniformity of diffusion generally increases with the dilution of the solutions. This appears on comparing the diffusion of the 4 per cent. solution of what may be called the sulphate of potash group, with the diffusions of the 2 per cent. solutions of the same salts.

Diffusion of Salts of the Sulphate of Potash Class.

| | 4. | 2. |
|-----------------------------|-------|------|
| Carbonate of potash | 10.27 | 5.45 |
| Sulphate of potash | 10.57 | 5.52 |
| Sulphate of ammonia..... | 10.51 | 5.58 |
| Acetate of potash | 10.70 | 5.85 |
| Bicarbonate of potash | 11.01 | 5.81 |
| Chromate of potash | 11.19 | 5.77 |
| Bichromate of potash | 11.49 | 5.65 |

Thus while the 4 per cent. solutions range from 10.27 to 11.49 grs., or from 100 to 111.8, the 2 per cent. solutions range from 5.45 grs. to 5.85 grs., or from 100 to 107.3.

As it appeared to be in dilute solutions that the greatest uniformity of diffusion is to be expected, a series of experiments was instituted upon the preceding salts, with

the addition of acetate of potash, which appeared to belong to the same class, the solution employed being that of 1 salt to 100 water. The experiments were made in a vault, of which the temperature was nearly uniform, falling in a gradual manner from 59° to 58° , with a mean of $58^{\circ}\cdot 5$ during the period of seven days which the diffusion lasted. Eight phials of each salt were diffused, and the liquids of four water-jars evaporated together.

Carbonate of potash gave 10·42 and 10·59 grs. of salt diffused: mean 10·51 grs., or 2·63 grs. for one cell.

Sulphate of potash gave 10·72 and 10·78 grs. of salt diffused: mean 10·75 grs., or 2·69 grs. for one cell.

Acetate of potash, its diffusion product being treated with an excess of hydrochloric acid, gave 8·30 and 8·04 grs. of chloride of potassium, equivalent to 10·91 and 10·57 grs. of acetate of potash; mean 10·74 grs. of acetate of potash, or 2·68 grs. for one cell. The diffusion of these three salts is therefore remarkably similar:—

Diffusion of 1 per cent. solutions at $58^{\circ}\cdot 5$.

Carbonate of potash 2·63 grs.

Sulphate of potash 2·69 grs.

Acetate of potash 2·68 grs.

The 1 per cent. solution of neutral or yellow chromate of potash in good crystals gave 11·28 and 11·35 grs.; mean 11·31 grs., or 2·83 grs. for each cell. It was remarked of the diffused chromate in this experiment, that it contained a sensible quantity of green oxide of chromium. The diffusion of a salt appears indeed to try its tendencies to decomposition very severely.

The bicarbonate of potash gave 8·83 and 8·35 grs. of chloride of potassium, the diffusion product being neutralized with hydrochloric acid; equivalent to 11·25 and 11·21 grs. of bicarbonate of potash; mean 11·23 grs., or 2·81 grs. for one cell.

The bichromate of potash gave 11·54 and 11·49 grs. of salt diffused; mean 11·51 grs., or 2·88 grs. for one cell. These last three salts give all a larger diffusion product than the preceding three, while they agree well together. It is doubtful whether this excess in their diffusion is occasioned by a partial decomposition in the act of diffusion, which might be of such a kind as to increase the real or apparent diffusion in every one of them, or whether it is a peculiar character of this little group, to which the ferricyanide of potassium, it will be afterwards seen, falls to be added, while the ferrocyanide appears to belong to the other group:—

Diffusion of 1 per cent. solutions at $58^{\circ}\cdot 5$.

Chromate of potash 2·83 grs.

Bicarbonate of potash 2·81 grs.

Bichromate of potash 2·88 grs.

The divergence from each other of two salts so closely isomorphous as sulphate and

chromate of potash, in the proportion of 100 to 105·2, is certainly remarkable, unless due to a slight decomposition of the latter.

(7.) *Ferrocyanide and Ferricyanide of Potassium.*

Of these two salts the 1 per cent. solution only was diffused. The time of diffusion was seven days, as usual; the mean temperature 54°·5. In evaporating the liquid of the water-jars, both salts were partially decomposed, so that it became necessary to estimate the diffusion product by a determination of the potash. Eight cells were employed for one salt and six for the other, and the liquids of the water-jars evaporated two together.

The diffusion product of ferrocyanide of potassium (anhydrous) was 5·02, 5·22, 5·02 and 5·20 grs.; mean 5·12 grs., or for one cell 2·56 grs.

The diffusion product of ferricyanide of potassium was 5·54, 5·64 and 5·36 grs.; mean 5·51 grs., or for one cell 2·75 grs.

Three cells of a similar solution of sulphate of potash which were diffused for seven days at a mean temperature 1° lower, or of 53°·5, gave 2·56, 2·53 and 2·62 grs.; mean for one cell 2·57 grs., a number which almost coincides with that of the ferrocyanide of potassium (2·56 grs.). The ferricyanide of potassium, on the other hand, is sensibly more diffusive, as 107·6 to 100, and appears to rank with the bicarbonate and bichromate of potash. The ferricyanide of potassium, again, is a salt which probably undergoes a slight decomposition in diffusion like those salts mentioned:—

Diffusion of 1 per cent. solutions.

| | |
|-------------------------------------|---------------------|
| Sulphate of potash | 2·57 grs. at 53°·5. |
| Ferrocyanide of potassium | 2·56 grs. at 54°·5. |
| Ferricyanide of potassium | 2·75 grs. at 54°·5. |

The salts of the nitre class may also be compared in the same manner, and I shall now add a third series of results obtained from the diffusion of 1 per cent. solutions of the same salts. The temperature of diffusion of this new series was 64°·5. Six phials of each salt were diffused, and they were evaporated afterwards two and two. This double diffusion product, however, is divided by 2 in the table.

Diffusion of Salts of the Nitre Class.

| | 4. | 2. | 1. |
|-----------------------------|-------|------|------|
| Nitrate of potash | 13·97 | 7·47 | 3·72 |
| Nitrate of ammonia | 14·48 | 7·73 | 3·75 |
| Chloride of potassium | 15·01 | 7·70 | 3·88 |
| Chloride of ammonium | 14·41 | 7·81 | 3·89 |
| Chlorate of potash..... | 13·31 | 7·22 | 3·66 |
| Mean | 14·23 | 7·58 | 3·78 |

It is interesting to observe how the chlorate of potash rises in the lower proportions and approaches to the normal rate of its class. The diffusion products of all the salts are obviously more uniform for the two than for the 4 per cent. solutions, and again more uniform for the 1 than for the 2 per cent. solutions. The extremes in the 1 per cent. solutions are 3.66 grs. chlorate of potash, and 3.89 grs. chloride of ammonium, which are as 1 to 1.0628. We have here an approach to equality in diffusion, which appears to be as close as the experimental determinations are of the specific heat of different bodies belonging to one class. The numbers for the specific heat of equivalents of the metallic elements are known to vary as 38 to 42.

The salts of potash thus appear to fall into two groups of very similar if not equal diffusibility. What is the relation between these groups?

The diffusion of 4 per cent. solutions of carbonate and nitrate of potash was repeated at a temperature rising gradually from 63° to 65° during the seven days of the experiment, with a mean of 64°.1. The diffusion products of the carbonate were 10.31, 10.05 and 10.44 grs. in three cells; mean 10.27 grs. Of the nitrate, 13.98, 13.86 and 13.60 grs.; mean 13.81 grs. We have thus a diffusion in equal times of—

| | | |
|---------------------|-----------|--------|
| Carbonate of potash | . 10.27 | 1 |
| Nitrate of potash | . . 13.81 | 1.3447 |

These experiments are almost identical with the former results, 10.25 carbonate of potash, and 13.97 nitrate of potash.

But the numbers thus obtained cannot be fairly compared, owing to the diminishing progression in which the diffusion of a salt takes place. Thus when the diffusion of nitrate of potash was interrupted every two days, as in a former experiment with chloride of sodium, the progress of the diffusion for eight days was found to be as follows in a 4 per cent. solution, with a mean temperature of 66°.

Nitrate of Potash.

| | | |
|-----------------------------|---------|-----------|
| Diffused in first two days | | 4.54 grs. |
| Diffused in second two days | | 4.13 grs. |
| Diffused in third two days | | 4.06 grs. |
| Diffused in fourth two days | | 3.18 grs. |
| | | 15.91 |

The absence of uniformity in this progression is no doubt chiefly due to the want of geometrical regularity in the form of the neck and shoulder of the solution phial. A plain cylinder, as the solution cell, might give a more uniform progression, but would increase greatly the difficulties of manipulation.

The diffusion of carbonate of potash will no doubt follow a diminishing progression also; but there is this difference, that the latter salt will not advance so far in its progression, owing to its smaller diffusibility, in the seven days of the experiment, as the more diffusible nitrate does. The diffusion of the carbonate will thus be given

in excess, and as it is the smaller diffusion, the difference of the diffusion of the two salts will not be fully brought out.

The only way in which the comparison of the two salts can be made with perfect fairness, is to allow the diffusion of the slower salt to proceed for a longer time, till in fact the quantity diffused is the same for this as for the other salt, and the same point in the progression has therefore been obtained in both; and to note the time required. The problem takes the form of determining the times of equal diffusion of the two salts. This procedure is the more necessary from the inapplicability of calculation to the diffusion progression.

Further, allowing the Times of Equal Diffusion to be found, it is not to be expected that they will present a simple relation. Recurring to the analogy of gaseous diffusion, the times in which equal volumes or equal weights of two gases diffuse are as the square roots of the densities of the gases. The times, for instance, in which equal quantities of oxygen and hydrogen escape out of a vessel into the air, in similar circumstances, are as 4 to 1; the densities of these two gases as 16 to 1. Or, the times of equal diffusion of oxygen and protocarburetted hydrogen are as 1.4142 to 1, that is as the square root of 2 to the square root of 1; the densities of these gases being 16 and 8, which are as 2 to 1. The densities are the squares of the equal-diffusion times. It is not therefore the times themselves of equal diffusion of two salts, but the squares of those times which are likely to exhibit a simple relation.

(1.) While the 4 per cent. solution of nitrate of potash was diffused as usual for seven days, the corresponding solution of carbonate of potash was now allowed to diffuse for 9.90 days; times which are as 1 to 1.4142, or as 1 to the square root of 2.

The results were as follows: diffused of—

Nitrate of potash at 64°1, in seven days, 13.81 grs. . . . 100

Carbonate of potash at 64°3, in 9.9 days, 13.92 grs. . . . 100.8

The three experiments on the nitrate of potash, of which 13.81 grs. is the mean, were 13.98, 13.86 and 13.60 grs., as already detailed. The three experiments on the carbonate were 14.00, 13.97 and 13.78 grs. The difference in the means of the two salts is only 0.11 gr. The results appear to be as near to equality as could be reasonably expected from the method of experimenting. Seven and 9.90 may therefore be considered as the times of equal diffusion indicated for nitrate and carbonate of potash. The times of equal diffusion, or the diffusibilities of nitrate and carbonate of potash, would appear therefore to be in the proportion of the square root of 1 to the square root of 2.

The explanation of such a relation suggested by gaseous diffusion has been anticipated. It is that the two salts have different densities in solution, that of nitrate of potash being 1, and that of carbonate of potash 2. We are thus led to ascribe, what may be called Solution Densities, to the salts. The two salts in question are related exactly like protocarburetted hydrogen gas, of density 1, to oxygen gas of density 2. The parallel would be completed by supposing that the single volume of oxygen to

be diffused was previously mixed with 100 volumes of air (or any other diluting gas), while the 2 volumes of protocarburetted hydrogen were also diluted with 100 volumes of air; the diluting air here representing the water in which the salts to be diffused are dissolved in the solution cell. The time in which a certain quantity of protocarburetted hydrogen would come out from a vessel containing 1 per cent. of that gas being 1 (the square root of density 1); the time in which an equal quantity of oxygen would diffuse out from a similar vessel containing 1 per cent. also would be 1.4142 (the square root of density 2).

(2.) A solution of 4 parts of sulphate of potash in 100 water was diffused simultaneously with the last solution of carbonate of potash, and therefore in similar circumstances. The diffusion products of three experiments were 14.46, 14.21 and 14.53 grs.; mean 14.40 grs. This is in the proportion of 104.27 sulphate of potash to 100 nitrate of potash; so that the approximation to equality of diffusion with nitrate of potash, in the selected times, is not so close for the sulphate as for the carbonate of potash.

(3.) The diffusion was repeated of 2 per cent. solutions of the nitrate and carbonate of potash at a lower temperature by about 10° . The temperature of the solutions was rather unsteady; ranging from 56° to $52^{\circ}.25$ for the first period of seven days, from 56° to $50^{\circ}.5$ for the period of 9.90 days, and from 55° to $50^{\circ}.5$ for a second period of seven days; the external atmospheric temperature having fallen during the same period more than 20 degrees. Six phials of each solution were diffused and evaporated two together; so that the results are all double quantities.

At a mean temperature of $54^{\circ}.3$, the nitrate of potash gave in seven days 12.60 and 12.13 grs.; mean 12.36 grs.

Again, at a mean temperature of $52^{\circ}.4$, the nitrate of potash gave in seven days 11.85, 12.40 and 11.95 grs.; mean 12.06 grs.

The carbonate of potash gave in 9.90 days, with a mean temperature of $53^{\circ}.4$, 12.69, 12.40 and 12.12 grs.; mean 12.40 grs.

The general results are—

| | |
|---|--------------|
| Nitrate of potash, in seven days, at $54^{\circ}.3$ | . 12.36 grs. |
| Carbonate of potash, in 9.9 days, at $53^{\circ}.4$ | . 12.40 grs. |
| Nitrate of potash, in seven days, at $52^{\circ}.4$ | . 12.06 grs. |

As the first nitrate is $0^{\circ}.9$ above the carbonate and the second nitrate 1° below it, we may take the mean of the two nitrates as corresponding to the temperature of the carbonate. We thus finally obtain, diffused at $53^{\circ}.4$, of—

| | |
|---|------------|
| Nitrate of potash in seven days, 12.22 grs. | . . 100 |
| Carbonate of potash in 9.9 days, 12.40 grs. | . . 101.47 |

The difference in the amount of the diffusion of the two salts in these times is only 0.18 gr., or $1\frac{1}{2}$ per cent.

These last experiments may be held therefore as tending to the same conclusion as

the former series, although the circumstances were more than usually unfavourable to their success. To find whether the same relation existed between the salts through a considerable range of temperature, an opportunity was taken during cold weather to repeat the experiments at a low temperature.

(4.) Solutions of 1 salt in 100 water were diffused from eight solution cells, for each salt. The times were increased, but the same ratio of 1 to 1.4142 was preserved between them. The liquids of the cells were found to retain a temperature ranging slowly between 41° and $38^{\circ}8$ during the whole period of the observations. Sulphate of potash was substituted for the carbonate, as of these two equi-diffusive salts the former had been found to be least in accordance with nitrate of potash, in the 4 per cent. solutions, and appeared therefore to afford the severest test of the relation.

For nitrate of potash, at a mean temperature of $39^{\circ}7$, during nine days, the diffusion product of two cells together was 6.97, 6.93, 6.77 and 6.64 grs.; mean 6.83 grs. for two cells.

For sulphate of potash, at the same mean temperature of $39^{\circ}7$, during 12.728 days (twelve days, seventeen hours, twenty-eight minutes), the diffusion product of two cells together was 7.05, 6.93, 7.28 and 6.90 grs.; mean 7.04 grs. for two cells.

The general results are—

| | | |
|--|-----------------|--------|
| Nitrate of potash in nine days at $39^{\circ}7$. . . | 6.83 grs. . . . | 100 |
| Sulphate of potash in 12.728 days at $39^{\circ}7$. . . | 7.04 grs. . . . | 103.07 |

(5.) Solutions of 2 salt in 100 water were diffused simultaneously with the preceding experiments, and in precisely the same conditions of time and temperature.

The diffusion product of nitrate of potash during nine days, at a mean temperature of $39^{\circ}7$, was 7.03, 6.63, 6.83 and 6.83 grs. for one cell; mean 6.83 grs. for one cell, or the same number as for two cells with the 1 per cent. solution.

The diffusion product of sulphate of potash during 12.728 days was 6.84, and 6.80; mean 6.82 grs. for one cell. These experiments almost coincide with the number for nitrate of potash.

| | |
|---------------------------------------|-------|
| Nitrate of potash, 6.83 grs. | 100 |
| Sulphate of potash, 6.82 grs. | 99.85 |

(6.) The existence of the relation in question was also severely tested in another manner. Preserving the ratio in the times of diffusion for the two salts, the actual times were varied in duration, in three series of experiments, as 1, 2 and 3. The experiments were made in the vault, with a uniformity of temperature favourable to accuracy of observation. Eight cells of the 1 per cent. solution of each salt were always diffused at the same time.

(a.) Nitrate of potash diffused for 3.5 days, at $47^{\circ}2$, gave for two cells, 3.55, 3.63, 3.33 and 3.51 grs.; mean for two cells, 3.50 grs.

Sulphate of potash diffused for 4.95 days, at $47^{\circ}3$, gave for two cells, 3.54, 3.31,

3.51 and 3.63 grs.; mean for two cells, 3.50 grs., or exactly the same as for nitrate of potash above.

(b.) Nitrate of potash diffused for seven days, at $48^{\circ}6$, gave 6.1, 6.2, 5.9 and 5.92 grs.; mean for two cells, 6.04 grs.

Sulphate of potash diffused for 9.9 days, at $49^{\circ}1$, gave 6.13, 5.92, 6.18 and 6.59 grs.; mean 6.20 grs., or, excluding the last experiment, 6.08 grs.

Chromate of potash diffused also for 9.9 days, at $49^{\circ}1$, gave 6.19, 6.18, 6.40 and 6.38 grs.; mean for two cells, 6.29 grs. The diffused chromate presented no appearance of decomposition on this occasion.

(c.) Nitrate of potash diffused for 10.5 days, at 48° , gave 8.36, 8.95, 8.82 and 8.84 grs.; mean for two cells, 8.74 grs.

Sulphate of potash diffused for 14.85 days, at $48^{\circ}6$, gave 8.99, 8.94, 8.66 and 8.56 grs.; mean for two cells, 8.79 grs.

The mean results for the three different sets of periods of diffusion are as follows:—

| | | | |
|---------------------|---|--|--------|
| 3.5 and 4.95 days | { | Nitrate of potash, at $47^{\circ}2$, 3.50 grs. | 100 |
| | | Sulphate of potash, at $47^{\circ}3$, 3.50 grs. | 100 |
| 7 and 9.9 days | { | Nitrate of potash, at $48^{\circ}6$, 6.04 grs. | 100 |
| | | Sulphate of potash, at $49^{\circ}1$, 6.20 grs. | 102.65 |
| | | Chromate of potash, at $49^{\circ}1$, 6.29 grs. | 104.14 |
| 10.5 and 14.85 days | { | Nitrate of potash, at 48° , 8.74 grs. | 100 |
| | | Sulphate of potash, at $48^{\circ}6$, 8.79 grs. | 100.57 |

The concurring evidence of these three series of experiments appears to be quite decisive in favour of the assumed relation of 1 to 1.4142, between the times of equal diffusion for the nitrate and sulphate of potash, and consequently of the times for the two classes of potash salts, of which the salts named are types. The same experiments are also valuable as proving the similarity of the progression of diffusion, in two salts of unequal diffusibility. I shall return again to the relation between nitrates and sulphates, under the salts of soda.

(8.) *Hydrate of Potash.*

(1.) Eight cells of the 1 per cent. solution of pure fused hydrate of potash were diffused for seven days in the vault, with a temperature ranging only from 59° to 58° , of which the mean was $58^{\circ}6$. The product of four cells evaporated together was 17.57 grs. of hydrate of potash, and of the other four cells 17.19 grs.; mean 17.38 grs., or 4.345 grs. for one cell. The hydrate of potash was estimated from the chloride of potassium which it gave when saturated with hydrochloric acid. The diffusion product of sulphate of potash for seven days, at $58^{\circ}5$, or almost the same temperature, was 10.75 grs. for the four cells, as already stated, and consequently 2.64 grs. for one cell. It thus appears that the hydrate of potash is greatly more diffusive than the sulphate of potash in the same period of seven days, namely, as 4.345 to 2.64.

Such a result indeed is not inconsistent with the times of equal diffusion of these two substances, differing as much as 1 to 2.

(2.) Of pure fused hydrate of potash, a 1 per cent. solution was diffused from four cells for 4.95 days at a mean temperature of 53°·7, against a 1 per cent. solution of nitrate of potash in six cells, for seven days, at a mean temperature 0°·1 lower, or of 53°·6. The hydrate of potash which diffused, is calculated as before from the chloride of potassium which it gave, when neutralized by hydrochloric acid. Hydrate of potash diffused from two cells 5.97 and 6.28 grs.; mean 6.12 grs., or 3.06 grs. for a single cell.

Nitrate of potash diffused from two cells 6.22, 6.54 and 5.93 grs; mean 6.23 grs., or 3.11 grs. for a single cell. The diffusion of nitrate of potash being 100, that of the hydrate of potash is 98.2, numbers which are sufficiently in accordance. But the times were as 1 to 1.4142, and their squares as 1 to 2. So far then as this series of experiments on hydrate of potash entitles us to conclude, we appear to have for the salts of potash a close approximation to the following simple series of squares of equal diffusion times:—

Squares of Times of Equal Diffusion, or Solution Densities.

| | |
|----------------------------|---|
| Hydrate of potash | 1 |
| Nitrate of potash | 2 |
| Sulphate of potash | 4 |

(3.) The hydrate of potash was also diffused at the lower temperature, 39°·7, in company with the nitrate and sulphate of potash for a period of 6.364 days (six days, eight hours, forty-four minutes).

The 1 per cent. solution of hydrate of potash gave in eight cells, evaporated two together, 6.93, 6.93, 6.93 and 6.89 grs.; mean 6.92 grs.

The 2 per cent. solution of hydrate of potash gave in three single cells, 6.77, 6.49 and 7.10 grs.; mean 6.79 grs.

The diffusion of nitrate of potash in nine days at the same temperature, as already detailed, was sensibly the same, or 6.83 grs. for both the 1 and 2 per cent. solutions. The times for the two salts were as 1 to 1.4142.

The diffusion of hydrate of potash, at 39°·7, may therefore be stated with reference to that of nitrate of potash, for the selected times, as follows:—

| | |
|--|-------|
| Nitrate of potash, 1 and 2 per cent. solutions | 100 |
| Hydrate of potash, 1 per cent. solution | 101.3 |
| Hydrate of potash, 2 per cent. solution | 99.4 |

These experiments at the low temperature concur, therefore, with those made at the higher temperature, in proving that the times of equal diffusion of the two substances have been properly chosen.

III. DIFFUSION OF SALTS OF SODA.

(1.) The only salts of soda which I have yet had an opportunity of diffusing in a sufficient variety of circumstances are the carbonate and sulphate. These salts appear to be equi-diffusive, but to diverge notwithstanding more widely in the solutions of the higher proportions of salt than the corresponding potash salts. It is a question whether this increased divergence is not due to the less solubility of the soda salts, and the nearer approach consequently to their points of saturation in the stronger solutions.

TABLE XIII.—Diffusion of Carbonate and Sulphate of Soda.

| Parts of anhydrous salt to 100 water. | Density of solution at 60°. | At 64°. | | At 37°·7. | |
|---------------------------------------|-----------------------------|----------------------------------|-------|----------------------|-------|
| | | Experiments. | Mean. | Experiments. | Mean. |
| Carbonate of soda. | | | | | |
| 2 | 1·0202 | 4·15 4·08 | | 2·78 2·62 | |
| 4 | 1·0405 | 4·21 7·96 7·70 | 4·14 | 2·73 5·31 4·94 | 2·71 |
| 6 $\frac{2}{3}$ | 1·0653 | 7·68 12·16 12·06 | 7·78 | 5·35 8·50 8·45 | 5·20 |
| 10 | 1·0957 | 12·45 17·13 16·53 17·00 | 12·22 | 8·05 | 8·33 |
| 16·88 | | | | | |
| Sulphate of soda. | | | | | |
| 2 | 1·0179 | 4·35 4·32 | | 2·96 3·03 | |
| 4 | 1·0352 | 4·25 8·14 8·10 | 4·31 | 3·09 5·63 5·64 | 3·03 |
| 6 $\frac{2}{3}$ | 1·0578 | 8·28 13·26 13·63 | 8·17 | 5·42 8·77 8·84 | 5·56 |
| 10 | 1·0847 | 13·61 18·71 19·73 18·91 | 13·50 | | 8·80 |
| 19·14 | | | | | |

The range of the thermometer during the continuance of the experiments at the higher temperature was from 64°·5 up to 65° and falling again to 63°; the mean of all the days being 64°. The temperature of the other series, or of the ice-box, was 42° the first day, 38° the second, and 37° steadily for the remainder of the period; the mean being 37°·7.

The mean results at 64° are as follows:—

| | 2. | 4. | 6 $\frac{2}{3}$. | 10. |
|-------------------------|------|------|-------------------|-------|
| Carbonate of soda | 4·14 | 7·78 | 12·22 | 16·88 |
| Sulphate of soda | 4·31 | 8·17 | 13·50 | 19·14 |

Another series of experiments was made upon a 1 per cent. solution of the same salts at a mean temperature of $64^{\circ}9$. Six phials of each solution were diffused, and the water of two jars afterwards evaporated together, so that the quantities stated are double.

The diffusion product in three experiments with the sulphate of soda was 4.77, 4.75 and 4.80 grs.; mean 4.77 grs. The diffusion product in three experiments with the carbonate of soda was 4.61, 4.68 and 4.67 grs.; mean 4.65 grs. The difference between the carbonate and sulphate is 0.12 gr.; it is less for the present proportion of 1 per cent. of salt, than for 2 per cent., so that the diffusion of the salts may be converging to a perfect equality in very weak solutions. One-half of the preceding quantities, or the mean results for a single diffusion cell, are—

Diffusion of 1 per cent. solutions at $64^{\circ}9$.

| | |
|--------------------------------------|--------|
| Carbonate of soda, 2.32 grs. | 100 |
| Sulphate of soda, 2.38 grs. | 102.58 |

(2.) The diffusion of the carbonate of soda was further compared with the nitrate of the same base, to find whether their times of equal diffusion are related like those of the corresponding potash salts. The mean temperature of the first seven days, which was the period of diffusion for the nitrate of soda, was $66^{\circ}9$; of the last three days, $65^{\circ}2$; and of the whole period of 9.9 days occupied by the carbonate of soda, $66^{\circ}4$. The 4 per cent. solutions were employed.

The nitrate of soda gave a diffusion product, in three experiments, of 11.48, 11.58 and 12.13 grs.; mean 11.73 grs.

The carbonate of soda, in three experiments, gave 11.66, 11.53 and 11.52 grs.; mean 11.57 grs. A slight addition should be made to the latter quantity to raise the diffusion product from $66^{\circ}4$ to $66^{\circ}9$. It will appear from a subsequent experiment that the diffusion of the carbonate of soda increases 0.096 gr. for a rise of one degree of temperature; which will give 0.05 gr. for the half degree in question. Bringing the diffusion of the two salts to the same temperature of $66^{\circ}9$, we have therefore diffused, of—

| | |
|--|-------|
| Nitrate of soda, in seven days, 11.73 grs. | 100 |
| Carbonate of soda, in 9.9 days, 11.62 grs. | 99.06 |

The difference in the quantity diffused of the two salts is only 0.11 gr., or 1 per cent., which is quite within the unavoidable errors of observation.

(3.) The diffusion of a 2 per cent. solution of the same salts was repeated at the same inferior temperature of $54^{\circ}3$ as with the salts of potash, and under the same difficulties from fluctuation of atmospheric temperature. Two water-jars were evaporated together, so that the results are double.

Nitrate of soda, diffused for seven days at a mean temperature of $54^{\circ}3$, gave 10.15, 10.24 and 9.92 grs. in three experiments; mean 10.10 grs.

Carbonate of soda, diffused for 9.9 days at a mean temperature of $53^{\circ}4$, gave 9.93, 9.54 and 10.10 grs. in three experiments; mean 9.86 grs. But the latter amount is to be increased by 0.09 gr. to bring it to the diffusion of $54^{\circ}3$. We have then for the diffusion product of the two salts at the same temperature of $54^{\circ}3$ —

| | |
|---|-------|
| Nitrate of soda, in 7 days, 10.10 grs. | 100 |
| Carbonate of soda, in 9.9 days, 9.95 grs. | 98.51 |

The difference is again small, namely, 0.15 gr., or $1\frac{1}{2}$ per cent., and within the limits of unavoidable error.

It appears therefore that the times of equal diffusion of the nitrate and carbonate of soda are related like those of the nitrate and carbonate of potash, or as the square root of 1 and 2, that is, as 1 to 1.4142.

Relation of Salts of Potash to Salts of Soda.

It appeared probable, from many of the experiments already recorded, that if any relation, in the times of equal diffusibility, existed between the corresponding salts of potash and soda, it was that of the square root of 2 to the square root of 3. They were accordingly diffused for times having this ratio; namely, the nitrate of potash for seven days, the nitrate of soda for 8.57325 days; the sulphate and carbonate of potash for 9.9 days, and the sulphate and carbonate of soda for 12.125 days. If these times are rightly chosen, the eventual diffusion products of all the experiments should be equal. The 1 per cent. solution was selected, and the number of experiments simultaneously made on each salt was eight or six. The liquids of two water-jars were evaporated together, so that each of the results in the table below represents the diffusion of two cells. These experiments also afford another opportunity of testing the assumed relation between the nitrates and sulphates of the same base.

TABLE XIV.—Solution: 1 Salt to 100 Water, at $55^{\circ}4$ — $56^{\circ}1$.

| | Tempe- rature. | Time in days. | Square of times. Sol. density. | Diffusion product of two cells in grs. | | | | |
|---------------------------|-------------------|------------------|--------------------------------------|--|----------|-----------|----------|-------|
| | | | | Exp. I. | Exp. II. | Exp. III. | Exp. IV. | Mean. |
| Nitrate of potash | $56^{\circ}1$ | 7 | 2 | 6.67 | 6.87 | 6.90 | 6.57 | 6.75 |
| Nitrate of soda | $55^{\circ}7$ | 8.57 | 3 | 6.59 | 6.80 | 6.94 | 6.57 | 6.78 |
| Sulphate of potash | $55^{\circ}4$ | 9.90 | 4 | 6.73 | 6.77 | 6.96 | 6.68 | 6.78 |
| Sulphate of soda | $55^{\circ}4$ | 12.125 | 6 | 6.43 | 6.94 | 6.80 | 6.68 | 6.72 |
| Carbonate of potash | $55^{\circ}4$ | 9.90 | 4 | 6.54 | 6.64 | 6.40 | 6.67 | 6.56 |
| Carbonate of soda | $55^{\circ}4$ | 12.125 | 6 | 6.40 | 6.63 | 6.60 | 6.67 | 6.54 |

The range of temperature during the period of these experiments rather exceeded 3 degrees, so that they cannot be considered as fortunate in that respect; but still the similarity between the different sets of experiments, and the near equality of their means, is very remarkable. The two nitrates and the two sulphates may be said to coincide, the extreme difference of the means of the four salts not being quite so much as 1 per cent. The two carbonates fall about 3.4 per cent. below the sul-

phates and nitrates, but agree perfectly with each other, showing a uniformity in their irregularity. This deviation of the carbonates would appear essential, as it has been observed every time they have been compared with the sulphates.

The double relation between salts of potash and salts of soda, and between the nitrate and sulphate class of each of these bases, will, I believe, be allowed to acquire considerable additional support from this new series of observations.

IV. DIFFUSION OF SULPHATE OF MAGNESIA.

In a set of preliminary experiments upon sulphate of magnesia in comparison with sulphate of potash, the 4 per cent. solutions of both salts were diffused for seven days at a mean temperature of $57^{\circ}9$, with very little fluctuation, the extreme range being from $58^{\circ}5$ to $57^{\circ}75$. The sulphate of magnesia is taken anhydrous in all the following experiments. The diffusion of sulphate of potash in three cells was 9.16, 9.22 and 9.57 grs.; mean 9.32 grs.

The diffusion of sulphate of magnesia in three cells was 5.21, 4.98 and 5.34 grs.; mean 5.18 grs. The diffusion, in equal times, appears here to be as 100 sulphate of potash to 55.58 sulphate of magnesia. We know, however, when unequally diffusible salts are diffused for equal times, that the diffusion of the slower is exaggerated. Consequently the diffusion of sulphate of magnesia is likely to be represented in excess in these experiments.

In a second preliminary series of experiments the same 4 per cent. solutions were diffused, the sulphate of potash for eight days and the sulphate of magnesia for nineteen days, with the view of discovering their times of equal diffusibility.

During the first period of eight days the temperature fluctuated considerably, beginning at 54° , falling gradually in four days to $50^{\circ}5$, and rising again in four days to 53° ; the average of the whole period was $52^{\circ}2$. The diffusion of sulphate of potash from three cells was 9.36, 9.25 and 10.52 grs.; mean 9.71 grs.

During the second period of nineteen days, which included the first period, the mean temperature was $54^{\circ}6$. The diffusion of sulphate of magnesia from three cells was 11.81, 11.61 and 10.90 grs.; mean 11.44 grs. The variation in the amounts diffused of both salts is greater than usual, owing no doubt to the changes of temperature, which were imperfectly controlled.

Dividing the quantity of salt diffused by the number of days, we have of sulphate of potash 1.214 gr. diffused per day, and of sulphate of magnesia 0.602 gr. per day; or the latter salt exhibits sensibly half the diffusibility of the former in equal times. This suggested the trial of times for these two salts in the proportion of 1 to 2, with the view of obtaining equal diffusions.

(1.) A one per cent. solution of sulphate of magnesia (anhydrous) was diffused for the long period of 19.8 days, at a mean temperature of $54^{\circ}7$, in eight cells. The diffusion products of four pairs of cells were 7.07, 6.71, 7.07 and 7.35 grs.; mean 7.05 grs., or for one cell, 3.53 grs.

A similar solution of sulphate of potash diffused for 9·9 days, or half the preceding period, at a mean temperature of $55^{\circ}4$, or $0^{\circ}7$ higher, gave a mean product, for two cells, of 6·79 grs., as before stated; or for one cell, of 3·40 grs. The diffusion of sulphate of potash being 100, that of sulphate of magnesia is therefore 103·7, a fair approximation to equality.

(2.) In a second series of experiments upon 1 per cent. solutions of the same two salts, diffused in the vault for fourteen and seven days respectively, with a mean temperature of $53^{\circ}8$ for the sulphate of magnesia, and $54^{\circ}3$ for the sulphate of potash, the temperature was remarkably uniform, gradually falling from $55^{\circ}2$ to 53° during the longer period, but without any injurious oscillation.

From eight cells, evaporated two together, the sulphate of magnesia obtained was 6·12, 6·12, 6·04 and 6·03 grs.; mean 6·08 grs., or 3·04 grs. for one cell.

The sulphate of potash gave from eight cells, in experiments already detailed, a mean result of 5·84 grs. of salt for two cells, or 2·92 grs. for one cell. The diffusion is in the proportion of 100 sulphate of potash to 104·11 sulphate of magnesia, the times being as 1 to 2 for the two salts respectively.

From these two series of experiments, it appears that, at 54° , sulphate of magnesia has nearly, if not exactly, half the diffusibility of sulphate of potash, and consequently one-fourth of that of hydrate of potash. Or, the times of equal diffusion for these three salts appear to be 1, 2 and 4. The squares of these times and the solution densities are 1, 4 and 16. Hydrate of potash may possibly therefore have the same relation to sulphate of magnesia in solution density and diffusibility that hydrogen gas has to oxygen gas.

(3.) A two per cent. solution of sulphate of magnesia, diffused for fourteen days, gave at $53^{\circ}9$, for two pairs of cells, 9·57 and 10·00 grs. of salt, of which the mean is 9·79 grs., or 4·85 grs. for one cell.

A similar solution of sulphate of potash diffused for seven days gave a mean result of 4·97 grs. of salt for one cell, at $54^{\circ}2$, as already stated. The result is a diffusion of 100 sulphate of potash to 97·59 sulphate of magnesia.

(4.) A four per cent. solution of sulphate of magnesia, diffused for fourteen days, gave at $53^{\circ}7$, in two pairs of cells, 18·00 and 18·20 grs. of salt; mean 18·10 grs. for two cells, or 9·05 grs. for a single cell.

A similar solution of sulphate of potash, diffused for seven days at $54^{\circ}2$, gave a mean result of 9·30 grs. of salt for a single cell, as already stated. This is a diffusion of 100 sulphate of potash to 97·4 sulphate of magnesia.

The diffusion of the 2 and 4 per cent. solutions of sulphate of magnesia is so nearly equal to the diffusion of the same proportions of sulphate of potash in half the time, that they may be considered as supplying additional support to the assumed relation between the diffusibilities of these salts.

I may add, that a 4 per cent. solution of anhydrous sulphate of zinc was diffused for fourteen days, simultaneously with the similar solution of sulphate of magnesia,

and of course at the same temperature of $53^{\circ}7$. Two cells, evaporated two together, gave 17.40 and 17.36 grs. of ignited sulphate of zinc; mean 17.38 grs. The salt remained, after ignition, entirely soluble. This is a diffusion of 8.69 grs. for one cell, while the sulphate of magnesia gave 9.05 grs.; or of 100 sulphate of zinc to 104.14 sulphate of magnesia. This result is interesting, as we here find two salts which are isomorphous, and of which the equi-diffusion is on that account in a high degree probable, differing between themselves so much as 4 per cent.

Another numerous series of experiments was made at a considerably lower temperature, with the view of testing several of the same relations. The temperature in commencing the diffusion was 41° , but fell in the course of three days to $38^{\circ}8$, and afterwards rose to 39° , from which it never varied afterwards more than a degree during the diffusion of the salts of potash and soda. The mean temperature for their periods did not vary above $0^{\circ}1$ or $0^{\circ}2$ from $39^{\circ}7$, so that it may be supposed the same for all these salts. For the sulphates of magnesia, the mean temperature was $38^{\circ}9$, or $0^{\circ}8$ lower. The times chosen are as the square-roots of 2, 3, 6 and 16.

TABLE XV.—Solutions of 1 and 2 Salt to 100 Water, at $39^{\circ}7$.

| | Time in days. | Square of times. Sol. density. | Diffusion product of two cells in 1 per cent. solutions, and one cell in 2 per cent. solutions. | | | | |
|---------------------------------------|---------------|-----------------------------------|---|----------|-----------|----------|-------|
| | | | Exp. I. | Exp. II. | Exp. III. | Exp. IV. | Mean. |
| Chloride of potassium, 2 per cent.... | 9 | 2 | 6.58 | 6.79 | 6.82 | | 6.73 |
| Nitrate of soda, 2 per cent. | 11.022 | 3 | 6.66 | 6.98 | 6.79 | | 6.81 |
| Chloride of sodium, 1 per cent. ... | 11.022 | 3 | 6.33 | 6.63 | 6.73 | 7.06 | 6.69 |
| Chloride of sodium, 2 per cent. ... | 11.022 | 3 | 6.50 | 6.60 | 6.64 | 6.74 | 6.62 |
| Sulphate of soda, 1 per cent..... | 15.589 | 6 | 6.60 | 6.56 | 6.56 | 6.50 | 6.55 |
| Sulphate of soda, 2 per cent..... | 15.589 | 6 | 6.50 | 5.43 | 6.33 | | 6.42 |
| Sulphate of magnesia, 1 per cent.... | 25.456 | 16 | 6.36 | 6.20 | 6.86 | 6.59 | 6.50 |
| Sulphate of magnesia, 2 per cent.... | 25.456 | 16 | 6.42 | 6.78 | 6.50 | 6.84 | 6.63 |

Several other salts were diffused in the same circumstances as the preceding, of which the diffusion products have been previously given. Of these salts, both the 1 and 2 per cent. solutions of nitrate of potash gave 6.83 in nine days, or in the same time as chloride of potassium in the table. The latter salt maintains a sensible equality of diffusion with the present series at the low, as well as it was found to do at the former high temperature. Chloride of sodium is here introduced for the first time: it appears to be equi-diffusive with nitrate of soda. If the sulphate of magnesia diffused be increased by 0.07, for its lower temperature, this salt will be in close accordance with the salts of potash and soda.

Taking nitrate of potash 6.83, as 100, for a standard, the salt which deviates most considerably is sulphate of soda, which for the 1 per cent. solution is 6.55, or 95.9. A low temperature, however, must be unfavourable to diffusion experiments, from increasing the tendency of salts to crystallize.

In conclusion, I may sum up the results of most interest which this inquiry respecting liquid diffusion has hitherto furnished.

1. I would place first the method of observing liquid diffusion. This method, although simple, appears to admit of sufficient exactness. It enables us to make a new class of observations which can be expressed in numbers, and of which a vast variety of substances may be the object, in fact everything soluble. Diffusion is also a property of a fundamental character, upon which other properties depend, like the volatility of substances; while the number of substances which are soluble and therefore diffusible, appears to be much greater than the number of volatile bodies.

2. The novel scale of Solution Densities, which are suggested by the different diffusibilities of salts, and to which alone, guided by the analogy of gaseous diffusion, we can refer these diffusibilities. Liquid diffusion thus supplies the densities of a new kind of molecules, but nothing more respecting them.

The fact that the relations in diffusion of different substances refer to equal weights of those substances, and not to their atomic weights or equivalents, is one which reaches to the very basis of molecular chemistry. The relation most frequently possessed is that of equality, the relation of all others most easily observed. In liquid diffusion we appear to deal no longer with chemical equivalents or the Daltonian atoms, but with masses even more simply related to each other in weight. Founding still upon the chemical atoms, we may suppose that they can group together in such numbers as to form new and larger molecules of equal weight for different substances, or if not of equal weight, of weights which appear to have a simple relation to each other. It is this new class of molecules which appear to play a part in solubility and liquid diffusion, and not the atoms of chemical combination.

3. The formation of classes of equi-diffusive substances. These classes are evidently often more comprehensive than the isomorphous groups, although I have reason to imagine that they sometimes divide such groups; that while the diffusion of salts of baryta and strontia, for instance, is similar, the diffusion of salts of lead may be different.

4. The separation of the whole salts (apparently) of potash and of soda into two divisions, the sulphate and nitrate groups, which must have a chemical significance. The same division of the salts in question has been made by M. GERHARDT, on the ground that the nitrate class is monobasic and the sulphate class bibasic.

5. The application of liquid diffusion to the separation of mixed salts, in natural and in artificial operations.

6. The application of liquid diffusion to produce chemical decompositions.

7. The assistance which a knowledge of liquid diffusion will afford in the investigation of endosmose. When the diffusibility of the salts in a liquid is known, the compound effect presented in an endosmotic experiment may be analysed, and the true share of the membrane in the result be ascertained.

But on the mere threshold of so wide a subject as liquid diffusion, I must postpone speculation to the determination of new facts and the enlargement of my data, of the present incompleteness of which I am fully sensible.

II. *On the Nitrogenated Principles of Vegetables as the Sources of Artificial Alkaloids.*

By Dr. JOHN STENHOUSE, F.R.S.

Received June 13,—Read June 21, 1849.

PART I.

THERE are few departments in organic chemistry which during the last six or seven years have attracted more of the attention of experimenters than the artificial formation of the alkaloids. This perhaps is not to be wondered at when we consider the interesting nature of this class of bodies, both as regards their well-defined chemical properties and the important medical virtues which many of them possess. All attempts to form the natural alkaloids, such as quinine, cinchonine, strychnine, &c., by artificial means have hitherto been unsuccessful, but chemists have been enabled by various processes to procure artificially a considerable number of true alkaloids quite analogous to those which occur in nature. Several of these artificial alkaloids, such as quinoline, narcogenine, cotarnine, &c., are obtained from the natural alkaloids by acting on them by various reagents.

A second group, comprising furfurine, thiosinamine, &c., are formed when ammonia is brought in contact with some of the essential oils, such as oil of mustard.

A third very numerous group, comprising nitraniline, toluidine, cumedine, &c., are obtained by the reducing action of sulphuretted hydrogen or sulphide of ammonium on nitrogenous compounds formed by treating certain hydrocarbons with nitric acid.

I shall conclude this enumeration by noticing a fourth very important group, comprising aniline, picoline, petenine, &c., which are obtained by the distillation of coal or animal substances, as in the case of bone-oil in the preparation of animal charcoal. To this last group I shall especially refer in the course of the present notice.

It is somewhat remarkable therefore, that while so many other sources have been examined, no attempt, so far as I am aware, should hitherto have been made to procure alkaloids from the highly nitrogenated principles, which under the names of vegetable albumen, fibrine, caseine, &c. are found in all plants, in many instances to a very considerable amount. These principles are, as is well known, almost as rich in nitrogen as the corresponding animal compounds, containing on an average about 15 per cent. of that element. What also renders the neglect of these substances by experiments still more singular, is the consideration that among the known sources of the artificial alkaloids coal has been one of the most productive, yielding as it does, in addition to ammonia, four other bases, aniline, quinoline, picoline and pyrrol, and not improbably containing also other organic bases which have hitherto escaped

observation. Now coal is universally admitted to be exclusively of vegetable origin, and to consist of the remains of a variety of vegetables, which, after having undergone putrefactive fermentation, and been subjected to probably enormous compression, have lain for countless ages in the bowels of the earth.

When reflecting therefore on the probable sources of the organic bases in coal, it has for some time past appeared to me highly probable that they are not derived from the woody fibre and other non-nitrogenated vegetable matters from which the coal has been principally formed; but that these bases are exclusively derived from the highly nitrogenated principles, previously enumerated, contained in the plants of the coal-fields. From the energetic agencies to which coal has been subjected, it seemed probable that much of the nitrogen originally present in the vegetables from which it has been formed must have been dissipated, and consequently the amount of bases now obtainable from coal proportionally diminished. It appeared therefore only reasonable to expect, that by acting on the nitrogenated principles of recent vegetables, the same organic bases as those contained in coal, or at any rate a series of analogous bases, would be obtained in proportionally greater abundance. In the sequel it will appear that this latter expectation has not been altogether disappointed.

It is extremely difficult to obtain vegetable albumen, fibrine, or caseine in considerable quantity in a state of purity. And though several chemists have bestowed much attention on the subject, as none of these principles are crystallizable, it is very doubtful if any of them have yet been obtained in a state of absolute purity. Instead therefore of endeavouring to purify these principles, I contented myself with selecting those portions of our commonest plants, usually their seeds, which contain them in the greatest abundance.

The first substance on which I operated was the seeds of the *Phaseolus communis*, or common horse-bean. This bean contains about 20·8 per cent. of caseine and 1·35 per cent. of albumen, amounting in all to a little more than 22 per cent. nitrogenous matter. The beans were destructively distilled in cast-iron cylinders, about three feet high and eight inches in diameter. The products of the distillation were collected by means of a large condensing LIEBIG'S apparatus, kept carefully cool. A great deal of combustible but non-condensable gas was evolved. It had a very disagreeable fœtid odour. The liquid which passed into the receiver was strongly alkaline, so much so as to require about a third of its bulk of muriatic acid of ordinary strength to neutralize it. It closely resembled the products of the distillation of bones, flesh and other animal matters, being very complex, and comprising, among other substances, acetone, wood-spirit, acetic acid, empyreumatic oils, tar, a great deal of ammonia, and several organic bases. The crude produce of the distillation was then treated with a considerable excess of muriatic acid, and the clear liquid, after subsidence, was poured off from the tar and other empyreumatic matters which had fallen to the bottom of the vessel. The tarry residue was also repeatedly agitated with small quantities of water, so long as any bases appeared to be dis-

solved. The several liquors were then mixed together, and were boiled for a couple of hours in a copper pan, or still more conveniently in an iron pot lined with enamel. This dissipated the acetone, wood-spirit, and a great deal of the neutral and acid empyreumatic volatile oils contained in the liquid. The boiling also rendered the tar less soluble by converting it and the fixed oils into imperfect resins. The acid liquor was then left at rest till it was quite cold, when it was passed through a cloth filter containing a quantity of pounded charcoal, which retained the greater portion of the resinous matter. The clear liquid was then introduced into a capacious still, and largely supersaturated either with quick-lime in fine powder, or with carbonate of soda, as was found most convenient.

As soon as heat was applied to the still a great deal of ammonia was evolved, and when the liquid boiled a quantity of oily bases began to appear in the ammoniacal liquor which passed into the receiver. Their amount increased as the distillation proceeded. As the first half of the liquid which came over was by much the richest in bases, it was collected separately from the succeeding portions, which contained scarcely any undissolved oil, but consisted chiefly of an aqueous solution of the bases. The distillation was continued however till the liquid which condensed in the receiver had only a slightly alkaline reaction. The mixture of oils which collected on the surface of the first portion of the distillation was drawn off with a pipette and then saturated with muriatic acid, which left any neutral oil which had been mixed with it undissolved. The oil was removed by passing the solution through a wet paper filter. The clear liquid was next supersaturated with carbonate of soda, and rectified in a large glass retort. It was found advantageous to employ a great excess of alkali for this purpose, as these bases are much more soluble in water than in strong alkaline lyes, and therefore distil over more readily from solutions which are strongly alkaline. The bases which passed over into the receiver were drawn off, as before, by means of a pipette from the ammoniacal liquor on which they floated, and were collected in any suitable bottle. The weak alkaline liquors of the previous distillation, which had ceased to yield bases by simple rectification, were again neutralized with muriatic acid, and cautiously concentrated to about half, or even a third, of their bulk, according to their state of dilution. Care should be taken however not to concentrate these liquors, unless in case of necessity, as long-continued boiling has always the effect of destroying a large portion of the bases, which are oxidated and converted into dark-coloured resins. The bases were again rectified with water, which removed much of the resinous matter which had come over with them during the previous distillations. As they still however retained a good deal of ammonia, from which it was necessary to free them, they were washed by being repeatedly agitated with successive portions of a strong solution of potash, which dissolved the ammonia and retained it in solution. The mixture of the lye and the bases was then poured into a long narrow-necked funnel, which was closed at the bottom, and the whole was left for a short time to subside. The bases quickly separated from the

potash solution and floated on its surface. The lye was then slowly run off by opening the bottom of the funnel, and when the whole of it was removed the escape of the bases was prevented by again closing the neck of the funnel. This operation was repeated till the whole of the ammonia was removed. A quantity of the bases remained dissolved in the alkaline lye, occasioning a loss, which however was unavoidable. The next step was to free the bases from the water they had absorbed, and which appeared to be nearly equal to that of their own bulk. The water was pretty readily removed by agitating the bases with bits of fused potash, so long as the alkali appeared to be in the least degree moistened. In order to ensure their being perfectly anhydrous, the bases were treated with successive quantities of fresh potash, and were kept in contact with the last portion for nearly a week. The clear liquid was then poured off from the potash into a small glass retort and cautiously rectified. The first two-thirds of the liquid which came over was a colourless transparent oil. The last portions, which distilled at a much higher temperature, had a slightly yellow colour, which increased in depth towards the close of the distillation. The colourless and the coloured portions were therefore collected separately. By repeated rectifications, however, the last portions of the bases were freed from the resinous matter they contained, and rendered as transparent and colourless as the first portion. As it was plain from the great variation in their boiling-points that the liquids were not homogeneous but consisted of a mixture of bases, many attempts were made to obtain them in a separate state by means of fractionated distillation. A thermometer was therefore inserted into the mixture of the bases by means of a perforated cork passed through the tubes of the retort. The mixture began to boil at 108° C., when a very small portion of a limpid colourless oil, which was collected separately, distilled over. The thermometer rapidly rose to 120° C., and from that to 130° , at both of which points small portions of oil were also collected. The boiling-point remained stationary for a considerable time between 150° and 155° C., when a considerable quantity of the oil distilled over, and a second large quantity also came over between 160° and 165° C. The boiling-points of the last portions of the bases ranged between 165° C. and 220° C. The products of these different distillations were again repeatedly rectified, and by this means bases were obtained corresponding more closely with those points at which the thermometer remained longest during the first distillation. Though these various bases differed, as we have just seen, so considerably in their boiling-points, they still exhibited great similarity of character. Thus they formed transparent colourless oils which refracted the light very strongly. They were all lighter than water, and possessed the peculiar, pungent, slightly aromatic smell, so characteristic of this class of compounds. When brought in contact with the hands or with clothes, their odour was very persistent. The smell of the more volatile bases was, as might have been expected, the most pungent. Their taste was hot, and when diluted not disagreeable, reminding one of oil of peppermint. The bases which distilled over at low temperatures were tolerably soluble in water,

at any rate more soluble than those whose boiling-points were high. They all dissolved in every proportion in alcohol and in ether. The bases exhibited strong alkaline reactions with turmeric paper, and restored the blue colour of litmus. They caused abundant fumes when a rod moistened with muriatic acid was held over them, and they neutralized acids perfectly, forming in general crystallizable salt. They formed double salts with the bichlorides of gold, platinum and mercury. These compounds were soluble in water to nearly the same extent as the corresponding ammoniacal salts. The platinum salts crystallized in four-sided prisms arranged in stars. The salts, which the bases with high boiling-points formed, were however often contaminated with a brownish resin, and crystallized but imperfectly. This was the case also with the gold salts. The bases also precipitated the persalts of iron and those of copper just as ammonia does, forming like it a fine blue colour when the bases were in excess. Though kept for a considerable time in loosely-stoppered bottles, which were not unfrequently opened, they remained transparent and colourless; but if exposed to a strong light, especially those of them which had the highest boiling-points, they gradually became of a deep yellow colour. These bases were pretty readily oxidizable. When treated with nitric acid, they were rapidly changed into yellowish resins, but no charbazotic acid was produced. When brought in contact with hypochlorite of lime, they were also changed into brownish resins, but not a trace of aniline could be found, though it was carefully sought for. When the bases were boiled for a few minutes in a retort, they gradually became coloured, though the liquid which distilled over was as colourless as at first. At the close of the distillation a small quantity of resinous matter remained in the retort. I shall now subjoin some very imperfect analytical details, in order to give in the meantime some idea of the nature of these bases. I regret that the difficulty I have hitherto experienced in procuring them in large quantities has prevented me from submitting them to the thorough examination they deserve, and which I hope ere long to accomplish. It is not that beans and other seeds, as we shall presently see, yield smaller quantities of bases than bones and other animal substances; on the contrary, their product in bases is equal to that obtained from the distillation of bones, and, as might have been expected, much greater than that from coal. The difficulty wholly arises from this circumstance, that as both bones and coal are regularly distilled on the largest scale for commercial purposes, the crude oils of both bones and coal may be easily procured in any quantity, and from these their respective series of bases may be readily prepared. In regard to the bases from beans and similar seeds, however, the case is very different, the scientific chemist requiring to distil these substances on purpose, an operation which cannot be conveniently conducted in a laboratory, as the necessary apparatus is so large as to be almost upon a manufacturing scale.

I. 0.298 gm. of the base, boiling between 150° and 155° C., when analysed gave 0.815 carbonic acid and 0.222 water.

II. 0.270 gm. gave 0.7405 Co^2 and 0.189 water.

| | | | I. | II. |
|------|--------|--------|-------|-------|
| 10 C | 750.0 | 74.98 | 74.60 | 74.78 |
| 6 H | 75.0 | 7.49 | 8.18 | 7.77 |
| 1 N | 175.2 | 17.53 | | |
| | <hr/> | <hr/> | | |
| | 1000.0 | 100.00 | | |

When the anhydrous base combined with muriatic acid much heat was evolved. The muriate was very soluble in water, but when sufficiently concentrated it crystallized in slender prisms. With sulphuric and nitric acids the base also formed similar compounds. The platinum double salt was readily procured by adding bichloride of platinum to a pretty concentrated solution of the base in muriatic acid. This salt crystallized in four-sided prisms, arranged in stars of a deep yellow colour. It was rather less soluble in water than the corresponding ammoniacal compound. It was purified by a second crystallization out of water, which freed it from a little resinous matter it was apt to contain at the first. The formula of this salt was $C_{10}H_6N, HCl, PtCl_2$, and the calculated quantity of platinum 34.50 per cent.

I. 0.7314 gm. salt, dried *in vacuo*, gave 0.254 Pl=34.72 per cent.

II. 0.3150 gm. salt gave 0.109 Pl=34.60 per cent.

When chloride of gold was added to a solution of this base in muriatic acid, a double salt was immediately formed. It crystallized very readily in pale yellow needles, which were very soluble in hot water, and were again deposited on the cooling of the liquid.

It is evident that this base, the probable formula of which is $C_{10}H_6N$, approaches very closely in its composition to nicotine, and in its characters to picoline, the base discovered by Dr. ANDERSON in coal-tar. The formula of nicotine is $C_{10}H_7N$. The boiling-point of the new base is higher than that of picoline, and its solubility in water is much less. Dr. ANDERSON says that picoline is soluble in water in every proportion, while this base requires at least six or seven times its bulk of water to dissolve it. The new base was lighter than water. Its smell was peculiar and slightly aromatic. Its taste was hot, reminding one of peppermint. It dissolved in every proportion, both in alcohol and in ether. It remained colourless, though kept in an imperfectly stoppered bottle, if not exposed to a strong light. It caught fire readily, and burnt with a bright smoky flame.

In order to obtain an approximative idea of the per-centage composition of the other bases with which this was accompanied, three of them were subjected to analysis.

I. 0.2632 gm. of the base, or not improbably mixture of bases, boiling between 160° and 165° C., gave 0.715 carbonic acid and 0.191 water.

II. 0.239 gm. of the liquid, boiling between 165° and 170° C., gave 0.661 carbonic acid and 0.1835 water.

III. 0.197 gm., boiling between 200° and 210° C., gave 0.547 Co^2 and 0.155 water.

| | I. | II. | III. |
|---|-------|-------|-------|
| C | 74.08 | 75.42 | 75.63 |
| H | 8.06 | 8.52 | 8.73 |

It is rather singular that the amount of carbon and hydrogen does not vary more, while the boiling-points of these bases, or not improbably mixture of bases, are so exceedingly different. They all form double salts with chlorides of gold and platinum. Those with the highest boiling-points do not crystallize so readily as the less volatile bases, and are apt to be contaminated with resinous matter. As the height of their boiling-points rises, the solubility of the bases in water diminishes. They all appear to possess equally strong basic properties. Their detailed examination must however be reserved for a future communication.

As the *Phaseolis communis* was selected as the representative of that numerous tribe of plants, the Leguminosæ, of which the various kinds of beans, peas, lentils, &c. are the most familiar examples, the next substance subjected to distillation was oil-cake, or the dried seeds of *Linum usitatissimum*, from which the fat oil had been expressed. Oil-cake was selected as the type of the numerous class of plants in which the starch of the Gramineæ is replaced by oil. Of these, the poppy, rape, mustard, &c. are the best known. They are all very rich in vegetable albumen. The oil-cake was broken into moderate-sized pieces and distilled in the same cylinders as were employed for the beans. The quantity on which I operated was about two hundred weight. It yielded, as might have been expected, a smaller amount of liquid products than the beans. Their odour was peculiarly offensive. They consisted of acetone, acetic acid, a great deal of tar and empyreumatic oils. The quantity of ammonia was also exceedingly great. I was however disappointed to find that the organic bases were much less than in the case of the beans, amounting to not more than a third of what they yielded. The only way in which I can account for this different result, is from the greatly higher temperature at which the oil-cake was distilled, the heat not being mitigated, as in the case of the beans, by the presence of much moisture. Now, as all these volatile alkaloids are when highly heated resolved into ammonia, I think there is every reason to conclude, that in this, as in many other instances, a large portion of the bases which would have been generated at a lower temperature, were either not formed at all, or were destroyed immediately after their formation. The large amount of ammonia and the deficiency of the other bases is thus very naturally accounted for. The bases from oil-cake were separated and purified by similar methods to those employed for the preceding bases. They also formed a different series from either the coal or the bone bases, as they contained neither aniline nor quinoline. Their odour also differed considerably from that of the bases from beans, which however they closely resembled in other respects; their basic properties were equally decided, and they also formed similar salts. It appears probable enough therefore that some of the bases in both series are identical. But on this subject I expect to be able to speak more decidedly in a future paper.

Wheat.

A considerable quantity of the flour of *Triticum hybernum*, or common wheat, was also destructively distilled. Wheat was selected as a type of the Gramineæ, a most important order of plants, of which barley, oats, maize, &c. are those with which we are most familiar.

The liquid which the wheat-flour yielded, unlike that of the two preceding substances, was strongly acid from the large quantity of acetic acid it contained, derived from the starchy matters of the grain. The amount of acetone and wood-spirit was also very considerable. The empyreumatic products had a much less offensive odour than those from either oil-cake or from beans. The amount of ammonia was by no means inconsiderable, but the quantity of organic bases was less than I expected. They amounted however to pretty nearly the same quantity as those yielded by oil-cake. They did not contain either aniline or quinoline, and closely resembled the two preceding series in their general characters. They seemed however to be more volatile, distilling over at a lower temperature. At present I shall confine myself to the statement, that wheat, and most probably the other Gramineæ when distinctly distilled, also yield organic bases. As the starch in wheat, the quantity of which is so considerable, only forms acetic acid and other non-nitrogenated products, I intend in repeating this experiment to employ the gluten from the starch-makers, which contains almost the whole of the nitrogen in the wheat, and being a refuse product can be had for a trifle.

Peat.

A quantity of peat from the moors in the neighbourhood of Glasgow was also destructively distilled. I selected for this purpose the densest peat I could find. It had a deep black colour, and was very free from earthy matters. The products of its distillation were very nearly neutral to test-paper, owing to the formation of a considerable amount of acetic acid. Acetone and wood-spirit were also present in considerable quantity. The crude liquor was saturated with muriatic acid and gently boiled for some time to drive off the acetone, wood-spirit, &c., by which much of the tarry matter was held in solution. On the cooling of the liquid, the tar readily solidified and formed a soft crust on the surface, which was easily removed. The clear liquid was then supersaturated with carbonate of soda and distilled. The ammoniacal liquor which passed into the receiver contained a considerable amount of bases, which floated in it as a light oil. These were freed from ammonia and purified by the same means as in the preceding instances. The bases from peat bore a much larger proportion to the amount of ammonia than was the case with oil-cake. I ascribe this result chiefly to the porous nature of peat which conducts heat but slowly, and also to the greater degree of moisture contained in it. The bases therefore being distilled at a much lower temperature, a smaller amount of them was resolved into ammonia than in the instance of oil-cake. I expected to have found

aniline among the bases, but they appeared to contain neither it nor quinoline. They resembled the preceding series pretty closely therefore, but whether they will prove identical with them or not I am at present unable to say.

Distillation of Wood.

Through the kindness of Mr. TURNBULL, an extensive manufacturer of pyroligneous acid in this city, I was enabled to examine considerable quantities of the crude acid liquor obtained from the destructive distillation of beech, oak, ash and other hard woods. The stems and the larger branches of these trees are alone employed for this purpose. I was astonished to find that these liquors contained scarcely a trace of ammonia or any other organic bases. The woody portions therefore of the stems and trunks of trees appear to be almost entirely devoid of nitrogenous matter, in which respect they exhibit a remarkable contrast to peat.

This circumstance appears to me as perhaps calculated to throw some light upon a question of great interest to geologists, viz. the origin of the coal-beds. Whether therefore have the coal-beds been formed by the submersion of whole forrests and the floating of uprooted timber into estuaries and lakes, or whether are they due to the submersion of beds of peat? Now irrespective of all other considerations which might be urged in favour of the latter opinion, I would remark that the amount of nitrogen in coal, and consequently the quantity of ammonia and other bases which it yields when destructively distilled, are very considerable, constituting in fact an extensive branch of chemical manufacture. Wood, however, as we have just seen, appears to be quite incapable of furnishing the amount of nitrogen which we find existing in coal. Peat, on the other hand, from the quantity of ammonia and other bases which it yields when destructively distilled, is capable of furnishing more than the required amount of ammonia. This circumstance appears therefore highly confirmatory of the opinion, that the true source of coal is only to be sought for in peat.

As was already observed, I expected to have been able to procure from peat, in addition to ammonia, aniline, quinoline, picoline and the other coal bases. I did not find these however, but merely an analogous series of bases. I can only account for this result on the assumption that the different genera of plants, when destructively distilled, yield different series of organic bases. This we already know to be the case in several instances; for when indigo or any of the indigoferæ are destructively distilled, they yield ammonia and aniline; tobacco leaves, when similarly treated, yield ammonia and nicotine; the different species of the Peruvian bark, quinoline, and beans, wheat, oil-cake, &c., as we have already seen, do not yield aniline and quinoline, but are analogous series of bases. I am induced to believe therefore that the reason why modern peat does not yield the identical bases found in coal is, because the peat beds of primitive times, which in the course of ages have been converted into coal, were formed from the decaying remains of quite different plants than the various species of *Erica* and those other vegetables which constitute the peat

mosses of the present day. Had the plants in both cases been the same, I see no reason for doubting that when distilled they would have yielded identical bases.

Formation of Organic Bases from the nitrogenous Principles of Vegetables and Animals otherwise than by destructive Distillation.

1. *By treating them with alkaline lyes.*—From the facts which have been previously stated, I think we are warranted to conclude, that when ammonia is produced in large quantities by the destructive distillation of either vegetable or animal substances, it is always accompanied by the formation of organic bases. Now as ammonia is known to be procurable from these substances by several other methods, it seemed by no means improbable that on these occasions organic bases would also be produced. It has long been known that ammonia is largely generated when the nitrogenous portions of either plants or animals are boiled with strong alkaline lyes. A quantity of beans was therefore introduced into the body of a large still, and was boiled with a strong solution of caustic soda. The beans were speedily disintegrated, being converted into a slimy, dark-coloured pulp. The greatest difficulty attending the operation was caused by the frothing up of the pasty mixture, which, unless the still was very capacious and the fire kept moderate, was very apt to boil over and choke up the worm of the distilling apparatus. By cautiously rectifying the product of the distillation, a clear, strongly alkaline liquid was procured. It contained a large amount of ammonia, a little of a very agreeably smelling aromatic oil, and a considerable quantity of organic bases. The liquid was neutralized with muriatic acid, and the aromatic oil separated by means of a moist filter. On supersaturating with caustic soda and redistilling it, a strongly ammoniacal liquid passed into the receiver. It contained a considerable quantity of oily bases, partly in solution and partly floating on the liquid. These bases closely resemble those obtained by destructively distilling the beans, but whether they will prove identical with them or not I am at present unable to say.

Oil-cake was also distilled with a strong soda lye. It also yielded ammonia and similar organic bases. I should therefore expect that the same results will be obtained with the corresponding nitrogenous portions of most other plants.

PART II.

Bases from Flesh by the Action of Caustic Lyes.

An ox-liver was cut into moderate sized pieces, and introduced into the body of a capacious still containing a quantity of tolerably strong caustic soda. The liver, speedily dissolved, formed a brownish and very liquid jelly, which frothed up exceedingly. A strongly ammoniacal liquid distilled over accompanied by an aromatic oil, very similar to that obtained from the beans. The ammoniacal liquid was neutralized with muriatic acid and concentrated. During this operation the aromatic

oil was converted into a brownish resin. The concentrated liquid was then supersaturated with carbonate of soda and redistilled. The ammoniacal solution which came over contained a considerable quantity of oily bases. I am at present unable to state what these bases are, but hope to do so in the course of a few weeks. One advantage in operating with caustic lyes is, that the bases are immediately obtained quite free from empyreumatic oils or resins.

2. *Formation of Bases by means of Sulphuric Acid.*—A quantity of beans was also digested with sulphuric acid, diluted with three or four times its bulk of water. The beans, as in the previous instance, were speedily disintegrated. Care was taken to prevent the action proceeding so far as to decompose the sulphuric acid and to generate sulphurous acid. The strongly acid liquid, after being filtered, was supersaturated with carbonate of soda and distilled. The ammoniacal liquid which passed into the receiver was, on examination, found also to contain organic bases. I think it may be inferred, therefore, that when other vegetable and animal substances are similarly treated they will also yield analogous results.

3. *Bases by Putrefaction.*—Putrefaction is the only other method I at present recollect by which ammonia is procurable, in quantity, from animal and vegetable substances. I have not at the moment an opportunity of ascertaining whether in these cases also the ammonia is accompanied with the formation of organic bases, though I feel strongly inclined to believe that it is. The peculiarly disagreeable odour of the ammoniacal liquors, derived from putrid substances, appears to indicate the presence of such bases. And I should not be at all surprised, if, from the very gentle nature of the process, putrefaction should prove to be the most advantageous method of preparing the volatile alkaloids on a large scale.

Guano.

Since the above was written, I distilled an aqueous solution of a quantity of Peruvian guano with an excess of quick-lime. The guano had a pale yellow colour, was very dry, and emitted a comparatively feeble odour. The strong ammoniacal liquid which distilled over was neutralized with muriatic acid, and concentrated to about a third of its bulk. It was then supersaturated with carbonate of soda and redistilled. The liquid which passed into the receiver contained a small, but very appreciable quantity of a basic oil, similar to that obtained from the preceding substances. Muriatic acid dissolved it very readily, forming a transparent solution, from which it was precipitated by alkalies. It was considerably more soluble in water than any of the bases previously described. Its amount was less than I expected, though guano cannot be regarded as a favourable example of the usual effects of putrefaction on a complex nitrogenous substance, as the chief portion of the nitrogen contained in it existed from the first in the state of ammoniacal salts. Guano, however, in addition to ammonia, also contains a quantity of volatile organic bases.

From the facts which have been now stated, I think it may be pretty safely

assumed, that "*whenever ammonia is generated in large quantity from complex, either animal or vegetable substances, it is always accompanied by the formation of a larger or smaller amount of volatile organic bases.*" If therefore researches similar to the present are actively prosecuted, and if the seeds and leaves of the various genera of plants especially are subjected to these or similar processes, it seems not unreasonable to expect that the number of the volatile organic alkaloids will ere long be considerably increased.

Another inference which we think may be fairly deduced from these experiments is, that the nitrogenous principles of plants, viz. vegetable albumen, caseine, fibrine, &c., though very analogous, are not identical with the corresponding principles of the animal kingdom, otherwise the products of their decomposition would have been the same. The same series of bases would therefore have been obtained from both beans and bones, and so also from the other animal and vegetable substances. This, as we have seen, however, is not the case; I should therefore be disposed to conclude that animal and vegetable fibrine, caseine, &c., though very analogous, are not identical substances, as has hitherto been supposed by some eminent chemists.

In conducting the destructive distillation of animal and vegetable substances, the chief point to be attended to is to operate at as low a temperature as possible, for I have not unfrequently found that when the heat had been inadvertently raised too high the organic bases were almost entirely destroyed, and ammonia was consequently almost the only alkaline product. I strongly suspect, therefore, that in many cases a considerable portion of the ammonia obtained from the distillation of animal and vegetable substances is really derived from the destruction of organic bases. This will appear still more probable when we consider that the organic bases are more complex in their structure than ammonia, and that if we pass even the most stable of them once or twice through a tube filled with red-hot charcoal, they are almost entirely resolved into that alkali. And even when organic bases are strongly heated in contact with potash or soda, or when their aqueous solutions are simply boiled for any length of time, they always undergo partial decomposition, ammonia being an invariable product.

I must again apologize for the imperfect state of this paper. It is however merely the first of a series, and will, I trust, be regarded as only preliminary to more mature investigations.

Glasgow, 11th June, 1849.

Addendum to the paper on the Nitrogenous principles of Vegetables as the sources of artificial Alkaloids.

Since the preceding paper was written several additional experiments have been made, some of the results of which I now beg leave to subjoin.

Bases by putrefaction.

A quantity of horse-flesh which had been cut into small pieces and the juice extracted by long-continued boiling, was moistened with water and was placed in a warm situation for nearly a month. It became very putrid and was full of maggots. It was then supersaturated with muriatic acid, and repeatedly agitated with water so long as anything was dissolved. The acid liquor was superfluous, concentrated to a moderate bulk, and filtered to remove the flocculent and albuminous matters collected in it. The clear liquid was next supersaturated with carbonate of soda and subjected to distillation. A highly alkaline liquor came over, consisting chiefly of carbonate of ammonia, but mixed with small quantities of organic bases. By repeated rectifications with caustic soda, a quantity of a light oily fluid consisting of one or more bases was separated. It had a pleasant aromatic odour, and was exceedingly soluble in water, from which however it separated, when sufficiently concentrated, as a transparent colourless oil, which was strongly alkaline, saturating acids and forming salts similar to those of the preceding bases. I was surprised however to find that it did not contain any aniline. The quantity of organic bases obtained by this experiment, though very appreciable in amount, was not nearly so great as I had anticipated; as, instead of yielding more than was obtained by destructive distillation, it gave a great deal less. Had however the superfluous putrefaction been carried far enough, and the whole of the flesh been decomposed, it is not improbable that as large or even a greater amount of bases would have been obtained as by destructive distillation; but a great deal of time would have been required to have effected the complete decomposition of the flesh by simple putrefaction. The present experiment however sufficiently proves that putrefaction forms no exception to the law I have ventured to lay down in a preceding part of this paper, viz. "that whenever ammonia is generated in quantity from a complex organic substance, it is always accompanied by the production of a larger or smaller amount of organic bases." It is also remarkable that the putrefaction of flesh in this instance yielded no aniline, which is a constant and considerable product when either flesh or bones are destructively distilled. The nature of the organic bases obtainable from the decomposition of nitrogenous substances appears to be dependent therefore on the processes to which they are subjected.

Bases from Lycopodium.

A quantity of lycopodium (pollen) was boiled with some strong soda-lye, and then evaporated to dryness. It was next destructively distilled in an iron retort, and the

products collected in the way already so frequently described. Besides much ammonia they contained a considerable quantity of a basic oil but slightly soluble in water, of a very peculiar and penetrating odour resembling that of the borage plant. It neutralized acids perfectly, and was evidently quite distinct from any of the bases previously met with. A quantity of lycopodium destructively distilled *per se* also yielded this base, but towards the close of the distillation it was mixed with other bases resembling those previously described. Lycopodium therefore affords us another proof that different tribes of vegetables, when destructively distilled, furnish a diversity of volatile organic bases.

Bases from the Common Fern (Pteris aquilina).

A quantity of the stems and leaves of the fern *Pteris aquilina* were also destructively distilled. They yielded a very alkaline liquid, containing much ammonia and a considerable quantity of oily bases similar in character to those obtained from beans, oil-cake, &c.; but I am at present unable to determine their nature individually.

III. *On the Mechanical Equivalent of Heat.* By JAMES PRESCOTT JOULE, F.C.S.,
 Sec. Lit. and Phil. Society, Manchester, Cor. Mem. R.A., Turin, &c. Commu-
 nicated by MICHAEL FARADAY, D.C.L., F.R.S., Foreign Associate of the Academy
 of Sciences, Paris, &c. &c. &c.

Received June 6,—Read June 21, 1849.

“Heat is a very brisk agitation of the insensible parts of the object, which produces in us that sensation from whence we denominate the object hot; so what in our sensation is *heat*, in the object is nothing but *motion*.”—LOCKE.

“The *force* of a moving body is proportional to the square of its velocity, or to the height to which it would rise against gravity.”—LEIBNITZ.

IN accordance with the pledge I gave the Royal Society some years ago, I have now the honour to present it with the results of the experiments I have made in order to determine the mechanical equivalent of heat with exactness. I will commence with a slight sketch of the progress of the mechanical doctrine, endeavouring to confine myself, for the sake of conciseness, to the notice of such researches as are immediately connected with the subject. I shall not therefore be able to review the valuable labours of Mr. FORBES and other illustrious men, whose researches on radiant heat and other subjects do not come exactly within the scope of the present memoir.

For a long time it had been a favourite hypothesis that heat consists of “a force or power belonging to bodies*,” but it was reserved for Count RUMFORD to make the first experiments decidedly in favour of that view. That justly celebrated natural philosopher demonstrated by his ingenious experiments that the very great quantity of heat excited by the boring of cannon could not be ascribed to a change taking place in the calorific capacity of the metal; and he therefore concluded that the motion of the borer was communicated to the particles of metal, thus producing the phenomena of heat:—“It appears to me,” he remarks, “extremely difficult, if not quite impossible, to form any distinct idea of anything, capable of being excited and communicated, in the manner the heat was excited and communicated in these experiments, except it be motion †.”

One of the most important parts of Count RUMFORD’s paper, though one to which

* Crawford on Animal Heat, p. 15.

† “An Inquiry concerning the Source of the Heat which is excited by Friction.” Phil. Trans. Abridged, vol. xviii. p. 286.

little attention has hitherto been paid, is that in which he makes an estimate of the quantity of mechanical force required to produce a certain amount of heat. Referring to his third experiment, he remarks that the "total quantity of ice-cold water which, with the heat actually generated by friction, and accumulated in 2^h 30^m, might have been heated 180°, or made to boil, = 26·58 lbs."* In the next page he states that "the machinery used in the experiment could easily be carried round by the force of one horse (though, to render the work lighter, two horses were actually employed in doing it)." Now the power of a horse is estimated by WATT at 33,000 foot-pounds per minute, and therefore if continued for two hours and a half will amount to 4,950,000 foot-pounds, which, according to Count RUMFORD's experiment, will be equivalent to 26·58 lbs. of water raised 180°. Hence the heat required to raise a lb. of water 1° will be equivalent to the force represented by 1034 foot-pounds. This result is not very widely different from that which I have deduced from my own experiments related in this paper, viz. 772 foot-pounds; and it must be observed that the excess of Count RUMFORD's equivalent is just such as might have been anticipated from the circumstance, which he himself mentions, that "no estimate was made of the heat accumulated in the wooden box, nor of that dispersed during the experiment."

About the end of the last century Sir HUMPHRY DAVY communicated a paper to Dr. BEDDOES' West Country Contributions, entitled, "Resarches on Heat, Light and Respiration," in which he gave ample confirmation to the views of Count RUMFORD. By rubbing two pieces of ice against one another in the vacuum of an air-pump, part of them was melted, although the temperature of the receiver was kept below the freezing-point. This experiment was the more decisively in favour of the doctrine of the immateriality of heat, inasmuch as the capacity of ice for heat is much less than that of water. It was therefore with good reason that DAVY drew the inference that "the immediate cause of the phenomena of heat is motion, and the laws of its communication are precisely the same as the laws of the communication of motion †."

The researches of DULONG on the specific heat of elastic fluids were rewarded by the discovery of the remarkable fact that "equal volumes of all the elastic fluids, taken at the same temperature, and under the same pressure, being compressed or dilated suddenly to the same fraction of their volume, disengage or absorb the same *absolute quantity of heat* ‡." This law is of the utmost importance in the development of the theory of heat, inasmuch as it proves that the calorific effect is, under certain conditions, proportional to the force expended.

In 1834 Dr. FARADAY demonstrated the "Identity of the Chemical and Electrical Forces." This law, along with others subsequently discovered by that great man, showing the relations which subsist between magnetism, electricity and light, have

* "An Inquiry concerning the Source of the Heat which is excited by Friction." Phil. Trans. Abridged, vol. xviii. p. 283.

† Elements of Chemical Philosophy, p. 94.

‡ Mémoires de l'Académie des Sciences, t. x. p. 188.

enabled him to advance the idea that the so-called imponderable bodies are merely the exponents of different forms of Force. Mr. GROVE and M. MAYER have also given their powerful advocacy to similar views.

My own experiments in reference to the subject were commenced in 1840, in which year I communicated to the Royal Society my discovery of the law of the heat evolved by voltaic electricity, a law from which the immediate deductions were drawn,—1st, that the heat evolved by any voltaic pair is proportional, *cæteris paribus*, to its intensity or electromotive force*; and 2nd, that the heat evolved by the combustion of a body is proportional to the intensity of its affinity for oxygen†. I thus succeeded in establishing relations between heat and chemical affinity. In 1843 I showed that the heat evolved by magneto-electricity is proportional to the force absorbed; and that the force of the electro-magnetic engine is derived from the force of chemical affinity in the battery, a force which otherwise would be evolved in the form of heat: from these facts I considered myself justified in announcing “that the quantity of heat capable of increasing the temperature of a lb. of water by one degree of FAHRENHEIT’S scale, is equal to, and may be converted into, a mechanical force capable of raising 838 lbs. to the perpendicular height of one foot‡.”

In a subsequent paper, read before the Royal Society in 1844, I endeavoured to show that the heat absorbed and evolved by the rarefaction and condensation of air is proportional to the force evolved and absorbed in those operations§. The quantitative relation between force and heat deduced from these experiments, is almost identical with that derived from the electro-magnetic experiments just referred to, and is confirmed by the experiments of M. SEGUIN on the dilatation of steam||.

From the explanation given by Count RUMFORD of the heat arising from the friction of solids, one might have anticipated, as a matter of course, that the evolution of heat would also be detected in the friction of liquid and gaseous bodies. Moreover there were many facts, such as, for instance, the warmth of the sea after a few days of stormy weather, which had long been commonly attributed to fluid friction. Nevertheless the scientific world, preoccupied with the hypothesis that heat is a substance, and following the deductions drawn by PICTET from experiments not sufficiently delicate, have almost unanimously denied the possibility of generating heat in that way. The first mention, so far as I am aware, of experiments in which the evolution of heat from fluid friction is asserted, was in 1842 by M. MAYER¶, who states that he has raised the temperature of water from 12° C. to 13° C., by agitating it, without however indicating the quantity of force employed, or the precautions taken to secure a correct result. In 1843 I announced the fact that “heat is evolved by the passage of water through narrow tubes**,” and that each degree of heat per lb. of water required for its evolution in this way a mechanical force represented by

* Phil. Mag. vol. xix. p. 275.

† Ibid. vol. xx. p. 111.

‡ Ibid. vol. xxiii. p. 441.

§ Ibid. vol. xxvi. pp. 375. 379.

|| Comptes Rendus, t. 25, p. 421.

¶ Annalen of WÖHLER and LIEBIG, May 1842.

** Phil. Mag. vol. xxiii. p. 442.

770 foot-pounds. Subsequently, in 1845* and 1847†, I employed a paddle-wheel to produce the fluid friction, and obtained the equivalents 781·5, 782·1 and 787·6, respectively, from the agitation of water, sperm-oil and mercury. Results so closely coinciding with one another, and with those previously derived from experiments with elastic fluids and the electro-magnetic machine, left no doubt on my mind as to the existence of an equivalent relation between force and heat; but still it appeared of the highest importance to obtain that relation with still greater accuracy. This I have attempted in the present paper.

Description of Apparatus.—The thermometers employed had their tubes calibrated and graduated according to the method first indicated by M. REGNAULT. Two of them, which I shall designate by A and B, were constructed by Mr. DANCER of Manchester; the third, designated by C, was made by M. FASTRÉ of Paris. The graduation of these instruments was so correct, that when compared together their indications coincided to about $\frac{1}{100}$ th of a degree FAHR. I also possessed another exact instrument made by Mr. DANCER, the scale of which embraced both the freezing and boiling-points. The latter point in this standard thermometer was obtained, in the usual manner, by immersing the bulb and stem in the steam arising from a considerable quantity of pure water in rapid ebullition. During the trial the barometer stood at 29·94 inches, and the temperature of the air was 50°; so that the observed point required very little correction to reduce it to 0·760 metre and 0° C., the pressure used in France, and I believe the Continent generally, for determining the boiling-point, and which has been employed by me on account of the number of accurate thermometrical researches which have been constructed on that basis‡. The values of the scales of thermometers A and B were ascertained by plunging them along with the standard in large volumes of water kept constantly at various temperatures. The value of the scale of thermometer C was determined by comparison with A. It was thus found that the number of divisions corresponding to 1° FAHR. in the thermometers A, B and C, were 12·951, 9·829 and 11·647, respectively. And since constant practice had enabled me to read off with the naked eye to $\frac{1}{20}$ th of a division, it followed that $\frac{1}{200}$ th of a degree FAHR. was an appreciable temperature.

Plate VII. fig. 1 represents a vertical, and fig. 2 a horizontal plan of the apparatus employed for producing the friction of water, consisting of a brass paddle-wheel furnished with eight sets of revolving arms, *a, a, &c.*, working between four sets of stationary vanes,

* Phil. Mag., vol. xxvii. p. 205. † Ibid. vol. xxxi. p. 173, and Comptes Rendus, tome xxv. p. 309.

‡ A barometrical pressure of 30 inches of mercury at 60° is very generally employed in this country, and fortunately agrees almost exactly with the continental standard. In the "Report of the Committee appointed by the Royal Society to consider the best method of adjusting the Fixed Points of Thermometers," Philosophical Transactions, Abridged, xiv. p. 258, the barometrical pressure 29·8 is recommended, but the temperature is not named,—a remarkable omission in a work so exact in other respects.

b, b, &c., affixed to a framework also in sheet brass. The brass axis of the paddle-wheel worked freely, but without shaking, on its bearings at *c, c*, and at *d* was divided into two parts by a piece of boxwood intervening, so as to prevent the conduction of heat in that direction.

Fig. 3 represents the copper vessel into which the revolving apparatus was firmly fitted: it had a copper lid, the flange of which, furnished with a very thin washer of leather saturated with white-lead, could be screwed perfectly water-tight to the flange of the copper vessel. In the lid there were two necks, *a, b*, the former for the axis to revolve in without touching, the latter for the insertion of the thermometer.

Besides the above I had a similar apparatus for experiments on the friction of mercury, which is represented by figs. 4, 5 and 6. It differed from the apparatus already described in its size; number of vanes, of which six were rotary and eight sets stationary; and material, which was wrought iron in the paddle-wheel, and cast iron in the vessel and lid.

Being anxious to extend my experiments to the friction of solids, I also procured the apparatus represented by fig. 7, in which *a a* is the axis revolving along with the beveled cast-iron wheel *b*; the rim of which was turned true. By means of the lever *c*, which had a ring in its centre for the axis to pass through, and two short arms *d*, the bevel turned cast-iron wheel *e* could be pressed against the revolving wheel; the degree of force applied being regulated by hand by means of the wooden lever *f* attached to the perpendicular iron rod *g*. Fig. 8 represents the apparatus in its cast-iron vessel.

Fig. 9 is a perspective view of the machinery employed to set the frictional apparatus just described in motion. *a a* are wooden pulleys, 1 foot in diameter and 2 inches thick, having wooden rollers *bb, bb*, 2 inches in diameter, and steel axles *cc, cc*, one quarter of an inch in diameter. The pulleys were turned perfectly true and equal to one another. Their axles were supported by brass friction wheels *dddd, dddd*, the steel axles of which worked in holes drilled into brass plates attached to a very strong wooden framework firmly fixed into the walls of the apartment*.

The leaden weights *e, e*, which in some of the ensuing experiments weighed about 29 lbs., and in others about 10 lbs. a piece, were suspended by string from the rollers *bb, bb*; and fine twine attached to the pulleys *a a*, connected them with the central roller *f*, which, by means of a pin, could with facility be attached to, or removed from, the axis of the frictional apparatus.

The wooden stool *g*, upon which the frictional apparatus stood, was perforated by a number of transverse slits, so cut out that only a very few points of wood came in contact with the metal, whilst the air had free access to almost every part of it. In this way the conduction of heat to the substance of the stool was avoided.

* This was a spacious cellar, which had the advantage of possessing an uniformity of temperature far superior to that of any other laboratory I could have used.

A large wooden screen (not represented in the figure) completely obviated the effects of radiant heat from the person of the experimenter.

The method of experimenting was simply as follows:—The temperature of the frictional apparatus having been ascertained and the weights wound up with the assistance of the stand *h*, the roller was refixed to the axis. The precise height of the weights above the ground having then been determined by means of the graduated slips of wood *k*, *k*, the roller was set at liberty and allowed to revolve until the weights reached the flagged floor of the laboratory, after accomplishing a fall of about 63 inches. The roller was then removed to the stand, the weights wound up again, and the friction renewed. After this had been repeated twenty times, the experiment was concluded with another observation of the temperature of the apparatus. The mean temperature of the laboratory was determined by observations made at the commencement, middle and termination of each experiment.

Previously to, or immediately after each of the experiments, I made trial of the effect of radiation and conduction of heat to or from the atmosphere, in depressing or raising the temperature of the frictional apparatus. In these trials, the position of the apparatus, the quantity of water contained by it, the time occupied, the method of observing the thermometers, the position of the experimenter, in short everything, with the exception of the apparatus being at rest, was the same as in the experiments in which the effect of friction was observed.

1st Series of Experiments.—Friction of Water. Weight of the leaden weights along with as much of the string in connexion with them as served to increase the pressure, 203066 grs. and 203086 grs. Velocity of the weights in descending, 2.42 inches per second. Time occupied by each experiment, 35 minutes. Thermometer employed for ascertaining the temperature of the water, A. Thermometer for registering the temperature of the air, B.

TABLE I.

| No. of experiment and cause of change of temperature. | Total fall of weights in inches. | Mean temperature of air. | Difference between mean of columns 5 and 6 and column 3. | Temperature of apparatus. | | Gain or loss of heat during experiment. |
|---|----------------------------------|--------------------------|--|-----------------------------|----------------------------|---|
| | | | | Commencement of experiment. | Termination of experiment. | |
| 1 Friction | 1256.96 | 57.698 | 2.252— | 55.118 | 55.774 | 0.656 gain |
| 1 Radiation ... | 0 | 57.868 | 2.040— | 55.774 | 55.882 | 0.108 gain |
| 2 Friction | 1255.16 | 58.085 | 1.875— | 55.882 | 56.539 | 0.657 gain |
| 2 Radiation ... | 0 | 58.370 | 1.789— | 56.539 | 56.624 | 0.085 gain |
| 3 Friction | 1253.66 | 60.788 | 1.596— | 58.870 | 59.515 | 0.645 gain |
| 3 Radiation ... | 0 | 60.926 | 1.373— | 59.515 | 59.592 | 0.077 gain |
| 4 Friction | 1252.74 | 61.001 | 1.110— | 59.592 | 60.191 | 0.599 gain |
| 4 Radiation ... | 0 | 60.890 | 0.684— | 60.191 | 60.222 | 0.031 gain |
| 1 | 2 | 3 | 4 | 5 | 6 | 7 |

TABLE I. (Continued.)

| No. of experiment and cause of change of temperature. | Total fall of weights in inches. | Mean temperature of air. | Difference be- tween mean of columns 5 and 6 and column 3. | Temperature of apparatus. | | Gain or loss of heat during experiment. |
|---|--|--------------------------------|---|--------------------------------|-------------------------------|---|
| | | | | Commencement of experiment. | Termination of experiment. | |
| 5 Friction | 1251.81 | 60.940 | 0.431 — | 60.222 | 60.797 | 0.575 gain |
| 5 Radiation ... | 0 | 61.035 | 0.237 — | 60.797 | 60.799 | 0.002 gain |
| 6 Radiation ... | 0 | 59.675 | 0.125 + | 59.805 | 59.795 | 0.010 loss |
| 6 Friction ... | 1254.71 | 59.919 | 0.157 + | 59.795 | 60.357 | 0.562 gain |
| 7 Radiation ... | 0 | 59.888 | 0.209 — | 59.677 | 59.681 | 0.004 gain |
| 7 Friction | 1254.02 | 60.076 | 0.111 — | 59.681 | 60.249 | 0.568 gain |
| 8 Radiation ... | 0 | 58.240 | 0.609 + | 58.871 | 58.828 | 0.043 loss |
| 8 Friction | 1251.22 | 58.237 | 0.842 + | 58.828 | 59.330 | 0.502 gain |
| 9 Friction | 1253.92 | 55.328 | 0.070 + | 55.118 | 55.678 | 0.560 gain |
| 9 Radiation ... | 0 | 55.528 | 0.148 + | 55.678 | 55.674 | 0.004 loss |
| 10 Radiation ... | 0 | 54.941 | 0.324 — | 54.614 | 54.620 | 0.006 gain |
| 10 Friction | 1257.96 | 54.985 | 0.085 — | 54.620 | 55.180 | 0.560 gain |
| 11 Radiation ... | 0 | 55.111 | 0.069 + | 55.180 | 55.180 | 0.000 |
| 11 Friction | 1258.59 | 55.229 | 0.227 + | 55.180 | 55.733 | 0.553 gain |
| 12 Friction | 1258.71 | 55.433 | 0.238 + | 55.388 | 55.954 | 0.566 gain |
| 12 Radiation ... | 0 | 55.687 | 0.265 + | 55.954 | 55.950 | 0.004 loss |
| 13 Friction | 1257.91 | 55.677 | 0.542 + | 55.950 | 56.488 | 0.538 gain |
| 13 Radiation ... | 0 | 55.674 | 0.800 + | 56.488 | 56.461 | 0.027 loss |
| 14 Radiation ... | 0 | 55.579 | 0.583 — | 54.987 | 55.006 | 0.019 gain |
| 14 Friction | 1259.69 | 55.864 | 0.568 — | 55.006 | 55.587 | 0.581 gain |
| 15 Radiation ... | 0 | 56.047 | 0.448 — | 55.587 | 55.612 | 0.025 gain |
| 15 Friction | 1259.89 | 56.182 | 0.279 — | 55.612 | 56.195 | 0.583 gain |
| 16 Friction | 1259.64 | 55.368 | 0.099 + | 55.195 | 55.739 | 0.544 gain |
| 16 Radiation ... | 0 | 55.483 | 0.250 + | 55.739 | 55.728 | 0.011 loss |
| 17 Friction | 1259.64 | 55.498 | 0.499 + | 55.728 | 56.266 | 0.538 gain |
| 17 Radiation ... | 0 | 55.541 | 0.709 + | 56.266 | 56.235 | 0.031 loss |
| 18 Radiation ... | 0 | 56.769 | 1.512 — | 55.230 | 55.284 | 0.054 gain |
| 18 Friction | 1260.17 | 56.966 | 1.372 — | 55.284 | 55.905 | 0.621 gain |
| 19 Radiation ... | 0 | 60.058 | 1.763 — | 58.257 | 58.334 | 0.077 gain |
| 19 Friction | 1262.24 | 60.112 | 1.450 — | 58.334 | 58.990 | 0.656 gain |
| 20 Radiation ... | 0 | 60.567 | 1.542 — | 58.990 | 59.060 | 0.070 gain |
| 20 Friction | 1261.94 | 60.611 | 1.239 — | 59.060 | 59.685 | 0.625 gain |
| 21 Friction | 1264.07 | 58.654 | 0.321 — | 58.050 | 58.616 | 0.566 gain |
| 21 Radiation ... | 0 | 58.627 | 0.018 — | 58.616 | 58.603 | 0.013 loss |
| 22 Friction | 1262.97 | 58.631 | 0.243 + | 58.603 | 59.145 | 0.542 gain |
| 22 Radiation ... | 0 | 58.624 | 0.505 + | 59.145 | 59.114 | 0.031 loss |
| 23 Friction | 1264.72 | 59.689 | 1.100 — | 58.284 | 58.894 | 0.610 gain |
| 23 Radiation ... | 0 | 59.943 | 1.027 — | 58.894 | 58.938 | 0.044 gain |
| 1 | 2 | 3 | 4 | 5 | 6 | 7 |

TABLE I. (Continued.)

| No. of experiment and cause of change of temperature. | Total fall of weights in inches. | Mean temperature of air. | Difference between mean of columns 5 and 6 and column 3. | Temperature of apparatus. | | Gain or loss of heat during experiment. | |
|---|----------------------------------|--------------------------|--|-----------------------------|----------------------------|---|------|
| | | | | Commencement of experiment. | Termination of experiment. | | |
| 24 Radiation ... | 0 | 60·157 | 1·160 — | 58·977 | 59·017 | 0·040 | gain |
| 24 Friction | 1263·94 | 59·811 | 0·505 — | 59·017 | 59·595 | 0·578 | gain |
| 25 Radiation ... | 0 | 59·654 | 0·061 — | 59·595 | 59·591 | 0·004 | loss |
| 25 Friction | 1263·49 | 59·675 | 0·185 + | 59·591 | 60·129 | 0·538 | gain |
| 26 Radiation ... | 0 | 59·156 | 0·609 — | 58·541 | 58·554 | 0·013 | gain |
| 26 Friction | 1263·49 | 59·333 | 0·488 — | 58·554 | 59·137 | 0·583 | gain |
| 27 Friction | 1263·99 | 59·536 | 0·198 — | 59·054 | 59·623 | 0·569 | gain |
| 27 Radiation ... | 0 | 59·726 | 0·101 — | 59·623 | 59·627 | 0·004 | gain |
| 28 Friction | 1263·99 | 59·750 | 0·155 + | 59·627 | 60·183 | 0·556 | gain |
| 28 Radiation ... | 0 | 59·475 | 0·102 + | 59·585 | 59·569 | 0·016 | loss |
| 29 Friction | 1263·31 | 58·695 | 0·182 — | 58·230 | 58·796 | 0·566 | gain |
| 29 Radiation ... | 0 | 58·906 | 0·108 — | 58·796 | 58·801 | 0·005 | gain |
| 30 Radiation ... | 0 | 59·770 | 1·286 — | 58·454 | 58·515 | 0·061 | gain |
| 30 Friction | 1263·99 | 60·048 | 1·223 — | 58·515 | 59·135 | 0·620 | gain |
| 31 Friction | 1263·49 | 59·343 | 0·022 + | 59·091 | 59·639 | 0·548 | gain |
| 31 Radiation ... | 0 | 59·435 | 0·198 + | 59·639 | 59·627 | 0·012 | loss |
| 32 Radiation ... | 0 | 59·374 | 0·357 — | 59·015 | 59·020 | 0·005 | gain |
| 32 Friction | 1263·49 | 59·407 | 0·105 — | 59·020 | 59·585 | 0·565 | gain |
| 33 Radiation ... | 0 | 59·069 | 0·201 — | 58·867 | 58·870 | 0·003 | gain |
| 33 Friction | 1263·49 | 59·234 | 0·081 — | 58·870 | 59·436 | 0·566 | gain |
| 34 Friction | 1262·99 | 56·328 | 0·331 + | 56·387 | 56·932 | 0·545 | gain |
| 34 Radiation ... | 0 | 56·643 | 0·287 + | 56·932 | 56·929 | 0·003 | loss |
| 35 Friction | 1262·99 | 56·790 | 0·413 + | 56·929 | 57·477 | 0·548 | gain |
| 35 Radiation ... | 0 | 56·772 | 0·687 + | 57·477 | 57·442 | 0·035 | loss |
| 36 Radiation ... | 0 | 55·839 | 0·304 — | 55·527 | 55·543 | 0·016 | gain |
| 36 Friction | 1262·99 | 56·114 | 0·281 — | 55·543 | 56·124 | 0·581 | gain |
| 37 Radiation ... | 0 | 56·257 | 0·127 — | 56·124 | 56·137 | 0·013 | gain |
| 37 Friction | 1262·99 | 56·399 | 0·024 + | 56·137 | 56·709 | 0·572 | gain |
| 38 Radiation ... | 0 | 55·826 | 0·065 — | 55·759 | 55·764 | 0·005 | gain |
| 38 Friction | 1262·99 | 55·951 | 0·093 + | 55·764 | 56·325 | 0·561 | gain |
| 39 Radiation ... | 0 | 56·101 | 0·220 + | 56·325 | 56·317 | 0·008 | loss |
| 39 Friction | 1262·99 | 56·182 | 0·409 + | 56·317 | 56·865 | 0·548 | gain |
| 40 Friction | 1262·99 | 56·108 | 0·100 + | 55·929 | 56·488 | 0·559 | gain |
| 40 Radiation ... | 0 | 56·454 | 0·036 + | 56·488 | 56·492 | 0·004 | gain |
| Mean Friction... | 1260·248 | | 0·305075— | | | 0·575250 | gain |
| Mean Radiation. | 0 | | 0·322950— | | | 0·012975 | gain |
| 1 | 2 | 3 | 4 | 5 | 6 | 7 | |

From the various experiments in the above Table in which the effect of radiation was observed, it may be readily gathered that the effect of the temperature of the surrounding air upon the apparatus was, for each degree of difference between the mean temperature of the air and that of the apparatus, $0^{\circ}\cdot04654$. Therefore, since the excess of the temperature of the atmosphere over that of the apparatus was $0^{\circ}\cdot32295$ in the mean of the radiation experiments, but only $0^{\circ}\cdot305075$ in the mean of the friction experiments, it follows that $0^{\circ}\cdot000832$ must be added to the difference between $0^{\circ}\cdot57525$ and $0^{\circ}\cdot012975$, and the result, $0^{\circ}\cdot563107$, will be the proximate heating effect of the friction. But to this quantity a small correction must be applied on account of the mean of the temperatures of the apparatus at the commencement and termination of each friction experiment having been taken for the true mean temperature, which was not strictly the case, owing to the somewhat less rapid increase of temperature towards the termination of the experiment when the water had become warmer. The mean temperature of the apparatus in the friction experiments ought therefore to be estimated $0^{\circ}\cdot002184$ higher, which will diminish the heating effect of the atmosphere by $0^{\circ}\cdot000102$. This, added to $0^{\circ}\cdot563107$, gives $0^{\circ}\cdot563209$ as the true mean increase of temperature due to the friction of water*.

In order to ascertain the absolute quantity of heat evolved, it was necessary to find the capacity for heat of the copper vessel and brass paddle-wheel. That of the former was easily deduced from the specific heat of copper according to M. REGNAULT. Thus, capacity of 25541 grs. † of copper $\times 0\cdot09515 =$ capacity of 2430·2 grs. of water. A series of seven very careful experiments with the brass paddle-wheel gave me 1783 grs. of water as its capacity, after making all the requisite corrections for the heat occasioned by the contact of the water with the surface of the metal, &c. But on account of the magnitude of these corrections, amounting to one-thirtieth of the whole capacity, I prefer to avail myself of M. REGNAULT'S law, viz. *that the capacity in metallic alloys is equal to the sum of the capacities of their constituent metals* ‡. Analysis of a part of the wheel proved it to consist of a very pure brass containing 3933 grs. of zinc. to 14968 grs. of copper. Hence

Cap. 14968 grs. copper $\times 0\cdot09515 =$ cap. 1424·2 grs. water.

Cap. 3933 grs. zinc $\times 0\cdot09555 =$ cap. 375·8 grs. water.

Total cap. brass wheel = cap. 1800 grs. water.

* This increase of temperature was, it is necessary to observe, a mixed quantity, depending partly upon the friction of the water, and partly upon the friction of the vertical axis of the apparatus upon its pivot and bearing, *c c*, fig. 1. The latter source of heat was however only equal to about $\frac{1}{80}$ th of the former. Similarly also, in the experiments on the friction of solids hereafter detailed, the cast-iron discs revolving in mercury, rendered it impossible to avoid a very small degree of friction among the particles of that fluid. But since it was found that the quantity of heat evolved was the same, for the same quantity of force expended, in both cases, *i. e.* whether a minute quantity of heat arising from friction of solids was mixed with the heat arising from the friction of a fluid, or whether, on the other hand, a minute quantity of heat arising from the friction of a fluid was mingled with the heat developed by the friction of solids, I thought there could be no impropriety in considering the heat as if developed from a simple source,—in the one case entirely from the friction of a fluid, and in the other entirely from the friction of a solid body.

† The washer, weighing only 38 grs., was reckoned as copper in this estimate. ‡ Ann. de Ch. 1841, t. i.

The capacity of a brass stopper which was placed in the neck *b*, fig. 3, for the purpose of preventing the contact of air with the water as much as possible, was equal to that of 10·3 grs. of water: the capacity of the thermometer had not to be estimated, because it was always brought to the expected temperature before immersion. The entire capacity of the apparatus was therefore as follows:—

| | |
|--------------------------|---------|
| Water | 93229·7 |
| Copper as water. | 2430·2 |
| Brass as water | 1810·3 |
| | 97470·2 |
| Total | 97470·2 |

So that the total quantity of heat evolved was $0^{\circ}\cdot563209$ in 97470·2 grs. of water, or, in other words, 1° FAHR. in 7·842299 lbs. of water.

The estimate of the force applied in generating this heat may be made as follows:—The weights amounted to 406152 grs., from which must be subtracted the friction arising from the pulleys and the rigidity of the string; which was found by connecting the two pulleys with twine passing round a roller of equal diameter to that employed in the experiments. Under these circumstances, the weight required to be added to one of the leaden weights in order to maintain them in equable motion was found to be 2955 grs. The same result, in the opposite direction, was obtained by adding 3055 grs. to the other leaden weight. Deducting 168 grs., the friction of the roller on its pivots, from 3005, the mean of the above numbers, we have 2837 grs. as the amount of friction in the experiments, which, subtracted from the leaden weights, leaves 403315 grs. as the actual pressure applied.

The velocity with which the leaden weights came to the ground, viz. 2·42 inches per second, is equivalent to an altitude of 0·0076 inch. This, multiplied by 20, the number of times the weights were wound up in each experiment, produces 0·152 inch, which, subtracted from 1260·248, leaves 1260·096 as the corrected mean height from which the weights fell.

This fall, accompanied by the above-mentioned pressure, represents a force equivalent to 6050·186 lbs. through one foot; and $0\cdot8464 \times 20 = 16\cdot928$ foot-lbs. added to it, for the force developed by the elasticity of the string after the weights had touched the ground, gives 6067·114 foot-pounds as the mean corrected force.

Hence $\frac{6067\cdot114}{7\cdot842299} = 773\cdot64$ foot-pounds, will be the force which, according to the above experiments on the friction of water, is equivalent to 1° FAHR. in a lb. of water.

2nd Series of Experiments.—Friction of Mercury. Weight of the leaden weights and string, 203026 grs. and 203073 grs. Velocity of the weights in descending, 2·43 inches per second. Time occupied by each experiment, 30 minutes. Thermometer for ascertaining the temperature of the mercury, C. Thermometer for registering the temperature of the air, B. Weight of cast iron apparatus, 68446 grs. Weight of mercury contained by it, 428292 grs.

TABLE II.

| No. of experiment and cause of change of temperature. | Total fall of weights in inches. | Mean temperature of air. | Difference between mean of columns 5 and 6 and column 3. | Temperature of apparatus. | | Gain or loss of heat during experiment. |
|---|----------------------------------|--------------------------|--|-----------------------------|----------------------------|---|
| | | | | Commencement of experiment. | Termination of experiment. | |
| 1 Friction | 1265.42 | 58.491 | 1.452 + | 58.780 | 61.107 | 2.327 gain |
| 1 Radiation ... | 0 | 58.939 | 2.056 + | 61.107 | 60.884 | 0.223 loss |
| 2 Radiation ... | 0 | 58.390 | 0.237 - | 58.119 | 58.188 | 0.069 gain |
| 2 Friction | 1265.77 | 58.949 | 0.467 + | 58.188 | 60.644 | 2.456 gain |
| 3 Friction | 1265.73 | 57.322 | 1.203 + | 57.325 | 59.725 | 2.400 gain |
| 3 Radiation ... | 0 | 57.942 | 1.678 + | 59.725 | 59.515 | 0.210 loss |
| 4 Radiation ... | 0 | 57.545 | 0.010 - | 57.518 | 57.553 | 0.035 gain |
| 4 Friction | 1264.72 | 58.135 | 0.624 + | 57.553 | 59.965 | 2.412 gain |
| 5 Friction | 1265.73 | 57.021 | 0.907 + | 56.715 | 59.141 | 2.426 gain |
| 5 Radiation ... | 0 | 57.596 | 1.474 + | 59.141 | 58.999 | 0.142 loss |
| 6 Radiation ... | 0 | 56.406 | 0.174 + | 56.565 | 56.595 | 0.030 gain |
| 6 Friction | 1265.65 | 57.057 | 0.749 + | 56.595 | 59.017 | 2.422 gain |
| 7 Friction | 1269.55 | 58.319 | 0.049 + | 57.115 | 59.622 | 2.507 gain |
| 7 Radiation ... | 0 | 58.771 | 0.831 + | 59.622 | 59.583 | 0.039 loss |
| 8 Radiation ... | 0 | 60.363 | 0.612 - | 59.691 | 59.811 | 0.120 gain |
| 8 Friction | 1257.70 | 60.842 | 0.209 + | 59.811 | 62.292 | 2.481 gain |
| 9 Friction | 1255.77 | 60.282 | 1.044 + | 60.129 | 62.524 | 2.395 gain |
| 9 Radiation ... | 0 | 60.862 | 1.576 + | 62.524 | 62.352 | 0.172 loss |
| 10 Friction | 1255.33 | 60.725 | 0.764 + | 60.266 | 62.713 | 2.447 gain |
| 10 Radiation ... | 0 | 61.340 | 1.313 + | 62.713 | 62.593 | 0.120 loss |
| 11 Radiation ... | 0 | 58.654 | 0.109 + | 58.755 | 58.772 | 0.017 gain |
| 11 Friction | 1266.47 | 59.234 | 0.746 + | 58.772 | 61.189 | 2.417 gain |
| 12 Radiation ... | 0 | 56.436 | 0.247 + | 56.673 | 56.694 | 0.021 gain |
| 12 Friction | 1265.80 | 57.240 | 0.673 + | 56.694 | 59.133 | 2.439 gain |
| 13 Friction | 1264.70 | 55.002 | 1.808 + | 55.638 | 57.982 | 2.344 gain |
| 13 Radiation ... | 0 | 55.633 | 2.213 + | 57.982 | 57.711 | 0.271 loss |
| 14 Friction | 1265.20 | 54.219 | 1.273 + | 54.290 | 56.694 | 2.404 gain |
| 14 Radiation ... | 0 | 54.595 | 1.972 + | 56.694 | 56.441 | 0.253 loss |
| 15 Radiation ... | 0 | 53.476 | 0.174 + | 53.633 | 53.667 | 0.034 gain |
| 15 Friction | 1265.63 | 53.995 | 0.872 + | 53.667 | 56.067 | 2.400 gain |
| 16 Radiation ... | 0 | 52.082 | 0.254 + | 52.332 | 52.341 | 0.009 gain |
| 16 Friction | 1265.45 | 52.479 | 1.047 + | 52.341 | 54.711 | 2.370 gain |
| 17 Friction | 1257.50 | 50.485 | 1.453 + | 50.772 | 53.105 | 2.333 gain |
| 17 Radiation ... | 0 | 50.821 | 2.164 + | 53.105 | 52.865 | 0.240 loss |
| 18 Radiation ... | 0 | 48.944 | 0.450 - | 48.434 | 48.554 | 0.120 gain |
| 18 Friction | 1257.50 | 49.330 | 0.462 + | 48.554 | 51.031 | 2.477 gain |
| 19 Friction | 1257.50 | 48.135 | 1.273 + | 48.219 | 50.598 | 2.379 gain |
| 19 Radiation ... | 0 | 48.725 | 1.780 + | 50.598 | 50.413 | 0.185 loss |
| 20 Radiation ... | 0 | 48.878 | 0.148 - | 48.687 | 48.773 | 0.086 gain |
| 20 Friction | 1257.50 | 49.397 | 0.597 + | 48.773 | 51.216 | 2.443 gain |
| Mean Friction | 1262.731 | | 0.8836 + | | | 2.41395 gain |
| Mean Radiation | 0 | | 0.8279 + | | | 0.06570 loss |
| 1 | 2 | 3 | 4 | 5 | 6 | 7 |

From the above Table, it appears that the effect of each degree of difference between the temperature of the laboratory and that of the apparatus was $0^{\circ}.13742$. Hence $2^{\circ}.41395 + 0^{\circ}.0657 + 0^{\circ}.007654 = 2^{\circ}.487304$, will be the proximate value of the increase of temperature in the experiments. The further correction on account of the mean temperature of the apparatus in the friction experiments having been in reality $0^{\circ}.028484$ higher than is indicated by the table, will be $0^{\circ}.003914$, which, added to the proximate result, gives $2^{\circ}.491218$ as the true thermometrical effect of the friction of the mercury.

In order to obtain the absolute quantity of heat evolved, it was requisite to ascertain the capacity for heat of the apparatus. I therefore caused it to be suspended by iron wire from a lever so contrived that the apparatus could be moved with rapidity and ease to any required position. The temperature of the apparatus having then been raised about 20° , it was placed in a warm air-bath, in order to keep its temperature uniform for a quarter of an hour, during which time the thermometer C, immersed in the mercury, was from time to time observed. The apparatus was then rapidly immersed into a thin copper vessel containing 141826 grs. of distilled water, the temperature of which was repeatedly observed by thermometer A. During the experiment the water was repeatedly agitated by a copper stirrer; and every precaution was taken to keep the surrounding atmosphere in a uniform state, and also to prevent the disturbing effects of radiation from the person of the experimenter. In this way I obtained the following results:—

| | Time of observation. | Temperature of water. | Temperature of apparatus. |
|-----------------------------|----------------------|-----------------------|---------------------------|
| Apparatus in air-bath . . . | { 0 | 47.705 | 70.518 |
| | { 5 | 47.705 | 70.492 |
| | { 10 | 47.713 | 70.518 |
| Instant of immersion . . . | 11 | | |
| Apparatus immersed in water | { 13½ | 49.836 | 57.673 |
| | { 16 | 50.493 | 52.641 |
| | { 21 | 50.694 | 50.941 |
| | { 26 | 50.690 | 50.778 |
| | { 31 | 50.667 | 50.744 |
| | { 36 | 50.636 | 50.709 |

By applying the correction to the temperature of the water due to its observed increase during the first ten minutes of the experiment, and the still smaller correction due to the rise of the water in the can covering 60 square inches of copper at the temperature of the atmosphere, $47^{\circ}.714$ was found to be the temperature of the water at the instant of immersion. To remove the apparatus from the warm air-bath, and to immerse it into the water, occupied only $10''$, during which it must (according to preliminary experiments) have cooled $0^{\circ}.027$. The heating effect of the air-bath

during the remaining 50'' (estimated from the rate of increase of temperature between the observations at 5' and 10') will be $0^{\circ}004$. These corrections, applied to $70^{\circ}518$, leave $70^{\circ}495$ as the temperature of the apparatus at the moment of immersion.

The temperature of the apparatus at 26' was $50^{\circ}778$, indicating a loss of $19^{\circ}717$. That of the water at the same time of observation, being corrected for the effect of the atmosphere (deduced from the observations of the cooling from 26' to 36' and of the heating from 0' to 10'), will be $50^{\circ}777$, indicating a gain of $3^{\circ}063$. Twenty such results, obtained in exactly the same manner, are collected in the following Table.

TABLE III.

| No. | Corrected temperature of water. | | Gain of heat by the water. | Corrected temperature of apparatus. | | Loss of heat by the apparatus. |
|---------|---------------------------------|----------------------------|----------------------------|-------------------------------------|----------------------------|--------------------------------|
| | Commencement of experiment. | Termination of experiment. | | Commencement of experiment. | Termination of experiment. | |
| 1 | 47.714 | 50.777 | 3.063 | 70.495 | 50.778 | 19.717 |
| 2 | 48.127 | 51.113 | 2.986 | 70.518 | 51.147 | 19.371 |
| 3 | 48.453 | 51.430 | 2.977 | 70.642 | 51.452 | 19.190 |
| 4 | 47.543 | 50.598 | 3.055 | 70.674 | 50.684 | 19.990 |
| 5 | 44.981 | 48.449 | 3.468 | 70.901 | 48.468 | 22.433 |
| 6 | 45.289 | 48.701 | 3.412 | 70.769 | 48.657 | 22.112 |
| 7 | 45.087 | 48.497 | 3.410 | 70.504 | 48.494 | 22.010 |
| 8 | 46.375 | 49.614 | 3.239 | 70.678 | 49.662 | 21.016 |
| 9 | 47.671 | 50.832 | 3.161 | 71.500 | 50.873 | 20.627 |
| 10 | 47.693 | 50.801 | 3.108 | 70.878 | 50.821 | 20.057 |
| 11 | 48.728 | 51.714 | 2.986 | 70.947 | 51.714 | 19.233 |
| 12 | 47.240 | 50.414 | 3.174 | 71.006 | 50.392 | 20.614 |
| 13 | 48.324 | 51.345 | 3.021 | 70.939 | 51.362 | 19.577 |
| 14 | 49.079 | 51.905 | 2.826 | 70.332 | 51.937 | 18.395 |
| 15 | 49.635 | 52.490 | 2.855 | 71.012 | 52.504 | 18.508 |
| 16 | 47.207 | 50.282 | 3.075 | 70.265 | 50.263 | 20.002 |
| 17 | 46.227 | 49.402 | 3.175 | 69.877 | 49.314 | 20.563 |
| 18 | 46.053 | 49.296 | 3.243 | 70.367 | 49.258 | 21.109 |
| 19 | 45.733 | 48.981 | 3.248 | 70.068 | 49.001 | 21.067 |
| 20 | 47.170 | 50.317 | 3.147 | 70.741 | 50.332 | 20.409 |
| Mean... | | | 3.13145 | | | 20.300 |

I did not consider these experiments on the capacity of the apparatus sufficiently complete, until I had ascertained the heat produced by the wetting of the surface of the iron vessel. For this purpose the following trials were made in a similar manner to the above, with the exception that the observations did not require to be extended beyond 26'.

TABLE IV.

| No. | Corrected temperature of water. | | Gain or loss of heat by water. | Corrected temperature of apparatus. | | Gain or loss of heat by apparatus. |
|---------|---------------------------------|----------------------------|--------------------------------|-------------------------------------|----------------------------|------------------------------------|
| | Commencement of experiment. | Termination of experiment. | | Commencement of experiment. | Termination of experiment. | |
| 1 | 50.558 | 50.556 | 0.002 loss | 50.565 | 50.589 | 0.024 gain |
| 2 | 49.228 | 49.232 | 0.004 gain | 49.239 | 49.254 | 0.015 gain |
| 3 | 48.095 | 48.106 | 0.011 gain | 48.034 | 48.099 | 0.065 gain |
| 4 | 47.416 | 47.425 | 0.009 gain | 47.384 | 47.429 | 0.045 gain |
| 5 | 47.484 | 47.532 | 0.048 gain | 48.103 | 47.782 | 0.321 loss |
| 6 | 47.429 | 47.439 | 0.010 gain | 47.703 | 47.610 | 0.093 loss |
| 7 | 47.624 | 47.637 | 0.013 gain | 47.870 | 47.790 | 0.080 loss |
| 8 | 47.705 | 47.712 | 0.007 gain | 47.915 | 47.859 | 0.056 loss |
| 9 | 47.685 | 47.702 | 0.017 gain | 47.891 | 47.837 | 0.054 loss |
| 10 | 48.733 | 48.793 | 0.060 gain | 49.498 | 49.112 | 0.386 loss |
| 11 | 49.689 | 49.694 | 0.005 gain | 49.946 | 49.842 | 0.104 loss |
| 12 | 48.191 | 48.168 | 0.023 loss | 47.972 | 48.134 | 0.162 gain |
| 13 | 48.101 | 48.119 | 0.018 gain | 48.310 | 48.254 | 0.056 loss |
| 14 | 49.413 | 49.390 | 0.023 loss | 49.249 | 49.413 | 0.164 gain |
| 15 | 49.243 | 49.241 | 0.002 loss | 49.343 | 49.318 | 0.025 loss |
| 16 | 49.103 | 49.103 | 0 | 49.172 | 49.172 | 0 |
| 17 | 46.991 | 46.902 | 0.089 loss | 46.204 | 46.923 | 0.719 gain |
| 18 | 46.801 | 46.814 | 0.013 gain | 47.139 | 46.953 | 0.186 loss |
| 19 | 46.624 | 46.624 | 0 | 46.652 | 46.652 | 0 |
| 20 | 46.266 | 46.158 | 0.108 loss | 45.369 | 46.167 | 0.798 gain |
| Mean... | | | 0.0016 loss | | | 0.03155 gain |

By adding these results to those of the former table, we have a gain of temperature in the water of $3^{\circ}13305$, and a loss in the apparatus of $20^{\circ}33155$. Now the capacity of the can of water was estimated as follows:—

| | | |
|----------------------------------|--------|------|
| Water | 141826 | grs. |
| 15622 grs. copper as water . . | 1486 | grs. |
| Thermometer and stirrer as water | 118 | grs. |
| Total | 143430 | grs. |

Hence $\frac{3.13305}{20.33155} \times 143430 = 22102.27$, the capacity of the apparatus as tried. The addition of 21.41 (the capacity of 643 grs. of mercury which had been removed in order to admit of the expansion of 70°) to, and the subtraction of 52 grs. (the capacity of the bulb of thermometer C, and of the iron wire employed in suspending the apparatus) from this result, leaves 22071.68 grs. of water as the capacity of the apparatus employed in the friction of mercury.

The temperature $2^{\circ}491218$ in the above capacity, equivalent to 1° in 7.85505 lbs. of water, was therefore the absolute mean quantity of heat evolved by the friction of mercury.

The leaden weights amounted to 406099 grs., from which 2857 grs., subtracted for the friction of the pulleys, leaves 403242 grs. The mean height from which they fell, as given in Table II., was 1262·731 inches, from which 0·152 inch, subtracted for the velocity of fall, leaves 1262·579 inches. This height, combined with the above weight, is equivalent to 6061·01 foot-lbs., which, increased by 16·929 foot-lbs. on account of the elasticity of the string, gives 6077·939 foot-lbs. as the mean force employed in the experiments.

$\frac{6077\cdot939}{7\cdot85505} = 773\cdot762$; which is therefore the equivalent derived from the above experiments on the friction of mercury. The next series of experiments were made with the same apparatus, using lighter weights.

3rd Series of Experiments.—Friction of Mercury. Weight of the leaden weights and string, 68442 grs. and 68884 grs. Velocity of the weights in descending, 1·4 inch per second. Time occupied by each experiment, 35 minutes. Thermometer for ascertaining the temperature of the mercury, C. Thermometer for registering the temperature of the air, B.

TABLE V.

| No. of experiment and cause of change of temperature. | Total fall of weights in inches. | Mean temperature of air. | Difference between mean of columns 5 and 6 and column 3. | Temperature of apparatus. | | Gain or loss of heat during experiment. |
|---|----------------------------------|--------------------------|--|-----------------------------|----------------------------|---|
| | | | | Commencement of experiment. | Termination of experiment. | |
| 1 Friction..... | 1292·12 | 49·539 | 0·399+ | 49·507 | 50·370 | 0·863 gain |
| 1 Radiation..... | 0 | 50·165 | 0·226+ | 50·370 | 50·413 | 0·043 gain |
| 2 Friction..... | 1292·00 | 49·865 | 0·189+ | 49·606 | 50·503 | 0·897 gain |
| 2 Radiation..... | 0 | 50·363 | 0·159+ | 50·503 | 50·542 | 0·039 gain |
| 3 Friction..... | 1293·18 | 50·139 | 0·460+ | 50·168 | 51·030 | 0·862 gain |
| 3 Radiation..... | 0 | 50·617 | 0·408+ | 51·030 | 51·021 | 0·009 loss |
| 4 Radiation..... | 0 | 50·750 | 0·146+ | 50·873 | 50·920 | 0·047 gain |
| 4 Friction..... | 1293·25 | 51·401 | 0·013— | 50·920 | 51·856 | 0·936 gain |
| 5 Radiation..... | 0 | 49·936 | 0·121+ | 50·031 | 50·083 | 0·052 gain |
| 5 Friction..... | 1294·92 | 50·551 | 0·020— | 50·083 | 50·980 | 0·897 gain |
| 6 Radiation..... | 0 | 50·638 | 0·135+ | 50·752 | 50·795 | 0·043 gain |
| 6 Friction..... | 1294·43 | 51·172 | 0·065+ | 50·795 | 51·680 | 0·885 gain |
| 7 Radiation..... | 0 | 51·553 | 0·260— | 51·237 | 51·349 | 0·112 gain |
| 7 Friction..... | 1294·07 | 52·194 | 0·371— | 51·349 | 52·298 | 0·949 gain |
| 8 Friction..... | 1293·30 | 52·774 | 0·019— | 52·298 | 53·212 | 0·914 gain |
| 8 Radiation..... | 0 | 53·029 | 0·204+ | 53·212 | 53·255 | 0·043 gain |
| 9 Friction..... | 1294·05 | 51·513 | 0·306+ | 51·379 | 52·259 | 0·880 gain |
| 9 Radiation..... | 0 | 52·093 | 0·177+ | 52·259 | 52·281 | 0·022 gain |
| 10 Friction..... | 1293·95 | 51·197 | 0·180+ | 50·907 | 51·847 | 0·940 gain |
| 10 Radiation..... | 0 | 51·960 | 0·079— | 51·847 | 51·916 | 0·069 gain |
| 11 Friction..... | 1292·80 | 50·577 | 0·652+ | 50·804 | 51·654 | 0·850 gain |
| 11 Radiation..... | 0 | 51·055 | 0·577+ | 51·654 | 51·611 | 0·043 loss |
| 1 | 2 | 3 | 4 | 5 | 6 | 7 |

TABLE V. (Continued.)

| No. of experiment and cause of change of temperature. | Total fall of weights in inches. | Mean temperature of air. | Difference be- tween mean of columns 5 and 6 and column 3. | Temperature of apparatus. | | Gain or loss of heat during experiment. |
|---|--|--------------------------------|---|--------------------------------|-------------------------------|---|
| | | | | Commencement of experiment. | Termination of experiment. | |
| 12 Radiation | 0 | 51.416 | 0.483 — | 50.860 | 51.006 | 0.146 gain |
| 12 Friction..... | 1293.25 | 52.057 | 0.551 — | 51.006 | 52.006 | 1.000 gain |
| 13 Radiation | 0 | 51.747 | 0.246 — | 51.456 | 51.547 | 0.091 gain |
| 13 Friction..... | 1293.25 | 52.403 | 0.389 — | 51.547 | 52.482 | 0.935 gain |
| 14 Friction..... | 1293.45 | 52.703 | 0.054 + | 52.294 | 53.221 | 0.927 gain |
| 14 Radiation | 0 | 53.201 | 0.050 + | 53.221 | 53.281 | 0.060 gain |
| 15 Friction..... | 1293.93 | 53.644 | 0.088 + | 53.281 | 54.183 | 0.902 gain |
| 15 Radiation | 0 | 54.061 | 0.145 + | 54.183 | 54.230 | 0.047 gain |
| 16 Radiation | 0 | 51.492 | 0.318 + | 51.821 | 51.800 | 0.021 loss |
| 16 Friction..... | 1292.83 | 52.011 | 0.242 + | 51.800 | 52.706 | 0.906 gain |
| 17 Radiation | 0 | 51.350 | 0.055 — | 51.272 | 51.319 | 0.047 gain |
| 17 Friction..... | 1292.83 | 52.057 | 0.264 — | 51.319 | 52.268 | 0.949 gain |
| 18 Friction..... | 1292.84 | 52.576 | 0.147 + | 52.268 | 53.178 | 0.910 gain |
| 18 Radiation | 0 | 52.906 | 0.276 + | 53.178 | 53.187 | 0.009 gain |
| 19 Radiation | 0 | 50.119 | 0.142 — | 49.928 | 50.027 | 0.099 gain |
| 19 Friction..... | 1292.33 | 50.760 | 0.272 — | 50.027 | 50.950 | 0.923 gain |
| 20 Friction..... | 1293.01 | 51.004 | 0.147 — | 50.370 | 51.345 | 0.975 gain |
| 20 Radiation | 0 | 51.798 | 0.385 — | 51.345 | 51.482 | 0.137 gain |
| 21 Radiation | 0 | 52.194 | 0.646 — | 51.482 | 51.615 | 0.133 gain |
| 21 Friction..... | 1292.83 | 52.383 | 0.298 — | 51.615 | 52.555 | 0.940 gain |
| 22 Friction..... | 1292.33 | 50.389 | 0.374 + | 50.332 | 51.195 | 0.863 gain |
| 22 Radiation | 0 | 50.958 | 0.239 + | 51.195 | 51.199 | 0.004 gain |
| 23 Radiation | 0 | 51.218 | 0.498 — | 50.636 | 50.804 | 0.168 gain |
| 23 Friction..... | 1294.69 | 51.848 | 0.546 — | 50.804 | 51.800 | 0.996 gain |
| 24 Friction..... | 1294.33 | 50.582 | 0.286 + | 50.435 | 51.302 | 0.867 gain |
| 24 Radiation | 0 | 51.223 | 0.092 + | 51.302 | 51.328 | 0.026 gain |
| 25 Radiation | 0 | 51.665 | 0.406 — | 51.190 | 51.328 | 0.138 gain |
| 25 Friction..... | 1294.33 | 52.281 | 0.464 — | 51.328 | 52.306 | 0.978 gain |
| 26 Friction..... | 1294.34 | 52.652 | 0.105 + | 52.306 | 53.208 | 0.902 gain |
| 26 Radiation | 0 | 52.957 | 0.259 + | 53.208 | 53.225 | 0.017 gain |
| 27 Friction..... | 1293.83 | 49.463 | 0.277 + | 49.293 | 50.188 | 0.895 gain |
| 27 Radiation | 0 | 50.068 | 0.142 + | 50.188 | 50.233 | 0.045 gain |
| 28 Radiation | 0 | 48.420 | 0.145 + | 48.537 | 48.593 | 0.056 gain |
| 28 Friction..... | 1294.33 | 49.132 | 0.093 — | 48.593 | 49.486 | 0.893 gain |
| 29 Friction..... | 1294.84 | 49.142 | 0.092 + | 48.773 | 49.696 | 0.923 gain |
| 29 Radiation | 0 | 49.783 | 0.053 — | 49.696 | 49.765 | 0.069 gain |
| 30 Radiation | 0 | 50.251 | 0.422 — | 49.765 | 49.894 | 0.129 gain |
| 30 Friction..... | 1294.33 | 50.597 | 0.246 — | 49.894 | 50.808 | 0.914 gain |
| Mean Friction ... | 1293.532 | | 0.00743 $\frac{1}{3}$ + | | | 0.9157 gain |
| Mean Radiation... | 0 | | 0.0048 + | | | 0.0606 gain |
| 1 | 2 | 3 | 4 | 5 | 6 | 7 |

The effect of each degree of difference between the temperature of the laboratory and that of the apparatus being $0^{\circ}\cdot18544$, $0^{\circ}\cdot9157 - 0^{\circ}\cdot0606 + 0^{\circ}\cdot000488 = 0^{\circ}\cdot855588$, will be the proximate mean increase of temperature in the above series of experiments. The correction, owing to the mean temperature of the mercury in the friction experiments being $0^{\circ}\cdot013222$ higher than appears in the table, will be $0^{\circ}\cdot002452$, which, being added to the proximate result, gives $0^{\circ}\cdot85804$ as the true thermometrical effect. This, in the capacity of 22071·68 grs. of water, is equal to 1° in 2·70548 lbs. of water.

The leaden weights amounted to 137326 grs., from which 1040 grs. must be subtracted for the friction of the pulleys, leaving 136286 grs. as the corrected weight. The mean height of fall was 1293·532 inches, from which 0·047 inch, subtracted on account of the velocity with which the weights came to the ground, leaves 1293·485 inches. This fall, combined with the above corrected weight, is equivalent to 2098·618 foot-lbs., which, with 1·654 foot-lb., the force developed by the elasticity of the string, gives 2100·272 foot lbs. as the mean force employed in the experiments.

$\frac{2100\cdot272}{2\cdot70548} = 776\cdot303$, will therefore be the equivalent from the above series of experiments, in which the amount of friction of the mercury was moderated by the use of lighter weights.

4th Series of Experiments.—Friction of Cast Iron. Weight of cast iron apparatus, 44000 grs. Weight of mercury contained by it, 204355 grs. Weight of the leaden weights and string attached, 203026 grs. and 203073 grs. Average velocity with which the weights fell, 3·12 inches per second. Time occupied by each experiment, 38 minutes. Thermometer for ascertaining the temperature of the mercury, C. Thermometer for registering the temperature of the air, A.

TABLE VI.

| No. of experiment and cause of change of temperature. | Total fall of weights in inches. | Mean temperature of air. | Difference between mean of columns 5 and 6 and column 3. | Temperature of apparatus. | | Gain or loss of heat during experiment. |
|---|----------------------------------|--------------------------|--|-----------------------------|----------------------------|---|
| | | | | Commencement of experiment. | Termination of experiment. | |
| 1 Friction..... | 1257.90 | 46.362 | 2.544 + | 46.837 | 50.976 | 4.139 gain |
| 1 Radiation | 0 | 46.648 | 3.950 + | 50.976 | 50.220 | 0.756 loss |
| 2 Radiation | 0 | 47.296 | 0.455 - | 46.730 | 46.953 | 0.223 gain |
| 2 Friction..... | 1258.97 | 47.891 | 1.247 + | 46.953 | 51.323 | 4.370 gain |
| 3 Friction..... | 1261.80 | 47.705 | 1.830 + | 47.352 | 51.718 | 4.366 gain |
| 3 Radiation | 0 | 48.547 | 2.950 + | 51.718 | 51.276 | 0.442 loss |
| 4 Radiation | 0 | 47.825 | 0.044 - | 47.756 | 47.807 | 0.051 gain |
| 4 Friction..... | 1260.35 | 48.385 | 1.598 + | 47.807 | 52.160 | 4.353 gain |
| 5 Radiation | 0 | 48.323 | 0.248 - | 48.009 | 48.142 | 0.133 gain |
| 5 Friction..... | 1260.15 | 48.833 | 1.494 + | 48.142 | 52.513 | 4.371 gain |
| 6 Friction..... | 1259.95 | 48.049 | 1.995 + | 47.902 | 52.186 | 4.284 gain |
| 6 Radiation | 0 | 48.632 | 3.283 + | 52.186 | 51.645 | 0.541 loss |
| 7 Radiation | 0 | 50.385 | 0.240 - | 50.053 | 50.237 | 0.184 gain |
| 7 Friction..... | 1263.13 | 51.018 | 1.408 + | 50.237 | 54.616 | 4.379 gain |
| 8 Friction..... | 1262.12 | 48.385 | 1.096 + | 47.249 | 51.714 | 4.465 gain |
| 8 Radiation | 0 | 49.199 | 2.343 + | 51.714 | 51.371 | 0.343 loss |
| 9 Friction..... | 1257.20 | 49.721 | 2.495 + | 50.160 | 54.273 | 4.113 gain |
| 9 Radiation | 0 | 50.338 | 3.643 + | 54.273 | 53.689 | 0.584 loss |
| 10 Radiation | 0 | 48.439 | 0.821 + | 49.271 | 49.250 | 0.021 loss |
| 10 Friction..... | 1258.70 | 49.690 | 2.282 + | 49.877 | 54.067 | 4.190 gain |
| Mean Friction ... | 1260.027 | | 1.7989+ | | | 4.303 gain |
| Mean Radiation... | 0 | | 1.6003+ | | | 0.2096 loss |
| 1 | 2 | 3 | 4 | 5 | 6 | 7 |

From the above Table, it appears that there was a thermometrical effect of $0^{\circ}20101$ for each degree of difference between the temperature of the laboratory and that of the apparatus. Hence $4^{\circ}303 + 0^{\circ}2096 + 0^{\circ}03992 = 4^{\circ}55252$, will be the proximate mean increase of temperature. The correction, owing to the mean temperature of the mercury in the friction experiments appearing $0^{\circ}07625$ too low in the table, will be $0^{\circ}01533$, which, added to the proximate result, gives $4^{\circ}56785$ as the true mean increase of temperature.

The capacity of the apparatus was obtained by experiments made in precisely the same manner that I have already described in the case of the mercurial apparatus for fluid friction. Their results are collected into the following Table.

TABLE VII.

| No. | Corrected temperature of water. | | Gain of heat by the water. | Corrected temperature of apparatus. | | Loss of heat by the apparatus. |
|---------|---------------------------------|----------------------------|----------------------------|-------------------------------------|----------------------------|--------------------------------|
| | Commencement of experiment. | Termination of experiment. | | Commencement of experiment. | Termination of experiment. | |
| 1 | 45°535 | 47°305 | 1°770 | 71°112 | 47°421 | 23°691 |
| 2 | 46°210 | 47°937 | 1°727 | 71°292 | 48°073 | 23°219 |
| 3 | 47°334 | 49°023 | 1°689 | 71°454 | 49°151 | 22°303 |
| 4 | 49°007 | 50°555 | 1°548 | 71°152 | 50°632 | 20°520 |
| 5 | 47°895 | 49°498 | 1°603 | 71°249 | 49°636 | 21°613 |
| 6 | 48°784 | 50°357 | 1°573 | 71°445 | 50°460 | 20°985 |
| 7 | 50°323 | 51°757 | 1°434 | 70°793 | 51°808 | 18°985 |
| 8 | 47°912 | 49°525 | 1°613 | 71°253 | 49°653 | 21°600 |
| 9 | 48°449 | 50°013 | 1°564 | 70°798 | 50°083 | 20°715 |
| 10 | 49°836 | 51°337 | 1°501 | 71°356 | 51°375 | 19°981 |
| 11 | 46°870 | 48°559 | 1°689 | 71°026 | 48°657 | 22°369 |
| 12 | 48°562 | 50°151 | 1°589 | 71°291 | 50°199 | 21°092 |
| Mean... | | | 1°60833 | | | 21°42275 |

By adding $0^{\circ}00071$ and $0^{\circ}0141$, the loss and gain of Table IV. reduced to the surface of the solid-friction apparatus, to the above mean results, we have a gain of $1^{\circ}60904$ by the water and a loss of $21^{\circ}43685$ by the apparatus. The capacity of the can of water was in this instance as follows:—

| | |
|----------------------------------|-------------|
| Water | 155824 grs. |
| Copper can as water | 1486 grs. |
| Thermometer and stirrer as ditto | 118 grs. |
| Total | 157428 grs. |

Hence $\frac{1.60904}{21.43685} \times 157428 = 11816.47$, will be the capacity of the apparatus as tried.

By applying the two corrections, one additive on account of the absence during the trials of 300 grs. of mercury, the other subtractive on account of the capacity of the thermometer C and suspending wire, we obtain 11796.07 grs. of water as the capacity of the apparatus during the experiments.

The temperature $4^{\circ}56785$ in the above capacity, equivalent to 1° in 7.69753 lbs. of water, was therefore the mean absolute quantity of heat evolved by the friction of cast iron.

The leaden weights amounted to 406099 grs., from which 2857 grs., subtracted on account of the friction of the pulleys, leaves 403242 grs. as the pressure applied to the apparatus.

Owing to the friction being in the simple ratio of the velocity, it required a good deal of practice to hold the regulating lever so as to cause the weights to descend to

the ground with anything like a uniform and moderate velocity. Hence, although the mean velocity was 3·12 inches per second, the force with which the weights struck the ground could not be correctly estimated by that velocity as in the case of fluid friction. However, it was found that the noise produced by the impact was on the average equal to that produced by letting the weights fall from the height of one-eighth of an inch. It generally happened also that in endeavouring to regulate the motion, the weights would stop suddenly before arriving at the ground. This would generally happen once, sometimes twice, during the descent of the weights, and I estimate the force thereby lost as equal to that lost by impact with the ground. Taking therefore the total loss at one-fourth of an inch in each fall, we have twenty times that quantity, or 5 inches, as the entire loss, which, subtracted from 1260·027, leave 1255·027 inches as the corrected height through which the weight of 403242 grs. operated. These numbers are equivalent to 6024·757 foot-lbs., and adding 16·464 foot-lbs. for the effect of the elasticity of the string, we have 6041·221 foot-lbs. as the force employed in the experiments.

The above force was not however entirely employed in generating heat in the apparatus. It will be readily conceived that the friction of a solid body like cast iron must have produced a considerable vibration of the framework upon which the apparatus was placed, as well as a loud sound. The value of the force absorbed by the former was estimated by experiment at 10·266 foot-lbs. The force required to vibrate the string of a violoncello, so as to produce a sound which could be heard at the same distance as that arising from the friction, was estimated by me, with the concurrence of another observer, at 50 foot-lbs. These numbers, subtracted from the previous result, leave 5980·955 foot-lbs. as the force actually converted into heat.

$\frac{5980\cdot955}{7\cdot69753} = 776\cdot997$, will therefore be the equivalent derived from the above experi-

ments on the friction of cast iron. The next series of experiments was made with the same apparatus, using lighter weights.

5th Series of Experiments.—Friction of Cast Iron. Weight of leaden weights, 68442 grs. and 68884 grs. Average velocity of fall, 1·9 inch per second. Time occupied by each experiment, 30 minutes. Thermometer for ascertaining the temperature of the mercury, C. Thermometer for registering the temperature of the laboratory, A.

TABLE VIII.

| No. of experiment and cause of change of temperature. | Total fall of weights in inches. | Mean temperature of air. | Difference be- tween mean of columns 5 and 6 and column 3. | Temperature of apparatus. | | Gain or loss of heat during experiment. |
|---|--|--------------------------------|---|--------------------------------|-------------------------------|---|
| | | | | Commencement of experiment. | Termination of experiment. | |
| 1 Friction..... 1 Radiation | 1281·07 0 | 47·404 48·003 | 0·852 + 0·998 + | 47·494 49·018 | 49·018 48·984 | 1·524 gain 0·034 loss |
| 2 Radiation | 0 | 48·269 | 0·702 + | 48·984 | 48·958 | 0·026 loss |
| 2 Friction..... | 1280·74 | 48·516 | 1·189 + | 48·958 | 50·452 | 1·494 gain |
| 3 Radiation | 0 | 49·003 | 0·133 - | 48·812 | 48·928 | 0·116 gain |
| 3 Friction..... | 1285·10 | 49·728 | 0·022 + | 48·928 | 50·572 | 1·644 gain |
| 4 Friction..... | 1283·89 | 50·138 | 1·172 + | 50·572 | 52·049 | 1·477 gain |
| 4 Radiation | 0 | 50·408 | 1·581 + | 52·049 | 51·929 | 0·120 loss |
| 5 Friction..... | 1282·45 | 46·798 | 0·558 + | 46·554 | 48·159 | 1·605 gain |
| 6 Friction..... | 1281·29 | 47·296 | 1·571 + | 48·159 | 49·576 | 1·417 gain |
| 5 Radiation | 0 | 47·535 | 1·929 + | 49·576 | 49·353 | 0·223 loss |
| 6 Radiation | 0 | 47·651 | 1·607 + | 49·353 | 49·164 | 0·189 loss |
| 7 Radiation | 0 | 46·261 | 0·298 - | 45·880 | 46·047 | 0·167 gain |
| 8 Radiation | 0 | 46·748 | 0·617 - | 46·047 | 46·215 | 0·168 gain |
| 7 Friction..... | 1276·07 | 46·810 | 0·978 + | 47·022 | 48·554 | 1·532 gain |
| 8 Friction..... | 1275·17 | 47·366 | 1·883 + | 48·554 | 49·945 | 1·391 gain |
| 9 Radiation | 0 | 46·771 | 0·271 - | 46·425 | 46·575 | 0·150 gain |
| 9 Friction..... | 1276·95 | 47·126 | 0·258 + | 46·575 | 48·194 | 1·619 gain |
| 10 Friction..... | 1276·84 | 47·238 | 1·655 + | 48·194 | 49·593 | 1·399 gain |
| 10 Radiation | 0 | 47·335 | 2·142 + | 49·593 | 49·361 | 0·232 loss |
| Mean Friction ... | 1279·957 | | 1·0138 + | | | 1·5102 gain |
| Mean Radiation... | 0 | | 0·764 + | | | 0·0223 loss |
| 1 | 2 | 3 | 4 | 5 | 6 | 7 |

From the above Table, it appears that the effect of each degree of difference between the temperature of the laboratory and that of the apparatus was $0^{\circ}\cdot1591$. Hence $1^{\circ}\cdot5102 + 0^{\circ}\cdot0223 + 0^{\circ}\cdot03974 = 1^{\circ}\cdot57224$, will be the proximate heating effect. To this the addition of $0^{\circ}\cdot00331$, on account of the mean temperature of the apparatus in the friction experiments having been in reality $0^{\circ}\cdot02084$ higher than appears in the Table, gives the real increase of temperature in the experiments at $1^{\circ}\cdot57555$, which, in the capacity of 11796·07 grs. of water, is equivalent to 1° in 2·65504 lbs. of water.

The leaden weights amounted to 137326 grs., from which 1040 grs., subtracted for the friction of the pulleys, leaves 136286 grs. The velocity of descent, which was in this case much more easily regulated than when the heavier weights were used, was 1·9 inch per second. Twenty impacts with this velocity indicate a loss of fall of 0·094 inch, which, subtracted from 1279·957, leaves 1279·863 inches as the corrected height from which the weights fell.

The above height and weight are equivalent to 2076·517 foot-lbs., to which the addition of 1·189 foot-lb. for the elasticity of the string, gives 2077·706 foot-lbs. as the

total force applied. The corrections for vibration and sound (deduced from the data obtained in the last series, on the hypothesis that they were proportional to the friction by which they were produced) will be 3·47 and 16·9 foot-lbs. These quantities, subtracted from the previous result, leave 2057·336 foot-lbs. as the quantity of force converted into heat in the apparatus.

$\frac{2057\cdot336}{2\cdot65504} = 774\cdot88$, will therefore be the equivalent as derived from this last series of experiments.

The following Table contains a summary of the equivalents derived from the experiments above detailed. In its fourth column I have supplied the results with the correction necessary to reduce them to a vacuum.

TABLE IX.

| No. of series. | Material employed. | Equivalent in air. | Equivalent in vacuo. | Mean. |
|----------------|--------------------|--------------------|----------------------|-----------|
| 1 | Water | 773·640 | 772·692 | 772·692 |
| 2 | Mercury | 773·762 | 772·814 | } 774·083 |
| 3 | Mercury | 776·303 | 775·352 | |
| 4 | Cast iron | 776·997 | 776·045 | } 774·987 |
| 5 | Cast iron | 774·880 | 773·930 | |

It is highly probable that the equivalent from cast iron was somewhat increased by the abrasion of particles of the metal during friction, which could not occur without the absorption of a certain quantity of force in overcoming the attraction of cohesion. But since the quantity abraded was not considerable enough to be weighed after the experiments were completed, the error from this source cannot be of much moment. I consider that 772·692, the equivalent derived from the friction of water, is the most correct, both on account of the number of experiments tried, and the great capacity of the apparatus for heat. And since, even in the friction of fluids, it was impossible entirely to avoid vibration and the production of a slight sound, it is probable that the above number is slightly in excess. I will therefore conclude by considering it as demonstrated by the experiments contained in this paper,—

1st. *That the quantity of heat produced by the friction of bodies, whether solid or liquid, is always proportional to the quantity of force expended. And,*

2nd. *That the quantity of heat capable of increasing the temperature of a pound of water (weighed in vacuo, and taken at between 55° and 60°) by 1° FAHR., requires for its evolution the expenditure of a mechanical force represented by the fall of 772 lbs. through the space of one foot.*

Oak Field, near Manchester,
June 4th, 1849.

IV. *On the Automatic Registration of Magnetometers, and Meteorological Instruments, by Photography.*—No. III. By CHARLES BROOKE, M.B., F.R.S.

Received June 21,—Read June 21, 1849.

On the Construction of the Self-registering Thermometer Apparatus.

IN my second paper on Automatic Registration*, the means of obtaining a photographic register of the variations of the thermometer were briefly mentioned, and in the annexed plate a specimen was given of the register thus obtained; but as an apparatus possessing the requisites for practical application had not then been constructed, it may not be undesirable to those who are interested in the advancement of meteorological science, to know the means by which this object has been accomplished. A vertical revolving cylinder, and the carrying time-piece described in the above paper (see Plate VI. figs. 4, 5, 6, 7, 8), are mounted on a stand measuring 30 inches by 12, supported by four legs; the stems of the thermometer and psychrometer pass up through the table, and between the lenses and the adjacent surfaces of the cylinder; and the long cylindrical bulbs are sufficiently below the stand to be freely influenced by the currents of air, and at the same time to remain wholly unaffected by the heat of the lamps which are placed on wooden supports at each end of the stand, at such a height that the flame may be opposite the middle of the photographic paper on the cylinder.

As it is impossible to superpose two registers of these instruments on the same paper, which may be done without inconvenience when the indication consists in a dark line, as in the photographs of the barometer and the magnetometers, the time-piece is so constructed that the hour-hand makes half a revolution in twenty-four hours. By this arrangement the two halves of the paper surrounding the cylinder give respectively a perfect diary of the two instruments. The glass cylinder is covered by a concentric cylindrical zinc case, having slits on opposite sides corresponding to the stems of the instruments, which are capable of being closed by sliding doors; by these means the cylinder, protected by its case, may be carried to or from the room in which the photographic manipulations are conducted, without any risk of exposure to light. The whole apparatus is also covered by a wind- and water-tight zinc case which rests on the stand, and is divided into separate compartments for the lamps by a partition towards each end, for the purpose of more completely isolating the thermometers from the heat produced by their combustion.

The cylindrical arrangement above described, so obviously desirable in enabling

* See Philosophical Transactions, 1847, Part I.

the two thermometric instruments to be registered by one apparatus and on one piece of paper, was at first open to a grave objection, which has however subsequently been entirely removed. The pencil of rays incident on the stem of the thermometer must necessarily be a fan-shaped pencil, by the oblique rays of which the points corresponding to each degree would not be transferred to the respectively opposite points of the paper. If the surface of the cylinder were always parallel to, and equidistant from, the stem of the thermometer, this distortion of the scale would be constant and uniform, and therefore readily estimated; but from the unavoidable imperfections in form and variations in size of the different cylinders employed, it would be extremely difficult to estimate correctly the distortion of the scale, and hence to infer the true temperature from the register. And this uncertainty would have been especially felt at very low temperatures, when the place of the mercury is impressed by the most oblique rays on the paper, and when small errors of relative temperature would largely affect the deduced hygrometric condition of the atmosphere. This difficulty has been obviated by enabling the apparatus to print continuously the scale of the thermometers, as well as to indicate the position of the mercury. This has been effected by placing fine wires, opposite to each degree, across the aperture in the scale frame, through which the light is transmitted to the stem of the instrument. By these wires a minute portion of the exposed paper is protected from light, and thus the darkened portion of the register is traversed by a series of parallel lines, corresponding with the scale of the thermometer. In order to remove any ambiguity in the reading of this scale, a coarser wire is placed at every ten degrees, and an additional coarse wire at the points 32° , 54° , 76° and 98° ; as one of these points may always be made to appear on the register, the relative position of the extra coarse wire will determine the point of the scale which it represents.

It may here be mentioned that the wet bulb, although more than 6 inches in length, is kept perfectly saturated by being moistened at three different points by small bundles of lamp-cotton placed round the muslin covering of the bulb, and immersed in a vessel of water placed nearly opposite its middle point.

It is very evident that the apparatus must afford some ready method of marking the time-scale on the paper, that is, of identifying any given epoch of time with the indications of the register: this is effected by closing at any two known times the sliding doors of the cylindrical case, for five minutes, and then re-opening them. Two undarkened lines will be observed on the paper, corresponding to the known times; the intervening space being subdivided by the elastic scale, the time-scale is rendered complete*.

It may also be remarked, that in all the other photographic registers obtained at the Royal Observatory by the instruments previously described, the only certain method of marking the time-scale is found to consist in breaking the continuity of the line at a known epoch: this is effected by a piece of brass similar to one side of a

* As a facsimile of a photographic diurnal register will be found in the Greenwich Magnetical and Meteorological Observations for 1837, it is unnecessary to introduce it in this place.

parallel ruler, placed edgewise, one of the connecting pieces being prolonged and passing down through the stand to act as a lever, by which the parallel moving piece is raised between the cylindrical lens and the cone of the cylinder, so as to intercept the pencil of light which traces the register line. The light is usually excluded for 5^m, admitted for 1^m, again excluded for 5^m, and then re-admitted, the times of exclusion, admission and re-admission being recorded. If, during the second passage of the tracing pencil of light over the paper, a break of six or eight minutes be made, without the intervening spot, it will be found a convenient method of distinguishing the two lines, in case of any ambiguity.

The scales of the thermometers in use have about 8° to 1 inch, from the registers of which the temperature may be readily read with certainty to less than a tenth of a degree. Of this scale, a space of about 60° may be illuminated at one time; and in order that the temperature indicated may always be within the field, the thermometers are capable of being raised or lowered by a screw, so as to bring the mean temperature of the season nearly opposite the middle of the paper: thus there is no probability that the record of any unusual and extreme changes of temperature will be lost.

In the description of the camphine lamp given in the first paper, previously referred to, the wick was stated to have been placed below the diaphragm in the chimney; it has since been found that there is another position in which equally perfect combustion takes place, which is when the wick is raised to about an equal distance above the diaphragm; with this position of the wick, the liability to smoke is very materially diminished.

Equally good effects have recently been produced by gas, saturated with the vapour of coal naphtha, which renders the light much whiter and more intense. Without this addition to the gas the photographic paper is feebly affected during periods of rapid movement of the magnet. The light used is that of a small fish-tail burner, so made as to spread the gas as much as possible; the flame is placed edgewise towards the mirror, in which position the illumination of the mirror is the brightest.

The employment of these instruments is not however limited to localities in which either camphine or gas is accessible; for the barometer and thermometers, in which large and rapid movements of the tracing pencil of light are never required to be depicted, an oil-lamp will answer sufficiently well: and by the same means the ordinary diurnal variations of the magnetometers may be delineated; but no opportunity has yet occurred of obtaining, by means of an oil-lamp, a register of the rapid movements occurring during a considerable disturbance.

On a New Method of determining the Scale and Temperature Coefficients of Magnets used in observing the Changes of Magnetic Force.

It appears from the ordinary formula expressing the equilibrium of the bifilar magnet, that small changes in the amount of horizontal force will have the same effect in displacing the magnet, as small corresponding changes in the suspended weight. Having then carefully weighed the magnet, the mirror and the suspending frame, two

small weights have been made, each equal to the $\frac{1}{1000}$ th part of the whole weight. While the register is in action, one of these weights is placed on the torsion circle, and at an interval of time equal to that of one oscillation of the magnet, the second is added: if this be carefully done, the magnet will be very nearly at rest in its new position. After half an hour, or any convenient interval of time, the weights are removed in the same manner; and this must be repeated sufficiently often to eliminate the error of reading by a finely divided scale the displacement of the register line. Half the scale reading of this displacement may therefore be taken as the value of 0.001 of the whole horizontal force. By this process the necessity of making several accurate linear measurements of the apparatus, and the errors that might arise therefrom, are avoided.

The following is the proposed method of determining the temperature coefficient. Let two magnets, one of them having a known coefficient, and that of the other to be now determined, be suspended in the bifilar method, at a distance of 15 feet from each other, the line joining their centres being a normal to the plane of the magnetic meridian. The torsion of the double threads should be in opposite directions, so that when the magnets are duly adjusted in equilibrium, in the line joining their centres, the similar poles may be towards each other.

The most convenient scale coefficient of the bifilar magnet, for the purpose of photographic registration, appears to be that which renders the angular value of the ordinary diurnal range nearly equal to the range of the declination magnet; the pulley over which the suspension thread of what may be called the standard magnet passes, being made of such a size as to give the required value to its scale coefficient, the distance between the threads of the other or trial magnet may be conveniently adjusted by a right- and left-handed screw (as in the suspension frame described in a former paper), so as to give a nearly equal value to its scale coefficient. The previously described arrangements for photographic registration being made, the registering apparatus is placed midway between the magnets, and by a few trials, the ratio of its distances from the magnets may be so arranged as to make their scale coefficients exactly equal. The magnets, having been previously protected by a coat of varnish, are suspended in water. The vessel made use of is a double zinc trough or box, the inner one being 18 inches long, 2 inches wide, and 4 inches deep, the outer one 3 inches longer and wider, leaving an equal space on all sides between the two, and half an inch deeper, with separate covers to each. For the standard magnet, the inner box only should be filled with water, the intervening space of air between the two tending to retard any variation of temperature of the water. For raising the temperature of the trial magnet, the outer box should be filled with warm water at such a temperature as will raise the water in the inner box to about 100° FAHR. For lowering it to 32° FAHR., the outer box, or rather the space between the two, should be filled with a freezing mixture. The whole being allowed to cool gradually in the one case, and in the other to be raised gradually to the temperature of the atmosphere, the change of temperature will be found to be so slow, that the

temperature of the magnet may be presumed identical with that of the water in which it is immersed. This is ascertained by a thermometer with a long cylindrical bulb reaching nearly from the top to the bottom of the vessel, by which means it is presumed that the average temperature of the water will be most nearly determined.

These arrangements having been made, a simultaneous register of the two magnets is obtained, during the progress of which, the temperature of the magnets must be observed at recorded times, and at any convenient intervals of from a quarter of an hour to two or three hours, the intervals of observation being least at the highest and lowest temperatures of the trial magnet, when the change is most rapid. Having marked upon the register the epochs of observation, the differences between the changes of position of the lines at these points may be measured by a scale, and these differences will very accurately represent the scale-value of the changes of force due to the corresponding changes of temperature of the trial magnet; for ordinarily the temperature of the standard magnet may be considered constant during each of the intervals of observation.

A sufficient number of these differential scale-readings having been obtained, they may for reduction be conveniently arranged in five groups, between the temperatures 32° , 45° , 60° , 75° , 90° , 100° . Denoting the differences of temperature by D , the mean temperatures of the periods of observation by M , and the scale-readings by R , the mean temperature of each group is found from the formula $\frac{\Sigma(M \times D)}{\Sigma(D)}$, and the corresponding mean value of R for an interval of 1° FAHR. from the formula $\frac{\Sigma(D \times R)}{\Sigma(D^2)}$, which may be represented by ΔK , K being the temperature coefficient. As it has been found convenient to reduce magnetic observations to the temperature of 32° FAHR., let the excess of the above mean temperatures above that point be represented by t , and let x and y be the coefficients of the first and second powers of t in the value of K ; then five equations will be obtained of the form

$$\Delta K = x + yt,$$

which being solved by the method of least squares, will give probably correct values of x and y . From the form of the preceding equation, it follows that

$$K = xt + \frac{1}{2}yt^2.$$

The above method has been applied to determine the temperature coefficients of two bar-magnets marked C.B. VIII. and C.B. IX*. But as the premises on which the observations were made present the usual obstacles of a dwelling-house to the free action of magnetic instruments, namely, the large mass of iron contained in the grates, only one position could be found in which the effects of the most contiguous masses of iron would nearly neutralize each other: and in consequence of this difficulty, the register of the trial-magnet here obtained has been compared with that obtained

* These magnets belong to a complete set of self-registering photographic apparatus intended to be presented to the Observatory at Cambridge by the Master of Trinity College.

simultaneously at the Royal Observatory; the result is therefore open to the objection of a *possible* difference in the changes of horizontal force at the two places. But it appears from a comparison of several photographic registers obtained simultaneously at Greenwich and in Keppel Street, some of which include periods of considerable disturbance, that a difference in the simultaneous changes of horizontal force in these two localities is very rarely perceptible.

The annexed Table contains the numerical observations from which the temperature coefficient of the bar C.B. VIII. has been determined. The scale-readings are taken

C.B. VIII.

| Times of observation. March, 1849. | | | Scale-readings of Royal Observatory registers. | Differ-ences. | Corre-sponding values on my scale. A × 1.115. | Differ-ences of myscale-readings. | Scale-readings of my registers. | Tempe-ratures. FAHR. | Differ-ences of tempera-ture. | Mean tempera-tures. | Reduced scale-readings. B + C. | D ² . | D × R. | D × M. |
|------------------------------------|----|----|--|---------------|---|-----------------------------------|---------------------------------|----------------------|-------------------------------|---------------------|--------------------------------|------------------|--------|--------|
| d | h | m | | A. | B. | C. | | | D. | M. | R. | | | |
| 0 | 22 | 5 | 627 | 3 | 3 | 80 | 55 | 100.5 | 5.3 | 97.9 | 83 | 2809 | 4399 | 51887 |
| | | 30 | 630 | 0 | 0 | 74 | 135 | 95.2 | 4.7 | 92.8 | 74 | 2209 | 3478 | 43616 |
| | 23 | 0 | 630 | -2 | -2 | 54 | 209 | 90.5 | 3.2 | 88.9 | 52 | 1024 | 1664 | 28448 |
| | | 30 | 628 | 2 | 2 | 42 | 263 | 87.3 | 3.1 | 85.8 | 44 | 961 | 1364 | 26598 |
| 1 | 0 | 0 | 630 | -4 | -5 | 49 | 305 | 84.2 | 3.0 | 82.7 | 44 | 900 | 1320 | 24810 |
| | | 30 | 626 | -16 | -18 | 51 | 354 | 81.2 | 2.4 | 80.0 | 33 | 576 | 792 | 19200 |
| | 1 | 0 | 610 | 0 | 0 | 89 | 405 | 78.8 | 5.4 | 76.1 | 89 | 2916 | 4806 | 41094 |
| | 2 | 4 | 610 | | | | 494 | 73.4 | | | | | | |
| | 22 | 0 | 635 | 4 | 5 | 78 | 30 | 92.8 | 4.4 | 90.6 | 83 | 1936 | 3652 | 39864 |
| | | 30 | 639 | 5 | 6 | 58 | 108 | 88.4 | 2.9 | 86.9 | 63 | 841 | 1827 | 25201 |
| | 23 | 0 | 644 | 24 | 28 | 14 | 166 | 85.5 | 2.2 | 84.4 | 42 | 484 | 924 | 18568 |
| | | 30 | 668 | -8 | -9 | 58 | 180 | 83.3 | 2.9 | 81.8 | 49 | 841 | 1421 | 23722 |
| 2 | 0 | 0 | 660 | -8 | -9 | 83 | 238 | 80.4 | 4.6 | 78.1 | 74 | 2116 | 3404 | 35926 |
| | 1 | 0 | 652 | 1 | 1 | 53 | 321 | 75.8 | 3.7 | 74.0 | 55 | 1369 | 2035 | 27380 |
| | 2 | 0 | 653 | -7 | -8 | 54 | 374 | 72.1 | 3.2 | 70.5 | 46 | 1024 | 1472 | 22560 |
| | 3 | 0 | 646 | 0 | 0 | 24 | 428 | 68.9 | 1.7 | 68.0 | 24 | 289 | 408 | 11560 |
| | 4 | 0 | 646 | -25 | -29 | 57 | 452 | 67.2 | 1.9 | 66.2 | 28 | 361 | 532 | 12578 |
| | 5 | 10 | 621 | -4 | -5 | 42 | 509 | 65.3 | 2.7 | 64.0 | 37 | 729 | 999 | 17280 |
| | 7 | 0 | 617 | -9 | -10 | 44 | 551 | 62.6 | 2.6 | 61.3 | 34 | 676 | 884 | 15938 |
| | 11 | 38 | 608 | 9 | 10 | 21 | 595 | 60.0 | 2.0 | 59.0 | 31 | 400 | 620 | 11800 |
| | 20 | 19 | 601 + 16 | | | | 616 | 58.0 | | | | | | |
| 8 | 21 | 8 | 563 | 9 | 10 | 74 | 18 | 103.0 | 4.5 | 100.8 | 84 | 2025 | 3780 | 45360 |
| | | 34 | 572 | 2 | 2 | 90 | 92 | 98.5 | 5.3 | 95.9 | 92 | 2809 | 4876 | 50827 |
| | 22 | 8 | 574 | 22 | 25 | 58 | 182 | 93.2 | 4.7 | 90.8 | 83 | 2209 | 3901 | 42676 |
| | | 48 | 596 | -12 | -14 | 95 | 240 | 88.5 | 4.6 | 86.2 | 81 | 2116 | 3726 | 39652 |
| | 23 | 38 | 584 | -28 | -32 | 63 | 335 | 83.9 | 2.1 | 82.8 | 31 | 441 | 651 | 17388 |
| 9 | 0 | 3 | 556 | 26 | 30 | 40 | 398 | 81.8 | 4.4 | 79.6 | 70 | 1936 | 3080 | 35024 |
| | 1 | 0 | 582 | -20 | -23 | 103 | 438 | 77.4 | 4.8 | 75.0 | 80 | 2304 | 3840 | 36000 |
| | 2 | 25 | 562 | -15 | -17 | 51 | 541 | 72.6 | 1.9 | 71.7 | 34 | 361 | 646 | 13623 |
| | 3 | 0 | 547 | 13 | 15 | 16 | 592 | 70.7 | 1.3 | 70.1 | 31 | 169 | 403 | 9113 |
| | | 30 | 560 | 9 | 10 | 19 | 608 | 69.4 | 1.2 | 68.8 | 29 | 144 | 348 | 8256 |
| | 4 | 0 | 569 | 4 | 4 | 30 | 627 | 68.2 | 1.5 | 67.5 | 34 | 225 | 510 | 10125 |
| | 5 | 7 | 573 | 0 | 0 | 38 | 657 | 66.7 | 1.7 | 65.9 | 38 | 289 | 646 | 11203 |
| | 6 | 0 | 573 | 3 | 3 | 24 | 695 | 65.0 | 1.3 | 64.4 | 27 | 169 | 351 | 8372 |
| | | 40 | 576 | -11 | -13 | 51 | 719 | 63.7 | 1.6 | 62.9 | 38 | 256 | 608 | 10064 |
| | 7 | 57 | 565 | 3 | 3 | 15 | 770 | 62.1 | 1.3 | 61.4 | 18 | 169 | 234 | 7982 |
| | 9 | 9 | 568 | -9 | -10 | 22 | 785 | 60.8 | 1.2 | 66.2 | 12 | 144 | 144 | 7224 |
| | 10 | 44 | 557 + 2 | 33 | 38 | 23 | 807 | 59.6 | 4.4 | 57.4 | 61 | 1936 | 2684 | 25256 |
| | 21 | 15 | 580 + 12 | | | | 830 | 55.2 | | | | | | |

C.B. VIII. (Continued.)

| Times of observation. March, 1849. | | | Scale-readings of Royal Observatory registers. | Differences. | Corresponding values on my scale. $A \times 1.115$. | Differences of my scale-readings. | Scale-readings of my registers. | Temperatures. FAHR. | Differences of temperature. | Mean temperatures. | Reduced scale-readings. $B+C$. | D^2 . | $D \times R$. | $D \times M$. |
|------------------------------------|----|----|--|--------------|--|-----------------------------------|---------------------------------|---------------------|-----------------------------|--------------------|---------------------------------|---------|----------------|----------------|
| d | h | m | | A. | B. | C. | | | D. | M. | R. | | | |
| 10 | 1 | 42 | 600 | | | | 195 | 33.5 | | | | | | |
| | 2 | 0 | 597 | 3 | 3 | 5 | 190 | 34.1 | 0.6 | 33.8 | 8 | 36 | 48 | 2028 |
| | 2 | 30 | 589 | 8 | 9 | 6 | 184 | 35.2 | 1.1 | 34.6 | 15 | 121 | 165 | 3806 |
| | 3 | 0 | 572 | 17 | 20 | -1 | 185 | 36.8 | 1.6 | 36.0 | 19 | 256 | 304 | 5760 |
| | | 30 | 569 | 3 | 3 | 18 | 167 | 38.7 | 1.9 | 37.7 | 21 | 361 | 399 | 7163 |
| | 4 | 0 | 569 | 0 | 0 | 20 | 147 | 40.4 | 1.7 | 39.5 | 20 | 289 | 340 | 6715 |
| | | 43 | 565 | 4 | 5 | 13 | 134 | 41.7 | 1.3 | 41.1 | 18 | 169 | 234 | 5343 |
| | 5 | 38 | 567 | -2 | -2 | 22 | 112 | 42.8 | 1.1 | 42.3 | 20 | 121 | 220 | 4653 |
| | 6 | 0 | 565 | 2 | 2 | 9 | 103 | 43.4 | 0.6 | 43.1 | 11 | 36 | 66 | 2586 |
| | 7 | 13 | 557 | 8 | 9 | 13 | 90 | 44.8 | 1.4 | 44.1 | 22 | 196 | 308 | 6174 |
| | 8 | 13 | 562 | -5 | -6 | 27 | 63 | 46.1 | 1.3 | 45.5 | 21 | 169 | 273 | 5915 |
| | 9 | 9 | 571 | -9 | -10 | 28 | 35 | 47.0 | 0.9 | 46.6 | 18 | 81 | 162 | 4194 |
| | | 43 | 565 | 6 | 7 | 1 | 34 | 47.5 | 0.5 | 47.3 | 8 | 25 | 40 | 2365 |
| | 11 | 28 | 565 | 0 | 0 | 19 | 15 | 48.7 | 1.2 | 48.2 | 19 | 144 | 228 | 5784 |
| 11 | 6 | 40 | 550 | -1 | -1 | 36 | 92 | 69.8 | 2.3 | 68.6 | 35 | 529 | 805 | 15678 |
| | 7 | 30 | 549 | 2 | 2 | 19 | 128 | 67.5 | 1.7 | 66.7 | 21 | 289 | 357 | 11339 |
| | 8 | 8 | 551 | -4 | -5 | 31 | 147 | 65.8 | 2.0 | 64.8 | 26 | 400 | 520 | 12960 |
| | 9 | 7 | 547 | 0 | 0 | 29 | 178 | 63.8 | 2.1 | 62.7 | 29 | 441 | 601 | 13167 |
| | 10 | 21 | 547 | 0 | 0 | 12 | 207 | 61.7 | 0.9 | 61.2 | 12 | 81 | 108 | 5508 |
| | | 59 | 547 | | | | 219 | 60.8 | | | | | | |
| 11 | 23 | 45 | 614 | 2 | 2 | 9 | 654 | 33.2 | 0.7 | 33.6 | 11 | 49 | 77 | 2352 |
| | | 58 | 612 | 4 | 5 | 14 | 645 | 33.9 | 1.5 | 34.6 | 19 | 225 | 285 | 5190 |
| 12 | 0 | 20 | 608 | 2 | 2 | 17 | 631 | 35.4 | 1.4 | 36.1 | 19 | 196 | 266 | 5084 |
| | | 45 | 606 | 10 | 11 | 3 | 614 | 36.8 | 1.0 | 37.3 | 14 | 100 | 140 | 3730 |
| | 1 | 0 | 596 | 17 | 20 | 17 | 611 | 37.8 | 2.9 | 39.2 | 37 | 841 | 1073 | 11368 |
| | | 48 | 579 | 10 | 11 | 8 | 594 | 40.7 | 1.3 | 41.4 | 19 | 169 | 247 | 5382 |
| | 2 | 18 | 569 | -10 | -11 | 33 | 586 | 42.0 | 1.5 | 42.8 | 22 | 225 | 330 | 6420 |
| | 3 | 0 | 579 | 13 | 15 | 13 | 553 | 43.5 | 1.9 | 44.4 | 28 | 361 | 532 | 8436 |
| | 4 | 0 | 566 | | | | 540 | 45.4 | | | | | | |

on a scale having 100 divisions in an inch. The differences of the scale-readings of the Royal Observatory registers are reduced to the scale of the observed magnet by multiplying them by the ratio of the scale coefficients: this ratio is expressed by 1.115*. The reduced scale-readings, R, are the sums of the readings B and C, because the variation is represented in opposite directions on the two registers.

These quantities being arranged in five groups according to the temperatures M, and the mean values obtained by the above formulæ, the five following equations result:—

$$\begin{array}{l}
 x + 7.2y = 13.42 \\
 x + 21.7y = 14.54 \\
 x + 34.6y = 15.55 \\
 x + 49.5y = 16.50 \\
 x + 62.8y = 17.20
 \end{array}
 \quad
 \text{residual errors}
 \left\{
 \begin{array}{l}
 -0.10 \\
 +0.02 \\
 +0.15 \\
 +0.08 \\
 -0.12
 \end{array}
 \right.$$

* In the very few instances in which it appeared necessary, a correction has been applied to the Greenwich scale-readings for observed changes of temperature.

These equations, solved by the method of least squares, give

$$x = 13.0269; \quad y = 0.0685.$$

By the method of weights described above, the scale value of 0.001 of the total horizontal force was found to be 25.27 sc. div., consequently the values of x and y expressed in parts of force are

$$x = 0.00051550; \quad y = 0.000002710.$$

As the effect of a small increase of weight in displacing the magnet is the same as that of a small corresponding diminution of force, when the correction is subsequently applied to the magnet suspended in air, the value of x above found must be diminished by a small quantity representing the effect of the increase of weight due to the weight of the water displaced by the magnet being diminished by expansion, as the temperature increases; this may be called the coefficient of expansion, and may be thus found.

Let w, s, b be the cubical expansions of water, steel and brass respectively, for 1° FAHR., then

$$w = 0.0001500 \text{ (URE)}$$

$$s = 0.0000204 \text{ (SMEATON)}$$

$$b = 0.0000291;$$

and if U be the weight lost by the magnet at 32° FAHR., and U' the weight lost at any observed temperature, $32^\circ + t^\circ$, the value of U will be

$$U \{1 + (w - s)t\} = U' (1 + 0.0001296 t);$$

and if V and V' similarly represent the weights lost by the stirrup and end of the frame immersed,

$$V = V' \{1 + (w - b)t\} = V' (1 + 0.0001209 t).$$

Let W be the weight in air of the magnet and its appendages, then the coefficient of expansion for t° above 32° expressed in parts of the force will be

$$\frac{U \times 0.0001296 + V \times 0.0001209}{W} t.$$

In the present instance the value of this coefficient is

$$0.00001022 t, \text{ or } 0.00001 t \text{ nearly,}$$

and the value of x being diminished by this quantity, the whole temperature coefficient will be

$$0.00050528 t + 0.000001355 t^2.$$

The temperature coefficient of the bar (C.B. IX.) similarly determined is

$$0.0003822 t + 0.000000947 t^2.$$

In both these instances, it will be seen that the temperature coefficient varies considerably from the uniform law usually employed in the reduction of magnetic ob-

servations* ; and as it is impossible to foresee what points of scientific interest in the investigation of magnetic changes may depend on the determination of small quantities, and on the relation of magnetic variation in warm and cold climates, it may be considered not undesirable to ascertain, with the greatest attainable degree of accuracy, the temperature coefficients of all magnets to be employed in observing the changes of force. In the method here proposed, the magnet is under circumstances precisely similar to those which would exist when it is subsequently used in observation ; it may therefore be considered less open to objection than the ordinary method of deflection, by which the temperature coefficient is inferred from the mutual action of two magnets and the earth on each other. Amongst other sources of uncertainty in the latter method, may be mentioned the unexplained difference in the result that has frequently been observed, according as the marked or unmarked pole of the deflecting, has been turned towards the deflected magnet ; arising probably from the unequal, and possibly variable, distribution of magnetism throughout the bar ; which conditions, if they really exist, will have precisely the same effect on the indications of the magnet when under trial, as they would have when it is in actual use.

By introducing the differences only of the scale-readings into the calculation, large numerical quantities are avoided, as well as the necessity of adopting a zero point, or scale-reading corresponding to no deflecting force.

* The fact of the decrease of magnetic intensity not being in the simple ratio of the increase of temperature, but in some higher ratio, was it is believed first announced by Professor CHRISTIE, Sec. R.S., in the Philosophical Transactions, 1825, p. 63.

Keppel Street, 1849, June 21.

V. *Researches regarding the Molecular Constitution of the Volatile Organic Bases.*

By Dr. A. W. HOFMANN, F.C.S., Professor of the Royal College of Chemistry of London. Communicated by Sir JAMES CLARK, Bart., F.R.S.

Received December 26, 1849,—Read January 17, 1850.

THE limited number of elementary substances which are concerned in the elaboration of the endless variety of organic compounds, long ago directed the course of chemical inquiry into the channel of speculations as to the mode in which the various constituents are grouped in bodies of this nature. The necessity of these speculations became more and more imperative as the boundary of the science extended; they were indeed forced upon us by the discovery of substances isomeric with each other which deprived us of the resort to mere quantity for the explanation of their contrasting qualities. Wild and incongruous though some of the views, proposed from time to time, may have been, it must be admitted that their influence upon the progress of chemistry has been most beneficial; especially in the organic department of this science, it is to the theory of the compound radicals, the result of these speculations, that we are indebted for the light which now begins to dawn upon the chaos of collected facts, even if we should never succeed in isolating these radicals.

Among the various classes of organic substances, there is perhaps none of which, from an early period, chemists have so constantly endeavoured to attain a general conception as the group of compounds which have received the name of organic bases, all—and they are now very numerous—being capable of combining, like the metallic oxides, with acids, and being derived either from vital processes in animals or plants, or from a variety of artificial reactions conducted in the laboratory.

The remarkable analogy between all these substances and ammonia, which in its turn imitates as it were in its chemical department the mineral oxides, naturally attracted the notice of chemists soon after SERTÜRNER'S discovery of the first of these alkaloids in the beginning of this century. Nor have they ever since been classified separately from ammonia; philosophers have only differed as to the mode of their relation with the typical compound.

Of the theories which have been enunciated respecting the constitution of the organic bases, there are two of chief importance, which may be designated as the ammonia- and the amidogen-theory, the former having been first proposed by BERZELIUS*, while the latter we owe to LIEBIG†. According to the former of the two

* *Traité de Chimie*, vi. p. ii.

† *Handwörterbuch der Chemie* von LIEBIG, WÖHLER und POGGENDORFF, Bd. i. p. 699. Artikel Organische Basen.

chemists, the ammonia would pre-exist in the organic bases; these bodies would be conjugated compounds of ammonia with various adjuncts, containing either carbon and hydrogen, or these elements together with nitrogen, oxygen and even sulphur, compounds in which the original character of the ammonia has only been slightly modified by the accession of the adjunct. This view is chiefly supported by the mode and the proportions in which these alkaloids combine with acids, and by the fact, that various organic substances, by directly uniting with ammonia, give rise to the formation of basic compounds which are perfectly analogous to the alkaloids occurring in the economy of nature. According to LIEBIG's opinion, ammonia would no longer exist in the organic bases. At the time when LIEBIG* wrote upon this subject, the attention of chemists was much engaged with the study of a class of compounds, known under the name of amides, the prototype of which, oxamide, was discovered by DUMAS. These substances, all strictly neutral, originate from ammonia by the loss of one equivalent of hydrogen, which is abstracted by the oxygen or chlorine of certain electro-negative bodies (as in the formation of oxamide and benzamide), a hypothetical substance, amidogen, H_2N , remaining in combination with the oxide or chloride, deprived of 1 equiv. of oxygen or chlorine. LIEBIG thought that the formation of the organic bases might take place in a similar manner, namely, by a reduction of ammonia to the state of amidogen, by the action of electro-positive organic oxides.

Each of these theories being expressed in a simple formula, the organic bases, according to BERZELIUS, would be represented by the terms



while LIEBIG's view would characterize them as



X denoting generally an organic compound containing carbon, hydrogen, and possibly nitrogen, oxygen and sulphur, while Y expresses an organic oxide, chloride, &c., *minus* 1 equiv. of oxygen, chlorine, &c.

Objections have been raised against either theory, and the opinions of chemists have remained divided. LIEBIG has not returned any more to the subject, but BERZELIUS took frequent occasion, both in his 'Annual Report' and in the several editions of his 'Traité,' to defend his notion by the skilful interpretation of every new fact which was elaborated by the progress of the science. The weight of his authority has not been without influence, for it cannot be denied that BERZELIUS's view has become more and more generally accepted, especially since a series of comparative researches, conducted of late upon the derivatives of the salts of ammonia and of organic bases, appeared to give fresh support to this theory. These experiments pointed out that the elimination of hydrogen from organic bases and ammonia is by no means confined to one equivalent; oxalate of ammonia, which by the loss of 2 equivs. of water is converted into oxamide, when deprived of the whole of its hydrogen in

* *Loc. cit.* p. 235.

the form of water, becomes cyanogen (oxalonitrile); an analogous change occurs with the acid salts of ammonia, resulting in the formation of two classes of compounds, differing, the one by two, the other by four equivalents of water, from the original salt.

The representation of several of these groups in analogous derivatives from the salts of organic bases, especially from the salts of aniline, could not but strengthen the belief that ammonia actually pre-exists in the organic alkaloids. Incidentally to some researches communicated to the Chemical Society of London*, I gave a synopsis of all the facts supporting the view of BERZELIUS.

The prosecution however of this inquiry has elicited many points, which are scarcely reconcilable with this theory. In another paper† I endeavoured to show that the force of the argument in favour of this view, derived from the considerations just stated, is greatly neutralized on the completion of the comparison between the two series by the failure of the analogy, just at the point where its occurrence would have been most decisive. Now this very failure is not only in perfect harmony with, but would be required by, the theory of amidogen-bases.

Yet stronger grounds for the acceptance of the latter view have been afforded by a splendid investigation of M. WURTZ‡ on the compounds of ethers with cyanic acid, which have actually realized a series of substances, anticipated in a most remarkable manner by LIEBIG on the theoretical ground of his conception of the nature of these compounds. Instances of such anticipation of discovery are so rare, that I may be allowed to quote the words in which LIEBIG§, in continuing the development of his ideas respecting the constitution of the organic bases, “we were enabled to replace by amidogen the oxygen in the oxides of methyl and ethyl, in the oxides of two basic radicals, we should without the slightest doubt obtain a series of compounds exhibiting a deportment similar in every respect to that of ammonia. Expressed in symbols, a compound of the formula



would be endowed with basic properties.”

Now these compounds, imagined in 1840 by LIEBIG in illustration of his views, have sprung into existence in 1849, with all the properties assigned to them by that chemist. At the beginning of the present year, M. WURTZ, in investigating the cyanates of ethyl, methyl and amyl, arrived at the unexpected result that these compounds, when decomposed by potassa, undergo a change analogous to that of cyanic acid. This acid, when treated with potassa, yielding carbonic acid and ammonia, the corresponding ethers were split into carbonic acid and compound ammonias of the exact formula indicated in LIEBIG's suggestion.

It would be difficult to imagine a more brilliant triumph for any theoretical specu-

* Researches on the Volatile Organic Bases, III. Action of Chloride, Bromide and Iodide of Cyanogen upon Aniline, Chem. Soc. Quart. Journ. i. p. 285.

† Chem. Soc. Quart. Journ. ii. p. 331.

‡ Compt. Rend. xxviii. p. 223.

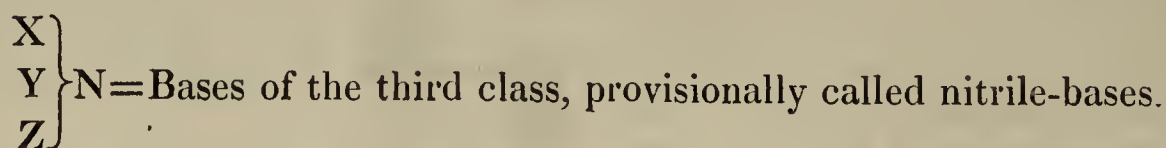
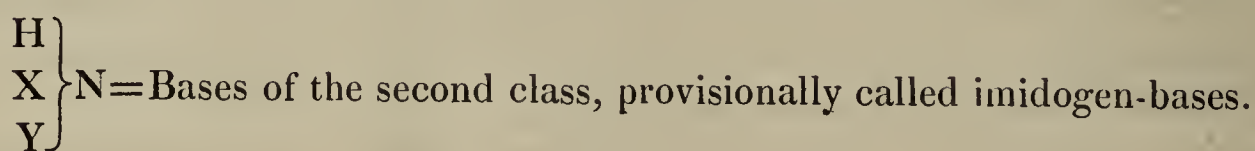
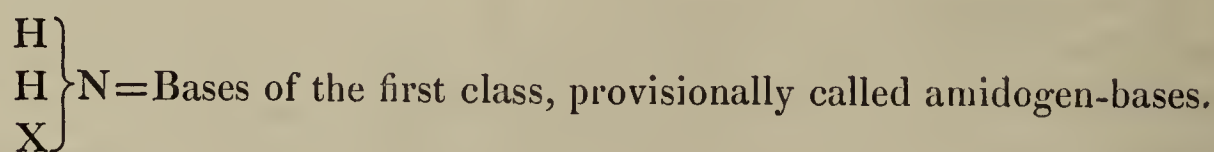
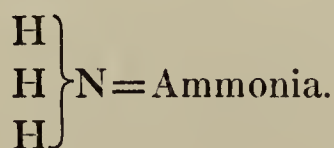
§ *Loc. cit.* p. 235.

lation; I have however no doubt that even the illustrious propounder of this view is at present far from believing that all the organic bases are amidogen-compounds. The progress of our knowledge has changed the form of this view, without shaking its foundation. A good theory is more than a *temporary* expression of the state of science, collecting under a general view the facts acquired up to the moment of its birth. It will not, like ephemeral hypothesis, vanish before the light of succeeding discoveries, but expanding with the growth of science, it will still correctly represent the known facts, though of necessity modified into a more general expression.

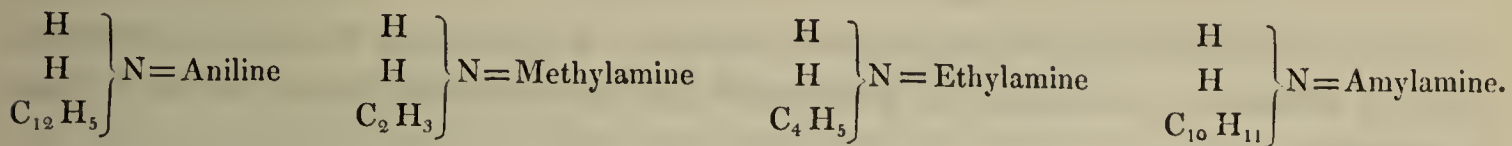
Such a theory then was that of LIEBIG. Resting as it did, upon the facts observed in the formation of the neutral amides, it was, as originally framed, an expression of the knowledge we then possessed. Subsequent researches showed that it was not only the 1 equiv. of hydrogen (the abstraction and replacement of which had led us to amidogen and the amides) that could be removed from the ammonia, but that similarly 2 equivs., and even the whole of the hydrogen could be withdrawn from their position in this base and substituted by other atoms, as in the imides and nitriles.

If then we give to LIEBIG'S view the extension of which it naturally admits, and which is demanded by the onward steps of science, we arrive at a more general conception of the nature of the organic bases; amidogen and the amides now presenting themselves to us only as particular instances of the permutations possible among the elements of the primary type ammonia. It seemed but logical to look among the bases for analogues too of the imidogen-compounds and the nitriles. In other words, it appeared desirable to inquire whether the several equivalents of hydrogen in ammonia could not be replaced, not only by atoms neutralizing the basic properties of the original system, but also by elements or groups of elements, not affecting, or but slightly modifying the alkaline character of the primary compound. Were this possible, we should arrive at the formation of three classes of organic bases, derived from ammonia by the replacement respectively of 1, 2 or 3 equivalents of hydrogen.

Expressed in formulæ, these compounds would be—



The bases belonging to the first class are pretty numerous represented. Aniline, methylamine, ethylamine, amylamine, when considered as amidogen-compounds, belong to this group.



Bases of the second and third of the above classes had not been hitherto obtained, although it is not improbable that many of the alkaloids, whose constitution is at present perfectly unknown, may be found on a closer investigation to be members of these latter groups.

The researches which I have the honour of presenting to the Royal Society will exhibit a series of artificial bases, which are evidently produced, by the substitution of carbohydrides, for the second and third equivalents of hydrogen in the ammonia.

Before proceeding however to the details of my experiments, I shall state, that I am far from supposing that the above formulæ include the constitution of all the complex bases with which we are acquainted. It is chiefly the volatile alkaloids whose constitution may be represented by this view, but even here exceptions may occur.

Both the ammonia- and the amidogen-theory of the organic bases appear to me to have the same defect, in that they endeavour to compress into a single proposition our notions respecting the endless variety of compounds which are united under the collective term organic bases. If we reflect upon the manifold sources from which the various groups of alkaloids are derived and the differences which we observe in their physical properties, and even in their chemical deportment, it is but natural to assume that in their constitution a diversity may exist similar to that of the organic acids, which we cannot attempt to include under one common theory of construction. On comparing the alkaloids of the Cinchona bark with urea and creatinine, or with nicotine and aniline, few chemists indeed will be inclined to believe that the constituents in these various substances are arranged in the same manner. The constitution of the non-volatile organic bases will probably present a very considerable diversity; and it is not at all unlikely that this class will exhibit even instances of conjugated ammonias in BERZELIUS'S acceptance of the term.

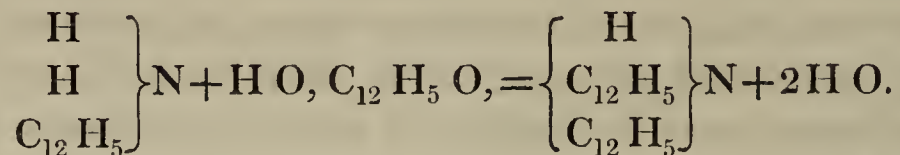
In commencing my experimental inquiry, the first step was to select the particular base which should be the subject of operation, and the radicals whose introduction should be attempted. On the one hand, my previous experimental occupations suggested aniline for the foundation; while, on the other, the radicals existing in aniline and its congeners, methylamine, ethylamine and amylamine, namely, phenyl, methyl, ethyl and amyl, presented themselves as materials for construction.

ACTION OF PHENYL-ALCOHOL ON ANILINE.

My endeavours to introduce into aniline a second equivalent of phenyl, in order to convert



have been unsuccessful up to the present moment. I had hoped that this conversion might be effected by the action of phenyl-alcohol on aniline according to the following equation:—



Phenyl-alcohol, however, has neither at the common nor at a high temperature—the mixture was exposed for several days in a sealed tube to 250° in an oil-bath—any action upon aniline. The residuary aniline was identified by analysis. When converted into a platinum-salt—

0·3120 grm. of the salt left on ignition 0·1024 grm. of platinum.

Experimental percentage of platinum.
32·82

Theoretical percentage in the aniline-platinum-salt.
32·98

This experiment, when repeated for a longer period, might possibly give a more satisfactory result. It is known that ammonia, by a similar treatment with phenyl-alcohol, is likewise only very slowly converted into aniline.

The action of chloride and bromide of phenyl $\text{C}_{12}\text{H}_5\text{Cl}$, and $\text{C}_{12}\text{H}_5\text{Br}$ upon aniline promised a better result; but the difficulties which I encountered in preparing these compounds, which are as yet but very imperfectly investigated, deterred me from farther pursuing this direction of the inquiry.

Much more successful were my endeavours to substitute methyl, ethyl and amyl for the remainder of the basic hydrogen in aniline. The compounds of these radicals with chlorine, bromine and iodine appeared to be the most appropriate substances for this purpose. I have worked with these three classes of compounds, but finding that the use of the chlorides and iodides is attended with inconveniences, the former compounds being exceedingly difficult to handle on account of their volatility, while the latter often complicate the reactions by the rapid decomposition of the hydriodic acid formed in the process, I have almost exclusively employed the bromides, whose action is so precise and definite as to preclude the necessity of seeking any farther agent; only when working in the methyl-series I have sometimes preferred to employ the iodide, which is far less volatile than the bromide. Still the deportment of the iodides presents some peculiarities, which require farther elucidation.

ACTION OF BROMIDE OF ETHYL UPON ANILINE.

On adding dry bromide of ethyl to aniline, no change takes place in the cold, but on gently heating the mixture in an apparatus which will allow the volatilized bromide to return to the aniline, a lively reaction ensues. The liquid remains for some time in a state of ebullition, and solidifies on cooling into a mass of crystals. If a

cold mixture of the two bodies be left for a few hours, it deposits crystals, which are much more definite than those obtained on the cooling of the hot solution. In either case the fluid assumes a deep amber colour which approaches brown, and the crystals are usually slightly yellow. These crystals vary in composition according to the proportions in which the two bodies have been mixed. If a very large excess of aniline has been used, they are of a prismatic character, and consist of pure hydrobromate of aniline. This compound was identified by analysis:—

0.0486 grm. of the crystals gave 0.0525 grm. of bromide of silver.

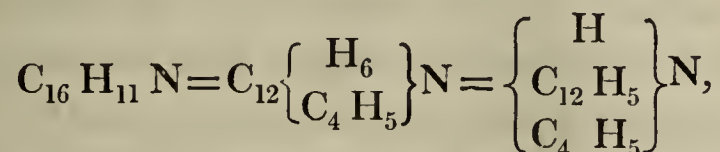
Experimental percentage of bromine.

45.88

Theoretical percentage of bromine in hydrobromate of aniline.

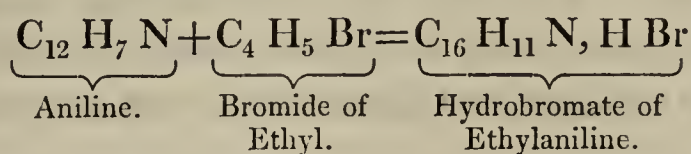
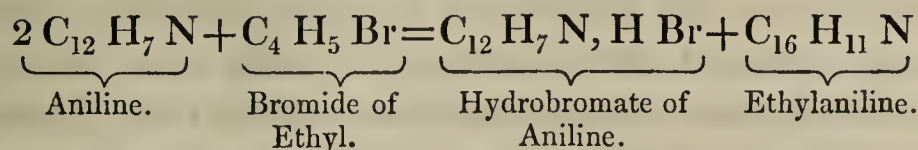
45.97

On the other hand, if the bromide of ethyl predominates to a considerable extent, the crystals are flat, four-sided tables, sometimes of considerable size. Several analyses, the details of which will be found below, showed that they were the hydrobromate of a new base*, represented by the formula—



i. e. of aniline in which 1 equiv. of hydrogen is replaced by 1 equiv. of ethyl, or ammonia in which 2 equivs. of hydrogen are replaced, the one by phenyl, the other by ethyl. The same base is contained in the free state, either alone or mixed with aniline in the mother-liquor of the crystals of hydrobromate of aniline, while the mother-liquor of the hydrobromate of the new base, especially if a large excess of the bromide has been employed, and after some days' standing, consists of nearly perfectly pure bromide of ethyl, only a small quantity of the hydrobromate in question being kept in solution.

The formation of the new basic compound, for which I propose the name Ethylaniline or Ethylphenylamine, takes place by the removal, from aniline, of 1 equiv. of hydrogen, in the form of hydrobromic acid, for which an equivalent of ethyl is substituted, the compound thus produced uniting with the hydrobromic acid. Hence the action of bromide of ethyl upon aniline may be represented by the following two simple equations:—



* Frequently, as may be imagined, mixtures of the two hydrobromates are deposited according to the proportion in which the constituents are mixed.

Ethylaniline (Ethylphenylamine).

This base may be readily obtained in a state of purity by decomposing the solution of the hydrobromate with a concentrated solution of potassa. A brown basic oil rises at once to the top of the liquid; it is separated by means of a pipette or a tap-funnel, and subjected to rectification, after having been freed from water by standing over solid potassa. Thus a colourless transparent oil is obtained, which rapidly turns brown on exposure to air and light, and has a very high refractive power. It has all the properties of the oily bases in general. From aniline it is distinguished by a slight difference in the odour, perhaps imperceptible to an inexperienced nose, by a higher boiling-point and a lower specific gravity. Ethylaniline boils (from platinum) constantly at 204° , the boiling-point of aniline being 182° ; the specific gravity of this base is 0.954 at 18° , that of aniline being 1.020 at 16° . Ethylaniline does not exhibit the violet coloration with chloride of lime which characterizes aniline. Its acid solutions impart a yellow colour to fir-wood and the pith of elder-tree, although less intensely than those of aniline. By dry chromic acid the base is inflamed like aniline.

Analyses performed with protoxide of copper gave the following results:—

- I. 0.2566 grm. of oil gave 0.7470 grm. of carbonic acid*.
- II. 0.3048 grm. of oil gave 0.8850 grm. of carbonic acid, and 0.2544 grm. of water.

| | Percentage-composition. | |
|------------------|-------------------------|-------|
| | I. | II. |
| Carbon | 79.39 | 79.19 |
| Hydrogen | — | 9.27 |

The formula



requires the following values:—

| | Theory. | | Mean of experiments. |
|------------------------------------|---------|--------|----------------------|
| 16 equivs. of Carbon | 96 | 79.33 | 79.28 |
| 11 equivs. of Hydrogen | 11 | 9.09 | 9.27 |
| 1 equiv. of Nitrogen | 14 | 11.58 | — |
| 1 equiv. of Ethylaniline | 121 | 100.00 | |

The salts of ethylaniline are remarkable for their solubility, especially in water. They are not easily obtained in well-defined crystals from an aqueous solution. From alcohol, in which they are somewhat less soluble than in water, several salts may be readily crystallized. Both the hydrochlorate and oxalate are obtained only on evaporating their solutions nearly to dryness, when the salts separate in the form of radiated masses; the sulphate and nitrate have not as yet been obtained in the solid form.

* The hydrogen was lost.

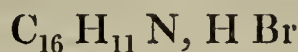
Hydrobromate of Ethylaniline.

The hydrobromate is extremely soluble in water, but crystallizes on spontaneous evaporation of its alcoholic solution in splendid regularly formed tables, of considerable size and perfect beauty. I intend to give the measurement of these crystals in a future communication. The analyses of this salt, dried at 100°, gave the following results:—

- I. 0.6412 grm. of hydrobromate gave 0.5956 grm. of bromide of silver.
- II. 0.5553 grm. of hydrobromate gave 0.5216 grm. of bromide of silver.

| Percentage of Hydrobromic Acid. | |
|---------------------------------|-------|
| I. | II. |
| 40.01 | 40.47 |

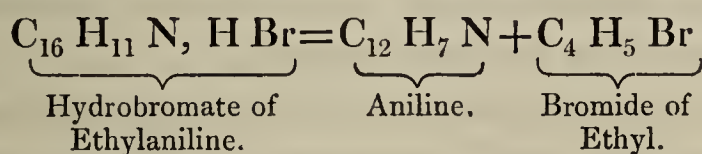
The formula



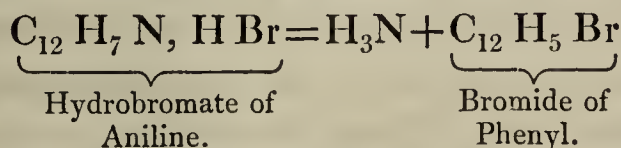
requires the following values:—

| | Theory. | | Mean of experiment. |
|--|---------|--------|---------------------|
| 1 equiv. of Ethylaniline | 121 | 59.91 | — |
| 1 equiv. of Hydrobromic Acid | 81 | 40.09 | 40.24 |
| 1 equiv. of Hydrobromate of Ethylaniline | 202 | 100.00 | |

The hydrobromate of ethylaniline when gently heated sublimes, like the corresponding aniline-salt, in splendid needles, but when subjected to the action of a rapidly increasing heat it undergoes a very remarkable decomposition, being re-decomposed into aniline and bromide of ethyl. On addition of hydrochloric acid to the distillate, the aniline dissolves, while the bromide of ethyl collects as a heavy oil at the bottom of the vessel.



I have in vain tried to split hydrobromate of aniline according to the equation



This salt sublimes, even when suddenly heated, without any decomposition.

Platinum-Salt of Ethylaniline.

I have controled the formula of ethylaniline moreover by the analysis of the platinum double salt of this substance. This salt is likewise very soluble, and may by this property be distinguished from the corresponding aniline-salt; on addition of a concentrated solution of bichloride of platinum to a concentrated solution of this

hydrochlorate, a deep orange-red oil is deposited, which solidifies, sometimes only after half a day, with crystalline texture. If a moderately concentrated solution be employed, the salt crystallizes in the course of a few hours in magnificent yellow needles, often of an inch in length. On account of its great solubility in water and alcohol, it has to be washed with a mixture of alcohol and ether, in which the latter predominates. It may be dried at 100° without decomposition.

On analysis the following numbers were obtained:—

0·3550 grm. of platinum-salt gave 0·3275 grm. of carbonic acid and 0·1055 grm. of water.

0·1812 grm. of platinum-salt gave 0·0545 grm. of platinum.

The formula



requires the following values:—

| | Theory. | | Experiment. |
|-------------------------------------|---------|--------|-------------|
| 16 equivs. of Carbon | 96·00 | 29·34 | 29·24 |
| 12 equivs. of Hydrogen | 12·00 | 3·66 | 3·83 |
| 1 equiv. of Nitrogen | 14·00 | 4·29 | — |
| 3 equivs. of Chlorine | 106·50 | 32·55 | — |
| 1 equiv. of Platinum | 98·68 | 30·16 | 30·07 |
| 1 equiv. of Platinum-salt | 326·18 | 100·00 | |

Terchloride of gold and protochloride of mercury yield with solutions of ethylaniline yellow oily precipitates, which are very readily decomposed.

Of the products of decomposition of ethylaniline, I know as yet almost nothing, although they will not be deficient in interest in a theoretical point of view.

The action of bromine gives rise to the formation of two compounds, both crystalline, one basic, the other indifferent and corresponding probably to tribromaniline. Neither of these substances has yet been analysed.

On passing cyanogen into an alcoholic solution of ethylaniline, short yellow prisms are deposited after some time, which are evidently cyanethylaniline, Cy, $C_{16} H_{11} N$, corresponding to cyaniline and cyanocumidine*. This new cyanogen-base dissolves in dilute sulphuric acid, and is thrown down from this solution by ammonia in form of a floury precipitate. The hydrochlorate, like the corresponding cyaniline-salt, is very insoluble in hydrochloric acid. It may be obtained in fine crystals on addition of hydrochloric acid to a solution of the base in dilute sulphuric acid. Cyanethylaniline, like cyaniline, forms a very soluble platinum-salt.

I have made also some qualitative experiments respecting the deportment of ethylaniline with chloride of cyanogen. This gas is rapidly absorbed, much heat being evolved. On cooling, the mass solidifies into a resinous mixture of a hydrochlorate and a neutral oil, which separates on addition of water. The base separated from

* Chemical Society, Quart. Journ. i. p. 159.

the hydrochlorate is an oil, and volatile, while melaniline, produced in the corresponding reaction of chloride of cyanogen with aniline, is solid and non-volatile.

Bisulphide of carbon gives rise to a gradual evolution of hydrosulphuric acid, no crystals being deposited from the mixture.

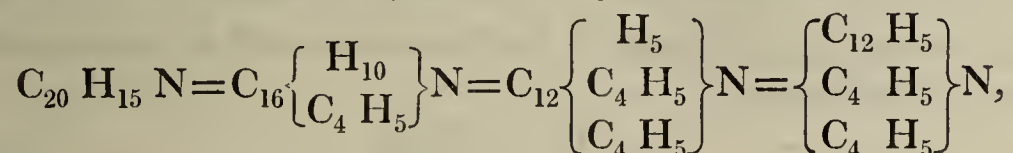
Phosgene gas acts powerfully on ethylaniline, a liquid compound being formed together with hydrochlorate of ethylaniline. No analysis having as yet been performed of these compounds, I refrain from entering into any farther details.

ACTION OF BROMIDE OF ETHYL UPON ETHYLANILINE.

The phenomena attending the action of bromide of ethyl upon ethylaniline resemble those which are observed in the corresponding treatment of aniline. The reaction however is less powerful, another equivalent of hydrogen in aniline being less easily eliminated or replaced. Four or five days elapse before the separation of crystals commences at the common temperatures. The formation however is considerably accelerated on application of heat.

The experience obtained in the preparation of ethylaniline suggested at once the use of a very large excess of bromide of ethyl, by which the formation of one compound only was secured. The mixture assumed a light-yellow colour, turned gradually brown, and deposited after five days four-sided tables of considerable size and remarkable beauty. The mother-liquor was coloured bromide of ethyl, leaving, when distilled off, a small quantity of the same crystalline compound.

The substance in question was, as a subsequent analysis will prove, the pure hydrobromate of a new base, which is represented by the formula—



i. e. of ethylaniline in which 1 equiv. of hydrogen is replaced by ethyl, or aniline in which 2 equivs. of the same radical are substituted for a corresponding number of hydrogen-equivalents, or lastly ammonia, in which the three equivalents of hydrogen are replaced, the one by phenyl, the two others each by ethyl.

The formation of this new substance, for which I propose the name diethylaniline or diethylophenylamine, requires no farther illustration: it is absolutely analogous to the production of ethylaniline.

Diethylaniline (Diethylophenylamine).

The preparation of this compound in a state of purity resembles that of the preceding base, whose physical properties have been only slightly modified by the introduction of the second equivalent of ethyl. The specific gravity was found to be 0.939 at 18°, showing a slight decrease when compared with that of ethylaniline (0.954). The boiling-point, however, was raised nearly 10 degrees; diethylaniline boils quite constantly at 213°.5. Diethylaniline is moreover distinguished from ethylaniline by re-

remaining perfectly bright and colourless when exposed to the air. Like ethylaniline it still imparts a yellow colour to fir-wood, but, like the former, fails to affect a solution of hypochlorite of lime.

Analysis performed with protoxide of copper gave the following results:—

0.2301 grm. of oil gave 0.6814 grm. of carbonic acid and 0.2118 grm. of water.

The formula



requires the following values, which may be placed in juxtaposition with the percentage deduced from the above analysis.

| | Theory. | | Experiment. |
|--------------------------------------|---------|--------|-------------|
| 20 equivs. of Carbon | 120 | 80.53 | 80.76 |
| 15 equivs. of Hydrogen | 15 | 10.06 | 10.22 |
| 1 equiv. of Nitrogen | 14 | 9.41 | — |
| 1 equiv. of Diethylaniline | 149 | 100.00 | |

To obtain farther evidence for the formula of this compound, both the hydrobromate and the platinum-salt were subjected to analysis.

Hydrobromate of Diethylaniline.

I have mentioned this salt when speaking of the formation of the second base. It is extremely soluble, and resembles in every respect the corresponding ethylaniline-compound. The bromine-determination gave the following results:—

0.4277 grm. of salt gave 0.3490 grm. of bromide of silver.

I place the experimental percentage of hydrobromic acid in juxtaposition with the theoretical value of the formula

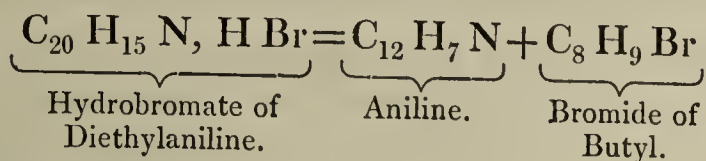


| | Theory. | | Experiment. |
|--|---------|--------|-------------|
| 1 equiv. of Diethylaniline | 149 | 64.78 | — |
| 1 equiv. of Hydrobromic acid | 81 | 35.22 | 35.14 |
| 1 equiv. of Hydrobromate of Diethylaniline | 230 | 100.00 | |

The hydrobromate of diethylaniline, when gently heated, fuses and sublimes like the corresponding aniline- and ethylaniline-salts. When rapidly heated, it is entirely converted into a colourless oil, which distils over. This oil contains equal equivalents of bromide of ethyl and ethylaniline. By this distillation we obtain indeed the very constituents from which the hydrobromate was originally prepared, and which would of course reconvert themselves into hydrobromate of diethylaniline. Only a trifling amount of undecomposed hydrobromate covers, after the distillation is finished, the sides of the retort in the form of a radiated coating.

The peculiar deportment then of the hydrobromates of the ethyl-bases, and probably of all their salts, allows us to remove the several equivalents of ethyl one after

the other from our fabric in the same manner as we had inserted them. When first I became acquainted with diethylated aniline, having then already observed the deportment of the salts of ethylaniline, which under the influence of heat are reconverted into aniline, I indulged for a moment in the pardonable illusion, that the salt of diethylaniline would exhibit the metamorphosis—



a mode of reaction which would have afforded a passage from the ethyl- into the butyl-series. This step however is reserved for a more fortunate experimenter.

Platinum-salt of Diethylaniline.

This salt resembles the corresponding compound of ethylaniline. On addition of a concentrated solution of bichloride of platinum to the hydrochlorate, it is precipitated in form of a deep orange-coloured oil, which rapidly solidifies into a hard crystalline mass. If the solutions are mixed in a dilute state, the salt is separated after some time in cross-like yellow crystals. It is not nearly so soluble in water and alcohol as the ethylaniline-salt. Analysis led to the following numbers:—

*I. 0.1715 grm. of platinum-salt gave 0.2125 grm. of carbonic acid and 0.0700 grm. of water.

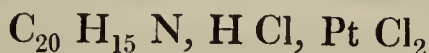
*II. 0.1848 grm. of platinum-salt gave 0.0513 grm. of platinum.

III. 0.5361 grm. of platinum salt gave 0.1476 grm. of platinum.

IV. 0.5550 grm. of platinum-salt gave 0.1533 grm. of platinum.

| | Percentage-composition. | | | |
|--------------------|-------------------------|-------|-------|-------|
| | I. | II. | III. | IV. |
| Carbon | 33.78 | — | — | — |
| Hydrogen | 4.53 | — | — | — |
| Platinum | — | 27.76 | 27.53 | 27.62 |

The formula



requires the following values, which I place in juxtaposition with the mean of the experimental results:—

| | Theory. | | Mean of experiments. |
|-----------------------------------|---------|--------|----------------------|
| | | | |
| 20 equivs. of Carbon | 120.00 | 33.78 | 33.78 |
| 16 equivs. of Hydrogen | 16.00 | 4.54 | 4.53 |
| 1 equiv. of Nitrogen | 14.00 | 3.91 | — |
| 3 equivs. of Chlorine | 106.50 | 29.99 | — |
| 1 equiv. of Platinum | 98.68 | 27.78 | 27.66 |
| 1 equiv. of Platinum-salt | 355.18 | 100.00 | |

* I. and II. are of a specimen recrystallized from alcohol.

I have not examined any other of the salts of diethylaniline: their deportment resembles in every respect that of the ethylaniline-salts.

ACTION OF BROMIDE OF ETHYL ON DIETHYLANILINE.

If we assume that the series of bases, aniline, ethylaniline and diethylaniline, arise from the gradual elimination of the three equivalents of hydrogen in ammonia, and their substitution by 1 equivalent of phenyl and 2 equivalents of ethyl, it is difficult to imagine that bromide of ethyl should have any farther action on diethylaniline, this compound ammonia containing, according to this view, no longer any replaceable hydrogen. However, it would have been deserting the path of inductive research, if this point had been left unestablished by rigorous experiments.

For this purpose diethylaniline was left in contact with bromide of ethyl for nearly a month, After the lapse of this time the mixture had undergone no change in its appearance. On treating however a portion with water, it was found that a small quantity of hydrobromate dissolved, from which on addition of potassa an oily base was separated. The quantity obtained in this manner from nearly two ounces of the united liquids being insufficient for a determination, I subjected a similar mixture, in a sealed tube, for several days to the temperature of boiling water. I was surprised to find that a yellow layer began to separate at the lower extremity of the tube, which increased gradually to a fifth of the liquid column. When allowed to cool, this layer solidified into a crystalline mass. On opening the tube, it was found that there was no pressure from within, except that exerted by the elasticity of bromide of ethyl. After separation of the excess of the bromide by distillation in the water-bath, water added to the viscid residue dissolved the crystals, while an oil floated upon the surface which was found to be entirely basic: it was separated by a distillation at a higher temperature, when it was carried over with the vapour of the water. The remaining liquid in the retort was found to be a solution of a hydrobromate. It was decomposed with potassa, and the liberated base separated from the bromide of potassium by distillation. The two basic oils obtained in this manner, when dissolved in hydrochloric acid and precipitated by bichloride of platinum, gave rise to the formation of two splendid platinum-salts. These salts left on ignition the following percentage of platinum; I. being the oil which had not been in combination; II. the base which had been separated from the hydrobromate.

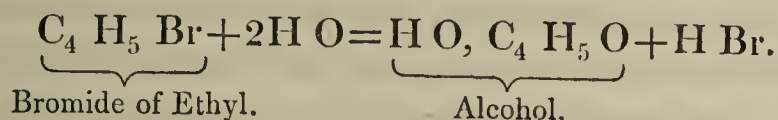
I. 0.5626 grm. of platinum-salt left 0.1559 grm. of platinum.

II. 0.5384 grm. of platinum-salt left 0.1495 grm. of platinum.

| Experimental percentage of platinum, | Theoretical percentage in diethyl- aniline-platinum-salt. |
|--|--|
| <div style="display: flex; justify-content: space-around; align-items: center;"> <div style="text-align: center;"> I. 27.70 </div> <div style="text-align: center;"> II. 27.76 </div> </div> | 27.78. |

These experiments prove that the basic oil obtained on direct distillation, or by distilling after treatment with potassa, had not assimilated a farther equivalent of

the alcohol-radical; but the question arose in what manner a portion of the base had been converted into hydrobromate? It was not impossible that the bromide of ethyl, although it had been in contact with chloride of calcium, might nevertheless still have retained a portion of water, whose elements could have induced a regeneration of alcohol with simultaneous formation of hydrobromic acid:



I now took care that both substances, the diethylaniline and the bromide of ethyl, should be perfectly dry before coming into contact. For this purpose, both liquids were left for several days over anhydrous caustic baryta and then subjected to distillation. The compounds at the common temperature were found to have no action upon one another. In order to place them in a condition most favourable for mutual action, the mixture was exposed for several days in a sealed tube to the temperature of boiling water. On opening the tube and extracting the mixture with water, a small quantity of hydrobromate was found to have nevertheless been formed. The portion insoluble in water was dissolved in hydrochloric acid and precipitated by bichloride of platinum. The salt obtained in this manner could not be mistaken. It fell down in the form of a yellow oil, which rapidly solidified into the orange-yellow crystalline aggregates characterizing the diethylaniline-compound.

From these experiments, it would appear that diethylaniline is no longer capable of fixing another equivalent of ethyl. Still the production of the small quantity of hydrobromate in the *last* experiment indicates that the phenomenon cannot be due to the formation of alcohol. Farther steps are necessary for the explanation of this transformation.

In aniline, ethylaniline and diethylaniline, then we have three bases, which may be considered as derived from ammonia by the elimination and replacement of its three hydrogen-equivalents. The successive formations of ethylaniline and diethylaniline from aniline have been detailed in the preceding paragraphs; the passage of ammonia into aniline, when exposed to the action of a phenyl-compound, has been proved at an earlier period by some experiments, made jointly by M. LAURENT and myself, upon the action, at a high temperature, of hydrated oxide of phenyl on ammonia. In this reaction a small but unequivocal quantity of aniline is formed.

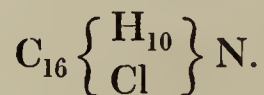
The formation of aniline, ethylaniline and diethylaniline, appeared to have established in a sufficiently satisfactory manner, the point of theory which is here in question; still I thought desirable the acquisition of additional facts in support of the position to which this inquiry has conducted me. Thus I have been led to study the action of bromide of ethyl upon several of the derivatives of aniline, and to try whether other alcohol-radicals, such as methyl and amyl, would have a similar

action; lastly, in order to complete the investigation, I was obliged to leave the amidogen-bases altogether in order to submit the typical ammonia itself to examination.

Among the bases derived from aniline, there is a class whose department with bromide of ethyl appeared to be more particularly worthy of a careful investigation. This is the group of compounds produced from aniline by substitution, and embracing chloraniline, dichloraniline and trichloraniline, the corresponding bromanilines, iodaniline and nitraniline. The question arose in what manner will these substances, in which the original aniline has lost already a certain quantity of its hydrogen, comport themselves under the influence of bromide of ethyl? The answer afforded by experiment was unequivocal and in perfect accordance with the result anticipated by theory, although it may here at once be stated, that the difficulty of obtaining the compounds in question in sufficient quantity has prevented me from pursuing this part of the investigation as far as I could have wished.

ACTION OF BROMIDE OF ETHYL UPON CHLORANILINE.

A solution of chloraniline in dry bromide of ethyl exhibits no apparent change even after several days' exposure to the temperature of boiling water. On adding however water and distilling off the excess of bromide of ethyl, it was found that the chloraniline had been converted into a hydrobromate, which was held in solution, scarcely a trace of uncombined base being left. Addition of potassa to the solution of the hydrobromate separated at once a yellow oily base, of a very characteristic aniseed-odour, differing from chloraniline in many respects. It remained liquid even at the temperature of a cold winter day, while chloraniline is distinguished by the facility with which it crystallizes. Its salts are much more soluble than the corresponding chloraniline-salts: I have only seen the sulphate and oxalate in a crystallized state. This liquid base is evidently ethylochloraniline—



I am sorry that I have not been able to verify this formula by direct analysis. The amount of substance at my disposal precluded the idea of submitting it to the processes of purification necessary before combustion. I had hoped to fix its composition by the determination of the platinum in the platinum-salt. Unfortunately this salt separated in the form of a yellow oil, which could not by any means be made to crystallize. Obligated to desist from direct analysis, I endeavoured to gain the requisite data by another mode of proceeding.

ACTION OF BROMIDE OF ETHYL UPON ETHYLOCHLORANILINE.

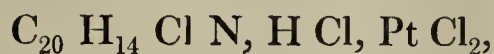
Recollecting that in almost all the instances which I have examined, the tendency exhibited by the various bases of producing readily crystallizable platinum-salts increased with the degree of their ethylation, I subjected the whole amount of the

still hypothetical ethylochloraniline, after having dried it by a current of hot air, to the action of a considerable excess of bromide of ethyl. After two days' exposure to 100° the mixture was found to contain a hydrobromate in solution, not a trace of free base being left. There was no doubt that a second equivalent of ethyl had been assimilated. On decomposing the hydrobromate with potassa, an oil separated resembling, in its appearance and also in its odour, the preceding compound. An attempt to purify the ethylochloraniline from the potassa by distillation with water having failed, on account of the high boiling-point of this substance, the purification of the diethylochloraniline, for as such the new compound was to be considered, was at once effected with ether. The ethereal solution of the oil was carefully washed with water to remove adhering potassa, and evaporated: the yellow oil remaining after this treatment was dissolved in hydrochloric acid, and the solution mixed with bichloride of platinum. Immediately a splendid orange-yellow crystalline precipitate was separated, which after washing with water was fit for analysis. This salt fused at 100°.

In the analysis a small quantity of platinum was lost.

0.2376 grm. of platinum-salt gave 0.0583 grm. of platinum.

The formula



requires the following values:—

| | Theory. | | Experiment. |
|------------------------------------|---------|--------|-------------|
| 1 equiv. of Diethylochloraniline . | 183.50 | 47.09 | — |
| 1 equiv. of Hydrochloric acid . . | 36.50 | 9.37 | — |
| 2 equivs. of Chlorine | 71.00 | 18.22 | — |
| 1 equiv. of Platinum | 98.68 | 25.32 | 24.53 |
| 1 equiv. of Platinum-salt | 389.68 | 100.00 | |

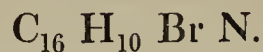
The result, although somewhat below theory, shows that chloraniline, when subjected to the action of bromide of ethyl, exhibits absolutely the same deportment as aniline itself, two equivalents of ethyl being consecutively introduced which give rise to the formation of two new terms, which demand the names ethylochloraniline (ethylochlorophenylamine) and diethylochloraniline (diethylochlorophenylamine).

ACTION OF BROMIDE OF ETHYL UPON BROMANILINE.

The absolute analogy existing between chloraniline and bromaniline, to which I have alluded in a former paper*, is maintained also in the deportment of these two substances towards bromide of ethyl. Bromaniline is rapidly converted into hydrobromate of ethylobromaniline which could not, except by analysis, be distinguished from the corresponding chlorine-base. The platinum-salt being likewise a viscid oil,

* Chem. Soc. Mem. ii. 291.

I have omitted to analyse it. There is however no doubt about the existence of an ethylobromaniline,



I have not attempted to ethylate this compound any farther.

ACTION OF BROMIDE OF ETHYL UPON NITRANILINE.

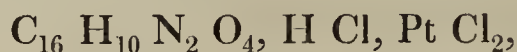
Ethylonitraniline (Ethylonitrophenylamine).

Nitraniline readily dissolves in bromide of ethyl. The solution soon deposits, even at the common temperature, pale-yellow crystals of considerable size. At the boiling temperature of water the conversion is rapidly accomplished. On addition of an alkali to the hydrobromate, the ethylonitraniline separates as a brown oily mass, which solidifies after some time with crystalline structure. In this substance, as well as in the other ethylated bases, the properties of the mother-compound are only slightly modified. Thus we find in the base ethylonitraniline still the yellow colour of nitraniline, which it readily imparts to the skin, but which it loses altogether in its salts. These salts are as easily soluble in water as the corresponding nitraniline-compounds, if not even more so, and possess the same peculiar sweetish taste; they all crystallize however on evaporating their solutions nearly to dryness. Ethylonitraniline dissolves readily in ether and alcohol, less so in boiling water; from a solution in the latter the base is deposited in stellated groups of yellow crystals, which are readily distinguished from the felted mass of long needles, separated on cooling from an aqueous solution of nitraniline.

I have fixed the composition of ethylonitraniline by a single number, namely, by the determination of the metal in the platinum double salt. This compound is prepared by adding bichloride of platinum to a very concentrated solution of the hydrochlorate; this must not contain much free acid, in which the salt would redissolve. After a short time pale-yellow scales are separated, which have to be washed with cold water. The small quantity of substance at my disposal may excuse the slight deficiency in the amount of platinum.

0.1544 grm. of ethylonitraniline gave 0.0405 grm. of platinum.

This percentage agrees with the formula



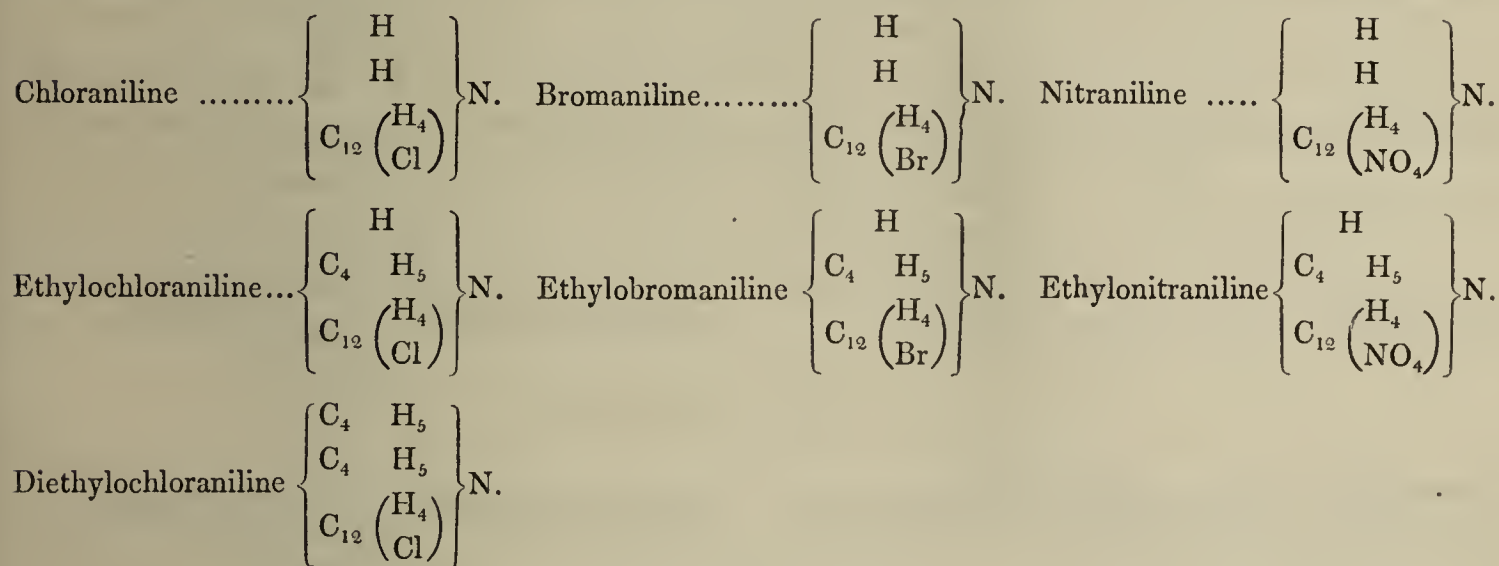
as will be seen from the following comparison:—

| | Theory. | | Experiment. |
|---------------------------------|---------|--------|-------------|
| 1 equiv. of Ethylonitraniline . | 166.00 | 44.60 | — |
| 1 equiv. of Hydrochloric acid . | 36.50 | 9.80 | — |
| 2 equivs. of Chlorine . . . | 71.00 | 19.09 | — |
| 1 equiv. of Platinum . . . | 98.68 | 26.51 | 26.23 |
| 1 equiv. of Platinum-salt . . | 372.18 | 100.00 | |

The nitraniline-salt contains 28.66 per cent of platinum. I have not prepared a diethylnitraniline.

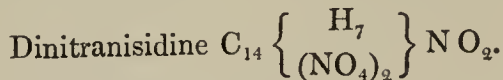
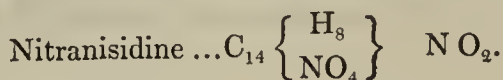
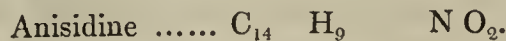
The deportment of chloraniline, bromaniline and nitraniline with bromide of ethyl, appears to throw much light upon the constitution of these substitution-bases. The possibility of introducing into these substances two equivalents of ethyl, shows that they must contain the same amount of basic hydrogen (an expression by which I may be allowed to represent briefly the hydrogen of the ammonia-skeleton) as aniline itself, and hence it is evident that it was the hydrogen of the phenyl which was replaced by chlorine, bromine and hyponitric acid in the transformation of aniline into its chlorinated, brominated, &c. relatives.

This transformation is due to a secondary substitution affecting the hydrogen in the radical, which replaced the original ammonia-hydrogen; and the constitution of the substances in question may hence be graphically represented by the following formulæ:—



This mode of viewing their constitution is in perfect harmony with the facts at present in our possession, both as regards the deportment of the substitution-anilines, and the substances similarly derived from hydrated oxide of phenyl. Experiment has shown that in aniline 1, 2 or 3 equivalents of hydrogen may be replaced by chlorine, bromine, and probably also by the elements of hyponitric acid*. In these substances their basic properties gradually diminish with the successive insertions

* At the present moment we have only nitraniline, but it is scarcely to be doubted that we shall soon become acquainted with the nitro-term corresponding to dichloraniline and trichloraniline. Recent researches of M. CAHOURS (Ann. Ch. Phys. sér. xxvii. 439) on the derivatives of anisole have pointed out the first alkalioid containing 2 equivs. of hyponitric acid.



In this series only the trinitranisidine $\text{C}_{14} \left\{ \begin{array}{c} \text{H}_6 \\ (\text{NO}_4)_3 \end{array} \right\} \text{N O}_2$ is wanting.

of chlorine or bromine into the compound. Bromaniline still retains a strongly alkaloidal character which in dibromaniline is so far impaired that by simple ebullition it is separated from its aqueous saline solutions; tribromaniline, lastly, is a perfectly indifferent compound. Now if we recollect that in monobrominated and dibrominated phenole (obtained by M. CAHOURS, by distilling respectively, bromosalicylic and dibromosalicylic acid), the original character of hydrated oxide of phenyl is gradually altered and becomes in tribromophenole (bromophenisic acid of M. LAURENT) powerfully acid, we cannot be surprised to find that the gradual development of electronegative properties in the radical should affect the nature of a basic system in which it replaces hydrogen. We have two parallel groups of bodies, the chemical character of which is differently affected by the modification induced in the radical, existing in both, by the assimilation of bromine.

| | | | | |
|---------------------------------------|---|----------------------|--|-------------------------|
| Hydrated protoxide of phenyl | } HO, C ₁₂ H ₅ O, slightly acid. | Phenylamine | $\left. \begin{array}{c} \text{H} \\ \text{H} \\ \text{C}_{12} \text{H}_5 \end{array} \right\}$ | N, powerfully basic. |
| Bromophenole | HO, C ₁₂ $\left\{ \begin{array}{c} \text{H}_4 \\ \text{Br} \end{array} \right\}$ O, more so. | Bromophenylamine ... | $\left. \begin{array}{c} \text{H} \\ \text{H} \\ \text{C}_{12} \left(\begin{array}{c} \text{H}_4 \\ \text{Br} \end{array} \right) \end{array} \right\}$ | N, less so. |
| Dibromophenole ... | HO, C ₁₂ $\left\{ \begin{array}{c} \text{H}_3 \\ \text{Br}_2 \end{array} \right\}$ O, more so. | Dibromophenylamine | $\left. \begin{array}{c} \text{H} \\ \text{H} \\ \text{C}_{12} \left(\begin{array}{c} \text{H}_3 \\ \text{Br}_2 \end{array} \right) \end{array} \right\}$ | N, less so. |
| Tribromophenole Bromophenisic acid | } HO, C ₁₂ $\left\{ \begin{array}{c} \text{H}_2 \\ \text{Br}_3 \end{array} \right\}$ O, powerfully acid. | Tribromophenylamine | $\left. \begin{array}{c} \text{H} \\ \text{H} \\ \text{C}_{12} \left(\begin{array}{c} \text{H}_2 \\ \text{Br}_3 \end{array} \right) \end{array} \right\}$ | N, neutral. |

Tribromophenylamine (tribromaniline) is a compound differing in its nature in no way from oxamide. Both these substances are ammonia, whose basic character has been counterbalanced by the insertion of a powerfully electronegative radical in the place of one of the hydrogen-equivalents. These two substances, when subjected to the influence of strong acids, comport themselves in exactly the same manner; they both reproduce ammonia, the one with formation of tribromophenisic, the other of oxalic acid.

The paragraphs now following are devoted to a brief account of the bases derived from aniline by the insertion of methyl and amyl. I have not however followed out the examination of these substances to the same extent, the principle having been in fact sufficiently established by the formation of the ethyl bodies.

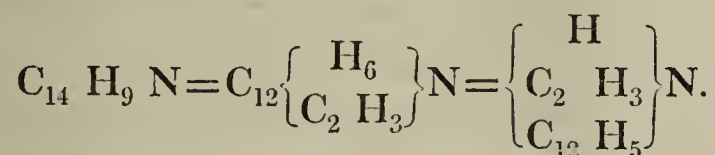
ACTION OF BROMIDE AND IODIDE OF METHYL UPON ANILINE.

Methylaniline (Methylophenylamine).

The deportment of aniline with bromide of methyl resembles its behaviour with the ethyl-compound. The mixture rapidly solidifies into a crystalline mass of hydrobromate of methylaniline. Bromide of methyl being extremely volatile, I have used also the iodide, which boils at a more convenient temperature. The action of the latter compound upon aniline is very remarkable, the evolution of heat, on mixing the two substances, being so great, that the liquid enters into violent ebullition, so that unless the substances be mixed gradually, the crystalline hydriodate, which is formed immediately, is actually thrown out of the vessel.

Methylaniline, when separated from the hydrobromate or hydriodate, appears as a transparent oil of a peculiar odour, somewhat different from that of aniline, and boiling at 192° ; it has retained the properties of aniline in a higher degree than the ethylated compound. This substance yields still the blue coloration with hypochlorite of lime, although in a less degree than aniline. Its salts are less soluble than those of ethylaniline; they are at once formed in the crystalline state on addition of the respective acids; the oxalate crystallizes very easily, but is rapidly decomposed with reproduction of aniline, and probably with formation of oxalate of methyl*.

The composition of methylaniline is represented by the expression



I have established this formula by the analysis of the platinum-salt. This is precipitated as a transparent oil, which rapidly changes into pale-yellow crystalline tufts, resembling the corresponding aniline-salt, but liable to rapid decomposition. The washing must be quickly done, for the salt is extremely soluble in water, and must be immediately followed by desiccation. Even when very carefully prepared, it has become dark by the time it is ready for combustion. It turns instantaneously black if an alcoholic solution of the hydrochlorate be employed for its preparation.

Analysis I. refers to a salt obtained with the base prepared by means of the bromide; for analysis II. the base had been formed by the iodide. The specimen analysed under III. again had been obtained with the bromide, but it was in an advanced state of decomposition, and had in consequence become perfectly black.

I. 0.1018 gram. of platinum-salt gave 0.0319 gram. of platinum.

II. 0.2467 gram. of platinum-salt gave 0.0784 gram. of platinum.

III. 0.2065 gram. of platinum-salt gave 0.0660 gram. of platinum.

* The aniline thus reproduced was identified by the analysis of the platinum-compound.

0.7910 gram. of platinum-salt gave 0.2615 gram. of platinum.

Experimental. Theoretical percentage of platinum in aniline-platinum-salt.

33.05

32.98

| Percentage of platinum. | | |
|-------------------------|-------|--------|
| I. | II. | III. |
| 31·33 | 31·78 | 31·96. |

The formula



requires the following values:—

| | Theory. | Mean of I. and II. |
|-------------------------------------|---------|--------------------|
| 1 equiv. of Methylaniline . . . | 107·00 | 34·16 |
| 1 equiv. of Hydrochloric acid . . . | 36·50 | 11·65 |
| 2 equivs. of Chlorine | 71·00 | 22·67 |
| 1 equiv. of Platinum | 98·68 | 31·52 |
| 1 equiv. of Platinum-salt | 313·18 | 100·00 |
| | 313·18 | 31·55 |

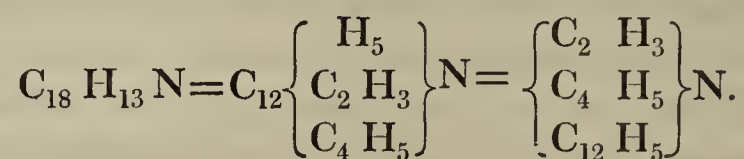
I have not attempted to form a dimethylaniline.

ACTION OF IODIDE OF METHYL UPON ETHYLANILINE.

Methylethylaniline (Methylethylophenylamine).

I have established the existence of this compound merely by qualitative experiments. The mixture of ethylaniline and iodide of methyl begins to crystallize after two days' exposure to the temperature of boiling water. Methylethylaniline resembles the preceding base in its odour, but has no longer any action upon hypochlorite of lime. I had not prepared a sufficient quantity of the compound for a determination of the boiling-point. The salts of this base are extremely soluble. With the exception of the hydrobromate, I have not been able to obtain a single one in crystals. Even the platinum-salt is not to be obtained in the crystalline form; it is extremely soluble, and separates, if very concentrated solutions be employed, as a yellow oil, which does not solidify even after lengthened exposure to the air. This circumstance has prevented me from fixing the composition of methylethylaniline by a number.

It cannot however be doubted that it is represented by the formula—



This compound presents a certain degree of interest, inasmuch as the 3 equivs. of hydrogen in the ammonia are replaced by three different radicals, namely by methyl, ethyl and phenyl. I have prepared however a similar compound containing, instead of methyl, amyl, whose properties permitted an easier analysis.

ACTION OF BROMIDE OF AMYL UPON ANILINE.

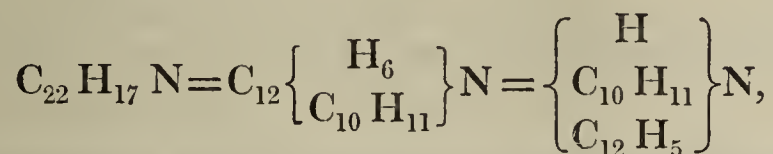
Amylaniline (Amylophenylamine).

A mixture of aniline and an excess of bromide of amyl, when left in contact at the common temperature for some days, deposits magnificent crystals of hydrobromate of aniline. Never have I obtained this salt in larger and more definite crystals; although I have seen it deposited of late from a good many solutions. The mother-liquor of this salt is a mixture of amylaniline and bromide of amyl. If aniline be heated in the water-bath with a very large excess of bromide of amyl, the whole is converted into hydrobromate of amylaniline, which remains dissolved in the excess of bromide.

When prepared without the co-operation of heat, the amylaniline may be purified simply by separating the crystals of the aniline-salt and distilling the remaining mixture, when the bromide of amyl passes over long before the amyl-base begins to volatilize. If the base has been produced by heating the mixture, it is necessary, after the excess of bromide has been removed, to distil the hydrobromate with potassa. On submitting the base, purified in the usual manner, to combustion, the following numbers were obtained:—

0.2760 grm. of oil gave 0.8161 grm. of carbonic acid, and 0.2560 grm. of water.

This analysis leads to the formula—



as may be seen from a juxtaposition of the theoretical and experimental values.

| | Theory. | | Experiment. |
|-----------------------------------|---------|--------|-------------|
| 22 equivs. of Carbon | 132 | 80.98 | 80.64 |
| 17 equivs. of Hydrogen | 17 | 10.42 | 10.30 |
| 1 equiv. of Nitrogen | 14 | 8.60 | — |
| 1 equiv. of Amylaniline | 163 | 100.00 | |

Amylaniline is a colourless liquid, possessing all the family-features of the group. It is distinguished, at the common temperature, by a very agreeable, somewhat rose-like odour, rather an unusual property for an amyl-compound; however, it does not deny its origin, for on heating the base the disgusting odour of the fusel-alcohol appears but slightly modified. Amylaniline boils constantly at 258°, or 54=3×18° higher than ethylaniline. This boiling-point is characteristic, inasmuch as the elementary group amyl raises the boiling-point of aniline 44° higher than does the insertion of two equivalents of ethyl, whose weight is not very inferior to that of the single amyl-equivalent.

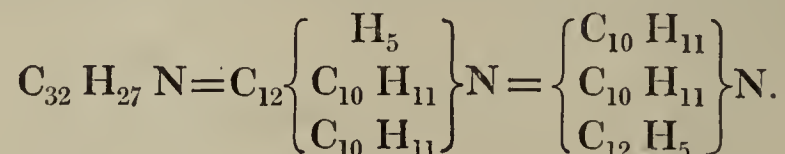
The amyl-base forms beautiful rather insoluble salts with hydrochloric, hydro-

bromic and oxalic acids; when heated with water, they form an oily layer on the surface, and crystallize only slowly on cooling: they have the peculiar fatty appearance which characterizes the crystalline amyl-compounds. The platinum-salt is precipitated as a yellow mass of an unctuous consistence; it crystallizes but very slowly, and usually not before partial decomposition has set in. It is on this account that I have not made an analysis of this compound.

ACTION OF BROMIDE OF AMYL UPON AMYLANILINE.

Diamylaniline (Diamylophenylamine).

A mixture of amylaniline and bromide of amyl solidifies after two days' exposure to the temperature of the water-bath. The new basic compound, when separated and purified in the usual manner, resembles the preceding base, especially with respect to odour. Its salts are so insoluble in water that at the first glance one is almost inclined to doubt the basicity of the substance, inasmuch as the oil appears to be perfectly insoluble in dilute hydrochloric and sulphuric acids. However, the oily drops floating in the acid solution are the salts themselves, which gradually solidify into splendid crystalline masses, having likewise the fatty appearance of amyl-substances. The composition of diamylaniline is represented by the expression—



I have established this formula by the analysis of the platinum-compound, which is precipitated as an oily mass, rapidly solidifying into a brick-red crystalline substance. If an alcoholic solution of the hydrochlorate be employed, it is immediately obtained in the crystalline state. When exposed to the heat of the water-bath this salt fuses, without however undergoing any decomposition.

On analysis the following results were obtained:—

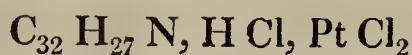
I. 0.3015 grm. of platinum-salt gave 0.4820 grm. of carbonic acid, and 0.1765 grm. of water.

II. 0.2550 grm. of platinum-salt gave 0.0572 grm. of platinum.

III. 0.4750 grm. of platinum-salt gave 0.1061 grm. of platinum.

| | Percentage. | | |
|--------------------|-------------|-------|-------|
| | I. | II. | III. |
| Carbon | 43.60 | — | — |
| Hydrogen | 6.50 | — | — |
| Platinum | — | 22.43 | 22.34 |

The formula



requires the following values :—

| | Theory. | | Experiment. |
|---------------------------------|---------|--------|-------------|
| 32 equivs. of Carbon | 192·00 | 43·71 | 43·60 |
| 28 equivs. of Hydrogen | 28·00 | 6·37 | 6·50 |
| 1 equiv. of Nitrogen | 14·00 | 3·19 | — |
| 3 equivs. of Chlorine | 106·50 | 24·25 | — |
| 1 equiv. of Platinum | 98·68 | 22·47 | 22·38 |
| 1 equiv. of Platinum-salt . . . | 439·18 | 100·00 | |

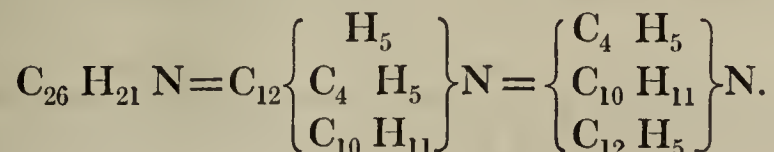
Diamylaniline boils between 275° and 280°: the small scale upon which I had to work prevented me from determining it more accurately. It is interesting to see how very little the boiling-point is raised by the introduction of the second equivalent of amyl, when compared with the effect produced by the insertion of the first. The same remark applies to the ethylanilines.

ACTION OF BROMIDE OF ETHYL UPON AMYLANILINE AND OF BROMIDE OF AMYL
UPON ETHYLANILINE.

Amylethylaniline (Amylethylophenylamine).

It remained now only to analyse a basic compound in which the three equivalents of the ammonia-hydrogen should be replaced by three different radicals. I found in amylethylaniline a substance similar in composition to methylethylaniline, but which by its properties admitted of a rigorous analytical examination.

Amylethylaniline is formed without difficulty by the action of bromide of ethyl upon amylaniline. The mixture having been exposed to the heat of the water-bath, the conversion was found to be complete after two days. When purified in the usual way, amylethylaniline forms a colourless oil, boiling at 262°, only 4° higher than the amyl-base. The properties of this substance are analogous to those of the other bases. It forms a beautiful crystalline hydrochlorate and hydrobromate; the platinum-salt is precipitated in form of a light orange-yellow pasty mass, which rapidly crystallizes. This salt fuses at 100°. By analysis of the platinum-compound I was enabled to fix without difficulty the composition of the base, which is represented by the formula



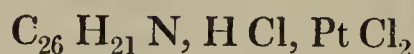
I. 0·2893 gm. of platinum-salt gave 0·4137 gm. of carbonic acid, and 0·1495 gm. of water.

II. 0·2647 gm. of platinum-salt gave 0·0652 gm. of platinum.

III. 0·2510 gm. of platinum-salt gave 0·0619 gm. of platinum.

| | Percentage-composition. | | |
|--------------------|-------------------------|-------|-------|
| | I. | II. | III. |
| Carbon | 39·00 | — | — |
| Hydrogen | 5·70 | — | — |
| Platinum | — | 24·63 | 24·66 |

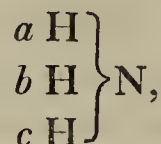
The formula



requires the following values:—

| | Theory. | | Experiment. |
|-------------------------------------|---------|--------|-------------|
| | I. | II. | |
| 26 equivs. of Carbon | 156·00 | 39·27 | 39·00 |
| 22 equivs. of Hydrogen | 22·00 | 5·54 | 5·70 |
| 1 equiv. of Nitrogen | 14·00 | 3·53 | — |
| 3 equivs. of Chlorine | 106·50 | 26·81 | — |
| 1 equiv. of Platinum | 98·68 | 24·84 | 24·64 |
| 1 equiv. of Platinum-salt | 397·18 | 100·00 | |

A substance of exactly the same composition as amylethylaniline may be obtained by the action of bromide of amyl upon ethylaniline. I was led to prepare this compound by some ideas which had suggested themselves in a perfectly different line of experiments. I wished to ascertain whether the several hydrogen-equivalents in ammonia were of the same value, if I may use this expression, or in other words, whether it was indifferent which of the three equivalents was replaced by a given radical. Supposing that in ammonia



it is the a hydrogen which is replaced by phenyl, the question arose whether the same substance would be formed, for instance, by substituting amyl and ethyl, either for b and c , or for c and b .

I have carefully compared the properties of amylethylaniline, by which name I designate the compound produced by the action of bromide of ethyl upon amylaniline with those of ethylamylaniline obtained by acting with bromide of amyl upon ethylaniline, and find that these substances comport themselves in every respect perfectly alike.

A last and decisive argument was hoped to be gained from the deportment of the salts of these bases, when subjected to the influence of heat. For this purpose the hydrobromates were prepared. When distilled, both these salts were split into bromide of amyl and ethylaniline; I hence assume that the action of bromide of ethyl upon amylaniline, and that of bromide of amyl upon ethylaniline, give rise to the formation of exactly the same basic compound.

ACTION OF BROMIDE OF ETHYL UPON AMMONIA.

After the termination of the experiments which have been detailed in the preceding pages, there remained no doubt in my mind respecting the deportment which ammonia itself would exhibit when subjected in a similar manner to the influence of bromide of ethyl. I had a right to expect in this reaction the consecutive formation of three alkaloids, differing from ammonia by containing respectively one, two or the three equivalents of hydrogen replaced by ethyl.

Experiment has realized this expectation in a very satisfactory manner. I intend to give here only an outline of the process employed, and a short description of the substances obtained, together with some characteristic numbers, fixing beyond a doubt the composition of the new bases formed under these circumstances. I hope that I shall soon be able to communicate a more detailed account of these compounds, as well as of the bases belonging to the methyl- and amyl-series.

Formation of Ethylamine (Ethylammonia).

Bromide of ethyl acts very slowly on an aqueous solution of ammonia in the cold. Action however takes place; after the lapse of a week or ten days the solution contains a considerable quantity of a hydrobromate in solution. This hydrobromate is a mixture of the salts of ammonia and ethylamine, the base discovered by M. WURTZ on decomposing cyanate of ethyl with potassa. The presence of this compound may be readily proved by evaporating the liquid, after the separation of the excess of bromide of ethyl, to dryness in the water-bath, in order to drive off alcohol which might have possibly been formed. On adding potassa-solution to the solid residue, an alkaline gas is at once evolved, which burns with the pale-blue flame of ethylamine.

If an alcoholic solution of ammonia be substituted for the aqueous liquid, the decomposition proceeds more rapidly. After twenty-four hours a copious crystalline precipitate of bromide of ammonium has been deposited. The mother-liquor contains hydrobromate of ethylamine and the base in the free state.

The action of bromide of ethyl upon ammonia may be considerably accelerated by raising the temperature to the boiling-point of water. I found it convenient to introduce a concentrated solution of ammonia, with an excess of bromide of ethyl, into pieces of combustion-tube 2 feet in length. These tubes, after having been carefully sealed before the blowpipe, were immersed to the height of about half a foot into boiling water. The bromide of ethyl enters at once into lively ebullition, rises through the supernatant layer of ammonia, condenses in the upper part of the tube, which is cold, and falls down to commence again the same circulation. During this process the bromide of ethyl diminishes rapidly in volume. The reaction may be considered terminated as soon as a quarter of an hour's ebullition ceases to effect a considerable change in the bulk of the bromide. On opening the tube, the solution

is found to be either neutral or even of an acid reaction, and to contain hydrobromate of ethylamine, which may be separated, by distillation with potassa, with all the properties enumerated by M. WURTZ. I have not to add a single word to the accurate description of this distinguished chemist, and will here only give the analysis of a platinum-salt prepared with ethylamine which had been obtained by this process:—

0.2521 grm. of platinum-salt gave 0.0992 grm. of platinum.

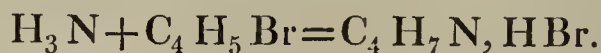
The formula



requires the following values:—

| | Theory. | | Experiment. |
|---------------------------------|---------|--------|-------------|
| 1 equiv. of Ethylamine . . . | 45.00 | 17.91 | — |
| 1 equiv. of Hydrochloric acid . | 36.50 | 14.55 | — |
| 2 equivs. of Chlorine . . . | 70.00 | 28.24 | — |
| 1 equiv. of Platinum . . . | 98.68 | 39.30 | 39.34 |
| 1 equiv. of Platinum-salt . . . | 260.18 | 100.00 | |

The production of ethylamine in this reaction is absolutely analogous to that of ethylaniline; it is represented by the equation



Formation of Diethylamine (Diethylammonia).

On treating an aqueous solution of ethylamine in the same manner with an excess of bromide of ethyl, phenomena of a perfectly analogous character are observed. The reaction however proceeds more rapidly and is terminated after a few hours' ebullition. The aqueous layer, which assumes a bright yellow colour, deposits acicular crystals on cooling, consisting of the hydrobromate of a new base, for which I propose the name diethylamine or diethylammonia. This base may be readily separated by distillation with potassa, when it passes over in form of a very volatile and inflammable liquid, which is still extremely soluble in water and of a powerful alkaline reaction. When dissolved in hydrochloric acid and mixed with a concentrated solution of bichloride of platinum, it yields a very soluble platinum-salt, which crystallizes in orange-red grains, very different from the orange-yellow leaves of the corresponding ethylamine-salt.

The analysis of this platinum-salt shows that diethylamine may be viewed as ammonia, in which 2 equivs. of hydrogen are replaced by 2 of ethyl.

0.2250 grm. of platinum-salt gave 0.1430 grm. of carbonic acid, and 0.0890 grm. of water.

0.3413 grm. of platinum-salt gave 0.1210 grm. of platinum.

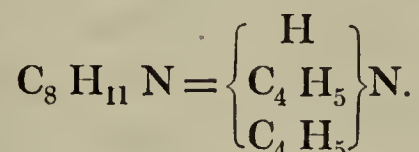
These numbers agree exactly with the formula



which requires the following values:—

| | Theory. | | Experiment. |
|----------------------------------|---------|--------|-------------|
| 8 equivs. of Carbon | 48·00 | 17·19 | 17·33 |
| 12 equivs. of Hydrogen | 12·00 | 4·30 | 4·39 |
| 1 equiv. of Nitrogen | 14·00 | 5·03 | — |
| 3 equivs. of Chlorine | 106·50 | 38·14 | — |
| 1 equiv. of Platinum | 98·68 | 35·34 | 35·45 |
| 1 equiv. of Platinum-salt. . . . | 279·18 | 100·00 | |

The preceding analyses establish the composition of diethylamine, which is represented by the formula



Formation of Triethylamine (Triethylammonia).

This arises from diethylamine in the same manner as the latter from ethylamine: however unlike the deportment observed in the formation of diethylaniline, the rapidity of the action increases with the progress of the ethylation. A mixture of a concentrated solution of diethylamine with bromide of ethyl solidifies after a very short ebullition into a mass of beautiful fibrous crystals, sometimes of several inches in length, being the hydrobromate of a new base, for which I propose the name of triethylamine or triethylammonia. This alkaloid may be readily separated by distillation with potassa, when it presents itself in the form of a light, colourless, powerfully alkaline liquid, still very volatile and inflammable, and also pretty soluble in water, but in a less degree than diethylamine.

To fix the composition of triethylamine, the platinum-salt was subjected to analysis. This is one of the finest salts which I have ever seen. It is extremely soluble in water, and crystallizes on the cooling of concentrated solutions in magnificent orange-red rhombic crystals, which are obtained of perfect regularity and of very considerable size (half an inch in diameter), even if very limited quantities of solution be employed. The analysis of this salt, which slightly fused at 100°, shows that triethylamine may be considered as ammonia, in which the 3 equivs. of hydrogen are replaced by 3 of ethyl.

I. 0·5950 gram. of platinum-salt gave 0·5110 gram. of carbonic acid, and 0·2800 gram. of water.

II. 0·1860 gram. of platinum-salt gave 0·0595 gram. of platinum.

III. 0·5230 gram. of platinum-salt gave 0·1679 gram. of platinum.

| | Percentage-composition. | | |
|--------------------|-------------------------|-------|-------|
| | I. | II. | III. |
| Carbon | 23·42 | — | — |
| Hydrogen | 5·22 | — | — |
| Platinum | — | 31·99 | 32·10 |

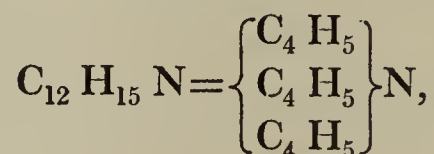
The formula



requires the following values:—

| | Theory. | | Experiment. |
|-------------------------------------|---------|--------|-------------|
| | | | |
| 12 equivs. of Carbon | 72·00 | 23·43 | 23·42 |
| 16 equivs. of Hydrogen | 16·00 | 5·20 | 5·22 |
| 1 equiv. of Nitrogen | 14·00 | 4·54 | — |
| 3 equivs. of Chlorine | 106·50 | 34·71 | — |
| 1 equiv. of Platinum | 98·68 | 32·12 | 32·04 |
| 1 equiv. of Platinum-salt | 307·18 | 100·00 | |

These numbers are sufficient to establish beyond a doubt the formula



as representing the compound in question.

Although not inclined to expect a farther action of bromide of ethyl upon triethylamine, after the experiments performed with diethylaniline, but hoping to obtain in this series more definite results than the latter had yielded, I thought it important to appeal once more to experiment. A mixture of an aqueous solution of triethylamine and bromide of ethyl, sealed for this purpose into a tube, solidified after two hours' ebullition. The crystals formed in this reaction had the fibrous aspect of the hydrobromate of triethylamine; still among the transparent prisms some white opaque granular crystals were observed. To gain more positive information, the excess of bromide of ethyl was volatilized and the residue distilled with potassa. The base obtained in this manner, converted into a platinum-salt and submitted in this form to analysis—

0·1040 grm. of platinum-salt left 0·0334 grm. of platinum.

Experimental percentage.

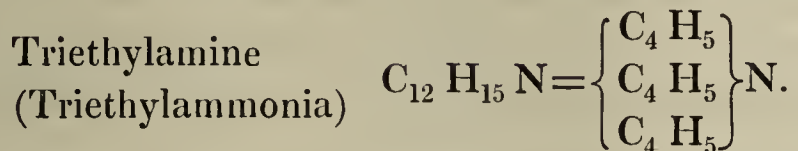
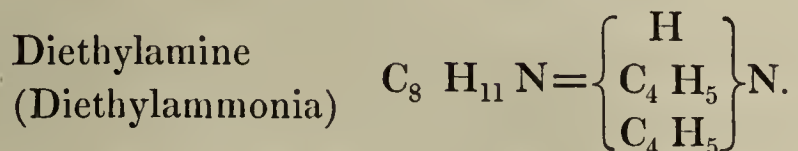
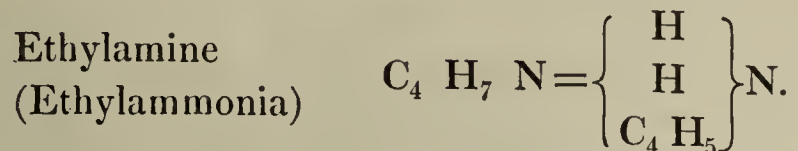
32·11

Theoretical percentage in the platinum-salt
of triethylamine.

32·11

Accordingly, the base which had distilled over, had evidently not been affected any farther by the influence of bromide of ethyl. The appearance however of the opaque crystals indicates that a second compound is formed, whose careful study is necessary for the elucidation of this reaction. I am at present engaged with this part of the inquiry.

The action then of bromide of ethyl upon ammonia gives rise to the formation of the following series of compounds:—



It cannot be doubted for a moment that the same compounds will be obtained in the methyl- and amyl-series, the first terms in each of these series having been actually prepared by M. WURTZ. Nor is it improbable that arseniетted and phosphoretted hydrogen, which, as is well known, imitate to a certain extent the habits of ammonia, when subjected to the action of the chlorides, bromides or iodides of the alcohol-radicals, will yield a series of arseniетted or phosphoretted bases, corresponding to the three classes observed with nitrogen. The highly remarkable bodies discovered by M. PAUL THENARD appear to warrant this expectation as far as the phosphorus-series is concerned, his compound



corresponding evidently in the phosphoretted methyl-series to triethylamine. I mean to extend these researches to the action of the bromides of the alcohol-radicals on phosphoretted and arseniетted hydrogen.

In the preceding pages, I have only endeavoured to establish the composition and the principal physical characters of the new compounds which form the subject of this investigation. To complete their history, it will be necessary to submit to a careful examination their deportment under the influence of the ordinary decomposing agents, and also their behaviour with other organic substances. The study of the imidogen- and nitrile-bases, to use this convenient though only provisional designation, will require particular attention, the character of the amidogen-bases being already pretty well established by the numerous researches respecting aniline, which have been performed within the last few years. We cannot but expect, that, although the general character of all these substances is very nearly the same, their special properties must present considerable diversity, which may be clearly defined by, and even anticipated from, the theoretical conception of their constitution, as deduced from the present investigation. Though fully aware of the dangers threatening the

inquirer as soon as he steps beyond the interpretation of well-established facts, it is difficult to resist the temptation of indulging even now in some speculations on the probable deportment of these alkaloids. In a former paper* I have pointed out that the methods which convert the ammonia-salts into nitriles, fail to produce a similar effect upon the salts of aniline, while experiment has shown that these salts are capable of producing compounds analogous to the amides, to the amidogen-acids and to the imides. This result is perfectly intelligible if we conceive aniline in the light of an amidogen-base. In the same manner we shall probably see that the imidogen-bases, such as ethylaniline and diethylamine, although still capable of giving rise to the formation of amides and amidogen-acids, will yield no longer compounds representing the imides of the ammonia-salts; in the nitrile-bases, lastly, such as diethylaniline or triethylamine, we shall probably find that the faculty of yielding derivatives by elimination of water is either restricted to the formation of compounds corresponding to the so-called amidogen-acids, or has entirely disappeared.

RELATION OF THE BASES DERIVED FROM ANILINE AND AMMONIA WITH
OTHER GROUPS OF ALKALOIDS.

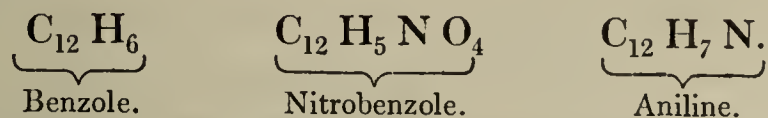
It is impossible to leave the history of these compounds without alluding to some remarkable relations existing between these substances and other bodies of an analogous character, whose constitution is likely to be illustrated by this line of researches. The basic substances derived from aniline, when expressed in formulæ excluding any peculiar view respecting the mode in which the elements are arranged, present a series which is exhibited in the following synoptical table:—

| | |
|------------------------------|---|
| Aniline | $C_{12} H_7 N =$ |
| Methylaniline | $C_{14} H_9 N = C_{12} H_7 N + C_2 H_2$ |
| Ethylaniline | $C_{16} H_{11} N = C_{12} H_7 N + 2 C_2 H_2$ |
| Methylethylaniline | $C_{18} H_{13} N = C_{12} H_7 N + 3 C_2 H_2$ |
| Diethylaniline | $C_{20} H_{15} N = C_{12} H_7 N + 4 C_2 H_2$ |
| Amylaniline | $C_{22} H_{17} N = C_{12} H_7 N + 5 C_2 H_2$ |
| Ethylamylniline | $C_{26} H_{21} N = C_{12} H_7 N + 7 C_2 H_2$ |
| Diamylniline | $C_{32} H_{27} N = C_{12} H_7 N + 10 C_2 H_2$ |

This table shows that the alkaloids in question differ from each other by $n C_2 H_2$, the elementary difference of the various alcohols and their derivatives; we perceive moreover that the series ascends regularly up to the term $C_{12} H_7 N + 5 C_2 H_2$, when the compound $C_{12} H_7 N + 6 C_2 H_2$ is wanting; lastly, we miss the terms $C_{12} H_7 N + 8 C_2 H_2$ and $C_{12} H_7 N + 9 C_2 H_2$. The first gap might be easily filled by submitting amylniline to the action of iodide of methyl, methylamylniline being in fact $C_{24} H_{19} N = C_{12} H_7 N + 6 C_2 H_2$. The other wanting terms cannot be reached from aniline before some of the missing alcohols are discovered.

* Chem. Soc. Quart. Journ. ii. p. 331.

On examining more closely the formulæ of the preceding conspectus, we find that several of them represent basic compounds previously known. Chemists are acquainted with the beautiful reaction by which ZININ first linked aniline to benzole through nitrobenzole.



Researches performed in the most different departments of organic chemistry have gradually elicited a series of carbohydrides differing from benzole by $n \text{C}_2 \text{H}_2$, and each of these terms, when treated with nitric acid, and subsequently exposed to the action of reducing agents, has yielded its corresponding base. We are now in the possession of the following series of alkaloids derived from hydrocarbons:—

| | | | |
|---------|--|-----------|--|
| Benzole | $\text{C}_{12} \text{H}_6$ | Aniline | $\text{C}_{12} \text{H}_7 \text{N}$ |
| Toluole | $\text{C}_{14} \text{H}_8 = \text{C}_{12} \text{H}_6 + \text{C}_2 \text{H}_2$ | Toluidine | $\text{C}_{14} \text{H}_9 \text{N} = \text{C}_{12} \text{H}_7 \text{N} + \text{C}_2 \text{H}_2$ |
| Xylole | $\text{C}_{16} \text{H}_{10} = \text{C}_{12} \text{H}_6 + 2 \text{C}_2 \text{H}_2$ | Xylidine* | $\text{C}_{16} \text{H}_{11} \text{N} = \text{C}_{12} \text{H}_7 \text{N} + 2 \text{C}_2 \text{H}_2$ |
| Cumole | $\text{C}_{18} \text{H}_{12} = \text{C}_{12} \text{H}_6 + 3 \text{C}_2 \text{H}_2$ | Cumidine† | $\text{C}_{18} \text{H}_{13} \text{N} = \text{C}_{12} \text{H}_7 \text{N} + 3 \text{C}_2 \text{H}_2$ |
| Cymole | $\text{C}_{20} \text{H}_{14} = \text{C}_{12} \text{H}_6 + 4 \text{C}_2 \text{H}_2$ | Cymidine‡ | $\text{C}_{20} \text{H}_{15} \text{N} = \text{C}_{12} \text{H}_7 \text{N} + 4 \text{C}_2 \text{H}_2$ |

On comparing the formulæ of the bases contained in the last table with those representing the alkaloids derived from aniline by the introduction of methyl and ethyl, we find that they exactly coincide. Toluidine has the same composition as methylaniline; xylidine, cumidine and cymidine are represented by the same formulæ as ethylaniline, methylethylaniline and diethylaniline. The question then arises, are these substances identical, or are they only isomeric with each other? I have carefully compared the properties of toluidine with those of methylaniline, and also methylethylaniline with cumidine. These substances are not identical, but only isomeric. The most striking dissimilarity we observe in the characters of toluidine and methylaniline. The former is a beautiful crystalline compound, boiling at 198° , yielding difficultly soluble, perfectly stable salts with almost all acids, and a splendid orange-yellow platinum-salt, which may be boiled without decomposition. We are unacquainted with any process by which we could convert this body into aniline. Methylaniline, on the other hand, is an oily liquid, boiling at 192° , whose salts are distinguished by their solubility and by the facility with which they are decomposed, aniline being reproduced (*vide* p. 113). The platinum-salt, even when freshly precipitated, is of a pale-yellow colour, which immediately darkens, turning perfectly black after the lapse of an hour. Scarcely less striking is the dissimilarity of cumidine and methylethylaniline, although in this case both substances are liquids. For

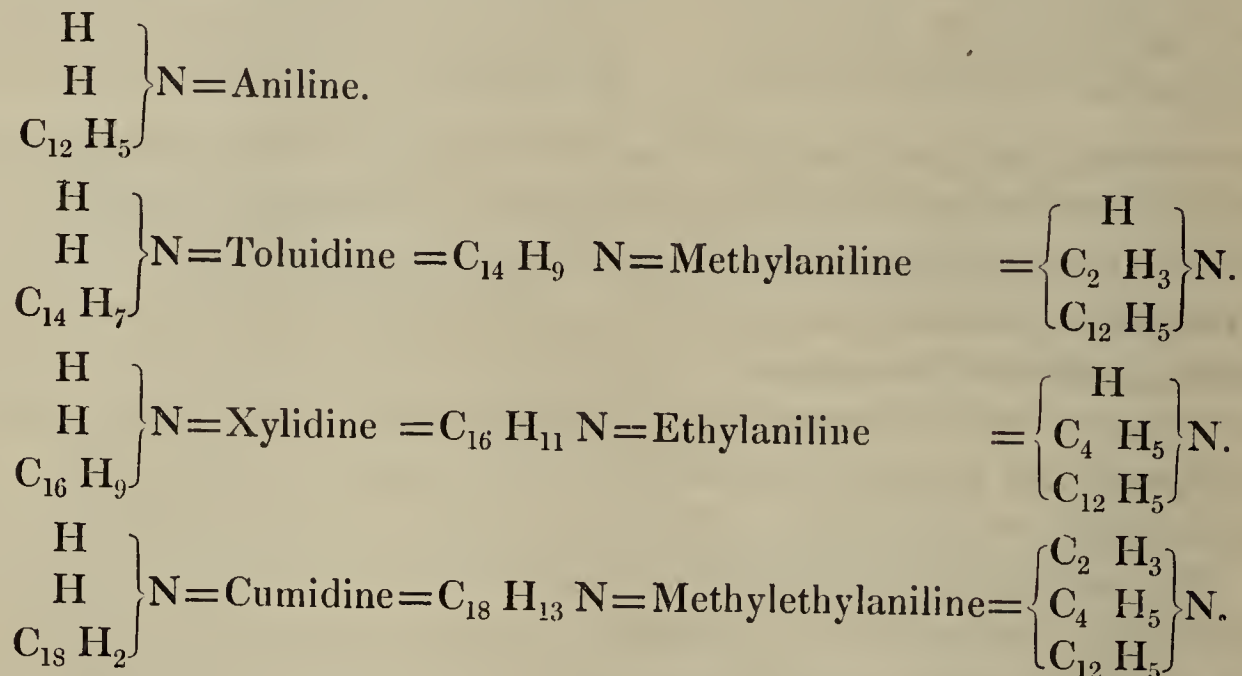
* Unpublished researches of M. CAHOURS. This chemist has lately found the long-wanted carbohydride $\text{C}_{16} \text{H}_{10}$, among the products of the distillation of wood. It comports itself exactly like benzole and its congeners, yielding nitroxylene and xylidine.

† On Cumidine, a new Organic Base, by E. CHAMBERS NICHOLSON, Chem. Soc. Quart. Journ. i. 1.

‡ This compound has been partly investigated by Mr. NOAD.

details I refer to Mr. NICHOLSON'S* paper on Cumidine, and to what I have stated about methylethylaniline (*vide* p. 114). The quantity of this substance I had at my disposal was not sufficient for a determination of the boiling-point; but if we recollect that ethylaniline boils at 204° , and that the introduction of methyl into aniline raised its boiling-point about 10° , it is evident that methylethylaniline cannot boil at a temperature much higher than 214° , *i. e.* eleven degrees below 225° , the boiling-point of cumidine observed by Mr. NICHOLSON. An account of the properties of xylidine has not yet been published; however, I have not the slightest doubt that M. CAHOURS will find them widely differing from those of ethylaniline.

Toluidine, xylidine and cumidine, resembling aniline, not only in their physical characters, but also in their origin from carbohydrides, evidently belong to the class of alkaloids for which I have provisionally retained the name amidogen-bases, while the basic compounds derived from aniline are either imidogen- or nitrile-bases. The difference of properties depends upon a difference in the molecular construction, as represented graphically by the following table:—



These formulæ assume the existence of a series of homologous radicals of compounds resembling in their chemical deportment, to a certain extent, the alcohols of the series $\text{C}_n \text{H}_{n+2} \text{O}_2$. In a former paper†, I have shown how this resemblance becomes more and more marked with every new investigation performed in this department of the science. A judicious application to these substances of the various methods hitherto employed in combining the radicals of the common alcohols with bromine or iodine, will probably enable us before long to obtain the corresponding products in the phenyl-, toluyl-, xylyl- and cumyl-series. The discovery of these substances will furnish us at once with new processes for the production of the basic compounds in question, for it cannot be doubted that their action upon ammonia will give rise to the formation of the respective alkaloids with the same facility with which the treatment of ammonia with bromide and iodide of ethyl induces the form-

* *Loc. cit.* p. 125.

† *Chem. Soc. Quart. Journ.* ii. p. 329.

ation of ethylamine; we may hope moreover to form the imidogen- and nitrile-terms of these radicals, in the phenyl-series for instance:—



the production of which, as mentioned in the commencement of this paper, I have in vain attempted by the action of the phenyl-alcohol at high temperatures upon aniline.

The view which I propose in the preceding remarks respecting the constitution of toluidine, xylidine and cumidine, must as yet be considered as a mere hypothesis. It will not however be difficult to establish it by facts. The action of bromide of ethyl upon these substances will at once decide this question. These bases, when subjected to the influence of the bromides, will give rise to the formation of a series of bases similar to those which I have obtained from aniline. I may mention that the deportment of toluidine and cumidine, in this respect, is now being studied by several of my pupils. There is no difficulty in introducing 1 equiv. of ethyl into toluidine; the experiments are however not yet sufficiently advanced as to affirm also the insertion of the second equivalent. The alkaloid obtained by acting with bromide of ethyl upon toluidine is represented by the formula

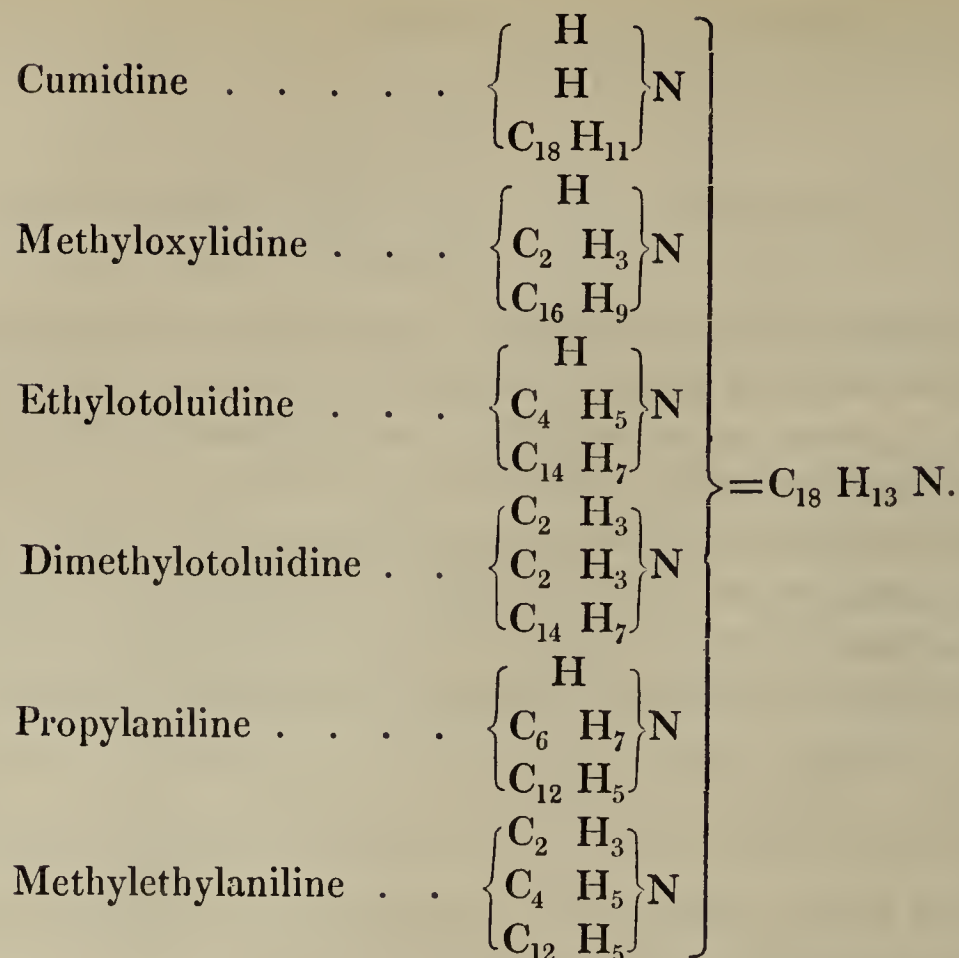


so that we are now in possession of three alkaloids of exactly the same composition, namely, ethyltoluidine, methylethylaniline and cumidine; and here I cannot but allude to the wonderful variety of isomeric compounds to which a continuation of these researches must necessarily lead. We see at a glance that substances of the formula



will also be obtained by inserting 1 equiv. of methyl into xylidine, by introducing 2 equivs. of methyl into toluidine, or by fixing upon aniline the radical (propyl) belonging to the missing alcohol of propionic acid* (metacetic acid). We thus arrive at six alkaloids, having all the same numerical formulæ, but widely differing in their construction.

* A more appropriate name for metacetic acid, proposed by DUMAS, MALAGUTI and LEBLANC (Compt. Rend. xxv. 656), as it is the *first* acid of the series $\text{C}_n \text{H}_n \text{O}_4$ that exhibits the character of a *fatty* acid, *i. e.* in being separated from solution as a layer of oil, and in forming salts with the alkalies that have a greasy appearance.



This multiplicity of course augments in the same measure as we ascend upon the scale of organic compounds. For every step the number of possible isomeric bases increases by two, so that on arriving at the term diamylaniline,



being the last member (*vide* p. 124) in the aniline-series which I have examined, we find that its numerical formula actually represents not less than twenty different alkaloids which the progress of science cannot fail to call into existence,—a striking illustration of the simplicity in variety that characterizes the creations of organic chemistry.

Not less numerous will be the isomerisms in the series of bases derived by the insertion into ammonia of the alcohol-radicals $\text{C}_n \text{H}_{n+1}$ only, as soon as the group of these alcohols themselves shall be more completely known. Ethylamine is isomeric with dimethylamine; diethylamine has the same composition as methylopropylamine, a base containing ethyl and propyl, the alcohol-radical in the propionic (meta-cetic) series, as dimethylethylamine, and lastly, as butylamine. Some chemists are actually inclined to consider as such a volatile alkaloid discovered by Dr. ANDERSON* among the products of the distillation of animal substances, and described by him under the name of petinine. The formula established by Dr. ANDERSON is



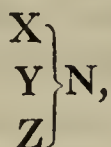
but it is not unlikely that on repeating the analysis an additional hydrogen-equivalent

* Transactions of the Royal Society of Edinburgh, xvi. 4.

will be found. The boiling-point of the compound (75°) is very much in favour of butylamine*.

In a similar manner a great number of bases identical in composition with triethylamine will soon be found; capronamine, methylamylamine, ethylobutylamine, dipropylamine, and a number of others.

In concluding this paper, which, from the great number of experimental details which I had to bring forward, has been swelled almost beyond legitimate dimensions, I cannot but allude to the aid which the study of the natural alkaloids may possibly derive from a prosecution of these researches. I am, as I have said, far from believing that the constitution of substances, like quinine and morphine, is as simple as that of the bases described in the preceding memoir; we know that the typical system



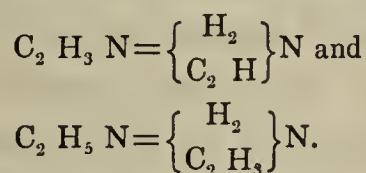
may in a variety of ways assimilate several other groups of elements without forfeiting its original character. Cyaniline, melaniline† and dicyanomelaniline, and their

* A perfectly similar remark applies to a compound lately discovered by ROCHLEDER among the products of decomposition of caffeine (Ann. Chem. und Pharm. lxxi. 7), and described by him under the name of formylamine.

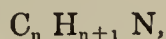
The formula



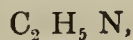
which ROCHLEDER gives for this compound, is, after we have become acquainted with the mode in which the methyl- and ethyl-bases are produced, very improbable. There appears to me a choice only between the formulæ



The former of these formulæ is improbable, on account of the great discrepancy both in the hydrogen and platinum observed and calculated; and it may be mentioned here that the existence of a series of bases of the formula



i. e. bases containing formyl, acetyl, propionyl (metacetyl), butyryl, &c., appears to be still doubtful on account of the electro-negative character of these radicals. By the action of bromide of acetyl, $C_4 H_7 Br$, upon ammonia, I have not as yet been able to obtain an alkaloid. The formula



which is that of methylamine, discovered by M. WURTZ, has analogy in its favour. The slight deficiency in the hydrogen can, it would appear, be scarcely adduced in opposition to the formulæ. The three formulæ are represented by the following numbers, which I place in juxtaposition with the mean of the analytical results.

| | $C_2 H_3 N.$ | $C_2 H_4 N.$ | $C_2 H_5 N.$ | Mean of analysis. |
|----------------|--------------|--------------|--------------|-------------------|
| Carbon | 5.10 | 5.09 | 5.06 | 4.86 |
| Hydrogen..... | 1.70 | 2.12 | 2.53 | 2.45 |
| Platinum | 42.52 | 41.77 | 41.60 | 41.39 |

† It seems that the homologues of aniline yield derivatives with the same facility as aniline itself: Mr. WILSON is at present engaged in studying the action of chloride of cyanogen upon toluidine; he has obtained a beautiful alkaloid represented by the formula $C_{30} H_{17} N_3$, which corresponds to melaniline.

congeners, are well-marked instances of such increasing complexity. The constitution of the natural alkaloids may be still more intricate. However, a series of well-devised experiments will not fail to exhibit the framework of these substances, an inspection of which will enable us to reconstruct them with the same facility as we build up our series of alcohol-bases.

The powerful and defined action of bromide of ethyl which I have pointed out in this paper will, it would appear, materially assist in the solution of this problem. We might by its aid succeed in ascertaining the state of substitution in which the ammonia exists in these compounds, or in other words, whether the alkaloid in question is an amidogen-, imidogen-, or nitrile-base. Some preliminary experiments made with two natural alkaloids, with nicotine and coniine, more closely allied, it is true, with the aniline-group than quinine, &c., appear to promise a harvest of interesting results. These substances evidently contain still basic hydrogen, for on mixing them with bromide of ethyl, they are rapidly attacked, with formation of the hydrobromates of two new bases, of which the salt of the nicotine-derivative is obtained in large beautiful crystals. An extension of this study to the bases of the cinchona bark and of opium, and to the bases of the series $C_n H_{n+1} N O_4$ (glycocine, sarcosine, leucine, &c.), whose constitution is at present still very enigmatical, may perhaps lead to similar results. These substances, complicated as their construction may appear at the first glance, will perhaps be found of a surprising simplicity when subjected to a closer examination. I may here quote the curious results which various chemists have obtained by treating with nitric acid and other powerful agents several of the natural alkaloids, results from which it would almost appear that several of these alkaloids, brucine and narcotine for instance, do actually contain methyl or ethyl, inasmuch as their decomposition seems to give rise to the formation of compounds of these radicals. The presence of such radicals as methyl and ethyl in natural alkaloids, is in itself scarcely a startling fact. We are still perfectly in the dark as to whether the pyroxylic spirit which we obtain in the dry distillation of wood is actually a product of destructive distillation, or whether it pre-existed in the wood before the process. At all events we know from the splendid researches of M. CAHOURS on the oil of *Gaultheria procumbens*, that methyl-compounds are actually secreted in the organism of plants. Ammonia in a nascent state coming into contact with these and other compounds, might easily give rise to the formation of basic substitution-products. In a recent communication, Dr. STENHOUSE* has proved that whenever ammonia separates from nitrogenous organic matter, by dry distillation, putrefaction, &c., we have invariably a formation of organic bases attending the evolution of this compound.

However, the question as to whether brucine and narcotine actually yield alcoholic compounds being still *sub judice*, it is better to defer for the present any farther speculations which might present themselves.

* Transactions of the Royal Society for 1850, Art. II. p. 56.

In conclusion, I append a synoptical view of the various basic compounds which I have derived from ammonia; this will exhibit the chief results of these researches, better perhaps than would a brief recapitulation of the several facts.

| TYPE. | AMIDOGEN-BASES. | IMIDOGEN-BASES. | NITRILE-BASES. |
|--------------------|-------------------------------------|---|---|
| Ammonia (Amine) | Aniline (Phenylamine) | Ethylaniline (Ethylophenylamine) | Diethylaniline (Diethylophenylamine) |
| | | Methylaniline (Methylophenylamine) | Methylethylaniline (Methylethylophenylamine) |
| | | Amylaniline (Amylophenylamine) | Diamylaniline (Diamylophenylamine) |
| | | | Ethylamylianiline (Ethylamylophenylamine) |
| | Chloraniline (Chlorophenylamine) | Ethylochloraniline (Ethylochlorophenylamine) | Diethylochloraniline (Diethylochlorophenylamine) |
| | Bromaniline (Bromophenylamine) | Ethylobromaniline (Ethylobromophenylamine) | |
| | Nitraniline (Nitrophenylamine) | Ethylonitraniline (Ethylonitrophenylamine) | |
| | Ethylamine (Ethylammonia) | Diethylamine (Diethylammonia) | Triethylamine (Triethylammonia) |

VI. *On the Development of the Great Anterior Veins in Man and Mammalia; including an Account of certain remnants of Fœtal Structure found in the Adult, a Comparative View of these Great Veins in the different Mammalia, and an Analysis of their occasional peculiarities in the Human Subject.* By JOHN MARSHALL, F.R.C.S., late Demonstrator of Anatomy in University College, London; Assistant Surgeon to the University College Hospital. Communicated by Professor SHARPEY, F.R.S.

Received June 19,—Read June 21, 1849.

THE principal object of the present paper is to state the result of observations on the metamorphosis of certain of the great veins in Man and Mammalia, and on the relation between the primitive and final condition of these vessels, both when they pass through their changes in the usual order, and in cases of deviation from it.

It is well known that in the mammalian embryo the great veins entering the heart from the upper or anterior part of the body are originally symmetrical on the two sides; and that in Man, the Quadrumana and most of the higher orders of quadrupeds, the venous trunk of the left side undergoes occlusion; whilst in other Mammalia that vessel continues, and constitutes, in the adult state, a left vena cava anterior, which passes down in front of the left lung, and then along the back of the heart in the auriculo-ventricular groove to terminate in the right auricle. Certain points of analogy between these different conditions are suggested by a careful examination of the great veins in adult hearts, more especially of what is usually regarded in the human subject as the dilated termination of the great coronary vein in the right auricle. This portion of the vessel (Plate I. fig. 1, *s*), which has muscular parietes, is, on account of its width, usually named the coronary sinus. Its length may be considered as defined by a valve (*x*) placed about an inch or more from its opening into the right auricle. This valve, which was known to VIEUSSENS*, has been again recently pointed out by Dr. JOHN REID†, and is described by him as generally existing and formed of one or two segments. In all the examinations which I have made I have found it present, and always consisting of two segments; a larger one placed on the side of the auriculo-ventricular furrow, and a smaller one situated on the free side of the vein, and therefore liable to be divided in slitting up

* *Traité de la Structure, &c. du Cœur.* Toulouse, 1715, p. 56.

† *Cyc. Anat. and Phys., Art. Heart,* p. 597.

that vessel (see Plate I.). Into the extremity of the coronary sinus, as thus defined, the great coronary vein (*g*) may be said to open, its entrance being guarded by the valve alluded to; and along the lower border of the sinus there enter three or four venous branches (*p, p, p*), which ascend from the back of the ventricles, one of them generally forming the middle cardiac vein (*m*); the mouths of these branches are also almost invariably provided with fine valves consisting of one or two segments, but beyond the coronary sinus and the larger valve first noticed, no more valves are met with either in the trunk of the principal cardiac or coronary vein, or in any of its tributary branches.

In the hearts of the Monkey, Cat and Dog, a precisely similar arrangement is observed.

In those animals which possess a left vena cava superior, the great cardiac or coronary vein ends in that additional venous trunk, as seen, for example, in the Marsupialia, many of the Rodentia, and in the Elephant. Moreover in certain Ruminant and other animals, as for example the Sheep (Plate I. fig. 2), in which a large left azygos vein exists, arching over the root of the left lung and thence pursuing the same course to the right auricle as the left vena cava superior in the cases already alluded to, the coronary vein (*g*) opens into this azygos venous trunk (*ss'*). In both these two conditions, as I have observed in the Rabbit, Hedgehog, Ox, Sheep and Pig, the lower part of the large left venous trunk is always dilated and muscular, and at the opening of the coronary vein into it, there is found a large valve composed in some cases of one segment (*x*), and in others of two. A series of small veins (*pmp*), ascending from the back of the heart, join it at intervals between the valved entrance of the coronary vein and the opening of the venous trunk itself into the right auricle; and, lastly, the mouths of these ascending cardiac veins are for the most part regularly provided with valves, whilst, on the contrary, no valves exist along the continuation upwards of the large venous trunk, at least in the neighbourhood of the heart; nor are valves met with, as a constant condition, in any other part of the cardiac veins themselves.

On comparing, in Man and Animals, the arrangement of these vessels and the disposition of their valves, I was led to conjecture that *the dilated and somewhat muscular portion of the coronary vein, usually named the coronary sinus* (Plate I. fig. 1, *s*), together with its large and important opening (*t*) into the right auricle, as seen in Man and such of the higher Mammalia as have no left vena cava superior or left azygos vein, *was strictly analogous to the expanded lower portion* (fig. 2, *s'*) and auricular orifice (*t*) *of those additional left venous trunks*, as found in other quadrupeds; and, in fact, that it *was the persistent lower part of the left anterior primitive venous trunk*.

On this supposition, the coronary vein *proper*, in Man and the higher Mammalia, might be said to end in the so-called coronary sinus, at the valved orifice above described; and thus its mode of termination, instead of varying in different cases, would be similar throughout the entire mammalian series,—the vessel in no case reaching

the right auricle directly, but always pouring its blood, like the posterior cardiac veins generally, into a larger venous trunk.

The analogy thus indicated between the coronary sinus on the one hand, and the lower portion of the left vena cava superior or left vena azygos on the other, is apparent, not only in their likeness as to shape and structure and the disposition of their branches and valves, but also in the similarity of their situation, direction and connections with the heart, and in the resemblance, not altogether overlooked by anatomists, of their respective openings into the right auricle.

According to RATHKE, however, whose authority is generally followed, the left anterior primitive venous trunk in the human subject closes and entirely disappears in the progress of development, from the root of the neck down to the heart. But if, on the contrary, the coronary sinus, as found in the adult condition, in Man and some of the higher Mammalia, be, as is above suggested, the *analogue* of, or, to express the fact in another form, be the *lower pervious portion* of the left primitive vein, might it not possibly happen that, even on the fully-formed heart, some remnant of its *upper occluded portion* should still exist, above the valved entrance of the coronary vein into the coronary sinus?

Searching, accordingly, in the adult human heart, I have found, in upwards of twenty different instances, certain parts or structures (Plate I. fig. 1, *o*, *l*, *v*) always clearly distinguishable, though varying in distinctness, which, from their position and general character, are undoubted remains of the upper portion of the left primitive venous trunk.

Analogous remnants of the left primitive vein are also to be seen, in all those Mammalia in which—as in the Dog, the Cat and the Monkey—the same amount of occlusion of that vessel occurs as in the human subject; and a comparative examination of the arrangement of the veins in different animals, of the various instances of deviation from the ordinary condition in Man*, and of the metamorphosis of these vessels in human and other embryos, has sufficed to establish, beyond a doubt, the identity of the parts under consideration.

The results of the entire investigation, together with due reference to the labours of others, may be conveniently presented under the following heads:—

1. Development of the great anterior veins.
2. Comparative view of the adult condition of these veins in Man and Mammalia.
3. Analysis of their varieties in the human subject.

* In the thirteenth observation out of twenty-four, I fortunately met with an example of double vena cava superior in the adult, a rare and interesting variety in relation to the present subject. Since then I have had presented to me a second example, occurring in a child between four and five years old. I may take the present opportunity of thanking Dr. SHARPEY, Mr. STREETER and Mr. W. BENNETT for aid in procuring materials for this investigation.

I. DEVELOPMENT OF THE GREAT ANTERIOR VEINS.

It has been shown by RATHKE*, to whom we are chiefly indebted for our knowledge of the development of the veins, that in Man and Mammalia, as in the Vertebrata generally, the blood of nearly all parts of the embryo is returned to the heart by two pairs of venous trunks, viz. an *anterior* and a *posterior* pair, placed symmetrically in the lateral halves of the body. Besides these, however, there is a median inferior venous trunk, which forms in succession the termination of the omphalomesenteric and umbilical veins, and finally becomes the *vena cava inferior*.

Of the four lateral veins, the anterior pair, formed by branches from the head and neck, constitute the *jugular veins*. The posterior pair, which return the blood from the Wolffian bodies and the hinder part of the embryo, are called the *cardinal veins*. The cardinal and the jugular vein of each side join to form a short wide vessel, named the *canal of CUVIER*; and again, the two canals of CUVIER (so named from their resemblance to the ductus Cuvieri in fishes) running downwards and forwards at the sides of the œsophagus, unite in front of that tube into a common trunk, which immediately enters the yet undivided auricular portion of the heart. In the subsequent enlargement of the yet single auricle, this common trunk comes, as it were, to form part of that cavity, into which accordingly the two canals of CUVIER henceforth open separately, and thus represent two superior venæ cavæ, one on each side.

When the Wolffian bodies disappear, the cardinal veins diminish in size, returning the blood from the hinder limbs and trunk of the embryo only. In the mean time the intercostal veins are formed and united together by vertical anastomoses on each side, so as to form the azygos and hemiazygos veins. Finally, in Man, the left cardinal vein becomes, according to RATHKE, *entirely obliterated*, whilst the upper portion of the vein of the right side is probably concerned in the formation of the termination of the azygos vein.

In the meantime a transverse connecting branch is developed across the lower part of the neck, between the two jugular veins. This transverse branch is rapidly enlarged, and then, in the human embryo, and also in those animals which have no permanent venous trunk on the left side, that portion of the original left jugular trunk which is situated lower down than the transverse branch, or nearer to the heart, and also the left canal of CUVIER which is continuous with it, shrink and disappear; the enlarging transverse branch across the neck forms the left innominate vein; and the lower part of the right jugular with its canal of CUVIER, receiving the remains of the right cardinal vein, now the terminal part of the vena azygos, constitutes the vena cava superior as ordinarily met with: thus the metamorphosis is complete.

In the Sheep, however, it was observed by RATHKE, that the upper part of the left

* RATHKE, "Ueber die früheste Form und die Entwicklung des Venensystemes beim Schafe" (MECKEL'S Archiv für. Anat. und Phys. 1830, p. 63); also, more particularly, "Ueber den Bau und die Entwicklung des Venensystems der Wirbelthiere"—(Dritter Bericht, über das Naturwissenschaftliche Seminar bei der Universität zu Königsberg. Königsberg, 1838).

cardinal vein and the left canal of CUVIER remain open to form the left azygos vein present in that animal; whilst that part of the left primitive venous trunk which is situated between the canal of CUVIER and the junction of the left subclavian and jugular veins, disappears, and only a subordinate twig is subsequently found in its place, which ends in a small left superior intercostal vein.

Lastly, in those animals which in the adult condition have a right and left superior vena cava, the left primitive jugular vein, together with the corresponding canal of CUVIER, remains pervious throughout life. This knowledge of the common type of formation of the veins in the Vertebrata, and of their metamorphosis in certain species by partial occlusion, suggested to RATHKE the explanation of the occasional occurrence of double vena cava superior in the human subject as the result of an arrest of development. Nevertheless, the details of this metamorphosis have not been fully indicated, nor, as far as I am aware, have any persistent remnants of the foetal structure been recognized in the adult. By RATHKE himself the left primitive vein is said, in Man, to *diminish and entirely disappear from opposite the left end of the transverse vein of the neck, down to the heart*; but this seems to have been an inference from the known adult condition, and I do not know that either he or others have given any description or delineation of the development of these veins, as actually traced in the human embryo.

The metamorphosis of the primitive lateral and symmetrical venous trunks in the higher Mammalia and in Man may be said to consist of *two fundamental changes*, viz. *a.* the formation of the cross branch or communication in the neck, and, *b.* the occlusion of a greater or less portion of the left primitive venous trunk. Besides this, however, there are, during embryonic life, *c.* certain concurrent and subsequent alterations in the size, position and direction of the venous trunks which finally remain pervious. Lastly, *d.* there are the changes which take place after birth.

Development in the Sheep.

a. Formation of the Transverse Communication in the Neck.

In embryos measuring $\frac{1}{20}$ ths of an inch, well-preserved in spirit, and in which the blood was hardened in the veins, no appearance of a cross branch was discernible. The earliest satisfactory indications of its commencement were met with in embryos from $\frac{1}{20}$ ths to $\frac{1}{10}$ ths of an inch in length. In these (Plate II. figs. 1, 2, 3), two little spur-shaped points, filled with hardened blood, projected towards each other from the inner borders of the jugular trunks (*aa'*) immediately above the commencing pericardium, on a level with the subdivision of the ascending aorta. In some cases, no intermediate portion of vein between these points could be detected; but in others the connection was evidently completed by a material, more opaque than that around, which could be often raised as an indistinct narrow cord, containing however no

hardened blood (fig. 5, *d*). Even in embryos as long as $\frac{1}{20}$ ths of an inch (fig. 4), no red line could be traced quite across the neck, although the lateral primitive veins were turgid with blood, and presented two conical projections at the situation of the cross branch.

This cross branch is supposed to be formed by the enlargement of a previously developed vessel of almost capillary dimensions, perhaps one of several such vessels passing across the neck; but it is possible that it might be formed in the same way as the other great vessels. The appearances above described would suggest the idea that this transverse branch was formed by the budding out and subsequent junction of two opposite points of the older veins, but this appearance is probably owing merely to the vessel being smaller and empty of blood in the middle of its course, or to its being accidentally broken at that point; but still it would seem that the extremities of the new transverse vein in connection with the older vessels are at first always enlarged more than the intermediate portion. In recent embryos of the Guinea Pig, measuring about half an inch in length, I have twice recognized the transverse branch as a very *minute continuous* vessel, passing quite across the neck, between the two jugular veins, just above the pericardium. In one very early embryo ($\frac{6}{20}$ ths of an inch long), a small vessel, evidently a vein, traversed the neck higher up, supported by the branchial arch which was being transformed into the lower jaw; the lower cross branch was not yet formed in this case.

During the widening of the cross branch, the two jugular trunks (*aa'*) at that point gradually approach each other,—the distance between them, absolutely as well as relatively, decreasing (compare figs. 2 and 6, representing embryos of $\frac{1}{20}$ ths and $\frac{1}{20}$ ths of an inch in length). Instead of descending parallel with each other, these veins now incline to the middle line of the neck, opposite the cross branch, and assisted by the shortening and widening out of that vessel, they appear at length to coalesce, almost by lateral adaptation, before any diminution of the left primitive vein has begun to take place (fig. 7, embryo 1 inch $\frac{2}{20}$ ths long).

In later embryos (fig. 8, 1 inch and $\frac{3}{20}$ ths long; fig. 10, $1\frac{1}{2}$ inch long), in which the neck is already becoming elongated, by the time that the occlusion of the left primitive vein is accomplished, the two jugular veins, having received the large superficial veins of the neck and those from the anterior limbs, are so closely applied to each other, and their connecting branch is become so entirely absorbed into them, that they join together at a very acute angle; or rather, the vein of the left side, now the left innominate vein, runs continuously into the lower part of the right primitive vein, or superior vena cava, whilst the right innominate vein appears to fall into this large continuous trunk at an acute angle.

At still later periods, when the vertebral column projects prominently forward at the lower end of the slender neck, immediately above the narrow aperture of the thorax, this obliquity of the junction between the innominate veins is as marked as in the adult animal.

b. *Occlusion of a portion of the Left Primitive Vein.*

Before the commencement of this stage of the metamorphosis, the jugular trunks are closely approximated and open freely into each other by means of the wide and very short communicating branch (fig. 7, *d*). Previously to this change also, that portion of both primitive jugulars which is situated below the cross branch, becomes elongated in accordance with the growth of the thorax, and now, inclining outwards, descends through a much longer course upon the pericardium, beneath the pleura, to join the cardinal vein of its own side and end in the corresponding canal of CUVIER. It is just this portion of the left primitive jugular vein, viz. from the transverse branch in the neck to the commencement of the left canal of CUVIER, which becomes closed in the Sheep. In embryos measuring 1 inch and 1 line (fig. 7), the vessel (*a'*) has either not begun, or is only just beginning to shrink; but so rapidly does the process take place, that in others scarcely 1 line longer (fig. 8), the vessel is already closed, and now appears as a semitransparent cord (*o*) extending from the point of junction of the primitive jugular trunks in the neck, to the arch formed by the left cardinal vein (*b'*) and left canal of CUVIER (*c'*). This cord is finer at its lower end; it lies at first in front of the aorta, and then passes down close to the pericardium, on the left side of the ductus arteriosus; it is in contact, below, with the left pleura; the par vagum descends behind it, and it is crossed by the phrenic nerve. Close behind the upper end of this cord, but not actually connected with it, a considerable vein, formed by the left vertebral and a large perforating intercostal from the back, joins the under side of the left innominate vein.

In later embryos the above-mentioned cord becomes less and less distinct; in an embryo measuring $1\frac{1}{2}$ inch long (fig. 10) it cannot be continuously traced, and in a foetal sheep, 4 inches in length (from the vertex to the tail), it is not perceptible. In its place, however, there is found a long ridge or elevation of the pericardium, containing fibrous tissue, which may be followed from below upwards, close to the left side of the large ductus arteriosus, in a direction towards the middle of the root of the neck. Above the pericardial sac, the traces of it are almost entirely lost.

c. *Concurrent and subsequent Changes in the Pervious Vessels.*

In *size*. As the left primitive vein is undergoing occlusion, the lower part of the right jugular vein (figs. 8, 10, *a*), and the right canal of CUVIER, simply enlarge, as RATHKE states, to form the superior vena cava. The adjoining part of the right cardinal vein, having first shrunk in consequence of the wasting of the Wolffian body, remains for a considerable time as a right azygos vein, equaling in size the left azygos; but about the middle of foetal life it is smaller than the vein on the left side, and afterwards, its connection with the right intercostal veins being gradually cut off, it slowly diminishes until it exists only as a very small vessel, or sometimes wholly disappears. The left cardinal vein (*b'*), on the contrary, forms, after the disappearance of the corresponding Wolffian body, a left vena azygos, which, though for

a time of the same size as the right azygos, afterwards surpasses it, in consequence of receiving the lower right intercostal veins, in addition to almost all those of its own side. The left canal of CUVIER (*c'*), reduced greatly in width after the occlusion of the primitive jugular vein, constitutes the intrapericardial part of the left azygos vein, and with the rest of that vessel forms a venous arch, which turns over the root of the left lung, and is connected above with the cord-like vestige of the occluded vein (*o*).

In *position* and *direction*. The cardinal veins, in order to unite with the jugular veins in the corresponding canals of CUVIER, bend forwards above the commencing lungs (figs. 1 and 2,—4, 4'), from which they are for a time separated by the upper end of the Wolffian bodies (5, 5'). The rudimentary right lung being, almost from the commencement, larger and somewhat higher up in the thorax than the left, the right cardinal vein (*b*), even at a very early period (see figs. 2 and 9), reaches higher than the vein of the left side (*b'*); a peculiarity in position which subsequently increases, so that in a foetus of 4 inches in length the arch of the right azygos rises three lines higher up in the thorax than that of the left vein.

The cardinal veins, like the jugulars, are altogether outside the pericardium; but as soon as that sac is formed, the canals of CUVIER are found almost entirely within it. At first (figs. 1, 2, 3, *c*, *c'*) these canals pass horizontally forwards and inwards to the back of the auricular portion of the heart, into which they open on the same level, one on either side, in front of the inferior cava; but as the lungs enlarge and occupy more of the thoracic cavity, the Cuvierian canals have to descend more and more obliquely in front of the roots of those organs to reach the heart (figs. 7 to 10). In accordance with the higher position of the root of the right lung, this change in direction is more marked in the right canal of CUVIER, or future vena cava superior.

The heart itself, in the progress of growth, becomes slightly twisted, especially at its base or auricular part, its right border being turned somewhat upwards, supposing the thorax to be placed vertically (fig. 9, embryo 1 inch and 2 lines long; the parts being seen from behind). Hence the enlarged right canal of CUVIER (*c*) or upper vena cava reaches the future right auricle sooner and more directly than the smaller left canal (*c'*) or left azygos venous trunk; the former having a comparatively short and almost vertical course, whilst the latter, after having descended in front of the root of the left lung, has to turn beneath the base of the heart to gain its destined end in the right auricle. At the same time the position of the openings of the metamorphosed canals of CUVIER in the future right auricle undergo a change; for instead of both of them being placed, as at first, on the same level, one on each side of the inferior cava, the orifice of the right canal or upper cava opens widely into the highest part of the auricle, nearly in a line with the lower cava (*e*), whilst the left canal or left azygos ends at the lower and back part of the auricle close to the commencing septum. The serous layer of the pericardium is at first equally reflected over both the Cuvierian canals, but in time, whilst it covers only a smaller and smaller part of the anterior surface of the right canal, or upper cava, it forms a more and more

distinct *fold* or duplicature (fig. 10 *c'*), in which the left canal or left azygos trunk is lodged as it passes down in front of the left pulmonary vessels to reach the side of the left auricle immediately behind the appendix. Beyond that point, the vein, as it lies on the back of the left auricle, and runs along the auriculo-ventricular groove to reach the right auricle, is also covered by the serous layer of the pericardium. In the heart of a foetus, 4 inches in length, several small veins from the substance of the left ventricle may be seen ending in the lower part of the left azygos trunk; and, amongst them, one, which joins it at an acute angle, is the future coronary vein.

d. *Changes at Birth.*

When, after birth, the short and wide ductus arteriosus shrinks, the long ridge of the pericardium with its contained fibrous tissue, already described as resting upon that vessel in the position of the occluded left vein, becomes closely applied to the left side of the aortic arch, and may be traced in the direction of a line drawn from the point of junction of the innominate veins at the root of the neck, down to the highest point of the arch of the left azygos vein.

Within the pericardium, the trunk of the left azygos occupies its proper *fold* of the serous membrane, and receives, shortly before its termination in the right auricle (as seen in Plate I. fig. 2), the coronary vein of the heart (*g*) and two posterior cardiac branches (*p, m*), besides a third smaller one (*p*), which might almost be said to end at once in the right auricle. The mouth (*t*) of this left azygos venous trunk is situated to the left of the orifice of the inferior cava (*e*), close to the interauricular septum, and below and behind the fossa ovalis, like that of the left superior cava in the lower Mammalia and in Birds. It has no Thebesian valve, which is represented, in the Sheep, merely by a slight ridge of the auricular parietes.

At the entrance of the coronary vein into the left azygos, there is, however, a large distinct valve (*x*), consisting of one strong segment. The two cardiac veins succeeding it are each guarded by finer valves of two segments, and the third vein generally by a single segment. Along the course of the coronary vein, there are from one to four other valves, consisting usually of one segment, but sometimes of two.

Lastly, the right azygos is now a much less important vein than that of the left side; it reaches from 3 to 5 inches higher in the chest, and is so small as to have been said by some anatomists, including RATHKE, to be always wanting. Occasionally, (once in five observations) it was found to be so trivial a vessel, that it was difficult to distinguish it as the actual persistent representative of the right cardinal vein.

Development in Man.

a. *Formation of the Transverse Branch in the Neck.*

No opportunity has offered itself of observing the time and mode of origin of the transverse branch in the human embryo, though it is probably originally formed in the same way as in the Sheep and Guinea Pig. In an embryo of $\frac{17}{20}$ ths of an inch in

length (Plate III. figs. 1, 2), the cross branch (*d*) was already formed. Owing to the width of the human thorax, the jugular veins do not approach each other closely at the root of the neck, as in the Sheep; the cross branch continues of a much greater length, and, at first horizontal in its direction, only assumes after a considerable time, the somewhat oblique position which it permanently holds as the left innominate vein. RATHKE describes it as formed opposite the point of junction of the jugular and subclavian veins; but in the embryos dissected by myself, it is a little *lower down* than that point and immediately above the commencing pericardium.

b. *Occlusion of part of the Left Primitive Veins.*

It is not until after the transverse connecting branch is already nearly as large as either jugular vein, that the venous channels destined to be occluded begin to shrink. Previously to the commencement of this stage of the metamorphosis, the cardinal veins (figs. 1, 2, *b*, *b'*) have much diminished in size owing to the wasting of the Wolfian bodies (5); but the two halves of the venous system are still quite symmetrical, except that the arch of the right cardinal vein is higher up than the left, in accordance with the greater size and relative altitude of the corresponding lung, as already pointed out in the Sheep. From opposite the cross branch, the two jugular veins descend behind the auricular appendices outside the pericardium, to become continuous with the canals of CUVIER (*c*, *c'*), which, having received the cardinal veins, immediately enter the pericardium, and bend inwards beneath the auricular portion of the heart, into which they open, one on each side of and somewhat before the inferior cava.

In addition to a part of the left primitive jugular vein, lying outside the pericardium below the cross branch in the neck, it will be found that in the human subject, in which there is no left azygos as in the Sheep, the left cardinal vein shrinks into an insignificant branch, and entirely disappears as a distinct trunk; whilst the greater part of the left canal of CUVIER, placed within the pericardium, is also closed; its last part, however, situated on the back of the left auricle, remaining permanently open. This pervious portion of the Cuvierian canal eventually forms the coronary sinus.

The first step towards this occlusion consists in a gradual shrinking of the left primitive venous channel from the left end of the cross branch down to the back of the heart, as shown in an embryo of 1 inch and $\frac{3}{20}$ ths in length (Plate III. fig. 3). The upper portion of the vein lies upon the aorta and ductus arteriosus, beneath the left pleura; whilst the lower portion, within the pericardium, crosses in front of the vessels of the left lung, lodged in a *duplicature* of the serous membrane, reminding one of the *fold* in which the left azygos vein is contained in the adult Sheep. The lower end of the vessel, placed on the back of the left auricle, is more dilated than the rest. In a more advanced embryo, 1 inch and $\frac{11}{20}$ ths long, the closure was complete, and had probably been accomplished a considerable time (fig. 4). The place of the primitive vein is now seen to be occupied by a *fine cord* (*c''*), which may be followed *from the under*

side of the left innominate vein down to the back of the auricle. This cord is covered by the pleura, and crossed by the left phrenic nerve; it descends in front of the par vagum, upon the side of the aorta and ductus arteriosus to the left pulmonary artery, opposite to which it penetrates the pericardium. Within this sac it crosses the small interval between the left pulmonary artery and veins, enclosed in a minute *fold* of the serous membrane; and then, becoming applied to the back of the left auricle, expands into a small *conical pouch* (*c'*), which is narrow and pointed above, but wider below, where it opens into the right part of the yet undivided auricular cavity. No left superior intercostal vein could be found in this embryo.

In no other foetus examined did the occlusion of the primitive left jugular vein extend quite up to the cross branch or left innominate vein; for there always remained a pervious but shrunken portion of the primitive vessel, which, as will immediately be shown, forms the *trunk* of the left superior intercostal vein. This fact is illustrated in fig. 5, *i*. In a somewhat later embryo (fig. 6), the cord of the occluded vein may be traced distinctly from the trunk of the left superior intercostal vein (*i*, which is here larger than usual), passing down through the fibrous layer of the pericardium, and entering its now narrow fold of the serous membrane (*c''*). Still later (Plate IV. fig. 9), the traces of a continuous cord above the pericardium are difficult to follow, and at the full period of foetal life it is generally impossible to find in that situation more than a few fine vertical fibrous bands lying close beneath the pleura. The *little fold* of the pericardium, so often alluded to, soon after the closure of its contained vessel, sinks, as it were, into the interval between the left pulmonary artery and veins (Plate III. figs. 5, 6, *c''*), where it is found in all future stages, and increases in size with the other parts (Plate IV. fig. 9, *v*). Below the fold, the remnant of the closed vein descends upon the left auricle, and may be traced for a time, as a slight ridge, but afterwards, when the auricle enlarges, as an *opaque line or streak*, passing close beneath the lowermost pulmonary vein, down to the apex of the *pouch-like* pervious portion of the primitive vein (Plate III. figs. 4, 5, 6; Plate IV. figs. 7, 8, 10, *c''*, and 9, *l*). By the period of birth (fig. 11), this opaque streak (*l*) has usually become interrupted or obscured.

c. Concurrent and subsequent Changes in the Pervious Vessels.

Contemporaneously with the shutting off of the left primitive venous channels, the cross branch in the neck (Plate III. figs. 1 to 6, *d*) enlarges and, together with a short portion of the left primitive vein below the entrance of the left subclavian, forms the *left innominate vein*; a small piece of the right primitive jugular, included between the entrance of the right subclavian and the junction with the cross branch, becomes the *right vena innominata*; whilst the remainder of the right primitive jugular, below the cross branch, together with the corresponding canal of CUVIER, becomes widened and forms the *superior vena cava* (*h*). At the junction of its two constituent parts, the vena cava receives the metamorphosed right cardinal vein, now the *vena azygos*, in which the right superior intercostal vein generally ends.

The métamorphosis of the pervious vessels on the *left* side is much more complicated.

Outside the pericardium.—In one embryo already mentioned (Plate III. fig. 4), the left primitive jugular vein was converted into a cord (c''), quite up to the cross branch or left innominate vein; and in that instance no trace whatever could be detected of the left cardinal vein. In such cases as the one referred to, the left superior intercostal vein may be subsequently formed through the development of small collateral veins, or it may be entirely wanting,—its intercostal branches ending then in some other vessels. Usually, however, a piece of the left primitive jugular vein, immediately below the cross branch, remains pervious and constitutes the trunk of the *left superior intercostal vein* (fig. 5, i), which passes over the side of the aorta at a higher point, as the thorax becomes elongated during development. The left cardinal vein may be entirely withered, but in some cases (fig. 7) the left primitive jugular remains open from the cross branch quite down to the commencement of the canal of CUVIER, where it receives the diminished left cardinal vein (b'), thus metamorphosed into the lowest branch of an unusually large left superior intercostal vein (i). This vein, besides intercostal branches, may be very early found to receive thymic, pericardiac and mediastinal branches, and often a bronchial vein. In all cases, however, the left cardinal vein is effectually cut off from the occluded left canal of CUVIER (c''), and is lost or interrupted at its lower part, so that the left intercostal system becomes broken up into several streams.

Within the pericardium.—The pouch-like pervious portion of the left primitive vein, seen on the back of the left auricle (Plate III. figs. 4, 5, 6, c' ; Plate IV. figs. 7, 8, s), is metamorphosed partly into a small *oblique auricular vein* (Plate IV. figs. 9, 10, 11, o), and partly into the *coronary sinus* (s).

On examining the back of the heart in a series of early embryos (Plate IV.)*, it will be seen, as already noticed in the Sheep, that in accordance with a certain twisting which takes place in this organ, important peculiarities in length and direction are early impressed upon the two canals of CUVIER, which are originally quite symmetrical. The right canal (figs. 1, 3, 5, c), or future superior cava, passes down perpendicularly from the neck, becomes widened and shortened, soon reaches the future right auricle, and enters by a wide orifice into the upper part of that cavity, nearly in a line with the inferior cava (e). The left canal (c'), whilst diminishing in size, pursues a more circuitous course along the left auricular cavity, beneath the base of the heart, to reach the lower and left part of the future right auricle, into which it opens by a constricted orifice surrounded by an opaque well-defined border.

Even at a very early period, when this left canal of CUVIER has scarcely begun to shrink, its lower part is found, on cutting it open (figs. 2, 4), to be a *distinct vascular tube*, applied to and connected with the back of the future left auricle, but not opening into that cavity; whilst its orifice maintains its connection with the right portion of

* All the figures in this Plate, excepting fig. 11, are enlarged to two diameters.

the yet undivided auricle, and is drawn with it, in the general movement of the heart, over to the right side. This being premised, it is easy to follow the changes which the lower pervious portion of the left canal of CUVIER undergoes, after the complete occlusion of its upper part, represented now by the opaque streak (fig. 9, *l*) on the wall of the left auricle, and by the minute fold of the pericardium (*v*) already described. For a time, the lower part of this canal persists as a conical pouch (Plate III. figs. 5, 6, *c'*); but subsequently (Plate IV. figs. 7, 8, from an embryo, $2\frac{1}{2}$ inches long) this conical venous channel becomes elongated; its upper part forms the *oblique vein* already mentioned, whilst its lower part (*s*) pursues its course to the right along the auriculo-ventricular furrow. The coronary vein (*g*), properly so called, is now seen to end, not in the right auricle itself, but *in this venous channel*, falling into its under side at an acute angle, at a short distance from its termination in the auricle. Still later, in a foetus 5 inches long, from vertex to coccyx, the same facts are as plainly observed (figs. 9, 10); and on cutting open the veins at this period, a *narrow oblique venous channel* (*o*), tapering to a point as it ascends to the left along the back of the auricle, may be traced from the point of entrance of the true coronary vein (*g*) upwards to the opaque streak (*l*), seen on the wall of the auricle; whilst below the entrance of the coronary vein, the venous channel becomes *dilated* (*s*) as it passes to the right, receives several cardiac veins, including generally the middle cardiac, and ends in the lower part of the right auricle, close to the interauricular septum, by a somewhat contracted orifice, which is guarded by a rudimentary valve. This wider lower portion of the persistent venous channel can even now be recognized, in all respects, as the *coronary sinus*, and the valve beginning to form at its auricular orifice is the Thebesian valve. The opening of the true coronary vein into it is marked by a sharply-ridged margin, but as yet there is no valve there.

As development advances to the full period of foetal life (fig. 11), the proper coronary vein (*g*), and the coronary sinus (*s*), become gradually more continuous in direction than heretofore, but the difference between them can be easily discerned, even externally. The muscularity of the sinus, as distinguished from the vein, becomes evident, and the opening of the latter into the former is protected by a valve, the two segments of which are for a time narrower in proportion than in the adult. Above the entrance of this vein into the sinus, a rounded recess leads upwards and to the left into the *small oblique vein* (*o*), which, taking the course of the primitive vessel, of which it is evidently the remnant, runs along the back of the left auricle, about half-way to the root of the pulmonary veins, and there ends in the opaque streak (*l*) previously mentioned. This small oblique vein is crossed superficially by the muscular fibres of the left auricle; it is peculiarly straight in its course, and receives tortuous branches from the walls of the auricle.

d. *Changes which take place at Birth.*

The shrinking of the ductus arteriosus, and the simultaneous enlargement of the pulmonary artery and veins and of the left auricle, are accompanied by changes in the intrapericardial remnants of the left primitive vein. The pericardial fold is, as it were, invaded by the enlarging pulmonary vessels, and becomes relatively shorter, and more deeply concealed between the left pulmonary artery and the subjacent vein. The narrow opaque streak running around the root of the pulmonary vein and along the back of the left auricle, pursues a longer course, and becomes attenuated or broken up. Lastly, as the left auricle expands, the oblique vein is less evident, and the true coronary vein and the coronary sinus become more alike to each other in direction and diameter.

Vestiges in the Adult Condition (Plate I. fig. 1, Plate V.).—The relation of the left superior intercostal vein to the primitive vessel in different cases has been already noticed. Commencing from the trunk of this vein (Plate V. *i*), there may frequently be traced a few *vertical fibrous bands* (*f*) lying beneath the pleura, posterior to the phrenic nerve, and usually accompanied by small blood-vessels and by a fine branch of the vagus nerve (13). Generally one of these bands may be actually followed to the left superior intercostal vein; and in most cases they are continued downwards through the pericardium into the pericardial fold.

This fold (Plate I. fig. 1, and Plate V. *v*), which might be named the *vestigial fold of the pericardium*, may be compared to the broad ligament of the liver, after the closure of the umbilical vein. As far as I know, it has hitherto escaped attention, though it is probably always present in the ordinary condition, as I have found it in twenty-two adult hearts*. In one instance, it could not be distinguished in consequence of complete adhesion of the pericardial surfaces, and in another, adventitious bands of membrane occupied its usual position. Sometimes it is obscured by fat, deposited within or near it. To demonstrate this vestigial fold and the opaque streak continuous with it below (which are almost unavoidably injured by dividing the great vessels within the pericardial sac), the heart, great vessels and pericardium, should be removed in connection with the root of the left lung; after which, on opening the pericardium and drawing asunder the left pulmonary artery and the subjacent pulmonary vein, the fold will be seen passing nearly vertically across the deep interval between those vessels (Plate V. *v*). Besides a duplicature of the serous layer of the pericardium, including cellular and fatty tissue, the vestigial fold contains some fibrous bands, small blood-vessels and nervous filaments. Its opaque well-defined and curved margin is commonly from half to three quarters of an inch in length, but I have once found it measure upwards of an inch and a half. It varies in thickness in different

* SENAC states (Traité du Mouvement du Cœur, &c. Paris 1749, p. 14) that HALLER, in his account of the reflections and cornua of the pericardium, following EUSTACHIUS and LANCISI, has described, amongst many others, a falciform process (*fauix*) between the left pulmonary artery and veins; but I can only find in HALLER a description of a "saccus" or depression between those vessels.

cases, and it may be from half an inch to an inch in depth, according to the nature of the interval between the pulmonary artery and vein. Above the pulmonary artery, the vestigial fold blends with the pericardium, and its fibrous bundles may frequently be traced into those already described as passing beneath the pleura up to the left superior intercostal vein. Its lower end is lost on the side of the left auricle in the *narrow opaque and often interrupted streak* (*l*), which courses around the root of the lower left pulmonary vein. This streak represents the part of the left Cuvierian canal which has undergone the greatest amount of obliteration, and it is sometimes almost entirely wanting. In the same situation scattered whitish bands are commonly seen beneath the serous membrane of the back of the left auricle, closely connected with the muscular fibres and descending towards the oblique vein: amongst them there are some fine branches of nerves. They mark only the *track* of the previously existing vein. In some instances a prominent ridge exists in their place upon the back of the auricle.

The *small oblique auricular vein* (*o*), which has been shown to form part of the pervious portion of the left canal of CUVIER, is remarkably constant; and indeed has been recognized by some of the early anatomists as a branch of the great coronary vein*. This short vessel is readily distinguishable from its tributary branches by its direct course, a character not possessed by the cardiac veins generally. Moreover, it is as if it were imbedded in the walls of the left auricle, so that it appears covered by muscular bundles, like the coronary sinus itself. Frequently it measures from half an inch to an inch in length, and sometimes is as large as a crow-quill, but more commonly it is smaller, and will admit only the head of a pin. I have once seen it an inch and a quarter in length, and as wide as a common goose-quill; but, however large it may be, its opening into the coronary sinus is never provided with a valve. Its upper end either tapers and ends in a fine branch; or, as more frequently found, especially in young subjects, it does not alter much in width as it ascends, but terminates rather abruptly, and receives, close to its extremity, one or two tortuous lateral branches of nearly equal size.

In some instances I have found a long slender vessel ascending from the upper part of this short vein, along the back of the auricle into the vestigial fold, and ultimately through the pericardium, just above the root of the left lung. It there joins

* It is represented by RUYSCHE (Thesaur. iv. tab. 3. fig. 1), and also by SENAC (*op. cit.* planche 2). HALLER (Oper. Minora, t. i. lib. i. p. 11) speaks of one particular branch of the great coronary vein coming from the left auricle. THEILE (SOEEMERRING'S Anatomy) has a similar statement. This small vein has also been occasionally indicated in drawings of the heart given for other purposes; and it may be seen readily in most injected hearts preserved in anatomical museums.

VIEUSSENS (Traité du Cœur, pp. 2, 55, planche 1. fig. 2, and planche 5. fig. 2) mentions and represents in two instances, as if ordinarily present, a large branch of the coronary vein in the situation of this oblique vessel, which he describes as returning the blood from the pericardial sac. HALLER remarks (Op. Min., t. i. lib. i. p. 11, note) that he has never seen this *vein of the pericardium*, which is certainly represented by VIEUSSENS, both longer and wider, than, according to my experience, the oblique vein ever is in the *human* heart.

a small branch descending from one of the veins accompanying the phrenic nerve, and so is connected with the left superior intercostal vein. This slender vessel, which receives many little branches along its course, is not however part of the metamorphosed left primitive vein, but is formed by the enlargement of the minute inosculating veins of the parts which occupy the position of the obliterated vessel. In one case indeed, which was carefully dissected, the lower end of this small vein was found not to coincide with the trunk of the oblique auricular vein, but to fall into one of the lateral tortuous branches of that persistent vessel.

The arrangement of the valves in the *coronary sinus* in the adult has been fully described in the introduction to this paper. The abrupt commencement of the sinus, pointed out by Dr. J. REID, is owing to a rounded recess, formed on the auricular side of the principal valve (Plate I. fig. 1, *x*), into which the unvalved orifice of the short oblique vein (*o*) is *constantly* found to open. The sinus itself is described by the same observer as having "the appearance of a muscular reservoir placed at the termination of the (coronary) vein, similar to the auricles (auricle?) at the termination of the two cavæ;" but its relations to the left primitive vein in the embryo, and its analogies in the lower animals, have not hitherto been mentioned by anatomical writers; though Professor SHARPEY has been accustomed to point out, in his lectures, the resemblance between the coronary sinus and the lower end of the left superior cava.

II. COMPARATIVE VIEW OF THE GREAT ANTERIOR VEINS IN MAN AND MAMMALIA.

Our knowledge of these veins in most of the Mammalia is still deficient, and many of the descriptions which exist are incomplete in points of detail. To the information gathered from other sources, I may add the results of observations made by myself on the veins of the Hedgehog, Rabbit, Rat, Mouse and Bat; of the common Mole, the Sheep, Ox, Hog, Guinea Pig and Horse; and of the Polecat, the Seal, the Dog, the Cat and the Monkey*.

* Since the observations and deductions contained in this paper were completed, and the paper itself entirely written, I have seen in the 4th and 5th No. of MÜLLER'S Archiv for 1848, a short but very interesting communication by Dr. BARDELEBEN of Giessen, entitled "Ueber vena azygos, hemi-azygos und coronaria cordis bei Säugethieren," in which, after classifying the different Mammalia according to the condition of the *Azygos* and *Hemi-azygos* veins, as observed by RATHKE (*op. cit.* 1838) and himself, into four groups,—viz. I. those having neither of these veins; II. those having both; III. those having an azygos only; and IV. those having a hemiazygos only,—he arrives, from a comparison of the adult condition of the veins in the different cases, at the same conclusion as myself in regard to the analogy of the coronary sinus with the lower part of the left vena azygos or left vena cava superior. "If," he says, "the left canal of CUVIER continues in connection with the left jugular vein, so as subsequently to form the left vena cava superior, the coronary vein is said to open into the left superior cava. If all the blood is conveyed across the neck by the anastomosing branch between the left and the right jugular veins, and the portion of the left jugular between this cross branch and the left canal of CUVIER disappears, the last-named vessel continues to be connected with the intercostal system only; and then the coronary vein may be said to end in the left or hemi-azygos, or *vice versâ*. Finally, this connection of the left canal of CUVIER being also obliterated, there remains only that portion of the vessel in which

All the varieties of arrangement hitherto observed in the great anterior veins of the Mammalia may be classified according to the amount of deviation which they present from the type, pointed out by RATHKE, as originally common to all the Vertebrata, viz. that of four lateral primitive trunks.

The modifications of this type observed in the cold-blooded Vertebrata are strictly of a subordinate kind, affecting merely the relative size which particular vessels ultimately acquire. Even in birds there is no fundamental deviation from the original type. The four primitive lateral veins persist. No transverse branch is formed across the root of the neck, though a free communication exists between the jugular veins just beneath the skull. The right and left superior cavæ remain independent of each other as originally laid down, and each receives its own azygos vein.

Amongst the Mammalia, however, there appears to be no instance in which some change from the common primitive type does not take place. Throughout the whole class, so far as is known, there is the addition of a communicating branch across the root of the neck, between the two anterior primitive venous trunks. It is found even in the low bird-like Monotremes; and, should it prove to be universal, it will constitute one characteristic mark of the mammalian venous system.

The formation of this transverse communicating branch, which of necessity *precedes* the occlusion of the left primitive vein in the higher mammalian embryo, appears as the first, the simplest and the only change in the lowest forms of the mammalian series. Superadded to this preliminary step in the foetal development, and superadded also in the highest forms of adult Mammalia and in Man, is found another change, depending on one of two modes of partial occlusion of the left anterior primitive venous trunk.

In this way *three* different permanent conditions arise. In all of them the transverse communication in the neck exists. The right venous trunk always constitutes the vena cava superior of that side; but the left vein either forms,—A, a similar large venous trunk on that side, named a left vena cava superior, which receives the left jugular and subclavian veins, the left intercostals and certain cardiac veins; or B, it is reduced to a smaller left venous trunk, which receives merely the left intercostal veins and some cardiac veins; or, C, it remains as a still smaller vessel, receiving only a few cardiac veins from the substance of the heart. These three conditions accordingly are distinguished by severally presenting—

A. A right and a left vena cava superior.

B. A right vena cava superior and a left azygos venous trunk.

C. A right vena cava superior and a left cardiac venous trunk or coronary sinus.

the veins from the substance of the heart terminate, and which will then be recognized as the great coronary vein. This is the condition in Man and in most Mammalia. In fact, in no mammalian does the left canal of CUVIER entirely disappear. Even in cases where by far the largest portion of it is obliterated, that part which runs along the posterior transverse furrow of the heart remains as the trunk of the cardiac veins." I have availed myself of Dr. BARDELEBEN'S memoir, to introduce some additional examples of varieties of the great veins in animals.

Group A. *A right and a left vena cava superior*.—This condition exists in a large number of the lower Mammalia, viz. in the Monotremata* and Marsupialia†; in most Rodentia, as in the Dormouse*, Marmotte*, Rat‡§, Echimys*, Mouse‡§, Squirrel*‡, Beaver*, Hamster*, Mole of the Cape*, Hare‡ and Rabbit*§‡. It is found also in the Elephant*|| amongst Pachydermata; and in the Hedgehog‡§ and Bat*‡§ amongst Insectivora and Chiroptera.

In all such cases, the cross branch in the neck, when sought for, has been found. The left vena cava superior always descends in front of the root of the left lung, and then turns beneath the base of the heart, and after receiving the great coronary and other cardiac veins in its course, opens into the right auricle¶.

Owing to *subordinate* modifications in the azygos veins, this group may be again subdivided as follows:—

a. An azygos vein on each side.

a. Of equal size.

Ex. Monotremes. Marsupials (?).

b. Of unequal size.

α. Left azygos the larger.

Ex. Hedgehog**, Rat, Mouse**.

β. Right azygos the larger.

Ex. Rabbit.

b. An azygos vein on one side only.

a. A left azygos only.

Ex. (?).

b. A right azygos only.

Ex. The Squirrel. The Hare. The Rabbit is a near approach to this condition, the left azygos being very insignificant.

c. Azygos vein wanting (?).

Group B. *A right vena cava superior and a left azygos venous trunk*.—This arrangement prevails in most of the larger quadrupeds. It occurs in the Ungulates, Rumi-

* MECKEL (Anat. Comp. par Jourdan, t. ix.) is the authority for including these animals.

† MECKEL. Also OWEN (Cycl. Anat. and Phys.).

‡ RATHKE (Dritter Bericht, &c. Königsberg, 1838).

§ The Author.

|| Mus. Anat. of University Coll. and of Royal Coll. of Surg. London.

¶ In the Marsupialia, and also in the Monotremata, the left upper cava joins the inferior cava just before that vein expands into the right auricle (OWEN, Articles *Marsup.* and *Monotrem.* Cycl. Anat. and Phys., vol. iii. pp. 307, 309 and 390). This peculiarity, which is particularly marked in those marsupials which have a large vena cava inferior (owing to the size of their hinder limbs), appears to be due merely to an opening out, as it were, of the orifices of the two veins, so that they meet and blend with each other.

** EUSTACHIUS (Opuscula Anat. de venâ sine pari, p. 273) describes the large left azygos of the Hedgehog and Mouse, and also a splitting of the inferior cava, in the former animal, into two branches, of which one is evidently the left upper cava.

nants and Solipeds, as illustrated in the Hog*†, Wild Boar and Guinea Pig†; in the Sheep*†, Goat*‡, Ox*†, Dicotyles‡ and *Moschus javensis*‡, and in the Horse†. It is also present in the common Mole†.

The cross branch in the neck is necessarily present and forms the left innominate vein. The left azygos trunk arching over the root of the corresponding lung, descends in front of it and then turns (like the left vena cava superior in the former group) beneath the base of the heart to reach the right auricle, being first joined by the great coronary and some other cardiac veins.

Several gradations in the size of this left azygos trunk are met with in this group, which further observation on recent animals would probably render more complete, and which conduct by degrees to the third group, where the left venous trunk, reduced to its smallest persistent remnant, receives only veins from the substance of the heart.

Thus in the Hog, the left azygos trunk is very large, and returns the blood not only from its own side, but from the lowermost intercostal spaces of the right side also§. In the Sheep and Ox it is, comparatively speaking, smaller. Finally, in the Horse, it is reduced to a very fine vessel, so that the left venous trunk conveys scarcely more than the blood from the cardiac veins; and in one case I found it quite closed as it passed along the left auricle||.

This gradual diminution of the left azygos trunk is accompanied by an equivalent increase in the size of the right azygos vein. For example: the right azygos is small and sometimes even wanting in the Hog; it is always an insignificant branch in the Sheep; it is very evident in the Ox; and very large in the Horse. In the last-named animal it returns most of the blood from the left intercostal spaces also, and thus exhibits the reverse of the condition observed in the Hog; and approaches, in this respect, the characters of the third and last group¶.

* EUSTACHIUS (*op. cit.* p. 273) describes the left azygos in the Ox, Goat, Sheep and Hog, as passing over the left bronchus, and states that the coronary vein ends in it. BARTHOLINE, THOM. (*Hist. Anat.* 84. Cent. ii. p. 322) appears to have seen the left azygos in the heart of a lamb. LANCISI (*Epist. de venâ sine pari*, MORGAGNI'S *Advers. Anat.* V. p. 80) mentions the left vena azygos in the same animals as named by EUSTACHIUS. RIDLEY (*Observat. Medic. Pract.* p. 219. In vitulo) says that, in the Sheep and Calf, the azygos is a *left* vein, which he imagined emptied itself into the left auricle or left pulmonary vein. SCARPA (*Tabulæ Neurolog.* tab. 7. fig. 4) mentions and also figures the left azygos vein in the Calf "ending in the trunk of the coronary vein."

† The Author.

‡ BARDELEBEN.

§ Correctly described by LANCISI (*op. cit.* p. 80).

|| It is said by RATHKE to be absent in the Horse; and by BARDELEBEN in the Ass.

¶ The transition from this to the third group is exemplified not only in the Horse and Ass, among Solipeds, but also in the Ruminantia; for I find that in the injected heart of the Camel (Museum of the Royal Coll. of Surgeons, London, Preparations 111, 112), the only trace of a left azygos visible consists apparently of a rather large oblique branch of the coronary vein on the back of the left auricle. The injected heart of the Tapir (Mus. Royal Coll. Surgeons, Preparation 105), in which animal BARDELEBEN says the left azygos is wanting, also exhibits a similar condition, the oblique vein being so large that it may be a rudimentary left azygos vein.

Group C. *A right vena cava superior, and a left cardiac venous trunk or coronary sinus.*—This arrangement prevails in the higher Mammalia, as in the Whale*, Dolphin* and Porpoise* among Cetacea, in the Seal†, Walrus*, Dog†, Cat†, Tiger‡, Hyæna‡, Polecat† and Ermine‡ among Carnivora, in the Quadrumana, as for example, in two small species of Monkey†; and lastly, in the human subject.

The left primitive trunk, now reduced to a cardiac vein, forms the *coronary sinus*, with its *small oblique branch* on the back of the left auricle, and having received the great coronary and some other cardiac veins, opens into the right auricle. The oblique vein is more or less evident in different cases. Thus it is large in the human subject; very apparent in the Dolphin, smaller in the Porpoise and the Dog, less evident in the Whale and Walrus, and very small in the Seal, Cat and Tiger§. The *vestigial fold* is more distinct in Man than in any animal which I have hitherto examined in the recent state; but it is readily seen in the Monkey, Dog and Cat.

Almost invariably the right azygos persists, whilst the lower intercostal veins of the left side, instead of forming a left azygos venous trunk, unite into an azygos minor which joins the right azygos. Variations in the extent of the azygos and azygos minor constitute subordinate peculiarities. In the Cetacea||, the remarkable condition is found of total absence of the right azygos as well as of the left azygos vein.

Peculiarities of the coronary vein and sinus in certain animals.—In the Ornithorhynchus, in which animal the left superior cava joins the inferior cava immediately before its termination in the right auricle, the coronary vein is said to open directly into the auricle by a separate orifice *to the right* of the inferior cava¶. It seems not improbable that in this case the vein in question is rather a *posterior cardiac vein*, ascending upon the back of the ventricles, the vessel in the ordinary position of the coronary vein being diminished in size or absent. In very small animals having a left anterior venous trunk, as in the Mouse and Bat, I have observed that this condition exists**.

The arrangement of the valves of the coronary and other cardiac veins at their respective terminations in the coronary sinus, the left azygos trunk or the left vena cava superior, has already been examined and compared (pp. 133, 134). As to the Thebesian valve, it is present in every instance in which the left venous trunk forms

* Preparations in Mus. Royal Coll. Surg. Lond.: Whale, No. 135; Dolphin, No. 127; Porpoise, No. 130; Walrus, No. 76; Tiger, No. 68: also Mus. University Coll. Lond.

† The Author.

‡ BARDELEBEN.

§ Some of these observations have been made only on dried injected hearts.

|| VON BAER (Nova Acta Acad. Cæs. Leop. Carol. vol. xvii. p. 408), also heart of the Whale, Mus. Royal Coll. Surg. Lond. Prep. No. 135.

¶ MECKEL (quoted in Prof. OWEN'S Art. *Monotremata*, Cycl. Anat. and Phys. p. 390).

** It is also seen in the small heart of the common fowl, though in the larger heart of the Ostrich the coronary vein occupies its usual position and opens into the left superior cava (OWEN, Art. *Aves*, Cycl. Anat. and Phys. vol. i. p. 330).

a coronary sinus receiving veins from the heart alone, as in Man, and in the Monkey, Dog and Cat: but amongst those animals which have a left azygos or left superior cava, it is certainly absent, as in the Calf, Hog, Sheep, Horse, Ass*, Rabbit and Hedgehog.

III. ANALYSIS OF THE VARIETIES OF THE GREAT ANTERIOR VEINS IN MAN.

The different conditions of the great anterior veins in the Mammalia having been classified according to their progressively increasing deviation from the common vertebrate type, an attempt may be made, in analysing the varieties of these vessels met with in Man, to retrace the series from forms presenting the most complex metamorphosis to such as manifest no fundamental change whatever. In this series the ordinary condition of the veins is included as the *most frequent* actual variety.

The formation of the cross branch at the root of the neck being regarded as the initial step in the metamorphosis of this portion of the human as of the mammalian venous system, the varieties of these veins in Man may be divided into two classes, according to the *presence* or *absence* of this transverse branch.

The occurrence, in one or another degree, or the entire failure of the subsequent stage of the metamorphosis, viz. the occlusion of one of the lateral primitive veins, suffices to distinguish the *first* class of varieties into three groups, corresponding with those already indicated as the regular conditions in different Mammalia. A. In the first group, comprehending the normal condition, in which the occlusion is of the greatest known extent †, the persistent portion of the vein, after metamorphosis, conveys only the blood from the substance of the heart, and forms a *cardiac venous trunk*. B. In the second, it would also return the blood from its own side of the thorax, and thus constitute an *azygos venous trunk*. C. In the third, where no occlusion occurs, it transmits the blood from the whole of its own side of the upper part of the body, and is then a *second vena cava superior*.

In all of these cases, one of the lateral primitive veins is developed into the ordinary vena cava superior, and in most instances this is the vein of the right side, whilst that of the left undergoes metamorphosis; but the reverse of this may happen, as

* REID (Art. *Heart*, Cycl. Anat. and Phys. p. 597).

† It has already been shown that *complete* occlusion of this primitive vein (*i. e.* from the neck down to its entrance in the right auricle) does not (as RATHKE supposed) occur, in the ordinary condition, even of the highest Mammalia or of Man, nor has it yet been seen as an occasional variety. That it ever does happen is scarcely probable; for just as in the utmost known amount of abnormal obliteration of the inferior cava, the hepatic veins always concur to form a short inferior trunk, which opens into the right auricle, so the confluence of the coronary and other cardiac veins may set a like limit to the occlusion of the left anterior primitive venous trunk. Nevertheless, it is possible that the process might extend to the closure of its lower end or coronary sinus also, the blood from the substance of the heart then returning to the right auricle directly through enlarged anterior or posterior cardiac veins, or taking some altogether different course. In a curious case recorded by LE CAT, and hereafter to be particularly mentioned, the auricular end of the left primitive vein seems really to have been closed, though its channel continued pervious up to the neck.

when the viscera are transposed; so that *transposition*, as an additional cause of peculiarity, may affect any of the preceding groups.

Lastly, the three principal groups may present subordinate variations, depending on peculiarities either in the upper vena cava itself, or in the azygos veins, or in the coronary vein of the heart.

In the *second* class of varieties, in which no cross branch is formed in the neck, both of the lateral primitive veins are necessarily persistent, each carrying back the blood of its own side. Such cases may also present peculiarities in the azygos system, or may be complicated by transposition of the heart.

Though the records of the varieties in these great veins in the human subject do not as yet supply examples of every conceivable deviation, and though the descriptions of many are somewhat obscure or incomplete, they appear to admit of arrangement according to the scheme just mentioned.

CLASS I. TRANSVERSE BRANCH IN THE NECK, PRESENT.

Group A. *The second anterior venous trunk reduced to a cardiac venous trunk.*

a. *Without transposition. A right vena cava superior, and a left cardiac venous trunk or coronary sinus.*—This is the ordinary condition of the great anterior veins. It is accompanied by numberless subordinate modifications, occurring either in the right superior cava itself, or in the azygos systems, or in the coronary vein of the heart, and includes by far the greater number of the recorded varieties of these veins.

a. *Varieties in the Right Superior Vena Cava.*

These appear to be very rare. A presumed example is recorded by ROSENTHAL*, in which, the auricles and ventricles being undivided, two superior veins, called two superior cavæ, joined immediately before ending in the single auricle, into which however they opened by separate mouths. In this case the upper cava may have been shorter than usual, so that the two superior veins were the venæ innominatæ; but the description is not sufficiently full†.

b. *Varieties in the Right and Left Azygos Systems.*

These are exceedingly numerous, and require to be referred to several heads:—

1. *The right intercostal system consolidated, the left intercostal system broken up.*—In this, the most frequent arrangement, the right intercostal veins end principally in the azygos vein, but partly also in a right superior intercostal vein. The left inter-

* Abhandl. aus dem Gebiete der Anat. Physiol. und Pathol. Berlin, 1824, p. 150.

† It may be here mentioned that WEESE (De Ectopia Cordis, &c. 1818, Berolin. sect. 37, 48) has twice found the left innominate vein (the primitive cross branch) in malformed fœtuses, passing across the neck behind the trachea and œsophagus.

costal system loses its integrity as development goes on; its middle and lower portions end in the azygos vein, either through an azygos minor, as in the usual case, or if that vessel be wanting, by independent intercostal branches*, or by both of these ways together†; or its lower branches may descend to the lumbar or renal veins‡. Its upper portion forms a left superior intercostal vein.

The azygos vein, in these cases, formed towards its termination by the persistent trunk of the right cardinal vein, usually ends in the upper vena cava (the right canal of CUVIER), but its place of termination is said, though very rarely, to be moved on, as if by the fusion of the canal of CUVIER with the right auricle, so that it may end in the auricle itself§, or even approach the neighbourhood of the inferior cava, within the pericardium¶(?), as occurs in some animals.

The right superior intercostal vein, which is not formed by any part of the primitive venous trunks, frequently joins the arch of the vena azygos itself||; but, without any other coexistent variation, its place of opening may be removed to the upper vena cava||, to the right innominate||, or subclavian veins¶¶, or even to the vertebral vein**.

The left superior intercostal vein, the trunk of which is generally formed by the metamorphosed portion of the primitive left jugular vein, immediately below the transverse branch in the neck, is, when present, almost constant in its mode of termination, ending at the underside of the commencement of the left innominate vein††.

2. *The right intercostal system retaining its integrity, but unusually large.*—There are various degrees of this condition, in which the azygos vein, besides receiving all the intercostal branches of its own side, including the superior intercostals, is joined by more than usual, or even by all the separate branches of the left side‡‡. In this latter case the ordinary left superior intercostal vein is very small or wanting, the left primitive jugular trunk having become obliterated quite up to the cross branch in the neck, as exemplified in the embryo, Plate III. fig. 4.

A still more remarkable enlargement of the azygos vein has been rather often met with, in those cases in which, the inferior cava being deficient, the azygos conveys all the blood usually brought back by that vessel excepting what returns from the liver, which continues to pass by a short hepatic venous trunk directly into the heart. The

* SOEMMERRING (*De Corporis Humani Fabricâ*, vol. v. p. 373).

† BRESCHET (*Recherches sur le Système Veineux*. Note, p. 8–10).

‡ CHESELDEN (*Philosophical Transactions*, 1713, vol. xxviii. p. 282). There is a doubt about this case, which is again noticed in p. 161. BRESCHET (*op. cit.* p. 9. note) in a child ten to twelve years of age. SOEMMERRING (*op. cit.* p. 372).

§ SOEMMERRING (*op. cit.* p. 376).

|| BRESCHET (*op. cit.* p. 12).

¶¶ HILDEBRANDT (*Lehrbuch der Anat. des Menschen*, 1803, vol. iv. p. 281).

** HALLER (*Element. Physiol.* t. iii. p. 107; also t. i. lib. iv. pp. 308, 320).

†† HILDEBRANDT (*l. c.*).

‡‡ BRESCHET (*l. c.*; also pl. 1. livr. i.).

course of the lower part of this devious vein may vary; but above, it may always be identified as the enlarged azygos (originally the right cardinal vein*).

3. *The trunks of the right and left intercostal systems nearly equal.*—The several modifications of this condition constitute the different varieties of so-called *double vena azygos*; but although the azygos minor or hemi-azygos is in all these cases much enlarged by consolidation of its parts, yet it must be carefully discriminated from that true form of left vena azygos which exists, for example, in the Sheep, and in some animals having a left vena cava superior.

α. In one set of these cases, the size and termination of the azygos vein itself being as usual, the azygos minor, enlarged and extending higher than ordinary, crosses over to the right side and joins the azygos vein near to or at its termination in the superior cava †, or ends in the upper cava itself ‡, or even it has been said in the right auricle §. Most frequently, the azygos vein ending as usual, the enlarged azygos minor or left azygos, as it is often called, ascends on its own side and ends in the place of the left superior intercostal vein in the left vena innominata, as if by persistent connection of the left cardinal vein, with the short part of the left primitive jugular below the cross branch in the neck ||.

* 1. WINSLOW (*Exposition Anatomique*, &c. t. iii. pp. 119 and 157). This example, which is clearly described, seems to have been overlooked.

2. ABERNETHY (*Philosophical Transactions*, 1793, p. 69). The preparation is figured in Prof. QUAIN'S *Anatomy of the Arteries*, pl. 5. fig. 5. The aorta arches over the right bronchus as well as the vena azygos.

3. WISTAR (*A System of Anatomy*, &c. Philadelphia, 1811–14, vol. ii. p. 320). This was originally regarded as an example of *absence* of the azygos vein, the enlarged vessel being considered as the inferior cava, rising higher up than usual, and ending in the vena cava superior. It is so quoted by GURLT (*ut infra*). The specimen was found in 1813, and afterwards given by WISTAR to Dr. HORNER, by whom it has been correctly described and explained in the *Journal of the Academy of Natural Sciences of Philadelphia*, 1818, vol. i. part ii. p. 407 (with a plate). OTTO (*Lehrbuch der Anat. Patholog.* p. 348, note 30) has been thus led to reckon it as two separate cases.

4. JEFFRAY. This preparation, mentioned by OTTO (*op. cit.* p. 348) as having been seen by him in the collection of Prof. JEFFRAY, is, as I am informed by Prof. ALLEN THOMSON, now in the Museum at Glasgow.

5. OTTO himself (*loc. cit.* and *seltene Beobacht.* p. 67) met with an instance, which was afterwards fully described and represented by GURLT (*De Venar. Deformatibus*, &c., 1819, p. 20).

6. WEBER (*RUST'S Magaz.* &c. vol. xiv. p. 536).

† HALLER (*op. cit.* t. iii. p. 107), WINSLOW (*op. cit.* p. 121), SANDIFORT, three cases (*Observ. Anat. Path.* lib. ii. c. vii. p. 126, and lib. iv. p. 12).

‡ BLASIUS (*Observat. Anatom.* p. 116; also *Observ. Medic.* p. 53. tab. 7. fig. ii. 1711). SANDIFORT (*op. cit.* lib. iv. p. 98).

§ SYLVIUS, JACOBUS (*Opera Medica*, Geneva, 1635, p. 144). In the body of ANTONIUS MASSA, *Chirurgus*, two azygos veins were found, “unam ab aure dextrâ, alteram inferiorem a cavâ cordi adaptâ.” It is assumed by EUSTACHIUS (*Opuscula*, &c. p. 274) that this was an example of double azygos, one left and the other right, but the brevity and obscurity of the original account render it impossible to decide on its true nature.

|| Most of the cases recorded as examples of “double vena azygos” are of this kind. See EUSTACHIUS (*Opuscula Anat.* p. 274; and *Explicat. Tab. Anat.* by ALBINUS, tab. 4. figs. i. ii. iii.). LANCISI (*De Venâ sine pari*, in MORGAGNI'S *Advers. Anat.* V. pp. 82, 87, 94). WINSLOW (*Expos. Anatom.* T. III. p. 121).

β. A variety of double vena azygos is described by BARTHOLINE, which may have been owing to the azygos and azygos minor, of nearly equal size, ending in the corresponding superior intercostal veins*.

γ. In other kinds of double azygos, a right and a left vein coexist, and becoming widened below, discharge themselves in the lumbar or emulgent veins†.

4. *The right intercostal system broken up, the left more consolidated.*—In this somewhat rare condition, the trunk of the azygos vein is reduced to a very small vessel, ending as usual in the superior cava; but most of the right intercostal veins pass over to the left side, where they form a large left azygos ending above in the left innominate vein through the left superior intercostal‡.

5. *The right azygos vein entirely wanting.*—In all the preceding varieties of the intercostal system of veins, with their intermediate gradations (excepting β), the vena azygos is still present, though sometimes represented by a very small vessel. The persistence of the right cardinal vein is therefore remarkably constant. It is possible, however, to conceive this vessel to be entirely obliterated, so that there should be no vein arching over the right bronchus to end in the upper cava. No perfectly unexceptionable example of this condition has been recorded§.

c. Varieties in the Coronary Vein of the Heart.

As might almost be anticipated, these are few and very rarely occur. One instance is mentioned by MECKEL and one by JEFFRAY in which the coronary vein ends in the left auricle||. The most unexpected deviation, however, is that in which the blood of the coronary vein reaches the heart through some remote vein instead of

MASCAGNI (Syst. Vas. Lymphat. tab. 19). HALLER (Element. Phys. t. iii. sect. i. p. 107). OTTO (*op. cit.* pp. 347, 348, notes 18, 20). WRISBERG (De Venâ Azygâ duplici, &c. 1778. Observat. 1 and 2). WILDE (Comment. Petropol. vol. xii. p. 318). BRESCHET (*loc. cit.* p. 9). LAUTH (Manuel d'Anatomiste. Paris, 1826, p. 592); and several other authors.

* BARTHOLINE, THOM. (Hist. Anatom. 84. Cent. ii. p. 322. 1641). "I have often seen," he says, "in man and animals a double vena azygos, one on each side, leading from the axillary veins."

† EUSTACHIUS (Explic. Tab. Anat. xxvi. xxvii.). BRESCHET (*loc. cit.*).

‡ VALENTIN (Journal de Médecine. Paris, 1791, tom. 86, p. 238).

§ One is related by WRISBERG (*op. cit.* Observat. 3), which, he remarks, was unique in 200 observations; but it seems probable that the vein was here obliterated by the effects of pressure. There was no azygos ending in the upper cava, but all the blood from the right side passed into the left vein, which was very large, and joined the left subclavian opposite to the termination of the thoracic duct. The subject was a boy, aged five years. The right lung was changed into a solid substance (steatoma), and it was universally and firmly adherent. Large hardened bronchial glands were found along the right side of the trachea down to the bronchus. On the left side the lung was free.

|| MECKEL (Handbuch der Mensch. Anat. vol. iii. p. 67). The case is also described by LINDNER (Diss. de Lymph. Syst. Halæ, 1787, p. 21). JEFFRAY (Observat. on the Heart of the Fœtus, p. 2). The preparation which exhibits this very remarkable deviation, is now in the Museum of the University of Glasgow, and has recently been carefully re-examined by Professor ALLEN THOMSON and Professor SHARPEY.

through the coronary sinus. LE CAT* has recorded the following interesting variety, occurring in a child eight days old, in which he found “les veines coronaires réunies dans un seul tronc, qui sans pénétrer dans l’oreillette droite, se jettoit dans la veine souclavière gauche.” The course pursued by this *single trunk* from the heart to the left subclavian vein is not described; and, anomalous as this remarkable case has hitherto appeared, it is, perhaps, an example of the closure of the orifice of the left primitive vein in the right auricle, accompanied by a pervious condition of that vessel up to the cross branch in the neck.

When the posterior cardiac vein is large and ends directly in the right auricle †, the great coronary vein and coronary sinus may be comparatively small, but instances of its extreme diminution, or entire absence, only occur with some other deviation ‡.

b. *With transposition.* The vena cava superior on the left side, and a coronary sinus on the right side.—When the arch of the aorta passes over the right bronchus, the veins do not always suffer transposition also, for in those cases in which the aorta regains the left side of the vertebral column as it descends, the vena cava superior, together with the azygos, continues on the right side §. But in complete transposition of the viscera (including the heart and great arteries), the vena cava superior descends on the left side, and the azygos vein is transposed to that side ||. Here, the metamorphosis by occlusion has affected the right primitive veins, instead of the left; and, the heart itself being entirely transposed, it is presumable that there would be found, in a recent specimen, a right cardiac venous trunk, that is to say, a coronary sinus on the right side, receiving the great coronary vein, together with an oblique auricular vein, a *vestigial fold* and the other remnants of the occluded second primitive venous trunk, as in the usual case.

* Mémoires de l’Acad. des Sciences, 1738, Hist. p. 44. This is a case already referred to in the note to p. 153. Dr. JOHN REID (Cyclop. Anat. and Phys. Article *Heart*, p. 597) has suggested that SÆMMERING had LE CAT’s case in view, when he states (De Corp. Humani Fabr. vol. v. p. 340) “rarissime vena hæc in venâ subclaviâ *dextrâ* finitur,” being probably misled by an inadvertence of HALLER, who, in quoting the case, has substituted the word “*dextram*” for “*sinistram*” (Elem. Physiol. t. i. p. 375, editio 1757). It may be added, that the termination of the coronary vein in the *left* subclavian is, as explained in the text, readily reconcileable with the mode of development.

† OTTO (*op. cit.* p. 347, n. 8) and other authors.

‡ In one instance recorded by LEMAIRE (Bull. des Scienc. Med. 1808, vol. v. p. 21), two coronary veins are said to have joined a pulmonary vein, and so reached the right auricle; but the facts seem to bear another explanation, the *pulmonary vein* in question being apparently a *left superior cava* descending in its wonted circuitous course beneath the root of the left lung, and receiving two cardiac veins as usual.

§ ABERNETHY (*loc. cit.*) and other cases by FIORATI, SANDIFORT, CAILLIOT, J. F. MECKEL, BERNHARD, OTTO, &c., quoted in QUAIN’S Arteries, p. 18.

|| A specimen in the Museum of University College, which is described and represented in Prof. QUAIN’S “Anatomy of the Arteries” (p. 17, plate 5. fig. 3). HALLER in the right fœtus of a double monster (De Monstri Dissection. i. 1739; Opera Minora, t. iii. p. 102). For references to other cases, see a paper by Dr. WATSON, Med. Gazette, June, 1836, p. 393. Also Mr. W. CLAPP, Med. Gazette, Jan. 1850.

Transposition of the great anterior veins may be further complicated by subordinate varieties, as for example, in the intercostal systems; and it is interesting to find that one of the most remarkable of the deviations met with in the azygos vein when holding its customary position, has been observed also in the transposed vein; viz. its excessive enlargement to enable it to return the blood from the lower half of the body, in cases where the inferior cava is deficient, and is represented only by the trunk of the hepatic veins*.

Lastly, the great anterior veins do not appear ever to undergo transposition, unless the heart itself be reversed†.

Group B. *The second anterior venous trunk, an azygos venous trunk existing on the left side, or by transposition on the right.*—This condition, which is regular in the Sheep, Ox, Goat, Pig, &c., has not, as far as I know, been met with as a deviation in the human subject, even in the most complex forms of transposition or malformation; but it is here referred to as one that may possibly be yet detected‡.

In the cases hitherto recorded as examples of a left vena azygos in Man, the unusual vein, as already fully particularized (pp. 156, 157), has ended in some of the branches or in the trunk of the vena cava superior. A true left vena azygos, however, sometimes exists in the human subject, in connection with an additional superior cava, as will immediately be shown.

Group C. *The second anterior venous trunk, an additional vena cava superior.*

a. *Without transposition.* In these cases the heart and great vessels, as well as the other viscera, holding their usual position, the superadded vein is a *left superior cava*. This condition constitutes that interesting variety of the great anterior veins commonly named *double vena cava superior*, in which the arrangement of the vessels

* HERHOLDT (Abhandlung der K. Acad. zu Kopenhagen, 1818).

McWHINNIE (London Med. Gazette, 1840). The preparation is in St. Bartholomew's Hospital Museum, and is figured in QUAIN'S "Anatomy of the Arteries," &c. (pl. 5. fig. 4). In both of these instances the transposed azygos receives all the branches of the inferior cava excepting the hepatic veins, and turns over the left bronchus to end in the ordinary upper cava, which, however, is on the left side.

† In an interesting case recorded by WILSON in the Philosophical Transactions, a vena cava superior, together with a perfect vena azygos, is found on the left side only of the thorax. This does not appear to have been an example of transposition of the right vein over to the left side; but rather one in which, the heart being reduced to a single auricle and a single ventricle and not transposed, the ordinary right upper cava is entirely wanting, whilst a true *left* upper cava alone exists, pursuing, as usual, a circuitous course to the heart (Philosophical Transactions, 1798, p. 346, with a plate). A case of ectopia cordis. The child lived seven days.

STANDERT (Philosophical Transactions for 1805, Part II. p. 228) gives an account of a child's heart, with undivided auricles and ventricles, in which the same condition of the veins, as far as can be understood from the figure, appears to have existed.

‡ Could the statement and figures of VIEUSSENS (*loc. cit.*) be considered free from *all* doubt, the so-called *vein of the pericardium*, which returned the blood from the outside of that sac, and descended in the position of the oblique vein into the coronary sinus, might be conceived to have been a true left azygos venous trunk, formed by a persistent left canal of CUVIER (see p. 147).

resembles that observed in the Elephant, in many of the Rodentia, the Marsupials and some other Mammalia.

In these cases the ordinary right superior cava is smaller than usual, being assisted by the additional vein on the left side. This left upper cava, generally smaller than the right one, invariably descends over the aortic arch, and afterwards in front of the root of the left lung, beneath which it turns backwards and then runs along the base of the heart to reach the right auricle.

Nearly thirty examples of this condition are on record, and to that list I am enabled to add two more cases, which will be here described. For convenience of reference they may be tabulated in the following form.

Tabular View of Examples of Double Vena Cava Superior in the Human Subject.

| Number in succeeding account. | Name of observer. | Date. | Sex and age. | Simple, or with other malformations. | Transverse branch present or not. | Azygos veins. | Figured or not. | Remarks. |
|-------------------------------|------------------------|------------|-------------------|--------------------------------------|-----------------------------------|--------------------|-----------------|---|
| 0. | Bartholine... | 1641. | | | | | | A doubtful case. |
| 1. | St. Thomas's | | Adult | | A cross branch? | Right. | | |
| 2. | { Boehmer and Theune } | 1763. | Male, 11 years... | | None | Right and left ... | Figured | |
| 3. | Haller | 1739-1762. | Fœtus | Double monster | None | | Figured | |
| 4. | Murray | 1781. | Female, 60 years. | | None | Right | Figured | |
| 5. | Ring | 1805. | Female, 1 year... | Auricles not divided. | ? | | Figured | |
| 6. | Lemaire | 1808. | Female, 30 years. | Auricles communicating | ? | | | Rather doubtful case. |
| 7. | Niemeyer | 1814. | Fœtus | Much deformed | ? | | Figured | |
| 8. | Meckel | 1816. | Fœtus | Monstrous | ? | | | |
| 9. | Meckel | 1816. | Fœtus | Monstrous | ? | | | |
| 10. | Meckel | 1818. | Fœtus | Monstrous | ? | | | |
| 11. | Meckel | 1820. | ? | | None (?) | | Figured | |
| 12. | Béclard | 1816. | Adult | | None (?) | Right and left (?) | | |
| 13. | { Bock and Cerutti } | | Adult | | | | | { Original description not referred to. |
| 14. | Hesselbach | | Adult | | | | | { Ditto. |
| 15. | Weese | 1819. | Fœtus | Ectopia cordis. | ? | | | Rather doubtful case. |
| 16. | Weese | 1819. | Fœtus | Ectopia cordis. | ? | | | |
| 17. | Weese | 1819. | Fœtus | Ectopia cordis. | None | | Figured | |
| 18, 19. | Wirtensohn.. | 1825. | Fœtus, double | Monsters | None | Right | Figured | |
| 20. | Wehrde | 1826. | Fœtus | Monster | | | | { Original account not referred to. |
| 21. | Breschet | 1827. | Male adult | | ? | | | |
| 22-24. | Breschet | 1827. | Fœtuses | Ectopia cordis. | ? | | | |
| 25. | Otto | 1830. | Fœtus | Malformed | ? | | | |
| 26. | Otto | 1830. | Fœtus | Malformed | ? | | | |
| 27. | Otto | 1830. | ? | | ? | | | |
| 28. | Houston | 1831. | Adult | | ? | | | |
| 29. | Sharpey | 1844. | Adult | | A cross branch | Right and left... | Figured | |
| 30. | Author | 1849. | Male, 56 years... | | A cross branch | Right and left... | Figured | |
| 31. | Author | 1849. | Female, 5 years. | Malformed | ? | | | |

Omitting BARTHOLINE'S case as doubtful, the thirty one remaining examples may be thus distributed. Sixteen have occurred in fœtuses more or less malformed; the age and condition of the subjects of two are uncertain; and, in two others, though the individual had lived in one case for a year, and in the other for five years, there was some accompanying defect in the heart; so that, including LEMAIRE'S case, not more than *eleven* examples of additional superior cava have yet been observed in the *adult*, uncomplicated by other deviations from the ordinary condition of the heart.

(St. THOMAS'S, BŒHMER and THEUNE, MURRAY, LEMAIRE (?), MECKEL, BÉCLARD, BRESCHET, OTTO, HOUSTON, SHARPEY, the Author*.)

Only those examples of left vena cava superior can be included in the present group, in which the cross branch at the root of the neck has been duly formed, the instances in which that characteristic preliminary step in the development has not taken place, being referable to the *second* class of peculiarities of the great anterior veins. Unfortunately, the descriptions of most of the known examples of double vena cava superior are incomplete, particularly as regards the existence of the transverse branch in the neck, and the condition of the azygos veins.

In two instances only is the presence of the cross branch placed beyond a doubt (Nos. 29, 30) †.

In six cases, in which the vessels appear to have been examined and preserved sufficiently high up in the neck to have determined the point one way or the other, the cross branch seems as certainly to have been wanting (Nos. 2, 3, 4, 17, 18, 19) ‡.

With regard to a *large number* of the examples, it is quite impossible, on reference to the descriptions or figures, to decide whether any transverse branch had ever existed or not (Nos. 1, 5, 7, 8, 9, 10, 11, 12, 16, 21, 22, 23, 24, 25, 26, 27, 28, 31) §.

* ROSENTHAL'S case, already mentioned (p. 154), has usually been considered an example of additional left superior cava, but it appears rather to be one of prolonged subdivision of the right vena cava. LE CAT'S interesting specimen (p. 158) might be considered to have been an example of a small left upper cava, closed at its lower end.

† No. 29. Professor SHARPEY met with this specimen in Edinburgh in 1833 or 1834. The preparation (injected and dried) is now in the Museum of Anatomy of University College, London. It is represented in Prof. R. QUAIN'S work on the Arteries, &c. (pl. 58, figs. 9, 10, pp. 371, 432). In all respects in which it can be compared, it resembles the following case, No. 30.

No. 30. The Author's example, described in pages 162–164.

‡ The references to these six cases are given in pages 164, 165.

§ No. 1. In the Museum of St. Thomas's Hospital there exists a specimen of double vena cava superior. The preparation in question, No. 1178, is an adult heart, which has been injected and dried. The cavities, which are now empty, are laid open. The left vena cava superior is smaller than the right, excepting its intrapericardial portion, which is much dilated. There are indications of a transverse branch, but its existence cannot now be confidently asserted. The azygos vein, which is of ordinary size, opens as high as usual in the right superior cava. The middle cardiac vein opens directly into the auricle. The coronary vein appears to be small. There is no azygos visible on the left side. The wide orifice of the left cava has, on its upper and right border, a narrow ridge, but there is no Thebesian valve. A small perforated Eustachian valve exists. CHESELDEN (Philosophical Transactions, 1713, vol. xxviii. p. 282) has described "a heart with the vena azygos inserted into the right auricle, and the descending cava coming round the basis of the heart, above the aorta and pulmonary vessels, to enter the auricle at the lower part with the ascending cava." This case has usually been regarded as an example of double vena cava superior. The preparation at St. Thomas's, the history of which is not known, but which Mr. SOUTH informs me is one of the oldest in the collection, may possibly be the specimen described by CHESELDEN; but as his account is so brief, and no drawing accompanies it, the point must remain doubtful. There is a discrepancy between the specimen and the account in the Philosophical Transactions in regard to the termination of the vena azygos.

No. 5. RING (Med. and Phys. Journal. London, vol. xiii. 1805, p. 120, with two figures). The preparation is in St. Thomas's Hospital Museum. This case shows a right and a left superior cava, with want of sepa-

In three instances, no access has been had to the original descriptions (Nos. 13, 14, 20)*.

The three remaining cases, though usually regarded as instances of superadded left superior cava, are somewhat doubtful examples of this variety (Nos. 0, 6, 15)†.

Further, the condition of the azygos veins is accurately known in only four cases (Nos. 2, 4, 29, 30).

In every instance, the course and connections of the left vena cava superior, so far as can be ascertained from the descriptions, correspond entirely. Reserving for the present the six cases in which the absence of the cross branch seems to be certain, I may here describe, as a characteristic example of double vena cava superior, accompanied with the cross branch, the specimen met with by myself.

The subject of this case (No. 30), a male aged fifty-six years, had not suffered from any disease of the heart. That organ is rather large: the right vena cava superior (Plate VI. *h*) is smaller than usual, and pursues its accustomed course to the ration of the auricles. Had the interauricular septum been formed, the left vein, which is now described as opening into the *left* auricle, would probably have had its orifice directed into the right auricle. Similar instances are recorded by WEESE and BRESCHET, Nos. 16 and 23, 24.

No. 7. NIEMEYER (De fœtu puellari edito abnormitatis exemplo. Halæ, 1814, cum fig.). The left cava superior is said to have descended to join the inferior cava, reminding one of CHESELDEN's description.

No. 8 to 11. MECKEL (Tabul. Anat. Path. 1820, tab. x. figs. 6, 7); two other cases (Hand. der Anat. Path. 1816, vol. ii. p. 125); and one (Archiv. f. d. Physiolog. vol. iv. p. 479, 480).

No. 12. BÉCLARD (Bull. de la Soc. de Med. 1816, vol. v. p. 115).

No. 16. WEESE (De Ectopia cordis, 1818, sect. 19). The same case is in WALTER's Museum Anat. P. i. p. 135, No. 826; and had been partially described by BUETTNER.

No. 21 to 24. BRESCHET (Le Système Veineux, 1827, p. 2, note 1). One example was in an adult male. Was this BECLARD's specimen? The other examples are in malformed fœtuses (Mém. sur l'Ectopie, &c.; and Répertoire d'Anat. et Phys., &c. t. ii. p. 12 and p. 17).

No. 25 to 27. OTTO (Beobachtung. ii. p. 69, and Verzeichniss, No. 2874). (Lehrbuch, &c., p. 344.) One example in an otherwise perfect subject. The two others in fœtuses malformed.

No. 28. HOUSTON's Catalogue of the Museum of the College of Surgeons, Dublin (vol. i. p. 58, B. b. 92).

No. 31. The Author. This heart, which is described at page 164, was presented to me by Dr. R. DAWSON HARLING.

* These cases are referred to in OTTO's Lehrbuch der Pathol. Anat. 1830, vol. i. p. 347, note 13, as follows:—

No. 13. BOCK in CERUTTI's Pathol. Anat. Museum, B. i. H. 3. p. 50.

14. HESSELBACH, Beschreibung der Pathol. Präparate zu Würtsburg, p. 229.

20. WEHRDE, Diss. Anat. Path. de Monstro rariore humano. Halæ, 1826, p. 11.

† No. 0. BARTHOLINE, TH. (Histor. Anatom. Montpelier, 1641, Hist. 84. Cent. ii. p. 322). This is quoted as an undoubted example by OTTO (*op. cit.* p. 347, note 13), but the statement of BARTHOLINE is not clear. He says, "that illustrious anatomist A. FALCOBURGH once showed me in a human dissection, an additional vein near the vena cava, similar to it, and which he considered a second cava."

No. 6. LEMAIRE (Bull. des Scien. Med. vol. v. 1808, p. 21). This (as already stated, p. 158) is described by LEMAIRE as an instance of the coronary vein ending in an *unusual left pulmonary vein*; but on careful perusal of the description, it appears more probable that the vein supposed to be pulmonary was really a *left vena cava superior*. There was a greater chance of error in this case, owing to there having been extensive adhesions of the pericardium.

- No. 15. WEESE (*op. cit.* sect. 45).

right auricle. The transverse branch in the neck (*d*) is not half the size of either jugular vein. It crosses over the commencement of the great arteries of the head and neck, and opens into the lateral venous trunks, somewhat below the point of junction of the jugular and subclavian veins of each side. This circumstance (observed also in Professor SHARPEY'S preparation) is interesting when considered in relation to the position of the cross branch in the embryo, and to the mode of formation of the right innominate vein.

From opposite the left end of this cross branch, the additional superior cava (*fvlos*) descends upon the aorta, to the front of the root of the left lung, and crossing the corresponding vessels, reaches the side of the left auricle immediately behind the appendix; then turning backwards under the lowermost pulmonary vein in close contact with the auricle, it runs obliquely inwards beneath the base of the heart along the auriculo-ventricular furrow; and finally opens by a wide orifice into the right auricle, to the left of, and somewhat before the inferior cava, *i. e.* in the ordinary situation of the orifice of the coronary sinus.

The azygos vein exists on the right side, and on the left there is a small vein opening into the left cava, about $1\frac{1}{2}$ inch below the cross branch, and close above the root of the lung: this small vein is a left azygos formed by the persistence of a part of the left cardinal vein: it fulfils the office of the left superior intercostal vein. The azygos and this small left azygos are also seen in Professor SHARPEY'S preparation.

From the cross branch down to the root of the lung, *i. e.* outside the pericardium, the left cava is rather narrower than the right. It is placed close beneath the pleura, and supports upon its outer side the left phrenic nerve (14). It rests first upon the left carotid and subclavian arteries, and then on the arch of the aorta. The par vagum (13) descends further back than the vein, and gives off a branch, which accompanies the vessel to the heart. On a level with the upper border of the pulmonary artery, the vein pierces the fibrous layer of the pericardium (11, 11).

Within the pericardium, as may be noticed in all the cases which have been fully described, the left vena cava becomes very much dilated. As it passes from the left pulmonary artery to the root of the subjacent pulmonary vein, it is lodged (*v*) in a tube-like fold of the serous membrane, the analogue of the *vestigial fold*. On the side and back of the left auricle (*lo*), and afterwards along the course of the auriculo-ventricular groove (*s*), the vessel is everywhere covered and bound down by the serous layer of the pericardium, and has muscular walls.

In turning horizontally to the right it receives the coronary vein (*g*), which appears small, and courses rather over the left border of the ventricle than comes from between the ventricle and the auricle. Further on, a posterior (*p*) and then the middle (*m*) cardiac vein enter it from below. The large vessel itself (*o*) occupies the place of the short oblique vein usually found on the back of the left auricle. The lower dilated part of the left vena cava superior (*s*), occupying the place of the coronary sinus, is distinctly muscular, its fibres for the most part being circular and ap-

parently blending with those of both auricles. There are no valves along its course, but the mouth of each of its cardiac branches is guarded with a fine valve, that of the coronary vein being the largest. The wide orifice of the vessel into the right auricle is marked above, below and to the right, by a slight rim, but there is no Thebesian valve, the absence of which, in this and all the other examples of double vena cava superior in which the point is capable of being determined (Nos. 1, 4, 12, 30, 31), suggests a comparison with the fact that it is also absent in those large quadrupeds which have a left vena cava superior or a left azygos venous trunk. The Eustachian valve is small and perforate; its left cornu does not reach the lower border of the fossa ovalis, owing, as it were, to the intervention of the large orifice of the left superior cava. The foramen ovale is quite closed.

The second example (No. 31) of double vena cava superior which I have to mention, occurred in the heart of a child between four and five years of age; in the ventricular portion of which there are some defects. The auricles, however, are perfectly shut off from each other. The lower part only of the left superior cava is present in the preparation, that vessel having been divided opposite the left pulmonary veins: it is very large and muscular, and receives the coronary and one other principal cardiac vein, the orifices of both being provided with valves. The opening of the vessel into the auricle is marked by a sharp border; but, as in other cases, the Thebesian valve is wanting. So, too, is the Eustachian valve.

b. *With transposition.*—There is, so far as I am aware, but one instance on record of the occurrence of double vena cava superior, together with transposition of the viscera. In this case the superadded vein is of course on the right side: a small vena azygos exists on that side, and ends in the right vena cava*.

CLASS II. TRANSVERSE BRANCH WANTING.

A failure in the preliminary step of the development of a cross branch in the neck necessarily implies the non-occlusion of either of the lateral primitive veins; for, though two superior cavæ may coexist with the transverse communication in the neck, yet, when the latter is absent, each primitive vein must continue to return the blood from its own side of the upper half of the body.

In such instances the characteristic cross branch of the mammalian venous system is wanting; the condition of the great anterior veins is like that of birds; and there is *no metamorphosis* excepting what is due to changes of size and position in the four simple lateral primitive veins typical of the vertebrate animal. Transposition has not been noticed in connection with this variety.

The best illustration of deficiency of the cross branch occurs in a case (No. 2) †

* Sir A. COOPER, in Dr. WATSON'S paper, Medical Gazette, June 1836, p. 394. The specimen is now in the Museum of the Royal College of Surgeons.

† No. 2. BÈHMER (Observ. Anat. rarior. fasciculi. Præfat. p. xii.). THEUNE (De confluxu trium cavar. in cord. atrio dextro, &c. Halæ, 1763, with a figure. Republished, Amsteld. 1764).

briefly recorded by BŒHMER, and subsequently clearly described and figured by THEUNE. The subject was a boy, aged 11 years. The vessels of the thorax and neck were injected with wax; and, though numerous small thyroid branches descended to the jugular veins, there was no appearance whatever of a transverse branch across the neck. Besides this, the case is interesting as affording a distinct example of the presence of both azygos veins ending, one in each of the superior cavæ. The right azygos was rather higher than usual; the *left* azygos, a little lower down than the right one, could be followed along the left side of the vertebræ as low as the lumbar veins in the abdomen.

Another specimen of double superior cava in an adult (No. 4)*, in which the cross branch must be regarded as wanting, has been elaborately described and represented in two figures by ADOLPHE MURRAY. With the exception of this deficiency of the cross branch, and of apparent absence of the left azygos also, the case resembles No. 30. The coronary vein is described as wanting: but it was represented by a branch which, as in case No. 30, turned over the left border of the heart.

The four remaining examples were in malformed fœtuses, carefully dissected by HALLER, by WEESE and by WIRTEHSOHN (Nos. 3, 17, 18 and 19)†.

Finally, such extreme cases of malformation as those in which (as in acephalous or almost shapeless fœtuses) the primitive plan of the venous system is altogether abrogated, do not here come under consideration.

DESCRIPTION OF THE PLATES.

PLATE I.

Fig. 1. Sketch of the human heart, seen on its left and posterior aspect, together with the great blood-vessels and a piece of the left lung:—reduced one-fifth. The coronary sinus, the great coronary vein, and the other posterior cardiac veins have been slit up. 1. The right auricle. 2. The left auricle. 3. The ventricular portion of the heart. 4. Portion of the root of the left lung. 8. The aorta. 9. The pulmonary artery. 10, 10. The left pulmonary veins. 11, 11. The cut edge of the pericardium. *c.* Vena cava superior. *e.* Vena cava inferior. *g.* Great coronary vein. *m.* Middle cardiac vein. *p, p.* Posterior cardiac veins. *s.* Coronary sinus laid open,

* MURRAY, AD. (Neue Schwedische Abhandl. aus der Naturlehre, &c., band 2, p. 283, with two plates). He refers to BARTHOLINE, CHESELDEN and HALLER; and also to BŒHMER and THEUNE, whose observation he considers the only one like his own.

† No. 3. HALLER (Descript. Monstr. dissect. i. 1739. Oper. Minora, t. iii. p. 102. 5. Tabul. xv.). The peculiarity in question occurs in the left fœtus only of a double monster. No. 17. WEESE (*op. cit.* sect. 47, p. 30. Tabul. vi. fig. 1). This was a case of Ectopia cordis which had been previously examined by KUESTNER. The left veins *did not join* those of the right side, but descended separately to the heart by a left venous trunk. Nos. 18, 19. WIRTEHSOHN, Diss. duor. Monstr. dupl. humanor. Berol. 1825, p. 23.

to show the large valve x , at the mouth of the great coronary vein (g), and smaller valves at the mouths of the posterior (p, p) and middle (m) cardiac veins. t . Orifice of the coronary sinus into the right auricle, with the Thebesian valve. o, l, v . Remains of the left primitive venous trunk above the coronary sinus, consisting of o , a small oblique auricular vein; l , lines or streaks on the wall of the left auricle; and v , a small duplicature of the serous layer of the pericardium, passing between the left pulmonary artery and the subjacent pulmonary vein, which is referred to in subsequent plates as the *vestigial fold of the pericardium*.

Fig. 2. Sketch of the back of the Sheep's heart; the great vessels being cut off short. 1, 2, 3, 8, 10, 10, c and e refer to the same parts as in fig. 1. s, s' . The trunk of the left azygos vein laid open, showing the large valve (x) at the entrance of the great coronary vein (g), and the smaller valves at the mouths of the veins marked p, m, p . The portion of the left azygos vein marked s' , is analogous to the coronary sinus in Man, s , fig. 1. t . Orifice of the left vena azygos, destitute of a Thebesian valve.

PLATE II.

Development of the great anterior veins in the embryo of the Sheep. Each figure is magnified two diameters. Corresponding letters of reference are used in common; viz. a . The right, and a' , the left primitive jugular vein; o , the occluded portion of the left primitive jugular vein. b . The right, and b' , the left cardinal vein. c . The right, and c' , the left canal of CUVIER. d . The transverse branch across the root of the neck, afterwards the left innominate vein. e . The trunk of the future vena cava inferior. 1. The right auricle. 2. The left auricle. 3. The ventricles. 4, 4'. The lungs, right or left. 5, 5'. The Wolffian bodies, right or left. 7. The stomach.

Figs. 1, 2, 3. Lateral and front views of an embryo, $\frac{1}{20}$ ths of an inch long. The great anterior veins are symmetrical, and consist of four lateral trunks, viz. two jugular and two cardinal veins, ending in the two Cuvierian canals. The jugular veins are short and vertical; the cross branch is wanting, but two little points are seen projecting from the inner side of the jugular veins where this transverse vessel is to appear. The dotted lines in figs. 1 and 3 indicate the outline of the liver, which has been removed.

Fig. 4. Embryo, $\frac{1}{20}$ ths of an inch long. The jugular veins elongated, and beginning to approach each other opposite the place of the future transverse branch, which could not be traced quite across the neck. The cardinal veins are smaller, owing to the wasting of the Wolffian bodies.

Fig. 5. Heart of an embryo, 1 inch long. The cross branch distinct, consisting of a fine vessel, which is wider at each end than in the middle.

Fig. 6. Embryo, $\frac{1}{20}$ ths of an inch, and fig. 7, embryo, $\frac{1}{20}$ ths of an inch long. The jugular veins have become more closely approximated at the root of the neck. The

cross branch is shorter and wider. The lower part of each primitive jugular, below the cross branch, inclines downwards and outwards, lying upon the pericardium. The left cardinal vein is still further reduced in size, but no occlusion has yet taken place.

Fig. 8. Embryo, 1 inch and $\frac{3}{20}$ ths long. In this embryo, and in embryo fig. 10, most part of the left lung has been cut away. The lower part of the left primitive jugular, extending from below the cross branch to the junction of the left cardinal vein and left canal of CUVIER, is occluded, and a fine opaque cord (*o*) exists in its place. The left cardinal vein and left Cuvierian canal now form the left vena azygos, as in the adult, the intrapericardial portion of which is seen to cross the left pulmonary vessels, and is lodged in a fold of the serous membrane. The cross branch now passes obliquely over to the right side, and forms the left innominate vein, which ends in the lower part of the right jugular, now the vena cava superior.

Fig. 9. Back of the heart of an embryo, $1\frac{1}{4}$ inch long, to show the differences, in size, length and direction, between the right and left Cuvierian canals, after the partial occlusion of the left jugular. The different heights of the right and left azygos veins are also exhibited.

Fig. 10. Embryo, $1\frac{1}{2}$ inch in length; it shows the state of the primitive anterior venous trunks after the completion of their metamorphosis, and therefore resembles the adult condition.

PLATE III.

Development of the great anterior veins in the human embryo. Each figure is magnified two diameters. Corresponding letters of reference are used in all cases, viz. *a*. The right, and *a'*, the left primitive jugular vein. *b*. The right, and *b'*, the left cardinal vein. *c*. The right, and *c'*, the left canal of CUVIER, or its pervious remnants. *c''*. Occluded portion of the left canal of CUVIER. *d*. The transverse branch in the neck, afterwards the left innominate vein. *e*. The vena cava inferior. *h*. The vena cava superior. *i*. Trunk of the left superior intercostal vein. 2. Left auricle. 3. Ventricular portion of the heart. 4. Lung, or part of lung. 5. Wolffian body. 6. Part of the liver. 7. The stomach.

Figs. 1, 2. Left and right lateral view of an embryo, $\frac{1}{20}$ ths of an inch in length. The cross branch is fully formed and very wide. The cardinal veins have diminished with the wasting of the Wolffian bodies; but no occlusion having taken place, the great lateral venous trunks are still symmetrical. N.B. Embryo damaged before dissection.

Fig. 3. Embryo, $1\frac{3}{20}$ ths of an inch long. The lower part of the left primitive jugular (below the cross branch) is elongated, and, as well as the left Cuvierian canal, is beginning to shrink.

Fig. 4. Embryo, $1\frac{1}{20}$ ths of an inch long. The left primitive jugular vein below the

cross branch is entirely occluded, and also the succeeding part of the left Cuvierian canal, the lower end of which, however, remains pervious as a little conical pouch (*c'*) on the back of the left auricle. A fine cord (*c''*) occupies the place of the occluded vessel. The left cardinal vein has disappeared. The cross branch, now oblique in direction, forms the left innominate vein (*d*), which ends in the vena cava superior (*h*).

Fig. 5. Embryo, $1\frac{5}{20}$ ths of an inch long from vertex to coccyx, and fig. 6, embryo, 3 inches from vertex to coccyx. In these embryos, a portion of the left primitive jugular vein immediately below the cross branch remains open, though reduced in size, and forms the trunk of the left superior intercostal vein (*i*); the succeeding portion is occluded and forms a fine semitransparent cord, which is continuous through the pericardium, with the occluded part of the left canal of CUVIER (*c''*). This latter lies in a fold of the serous membrane in front of the left pulmonary vessels, and descends on the back of the left auricle to the conical pouch (*c'*) above mentioned. The left cardinal vein (*b'*) in fig. 6, relatively very much diminished in size, appears to form a branch of the left superior intercostal vein.

PLATE IV.

Several views of the hearts of human embryos to show the gradual alterations in the size, length and direction of the two canals of CUVIER, and the particular metamorphosis of the left canal. Figs. 1 to 6 and figs. 8, 10 and 11 are views of the under surface of the organ. Figs. 7 and 9 are representations of its left side. All the figures, excepting fig. 11, are shown magnified two diameters.

The letters of reference employed in the several figures are as follows. *a*. Right and *a'* left jugular. *c*. Right, and *c'*, left canal of CUVIER. *c''*. Occluded portion of this canal. *d*. Cross branch in the neck, or left innominate vein. *e*. Vena cava inferior. *f v l o s*. Parts occupying the place of the left canal of CUVIER, viz. *f*. Fibrous bands beneath the left pleura outside the pericardium, *v*. Vestigial fold of the pericardium, *l*. Lines or streaks on the back of the left auricles, *o*. Oblique auricular vein, and *s*. Coronary sinus. *g*. Great cardiac or coronary vein. *h*. Vena cava superior. 1. Right, and 2, left auricle. 3. Ventricles. 4. Part of left lung. 8. Aorta. 9. Pulmonary artery. 10. Left pulmonary veins. 11. Cut edge of the pericardium.

Figs. 1, 2. Heart of an embryo, $\frac{17}{20}$ ths of an inch long. Figs. 3, 4. Heart of an embryo, 1 inch long. Figs. 5, 6. Heart of an embryo, $1\frac{6}{20}$ ths of an inch long. In these figures, viz. 1, 3 and 5, the right canal of CUVIER (*c*), is seen progressively to become shorter, wider and more vertical: the left canal (*c'*), which is shown opened in figs. 2, 4 and 6, becomes longer, narrower, and more circuitous in its course to the right auricle.

Fig. 7, left side, and fig. 8, the under surface of the heart of an embryo, $2\frac{1}{2}$ inches long. The cavities of the heart are filled with hardened blood. The upper occluded part of the left canal of CUVIER (*c''*) is well seen; and also the transformation of its

lower portion into a small oblique vein and the coronary sinus (*s*), into which, at its junction with the oblique vein, the coronary vein (*g*) enters.

Fig. 9. Outline plan carefully constructed from the heart of an embryo, measuring 5 inches from the vertex to the coccyx. The essential stages of the metamorphosis of the left primitive venous trunks are so complete, that the parts now representing it are nearly the same as in the adult condition, viz. the trunk of the left superior intercostal vein (*i*), the vertical fibres beneath the left pleura (*f*), the vestigial fold (*v*), and the lines or streaks (*l*) on the left auricle. The lower persistent portion of the left canal of CUVIER is transformed into a short oblique vein (*o*) and the coronary sinus (*s*), which are only partly seen, and which are joined by the great cardiac or coronary vein (*g*).

Fig. 10. Heart of the same embryo. The lines or streaks (*c''*), the oblique vein, the coronary sinus (*s*) and the coronary vein (*g*) appear almost as in the adult heart.

Fig. 11. Heart of a small foetus, still-born at the full period. The drawing is of the natural dimensions. The metamorphosed parts are easily recognized. The coronary vein (*g*) and sinus (*s*) are slit up, to show the commencing valve at their point of junction, and the place of opening of the oblique vein (*o*), which is continued up into the line or streak (*l*).

PLATE V.

Sketch of the under surface and left side of the heart, great blood-vessels, and root of the left lung, from a female aged 19; exhibiting the remains of the left anterior primitive vein, as ordinarily seen in the adult human heart. 1, 2, 3, 4, 8, 9, 10, 10, 11 and *e*, refer to the same parts as in Plate I. fig. 1. 13. The left vagus nerve. *d*. Left innominate vein, formed by the primitive cross branch and part of left primitive jugular. *i*. Trunk of the left superior intercostal vein, formed by the part of the metamorphosed left jugular vein situated immediately below the cross branch in the neck. *f*. Indistinct fibrous bands, mixed with small vessels and nervous cords, shown after removal of the pleura, lying in the track of the previously existing vein, and passing down to the root of the left lung, and thence through the pericardium into the fold marked *v*. *v*. The *vestigial fold* of the pericardium, persisting after the occlusion of the corresponding part of the left canal of CUVIER. *l*. Lines or streaks on the wall of the left auricle, descending from the vestigial fold to a small oblique vein, marked *o*. This oblique vein (*o*) enters the coronary sinus (*s*) close by the valved orifice of the coronary vein (*g*): together with the sinus, it forms the lower persistent pervious portion of the left primitive vein or canal of CUVIER.

PLATE VI.

Sketch of the under surface and left side of the heart and great vessels of a man, aged 56 years, in which there is a second superior cava on the left side, constituting

what is termed a case of "double vena cava superior." 1, 2, 3, 4, 8, 9, 10, 11 and *e*, refer to the same parts as in Plate I. fig. 1. 13. The vagus nerve. 14. Portion of the left phrenic nerve resting on the left vena cava superior. *d*. The cross branch at the root of the neck passing across below the place of junction of the subclavian and jugular veins. *h*. Part of the right vena cava superior. *i*. A left superior intercostal vein crossing over the descending aorta and acting as a small left azygos vein. *f*, *v*, *l*, *o* and *s*, are placed on the successive portions of the left vena cava, or persistent left primitive vein, which correspond with the successive remains met with in the ordinary condition, viz. *f*, with the subpleural fibrous bands; *v*, with the vestigial fold between the left pulmonary artery and veins; *l*, with the lines on the back of the left auricle; *o*, with the oblique vein; and *s*, with the coronary sinus. Into this latter there open, *g*, the great coronary vein, *p*, a posterior, and *m*, the middle cardiac vein.

VII. *Experimental Researches in Electricity.—Twenty-third Series.* By MICHAEL FARADAY, Esq., D.C.L., F.R.S., Fullerian Prof. Chem. Royal Institution, Foreign Associate of the Acad. Sciences, Paris, Ord. Boruss. Pour le Mérite, Eq., Memb. Royal and Imp. Acadd. of Sciences, Petersburg, Florence, Copenhagen, Berlin, Göttingen, Modena, Stockholm, Munich, Bruxelles, Vienna, Bologna, &c. &c.

Received January 1,—Read March 7 and 14, 1850.

§ 29. *On the polar or other condition of diamagnetic bodies.*

2640. FOUR years ago I suggested that all the phenomena presented by diamagnetic bodies, when subjected to the forces in the magnetic field, might be accounted for by assuming that they then possessed a polarity the same in kind as, but the reverse in direction of, that acquired by iron, nickel and ordinary magnetic bodies under the same circumstances (2429. 2430.). This view was received so favourably by PLÜCKER, REICH and others, and above all by W. WEBER*, that I had great hopes it would be confirmed; and though certain experiments of my own (2497.) did not increase that hope, still my desire and expectation were in that direction.

2641. Whether bismuth, copper, phosphorus, &c., when in the magnetic field, are polar or not, is however an exceedingly important question; and very essential and great differences, in the mode of action of these bodies under the one view or the other, must be conceived to exist. I found that in every endeavour to proceed by induction of experiment from that which is known in this department of science to the unknown, so much uncertainty, hesitation and discomfort arose from the unsettled state of my mind on this point, that I determined, if possible, to arrive at some experimental proof either one way or the other. This was the more needful, because of the conclusion in the affirmative to which WEBER had come in his very philosophical paper; and so important do I think it for the progress of science, that, in those imperfectly developed regions of knowledge, which form its boundaries, our conclusions and deductions should not go far beyond, or at all events not aside from the results of experiment (except as suppositions), that I do not hesitate to lay my present labours, though they arrive at a negative result, before the Royal Society.

2642. It appeared to me that many of the results which had been supposed to indicate a polar condition, were only consequences of the law that diamagnetic bodies tend to go from stronger to weaker places of action (2418.); others again appeared to have their origin in induced currents (26. 2338.); and further consideration seemed

* POGGENDORFF'S Annalen, January 7, 1848, or TAYLOR'S Scientific Memoirs, v. p. 477.

to indicate that the differences between these modes of action and that of a real polarity, whether magnetic or diamagnetic, might serve as a foundation on which to base a mode of investigation, and also to construct an apparatus that might give useful conclusions and results in respect of this inquiry. For, if the polarity exists it must be in the particles and for the time permanent, and therefore distinguishable from the momentary polarity of the mass due to induced temporary currents; and it must also be distinguishable from ordinary magnetic polarity by its contrary direction.

2643. A straight wooden lever, 2 feet in length, was fixed by an axis at one end, and by means of a crank and wheel made to vibrate in a horizontal plane, so that its free extremity passed to and fro through about 2 inches. Cylinders or cores of metal or other substances, $5\frac{1}{2}$ inches long and three-quarters of an inch diameter, were fixed in succession to the end of a brass rod 2 feet long, which itself was attached at the other end to the moving extremity of the lever, so that the cylinders could be moved to and fro in the direction of their length through the space of 2 inches. A large cylinder electro-magnet was also prepared (2191.), the iron core of which was 21 inches long and 1.7 inch in diameter; but one end of this core was made smaller for the length of 1 inch, being in that part only 1 inch in diameter.

2644. On to this reduced part was fixed a hollow helix consisting of 516 feet of fine covered copper wire: it was 3 inches long, 2 inches external diameter, and 1 inch internal diameter: when in its place, 1 inch of the central space was occupied by the reduced end of the electro-magnet core which carried it; and the magnet and helix were both placed concentric with the metal cylinder above mentioned, and at such a distance that the latter, in its motion, would move within the helix in the direction of its axis, approaching to and receding from the electro-magnet in rapid or slow succession. The least and greatest distances of the moving cylinder from the magnet during the journey were one-eighth of an inch and 2.2 inches. The object of course was to observe any influence upon the experimental helix of fine wire which the metal cylinders might exert, either whilst moving to or from the magnet, or at different distances from it*.

2645. The extremities of the experimental helix wire were connected with a very delicate galvanometer, placed 18 or 20 feet from the machine, so as to be unaffected directly by the electro-magnet; but a commutator was interposed between them. This commutator was moved by the wooden lever (2643.), and as the electric currents which would arrive at it from the experimental helix, in a complete cycle of motion or to and fro action of the metal cylinder (2643.), would consist of two contrary portions, so the office of this commutator was, sometimes to take up these portions in succession and send them on in one consistent current to the galvanometer, and at

* It is very probable that if the metals were made into cylinders shorter, but of larger diameter than those described above, and used with a corresponding wider helix, better results than those I have obtained would be acquired.

other times to oppose them and to neutralize their result ; and therefore it was made adjustable, so as to change at any period of the time or part of the motion.

2646. With such an arrangement as this, it is known that, however powerful the magnet, and however delicate the other parts of the apparatus, no effect will be produced at the galvanometer as long as the magnet does not change in force, or in its action upon neighbouring bodies, or in its distance from, or relation to, the experimental helix ; but the introduction of a piece of iron into the helix, or anything else that can influence or be influenced by the magnet, can, or ought to, show a corresponding influence upon the helix and galvanometer. My apparatus I should imagine, indeed, to be almost the same in principle and practice as that of M. WEBER (2640.), except that it gives me contrary results.

2647. But to obtain correct conclusions, it is most essential that extreme precaution should be taken in relation to many points which at first may seem unimportant. All parts of the apparatus should have perfect steadiness, and be fixed almost with the care due to an astronomical instrument ; for any motion of any portion of it is, from the construction, sure to synchronize with the motion of the commutator ; and portions of effect, inconceivably small, are then gathered up and made manifest as a whole at the galvanometer ; and thus, without care, errors might be taken for real and correct results. Therefore, in my arrangements, the machine (2643, &c.), the magnet and helix, and the galvanometer stood upon separate tables, and these again upon a stone floor laid upon the earth ; and the table carrying the machine was carefully strutted to neighbouring stone-work.

2648. Again, the apparatus should itself be perfectly firm and without shake in its motion, and yet easy and free. No iron should be employed in any of the moving parts. I have springs to receive and convert a portion of the momentum of the whole at the end of the to and fro journey ; but it is essential that these should be of hammered brass or copper.

2649. It is absolutely necessary that the cylinder or core in its motion should not in the least degree disturb or shake the experimental helix and the magnet. Such a shake may easily take place and yet (without much experience) not be perceived. It is important to have the cores of such bodies as bismuth, phosphorus, copper, &c., as large as may be, but I have not found it safe to have less than one-eighth of an inch of space between them and the interior of the experimental helix. In order to float, as it were, the core in the air, it is convenient to suspend it in the bight or turn of a fine copper wire passing once round it, the ends of which rise up, and are made fast to two fixed points at equal heights but wide apart, so that the wire has a V form. This suspension keeps the core parallel to itself in every part of its motion.

2650. The magnet, when excited, is urged by an electric current from five pairs of GROVE'S plates, and is then very powerful. When the battery is not connected with it, it still remains a magnet of feeble power, and when thus employed may be referred to as in the *residual state*. If employed in the residual state, its power may for

the time be considered constant, and the experimental helix may at any moment be connected with the galvanometer without any current appearing there. But if the magnet be employed in the excited state, certain important precautions are necessary; for upon connecting the magnet with the battery and then connecting the experimental helix with the galvanometer, a current will appear at the latter, which will, in certain cases, continue for a minute or more, and which has the appearance of being derived at once from that of the battery. It is not so produced, however, but is due to the *time* occupied by the iron core in attaining its maximum magnetic condition (2170. 2332.), during the whole of which it continues to act upon the experimental helix, producing a current in it. This time varies with several circumstances, and in the same electro-magnet varies especially with the period during which the magnet has been out of use. When first employed, after two or three days' rest, it will amount to eighty or ninety seconds, or more. On breaking battery contact and immediately renewing it, the effect will be repeated, but occupy only twenty or thirty seconds. On a third intermission and renewal of the current, it will appear for a still shorter period; and when the magnet has been used at short intervals for some time, it seems capable of receiving its maximum power almost at once. In every experiment it is necessary to wait until the effect is shown by the galvanometer to be over; otherwise the last remains of such an effect might be mistaken for a result of polarity, or some peculiar action of the bismuth or other body under investigation.

2651. The galvanometer employed was made by RUHMKORFF and was very sensible. The needles were strengthened in their action and rendered so nearly equal, that a single vibration to the right or to the left occupied from sixteen to twenty seconds. When experimenting with such bodies as bismuth or phosphorus, the place of the needle was observed through a lens. The perfect communication in all parts of the circuit was continually ascertained by a feeble thermo-electric pair, warmed by the fingers. This was done also for every position of the commutator, where the film of oxide formed on any part by two or three days' rest was quite sufficient to intercept a feeble current.

2652. In order to bring the phenomena afforded by magnetic and diamagnetic bodies into direct relation, I have not so much noted the currents produced in the experimental helix, as the effects obtained at the galvanometer. It is to be understood, that the standard of deviation, as to direction, has always been that produced by an iron wire moving in the same direction at the experimental helix, and with the same condition of the commutator and connecting wires, as the piece of bismuth or other body whose effects were to be observed and compared.

2653. A thin glass tube, of the given size (2643.), $5\frac{1}{2}$ by $\frac{3}{4}$ inches, was filled with a saturated solution of protosulphate of iron, and employed as the experimental core: the velocity given to the machine at this and all average times of experiment was

such as to cause five or six approaches and withdrawals of the core in one second; yet the solution produced no sensible indication at the galvanometer. A piece of magnetic glass tube (2354.), and a core of foolscap paper, magnetic between the poles of the electro-magnet, were equally inefficient. A tube filled with small crystals of protosulphate of iron caused the needle to move about 2° , and cores formed out of single large crystals, or symmetric groups of crystals of sulphate of iron, produced the same effect. Red oxide of iron (colcothar) produced the least possible effect. Iron scales and metallic iron (the latter as a thin wire) produced large effects.

2654. Whenever the needle moved, it was consistent in its direction with the effect of a magnetic body; but in many cases, with known magnetic bodies, the motion was little or none. This proves that such an arrangement is by no means so good a test of magnetic polarity as the use of a simple or an astatic needle. This deficiency of power in that respect does not interfere with its ability to search into the nature of the phenomena that appear in the experiments of WEBER, REICH and others.

2655. Other metals than iron were now employed and with perfect success. If they were magnetic, as nickel and cobalt, the deflection was in the same direction as for iron. When the metals were diamagnetic, the deflection was in the contrary direction; and for some of the metals, as copper, silver and gold, it amounted to 60° or 70° , which was permanently sustained as long as the machine continued to work. But the deflection was not the greatest for the most diamagnetic substances, as bismuth or antimony, or phosphorus; on the contrary, I have not been able to assure myself, up to this time, that these three bodies can produce any effect. Thus far the effect has been proportionate to the *conducting power* of the substance for electricity. Gold, silver and copper have produced large deflections, lead and tin less. Platina very little. Bismuth and antimony none.

2656. Hence there was every reason to believe that the effects were produced by the currents induced in the mass of the moving metals, and not by any polarity of their particles. I proceeded therefore to test this idea by different conditions of the cores and the apparatus.

2657. In the first place, if produced by induced currents, the great proportion of these would exist in the part of the core near to the dominant magnet, and but little in the more distant parts; whereas in a substance like iron, the polarity which the whole assumes makes length a more important element. I therefore shortened the core of copper from $5\frac{1}{2}$ inches (2643.) to 2 inches, and found the effect not sensibly diminished; even when 1 inch long it was little less than before. On the contrary; when a fine iron wire, $5\frac{1}{2}$ inches in length, was used as core, its effects were strong; when the length was reduced to 2 inches, they were greatly diminished; and again, with a length of 1 inch, still further greatly reduced. It is not difficult to construct a core of copper, with a fine iron wire in its axis, so that when above a certain length it should produce the effects of iron, and beneath that length the effects of copper.

2658. In the next place, if the effect were produced by induced currents in the mass (2642.), division of the mass would stop these currents and so alter the effect; whereas if produced by a true diamagnetic polarity, division of the mass would not affect the polarity seriously, or in its essential nature (2430.). Some copper filings were therefore digested for a few days in dilute sulphuric acid to remove any adhering iron, then well-washed and dried, and afterwards warmed and stirred in the air, until it was seen by the orange colour that a very thin film of oxide had formed upon them: they were finally introduced into a glass tube (2653.) and employed as a core. It produced no effect whatever, but was now as inactive as bismuth.

2659. The copper may however be divided so as either to interfere with the assumed currents or not, at pleasure. Fine copper wire was cut up into lengths of $5\frac{1}{2}$ inches, and as many of these associated together as would form a compact cylinder three-quarters of an inch in diameter (2643.); it produced no effect at the galvanometer. Another copper core was prepared by associating together many discs of thin copper plate, three-quarters of an inch in diameter, and this affected the galvanometer, holding its needle 25° or 30° from zero.

2660. I made a solid helix cylinder, three-quarters of an inch in diameter and 2 inches long, of covered copper wire, one-sixteenth of an inch thick, and employed this as the experimental core. When the two ends of its wire were unconnected, there was no effect upon the experimental helix, and consequently none at the galvanometer; but when the ends were soldered together, the needle was well affected. In the first condition, the currents, which tended to be formed in the mass of moving metal, could not exist because the metal circuit was interrupted; in the second they could, because the circuit was not interrupted; and such division as remained did not interfere to prevent the currents.

2661. The same results were obtained with other metals. A core cylinder of gold, made of half-sovereigns, was very powerful in its effect on the galvanometer. A cylinder of silver, made of sixpenny pieces, was very effectual; but a cylinder made of precipitated silver, pressed into a glass tube as closely as possible, gave no indications of action whatever. The same results were obtained with disc cylinders of tin and lead, the effects being proportionate to the condition of tin and lead as bad conductors (2655.).

2662. When iron was divided, the effects were exactly the reverse in kind. It was necessary to use a much coarser galvanometer and apparatus for the purpose; but that being done, the employment of a solid iron core, and of another of the same size or weight formed of lengths of fine iron wire (2659.), showed that the division had occasioned no inferiority in the latter. The excellent experimental researches of DOVE* on the electricity of induction, will show that this ought to be the case.

2663. Hence the result of division in the diamagnetic metals is altogether of a nature to confirm the conclusion, that the effects produced by them are due to in-

* TAYLOR'S Scientific Memoirs, v. p. 129. I do not see a date to the paper.

duced currents moving through their masses, and not to any polarity correspondent in its general nature (though opposed in its direction) to that of iron.

2664. In the third place (2656.), another and very important distinction in the actions of a diamagnetic metal may be experimentally established according as they may be due either to a true polarity, or merely to the presence of temporary induced currents; and as for the consideration of this point diamagnetic and magnetic polarity are the same, the point may best be considered, at present, in relation to iron.

2665. If a core of any kind be advanced towards the dominant magnet and withdrawn from it by a motion of uniform velocity, then a complete journey or *to* and *from* action might be divided into four parts; the *to*, the *stop* after it; the *from*, and the *stop* succeeding that. If a core of iron make this journey, its end towards the dominant magnet becomes a pole, rising in force until at the nearest distance, and falling in force until at the greatest distance. Both this effect, and its *progression* inwards and outwards, cause currents to be induced in the surrounding helix, and these currents are in one direction as the core advances, and in the contrary direction as it recedes. In reality, however, the iron does not travel with a constant velocity; for, because of the communication of motion from a revolving crank at the machine (2643.), it, in the *to* part of the journey, gradually rises from a state of rest to a maximum velocity, which is half-way, and then as gradually sinks to rest again near the magnet:—and the *from* part of the journey undergoes the same variations. Now as the maximum effect upon the surrounding experimental helix depends upon the velocity conjointly with the intensity of the magnetic force in the end of the core, it is evident that it will not occur with the maximum velocity, which is in the middle of the *to* or *from* motion; nor at the *stop* nearest to the dominant magnet, where the core end has greatest magnetic force, but somewhere between the two. Nevertheless, during the *whole* of the advance, the core will cause a current in the experimental helix in one direction, and during the whole of the recession it will cause a current in the other direction.

2666. If diamagnetic bodies, under the influence of the dominant magnet, assume also a polar state, the difference between them and iron being only that the poles of like names or forces are changed in place (2429. 2430.), then the same kind of action as that described for iron would occur with them; the only difference being, that the two currents produced would be in the reverse direction to those produced by iron.

2667. If a commutator, therefore, were to be arranged to gather up these currents, either in the one case or the other, and send them on to the galvanometer in one consistent current, it should change at the moments of the two *stops* (2665.), and then would perform such duty perfectly. If, on the other hand, the commutator should change at the times of maximum velocity or maximum intensity, or at two other times equidistant either from the one *stop* or from the other, then the parts of the opposite currents intercepted between the changes would exactly neutralize each other, and no final current would be sent on to the galvanometer.

2668. Now the action of the iron is, by experiment, of this nature. If an iron wire be simply introduced or taken out of the experimental helix with different conditions of the commutator, the results are exactly those which have been stated. If the machine be worked with an iron wire core, the commutator changing at the stops (2665.), then the current gathered up and sent on to the galvanometer is a maximum; if the commutator change at the moments of maximum velocity, or at any other pair of moments equidistant from the one stop or the other, then the current at the commutator is a minimum, or 0.

2669. There are two or three precautions which are necessary to the production of a pure result of this kind. In the first place, the iron ought to be soft and not previously in a magnetic state. In the next, an effect of the following kind has to be guarded against. If the iron core be away from the dominant magnet at the beginning of an experiment, then, on working the machine, the galvanometer will be seen to move in one direction for a few moments, and afterwards, notwithstanding the continued action of the machine, will return and gradually take up its place at 0°. If the iron core be at its shortest distance from the dominant magnet at the beginning of the experiment, then the galvanometer needle will move in the contrary direction to that which it took before, but will again settle at 0°. These effects are due to the circumstance, that, when the iron is away from the dominant magnet, it is not in so strong a magnetic state, and when at the nearest to it is in a stronger state, than the *mean* or *average state*, which it acquires during the continuance of an experiment; and that in rising or falling to this average state, it produces two currents in contrary directions, which are made manifest in the experiments described. These existing only for the first moments, do, in their effects at the galvanometer, then appear, producing a vibration which gradually passes away.

2670. One other precaution I ought to specify. Unless the commutator changes accurately at the given points of the journey, a little effect is gathered up at each change, and may give a permanent deflection of the needle in one direction or the other. The tongues of my commutator, being at right angles to the direction of motion and somewhat flexible, dragged a little in the *to* and *from* parts of the journey: in doing this they approximated, though only in a small degree, to that which is the best condition of the commutator for gathering up (and not opposing) the currents; and a deflection to the right or left appeared (2677.). Upon discovering the cause and stiffening the tongues so as to prevent their flexure, the effect disappeared, and the iron was perfectly inactive.

2671. Such therefore are the results with an iron core, and such would be the effects with a copper or bismuth core if they acted by a diamagnetic polarity. Let us now consider what the consequences would be if a copper or bismuth core were to act by currents, induced for the time, in its moving mass, and of the nature of those suspected (2642.). If the copper cylinder moved with uniform velocity (2665.), then currents would exist in it, parallel to its circumference, during the whole time of its

motion; and these would be at their maximum force just before and just after the *to* or inner stop, for then the copper would be in the most intense parts of the magnetic field. The rising current of the copper core for the *in* portion of the journey would produce a current in one direction in the experimental helix, the stopping of the copper and consequent falling of its current would produce in the experimental helix a current contrary to the former; the first instant of motion *outwards* in the core would produce a maximum current in it contrary to its former current, and producing in the experimental helix its inductive result, being a current the same as the last there produced; and then, as the core retreated, its current would fall, and in so doing and by its final stop, would produce a fourth current in the experimental helix, in the same direction as the first.

2672. The four currents produced in the experimental helix alternate by twos, *i. e.* those produced by the falling of the first current in the core and the rising of the second and contrary current, are in one direction. They occur at the instant before and after the stop at the magnet, *i. e.* from the moment of maximum current (in the core) before, to the moment of maximum current after, the stop; and if that stop is momentary, they exist only for that moment, and should during that brief time be gathered up by the commutator. Those produced in the experimental helix during the falling of the second current in the core and the rising of a third current (identical with the first) in the return of the core to the magnet, are also the same in direction, and continue from the beginning of the retreat to the end of the advance (or from maximum to maximum) of the core currents, *i. e.* for almost the whole of the core journey; and these, by its change at the maximum moments, the commutator should take up and send on to the galvanometer.

2673. The motion however of the core is not uniform in velocity, and so, sudden in its change of direction, but, as before said (2665.), is at a maximum as respects velocity in the middle of its approach to and retreat from the dominant magnet; and hence a very important advantage. For its stop may be said to commence immediately after the occurrence of the maximum velocity; and if the lines of magnetic force were equal in position and power there to what they are nearer to the magnet, the contrary currents in the experimental helix would commence at those points of the journey; but, as the core is entering into a more intense part of the field, the current in it still rises though the velocity diminishes, and the consequence is, that the maximum current in it neither occurs at the place of greatest velocity, nor of greatest force, but at a point between the two. This is true both as regards the approach and the recession of the core, the two maxima of the currents occurring at points equidistant from the place of rest near the dominant magnet.

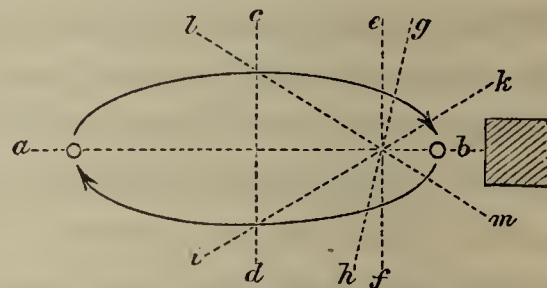
2674. It is therefore at these two points that the commutator should change, if adjusted to produce the greatest effect at the galvanometer by the currents excited in the experimental helix, through the influence of, or in connection with, currents of induction produced in the core; and experiment fully justifies this conclusion.

If the length of the journey from the stop out to the stop in, which is 2 inches (2643. 2644.), be divided into 100 parts, and the dominant magnet be supposed to be on the right-hand, then such an expression as the following, 50|50, may represent the place where the commutator changes, which in this illustration would be midway in the to and from motion, or at the places of greatest velocity.

2675. Upon trial of various adjustments of the commutator, I have found that from 77|23 to 88|12, gave the best result with a copper core. On the whole, and after many experiments, I conclude that with the given strength of electro-magnet, distance of the experimental core when at the nearest from the magnet, length of the whole journey, and average velocity of the machine, 86|14 may represent the points where the induced currents in the core are at a maximum and where the commutator ought to change.

2676. From what has been said before (2667.), it will be seen that both in theory and experiment these are the points in which the effect of any polarity, magnetic or diamagnetic, would be absolutely nothing. Hence the power of submitting by this machine metals and other bodies to experiment, and of eliminating the effects of magnetic polarity, of diamagnetic polarity, and of inductive action, the one from the others: for either by the commutator or by the direction of the polarity, they can be separated; and further, they can also be combined in various ways for the purpose of elucidating their joint and separate action.

2677. For let the arrows in the diagram represent the to and from journey, and the intersections of the lines *a, b* or *c, d*, &c. the periods in the journey when the commutator changes (in which case *c, d* will correspond to 50|50, and *e, f* to 86|14), then *a, b* will represent the condition of the commutator for the maximum effect of iron or any other polar body. If the line *a, b* be gradually revolved until parallel to *c, d*, it will in every position indicate points of commutator change, which will give the iron effect at the galvanometer by a deflection of the needle always in the same direction; it is only when the ends *a* and *b* have passed the points *c* and *d*, either above or below, that the direction of the deflection will change for iron. But the line *a, b* indicates those points for the commutator with which no effect will be produced on the galvanometer by the induction of currents in the mass of the core. If the line be inclined in one direction, as *i, k*, then these currents will produce a deflection at the galvanometer on one side; if it be inclined in the other direction, as *l, m*, then the deflection will be on the other side. Therefore the effects of these induced currents may be either combined with, or opposed to, the effects of a polarity, whether it be magnetic or diamagnetic.



2678. All the metals before mentioned (2655.), namely, gold, silver, copper, tin, lead, platina, antimony and bismuth, were submitted to the power of the electro-magnet under the best adjustment (2675.) of the commutator. The effects were stronger

than before, being now at a maximum, but in the same order; as regarded antimony and bismuth, they were very small, amounting to not more than half a degree, and may very probably have been due to a remainder of irregular action in some part of the apparatus. All the experiments with the divided cores (2658, &c.) were repeated with the same results as before. Phosphorus, sulphur and gutta percha did not, either in this or in the former state of the commutator, give any indication of effect at the galvanometer.

2679. As an illustration of the manner in which this position of the commutator caused a separation of the effects of copper and iron, I had prepared a copper cylinder core 2 inches in length having an iron wire in its axis, and this being employed in the apparatus gave the pure effect of the copper with its induced currents. Yet this core, as a whole, was highly magnetic to an ordinary test-needle; and when the two changes of the commutator were not equidistant from the one stop or the other (2670. 2677.), the iron effect came out powerfully, overruling the former and producing very strong contrary deflections at the needle. The platinum core which I have used is an imperfect cylinder, 2 inches long and 0.62 of an inch thick: it points magnetically between the poles of a horseshoe electro-magnet (2381.), making a vibration in less than a second, but with the above condition of the commutator (2675.) gives 4° of deflection due to the induced currents, the magnetic effect being annulled or thrown out.

2680. Some of the combined effects produced by oblique position of the commutator points were worked out in confirmation of the former conclusions (2677.). When the commutator was so adjusted as to combine any polar power which the bismuth, as a diamagnetic body, might possess, with any conducting power which would permit the formation of currents by induction in its mass (2676.), still the effects were so minute and uncertain as to oblige me to say that, experimentally, it is without either polar or inductive action.

2681. There is another distinction which may usefully be established between the effects of a true sustainable polarity, either magnetic or diamagnetic, and those of the transient induced currents dependent upon *time*. If we consider the resistance in the circuit, which includes the experimental helix and the galvanometer coil, as nothing, then a magnetic pole of constant strength passed a certain distance into the helix, would produce the same amount of current electricity in it, whether the pole were moved into its place by a quick or a slow motion. Or if the iron core be used (2668.) the same result is produced, provided, in any alternating action, the core is left long enough at the extremities of its journey to acquire, either in its quick or slow alternation, the same state. This I found to be the fact when no commutator nor dominant magnet was used; a single insertion of a weak magnetic pole gave the same deflection, whether introduced quickly or slowly; and when the residual dominant magnet, an iron wire core, and the commutator in its position *a, b* (2677.) were used, four journeys to and from produced the *same* effect at the galvanometer when the velocities were as 1 : 5 or even as 1 : 10.

2682. When a copper, silver, or gold core is employed in place of the iron, the effect is very different. There is no reason to doubt, that, as regards the core itself, the same amount of electricity is thrown into the form of induced circulating currents within it, by a journey to or from, whether that journey is performed quickly or slowly: the above experiment (2681.) in fact confirms such a conclusion. But the effect which is produced upon the experimental helix is not proportionate to the whole amount of these currents, but to the maximum intensities to which they rise. When the core moves slowly, this intensity is small; when it moves rapidly, it is great, and necessarily so, for the same current of electricity has to travel in the two differing periods of time occupied by the journeys. Hence the quickly moving core should produce a far higher effect on the experimental helix than the slowly moving core; and this also I found to be the fact.

2683. The short copper core was adjusted to the apparatus, and the machine worked with its average velocity until forty journeys to and from had been completed; the galvanometer needle passed 39° west. Then the machine was worked with a greater rapidity, also for forty journeys, and the needle passed through 80° or more west; finally, being worked at a slow rate for the same number of journeys, the needle went through only 21° west. The extreme velocities in this experiment were probably as 1:6; the time in the longest case was considerably less than that of one vibration of the needle (2651.), so that I believe all the force in the slowest case was collected. The needle is very little influenced by the swing or momentum of its parts, because of the deadening effect of the copper plate beneath it, and, except to return to zero, moves very little after the motion of the apparatus ceases. A silver core produced the same results.

2684. These effects of induced currents have a relation to the phenomena of revulsion which I formerly described (2310. 2315. 2338.), being the same in their exciting cause and principles of action, and so the two sets of phenomena confirm and illustrate each other. That the revulsive phenomena are produced by induced currents, has been shown before (2327. 2329. 2336. 2339.); the only difference is, that with them the induced currents were produced by exalting the force of a magnet placed at a fixed distance from the affected metal; whilst in the present phenomena, the force of the magnet does not change, but its distance from the piece of metal does.

2685. So also the same circumstances which affect the phenomena here affect the revulsive phenomena. A plate of metal will, as a whole, be well-revulsed; but if it be divided across the course of the induced currents it is not then affected (2529.). A ring helix of copper wire, if the extremities be unconnected, will not exhibit the phenomena, but if they be connected then it presents them (2660.).

2686. On the whole, the revulsive phenomena are a far better test and indication of these currents than the present effects; especially if advantage be taken of the division of the mass into plates, so as to be analogous, or rather superior, in their action to the disc cylinder cores (2659. 2661.). Platinum, palladium and lead in leaf or foil, if cut or folded into squares half an inch in the side, and then packed regularly

together, will show the phenomena of revulsion very well; and that according to the direction of the leaves, and not of the external form. Gold, silver, tin and copper have the revulsive effects thus greatly exalted. Antimony, as I have already shown, exhibits the effect well (2514. 2519.). Both it and bismuth can be made to give evidence of the induced currents produced in them when they are used in thin plates, either single or associated, although, to avoid the influence of the diamagnetic force, a little attention is required to the moments of making and breaking contact between the voltaic battery and the electro-magnet.

2687. Copper, when thus divided into plates, had its revulsive phenomena raised to a degree that I had not before observed. A piece of copper foil was annealed and tarnished by heat, and then folded up into a small square block, half an inch in the side and a quarter of an inch thick, containing seventy-two folds of the metal. This block was suspended by a silk film as before (2248.), and whilst at an angle of 30° or thereabouts with the equatorial line (2252.), the electro-magnet was excited; it immediately advanced or turned until the angle was about 45° or 50° , and then stood still. Upon the interruption of the electric current at the magnet the revulsion came on very strongly, and the block turned back again, passed the equatorial line, and proceeded on until it formed an angle of 50° or 60° on the other side; but instead of continuing to revolve in that direction as before (2315.), it then returned on its course, again passed the equatorial line, and almost reached the axial position before it stood still. In fact, as a mass, it vibrated to and fro about the equatorial line.

2688. This however is a simple result of the principles of action formerly developed (2329. 2336.). The revulsion is due to the production of induced currents in the suspended mass during the falling of the magnetism of the electro-magnet; and the effect of the action is to bring the axis of these induced currents parallel to the axis of force in the magnetic field. Consequently, if the time of the fall of magnetic force, and therefore of the currents dependent thereon, be greater than the time occupied by the revulsion of the copper block as far as the equatorial line, any further motion of it by momentum will be counteracted by a contrary force; and if this force be strong enough the block will return. The conducting power of the copper and its division into laminae, tend to set up these currents very readily and with extra power; and the very power which they possess tends to make the time of a vibration so short, that two or even three vibrations can occur before the force of the electro-magnet has ceased to fall any further. The effect of *time*, both in the rising and falling of power, has been referred to on many former occasions (2170. 2650.), and is very beautifully seen here.

2689. Returning to the subject of the assumed polarity of bismuth, I may and ought to refer to an experiment made by REICH, and described by WEBER*, which, if

* TAYLOR'S Scientific Memoirs, v. p. 480.

I understand the instruction aright, is as follows: a strong horseshoe magnet is laid upon a table in such a position that the line joining its two poles is perpendicular to the magnetic meridian and to be considered as prolonged on one side; in that line, and near the magnet, is to be placed a small powerful magnetic needle, suspended by cocoon silk, and on the other side of it, the pole of a bar magnet, in such a position and so near, as exactly to counteract the effect of the horseshoe magnet, and leave the needle to point exactly as if both magnets were away. Then a mass of bismuth being placed between the poles of the horseshoe magnet is said to react upon the small magnet needle, causing its deflection in a particular direction, and this is supposed to indicate the polarity of the bismuth under the circumstances, as it has no such action when the magnets are away. A piece of iron in place of the bismuth produces the contrary deflection of the needle.

2690. I have repeated this experiment most anxiously and carefully, but have never obtained the slightest trace of action with the bismuth. I have obtained action with the iron; but in those cases the action was far less than if the iron were applied outside between the horseshoe magnet and the needle, or to the needle alone, the magnets being entirely away. On using a garnet, or a weak magnetic substance of any kind, I cannot find that the arrangement is at all comparable for readiness of indication or delicacy, with the use of a common or an astatic needle, and therefore I do not understand how it could become a test of the polarity of bismuth when these fail to show it. Still I may have made some mistake; but neither by close reference to the description, nor to the principles of polar action, can I discover where.

2691. There is an experiment which PLÜCKER described to me, and which at first seems to indicate strongly the polarity of bismuth. If a bar of bismuth (or phosphorus) be suspended horizontally between the poles of the electro-magnet, it will go to the equatorial position with a certain force, passing, as I have said, from stronger to weaker places of action (2267.). If a bar of iron of the same size be fixed in the equatorial position a little below the plane in which the diamagnetic bar is moving, the latter will proceed to the equatorial position with much greater force than before, and this is considered as due to the circumstance, that, on the side where the iron has N polarity, the diamagnetic body has S polarity, and that on the other side the S polarity of the iron and the N polarity of the bismuth also coincide.

2692. It is however very evident that the lines of magnetic force have been altered sufficiently in their intensity of direction, by the presence of the iron, to account fully for the increased effect. For, consider the bar as just leaving the axial position and going to the equatorial position; at the moment of starting its extremities are in places of stronger magnetic force than before, for it cannot be doubted for a moment that the iron bar determines more force from pole to pole of the electro-magnet than if it were away. On the other hand, when it has attained the equatorial position, the extremities are under a much weaker magnetic force than they were subject to in the *same places* before; for the iron bar determines downwards upon itself much

of that force, which, when it is not there, exists in the plane occupied by the bismuth. Hence, in passing through 90° , the diamagnetic is urged by a much greater difference of intensity of force when the iron is present than when it is away; and hence, probably, the whole additional result. The effect is like many others which I have referred to in magnecrystallic action (2487–2497.), and does not, I think, add anything to the experimental proof of diamagnetic polarity.

2693. Finally, I am obliged to say that I can find no experimental evidence to support the hypothetical view of diamagnetic polarity (2640.), either in my own experiments, or in the repetition of those of WEBER, REICH, or others. I do not say that such a polarity does not exist; and I should think it possible that WEBER, by far more delicate apparatus than mine, had obtained a trace of it, were it not that then also he would have certainly met with the far more powerful effects produced by copper, gold, silver, and the better conducting diamagnetics. If bismuth should be found to give any effect, it must be checked and distinguished by reference to the position of the commutator, division of the mass by pulverization, influence of time, &c. It appears to me also, that, as the magnetic polarity conferred by iron or nickel in very small quantity, and in unfavourable states, is far more readily indicated by its effect on an astatic needle, or by pointing between the poles of a strong horseshoe magnet, than by any such arrangement as mine or WEBER'S or REICH'S, so diamagnetic polarity would be much more easily distinguished in the same way, and that no indication of that polarity has as yet reached to the force and value of those already given by BRUGMANN and myself.

2694. So, at present, the actions represented or typified by iron, by copper and by bismuth, remain distinct; and their relations are only in part made known to us. It cannot be doubted that a larger and simpler law of action than any we are yet acquainted with, will hereafter be discovered, which shall include all these actions at once; and the beauty of WEBER'S suggestion in this respect was the chief inducement to me to endeavour to establish it.

2695. Though from the considerations above expressed (2693.) I had little hopes of any useful results, yet I thought it right to submit certain magnecrystallic cores to the action of the apparatus. One core was a large group of symmetrically disposed crystals of bismuth (2457.); another a very large crystal of red ferroprussiate of potassa; a third a crystal of calcareous spar; and a fourth and fifth large crystals of protosulphate of iron. These were formed into cylinders of which the first and fourth had the magnecrystallic axes (2479.) parallel to the axis of the cylinder, and the second, third and fifth, had the equatorial direction of force (2594. 2595. 2596.) parallel to the axis of the cylinder. None of them gave any effect at the galvanometer, except the fourth and fifth, and these were alike in their results, and were dependent for them on their ordinary magnetic property.

2696. Some of the expressions I have used may seem to imply, that, when employing the copper and other cores, I imagine that currents are first induced in them by the

dominant magnet, and that these induce the currents which are observed in the experimental helix. Whether the cores act directly on the experimental helix or indirectly through their influence on the dominant magnet, is a very interesting question, and I have found it difficult to select expressions, though I wished to do so, which should not in some degree prejudice that question. It seems to me probable, that the cores act indirectly on the helix, and that their immediate action is altogether directed towards the dominant magnet, which, whether they consist of magnetic or diamagnetic metals, raises them into power either permanently or transiently, and has their power for that time directed towards it. Before the core moves to approach the magnet, the magnet and experimental helix are in close relation; and the latter is situated in the intense field of magnetic force which belongs to the pole of the former. If the core be iron, as it approaches the magnet it causes a strong convergence and concentration of the lines of magnetic force upon itself; and these, as they so converge, passing through the helix and across its convolutions, are competent to produce the currents in it which are obtained (2653. 2668.). As the iron retreats these lines of force diverge, and again crossing the line of the wire in the helix in a contrary direction to their former course, produce a contrary current. It does not seem necessary, in viewing the action of the iron core, to suppose any direct action of it on the helix, or any other action than this which it exerts upon the lines of force of the magnet. In such a case its action upon the helix would be indirect.

2697. Then, by all parity of reasoning, when a copper core enters the helix its action upon it should be indirect also. For the currents which are produced in it are caused by the direct influence of the magnet, and must react equivalently upon it. This they do, and because of their direction and known action, they will cause the lines of force of the magnet to diverge. As the core diminishes in its velocity of motion, or comes to rest, the currents in it will cease, and then the lines of force will converge; and this divergence and convergence, or passage in two directions across the wire of the experimental helix, is sufficient to produce the two currents which are obtained in the advance of the core towards the dominant magnet (2671. 2673.). A corresponding effect in the contrary direction is produced by the retreat of the core.

2698. On the idea that the actions of the core were not of this kind, but more directly upon the helix, I interposed substances between the core and the helix during the times of the experiment. A thick copper cylinder 2·2 inches long, 0·7 of an inch external diameter, and 0·1 of an inch internal diameter, and consequently 0·3 of an inch thick in the sides, was placed in the experimental helix, and an iron wire core (2668.) used in the apparatus. Still, whatever the form of the experiment, the kind and amount of effect produced were the same as if the copper were away, and either glass or air in its place. When the dominant magnet was removed and the wire core made a magnet, the same results were produced.

2699. Another copper lining, being a cylinder 2·5 inches long, 1 inch in external

diameter, and one-eighth of an inch in thickness, was placed in the experimental helix, and cores of silver and copper five-eighths of an inch in thickness, employed as before, with the best condition of the commutator (2675.): the effects, with and without the copper, or with and without the glass, were absolutely the same (2698.).

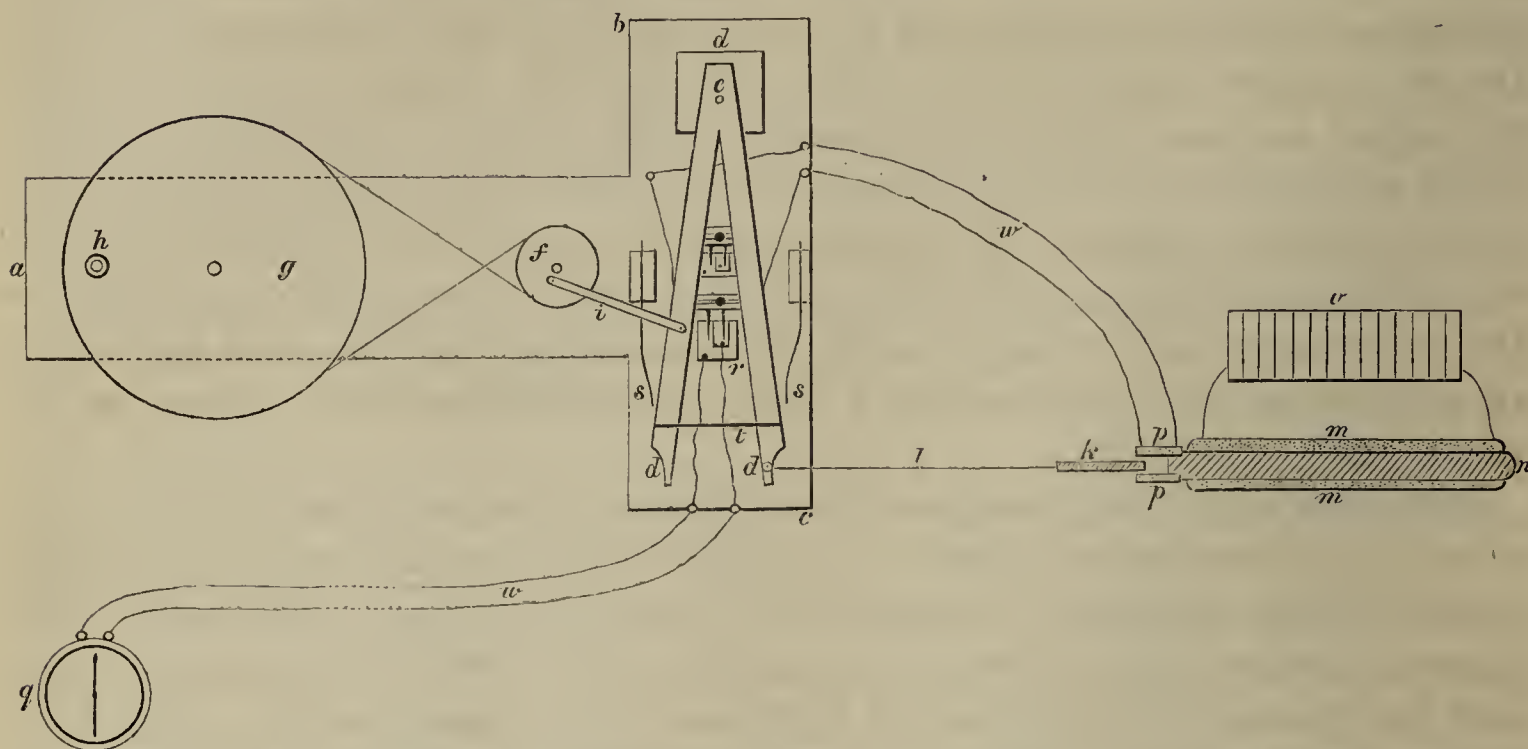
2700. There can be no doubt that the copper linings, when in place, were full of currents at the time of action, and that when away no such currents would exist in the air or glass replacing them. There is also full reason to admit, that the divergence and convergence of the magnetic lines of force supposed above (2697.) would satisfactorily account for such currents in them, supposing the indirect action of the cores were assumed. If that supposition be rejected, then it seems to me that the whole of the bodies present, the magnet, the helix, the core, the copper lining, or the air or glass which replaces it, must all be in a state of tension, each part acting on every other part, being in what I have occasionally elsewhere imagined as the electro-tonic state (1729.).

2701. The advance of the copper makes the lines of magnetic force diverge, or, so to say, drives them before it (2697.). No doubt there is reaction upon the advancing copper, and the production of currents in it in such a direction as makes them competent, if continued, to continue the divergence. But it does not seem logical to say, that the currents which the lines of force cause in the copper, are the cause of the divergence of the lines of force. It seems to me, rather, that the lines of force are, so to say, diverged, or bent outward by the advancing copper (or by a connected wire moving across lines of force in any other form of the experiments), and that the reaction of the lines of force upon the forces in the particles of the copper cause them to be resolved into a current, by which the resistance is discharged and removed, and the line of force returns to its place. I attach no other meaning to the words *line of force* than that which I have given on a former occasion (2149.).

Royal Institution,

14 *Dec.* 1849.

Plan of the Apparatus employed in Dr. FARADAY'S Researches, Series XXIII. p. 172.



a, b, c frame board; *d, d, d* wooden lever, of which *e* is the axis, *f* the crank-wheel, and *g* the great wheel with its handle *h*; *i* the bar connecting the crank-wheel and lever; *k* a cylinder or core of metal to be submitted to experiment; *l* the rod connecting it with the lever; *m* the helix of the electro-magnet; *n* the iron core, and *o* the exciting battery; *p* the experimental helix; *q* the galvanometer, 20 feet from the electro-magnet; *r* the commutator; *w, w* connecting wires; *s, s* springs of brass or copper; *t* a copper rod connecting the two arms of the lever, to give strength. The plan is to a scale of one-fifteenth: the part at the electro-magnet and experimental helix is in section; the further description is in paragraphs 2643, 2644, 2645 and 2648 of the Experimental Researches.

VIII. *On the Development of the Retina and Optic Nerve, and of the Membranous Labyrinth and Auditory Nerve.* By HENRY GRAY, M.R.C.S. Communicated by W. BOWMAN, F.R.S., Professor of Physiology and of General and Morbid Anatomy in King's College, London.

Received October 18, 1849,—Read January 31, 1850.

THE following observations, which I have ventured to offer to the Royal Society, are intended to demonstrate the mode of evolution of the essential parts of the visual and auditory apparatus.

In the first part I have considered the mode of development of the optic nerve and retina, and also of the various layers of this membrane. In the second part, I have traced the evolution of the membranous labyrinth and auditory nerve. Many of these observations have not (as far as I am acquainted) been previously made, at the same time they will, I think, confirm in a remarkable manner the account that has already been given of the structure of these parts*.

In the minute and accurate account of the structure of the retina which Mr. BOWMAN has lately given in a series of lectures on the Anatomy of the Eye, he has shown that this essential part of the visual organ “is a nervous sheet containing nearly all the structural elements that are found in any part of the nervous system, consisting of an unbroken sheet of gray nervous matter, continuous by its fibrous internal surface with the axes of the tubules of the optic nerve, and having its external surface formed by a structure similar to that of the cineritious substance of the cerebral hemispheres. Its permeation by a close network of capillaries assimilates it still further to the gray nervous matter, for which reasons it may be considered as a portion of the cerebrum advanced towards the surface of the body in a suitable relation to a dioptric apparatus for the reception of rays of light from external objects.”

The following observations are intended to demonstrate the evolution and mode of development of this membrane in the embryo chick, and they will, I think, confirm in a most striking manner the account that has been given of the structure of this part.

It is not until the thirty-third hour of incubation that there is any indication of the evolution of the retina or of the rudimentary eye. At the thirty-first hour (Plate VIII. fig. 1) the cephalic extremity of the embryo is indicated by its presenting a somewhat

* Some of the observations on the development of the retina may be found in my Prize Essay “On the Anatomy and Physiology of the Nerves of the Human Eye,” contained in the Library of the Royal College of Surgeons, but unpublished.

dilated end, but no protrusion can be observed in the situation where the eye is to be subsequently formed. At the thirty-third hour (fig. 2) there is observed on each side of the cephalic extremity a protrusion of its walls, which at the thirty-sixth hour (fig. 3) has very much increased, having become more elongated and protruded outwards, presenting a somewhat dilated end, and being slightly constricted at its connection with the cerebral cell from which it arises; the whole embryo is enlarged, and now there is a distinct division of the brain into its several primitive cells; this protrusion, which is well represented in fig. 3, is the first distinct indication of the mode of development of this membrane.

In an embryo chick, examined at the forty-sixth hour of incubation from the cerebral aspect (figs. 4 and 5), the future brain consisted of several cells; the anterior, which was the largest, corresponded to the cerebral lobes; the middle, smaller in size, to the future optic lobes; and the posterior, the smallest, but most elongated, to the medulla oblongata. From the most anterior one there arose a protrusion on each side, having a somewhat dilated extremity: this protrusion I will call the optic vesicle. The cavity of the cerebral cell from which it arose was very distinct and its wall clear and pellucid, and appeared to communicate with the optic vesicle, which was also hollow.

As the cavity of the cerebral cell passed outwards on both sides into the optic vesicle it became less distinct, as there the wall of the vesicle, which is darkly granular, makes it in this situation less apparent, whilst the cavity in the cerebral cell itself was distinctly seen from the thinness of its wall on its ventral aspect. If the embryo is examined from its dorsal surface (its natural position in the egg), the cerebral cell presents an external convex surface, whilst projecting from each side are seen the optic vesicles. The cavity of the cell and its communication with the optic vesicle, cannot on this surface be distinctly demonstrated on account of its wall being thicker than on the ventral side. The optic vesicle is bounded externally by a well-defined line which lines the outer surface of the protrusion, and seems to be connected with the envelopes of the cerebral mass; this is again bounded by the tegumentary layer of the embryo. When examined with a high magnifying power, the vesicle presented a pale granular texture without any indication of cellular structure. This description of the origin of the retina, although confirmed by similar observations, described by BAER in the *Encyclopédie Anatomique*, tom. viii., is not in accordance with that of some other celebrated physiologists. According to WAGNER, the protrusion which forms the future retina arises from the middle and anterior cerebral cells, whilst HUSCHKE describes it as "a simple rudiment, consisting of a fosome; that the dorsal laminæ form in front of their anterior dilatation, the first cerebral cell ultimately dividing this into two lateral halves, from which result the two rudimentary eyes." He says also that this fosome is formed before the end of the first day. From many observations I have made I could never see what these observers have described, and, coinciding as my observations do so exactly with those of BAER, the conclusions which I have stated regarding the origin of this membrane would seem

to be thereby confirmed. On examining a chick nine hours after this period, that is, at the fifty-fifth hour of incubation (fig. 6), the cavity before so distinctly seen in the anterior cerebral cell was much less apparent; the walls of the cell have also much increased in size, not only projecting upwards but laterally, so as partly to cover over the inner portion of the protruded optic vesicle, which at the second day was so distinctly seen; the head had also become more curved, which rendered a good examination of the eye somewhat difficult. On manipulating the specimen so as to obtain a view from above downwards, the embryo lying on its ventral surface, the outer portion of the protruded vesicle was distinctly seen bounded by a clear defined inner border and an outer paler one; the dark inner one was lost in the dark granular mass, which by its circular form indicated the rudimentary eye; the outer layer was the external tegumentary membrane of the embryo. At the sixty-second hour (Plate IX. fig. 8) the optic vesicle is seen to be apparently situated between the anterior and middle cerebral cells; this I believe depends on the great increase of development of these cells, and the curved form which the head now assumes, making its apparent origin to be from both, as stated by WAGNER. On carefully examining it, the exterior dark line was beautifully defined all around, and presented the appearance of an outer covering to the eyeball; in this apparent cavity was seen a pyriform vesicle, the future retina, presenting a distinct outline, except at its inner side, where it became constricted and of a tubular form, and to all appearance was continuous with the cerebral mass; this constricted portion, the tubular end, I suppose to be the optic nerve, the dilated portion the retina. Internal to the retina was the circular crystalline lens, with its central but indistinct nucleus. The conclusions I have come to, from the observations made on the specimens from which the drawings 5, 6 and 8 are taken, are quite at variance with those of HUSCHKE. He says that between the second and third days the two layers of the retina are formed in the following manner. He describes the capsule of the lens as being an inverted portion of the common integument, which pushes inwards the dilated end of the optic vesicle, and thus forms a double layer; the outer one he describes as JACOB'S membrane, the inner inverted one the true retina. In order to ascertain the correctness of this statement, I examined the eye at four successive periods between the second and third days, at the forty-eighth, fifty-fifth, sixty-second and seventy-second hours. I not only examined them laterally, as they naturally presented themselves on removing them from the egg, but both on their dorsal and ventral aspect; and if the lens had been, as he described, an inversion of the integument pressing in the dilated end of the optic vesicle, both of the latter positions would have been most favourable for demonstrating it. The lens is however formed in quite a different manner; it is first seen as a rather ill-defined granular mass in the cavity of the vesicle itself, containing in its centre a nucleus: this is seen on the first half of the third day. On the third it becomes more distinct, a well-defined line now bounds its margin; between the fourth and fifth days, the granules become darker and more aggregated towards the centre, leaving a space

bounded by a dark outer line; this is now the capsule of the lens, the inner one the bounding margin of the lens itself. Nor could I ever see satisfactorily any doubling-in of the retina so as to form two layers, for in no position that I put the embryo, in each of the several examinations that I made, could I ever detect but a single layer; and besides, as I shall show hereafter, JACOB'S membrane is not developed until a much later period. I cannot forbear here adding the conclusions BISCHOFF has come to from his observations on this point. Although many anatomists of great reputation follow the opinion of HUSCHKE, he says, "Malgré ces autorités je dois avouer qu'il m'a été impossible même chez de très jeunes embryons de chien, de lapin, et de rat, d'apercevoir sur la face antérieure de l'œil aucune trace d'une semblable intrusion des téguments extérieurs, quoique dans certains cas, je sois resté incertain de savoir s'il existait déjà une capsule cristalline et un cristallin*."

At the seventieth hour (fig. 7) the circular outline of the eyeball has become quite distinct, not only externally, but now the line may be traced internally, where previously it was only indicated by the dark circular granular mass, the forming eyeball. The lens is also more distinctly seen bounded by its well-defined circular border, indicating its forming capsule, and the nucleus in its centre is plainly visible. When examined on its under surface, the embryo lying on its dorsal aspect, the original protrusion is seen to have become still more pyriform in shape and more constricted at its inner part, so that the more dilated portion now clearly resembles the future retina, the constricted and tubular portion the optic nerve; the more gradual contraction of this protrusion and separation of it from the cerebral mass is also now more clearly seen. The cavity, which on the second day existed in the cerebral cell and communicated with the protrusion, is now closed in, with the exception of a distinct fissure, which, commencing by curved borders at the margin of the lens, was seen to be continued inwards in the direction of the cerebral mass through the tubular portion of the protrusion, the optic nerve.

The fissure seems to be evidently connected (as BISCHOFF also supposes) with the separation which is effected between the ocular vesicle and the pedicle by which it is connected with the cerebral cell, the fissure at first being wide and extending as far as the anterior part of the eye, at its inferior and inner side; but as the tubular portion of the protrusion becomes more solidified and converted into the true optic nerve, the fissure becomes much narrowed. No doubt this is analogous to the fissure which exists permanently in the retina and optic nerve in Fishes, as is seen in the Cod. In the Turtle the fissure exists in the nerve though not in the retina, whilst in Birds it appears to be the same slit which is here described, through which the pecten gains admission into the interior of the eye.

On the first half of the fourth day (fig. 9) the whole organ seems to be increased in size: the exterior lamina was distinctly continuous all round, and was of a dark granular texture; the second layer the retina presented a different appearance to

* Anatomie Encyclopédie, tom. viii. p. 324.

what was seen on the third day; it had become more spherical in shape and increased in size; it now appeared to commence at the margin of the lens, which was situated at the more anterior part of the eye; it could not be traced around it, as in some of the preceding observations, but only overlapped it slightly by a thin beveled border, so that it appeared that the most external part of the original protruded vesicle had become absorbed to complete the formation of this rapidly developing membrane. The tubular portion of the original protrusion (the optic nerve), from the great development of the cerebral mass, was hidden from view.

On the fourth day (fig. 10) the eye had become more spherical in form, the outer envelope was distinct and darkly granular; it appeared now to terminate at the edge of the lens, whilst a paler line could be traced over this body, an evident indication of the formation of the sclerotic and cornea. The retina was now less distinctly marked on account of the dark granular tinge beneath the outer envelope; from the formation of the pigment in the epithelial cells of the choroid, it could now only be traced to the edge of the lens, not overlapping it as in the last examination: a distinct fissure was still perceptible on the under surface.

On the fifth day (fig. 11) the eye had greatly increased in size; and along its under surface the fissure was seen running, from its anterior part at the margin of the lens, to a line which bordered the back part of the sclerotic; the capsule of the lens was distinctly formed and separate from the lens itself. Both optic nerves were seen; they were tubular in form and presented a pale granular appearance; they passed inwards in the direction of the under surface of the corpora quadrigemina, but they were not united together in the chiasma until the seventh day. At this period, on making a vertical section of the organ, the retina was to the naked eye distinctly observed to arise from the margin of the lens, and could be detached from the other membranes as a perfectly distinct and separate layer.

From these observations it is seen that the retina is originally a protrusion from the anterior cerebral cell, being hollow and communicating with its cavity; that as the progressive development of the brain takes place, the optic vesicle becomes more separated from its parent cell and assumes a pyriform shape, presenting a dilated extremity, the future retina, and a tubular portion (the optic nerve). In progress of development a fissure is observed on its under surface, which is evidently connected with the separation which is effected between the ocular vesicle and the tubular pedicle (the optic nerve) which connects it with the cerebral cell. As this tubular prolongation becomes solidified so as to form the optic nerve, no communication can be traced between the optic vesicle and the cavity, from which it is an offset. By degrees the spherical end of the protrusion is absorbed, and the retina, now fully formed, becomes attached to the margin of the lens, having previously completely surrounded that body. The optic nerve can then be seen not only to be connected to the anterior cerebral cell, but uniting with its fellow at the under surface of the optic lobes, is seen partly to terminate in those bodies.

I shall proceed, in the next place, to consider the development of the various layers of the retina.

Structure of the Retina of the Chick at the Eighth Day of Incubation.

The retina may at this period be distinctly separated as a thin transparent layer from the other membranes. Its choroidal surface appears to be composed of a closely aggregated mass of globular nuclei; these bodies are about the size of the red corpuscles of the blood, and form about one-half of the entire thickness of the membrane; they apparently correspond to the "agglomerated granules" mentioned by BOWMAN as forming a considerable portion of the membrane in the normal state; they are highly refractive and of a slight yellow tinge. The deep surface of the membrane consists of some fine granular matter, and a mass of pale and exceedingly delicate nucleated cells, precisely similar to those surrounding the meshes of the fibrous lamina in the normal structure of the membrane. No trace at this period existed of either the membrana Jacobi, or the fibrous lamina of the retina.

On the Development of the Membrana Jacobi.

Between the thirteenth and fourteenth days the choroidal surface of the retina presents an exceedingly fine pale granular stratum, which covers in the "agglomerated granular mass" beneath. On the fifteenth day numerous exceedingly minute and highly refractive yellowish granules are imbedded in it; they vary in size, between the 5000th and the 8000th part of an inch in diameter, and around some of these a fine delicate cell-wall can be traced; if a good view can now be obtained of this surface, it will present the appearance of a delicate epithelial layer. This I believe to be the first stage in the development of JACOB'S membrane; for on the eighteenth day the cells, which were previously of a circular form, had now become elongated, some being of an oval shape, whilst in others the almost perfect rod-like body was formed; they now lie in a slightly imbricated manner, and their nuclei, which are of a bright yellow colour, are placed at the apices of the rods; in some cases however they occupy the middle of these bodies; their deep ends are larger than their choroidal ends, and are strongly attached by this surface to the "agglomerated granular layer" beneath; so intimate is their connexion that it is difficult to get a good view of a single rod in the field whilst examining them, probably on account of their perfect separation from this layer not having yet taken place. On the twenty-first day JACOB'S membrane is similar to what is seen in the full-grown bird; the rods are now closely packed together, standing perpendicularly upwards, and all of an elongated cylindrical form, their tips being occupied by the brilliant yellow bodies before noticed.

On the Development of the Fibrous Lamina.

The first trace of the fibrous lamina is seen between the fourteenth and fifteenth days: on examining the deep surface of the retina at this period, it is seen to be com-

posed of a very fine pale granular lamina, marked by numerous faint longitudinal striæ: on the eighteenth, this lamina, when separated from the rest of the membrane, is composed of numerous fibrillated bundles, which interlacing with each other form numerous meshes, in which are deposited the gray nucleated vesicles, which are seen to be formed as early as the eighth day. On the twenty-first day this lamina presents the same structure as is found in the full-grown bird. The preceding observations can, I think, be applied in explanation of some lately disputed points in connection with the anatomy and physiology of the retina and optic nerve. And first of the retina.

This membrane has been seen to arise as a protrusion from the cells forming the future brain. Now in the microscopic anatomy of this membrane, as described by BOWMAN, the vesicular layer of the retina is stated to be analogous to the vesicular layer of the hemisphere of the brain, whilst HENLE, and other anatomists of great note, consider the elements of this layer to be more analogous to epithelium. From the circumstance of the retina arising, as it undoubtedly does, from the cerebral cells, being in fact part of them and performing a similar function, we have, I think, a great proof of the similarity in the structure of these two parts. There is another point also, I think, of some importance in proving, as it does, that the opinion of some modern anatomists is incorrect in stating that none of the fibres of the optic nerve can be traced to the optic thalamus. I have said that the origin of the retina is from the anterior cerebral cell, and that at a future period the optic nerve could be traced uniting with its fellow of the opposite side beneath the optic lobes. It is in the anterior cerebral cell that the thalami are subsequently formed, which makes it exceedingly probable that some of its fibres are connected with it, although the greater majority may be traced to the optic lobes.

These facts I think are of some importance, and prove how deductions formed from microscopic embryology may be applied to confirm dissections or microscopic investigations made on the same parts in the mature animal.

On the Development of the Membranous Labyrinth and Auditory Nerve.

The observations I made prior to my description of the mode of evolution of the retina will almost apply here as a preface to my observations on the development of the membranous labyrinth and auditory nerve, for the essential part of this membrane consists, like the retina, of a fibrous lamina formed of the terminal axes, cylinders of the nerve tubules or of terminal loops of nerves, which are in intimate relation with a layer of dark and closely-set nucleated cells, not unlike those found lying between the meshes of the fibrous lamina of the retina; like it also, it may be regarded (as the following observations will show) as a protruded portion of the brain, modified somewhat in its texture and connected with an appropriate apparatus, which receives and transmits its peculiar impressions.

The following observations are intended to demonstrate the mode of development of this membrane, and they will, I think, confirm, not only the description given of

the structure of this part, but show the striking analogy which exists between it and the retinal expansion.

At present two opinions exist regarding the evolution of the ear-bulb. It is stated by BAER that it arises soon after the appearance of the eye, in the form of a tubular prolongation of the brain, which is hollow, and communicates with the cavity of the fourth ventricle, its peripheral extremity forming a vesicular dilatation, which is gradually separated from the brain. Into this vesicle, which is the analogue of the labyrinth, there is protruded inwards a reflection of the integument, which forms all the accessory parts of the organ of hearing. HUSCHKE's account is entirely different; he says that the membranous labyrinth does not arise from the brain, but is originally a blind sac of the skin with an excretory duct, which gradually contracting, is at last separated from the common integument and exists as a separate sac beneath it. The following observations coincide partly with the description given by BAER; at the same time I shall venture to state some facts in connection with this point, that have not been (as far as I am acquainted) previously noticed. In the embryo chick at the fiftieth hour, soon after the close of the second day, I observed that the medulla oblongata was not closed in above, but presented a large open shallow cavity, the analogue of the fourth ventricle. At the cephalic extremity it communicated with the optic lobes and the anterior cerebral cell by means of a small circular orifice. From the central part of the wall of this cavity, and exactly opposite to the second branchial cleft, the first rudiment of the auditory sac was visible, in the form of a small protruded vesicle of a somewhat flattened circular shape; this vesicle was hollow, clear and pellucid, and communicated with the ventricular cavity by a small circular orifice. This communication was most distinctly seen on examining the embryo from the dorsal aspect, as shown in fig. 13, where the aperture leading into the protruded sac is visible on one side, bounded by its well-defined margin. In order to satisfy myself of the correctness of this observation, and to test the accuracy of HUSCHKE's statement, I examined numerous embryos every second hour, from the thirty-sixth hour to the time when the above appearances were observed, but in none could I detect a protrusion of the tegumentary layer in that situation, and, coinciding as my observations do with those of BAER as regards the origin of this membrane, they justify, I think, the conclusions which are above stated.

At the fifty-sixth hour (fig. 14) the auditory vesicle occupies its usual position; it has become however increased in size, and has assumed a pyriform shape, so that now it presents a narrow contracted tubular portion, the rudiment of the auditory nerve, and a dilated spherical extremity, the auditory sac, or rudimentary vestibule. This latter portion projects into and becomes encased by the muscular and tegumentary layers of the embryo, forming a distinctly marked projection beneath the integument; the vesicle itself has become darkly granular and more opaque, but the cavity in its interior is still distinctly seen communicating with the ventricular cavity, through the tubular prolongation of the vesicle (the auditory nerve); the

aperture of communication is however much smaller, having become more contracted, and this contraction apparently increases as the separation between the auditory vesicle and its parent cell takes place. At the sixty-fifth hour (see fig. 15) the ear-bulb has increased considerably in size, and a more marked separation is now seen to exist between the auditory nerve and the expanded vestibular sac; the latter has assumed an oval shape and is now directed slightly backwards, the cavity in its interior still existing; but the auditory nerve has become now quite solidified, so that no communication exists at this period between it and the ventricular cavity. From the description which I have already given, a marked similarity may be observed between the origin of this membrane and that of the retina and optic nerve; these parts arise in both cases as a protruded portion of the cerebral mass, being hollow and communicating with the cavity of the parent cell; in process of time a gradual separation takes place between them and the parts from which they arise; they then assume a pyriform shape, but still communicate with the cerebral cavity; as however the nerve becomes solidified and more fully formed, and the separation between them is more fully effected, then no communication can be traced between the two cavities. It is in this stage of the development of the auditory apparatus in the Bird, that a remarkable similarity is to be observed between it and the normal condition of the same part in some of the lower animals. There are in fact now formed the two elementary portions of this apparatus, the auditory nerve and its vesicular bulb (the analogue of the vestibular sac). Such is the simple condition of this organ in the crustacea and in the cephalopod mollusks.

I shall, in the next place, proceed to describe the observations I have made on the development of the semicircular canals, or rather of those portions of the membranous labyrinth which line those cavities, and which are found superadded in most Birds, Fishes, and Mammalia.

At the seventy-second hour (fig. 16) the vestibular sac has become more distinctly separated from the cavity from which it originated, but is connected with it by the auditory nerve, which is fully formed and of large size; the vesicle is still quite hollow, and contains a thin limpid fluid; but its oval form is lost from a distinct contraction of its (apparent) entire circumference, which is observed about its centre; this contraction is seen to exist both on the outer and also on the inner wall, and is the first indication of the separation of the vestibule from the membranous semicircular canals, which are ultimately formed from the terminal portion of the vesicle. At the eighty-second hour (fig. 17) the contraction is observed to have become more marked, so as partially to subdivide the vestibular sac into two unequal portions; the lower one, that connected with the auditory nerve, is the future vestibule, the upper terminal one being developed into the semicircular canals; the cavity still exists in the interior of the vesicle, and the auditory nerve has increased in size. At the close of the fourth day (fig. 18) the terminal bulbous portion of the original vestibular sac has become very considerably enlarged, and of an oval-elongated form; the contraction originally

existing and separating it from the vestibule itself has increased very considerably, so that now a well-marked separation is seen to exist, although both cavities communicate with each other. A slight depression or shallow pit is now observed to exist at the end of the terminal vesicle, which soon becomes very distinct. This I believe indicates the first rudiment of one of the semicircular canals; no trace of the folding-in or depression of the integument in this situation could be observed.

About the sixth day this depression is more marked, and it is apparently from the amalgamation of this reflected portion and the inner wall of the vesicle with each other, that the membranous semicircular canals are formed. At first they appear to retain the same diameter throughout, but between the twelfth and thirteenth days they become somewhat contracted in parts, leaving some portions of their original diameter: it is these that apparently ultimately form the ampullæ. At about the same period a cartilaginous nidus is deposited on the outer side of the membranous labyrinth, which is soon developed into the various parts of the osseous labyrinth: at the same time also a small quantity of calcareous matter is deposited in the vestibular sac. It is interesting to observe that the membranous labyrinth between the eighth and thirteenth days has a structure almost precisely similar to that of the retinal expansion of the same period, consisting, like it, of a distinct but very delicate fibrous mesh, in the spaces between which are deposited a quantity of granular matter and numerous nucleated cells, its exterior surface being composed of a dense mass of nuclei, almost precisely analogous to the "agglomerated granules" which form so large a portion of the entire substance of the retina. From the preceding observations the following conclusions may be drawn.

That the membranous labyrinth, like the retina, is a protruded portion of the brain, being hollow and communicating with the ventricular cavity from which it arises. As the progressive development of the brain proceeds, the auditory sac becomes more elongated and of a pyriform shape, the dilated portion being analogous to the vestibule, the contracted tubular portion to the auditory nerve; this subsequently becomes solid, and the cavity in the vestibule does not then communicate with the ventricle, from the wall of which it is an offset. This representative of the normal condition of the organ in some of the lower animals now takes on a higher form of development, for the membranous semicircular canals are now added to the vestibule, being formed by a contraction, and subsequently, a folding inwards and union of a portion of the walls of the vesicle itself; lastly, the walls of these canals becoming in parts contracted, the dilated ampullæ are formed.

EXPLANATION OF THE PLATES.

PLATE VIII.

- Fig. 1. An embryo chick at the thirty-first hour of incubation.
- Fig. 2. An embryo chick at the thirty-third hour.
- Fig. 3. An embryo chick at the thirty-sixth hour. The first rudiment of the eye is here seen to be visible in the form of a protrusion from the anterior cerebral cell.
- Fig. 4. An embryo chick at the forty-sixth hour. The optic vesicle is seen now very distinct, presenting a slight contraction at its connection with the cerebral cell from which it arises.
- Fig. 5. The cephalic extremity of a chick at the same period more highly magnified. This Plate is intended to represent the cavity which exists both in the cerebral cell and optic vesicle, and the communication between them.
- Fig. 6. The cephalic extremity of an embryo at the fifty-fifth hour viewed from the dorsal aspect, principally intended to represent the mode of formation of the crystalline lens.
- Fig. 7. The under surface of the eye of a chick at the seventieth hour. This figure shows the spherical form of the eyeball, its contracted tubular end, the optic nerve, the mode of formation of the lens, and the fissure which exists on the under surface of the eye.

PLATE IX.

- Fig. 8. The cephalic extremity of an embryo chick at the sixty-second hour (lateral view).
- Fig. 9. In this Plate the retina is seen overlapping the margin of the lens at the latter half of the third day.
- Figs. 10 and 11. The eye of an embryo chick on the fourth day.
- Fig. 12. The eye of an embryo chick on the fifth day.
- Fig. 13. In this Plate the first rudiment of the ear is visible in the form of a small vesicular protrusion from the central part of the medulla oblongata (from an embryo chick at the fiftieth hour of incubation).
- Fig. 14. An embryo chick at the fifty-sixth hour. The ear-bulb is now seen to be of a pyriform shape, and communicating with the cavity from which it arises.
- Fig. 15. The cephalic extremity of an embryo chick at the sixty-fifth hour of incubation. The rudimentary vestibule and auditory nerve are now seen fully formed.
- Fig. 16. The ear of an embryo chick at the seventy-second hour of incubation. The

auditory nerve is now seen quite solid, and the vestibule presents a slight contraction near its centre.

Fig. 17. An embryo chick at the eighty-second hour, viewed from the dorsal aspect. The cavity of the fourth ventricle is distinctly seen, and on either side the rudimentary ear is shown *in situ*; the contraction of the wall of the vestibule is more marked.

Fig. 18. The ear of an embryo chick at the ninety-sixth hour. The vestibular contraction is more marked, and a depression is observed at the extremity of the terminal vesicle, which subsequently forms one of the semicircular canals.

8 *Wilton Street*,
October 14th, 1849.

IX. *On the means adopted in the British Colonial Magnetic Observatories for determining the Absolute Values, Secular Change, and Annual Variation of the Magnetic Force.* By Lieut.-Colonel EDWARD SABINE, R.A., For. Sec. R.S.

Received February 6,—Read April 25, 1850.

SO many of the magnetic observatories which professed to adopt and pursue the system of observation recommended by the Royal Society have confined themselves, apparently even in what they have attempted, to investigations into the *diurnal* fluctuations of the magnetic elements, and into what have been called magnetic *disturbances*, that it may not be inappropriate to recall to recollection the far more extensive system of observation which it was the purpose of the Royal Society to institute.

The diurnal variations and the magnetic disturbances form, it is true, a portion, and an important portion, of the objects contemplated; but they can only be regarded as the effects of minor forces, superimposed upon the far more powerful and important agency of the terrestrial magnetism itself, and from which they are probably distinct both in their nature and in their origin.

In the provision of instruments and in the elaborate instructions contained in the Report of the Royal Society for the determination of the *absolute values* and *secular changes*, as well as of the periodical variations of the three magnetic elements, it was obviously the purpose to comprehend as the objects of investigation the *whole* of the phenomena by which the magnetic state of our planet is either permanently or temporarily affected; and particularly the permanent and systematic part of the phenomena which results from that more powerful agency to which the name of “Terrestrial Magnetism” more strictly belongs.

The determination of the mean numerical values of the elements of terrestrial magnetism in direction and force at different points of the earth’s surface, (the force being expressed in absolute measure, intelligible consequently to future generations however distant, and conveying to them a knowledge of the present magnetic state of the globe,) and the determination of the nature and amount of the secular changes which the elements are at present undergoing, are the first steps in that great inductive inquiry, by which it may be hoped that the inhabitants of the globe may at some date, perhaps not very distant, obtain a complete knowledge of the laws of the phenomena of terrestrial magnetism, and possibly gain an insight into the physical causes of one of the most remarkable forces by which our planet is affected.

It is true that the instruments proposed by the Royal Society, as well as the in-

structions for their use, were found on the experience of the first few years to be not fully adequate to the satisfactory attainment of all the purposes for which they had been designed. This was especially the case in regard to the Bifilar Magnetometer, the magnet of which, 15 inches long, was directed to be used, in conjunction with the magnet of the Declinometer (which was of similar length), for the determination of the horizontal component of the magnetic force. It was soon found that at a suitable distance from each other, necessarily regulated by their length, the magnets were too far apart in the experiments of deflection, to produce angles of deflection bearing a sufficient proportion to the unavoidable errors of observation; whence the results so obtained were charged with a probable error far too great for the purposes contemplated. It was also found, that, whenever the magnets of the Bifilar and Declinometer were thus employed, a break was unavoidably made in the series with the Bifilar, on the continuity of which its value as a differential instrument, and therefore as an instrument for determining secular changes, must necessarily in great measure depend. To obviate these inconveniences, and particularly the latter, "Revised Instructions" were drawn up and circulated by the Royal Society, recommending the employment of an auxiliary apparatus, by which the experiments of vibration and deflection required for the determination of the horizontal component of the Force might be made in a separate apartment, and therefore without disturbing the magnetometers of the observatory, which from thenceforward would be employed solely as differential instruments. The magnets of the auxiliary apparatus were reduced from 15 inches to 12 and 9 inches in length. It was found however on trial, that when these magnets were placed at the minimum admissible distance from each other corresponding to their length, their distance apart was still too great to produce angles of deflection of sufficient magnitude, to lessen the probable error of the results to an amount, which would enable the secular change from month to month, or even from year to year, to be ascertained by their means within any reasonable period of observation. A few months' additional experience also served to show that when the Bifilar was thus set free to be appropriated wholly as a differential instrument, and when the magnet was left perfectly undisturbed, the conclusions which might be derived from it were still subject to two instrumental irregularities, which did not conveniently admit of elimination by any known process of experiment, and which prevented the observations made with the Bifilar from being strictly comparable with each other for more than very short intervals of time. One of these sources of irregularity had been anticipated, and it was hoped might have been surmounted; but the other had been apparently wholly unforeseen. The first consisted in the liability of the magnet bar to lose a portion of its magnetism. It was hoped if the magnet were entirely undisturbed by removals, that after a few months it might gradually attain a state in which its magnetism might undergo no further change (at least while it remained undisturbed), and that even whilst the period of change continued, the loss might be of a sufficiently uniform character to admit of its being allowed for. This has however

been by no means found to be the case with the magnets employed in the different Biflars of the Colonial Observatories, whose loss of magnetism appears to be subject to no general or systematic law, and even occasionally to intermit and to recommence without any apparent or discernible cause. To eliminate the effect of the loss, the magnetic moment of the bar would require therefore to be examined from time to time, and at short intervals; but the removal of the magnet for this purpose would break the connexion and thus interrupt the continuity of the series.

The source of the other irregularity in the indications of the Biflar, and which does not appear to have been anticipated, is still somewhat obscure: the effect is of the opposite character to that of the loss of magnetism in the magnet bar; and the position of equilibrium of the bar has been in more than one instance so much affected by it, that the bar has in a few months progressively passed out of the field of view of the telescope. The position of equilibrium is determined on the one side by the two variables, the magnetism of the earth and that of the bar; and on the other side by the supposed constants, the weight of the bar, the length and distance between the parallel suspension wires, and the angle of torsion. The weight of the bar cannot alter; the angle of torsion and the distance between the wires, observed before and after the change in the instances referred to, were ascertained to have undergone no alteration. A lengthening of the suspension wire has been therefore supposed to be the cause of the irregularity in question, the effect being precisely that which would be produced by an elongation of the wire; but no direct proof of this has yet been obtained, because when the Biflars were first adjusted no such effect was anticipated, and the exact length of the suspension wire at the period of the first adjustment appears to have been in no case measured*.

The Biflar being thus found to be affected by two sources of instrumental irregularity opposite in character, neither of which admitted of being satisfactorily eliminated, the comparability of the differential results obtained with that instrument, constructed according to the specifications in the Instructions of the Royal Society, could only be relied on for short intervals, and they would consequently admit of no certain inference being drawn from them in respect to secular changes.

The observations made during the first years of the Colonial Observatories having thus failed in accomplishing a very important, if not the most important, part of the objects contemplated, I requested Captain RIDDELL, who was at that time my assistant in the superintendence of the British Colonial Magnetic Observatories, to make

* The Toronto Biflar was adjusted on the 25th February 1843, with the intention that it should remain undisturbed. Between this date and the 11th of October of the same year the reading of the scale had altered 470 scale divisions, equivalent (approximately) to $\cdot 044$ parts of the force. At Hobarton the Biflar was adjusted, with the intention of its being left undisturbed, on the 16th of July, 1843. On the 1st of March, 1846, the scale reading had altered 78 scale divisions, equivalent (approximately) to $\cdot 017$ parts of the force. The alterations in both cases are in the opposite direction to what would be occasioned by a loss of force in the magnet bar, and must be regarded as the excess of one instrumental irregularity over a second, the real value of either being unknown.

such modifications in the Portable Magnetometer originally devised by Professor WILHELM WEBER*, the magnets of which were only from 3 to 4 inches in length, as would be likely to remedy several practical defects which experience had pointed out in that instrument; and to draw up such instructions for its use as might make it, when thus modified, an efficient instrument for effecting those purposes, originally prescribed by the Royal Society, which had hitherto failed of accomplishment; viz. the determination of the absolute values, secular changes, and annual variations of the horizontal component of the magnetic force. The modifications thus introduced and the methods of observation recommended, are contained in a work entitled “MAGNETICAL INSTRUCTIONS *for the use of Portable Instruments adapted for Magnetical Surveys and Portable Observatories, and for the use of a set of small Instruments adapted for a fixed Magnetic Observatory; with Forms for the Registry of Magnetical and Meteorological Observations;*” in which work, various other forms of instruments, suited for particular magnetic purposes, are also described, together with the best methods of using them, and of determining the several constants required in calculating the final results. The Portable Unifilar Magnetometer, with the modifications thus introduced, was shown to the magneticians assembled at the meeting of the British Association at Cambridge in 1845; and Captain RIDDELL’s Manual, printed by the authority of Government, has been extensively circulated amongst those persons who are engaged in magnetic researches, and has been found extremely useful, I believe, by those who have consulted it. A statement was made at the meeting of the British Association in 1845 of what had then been accomplished by the Colonial Observatories, and also of what still remained to be accomplished, to fulfil the objects for which the institution of those establishments had been recommended jointly by the Royal Society and British Association; and the probability was shown of speedily fulfilling *all* those objects by the means which had been adopted. Upon this statement a further but limited continuance of the observatories was recommended to Government and sanctioned. I am desirous of taking the earliest opportunity in my power of laying before the Royal Society a statement of the success which has attended the employment of the means thus referred to; because I am in hopes it may be an inducement to other observatories, which have either been instituted for the purpose of cooperating in the plan proposed by the Royal Society, or who have expressed the intention or desire of cooperating, to persevere in the fulfilment of *all* the objects originally contemplated; either by the adoption of the means which will be now described, or by the invention and employment of others which may serve the purpose as well or still more effectually. I shall avail myself of the observations which have been made at the Colonial Observatory of Toronto in Canada, under the direction of Captain

* A description of this instrument, translated by Mrs. SABINE, partly from an original account printed by M. WEBER in the ‘Resultate des Magnetischen Vereins,’ and partly from manuscript communications kindly furnished by M. WEBER himself, was presented to the Editor of TAYLOR’S Scientific Memoirs, and forms art. XVIII. in the second volume of that work.

LEFROY, R.A., F.R.S., for the purpose of illustrating the objects which I have in view. I might also have availed myself of similar observations made at the observatory at Hobarton in Van Diemen Island, under the direction of Commander KAY, R.N., F.R.S., but for the fear of encumbering this communication with too much detail.

The magnets employed for the monthly series of observations on the absolute horizontal force at Toronto are solid cylinders of 0·3 inch diameter; the suspension magnet being 3 inches and the deflecting magnet 3·67 inches in length. The same magnets have been used throughout the series. The observations are made about the same period in every month, and are extended over three days, usually the 16th, 17th and 18th of the month. Three distances are employed, the least being 1 foot, and the greatest 1 foot and four-tenths from the centre of the suspended magnet. The deflections are read on a circle of 6 inches diameter, having two verniers reading to 20". The deflections vary, according to the distance, from 6° to 10°. The reading telescope is attached to and moves with the azimuth circle; the deflecting magnet is therefore always perpendicular to the suspended magnet when the deflections caused by the latter are read off. The deflecting magnet is suspended for vibration in a stirrup with a mirror, in a detached wooden box, by a silk thread, of which the line of detorsion is brought approximately into the magnetic meridian. The time of vibration is determined by the mean of 300 vibrations in very small arcs, the commencing arc being always the same, *i. e.* 50', and a correction for the arc is applied. Actual changes in the horizontal force of the earth occurring between the two parts of the experiment, *i. e.* between the experiments of deflection and vibration, are eliminated by a correction derived from the Observatory Bifilar, which is read off concurrently with the deflections and vibrations, and both are reduced by this means to what they would have been, had the horizontal force, at the time of each observation, coincided with the mean horizontal force shown by the Bifilar on the same day. The reduction might obviously have been made with equal convenience to the mean reading of the Bifilar in the *month*; but this reduction would have involved the question of the dependence to be placed on the Bifilar itself for longer periods than for a few hours; and as the absolute determinations extend in every month over three days, I have preferred to keep their results independent of this reduction, except in two instances, *viz.* October and November 1848, when disturbances of unusual magnitude and continuance lessened the force on the days of observation to a more than ordinary degree. In those two instances therefore the results of the absolute determinations have been reduced to the mean reading of the Bifilar in the respective *months*, instead of its reading on the respective *days* of observation.

Differences of temperature occurring in the experiments of deflection and vibration have been eliminated by a temperature correction applied to the deflecting magnet, in which the coefficient has been very carefully determined by the usual process directed in the Revised Instructions of the Royal Society.

The constant, depending upon the value of the moment of inertia of the deflecting

magnet when suspended for vibration, has been carefully determined by repeated experiments made at Toronto with inertia rings of different weights and dimensions; and for greater security these experiments will be repeated with other rings at Woolwich when the series is closed. The intercomparison of the partial results with all the rings will give to the determination of the value of this constant a probable error, which, converted into terms of the intensity of the force, will enter as one of the constituents into the probable error of the value of the force at Toronto corresponding to the mean period of observation derived from the complete series.

There is also another constant which enters into the absolute value, which has yet to be determined for the Toronto deflecting magnet, namely, that which enables us to eliminate the variation induced by the magnetism of the earth in the magnetic moment of a bar, in the different positions in which it is employed in the experiments of deflection and vibration. An apparatus for the determination of this constant has been constructed at Woolwich, where the necessary experiments will be made at the close of the series; here also a comparison of different trials will give the probable error of the determination of this constant, which will thus enter into and be made a part of the probable error which shall ultimately be assigned to the final mean determination of the absolute horizontal force at Toronto.

For the purposes to be considered in this paper, however, it is not necessary that the values of the constants, representing the moment of inertia and the variation of the induction moment, should be precisely known: the mutual relation of the results obtained in different months would manifestly be the same, although the whole series might be affected by some slight inaccuracy in one or more of the constants employed in the calculation. It is not necessary therefore to wait until the constants above described have been determined with ultimate precision, in order to discuss the probable error of a single monthly determination by the absolute method, and the value of a series of monthly determinations of this nature in investigating the secular change and the annual variation of the force. These will be the same, although the absolute value of the force when finally determined might prove to be one thousandth part greater for example, or one thousandth part less, than we may at present assume it to be.

I subjoin therefore the following series of the results of the monthly observations at Toronto, from January 1845 to April 1849, as *relatively* correct; and as exhibiting the values of the horizontal force on the days of the respective months on which the observations were made, with an accuracy which, as respects observation error strictly so called, must be greater than that which would be inferred from the probable error of a single monthly determination obtained in the usual manner; because the probable error so obtained will include, besides observation error properly so called, the effects of regular or irregular variations which may have affected the force itself on the particular days of observation.

TABLE I.

| | 1845. | 1846. | 1847. | 1848. | 1849. |
|-----------------|--------|--------|--------|--------|--------|
| January | 3·5377 | 3·5378 | 3·5337 | 3·5222 | 3·5213 |
| February..... | 3·5376 | 3·5313 | 3·5320 | 3·5255 | 3·5210 |
| March..... | 3·5375 | 3·5341 | 3·5284 | 3·5270 | 3·5240 |
| April | 3·5351 | 3·5323 | 3·5249 | 3·5261 | 3·5260 |
| May | 3·5388 | 3·5317 | 3·5283 | 3·5286 | |
| June | 3·5421 | 3·5367 | 3·5302 | 3·5274 | |
| July..... | 3·5413 | 3·5365 | 3·5287 | 3·5305 | |
| August | 3·5383 | 3·5313 | 3·5335 | 3·5279 | |
| September | 3·5373 | 3·5303 | 3·5257 | 3·5239 | |
| October | 3·5363 | 3·5290 | 3·5251 | 3·5223 | |
| November | 3·5360 | 3·5278 | 3·5266 | 3·5184 | |
| December | 3·5379 | 3·5334 | 3·5237 | 3·5214 | |

Regarding each monthly determination as entitled to equal weight, and taking the arithmetical mean of all the observed values as the most probable mean value, we find the mean value to be 3·53043 with a probable error of ± 00055 ; and the probable error of a single monthly determination ± 0040 .

This is on the most simple hypothesis, in which neither secular change nor annual variation is supposed to exist. If we call X the arithmetical mean as above derived, and $X'_1, X'_2, X'_3 \dots X'_{52}$ the several observed monthly results, we shall have the several errors remaining over, $X'_1 - X, X'_2 - X, \dots X'_{52} - X$, as follows:—

TABLE II.

| | 1845. | 1846. | 1847. | 1848. | 1849. |
|-----------------|--------|--------|--------|--------|--------|
| January | +·0073 | +·0074 | +·0033 | −·0082 | −·0091 |
| February..... | +·0072 | +·0009 | +·0016 | −·0049 | −·0094 |
| March..... | +·0071 | +·0037 | −·0020 | −·0034 | −·0064 |
| April | +·0047 | +·0019 | −·0055 | −·0043 | −·0044 |
| May | +·0084 | +·0013 | −·0021 | −·0018 | |
| June | +·0117 | +·0063 | −·0002 | −·0030 | |
| July..... | ·0109 | +·0061 | −·0017 | +·0001 | |
| August | +·0079 | +·0009 | +·0031 | −·0025 | |
| September | +·0069 | −·0001 | −·0047 | −·0065 | |
| October | +·0059 | −·0014 | −·0053 | −·0081 | |
| November | +·0056 | −·0026 | −·0038 | −·0120 | |
| December | +·0075 | +·0030 | +·0067 | −·0090 | |

The prevalence of + signs in the earlier portion of the period, and of − signs in the later portion, points obviously to the existence of secular change, viz. to a decrease of the horizontal force in successive years during the period of observation. For the purpose of obtaining the mean annual value of this decrease, we may derive an equation from each of the monthly determinations of the form $X' = X + ay$, in which X is the most probable value of the horizontal force in the middle period of the series, *i. e.* on the 1st of March, 1847, X' the observed horizontal force in any other month,

a the interval in months between the date of X' and March the 1st, 1847, and y the monthly variation occasioned by secular change. We have fifty-two such equations furnished by the series, which, treated by the method of least squares, give $X=3\cdot53043$, and $y=-\cdot000347$ the monthly secular change, the latter number being equivalent to an annual decrease of $\cdot0042$ in the horizontal force during the period comprehended by the observations. For the purpose of obtaining the errors remaining over on this hypothesis of secular change, we must apply to each of the results in Table I. a correction, equivalent to the effect of secular change in the interval elapsed between the dates of the particular observation and the mean epoch of the 1st of March, 1847; and having done so, we now find, on the hypothesis of the existence of a uniform secular decrease of the horizontal force annually of $\cdot0042$, $3\cdot53043$ as the value of the horizontal force on the 1st of March, 1847, with a probable error of $\pm\cdot00025$; whilst the probable error of a single monthly determination is reduced to $\pm\cdot0018$ instead of $\pm\cdot0040$ as before; and as the weights of different hypotheses are measured by the inverse squares of the probable errors, the hypothesis which supposes a secular decrease of force amounting to $\cdot0042$ annually is more probable than the hypothesis which supposes no secular change, in the proportion of 4·7 (nearly) to 1.

Having thus obtained the value of the horizontal component of the magnetic force corresponding to the 1st of March, 1847, and the mean value of the secular change of this element during the period of the observations, we require, for the purpose of deriving the values of the *total* magnetic force and its secular change, at the same epoch, to know the magnetic inclination corresponding to the epoch, and the secular change of that element also. For the first we have to seek the mean result of the observations of inclination, which were also made monthly during the same fifty-two months. In the three first years, 1845 to 1847 inclusive, the observations of inclination were made on every Tuesday and Friday, three hours before noon on the Tuesdays, and three hours after noon on the Fridays; thus furnishing eight or nine partial determinations in each month according to the number of Tuesdays and Fridays contained in it; each determination being complete in respect to the several positions of the circle and needle required for that purpose. In 1848 and 1849 the same number, or occasionally a greater number, of partial determinations was made monthly; but instead of the Tuesdays and Fridays, the days of observation were the same as those on which the horizontal force was observed. The circle employed, from January 1845 to March 1846 inclusive, was one of GAMBEY'S well-known 9-inch circles, and from April 1846 to April 1849 one of ROBINSON'S, of the same dimension and of the same pattern. In GAMBEY'S circle two needles were used, one from January 1845 to December of the same year, and the second from January 1846 to March of the same year; in ROBINSON'S circle also two needles were used, one from April 1846 to August 1847, when an accident befell it, and a second from September 1847 to April 1849. The needles used in GAMBEY'S and ROBINSON'S circles were made by those artists respectively, and both circles and needles were probably as perfect of their kind as any

that have ever been made. The intercomparability of the results might possibly have been more perfect if one and the same instrument had been used throughout (an important consideration in respect to the secular change); but, on the other hand, the probable accuracy of the general result as regards the mean inclination must be viewed as in some degree strengthened by the employment of different instruments. The following Table exhibits the fifty-two monthly results:—

TABLE III.

| | 1845. | 1846. | 1847. | 1848. | 1849. |
|-----------------|----------|----------|----------|----------|----------|
| January | 75° 18.4 | 75° 13.8 | 75° 15.0 | 75° 20.3 | 75° 19.5 |
| February | 19.5 | 14.2 | 15.2 | 18.7 | 18.1 |
| March..... | 14.5 | 13.8 | 16.2 | 17.2 | 16.7 |
| April | 11.5 | 14.3 | 15.9 | 18.0 | 18.4 |
| May | 15.4 | 14.4 | 16.1 | 17.2 | |
| June | 15.0 | 14.8 | 13.1 | 16.8 | |
| July | 14.5 | 14.0 | 11.3 | 16.4 | |
| August | 14.6 | 14.4 | 12.6 | 19.0 | |
| September | 16.6 | 15.7 | 12.5 | 17.3 | |
| October | 14.3 | 15.4 | 17.6 | 19.0 | |
| November | 16.8 | 15.0 | 17.7 | 19.4 | |
| December | 15.2 | 15.0 | 17.0 | 20.6 | |

On the hypothesis of the terrestrial magnetic inclination having been constant during the period of observation (*i. e.* constant in respect to secular change and annual variation, and subject only to irregular and diurnal fluctuations), we obtain from the results in the Table a mean inclination of 75° 16'·09, with a probable error of ±0'·20, and ±1'·46 as the probable error of a single monthly determination. These probable errors include of course the effects of irregular fluctuation as well as those of observation error properly so called, besides the possible influence of secular change and annual variation; the two latter being excluded by the hypothesis.

The errors remaining over on this hypothesis are shown in the following Table:—

TABLE IV.

| | 1845. | 1846. | 1847. | 1848. | 1849. |
|-----------------|-------|-------|-------|-------|-------|
| January | +2.3 | -2.3 | -1.1 | +4.2 | +3.4 |
| February | +3.4 | -1.9 | -0.9 | +2.6 | +2.0 |
| March | -1.6 | -2.3 | +0.1 | +1.1 | +0.6 |
| April | -4.6 | -1.8 | -0.2 | +1.9 | +2.3 |
| May | -0.7 | -1.7 | 0.0 | +1.1 | |
| June | -1.1 | -1.3 | -3.0 | +0.7 | |
| July | -1.6 | -2.1 | -4.8 | +0.3 | |
| August | -1.5 | -1.7 | -3.5 | +2.9 | |
| September | +0.5 | -0.4 | -0.6 | +1.2 | |
| October | -1.8 | -0.7 | +1.5 | +2.9 | |
| November | +0.7 | -1.1 | +1.6 | +3.3 | |
| December | -0.9 | -1.1 | +0.9 | +4.5 | |

The prevalence of — signs in the earlier months, and of + signs in the later

months, indicates distinctly the existence of secular change. Pursuing therefore the same method of obtaining its mean value during the period of observation as was adopted in the case of the horizontal force, we obtain from the fifty-two conditional equations $y = +0'0741$ as the monthly value of the secular change, equivalent to a mean annual increase of the inclination during the period of observation of $0'89$; and $75^\circ 16'09$ as the mean inclination on the 1st of March, 1847, with a probable error reduced to $\pm 0'17$, the probable error of a single monthly determination being $\pm 1'23$; whence we may infer that the hypothesis of a secular increase in the inclination of $0'89$ annually during the period of observation is more probable than the hypothesis of no secular change, in the proportion of 1.4 to 1.

Total Force; its mean value and secular change.—Having thus derived from the series of fifty-two months of observation the mean value of the horizontal force $= 3.53043$, and of the inclination $75^\circ 16'09$, each for the epoch of the 1st of March, 1847, we have for the value of the total force in absolute measure at the same epoch $3.53043 \times \sec. 75^\circ 16'09 = 13.8832$. With reference to the inclination element of the result, we might safely regard this value as a final determination; but we cannot quite do as much in respect to the element of the horizontal force, as it may yet have to receive the corrections already noticed (though they are likely to be extremely small), when the values of the constants of inertia and induction shall be finally ascertained on the return of the instruments to Woolwich. When these constants and their probable errors are known, the probable error of the finally corrected value of the total force will also be assignable.

The elements from which we have to infer the *secular change* of the total force are the secular changes of the horizontal force and of the inclination derived from the observations; these are an annual decrease of $.0042$ in absolute measure of the horizontal force, and an annual increase of $0'89$ of inclination. A secular change of the horizontal force may be produced, either by a secular change of the inclination affecting the horizontal component of the total force according to the known principles of the resolution of forces, or by a secular change in the total force itself; or, finally, it may be the joint production of both. An increase of the inclination causes a decrease of horizontal force, and *vice versa*; so far therefore we may regard the annual decrease of the horizontal force at Toronto as attributable in part at least to the annual increase of the inclination. But an annual increase of $0'89$ in the latter element is equivalent to an annual decrease in the horizontal component of the force of not more than $.0035$. There remains, therefore, an excess of $.0007$ in the secular decrease of the horizontal force, which is unaccounted for by the secular change of the inclination, and is indicative of the existence of a small annual decrease in the total force during the period of observation. The uncompensated portion of the horizontal force on which this inference is founded is indeed small in absolute amount, but its magnitude must be judged of in relation to the probable errors

of the determinations of secular change of the inclination and horizontal force. Viewed in this light, the probabilities are in favour of the existence of a small annual decrease in the total force, as the legitimate conclusion from the portion of the series of absolute determinations in progress at Toronto which has been received in this country, and is here discussed: whilst it is obvious that the groundwork is laid of a positive conclusion, admitting of no uncertainty, attainable by steady perseverance in the prolongation of the series; avoiding as far as possible, upon all occasions, all changes in the instruments employed or in the methods of observation. It will be shown in the sequel that certainty in respect to the question, whether the total force at Toronto is at the present epoch increasing or decreasing, may have a very considerable theoretical importance.

Annual Variation.—We may now proceed to a consideration of the inferences which the observations will afford in regard to annual variation; but in entering on this investigation, we must remember, in the first place, that fifty-two months constitute but a short period from which to derive an *annual* variation; and in the second place, that we are as yet unable to eliminate the effects of the *irregular* disturbances from the residual errors, which consequently remain charged with them to the last; and that if these effects are not themselves the sole cause of an annual variation, by reason of their greater frequency or magnitude at certain seasons of the year than at others, we must be prepared to expect that they will embarrass the research, by rendering the effects of other causes less apparently systematic than they would otherwise have been found. In the horizontal force particularly we may have reason to apprehend the influence of disturbances, because that element is greatly affected by them at Toronto, and their average effect appears to be to depress the force at the periods of their occurrence below its mean value.

We have shown in the preceding pages the fifty-two monthly results of the observations of the inclination and horizontal force, and their arithmetical means constituting the mean values of those elements on the 1st of March, 1847; we have also derived from the observations the most probable values of the secular change of the elements during the period of observation. When each of the fifty-two results has received a correction for secular change proportioned to the interval of time elapsed between the date to which it refers and the 1st of March, 1847, and the differences are taken between the fifty-two results thus corrected and the arithmetical means, we obtain a suite of residual quantities, by which the influence of annual variation, if it exists, might be expected to be indicated. The following Table exhibits the mean difference in each month of the observed results, (when corrected as above noticed for secular change,) from the arithmetical means.

TABLE V.

| | Residual quantities. | |
|----------------------------------|----------------------|-------------------|
| | Inclination. | Horizontal force. |
| January, mean of 5 years | +1.40 | -.0004 |
| February, mean of 5 years | +1.06 | -.0012 |
| March, mean of 5 years | -0.44 | .0000 |
| April, mean of 5 years | -0.58 | -.0010 |
| May, mean of 4 years | -0.38 | +0.0002 |
| June, mean of 4 years | -1.03 | +0.0028 |
| July, mean of 4 years | -1.93 | +0.0033 |
| August, mean of 4 years | -0.90 | +0.0022 |
| September, mean of 4 years | +0.13 | -.0009 |
| October, mean of 4 years | +0.35 | -.0017 |
| November, mean of 4 years | +0.97 | -.0023 |
| December, mean of 4 years | +0.60 | -.0002 |

When due allowance has been made for the shortness of the period of observation, and for the influence of disturbing action, we find in this tabular view a much more conclusive indication of the existence of annual variation than we might perhaps have been prepared to expect. The inclination is obviously highest in the winter months and lowest in the summer months, passing through its mean value about the period of the equinoxes. The horizontal force has a corresponding variation, but with opposite signs. The occasional irregularities are more marked in the horizontal force than in the inclination, and in both they prevail chiefly in the months of spring and autumn. It must remain for a separate discussion, to deduce from the great mass of facts which have now been collected at Toronto, the numerical conclusions which they will afford in regard to the frequency and magnitude of the disturbances in the different months of the year; but antecedently to the certain conclusions to be drawn from such numerical values, it is not an improbable supposition, that the months of spring and autumn (and notably those of autumn) may prove to be generally the most disturbed months, and consequently those of the greatest depression of the horizontal force resulting from the disturbances. The irregularities may be expected to diminish as the series is extended; but if they are, in part at least, occasioned by actual irregularities in the force itself produced by the disturbances, they may have a character of permanency in certain months which no continuation of the series would remove, if it should prove that the disturbances prevail more in some months than in others, and if their action has on the average a special tendency.

In commenting on the fortnightly means of the Bifilar observations at Toronto in 1842*, (in which year the Bifilar observations were suitable for the investigation, inasmuch as the scale-reading returned nearly to the same division at the close, as that at which it had stood at the commencement, of the year,) I called attention to the remarkable feature, indicated by the Bifilar readings, of an excess in the value of the horizontal force in the summer months over the other months of the year; and I

* Toronto Observations, vol. i. p. xxxvii and xxxviii.

remarked on that occasion, that “the excess appeared to be too large to be caused by any conceivable error in the determination of the temperature correction of the magnet, or generally of the apparatus by which it was suspended.” The average difference between the summer and winter months, derived from the observations of the Bifilar in the single year referred to, was $\cdot 00161$ parts of the whole horizontal force, or $\cdot 0056$ in absolute measure.

The question of an annual variation of the horizontal force appeared to me so important either to verify or disprove, that, at my request, Captain LEFROY employed, during the years 1847 and 1848, a third method of experimenting, which, although it may not be quite so satisfactory in respect to the individual monthly results as the method of absolute determinations, in consequence of the magnetic moment of the bar not being subject to monthly examination, has yet the advantage of affording a third conclusion perfectly independent of the others, and but little inferior to the absolute method in proportion to the time of their respective continuance. One of the cylindrical magnets of 3.67 inches in length, which had been employed in the North American survey, and appeared to have attained a state of steady magnetism (which however did not prove so thoroughly steady as was expected), was suspended in the usual manner in a light stirrup, with an attached mirror and a detached telescope. The horizontal force of the earth was measured at stated hours, twice in every day, at 10 A.M. and 5 P.M., by the times of vibration of the bar derived from four hundred vibrations observed in the usual manner, and reduced to a standard temperature and to infinitely small arcs. The magnetic moment of the bar was carefully examined before the commencement and after the conclusion of the series, viz. on the 31st of December, 1846, and on the 3rd of January, 1849, and also intermediately on January 5th, 1848. The magnetic moment at these periods was as follows:—

| | |
|------------------------------|---|
| | Loss of magnetism in nearly equal intervals. |
| 1846. December 31st = 0.6104 | } |
| 1848. January 5th = 0.6000 | |
| 1849. January 3rd = 0.5913 | |
| | .0104 .0087 |

The value of the magnetic moment has been assumed on the hypothesis of uniform loss of magnetism in the whole period, and has been computed for every day of observation. Now if we take the arithmetical mean of the absolute values of the force in the twenty-four months derived by this bar as the mean result corresponding to the 1st January 1848, and if for the purpose of eliminating secular change we combine the values in January 1847 and December 1848, February 1847 and November 1848, &c., we obtain the excess or defect in the horizontal force in absolute measure for the months of winter and summer as follows:—

TABLE VI.

| | | | | | |
|--------|---|---------------------------------|--------|---|--------|
| Winter | { | January 1847 and December 1848 | —·0043 | } | —·0038 |
| | | December 1847 and January 1848 | —·0034 | | |
| | | February 1847 and November 1848 | —·0039 | | |
| | | November 1847 and February 1848 | —·0037 | | |
| Summer | { | May 1847 and August 1848 | —·0006 | } | +·0047 |
| | | August 1847 and May 1848 | +·0042 | | |
| | | June 1847 and July 1848 | +·0084 | | |
| | | July 1847 and June 1848 | +·0070 | | |

We have here a still further confirmation of the greater amount of the horizontal force in the summer than in the winter months; the difference between the two seasons is in this experiment greater than that shown by the Bifilar observations for 1842, or than that derived from the more extended absolute series from January 1845 to April 1849. It is quite conceivable however that, independently of errors of measurement, the actual numerical difference between the summer and winter months may be liable to vary in different years.

By three independent methods of experiment, therefore, the general fact of an annual variation of the horizontal force at Toronto has been shown, the force being greater in the summer than in the winter months; but the question of whether this variation, as well as that of the inclination, is progressive from one extreme in mid-winter to the opposite extreme in midsummer, and *vice versa*, the regularity of the progression being only interrupted by the complication of irregular disturbances,—or whether, as in the case of the diurnal variation, the change from one half-yearly phase to the other takes place (subject to the same complication) about the time of the equinoxes,—will require a longer period for its determination than that which we have at present before us. Upon the latter supposition, we find, from the absolute series at Toronto, that the inclination is on the average 0'·88 above its mean value, and the horizontal force ·0015 below its mean value during the five months when the sun is in the southern signs,—and the inclination 0'·90 below, and the horizontal force ·0011 above, their respective mean values, when the sun is in the northern signs.

The sum of the differences of the inclination at the opposite seasons (1'·78) is equivalent, in the resolution of the total force into its horizontal and vertical components, to ·0070 of horizontal force. The annual variation of the horizontal force derived from the observations, corresponds in *direction* in each of the seasons to that which is indicated for it by the change of the inclination, but the *amount* falls considerably short of that which would be the equivalent of the alteration in the latter element. Hence we must infer the probable existence of an annual variation of the total force, the force being greatest in the winter months, or when the sun is in the southern signs; and least in the summer months, or when the sun is in the northern signs.

Although I have been unwilling to encumber this communication with details from the Hobarton Observatory similar to those from Toronto, I may be permitted to state very briefly the *results* obtained at Hobarton in respect to the annual variation of the Inclination and Force, as they have a very considerable interest when viewed in connection with those obtained at Toronto.

A series of monthly determinations of the inclination, in which no change was made in the instruments employed, or in the methods or place of observation, was commenced at Hobarton in June 1843, and was still continuing at the date of the last returns received from thence in December 1848. From this series we have sixty-eight consecutive monthly determinations, strictly intercomparable, bearing on the question of annual variation. It will be remembered that the summer of the southern hemisphere is when the sun is in the *southern* signs, and *vice versâ*; and that at Hobarton it is the *south* end of the needle which dips below the horizon. The investigation, conducted in the same manner as at Toronto, shows at Hobarton a decrease of *south* inclination of $0'89$ on the average of the months from April to August inclusive, *i. e.* in the southern winter; and an increase of $0'85$ from October to February inclusive, *i. e.* in the southern summer. Thus in the months from April to August the North Inclination at Toronto and the South Inclination at Hobarton are both diminished; and from October to February inclusive they are both increased. The North Inclination at Toronto is lowest and the South Inclination at Hobarton highest, in the respective summers of the two stations, and *vice versâ*, and in both cases the variation is nearly to the same amount.

In the case of the horizontal force, a regular and consecutive series of monthly determinations, similar to that at Toronto, was commenced at Hobarton in January 1846, and the results have been received in England to December 1848 inclusive. The series treated in a similar manner to that at Toronto shows an annual variation of the same character as respects the seasons, and almost identical in amount with that at Toronto. In the months from October to February inclusive (or in the summer months at Hobarton), the horizontal force is $\cdot0017$ *greater* on the average than its mean amount, and from April to August inclusive (or in the winter months at Hobarton), it is on the average $\cdot0013$ *less* than its mean amount.

The inferences to be drawn from these variations of the inclination and horizontal force taken conjointly, as respects the total force at Hobarton, are as follows: the inclination being greater from October to February than from April to August, if the total force remained unaltered, the horizontal force should be *below* its mean amount in the months from October to February, whereas we find a *higher* amount in those months; therefore, so far as the observations have yet gone, the total force at Hobarton appears to be subject to an annual variation, being *higher* than its mean amount from October to February, and *lower* than its mean amount from April to August.

It may assist the recollection of the facts regarding the annual variation of the two

magnetic elements at Toronto and Hobarton to state;—that in the months from October to February the magnetic needle more nearly approaches the *vertical* direction at both stations, and from April to August the *horizontal* direction;—and that the total force is greatest at both stations from October to February, and least from April to August.

It is much to be desired that so remarkable a result should receive a full confirmation, by the continuance of the observations at Toronto and at Hobarton for such an additional period as may appear necessary for that purpose; and that the general conclusion indicated by the observations at those stations should be verified by similar investigations in other parts of the globe, especially at the observatories which now exist. The facts, as far as they go, indicate the existence of a general affection of the whole globe having an annual period, and would appear to conduct us naturally to the position of the earth in its orbit as the first step towards an explanation of the periodic change*. It might possibly be regarded as premature, in the present stage of the inquiry, to enter on the discussion of such physical hypotheses as may present themselves on the supposition of a causal connection of this nature; but it cannot be open to the same objection, to press on the consideration of those who are engaged in experimental researches in terrestrial magnetism, (or of others who may have it in their power, from station or influence, to give countenance or support to those who are so engaged), the importance of following up without delay, and in the most effective manner, a branch of the research which gives so fair a promise of establishing a conclusion of so much theoretical moment upon the basis of competent experiment†.

I may be permitted, in conclusion, to advert, though very briefly, to considerations which may give a particular importance to accurate numerical values of the magnetic elements and their secular changes determined at Toronto.

That station was selected on account of its proximity to one of those remarkable points on the globe which have a peculiar importance in theoretical respects: viz. to one of the two points in the northern hemisphere which are the centres of the loops

* The portion of the year when the magnetic force is greatest and the direction of the needle most vertical in both hemispheres, viz. from October to February, coincides with that in which the earth is nearest to the sun, and also moves with greatest velocity in her orbit. There is another curious annual coincidence of a wholly different nature, unconnected with the position of the earth in her orbit; during the months from October to February, when the magnetic force is greatest and the direction of the needle in both hemispheres most vertical, Mr. Dove's recent investigations have shown that, owing to meteorological causes traceable to the unequal distribution of land and sea in the two hemispheres, the aggregate temperature of the whole earth is lower than in the opposite period of the year.

† I am glad to be able to add, that by a letter received from Lieut. GILLISS of the United States Navy, Director of the Astronomical Observatory established at Santiago in Chili, magnetical observations, similar to those referred to in this communication as being in progress at Toronto and Hobarton, were commenced at Santiago in January of the present year, with instruments which had been prepared at Woolwich at the expense and by the request of the Government of the United States.

of the isodynamic lemniscates (as they have been usually called), and are the points of greatest intensity of the force (on the surface of the globe) of apparently two magnetic systems, distinguished from each other by the very remarkable difference in the rate of secular change to which the phenomena in each system appear to be subject. In the present state of the terrestrial magnetic phenomena, the principal of these two points, or the centre of the larger loop of the lemniscates, is situated within the British territories in North America; and by the magnetic survey of those territories, undertaken by the British Government on the recommendation of the Royal Society, and executed in 1842 and 1843 by Captain LEFROY, its geographical position was approximately ascertained, and the difference between the magnetic force at this central point and at the Toronto Observatory was very carefully measured, and is recorded in the Philosophical Transactions (Part III. for 1846). In this point of view therefore the accurate determination of the Force at the observatory at Toronto has a peculiar value, both for the present and for after times. It will, I think, be clear to those who have followed the details of this communication, that by the skill, assiduity and perseverance of the Director of the Toronto Observatory and his assistants, (non-commissioned officers of the Royal Artillery,) this object has been accomplished within very small limits of uncertainty as dependent on observation or accidental error; and that when the small corrections which have been noticed, as requiring to be investigated on the return of the instruments to England at the close of the series, have been ascertained and applied, the value of the total force in absolute measure at Toronto, and by its means the value at the central point, will be assigned with a degree of accuracy which we may believe will be regarded as satisfactory, not only at the present day, but at those distant periods, when the determination may be referred to as presenting the earliest record of the value of the terrestrial magnetic force at its point of maximum in the northern hemisphere.

The determination of this value at this particular time may derive an additional importance from the present relative situation of the two magnetic centres* which are not yet far removed from their greatest distance apart, viz. 180° in geographical longitude; a state of the phenomena constituting possibly an epoch in the cycle of secular change, characterized by that portion of the force at each centre which is derived from mutual influence being a minimum. The analogy of the southern hemisphere, where the two centres are nearer to each other in respect to geographical longitude than in the northern hemisphere, and where the force at each is higher than at the corresponding northern centre, may justify this supposition. The geographical longitude of the principal northern maximum was ascertained by Captain LEFROY, in the years 1842 and 1843, to be about 270° East; that of the minor maxi-

* It will of course be understood that by the employment of the word "centres" it is not intended to convey that the points of maximum are themselves centres of the magnetic force of the systems to which they may respectively belong. The expression is merely used to designate central points of certain phenomena observed on the earth's surface, where alone it is in our power to observe them.

mum, in the same hemisphere, was determined a few years earlier (1828 and 1829), by the expedition of MM. HANSTEEN, ERMAN and DUE; and we may gather the result from the following passage in M. ERMAN'S 'Reise um die Erde,' which I quote from Mr. COOLEY'S translation, vol. ii. p. 365:—"The magnetical results of the last journey were now examined more narrowly, and it was clear that we had in fact crossed the meridian of the Siberian magnetic pole between Irkutsk and Yakutsk. The magnetic attraction of the earth was decidedly greater between Kirensk and Beresovoi Ostrov than at any other point which we had visited in the same parallel of latitude to the east or west. The pole sought for had there exhibited its greatest force, and extended its influence furthest to the south; and consequently we must have been there on the same meridian with it. This probably took place at Parshinsk in longitude $111^{\circ} 27' E.$ *" Omitting the consideration of the small amount of secular change which may have taken place between the expedition of MM. HANSTEEN, ERMAN and DUE and that of Captain LEFROY, we have here an interval of $(270^{\circ} - 111^{\circ} =) 159^{\circ}$ as the approximate difference of longitude (on the side of Behring's Straits and the adjacent continents) between the two northern centres. This difference is diminishing by the effect of secular change, and the epoch, when the centres were 180° apart, must therefore have taken place a few years antecedently to either of the determinations above referred to; probably about the close of the last century, when, as we learn by Professor LOOMIS'S discussion of the observations of magnetic inclination in the northern parts of the United States†, the inclination which had previously diminished in that quarter began to increase.

The change in the geographical position of both the points of maximum in the northern hemisphere has been from west to east since the earliest period at which inferences of this nature could be drawn from the phenomena; the diminution of the meridional distance between them on the one side, and its increase on the other, being occasioned by the more rapid movement of translation of the minor maximum. It has been conjectured that the motion of the principal maximum might cease to be progressive in the easterly direction when the two centres or maxima should be 180°

* It is obvious that M. ERMAN uses the term "magnetic pole" to designate the central point of a loop of the isodynamic lemniscates, or the point of greatest intensity of the force. This also is the sense in which it is employed by M. KUPFFER, when he says "il y a un pole magnétique dans la Sibérie." The term "pole" cannot however be understood to have the same signification in those writings which assert a supposed connection between "two magnetic poles" and "two poles of cold" in the northern hemisphere; for, in North America at least, the point of maximum intensity of the force is certainly very far distant from that of the lowest annual temperature: the "magnetic poles" in this case may possibly be intended to refer to the centres of the loops of the *isoclinical* instead of those of the *isodynamic* (so-called) lemniscates. But either of these significations differs materially from M. GAUSS'S definition of a magnetic pole, *i. e.* "where the horizontal terrestrial force is zero." I have subjoined this note in illustration of some remarks which I ventured to make in a former communication on the inconvenience of the employment of a term which appears to be used in different meanings by different writers.

† In Silliman's Journal.

of geographical longitude apart, and that it might thenceforward be retrograde. The observatory at Toronto seems well situated for deciding this question. If the progression of the secular change of both systems continues to be the same after that epoch is past as it was before, the force at Toronto might be expected to sustain on the whole an annual *decrease*, as it would be more diminished by the recession of the neighbouring greater maximum, than increased by the approach of the far more distant minor maximum. If, on the other hand, the movement of the principal maximum should be retrograde, the force at Toronto might be expected to undergo a considerable annual *increase*. By the observations which have been discussed in this paper, it has been shown that the probabilities are considerably in favour of the existence of a small annual *decrease* of force at the present time: and as time alone is wanting to convert this probability into certainty, it would seem particularly desirable that the series of monthly observations of the horizontal force and of the inclination at Toronto should be continued, until the direction and approximate value of the secular change of the total force shall be thoroughly determined.

X. *Observations on the Freezing of the Albumen of Eggs.* By JAMES PAGET, Esq.,
Professor of Anatomy and Surgery to the Royal College of Surgeons of England.
Communicated by THOMAS BELL, Sec. R.S.

Received September 26, 1849,—Read January 24th, 1850.

IN 1777, JOHN HUNTER communicated to the Royal Society a series of experiments on the heat of animals and vegetables, among which were some showing that an egg, after having been frozen and thawed, will, on a second exposure to cold, freeze more quickly than it did before, and more quickly than a fresh egg does when exposed to the same temperature. From these and other experiments, he concluded “that a fresh egg has the power of resisting heat, cold and putrefaction in a degree equal to many of the more imperfect animals;” and he adds, “it is more than probable this power arises from the same principle [*i. e.* a living principle] in both*.” Mr. HUNTER’s pupils generally adopted this conclusion: and the facts on which it was based have formed a chief part of the evidence for the existence of a special vital principle capable of resisting, by a kind of passive opposition, the changes that physical forces produce in dead organic matter.

In the course of some inquiries into the nature of the life of the blood, I repeated and extended Mr. HUNTER’s experiments, and obtained results which, I venture to hope, may be deemed worthy of the consideration of the Society.

My experiments consisted chiefly in submitting to temperatures near to zero of FAHRENHEIT, fowls’ eggs, into which thermometers with slender bulbs were introduced. The decrements of heat were registered every minute, and the time was noted at which each egg began to freeze, the general indication of that event being the swelling of the albumen, and its protrusion from the aperture through which the thermometer was passed.

I found, as Mr. HUNTER did, that a fresh egg generally resists freezing longer than one does which, having been previously frozen and thawed, is exposed, in all similar circumstances, to the same temperature. The result of twenty experiments, in which such eggs were placed in temperatures ranging from zero to 10° FAHR., was, that the fresh eggs were frozen, on an average, in 26 minutes, and the eggs that had been previously frozen and thawed, were frozen for the second or third time in 15½ minutes.

I next determined, by similar experiments, the respective times of freezing of fresh eggs, and of such as were variously changed in structure and chemical composition. Similar results appeared. If the yolks of the eggs were broken, so as to be mingled

* HUNTER’s Works, by PALMER, vol. iv. p. 150.

with the albumen ; if their whole substance were decomposed, so as to emit a more or less putrid odour ; if a powerful electric shock had been passed through them,—in all these conditions, they froze more quickly than fresh and uninjured eggs did, that were exposed with them to the same low temperature. The average difference in the respective times of freezing was nearly the same as that already stated.

All these experiments tended to confirm Mr. HUNTER's explanation ; for all seemed to show that, by the influence of such forces as commonly destroy animal life, eggs lose some capacity of resisting the abstraction of heat. But when I examined the registers of the decrements of heat sustained by the several eggs during each minute of their exposure to the cold, it appeared that the fresh eggs almost always lost heat more rapidly than those did which had been frozen, broken, decomposed, or electrified. An average result of experiments upon thirty-three eggs of each class was, that, between the fifth and fifteenth minutes after first exposure to a temperature of from 5° FAHR. to 10° FAHR., the fresh eggs lost 17° of heat, and the others only $13\frac{1}{2}^{\circ}$. The reason why the fresh eggs, though they lost heat more rapidly than the others, yet were longer in freezing, was, that in most cases their temperature was reduced some degrees below 32° before freezing took place ; while the eggs that had been frozen before, or that were in any other way spoiled, always began to freeze as soon as they reached the temperature of 32° .

Mr. HUNTER had remarked this difference. In one of his experiments, he says, “ a fresh egg sank to $29\frac{1}{2}^{\circ}$, and in twenty-five minutes later than the dead one, it rose to 32° , and began to swell and freeze.” But I found that fresh eggs could be reduced to a much lower temperature without freezing. In several experiments they fell to 20° ; in some to 16° , before, with a rapid rise to 32° , freezing took place ; and from some observations, which will be hereafter mentioned, I believe that, under favourable circumstances*, the temperature of a fresh and unbroken egg may be reduced to within 5° of zero of FAHRENHEIT without freezing, although its proper freezing-point, and that to which its temperature rises when it begins to freeze, is 32° or between 31° and 32° †.

It thus appeared that a fresh egg does not resist freezing as a living animal does, which either parts with its heat slowly, or else produces heat, compensating in some measure for that which is lost. It is as much the peculiarity of the fresh egg to lose its heat more quickly than another does, as it is to be longer in freezing ; and, indeed, this quicker loss of heat seems essentially connected with the ability to be reduced far below 32° without freezing ; for, among thirty-two fresh eggs, there were eleven which began to freeze at 32° , and all these had lost heat slowly ; the average decrement between the fifth and fifteenth minutes of their exposure to cold being only $13\frac{2}{3}^{\circ}$.

* The chief of these circumstances are, that the egg should be unmoved, and that its albumen should be not even so much disturbed as it is by the introduction of the thermometer.

† With so slender thermometers as I was obliged to use, it was not possible to determine within half a degree the precise freezing-point.

Many things observed in the course of these experiments seemed to indicate that the freezing of the fresh egg was retarded by some peculiarity of its mechanical construction, which was destroyed by the several means supposed to destroy its life. It was, therefore, desirable to ascertain whether the capability of being reduced far below 32° without freezing, and the consequent apparent resistance to freezing, could be destroyed by any means that would not at the same time prevent the egg from manifesting, by development in incubation, the surest evidences of vitality. In experiments to determine this point, I found that one might, with a bent probe, gently detach the whole of the albumen of an egg from its connection with the membrane of the shell, and that after this the chick would be developed, although, perhaps, not to perfection. But when eggs with the albumen thus disturbed were exposed to cold, they did not descend below 32° without freezing; they lost heat less quickly, but froze sooner, than uninjured eggs did, when exposed with them to the same temperature; they froze like the eggs which Mr. HUNTER considered dead.

Again, cracking the shell of an egg does not prevent the development of the young bird, although, in consequence of the excessive evaporation through the fissures, the development may be imperfect. But when eggs with their shells cracked in many places, and with slight injuries of the membrane of the shell, were exposed to cold, they lost heat and froze just as those did which might be reputed dead. Thus, then, mechanical injuries, such as could not have affected the chemical composition of the fresh egg, and such as did not prevent its development in incubation, were found sufficient to deprive it of its power of resisting freezing; and thus its power of resistance appeared to be due, not to any vital principle, but to some peculiarity of mechanical construction.

It may be very difficult to prove what this peculiarity of construction is. That it is a property of the albumen was proved by some experiments, in which albumen, gently removed from fresh eggs, exhibited the same mode of freezing as the entire fresh eggs did: and the following facts, as well as those already mentioned, are favourable to the opinion, that the property which enables fresh albumen to descend far below 32° without freezing, is its peculiar tenacity or viscosity, by means of which the water combined with it is held so steadily, that the agitation favourable, or even necessary, to the freezing at or near 32° cannot take place.

1. The decay and putrefaction of an egg, the freezing and again thawing of one, and (as egg-preservers well know) the stirring and frequent concussion all tend to diminish the viscosity of the albumen to such a degree, that, instead of forming a consistent substance, the greater part of it will flow like a thin liquid from an aperture in the egg-shell.

2. The albumen of eggs does not freeze like a dense solution of albumen, or of saline substances, in water, but like water of which the ordinary freezing is prevented. The freezing-points of aqueous solutions are, according to their densities, more or less below 32° ; and if, in exposure to intense cold, the temperature of any

such solution be reduced below its freezing-point, it will, at the instant of freezing, rise to that point, whatever it may be, and not to 32° . Thus, I placed in a freezing-mixture of which the average temperature was 10° FAHR., solutions of common salt in the proportions of 3, 5, 6 and 9 parts to 100 of distilled water; they fell to from one to six degrees below their several freezing-points, and then, in the act of freezing, rose respectively to 28° , 25° , $24\frac{1}{2}^{\circ}$, and 23° . At these temperatures they remained till they were thoroughly frozen, and then they all descended to the temperature of the medium in which they were placed. The same is observable in the freezing of serum and blood, which, in their relations to heat, may be regarded as mere solutions of albumen and saline matters: they freeze at from 29° to 31° , and retain these temperatures till they are thoroughly frozen. I found the same also in the freezing of milk and of thick mucilage of gum; the former froze at 30° , the latter at 28° , but neither of them in freezing rose to 32° . Unlike all these substances, the albumen of fresh eggs, however far below its freezing-point it may have descended, always in freezing rises to 32° ; it freezes therefore like water, or like a very weak saline solution, which, by some mechanical disposition of its particles, is prevented from freezing as soon as it is reduced to 32° , or a few degrees lower.

3. The sudden strong agitation of fresh albumen, when its temperature is reduced several degrees below 32° , will often cause it to freeze at once*, as water under the same circumstances freezes.

4. It is well known, that when once a portion of any given quantity of water is frozen, the portion in contact with the ice cannot be reduced below 32° without freezing. I thought, therefore, that if I could bring ice just formed into contact with the albumen of an egg, the water in the albumen would freeze as soon as it fell to 32° , and so it proved; for in three experiments, in which the air-cavities of fresh eggs were filled with water before exposing them to cold, the albumen did not descend below 32° , but froze at that temperature.

Whether the explanation here offered of the peculiar property of the albumen of fresh eggs be right or not, the property will, I think, merit consideration in reference to both the nature and the purpose of the substance to which it belongs.

For, in regard to the nature of this form of albumen, its mode of freezing proves it to be essentially different both from all solutions of albumen and from organic tissues holding albuminous matter in suspension. As I have already stated, the freezing-

* In the course of the experiments, I observed that the effect of agitation, on either albumen or a saline solution, when its temperature is reduced below its freezing-point, depends in some measure on the temperature of the medium in which it is placed. Thus a saline solution, whose freezing-point was 28° , might be reduced to 25° in a medium of 24° , and, on being now agitated, it would not freeze; but a similar solution, reduced to 25° in a medium of 10° , would freeze at the instant of agitation. In a medium of which the temperature averaged 21° , no length of exposure and no agitation would, in one of my experiments, make albumen freeze, though it fell to the temperature of the medium; but in others, when albumen, in a medium averaging 10° , fell to 28° , it froze as soon as it was agitated.

points of albuminous solutions are lower than 32° in direct proportion to their densities; they do not, in freezing, rise to 32° , but freeze in all respects like saline solutions. And the same mode of freezing may be observed in organic tissues in which albuminous fluids are suspended or infiltrated. An eye, or its vitreous humour, a piece of muscle, gland, or brain, exposed to intense cold, loses temperature to 32° or $31\frac{1}{2}^{\circ}$, and remains at this, its freezing-point, till it is frozen hard throughout, and then descends to the temperature of the medium in which it is placed.

The purpose or utility of this peculiar property of the albumen of eggs is manifest in the defence which it provides for eggs exposed to a temperature below 32° . If an egg be frozen, the damage sustained by its structure is such that the germ cannot be fully developed; but mere cold, however intense, if freezing does not take place, does not prevent the complete development of the young bird. I placed three eggs in a freezing mixture, varying from zero to 5° FAHR.: one of them froze, and its shell was cracked from end to end; another froze, and when it thawed, its yelk was burst and mixed with the albumen. In incubation, two spots of blood were developed in the former, and an enlargement of the cicatricula ensued in the latter of these two eggs,—sufficient indications that the intense cold and freezing had not killed them, though it had spoiled their structure. But in the third egg, which had been exposed for nearly an hour to a temperature below 5° FAHR., perfect development took place in incubation. Even this degree of cold therefore had neither killed nor frozen the egg, though, according to the average rate at which eggs part with heat, its whole substance must have been for half an hour at a temperature between 5° and 10° FAHR.

This security of eggs from the injurious influence of cold has also been proved, on a large scale, by the ingenious inventor of the hydro-incubator, Mr. CANTELO. He has told me, that, to test the truth of the popular belief that eggs are always destroyed by exposure to a frosty air, he sometimes exposed baskets of eggs, through the whole of a Canadian winter's night, to a temperature ranging, he believes, between 5° and 10° FAHR. Some of them were cracked, and these he threw away; they were doubtless frozen and spoiled; but the rest were placed in his incubator, and the usual proportion were hatched.

The need of such a provision against the influence of cold must exist in the case of many, or perhaps of all, birds that breed in cold climates; for accident must occasionally drive from their nests even those parent-birds that have not, like the common fowl, the custom of leaving their eggs for a certain time exposed to the open air.

In conclusion, I may repeat that the experiments I have related show that it is not by the power of a vital principle that eggs resist the influence of cold. They show that certain things will destroy the power of resisting cold without affecting the capability of being developed, and of therein manifesting the best evidence of life; and that when eggs yield to the influence of intense cold, they are not damaged unless

they are frozen, and are not killed even when frozen. The experiments thus remove almost the only remaining support of the hypothesis that such a vital principle may exist in organized bodies, as may enable them, even while inactive and displaying no other signs of life, to resist passively the influence of physical forces.

XI. *Researches on the Tides.—Fourteenth Series.*

On the Results of continued Tide Observations at several places on the British Coasts.

By the Rev. W. WHEWELL, D.D., F.R.S.

Received October 24, 1849,—Read January 31, 1850.

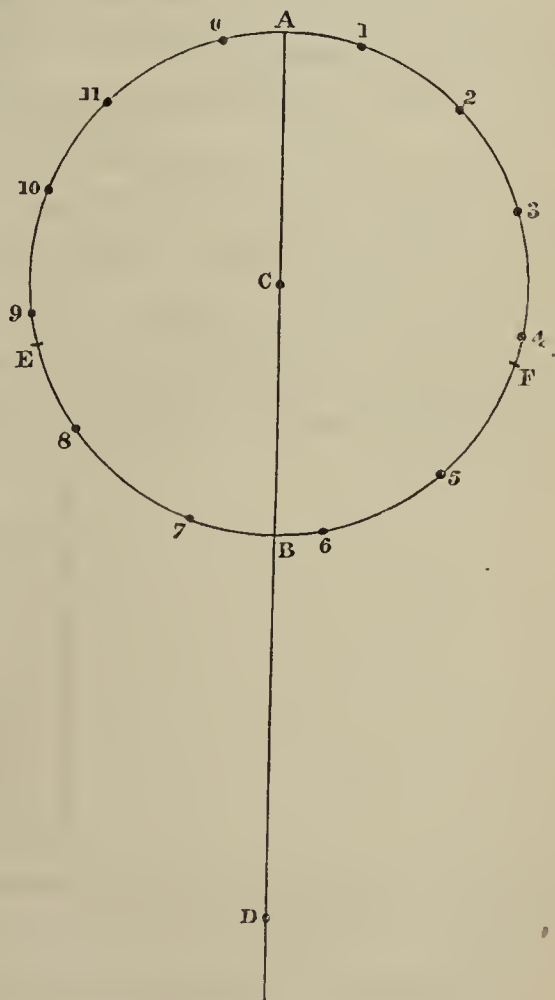
TIDE observations made at several different parts of the British and the neighbouring shores, and in some instances continued for a considerable period, have been discussed by Mr. D. Ross of the Hydrographer's Office, with great labour and perseverance; and as the results which his labours afford may be of use to mariners, I offer to the Royal Society a brief statement of these results.

The discussions at present referred to relate to the height of high water, and the variations which this height undergoes in proceeding from springs to neaps and from neaps to springs. It is found, by examining the observations at 120 places and throwing the heights into curves, that the curve is very nearly of the same form at all these places. Hence the semimensual series of heights at any place affords a rule for the series of heights at all other places where the difference of spring height and neap height is the same. For instance, Portsmouth, where the difference of spring height and neap height is 2 feet 8 inches, is a rule for Cork, Waterford, Inverness, Bantry, Boucout on the French coast, and other places.

And the Tables of the height of high water at one of these places suffice for all the others, a constant being of course added or subtracted according to the position of the zero-point from which the heights at each place are measured.

The series of heights of high water for a semi-lunation also agrees very exactly, as to the form of the curve, with the equilibrium theory. The following construction gives this curve.

With centre C and radius CA (half the difference of the height at spring and neaps), describe a circle; and in AC produced take CD to CA as 12 to 5. Divide the circumference of the circle into twelve hours, representing the twelve hours of moon's transit; and join D with each of these divisions. The lines thus drawn to the hours will give the heights of high water for each hour of the moon's



transit; a constant quantity being, as before stated, added or subtracted in order to refer the height to the proper zero.

According to the theory, the 0^h or 12^h hour-points would be at A; the ratio of DC to AC would be that of the lunar to the solar tide; and the distances of the hour-points from D would be the heights of high water above mean water. But all these properties are, in the actual cases, modified in a manner which must be noticed.

The tides in these discussions are not referred to the transit of the moon *immediately* preceding, but to some earlier transit, namely, the second, third, fourth or fifth preceding transit; it being found that in this way the accordance with the theory becomes more exact. Thus in the British Channel the tides are referred to the *third* preceding transit; and this extends also to Ireland and to the west coast of England and Scotland. On the east coast of England, in the northern parts, as at Shields, Sunderland, Scarborough and Hull, the *fourth* preceding transit is used; at Harwich, Sheerness and London, the *fifth* (see Table B). But this reference to an earlier transit does not make the highest tide correspond exactly with the hour of transit 0^h or 12^h: and it is found, in the cases which have been included in the present examination, that a displacement of the 0^h point about fifteen minutes from A will best make the theoretical and the observed curves agree with each other.

The ratio of DC to AC is, as has been said, 12 to 5; and this, according to the theory, would be the ratio of the lunar to the solar tide. If this were the case, the spring tide measured above mean water would be 17, and the total spring tide above spring tide low water would be 34. The neap tide in this case would be 7 above mean water, and therefore 24 above spring tide low water. Hence the difference of springs and neaps would be to the height of neaps above low water springs as 10 to 24, a ratio constant for all places.

But in fact, this ratio of the excess of springs to the total height of neaps above low water springs is different at different places: and the observations now under consideration show in some measure the law of this difference. The ratio is smaller when the tide is smaller. This appears from the observations at different places, as arranged by Mr. Ross in the annexed Table A. We have there the following results, taking the means of groups of places according to the amount of tide.

| Number of places. | Mean neap tide above spring low water. | | Mean excess of spring high water above neap. | | Ratio. |
|-------------------|--|-----|--|-----|---------|
| | ft. | in. | ft. | in. | |
| 37 | 9 | 3 | 2 | 5 | 38 : 10 |
| 40 | 12 | 0 | 3 | 8 | 33 : 10 |
| 39 | 17 | 10 | 5 | 9 | 31 : 10 |
| 4 | 27 | 0 | 9 | 8 | 28 : 10 |

Where it appears that the actual ratio approaches to the theoretical ratio in proportion as the amount of tide increases.

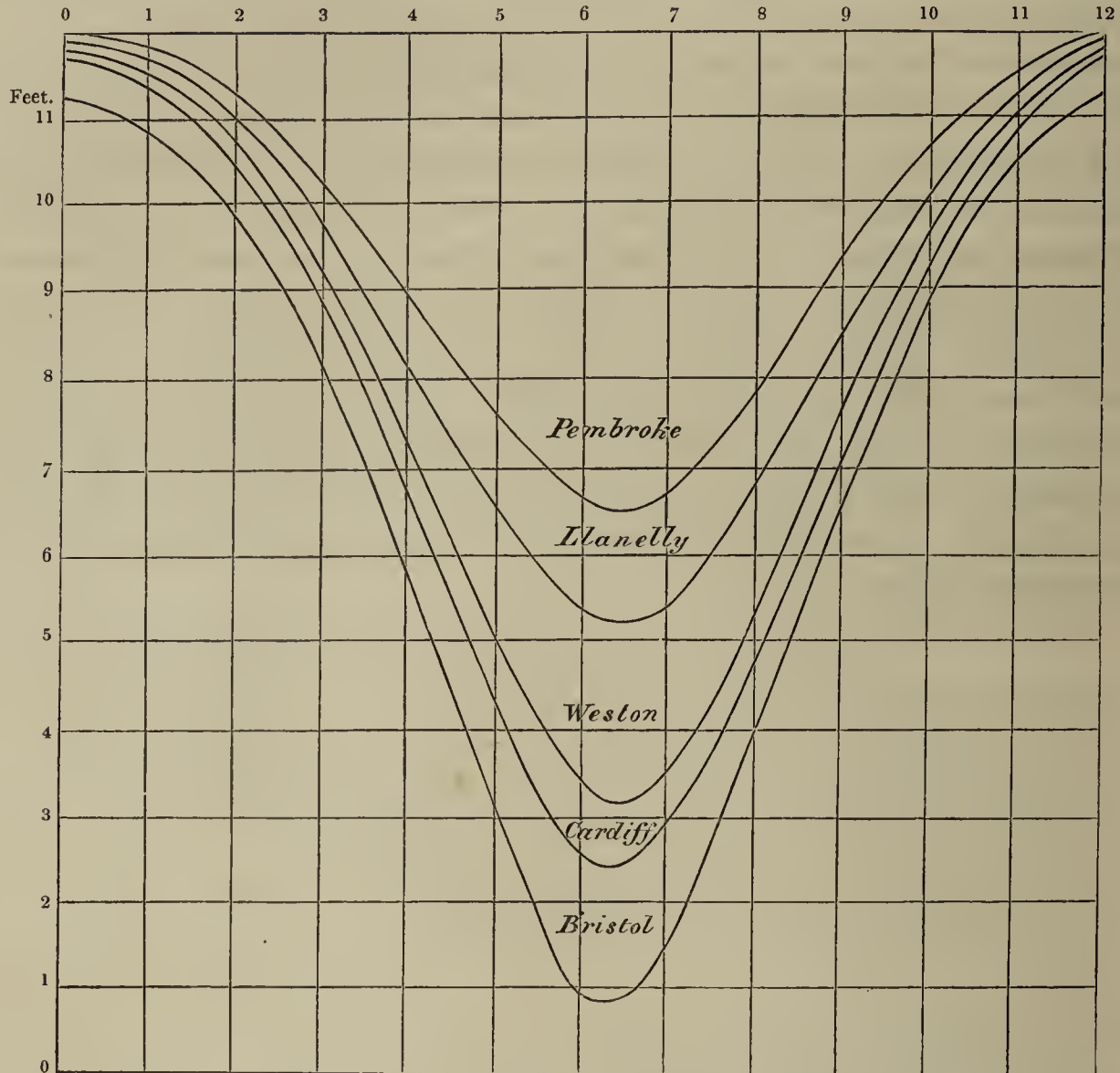
If the ratio just spoken of were constant, we should be able to find the height of

mean water by knowing the excess of springs above neaps: the excess being 10, the mean water would be 7 below the neap high water. But it appears that in general the mean water is lower than this: and the excess of springs being 10, the mean water is from 14 to 19 below neap high water at various points on the coast of Great Britain and France.

In consequence of the law of the high waters, given alike by the theory and by the observations, the spring high waters are above the mean high water for a longer period than the neaps are below it. For it is evident that if DE and DF be each equal to DC , the heights are greater than the mean DC through the arc EAF , which is greater than a semicircle. And it is evident that the excess of AE above a quadrant will be an arc of which the sine is $\frac{\frac{1}{2}EC}{DC}$ or $\frac{5}{24}$; or 12° nearly. Hence the two portions of the semicircle will be, in time, $3^h 24^m$ and $2^h 38^m$; and the tides will be above the mean during $6^h 48^m$ of lunar transit, and below the mean during $5^h 12^m$; and this is found to be very nearly the case at all the places examined; thus confirming the identity of the rule of different places one with another, and with the construction given above.

Additional Note on the Tides of the Bristol Channel.

Mr. Ross has traced the modification which the semimensual inequality of heights undergoes in ascending the Bristol Channel from Pembroke to Bristol. This modification is shown in the accompanying figure. It appears from the diagram which



Mr. Ross has drawn from the observations, that the difference of springs and neaps increases gradually from Pembroke to Llanelly, Weston, Cardiff, and finally Bristol, the difference being 5 ft. 6 in. at the first place, and 10 ft. 6 in. at the last; and the curve which represents the change from day to day being at all the places of the same form, namely, of the form described in the preceding paper.

W. W.

*Trinity College, Cambridge,
Nov. 3, 1849.*

TABLE A.—Results of Tide Observations arranged according to the amount of excess of Springs above Neaps.

TABLE B.—Places along the same coasts arranged in the order of their “Establishment.”

TABLE A.

| Number of observations from which curves were formed. | | "Establishment" of the port. | Mean spring rise above mean low water spring. | | Mean neap rise above mean low water spring. | | Excess of spring over neap. | | | |
|---|------------------------------|------------------------------|---|----|---|-----|-----------------------------|-----|----|---------------------------|
| | | | h | m | ft. | in. | ft. | in. | | ft. |
| 128 | Ardrishaig | 12 | 0 | 9 | 2 | 8 | 7 | 0 | 7 | |
| 704 | Lowestoft..... | 9 | 57 | 6 | 6 | 5 | 4 | 1 | 2 | |
| 673 | Belfast | 10 | 43 | 9 | 5 | 8 | 1 | 1 | 4 | Third preceding transit. |
| 375 | Greenock..... | 12 | 8 | 9 | 9 | 8 | 2 | 1 | 7 | Third preceding transit. |
| 107 | Ayr Harbour | 12 | 10 | 8 | 9 | 7 | 2 | 1 | 7 | |
| 418 | Harwich | 0 | 6 | 11 | 6 | 9 | 9 | 1 | 9 | Fifth preceding transit. |
| 595 | Donaghadee | 11 | 13 | 11 | 3 | 9 | 5 | 1 | 10 | |
| 218 | Crookhaven..... | 4 | 9 | 9 | 10 | 8 | 0 | 1 | 10 | |
| 190 | Baltimore..... | 4 | 23 | 10 | 2 | 8 | 3 | 1 | 11 | |
| 144 | Courtmacsherry | 4 | 36 | 10 | 8 | 8 | 7 | 2 | 1 | |
| 233 | Skull | 4 | 2 | 9 | 8 | 7 | 7 | 2 | 1 | |
| 1,059 | Kingstown | 11 | 10 | 11 | 0 | 8 | 10 | 2 | 2 | Third preceding transit. |
| 209 | Castletown | 4 | 14 | 9 | 10 | 7 | 7 | 2 | 3 | |
| 351 | Peterhead | 0 | 34 | 10 | 9 | 8 | 6 | 2 | 3 | |
| 130 | Bantry Harbour | 3 | 47 | 10 | 2 | 7 | 8 | 2 | 6 | |
| 90 | Arcachon, France | 4 | 37 | 11 | 8 | 9 | 2 | 2 | 6 | |
| 77 | Boucout, France | 3 | 39 | 8 | 8 | 6 | 1 | 2 | 7 | |
| 123 | Dunmore..... | 5 | 27 | 12 | 3 | 9 | 8 | 2 | 7 | |
| 4,230 | Portsmouth | 11 | 41 | 12 | 8 | 10 | 0 | 2 | 8 | Third preceding transit. |
| 373 | Cork..... | 5 | 1 | 11 | 9 | 9 | 1 | 2 | 8 | Third preceding transit. |
| 51 | Castletownsend | 4 | 21 | 10 | 9 | 8 | 1 | 2 | 8 | |
| 299 | Waterford | 6 | 6 | 13 | 5 | 10 | 9 | 2 | 8 | |
| 193 | Inverness | 12 | 18 | 12 | 2 | 9 | 6 | 2 | 8 | |
| 171 | Kinsale | 4 | 43 | 11 | 7 | 8 | 9 | 2 | 10 | |
| 522 | Sligo | 6 | 0 | 8 | 8 | 5 | 9 | 2 | 11 | Third preceding transit. |
| 377 | Sheephaven..... | 5 | 25 | 11 | 11 | 9 | 0 | 2 | 11 | |
| 1,383 | Ramsgate..... | 11 | 41 | 15 | 6 | 12 | 7 | 2 | 11 | |
| 124 | Bordeaux, France | 6 | 50 | 14 | 1 | 11 | 2 | 2 | 11 | |
| 4,233 | Sheerness..... | 0 | 37 | 16 | 1 | 13 | 1 | 3 | 0 | Fifth preceding transit. |
| 105 | Loch Inver | 6 | 41 | 13 | 11 | 10 | 11 | 3 | 0 | |
| 69 | East Looe | 5 | 26 | 16 | 2 | 13 | 2 | 3 | 0 | |
| 446 | Inishbofin | 5 | 5 | 12 | 10 | 9 | 9 | 3 | 1 | |
| 76 | Omonville, France | 7 | 29 | 15 | 6 | 12 | 5 | 3 | 1 | |
| 692 | Westport | 4 | 57 | 12 | 8 | 9 | 6 | 3 | 2 | |
| 92 | Peel, Isle of Man..... | 11 | 8 | 16 | 3 | 13 | 1 | 3 | 2 | |
| 103 | Caernarvon | 9 | 33 | 13 | 9 | 10 | 7 | 3 | 2 | |
| 156 | Port Navallo, France | 3 | 42 | 12 | 11 | 9 | 9 | 3 | 2 | |
| 183 | Tobermorey..... | 5 | 36 | 12 | 10 | 9 | 7 | 3 | 3 | |
| 79 | Ramsay, Isle of Man | 11 | 12 | 19 | 3 | 16 | 0 | 3 | 3 | |
| 125 | Royan, France..... | 3 | 38 | 13 | 3 | 10 | 0 | 3 | 3 | |
| 86 | St. Surin, France | 4 | 11 | 14 | 3 | 11 | 0 | 3 | 3 | |
| 277 | Roundstone..... | 4 | 28 | 13 | 6 | 10 | 2 | 3 | 4 | |
| 117 | Goodick Pier | 6 | 56 | 11 | 7 | 8 | 3 | 3 | 4 | |
| 937 | Dundee | 2 | 32 | 14 | 7 | 11 | 3 | 3 | 4 | |
| 125 | Patiras, France | 5 | 10 | 15 | 6 | 12 | 2 | 3 | 4 | |
| 13,400 | London | 1 | 59 | 19 | 6 | 16 | 1 | 3 | 5 | Fifth preceding transit. |
| 705 | Sunderland | 3 | 22 | 14 | 5 | 11 | 0 | 3 | 5 | Fourth preceding transit. |
| 541 | Holyhead..... | 10 | 11 | 16 | 0 | 12 | 7 | 3 | 5 | Third preceding transit. |
| 236 | Foynes Island, Shannon | 5 | 35 | 15 | 5 | 12 | 0 | 3 | 5 | |
| 356 | Scarborough | 4 | 11 | 15 | 10 | 12 | 5 | 3 | 5 | Fourth preceding transit. |
| 821 | Hartlepool | 3 | 28 | 15 | 0 | 11 | 7 | 3 | 5 | Fourth preceding transit. |
| 688 | Granton Pier | 2 | 20 | 16 | 0 | 12 | 7 | 3 | 5 | |
| | North Shields | 3 | 30 | 13 | 8 | 10 | 3 | 3 | 5 | Fourth preceding transit. |
| 148 | Socoa, France | 3 | 19 | 12 | 3 | 8 | 10 | 3 | 5 | |
| 159 | Dunkirk, France..... | 12 | 8 | 16 | 10 | 13 | 5 | 3 | 5 | |
| 2,820 | Devonport | 5 | 43 | 15 | 5 | 11 | 11 | 3 | 6 | Fourth preceding transit. |
| 2,823 | Leith | 2 | 17 | 16 | 4 | 12 | 9 | 3 | 7 | Fourth preceding transit. |
| 299 | Barfleur, France | 8 | 51 | 17 | 0 | 13 | 5 | 3 | 7 | |
| 155 | Concarneau, France | 3 | 12 | 13 | 1 | 9 | 6 | 3 | 7 | |
| 154 | Port Louis, France..... | 3 | 11 | 13 | 1 | 9 | 5 | 3 | 8 | |

TABLE A. (Continued.)

| Number of observations from which curves were formed. | | "Establishment" of the port. | | Mean spring rise above mean low water spring. | Mean neap rise above mean low water spring. | Excess of spring over neap. | |
|---|--------------------------------|------------------------------|----|---|---|-----------------------------|---------------------------|
| | | h | m | ft. in. | ft. in. | ft. in. | |
| 104 | Cordouan Lighthouse, France | 3 | 37 | 13 10 | 10 2 | 3 8 | |
| 437 | Thurso | 8 | 27 | 13 3 | 9 6 | 3 9 | Third preceding transit. |
| 134 | Melville, France | 9 | 36 | 21 1 | 17 4 | 3 9 | |
| 107 | La Hougue, France | 8 | 42 | 18 5 | 14 7 | 3 10 | |
| 66 | Aberystwyth | 7 | 31 | 13 5 | 9 7 | 3 10 | |
| 684 | Galway | 4 | 35 | 14 10 | 10 11 | 3 11 | Third preceding transit. |
| 164 | Belleisle, France | 3 | 18 | 14 3 | 10 4 | 3 11 | |
| 147 | Calais, France | 11 | 49 | 19 6 | 15 7 | 3 11 | |
| 121 | Ile d'Yeu | 3 | 6 | 14 2 | 10 2 | 4 0 | |
| 125 | Pwllheli | 7 | 46 | 13 8 | 9 8 | 4 0 | |
| 1,207 | Great Grimsby | 5 | 36 | 19 2 | 15 1 | 4 1 | |
| 153 | Limerick, Shannon | 6 | 20 | 16 10 | 12 8 | 4 2 | |
| 194 | Tarbert Island, Shannon..... | 4 | 57 | 14 6 | 10 4 | 4 2 | |
| 259 | Cherbourg, France | 7 | 49 | 16 11 | 12 9 | 4 2 | |
| 134 | Havre, France..... | 9 | 51 | 22 1 | 17 11 | 4 2 | |
| 2,116 | Dover | 11 | 12 | 18 8 | 14 5 | 4 3 | Third preceding transit. |
| 170 | Aix Island, France | 3 | 20 | 16 11 | 12 8 | 4 3 | |
| 174 | St. Nazaire, France..... | 3 | 40 | 15 2 | 10 11 | 4 3 | |
| 154 | Beagh Castle, Shannon | 5 | 49 | 17 6 | 13 2 | 4 4 | |
| 157 | Mellon, Shannon..... | 6 | 1 | 18 3 | 13 10 | 4 5 | |
| 115 | Port en Bessin, France | 8 | 57 | 19 11 | 15 6 | 4 5 | |
| 703 | Hull | 6 | 29 | 20 10 | 16 4 | 4 6 | Fourth preceding transit. |
| 118 | Alderney | 6 | 46 | 17 4 | 12 10 | 4 6 | |
| 258 | Douglas, Isle of Man | 11 | 12 | 20 8 | 16 1 | 4 7 | |
| 156 | Noirmoutier Island, France ... | 3 | 2 | 15 11 | 11 4 | 4 7 | |
| 129 | Goury, France..... | 7 | 6 | 21 11 | 17 3 | 4 8 | |
| 153 | Cape Grisnez, France | 11 | 27 | 21 6 | 16 9 | 4 9 | |
| 223 | Tarn Point | 11 | 22 | 23 1 | 18 1 | 5 0 | |
| 213 | Whitehaven | 11 | 14 | 23 3 | 18 2 | 5 1 | |
| 138 | Beaumaris | 10 | 32 | 21 5 | 16 4 | 5 1 | |
| 132 | Fécamp, France | 10 | 44 | 23 3 | 18 1 | 5 2 | |
| 513 | Brest, France | 3 | 47 | 19 1 | 13 10 | 5 3 | Third preceding transit. |
| 62 | Honfleur, France..... | 9 | 29 | 23 4 | 18 1 | 5 3 | |
| 13,400 | Liverpool..... | 11 | 16 | 25 7 | 20 3 | 5 4 | Third preceding transit. |
| 135 | Boulogne, France | 11 | 25 | 24 10 | 19 5 | 5 5 | |
| 74 | Sein Island, France..... | 3 | 21 | 17 6 | 12 1 | 5 5 | |
| 4,236 | Pembroke | 6 | 12 | 21 0 | 15 6 | 5 6 | Third preceding transit. |
| 74 | Ushant..... | 3 | 32 | 19 4 | 13 9 | 5 7 | |
| 143 | Pontasval, France | 4 | 26 | 22 4 | 16 8 | 5 8 | |
| 305 | Roscoff, France | 4 | 46 | 23 1 | 17 4 | 5 9 | |
| 175 | Poulton-le-Sands..... | 11 | 26 | 27 3 | 21 6 | 5 9 | |
| 149 | Ploumarach, France | 5 | 15 | 24 3 | 18 5 | 5 10 | |
| 176 | Abervrach, France | 4 | 14 | 21 9 | 15 10 | 5 11 | |
| 184 | Morlaix Roads, France | 4 | 53 | 23 9 | 17 10 | 5 11 | |
| 122 | St. Ives | 4 | 44 | 21 0 | 15 1 | 5 11 | |
| 72 | Ilfracombe | 5 | 42 | 27 4 | 21 4 | 6 0 | |
| 221 | Dieppe..... | 11 | 6 | 27 0 | 20 8 | 6 4 | |
| 303 | Fleetwood | 11 | 12 | 26 3 | 19 8 | 6 7 | |
| 292 | Port des Enfants, France..... | 5 | 17 | 25 5 | 18 10 | 6 7 | |
| 117 | Cayeux, France | 11 | 5 | 27 6 | 20 11 | 6 7 | |
| 391 | Brehat, France | 5 | 51 | 31 2 | 23 7 | 7 7 | |
| 81 | Lezardrieux, France | 5 | 54 | 30 3 | 22 2 | 8 1 | |
| 119 | Jersey | 6 | 15 | 29 9 | 21 5 | 8 4 | |
| 370 | Weston-super-Mare..... | 6 | 54 | 37 3 | 28 9 | 8 6 | Third preceding transit. |
| 129 | Ecrehou | 6 | 32 | 30 11 | 22 5 | 8 6 | |
| 139 | Erqui | 5 | 59 | 33 3 | 24 5 | 8 10 | |
| 153 | St. Malo, France..... | 6 | 5 | 35 0 | 25 10 | 9 2 | |
| 277 | Chausey, France | 6 | 9 | 35 2 | 25 10 | 9 4 | |
| 294 | Granville, France | 6 | 13 | 37 1 | 27 2 | 9 11 | |
| 138 | Portishead | 7 | 11 | 41 4 | 31 1 | 10 3 | |

TABLE B.

| | Establishment. | | Establishment. | | Establishment. |
|---|----------------|---|----------------|---|----------------|
| | h m | | h m | | h m |
| <i>From the Land's End to Ramsgate.</i> | | Sunderland (4)..... | 3 22 | <i>From Arcachon in the Bay of Biscay to Dunkirk.</i> | |
| East Looe..... | 5 26 | Hartlepool..... | 3 28 | Arcachon | 4 37 |
| Devonport (4th transit?) | 5 43 | Scarborough (4) | 4 11 | Bordeaux | 6 50 |
| Portsmouth (3rd transit) | 11 41 | Hull (4) | 6 29 | St. Surin | 4 11 |
| Dover (3)..... | 11 12 | Great Grimsby | 5 36 | Royan | 3 38 |
| Ramsgate | 11 41 | Lowestoft | 9 57 | Cordouan | 3 27 |
| <i>From the Land's End up St. George's Channel round the North of Scotland to London.</i> | | Harwich (5)..... | 0 6 | Ile d'Aix | 3 20 |
| St. Ives..... | 4 44 | Sheerness (5) | 0 37 | Ile d'Yeu | 3 6 |
| Ilfracombe | 5 42 | London (5) | 1 59 | Noirmoutier Island | 3 2 |
| Weston-super-Mare (3) | 6 54 | <i>From Bantry Bay up St. George's Channel round the North of Ireland to the Shannon.</i> | | St. Nazaire..... | 3 40 |
| Portishead | 7 11 | Bantry Harbour | 3 47 | Belleisle..... | 3 18 |
| Pembroke (3) | 6 12 | Castletown (Berehaven) | 4 14 | Port Louis..... | 3 11 |
| Goodick Pier | 6 56 | Skull | 4 2 | Concarneau | 3 12 |
| Aberystwyth..... | 7 31 | Crookhaven | 4 9 | Brest (3) | 3 47 |
| Pwllheli | 7 46 | Baltimore | 4 23 | Ushant | 3 32 |
| Caernarvon | 9 33 | Castletownsend | 4 21 | Morlaix Roads | 4 53 |
| Holyhead | 10 11 | Courtmacsherry | 4 36 | Brehat | 5 51 |
| Beaumaris..... | 10 32 | Kinsale | 4 43 | Erqui..... | 5 59 |
| Liverpool (3) | 11 16 | Cork (3) | 5 1 | St. Malo | 6 5 |
| Fleetwood..... | 11 12 | Dunmore | 5 27 | Granville | 6 13 |
| Tarn Point | 11 22 | Waterford | 6 6 | Chausey..... | 6 9 |
| Poulton-le-Sands | 11 26 | Kingstown (3) | 11 10 | Jersey | 6 15 |
| Peel, Isle of Man..... | 11 8 | Donaghadee | 11 13 | Ecrehou..... | 6 32 |
| Douglas, Isle of Man ... | 11 12 | Belfast (3)..... | 10 43 | Alderney | 6 46 |
| Ramsay, Isle of Man ... | 11 12 | Sheephaven | 5 25 | Cherbourg..... | 7 49 |
| Whitehaven | 11 14 | Sligo (3) | 6 0 | Barfleur | 8 51 |
| Ayr | 12 10 | Westport | 4 57 | La Hougue | 8 42 |
| Greenock (3) | 12 8 | Inishbofin | 5 5 | Honfleur | 9 29 |
| Thurso (3) | 8 27 | Roundstone | 4 28 | Havre | 9 51 |
| Inverness | 12 18 | Galway (3) | 4 35 | Fécamp | 10 44 |
| Peterhead..... | 0 34 | Tarbert, Shannon | 4 57 | Dieppe | 11 6 |
| Dundee..... | 2 32 | Foynes Island, Shannon | 5 35 | Cayeux | 11 5 |
| Granton (4)..... | 2 20 | Beagh Castle, Shannon... | 5 49 | Boulogne | 11 25 |
| Leith..... | 2 17 | Mallon, Shannon | 6 1 | Cape Grisnez..... | 11 27 |
| North Shields (4) | 3 30 | Limerick, Shannon | 6 20 | Calais..... | 11 49 |
| | | | | Dunkirk..... | 12 8 |

For the places not otherwise marked in these Tables, the tides were referred to the transit immediately preceding, as giving sufficient exactness for general maritime purposes: but observations received at the Admiralty since the above laws were discovered, have been referred to the third, fourth, or fifth preceding transit, according to their place in Table B.

The Devonport tides discussed some years ago, apart from those of neighbouring places, appeared to give the greatest exactness with the *fourth* preceding transit, which has accordingly been used in the Admiralty Tables. There can be no doubt at present that the *third* preceding transit is more correct for this port; but the labour of recalculating new Tables would be great, and the difference of the result would never be more than one minute in the time and one inch in the height.

XII. *Experiments and Observations upon the Properties of Light.**By Lord BROUGHAM, F.R.S.,**Member of the National Institute, and of the Royal Academy of Naples.*

Received November 6, 1849,—Read January 10, 1850.

THE optical inquiries of which I am about to give an account, were conducted at this place in the months of November and December 1848, and continued in autumn 1849 at Brougham, where the sun proved of course much less favourable than in Provence: they were further prosecuted in October. I had thus an opportunity of carefully reconsidering the conclusions at which I had originally arrived; of subjecting them first to analytical investigation, and afterwards to repetition and variation of the experiments; and of conferring with my brethren of the Royal Society and of the National Institute. The climate of Provence is singularly adapted to such studies. I find, by my journal of 1848, that during forty-six days which I spent in those experiments, from 8 A.M. to 3 P.M., I scarcely ever was interrupted by a cloud, although it was November and December*. I have since had the great benefit of a most excellent set of instruments made by M. SOLEIL of Paris, whose great ingenuity and profound knowledge of optical subjects can only be exceeded by his admirable workmanship. I ought however to observe, that although his heliostate is of great convenience in some experiments, it yet is subject (as all heliostates must be) to the imperfection of losing light by reflexion, and consequently I have generally been obliged to encounter the inconvenience of the motion of the sun's image; especially when I had to work with small pencils of light. This inconvenience is materially lessened by using horizontal prisms and plates.

Although I have made mention of the apparatus of great delicacy which I employed, it must be observed that this is only required for experiments of a kind to depend upon nice measurements. All the principles which I have to state as the result of my experiments in this paper, can be made with the most simple apparatus, and without any difficulty or expense, as will presently appear.

It is perhaps unnecessary to make an apology for the form of definitions and propositions into which my statement is thrown. This is adopted for the purpose of making the narrative shorter and more distinct, and of subjecting my doctrines to a fuller scrutiny. I must further premise that I purposely avoid all arguments and

* Of seventy-eight days of winter in 1849, I had here only five of cloudy weather. Of sixty-one days of summer at Brougham, I had but three or four of clear weather; one of these fortunately happened whilst Sir D. BREWSTER was with me, and he saw the more important experiments.

suggestions upon the two rival theories—the Newtonian or Atomic, and the Undulatory. The conclusions at which I have arrived are wholly independent, as it appears to me, of that controversy. I cautiously avoid giving any opinion upon it; and instead of belonging to the sect of undulationists or anti-undulationists, I incline to agree with my learned and eminent colleague M. BIOT, who considers himself as a “*Rieniste*,” and neither “*ondulationiste*” nor “*anti-ondulationiste*.”

Chateau Eleanor-Louise (Provence),*

1st November 1849.

DEFINITIONS.

1. *Flexion* is the bending of the rays of light out of their course in passing near bodies. This has been sometimes termed *diffraction*, but *flexion* is the better word.

2. Flexion is of two kinds—*inflexion*, or the bending towards the body; *deflexion*, or the bending from the body.

3. *Flexibility*, *deflexibility*, *inflexibility*, express the disposition of the homogeneous or colour-making rays to be bent, deflected, inflected by bodies near which they pass.

Although there is always presumed to be a flexion and a separation of the most flexible rays from the least flexible (the red from the violet for example) when they pass by bodies, yet the compound rays are not so presumed to be decomposed when reflected by bodies. This is probably owing to the successive inflexions and deflexions before and after reflexion, correcting each other and making the whole beam continue parallel and undecomposed instead of becoming divergent and being decomposed.

PROPOSITION I.

The flexion of any pencil or beam, whether of white or of homogeneous light, is in some constant proportion to the breadth of the coloured fringes formed by the rays after passing by the bending body. Those fringes are not three, but a very great number, continually decreasing as they recede from the bending body, in deflexion, where only one body is acting; and they are real images of the luminous body by whose light they are formed.

Exp. 1. If an edge be placed in a beam or in a pencil of white light, fringes are formed outside the shadow of the edge and parallel to it, by deflexion. They are seen distinctly to be coloured, the red being furthest from the shadow, the violet nearest, the green in the middle between the red and the violet. The best way to observe this is to receive the light on an instrument composed of two vertical and two horizontal plates, each moving by a screw so as to increase or lessen the distance

* In experiments at this place, in winter, I found one great advantage, namely, the more horizontal direction of the rays. In summer they are so nearly vertical, that a mirror must be used to obtain a long beam or pencil, which is often required in these experiments, and so the loss of light countervails the greater strength of the summer sun's light.

between the opposite edges. a, a' are (Plate X. fig. 1) the vertical, b, b' the horizontal edges, s, s' are the screws; and these may be fitted with micrometers, so as to measure very minute distances of the edges by graduated scales $BB', B'C$. For the purpose of the present proposition the aperture only needs be considered, of about a quarter of an inch square. The light passing through this aperture is received on a chart placed first one foot, and then several feet from the instrument. The fringes are increased in breadth by inclining the chart till it is horizontal, or nearly so, when the fringes parallel to b, b' are to be examined, and holding it inclined laterally when the fringes parallel to a, a' are to be examined. It is also convenient to let the white light beyond the fringes pass through; and for this purpose, a'', b'' being the figure of the instrument (fig. 2), and the light received on the chart, a hole may be made in its centre opq , through which the greater portion of the white light may be suffered to pass. The fringes are plainly seen to run parallel to the edges forming them; as op parallel to b'' and pq parallel to a'' . The reddish is furthest from the shadow, the bluish nearest that shadow; also the fringe nearest the shadow is the broadest, the rest decrease as they recede from the shadow into the white light of the disc. Sometimes it is convenient to receive the fringes on a ground glass plate, and to place the eye behind it. They are thus rendered more perceptible.

When the edges are placed in homogeneous light, they are all of the colour which passes by any edge; and two diversities are here to be noted carefully. *First*, the fringes made by the red light are broader than those made by any of the other rays, and the violet are the narrowest, the intermediate fringes being of intermediate breadths. *Second*, the fringes made by the red are furthest from the direct rays, the violet nearest those rays, the intermediate at intermediate distances. This is plainly shown in the following experiment.

Exp. 2. In fig. 3, C represents the image of the aperture when the rays of the prismatic spectrum are made to pass through it. But instead of making the fringes by a single edge deflecting, and so casting them in the spectrum, I approach the opposite edges, so that both acting together on the light, the fringes are seen in the shadow and surrounding the spectrum. These fringes are no longer parallel to the shadows of the edges as they were in the white light, but incline towards the most refrangible and least flexible rays, and away from the least refrangible and most flexible. Thus the red part r of the fringes is nearest the shadow of the edge a' ; the orange, o , next; then yellow, y ; green, g ; blue, b ; indigo, i ; and violet, v . Moreover, the fringe rv is both inclined in this manner, so that its axis is inclined, and also its breadth increases gradually from v to r . This is a complete refutation of the notion entertained by some that Sir I. NEWTON's experiment of measuring the breadths in different coloured lights and finding the red broadest, the violet narrowest, explains the colours of the fringes made in white light as if these were only owing to the different breadths of the fringes formed by the different rays. The present experiment clearly proves, that not only the fringes are broadest in the least refrangible rays, but

those rays are bent most out of their course, because both the axis of the fringes is inclined, and also their breadths are various.

Exp. 3. Though called by GRIMALDI, the discoverer, the three fringes, as well as by NEWTON and others who followed him, they are seen to be almost innumerable, if viewed through a prism to refract away the scattered light that obscures them. I stated this fact many years ago*.

Exp. 4. That the fringes are images may be at once perceived, not when formed in the light disc as in some of the foregoing experiments, but when formed in the shadow. Thus when the opposite edges are moved so near one another as to form fringes bordering the luminous body's image, they are formed like the disc they surround. When you view a candle through the interval of the opposite edges, you perceive that the fringes are images of its flame, with the wick, and that they move as the flame moves to and fro. When you observe the half-moon in like manner, you perceive that the side of the fringes answering to the rectilinear side of the moon, are rectilinear, and the other side circular; and when the full moon is thus viewed, the fringes on both sides are circular. The circular disc of the moon is, indeed, drawn or elongated as well as coloured. It is, that is to say, the fringe or image is exactly a spectrum by flexion. Like the prismatic spectrum, it is oblong, not circular, and it is coloured; only that its colours are much less vivid than those of the prismatic spectrum.

PROPOSITION II.

The rays of light, when inflected by bodies near which they pass, are thrown into a condition or state which disposes them to be on one of their sides more easily deflected than they were before the first flexion; and disposes them on the other side to be less easily deflected: and when deflected by bodies, they are thrown into a condition or state which disposes them on one side to be more easily inflected, and on the other side to be less easily inflected than they were before the first flexion.

Let RA (fig. 4) be a ray of light whose opposite sides are RA, R'A', and let A be a bending edge near which the ray passes, the side R'A' acquires by A's inflexion, a disposition to be more easily deflected by another body placed between A and the chart C, and the side RA acquires a disposition to be less easily deflected than before its first flexion; and in like manner R'A' acquires a disposition to be more easily inflected, and RA a disposition to be less easily inflected by a body placed between A and C.

Exp. 1. Place A' (fig. 5) in any position between A and vr , the image made on C by A's influence, as at A' or A'', or close to A at A'''. If it is placed on the same side of the ray with A, no difference whatever can be perceived to be made on the breadth of rv , or on its distance vR' from the direct ray RR'. In like manner the image by deflexion $r'v'$ is not affected at all, either in its breadth, or in its removal from RR' by any object, a, a' , placed on the same side with A of the deflected ray Av'.

* Philosophical Transactions, 1797, Part II.

But (fig. 6) place B anywhere between A and vr on the side of the ray opposite to A, and the breadth of rv is increased, and also its distance from the direct ray RR' , as $v'r'$; and in like manner (fig. 7) the deflected rays Av, Ar are both more separated, making a broader image at $r''v''$, and are further removed from RR' by B's inflexion.

Exp. 2. If you bend the rays either by a single edge, or by the joint action of two edges, it makes not the least difference either in the breadth or in the distance from the direct rays of the images, or in the distension or elongation of the luminous body's disc, whether the bending body is a perfectly sharp edge (which in regard to the rays of light is a surface, though a narrow one), or is a plane (that is, a broader surface), or is a curve surface of a very small, or of a very large radius of curvature.

In fig. 8, ae is an instrument composed of four pieces of different forms, but all in a perfectly straight line; ab is an extremely sharp edge; bc a flat surface; cd a cylindrical or circular surface of a great radius of curvature; de one of a small radius of curvature. But all these pieces are so placed that $E\delta\gamma$ is a tangent to ed, dc , and is a continuation of $\gamma\beta K$, that is, of cb, ba . So the light passing by the whole $abcde$, passes by one straight line EK , uniting or joining the four surfaces. It is found that the image or fringe II' , made by $abcde$ (or $E\delta\gamma\beta K$), is of the same breadth and in the same position throughout its whole length. So if directly opposite to this edge another straight edge is placed, and acts together with $abcde$ on the light passing, the breadth of the fringe I is increased, and its distance is increased from the direct rays, but it has the exact same breadth from I to I' ; its portion $I'q$ answering to ab , qP answering to bc , PO answering to cd , and OI answering to de , are of the same breadth, provided care be taken that the second edge is exactly parallel to the edge EK . And this experiment may be made with the second edge behind $abcde$, as in Exp. 1 of this proposition; also it may be usefully varied by having the second edge composed of four surfaces like the first, only it becomes the more necessary to see that this compound edge is accurately made and kept quite parallel to the first, any deviation, however minute, greatly affecting the result. When care is thus used the fringes are as in $rv, v'r'$, quite the same in breadth and in position through their whole length; and not the least difference is to be discerned in them, whether made by a second edge, which is one sharp edge, or by a compound second edge, similar to $abcde$.

Hence I conclude that the beam passing by the compound edge, or compound edges, is exactly as much distended by the different flexibility of the rays, and is exactly as much bent from its direct course when the flexion is performed by a sharp edge, by a plane surface, by a very flat cylinder, or by a very convex cylinder; and therefore that all the action of the body on the rays is exercised by one line, or one particle, and not first by one and then by others in succession; and this clearly proves that after a first flexion takes place, no other flexion is made by the body on the same side of the rays. This is easily shown.

For a plane surface is a series or succession of edges infinitely near each other;

and a curve surface in like manner is a succession of infinitely small and near plane surfaces or edges. Let ab (fig. 9) be the section of such a curve surface. The particle P coming first near enough the ray RR' to bend it, then the next particle O is only further distant from RR' , the unbent ray, than the particle P by the versed sine of the infinitely small arch OP . But O is not at all further distant than P from the ray bent by P into qr , and yet we see that O produces no effect whatever on the ray after P has once bent it. No more do any of the other particles within whose spheres of flexion the ray bent by P passes. The deflected ray qr' no doubt is somewhat more distant from O than the incident ray was from P , but not so far as to be beyond O 's sphere of deflexion; for O acts so as to make the other fringes at greater distances than the first. Consequently O could act on the first fringe made by P as much as P can in making the second, third, and other fringes; and if this be true of a curve surface, it is still more so of a plane surface; all whose particles are clearly equidistant from the ray's original path, and the particles after the first are in consequence of that first particle's flexion nearer the bent ray, at least in the case of inflexion. But it is to be observed, moreover, that in the experiment with two opposite edges, inflexion enters as well as deflexion, and consequently this demonstration, founded on the exact equality of the fringes made by compound double edges, appears to be conclusive. For it must be observed that this experiment of the different edges and surfaces, plane and curve, having precisely the same action, is identical with the former experiment of two edges being placed one behind the other, and the second producing no effect if placed on the same side of the ray with the first edge. These two edges are exactly like two successive particles of the same surface near to which the rays pass. Consequently the two experiments are not similar but identical; and thus the known fact of the edge and the back of a razor making the same fringes, proves the polarization of the rays on one side. Thus the proposition is proved as to polarization.

Exp. 3. The proposition is further demonstrated, as regards disposition, in the clearest manner by observing the effect of two bodies, as edges, whether placed directly opposite to each other while the rays pass between them so near as to be bent, or placed one behind the other but on opposite sides of the rays. Suppose the edges directly opposite one to the other, and suppose there is no disposition of the rays to be more easily bent by the one edge in consequence of the other edge's action. Then the breadth and distension and removal of the fringes caused by the two edges acting jointly, would be in proportion to the sum of the two separate actions. Suppose that one edge deflects and the other inflects, and suppose that inflexion and deflexion are equal at equal distances, following the same law; then the force exerted by each edge being equal to d , that exerted by both must be equal to $2d$. But instead of this we find it equal to $5d$, or $6d$, which must be owing to the action of the two introducing a new power, or inducing a new disposition on the rays beyond what the action of one did.

If, however, we would take the forces more correctly (fig. 10), let A and B be the two edges, and let their spheres of flexion be equal, AC(= a) being A's sphere of inflexion and B's sphere of deflexion; BC(= a) being A's sphere of deflexion and B's sphere of inflexion; and let the flexion in each case be inversely as the m th power of the distance. Let CP= x , PM= y , the force acting on a ray at the distance $a+x$ from A and $a-x$ from B. Then if B is removed and only A acts, $y = \frac{1}{(a+x)^m}$. If B also acts, $y' = \frac{1}{(a+x)^m} + \frac{1}{(a-x)^m}$.

Now the loci of y and y' are different curves, one similar to a conic hyperbola, the other similar to a cubic; but of some such form when $m=1$, as SS' and TT'. It is evident that the proportion of $y:y'$ can never be the same at any two points, and consequently that the breadths of the fringes made by the action of one can never bear the same proportion to the breadths of those made by the action of both, unless we introduce some other power as an element in the equation, some power whereby from both values, y and y' , x may disappear, else any given proportion of $y:y'$ can only exist at some one value of x . Thus suppose (which the fact is) $y:y'::1:5$ or $1:6$, say $::1:6$, this proportion could only hold when

$$x = \frac{\left(\frac{1}{5^m}-1\right)a}{\frac{1}{5^m}+1} \text{ or } = \frac{\left(\frac{1}{4^m}-1\right)a}{\frac{1}{4^m}+1}, \text{ if } y:y'::1:5.$$

When $m=2$, the force being inversely as the square of the distance, then $x = \frac{a}{3}$ and $x = \frac{(\sqrt{5}-1)}{\sqrt{5}+1} a$, are the values at which alone $y:y'::1:5$ and $1:6$ respectively.

But this is wholly inconsistent with all the experiments; for all of these give nearly the same proportion of $y:y'$ without regard to the distance, consequently the new element must be introduced to reconcile this fact. Thus we can easily suppose the conditions, *disposition* and *polarization* (I use the latter term merely because the effect of the first edge resembles polarization, and I use it without giving any opinion as to its identity), to satisfy the equation by introducing into the value of y some function of $a-x$. But that the joint action of the two edges never can account for the difference produced on the fringes, is manifest from hence, that whatever value we give to m , we find the proportion of $y':y$ when $x=0$ only that of double, whereas 5 or 6 times is the fact. The same reasoning holds in the case of the spheres of flexion being of different extent; and there are other arguments arising from the analysis on this head, which it would be superfluous to go through, because what is delivered above enables any one to pursue the subject. The demonstration also holds if we suppose the deflective force to act as $\frac{1}{n}$ of the distance, while that of inflexion acts as $\frac{1}{m}$.

But I have taken $m=n$ as simpler, and also as more probably the fact.

I have said that the rays become less easily inflected and deflected; but it is plain

that on the polarized side they are not inflected or deflected at all. Their disposition on the opposite side is a matter of degree; their polarization is absolute and their flexion null.

PROPOSITION III.

The rays disposed on one side by the first flexion are polarized on that side by the second flexion, and the rays polarized on the other side by the first flexion are depolarized and disposed on that side by the second flexion.

This proposition is proved by carefully applying the first experiment of Prop. II.; but great care is required in this experiment, because when three edges are used consecutively, the third edge often appears to act on rays previously acted on by both the other two, when it is only acting on those previously acted on by one or other of those two. Thus when edge A has inflected and edge B afterwards deflects the rays disposed by A, a third edge C may, when applied on the side opposite to B, seem to increase the flexion, and yet on removing A altogether we may find the same effect continue, which proves that the only action exercised had been by B and C, and that C had not acted on rays previously bent by both A and B, which the experiment of course requires to prove the proposition. I was for a long while kept in great uncertainty by this circumstance, whether the third edge ever acted at all. That it never acted on the side of the ray on which the second edge acted, I plainly saw; but I frequently changed my opinion whether or not it acted on the opposite side, that is, on the same side with the first edge. Nor could I confidently determine this important point until I had the benefit of an instrument which I contrived for the purpose, and which, executed by M. SOLEIL, enabled me satisfactorily to perform the *experimentum crucis* as follows:—

In fig. X. AB is a beam, on a groove (of which the sides are graduated) three uprights are placed, the one, B, fixed, the other two, C and D, moving in the groove

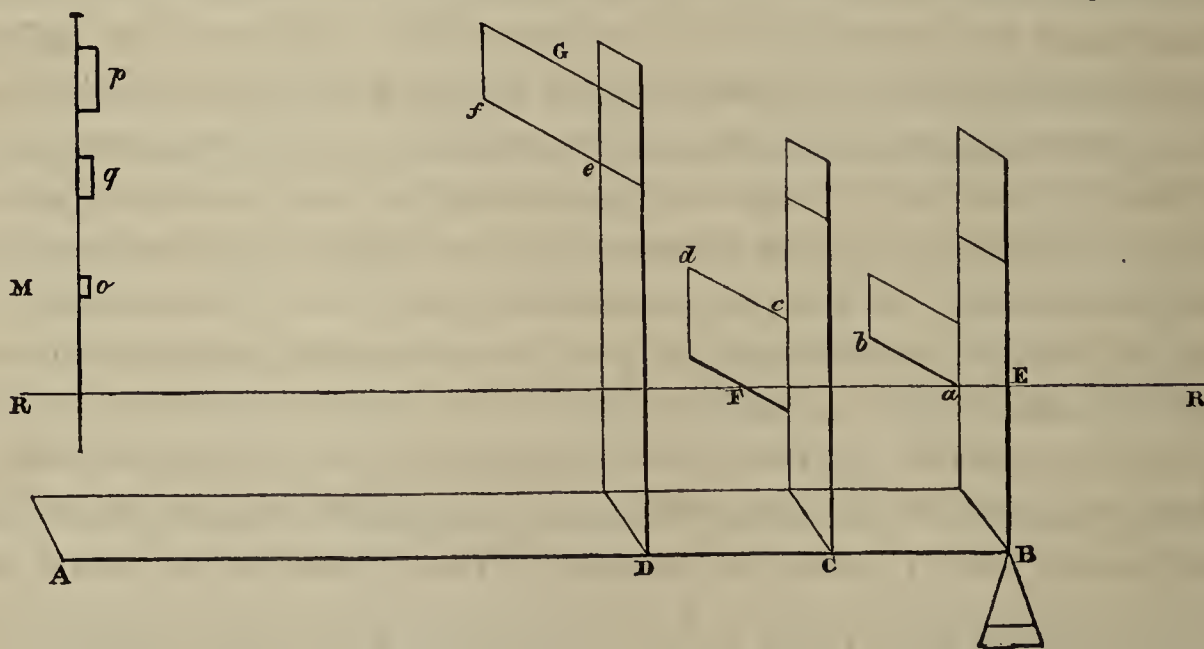


fig. X.

of AB. On each of the uprights is a broad sharp-edged plate, moving up and down the upright by a rack and pinion, so that both the plates F, G could be approached as near as possible to each other, and so could F be approached to the plate E on the

fixed upright B; while also each of the three plates could be brought as near the rays that passed as was required; and so could each be brought as near the opposite edge of the neighbouring plate. It is quite necessary that this instrument should be heavy in order to give it solidity; it is equally necessary that the rack and pinion movement should be just and also easy; for the object is to fix the plates at will, so that their position in respect of the rays may be easily changed, and when once adjusted may be immovable until the observer desires to change their position.

The light was passed under the plate E and acted upon by ab , its lower edge. The second plate E was then raised on C so as to act on the side of the rays opposite to ab , by its upper edge cd . The fringes inflected by ab were thus deflected by cd , in virtue of the disposition given to the side next cd . Then the third plate G, on its stand D, was moved so that it could be brought to act by its lower edge ef , which was approached to the rays deflected by cd , and placed on their opposite side. The action was observed by examining the fringes on the chart M. Those which had been as o , made by the joint action of the two first edges E, F, were seen to move upwards to p as the third edge G came near the rays; and p was both broader than o , and further removed from the direct rays R R'. In order to make quite sure that this change in the size and position of o had not been occasioned by the mere action of two plates, as E and G or F and G, it was quite necessary to remove first E, by drawing it up the stand B. If the fringe p then vanished, complete proof was afforded that E had acted as well as G. Then F was removed, and if p vanished, proof was afforded that F acted as well as E and G. A very convenient variation of the experiment was also continued and was found satisfactory. When the joint action of F and G gave a fringe, as at q , E being removed up the stand B, then E was gently moved down that stand, and as it approached the pencil, which was on its way to F and G, you plainly perceived the fringe enlarged and removed from q to p . These experiments were therefore quite crucial, and demonstrated that all the edges had concurred to form the fringe at p , the first and third inflecting, the second deflecting.

The same experiments were made on the fringes formed by the deflexion of the first edge and the inflexion of the second, and the deflexion of the third.

It is thus perfectly clear that the rays bent by the first edge and disposed on their side opposite to that edge, are bent in the other direction by the second edge acting on that opposite side, and are afterwards again bent in the direction of the first bending by the action of the third edge upon the side which was opposite the second edge and nearest the first edge. But this side is the one polarized by the first edge, and therefore that side is depolarized by the action of the second edge. Hence it is proved that the rays polarized by one flexion are depolarized by a second; and as it is proved by repeated experiments that no body placed on the same side of the rays with any of the bending bodies, whether the first or the second or the third, exercises any action on those rays, it is thus manifest that any one flexion having

disposed, a second polarizes the disposed side; and that any one flexion having polarized, a second flexion depolarizes and disposes the polarized side.

Exp. 3. Another test may be applied to this subject. Instead of a rectilinear edge, I made use of edges formed into a curve, as in fig. 12, where C is such an edge, and then the figure made is gh , corresponding to the curve eb . The first edge in the last experiment being formed like C, instead of a straight-lined edge, we can at once perceive that it has acted on the rays as well as the second and third edges, because these being straight-lined, never could give the comb-like shape gh to the fringes. This completely confirmed the other observations, and made the inference irresistible.

PROPOSITION IV.

The disposition communicated by the flexion to the rays is alternative; and after inflexion they cannot be again inflected on either side; nor after deflexion can they be deflected. But they may be deflected after inflexion and inflected after deflexion, by another body acting upon the sides disposed, and not by its acting upon the sides polarized.

This is gathered from the experiments in proof of the second and third propositions.

PROPOSITION V.

The disposition impressed upon the rays, whether to be easily deflected or easily inflected by a second bending body, is strongest nearest the first bending body, and decreases as the distance between the two bodies increases.

Plate XI. fig. 11. Let $AB = a$ be the distance between the first bending body and a given point, more or less arbitrarily assumed; P the second body; $AP = x$; $PM = y$, the force exerted by the second body at P ; $C =$ the chart; $PM = y$ is in some inverse proportion to AP , but not as $\frac{1}{AP^m}$ or $\frac{1}{x^m}$, because it is not infinite at A , but of an

assignable value there; therefore $y = \frac{1}{(a+x)^m}$; and the curve which is the locus of P has an asymptote at B , when $x = -a$. The fringes being received on the chart at C , it might be supposed that the difference in their breadth, by which I measure the force, or y , is owing to P approaching the chart C , in proportion as it recedes from A , and thus making the divergence less in the same proportion; but the experiments are wholly at variance with this supposition.

Exp. 1. The following table is the result of one such experiment. The first column contains the distances horizontally of P from A , being the sines of the angle made by the rays with the vertical edges; the second column contains the real distance of the second from the first edge, the secant of that angle; the third column gives the breadths of the fringes at the distances given in the preceding columns; the fourth gives the values of y , supposing MN were a conic hyperbola.

| Sines. | Secants. | Real value of y . | Hyperbolic value. |
|--------|------------------|---------------------|-------------------|
| 20 | 35 | $3\frac{1}{2}$ | $3\frac{1}{2}$ |
| 65 | 85 | $1\frac{2}{3}$ | $1\frac{1}{17}$ |
| 85 | $107\frac{1}{2}$ | $1\frac{1}{2}$ | $1\frac{1}{3}$ |
| 195 | 240 | $0\frac{1}{2}$ | $0\frac{17}{12}$ |

The unit here is $\frac{1}{20}$ th of an inch.

It is plain that this agrees nearly with the conic hyperbola, but in no respect with a straight line; and upon calculating what effect the approach of P to C would have had, nothing could be more at variance with these numbers. But

Exp. 2. All doubt on this head is removed by making P the fixed point, and moving the first edge A nearer or further from it. In this experiment, the disturbing cause, arising from the varying distance from the chart, is entirely removed; and it is uniformly found that the decrease in the force varies notwithstanding with the increase of the distance. I have here only given the measures by way of illustration, and not in order to prove what the locus of y (or P) is, or, in other words, what the value of m is.

Exp. 3. When one plate with a rectilinear edge is placed in the rays, and a second such plate is placed at any distance between it and the chart, the fringes are of equal breadth throughout their length, and all equally removed from the direct rays, each point of the second edge being at the same distance from the corresponding point of the first. But let the second plate be placed at an angle with the first, and the fringes are very different. It is better to let the second be parallel to the chart, and to incline the first; for thus the different points of the fringes are at the same distance from the edge which bends the disposed rays. In fig. 13, B is the second plate, parallel to the chart C; A is the first plate; all the points of B, from D to E, are equidistant from C; therefore nothing can be ascribed to the divergence of the bent rays. B bends the rays disposed by A at different distances DD' and EE' from the point of disposition. The fringe is now of various breadths from $d d'$ to e , the broadest part being that answering to the smallest distance of D, the point of flexion, from D' the point of disposition; the narrowest part, e , answering to EE', or the greatest distance of the point of flexion from the point of disposition. Moreover, the whole fringe is now inclined; it is in the form of a curve from $d d'$ to e , and the broad part $d d'$, formed by the flexion nearest the disposition, is furthest removed from the direct rays; the narrowest part, e , is nearest these direct rays. It is thus quite clear that the flexion by B is in some inverse proportion to the distance at which the rays are bent by B from the point where they were disposed by A. I repeatedly examined the curve $d e$, and found it certainly to be the conic hyperbola. Therefore $m=1$, and the equation to the force of disposition is $y = \frac{1}{x}$.

In order to ascertain the value of m , I was not satisfied with ordinary admeasurements, but had an instrument made of great accuracy and even delicacy. It con-

sisted of two plates, A and B (Plate VI.), with sharp rectilinear edges, one, A, horizontal, the other, B, moving vertically on a pivot, and both nicely graduated. The angle at which the second plate was vertically inclined to the first, was likewise ascertained by a vertical graduated quadrant E. Moreover the edges moved also horizontally, and their angle with each other was measured by a horizontal graduated quadrant K. There was a fine micrometer F to ascertain the distances of the two edges from each other, and another to measure the breadth of the fringes on the chart. The observations made with this instrument gave me undoubted assurance that the equation to the curve M N in fig. 11 is $yx=a$, a conic hyperbola, and that the disposing force is inversely as the distance at which the flexion of the rays bent and disposed takes place.

Scholium.—It is clear that the extraordinary property we have now been examining, has no connexion with the different breadths of the pencils at different distances from the point of the first flexion, owing to the divergence caused by that flexion.

By the same kind of analysis, which we shall use in demonstrating the 6th Proposition, it may be shown,—*first*, that the divergence of the rays alone would give a different result, the fringes made by an inflexion following a deflexion and those made by a deflexion following an inflexion; *secondly*, that in no case would the equation to the disposing force be the conic hyperbola, even where that fringe decreased with the increase of the distance; *thirdly*, even where the effect of increasing the distance is such as the dispersion would lead to expect, the rate of decrease of the fringes is very much greater in fact than that calculation would lead to, five or six times as great in many cases; and *lastly*, that instead of the law of decrease being uniform, it would, if caused by the dispersion, vary at different distances from the two edges*. Nothing therefore can be more manifest than that the phenomena in question depend upon a peculiar property of the rays, which makes them change in their disposition with the length of the space through which they have travelled.

It should seem that light may be compared, when bent and thereby disposed, to a body in its nascent state, which, as we find by constant experience, has properties different from those which it has afterwards; and I have therefore contrived some experiments for the purpose of ascertaining whether or not light at the moment of its production (by artificial means) has properties other than those which it possesses after it has been some time produced. This will form the subject of a future inquiry. I would suggest, however, at present that the electric fluid ought to be examined with a view to find whether or not it has any property analogous to disposition, that is, whether it becomes more difficultly attracted at some distance from its evolution, as light is more difficultly bent at a distance from the point of its being disposed. On heat a like experiment may be made. The thermometer would no doubt stand at a different height at different distances from the source of the heat; but the question

* I have given demonstrations of these propositions in a memoir presented to the National Institute, but I am reluctant to load the present paper with them.

is if it will not reach its full height, whatever that may be, more quickly near its source than far from it. This experiment ought above all to be made on radiant heat, in which I confidently expect a property will be found similar to the disposition of light. It is also plain that we may expect strong analogies in magnetism and electro-magnetism.—I throw out these things because my time for such investigations may not be sufficiently extended to let me undertake them with success.

PROPOSITION VI.

The figures made by the inflexion of the second body acting upon the rays deflected by the first, must, according to the calculus applied to the case, be broader than those made by the second body deflecting those rays inflected by the first.

In fig. 14, let $A v'$ be the violet rays and $A r'$ the red, inflected by A and deflected by B. Let $A r$ be the red and $A v$ the violet deflected by A and inflected by B. The action of B must inflect $A r$, $A v$ into a broader fringe F, than the action of B deflects $A v'$, $A r'$ into the fringe f .

Let $B r = a$ be the distance at which B acts on $A r$; $r v = d$ be the divergence of the red and violet; c be the distance of the two bent pencils, and $v' r'$ the divergence of the inflected pencil, equal also to d , because we may take the different inflexibility to be as the different deflexibility. B acts on the red of $A r v$ as $\frac{r}{a^m}$; on the violet as $\frac{v}{(a+d)^m}$; and so on $A v'$ as $\frac{v}{(a+d+c)^m}$; on $A r'$ as $\frac{r}{(a+2d+c)^m}$. It is evident that the action in bending $A r$, $A v$, or the fringe made by that action, is to the fringe made by the action on $A r'$, $A v'$, as $\frac{r}{a^m} - \frac{v}{(a+d)^m} : \frac{r}{(a+2d+c)^m} - \frac{v}{(a+d+c)^m}$; and ultimately the two actions (or sets of fringes) are (supposing $a=1$ and d also $=1$, for simplifying the expression) as

$$2^m \times r (3+c)^m (2+c)^m - v (3+c)^m (2+c)^m \text{ to } 2^m r (2+c)^m - 2^m v (3+c)^m.$$

Now the former of these expressions must always be greater than the latter, because $(3+c)^m > 1$, and also $(3+c)^m - 1 > (2+c)^m - 1$; and this whatever be the value of m and of c , and whatever proportion we allow of r to v , the flexibilities. But it is also manifest that the excess of the first expression above the second will be greater if the flexibility of the red exceed that of the violet, or if r is greater than v , as $2v$. Hence we conclude; *first*, that in mixed or white light the fringes inflected by B after deflexion by A are greater than those deflected by B after inflexion by A; *secondly*, that they are also greater in homogeneous light; *thirdly*, that the excess of the inflected fringes over the deflected is greater in mixed than in homogeneous light.

The action of flexion after disposition is so much greater than that of simple flexion, that I have only taken into the calculation the compound flexion. But the most accurate analysis is that which makes the two fringes as

$$D + \frac{r}{a^m} - \frac{v}{(a+d)^m} \text{ to } D + \frac{r}{(a+2d+c)^m} - \frac{v}{(a+d+c)^m},$$

D being the breadth of the fringes on the chart by simple flexion in case the rays had passed on without disposition and without a second flexion. If it be carefully kept in mind that D is much less than $\frac{r}{a^m}$, or even $\frac{r}{(a+2d+c)^m}$, and that d is still less than D , then it will always be certain that the first quantity is larger than the second.

Cor.—It is a corollary to this proposition that the difference of the two sets of fringes is increased by the disposition communicated by the rays in passing by the first body. For the excess of the value of r over that of v being increased, the difference between the two expressions is increased.

PROPOSITION VII.

When one body only acts upon the rays, it must, by deflexion, form them into fringes or images decreasing as the distance from the bending body increases. But when the rays deflected and disposed by one body are afterwards inflected by a second body, the fringes will increase as they recede from the direct rays. Also when the fringes made by the inflexion of one body, and which increase with the distance from the direct rays, are deflected by a second body, the effect of the disposition and of the distances is such as to correct the effect of the first flexion, and the fringes by deflexion of the second body are made to decrease as they recede from the direct rays.

In fig. 15, AP is the pencil inflected by A and forming the first and narrower fringe p ; Ar is the pencil inflected nearer to A and forming the broader fringe r . Such are the relative breadths, because they are inversely as some power of the distance at which A acts on them. But if B afterwards acts, it is shown by the same reasoning which was applied to the last proposition that r will be less than p ; and so in like manner will r' be made less than o' , though o' was greater than r' , until B 's action, and the effects of disposition with the greater proximity of the smaller fringe, altered the proportions.

PROPOSITION VIII.

It is proved by experiment that the inflexion of the second body makes broader fringes or images than its deflexion after the inflexion of the first body; and also that the inflecto-deflexion fringes decrease, and the deflecto-inflexion fringes increase with the distance from the direct rays.

Exp. 1. It must be observed that when we examine the fringes (or images) made by the second edge deflecting the rays which the first had inflected, we can see the effects of the disposition communicated to the rays at a much greater distance of the second edge from the first, than we can perceive the effects of that disposition upon the inflexion by the second edge of the rays deflected by the first. Indeed we only lose the fringes thus made by deflexion, in consequence of their becoming so minute as to be imperceptible to our senses. But it is otherwise with the fringes or images

made by the second edge inflecting the rays which the first had deflected. These can only be seen when the second edge is near the first, because the rays cannot pass on so as to form the images on the chart, if the second is distant from the first. The pencils diverge both by the deflexion and by the inflexion of the first edge. But we can always, when the inflected rays pass too far from the second edge, bring this so near them as to act on them, whereas we in so doing intercept the deflected rays. However, after this is explained, we find no difficulty in examining the effects of the inflexion by the second edge, only we must place it near the first, and thus we have two sets of fringes, one extending into the shadow of the first edge at an inch distance between the two edges; but at three-fourths of an inch, nay, at two inches, or even more, this experiment can well be made.

Exp. 2. At these distances I examined repeatedly the comparative breadths of the two sets. In fig. 16, ab is the white disc, on each side of which are fringes; those on the one side, bc, cd , are by the inflexion of the second edge; those on the opposite side, af, fe , are by the deflexion of that second edge. I repeatedly measured these sets of fringes, and at various distances from the second edge; and I always found them much broader on the side of the second edge than on the opposite side. Thus ab being the breadth of 5, bc was 3, and cd $4\frac{1}{2}$, while, on the opposite side, af was $=1$ and fe only $\frac{3}{4}$ or $\frac{1}{2}$. The fringes by inflexion of the second edge also uniformly increased as they receded from ab , the direct rays, whereas the opposite fringes as constantly decreased.

Exp. 3. If however the distance between the two edges be reduced, it is observed that the disparity between the two sets of fringes decreases, and they become gradually nearly equal; and when the edges are quite opposite each other there is no difference observable in the two sets. Each ray is disposed and polarized alike and affected alike by the two edges, and no difference can be perceived between the two sets.

Exp. 4. The experiments also agree entirely with the calculus in respect of the relative values of r and v affecting the result. It appears that the fringes by the second edge's inflexion are broader than those by that edge's deflexion, whether we use white or homogeneous light. In the latter, however, the difference is not so considerable. This I have repeatedly tried and made others try, whose sight was better than my own. I may take the liberty of mentioning my friend Lord Douro, who has, I believe, hereditarily, great acuteness of vision.

PROPOSITION IX.

The joint action of two bodies situated similarly with respect to the rays which pass between them so near as to be affected by both bodies, must, whatever be the law of their action, provided it be inversely as some power of the distance, produce fringes or images which increase with the distance from the direct rays.

Let (fig. 17) A and B be the two bodies, and $AC=CB=a$ be their spheres of

flexion, so that A inflects and B deflects through A C, and A deflects and B inflects through C B. Let $CP=x$, $PM=y$. The force y , exerted by the joint action of A and B on any ray passing between them at P, is equal to $\frac{1}{(a+x)^m} + \frac{1}{(a-x)^n}$, supposing deflexion and inflexion to follow different laws. To find the minimum value of y , take its differential $dy=0$; therefore we have

$$-m(a+x)^{-m-1}dx + n(a-x)^{-n-1}dx = 0, \text{ or } m(a-x)^{n+1} = n(a+x)^{m+1}.$$

If $m=n$ (as there is every reason for supposing), then $a-x=a+x$, or $x=0$; and therefore, whatever be the value of m (that is whatever be the law of the force), the minimum value of y is at the point C where A's deflexion begins. The curve SS' , which is the locus of M, comes nearest the axis at C, and recedes from that axis constantly between C and B. Hence it is plain that the fringes must increase (they being in proportion to the united action of A and B) from C to B; and in like manner must those made by B's deflexion and A's inflexion increase constantly from C to A; and this is true whatever be the law of the bending force, provided it is in some inverse ratio to the distance.

PROPOSITION X.

It is proved by experiment that the fringes or images increase as the distance increases from the direct rays.

Exp. 1. Repeated observations and measurements satisfy us of this fact. We may either receive the images on a chart at various distances from the double edge instrument, approaching the edges until the fringes appear, or we may receive them on a plate of ground glass held between the sun and the eye. We may thus measure them with a micrometer; but no such nicety is required, because their increase in breadth is manifest. The only doubt is with respect to their relative breadth when the edges are not very near and just when they begin to form fringes. Sometimes it should seem that these very narrow fringes decrease instead of increasing. However, it is not probable that this should be found true, at least when care is taken to place the two edges exactly opposite each other; because if it were true that at this greater distance of A from B (fig. 17) they decreased, then there must be a minimum value of PM between C and B, and between C and A; and consequently the law of flexion must vary in the different distances of A and B from the rays P, a supposition at variance it should seem with the law of continuity.

Exp. 2. The truth of this proposition is rendered more apparent by exposing the two edges to the rays forming the prismatic spectrum. The increase is thus rendered manifest. If the fringes are received on a ground glass plate, you can perceive twelve or thirteen on each side of the image by the direct rays. It is also worth while to make similar observations on artificial lights, and on the moon's light. The proposition receives additional support from these. But care must always be taken in such observations, which require the eye to be placed near the edges, that we are

not misled by the effect of the small aperture in reversing the action of the edges. Thus when viewing the moon or a candle through the interval of two edges, one being in advance of the other, we have the coloured images (or fringes) cast on the wrong side. But if we are only making the experiment required to illustrate this proposition, the edges being to be kept directly opposite, no confusion can arise.

It is to be noted that the increase of breadth in the fringes is not very rapid in any of these experiments; nor are we led by the calculus to expect it. Thus suppose $m=1$, we find (because $y = \frac{2a}{a^2-x^2}$) at the point C, when $x=0$, the breadth should be proportional to $\frac{2}{a}$. Take $x = \frac{a}{10}$, and the breadth is as $\frac{200}{99}$, or the breadth of the one fringe is to the other only as 200 to 198 or 100:99. We need not wonder therefore if there is only a gradual increase of breadth from C to B and from C to A. The increase is more rapid between $x = \frac{a}{2}$ and B than between C and $\frac{a}{2}$. Thus between the value of $x = \frac{a}{4}$ and $\frac{a}{2}$ the increase is as 4:5. But from $\frac{a}{2}$ to $\frac{3a}{4}$ the increase is as 7:12; and this too agrees exactly with the experiments; for as the edges are approached the increase of the fringes becomes more apparent.

PROPOSITION XI.

The phenomena described in the foregoing propositions are wholly unconnected with interference, and incapable of being referred to it.

1. When the fringes in the shadow are formed by what is supposed to be interference, there are also formed other fringes outside the shadow and in the white light. If the rays passing on one side the bending body (as a pin or needle) are stopped, the internal fringes on the opposite side of the shadow are no longer seen. But no effect whatever is produced on the external fringes. These continue as long as the rays passing on the same side of the body on which they are formed, continue to pass. The external fringes have many other properties which wholly distinguish them from the internal or interference fringes.

2. Interference is said to be in proportion to the different lengths of the interfering rays, and not to operate unless those lengths are somewhat near an equality. In my experiments the second body may be placed a foot and a half away from the first, and the fringes by disposition are still found, though much narrower than when the bending bodies are more near to one another.

3. The breadth of the interference fringes is said to be in some inverse proportion to the difference in length of the interfering rays. It is commonly said to be inversely as that difference.

In fig. 20, A is the first and B the second edge. By interference the fringe at C should be broadest and at D narrowest, because $AC - BC = AO$ is less than $AD - BD = AP$; and so as you recede from D, the fringes should become broader and broader, because the two rays become more nearly equal. But the very reverse is

notoriously the case, the breadth of the fringes decreasing with their distance from the direct rays.

4. In the case of the fringes formed by the second body inflecting and the first deflecting, there can be no interference at all; for the whole action is on one and the same pencil or beam. A deflects and then B inflects the same ray; and when a third edge is placed on the opposite side to B, it only deflects the same ray, which is thus twice bent further from the direct rays, the last bending increasing that distance.

5. Let A be the first and B the second edge as before (fig. 20). Suppose B to be moveable, and find the equation to the disposing force at different distances of the two edges, we shall find this to be $y = \frac{1}{\sqrt{a^2 + b^2} - \sqrt{(a-x)^2 + b^2}}$, a being = A E, b = E D, and $AB = x$. But all the experiments show it to be $y = \frac{a}{x}$, a wholly different curve.

Again, let B be fixed, or the distance of the two edges be constant, we shall get the equation (a being = A E, b = B E, b = D E and $EC = x$) $y = \frac{1}{\sqrt{a^2 + (x-b)^2} - \sqrt{c^2 + x^2}}$ also a wholly different curve from the conic hyperbola, which all experiments give. Therefore the conclusion from the whole is that the phenomena have no reference to interference.

Having delivered the doctrines resulting from these experiments, I have some few particulars to add, both as illustrating and confirming the foregoing propositions, as removing one or two difficulties which have occurred to others until they were met by facts, and also as showing the tendency of the results at which we have arrived.

1. It may have been observed that in all these propositions I have taken for granted the inflexion of the rays by the body first acting upon them as well as their deflexion by that body, and have reasoned on that supposition. It is, however, not to be denied that we cannot easily perceive the fringes made by the single inflexion, as we can without any difficulty perceive those made by the single deflexion, and fully described in Proposition I. Sir I. NEWTON even assumes that no fringes are made within the shadow. I here purposely keep out of view the fringes made in the shadow of a hair or other small body, because the principle of interference there comes into play. However, I will now state the grounds of my assuming inflexion and separation of the rays by their different flexibility, when only a single body acts on them. In the *first* place, the first body does act in some way; for the second only acts after the first, and if the first be removed the fringes made in its shadow by the second at once vanish. *Secondly*, these fringes made by the second depend upon its proximity to the first. *Thirdly*, the following experiment seems decisive. Place instead of a straight edge one of the form in fig. 18, and then apply at some distance from it, the second edge, as in the former experiments. You find that the fringes assume the form, somewhat like a small tooth-comb, of $a b$. If the second edge is

furnished with a similar curve surface the form is more complete, as in *cd*. But the straight edge being used after the first flexion of the curved one, clearly shows that the first edge bends as well as the second, indeed more than the second, for the side of the figure answering to that curved edge is most curved. *Fourthly*, the whole experiments with two edges directly opposite each other negative the idea of there being no inflexion; indeed they seem to prove the inflexion equal to the deflexion. The phenomena under Proposition X. can in no way be reconciled to the supposition of the first edge not inflecting the rays*.

2. We must ever keep in view the difference between the fringes or images described by Sir I. NEWTON and measured by him, as made by the rays passing on each side of a hair, and the fringes or images which are made without the interference of rays passing on both sides. It is clear that the rays which form those fringes with their dark intervals do not proceed after passing the hair in straight lines. Sir I. NEWTON's measures † prove this; for at half a foot from the hair he found the first fringe $\frac{1}{170}$ th of an inch broad, and the second fringe $\frac{1}{290}$; and at nine feet distance the former were $\frac{1}{32}$, the latter $\frac{1}{55}$, instead of being $\frac{1}{9}$ and $\frac{1}{10}$, and the latter less than $\frac{1}{16}$, and so of all the other measures in the table, each being invariably about one-third what it ought to be if the rays moved in straight lines; and this also explains why the fringes do not run into one another, or encroach on the dark intervals in the case of the hair, as they must do if the rays moved in straight lines.

But the case of the fringes or images which we have been examining and reasoning upon is wholly different. I have measured the breadths of those formed by disposition and polarization, and found that they are broad in proportion to the distance from the bending edge of the chart on which they are received; and vary from the results given by similar triangles in so trifling a degree, that it can arise only from error in measurement. Thus in an average of five trials, at the relative distances of 41 and 73 inches, the disc was $6\frac{3}{5}$ at the shorter, and $10\frac{1}{5}$ at the longer distance; the fringe next it $3\frac{7}{10}$ at the shorter, and $5\frac{7}{10}$ at the longer distance, whereas the proportions by similar triangles would have been $9\frac{1}{8}$ and $5\frac{1}{8}$, so that the difference is small, and is by excess, and not, as in the hair experiment, by defect. Had the difference been as in Sir I. NEWTON's experiment, instead of $10\frac{1}{5}$ and $5\frac{7}{10}$, it would have been $3\frac{1}{4}$ and $1\frac{1}{4}$. In another measurement at 101 and 158 inches respectively, the disc was $15\frac{1}{3}$, the fringe $8\frac{1}{3}$ instead of $14\frac{3}{5}$ and $9\frac{1}{8}$ respectively. But by Sir I. NEWTON's proportions these should have been $4\frac{3}{5}$ and $3\frac{1}{4}$. It is plain that if the measures had been taken with the micrometer instruments, which had not been then furnished, there would have been no deviation. I have since tried the experiment, not as above, on the fringes formed by the double-edged instrument, but on those formed by one edge at a distance behind the other, and have found no reason to doubt that the rays follow a rectilinear course.

* If you hold a body between the eye and a light, as that of a candle, and approach it to the rays, you see the flame drawn towards the body; and a beginning of images or fringes is perceived on that side.

† Optics, B. iii. obs. 3.

It may further be observed, that in the fringes or images by disposition and polarization, the dark intervals disappear at short distances from the point of flexion, and that the fringes run into one another, so that we find the red mixed with the blue and violet. This is one reason why I often experimented with the prismatic rays.

3. It follows from the property of light, which I have termed disposition, on one side the ray, and polarization on the opposite side, superinduced by flexion, that those two sides only being affected, the other two at right angles to these are not at all affected by the flexion which has disposed and polarized the two former. Consequently, although an edge placed parallel to the disposing edge and opposite to it acts powerfully on the disposed light, yet an edge placed at right angles to the former edge or across the rays, does not affect them any more than it would rays which had not been subjected to the previous action of a first edge. Thus (fig. 19) if $abcd$ be the section of the ray, an edge parallel to ab , after the ray has been disposed, will affect the ray greatly, provided it had been disposed by an edge also parallel to ab . The sides ab and cd , however, are alone affected; and therefore the second edge, if placed parallel to ad or bc , will not at all bend the ray more or make images (or fringes) more powerfully than it would do if no previous flexion and disposition had taken place. Let us see how this is in fact: $efgh$ is the distended disc after flexion, by passing through the aperture of the two-edged instrument (Plate XI.). It is slightly tinged with red at the two ends fg and eh , beyond which, and in the shadow of the edges, are the usual fringes or coloured images by flexion and disposition, e, c , the edges being parallel to eh, fg . Place another edge at some distance from the two, as 3 or 4 inches, and parallel to these two, but in the light, and you will see in the disc a succession of narrow fringes parallel to the edges, and in front of the third edge's shadow. These fringes are on the white disc, and their colours are very bright, much more so than the colours of those fringes described in Proposition I., and which are fringes made by deflexion without any disposition. But whether this superior brightness is owing to the glare of the disc's light being diminished by the flexion of the first two edges, or not, for the present I stop not to inquire. This is certain, that if the third edge be placed across the beam, and at right angles to the two first edges, you no longer have the small fringes. They are not formed in the direction hg , parallel to the edges as now placed. If the double edges are changed, and are placed in the direction $h'g'$, you again have the bright fringes; but then, if the third edge is now placed parallel to $h'e'$, you cease to have them. Care must, however, be taken in this experiment not to mistake for these bright fringes the ordinary deflexion fringes made by one flexion without disposition, as described in Proposition I. For these may be perceived, and even somewhat more distinctly in the disc than in the full light of the white pencil or beam.

Now are these bright fringes only the flexion fringes, that is fringes by simple flexion without disposition? To ascertain this I made these experiments.

Exp. 1. If they are the common fringes, and only enlarged by the greater divergence of the rays after flexion, and more bright by the dimness of the distended disc,

then it will follow that the greater the distension, and the greater the divergence of the rays, the broader will be the bright fringes in question. I repeatedly have tried the thing by this test, and I uniformly find that increasing the divergence, by approaching the edges of the instrument, has no effect whatever in increasing the breadth of the fringes in question.

Exp. 2. If these fringes are not connected with disposition, it will follow that the distance of the edge which forms them from the double-edged instrument cannot affect them. But I have distinctly ascertained that their breadth does depend on that distance, and in order to remove all doubt as to the distance between the chart and the third edge which forms them, I allowed that edge to remain fixed, and varied its distance from the other two by bringing the double-edge instrument nearer the third edge. The breadths of the bright fringes varied most remarkably, being in some inverse power of that distance. Thus, to take one measurement as an example of the rest, at 4 feet from the third edge the chart was fixed and the third edge kept constantly at that distance from it. Then the double-edge instrument was placed successively at $14\frac{1}{2}$, at 9 and at $4\frac{1}{2}$ eighths of an inch from the third edge. The breadths were respectively 2, $3\frac{3}{4}$ and $4\frac{1}{4}$ twentieths of an inch. In some experiments these measures approached more nearly the hyperbolic values of y , but I give the experiment now only for the important and indeed decisive evidence which it affords, that these fringes are caused by disposition, and are wholly different from those formed without previous flexion.

Exp. 3. If the greater breadth of these fringes is owing to dispersion, then they should be formed more in the rays of the prismatic spectrum than in white light, or even in light bent by flexion. Yet we find it more difficult to trace fringes across the prismatic spectrum than in white light, and more difficult across the spectrum when there is divergence, than when formed parallel to its sides when there is no divergence. There are fringes formed, but of the narrow kind, which are described in Prop. I.

Exp. 4. I have tried the effect on the fringes in question of the curvilinear edge described in the first article of these observations, and the effect of which is represented in fig. 18. It is certain that at a distance from the double-edge instrument the third edge seems only to form fringes rectilinear, or of its own form. But when placed very near, as half an inch from the instrument, plainly there is a curvilinear form given to the fringes in question; and this is most easily perceived, when, by moving the third edge towards the side of the pencil, you form the smaller fringes so as to be drawn across or along the greater ones made by the two first edges.

I think, without pursuing this subject further, it must be admitted that these fringes in light, which is bent and disposed, lend an important confirmation to the doctrine of disposition. It is clear that the rays are affected only on two of their four sides, or ab and cd , if these are parallel to the bending body's edge, and not at all on the sides cb and da ; that, on the other hand, cb and da are affected when the

edges are placed parallel to these two sides of the rays; and thus the connection of the fringes in question, with the preceding action of which disposed and polarized, is clearly proved.

4. It is an obvious extension and variation of this experiment both to apply edges parallel to the first and disposing edges, and also to apply edges at right angles to their direction; and important results follow from this experiment. But until a more minute examination of the phenomena with accurate admeasurements can be had, I prefer not entering on this subject further than to say, that the extreme difficulty of obtaining fringes or images at once from the edges parallel to the first two, and from edges at right angles to these, indicates an action not always at right angles to the bending body, but whether conical or not I have not hitherto been able to ascertain. That the first body only disposes and polarizes in one direction is certain. But it seems difficult to explain the effect of the first two edges in preventing the fringes or images from being made by the second at right angles to those formed by the first two edges, if no lateral action exists. One can suppose the approaching of those two first edges to make the fringes narrower and narrower than those which the second two edges form when placed at right angles to the first. But this is by no means all that happens. There is hardly any set of fringes at all formed at right angles to the first set (parallel to the first two edges) when the first two are approached so near each other as greatly to distend the disc.

5. I reserve for future inquiry also the opinion held by Sir I. NEWTON, that the different homogeneous rays are acted upon by bodies at different distances, this action extending furthest over the least refrangible rays. He inferred this from the greater breadth of the fringes in those rays.

It is in my apprehension, though I once held a different opinion*, not impossible to account for the difference of the breadth of the fringes by the different flexibility of the rays; and the reasoning in one of the foregoing propositions shows how this inquiry may be conducted. But one thing is certain, and probably Sir I. NEWTON had made the experiment and grounded his opinion upon the result. If you place a screen, with a narrow slit in the prismatic spectrum's rays, parallel to the rectilinear sides, and then place a second prism at right angles to the first and between the screen and the chart, you will see the image of the slit drawn on one side, the violet being furthest drawn, the red least drawn; but you will find no difference in the breadth of the image cast by the slit. Flexion, however, operates in a different manner, because it acts on rays, which, though of the same flexibility, are at different distances from the body.

6. The internal fringes in the shadow (said by interference) deserve to be examined much more minutely than they ever have been; and I have made many experiments on these, by which an action of the rays on one another is, I think, sufficiently proved. I shall here content myself with only stating such results as bear on

* Philosophical Transactions, 1797.

the question of interference affecting my own other experiments. *First.* I observe that when one side of a needle or pin is grooved so as to be partly curvilinear, the other side remaining straight, we have internal fringes of the form in fig. 21. *Secondly.* It is not at all necessary the pin or other body forming them should be of very small diameter, although it is certain that the breadth of the fringes is inversely as the diameter. I have obtained them easily from a body one-quarter or one-third of an inch in diameter, but they must be received at a considerable distance from the body. *Thirdly,* and this is very material as to interference at all affecting my experiments, although certainly the internal fringes vanish when the rays are stopped coming from the opposite side of the object, the external fringes are not in the smallest degree affected, unless you stop the light coming on their own side; stopping the opposite rays has no effect whatever. Thus, stopping the light on the side *a* (fig. 19), the fringes *ff* vanish, but not the external fringes *c*. This at once proves there is no interference in forming the external ones. *Lastly.* I may observe, that the law of disposition and polarization in some sort, though with modification, affects the internal fringes as well as the external.

It is a curious fact connected with polarization by inflexion, and which indeed is only to be accounted for by that affection of light, that nothing else prevents the rays from circulating round bodies exposed to them, at least bodies of moderate diameter. If the successive particles of the surface inflected, one particle acting after the other, the rays must necessarily come round to the very point of the first flexion. We should thus see a candle placed at *A* (fig. 22) when the eye was placed at *B*, because the rays would be inflected all round; and even in parts of the earth where the sea is smooth, nothing but the small curvature of the surface could prevent us from seeing the sun many hours after light had begun by placing the eye close to the ground. This, however, in bodies of a small diameter, must inevitably happen. The polarization of the rays alone prevents it, by making it impossible they should be more than once inflected on their side which was next the bending body, therefore they go on straight to *C*. But for polarity they must move round the body.

7. It must not be lightly supposed, that because such inquiries as we have been engaged in are on phenomena of a minute description and relate to very small distances, therefore they are unimportant. Their results lead to the constitution of light, and its motion, and its action, and the relations between light and all bodies. I purposely abstain from pursuing the principles which I have ventured to explain into their consequences, and reserve for another occasion some more general inquiries founded upon what goes before. This course is dictated by the manifest expediency of first expounding the fundamental principles, and I therefore begin by respectfully submitting these to the consideration of the learned in such matters.

In the meantime, however, I will mention one inference to be drawn from the foregoing propositions of some interest.

As it is clear that the disposition varies with the distance, and is inversely as that

distance, and as this forms an inherent and essential property of the light itself, what is the result? Plainly this, that the motion of light is quite uniform after flexion, and apparently before also. The flexion produces acceleration but only for an instant. If ss is the space through which the ray moves after entering the sphere of flexion, and v the velocity before it enters that sphere; it moves after entering with a velocity $=\sqrt{v^2+Zdz}$, Z being the law of the bending force. Then this is greater than v ; consequently there is an acceleration, though not very great; but because $y=\frac{a}{x}$, if s is the space, t the time, the force of acceleration is $\frac{s}{tds} \times \frac{tds-sdt}{t^2}$; but $y=\frac{a}{x}$ shows that s is as t , else $y=\frac{a}{x}$ would be impossible; therefore the accelerating force $\frac{s}{ds} \times \frac{tds-sdt}{t^3}=0$, and so it is shown there is no acceleration after the ray leaves the sphere of flexion.

DESCRIPTION OF THE INSTRUMENTS.

PLATE XII.

Is the instrument with two plates or edges. A, B, horizontal, D, C vertical; the former moved by the screw E, which has also a micrometer for the distances on the scale G; the latter, in like manner, moved by F, connected with micrometer and scale H.

PLATE XIII.

Is the instrument with four surfaces. A D, $a d$ are two parallel plates, moving horizontally by a rack and pinion E. Each plate has an edge composed of four surfaces; A, a , a sharp edge or very narrow surface; B, b , a flat surface; C, c , a cylindrical surface of large radius of curvature, and so flat; D, d , one of small radius, and so very convex: this is represented on the figure by A' B' C' D' beside the other. Care is to be taken that A B C D and $a b c d$ be a perfectly straight line, made up of the sharp edge, the plane surface and the tangents to the two cylinders. H is a plate with a sharp and straight edge, $o p$, which can be brought by its handle F to come opposite to the compound edge $a b c d$, when it is desired to try the flexion by the latter, without another flexion by an opposite compound edge, but only with a flexion by a rectilinear simple edge.

PLATE XIV.

Is the instrument by which is tried the *experimentum crucis* on the action of the third edge, and also the experiments on the distances of the edges as affecting the disposing force. G is the groove in which the uprights H, I, K move. There is a scale

graduated, F, by which the relative distances can always be determined of the plates A, C and B. A moves up and down upon H, B upon I, and C upon K; each plate is moved up and down by rack and pinion D. The uprights also move along the groove G by rack and pinion E.

PLATE XV.

Is the instrument for ascertaining more nicely the effects of distance on disposition. A is a plate with graduated edge; it moves vertically on a pivot, and its angle with the horizontal line is measured by the quadrant E. A also moves horizontally, and its horizontal angle is measured by the quadrant K. B is another plate with graduated edge, moving in a groove D, by rack and pinion H, and along a graduated beam I. F is a fine micrometer, by which the distance of A above B, when A is horizontal, can always be measured to the greatest nicety by the circle F and the scale G.

PLATE XVI.

Is an instrument also for measuring the effect of the distance of the edges upon the disposing forces. C C C is a graduated beam, adjusted by the spirit-level, and on it moves the upright on which a plate A moves by micrometer screw E, so that the distance of A from the rays that pass along C C C after flexion by a plate fixed at one end of the beam, can be ascertained by the scale D. I have experimented with this, but I did not find it so easy to work by as the other apparatus. C C C is brought to an exact level by screws not noted in the drawing.

XIII. *General Methods in Analysis for the resolution of Linear Equations in Finite Differences and Linear Differential Equations.* By CHARLES JAMES HARGREAVE, Esq., L.L.B., F.R.S., Professor of Jurisprudence in University College, London.

Received March 15,—Read March 29, 1849.

Preliminary Remarks.

1. THE investigations presented in this paper consist of two parts; the first offers a solution, in a certain qualified sense, of the general linear equation in finite differences; and the second will be found to give an almost complete analysis of the resolution in series of the general linear differential equation with rational factors. The second part is deduced directly from the results of the first, although the subjects of which they respectively treat appear to be wholly independent of each other.

With the exception of a few cases capable of solution by partial and artificial methods, there does not at present exist any mode of solving linear equations in finite differences of an order higher than the first; and with reference to such equations of the first order, we are obliged to be content with those insufficient forms of functions which are intelligible only when the independent variable is an integer, and which may be obtained directly from the equation itself by merely giving to the independent variable its successive integer values. It is in this insufficient and qualified sense that the solutions here given are to be taken; and the first part of the following investigations may be considered as an extension of this form of solution from the general equation of the first order to the general equation of the n th order.

Linear Equations in Finite Differences.

2. A complete analytical theory of the general equation of the n th order,

$$u_x = P_x u_{x-1} + Q_x u_{x-2} + R_x u_{x-3} + S_x u_{x-4} + \dots + W_x u_{x-n+1} + Z_x u_{x-n} + G_x, \quad (1.)$$

would involve its resolution into a series of equations of the first order of the form

$$\begin{aligned} u_x - P'_x u_{x-1} &= G'_x, \\ u_x - P''_x u_{x-1} &= G''_x, \\ &\cdot \quad \cdot \quad \cdot \\ &\cdot \quad \cdot \quad \cdot \\ u_x - P^{(n)}_x u_{x-1} &= G^{(n)}_x; \end{aligned}$$

from which the complete solution would result, so far as known methods extend, in the form

$$u_x = P'_1 P'_2 \dots P'_x \Sigma \left(\frac{G'_x}{P'_1 P'_2 \dots P'_{x+1}} \right) + \dots + P_1^{(n)} P_2^{(n)} \dots P_x^{(n)} \Sigma \left(\frac{G_x^{(n)}}{P_1^{(n)} P_2^{(n)} \dots P_{x+1}^{(n)}} \right),$$

or in an expanded form,

$$\begin{aligned} u_x = & G'_x + P'_x G'_{x-1} + P'_{x-1} P'_x G'_{x-2} + P'_{x-2} P'_{x-1} P'_x G'_{x-3} + \dots + c' P'_m P'_{m+1} \dots P'_x \\ & + G''_x + P''_x G''_{x-1} + P''_{x-1} P''_x G''_{x-2} + P''_{x-2} P''_{x-1} P''_x G''_{x-3} + \dots + c'' P''_m P''_{m+1} \dots P''_x \\ & + \dots \\ & + G_x^{(n)} + P_x^{(n)} G_x^{(n)} + P_{x-1}^{(n)} P_x^{(n)} G_{x-2}^{(n)} + P_{x-2}^{(n)} P_{x-1}^{(n)} P_x^{(n)} G_{x-3}^{(n)} + \dots + c^{(n)} P_m^{(n)} P_{m+1}^{(n)} \dots P_x^{(n)}. \end{aligned}$$

The last column contains, as is well known, the general solution of the original equation deprived of the term G_x ; and the remaining columns contain the particular solution of the original equation.

3. The investigation the results of which are given in this part, although it actually succeeds in solving the original equation, will be found to contribute little or nothing to the analytical theory as above explained; and this arises from the circumstance, that the particular solution, instead of being produced in the separated form above written, is produced in an aggregated form,

$$G_x + AG_{x-1} + BG_{x-2} + \dots;$$

and the complementary part of the general solution, instead of being produced as above, appears in the form of a *sum* of the complementary functions above written, the constants c' , c'' , &c. being the same in all. But as we shall thus obtain a solution with an arbitrary constant, capable of solving the original equation deprived of G_x , we have it in our power to solve the equation completely by reducing the order of the equation in successive steps.

If we take the equation of the first order,

$$u_x = P_x \dot{u}_{x-1} + G_x,$$

and arrive at its solution, not properly by any analytical method, but by giving to x the successive values

$$x, x-1, x-2 \dots m+1, m, m-1,$$

and eliminating all values of u_x between the first and the last, we have

$$\begin{aligned} u_x = & P_x u_{x-1} + G_x \\ = & P_x (P_{x-1} u_{x-2} + G_{x-1}) + G_x \text{ or } P_x P_{x-1} u_{x-2} + P_x G_{x-1} + G_x \\ = & P_x P_{x-1} (P_{x-2} u_{x-3} + G_{x-2}) + P_x G_{x-1} + G_x \text{ or } P_x P_{x-1} P_{x-2} u_{x-3} + P_x P_{x-1} G_{x-2} + P_x G_{x-1} + G_x \\ = & \dots \\ = & (P_x P_{x-1} \dots P_m) u_{m-1} + (P_x \dots P_{m+1}) G_m + (P_x \dots P_{m+2}) G_{m+1} + \dots + P_x P_{x-1} G_{x-2} + P_x G_{x-1} + G_x \end{aligned}$$

$$\begin{aligned}
&= (P_x \dots P_m) \left\{ u_{m-1} + \frac{G_m}{P_m} + \frac{G_{m+1}}{P_m P_{m+1}} + \dots + \frac{G_{x-2}}{P_m \dots P_{x-2}} + \frac{G_{x-1}}{P_m \dots P_{x-1}} + \frac{G_x}{P_m \dots P_x} \right\} \\
&= P_x \dots P_m \left(\sum \frac{G_{x+1}}{P_m \dots P_{x+1}} + c \right);
\end{aligned}$$

which is the solution ordinarily given, though it is arrived at by a process somewhat less coarse than the above.

By applying the same process of successive elimination to the general linear equation (1.), and carefully observing the law by which the entrance of the factors $P_x, Q_x, R_x, \&c.$ is governed, it will be found that an exactly similar solution may be found in the form

$$u_x = \varepsilon^v \left\{ P_x \dots P_m \left(\sum \left(\frac{G_{x+1}}{P_m \dots P_{x+1}} \right) + c \right) \right\},$$

or

$$u_x = G_x + P_x G_{x-1} + \varepsilon^v (P_x P_{x-1}) \cdot G_{x-2} + \varepsilon^v (P_x \dots P_{x-2}) \cdot G_{x-3} + \dots + \varepsilon^v (P_x \dots P_{m+1}) \cdot G_m + c \varepsilon^v (P_x \dots P_m);$$

where v denotes the sum of a set of distributive operations $V_1, V_2, V_3, \dots, V_{n-1}$ not of a strictly algebraical character, which are capable of being performed only upon factorial expressions containing consecutive values of P_x , and which have the following significations. V_1 denotes one operation of this character, signifying that the factor $P_{m-1} P_m$ is changed into Q_m as often as it occurs, any term in which it does not occur disappearing, and the sum of the terms thus obtained being the result of the operation; so that, for example,

$$V_1(P_{x-1} P_x) = Q_x, \quad V_1^2(P_{x-1} P_x) = 0,$$

$$V_1(P_{x-2} P_{x-1} P_x) = Q_{x-1} P_x + P_{x-2} Q_x, \quad V_1^2(P_{x-2} P_{x-1} P_x) = 0,$$

$$V_1(P_{x-3} P_{x-2} P_{x-1} P_x) = Q_{x-2} P_{x-1} P_x + P_{x-3} Q_{x-1} P_x + P_{x-3} P_{x-2} Q_x, \quad V_1^2(P_{x-3} P_{x-2} P_{x-1} P_x) = 2Q_{x-2} Q_x, \&c. \&c.$$

Again, V_2 denotes another operation of a similar character, signifying that the factor $P_{m-2} P_{m-1} P_m$ is changed into R_m as often as it occurs, the result of the operation being as before the sum of the terms; so that, for example, we have

$$V_2(P_{x-2} P_{x-1} P_x) = R_x,$$

$$V_2(P_{x-3} P_{x-2} P_{x-1} P_x) = R_{x-1} P_x + P_{x-3} R_x,$$

$$V_2(P_{x-4} P_{x-3} P_{x-2} P_{x-1} P_x) = R_{x-2} P_{x-1} P_x + P_{x-4} R_{x-1} P_x + P_{x-4} P_{x-3} R_x,$$

$$V_2(P_{x-5} \dots P_x) = R_{x-3} P_{x-2} P_{x-1} P_x + P_{x-5} R_{x-2} P_{x-1} P_x + P_{x-5} P_{x-4} R_{x-1} P_x + P_{x-5} P_{x-4} P_{x-3} R_x,$$

$$V_2^2(P_{x-5} \dots P_x) = 2R_{x-3} R_x, \&c. \&c.;$$

V_3 denotes the change in a similar manner of $P_{m-3} P_{m-2} P_{m-1} P_m$ into S_m ;

.

.

V_{n-2} denotes the change in a similar manner of $P_{m-n+2} \dots P_m$ into W_m ;

and

V_{n-1} denotes the change in a similar manner of $P_{m-n+1} \dots P_m$ into Z_m .

It might at first sight be supposed that this process, if successful at all, would give the complete complementary solution in the form

$$u_x = c_1 \varepsilon^v (P_1 \dots P_x) + c_2 \varepsilon^v (P_2 \dots P_x) + \dots;$$

but it will be found that in reality this introduces only one arbitrary constant.

It now remains to place these expressions under a properly algebraic form, and to verify the result; and in order to do this we must express the general term $\varepsilon^v (P_x \dots P_{p+1})$ in terms of the factors of the original equation; and afterwards give to p , which in the first instance is regarded as a constant, the successive values required for forming the several terms of the solution.

This may be done as follows:—

$$\text{Let } \frac{Q_x}{P_{x-1}P_x} = q_x, \frac{R_x}{P_{x-2}P_{x-1}P_x} = r_x, \frac{S_x}{P_{x-3}P_{x-2}P_{x-1}P_x} = s_x, \dots, \frac{W_x}{P_{x-n+2} \dots P_x} = w_x, \text{ and } \frac{Z_x}{P_{x-n+1} \dots P_x} = z_x.$$

Then it is easily seen that

$$V_1(P_x \dots P_{p+1}) = P_x \dots P_{p+1} \{q_{p+2} + q_{p+3} + \dots + q_x\} = P_x \dots P_{p+1} \sum_{p+1}^x q_{x+1},$$

$$V_2(P_x \dots P_{p+1}) = P_x \dots P_{p+1} \{r_{p+3} + r_{p+4} + \dots + r_x\} = P_x \dots P_{p+1} \sum_{p+2}^x r_{x+1},$$

and generally

$$v(P_x \dots P_{p+1}) = P_x \dots P_{p+1} \left\{ \sum_{p+1}^x q_{x+1} + \sum_{p+2}^x r_{x+1} + \sum_{p+3}^x s_{x+1} + \dots + \sum_{p+n-2}^x w_{x+1} + \sum_{p+n-1}^x z_{x+1} \right\}.$$

To find $V_1^2(P_x \dots P_{p+1})$, it will be convenient to proceed by steps, beginning with a small number of terms.

Thus

$$V_1(P_x \dots P_{x-3}) = (P_x \dots P_{x-3})(q_x + q_{x-1} + q_{x-2}), \quad \frac{1}{2} V_1^2(P_x \dots P_{x-3}) = P_x \dots P_{x-3}(q_x q_{x-2})$$

$$V_1(P_x \dots P_{x-4}) = (P_x \dots P_{x-4})(q_x + q_{x-1} + q_{x-2} + q_{x-3}), \quad \frac{1}{2} V_1^2(P_x \dots P_{x-4}) = P_x \dots P_{x-4}(q_x(q_{x-2} + q_{x-3}) + q_{x-1}q_{x-3})$$

$$V_1(P_x \dots P_{x-5}) = (P_x \dots P_{x-5})(q_x + q_{x-1} + q_{x-2} + q_{x-3} + q_{x-4}),$$

$$\frac{1}{2} V_1^2(P_x \dots P_{x-5}) = (P_x \dots P_{x-5})(q_x(q_{x-2} + q_{x-3} + q_{x-4}) + q_{x-1}(q_{x-3} + q_{x-4}) + q_{x-2}q_{x-4}) \text{ \&c. ;}$$

and generally, $V_1(P_x \dots P_{p+1})$ being $P_x \dots P_{p+1}(\sum_{p+1}^x q_{x+1})$, we have

$$\frac{1}{2} V_1^2(P_x \dots P_{p+1}) = P_x \dots P_{p+1} (q_x \sum_{p+1}^{x-2} q_{x+1} + q_{x-1} \sum_{p+1}^{x-3} q_{x+1} + \dots + q_{p+4} \sum_{p+1}^{p+2} q_{x+1})$$

$$= P_x \dots P_{p+1} \sum_{p+3}^x (q_{x+1} \sum_{p+1}^{x-1} q_{x+1}).$$

Similarly, it will be seen that

$$\frac{1}{2.3} V_1^3(P_x \dots P_{p+1}) = P_x \dots P_{p+1} \sum_{p+5}^x (q_{x+1} \sum_{p+3}^{x-1} (q_{x+1} \sum_{p+1}^{x-1} q_{x+1})), \text{ and so on.}$$

In like manner we shall find

$$\frac{1}{2} V_2^2(P_x \dots P_{p+1}) = P_x \dots P_{p+1} \sum_{p+5}^x (r_{x+1} \sum_{p+2}^{x-2} r_{x+1})$$

$$\frac{1}{2.3} V_2^3(P_x \dots P_{p+1}) = P_x \dots P_{p+1} \sum_{p+8}^x (r_{x+1} \sum_{p+5}^{x-2} (r_{x+1} \sum_{p+2}^{x-2} r_{x+1})), \text{ and so on,}$$

$$\frac{1}{2} V_m^2(P_x \dots P_{p+1}) = (P_x \dots P_{p+1}) \sum_{p+2m+1}^x (v_{x+1} \sum_{p+m}^{x-m} v_{x+1}),$$

$$\frac{1}{2.3} V_m^3(P_x \dots P_{p+1}) = (P_x \dots P_{p+1}) \sum_{p+3m+2}^x (v_{x+1} \sum_{p+2m+1}^{x-m} (v_{x+1} \sum_{p+m}^{x-m} v_{x+1})), \text{ and so on,}$$

v_x being that term of the series $q_x r_x s_x$, &c. which corresponds to the operation V_m , as q_x corresponds to V_1 , r_x to V_2 , &c.

$$V_1 V_2(P_x \dots P_{p+1}) = P_x \dots P_{p+1} \sum_{p+4}^x (r_{x+1} \sum_{p+1}^{x-2} q_{x+1}),$$

$$V_l V_m(P_x \dots P_{p+1}) = P_x \dots P_{p+1} \sum_{p+m+l+1}^x (t_{x+1} \sum_{p+m}^{x-l} v_{x+1}), \text{ (} t_x \text{ corresponding to } V_l),$$

$$V_l^2 V_m(P_x \dots P_{p+1}) = P_x \dots P_{p+1} \sum_{p+m+2l+2}^x (t_{x+1} \sum_{p+m+l+1}^{x-l} (t_{x+1} \sum_{p+m}^{x-l} v_{x+1})), \text{ \&c. \&c.}$$

Finally, if $N'_{x,p} + N''_{x,p} + N'''_{x,p} + \dots$ represent a series in which

$$N'_{x,p} = 1, N''_{x,p} = \sum_{p+1}^x q_{x+1} + \sum_{p+2}^x r_{x+1} + \dots + \sum_{p+x-1}^x z_{x+1},$$

and generally

$$N_{x,p}^{(a+1)} = \sum_{p+2a-1}^x (q_{x+1} N_{x-1,p}^{(a)}) + \sum_{p+3a-1}^x (r_{x+1} N_{x-2,p}^{(a)}) + \sum_{p+4a-1}^x (s_{x+1} N_{x-3,p}^{(a)}) + \dots \\ + \sum_{p+(n-1)a-1}^x (w_{x+1} N_{x-n+2,p}^{(a)}) + \sum_{p+na-1}^x (z_{x+1} N_{x-n+1,p}^{(a)});$$

then, if this series be called $N_{x,p}$, we shall find that $\varepsilon^v(P_x \dots P_{p+1}) = (P_x \dots P_{p+1}) N_{x,p}$.

It may be here observed that the number of the terms of the series $N'_{x,p} + N''_{x,p} + \dots$ cannot exceed $\frac{1}{2}(x-p) + 1$ when $x-p$ is even, and $\frac{1}{2}(x-p+1)$ when $x-p$ is odd; and since p has the successive values $x-2$, $x-3$, &c., it is always known whether $x-p$ be odd or even. The number of terms may be less; for if Q_x be zero, the number of terms would be the next whole number above $\frac{1}{3}(x-p)$, &c.

That the equation

$$u_x = c(P_x \dots P_{p+1}) N_{x,p}$$

is a complementary solution of the original equation, or in other words, a solution of the original equation wanting the term G_x , may be directly verified; for we have

$$u_x - P_x u_{x-1} = c(P_x \dots P_{p+1}) (N_{x,p} - N_{x-1,p}) \\ = c(P_x \dots P_{p+1}) \Delta N_{x-1,p}.$$

Now $\Delta N'_{x-1,p} = 0,$

$$\Delta N''_{x-1,p} = q_x + r_x + s_x + \dots + z_x,$$

$$\Delta N'''_{x-1,p} = q_x N''_{x-2,p} + r_x N''_{x-3,p} + s_x N''_{x-4,p} + \dots + w_x N''_{x-n+1,p} + z_x N''_{x-n,p},$$

and generally

$$\Delta N_{x-1,p}^{(a+1)} = q_x N_{x-2,p}^{(a)} + r_x N_{x-3,p}^{(a)} + s_x N_{x-4,p}^{(a)} + \dots + w_x N_{x-n+1,p}^{(a)} + z_x N_{x-n,p}^{(a)},$$

whence

$$\Delta N_{x-1,p} = q_x N_{x-2,p} + r_x N_{x-3,p} + s_x N_{x-4,p} + \dots + w_x N_{x-n+1,p} + z_x N_{x-n,p},$$

and

$$u_x - P_x u_{x-1} = Q_x u_{x-2} + R_x u_{x-3} + S_x u_{x-4} + \dots + W_x u_{x-n+1} + Z_x u_{x-n}.$$

In this part of the solution, I apprehend that it will not generally be necessary to have regard to the lower limits, since p may have any constant value, and that value may be taken which is most convenient in each case; and if we make $p = -\infty$, all the lower limits will have this value.

This part of the solution would then be

$$u_x = cP_x \dots P_1 \{1 + A_x + B_x + C_x + \dots\},$$

where

$$A_x = \sum q_{x+1} + \sum r_{x+1} + \sum s_{x+1} + \dots + \sum w_{x+1} + \sum z_{x+1};$$

and generally each term of the part within the brackets is formed from the preceding term thus: first change x into $x-1$, multiply by q_{x+1} , and effect a summation; then change (in such preceding term) x into $x-2$, multiply by r_{x+1} , and effect a summation; and so on until lastly we change x into $x-n+1$, multiply by z_{x+1} , and effect a summation; and the sum of the parts thus obtained is the next term.

The verification of the particular solution is easily derived from the above; but it rests on the assumption that the algebraic value above given for $\varepsilon^v(P_x \dots P_{p+1})$ is correct; to which therefore particular attention is directed.

The equation

$$u_x = c\varepsilon^v(P_x \dots P_{p+1}),$$

considered as a solution of the original equation wanting the term G_x , implies that

$$\varepsilon^v(P_x \dots P_{p+1}) = P_x \varepsilon^v(P_{x-1} \dots P_{p+1}) + Q_x \varepsilon^v(P_{x-2} \dots P_{p+1}) + R_x \varepsilon^v(P_{x-3} \dots P_{p+1}) + \dots + Z_x \varepsilon^v(P_{x-n} \dots P_{p+1}).$$

Now in order to verify the particular solution,

$$u_x = G_x + P_x G_{x-1} + \varepsilon^v(P_x P_{x-1}) G_{x-2} + \varepsilon^v(P_x P_{x-1} P_{x-2}) G_{x-3} + \dots + \varepsilon^v(P_x \dots P_{x-p+1}) G_{x-p} + \dots,$$

it is only requisite that

$$\varepsilon^v(P_x \dots P_{x-p+1}) = P_x \varepsilon^v(P_{x-1} \dots P_{x-p+1}) + Q_x \varepsilon^v(P_{x-2} \dots P_{x-p+1}) + R_x \varepsilon^v(P_{x-3} \dots P_{x-p+1}) + \dots + Z_x \varepsilon^v(P_{x-n} \dots P_{x-p+1});$$

and this is true, for it is identical in form with the equation last above given, notwithstanding the occurrence of x in the lowest value of P , for this lowest value remains the same throughout the expression.

7. If $P_x = 0$, the expressions $\varepsilon^v(P_x \dots P_{x-m})$ reduce themselves to those terms which do not contain any value of P . It would not be difficult to determine generally what terms these are; but probably the most convenient general method of arriving at the solution in an algebraical form would be to make P_x equal to a constant b , and to make b equal to zero in the result finally obtained.

8. The above particular solution of the original equation is in such a form that the general term of the indefinite series representing the solution is given in explicit terms; but that general term may be represented in an implicit form, which perhaps is more convenient for practical use.

By attending to the formation of the successive expressions $\varepsilon^v(P_x \dots P_m)$, it will readily be seen that the series

$$M_0 G_x + M_1 G_{x-1} + M_2 G_{x-2} + \dots + M_p G_{x-p} + \dots$$

is a solution of the original equation, if

$$M_0 = 1,$$

$$M_1 = P_x M_0,$$

$$M_2 = P_{x-1} M_1 + Q_x M_0,$$

$$M_3 = P_{x-2} M_2 + Q_{x-1} M_1 + R_x M_0,$$

$$\begin{array}{cccc} \cdot & \cdot & \cdot & \cdot \\ \cdot & \cdot & \cdot & \cdot \\ \cdot & \cdot & \cdot & \cdot \end{array}$$

$$M_p = P_{x-p+1} M_{p-1} + Q_{x-p+2} M_{p-2} + R_{x-p+3} M_{p-3} + \dots + W_{x-p+n-1} M_{p-n+1} + Z_{x-p+n} M_{p-n};$$

which last is a general relation determining the coefficient of any term from the coefficients of the n preceding terms; or from the coefficients of all the preceding terms when the number of these preceding terms is less than n . This relation is the equation of formation, and may be regarded as universal, bearing in mind that when p is less than n some of the terms of this relation vanish.

The solution of the original equation is therefore reduced to that of a similar equation without second member: and, by what has preceded, this solution is

$$M_p = \varepsilon^v (P_{x-p+1} \dots P_x),$$

it being understood that $M_0 = 1$; and this is the value of M_p before given.

But the value of M_p may be found otherwise, thus:

$$\text{Make} \quad P_{x-p+1} = P'_p, \quad Q_{x-p+2} = Q'_p, \quad \&c. \quad \&c.$$

Then the solution is evidently

$$M_p = \varepsilon^v (P'_p \dots P'_1),$$

where the operation v has the same meaning as before, except that it is applied to the accented letters.

Consequently

$$M_p = (P'_p \dots P'_1) \{1 + A_p + B_p + C_p + \dots\},$$

where

$$A_p = \sum_1 q'_{p+1} + \sum_2 r'_{p+1} + \dots + \sum_{x-1} z'_{p+1},$$

$$B_p = \sum_3 (q'_{p+1} A_{p-1}) + \sum_5 (r'_{p+1} A_{p-2}) + \dots + \sum_{2x-1} (z'_{p+1} A_{p-x+1}),$$

and generally the terms are formed as stated in section 5, using p for x .

9. I shall conclude this part of the subject with a few simple examples for the purpose of illustrating the processes here given.

Ex. 1. Let the equation be

$$u_x = au_{x-1} + b^2 u_{x-2} + G_x.$$

That part of the solution which is independent of G_x , is

$$u_x = c \left\{ a^x + (x-1)a^{x-2}b^2 + \frac{1}{2}(x-2)(x-3)a^{x-4}b^4 + \frac{1}{2 \cdot 3}(x-3)(x-4)(x-5)a^{x-6}b^6 + \dots \right\};$$

and since in the present case P_x and Q_x are constants, we have

$$M_p = a^p + (p-1)a^{p-2}b^2 + \frac{1}{2}(p-2)(p-3)a^{p-4}b^4 + \frac{1}{2.3}(p-3)(p-4)(p-5)a^{p-6}b^6 + \dots$$

whence the particular value of u_x is a series of terms of the form

$$G_x + aG_{x-1} + (a^2 + b^2)G_{x-2} + (a^3 + 2ab^2)G_{x-3} + (a^4 + 3a^2b^2 + b^4)G_{x-4} + (a^5 + 4a^3b^2 + 3ab^4)G_{x-5} + \dots$$

The difference in character between the solution proposed in this paper, and that which would result from a perfect analysis of the general equation, may be exemplified by the present instance.

The perfect solution of this equation is known to be

$$u_x = \frac{1}{\alpha - \beta} \left(\alpha^x \Sigma \frac{G_{x+2}}{\alpha^{x+1}} - \beta^x \Sigma \frac{G_{x+2}}{\beta^{x+1}} \right),$$

where α and β are the roots of $t^2 - at - b^2 = 0$, and each Σ introduces a constant. Now if the constants be made equal, and the expression be written at length, we shall obtain the form derived above.

The expansion of the two terms within the parenthesis gives

$$G_{x+1} + \alpha G_x + \alpha^2 G_{x-1} + \dots + \alpha^{p+1} G_p + \dots + c\alpha^x$$

and

$$G_{x+1} + \beta G_x + \beta^2 G_{x-2} + \dots + \beta^{p+1} G_p + \dots + c\beta^x;$$

and if the difference of these be divided by $\alpha - \beta$, we get

$$G_x + \frac{\alpha^2 - \beta^2}{\alpha - \beta} G_{x-1} + \dots + \frac{\alpha^{p+1} - \beta^{p+1}}{\alpha - \beta} G_p + \dots + c \frac{\alpha^x - \beta^x}{\alpha - \beta},$$

which is the same in effect as the result which we have obtained.

Ex. 2. Let the equation be

$$u_x = xu_{x-1} + au_{x-2}.$$

Then

$$\begin{aligned} u_x &= c\Gamma(x+1) \left\{ 1 + a \Sigma^x \frac{1}{x(x+1)} + a^2 \Sigma^x \left(\frac{1}{x(x+1)} \Sigma^{x-1} \frac{1}{x(x+1)} \right) + \dots \right\} \\ &= c\Gamma(x+1) \left\{ 1 - a \frac{1}{x} + a^2 \frac{1}{(x-1)x} - \frac{a^3}{2.3} \frac{1}{(x-2)(x-1)x} + \dots \right\} \\ &= c \left\{ \Gamma(x+1) - a\Gamma x + \frac{a^2}{2} \Gamma(x-1) - \frac{a^3}{2.3} \Gamma(x-2) + \dots \right\}; \end{aligned}$$

which may be put under the form of the definite integral

$$u_x = c \int_0^\alpha \varepsilon^{-v - \frac{a}{v} v^x} dv.$$

If we add a second member G_x , the equation for determining M_p is

$$M_p = (x-p+1)M_{p-1} + aM_{p-2};$$

whence

$$\begin{aligned}
 M_p &= x \dots (x-p+1) \left\{ 1 + a \sum_1^p \frac{1}{(x-p+1)(x-p)} + a^2 \sum_3^p \left(\frac{1}{(x-p+1)(x-p)} \sum_1^{p-1} \frac{1}{(x-p+1)(x-p)} \right) + \dots \right\} \\
 &= x \dots (x-p+1) \left\{ 1 + a \left(\frac{1}{x-p+1} - \frac{1}{x} \right) \right. \\
 &\quad \left. + a^2 \left(\frac{1}{2} \left(\frac{1}{(x-p+2)(x-p+1)} - \frac{1}{(x-1)(x-2)} \right) - \frac{1}{x} \left(\frac{1}{x-p+1} - \frac{1}{x-2} \right) \right) + \dots \right\}
 \end{aligned}$$

from which the series for u_x can be expressed.

Ex. 3. Let the equation be

$$u_x = au_{x-1} + xu_{x-2}.$$

Then

$$\begin{aligned}
 u_x &= ca^x \left\{ 1 + \frac{1}{a^2} \sum^x (x+1) + \frac{1}{a^4} \sum^x ((x+1) \sum^{x-1} (x+1)) + \dots \right\} \\
 &= c \left\{ a^x + \frac{1}{2} x(x+1) a^{x-2} + \frac{1}{2.4} (x+1)x(x-1)(x-2) a^{x-4} + \frac{1}{2.4.6} (x+1)x \dots (x-4) a^{x-6} + \dots \right\}.
 \end{aligned}$$

Ex. 4. Let the equation be

$$u_x = \frac{n}{x} u_{x-1} + c^2 u_{x-2}.$$

Then

$$\begin{aligned}
 u_x &= \frac{n^x}{\Gamma(x+1)} \left\{ 1 + \frac{c^2}{x^2} \sum^x x(x+1) + \frac{c^4}{x^4} \sum^x (x(x+1) \sum^{x-1} x(x+1)) + \dots \right\} \\
 &= \frac{n^x}{\Gamma(x+1)} \left\{ 1 + \frac{c^2}{x^2} \frac{1}{3} (x-1)x(x+1) \right. \\
 &\quad \left. + \frac{c^4}{x^4} \left(\frac{1}{6} (x+1)x(x-1)(x-2)(x-3)(x-4) + \frac{3}{5} (x+1)x(x-1)(x-2)(x-3) \right) + \dots \right\}.
 \end{aligned}$$

Ex. 5. Let the equation be

$$u_x = P_x u_{x-1} + x P_x P_{x-1} u_{x-2} + G_x.$$

Here

$$\begin{aligned}
 q_x &= x, \quad N'_{x,p} = 1, \quad N''_{x,p} = \frac{x(x+1)}{2} - \frac{(p+1)(p+2)}{2}, \\
 N'''_{x,p} &= \frac{(x+1)x(x-1)(x-2)}{2.4} - \frac{(p+2)(p+1)}{2} \cdot \frac{(x+1)x}{2} + \frac{(p+4)(p+3)(p+2)(p+1)}{2.4}, \\
 N^{(iv)}_{x,p} &= \frac{(x+1)x(x-1)(x-2)(x-3)(x-4)}{2.4.6} - \frac{(p+2)(p+1)}{2} \cdot \frac{(x+1)x(x-1)(x-2)}{2.4} \\
 &\quad + \frac{(p+4)(p+3)(p+2)(p+1)}{2.4} \cdot \frac{(x+1)x}{2} - \frac{(p+6)(p+5)(p+4)(p+3)(p+2)(p+1)}{2.4.6}, \\
 N^{(m+2)}_{x,p} &= \frac{(x+1) \dots (x-2m)}{2.4 \dots (2m+2)} - \frac{(p+2)(p+1)}{2} \cdot \frac{(x+1) \dots (x-2m+2)}{2.4 \dots 2m} + \frac{(p+4) \dots (p+1)}{2.4} \cdot \frac{(x+1) \dots (x-2m+4)}{2.4 \dots (2m-2)} \\
 &\quad + \dots + \frac{(p+2m) \dots (p+1)}{2.4 \dots 2m} \cdot \frac{(x+1)x}{2} - \frac{(p+2m+2) \dots (p+1)}{2.4 \dots (2m+2)}.
 \end{aligned}$$

The particular solution, therefore, is

$$u_x = G_x + P_x G_{x-1} + (1+x)P_x P_{x-1} G_{x-2} + 2xP_x P_{x-1} P_{x-2} G_{x-3} + (x^2+x-2)(P_x \dots P_{x-3}) G_{x-4} \\ + (3x^2-5x-2)(P_x \dots P_{x-4}) G_{x-5} + (x^3-11x+6)(P_x \dots P_{x-5}) G_{x-6} + \dots;$$

and the part of the general solution found by this method is

$$u_x = c(P_x \dots P_0) \left(1 + \frac{(x+1)x}{2} + \frac{(x+1)\dots(x-2)}{2.4} + \frac{(x+1)\dots(x-4)}{2.4.6} + \dots \right).$$

Ex. 6. Let the equation be

$$u_x + a_1 P_x u_{x-1} + a_2 P_x P_{x-1} u_{x-2} + \dots + a_n (P_x \dots P_{x-n+1}) u_{x-n} = G_x;$$

then the equation for determining M_p is

$$M_p + a_1 P_{x-p+1} M_p + a_2 P_{x-p+1} P_{x-p+2} M_{p-2} + \dots + a_n (P_{x-p+1} \dots P_{x-p+n}) M_{p-n} = 0;$$

or making

$$P_{x-p+1} = P'_p,$$

$$M_p + a_1 P'_p M_{p-1} + a_2 P'_p P'_{p-1} M_{p-2} + \dots + a_n (P'_p \dots P'_{p-n+1}) M_{p-n} = 0;$$

the solution of which is evidently the solution of

$$M_p + a_1 M_{p-1} + a_2 M_{p-2} + \dots + a_n M_{p-n} = 0,$$

multiplied by $(P'_p \dots P'_1)$.

$$\text{Let } (t^n + a_1 t^{n-1} + a_2 t^{n-2} + \dots + a_n)^{-1} = \frac{A}{t-\alpha} + \frac{B}{t-\beta} + \dots,$$

then

$$M_p = (P'_p \dots P'_1) \{ c_1 A \alpha^{p+n} + c_2 B \beta^{p+n} + \dots \};$$

and taking the parts affected by each constant separately, it will be seen that the original equation reduces itself to a set of equations of the first order,

$$v_x - \alpha P_x v_{x-1} = \alpha^{n-1} A G_x,$$

$$v_x - \beta P_x v_{x-1} = \beta^{n-1} B G_x,$$

$$\begin{array}{ccc} \cdot & \cdot & \cdot \\ \cdot & \cdot & \cdot \\ \cdot & \cdot & \cdot \end{array}$$

so that its complete solution can be adequately represented.

Solution of Differential Equations in Series.

10. I now proceed to point out a method by which the processes above indicated may be made to give solutions of certain general forms of linear differential equations.

In a paper on Linear Differential Equations presented by me to the Royal Society, and which the Society has done me the honour to publish in the Philosophical Transactions (Part I. for 1848, p. 31), I have enunciated, and so far as is material to the present purpose, demonstrated the following theorem:—

That if, in a linear differential expression $\phi(x, D)u = X$ and its solution $u = \psi(x, D)X$, the letter x be changed into the operative symbol D and D into $-x$, we shall thus

obtain another linear differential expression $\varphi(D, -x)u = X$, the solution of which will be $u = \psi(D, -x)X$.

In the application of this theorem, care must be taken that the first-mentioned solution is so written that the operations included under the function ψ are not suppressed; and it must also be borne in mind that the expressions obtained by this interchange of symbols will not in all cases be obviously interpretable.

For applications of this singular analytical process I beg leave to refer to the memoir above cited, where it is employed for the solution, in finite terms, of extensive classes of linear differential equations, and equations in finite differences. So far as the process is legitimate, it is to be observed that it is founded on reasoning of a purely analytical character. It does not in any manner whatever flow from the calculus of operations, or depend for its validity upon the soundness of the logical basis on which this calculus rests.

Now it is a remarkable property of this mechanical interchange of symbols, that it instantaneously converts a linear equation in finite differences into a linear differential equation; so that wherever the former is soluble, the latter is soluble also, provided the result be intelligible, a condition always satisfied when the functions employed are rational algebraical functions.

As an instance worthy of notice, let us take the example last above given (*Ex. 6.*). Bearing in mind that $u_{x-n} = \varepsilon^{-nD}u_x$, the proposed interchange gives the equation (writing φx for P_x),

$$u + a_1\varphi(D)(\varepsilon^x u) + a_2\varphi(D)\varphi(D-1)(\varepsilon^{2x} u) + \dots + a_n\varphi(D)\dots\varphi(D-n+1)(\varepsilon^{nx} u) = G;$$

whose solution, therefore, depends upon that of

$$v - \alpha\varphi(D)(\varepsilon^x v) = \alpha^{n-1}AG,$$

a proposition established by MR. BOOLE by the methods of the Calculus of Operations.

I propose, therefore, now to employ this theorem of the interchange of symbols for the purpose of converting the forms of solution, above given, of equations in finite differences into the particular solutions of some general forms of differential equations; viz. those equations whose factors do not contain any irrational or transcendental functions of x , or contain them only in the form of series of ascending powers of x .

11. MR. BOGLE, in his *General Method in Analysis*, has shown that expressions of this character may be placed in the form

$$f_0(D)u + f_1(D)(\varepsilon^\theta u) + f_2(D)(\varepsilon^{2\theta} u) + \dots = U,$$

by changing the independent variable from x to its logarithm θ , and making use of the relation, (D being $\frac{d}{d\theta}$),

$$D(D-1)\dots(D-n+1)u = x^n \left(\frac{d}{dx}\right)^n u.$$

Making use of this relation, we immediately convert our equation, which we assume to be in the form

$$(a_n + b_n x + \dots + k_n x^{p-1} + l_n x^p + \dots) \frac{d^n u}{dx^n} + (a_{n-1} + b_{n-1} x + \dots + k_{n-1} x^{p-1} + l_{n-1} x^p + \dots) \frac{d^{n-1} u}{dx^{n-1}} + \dots + (a_0 + b_0 x + \dots + k_0 x^{p-1} + l_0 x^p + \dots) u = G,$$

into

$$\left. \begin{aligned} a_n(D \dots (D-n+1))u + & b_n((D-1) \dots (D-n))(\varepsilon^\theta u) + c_n((D-2) \dots (D-n-1))(\varepsilon^{2\theta} u) + \dots + l_n((D-p) \dots (D-n-p+1))(\varepsilon^{p\theta} u) + \dots \\ + a_{n-1}((D-1) \dots (D-n+1))(\varepsilon^\theta u) + & b_{n-1}((D-2) \dots (D-n))(\varepsilon^{2\theta} u) + \dots + k_{n-1}((D-p) \dots (D-n-p+2))(\varepsilon^{p\theta} u) + \dots \\ + a_{n-2}((D-2) \dots (D-n+1))(\varepsilon^{2\theta} u) + & \dots + k_{n-2}((D-p) \dots (D-n-p+3))(\varepsilon^{p\theta} u) + \dots \\ & + \dots \end{aligned} \right\} = \varepsilon^{n\theta} G.$$

or

$$a_n u + \left(\frac{b_n(D-n) + a_{n-1}}{D} \right) (\varepsilon^\theta u) + \left(\frac{c_n(D-n)(D-n-1) + b_{n-1}(D-n) + a_{n-2}}{D(D-1)} \right) (\varepsilon^{2\theta} u) + \left(\frac{d_n(D-n)(D-n-1)(D-n-2) + c_{n-1}(D-n)(D-n-1) + b_{n-2}(D-n) + a_{n-3}}{D(D-1)(D-2)} \right) (\varepsilon^{3\theta} u) + \dots = (D \dots (D-n+1))^{-1} G$$

Now if in this equation we change D into θ and θ into $-\theta$, we obtain the equation in finite differences (which suppose to be of the n th order),

$$a_n u_\theta + \frac{b_n(\theta-n) + a_{n-1}}{\theta} u_{\theta-1} + \frac{c_n(\theta-n)(\theta-n-1) + b_{n-1}(\theta-n) + a_{n-2}}{\theta(\theta-1)} u_{\theta-2} + \dots = (\theta(\theta-1) \dots (\theta-n+1))^{-1} G_{\theta-n},$$

or

$$u_\theta + \frac{f_1 \theta}{f_0 \theta} u_{\theta-1} + \frac{f_2 \theta}{f_0 \theta} u_{\theta-2} + \frac{f_3 \theta}{f_0 \theta} u_{\theta-3} + \dots = (f_0 \theta)^{-1} G_{\theta-n} = H_{\theta-n} \text{ (suppose);}$$

the solution of which, by section 8, is of the form

$$u_\theta = M_0 H_{\theta-n} + M_1 H_{\theta-n-1} + M_2 H_{\theta-n-2} + \dots + M_m H_{\theta-n-m} + \dots,$$

where $M_0 = 1,$

$$M_1 + \frac{f_1 \theta}{f_0 \theta} M_0 = 0,$$

$$M_2 + \frac{f_1(\theta-1)}{f_0(\theta-1)} M_1 + \frac{f_2 \theta}{f_0 \theta} M_0 = 0,$$

$$\vdots$$

$$M_m + \frac{f_1(\theta-m+1)}{f_0(\theta-m+1)} M_{m-1} + \frac{f_2(\theta-m+2)}{f_0(\theta-m+2)} M_{m-2} + \dots + \frac{f_r(\theta-m+r)}{f_0(\theta-m+r)} M_{m-r} = 0.$$

Restoring the symbols, and thereby converting $H_{\theta-n}$ into $(f_0(D))^{-1}(\varepsilon^{n\theta} G)$, which call H, we have

$$u = M_0 H + M_1(\varepsilon^\theta H) + M_2(\varepsilon^{2\theta} H) + \dots + M_m(\varepsilon^{m\theta} H) + \dots,$$

where $M_0, M_1 \dots$ denote a series of operations having the following significations and relations;—

$$M_0 = 1,$$

$$M_1 + \frac{f_1(D)}{f_0(D)} M_0 = 0,$$

$$M_2 + \frac{f_1(D-1)}{f_0(D-1)} M_1 + \frac{f_2(D)}{f_0(D)} M_0 = 0,$$

⋮

$$M_m + \frac{f_1(D-m+1)}{f_0(D-m+1)} M_{m-1} + \frac{f_2(D-m+2)}{f_0(D-m+2)} M_{m-2} + \dots + \frac{f_r(D-m+r)}{f_0(D-m+r)} M_{m-r} = 0;$$

or, by passing $\varepsilon^\theta, \varepsilon^{2\theta},$ &c. outside the operations by the equation

$$\varphi(D)(\varepsilon^{m\theta}H) = \varepsilon^{m\theta}\varphi(D+m)H,$$

$$u = M_0H + \varepsilon^\theta M_1H + \varepsilon^{2\theta} M_2H + \dots + \varepsilon^{m\theta} M_mH + \dots \quad (3.)$$

where the general law of relation is

$$M_m + \frac{f_1(D+1)}{f_0(D+1)} M_{m-1} + \frac{f_2(D+2)}{f_0(D+2)} M_{m-2} + \dots + \frac{f_r(D+r)}{f_0(D+r)} M_{m-r} = 0.$$

Now the expression $H,$ which is the subject of all the operations, contains n arbitrary constants, since $f_0(D)$ is of the n th order; that is, provided a_n is not zero.

Let $\beta_1 \beta_2 \dots \beta_n$ be the roots of $f_0t=0$; then the complete value of H is

$$(f_0(D))^{-1}(\varepsilon^{n\theta}G) + c_1\varepsilon^{\beta_1\theta} + c_2\varepsilon^{\beta_2\theta} + \dots + c_n\varepsilon^{\beta_n\theta};$$

of which the first term will give us the particular solution of the original equation, and each of the other terms a complementary solution. Bearing in mind the equation $\varphi(D)(\varepsilon^{p\theta}) = \varphi p \cdot \varepsilon^{p\theta},$ we see at once that the first complementary solution is

$$c_1\varepsilon^{\beta_1\theta}(A_0 + A_1\varepsilon^\theta + A_2\varepsilon^{2\theta} + \dots + A_m\varepsilon^{m\theta} + \dots),$$

or

$$c_1x^{\beta_1}(A_0 + A_1x + A_2x^2 + \dots + A_mx^m + \dots),$$

where $A_0=1,$ and the law of formation of the coefficients is

$$f_0(\beta_1+m)A_m + f_1(\beta_1+m)A_{m-1} + f_2(\beta_1+m)A_{m-2} + \dots + f_r(\beta_1+m)A_{m-r} = 0;$$

and the remaining complementary solutions merely require the substitution of $\beta_2 \dots \beta_n$ successively for $\beta_1,$ with new constants.

The reader will not fail to perceive the peculiarity of the series when a_n is unity, (which value it can always have when it is not zero); for in that case the roots of $f_0t=0$ are the natural numbers from 0 to $n-1$ inclusive, so that the series begin respectively with the terms 1, $x, x^2, \dots x^{n-1}.$

If a_n be zero, that is, if the factor of the highest differential coefficient of u do not contain an absolute term, then in order that the transformed equation may take the form (2.), it will be necessary to pass ε^θ outside the operative functions in each term, and divide by $\varepsilon^\theta.$ The initial function f_0t will then be of the form

$$b_n(t \dots (t-n+1)) + a_{n-1}(t \dots (t-n+2)),$$

and H will be

$$(f_0(D))^{-1}(\varepsilon^{(n-1)\theta}G).$$

Similarly, if in addition to a_n being zero, we have also b_n and a_{n-1} respectively equal to zero, it will be necessary to pass $\varepsilon^{2\theta}$ outside the operative functions, and divide by

$\varepsilon^{2\theta}$; and so on if other terms of the factors are wanting. Thus we can in all cases obtain the transformed equation in the required shape; but in all the cases where coefficients thus vanish, there is the important qualification that $f_0 t$ is no longer necessarily of the n th order; so that H does not necessarily contain the proper number of arbitrary constants. The consequences of this consideration will be afterwards developed; in the meantime we proceed to consider what modifications the series undergo where $f_0 t$ has two or more equal roots.

12. If there should be two roots of $f_0 t = 0$ equal to β_1 , one series will be deficient; and it will be supplied as follows. The expression H, or $(f_0(D))^{-1}(\varepsilon^{n\theta}G)$, contains in that case a term of the form $k_1 \theta \varepsilon^{\beta_1 \theta}$; and it is easily seen that

$$\varphi(D)(\theta \varepsilon^{\beta_1 \theta}) = \theta \varphi(D)(\varepsilon^{\beta_1 \theta}) + \varphi'(D)(\varepsilon^{\beta_1 \theta}).$$

The wanting series is, therefore,

$$k_1 x^{\beta_1} \{ \log x (1 + A_1 x + A_2 x^2 + \dots) + (A'_1 x + A'_2 x^2 + \dots) \},$$

where

$$A'_1 = \frac{dA_1}{d\beta_1} \text{ \&c.}$$

If there should be three roots of $f_0 t = 0$ equal to β_1 , two series will be deficient, one of which will be supplied as last mentioned; and the other by the introduction of the series

$$k_2 x^{\beta_1} \{ (\log x)^2 (1 + A_1 x + A_2 x^2 + \dots) + 2 \log x (A'_1 x + A'_2 x^2 + \dots) + (A''_1 x + A''_2 x^2 + \dots) \},$$

where $A''_1 = \frac{d^2 A_1}{d\beta_1^2}$ &c.; for we have a term $k_2 \theta^2 \varepsilon^{\beta_1 \theta}$; and it is easily seen that

$$\varphi(D)(\theta^2 \varepsilon^{\beta_1 \theta}) = \theta^2 \varphi(D) \varepsilon^{\beta_1 \theta} + 2\theta \varphi'(D) \varepsilon^{\beta_1 \theta} + \varphi''(D) \varepsilon^{\beta_1 \theta}.$$

And generally since, where there are $p+1$ equal roots β_1 , we have terms

$$c_1 \varepsilon^{\beta_1 \theta} + k_1 \theta \varepsilon^{\beta_1 \theta} + k_2 \theta^2 \varepsilon^{\beta_1 \theta} + \dots + k_p \theta^p \varepsilon^{\beta_1 \theta};$$

and since

$$\varphi(D)(\theta^p \varepsilon^{\beta_1 \theta}) = \theta^p \varphi(D) \varepsilon^{\beta_1 \theta} + p \theta^{p-1} \varphi'(D) \varepsilon^{\beta_1 \theta} + p \frac{p-1}{2} \theta^{p-2} \varphi''(D) \varepsilon^{\beta_1 \theta} + \dots;$$

the deficient series will be supplied by the following, taken with a different constant for every value of p from unity upwards:

$$k_p x^{\beta_1} \left\{ (\log x)^p (1 + A_1 x + A_2 x^2 + \dots) + p (\log x)^{p-1} (A'_1 x + A_2 x^2 + \dots) \right. \\ \left. + p \frac{p-1}{2} (\log x)^{p-2} (A''_1 x + A_2 x^2 + \dots) + \dots + p \log x (A_1^{(p-1)} x + A_2^{(p-1)} x^2 + \dots) + (A_1^{(p)} x + A_2^{(p)} x^2 + \dots) \right\}.$$

As a matter of convenience, when the equal roots are zero, a temporary nominal value should be given to them for the purpose of differentiating A_1 , &c.

13. Hitherto we have attended especially to the complementary solutions, or in other words, regarded G as zero. The operations, however, indicated in (3.) may be readily performed when G is a rational function of x ; which we will suppose to be

cleared of fractions, and so cleared to consist of a set of terms $\alpha_p x^p$. Then for this term $(f_0(D))^{-1}(\varepsilon^{n\theta} G) = \alpha_p (f_0(D))^{-1} \varepsilon^{(n+p)\theta} = \alpha_p (f_0(n+p))^{-1} \varepsilon^{(n+p)\theta}$; and we have, as before,

$$u = \alpha_p x^{(n+p)} (B_0 + B_1 x + B_2 x^2 + \dots + B_m x^m + \dots),$$

where $B_0 = 1$, and the law of formation is

$$f_0(n+p+m)B_m + f_1(n+p+m)B_{m-1} + f_2(n+p+m)B_{m-2} + \dots = 0;$$

and the whole solution is found by taking all the values of p . This will undergo a slight alteration, as the incipient term will be of the form $f_0(D)(\varepsilon^{(n-r)\theta} G)$, where r factors of (2.) vanish by reason of some of the constant coefficients a_n , &c. being zero.

In like manner it would be easy to represent the series if G contained $\log x$ and its powers; but for most other forms it would be necessary to expand G in order to represent the series explicitly. The solution however is theoretically complete, since it consists solely in the performance of operations which are known explicit functions of D .

14. Before proceeding further with the main subject, I shall illustrate this process by a few examples.

Ex. 1. Let the equation be

$$(1 + b_2 x + c_2 x^2) \frac{d^2 u}{dx^2} + (a_1 + b_1 x) \frac{du}{dx} + a_0 u = G.$$

Referring to (2.), we have

$$f_0 D = D(D-1), \quad f_1 D = b_2(D-1)(D-2) + a_1(D-1),$$

$$f_2(D) = c_2(D-2)(D-3) + b_1(D-2) + a_0;$$

roots of $f_0 t = 0$ are 0 and 1.

First complementary series,

$$c_1(A_0 + A_1 x + A_2 x^2 + \dots + A_m x^m + \dots),$$

where

$A_0 = 1$, and $m(m-1)A_m + (b_2(m-1)(m-2) + a_1(m-1))A_{m-1} + (c_2(m-2)(m-3) + b_1(m-2) + a_0)A_{m-2} = 0$ is the law of formation.

Second complementary series,

$$c_2 x (A_0 + A_1 x + A_2 x^2 + \dots + A_m x^m + \dots),$$

where

$A_0 = 1$, and $(m+1)mA_m + (b_2(m)(m-1) + a_1 m)A_{m-1} + (c_2(m-1)(m-2) + b_1(m-1) + a_0)A_{m-2} = 0$ is the law of formation.

Particular solution,

$$u = \psi_0(D)H + \varepsilon^\theta \psi_1(D)H + \varepsilon^{2\theta} \psi_2(D)H + \dots + \varepsilon^{m\theta} \psi_m(D)H + \dots,$$

where

$H = \left(\frac{d}{dx}\right)^{-2} G$, $\psi_0(D) = 1$, and $f_0(D+m)\psi_m(D) + f_1(D+m)\psi_{(m-1)}(D) + f_2(D+m)\psi_{(m-2)}(D) = 0$

is the law of the formation of the operative functions.

The three laws of formation, which are here written down at length, are in substance the same; for from the last the others are made by merely writing the roots successively in lieu of D in the factors.

Ex. 2. Let the equation be

$$(x^2 + qx^4) \frac{d^2u}{dx^2} + (x + px^2 + 5qx^3) \frac{du}{dx} + (px - n^2 + (4q + r)x^2)u = G.$$

Referring to (2.), we have in the first instance,

$$((D-2)^2 - n^2)(\varepsilon^{2\theta}u) + p(D-2)(\varepsilon^{3\theta}u) + (q(D-4)D + 4q + r)\varepsilon^{4\theta}u = G,$$

whence

$$(D^2 - n^2)u + pD(\varepsilon^\theta u) + (qD^2 + r)(\varepsilon^{2\theta}u) = \varepsilon^{-2\theta}G;$$

roots of $f_0t=0$ are n and $-n$.

First complementary series,

$$c_1x^n(A_0 + A_1x + A_2x^2 + \dots + A_mx^m + \dots),$$

where

$$A_0 = 1, \text{ and } ((n+m)^2 - n^2)A_m + p(n+m)A_{m-1} + (q(n+m)^2 + r)A_{m-2} = 0$$

is the law of formation.

Second complementary series,

$$c_2x^{-n}(A_0 + A_1x + A_2x^2 + \dots + A_mx^m + \dots),$$

where the law is, as before, changing the sign of n .

Particular solution,

$$u = \psi_0(D)H + \varepsilon^\theta \psi_1(D)H + \dots + \varepsilon^{m\theta} \psi_m(D)H + \dots,$$

where

$$H = (D^2 - n^2)^{-1}(\varepsilon^{-2\theta}G), \quad \psi_0(D) = 1,$$

and

$$((D+m)^2 - n^2)\psi_m(D) + p(D+m)\psi_{m-1}(D) + (q(D+m)^2 + r)\psi_{m-2}(D) = 0$$

is the law of the formation of the operative functions.

If $p=0$, $q=0$, and $r=1$, so that the equation becomes

$$x^2 \frac{d^2u}{dx^2} + x \frac{du}{dx} + (x^2 - n^2)u = 0,$$

the law is

$$A_m = -\frac{A_{m-2}}{m(2n+m)},$$

whence

$$u = c_1x^n \left\{ 1 - \frac{1}{4}(1+n)^{-1}x^2 + \frac{1}{4.8}(1+n)^{-1}(2+n)^{-1}x^4 - \frac{1}{4.8.12}(1+n)^{-1}(2+n)^{-1}(3+n)^{-1}x^6 + \dots \right\},$$

$$+ c_2x^{-n} \left\{ 1 - \frac{1}{4}(1-n)^{-1}x^2 + \frac{1}{4.8}(1-n)^{-1}(2-n)^{-1}x^4 - \frac{1}{4.8.12}(1-n)^{-1}(2-n)^{-1}(3-n)^{-1}x^6 + \dots \right\}.$$

Ex. 3. Let the equation be

$$x^3 \frac{d^3u}{dx^3} + 3x^2 \frac{d^2u}{dx^2} + x \frac{du}{dx} + qx^n u = G.$$

Referring to (2.), we have

$$\begin{aligned} D^3u + q\varepsilon^{n\theta}u &= G; \\ f_0(D) &= D^3; \text{ three roots equal to zero;} \\ f_n(D) &= q; \\ m^3A_m + qA_{m-n} &= 0, \text{ law of formation.} \end{aligned}$$

Hence the complementary series are,

$$\begin{aligned} u &= c_1 \left\{ 1 - \frac{q}{n^3}x^n + \frac{q}{n^3} \frac{q}{(2n)^3}x^{2n} - \frac{q}{n^3} \frac{q}{(2n)^3} \frac{q}{(3n)^3}x^{3n} + \dots \right\} \\ &+ c_2 \left\{ \log x \left(1 - \frac{q}{n^3}x^n + \frac{q}{n^3} \frac{q}{(2n)^3}x^{2n} - \frac{q}{n^3} \frac{q}{(2n)^3} \frac{q}{(3n)^3}x^{3n} + \dots \right) \right. \\ &\quad \left. + 3 \left(\frac{1}{n} \frac{q}{n^3}x^n - \left(\frac{1}{n} + \frac{1}{2n} \right) \frac{q}{n^3} \frac{q}{(2n)^3}x^{2n} + \left(\frac{1}{n} + \frac{1}{2n} + \frac{1}{3n} \right) \frac{q}{n^3} \frac{q}{(2n)^3} \frac{q}{(3n)^3}x^{3n} + \dots \right) \right\} \\ &+ c_3 \left\{ (\log x)^2 \left(1 - \frac{q}{n^3}x^n + \frac{q}{n^3} \frac{q}{(2n)^3}x^{2n} - \frac{q}{n^3} \frac{q}{(2n)^3} \frac{q}{(3n)^3}x^{3n} + \dots \right) \right. \\ &\quad + 6 \log x \left(\frac{1}{n} \frac{q}{n^3}x^n - \left(\frac{1}{n} + \frac{1}{2n} \right) \frac{q}{n^3} \frac{q}{(2n)^3}x^{2n} + \left(\frac{1}{n} + \frac{1}{2n} + \frac{1}{3n} \right) \frac{q}{n^3} \frac{q}{(2n)^3} \frac{q}{(3n)^3}x^{3n} + \dots \right) \\ &\quad + 6 \left(-\frac{2}{n^2} \frac{q}{n^3}x^n + \left(\frac{2}{n^2} + \frac{2}{(2n)^2} + \frac{3}{n(2n)} \right) \frac{q}{n^3} \frac{q}{(2n)^3}x^{2n} \right. \\ &\quad \left. - \left(\frac{2}{n^2} + \frac{2}{(2n)^2} + \frac{2}{(3n)^2} + \frac{3}{n(2n)} + \frac{3}{n(3n)} + \frac{3}{(2n)(3n)} \right) \frac{q}{n^3} \frac{q}{(2n)^3} \frac{q}{(3n)^3}x^{3n} + \dots \right) \left. \right\}; \end{aligned}$$

and the particular solution is

$$u = H - qx^n(D+n)^{-3}H + q^2x^{2n}(D+n)^{-3}(D+2n)^{-3}H - \dots,$$

H being $D^{-3}(\varepsilon^{3\theta}G)$.

15. The completeness of the preceding forms of solution depends, as above intimated, upon the circumstance that the function $f_0(D)$ is of an order not lower than the order of the original equation. It may however be of a lower order, as would take place in the first of the examples above given, if a_2 instead of being 1 were zero and b_2 were also zero.

Let the equation then be (*Ex. 4.*),

$$c_2x^2 \frac{d^2u}{dx^2} + (1 + b_1x) \frac{du}{dx} + a_0u = G.$$

Referring to (2.), we have, in the first instance,

$$(D-1)(\varepsilon^\theta u) + (c_2(D-2)(D-3) + b_1(D-2) + a_0)(\varepsilon^{2\theta}u) = G,$$

or

$$Du + (c_2(D-1)(D-2) + b_1(D-1) + a_0)(\varepsilon^\theta u) = \varepsilon^{-\theta}G;$$

so that $f_0(D)$ is of the first order, and the root is zero.

The only complementary function to be obtained is therefore

$$u = c_1 \left\{ 1 - a_0 x + \frac{1}{2} a_0 (b_1 + a_0) x^2 - \frac{1}{2.3} a_0 (b_1 + a_0) (1.2c_2 + 2b_1 + a_0) x^3 \right. \\ \left. + \frac{1}{2.3.4} a_0 (b_1 + a_0) (1.2c_2 + 2b_1 + a_0) (2.3c_2 + 3b_1 + a_0) x^4 - \dots \right\},$$

a series which is divergent, but which, as will also be seen afterwards, is finite when the constant coefficients are connected by the formula $(p-1)pc_2 + pb_1 + a_0 = 0$, p being any positive integer.

Further, it may happen that the series obtained by the process, even when they afford a complete solution in respect of the number of constants, are divergent for all or for some values of x . This may evidently be the case in the solution of the second of the examples above given; for the law of the coefficients, as we advance in the series, approximates to $A_m = -qA_{m-2}$.

In these cases, other solutions in series may be obtained by resolving the equation in finite differences in a series of terms of the form $H_{\theta+p}$ instead of $H_{\theta-p}$. In order to effect this, all that is necessary is to write $\theta+r$ for θ , (r being the order of the equation in finite differences), and to divide by the factor of the last term instead of the factor of the first term; or in other words, we must pass $\varepsilon^{r\theta}$ outside the functions in (2.), and multiply by $\varepsilon^{-r\theta}$; so that this equation now assumes the form

$$f_r(D)u + f_{r-1}(D)(\varepsilon^{-\theta}u) + f_{r-2}(D)(\varepsilon^{-2\theta}u) + \dots = \varepsilon^{(n-r)\theta}G;$$

and the equation in finite differences is

$$f_r(\theta)u_\theta + f_{r-1}(\theta)u_{\theta+1} + f_{r-2}(\theta)u_{\theta+2} + \dots = G_{\theta+r-n}.$$

We have now to inquire for the roots of $f_r t = 0$; the incipient term is $(f_r(D))^{-1}(\varepsilon^{(n-r)\theta}G)$, which call H_1 ; and the particular solution will be found to be

$$u = \psi_0(D)H_1 + \varepsilon^{-\theta}\psi_1(D)H_1 + \varepsilon^{-2\theta}\psi_2(D)H_1 + \dots + \varepsilon^{-m\theta}\psi_m(D)H_1 + \dots,$$

where

$$\psi_0(D) = 1, \text{ and } f_r(D-m)\psi_m(D) + f_{r-1}(D-m)\psi_{m-1}(D) + \dots = 0$$

is the law of the formation of the operative functions.

The substitution of the roots of $f_r t$ successively for D gives the law of formation of the complementary series.

Taking the last example, the transformed equation now becomes

$$(c_2 D(D-1) + b_1 D + a_0)u + (D+1)(\varepsilon^{-\theta}u) = \varepsilon^{-2\theta}G.$$

Let the roots of $f_r t$ or $c_2 t(t-1) + b_1 t + a_0 = 0$, be β_1 and β_2 .

The first complementary series is

$$c_1 x^{\beta_1} (A_0 + A_1 x^{-1} + \dots + A_m x^{-m} + \dots),$$

where $A_0=1$, and $f_r(\beta_1 - m)A_m + (\beta_1 - m + 1)A_{m-1} = 0$ is the law of formation ; the series then are

$$c_1 \left\{ x^{\beta_1} - \frac{\beta_1}{f_r(\beta_1-1)} x^{\beta_1-1} + \frac{\beta_1}{f_r(\beta_1-1)} \frac{\beta_1-1}{f_r(\beta_1-2)} x^{\beta_1-2} - \frac{\beta_1}{f_r(\beta_1-1)} \frac{\beta_1-1}{f_r(\beta_1-2)} \frac{\beta_1-2}{f_r(\beta_1-3)} x^{\beta_1-3} + \dots \right\}$$

+ c_2 { similar function of β_2 } ,

which is, (since $f_r(\beta_1 - n) = n(n+1)c_2 - 2n\beta_1 - nb_1$),

$$c_1 \left\{ x^{\beta_1} - \frac{\beta_1}{2c_2 - 2\beta_1 - b_1} x^{\beta_1-1} + \frac{\beta_1}{2c_2 - 2\beta_1 - b_1} \frac{\beta_1-1}{2.3c_2 - 4\beta_1 - 2b_1} x^{\beta_1-2} - \frac{\beta_1}{2c_2 - 2\beta_1 - b_1} \frac{\beta_1-1}{2.3c_2 - 4\beta_1 - 2b_1} \frac{\beta_1-2}{3.4c_2 - 6\beta_1 - 3b_1} x^{\beta_1-3} + \dots \right\}$$

+ c_2 { similar function of β_2 } .

When β_1 or β_2 is a positive integer, one of these series is terminable ; and if both are positive integers, the series derived from the smaller root is terminable, and the other gives no result, the coefficients becoming infinite. The first of the series will then be found to give the same result as that produced from the divergent series (which is evidently terminable in form in the case indicated), except that it begins at the other end. In this case the other complementary solution can be found in finite terms by reducing the order of the equation.

The particular solution is

$$u = H_1 - x^{-1} \frac{D}{f_r(D-1)} H_1 + x^{-2} \frac{D}{f_r(D-1)} \frac{D-1}{f_r(D-2)} H_1 - \dots,$$

H_1 being $(f_r(D))^{-1}(\varepsilon^{-2\theta}G)$.

Let us now return to example 2, the solution of which, as above found, is in some cases divergent.

The transformed equation now becomes

$$(q(D+2)^2 + r)u + p(D+2)(\varepsilon^{-\theta}u) + ((D+2)^2 - r^2)(\varepsilon^{-2\theta}u) = \varepsilon^{-4\theta}G.$$

Roots of $f_r t = 0$ are $-2 \pm \sqrt{\left(\frac{r}{q}\right)}$, which call β_1 and β_2 .

First complementary series,

$$c_1 x^{\beta_1} \left(A_0 + \frac{A_1}{x} + \frac{A_2}{x^2} + \dots + \frac{A_m}{x^m} + \dots \right),$$

where

$$A_0 = 1, \text{ and } (q(\beta_1 - m + 2)^2 + r)A_m + p(\beta_1 - m + 2)A_{m-1} + ((\beta_1 - m + 2)^2 - r^2)A_{m-2} = 0,$$

is the law of formation ; and the second complementary series is the same, using the other root with a different constant.

In like manner the particular solution is easily represented.

16. We are now in a position to discuss the character of the various series obtained by this process with reference to their convergency or divergency, a subject of the highest importance to the value of the process. The investigations which follow, will, it is apprehended, be found to afford a complete test of the nature of the series.

In general, it will of course be understood that these researches, as to convergency and divergency, relate only to the complementary series, or in other words, to equations deprived of their second member; nevertheless they will to a great extent, if not throughout, apply to cases in which the second member is in the form of integer powers of x or of $\log x$.

1st. When in the set of functions

$$f_0(D), f_1(D), f_2(D), \dots, f_{r-1}(D), f_r(D),$$

the function $f_0(D)$ is of a higher dimension with regard to D than any other of the set, or is what we shall here call the dominant function, the solution of the equation can always be found in a *convergent* series of ascending powers of x ; and if in such a case we solve the equation in a series of descending powers of x , which we can do if we please, that series is certainly divergent.

This is immediately apparent from the consideration of the law of the coefficients

$$f_0(\beta_1 + m)A_m + f_1(\beta_1 + m)A_{m-1} + \dots + f_r(\beta_1 + m)A_{m-r} = 0;$$

which, as m increases without limit, approaches to the form

$$A_m = -\frac{f_1^m}{f_0^m}A_{m-1} - \frac{f_2^m}{f_0^m}A_{m-2} - \dots - \frac{f_r^m}{f_0^m}A_{m-r}, \text{ or } mA_m = -a_{n-1}A_{m-1} - b_{n-1}A_{m-2} - \dots,$$

assuming that all the functions are only one degree lower than A_m , which is the least favourable case for convergency. Therefore, if the largest of the terms of the right-hand side of this equation be $l_{n-1}A_{m-p}$, we have

$$A_m < \frac{r l_{n-1}}{m} A_{m-p};$$

and we can therefore arrive at a point in the series at which the ratio of the coefficient of x^m to that of x^{m-p} diminishes without limit.

It will also be observed that the series introduced by two or more equal roots are of the same character as the original series from which they are derived; for, A_m being of the form $\varphi(\beta_1 + m)$, we have $\frac{dA_m}{d\beta_1} = \frac{dA_m}{dm}$; and when A_{m-p} is of a higher order with reference to m than A_m , $\frac{dA_{m-p}}{dm}$ is also of a higher order than $\frac{dA_m}{dm}$, and so for the other differential coefficients.

We have now merely to inquire what must be the form of the original equation that $f_0(D)$ may be the dominant function. Referring to (2.), we see that it is necessary that the factor of the highest differential coefficient of u should contain one term only. If this factor be 1 or x , no restriction need be imposed on the succeeding factors. If it be x^2 , the factor of the next lower differential coefficient must not contain an absolute term; and generally, if x^p be the factor of $\frac{d^n u}{dx^n}$, the factor of $\frac{d^{n-1} u}{dx^{n-1}}$ must begin with a term not lower than x^{p-1} , that of $\frac{d^{n-2} u}{dx^{n-2}}$ with a term not lower than x^{p-2} , and so on.

In short, all equations where x does not enter into the factor of $\frac{d^n u}{dx^n}$, and all equations of the form

$$x^p \frac{d^n u}{dx^n} + (k_n x^{p-1} + l_n x^p + \dots) \frac{d^{n-1} u}{dx^{n-1}} + (h_n x^{p-2} + \dots) \frac{d^{n-2} u}{dx^{n-2}} + \dots = 0,$$

where p is a positive integer, are soluble in *convergent* series of *ascending* powers of x . The third example above given is an instance of this form.

2ndly. When in the set of functions

$$f_r(\mathbf{D}), f_{r-1}(\mathbf{D}), \dots, f_1(\mathbf{D}), f_0(\mathbf{D}),$$

the function $f_r(\mathbf{D})$ is the dominant function, the solution of the equation can always be found in a *convergent* series of descending powers of x ; and if in such a case we solve the equation in a series of ascending powers of x , that series is certainly divergent.

This is apparent, as before, from the consideration of the law of the coefficients,

$$f_r(\beta_1 - m)A_m + f_{r-1}(\beta_1 - m)A_{m-1} + \dots + f_0(\beta_1 - m)A_{m-r} = 0,$$

which, as m increases without limit, approaches to

$$mA_m = h_{n-1}A_{m-1} - k_{n-1}A_{m-2} + \dots$$

in the least favourable case for convergency.

On proceeding to inquire what must be the form of the original equation, we see again that it is necessary that the factor of the highest differential coefficient of u should contain one term only. If this be x^p , then the other restrictions are, that the factor of the next differential coefficient must stop at x^{p-1} , that of the next at x^{p-2} , and so on.

In short, for all integer values of p the equation

$$x^p \frac{d^n u}{dx^n} + (a_{n-1} + b_{n-1}x + \dots + k_n x^{p-1}) \frac{d^{n-1} u}{dx^{n-1}} + (a_{n-2} + b_{n-2}x + \dots + h_{n-2} x^{p-2}) \frac{d^{n-2} u}{dx^{n-2}} + \dots = 0$$

is soluble in a *convergent* series of *descending* powers of x . The 4th example above given is an instance of this form.

3rdly. When in the set of functions

$$f_0(\mathbf{D}), f_1(\mathbf{D}), \dots, f_{r-1}(\mathbf{D}), f_r(\mathbf{D}),$$

the functions $f_0(\mathbf{D})$ and $f_r(\mathbf{D})$ are of the same dimensions, and are both dominant over all the other functions, the solution of the equation can be found in a series of ascending powers of x , which for some values of x is convergent, and for other values of x is divergent; and the solution can also be found in a series of descending powers of x which is divergent for all values of x for which the other series is convergent, and convergent for all values of x for which the other series is divergent.

For in the ascending series the law of the coefficients approaches the form, (the

coefficient of the highest power of m in $f_0 m$ being 1, and that in $f_r m$ being l_n ,

$$A_m = -l_n A_{m-r},$$

and in the descending series the law approaches to

$$l_n A_m = \pm A_{m-r}.$$

The former series is therefore convergent for all values of x numerically less than $(l_n)^{-\frac{1}{r}}$, and divergent for all values of x numerically greater than this limit; and the latter series is divergent for all values of x numerically greater than this quantity, and divergent for all values of x numerically less.

The equations to which this rule is applicable are of the forms, (p' being less than p),

$$(x^{p'} + l_n x^p) \frac{d^p u}{dx^p} + (h'_{n-1} x^{p'-1} + \dots + k_{n-1} x^{p-1}) \frac{d^{p-1} u}{dx^{p-1}} + (g_{n-2} x^{p'-2} + \dots + h_{n-2} x^{p-2}) \frac{d^{p-2} u}{dx^{p-2}} + \dots = 0,$$

and

$$(a_n + l_n x^p) \frac{d^p u}{dx^p} + (a_{n-1} + b_{n-1} x + \dots + k_{n-1} x^{p-1}) \frac{d^{p-1} u}{dx^{p-1}} + (a_{n-2} + \dots + h_{n-2} x^{p-2}) \frac{d^{p-2} u}{dx^{p-2}} + \dots = 0.$$

The second example above given is an instance of the first of these forms.

4thly. When in the set of functions

$$f_0(D), f_1(D), \dots, f_{r-1}(D), f_r(D),$$

one or more of the intermediate functions is or are of the same order as the extreme functions $f_0(D)$ and $f_r(D)$, or as the highest of these two when they differ in dimensions, the series obtained by the above processes will be divergent for some values of x , and we have not as yet any method of deriving a convergent series corresponding to these values; and if one or more of the intermediate functions be of a higher dimension than the extreme functions, the series obtained by the above processes will certainly be divergent.

These remaining cases therefore sever into two species; first, where some of the intermediate functions are of the same order as the highest of the extreme functions; secondly, where one or more of the intermediate functions are dominant.

The first of these species includes equations of the two following forms:—

$$(a_n x^{p'} + b_n x^{p'+1} + \dots + l_n x^p) \frac{d^p u}{dx^p} + (a_{n-1} x^{p'-1} + b_{n-1} x^{p'} + \dots) \frac{d^{p-1} u}{dx^{p-1}} + \dots + (a_0 x^{p'-n} + \dots) u = 0,$$

in which there can be no function higher than $f_0(D)$; and

$$(a_n + b_n x + \dots + l_n x^p) \frac{d^p u}{dx^p} + (a_{n-1} + b_{n-1} x + \dots + k_{n-1} x^{p-1}) \frac{d^{p-1} u}{dx^{p-1}} + \dots = 0,$$

in which there can be no function higher than $f_r(D)$.

In these cases it will easily be seen that the law of the coefficients of the ascending series, as m increases without limit, approximates to

$$a_n A_m + b_n A_{m-1} + \dots + l_n A_{m-p} = 0,$$

and the series therefore approaches without limit to a recurring series, in which the constants of relation are

$$-\frac{b_n}{a_n}x, -\frac{c_n}{a_n}x^2, \dots -\frac{l_n}{a_n}x^p;$$

and the denominator of the rational fraction, to which the residue of the series approaches, is

$$\frac{1}{a_n}(a_n + b_nx + \dots + l_nx^p).$$

In the descending series, the law of the coefficients approximates to

$$l_nA_m + k_nA_{m-1} + \dots + a_nA_{m-p} = 0,$$

and the series approaches without limit to a recurring series, in which the constants of relation are

$$-\frac{k_n}{l_n}\frac{1}{x}, \dots -\frac{b_n}{l_n}\frac{1}{x^{p-1}}, -\frac{a_n}{l_n}\frac{1}{x^p};$$

and the denominator of the rational fraction, to which the residue of the series approaches, is

$$\frac{1}{l_nx^p}(a_n + b_nx + \dots + l_nx^p).$$

When $f_0(D)$ is higher than $f_r(D)$, the ascending series alone can be used; when $f_r(D)$ is higher than $f_0(D)$, the descending series alone can be used; and when $f_0(D)$ and $f_r(D)$ are of the same dimension, either may be used; and the approximations above referred to render it probable that these series, notwithstanding that they may be divergent, are the developments of continuous algebraical expressions.

The second of the species above referred to includes all equations which are excluded from the preceding forms; that is, all forms which transgress *both* the restrictions to which the equation in the third case is subjected.

Of these forms, the solutions, whether obtained in ascending or in descending series, are always divergent; and the divergency appears to be of an extreme and unmanageable character. In this case we have an intermediate dominant function; and the convergent solutions might, from considerations of analogy, be presumed to be series infinite in both directions, the roots of the dominant function determining the incipient terms.

The treatment of these forms requires the solution of the equation in finite differences

$$\dots + R'_x u_{x+3} + Q'_x u_{x+2} + P'_x u_{x+1} + u_x + P_x u_{x-1} + Q_x u_{x-2} + R_x u_{x-3} + \dots = G_x,$$

not starting from either of the two extreme terms, as is done above, but from the term u_x , so as to get a result in the form

$$u_x = \dots + M_{-2}G_{x+2} + M_{-1}G_{x+1} + M_0G_x + M_1G_{x-1} + M_2G_{x-2} + \dots$$

It would probably not be difficult to show that such a solution exists; but I have not found one in a form available for the purpose to which it is desired to be applied.

17. Throughout the preceding investigations, the series obtained by the processes here displayed undergo a modification of form in the event of the expression $f_0 t$ or $f_1 t$, as the case may be, having one or more sets of imaginary roots.

Let there be a couple of such roots of the form $\alpha \pm \beta \sqrt{-1}$. In the ascending series these roots give

$$c_1 x^{\alpha + \beta \sqrt{-1}} (A_0 + A_1 x + A_2 x^2 + \dots + A_m x^m + \dots) \\ c_2 x^{\alpha - \beta \sqrt{-1}} (B_0 + B_1 x + B_2 x^2 + \dots + B_m x^m + \dots),$$

where

$$f_0(\alpha + m + \beta \sqrt{-1}) A_m + f_1(\alpha + m + \beta \sqrt{-1}) A_{m-1} + \dots = 0$$

and

$$f_0(\alpha + m - \beta \sqrt{-1}) B_m + f_1(\alpha + m - \beta \sqrt{-1}) B_{m-1} + \dots = 0$$

are the respective laws of formation.

It is apparent, therefore, that if A_m be of the form $\varphi(\alpha + \beta \sqrt{-1})$, B_m is of the form $\varphi(\alpha - \beta \sqrt{-1})$.

Making $c_2 = c_1$, and remembering that

$$x^{\beta \sqrt{-1}} + x^{-\beta \sqrt{-1}} = 2 \cos(\beta \log x) \\ x^{\beta \sqrt{-1}} - x^{-\beta \sqrt{-1}} = 2 \sqrt{-1} \sin(\beta \log x),$$

the sum of the two series gives the double series,

$$2c_1 x^\alpha (\cos(\beta \log x) \{A_0 + B_0 + (A_1 + B_1)x + \dots + (A_m + B_m)x^m + \dots\} \\ + \sqrt{-1} \sin(\beta \log x) \{A_0 - B_0 + (A_1 - B_1)x + \dots + (A_m - B_m)x^m + \dots\});$$

which is necessarily real, since $A_m + B_m$ is purely real, and $A_m - B_m$ is purely imaginary.

Making now $c_1 = -c_2$, the sum of the two series gives another double series, (making $c_2 = -k \sqrt{-1}$),

$$2kx^\alpha (\sqrt{-1} \cos(\beta \log x) \{A_0 - B_0 + (A_1 - B_1)x + \dots + (A_m - B_m)x^m + \dots\} \\ + \sin(\beta \log x) \{A_0 + B_0 + (A_1 + B_1)x + \dots + (A_m + B_m)x^m + \dots\}),$$

which is likewise real.

The descending series may be treated in a similar manner.

18. Most of the examples to which the preceding processes are applied have been taken from the paper in the Philosophical Transactions for 1844, in which Mr. BOOLE developed his new General Method in Analysis, with which the subject matter of the present paper is closely connected, though the methods exhibited are distinct; unless indeed it should prove, that the interchange of the symbol of operation and the independent variable, and the general relation exhibited by Mr. BOOLE's fundamental theorem of development connecting any system of linear differential equations with a corresponding system of equations in finite differences, are merely different representations of a part of some more general method or process.

The principal difference in results, so far as concerns the solution in series of linear differential equations, appears to be, that in this paper the law of relation of the

coefficients of each series is distinct, and substantially the same in form for all; and that it is not necessary to have recourse to the method of parameters in the cases of equal roots, or in the case of there being a term G on the right-hand side of the equation. In the case of imaginary roots, the laws of the series are in the first instance distinct from each other, and afterwards combined in couples.

19. The investigations contained in the latter part of this paper reduce the problem of the integration in finite terms of the general linear differential equation with rational coefficients, to the finding of an algebraical expression representing the development

$$A_0 + A_1x + A_2x^2 + \dots + A_mx^m + \dots,$$

where $A_0=1$, and the law of relation is

$$f_0mA_m + f_1mA_{m-1} + f_2mA_{m-2} + \dots + f_rmA_{m-r} = 0;$$

the functions $f_0f_1f_2\dots f_r$ being known specific functions. The series to be summed closely resembles a recurring series; it differs from it in this particular, that the law of relation, instead of being constant, has a uniform and simple variation as it progresses along the series. If the rational coefficients should be themselves infinite series, the process still applies, the only difference being that each term would be formed from all the preceding terms, instead of being formed from the r immediately preceding terms, or from all the preceding terms when the number of them is less than r .

In those cases in which the equation is soluble in finite terms by known methods, we are enabled to assign the algebraical expression for the series; a result which may be used for the discovery of generating functions.

Thus, taking the general equation of the first order,

$$(a_1 + b_1x + c_1x^2 + \dots + l_1x^n) \frac{du}{dx} + (a_0 + b_0x + c_0x^2 + \dots + k_0x^{n-1})u = 0,$$

we see that

$$\int_0^x \frac{a_0 + b_0x + \dots + k_0x^{n-1}}{a_1 + b_1x + \dots + l_1x^n} dx = A_0 + A_1x + A_2x^2 + \dots + A_mx^m + \dots,$$

where $A_0=1$, and the general law of the series is

$$a_1mA_m + (b_1(m-1) + a_0)A_{m-1} + (c_1(m-2) + b_0)A_{m-2} + \dots + (l_1(m-n) + k_0)A_{m-n} = 0.$$

If we take the general equation of the second order,

$$(a_2 + b_2x + \dots + l_2x^n) \frac{d^2u}{dx^2} + (a_1 + b_1x + \dots + k_1x^{n-1}) \frac{du}{dx} + (a_0 + b_0x + \dots + h_0x^{n-2})u = 0,$$

the law of the series will be

$$a_2m(m-1)A_m + (b_2(m-1)(m-2) + a_1(m-1))A_{m-1} + (c_2(m-2)(m-3) + b_1(m-2) + a_0)A_{m-2} + \dots + (l_2(m-n)(m-n-1) + k_1(m-n) + h_0)A_{m-n} = 0;$$

and generally, in equations of the n th order, the law of relation involves the n th power of m , the number of the term sought for. Thus the determination of soluble

cases of linear equations resolves itself into the inquiry, in what cases can a series whose scale is of the n th order be resolved into a number of series whose scale is of the first order.

20. I have not thought it necessary here to extend these solutions in series to linear partial differential equations. The process by which the extension can be made is well known, and has no peculiar relation to the methods here developed.

XIV. *Electro-Physiological Researches.—Eighth Series.* By Signor CARLO MATTEUCCI. Communicated by W. R. GROVE, Esq., F.R.S.

Received September 10, 1849,—Read January 10, 1850.

I PROPOSED to myself in my former memoirs* to embrace under some general views the phenomena of muscular contraction, of the production of electricity in fishes, and of the relation between the electric current and nervous force. I shall now endeavour to redeem my pledge, thankful to Providence in being permitted to resume my studies, and to seek in them some alleviation of the profound grief occasioned by the recent disasters of my country.

Previously to giving an account of my recent researches, it will be advisable to recall, in a few words, the leading results which may be said to form the summary of my former studies on electro-physiology, and which have been the starting-point of my later investigations.

1. A constant development of electricity takes place in all animal tissues, and principally in the muscles. All the laws of the muscular current, which have been established by a great number of experiments, lead to the conclusion that this development of electricity is owing to the chemical actions of nutrition, and particularly to that of muscular fibre on arterial blood. This electro-physiological phenomenon is therefore simply dependent on a general physical law: we may compare a muscle in which arterial blood circulates, conveying thither the elements of nutrition, to a collection of particles of zinc surrounded by acidulated water. The two electricities separate, and are reunited instantaneously between the molecules of metal and of liquid. If we establish a circuit between muscular tissues and the parts which communicate with them, which do not suffer the same chemical action on the part of the blood, we obtain signs of an electric current the direction of which is already determined by the physical conditions of this source of electricity.

2. In each prism of the electrical organ of fishes, the two electricities are separated under the influence of nervous action propagated from the brain towards the extremities of the nerves: a relation exists between the direction and the intensity of the nervous current, and also between the position and the quantity of the two electricities developed in the prism: according to this relation, verified by experiment, if we represent (as AMPÈRE did for electro-magnetic action) the nervous current by the figure of a man extended on the nerve and looking towards the tail of the torpedo, or the dorsal surface of the gymnotus, the positive electricity of the prism

* Phil. Trans. 1847.

is found invariably to the left of the man. We may account for the position of the poles at the extremities of each prism, and the intensity of the discharge being proportionate with the length of the prisms, by the fact that each prism of the organ is a temporary electrical apparatus, as has been proved by numerous experiments.

3. It is proved by experiments that the strictest analogy exists between the discharge of electrical fishes and muscular contraction; there is not a circumstance which modifies one of these phenomena without acting equally on the other.

4. The contraction of a muscle develops in the nerve with which it is in contact, the cause by means of which the nerve excites contractions in the muscle through which it is ramified. Although it has not been possible as yet to decide by experiment whether this phenomenon ought to be considered as a case of nervous induction, or as the proof of an electric discharge produced by muscular contraction, we are compelled by analogy to adopt the latter hypothesis.

5. The electric current modifies the excitability of the nerve which it traverses, in a manner which differs greatly according to its direction: the electric current which is propagated in the same direction as the ramification of the nerve, destroys its excitability: the current which is propagated in a direction contrary to that of the ramification of the nerve, increases its sensibility: the phenomena excited by the cessation of the electric current which traverses the nerves of the animal, are produced by the modification which the excitability of the nerve has undergone by the passage of the current according to its direction: the voltaic alternatives are explained by the same cause, which is as follows:—the muscular contractions are excited by a current which is made to pass in a contrary direction to that in which its action is nullified.

After having thus briefly recapitulated the fundamental conclusions which I have scrupulously drawn from my lengthened researches in electro-physiology, I shall begin the exposition of my recent studies on this subject by describing some experiments the application of which I shall give in the sequel. I wished to satisfy myself whether the nervous filaments which conduct an electric current into a liquid, are capable, like metallic wires, of acting as electrodes and giving rise to the production of electro-chemical decomposition. In order to ascertain this point, I plunged in a solution of iodide of potassium two large nervous filaments taken from living animals, each of which was separately attached to the metallic extremities of a pile of fifteen couples. I did not obtain the slightest trace of electro-chemical decomposition. I concluded from this experiment that terminals formed of nervous filaments cannot serve to obtain electro-chemical decomposition, which appears to me to demonstrate that the conductibility of nervous matter is due to the liquid part of the matter itself.

I studied again the relative conductibility of the muscles to that of the nerves: I had already discovered that one might estimate the conductibility of the muscle as four times greater than that of the nervous substance. I had also found that a

hempen thread soaked in water, and a very fresh nervous filament, both being as nearly as possible of equal dimensions, presented resistances to the electric current in the proportion of 12 to 15. But the main object which I had in view in studying the relative conducting power of muscles and nerves, was to ascertain whether, when a current was impelled through a mass of muscle, any part of the current might have passed through the nervous filaments spread throughout that muscle. For this purpose I took a piece of muscle from the thigh of a rabbit, a dog, or a fowl which had been dead for sufficient time for muscular irritability to have ceased; I cut this mass of muscle with a knife, and introduced into the opening thus made the nerve of a highly sensitive galvanoscopic frog; I covered over the nerve and a part of the leg, endeavouring to envelope them perfectly in the piece of muscle. When the contractions, which often occur in the galvanoscopic frog itself immediately after it has been prepared, had ceased, I passed an electric current of from 25 to 30 elements of FARADAY through the mass of muscle, applying the poles to different parts of its surface. In whatever way I varied this experiment, provided I did not touch very close to the nerves of the galvanoscopic frog, this frog never entered into contraction, although a very powerful electrical current traverses in all directions the mass of muscle in which the nerve of the frog was contained. I have remarked already that in this experiment a mass of muscle must be employed in which all irritability is extinct, because if muscles are made use of which contract on the passage of the electric current, the galvanoscopic frog exhibits phenomena of *induced* contraction; we are convinced of this by observing that they cease when the muscular irritability has disappeared. We may therefore conclude from this experiment, that when the poles of a pile of 25 or 30 elements are applied to the surface of the muscles of a living animal, the phenomena produced by the passage of the current must depend either on the *direct* action of the current on the muscular fibre, or on the *indirect* action or *influence* of the electric current transmitted by the muscular fibre on its own nervous filaments, or, to express it more clearly, on the nervous force existing in these filaments.

Convinced of the great importance of this conclusion, I have varied these experiments in order to confirm them in different ways. I have already, in the commencement of this memoir, spoken of the difference of excitability produced in a nerve by an electric current according to its direction. This electro-physiological law is easily demonstrated by an experiment which I have detailed at some length in my memoirs*, and which is made by preparing the frog in the ordinary manner,—cutting it at the junction of the two thigh-bones, and then placing it astride between two glasses of water with one foot in one glass and one in another. When the two poles of the pile are plunged into the liquid (pure water) contained in the two glasses, it is obvious that one of the limbs is traversed by the electric current in the same direction as the ramification of the nerve, and the other in a contrary direction.

* Philosophical Transactions, 1846.

The experiment consists in this: that after fifteen or twenty minutes of the passage of the current, that limb only which is traversed by the inverse current, that is to say, in a direction contrary to the ramification of the nerve, contracts at the opening of the circuit.

When the frog is reduced to this state, if the nerve traversed by the inverse current is touched by a small portion of muscle, we see the limb instantly contract as if the circuit had been interrupted; and in fact the current ceases to pass through the nerve and enters the muscle on account of the greater conductivity of the latter substance.

I shall cite another experiment of the same kind. Having succeeded in modifying the excitability of the nerve by the passage of the current, as in the experiment just described, we can easily convince ourselves that this modification is confined to the exposed or isolated portion of the nerves. For if those portions of the nerves in both thighs, which had been previously buried in the muscles, be now laid bare, no alteration in their excitability is found to have occurred; but the altered excitability is limited to the pelvic portions of the nerves previously exposed and traversed by the current. It is evident that if the nerve, buried among the muscles of the thigh, were traversed by the current as its exposed portion above is, the modification of the excitability would extend through the whole length of the nerve. I repeat, therefore, once again, that when a muscular mass is traversed by an electric current, we are compelled to admit that no sensible quantity of that current is conducted by the nervous filament belonging to such muscle.

Another subject of research which has greatly interested me, and the exposition of which will precede that of the experiments which form the principal subject of this memoir, relates to the influence which the integrity of the nervous system exercises on the excitability of the nerves. In other words, supposing that a certain contraction is produced in the limb of a frog by the passage of a constant electric current through its lumbar nerves, would that contraction remain the same, or would it be increased or diminished were the spinal marrow to be cut? I had read in the 'Comptes Rendus' of the Academy of Paris an experiment by M. BOIS SEGUARD, from which one would be led to conclude that the section of the spinal marrow increased the excitability of the lumbar nerve, at least during a certain period of time.

In order completely to satisfy myself on this point, which I consider as very important with regard to the theory of nervous functions, I was obliged to operate with the greatest possible exactitude, and to measure in every instance the contractions excited. In order to this I employed an apparatus invented by M. BREGUET, the description of which I have given in my fourth memoir*. The results to be obtained from this apparatus are as exact as can be desired, provided the operation is carried on with sufficient patience, and that the necessary degree of practice has been acquired in the use of the machine. As it is necessary, in the first instance, that the current

* Philosophical Transactions, 1846.

should be constant, a WHEATSTONE'S pile is the best adapted for the experiment. As the nervous filament by which the current is transmitted must be perfectly free from all trace of blood or other animal substance, it must be carefully cleaned, using a pair of forceps and lightly wiped with a piece of blotting-paper. It is also requisite that the gilded steel needle, which is introduced into the muscle of the thigh as nearly as possible to the insertion of the nerve, and which serves to complete the circuit, should, so far as is practicable, be always inserted in the same position in all the experiments. Lastly, care must be taken in choosing suitably the weight attached to the limb of the frog: if the weight be too small, the limb is not brought back to its position after contraction; on the other hand, if the weight be too great, the nerve is stretched, and the indications given by the apparatus are too small. I found that a weight of 0.600 gr. is the best adapted for the purpose.

I here give one of a series of experiments, undertaken with the view of resolving the question which I had proposed to myself.

I fasten a living frog to the clamp of the apparatus by passing a thread of silk round the thorax under the front claws: I then remove all the viscera of the abdomen, one of the limbs, and the muscles, as well as the bones of the pelvis: the frog, thus prepared, retains its natural liveliness for at least twenty or thirty minutes. I proceed to pass the *direct* current through the lumbar nerve, and I obtain contractions measured by the apparatus at 14° , 12° , 10° , 9° , 8° . I continue the passage of the current as short a time as possible, and close the circuits instantly after having opened them. The contractions first of all diminish rapidly, and then for a certain time they remain the same, if we are careful to leave the circuits closed as short a time as possible. When the deviation of the needle points constantly at 8° , I cut the spinal marrow of the frog, and pass the current again immediately: I have again the contraction 8° as before. I have frequently repeated this same experiment, and invariably with the same result. I also found that the duration of the contractions which persist the longest does not vary, in consequence of the section of the spinal marrow. It is therefore certain that the excitability of the nerve undergoes no immediate change after its separation from the nervous centre.

I then continued my investigations of this subject, conducting my experiments in a different manner from that already described, that is, by comparing the contraction of the muscular fibre excited by the passage of the electric current in a nerve which had been separated for several hours from the nervous centre, to that of another similar muscle the nerve of which had not undergone this operation.

It is hardly necessary to repeat, that, in order to the success of these experiments, BREGUET'S apparatus must be used, employing the precautions already mentioned; the most indispensable of which is the careful removal of all traces of blood, &c. from the lumbar nerves of frogs submitted to these comparative experiments; they should also, as far as possible, be prepared in the same manner, so that their conditions should be similar.

I took the frogs as they came to hand, from among a considerable number, and divided the spinal marrow at about the middle. Twelve hours after this operation I began an experiment, preparing at the same time the frogs whose spinal marrow had been divided, and others which were intact.

In order that the comparison should be as perfect as possible, I employed successively in BREGUET'S apparatus for measuring contractions, two frogs, one of which had the spine divided, the other entire. In each experiment I operated on four frogs in the former, and four in the latter state. I made my experiments with a direct current, keeping the circuit closed as short a time as possible, and marking the variations of the needle of the dynamometer after ten or twelve passages of the current, because it is then only that the variations become constant; if the passage of the current in the same frog is prolonged, the variations gradually diminish; operating with a certain degree of dexterity, experiments on eight frogs may be completed in less than a quarter of an hour.

The following are the results of two experiments:—

Exp. 1.

| Contraction of a frog the spinal marrow of which had been divided 12 hours. | Contraction of a frog with the spinal marrow entire. |
|--|---|
| 16° to 14° | 14° |
| 18 20 | 18 |
| 18 16 | 12 |
| 20 | 12 |
| 20 | 12 |

Exp. 2.

After 18 hours.

| | |
|------------|----|
| 24° to 22° | 8° |
| 22 24 | 10 |
| 22 16 | 12 |
| 17 16 | 12 |

According to these results, and others of the same kind, which it is unnecessary to give here, it is clearly proved by experiment that the contraction excited in the muscles of a frog, of which the spinal marrow has been divided from twelve to eighteen hours, is stronger than that which is obtained under the same circumstances from the muscle of a frog immediately after it is killed, without having been previously subjected to any alteration in its nervous system.

An observation which I had occasion to make in all my experiments, gave me some insight into the cause of this singular phenomenon. If a vigorous frog is rapidly prepared and subjected to experiment in the dynamometer, the first con-

tractions which are obtained are very feeble, particularly if the weight attached to the limb, to bring it back to its position after the contractions have ceased, be extremely small. If we continue to operate on this same frog, we see the contractions become stronger and increase during a certain time. In all cases the muscles of frogs killed and prepared rapidly, are stiff, and seized with a kind of tetanic contraction; while the muscles are in this state, the contractions which are obtained by the passage of the electric current are necessarily less strong than those which are developed when these same muscles have ceased to be contracted naturally.

After having repeated some experiments of this kind with the dynamometer, I soon came to the conviction that this was the real cause of the phenomenon under observation. I shall only give one of these experiments, which proves the truth of this explanation.

I operated on very vigorous frogs, four of which had had the spinal marrow divided twenty-four hours before experiment, and four other similar frogs which were intact.

The following are the numbers found immediately after the preparation :—

| Contraction of the frog of which the spinal marrow had been divided for 24 hours. | Contraction of the frog in the natural state. |
|--|--|
| 30 ^o | 26 ^o |
| 28 | 24 |
| 26 | 24 |
| 24 | 20 |

I left the frogs untouched for forty minutes, and then repeated the experiment: the following are the results :—

| | |
|-----------------|-----------------|
| 10 ^o | 22 ^o |
| 8 | 20 |
| 8 | 16 |
| 8 | 16 |

The difference of contraction obtained in the two experiments is therefore evidently due to the state of the muscles differing in the two cases, according to whether the frog was submitted to experiment immediately after death, or whether it had had the spinal marrow divided for a long time, and consequently the muscle relaxed for a considerable period. The contractions excited by the electric current in a frog immediately after death, are feeble at first, on account of the nearly tetanic condition of the muscles; whereas, if left in repose, so as to give time for the muscles to become relaxed, the contractions then excited by the current are stronger. The contrary to this occurs if the experiment be made on a frog the muscles of which have been for some time without contraction, in consequence of the spinal marrow having been

divided ; the contractions are very strong at first, but they soon diminish in strength, and that rapidly.

It would therefore be a mistake to conclude that muscular contraction increases because the nerve traversed by the electric current has been separated from the nervous centre : we have seen what is the true explanation of the phenomenon, and that this conclusion is only apparent.

On the other hand, these experiments prove, as did also those of the preceding section, that the excitability of a nerve is not altered by its separation from the nervous centres, or, rather, that the only alteration which it undergoes consists in the increased rapidity with which the excitability diminishes under the action of stimulants. Thus, the contraction produced by the passage of an electric current through a nerve is sensibly the same, whether this nerve be in communication with the nervous centres, or separated from them for several hours, or an instant after the separation has been effected : when the action of the current is repeated, its effects diminish the more rapidly exactly in proportion to the length of time which has elapsed since the separation of the nerve from the nervous centre.

I think it is scarcely necessary for me to remark, that these conclusions are not contrary to those of MÜLLER and LONGET ; according to which it was shown that when the nerves had been separated from the central mass, for weeks and months, the sensibility of these nerves and the irritability of the muscular fibre were diminished. M. LONGET has given the interpretation of this phenomenon, grounded on experiment.

In order to complete the first part of this memoir, I now proceed to relate the experiments and considerations by which the strict analogy existing between electricity and nervous force, together with the nature of that analogy, are demonstrated in a most satisfactory manner.

At the beginning of this memoir, referring to my preceding researches in electrophysiology, I mentioned the law according to which, by the influence of the nervous current, a development of electricity takes place in the organ of electrical fishes. We shall now consider what may be called the converse of this phenomenon, that is to say, the development of nervous force under the influence of the electric current, which development is produced exactly according to the same law as that of electricity by nervous force. This influence of electricity on nervous force is manifested in the muscular fibre : we have already observed at the beginning of this memoir that the phenomena presented by the organ of electrical fishes, as well as those of the muscular fibre, together with the modifications of these phenomena under various circumstances, invariably followed the same course, and preserved the strictest analogy with each other, so that what was true with regard to the electrical discharge of the torpedo, was equally so with regard to muscular contraction.

This fact admitted, we proceed to the experiments.

Expose in a living dog, rabbit or frog, the muscles of the thighs, removing entirely the skin and membranes, then transmit through the muscles the electric current

from an ordinary pile of from 30 to 40 elements, applying one of the poles to the upper, and the other to the lower part of the thigh. If the positive pole is placed above and the negative below, the current traverses the muscle in the same direction as the ramification of the nerves; the contrary is the case if the position of the poles be reversed.

Experiments of this kind date from the earliest times of galvanism; but the difficulty in these researches of separating truth from error, that which is constant and invariable from that which is merely accidental, and, above all, the still imperfect state of electro-physiological science, have hitherto prevented the attainment of any positive conclusions.

In experiments on this subject, great precaution is necessary in order to be certain that the electric current does not traverse the nervous filaments of the muscle; this certainty is obtained, as we have already seen, by keeping the poles of the electrical pile in contact with the surface of the muscle, at the greatest possible distance from the nervous filaments which spread through its interior. We must carefully remove from the surface of the muscle all traces of blood or other liquids; and I have generally been in the habit of applying one pole to the upper and the other to the under surface of the muscle.

When the electric current traverses the muscular mass of the thigh of a living animal in the same direction as the ramification of the nerves, a very strong contraction always takes place, which contraction is excited not only in the muscle directly traversed by the current, but also in the inferior muscles of the leg and in the foot.

When the electric current traverses the muscular mass in the contrary direction to that of the ramification of the nerves, the animal utters loud cries, and gives other indications of suffering severe pain, accompanied by contractions much less violent than in the preceding case, and which never extend beyond the muscles traversed by the current.

If we were to satisfy ourselves with seeing these experiments once only, or were to confine ourselves to a few trials only, we might easily be led to form an erroneous conclusion; in fact, at the beginning of the experiment, particularly if a somewhat powerful current be employed, there are both cries of pain and contractions at the same time; but this soon ceases, particularly if we know how to regulate duly the strength of the current. The constant effects which distinguish the action of the electric current, according to its direction, in the muscles of living animals, are those which I have indicated, namely, pain, when the electric current is what is commonly called inverse,—contraction, when the current is direct.

Now, setting aside all hypothesis, there can be but one way of explaining these phenomena: when there is a contraction, there must necessarily be a current of nervous force propagated from the brain towards the extremities of the nerves: when there is a sensation of pain, this current must be impelled in a contrary direction, that is,

from the nervous extremities towards the brain. We must bear in mind that it has been demonstrated by direct experiments; that when an electric current is propagated in a muscle, this current never quits the muscular fibre in order to pass into the nervous filaments. It is therefore perfectly evident that the phenomena of which we have spoken, excited by the passage of the electrical current through a mass of living muscle, are exclusively owing to the *influence* of electrical states propagated in the muscles upon the nervous force contained in the nerves. To speak with more precision, we should say thus: it is demonstrated by experiment, that an electric current transmitted through a living mass of muscle in the same direction as its nervous ramification, develops a nervous current which is propagated in the direction of the ramification of the nerve, and which reaches to its extremities; if the electric current pass in a contrary direction to that of the ramification of the nerve, the nervous current which it develops follows the same direction, that is, from the extremity of the nerve towards the brain.

The great importance of the conclusions drawn from these experiments consists in this, that they lead to the same law which establishes the analogy between nervous force and the electrical discharge of fishes.

We obtain an electrical discharge in fishes, when we produce a nervous current by stimulating the nerve which communicates with the organ. In experimenting on living animals, we produce a nervous current by the electric discharge which we transmit through the muscles. When this discharge is directed through the muscle in such a way as that the positive and negative states of electricity are disposed relatively to the ramification of the nerves, as in the discharge of electrical fishes, a nervous current is produced by the influence of the electric current having the same direction in both cases; in the torpedo, the nervous current produces the electrical states; in the muscular fibre, the nervous current is produced by the influence of the electric current.

Following up the analogy, we are led to expect that when the electric current traverses a muscular mass in a contrary direction to that of the ramification of the nerve, it would produce a nervous current in an opposite direction to that which is developed by the electric current passing along the muscle in the same direction as the ramification of the nerves. This is a conclusion the truth of which is clearly demonstrated by the phenomena of sensation or of pain, which are produced by the passage of the electric current in a contrary direction to that of the ramification of the nerves.

Satisfied to go forward with a slow but sure step in the vast and very obscure field of electro-physiological science, I cannot but regard as highly important the discovery set forth at the close of this memoir, of the strict correlation existing between the electric current and nervous force.

Pisa, June 1849.

[PART II]

PHILOSOPHICAL TRANSACTIONS.

XV. *Discussion of Meteorological Observations taken in India, at various heights, embracing those at Dodabetta on the Neelgherry Mountains, at 8640 feet above the level of the sea. By Lieutenant-Colonel W. H. SYKES, F.R.S.*

Received January 12.—Read March 21, 1850.

IN the year 1835 the Royal Society did me the honour to publish the results of six years' meteorological observations, taken by me on the elevated plateau of the Dukhun (Deccan) from 1825 to 1830, both years inclusive; my chief object being to illustrate the diurnal oscillations of the barometer as indicative of the periodic tides (if they may be so called) of the atmosphere. I showed that in many thousand observations, taken personally, there was not a solitary instance in which the barometer was not higher at 9—10 A.M. than at sunrise; and lower at 4—5 P.M. than at 9—10 A.M., *whatever the state of the weather or the indications of the thermometer or hygrometer might be*; nor was there a solitary instance in 1830, during which year only I took systematic night observations, and observed at the turning-points every five minutes, in which the maximum nocturnal tide was not higher at 9—10 P.M. than at 4—5 P.M. The 4—5 A.M. minimum tide was less regularly noticed than the other three tides; but nevertheless sufficiently often to render it perfectly clear, that in the twenty-four hours there were two minima as well as two maxima of pressure in twenty-four hours. I had the advantage at times of carrying on my observations in the six years, at a mean elevation of 1800 feet, simultaneously with observations made in Bombay at the level of the sea; and at Mahabuleshwur at 4500 feet above the sea. These simultaneous observations for limited periods led me to remark, that the amount or range of the diurnal oscillation between the maximum and minimum hours did not correspond at the different elevations. At the level of the sea in Bombay the range between 9—10 A.M. and 4—5 P.M., appeared generally to be less than the range between the same hours in Dukhun (Deccan) at 1800 feet above the sea; but at Mahabuleshwur, at 4500 feet, the range was *constantly* less than in Bombay or on the plateau of the Deccan. Not having had further means of prosecuting inquiry into the fact, it was with much interest I remarked that the orders of the Court of Directors of the East India Company had been carried out by the astronomer at Madras, and meteorological observations taken for a whole year at a

greater elevation above the sea-level, than had ever been attempted before in India. Observations so made were peculiarly acceptable to me, as they would subject the accuracy of my own observations to an additional test, and would supply the means of investigating the supposed diminished diurnal oscillation of the barometer in relation to elevation above the sea. At the present time I have the further advantage of being enabled to subject my Deccan observations to the test of comparison with recent observations at the Bombay and Madras Observatories, taken chiefly with a view to determine the amount of the hourly and diurnal changes of the barometer. Those for Madras are from the years 1841 to 1845, both inclusive*: for Bombay, I am sorry to say, the records which have reached my hands are for more limited periods. Dr. BUIST, LL.D., while in temporary charge of the observatory, made observations for 1842, 1843 and 1844, but those for 1843 and 1844 only are available to me, and Professor ORLEBAR has published observations from April to December 1845. In addition to the above, a meteorological register is kept in the office of the Deputy Surveyor-General in Calcutta, the instruments since 1844 being new, and of NEWMAN'S construction; but hourly observations do not appear to have been taken, and three out of the five periods of observation, namely, sunrise, noon and sunset, are useless for determining the diurnal oscillation of the barometer; and the barometrical observations taken before the receipt of the new instruments, which came to hand respectively in 1844 and 1847, were recorded from defective instruments.

| | |
|---|--------|
| TROUGHTON'S barometer reduced to 32° stood at | 29·493 |
| Colonel EVEREST'S reduced to 32° stood at | 29·637 |
| While NEWMAN'S barometer of Sept. 1844 stood at | 29·654 |
| And that of April 1847 at | 29·667 |

The height of the cistern above the level of the sea being 18·21 feet. Observations are also taken at the Royal Observatory at Oude, and at the Rajah of Travancore's Observatory at Trevandrum; but the records have not reached my hands, nor are those of the magnetic observatory at Simla available to me.

Independently of the diurnal atmospheric tides, the Dodabetta observations afford the means of further investigating the debatable question of the influence of elevation upon the quantity of rain precipitated; for these observations, contrasted with the records from Mahabuleshwur, Mercara in Coorg, and from the numerous stations in Travancore furnished by General CULLEN (all the localities being under nearly the same meridian, although differing greatly in latitude), will supply data, which, if they do not set the question at rest, will assist to guide the judgement to deductions approximating to the truth.

Diurnal Tides.—I shall first notice the observations taken at the greatest elevation. The Dodabetta observations commenced in February 1847. The locality of the observatory, which is in latitude 11° 23' 22" N., and longitude approximately 76° 47' E. of Greenwich, is understood to be the highest point in the range of Ghauts in Western

* At Madras, from the years 1822 to 1837, the barometric records are useless for determining the daily atmospheric tides, the hours of observation being sunrise,—10 A.M., noon,—2 P.M., and sunset,—10 P.M. was added in some of the latter years. Hourly observations only commenced in 1841.

India, that run parallel to the sea-coast from latitude 24° — 25° to Cape Comorin. This range of mountains rise abruptly above the western coast of India, and the watershed from them is almost entirely to the Coromandel or eastern coast of the Peninsula of India. The aqueous vapours from the ocean are condensed on these mountains, and as Dodabetta is within the influence of both the south-west and north-east monsoons, it would appear to be favoured with rain in every month in the year. The observations were taken by an assistant of the Madras Observatory, JOHN DE CRUZ; and as the instruments had been selected by the astronomer, Mr. TAYLOR, and every precaution taken to ensure accuracy in the observations, there is every reason to suppose they are worthy of confidence. To determine the pressure of the atmosphere, observations were taken only twice in the day at the supposed hours of maxima and minima; namely, $9^{\text{h}} 40^{\text{m}}$ A.M. and $3^{\text{h}} 40^{\text{m}}$ P.M., excepting on the 21st and 22nd of each month, when the observations were taken hourly for twenty-four consecutive hours.

With respect to the daily oscillation of the barometer the following Tables are given, and the records show, that, as in my observations in the Deccan, there is not at this great elevation *a single day throughout the whole year* in which the pressure at $3^{\text{h}} 40^{\text{s}}$ P.M. is higher than at $9^{\text{h}} 40^{\text{s}}$ A.M., and there is but a solitary instance in which the pressure at the two hours is identical. On the 15th of August the barometer is recorded as standing at $21^{\circ}952$ at $9^{\text{h}} 40^{\text{m}}$ A.M., and at $21^{\circ}952$ at $3^{\text{h}} 40^{\text{m}}$ P.M.; but as there is not an approximation to anything similar in the preceding or following days, it may be questioned whether this supposed suspension of the atmospheric tide may not be a typographical error, that might well be excused in a multitude of figures. As these observations taken at such a height are the first of the kind recorded in India, I have thought it right to append them *in extenso*; at least for pressure and temperature, and wet bulb depression*.

* While this paper is passing through the press, Lieut. R. STRACHEY of the Bengal Engineers is arrived in England from his travels in the Himalayas and Thibet. He made some hourly observations of the barometer at an elevation of 18,400, at 16,000, and at 11,500 feet, and found that the horary oscillations or atmospheric tides were as regular as on the plains of Hindoostan, and the hours of maxima and minima were the same.

Meteorological observations made by Lieut. R. STRACHEY on Lunjar Mountain in Thibet (lat. $31^{\circ} 2'$ north) at an elevation of 18,400 feet above the sea, August 22nd and 23rd, 1849.

| Date. | Hour. | Bar. at 32° . | Air. | Wet bulb. | | Date. | Hour. | Bar. at 32° . | Air. | Wet bulb. | |
|----------|-------------|------------------------|------|-----------|---------------------------------------|----------|-------------|------------------------|-------|------------------------------|--------------------------------|
| Aug. 22. | P.M. h m | in. | | | | Aug. 23. | P.M. h m | in. | | | |
| | 2 0 | 15.374 | 45.0 | 37.7 | Moderate wind and a few light clouds. | | 4 0 | 15.381 | 29.0 | 24.3 | Calm, clear. |
| | 4 30 | .355 | 48.7 | 37.8 | Moderate wind and a few light clouds. | | 5 0 | .389 | 29.0 | 24.5 | Calm, clear. |
| | 5 0 | .355 | 42.7 | 36.2 | Moderate wind and a few light clouds. | | 6 0 | .393 | 28.0 | 26.5 | Sunrise. |
| | 6 0 | .362 | 37.7 | 35.5 | Moderate wind and a few light clouds. | | 7 0 | .397 | 33.0 | 32.8 | Calm and clear. |
| | 7 0 | .369 | 31.5 | 29.9 | Wind light. | | 8 0 | .405 | 36.0 | 35.8 | Calm and clear. |
| | 8 0 | .396 | 34.0 | 29.5 | Wind light. | | 9 0 | .420 | 39.8 | 31.75 | Calm and clear. |
| | 9 0 | .410 | 33.6 | 28.9 | Calm, clear. | | 10 0 | .424 | 44.9 | 35.5 | Light winds, S.E., few clouds. |
| | 10 0 | .412 | 33.0 | 28.5 | Calm, clear. | | 11 0 | .421 | 56.2 | 46.5 | Wind increasing, also clouds. |
| | 11 0 | .414 | 32.0 | 26.7 | Calm, clear. | | noon. | .415 | 56.0 | 40.2 | |
| | midnight. | .394 | 31.7 | 27.7 | Calm, clear. | | 1 0 | .407 | 56.9 | 40.9 | |
| Aug. 23. | 1 15 | .399 | 31.0 | 25.25 | Calm, clear. | 1 30 | .404 | | | | |
| | 2 0 | .395 | 30.7 | 27.4 | Calm, clear. | 2 0 | .397 | 49.1 | 37.15 | | |
| | 3 0 | .383 | 29.7 | 27.6 | Calm, clear. | 3 0 | .387 | 46.5 | 36.5 | Strong wind and more cloudy. | |

Daily Oscillations of the Barometer at Dodabetta, at 8640 feet above the level of the sea, &c.

| FEBRUARY. | | | | | | | | | | MARCH. | | | | | | | | | | APRIL. | | | | | | | | | |
|-----------------|------|------------------|-----------------|------------------|--------|-----------------|------|-------|-----------------|------------------|--------|------------------|--------|--------|-----------------|-------|------|------------------|------|------------------|-----------------|-------|---------|-------|------|--|--|--|--|
| Date. | | h m 9 40 A.M. | | h m 3 40 P.M. | | Rain. | | Date. | | h m 9 40 A.M. | | h m 3 40 P.M. | | Rain. | | Date. | | h m 9 40 A.M. | | h m 3 40 P.M. | | Rain. | | | | | | | |
| Baro- meter. | Att. | Det. | Baro- meter. | Att. | Det. | Baro- meter. | Att. | Det. | Baro- meter. | Att. | Det. | Baro- meter. | Att. | Det. | Baro- meter. | Att. | Det. | Baro- meter. | Att. | Det. | Baro- meter. | Att. | Det. | | | | | | |
| 1847. | 1 | 22.105 | 52.5 | 54.0 | 22.046 | 51.0 | 52.0 | — | 1847. | 1 | 22.166 | 52.0 | 53.0 | 22.072 | 51.0 | 52.0 | — | 1847. | 1 | 22.180 | 58.0 | 59.0 | 22.106 | 58.0 | 58.5 | | | | |
| | 2 | .115 | 53.0 | 54.0 | -.062 | 50.0 | 52.0 | — | | 2 | .182 | 54.0 | 54.0 | .130 | 52.0 | 53.0 | — | | 2 | .177 | 59.5 | 61.5 | -.080 | 58.5 | 60.0 | | | | |
| | 3 | .114 | 53.0 | 53.8 | -.068 | 53.0 | 52.9 | 0.02 | | 3 | .186 | 53.0 | 53.4 | .122 | 52.8 | 53.0 | 2.29 | | 3 | .172 | 59.0 | 60.5 | -.115 | 58.0 | 59.0 | | | | |
| | 4 | .124 | 51.8 | 52.5 | -.060 | 53.0 | 52.8 | 0.31 | | 4 | .168 | 50.0 | 50.5 | .116 | 50.0 | 51.0 | 0.03 | | 4 | .186 | 58.0 | 59.0 | — | — | — | | | | |
| | 5 | .128 | 50.0 | 51.0 | -.072 | 52.9 | 52.5 | 0.03 | | 5 | .180 | 50.4 | 50.8 | .124 | 50.5 | 51.5 | — | | 5 | .199 | 57.5 | 58.5 | .164 | 58.0 | 58.0 | | | | |
| | 6 | .140 | 48.8 | 50.0 | -.086 | 52.2 | 50.0 | 0.02 | | 6 | .174 | 50.0 | 53.0 | .126 | 50.8 | 51.8 | — | | 6 | .188 | 56.0 | 57.0 | .150 | 60.0 | 59.0 | | | | |
| | 7 | .136 | 47.8 | 48.0 | -.085 | 51.0 | 51.0 | — | | 7 | .166 | 50.0 | 52.0 | .130 | 50.0 | 51.0 | — | | 7 | .172 | 56.0 | 57.5 | .119 | 57.0 | 57.4 | | | | |
| | 8 | .138 | 51.4 | 53.0 | -.082 | 52.0 | 52.5 | 0.38 | | 8 | .182 | 52.2 | 53.0 | .130 | 54.0 | 54.0 | — | | 8 | .160 | 57.0 | 58.5 | .110 | 58.5 | 58.5 | | | | |
| | 9 | .144 | 51.5 | 52.5 | -.064 | 52.5 | 52.5 | 0.03 | | 9 | .159 | 50.0 | 51.8 | .098 | 53.0 | 53.0 | — | | 9 | .162 | 54.8 | 56.0 | .106 | 57.0 | 58.0 | | | | |
| | 10 | -.082 | 51.4 | 48.0 | -.022 | 50.0 | 50.5 | 0.03 | | 10 | .172 | 54.0 | 55.0 | .100 | 56.8 | 57.0 | — | | 10 | .176 | 56.0 | 57.0 | .110 | 56.5 | 57.5 | | | | |
| | 11 | -.082 | 50.0 | 51.0 | -.014 | 51.0 | 51.4 | 0.05 | | 11 | .153 | 55.0 | 56.0 | -.078 | 53.0 | 54.0 | — | | 11 | .136 | 56.5 | 57.0 | .114 | 56.0 | 57.0 | | | | |
| | 12 | .120 | 52.2 | 53.0 | -.056 | 50.5 | 52.2 | 0.05 | | 12 | .148 | 55.0 | 56.0 | .106 | 53.0 | 55.0 | — | | 12 | .122 | 56.5 | 57.5 | .058 | 57.0 | 58.0 | | | | |
| | 13 | .154 | 52.4 | 53.0 | -.081 | 52.4 | 53.0 | 1.39 | | 13 | .158 | 55.0 | 56.0 | .105 | 55.0 | 55.0 | — | | 13 | .098 | 55.0 | 56.0 | .038 | 56.0 | 56.0 | | | | |
| | 14 | .134 | 51.8 | 52.0 | -.068 | 52.0 | 53.0 | 0.39 | | 14 | .152 | 52.0 | 53.0 | .118 | 58.8 | 59.0 | — | | 14 | .100 | 53.8 | 54.0 | .026 | 55.0 | 55.0 | | | | |
| | 15 | .142 | 53.0 | 54.0 | -.073 | 53.0 | 53.4 | 0.69 | | 15 | .150 | 51.8 | 53.0 | .088 | 53.0 | 53.5 | 0.77 | | 15 | .036 | 52.5 | 53.5 | .21983 | 51.8 | 51.5 | | | | |
| | 16 | .138 | 54.4 | 55.0 | -.072 | 54.5 | 54.5 | 3.24 | | 16 | .176 | 51.0 | 52.0 | .147 | 53.0 | 53.0 | 0.16 | | 16 | .036 | 52.5 | 53.5 | 21.983 | 51.8 | 51.5 | | | | |
| | 17 | .140 | 53.5 | 55.0 | -.089 | 54.5 | 54.5 | — | | 17 | .218 | 21.0 | 51.5 | .128 | 52.0 | 52.0 | 0.21 | | 17 | .0946 | 53.5 | 54.0 | .886 | 53.0 | 53.0 | | | | |
| | 18 | .165 | 52.0 | 54.0 | -.099 | 53.0 | 53.5 | — | | 18 | .186 | 54.2 | 55.2 | .084 | 53.0 | 53.0 | 0.25 | | 18 | .052 | 53.0 | 53.0 | .952 | 53.5 | 53.5 | | | | |
| | 19 | .158 | 52.0 | 52.5 | -.066 | 52.5 | 53.0 | — | | 19 | .136 | 52.0 | 53.0 | .066 | 54.0 | 54.0 | — | | 19 | .056 | 53.0 | 53.0 | .22.012 | 53.0 | 53.5 | | | | |
| | 20 | .132 | 50.5 | 51.0 | -.046 | 53.0 | 53.0 | 0.03 | | 20 | .160 | 53.0 | 54.0 | .123 | 55.0 | 55.0 | — | | 20 | .088 | 52.0 | 53.0 | .056 | 54.0 | 54.0 | | | | |
| | 21 | .123 | 51.8 | 51.8 | -.068 | 53.8 | 53.0 | 0.03 | | 21 | .186 | 53.0 | 54.8 | .150 | 55.0 | 56.0 | — | | 21 | .126 | 52.0 | 52.0 | .078 | 57.0 | 57.0 | | | | |
| | 22 | .139 | 49.8 | 50.5 | -.079 | 51.8 | 52.0 | 0.77 | | 22 | .168 | 51.0 | 50.0 | .104 | 55.0 | 56.0 | — | | 22 | .128 | 52.8 | 53.0 | .072 | 54.0 | 55.0 | | | | |
| | 23 | .132 | 50.5 | 51.0 | -.080 | 51.3 | 52.0 | — | | 23 | .140 | 56.0 | 57.0 | .116 | 56.0 | 56.5 | — | | 23 | .128 | 54.5 | 54.0 | .060 | 57.0 | 58.0 | | | | |
| | 24 | .128 | 51.0 | 52.0 | -.066 | 52.5 | 53.0 | — | | 24 | .131 | 58.0 | 58.0 | .076 | 55.0 | 56.8 | — | | 24 | .128 | 54.8 | 55.5 | .070 | 55.0 | 56.5 | | | | |
| | 25 | .134 | 51.8 | 54.0 | -.076 | 52.0 | 53.0 | — | | 25 | .146 | 57.0 | 55.0 | .086 | 58.5 | 58.0 | — | | 25 | .142 | 58.0 | 58.0 | .074 | 55.0 | 56.0 | | | | |
| | 26 | .116 | 51.0 | 52.0 | -.080 | 52.0 | 52.0 | — | | 26 | .132 | 57.0 | 58.0 | .089 | 57.0 | 57.5 | — | | 26 | .170 | 56.5 | 57.0 | .100 | 57.0 | 58.0 | | | | |
| | 27 | .110 | 50.0 | 51.0 | -.062 | 51.0 | 52.4 | — | | 27 | .138 | 56.0 | 57.0 | .064 | 56.0 | 57.5 | — | | 27 | .164 | 57.0 | 58.0 | .090 | 58.0 | 59.0 | | | | |
| | 28 | .128 | 48.5 | 49.5 | -.084 | 50.0 | 51.0 | — | | 28 | .140 | 56.0 | 57.0 | .072 | 56.0 | 57.0 | — | | 28 | .172 | 58.0 | 59.0 | .093 | 57.0 | 56.5 | | | | |
| Mean | | 22.129 | 51.3 | 52.1 | 22.068 | 52.1 | 52.5 | 7.43 | Mean | 22.160 | 53.5 | 54.4 | 22.105 | 54.2 | 54.6 | 3.61 | Mean | 22.128 | 55.5 | 56.3 | 22.066 | 56.1 | 56.6 | 19.80 | | | | | |
| | | | | | | | | | | | | | | | | | | | | | | | | | | | | | |

Depression of the wet bulb.

February.

March.

April.

h m
9 40 A.M.

h m
3 40 P.M.

h m
9 40 A.M.

h m
3 40 P.M.

h m
9 40 A.M.

h m
3 40 P.M.

h m
9 40 A.M.

h m
3 40 P.M.

h m
9 40 A.M.

h m
3 40 P.M.

h m
9 40 A.M.

h m
3 40 P.M.

h m
9 40 A.M.

h m
3 40 P.M.

h m
9 40 A.M.

h m
3 40 P.M.

h m
9 40 A.M.

h m
3 40 P.M.

h m
9 40 A.M.

h m
3 40 P.M.

h m
9 40 A.M.

h m
3 40 P.M.

h m
9 40 A.M.

h m
3 40 P.M.

h m
9 40 A.M.

h m
3 40 P.M.

h m
9 40 A.M.

h m
3 40 P.M.

h m
9 40 A.M.

h m
3 40 P.M.

h m
9 40 A.M.

h m
3 40 P.M.

h m
9 40 A.M.

h m
3 40 P.M.

h m
9 40 A.M.

h m
3 40 P.M.

h m
9 40 A.M.

h m
3 40 P.M.

h m
9 40 A.M.

h m
3 40 P.M.

h m
9 40 A.M.

h m
3 40 P.M.

h m
9 40 A.M.

h m
3 40 P.M.

h m
9 40 A.M.

h m
3 40 P.M.

h m
9 40 A.M.

h m
3 40 P.M.

h m
9 40 A.M.

h m
3 40 P.M.

h m
9 40 A.M.

h m
3 40 P.M.

h m
9 40 A.M.

h m
3 40 P.M.

h m
9 40 A.M.

h m
3 40 P.M.

h m
9 40 A.M.

h m
3 40 P.M.

h m
9 40 A.M.

h m
3 40 P.M.

h m
9 40 A.M.

h m
3 40 P.M.

h m
9 40 A.M.

h m
3 40 P.M.

h m
9 40 A.M.

h m
3 40 P.M.

h m
9 40 A.M.

h m
3 40 P.M.

h m
9 40 A.M.

h m
3 40 P.M.

h m
9 40 A.M.

h m
3 40 P.M.

h m
9 40 A.M.

h m
3 40 P.M.

h m
9 40 A.M.

h m
3 40 P.M.

h m
9 40 A.M.

h m
3 40 P.M.

h m
9 40 A.M.

h m
3 40 P.M.

h m
9 40 A.M.

h m
3 40 P.M.

h m
9 40 A.M.

h m
3 40 P.M.

h m
9 40 A.M.

h m
3 40 P.M.

h m
9 40 A.M.

h m
3 40 P.M.

h m
9 40 A.M.

h m
3 40 P.M.

h m
9 40 A.M.

h m
3 40 P.M.

TABLE (Continued).

| AUGUST. | | | | | | | | | | SEPTEMBER. | | | | | | | | | | OCTOBER. | | | | | | | | | | | |
|---------------|-----------------|--------|---------------|-----------------|--------|---------------|-------|-----------------|---------------|------------|-----------------|---------------|------|-------|-----------------|--------|------|---------------|-----------------|----------|---------------|-------|-----------------|---------------|-------|-------|-----------------|------|------|-------|-------|
| h m 9 40 A.M. | | | h m 3 40 A.M. | | | h m 9 40 A.M. | | | h m 3 40 P.M. | | | h m 9 40 A.M. | | | h m 3 40 P.M. | | | h m 9 40 A.M. | | | h m 3 40 P.M. | | | h m 9 40 A.M. | | | h m 3 40 P.M. | | | | |
| Date. | Baro- meter. | Att. | Det. | Baro- meter. | Att. | Det. | Rain. | Baro- meter. | Att. | Det. | Baro- meter. | Att. | Det. | Rain. | Baro- meter. | Att. | Det. | Date. | Baro- meter. | Att. | Det. | Rain. | Baro- meter. | Att. | Det. | Date. | Baro- meter. | Att. | Det. | Rain. | |
| 1847. | in. | 22-012 | 52.1 | 52.2 | 21-934 | 52.4 | 52.9 | 0.46 | in. | 22-032 | 53.5 | 53.8 | 53.0 | 0.36 | in. | 22-000 | 51.0 | 51.5 | 1847. | in. | 22-000 | 51.0 | 51.5 | 51.0 | 0.02 | in. | 22-000 | 51.0 | 51.5 | 51.0 | 0.02 |
| 1 | | 22-012 | 52.1 | 52.2 | 21-934 | 52.4 | 52.9 | 0.46 | in. | 22-032 | 53.5 | 53.8 | 53.0 | 0.36 | in. | 22-000 | 51.0 | 51.5 | 1 | in. | 22-000 | 51.0 | 51.5 | 51.0 | 0.02 | in. | 22-000 | 51.0 | 51.5 | 51.0 | 0.02 |
| 2 | | 21-972 | 52.8 | 53.0 | .912 | 52.2 | 52.2 | 0.25 | in. | .050 | 53.1 | 53.2 | 53.5 | 0.55 | in. | .046 | 52.5 | 53.0 | 2 | in. | .046 | 52.5 | 53.0 | 53.5 | 0.55 | in. | .046 | 52.5 | 53.0 | 53.5 | 0.55 |
| 3 | | .979 | 52.0 | 52.2 | .937 | 52.0 | 52.1 | 0.21 | in. | .052 | 53.5 | 53.4 | 53.0 | 0.17 | in. | .086 | 52.8 | 53.1 | 3 | in. | .086 | 52.8 | 53.1 | 53.0 | 0.17 | in. | .086 | 52.8 | 53.1 | 53.0 | 0.17 |
| 4 | | .971 | 51.0 | 51.2 | .920 | 52.5 | 52.8 | 0.12 | in. | .030 | 51.8 | 52.0 | 53.0 | 0.35 | in. | .122 | 53.5 | 53.8 | 4 | in. | .122 | 53.5 | 53.8 | 53.0 | 0.35 | in. | .122 | 53.5 | 53.8 | 53.0 | 0.35 |
| 5 | | .979 | 51.9 | 52.0 | .920 | 52.1 | 52.2 | 0.59 | in. | .030 | 50.1 | 50.2 | 51.8 | 0.36 | in. | .100 | 53.4 | 54.0 | 5 | in. | .100 | 53.4 | 54.0 | 53.6 | 0.36 | in. | .100 | 53.4 | 54.0 | 53.6 | 0.36 |
| 6 | | .978 | 51.8 | 51.9 | .910 | 52.4 | 52.5 | 0.79 | in. | 21-928 | 48.5 | 48.6 | 50.1 | 0.15 | in. | .084 | 51.6 | 52.0 | 6 | in. | .084 | 51.6 | 52.0 | 52.5 | 0.44 | in. | .084 | 51.6 | 52.0 | 52.5 | 0.44 |
| 7 | | .974 | 52.4 | 52.5 | .892 | 51.4 | 51.5 | 0.74 | in. | .948 | 51.5 | 51.8 | 50.2 | 0.48 | in. | .104 | 52.0 | 52.5 | 7 | in. | .104 | 52.0 | 52.5 | 53.0 | 0.02 | in. | .104 | 52.0 | 52.5 | 53.0 | 0.02 |
| 8 | | .972 | 52.0 | 52.2 | .932 | 53.0 | 53.2 | 0.03 | in. | .932 | 50.4 | 50.5 | 51.6 | 0.50 | in. | .124 | 52.5 | 53.1 | 8 | in. | .124 | 52.5 | 53.1 | 53.5 | 0.14 | in. | .124 | 52.5 | 53.1 | 53.5 | 0.14 |
| 9 | | 22-034 | 53.4 | 53.5 | .974 | 53.1 | 53.1 | 0.50 | in. | .880 | 50.8 | 50.8 | 51.9 | 0.32 | in. | .116 | 52.6 | 53.0 | 9 | in. | .116 | 52.6 | 53.0 | 53.5 | 0.05 | in. | .116 | 52.6 | 53.0 | 53.5 | 0.05 |
| 10 | | .072 | 53.2 | 53.4 | 22-026 | 54.0 | 54.2 | 0.37 | in. | .976 | 51.2 | 51.5 | 52.5 | 0.34 | in. | .090 | 53.9 | 54.3 | 10 | in. | .090 | 53.9 | 54.3 | 53.4 | 0.45 | in. | .090 | 53.9 | 54.3 | 53.4 | 0.45 |
| 11 | | .090 | 53.2 | 53.5 | .032 | 53.0 | 53.0 | 0.18 | in. | .967 | 51.8 | 51.9 | 52.2 | 0.28 | in. | .072 | 53.4 | 53.5 | 11 | in. | .072 | 53.4 | 53.5 | 53.4 | 1.21 | in. | .072 | 53.4 | 53.5 | 53.4 | 1.21 |
| 12 | | .070 | 52.0 | 52.2 | .009 | 53.0 | 53.2 | 0.73 | in. | .967 | 51.2 | 51.5 | 52.0 | 0.28 | in. | .098 | 53.8 | 54.1 | 12 | in. | .098 | 53.8 | 54.1 | 54.4 | 0.67 | in. | .098 | 53.8 | 54.1 | 54.4 | 0.67 |
| 13 | | .052 | 52.2 | 52.5 | 21-988 | 52.1 | 52.1 | 0.08 | in. | .984 | 51.3 | 51.5 | 52.0 | 0.20 | in. | .076 | 53.0 | 53.2 | 13 | in. | .076 | 53.0 | 53.2 | 53.0 | 0.11 | in. | .076 | 53.0 | 53.2 | 53.0 | 0.11 |
| 14 | | 21-973 | 50.2 | 50.3 | .932 | 50.6 | 50.9 | 0.18 | in. | 22-006 | 51.6 | 52.2 | 52.0 | 0.20 | in. | .076 | 53.0 | 53.2 | 14 | in. | .076 | 53.0 | 53.2 | 53.0 | 1.82 | in. | .076 | 53.0 | 53.2 | 53.0 | 1.82 |
| 15 | | .952 | 52.0 | 52.2 | .952 | 51.1 | 51.2 | — | in. | .024 | 52.2 | 52.4 | 52.1 | 0.15 | in. | 21-999 | 51.9 | 52.1 | 15 | in. | 21-999 | 51.9 | 52.1 | 52.1 | 0.92 | in. | 21-999 | 51.9 | 52.1 | 52.1 | 0.92 |
| 16 | | 22-022 | 51.4 | 51.8 | .984 | 51.5 | 51.8 | 0.25 | in. | .066 | 52.3 | 53.5 | 54.5 | 0.07 | in. | 22-016 | 53.1 | 53.4 | 16 | in. | 22-016 | 53.1 | 53.4 | 53.4 | 0.17 | in. | 22-016 | 53.1 | 53.4 | 53.4 | 0.17 |
| 17 | | .046 | 53.3 | 53.4 | .993 | 54.5 | 54.9 | 0.25 | in. | .070 | 52.6 | 53.0 | 54.1 | 0.08 | in. | .052 | 53.5 | 53.8 | 17 | in. | .052 | 53.5 | 53.8 | 54.1 | 0.17 | in. | .052 | 53.5 | 53.8 | 54.1 | 0.17 |
| 18 | | .057 | 53.9 | 53.2 | 22-017 | 55.1 | 55.5 | 0.20 | in. | .078 | 49.5 | 49.8 | 53.8 | 0.08 | in. | .088 | 53.4 | 53.5 | 18 | in. | .088 | 53.4 | 53.5 | 53.8 | 0.09 | in. | .088 | 53.4 | 53.5 | 53.8 | 0.09 |
| 19 | | .066 | 52.5 | 52.8 | .018 | 54.0 | 54.2 | — | in. | .074 | 49.5 | 49.8 | 53.8 | 0.08 | in. | .110 | 53.5 | 53.5 | 19 | in. | .110 | 53.5 | 53.5 | 53.5 | 0.11 | in. | .110 | 53.5 | 53.5 | 53.5 | 0.11 |
| 20 | | .071 | 55.4 | 56.0 | .022 | 53.8 | 54.2 | 0.02 | in. | .088 | 52.0 | 52.4 | 53.2 | — | in. | .089 | 54.2 | 54.4 | 20 | in. | .089 | 54.2 | 54.4 | 54.5 | 0.30 | in. | .089 | 54.2 | 54.4 | 54.5 | 0.30 |
| 21 | | .090 | 53.5 | 54.0 | .022 | 55.0 | 55.2 | — | in. | .066 | 53.6 | 54.0 | 54.7 | 0.78 | in. | .122 | 53.4 | 54.0 | 21 | in. | .122 | 53.4 | 54.0 | 53.8 | 1.24 | in. | .122 | 53.4 | 54.0 | 53.8 | 1.24 |
| 22 | | .084 | 54.9 | 55.0 | .022 | 55.1 | 55.3 | 0.18 | in. | .071 | 53.2 | 53.5 | 54.3 | 0.66 | in. | .116 | 54.0 | 54.5 | 22 | in. | .116 | 54.0 | 54.5 | 54.8 | 0.54 | in. | .116 | 54.0 | 54.5 | 54.8 | 0.54 |
| 23 | | .055 | 53.2 | 53.3 | .006 | 54.3 | 54.5 | 1.63 | in. | .100 | 53.4 | 54.0 | 54.0 | — | in. | .104 | 52.2 | 52.5 | 23 | in. | .104 | 52.2 | 52.5 | 53.8 | 2.39 | in. | .104 | 52.2 | 52.5 | 53.8 | 2.39 |
| 24 | | .048 | 54.5 | 54.8 | .014 | 53.0 | 53.5 | — | in. | .088 | 47.2 | 48.0 | 54.0 | — | in. | .111 | 52.2 | 52.5 | 24 | in. | .111 | 52.2 | 52.5 | 52.5 | 0.07 | in. | .111 | 52.2 | 52.5 | 52.5 | 0.07 |
| 25 | | .078 | 53.1 | 53.4 | .010 | 53.6 | 54.0 | 0.50 | in. | .079 | 49.8 | 51.0 | 53.0 | — | in. | .092 | 52.4 | 52.8 | 25 | in. | .092 | 52.4 | 52.8 | 53.5 | 0.19 | in. | .092 | 52.4 | 52.8 | 53.5 | 0.19 |
| 26 | | .060 | 52.2 | 52.5 | 21-986 | 55.0 | 55.2 | 0.30 | in. | .082 | 51.5 | 52.2 | 53.4 | — | in. | .116 | 53.9 | 54.2 | 26 | in. | .116 | 53.9 | 54.2 | 53.5 | 0.01 | in. | .116 | 53.9 | 54.2 | 53.5 | 0.01 |
| 27 | | .032 | 52.0 | 52.0 | .998 | 53.5 | 53.5 | 0.23 | in. | .064 | 52.5 | 53.1 | 53.1 | 0.03 | in. | .092 | 55.2 | 55.3 | 27 | in. | .092 | 55.2 | 55.3 | 54.0 | 0.01 | in. | .092 | 55.2 | 55.3 | 54.0 | 0.01 |
| 28 | | .059 | 54.8 | 55.1 | .990 | 53.1 | 53.1 | 0.06 | in. | .047 | 52.3 | 52.5 | 53.0 | 0.55 | in. | .102 | 51.6 | 52.2 | 28 | in. | .102 | 51.6 | 52.2 | 52.2 | 0.04 | in. | .102 | 51.6 | 52.2 | 52.2 | 0.04 |
| 29 | | .040 | 52.2 | 52.5 | .980 | 51.9 | 52.0 | 0.29 | in. | .029 | 49.6 | 50.1 | 53.1 | 0.18 | in. | .077 | 49.4 | 50.2 | 29 | in. | .077 | 49.4 | 50.2 | 51.5 | 0.06 | in. | .077 | 49.4 | 50.2 | 51.5 | 0.06 |
| 30 | | .019 | 53.0 | 53.1 | .960 | 53.5 | 53.8 | 0.03 | in. | .028 | 51.4 | 52.0 | 52.6 | 0.07 | in. | .056 | 51.4 | 51.6 | 30 | in. | .056 | 51.4 | 51.6 | 52.0 | 0.10 | in. | .056 | 51.4 | 51.6 | 52.0 | 0.10 |
| 31 | | .028 | 53.0 | 53.0 | .955 | 53.0 | 53.0 | 0.15 | in. | 22-031 | 51.6 | 52.0 | 52.5 | — | in. | .064 | 52.2 | 52.5 | 31 | in. | .064 | 52.2 | 52.5 | 53.0 | 0.66 | in. | .064 | 52.2 | 52.5 | 53.0 | 0.66 |
| Mean. | | 22-030 | 52.8 | 52.9 | 21-976 | 53.1 | 53.3 | 9.32 | in. | 22-031 | 51.6 | 52.0 | 52.7 | 7.52 | in. | 22-086 | 52.8 | 53.2 | Mean. | in. | 22-086 | 52.8 | 53.2 | 53.2 | 12.49 | in. | 22-086 | 52.8 | 53.2 | 53.2 | 12.49 |
| | | 22-030 | 52.8 | 52.9 | 21-976 | 53.1 | 53.3 | 9.32 | in. | 22-031 | 51.6 | 52.0 | 52.7 | 7.52 | in. | 22-086 | 52.8 | 53.2 | | in. | 22-086 | 52.8 | 53.2 | 53.2 | 12.49 | in. | 22-086 | 52.8 | 53.2 | 53.2 | 12.49 |

Range of Barometer at Dodabetta.

An inspection of the above Tables shows that the range of the daily pressure, on the whole, had been very regular. The minimum oscillation was 0·08 on the 25th of July, although on the preceding and following days it was respectively 0·059 and 0·069; on the 25th of July 0·18 of rain fell, but the oscillation was only 0·16 on the 10th of June, on which day no rain fell, and the wet bulb was depressed 3°·6 in the morning and 1° in the afternoon. There are two other instances in which the diurnal oscillation was less than three hundredths,—on the 11th of April ·022, and on the 3rd of June ·026. The maximum oscillation occurred on the 16th of June, and was ·144. The preceding day it was ·102, but the following day it was only ·040. On the 18th of March it was ·102, on the 1st of March ·094, and on the 19th of February ·092; with these few exceptions of maxima and minima in diurnal oscillation, the daily range of the barometer was from ·040 to ·060, showing no violent atmospheric changes. The maximum pressure was on the 17th of March, and was 22·218 in., and the minimum on the 23rd of June, when the barometer stood at 21·800, although only ·09 of an inch of rain fell on that day, and little for several days before. The extreme annual range of the barometer, therefore, was only ·418, or less than half an inch. I have shown, in my former paper in the Philosophical Transactions, that the annual range in the Deccan, at 1800 feet above the sea, was only ·672 in 1830, from 28·242 in. in January to 27·570 in July, the difference of the thermometer at the extreme periods being only 1°·4; and in no instance, on comparing the maximum pressure of one year with the minimum pressure of any other year, did the difference amount to eight-tenths of an inch. In GOLDINGHAM'S tables at Madras, for twenty-one years, the greatest range in any year (with the single exception of a terrific storm in May 1820) appears to have been ·960 in 1818. In the more careful observations recorded by Capt. LUDLOW at the Madras Magnetic Observatory, from 1841 to 1845 both inclusive, *taken hourly*, the maximum range in 1842 (the observations for 1841 being imperfect) was from 30·156 at forty-one minutes past 9 A.M. on the 5th of December, to 29·454 on the 1st of June at 3^h 41^m P.M., and 29·455 on the 3rd of June at 4^h 41^m P.M., the range being 0·702 of an inch, the standard thermometer at the maximum pressure being 80°·6, and at the minimum 77°·3. In 1843 the maximum pressure was 30·208 on the 24th of January at 9^h 41^m A.M., and the minimum on the 21st of May being 29·256 at 3^h 41^m A.M., the range therefore 0·952; the thermometer at the maximum 81°·2, and at the minimum period 77° 8^m. In 1844 the maximum pressure was on the 16th of January, *i. e.* 30°·170 at 9^h 41^m A.M., and the minimum on the 1st of June, at 4^h 41^m P.M., *i. e.* 29·537, the range therefore 0·633, the thermometer at the first period being 79°·5, and at the second 89°·8. In 1845 the maximum pressure was on the 10th of January, 30°·196 at 9^h 41^m A.M., and the minimum on the 31st of May, 29°·531 at 4^h 41^m P.M., the range therefore 0·665: the thermometer at the maximum period was 79°·9, and at the minimum it was 101°·5. The following Table shows the extreme range of pressure at Madras, Bombay, Calcutta, &c.

Dates and Hours of the Maximum and Minimum Pressure at Madras, and extreme range of Barometer at Madras, Bombay, Calcutta, &c.

| Years. | Max. Pres. | Date. | Hour. | Min. Pres. | Date. | Hour. | Annual range at Madras. | Annual range at Bombay. | Annual range at Calcutta. | Annual range at Poona. | Annual range at Mahabuleshwur. | Annual range at Dodabetta. |
|--------|------------|----------|-------------------------------------|------------|---------|-------------------------------------|-------------------------|-------------------------|---------------------------|------------------------|--------------------------------|----------------------------|
| 1842. | 30·156 | Dec. 5. | 9 ^h 41 ^m A.M. | 29·454 | June 1. | 3 ^h 41 ^m P.M. | 0·702 | | | *0·672 | | |
| 1843. | 30·208 | Jan. 24. | 9 41 A.M. | 29·256 | May 21. | 3 41 P.M. | 0·952 | 0·705 | | | | |
| 1844. | 30·170 | Jan. 16. | 9 41 A.M. | 29·537 | June 1. | 4 41 P.M. | 0·633 | 0·661 | 0·957 | | | |
| 1845. | 30·196 | Jan. 10. | 9 41 A.M. | 29·531 | May 31. | 4 41 P.M. | 0·665 | | | | | |
| 1846. | | | | | | | 0·723 | | 0·869 | | | |
| 1847. | | | | | | | | | 0·859 | | | 0·418 |
| 1848. | | | | | | | | | 0·961 | | 0·443† | |

The maximum pressure, therefore, at Madras occurred at the *same hour* annually and within a range from the 5th of December to the 24th of January; and the minimum pressure occurred between 3^h 41^m and 4^h 41^m P.M., and within the range of ten days between the 21st of May and 1st of June. The maximum pressure at Dodabetta, in 1847, was on the 17th of March, instead of December or January, as at Madras, but the minimum occurred in June, as at Madras. The Poona maximum was in January and the minimum in July; at Bombay, in 1843, the maximum pressure occurred on the same day and the same hour as at Madras, and the minimum pressure occurred equally in May, but on the 16th instead of the 21st of May. These facts Dr. BUIST recorded in a series of meteorological observations, taken hourly in Bombay for the year 1843, on the opposite side of the peninsula from Madras; and in his tables it is stated that the maximum pressure of the atmosphere, 30·136, occurred on the 24th of January at 10 A.M., and the minimum pressure, 29·431, on the 16th of May, before the monsoon set in, at 4 P.M.; the extreme range therefore being 0·705, while the extreme range at Madras in that year was 0·952, but the mean of the five years at Madras was 0·735. In Bombay, in 1844, the range was ·661 from 30·119 on the 13th of January to 29·458 on the 4th of June. At Calcutta unfortunately the observations were not taken hourly, and exact data are not attainable; but the record in 1846 states that the maximum pressure occurred on the 12th of January at 9^h 50^m A.M., viz. 30·225, and the minimum on the 25th of July at 4 P.M. 29·356, the annual range therefore 0·869. In 1847 the barometer stood highest on the 5th of February at 9^h 50^m, being 30·169, and the least pressure was on the 25th of May, at *sunset*, 29·310, the annual range therefore 0·859, singularly approximating to that of the preceding year, but in both years being greater than at Madras or Bombay. In 1848, at Calcutta, the maximum pressure was on the 24th of December 30·231 (9th of February 30·200, and 16th of February 30·191), and the minimum pressure on the 20th of July 29·270 (on 18th of June 29·353, and on 20th of May 29·459), the extreme range in the year

* For 1830.

† For ten months of 1828-29.

therefore was 0.961. At no one of the places in the Table does there appear to have been a range of an inch; not only within the year, but taking the maximum pressure of one year with the minimum pressure of another year, the range of the barometer never amounted to 1 inch; and but for a record left by the late Mr. GOLDINGHAM, astronomer at Madras, it might be supposed the peninsula of India was not subject to any great changes of pressure. In a furious hurricane however which occurred at Madras on the 30th of October 1836, at 6 A.M., the barometer stood at 29.940, and at 7 P.M. it stood at 28.285, and stood at that during an awful lull until 7^h 45^m P.M., when the hurricane recommenced and the barometer rose to 28.725; the removal of pressure in thirteen hours amounting to 1.665 inch. But the area of any such removal of pressure would appear to be comparatively limited, and we are indebted to the elaborate researches of Mr. PIDDINGTON of Calcutta, and Colonel REID of the Royal Engineers, in their investigation of the Rotatory Storms or Cyclones within the tropics, for enabling us to give an approximative area to the great depressions of the barometer at sea, of which the observations on shore scarcely record a trace. For instance, in a storm at Madras on the 16th of May 1841, the hourly observations at the observatory gave the barometer 29.650 at 10 $\frac{1}{2}$ A.M., and the lowest depression was 29.513 at 4^h 41^m P.M., while the barque Tenasserim, which had been compelled to slip her cable and run to sea at 1 P.M., at 8 P.M., when not many miles distant from Madras, had the barometer at 28.60, the mercury at Madras at the same hour standing at 29.641, there being a difference of pressure of more than an inch of mercury *within a few miles*. The only effects of this storm upon the diurnal tide at Madras were, that the maximum nocturnal tide turned at 10^h 41^m P.M. instead of 9^h 41^m P.M., and the minimum ebb tide stopped at 2^h 41^m A.M. instead of 3^h 41^m A.M., but the minimum day-tide turned at the usual hour, 3^h 41 P.M.

Again, in a storm at Madras which took place on the 21st of May 1843, the simultaneous record of the barometer at the observatory and on board the General Kyd, which had been compelled to slip her cables and put to sea from Madras roads, was as follows:—

| | Hours. | | | | | | | | | | | |
|--------------|--------------|-------------|-------------|-------------|-------------|--------------|--------------|------------------|--------------|------------------|-------------|------------|
| | h m 12 41 | h m 3 41 | h m 5 41 | h m 7 41 | h m 9 41 | h m 11 41 | h m 12 41 | h m 2 41 A.M. | h m 12 41 | h m 2 41 P.M. | h m 5 41 | 23rd noon. |
| Madras | 29.323 | 29.256 | 29.284 | 29.381 | 29.420 | 29.412 | 29.391 | 29.333 | 29.409 | 29.382 | 29.411 | 29.522 |
| General Kyd | 29.45 | 29.38 | 29.28 | 29.26 | 29.19 | 28.17 | 29.11 | 29.11 | 29.18 | 29.19 | 29.27 | 29.42 |

From this Table it is seen that at 11^h 41^m on the night of the 21st of May, the barometer stood respectively at Madras and on board the General Kyd at 29.412 and 28.17, a difference of 1.242; and as the General Kyd was only sixty-eight miles east of Madras at noon on the 22nd, this prodigious difference of pressure occurred within fifty or sixty miles. The daily atmospheric tides continued at Madras despite the storm. The barometer reached its maximum at 9^h 41^m A.M., 29.421; and at 3^h 41^m P.M. it had fallen to its minimum, 29.360; then as usual it rose to 29.498 at 9^h 41^m P.M., and

as usual fell gradually to 29·373 at 3^h 41^m A.M. Although therefore the general pressure of the atmosphere had been lowered three or four-tenths of an inch from the 20th and 21st of May, the daily tides had not been interrupted, the maxima and minima occurring at their usual hours. In a storm at Madras on the 24th of October 1842, the P.M. tide reached its maximum at 10^h 41^m P.M., but the ebb stopped at 1^h 41^m A.M. instead of 3^h 41^m A.M., and then rose until 9^h 41^m A.M., the duration of the ebb being three hours only, and the flow from 1^h 41^m A.M. to 9^h 41^m A.M., no less than eight hours; the next ebb six hours, and the subsequent flow seven hours. One other illustration will show how little the pressure of the atmosphere is affected at a great height by a proximate storm. On the 17th and 18th of April 1847 a great storm occurred on the Malabar coast. The following is the record of the barometer on the 17th, at different distances from the *centre of the storm*, as recorded by Colonel REID; the Dodabetta observations being interpolated by myself.

| | |
|---|--------|
| | in. |
| Madras, 300 miles distant from centre, barometer . . . | 29·97 |
| Dodabetta, 166 miles distant from centre, barometer . . . | 21·917 |
| Cannanore, 100 miles distant from centre, barometer . . . | 29·64 |
| Ship Mermaid, 60 miles distant from centre, barometer . . . | 29·35 |

On the 18th of April.

| | |
|--|--------|
| | in. |
| Madras, 400 miles distant from centre of storm, barometer | 29·94 |
| Bombay, 240 miles distant from centre of storm, barometer | 29·70 |
| Dodabetta, 196 miles distant from centre of storm, barometer | 21·984 |
| Cannanore, 130 miles distant from centre of storm, barometer | 29·78 |
| Ship Buckinghamshire, 20 miles distant from centre of storm, barometer | 28·35 |
| Ship in centre of the storm, barometer | 28·00 |

At the centre of the storm, distant from Cannanore 130 miles, the difference of pressure therefore was 1·78; at Dodabetta, at 8642 feet above the sea, and 196 miles from the Buckinghamshire, the greatest difference on the 17th, 18th, or 19th of April from the mean pressure of the month, was less than two-tenths of an inch, as the following records at Dodabetta show:—

| 1847. April 17. | | April 18. | | April 19. | | Mean pressure of month of April. | |
|-----------------|--------------|------------|--------------|------------|--------------|----------------------------------|--------------|
| Barometer. | Oscillation. | Barometer. | Oscillation. | Barometer. | Oscillation. | Barometer. | Oscillation. |
| 21·917 | ·058 | 21·984 | ·064 | 22·034 | ·044 | 22·097 | ·062 |

And although the wind at Dodabetta on the 17th and 18th blew from the east round to the west with a maximum pressure of 35 and 22 lbs., and with a mean pressure for the two days of 21 and 14 lbs.; and though ten inches of rain fell on the 18th, the daily atmospheric tides were neither suppressed, inverted, nor interrupted, and scarcely differed from the daily mean oscillation of the month. Sufficient instances have thus been

adduced of the comparatively narrow area of very great barometrical depressions, and the annual ranges given in the preceding Table may for the present be considered normal conditions, at least at Madras.

The following Table gives the monthly means of the diurnal oscillation of the barometer at Dodabetta, together with the monthly and annual range of the barometer, and the monthly fall of rain :—

Barometer at Dodabetta, at 8640 feet above the level of the sea.

| | Barometer. Monthly means. | | Difference. | Maximum. | Minimum. | Extreme monthly range. | Rain. |
|-----------------|--------------------------------|--------------------------------|-------------|----------|----------|---------------------------|--------|
| | 9 ^h 40' A.M. in. | 3 ^h 40' P.M. in. | | | | | |
| 1847. | | | | in. | in. | | |
| February | 22·129 | 22·068 | ·061 | 22·165 | 22·014 | ·151 | 7·43 |
| March | 22·160 | 22·105 | ·055 | 22·218 | 22·064 | ·154 | 3·61 |
| April | 22·128 | 22·066 | ·062 | 22·199 | 21·888 | ·311 | 19·80 |
| May | 22·087 | 22·024 | ·063 | 22·169 | 21·930 | ·239 | 4·86 |
| June | 21·992 | 21·940 | ·052 | 22·069 | 21·800 | ·269 | 4·55 |
| July | 22·000 | 21·949 | ·051 | 22·032 | 21·889 | ·143 | 7·41 |
| August | 22·030 | 21·976 | ·054 | 22·090 | 21·898 | ·198 | 9·32 |
| September | 22·031 | 21·977 | ·054 | 22·100 | 21·876 | ·224 | 7·52 |
| October | 22·086 | 22·014 | ·072 | 22·129 | 21·958 | ·171 | 12·49 |
| November | 22·117 | 22·038 | ·079 | 22·152 | 21·966 | ·186 | 11·85 |
| December | 22·073 | 22·013 | ·060 | 22·150 | 21·921 | ·229 | 12·28 |
| 1848. | | | | | | | |
| January | 22·113 | 22·050 | ·063 | 22·163 | 22·016 | ·147 | 0·12 |
| Year | 22·079 | 22·019 | ·060 | 22·218 | 21·800 | ·418 | 101·24 |

Horary Oscillations.

It is thus shown that the mean daily range for the year is 0·060, and in no month of the year did it exceed 0·079 in. This is different from Mahabuleshwur, Poona, Madras and Bombay. At Mahabuleshwur, at 4500 feet, the mean diurnal oscillation for ten months, by simultaneous observations, was 0·0694, and in no month did the monthly mean exceed 0·0835. At Poona, at 1823 feet, for 1827, it was 0·1009, for 1828 it was 0·1075, and for 1829 it was 0·0991; but this last diminished oscillation is partly to be attributed to three months' observations having been taken at an elevation of 4000 feet above the sea; but in 1830 the barometers were stationed for the whole year at Poona, at 1823 feet, and the mean diurnal fall of the barometer from 9—10 A.M. to 4—5 P.M. was 0·1166; the mean of the four years was 0·1060. The greatest *mean* diurnal range for any month in those four years was 0·1616 in the month of December 1827. At Madras hourly observations were recorded from the years 1842 to 1845, both inclusive, and for ten months in 1841, of which I shall not take any account, as the year is incomplete. The mean monthly fall of the barometer from 9^h 41^m A.M. to 3^h 41^m P.M. daily, was respectively 0·124, 0·120, 0·122 and 0·121, exhibiting a singular uniformity, the differences being only in the thousandths of an inch of pressure. This uniformity is equally marked in the successive months of the several years, and I have gone through the labour of working out the details to show it, the Madras printed observations being a record of facts only without deductions or comment.

Mean Diurnal Horary Oscillations.

| | Madras. | | | | Bombay, 35 feet. | | Calcutta, 18 feet. | | Deccan, about 1800 feet. | | | Poona, 1823 feet. | Mahabuleshwur, 4500 feet. | | Dodabetta, 8640 feet. |
|---------------|---------------|-------|-------|-------|------------------|-------|--------------------|-------|--------------------------|-------|-------|-------------------|---------------------------|---------------------|-----------------------|
| | 1842. | 1843. | 1844. | 1845. | 1843. | 1844. | Means. 1829-31. | 1848. | 1827. | 1828. | 1829. | 1830. | 1828-29. | Means, 15 years. | 1847-48. |
| | January | 0.120 | 0.105 | 0.114 | 0.111 | 0.112 | 0.120 | 0.123 | 0.142 | 0.113 | 0.148 | 0.125 | 0.136 | 0.073 | 0.158 |
| February ... | 0.119 | 0.121 | 0.119 | 0.120 | 0.114 | 0.112 | 0.117 | 0.147 | 0.125 | 0.150 | 0.108 | 0.140 | 0.066 | 0.087 | 0.061 |
| March | 0.126 | 0.127 | 0.128 | 0.125 | 0.113 | 0.123 | 0.125 | 0.121 | 0.124 | 0.112 | 0.102 | 0.133 | 0.082 | 0.094 | 0.055 |
| April | 0.134 | 0.133 | 0.134 | 0.138 | 0.119 | 0.118 | 0.124 | 0.131 | 0.083 | 0.133 | 0.098 | 0.143 | 0.083 | 0.092 | 0.062 |
| May | 0.126 | 0.111 | 0.121 | 0.120 | 0.110 | 0.098 | 0.115 | 0.131 | 0.062 | 0.083 | 0.093 | 0.132 | 0.075 | 0.085 | 0.063 |
| June | 0.126 | 0.119 | 0.118 | 0.120 | 0.074 | 0.071 | 0.095 | 0.094 | 0.090 | 0.100 | 0.073 | 0.106 | 0.052 | 0.062 | 0.052 |
| July | 0.135 | 0.129 | 0.126 | 0.118 | 0.034 | 0.063 | 0.090 | 0.094 | 0.048 | 0.047 | 0.065 | 0.075 | 0.055 | 0.017 | 0.051 |
| August | 0.131 | 0.127 | 0.129 | 0.139 | 0.087 | 0.070 | 0.099 | 0.103 | 0.060 | 0.070 | 0.086 | 0.085 | 0.053 | 0.043 | 0.054 |
| September ... | 0.124 | 0.134 | 0.131 | 0.128 | 0.086 | 0.097 | 0.101 | 0.105 | 0.081 | 0.091 | 0.077 | 0.090 | | 0.073 | 0.054 |
| October | 0.123 | 0.115 | 0.123 | 0.122 | 0.108 | 0.122 | 0.110 | 0.113 | 0.114 | 0.110 | 0.111 | 0.125 | | 0.130 | 0.072 |
| November ... | 0.108 | 0.110 | 0.111 | 0.103 | 0.119 | 0.127 | 0.107 | 0.125 | 0.144 | 0.127 | 0.106 | 0.125 | 0.080 | 0.152 | 0.079 |
| December ... | 0.116 | 0.110 | 0.108 | 0.107 | 0.116 | 0.122 | 0.114 | 0.129 | 0.161 | 0.114 | 0.133 | 0.110 | 0.073 | 0.082 | 0.060 |
| Year | 0.124 | 0.120 | 0.122 | 0.121 | 0.099 | 0.095 | 0.110 | 0.097 | 0.102 | 0.109 | 0.099 | 0.116 | 0.069 | 0.089 | 0.060 |

Note.—The above means are the daily fall of the barometer from 9 to 10 A.M. to 4 to 5 P.M.

At Madras the mean daily oscillation would appear to have been least when the barometer was highest in November, December, or January; and the reverse of this was the case when the barometer was lowest in May, June and July. The *mean* of the four years, at Madras, in the months of highest pressure, December and January, is 0·111, and the mean of the four years in the months of least pressure 0·122. The mean daily oscillation therefore was greatest when the pressure of the atmosphere was least. The same was not observed to be the case in the observations made in the Dukhun in the years 1827, 1828, 1829 and 1830; the means for the two periods being 0·131 and 0·081; nor in Calcutta in the years 1829, 1830 and 1831, the oscillations being respectively 0·118 and 0·100; and in 1848 the difference was more marked, the means of the daily oscillation for the periods of greatest and least annual pressure being 0·135 and 0·106: the same was the case at Bombay and at Dodabetta. This peculiar feature exhibited at Madras is not satisfactorily explained by its not being subjected, like Calcutta and Bombay, to the south-west monsoon, because the general curve of pressure at Madras follows the order of pressure at Calcutta and Bombay, with the exception of the month of November in the years 1844 and 1845, when the mean monthly pressure was greater in that month than in December. The hourly observations at Madras were too systematically and apparently accurately taken to suppose there could have been inaccuracy in the records, and they are quite as trustworthy, if not more so, than any other meteorological records in India. There appears a great discrepancy in the mean daily range at Madras and Bombay in the months from March to November, particularly in the month of April, which does not belong to the monsoon of either place. In the other months, the small range at Bombay may be accounted for by the prevalence of the monsoon at Bombay and the absence of the monsoon at Madras, but the means of the daily range for the year indicate a greater oscillation at Madras than might have been expected.

Times of ebb and flow of the Atmospheric Tides, or Turning-points.

I have given separately the chief of the four daily tides, namely, the fall between 9—10 A.M. to 4—5 P.M., to facilitate comparison of the movements of the same tide at different places by simple inspection. The following Table gives the movements of the three other daily tides; but I have confined it to the Madras records, as three daily movements for various places could not have been put conveniently into juxtaposition.

Monthly means of the Daily Atmospheric Tides between the hours 3^h 41^m—4^h 41^m P.M. to 9^h 41^m—10^h 41^m A.M.

| | Madras, 1842. | | Madras, 1843. | | Madras, 1844. | | Madras, 1845. | |
|-------|--|--|--|--|--|--|--|--|
| | 3 ^h 41 ^m —4 ^h 41 ^m P.M. to 9 ^h 41 ^m —10 ^h 41 ^m P.M. | 3 ^h 41 ^m —4 ^h 41 ^m A.M. to 9 ^h 41 ^m —10 ^h 41 ^m A.M. | 3 ^h 41 ^m —4 ^h 41 ^m P.M. to 9 ^h 41 ^m —10 ^h 41 ^m P.M. | 3 ^h 41 ^m —4 ^h 41 ^m A.M. to 9 ^h 41 ^m —10 ^h 41 ^m A.M. | 3 ^h 41 ^m —4 ^h 41 ^m P.M. to 9 ^h 41 ^m —10 ^h 41 ^m P.M. | 3 ^h 41 ^m —4 ^h 41 ^m A.M. to 9 ^h 41 ^m —10 ^h 41 ^m A.M. | 3 ^h 41 ^m —4 ^h 41 ^m P.M. to 9 ^h 41 ^m —10 ^h 41 ^m P.M. | 3 ^h 41 ^m —4 ^h 41 ^m A.M. to 9 ^h 41 ^m —10 ^h 41 ^m A.M. |
| Jan. | +0.078 | -0.063 | +0.105 | +0.069 | +0.078 | -0.060 | +0.079 | -0.062 |
| Feb. | +0.091 | -0.068 | +0.096 | -0.058 | +0.072 | -0.049 | +0.083 | -0.063 |
| March | +0.100 | -0.064 | +0.090 | -0.058 | +0.092 | -0.055 | +0.097 | -0.071 |
| April | +0.113 | -0.056 | +0.077 | -0.059 | +0.103 | -0.048 | +0.116 | -0.046 |
| May | +0.114 | -0.064 | +0.076 | -0.065 | +0.110 | -0.059 | +0.100 | -0.053 |
| June | +0.106 | -0.046 | +0.064 | -0.052 | +0.090 | -0.038 | +0.105 | -0.043 |
| July | +0.113 | -0.046 | +0.068 | -0.043 | +0.106 | -0.052 | +0.102 | -0.039 |
| Aug. | +0.110 | -0.054 | +0.075 | -0.046 | +0.107 | -0.048 | +0.106 | -0.036 |
| Sept. | +0.108 | -0.059 | +0.075 | -0.039 | +0.104 | -0.048 | +0.105 | -0.044 |
| Oct. | +0.101 | -0.058 | +0.080 | -0.058 | +0.097 | -0.058 | +0.093 | -0.050 |
| Nov. | +0.085 | -0.063 | +0.086 | -0.070 | +0.086 | -0.059 | +0.096 | -0.075 |
| Dec. | +0.087 | -0.063 | +0.092 | -0.067 | +0.091 | -0.070 | +0.086 | -0.048 |
| Means | +0.1005 | -0.0587 | +0.082 | -0.0577 | +0.0947 | -0.0537 | +0.0973 | -0.0525 |
| | | | +0.0846 | +0.0804 | +0.0786 | | | |

A close inspection of the hourly observations upon which the above Table of means is founded, shows that the tides turn occasionally on consecutive days at different hours, and the intervals between the maxima and minima in the several diurnal tides frequently vary from five hours to seven hours in the duration of each tide; and not less frequently it is found that at the turning-point or turn of the tide, there is no movement of the atmosphere at all

for an hour to an hour and a half; nevertheless the *monthly means* of the same tide for successive years are almost identical; take for instance the *rising* afternoon tide from 3—4 P.M. to 10 or 11 P.M. in the month of January, and it is seen that the means in the successive four years were ·078, ·080, ·078 and ·079, so that the daily irregularities were merged in the monthly means. Similarly, the rising tide from 3^h 41^m—4^h 41^m A.M. to 9^h 41^m—10^h 41^m A.M. in the month of February was ·096, ·095, ·095 and ·100 in successive years. The falling night-tide between P.M. and A.M. does not exhibit quite the same regular features; for instance, in the month of March we have ·064, ·058, ·055 and ·071. November also has ·063, ·070, ·059 and ·075; but the annual means of each tide, as in the great diurnal tide, remarkably approximate to each other in successive years, as is shown by the Table, which is worked out from the Madras hourly observations. Another feature exhibited by the Table is the alteration in the range of the monthly means of the diurnal movement of the same tide in different months of the year, the increment and decrement alternating at different seasons of the year with the increment and decrement of another of the tides; for instance, in the month of January throughout the four years the rising tide from 3^h 41^m—4^h 41^m P.M. to 9^h 41^m—10^h 41^m P.M. is LESS than the rising tide from 3^h 41^m—4^h 41^m A.M. to 9^h 41^m—10^h 41^m A.M.; but the reverse of this takes place as the year advances, and in April the P.M. *rising* tide is considerably greater than the A.M. rising tide, and this continues until November, when the previous relations return. The same remarks do not apply to the two *falling* tides, as the falling tide by day is invariably greater (more than double) than that of the falling tide by night.

In my paper on the Atmospheric Tides of the Deccan, I gave a Table (No. 3) of the anomalies in the period of the ebb and flow of the different tides in 1830, and to enable me to do this I had observed the barometer every five minutes about the period of the expected turn of the tide. The anomalies were numerous. In the Madras hourly observations the same anomalies are observable, as the intervals of maxima and minima vary from five hours to eight hours, although the absolute time of the turn of the tide within the hour is not shown. Dr. BUIST'S observations in Bombay for 1843 and 1844 are also hourly, and exhibit the same occasional irregularities in the time of the tides turning as at Poona and Madras. The recent observations at Calcutta do not afford the means of detecting this no doubt existing fact; for observations at Calcutta are not recorded by night at all, and only every two hours during the day. A bare inspection of and reliance upon the Calcutta monthly tables therefore would justify the assertion that the daily maxima and minima in the oscillations of the barometer occurred at fixed hours, which, although generally true, is not absolutely so. The observations at Dodabetta were unfortunately not made hourly, with the exception of those for twenty-four hours between the twenty-first and twenty-second days of each month; the means of comparison therefore of the diurnal hourly oscillations with those of Madras and Bombay, are limited to those twenty-four hours in each month; but although so limited, features of interest are exhibited. It has hitherto I believe been supposed that the two ascending and two descending diurnal

tides of the atmosphere within the tropics, although turning after a longer or shorter interval in each tide, were never interrupted or retrograde in the onward or backward movement of each tide. The Dodabetta hourly observations indicate that such is not the case, and I have thrown the facts into a table for a comprehensive view of them.

Movements of the Atmosphere in twenty-four hours in each month (21st to 22nd) of the year 1847-48 at Dodabetta, at 8640 feet above the sea.

| | Hours. | | | | | | | | | | | | | | | | | | | | | | | |
|-------|--------|-------|-------|-------|-------|-------|-------|-------|-------|-------|-------|-------|-------|-------|-----------|-------|-------|-------|-------|-------|-------|-------|-------|-------|
| | A.M. | | | | | | | | | | | | P.M. | | | | | | | | | | | |
| | 10 | 11 | Noon. | 1 | 2 | 3 | 4 | 5 | 6 | 7 | 8 | 9 | 10 | 11 | Midnight. | 1 | 2 | 3 | 4 | 5 | 6 | 7 | 8 | 9 |
| Feb. | | | | | | | | | | | | | | | | | | | | | | | | |
| March | +·310 | | | | | | | | | | | | | | | | | | | | | | | |
| April | +·130 | | | | | | | | | | | | | | | | | | | | | | | |
| May | | | | | | | | | | | | | | | | | | | | | | | | |
| June | +·962 | | | | | | | | | | | | | | | | | | | | | | | |
| July | +·026 | | | | | | | | | | | | | | | | | | | | | | | |
| Aug. | | | | | | | | | | | | | | | | | | | | | | | | |
| Sept. | | | | | | | | | | | | | | | | | | | | | | | | |
| Oct. | +·128 | | | | | | | | | | | | | | | | | | | | | | | |
| Nov. | | | | | | | | | | | | | | | | | | | | | | | | |
| Dec. | +·120 | | | | | | | | | | | | | | | | | | | | | | | |
| Jan. | | | | | | | | | | | | | | | | | | | | | | | | |

+ Indicates the maximum tide.

— Indicates the minimum tide.

± Indicates an interruption to usual rise or fall.

The barometer ranged between 21·800 and 22·218 inches.

Observations on Horary Oscillations.

It is hence seen that in the month of March the diurnal tide, which usually falls from 10 A.M. until 4 P.M., turned at 3 P.M., and should then have gradually risen until 9—10 P.M., instead of which it rose only until 4 P.M. and then fell until 5 P.M., when it turned again and ran its usual course. In the same month the A.M. tide, which usually falls from 10 P.M. until 4 A.M., had its fall interrupted at 2 A.M. and rose until 3 A.M., when it turned and fell to its ordinary minimum, and then gradually rose until 10 A.M. In the month of May the daily minimum occurred at the proper hour, 4 P.M., and its ordinary regular rise continued until 5 P.M.; but at this hour it changed and fell until 6 P.M., but at that hour resumed its usual course. The other tides were free from these aberrations, but two of them turned at 3 and 9 A.M. instead of 4 and 10 A.M. In the month of June the flow is irregular in the 4 A.M. tide. Its minimum occurs properly at 4 A.M., and it rises until 5 A.M., but at this hour it has turned, instead of continuing to rise, and falls until 6 A.M., when the barometer is as low as at 4 A.M.,—a solitary instance within the year. In the month of January 1848, the falling tide from 10 P.M. goes on regularly until midnight, when it turns and rises until 1 A.M.; it then turns again in the proper direction, but instead of stopping at 4 A.M., the minimum hour, it continues until 5 A.M. and then turns. An inspection of the Table shows that the barometer never appeared to remain stationary at the turning hour of the maximum A.M. (9—10) tide, but that in the months of January, February and April, no movement of the tide took place for a full hour at the 9—10 P.M. maximum tide. In August, although the other tides flowed as usual, that of the A.M. period remained stationary from 2—4 A.M., both inclusive. The maximum A.M. tide occurred six times in six months of the year at 9 A.M., and six times in the other six months at 10 A.M. The maximum nocturnal tide took place only twice at 11 P.M., thrice at 9 P.M., five times at 10 P.M., and thrice was stationary between 9 and 10 P.M. The minimum diurnal tide turned once only at 6 P.M. The chief irregularities appear to have been in the A.M. minimum nocturnal tide, embracing the hours from 1—6 A.M. On looking over the Madras hourly observations for four years for the twenty-four hours between the 21st and 22nd of each month in the year 1842, there are *only two instances of similar irregularities*. On the 22nd of March in the falling A.M. tide at 2^h 41^m A.M., the barometer stood at 29·859, and at 3^h 41^m A.M., instead of continuing to fall, it had risen to 29·869, but at 4^h 41^m it resumed its regular course and fell to 29·865. On the 22nd of November an irregularity occurred in the nocturnal P.M. tide. At 10^h 41^m the barometer stood at 30·004; at 11^h 41^m it had fallen in due course to 29·991, but at 12^h 41^m it had risen to 29·992, and only at 1^h 41^m resumed its usual ebb, and fell to 29·981. In the year 1843 there are also *only two instances* of irregularity in the specified days; namely, on the 21st of August in the A.M. falling tide. At 1^h 41^m A.M. the barometer stood at 29·722; at 2^h 41^m, instead of falling, it rose to 29·725, then fell, at 3^h 41^m, to 29·724; then rose, at 4^h 41^m, to 29·726, and continued regular to the maximum period at 9 A.M. On the 21st of December, at 11^h 41^m

P.M., the barometer was 30·121 ; at 12^h 41^m, instead of continuing to fall, it had risen to 30·125, but then changed ; and at 2^h 41^m it was 30·104, and fell regularly till 3^h 41^m A.M., when it was at its minimum, 30·089. On the 21st of September, in 1843, the minimum A.M. nocturnal tide occurred at 1^h 41^m A.M. instead of 3^h 41^m, at which hour it took place on the morning of the 22nd ; the interval, therefore, between the minimum of this A.M. nocturnal tide and the maximum of the 9—10 morning tide, was seven hours, the maximum occurring at 8^h 41^m, a very rare instance of the continued flow of this A.M. tide, which usually runs its course within four or five hours, and on rare occasions in three hours ; the change of pressure, however, was only equal to 0·114, from 29·763 to 29·877. In 1844 there is *but one instance* of irregularity within the prescribed hours. On the 22nd of September, at 12^h 41^m A.M., the barometer stood at 29·820 ; at 1^h 41^m it had fallen as usual to 29·808, but at 2^h 41^m it had risen to 29·819 ; at 3^h 41^m to 29·833 ; but at 4^h 41^m it had fallen to 29·832, and then continued regular. In 1845 there is also *only a solitary instance* on the 21st of March. At 7^h 41^m A.M. the barometer stood at 29·933 ; at 8^h 41^m it had fallen, instead of rising, to 29·932, but at 9^h 41^m resumed its usual course. It will be remarked that at Madras there is *not a single instance* of irregularity in four years in the fall of the great diurnal tide from 9—10 A.M. to 4—5 P.M., and the instances of irregularities in the other tides only serve to prove that the laws are not without exceptions. From the above comparisons it is seen that the irregular movements in the tides were not common to Dodabetta and Madras at simultaneous periods of time, nor at proximate periods of time. The irregularities in the intervals of the different tides are numerous, as are also the instances of stationary periods in which the atmosphere appears to be quiescent from one to two hours. It now remains to notice the deviations from the usual laws at Bombay, as recorded by Dr. BUIST in his Bombay hourly observations for 1843 and 1844. On the 21st of January, at 3 A.M., the barometer stood at 29·864, at 4 A.M. at 29·865 ; but at 5 A.M., instead of continuing to rise, it had fallen to 29·863, and continued to fall until 6 A.M., when it stood at 29·856 ; at 7 A.M. it resumed its usual course, and continued to rise until the maximum hour. At Madras, on the same day, making allowance for the difference of longitude, *nothing of the kind occurred*. At Bombay, on the 21st of March, at 11 P.M., the barometer stood at 29·688 ; but at midnight, instead of continuing to fall, it had risen to 29·699, and it was only at 1 A.M. it resumed its ebb. *There was nothing of the kind at Madras*, where the maximum, 29·861, was attained at 10^h 41^m with the ordinary regularity. On the 22nd of May, at Bombay, there were irregularities in all the tides, a thing so unusual, and not occurring at all on the 20th or 23rd of May, as to render the table apocryphal, either from error in the record or in the lithography ; the A.M. falling tide stops at 2 A.M., then rises to 8 A.M., falls to 9 A.M., and then rises to 10 A.M., its maximum, however, being at 8 A.M. From 4 P.M. the tide as usual rises to 6 P.M., then falls to 8 P.M., and afterwards proceeds to attain its maximum at 11 P.M. Something similar occurs between 1 and 5 A.M. on the 21st of June, but not on the 22nd. *Nothing of the kind occurs at Madras, either on the*

20th, 21st, 22nd or 23rd of May. The last irregularity to be noticed at Bombay, within the limit hours, was on the 21st of October. At midnight the barometer stood at 29·803; at 1 A.M. it had risen in the usual course to 29·887, but at 2 o'clock it had fallen to 29·881, and only resumed its ordinary rise at 3 A.M.; as far as the record goes, there does not appear to have been any irregularity at Madras*. Similar instances occur within the limit hours in 1844,—on 21st of January at 3 A.M., 21st of May at 1 A.M., when the tide remained stationary at 3^h 41^m, and 5 A.M., and at 1 A.M. on the 22nd of December. In September the maximum horary pressure occurred at 11^h 30^m A.M., and in other months several times at 11 A.M.

If we extend our comparisons to Aden, on the coast of Arabia, nearly in the latitude of Madras, but 35° 6' of longitude to the west of Madras, we find the very same exceptions to normal conditions. Dr. BUIST has been kind enough to transmit to me proof sheets, now going through the press, of part of a meteorological journal kept at Aden for 1847 and 1848. Hourly observations were taken on certain term-days monthly; instead of taking up the whole of these term-days, it will suffice to select those of January and June of each year, these being months in which the maximum and minimum pressure of the atmosphere usually occur in India. Barometer 187 feet above the sea at Aden. All corrections made.

| | Hours. | | | | | | | | | | | | | | | | | | | | | | Means. | | | | |
|----------------|--------|-----|------|------|------|-----|-----|------|------|------|------|------|------|-----|------|-----|-----|------|------|-----|-----|-----|--------|------|-----|--------|--------|
| | P.M. | | | | | | | | | | | | A.M. | | | | | | | | | | | | | | |
| | Noon. | 1 | 2 | 3 | 4 | 5 | 6 | 7 | 8 | 9 | 10 | 11 | 12 | 1 | 2 | 3 | 4 | 5 | 6 | 7 | 8 | 9 | | 10 | 11 | 12 | |
| January, 1847. | | | | | | | | | | | | | | | | | | | | | | | | | | | |
| 15 | 29·760 | ... | ... | ·743 | ... | ... | ... | ... | ·821 | ... | ... | ·778 | ·780 | ... | ·770 | ... | ... | ... | ... | ... | ... | ... | ·853 | ... | ... | 29·790 | |
| 25 | 29·684 | ... | ... | ·661 | ... | ... | ... | ·717 | ... | ... | ... | ... | ... | ... | ·646 | ... | ... | ... | ... | ... | ... | ... | ·743 | ... | ... | 29·691 | |
| 30 | 29·763 | ... | ... | ·716 | ... | ... | ... | ... | ... | ... | ... | ... | ... | ... | ·722 | ... | ... | ... | ... | ... | ... | ... | ·808 | ... | ... | 29·760 | |
| June, 1847. | | | | | | | | | | | | | | | | | | | | | | | | | | | |
| 8 | 29·648 | ... | ... | ·557 | ... | ... | ... | ... | ... | ·637 | ... | ... | ... | ... | ·583 | ... | ... | ... | ... | ... | ... | ... | ... | ·698 | ... | ... | 29·614 |
| 16 | 29·582 | ... | ... | ·488 | ·488 | ... | ... | ... | ·542 | ... | ... | ... | ... | ... | ·507 | ... | ... | ... | ... | ... | ... | ... | ... | ·613 | ... | ... | 29·533 |
| 20 | 29·631 | ... | ... | ·502 | ... | ... | ... | ·574 | ... | ... | ... | ... | ... | ... | ·506 | ... | ... | ... | ... | ... | ... | ... | ... | ·620 | ... | ... | 29·552 |
| 29 | 29·490 | ... | ... | ... | ·385 | ... | ... | ... | ... | ·484 | ... | ... | ... | ... | ·431 | ... | ... | ... | ... | ... | ... | ... | ... | ·548 | ... | ... | 29·468 |
| January, 1848. | | | | | | | | | | | | | | | | | | | | | | | | | | | |
| 7 | 29·856 | ... | ·810 | ... | ... | ... | ... | ... | ·921 | ... | ... | ·858 | ·864 | ... | ·844 | ... | ... | ... | ... | ... | ... | ... | ·914 | ... | ... | ... | 29·876 |
| 14 | 29·868 | ... | ... | ·835 | ... | ... | ... | ... | ... | ·902 | ... | ... | ... | ... | ·860 | ... | ... | ... | ... | ... | ... | ... | ... | ·915 | ... | ... | 29·874 |
| 24 | 29·791 | ... | ... | ·732 | ... | ... | ... | ... | ... | ·807 | ... | ... | ... | ... | ·733 | ... | ... | ... | ... | ... | ... | ... | ... | ·853 | ... | ... | 29·781 |
| 28 | 29·774 | ... | ·720 | ·720 | ... | ... | ... | ... | ... | ·814 | ... | ... | ... | ... | ·761 | ... | ... | ... | ... | ... | ... | ... | ... | ·853 | ... | ... | 29·781 |
| June, 1848. | | | | | | | | | | | | | | | | | | | | | | | | | | | |
| 8 | 29·497 | ... | ... | ·416 | ... | ... | ... | ... | ... | ·507 | ... | ... | ... | ... | ·395 | ... | ... | ... | ... | ... | ... | ... | ... | ·532 | ... | ... | 29·460 |
| 15 | 29·546 | ... | ... | ·481 | ... | ... | ... | ... | ·549 | ... | ... | ... | ... | ... | ·479 | ... | ... | ·572 | ·563 | ... | ... | ... | ... | ·609 | ... | ... | 29·533 |
| 21 | 29·522 | ... | ... | ·382 | ·382 | ... | ... | ... | ·469 | ·446 | ·466 | ·462 | ... | ... | ·377 | ... | ... | ... | ... | ... | ... | ... | ... | ·567 | ... | ... | 29·456 |
| 29 | 29·651 | ... | ... | ·542 | ... | ... | ... | ... | ... | ·599 | ... | ... | ... | ... | ·544 | ... | ... | ... | ... | ... | ... | ... | ... | ·673 | ... | ... | 29·589 |

A glance of the eye over the above Table shows the turning-points of the several tides and their irregularities. The first marked feature is the almost constant turning of the descending P.M. tide and ascending A.M. tide at 3 P.M. and 3 A.M., instead of at 4 or 5 P.M. and A.M., as on the continent of India; to this there are only five

* In a diagram of the comparative readings of seven barometers at Bombay, between the 20th and 21st of June 1843, these anomalies appear to have occurred between 2 and 3 P.M., 7 and 8 P.M., 10 and 11 P.M. and 1 to 4 A.M., but the barometers did not exactly harmonize in their movements.

exceptions to the former and only one to the latter ; but two of the exceptions are remarkable, the tide having turned on the 7th and 28th of January 1848, at 2 P.M. I do not recollect a single case of the kind in the records in India. In the first of these cases the tide flowed from 2 until 9 P.M., seven hours ; and in the second it remained stationary from 2 until 3 P.M., and then flowed until 10 P.M. ; this portion of the diurnal movement of the atmosphere occupying eight hours instead of six. As a contrast to these lengthened periods, we find that the 3 P.M. ascending tide, on the 25th of January and 20th of June 1847, flowed only from 3 P.M. until 8 P.M., five hours instead of eight. On the 15th of January 1848, the ascending A.M. tide did not attain its maximum until 11 A.M., but this retardation was probably owing to an inversion in the flow at 7 A.M. ; the pressure, instead of increasing at this hour, having diminished from 29.572 at 6 A.M. to 29.563, but after this interruption the usual increase took place up to 11 A.M. It will be seen that there are two instances of a stationary state of the barometer on the 28th of January 1848, from 2 to 3 P.M., and on the 21st of June 1848, from 3 to 4 P.M. Meteorologists know that this circumstance, which would excite no attention without the tropics, is of rare occurrence within the tropics. The next great feature in this Table is the absence of any retrograde movement in the P.M. descending and ascending tides ; but this is not the case with the other two tides ; as at Dodabetta, several interruptions in the flow or ebb are recorded. In the descending nocturnal A.M. tide there are three instances. On the 15th of January 1847, at 1 A.M., the tide has risen from midnight instead of continuing to fall. Precisely the same thing occurs on the 7th of January 1848, at the same hours. On the 21st of June the interruption occurs at an earlier hour. The pressure is at its maximum at 9 P.M. ; it then diminishes until 10 P.M., but instead of continuing to diminish it increases until 11 P.M., but at midnight has resumed its usual course. In the A.M. ascending tide there is only one instance of inversion ; on the 15th of June 1848, the usual rise stops at 6 A.M. and retrogrades until 7 A.M., it then resumes its usual flow and continues until 11 A.M., a very unusual hour for the period of the maximum of the A.M. tide. Had the term-days of the other months been noticed, numerous instances of deviations from normal conditions could have been given. *It would be desirable to ascertain whether these aberrations have any relation with changes in the electrical tension in the atmosphere.*

If these anomalies be tested by a comparison with hourly readings of the barometer, at Aden CORRECTED FOR THE TENSION OF VAPOUR*, for four days in each month of the year 1847, not only is their occurrence rendered unquestionable, but new phases in abnormal conditions appear. Annexed is a Table of the " Means " of hourly readings of the barometer in four days in each month at Aden in 1847, CORRECTED FOR MOISTURE.

* Corrected by the observer.

It has been asserted that when the barometer is corrected for moisture its diurnal movements in the tropics are resolvable into a simple ascending and descending curve in the twenty-four hours, nevertheless the first feature of the Table is the existence of two ascending and two descending tides, although the correction for moisture had reduced the air in which the mercurial column had moved to a supposed dry state. The usual hours of the ebb and flow are generally sufficiently manifest, particularly in the hours of greatest pressure, yet there is the unusual circumstance of the ascending A.M. tide turning in five months at 6 A.M. instead of 9—10 A.M., and in this tide also there are three instances of a check to its usual movements. The ascending P.M. tide has also its anomalies. In eight months it attained its maximum at the usual time between 9 and 10 P.M., but in July there is the rare circumstance of its turning at 5 P.M. instead of 9—10 P.M., and in June and August the equally rare circumstance of its turning at 7 P.M.; the next anomaly in this tide is in October, when it did not turn until midnight. The chief anomalies, as at Madras, Bombay and Dodabetta, occur in the A.M. and P.M. ebb or descending tide. The Table shows that the turning-points of the P.M. diurnal ebb, ranged from noon in February, and July, to 4 P.M. in April and June. In February, when the minimum occurred at noon, the maximum took place at the usual hour, 10 P.M.; there was therefore the almost unprecedented circumstance of *a tide continuing to flow for nine hours*. In the A.M. descending or ebb tide, the anomalies are even more marked than in the corresponding P.M. tide, for the turning-points range from 1 A.M. to 5 A.M. In January it turned at 1 A.M., and then the ascending tide continued to flow uninterruptedly until 10 A.M., a second instance of a *nine hours' flow*. In July, September and November, it also turned at 1 A.M., but the maximum occurred at 6 A.M. instead of 10 A.M., the flow in each of these months being five hours! a glance of the eye over the Table will show; although the different tides ultimately attained their respective maxima and minima, yet in many instances they were subject to checks or interruptions, which appeared to give way after a short resistance to the periodic movements of the atmosphere. In the month of August, however, the atmosphere appeared in so vacillating and disturbed a state, that the only tide which turned at the normal hour was the 10 A.M. maximum tide. The means of the hourly readings on four days in each month, corrected for moisture, give a mean curve of pressure in each month which nearly corresponds with the curve of pressure of the daily readings of the barometer corrected for temperature only. The maximum pressure with both corrections occurs in December, but the minimum occurs in June corrected for temperature and in July with both corrections. The whole of the facts connected with the meteorology of Aden of which I have made use, are from observations taken by Sergeant MOYES, with excellent instruments, and Dr. BUIST is now passing the observations through the press.

These facts, which could be very greatly multiplied, have been somewhat dwelt upon, with a view to a right understanding of HUMBOLDT'S observations in his *Cosmos**

* BOHN'S Edition, vol. i. p. 320.

where, speaking of the horary oscillations of the barometer, he says, "their regularity is so great, that in the day-time especially, the hour may be ascertained from the height of the mercurial column without error, on the average of fifteen or seventeen minutes. In the torrid zones of the new continent, on the coasts, as well as at elevations of nearly 13,000 feet above the level of the sea, where the mean temperature falls to $44^{\circ}6$, I have found the regularity of the ebb and flow of the aërial ocean undisturbed by storms, hurricanes, rain and earthquakes." It is now shown that the horary oscillations have a different range in different months of the year; their range is influenced by height above the sea, and the tides do not always flow and ebb in equal periods of time; but the existence of two ascending and two descending but unequal tides within twenty-four hours within the tropics, is established beyond all question; and if not altogether *undisturbed*, as HUMBOLDT says, by storms, hurricanes or rain, yet the meteorological records in India prove that the periodic daily movements of the aërial ocean are never suppressed*.

Pressure of the Atmosphere.

With respect to the mean pressure of the atmosphere in India near the sea-level, I shall limit myself to the insertion of a comparative *table* showing the means of four years' hourly observations at Madras, the means of two years' hourly observations at Bombay, and the observations taken every two hours (but during the day only) at Calcutta, for 1843-44 and 1848. I append however curves of pressure at these places projected for longer periods, and for which I am indebted to Dr. BUIST, LL.D. The barometers at these respective localities, being each only a few feet above the sea-level, should have differed from each other in their mean annual results only in the third place of decimals, or at most only slightly in the second place of decimals, nevertheless the pressure at Bombay differs from that at Madras a twentieth of an inch; and at Calcutta, where the barometer is 17 feet nearer the mean sea-level than at Bombay, the mean annual pressure is even less than at Bombay, while on the other hand the pressure at Aden reduced to the sea-level is greater than anywhere else. These discrepancies originate probably in the neglect of using previously compared instruments. At Madras, the annual means in successive years differ from each other only in hundredths of an inch. For the mean pressure at different elevations tables are annexed.

* The observations of Lieut. R. STRACHEY in Thibet, at 18,400 feet above the sea, show that on the 22nd and 23rd of August 1849, the following were the oscillations of the four tides:—

| | B. uncorrected for temperature. | B. corrected for temperature. |
|-------------------|------------------------------------|----------------------------------|
| 5 P.M. to 11 P.M. | +·059 | +·075 |
| 11 P.M. to 4 A.M. | -·033 | -·029 |
| 4 A.M. to 10 A.M. | +·043 | +·016 |
| 10 A.M. to 3 P.M. | -·037 | -·032 |

Monthly Mean Pressure of the Atmosphere, reduced to 32°.

| Madras. | | | | Bombay, 35 feet. | | Calcutta, 18 feet. | | Aden, 187 feet. | | Poona, 1823 feet. | Mahabuleshwur, 4500 feet. | | Dodabetta, 8640 feet. | Royal Ob- servatory, Green- wich, 159 feet. | |
|--------------------|---------|---------|--------|------------------|--------|--------------------|---------|-----------------|--------|-------------------------|------------------------------|----------------|--------------------------|---|--|
| Years | 1842. | 1843. | 1844. | 1845. | 1843. | 1844. | 1848. | 1843, 1844. | 1847. | 1848. | 1830. | 1828, 1829. | Means of 1 year. | 1847, 1848. | Means of 8 years, 1841 to 1848. |
| January. | 29.995 | 29.985 | 29.998 | 30.015 | 29.923 | 29.947 | 30.000 | 29.937 | 29.774 | 29.872 | 28.087 | 25.465 | 25.737 | 22.081‡ | 29.766 |
| February | 29.972 | 29.966 | 29.980 | 29.965 | 29.889 | 29.928 | 29.980 | 29.915 | 29.832 | 29.853 | 28.002 | 25.452 | 25.765 | 22.098 | 29.737 |
| March... | 29.860 | 29.886 | 29.907 | 29.924 | 29.839 | 29.869 | 29.838 | 29.793 | 29.770 | 29.783 | 27.952 | 25.576 | 25.688 | 22.132 | 29.750 |
| April ... | 29.805 | 29.864 | 29.809 | 29.818 | 29.813 | 29.804 | 29.716 | 29.656 | 29.690 | 29.711 | 27.907 | 25.538 | 25.667 | 22.097 | 29.708 |
| May ... | 29.713 | 29.692 | 29.700 | 29.712 | 29.662 | 29.750 | 29.636 | 29.563 | 29.635 | 29.584 | 27.846 | 25.467 | 25.643 | 22.055 | 29.785 |
| June ... | 29.664 | 29.709 | 29.668 | 29.705 | 29.654 | 29.628 | 29.516 | 29.184 | 29.545 | 29.511 | 27.768 | 25.377 | 25.664 | 21.966 | 29.797 |
| July ... | 29.697 | 29.709 | 29.723 | 29.726 | 29.661 | 29.648 | 29.528 | 29.517 | 29.491 | 29.475 | 27.766 | 25.319 | 25.600 | 21.974 | 29.799 |
| August.. | 29.729 | 29.759 | 29.731 | 29.742 | 29.730 | 29.701 | 29.571 | 29.516 | 29.540 | 29.483 | 27.840 | 25.387 | 25.647 | 22.003 | 29.787 |
| Sept. ... | 29.768 | 29.788 | 29.793 | 29.830 | 29.779 | 29.795 | 29.713 | 29.662 | 29.639 | 29.626 | 27.925 | | 25.524 | 22.004 | 29.809 |
| October | 29.873 | 29.863 | 29.868 | 29.850 | 29.845 | 29.825 | *29.881 | 29.633 | 29.811 | 29.745 | 27.923 | | 25.810 | 22.050 | 29.858 |
| Nov. ... | 29.941 | 29.926 | 29.963 | 29.984 | 29.887 | 29.924 | 30.005 | 29.867 | 29.897 | 29.855 | 28.018 | †25.500 | 25.733 | 22.077 | 29.714 |
| Dec. ... | 30.201 | 30.001 | 29.926 | 29.965 | 29.961 | 29.893 | 30.021 | 29.951 | 29.902 | 29.876 | 28.068 | †25.498 | 25.739 | 22.043 | 29.857 |
| Means of year } | 29.8515 | 29.8457 | 29.839 | 29.853 | 29.805 | 29.809 | 29.783 | 29.707 | 29.711 | 29.698 | 27.925 | | 25.684 | 22.046 | 29.781 |

The mean monthly pressure at Calcutta for 1843–44 is from reductions of Dr. M'CLELLAND, and the record commences in November 1843 and ends in October 1844. An inspection of the above Table shows that the maximum mean monthly pressure does not occur in the same month in successive years. At Madras, in 1842 and 1843, the maximum pressure was in the month of December, in the two following years it was in the month of January. At Bombay, in 1843, the maximum was in December, in 1844 in January, at Calcutta, in 1843, in December, and in 1848 it was in December. At Madras the minimum monthly mean pressure, in three years out of the four, occurred in the month of June. In 1843 it was in the month of May, but at Bombay in the same year in June: at Bombay and Calcutta in 1844, and in 1848, at Calcutta, it took place also in June. At Poona, at 1823 feet, the maximum was in January and the minimum in July. At Dodabetta, at 8640 feet, unlike any of the stations at the sea-level, the maximum mean monthly pressure took place in March: the same thing occurred at Mahabuleshwur § in 1828–29, at 4500 feet above the sea; but like the other stations the minimum pressure at Dodabetta occurred in June, but at Mahabuleshwur in July. Dr. BUIST of Bombay mentions that for three years at Aden (1846–48) the minimum occurred in July, and the maximum in February, but by the preceding Table the maximum in 1847 and 1848 occurred in December, and the minimum in both years in July. At Greenwich the means of thirty years' observations, recorded in BELVILLE'S Manual, give results inverse to those in India, as the maximum pressure is in June and the minimum in November; but there is a second maximum in January and a second minimum in March; but the greatest *daily* mean pressure occurs about the 9th of January, and

* Thirteen days' observations wanting.

† For 1828, remaining months for 1829.

‡ For 1848, remaining months for 1847.

§ The means of one year's pressure at Mahabuleshwur is inserted from the Bombay Medical Journal, but the observations do not appear to have been corrected for temperature, and as the maximum pressure is represented to occur in October and the minimum in September, there evidently must be some mistake, and I therefore only notice my own simultaneous observations with Dr. WALKER for 1828–29.

the minimum daily mean depression at the end of November. From the means of eight years' observations, obligingly furnished to me by Mr. GLAISHER, from the Royal Observatory, Greenwich, the maximum was in October; with a second maximum in December, the minimum was in April; corrected however for the tension of vapour, the maximum was in December and the minimum in August; but consecutive years differ greatly when the vapour correction is applied.

I attempt no explanation of these anomalies, as much more lengthened observations are required than those at my disposal afford for philosophical deductions. From the month of the maximum pressure, there is a gradual mean monthly decline of pressure until the minimum pressure; then there is a gradual monthly increase of pressure, even when the monsoon sets in at Madras in October until the maximum is attained again; but there is no rule without an exception, and the curve was interrupted in the month of December in the years 1844 and 1845 at Madras, and in 1844 at Bombay; but in Calcutta, in October 1844, and at Mahabuleshwur, and at Doda-betta in December 1828 and 1847 respectively. At Aden, in 1847, it was interrupted in February. In 1848 the curve was regular.

Appended to this paper are annual pressure curves at Madras, Bombay and Calcutta, protracted from the records of the barometer at the several places. The three localities are under very different conditions of temperature and moisture in the same months, and they differ considerably in latitude and longitude; Madras and Bombay, situated upon opposite sides of the peninsula of India, are subject to different monsoons; Madras to the N.E. monsoon, which commences in October and ends in February, and Bombay is subject to the S.W. monsoon, which commences in June and ends in October. Calcutta is under the full influence of the S.W. monsoon, but has occasional showers from the Madras rains. When Bombay is deluged with rain Madras is comparatively dry, and the hot weather prevails; and when Madras is under the influence of the Coromandel rains, Bombay is cold and dry. Very different atmospheric conditions therefore exist at the two places in the same months. Nevertheless the annual curves of pressure protracted from monthly means, may be said to be identical, not only for Madras and Bombay, but also for Calcutta. The few exceptional cases are lost or disappear in the means, and may originate in local causes. It would thus appear that the periodic movements of the *mass* of the atmosphere within the northern tropic are independent of, or only very slightly affected by, the hygrometric and thermometric conditions of the *lower strata of the atmosphere*. It occurs to me that this phenomenon may be owing to the sun's place in the ecliptic. When the sun is at the southern tropic, the air above the northern tropic is comparatively cold and therefore dense, and at its greatest pressure; this would be from December to January inclusive. As the sun returns to the north the air gets gradually warmer and dilates, and the pressure being inversely as the volume, the barometer gradually sinks, until the sun is returning from the northern tropic again, when the mass of the atmosphere gradually cools, gets denser, and the pressure gradually increases again. Supposing this explanation to have any foundation in truth, the curve of pressure within the tropic south of the equator would be the reverse of that in the tropic north of the equator. The maximum pressure would be from June to July inclusive,

and the minimum pressure from December to January inclusive. On referring to the St. Helena observations for 1843 this is very nearly the case, the maximum pressure and minimum temperature being in August instead of July, and the minimum pressure and maximum temperature in February to March instead of January.

Meteorological Observations at St. Helena, 1843.

| | Barom. in. | Therm. ° |
|-------------------|---------------|-------------|
| January | 28·238 | 64·76 |
| February | 28·214 | 66·25 |
| March | 28·214 | 65·35 |
| April | 28·251 | 64·93 |
| May | 28·292 | 61·53 |
| June | 28·335 | 58·88 |
| July | 28·341 | 57·43 |
| August | 28·358 | 56·71 |
| September | 28·328 | 56·92 |
| October | 28·279 | 57·23 |
| November | 28·250 | 59·54 |
| December | 28·251 | 62·44* |

From the occurrence of the maxima and minima of the horary oscillations of the barometer at the same *local hours* in different meridians, these phenomena also would seem to be connected with the sun's action upon the atmosphere.

In the fitful movements of the atmosphere beyond the northern tropic the sun's influence would not appear to be similarly felt, as the maximum pressure at Greenwich is in October, with a second maximum in December, and the minimum pressure, instead of being when the sun is at the northern tropic, is in November.

Temperature.

The hourly observations at Madras for four years afford the most complete and trustworthy data for determining at that place the fluctuations of temperature, the exact diurnal and annual range, and the exact periods of the fluctuations in the occurrence of the maxima and minima, which cannot be satisfactorily shown by any observations short of hourly record. For Bombay I have only such records made by Dr. BUIST for the years 1843 and 1844. Those at Calcutta were two-hourly only during the daytime, and those at Dodabetta were made but twice a day, with the exception of twenty-four hours once a month between the 21st and 22nd, when the observations were taken hourly. For exact determinations I am constrained to abandon many proposed comparisons, and in many instances to use less frequently recorded observations to express general features. The following Table shows the monthly means and annual temperatures at Madras and Bombay from hourly observations. For the other localities the means are derived from less frequent observations, and are therefore only approximations to the truth.

* The above table is confirmed by the Mauritius and Cape observations; the minimum pressure being from January to February inclusive, and the maximum July to September inclusive.

Monthly Mean Temperatures at Madras and Bombay from Hourly Observations, and at Calcutta and elsewhere from less frequent periods of record.

| | Madras. | | | | Bombay, 35 feet. | | Calcutta, 18 feet. | | | | Aden, 197 feet. | Phul-ton, about 1700 feet. | Bija-poor, about 1700 feet. | Poona, 1823 feet. | Sattarah, 2320 feet. | Mahabuleshwur, 4500 feet. | | | Mercara, Coorg, 4500 feet. | Uttra Mullay, 4500 feet. | | Dodabetta, 8640 feet. |
|-------|---------|-------|-------|-------|------------------|-------|--------------------|-------|-------|--------|-----------------|----------------------------|-----------------------------|-------------------|----------------------|---------------------------|-------|---------------|----------------------------|--------------------------|-------|-----------------------|
| | 1842. | 1843. | 1844. | 1845. | 1843. | 1844. | 1845. | 1846. | 1847. | 1848. | 1848. | 1847. | 1848. | 1830. | Means of 1844-47. | 1828-29. | 1834. | 1829 to 1843. | Means of 1838-40. | 1845. | 1846. | 1847-48. |
| Jan. | 76.98 | 77.59 | 75.71 | 76.81 | 76.4 | 74.9 | 76.52 | 75.72 | 75.95 | 73.70 | 72.6 | 74.8 | 75.4 | 70.0 | 65.38 | 65.70 | 64.0 | 66.6 | 62.08 | 63.42 | 52.20 | |
| Feb. | 77.92 | 77.90 | 77.74 | 79.41 | 78.1 | 76.0 | 78.55 | 76.78 | 76.08 | 80.20 | 73.4 | 76.9 | 78.85 | 72.6 | 68.30 | 67.50 | 66.3 | 70.80 | 64.25 | 65.75 | 52.30 | |
| March | 82.36 | 81.52 | 82.20 | 83.13 | 79.9 | 79.3 | 89.05 | 87.85 | 87.90 | 88.08 | 76.8 | 83.9 | 84.8 | 77.8 | 74.68 | 74.00 | 71.5 | 73.7 | 69.58 | 65.58 | 54.55 | |
| April | 85.67 | 85.19 | 86.34 | 86.58 | 84.3 | 83.9 | 87.97 | 91.85 | 83.60 | 88.08 | 80.6 | 83.9 | 88.4 | 80.6 | 75.71 | 74.40 | 74.5 | 73.1 | 68.42 | 67.83 | 56.20 | |
| May | 88.09 | 85.02 | 86.98 | 88.63 | 85.9 | 85.7 | 90.67 | 88.67 | 89.93 | 91.80 | 84.8 | 86.1 | 88.5 | 80.1 | 74.79 | 73.90 | 72.4 | 71.9 | 67.83 | 65.33 | 57.20 | |
| June | 88.05 | 85.52 | 88.58 | 86.64 | 85.4 | 85.0 | 88.12 | 87.00 | 87.50 | 89.85 | 85.5 | 81.2 | 85.0 | 77.0 | 68.08 | 66.30 | 66.3 | 69.1 | 65.08 | 62.33 | 52.50 | |
| July | 86.68 | 85.79 | 85.76 | 86.12 | 83.1 | 81.8 | 86.25 | 86.88 | 85.88 | 86.03* | 83.4 | 80.2 | 81.2 | 73.8 | 65.43 | 64.90 | 63.2 | 67.1 | 66.00 | 63.83 | 52.65 | |
| Aug. | 84.45 | 84.51 | 85.25 | 85.88 | 81.1 | 81.4 | 85.20 | 86.28 | 85.82 | 85.18* | 81.5 | 79.3 | 78.7 | 73.0 | 64.60 | 65.30 | 63.2 | 66.0 | 66.66 | 64.42 | 53.10 | |
| Sept. | 82.36 | 84.26 | 82.97 | 83.91 | 81.2 | 80.5 | 87.70 | 85.35 | 85.66 | 86.10* | 84.9 | 78.9 | 78.2 | 74.0 | 64.34 | 65.00 | 63.9 | 65.6 | 67.50 | 64.92 | 52.45 | |
| Oct. | 81.86 | 80.72 | 80.53 | 82.95 | 82.3 | 83.4 | 85.30 | 83.70 | 84.58 | 83.55* | 83.4 | 80.0 | 76.6 | 76.1 | 65.68 | 65.50 | 66.6 | 66.8 | 65.58 | 63.42 | 53.30 | |
| Nov. | 78.27 | 77.83 | 79.17 | 79.11 | 80.2 | 80.4 | 80.42 | 80.65 | 77.88 | 78.50* | 78.5 | 73.5 | 76.7 | 72.0 | 64.76 | 63.50 | 64.4 | 66.5 | 65.58 | 63.92 | 52.15 | |
| Dec. | 76.57 | 75.89 | 76.94 | 77.70 | 76.6 | 79.3 | 73.55 | 73.08 | 73.28 | 75.30* | 77.2 | 72.9 | 79.2 | 71.8 | 63.56 | 62.30 | 63.2 | 64.4 | 63.50 | 63.17 | 50.80 | |
| Year | 82.44 | 81.81 | 82.35 | 83.07 | 81.2 | 80.9 | 84.11 | 83.65 | 83.26 | 83.86 | 80.2 | 79.2 | 81.7 | 75.0 | 67.52 | 67.30 | 66.60 | 68.6 | 66.00 | 64.49 | 53.20 | |

* Means of two-hourly observations. The mean temperature at Madras, in 1848, was 83°.15, and the curve the same as that of the preceding years. Sattarah is in Lat. 17° 40'. Long. 74° 2'. Mercara is sixty-five miles E. of Cannanore. Uttra Mullay, twenty-two miles N.E. by E. from Trevandrum. The mean temperature at Mahabuleshwur, from 1829 to 1843, was deduced from the mean of a daily maximum and minimum thermometer in the shade.

The first feature is the close approximation of the annual means at Madras for the four years; the difference between the greatest and least being only $1^{\circ}26$ FAHR., although the difference between the means of the same month in successive years may have exceeded three degrees. Nevertheless the means of most of the months in successive years show a great amount of uniformity. The coldest months are December or January, and the hottest May or June. In 1842 and 1843 December was the coldest month. In 1844 and 1845 January was the coldest. In 1842 and 1845 May was the hottest month. In 1843 the maximum mean heat was not reached until July, and in 1844 it occurred in June. Although these discrepancies occur, the monthly increment or decrement to or from the maximum period is gradual, and rarely checked or inverted. In Bombay the annual mean temperature for 1843 is almost identical with that of Madras for 1843, although the two places differ $5^{\circ}41'$ in latitude. The monthly means of the two places correspond tolerably well from January until July; for instance, February corresponds within a tenth of a degree, and June within two-tenths. But in July there is a difference of $3^{\circ}79$, August $3^{\circ}31$, September $3^{\circ}16$, Madras being plus: then the sign changes and Bombay becomes plus for the remaining months of the year, and also in January. The coldest month in Bombay was January, and the hottest May. In Bombay, in 1843 and 1844, unlike Madras, there is an inversion in the decrement of heat on the sun's going south; for October is represented as hotter than September in both years: a very remarkable fact is exhibited by these hourly means, *namely, that neither the south-west monsoon at Bombay, nor the north-east monsoon at Madras, at all affect the monthly mean regular increment or decrement of heat*, with the exception of October in Bombay. It will be observed that the maximum heat, both at Madras and Bombay, was not when the sun was vertical at either place passing to the northern tropic; but when the sun was near to the northern tropic in June, the mean temperature in 1843 at Madras, in lat. $13^{\circ}4'$, was at its maximum in July, while at Bombay, in lat. $18^{\circ}55'$, the greatest heat was in May of that year; and though the sun passes over both places again to the south the mean temperature gradually declines in each year, with the exceptions noticed. I was desirous of inserting in the Table of Mean Temperatures those for 1843 and 1844 at Calcutta, for comparison with the Madras and Bombay observations for the same year; but on referring to the volumes of the Bengal Asiatic Researches for 1843 and 1844, I found that the tables had not been inserted. They were met with however in the Journal of the Horticultural Society of Calcutta, but proved to be records of the temperature during the day only at $9\frac{1}{2}$ A.M., noon, 4 P.M. and sunset*. A mean temperature from such data would neces-

* In the fifth volume of the Calcutta Journal of Natural History, Dr. M'CLELLAND states that the mean temperature of 1844, from daily observations, was $82^{\circ}35$, the coldest period at sunrise, and the hottest at $2^{\text{h}}40^{\text{m}}$ P.M. daily; the maximum heat 104° on the 10th of April, the minimum $51^{\circ}7$ on the 19th of January, and the annual range $52^{\circ}3$. He speaks also of the minimum daily pressure of the barometer occurring twice at 6 P.M. in January, February and May.

sarily be unsatisfactory. In 1847 meteorological tables appear in the Journal of the Asiatic Society of Bengal from the same source as those used by the Horticultural Society in the preceding years, namely, from the office of the Deputy Surveyor-General in Calcutta, but they were even of less use than the preceding tables, for they had but two daily records, namely, at $9\frac{1}{2}$ A.M. and 4 P.M., and the records were otherwise useless for determining the absolute range of the thermometer, as there was only a record of the maximum temperature and no minimum. In 1848 more elaborate tables make their appearance, containing two-hourly records from sunrise to sunset, at sunrise, $9\frac{1}{2}$ A.M., noon, $2^h 40^m$ P.M., 4 P.M., and sunset, together with the indications of a maximum and minimum thermometer, but without any observations after sunset. This is an improvement upon the former records, but falls short of the requisites for scientific purposes. The maximum and minimum thermometer certainly gives the range of temperature, but does not give the hours of the occurrence of the maxima and minima. Mean temperatures deduced from a maximum and minimum thermometer may possibly be true; but an arithmetical mean from two extreme observations daily would be incorrect, unless the increment and decrement of heat from a mean point were regular, which is known to be rarely the case. Annual mean temperatures deduced from formulæ, of which the latitude is the element, are often fallacious; for independently of the great discrepancies in mean temperatures between America and Europe on the same parallels of latitude, and as indicated also by isothermal lines in Europe, there are places differing little in longitude where the annual mean temperature is higher than at places nearer to the equator, both within and without the tropics: taking an instance from DOVE'S temperature tables, we have the following:—

| | | |
|-----------------------|---------------------------|---|
| 1 Aberdeen | Latitude $57^{\circ} 9'$ | Mean temperature $49^{\circ} 18'$ |
| 2 Dundee | Latitude $56^{\circ} 27'$ | Mean temperature $51^{\circ} 94'$ |
| 3 Edinburgh | Latitude $55^{\circ} 58'$ | Mean temperature $47^{\circ} 13'$ |
| 4 Liverpool | Latitude $53^{\circ} 25'$ | Mean temperature $50^{\circ} 80'$ |
| 5 London | Latitude $51^{\circ} 30'$ | Mean temperature $50^{\circ} 83'$, or $49^{\circ} 7'$ by GLAISHER. |

Aberdeen, therefore, nearly six degrees north of London, has almost the same mean temperature as London: and Edinburgh, intermediate between both, has a lower mean temperature than either. Dundee, five degrees north of London, has absolutely a higher mean temperature; and Liverpool, two degrees north of London, has the same mean temperature. In the tropics similar instances are found.

| | | |
|--------------------|--------------------------------|-----------------------------------|
| Calcutta | Latitude $22^{\circ} 34' 40''$ | Mean temperature $83^{\circ} 72'$ |
| Bombay | Latitude $18^{\circ} 55' 42''$ | Mean temperature $81^{\circ} 1'$ |
| Madras | Latitude $13^{\circ} 4' 10''$ | Mean temperature $82^{\circ} 42'$ |
| Aden | Latitude $12^{\circ} 46' 26''$ | Mean temperature $80^{\circ} 2'$ |

In this case Calcutta, 9 degrees north of Madras and $3\frac{1}{2}$ of Bombay, has a higher mean temperature than either; and Aden, in a lower latitude than any of the places,

instead of a higher has a lower mean temperature than Calcutta, Bombay or Madras. This mean temperature at Madras and Bombay is deduced from hourly observations; and had DOVE's previously noticed mean temperature been derived from similar records, the anomalies might have been modified or have disappeared altogether. With the reservations contingent upon the explanations given, I shall comprise my observations upon the temperature tables of places other than those for Madras and Bombay, within very narrow limits. And first, with respect to Calcutta, the means are derived from observations taken at the Surveyor-General's office, with excellent instruments, but the observations are day observations, and it is only for the last six months of 1848 that records were made every two hours. The means, however, of those six months correspond sufficiently near with those of the same six months in the three preceding years to show that the conversion of three-hourly observations into two-hourly observations, had very little effect upon the mean results. What was wanting were observations at night, and of these there are not any. The mean temperature of the years, from 1845 to 1848, both inclusive, never falls below $83^{\circ}\cdot26$ (in 1847), and was as high as $84^{\circ}\cdot11$ in 1845, and the mean temperature of the four years is $83^{\circ}\cdot72$. The coldest month was December, excepting in 1848, when January was the coldest. The hottest month was May, excepting in 1846, when April was the hottest; the mean temperature of April and May, for the four years, being respectively $87^{\circ}\cdot12$ and $90^{\circ}\cdot27$. For the years 1846 and 1847 the mean monthly increment to the maximum heat, and mean monthly decrement to the minimum heat, is gradual and regular, but in 1845 and 1847 there are instances of inversion; in 1845 March is hotter than April; September is hotter than August; in 1848 September is also hotter than August, instead of being cooler. This very high mean temperature of Calcutta is not of ready explanation, even after making an allowance for the want of night observations: situated on a broad river, in the midst of cultivated, well-wooded and moist plains, and within the influence of the sea; on the verge of the northern tropic, it might have been supposed that its position, in respect to latitude, would have affected its mean temperature. The sun is vertical at Calcutta in the first week in June and July, but Calcutta attains its maximum heat in May, while the sun is yet approaching, and the mean temperature is actually diminishing, while the sun is passing and repassing from the tropic, and while the heat ought to be accumulating from the lengthened days, as is shown in the following tabular statement:—

| Latitude N. | Longitude E. | Sun vertical. | Longest day. |
|----------------|-----------------------|-----------------------|--------------|
| Calcutta | $22^{\circ} 34' 40''$ | $88^{\circ} 28' 15''$ | h m 13 23 |
| Bombay | $18^{\circ} 55' 42''$ | $72^{\circ} 54' 24''$ | 13 08 |
| Madras | $13^{\circ} 4' 10''$ | $80^{\circ} 21' 35''$ | 12 46 |
| Aden..... | $12^{\circ} 46' 26''$ | $45^{\circ} 15' 0''$ | |

Admitting that the lengthened time for which the sun is nearly vertical over Calcutta might raise the mean temperature of May, June and July, there would be a corresponding diminution in the months of December, January and February, in the long nights, and the mean temperature of the year should not be raised by the

great heats of April and May; but such, nevertheless, would not appear to be the case, at least in the absence of night observations. It will be remarked also, that the return of the sun over Bombay in July does not prevent a reduction of three degrees in mean temperature; this however might be attributed to the rains commencing; but in its passage over Madras in August the continued mean monthly fall of the thermometer is not interrupted, although it will be recollected there is not any monsoon at Madras in August to correct the effect of the sun's passage. The slanting rays of the sun, within certain angles of incidence without the tropics, produce a heat of great intensity, even where the physical characters of the country do not lead us to expect such a result; for instance, on the banks of the broad Indus in Scinde the thermometer is known to rise in the shade to 110° — 120° FAHR. Recently, at Peshawur, the following is the record of the thermometer in a house from the 7th to the 14th of May 1849:—

| | Sunrise. | 8 A.M. | Noon. | 4 P.M. | 9 P.M. | Latitude N. |
|---------------|----------|--------|-------|--------|--------|-------------|
| Highest | 75° | 89° | 102° | 104° | 86° | 33° 59' |
| Lowest | 67 | 84 | 96 | 98 | 78 | |

On the 16th of June, at 4 P.M., thermometer 109° ; on the 25th of July, 109° ; August 3rd, 4th and 13th, 104° ; the extremes being 67° and 104° , the mean 87° , and the range 37° . A register for the whole month, by Dr. J. MALCOLMSON, gives the following facts; the maximum being 109° on the 6th in a tent, and 106° on the 24th and 31st in a house.

Register of the Thermometer at Peshawur for May 1849.

| FAHRENHEIT Thermometer. In the shade in a house in the city. | | | | | | | |
|--|----------|-------|--------|-------|----------|-------|--------|
| Date. | Sunrise. | Noon. | 4 P.M. | Date. | Sunrise. | Noon. | 4 P.M. |
| 1 | 63° | 79° | 66° | 17 | 70° | 98° | 104° |
| 2 | 65 | 73 | 66 | 18 | 73 | 99 | 100 |
| 3 | 64 | 87 | 91 | 19 | 81 | 97 | 103 |
| 4 | 63 | 75 | 85 | 20 | 80 | 102 | 105 |
| 5 | 61 | 96 | 91 | 21 | 83 | 99 | 105 |
| 6 | 64 | 102 | 109 | 22 | 91 | 102 | 105 |
| 7 | 90 | 100 | 104 | 23 | 85 | 100 | 104 |
| 8 | 67 | 108 | 99 | 24 | 88 | 98 | 106 |
| 9 | 70 | 107 | 101 | 25 | 82 | 99 | 105 |
| 10 | 70 | 104 | 100 | 26 | 85 | 99 | 104 |
| 11 | 65 | 102 | 95 | 27 | 84 | 99 | 104 |
| 12 | 70 | 106 | 106 | 28 | 84 | 97 | 103 |
| 13 | 70 | 107 | 104 | 29 | 85 | 99 | 104 |
| 14 | 71 | 100 | 101 | 30 | 84 | 99 | 105 |
| 15 | 90 | 106 | 98 | 31 | 88 | 102 | 106 |
| 16 | 70 | 104 | 105 | | | | |

Note by Dr. J. MALCOLMSON.—The register was kept in a house, and that may account for the maximum being no higher than 109° .

Heavy rain, with thunder, lightning and hail, for the first four days in the month. Winds generally westerly, and south-west. Severe dust-storms occasionally.

On the 22nd of May 1849, at Ferozepore, lat. $30^{\circ} 53'$, on the Sutlege river, the thermometer stood at 104° in a good house, the usual precautions being taken against the hot winds. Even in August, at Peshawur, with thunder-storms and heavy rain on the 7th, 9th, 15th, 16th, 17th, 20th and 29th, and with several light showers besides, the maximum was 104° at 4 P.M., the minimum at sunrise 81° , the midday maximum 101° , and with a *midnight* maximum of 100° , and yet the Report says, "The month had not however been characterized, as would be supposed by the indications of the thermometer, by any unusual degree of heat *over those which had just preceded it*. It even did not range so high as in May, June and July*."

Even at Alten, in Finmark in Norway, in latitude $69^{\circ} 58'$, where the mean annual temperature is between 35° and 36° FAHR., and where in 1846 the thermometer sunk to $14^{\circ} 8$ below zero; on the 27th of July 1847, at noon, the thermometer in the shade rose to $84^{\circ} 7$ FAHR. Capt. SCORESBY, in his Arctic Voyages, somewhere mentions, I think, that the rays of the sun were sufficiently powerful to melt the pitch on the sunny side of his vessel, while the air was at a freezing temperature on the shady side. But these intense heats of summer are compensated for by a depression of temperature when the sun is at the southern tropic and the mean annual temperature is not raised. The high mean temperature of Calcutta, therefore, would seem to be influenced by local causes, independently of the vertical or oblique action of the sun, or the length of time the sun is above the horizon. But the anomalies of mean temperature are not limited to Calcutta. Aden, situated in latitude $12^{\circ} 46' 26''$ N., longitude $45^{\circ} 15'$ E., on the shores of Arabia,—shores dreaded for their supposed intolerable heat, has a mean temperature ($80^{\circ} 2$) lower than that of Bombay, Madras or Calcutta, with a less range of the thermometer, with a maximum heat only of 89° in May and October, and a minimum of $68^{\circ} 5$ in January! and most singularly the mean temperature for *every month* in 1848 is lower than the temperature of the corresponding month at Calcutta, and, with the exception of November, December and January, lower than at Madras or Bombay. From the maximum mean monthly heat in April 1830, at Calcutta, the temperature gradually declined until the mean monthly minimum in December, excepting in September and October, when the curve was interrupted by a rise of $1^{\circ} 5$ in the former month, and of $2^{\circ} 3$ in the latter; after December the temperature gradually rose to its mean maximum.

* Dr. WALLIN of Helsingfors, the traveller in Arabia, has furnished me with a copy of his register of the thermometer, from which I learn that at Bagdad, lat. $33^{\circ} 20'$ N., long. $44^{\circ} 24'$ E., the thermometer in the shade of a house on the second story, with a N.W. aspect upon the banks of the Tigris, on the 19th of July 1848, at 2 P.M. stood at $122^{\circ} 9$ FAHR., wind W.N.W., on the 13th and 18th at $120^{\circ} 2$, and on seven other days in the month of July at $118^{\circ} 4$; and the *lowest* heat in the month at 2 P.M. was $101^{\circ} 3$ on the 2nd of July, wind N.W., clear.

Curves of Temperature at High Levels.

Proceeding from the sea-level to considerable altitudes, we find that the mean temperature at Poona, in 1830, at 1823 feet above the sea-level, was $80^{\circ}28$, differing only six-tenths from the mean temperature of Bombay for 1844, and less than one degree of FAHR. from the mean temperature of 1843 at Bombay. A difference of level of 1823 feet therefore gave a difference of less than one degree of temperature.

The comparison of the temperatures of the three stations of Mahabuleshwur, Mercara in Coorg, and Uttray Mullay in Travancore, all at the height of 4500 feet above the sea-level, and differing little in longitude, but several degrees in latitude, affords some interesting facts. The latitude of Uttray Mallay is *about* $8^{\circ}00'$ N., long. $76^{\circ}00'$ E., Mercara, lat. $12^{\circ}30'$, long. $73^{\circ}30'$, Mahabuleshwur, lat. $17^{\circ}58'$, long. $73^{\circ}29'$. The mean temperature of Uttray Mullay, situated nearest to the equator, is *lower* by $3^{\circ}35$ than the mean temperature of Mercara, and $2^{\circ}66$ lower than that of Mahabuleshwur, while the mean temperatures of Mercara and Mahabuleshwur are almost identical. The maximum heat of Mahabuleshwur, in both years recorded, is in April, while the mean of three years at Mercara fixes it in March. At Uttray Mullay the maximum heat, in 1845, was in April, while in 1846 it was in March. At 4140 feet above these levels, namely, at Dodabetta, the maximum heat was, in May, as in Bombay and Calcutta. The minimum heat, at the height of 4500 feet, was in December, at Mahabuleshwur and Mercara in all the years. At Uttray Mullay, in 1845, the minimum mean monthly heat was in June, the only instance of the kind in all the observations discussed in this paper; and in this same year January and October had the same mean temperature. In the next year the minimum heat was in January. At Dodabetta, at 8640 feet, in 1847, the minimum temperature was in December, but, with the exceptions of April and May, the mean monthly range was so small that most of the months were nearly the same in their mean heat. Mahabuleshwur and Mercara being within the S.W. monsoon, while Uttray Mullay and Dodabetta are subject to both S.W. and N.E. monsoons, the annual curves of temperature might be expected to vary considerably. At Mahabuleshwur and Mercara there is a gradual decrement of heat from the maximum point until the month of October, when the mean monthly temperature rises at both places, but falls after that month to the minimum of the year. The same thing occurs in Bombay and Poona, but there is no rise in October at Madras nor at Calcutta in 1846 or 1847; and in 1845 and 1848, when the gradual decrement of heat was interrupted, it occurred in September instead of October, as at the other places within the influence of the same monsoon. At Uttray Mullay and Dodabetta, within the influence of both monsoons, we find the annual curve of temperature interrupted in the first place in March, then in July, October and November in 1845, and in July, August and September in 1846. At Dodabetta the increase is quite gradual from December to May; but the natural decrement is interrupted in July, and the temperature rises in August, sinks in September, rises in October, and then falls to the minimum of the year. From these facts, it appears that the two monsoons derange the

curves of temperature at the different places, which might be expected otherwise to coincide with the sun's path in the ecliptic; but further observations from the hill stations may modify these conclusions.

Range of Temperature and Hours of Maxima and Minima.

Unless where hourly observations are taken, the exact periods of the occurrence of the maxima and minima cannot be determined; and though a self-registering thermometer will determine the range of temperature, yet the hours of the turning-points cannot be learnt from it. For the hours of the occurrence of the maxima and minima, therefore, I am limited to the hourly observations taken at Madras and Bombay; but for the range of temperature, without reference to specific times, I can avail myself of a maximum thermometer registered at Aden for 1848, and one at Calcutta registered since June 1848.

Madras.—Hours of Maximum and Minimum Temperature.

The usual impression in India is, that the maximum heat occurs about 2 P.M., and the minimum a little after sunrise. The Madras hourly observations for four years, from which the following Table is prepared, exhibit great anomalies in the hours of the occurrence of the maxima and minima. In the forty-eight months of monthly range there are seventeen records of the greatest heat occurring about noon (between 11^h 41^m and 12^h 41^m); eighteen records between 1 and 2 P.M., and thirteen records between 2 and 3 P.M. In 1842 the maximum daily heat occurred only *once* about noon (12^h 41^m) on the 20th of April (96°·5). In 1843 it occurred at the same hour, or before it, in January, February, March, May and November. In 1844, at the same hour, in January, April, November and December. In 1845, in March, April, May, September, October, November and December; so that in fact the maximum daily heat, although it took place only at noon in the month of April in 1842, in the other three years, either in one year or the other, occurred at noon in all the months. There is not a single instance of the maximum daily heat occurring after 2^h 41^m P.M. The minimum heat of the month, in 1842, occurred in May at 2^h 41^m A.M. (81°·1), the only record of the kind in the year. In 1843 there is no similar record, but in 1844 there are two instances of the least heat taking place in July and August at 41^m past midnight, and one instance at 2^h 41^m A.M. in September. In 1845 there is a solitary case of the lowest temperature at 2^h 41^m A.M. In the whole four years there are only three instances of the minimum heat being at 3^h 41^m A.M., two at 4^h 41^m A.M.; twenty-five at 5^h 41^m A.M., and twelve at 6^h 41^m A.M.; and one singular instance of the greatest cold in the month being as late as 7^h 41^m A.M. on the 14th of May 1844. It may be affirmed, therefore, that the greatest cold occurs at Madras most often at 5^h 41^m A.M. The monthly range of the thermometer does not differ very much in the different months of the year, nor does the range of the

thermometer in the same months in successive years exhibit very marked discrepancies, although there are some differences; for instance, in February 1842 the range was $20^{\circ}8$, and in February 1845 only $14^{\circ}2$. In April 1842 the range was $22^{\circ}0$, and in April 1843 only $14^{\circ}8$. It might have been expected that the greatest range, as at Bombay and Calcutta, would have occurred in the coldest months, and that the greatest discrepancies would have occurred in the comparisons of the same months in succeeding years, but such was not the case. The greatest monthly range in any month at Madras, twice occurred in the month of May in 1844 and 1845, namely, $25^{\circ}9$ and $25^{\circ}6$ respectively. The least range, $12^{\circ}5$, took place in January 1843. The annual ranges varied only from $27^{\circ}0$ in 1843 to $37^{\circ}1$ in 1844*. For Bombay I have only hourly readings of the thermometer for 1843 and 1844. The maximum heat twice occurred at noon, on the 11th of August and 6th of December; twice at 1 P.M., on 31st of March and 29th of April; five times at 2 P.M., and three times at 5 P.M. There is not any conformity in the times or dates of these maxima with those of the same year at Madras. A remarkable feature in the minimum daily heat at Bombay is the comparatively late period of the morning at which it took place. On the 4th of January the minimum heat was at 8 A.M., in five other months it occurred at 7 A.M., in two months at 6 A.M., and once only at 5 A.M.; and entirely unlike the numerous instances at Madras, there is not a single case of the minimum heat falling before 5 A.M. in 1843. The greatest range of the thermometer was in the cold months and least in the monsoon; the maximum, $19^{\circ}3$, was in January, and the minimum, $8^{\circ}4$, in August. The annual range for 1843 was $24^{\circ}4$. In 1844 the chief feature is, that the minimum heat in the month occurred at midnight on the 28th of August, and the minimum temperature occurred at 1 and 2 A.M. on the 22nd of July, as well as at 5 A.M.; twice only the least heat occurred as late as 7 A.M.; the maximum heat never occurred after 3 or before 1 P.M. The maximum heat was $91^{\circ}9$ and the minimum $64^{\circ}7$, the annual range therefore $27^{\circ}2$. The greatest monthly range was in February, $20^{\circ}7$, and the least in August, $8^{\circ}5$. The monthly ranges of the two years had a close correspondence. The maximum heat observed in the sun in Bombay was $142^{\circ}6$ at 1 P.M., 10th of November 1846.

Calcutta Range of Temperature.

Hourly observations not having been taken at Calcutta, and the records of a maximum and minimum thermometer having only appeared in the Asiatic Journal since June 1848, I can only give the range of temperature since that date; but I know nothing of the days or hours of record, excepting what is derived from a foot-note at page 550 of the Number of the Journal for June 1848. As at Bombay, the greatest monthly range was in the cold months and least in the monsoon months. Two

* A memorandum just received gives the mean temperature of Madras for 1848 at $83^{\circ}15$; the maximum on the 20th of June 106° , at 3^h 41^m P.M., and the minimum $63^{\circ}5$ on January 26th, at 6^h 41^m A.M.; the annual range therefore was $42^{\circ}5$.

Range of Thermometer and Hours of occasional Minima and Maxima.

| | Madras, 1842. | | | | | | | Madras, 1843. | | | | | | | Madras, 1844. | | | | | | | Madras, 1845. | | | | | | | Bombay, 1843. | | | | | | | Bombay, 1844. | | | | | | | Aden, 1848. | | | Calcutta, 1848-49. | | | |
|---------------|---------------|---------------|-------|----------|---------------|-------|--------|---------------|---------------|-------|----------|---------------|-------|--------|---------------|---------------|-------|----------|---------------|-------|--------|---------------|---------------|-------|----------|---------------|-------|--------|---------------|---------------|-------|----------|---------------|-------|--------|---------------|----------|--------|------|--------|--------|------|-------------|------|------|--------------------|------|------|------------|
| | Minimum. | | | Maximum. | | | | Minimum. | | | Maximum. | | | | Minimum. | | | Maximum. | | | | Minimum. | | | Maximum. | | | | Minimum. | | | Maximum. | | | | Min. | Max. | Range. | Min. | Max. | Range. | | | | | | | | |
| | Therm. | Hour. A.M. | Date. | Therm. | Hour. P.M. | Date. | Range. | Therm. | Hour. A.M. | Date. | Therm. | Hour. P.M. | Date. | Range. | Therm. | Hour. A.M. | Date. | Therm. | Hour. P.M. | Date. | Range. | Therm. | Hour. A.M. | Date. | Therm. | Hour. P.M. | Date. | Range. | Therm. | Hour. A.M. | Date. | Therm. | Hour. P.M. | Date. | Range. | | | | | | | | | | | | | | |
| January | 69°5 | h m 6 41 | 6 | 85°1 | h m 1 41 | 27 | 15°6 | 70°5 | h m 5 41 | 5 | 83°0 | h m 0 41 | 4 | 12°5 | 66°2 | h m 6 41 | 24 | 82°8 | h m 0 41 | 27 | 16°6 | 68°2 | h m 6 41 | 23 | 84°3 | h m 2 41 | 30 | 16°1 | 65°9 | h 8 | 4 | 85°2 | h 3 | 31 | 19°3 | 66°0 | h 6 | 12 | 83°9 | h 1 | 13 | 17°9 | 68°5 | 76°7 | 8°2 | 57°5 | 78°5 | 21°0 | January. |
| February..... | 67°2 | 5 41 | 17 | 88°0 | 2 41 | 28 | 20°8 | 69°2 | 6 41 | 9 | 85°4 | 0 41 | 19 | 16°2 | 67°7 | 5 41 | 19 | 87°2 | 1 41 | 26 | 19°5 | 71°8 | 5 41 | 28 | 86°0 | 1 41 | 21 | 14°2 | 70°9 | 7 | 18 | 85°6 | 2 | 2 | 14°7 | 64°7 | 7 | 9 | 85°4 | 3 | 14 | 20°7 | 69°0 | 77°8 | 8°8 | 64°6 | 83°5 | 19°9 | February. |
| March..... | 72°4 | 6 41 | 10 | 92°0 | 1 41 | 20 | 19°6 | 74°1 | 3 41 | 16 | 89°8 | 0 41 | 26 | 15°7 | 72°0 | 6 41 | 10 | 90°7 | 1 41 | 25 | 18°7 | 73°6 | 5 41 | 7 | 92°3 | 0 41 | 30 | 18°7 | 73°0 | 7 | 2 | 88°2 | 1 | 31 | 15°2 | 70°4 | 6 | 3 | 87°0 | 1 | 29 | 16°6 | 71°6 | 82°0 | 10°4 | 72°0 | 93°7 | 21°5 | March. |
| April | 74°5 | 5 41 | 1 | 96°5 | 0 41 | 20 | 22°0 | 78°5 | 4 41 | 9 | 93°3 | 1 41 | 30 | 14°8 | 77°2 | 5 41 | 8 | 99°0 | 0 41 | 3 | 21°8 | 78°5 | 6 41 | 30 | 94°0 | 0 41 | 11 | 15°5 | 79°0 | 6 | 3 | 90°0 | 1 | 29 | 11°0 | 77°3 | 6 | 2 | 90°2 | 2 | 21 | 12°9 | 75°5 | 85°8 | 10°3 | 79°4 | 99°4 | 20°0 | April. |
| May | 81°1 | 2 41 | 1 | 100°8 | 2 41 | 31 | 19°7 | 76°2 | 5 41 | 23 | 93°8 | 11 41 | 1 | 17°6 | 77°4 | 7 41 | 14 | 103°3 | 1 41 | 5 | 25°9 | 78°8 | 4 41 | 6 | 104°4 | 0 41 | 12 | 25°6 | 80°9 | 6 | 4 | 90°3 | 2 | 1 | 9°4 | 81°9 | 5 | 10 | 91°9 | 2 | 27 | 10°0 | 80°6 | 89°0 | 8°4 | 79°6 | 97°8 | 18°2 | May. |
| June | 78°8 | 5 41 | 12 | 100°2 | 2 41 | 21 | 21°4 | 78°7 | 3 41 | 14 | 95°4 | 1 41 | 9 | 16°7 | 80°3 | 3 41 | 16 | 103°2 | 1 41 | 11 | 22°9 | 78°8 | 2 41 | 18 | 101°0 | 1 41 | 6 | 22°2 | 80°5 | 6 | 19 | 90°0 | 2 | 10 | 9°5 | 78°0 | 4 | 30 | 90°8 | 2 | 13 | 12°8 | 82°5 | 88°5 | 6°0 | 81°1 | 92°8 | 11°7 | June. |
| July | 79°1 | 5 41 | 5 | 98°6 | 1 41 | 10 | 19°5 | 78°7 | 5 41 | 31 | 95°5 | 2 41 | 21 | 16°8 | 77°8 | 0 41 | 21 | 96°2 | 2 41 | 8 | 18°4 | 79°3 | 5 41 | 20 | 97°7 | 2 41 | 10 | 18°4 | 78°3 | 7 | 15 | 88°1 | 2 | 1 | 9°8 | 78°0 | 5 | 22 | 87°2 | 2 | 2 | 9°2 | 80°4 | 86°4 | 6°0 | 81°4 | 91°8 | 10°4 | July. |
| August | 75°6 | 6 41 | 19 | 94°8 | 2 41 | 1 | 19°2 | 78°2 | 5 41 | 28 | 95°3 | 1 41 | 7 | 17°1 | 78°1 | 0 41 | 6 | 95°3 | 1 41 | 23 | 17°2 | 79°0 | 5 41 | 19 | 97°1 | 1 41 | 28 | 18°0 | 77°5 | 7 | 22 | 85°9 | 12* | 11 | 8°4 | 77°0 | Midnight | 28 | 85°5 | 2 | 26 | 8°5 | 78°4 | 84°6 | 6°2 | 80°8 | 90°2 | 9°4 | August. |
| September ... | 75°7 | 6 41 | 12 | 92°5 | 1 41 | 6 | 16°8 | 76°9 | 6 41 | 28 | 95°3 | 2 41 | 1 | 18°4 | 75°4 | 2 41 | 18 | 94°7 | 2 41 | 9 | 19°3 | 76°2 | 5 41 | 16 | 94°8 | 0 41 | 2 | 18°6 | 76°4 | 6 | 29 | 87°6 | 2 | 23 | 11°2 | 75°4 | 4 | 14 | 86°1 | 3 | 29 | 10°7 | 81°6 | 88°2 | 6°6 | 80°7 | 92°4 | 11°7 | September. |
| October | 74°2 | 5 41 | 25 | 90°5 | 2 41 | 3 | 16°3 | 72°9 | 5 41 | 23 | 87°5 | 2 41 | 23 | 14°7 | 73°5 | 5 41 | 24 | 88°5 | 2 41 | 25 | 15°0 | 75°3 | 5 41 | 27 | 91°5 | 0 41 | 3 | 16°2 | 77°0 | 5 | 24 | 87°8 | 3 | 21 | 10°8 | 75°3 | 5 | 28 | 90°5 | 1 | 4 | 15°2 | 77°8 | 89°0 | 11°2 | 75°8 | 89°1 | 14°3 | October. |
| November ... | 71°0 | 5 41 | 21 | 84°6 | 1 41 | 2 | 13°6 | 69°4 | 5 41 | 29 | 85°2 | 0 41 | 1 | 15°8 | 70°9 | 5 41 | 19 | 86°0 | 11 41 | 8 | 15°1 | 70°3 | 5 41 | 26 | 88°2 | 11 41 | 6 | 17°9 | 76°5 | 6 | 30 | 88°0 | 3 | 6 | 16°5 | 73°9 | 6 | 21 | 90°9 | 2 | 3 | 19°0 | 73°7 | 83°1 | 9°4 | 68°3 | 84°9 | 16°6 | November. |
| December ... | 68°5 | 6 41 | 12 | 82°8 | 1 41 | 25 | 14°3 | 68°0 | 5 41 | 31 | 82°5 | 1 41 | 8 | 14°5 | 69°6 | 6 41 | 3 | 83°5 | 0 41 | 2 | 13°9 | 70°0 | 5 41 | 18 | 83°5 | 11 41 | 10 | 13°5 | 68°4 | 7 | 20 | 85°9 | 12* | 6 | 17°5 | 69°8 | 7 | 9 | 87°8 | 1 | 19 | 18°0 | 75°0 | 81°6 | 6°6 | 68°8 | 82°4 | 18°6 | December. |
| Year | 67°2 | 5 41 | ... | 100°8 | 2 41 | ... | 33°6 | 68°0 | 5 41 | ... | 95°5 | 2 41 | ... | 27°0 | 66°2 | 6 41 | ... | 103°3 | 1 41 | ... | 37°1 | 68°2 | 6 41 | ... | 104°4 | 0 41 | ... | 36°2 | 65°9 | 8 | ... | 90°3 | 2 | ... | 24°4 | 64°7 | 7 | ... | 91°9 | 2 | ... | 27°2 | 68°5 | 89°0 | 20°5 | 57°5 | 99°4 | 41°9 | Year. |

[Lieut.-Colonel SYKES's Discussion of the Meteorological Observations taken in India.]

* Noon.



maxima ranges of $21^{\circ}5$ and 21° occur in March and January, and the minimum, $9^{\circ}4$, was in August. The annual range was nearly double that of Bombay, namely, $41^{\circ}9$. The foot-note above alluded to has the following records:—

| | |
|--|----------------|
| 1846. Maximum heat in May | $105^{\circ}0$ |
| 1846. Minimum heat in January | $55^{\circ}0$ |
| 1847. Maximum heat in May | $109^{\circ}6$ |
| 1847. Minimum heat in February | $50^{\circ}0$ |

The range in these two years, therefore, being respectively 50° and $59^{\circ}6$ FAHR.; the thermometer rising higher and sinking lower than either at Madras, Bombay or Aden near the sea-level.

Range of Temperature at Aden.

Extending the comparison of thermometric range near the sea-level to Aden, in the latitude of Madras, but $35^{\circ}6$ to the westward of Madras, it will be seen that, unlike Bombay or Calcutta, the greatest range is not in the cold months, nor in the months in which the maximum heat occurs, but in those months in which the mean temperature is comparatively moderate, viz. March, April and October; the smallest range however occurring, as at Calcutta and Bombay, in what are called the monsoon months at those places, namely, May, June, July, August and September, while in those months at Madras the greatest range of the thermometer takes place. The greatest monthly range at Aden, $11^{\circ}2$, occurs in October, and the least monthly range, $6^{\circ}0$, is almost identical in the consecutive months of June, July, August and September. The annual range is $20^{\circ}5$. If the records of 1848 exhibit normal conditions, then the climate of the dreaded Aden is more equable than that of places on the sea-level on the coasts of India.

The annexed Table contains the elements of the preceding notices:—

Range of Temperature at High Levels.

With respect to the majority of the stations at different elevations above the sea, as hourly observations were not kept, and a maximum and minimum thermometer only used, at Mahabuleshwur and Dodabetta the *hours* of the occurrence of maxima and minima cannot be stated.



Sattarah.—Range of Thermometer.

At Sattarah, the results of four years' observations by Dr. MURRAY, from 1844 to 1847 inclusive, are as follows:—

| | Minimum temperature. | Maximum temperature. | Maximum daily range. | Maximum monthly range. |
|-----------------|----------------------|----------------------|----------------------|------------------------|
| January | 53°0 | 86°0 | 23°0 | 31°0 |
| February | 50°5 | 90°0 | 26°0 | 33°0 |
| March..... | 62°0 | 100°0 | 32°0 | 38°5 |
| April | 64°0 | 102°0 | 31°5 | 36°5 |
| May | 70°0 | 103°0 | 26°0 | 29°5 |
| June | 69°0 | 93°0 | 22°0 | 22°0 |
| July | 60°0 | 91°0 | 7°5 | 11°0 |
| August | 60°0 | 80°0 | 10°0 | 10°0 |
| September | 64°0 | 83°0 | 16°0 | 19°0 |
| October | 63°0 | 93°0 | 21°0 | 30°0 |
| November | 58°0 | 85°0 | 21°0 | 25°0 |
| December | 57°0 | 86°0 | 25°0 | 27°0 |
| Year | 50°5 | 103°0 | 32°0 | 38°5 |

The minima and maxima in temperature represent the highest and lowest state of the thermometer ever indicated in January in four years, and the same for the other months; and the maxima and minima are not necessarily in the same year. The ranges represent the greatest and least in any particular day or month.

The maximum temperature, at 2320 feet, exceeded that recorded in Bombay, and the daily and monthly range were greater, but considerably less than at Mahabuleshwur at 4500 feet. In four years at Sattarah the extreme range of the thermometer was 52°·5, from 50°·5 to 103°·0, while at Mahabuleshwur in fifteen years the range was only 47°·0. The minimum temperature does not appear to have been below 50°·5, while I have observed it about the latitude of Sattarah, and at 400 feet lower level, at 40°·5 in January; and at 3123 feet in May I had it rise, at 3½ P.M., to 105°.

The following is extracted from a synopsis of fifteen years' observations at Mahabuleshwur, from January 1829 to December 1843, from observations successively taken by Doctors WALKER, MOREHEAD and MURRAY:—

| Extreme daily range. | Extreme monthly range. | Extreme depression at night, thermometer exposed. | Months. | Maximum temperature. | Minimum temperature. | Range in fifteen years. |
|----------------------|------------------------|---|-----------------|----------------------|----------------------|-------------------------|
| 21°0 | 30°5 | 30°0 | January | 79°5 | 45°0 | 34°5 |
| 23·8 | 32·1 | 31·5 | February | 85·5 | 46·0 | 39·5 |
| 23·5 | 38·0 | 33·0 | March | 89·0 | 49·5 | 40·5 |
| 22·0 | 34·5 | 36·5 | April | 92·0 | 56·0 | 36·0 |
| 22·0 | 32·0 | 30·2 | May | 90·0 | 57·3 | 32·7 |
| 18·5 | 25·5 | | June..... | 84·0 | 53·0 | 31·0 |
| 12·7 | 18·5 | | July | 73·8 | 51·5 | 22·3 |
| 11·1 | 13·0 | | August..... | 70·8 | 53·0 | 17·8 |
| 14·0 | 17·0 | | September | 77·0 | 56·0 | 21·0 |
| 17·5 | 23·0 | 34·1 | October | 78·5 | 54·0 | 24·5 |
| 16·5 | 23·0 | 29·5 | November | 75·0 | 51·5 | 23·5 |
| 19·0 | 27·5 | 27·5 | December | 76·0 | 48·5 | 28·5 |
| 23·8 | 38·0 | 27·5 | Year..... | 92·0 | 45·0 | 47·0 |

Mahabuleshwur.—Range of Thermometer.

The range of the thermometer in fifteen years was 47° FAHR., from 92° in April to 45° in January, but it will be seen that the thermometer exposed to radiation at night had been as low as $27^{\circ}\cdot 5$, and in every month of the year, excepting the four monsoon months, verged upon the freezing-point; the maximum heat in the sun was 110° in April and May, at 9 A.M., but at midday it had risen to 127° . The extreme daily range never exceeded $23^{\circ}\cdot 8$, and the maximum monthly range was 38° FAHR. The record of the night thermometer at Mahabuleshwur giving instances of the temperature in five months of the year sinking below the freezing-point, although it is not described as being placed on the grass or ground, affords an explanation of an otherwise puzzling record in the Dodabetta observations, namely, "on the 15th, 16th, 17th and 22nd of November 1847, found ice around the office" (at sunrise?), although there is not any record of the thermometer below $45^{\circ}\cdot 2$ on the 16th at Dodabetta, and in the *hourly* observations of the 22nd the thermometer only once sank to $48^{\circ}\cdot 6$ at 11 o'clock at night; the extreme cold, therefore, must have been caused by radiation and evaporation*. An old officer, who had often resided at Mahabuleshwur, tells me that he has frequently witnessed hoar-frost on the ground at Mahabuleshwur, though he had never *remarked* the thermometer sinking below 45° . The highest temperature in the sun at Mahabuleshwur was 127° in March and May.

Dodabetta.—Range of Thermometer.

At Dodabetta the following are the maxima, minima and ranges:—

| | Minimum temperature. | Maximum temperature. | Maximum daily range. | Maximum monthly range. |
|-----------------|----------------------|----------------------|----------------------|------------------------|
| 1847. | | | | |
| February..... | $41^{\circ}\cdot 2$ | $61^{\circ}\cdot 0$ | $12^{\circ}\cdot 0$ | $19^{\circ}\cdot 8$ |
| March..... | $43^{\circ}\cdot 5$ | $67^{\circ}\cdot 0$ | $15^{\circ}\cdot 5$ | $23^{\circ}\cdot 5$ |
| April | $47^{\circ}\cdot 0$ | $66^{\circ}\cdot 5$ | $16^{\circ}\cdot 7$ | $19^{\circ}\cdot 5$ |
| May | $46^{\circ}\cdot 0$ | $65^{\circ}\cdot 8$ | $15^{\circ}\cdot 3$ | $19^{\circ}\cdot 8$ |
| June | $44^{\circ}\cdot 0$ | $60^{\circ}\cdot 0$ | $11^{\circ}\cdot 8$ | $16^{\circ}\cdot 0$ |
| July..... | $44^{\circ}\cdot 3$ | $59^{\circ}\cdot 0$ | $13^{\circ}\cdot 9$ | $14^{\circ}\cdot 7$ |
| August | $44^{\circ}\cdot 5$ | $59^{\circ}\cdot 1$ | $14^{\circ}\cdot 1$ | $14^{\circ}\cdot 6$ |
| September | $41^{\circ}\cdot 8$ | $59^{\circ}\cdot 0$ | $10^{\circ}\cdot 6$ | $17^{\circ}\cdot 2$ |
| October | $42^{\circ}\cdot 8$ | $58^{\circ}\cdot 8$ | $10^{\circ}\cdot 3$ | $16^{\circ}\cdot 0$ |
| November | $42^{\circ}\cdot 9$ | $61^{\circ}\cdot 1$ | $13^{\circ}\cdot 1$ | $18^{\circ}\cdot 2$ |
| December | $41^{\circ}\cdot 0$ | $60^{\circ}\cdot 4$ | $15^{\circ}\cdot 5$ | $19^{\circ}\cdot 4$ |
| 1848. | | | | |
| January | $38^{\circ}\cdot 5$ | $62^{\circ}\cdot 8$ | $19^{\circ}\cdot 5$ | $24^{\circ}\cdot 3$ |
| Year | $38^{\circ}\cdot 5$ | 67 | $19^{\circ}\cdot 5$ | $28^{\circ}\cdot 5$ † |

Hence it is seen that the Dodabetta temperature, at 8642 feet, compared with that of Mahabuleshwur at 4500 feet, has a decidedly diminished daily, monthly and annual range. It so happens that the lowest but not the highest state of the thermo-

* There is not any record of the radiation thermometer in November at Dodabetta, but in February it appears to have been twice below the freezing-point.

† Annual range.

meter, and the greatest daily and monthly range, occur in the same month at Dodabetta, namely, January 1848. The lowest temperature in the year was $38^{\circ}5$, the highest 67° , and the annual range $28^{\circ}5$. The greatest monthly range was $24^{\circ}3$.

Aqueous Vapour.

Preliminary to the discussion of the question of aqueous vapour, a few words are necessary on the caution requisite in generalizing on a limited number of facts, or on observations not extending over lengthened periods of time. The hourly observations of the wet bulb at Madras and Bombay, for 1843 and 1844, are apparently trustworthy and satisfactory, supposing the wet bulb theorem to be correct. Those at Calcutta were taken only twice daily, at $9^{\text{h}} 40^{\text{m}}$ A.M. and 4 P.M., and how far observations, taken twice only during the daytime, can be relied upon for the expression of normal conditions, will best be shown by the following comparison of observations of the wet bulb at Dodabetta at 8640 feet above the sea-level. The regular meteorological observations were recorded twice a day only, at $9^{\text{h}} 40^{\text{m}}$ A.M. and $3^{\text{h}} 40^{\text{m}}$ P.M., but on one day in each month independent observations were taken for twenty-four consecutive hours. In a table I have compared the means of the $9^{\text{h}} 40^{\text{m}}$ A.M. and $3^{\text{h}} 40^{\text{m}}$ P.M. observations with the means of the twenty-four consecutive hours for the same day. The discrepancies are considerable, and too numerous to admit of the supposition of their resulting from accident or carelessness. On the 21st and 22nd of January the hourly observations give a depression of the wet bulb of $9^{\circ}2$. The twice a day observations give a depression of $9^{\circ}4$; on the 21st and 22nd of March a depression respectively of $5^{\circ}7$ and $7^{\circ}7$; on the 21st and 22nd of April of $5^{\circ}2$ and $4^{\circ}2$; on the 21st and 22nd of May of $1^{\circ}8$ and $1^{\circ}33$; and on the 21st and 22nd of November of $7^{\circ}8$ and $6^{\circ}1$. A bare inspection of the several hygrometric records for Dodabetta will show the anomalous results in working out the dew-points, elastic force of vapour, and per-centage of vapour or fraction of saturation in the atmosphere by the tables founded on Dr. APJOHN'S formula. The hourly observations also demonstrate, that on the same day, in a transient fog without rain, there shall not be any depression whatever of the wet bulb; while in the course of the twenty-four hours there may be a great depression. For instance, at noon, on the 21st of December 1847, there was not any depression, but at 9 the next morning there was a depression of $3^{\circ}2$, the mean being $1^{\circ}6$, while the mean of the twenty-four hours was $0^{\circ}7$. At the former hour there was a fog, at the latter, partly a blue sky. Again, at 5 P.M., on the 21st of November, the depression was $1^{\circ}5$, but at 8 P.M. the depression was $10^{\circ}9$, the mean being $6^{\circ}2$, the mean of the twenty-four hours $7^{\circ}8$; in both cases there was nearly a blue sky. At noon, on the 21st of July, there was not any depression in a fog; at 5 A.M. of the 22nd a depression of $2^{\circ}0$, and *yet it was raining*. On the 21st of April, at 8 P.M., the depression was nil, an hour after it was $5^{\circ}5$; at both hours with nearly a blue sky, while at 7 A.M. of the 22nd the depression was $9^{\circ}5$, with a cloudy sky. Supposing these to have been the only observations available for the respective days,

could any of them or their means have been safely taken to express normal conditions? Professor ORLEBAR, in his Meteorological Observations at Bombay for 1846, gives proofs of the necessity for caution in the use of the wet bulb: in the first place, he was obliged to abandon the records of the air-thermometer attached to the wet bulb from the irregular depression of the former, by the cold of the evaporating surface of the latter; and in the next place, on the comparison of the action of two wet bulbs, one inside the observatory and the other outside, he records discrepancies in March ranging from $3^{\circ}2$ plus to $2^{\circ}6$ minus; the comparisons in April and May exhibited minor discrepancies, excepting on the 27th of April at the 18th hour, when the discrepancy was 3° minus. Professor ORLEBAR having used DANIELL'S hygrometer simultaneously with the wet bulb for eight months in 1846, the means of comparison are afforded, and the following Table exhibits the results. I have taken the two daily observations at $9^{\text{h}} 12^{\text{m}}$ A.M. and $3^{\text{h}} 12^{\text{m}}$ P.M. on the first day of each month for the comparison.

| Dates. | | | Barometer. | Thermometers. | | Dew-point by | | Tension of vapour by | | Fraction of saturation or per-centage of moisture in the air by | |
|---------------|------|--------------|------------|---------------|------|--------------|-----------------------|----------------------|-----------------------|---|-----------------------|
| Months. | Day. | Local hours. | | Dry. | Wet. | Wet bulb. | DANIELL'S hygrometer. | Wet bulb. | DANIELL'S hygrometer. | Wet bulb. | DANIELL'S hygrometer. |
| January | 1st | h m | in. | | | | | | | | |
| | | 9 12 | 30.092 | 79° | 72.8 | 70° | 66.8 | 0.726 | 0.655 | 75 | 67½ |
| February ... | 1st | 3 12 | 29.942 | 83.5 | 73.3 | 68.6 | 69.9 | 0.695 | 0.724 | 62 | 64¾ |
| | | 9 12 | 29.987 | 76.3 | 71.6 | 69.4 | 73.0 | 0.713 | 0.801 | 80 | 90 |
| March..... | 1st | 3 12 | 29.879 | 80.4 | 72.0 | 68.05 | 71.0 | 0.682 | 0.751 | 67 | 74 |
| | | 9 12 | 30.003 | 79.6 | 73.5 | 70.8 | 75.1 | 0.746 | 0.856 | 75½ | 86¾ |
| April | 1st | 3 12 | 29.878 | 83.3 | 75.6 | 72.35 | 75.5 | 0.785 | 0.867 | 70 | 78 |
| | | 9 12 | 29.899 | 84.4 | 75.4 | 71.6 | 73.5 | 0.765 | 0.814 | 66½ | 70¾ |
| May | 1st | 3 12 | 29.804 | 87.6 | 74.2 | 68.15 | 73.1 | 0.684 | 0.803 | 54 | 63¼ |
| | | 9 12 | 29.834 | 92.5 | 80.8 | 76.55 | 80.8 | 0.897 | 1.027 | 60¾ | 69 |
| June | 1st | 3 12 | 29.731 | 96.8 | 80.5 | 74.4 | 76.9 | 0.838 | 0.907 | 50 | 54 |
| | | 9 12 | 29.748 | 83.2 | 80.8 | 80.0 | 81.5 | 1.000 | 1.049 | 90 | 94¾ |
| July | 1st | 3 12 | 29.668 | 90.7 | 84.4 | 82.45 | 81.5 | 1.081 | 1.049 | 78 | 75 |
| | | 9 12 | 29.615 | 81.4 | 80.0 | 79.2 | 78.5 | 0.976 | 0.955 | 90 | 88½ |
| August | 2nd | 3 12 | 29.585 | 81.8 | 79.0 | 78.0 | 78.8 | 0.939 | 0.964 | 88¾ | 91½ |
| | | 9 12 | 29.728 | 81.2 | 79.9 | 79.45 | 78.6 | 0.984 | 0.958 | 94¾ | 92 |
| September ... | 1st | 3 12 | 29.678 | 84.4 | 81.0 | 79.85 | 77.5 | 0.996 | 0.925 | 86¾ | 80½ |
| | | 9 12 | 29.735 | 84.0 | 80.0 | 78.6 | 77.5 | 0.957 | 0.925 | 84½ | 81½ |
| | | 3 12 | 29.666 | 83.8 | 80.0 | 78.7 | 76.3 | 0.959 | 0.890 | 85 | 79 |

These observations having been made by the instructed and practiced manipulators of the Bombay Observatory, claim to be worthy of confidence; but we find ourselves in doubt which of the two sets to use for the correction of the barometer and to determine the real amount of moisture in the atmosphere. It would appear, that when the depression of the wet bulb and of DANIELL'S hygrometer is small in the monsoon months, their results do not differ very widely, the wet bulb however giving a higher tension of vapour and greater per-centage of moisture or fraction of saturation in the atmosphere than DANIELL'S hygrometer; but in the cold and hot months of the year

this is reversed; considerable discrepancies occur in the results, and the tension of vapour is much higher (with one exception) and the per-centage of moisture much greater by DANIELL's hygrometer than by the wet bulb, the dew-point by the two instruments differing from 3° to 5° . On the 1st of February, in the morning, the two instruments differ ten per cent. in the amount of moisture in the atmosphere. In the afternoon they differ seven per cent., in both instances DANIELL's hygrometer giving the greatest amount. On August the 2nd and September the 1st, in the afternoon, the instruments differ above six per cent., but at this period of the year the wet bulb gives the greatest amount of moisture in the atmosphere and DANIELL's hygrometer the least. The greatest depression of the dew-point in the above observations was $22^{\circ}\cdot4$ on the 1st of May at $3^{\text{h}} 12^{\text{m}}$ P.M. In a former paper in the Philosophical Transactions I mentioned a depression of 40° , from 67° to 27° , on the 13th of March 1828 at sunrise in the Hill Fort of Loghur, and of 61° on the 16th of February 1828 at 4 P.M. at Downde near Pairgaum on the Beema river.

I have put into juxtaposition with this table a comparison of the results of hourly observations at Dodabetta of the wet bulb, with the two regular observations made on the same day. In November the simultaneous dew-points by the two processes are $36^{\circ}\cdot1$ and $42^{\circ}\cdot15$; in January $30^{\circ}\cdot7$ and $33^{\circ}\cdot2$; in March $43^{\circ}\cdot3$ and $39^{\circ}\cdot6$, and in April $42^{\circ}\cdot2$ and $40^{\circ}\cdot95$. Whether therefore there be $59\frac{1}{2}$ or 69 per cent. of moisture in the atmosphere in November; 71 or $61\frac{1}{2}$ per cent. in March; or 73° or $78\frac{1}{2}$ per cent. in April, nothing short of continued hourly observations, like those at Madras and Bombay, will enable the meteorologist to determine.

Dodabetta.—Simultaneous observations, 8640 feet, on the 21st and 22nd of each month.

| Depression of the wet bulb by | | | | |
|-------------------------------|----------------------|---------------------|----------------------|---------------------------|
| | Hourly observations. | Twice a day, ditto. | Dew-point by hourly. | Dew-point by twice a day. |
| January | 9·2 | 9·4 | 30·7 | 33·2 |
| February | 1·4 | 0·9 | 49·7 | 50·3 |
| March | 5·7 | 7·7 | 43·3 | 39·6 |
| April | 5·2 | 4·2 | 42·2 | 40·95 |
| May | 1·8 | 1·33 | 54·2 | 55·8 |
| June | 0·5 | 0·2 | 51·2 | 51·75 |
| July | 0·8 | 0·23 | 53·15 | 53·75 |
| August | 0·5 | 0·37 | 54·35 | 55·43 |
| September | 0·4 | 0·6 | 52·95 | 53·1 |
| October | 0·7 | 0·4 | 53·1 | 52·9 |
| November | 7·8 | 6·1 | 36·1 | 42·15 |
| December | 0·7 | 0·95 | 50·65 | 50·65 |

Any such high per-centage of moisture however was not the case on the plains of the Deccan, where the dew-point was determined by DANIELL's hygrometer.

The natives of the Deccan divide the year into three seasons—the Hewalla (cold), Oonalla (hot), and Pawsalla (wet) seasons; the per-centage of vapour was in the

Cold months, Nov., Decem., Jan., Feb. 46½ per cent. of moisture.
 Hot months, March, April and May 42½ per cent. of moisture.
 Wet or monsoon months, June, July, Aug., Sept., Oct. . . 77·4 per cent. of moisture.

But another uncertainty is the numerical value to be given to the wet bulb readings, whether by APJOHN'S formula or by the means of factors, which Mr. GLAISHER of the Royal Observatory has adopted from a comparison of observations between the wet bulb and DANIELL'S hygrometer. Dr. MURRAY, in charge of the Sanatorium at Mahabuleshwur, at 4500 feet, observed with the wet bulb for nine years, and has given the mean monthly depression of the wet bulb for that period in the Journal of the Physical Society of Bombay. He does not give any details of the character of his instruments, or with what precautions he used them, and as from 250 to 300 inches of rain fall at Mahabuleshwur in the S.W. monsoon months, it might have been expected that the air would have been much nearer to a state of saturation in those months than appears to be the case at Dodabetta in the same months, in which only 29 to 30 inches of rain fall. Subjecting these observations to the two methods, it is seen that the results go very well together with small depressions of the wet bulb and at temperatures ranging from 65° to 75°, but with depressions above 10° they immediately diverge, and the divergence would increase with greater depressions and at lower temperatures of the air.

Mahabuleshwur.—Nine years' Means of the Wet Bulb.

| | Dry. | Depression. | Dew-point by GLAISHER. | Dew-point by APJOHN. | Tension by GLAISHER. | Tension by APJOHN. | Per-centage moisture by GLAISHER. | Per-centage moisture by APJOHN. |
|-------------------|------|-------------|---------------------------|-------------------------|-------------------------|-----------------------|---|---------------------------------------|
| January | 69·2 | 9·8 | 54·5 | 53·35 | ·435 | ·418 | 61·4 | 59·0 |
| February | 69·6 | 13·0 | 50·1 | 47·4 | ·376 | ·341 | 32·3 | 47·5 |
| March | 75·3 | 15·7 | 51·75 | 49·35 | ·396 | ·365 | 45·9 | 42·3 |
| April | 78·1 | 15·4 | 55·0 | 53·8 | ·442 | ·424 | 46·9 | 44·9 |
| May | 76·4 | 9·5 | 62·15 | 62·4 | ·562 | ·566 | 62·9 | 63·3 |
| June | 70·7 | 2·6 | 66·8 | 67·0 | ·655 | ·658 | 88·1 | 88·5 |
| July | 68·8 | 1·8 | 66·1 | 66·2 | ·640 | ·641 | 91·5 | 91·6 |
| August | 67·4 | 1·7 | 64·68 | 64·95 | ·611 | ·615 | 91·4 | 92·0 |
| September | 67·9 | 2·7 | 63·58 | 63·95 | ·589 | ·596 | 86·7 | 87·7 |
| October | 68·2 | 6·4 | 57·96 | 58·25 | ·489 | ·493 | 71·4 | 71·9 |
| November | 67·3 | 7·7 | 54·98 | 54·95 | ·442 | ·442 | 66·4 | 66·4 |
| December | 66·9 | 7·8 | 54·42 | 54·35 | ·434 | ·432 | 66·0 | 65·7 |
| Fifteen years ... | 70·4 | 7·84 | 58·64 | 58·25 | ·500 | ·493 | 67·9 | 66·9 |

Bearing therefore these discrepancies in mind, it may be justifiable to generalize so far only as to assert that two or three (or even four) observations with any meteorological instrument within the twenty-four hours, even under favourable circumstances, can do little more than give approximations to the truth; and that hourly observations, extending through four or five years at least, can alone satisfy the scientific

meteorologist, to enable him to determine the normal or abnormal atmospheric phenomena of the *locality* in which the observations are taken; and he will distrust the applicability of these *local* determinations to any other places situated beyond a certain circumscribed area.

With these remarks I proceed to consider the hygrometric features of certain widely separated stations in India, both at the sea-level and elevated at 1800 and 4500 and 8640 feet above the sea. The most marked feature is the singularly small monthly mean depression of the wet bulb, the high figures of the elastic force of vapour, and the great per-centage of moisture in the atmosphere; not only at the sea-levels of Madras, Bombay, Aden and Calcutta, but at Dodabetta, at 8640 feet above the sea, whether during the monsoons or during the cold and hot months, which are generally supposed to be the dry portion of the year, and the annexed Table exhibits the results.

At neither of the Presidencies is there a mean monthly per-centage of vapour at Madras below 67, at Bombay below 66, at Calcutta below 63, and at Dodabetta below 51, while the maximum at Dodabetta goes up to 98, and at Calcutta to 94; at Bombay it did not exceed 88, and at Madras, in two years, it only twice attained a mean maximum of 83 per cent. of moisture in the atmosphere. The mean annual per-centage of moisture in the air, it will be seen for the years 1843 and 1844, was at Madras respectively 75 and $74\frac{1}{2}$, at Bombay 76 and 76, at Calcutta 80 and 84, at Aden 71, at Mahabuleshwur $67^{\circ}9$, and at Dodabetta, for 1847-48, it was 90° . In the Deccan, in 1827, only 55° , as determined by DANIELL'S hygrometer. The difference between the annual mean temperature of the air and the annual mean temperature of the dew-point, was—

| Madras. | | Bombay. | | Calcutta. | | Dodabetta. | Deccan. | Aden. | Mahabuleshwur. |
|---------|-------|---------|-------|-----------|-------|------------|---------|-------|-------------------|
| 1843. | 1844. | 1843. | 1844. | 1843. | 1844. | 1847-48. | 1827. | 1848. | Means of 9 years. |
| 9 | 9.24 | 8.65 | 8.65 | 6.95 | 5.3 | 3.1 | 17.9 | 7.5 | 12.2 |

The air at Madras, Bombay and Calcutta, is unquestionably more moist than that of the interior; but the feeling and experience so little lead one to expect the high dew-points indicated, particularly in the cold and hot months, that some inaccuracy of observation or fallacy in deduction might be feared, were not the ability and zeal of the observers at Madras and Bombay, combined with the observations being hourly, a sufficient guarantee against error. At Calcutta, however, situated sixty miles from the sea, the hygrometric observations make the air much more moist even than at Madras and Bombay. This is contrary to probability, and may be owing to the means of the observations, made only twice a day, not giving the real mean of the twenty-four hours. At the peak or ridges of Dodabetta the air would appear to be nearly in a constant state of saturation; and there is a possibility in the circumstance, considering that it is the highest eminence in the peninsula of India and might be expected

| Months. | Madras. | | | | | | | | Bombay. | | | | | | | | Calcutta. | | | | | | | | Aden, 187 feet. | | | | Deccan, mean height 1800 feet. | | | | Mahabuleshwur, 4500 feet. | | | | Dodabetta, 8640 feet. | | | | Dodabetta, 8640 feet. | | | | Month. |
|---------------|-------------------|-------------------|----------------|------------------------|-------------------|-------------------|----------------|------------------------|-------------------|-------------------|----------------|------------------------|-------------------|-------------------|----------------|------------------------|-------------------|-------------------|----------------|------------------------|-------------------|-------------------|----------------|------------------------|-------------------|-------------------|----------------|------------------------|--|-----------------------|----------------|------------------------|---|-------------------|----------------|------------------------|------------------------------|-------------------|----------------|------------------------|--|-------------------|----------------|------------------------|------------|
| | 1843. | | | | 1844. | | | | 1843. | | | | 1844. | | | | 1843. | | | | 1844. | | | | 1848. | | | | Sunrise 9 to 10 A.M. and 4 to 5 P.M. 1827. | | | | Means of 9 years, 1835 to 1843 inclusive. | | | | 1847 to 1848. Monthly means. | | | | Hourly observations, 21st to 22nd. Monthly, 1847-48. | | | | |
| | Thermometer, dry. | Thermometer, wet. | Elastic force. | Per-centage of vapour. | Thermometer, dry. | Thermometer, wet. | Elastic force. | Per-centage of vapour. | Thermometer, dry. | Thermometer, wet. | Elastic force. | Per-centage of vapour. | Thermometer, dry. | Thermometer, wet. | Elastic force. | Per-centage of vapour. | Thermometer, dry. | Thermometer, wet. | Elastic force. | Per-centage of vapour. | Thermometer, dry. | Thermometer, wet. | Elastic force. | Per-centage of vapour. | Thermometer, dry. | Thermometer, wet. | Elastic force. | Per-centage of vapour. | Thermometer, dry. | DANIELL'S hygrometer. | Elastic force. | Per-centage of vapour. | Thermometer, dry. | Thermometer, wet. | Elastic force. | Per-centage of vapour. | Thermometer, dry. | Thermometer, wet. | Elastic force. | Per-centage of vapour. | Thermometer, dry. | Thermometer, wet. | Elastic force. | Per-centage of vapour. | |
| January | 77°59 | 72°32 | ·726 | 79 | 75°71 | 69°57 | ·651 | 75 | 76°3 | 68°0 | ·598 | 69 | 75°4 | 67°5 | ·581 | 67 | 74°9 | 68°9 | ·674 | 79 | 74°1 | 68°7 | ·636 | 76 | 74°9 | 68°9 | ·634 | 74½ | 72°53 | 50°31 | ·377 | 47 | 69°2 | 59°4 | ·435 | 61·4 | 52°1 | 46°15 | ·277 | 69 | 49°5 | 40°3 | ·190 | 51½ | January. |
| February ... | 77°90 | 71°86 | ·705 | 76 | 77°74 | 71°45 | ·694 | 75 | 78°0 | 70°7 | ·645 | 68 | 73°3 | 68°6 | ·608 | 68 | 81°4 | 71°8 | ·663 | 63 | 79°3 | 72°8 | ·723 | 73 | 75°6 | 69°4 | ·643 | 74 | 75°19 | 44°39 | ·308 | 36 | 69°6 | 56°6 | ·375 | 52·3 | 52°3 | 50°8 | ·379 | 93 | 52°0 | 50°6 | ·369 | 91 | February. |
| March | 81°52 | 75°22 | ·791 | 76 | 82°20 | 75°51 | ·796 | 75 | 79°7 | 73°0 | ·726 | 73 | 79°5 | 73°4 | ·743 | 75 | 86°9 | 79°9 | ·920 | 74 | 88°4 | 81°3 | ·965 | 74 | 78°4 | 72°9 | ·737 | 77½ | 74°73 | 48°83 | ·358 | 42 | 75°3 | 59°6 | ·396 | 45·9 | 53°0 | 48°8 | ·323 | 78 | 53°3 | 47°6 | ·296 | 71 | March. |
| April | 85°19 | 78°93 | ·899 | 77 | 86°34 | 79°73 | ·921 | 76 | 84°2 | 77°9 | ·867 | 76 | 84°1 | 78°1 | ·876 | 77 | 91°3 | 83°2 | ·918 | 64 | 91°5 | 84°9 | 1·095 | 76 | 81°3 | 75°4 | ·800 | 76¾ | 87°22 | 55°34 | ·447 | 36 | 78°1 | 62°7 | ·442 | 46·9 | 56°4 | 53°35 | ·393 | 84 | 52°4 | 47°2 | ·296 | 78 | April. |
| May | 85°02 | 79°06 | ·908 | 78 | 86°98 | 79°98 | ·925 | 75 | 85°9 | 79°8 | ·927 | 77 | 85°9 | 78°8 | ·885 | 73 | 91°2 | 84°2 | 1·066 | 75 | 89°0 | 85°7 | 1·161 | 87 | 86°7 | 79°4 | ·902 | 73 | 84°75 | 64°54 | ·608 | 52 | 76°4 | 66°9 | ·561 | 62·9 | 57°2 | 54°95 | ·423 | 88 | 57°9 | 56°1 | ·444 | 91¼ | May. |
| June | 85°52 | 78°05 | ·860 | 73 | 88°58 | 78°82 | ·859 | 67 | 85°3 | 80°0 | ·943 | 79 | 85°3 | 79°9 | ·938 | 79 | 89°0 | 84°3 | 1·085 | 79 | 87°9 | 85°1 | 1·144 | 90 | 87°4 | 79°4 | ·895 | 71 | 79°99 | 72°48 | ·788 | 84 | 70°7 | 68°1 | ·655 | 88·1 | 52°5 | 51°8 | ·391 | 96 | 52°0 | 51°5 | ·389 | 97 | June. |
| July | 85°79 | 76°73 | ·803 | 67 | 85°76 | 77°86 | ·850 | 72 | 82°0 | 78°4 | ·912 | 85 | 81°9 | 79°0 | ·938 | 88 | 87°0 | 82°9 | 1·052 | 84 | 85°1 | 83°7 | 1·109 | 93 | 86°5 | 77°8 | ·839 | 68½ | 77°03 | 71°69 | ·768 | 84 | 68°8 | 67°0 | ·640 | 91·5 | 52°60 | 52°15 | ·398 | 97 | 54°4 | 53°6 | ·415 | 96 | July. |
| August | 84°51 | 76°95 | ·826 | 72 | 85°25 | 77°94 | ·858 | 73 | 81°2 | 77°2 | ·872 | 84 | 81°6 | 78°0 | ·900 | 85 | 86°6 | 82°6 | 1·043 | 85 | 84°6 | 83°3 | 1·096 | 94 | 85°5 | 76°0 | ·778 | 65½ | 76°21 | 71°03 | ·751 | 84 | 67°4 | 65°7 | ·611 | 91·4 | 53°10 | 52°5 | ·401 | 96 | 55°1 | 54°6 | ·432 | 97 | August. |
| September ... | 84°26 | 77°21 | ·839 | 74 | 82°97 | 77°37 | ·861 | 79 | 81°1 | 77°3 | ·876 | 84 | 80°7 | 77°0 | ·869 | 86 | 86°7 | 82°7 | 1·046 | 85 | 86°4 | 84°3 | 1·123 | 92 | 86°1 | 78°0 | ·851 | 70¼ | 77°24 | 71°11 | ·753 | 82 | 67°9 | 65°2 | ·589 | 86·7 | 52°45 | 51°75 | ·390 | 96 | 53°6 | 53°2 | ·413 | 98 | September. |
| October | 80°72 | 76°50 | ·851 | 83 | 80°53 | 75°86 | ·828 | 82 | 82°2 | 76°5 | ·832 | 77 | 83°5 | 78°0 | ·879 | 79 | 86°4 | 80°6 | ·956 | 78 | 84°6 | 82°8 | 1·073 | 93 | 83°2 | 75°7 | ·790 | 71¼ | 77°71 | 58°68 | ·501 | 53 | 68°2 | 65°8 | ·489 | 71·4 | 53°30 | 52°8 | ·406 | 97 | 54°2 | 53°5 | ·415 | 96 | October. |
| November ... | 77°83 | 71°71 | ·702 | 76 | 79°17 | 72°41 | ·713 | 73 | 80°3 | 72°2 | ·690 | 68 | 80°8 | 72°1 | ·681 | 66 | 80°3 | 74°4 | ·772 | 76 | 82°1 | 78°9 | ·931 | 87 | 81°7 | 71°3 | ·642 | 60¾ | 75°46 | 55°54 | ·451 | 54 | 67°3 | 59°6 | ·442 | 66·0 | 52°15 | 50°95 | ·378 | 94 | 51°0 | 43°2 | ·230 | 59½ | November. |
| December ... | 75°89 | 70°73 | ·691 | 79 | 76°94 | 72°90 | ·755 | 83 | 76°7 | 68°6 | ·603 | 67 | 79°6 | 71°6 | ·676 | 68 | 74°3 | 69°1 | ·762 | 94 | 75°9 | 71°8 | ·724 | 82 | 76°8 | 69°8 | ·644 | 71¼ | 72°59 | 51°31 | ·390 | 49 | 66°9 | 59°1 | ·434 | 66·0 | 50°80 | 48°75 | ·341 | 86 | 51°8 | 51°1 | ·382 | 96 | December. |
| | 81°81 | 75°44 | ·796 | 75 | 82°34 | 75°78 | ·803 | 74½ | 81°1 | 75°0 | ·736 | 76 | 81°2 | 75°1 | ·789 | 76 | 83°8 | 78°7 | ·905 | 80 | 84°07 | 80°25 | ·961 | 84 | 82°0 | 74°5 | ·758 | 71 | 77°55 | 59°60 | ·516 | 55 | 70°4 | 62°56 | ·500 | 66·9 | 53°16 | 51°2 | ·373 | 90 | 53°02 | 50°13 | ·352 | 87 | Year. |

[Lieut.-Colonel SYKES'S Discussion of Meteorological Observations taken in India.]



to attract much vapour, nevertheless the greatest quantity of rain does not fall at Dodabetta. The mean of the hourly observations once a month, and the mean of the two observations daily throughout the year, giving respectively 87 per cent. and 90 per cent. of moisture in the air at Dodabetta, observation and expectation thus go pretty well together, and the records might be satisfactory, were there not doubts about the manipulations with the wet bulb. The hygrometric observations in the Deccan with DANIELL'S hygrometer, which were taken by myself thrice daily, are quite in accord with the feelings and with the expectations of the observer, excepting for the month of March, in which the feelings indicate the air to be quite as dry as in the months of February or April, but which the hygrometer indicates to be 6 per cent. nearer to saturation than in either February or April. At Aden, in the latitude of Madras, on the arid coast of Arabia, where little rain falls, the mean monthly and annual per-centage of moisture appears unexpectedly high; the lowest per-centage ($60\frac{3}{4}$) is in November, and the next lowest $68\frac{1}{2}$ and $65\frac{1}{2}$ respectively in August and September. The maximum per-centage was $77\frac{1}{2}$ in March, and the mean for the year 71. These results have a certain relation to the phenomena at Madras, which is destitute of a S.W. monsoon. The mean maximum tension of vapour was .902 in May at Aden.

The mean monthly and annual results at the several stations have no doubt a certain relation to truth, as it is seen that the per-centages of moisture or fractions of saturation in the atmosphere in the different months of the year have an increasing or diminishing amount as the several months approximate to, or recede from, the monsoon months of the year; this is sufficiently shown at Madras, where the monsoon months are the dry months at Bombay and in the Deccan. Nevertheless the amount of moisture in the atmosphere, deduced from the observations of the wet bulb, is so very great compared with the amount determined by the direct method by DANIELL'S hygrometer (itself an imperfect instrument) in the Deccan, and at some of the stations is so little in accord with personal recollections and experience, that I cannot refrain from suspecting some error of observation, some mismanagement in the manipulations, or a fallacy in the formula by which the dew-point is deduced from the temperature of the wet bulb. The first cause of error that struck me was that arising from the proximity of the dry to the wet bulb, as noticed by Professor ORLEBAR in his Report of Meteorological Observations taken at the Bombay Observatory in 1846. He had a stand erected out of doors, 6 feet high, and with a thatched roof, and every precaution was taken to guard off radiation by layers of cotton and tow upon a board under the roof upon which the meteorologic instruments were placed; there was lateral access for the air all round. He soon found that the dry bulb, in the neighbourhood of the wet bulb, was almost always depressed below the neighbouring *standard* thermometer, and that the depression of the *dry* bulb was greater as the depression of the wet bulb below the standard was greater. Professor ORLEBAR explains this in the following words:—“This seems accountable only on the

supposition that heat is extracted from the air to form the shell of moisture round the wet bulb at a distance as far off as the dry bulb." These discrepancies amounted on the 3rd and 14th of November, at the 19th hour, Göt. mean time:—

| | | | | | | | |
|----------------|-------|-----------|------|----------------|------|-------------|------|
| Standard . . . | 82°·4 | Dry . . . | 76·5 | Wet bulb . . . | 71·8 | Diff. . . . | 5°·9 |
| Standard . . . | 82°·4 | Dry . . . | 75·4 | Wet bulb . . . | 69·3 | Diff. . . . | 7·0 |

Professor ORLEBAR therefore abandoned observing with the attached dry bulb. But supposing this cause of error to have been overlooked by other observers, the tension of vapour and the per-centage humidity would have been recorded by them greatly higher than the truth; and if we apply this source of error to the mean monthly and annual results in the comparative table I have given;—for instance, to the annual mean for Dodabetta, the 90 per cent. is reduced, for the first difference, to 64 per cent., and if the correction be made for 7°, by depression of the dry bulb below a standard owing to its proximity to the wet bulb, the 90 per cent. of moisture at Dodabetta is reduced to 60 per cent. Professor ORLEBAR says the dry bulb *always* stood below the standard (and he had determined that it was not owing to error in graduation of the thermometers), often to the extent of 2°, and even in the monsoon month of September I observe that on the 2nd it was 3°·4 minus. Any amount of error in depression would necessarily affect the numerical determinations of the tension of vapour and degree of humidity; but supposing it not to exceed 2°, even this small depression would reduce the 90 per cent. of moisture in the air at Dodabetta to 80 per cent. Supposing therefore that the same error was not discovered at the other places of observation as was discovered in Bombay, there is necessarily some ground for the expression of my doubts, whether the air really did hold at the different stations the quantity of moisture represented by the figures I have elaborated. But Professor ORLEBAR observed another source of error, contingent upon the *locality* of the wet bulb apparatus, whether placed within doors or out of doors. To determine the amount of error he placed a wet bulb *within* the observatory, observing simultaneously with the wet bulb *out* of doors upon the meteorologic stand. This was done hourly for March, April, and to the 10th of May. The reading was almost always plus with the wet bulb inside; on the 22nd of March, at 19th hour, to the extent of 3°·2, while at 18th hour it had been only 0·2 plus; but there were great irregularities in the readings, being plus or minus dependent apparently upon drafts of air within the observatory, which would depress the wet bulb or raise it. Also the "atmosphere within the room would tend to keep up a reading at any time to whatever it had been at a time preceding," and the latter, Professor ORLEBAR says, was the principal cause of the plus readings in-doors. Supposing this error of 3° to be applied as a correction to the reading of the annual means of the wet bulb at Bombay for 1843, the percentage of moisture in the atmosphere would only be 65 instead of 76. The distinguished experimental philosopher REGNAULT has pointed out the same sources of error. He placed the dry and wet bulb in the open air in the court of the College of

France, in a closed room in the College, and in the theatre of the College, opening the windows. In the open air, with a temperature ranging from $7^{\circ}16$ to $17^{\circ}88$ Centigrade, and a depression ranging from $1^{\circ}86$ to $9^{\circ}60$, the results, by observation and by M. REGNAULT's tentative formula*, were sufficiently satisfactory; but in the closed chamber he says, "Les fractions de saturation calculées avec la formule †, sont ici beaucoup plus fortes que celles que l'on dednit des pesées directes de l'eau renfermée dans l'air; en d'autres termes la température t' marquée par le thermomètre mouillé n'est pas assez abaissée par la vaporisation de l'eau que se fait à sa surface pour donner dans la formule la véritable force élastique x de la vapeur. Cette circonstance tient évidemment à ce que l'air se trouve beaucoup moins agité qu'à l'extérieur."—Page 219. At page 220 M. REGNAULT adds, "Ces expériences démontrent de la manière la plus évidente que la formule ne peut pas rester la même pour les divers états d'agitation de l'air."

Here then is a second source of error; and it is somewhat curious that Professor ORLEBAR, in guarding against another grave source of error, which will be adverted to, himself contributes to an error of observation. He had observed the effect of wind blowing upon the wet bulb in unduly depressing the temperature, and to guard against this he says, "As it was equally essential that the bulb of this thermomètre should not be exposed to the wind, and that it should be in the same body of air as the air-thermometer when the latter was exposed to the wind, a small mirror, about an inch square, was put on a little stand, and this being placed upon the tin board could be moved about by the observer into such a position that it might always *cut off the wind from the bulb of the wet thermometer only*" (page lxiii.). Now the wet bulb being thus screened, would be buried in its own vapour and the reading would necessarily be too high. When the air is perfectly calm the same would be the result without the screen, for there would be a shell or coat of saturated air round the bulb. I had occasion to notice this local character of aqueous vapour in my Meteorology of the Deccan, where I constantly witnessed it, as regulated in its distribution by nature. Speaking of dew, I said in the year 1828, "At Marheh in the Pergunnah of Mohol, garden produce (which is usually irrigated during the day-time) was covered with a copious dew every morning; the lands bordering the gardens for forty or fifty yards around were slightly sprinkled with it, *but there was not a vestige of it* in the fields constituting the rising ground north and south of the tract of garden land." Hence I inferred that "aqueous vapour had been taken up by the action of the sun during the day, *suspended over the spot*, and deposited by the lower temperature at night as dew upon the land in proportion to the supply obtained by day." My tents were within 200 yards of the fields where I observed these phenomena, but from the 11th to the 30th of January 1828, there was not any deposition of dew about them, excepting on the 13th of January. In consequence of these observations I was induced

* Annales de Chimie, tom. xv. p. 218.

† $x = f' - \frac{0.429(t-t')}{610-t'}H.$

to remark particularly the localities of dew at Poona and in its neighbourhood. In September and October I found that when there was not a trace of dew in the cantonment, there would be a deposition on the fields of standing grain half a mile distant, and when there was not any dew either in the cantonment or in the fields, it would yet be found on the banks of running rivulets and on the banks of the Mota Mola River; but with respect to the rivulets, "*fifteen or twenty feet from the water were the limits of the deposition.*" I gave numerous other instances of the local deposition of dew proximate to irrigated lands, or in the neighbourhood of water, indicating the suspension of vapours over the localities, in complete analogy with what occurs to the wet bulb thermometer when the air is calm. That agitation of the air is necessary to disperse the vapour surrounding a wet bulb, has been noticed by British chemists. BRAND says (page 111, last edition), "It is now established that the pressure of air is really an obstacle to evaporation, and that *a current* is useful, not by supplying new quantities of air, but *by removing the vapour* according as it is formed and leaving fresh spaces into which the vapours may expand." He elsewhere says (page 82), "Evaporation is proportional to the surface exposed; it is also accelerated by agitating the superincumbent air, as in the case of a brisk wind, or by artificial means. When the *air is tranquil the vapour rests upon the surface of the water, and it is the pressure of its own vapour on the surface of a liquid, and not that of the gaseous atmosphere which stops the process.*" M. REGNAULT has demonstrated the truth of this in an elaborate manner. Accounting for the different results of observations in a closed and open chamber, he says the wet bulb was not sufficiently depressed in the closed chamber. "Cette circonstance tient évidemment à ce que l'air se trouve beaucoup moins agité qu'à l'extérieur*." After experimenting in a room with two windows open, he adds, as before stated, "Ces expériences démontrent de la manière la plus évidente que la formule ne peut pas rester la même pour divers états d'agitation de l'air." (P. 220.) The vapour therefore resting upon the wet bulb is a source of error, but the removal of it leads to one much more grave. M. REGNAULT, in reference to M. AUGUST's formula, says (p. 207), "La formule ne tient aucun compte de la vitesse du courant d'air; d'après cette formule, la différence de température devrait être la même, quelle que soit cette vitesse. Ce résultat paraît impossible à priori. J'ai cherché à déterminer *par des expériences directes*, l'influence de cette vitesse et à reconnaître si, à partir d'une certaine valeur de la vitesse, les différences de température des thermomètres sec et mouillé deviendraient indépendantes de la vitesse absolue du courant d'air, conséquence à laquelle on se trouve naturellement conduit par le raisonnement que M. AUGUST applique au calcul de la formule du psychromètre." M. REGNAULT then describes his apparatus and mode of making his experiments. He gives two series of experiments; in the second experiment the air being made to blow upon the wet bulb with a greater velocity than in the first. It will be sufficient to give the first and sixth figures of each series.

* Annales de Chimie, tom. xv. p. 219.

| | t^* . | t' . | $t-t'$. |
|----------------------------|---------------------|--------------------|---|
| 1st series. 1st experiment | 14 ^o ·66 | 7 ^o ·28 | 7 ^o ·38 Centigrade thermometer. |
| 2nd experiment | 14·96 | 4·33 | 10 ^o ·63 Centigrade thermometer. |
| 2nd series. 1st experiment | 21·48 | 10·78 | 10·70 Centigrade thermometer. |
| 2nd experiment | 21·70 | 8·56 | 13·14 Centigrade thermometer. |

In FAHRENHEIT'S scale.

| | | |
|-------|-------|-------|
| 58·37 | 45·10 | 13·27 |
| 58·93 | 39·79 | 19·14 |
| 70·66 | 51·40 | 19·26 |
| 71·06 | 47·41 | 23·65 |

In the first series, in the second experiment, the wind blows faster than in the first, and the wet bulb is reduced nearly 3°, and the difference between the wet and dry bulbs is increased from 7°·38 to 10°·63, while the temperature of the dry bulb is only raised 0°·30. In the second series the temperature of the wet bulb is reduced from 10°·78 to 8°·56, and the difference between the wet and dry is increased from 10°·70 to 13°·14, while the temperature of the dry bulb is only raised 0°·22. Upon these experiments M. REGNAULT says, “On voit que, pour une même température t les températures t' dependent beaucoup de la vitesse du courant d'air” (p. 209); and he further says (p. 210) that these depressions are less than he has found on other occasions with an increased velocity of the air; and on using dry air he found the depression $t-t'=13°·52$ instead of 5°·91, and another depression of 15°·60 instead of 8°·60. M. REGNAULT gives other experiments, and finishes by saying, “Il résulte de tout ce qui vient d'être dit, que l'agitation de l'air doit exercer une influence très-sensible sur les indications du psychromètre” (p. 211). The truth of M. REGNAULT'S experiments are borne out by the experience of families in the Deccan (and no doubt elsewhere) in India in the fair season, who cool their wine and beer by the following simple process down to a temperature the cold of which makes the teeth ache in drinking. At any time of the day a thick layer of straw is put down on the ground in the shade of a building, but not in the lee of the wind. The bottles of wine or beer to be cooled are put upon the straw, some more straw is thinly and lightly shaken over the prostrate bottles, and the mass is sprinkled at intervals with water through the nozzle of a watering-pot with very fine apertures, thus dewing as it were the straw; the force of evaporation and the consequent cold is proportioned to the velocity and dryness of the wind; but even with a moderate wind the temperature of the liquors is soon greatly lowered; and in certain hot and therefore parching winds, even at a temperature of the air ranging from 85° to 90° FAHR., I have often, at Ahmednugger, had the temperature of the wine or beer (judging from my sensations at the moment) approaching to the freezing-point †. In this cooling process we have

* t . Temperature of dry thermometer. t' . Temperature of wet bulb.

† My sensations deceived me. While this paper is going through the press, I have received from a friend, commanding the Artillery at Ahmednugger, the following results of experiments he made at my request, with

the bottle of wine or beer corresponding to the bulb of the thermometer; the straw lying thinly over it represents the muslin, and the operations of the watering-pot complete the wet bulb apparatus, evaporation does the rest; but as the velocity and dryness of the wind regulate this, it is plain that such an instrument can only give uncertain and fallacious results when used to determine, with any pretension to accuracy, the fractional saturation of the atmosphere. I come now to a source of error in my reductions of the wet bulb observations which I have collected in this paper from various parts in India, a source of error that may operate with a greater or less power as the depression of the wet bulb is greater or less. I allude to the formula used for the reductions of the readings of the wet bulb. M. REGNAULT says that M. GAY-LUSSAC was the first to propose the determination of the dew-point by the observations of a dry and wet bulb apparatus*, but that to effect the object satisfactorily it would require extensive observations upon which to found tables. Subsequently to the period of M. GAY-LUSSAC's proposition, AUGUST, Professor at Berlin, occupied himself with the subject and published some papers, in which he sought to determine, upon theoretical considerations, the formula by which the elastic force of aqueous vapour, really existing in the air, could be found by the difference of temperature of a dry and wet bulb thermometer. The dry and wet bulb apparatus he called a Psychromètre. His chief memoir is published in the *Annalen der Physik und Chemie*, V. Band. Leipzig, 1825. It will suffice to say that he considered the wet bulb surrounded at all times with a coat of vapour of the same temperature as the bulb, which was, he stated, necessarily lower than that of the surrounding air,—that the successive supplies of air coming into contact with the wet bulb, parted with a portion of their heat and took the temperature of the wet bulb; but on the other hand, the air so supplied in vaporizing the water upon the surface of the wet bulb took from it a portion of its heat; and a stationary state of the temperature of the wet bulb was established by these two quantities of heat balancing each other.

AUGUST's formula was $x = \frac{1 + \frac{\gamma}{\delta\lambda}(t-t')}{1 + \frac{x}{\lambda}(t-t')} f' - \frac{\frac{\gamma}{\delta\lambda}(t-t')}{1 + \frac{x}{\lambda}(t-t')} h$, where t denotes the tempe-

perature of the dry bulb (in Centigrade degrees), t' the temperature of the wet bulb, γ the specific heat of dry air, δ the density of aqueous vapour, λ the latent heat of aqueous vapour between the temperatures t and t' , x the specific heat of vapour, h the height of the barometer, f' the elastic force of vapour in saturated air at the temperature t' , and x the elastic force of the vapour actually existing in the atmosphere; x , f' and h being expressed in inches, or in terms of any common unit.

the wet straw process, on the 21st of May 1850, and preceding days. Temperature of air in shade, free from radiation, 98° FAHR. Temperature of water in bottles under wet straw exposed to wind 65°, difference 33°. The dew-point by APJOHN's formula would be about 41°·7, and by GLAISHER's factors about 48°·5. My friend says, "When the wind does not blow, the temperature of the water in the bottles, under the straw, cannot be got lower than 71° FAHR. When the wind blows, the bottles cool to 65° FAHR."

* *Annales de Chimie et de Physique*, 2nd series, t. xxi. p. 91.

With assumed values for γ , δ and λ , as the real values are not accurately known, and neglecting small quantities, and supposing $z=\gamma$, AUGUST'S formula became

$$x=f' - \frac{0.428(t-t')}{640-t} h,$$

for the determination of the elastic force and consequently the dew-point, and after certain comparisons of the dew-point from his formula with the direct dew-point from DANIELL'S hygrometer, he found what he considered a sufficient agreement between them. In a comparative table* of the results by his formula and the results by DANIELL'S hygrometer, they appear to go pretty well together, while the variations of temperature and of the depression of the wet bulb are small; but the moment the temperature exceeds 20° Centigrade (68° FAHR.), and the depression exceeds 5° (9° FAHR.), the discrepancy is very considerable; for instance, at bar. 755.3 millims. (29.736 inches), dry $28^{\circ}.5$ ($83^{\circ}.3$ FAHR.), wet $21^{\circ}.1$ ($69^{\circ}.98$ FAHR.), depression $7^{\circ}.4$ ($13^{\circ}.32$ FAHR.), the tension of vapour by the formula is 14.181 millims. ($\cdot558$ in. =dew-point 62°), and by DANIELL'S hygrometer 12.087 millims. ($\cdot475$ in. =dew-point $57^{\circ}.15$), the difference 2.094 millims ($\cdot083$ in.). Even with a depression of only 0.6 ($1^{\circ}.08$ FAHR.) the tension of vapour by the formula and by DANIELL is respectively 8.612 millims. ($\cdot339$ in.), and 8.534 millims. ($\cdot335$ in.), difference 0.078. These discrepancies induced M. REGNAULT to modify, in 1845, nearly twenty years afterwards, AUGUST'S formula, and he in common with AUGUST assumed $\gamma=0.2669$, $\delta=0.622$ and $z=\gamma$, but $\lambda=610-t$. Substituting these numbers and neglecting small quantities, the formula became $x=f' - \frac{0.429(t-t')}{610-t'} h$, and it is this formula that

M. REGNAULT tests by his various experiments; and at the close of his able and elaborate paper he says, "Je ne pense pas que l'on puisse admettre comme base du calcul du psychromètre l'hypothèse fondamentale adoptée par AUGUST: à savoir, que tout l'air qui fournit de la chaleur au thermomètre mouillé descend jusqu'à la température t' indiquée par celui-ci, et se sature complètement d'humidité. Il me paraît probable que la portion de l'air que se refroidit ne descend pas jusqu'à t' , et qu'elle ne se sature pas d'humidité. Le rapport de la quantité de chaleur que l'air enlève à la boule par vaporisation de l'eau, à la quantité de chaleur qu'il perd en se refroidissant, est probablement d'autant plus grand que cet air est plus sec, parceque dans cet état, il est beaucoup plus avide d'humidité que quand il approche de son état de saturation.

"Enfin, la température de la boule mouillée est influencée encore autrement que par l'air immédiatement ambiant, elle est soumise au rayonnement de l'enceinte dont l'influence sera variable suivant l'état d'agitation de l'air.

"Il me paraît impossible de faire entrer toutes ces circonstances dans le calcul théorique de l'instrument; est je crois qu'il est plus sage de ne faire servir les considérations théoriques qu'à la recherche de la forme de la fonction, et à déterminer ensuite les constantes par des expériences faites dans les conditions déterminées. Cette

* Annalen der Physik, B. v. p. 87.

manière d'opérer me paraît d'autant plus nécessaire, qu'il reste beaucoup d'incertitude sur plusieurs des éléments numériques que entrent dans le calcul, notamment sur la chaleur spécifique de l'air, sur celle de la vapeur, et sur la chaleur absorbée par l'eau lorsqu'elle se vaporise dans l'air."—(P. 212.)

These are the opinions of M. REGNAULT expressed twenty years after AUGUST had invented his formula, and after his own elaborate experiments; and I have preferred giving them in his own language to free myself from any possible misconstruction in translation. M. REGNAULT thought that AUGUST's formula modified by him, would meet some of the difficulties expressed by him in the above quoted opinions, and he gives tables of results, which, with a limited range of the thermometer and small depressions, are sufficiently satisfactory; but he candidly admits "l'accord a été beaucoup moins parfait dans les bas températures et dans l'air très humide;" in these cases M. REGNAULT says the fractions of saturation calculated are always above the fractions of saturation obtained by direct means, often to a very notable extent. M. REGNAULT got one of his pupils to try the psychrometer, under considerably diminished pressure, on the mountains in Switzerland, but the results were so little satisfactory that he does not give a detail of them. He induced also his friend M. IZARN, to compare the readings of the wet bulb in the Pyrenees, at a pressure of 700 millims. (27.559 in.), with the readings of an hygrometer invented by himself, which he calls "hygromètre condenseur," and which he considers to be free from the objections to which DANIELL'S hygrometer is subject; and in a table given, the fractions of saturation are almost always much higher by the wet bulb than by the condenser, the depression in no case exceeding $3^{\circ}91$. In a depression of $1^{\circ}97$, the differences of the fraction of saturation are respectively 0.7542 and 0.7937. Finally, M. REGNAULT says that his modified formula may give the elastic force of x a little too high, and that the coefficient 0.480 might be used instead when the fraction of saturation exceeds 0.40 Centigrade, but that the coefficient 0.429 gives results nearer to the truth where the fraction of saturation is below 0.40. When the wet bulb descends below zero, he considers that the value of λ should be increased from 610 to 689, but in the present imperfect knowledge of the true numerical value of several of the elements he will not venture to put forth a new formula for the psychrometer (p. 227). Several other philosophers have also given formulæ: BURG from observation, $f'' = f' - 0.0004528(t - t')p$; BOHNENBERGER also from observation, $f'' = f' - 0.0003962(t - t')p$; also KUPFFER, ERMAN and KAMTZ.

On the 24th of November 1834 and 27th of April 1835, Dr. APJOHN of Dublin read to the Royal Irish Academy a very elaborate and able paper upon the theory of the moist bulb hygrometer. The results of his observations, experiments and theoretical considerations, induced him to adopt the formula

$$f'' = f' - \frac{d}{87} \times \frac{p}{30};$$

at p. 436 of the volume of the Proceedings of the Royal Irish Academy for 1840, the

formula is

$$f'' = f' - \frac{48a(t - t')}{e} \times \frac{p - f'}{30};$$

and finally, with the coefficient

$$f'' = f' - \cdot 01147(t - t') \times \frac{p - f'}{30}^* ;$$

and with this formula † Colonel BOILEAU of the Bengal Engineers, in charge of the Magnetic Observatory at Simla, to aid meteorologists, has calculated a series of tables of the tension of vapour from minus 10° FAHR. to 170° FAHR. for 30° of depression of the wet bulb by tenths, and for variations of pressure from 19 inches to 31 inches. It was these tables I used in the reduction of the preceding wet bulb observations; and it was in the progress of their use, during several months' labour, that at certain temperatures doubts were raised in my mind respecting the accuracy of the formula, from supposing the fraction of saturation unreasonably high when the depression of the wet bulb was inconsiderable, and unreasonably low when the depression of the wet bulb was considerable. The tension of vapour at considerable depressions startled me, until at last I found in testing the tables that with a depression of the wet bulb of 19° at a temperature of 52° FAHR., and at a pressure of 29 or 30 inches, the results became impossible; that is to say, the tension of vapour of the dew-point arrived at by the formula had a greater numerical value than the tension of vapour at the temperature of the wet bulb, *e. g.*

| | | | |
|---------------------|---------------------|-----------|-------|
| | FAHR. | Bar. | |
| | ° | in. | |
| Dry bulb | 52 | 30 | |
| Wet bulb | 33 | | 20640 |
| Difference 19 = (a) | = ·01147 (t - t') = | | 21794 |

It is objected that a depression of the *wet* bulb of 19°, at a temperature of 52°, never can occur in nature ‡: but very considerable depressions, both of the wet

* APJOHN'S formula is expressed in English measures: f'' is the force of aqueous vapour at the dew-point; f' the tension of vapour at the temperature of evaporation; a specific heat of air; e the latent heat of aqueous vapour; d the depression or difference between the temperature of the air and wet bulb ($t - t'$); p the pressure of the air in inches.

† Differing little from AUGUST'S formula, and converting it into the measures and scale used by AUGUST; for all practical purposes, the two formulæ are the same.

‡ In a synopsis of nine years' observations of the wet bulb at Mahabuleshwur, the following maximum depressions of the *wet* bulb occur in the respective months of the year:—

| Months. | Depression of the wet bulb. | Months. | Depression of the wet bulb. |
|----------------|-----------------------------|-----------------|-----------------------------|
| January | 17·2 | July | 5·2 |
| February | 24·0 | August | 7·7 |
| March | 24·6 | September | 8·5 |
| April | 26·3 | October | 16·0 |
| May | 26·0 | November | 15·5 |
| June | 7·0 | December | 16·7 |

In a preceding page it was shown that water in bottles under wet straw, exposed to the wind at Ahmednugger, cooled down to 65° FAHR., the temperature of the air being 98°, difference 33°, barometer 28 inches, dew-point by APJOHN 41°·7, by GLAISHER 48°·5.

bulb and of the dew-point, have been observed even in our damp climate at the Royal Observatory at Greenwich. For instance, in the records on the 6th of April 1845, at 6 P.M., the dry bulb was $52^{\circ}6$, wet bulb $39^{\circ}2$, and *dew-point* by DANIELL'S hygrometer 22° . The depression of the wet bulb being $13^{\circ}4$, the *dew-point* by APJOHN'S formula would be 14° , by GLAISHER'S factors $25^{\circ}8$, and by DANIELL'S hygrometer it is found to be 22° . Which of these dew-points is to be taken to give the real numerical value of the tension of vapour? At Greenwich, on the 3rd of June 1846, at 4 P.M., the dry bulb was $79^{\circ}1$, and the dew-point by DANIELL'S hygrometer 44° , the depression therefore $35^{\circ}1$. But I have recorded in the Meteorology of the Deccan, a depression of 61° of DANIELL'S hygrometer taking place before the deposition of dew; the temperature of the air being 90° , the dew-point 29° , at 4 P.M., on the 16th of February 1828, at Dwnd, near Pairgaon, on the Beema River*. Mr. GLAISHER, of the Royal Observatory, a most persevering and able observer, finding from experience that the formulæ in use with a constant coefficient did not give satisfactorily the dew-points at varying temperatures and varying depressions of the wet bulb, adopted a series of factors quite independent of theory, from the results of very extensive comparisons of simultaneous observations of the wet bulb with DANIELL'S hygrometer. These comparisons extended over several years, and through several thousand observations. He found that "the dew-point temperature was so related to the temperatures of air and evaporation, that at the same temperature of the air, the difference of temperatures of air and of the dew-point, divided by the difference of the temperature of the air and evaporation, was constant, but that it was different at every different temperature." Arranging several thousand observations made during five years at Greenwich, and during three years at Toronto, and taking the mean value at every degree of temperature, he obtained a series of factors ranging from 8.5 at temperatures below 24° FAHR., up to 1.5 above 70° FAHR.; these were published in the volume of the Greenwich Magnetical and Meteorological Observations for 1842, 1843 and 1844. In 1847 Mr. GLAISHER published hygrometrical tables in which some slight alterations of the original factors were made, and he has since made some further slight modifications. For the limited range in temperature, depression of the wet bulb and pressure, in which the comparisons were made and the factors deduced, they are probably the very best agents (at least above the freezing-point) for giving a close approximation to the true value of the readings of the wet bulb; supposing always the wet bulb not to be subjected to the anomalous indications noticed by Professor ORLEBAR and M. REGNAULT. For considerable differences of barometrical pressure, and very considerable depressions of the wet bulb, the factors would require further correction. When the dew-point was obtained with difficulty by DANIELL'S hygrometer, or in other words, when the depression of the temperature of evaporation was great, Mr. GLAISHER found that his method of determining his factors would not hold good, which he attributed to certain objec-

* Philosophical Transactions, Part I. for 1835, p. 184.

tions to DANIELL'S hygrometer, and to which it is no doubt subject, but which are applicable to all temperatures and all depressions, objections which were urged by M. REGNAULT, and which induced him to invent his "hygromètre condenseur," an instrument which he pronounces to be free from the errors of DANIELL'S instrument, but the use of which I have not heard of in England.

I have thus reviewed, *in extenso*, the possible, indeed the probable sources of error in the very high degree of humidity constantly in the air, as represented by the wet bulb observations made in India, and I have no hesitation in expressing my belief that the results, which I have obtained with the labour of some months, do not represent the real fractions of saturation of the air at the several places where the wet bulb was observed*; and I am the more confirmed in this opinion, with respect to the Neelgherries, by an officer now in London, who resided some time at Ootacamund and kept a meteorological register, who says that if the mean annual moisture in the air had amounted to anything like 90 per cent. it must have been most inconveniently felt in the clothes, hats, bedding and furniture of the residents; but so far from such being the case, that, with the exception of occasional fogs, the hills were looked upon as rather dry than otherwise. From my doubts respecting the correctness of the deduced fraction of saturation of the air at places in India, with the formulæ I have passed in review, I may possibly except the observations made in the Deccan with DANIELL'S hygrometer, which observations have a semblance of truth, although the instrument may be imperfect. Even with a comparatively low mean annual percentage of 55 of moisture in the air, I would say such fraction of saturation was rather higher than the truth, for during some months of the year in the Deccan the air is so dry that it is difficult to prevent the disposition of the leaves of tables to curl up into hollow cylinders, and the nib of a quill pen is always most provokingly straddling out into the form of a pair of open compasses.

By reason of the above-noticed sources of error in the wet bulb itself, and of the inadequacy of the formulæ to give a satisfactory value to its readings, supposing the indications to be correct, I have deliberately *not* applied any corrections to the readings of the barometer on account of moisture. But even had the instrument been free from error and the formulæ exact, I still should have deemed it ineffectual to attempt to measure the moisture in a whole column of the atmosphere *from a local observation* † with a view to apply to the barometer, which represents the pressure of an entire column of the atmosphere, a correction for the tension of vapour ‡. Further, I have doubts of the propriety of applying to the barometer a correction for

* Dr. M'CLELLAND says, "The wet bulb thermometer would add greatly to the value of these results, but there are discrepancies in the register of the instrument in use (at Calcutta) which *prove it to be imperfect*."—Calcutta Journal of Nat. Hist., vol. v. p. 554.

† "This instrument [wet bulb] simply indicates the conditions of the air of the place where it is situated: at 100 feet above it the conditions may be very different."—GLAISHER'S Hygrometrical Tables, p. 16, edition of 1847.

‡ The capacity of air to hold water in solution, or in a state of vapour, diminishes with the temperature.

moisture *subtractively*, even were the tension of vapour satisfactorily determined for the *whole pressure*. The barometer *falls* with increasing saturation of the atmosphere with moisture, indicating the displacement of comparatively dry air by *dilated* vapour, the density of which is less than that of drier air, and a certain amount of pressure is taken off the barometer and the mercury falls on account of the diminished density and elasticity of humid air; but as soon as this vapour is condensed into rain the drier air resumes its ordinary density and elasticity, and the mercury mounts again. If the vapour came simply as an *addition* to the drier air, the density and pressure of the compound should increase, and the barometer should rise; but this is contrary to fact. I would therefore not apply a subtractive correction for that vapour, which has already acted directly upon the barometer in diminishing pressure by displacing denser air. The object of applying any corrections at all to the barometer, on account of moisture in the atmosphere, is stated to be to "obtain from them the pressure of the atmosphere of dry air*;" but as such a state of the air is a physical impossibility as long as there is a drop of water upon the earth to be vaporized, as evaporation goes on at all temperatures, it may be asked, what practical advantage can be obtained from any such determination? and the more so, may the question be asked, when experimenters are not in accord with respect to the numerical values of the tension of vapour at different temperatures to be applied as corrections†.

On the whole it appears very desirable that to DIRECT MEANS recourse should always be had, if possible, for the determination of the dew-point, to DANIELL'S hygrometer, or to REGNAULT'S condensing hygrometer; and short of this, that persevering comparisons should be made for years, in *extended* ranges of *temperature, depression* and *pressure*, and at different elevations, to obtain a more trustworthy wet bulb formula, or an unquestionable series of factors.

Rain.

If it were necessary to suggest caution in generalizations from a limited number of local observations for the determination of the dew-point, caution is equally, if not more necessary in attempting to fix the normal rain-fall even in a narrow area, much less in a district or province. For instance, within the limits of part of the small island of Bombay, seven miles by two miles, the following is the result of observations with nine rain-gauges. The Fort and Esplanade are necessarily proximate; the Observatory at Colabah two miles distant, and the most remote gauge at the Government House at Parell, only five miles from the Fort, the other stations being intermediate between the Fort and Parell.

* GLAISHER'S Hygrometrical Tables, p. 12, edition of 1847.

† At 32° FAHR. DALTON'S tension of vapour, in inches of mercury, is 0·200, at 95° = 1·59297, at 122° = 3·500 in. The Physical Committee of the Royal Society adopted for 32° FAHR. 0·186, and for 95° = 1·610, and 122° FAHR. 3·542; REGNAULT, at 32° FAHR., has 0·18124, and at 95° FAHR. 1·64380, and at 122° = 3·619. KAEMTZ, at 32° FAHR., has 0·17999, and at 95° FAHR. 1·57789; of course different results are come at by the use of these different values.

Bombay, 1849. Rain-fall.

| | Colabah Observatory. | Fort. | Esplanade. | Byculla. | Chinchpoogly. | Airy Cottage, Mazagon. | Agricultural garden, Parell. | Parell Flagstaff. | Parell Hill. |
|--------|-------------------------|-------|------------|----------|---------------|---------------------------|---------------------------------|----------------------|--------------|
| | in. | in. | in. | in. | in. | in. | in. | in. | in. |
| 1 | 0·86 | 0·36 | 0·28 | 0·40 | 0·00 | 0·35 | 0·00 | 0·00 | 0·00 |
| 2 | 0·00 | 0·00 | 0·00 | 0·00 | 0·00 | 0·04 | 0·35 | 0·00 | 0·30 |
| 3 | 0·39 | 0·14 | 0·00 | 0·06 | 0·00 | 0·03 | 0·05 | 0·06 | 0·05 |
| 4 | 0·39 | 0·55 | 0·76 | 0·58 | 0·00 | 0·70 | 0·66 | 1·23 | 0·55 |
| 5 | 0·31 | 0·21 | 0·12 | 0·08 | 0·00 | 1·50 | 0·55 | 0·80 | 0·55 |
| 6 | 0·00 | 0·00 | 0·00 | 0·02 | 0·00 | | 0·30 | 0·46 | 0·25 |
| 7 | 0·25 | 0·10 | 0·06 | 0·00 | 0·00 | 0·00 | 0·00 | 0·00 | 0·00 |
| 8 | 0·00 | 0·00 | 0·00 | 0·04 | 0·00 | 0·00 | 0·10 | 0·00 | 0·10 |
| 9 | 0·00 | 0·03 | 0·00 | 0·03 | 0·00 | 0·00 | 0·00 | 0·00 | 0·00 |
| 10 | 0·00 | 0·01 | 0·00 | 0·00 | 0·00 | 0·00 | 0·15 | 0·10 | 0·20 |
| 11 | 0·16 | 0·32 | 0·27 | 0·88 | 0·00 | 0·09 | 0·30 | 0·70 | 0·30 |
| 12 | 3·14 | 1·78 | 1·35 | 1·06 | 0·00 | 1·26 | 0·82 | 1·92 | 0·95 |
| 13 | 0·34 | 0·00 | 0·00 | 0·08 | 4·00† | 0·00 | 1·20 | 2·16 | 1·30 |
| 14 | 0·00 | 0·00 | 0·00 | 0·02 | 1·86 | 1·70 | 0·00 | 0·00 | 0·00 |
| 15 | 0·00 | 0·83 | 1·57 | 1·43 | 2·25 | 0·00 | 1·25 | 2·18 | 1·30 |
| 16 | 4·20 | 4·65 | 2·10 | 3·76 | 4·75 | 5·00 | 3·50 | 6·79 | 3·70 |
| 17 | 4·61 | 2·34 | 2·60 | 2·22 | 2·54 | 2·25 | 3·30 | 7·58 | 3·35 |
| 18 | 0·65 | 0·86 | 1·01 | 1·09 | 1·10 | 0·06 | 1·35 | 3·56 | 1·50 |
| 19 | 0·16 | 2·25 | 1·81 | 1·34 | 0·75 | 2·58 | 1·65 | 3·38 | 1·50 |
| 20 | 1·77 | 5·22 | 2·20 | 4·55 | 4·67 | 4·70 | 0·90 | 1·60 | 0·70 |
| 21 | 3·34 | 0·40 | 0·50 | 0·43 | 0·55 | 0·74 | 3·95 | 11·10 | 4·10 |
| 22 | 4·46 | 4·28 | 4·38 | 3·93 | 5·11 | 4·70 | 3·50 | 7·66 | 3·40 |
| 23 | 0·21 | 0·11 | 0·10 | 0·13 | 0·24 | 0·30 | 3·80 | 5·88 | 3·70 |
| 24 | 3·62 | 4·53 | 5·20 | 5·22 | 6·00 | 6·43 | 0·43 | 0·90 | 0·45 |
| 25 | 3·93 | 10·51 | 6·73 | 7·10* | 7·50‡ | 11·75§ | 5·40 | 13·72 | 5·50 |
| 26 | 5·72 | 1·26 | 1·50 | 0·85 | 0·85 | 1·05 | 4·95 | 9·00 | 4·90 |
| 27 | 1·25 | 1·27 | 1·86 | 3·35 | 2·55 | 2·70 | 1·25 | 1·90 | 1·25 |
| 28 | 2·22 | 2·54 | 3·00 | 2·28 | 2·80 | 3·25 | 6·25 | 11·50 | 6·10 |
| 29 | 2·78 | 1·90 | 2·50 | 2·13 | 2·20 | 2·90 | 2·10 | 2·85 | 2·15 |
| 30 | 1·41 | 1·55 | 2·15 | 1·42 | 2·55 | 2·70 | 2·15 | 3·40 | 2·40 |
| 31 | 2·47 | 3·68 | 4·50 | 4·57 | 3·75 | 4·40 | 2·35 | 3·15 | 2·45 |
| July | 48·67 | 51·68 | 46·55 | 49·05 | 56·02 | 61·23 | 52·50 | 102·14 | 53·00 |
| June | 23·37 | 22·82 | 23·34 | 19·40 | | 25·56 | 28·54 | 46·60 | 26·71 |
| Totals | 72·04 | 74·50 | 69·89 | 68·45 | | 86·79 | 81·04 | 148·74 | 79·71 |

It is seen that in June the fall of rain varied from 19·46 in. at Byculla to 46·60 in. at the flagstaff at Parell, and in July from 46·55 in. on the Esplanade to 102·14 in. at the flagstaff at Parell; or omitting this as a doubtful return, to 61·23 in. at Airy Cottage, Mazagon; and the total of the two months varies from 68·15 in. to 86·79 (omitting the gauge at the Parell flagstaff) at Airy Cottage. I do not know whether the investigations were carried out for a whole monsoon, but in case the discrepancies continued, it would be difficult to determine the normal fall of rain in Bombay. But the anomaly is not confined to Bombay; Dr. MURRAY, in a paper published in the Journal of the Physical Society of Bombay, No. 9, p. 172, has the following

* Gauge overflowed.

† No register kept for first thirteen days—4 inches set down at guess.

‡ Gauge overflowed.

§ The gauge was running over, but this seems pretty nearly all that fell. It poured in torrents from 5 P.M. on the 25th till 6 A.M. 26th.

|| The difference here is the same as last month (twice as much of fall being set down here as fell everywhere else); and so enormous and unaccountable as to lead to the inference of some tremendous blunder.

observations respecting the fall of rain in the town of Sattarah and military cantonment adjoining: "The quantity of rain in the town of Sattarah usually exceeds that in the cantonment, situated a mile N.E., by 6 or 8 inches." Annexed are the results, to which he has added the fall at his own bungalow or house, equidistant between the town and cantonment, so that the three localities are within the range of a mile.

| Years. | 1844. | 1845. | 1846. | 1847. | 1848. |
|--|-------|-------|-------|-------|-------|
| Town Hospital | | 44·39 | 42·92 | 43·17 | 33·41 |
| Dr. MURRAY'S bungalow | 36·06 | 40·24 | 39·52 | 40·98 | |
| Cantonment Hospital | | 38·34 | 31·65 | 39·00 | 27·81 |
| Hill Fort, above the town of Sattarah... | | | | | 39·36 |

The increased fall of rain in the town of Sattarah, which is 2320 feet above the sea-level, is no doubt chiefly caused by the hill, 3200 feet above the sea-level, upon which the fort is situated, rising from the back of the town; but this will not account for the difference in the fall at the Bungalow and Cantonment Hospital. The facts show how necessary is a local knowledge of physical features before generalizations can be ventured upon safely.

In my former paper in the Philosophical Transactions I pointed out the remarkable differences in the fall of rain, twenty to twenty-five years ago on the sea coast, at the top of the Ghâts, and at Poona, thirty-five miles to the eastward of the Ghâts. Dr. MURRAY confirms my views in a much more detailed manner than I was enabled to attempt, in the following Table for the year 1848:—

| | Bombay. | Ghâts. | | Western Districts. | | | | | | | Eastern districts. | | | | |
|---------------|--------------------|-----------------------------|----------------|--------------------|------------|------------|-------|-------------|--------|-------|--------------------|--------|-----------|-------------|-----------|
| | Means of 33 years. | Mahabuleshwur. | | Meera. | Enteshwar. | Sattarah. | | | Bhore. | Wye. | Phultun. | Jhutt. | Bijapoor. | Punderpoor. | Akalkote. |
| | | Sanatarium, means 14 years. | Sindola, 1848. | | | Hill Fort. | Town. | Cantonment. | | | | | | | |
| January | | 0·05 | | | | | | | | | | | | | |
| February..... | | 0·20 | | | | | | | | | | | | | |
| March..... | | 0·15 | | | | | 0·80 | 0·04 | | | | | | | |
| April | | 1·31 | | | | | 0·74 | 0·76 | | | | | | | |
| May | | 3·31 | 3·60 | 2·75 | 2·60 | 2·50 | 3·04 | 2·79 | 2·10 | 2·09 | 6·24 | | | 0·75 | 1·83 |
| June | 22·26 | 46·53 | 41·70 | 10·93 | 5·98 | 4·10 | 3·71 | 3·26 | 2·37 | 2·20 | 4·30 | 1·59 | 0·80 | 2·02 | 3·68 |
| July | 25·04 | 92·10 | 74·28 | 22·90 | 19·83 | 18·77 | 14·64 | 12·02 | 13·20 | 9·05 | 2·70 | 3·07 | 3·67 | 4·38 | 4·65 |
| August | 17·08 | 72·33 | 47·81 | 6·16 | 6·02 | 5·00 | 2·60 | 2·55 | 5·19 | 1·61 | 1·24 | 4·82 | 8·52 | 6·21 | 4·83 |
| September ... | 11·25 | 31·32 | 6·17 | 2·30 | 1·80 | 1·46 | 2·14 | 1·40 | 0·91 | 0·96 | 3·66 | 2·64 | 4·01 | 4·35 | 2·84 |
| October | 1·19 | 4·58 | 7·23 | 2·75 | 2·27 | 4·64 | 4·89 | 3·28 | 1·50 | 2·75 | 2·45 | 3·88 | 4·64 | 8·35 | 5·32 |
| November ... | | 2·07 | 4·37 | 1·85 | 0·19 | 2·91 | 1·57 | 1·71 | 4·15 | 2·25 | 3·59 | 2·17 | 3·78 | 2·49 | 2·30 |
| December ... | | 0·05 | | | | | | | | | | | | | |
| Year | 76·82 | 254·05 | 185·16 | 49·64 | 38·69 | 39·38 | 33·41 | 27·81 | 29·42 | 20·73 | 24·18 | 18·17 | 25·42 | 28·55 | 25·45 |

With the exception of Bombay and the Sanatarium at Mahabuleshwur, the records are for the year 1848. The following are the respective elevations of the places above the sea-level:—

| Mahabuleshwur. | Sindola. | Meera. | Enteshwar. | Sattarah Fort. | Sattarah Town. | Sattarah Cantonment. | Bhore. | Wye. | Phultun. | Jhutt. | Bijapoor. | Punderpoor. | Akalkote. |
|----------------|----------|--------|------------|----------------|----------------|----------------------|--------|--------|----------|--------|-----------|-------------|-----------|
| 4500 | 4600 | 2340 | 3700 | 3200 | 2320 | 2320 | 2350 ? | 2320 ? | 2000 ? | 2000 ? | 2000 ? | 2000 ? | 2000 ? |

Dr. MURRAY adds, "The prodigious influence of the Ghâts in modifying the amount of the S.W. monsoon rain, is perhaps nowhere more strikingly shown than in the N.W. parts of the Sattarah territory. If we draw a line nearly straight from west to east, from Mahabuleshwur, on the summit of the Ghâts, to Phultun, a distance of little more than forty miles, we shall find at the commencement of the line a rain-fall of 240 inches, at an altitude of 4500 feet; 180 inches at Sindola, *a mile distant*, and elevated 4600 feet; 50 inches at Paunchgunnee, at a further distance of eleven miles and an elevation of 4000 feet; 25 inches at Wye, four miles further east and 2300 feet in height above the sea, while at the extremity of the line at Phultun, thirty miles from Sattarah, and about the same level as Wye, the quantity is reduced to 7 or 8 inches." But Dr. MURRAY must have meant during the S.W. monsoon, as he had previously represented the fall of rain at Phultun at 24·18 in. in 1848, in 1847 at 24·04 in., and in 1846 at 18·09 in. Some inches of those amounts however are attributable to the Madras monsoon, which commences in October, when the Malabar coast monsoon terminates, and Phultun, from its easterly position, gets an uncertain sprinkling from the Madras side.

Dr. MURRAY, with a view to show not only the discrepancies in the total annual fall of rain at places within comparatively limited distances situated on the plateau of the Deccan, but the remarkable contrasts in the monthly fall at two proximate places, has given the following Table of the fall of rain at Sattarah and Phultun for 1846 and 1847, Phultun being thirty miles east of Sattarah :—

| | Sattarah. | | Phultun. | |
|-----------------|-----------|-------|----------|-------|
| | 1846. | 1847. | 1846. | 1847. |
| January | 0·18 | | | |
| February | 0·18 | | | 0·02 |
| March | | 0·18 | | 0·52 |
| April | | 10·88 | 1·44 | 4·19 |
| May | 3·49 | 0·39 | 1·06 | 2·88 |
| June | 10·49 | 3·77 | 3·80 | 1·53 |
| July | 16·04 | 6·28 | 1·95 | 0·84 |
| August | 2·13 | 2·68 | | 0·50 |
| September | 0·77 | 3·55 | 1·05 | 2·00 |
| October | 2·98 | 5·25 | 2·50 | 3·06 |
| November | 0·98 | 8·00 | 5·04 | 4·60 |
| December | 2·46 | 0·05 | 1·53 | 0·89 |
| Year | 39·52 | 40·98 | 18·09 | 24·04 |

Dr. MURRAY, in a paper published in the autumn Number of the Journal of the Physical Society of Bombay for 1849, adds to the proofs of the extraordinary discrepancies in the fall of rain in proximate localities. He states (page 18), "At the Sanatorium at Mahabuleshwur, at 4500 feet, the rain-fall during 1848 was 245 inches, being within 3 inches of the average fall during the preceding twenty years. At Sindola, the residence of Mr. FRERE (the British minister), situated *a mile* east from

the Sanatorium, about 100 feet higher, with the *intervening* eminence of Mount Charlotte rising to a further height of 100 feet, the quantity of rain did not exceed 185 inches during the same period; hence a difference of 60 inches or 24 per cent. at two houses *situated at the same station*. The position of the ground explains the difference, but probably few people, on examining the localities, would have anticipated its amount. It shows the supreme importance of instituting multiplied observations, before deciding on the site of a sanitary hill station."

To add to the means of comparison, some other rain-fall localities from the sea-coast, and Konkun, or country between the Ghâts and the sea,—from the Ghâts and from the plateau of the Deccan, are annexed, being the mean fall for the years 1844–47.

| Sea-coast of Konkun. | | Konkun, somewhat inland. | | Western Ghâts. | | Western Ghâts, East branch. | Deccan. | | | | | | | |
|----------------------|------------------------|--------------------------|---------------------|-------------------------------------|---------------------------|---|----------------------|-----------------|-------------------|----------|---------------------|----------|-------------------------|------------------|
| Bombay, sea-level. | Rutnagherry, 150 feet. | Tanna, sea-level. | Dapoolee, 900 feet. | Kundalla, 1740 feet, 1833 and 1835. | Mahabuleshwur, 4500 feet. | Paunehgunnee, 4000 feet, 1835, 1842 and 1843. | Sattarah, 2320 feet. | Kolapoor, 1847. | Poona, 1842 feet. | Nassick. | Belgaum, 2000 feet. | Dharwar. | Ahmednugger, 1900 feet. | Sholapoor, 1847. |
| 68·73 | 114·55 | 106·16 | 134·96 | 141·59 | 254·84 | 50·69 | 39·20 | 20·74 | 19·02 | 26·72 | 40·90 | 38·81 | 21·83 | 32·16 |

Tanna and Dapoolee are situated between the sea-coast and the foot of the Ghâts. Kundalla is on the crest of the Ghâts on the high road from Bombay to Poona. The places in the Deccan lie eastward of the Ghâts. Arranging the above places according to their supply of rain, it appears the greatest fall is on the crest of the Ghâts, increasing from 141·59 inches at Kundalla at 1740 feet to a mean fall of 254·84 inches at Mahabuleshwur, at 4500 feet. From the crest of the Ghâts the supply of rain decreases towards the sea-coast westward, but decreases in an infinitely greater ratio eastward on the plateau of the Deccan. Along the coast the supply of rain diminishes with the increase in latitude.

In further illustration of the unequal fall of rain in the Bombay Presidency, the returns for May, June and July 1849 are annexed. They are the latest I have received except from Bombay.

| | Bombay. | Poona. | Surat. | Nassick. | Asseerghur. | Ahmedabad. | Phoonda Ghât. | Mahabuleshwur. | Paunehgunnee. | Calcutta. |
|-------------|---------|--------|--------|----------|-------------|------------|---------------|----------------|---------------|-----------|
| May | 0·00 | 0·405 | 0·00 | 0·00 | 0·23 | 2·03 | 0·00 | 0·00 | | 6·00 |
| June | 22·82 | 9·055 | 11·16 | 8·63 | 5·45 | 4·10 | 50·00 | 59·90 | | 13·0 |
| July | 51·68 | 6·425 | 19·00 | 7·03 | 16·31 | 7·62 | 83·00 | 89·24 | | 8·25 |
| Total | 74·50 | 15·885 | 30·16 | 15·66 | 21·99 | 13·75 | 133·00 | 149·14 | 11·95 | 27·25 |

To General CULLEN of the Madras Artillery, and British minister, with the Rajah of Travancore, I am indebted for the following comparison of rain-fall at stations on the coast of Malabar and Coromandel:—

| | Years. | January. | February. | March. | April. | May. | June. | July. | August. | September. | October. | November. | December. | Total. | |
|---|-------------|----------|-----------|--------|--------|-------|-------|-------|---------|------------|----------|-----------|--------------|--------|-------|
| 20 feet. Cochin. | 1842. | ... | ... | ... | 3.05 | 25.07 | 25.05 | 13.70 | 21.95 | 10.15 | 3.55 | 3.65 | | 105.27 | |
| | 1843. | 5.15 | ... | 2.00 | 4.50 | 27.15 | 37.32 | 21.05 | 4.27 | 7.75 | 9.45 | 0.10 | 5.75 | 124.49 | |
| | 1844. | ... | 0.45 | 1.70 | 1.70 | 19.35 | 22.42 | 19.10 | 11.75 | 2.37 | 17.55 | 4.50 | 1.07 | 101.97 | |
| | 1845. | 3.42 | ... | 5.80 | 2.20 | 3.57 | 31.37 | 16.10 | 11.22 | 1.67 | 11.85 | 0.92 | 4.45 | 92.60 | |
| | 1846. | 0.02 | ... | 0.70 | 4.80 | 19.70 | 37.32 | 16.72 | 16.27 | 2.15 | 5.95 | 2.25 | 0.10 | 106.00 | |
| Means | | 1.72 | 0.09 | 2.04 | 3.25 | 18.97 | 30.69 | 17.33 | 13.09 | 4.82 | 9.67 | 2.28 | 2.27 | 106.06 | |
| 30 feet. Quilon. | 1842. | ... | 1.17 | 1.32 | 3.30 | 22.24 | 16.00 | 8.65 | 8.60 | 7.42 | 4.87 | 7.47 | | 81.06 | |
| | 1843. | 1.42 | 0.47 | 0.50 | 9.85 | 24.62 | 26.52 | 20.72 | 7.45 | 5.15 | 5.85 | 2.15 | 1.00 | 105.72 | |
| | 1844. | ... | ... | 0.55 | 0.70 | 8.15 | 15.55 | 5.75 | 6.70 | 2.37 | 13.95 | 3.25 | 3.60 | 60.57 | |
| | 1845. | 3.30 | ... | 4.65 | 0.25 | 4.85 | 13.80 | 9.55 | 3.95 | 0.45 | 15.35 | 1.85 | 3.70 | 61.70 | |
| | 1846. | ... | ... | 2.90 | 1.60 | 22.70 | 17.65 | 10.55 | 3.80 | 1.30 | 9.40 | 4.75 | 0.10 | 74.75 | |
| Means | | 0.94 | 0.33 | 1.98 | 3.14 | 16.51 | 17.90 | 11.04 | 6.10 | 3.34 | 9.88 | 3.89 | 1.68 | 76.76 | |
| 30 feet. Allepy. | 1842. | 1.15 | 0.25 | 2.92 | 2.50 | 27.67 | 20.00 | 10.60 | 12.30 | 7.57 | 12.95 | 6.50 | 0.10 | 104.52 | |
| | 1843. | 3.20 | 0.75 | 6.90 | 5.75 | 30.12 | 32.80 | 21.57 | 5.22 | 9.72 | 9.12 | 0.90 | 5.77 | 131.85 | |
| | 1844. | 0.37 | 2.87 | 2.55 | 3.00 | 24.33 | 23.12 | 16.60 | 10.42 | 4.92 | 15.37 | 9.90 | 5.40 | 118.70 | |
| | 1845. | 4.92 | 0.50 | 8.80 | 2.65 | 17.80 | 25.20 | 11.92 | 6.47 | 1.00 | 9.67 | 4.35 | 4.50 | 97.80 | |
| | 1846. | 0.00 | 1.70 | 0.20 | 3.15 | 31.45 | 29.00 | 12.45 | 12.27 | 3.42 | 13.00 | 5.77 | 1.00 | 113.43 | |
| Means | | 1.93 | 1.21 | 4.27 | 3.41 | 26.27 | 26.02 | 14.63 | 9.33 | 5.32 | 12.02 | 5.48 | 3.35 | 113.26 | |
| 50 feet. Cape Comorin. | 1843. | 0.90 | ... | ... | ... | 6.50 | 0.80 | 0.95 | | 0.65 | 4.80 | | 4.60 | 19.20 | |
| | 1844. | ... | ... | ... | ... | 1.20 | 3.00 | | | 1.00 | 7.50 | 4.60 | 2.20 | 19.50 | |
| | 1845. | 0.20 | ... | 0.90 | ... | 1.30 | 2.20 | 0.70 | | | 10.70 | 1.40 | Heavy shower | 18.00 | |
| | 1846. | ... | ... | 2.80 | 3.30 | 9.40 | 12.25 | 1.20 | 1.45 | | 12.10 | 9.82 | 4.40 | 56.72 | |
| | Means | | 0.27 | ... | 0.92 | 0.75 | 4.55 | 4.56 | 0.71 | 0.36 | 0.41 | 8.77 | 3.95 | 2.80 | 28.35 |
| 60 feet. Vaurioor, close to Cape Comorin. | 1842. | 0.35 | 0.65 | ... | ... | 2.25 | 1.20 | | 0.40 | 1.82 | 4.35 | 9.25 | | 20.27 | |
| | 1843. | 1.40 | 1.00 | 0.75 | 0.40 | 9.90 | 2.05 | 0.80 | 0.10 | 0.35 | 4.15 | 0.45 | 4.40 | 25.75 | |
| | 1844. | ... | 0.50 | 0.20 | ... | 0.90 | 3.00 | 0.80 | | 0.15 | 7.45 | 3.70 | 1.35 | 18.05 | |
| | 1845. | 2.75 | ... | 3.65 | ... | 1.70 | 1.45 | 2.70 | | 0.35 | 12.92 | 2.40 | 8.90 | 36.82 | |
| | 1846. | ... | ... | 0.90 | 1.65 | 5.20 | 2.90 | 0.55 | | | 4.00 | 5.50 | 1.75 | 22.45 | |
| Means | | 0.90 | 0.43 | 1.10 | 0.41 | 3.99 | 2.12 | 0.97 | 0.10 | 0.53 | 6.57 | 4.26 | 3.28 | 24.67 | |
| 130 feet. Trevandrum. | 1842. | 3.70 | 0.35 | 0.85 | 3.60 | 13.70 | 9.50 | 4.25 | 3.75 | 6.30 | 3.05 | 8.30 | 0.35 | 57.70 | |
| | 1843. | 0.80 | 0.02 | 2.52 | 8.80 | 17.12 | 16.62 | 12.90 | 2.55 | 3.10 | 7.52 | 2.05 | 11.42 | 85.45 | |
| | 1844. | ... | ... | 1.10 | 0.30 | 4.55 | 6.15 | 3.80 | 5.67 | 3.75 | 15.17 | 4.40 | 2.15 | 47.05 | |
| | 1845. | 4.40 | 0.77 | 3.40 | 0.85 | 4.55 | 15.80 | 4.30 | 0.90 | 0.15 | 18.52 | 3.92 | 5.00 | 62.57 | |
| | 1846. | 0.10 | ... | 1.07 | 4.02 | 11.42 | 17.75 | 6.92 | 3.67 | 0.75 | 17.50 | 4.40 | 2.30 | 69.92 | |
| Means | | 1.80 | 0.23 | 1.79 | 3.51 | 10.27 | 13.16 | 6.53 | 3.31 | 2.81 | 12.35 | 4.61 | 4.24 | 64.54 | |
| 200 feet. Palemcottah. | 1842. | 1.20 | 0.19 | 1.05 | 0.45 | 0.55 | 0.02 | 0.01 | 0.03 | 2.50 | 6.60 | 9.62 | 0.95 | 23.12 | |
| | 1843. | 4.02 | 2.50 | 0.77 | 1.20 | 5.65 | | | | | 7.15 | 1.65 | 3.95 | 26.90 | |
| | 1844. | 0.20 | 0.55 | ... | 0.75 | 0.10 | 1.17 | 0.05 | | | 1.75 | 2.65 | 1.70 | 2.76 | 11.68 |
| | 1845. | 0.43 | ... | 5.27 | 0.55 | 1.62 | 0.15 | | | 0.65 | 6.17 | 2.02 | 8.75 | 25.63 | |
| | 1846. | 0.80 | 1.35 | 0.57 | 2.30 | 4.05 | 0.07 | 0.07 | | 0.30 | 1.80 | 5.97 | 0.65 | 17.75 | |
| Means | | 1.33 | 0.92 | 1.53 | 1.05 | 2.39 | 0.28 | 0.03 | 0.006 | 1.05 | 4.87 | 4.19 | 3.41 | 21.06 | |
| 600 or 700 feet. Shenkottah. | 1842. | 1.20 | 1.30 | ... | 2.05 | 3.90 | 5.65 | 2.80 | 1.40 | 3.10 | 3.20 | 14.85 | | 39.45 | |
| | 1843. | 4.15 | 0.80 | 2.45 | 4.15 | 11.20 | 4.80 | 6.20 | 1.05 | 1.15 | 7.15 | 1.50 | 3.50 | 48.10 | |
| | 1844. | ... | ... | 2.40 | ... | 0.50 | 3.60 | | 1.80 | 1.60 | 6.25 | 4.25 | 3.70 | 24.10 | |
| | 1845. | 2.00 | ... | 4.40 | 2.20 | | 3.80 | 4.65 | 0.35 | | 15.40 | 4.05 | 5.85 | 42.70 | |
| | 1846. | 0.57 | ... | 0.70 | 4.65 | 6.20 | 8.60 | 3.40 | 1.10 | 2.50 | 5.95 | 4.47 | 3.45 | 41.60 | |
| Means | | 1.58 | 0.42 | 1.99 | 2.61 | 4.36 | 5.29 | 3.41 | 1.14 | 1.67 | 7.59 | 5.82 | 3.30 | 39.19 | |

The stations extend along the Travancore or western coast from Cape Comorin, lat. $8^{\circ} 4'$, to Cochin, lat. $10^{\circ} 30'$. Of the three stations on the Tinnevely or Coromandel coast, Shenkottah is near Courtallum, immediately at the east base of the Ghâts, and about sixty miles from the sea-coast of Travancore; Palamcottah is about thirty miles from the east base of the Ghâts, is sixty miles from the western coast, and in the latitude of Quilon; Vaurioor is only three miles north and a little east of Cape Comorin. The western and eastern stations are separated by the Ghâts, which in some places rise to a height of 6000 feet, but within ten miles of Cape Comorin they break off into separate groups and peaks of greatly diminished height.

Bearing in mind the preceding extraordinary discrepancies, not only in the annual and monthly fall of rain in the same locality and in proximate localities, I proceed to place in juxtaposition the fall of rain at various places in India, from such returns as are within my reach, from places at the sea-level and at different elevations above the sea-level; and it may well be a question how far even the means of many years' observations in any one locality, exhibit normal conditions for the fall of rain in circumscribed areas, much less for districts or provinces.

The relative positions of the stations on the Malabar and Coromandel coasts having been previously stated, it only remains to notice the places somewhat inland. Poona, at 1823 feet, is about forty miles eastward of the western scarp of the Ghâts, and about sixty miles as the crow flies from the sea-shore. Kotergherry, at 6100 feet, is part of the Neelgherry mountains, and lies a little to the eastward of the ridges of Dodabetta at a lower level of 2340 feet. Dodabetta is part of the Neelgherries, and the highest point of the peninsula of India. Mahabuleshwur, Mercara and Utra Mullay, at the common level of 4500 feet, are nearly in the same meridian, but lie between 9° and 18° north latitude, and are situated near to the western scarp of the Ghâts. (See annexed Table.)

The first feature of this Table is the almost total want of rain at every station in the month of February, with the exception of Kotergherry and Dodabetta, and it may be accounted for by this month being intermediate between the times of the S.W. and N.E. monsoons; the former, on the Malabar coast, commencing in May and ending in October, and the latter commencing on the Coromandel coast in October and ending in January. The other two intermediate months, March and April, have very limited falls of rain, excepting at Kotergherry, Utray Mullay and Dodabetta, at which places the supply is very liberal; indeed at Kotergherry and Dodabetta the maximum monthly fall of the year appears to occur in April, a month that belongs to neither the Malabar nor Coromandel monsoons, but as the wind at Dodabetta was almost entirely from northerly and easterly points, the supply of rain may be more reasonably considered to appertain to the tail of the N.E., rather than to the commencement of the S.W. monsoon. Poona, at 1823 feet, and Mahabuleshwur in the Deccan and Mercara in Coorg, at 4500 feet, have scarcely a sprinkling from the N.E. monsoon, and the months of December, January, February, March and April, may be

| | Madras, sea-level. | | | | | Calcutta, 18 feet. | | | | | | | | | | Bombay, sea-level. | Malabar Coast. | | | | Cape Comorin, 50 feet. | Coromandel Coast. | | | | Poona, 1823 feet. | | | | | Mahabuleshwur, 4500 feet. | | | Mercara in Coorg, 4500 feet. | Uttray Mullay, 4500 feet. | | Doda-betta, 8640 feet. | | | | | | | | |
|---------------|--------------------|-------|-------|-------|----------------------------------|--------------------|----------|---------|----------|---------|---------|---------|---------|---------|----------|--------------------|----------------|--------|-------|-------|------------------------|-------------------|-------|------------|-------|-------------------|--|----------------------|----------------------|----------------------|---------------------------|---------------|--------------------|------------------------------|---------------------------|----------------------|------------------------|---------|-------|-------|-------|-------|-------|-------|--------------------|
| | 1842. | 1843. | 1844. | 1845. | Means of 22 years, 1822 to 1843. | 4 feet. | 40 feet. | 4 feet. | 40 feet. | 4 feet. | 4 feet. | 4 feet. | 4 feet. | 4 feet. | 40 feet. | | 1843. | 1843. | 1844. | 1844. | | 1845. | 1846. | 1847. | 1848. | 1848. | Means of 32 years, 1817 to 1849. Monsoons. | Means, 1842 to 1846. | Means, 1842 to 1846. | Means, 1842 to 1846. | Means, 1842 to 1846. | 1843 to 1846. | Means, 1842, 1843. | | Means, 1842 to 1846. | Means, 1842 to 1846. | | | 1847. | 1826. | 1827. | 1828. | 1829. | 1830. | Means of 15 years. |
| January | 1.76 | 6.40 | 0.67 | 1.51 | 1.33 | 1.67 | 1.55 | 0.22 | 0.20 | 1.10 | 0.82 | 0.0 | 0.0 | 0.0 | | 1.72 | 0.94 | 1.93 | 1.80 | 0.27 | 0.90 | 1.33 | 1.58 | 1.74 | 0.0 | 2.29 | 0.0 | 0.0 | 0.0 | 0.0 | 0.05 | 0.0 | 0.66 | 0.00 | 8.40 | 4.65 | 0.12 | January | | | | | | | |
| February ... | 0.0 | 0.03 | 0.49 | 0.0 | 0.23 | 0.64 | 0.49 | 0.08 | 0.05 | 0.64 | 1.80 | 0.0 | 0.0 | 0.10 | | 0.09 | 0.33 | 1.21 | 0.23 | | 0.43 | 0.92 | 0.42 | 13.88 | 0.0 | 0.0 | 0.0 | 0.0 | 0.0 | 0.25 | 0.25 | 0.0 | 0.45 | 0.15 | 0.45 | 7.43 | February | | | | | | | | |
| March..... | 0.25 | 0.79 | 0.0 | 0.04 | 0.36 | 1.20 | 0.92 | 0.22 | 0.15 | 1.17 | 2.30 | 0.0 | 0.41 | 0.32 | | 2.04 | 1.98 | 4.27 | 1.79 | 0.92 | 1.10 | 1.53 | 1.99 | 6.88 | 0.0 | 0.4 | 0.0 | 0.0 | 0.0 | 0.15 | 0.0 | 0.02 | 1.51 | 14.20 | 0.73 | 3.61 | March. | | | | | | | | |
| April | 0.00 | 0.04 | 0.00 | 0.04 | 0.63 | 2.42 | 2.04 | 3.13 | 2.63 | 7.30 | 0.57 | 2.33 | 1.31 | 1.12 | | 3.25 | 3.14 | 3.41 | 3.51 | 0.75 | 0.41 | 1.05 | 2.61 | 18.56 | 0.0 | 0.0 | 0.0 | 0.0 | 1.04 | 1.31 | { Two showers. } | 0.0 | 2.60 | 1.37 | 9.60 | 19.80 | April. | | | | | | | | |
| May | 0.37 | 14.07 | 2.70 | 1.51 | 1.03 | 5.33 | 4.43 | 7.44 | 6.29 | 2.58 | 2.49 | 4.79 | 6.22 | 5.51 | | 18.97 | 16.51 | 26.27 | 10.27 | 4.55 | 3.99 | 2.39 | 4.36 | No record. | 3.41 | 0.04 | 1.95 | 2.74 | 0.79 | 3.31 | 0.16 | 3.74 | 7.37 | 22.68 | 36.50 | 4.86 | May. | | | | | | | | |
| June | 1.51 | 1.93 | 2.66 | 2.36 | 2.03 | 8.64 | 7.62 | 12.13 | 9.95 | 10.66 | 12.14 | 12.01 | 13.52 | 12.68 | 22.26 | 30.69 | 17.90 | 26.02 | 13.66 | 4.56 | 2.12 | 0.28 | 5.29 | 0.41 | 3.30 | 13.47 | 1.63 | 4.86 | 5.57 | 46.53 | 32.03 | 37.86 | 30.40 | 52.15 | 51.05 | 4.55 | June. | | | | | | | | |
| July | 3.42 | 1.39 | 3.22 | 2.90 | 3.20 | 10.18 | 8.67 | 13.72 | 11.40 | 12.80 | 20.07 | 15.69 | 17.50 | 16.09 | 25.04 | 17.33 | 11.04 | 14.63 | 6.53 | 0.71 | 0.97 | 0.003 | 3.41 | 3.70 | 8.43 | 1.79 | 7.58 | 4.38 | 5.35 | 92.10 | 118.60 | 117.76 | 55.88 | 50.15 | 33.32 | 7.45 | July. | | | | | | | | |
| August | 3.07 | 2.20 | 2.66 | 2.01 | 5.24 | 20.05 | 17.99 | 26.91 | 22.89 | 15.36 | 13.26 | 15.09 | 9.22 | 7.00 | 17.08 | 13.09 | 6.10 | 9.33 | 3.31 | 0.36 | 0.12 | 0.006 | 1.14 | 2.66 | 1.03 | 2.01 | 3.35 | 3.21 | 1.72 | 72.33 | 75.91 | 77.75 | 27.00 | 25.57 | 21.12 | 9.32 | August | | | | | | | | |
| September ... | 5.56 | 4.14 | 12.42 | 4.09 | 4.76 | 11.19 | 9.92 | 5.02 | 4.25 | 4.80 | 9.97 | 10.95 | 4.74 | 4.10 | 11.25 | 4.82 | 3.34 | 5.32 | 2.81 | 0.41 | 0.53 | 1.05 | 1.67 | 1.36 | 1.54 | 4.51 | 6.92 | 0.33 | 0.29 | 31.32 | 65.97 | 56.00 | 11.91 | 8.08 | 7.33 | 7.52 | Septem | | | | | | | | |
| October | 7.99 | 6.25 | 13.50 | 3.36 | 10.09 | 2.16 | 1.88 | 4.99 | 4.54 | 5.86 | 10.76 | 5.86 | 5.41 | 5.18 | *1.19 | 9.67 | 9.88 | 12.02 | 12.35 | 8.77 | 6.51 | 4.87 | 7.59 | 12.33 | 1.90 | 4.33 | 6.34 | 1.81 | 3.07 | 4.58 | 9.29 | 7.48 | 4.60 | 70.70 | 38.25 | 12.49 | Octobe | | | | | | | | |
| November ... | 12.32 | 5.27 | 3.67 | 5.12 | 12.42 | 0.0 | 0.0 | 0.0 | 0.0 | 0.0 | 0.74 | 5.59 | 0.20 | 0.13 | | 2.28 | 3.89 | 5.48 | 4.61 | 3.95 | 4.26 | 4.19 | 5.82 | 10.62 | 2.33 | 0.15 | 2.04 | 0.0 | 0.0 | 2.07 | 0.0 | 4.00 | 1.38 | 16.10 | 21.67 | 11.85 | Novem | | | | | | | | |
| December ... | 0.19 | 7.25 | 2.32 | 15.33 | 3.25 | 0.86 | 0.79 | 0.0 | 0.0 | 0.81 | 1.52 | 0.05 | 0.16 | 0.09 | | 2.27 | 1.68 | 3.35 | 4.24 | 2.80 | 3.28 | 3.41 | 3.30 | 9.57 | 0.40 | 0.0 | 0.0 | 1.20 | 0.0 | 0.05 | { One light shower. } | 0.0 | 0.25 | 21.00 | 10.20 | 12.28 | Decem | | | | | | | | |
| Year | 36.39 | 49.76 | 44.31 | 38.27 | 44.57 | 64.34 | 56.30 | 73.86 | 62.35 | 63.08 | 76.44 | 72.38 | 58.69 | 52.32 | 76.82 | 106.06 | 76.76 | 113.26 | 64.54 | 28.35 | 24.67 | 21.06 | 39.19 | 81.71 | 22.34 | 28.63 | 29.81 | 18.53 | 17.83 | 254.05 | 302.21 | 305.27 | 143.35 | 298.55 | 235.87 | 101.24 | Year. | | | | | | | | |

[Lieut.-Colonel SYKES's Discussion of Meteorological Observations taken in India.]

* This average is for the monsoon months only.

considered their dry months; but Mercara, lying much further south than Mahabuleshwur, would appear to benefit slightly from the terminal falls of the N.E. monsoon, or from the preliminary squalls of the S.W. monsoon. On the eastern or Coromandel coast, the months that are comparatively dry (or rather destitute of rain, for the wet bulb won't admit them to be dry) on the western coast, are necessarily the reverse of the eastern, and we thus see October, November, December and January, at Madras, and the other stations on the east coast, with a monthly fall of rain ranging from 0.90 to 15.13 inches. The mean annual fall at Madras, for twenty-two years, from 1822 to 1843, ranges from 18.45 inches in 1832 to 88.68 inches in 1827. Calcutta, although within the regular S.W. monsoon, appears to benefit more from the Coromandel monsoon in January than any other of the stations noticed in the Table. The Tables indicate that as the stations approximate towards each other, and lie nearer to the apex of the triangular-formed peninsula of India, excepting at Cape Comorin, so do they respectively benefit in an increasing ratio from the monsoons of either coast. For instance, Madras derives considerable advantage from the Malabar monsoon in the months of July, August and September, while Cochin, Quilon, Allepy and Trevandrum, on the Malabar coast, and the mountain stations of Uttray Mullay, Kotergherry and Dodabetta, lying between the Malabar and Coromandel coasts, are liberally supplied from the N.E. monsoon in the months of October, November and December, while Mercara and Mahabuleshwur, similarly situated as Uttray Mullay and Dodabetta, but in a higher latitude, and nearly in the same meridian, derive scarcely any benefit from the N.E. monsoon; indeed, north of the eighteenth parallel of latitude, that is to say of Poona, the rain-fall of the N.E. monsoon does not extend, at least as far as the returns I have been able to collect afford me the means of judging. Another feature of the Table indicates that the S.W. monsoon does not burst simultaneously along the whole line of the Malabar coast, but would appear to creep up slowly from Allepy towards Bombay, commencing in fact on the coast of Travancore partly in April, but absolutely in May, and rarely, if ever, commencing in Bombay before the first week in June; the S.W. monsoon therefore on the coast of Travancore and Malabar, precedes the time of its occurrence at Bombay by a month at least. I had thought that along the coast the quantity of rain diminished as the latitude increased, and the large annual fall at Allepy and Cochin, compared with the fall at Bombay, seemed to justify the opinion; but the fall at Cape Comorin, Trevandrum and Quilon, does not justify the opinion; and supposing that any such law held good on the Malabar coast, it plainly has not any existence on the Coromandel coast. It is certain, however, that as the tropic is approached on the western side of India, the annual fall of rain sensibly diminishes along the coasts of Kattywar and Cutch; and at the mouths of the Indus, not only is there no trace of the S.W. monsoon, but Lower Scinde would appear to resemble those singular tracts on the earth, the Deserts of Sahara and Gobi, and the coast of Chili, denominated "rainless." I regret not having been enabled to get more than one re-

gular meteorological register from the military cantonment at Kurrachee, situated near one of the mouths of the Indus; but the scanty information supplied to me affords sufficient proof that if Lower Scinde does not belong absolutely to the rainless districts, it approaches very nearly to them. Unfortunately, neither in the large cantonment at Kurrachee, nor at other stations in Scinde, up to 1849 were regular meteorological registers kept, excepting perhaps for mere temperature, or if kept they were not made available to the public. Casual observations have been made and sufficient attention paid to the rain-fall, or rather the absence of it, to enable us to say definitely, that to Lower Scinde the S.W. monsoon, in its usual sense, does not extend, and that the country does not appear to have other sources of supply. The following Table is arranged from the details in a letter dated Kurrachee, July 6th, 1848, noticing the occasional showers that fell from April 1847, a pluviometer having been set up, but apparently for very little purpose:—

Register of Rain at Kurrachee, from April 1847 to July 1848.

| 1847. | | | | | | | | 1848. | | | | | | |
|-------|-------|-----------|---------|-------|-------|-------|-------|-------|-------|--------|--------|-------|-------|--------------|
| May. | June. | July. | August. | Sept. | Oct. | Nov. | Dec. | Jan. | Feb. | March. | April. | May. | June. | July. |
| None. | None. | A shower. | None. | None. | None. | None. | None. | None. | None. | None. | None. | None. | None. | A few drops. |

It thus appears, if the register be correct, that in fifteen months only two showers occurred, and those so light as not to be appreciable by the pluviometer.

The following extract from a subsequent letter, dated 1st of September 1849, to a certain extent is in harmony with the previous record:—

“ We have had a few smart showers lately. Ever since June it has been constantly threatening rain; the sky has been always overcast, and both in July and August showers fell, but the whole fall for the season has hardly amounted to 3 inches; and yet in Upper Scinde, at Mooltan, in the Punjab, and generally in India, where the S.W. monsoon prevails, the usual averages have in some places been doubled.”

In this year, at Bombay, the unusual quantity of 118·88 inches fell. The only other part of Scinde from which I have any record is from Kotri near to Hyderabad on the Indus, and the return transmitted to me is annexed. The public duties of the observer called him occasionally away from his station and prevented a continuous record, and it is only for 1846 that a year's observations are complete, and in 1847 four months were omitted.

Extract from a journal kept at Kotri near Hyderabad on the Indus, by Mr. STRATH, engineer; for the months entered the blanks indicate the months of no observation.

| | 1845. | 1846. | 1847. | 1848. | 1849. |
|---------------|-------|----------|-------|-------|----------|
| January | | None. | None. | | None. |
| February ... | | None. | | | None. |
| March | | * | None. | | 0·35 in. |
| April | | None. | † | | |
| May | | 1·75 in. | None. | | |
| June | | 6·33 in. | | | |
| July | | 0·27 in. | | | |
| August | | None. | ‡ | | |
| September ... | | None. | None. | None. | |
| October | | None. | None. | § | |
| November ... | | None. | None. | None. | |
| December ... | None. | None. | None. | None. | |
| | | 8·35 in. | | | 0·35 in. |

I am enabled, however, since the preceding notices were written, by the arrival in England of the medical returns from the Bombay army for 1847, to give an official and authentic record of the rain-fall and temperature at Kurrachee for 1847. It will be seen that for *eleven* months not a single shower fell, and that in one month only did rain fall, the record being in accord so far with the letter dated 6th of July 1848, differing, however, inasmuch as the rain in the official report is represented to have fallen in June and the latter in July.

| 1847. | Thermometer. | | | Rain. | Rain. |
|---------------|--------------|-------|-------|-------|--|
| | Max. | Min. | Mean. | | |
| January | 83° | 53° | 67° | in. | On 24th, 25th and 31st. |
| February ... | 74 | 59 | 67 | | |
| March | 84 | 70 | 77 | | |
| April | 84 | 75 | 79 | | Heavy showers, 23rd and 24th. On 24th and 25th. |
| May | 90 | 77 | 83 | | |
| June | 94 | 80 | 87 | 3·0 | Slight showers. |
| July | 90 | 78 | 84 | | |
| August | 95 | 82 | 88 | | |
| September ... | 90 | 80 | 86 | | |
| October | 93 | 72 | 80 | | |
| November ... | 91 | 59 | 72 | | |
| December ... | 83 | 44 | 63 | | |
| Mean | 88·42 | 69·08 | 77·75 | | |

In a review of the above rain-records we find some singular features. Along the western coast of India, from Cape Comorin to the mouth of the Indus, there is a paucity of rain at the former place, and an almost total absence of it at the latter,

* On the 4th of this month a few drops of rain fell at sunset.

† Rain during the night and light showers during the day.

‡ At sunset drops of rain.

§ At P.M. of the 7th heavy showers of rain with wind, thunder and lightning.

|| On the 30th light showers.

while a few miles from Cape Comorin the annual supply amounts to 113 inches; and in the latitude of Bombay it does not fall below a mean of 76·82 inches for the monsoon alone, but proceeding along the coast northwards the supply further diminishes, or becomes irregular and uncertain in quantity, and at the mouths of the Indus almost disappears. Along the Coromandel coast the N.E. monsoon does not appear to supply much more than one-half of the fall on the Malabar coast, the mean of twenty-two years at Madras being 44·57 inches, the quantity slightly increasing with the latitude from Cape Comorin. Another marked feature is the greatly increased fall of rain with the increased elevation above the sea-level of the place of observation up to a certain height, beyond which the quantity of rain gradually diminishes as the place of observation is more elevated; at least such are the indications in the tract of land which lies between the sea-shore and the base of the Ghâts between Cape Comorin and Goozerat, and along the western face of the Ghâts themselves. The observation does not hold good however on the elevated lands to the eastward of the crest of the Bombay and Malabar Ghâts. Along the sea-coast the falls vary from 28·35 inches at Cape Comorin to 113·26 inches at Allepy, but increase at stations nearing the Ghâts at different elevations to more than 300 inches at 4500 feet, and above that height the falls gradually diminish in quantity. For instance, the

| | inches. |
|---|---------|
| Mean of seven stations at sea-level, western coast, is | 81·70 |
| At 150 feet, Rutnagherry, in the Konkun | 114·55 |
| At 900 feet, Dapoolee, Southern Konkun | 134·96 |
| At 1740 feet, Kundalla, the pass from Bombay to Poona | 141·59 |
| At 4500 feet, Mahabuleshwur, means of fifteen years | 254·05 |
| At 4500 feet, Mercara in Coorg, means of three years | 143·35 |
| At 4500 feet, Uttray Mullay*, in Travancore, means of two years | 263·21 |
| At 6100 feet, Kotergherry, on the Neelgherries, one year | 81·71 |
| At 8640 feet, Dodabetta, highest point of Western India, one year | 101·24 |

Hence the elevation of the line of maximum fall would appear to be about 4500 feet, and above this level the supply of rain is diminished; Mahabuleshwur, Mercara and Uttray Mullay, although differing greatly in latitude, lie nearly in the same meridian, and are all at the same elevation. The comparative small fall at Mercara is accounted for by the fact of its not being so near the western scarp of the Ghâts as Mahabuleshwur and Uttray Mullay, and the effect of a station being placed a few

* Since the above was written I have received a letter from General CULLEN, dated Trevandrum, 6th of January 1850, giving an account of the fall of rain for 1849 at the Uttray Mullay range.

| | inches. |
|-----------------------------------|---------|
| At 500 feet, base of range..... | 99 |
| At 2200 feet, Attagherry..... | 170 |
| At 4500 feet, Uttray Mullay | 240 |
| At 6200 feet, Augusta Peak | 194 |

Showing at 6200 feet a fall of 46 inches less of rain than at 4500 feet.

miles east of the Ghâts upon the fall of rain has already been shown at Mahabuleshwur and Paunchgunny, the latter place being eleven miles eastward of the former, and at a lower level of only 500 feet, yet the mean fall of 15 years at Mahabuleshwur was 254·05 inches, and of the latter 50·69 inches. In 1849 the contrast was still greater, the fall at Mahabuleshwur amounting to the enormous quantity of 338·38 inches, while at Paunchgunny only 58 inches fell.

Rain at different Elevations.

Mr. MILLER, in his Meteorology of the Lake Districts of Cumberland and Westmoreland, has adduced sufficient evidence to prove that the same law, if it be a law, obtains in England in mountainous districts, but Mr. MILLER's elevation of maximum fall is about 2000 feet instead of 4500, as in India. This difference no doubt results from the differences of latitude and consequent mean temperature, and would indicate that the stratum of vapour supplying the maximum quantity of rain floats at a less height beyond the tropics than within them.

In a communication from Mr. MILLER, dated June 7, 1849, he gives as follows the fall of rain at different heights in the Lake Districts of Cumberland and Westmoreland.

“The Mountain Gauges.

| No. | | In 13 months. 31st of December 1847 to 31st of December 1848. | Summer months. 1st of May to 31st of October. | Winter months. December 1847 to April 1848, and November and December 1848. |
|--------|---|--|---|--|
| XXI. | Sea Fell Pike, 3166 feet above the sea | in. 64·73 | in. 49·46 | in. |
| XXII. | Great Gable, 2928 feet above the sea | From 1st of May. 91·32 | 46·81 | 44·51 |
| XXIII. | Sprinkling Tarn, 1900 feet above the sea | 148·59 | 70·95 | 77·64 |
| XXIV. | Stye Head, 1290 feet above the sea | 138·72 | 60·35 | 78·37 |
| XXV. | Brunt Rigg, 500 feet above the sea | 109·19 | 43·18 | 66·01 |
| XIV. | Valley to the west, Wastdale | 127·47 | 50·16 | 77·81 |
| XIII. | Valley to the S.E., Eskdale | 95·71 | 37·69 | 58·02 |
| XXVI. | Seatollar Common, } 1334 feet above the sea ... | 139·48 | 57·97 | 81·51 |
| XIX. | Valley, Seathwaite, } Borrowdale | 177·55 | 68·96 | 108·59 |

“From the table for the summer months, it appears that between the 1st of May and the 31st of October, the gauge at 1290 feet has received $20\frac{1}{2}$ per cent. more rain than the valley; at 1334 feet, $15\frac{1}{2}$ per cent. more; at 1900 feet, $41\frac{1}{2}$ per cent. more; at 2928 feet, 6 per cent. less; and at 3166 feet, 1 per cent. less than the valley.

“In the winter months, the gauge at 1290 feet has collected 0·5 per cent. more; at 1344 feet, $5\frac{1}{2}$ per cent. more; at 1900 feet, 1 per cent. more; and at 2928 feet, $42\frac{1}{2}$ per cent. less than the adjacent valley.”

These results are in accordance with the observations I have given from India. In addition to the preceding from Mr. MILLER, I annex his rain-records at lower levels

for the years 1845, 1846, 1847 and 1848, as they confirm, from European localities, the facts I have stated respecting the great discrepancies in the fall of rain at proximate stations.

Fall of Rain in the Lake Districts of Cumberland and Westmoreland at various heights up to 3166 feet. Wind almost uniformly from a westerly quarter.

| Years. | Whitehaven. | | | | Keswick, 258 feet. | Cockermouth. | Bassenthwaite Hills, 210 feet. | Vale of Gillerthwaite, Ennerdale, 286 feet. | Loweswater, 336 feet. | Foot of Crummock Lake, 283 feet. | Gatesgarth, Buttermerc, 326 feet. | Eskdale. | | Wastdale Head, 166 feet. | Westmoreland. | | | Borrowdale. | | | |
|--------|-----------------------|------------------------|--|---|--------------------|--------------|--------------------------------|---|-----------------------|----------------------------------|-----------------------------------|---------------------------|---------------|--------------------------|-------------------------------|-----------------------|--------------------------|--|--|----------------|------------------------------|
| | High Street, 90 feet. | Round Close, 480 feet. | Saint James's Church Steeple, 78 feet. | The Flosh, 3 miles south of Whitehaven. | | | | | | | | Centre of Vale, 166 feet. | Head of Vale. | | The How, Troutbeck, 300 feet. | Amble-side, 190 feet. | Langdale Head, 250 feet. | Seathwaite, in Garden, at 6 inches, 1334 feet. | Seathwaite, in the Field, at 18 inches, 1334 feet. | Stone-thwaite. | Seatollar Common, 1334 feet. |
| 1848. | 47·342 | 46·700 | 36·344 | 60·82 | 66·407 | 52·37 | 47·06 | 97·73 | 76·668 | 98·07 | 133·55 | 86·78 | 70·38 | 115·32 | 91·347 | 76·82 | 130·38 | 160·89 | 157·22 | 130·24 | 139·48 |
| 1847. | 42·921 | 42·023 | 30·713 | 47·80 | 58·286 | 42·55 | 44·45 | 80·13 | 66·209 | 82·32 | 106·25 | 58·66 | 74·93 | 96·34 | 78·004 | | 112·95 | 129·24 | 126·80 | 106·21 | |
| 1846. | 49·134 | | 35·422 | 55·16 | 67·678 | 52·41 | | 83·87 | 70·249 | 96·47 | 121·90 | | | 106·93 | 77·719 | | 127·40 | 143·51 | | | |
| 1845. | 49·207 | | 33·480 | 53·00 | 62·212 | 46·93 | | 76·88 | 69·542 | 87·48 | 124·13 | | | 108·55 | 76·305 | | 136·00 | 151·87 | | | |

These records attest that in the town of Whitehaven the difference in the fall of rain in the High Street and on the steeple of St. James's Church in 1845, was 15·727 inches, and in 1848 the difference was 10·998 inches, while at the Flosh, only three miles south of Whitehaven, the fall was in excess in those years respectively over the fall in the High Street, 2·873 inches and 13·478 inches, while the excess over the fall on the steeple was 19·600 inches and 24·476 inches. In Borrowdale also, in a field adjoining a garden, in the years 1847 and 1848, the fall was in excess in the garden of 2·44 inches and 3·67 inches respectively. These facts suggest caution to all observers in other parts of England and elsewhere.

Professor PHILLIPS for some years made observations at York on the top of the Minster, the Museum, and on the ground, to determine the effect of elevation upon the rain-fall, but objections being taken to the results in respect to eddies of wind and other causes of error, he lifted rain-gauges into the air, independently of buildings, and the results of the observations for the years 1843 and 1844 he communicated to the British Association at York in 1844.

The sums of the rain-fall in the two years at different heights were,—

| | |
|------------------|---------|
| | inches. |
| 24 feet. | 24·158 |
| 12 feet. | 26·039 |
| 6 feet. | 26·109 |
| 3 feet. | 26·298 |
| 1½ foot. | 26·559 |

The nearer the earth, therefore, the greater the amount of rain collected. Mr. MILLER's records at Whitehaven, giving for four years the amount of rain collected in the High Street and on the Church Steeple, confirm Professor PHILLIPS's observations, supposing the steeple to be 78 feet above the High Street. At Calcutta, in the

Surveyor-General's Office, similar observations were made at the respective heights of 4 feet and 40 feet, and I have inserted the results in the general rain-fall Table for four years. The sums were respectively 261·97 inches and 247·41 inches, and the annual means 65·49 inches and 61·85 inches.

Dr. BUIST states that at the observatory in Bombay, in two rain-gauges, one at 3 feet from the ground, and the other above the observatory at 32 feet, the

| | |
|----------------------------|-------------------|
| Lower gauge for 1843 . . . | inches. =56·24 |
| Upper gauge for 1843 . . . | =49·07 |
| Lower gauge for 1844 . . . | =66·51 |
| Upper gauge for 1844 . . . | =66·08 |

These results therefore are in accordance with Professor PHILLIPS and Mr. MILLER's observations, taken at limited heights, but entirely antagonist to Mr. MILLER's own observations and those I have supplied in this paper from India for heights exceeding a few hundred feet. The supposed law may hold good for small differences in elevation on the plains, but the law is reversed in mountainous districts.

Two great features of my Rain-table demand express notice, the paucity of rain at Cape Comorin and at Kurrachee, at the extremities of nearly the same meridional line, and the prodigious fall of rain at the elevation of 4500 feet at three stations differing greatly in latitude, but situated nearly in the same meridian. I have not any satisfactory explanation to offer of the want of rain either at Cape Comorin or at Kurrachee. I am not at all acquainted with the physical character of the country about Cape Comorin, and cannot therefore express an opinion how far local circumstances occasion the phenomenon. I had thought that a very high mean temperature, with a limited range of the thermometer, might account for the want of rain at Kurrachee on the Indus, the vapour from the ocean not coming into an air cold enough to condense it; but the register of the thermometer for 1847 at Kurrachee shows that I could not find a satisfactory argument upon its records, for the maxima are not so great as at Calcutta, Madras and Bombay; the minima are lower, and the mean temperature is lower than at either of the places; some other cause therefore must be looked for than a high mean temperature. The clouds which constantly pass over Kurrachee, would appear not to be condensed until they impinge upon the Sulimanee Mountains, which run parallel to the right bank of the Indus. The explanation of the prodigious fall of rain at the level of 4500 feet is simple and satisfactory. The chief stratum of aqueous vapour brought from the equator by the S.W. monsoon is of a high temperature, and floats at a *lower* level than 4500 feet; indeed I have looked over, or upon the upper surface of the stratum at 2000 feet. It is dashed with considerable violence against the western mural faces of the Ghâts, and is thrown up by these barriers in accumulated masses into a colder region than that in which it naturally floats; it is consequently rapidly condensed and rain falls in floods. The uncondensed vapour which escapes up the chasms and over the crest of the Ghâts,

affords the precarious and scanty supply to the lands to the eastward, which the Tables show.

Maximum Daily Rain-Fall.

As might be looked for, the greatest fall of rain in any one day is met with in the records of those stations where there is the greatest annual fall, Mahabuleshwur and Uttray Mullay. At the former station the greatest fall in any one day in fifteen years was 13·06 inches on the 2nd of September 1833, but the months of June, July and August, have numerous instances of a daily fall of 11·32 inches, 12·76 inches, and 12·69 inches in those months respectively. The greatest monthly fall at Mahabuleshwur was 134·42 inches in July 1840. At Uttray Mullay the greatest daily fall in three years was 15·1 inches on the 14th of October 1845. On the 11th of December of the same year there was a fall in one day of 11·4 inches, and on the 9th of October 1844 the fall in one day was 9·0 inches. In 1846 there was not a daily fall approaching these figures. In Bombay, in 1845, the greatest daily fall was 4·71 inches on the 24th of July, and the next year, on the 16th of July, a daily fall occurred of 5·16 inches; but Dr. Buist mentions that on the 1st of July 1844 there was a fall of rain in twenty-four hours of 7·44 inches, two inches having fallen in seventy minutes; but this was on the first burst of the monsoon, which set in later than usual by three weeks. On the 10th of July, however, 9·43 inches fell, the greatest of the year. In the Deccan there is rarely a greater daily fall than two inches, but in the Sattarah records a maximum daily fall of 4·40 inches in four years is stated to have occurred in April; but this was in one of the squalls which are the precursors of the monsoon. Annexed is a comparison of the fall of rain in Bombay and at Mahabuleshwur for many years.

Register of the Pluviometer at Bombay, from the year 1817 to 1849.

| Years. | June. | July. | August. | September. | October. | Total fall in June, July, August, September, and October of each year. | Mahabuleshwur, 4500 feet. |
|----------------------------|-------|-------|---------|------------|----------|--|------------------------------|
| | in. | in. | in. | in. | in. | in. | |
| 1817. | 45.72 | 23.67 | 9.34 | 24.87 | | 103.60 | |
| 1818. | 22.54 | 17.69 | 28.45 | 10.39 | 2.07 | 81.14 | |
| 1819. | 15.95 | 31.66 | 20.24 | 10.11 | | 77.96 | |
| 1820. | 18.82 | 28.37 | 29.49 | 10.66 | | 77.34 | |
| 1821. | 15.18 | 20.60 | 28.52 | 18.29 | | 82.59 | |
| 1822. | 29.64 | 26.59 | 33.83 | 22.16 | | 112.22 | |
| 1823. | 21.76 | 15.96 | 19.70 | 4.28 | | 61.70 | |
| 1824. | 3.89 | 8.07 | 17.86 | 1.78 | 2.37 | 33.97 | |
| 1825. | 24.45 | 25.17 | 12.94 | 9.68 | | 72.24 | |
| 1826. | 17.75 | 26.97 | 8.40 | 23.50 | 1.87 | 78.49 | |
| 1827. | 49.15 | 10.29 | 10.51 | 10.16 | 0.92 | 81.03 | |
| 1828. | 23.53 | 52.75 | 17.22 | 22.08 | 6.40 | 121.98 | |
| 1829. | 27.86 | 19.78 | 12.40 | 4.95 | 0.66 | 65.65 | 257.06 |
| 1830. | 20.96 | 32.46 | 10.66 | 7.78 | | 71.86 | 232.93 |
| 1831. | 22.46 | 27.31 | 27.64 | 22.34 | 2.08 | 101.83 | 185.82 |
| 1832. | 13.63 | 48.05 | 4.65 | 7.11 | 0.65 | 74.09 | 226.87 |
| 1833. | 12.50 | 21.80 | 13.35 | 23.54 | 0.20 | 71.39 | 203.74 |
| 1834. | 14.16 | 21.83 | 18.05 | 12.55 | 3.88 | 70.47 | 297.31 |
| 1835. | 9.99 | 4.27 | 35.76 | 12.17 | 0.42 | 62.61 | 226.71 |
| 1836. | 21.36 | 24.53 | 37.41 | 4.69 | | 87.99 | 243.56 |
| 1837. | 12.61 | 24.39 | 22.43 | 5.15 | | 64.58 | 267.76 |
| 1838. | 29.70 | 8.70 | 7.34 | 5.04 | | 50.78 | 180.17 |
| 1839. | 18.28 | 32.19 | 18.45 | 4.70 | | 73.62 | 233.23 |
| 1840. | 25.04 | 24.24 | 4.20 | 7.55 | 2.12 | 63.15 | 284.43 |
| 1841. | 25.27 | 21.21 | 20.53 | 1.27 | 3.21 | 71.49 | 281.04 |
| 1842. | 16.84 | 26.45 | 37.10 | 10.41 | 4.36 | 95.16 | 304.90 |
| 1843. | 9.33 | 22.49 | 18.20 | 9.00 | 0.25 | 59.27 | 285.67 |
| 1844. | 14.17 | 35.52 | 6.55 | 9.16 | | 65.40 | 262.32 |
| 1845. | 19.70 | 20.44 | 6.56 | 8.03 | | 54.73 | 249.93 |
| 1846. | 31.71 | 40.56 | 5.60 | 8.45 | 1.16 | 87.48 | 288.34 |
| 1847. | 35.47 | 16.80 | 8.92 | 5.80 | 0.32 | 67.31 | 218.83 |
| 1848. | 42.37 | 13.83 | 7.87 | 4.01 | 5.34 | 73.42 | 245.01 |
| 1849. | 22.82 | 51.68 | 13.66 | 29.65 | 1.07 | 118.88 | 338.38 |
| Average for 33 years. } | 22.26 | 25.04 | 17.08 | 11.25 | 1.19 | 76.82 | |

Note.—The Bombay register is only for the months of the monsoon, and it does not appear that any record has been kept of the fall in the other months annually. The record at Mahabuleshwur is for the whole year.

Winds at Madras.

Direction of the Wind at Madras, blowing from the different *quarters* of the compass, from hourly observations.

| | 1841. | | | | 1842. | | | | 1843. | | | | 1844. | | | | 1845. | | | |
|---------|-------|------|------|------|-------|------|------|------|-------|------|------|------|-------|------|------|------|-------|------|------|------|
| | N.W. | S.W. | S.E. | N.E. | N.W. | S.W. | S.E. | N.E. | N.W. | S.W. | S.E. | N.E. | N.W. | S.W. | S.E. | N.E. | N.W. | S.W. | S.E. | N.E. |
| Jan.... | ... | ... | ... | ... | 105 | 51 | 80 | 508 | 74 | 29 | 92 | 549 | 64 | 47 | 193 | 440 | 87 | 27 | 196 | 434 |
| Feb.... | ... | ... | ... | ... | 95 | 124 | 227 | 229 | 23 | 82 | 434 | 133 | 45 | 92 | 309 | 249 | 11 | 71 | 393 | 197 |
| March | 2 | 170 | 372 | 0 | 26 | 201 | 276 | 1 | 15 | 179 | 527 | 23 | 12 | 266 | 449 | 17 | 13 | 221 | 477 | 33 |
| April | 120 | 471 | 115 | 14 | 0 | 307 | 269 | 0 | 0 | 230 | 488 | 2 | 15 | 236 | 451 | 19 | 3 | 380 | 335 | 2 |
| May | 57 | 407 | 219 | 37 | 56 | 468 | 211 | 9 | 73 | 376 | 260 | 35 | 67 | 426 | 215 | 36 | 73 | 437 | 204 | 30 |
| June | 86 | 539 | 86 | 9 | 86 | 447 | 133 | 30 | 88 | 553 | 76 | 3 | 196 | 397 | 84 | 43 | 228 | 396 | 51 | 45 |
| July... | 144 | 511 | 76 | 13 | 96 | 578 | 62 | 13 | 121 | 562 | 54 | 7 | 127 | 498 | 111 | 8 | 128 | 498 | 108 | 10 |
| Aug. | 85 | 352 | 288 | 19 | 37 | 487 | 144 | 26 | 120 | 494 | 117 | 3 | 200 | 411 | 95 | 38 | 135 | 472 | 129 | 8 |
| Sept. | 115 | 356 | 182 | 43 | 91 | 377 | 174 | 76 | 153 | 355 | 168 | 44 | 114 | 359 | 187 | 60 | 93 | 371 | 228 | 28 |
| Oct.... | 265 | 93 | 145 | 241 | 101 | 203 | 221 | 219 | 194 | 183 | 119 | 248 | 171 | 251 | 125 | 197 | 83 | 274 | 229 | 158 |
| Nov. | 232 | 16 | 58 | 414 | 139 | 16 | 34 | 531 | 194 | 2 | 11 | 513 | 236 | 0 | 51 | 433 | 96 | 0 | 66 | 558 |
| Dec. | 219 | 0 | 10 | 515 | 157 | 16 | 70 | 501 | 207 | 19 | 144 | 374 | 246 | 8 | 64 | 426 | 149 | 14 | 104 | 477 |
| Total | ... | ... | ... | ... | 1039 | 3275 | 1901 | 2145 | 1262 | 3064 | 2490 | 1934 | 1493 | 2991 | 2340 | 1966 | 1099 | 3161 | 2520 | 1980 |

Note.—N.W. includes the winds blowing between N. and W. points, and the same applies to the other quarters.

The prevailing wind at Madras is the S.W., which wind brings to Bombay and the Malabar coast their monsoon rains, but which to Madras becomes mostly a *hot* wind after traversing the peninsula, and carries with it to Madras only a few showers. The S.W. wind begins to prevail at Madras over every other wind in the month of April, and mostly remains the dominant wind until the end of September: the S.E. wind then prevails until October, about the middle of which month the approaching N.E. or rainy monsoon of the Coromandel coast almost displaces the S.E. wind. Its full development takes place in November, and it remains the prevailing wind until February, when the S.E. regains its influence, and is greatly the dominant wind until April, when it is gradually displaced by the S.W. wind. The N.W. wind makes its appearance in every month of the year, chiefly in the months of the S.W. or Malabar monsoon, but least so in the months of March and April, in the years 1841 not in March, and 1842 not at all in April; the N.E. wind failed in the same months in the respective years. The N.W. is the quarter from whence Madras has the smallest amount of wind. The largely prevailing wind is the S.W., which, coming up from the equator, is the chief source of rain supply to India generally, but of which the Coromandel coast gets but a scanty proportion in consequence of the high western Ghâts intercepting and condensing the chief part of the vapour brought by that wind. The next prevailing wind is the S.E., and this equally blows from the equator upon Madras and the Coromandel coast; but it is nevertheless not the rain-bearing wind of the Madras monsoon, which is from the N.E., sweeping over the bay of Bengal from Burmah. The S.W. wind from the Indian Ocean is a rain-bearing wind, but

the S.E. wind, also from the Indian Ocean, is not a rain-bearing wind in the sense of a monsoon. By a comparison of the Wind-table with the Rain-table of Madras, it will be seen that in the months in which the S.E. winds prevail, February, March, April, September, and early part of October, the first three months are almost entirely rainless, and the little that falls in September is owing to occasional S.W. winds. This may be owing to the air over the peninsula in those months, from the position of the sun in the ecliptic being too hot to condense the S.E. vapour. On the contrary, the N.E. wind from the bay of Bengal comes loaded with vapour in November, December and January, and the sun being far south, the peninsula is rapidly cooling, and the vapour from the bay of Bengal being of a higher temperature than the air upon which it is thrown, is condensed. The valuable table from the Madras Observatory shows by inspection, the gradual changes of the wind from one quarter to another, and the total annual numbers under each quarter show considerable uniformity in successive years.

Winds at Bombay.

The following Table of the winds at Bombay, for the year 1843, is from the *hourly* observations taken by Dr. BUIST, LL.D. Although the numbers of hours at which the winds blew are placed under the points N.W., S.W., S.E., N.E., the numbers embrace the winds within each quarter of the compass; for instance, N.W. embraces all the winds blowing between N. and W., and so on for the other quarters.

| | N.W. | S.W. | S.E. | N.E. |
|-----------------|------|------|------|------|
| January | 382 | 56 | 11 | 157 |
| February | 397 | 15 | 32 | 132 |
| March..... | 451 | 30 | 28 | 138 |
| April | 442 | 94 | 17 | 47 |
| May | 380 | 273 | 12 | 1 |
| June | 85 | 438 | 73 | 7 |
| July | 133 | 491 | 0 | 0 |
| August | 184 | 460 | 2 | 3 |
| September | 98 | 390 | 43 | 53 |
| October | 280 | 41 | 50 | 253 |
| November | 224 | 1 | 51 | 348 |
| December | 130 | 0 | 64 | 382 |
| Year | 3184 | 2289 | 383 | 1521 |

The Table shows that the prevailing wind at Bombay, in 1843, was from the points between N. and W., having blown at 3184 hours. The next prevailing wind is from the points between S. and W., having blown for 2289 hours, being the rain-bearing wind of the so-called S.W. monsoon, from May to September inclusive; but in truth the wind most generally blows from the W.S.W., with a leaning to a point more westward, and a S.W. and by S. wind during the monsoon is of rare occurrence. The wind from the points between N. and E. is the next most prevalent. It begins to prevail in October, and continues prevalent as long as the N.E. monsoon blows at

Madras, on the opposite coast of India ; it may be said to cease entirely when the Malabar monsoon approaches in May. The S.E. wind, unlike Madras, is little felt at Bombay, having blown at 383 hours only during 1843. Few as the occasions are on which it blew at Bombay, it would appear to have resulted from the veering of the N.E. wind through E. to a point southward of east ; a wind strictly from the S. is scarcely known at Bombay. The N.W. wind, which is the dominant wind at Bombay and the least prevailing wind at Madras, blows at Bombay most in those months when it is least felt at Madras, namely, the first five months of the year, and in the months of March and April it almost disappears at Madras ; but at Bombay in those months it blows at more hours than any other wind blows in any other two months of the year, excepting probably the W.S.W. in July and August. In January, February, March, April, and up to the third week in May, the wind from the N. to W. points blows from eleven to twenty-two hours daily, the remaining hours having the wind from the N. to E. points, constituting the land-wind, the N.W. being considered the sea-breeze. In part of October, November and December, the reverse is the case, the N.E. or land-wind prevailing from thirteen to nineteen hours daily, and the sea-breezes appearing between noon and 10 p.m. The suddenness with which the prevailing winds commence and terminate is a marked feature in the meteorology of Bombay. The wind from the S. to W. points begins suddenly the third or fourth week in May, and as suddenly terminates in the first or second week of October. The wind from the N. to E. points takes the place of the S.W. wind and terminates suddenly in May. The N.W. wind, owing to its being a daily alternating wind with the land-breeze, from the heating action of the sun upon the land daily, has a more continuous character throughout the year, appearing even in the monsoon months, when a few days' sunshine heats the land ; it is however much less frequent in those months than when the sun bears with continued force upon the land.

Winds at Calcutta.

With regard to the winds at Calcutta, Dr. J. M'CLELLAND, in the fifth volume of the Calcutta Journal of Natural History, has given a reduction of the meteorological register kept at the Surveyor-General's Office, Calcutta, from the 31st of October 1843 to the 31st of October 1844 ; from his paper the following extracts are made in a condensed form :—

| | Wind at noon. | | | |
|-----------------|---------------|------|------|------|
| | N.W. | S.W. | S.E. | N.E. |
| 1843. | | | | |
| November | 26 | 1 | 0 | 3 |
| December | 24 | 0 | 0 | 5 |
| 1844. | | | | |
| January | 25 | 0 | 3 | 3 |
| February | 23 | 2 | 0 | 4 |
| March..... | 1 | 20 | 8 | 0 |
| April | 0 | 26 | 3 | 1 |
| May | 0 | 24 | 4 | 3 |
| June | 5 | 21 | 3 | 2 |
| July | 1 | 17 | 11 | 1 |
| August | 1 | 17 | 13 | 0 |
| September | 4 | 19 | 5 | 2 |
| October | 4 | 7 | 6 | 3 |
| Year | 114 | 154 | 56 | 27 |

As these observations are only for noon in each day of the year, they are of little value; supposing them however to be typical of the variations of the wind, there is a certain accordance with the winds at Madras and Bombay in the respective months of the year, with respect to the winds blowing between the points S. and W., and with Bombay in the winds blowing between the points N. and W., excepting that the latter cease to prevail in March in Calcutta, but do not relax in Bombay until June. The winds of the S.W. monsoon would appear to commence in March in Calcutta, but not until May in Bombay. The tendency of the N.W. and S.W. winds in Calcutta, however, is rather to blow, the former from the N. and the latter from the S., than from intermediate points; out of 353 observations, the wind blew sixty-eight times from the N. and ninety-one times from the S., while the N.W. blew only thirty-four times and the S.W. wind only forty-two times. Judging from the Table, Calcutta is little affected by the winds of the N.E. monsoon. There is only a single instance of "no wind" at noon during the whole twelve months.

The following Table shows the direction of the wind at six different hours, and the relative duration of each wind throughout the year:—

| | N. | N.W. | W. | S.W. | S. | S.E. | E. | N.E. | Calm. | No. of observations. |
|--|------|------|-----|------|------|------|------|------|-------|----------------------|
| Sunrise | 32 | 16 | 7 | 19 | 68 | 29 | 25 | 20 | 137 | 353 |
| 9 ^h 50 ^m A.M. | 59 | 29 | 42 | 49 | 75 | 34 | 23 | 37 | 3 | 351 |
| Noon | 58 | 34 | 53 | 42 | 90 | 19 | 29 | 26 | 1 | 352 |
| 2 ^h 40 ^m P.M. | 52 | 40 | 58 | 27 | 105 | 20 | 20 | 24 | 6 | 352 |
| 4 ^h P.M. | 53 | 42 | 45 | 36 | 93 | 34 | 31 | 12 | 6 | 352 |
| Sunset | 56 | 18 | 11 | 23 | 116 | 23 | 17 | 9 | 78 | 341 |
| Total | 310 | 179 | 216 | 190 | 536 | 150 | 145 | 118 | 231 | 2101 |
| Proportion of each..... | 51.6 | 29.8 | 36 | 32.6 | 89.3 | 26.5 | 24.1 | 19.6 | 38.5 | 350 |

From this Table the S.W. monsoon, which at Bombay has a disposition chiefly to

blow half a point to the westward of W.S.W., at Calcutta blows chiefly from the S., and the prevailing N.W. wind of Bombay becomes a northerly wind in Calcutta. The Table shows that almost the only hours of calm are at sunrise and at sunset.

Winds at Mahabuleshwur.

At Mahabuleshwur, at 4500 feet above the sea-level, the following is the mean monthly direction of the wind, as given by Dr. MURRAY in a synoptical view of fifteen years' observations:—

| | Direction. | Force. |
|-----------------|----------------|-----------|
| January | Easterly. | Moderate. |
| February | E.N.E., N.N.W. | Moderate. |
| March | N.E., N.N.W. | Moderate. |
| April | N.E., N.N.W. | Moderate. |
| May | N.E., N.N.W. | Moderate. |
| June | W.S.W. | Moderate. |
| July | W.S.W. | High. |
| August | W.S.W. | High. |
| September | W.S.W. | Moderate. |
| October | Variable. | Light. |
| November | Easterly. | High. |
| December | Easterly. | High. |

From the generalities in the Table, it would not be safe to deduce any normal conditions from comparisons with the wind tables of Madras, Calcutta or Bombay. In the months of January, November and December, Mahabuleshwur would appear to share more largely in the easterly winds of Madras than in the N.W. winds of Bombay in those months; but in February, March, April and May, and the rest of the year, the station would appear to have much the same winds as prevail at Bombay. Its elevated position, therefore, does not remove it from the periodic currents of air of a lower level. Even Dodabetta, at its great elevation of 8640 feet, is partly subject to the periodic winds of Madras and Bombay, at least as far as one year's record of observations recorded *hourly* from OSLER'S anemometer enables us to judge.

Winds at Dodabetta.

| | N.W. | S.W. | S.E. | N.E. |
|-----------------|------|------|------|------|
| 1847. | | | | |
| February | 5 | 0 | 17 | 6 |
| March | 4 | 0 | 2 | 25 |
| April | 7 | 3 | 2 | 18 |
| May | 3 | 8 | 2 | 18 |
| June | 4 | 26 | 0 | 0 |
| July | 18 | 13 | 0 | 0 |
| August | 27 | 0 | 1 | 3 |
| September | 21 | 5 | 0 | 4 |
| October | 9 | 0 | 12 | 10 |
| November | 5 | 7 | 3 | 15 |
| December | 6 | 0 | 8 | 17 |
| 1848. | | | | |
| January | 2 | 0 | 16 | 13 |
| Year | 111 | 62 | 63 | 129 |

The winds of the S.W. monsoon, however, terminate in July instead of October. This is the more remarkable, as Dodabetta lies between Madras, where these winds are the prevailing winds of May, June, July, August and September, and Bombay, where the same winds prevail in the same months. It is probable, therefore, that Dodabetta is situated just above the upper surface of the stratum of wind and aqueous vapour which supplies the S.W. monsoon to Western India, and therefore has comparatively a small supply of rain from this source. But it is not situated (although on the western coast) above the stratum of wind and aqueous vapour which supplies the Coromandel coast during the N.E. monsoon, as it has the same prevailing winds between the N. and E. points in the same months as at Madras, from October to February, when the N.E. ceases at Madras, but continues at Dodabetta until late in May. The *prevalence* of winds from points between N. and W. in the months of July, August and September, is peculiar to Dodabetta: neither Mahabuleshwur, at 4500 feet, nor Madras, Bombay nor Calcutta has similar indications. However, as this so-denominated N.W. wind very frequently blows from only one or two points to the northward of west, the wind may belong to the monsoon of Western India, local physical circumstances having given it a slant. On the whole it may be said, that the peninsula of India, in its length and breadth and the atmosphere over it to the height of nearly 9000 feet, is subject to periodic winds; but at widely separated places, varying a point or two from the apparent normal winds, and commencing or terminating a week or two earlier or later. May, June, July, August and September have prevailing winds from points between W. and S.; October, November, December, January and February have prevailing winds from points between N. and E.; February, March and April, at Madras, have a prevailing wind from points between S. and E., as opposed to Bombay, where the wind in those months prevails from points between N. and W., with rare instances of a S.E. wind; while at Calcutta the N.W. wind terminates in February; but a series for years of hourly observations, like those at Madras, are necessary to give that confidence which cannot be given to deductions from the meteorological data at present available from India.

It is usually understood that very high winds materially depress the barometer, but the records at Dodabetta do not support this view. On the 17th and 18th of April 1847, the wind blew with a mean pressure of 21 lbs., and 14 lbs. respectively upon the square foot; but the barometer only fell from 21·955 on the 16th to 21·917 on the 17th, and rose to 21·984 on the 18th; and there was a maximum pressure from the wind on the 17th at one time of 35 lbs. 26th of May, maximum wind 28·5 lbs., barometer not affected more than 0·010 inch; 12th of June 30 lbs., 26th of July 32 lbs., 10th of September 35 lbs., and 14th of October 22 lbs.; but these pressures of the wind had little or no effect upon the barometer.

Fogs.

In the Madras observations there is not any mention made of fogs; and Captain LUDLOW of the Madras Engineers, who recorded the observations, tells me that fogs are almost unknown at Madras, the nearest approach to a fog being an occasional mist on the ground, not visible more than 3 feet above the surface.

| | Madras. | Bombay. 1843. | Calcutta, 1843-44. | Mahabuleshwur, 15 years. | Dodabetta, 1847-48. | |
|-----------------|---------|------------------|-----------------------|-----------------------------|---------------------|------------|
| | Fogs. | Fogs. | Fogs. | Fogs. | Fogs. | Dense fog. |
| January | 0 | 0 | 5 | 0 | 0 | 5 |
| February | 0 | 0 | 3 | 0 | 11 | 9 |
| March | 0 | 0 | 4 | 0 | 4 | 0 |
| April | 0 | 0 | 4 | 0 | 1 | 4 |
| May | 0 | 0 | 0 | Foggy last half. | 6 | 1 |
| June | 0 | 0 | 0 | | | |
| July | 0 | 0 | 1 | Continued dense fogs. | 2 | 9 |
| August | 0 | 0 | 0 | | | |
| September | 0 | 0 | 0 | Frequent light fogs. | 2 | 15 |
| October | 0 | 0 | 1 | | | |
| November | 0 | 0 | 0 | 0 | 3 | 26 |
| December | 0 | 0 | 2 | 0 | 1 | 16 |
| Year | 0 | 0 | 20 | 0 | 53 | 136 |

At Bombay there are not any records of fogs in the hourly observations for 1843 nor 1844, but Dr. BUIST informs me that mists are of regular occurrence in March; they begin early in February and continue for five or six weeks. They disappear after sunset, and are slightest from sunrise to noon*. At Calcutta, from Dr. M'CLELLAND'S Report, there were only twenty instances in 1843-44, almost entirely at sunrise. At Mahabuleshwur, from the latter end of May until the middle of October, there is almost a continued fog with deluges of rain. At Dodabetta the prevalence of fogs is very remarkable, there being no less than 136 records of dense fogs and 53 of light fogs during the year. Of the dense fogs 52 occurred at 9^h 40^m A.M. and 85 at 3^h 40^m P.M.; 27 light fogs at 9^h 40^m A.M. and 25 at 3^h 40^m P.M.

Electricity.

I have not any data of a character to enable me to speak satisfactorily on the subject of the electric state of the air at the several stations.

I conclude with a rapid analysis of the preceding Tables.

In my paper published in the Philosophical Transactions in 1835 upon the Meteorology of the Deccan, I arrived at the following conclusions:—That HUMBOLDT was mistaken in supposing, upon the authority of HORSBURGH, that the diurnal atmo-

* I presume Dr. BUIST means misty and comparatively semi-transparent *heated* air, as distinct from fogs.

spheric tides were suspended during the monsoon in Western India. The fact was also unquestionably established of the existence of four atmospheric tides within twenty-four hours,—two diurnal and two nocturnal, each consisting of a maximum and minimum tide, and the occurrence of these tides within the same limit hours as in America and Europe; the greatest mean diurnal oscillations taking place in the coldest months, and the smallest tides in the damp months of the monsoon in the Deccan, whilst at Madras the smallest oscillations were in the hottest months: it was shown also that these tides took place regularly without a single instance of interruption, whatever the thermometric or hygrometric indications might be, or whatever the state of the weather, even storms and hurricanes only modifying and not interrupting them. The anomalous fact was also shown of the mean diurnal oscillations being greater at Poona, at an elevation of 1823 feet, than at the level of the sea, in a lower latitude at Madras or Bombay, while at an elevation greater than Poona, the mean diurnal oscillations were *less* than at Poona. It was shown also that the seasons did not affect the limit hours of the tides; but it was shown at the same time that the turning-points of the tides were sometimes irregular; that a tide flowed for a longer or shorter period, and that there were numerous cases of a stationary state of the atmosphere at the hours when the tides should turn. It was shown that the maximum mean pressure of the atmosphere was greatest in December or January, gradually diminished to June, July or August, and subsequently increased to the coldest months. The trifling daily and annual range of the barometer, compared with the ranges in extra-tropical climates, was shown; also the more limited annual range of the thermometer in the Deccan than in Europe, but the existence of a greater daily range; the maximum mean temperature was in April or May, and then gradually declined to the coldest months; very considerable differences in the dewing-points within very narrow areas were shown; dew being frequently local and occurring under anomalous circumstances, and the great contrast between the dewing-points, on the sea-coast at Bombay and in the Deccan, was pointed out; the rain in the Deccan was not more than 28 per cent. of the quantity that fell in Bombay; the winds principally westerly and easterly, rarely from due north or south; and finally, the rarity of fogs was stated.

It is very satisfactory to find in the discussion of the meteorological observations in the present paper, from a very extended area, from different heights and from observations, some of which are hourly, and which run through several years at the same station, that after an interval of twenty years the accuracy of the former deductions should be established almost to the letter; but as some of the observations now discussed were from hourly records, continued through considerable periods of time, an opportunity has been afforded of investigating abnormal conditions, which the former limited number of diurnal observations did not permit; and from these sources a rapid review of what appear to be normal and abnormal conditions is now appended.—1st. The annual and daily range of the barometer diminishes from the sea-level up to

the greatest height observed, 8640 feet at Dodabetta, from a mean annual and mean daily range at Madras of 0·735 and 0·122 to 0·410 and 0·060 at Dodabetta;—the annual range would appear to increase, about and beyond the northern tropic, as the annual range at Calcutta (not by hourly observations) is 0·911: but the diurnal range is somewhat less (0·115) than at Madras. At no one of the places of observation, even taking the maximum pressure of one year with the minimum pressure of another year, does there appear to have been a range of pressure equivalent to an inch of mercury; nevertheless in the Cyclones, or rotatory storms, there occurs at times a range of pressure of nearly 2 inches of mercury within forty-eight hours; but it is shown from a comparison of the simultaneous records on board ship, where these great depressions were noted, with the records at the observatories on shore, that the great depressions occurred within very limited areas.

I had formerly shown that the times or turning-points of ebb and flow (if the terms be permitted) of the aërial ocean were occasionally retarded or accelerated, although the means fixed the turning-points within certain limit hours; but I was not aware that in the ebb or flow of the four daily tides, they ever retrograded or halted in their onward or retiring course. The hourly observations now satisfy us that abnormal conditions are of no infrequent occurrence,—that the tides at times flow or ebb for four, five, six or even seven and eight hours*,—that frequent instances occur of retrograde movements for short periods of time, as if the tide had met with a check and been turned back; and at the turning-points there are numerous instances of the atmosphere being stationary for a couple of hours.

The maximum pressure of the atmosphere is in the coldest months, December or January, but the minimum pressure is not in the hottest months, but in June or July. The barometric readings, when protracted †, show a gradual curve from December or January descending to June or July, and then ascending again to December or January, there being an occasional interruption in October or November; and as the curves at Madras, Bombay and Calcutta correspond, and as Madras has no S.W. monsoon, while Bombay has a S.W. monsoon, and as Bombay is destitute of the N.E. monsoon of Madras, it would appear that the general movements of the mass of the atmosphere are little influenced by any conditions of its lower strata; but the curve of pressure would seem to have some relation to the sun's place in the ecliptic.

The normal conditions of daily temperature are, that it is coldest in India at sunrise, and hottest between the hours of 1 and 3 P.M.; but the preceding tables show many aberrations from this rule. The regular increment or decrement of mean monthly heat from the maximum or minimum period is somewhat remarkable, as the curve is independent of the S.W. monsoon at Bombay and the N.E. monsoon at Ma-

* One instance at Aden of nine hours!

† To that very able and zealous meteorologist, Dr. BUIST, LL.D. of Bombay, I am indebted for the protracted curves of pressure of the barometer appended to this paper. Plates XVII. XVIII. XIX. XX.

dras ; and the passage of the sun twice over both places does not derange the curve. The anomalies of the annual mean temperatures of Madras, Bombay, Calcutta and Aden, not diminishing with the increase in the latitude of the respective places, are pointed out, and numerous instances are given of the very great power of the slanting rays of the sun beyond the tropic. As is the case with the barometric, so do the heat tables indicate that the annual and daily ranges of the thermometer diminish with the elevation of the place of observation above the sea-level, the elevated table-land of the Deccan however being an exception to this rule. At Mahabuleshwur, at 4500 feet, the temperature of *the air* was never below 45° with a maximum and minimum thermometer ; and at Dodabetta the temperature of *the air* was never below $38^{\circ}5$; nevertheless at both places ice and hoar-frost were frequently found on the ground at sunrise, resulting from the separate or conjoined effects of radiation and evaporation. I have already stated that I do not attach much value to the readings of the wet bulb, owing to the various sources of error in the instrument itself, and to the manifest sources of error in the existing theoretical formulæ for giving a numerical value to its readings to fix the tension of vapour in the atmosphere for the determination of the dew-point. No doubt the dew-points obtained by means of the wet bulb have a certain relation to the truth ; and in some favourably concurring conditions may be as proximate to the truth as dew-points would be, obtained by direct means ; but the elaborate experiments of REGNAULT show that in a calm in the open air or in a chamber, the wet bulb surrounds itself with its own humid atmosphere, and with a breeze blowing upon it the temperature of the wet bulb falls or alternates as the wind blows more or less rapidly upon it. Moreover, Professor ORLEBAR points out a source of error to which no doubt all the observations in India were more or less subject, namely, the proximity of the dry bulb to the wet bulb, and the cold from the latter in consequence depressing the temperature of the dry bulb, two, three, or more degrees below the temperature of the air, necessarily producing fallacious results. Making allowance for the defects of DANIELL'S hygrometer, the dew-points obtained by its means are infinitely more worthy of confidence than those obtained by means of the wet bulb. On the whole, I would not venture to say more with respect to normal conditions of moisture in India, than that the air of the sea-coast has always a much greater fraction of saturation than the lands of the interior, and that the elevated plateau of the Deccan is periodically subject to very great degrees of dryness.

The rain-tables are so extensive that it will only be necessary to point out some unexpected phenomena connected with the distribution of rain. It is found both on the sea-coasts and on the table-lands of the Deccan, that within very limited areas, the differences in the fall of rain may be very great. With nine rain-gauges employed in the small island of Bombay in the months of June and July, in the monsoon of 1849, the quantity collected in the different gauges ranged in July from 46 inches to 102 inches, and in June from 19 inches to 46 inches. At Sattarah, with three rain-

gauges within the distance of a mile, they differed in their contents several inches from each other ; and at Mahabuleshwur and Paunchgunny, nearly on the same level, the latter place being only eleven miles to the eastward of the former, the difference in the annual fall of rain was respectively 254 inches and 50 inches ! The normal conditions are, that there is a much greater fall of rain on the sea-coasts than on the table-lands of the Deccan, but that the Ghâts intervening between the coasts and the table-lands have three times the amount of the fall on the coasts, and from ten to fifteen times the amount of the fall on the table-lands of the interior ; the paucity of the fall of rain at Cape Comorin and in the mouths of the Indus would also appear to be normal conditions.

The Tables must be referred to for the winds ; the normal states are those of the S.W. and N.E. monsoons, and the influence of the latter is periodically felt at the height of 8640 feet, which height would appear just at the upper surface of the stratum of air constituting the S.W. monsoon ; but hourly observations for lengthened periods of time are necessary from Dodabetta, to determine what really are the periodical winds at that height. From the points other than those between S. and W., and N. and E., there is also at the several stations a certain amount of periodicity in the winds ; the winds that are common to different stations having only a slant more or less at the different stations ; for instance, the S.W. and N.W. winds of Bombay blowing in the summer months in Calcutta incline rather to be S. and N. winds, than S.W. and N.W. winds ; but to be enabled to speak with any precision upon this branch of the meteorology of India, and indeed upon most other branches with a comprehensive and philosophical object, hourly observations are necessary,—simultaneously taken with previously compared instruments by zealous observers ; and having the records in a form common to all the observers, so as to admit of rigid comparisons :—when this is done, not only in India but in Europe, meteorologists will be in a better condition to generalize and propound normal conditions, than the state of our knowledge at present would justify, for it must be borne in mind that “Error latet in generalibus.”

The Plates referred to in the preceding paper are numbered XVII. XVIII. XIX. XX.

XVI. *On the PELOROSAURUS ; an undescribed gigantic terrestrial reptile whose remains are associated with those of the Iguanodon and other Saurians in the Strata of Tilgate Forest, in Sussex.*

By GIDEON ALGERNON MANTELL, *Esq.*, LL.D., F.R.S., F.L.S.,
Vice-President of the Geological Society, &c.

Received November 22, 1849,—Read February 14, 1850.

I HAD for a long while entertained the idea that among the fossil remains collected from the Wealden deposits of the South-East of England, there were indications of an enormous Lizard entirely distinct from the Iguanodon, Megalosaurus, Cetiosaurus, and other genera which have been named and more or less accurately determined ; and I have at length obtained such evidence in support of my opinion, as induces me to submit to the Royal Society the data which appear to establish the existence of a terrestrial reptile contemporary with the Iguanodon, and which equalled, if not surpassed in magnitude, that colossal herbivorous Saurian.

I shall not on the present occasion enter upon those minute anatomical details which are indispensable for the solution of many of the difficult problems which but too often perplex and bewilder the palæontologist, but content myself with faithful descriptions and figures of such facts as will suffice to establish my proposition ; in the hope that these guesses at truth, which recent investigations have suggested to my mind, may serve to direct future labourers in the right path of inquiry, and tend to enlarge our knowledge of that remarkable fauna which prevailed in the islands and continents of the Cretaceous, Wealden, and Oolitic ages.

The occurrence of very large isolated vertebræ, and portions of femora with medullary cavities, indicating animals of terrestrial habits, and of great size, and which, though assigned to the Cetiosaurus, could not properly be included in a genus of aquatic marine reptiles with solid bones like the Cetaceans, first suggested to me the probability of there having existed another genus of Saurians contemporary with those previously mentioned, and to which some of the supposed Cetiosaurian remains might belong. This idea, though vague, seemed to offer an explanation of certain discrepancies between some of my statements and those of other cultivators of this branch of comparative anatomy.

The stupendous humerus or arm-bone of a terrestrial reptile from the strata of Tilgate Forest, in Sussex, which I have now the honour to place before the Royal Society, will, I believe, establish the correctness of that opinion.

This splendid fossil was obtained from the locality in which was situated the

quarry represented in the frontispiece of my work on the Geology of the South-East of England, and that yielded to my early researches the teeth of the Iguanodon and numerous other highly interesting remains. The bone was imbedded in the fawn-coloured sandstone that prevails in the Wealden of that part of Sussex, at the depth of 25 feet beneath the surface of the soil. The distal part of the bone, to the extent of 2 feet, was discovered in 1847, by Mr. PETER FULLER of Lewes, and some months afterwards the middle portion was found at a higher level; a line of fault having traversed the rock and imbedded bone, and occasioned the subsidence of the portion previously met with. At length other fragments were discovered and extricated from the rock, and the whole replaced and cemented together in the admirable state in which the fossil now appears, by the intelligent collector in whose possession I had, a few weeks since, first the gratification of seeing this unique and stupendous relic from the Weald of my native county*.

This bone is the right humerus, and bears a closer resemblance in its general character to the analogous element in the Crocodile, than to that of the Lacertians. It is $4\frac{1}{2}$ feet long, and 32 inches in circumference at the distal extremity. It is in the ordinary state of mineralization of the bones from the Wealden sandstones, being of a rich umber colour, and very heavy from an impregnation of oxide of iron. The surface presents a smooth appearance, but upon close inspection is found to be finely striated: it evidently belonged to an animal arrived at maturity, but not aged †.

The inferior or distal end, and nearly three-fourths of the shaft, are perfect; but a considerable part is wanting on each side the proximal extremity. Fortunately the base of the salient deltoid process, so characteristic of the humerus in the Crocodiles, is well-defined (Plate XXI. fig. 1^b c), and affords grounds for supposing that the upper part, which is deficient, did not materially differ from the recent type.

The transverse fracture through the middle of the shaft (Plate XXI. fig. 1^a f) has been left disunited, to show the large medullary canal which is filled up with concreted sand; as is usually the case in the long bones of the Iguanodon from the same locality.

The thickness of the wall of the shaft at this section (Plate XXI. fig. 1^e) is 1 inch; the transverse diameter of the medullary cavity 3 inches. Mr. FULLER informs me that the canal extended to within one-third of the head of the bone, as in the femur of the Iguanodon.

The fossil, in its general form, is straighter than the humerus of the Crocodile, and the depressions between the condyles, both anteriorly and posteriorly, are relatively shallower. The surface for articulation with the fore-arm (Plate XXI. fig. 1 b) is

* I cannot refrain from expressing my warmest thanks to Mr. FULLER, for the gratifying compliment paid me (though a personal stranger) as the original explorer of the Geology of Sussex, in allowing me to possess this interesting fossil, although he had previously refused several liberal offers.

† Thin sections of the bone exhibit under the microscope the intimate structure beautifully preserved; the bone-cells, and Haversian canals, are as distinct as in recent bones.

smoother and more uniform, but as the epiphyses are wanting, and both extremities of the bone somewhat abraded by attrition, I am led to conclude that in the recent state, the radio-ulnar articulation must have closely resembled the crocodilian type.

In the posterior aspect (Plate XXI. fig. 1^b), the double bend or curve so strikingly conspicuous in the shaft of the crocodilian arm-bone, is wanting; the deltoid ridge (Plate XXI. fig. 1^b c) commences much lower down, and above the fractured end of this process (fig. 1^b c) the bone expands into the wide flattened head, for articulation with the glenoid socket, formed by the union of the coracoid and scapula. Although the general character of the fossil corresponds in so many respects with that of the Crocodile, yet there are such marked discrepancies, that I have not ventured to introduce an outline indicative of the probable form of the parts that are deficient; for there is ample space for the commission of important errors in such a substitution, which might form a stumbling-block to future observers.

To facilitate comparison I have subjoined figures of the right humerus of the recent Gavial, and of the Iguanodon, and Hylæosaurus, reduced to an uniform scale: the arm-bone of the Gavial belongs to a skeleton 18 feet long, in the museum of that eminent physiologist, my friend Dr. ROBERT GRANT.

It will be seen at a glance that the enormous bone under consideration differs essentially from the humeri of all the Saurians with whose remains it was found associated. The large medullary cavity at once separates it from the bones referred to the Polyptychodon and Cetiosaurus; for in these animals the long bones are composed of "coarse cancellous tissue without any trace of medullary cavity*."

These data appear to me sufficient to warrant the establishment of a new genus for the colossal air-breathing reptile to which this remarkable humerus belonged, and I propose the name of *Pelorosaurus*† to indicate the enormous magnitude of the original.

I now pass to the consideration of other parts of the skeleton, or, to express myself more correctly, of certain detached and isolated bones found in the same quarry with the gigantic humerus, and which, for reasons to be stated in the sequel, may with greater probability be assigned to the *Pelorosaurus*, than to any other of the colossal reptiles obtained from the Wealden deposits.

Anterior Caudal Vertebræ of the Pelorosaurus, Plate XXII. and Plate XXIV. and XXV.

The vertebræ which I would assign to the *Pelorosaurus* with but little hesitation, are four anterior caudals of a very remarkable character, which I found many years since in the same stratum as the humerus above described, and at the distance of but a few yards. They were firmly imbedded and lying in various positions in a

* Reports on British Fossil Reptiles, 1841, p. 102. I have a series of bones from Brook in the Isle of Wight, through the kindness of my distinguished friend Sir R. I. MURCHISON, proving the existence of Cetiosaurs in the Wealden; all the long bones are destitute of a medullary cavity.

† Πέλωρ *pelor*, monster, unusually gigantic.

large block of sandstone, and I succeeded, after much labour, in clearing them from the stone with their processes nearly entire; in the progress of my task a chevron bone of the crocodilian type, 10 inches long (Plate XXII. fig. 8), was laid bare and extricated.

When these splendid fossils were first discovered, I referred them to the Iguanodon; subsequently they were named by Professor OWEN *Cetiosaurus brevis**; and lastly, Dr. MELVILLE and myself, in my Memoir on the Iguanodon †, suggested the necessity of adopting a different specific appellation, and proposed that of "*Conybeari*;" we were unwilling to remove them from the genus *Cetiosaurus*, till corroborative evidence was obtained to justify the change.

The description of these vertebræ in detail will be found in the British Association Reports for 1841 (p. 97), and by Dr. MELVILLE in the Philosophical Transactions, 1849 (p. 296); but without figures no adequate idea can be given of the originals ‡. I have therefore annexed delineations on a reduced scale, $\frac{1}{4}$ linear, Plate XXII., and two views of the largest vertebra $\frac{5}{8}$ ths the natural size, Plate XXIV. and XXV. I have been induced to add the two last drawings in order that the subject may be fully comprehended.

These vertebræ are distinguished by the subquadrangular form of the articulating facets of the centrum or body, and the relative shortness of the antero-posterior diameter (Plate XXII. fig. 7). The largest is $7\frac{1}{2}$ inches in the transverse, and $6\frac{3}{4}$ inches in the vertical diameter of the anterior face, and but 6 inches in the posterior: the length or antero-posterior dimension is but $3\frac{1}{2}$ inches. The height to the top of the spinous process is 13 inches. The diameter of the neural canal, for the spinal marrow, is 2 inches. The other three bones are somewhat smaller; the most distal being only 6 inches transversely.

These vertebræ are slightly concave in front, and almost flat behind; the upper part of the anterior face being the deepest, as shown in Plate XXII. fig. 5^a. The sides of the body are concave, both lengthwise and vertically, with a transverse median convexity, as seen in Plate XXII. fig. 5^a.

The inferior surface of the centrum (Plate XXII. fig. 6) is slightly concave in its antero-posterior diameter, and divided by a longitudinal sulcus into two ridges, whose terminations obscurely indicate the position of the hæmapophysial articulations. It is noticeable, that in vertebræ of such magnitude, well-defined articulating spaces for the chevron bone are not present.

The neural arch presents the most peculiar characters; it is large, and anchylosed to the anterior half of the upper surface of the centrum; the posterior part of which is left free, as shown in fig. 5^c and 7, Plate XXII. The anterior oblique processes

* These vertebræ and the chevron bone, are placed in the same case as the bones of the Iguanodon, in the Gallery of Organic Remains of the British Museum.

† Philosophical Transactions, 1849, p. 297.

‡ Sir J. G. DALYELL very properly remarks, that "delineation should be the inseparable accompaniment of description in natural history."

(Plate XXII. fig. 5^a, *g*, *g*) project directly forwards, and advance over the exposed part of the body of the contiguous vertebra (Plate XXII. fig. 7); as there are no posterior oblique processes, the anterior are received in depressions on each side the spinous process (see Plate XXII. fig. 5 and 7 *h*, *h*). The transverse processes (*f*, *f*) are very strong and short, and project at nearly right angles from the body; the spinous process (*e*) is short and thick.

In Plate XXII. fig. 7, the four vertebræ are represented in a consecutive line, for the purpose of explaining the mode of articulation above described, but it is doubtful whether the two posterior bones are in their natural position; it seems probable that there was an intermediate vertebra between the second and third, and between the third and fourth, so that two more would be required to complete the series. The hæmapophysis or chevron bone, Plate XXII. fig. 8, is obviously too small for articulation with either of the above vertebræ; it is however important, as showing the crocodilian modification of this caudal element of the gigantic original.

Median caudal vertebræ, Plate XXIII. fig. 1 and 3, and Plate XXVI.—From the same quarry I obtained two vertebræ belonging in all probability to the middle part of the tail; and which, though scarcely large enough to appertain to the same individual as the above anterior caudal, present such characters as might be expected in the more distal part of the same region. The centrum of the largest specimen (Plate XXIII. fig. 10 and Plate XXVI.) is $7\frac{1}{4}$ inches long; the transverse diameter of the anterior face is 5 inches, the vertical $4\frac{1}{4}$ inches; height to the top of the spine $5\frac{1}{4}$ inches. Both the facets of the centrum are slightly concave, and are most deeply excavated in the upper part, as in the large anterior caudals. The neural arch is ankylosed to the anterior half of the body, the posterior part being uncovered. The inferior surface (Plate XXIII. fig. 10^a *c*) is concave antero-posteriorly, and two slightly elevated ridges terminate behind in distinct hæmapophysial surfaces (*k*, *k*), which are $1\frac{3}{4}$ inch apart, and are evidently fitted for articulation with a chevron bone of the type already described (Plate XXII. fig. 8).

Distal caudal vertebra, Plate XXIII. fig. 11.—In referring the unique caudal here figured to the same category as the preceding, I offer the suggestion as only probable. The centrum is of a subcylindrical form, $4\frac{1}{2}$ inches long, and slightly concave on both facets. The most remarkable feature in this bone is the ankylosis or rather confluence of the heads of the chevron bone with the body (Plate XXIII. fig. 11 *j*, *j*), a character common in fishes, but which, I believe, is unknown in reptiles, save in one genus, the fossil animal of Mæstricht, the Mosasaurus, whose occurrence in the English chalk was first ascertained in 1820, by my discovery of two concavo-convex caudals with confluent chevron bones*. The remarks of the illustrious CUVIER on the caudal vertebræ of the Mosasaurus, are in every respect applicable to the specimen under consideration. After mentioning the median caudals as having “à leur face inférieure deux petites facettes pour porter l'os en chevron,” he describes the more

* Geology of the South Downs, Plates XXXIII. and XLI.

distal series which form a great part of the tail; in these “*l'os en chevron n'y est plus articulé, mais sondé, et fait corps avec elles**.”

The structure of the spinal column of the Mosasaurus therefore proves that vertebræ having the chevron bone articulated by two distinct facets (as Plate XXII. fig. 8), may be followed, in a more distal part of the caudal region, by a series with the hæmapophysis ankylosed to the centrum (as in Plate XXIII. fig. 11).

Femora and Tibiæ.—From the Wealden strata of Tilgate Forest, Hastings, and the Isle of Wight, I have seen fragments of the distal extremity of femora with medullary cavities, which, though too imperfect to admit of accurate determination, were obviously those of a gigantic terrestrial reptile, distinct from the Iguanodon and Megalosaurus.

From Sandown Bay, in the Isle of Wight, I have the proximal end of a tibia of enormous size, the circumference of the head of the bone being 34 inches, a magnitude surpassing that required for a tibia to articulate with the largest known femur, and presenting such deviations in form from the tibiæ of the Iguanodon, as to render it highly probable that this bone belonged to the *Pelorosaurus*.

Indications of the Pelorosaurus in the Oolitic strata.—The general accordance of the terrestrial fauna and flora of the Oolitic period, (as proved by the remains of land animals and plants imbedded in the fluvio-marine deposits of that formation,) with those of the Cretaceous and Wealden, renders it probable that vestiges of most, if not all, of the genera and species of land reptiles that occur in the latter will be found in the former strata. Thus as the Iguanodon, Pterodactyles, with Clathrariæ and Dracænæ, are found in the Chalk, and the Megalosaurus, with Cycadeæ and Coniferæ, in the Wealden, traces of the *Pelorosaurus* may be expected to occur in the Oolite. To ascertain this fact, I availed myself of the liberal permission of my friend the DEAN OF WESTMINSTER to examine his splendid collection, and I repaired to Oxford and diligently inspected the numerous specimens of Saurian remains which it contains, especially those from the Wealden and Oolite.

To avoid prolixity I will but remark, that among immense quantities of huge vertebræ and bones of the extremities of unequivocally marine Saurians, as proved by the cancellated structure of their centres, and which had been properly referred to Pliosaurus, Cetiosaurus, &c., there are portions of femora, vertebræ, and tarsal phalangeal and ungueal bones, which appear to be distinct from those of any established genus. I refer especially to several caudal vertebræ resembling that from Tilgate Forest (Plate XXIII. figs. 9 and 10), which are probably of the *Pelorosaurus*, and large curved claw-bones, from 4 to 6 inches long. These were found at Chipping Norton, associated with vertebræ, &c. of Cetiosaurus, and were accordingly assumed to belong to the same genus of reptiles.

But the specimens which come more immediately within the scope of this inquiry are portions of femora from Enstone, which appear to differ from those of the Mega-

* Ossemens Fossiles, tome v. p. 327. Edit. 1824.

losaurus and Iguanodon. They belong to a huge terrestrial reptile, in which the *patellar* space is smooth, and not traversed by a deep furrow as in the femur of the latter. The structure of these fossils led me to examine with great care the enormous femur obtained by Mr. STRICKLAND from the Bradford clay at Enslow Bridge, on the Charwell, eight miles from Oxford. This specimen is now affixed to the wall in Dr. BUCKLAND'S museum, at a considerable height from the floor, and therefore cannot be examined with facility. Unfortunately too the bone was found in so shattered a condition that it was necessary to cement its anterior face to a board. The posterior surface pressed flat, the condyles and popliteal space, and the outline of the sides of the shaft, are therefore the only characters now displayed; the proximal extremity or head is wanting. This bone exactly corresponds in length and width with the humerus of the *Pelorosaurus*. The condyloid extremity is the only portion in a normal state. The condyles (so far as I could ascertain from an elevated and inconvenient position on a ladder) are more equal, and wider apart, than in the Iguanodon and Megalosaurus; but the general appearance of the bone is so similar to that of the femur of the Iguanodon when shattered and pressed flat, that until I ascertained there were no indications of a median trochanter on the mesial border of the shaft, I could not convince myself it did not belong to that reptile. There were no visible traces of a medullary cavity, yet it seemed improbable that the shaft of this enormous and strong bone could have admitted of the degree of compression it had sustained, (for the entire thickness did not appear to exceed 3 or 4 inches,) if it was solid as in the *Cetiosauri*: Dr. BUCKLAND entirely concurred in this opinion.

To ascertain this important point I wrote to Mr. STRICKLAND, who very obligingly favoured me with an immediate reply. In answer to my inquiries, Mr. STRICKLAND stated, that upon comparing the femur with that of the Megalosaurus, it was evident that it belonged to a different genus: and he had labelled it "*Cetiosaurus*," from its resemblance to portions of femora and other bones found in the same locality, and so named in the Oxford Museum; and likewise, because in the crushed mass of bony fibre which filled the interior, he did not perceive any traces of a medullary cavity; but it is quite possible, Mr. STRICKLAND adds, "that such a cavity may have existed, though now so much obliterated by compression as to have escaped my observation."

The character of the condyloid extremity, and the general form of this bone, appear to me to separate it from the femur of the marine reptiles, to which it has been referred, provisionally, by this distinguished naturalist; if upon a more accurate examination a medullary cavity should be detected, there will be strong grounds for assigning this gigantic thigh-bone to the *Pelorosaurus*; on the contrary, if the shaft should prove to be solid throughout, the supposed relation of this femur to the humerus previously described, will of course be negatived.

Summary.—From the facts described the following inferences result:—

1st. Upon the evidence of the humerus alone, the existence during the Wealden

æra, of a stupendous terrestrial Saurian, generically distinct from any previously described; this reptile I propose to name *Pelorosaurus Conybeari*.

2ndly. The great probability that the four large anterior caudal vertebræ with the chevron bone, termed *Cetiosaurus brevis* by Professor OWEN, and the two median caudals found in the same stratum as the humerus, and at no great distance from it, belong to the same species; and

3rdly. That certain large bones of Saurians from the oolitic deposits of Oxfordshire, at Enstone and at Enslow Bridge, and hitherto considered as Cetiosaurian, may appertain to the Pelorosaurus.

It may perhaps be expected that some estimate should be given of the probable magnitude of the reptile to which the humerus belonged; but calculations of the length and proportions of the original animal taken from a single bone, or from a few detached bones, can afford but vague and unsatisfactory results. With the view, however, of conveying some idea of the almost incredible bulk of the *Pelorosaurus*, it may be stated, that in the Gavial or Gangetic Crocodile, the length of the humerus is equal to one-eighteenth of the entire length of the animal from the snout to the end of the tail; thus in Dr. GRANT'S specimen the humerus is 1 foot long; the entire skeleton 18 feet. Computed by this standard the length of the Pelorosaurus would be 81 feet, and the girth of its body about 20 feet. But if we assume the length and number of the vertebræ as the scale, we should have a reptile of relatively very abbreviated proportions; but in either case, a Saurian far exceeding in size all living types, and equalling if not surpassing in magnitude the most colossal of the extinct forms.

From what has been advanced, we perceive that every addition to the zoology of the countries that flourished during the secondary geological ages, affords proof of the high development of the terrestrial reptiles, which appear to have enjoyed the same predominance in those ancient faunas, as the large Mammalia in those of the tertiary and human epochs. The trees and plants associated with the remains of the extinct Saurians, manifest by their affinity to existing forms, that the countries in which they grew possessed as pure an atmosphere, as high a temperature, and as unclouded skies, as those of our tropical climes. There are, therefore, no legitimate grounds to support the hypothesis that during the "Age of Reptiles"—the period when the reptilian class most prevailed—the earth was "in the state of a half-finished planet," and its atmosphere too heavy from an excess of carbon, for the respiration of warm-blooded animals! Such an opinion can only have originated from an imperfect view of the phenomena which these problems embrace. There is as great a discrepancy between certain existing faunas and those of modern Europe, as that presented by the Wealden: for example, those of Australia, Tasmania, New Zealand, and the Galapagos Islands.

By a singular coincidence, on the same day that I obtained the humerus of the *Pelorosaurus* from Tilgate Forest, I received from my eldest son in New Zealand, the most interesting collection of the remains of the extinct gigantic birds of those

islands that has reached this country: and I could but think, that had the respective localities and periods of these birds and reptiles,—both of a size far surpassing all other known types of their respective classes,—been interchanged, and the bones of the *Dinornis* of New Zealand referred to the Wealden epoch, what speculations would in all probability be hazarded to account for physical conditions assumed to be required by so marvellous a development in numbers and magnitude of the class Aves, to the almost entire exclusion of the Mammalia!

In attempting to explain the natural records of the ancient physical history of the globe and its inhabitants, by our acquaintance with the physiology, anatomy, and economy, of existing organic beings, we cannot be too often reminded of the caution of the sagacious QUETELET, that “our knowledge and our judgments are in general only founded on probabilities more or less great, which it is very important, but very difficult, to estimate at their just value.”

In conclusion I would beg to remark, that in adding another genus of terrestrial reptiles to those previously established as belonging to the Fauna of the Wealden, I am fully aware of the imperfect manner in which, from various unavoidable causes—especially the pressure of professional duties—my investigations have been carried out. But encouraged in my earliest researches by the illustrious founder of Palæontology, Baron CUVIER, and honoured by the highest award of the Geological Society, I felt reluctant to discontinue researches which no other naturalist seemed disposed to undertake, lest some important additions to our knowledge of the ancient physical condition of the earth and its inhabitants should be unrecorded and forgotten.

Chester Square, Pimlico,
November 1849.

DESCRIPTION OF THE PLATES.

PLATE XXI.

. The figures of this Plate are all on the same scale, which is $\frac{1}{6}$ linear the natural size.

Fig. 1. The right humerus of the *Pelorosaurus Conybeari*, obtained from the strata of Tilgate Forest in Sussex, by Mr. PETER FULLER of Lewes, and now in the possession of the author.

1^a. Anterior view.

1^b. Posterior view.

1^c. Transverse section of the shaft; *m*, the medullary canal filled with fawn-coloured sandstone.

The dimensions of this bone are as follow :—

Length 54 inches.

Circumference of the distal end 32 inches.

Transverse diameter of the same 13 inches.

Circumference of the shaft at the transverse section 17 inches.

————— the fractured end of the deltoid ridge 23 inches.

a. The head or proximal extremity.

b. Distal or radio-ulnar articulation.

c. Deltoid ridge.

d. Inner condyle.

e. Outer condyle.

f. Transverse fracture exposing the section seen in fig. 1^c.

Fig. 2. Outline of the right humerus of a Gavial 18 feet long.

2^a. Anterior view.

2^b. Posterior view.

Fig. 3. Humerus of the Hylæosaurus.

Fig. 4. Humerus of the Iguanodon; from Philosophical Transactions, Part II. 1849, Plate XXXI. fig. 19*.

PLATE XXII.

. All the specimens here delineated are in the British Museum: the figures are reduced $\frac{1}{4}$ linear the natural size.

Anterior caudal vertebræ and chevron bone of the *Pelorosaurus*?

Fig. 5. The largest and most anterior bone of the series.

5^a. Perspective view showing the slightly concave anterior face of the body of the vertebra (*a*), the excavated form of the sides, the anterior oblique processes (*g, g,*) and the spinous process (*e*), with the pits or depressions for the reception of the heads of the oblique processes of the contiguous posterior vertebra (*h*).

5^b. Front view of the same fossil.

5^c. Posterior view, to show the remarkable character occasioned by the absence of oblique processes. The several parts in this and the vertebræ figured in the subsequent plates are thus indicated :—

a. Anterior articulating surface of the body or centrum.

b. Posterior face.

c. Inferior or visceral aspect of the body.

d. Neural arch, or neurapophysis.

* There is a typographical error both in the text and lithograph of this bone in the Philosophical Transactions, *loc. cit.*, as to the scale of the figure; it is marked reduced to $\frac{1}{1\frac{1}{2}}$, it should be $\frac{1}{8}$ linear the natural size.

- e.* Spinous process.
- f.* Transverse process.
- g.* Anterior oblique process.
- h.* Depression on the spinous process, occupying the usual situation of the origin of the posterior oblique.
- i.* Spinal canal.
- j.* Chevron bone or hæmapophysis.
- k.* Hæmapophysial surfaces for articulation with the chevron bone.

Fig. 6. A vertebra seen on the inferior aspect.

Fig. 7. Four anterior caudal vertebræ placed in a consecutive series.

Fig. 8. A chevron bone 10 inches long, found imbedded in the same block of sandstone as the vertebræ.

8^a. Outer aspect.

8^b. Inner aspect.

8^c. Lateral view.



PLATE XXIII.

. The figures are $\frac{1}{2}$ linear the natural size.

Median and distal caudal vertebræ of the Pelorosaurus?

Fig. 9. A median or distal caudal vertebra with two eminences on the posterior end of the inferior aspect of the body, to articulate with a double-headed chevron of the crocodilian type.

9^a. Lateral view.

9^b. Posterior face.

9^c. View of the inferior surface.

k, k. The articulating facets to unite with the chevron bone.

Fig. 10. A larger vertebra of a similar type, obtained from the same locality in Tilgate Forest as the other specimens figured in this memoir, by my friend Capt. LAMBART BRICKENDEN, F.G.S.

10^a. Inferior surface.

10^b. Lateral view.

10^c. Anterior view, showing the neural arch.

Fig. 11. A caudal vertebra with the chevron bone anchylosed to the body, as in the distal caudals of the Mosasaurus.

11^a. Lateral view.

11^b. View of the inferior surface.

PLATE XXIV.

Perspective view of the largest anterior caudal, $\frac{5}{8}$ th the natural size.

PLATE XXV.

Anterior view of the same.

PLATE XXVI.

Perspective view of a median caudal vertebra of the Pelorosaurus, of the natural size; found in the same quarry and stratum as the specimens figured in the preceding Plates; by Capt. LAMBART BRICKENDEN.

XVII. *On a Dorsal dermal Spine of the Hylæosaurus, recently discovered in the Strata of Tilgate Forest.*

By GIDEON ALGERNON MANTELL, *Esq.*, LL.D., F.R.S., F.L.S.,
Vice-President of the Geological Society, &c.

Received June 13,—Read June 13, 1850.

IN the highly interesting and unique specimen of part of the skeleton of the Hylæosaurus discovered by me in 1832, and now preserved in the Gallery of Organic Remains of the British Museum, the most striking peculiarity is a series of large thin angular processes extending nearly parallel with the left side of the vertebral column. These bones vary in length from 4 to 17 inches, and in form from a somewhat obtuse to an isosceles triangle: there are six or seven in a connected line, and several others detached and dispersed in the block. They terminate distally in a blunt apex, and are expanded at the base in the antero-posterior diameter, but unfortunately in every instance the proximal end is so imperfect that their mode of attachment to the other parts of the skeleton is not clearly demonstrable.

From the general resemblance of these processes to the dermal bones imbedded in the surrounding stone, I was induced to consider them as the remains of a dorsal crest formed by a series of erect dermal plates or spines, which extended along the back of the Hylæosaurus, in the same manner as the cartilaginous scaly dorsal fringe in the Iguana; an opinion which appeared to be corroborated by some detached specimens of a similar character that were subsequently discovered*.

Professor OWEN, however, whilst admitting the probability of that suggestion, considered it more likely that the bones in question were abdominal ribs, remarking that “the want of symmetry, and the difference in size and form, in the four succeeding spine-shaped plates, agreed better with the costal than with the dermal hypothesis †.” Mr. BRODERIP and other naturalists have regarded this opinion of Professor OWEN as conclusive ‡.

For reasons fully stated in my former memoirs on the Wealden Reptiles, it appeared to me highly improbable that these spines could have belonged to the costal system. In 1848 I had an opportunity, for the first time, of making sections of a specimen for microscopical examination, and I then found the internal structure to

* A comparison of these spines with the dermal crest of the *Cyclura*, is given in my original memoir on the Hylæosaurus; *Geology of the South-East of England*, 1832.

† *British Association Report on Fossil Reptiles*, by Professor OWEN, 1841, p. 116.

‡ *Zoological Researches*, Chapter on Reptiles.

be identical with that of the dermal scutes of the Hylæosaurus, presenting "long, straight, spicular fibres, decussating each other in all directions, and representing, as it seems, the ossified ligamentous fibres of the original corium*."

At length, after the lapse of eighteen years, I have obtained one of these spines in which the proximal end or base is sufficiently entire to show the nature of its connection with the body of the reptile. This specimen (for which I am indebted to the liberality of Mr. PETER FULLER of Lewes) was found a few weeks since in the same quarry in Tilgate Forest, whence the first discovered skeleton of the Hylæosaurus was obtained; and there is reason to conclude that it may have belonged to the same individual, for several detached dermal scutes and spines of corresponding size and character, have from time to time been found in the sandstone near the spot.

This spine, if perfect, would be 15 inches in length; its base or proximal end is of an elliptical form, with a longitudinal median depression, which is bordered by a gentle rounded eminence; the articulating surface has the corrugated aspect that characterizes the ossified dermal scutes of the Hylæosaurus; and a comparison of the base of this spine with that of the unquestionable dermal bones, confirms the correctness of my original interpretation of the nature of these remarkable processes.

In the accompanying drawings the characters of the original are sufficiently defined, to render further description unnecessary.

This fact is of considerable interest, since it demonstrates in the dermal system of the extinct colossal Saurians of the secondary geological æras, a similar exaggerated development to that which prevails in the living diminutive representatives; but while in the existing Lizards the dermal appendages are flexible and cartilaginous, in the fossil reptiles they are rigid osseous spines; the difference arising from the ossification of the ligamentous fibres of the corium in the dermal bones and spines of the Hylæosaurus.

DESCRIPTION OF THE PLATE.

PLATE XXVII.

- Fig. 1. Lateral view of the dorsal dermal spine of the Hylæosaurus; reduced to one-half linear.
- Fig. 2. View of the articulating surface of the base.
- Fig. 3. Magnified view of a portion of the internal structure, showing the decussating ossified fibres of the corium, the bone-cells, and the Haversian canals, as exposed in a section seen by transmitted light.

Chester Square, Pimlico,
June 1850.

* See Wonders of Geology, 6th edition, p. 437.

XVIII. *Supplementary Observations on the Structure of the BELEMNITE and BELEMNOTEUTHIS.*

By GIDEON ALGERNON MANTELL, *Esq., LL.D., F.R.S., F.L.S.,*
Vice-President of the Geological Society, &c.

Received November 5, 1849,—Read February 14, 1850.

AS several eminent naturalists have expressed doubts of the correctness of my interpretation of some of the facts described in the Memoir on the Belemnite and Belemnoteuthis, published in the Philosophical Transactions, Part II. 1848, I am induced to lay before the Royal Society the following additional observations in confirmation of the opinions advanced in my previous communication on this subject.

That distinguished naturalist, Mr. J. E. GRAY, has especially controverted my statement that the phragmocone of the Belemnites of the Oxford Clay* possessed a pair of elongated shelly processes, which extended beyond the peristome or upper border of the conical chambered shell; the aperture resembling in this respect that of certain species of Ammonites†. In the recently published “*Catalogue of the Mollusca in the Collection of the British Museum‡*,” Mr. GRAY remarks, “Dr. MANTELL has figured a specimen which appears to have an elongated process on each side, like the processes on the sides of the mouth of certain Ammonites; but on examining his specimen I am very doubtful if this appearance does not arise from an accidental fracture of the upper part of the conical shell.”

Since the publication of my former Memoir, three Belemnites with phragmocones, in which the parts in question are unequivocally manifest, have come under my observation. Two of these interesting fossils are in the Gallery of Organic Remains in the British Museum: the third is in my possession. In addition to these examples, evidence in proof that this structure is normal, and not the result of accident, has been afforded by numerous detached portions of belemnital phragmocones from the Oxford Clay and Lias, which display well-defined vestiges of the expanded bases of these processes: and that eminent palæontologist, Mr. JOHN MORRIS of Kensington, informs me that he has recognized their presence in specimens from various strata and localities.

In the three examples above mentioned, that part of the process which extends

* The species of Belemnite to which my observations refer, Mr. MORRIS informs me is *Belemnites Puzosianus* of D'ORBIGNY, *B. Owenii* of Mr. PRATT.

† Philosophical Transactions, 1848, Plate XIII. fig. 3. p. 181.

‡ Part 1, *Cephalopoda Antepedia*, p. 124.

beyond the upper or basilar margin of the phragmocone is well defined; and in each of these specimens the extension of the longitudinal plates or bands may be distinctly traced downwards, almost to the distal end or apex, as a thin nacreous shelly plate, striated longitudinally, and having obliquely divergent lines on the ventral margin.

The finest specimen from Wiltshire in the British Museum (Plate XXVIII. fig. 1), like that discovered by my son*, consists of the osselet or guard (*b*) partially invested by its capsule, with the phragmocone in natural apposition: the latter is shattered and pressed almost flat, but preserves a conical outline, and has on the upper part the *right process* (*e*), which extends 5 inches above the peristome or border of the chambered cone: a portion of the left process is seen at *f*; *c*, denotes the lower termination of the process.

Fig. 2 represents the upper portion of this fossil of the natural size, and so clearly shows the parts described that further detail is unnecessary.

I would particularly direct attention to the evident extension of the base of the process (*x, x, x*) down the phragmocone as a nacreous band or plate finely striated. Under a slightly magnifying power this expansion appears like a thin shelly integument deposited on the external surface of the chambered cone, and is marked with curved diverging lines on the lateral border.

In the former Memoir the number and position of these processes could not be determined with precision; the specimens recently obtained show that there were but two,—one on each side the aperture or peristome,—and these were situated nearer to the dorsal than to the ventral aspect. The siphunculus always occupies the median and ventral side of the phragmocone; and its excentric apex is directed towards the same region, in which is also situated the sulcus of the guard (see Plate XXIX. fig. 5).

In the fragment of a large uncompressed belemnital phragmocone from Lyme Regis, for the loan of which I am indebted to Mr. MORRIS, the relative position of the parts above described is distinctly exhibited, Plate XXIX.: fig. 3, *f, f*, the remains of the lateral processes; *g*, the siphunculus, occupying the ventral aspect; *h*, the dorsal line.

The outline, Plate XXIX. fig. 4, is intended to express concisely the facts described.

With regard to the osselet (the distal solid part of which is generally termed the *guard* or *rostrum*), I would remark, that since my former communication I have inspected many hundred specimens from various localities, and have ascertained that although in detached examples (the ordinary condition in which these fossils occur) the rostrum appears to terminate by a well-defined line at the upper part, yet this is not really the case; for the same radiated structure originally extended upwards, and surrounded and protected the phragmocone as a sheath, and gradually became confluent with the investing capsule or periostricum; probably terminating in a horny flexible integument. A fragment of the receptacle taken from the upper part of a specimen, and which is not thicker than stout paper, is delineated under a mag-

* Philosophical Transactions, 1848, Plate XV. fig. 3.

nifying power of eight diameters in Plate XXIX. fig. 6. In this section are clearly seen the outer integument or periostricum (*a*), the radiated structure of the osselet (*b*), and the shell of the phragmocone (*c*). Among the numerous Belemnites I have examined, *not the slightest trace of an ink-bag or its contents, the sepia*, could be detected.

BELEMNOTEUTHIS.—Some uncompressed examples of the distal end of the phragmocones of this Cephalopod have lately been discovered, which must dispel any remaining doubts as to the generic distinction, first established by the late Mr. CHANNING PEARCE in 1842, being based on natural characters.

The specimen figured, Plate XXIX. fig. 7, appears to me to afford conclusive evidence on the points in dispute. By a reference to my former paper, it will be seen that the longitudinal ridges, which are always present on the distal end of the phragmocone of the Belemnoteuthis, are regarded by those observers who contend that the latter belong to Belemnites, as plaits, or folds, originating from fracture and lateral compression. In the fossil before us these ridges are entire and well-defined; two are situated on the ventral and one on the dorsal region. Fig. 7^a is a transverse section, enlarged four diameters, in which are shown the form of the ridges and the *radiated structure of the solid part of the phragmocone*: I scarcely need observe, that in the true Belemnite the cone is chambered to the extreme apex. These characters will remind the palæontologist of the very analogous organization of the *Beloptera* of the tertiary strata, alluded to in my former memoir*. In fact it is now proved that the Belemnoteuthis (as was originally suggested by Mr. CHANNING PEARCE and Mr. CUNNINGTON) possessed an osselet of a radiated structure containing a chambered siphunculated cone, but without an extended rostrum or guard; thus forming an interesting transition to the Belemnite, from which it is generically distinct†. From the facts before us, our knowledge of the organization of the genus *Belemnites* comprises the following structures:—

1. The investing periostricum or *capsule*, which enveloped the osselet, and extending upwards, constituted the external parietes of the receptacle.

2. The *Osselet*, characterized by its radiated structure, composed of trihedral prismatic fibres, which terminated distally in a solid rostrum having an alveolus or conical hollow to receive the lower portion of the chambered phragmocone, and proximally in a thin cup-like expansion, which became confluent with the capsule, and formed the receptacle for the viscera.

3. The *Phragmocone*, or conical siphunculated chambered internal shell, the apex of which occupied the alveolus of the rostrum, and the upper part expanded into a capacious chamber, from the basilar margin of which proceeded two elongated testaceous processes.

* Philosophical Transactions, 1848, p. 176.

† The *Conoteuthis Dupinianus* of M. D'ORBIGNY, from the Upper Neocomian strata of the Department d'Aube, appears, so far as can be determined by mere description, to approach very closely to the Belemnoteuthis. It is stated to have a long slender osselet, terminated by a chambered cone, but without a guard or rostrum.

Some of the specimens in the British Museum and in my own cabinet exhibit on the space around and between the processes, delicate striæ, apparently produced by the imprint of the muscular fibres of the mantle or other tissues; and these I believe are the only indications hitherto observed of the soft parts of the animal to which the Belemnite belonged.

In fine, the *Belemnite* is characterized by its rostrum and the investing capsule, and its phragmocone chambered to the extreme apex and having a pair of testaceous processes at the basilar margin of the peristome*; while the *Belemnoteuthis* has simply an osselet of a radiated fibrous structure, inclosing a conical chambered shell that terminates distally in a solid obtuse point†. Whether the Belemnite resembled the Belemnoteuthis in possessing an ink-bag, and having a body with eight uncinated arms and a pair of long tentacula, future discoveries can alone determine.

Although this communication may be devoid of interest to those who do not especially cultivate the department of natural science to which this inquiry belongs, it will not I trust be deemed unimportant by the palæontologist, since the new facts herein described tend to remove in some degree the obscurity which veils the original structure of a race of highly organized beings, that swarmed in the seas of every part of the globe‡ during the secondary geological periods, from the Lias to the Chalk inclusive, and which appears to have become extinct with the contemporary Cephalopoda, the Ammonites, at the close of the cretaceous epoch§.

Chester Square, Oct. 1849.

Additional Note.

February 14, 1850.

Since the previous observations were communicated to the Secretary of the Royal Society, I have been so fortunate as to obtain from the Oxford Clay of Wiltshire, a Belemnite in which the two dorsal processes of the phragmocone are more perfectly displayed than in any specimen hitherto discovered (see Plate XXX.).

From the rarity of such fossils, and their extreme fragility and perishable nature,

* I do not mean to aver that similar processes exist in *every species* of Belemnite, for it is probable that, as in Ammonites, there may have been considerable diversity in the form and size of these appendages; and in some species the basilar margin of the peristome may have been destitute of them: my remarks exclusively refer to the species of Belemnites described in the text.

† The facts described in the text are of course directly opposed to the views expressed in the following extract from the Philosophical Transactions for 1844, p. 74: "The association of the spathose guards with crushed phragmocones *identical in structure* with those in connection with the fossil ink-bags and muscular parts."

‡ Belemnites have recently been discovered in limestone in the Middle Island of New Zealand, by my eldest son, Mr. WALTER MANTELL.—See Geological Journal for August, 1850.

§ Belemnites first appear in the Lias, where they suddenly attain their maximum development. Many species abound in the Oolitic or Jurassic formation: in the *Greensand* they are likewise abundant; in the *Galt* there are but two or three small species. In the Chalk strata a modification of the type, termed *Belemnitellæ*, appear, and with these the race seems to have become extinct; at least no traces of its existence have been detected in any newer deposits, save the *Beloptera* of the tertiary previously mentioned. I am not aware that any examples of Belemnoteuthis have been found in the Lias: hitherto I have obtained specimens only from the Oxford Clay and contiguous strata.

it is important to preserve faithful representations taken whilst the specimens are fresh from the stratum, for when the clay contracts by drying, the delicate shelly structure of the phragmocone but too frequently shrivels and flakes off; I know of no means by which this decomposition can be prevented, and am therefore desirous of adding to the illustrations of this communication the accompanying drawing, by Mr. MOUNSEY, of the beautiful fossil above mentioned, in which are shown the elongated processes of the phragmocone in their natural position on each side the dorsal line; the interval between them is occupied by a thin pellicle of a dark integument marked with very fine diverging parallel striæ; this substance is probably the inner lining of the capsule of the sepistaire in a carbonized state, a condition in which animal tissues so often occur in argillaceous deposits.

I likewise annex a drawing of another specimen (Plate XXIX. figs. 9, 10) of the distal termination of the osselet of the *Belemnoteuthis*, in which the alveolus or hollow occupied by the chambered shelly cone is exposed; the cavity is filled with calcareous spar, and is surrounded by a dense fibrous radiated structure, analogous to that of the osselet of the true Belemnite; an additional proof that in the *Belemnoteuthis* this investment is the osselet or guard of the phragmocone. After this evidence, the presumed generic identity of the Belemnite and *Belemnoteuthis* must, I conceive, be abandoned by every accurate observer; consequently the form and structure of the body and arms, and other soft parts of the Cephalopoda to which the Belemnites belonged, have yet to be discovered.

DESCRIPTION OF THE PLATES.

PLATE XXVIII.

Fig. 1. Outline of a remarkably fine specimen of a Belemnite with the phragmocone and its elongated processes, from the Oxford Clay, Wilts. In the British Museum. The length of the original is 22 inches.

Fig. 2. Represents the basilar or upper portion of the above fossil of the natural size.

e. The right, and *f.* the left process.

x, x, x. The base of the process spread over the conical shell of the phragmocone.

PLATE XXIX.

Fig. 3. Part of the phragmocone of a Belemnite from the Lias, in the collection of JOHN MORRIS, Esq.

3^a. Lateral view of a portion of the same, showing the remains of one of the longitudinal processes on the shell of the phragmocone.

Fig. 4. Outline exhibiting all the known parts of the Belemnite in their relative position, the osselet being split asunder longitudinally, and one side removed to show the situation of the alveolus, &c.

Fig. 5. The rostrum of the osselet of *Belemnites Puzosianus* from the Oxford Clay, Trowbridge, Wilts. In this specimen the upper part of the guard is removed and exposes the distal extremity of the phragmocone lying in its natural position in the alveolus. The ventral aspect is delineated to show the form and situation of the sulcus or groove (the characteristic of this species) in that region: the siphunculus is on the front of the phragmocone in this view.

The several parts represented in the above figures are indicated as follow:—

a, a. The pair of elongated processes of the phragmocone.

b. Osselet, rostrum, or guard.

b'. The upward extension of the expanded osselet.

c, c. Siphuncle.

d, d. The phragmocone.

e. Section of the capsule or outer investment of the osselet.

f. The apical or distal termination of the phragmocone.

g. The alveolus or hollow in the rostrum in which the end of the phragmocone is situated.

h. Vertical section of the guard, showing its fibrous and radiated structure.

i. Ventral aspect.

k. Ventral sulcus or groove.

l. Section of the capsule investing the guard.

Fig. 6. Transverse section of a fragment from the upper part of the receptacle of the Belemnite near the base of the process; magnified eight diameters.

In this thin pellicle are seen, *a.* the Capsule; *b.* the radiated fibrous structure of the osselet distinctly visible, though taken several inches from above the line which is usually regarded as the termination of the spathose osselet; *c.* the shell of the phragmocone.

Fig. 7. The apical or distal end of the phragmocone of the Belemnite, showing the ventral aspect, and the pair of ridges: natural size.

7^a. A transverse section of the same, displaying the internal radiated structure of the phragmocone and its solid apex: magnified four diameters.

** The two ventral ridges. This specimen is in my collection.

Figs. 9, 10. The apical portion of the osselet of the Belemnite, exposing the alveolus, or cavity occupied by the apex of the chambered cone, filled with spar, and surrounded by the dense, fibrous, radiated investment, analogous to that of the guard of the true Belemnite: the figures are magnified four diameters.

PLATE XXX.

A Belemnite from the Oxford Clay of Wiltshire, showing the pair of dorsal processes in their natural position: size of the original.

XIX. *On the Algebraic Expression of the number of Partitions of which a given number is susceptible.* By Sir J. F. W. HERSCHEL, *Bart., K.H., F.R.S.*

Received April 18,—Read May 16, 1850.

(1.) BEFORE entering on the investigation which forms the object of this communication, it will be necessary to recall to recollection some general properties of the differences of the powers of the natural numbers, or of the numbers comprised in the general expression $\Delta^m 0^n$, which I have elsewhere demonstrated, as well as to establish certain preliminary theorems by the aid of those properties, which will be useful in the progress of the inquiry. I shall employ throughout the separation of the symbols of operation from those of quantity, as respects Δ and 0 , in the manner followed in my paper “On the Development of Exponential Functions,” published in the *Philosophical Transactions*, vol. cvi. p. 25 (1816), and further extended in its application in my “Collection of Examples of the Applications of the Calculus of Finite Differences,” appended to the translation of LACROIX’S *Differential and Integral Calculus* in 1820*, to which paper and collection the reader is referred for the demonstration of the fundamental properties in question.

(2.) Denoting by $F(x)$ any series of powers of x , such as

$$F(x) = Ax^a + Bx^b + Cx^c + \&c.,$$

and by $f(x)$ any other as

$$f(x) = Px^p + Qx^q + Rx^r + \&c.$$

the series

$$AP.\Delta^a 0^p + AQ.\Delta^a 0^q + BP.\Delta^b 0^p + \&c.,$$

continued till the terms vanish, by reason of the peculiar properties of the numbers $\Delta^a 0^p$ &c., will be abbreviatively represented by

$$F(\Delta)f(0);$$

and the following properties of the differences in question will be either found demonstrated in the works above cited, or may very easily be derived from the formulæ therein given:—

$$(1 + \Delta)^x 0^y = x^y \dots \dots \dots (1.)$$

$$(1 + \Delta)^x F(\Delta) 0^y = F(\Delta)(x + 0)^y \dots \dots \dots (2.)$$

$$(1 + \Delta)^x F(\Delta) f(0) = F(\Delta) f(x + 0) \dots \dots \dots (3.)$$

$$(1 + \Delta)^x f(0) = f(x) \dots \dots \dots (4.)$$

$$\{\log(1 + \Delta)\}^x F(\Delta) 0^y = y \cdot \overline{y-1} \dots \overline{y-x+1} \cdot F(\Delta) 0^{y-x} \dots \dots \dots (5.)$$

$$\{\log(1 + \Delta)\}^x F(\Delta) f(0) = F(\Delta) \left(\frac{d}{d0}\right)^x f(0) \dots \dots \dots (6.)$$

* A separate edition of this collection (now out of print) is in preparation.

(3.) Furthermore, if we observe that

$$1 - (1 + \Delta)^{p+q} = \{1 - (1 + \Delta)^p\} + (1 + \Delta)^p \{1 - (1 + \Delta)^q\},$$

we shall have, by applying each of these operative symbols to $F(\Delta)f(0)$,

$$\{1 - (1 + \Delta)^{p+q}\}F(\Delta)f(0) = \{1 - (1 + \Delta)^p\}F(\Delta)f(0) + \{1 - (1 + \Delta)^q\}F(\Delta)f(p+0); \quad (7.)$$

and therefore

$$\{1 - (1 + \Delta)^p\}F(\Delta)f(q+0) - \{1 - (1 + \Delta)^q\}F(\Delta)f(p+0) = \{(1 + \Delta)^p - (1 + \Delta)^q\}F(\Delta)f(0); \quad (8.)$$

(4.) In the particular case where $F(\Delta) = \frac{1}{\Delta}$, these become

$$\frac{1 - (1 + \Delta)^{p+q}}{\Delta} f(0) = \frac{1 - (1 + \Delta)^p}{\Delta} f(0) + \frac{1 - (1 + \Delta)^q}{\Delta} f(p+0); \quad \dots \dots \dots (9.)$$

and

$$\frac{1 - (1 + \Delta)^p}{\Delta} f(q+0) - \frac{1 - (1 + \Delta)^q}{\Delta} f(p+0) = \frac{(1 - \Delta)^p - (1 + \Delta)^q}{\Delta} f(0). \quad \dots \dots (10.)$$

(5.) Designating by $S(x^n)$ the sum of the n th powers of the natural numbers from 1 to x inclusive, or putting

$$S(x^n) = 1^n + 2^n + \dots \dots \dots x^n,$$

it is demonstrated (Examples, § 6. Ex. 23.) that

$$S(x^n) = (-1)^n \cdot \frac{1 - (1 + \Delta)^{-x}}{\Delta} 0^n = (-1)^n \cdot \left\{ \frac{x}{1} \cdot 0^n - \frac{x(x+1)}{1 \cdot 2} \Delta 0^n + \frac{x(x+1)(x+2)}{1 \cdot 2 \cdot 3} \Delta^2 0^n - \&c. \right\}; \quad \dots \dots (11.)$$

and again, in § 8, Exp. 11 of the same work, that

$$S(x^n) = (1 + \Delta) \cdot \frac{(1 + \Delta)^x - 1}{\Delta} 0^n. \quad \dots \dots \dots (12.)$$

(6.) Furthermore, it will be necessary to recall in what follows, the notation and conventions of ‘circulating functions,’ as explained in my paper on that subject, published in the Philosophical Transactions for 1818, vol. cviii. p. 144. Denoting by s_x the sum of the x th powers of the s th roots of unity divided by s , or the function

$$\frac{1}{s}(\alpha^x + \beta^x + \gamma^x + \&c.),$$

where $\alpha, \beta, \gamma, \&c.$ are those roots, any function of the form

$$A_x \cdot s_x + B_x \cdot s_{x-1} + \dots \dots N_x \cdot s_{x-s+1}$$

will circulate in its successive values as x increases by units from 0: being expressed by A_x when x is a multiple of s ; by B_x , when $x - 1$ is such a multiple, and so on. If $A_x, B_x, \&c.$ be simply constant, the function may be termed a *periodic* one, since it assumes in periodic and constantly recurring succession the values $A, B, C \dots N, A, B, \&c. ad infinitum$. If s be a specified number, as 2, 3, &c., we shall not the less use the notations $2_x, 3_x, \&c.$ to express the respective quantities $\frac{1}{2}(\alpha^x + \beta^x), \frac{1}{3}(\alpha^x + \beta^x + \gamma^x), \&c.$, where $\alpha, \beta, \&c.$ are the corresponding roots of unity. And we shall accordingly

mon measure, and the functions to be combined be

$$P_x = a_x \cdot s_x + b_x \cdot s_{x-1} + \&c.$$

$$Q_x = A_x \cdot t_x + B_x \cdot t_{x-1} + \&c.,$$

we have by equation (22.),

$$P_x = a_x \cdot m_x + b_x \cdot m_{x-1} + \dots + a_x \cdot m_{x-s} + b_x \cdot m_{x-s-1} + \dots \&c.$$

$$Q_x = A_x \cdot m_x + B_x \cdot m_{x-1} + \dots + A_x \cdot m_{x-t} + B_x \cdot m_{x-t-1} + \dots \&c.,$$

and consequently

$$f\{P_x, Q_x\} = f\{a_x, A_x\} \cdot m_x + f\{b_x, B_x\} m_{x-1} + \&c.\dots$$

For example,

$$(a \cdot 2_x + b \cdot 2_{x-1})(A \cdot 3_x + B \cdot 3_{x-1} + C \cdot 3_{x-2}) = aA \cdot 6_x + bB \cdot 6_{x-1} + aC \cdot 6_{x-2} + bA \cdot 6_{x-3} + aB \cdot 6_{x-4} + bC \cdot 6_{x-5}.$$

(11.) The readiest way in practice and the surest way to avoid mistakes, which in complex cases are very likely to occur, is to proceed by a much easier process, as in the following example. Suppose we would express the product of the three periodic functions

$$P_x = 2_x + 2 \cdot 2_{x-1}, \quad Q_x = 3_x + 2 \cdot 3_{x-1} + 3 \cdot 3_{x-2}, \quad R_x = 4_x + 2 \cdot 4_{x-1} + 3 \cdot 4_{x-2} + 4 \cdot 4_{x-3},$$

the product of 2, 3, 4 divided by the greatest common measure of 2 and 4 is 12, which will therefore be the period of the product. Write then the several coefficients in order as follows: for

| | |
|-------|---|
| P_x | 1, 2; 1, 2; 1, 2; 1, 2; 1, 2; 1, 2; &c. |
| Q_x | 1, 2, 3; 1, 2, 3; 1, 2, 3; 1, 2, 3; &c. |
| R_x | 1, 2, 3, 4; 1, 2, 3, 4; 1, 2, 3, 4; &c. |
| | |
| | 1, 8, 9, 8, 2, 12, 3, 16, 3, 4, 6, 24, |

and we shall have for the product

$$12_x + 8 \cdot 12_{x-1} + 9 \cdot 12_{x-2} + 8 \cdot 12_{x-3} + 2 \cdot 12_{x-4} + \dots \dots \dots 24 \cdot 12_{x-11}.$$

If the signs of the coefficients, or any of them, differ, they must be of course annexed to each, and the proper sign affixed to each product.

(12.) If we denote by $\frac{x}{s}$ the integer part of the quotient of any number x divided by another s , then, universally,

$$\frac{x}{s} = \frac{x}{s} \cdot s_x + \frac{x-1}{s} s_{x-1} + \dots \frac{x-s+1}{s} s_{x-s+1}; \dots \dots \dots (23.)$$

$$= \frac{x}{s} - \frac{1}{s} \left\{ 0 \cdot s_x + 1 \cdot s_{x-1} + 2 \cdot s_{x-2} + \dots \overline{s-1} \cdot s_{x-s+1} \right\}$$

and therefore the remainder, in the same division, is expressed by

$$x - s \cdot \frac{x}{s} = 0 \cdot s_x + 1 \cdot s_{x-1} + 2 \cdot s_{x-2} + \dots \overline{s-1} \cdot s_{x-s+1}. \dots \dots \dots (24.)$$

(13.) If, again, we would express the integer part of the quotient in the division of

$\frac{x}{s}$ by a second integer division t , we have, putting y for $\frac{x}{s}$,

$$\begin{aligned} \frac{y}{t} &= \frac{y}{t} - \frac{1}{t} \left\{ 0 \cdot t_y + 1 \cdot t_{y-1} + \dots (t-1) \cdot t_{y-t+1} \right\} \\ &= \frac{x}{st} - \frac{1}{st} \left\{ 0 \cdot s_x + 1 \cdot s_{x-1} + \dots (s-1) s_{x-s+1} \right\} \\ &\quad - \frac{1}{t} \left\{ 0 \cdot t_y + 1 \cdot t_{y-1} + \dots (t-1) \cdot t_{y-t+1} \right\}; \dots \dots \dots (25.) \end{aligned}$$

and so on as far as we please.

(14.) The periodic function $0 \cdot t_y + 1 \cdot t_{y-1} + \&c.$ depends implicitly on x , because y is dependent on x . Its value however (as well as that of any other implicit periodical function) is very easily obtained by following out the process explained in (art. 11). Suppose, for example, we had the more general periodic function of y ,

$$q_y = a \cdot t_y + b \cdot t_{y-1} + \dots h \cdot t_{y-t+1}.$$

Then we may write down the successive values of x, y, q_y in order thus:

| | | | |
|-------|---------------------|-------------------------|------------------------|
| x | 0, 1, 2, ... (s-1); | $s, s+1, \dots (2s-1);$ | $2s, \dots; ts, \dots$ |
| y | 0, 0, 0, ... | 0; 1, 1, ... | 1; 2, ...; t, ... |
| q_y | a, a, a, ... | a; b, b, ... | b; c, ...; a, ... |

Thus we see that q_y is a periodical function of x , having for its period st instead of either s or t separately, the first s coefficients being all alike and each $=a$, the next s all alike and each $=b$, and so on; or

$$q_y = a \{ (st)_x + \dots (st)_{x-s+1} \} + b \{ (st)_{x-s} + \dots (st)_{x-2s+1} \} + \dots + h \{ (st)_{x-ts+s} + \dots (st)_{x-ts+1} \}. \quad (26.)$$

(15.) Hence we are enabled to express the value of $\frac{y}{t}$ explicitly as a periodic function of x ; for by equation (25.), if we put $st=n$,

$$\begin{aligned} \frac{y}{t} &= \frac{x}{n} - \frac{1}{n} \left\{ 0 \cdot s_x + 1 \cdot s_{x-1} + \dots \overline{s-1} \cdot s_{x-s+1} \right\} \\ &\quad - \frac{1}{n} \left\{ 0 \cdot t_y + s \cdot t_{y-1} + \dots \overline{s \cdot t-1} \cdot t_{y-t+1} \right\}. \end{aligned}$$

But by equation (21.) we have

$$\begin{aligned} s_x &= n_x + n_{x-s} + n_{x-2s} + \dots n_{x-ns+s} \\ s_{x-1} &= n_{x-1} + n_{x-s-1} + \dots n_{x-ns+s-1}, \&c.; \end{aligned}$$

and by the equation (26.) of the foregoing article,

$$\begin{aligned} t_y &= n_x + n_{x-1} + \dots n_{x-s+1} \\ t_{y-1} &= n_{x-s} + n_{x-s-1} + \dots n_{x-2s+1} \\ t_{y-2} &= n_{x-2s} + n_{x-2s-1} + \dots n_{x-3s+1}, \&c.; \end{aligned}$$

and consequently by substitution,

$$\frac{y}{t} = \frac{x}{n} - \frac{1}{n} \left\{ 0 \cdot n_x + 1 \cdot n_{x-1} + 2 \cdot n_{x-2} + \dots \overline{n-1} \cdot n_{x-n+1} \right\}. \dots \dots \dots (27.)$$

(16.) These relations premised, let it be required to express the sum of x terms of the series

$$\phi(a+b) + \phi(a+2b) + \dots + \phi(a+xb) = S_x.$$

Developing the several terms, we find

$$\begin{aligned} S_x &= \phi(a) \{1 + 1 + \dots x \text{ terms}\} \\ &+ \frac{b}{1} \cdot \phi'(a) \{1 + 2 + 3 + \dots x\} \\ &+ \frac{b^2}{1.2} \phi''(a) \{1^2 + 2^2 + 3^2 + \dots x^2\} + \&c. \end{aligned}$$

Substituting then for the series of powers of 1, 2, 3, &c. their values as given by equation (11.), and separating the symbols of operation from that of quantity, we get

$$S_x = \frac{1 - (1 + \Delta)^{-x}}{\Delta} \left\{ \phi(a) \cdot 0^0 - \phi'(a) \cdot \frac{b}{1} \cdot 0^1 + \phi''(a) \cdot \frac{b^2}{1.2} \cdot 0^2 - \&c. \right\} = \frac{1 - (1 + \Delta)^{-x}}{\Delta} \phi(a - b \cdot 0). \quad (28.)$$

(17.) If we use in like manner equation (12.), it gives

$$S_x = (1 + \Delta) \frac{(1 + \Delta)^x - 1}{\Delta} \phi(a + b \cdot 0) = \frac{(1 + \Delta)^x - 1}{\Delta} \phi(\overline{a + b} + b \cdot 0), \quad \dots \quad (29.)$$

by employing the transformation of equation (3.), in which $x=1$, $f(0) = \phi(a + b \cdot 0)$. Hence also, if

$$S_x = \phi(a) + \phi(a + b) + \dots + \phi(a + \overline{x-1} \cdot b),$$

we find in like manner

$$S_x = \frac{(1 + \Delta)^x - 1}{\Delta} \phi(a + b \cdot 0). \quad \dots \quad (30.)$$

(18.) Let it next be required to find the sum of the series

$$S_y = \phi(a + b) + \phi(a + 2b) + \dots + \phi(a + yb)$$

to y terms, where $y = \frac{x}{s}$ the integer part of the quotient of an independent index number x , divided by any given number s . By equation (28.) we have

$$S_y = \frac{1 - (1 + \Delta)^{-y}}{\Delta} \phi(a - b \cdot 0).$$

Now since

$$\begin{aligned} y &= \frac{x}{s} s_{x-1} + \frac{x-1}{s} s_{x-1} + \dots + \frac{x-s+1}{s} s_{x-s+1} \\ &= \frac{x}{s} - \frac{1}{s} \left\{ 0 \cdot s_x + 1 \cdot s_{x-1} + \dots + (s-1) \cdot s_{x-s+1} \right\}. \end{aligned}$$

If we put

$$p = -\frac{x}{s}; \quad q = \frac{1}{s} \left\{ 0 \cdot s_x + 1 \cdot s_{x-1} + \&c. \right\},$$

we get by equation (9.),

$$S_y = \frac{1 - (1 + \Delta)^p}{\Delta} \phi(a - b \cdot 0) + \frac{1 - (1 + \Delta)^q}{\Delta} \phi(\overline{a - pb} - b \cdot 0).$$

Now the first portion of this, since $p = -\frac{x}{s}$, is explicit in terms of x , but the other requires further development, for which we must have recourse to equation (16.), putting $Q_x = (1 + \Delta)$ and $P_x = q = \frac{1}{s}(0 \cdot s_x + 1 \cdot s_{x-1} + \&c.)$, where we find

$$(1 + \Delta)^q = (1 + \Delta)^0 \cdot s_x + (1 + \Delta)^{\frac{1}{s}} \cdot s_{x-1} + (1 + \Delta)^{\frac{2}{s}} \cdot s_{x-2} + \&c.$$

But we also have by equation (18.),

$$1 = s_x + s_{x-1} + s_{x-2} + \&c.$$

Therefore, subtracting and dividing by Δ , and applying each term of operation to the term $\varphi(\overline{a - pb - b \cdot 0})$ of quantity,

$$\begin{aligned} \frac{1 - (1 + \Delta)^q}{\Delta} \varphi(\overline{a - pb - b \cdot 0}) &= \left\{ 0 \cdot s_x + \frac{1 - (1 + \Delta)^{\frac{1}{s}}}{\Delta} s_{x-1} + \frac{1 - (1 + \Delta)^{\frac{2}{s}}}{\Delta} s_{x-2} + \&c. \right\} \varphi(\overline{a - pb + b \cdot 0}) \\ &= 0 \cdot s_x + \frac{1 - (1 + \Delta)^{\frac{1}{s}}}{\Delta} \varphi(\overline{a - pb - b \cdot 0}) \cdot s_{x-1} + \frac{1 - (1 + \Delta)^{\frac{2}{s}}}{\Delta} \varphi(\overline{a - pb - b \cdot 0}) \cdot s_{x-2} + \&c. \quad (31.) \end{aligned}$$

(19.) The expression for S_y in the last article is general and entirely independent of any particular values assigned to x, a, b, s , the only relation established being that expressed by the equation $y = \frac{x}{s}$. Suppose therefore that in a certain proposed case we should have

$$a = x + s - 1; \quad b = -s;$$

and therefore

$$pb = x; \quad a - pb = s - 1,$$

and the expression for the sum of the series becomes

$$\begin{aligned} S_y &= \frac{1 - (1 + \Delta)^{-\frac{x}{s}}}{\Delta} \varphi(x + s - 1 + s \cdot 0) \\ &+ \frac{1 - (1 + \Delta)^{\frac{1}{s}}}{\Delta} \varphi(\overline{s - 1 + s \cdot 0}) \cdot s_{x-1} \\ &+ \frac{1 - (1 + \Delta)^{\frac{2}{s}}}{\Delta} \varphi(\overline{s - 1 + s \cdot 0}) \cdot s_{x-2} + \&c.; \quad \dots \quad (32.) \end{aligned}$$

in which expression the first member or non-periodical part is an explicit function of x and s , and the periodical part has all its coefficients independent on x and functions of s alone.

(20.) The periodical part of S_y is however susceptible of another form, better adapted for numerical calculation, into which it may be thrown by making $p = q = \frac{1}{s}$ in equation (9.), when it becomes

$$\frac{1 - (1 + \Delta)^{\frac{2}{s}}}{\Delta} f(0) = \frac{1 - (1 + \Delta)^{\frac{1}{s}}}{\Delta} f(0) + \frac{1 - (1 + \Delta)^{\frac{1}{s}}}{\Delta} f\left(\frac{1}{s} + 0\right),$$

in which, for $f(0)$ writing $\overline{\varphi(s-1+s.0)}$, it becomes

$$\frac{1-(1+\Delta)^{\frac{2}{s}}}{\Delta} \overline{\varphi(s-1+s.0)} = \frac{1-(1+\Delta)^{\frac{1}{s}}}{\Delta} \left\{ \varphi(s-1+s.0) + \varphi(s+s.0) \right\}.$$

Similarly,

$$\frac{1-(1+\Delta)^{\frac{3}{s}}}{\Delta} \overline{\varphi(s-1+s.0)} = \frac{1-(1+\Delta)^{\frac{1}{s}}}{\Delta} \left\{ \overline{\varphi(s-1+s.0)} + \varphi(s+s.0) + \overline{\varphi(s+1+s.0)} \right\},$$

and so on; the general form assumed by our equation (9.), on applying this process, being

$$\frac{1-(1+\Delta)^{np}}{\Delta} f(0) = \frac{1-(1+\Delta)^p}{\Delta} \left\{ f(0) + f(p+0) + f(2p+0) \dots + \overline{f(n-1.p+0)} \right\} \dots \quad (33.)$$

Supposing, then, for brevity, we denote the combination $\frac{1-(1+\Delta)^{\frac{1}{s}}}{\Delta}$ by ∇ , and that we put

$$\psi_1(s) = \varphi(s-1); \quad \psi_2(s) = \varphi(s-1) + \varphi(s); \quad \psi_3(s) = \varphi(s-1) + \varphi(s) + \varphi(s+1); \quad \&c.,$$

then we shall have, finally,

$$\begin{aligned} S_y = \frac{1-(1+\Delta)^{-\frac{x}{s}}}{\Delta} \overline{\varphi\left\{x+s-1+s.0\right\}} &+ 0.s_x + s_{x-1} \cdot \nabla \psi_1(s+0.s) \\ &+ s_{x-2} \cdot \nabla \psi_2(s+0.s) \\ &+ \&c.; \quad \dots \dots \dots \quad (34.) \end{aligned}$$

$$= X + Y,$$

where X represents the non-periodical part, a function of x , and Y the periodical, whose coefficients are constant.

(21.) For the actual evaluation of these functions, all we have to do is to develop the operative characteristic in powers of Δ , and the attached functions in powers of 0, and to apply them term by term to each other. As regards the function X, we find, by so doing,

$$\begin{aligned} X = \frac{1}{s} \left\{ \frac{x}{1} \cdot \varphi(x+s-1) - \frac{x(x+s)}{1.2} \cdot \Delta 0 \cdot \frac{\varphi'(x+s-1)}{1} \right. \\ + \left. \left\{ \frac{x(x+s)(x+2s)}{1.2.3} \cdot \Delta^2 0^2 - \frac{x(x+s)}{1.2} \cdot s \cdot \Delta 0^2 \right\} \cdot \frac{\varphi''(x+s-1)}{1.2} \right. \\ - \left. \left\{ \frac{x(x+s) \dots (x+3s)}{1 \dots 4} \Delta^3 0^3 - \frac{x(x+s)(x+2s)}{1.2.3} \cdot s \Delta^2 0^3 + \frac{x(x+s)}{1.2} \cdot s^2 \cdot \Delta 0^3 \right\} \cdot \frac{\varphi'''(x+s-1)}{1.2.3} \right. \\ + \&c., \dots \dots \dots \quad (35.) \end{aligned}$$

in which it will be recollected that

$$\Delta 0 = 1; \quad \Delta 0^2 = 1, \quad \Delta^2 0^2 = 2; \quad \Delta 0^3 = 1, \quad \Delta^2 0^2 = 6; \quad \Delta^3 0^3 = 6; \quad \&c. \quad \&c.$$

(22.) In like manner, denoting by $\psi(s)$ in general, any of the functions $\psi_1(s), \psi_2(s),$

But by equation (5.),

$$\frac{\{\log(1+\Delta)\}^{i+1}}{\Delta} 0^n = \{\log(1+\Delta)\}^i \cdot \frac{\log(1+\Delta)}{\Delta} 0^n$$

$$= n(n-1) \dots (n-i+1) \cdot \frac{\log(1+\Delta)}{\Delta} 0^{n-i},$$

and therefore the foregoing expression becomes

$$\frac{x}{s} \cdot \frac{\log(1+\Delta)}{\Delta} 0^n - \frac{n}{2} \left(\frac{x}{s}\right)^2 \cdot \frac{\log(1+\Delta)}{\Delta} 0^{n-1} + \frac{n(n-1)}{2.3} \cdot \&c.;$$

or, inverting the order of the terms,

$$(-1)^n \cdot \left\{ \frac{1}{n+1} \left(\frac{x}{s}\right)^{n+1} \cdot \frac{\log(1+\Delta)}{\Delta} 0^0 - \left(\frac{x}{s}\right)^n \cdot \frac{\log(1+\Delta)}{\Delta} 0^1 + \right.$$

$$\left. + \frac{n}{2} \left(\frac{x}{s}\right)^{n-1} \cdot \frac{\log(1+\Delta)}{\Delta} 0^2 - \frac{n(n-1)}{2.3} \left(\frac{x}{s}\right)^{n-2} \cdot \frac{\log(1+\Delta)}{\Delta} 0^3 + \&c. \right\}.$$

Now if $B_1, B_3, B_5, \&c.$ be the numbers of BERNOULLI in their order (the even values $B_2, B_4, \&c.$ being severally $=0$), we have

$$\frac{\log(1+\Delta)}{\Delta} 0^0 = 1; \quad \frac{\log(1+\Delta)}{\Delta} 0^1 = -\frac{1}{2}; \quad \frac{\log(1+\Delta)}{\Delta} 0^2 = B_1 = \frac{1}{6},$$

and so on. Consequently

$$\frac{1 - (1+\Delta)^{-\frac{x}{s}}}{\Delta} 0^n = (-1)^n \cdot \left\{ \frac{1}{n+1} \left(\frac{x}{s}\right)^{n+1} + \frac{1}{2} \left(\frac{x}{s}\right)^n + \frac{n}{2} B_1 \left(\frac{x}{s}\right)^{n-1} + \right.$$

$$\left. + \frac{n(n-1)}{2.3} \cdot B_2 \left(\frac{x}{s}\right)^{n-2} + \frac{n(n-1)(n-2)}{2.3.4} B_3 \cdot \left(\frac{x}{s}\right)^{n-3} + \&c. \right\}, \dots \dots \dots (38.)$$

the series on the right-hand side being continued to $n+1$ terms. This is in fact no other than EULER'S expression for the sum of the series $1^n + 2^n + 3^n + \&c.$ to a given number of terms represented by $\frac{x}{s}$, only that in the case here under consideration $\frac{x}{s}$ may be any fraction, while EULER'S demonstration of the series in question is essentially confined to $\frac{x}{s} =$ a positive integer.

(24.) If we make $x = -1$, the foregoing expression becomes

$$\frac{1 - (1+\Delta)^{\frac{1}{s}}}{s} 0^n = \nabla 0^n = -\frac{1}{n+1} \left(\frac{1}{s}\right)^{n+1} + \frac{1}{2} \left(\frac{1}{s}\right)^n - \frac{n}{2} B_1 \cdot \left(\frac{1}{s}\right)^{n-1} - \frac{n(n-1)}{2.3} \cdot B_2 \left(\frac{1}{s}\right)^{n-2} + \&c.$$

$$= -\frac{1}{s^{n+1}} \left\{ \frac{1}{n+1} - \frac{1}{2} \cdot s + \frac{n}{2} B_1 \cdot s^2 - \frac{n(n-1)}{2.3} B_2 \cdot s^3 + \&c. \right\} \dots \dots \dots (39.)$$

continued to $n+1$ terms, inclusive of the vanishing ones having $B_2, B_4, \&c.$ for coefficients.

(25.) Thus the expression for X becomes

$$\begin{aligned}
 X = & \frac{x}{s} \cdot \phi(x+s-1) - \frac{x^2+sx}{2 \cdot s} \phi'(x+s-1) \dots \dots \dots (40.) \\
 & + \frac{2x^3+3sx^2+s^2x}{12 \cdot s} \phi''(x+s-1) \\
 & - \frac{x^4+2sx^3+s^2x^2}{24 \cdot s} \phi'''(x+s-1) \\
 & + \frac{6x^5+15x^4s+10s^2x^3+s^4x}{720 \cdot s} \phi^{iv}(x+s-1) - \&c.
 \end{aligned}$$

$$\begin{aligned}
 Y = & -\frac{1}{s} \left\{ \Psi(s) - \frac{s-1}{2} \cdot \Psi'(s) + \frac{s^2-3s+2}{12} \cdot \Psi''(s) + \frac{s^2-2s+1}{24} \Psi'''(s) + \right. \\
 & \left. + \frac{s^4+10s^2-15s+6}{720} \cdot \Psi^{iv}(s) + \&c. \right\} \dots \dots \dots (41.)
 \end{aligned}$$

(26.) We shall now proceed to the more immediate object of this paper, viz. the expression of the number of ways in which a given number x is susceptible of partition, the number of parts being given.

Let s be the number of parts into which x is to be divided, and let ${}^s\Pi(x)$ represent the number of s -partitions of which it is susceptible. It is evident then that if $s=1$ there is but one possible, so that in all cases ${}^1\Pi(x)=1$.

If $s=2$, the partitions stand thus :

$$1, x-1; \quad 2, x-2; \quad 3, x-3; \quad \dots$$

whose number is $\frac{x}{2}$. Therefore we have

$${}^2\Pi(x) = \frac{x}{2} = \frac{x}{2} - \frac{1}{2} \cdot 2_{x-1}.$$

If $s=3$, the partitions so grouped as that none shall be twice repeated, will stand as follows :—

| | | |
|-------------|-------------|-------------------|
| 1, 1, $x-2$ | 2, 2, $x-4$ | 3, 3, $x-6$, &c. |
| 1, 2, $x-3$ | 2, 3, $x-5$ | &c. |
| 1, 3, $x-4$ | &c. | |
| &c. | | |

The first column will consist of all the possible bipartitions of $x-1$, each associated with 1, and their number is therefore ${}^2\Pi(x-1)$. The second will consist of the bipartitions of $x-2$, exclusive of $(1, x-3)$, each associated with 2. Their number therefore will be identical with the total number of bipartitions of $x-4$, because, so far as the number of cases is concerned, it matters not whether we consider $x-4$ as parted into $(1, x-5)$, $(2, x-6)$, &c., or $x-2$ as parted into $(2, x-4)$, $(3, x-5)$, &c., the reason of which will be obvious on trying any particular case. The number of terms therefore in the second column will be ${}^2\Pi(x-4)$. In like manner that in the third will be ${}^2\Pi(x-7)$, the bipartitions of $x-3$ beginning with $(3, x-6)$, being

identical in number with those of $x-7$, beginning with $(1, x-8)$, and so on. Thus we have

$${}^3\Pi(x) = {}^2\Pi(x-1) + {}^2\Pi(x-4) + {}^2\Pi(x-7) + \&c.$$

Next, with respect to the number of terms to which the right-hand member of this equation is to be continued: it will be that of the columns, which will continue without repetition so long as the number $x-2m$ in the first combination $(m, m, x-2m)$ of any one of them shall be not less than m , or so long as $x-3m$ shall not be negative.

Hence we must have $m = \frac{x}{3}$, since the next greater value of m , viz. $m = \frac{x}{3} + 1$, will give the tripartition $(\frac{x}{3} + 1, \frac{x}{3} + 1, x - 2\frac{x}{3} - 2)$. Now x cannot exceed $3\frac{x}{3}$ by more than 2, so that $x - 2\frac{x}{3} - 2$ cannot exceed $\frac{x}{3}$, and must therefore be less than $\frac{x}{3} + 1$. Hence we conclude that the number of tripartitions is derived from that of bipartitions by the equation

$${}^3\Pi(x) = {}^2\Pi(x-1) + {}^2\Pi(x-4) + \dots + {}^2\Pi(x-7) \dots \text{to } \frac{x}{3} \text{ terms.}$$

(27.) Applying a similar reasoning to the higher cases, we shall find as follows:—

$${}^s\Pi(x) = {}^{s-1}\Pi(x-1) + {}^{s-1}\Pi(x-s-1) + {}^{s-1}\Pi(x-2s-1) \dots \frac{x}{s} \text{ terms; } \dots \dots \dots (42.)$$

a relation which, with many others of greater generality, has also been arrived at by Mr. WARBURTON.

(28.) Suppose now we set out from the equation ${}^1\Pi(x) = 1$, and proceed to derive from this value those of ${}^2\Pi(x)$, ${}^3\Pi(x)$, &c. in succession. It will be apparent from the course of the foregoing investigations, and from the nature of circulating functions, that the general expression for ${}^s\Pi(x)$ must consist of two portions, the one non-periodical, a function of x , and which may be represented by $\varphi(x)$, the other periodical or circulating, which we may denote by Q_x , so that we shall have in general to consider the following form of ${}^s\Pi(x)$,

$${}^s\Pi(x) = \varphi(x) + Q_x,$$

from which to derive the value of ${}^s\Pi(x)$.

When we substitute this in the general expression (equation 42.), we get

$$\begin{aligned} {}^s\Pi(x) &= \varphi(x-1) + \varphi(x-s-1) + \dots (y \text{ terms}) \\ &+ Q_{x-1} + Q_{x-s-1} + \dots (y \text{ terms}), \end{aligned}$$

where $y = \frac{x}{s}$. Now with respect to the first portion of this, if $\varphi(x)$ in any one case be a rational integral function of x , it will be so in all subsequent cases, as is evident from the course of the preceding investigations. This part of ${}^s\Pi(x)$ then has been already dealt with, and its complete expression is $X+Y$ of equations (34. 35.), or (38. 39.).

(29.) We have therefore now only to consider the remaining portions, which we shall call Z, viz.

$$Z = Q_{x-1} + Q_{x-s-1} + \dots y \text{ terms,}$$

Q_x may represent any circulating function. Suppose it to be such that

$$Q_{x-1} = \chi_0(x) \cdot m_x + \chi_1(x) \cdot m_{x-1} + \dots \chi_{m-1}(x) \cdot m_{x-m+1},$$

and let any term of this, as $\chi_i(x)m_{x-i}$ (which for brevity we will write simply $\chi(x) \cdot m_x$, putting $x = x - i$), be separately considered. Let R be the portion of Z which originates from this term. Then

$$R = \chi(x) \cdot m_x + \chi(x-s) \cdot m_{x-s} + \chi(x-2s) \cdot m_{x-2s} \dots (y \text{ terms}).$$

Let $ts = n$ be the first multiple of s , which is also a multiple of m . Then after t terms the value of $m_x, m_{x-s}, \&c.$ will recur, and therefore R resolves itself into t separate series, as follows :

$$\begin{aligned} R = & m_x \left\{ \chi(x) + \chi(x-n) + \chi(x-2n) + \dots \left(\frac{y-1}{t} + 1 \right) \text{ terms} \right\} \\ & + m_{x-s} \left\{ \chi(x-s) + \chi(x-n-s) + \dots \left(\frac{y-2}{t} + 1 \right) \text{ terms} \right\} \\ & + m_{x-2s} \left\{ \chi(x-2s) + \chi(x-n-2s) + \dots \left(\frac{y-3}{t} + 1 \right) \text{ terms} \right\} \\ & + \&c. (t \text{ series}). \end{aligned}$$

Now we have

$$\frac{y}{t} = \frac{y}{t} t_y + \frac{y-1}{t} t_{y-1} + \dots \frac{y-t+1}{t} t_{y-t+1},$$

whence

$$\frac{y-1}{t} = \frac{y-1}{t} t_{y-1} + \frac{y-2}{t} t_{y-2} + \dots \frac{y-t}{t} t_y = \frac{y}{t} - t_y;$$

and similarly,

$$\frac{y-2}{t} = \frac{y-2}{t} t_{y-2} + \frac{y-3}{t} t_{y-3} + \dots \frac{y-t-1}{t} t_{y-1} = \frac{y}{t} - (t_y + t_{y-1}),$$

and so on. But by equation (25.), since $st = n$, we have

$$\frac{y}{t} = \frac{x}{n} - \frac{1}{n} \left\{ 0 \cdot n_x + 1 \cdot n_{x-1} + 2 \cdot n_{x-2} + \dots \overline{n-1} \cdot n_{x-n+1} \right\}.$$

If therefore we put

$$\xi = \frac{x}{n}$$

$$\begin{aligned} p_x &= \frac{1}{n} \left\{ 0 \cdot n_x + 1 \cdot n_{x-1} + \dots \overline{n-1} \cdot n_{x-n+1} \right\} - 1 \\ &= -\frac{1}{n} \left\{ n \cdot n_x + \overline{n-1} \cdot n_{x-1} + \dots 1 \cdot n_{x-n+1} \right\} \end{aligned}$$

$$q'_x = n_x + n_{x-1} + \dots n_{x-s+1}$$

$$q''_x = n_x + n_{x-1} + \dots n_{x-2s+1}$$

$$q'''_x = n_x + n_{x-1} + \dots n_{x-3s+1}, \&c.,$$

we shall have

$$1 + \frac{y-1}{t} = \xi - (p_x + q'_x); \quad 1 + \frac{y-2}{t} = \xi - (p_x + q''_x); \quad \&c.,$$

and therefore by equation (27.),

$$\begin{aligned} R &= m_z \cdot \frac{1 - (1 + \Delta)^{-\xi + p_x + q'_x}}{\Delta} \chi(x + n + n.0) \\ &\quad + m_{z-s} \cdot \frac{1 - (1 + \Delta)^{-\xi + p_x + q''_x}}{\Delta} \chi(x + n - s + n.0) \\ &\quad + m_{z-2s} \cdot \&c. + \&c., \end{aligned}$$

which resolves itself, by the transformation of equation (9.), into two sets of terms, $R' + R''$, viz.

$$R' = m_z \cdot \frac{1 - (1 + \Delta)^{-\xi}}{\Delta} \chi(x + n + n.0) + m_{z-s} \cdot \frac{1 - (1 + \Delta)^{-\xi}}{\Delta} \chi(x + n - s + n.0) + \&c. \quad (43.)$$

and

$$R'' = m_z \cdot \frac{1 - (1 + \Delta)^{p_x + q'_x}}{\Delta} \chi(n + n.0) + m_{z-s} \cdot \frac{1 - (1 + \Delta)^{p_x + q''_x}}{\Delta} \chi(n - s + n.0) + \&c. \quad (44.)$$

(30.) If, in pursuance of the process followed in the development of Y , we put

$$X(x) = m_z \cdot \chi(x + n) + m_{z-s} \cdot \chi(x + n - s) + \&c. \quad (t \text{ terms}),$$

(denoting also by $X_0(x)$, $X_1(x)$ &c., what this expression becomes when for z we put successively x , $x-1$, $x-2$, &c.), we shall have

$$\begin{aligned} R' &= \frac{1 - (1 + \Delta)^{-\frac{x}{n}}}{\Delta} X(x + n.0) \\ &= \frac{1}{n} \left\{ \frac{x}{1} X(x) - \frac{x(x+n)}{1.2} \Delta 0 \cdot X'(x) + \left\{ \frac{x(x+n)(x+2n)}{1.2.3} \Delta^2 0^2 - \frac{x(x+n)}{1.2} \cdot n \Delta 0^2 \right\} \cdot \frac{X''(x)}{1.2} - \&c. \right\} \quad (45.) \end{aligned}$$

The whole assemblage of such terms, giving z all its values, from x to $x-m+1$, therefore will constitute a circulating function explicit in x , and which we shall denote by Z' .

As regards R'' , since s and t are given numerically, it constitutes a periodic function with constant coefficients, to obtain which we have only to consider that, supposing any one of the exponents $p_x + q_x$ to be represented by

$$a \cdot n_x + b \cdot n_{x-1} + c \cdot n_{x-2} + \&c.,$$

we shall have by equation (16.),

$$\frac{1 - (1 + \Delta)^{p_x + q'_x}}{\Delta} = \frac{1 - (1 + \Delta)^a}{\Delta} \cdot n_x + \frac{1 - (1 + \Delta)^b}{\Delta} \cdot n_{x-1} + \&c.$$

(31.) In the particular case in which all the functions $\chi_0(x)$, $\chi_1(x)$, &c. are constant, we may consider them as being themselves the coefficients of a periodic function, such that

$$\chi_i = \chi_0 \cdot m_i + \chi_1 \cdot m_{i-1} + \dots + \chi_{m-1} \cdot m_{i-m+1}$$

so that if we should meet with such expressions as χ_m , χ_{m+1} , &c., they are to be taken as equivalent to χ_0 , χ_1 , &c., a mode of regarding a series of arbitrary constants occurring in a certain order which will tend greatly to simplify and add clearness to what follows. Now we have, generally χ_i being constant,

$$\frac{1 - (1 + \Delta)^h}{\Delta} \chi_i = -h \cdot \chi_i.$$

Consequently, the terms R'_i and R''_i of R_i , corresponding to χ_i in the same way as R' and R'' in general to χ , will become

$$\begin{aligned} R'_i &= \{m_z + m_{z-s} + \dots + m_{z-ts+s}\} \cdot \frac{x}{n} \cdot \chi_i \\ R''_i &= - \{m_z + m_{z-s} + \dots + m_{z-ts+s}\} \cdot p_x \cdot \chi_i \\ &\quad - m_z \{n_x + n_{x-1} + \dots + n_{x-s+1}\} \cdot \chi_i \\ &\quad - m_{z-s} \{n_x + n_{x-1} + \dots + n_{x-2s+1}\} \cdot \chi_i - \&c., \end{aligned}$$

in which it will be recollected that $z = x - i$.

(32.) Now if v be the greatest common measure of m and s (v being 1, if these numbers be prime to each other), we have

$$m_z + m_{z-s} + \dots + m_{z-ts+s} = v_z,$$

and consequently the value of R_i or $R_i + R_i$ becomes

$$\begin{aligned} R_i &= \left(\frac{x}{n} - p_x\right) \cdot \chi_i \cdot v_{x-i} - m_{x-i} \{n_x + \dots + n_{x-s+1}\} \cdot \chi_i \\ &\quad - m_{x-s-i} \{n_x + \dots + n_{x-2s+1}\} \cdot \chi_i \\ &\quad - \&c. \end{aligned}$$

(33.) Assembling together similar results for R_0, R_1, \dots, R_{m-1} , we have

$$\begin{aligned} Z &= \{\chi_0 \cdot v_x + \chi_1 \cdot v_{x-1} + \dots + \chi_{m-1} \cdot v_{x-m+1}\} \cdot \left(\frac{x}{n} - p_x\right) \\ &\quad - \{n_x + \dots + n_{x-s+1}\} \{\chi_0 \cdot m_x + \chi_1 \cdot m_{x-1} + \dots + \chi_{m-1} \cdot m_{x-m+1}\} \\ &\quad - \{n_x + \dots + n_{x-2s+1}\} \{\chi_0 \cdot m_{x-s} + \chi_1 \cdot m_{x-s-1} + \dots + \chi_{m-1} \cdot m_{x-s+1}\} \\ &\quad - \{n_x + \dots + n_{x-3s+1}\} \{\chi_0 \cdot m_{x-2s} + \chi_1 \cdot m_{x-2s-1} + \dots + \chi_{m-1} \cdot m_{x-2s+1}\} \\ &\quad - \&c. \end{aligned}$$

Now because m and s have v for a common measure, and that $n = ts$ is the first multiple of s , which is also a multiple of m , it follows that $n = \frac{s}{v} \cdot m$, $\frac{s}{v}$ being an integer.

Hence we have by equation (22.),

$$\begin{aligned} m_x &= n_x + n_{x-m} + n_{x-2m} \dots + n_{x-n+m} \\ m_{x-1} &= n_{x-1} + n_{x-m-1} + \dots + n_{x-n+m-1} \\ \&c. &= \&c. \end{aligned}$$

Substituting these therefore, and so arranging the terms that n_x shall always stand first, the series within the brackets on the right-hand, in the expression for Z , become respectively

$$\begin{aligned} &\chi_0 \cdot n_x + \chi_1 \cdot n_{x-1} + \dots + \chi_{m-1} \cdot n_{x-n+1} \\ &\chi_{m-s} \cdot n_x + \chi_{m-s+1} \cdot n_{x-1} + \dots + \chi_{m-s+n-1} \cdot n_{x-n+1} \\ &\chi_{m-2s} \cdot n_x + \chi_{m-2s+1} \cdot n_{x-1} + \dots + \chi_{m-2s+n-1} \cdot n_{x-n+1}, \&c., \end{aligned}$$

which being multiplied by their respective coefficients, $n_x + n_{x-1} + \&c.$, we get for Z as follows:—

$$\begin{aligned}
 Z = & \frac{x}{n} \left\{ \chi_0 \cdot v_x + \chi_1 \cdot v_{x-1} + \dots + \chi_{m-1} \cdot v_{x-m+1} \right\} \dots \dots \dots (46.) \\
 & - p_x \cdot \{ \chi_0 \cdot v_x + \chi_1 \cdot v_{x-1} + \dots + \chi_{m-1} \cdot v_{x-m+1} \} \\
 & - \{ \chi_0 \cdot n_x + \chi_1 \cdot n_{x-1} + \chi_2 \cdot n_{x-2} + \dots (s \text{ terms}) \} \\
 & - \{ \chi_{m-s} \cdot n_x + \chi_{m-s+1} \cdot n_{x-1} + \dots (2s \text{ terms}) \} \\
 & - \{ \chi_{m-2s} \cdot n_x + \chi_{m-2s+1} \cdot n_{x-1} + \dots (3s \text{ terms}) \} \\
 & - \&c.
 \end{aligned}$$

The first line of this is a circulating function, linear in x in all cases except when $v=1$, or m and s are prime to each other, in which case it loses its circulating character and becomes simply

$$\frac{x}{n} (\chi_0 + \chi_1 + \chi_2 + \dots + \chi_{m-1}) \dots \dots \dots (47.)$$

As regards the second line, we have

$$-p_x = \frac{1}{n} \left\{ n \cdot n_x + \overline{n-1} \cdot n_{x-1} + \dots + 1 \cdot n_{x-n+1} \right\};$$

and since n is a multiple of s , and therefore of v , the multiplier within the brackets is readily reduced to a periodic function having n for its period, such as $a \cdot n_x + b \cdot n_{x-1} + \&c.$, which, multiplied by $-p_x$, gives

$$\frac{1}{n} \left\{ na \cdot n_x + \overline{n-1} \cdot b \cdot n_{x-1} + \&c. \right\},$$

except when $v=1$, in which case this expression reduces itself to

$$\frac{1}{n} (\chi_0 + \chi_1 + \dots + \chi_{m-1}) \{ n \cdot n_x + \overline{n-1} \cdot n_{x-1} + \dots + 1 \cdot n_{x-n+1} \} \dots \dots \dots (48.)$$

(34.) To apply the foregoing formulæ to the expression of particular cases as $\overset{2}{\Pi}(x)$, $\overset{3}{\Pi}(x)$, $\overset{4}{\Pi}(x)$, &c., we begin with $\overset{1}{\Pi}(x) = 1$. Therefore, to find $\overset{2}{\Pi}(x)$, we have

$$\varphi(x) = 1, \quad \varphi'(x) \&c. = 0, \quad \psi_1(s) = s - 1, \quad s = 2;$$

consequently

$$X = \frac{x}{2}; \quad \nabla(s+0 \cdot s) = -\frac{1}{2}; \quad Y = -\frac{1}{2} \cdot 2_{x-1},$$

and therefore

$$\overset{2}{\Pi}(x) = \frac{1}{2} (x - 2_{x-1}) \dots \dots \dots (49.)$$

(35.) For the case of $s=3$, we have

$$\varphi(x) = \frac{x}{2}; \quad \varphi'(x) = \frac{1}{2};$$

$$\psi_1(s) = \frac{s-1}{2} = 1; \quad \psi'_1(s) = \frac{1}{2}; \quad \psi_2(s) = \frac{\overline{s-1} + s}{2} = \frac{5}{2}; \quad \psi'_2(s) = 1;$$

and therefore

$$X = \frac{1}{6} \left\{ x(x+2) - \frac{x(x+3)}{2} \right\} = \frac{x^2+x}{12}.$$

For Y we have

$$\begin{aligned} \Psi(s) &= 0.3_x + 1.3_{x-1} + \frac{5}{2}.3_{x-2} \\ \Psi'(s) &= 0.3_x + \frac{1}{2}.3_{x-1} + 3_{x-2} \end{aligned}$$

whence by equation (37.),

$$Y = -\frac{1}{12} \left\{ 2.6_{x-1} + 6.6_{x-2} + 2.6_{x-4} + 6.6_{x-5} \right\}.$$

For Z we have

$$Q_x = -\frac{1}{2}.2_{x-1} \quad Q_{x-1} = -\frac{1}{2}.2_x$$

whence

$$m=2, s=3, ms=6, v=1, \chi_0 = -\frac{1}{2}, \chi_1 = 0$$

and by (45.), (46), (47.),

$$\begin{aligned} Z &= -\frac{x}{12} - \frac{1}{12} \left\{ 6.6_x + 5.6_{x-1} + 4.6_{x-2} + 3.6_{x-3} + 2.6_{x-4} + 1.6_{x-5} \right\} \\ &\quad + \frac{6}{12} \left\{ 6_x + 6_{x-2} \right\} + \frac{6}{12} \left\{ 6_{x-1} + 6_{x-3} + 6_{x-5} \right\} \\ &= -\frac{x}{12} + \frac{1}{12} \left\{ 6_{x-1} + 2.6_{x-2} + 3.6_{x-3} - 2.6_{x-4} + 5.6_{x-5} \right\} \end{aligned}$$

adding all which parts together, we have X+Y+Z, or

$$\Pi^3(x) = \frac{1}{12} \left\{ x^2 - 6_{x-1} - 4.6_{x-2} + 3.6_{x-3} - 4.6_{x-4} - 6_{x-5} \right\} \dots \dots \dots (50.)$$

(36.) When s=4, we have, therefore,

$$\phi(x) = \frac{x^2}{12}, \quad \phi'(x) = \frac{2x}{12}, \quad \phi''(x) = \frac{2}{12}$$

and, therefore, by equation (35.),

$$X = \frac{1}{48} \left\{ x(x+3)^2 - \frac{x(x+4)}{2}.2(x+3) + \left\{ \frac{x(x+4)(x+8)}{6}.2 - \frac{x(x+4)}{2}.4 \right\} \cdot \frac{2}{1.2} \right\} = \frac{x^3 + 3x^2 - x}{144}.$$

For Y we have

$$\begin{aligned} \psi_1(s) &= \frac{(s-1)^2}{12} = \frac{9}{12}; & \psi_1'(s) &= \frac{2(s-1)}{12} = \frac{6}{12}; & \psi_1''(s) &= \frac{2}{12} \\ \psi_2(s) &= \frac{(s-1)^2 + s^2}{12} = \frac{25}{12}; & \psi_2'(s) &= \frac{2(s-1) + 2s}{12} = \frac{14}{12}; & \psi_2''(s) &= \frac{4}{12} \\ \psi_3(s) &= \frac{(s-1)^2 + s^2 + (s+1)^2}{12} = \frac{50}{12}; & \psi_3'(s) &= \frac{2(s-1) + 2s + 2(s+1)}{12} = \frac{24}{12}; & \psi_3''(s) &= \frac{6}{12} \end{aligned}$$

$$\begin{aligned} \Psi(s) &= \frac{1}{12} \left\{ 0.4_x + 9.4_{x-1} + 25.4_{x-2} + 50.4_{x-3} \right\} \\ \Psi'(s) &= \frac{1}{12} \left\{ 0.4_x + 6.4_{x-1} + 14.4_{x-2} + 24.4_{x-3} \right\} \\ \Psi''(s) &= \frac{1}{12} \left\{ 0.4_x + 2.4_{x-1} + 4.4_{x-2} + 6.4_{x-3} \right\}, \end{aligned}$$

whence by equation (37.),

$$\begin{aligned} Y &= -\frac{1}{48} \left\{ \Psi(s) - \frac{3}{2} \Psi'(s) + \frac{1}{2} \Psi''(s) \right\} \\ &= -\frac{1}{48} \left\{ 0.4_x + 1.4_{x-1} + 6.4_{x-2} + 17.4_{x-3} \right\} \\ &= -\frac{1}{144} \left\{ 0.12_x + 3.12_{x-1} + 18.12_{x-2} + 51.12_{x-3} + 0.12_{x-4} + 3.12_{x-5} + 18.12_{x-6} + \right. \\ &\quad \left. + 51.12_{x-7} + 0.12_{x-8} + 3.12_{x-9} + 18.12_{x-10} + 51.12_{x-11} \right\}. \end{aligned}$$

Lastly, for Z we have

$$\begin{aligned} Q_x &= \left\{ -0.6_x - 1.6_{x-1} - 4.6_{x-2} + 3.6_{x-3} - 4.6_{x-4} - 1.6_{x-5} \right\} \cdot \frac{1}{12} \\ Q_{x-1} &= \left\{ -1.6_x - 0.6_{x-1} - 1.6_{x-2} - 4.6_{x-3} + 3.6_{x-4} - 4.6_{x-5} \right\} \cdot \frac{1}{12}, \end{aligned}$$

consequently

$$\begin{aligned} m &= 6, \quad s = 4, \quad v = 2, \quad t = 3, \quad n = st = 12 \\ \chi_0 &= -\frac{1}{12}, \quad \chi_1 = 0, \quad \chi_2 = -\frac{1}{12}, \quad \chi_3 = -\frac{4}{12}, \quad \chi_4 = +\frac{3}{12}, \quad \chi_5 = -\frac{4}{12}, \end{aligned}$$

and therefore, by equation (46.), which gives the value of Z in this case, putting Z' for the first line of Z, Z'' for the second and Z''' for the rest,

$$\begin{aligned} Z' &= \frac{x}{144} \left\{ -1.2_x - 0.2_{x-1} - 1.2_{x-2} - 4.2_{x-3} + 3.2_{x-4} - 4.2_{x-5} \right\} \\ &= \frac{x}{144} \left\{ (-1 - 1 + 3).2_x + (0 - 4 - 4).2_{x-1} \right\} \\ &= \frac{x}{144} \left\{ 2_x - 8.2_{x-1} \right\} = \frac{x}{144} - \frac{9x}{144}.2_{x-1} \\ Z'' &= (2_x - 8.2_{x-1}) \cdot \frac{1}{144} \left\{ 12.12_x + 11.12_{x-1} + 10.12_{x-2} + \dots + 1.12_{x-11} \right\}, \end{aligned}$$

which, putting for 2_x and 2_{x-1} their values

$$12_x + 12_{x-2} + 12_{x-4} \dots + 12_{x-10},$$

and

$$12_{x-1} + 12_{x-3} + \dots + 12_{x-11}$$

becomes

$$\begin{aligned} Z'' &= \frac{1}{144} \left\{ 12.12_x - 88.12_{x-1} + 10.12_{x-2} - 72.12_{x-3} + 8.12_{x-4} - 56.12_{x-5} + 6.12_{x-6} - \right. \\ &\quad \left. - 40.12_{x-7} + 4.12_{x-8} - 24.12_{x-9} + 2.12_{x-10} - 8.12_{x-11} \right\}; \end{aligned}$$

and lastly,

$$\begin{aligned} Z''' &= \frac{1}{12} \left\{ 1.12_x + 0.12_{x-1} + 1.12_{x-2} + 4.12_{x-3} \right\} \\ &\quad + \frac{1}{12} \left\{ 1.12_x + 4.12_{x-1} - 3.12_{x-2} + 4.12_{x-3} + 1.12_{x-4} + 0.12_{x-5} + 1.12_{x-6} + 4.12_{x-7} \right\} \\ &\quad + \frac{1}{12} \left\{ -3.12_x + 4.12_{x-1} + 1.12_{x-2} + 0.12_{x-3} + 1.12_{x-4} + 4.12_{x-5} - 3.12_{x-6} + 4.12_{x-7} \right. \\ &\quad \left. + 1.12_{x-8} + 0.12_{x-9} + 1.12_{x-10} + 4.12_{x-11} \right\} \end{aligned}$$

$$= \frac{12}{144} \left\{ -12_x + 8 \cdot 12_{x-1} - 1 \cdot 12_{x-2} + 8 \cdot 12_{x-3} + 2 \cdot 12_{x-4} + 4 \cdot 12_{x-5} - 2 \cdot 12_{x-6} + 8 \cdot 12_{x-7} + \right. \\ \left. + 1 \cdot 12_{x-8} + 0 \cdot 12_{x-9} + 1 \cdot 12_{x-10} + 4 \cdot 12_{x-11} \right\}.$$

And assembling these several portions, $X + Y + (Z' + Z'' + Z''')$, we get

$$\begin{aligned} \Pi(x) = \frac{1}{144} \left\{ x^3 + 3x^2 - 9x \cdot 2_{x-1} \right\} + \frac{1}{144} \left\{ 0 \cdot 12_x + 5 \cdot 12_{x-1} - 20 \cdot 12_{x-2} - 27 \cdot 12_{x-3} + 32 \cdot 12_{x-4} \right. \\ \left. - 11 \cdot 12_{x-5} - 36 \cdot 12_{x-6} + 5 \cdot 12_{x-7} + 16 \cdot 12_{x-8} - 27 \cdot 12_{x-9} - 4 \cdot 12_{x-10} - 11 \cdot 12_{x-11} \right\}. \quad (51.) \end{aligned}$$

(37.) Proceeding now to the case where $s=5$, we have

$$\phi(x) = \frac{x^3 + 3x^2}{144}, \quad \phi'(x) = \frac{3x^2 + 6x}{144}, \quad \phi''(x) = \frac{6x + 6}{144}, \quad \phi'''(x) = \frac{6}{144},$$

whence

$$\phi(x+4) = \frac{(x+4)^2(x+7)}{144}, \quad \phi'(x+4) = \frac{3(x+4)(x+6)}{144}, \quad \phi''(x+4) = \frac{6(x+5)}{144}, \quad \phi'''(x+4) = \frac{6}{144},$$

and executing the reductions, arising from the substitution of these in equation (35.), we find

$$X = \frac{x^4 + 10x^3 + 19x^2 - 22x}{2880}.$$

Again for Y we have

$$\psi_1(5) = \phi(4); \quad \psi_2(5) = \phi(4) + \phi(5); \quad \psi_3(5) = \phi(4) + \phi(5) + \phi(6), \quad \&c.,$$

whence

$$\psi_1(5) = \frac{112}{144}; \quad \psi_2(5) = \frac{312}{144}; \quad \psi_3(5) = \frac{636}{144}; \quad \psi_4(5) = \frac{1126}{144}$$

$$\psi'_1(5) = \frac{72}{144}; \quad \psi'_2(5) = \frac{177}{144}; \quad \psi'_3(5) = \frac{321}{144}; \quad \psi'_4(5) = \frac{510}{144}$$

$$\psi''_1(5) = \frac{30}{144}; \quad \psi''_2(5) = \frac{66}{144}; \quad \psi''_3(5) = \frac{108}{144}; \quad \psi''_4(5) = \frac{156}{144}$$

$$\psi'''_1(5) = \frac{6}{144}; \quad \psi'''_2(5) = \frac{12}{144}; \quad \psi'''_3(5) = \frac{18}{144}; \quad \psi'''_4(5) = \frac{24}{144}$$

$$\Psi(5) = \frac{1}{144} \left\{ 0 \cdot 5_x + 112 \cdot 5_{x-1} + 312 \cdot 5_{x-2} + 636 \cdot 5_{x-3} + 1126 \cdot 5_{x-4} \right\}$$

$$\Psi'(5) = \frac{1}{144} \left\{ 0 \cdot 5_x + 72 \cdot 5_{x-1} + 177 \cdot 5_{x-2} + 321 \cdot 5_{x-3} + 510 \cdot 5_{x-4} \right\}$$

$$\Psi''(5) = \frac{1}{144} \left\{ 0 \cdot 5_x + 30 \cdot 5_{x-1} + 66 \cdot 5_{x-2} + 108 \cdot 5_{x-3} + 156 \cdot 5_{x-4} \right\}$$

$$\Psi'''(5) = \frac{1}{144} \left\{ 0 \cdot 5_x + 6 \cdot 5_{x-1} + 12 \cdot 5_{x-2} + 18 \cdot 5_{x-3} + 24 \cdot 5_{x-4} \right\}$$

$$Y = -\frac{4}{2880} \left\{ \Psi(5) - 2 \cdot \Psi'(5) + \Psi''(5) + \frac{2}{3} \Psi'''(5) \right\}$$

$$= -\frac{1}{2880} \left\{ 0 \cdot 5_x + 8 \cdot 5_{x-1} + 128 \cdot 5_{x-2} + 456 \cdot 5_{x-3} + 1112 \cdot 5_{x-4} \right\}.$$

(38.) For Z we have

$$Q_x = -\frac{9x}{144} \cdot 2_{x-1} + \frac{1}{144} \left\{ 0 \cdot 12_x + 5 \cdot 12_{x-1} + \dots - 11 \cdot 12_{x-11} \right\}$$

$$Q_{x-1} = -\frac{9(x-1)}{144} \cdot 2_x + \frac{1}{144} \left\{ -11 \cdot 12_x + 0 \cdot 12_{x-1} + 5 \cdot 12_{x-2} \dots - 4 \cdot 12_{x-11} \right\}.$$

It will be convenient to separate this into two parts, viz.

$$Q'_{x-1} = -\frac{9(x-1)}{144} \cdot 2_x,$$

and

$$Q''_{x-1} = \frac{1}{144} \left\{ -11 \cdot 12_x + 0 \cdot 12_{x-1} + \&c. \right\}.$$

First, then, for Q'_{x-1} , proceeding as in article 30, we have

$$z = x, \chi_0(x) = -\frac{9}{144}(x-1); \chi_1(x) = 0.$$

$$\begin{aligned} X(x) &= 2_x \cdot \chi_0(x+10) + 2_{x-1} \chi_0(x+5) \\ &= -\frac{9}{144} \left\{ (x+9) \cdot 2_x + (x+4) \cdot 2_{x-1} \right\} \end{aligned}$$

$$X'(x) = -\frac{9}{144} (2_x + 2_{x-1}) = -\frac{9}{144},$$

whence Z' consisting now of the single term R' ,

$$\begin{aligned} Z' &= -\frac{9}{1440} \left\{ x^2 + x(9 \cdot 2_x + 4 \cdot 2_{x-1}) - \frac{x(x+10)}{2} \right\} \\ &= -\frac{9}{2880} \left\{ x^2 - 2x + 10x \cdot 2_x \right\}. \end{aligned}$$

As regards the other portion of Z , which in this case is R'' , it has for its expression

$$-\frac{9}{144} 2_x \cdot \frac{1 - (1 + \Delta)^{p_x + q'_x}}{\Delta} (9 + 10 \cdot 0) + 2_{x-1} \cdot \frac{1 - (1 + \Delta)^{p_x + q''_x}}{\Delta} (4 + 10 \cdot 0).$$

Now, whatever be h and c , we have always

$$\frac{1 - (1 + \Delta)^h}{\Delta} (c + 10 \cdot 0) = (5 - c)h - 5h^2.$$

In this, if we write for h successively $h' = p_x + q'_x$ and $h'' = p_x + q''_x$, and for c , 9 and 4, we find

$$Z'' = +\frac{9}{144} \left\{ 2_x (4h' + 5h'^2) - 2_{x-1} (h'' - 5h''^2) \right\}.$$

But since $x = 10$ and $s = 5$, we have

$$\begin{aligned} h' &= \frac{1}{10} \left\{ 0 \cdot 10_x + 1 \cdot 10_{x-1} + 2 \cdot 10_{x-2} + 3 \cdot 10_{x-3} + 4 \cdot 10_{x-4} - 5 \cdot 10_{x-5} - 4 \cdot 10_{x-6} - 3 \cdot 10_{x-7} - 2 \cdot 10_{x-8} - 1 \cdot 10_{x-9} \right\} \\ h'' &= \frac{1}{10} \left\{ 0 \cdot 10_x + 1 \cdot 10_{x-1} + 2 \cdot 10_{x-2} + \dots + 9 \cdot 10_{x-9} \right\}. \end{aligned}$$

Substituting which in Z'' and employing the property of equation (14.) for the com-

putation of the coefficients, we find

$$Z'' = \frac{9}{2880} \left\{ 2_x \{ 0.10_x + 9.10_{x-1} + 20.10_{x-2} + 33.10_{x-3} + 48.10_{x-4} - 15.10_{x-5} - 16.10_{x-6} - 15.10_{x-7} - 12.10_{x-8} - 7.10_{x-9} \} \right. \\ \left. + 2_{x-1} \{ 0.10_x - 1.10_{x-1} + 0.10_{x-2} + 3.10_{x-3} + 8.10_{x-4} + 15.10_{x-5} + 24.10_{x-6} + 35.10_{x-7} + 48.10_{x-8} + 63.10_{x-9} \} \right. \\ \left. = \frac{9}{2880} \{ 0.10_x - 1.10_{x-1} + 20.10_{x-2} + 3.10_{x-3} + 48.10_{x-4} + 15.10_{x-5} - 16.10_{x-6} + 35.10_{x-7} - 12.10_{x-8} + 63.10_{x-9} \} \right.$$

(39.) Finally, we have to consider the portion Z''' of Z originating in Q''_{x-1} , in which the values of $\chi_0, \chi_1, \&c.$ are given by the equation

$$\chi_i = \frac{1}{144} \left\{ -11.12_i + 0.12_{i-1} + 5.12_{i-2} - 20.12_{i-3} \dots \dots - 4.12_{i-11} \right\},$$

the coefficients being those of equation (51.) in their order of circulation. We have also, since in this case $m=12, s=5$, and therefore prime to each other, $v=1, t=12, n=60$. Whence

$$\chi_0 \cdot v_x + \chi_1 v_{x-1} + \dots + \chi_{m-1} v_{x-m+1} = \chi_0 + \chi_1 + \dots + \chi_{m-1} = -\frac{78}{144},$$

and therefore

$$Z''' = -\frac{26x}{2880} - \frac{26}{2880} \left\{ 60.60_x + 59.60_{x-1} + 58.60_{x-2} + \dots + 1.60_{x-59} \right\} \\ - \frac{20}{2880} \left\{ -11.60_x + 0.60_{x-1} + 5.60_{x-2} - 20.60_{x-3} - 27.60_{x-4} \right\} \\ - \frac{20}{2880} \left\{ -36.60_x + 5.60_{x-1} + 16.60_{x-2} - 27.60_{x-3} - 4.60_{x-4} - 11.60_{x-5} + 0.60_{x-6} + 5.60_{x-7} - 20.60_{x-8} - 27.60_{x-9} \right\} \\ - \frac{20}{2880} \left\{ +5.60_x - 20.60_{x-1} - 27.60_{x-2} \dots \dots \dots - 27.60_{x-14} \right\} \\ - \frac{20}{2880} \left\{ +16.60_x - 27.60_{x-1} - 4.60_{x-2} \dots \dots \dots - 27.60_{x-19} \right\} \\ - \frac{20}{2880} \left\{ -27.60_x + 32.60_{x-1} - 11.60_{x-2} \dots \dots \dots - 27.60_{x-24} \right\} \\ - \frac{20}{2880} \left\{ -4.60_x - 11.60_{x-1} + 0.60_{x-2} \dots \dots \dots - 27.60_{x-29} \right\} \\ - \frac{20}{2880} \left\{ -11.60_x - 36.60_{x-1} + 5.60_{x-2} \dots \dots \dots - 27.60_{x-34} \right\} \\ - \frac{20}{2880} \left\{ 0.60_x + 5.60_{x-1} - 20.60_{x-2} \dots \dots \dots - 27.60_{x-39} \right\} \\ - \frac{20}{2880} \left\{ +5.60_x + 16.60_{x-1} - 27.60_{x-2} \dots \dots \dots - 27.60_{x-44} \right\} \\ - \frac{20}{2880} \left\{ -20.60_x - 27.60_{x-1} + 32.60_{x-2} \dots \dots \dots - 27.60_{x-49} \right\} \\ - \frac{20}{2880} \left\{ -27.60_x - 4.60_{x-1} - 11.60_{x-2} \dots \dots \dots - 27.60_{x-54} \right\} \\ - \frac{20}{2880} \left\{ +32.60_x - 11.60_{x-1} - 36.60_{x-2} \dots \dots \dots - 27.60_{x-59} \right\}$$

Assembling, finally, the several portions, X, Y, Z', Z'', Z''' , of which $\Pi(x)$ consists, and reducing those periodic functions, which have 5 and 10 for their period, to a period of 60, we see

$$\begin{aligned}
\Pi(x) = & \frac{1}{2880} \left\{ x^4 + 10x^3 + 10x^2 - 30x - 90x \cdot 2_x \right\} \\
& + \frac{1}{2880} \left\{ 0 \cdot 60_x + 9 \cdot 60_{x-1} + 104 \cdot 60_{x-2} - 387 \cdot 60_{x-3} - 576 \cdot 60_{x-4} + 905 \cdot 60_{x-5} \right. \\
& \quad - 216 \cdot 60_{x-6} - 351 \cdot 60_{x-7} - 256 \cdot 60_{x-8} + 9 \cdot 60_{x-9} + 360 \cdot 60_{x-10} - 31 \cdot 60_{x-11} \\
& \quad - 576 \cdot 60_{x-12} + 9 \cdot 60_{x-13} + 104 \cdot 60_{x-14} + 225 \cdot 60_{x-15} - 576 \cdot 60_{x-16} + 329 \cdot 60_{x-17} \\
& \quad - 216 \cdot 60_{x-18} - 351 \cdot 60_{x-19} + 320 \cdot 60_{x-20} + 9 \cdot 60_{x-21} - 216 \cdot 60_{x-22} - 31 \cdot 60_{x-23} \\
& \quad - 576 \cdot 60_{x-24} + 585 \cdot 60_{x-25} + 104 \cdot 60_{x-26} - 351 \cdot 60_{x-27} - 576 \cdot 60_{x-28} + 329 \cdot 60_{x-29} \\
& \quad + 360 \cdot 60_{x-30} - 351 \cdot 60_{x-31} - 256 \cdot 60_{x-32} + 9 \cdot 60_{x-33} - 216 \cdot 60_{x-34} + 545 \cdot 60_{x-35} \\
& \quad - 576 \cdot 60_{x-36} + 9 \cdot 60_{x-37} + 104 \cdot 60_{x-38} - 351 \cdot 60_{x-39} + 0 \cdot 60_{x-40} + 329 \cdot 60_{x-41} \\
& \quad - 216 \cdot 60_{x-42} - 351 \cdot 60_{x-43} - 256 \cdot 60_{x-44} + 585 \cdot 60_{x-45} - 216 \cdot 60_{x-46} - 31 \cdot 60_{x-47} \\
& \quad - 576 \cdot 60_{x-48} + 9 \cdot 60_{x-49} + 680 \cdot 60_{x-50} - 351 \cdot 60_{x-51} - 576 \cdot 60_{x-52} + 329 \cdot 60_{x-53} \\
& \quad \left. - 216 \cdot 60_{x-54} + 225 \cdot 60_{x-55} - 256 \cdot 60_{x-56} + 9 \cdot 60_{x-57} - 216 \cdot 60_{x-58} - 31 \cdot 60_{x-59} \right\} . \quad (52.)
\end{aligned}$$

(40.) The periodic function $0 \cdot 60_x + \dots \&c.$ may be somewhat simplified by resolving it into the sum of three others, having respectively 10, 20 and 30 for their periods. For on inspecting its coefficients, we find that the differences of any two, distant from each other by 30, are alternately $+360$ and -360 . Now if we suppose, generally, any such function as

$$a_0 \cdot 60_x + a_1 \cdot 60_{x-1} + \&c.$$

to be made up of the sum of three others,

$$p_0 \cdot 30_x + p_1 \cdot 30_{x-1} + \&c.$$

$$q_0 \cdot 20_x + q_1 \cdot 20_{x-1} + \&c.$$

$$r_0 \cdot 10_x + r_1 \cdot 10_{x-1} + \&c.,$$

we shall have, supposing i any number of the series 0, 1, 2, ... 9,

$$p_i + q_i + r_i = a_i, \quad p_{i+10} + q_{i+10} + r_i = a_{i+10}, \quad p_{i+20} + q_i + r_i = a_{i+20}$$

$$p_i + q_{i+10} + r_i = a_{i+30}, \quad p_{i+10} + q_i + r_i = a_{i+40}, \quad p_{i+20} + q_{i+10} + r_i = a_{i+50}$$

which give the following equations of condition among the coefficients a ,

$$a_{30+i} - a_i = - (a_{40+i} - a_{10+i}) = a_{50+i} - a_{20+i}$$

And if these be satisfied (as in this case they are), we have only further to establish the following relations between p , q , r , viz.

$$p_i + q_i + r_i = a_i$$

$$p_{i+10} = p_i + (a_{i+10} - a_{i+30}); \quad p_{i+20} = p_i + (a_{i+20} - a_i)$$

$$q_{i+10} = q_i + (a_{i+30} - a_i).$$

Among the sixty coefficients therefore which this assumption places at our disposal, twenty remain arbitrary, and may be put $=0$.

Suppose, for example,

$$q_i = 0, \quad p_{i+20} = 0,$$

which give

$$p_i = a_i - a_{i+20}, \quad p_{i+10} = (a_i - a_{i+30}) + (a_{i+10} - a_{i+20})$$

$$q_{i+10} = a_{i+30} - a_i, \quad r_i = a_{i+20}.$$

These being calculated, the function $0.60_x + 9.60_{x-1} + \&c.$ reduces itself to the following, which seems the simplest form it admits :

$$\begin{aligned} & -320\{30_x - 30_{x-2} + 30_{x-3} - 30_{x-5} + 30_{x-6} - 30_{x-8} + 30_{x-9} + 30_{x-10} - 30_{x-11} + 30_{x-13} \\ & \quad - 30_{x-14} + 30_{x-16} - 30_{x-17} + 30_{x-19}\} \\ & + 360\{20_{x-10} + 20_{x-11} + 20_{x-12} + 20_{x-13} + 20_{x-14} + \dots + 20_{x-19}\} \\ & + \{320.10_x + 9.10_{x-1} - 216.10_{x-2} - 31.10_{x-3} - 576.10_{x-4} + 585.10_{x-5} + 104.10_{x-6} \\ & \quad - 351.10_{x-7} - 576.10_{x-8} + 329.10_{x-9} \dots \dots \dots (53.) \end{aligned}$$

(41.) The problem, "In how many ways can a given number be constructed," is reduced by the author of a short but interesting paper in the Cambridge Mathematical Journal, iv. p. 87*, to the integration of the equations of differences

$$u_{x,y} = u_{x-y, x+y} \quad \text{and} \quad u_{x,y} - u_{x-y, y} = u_{x-1, y-1},$$

which last equation corresponds to the case where it is required to find in how many ways x can be composed of numbers none greater and not all less than y . The analogy of this problem with that here treated is obvious, the function $u_{x,y}$ being in effect identical with that which in the above notation would be expressed by $\overset{y}{\Pi}(x)$, y corresponding to our s . Accordingly, as far as $y=4$, to which limit only the inquiry is there extended, the results are identical (the mode of expression excepted) with those of our equations (49.), (50.), (51.)†. The method there pursued (by the successive integration of equations of differences) would of course continue to afford similar results, but without some systematic processes of notation, transformation and reduction, such as those delivered in the foregoing pages, would speedily become too complicated to be followed out, though the sort of form which would ultimately be assumed by the result seems to have been clearly apprehended. Observing that in the cases of $y=2, 3, 4$, the results express in fact *the nearest integers* to certain rational fractions, such as $\frac{x^2}{12}$ in the case of $y=3$, $\frac{x^3+3x^2}{2}$ (x even) and $\frac{x^3+3x^2-9x}{2}$ (x odd) when $y=4$, it is suggested that "probably this simple species of description might be continued." This, on examination of the value above given, when y or $s=5$, appears to be the case, but for higher values it will be necessary to enlarge the terms of the description, so as to take in circulating functions of higher orders, and with more complicated coefficients. To make this apparent, suppose $s=6$. Then, without going into the whole calculation (which however would not be materially more complicated than for $s=5$, and would lead, as in that case, to a final period of 60, only not reducible to the sum

* It bears no name, but I have reason to believe it to be the production of PROFESSOR DEMORGAN.

† Mr. WARBURTON has also obtained expressions for the number of partitions as far as 4, and his results, *mutatis mutandis*, agree with the above.

of lower periods), it is easy to see, that besides a non-periodic portion of 5 dimensions in x , and a periodic one with 60 constant coefficients, there will also be a circulating portion of the form

$$a_x \cdot 6_x + b_x \cdot 6_{x-1} + \dots + f_x \cdot 6_{x-5},$$

whose coefficients may rise to the second dimension in x . In fact, if we execute the calculation of this portion by the foregoing processes, we find for the values of the coefficients

$$a_x = e_x = 0; \quad b_x = d_x = -\frac{4500x^2 + 15750x}{172800}; \quad c_x = \frac{3209x}{172800}.$$

With regard to the constant coefficients of the periodic portion, it is easy to see, from the manner of their formation, that they must all fall very far short, in numerical magnitude, of the half of 172800, so that the whole effect of this periodical part does, in effect, go to adjust the final value to *the nearest integer* of the rational fraction arising from the assemblage of all the terms in x , and a similar reasoning will apply in all cases.

(42.) The number of partitions of which a given number x is susceptible, admitting 0 into them as a component part, is the sum of the number of 1-partitions, bipartitions, tripartitions up to s -partitions. It may therefore be found, by adding together all the values of $\Pi(x)$, from $s=1$ to $s=s$ inclusive. But it may also be obtained by formulæ in all respects similar to those above demonstrated; for if we take $\Pi_s(x)$ to represent this species of partition, we have, if $s=1$, $\Pi_1(x)=1$ as before. For $s=2$ the partitions stand $0, x; 1, x-1; 2, x-2; \dots \left(\frac{x}{2}+1\right)$ terms, that is,

$$\Pi_2(x) = \Pi_1(x) + \Pi_1(x-2) + \dots \left(\frac{x}{2}+1\right) \text{ terms.}$$

Similarly,

$$\Pi_3(x) = \Pi_2(x) + \Pi_2(x-3) + \dots \left(\frac{x}{3}+1\right) \text{ terms,}$$

and so on to

$$\Pi_s(x) = \Pi_{s-1}(x) + \Pi_{s-1}(x-s) + \dots \left(\frac{x}{s}+1\right) \text{ terms,}$$

of which the formulæ of (30.) and (31.), duly applied, give the value

$$\Pi_s(x) = \frac{1 - (1 + \Delta)^{-\frac{x}{s}}}{\Delta} \Pi_{s-1}(x + s + s \cdot 0) + \frac{1 - (1 + \Delta)^q}{\Delta} \Pi_{s-1}(s + s \cdot 0),$$

where

$$q = -\frac{1}{s} \left\{ s-1 \cdot s_{x-1} + s-2 \cdot s_{x-2} + \dots + 1 \cdot s_{x-s+1} \right\},$$

which, developed, affords a calculable value of the function in question.

Collingwood, April 17, 1850.

XX. *Experiments on the Section of the Glossopharyngeal and Hypoglossal Nerves of the Frog, and observations of the alterations produced thereby in the Structure of their Primitive Fibres.* By AUGUSTUS WALLER, M.D. Communicated by Professor OWEN, F.R.S.

Received November 22, 1849,—Read February 21, 1850.

THE object of the present observations is to describe certain alterations which take place in the elementary fibres of the nerve after they have been removed from their connection with the brain or spinal marrow.

The following is a brief summary of the opinions and researches of modern physiologists on alterations of the nerve-tubes.

BURDACH* placed a ligature on the sciatic nerve of a frog, and after the lapse of a week found no alteration of the primitive fibres either above or below the ligature.

STEINRUCK† did the same, and states that in three cases the whole nerve was more slender than on the healthy side, and ascribed it to the atrophy of the neurolema.

VALENTIN‡ denies likewise that there is any alteration of the primitive fibres in the lower portion of the nerve.

GUNTHER and SCHÖN§, whose researches are most interesting, state that the primitive fibres being examined towards the end of a week, after division of the nerve when it had lost its irritability, it was perceived that they had no longer the full round appearance of the sound ones. Here and there their contents appeared as if curdled; from eight to fourteen days after section these structural changes became still more evident, and continued to increase until the fibres appeared flat, broken up, entirely losing their transparency, their contents appearing as if disjointed.

NASSE|| states, that five months after section of the sciatic nerve of a frog, the tubes below the section were broken up into granules and small clumps; that all the nerve-tubes were strongly granulated, in some the small granules being united into oval bodies, which appeared to be surrounded by a pale cylindrical membrane, which in some was wanting, owing probably to its disorganization.

Having in a former communication to the Royal Society described the nerves of the papillæ and of the muscular fibre in the frog's tongue in their normal condition,

* Beitrag zur Mikroskopischer Anatomie der Nerven, E. BURDACH. Königsberg, 1837, p. 42.

† De Nervorum Regeneratione. Berolini, 1838, p. 72.

‡ De Functionibus Nervor Cerebral, &c. Lib. iv. 1839, p. 127.

§ MÜLLER'S Archiv, 1840, Versuche und Bemerkungen über Regeneration der Nerven, p. 276.

|| Ueber die Veränderungen der Nerven-fasern nach ihrer Durchschneidung, MÜLLER, Arch. 1839, p. 409.

it is my intention at present to describe various alterations, as seen under the microscope, which take place in the structure of the same nerves after their continuity with the brain has been interrupted by section. The innervation of the frog's tongue is, as I have already shown, derived from two pairs of nerves, one arising from the brain, and traversing a foramen in the posterior part of the cranium, accompanied by the pneumogastric nerve. This pair corresponds to the glossopharyngeal in Man. In its course it descends until it reaches the hyoglossus muscle, when it is accompanied by the lingual vessels passing over part of the hyoid bone, and entering the tongue without giving off any branch to the throat. The other pair arises from the anterior part of the spinal marrow, traverses the first cervical foramen, and constitutes the first cervical pair of nerves. Following the example of BURDACH, I regard this pair as corresponding to the hypoglossal in Man, and shall apply that term to it. It takes its course towards the tongue in a similar direction to that of the former pair, giving off several branches to the muscles of the neck and throat, and when it reaches the hyoglossus muscle it is considerably smaller than the glossopharyngeal. After attaining this muscle it runs parallel to the former nerve, passing below the hyoid bone in its transit to the tongue. For a more minute description I must refer to the paper of E. BURDACH, of which a translation has appeared in the *Annales des Sciences Naturelles*.

Division of the Glossopharyngeal Nerve.

That division of these nerves produces some serious lesion is proved by the death of the animal, which generally takes place a few days after the operation. Considering the well-known tenacity of life possessed by these animals this was quite an unexpected result, for which I am unable at present to afford any satisfactory reason. We can only surmise, that besides their gustatory powers, they have others connected with respiration, in regulating the action of the tongue in closing the nares, for forcing the air into the lungs. Whatever may be the true explanation, it is impossible not to regard this result with surprise, when we consider the serious lesions which this animal is capable of undergoing at other points of the frame without loss of life. The usual time which it survives is variable, and depends greatly on the season of the year. If the examination takes place in summer, death frequently ensues on the fifth day; if in winter, not before the twentieth. For the purpose of avoiding this loss of life, I adopt the plan of dividing the glossopharyngeal on one side only of the tongue, and I find that it has the desired effect of preserving the life of the animal, while we can observe the same alterations on the corresponding side, as well as when both nerves are divided. Another advantage found in the division of a single nerve is, that on the uninjured side we have constantly at hand a means of comparison by which we can judge with certainty respecting any alterations that may be produced in the divided nerve. In cases of any doubt, it will always be found of the greatest service to examine at the same time a minute fragment from each side of the tongue.

The first effects of section of a glossopharyngeal nerve at the throat, are decreased

power of moving the tongue, diminished sensibility, generally very slight on the divided side, and symptoms indicative of some disturbance of the nutritive functions. The diminution of motor power is very slight, as is evident by the almost molecular tremor which still exists in any part irritated, and by the capability of retracting the tongue. The loss of sensation, which is also very slight, arises from the section of a few sensitive filaments which are contained in the glossopharyngeal nerve, and are distributed principally about the tubercular extremities. The lesions of nutrition and circulation on the side of the division are very variable and uncertain. Sometimes that half is œdematous, particularly towards the tubercle. Sometimes the papillæ are much injected and congested, while in other cases this side is more pale than the other. In many instances no difference can be detected between the two sides, until the organ has been slightly irritated, when on the divided side the vessels, and especially those of the fungiform papillæ, become congested and of a deeper red than on the other. Some of these differences probably arise from causes independent of the nervous lesion, as the vessels of the tongue which accompany these nerves are doubtless injured in some of the experiments.

During the first two or three days after section, no alteration in the texture and transparency of the tubes of the papillary nerves can be detected. Generally, at the end of the third and fourth day, we detect the first alteration by a slightly turbid or coagulated appearance of the medulla, which no longer appears completely to fill the tubular membrane, which does not appear to be affected. These alterations of the medulla are best seen in a fragment to which a little distilled water has been added to render it more transparent. When examined twenty-four hours after death, the difference between these and the nerves on the healthy side is still more evident. Commencing decomposition on the healthy side causes the nerve-tubes to swell considerably, so as to attain nearly double their ordinary size. On the divided side the disorganized nerve retains nearly the same size and appearance as when fresh. Caustic potash, which dissolves all the tissues except the nerves, renders the altered nerves more transparent, and consequently the morphological changes are less apparent. Nevertheless, by comparative experiments made simultaneously, we may still detect a difference between the nerves of the two sides. In some cases, in about three or four days after section, I have traced the turbid state of the nerve from the fungiform papillæ into branches containing forty or fifty tubes, where it did not appear to terminate, but where the opacity of the nerve prevented my observing it any further. About five or six days after section, the alteration of the nerve-tubes in the papillæ has become much more distinct, by a kind of coagulation or curdling of the medulla into separate particles of various sizes. Sometimes the coagulated particles have an uneven spongy appearance, as if the component parts of the medulla, *i. e.* the white substance and the axis cylinder, were mixed together. Often they appear merely like separated particles of the medulla, such as are frequently effused from the ends of a divided nerve, and present the double contour and the central nucleus cha-

racteristic of the nervous medulla. In some cases the coagulated particles are very uniform in size and appearance, averaging $\frac{1}{7000}$ th of an inch. In others, the limits between the maximum and minimum dimensions are far greater, namely, from $\frac{1}{2500}$ th to $\frac{1}{12,500}$ th of an inch. The diameter of the altered tubes, examined in the ordinary manner in water, is about a fourth smaller than that of the sound ones, and in many instances the tubular cylinders appear wanting, and the medullary particles to have escaped from the cylinder, and to be merely held together by the neurilema which surrounds the whole nerve. After the application of potash, the diameter of the altered and unaltered nerves is as nearly as possible the same. This equalization of the two is produced almost entirely by a decrease in the size of the sound tubes, which swell considerably in water, and afterwards contract by the application of the alkali. It is therefore probable that the difference of size at this stage between the altered and unaltered nerves arises from the former not absorbing so much within them as the latter. Whether this arises from a ruptured state of the membrane or from a chemical change of the medulla, is not evident. After the surrounding tissues have been removed by potash, the tubular membrane offers no signs of rupture, and the medulla appears less disorganized than before the denudation. The disjointed condition of the medulla is greatest towards the extremities. A portion of each nerve-tube is frequently so disorganized as to be carried away among the tissues dissolved by the alkali. The circular rim so frequently presented by the extremity of the tubes is absent. We often observe around the healthy nervous branches, and the papillary nerve in particular, a common sheath or neurilema fitting closely to the nerve. After disorganization has attained this degree, it appears to form a kind of loose pouch around the nerve and separated from it by an interval of $\frac{1}{5000}$ th of an inch. This pouch appears to form the sole investment of the curdled medullary particles, which, as we have stated, previous to the action of the alkali, appear void of any tubular investment. As we ascend towards the brain the disorganization appears to decrease, the coagulated medulla is more apt to assume the oval form, and at some places it presents its double contour apparently unaffected. The effect of decomposition in the unaltered and altered nerve is similar to that in the former stage. In consequence of the above changes the disorganized nerve is more opaque than the unaltered one. In the tubercles some of the ramifications of the tubes belonging to common sensation become disorganized after the section of the corresponding glossopharyngeals. These alterations take place in the same period and in the same manner as in the papillary nerves. With this exception, all the other nerves of the tongue, which comprise those of common sensation and of muscular action, remain unaltered. The muscular fibres of the papillæ are slightly altered at this period; their transverse striæ are not so distinct as on the healthy side, while their longitudinal ones are more so. The fibre itself is usually paler, narrower and more wavy in its course.

The capillaries are either much congested with dark blood, or they are completely empty and scarcely to be detected.

The epithelium and the ciliary filaments are unaltered.

On the seventh, eighth and ninth days the disorganization of the nervous structure continues to progress. In the papillæ the curdled particles of medulla become still more disconnected, and in parts are removed by absorption. The tubular sheath also is ruptured and disorganized near the extremities of the tubes. In the other ramifications of the glossopharyngeal, the medulla becomes more and more disjointed and collected into oval or circular coagulated masses.

On the tenth day and upwards we perceive another morphological state of the medulla. The coagulated particles lose their amorphous structure and assume a granulated texture. The granules, retained together by slight cohesion, are dark by transmitted light, but of a light white colour by reflexion, and average $\frac{1}{20,000}$ th of an inch.

About the twentieth day the medullary particles are completely reduced to a granular state. The condition of the papillary nerve is represented in Plate XXXI. fig. 2, where we find the presence of the nervous element merely indicated by numerous black granules, generally arranged in a row like the beads of a necklace. In their arrangement it is easy to detect the wavy direction characteristic of the nerves. They are still contained in the tubular membrane, which is but very faintly distinguished, probably from the loss of the medulla and from atrophy of its tissue. The resistance of these granular bodies to chemical agents is most remarkable, for they remain unaffected by acids, alkalies and the ethers, which have so great an influence over the nervous medulla. These granules may be detected within the papillary nerves for a considerable period of time. I have seen them apparently unaltered in the papillæ upwards of five months after division of the nerve, reunion not having taken place.

Division of the Hypoglossal Nerve.

When the hypoglossal nerves are divided at their exit from the spine, all movements of the throat and tongue are abolished, and the process of respiration entirely at an end. The tongue may be drawn from the mouth remaining completely inert, pinching or cutting causing no appearance of pain. Hence we may conclude that this nerve is of a mixed nature, containing sensorial as well as motor filaments. Another experiment, which shows this more plainly, consists in dividing one hypoglossal nerve near the spine on one side, and on the other the glossopharyngeal at its exit from the cranium. Pinching and other modes of irritation cause no pain on the side where the hypoglossal is divided, while on the other undoubted pain is caused.

After division of the hypoglossals at the throat, the motor and sensorial powers of the tongue are not entirely lost. When drawn out of the mouth, the extremity only remains fixed between the jaws, flaccid and powerless. At the inner half the fibres are still contractile, on account of their belonging to the hypoglossus, which at its lower half receives a branch from the hypoglossal nerve above the point of section. By this

means, aided also by the mylohyoid muscle, which is left unaffected for the same reason, the inner half of the tongue still enjoys contractile powers.

Respiration is hurried and laboured, and death is the invariable result of division of these nerves, whether made at the spine or at the throat. In summer, the animals died at the end of two or three days.

Division of a single hypoglossal only causes paralysis of the corresponding half of the tongue, complete when the section is near the spine, and imperfect when at the throat. The animals generally survive after the section of one nerve.

The peripheric extremities of the hypoglossal nerves are most easily found at the inferior surface of the tongue. By removing a minute fragment at this region, we can observe, without any further preparation, ramifications of nerves, which are gradually reduced to a network of single tubules on the surface, among the capillary network. At the same time, among the muscular fibres are other ramifications, either crossing them in a transverse direction or running parallel. Like the former, they are reduced to single fibres, running in all directions without forming any free ends. It is at the under surface that the alterations of the hypoglossal must be studied.

During the four first days, after section of the hypoglossal nerve, no change is observed in its structure. On the fifth day the tubes appear more varicose than usual, and the medulla more irregular. About the tenth day the medulla forms disorganized, fusiform masses at intervals, and where the white substance of SCHWANN cannot be detected. These alterations, which are most evident in the single tubules, may be found also in the branches. After twelve or fifteen days many of the single tubules have ceased to be visible, their granular medulla having been removed by absorption. The branches contain masses of amorphous medulla.

We are naturally led to inquire, whether extraneous circumstances have any influence over the removal of the tissue. We find that in the summer-time, when the renewal of the tissues must be considerably more active, in consequence of the increased respiration and activity of the animals experimented upon, that the alteration is more rapid than in winter, when they are in a state of torpor and hybernation.

At present we have restricted our observations to the alterations which take place in the ramifications originating from two trunks, but we cannot suppose that this is a local phenomenon, and that other nerves do not participate in similar alterations, and that the brain itself, composed in great part of tubular fibres, must be excluded. Experiments on other nerves already enable me to affirm that such is not the case, and that they are to be found on other nerves, such as the sciatic, &c., and, moreover, that they are as extensive as the nervous system itself. It is impossible not to anticipate important results from the application of this inquiry to the different nerves of the animal system. But it is particularly with reference to nervous diseases that it will be most desirable to extend these researches. If one conviction impresses itself more firmly on the mind than another, it is that what we term functional diseases of

the nerves are in reality owing to certain organic and physical changes in the tubular fibre, which it will be the province of the microscope to ascertain. If a few days' inactivity of a nervous trunk, such as is produced by ligature or section, is sufficient to cause such disorganization of the medulla, how can we refuse to admit of its being altered in cases of prolonged paralysis?

Kensington, October 27, 1849.

DESCRIPTION OF THE PLATE.

PLATE XXXI.

- Fig. 1. Papillary nerve of frog, six days after ligature.
- Fig. 2. Papillary nerve, three weeks after section, with muscular fibres in the interior of the capillary coil at the summit of the fungiform papilla.
- Fig. 3. Disorganized muscular nerve, from the inferior surface of the tongue, five days after section. The muscular fibre has been omitted in this drawing.

XXI. *Influence of Physical Agents on the development of the Tadpole of the Triton and the Frog.* By JOHN HIGGINBOTTOM, *Hon. Fellow of the Royal College of Surgeons of England.* Communicated by THOMAS BELL, *Esq., Sec. R.S.*

Received April 6,—Read May 16, 1850.

AN opinion has been generally entertained by physiologists that the tadpole of the Frog, when deprived of *the influence of light*, cannot arrive at its full development, or assume the form of the perfect frog.

I made a series of experiments in different positions and degrees of temperature, but particularly in a rock-cellar thirty feet deep, where no solar light ever entered; this situation was also favourable in point of temperature, being

48° FAHR. from March 11th to May 15th.

50° to 54° FAHR. from May 15th to July 6th, and

55° FAHR. from July 6th to October 31st.

My first experiments were performed on the tadpole of the Triton.

Exp. 1.—I found the tadpole of the *Triton punctatus* more tenacious of life than that of the *Triton cristatus*. I commenced with placing a number of the ova, enveloped in blades of grass in the manner usual with this animal, in three open shallow vessels containing water. One vessel I placed in a room where the mean temperature was 60° FAHR., another in the open air at a mean temperature of 50°, and the remaining one in a deep rock-cellar at 48°.

In the temperature of 60° FAHR. some of the tadpoles escaped from the ova in fourteen days, those at 50° in twenty-one days, and those at 48° in the rock-cellar in twenty-one days.

Although the tadpoles in the cellar at 48° escaped as early as those out of doors, they did not afterwards increase in growth, whilst those in the room at 60° and in the open air at 50° became more developed, the former of these having the anterior extremities in thirty-nine days, the latter in forty-nine days, whilst those in the cellar had no appearance of an extremity at the end of sixty-two days.

Exp. 2.—On the 4th of July I made another experiment with the ova of the Triton in the rock-cellar at its maximum temperature of 55° FAHR. I placed a number of ova in that situation; the tadpoles escaped in due time, but, as in the former experiment, they did not proceed in their development, having no appearance of anterior extremities in 105 days, when they died for want of proper food.

Exp. 3.—On the 11th of August I put twenty-four tadpoles of the Triton in water,

in an earthen vessel enveloped in four or five folds of black calico, so as to exclude the light, the mean temperature of the room being 65° FAHR. I placed the same number under a shed where the mean temperature of the atmosphere was 60° , and a similar number in the deep, dark rock-cellar then at a constant temperature of 55° .

In six days several of the tadpoles in the vessel in the room at 65° and in the open air at 60° were dead, and on examination I found that their branchiæ were absorbed, and their opercula nearly closed, and I concluded that they had died of asphyxia. I now took the precaution to place a stone in the centre of each vessel, so as to allow the tritons to leave the water as they lost their branchiæ. Two days afterwards the top of the stones had a number of tritons upon them in the vessels in the room and in the open air.

All those placed in the rock-cellar retained their branchiæ, not one having left the water, although I had placed stones for that purpose. No more tritons died after the stones had been placed in the vessels, as they afforded them the opportunity of leaving the water when the branchiæ were absorbed.

In about twenty-one days afterwards, during the month of September, two or three had left the water and were on the stones placed in the vessel *in the cellar*, fully proving that the animal came to its full development in the absence of light, though this development was retarded by the low temperature of 55° .

Exp. 4.—On the 25th of August I deprived three tritons, one of an anterior, another of a posterior extremity, and the third of the tail. I put these into a vessel, which I enveloped in five or six folds of black-glazed calico so as to exclude the light, and placed it in a dark part of a room where the maximum temperature was 70° FAHR. As it was then the time of the year when the full-grown tritons leave the water, I placed a quantity of clay and flat stones in the vessel with a little water at the lowest part, in order to allow them to remain in the water or out of it.

In a month the amputated limbs had undergone the reproductive process; in one a miniature posterior extremity furnished with toes had been formed, in another the tail, and in fourteen days later the anterior extremity and the toes of the third were reproduced.

I now began a series of experiments on the Frog (the *Rana Temporaria*); this batrachian being more manageable in regard to food, and arriving at its full development in much less time than the Triton, the former only requiring about ten weeks, the latter about five months.

I commenced my experiments and observations on the Frog in March 1848, ascertaining accurately the influence of air, food, temperature and light, *from the ovum to its full development*.

On the Influence of the Atmospheric Air.

There are three modes of respiration in the tadpole of the Frog:—1st, the Branchial; 2nd, the Pulmonary; 3rd, the Cutaneous.

In the branchial state the body of the tadpole is very small, and at this period they flock to the sides of the vessel in which they are contained close to the edge of the water, nearly exposing the branchiæ to the atmospheric air, the lungs being as yet unemployed.

About a fortnight before the metamorphosis of the tadpole into the frog, its body is very large, and the cutaneous surface for respiration, including the tail, is very considerable; but when the development takes place, the body of the frog is again small, and there is not a sufficient surface for respiration, so that if the animal continues in the water, it becomes asphyxiated. Life then depends more on the pulmonary than the cutaneous respiration.

I found that the tadpole of the Frog soon dies in either aërated or boiled water if excluded from atmospheric air; those in aërated water live the longest; some of them I found at the top of the water, and on examination the lungs were observed to be inflated, whilst those tadpoles in the boiled water sank to the bottom of the vessel. Tadpoles put into boiled water exposed to the atmospheric air live as in aërated water.

2. *On the Influence of Food.*

The food of the tadpole is derived from two sources. The first is the gelatine of the ova, the second the plants growing in the water in which they are deposited.

1848.—On the 11th of March I put some spawn of the frog, newly deposited, into eight shallow earthenware vessels containing water; in four of them I added grass and duck-weed to serve as food for the future tadpoles, in the other four I put none. I observed in all the vessels that the tadpoles, after escaping from the ova, had about an equal growth, as long as any of the jelly-like substance of the ova remained; but after that was consumed, the tadpoles in the vessels where there was no grass were promptly retarded in their growth.

April 17th.—To prove whether the jelly of the ova was food for the young tadpoles, I separated a number from the jelly, putting the tadpoles in one vessel with water, and the jelly in another.

In thirteen days I found the tadpoles had not increased in size, and that some of them were very weak and nearly inanimate. On this day I placed them all with the jelly. In seven days the jelly was consumed, and some of the tadpoles had much increased in size, others of them had died from having been so long and at so early a period deprived of their *first food*.

After the tadpole has finished feeding on the jelly, nothing more is required for food than grass and duck-weed, the grass serving for food, the duck-weed both for food and as a shelter, and also probably yielding its influence as a living vegetable in the water. The grass is sufficient as food to produce the full development of the tadpole, which feeds upon the chlorophyle which adheres to the cells of the plant,

when the plant is in a state of decomposition, leaving the fibrous part. They generally feed on the under part of the plant with the abdomen upwards, owing to the position of the mouth.

I supplied the tadpoles with fresh water every third day, and with grass as often as necessary. In those vessels which were placed in the dark it was necessary to add grass more frequently, on account of the loss of the green colour it sustained in that situation.

I observed they did not feed so well at a low temperature. The life of the tadpole cannot be preserved very long with fresh water and air alone without proper food. I placed a number of tadpoles in eight vessels, of which four were excluded from the light, and four exposed to the light in different degrees of temperature; no food was put in any of the vessels after they had consumed the jelly. On the 11th of May, eight weeks and four days after the deposition of the spawn, the tadpoles remained very small, and the last of them died on that day.

The jelly appears to be quite essential as nutriment to sustain the early life of the tadpole. Had they been deprived of it, they would have died at a much earlier period, as proved by my former experiment*.

3. *On the Influence of Temperature.*

On the 11th of March 1848, I procured four round open earthenware vessels, each containing about three pints of water, and filled them about three parts full. In each I put a small quantity of the spawn of the frog just deposited, and I then placed them in four different degrees of temperature.

The *first* was placed near the ceiling in a shaded part of a room, where the mean temperature was 60° FAHR., six or eight folds of black-glazed calico being tied over it so as to exclude all light.

On the 20th of March (see Plate XXXII.) the tadpoles left the ova; on the 23rd the branchiæ were fully formed; on the 22nd of May the first was fully developed at a much earlier period than others placed in a lower part of the same room, exposed to the light at the mean temperature of 58° FAHR., and also earlier than in the pools.

The *second* was placed at the same time in a situation where the mean temperature was 56°. On the 20th of March, nine days after the deposition of the ova, the embryos were lengthened, indicating the head, body and caudal extremity, and lay in a curved position within the ova. On the 25th some escaped from the ova. On the 28th the branchiæ were fully formed, and on the 6th of April they were absorbed. On the 22nd of May the tadpoles had increased in size. On the 18th of August the first was fully developed.

The *third* vessel was put within a larger one and placed in the open air, on a shaded

* According to Mr. Brande (Philosophical Transactions for 1810), the jelly appears to be an intermediate substance between albumen and gelatine.

side of a house, and entirely covered with wood, so as to exclude all light, the mean temperature being 53° FAHR.

March 20th.—In nine days after the deposition of the ova, the embryos retained their globular form, but considerably increased in size.

On the 25th they had the elongated form within the ova; on the 31st they escaped. On the 4th of April the branchiæ were fully formed, and on the 11th they were absorbed. May 22nd, the tadpoles were increased in size. On the 28th of August the first was fully developed (see Plate XXXII.).

The *fourth* vessel I placed in the rock-cellar. The temperature was uniformly 48° FAHR. from the 11th of March to the 15th of May, 50° to 54° FAHR. from May 15th to July 6th, and 55° FAHR. uniformly from July to October 31st.

March 31st.—The tadpoles escaped from their ova on the same day as in that in the open air, the temperature being in the cellar uniformly 48° FAHR., in the open air 53° mean temperature.

On the 6th of April the branchiæ were formed, and on the 18th they were absorbed. On the 22nd of May the tadpoles were very small, but from that period to the 5th of September they grew much more rapidly. On the 31st of October the first was fully developed.

It will be observed (Plate XXXII.) that when the tadpole in the room was fully developed at the mean temperature of 60° FAHR., those in the open air were small at the mean temperature of 53° , but those in the cellar were smaller still, having been influenced by the low temperature of 48° ; from March 11th to May 6th, when the temperature became constantly 55° , they advanced more rapidly in size until their full development.

November 17th.—Soon after this period the temperature in the rock-cellar was from 50° to 54° FAHR. for a month, and during that time there were no more tadpoles fully developed. One of them had three legs only; for upwards of three weeks the fourth leg could be seen distinctly under the skin when the animal moved, but it did not protrude.

All these results are displayed in Plate XXXII., in which the difference of temperature and its effects are registered.

4. *On the Influence of Light.*

With regard to the question of full development of the tadpole of the Frog in the absence of light, I am enabled by the most minute observation to state that it advances in growth equally well in the dark and in the light, and that absence of light has therefore no influence in retarding its development.

I have ascertained this by frequent experiments during the last two years; one experiment was made on an extensive scale.

I had six vessels with tadpoles, three exposed to the light in different degrees of temperature, and three from which the light was excluded.

At the first I was led to think the absence of light was even favourable to development, but I afterwards found that the difference depended on a slight increase of temperature owing to the vessel being covered. This fact is rendered obvious by the Plate, in which the temperature and absence of light are fully illustrated.

Nottingham,
February 5, 1850.

P.S. I made these experiments in 1848; they were repeated in the year 1849 with similar results.

XXII. *On the Temperature of Man within the Tropics.*

By JOHN DAVY, M.D., F.R.S., L. & E., *Inspector-General of Army Hospitals.*

Received February 26,—Read May 2, 1850.

IN a paper on the Temperature of Man, which I had the honour to submit to the Royal Society in 1845, and which was published in the Philosophical Transactions for the same year, I expressed the hope of being able to continue the inquiry in the West Indies, to which I was then about to proceed.

In the present communication I propose to lay before the Society the results of the trials made whilst there, viz. during a period of about three years and a half, exclusive of trifling interruptions, and of one prolonged through several weeks, between June 1847 and October of that year, owing to illness.

In making the trials, the same instrument as that before used was employed, and with like precautions to ensure accuracy, and as then, the subject of the observations was the same individual; also, as then, the pulse and respirations were noticed at the time, and invariably in the sitting posture.

The greater number of the observations were made in Barbados, in a house situated about half a mile from the sea-shore and a few feet only above its level,—where the mean annual temperature of the atmosphere is about 80° FAHR., and the range of temperature throughout the year from about 10° to 18° in the open air.

For the sake of comparison, I shall follow as closely as possible the order observed in my former paper in stating the results.

1. *Of the Variation of Temperature during the twenty-four hours.*

To ascertain this, observations were made commonly three times a day, viz. immediately on rising, about 6 A.M., before taking any food, and before making any exertion, even in dressing, clad merely in a light dress consisting of loose drawers and gown, which in that climate are almost always sufficient for comfort;—next, about 2 P.M., sometimes an hour earlier or later, and generally after occupation, either within doors at home, or at an office a mile and a half distant nearly, to which I went in a carriage,—the occupation being chiefly that of reading or writing, or some other requiring little bodily exertion;—next, the last thing before retiring to rest at night, which was commonly at 10 o'clock, rarely later than 11.

It may be further premised, that the manner of living, as to diet and the time of meals, was much the same as in England,—breakfasting commonly at 9 o'clock, dining about 5, without intermediate luncheon, and drinking tea about 7.

The following Table exhibits the observations made in accordance with the above,

daily, during a period of thirty-six months: in an Appendix, the observations as daily recorded will be given, omitting only those which may be considered abnormal, either owing to bodily ailment, or other cause of a special kind, requiring particular notice:—

| | Temperature under the tongue. | | | Pulse. | | | Respirations. | | | Temperature of air of room. | | |
|---------------|-------------------------------|-----------|-----------|----------|-----------|-----------|---------------|-----------|-----------|-----------------------------|-----------|-----------|
| | 6-7 A.M. | 12-2 P.M. | 9-11 P.M. | 6-7 A.M. | 12-2 P.M. | 9-11 P.M. | 6-7 A.M. | 12-2 P.M. | 9-11 P.M. | 6-7 A.M. | 12-2 P.M. | 9-11 P.M. |
| 1845. | | | | | | | | | | | | |
| July | 98.2 | 99 | 98.2 | 56 | 61 | 60 | 14.7 | 15.5 | 16 | 78.3 | 81.5 | 79.4 |
| August | 98 | 98.7 | 98.2 | 53.8 | 53.6 | 57.9 | 15 | 15.7 | 15.8 | 78.7 | 84 | 80.3 |
| September ... | 98 | 98.9 | 98.9 | 54.3 | 55 | 62.1 | 15.2 | 15.6 | 15.6 | 78.6 | 84.7 | 80.5 |
| October | 97.9 | 99 | 98.8 | 53.4 | 56.3 | 61.3 | 14.6 | 15.9 | 16.8 | 78 | 85.4 | 81 |
| November ... | 98 | 98.6 | 98.7 | 53.3 | 56.5 | 61 | 14.8 | 15.6 | 16 | 78 | 83.4 | 79.9 |
| December ... | 98 | 98.6 | 98.6 | 53.8 | 55.2 | 66 | 14.4 | 15.5 | 15.7 | 75 | 81.8 | 77 |
| 1846. | | | | | | | | | | | | |
| January | 98.2 | 99 | 98.7 | 54.3 | 58.5 | 61.7 | 14.6 | 15.7 | 15.6 | 74.3 | 82 | 78.2 |
| February ... | 98.1 | 99.1 | 98.6 | 55.1 | 57.1 | 59.9 | 14.3 | 15.5 | 15.2 | 74 | 83 | 76.6 |
| April | 98.1 | 98.7 | 98.6 | 54 | 54.5 | 59.5 | 14.4 | 15.6 | 15.4 | 77 | 84 | 79 |
| May | 98.2 | 98.9 | 98.9 | 56.2 | 55.2 | 61.4 | 15 | 15.8 | 15.6 | 78.7 | 85.8 | 80 |
| June | 98.2 | 99 | 98.8 | 55.1 | 55.6 | 59.7 | 14.6 | 15.7 | 15.4 | 79 | 84.7 | 81 |
| July | 98.2 | 99 | 98.9 | 54.5 | 54.5 | 60.7 | 14.7 | 16 | 15.3 | 78.8 | 84.8 | 81.4 |
| August | 98.1 | 99 | 98.9 | 54.2 | 55.6 | 60.5 | 14.6 | 15.9 | 15.6 | 77.7 | 85.5 | 81.7 |
| September ... | 98 | 99 | 98.2 | 55 | 54 | 60.8 | 14.3 | 15.9 | 16 | 78.7 | 85.1 | 81.3 |
| October | 98.2 | 99 | 99 | 52 | 55 | 61 | 14.4 | 15.4 | 15.3 | 78.2 | 85.1 | 81.2 |
| November ... | 98.1 | 98.9 | 98.8 | 56.2 | 55.4 | 60.1 | 14.6 | 15.8 | 15.6 | 77.4 | 84.4 | 80 |
| December ... | 98.1 | 98.9 | 98.9 | 55.3 | 55.3 | 63.5 | 14.5 | 15.8 | 15.8 | 76 | 80.5 | 77.4 |
| 1847. | | | | | | | | | | | | |
| January | 98.1 | 98.9 | 98.8 | 54.8 | 55.3 | 60.8 | 14.4 | 15.4 | 15 | 74.6 | 81.3 | 77.3 |
| February ... | 98 | 98.8 | 98.8 | 55.5 | 57.6 | 61.7 | 14.2 | 15.5 | 15.3 | 73 | 81.5 | 76.3 |
| March | 98.1 | 98.8 | 98.9 | 54.8 | 59.2 | 62.7 | 14.5 | 15.6 | 15 | 74.6 | 83.5 | 77.1 |
| April | 98.1 | 98.7 | 98.8 | 55 | 56.4 | 62.3 | 14.2 | 15.5 | 15.6 | 74.7 | 82.2 | 77.1 |
| May | 98.1 | 98.9 | 98.8 | 56.6 | 57.8 | 61.3 | 14.5 | 15.8 | 15.6 | 76.7 | 85 | 79.2 |
| October | 98 | 99 | 99 | 54.7 | 56 | 55.7 | 14.5 | 15.1 | 15.7 | 77.7 | 84.8 | 80 |
| November ... | 98.1 | 98.8 | 98.8 | 53.3 | 54.8 | 59.2 | 14.5 | 15.1 | 15.2 | 76.7 | 82.3 | 79 |
| December ... | 98 | 98.8 | 98.3 | 52.9 | 53.5 | 58 | 14.1 | 14.6 | 15.3 | 74.5 | 81.1 | 76.9 |
| 1848. | | | | | | | | | | | | |
| January | 98.1 | 98.9 | 98.8 | 54.5 | 56.8 | 59.3 | 14.1 | 14.9 | 15.2 | 74.1 | 80.5 | 76.6 |
| February ... | 98 | 98.8 | 98.8 | 54.9 | 57 | 59.7 | 14.5 | 15.1 | 15.5 | 73.6 | 82.1 | 77.5 |
| March | 98 | 98.9 | 98.9 | 54.9 | 57.6 | 59.7 | 14.3 | 15.5 | 15.4 | 75.1 | 81.9 | 78.2 |
| April | 98 | 98.9 | 98.9 | 54.9 | 57.7 | 60.9 | 14.7 | 15.2 | 15.3 | 74.8 | 82.9 | 78.1 |
| May | 98.1 | 99 | 98.9 | 55.1 | 56.2 | 60.6 | 14.3 | 15 | 15.6 | 78.2 | 85.6 | 80.6 |
| June | 98 | 98.8 | 99 | 51 | 56.1 | 56.8 | 14.1 | 14.8 | 14.9 | 77.5 | 84.7 | 80.4 |
| July | 98 | 98.3 | 98.9 | 53 | 54.2 | 59.5 | 14 | 14.7 | 14.8 | 77.7 | 84.3 | 79.4 |
| August | 98.1 | 99.1 | 99.1 | 55.4 | 56.3 | 59.5 | 13.9 | 15 | 14.7 | 78.4 | 85.3 | 80.9 |
| September ... | 98.1 | 99.1 | 99.1 | 54.4 | 57.3 | 60.4 | 14 | 15 | 15.2 | 78.9 | 86.2 | 81.7 |
| October | 98.2 | 99.1 | 99 | 54.3 | 55.8 | 61 | 14.2 | 15 | 15.3 | 78.9 | 84.8 | 80.8 |
| November ... | 98.1 | 99.1 | 98.6 | 55.3 | 57.7 | 59.2 | 14.2 | 15.4 | 15.4 | 77 | 83.5 | 79 |
| | 98.07 | 98.9 | 99 | 54.4 | 56 | 60.3 | 14.4 | 15.4 | 15 | 76.7 | 83.6 | 79.8 |

These results, compared with those obtained in England, show marked differences, as will best appear by presenting them together.

| Mean temperature under the tongue in England. | | | Pulse. | | | Respirations. | | | Temperature of room. | | |
|---|-----------|-----------|----------|-----------|-----------|---------------|-----------|-----------|----------------------|-----------|-----------|
| 7-8 A.M. | 3-4 P.M. | 12 P.M. | 7-8 A.M. | 3-4 P.M. | 12 P.M. | 7-8 A.M. | 3-4 P.M. | 12 P.M. | 7-8 A.M. | 3-4 P.M. | 12 P.M. |
| 98.74 | 98.52 | 97.92 | 57.6 | 55.2 | 54.7 | 15.6 | 15.4 | 15.2 | 50.9 | 54.7 | 62 |
| In Barbados:— | | | | | | | | | | | |
| 6-7 A.M. | 12-2 P.M. | 9-11 P.M. | 6-7 A.M. | 12-2 P.M. | 9-11 P.M. | 6-7 A.M. | 12-2 P.M. | 9-11 P.M. | 6-7 A.M. | 12-2 P.M. | 9-11 P.M. |
| 98.07 | 98.9 | 99 | 54.4 | 56 | 60.3 | 14.4 | 15.4 | 15 | 76.7 | 83.6 | 79 |

The observations from which these mean results are deduced are so consistent, as may be seen by reference to them in detail in the Appendix, as hardly to admit of doubt in relation to their accuracy.

Probably the low morning temperature of the body within the tropics, as shown above, may be owing principally to three circumstances,—to the depressing or lowering power of sleep,—to the light bed-covering used there, and the free circulation of the air in the room. A sheet and a thin coverlet were the only protection from the air; and the windows mostly being open, the outer air had free access, so that towards morning the temperature of the air of the room did not differ from that of the external air commonly more than two or three degrees. Moreover, the higher temperature observed at night, before going to rest, may have conduced to the lower morning temperature noticed on rising, as the lower temperature at night in England, with the opposite circumstances as to bed-clothing and air of sleeping-room, may have conduced to the higher morning temperature recorded there,—fluctuations these in accordance with well-known physiological laws.

2. *Of the Variation of Temperature during different seasons of the year.*

The following Table, formed from the first, exhibits the mean of the observed temperature during the several months comprised therein, as well as the mean of the in-door temperature.

| | Mean temperature under the tongue. | Air of room. | | Mean temperature under the tongue. | Air of room. |
|---------------|------------------------------------|--------------|---------------|------------------------------------|--------------|
| 1845. | | | 1847. | | |
| July | 98·43 | 76·00 | January | 98·60 | 77·70 |
| August | 98·30 | 80·60 | February ... | 98·53 | 80·26 |
| September ... | 98·60 | 81·20 | March | 98·60 | 77·40 |
| October | 98·56 | 81·46 | April | 98·53 | 78·00 |
| November ... | 98·46 | 80·56 | October | 98·66 | 80·83 |
| December ... | 98·40 | 77·90 | November ... | 98·56 | 79·66 |
| 1846. | | | December ... | 98·36 | 77·36 |
| January | 98·63 | 78·16 | 1848. | | |
| February ... | 98·60 | 77·88 | January | 98·60 | 77·06 |
| April | 98·46 | 80·00 | February ... | 98·53 | 77·73 |
| May | 98·66 | 81·50 | March | 98·60 | 78·40 |
| June | 98·66 | 81·56 | April | 98·60 | 78·26 |
| July | 98·36 | 81·00 | May | 98·66 | 81·46 |
| August | 98·70 | 81·60 | June | 98·60 | 80·86 |
| September ... | 98·40 | 81·36 | July | 98·36 | 80·46 |
| October | 98·73 | 81·50 | August | 98·76 | 81·56 |
| November ... | 98·60 | 80·60 | September ... | 98·76 | 82·26 |
| December ... | 98·63 | 77·96 | October | 98·76 | 81·50 |
| | | | November ... | 98·60 | 79·83 |
| | | | | 98·54 | 79·75 |

Comparing the temperature under the tongue with that of the air of the room, it will be seen that there is some accordance between them, though not a strict one, as if other circumstances than differences of atmospheric temperature have a marked

effect in modifying the temperature of the body within the tropics, where the variations of atmospheric temperature throughout the year are so inconsiderable—circumstances, for instance, of state of health, kind of life led as to exercise, diet, &c., and quality of atmosphere, as to degree of moisture or dryness, and the direction and force of the winds.

3. *Of the Effect of Active Exercise on the Temperature and of Rest after Exercise.*

On most occasions, when active exercise was taken, especially when on military duty, the dress worn was heavier and warmer than that in common use, to which partly the increase of temperature observed may be justly referred. This remark applies to the majority of the following observations:—

| | Tongue. | Pulse. | Respirations. | Air of room. |
|---|---------|--------|---------------|--------------|
| December 17, 1846, 1 P.M. After attending an inspection of a regiment on parade, exposed to the sun about half an hour | 99·3 | 66 | 17 | 82 |
| December 28, 1846, 3 P.M. After returning from office in Barbados, with some difficulty in carriage, the latter part of the road being flooded, a torrent rushing over it, 4·39 inches of rain having fallen between 9 A.M. and 3 ^h 30 ^m P.M..... | 99· | 56 | 17 | 75 |
| December 28, 1846, 4 P.M. The last hour sitting lightly clad..... | 98·1 | 52 | 16 | 77 |
| January 5, 1847, 1 P.M. After visiting hospitals | 99·3 | 54 | 16 | 82 |
| January 5, 1847, 4 P.M. The last hour sitting lightly clad, reading | 98·0 | 50 | 14 | 78 |
| January 6, 1847, 1 P.M. After inspecting an hospital | 99·2 | 54 | 15 | 82 |
| January 6, 1847, 4 P.M. Since 1 P.M. chiefly reading, lightly clad | 98·2 | 50 | 14 | 81 |
| March 26, 1847, 4 P.M. After inspecting hospitals, &c., occupied several hours, the greater part of the time walking..... | 99·8 | 70 | 16 | 85 |
| March 29, 1847, 6 A.M. After rising, before any exertion | 98·4 | 56 | 15 | 68 |
| March 29, 1847, 9 A.M. After a walk of three hours, ascending and descending a hill in the neighbourhood of Port of Spain, Trinidad; perspiring ... | 99·1 | 68 | 17 | 79 |
| March 29, 1847, 7 ^h 30 ^m P.M. After a ride of about four hours, most of the way at a quick pace; perspiring | 99·6 | 78 | 17 | 80 |
| April 3, 1847, 6 A.M. Just risen | 98·2 | 54 | 14 | 73 |
| April 3, 1847, 1 P.M. At the foot of the fall of the Marraca, in Trinidad, approached by a steep ascent through forest, an hour's walk, preceded by a ride at a quick pace of several miles; perspiring, temperature of hand 99°·5; that of the air (81° at the fall) was comparatively low from the evaporation of copious spray | 100· | 110 | 20 | 81 |
| April 3, 1847, 6 ^h 15 ^m P.M. On return from Marraca; the last few miles in an open carriage | 98·7 | 68 | 16 | 79 |
| April 10, 1848, 3 ^h 30 ^m P.M. After inspecting the hospital at St. Vincent and riding an hour or two..... | 99·4 | 62 | 16 | 85 |
| April 11, 1848, 3 ^h 30 ^m P.M. After visiting the barracks; perspiring | 99·4 | 78 | 17 | 84 |
| July 15, 1848, 1 P.M. After a ride of about an hour from Courland Bay, Tobago | 99·6 | 64 | 16 | 83 |
| July 15, 1848, 6 ^h 30 ^m P.M. After visiting barracks, &c. | 99·7 | 64 | 15 | 81 |

These results (many more of the like kind might be given) show how readily, when in health, the temperature of the body rises from active exercise and subsides on rest,—both, very much in the same manner and degree as in a cooler climate; and also, unless the exercise be severe, how the temperature is proportionally more affected than either the pulse or respiration.

4. *Of the Effect of Carriage Exercise on the Temperature.*

The carriage used was a light one adapted to the climate, open behind as well as in front, and well-protected from the sun, except when low, by a deep hood: the rate of going was commonly between six and seven miles an hour; a servant drove.

| | Tongue. | Pulse. | Respira- tions. | Air of room. |
|--|---------|--------|--------------------|-----------------|
| January 28, 1846, 9 P.M. After coming from Mount Wilton, about 900 feet above the level of the sea | 97·9 | 70 | 15 | 73 |
| August 27, 1846, 5 P.M. After a drive of about sixteen miles, going to and returning from Villa Nova, in Barbados, in a cool situation about 700 feet above the level of the sea | 97·8 | 48 | 14 | 80 |
| September 3, 1846, 11 P.M. After coming from Villa Nova | 97·7 | 58 | 16 | 79 |
| November 18, 1846, 5 P.M. After a drive of about twenty-four miles in the heat of the day, going and returning, and some walking exercise in a low district of Barbados, fasting | 98·3 | 60 | 16 | 82 |
| November 18, 1846, 10 P.M. Feeling weary, after dinner, followed by tea... | 99·1 | 58 | 15 | 79 |
| November 21, 1846, 11 ^h 30 ^m P.M. After coming from Villa Nova | 97·7 | 58 | 16 | 79 |
| December 18, 1846, 5 P.M. After coming from Blackman's, situated like Villa Nova, and about the same distance; took a good deal of walking exercise there; the wind high | 98·6 | 70 | 15 | 80 |
| December 18, 1846, 9 P.M. Feeling weary, hot and thirsty | 99·7 | 80 | 16 | 79 |
| February 4, 1847, 12 P.M. After coming from Villa Nova | 97·5 | 58 | 15 | 74 |
| April 25, 1847, 10 ^h 30 ^m P.M. After coming from Villa Nova | 97·1 | 54 | 14 | 77 |
| June 14, 1848, 10 P.M. After coming from Villa Nova | 98·2 | 58 | 15 | 82 |

Many other instances, of which I have notes, might be adduced to show the effects of carriage exercise in lowering the temperature,—an effect previously observed in England. Those given, which were chiefly at night, were best marked, no doubt owing to the temperature of the air then being lower than by day, and the heat from the reflected and direct rays of the sun being then entirely avoided. When coming from the higher grounds of the interior of Barbados at night, and often when ascending them by day, the feeling of coolness was such as to render agreeable some additional clothing, which was always provided, though the difference of atmospheric temperature was only of a very few degrees. The latter observations, those of the 18th of November 1846 and of the 18th of December, are given as showing the tendency to augmentation of temperature of body in an undue degree after unusual depression, preceded by fatiguing exercise. The rise, so far as it was abnormal, was probably owing to the influence of the fatigue, for it was not witnessed if such exercise had not been taken.

5. *Of the Effect of Gentle Walking Exercise on the Temperature.*

The following observations were made when convalescing from illness (an anthrax with extensive sloughing and general derangement of health), a time when the body in a delicate state seems to be very readily acted on and to show the effects with unusual distinctness:—

| | Tongue. | Pulse. | Respira- tions. | Air of room. |
|---|---------|--------|--------------------|-----------------|
| March 7, 1847, 6 ^h 15 ^m A.M. Just risen | 97·8 | 52 | 14 | 74 |
| March 7, 1847, 3 P.M. During the last two hours taking gentle exercise within doors, making some chemical experiments | 98·3 | 56 | 15 | 82 |
| August 17, 1847, 5 ^h 45 ^m A.M. Just risen | 97·8 | 62 | 15 | 77 |
| August 17, 1847, 7 ^h 45 ^m A.M. During last half hour walking slowly in shaded gallery, exposed to the wind; feelings agreeable; feet and hands warm | 97·8 | 68 | 16 | 80 |
| August 19, 1847, 5 ^h 45 ^m A.M. Just risen | 98·6 | 62 | 15 | 79 |
| August 19, 1847, 8 A.M. Last half hour walking in gallery; not exposed to the wind; perspiring gently | 98·4 | 70 | 17 | 81 |
| August 21, 1847, 5 ^h 35 ^m A.M. Just risen | 98·4 | 60 | 15 | 78 |
| August 21, 1847, 7 ^h 30 ^m A.M. After walking about half an hour; hands and feet glowingly warm | 98·2 | 76 | 17 | 81 |
| August 22, 1847, 5 ^h 45 ^m A.M. Just risen | 98·5 | 62 | 16 | 79 |
| August 22, 1847, 7 ^h 45 ^m A.M. After walking in gallery about half an hour, very lightly clad, exposed to the wind; hands and feet very warm | 98·2 | 78 | 17 | 82 |

To appreciate the effect of gentle exercise on the temperature, it requires to be mentioned and kept in mind, that had not such exercise been taken, the thermometer would have risen on its second application from $\cdot 3^{\circ}$ to $\cdot 5^{\circ}$ higher than at the first.

The feeling of increased warmth in the hands and feet from gentle exercise has been noticed in three instances. The diffusion of heat to the extremities, owing no doubt to a freer circulation of the warming medium—the blood—may partly account for the cooling effect under the tongue, and probably in the deep-seated parts from the exercise under consideration. The high temperature commonly observed in the extremities within the tropics, is a circumstance very deserving of note. In the daily observations appended, a record is given of the temperature of the hand during two months, noticed three times a day; from which it appears that on an average it was less than that under the tongue by only 1° . For the purpose of ascertaining the heat of the hand, the bulb of the thermometer was placed between the middle of the palm and the ball of the thumb, and so covered was gently pressed.

6. *Of the Effect of Change of the Temperature of the Atmosphere on the Temperature.*

In illustration of this effect, I shall notice only a very few of the observations obtained in the West Indies, corroborative of those collected many years ago in the island of Ceylon.

The situation of Villa Nova has already been mentioned: it was there that most of them were made, that spot being well-fitted for trials of the kind, the temperature there by day rarely exceeding 80° , even at the hottest time, and always below 80° at night, often requiring the closure of the bed-room windows, and occasionally a blanket in addition to the bed-clothes.

| | Tongue. | Pulse. | Respira- tions. | Air of room. |
|---|---------|--------|--------------------|-----------------|
| November 15, 1847, 6 A.M. Just risen, at Villa Nova | 98° | 56 | 15 | 76 |
| November 15, 1847, 2 P.M. | 98·7 | 50 | 15 | 76 |
| November 15, 1847, 9 ^h 30 ^m P.M. | 97 | 58 | 16 | 76 |
| November 16, 1847, 6 A.M. | 98·4 | 54 | 15 | 76 |
| November 16, 1847, 1 ^h 30 ^m P.M. | 98·5 | 50 | 16 | 78 |
| November 16, 1847, 9 ^h 30 ^m P.M. Windows closed; feet and hands agreeably warm | 97·8 | 58 | 16 | 76 |
| November 17, 1847, 6 ^h 15 ^m A.M. | 98·3 | 54 | 14 | 75 |
| November 17, 1847, 9 ^h 25 ^m . At home, in the neighbourhood of Bridgetown | 98·8 | 54 | 16 | 77 |
| November 22, 1847, 1 ^h 30 ^m P.M. At home, variously occupied | 99·2 | 62 | 16 | 79 |
| November 22, 1847, 4 P.M. Last hour; sitting reading; raining; feel cold; hand 85° | 97·9 | 48 | 14 | 75 |
| December 24, 1847, 6 A.M. At home; just risen | 98·1 | 52 | 14 | 74 |
| December 24, 1847, 1 ^h 3 ^m P.M. At home; variously employed | 99·1 | 58 | 16 | 80 |
| December 24, 1847, 9 ^h 30 ^m P.M. Villa Nova; arrived there 5 P.M. | 97·8 | 56 | 14 | 74 |
| December 25, 1847, 6 ^h 15 ^m A.M. Villa Nova; just risen; slept warm; windows closed | 98·9 | 60 | 14 | 73 |
| December 25, 1847, 12 A.M. Agreeably cool..... | 98·5 | 54 | 14 | 76 |
| December 25, 1847, 5 P.M. A feeling almost of cold..... | 98·5 | 52 | 14 | 74 |
| December 25, 1847, 9 ^h 30 ^m P.M. | 97·85 | 52 | 15 | 74 |
| December 26, 1847, 6 ^h 15 ^m A.M. | 98·5 | 60 | 15 | 73 |
| December 26, 1847, 9 ^h 15 ^m P.M. At home; left Villa Nova at noon | 98·7 | 64 | 16 | 80 |

The observations made at Villa Nova, if compared with those made in England, will be found to approximate, especially as regards the morning and night temperature, and may be adduced in confirmation of the explanation given under Section 1, regarding the contrast of observed temperatures there adverted to.

7. *Of the Effect of Excited and Sustained Attention on the Temperature.*

A few instances may suffice to illustrate this effect, selecting those in which it was most strongly marked; between which and those least notable there is a fine gradation, according to degree of exertion of mind, which it would be difficult to appreciate on account of interfering disturbing circumstances.

| | Tongue. | Pulse. | Respira- tions. | Air of room. |
|---|---------|--------|--------------------|-----------------|
| December 22, 1846, 3 ^h 30 ^m P.M. After delivering a discourse in public, in a well-aired room, lasting about an hour | ° | | | ° |
| December 22, 1846, 5 ^h 20 ^m P.M. | 99·8 | 78 | 16 | 82 |
| December 22, 1847, 6 A.M. Just risen | 98·9 | 58 | 15 | 80 |
| December 22, 1847, 3 ^h 15 ^m P.M. After delivering a discourse in the same place as the preceding and of about the same length | 98·1 | 52 | 13 | 75 |
| December 22, 1847, 9 ^h 30 ^m P.M. | 100·3 | 90 | 15 | 82 |
| December 22, 1847, 9 ^h 30 ^m P.M. | 98·9 | 66 | 15 | 77 |
| December 23, 1847, 6 A.M. | 97·9 | 54 | 14 | 75 |
| June 24, 1848, 3 ^h 30 ^m P.M. After occupation similar to that last mentioned, and in the same place | 99·9 | 82 | 15 | 81 |
| August 30, 1848, 2 P.M. After delivering a chemical lecture in a close and crowded room | 100·1 | 84 | 15 | 88 |
| August 30, 1848, 9 P.M. | 99·4 | 62 | 14 | 82 |
| August 31, 1848, 6 A.M. | 98·2 | 58 | 14 | 80 |
| September 6, 1848, 2 P.M. Similarly occupied; the heat of the room greater; immediately after the pulse was 100 | 100·4 | 80 | 16 | 88 |
| September 6, 1848, 9 P.M. | 99·2 | 64 | 15 | 81 |
| September 7, 1848, 5 ^h 45 ^m A.M. | 98·2 | 54 | 14 | 78 |

The additional observations—those made some hours after the exertion—are given as illustrating an important fact, viz. the rapid manner in which, when the body is free from disease, the functions on rest return to their ordinary state; whilst, on the contrary, when disease is present, especially of an organic kind, even though latent in relation to the most obvious class of symptoms, indications of it may be obtained by attention to the temperature, pulse and respiration; and often, as in instances of pulmonary disease, in a very remarkable and decided manner.

8. *On the Effect of Cool and Well-ventilated Rooms, and of Close and Heated Rooms on the Temperature.*

As regards ventilation, and consequently coolness where there is a concourse of people, the cathedral church of Barbados, and HARRISON'S school-room adjoining, in which lectures were given on the opening of the "REID School of Practical Chemistry," may be mentioned as good and bad examples. In illustration of the effects of each, I shall give a few observations on temperature, noted down when made, which was within about half an hour after quitting the church and the school, conveyed in a carriage, attending in the one divine service, in the other a lecture. The temperature of the air marked, as usual, was that of my sitting-room, which was cooler by several degrees than the school-room, but less cool commonly than the church.

| | Tongue. | Pulse. | Respirations. | Air of room. |
|---|---------|--------|---------------|--------------|
| February 28, 1847, 1 P.M. Just come from church | 98·4 | 54 | 16 | 83 |
| March 7, 1847, 1 P.M. Just come from church | 98·5 | 54 | 15 | 84 |
| March 5, 1848, 2 ^h 45 ^m P.M. Just come from church | 98·5 | 56 | 15 | 82 |
| August 2, 1848, 2 ^h 30 ^m P.M. Just come from school-room | 99·8 | 66 | 13 | 85 |
| August 9, 1848, 2 P.M. Just come from school-room | 99·8 | 60 | 16 | 82 |
| August 16, 1848, 2 ^h 30 ^m P.M. Just come from school-room | 99·9 | 64 | 16 | 87 |
| October 18, 1848, 3 ^h 30 ^m P.M. Room less crowded | 99·5 | 58 | 15 | 82 |
| October 25, 1848, 5 ^h 15 ^m P.M. Room less crowded | 99·4 | 62 | 15 | 83 |

9. *On the Effect of taking Food and Wine on the Temperature.*

The effect of a meal in moderation, whether the light one of breakfast or the fuller and heavier one of dinner, was to raise the temperature; and this also when wine was sparingly used at the latter, viz. to the extent of two or three glasses; but when more freely drunk, as it commonly is in company, then often its influence on temperature appeared to be depressing. I shall give a few instances in illustration:—

| | Tongue. | Pulse. | Respirations. | Air of room. |
|--|---------|--------|---------------|--------------|
| December 21, 1846, 10 P.M. Dinner at 6; wine chiefly champagne and Madeira; no headache; no malaise..... | ° | | | ° |
| February 6, 1847, 10 P.M. Dinner at 7; the wines similar | 98·1 | 70 | 15 | 77 |
| February 13, 1848, 11 ^h 30 ^m P.M. Dinner at 6; about seven miles distant in the country, from whence just returned; kind of wine not noticed | 97·8 | 70 | 15 | 71 |
| March 9, 1848, 10 ^h 30 ^m P.M. Dinner at 7; kind of wine not noted down ... | 97·3 | 64 | 16 | 78 |
| May 29, 1848, 12 P.M. Dinner at 7; wines chiefly champagne and claret ... | 97·9 | 64 | 15 | 77 |
| August 9, 1848, 11 P.M. Dinner at 7; the wines like the last | 98 | 72 | 16 | 79 |
| | 98 | 70 | 15 | 79 |

It is deserving of remark, that whenever wine was used, except in great moderation, though never to the excess of an inebriating effect, on the following morning the temperature under the tongue was found to be more or less above the average, and the pulse commonly quicker than usual. It is also worthy of remark, that occasionally the effect at night was to increase the temperature of the body, and that in a marked manner; but whether from some peculiar quality of the wine used, or from some deranged state of the system or other adventitious circumstance, I have not been able to determine.

10. *Of the Effect of Sea-sickness on the Temperature.*

During a voyage from Barbados to St. Christopher, and from thence to Barbados in May and June 1848, in a transport, stopping at some of the intermediate islands, an opportunity offered of making some observations on the effect of sea-sickness, from which I suffered more or less on the several days noticed in the subjoined Table. The degree of sickness, often amounting to vomiting, was such as to render rising disagreeable. Little food was taken on those days, excepting chicken broth with some bread; no wine was drunk. The observations were made in the sitting posture in bed in a well-ventilated cabin.

| | Temperature under the tongue. | | | Pulse. | | | Respirations. | | | Temperature of cabin. | | |
|---------|-------------------------------|-----------|-----------|----------|-----------|-----------|---------------|-----------|-----------|-----------------------|-----------|-----------|
| | 6-7 A.M. | 12-2 P.M. | 6-10 P.M. | 6-7 A.M. | 12-2 P.M. | 6-10 P.M. | 6-7 A.M. | 12-2 P.M. | 6-10 P.M. | 6-7 A.M. | 12-2 P.M. | 6-10 P.M. |
| May 14. | 98·7 | 98·9 | | 58 | 68 | ... | 16 | 16 | ... | 81 | 83 | ° |
| 15. | 98·8 | | | 60 | ... | ... | 14 | ... | ... | 80 | ... | |
| 18. | 98·2 | 98·6 | | 54 | 64 | ... | 14 | 15 | ... | 80 | 81 | |
| 26. | 98·7 | | | 60 | ... | ... | 15 | ... | ... | 79 | ... | |
| 27. | 98·8 | | | 60 | ... | ... | 15 | ... | ... | 79 | ... | |
| 31. | | 98·7 | 99·1 | ... | 58 | 58 | ... | 15 | 14 | ... | 82 | 82 |
| June 1. | 98·6 | 98·8 | 99·3 | 58 | 56 | 58 | 14 | 15 | 15 | 81 | 83 | 83 |
| 2. | 98·7 | 98·3 | | 56 | 58 | ... | 14 | 14 | ... | 81 | 80 | |
| 3. | 98·7 | 99·2 | 99·4 | 58 | 56 | 60 | 15 | 16 | 15 | 80 | 82 | 82 |
| 4. | 98·7 | | | 58 | ... | ... | 14 | ... | ... | 80 | ... | |
| | 98·65 | 98·75 | 99·23 | 57·55 | 60·28 | 58·66 | 14·44 | 15·14 | 14·66 | 80·24 | 81·71 | 82·33 |

It appears from these few observations, that under the influence of sea-sickness, the morning temperature was higher than ordinary and the pulse somewhat quicker; when the former was lowest, as on the 18th of May, then the vessel being in smooth water, there was scarcely any uneasiness experienced. Comparing the several observations, perhaps the inference may be justifiable, that the tendency of sea-sickness, when not in its severest form, is of an equalizing kind in relation to the temperature, pulse and respiration,—a tendency no doubt promoted by the little variation to which the sea atmosphere is liable, especially within the tropics. On so obscure a subject, however, as sea-sickness, this remark is offered with some hesitation.

11. *Of the Temperature at Sea, when not under the influence of Sea-sickness.*

In returning from the West Indies in the well-appointed steam-packet Clyde, I availed myself of the opportunity to continue the observations on temperature. The results are given in the following Table, commencing on the day after leaving St. Thomas, when all feeling of sea-sickness had ceased, and ending on the 2nd of December, the day before coming in sight of the coast of England. The weather during the greater part of the voyage was favourable: after leaving Fayal, on the 27th of November, it was more or less tempestuous; on the 29th and 30th, it was necessary to have the cabin ports closed. The observations were made in a well-ventilated cabin in the sitting posture,—the port commonly open excepting at night. The diet was fuller and more nourishing than that used in the West Indies, the appetite increasing on passing into a cooler climate; rather more wine was used, viz. a pint of sound Bordeaux at dinner; and the clothing was rendered warmer as required by diminution of warmth of atmosphere:—

| | Position of ship at noon. | | Temperature under the tongue. | | | Pulse. | | | Respirations. | | | Temperature of cabin. | | |
|------|---------------------------|----------|-------------------------------|-----------|---------|----------|-----------|---------|---------------|-----------|---------|-----------------------|-----------|---------|
| | Lat. N. | Long. W. | 6-7 A.M. | 12-2 P.M. | 10 P.M. | 6-7 A.M. | 12-2 P.M. | 10 P.M. | 6-7 A.M. | 12-2 P.M. | 10 P.M. | 6-7 A.M. | 12-2 P.M. | 10 P.M. |
| Nov. | | | | | | | | | | | | | | |
| 16. | 22° 39' | 61° 8' | 98·5 | 98·8 | 98·9 | 54 | 50 | 60 | 14 | 15 | 16 | 78° | 81° | 78° |
| 17. | 24 16 | 58 11 | 98·2 | 98·3 | 98·4 | 56 | 54 | 66 | 14 | 16 | 15 | 76 | 77 | 77 |
| 18. | 25 39 | 55 30 | 98·2 | 98·7 | 98·2 | 56 | 52 | 60 | 14 | 16 | 15 | 75 | 77 | 77 |
| 19. | 27 33 | 53 13 | 98·6 | 99·3 | ... | 52 | 72 | ... | 14 | 15 | ... | 77 | 79 | 77 |
| 20. | 29 19 | 50 45 | 98·6 | 98·1 | 97·7 | 60 | 56 | 60 | 14 | 15 | 15 | 77 | 77 | 77 |
| 21. | 31 6 | 48 9 | 98·5 | 97·9 | 97·8 | 56 | 50 | 62 | 14 | 15 | 15 | 75 | 75 | 73 |
| 22. | 32 53 | 45 16 | 98·7 | 97·7 | 97·7 | 54 | 54 | 60 | 14 | 14 | 15 | 71 | 73 | 72 |
| 23. | 34 43 | 41 18 | 98·2 | 98 | 98·1 | 54 | 56 | 58 | 15 | 15 | 15 | 71 | 71 | 72 |
| 24. | 36 23 | 37 21 | 98·5 | 98·1 | 98·6 | 58 | 54 | 60 | 14 | 15 | 15 | 69 | 67 | 67 |
| 25. | 37 21 | 33 34 | 98·3 | 98·5 | ... | 52 | 56 | ... | 14 | 14 | ... | 64 | 66 | |
| 26. | 38 28 | 30 2 | 98·5 | 98·7 | ... | 56 | 56 | ... | 14 | 14 | ... | 66 | 69 | |
| 27. | 38 32 | 28 40 | 98·3 | 98·5 | 97·5 | 54 | 54 | 54 | 14 | 15 | 15 | 68 | 67 | 66 |
| 28. | 41 2 | 25 18 | 98·4 | 98·7 | 98·3 | 52 | 58 | 60 | 14 | 16 | 15 | 66 | 61 | 65 |
| 29. | 43 19 | 21 32 | 98·6 | 99·4 | 98 | 56 | 62 | 58 | 14 | 15 | 15 | 65 | 63 | 68 |
| 30. | 44 59 | 17 13 | 98·1 | 98·9 | 97·3 | 54 | 56 | 54 | 14 | 15 | 14 | 61 | 59 | 64 |
| Dec. | | | | | | | | | | | | | | |
| 1. | 46 33 | 12 7 | 98·4 | 98·9 | 97·9 | 54 | 60 | 56 | 14 | 14 | 14 | 59 | 59 | 63 |
| 2. | 48 33 | 6 44 | 98·7 | 98 | 97·6 | 58 | 62 | 48 | 14 | 15 | ... | 58 | 57 | 59 |

Comparing these results with those obtained in England and in the West Indies, they will be found to accord more with the former than the latter, the morning being on an average higher than those obtained at night. The small range of temperature is also worthy of note, and its decrease with diminution of atmospheric temperature. In those instances in which the variation was greatest, the higher temperature noted down, was in the middle of the day, commonly in connection with active walking exercise just before taken,—and the lower than ordinary at the same period of the day, was, after sitting for an hour or two exposed to the wind on deck.

Conclusions.

The following are some of the conclusions that appear to be either proved or rendered probable by the preceding results, or by those given in the Tables appended,—supposing, as it is believed, that, were the observations extended to many individuals, no material discrepancy would be witnessed.

1. That the average temperature of man within the tropics is a little higher, nearly 1° , than in a temperate climate, such as that of England.

2. That within the tropics, as had before been found in cooler regions, the temperature of the body is almost constantly fluctuating,—varying according to the variety of agencies to which it is subject, some of which are distinct, others obscure.

3. That the order of fluctuation observed there is different from that in a cooler climate, the minimum degree of temperature being commonly early in the morning, after the night's rest, and not at night previous to going to rest.

4. That all exertion, whether of body or mind, except it be very gentle, coming under the designation of passive rather than active exercise, has a heightening effect on the temperature, while the latter, the passive kind, has rather a lowering tendency, especially carriage exercise.

5. That heavy clothing, especially if tight and close, obstructing the admission and circulation of air, tends to raise the temperature unduly, especially under active exercise; and that close, ill-ventilated rooms, especially when crowded, have in a marked manner the same tendency.

6. That when the body is in a healthy state, then on rest after exercise or exposure to any other exciting cause, it rapidly recovers its normal condition as to temperature.

7. That when labouring under disease, however slight, the temperature is abnormally elevated; and that—judging from observations made, but not recorded, in the Tables—its undue degree is some criterion of the intensity of the diseased action.

8. That within the tropics there is comparatively little difference of temperature between the surface of the body, especially the extremities and the internal parts;—and that there the skin is more active in its function of transpiration and the kidneys are less active as secreting organs; with which it may be conjectured is connected a rapid production and desquamation of cuticle, and the absence, in great part or entirely, of lithic acid in the urinary secretion. This latter fact, however, may be explained in a different manner, on the supposition that the acid is not formed in the blood, or if formed, in a greatly diminished quantity.

9. That the effect of wine, unless used in great moderation, is commonly lowering, that is as to temperature, whilst it accelerates the heart's action, followed after a while by an increase of temperature.

10. That the tendency of sea-sickness is to check what may be considered the natural fluctuation of the temperature, and when severe, like disease, to elevate the temperature.

11. That the tendency of a sea voyage, apart from sea-sickness, is to equalize the temperature without elevating it, an equalization that is best witnessed in voyaging in a tropical sea, where the atmospheric temperature is so little variable.

12. That even at sea, with a change of atmospheric temperature, there is a tendency to change of temperature of the body, the average increasing in proceeding towards the tropics, and diminishing in receding from them.

These conclusions obviously admit of application, and that variously in relation to health and disease. It would be unsuitable to the occasion to dwell on this part of the subject; I shall merely remark, that it is a happy circumstance for man, and seems wisely ordered, that fluctuation of temperature should be connected with a healthy state of the system, and probably conducive to it, in whatever manner produced, whether by change of climate, or atmospheric variation, or by exercise, whether of body or mind. The excellent health which the crews of the West Indian steam-packets have, that are in constant transition from heat to cold, is a striking proof of this, and other instances of a like kind, were it necessary, might be adduced in confirmation.

Lesketh How, Ambleside,

February 14, 1850.

APPENDIX.

The thermometer used in making the observations contained in these Tables, was compared with a standard one, and was found to require no correction in its scale for the degrees of temperature indicated when placed under the tongue.

| | Temperature under the tongue and in hand. | | | | | | Pulse. | | | Respirations. | | | Temp. of air of room. | | | |
|--------------|---|-------|-----------|-------|-----------|-------|----------|-----------|-----------|---------------|-----------|-----------|-----------------------|-----------|-----------|-------|
| | 6-7 A.M. | | 12-2 P.M. | | 9-11 P.M. | | 6-7 A.M. | 12-2 P.M. | 9-11 P.M. | 6-7 A.M. | 12-2 P.M. | 9-11 P.M. | 6-7 A.M. | 12-2 P.M. | 9-11 P.M. | |
| | Tongue. | Hand. | Tongue. | Hand. | Tongue. | Hand. | | | | | | | | | | |
| July 1845. | 12. | 98.7 | 97.5 | 99.5 | 98 | 98.25 | 97.5 | 64 | 66 | 62 | 15 | 15 | 16 | 80 | 84 | 82 |
| | 13. | 98.35 | 97.5 | 99.1 | 98 | 98.5 | 98 | 58 | 54 | 64 | 17 | 15 | 16 | 79 | 78 | 80 |
| | 14. | 98.4 | 97.5 | 99.1 | 98 | 98.95 | 98 | 58 | 60 | 70 | 15 | 16 | 17 | 77 | 84 | 80 |
| | 15. | 98.7 | 98 | 99.3 | 98.5 | 99.2 | 98 | 60 | 76 | 76 | 15 | 16 | 16 | 78 | 83 | 80 |
| | 18. | 98.4 | 97.25 | 99.3 | 98 | 99.5 | 98.5 | 60 | 64 | 70 | 15 | 16 | 17 | 78 | 83 | 77 |
| | 19. | 98.4 | 97.5 | 99.2 | 98 | 99 | 97.5 | 62 | 62 | 60 | 16 | 16 | 16 | 77 | 83 | 79 |
| | 20. | 98.1 | 97.25 | 98.6 | 97.5 | 98.7 | 97.25 | 56 | 52 | 52 | 15 | 15 | 16 | 77 | 74 | 79 |
| | 21. | 98.6 | 97.5 | 99 | 97.5 | 98.8 | 97.5 | 54 | 64 | 54 | 15 | 15 | 16 | 78 | 83 | 80 |
| | 22. | 97.5 | 96 | 98.4 | 97.5 | 98.3 | 97 | 56 | 56 | 60 | 15 | 16 | 16 | 78 | 81 | 81 |
| | 23. | 97.8 | 97 | 98.9 | 97.5 | | | 54 | 60 | | 16 | 16 | | 79 | 84 | |
| | 24. | 97.9 | 96.25 | | | 98.4 | 97 | 54 | | 54 | 15 | | 16 | 79 | | 79 |
| | 25. | 97.8 | 97 | 98.8 | 97.5 | 98.3 | 97.5 | 50 | 62 | 62 | 15 | 16 | 16 | 78 | 85 | 80 |
| | 26. | 98.1 | 97.5 | 99.1 | 98 | 98.7 | 97.25 | 62 | 60 | 54 | 14 | 15 | 16 | 78 | 85 | 81 |
| | 27. | 98.2 | 97 | 98.6 | 97 | 98.1 | 96.5 | 52 | 54 | 54 | 15 | 15 | 15 | 80 | 86 | 79 |
| 28. | 98.2 | 96.5 | 98.7 | 97.25 | 98.4 | 97.5 | 54 | 54 | 64 | 15 | 15 | 16 | 78 | 84 | 80 | |
| 29. | 98.2 | 96.75 | | | 98.7 | 97.5 | 50 | | 64 | 14 | | 16 | 78 | | 80 | |
| 30. | 98.1 | 96.5 | 98.9 | 97.5 | 98.4 | 97.5 | 50 | 62 | 50 | 14 | 16 | 50 | 78 | 85 | 79 | |
| 31. | 98.2 | 97 | 99.1 | 97.7 | 98.3 | | 56 | 61 | 61 | 15 | 16 | 16 | 79 | 85 | 80 | |
| | | 98.2 | 97.1 | 99 | 97.7 | 98.2 | 97.35 | 56 | 61 | 66.5 | 14.7 | 15.5 | 16 | 78.3 | 81.5 | 79.4 |
| August 1845. | 4. | 98.4 | 97 | 99 | 97.5 | 99 | 97.5 | 56 | 64 | 60 | 15 | 16 | 16 | 79 | 83 | 82 |
| | 5. | 98 | 96.5 | 98.7 | 97.25 | 98 | 96.5 | 52 | 52 | 52 | 15 | 15 | 15 | 78 | 85 | 78 |
| | 6. | 97.7 | 97 | 99.1 | 97.5 | 98 | 97 | 54 | 54 | 60 | 14 | 16 | 16 | 78 | 84 | 79 |
| | 7. | 98.25 | 97.5 | 98.7 | 97.7 | 98.7 | 98 | 60 | 54 | 54 | 16 | 16 | 15 | 78 | 85 | 82 |
| | 8. | 97.7 | 96.7 | 98.3 | 96.5 | 98.3 | 97.5 | 50 | 52 | 60 | 15 | 16 | 16 | 78 | 85 | 81 |
| | 9. | 98.2 | 97 | 98.5 | 97 | 98.6 | 97.5 | 52 | 54 | 62 | 15 | 16 | 16 | 79 | 84 | 80 |
| | 10. | 93.9 | 97 | 98.7 | 97.5 | 97.8 | 96.7 | 52 | 58 | 64 | 16 | 16 | 16 | 79 | 85 | 80 |
| | 11. | 98.5 | 97.5 | 98.8 | 97 | 98.5 | 97.25 | 60 | 52 | 56 | 16 | 15 | 16 | 80 | 85 | 80 |
| | 12. | 97.8 | 97 | 98.9 | 98 | 98.9 | 98 | 54 | 54 | 62 | 15 | 15 | 16 | 79 | 87 | 81 |
| | 13. | 97.9 | 97 | 98.8 | 97.5 | 98.3 | 97.5 | 54 | 52 | 58 | 14 | 15 | 16 | 78 | 83 | 80 |
| | 14. | 97.7 | 96.5 | 99 | 97.5 | 98.7 | 97.5 | 50 | 54 | 56 | 15 | 16 | 16 | 78 | 88 | 80 |
| | 15. | 97.8 | 97 | 98.7 | 97.75 | 98.7 | 97 | 52 | 52 | 54 | 14 | 15 | 16 | 79 | 85 | 81 |
| | 16. | 97.9 | 96.5 | 98.7 | 97.5 | 98.7 | 97.5 | 52 | 54 | 54 | 15 | 16 | 15 | 79 | 86 | 81 |
| | 17. | 97.9 | 97 | 98.4 | 97.25 | 98.2 | 97.3 | 54 | 50 | 62 | 15 | 16 | 15 | 79 | 82 | 80 |
| 18. | 98.1 | 97 | 98.7 | 97 | 98.7 | 97.5 | 54 | 50 | 60 | 14 | 15 | 16 | 77 | 87 | 82 | |
| 19. | 98.3 | 97 | 98.4 | 97.5 | 98.5 | 97 | 54 | 50 | 60 | 14 | 15 | 15 | 78 | 87 | 82 | |
| 20. | 98.3 | 97.5 | 98.7 | 97.5 | 98.8 | 97.5 | 52 | 56 | 56 | 15 | 16 | 15 | 78 | 77 | 78 | |
| 21. | 98.2 | 97 | 98.5 | 97 | 98.4 | 97.5 | 56 | 54 | 58 | 15 | 15 | 16 | 78 | 82 | 78 | |
| 22. | 98 | 97 | 98.7 | 97.7 | 98.6 | 97.7 | 52 | 54 | 54 | 15 | 16 | 15 | 78 | 83 | 80 | |
| 23. | 98 | 97.7 | 99 | 98.5 | 98.5 | 97.7 | 52 | 54 | 54 | 15 | 16 | 15 | 78 | 85 | 81 | |
| 24. | 98.2 | 97.7 | 99 | 98 | 98.6 | 97.5 | 52 | 50 | 54 | 15 | 15 | 15 | 77 | 84 | 81 | |
| 25. | 98.1 | 97 | 98.7 | 97.5 | 98.7 | 97.5 | 54 | 56 | 56 | 16 | 15 | 16 | 78 | 84 | 77 | |
| 27. | 97.9 | 97 | 98.8 | 97.5 | 98.8 | 97.5 | 54 | 52 | 62 | 15 | 16 | 16 | 78 | 86 | 80 | |
| 28. | 98.1 | 97 | | | | | 60 | | | 16 | | | 78 | | | |
| 30. | 98.2 | | 99 | | 98.9 | | 54 | 58 | 60 | 15 | 16 | 15 | 79 | 86 | 81 | |
| 31. | 97.9 | | 98.6 | | 99.2 | | 54 | 50 | 60 | 15 | 15 | 16 | 80 | 86 | 82 | |
| | | 98 | 97 | 98.7 | 97.4 | 98.16 | 97.4 | 53.8 | 53.6 | 57.9 | 15 | 15.7 | 15.8 | 78.7 | 84 | 80.3 |

| | Temp. under the tongue. | | | Pulse. | | | Respirations. | | | Temperature of room. | | | |
|-----------------|-------------------------|-----------|-----------|----------|-----------|-----------|---------------|-----------|-----------|----------------------|-----------|-----------|------|
| | 6-7 A.M. | 12-2 P.M. | 9-11 P.M. | 6-7 A.M. | 12-2 P.M. | 9-11 P.M. | 6-7 A.M. | 12-2 P.M. | 9-11 P.M. | 6-7 A.M. | 12-2 P.M. | 9-11 P.M. | |
| September 1845. | 1. | 98 | 98.9 | 99.3 | 54 | 52 | 66 | 15 | 16 | 15 | 78 | 86 | 81 |
| | 2. | 98.3 | 99.3 | 99.9 | 60 | 56 | 70 | 14 | 15 | 15 | 79 | 86 | 81 |
| | 3. | 98.1 | 98.6 | 99.3 | 54 | 50 | 58 | 14 | 16 | 15 | 78 | 82 | 80 |
| | 4. | 98.1 | 99.1 | 99.1 | 60 | 56 | 66 | 15 | 15 | 16 | 79 | 85 | 80 |
| | 5. | 98 | 98.9 | 98.9 | 52 | 54 | 60 | 15 | 16 | 14 | 78 | 85 | 79 |
| | 6. | 98 | 98.3 | 99.1 | 46 | 50 | 66 | 14 | 15 | 16 | 79 | 80 | 81 |
| | 7. | 97.95 | 98.7 | 99 | 50 | 48 | 64 | 15 | 16 | 16 | 77 | 84 | 80 |
| | 8. | 98.2 | 99.1 | 98.6 | 54 | 50 | 60 | 15 | 15 | 16 | 77 | 86 | 80 |
| | 9. | 97.9 | 99.1 | 99 | 52 | 56 | 62 | 15 | 16 | 16 | 78 | 83 | 80 |
| | 10. | 98.1 | 98.9 | 98.5 | 54 | 56 | 70 | 15 | 16 | 16 | 78 | 85 | 80 |
| | 11. | 98.6 | 99 | 98.4 | 70 | 54 | 52 | 15 | 15 | 16 | 78 | 80 | 80 |
| | 12. | 97.8 | 98.9 | 98.6 | 52 | 52 | 60 | 15 | 15 | 15 | 78 | 85 | 78 |
| | 13. | 98.1 | 99.2 | 99 | 52 | 56 | 62 | 15 | 16 | 16 | 78 | 82 | 80 |
| | 14. | 97.9 | 98.6 | 98.9 | 52 | 52 | 62 | 15 | 16 | 15 | 78 | 84 | 80 |
| | 15. | 98.1 | 99 | 98.7 | 52 | 60 | 54 | 15 | 16 | 16 | 78 | 85 | 82 |
| | 16. | 98 | 98.5 | 98.6 | 60 | 60 | 60 | 16 | 16 | 15 | 78 | 85 | 82 |
| | 17. | 98.1 | 98.9 | 98.8 | 60 | 56 | 58 | 16 | 16 | 15 | 78 | 85 | 81 |
| | 18. | 98.2 | 99 | 99.3 | 56 | 60 | 70 | 15 | 15 | 16 | 79 | 87 | 82 |
| | 19. | 98.3 | 99 | 99.2 | 56 | 56 | 62 | 14 | 15 | 15 | 79 | 86 | 82 |
| | 20. | 98.4 | 99.5 | 99.3 | 54 | 58 | 60 | 15 | 16 | 16 | 77 | 86 | 77 |
| | 21. | 98.5 | 98.8 | 98.9 | 52 | 56 | 58 | 14 | 15 | 15 | 80 | 85 | 82 |
| | 22. | 98.2 | 99.4 | 99.4 | 52 | 62 | 76 | 15 | 16 | 15 | 79 | 84 | 81 |
| | 23. | 98.3 | 99.4 | 99 | 56 | 60 | 68 | 16 | 16 | 16 | 78 | 85 | 81 |
| | 24. | 98 | 98.8 | 98.3 | 52 | 52 | 51 | 15 | 16 | 15 | 80 | 86 | 80 |
| | 26. | 98.1 | 98.4 | 99 | 52 | 52 | 62 | 15 | 16 | 16 | 77 | 85 | 81 |
| | 27. | 97.9 | 98.5 | 98.7 | 54 | 58 | 62 | 15 | 16 | 16 | 78 | 85 | 82 |
| | 28. | 97.7 | 98.5 | 98.7 | 52 | 54 | 58 | 15 | 15 | 16 | 80 | 87 | 81 |
| | 29. | 97.9 | 98.9 | 98.9 | 52 | 52 | 62 | 15 | 15 | 15 | 78 | 86 | 80 |
| | 30. | 97.9 | 99.3 | 99.3 | 54 | 58 | 62 | 15 | 15 | 16 | 78 | 86 | 82 |
| | | 98 | 98.9 | 98.9 | 54.3 | 55 | 62.1 | 15.2 | 15.6 | 15.5 | 78.6 | 84.7 | 80.5 |

| | | | | | | | | | | | | | |
|---------------|------|-------|-------|-------|-------|-------|-------|-------|-------|-------|-------|-------|-------|
| October 1845. | 1. | 97.6 | 99.1 | 98.9 | 54 | 54 | 58 | 15 | 14 | 16 | 78 | 86 | 82 |
| | 2. | 97.9 | 99.3 | 99 | 54 | 62 | 60 | 15 | 15 | 15 | 78 | 86 | 81 |
| | 3. | 98 | 99 | 99 | 52 | 54 | 66 | 15 | 16 | 16 | 78 | 87 | 82 |
| | 4. | 97.9 | 98.8 | 98.7 | 51 | 56 | 62 | 14 | 16 | 16 | 78 | 86 | 80 |
| | 5. | 98.1 | 98.6 | 98.4 | 56 | 56 | 54 | 14 | 16 | 15 | 79 | 85 | 80 |
| | 6. | 97.9 | 99.1 | 98.7 | 56 | 66 | 60 | 14 | 15 | 15 | 79 | 84 | 84 |
| | 7. | 98.2 | | 98.7 | 52 | | 64 | 14 | | 16 | 80 | | 82 |
| | 8. | 98.5 | 98.6 | 98.8 | 52 | 56 | 56 | 15 | 15 | 16 | 78 | 86 | 82 |
| | 9. | 97.8 | 98.6 | 98.4 | 53 | 54 | 60 | 15 | 16 | 16 | 77 | 86 | 82 |
| | 10. | 98.2 | | 98.9 | 54 | | 68 | 15 | | 16 | 78 | | 82 |
| | 11. | 98 | 98.7 | 98.9 | 52 | 58 | 56 | 14 | 16 | 16 | 78 | 87 | 82 |
| | 12. | 97.9 | 98.7 | | 52 | 52 | | 15 | 16 | | 78 | 86 | |
| | 13. | 98 | 98.7 | 98.8 | 53 | 56 | 62 | 15 | 16 | 16 | 78 | 87 | 82 |
| | 14. | 98 | 99.1 | 98.8 | 52 | 56 | 62 | 14 | 15 | 16 | 77 | 87 | 81 |
| | 15. | 98.1 | 99 | 98.9 | 54 | 58 | 56 | 15 | 16 | 16 | 78 | 85 | 80 |
| | 16. | 98.2 | 98.8 | 98.9 | 54 | 62 | 62 | 15 | 17 | 15 | 79 | 86 | 81 |
| | 17. | 98.2 | 99.6 | 99.4 | 56 | 58 | 64 | 15 | 16 | 16 | 80 | 87 | 83 |
| | 18. | 97.9 | 98.9 | 99 | 52 | 60 | 76 | 14 | 16 | 17 | 80 | 82 | 77 |
| | 19. | 98 | 99.4 | 98.8 | 64 | 66 | 56 | 16 | 16 | 15 | 78 | 83 | 79 |
| | 20. | 98 | 99.7 | 98.6 | 56 | 62 | 70 | 15 | 16 | 16 | 77 | 84 | 79 |
| | 21. | 98 | 99.5 | 99 | 54 | 60 | 58 | 15 | 17 | 16 | 77 | 84 | 80 |
| | 22. | 97.9 | 98.9 | 98.8 | 50 | 60 | 60 | 14 | 17 | 17 | 77 | 86 | 82 |
| | 23. | 98.2 | 99.1 | 98.9 | 56 | 60 | 60 | 15 | 16 | 16 | 79 | 87 | 82 |
| | 24. | 98.1 | 99 | 99.4 | 58 | 60 | 62 | 14 | 16 | 16 | 79 | 87 | 82 |
| | 25. | 97.9 | 98.9 | 99.3 | 56 | 54 | 60 | 15 | 16 | 16 | 78 | 86 | 82 |
| | 26. | 97.9 | 98.7 | 98.9 | 50 | 60 | 52 | 15 | 16 | 15 | 78 | 84 | 80 |
| | 27. | 97.9 | 99.1 | 99.1 | 53 | 60 | 60 | 15 | 16 | 15 | 80 | 84 | 80 |
| | 28. | 97.7 | | | 54 | | | 15 | | | 78 | | |
| | 29. | | 98.7 | 99 | | 54 | 56 | | 16 | 16 | | 86 | 81 |
| | 30. | 97.8 | 98.7 | 99 | 52 | 58 | 62 | 15 | 17 | 16 | 78 | 85 | 81 |
| | 31. | 97.8 | 98.6 | 98.7 | 52 | 56 | 60 | 15 | 16 | 16 | 78 | 83 | 81 |
| | 97.9 | 99 | 98.8 | 53.4 | 56.3 | 61.3 | 14.6 | 15.9 | 16.8 | 78 | 85.4 | 81 | |

| | Temp. under the tongue. | | | Pulse. | | | Respirations. | | | Temperature of room. | | | |
|----------------|-------------------------|-----------|-----------|----------|-----------|-----------|---------------|-----------|-----------|----------------------|-----------|-----------|----|
| | 6-7 A.M. | 12-2 P.M. | 9-11 P.M. | 6-7 A.M. | 12-2 P.M. | 9-11 P.M. | 6-7 A.M. | 12-2 P.M. | 9-11 P.M. | 6-7 A.M. | 12-2 P.M. | 9-11 P.M. | |
| November 1845. | 1. | 97.8 | 98.7 | 99 | 54 | 56 | 60 | 15 | 16 | 16 | 78 | 85 | 81 |
| | 2. | 97.8 | 98.6 | 98.8 | 52 | 56 | 66 | 15 | 16 | 16 | 78 | 85 | 81 |
| | 3. | 97.9 | 98.8 | 99 | 52 | 60 | 66 | 15 | 17 | 16 | 79 | 86 | 82 |
| | 4. | 97.8 | 98.9 | 98.9 | 53 | 58 | 62 | 15 | 16 | 16 | 78 | 86 | 81 |
| | 5. | 97.9 | 99.1 | 99.1 | 54 | 56 | 64 | 15 | 16 | 16 | 80 | 85 | 82 |
| | 6. | 98 | 98.7 | 98.6 | 53 | 56 | 60 | 15 | 16 | 15 | 77 | 83 | 80 |
| | 7. | 98 | 98.7 | 98.7 | 54 | 56 | 60 | 15 | 15 | 16 | 78 | 80 | 80 |
| | 8. | 98.1 | 99.4 | 99 | 52 | 58 | 68 | 15 | 16 | 15 | 78 | 84 | 81 |
| | 9. | 98 | 98.6 | 98.5 | 52 | 54 | 56 | 15 | 15 | 15 | 77 | 83 | 80 |
| | 10. | 98.1 | 98.6 | 98.8 | 56 | 56 | 64 | 15 | 15 | 16 | 78 | 86 | 81 |
| | 11. | 98.2 | 98.8 | 98.8 | 56 | 56 | 64 | 14 | 16 | 16 | 79 | 86 | 81 |
| | 12. | 97.8 | 98.2 | 98.5 | 54 | 52 | 62 | 14 | 15 | 16 | 79 | 79 | 78 |
| | 13. | 98.2 | 98.8 | 98.5 | 54 | 56 | 58 | 15 | 16 | 16 | 79 | 83 | 81 |
| | 14. | 98 | 99.2 | 98.6 | 50 | 60 | 54 | 14 | 15 | 15 | 78 | 82 | 80 |
| | 15. | 97.9 | 98.6 | 98.2 | 54 | 54 | 58 | 15 | 15 | 16 | 78 | 81 | 79 |
| | 16. | 98 | 98.5 | 98.4 | 56 | 56 | 60 | 15 | 15 | 15 | 78 | 84 | 78 |
| | 17. | 98 | 98.5 | 98.9 | 52 | 56 | 62 | 15 | 15 | 15 | 78 | 81 | 79 |
| | 18. | 98 | 98.5 | 98.7 | 50 | 54 | 58 | 15 | 16 | 16 | 78 | 82 | 79 |
| | 19. | 98.1 | 98.9 | 98.6 | 54 | 60 | 60 | 15 | 16 | 15 | 77 | 84 | 80 |
| | 20. | 98 | 99 | 98.6 | 54 | 56 | 58 | 15 | 15 | 16 | 77 | 84 | 80 |
| | 21. | 97.9 | 98.3 | 98.9 | 54 | 54 | 60 | 14 | 16 | 16 | 77 | 84 | 80 |
| | 22. | 98 | 99.2 | 98.3 | 54 | 62 | 60 | 14 | 16 | 16 | 79 | 85 | 79 |
| | 23. | 98.5 | 98.8 | 98.5 | 54 | 56 | 60 | 15 | 15 | 16 | 78 | 85 | 77 |
| | 24. | 97.9 | 99 | 99.2 | 50 | 58 | 66 | 14 | 16 | 17 | 77 | 83 | 81 |
| | 25. | 98.4 | 99.1 | 98.6 | 54 | 58 | 58 | 16 | 17 | 16 | 78 | 85 | 78 |
| | 26. | 97.8 | 98.3 | 99 | 52 | 54 | 56 | 15 | 16 | 15 | 77 | 83 | 80 |
| | 27. | 98.5 | 98.6 | 99 | 52 | 54 | 62 | 14 | 16 | 16 | 78 | 83 | 80 |
| | 28. | 98.2 | 99.2 | 98.2 | 56 | 60 | 70 | 15 | 16 | 16 | 78 | 81 | 78 |
| | 98 | 98.6 | 98.7 | 53.3 | 56.5 | 61 | 14.8 | 15.6 | 16 | 78 | 83.8 | 79.9 | |

| | | | | | | | | | | | | | |
|----------------|-----|------|-------|-------|------|-----|------|------|------|-----|------|-----|-----|
| December 1845. | 1. | 97.9 | 98.6 | 98.4 | 48 | 54 | 58 | 15 | 15 | 16 | 78 | 80 | 77 |
| | 2. | 97.9 | 98.4 | 98.5 | 52 | 52 | 60 | 14 | 15 | 16 | 77 | 82 | 79 |
| | 3. | 97.8 | 98.9 | 98.8 | 50 | 56 | 56 | 14 | 16 | 16 | 77 | 81 | 77 |
| | 4. | 98.1 | 98.7 | 98.5 | 54 | 56 | 60 | 14 | 16 | 16 | 77 | 79 | 79 |
| | 5. | 97.9 | 98.4 | 98.5 | 52 | 56 | 70 | 15 | 16 | 17 | 77 | 81 | 79 |
| | 6. | 98.1 | 98.7 | 98.4 | 52 | 56 | 60 | 14 | 15 | 16 | 77 | 81 | 79 |
| | 7. | 97.9 | 98.3 | 98.2 | 50 | 52 | 76 | 15 | 16 | 17 | 77 | 82 | 77 |
| | 8. | 98 | 98.5 | | 64 | 60 | ... | 14 | 15 | ... | 75 | 82 | ... |
| | 9. | 98.4 | 98.5 | 98.9 | 52 | 56 | 56 | 14 | 15 | 16 | 75 | 83 | 77 |
| | 10. | 97.9 | 98.4 | 98.8 | 54 | 52 | 60 | 14 | 15 | 15 | 76 | 82 | 78 |
| | 11. | 97.9 | 98.9 | 98.4 | 56 | 56 | 62 | 14 | 16 | 15 | 75 | 83 | 79 |
| | 12. | 97.8 | | | 56 | ... | ... | 14 | ... | ... | 77 | ... | ... |
| | 13. | 97.9 | 98.4 | 98.8 | 54 | 54 | 62 | 15 | 15 | 15 | 97 | 81 | 78 |
| | 14. | 98 | 98.5 | 98.6 | 54 | 54 | 56 | 13 | 15 | 16 | 75 | 81 | 78 |
| | 15. | 97.7 | 98.3 | 98.9 | 50 | 54 | 60 | 14 | 15 | 15 | 70 | 80 | 77 |
| | 16. | 98.2 | 98.8 | 98.2 | 50 | 54 | 60 | 15 | 16 | 16 | 76 | 82 | 78 |
| | 17. | 98.4 | 98.8 | 98.6 | 52 | 58 | 66 | 15 | 16 | 16 | 77 | 83 | 78 |
| | 18. | 97.9 | 98.6 | | 50 | 52 | ... | 15 | 15 | ... | 75 | 82 | ... |
| | 19. | 98.4 | 98.8 | 98.7 | 58 | 52 | 64 | 15 | 16 | 16 | 73 | 80 | 78 |
| | 20. | 97.8 | 98.8 | | 52 | 50 | ... | 15 | 16 | ... | 74 | 82 | ... |
| | 21. | 98.1 | 98.9 | 98.6 | 66 | 56 | 60 | 16 | 16 | 15 | 73 | 80 | 74 |
| | 22. | 97.6 | 98.6 | 98.5 | 52 | 56 | 60 | 14 | 16 | 16 | 74 | 82 | 77 |
| | 23. | 97.9 | 98.6 | 99 | 60 | 54 | 56 | 14 | 16 | 15 | 73 | 82 | 76 |
| | 24. | 97.8 | 98.6 | 98.6 | 54 | 58 | 56 | 14 | 16 | 15 | 74 | 82 | 78 |
| | 25. | 98.3 | 99.2 | 98.9 | 52 | 60 | 66 | 15 | 16 | 16 | 74 | 81 | 76 |
| | 26. | 98.1 | 98.7 | 99.2 | 52 | 56 | 58 | 14 | 14 | 15 | 74 | 80 | 76 |
| | 27. | 98.2 | 99.3 | 98.4 | 54 | 58 | 60 | 15 | 15 | 16 | 73 | 82 | 75 |
| | 28. | 98.3 | | 98.6 | 56 | ... | 70 | 14 | ... | 15 | 72 | ... | 75 |
| | 29. | 98.1 | 98.4 | 98.5 | 52 | 52 | 58 | 14 | 15 | 16 | 72 | 82 | 78 |
| | 30. | 98.3 | 98.5 | 98.4 | 54 | 58 | 76 | 15 | 16 | 16 | 75 | 82 | 78 |
| | 31. | 98.2 | 98.6 | 98.6 | 60 | 56 | 66 | 15 | 16 | 17 | 76 | 82 | 76 |
| | 98 | 98.6 | 98.6 | 53.8 | 55.2 | 66 | 14.4 | 15.5 | 15.7 | 75 | 81.3 | 77 | |

| | Temp. under the tongue. | | | Pulse. | | | Respirations. | | | Temperature of room. | | | |
|----------------|-------------------------|-----------|-----------|----------|-----------|-----------|---------------|-----------|-----------|----------------------|-----------|-----------|----|
| | 6-7 A.M. | 12-2 P.M. | 9-11 P.M. | 6-7 A.M. | 12-2 P.M. | 9-11 P.M. | 6-7 A.M. | 12-2 P.M. | 9-11 P.M. | 6-7 A.M. | 12-2 P.M. | 9-11 P.M. | |
| January 1846. | 1. | 98.2 | 98.5 | 99.2 | 54 | 56 | 78 | 15 | 15 | 16 | 72 | 83 | 79 |
| | 2. | 98 | | | 52 | | | 14 | | | 76 | | |
| | 3. | 98.5 | 99 | 98.8 | 56 | 62 | 66 | 15 | 15 | 17 | 74 | 80 | 78 |
| | 4. | 98.1 | 98.8 | 98.8 | 56 | 56 | 62 | 15 | 16 | 16 | 76 | 82 | 77 |
| | 5. | 98.2 | 99.1 | 98.5 | 56 | 60 | 76 | 15 | 16 | 15 | 75 | 83 | 78 |
| | 6. | 98.3 | 98.9 | 98.7 | 54 | 60 | 70 | 15 | 16 | 16 | 72 | 81.5 | 78 |
| | 7. | 98.3 | 99 | 98.7 | 56 | 60 | 62 | 14 | 16 | 15 | 76 | 81 | 78 |
| | 8. | 98.2 | 98.8 | 98.5 | 54 | 56 | 62 | 15 | 16 | 16 | 74 | 82 | 77 |
| | 9. | 98.3 | 99.3 | | 58 | 66 | | 15 | 16 | | 76 | 82 | |
| | 18. | 98.2 | 99.1 | 98.6 | 52 | 60 | 58 | 15 | 16 | 15 | 76 | 84 | 78 |
| | 19. | 98.2 | 98.7 | 98.9 | 54 | 58 | 60 | 14 | 16 | 15 | 76 | 82 | 79 |
| | 20. | 98.2 | 99.1 | 98.7 | 54 | 60 | 60 | 14 | 16 | 16 | 76 | 83 | 79 |
| | 23. | 98.3 | 98.9 | 98.5 | 56 | 60 | 56 | 14 | 15 | 15 | 75 | 83 | 79 |
| | 24. | 98.1 | 98.9 | 99.2 | 56 | 60 | 60 | 15 | 16 | 15 | 76 | 82 | 79 |
| 25. | 98.1 | 98.7 | 98.9 | 50 | 52 | 52 | 14 | 15 | 15 | 75 | 81 | 78 | |
| 26. | 98.2 | | | 54 | | | 14 | | | 75 | | | |
| 29. | 98.3 | 98.9 | | 52 | 52 | | 14 | 16 | | 72 | 82 | | |
| | 98.2 | 99 | 98.7 | 54.3 | 58.5 | 61.7 | 14.6 | 15.7 | 15.6 | 74.3 | 82 | 78.2 | |
| February 1846. | 3. | 98.3 | 99.6 | 98.7 | 54 | 62 | 74 | 15 | 16 | 16 | 72 | 82 | 76 |
| | 4. | 97.9 | 98.8 | | 58 | 54 | | 15 | 15 | | 73 | 78 | |
| | 5. | 98.5 | 99.1 | 98.5 | 60 | 56 | 56 | 14 | 16 | 15 | 74 | 82 | 75 |
| | 6. | 98.3 | 99.3 | 98.5 | 56 | 58 | 58 | 14 | 16 | 15 | 73 | 81 | 76 |
| | 7. | 98.3 | 99.3 | 98.8 | 52 | 56 | 66 | 14 | 16 | 16 | 72 | 82 | 76 |
| | 8. | 98.2 | 99.3 | 98.2 | 52 | 58 | 70 | 14 | 16 | 16 | 72 | 85 | 76 |
| | 9. | 98.3 | 99.2 | 98.9 | 62 | 62 | 64 | 15 | 15 | 16 | 76 | 85 | 78 |
| | 10. | 97.9 | 99 | | 50 | 56 | | 14 | 16 | | 75 | 82 | |
| | 12. | 98 | 98.8 | 98.8 | 52 | 52 | 50 | 14 | 15 | 15 | 72 | 82 | 75 |
| | 13. | 98.2 | 98.6 | 98.6 | 52 | 54 | 62 | 14 | 15 | 15 | 73 | 84 | 75 |
| | 14. | 98.3 | 99.1 | 98.5 | 58 | 56 | 56 | 14 | 16 | 15 | 75 | 84 | 76 |
| | 15. | 97.9 | | 98.8 | 52 | | 60 | 14 | | 15 | 75 | | 81 |
| | 16. | 98 | 99.3 | 99.1 | 52 | 60 | 62 | 14 | 16 | 15 | 75 | 84 | 78 |
| | 17. | 98.1 | 98.8 | 98.4 | 58 | 58 | 60 | 14 | 15 | 15 | 75 | 83 | 76 |
| 18. | 98.1 | 99 | 98.5 | 56 | 56 | 56 | 15 | 16 | 15 | 75 | 83 | 78 | |
| 19. | 98 | 99.1 | 98.6 | 52 | 56 | 60 | 15 | 16 | 15 | 75 | 83 | 78 | |
| 20. | 98 | 99.3 | 98.4 | 56 | 60 | 66 | 14 | 15 | 16 | 75 | 85 | 79 | |
| 21. | 98.3 | 99.3 | 98.8 | 56 | 58 | 70 | 14 | 16 | 16 | 76 | 83 | 78 | |
| 22. | 98 | 98.8 | 99.1 | 58 | 56 | 62 | 15 | 15 | 15 | 75 | 85 | 80 | |
| 23. | 98.4 | 99.2 | 98.8 | 56 | 58 | 56 | 14 | 16 | 14 | 77 | 85 | 78 | |
| | 98.1 | 99.1 | 98.6 | 55.1 | 57.1 | 59.9 | 14.3 | 15.5 | 15.2 | 74 | 83 | 76.6 | |

| | Temp. under the tongue. | | | Pulse. | | | Respirations. | | | Temperature of room. | | | | |
|-------------|-------------------------|-----------|-----------|----------|-----------|-----------|---------------|-----------|-----------|----------------------|-----------|-----------|----|----|
| | 6-7 A.M. | 12-2 P.M. | 9-11 P.M. | 6-7 A.M. | 12-2 P.M. | 9-11 P.M. | 6-7 A.M. | 12-2 P.M. | 9-11 P.M. | 6-7 A.M. | 12-2 P.M. | 9-11 P.M. | | |
| April 1846. | 9. | 97.8 | 98.3 | 98.5 | 52 | 54 | 56 | 14 | 15 | 15 | 74 | 79 | 77 | |
| | 10. | 98.2 | 98.5 | 98.6 | 56 | 56 | 52 | 15 | 14 | 15 | 77 | 83 | 78 | |
| | 11. | 98.2 | 98.8 | | 56 | 58 | | 14 | 16 | | 77 | 84 | | |
| | 12. | 98.4 | 99 | 98.6 | 56 | 54 | 64 | 14 | 16 | 16 | 77 | 85 | 80 | |
| | 13. | 98.1 | 99.2 | 99 | 54 | 56 | 72 | 15 | 16 | 16 | 78 | 84 | 77 | |
| | 14. | 98.1 | 99.3 | 98.2 | 52 | 58 | 70 | 14 | 16 | 16 | 76 | 83 | 79 | |
| | 15. | 98.3 | 98.7 | 98.5 | 54 | 52 | 62 | 14 | 15 | 15 | 77 | 84 | 79 | |
| | 16. | 97.9 | 98.8 | 98.7 | 56 | 52 | 64 | 14 | 15 | 16 | 77 | 85 | 79 | |
| | 17. | 98.1 | 98.6 | 98.4 | 54 | 52 | 60 | 14 | 15 | 15 | 77 | 84 | 79 | |
| | 18. | 98.1 | 99.3 | 98.5 | 52 | 56 | 58 | 14 | 16 | 15 | 77 | 84 | 80 | |
| | 19. | 98.2 | 98.6 | 98.3 | 56 | 54 | 56 | 14 | 16 | 16 | 77 | 82 | 79 | |
| | 20. | 98.2 | 98.6 | 98.5 | 50 | 52 | 52 | 15 | 15 | 15 | 77 | 83 | 79 | |
| | 21. | 98.3 | 98.9 | 98.8 | 52 | 54 | 58 | 15 | 16 | 15 | 76 | 84 | 79 | |
| | 22. | 98.3 | 98.9 | 98.6 | 56 | 56 | 54 | 15 | 15 | 14 | 75 | 83 | 79 | |
| | 23. | 98.3 | 99.3 | | 52 | 56 | | 14 | 15 | | 77 | 85 | | |
| | 24. | 98.3 | 99.1 | 98.6 | 60 | 54 | 60 | 16 | 16 | 16 | 77 | 86 | 80 | |
| | 25. | 98.1 | 99 | 98.8 | 52 | 56 | 62 | 14 | 16 | 16 | 78 | 85 | 81 | |
| | 26. | 98.3 | 99.1 | 98.8 | 54 | 54 | 56 | 14 | 17 | 16 | 77 | 85 | 82 | |
| | 27. | 98.2 | 99.1 | 99 | 52 | 56 | 58 | 14 | 17 | 15 | 79 | 85 | 81 | |
| | 28. | 98.2 | 98.8 | | 54 | 56 | | 15 | 16 | | 78 | 86 | | |
| | 29. | | 98.9 | 98.7 | | 50 | 54 | | 16 | 15 | | 85 | 80 | |
| | 30. | 98.1 | 98.6 | 98.6 | 54 | 50 | 62 | 15 | 15 | 16 | 77 | 82 | 79 | |
| | | 98.1 | 98.7 | 98.6 | 54 | 54.5 | 59.5 | 14.4 | 15.6 | 15.4 | 77 | 84 | 79 | |
| | May 1846. | 1. | 98.1 | 98.5 | 99 | 54 | 54 | 62 | 15 | 16 | 16 | 77 | 82 | 79 |
| | | 2. | 98.1 | 99.1 | 99 | 54 | 56 | 66 | 14 | 16 | 15 | 76 | 85 | 78 |
| | | 3. | 98.4 | 98.9 | 99.2 | 54 | 56 | 64 | 15 | 16 | 15 | 77 | 85 | 80 |
| | | 4. | 98.1 | 99 | 99 | 52 | 56 | 62 | 15 | 16 | 16 | 76 | 85 | 81 |
| | | 5. | 98.2 | 99 | 98.8 | 56 | 54 | 66 | 15 | 16 | 16 | 77 | 84 | 81 |
| | | 6. | 98.1 | 98.9 | | 52 | 54 | | 15 | 15 | | 77 | 86 | |
| | | 7. | 98.3 | 99 | 98.5 | 60 | 56 | 72 | 16 | 16 | 16 | 79 | 86 | 81 |
| 8. | | 98.2 | 98.8 | 98.7 | 56 | 56 | 58 | 15 | 16 | 16 | 78 | 86 | 80 | |
| 9. | | 98.2 | 98.8 | | 56 | 56 | | 15 | 16 | | 79 | 86 | | |
| 10. | | 98.1 | 99.1 | 99.3 | 54 | 56 | 60 | 15 | 16 | 16 | 79 | 86 | 81 | |
| 11. | | 98.1 | 98.9 | 99.1 | 56 | 56 | 64 | 15 | 17 | 16 | 78 | 86 | 81 | |
| 12. | | 98.4 | 99.1 | 98.7 | 54 | 56 | 58 | 15 | 16 | 16 | 79 | 86 | 82 | |
| 13. | | 98.1 | 98.5 | 98.4 | 54 | 48 | 54 | 15 | 16 | 15 | 78 | 84 | 81 | |
| 14. | | 98.6 | 99.1 | 98.9 | 54 | 60 | 60 | 15 | 16 | 16 | 78 | 86 | 81 | |
| 15. | | 98.3 | 98.9 | 98.4 | 52 | 54 | 80 | 14 | 15 | 16 | 78 | 86 | 81 | |
| 16. | | 98.1 | 99.1 | 98 | 56 | 58 | 60 | 16 | 16 | 16 | 79 | 87 | 82 | |
| 17. | | 98.3 | 98.9 | 98.1 | 62 | 54 | 72 | 14 | 17 | 16 | 80 | 88 | 81 | |
| 18. | | 98 | 99.2 | 98.6 | 70 | 56 | 56 | 14 | 16 | 16 | 77 | 88 | 82 | |
| 19. | | 98.1 | 98.7 | 98.9 | 54 | 54 | 60 | 15 | 16 | 16 | 80 | 87 | 82 | |
| 20. | | 98.1 | | | 56 | | | 14 | | | 79 | | | |
| 21. | | 98.2 | 99 | 98.4 | 54 | 58 | 54 | 15 | 16 | 15 | 80 | 87 | 81 | |
| 22. | | 98.4 | 98.7 | 98.8 | 54 | 50 | 58 | 15 | 16 | 16 | 79 | 88 | 77 | |
| 23. | | 98.4 | 99.1 | 98.7 | 60 | 56 | 70 | 15 | 16 | 16 | 81 | 87 | 82 | |
| 24. | | 98.2 | 99 | 98.5 | 58 | 56 | 56 | 15 | 16 | 15 | 79 | 88 | 82 | |
| 25. | | 98.2 | 99.1 | | 56 | 56 | | 14 | 16 | | 79 | 88 | | |
| 26. | | 98.3 | 98.6 | 98.5 | 60 | 52 | 58 | 15 | 15 | 15 | 79 | 79 | 81 | |
| 27. | | 98.4 | 99.1 | 98.7 | 56 | 56 | 56 | 14 | 14 | 15 | 80 | 82 | 82 | |
| 28. | | 98.3 | 99 | 99 | 56 | 56 | 60 | 15 | 16 | 14 | 81 | 86 | 84 | |
| 29. | | 98.4 | 99.4 | 98.8 | 60 | 60 | 60 | 15 | 16 | 16 | 82 | 88 | 83 | |
| 30. | | 98.5 | 99.3 | 99.3 | 56 | 56 | 62 | 15 | 16 | 16 | 80 | 87 | 83 | |
| 31. | | 98.2 | 99 | 99 | 54 | 52 | 58 | 15 | 15 | 16 | 80 | 85 | 76 | |
| | 98.2 | 98.9 | 98.8 | 56.1 | 55.2 | 62 | 15 | 15.8 | 15.6 | 78.7 | 85.8 | 80 | | |

| | Temp. under the tongue. | | | Pulse. | | | Respirations. | | | Temperature of room. | | | | |
|------------|-------------------------|-----------|-----------|----------|-----------|-----------|---------------|-----------|-----------|----------------------|-----------|-----------|------|----|
| | 6-7 A.M. | 12-2 P.M. | 9-11 P.M. | 6-7 A.M. | 12-2 P.M. | 9-11 P.M. | 6-7 A.M. | 12-2 P.M. | 9-11 P.M. | 6-7 A.M. | 12-2 P.M. | 9-11 P.M. | | |
| June 1846. | 1. | 98.3 | 99.5 | 99.2 | 52 | 56 | 62 | 14 | 16 | 16 | 79 | 87 | 83 | |
| | 3. | 98.4 | 99.4 | 98.9 | 58 | 58 | 56 | 15 | 15 | 15 | 80 | 88 | 83 | |
| | 4. | 98.2 | 99.5 | 98.7 | 58 | 68 | 64 | 15 | 17 | 16 | 82 | 88 | 82 | |
| | 7. | 98.2 | 98.7 | 98.9 | 60 | 54 | 70 | 15 | 15 | 16 | 78 | 82 | 82 | |
| | 8. | 98.4 | 99.1 | 98.7 | 54 | 58 | 60 | 15 | 15 | 16 | 79 | 86 | 81 | |
| | 9. | 98.4 | 99 | 98.8 | 54 | 54 | 60 | 15 | 16 | 15 | 79 | 86 | 81 | |
| | 10. | 98.3 | 98.9 | 98.7 | 50 | 56 | 58 | 14 | 16 | 16 | 79 | 84 | 79 | |
| | 11. | 98.2 | | | 56 | | | 15 | | | 78 | | | |
| | 12. | 98.5 | 99 | 98.6 | 58 | 54 | 80 | 16 | 14 | 17 | 79 | 86 | 82 | |
| | 13. | 98.4 | 98.9 | 98.7 | 66 | 56 | 60 | 14 | 16 | 15 | 80 | 85 | 82 | |
| | 14. | 98.4 | 98.5 | | 58 | 52 | | 15 | 15 | | 80 | 87 | | |
| | 15. | 98 | 98.7 | 98.9 | 52 | 50 | 58 | 14 | 16 | 16 | 80 | 85 | 82 | |
| | 16. | 98.2 | 99.1 | 98.7 | 52 | 56 | 56 | 14 | 16 | 16 | 79 | 82 | 80 | |
| | 17. | 98.4 | 99 | 98.7 | 58 | 58 | 56 | 15 | 16 | 14 | 79 | 85 | 81 | |
| | 18. | 98.1 | 98.7 | | 52 | 52 | | 15 | 16 | | 77 | 81 | | |
| | 20. | 98.1 | | | 56 | | | 15 | | | 79 | | | |
| | 23. | 98.3 | 98.6 | 98.9 | 50 | 54 | 58 | 14 | 16 | 15 | 79 | 82 | 79 | |
| | 24. | 98.1 | 98.8 | 98.8 | 58 | 54 | 56 | 15 | 16 | 15 | 79 | 85 | 82 | |
| | 25. | 98.1 | 99.1 | | 56 | 56 | | 15 | 16 | | 79 | 85 | | |
| | 26. | 98.3 | 98.5 | 98.8 | 54 | 54 | 54 | 15 | 16 | 16 | 79 | 84 | 81 | |
| | 27. | 98.2 | 98.9 | 98.8 | 54 | 56 | 52 | 14 | 16 | 14 | 79 | 86 | 78 | |
| | 28. | 98 | 98.7 | 98.5 | 52 | 52 | 52 | 14 | 15 | 15 | 79 | 85 | 81 | |
| | 29. | 98.1 | 99.2 | 98.7 | 52 | 54 | 62 | 14 | 16 | 15 | 79 | 83 | 80 | |
| | 30. | 97.9 | 99.1 | | 54 | 62 | | 14 | 15 | | 77 | 86 | | |
| | | 98.2 | 99 | 98.8 | 55.1 | 55.6 | 59.7 | 14.6 | 15.7 | 15.4 | 79 | 84.7 | 81 | |
| | July 1846. | 2. | 98.3 | 99 | 99.3 | 62 | 56 | 62 | 15 | 16 | 16 | 79 | 84 | 81 |
| | | 3. | 98.3 | 98.9 | | 54 | 54 | | 15 | 15 | | 79 | 86 | |
| | | 4. | 98.1 | 98.9 | 98.5 | 54 | 52 | 75 | 14 | 16 | 16 | 79 | 86 | 82 |
| | | 5. | 98.3 | 98.6 | | 52 | 54 | | 15 | 16 | | 79 | 86 | |
| | | 6. | 98.5 | 99 | 98.8 | 60 | 56 | 56 | 16 | 16 | 16 | 79 | 86 | 82 |
| 7. | | 98 | 98.6 | 98.4 | 52 | 56 | 80 | 15 | 17 | 16 | 79 | 85 | 80 | |
| 8. | | 98.3 | 98.8 | 98.6 | 60 | 50 | 52 | 15 | 15 | 15 | 78 | 83 | 81 | |
| 9. | | 98.2 | 98.9 | 99 | 54 | 56 | 60 | 14 | 16 | 15 | 79 | 86 | 81 | |
| 10. | | 98 | 98.6 | 98.8 | 54 | 54 | 54 | 14 | 17 | 16 | 79 | 86 | 81 | |
| 11. | | 98 | | | 56 | | | 14 | | | 80 | | | |
| 12. | | 98.4 | 99 | 99.3 | 54 | 54 | 60 | 16 | 15 | 15 | 78 | 85 | 82 | |
| 13. | | 98.2 | 99 | 99 | 52 | 56 | 60 | 15 | 15 | 16 | 79 | 86 | 81 | |
| 14. | | 97.7 | 98.7 | 98.9 | 54 | 54 | 56 | 15 | 16 | 15 | 79 | 86 | 80 | |
| 15. | | 98.4 | 99 | 98.9 | 56 | 56 | 80 | 14 | 17 | 15 | 80 | 86 | 82 | |
| 16. | | 98.4 | 98.9 | 98.9 | 56 | 56 | 58 | 15 | 16 | 16 | 79 | 82 | 82 | |
| 17. | | 98.1 | 98.8 | 99.1 | 50 | 56 | 56 | 14 | 15 | 16 | 76 | 84 | 81 | |
| 18. | | 98.1 | 98.6 | 99 | 52 | 56 | 58 | 15 | 16 | 16 | 79 | 86 | 82 | |
| 19. | | 98.1 | | 99 | 52 | | 58 | 14 | | 16 | 79 | | 82 | |
| 20. | | 98.3 | 99.1 | 99.3 | 52 | 58 | 56 | 15 | 17 | 15 | 78 | 86 | 82 | |
| 21. | | 98 | 98.8 | | 54 | 56 | | 14 | 17 | | 79 | 85 | | |
| 23. | | 98.3 | 98.8 | 99 | 56 | 56 | 58 | 15 | 15 | 17 | 79 | 84 | 81 | |
| 24. | | 98.3 | 98.8 | 99.1 | 54 | 50 | 64 | 15 | 16 | 15 | 78 | 83 | 82 | |
| 25. | | 98.2 | 98.6 | 99 | 54 | 52 | 56 | 15 | 17 | 16 | 79 | 83 | 81 | |
| 26. | | 98.2 | 98.8 | 98.8 | 50 | 50 | 58 | 15 | 15 | 15 | 79 | 85 | 81 | |
| 27. | | 98.1 | 99 | 98.9 | 54 | 54 | 56 | 15 | 17 | 15 | 79 | 84 | 82 | |
| 28. | | 98.2 | 99.2 | 98.7 | 52 | 58 | 68 | 14 | 16 | 15 | 78 | 84 | 81 | |
| 29. | | 98.4 | 98.9 | | 54 | 52 | | 14 | 16 | | 79 | 84 | | |
| | | 98.2 | 99 | 98.9 | 54.5 | 54.5 | 60.7 | 14.7 | 16 | 15.3 | 78.8 | 84.8 | 81.4 | |

| | Temp. under the tongue. | | | Pulse. | | | Respirations. | | | Temperature of room. | | | |
|--------------|-------------------------|-----------|-----------|----------|-----------|-----------|---------------|-----------|-----------|----------------------|-----------|-----------|----|
| | 6-7 A.M. | 12-2 P.M. | 9-11 P.M. | 6-7 A.M. | 12-2 P.M. | 9-11 P.M. | 6-7 A.M. | 12-2 P.M. | 9-11 P.M. | 6-7 A.M. | 12-2 P.M. | 9-11 P.M. | |
| August 1846. | 1. | 98.2 | 98.8 | 98.5 | 56 | 54 | 70 | 15 | 16 | 17 | 78 | 86 | 82 |
| | 2. | 98.1 | 98.7 | 99.2 | 54 | 54 | 62 | 15 | 15 | 16 | 79 | 87 | 81 |
| | 3. | 98.2 | 99.1 | 99.2 | 52 | 58 | 60 | 14 | 17 | 16 | 79 | 86 | 82 |
| | 4. | 98.1 | 98.9 | 98.9 | 54 | 56 | 64 | 15 | 16 | 16 | 79 | 86 | 82 |
| | 5. | 98.2 | 99.2 | 98.9 | 52 | 54 | 60 | 15 | 16 | 15 | 79 | 83 | 79 |
| | 6. | 98.2 | 99 | 99.1 | 54 | 56 | 70 | 15 | 16 | 16 | 75 | 84 | 81 |
| | 7. | 97.9 | 99.1 | 99 | 52 | 60 | 60 | 15 | 16 | 15 | 77 | 86 | 82 |
| | 8. | 98.3 | 98.7 | 98.7 | 58 | 56 | 60 | 15 | 16 | 16 | 79 | 83 | 80 |
| | 9. | 98.1 | 98.6 | 98.8 | 54 | 54 | 56 | 15 | 15 | 16 | 79 | 85 | 81 |
| | 10. | 98.2 | 98.9 | 98.9 | 54 | 54 | 60 | 15 | 16 | 15 | 79 | 87 | 83 |
| | 11. | 98.2 | 98.4 | 99 | 54 | 54 | 62 | 14 | 14 | 16 | 78 | 83 | 81 |
| | 12. | 98.3 | 99.2 | 98.9 | 56 | 60 | 64 | 15 | 16 | 16 | 80 | 86 | 82 |
| | 13. | 98.5 | 99.1 | 98.8 | 56 | 54 | 60 | 15 | 15 | 16 | 79 | 84 | 81 |
| | 14. | 98.1 | 98.9 | 99.2 | 54 | 58 | 64 | 15 | 17 | 16 | 79 | 86 | 82 |
| | 15. | 98.4 | 99 | 98.7 | 54 | 58 | 54 | 15 | 16 | 15 | 80 | 87 | 82 |
| | 16. | 98.3 | | 98.8 | 54 | | 56 | 15 | | 16 | 80 | | 83 |
| | 17. | 98.3 | 98.9 | 98.9 | 54 | 56 | 54 | 14 | 16 | 16 | 79 | 85 | 79 |
| | 18. | 98 | 98.8 | 98.9 | 54 | 52 | 64 | 15 | 16 | 16 | 77 | 86 | 83 |
| | 19. | 98.4 | 99.2 | 99 | 56 | 56 | 60 | 14 | 16 | 16 | 80 | 86 | 82 |
| | 20. | 98.3 | 98.9 | | 54 | 52 | | 15 | 16 | | 79 | 86 | |
| | 21. | 98.4 | 99.3 | 99.1 | 62 | 60 | 62 | 16 | 17 | 16 | 80 | 88 | 83 |
| | 22. | 98.2 | 99 | 99.3 | 54 | 54 | 60 | 14 | 16 | 16 | 79 | 86 | 81 |
| | 23. | 98.2 | 98.8 | 98.8 | 54 | 54 | 60 | 14 | 17 | 16 | 79 | 87 | 78 |
| | 24. | 98.2 | 99.1 | 99.2 | 54 | 54 | 54 | 14 | 16 | 16 | 79 | 87 | 82 |
| | 25. | 98.2 | 99.4 | 98.8 | 52 | 54 | 60 | 14 | 16 | 16 | 78 | 82 | 80 |
| | 26. | 98.3 | 98.9 | 99 | 54 | 54 | 62 | 14 | 15 | 15 | 78 | 84 | 83 |
| | 27. | 98.2 | 98.7 | 98.8 | 54 | 58 | 60 | 14 | 16 | 16 | 78 | 82 | 78 |
| | 28. | 98.3 | 99 | 98.5 | 54 | 54 | 54 | 15 | 16 | 16 | 78 | 86 | 82 |
| | 29. | 98.3 | 98.9 | 98.9 | 54 | 56 | 60 | 14 | 15 | 15 | 79 | 84 | 81 |
| | 30. | 98.2 | | | 56 | | | 15 | | | 79 | | |
| | 31. | 98 | 99.1 | 99 | 58 | 58 | 64 | 15 | 16 | 16 | 79 | 86 | 82 |
| | 98.1 | 99 | 98.9 | 54.2 | 55.6 | 60.5 | 14.6 | 15.9 | 15.6 | 78.7 | 85.5 | 81.7 | |

| | | | | | | | | | | | | | |
|-----------------|-----|------|-------|-------|----|-------|-------|------|-------|-------|------|-------|----|
| September 1846. | 1. | 98.2 | 99 | 98.8 | 56 | 58 | 56 | 14 | 17 | 16 | 79 | 86 | 79 |
| | 2. | 98.2 | 98.8 | 99 | 54 | 56 | 56 | 14 | 16 | 16 | 79 | 85 | 83 |
| | 3. | 98.2 | 99.1 | | 54 | 54 | | 15 | 16 | | 78 | 85 | |
| | 4. | 98 | 99.2 | 99.2 | 52 | 56 | 62 | 15 | 16 | 16 | 78 | 85 | 84 |
| | 5. | 98.2 | 98.9 | 98.9 | 54 | 54 | 78 | 15 | 17 | 17 | 80 | 87 | 83 |
| | 6. | 98.1 | 98.9 | 98.8 | 56 | 56 | 60 | 15 | 15 | 15 | 80 | 87 | 79 |
| | 7. | 98.1 | 98.9 | 98.4 | 54 | 52 | 54 | 15 | 15 | 16 | 80 | 84 | 79 |
| | 8. | 97.7 | 98.8 | 99.2 | 52 | 54 | 60 | 15 | 15 | 16 | 78 | 86 | 83 |
| | 9. | 98.4 | 98.9 | 98.7 | 56 | 56 | 62 | 15 | 15 | 15 | 79 | 86 | 82 |
| | 10. | 98 | 99 | 98.9 | 54 | 56 | 54 | 14 | 15 | 15 | 80 | 87 | 83 |
| | 11. | 98.3 | 99.1 | 98.8 | 54 | 60 | 62 | 15 | 16 | 16 | 81 | 83 | 81 |
| | 12. | 98.2 | 98.6 | 99.1 | 56 | 52 | 58 | 14 | 14 | 14 | 80 | 82 | 81 |
| | 13. | 98.2 | 98.7 | 98.5 | 54 | 50 | 56 | 15 | 15 | 16 | 78 | 86 | 82 |
| | 14. | 98.3 | 99.1 | 98.1 | 56 | 54 | 64 | 15 | 16 | 16 | 78 | 86 | 81 |
| | 15. | 98.5 | 98.8 | 98.9 | 52 | 56 | 56 | 15 | 16 | 16 | 79 | 85 | 82 |
| | 16. | 97.9 | | 98.5 | 56 | | 60 | 15 | | 16 | 78 | | 80 |
| | 17. | 98.2 | 99.3 | 98.6 | 58 | 60 | 60 | 15 | 16 | 16 | 79 | 85 | 80 |
| | 18. | 98.2 | 99.1 | 98.9 | 54 | 56 | 60 | 15 | 16 | 16 | 78 | 84 | 81 |
| | 19. | 98.2 | 99 | 99.2 | 54 | 52 | 58 | 14 | 15 | 15 | 79 | 86 | 82 |
| | 20. | 98.3 | 99.2 | 98.7 | 52 | 58 | 56 | 14 | 15 | 15 | 77 | 86 | 80 |
| | 21. | 98.3 | 99.2 | 99 | 58 | 60 | 60 | 15 | 16 | 15 | 79 | 86 | 78 |
| | 22. | 98.2 | 98.9 | 98.8 | 56 | 56 | 56 | 15 | 16 | 16 | 79 | 85 | 79 |
| | 23. | 98.6 | 99 | 99 | 54 | 52 | 80 | 14 | 15 | 17 | 79 | 85 | 81 |
| | 24. | 98.5 | 99.4 | 99.2 | 62 | 58 | 60 | 15 | 15 | 16 | 78 | 86 | 82 |
| | 25. | 98.3 | 99.1 | 98.7 | 60 | 62 | 60 | 15 | 16 | 15 | 80 | 82 | 79 |
| | 26. | 98.1 | 99.2 | 98.5 | 56 | 56 | 80 | 14 | 16 | 16 | 77 | 84 | 79 |
| | 27. | 98.5 | 99.1 | 99 | 62 | 54 | 62 | 15 | 16 | 16 | 78 | 85 | 82 |
| | 28. | 98.2 | 99 | 99.1 | 54 | 56 | 62 | 14 | 15 | 15 | 79 | 85 | 81 |
| | 29. | 98 | 99.1 | 98.7 | 52 | 56 | 56 | 15 | 15 | 16 | 77 | 85 | 80 |
| | 30. | 98.2 | 98.7 | 98.7 | 54 | 58 | 56 | 15 | 16 | 16 | 77 | 85 | 81 |
| | 98 | 99 | 98.8 | 55 | 54 | 60.8 | 14.3 | 15.9 | 16 | 78.7 | 85.1 | 81.3 | |

| | Temp. under the tongue. | | | Pulse. | | | Respirations. | | | Temperature of room. | | | | |
|---------------|-------------------------|-----------|-----------|----------|-----------|-----------|---------------|-----------|-----------|----------------------|-----------|-----------|------|------|
| | 6-7 A.M. | 12-2 P.M. | 9-11 P.M. | 6-7 A.M. | 12-2 P.M. | 9-11 P.M. | 6-7 A.M. | 12-2 P.M. | 9-11 P.M. | 6-7 A.M. | 12-2 P.M. | 9-11 P.M. | | |
| October 1846. | 1. | 98.1 | | | 52 | | | 15 | | | 79 | ° | ° | |
| | 2. | 98.4 | 98.8 | 98.7 | 54 | 54 | 54 | 15 | 16 | 15 | 78 | 82 | 80 | |
| | 4. | 97.9 | 98.5 | 58 | 52 | 54 | 15 | 15 | 15 | 15 | 77 | 83 | 79 | |
| | 5. | 98.3 | 99.1 | 99 | 56 | 56 | 64 | 15 | 15 | 16 | 77 | 85 | 80 | |
| | 6. | 98.1 | 98.7 | | 52 | 54 | | 14 | 15 | | 78 | 86 | | |
| | 7. | 98.5 | 99.1 | 98.9 | 62 | 58 | 60 | 15 | 16 | 16 | 79 | 84 | 80 | |
| | 8. | 98.4 | 99.3 | 99 | 52 | 56 | 74 | 15 | 16 | 16 | 78 | 85 | 81 | |
| | 9. | 98.3 | 99.2 | 99.3 | 52 | 56 | 62 | 15 | 16 | 15 | 78 | 86 | 82 | |
| | 10. | 97.9 | 98.9 | 98.8 | 54 | 56 | 72 | 15 | 15 | 16 | 78 | 86 | 79 | |
| | 11. | 98.2 | | | 56 | | | 15 | | | 78 | | | |
| | 13. | 98.2 | 99 | 99.4 | 50 | 56 | 64 | 14 | 16 | 15 | 79 | 86 | 82 | |
| | 14. | 98.3 | 98.7 | | 50 | 56 | | 14 | 15 | | 78 | 87 | | |
| | 15. | 98.4 | 98.9 | 98.9 | 60 | 54 | 62 | 14 | 16 | 16 | 80 | 86 | 81 | |
| | 16. | 98.5 | 98.7 | 99 | 52 | 56 | 62 | 14 | 15 | 16 | 80 | 85 | 81 | |
| | 17. | 98.1 | 99 | 98.7 | 50 | 52 | 56 | 14 | 16 | 15 | 78 | 86 | 81 | |
| | 18. | 98.2 | 98.9 | 99 | 50 | 56 | 56 | 14 | 14 | 15 | 77 | 86 | 80 | |
| | 19. | 98 | 98.9 | 99.1 | 52 | 54 | 60 | 14 | 15 | 15 | 76 | 86 | 80 | |
| | 20. | 98.3 | 99.1 | | 52 | 56 | | 14 | 16 | | 78 | 86 | | |
| | 21. | 98.2 | 98.9 | 99.2 | 60 | 52 | 60 | 16 | 15 | 16 | 79 | 88 | 83 | |
| | 22. | 98 | 98.8 | 98.8 | 52 | 50 | 60 | 14 | 16 | 15 | 80 | 87 | 82 | |
| | 23. | 98.1 | 99 | 98.8 | 50 | 56 | 56 | 14 | 16 | 16 | 78 | 87 | 81 | |
| | 24. | 98.3 | 99 | 98.4 | 54 | 60 | 64 | 15 | 15 | 17 | 79 | 83 | 80 | |
| | 25. | 98.2 | 98.8 | 99 | 52 | 54 | 60 | 14 | 16 | 15 | 80 | 83 | 82 | |
| | 26. | 98.2 | 98.9 | | 54 | 52 | | 14 | 15 | | 78 | 84 | | |
| | 27. | 98.2 | 98.7 | 99.2 | 54 | 54 | 62 | 14 | 15 | 17 | 78 | 85 | 81 | |
| | 28. | 97.8 | 98.8 | 98.9 | 52 | 54 | 56 | 14 | 15 | 16 | 77 | 85 | 82 | |
| | 29. | 98.2 | | 98.6 | 54 | | 70 | 14 | | 15 | 79 | | 81 | |
| | 30. | 98.3 | 98.6 | | 60 | 58 | | 14 | 16 | | 79 | 85 | | |
| | 31. | 98.1 | 99.4 | 98.7 | 60 | 62 | 56 | 15 | 16 | 16 | 76 | 82 | 78 | |
| | | | 98.2 | 99 | 99 | 52 | 55 | 61 | 14.4 | 15.4 | 15.3 | 78.2 | 85.1 | 81.2 |
| | November 1846. | 1. | 98.2 | 99.2 | 98.6 | 56 | 58 | 58 | 15 | 16 | 16 | 75 | 84 | 79 |
| 2. | | 98.1 | 99.2 | 98.7 | 54 | 58 | 56 | 14 | 16 | 15 | 77 | 85 | 81 | |
| 3. | | 98 | 98.7 | 98.8 | 54 | 52 | 58 | 14 | 14 | 16 | 77 | 85 | 81 | |
| 4. | | 98.3 | 99.1 | | 54 | 54 | | 15 | 16 | | 78 | 85 | | |
| 5. | | 98 | 99.3 | 99.1 | 54 | 56 | 60 | 15 | 16 | 15 | 79 | 85 | 80 | |
| 6. | | 98 | 98.7 | | 54 | 52 | | 14 | 15 | | 78 | 86 | | |
| 7. | | 97.9 | 99.1 | 98.8 | 56 | 50 | 52 | 14 | 16 | 15 | 75 | 82 | 78 | |
| 8. | | 98 | 98.5 | 98.9 | 52 | 52 | 54 | 14 | 15 | 15 | 77 | 83 | 80 | |
| 9. | | 98.2 | 98.8 | 99.1 | 56 | 56 | 60 | 15 | 16 | 15 | 78 | 86 | 81 | |
| 10. | | 98 | 99.2 | 99.2 | 56 | 60 | 62 | 15 | 16 | 16 | 78 | 87 | 82 | |
| 11. | | 98.1 | 99.2 | 99 | 56 | 60 | 60 | 15 | 16 | 16 | 79 | 87 | 82 | |
| 12. | | 98 | | | 52 | | | 14 | | | 78 | | | |
| 13. | | 98.3 | 99.1 | 99.4 | 52 | 54 | 64 | 15 | 16 | 16 | 79 | 87 | 82 | |
| 14. | | 98.3 | 98.9 | | 56 | 56 | | 15 | 17 | | 78 | 87 | | |
| 15. | | 98.5 | 99.1 | 98.9 | 66 | 58 | 60 | 15 | 15 | 16 | 78 | 86 | 82 | |
| 16. | | 98.3 | 99 | 98.8 | 56 | 56 | 60 | 14 | 16 | 16 | 79 | 87 | 80 | |
| 17. | | 98.2 | 98.2 | 98.6 | 56 | 52 | 56 | 15 | 15 | 15 | 79 | 78 | 79 | |
| 18. | | 98.4 | | | 56 | | | | 14 | | | | | |
| 19. | | 98.1 | 99 | 99 | 58 | 60 | 66 | 15 | 16 | 16 | 79 | 79 | 80 | |
| 20. | | 97.9 | | 98.8 | 66 | | 62 | 16 | | 16 | 79 | | 81 | |
| 21. | | 98 | 98.7 | | 56 | 54 | | 14 | 16 | | 78 | 85 | | |
| 22. | | 98.4 | 98.7 | 99.1 | 58 | 58 | 58 | 14 | 16 | 15 | 78 | 85 | 81 | |
| 23. | | 98.2 | 98.7 | 98.9 | 56 | 56 | 62 | 15 | 16 | 16 | 77 | 84 | 81 | |
| 24. | | 98.2 | 98.9 | 98.8 | 56 | 56 | 58 | 15 | 16 | 16 | 78 | 85 | 80 | |
| 25. | | 98 | 98.8 | 99 | 56 | 54 | 60 | 15 | 15 | 15 | 76 | 83 | 78 | |
| 26. | | 97.9 | 99.1 | 98.4 | 56 | 60 | 70 | 15 | 17 | 16 | 76 | 83 | 79 | |
| 27. | | 98.3 | 98.8 | 98.7 | 56 | 56 | 58 | 15 | 17 | 16 | 78 | 84 | 81 | |
| 28. | | 98.1 | 98.6 | 99.2 | 54 | 54 | 62 | 14 | 15 | 16 | 75 | 84 | 80 | |
| 29. | | 98.1 | 98.9 | 98.8 | 54 | 54 | 64 | 15 | 16 | 16 | 77 | 83 | 80 | |
| 30. | | 98.3 | | 98.8 | 54 | | 62 | 15 | | 16 | 76 | | 80 | |
| | | 98.1 | 98.9 | 98.8 | 56.2 | 55.4 | 60.1 | 14.6 | 15.8 | 15.6 | 77.4 | 84.4 | 80 | |

| | Temp. under the tongue. | | | Pulse. | | | Respirations. | | | Temperature of room. | | | |
|----------------|-------------------------|-----------|-----------|----------|-----------|-----------|---------------|-----------|-----------|----------------------|-----------|-----------|------|
| | 6-7 A.M. | 12-2 P.M. | 9-11 P.M. | 6-7 A.M. | 12-2 P.M. | 9-11 P.M. | 6-7 A.M. | 12-2 P.M. | 9-11 P.M. | 6-7 A.M. | 12-2 P.M. | 9-11 P.M. | |
| December 1846. | 1. | 98·3 | 98·9 | 98·6 | 54 | 54 | 62 | 15 | 16 | 16 | 78 | 79 | 78 |
| | 2. | 98·3 | 99·2 | | 56 | 64 | | 15 | 16 | | 78 | 77 | |
| | 3. | 98 | 98·8 | 98·9 | 54 | 54 | 68 | 15 | 15 | 16 | 75 | 79 | 79 |
| | 4. | 97·9 | 98·5 | | 54 | 52 | | 15 | 15 | | 77 | 77 | |
| | 5. | 98·3 | 98·7 | 98·8 | 64 | 56 | 74 | 16 | 16 | 17 | 77 | 81 | 78 |
| | 6. | 98·2 | 98·4 | 99 | 60 | 54 | 64 | 15 | 16 | 15 | 78 | 80 | 78 |
| | 7. | 98·1 | 98·8 | 98·8 | 54 | 50 | 76 | 15 | 15 | 16 | 76 | 79 | 78 |
| | 8. | 97·9 | 98·8 | 98·9 | 50 | 50 | 60 | 15 | 15 | 16 | 76 | 80 | 75 |
| | 9. | 97·9 | 99·3 | 98·7 | 52 | 56 | 60 | 14 | 16 | 16 | 75 | 82 | 78 |
| | 10. | 98 | 99 | 98·9 | 50 | 56 | 56 | 15 | 15 | 15 | 75 | 82 | 78 |
| | 11. | 97·9 | 98·7 | 98·5 | 56 | 52 | 60 | 15 | 15 | 16 | 75 | 82 | 77 |
| | 12. | 97·9 | 98·7 | 98·8 | 54 | 56 | 60 | 15 | 16 | 15 | 75 | 82 | 78 |
| | 13. | 98·1 | 98·7 | 99·2 | 56 | 56 | 64 | 15 | 16 | 16 | 75 | 82 | 77 |
| | 14. | 97·9 | 98·8 | 99·1 | 54 | 56 | 58 | 15 | 16 | 16 | 75 | 82 | 79 |
| | 15. | 98·1 | 98·5 | 98·5 | 56 | 54 | 60 | 15 | 16 | 15 | 75 | 77 | 76 |
| | 16. | 98·1 | 99·2 | 99 | 54 | 60 | 64 | 15 | 16 | 16 | 76 | 82 | 78 |
| | 17. | 98·3 | | 98·7 | 56 | | 56 | 15 | | 16 | 77 | | 78 |
| | 18. | 98·1 | | | 56 | | | 15 | | | 76 | | |
| | 19. | 98·2 | 98·8 | 99·2 | 54 | 56 | 62 | 14 | 17 | 16 | 76 | 84 | 79 |
| | 20. | 98·3 | 98·7 | | 56 | 62 | | 15 | 16 | | 78 | 83 | |
| | 21. | 98·3 | 98·7 | | 56 | 62 | | 15 | 16 | | 78 | 83 | |
| | 22. | 98·7 | | | 68 | | | 16 | | | 77 | | |
| | 23. | 97·9 | 98·9 | 98·9 | 62 | 54 | 62 | 15 | 17 | 16 | 76 | 82 | 78 |
| | 24. | 97·9 | 98·8 | 99·1 | 52 | 54 | 62 | 14 | 15 | 16 | 76 | 82 | 78 |
| | 25. | 98·3 | 98·7 | | 52 | 54 | | 14 | 15 | | 76 | 81 | |
| | 28. | 98 | 99 | 99 | 52 | 56 | 70 | 15 | 17 | 16 | 75 | 75 | 77 |
| | 29. | 98·1 | | | 52 | | | 14 | | | 77 | | |
| | 30. | 97·9 | 98·9 | 98·6 | 60 | 56 | 58 | 14 | 15 | 16 | 73 | 81 | 71 |
| | 31. | 98·1 | 98·8 | 98·9 | 52 | 56 | 56 | 15 | 16 | 14 | 73 | 80 | 78 |
| | | 98·1 | 98·9 | 98·9 | 55·3 | 55·3 | 63·5 | 14·5 | 15·8 | 15·8 | 76 | 80·5 | 77·4 |
| | January 1847. | 1. | 98·4 | 98·8 | 98·7 | 56 | 54 | 66 | 14 | 16 | 16 | 73 | 82 |
| 2. | | 98·3 | 98·8 | | 64 | 56 | | 14 | 16 | | 76 | 82 | |
| 3. | | 98·5 | | 99 | 60 | | 60 | 15 | | 15 | 76 | | 78 |
| 4. | | 98·1 | 98·9 | 98·9 | 56 | 56 | 60 | 15 | 16 | 16 | 77 | 82 | 79 |
| 5. | | 98·1 | 99·3 | 98·7 | 54 | 54 | 56 | 14 | 16 | 14 | 76 | 82 | 78 |
| 6. | | 98·3 | 99·2 | 99·1 | 54 | 54 | 60 | 14 | 15 | 16 | 76 | 82 | 78 |
| 7. | | 98 | 99·1 | 98·9 | 50 | 60 | 60 | 14 | 16 | 15 | 76 | 82 | 77 |
| 8. | | 98·3 | 98·9 | 98·9 | 52 | 58 | 62 | 14 | 16 | 16 | 76 | 83 | 78 |
| 9. | | 98·5 | 99·5 | 98·9 | 58 | 62 | 62 | 15 | 16 | 16 | 75 | 83 | 77 |
| 10. | | 97·9 | 98·4 | 98·5 | 56 | 52 | 56 | 14 | 15 | 14 | 75 | 79 | 76 |
| 11. | | 98·4 | 98·8 | 98·5 | 60 | 54 | 54 | 15 | 16 | 15 | 75 | 79 | 77 |
| 12. | | 97·9 | 98·9 | 98·9 | 54 | 56 | 60 | 15 | 16 | 16 | 74 | 81 | 77 |
| 13. | | 98 | 99 | 98·9 | 54 | 56 | 62 | 15 | 16 | 15 | 74 | 81 | 78 |
| 14. | | 97·9 | 98·9 | 99·1 | 50 | 56 | 64 | 14 | 16 | 15 | 74 | 82 | 77 |
| 15. | | 98 | 98·8 | 98·9 | 52 | 52 | 58 | 14 | 15 | 15 | 74 | 81 | 77 |
| 16. | | 98·3 | 98·8 | 99 | 52 | 52 | 58 | 14 | 14 | 14 | 74 | 82 | 77 |
| 17. | | 98·5 | 99 | 98·8 | 60 | 54 | 66 | 15 | 15 | 14 | 74 | 81 | 77 |
| 18. | | 98 | 99 | 98·9 | 54 | 54 | 62 | 14 | 14 | 14 | 74 | 81 | 77 |
| 19. | | 98·3 | | | 56 | | | 15 | | | 75 | | |
| 21. | | 98·3 | 99 | 98·7 | 56 | 54 | 62 | 15 | 16 | 15 | 73 | 79 | 77 |
| 22. | | 98·2 | | | 56 | | | 15 | | | 74 | | |
| 23. | | 98 | 98·6 | 99 | 54 | 48 | 64 | 14 | 14 | 16 | 74 | 81 | 78 |
| 24. | | 98 | 98·4 | 98·6 | 52 | 54 | 60 | 14 | 15 | 15 | 74 | 81 | 77 |
| 25. | | 98·5 | 99·2 | 99·1 | 54 | 56 | 68 | 14 | 15 | 15 | 75 | 82 | 77 |
| 26. | | 97·9 | 98·9 | 98·7 | 54 | 56 | 56 | 14 | 16 | 15 | 74 | 82 | 77 |
| 28. | | 98·1 | | | 56 | | | 14 | | | 74 | | |
| 29. | | 97·9 | 99·1 | | 52 | 64 | | 14 | 16 | | 73 | 80 | |
| 30. | | 98·5 | 98·9 | 99·3 | 58 | 58 | 66 | 14 | 15 | 15 | 73 | 82 | 76 |
| 31. | | 97·9 | 98·4 | 98·5 | 54 | 52 | 58 | 15 | 15 | 15 | 74 | 81 | 77 |
| | | 98·1 | 98·9 | 98·8 | 54·8 | 55·3 | 60·8 | 14·4 | 15·4 | 15 | 74·6 | 81·3 | 77·3 |

| | Temp. under the tongue. | | | Pulse. | | | Respirations. | | | Temperature of room. | | | |
|----------------|-------------------------|-----------|-----------|----------|-----------|-----------|---------------|-----------|-----------|----------------------|-----------|-----------|------|
| | 6-7 A.M. | 12-2 P.M. | 9-11 P.M. | 6-7 A.M. | 12-2 P.M. | 9-11 P.M. | 6-7 A.M. | 12-2 P.M. | 9-11 P.M. | 6-7 A.M. | 12-2 P.M. | 9-11 P.M. | |
| February 1847. | 1. | 97.9 | 99.2 | 98.7 | 52 | 60 | 60 | 14 | 16 | 15 | 73 | 82 | 75 |
| | 2. | 97.9 | 99.2 | 98.3 | 56 | 60 | 60 | 14 | 16 | 15 | 72 | 82 | 74 |
| | 3. | 98.1 | | | 56 | | | 14 | | | 71 | | |
| | 4. | 97.9 | 98.9 | | 56 | 62 | | 14 | 15 | | 71 | 81 | |
| | 5. | 97.9 | 99 | 99.1 | 56 | 56 | 64 | 14 | 16 | 16 | 71 | 81 | 74 |
| | 6. | 97.7 | 99 | | 58 | 56 | | 14 | 15 | | 70 | 79 | |
| | 7. | 98.1 | 98.5 | 99.1 | 58 | 60 | 60 | 15 | 15 | 15 | 71 | 81 | 75 |
| | 8. | 97.8 | 98.7 | 99 | 54 | 56 | 64 | 14 | 16 | 16 | 73 | 82 | 75 |
| | 9. | 97.8 | 99.2 | 98.9 | 54 | 60 | 64 | 14 | 16 | 15 | 72 | 81 | 78 |
| | 10. | 98.2 | 98.8 | 98.9 | 56 | 54 | 64 | 14 | 15 | 15 | 74 | 82 | 78 |
| | 11. | 98.2 | 98.9 | 99.1 | 56 | 54 | 62 | 14 | 16 | 16 | 73 | 83 | 77 |
| | 12. | 98.2 | 98.7 | 98.6 | 58 | 56 | 58 | 15 | 16 | 15 | 74 | 80 | 76 |
| | 13. | 98.3 | 98.5 | | 56 | 50 | | 14 | 14 | | 72 | 80 | |
| | 14. | 98.2 | 98.7 | 98.8 | 58 | 56 | 56 | 16 | 14 | 15 | 74 | 79 | 75 |
| | 15. | 98.1 | 98.8 | 98.7 | 54 | 60 | 58 | 14 | 16 | 15 | 71 | 82 | 76 |
| | 16. | 97.7 | 98.5 | 98.8 | 58 | 54 | 60 | 15 | 16 | 15 | 74 | 82 | 78 |
| | 17. | 98 | 98.8 | 99.1 | 58 | 58 | 58 | 15 | 16 | 15 | 75 | 82 | 77 |
| | 18. | 97.8 | 98.9 | 98.6 | 54 | 58 | 76 | 14 | 16 | 16 | 74 | 82 | 78 |
| | 19. | 97.8 | 98.8 | 98.8 | 58 | 58 | 60 | 16 | 16 | 15 | 74 | 81 | 77 |
| | 20. | 98.2 | | | 58 | | | 14 | | | 74 | | |
| | 21. | 98.2 | | | 54 | | | 15 | | | 75 | | |
| | 23. | 98 | 99 | 98.9 | 56 | 54 | 64 | 14 | 16 | 16 | 76 | 83 | 79 |
| | 24. | 97.9 | 98.9 | 98.9 | 52 | 60 | 62 | 14 | 15 | 15 | 75 | 83 | 77 |
| | 25. | 98.2 | 99.3 | | 54 | 64 | | 14 | 16 | | 74 | 82 | |
| | 26. | 98.1 | 98.9 | 99.2 | 56 | 56 | 62 | 14 | 14 | 15 | 74 | 81 | 76 |
| | 27. | 97.9 | 98.8 | 98.1 | 56 | 56 | 60 | 14 | 15 | 16 | 72 | 82 | 76 |
| | 28. | 98 | 98.4 | | 54 | 54 | | 14 | 16 | | 74 | 83 | |
| | | 98 | 98.8 | 98.8 | 55.5 | 57.6 | 61.7 | 14.2 | 15.5 | 15.3 | 73 | 81.5 | 76.3 |
| March 1847. | 1. | 98 | 98.9 | 99.3 | 52 | 54 | 64 | 15 | 16 | 15 | 74 | 83 | 76 |
| | 2. | 98.1 | 98.6 | 98.7 | 54 | 56 | 56 | 14 | 16 | 15 | 75 | 84 | 78 |
| | 3. | 98.2 | 99 | 98.6 | 54 | 60 | 80 | 14 | 15 | 16 | 75 | 83 | 78 |
| | 4. | 98.4 | 98.7 | 99 | 62 | 60 | 66 | 15 | 16 | 16 | 76 | 83 | 78 |
| | 5. | 98.1 | 98.8 | 99.2 | 52 | 54 | 68 | 14 | 16 | 16 | 75 | 84 | 77 |
| | 6. | 97.9 | 98.8 | 98.5 | 54 | 56 | 62 | 14 | 15 | 15 | 75 | 84 | 77 |
| | 7. | 98.2 | 98.5 | 98.9 | 54 | 54 | 64 | 14 | 15 | 15 | 74 | 84 | 77 |
| | 8. | 98.1 | 98.8 | 98.9 | 54 | 54 | 62 | 14 | 15 | 16 | 74 | 84 | 76 |
| | 9. | 97.9 | 98.7 | 98.9 | 54 | 52 | 56 | 14 | 16 | 15 | 74 | 83 | 78 |
| | 10. | 98.4 | 98.8 | 98.9 | 56 | 56 | 66 | 15 | 16 | 16 | 75 | 84 | 78 |
| | 11. | 98.1 | 98.8 | 98.9 | 56 | 50 | 64 | 15 | 16 | 16 | 74 | 83 | 76 |
| | 12. | 98.1 | | | 54 | | | 15 | | | 74 | | |
| | 13. | 98.2 | 99.2 | 99.3 | 56 | 58 | 60 | 15 | 15 | 15 | 74 | 83 | 78 |
| | 14. | 98.2 | 98.9 | 98.5 | 56 | 60 | 60 | 15 | 15 | 15 | 75 | 84 | 79 |
| | 15. | 98 | 99.1 | 99.2 | 56 | 62 | 60 | 15 | 16 | 16 | 76 | 85 | 78 |
| | 16. | 98.3 | 98.8 | 98.4 | 54 | 54 | 60 | 15 | 16 | 15 | 75 | 83 | 76 |
| | 17. | 98.4 | 99.2 | 98.8 | 56 | 54 | 62 | 15 | 15 | 16 | 73 | 75 | 76 |
| | 18. | 98 | 98.8 | 99.1 | 52 | 56 | 70 | 14 | 16 | 16 | 75 | 84 | 78 |
| | 19. | 98.2 | 98.7 | 98.8 | 52 | 54 | 60 | 15 | 16 | 16 | 75 | 83 | 78 |
| | 20. | 98.2 | 98.8 | 98.9 | 56 | 52 | 62 | 15 | 15 | 16 | 76 | 83 | 77 |
| | 21. | 98.2 | 98.7 | 98.9 | 52 | 52 | 60 | 14 | 15 | 15 | 74 | 83 | 77 |
| | 23. | 98.1 | 99.1 | 98.7 | 58 | 60 | 60 | 14 | 16 | 15 | 75 | 83 | 76 |
| | 24. | 98.1 | 99.2 | | 60 | 64 | | 14 | 16 | | 75 | 82 | |
| | | 98.1 | 98.8 | 98.9 | 54.8 | 59.2 | 62.7 | 14.5 | 15.6 | 15 | 74.6 | 83.5 | 77.1 |

| | Temp. under the tongue. | | | Pulse. | | | Respirations. | | | Temperature of room. | | | | |
|-------------|-------------------------|-----------|-----------|----------|-----------|-----------|---------------|-----------|-----------|----------------------|-----------|-----------|------|------|
| | 6-7 A.M. | 12-2 P.M. | 9-11 P.M. | 6-7 A.M. | 12-2 P.M. | 9-11 P.M. | 6-7 A.M. | 12-2 P.M. | 9-11 P.M. | 6-7 A.M. | 12-2 P.M. | 9-11 P.M. | | |
| April 1847. | 1. | 98.3 | 99 | 99.1 | 52 | 70 | 66 | 14 | 17 | 15 | 72 | 78 | 75 | |
| | 2. | 98.2 | 98.7 | 98.1 | 54 | 56 | 66 | 14 | 16 | 16 | 76 | 81 | 74 | |
| | 3. | 98.2 | 98.7 | 99.2 | 54 | 68 | 70 | 14 | 16 | 16 | 73 | 79 | 75 | |
| | 4. | 98.2 | 98.6 | 98.3 | 54 | 52 | 66 | 15 | 14 | 16 | 72 | 86 | 72 | |
| | 5. | 98 | | | 54 | | | 14 | | | 70 | | | |
| | 8. | 98.1 | 98.3 | 98.6 | 54 | 54 | 60 | 14 | 15 | 15 | 74 | 83 | 77 | |
| | 9. | 97.9 | 98.7 | 98.8 | 54 | 54 | 60 | 14 | 15 | 15 | 75 | 83 | 78 | |
| | 10. | 98.2 | 98.2 | 99 | 52 | 52 | 66 | 14 | 15 | 16 | 74 | 78 | 76 | |
| | 11. | 98.3 | 98.6 | 98.8 | 50 | 54 | 56 | 14 | 15 | 16 | 74 | 81 | 78 | |
| | 12. | 98 | 98.7 | 98.4 | 56 | 54 | 56 | 15 | 16 | 15 | 75 | 83 | 77 | |
| | 13. | 97.8 | 98.7 | 98.7 | 54 | 54 | 64 | 14 | 15 | 16 | 73 | 77 | 78 | |
| | 14. | 97.9 | 98.7 | 98.7 | 56 | 56 | 64 | 14 | 15 | 15 | 76 | 82 | 77 | |
| | 15. | 97.9 | 99.2 | 99 | 54 | 64 | 70 | 15 | 15 | 15 | 75 | 82 | 78 | |
| | 16. | 98.3 | 98.5 | 98.8 | 54 | 54 | 60 | 15 | 15 | 16 | 75 | 82 | 78 | |
| | 17. | 97.7 | 99 | | 58 | 56 | | 14 | 15 | | 75 | 83 | | |
| | 18. | 98.2 | 98.4 | 99.1 | 60 | 56 | 60 | 15 | 15 | 15 | 75 | 83 | 79 | |
| | 19. | 98.3 | 98.7 | 99 | 56 | 56 | 62 | 15 | 16 | 16 | 75 | 84 | 78 | |
| | 20. | 98.2 | 98.9 | 99.1 | 56 | 58 | 54 | 13 | 16 | 15 | 75 | 81 | 77 | |
| | 21. | 97.5 | 99 | 98.8 | 54 | 60 | 58 | 14 | 17 | 16 | 76 | 83 | 78 | |
| | 22. | 98.2 | 98.7 | 98.5 | 56 | 54 | 62 | 14 | 16 | 16 | 75 | 83 | 78 | |
| | 23. | 98.1 | 98.7 | 99.1 | 58 | 54 | 70 | 14 | 16 | 16 | 76 | 84 | 79 | |
| | 24. | 98.3 | 99 | 98.8 | 54 | 56 | 70 | 14 | 15 | 15 | 76 | 84 | 78 | |
| | 25. | 98.2 | | | 56 | | | 14 | | | 75 | | | |
| | 26. | 98.6 | 98.7 | 99 | 56 | 56 | 62 | 14 | 16 | 16 | 76 | 83 | 79 | |
| | 27. | 98 | 99 | 98.9 | 54 | 54 | 60 | 14 | 16 | 15 | 76 | 84 | 78 | |
| | 28. | 97.9 | 99 | | 56 | 56 | | 14 | 15 | | 75 | 84 | | |
| | 29. | 98.4 | 98.9 | 98.9 | 58 | 54 | 56 | 15 | 16 | 15 | 76 | 85 | 78 | |
| | 30. | 98.2 | 98.8 | 99.2 | 58 | 54 | 58 | 14 | 16 | 15 | 76 | 83 | 78 | |
| | | | 98.1 | 98.7 | 98.8 | 55 | 56.4 | 62.3 | 14.2 | 15.5 | 15.6 | 74.7 | 82.2 | 77.1 |
| | May 1847. | 1. | 97.8 | 99.2 | 98.5 | 56 | 58 | 58 | 14 | 16 | 16 | 76 | 84 | 79 |
| 2. | | 98.3 | 98.7 | 98.7 | 56 | 52 | 62 | 14 | 15 | 15 | 77 | 84 | 79 | |
| 3. | | 98.4 | 98.8 | 99.2 | 54 | 58 | 60 | 14 | 16 | 16 | 76 | 85 | 79 | |
| 4. | | 98.1 | 98.7 | 98.3 | 56 | 60 | 52 | 14 | 16 | 15 | 75 | 83 | 77 | |
| 5. | | 98.4 | 98.9 | 98.9 | 58 | 56 | 60 | 14 | 16 | 16 | 75 | 84 | 79 | |
| 6. | | 98.4 | 98.7 | | 56 | 58 | | 15 | 17 | | 76 | 84 | | |
| 7. | | 98.4 | 98.9 | 99.2 | 56 | 58 | 58 | 15 | 17 | 15 | 77 | 85 | 79 | |
| 8. | | 98.2 | 99.2 | 99.2 | 54 | 60 | 72 | 15 | 16 | 16 | 77 | 85 | 79 | |
| 9. | | 98 | 99.2 | 99 | 54 | 60 | 66 | 15 | 16 | 16 | 77 | 84 | 78 | |
| 10. | | 98.1 | 98.9 | 98.7 | 60 | 58 | 58 | 15 | 15 | 16 | 75 | 83 | 78 | |
| 11. | | 98 | 98.7 | | 56 | 58 | | 15 | 16 | | 75 | 84 | | |
| 12. | | 98.2 | 98.8 | 98.9 | 58 | 56 | 66 | 14 | 16 | 15 | 76 | 84 | 79 | |
| 13. | | 97.9 | 99.1 | 98.9 | 56 | 56 | 64 | 15 | 15 | 16 | 77 | 84 | 79 | |
| 14. | | 98.1 | 98.9 | 98.6 | 54 | 64 | 58 | 15 | 16 | 15 | 78 | 87 | 80 | |
| 15. | | 98.1 | 99.1 | 98.7 | 56 | 62 | 58 | 15 | 16 | 15 | 78 | 86 | 79 | |
| 16. | | 98.2 | 98.8 | 99.2 | 54 | 58 | 62 | 15 | 15 | 16 | 78 | 86 | 80 | |
| 17. | | 98.1 | 99.1 | 99.2 | 56 | 58 | 64 | 15 | 16 | 16 | 77 | 87 | 80 | |
| 18. | | 98.3 | 98.6 | 98.7 | 56 | 54 | 58 | 14 | 16 | 15 | 77 | 84 | 79 | |
| 19. | | 98.4 | 99 | | 56 | 62 | | 14 | 16 | | 77 | 87 | | |
| 20. | | 98.1 | 98.7 | 99.2 | 60 | 56 | 64 | 15 | 16 | 16 | 78 | 86 | 81 | |
| 21. | | 98.1 | 98.9 | | 58 | 60 | | 14 | 15 | | 78 | 86 | | |
| 22. | | 98.3 | 98.8 | 98.6 | 62 | 56 | 66 | 14 | 16 | 16 | 78 | 87 | 82 | |
| 23. | | 98.2 | 98.8 | 99.1 | 60 | 54 | 60 | 15 | 15 | 15 | 79 | 85 | 80 | |
| 24. | | 98.4 | | | 58 | | | 14 | | | 77 | | | |
| | | 98.1 | 98.9 | 98.8 | 56.6 | 57.8 | 61.3 | 14.5 | 15.8 | 15.6 | 76.7 | 85 | 79.2 | |

| | Temp. under the tongue. | | | Pulse. | | | Respirations. | | | Temperature of room. | | | |
|---------------|-------------------------|-----------|-----------|----------|-----------|-----------|---------------|-----------|-----------|----------------------|-----------|-----------|----|
| | 6-7 A.M. | 12-2 P.M. | 9-11 P.M. | 6-7 A.M. | 12-2 P.M. | 9-11 P.M. | 6-7 A.M. | 12-2 P.M. | 9-11 P.M. | 6-7 A.M. | 12-2 P.M. | 9-11 P.M. | |
| October 1847. | 1. | 98.2 | 99 | 99.2 | 56 | 56 | 60 | 15 | 16 | 17 | 77 | 85 | 81 |
| | 2. | 98.2 | 99 | 99.1 | 56 | 58 | 60 | 15 | 15 | 17 | 78 | 86 | 83 |
| | 3. | 98 | 98.9 | 98.6 | 56 | 56 | 56 | 14 | 15 | 16 | 78 | 85 | 81 |
| | 4. | 98.3 | 98.9 | 99.2 | 58 | 58 | 60 | 15 | 15 | 16 | 78 | 87 | 81 |
| | 5. | 98.5 | 98.8 | 98.8 | 56 | 56 | 56 | 15 | 15 | 16 | 78 | 83 | 78 |
| | 6. | 98 | 98.7 | 99 | 56 | 52 | 64 | 14 | 16 | 17 | 77 | 85 | 79 |
| | 7. | 98 | 99 | 98.5 | 54 | 56 | 54 | 15 | 15 | 16 | 78 | 86 | 78 |
| | 8. | 98.2 | 99.6 | 98.9 | 56 | 62 | 58 | 15 | 16 | 16 | 77 | 85 | 81 |
| | 9. | 98 | 99.1 | 98.8 | 56 | 54 | 54 | 15 | 16 | 15 | 78 | 86 | 82 |
| | 10. | 98.3 | 99 | 98.7 | 54 | 56 | 58 | 15 | 15 | 16 | 79 | 87 | 81 |
| | 11. | 98.5 | 98.8 | 99.1 | 56 | 58 | 56 | 15 | 16 | 16 | 80 | 83 | 81 |
| | 12. | 98.4 | 98.8 | 98.7 | 56 | 58 | 54 | 15 | 14 | 16 | 78 | 86 | 79 |
| | 13. | 98 | 99.2 | 98.8 | 52 | 60 | 60 | 14 | 15 | 16 | 78 | 85 | 80 |
| | 14. | 98.2 | 99 | 98.8 | 58 | 58 | 15 | 16 | 16 | 16 | 77 | 85 | 80 |
| | 15. | 98 | 98.8 | 98 | 54 | 56 | 58 | 15 | 15 | 16 | 77 | 84 | 80 |
| | 16. | 98.1 | 99.1 | 98.6 | 56 | 54 | 56 | 15 | 17 | 16 | 78 | 86 | 80 |
| | 17. | 98 | 98.9 | 99.1 | 54 | 56 | 60 | 15 | 15 | 16 | 78 | 86 | 80 |
| | 18. | 97.9 | 98.7 | 98.6 | 54 | 52 | 56 | 15 | 15 | 16 | 78 | 86 | 80 |
| | 19. | 98.1 | 99 | 98.7 | 54 | 52 | 54 | 14 | 15 | 16 | 78 | 87 | 81 |
| | 20. | 98 | 99.2 | 98.6 | 52 | 58 | 54 | 14 | 15 | 15 | 78 | 86 | 82 |
| | 21. | 98 | 99 | 99.1 | 52 | 56 | 60 | 14 | 15 | 16 | 78 | 85 | 80 |
| | 22. | 98.1 | 99 | 98.4 | 58 | 54 | 56 | 14 | 15 | 15 | 78 | 84 | 79 |
| | 23. | 97.9 | 99.6 | 98.9 | 52 | 58 | 60 | 14 | 15 | 15 | 77 | 86 | 80 |
| | 24. | 98.1 | 98.9 | 98.5 | 56 | 56 | 54 | 15 | 15 | 15 | 77 | 85 | 80 |
| | 25. | 97.7 | 98.5 | 98.3 | 54 | 50 | 54 | 15 | 15 | 15 | 79 | 79 | 78 |
| | 26. | 97.9 | 98.2 | 98.6 | 52 | 54 | 54 | 14 | 15 | 15 | 77 | 80 | 79 |
| | 27. | 97.9 | 99.2 | 98.4 | 56 | 56 | 54 | 15 | 14 | 15 | 77 | 85 | 77 |
| | 28. | 98.1 | 98.7 | 98.7 | 54 | 52 | 56 | 14 | 15 | 15 | 77 | 83 | 79 |
| | 29. | 98 | 98.8 | 98.8 | 54 | 58 | 58 | 14 | 14 | 15 | 77 | 82 | 80 |
| | 30. | 98.1 | 98.8 | 99 | 56 | 58 | 60 | 14 | 15 | 16 | 76 | 85 | 80 |
| | 31. | 98 | 98.9 | 98.8 | 52 | 60 | 58 | 14 | 14 | 15 | 77 | 85 | 81 |
| | 98 | 99 | 99 | 54.7 | 56 | 55.7 | 14.5 | 15.1 | 15.7 | 77.7 | 84.8 | 80 | |

| | | | | | | | | | | | | | |
|----------------|------|------|------|-------|------|------|-------|------|------|-------|------|----|----|
| November 1847. | 1. | 98.2 | 99.7 | 99.1 | 56 | 66 | 60 | 15 | 15 | 16 | 77 | 84 | 79 |
| | 2. | 98.3 | 99 | 98.9 | 54 | 62 | 58 | 14 | 15 | 15 | 77 | 83 | 82 |
| | 3. | 98.1 | 98.7 | 98.9 | 56 | 50 | 58 | 15 | 15 | 16 | 78 | 86 | 82 |
| | 4. | 98 | 98.9 | 99.1 | 54 | 52 | 58 | 14 | 14 | 15 | 78 | 86 | 82 |
| | 5. | 98 | 98.8 | 98.9 | 50 | 56 | 56 | 15 | 15 | 15 | 78 | 86 | 80 |
| | 6. | 98.2 | 99.4 | 98.8 | 56 | 54 | 62 | 14 | 15 | 16 | 78 | 86 | 82 |
| | 7. | 98.3 | 99.3 | | 56 | 62 | | 14 | 16 | | 79 | 87 | |
| | 8. | 98 | 98.8 | 98.9 | 56 | 56 | 60 | 14 | 14 | 15 | 78 | 84 | 79 |
| | 9. | 98 | 98.5 | 98.9 | 56 | 52 | 54 | 14 | 16 | 16 | 78 | 86 | 81 |
| | 10. | 98.2 | 99 | 98.9 | 56 | 56 | 56 | 14 | 15 | 16 | 79 | 86 | 81 |
| | 11. | 98.4 | 98.8 | 98.8 | 58 | 58 | 56 | 14 | 15 | 16 | 79 | 85 | 81 |
| | 12. | 98.2 | 99.3 | 99 | 56 | 56 | 62 | 14 | 15 | 15 | 79 | 84 | 81 |
| | 13. | 98.4 | 99.5 | 99 | 58 | 60 | 58 | 15 | 16 | 16 | 79 | 86 | 81 |
| | 14. | 98.6 | 99.1 | 98.6 | 60 | 58 | 56 | 15 | 16 | 15 | 78 | 83 | 78 |
| | 15. | 98 | 98.7 | 97.7 | 56 | 50 | 58 | 15 | 15 | 16 | 75 | 76 | 76 |
| | 16. | 98.4 | 98.5 | 97.8 | 54 | 50 | 58 | 15 | 16 | 16 | 76 | 78 | 76 |
| | 17. | 98.3 | 98.5 | 98.8 | 54 | 52 | 54 | 14 | 15 | 16 | 75 | 79 | 77 |
| | 18. | 98.2 | 99.4 | | 54 | 62 | | 15 | 16 | | 77 | 83 | |
| | 19. | 98.2 | 98.5 | 98.6 | 58 | 52 | 58 | 15 | 15 | 15 | 75 | 82 | 76 |
| | 20. | 98.1 | 98.9 | 99 | 52 | 56 | 58 | 15 | 15 | 15 | 74 | 83 | 78 |
| | 21. | 98 | 98.2 | 98.5 | 56 | 54 | 64 | 14 | 15 | 16 | 74 | 77 | 77 |
| | 22. | 98.2 | 99.2 | 98.6 | 56 | 62 | 60 | 14 | 16 | 16 | 75 | 78 | 77 |
| | 23. | 98.2 | 99.2 | 98.7 | 60 | 70 | 60 | 15 | 15 | 16 | 75 | 83 | 78 |
| | 24. | 98.2 | 98.8 | 99.3 | 54 | 54 | 64 | 14 | 15 | 16 | 75 | 75 | 79 |
| | 25. | 98.2 | 99.2 | 99 | 54 | 56 | 66 | 15 | 15 | 17 | 77 | 83 | 79 |
| | 26. | 98.2 | 98.9 | 98.5 | 54 | 56 | 56 | 14 | 15 | 15 | 77 | 82 | 78 |
| | 27. | 98 | 98.6 | 98.7 | 54 | 56 | 62 | 15 | 15 | 16 | 74 | 81 | 78 |
| | 28. | 98 | 98.6 | 98.3 | 54 | 54 | 56 | 14 | 15 | 15 | 75 | 82 | 76 |
| | 29. | 98.1 | 98.9 | 99 | 52 | 54 | 68 | 15 | 15 | 15 | 77 | 77 | 78 |
| | 30. | 98.4 | 99.3 | 98.6 | 58 | 58 | 54 | 15 | 14 | 15 | 76 | 81 | 78 |
| | 98.1 | 98.8 | 98.8 | 53.3 | 54.8 | 59.2 | 14.5 | 15.1 | 15.2 | 76.7 | 82.3 | 79 | |

| | Temp. under the tongue. | | | Pulse. | | | Respirations. | | | Temperature of room. | | | |
|----------------|-------------------------|--------------------|--------------------|--------------------|-----------|-----------|---------------|-----------|-----------|----------------------|-----------------|-----------------|-----------------|
| | 6-7 A.M. | 12-2 P.M. | 9-11 P.M. | 6-7 A.M. | 12-2 P.M. | 9-11 P.M. | 6-7 A.M. | 12-2 P.M. | 9-11 P.M. | 6-7 A.M. | 12-2 P.M. | 9-11 P.M. | |
| December 1847. | 1. | 98 ^o ·1 | 98 ^o ·7 | 98 ^o ·9 | 52 | 56 | 62 | 14 | 15 | 15 | 77 ^o | 83 ^o | 77 ^o |
| | 2. | 97·9 | 98·6 | 98·6 | 52 | 52 | 58 | 14 | 15 | 16 | 74 | 81 | 68 |
| | 3. | 97·9 | 99·2 | 99·2 | 52 | 58 | 68 | 14 | 14 | 16 | 75 | 73 | 77 |
| | 4. | 97·9 | 98·7 | 98·7 | 52 | 54 | 60 | 15 | 15 | 16 | 74 | 82 | 73 |
| | 5. | 97·7 | 99·1 | 97·8 | 54 | 60 | 56 | 14 | 15 | 14 | 68 | 82 | 73 |
| | 6. | 98·2 | 98·4 | 98·5 | 56 | 58 | 56 | 14 | 15 | 16 | 72 | 83 | 78 |
| | 7. | 97·9 | 98·6 | 98·2 | 56 | 54 | 56 | 14 | 15 | 16 | 77 | 83 | 78 |
| | 8. | 98·1 | 99·1 | 98·8 | 54 | 58 | 58 | 14 | 15 | 15 | 77 | 84 | 78 |
| | 9. | 98 | 99·2 | 98·5 | 54 | 62 | 58 | 15 | 16 | 15 | 76 | 83 | 77 |
| | 10. | 98·2 | 98·7 | 98·5 | 54 | 54 | 60 | 15 | 15 | 16 | 76 | 83 | 78 |
| | 11. | 98·3 | 98·8 | 98·6 | 54 | 54 | 60 | 15 | 15 | 16 | 77 | 81 | 78 |
| | 12. | 98·3 | 98·9 | 98·7 | 54 | 50 | 58 | 14 | 14 | 16 | 77 | 81 | 77 |
| | 13. | 98·2 | 99·1 | 98·8 | 56 | 56 | 60 | 14 | 15 | 15 | 79 | 80 | 78 |
| | 14. | 98 | 98·9 | 98·4 | 52 | 52 | 64 | 14 | 14 | 16 | 73 | 77 | 77 |
| | 15. | 97·9 | 99·2 | 98 | 52 | 58 | 64 | 14 | 15 | 16 | 76 | 80 | 77 |
| | 16. | 97·9 | 98·8 | 98·6 | 52 | 56 | 60 | 14 | 15 | 16 | 75 | 80 | 76 |
| | 17. | 98·1 | 98·7 | 98·7 | 52 | 54 | 60 | 15 | 15 | 15 | 76 | 81 | 77 |
| | 18. | 97·9 | 98·2 | 98·5 | 54 | 50 | 56 | 14 | 15 | 15 | 76 | 81 | 77 |
| | 19. | 98·1 | 98·9 | 98·5 | 52 | 60 | 58 | 14 | 15 | 15 | 75 | 82 | 77 |
| | 20. | 98·2 | 98·7 | 98·6 | 56 | 56 | 60 | 14 | 14 | 16 | 76 | 82 | 78 |
| | 21. | 98 | 98·8 | 98·7 | 52 | 56 | 58 | 14 | 15 | 15 | 75 | 82 | 78 |
| | 22. | 98·1 | | 98·9 | 52 | | 66 | 13 | | 15 | 75 | | 77 |
| | 23. | 97·9 | 98·8 | 98·1 | 54 | 56 | 62 | 14 | 14 | 15 | 75 | 82 | 76 |
| | 24. | 98·1 | 99·1 | | 52 | 58 | | 14 | 16 | | 74 | 80 | |
| | 27. | 98·1 | 98·5 | 98·7 | 54 | 52 | 56 | 14 | 14 | 15 | 73 | 81 | 76 |
| | 28. | 97·9 | 98·4 | 98·3 | 52 | 56 | 58 | 14 | 15 | 15 | 74 | 82 | 76 |
| | 29. | 98 | 98·4 | 98·9 | 50 | 52 | 62 | 14 | 14 | 15 | 73 | 81 | 75 |
| | 30. | 97·7 | 99·2 | 99·4 | 50 | 60 | 58 | 14 | 15 | 15 | 73 | 81 | 78 |
| | 31. | 98·1 | 98·5 | 98·4 | 52 | 50 | 58 | 14 | 15 | 15 | 75 | 79 | 78 |
| | | 98 | 98·8 | 98·3 | 52·9 | 53·5 | 58 | 14·1 | 14·6 | 15·3 | 74·5 | 81·1 | 76·9 |
| | January 1848. | 1. | 98 | 99 | 98·8 | 56 | 60 | 66 | 14 | 15 | 14 | 76 | 80 |
| 2. | | 98·1 | 99·2 | 98·9 | 54 | 56 | 60 | 15 | 15 | 15 | 75 | 81 | 78 |
| 3. | | 98 | 99·1 | 99 | 54 | 60 | 66 | 14 | 15 | 15 | 76 | 82 | 78 |
| 4. | | 98·2 | 99 | 98·8 | 52 | 56 | 58 | 14 | 15 | 15 | 75 | 80 | 76 |
| 5. | | 98·1 | 99·1 | 99 | 52 | 58 | 58 | 14 | 14 | 16 | 75 | 80 | 76 |
| 6. | | 97·9 | 99·1 | 98·5 | 54 | 58 | 58 | 14 | 15 | 15 | 75 | 80 | 78 |
| 7. | | 98·2 | 98·7 | 98·8 | 56 | 54 | 58 | 14 | 15 | 15 | 74 | 81 | 78 |
| 8. | | 98·3 | 99·1 | 98·8 | 56 | 62 | 64 | 14 | 16 | 16 | 75 | 83 | 78 |
| 9. | | 98·3 | 98·8 | 99·1 | 52 | 56 | 60 | 15 | 15 | 16 | 74 | 82 | 78 |
| 10. | | 98·4 | 98·3 | 98·8 | 54 | 58 | 60 | 14 | 15 | 16 | 73 | 81 | 71 |
| 11. | | 97·9 | 98·4 | 98·5 | 52 | 54 | 60 | 14 | 16 | 15 | 73 | 81 | 75 |
| 12. | | 98·1 | 98·3 | 98·7 | 58 | 54 | 66 | 14 | 15 | 16 | 73 | 82 | 77 |
| 13. | | 97·9 | 98·6 | 98·5 | 54 | 58 | 64 | 14 | 16 | 15 | 74 | 80 | 77 |
| 14. | | 98 | 99·1 | 98·9 | 56 | 60 | 56 | 14 | 16 | 14 | 73 | 81 | 77 |
| 15. | | 98 | 98·9 | 99 | 56 | 62 | 60 | 14 | 16 | 15 | 73 | 81 | 78 |
| 16. | | 98·3 | 99 | 98·7 | 56 | 52 | 58 | 14 | 15 | 16 | 75 | 80 | 78 |
| 17. | | 98·1 | 98·8 | 98·8 | 54 | 56 | 60 | 15 | 15 | 15 | 75 | 75 | 75 |
| 18. | | 97·9 | 98·6 | 98·9 | 56 | 56 | 56 | 14 | 15 | 16 | 73 | 77 | 77 |
| 19. | | 98·3 | 98·8 | 98·8 | 54 | 54 | 58 | 14 | 15 | 15 | 74 | 80 | 77 |
| 20. | | 98·3 | 99 | 98·5 | 56 | 58 | 56 | 14 | 15 | 16 | 74 | 81 | 77 |
| 21. | | 97·9 | 98·6 | 98·8 | 54 | 58 | 58 | 14 | 16 | 16 | 74 | 80 | 78 |
| 22. | | 98·1 | 98·7 | 98·7 | 56 | 56 | 58 | 14 | 15 | 15 | 74 | 82 | 78 |
| 23. | | 98·1 | 99·1 | 98·7 | 56 | 58 | 54 | 14 | 14 | 14 | 73 | 81 | 76 |
| 24. | | 98·3 | 99 | 98·8 | 52 | 54 | 60 | 14 | 14 | 15 | 73 | 79 | 76 |
| 25. | | 97·8 | 98·9 | 98·4 | 52 | 54 | 60 | 14 | 15 | 15 | 73 | 80 | 76 |
| 26. | | 98·2 | 98·9 | 99 | 53 | 56 | 56 | 14 | 15 | 16 | 73 | 81 | 77 |
| 27. | | 97·9 | 98·8 | 98·8 | 56 | 54 | 56 | 14 | 15 | 15 | 69 | 80 | 74 |
| 28. | | 98 | 98·8 | 98·9 | 54 | 56 | 62 | 14 | 15 | 15 | 68 | 80 | 76 |
| 29. | | 98 | 99·3 | 99·1 | 54 | 60 | 62 | 14 | 16 | 15 | 72 | 80 | 74 |
| 30. | | 98·3 | 99·3 | 98·8 | 56 | 56 | 56 | 14 | 14 | 15 | 71 | 82 | 77 |
| 31. | | 98·1 | 98·9 | 99 | 54 | 56 | 54 | 15 | 15 | 15 | 74 | 82 | 78 |
| | 98·1 | 98·9 | 98·8 | 54·5 | 56·8 | 59·3 | 14·1 | 14·9 | 15·2 | 74·1 | 80·5 | 76·6 | |

| | Temp. under the tongue. | | | Pulse. | | | Respirations. | | | Temperature of room. | | | |
|----------------|-------------------------|-----------|-----------|----------|-----------|-----------|---------------|-----------|-----------|----------------------|-----------|-----------|------|
| | 6-7 A.M. | 12-2 P.M. | 9-11 P.M. | 6-7 A.M. | 12-2 P.M. | 9-11 P.M. | 6-7 A.M. | 12-2 P.M. | 9-11 P.M. | 6-7 A.M. | 12-2 P.M. | 9-11 P.M. | |
| February 1848. | 1. | 98.4 | 99 | 98.8 | 56 | 56 | 56 | 14 | 15 | 15 | 73 | 81 | 78 |
| | 2. | 98.2 | 99 | 98.8 | 54 | 58 | 56 | 15 | 15 | 15 | 73 | 83 | 75 |
| | 3. | 97.9 | 99.2 | 98.9 | 56 | 60 | 58 | 15 | 15 | 15 | 75 | 82 | 78 |
| | 4. | 98 | 98.8 | 98.6 | 54 | 62 | 56 | 14 | 16 | 15 | 74 | 81 | 78 |
| | 5. | 98.1 | 98.8 | 98.9 | 56 | 60 | 62 | 14 | 16 | 15 | 73 | 83 | 77 |
| | 6. | 98 | 98.8 | 98.8 | 56 | 56 | 60 | 14 | 15 | 16 | 72 | 82 | 77 |
| | 7. | 98 | 98.9 | 99.3 | 56 | 54 | 62 | 14 | 14 | 16 | 73 | 81 | 78 |
| | 8. | 98 | 99.2 | 98.8 | 57 | 58 | 56 | 14 | 16 | 15 | 73 | 83 | 77 |
| | 9. | 98.1 | 98.7 | 99.2 | 56 | 58 | 64 | 15 | 15 | 16 | 74 | 83 | 78 |
| | 10. | 97.9 | 99.6 | 99 | 54 | 54 | 56 | 14 | 15 | 16 | 74 | 81 | 77 |
| | 11. | 98 | 98.5 | 98.9 | 55 | 56 | 62 | 15 | 15 | 16 | 74 | 80 | 78 |
| | 12. | 98.1 | 98.5 | 99 | 56 | 54 | 64 | 15 | 16 | 17 | 73 | 81 | 77 |
| | 13. | 98 | 98.4 | 98.5 | 52 | 56 | 56 | 14 | 15 | 16 | 73 | 81 | 77 |
| | 14. | 98 | 99.4 | 98.9 | 56 | 58 | 60 | 14 | 15 | 16 | 74 | 83 | 78 |
| | 15. | 98 | 98.6 | 99.3 | 52 | 56 | 64 | 15 | 15 | 15 | 74 | 83 | 77 |
| | 16. | 98 | 98.7 | 98.9 | 57 | 56 | 62 | 15 | 15 | 16 | 73 | 82 | 78 |
| | 17. | 98.3 | 99 | 99.2 | 58 | 58 | 58 | 16 | 16 | 16 | 75 | 81 | 78 |
| | 18. | 98.1 | 98.3 | 98.8 | 54 | 52 | 58 | 15 | 15 | 15 | 73 | 77 | 77 |
| | 19. | 97.9 | 99.2 | 98.7 | 52 | 56 | 56 | 14 | 15 | 16 | 73 | 81 | 77 |
| | 20. | 98 | 99 | 98.7 | 56 | 54 | 56 | 14 | 15 | 15 | 74 | 81 | 78 |
| | 21. | 97.7 | 98.9 | 98.9 | 52 | 56 | 58 | 15 | 16 | 16 | 73 | 81 | 77 |
| | 22. | 97.8 | 99.2 | 99.1 | 52 | 58 | 62 | 15 | 14 | 15 | 73 | 83 | 78 |
| | 23. | 98.2 | 99 | 98.9 | 56 | 56 | 64 | 15 | 15 | 16 | 75 | 82 | 79 |
| | 24. | 97.9 | 99.1 | 99 | 54 | 64 | 64 | 14 | 16 | 16 | 74 | 83 | 79 |
| | 25. | 97.9 | 98.7 | 99 | 58 | 56 | 58 | 15 | 15 | 15 | 74 | 82 | 78 |
| | 26. | 97.9 | 98.7 | | 54 | 56 | | 15 | 16 | | 74 | 81 | |
| | 27. | 97.8 | 99.2 | 99 | 56 | 56 | 60 | 14 | 15 | 15 | 74 | 82 | 78 |
| | 28. | 98.1 | 98.8 | 98.8 | 54 | 54 | 62 | 14 | 15 | 15 | 75 | 77 | 77 |
| | 29. | 97.8 | 98.6 | 98.9 | 52 | 56 | 62 | 15 | 15 | 15 | 74 | 81 | 78 |
| | | 98 | 98.8 | 98.8 | 54.9 | 57 | 59.7 | 14.5 | 15.1 | 15.5 | 73.6 | 82.1 | 77.5 |

| | | | | | | | | | | | | | |
|-------------|-----|------|-------|-------|------|-------|-------|------|-------|-------|------|------|------|
| March 1848. | 1. | 98 | 98.8 | 99.3 | 54 | 56 | 62 | 15 | 16 | 16 | 75 | 83 | 79 |
| | 2. | 98.1 | 99.6 | 99.2 | 56 | 58 | 66 | 15 | 16 | 16 | 76 | 84 | 80 |
| | 3. | 98.2 | 98.8 | 99 | 56 | 56 | 64 | 15 | 15 | 17 | 76 | 83 | 80 |
| | 4. | 97.8 | 98.9 | | 52 | 56 | | 14 | 15 | | 73 | 81 | |
| | 5. | 98.1 | 98.5 | 99 | 60 | 56 | 60 | 14 | 15 | 16 | 74 | 82 | 78 |
| | 6. | 97.9 | 98.7 | 98.6 | 56 | 56 | 56 | 14 | 15 | 15 | 74 | 82 | 79 |
| | 7. | 97.8 | 98.3 | 98.9 | 52 | 56 | 56 | 14 | 15 | 15 | 74 | 82 | 77 |
| | 8. | 97.9 | 99.5 | 99 | 52 | 74 | 58 | 14 | 16 | 15 | 74 | 83 | 79 |
| | 9. | 98.1 | 99.4 | | 54 | 60 | | 14 | 14 | | 76 | 82 | |
| | 10. | 98.4 | 99.1 | 99 | 58 | 56 | 62 | 15 | 14 | 15 | 75 | 83 | 78 |
| | 11. | 98.1 | 99 | 98.7 | 54 | 60 | 62 | 14 | 16 | 16 | 74 | 81 | 78 |
| | 12. | 98.1 | 98.9 | 98.9 | 54 | 62 | 60 | 15 | 15 | 16 | 74 | 83 | 78 |
| | 13. | 98 | 98.9 | 99.1 | 56 | 56 | 60 | 14 | 15 | 16 | 73 | 82 | 78 |
| | 14. | 98.1 | 98.9 | 99 | 58 | 60 | 62 | 15 | 16 | 15 | 75 | 82 | 79 |
| | 15. | 98 | 98.8 | 98.7 | 56 | 56 | 56 | 14 | 15 | 15 | 76 | 83 | 78 |
| | 16. | 98.3 | 98.7 | 99.2 | 56 | 58 | 62 | 15 | 16 | 16 | 76 | 80 | 77 |
| | 17. | 98.1 | 98.7 | 98.9 | 54 | 54 | 62 | 14 | 14 | 15 | 75 | 83 | 79 |
| | 18. | 98.1 | | | 56 | | | 14 | | | 76 | | |
| | 19. | 98.2 | 99.2 | 99 | 56 | 60 | 54 | 15 | 15 | 15 | 75 | 83 | 82 |
| | 20. | 98.2 | 98.7 | 98.6 | 54 | 54 | 54 | 14 | 16 | 15 | 75 | 76 | 77 |
| | 21. | 98 | 98.7 | 99.1 | 52 | 56 | 56 | 15 | 16 | 15 | 73 | 82 | 78 |
| | 22. | 98 | 99 | 99 | 56 | 56 | 58 | 15 | 15 | 16 | 75 | 82 | 79 |
| | 23. | 98.1 | 98.8 | 98.9 | 54 | 58 | 60 | 14 | 15 | 15 | 77 | 83 | 79 |
| | 24. | 98.3 | 98.9 | 99 | 54 | 56 | 62 | 14 | 15 | 16 | 75 | 82 | 78 |
| | 25. | 98 | 98.6 | 98.9 | 56 | 56 | 56 | 14 | 15 | 15 | 76 | 79 | 78 |
| | 26. | 98.2 | 98.9 | 98.5 | 54 | 58 | 60 | 14 | 15 | 14 | 75 | 81 | 79 |
| | 27. | 97.9 | 98.7 | 99.1 | 52 | 52 | 56 | 14 | 15 | 15 | 75 | 83 | 78 |
| | 28. | 97.9 | 99.1 | 98.8 | 52 | 54 | 60 | 14 | 15 | 15 | 76 | 84 | 80 |
| | 29. | 98 | 99.2 | 99.2 | 54 | 64 | 66 | 14 | 16 | 16 | 77 | 85 | 77 |
| | 30. | 98.2 | 99.1 | 99.1 | 54 | 56 | 60 | 14 | 15 | 14 | 77 | 83 | 78 |
| | 31. | 98 | 99.4 | 99 | 58 | 58 | 62 | 14 | 15 | 15 | 78 | 79 | 75 |
| | | 98 | 98.9 | 98.9 | 54.9 | 57.6 | 59.7 | 14.3 | 15.5 | 15.4 | 75.1 | 81.9 | 78.2 |

| | Temp. under the tongue. | | | Pulse. | | | Respirations. | | | Temperature of room. | | | |
|-------------|-------------------------|-----------|-----------|----------|-----------|-----------|---------------|-----------|-----------|----------------------|-----------|-----------|----|
| | 6-7 A.M. | 12-2 P.M. | 9-11 P.M. | 6-7 A.M. | 12-2 P.M. | 9-11 P.M. | 6-7 A.M. | 12-2 P.M. | 9-11 P.M. | 6-7 A.M. | 12-2 P.M. | 9-11 P.M. | |
| April 1848. | 1. | 98.2 | 99 | 98.6 | 56 | 58 | 58 | 15 | 15 | 14 | 75 | 79 | 78 |
| | 2. | 98.1 | 99.2 | 99 | 60 | 56 | 58 | 14 | 16 | 15 | 73 | 81 | 77 |
| | 3. | 97.9 | 98.8 | 98.9 | 54 | 56 | 60 | 15 | 15 | 16 | 71 | 81 | 77 |
| | 4. | 98 | 98.7 | | 54 | 58 | | 14 | 15 | | 71 | 81 | |
| | 5. | 98.2 | 98.8 | 98.9 | 60 | 60 | 64 | 15 | 16 | 15 | 72 | 83 | 78 |
| | 6. | 98.1 | 99.3 | 98.7 | 56 | 58 | 64 | 14 | 15 | 16 | 73 | 85 | 79 |
| | 7. | 98.2 | 99.2 | 99.2 | 56 | 58 | 64 | 15 | 15 | 16 | 76 | 85 | 79 |
| | 8. | 97.8 | 99.3 | 99.3 | 54 | 58 | 58 | 15 | 15 | 15 | 77 | 83 | 81 |
| | 9. | 98.4 | | | 58 | | | 15 | | | 75 | | |
| | 25. | 98.1 | 98.9 | 98.9 | 54 | 54 | 62 | 14 | 15 | 15 | 75 | 80 | 77 |
| | 26. | 98 | 98.7 | 98.9 | 52 | 56 | 60 | 15 | 16 | 16 | 77 | 85 | 81 |
| | 27. | 98 | 98 | 99 | 54 | 58 | 60 | 15 | 15 | 15 | 78 | 84 | 79 |
| | 28. | 97.9 | 99 | 98.9 | 52 | 58 | 60 | 14 | 15 | 15 | 77 | 85 | 79 |
| | 29. | 97.7 | 98.5 | 98.8 | 52 | 56 | 62 | 14 | 16 | 15 | 76 | 84 | 79 |
| 30. | 97.9 | 99 | 99.1 | 52 | 64 | 62 | 15 | 16 | 16 | 77 | 85 | 82 | |
| | 98 | 98.9 | 98.9 | 54.9 | 57.7 | 60.9 | 14.7 | 15.2 | 15.3 | 74.8 | 82.9 | 78.1 | |
| May 1848. | 1. | 98.3 | 99.1 | 98.7 | 52 | 58 | 60 | 14 | 15 | 15 | 78 | 86 | 81 |
| | 2. | 97.9 | 98.7 | 98.6 | 52 | 56 | 58 | 15 | 15 | 16 | 79 | 85 | 79 |
| | 3. | 98.1 | 98.7 | 99 | 56 | 54 | 60 | 14 | 15 | 16 | 77 | 85 | 80 |
| | 4. | 97.9 | 98.8 | 99 | 52 | 56 | 54 | 14 | 16 | 16 | 78 | 87 | 82 |
| | 5. | 98 | 99.2 | 99 | 56 | 54 | 60 | 15 | 16 | 15 | 79 | 85 | 81 |
| | 6. | 98.2 | 99 | 99.1 | 54 | 56 | 70 | 15 | 14 | 16 | 79 | 86 | 81 |
| | 7. | 98 | 99.1 | 99 | 58 | 56 | 60 | 14 | 15 | 16 | 78 | 86 | 82 |
| | 8. | 98.1 | 98.8 | 99.1 | 54 | 56 | 60 | 14 | 15 | 15 | 78 | 86 | 82 |
| | 9. | 98.3 | 99.3 | 98.4 | 56 | 58 | 58 | 15 | 15 | 15 | 79 | 85 | 78 |
| | 10. | 98.4 | 99.2 | 99 | 58 | 58 | 66 | 15 | 14 | 16 | 78 | 84 | 80 |
| | 11. | 98.2 | | | 58 | | | 14 | | | 78 | | |
| | 98.1 | 99 | 98.9 | 55.1 | 56.2 | 60.6 | 14.3 | 15 | 15.6 | 78.2 | 85.6 | 80.6 | |
| June 1848. | 7. | 98 | 98.6 | | 56 | 60 | | 15 | 16 | | 78 | 81 | |
| | 8. | 98 | 98.9 | 98.6 | 52 | 58 | 62 | 14 | 15 | 15 | 78 | 84 | 81 |
| | 9. | 97.9 | 98.6 | 98.8 | 54 | 58 | 64 | 14 | 16 | 14 | 77 | 85 | 82 |
| | 10. | 98.8 | 98.9 | 99 | 54 | 58 | 60 | 15 | 15 | 16 | 78 | 85 | 80 |
| | 11. | 97.8 | 99 | 98.9 | 52 | 56 | 56 | 14 | 14 | 14 | 77 | 86 | 81 |
| | 12. | 97.9 | 98.9 | 98.9 | 52 | 54 | 58 | 14 | 15 | 14 | 78 | 83 | 80 |
| | 13. | 98.1 | 99 | 98.7 | 54 | 62 | 58 | 14 | 15 | 15 | 78 | 86 | 81 |
| | 14. | 98.1 | 98.9 | | 54 | 58 | | 14 | 14 | | 78 | 86 | |
| | 15. | 98 | 98.5 | 99.3 | 50 | 52 | 56 | 14 | 14 | 15 | 79 | 85 | 78 |
| | 16. | 97.9 | 98.7 | 99.1 | 52 | 54 | 62 | 14 | 15 | 15 | 77 | 86 | 80 |
| | 17. | 97.9 | 98.8 | 99 | 54 | 60 | 76 | 14 | 15 | 15 | 77 | 86 | 81 |
| | 18. | 98 | 98.9 | 98.9 | 56 | 58 | 56 | 14 | 14 | 16 | 77 | 85 | 81 |
| | 19. | 98 | 98.7 | 99 | 52 | 54 | 58 | 14 | 15 | 15 | 78 | 79 | 80 |
| | 20. | 98 | 99.1 | 98.7 | 50 | 56 | 62 | 14 | 15 | 15 | 77 | 85 | 81 |
| | 21. | 97.9 | 98.8 | 99 | 50 | 56 | 60 | 14 | 15 | 15 | 78 | 85 | 80 |
| | 22. | 98 | 98.7 | 99.2 | 50 | 56 | 60 | 14 | 15 | 15 | 77 | 85 | 82 |
| | 23. | 98 | 98.9 | 99 | 54 | 54 | 56 | 14 | 14 | 14 | 78 | 86 | 82 |
| | 24. | 98.1 | | 98.9 | 54 | | 62 | 14 | | 15 | 79 | | 79 |
| | 25. | 97.8 | 98.6 | 98.8 | 52 | 56 | 56 | 14 | 16 | 15 | 78 | 83 | 81 |
| | 26. | 97.9 | 98.9 | 99.2 | 52 | 52 | 60 | 14 | 15 | 14 | 78 | 84 | 81 |
| 27. | 98.2 | 98.9 | 98.8 | 54 | 54 | 58 | 14 | 15 | 14 | 77 | 86 | 80 | |
| 28. | 97.9 | 98.9 | 98.8 | 50 | 54 | 58 | 14 | 15 | 15 | 77 | 85 | 79 | |
| 29. | 97.9 | 98.8 | 99.2 | 52 | 56 | 60 | 14 | 14 | 16 | 75 | 86 | 89 | |
| 30. | 97.8 | 99 | 99.3 | 54 | 54 | 62 | 14 | 14 | 15 | 77 | 86 | 80 | |
| | 98 | 98.8 | 99 | 51 | 56.1 | 56.8 | 14.1 | 14.8 | 14.9 | 77.5 | 84.7 | 80.4 | |

| | Temp. under the tongue. | | | Pulse. | | | Respirations. | | | Temperature of room. | | | |
|--------------|-------------------------|-----------|-----------|----------|-----------|-----------|---------------|-----------|-----------|----------------------|-----------|-----------|----|
| | 6-7 A.M. | 12-2 P.M. | 9-11 P.M. | 6-7 A.M. | 12-2 P.M. | 9-11 P.M. | 6-7 A.M. | 12-2 P.M. | 9-11 P.M. | 6-7 A.M. | 12-2 P.M. | 9-11 P.M. | |
| July 1848. | 1. | 97.9 | 99.1 | 98.9 | 48 | 54 | 58 | 14 | 15 | 15 | 79 | 86 | 82 |
| | 2. | 98.1 | 98.3 | 98.9 | 58 | 52 | 56 | 14 | 15 | 14 | 78 | 87 | 82 |
| | 3. | 98.2 | 99 | 99.1 | 52 | 56 | 64 | 13 | 13 | 15 | 78 | 84 | 81 |
| | 4. | 98.1 | 98.6 | 98.5 | 52 | 54 | 78 | 13 | 15 | 15 | 76 | 79 | 79 |
| | 5. | 98.3 | 98.9 | 98.5 | 60 | 54 | 58 | 14 | 15 | 15 | 75 | 84 | 79 |
| | 6. | 98.1 | 99 | 99.1 | 52 | 52 | 58 | 14 | 14 | 14 | 78 | 85 | 81 |
| | 7. | 97.9 | 98.9 | 99.1 | 52 | 56 | 58 | 14 | 14 | 15 | 78 | 83 | 81 |
| | 8. | 98.1 | 99 | 98.5 | 51 | 54 | 72 | 14 | 15 | 14 | 78 | 84 | 81 |
| | 9. | 98.2 | | 99.3 | 56 | | 58 | 14 | | 15 | 78 | | 82 |
| | 10. | 98.2 | 98.9 | 99.1 | 52 | 54 | 58 | 14 | 16 | 15 | 77 | 85 | 80 |
| | 11. | 97.8 | 98.7 | 99 | 50 | 56 | 54 | 14 | 14 | 14 | 77 | 85 | 80 |
| | 12. | 98 | | | 50 | | | 14 | | | 77 | | |
| | 26. | 97.9 | 99 | 99.4 | 54 | 56 | 58 | 14 | 15 | 15 | 77 | 85 | 80 |
| | 27. | 98 | 98.9 | 98.7 | 54 | 56 | 58 | 14 | 15 | 15 | 77 | 85 | 80 |
| | 28. | 98.2 | 99 | 98.9 | 54 | 56 | 56 | 15 | 15 | 15 | 79 | 85 | 82 |
| 29. | 98.2 | 98.4 | 98.9 | 54 | 50 | 52 | 14 | 15 | 15 | 79 | 85 | 81 | |
| 30. | 98.1 | 98.9 | 98.5 | 54 | 50 | 54 | 14 | 13 | 15 | 78 | 83 | 81 | |
| 31. | 98.1 | 99.2 | 99 | 52 | 58 | 58 | 14 | 14 | 15 | 78 | 85 | 80 | |
| | 98 | 98.3 | 98.9 | 53 | 54.2 | 59.5 | 14 | 14.7 | 14.8 | 77.7 | 84.3 | 79.4 | |
| August 1848. | 1. | 97.8 | 99 | 98.7 | 52 | 54 | 56 | 14 | 15 | 15 | 78 | 85 | 80 |
| | 2. | 97.8 | | 98.5 | 52 | | 76 | 13 | | 15 | 78 | | 79 |
| | 3. | 98.3 | 98.7 | 98.7 | 54 | 54 | 54 | 14 | 15 | 14 | 78 | 86 | 80 |
| | 4. | 98.1 | 98.7 | 98.6 | 54 | 52 | 54 | 15 | 15 | 14 | 79 | 82 | 81 |
| | 5. | 98.1 | 99 | 98.9 | 56 | 52 | 56 | 14 | 15 | 15 | 78 | 85 | 80 |
| | 6. | 97.8 | 99 | 99 | 52 | 54 | 58 | 13 | 14 | 15 | 76 | 85 | 81 |
| | 7. | 98.2 | 99 | 99.6 | 56 | 58 | 66 | 14 | 15 | 15 | 78 | 86 | 81 |
| | 8. | 98.1 | 99.1 | 99 | 56 | 54 | 60 | 14 | 16 | 15 | 79 | 85 | 80 |
| | 9. | 98.2 | | | 54 | | | 15 | | | 79 | | |
| | 19. | 98.3 | 98.9 | 98.7 | 66 | 54 | 58 | 15 | 15 | 15 | 77 | 83 | 80 |
| | 11. | 97.9 | 99.1 | 99.2 | 54 | 54 | 58 | 14 | 15 | 16 | 77 | 86 | 81 |
| | 12. | 98.1 | 99.3 | 99.1 | 54 | 56 | 58 | 14 | 15 | 15 | 79 | 86 | 82 |
| | 13. | 98.2 | 98.9 | 98.9 | 56 | 54 | 60 | 14 | 14 | 15 | 79 | 86 | 83 |
| | 14. | 98.2 | 99 | 99.6 | 56 | 58 | 62 | 14 | 15 | 15 | 80 | 85 | 82 |
| | 15. | 98 | 99.2 | 98.8 | 56 | 58 | 62 | 14 | 15 | 16 | 79 | 86 | 80 |
| | 16. | 98.2 | | | 56 | | | 14 | | | 79 | | |
| | 17. | 98.2 | 99.7 | 99.7 | 58 | 60 | 58 | 14 | 14 | 14 | 79 | 84 | 81 |
| | 18. | 98.1 | 99.2 | 99.1 | 54 | 58 | 58 | 15 | 14 | 15 | 79 | 86 | 79 |
| | 19. | 98.1 | 99.3 | 99.2 | 54 | 56 | 56 | 14 | 15 | 15 | 79 | 86 | 81 |
| | 20. | 98.2 | 99 | | 54 | 54 | | 14 | 15 | | 78 | 81 | |
| | 22. | 98.2 | 99.1 | 99.5 | 54 | 56 | 66 | 14 | 16 | 15 | 80 | 87 | 82 |
| 23. | 98.1 | | | 56 | | | 14 | | | 78 | | | |
| 24. | 98.1 | 99.4 | 99.4 | 60 | 60 | 60 | 14 | 16 | 15 | 77 | 86 | 82 | |
| 25. | 98.1 | 99.4 | 98.8 | 56 | 56 | 54 | 14 | 15 | 15 | 79 | 86 | 82 | |
| 26. | 98.2 | 99.3 | 99.2 | 54 | 66 | 60 | 14 | 16 | 15 | 79 | 87 | 82 | |
| 27. | 98.1 | 99.1 | 99.2 | 52 | 60 | 56 | 13 | 15 | 15 | 78 | 86 | 79 | |
| 28. | 98.1 | 99.4 | 99.6 | 56 | 60 | 66 | 14 | 15 | 15 | 78 | 86 | 82 | |
| 29. | 98.2 | | 98.9 | 56 | | 70 | 14 | | 14 | 79 | | 80 | |
| 30. | 98.2 | | 99.4 | 56 | | 66 | 14 | | 14 | 79 | | 82 | |
| 31. | 98.2 | 99.1 | 99.4 | 58 | 60 | 66 | 14 | 15 | 14 | 80 | 87 | 82 | |
| | 98.1 | 99.1 | 99.1 | 55.4 | 56.3 | 59.5 | 13.9 | 15 | 14.7 | 78.4 | 85.3 | 80.9 | |

| | Temp. under the tongue. | | | Pulse. | | | Respirations. | | | Temperature of room. | | | |
|-----------------|-------------------------|-----------|-----------|----------|-----------|-----------|---------------|-----------|-----------|----------------------|-----------|-----------|-------|
| | 6-7 A.M. | 12-2 P.M. | 9-11 P.M. | 6-7 A.M. | 12-2 P.M. | 9-11 P.M. | 6-7 A.M. | 12-2 P.M. | 9-11 P.M. | 6-7 A.M. | 12-2 P.M. | 9-11 P.M. | |
| September 1848. | 1. | 98° | 99·2 | 99 | 52 | 56 | 64 | 14 | 15 | 16 | 78° | 87° | 81° |
| | 2. | 98·1 | 99 | 99·2 | 54 | 52 | 60 | 14 | 15 | 16 | 78 | 88 | 81 |
| | 3. | 98 | 99·3 | 99 | 52 | 54 | 60 | 14 | 14 | 14 | 79 | 88 | 84 |
| | 4. | 98·1 | 99·6 | 99·4 | 52 | 62 | 60 | 14 | 14 | 15 | 80 | 87 | 82 |
| | 5. | 98·2 | 99·4 | 99·4 | 56 | 66 | 64 | 14 | 15 | 16 | 79 | 87 | 80 |
| | 6. | 98 | | 99·2 | 54 | | 64 | 14 | | 15 | 79 | | 81 |
| | 7. | 98·2 | 99·6 | 99·6 | 54 | 60 | 62 | 14 | 16 | 15 | 78 | 88 | 82 |
| | 8. | 98·5 | 99·5 | 99·2 | 56 | 60 | 58 | 14 | 15 | 15 | 79 | 88 | 86 |
| | 9. | 98·3 | 99·5 | 99·6 | 56 | 60 | 66 | 15 | 15 | 15 | 83 | 89 | 84 |
| | 10. | 98·3 | 99 | 99·3 | 56 | 56 | 66 | 15 | 16 | 15 | 80 | 89 | 82 |
| | 11. | 98·3 | 97·9 | 99·2 | 56 | 60 | 66 | 14 | 15 | 15 | 80 | 89 | 82 |
| | 12. | 97·9 | 99·2 | 99·3 | 52 | 58 | 60 | 14 | 15 | 14 | 80 | 88 | 83 |
| | 13. | 98·1 | | | 54 | | | 14 | | | 79 | | |
| | 14. | 98 | 99·3 | 99 | 56 | 60 | 62 | 14 | 15 | 15 | 78 | 86 | 81 |
| | 15. | 98·5 | 99·2 | 98·9 | 54 | 56 | 72 | 14 | 15 | 16 | 79 | 85 | 81 |
| | 17. | 98 | 99 | 98·9 | 54 | 54 | 66 | 14 | 15 | 15 | 76 | 85 | 82 |
| | 18. | 98·3 | 99·4 | 99·9 | 54 | 58 | 74 | 14 | 15 | 16 | 79 | 84 | 82 |
| | 19. | 98·5 | 98·8 | 99·3 | 58 | 56 | 70 | 14 | 15 | 14 | 79 | 80 | 81 |
| | 20. | 98·3 | 98·9 | 98·7 | 58 | 54 | 66 | 14 | 15 | 16 | 80 | 84 | 82 |
| | 21. | 98·3 | 99 | 98·8 | 58 | 52 | 56 | 14 | 15 | 16 | 81 | 86 | 82 |
| | 22. | 98·1 | 98·7 | 99·2 | 52 | 52 | 60 | 14 | 15 | 16 | 81 | 86 | 82 |
| | 23. | 98 | 98·9 | | 52 | 56 | | 14 | 16 | | 78 | 86 | |
| | 24. | 98·5 | 98·7 | 99·1 | 62 | 56 | 62 | 14 | 15 | 15 | 80 | 86 | 80 |
| | 25. | 98 | 99·3 | 99·1 | 52 | 56 | 56 | 14 | 16 | 15 | 78 | 85 | 82 |
| | 26. | 98·2 | 99·2 | 98·8 | 54 | 52 | 56 | 14 | 15 | 15 | 78 | 85 | 80 |
| | 27. | 98·1 | | | 52 | | | 14 | | | 77 | | |
| | 28. | 98·3 | 98·8 | 99·3 | 54 | 56 | 58 | 14 | 16 | 15 | 75 | 85 | 80 |
| | 29. | 98·5 | 99·2 | 99·3 | 54 | 58 | 60 | 14 | 15 | 15 | 78 | 86 | 82 |
| | 30. | 98·2 | 98·8 | 99 | 52 | 58 | 66 | 14 | 16 | 15 | 79 | 85 | 82 |
| | | | 98·1 | 99·1 | 99·1 | 54·4 | 57·3 | 60·4 | 14 | 15 | 15·2 | 78·9 | 86·2 |
| October 1848. | 1. | 98·3 | 98·8 | 98·8 | 56 | 56 | 66 | 14 | 15 | 16 | 79 | 86 | 83 |
| | 2. | 98·2 | 99 | 98·7 | 52 | 56 | 60 | 14 | 14 | 15 | 79 | 82 | 80 |
| | 3. | 98·2 | 99 | | 52 | 56 | | 14 | 15 | | 78 | 86 | |
| | 4. | 98·4 | 99·3 | 99·2 | 60 | 56 | 60 | 15 | 15 | 15 | 79 | 87 | 84 |
| | 5. | 98·5 | | 99·3 | 54 | | 72 | 14 | | 15 | 82 | | 83 |
| | 6. | 98·1 | 99·3 | 99·1 | 50 | 56 | 58 | 14 | 16 | 15 | 80 | 87 | 82 |
| | 7. | 98·3 | 99·2 | 99·4 | 54 | 54 | 60 | 15 | 15 | 15 | 80 | 87 | 80 |
| | 8. | 97·9 | 99·1 | 98·8 | 52 | 58 | 58 | 14 | 16 | 15 | 78 | 84 | 80 |
| | 9. | 98·1 | 99·4 | 99·4 | 54 | 56 | 60 | 14 | 15 | 15 | 76 | 87 | 81 |
| | 10. | 97·9 | 99·2 | 98·7 | 54 | 52 | 58 | 15 | 15 | 15 | 80 | 84 | 81 |
| | 11. | 98·3 | 99·5 | 99·9 | 54 | 58 | 60 | 14 | 16 | 15 | 79 | 87 | 81 |
| | 12. | 98·1 | 99·4 | 99·3 | 54 | 58 | 64 | 15 | 15 | 16 | 79 | 86 | 80 |
| | 13. | 98·1 | 99 | 99·1 | 56 | 58 | 62 | 14 | 16 | 15 | 79 | 87 | 78 |
| | 14. | 98·3 | 99·3 | | 54 | 58 | | 14 | 16 | | 78 | 88 | |
| | 15. | 98·2 | 98·9 | 99·3 | 56 | 58 | 66 | 14 | 14 | 16 | 78 | 86 | 82 |
| | 16. | 97·9 | 98·8 | 98·6 | 54 | 52 | 58 | 14 | 14 | 15 | 80 | 80 | 78 |
| | 17. | 98 | 99·1 | 99 | 52 | 54 | 60 | 14 | 16 | 15 | 77 | 86 | 80 |
| | 18. | 98·5 | | 98·6 | 58 | | 58 | 15 | | 16 | 78 | | 80 |
| | 19. | 98·1 | 98·9 | 99·2 | 56 | 58 | 62 | 15 | 15 | 16 | 78 | 85 | 82 |
| | 20. | 98·1 | 98·9 | 98·7 | 58 | 58 | 64 | 14 | 15 | 16 | 79 | 80 | 79 |
| | 21. | 98·4 | 98·6 | 98·9 | 54 | 52 | 62 | 15 | 15 | 16 | 77 | 86 | 82 |
| | 22. | 98·3 | | 99·1 | 56 | | 58 | 14 | | 16 | 79 | | 80 |
| | 23. | 98·2 | 98·8 | 98·9 | 52 | 52 | 56 | 14 | 15 | 15 | 79 | 82 | 80 |
| | 24. | 98·4 | 99·1 | 98·4 | 56 | 54 | 60 | 14 | 15 | 15 | 77 | 83 | 79 |
| | 25. | 98·5 | | | 52 | | | 14 | | | 77 | | |
| | 26. | 98·2 | 99·3 | 99·3 | 58 | 56 | 66 | 14 | 15 | 15 | 76 | 86 | 82 |
| | 27. | 98 | 99·1 | 98·8 | 54 | 56 | 58 | 14 | 14 | 15 | 77 | 86 | 81 |
| | 28. | 98·1 | 99·1 | 99·1 | 52 | 56 | 62 | 14 | 15 | 16 | 78 | 87 | 83 |
| | 29. | 98·4 | 99·5 | | 54 | 58 | | 14 | 15 | | 80 | 83 | |
| | 31. | 98·3 | 98·8 | 98·8 | 52 | 52 | 60 | 14 | 15 | 15 | 78 | 77 | 79 |
| | | | 98·2 | 99·1 | 99 | 54·3 | 55·8 | 61 | 14·2 | 15 | 15·3 | 78·9 | 84·8 |

| | Temp. under the tongue. | | | Pulse. | | | Respirations. | | | Temperature of room. | | | |
|----------------|-------------------------|-----------|-----------|----------|-----------|-----------|---------------|-----------|-----------|----------------------|-----------|-----------|----|
| | 6-7 A.M. | 12-2 P.M. | 9-11 P.M. | 6-7 A.M. | 12-2 P.M. | 9-11 P.M. | 6-7 A.M. | 12-2 P.M. | 9-11 P.M. | 6-7 A.M. | 12-2 P.M. | 9-11 P.M. | |
| November 1848. | 1. | 98·2 | 99·3 | 99 | 50 | 58 | 60 | 14 | 16 | 15 | 77 | 85 | 81 |
| | 2. | 98·1 | 99 | | 52 | 56 | | 14 | 15 | | 78 | 82 | |
| | 3. | 98·5 | 98·8 | 98·5 | 58 | 56 | 58 | 15 | 15 | 15 | 77 | 82 | 78 |
| | 4. | 98·2 | 99·1 | | 50 | 58 | | 14 | 15 | | 77 | 84 | |
| | 5. | 98·1 | 99·4 | 98·5 | 62 | 58 | 58 | 15 | 16 | 16 | 78 | 86 | 79 |
| | 6. | 98·1 | 99·2 | 98·4 | 56 | 58 | 58 | 14 | 15 | 15 | 77 | 83 | 78 |
| | 7. | 98 | 98·9 | | 58 | 56 | | 14 | 15 | | 77 | 83 | |
| | 8. | 98·2 | 99·3 | 98·9 | 54 | 62 | 62 | 14 | 16 | 16 | 76 | 83 | 79 |
| | 9. | 98·1 | | | 58 | | | 14 | | | 78 | | |
| | 98·1 | 99·1 | 98·6 | 55·3 | 57·7 | 59·2 | 14·2 | 15·4 | 15·4 | 77 | 83·5 | 79 | |

Postscript to Dr. DAVY'S Paper on the Temperature of Man.

Received May 8,—Read May 16, 1850.

The thermometer with which the preceding observations were made was broken immediately after my return to England, when travelling by railway, no special precaution having been taken in the packing of it, as by inclosing it in elastic horse-hair; and in consequence I had not the means at once of making further trials on temperature for the purpose of comparison. Recently, having had another thermometer constructed as delicate as that before used and divided with the same minuteness—each degree of FAHRENHEIT into ten parts—I have been enabled to continue the trials; as yet, however, only for one month, that of April, without interruption. They have been made thrice daily, at about the same hours as those recorded in my former paper. The results, under ordinary circumstances of health, exercise, &c., have accorded with those then obtained, the highest temperature having been found to be immediately on rising in the morning after the night's rest, and the lowest at night, just before retiring to rest. This accordance will probably be received in proof that the difference of results in the West Indies and in England has been mainly owing to difference of climate and the habits of life connected therewith; and apart from these, to no change in the individual, the subject of the trials.

May 4, 1850.

XXIII. *On the Oils produced by the Action of Sulphuric Acid upon various Classes of Vegetables.* By JOHN STENHOUSE, Esq., Ph.D., F.R.S.

Received March 28,—Read April 18, 1850.

NEARLY thirty years ago DÖBEREINER observed, when preparing formic acid by distilling a mixture of starch, peroxide of manganese and sulphuric acid, that the liquid which passed into the receiver contained a small quantity of oil which rendered it turbid. To this oil DÖBEREINER gave the somewhat fanciful name of “artificial oil of ants,” though the very limited quantity in which he was enabled to procure it prevented him from determining almost any of its properties.

My attention was first directed to the subject in 1840, when I found that the oxide of manganese was quite unnecessary, and that this oil could be readily prepared by operating on most vegetable substances with slightly diluted sulphuric acid.¹ In this way I succeeded in procuring considerable quantities of the oil from wheaten and oaten flour, from saw-dust, bran, chaff, &c., and was thus enabled to subject it to a more detailed examination. The oil, when analysed, was found to have the formula $C_5 H_2 O_2$, or the triple of this, $C_{15} H_6 O_6$, presenting the remarkable circumstance of a volatile aromatic oil containing oxygen and hydrogen in the proportions to form water. This proved it to differ essentially from other known oils, all of which contain an excess of hydrogen.

Dr. FOWNES took up the subject in 1845, and made the interesting discovery, that when the oil was agitated with a considerable excess of aqueous ammonia and set aside for a few hours, it was converted into a bulky crystalline mass, becoming $C_{15} H_6 O_3 N_1$ by the absorption of one equivalent of nitrogen and the elimination of three equivalents of oxygen which had united with the hydrogen of the ammonia. To this compound Dr. FOWNES gave the name of furfuramide, and to the oil itself that of furfurol. Dr. FOWNES also made the still more important discovery, that when furfuramide is boiled for a short time with dilute potash lye, it is without any alteration of its per-centage composition, but merely by a new arrangement of its component elements converted into a crystalline base, furfurine, the formula of which is $C_{30} H_{12} O_6 N_2$.

Furfurol was also examined in 1848 by M. CAHOURS, who, in addition to confirming Dr. FOWNES’s discoveries, observed that when a stream of sulphuretted hydrogen is passed through an alcoholic solution of furfuramide, the half of the oxygen in that body is removed and replaced by sulphur. This new compound, which he called thiofurfurol, precipitates as a crystalline powder and has the formula $C_{10} H_4 S_2 O_2$.

M. CAHOURS also found that when thiofurfurol is distilled it is entirely decomposed, producing a beautifully crystalline substance containing no sulphur. Its formula is $C_{18} H_8 O_4$, or some multiple of these numbers.

As furfurol, both from its composition and properties, occupies a somewhat isolated position in regard to other essential oils, it appeared to me not improbable that it would be found on more extended investigation not to stand really alone in nature, but to be one of a series of similar oils. This consideration induced me about six months ago to resume its examination, and, as will presently be seen, the expectation I had formed was not altogether without foundation. Before detailing these researches, however, I shall shortly state a few additional observations which I have recently made upon furfurol and some of its compounds.

Furfurol is most advantageously prepared by distilling one part of bran with rather more than half its weight of sulphuric acid diluted with two parts of water. I find, however, that furfurol may be also produced with muriatic acid, though in practice it is more advantageous to employ sulphuric acid, as it remains in the retort and does not distil over with the oil, as is the case with muriatic acid.

The arrangement for preparing furfurol on a considerable scale which I have found most suitable, is the following. About 32 lbs. of wheaten bran and 20 lbs. of sulphuric acid diluted with twice its bulk of water, were introduced into a large three-necked WOLF'S-bottle made of salt-glazed earthenware. These bottles are usually employed as condensers in the manufacture of muriatic and nitric acids, and are capable of containing from twenty to thirty gallons each. A leaden pipe connected with a tolerably large steam-boiler is passed through a perforated cork to near the bottom of the stone-ware bottle, from the top of which, on the opposite side, a second pipe is carried into the worm of a condensing apparatus, which is kept cool by means of a plentiful supply of cold water. The steam from the boiler is then passed through the mixture of the acid and the bran, which soon becomes hot and then boils, when a weak aqueous solution of furfurol passes over into the condensing apparatus and is collected in the usual way: the whole of the oil usually comes over in from 16 to 18 hours. This weak liquid is pretty strongly acid, and requires to be exactly neutralized with pounded chalk, and to be rectified till about the half of it has distilled over. It is important to avoid adding an excess of chalk, and rather to leave the liquid slightly acid, as an excess of chalk sets free the ammonia present in the solution, which, combining with the furfurol, oxidizes it, and thus greatly diminishes the amount which would otherwise be obtained. The first portion only of the liquid which distils over is preserved, as that which remains in the still contains scarcely any oil. The now somewhat stronger solution of the oil is then supersaturated with common salt and again cautiously rectified. The first portions of the liquid which come over yield a considerable amount of oil, and by repeatedly saturating the weaker solutions with salt and rectifying, the whole of the oil they contain may be pretty readily obtained. The 32 lbs. of bran yielded from 12 to 13 ozs. of furfurol. I have invariably found

that crude furfurool always contains a considerable quantity of acetone, a circumstance which appears to have escaped the notice of preceding experimenters.

In addition to the substances which had been previously employed for preparing furfurool, I may mention that I have obtained it from oil-cake, from cocoa-nut husk, and from the raspings of mahogany. The two first substances, from their cheapness and the large quantity of oil which they yield, are very well fitted for this purpose. The furfurool from mahogany, though smaller in quantity, is pretty free from resin, and is therefore more readily purified than that from bran or oil-cake.

Crude furfurool, from whatever source it is prepared, always contains a quantity of another essential oil, which has a much higher boiling-point and does not form a crystallizable amide. This second oil is exceedingly oxidizable, and every time it is distilled a considerable portion of it is changed into a brownish resin, which instantly strikes a deep red colour when mixed with a few drops of cold muriatic, nitric or sulphuric acids. In a previous paper I mentioned this reaction as characteristic of furfurool, and in this statement I have been followed by Dr. FOWNES. It is a mistake, however, as furfurool never yields this deep red colour with acids when it has been freed from this accompanying oil, which, as it appears to be invariably formed along with furfurool, I shall call meta-furfurool.

Furfurool may be pretty readily freed from this oil by being repeatedly rectified with water; the meta-furfurool, as it is much less volatile, remains chiefly in the retort, where it is rapidly oxidized. Two, or at most three rectifications, are therefore sufficient to render furfurool perfectly free from meta-furfurool. The absence of meta-furfurool may be easily ascertained by boiling an aqueous solution of furfurool with an excess of lime for a few minutes. The furfurool is immediately oxidized, and the solution acquires a deep yellow colour. If this solution is then treated with an excess of muriatic or sulphuric acids, not the slightest reddening is produced if the furfurool is free from meta-furfurool, but if even a trace of this latter oil is present, the characteristic deep red colour immediately appears. When pure furfurool is added to strong muriatic or sulphuric acid in the cold, it instantly changes to a brownish black colour, being rapidly oxidized, but not the slightest reddening is visible. Meta-furfurool is also much less soluble in water than furfurool. It also dissolves with difficulty in aqueous ammonia, with which it forms no crystallizable amide, but is rapidly changed into a brownish amorphous resin. When meta-furfurool is digested with strong nitric acid, it is changed into a nitrogenated crystallizable acid, which is either oxypicric acid, or a closely analogous compound. It yields chloropicrine when it is treated with either muriatic acid or hypochlorite of lime. Furfurool, on the contrary, when digested with nitric acid, is wholly converted into oxalic acid. Crude furfurool made from bran contains a good deal of meta-furfurool, but the crude furfurool from mahogany and other hard woods is comparatively free from meta-furfurool.

Furfurool stains the skin of a deep yellow colour, but if the part moistened with it is also touched with a few drops of aniline it becomes of a bright red colour. The

same effect is also produced when paper, white silk, linen or cotton cloth is similarly treated. The red colour begins to appear in the course of a few minutes and remains for some days, after which it changes to a brownish yellow. I regard this coloration as an effect of mutual oxidation, for I have failed in procuring any crystalline compound similar to furfuranide, either with aniline or with some others of the volatile alkaloids.

Double Chloride of Furfurine and Platinum.

Dr. FOWNES, who first prepared this salt, states that a solution of hydrochlorate of furfurine, when treated with a slight excess of bichloride of platinum, forms a nearly insoluble bright yellow precipitate. This is true only when the double salt is produced by mixing cold aqueous solutions. When however chloride of platinum is poured into a hot solution of muriate of furfurine in weak spirits, the same salt is slowly deposited on the cooling of the liquid in bright yellow needles, often an inch in length, and closely resembling carbazotate of potash in appearance.

I. 0.4265 grm. salt prepared in the way just described and dried *in vacuo*, gave 0.089 platinum = 20.86 per cent. platinum.

II. 0.326 grm. salt prepared in the way just described and dried *in vacuo*, gave 0.0670 platinum = 20.55 per cent. platinum.

The calculated quantity for the formula $C_{30}H_{12}N_2O_6 + HCl + PtCl$, is 20.82 platinum per cent. Dr. FOWNES found 20.45. There can be no doubt, therefore, notwithstanding the difference in their mode of preparation and crystalline state, that both salts are identical.

Nitrate of Furfurine.

Dr. FOWNES also analysed nitrate of furfurine crystallized from an aqueous solution. It then forms irregular long acicular crystals arranged in stars. From alcohol it is deposited in large very regular rhombic prisms, which possess great lustre, and may be readily obtained nearly an inch in length. If the spirituous solution out of which the salt has crystallized is very strong, its crystals, which are at first perfectly transparent, on being kept for some time in a dry atmosphere become quite opaque, but if they are crystallized out of dilute spirits they retain their transparency.

0.2905 grm. salt crystallized out of spirits and dried *in vacuo*, gave 0.580 carbonic acid and 0.109 water.

| | Found numbers. |
|---------|----------------|
| C 54.35 | 54.45 |
| H 3.93 | 4.16 |

The formula of this salt is $C_{30}H_{12}N_2O_6 + NO_5 + HO$.

It is plain therefore that the nitrate, whether it is crystallized out of water or weak spirits, does not vary in composition after it has been dried *in vacuo*.

Fucusol.

It has been satisfactorily ascertained by various experimenters that furfural is not produced by the action of acids on either the amylaceous or saccharine portions of the vegetables which yield it. Neither do the lignine, the gluten or the other nitrogenous principles of plants, at all contribute to its formation. The source of furfural requires to be referred therefore to some other very generally diffused proximate principle. Dr. FOWNES has thrown out the conjecture, that the substance which yields furfural is the *matière incrustante* of M. PAYEN, viz. the matter with which the interior of the cells of plants is lined. This is a hypothesis which I feel disposed to regard as exceedingly probable, though it must be confessed that the *matière incrustante* is not a simple proximate principle, but consists, according to M. PAYEN, of four kindred substances, no one of which the present state of our knowledge enables us with any great degree of certainty to prepare absolutely pure.

Now as it appeared very probable that the *matière incrustante* of the different great classes of plants would be found on examination to be analogous but not identical, I thought it likely that the oils derivable from them would also prove not identical with furfural, though probably very analogous to it in their nature and properties. The Algæ therefore, as possessing a structure which differs very widely from ordinary herbaceous plants, were selected in the first instance as a very good test of the truth of this hypothesis. A quantity of the commonest sea-weeds, consisting chiefly of *Fucus nodosus*, *F. vesiculosus*, *F. serratus*, &c., were cut into pieces and introduced along with a good deal of sulphuric acid diluted with two parts of water, into the apparatus described in a preceding part of this paper. Steam was then passed through the mixture during sixteen to eighteen hours, so long indeed as the liquid which distilled over appeared to contain any considerable amount of oil. The acid liquor which collected in the receiver was nearly neutralized with pounded chalk, and the oil separated from it exactly in the same way as with furfural.

The crude oil from Fuci, which I shall call fucusol, always contained a considerable amount of acetone, which required to be removed by washing it with water, carefully rectifying it at a low temperature, and rejecting the first portions of the oil which distilled over. I may mention in passing, that I have invariably found acetone to be a constant product, and that to a considerable extent, of the action of sulphuric acid upon vegetable substances. Crude fucusol also contains a quantity of meta-furfural, or at any rate of a very similar oil, from which it requires to be freed by being repeatedly rectified along with water, precisely in the same way as furfural. The sea-weeds yielded only about a fourth part of the oil which a similar quantity of bran would have done.

When dried by standing over fused chloride of calcium and then rectified, fucusol possesses the following properties. When newly distilled it is nearly colourless, but in a few days, especially if exposed to the light, it becomes brownish yellow, and in the course of a few weeks of a deep brown colour. If the fucusol is not quite free

from meta-furfurol it colours still more rapidly, and in the course of a few days becomes perfectly black; pure fucusol may however be kept in hermetically sealed vessels for any length of time without change. Its specific gravity at $13\frac{1}{2}^{\circ}\text{C}$. is 1.150. I found that of furfurol at the same temperature 1.1636. Dr. FOWNES makes it 1.1648 at 60°FAHR . When heated in a glass retort containing some thin slips of copper, fucusol boils regularly and uniformly between 171° and 172°C . As the boiling proceeds, the oil grows coloured, and a small portion of it is destroyed by every distillation, being converted into a dark-coloured resin which remains in the retort. I found the boiling-point of furfurol from bran to be 166°C ., while Messrs. FOWNES and CAHOURS found it only to be $162\frac{1}{2}^{\circ}\text{C}$. Neither of these gentlemen make any mention of the acetone which is always present in crude furfurol; I do not however affirm that the oil examined by these chemists contained acetone, though, judging from the lowness of its boiling-point, I think this by no means improbable.

Fucusol very closely resembles furfurol both in its taste and smell, though the odour of fucusol is much fainter and more agreeable. Fucusol requires 14 parts by weight of water at 13°C . to dissolve it, while furfurol dissolves in 11 parts of water at the same temperature. Furfurol dissolves in 9 times its weight of pretty concentrated liquor ammoniæ at $13\frac{1}{2}^{\circ}\text{C}$., while fucusol requires 12 times its weight of the same liquid for its solution. The difference therefore between the oils in regard to solubility is considerable. Fucusol also shows much less stability, and is therefore more readily decomposed than furfurol. With muriatic acid, fucusol strikes a pale green colour, which on standing becomes greenish black. Nitric acid gives it a pale yellow colour, sulphuric acid a greenish brown, which in time becomes bluish black. Solution of potash turns it first yellow, then pale red, and lastly dark red. Lime and soda produce similar results. If however the fucusol contains any meta-furfurol, it instantly strikes a bright red colour with either muriatic, nitric or sulphuric acids. Fucusol stains the skin of a deep yellow colour, which is tolerably persistent. If these yellow spots are moistened with aniline, they immediately become bright red, exhibiting the same reaction as furfurol. Pure fucusol when dried was analysed.

I. 0.2605 grm. oil gave 0.594 carbonic acid and 0.104 water.

II. 0.254 grm. oil gave 0.583 carbonic acid and 0.105 water.

III. 0.228 grm. oil gave 0.521 carbonic acid and 0.092 water.

| | Calculated numbers. | | Found numbers. | | |
|------|---------------------|--------|----------------|--------|--------|
| | | | I. | II. | III. |
| 15 C | 1125 | 62.50 | 62.19 | 62.59 | 62.32 |
| 6 H | 75 | 4.17 | 4.43 | 4.59 | 4.48 |
| 6 O | 600 | 33.33 | 33.38 | 32.82 | 33.20 |
| | <hr/> | <hr/> | <hr/> | <hr/> | <hr/> |
| | 1800 | 100.00 | 100.00 | 100.00 | 100.00 |

It is plain therefore, from the results of these analyses, that the formula of fucusol is $\text{C}_{15}\text{H}_6\text{O}_6$, and consequently that furfurol and fucusol are isomeric compounds.

Fucusamide.

When fucusol is intimately mixed with eight or nine times its bulk of pretty concentrated aqua ammoniæ, the oil and ammonia combine to form a slightly yellow crystalline mass. As fucusol is less soluble in liquor ammoniæ than furfurool, it requires a greater quantity of ammonia, and both liquids must be brought thoroughly into contact, otherwise the fucusol is apt to be acted on chiefly at the surface, while the interior of the mass contains a portion of nearly unaltered oil. The amide, which I shall call fucusamide, may be readily obtained in pretty long needles radiating from a centre by crystallizing it out of hot spirits of wine, in which it is very soluble. In appearance it closely resembles furfuramide, but is a much less stable compound.

I. 0.413 gm. amide dried *in vacuo*, gave 1.02 carbonic acid and 0.174 water.

II. 0.332 gm. amide dried *in vacuo*, gave 0.809 carbonic acid and 0.138 water.

III. 0.357 gm. amide dried *in vacuo*, gave 0.884 carbonic acid and 0.152 water.

0.402 gm. amide dried *in vacuo* by WILL's method, gave 0.655 double chloride of platinum and ammonia = 10.23 per cent. nitrogen.

| | Calculated numbers. | | I. | II. | III. |
|------|---------------------|--------|--------|--------|--------|
| 15 C | 1125 | 67.17 | 67.35 | 66.46 | 67.53 |
| 6 H | 75 | 4.47 | 4.67 | 4.61 | 4.72 |
| 3 O | 300 | 17.91 | 17.75 | 18.70 | 17.52 |
| 1 N | 175 | 10.45 | 10.23 | 10.23 | 10.23 |
| | <hr/> | <hr/> | <hr/> | <hr/> | <hr/> |
| | 1675 | 100.00 | 100.00 | 100.00 | 100.00 |

The formula of fucusamide is therefore $C_{15} H_6 O_3 N_1$, being identical with that of furfuramide.

Thiofucusol.

M. CAHOURS observed, that when furfuramide is dissolved in spirits of wine, and a current of sulphuretted hydrogen sent through the solution, a whitish granular precipitate falls, which consists of a compound in which the half of the oxygen in furfuramide is replaced by sulphur. On passing a current of sulphuretted hydrogen through a cold alcoholic solution of fucusamide, a corresponding compound was formed, which closely resembles thiofurfurool in appearance and properties.

0.477 gm. thiofucusol dried *in vacuo*, gave 0.929 carbonic acid and 0.170 water.

0.6045 gm. thiofucusol dried *in vacuo*, gave 1.26 sulphate of baryta = 28.65 sulphur.

| | Calculated numbers. | | Found numbers. |
|------|---------------------|--------|----------------|
| 10 C | 705 | 53.58 | 53.12 |
| 4 H | 50 | 3.58 | 3.95 |
| 2 S | 400 | 28.58 | 28.65 |
| 2 O | 200 | 14.26 | 14.28 |
| | <hr/> | <hr/> | <hr/> |
| | 1355 | 100.00 | 100.00 |

Pyrofucusol.

When thiofurfurol is destructively distilled it is decomposed with the formation of a curious substance called pyrofurfurol, which crystallizes in long needles and contains no sulphur. M. CAHOURS's formula for it is $C_{18} H_8 O_4$. Thiofucusol, when distilled, yields a similar compound, which I shall call pyrofucusol. It also crystallizes in long needles, and has probably the same composition as pyrofurfurol, though from the very small quantity at my disposal I was unable to ascertain this by analysis.

Fucusine.

When pure fucusamide, which should be nearly colourless, having only a slightly yellowish shade, is boiled for 20 minutes or half an hour with moderately strong soda or potash lye, no ammonia is evolved, and the amide is changed into a light brownish-coloured oil, which solidifies on the cooling of the liquid. It consists of a salifiable base, which I shall call fucusine, combined with a quantity of a brownish resin. This crude fucusine, when separated from the lye in which it has been boiled, is always soft, even at low temperatures, and does not exhibit the least approach to crystallization. At the temperature of $10^{\circ} C$. it is exceedingly tenacious, and may be easily drawn into threads, which resemble those of half-dried molasses. If we attempt to separate fucusine from adhering resin by boiling it with water and filtering, we find, on the cooling of the solution, that a yellowish amorphous resin is deposited on the sides and bottom of the vessel. This method therefore, by which furfurine is so readily purified and obtained in a crystalline state, does not at all succeed with fucusine. Though I made many attempts, I was equally unsuccessful in crystallizing crude fucusine either from alcoholic or etherial solutions. If the fucusamide which has been employed in the preparation of fucusine is so impure as to have a brownish colour, it is next to impossible to extract any pure fucusine from it. In this respect therefore fucusine differs very considerably from furfurine, which, even when very impure, solidifies on cooling to a hard crystalline mass; and if it is digested with a little animal charcoal and crystallized two or three times out of boiling water, it is deposited on the cooling of its solution in long slender colourless needles. Fucusine, on the other hand, so long as it is mixed with a little resinous matter, does not crystallize at all, and even when perfectly pure does not crystallize nearly so readily as the analogous base.

The way in which I succeeded in purifying fucusine, was by preparing some of its salts, which crystallize pretty readily, even from impure solutions. The salt best adapted for this purpose is the nitrate, and the mode of proceeding was the following. The crude fucusine was digested with a very slight excess of dilute nitric acid at a heat little higher than was necessary to melt it. The crude fucusine was constantly stirred with a spatula, so as to bring every portion of it into contact with the acid liquid. The mixture was then allowed to cool for a few minutes till the resinous matter had solidified, when the liquid portion was poured off into a second basin, where it soon deposited a quantity of hard shining crystals. By repeatedly digesting

the crude fucusine with the acid mother-liquors out of which the crystals of nitrate had been deposited, successive crops of crystals may be readily obtained. These are still further purified by being repeatedly crystallized out of hot water, and they may be easily obtained in large shining rhombic prisms when deposited from an alcoholic solution. By dissolving the colourless crystals of pure nitrate of fucusine in water, and slightly supersaturating the solution with ammonia, fucusine gradually subsides in white, short flattish prisms forming small stars.

When pure fucusine is dissolved in boiling water, the solution, so soon as it begins to cool, grows turbid, and in the course of a few hours the fucusine is deposited in short flattish prisms arranged in fan-shaped figures on the sides and bottom of the vessel. Its mode of crystallizing strongly contrasts with that of furfurine, which, so soon as its solution begins to cool, forms long slender needles which in a short time fill the whole of the liquid. Furfurine may be obtained from pure furfuramide with little more than a trace of adhering resin, but even from nearly colourless fucusamide I was seldom able to procure much more than two-thirds of fucusine, the remainder being changed into a dark-coloured tenacious resin.

The cold aqueous solution of fucusine is distinctly alkaline to test-paper, and its alcoholic solution, as might have been expected, is still more strongly so. Fucusine and furfurine are nearly equally soluble in boiling water, but fucusine dissolves in 2.400 parts by weight of water at 8° C., while furfurine requires 4.800, or exactly twice the quantity at the same temperature. This is one reason that while a hot aqueous solution of furfurine, on cooling, is filled with long slender crystals of that base, a much smaller portion of fucusine crystallizes out, as twice as much of it is retained in the cold solution. Fucusine is however considerably less soluble in dilute spirits, at ordinary temperatures, than furfurine.

I. 0.393 grm. fucusine dried *in vacuo*, gave 0.97 carbonic acid and 0.162 water.

II. 0.457 grm. fucusine dried *in vacuo*, gave by WILL'S process 0.75 ammonio-chloride of platinum = 10.30 nitrogen.

| Calculated numbers. | | Found numbers. | |
|---------------------|--------|----------------|--------|
| 30 C | 2250.0 | 67.17 | 67.30 |
| 12 H | 149.7 | 4.47 | 4.58 |
| 2 N | 350.4 | 10.45 | 10.30 |
| 6 O | 600.0 | 17.91 | 17.82 |
| | <hr/> | <hr/> | <hr/> |
| | 3350.0 | 100.00 | 100.00 |

It is plain from the result of this analysis, that fucusine and furfurine are also isomeric compounds.

Nitrate of Fucusine.

This is one of the salts of fucusine which crystallizes most readily. I have already detailed the mode of preparing and purifying it, and shall not therefore repeat it again. When crystallized out of a hot aqueous solution, it forms long prisms tapering towards their extremities, and united by their broad ends so as to form large stars. But when crystallized out of spirits of wine, it forms large rhombic prisms of great regularity of structure and adamantine lustre. When deposited from strong spirits of wine, these

crystals become opaque when dried, but when crystallized out of weak spirits, they retain their transparency. When dried under the air-pump and subjected to analysis, the salt was found to have the same formula as the corresponding salt of furfurine, viz. $C_{30} H_{12} N_2 O_6 + NO_5 + HO$.

0.488 grm. salt gave 0.972 carbonic acid and 0.1875 water.

| | Calculated numbers. | Found numbers. |
|---|---------------------|----------------|
| C | 54.30 | 54.32 |
| H | 3.99 | 4.26 |

When the nitrate of fucusine is heated in the water-bath to $100^\circ C.$, it soon becomes coloured and decomposes.

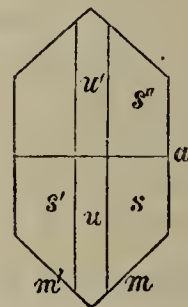
Through the kindness of Professor W. H. MILLER of Cambridge, which I have often formerly experienced, I am enabled to subjoin the annexed figures and measurements of the crystals of the nitrates of fucusine and furfurine.

Nitrate of Fucusine.

Prismatic:—The symbols of the simple forms are,— $a 100, u 011, m 110, s 111$.

The angles between normals to the faces are,—

| | | |
|---------|------------|------|
| uu' | 64° | $0'$ |
| ma | 47 | 51 |
| mm' | 84 | 18 |
| sa | 68 | 6 |
| su | 21 | 54 |
| ss' | 43 | 48 |
| ss'' | 60 | 42 |
| $s's''$ | 71 | 0 |



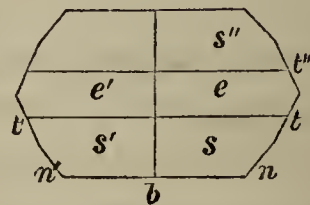
Cleavage:— a , very perfect; u, s , less perfect.

Nitrate of Furfurine.

Prismatic:—The symbols of the simple forms are,— $a 100, b 010, e 101, t 310, n 320, s 111$: a truncates the edge tt' .

The angles between normals to the faces are,—

| | | |
|---------|------------|-------|
| ea | 70° | $40'$ |
| ee' | 38 | 40 |
| nb | 47 | 50 |
| tb | 65 | 40 |
| ab | 90 | 0 |
| nn' | 84 | 20 |
| tt' | 48 | 40 |
| sa | 72 | 8 |
| ss' | 35 | 44 |
| sb | 67 | 39 |
| ss'' | 44 | 42 |
| $s's''$ | 58 | 44 |



Cleavage:— b , very perfect; a, t , less perfect.

Muriate of Fucusine.

Muriate of fucusine is an extremely soluble salt, which crystallizes, when very concentrated, in short slender needles arranged in stars.

The Double Platinum Salt.

When bichloride of platinum is added to a cold aqueous solution of hydrochlorate of fucusine, a crystalline yellow precipitate immediately subsides. But if the solutions of the two salts are hot, and especially if some spirits of wine are added to the mixture, the double platinum salt is slowly deposited in large broad four-sided prisms. These prisms are very thin, having two broad sides and two very narrow ones. They are usually united together at the one extremity, while the other is square and regular. The double hydrochlorate of fucusine and platinum does not at all resemble in appearance the corresponding salt of furfurine, which, as formerly stated when crystallized out of weak spirits, forms long needle-shaped crystals like those of carbazotate of potash.

0.3733 grm. salt dried *in vacuo*, gave 0.518 carbonic acid and 0.109 HO.

0.6595 grm. salt dried *in vacuo*, gave 0.650 chloride of platinum and ammonia = 0.4085 nitrogen.

0.640 grm. salt dried *in vacuo*, gave 0.580 chloride of silver = 0.1434 CL.

I. 0.416 grm. salt gave 0.086 platinum = 20.67 per cent.

II. 0.5025 grm. salt gave 0.1035 platinum = 20.58 per cent.

III. 0.409 grm. salt gave 0.840 platinum = 20.53 per cent.

| | Calculated numbers. | | Found numbers. | |
|------|---------------------|--------|----------------|--|
| 30 C | 2250.0 | 37.97 | 37.84 | |
| 13 H | 162.5 | 2.74 | 3.21 | |
| 6 O | 600.0 | 10.12 | 9.70 | |
| 2 N | 350.0 | 5.90 | 6.18 | |
| 3 Cl | 1329.0 | 22.45 | 22.40 | |
| Pt | 1233.5 | 20.82 | 20.67 | |
| | <hr/> | <hr/> | <hr/> | |
| | 5925.0 | 100.00 | 100.00 | |

The formula of the double platinum salt therefore is $C_{30}H_{12}N_2O_6 + HCl + PtCl_2$.

The Acid Oxalate of Fucusine.

This salt may be pretty readily prepared from crude fucusine by digesting it with an excess of oxalic acid. The hot filtered solution deposits, on cooling, the acid oxalate in long needle-shaped crystals arranged in stars. These crystals are usually coloured at first, but by repeated digestions with animal charcoal they are rendered colourless, when they have a silky lustre. They are not very soluble in cold water, but readily dissolve in boiling water and in hot spirits. Their solution is distinctly acid to test-paper.

0.3155 grm. salt dried *in vacuo*, gave 0.664 carbonic acid and 0.120 water.

0.336 grm. salt dried *in vacuo*, gave 0.419 double chloride of Pt and ammonia.

| Calculated numbers. | | Found numbers. |
|---------------------|--------------|----------------|
| C | 34 57.01 | 57.08 |
| H | 14 4.06 | 4.22 |
| N | 2 7.74 | 7.82 |
| O | 14 31.19 | 30.88 |
| | <hr/> 100.00 | <hr/> 100.00 |

The formula of this salt therefore is $C_{30}H_{12}N_2O_6 + 2C_2O_3 + 2HO$. It is the binoxalate of fucusine with two equivalents of water. The neutral oxalate is much more soluble than the acid salt, but the crystalline form of both salts is the same.

The perfect isomerism which subsists between furfurool and fucusol, extending as it does to the products of their decomposition, is certainly not a little astonishing, and may perhaps induce some chemists still to regard them as identical substances. I was, in fact, for a long time inclined to the same opinion, and it was only after a careful comparative examination of both oils, and especially of their respective bases, that I was led to conclude that they are only very analogous, but not identical compounds.

Oil from Moss.

A quantity of common Sphagnum was digested in a distilling apparatus with dilute sulphuric acid, exactly in the way already so fully described. It yielded a considerable quantity of an oil, which, so far as I could judge, is identical with fucusol. It formed amide with ammonia, which, when it was boiled with an alkaline lye, yielded a similar difficultly crystallizable base, whose double platinum salt crystallized in the same thin flat prisms as those of fucusine.

Oil from Lichens.

A quantity of *Lichen Islandicum*, along with several species of *Usnea*, *Ramalinia fraxinea*, &c., were also digested with sulphuric acid. They yielded an oil which appeared to be identical with fucusol, judging from its characters and those of its amide, base and platinum salt.

Oil from Ferns.

The common fern, *Pteris aquilina*, when digested with sulphuric acid, also yielded an oil which formed an amide and a base, crystallizing readily in long slender needles, closely resembling those of furfurine. I felt at first much inclined to regard this oil as identical with furfurool, but as the double platinum salt of its base does not crystallize in the same form as the corresponding salt of furfurine, but in broad flat prisms, I strongly suspect that it is different from both fucusol and furfurool.

The results of the preceding investigation, imperfect as they confessedly are, seem to me to indicate some curious botanical relations; for it appears highly probable that the *matière incrustante*, or some such principle, is the same in all phanerogamous

plants, as it yields an identical product of decomposition, viz. furfurool when it is digested with sulphuric or muriatic acids.

The *matière incrustante* in Fuci, on the other hand, though analogous, appears to be not identical with the corresponding principle in phanerogamous plants, as it yields fucusol instead of furfurool; and this seems also to be the case with the *matière incrustante* of mosses and lichens, both of which families approximate much more closely in their botanical structure to the Algæ than to ordinary phanerogamous plants. As might almost have been expected, therefore, both mosses and lichens appear to yield fucusol, or at any rate an exceedingly similar oil, which is certainly not furfurool. Ferns, on the contrary, whose woody structure differs from that of either mosses, algæ, or lichens, and approaches pretty closely to that of ordinary phanerogamous plants, appear to yield an oil with properties intermediate between those of furfurool and fucusol.

NOTE received September 4, 1850, from Professor MILLER of Cambridge.

I consider it very probable that the crystals of nitrate of fucusine do not belong to the prismatic system, but are twin crystals of the oblique system. The faces of the form *s* are however too imperfect to settle this point.

The angles between normals to the faces are,—

$$\begin{array}{l} ma \quad 47^{\circ} 52' \\ mm' \quad 84 \quad 16 \end{array}$$

I have re-examined the crystals with all possible care, but cannot pretend to correct the angles which the faces of the forms *s*, *u* make with each other, and with the faces of the forms *a*, *m*.

Corrected angles between the normals to the faces of nitrate of furfurine (*not* from solution in alcohol) are,—

$$\begin{array}{l} ea \quad 71^{\circ} 5' \\ ee' \quad 37 \quad 50 \\ nb \quad 47 \quad 54 \\ tb \quad 65 \quad 41 \\ ab \quad 90 \quad 0 \\ nn' \quad 84 \quad 12 \\ tt' \quad 48 \quad 18 \\ sa \quad 72 \quad 44 \\ ss' \quad 34 \quad 32 \\ sb \quad 66 \quad 16 \\ ss'' \quad 47 \quad 28 \\ s's'' \quad 60 \quad 0 \end{array}$$

The values of the angles between the faces of the form *s* are very uncertain.

Opake Crystals of Nitrate of Furfurine.

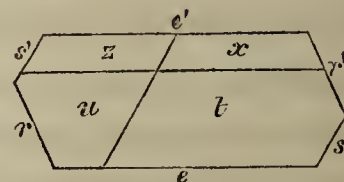
Crystals obtained from a solution in alcohol, which effloresced readily, and became in consequence opake.

These crystals belong to the anorthic system.

The symbols of the simple forms are,— $s\ 100$, $r\ 010$, $x\ 001$, $u\ 011$, $z\ 101$, $e\ 110$, $t\ 111$.

The angles between normals to the faces are,—

| | |
|-------|-------------------|
| se | $58^{\circ}\ 50'$ |
| re | $65\ 50$ |
| sr' | $55\ 20$ |
| xs | $76\ 50$ |
| zv | $57\ 17$ |
| zs' | $45\ 53$ |
| te | $47\ 58$ |
| xt | $51\ 14$ |
| xe' | $80\ 48$ |
| ur | $52\ 49$ |
| ux | $60\ 21$ |
| xr' | $66\ 50$ |
| us' | $69\ 57$ |
| tu | $55\ 31$ |
| st | $54\ 32$ |
| ze' | $54\ 43$ |
| uz | $49\ 40$ |
| eu | $75\ 37$ |



XXIV. *On the Développement and Homologies of the Molar Teeth of the Wart-Hogs (Phacochærus), with Illustrations of a System of Notation for the Teeth in the Class MAMMALIA.* By Professor OWEN, F.R.S. &c.

Received November 12, 1849,—Read February 7, 1850.

IN a paper by EVERARD HOME, Esq., read before the Royal Society, May 30, 1799, some observations were communicated upon the form, structure and succession of the teeth of the Wart-Hogs of Africa, now included in the genus of the Hog-family called *Phacochærus*, but noticed in that paper as a single species under the name of *Sus Æthiopicus*. The observations are illustrated by two plates. The first (tab. xviii.) gives “a side view of the skull of the *Sus Æthiopicus* (half the natural size), to show the situation and appearance of the large grinder, and the remains of the alveoli belonging to the fangs of the preceding one*.” The second (tab. xix.) gives a “side view of the skull of the young *Sus Æthiopicus*, to show the mode in which the grinders come forward as the large one increases in size†.” This plate includes also a side view and a transverse section of the crown of the large full-grown grinding tooth.

The conclusions drawn from the facts given are, that the *Sus Æthiopicus* resembles the Elephant “in the whole number of grinding teeth belonging to each side of the jaw being confined in a case of bone, so as to form one large grinding surface, and the teeth being pushed forward from behind, instead of a second set being formed immediately under the fangs of the first, as in other animals; which are peculiarities not met with in any teeth hitherto described, except those of the Elephant‡.” The grinding teeth of the *Sus Æthiopicus* are described to be “four in number on each side of the jaw”§; . . . the fourth or last large tooth is considered to be a second set of teeth, which, as it advances forwards, pushes the other teeth before it; . . . “the most anterior of these, as soon as its body is worn away, has its fangs removed by absorption and drops out: the same thing takes place with the second and third; and, in this way, room is made for the large one to supply the place of all the others||.” The mode in which they succeed one another is stated to be illustrated by the side view of the jaw given in tab. xix., in which the fangs of the different teeth are exposed.

I have shown in my ‘Odontography’ ¶, that the facts detailed in HOME’s paper were insufficient to enable him to explain all the necessary circumstances respecting the curious mode of dentition of the Wart-Hogs; that other stages of dentition, unknown to that author, had demonstrated a second set of teeth formed under the fangs of some

* Philosophical Transactions, 1799, p. 256.

§ Ibid. p. 250.

† Ibid. p. 257.

|| Ibid. p. 250.

‡ Ibid. p. 247.

¶ Vol. i. p. 554.

of the first set, or above them in the upper jaw; and also that the subsequent shedding of the teeth in advance of the last large grinder was not in the order in which they are pushed out in the Elephant, the Wart-Hogs deviating very remarkably from that and all other quadrupeds in this respect.

In the course of subsequent researches and comparisons, I have determined the original specimens in the British Museum and that of the Royal College of Surgeons, which were drawn and engraved to illustrate HOME's paper, by which I have ascertained that the drawings were taken from two distinct species of *Phacochærus*; and I have been able to detect certain inaccuracies in the reduced figures in the engravings, which give countenance, not afforded by the specimens themselves, to the ideas of the mode of succession of the teeth described in HOME's paper. I propose, therefore, to give a more precise description of the subjects of the beautiful engravings, tab. xviii. and xix. of the Philosophical Transactions for 1799, and to add the additional facts and illustrations of the peculiarities of the dentition characteristic of the two species of Wart-Hog, and which determine the true number, kinds and succession of the grinding-teeth in both species.

Tab. xvii. (Philosophical Transactions, 1799) gives a view of the skull of an old *Phacochærus Æliani*, VAN DER HOEVEN, the common species of Nubia, Abyssinia, Senegal and Cordofan, and sometimes called the North African Wart-Hog. It is well characterized by having, when fully grown, six functional incisors in the under jaw and two incisors (*i.* 1.) in the upper jaw, together with forms and proportions of the other teeth, which will be subsequently adverted to. The characteristic incisors are sufficiently indicated in the figure; the large posterior grinders are alone retained in the molar series of both jaws.

Tab. xix. fig. 1 (Philosophical Transactions, 1799) gives a view of the cranium of a younger individual of the *Phac. Pallasii*, VAN DER HOEVEN, the Wart-Hog most common, though not peculiar to the Cape and the Guinea coast districts. The molar teeth which are exposed in this figure are, taking them from before backwards, the last premolar, the symbol of which is *p* 4; the first true molar, *m* 1; the second true molar, *m* 2; and the last true molar, *m* 3.

The teeth are drawn somewhat reduced in size, but not in a just proportion to the reduction of the size of the cranium and of the upper tusks; nor are the relative lengths of the crown and fangs correctly given. The crown of the first true molar, *e. g.*, is represented of the same length as that of the fourth premolar which precedes it, and nearly of the same length as that of the second true molar, whereas in the original specimen it is much shorter in consequence of having been longer in use. Had the differences which these teeth actually show in the extent of the abrasion of their respective crowns been appreciated and duly considered, it might have excited the suspicion that the second tooth, with an almost exhausted crown and much-absorbed fangs, would be shed before the first tooth, the summit of whose long, obtuse and cement-covered crown had only recently been subject to the wear of mastication.

The grinder, which is the subject of figs. 2 and 3, tab. xix., is the last molar from the right side, lower jaw, of the *Phac. Æliani*, of the natural size.

To determine whether any successional teeth were developed above or beneath the fangs of pre-existing teeth destined to be displaced by such development, in other words, whether a true deciduous series and a premolar series of teeth existed in the Wart-Hogs, required an examination of the jaws of an individual younger than the youngest specimen examined and figured by HOME.

The subject of Plate XXXIII. fig. 1 of the present communication is of the required immaturity, and, with the other specimens to be described, supplies those links in the series which were wanting for the explanation of the entire course of the truly remarkable dentition of the genus *Phacochoerus*.

Fig. 1 shows a side view of the teeth in the young *Phac. Æliani*; the grinding surface of the molar teeth in use is given, from the upper jaw in fig. 2, and from the under jaw in fig. 3. These teeth include all the milk-molars which are developed, together with the first permanent true molar. The milk-molars are 3—3 in number in the upper jaw, and 2—2 in the lower jaw. The first true molar, *m* 1, is also fully developed and in use in both jaws. The summit of the second true molar (*m* 2) is just appearing above the socket.

The length of the skull exhibiting this instructive phase of dentition is 10 inches.

The milk-molars answer to the teeth of the typical dentition symbolized by *d* 2, *d* 3, and *d* 4 in the upper jaw, and to *d* 3 and *d* 4 in the lower jaw.

The first is implanted by two fangs, the second by three, the third by four fangs; the shape of these teeth is sufficiently illustrated by the figures.

Their rate of increase in size from the first to the last is considerable, yet not equal to that manifested in the true molars. Upon examining the substance of the jaws above the deciduous molars of the upper jaw and beneath those of the lower jaw, two formative alveoli and the trace of a third were detected in the upper jaw, one above *d* 4, containing the crown of a premolar; the other above *d* 3, and the rudimental cell above *d* 2. The matrix, which the latter might have contained, had not begun to be calcified. A small formative socket was found beneath the last milk-molar of the lower jaw containing the crown of a premolar. The gubernacular canal from this socket opened between the fangs on the inner side of the milk-tooth. A second still smaller socket of an anterior premolar was beneath the interspace between the two milk-molars.

The true nature of the molar behind the milk-teeth in both jaws was plainly shown by its long fangs extending beyond the parallel of the formative sockets of the successors of the milk-teeth, and widely open at their ends: this tooth has no vertical successor and is the first true molar, *m* 1. Only the crown of the second true molar (*m* 2) is formed at the stage here described; and a few detached columns of the still larger and more complex third molar (*m* 3) were all that were calcified in its commencing formative alveolus.

In none of the other members of the Hog family is the first true molar ($m 1$) so much worn down at the corresponding early stage of development of the second true molar, and it is upon this precocious growth of the first true molar that the chief peculiarity of the order of shedding of the teeth of the *Phacochæri* depends.

In the *Phac. Æliani*, the penultimate and last milk-teeth ($d 3$, $d 4$) in the upper jaw are displaced and succeeded by corresponding premolars, which therefore answer to $p 3$ and $p 4$ of the typical series. The anterior small milk-grinder, $d 2$, is sometimes succeeded by a minute premolar, but occasionally this is abortive, or absorbed before it cuts the gum. In the lower jaw both milk-molars ($d 3$ and $d 4$) are succeeded by the corresponding premolars $p 3$, $p 4$, at least in the *Phac. Æliani*.

The stage of dentition of the *Phac. Æliani*, given in figs. 1, 2 and 3, corresponds with that in the common Hog, illustrated by the teeth in the lower jaw in Plate XX. fig. 1 of the Philosophical Transactions for 1801. In that figure the last grinder in place is the first true molar, $m 1$; the penultimate is the last milk-molar, $d 4$; the next is $d 3$, the next $d 2$; and a little in advance of this, between it and the rudimental canine, is the small anterior premolar, $p 1$. The germs of the other premolars, $p 2$, $p 3$ and $p 4$, are shown in their formative sockets beneath the deciduous teeth they are destined to replace.

If the symbols above given be marked upon the teeth in the figure cited, the homologies of those in the reduced dentition of the young Wart-Hog will be readily appreciated. The teeth developed in the lower jaw of that species are,— $d 3$, $d 4$, $p 3$, $p 4$ and $m 1$: in both jaws $m 2$ has only its crown developed, and $m 3$ only the commencement of its crown. The teeth which are suppressed in the *Phac. Æliani* are, in the lower jaw, $d 1$, $d 2$, $p 1$ and $p 2$. In the upper jaw $d 1$ and $p 1$ are suppressed, and sometimes also $p 2$.

The next stage of dentition (Plate XXXIV. figs. 4 and 5) shows the shedding of the deciduous molars to be concomitant with the coming into place of the second true molar, $m 2$; it is well illustrated in the cranium of a young *Phac. Æliani* from Senegal in the Museum of Comparative Anatomy in the Garden of Plants: in which each of the three deciduous molars of the upper jaw have been succeeded by a premolar ($p 2$, $p 3$, $p 4$, fig. 4), and the same with regard to the two deciduous molars in the lower jaw ($p 3$, $p 4$, fig. 5). The anterior angle of the crown of the last huge molar has also begun to protrude from the formative alveolus, so that the permanent or second molar series now shows $\frac{6-6}{5-5} = 22$, which is the greatest number of grinders presented at any given time in the genus *Phacochærus*. The first true molar, $m 1$, is however worn to near the fangs, and its grinding surface, as compared with that in Plate XXXIII. fig. 2, begins to be simplified. The homologies of the teeth at this period are indicated by the symbols attached to them in the figures.

The stage of dentition of the young *Phac. Pallasii*, figured by HOME in tab. xix. of his memoir, is a little more advanced than that of the *Phac. Pallasii* above de-

scribed; but although scarcely half the grinding surface of the last molar, $m\ 3$, has come into use, all the premolars in advance of the last, $p\ 4$, have been shed, Plate XXXIV. fig. 8.

In the specimen of *Phac. Æliani*, of which the grinding surface of the teeth is figured in Plate XXXIV. figs. 6 and 7 of the present memoir, although the major part of the last large grinder is in use, the penultimate premolar ($p\ 3$) is retained as well as the last ($p\ 4$). The molar series here shows 5—5 in the upper jaw and 4—4 in the lower jaw; their homologies are indicated by the symbols attached. By reason of the precocious development of $m\ 1$, we now find it quite worn down to the fangs; and in the lower jaw (fig. 7) it is wedged between $p\ 4$ and $m\ 2$ into a space which is two-thirds less than the antero-posterior extent of the crown of the same tooth shown in the younger specimen (Plate XXXIII. fig. 2). The reduction of size of $m\ 1$ is however quite intelligible by observing the much-constricted neck from which the long fangs are continued in that specimen (see $m\ 1$, fig. 1).

The figures of the grinding surface (figs. 6 and 7) suffice for the characteristic forms of the grinding-teeth now in use.

The specimen of *Phac. Æliani* (No. 773. Mus. Coll. Chir.) shows the last remnant of $m\ 1$ wedged into the diminished interspace between $p\ 4$ and $m\ 2$, and the corresponding interspace in the lower jaw, from which such remnant of the first true molar has been shed.

The skull of an older *Phac. Æliani* (No. 772) shows the displacement of the first true molar in both jaws and the reduction of the molar series to $\frac{4-4}{3-3}$; the teeth being $p\ 3$, $p\ 4$, $m\ 2$ and $m\ 3$ above (fig. 9), $p\ 4$, $m\ 2$ and $m\ 3$ below (fig. 10). There is no vacuity now in the series to show a true molar to have been shed, as it has been in so unusual an order.

The next stage of dentition which I have observed in this species is the loss of the anterior premolar $p\ 3$, and the great wearing down of $m\ 2$ (fig. 11), and in one instance in the lower jaw $m\ 2$ was shed before $p\ 3$.

The skull of a male *Phacochærus* in the British Museum*, from the Cape de Verd, measuring 16 inches 6 lines in length, with the incisors of the *Phac. Æliani*, viz. $\frac{1-1}{3-3}$, and the same broad and shallow posterior channel upon the canines $\frac{1-1}{1-1}$, shows the same numerical molar formula as No. 772, but the teeth are different in the upper jaw, they are $p\ 3$, $p\ 4$, $m\ 2$ and $m\ 3$; in the lower jaw they are $p\ 3$, $p\ 4$ and $m\ 3$; both first and second true molars being shed in this jaw, whilst the last two premolars are retained.

In the skull of a female *Phacochærus*, $13\frac{1}{2}$ inches in length, from South Africa, in the British Museum, but with the incisive formula of the *Phac. Æliani*, the molar

* The term *Phacochærus Æthiopicus* is retained for the species represented by this skull in the British Museum.

series is $p \frac{1}{1}$, $m \frac{2-2}{2-2}$; the teeth in both jaws being $p 4$, $m 2$ and $m 3$: here the penultimate premolar has been shed before the penultimate true molar, the socket of which however alone indicates it in the lower jaw.

In a still older specimen, $p 3$ and $m 2$ have been shed in both jaws, and the dental series is reduced to $\frac{2-2}{2-2}$; the teeth being $p 4$, $m 3$ on each side of both jaws (fig. 12).

Finally, $p 4$ is shed, and only the great posterior molar remains, as in the old *Phac. Æliani* figured in tab. xviii. of HOME's memoir.

It is interesting and suggestive thus to observe that an analogous duration or longevity, so to speak, characterizes the last tooth of both premolar and true molar series; an analogy so little to be expected from their different size and widely different original position in the jaws, by which characters, HOME, not sufficiently extending his observations and trusting to the analogy of the Elephant, was misled.

With respect to the *Phac. Pallasii*, my opportunities of tracing the course of dentition are not so extensive as with regard to the *Phac. Æliani*. I have observed none younger than the specimen figured by HOME (tab. xix.), and am not acquainted, therefore, with the characters of its deciduous dentition.

All the four teeth on each side of the upper jaw of that specimen, and there are the same number in the lower jaw, belong to the permanent series; tracing them from before backwards they are $p 4$, $m 1$, $m 2$ and $m 3$ in both jaws. The homologue of $p 3$ in the upper jaw of *Phac. Æliani*, if it be developed, is sooner shed in the *Phac. Pallasii* than in the *Phac. Æliani*. From the defects that have been pointed out in HOME's reduced figures of these teeth, more accurate views of them of the natural size may be acceptable, especially as they have not been elsewhere represented. I subjoin, therefore (Plate XXXIV. fig. 8), a side view and a view of the grinding surface of each. These figures, also, preclude the necessity of verbal description. I will only state that $p 4$, in the upper jaw, is implanted by three fangs, and is relatively smaller than its homologue in *Phac. Æliani*: $p 4$ in the lower jaw offers corresponding differences with its homologue in *Phac. Æliani*; $m 2$ has a narrower crown in relation to its antero-posterior extent than in *Phac. Æliani*; and a similar and more compressed form distinguishes the third molars in both jaws of the *Phac. Pallasii*. In the skull of a female Phacochoerus, called 'Haruja,' from Caffraria, in the British Museum, which differs from the typical *Phac. Æliani* of North Africa in having only two incisors in each ramus of the lower jaw, the following is the dental formula:—

$$i \frac{1-1}{2-2}, c \frac{1-1}{1-1}, p \frac{2-2}{1-1}, m \frac{2-2}{2-2}:$$

the grinders of the upper jaw are $p 3$, $p 4$, $m 2$ and $m 3$: those of the lower jaw are $p 4$, $m 2$ and $m 3$. The first true molar has been shed, and its place obliterated in both jaws.

There is a stuffed skin of this species which shows the same number of incisors, viz. $\frac{1-1}{2-2}$.

I have seen no stage of dentition of the *Phac. Pallasii* corresponding with figs. 6 and 7 of *Phac. Æliani*. The next example, after the stage figured by HOME, is shown in a skull from the Guinea Coast, in which the grinding series includes 3—3 in both jaws, like that in the upper jaw of the *Phac. Pallasii* and lower jaw of the *Phac. Æliani*, figured in 'Les Dents des Mammifères' of M. F. CUVIER, Tab. 87. These teeth, in each case, are *p* 4, *m* 2 and *m* 3 on each side of both jaws. In the specimen before me, *p* 4 is much worn, and is pressed into close contact with *m* 2. The anterior half of the grinding surface of this tooth is worn down to the common dental base, and both the anterior and posterior surfaces of the crown are excavated by the pressure of the two contiguous teeth, as in fig. 10. That a large grinder, like *m* 1, figs. 4, 5 and 6, should have been interposed between the first and second grinders in the specimen here described, could never have been suspected without a knowledge of those earlier stages of the dentition of the genus which have been described.

BARON CUVIER describes the molar teeth of the Phacochere as being three on each side of both jaws in the 4th edition of the 'Ossemens Fossiles' (1822)*, and the same numerical formula is retained in the posthumous 8vo edition of 1834†. With regard to the mode of succession of these teeth, the Baron adopts the conclusions of SIR EVERARD HOME; and in both editions of the 'Règne Animal,' after noticing the similarity of composition of these teeth with the grinders of the Elephant, he adds that they, in like manner, succeed one another from behind forwards‡.

His brother, M. FR. CUVIER, adopting the same view in the 'Dents de Mammifères,' describes the dentition of the Wart-Hogs as differing altogether from that of the rest of the Hog-tribe. "Nous voici arrivés," he writes, "à un système de dentition tout à fait différent de celui des sangliers" (p. 213): he adopts the specimens represented in the pl. 87 above cited, and describes the figures of that plate as exemplifying the normal adult dentition of the genus§. The anterior of the three grinders is described as the 'première mâchelière' (p. 214); and the second as 'la seconde mâchelière,' the latter being said to be composed of four tubercles, which by usage present four little elliptical or circular figures surrounded by enamel. And this, indeed, is the case at the extreme stage of attrition which he has figured; but, at an earlier period of usage, the crown of the tooth presents ten of those enamel-girted circular or elliptical islands of dentine, surrounding two, three, or four median ones (figs. 4, 5, 6, *m* 2). The last large molar presents twenty-five of these islands in the upper jaw in three linear series, nine being central, and twenty-six in the lower jaw, nine

* Tom. ii. p. 123.

† Tom. iii. p. 235.

‡ Tom. i. p. 244.

§ In this he is followed by LESSON (Manuel de Mammalogie, p. 340), FISCHER (Synopsis Mammalium, p. 423) and other systematic mammalogists, who assign molars $\frac{3-3}{3-3}$ as one of the characters of the genus *Phacocharus*.

also being central, and the islands smaller and more regularly disposed. This tooth extends to within one or two lines of the thin compact inferior bony wall of the deep ramus of the jaw, where the constituent columns terminate in the basal openings of as many pulp-cavities, with the exception of the first four, which are blended together, and from which no root has begun to be developed. It is therefore plain that this large and singularly complex grinder will continue to serve the purposes of mastication long after the shedding of the molar in advance, and the substance of which is already wasting away by the pressure of the larger tooth. We shall see, in the next specimen, that that molar is actually worn away and shed, whilst the smaller grinder in advance of it remains.

In the lower jaw of the specimen (No. 775 A.), the gum has grown over the sockets of the second true molar between the persistent remnant of the fourth premolar and the third true molar. In the upper jaw the last remnant of the second true molar remains on the right side, the crown having been worn to its base and the fangs absorbed.

Thus, in the *Phac. Pallasii*, as in the *Phac. Æliani*, the last of the premolar series, like the last of the true molar series, is distinguished by its longevity, although inferior in this respect to the large true grinder which continues to do the work of mastication to the end of the animal's existence.

The analogy of the Phacochæres to the Elephants in the superior size, complexity, and duration of the last grinders is close and interesting; but it does not extend to the horizontal mode of succession, in other words to the absence of premolars or vertical successors of deciduous teeth, as HOME led CUVIER to believe. In the development and succession of these premolars, and in the shape, proportions and position of the true deciduous teeth, the Wart-Hogs much more closely and essentially agree with the rest of the *Suidæ*. They differ, however, as we have seen, in the inferior number of both milk-molars and premolars which are developed, and in the speedier loss of all the true molars in advance of the last large one; but, in the order of shedding of those teeth, more especially in the very early displacement of the first true molar, and the total obliteration of its place in the series by the approximation of the last premolar to the second true molar, and in the subsequent displacement of this tooth with the approximation of the last premolar to the last true molar, the genus *Phacochærus* is quite peculiar and different from all other Mammalia.

The author, who first called the attention of naturalists to the peculiarities of the dentition of the *Phacochæri*, has indicated another difference between the Wart-Hog and the common Hog, by affirming that the latter has a molar tooth developed behind the third true molar, at least in the lower jaw; which, if it were so, would have shown the common Hog to differ, also, from almost every other placental mammal with two sets of teeth*. In the description of Plate XX. of the Philoso-

* The *Megalotis Lalandii* is the only example, as far as I have observed, of the constant occurrence of *four* true molars on each side the lower jaw: the typical number *three* being retained above.

phical Transactions for 1801, HOME states that "fig. 3 represents the jaw in a still more advanced stage of its growth, with the tooth which was only forming in the second figure now come to its full size, and in its proper place in the row of teeth: there is also a new cell formed for a succeeding tooth*." The original specimen from which the figure is taken is preserved in the Hunterian Collection, and it shows that the supposed formative cell is one of a series of the medullary cells of the cancellous structure of this part of the jaw; it is itself subdivided into smaller cells, and is not a simple cavity like the true cell of a forming tooth. It is also represented of twice its natural size in the figure cited, not having been reduced in proportion to the other parts of the jaw.

The latest author on the subject of the dentition of the *Phacochæri*, has ascribed to that part of their structure a character which would have added a still more remarkable anomaly to it, viz. that the last true molar represents both that tooth and the penultimate one in the Wild Boar and other herbivorous mammals †.

To this conclusion M. DE BLAINVILLE was necessarily led by his determination of the antecedent teeth. Thus in a *Phacochærus* with the dentition answering to that represented in figs. 4 and 5 of the present memoir, he regards the teeth marked *p* 3, *p* 4 and *m* 1 as belonging to the deciduous series, 'dents de lait ‡,' and the rest as belonging to the second dentition; *p* 2 being described as a small, speedily lost, false molar, *m* 2 as the first or antepenultimate true molar, and *m* 3 as the penultimate and last true molars, "already blended together, although not yet protruded from their formative alveolus §."

With regard to the five teeth in the lower jaw, the first, *p* 3, is described as the first tooth of the second dentition; the two following, *p* 4 and *m* 1, as milk teeth; the fourth, *m* 2, as the antepenultimate molar of the second dentition, and the last, *m* 3, as the penultimate and last molar coalesced. The dentition ascribed to the adult *Phacochærus* is that phase which is illustrated in figs. 9 and 10, Plate XXXIV. of the present memoir, of which the numerical formula is $\frac{4-4}{3-3} = 14$. M. DE BLAINVILLE, struck by the resemblance in the degree of attrition which the molar, *m* 2, presents to the antepenultimate molar, *m* 1, in the adult common Hog, deems them homologous, and deduces from that resemblance another argument for the homology of the last great molar of the Phacochere with the penultimate and last molars combined of the Hog ||.

* Philosophical Transactions, 1801, p. 331.

† Ostéographie des Ongulogrades, *Hippopotamus* and *Sus*, 4to, 1847. ‡ Ibid. p. 148. § Ibid. p. 148.

|| "Mais quelle est la signification de cette dent par rapport à ce qui existe chez la sanglier? C'est la une question qui, malgré son intérêt, n'a pas même encore été soulevée.

"J'ai cru un moment qu'on pourrait la considérer comme représentant les trois arrière-molaires qui se seraient soudées de manière à n'en former qu'une, les trois molaires qui la précèdent étant alors celles de remplacement. Cette façon de voir était surtout appuyée sur la composition de cette dent à la mandibule où l'on peut voir dans les cannelures latérales des séparations plus marquées, paraissant indiquer l'antépénultième, la pénultième et la dernière avec son talon.

"Mais en réfléchissant sur le caractère sérial des espèces de ce genre, il m'a semblé que cette opinion devait

But had the preceding stage of dentition, which is represented in fig. 7, Plate XXXIV., presented itself to the observation of M. DE BLAINVILLE, that acute observer would doubtless have seen that $m 1$,—the true homologue of the much-worn antepenultimate molar of the common Hog,—presented the same abraded condition. And the actual difference is as follows, viz. that, owing to its earlier development in the *Phacochærus*, the true antepenultimate molar, $m 1$, is sooner worn out and shed; whilst, from the very long period during which the last molar is adapted to perform the work of mastication, the penultimate molar, $m 2$, undergoes the same exhaustive usage and premature expulsion.

I have figured in parallel juxtaposition the molar series of a Phacochere and a Wild Boar, in plate 141 of my 'Odontography,' to illustrate the corresponding extent of abrasion in the first or antepenultimate true molar ($m 1$) at the period when the last true molar has come into place in the Wart-Hog, and when two of the premolar series are retained; and I have indicated my conclusions as to the signification or homology of each of the teeth by the symbols, the aptness and exactitude of which all my later researches have convinced me of. With regard to the deciduous teeth of the Phacochere and other diphyodont mammals, I may remark that there is but one mode of determining and of distinguishing them from the premolars and true molars of the second dentition, in cases where some of the latter are obviously present, as in the young Phacochere with a grinding series of $\frac{6-6}{5-5}$ (see figs. 4 and 5) or of $\frac{5-5}{4-4}$ (as in Plate XXXIII.): that mode is to excavate the substance of the jaws above the fangs of the upper teeth and beneath those of the lower ones, as in the skull represented in Plate XXXIII., and in the lower jaw figured in my 'Odontography,' pl. 141, fig. 1*. The deciduous tooth is demonstrated by the formative

être modifiée, et que dans cette dent il ne fallait voir que les deux dernières, et alors la terminale aurait son talon dans la proportion convenable.

"Ce qui milite encore en faveur de cette manière de voir, c'est que la dent sur laquelle porte davantage l'usure dans le sanglier, l'antépénultième ou cinquième, a son analogue chez le sanglier d'Ethiopie dans la dent qui précède la dent complexe, et qui serait en effet l'antépénultième, celle-ci représentant la pénultième soudée à la dernière.—*Loc. cit.* p. 148.

* "Le système dentaire de cet animal a été fort incomplètement figuré sans description par EVERARD HOME (Lect. on Comp. Anatom. t. 11. pl. 38 et 39), M. G. CUVIER lui a consacré un court paragraphe (Ossem. Foss. t. 11. p. 132, sans figures), et M. OWEN s'est borné à représenter la couronne des molaires supérieures du côté droit (Odontographie, pl. 140, fig. 31), mais personne n'en a soupçonné la signification." M. DE BLAINVILLE had overlooked pl. 141, where that signification is given: but he adds in a supplementary note,—"Il relève, comme inexacte, l'assertion de M. RUPPELL, que dans tous les individus des deux sexes, jeunes et adultes, il y a quatre molaires en haut et trois en bas; et en effet il en décrit une de plus, en reconnaissant que dans la première dentition il n'y en a que trois à la mâchoire et deux à la mandibule. Du reste M. R. OWEN accepte la distinction spécifique du *S. Æliani* et du *S. Pallasii*; le premier pourvu et le second dépourvu de dents incisives, mais sans autres différences vraiment spécifiques." If, however, the difference cited be of specific value, as M. DE BLAINVILLE seems here to admit, others were not needed for accepting the conclusion. I may, however, add that the upper canines of the *Phac. Pallasii* have the groove on their upper surface narrower than in the *Phac. Æliani*, and that the premolars are relatively smaller.

socket containing the germ of its successor in a vertical line with it; this is more especially the case with the last or hindmost deciduous tooth, because the hindmost premolar, its successor, is late in coming into place, and the contiguous true molar, which is always formed much sooner, is characterized by its deeply implanted fangs, and by the absence of any formative socket in vertical relation to them. Without the dissection of the jaws figured in Plate XXXIII., I could have had no true or scientific knowledge of the nature of the teeth there symbolized. As I availed myself of symbols to denote the signification or homology of the teeth of the *Phacochærus* in my 'Odontography' (pages 549 to 557, pl. 140, 141), I shall sum up or indicate in the same way the results of the additional observations recorded in the foregoing pages.

Phases of the molar series of the genus Phacochærus.

Phase

- I. Plate XXXIII. $\frac{5-5}{4-4}$ viz. $\begin{cases} d2, d3, d4, m1, m2. \\ d3, d4, m1, m2. \end{cases}$
- II. Plate XXXIV. figs. 4 and 5, $\frac{6-6}{5-5}$ viz. $\begin{cases} p2, p3, p4, m1, m2, m3. \\ p3, p4, m1, m2, m3. \end{cases}$
- III. Plate XXXIV. figs. 6 and 7, $\frac{5-5}{4-4}$ viz. $\begin{cases} p3, p4, m1, m2, m3. \\ p4, m1, m2, m3. \end{cases}$
- IV. Plate XXXIV. fig. 13 (*Phac. Pallasii*), $\frac{4-4}{4-4}$ viz. $p4, m1, m2, m3.$
- V. Plate XXXIV. figs. 9 and 10, $\frac{4-4}{3-3}$ viz. $\begin{cases} p3, p4, m2, m3 \\ p4, m2, m3 \end{cases}$ (or $\begin{cases} p3, p4, m2, m3. \\ p3, p4, m3. \end{cases}$)
- VI. Plate XXXIV. fig. 11, $\frac{3-3}{3-3}$ viz. $p4, m2, m3.$
- VII. Plate XXXIV. fig. 12, $\frac{2-2}{2-2}$ viz. $p4, m3.$
- VIII. $\frac{1-1}{1-1}$ viz. $m3.$

The above symbols express, with regard to the first phase, I. e. g., that there are five grinders on each side of the upper jaw, and four grinders on each side of the under jaw: that those above answer to the second, third, and fourth deciduous molars, and to the first and second permanent true molars; and that those below answer to the third and fourth deciduous molars, and to the first and second true molars,—of the typical dentition. With regard to the second phase, the symbols express that there are six grinders on each side of the upper, and five grinders on each side of the under jaw: those above answering to the second, third and fourth premolars, and to the first, second and third true molars; those below answering to the third and fourth premolars, and the first, second and third true molars—of the typical dentition.

As to the fourth phase with four grinders on each side of both jaws, these answer,

in both, to the fourth premolar, and to the first, second and third true molars of the typical dentition of the placental Diphyodonts.

These explanations will serve to render the symbols of the remaining phases readily understood by those who may not have studied the principles of dental notation which I communicated to the 'British Association' in 1848, and have more fully exemplified in the article 'Teeth' of the 'Cyclopædia of Anatomy and Physiology;' their utility will be obvious when they are found to express, in a few lines, facts in Comparative Anatomy which would require almost as many pages if recounted by ordinary description.

This system of anatomical notation is the practical fruit of the discovery or determination of a type or common pattern of dentition to which the teeth of a certain proportion of the Animal Kingdom could be referred, and of a concomitant attainment of the power to trace a particular tooth under every modification and disguise of size and shape, throughout the different species of those animals. Every tooth, thus capable of being individualized and determined, merits and, for the purposes of description, requires to have a proper name, and can be signified by a symbol, which is still more convenient for those purposes.

The dental system manifests this regular and determinable character in a large proportion of the mammalian Class; but not in any animal of inferior organization. Like the definition of a species, the definition of a tooth or other part of an organism becomes possible only when its characters are constant and definite, and is easy in proportion as those qualities are exalted. The definition of a mineral species is more difficult than that of a vegetable species, and the definition of a species of low cellular plant is more difficult than that of the highly organized dicotyledon. In proportion as wholes rise in the scale of nature or of life, their recognition and definition becomes easier, and the like obtains also of their parts. As animals ascend in the scale of complexity their organs and parts become more definite; and homologies are more extensively, easily and satisfactorily determinable.

We cannot point out in one species of *Echinus* the answerable spine of any given spine in another species, nor can we determine the homology of a tufted foot from one species of the many-jointed Annelides to another; but in insects each particular leg may be determined through all its modifications of form and function throughout the class. So, likewise, with the teeth: the same individual tooth cannot be traced from fish to fish, or from reptile to reptile; the teeth in the cold-blooded classes differ too much in their number in different individuals, and too little in their development and succession, to yield the requisite characters to the homologist who keeps his faculty of comparison under due control. In those Mammalia, likewise, as *e. g.* the Cachalots, Dolphins and Armadillos, in which the teeth are very variable in number and often very numerous, but without any definite order of shedding and replacement, no particular tooth can be identified and traced from one species to another.

The class *Mammalia* presents, in fact, two primary conditions of the dental system, according to which it might be divided into,—

1st. Those that generate one set of teeth, or the ‘Monophyodonts*,’ and

2nd. Those that generate two sets, or ‘Diphyodonts†.’

The ‘Monophyodonts’ include the orders *Monotremata* and *Bruta* (or the *Edentata* of CUVIER) and the *Cetacea vera* of CUVIER.

The Diphyodonts include the *Marsupialia*, *Rodentia*, *Insectivora*, *Cheiroptera*, *Ruminantia*, *Pachydermata*, *Sirenia*, *Carnivora*, *Quadrumana* and *Bimana*.

I would not be misunderstood, however, as proposing this difference as a basis of classification: such dental characters are associated with too few corresponding differences of organization to lead to a natural binary division of the *Mammalia*. But, as regards the philosophy of the organs in question, considered in that class, the differences above enunciated form one of the highest generalizations, and the exigencies of clear and brief description require such general ideas to have their appropriate signs or names.

The Diphyodont Mammals, then, are characterized by having a first set of teeth, commonly called the ‘milk-teeth’ or ‘deciduous teeth,’ and a second set called the ‘permanent teeth.’ But the development of the latter, in relation to the milk-teeth, presents two modifications; some of the permanent teeth are found in the same vertical line with the milk-teeth, push them out and take their place; others are formed one after another behind the milk-teeth, in what may be called the same horizontal line, and come into place without pushing out any deciduous predecessors. Here, therefore, we have certain characters from development for particular teeth, and when to these characters are added others of equal constancy, derived from relative position, it will be readily understood how such characters, when clearly appreciable and firmly maintained through a series of comparisons, should enable the homologist to point out the very tooth in Man which becomes the great carnassial tooth in the jaw of the Tiger or the great complex grinder in that of the Wart-Hog. With respect to the accessory characters, one of the best is afforded by the relation of certain teeth to the constituent dentigerous bones of the complex jaws. Implantation in the premaxillary bone, or premaxillary part of the upper jaw, *e. g.*, characterizes the tooth called ‘incisor,’ whatever be its shape or size; and the true and constant character of such tooth being thus determined, the name ‘incisor’ becomes its arbitrary sign and loses all its primitive signification as descriptive of a particular shape or use. In like manner the tooth at the fore part of the maxilla, or the maxillary part of the upper jaw which coalesces with the premaxilla in Man, is called the ‘canine.’ The molar series, according to the characters of development and succession above described, is divided into ‘milk-molars,’ ‘premolars’ and ‘true molars.’ The two latter kinds constitute the adult or permanent set of molars. Now these, in the diphyodont mammals, do not exceed $\frac{7-7}{7-7}=28$, *i. e.* seven on each side of both jaws. In the marsupial Diphy-

* Μόνος once; φύω I generate; ὀδούς, tooth.

† Δίς twice; φύω and ὀδούς.

odonts three of the seven on each side of both jaws are 'premolars,' four are 'true molars.' In the placental Diphyodonts four of the seven on each side of both jaws are 'premolars,' and three are 'true molars.' The exceptions, by way of excess to this typical number, are few and are confined to the marsupial order, *e. g.* in the *Myrmecobius*: the deviations from the type by deficiency are numerous, especially in the placental series. But to whatever point the number may be reduced, the teeth that are retained may be identified with their homologues in the typical series. This power is fortunately given by the constancy in respect of their existence of the contiguous teeth of the premolar and molar series, those, *e. g.* marked *p* 4 and *m* 1 in Plate XXXIII.; and by the absent teeth being taken from a definite part of each of those series, *viz.* from the fore part of the premolars and from the back part of the true molar series.

The Bears and some Carnivora offer a partial exception in the occasional retention of *p* 1 when *p* 2 and *p* 3 may be absent, but *p* 4 is constantly present.

Thus it needs only to determine, in any given species of diphyodont mammal, the last premolar and the first true molar, as has been done in the young Phacochere, Plate XXXIII., in order to know the homologies of the rest. The true molars are counted from before backwards,—'first,' 'second,' 'third:' the premolars from behind forwards,—'fourth,' 'third,' 'second,' 'first,' or as far as the series may extend. In Man, *e. g.* it stops at the third; the first and second, which exist in the Hog, being absent, but all the true molars are present. The teeth being thus determined their symbols can be applied to them, *m* 1, *m* 2, *m* 3, for the molars,—*p* 4, *p* 3, *p* 2, *p* 1, for the premolars. It needs only to apply the symbols to one side of each jaw, the teeth being symmetrically repeated on the opposite side: and in most cases they are alike in both jaws. The right canine is the homotype of the left canine, as the right arm is of the left arm, agreeably with the principle of 'bilateral symmetry:' the first true molar in the lower jaw is the homotype of the first true molar of the upper jaw, as the leg is the homotype of the arm, in accordance with the law of the composition of the vertebrate framework of a successive series of essentially similar segments. In whatever direction or to whatever degree two or more of these segments may deviate from the type, the same elements may be discerned in them beneath those modifications. If the neural arch be vastly expanded, as in the cranial vertebræ of mammals, we trace the broad and bifid neural spine from one to the other, and recognise, *e. g.* the frontal bones and parietal bones as homotypal elements. If the diverging appendages be the seat of adaptive development, as in the occipital and pelvic vertebræ, we find the same plan of modification is followed, and we can trace the homotypal parts, *e. g.* *humerus* and *femur*, *radius* and *tibia*, *ulna* and *fibula*, *carpus* and *tarsus*, as also the homotypal ossicles in the carpus and tarsus, even when the common plan is so varied in such appendages, as to produce the different powers and functions which characterize the leg and the arm in Man.

So, likewise, when two costal arches are converted into jaws and made to support teeth, we find the same laws of development so strictly followed as to enable us to

determine the homotypal teeth in those two jaws with the same certainty as the homologous teeth in the jaws of different species.

When the mouth is shut the teeth in the lower jaw are a little in advance of their homotypes in the upper jaw; thus in the Carnivora the great canine tooth of the lower jaw always passes in front of the canine above. Even in the human subject this characteristic relative position is shown by the molars and premolars, when the upper incisors are produced beyond the lower ones.

The existing species of Mammalia that retain the typical formula of dentition, viz.

$$i \frac{3-3}{3-3}, c \frac{1-1}{1-1}, p \frac{4-4}{4-4}, m \frac{3-3}{3-3} = 44,$$

are few: but that formula was much less frequently departed from in the species of placental Mammalia which were first introduced into this planet. This is a very significant fact, and became manifest in the course of working out such typical formula by tracing and comparing the development of the teeth in the recent species.

In the oldest known strictly carnivorous mammal, *e. g.* the *Hyænodon*, remains of which have been discovered in the newer eocene deposits of Hampshire, and in the miocene formations of France, the complete typical dentition is retained, and each of the three true molars presents the peculiar trenchant form of crown which characterizes the single tooth called by CUVIER 'le dent carnassière' in the Lion: here, therefore, we use the term 'molar' in the same technical or arbitrary sense as the term 'incisor' when applied to the tusks of the Elephant or the prongs of the Hippopotamus. In the mixed-feeding *Amphicyon*, a larger extinct miocene Carnivore, allied to the Plantigrades, the three true molars have broad tuberculate crowns. Almost all the herbivorous genera of the eocene and miocene tertiary periods had the typical number and kinds of teeth, as, *e. g.*, *Anoplotherium*, *Palæotherium*, *Dichodon*, *Chæropotamus*, *Dichobune*, *Anthracotherium*, *Hyopotamus*, *Hyracotherium*, *Oplotherium*, *Merycopotamus*, *Hippohyus*, &c. When a modern genus or family has been represented as far back as the miocene period by extinct species, it is usual to find some nearer approach made by such species to the typical dentition than is made by the existing species. Thus, in existing Ruminants, the first premolar is suppressed; but in the ancient *Dorcatherium* it was retained. In the modern *Hippopotami* the incisors are reduced to $\frac{2-2}{2-2}$, and the first premolar is speedily lost; in the oldest known representatives of the genus—the *Hexaprotodon* of the Himalayan tertiary beds—the incisors were in the typical number $\frac{3-3}{3-3}$, as the name imposed upon it by its discoverers, CAUTLEY and FALCONER, indicates, and the first premolar was long retained; the whole dentition, in short, presented the typical formula.

The existing species of the gigantic Proboscidian family, viz. the Asiatic and African Elephants, are totally devoid of incisors in the lower jaw, and all their grinding-teeth succeed each other horizontally; so that it is only by a more than proportional in-

crease of size that the antepenultimate grinder is recognizable as the first of the true molar series, and the antecedent smaller grinders as the homologues of the milk-molars of other Diphyodonts, which milk-molars have no vertical successors in the Elephants. In certain Mastodons, however, which are the earliest known forms of the Proboscidian family, the last milk-molar was displaced by a vertical successor or premolar. Two incisors, moreover, were developed in the lower jaw of the young Mastodons, one of which was retained in the male of the *Mastodon giganteus* of North America, and both in that of the *Mastodon longirostris* of Europe.

The human dentition deviates from the typical formula by the suppressed development of several teeth; as might be anticipated from the characteristic shortness of the jaws, which is such as only to allow space for the comparatively few teeth retained, in close juxtaposition, without any break in the series.

The numerical formula is

$$i \frac{2-2}{2-2}, c \frac{1-1}{1-1}, p \frac{2-2}{2-2}, m \frac{3-3}{3-3} = 32;$$

the principal phases in the development of this dentition may be symbolized as follows:—

$$\text{I. 3 years old, } i \frac{2-2}{2-2}, c \frac{1-1}{1-1}, m \frac{2-2}{2-2} = 20;$$

all of the deciduous series, the molars answering to *d* 3 and *d* 4 of the typical dentition.

$$\text{II. 7 years old, } i \frac{2-2}{2-2}, c \frac{1-1}{1-1}, m \frac{3-3}{3-3} = 24;$$

the molars being *d* 3, *d* 4, *m* 1.

$$\text{III. 10 to 12 years old, } i \frac{2-2}{2-2}, c \frac{1-1}{1-1}, m \frac{3-3}{3-3} = 24;$$

the molars being *p* 3, *p* 4, *m* 1, and the milk incisors and canines replaced by the permanent ones.

$$\text{IV. 12 to 16 years old, } i \frac{2-2}{2-2}, c \frac{1-1}{1-1}, m \frac{4-4}{4-4} = 28, \text{ viz. } p 3, p 4, m 1, m 2.$$

$$\text{V. 18 to 30 years old, } i \frac{2-2}{2-2}, c \frac{1-1}{1-1}, m \frac{5-5}{5-5} = 32, \text{ viz. } p 3, p 4, m 1, m 2, m 3.$$

The teeth which are wanting in Man to complete the typical formula are *i* 3, *p* 1 and *p* 2. The teeth in Man which answer to the carnassials of the Lion and other Feræ are *p* 4 in the upper jaw, or the second bicuspid of human anatomy, and *m* 1 in the lower jaw, or the first multicuspid molar. The tooth which is homologous to the great complex molar of the Wart-Hog is *m* 3 in both jaws.

The symbols here proposed to denote the kinds of teeth are, it is hoped, so plain and simple as to present no obstacle to the ready comprehension of the facts which have been recorded by means of them. Had those facts been explained by means of the usual phrases or definitions of the teeth, *e. g.* “the second deciduous molar repre-

senting the fourth of the typical dentition," instead of *d*4, and so on, the descriptions must have run to much greater length, and have levied such a tax upon the attention and memory as to have proportionally enfeebled the judgment and impaired the power of seizing and appreciating the results of the comparisons.

Each year's experience strengthens my conviction that the rapid and successful progress of anatomy depends greatly on the determination of the nature or homology of the parts observed, and on the concomitant acquisition of the power of denoting them by symbols equivalent to their single substantive names.

In my work on the 'Archetype of the Vertebrate Skeleton,' I have denoted most of the bones by simple numerals, which, if generally adopted, might take the place of names: and all the propositions, *e. g.* relative to the centrum of the occipital vertebra, might be predicated as effectually and intelligibly of the figure 1 as of the word 'basioccipital.' The symbols of the teeth are fewer, are easily understood and remembered, render unnecessary the endless repetition of the verbal definition of the parts, harmonize conflicting synonyms, serve as a universal language, and express the author's meaning in the fewest and clearest terms.

The Entomologist has long found the advantage of such signs as ♂ and ♀, signifying male and female, and the like; and it is time that the Anatomist should avail himself of this powerful instrument of thought, instruction and discovery, from which the Chemist, the Astronomer and the Geometrician have obtained such important results.

DESCRIPTION OF THE PLATES.

PLATE XXXIII.

Fig. 1. Side view of the skull of a very young *Phacochærus Æliani*, natural size, with the outer walls of the alveoli removed to expose the deciduous molars, premolars and true molars, *in situ*.

Fig. 2. The grinding series, composed of milk-molars and true molars, from the upper jaw.

Fig. 3. The same from the lower jaw. (The symbols are explained in the text.)

PLATE XXXIV.

Fig. 4. Grinding surface and side view of the crowns of the molar series of the upper jaw of a young *Phacochærus Æliani*.

Fig. 5. Grinding surface and side view of the crowns of the molar series of the lower jaw of the same skull.

Fig. 6. View of the grinding surface of the upper molar series of a full-grown but young *Phacochærus Æliani*.

Fig. 7. A similar view of the molar series of the lower jaw of the same specimen.

Fig. 8. Side view and view of the grinding surface of the molar series of a similarly aged *Phacochærus Pallasii*.

Fig. 9. View of the grinding surface of the upper molar series of an older *Phacochærus Æliani*.

Fig. 10. Similar view of the lower molar series of the same animal.

Fig. 11. View of the grinding surface of the upper molar series of an older *Phacochærus Pallasii*.

Fig. 12. Similar view of the upper molar series of a still older *Phacochærus Æliani*.
(The symbols are explained in the text, especially at p. 491.)

XXV. *Observations on the Nebulæ.* By The Earl of ROSSE, Pres. R.S., &c. &c.

Received June 19,—Read June 20, 1850.

IN laying before the Royal Society an account of the progress which has been made up to the present date in the re-examination of SIR JOHN HERSCHEL'S Catalogue of Nebulæ published in the Philosophical Transactions for 1833, it will be necessary to say something of the qualities of the instrument employed.

The telescope has a clear aperture of 6 feet, and a focal length of 53 feet. It has hitherto been used as a Newtonian, but in constructing the galleries provision was made for the easy application of a little additional apparatus to change the height of the observer, so that the focal length of the speculum remaining the same, the instrument could be conveniently worked as a Herschelian.

Although with an aperture so great in proportion to the focal length, the performance of a parabolic speculum placed obliquely would no doubt be very unsatisfactory, still additional light is so important in bringing out faint details, that it is not improbable in the further examination of the objects of most promise with the full light of the speculum, *undiminished by a second reflexion*, some additional features of interest will come out.

The second reflexion is accomplished in the usual way by a surface of speculum metal; some experiments have been made, suggested by JAMIN'S paper in the *Annales de Chimie* for 1848, to procure a surface of silver suited to the purpose, but without complete success. Arrangements also have been for some time in contemplation with the view of effecting the second reflexion occasionally by a small glass prism; and about a year ago a prism was procured from Munich for the purpose: in both cases there would be a great saving of light; but I am speaking of the instrument as it is, not as it may become, if further improved.

The tube reposes at its lower end upon a very massive universal joint of cast iron, resting on a pier of stonework buried in the ground; and it is counterpoised so that it can be moved in polar distance with great facility. A quick motion in polar distance is given by a windlass below, and a slow motion is given by hand above for measurements. The extreme range of the tube in right ascension at the equator is one hour; but greater as the polar distance diminishes. The quick movement in right ascension is given below by a wheel turned by a workman, and the slow motion by hand above; the instrument is therefore completely under the dominion of the observer. The tube is slung entirely by chains, and is perfectly steady even in a gale of wind.

As the chain which governs the movement of the telescope passes over a pulley capable of being brought by a little subsidiary apparatus into a line drawn from the

axis of motion parallel to the axis of the earth, the movement of the telescope can be rendered almost exactly equatorial: there was some mechanical advantage in placing the pulley a little out of that line; and for such measurements as we have required, we have found the movement of the telescope sufficiently equatorial without the subsidiary apparatus, and therefore have not up to the present time made use of it. When the telescope is in the meridian, as it moves in polar distance it is guided by a cast-iron arc of a circle about 85 feet diameter nicely planed. The arc is composed of pieces 5 feet long, each adjusted independently in the meridian by the transit instrument, and secured to massive stonework. The horizontal axis of the great universal joint gives motion to an index which points to polar distances on an arc of 6 feet radius, by which the telescope is very quickly set in polar distance. A 20-inch circle with a very delicate level, attached to the telescope, performs the same office, more slowly but with greater accuracy; and also gives polar distances with considerable precision when duly corrected. The whole mounting was planned especially with a view of carrying on a regular system of sweeping, for which it is peculiarly adapted; but the known objects which require examination are so numerous that hitherto we have been fully occupied with them; and the discovery of new nebulæ has as yet formed no part of the systematic work of the observatory.

As yet the telescope is not provided with a clock movement. A clock movement was part of the original design, and there would have been no serious difficulty in carrying it out; but the want of it has not been very much felt, and there were other matters requiring more immediate attention.

Various micrometers have been tried, but upon the whole the common wire micrometer with thick lines succeeds the best. The thick lines are formed by coiling very fine silver wire four times round the forks, soldering it there, and then removing the lower half of the coil. A little spirit varnish unites the fine wires into a thin ribbon with a straight edge, perhaps as perfect as can be made. The micrometer is used without illumination; and I have never failed to see the lines in the darkest night; but of course measurements with thick lines are inferior in point of accuracy to measurements with thin lines in an illuminated field. Unfortunately any micrometrical contrivance which either diminishes the light of the telescope, or renders the field less dark, extinguishes the faint details of the nebulæ, which even with an aperture of 6 feet are often barely perceptible. There have been many ingenious attempts to make fine lines visible in a perfectly dark field, but they have not, at least as far as my experience goes, been entirely successful.

The telescope has two specula, one about three and a half, and the other a little more than four tons weight. Each speculum was originally provided with a system of levers to afford it an equable support: it was placed upon this system before it was ground, and it has rested upon it ever since. The system of levers is a combination of three systems in every respect similar, resting on three points under the centres of gravity of the three equal sectors into which the speculum may be supposed to be

divided. Each system consists of one triangle with its point of support directly under its centre of gravity, upon which it freely oscillates. This triangle carries at its angles three similar points of support for three other triangles, under their centres of gravity, and they again at their angles carry in a similar way cast-iron platforms formed of thin ribs so as to make a kind of irregular open-work grating, supported under their centres of gravity. These platforms are all of equal area though not of similar shape. As there are three systems there are therefore twenty-seven platforms, which together make a circular disc about an inch in diameter less than the speculum: when arranged however a little apart so as not to touch, they make a disc about the same diameter as the speculum. Each platform is coated with greased cloth, and may be considered as bearing up one twenty-seventh of the weight of the speculum. Between the platforms and the speculum pieces of tin plate are inserted to diminish the friction as much as possible. The platforms being of open-work, they do not prevent the water in which the speculum is immersed from freely carrying away the heat as it is developed during the process of polishing, which is essential.

It is evident that a speculum so supported will be practically free from strain while in a horizontal position, provided the due action of the levers is not interfered with by any disturbing force; it will be very much in the same condition as if floating in a vessel of mercury; when it ceases to be horizontal however new forces come into play: part of the weight must then be resisted by pressure against the edge. Four very strong segments of cast iron, each about one-eighth of the circumference, were adjusted to the edge by screws, the segments bearing upon the massive castings which sustained the three primary supports of the lever apparatus. Provision was made to allow a little motion perpendicular to the plane of the speculum, to guard as much as possible against strain from the elasticity of the lever apparatus, which was however very small, the yielding being less than one-fortieth of an inch.

The two specula of 3 feet aperture I have so long employed are mounted on a similar principle: they have however fewer points of support, and by a little sacrifice of the condition of perfect equilibrium, the whole system of levers was thrown without difficulty almost exactly into one plane. They are free from perceptible flexure in the different positions of the instrument. With the two specula of 6 feet diameter the case was otherwise. The 3-foot specula, weighing each about thirteen hundred weight, were very much stiffer, in proportion to their weight, than the 6-foot specula. To have made the 6-foot specula of equal proportionate stiffness, either they should have been enormously heavy, or the material should have been so disposed as to give greater stiffness than when simply cast into the shape of a solid disc. Some years ago it was ascertained by experiments, but on a small scale, that it would be practicable to dispose of three-fourths of the material of a speculum so as to secure a great increase of stiffness; the form adopted was a system of hexagonal cells. Whether on a great scale the difficulties would be too serious to be surmounted is a question; however it is with solid discs we have had to deal. The relative stiffness of

speculum metal and wrought iron is about five to six three-tenths; yet strange as it may appear, so delicate is the optical test, that strong pressure of the hand at the back of a speculum, four tons weight, and nearly six inches thick, produces flexure sufficient to distort the image of a star. It is obvious, therefore, that a slight inequality in the action of the lever apparatus supporting a 6-foot speculum would produce an amount of flexure sufficient to destroy definition. It has not been found possible so to secure the 6-foot specula as to prevent a slight change of place in a plane parallel to the plane of the levers, and as the levers are not all in one plane as in the case of the 3-foot specula, and a considerable amount of friction exists between the speculum and its lever supports, when the speculum changes place, however slightly, there will be a force tending to disturb the equal actions of the levers. It has been found that when the speculum changes its place one-thirtieth of an inch, still adhering to its levers, unmistakeable distortion will be produced. We have occasionally observed, even during a night's work, the sudden appearance, and the as sudden disappearance of the rudiments of focal lines, the undoubted evidences of flexure; but we have not found that flexure, even to the extent of materially disfiguring the image of a large star, interferes much with the action of the speculum on the faint details of nebulæ, although it greatly lessens its power in bringing out minute points of light, and in showing resolvability where under favourable circumstances resolution had been previously effected.

In the spring of 1848 the heavier of the two specula for nearly three months performed admirably, very rarely exhibiting the slightest indication of flexure. It then remained inactive for some time before and after the solstice, and when we again commenced observing it was found to be in a state of strain; the friction between the lever apparatus and the speculum had no doubt in the meantime increased considerably, and the levers being therefore unable to adjust themselves to some slight but permanent change in the place of the speculum, they no longer supported it equably. It was cautiously raised a little by screws for the purpose of re-adjusting the levers, and to our surprise the unequal strain of the screws was found to have produced permanent flexure, so that the speculum did not again perform well till after it had been reground. From the experiments of Mr. EATON HODGKINSON and others, we should have been prepared for a change of figure in a mass of cast iron, but with a material so brittle and so elastic as speculum metal, the result was quite unexpected. Recently, in supporting the lighter of the two specula, twenty-seven triangles have been substituted for the twenty-seven platforms, each triangle carrying at its angles three brass balls, so that the speculum rolls freely on eighty-one balls, which support it pretty nearly equably. This appears to be a great improvement, but I will not dwell further on the subject. To describe the experiments which have been made with a view of discovering the best means of supporting very large specula, a question of great theoretical and practical difficulty, would occupy too much space, and would require elaborate engravings; it would besides be foreign to the object of this paper.

The same considerations also forbid any more minute description of the telescope and its mounting.

From what has been said, it is evident that the 6-foot specula being occasionally in a state of strain, were not uniform in their action. There was however another cause of unequal action. The 6-foot specula, after they have been polished, cannot be tested till they have been removed from the laboratory to the telescope, there to await a good night, the great focal length making it impossible to test them while on the engine. Now it has often happened that a speculum which has subsequently proved to be incapable of very fine definition, has remained in the telescope during a succession of moderately good nights, when a great deal of work was done, awaiting a night when the air was in a state to warrant a decisive opinion. Such a speculum might do good work, but it would not resolve difficult nebulæ, neither would it bring out faint points of light, even when wide apart. There is still another cause of the unequal action of our specula far more serious, the varying state of the atmosphere. When the air is unsteady, minute stars are no longer points, the diffused image is much fainter, and single stars, easily seen when the air is steady, are no longer visible. When many minute stars are crowded together the whole become blended, and instead of a resolved nebula we have merely a diffused, perhaps bright nebulosity. The transparency of the air varies also quite as much; and the aspect of the nebulæ changes from night to night, just as the appearance of a distant building alters as the details of the architecture are more or less obscured by the intervening mist. With these facts, the Society will not be surprised should it be in our power at a future time to communicate some additional particulars, even as to the nebulæ which have been the most frequently observed.

The sketches which accompany this paper are on a very small scale, but they are sufficient to convey a pretty accurate idea of the peculiarities of structure which have gradually become known to us: in many of the nebulæ they are very remarkable, and seem even to indicate the presence of dynamical laws we may perhaps fancy to be almost within our grasp. To have made full-sized copies of the original sketches would have been useless, as many micrometrical measures are still wanting, and there are many matters of detail to be worked in before they will be entitled to rank as astronomical records, to be referred to as evidence of change, should there hereafter be any reason to suspect it.

Much however as the discovery of these strange forms may be calculated to excite our curiosity, and to awaken an intense desire to learn something of the laws which give order to these wonderful systems, as yet, I think, we have no fair ground even for plausible conjecture; and as observations have accumulated the subject has become, to my mind at least, more mysterious and more inapproachable. There has therefore been little temptation to indulge in speculation, and consequently there can have been but little danger of bias in seeking for the facts. When certain phenomena can only be seen with great difficulty, the eye may imperceptibly be in some

degree influenced by the mind; therefore a preconceived theory may mislead, and speculations are not without danger. On the other hand, speculations may render important service by directing attention to phenomena which otherwise would escape observation, just as we are sometimes enabled to recognize a faint object with a small instrument, having had our attention previously directed to it by an instrument of greater power. The conjectures therefore of men of science are always to be invited as aids during the active prosecution of research.

It will be at once remarked, that the spiral arrangement so strongly developed in Plate XXXV. H. 1622, 51 MESSIER, fig. 1, is traceable, more or less distinctly, in several of the sketches. More frequently indeed there is a nearer approach to a kind of irregular interrupted annular disposition of the luminous material than to the regularity so striking in 51 MESSIER; but it can scarcely be doubted that these nebulæ are systems of a very similar nature, seen more or less perfectly, and variously placed to the line of sight. In general the details which characterize objects of this class are extremely faint, scarcely perhaps to be seen with certainty on a moderately good night with less than the full aperture of 6 feet: in 51 MESSIER, however, and perhaps a few more, it is not so. A 6-foot aperture so strikingly brings out the characteristic features of 51 MESSIER, that I think considerably less power would suffice, on a very fine night, to bring out the principal convolutions. This nebula has been seen by a great many visitors, and its general resemblance to the sketch at once recognized even by unpractised eyes. MESSIER describes this object as a double nebula without stars; Sir WILLIAM HERSCHEL as a bright round nebula, surrounded by a halo or glory at a distance from it, and accompanied by a companion; and Sir JOHN HERSCHEL observed the partial subdivision of the *s. f.* limb of the ring into two branches. Taking Sir J. HERSCHEL's figure, and placing it as it would be if seen with a Newtonian telescope, we shall at once recognise the bright convolutions of the spiral, which were seen by him as a divided ring. We thus observe, that with each successive increase of optical power, the structure has become more complicated and more unlike anything which we could picture to ourselves as the result of any form of dynamical law, of which we find a counterpart in our system. The connection of the companion with the greater nebula, of which there is not the least doubt, and in the way represented in the sketch, adds, as it appears to me, if possible, to the difficulty of forming any conceivable hypothesis. That such a system should exist, without internal movement, seems to be in the highest degree improbable: we may possibly aid our conceptions by coupling with the idea of motion that of a resisting medium; but we cannot regard such a system in any way as a case of mere statical equilibrium. Measurements therefore are of the highest interest, but unfortunately they are attended with great difficulties. Measurements of the points of maximum brightness in the motling of the different convolutions must necessarily be very loose; for although on the finest nights we see them breaking up into stars, the exceedingly minute stars cannot be seen steadily, and to identify one in each case would be im-

possible with our present means. The nebula itself, however, is pretty well studded with stars, which can be distinctly seen of various sizes, and of a few of these, with reference to the principal nucleus, measurements were taken by my assistant, Mr. JOHNSTONE STONEY, in the spring of 1849, during my absence in London; for some time before the weather had been continually cloudy. These measurements have been again repeated by him this year, 1850, during the months of April and May. Just as was the case last year, in February and March the sky was almost constantly overcast. He has also taken some measures from the centre of the principal nucleus to the apparent boundary of the coils, in different angles of position. The micrometer employed was furnished with broad lines formed of a coil of silver wire in the way I have described, seen without illumination. Some of the stars in the nebula are so bright, I have little doubt they would bear illumination; if so, their positions with respect to some one star might be obtained with great accuracy of course by employing spiders' lines; this season however it is too late to make the attempt. Several of these stars are no doubt within the reach of the great instruments at Pulkova and at Cambridge, U.S., and I hope the distinguished astronomers who have charge of them will consider the subject worthy of their attention. Their better climate gives them many advantages, of which not the least is the opportunity of devoting time to measurements without any serious interruption to other work. I need perhaps hardly add, that measurements taken from the estimated centre of a nucleus, and still more from the estimated termination of nebulosity, are but the roughest approximations; they are however the only measurements nebulosity admits of, and if sufficiently numerous, I think they will bring to light any considerable change of place, or form, which may occur.

The spiral arrangement of 51 MESSIER was detected in the spring of 1845. In the following spring an arrangement, also spiral but of a different character, was detected in 99 MESSIER, Plate XXXV. fig. 2. This object is also easily seen, and probably a smaller instrument, under favourable circumstances, would show everything in the sketch. Numbers 3239 and 2370 of HERSCHEL'S Southern Catalogue are very probably objects of a similar character, and as the same instrument does not seem to have revealed any trace of the form of 99 MESSIER, they are no doubt much more conspicuous. It is not therefore unreasonable to hope, that whenever the southern hemisphere shall be re-examined with instruments of great power, these two remarkable nebulae will yield some interesting result.

The other spiral nebulae discovered up to the present time are comparatively difficult to be seen, and the full power of the instrument is required, at least in our climate, to bring out the details. It should be observed that we are in the habit of calling all objects spirals in which we have detected a curvilinear arrangement not consisting of regular re-entering curves; it is convenient to class them under a common name, though we have not the means of proving that they are similar systems. They at present amount to fourteen, four of which have been discovered this spring; there are besides other nebulae in which indications of the same character have been

observed, but they are still marked doubtful in our working list, having been seen when the air was not very transparent; 51 MESSIER, Plate XXXV. fig. 1, is the most conspicuous object of that class.

The question may perhaps suggest itself whether there is not something in the aspect of a spiral nebula, which forces upon us the conviction that it is a system with an organization quite different from that of any known cluster. The only answer I am enabled to give to that question is, that in the exterior stars of some clusters there appears to be a tendency to an arrangement in curved branches, which cannot well be unreal, or accidental. Nos. 480, 1916, 1968, 1972, are the objects in which I observe that peculiarity noted down in our list of observations as suspected. As to 1968, Sir JOHN HERSCHEL uses the following words in his Catalogue, "has hairy-looking curvilinear branches." Careful drawings based on measurements would settle the question, whether the suspected curvilinear distribution of the stars is real or not; this would also perhaps settle another question of interest, whether the distribution of the stars in these objects is reconcileable with the hypothesis of an equal distribution of the stars of the system; as yet however there has not been time to make the required measurements. In passing from the spiral to the regular annular nebulae, we perceive we are at once engaged with objects of a very different character: still here even there seems to be something like a connecting link; the great round planetary nebula, H 838, Plate XXXVII. fig. 11, with a double perforation appears to partake of the structure both of the annular and spiral nebulae. There were but two annular nebulae known in the northern hemisphere when Sir JOHN HERSCHEL'S Catalogue was published; now there are seven, as we have found that five of the planetary nebulae are really annular. Of these objects, the annular nebula in Lyra is the one in which the form is by far the most easily recognized. I have not yet sketched it with the 6-foot instrument, because I have never seen it under favourable circumstances; the opportunities of observing it well on the meridian are comparatively rare owing to twilight. It was however observed seven times in 1848 and once in 1849. The only additional particulars I collect from the observations, are that the central opening has considerably more nebulosity in it than it appeared to have with the 3-foot instrument, and that there is one pretty bright star in it, *s. f.* the centre, and a few other very minute stars. In the sky round the nebula and near it there are several very small stars which were not before seen, and therefore the stars in the dark opening may possibly be merely accidental. In the annulus, especially at the extremities of the minor axis, there are several minute stars, but there was still much nebulosity not seen as distinct stars.

The other annular nebula of HERSCHEL'S Northern Catalogue is a much fainter object: it has been observed but once with the large instrument, August 1, 1848; but the evidence of resolution appears to have been more complete; many stars were seen in the annulus; one of them was very conspicuous. That a faint nebula should be more easily resolvable than a bright one is not unusual, neither is it contrary to probability; faintness may be owing to distance, or to a wider separation of the stars,

either physically or optically; in the latter case it is not unlikely that in a faint nebula they might be seen separate with an instrument of great aperture, while in the brighter and more closely packed nebula they were blended together, owing to imperfect definition, arising out of the state of the air, or instrument. As an example, the dumb-bell is a bright nebula: on three exceedingly fine nights succeeding each other at short intervals, the stars in the brighter parts of the nebula were better shown with 3 feet aperture than they have since been with 6 feet. Very fine nights, when the air seems to set no limits to magnifying power, are extremely rare, and the dumb-bell has not been seen with the great instrument on such nights. On the other hand, on all ordinary nights, a variety of details are shown by the great instrument which were not seen on the finest nights with the smaller instrument. There is another fact I may perhaps add, that while high magnifying power brings out minute stars it extinguishes faint nebulosity. The optical reason is obvious; but in sketching the dumb-bell nebula in 1845 that fact was overlooked, and but one eye-piece was used, a very high one; had there been a low one also used the sketch would have been more complete. To return to the annular nebulæ. The five planetary nebulæ we have ascertained to be annular, are as follows: 464, Plate XXXVIII. fig. 12, has two stars within it; 2075 has one star a little following the centre; 2241, Plate XXXVIII. fig. 13, has no star, but is surrounded with a faint external annulus; 2050 has a perforation not round nor quite symmetrical with the star; 838, Plate XXXVII. fig. 11, has two stars and two perforations. In no instance is the central opening quite dark. The planetary nebula, 2047, is marked in our journal as annular, but the observation is without date and other particulars, and therefore I do not consider it altogether trustworthy. In 2098, Plate XXXVIII. fig. 14, another planetary nebula, we have not detected any perforation, but it has ansæ, which probably indicate a surrounding nebulous ring seen edgewise, just as 450, Plate XXXVIII. fig. 15, has apparently a nebulous ring seen on the flat; and if the annular nebulæ are really hollow shells, the nebulous ring would cover the comparatively transparent centre; 365 and 2037 have never been observed.

Passing from the annular nebulæ to the nebulous stars, there are two objects well-worthy of especial notice.

Sir JOHN HERSCHEL very accurately describes a nebulous star thus:—"A sharp and brilliant star concentrically surrounded by a perfectly circular disc or atmosphere of faint light, in some cases dying away insensibly on all sides, in others almost suddenly terminated*." No. 450 of Sir JOHN HERSCHEL'S Catalogue is one of these nebulous stars, and is there thus described:—"A star of the 8th magnitude, exactly in the centre of an exactly round and bright atmosphere, 25" diameter. The star is quite stellar, not a mere nucleus. Another star, 8th magnitude, distant 100", and about 85° n p, has no such atmosphere.—A most remarkable object."

Plate XXXVIII. fig. 15 represents this wonderful object as seen with the 6-foot telescope. It has been several times examined, and as yet we have not seen the

* Outlines of Astronomy, p. 605.

slightest indication of resolvability. The outer ring is seen on a pretty good night completely separated from the nucleus surrounding the brilliant point or star. The light is very bright, and always appeared to be flickering, owing no doubt to the unsteadiness of the atmosphere. There is a small dark space to the right of the star, which indicates a perforation similar perhaps to that discovered in Nos. 838, 2050, and others. The annular form of this object was detected by Mr. JOHNSTONE STONEY, my assistant, when observing alone, and the sketch is his; I have however since had ample opportunities of satisfying myself that the object has been accurately represented. Plate XXXVIII. fig. 16 represents the other nebulous star, ι Orionis: the remarkable feature in this object, the dark cavity, not symmetrical with the star, was also discovered by Mr. JOHNSTONE STONEY when observing alone with the 3-foot telescope: I have since seen it several times and sketched it. The components of ι Orionis have not been laid down micrometrically, or even with care by the eye, but the dark cavity with respect to the stars is faithfully represented. If the dark cavity was symmetrical with the stars, it might perhaps be thought by some that the phenomenon was optical, but as it is the thing is impossible. A small double star $n f$ has similar openings, but they are not so easily seen. These openings appear to be of the same character as the opening within the bright stars of the trapezium of Orion, the stars being at the edges of the opening. Had the stars been situated all together within the openings, the suspicion would perhaps have suggested itself more strongly that the nebula had been absorbed by the stars. As it is, I think we can hardly fail to conclude that the nebula is in some way connected with these bright stars, in fact that they are equidistant, and therefore, if the inquiries about parallax, now proceeding with so much activity, should result in giving us the distances of these bright stars, we shall have the distance of this nebula.

The long elliptic or lenticular nebulæ are very numerous; I have given three sketches of remarkable objects of this class: the appearance of Plate XXXVII. fig. 7 suggests the idea of an elliptic annular system seen very obliquely. A series of very elliptic shells enveloping the nucleus, seen somewhat obliquely, would perhaps also present the same aspect. The dark chink in Plate XXXVII. fig. 8 might indicate either a real opening, the system being an elliptic ring, or merely a line of comparative darkness, the section through the axis of a very long narrow elliptic shell. In Plate XXXVII. fig. 9 there is a well-marked stratification, which might possibly be the appearance, Plate XXXVII. fig. 7, on the first supposition, would present if seen in another direction. It is to be hoped that as observations multiply, and these extraordinary objects which abound in the heavens are seen in various directions, we shall gradually become acquainted with their real form. At present further conjectures would be to no purpose.

The remaining sketch, Plate XXXVIII. fig. 17, is the dumb-bell nebula as seen with the 6-foot telescope: the sketch is by Mr. JOHNSTONE STONEY, and the form of the nebulosity and its various gradations of intensity have been represented with considerable fidelity. There was no subsequent opportunity of marking in the stars,

and therefore they have been inserted at random to complete the general effect, and many minute details are still wanting to make the figure complete.

As we have proceeded with our task of re-examining Sir JOHN HERSCHEL'S Catalogue, several groups of nebulæ have been discovered, although new objects have not been as yet sought for. In some cases a nebulous connection has been detected between the individuals of the group, in others not. Sketches have been made and some measures taken. The whole subject of the grouped or knotted nebulæ is one of deep interest; but we have not proceeded sufficiently far with it to make it worthwhile to enter upon it in the present paper, and it only remains to point out a defect common to all the sketches which might mislead if not specially noticed. In sketching we necessarily employ the smallest amount of light possible, very feeble lamp-light, especially where the objects or their details are of the last degree of faintness. To see the sketch as we proceed it is often necessary to mark it too strongly: this would be of little moment if the excess of colour was always in the same proportion, especially as different eyes form a very different estimate of the relative intensities of a nebula and its representation on paper, but it is not so; the contrast between the faint and bright nebulæ and between the faint and bright parts of the same nebula is very liable to be made too slight. The most important error to guard against is that of supposing that the well-marked confines of the nebula on paper really represent the boundaries of the object in space in all cases. Frequently there is a very gradual fading away at the edge, the last trace of which is either a luminous mist becoming rarer till imperceptible; a gauge-like tissue of the faintish imaginary flocculi, or hairy filaments, which become finer and more scattered till they cease to be visible, showing that the real boundary has not been seen, and that the form of the object would alter if additional optical power could be brought to bear upon it. The same remark applies to the faint interior details, in most cases probably only in part seen.

Plate XXXV. figs. 1 and 2 are seen on a scale of half an inch to a minute; the others are on no regular scale: they are about the size of the figures which accompany Sir JOHN HERSCHEL'S Catalogue, the smaller however have been somewhat enlarged where there were details which otherwise could not have been well represented.

Annexed are a few remarks relating to each figure, which seem to make the information conveyed by it more complete: they are for the most part extracts selected from our journal of observations; in a few cases, however, to save space, merely the substance is given.

Where the 3-foot instrument was employed it is specially mentioned; in every other case it was the 6-foot instrument.

Plate XXXV. fig. 1, H. 1622.—This object has been observed twenty-eight times with the 6-foot instrument; it had been repeatedly observed previously with the 3-foot instrument.

September 18, 1843.—Observed with the 3-foot instrument; power single lens,

1-inch focus; a great number of stars clearly visible in it, still HERSCHEL'S rings not apparent, at least no such uniformity as he represents in his drawing.

April 11, 1844.—Observed with the 3-foot instrument, two friends assisting; both saw centre clearly resolved.

April 26, 1848.—6-foot instrument. Saw the spirality of the principal nucleus very plainly; saw also spiral arrangement in the smaller nucleus.

The following measurements were taken by my assistant, Mr. JOHNSTONE STONEY, in the spring of 1849 and 1850.

| | Mean of the observations of position. | No. of observations. | Greatest difference between observations and the mean. | Mean of the observations of distance. | No. of observations. | Greatest difference between observations and the mean. |
|------------------|---------------------------------------|----------------------|--|---------------------------------------|----------------------|--|
| N. <i>n.</i> | 16° 34' | 4 | 3° 27' | 4 22.2 | 4 | 9.6 |
| N. 1. | 52 4 | 1 | | 2 6.6 | 1 | |
| N. 2. | 54 0 | 4 | 1 57 | 5 0.0 | 4 | 5.4 |
| N. 3. | 104 20 | 2 | 2 3 | 2 45.6 | 2 | 3.6 |
| N. 4. | 111 57 | 2 | 0 40 | 4 3.6 | 2 | 0.6 |
| N. 5. | 165 35 | 2 | 0 31 | 1 43.2 | 2 | 1.1 |
| N. 6. | 191 42 | 1 | | 3 54.0 | 1 | |
| N. 7. | 211 2 | 1 | | 2 36.6 | 1 | |
| 7, 8. | 270 42 | 1 | | 0 34.8 | 1 | |
| N. 9. | 231 32 | 4 | 3 35 | 1 23.4 | 3 | 6.6 |
| 9, 10. | 197 57 | 1 | | 0 27.0 | 1 | |
| N. 11. | 279 21 | 4 | 4 18 | 1 49.8 | 3 | 22.2 |
| 11, 12. | 225 27 | 1 | | 0 12.6 | 1 | |
| N. 13. | 281 37 | 2 | 0 22 | 3 59.0 | 1 | |
| 14, 15. | 297 15 | 1 | | | | |
| N. 15. | 310 34 | 4 | 4 17 | 2 55.8 | 4 | 13.8 |
| N. α | 5 7 | ... | | 3 22.8 | 2 | 0.1 |
| N. β | | | | 1 28.2 | 3 | 3.0 |
| N. γ | | | | 2 37.8 | 3 | 2.4 |
| N. δ | | | | 1 46.2 | 1 | |
| N. ε | 95 7 | ... | | 2 46.8 | 1 | |
| N. ζ | | | | 1 40.8 | 1 | |
| N. η | | | | 3 15.6 | 1 | |

Observations.—There is a great discrepancy between the measured position of 11 and 12 and the rough diagram made at the time of observation.

N. 13 is twice noticed in the observing-book.

Once N. 11, 13 is taken as one position; the other times N. 11 and 13 are taken separately, N. 13 being made 1° 40' less than N. 11; hence 270° 31' is a more probable position for N. 13 than that given in the Table.

The Greek letters are perpendiculars from N. on tangents to the outsides of the convolutions, the tangents from α , β , γ being vertical, that is, parallel to the position 95° 7', and those for δ , ε , ζ , η horizontal, *i. e.* parallel to position 5° 7'.

The greater part of the observations were made when the eye was affected by lamp-light, which made it difficult to estimate correctly the centre of the nucleus; it was of importance that no time should be unnecessarily spent, and after the lamp had been used a new measure was taken, as it was judged that the object was sufficiently seen. With the brighter stars this would frequently happen before the nucleus was

well defined, as all impediments to vision seem to affect nebulæ much more than stars the light of which would be estimated as of the same intensity. In the foregoing list the greatest discrepancies are in the measures of bright objects, and this is probably the proper account of it. No stars have been inserted in the sketch which are not in the table of measurements. The general appearance of the object would have been better given if the minute stars had been put in from the eye-sketch, but it would have created confusion.

Plate XXXV. fig. 2, H. 1173.—This nebula has been repeatedly observed with the 6-foot instrument.

March 11, 1848.—Spiral with a bright star above; a thin portion of the nebula reaches across this star and some distance past it. Principal spiral at the bottom, and turning towards the right.

March 20, 1848.—Spirality very evident, though night bad: nebula not traced to upper star.

April 16, 1849.—Took measures of the stars 1, 2.

April 17, 1849.—Took measures of the stars 1, 2, 3, 4 from the nucleus; they are as follows:—

| No. | Mean of observations of position from north in direction <i>n. f. s. p.</i> | No. of observations. | Greatest difference between mean and observation. | Mean of observations of distance. | No. of observations. | Greatest difference between mean and observation. |
|-----|---|----------------------|---|-----------------------------------|----------------------|---|
| 1. | 34° 1' | 1 | | 2 54.6 | 2 | 9.6 |
| 2. | 80 35 | 2 | 0 18 | 1 46.3 | 3 | 14.4 |
| 3. | 117 3 | 3 | 0 23 | 1 48.4 | 4 | 13 6 |
| 4. | 177 57 | 1 | | 2 48.1 | 1 | |

Three very minute stars in the eye-sketch have not been inserted, not having been measured.

Plate XXXVI. fig. 3, H. 604.—This nebula was observed frequently with the 3-foot instrument, but nothing remarkable seems to have been made out, except the resolvable character of the nucleus. It was first observed with the great telescope, March 24, 1846, and a tendency to an annular or spiral arrangement discovered; night bad; March 5, 1848, sketched.

March 9, 1848.—“Night excellent, a spiral seen in an oblique direction, resolved well, particularly towards the centre, where it is very bright; Dr. ROBINSON observing.” Observed March 3, 1850; badly seen.

With the single exception of March 3, 1850, we have unfortunately no recent observation of this extraordinary object: it has been passed over, because to observe it, except on a very fine night, would be waste of time.

Plate XXXVI. fig. 4, H. 2205.—Observed frequently, and by many friends. The drawing represents the object with considerable accuracy.

“September 10, 1849.—Spiral, but query whether this is not more properly an annular than a spiral nebula.”

The details are faint, but can be seen on any moderately fine night.

Plate XXXVI. fig. 5, H. 131.—This figure represents the central portion of a very large nebula. The nebula itself has not been sufficiently examined, but as yet no other portion appears to have a spiral, or indeed any regular arrangement. The sketch is not very accurate, but represents sufficiently well the general character of the central portion.

“September 6, 1849.—A spiral.

“September 16, 1849.—New spiral; α the brightest branch; γ faint; δ short but pretty bright; β pretty distinct; ε but suspected; the whole involved in faint nebula, which probably extends past several knots which lie about it in different directions. Faint nebula seems to extend very far following: drawing taken.

“September 10, 1849.—An attempt at a drawing taken: fog.

“October 1849.—The whole nebula in flocculi.”

Plate XXXVII. fig. 6, H. 444.—“December 19, 1848.—Bright star between; tails and curved filaments; perhaps annulus around the two nebulæ.

“December 22, 1848.—Sketch made.

“February 11, 1849.—Lower streak seems to reach the filaments of right-hand nucleus.”

Plate XXXVII. fig. 7, H. 854.—“March 31, 1848.—A curious nebula with a bright nucleus; resolvable; a spiral or annular arrangement about it; no other portion of the nebula resolved. Observed April 1, 1848, and April 3, with the same results.”

Plate XXXVII. fig. 8, H. 1909.—“April 27, 1848.—A very bright resolvable nebula, but none of the component stars to be seen distinctly even with a power of a thousand. A perfectly straight and longitudinal division in the direction of the major axis. Resolvability most strongly indicated towards the nucleus.

“May 2, 1848.—Not seen so well as on April 27. Darkness in the middle, along the major axis barely visible.

“April 1849.—A long ray elliptical. Major axis perhaps eight times minor axis. Surface somewhat broken up, and a slight darkness in the direction of the major axis: night indifferent: at intervals a few stars faintly perceptible.”

Plate XXXVII. fig. 9, H. 1397.—This sketch was made with great care by my assistant, Mr. JOHNSTONE STONEY, and I have no doubt it is very accurate. Observed and sketched, April 19, 1849. It had been previously observed, March 26, 1848, by my former assistant, Mr. RAMBAUT, and I find the following note by him:—“A most extraordinary object, masses of light appear through it in knots.”

Plate XXXVII. fig. 10, H. 399.—Observed December 22, 1848, February 11, 1849, and January 16, 1850, when the drawing was taken. The two comparatively dark spaces, one near the vertex and the other near the base of the cone, are very remarkable.

Plate XXXVII. fig. 11, H. 838.—September 27, 1843.—(3-feet telescope.) Night pretty good; a star in the centre and apparently ragged outline.

March 7, 1848.—(6-feet telescope).—Night bad : aurora. Darkness in the centre ; star not certainly seen ; outline ragged.

March 11, 1848.—Seen by Dr. ROBINSON and my former assistant, Mr. RAMBAUT ; sketch made of it. “Two stars considerably apart in the central region ; dark penumbra around each spiral arrangement, with stars as apparent centres of attraction ; stars sparkling in it, resolvable ; night excellent.” Note by Mr. RAMBAUT : “March 5, 1848.—Saw two dark and very large spots in the middle ; Lord ROSSE remarked that all round its edge the sky appeared darker than the average.”

“March 11, 1848.—Remarkably fine night ; a brilliant star in the centre ; also star to the right ; round each a black space (see sketch).” Note by Mr. RAMBAUT : “March 25, 1848.—Air steady, but slight haze ; large star visible. Only at one clear interval could I get a glimpse of the spiral arrangement of this nebula, which I should have totally overlooked had I not seen it so plainly on a former occasion.

“March 26, 1848.—Second bright star visible ; spiral arrangement hardly perceptible ; not seen so well as on the 11th of March.

“March 27, 1848.—Not seen so well as last night ; second star seen at rare intervals, power 468.

“March 28, 1848.—Night hazy, could not see second star.”

“March 31, 1848.—Caught one glimpse of second star, but saw the large star very plainly.

“April 1, 1848.—Night hazy ; spiral arrangement little more than suspected ; nebula very faint.

“April 3, 1848.—Small star distinctly seen ; spirals tolerably well brought out ; hazy, but air steady.

“April 6, 1848.—First star seen easily, though hazy ; the second only occasionally ; spiral arrangement hardly discernible.

“January 1850.—Seen very imperfectly ; only one of the stars seen.

“March 9, 1850.—Second star only seen for a moment.” Several attempts were made to procure measures of position and distance of the two stars this spring, but in vain, the season was so unfavourable. In 1848, the micrometer requiring illumination, no attempt was made. With the micrometer as at present mounted there would not have been the slightest difficulty in procuring measures.

Fig. 12, H. 464.—“Annular nebula at the edge of the cluster M. 46. Sketched December 22, 1848 annular, two stars in it.

“January 27, 1849.—A third star suspected in brightest part.

“January 29, 1849.—Third star strongly suspected.

“February 13, 1849.—Observed, nothing further.

“March 16, 1849.—Saw but two stars in it.”

Fig. 13, H. 2241.—“October 31, 1848.—Has a central spot, at moments very dark.

“December 13, 1848.—Nothing more, except perhaps that faint external annulus extends further than had been seen before.

“December 14, 1848.—Note by Mr. JOHNSTONE STONEY:—‘Three stars near it, somewhat in this fashion; showed it to Sir JAMES SOUTH.’

“December 16, 1848.—Sketches made by Lord Rosse and Mr. JOHNSTONE STONEY.

“December 19, 1848.—Drawing confirmed.”

Fig. H. 14, 2098.—“Observed October 23, 1848, and sketch made.

“October 25, 1848.—Sketch confirmed.

“August 16, 1849.—Position of ring taken with an eye-piece furnished with a level and a position circle. Inclination of ring to horizon 9° .”

Fig. 15, H. 450.—“February 20, 1849.—Most astonishing. The star perhaps a little nearer the *np* edge. Drawing made; breadth of ring less on *f* side.

“February 22, 1849.—Observed again; dark space to the right of star.

“January 16, 1850.—Observed; examined with the 700 and 900 eye-pieces; both the dark and the bright rings seemed unequal in breadth; the light appeared unsteady and flickering. The night was rather foggy, but the sky black.”

Fig. 16, H. 361.—“January 28, 1849.— ι Orionis. Dark space in the nebula containing nearest companion; light nearly equable; sketch made; 3-foot telescope employed. All the stars in the neighbourhood are nebulous, of these two a little *sp*, last seem to have dark spaces as in figure. To the *nf* of this there is another smaller double star, suspected to have similar dark spaces to ι Orionis.

“February 16, 1849.—Three-foot telescope confirmed observation of January 28, 1849.

“March 17, 1849.—Large triple star to south of nebula Orionis; confirmed observation of opening in its atmosphere, also the openings at double star *sp* last.”

Fig. 17, H. 2060.—“Observed September 9, 1849. Drawing commenced.

“September 16, 1849.—Drawing proceeded with; examined also with 3-foot telescope to find if any evidence of change since drawing in Philosophical Transactions was taken; none decisive.”

List of some remarkable Nebulæ.

Spiral or curvilinear.

H. 142, 262, 327, 695, 749, 910, 1002, 1211, 1312, 1368, 1451, 1570, 1776, 2172.

With dark spaces.

264, 368, 491, 514, 692, 731, 788, 857, 887, 1107, 1225, 1909, 2241.

Ray with split.

1041, 1149, 1357.

Knotted nebulæ.

84, 257, 320, 409, 446, 581, 1274, 1901.

XXVI. *On the Structure and Use of the Ligamentum Rotundum Uteri, with some observations upon the change which takes place in the Structure of the Uterus during Utero-gestation.* By G. RAINEY, M.R.C.S., Demonstrator of Anatomy at St. Thomas's Hospital. Communicated by JOSEPH HENRY GREEN, Esq., F.R.S.

Received January 15,—Read April 11, 1850.

PRIOR to the discovery of the striated character of voluntary muscle, about 1765, by FONTANA, physiologists were unacquainted with any certain mark by which they could distinguish this variety of muscle from many other structures; and physiology being at that period in advance of anatomy, the question of the muscularity of many parts was obliged to be decided by their function instead of by their structure; but in the present state of minute anatomy, improved as it has been of late by the researches of microscopists, physiology and anatomy are made to move more in parallelism; this is especially the case with respect to the muscular system, so that if a muscle be made up of a bundle of fascicles of nearly equal size, and each one be marked transversely with parallel striæ, it is known to act either directly in obedience to the will, or to be capable of being called into operation through excito-motory influence, whilst a muscle consisting merely of an aggregation of fibres more or less distinctly nucleated, is known to act independently of the will; hence muscles are now named according to their function, voluntary and involuntary; or according to their structure, striped and unstriped. In the class of striped muscles physiologists are agreed to place the voluntary muscles, the upper part of the human œsophagus, and the heart; in that of unstriped ones, the muscular coat of the intestinal canal, the bladder, the uterus and round ligaments. As it respects the parts included in the latter division of this classification, I am obliged to dissent altogether in reference to the structure of the round ligaments of the uterus, having found in every subject in which I have examined them (the number being about a dozen) well-marked muscular fibres of the striped variety, in fact that they correspond in all respects to regular voluntary muscles: with this conviction I am desirous to communicate the result of my observations to the Royal Society. I may also add, that I have in my possession numerous preparations, microscopic as well as ordinary dissections, in which the accuracy of the facts stated in this paper are easily demonstrable.

The so-called round ligament of the uterus, regarded as a muscle, may be said to arise by three fasciculi of tendinous fibres; the inner one from the tendon of the internal oblique and transversalis near to the symphysis pubis, the middle one from the superior column of the external abdominal ring near to its upper part, and the

external fasciculus from the inferior column of the ring just above GIMBERNAT'S ligament; from these attachments the fibres pass backwards and outwards, soon becoming fleshy; they then unite into a rounded cord, which crosses in front of the epigastric artery and behind the lower border of the internal oblique and transversalis muscles, from which it is separated by a thin fascia continuous with the fascia transversalis; it then gets between the layers of peritoneum forming the broad ligament of the uterus, along which it passes backwards, downwards, and inwards to the anterior and superior part of the uterus, into which its fibres, after spreading out a little, may be said to be inserted.

The striated muscular fibres are not confined merely to the surface of the round ligament, as if only accessory to some more important part of it, but they form almost the whole of its substance, and are more particularly distinct near to its centre; nor do they extend completely to the uterus, but after passing between the layers of the broad ligament to about the distance of an inch or an inch and a half from its superior part, they gradually lose their striated character, and degenerate into fasciculi of granular fibres mixed with long threads of fibro-cellular tissue. Plate XXXIX. fig. 1 is an accurate representation of some muscular fibres taken from the centre of the round ligament, where it is situated between the layers of the broad ligament, about one inch and a half from the uterus. Fig. 2 is also a representation of some muscular fibres taken from a part rather nearer to the uterus, showing the manner in which the striped muscular fibre terminates in the granular fibres above mentioned. This structure of the round ligaments is not, as might be expected, confined to the human species. In the Monkey these ligaments are composed almost entirely of striped muscular fibre, which extends all along them nearly as far as the uterus. The uterus in a monkey which I examined was very small, but the round ligaments were proportionally large: the primary fasciculi of muscular fibres were pale but very distinctly striated. In the Dog, as most probably in other animals in which the uterus divides into cornua extending into the abdomen considerably beyond the brim of the pelvis, the round ligaments, instead of passing downwards to be attached to the pelvis, as they are in the human subject, in whom the uterus is situated below its brim, pass from the extremities of the cornua of the uterus upwards, or rather forwards to the last rib. Hence in these instances, these ligaments, or rather muscles, may be said to arise from the last rib, and from the aponeurosis of the diaphragm, by a thin triangular expansion, partly tendinous, and partly muscular (the fibres of the muscle being pale but of the striped kind), and to be inserted into the cornua of the uterus, having the same relation to the Fallopian tubes and ligaments of the ovaries as in the animals which have a simple uterus. In the Sheep and the Cow the attachments of the round ligaments are similar to those in the Dog, and composed likewise of muscular fibres distinctly striated. Besides striped muscular fibres these ligaments contain numerous vessels, also some nerves and absorbents. The arterial trunks are large, but the capillaries into which they ultimately divide have the same size and arrangement as

those of ordinary muscle. The lymphatics are situated on the outer side of the ligament; their glands are sometimes of considerable length, and even pass through the external abdominal ring; connecting all these parts together, there is a considerable quantity of areolar tissue, especially where the striated muscular fibres are absent, or are about to terminate. In this part the detection of these fibres will be facilitated by examining the part in glycerine, which renders the fibro-cellular tissue more transparent without impairing in any considerable degree the distinctness of the striated muscle*. It is generally said that the round ligament passes through the external abdominal ring, and "is lost in the cellular tissue of the mons veneris and labia pudendi." It is true that the vessels supplying it, and a nerve, and some lymphatics, and frequently a gland, pass through the external abdominal ring, but the substance of the ligament is situated altogether above it so as in part to close it, and thus to tend very much to prevent the protrusion of intestine at this part, whilst it would facilitate its passage through the crural ring by directing it towards GIMBERNAT'S ligament; hence probably the reason why females are more liable to femoral than to inguinal hernia.

Those who have written upon the office of the round ligaments of the uterus, regarding them either as made up of muscular fibres of the same kind as those of the uterus itself, or considering them as composed merely of "condensed cellular tissue," have considered their office, either as subservient to the process of utero-gestation, or as acting merely as mechanical supports to the uterus, that is, as uterine suspensory ligaments. Now the presence of voluntary (striped) muscular fibre in these so-called ligaments, proves that neither of these suppositions is correct, since striped or voluntary muscular fibre would be as unfit for the one purpose as it would be superfluous for the other; hence there can be but little doubt that these ligaments, or rather muscles, are concerned in some way or other with the act of copulation, rather than with those changes which are so slowly induced in the uterus during utero-gestation. Considering the position of the points of attachment of the round ligaments,

* Besides the structures just mentioned, these fibres are mixed with several pale, and much less distinctly striated ones, which resemble in all respects the tissue of the Dartos. The fibres of the Dartos are generally considered merely as fibro-cellular tissue, but they seem to possess characters by which they can be distinguished from other tissues. These fibres, both from the scrotum and the round ligament, the upper part especially, when examined by the microscope in water, appear to be made up of very fine threads of wavy fibre, mixed with extremely minute granules or molecules, by which their distinctness of outline is much obscured and rendered much less apparent than in the fibres of common areolar tissue; they are also more collected into bundles than is fibro-cellular tissue; but these same fibres, when examined in glycerine, become corrugated, resembling somewhat striped muscle; in some instances, indeed, the resemblance is so great, that it is difficult, if not impracticable, to distinguish between a bad specimen of striped muscular fibre and a good one of this tissue. Common fibro-cellular tissue is not corrugated by glycerine, but only rendered more transparent.

The distance to which the striped fibre extends towards the uterus, and the degree of its distinctness, differ very much in different subjects; in one subject I found it not more than an inch from the uterus. In the employment of glycerine to aid the detection of striped muscle and the corrugated tissue, it is sometimes necessary to allow these structures to remain in the glycerine a few minutes before its full effect is produced.

and the direction of their fibres, it is evident that their combined action will bring the uterus nearer to the symphysis pubis, and thus tend to draw it somewhat from the vagina, in this way increasing the length of the latter. Now the only way in which I can imagine that these changes in the position of these parts assist in sexual intercourse, is by their causing the semen to be attracted more into the upper part of the vagina and vicinity of the os uteri. [Since the communication of this paper to the Royal Society I have been informed that this opinion is not new, but that this view of the use of the round ligament had been published by M. VELPEAU*, and that it is also partly in accordance with that of MAYGRIERS†.] This supposition seems to accord with the position and attachments of the round ligaments in those animals in which the uterus extends into the cavity of the abdomen beyond the brim of the pelvis, as was noticed in the Dog, the Sheep and the Cow, where their action would, obviously, be the same in drawing the uterus from the vagina, and in tending to elongate the latter, as in the human subject in whom the angles of the uterus are below the level of the broad ligaments. In such an act the muscular fibres of the round ligaments could scarcely be said to be voluntary; but still they would be as much so as the other muscles concerned in the same process, that is, as those of the male organs of generation. In these instances muscles are said to act under excitatory influence, but muscles which are thus excited have the same structure as those more obviously under the control of the will, namely, striped fibres.

Some observations upon the change which takes place in the Structure of the Uterus during Utero-gestation.

The fasciculi of fibres composing the upper part of the round ligament separate as they approach the fundus of the uterus, become spread out over its surface, and ultimately blend with its fibres. Although the fibres of the round ligament are generally said to be of the same kind as those of the uterus, I have not been able to perceive much similarity, either with those of the unimpregnated or the impregnated uterus, the fibres in both these states of the uterus being peculiar. The proper tissue of the unimpregnated uterus is so remarkably dense that there is considerable difficulty in unraveling it sufficiently to display the true character of its fibres, and sections thin enough to admit of being seen as a transparent object by the microscope, give no distinct idea of its real nature. Its characters can be best understood by breaking up portions of the uterus with needles, and examining them in glycerine, but still they should be first seen in water; also the arteries of the uterus should be fully injected (these are remarkably tortuous, and possessed of very thick coats), otherwise the tissue of the small vessels, and the nuclei in the coat of the capillaries, may be examined instead of, and mistaken for, the proper fibre of the uterus. Any part of the unimpregnated uterus, after having been thus treated, will be seen to be made up

* Anatomie Chirurgicale, 1833, vol. ii. p. 372.

† Nouvelles Démonstrations d'Accouchements, p. 62.

of fusiform nucleated fibres, contained in a matrix of exceedingly coherent granular matter; these are well represented in fig. 3. The average breadth of one of these fibres, at its dilated or nucleated part, is about $\frac{1}{4000}$ th of an inch; their length cannot be ascertained with certainty, as it is impossible to estimate the degree of curtailment which they suffer in being separated from the granular matrix in which they lie imbedded. Their structure and size are about the same in every part of the uterus from which I have taken them, so that they are easily recognizable as the peculiar fibres of the unimpregnated uterus. Now comparing these fibres with those forming the walls of the impregnated one, at the full, or at a very advanced period of impregnation, it will be seen that these fibres are become greatly increased in size, deprived of nuclei, and more loosely connected together; they lie in separate planes, which cross each other in various directions; they are accompanied with vessels of various sizes, also with more or less fibro-cellular tissue. The size of these fibres is moderately uniform, but those near to the external surface are rather smaller than those more deeply seated. A fibre detached from the rest measured about $\frac{1}{40}$ th of an inch in length and about $\frac{1}{2000}$ th in breadth at its widest part; for the breadth varies much in different parts of the same fibre, being alternately large and small; at their extremities they taper off to a very fine point; their colour is yellowish, and when minutely examined, they appear to be made up of very small irregular granules and extremely slender threads blended together without any definite arrangement (see fig. 4). Acted upon by acetic acid they give no indication whatever of being nucleated, therefore in this respect they differ from the common form of organic muscular fibre*. The two kinds of fibres, represented in figs. 3 and 4, were both drawn under the same magnifying power, in order to show, by a comparison of their dimensions, that the increase which takes place in the individual fibres in these different states of the uterus, is quite sufficient to account for the amount of augmentation of the entire organ, without supposing, as some physiologists do, that organic muscular fibres, not present in the inactive state of the uterus, are absolutely formed during the various stages of its enlargement; it also, besides being supported by the fact just stated, perfectly accords with the laws of development, and harmonizes with the changes which are going on simultaneously in the walls of the impregnated uterus and its contents; the unimpregnated uterus being, according to this notion, little more than an assemblage of embryonic nucleated fibres, wholly inactive, until after the reception of the ovum, when, being aroused by an appropriate stimulus, they are called into active operation, and become developed simultaneously and proportionally to the development of the foetus contained within it, so that when the one has arrived at a state requiring to be expelled, the other has acquired the utmost degree of fitness necessary to effect its expulsion. Now after the expulsion of the foetus, since, according to the laws of de-

* Professor KÖLLIKER has described the fibres both of the unimpregnated and impregnated uterus. The latter he has described and figured as having nuclei, which I have never been able to verify although I have examined these fibres with the greatest possible care.

velopment, it is as impossible that these fibres of the impregnated uterus can return again to their primitive or embryonic condition, as that a full-formed foetus could relapse into the state of an ovum, they must necessarily become absorbed, and therefore a new set of embryonic fibres would require to be formed for the expulsion of the next ovum, so that each foetus will have, according to this conclusion, its own peculiar expulsive fibres. This view is perfectly in accordance with the late researches of Drs. SHARPEY and WEBER on the membrana decidua; and it agrees with the same function in vegetables, in which the part corresponding to the uterus in animals is always cast off after its contents have been brought to maturity, and separated from the parent plant.

DESCRIPTION OF THE PLATE.

PLATE XXXIX.

- Fig. 1. Represents some muscular fibres taken from the central part of the round ligament of the uterus of the human subject, where it is situated between the layers of the broad ligament.
- Fig. 2. Represents some muscular fibres taken from a part of the round ligament nearer to the uterus than those shown in fig. 1: there the termination of the striated fibres in fasciculi of granular ones is shown.
- Fig. 3. Represents nucleated fibres taken from the unimpregnated human uterus, and the granular matrix in which they are imbedded.
- Fig. 4. Represents fibres taken from the impregnated human uterus at the eighth month of pregnancy.



XXVII. *On the Communications between the Cavity of the Tympanum and the Palate in the Crocodilia (Gavials, Alligators and Crocodiles).*

By Professor OWEN, F.R.S. &c.

Received December 20, 1849,—Read February 28, 1850.

THERE are three perforations which succeed each other along the middle line of the base of the cranium in the Crocodilian Reptiles. The hindmost (Plate XL. fig. 1, *v*), situated in the basioccipital, near the condyle, is the smallest and least constant in size and existence: it gives passage to a vein, which traverses a vertical canal in the bone homotypal with the vertical vascular canal that opens upon the under surface of the bodies of the vertebræ of the trunk. The next foramen in advance, *e*, is larger and on a lower level; it is constantly present and is regular in its size and position: it perforates the fore part of the basioccipital close to the basisphenoid. The third or anterior foramen, *n*, is the largest, and opens on a still lower plane: it is formed entirely by the pterygoids, which it perforates in a forward direction, and is the posterior aperture of the nasal passages.

There exists a difference of opinion as to the nature of these latter foramina, and especially as to the function of the middle foramen, *e*, viz. that which perforates the basioccipital close to the basisphenoid. CUVIER describes it in his celebrated chapter on the Osteology of the Crocodile, in the last volume of the ‘*Ossemens Fossiles*,’ p. 78, 4to, 1824, as leading to “a canal which traverses the body of the sphenoid, and terminates by two branches opening into the ‘*sella turcica*,’ and, at p. 133, he refers to it in the cranium of the ‘*Gavial de Caen*’ (*Teleosaurus cadonensis*, GEOFFROY), as an arterial foramen (‘*le trou des artères*’).” The continuators of CUVIER, in the posthumous edition of the ‘*Leçons d’Anatomie Comparée*,’ t. ii. p. 523, describe the foramen in question more accurately, as leading to a canal which bifurcates as it ascends; one of the branches traversing obliquely the body of the sphenoid, whilst the other perforates the basilar part of the occipital, and opens into the cavity of the internal ear. They do not state where the branch terminates which traverses the basisphenoid*, nor what passes through either canal.

In the description of the tympanic cavity of the Crocodile†, no mention is made of this communication, or of the Eustachian tube, which is described in the Saurians

* I use here, and throughout this paper, the English equivalents of the French phrases defining the bones of the Crocodile’s skull, according to the table of synonyms, No. 1, in my work ‘*On the Archetype of the Vertebrate Skelton*,’ 8vo, 1848.

† *Op. cit.*, tom. iii. p. 512.

generally as communicating with the palate by a wide and short canal (p. 511). But in a supplementary paragraph to CUVIER's description of the foramina in the base of the skull of the Crocodile, the osseous aperture of the Eustachian tube is stated to be perforated in the exoccipital, near its junction with the basioccipital, and to be situated below the anterior condyloid foramen*.

In the 'Report on British Fossil Reptiles,' communicated to the British Association in 1841†, I described the foramen in the basioccipital, *e*, as the common terminal canal of the Eustachian tubes, and the foramen in advance of it, *n*, as the posterior aperture of the nasal canals.

In the 'Abhandlungen über die Gavial-artigen Reptilien des lias-formation,' fol. 1841, by Professors BRONN and KAUP, it is argued at great length (pp. 12, 16, 24) that the median foramen, *e*, is the true posterior aperture of the nostrils; and a letter from Professor DE BLAINVILLE, dated December 8th, 1841, is cited by those authors in support of their view, in which letter CUVIER's determination, that it was 'an arterial foramen,' is rejected, and Professor BRONN's opinion is stated to be completely confirmed by the appearances in the original fossil skull of the *Teleosaurus* from Caen, described and figured by CUVIER.

Besides the median foramina above specified, there are several lateral foramina, in symmetrical pairs, in the same part of the base of the skull of the Crocodile. One on each side the base of the condyle, Plate XL. fig. 1, *p*, is the 'precondyloid foramen,' which gives exit to the hypoglossal nerve: external to this is a larger foramen, *t*, through which pass the eighth pair of nerves and a vein from the tympanic cavity; below these, and still in the exoccipital (2), is the foramen, *c*, described by the continuators of CUVIER as the bony outlet of the Eustachian canal; and still lower down, in the suture between the basioccipital (1) and basiphenoid (5), is the foramen, *el*, which I have not found noticed by any anatomical author.

The decisive test of the nature of these latter foramina, *el*, and of the different opinions respecting the foramina, *c*, *c*, and the median foramina, *e* and *n*, was, of course, to be sought for in the results of an accurate anatomical examination of the parts in the recent Crocodile. I have, accordingly, availed myself of the opportunities liberally afforded to me by the Council of the Zoological Society, to dissect for this purpose specimens of an Alligator (*Alligator lucius*) and a Crocodile (*Crocodilus acutus*) which have died at the Zoological Gardens; the examination being made after injecting the vessels of the head with coloured wax.

The entocarotid arteries (Plate XL. fig. 2, *c*) enter the foramina (fig. 1 *c*, *c*) situated, one in each exoccipital bone, 2, at the side of the base of the condyle, below

* "Le trou condyloïdien est dans l'occipital latéral, et en dehors de lui est un trou assez grand pour des vaisseaux. L'ouverture osseuse de la trompe d'Eustache est au dessous des précédents, aussi dans l'occipital latéral, et tout près du point de réunion de cet os avec le basilaire et le sphénoïde."—Leçons d'Anat. Comp. tom. ii. p. 524, 1837.

† Reports, 8vo, p. 96.

the outlet for the hypoglossal and eighth pair of nerves, *t* and *p*. In a young Crocodile, with a head of eleven inches in length, the common trunk, fig. 2, *cc*, of both carotids is continued along the under surface of the cervical vertebræ as far as the dentata, where it bifurcates into the two carotids: these diverge, ascend, inosculate with the vertebral artery, *v*, and subdivide into the ectocarotid, *ec*, and entocarotid. The latter artery, *c*, at the first part of its course, extends obliquely forwards inwards and upwards, protected by a bony canal, half an inch in length, which terminates by projecting freely as a tube of a line in length (Plate XLI. fig. 4, *c*), opening into the cavity of the tympanum beneath the bony plate, 16, to which I have restricted the term 'petrosal*.' The artery emerging from the bony canal extends forward across the base of the tympanic cavity, covered only by a reflexion of its lining membrane, for about a third of an inch, and then enters a second bony canal, opening into the fore part of the tympanum, and continued to the 'sella turcica,' where the carotid enters the cranial cavity, as is shown in Plate XL. fig. 3, *c*.

No artery enters the single median foramen, Plate XL. fig. 1, *e*, situated close to the suture between the basioccipital and basisphenoid. The soft palate which covers this part, immediately behind the true posterior nares, forms a subcircular protuberance with a single central aperture (Plate XLI. fig. 5); this aperture is also partly closed by a valvular membranous prominence, *x*, which reduces its area to a crescentic form. This orifice in the soft palate is not, as I had supposed, continued exclusively from the bony orifice in question, *e*, immediately above it; but is the common palatal outlet of three canals, one of which, *e*, is median, extending into the bony canal, figs. 6 and 7, *e*, which ascends into the substance of the basisphenoid; the other two, *el*, are membranous for the extent of eight lines, and diverge as they ascend to penetrate the fissures, fig. 7, *el*, one on each side of the larger median foramen, and which lead to canals, fig. 7, *el'*, extending upwards between the basioccipital and basisphenoid.

From the inferior openings, Plate XL. fig. 1, *el*, of these canals in the dry skull, grooves lodging their membranous prolongations are continued to the common median fossa into which the middle osseous canal, fig. 7, *e'*, opens by the foramen, *e*, in question. Dissections of the recent parts demonstrated that this foramen, like the two lateral canals, communicated by a membranous tube (fig. 5, *e*) with the surface of the palate and would receive air from the mouth. It was next to be determined where the air would be conducted by those tubes; and the passage leading from the median foramen was first traced. In an alligator with a head 14 inches in length, the foramen, *e*, leads to a canal lined by a continuation of the palatal membrane, which ascends along the suture between the basioccipital and basisphenoid, for nearly 2 inches, and then bifurcates; one branch inclining forward into the basisphenoid, the other rising vertically into the basioccipital, and both in the same

* It was probably the observation of this structure in the dry skull that misled the continuators of CUVIER into the belief that the canal, *c*, was the osseous part of the Eustachian tube.

median plane. I followed out the further course of these canals in the skull of a *Crocodilus acutus* of about the same size as the recent Alligator. Figure 7, Plate XLI. shows the common median canal extending from e to e' , where it divides. Each of these branches subdivides, and sends its subdivisions, one to the right the other to the left, to communicate with the tympanic cavity. The lateral canals, $e'l'$, which commence below at el , one on each side of the median foramen, communicate with the lateral subdivisions, eo , of the posterior or basioccipital branch of the common median canal; a small rhomboidal sinus, eo' , being formed at their point of union, from which a short canal is continued to the tympanic cavity. Thus each lateral canal, $e'l'$, with each posterior lateral subdivision, eo , of the basioccipital branch of the median canal, has a common opening into the base of the tympanic cavity of its own side. Each lateral subdivision, es , fig. 8, Plate XLII., of the anterior or basisphenoid branch of the median canal opens into the tympanic cavity at es , fig. 10, in advance of the preceding orifice. The lining membrane of these several canals here becomes continuous with that of the tympanic cavity.

Thus it was seen that no passage from the median orifice or canal in question, e , figs. 1 and 7, between the basioccipital and basisphenoid, conducted to the nasal passages, but that all the branches from that common orifice opened into the tympanic cavity: at the same time it was demonstrated, that the communication between the tympanum and the palate, commonly called the 'Eustachian tube,' was more complex in the Alligator and Crocodile than had been suspected, or than was known to exist in any other animal. It may be described as follows:—From each tympanic cavity two passages are continued downward, one from the fore part, Plate XLII. fig. 10, es , the other from the floor, $ib. eo$, of the cavity. The anterior canal, es , passes downwards and inwards, expands and again contracts before it unites with its fellow from the opposite side at es' , fig. 8, to form a median canal, es' to e' , which passes from the basisphenoid to the space or broad suture between that bone and the basioccipital, where it terminates in the single subvertical canal, e' to e , descending along that suture to the median foramen in question, e , fig. 1.

The opening at the floor of the tympanic cavity, eo , fig. 10, leads to a short canal, eo , figs. 7 and 8, which curves towards its fellow from the opposite tympanum, but first swells into the rhomboid sinus, fig. 7, eo' , and divides; one branch descends almost vertically, $e'l'$, and terminates by the small foramen, el , fig. 1, in the osseous groove or channel leading to the central aperture and fossa; the other branch, eo to eo' , fig. 8, continues the course inwards and downwards until it meets its fellow at the median line of the basioccipital at eo' , and forms the posterior primary division of the common median canal, eo to e : this soon joins the anterior division, at e' , to form that common canal, which then descends and terminates by slightly expanding into the foramen, e , at the middle of the fossa between the basioccipital and basisphenoid; which fossa receives also the grooves lodging the membranous canals from the lateral fissures. Finally, the three bony canals terminate by their membranous continuations

e and *el*, fig. 5, Plate XLI., in the single Eustachian valvular outlet, *x*, on the soft prominence behind the posterior nares, *n*.

The canals from the lateral orifices, *el*, are partially divided by a longitudinal ridge of bone projecting into them from their anterior wall: and the dilated lateral branches of the alisphenoid division of the median canal, *es*, are impressed by a longitudinal groove. I may also remark, that at the upper part of their place of confluence or termination, there is a median fossa leading to a small vascular canal.

The tympanum of the Crocodiles, Plate XLII. fig. 10, is very extensive, by reason of the air-cells continued from it, not only into the mastoid, but across the basioccipital and basisphenoid*, and into the exoccipital, supraoccipital†, alisphenoid and parietal bones‡.

By the dissection of a young Gavial of the Ganges, preserved in spirits, and a comparison of this with sections of the cranium of a full-grown specimen, I have satisfied myself that the third median system of Eustachian tubes, as well as the two lateral tubes, exist in the Gavials as in the Alligators and true Crocodiles; only in the Gavial the common terminal canal of the median system is shorter, as is shown in Plate XLII. fig. 9, *e*, *es*, *eo*.

It appears to have been still shorter in the extinct *Teleosauri*; the posterior primary division of the canal which penetrates the basioccipital forms, in the section of the skull of the Caen Teleosaur, a subcircular depression, which is filled with the matrix in the Parisian specimen. The anterior primary division, answering to *es*, fig. 9, plainly perforates the substance of the basisphenoid, as it ascends obliquely forwards, and therefore can by no means be regarded as the posterior termination of the nasal passages, which, in the *Teleosauri*, are surrounded exclusively by the pterygoids, as in all the existing forms of *Crocodylia*.

With regard to the homologies of the above described complex Eustachian or palato-tympanic air-passages in the *Crocodylia*, the lateral bony canals, *el'*, fig. 7, terminating at the grooves, *el*, answer to the simple Eustachian tubes of lizards and mammals: the median canal, *e*, *e'*, with its dichotomous divisions, is a speciality peculiar to the *Crocodylia*.

I forbear, with my present limited experience of the living habits and actions of the Crocodylian Reptiles, to offer any hypothesis as to the function of the complex canals which conduct the air and would convey its sonorous vibrations from the nose to the ear: but one peculiarity I may suggest, as being probably related to the structures in question, in which the Crocodiles and Gavials differ from all the Lizard-tribe, viz. that of habitually floating with the operculated meatus externus submerged, and only the eyes and the prominent nostril exposed above the surface of the water. Any noise in the air that might reach the floating reptile would, under such conditions, be conveyed to the tympanum by the canals conducting to that cavity from near the

* On the Archetype of the Vertebrate Skeleton. 8vo. VAN VOORST, fig. 9, p. 22, 1 and 5.

† *Ibid.* 3.

‡ *Ibid.* fig. 19, p. 120, 6 and 7.

hinder opening of the long nasal passage; and it may also be remembered, that there is a peculiar valve in the Crocodiles which shuts off all communication between that passage and the mouth.

DESCRIPTION OF THE PLATES.

PLATE XL.

Fig. 1. A view of the hinder part of the base of the skull of a Crocodile, showing :—

- v.* The venous foramen.
- e.* The median Eustachian foramen.
- el.* The lateral Eustachian foramina (the canal, *el'*, is laid open on the right side).
- n.* The posterior nasal aperture.
- c.* The carotid foramina.
- p.* The precondyloid nervous foramina.
- t.* The foramen jugulare.
- 1. The basioccipital.
- 2. The exoccipital.
- 5. The basisphenoid.
- 24. The pterygoid. The bristle ending at this figure is passed through the median canal and right subdivision of its basioccipital branch through the sinus of communication with the lateral canal, which is laid open between *t* and *c*.

Fig. 2. A view of an injected preparation of the *Crocodilus acutus*, showing the course of the carotids *cc*, vertebral artery *v*, and entocarotid *c*, to its foramen, and through the posterior bony canal into the tympanic cavity.

Fig. 3. Showing the emergence of the entocarotids, *c*, from their anterior bony canals opening into the sella turcica, their sinuous course forwards, and confluence into the single artery continued into the rhinencephalic division of the cranium.

PLATE XLI.

Fig. 4. A section of the skull of a *Crocodilus biporcatus*, showing the free or prominent tubular termination of the posterior bony carotid canal in the tympanic cavity; *c*, a style passed through the canal; 16, the petrosal.

Fig. 5. A section of the bony and soft parts of the palate of an Alligator (*All. lucius*), showing the posterior nares, *n*, the common median valvular aperture, *x*, of the median, *e*, and the two lateral, *el*, Eustachian canals; bristles are passed along the membranous portions of these tubes.

Fig. 6. The opposite side of the same section, showing the median bony Eustachian canal, *e*, the lateral membranous Eustachian canals, *el*, cut off where they join the lateral bony canals, and the pterygoid air-cells, *pt*, communicating with the posterior nares, *n, n*.

Fig. 7. A section of the cranium of the *Crocodylus acutus*, showing the course of the median Eustachian canal, *e*, to its bifurcation at *e'*, the division of the basioccipital branch, *e'* to *eo*; the course of the left lateral Eustachian canal, *el'*, to its communication, at the rhomboidal sinus, *eo'*, with the tympanic branch of the basioccipital division of the median Eustachian canal.

PLATE XLII.

Fig. 8. A vertical section of the cranium of the *Crocodylus biporcatus*, a little to the left of the median line, showing part of the left tympanic branches, *es, eo*, and the orifices, *es', eo'*, of the right tympanic branches, of the primary divisions of the median canal, *e'* to *e*.

Fig. 9. A vertical median section of the cranium of a Gavial, *Gavialis gangeticus*, showing the basioccipital division, *eo*, and the basisphenoid division, *es*, of the median Eustachian canal, *e*.

Fig. 10. A vertical section of the tympanic cavity of the *Crocodylus biporcatus*, showing bristles inserted into the basioccipital branch, *eo*, and basisphenoid branch, *es*, of the Eustachian tube; *c*, the entry of the entocarotid canal.

XXVIII. *On the Structure of the Dental Tissues of the Order Rodentia.*By JOHN TOMES, *Surgeon-Dentist to the Middlesex Hospital.**Communicated by WILLIAM BOWMAN, Esq., F.R.S.*

Received February 19,—Read May 30, 1850.

IN a memoir on the Structure of the Dental Tissues of Marsupial Animals, printed in the second Part of the Philosophical Transactions for 1849, I pointed out certain peculiarities in the structure of the enamel common, with one known exception only, throughout that order of quadrupeds, and found in other mammalian teeth in a few isolated cases only*.

* Having in a former paper † stated that the continuation of the dentinal tubes into the enamel appears to be a constant character in the teeth of marsupial animals, excepting only in those of the Wombat, I can now add that I have found it to hold good in many other members of the families from which I have already given examples; and also in members of those families which are not mentioned in my paper; and moreover, that further research has exposed no other exception to the rule than that which I have already cited.

I find that in *Macropus penicillatus* most, if not all, of the coronal dentinal tubes are continued into the enamel, and in the latter part of their course are bent rectangularly downwards towards the fang of the tooth. In *Halmaturus Derbyanus* the dentinal tubes are continued into the enamel, but are not subject to the terminal flexure observed in the preceding example. The dental tissues of the *Dasyurus viverrinus* closely resemble those of the *Dasyuri* already described. The teeth of *Didelphis californica* and *Didelphis cancrivora*, approach very closely in structure to those of the *Didelphis virginiana*.

I am indebted to Mr. GOULD for opportunities of examining the teeth of *Myrmecobius fasciatus*, *Perameles nasuta* and *Chacropus*. In each of these creatures the dentinal tubes are continued into the enamel. In *Phascolarctos fuscus*, the dentinal tubes that proceed towards the tubercles of the teeth are continued in considerable numbers into the enamel; but on the sides of the teeth their continuation is less frequent. Here the enamel fibres are more strongly marked, and larger than in any other marsupial tooth that I have examined.

Several specimens of fossil marsupial teeth have been examined, and are found to correspond in structure with those of the recent species, to which the fossil ones are most nearly related.

November 24, 1849.

† Philosophical Transactions, Part II. for 1849.

It is the purpose of the present communication to lay before the Society results obtained from an examination of the teeth of various members of the order Rodentia. I have had the opportunities necessary for extended researches in this division of Odontography, partly through the assistance of numerous friends, but principally through the liberality of the Council of the Zoological Society, who granted me the privilege of examining teeth from the duplicate specimens of their large collection of skulls. At the time I commenced the investigation, there seemed but little hope of finding any strongly marked and characteristic differences of structure in the dental tissues of the several families of this order of quadrupeds. The teeth of many rodents had already been submitted to the microscope, and the results published*. I had not proceeded far, however, in the investigation of this highly interesting subject, before it became apparent to me that the family Hystricidæ and the Sect. Bathyergina of WATERHOUSE have a constant and exclusive character in the structure of the enamel; that the Sciuridæ have another character; that the first and second sections of the family Muridæ possess a third; and that the remaining sections of that family possess a fourth well-marked character, and the Leporidæ a fifth. I am told by Mr. WATERHOUSE that these results are of great importance, as affording evidence on the position of several species whose place in the order has not been definitely fixed, either by their external characters or by the structure of the skull, and hence they have been variously placed by naturalists, and even by the same author at different times.

Before entering on a description of the structural characters that pertain to the teeth of the rodentia families, or of individual teeth, it will be desirable to state those conditions which are common to the whole order, otherwise it would be necessary to repeat frequently the same fact. It has long been known that the incisors of Rodentia have the property of unlimited growth, and that the rate of growth equals the rate of loss by wear; hence the exposed portion of the tooth is, in the normal state of the dental apparatus, maintained of uniform length. The pulp-cavity in a longitudinal section of the tooth is irregularly conical or wedge-shaped, and in a transverse section corresponds in some measure with the outline of the tooth. The dentinal tubes pass from every part of the cavity outwards and upwards towards the surface in more or less curved lines.

The tubes which proceed from the cavity near the base of the tooth, are in many cases perceptibly larger than those that are situated higher up; hence it follows, that, as the latter were once near the base of the tooth, the dentinal tubes undergo a diminution of calibre after their formation. In the teeth of the Sciuridæ, I have found a difference of size amounting to a third or half between the tubes near the base and those near the surface, in wear. Professor OWEN has observed that the tubes in the posterior or lingual half give off larger and more numerous branches than those constituting the anterior half of the tooth. My own observations lead to the conclusion, that this difference does not always exist near the surface of the pulp-cavity,

* Odontography, Prof. ERDL.

but is generally present towards the outer surface of the tooth. The tubes in the anterior half gradually diminish in calibre from their commencement, while those in the posterior half retain their dimensions until they arrive near the surface, where they break up into branches.

At and near the apex of the pulp-cavity the development of dentinal tubes is suspended. The tooth at this point is rendered solid by the conversion of the pulp into a clear laminated subgranular mass, into which very few, if any tubes are continued; and the few that are sometimes found are usually small in size, irregular in form and direction, and never reach the centre. The ends of the dentinal tubes are perfectly sealed up, and their connection with the pulp-cavity and its vascular contents completely cut off in the manner shown in Plate XLIII. fig. 1. The perfected part of the tooth is rendered by this process in the fullest sense of the word extra-vascular. A similar condition may be seen in the molars of persistent growth, and offers a striking difference to the condition of the rooted teeth, in which the dentinal tubes retain their connection with the pulp-cavity until the tooth becomes diseased or dead, or the crown worn down by mastication. In the latter case, as the crown wears down, the pulp is converted into secondary dentine, in which but few tubes exist, and these do not reach a vascular surface like that which lies in contact with the surface of the pulp-cavity in the normal state of the tooth.

Professor OWEN*, after describing the manner in which the incisor teeth of rodents are developed, says, "The tooth thence projecting consists of a body of compact dentine, sometimes with a few short medullary canals continued into it from the persistent pulp-cavity, with a plate of enamel laid on its anterior surface, and a general investment of cement, which is very thin upon the enamel, but less thin, in some rodents, upon the posterior and lateral parts of the incisor."

The medullary canals described by Professor OWEN, pursue a course parallel with the dentinal tubes, form a narrow loop, and return to the pulp-cavity. The dentinal tubes never radiate from them, but enter through the medium of lateral branches only (fig. 5). Hence the teeth so constituted do not form an exception to the law, that the incisors of rodents are formed of a single denticle †, which, exclusive of the enamel, is comparable to an Haversian system.

* Odontography, page 399.

† It is proposed to restrict the term *dentinal system* to a canal from which dentinal tubes radiate (fig. 2), and *denticle* to a dentinal system coated with enamel or cementum; and that a tooth composed of a series of dentinal systems, each coated with enamel and united into one tooth by cementum, shall be described as a tooth composed of denticles. The molars of the Capybara afford an excellent example of a tooth constituted in the latter manner, while the *Orycteropus* affords an equally good example of a tooth compounded of a series of dentinal systems—a tooth in which we have a number of medullary canals from which dentinal tubes radiate, the terminal branches of which inosculate with the terminal branches from neighbouring systems, either by confluence or the intervention of small cells (fig. 2). Teeth composed of a series of dentinal systems may or may not have an external investment of enamel; in the *Orycteropus* enamel is absent, while in the *Labyrinthodon*, *Varanus* and *Lepidosteus*, it is present near the upper extremity of the tooth. The dentinal systems commonly run into each other at some

In those rodents whose molars are of persistent growth, whether the tooth is composed of denticles or confluent denticles, the dentinal tubes of that part of the tooth which is protruded and exposed to wear, are cut off from their connection with the pulp-cavity in the same manner as in the incisors. This beautiful provision of nature for rendering solid and extra-vascular parts that are about to be exposed to mechanical abrasion from external objects, is not confined to the teeth of rodents, or to dental tissues alone.

The *Orycteropus* has teeth which are permeated by a series of canals, which take a parallel course at tolerably regular intervals in the length of the tooth. From each canal a system of dentinal tubes radiates, the terminal branches of which inosculate with corresponding ones from neighbouring systems. In the protruded portion of the tooth, the medullary canals are rendered solid by the development of a clear non-tubular tissue, whereby the once open extremities of the tubes are closed (fig. 2).

The teeth of reptiles of the genus *Varanus* are at their middle part and base composed of a series of dentinal systems, as are those of the *Labyrinthodon** (fig. 3). In

parts, in the same manner as the Haversian systems do in bone. But there are many instances in which parallel dentinal systems are united to each other, throughout their whole length, by a thin longitudinal lamina of dentine, the tubes of which belong as much to the one as to the other system, while the free parts of each system are coated with enamel, and this with cement. The molar teeth of the Water-Rat and *Ondatra* offer good examples. It is desirable to have a term to express this condition; *confluent denticles* would, I think, answer the purpose, and *confluent dentinal systems* where a like condition is observed, without the presence of enamel or cementum as a uniting medium.

* It has been usual to describe the tooth of the *Labyrinthodon* as being divided into numerous compartments, by tortuous inflections of the cementum from the surface towards the centre. I believe it is admitted by writers on Odontology, that when enamel and cementum are present in the same tooth, the latter tissue holds a position external to the enamel. Professor OWEN, in his paper on the teeth of the *Labyrinthodon*, printed in the Geological Transactions, says of the *Ichthyosaurus*, "In this extinct Saurian the external layer of cement (for the enamel ceases at the base of the crown) is inflected at pretty regular distances around the circumference of the tooth towards its centre:" then again, "The plan and principle of the structure of the tooth of the *Labyrinthodon* are the same as those of the tooth of the *Ichthyosaurus*, but are carried out to the highest degree of complication." But in a beautiful series of sections of the tooth of the *Labyrinthodon Jaegeri* in the possession of Dr. MANTELL (to whom I am indebted for their use), it is clearly shown that the division of the tooth into numerous compartments takes place within a general investment of enamel, external to which the cementum would be placed if it existed on this part of the tooth.

The inflections of the cementum, observed by Professor OWEN in the tooth of the *Ichthyosaurus*, and compared by him to the supposed inflection in the tooth of the *Labyrinthodon*, take place, as he observes, below the terminal line of the enamel; hence the two cases do not admit of comparison. Similar cells to those which occupy the line which lie between the dentinal system and serve as a medium of connection between the dentinal tubes of adjoining systems in the latter animal, are found in equal or even greater numbers near the periphery of the dentine, and within the enamel of very many teeth. Hence the presence of these cells in the tooth of the *Labyrinthodon* is not sufficient to prove the existence of cement between the dentinal systems, unless it is at the same time shown that they are external to the enamel, or that that tissue is absent. The tooth of the *Labyrinthodon* is in truth made up at its apex of a single dentinal system coated with enamel; below, it is divided into numerous systems, which have a peculiar and characteristic outline and position. Each system usually coalesces at one part of its circumference with a neighbouring system, by a narrow vertical process of

fish we have the teeth of the *Dendrodon*, the *Lepidosteus*, *Myliobates*, and sharks of the genus *Lamna*, also composed of a series of dentinal systems. In all of these the open extremities of the dentinal tubes are closed previous to the part being exposed by wear. A similar condition, in a beautiful state of preservation, is found in many fossil fish teeth, especially in the *Cestracion*s. I cannot refrain from noticing one other instance of this condition. The antlers of the Stag are composed of Haversian systems of medullary or vascular canals, surrounded by concentric laminae of osseous tissue interspersed with lacunae, the canaliculi of which anastomose freely, and those situated near a vascular canal terminate by open mouths on its surface. Previous to the shedding of the antler, each of the larger canals becomes lined with a layer of transparent, dense and almost structureless tissue, which completely closes the mouths of the canaliculi and cuts off the connection of the elaborate system of tubes and lacunae with the vascular canals (fig. 4).

The division of the enamel of the incisors into two layers, described by Professor OWEN, I have found common throughout the order, excepting in the incisors of the Hares and the Rabbit: the *Lagomys* I have not had an opportunity of examining, but from their close relation to the Hares, it is more than probable that in their incisors the enamel is not divided into an outer and inner layer.

The term layer is open to objection, as the two parts are made up of continuous fibres. In the inner part they decussate, while in the outer they are parallel, but their continuity may be distinctly traced (fig. 6 to 50). In the molars of many Hystricine teeth, the usual order is reversed; in the inner portion the fibres are parallel, and in the outer part of the enamel they decussate.

Professor OWEN, in the passage cited, and in other parts of his great and valuable work, states that the cementum is continued over the enamel in the incisors of rodents, and objects to some of Professor ERDL's figures printed in his work on the *Microscopic Structure of the Molars of Rodentia*, because this tissue is left out. He says Professor RETZIUS failed to recognize the cementum from its being coloured. Professor OWEN*, in his description of the incisor of the Water Vole, says, "The layer of cement becomes thinner at the margin of the enamel, where it is continued from the dentine upon that part, but soon increases in thickness, acquiring the bright brown tint, and separated by a well-defined line from the outer clear layer of the enamel."

I have sought with care for cementum on the anterior surface of the incisors of the Water Vole, of which the foregoing quotation is a description, and also in numberless other teeth, but have failed to find that tissue. In most, if not in all incisors of rodents, cementum may be seen investing the posterior surface, and it may be traced dentine, much in the same manner as the confluent denticles of the molar teeth of *Rodentia* are united. In the teeth of the *Lepidosteus* and Lizards of the genus *Varanus*, the dentine of the middle and basal portions is divided into systems somewhat in the same manner as in the *Labyrinthodon*, and in the upper part of the tooth within a general circumferential investment of enamel. I have in my possession sections from two species of *Varanus*, *V. Bellii* and *V. Niloticus*, in which this point is incontrovertibly shown. I am indebted to the kindness of Dr. ANDREW SMITH for the teeth of these species.

* *Odontography*, page 405.

on to the edge of the enamel, where it speedily thins and is lost. The bright brown coloured part is very distinct in many teeth, and when the section is thick and a little oblique looks like a distinct layer; but if the section be reduced in thickness, all appearance of a layer will be lost. The colour graduates insensibly into the enamel, and no defined line of separation between the coloured and colourless parts can be distinguished. The colour has the aspect of a stain, deepest at the surface, and fading as it proceeds inwards. In a favourable section, the enamel fibres may be traced through the coloured part to the surface of the tooth, as shown in many of the figures. In the molar teeth of continuous growth, the cement may be traced over the whole surface of the enamel, and as a thin transparent layer devoid of lacunæ. In these teeth it is however separated from the enamel by a sharply-marked boundary line. In no instance have I found it graduated into the latter tissue in the manner Professor OWEN supposes it to be in the coloured external portion of the enamel of the incisors. In the incisors of the Wombat, the cementum is continued over the enamel, but the two tissues are separated from each other by a sharply-marked line. The cementum is nowhere graduated into, or "blended with*" the enamel. It is more than probable that the thin transparent and almost structureless basement tissue of the enamel-pulp becomes calcified with the attached columns of the pulp itself, but this tissue is quite distinct from the cementum matrix, and exists in those teeth in which we have an external investment of cement.

The rootless molars of rodents have generally a very close resemblance in structure to the incisors, especially in the structure of the enamel. But the rooted molars are less like the front teeth, and in many instances cannot be distinguished by their structure from other small teeth. In the Rat-tribe, however, the enamel near its terminal edge assumes an arrangement similar to that of the incisors. In those molars which have an intermediate character, the structure of the enamel in the upper part of the tooth resembles that of the rootless molars †.

* Odontography, page 405.

† In describing individual teeth, it will be necessary to repeat frequently the same expression, I will therefore state once for all the meaning I attach to such terms. Thus by a vertical or longitudinal section of an incisor, I mean a section from back to front through the median line of the long axis of the tooth; by an oblique section through the long axis of the tooth or oblique longitudinal section, I mean that the section should pass from the mesian side of the anterior to the outer side of the posterior surface of the tooth, or *vice versa*; by longitudinal section from the anterior surface, I mean a section by which a portion of the anterior convex surface is removed with a portion of enamel at each end of the section; by a transverse section, a section at a right angle with the long axis of the tooth; by an *oblique transverse section*, or a section parallel with the surface in wear, a section crossing the long axis of the tooth obliquely from back to front. The surface in wear will be described as the upper surface, both in upper and lower teeth; and the angle at which the enamel layer leaves the dentine, will be that formed between the enamel lamellæ and the surfaces of the dentine immediately above them.

When the thickness of the enamel and the dentine is given, the measurements will be taken from back to front, through the centre of the long axis of a transverse section.

Teeth obtained from the Zoological Society are indicated by the Society's name being affixed to the name of the species.

In the genera *Sciurus* and *Pteromys*, I have examined the dental tissues of many species, and find the teeth so like the one to the other, that the microscope affords no aid in the distinction of species. Under these circumstances it will be necessary to describe minutely the structure of the component tissues of the teeth of one species only.

Sciurus niger, LINN. (Zoological Society).—The anterior surface of the incisors is coated with an extremely thin layer of enamel, scarcely exceeding in thickness the 428th part of an inch. The dentine measured from the front to the back, is about the 8th part of an inch in thickness. A longitudinal section, taken from the centre of an upper incisor, exhibits the dentinal tubes in their length. Those destined for the anterior half commence at the surface of the pulp-cavity, and proceed with slight secondary undulations, and a decreasing calibre upwards towards the enamel. In the earlier part of their course, a few short, minute, rectangular branches are given off, and are soon lost; but when nearing the enamel, the tubes break up into a lash of branches, which pass onwards with but slight divergence, and after becoming excessively minute, are lost at the juncture of the external tissue; a few, however, terminate by forming loops. The dimensions of the dentinal tubes vary at different parts of the same tooth. At the lower part of the pulp-cavity the tubes destined for the anterior and posterior surfaces have a diameter of the 6000th of an inch, while those that proceed from the upper and narrowed part of the pulp-cavity, and from the central line of the solid part of the tooth, seldom exceed the 14,000th of an inch, and are often reduced to a scarcely perceptible line. Usually they do not preserve this small size, but quickly dilate to the 10,000th or 12,000th of an inch; these conditions are not however peculiar to the teeth of this group. The tubes that form the posterior part of the incisors give off branches pretty freely throughout the whole of their course, and when near the surface break up into a rich plexus of anastomosing tubules, in addition to which they occasionally dichotomize. Many of the earlier branches are small and short, but a few are large, go off at a right angle, and may be traced for some distance crossing the course of the neighbouring tubes. In the median line of the sides of the tooth, independent of the secondary curves or undulations, the dentinal tubes pursue a tolerably straight course, as do those in the median line of the anterior and posterior surface. But the dentinal tubes of the anterior halves of the sides describe one large curve, the convexity of which is turned towards the anterior surface of the tooth; and those composing the posterior part of the tooth follow a similar curve, the convexity of which is directed towards the posterior surface; similar relations between the tubes and the several parts of the incisor may be observed in the teeth of other rodents.

Professor OWEN*, when treating on the teeth of rodents, says, "The substances of the incisor diminish in hardness from the front to the back part of the tooth; the enamel consists of two layers, of which the anterior and external is denser than the

* Odontography, page 399.

posterior layer." He does not however anywhere state that the incisors of *Sciuridæ* have any structural peculiarity resident in the enamel, by which their teeth are distinguished from those of other rodents; neither am I aware that any subsequent author has noted its existence. Nevertheless so great a peculiarity exists throughout this family of Rodents, that a vertical section of an incisor, either of a *Sciurus*, *Pteromys*, *Tamias* or *Spermophilus*, may be recognized at first sight as belonging to the family *Sciuridæ*.

It has been usual to describe the enamel fibres from the view obtained in a longitudinal section of the tooth, from which circumstance the true structure has not been recognized. The supposed fibres are composed of layers of fibres, and each layer of a single series, the fibres of which are parallel to each other, and at right angles with those composing the layers immediately above and below. In the outer part of the enamel the fibres of all the layers become parallel, and the lamination ceases.

The enamel layers, as seen in a vertical section of an incisor of *Sciurus niger*, and portrayed in fig. 6, are about the 6000th of an inch in thickness, and have straight and even margins. They form a right angle with the surface of the dentine, increasing slightly in thickness in their course outwards (fig. 6 E). Each layer is composed of a single series of squarish fibres, laid side by side, and closely united. During the first part of their course they are straight and parallel, and proceed to the right in one layer and the left in the next, at such an angle as to produce a square pattern over the inner part of the enamel. The appearance thus produced in the central part of the enamel of a transverse section is shown in fig. 7 E. On the side of the incisor the decussation is less strongly marked, and at the thin terminal edges is almost lost. The fibres, after traversing in a diagonal course in the horizontal plane of the tooth two-thirds of the thickness of the enamel, turn abruptly upwards and outwards at an angle of 45 degrees with their original direction. In this, the outer third of their course, the whole of the fibres become parallel, and in proceeding outwards make a gentle curve, the convexity of which is turned towards the cutting edge of the tooth. In the change of direction, the fibres which have followed a diagonal course make an angle not only in the vertical, but in the horizontal plane of the tooth, while those situated near the terminal edge of the enamel are bent in the vertical plane only.

The colouring matter resident in the enamel of the incisors of squirrels, is seen in a thin transverse section to be confined to the outer third, and looks like a stain in the terminal ends of the fibres, which diminishes in intensity from without inwards until it is lost.

In a vertical section through the centre of an incisor, viewed by transmitted light, the superimposed laminae of enamel fibres will, to an inexperienced eye, appear as parallel fibres; a little patience will however enable the observer to see that they are composed of fibres cut obliquely (fig. 6 E). In places, faint transverse markings will be seen, which indicate the oblique sections of the fibres. Not unfrequently, however, the lateral union of the fibres is so perfect, that in the layers near the cutting edge of

the tooth no transverse marking can be traced. If a section be made obliquely in the vertical plane of the tooth, so as to cut the fibres of one set of layers in their length and the others transversely, we shall have straight fibres with intervening rows of fibres cut across (fig. 8 E). If the section be taken from the protruded portion of the tooth, the cut extremities will be nearly square; but if it be taken from near the base, where the enamel has not attained its full solidity, they will have a less regular outline. Sections of this kind show that the fibres are a little longer than broad, and that the longer axis is placed in the length of the tooth.

A vertical section will however show most strongly the peculiarities that belong to this family of rodents, namely, the small relative amount of enamel, the uniform character of the layers, the uniform lines that mark their junction, and their straight and rectangular course outwards from the surface of the dentine, together with the angle at which they are bent in the external portion of the enamel.

An incisor in which these several conditions of the enamel are found to exist, may I think be safely pronounced to belong to a species included in the family Sciuridæ, and in all probability a member of the genus *Sciurus* or *Pteromys*.

The molar teeth of *S. niger* present no sufficient peculiarity in the structure of the dentine to render a description necessary. Neither can I find any point of difference worthy of notice in the corresponding teeth of *S. vulgaris*, *capistratus* or *cinereus*. In *S. erythropus* the dentinal tubes are continued, the 1500th of an inch, into the enamel, and in this short course branch in the manner shown in fig. 11 E. I have not found this peculiarity in any other squirrel which has come under my notice.

The cementum of the molar teeth is not very abundant, even at the extremity of the fang; I cannot discover that it is continued over the surface of the enamel. If a vertical section of a molar tooth from either of the species I have named be carefully examined, it will be seen that the cementum, where it commences in a thin layer, at the neck of the tooth is composed of uniform rods, directed from without inwards and a little downwards. When this tissue is thicker the rods are seen near the surface, but are lost amongst the lacunæ and their canaliculi. The cemental rods are subgranular in structure, and exceed the enamel fibres in dimension. They average the 3450th of an inch in diameter, and are portrayed in fig. 10 C. I am not aware that this character of the cementum has been previously noticed, it is not however confined to the molars of the Sciuridæ.

In the molar teeth of Squirrels the enamel is far less peculiar than in the incisors, and offers no strongly marked characters by which the teeth can be recognized. The fibres are less regular in form, less clear and transparent, and less free from minute cells than in the front teeth; neither have we a terminal portion taking suddenly an altered direction; nor is there any evidence that the fibres are arranged in parallel layers transverse to the long axis of the tooth. Their course is however, throughout, more or less waved; and although many cross each other, yet all do not; and when they do, the definite and constant angle preserved in the incisors is not observed in the molar

teeth. A vertical section of a molar of *S. niger* exhibits the usual characters of the dental tissues in these teeth (fig. 9). In *S. cinereus* the enamel fibres are in a vertical section, seem to be minutely granular, well-marked, and subject to one or two gentle curves near the surface; they are in the outer part of the tooth very strongly marked, from being highly granular, and less perfectly united laterally than in some other teeth.

Tamias Lysteri, RICH. (Zoological Society).—I have been able to procure a lower incisor only of this creature. The structure of the tooth very closely resembles the incisors of squirrels: the dentine is similar, as are the enamel layers both in shape and arrangement; and the component fibres of the contiguous layers cross each other at the same angle. The decussation however ceases, and the parallel arrangement is assumed in about the middle of the enamel; this difference, if found constant in all the species, will serve to distinguish the *Tamias* from the Squirrels.

Spermophilus (Zoological Society).—The structure in the incisors of this animal deviates a little from that in the Squirrels; in thickness, the enamel, as seen in a transverse section, is about 300th and the dentine the 12th of an inch; the dentine is much the same as in the genus *Sciurus*, excepting that the dentinal tubes of the anterior half of the tooth measure about the 7500th of an inch in diameter, while in the posterior half they average the 6000th of an inch: the enamel is different, and advances a step towards another type. The enamel layers incline upwards at an angle of 78° , instead of preserving the rectangular position, and they are less regular in their course, and less uniform in size than in the former genus. A transverse section shows that the component fibres of the adjoining layers decussate one another throughout the inner half of the enamel, and then become parallel. An oblique section in the long axis of the tooth will expose alternate straight fibres and rows of ends of fibres cut transversely; and in the latter it may be observed that they have an oval rather than a square section, the long diameter of which is one-third greater than the short; this is best seen near the cutting edge of the tooth. If the section be taken from near the base, the fibres in their transverse section are more circular, less compressed, and much less intimately united to their fellows, while at the opposite extremity of the tooth they are so closely connected, that in places the enamel seems a dense transparent structureless mass.

The enamel layers in a vertical section have a thickness of about the 5000th of an inch. In a transverse section, the fibres have a diameter of about the 10,000th of an inch in their smaller, and the 5000th in their greater diameter.

Arctomys Empetra, SCHREB. (Zoological Society).—In a lower incisor the enamel has an average thickness of 75th of an inch, and the dentine the $\frac{3}{20}$ th of an inch. The dentinal tubes have an average diameter of the 10,000th of an inch: I do not find any difference in the dimensions of the dentinal tubes at the anterior and posterior parts of the incisor. They terminate at the enamel in a peripheral layer of minute irregular cells, much in the manner shown in fig. 12 and 13. Those directed towards the back

part of the tooth, in the terminal fifth of their course, form a rich plexus of branches, and finally terminate in minute irregular cells. Then comes a thin investment of transparent cementum, which terminates at the margin of the enamel. The dentine is dotted throughout with fine cellular markings, which seem to indicate the form of the cells of the dentinal pulp previous to its calcification, and give a coarse appearance to the tissue. The dental tissues of this tooth are not distinguishable from those of the next species.

Arctomys pruinosus, GMEL. (Zoological Society).—In an upper incisor the enamel averages the 75th, and the dentine the 5th of an inch; as the dentine closely resembles that of the Quebec Marmot, the description need not be repeated. The enamel exhibits a considerable departure from that of the Sciuridæ, though not wholly different in type of structure. The fibres in the first part of their course are arranged in parallel layers, which have a thickness of about the 4580th of an inch, as seen in a longitudinal section and illustrated in fig. 12 E. The layers lie at right angles with the surface of the dentine, and extend across the inner two-fifths of the enamel, at which point the uniform lamelliform arrangement is broken up by a change in the direction of the component fibres. In a transverse section of the tooth the component fibres of the enamel layers are seen arranged in a single series, lying side by side, and crossing those of the adjoining layers at an angle so as to form a diamond pattern over the inner part of the tissue (fig. 13). The decussating fibres of the superimposed layers, after traversing the inner two-fifths of the enamel, change their direction, become more parallel, and in waved course advance upwards and outwards till they reach the surface of the tooth. But although the course is much more parallel in the outer three-fifths than in the inner two-fifths of the enamel, yet if the focus of the instrument be carefully changed, alternate layers of fibres may be seen crossing each other at an angle to form very elongated and irregular diamond-shaped figures.

The line at which the change of direction takes place is not definitely marked as in the Sciuridæ and many other rodents. In a longitudinal section, it will be seen that the fibres in the terminal part of their course are directed upwards at an angle of 70° with the surface of the dentine, and that small cells are scattered through this part of the enamel. In addition to these minute irregularly disposed cells, lines of cells may be seen commencing at the surface of the dentine, pursuing a curved course, and finally crop out at the surface of the enamel: I have not seen similar out-cropping lines of cells in the enamel of any other rodentia teeth. The enamel fibres may in a transverse section be traced through the coloured portion of the enamel to the surface of the tooth.

Castor fiber, LINN. (Zoological Society).—In an upper incisor the enamel is about the 100th and the dentine the 5th of an inch in thickness.

It has been observed by Professor OWEN, that vascular canals are continued from the pulp-cavity a short distance into the dentine. In the specimen before me, the middle third of the dentine is traversed by vascular canals, which turn short upon

themselves and return to the pulp-cavity not far from whence they started. The canals in radiating from the pulp-cavity pass directly outwards and a little upwards parallel with the course of the dentinal tubes, excepting where they turn to reverse their course, in doing which they do not occupy more than twice or thrice their own diameter. I have not observed that they ever branch or anastomose with neighbouring canals; many indeed so quickly return to the pulp-cavity, that there would scarcely be space enough for branching, while others advance a considerable distance.

The dentinal tubes destined for the anterior part of the tooth commence with a diameter of about the 7500th of an inch and give off branches in the earlier part of their course, which connect themselves with the vascular canals. The disposition to branch ceases however after they have passed the vascular portion of the dentine, and is not resumed until they come near the enamel, when they form a plexus, towards the surface of which is a layer of elongated cells, placed obliquely both to the course of the tubes and the surface of the dentine; the cells are shown in their relative position in fig. 14. Previous to the formation of the peripheral plexus, the dentinal tubes make several curves in a contour line with the length of the tooth. This point is not shown in the figure, as it occurs internal to the part represented. The dentinal tubes of the posterior part of the tooth commence with a diameter of about the 6000th of an inch.

The vascular canals measure from the 750th to the 2500th of an inch in diameter. Those situated near the worn surface are the smallest, from being lined or filled with a transparent tissue, into which the branches of the dentinal tubes do not penetrate.

In the enamel we find a further deviation from the Sciuroid type than was observed in the Marmots. The layers of enamel fibres no longer lie at a right angle with the surface of the dentine, but are directed upwards at an angle of 60° , and moreover describe a slight sigmoid curve, which terminates a little short of the centre of the enamel, from whence the fibres become parallel and proceed at an angle of 30° with the surface of the dentine. These appearances are best seen in a longitudinal section, and are shown in fig. 14 E. In a transverse section made parallel with the course of the layers, as seen in a longitudinal section, the arrangement of the fibres composing the layers becomes apparent. Each layer is composed of a single series of fibres, which pass in straight lines alternated to the right and left in the adjoining layers, and produce an infinite number of minute square tracings over the inner portion of the enamel. When near the middle the decussation ceases, the fibres become parallel and proceed upwards and outwards; but instead of proceeding directly outwards, they bear towards the median line of the skull, as shown in fig. 15. In examining the fibres in the terminal part of their course, a section must be made parallel with their length.

The enamel fibres, as seen in a transverse section, measure about the 6000th of an inch, and may be traced to the surface.

Professor OWEN says, "In a transverse section of the incisor (of the Beaver), the

distinction between the two layers of enamel is still more obvious: the fibres of the inner half, being cut across, give the appearance of fine decussation, oblique lines; while those of the outer half run transversely to the surface, and are crossed by traces of concentric layers*." That the appearance of decussation here mentioned is due to the crossing of fibres, and not to the direction of the section, is proved beyond doubt by taking a thin transverse section and breaking it across the centre, when the fibres of the layers included in the section may be viewed projecting from the broken edges; or it may be even more distinctly demonstrated by removing a little of the partially calcified enamel from the lower portion of the tooth, and placing it with a drop of water between two pieces of glass.

In the dentine of the molar teeth of the Beaver, I can find no characteristic peculiarity that needs description. The root of the tooth is composed partly of cementum, into which the dentine graduates, and through which vascular canals lead to the pulp-cavity.

The fibres of the enamel correspond in arrangement with the external portion of those which form the enamel of the incisor teeth, and like them have a greater and less diameter, the former of which is placed in the length of the tooth.

The enamel fibres are usually directed upwards at an angle of 30° with the surface of the dentine, and near the surface curve a little outwards; but they may be found in some parts of the tooth making two slight curves before arriving at the surface.

Near the upper part of the tooth the fibres are so closely united, that the enamel in places seems almost structureless; but toward the roots, and where it is reflected into the depressions, the fibres are sufficiently distinct to be examined and measured.

The enamel, where it attains its greatest thickness, is marked by oblique lines, which proceed from within outwards and speedily crop out on the surface. They appear to result from a difference of density rather than from the presence of minute cells, such as are found in the incisors of the Marmots.

The cementum of the molars is granular, plentifully supplied with lacunæ, and arranged in concentric laminæ round the vascular canals and the roots of the tooth; here and there a slight tendency to the arrangement in rods, similar to that of the *Sciuridæ*, may be observed.

Spalax typhlus, PALL. (Zoological Society).—This animal, though placed by Mr. WATERHOUSE in a section between *Murina* and *Arvicolina* in the family MURIDÆ, resembles the Beaver in the structure of the enamel more closely than any other animal, which circumstance offers a sufficient reason for describing the dental tissue in this place.

In an upper incisor the dentinal tubes present an oval transverse section with the long diameter placed in the long axis of the tooth. The long diameter attains the 5000th, while the short diameter does not exceed the 10,000th of an inch. In their passage outwards they describe a sigmoid curve, with the general direction a little

* Odontography, page 407.

upwards, and from their commencement at the pulp-cavity give off rectangular branches which take a downward course. When near the enamel, the dentinal tubes bend upwards and emit branches from the convex surface only, as shown in fig. 16 D. These are lost at the junction of the enamel and dentine, and terminate without the presence of peripheral cells, such as are found in the Beaver.

The enamel in the inner part of the tissue is arranged in transverse layers, which in a longitudinal section are seen to proceed from the surface of the dentine at an angle of 73° . Each layer measures about the 6000th of an inch in thickness, and extends about half-way to the surface, where the component fibres of the different layers assume a more parallel arrangement. The layers in a favourable section have even margins, but if the section inclines slightly from the centre of the tooth in either direction, the margins will be a little irregular; indeed this observation applies with equal force to similar sections of other rodentia teeth.

In a transverse section the contiguous layers cross each other at a right angle, and at places look as though plaited, as in the *Sciuridæ*. In the outer division of the enamel, the fibres proceed in straight lines to the surface (fig. 17). An oblique section in the length of the incisor will expose alternate layers of straight fibres, and fibres divided transversely; the appearances thus produced are delineated in fig. 16 A. On the whole, the enamel is more transparent and the structure is less distinctly marked than in any other incisor I have as yet described; indeed the peripheral division in a longitudinal section frequently seems structureless.

The enamel varies a little in thickness in different parts of the tooth, the average being about the 200th of an inch, the inner or decussating and outer or parallel being nearly equal in breadth.

The rooted molars of the *Spalax* present a slight structural resemblance to those of the *Sciuridæ*. The dentinal tubes leave the pulp-cavity with about the 7500th of an inch, which is preserved till they arrive near the enamel. In the upper and middle part of the tooth the tubes describe a sigmoid curve in passing outwards, and give off branches during the two outer thirds of their course. In a longitudinal section, the enamel is seen to be composed of fibres which pass upwards and outwards with a slight curve, and have a diameter of the 6000th of an inch.

The cement resembles that of squirrels' molars in being composed of rods arranged transversely to the length of the tooth.

In the family *MURIDÆ* of *WATERHOUSE**, a distinguishing character in the enamel runs through the various sections, excepting the three first, the fifth and seventh, and in the first of those (genus *Myoxus*) it exists partially. The teeth of the *Dormice* are in structure intermediate between those of the *Squirrel-tribe* and the *Rat-tribe*. The incisors of the *Jerboas* are however wholly different from any other members of this family, and the incisors of *Bathyergina* resemble those of the *Hystricidæ*. The *Spalax* I have already described.

* Johnston's Physical Atlas.

Myoxus avellanarius (LINN).—In the upper incisors of the Dormouse may be observed the first indications of the peculiar arrangement of the enamel layers, which holds in the great majority of the members of the family Muridæ.

The arrangement of the component layers of the enamel is, however, not alike in the incisors of the upper and lower jaws; hence a description of each is needed.

In the upper incisors, the enamel is composed of flexuous layers of fibres arranged transversely to the long axis of the tooth. In a longitudinal section each layer is seen to proceed upwards, then obliquely outwards, and afterwards again upwards, the general direction being at an angle of 70° with the surface of the dentine. The layers have serrated margins through the first curve, but during the after part of their course the margins are even, as in the Sciuridæ. The layers, after extending the 500th of an inch across the enamel, are broken up and the fibres are continued in parallel lines through the 750th of an inch to the surface, and at an angle of 30° with the surface of the dentine: these characters are shown in fig. 18 E.

The enamel layers are subject to a little variety in thickness, the average being about the 7500th of an inch; and here and there a layer may be found which gradually diminishes till it comes to a point and is lost before reaching the external portion of the enamel. An oblique section in the length of the tooth may be made at such an angle as to expose one layer of fibres in their length and the adjoining layer cut transversely. This view is shown in fig. 19. It will be seen that the fibres have a greater breadth than thickness.

In a transverse section the component fibres of one layer are shown crossing those of the layer above and below at a right angle, thus producing a square pattern over the lamelliform portion of the enamel, which is represented in fig. 20. The fibres give a transverse measurement of the 8823rd of an inch. The fibres in the outer division of the enamel are straight, and lean obliquely towards the median line of the skull.

In the lower incisors of this little creature the position of the enamel layers is reversed. A transverse section exhibits them extended in the length of the tooth, presenting an appearance similar to that seen in a longitudinal section of the corresponding upper tooth, excepting that they make but one curve with a flattened and slightly enlarged middle portion (fig. 22). A longitudinal section of a lower incisor presents an appearance similar to a transverse section of the corresponding upper tooth, as shown in fig. 21.

The dentine of the incisors of the Dormouse is not sufficiently peculiar to render a minute description necessary. The tubes are perceptibly larger at the lower than at the upper part of the tooth, and those in the posterior half of the tooth retain their full dimensions till near their termination.

The enamel is about the 300th, and the dentine the 23rd of an inch thick.

In the molar teeth, the lamelliform arrangement of the enamel exists in a perceptible degree near the terminal edge only, and so far establishes a resemblance to the molars of the Rat-tribe. The dentine offers no peculiarity worthy of notice in this communication.

Jerboa Ægyptius.—The teeth of this animal present great structural peculiarities. The upper and lower incisors are subject to the same difference in the arrangement of the lamellæ of the enamel as the corresponding teeth of the Dormouse; while the molars resemble in structure the teeth of marsupial animals. In the long axis of a transverse section of an incisor, the enamel measures the 150th and the dentine from the 17th to the 20th of an inch.

The dentinal tubes radiate from the pulp-cavity without exhibiting a specific peculiarity. Many of those distributed to the anterior as well as those to the lateral and posterior parts of the tooth, dichotomize once or twice in the early part of their course, and afterwards give off small branches. When near the enamel the dentinal tubes break up into a rich plexus of branches, many of which uniting, form a series of loops, and give a greater opacity to this than to any other part of the section. External to this plexus the dentine is comparatively transparent and traversed by a diminished number of dentinal tubes, a few of which are continued into the enamel; these, after following the course of the lamellæ, are lost in the peripheral portion of that tissue. The dentinal tubes at their largest parts do not exceed the 7500th of an inch.

The peculiar character of the enamel of the upper incisor is best seen in a longitudinal section, in which the lamellæ are shown proceeding from the dentine in straight lines directed obliquely upwards at an angle of 60° . In this section each layer appears slightly fibrous and a little indefinite in outline; in both respects differing from the teeth of this and the preceding family. These conditions are partly due to the presence of tubes continued from the dentine, and are portrayed in fig. 23.

The layers, after proceeding for about the 250th of an inch across the enamel, suddenly change their direction, and the component fibres lose the lamelliform arrangement, become parallel, and in tolerably straight lines pass upwards at an angle of 21° with the surface of the dentine. In this, the external part of the enamel, the tissue is very transparent, the fibres are rather indistinct, and the indistinctness increases the nearer we approach the worn extremity of the tooth. Here and there one or two tubes may be seen emerging from the lamelliform portion, and advancing into the outer transparent part of the enamel, but they are soon lost in their own minuteness.

An oblique longitudinal section may be so made as to expose alternate layers of fibres cut in their length, and the intervening ones cut transversely. The latter are oval, and present a long diameter of about the 5550th and a short diameter of about the 8824th of an inch. And it will also be seen, that although the fibres have their long axes placed in the length of the tooth, and hence transversely to the adjoining fibres longitudinally exposed, yet that the long axes are not at a right angle or any constant angle with them, but present various degrees of obliquity, as shown in fig. 24. This want of regularity in the arrangement of the fibres no doubt contributes to the fibrous appearance of the layers in the longitudinal section of the tooth, in which the component fibres are of course cut across with various degrees of obliquity.

In a transverse section of an upper incisor the fibres of the alternate layers are

seen crossing each other at something short of a right angle; in the inner and in the outer part of the enamel they are seen proceeding in straight lines to the surface, without inclining to either side.

A thin layer of cement may be distinguished on the posterior part of the tooth, but is lost when it has passed over the terminal edge of the enamel.

In the lower incisors of the *Jerboa* the enamel lamellæ are arranged in the long axis of the tooth, much in the same manner as in the corresponding teeth of the *Dormouse*. A longitudinal section will expose the decussation of the fibres of the contiguous layers, the one set proceeding upwards and outwards, and the other downwards and outwards. The fibres in the external division of their course lose the lamelliform arrangement and proceed upwards and outwards in a gentle curve (fig. 26).

An oblique section in the length of the tooth will cut across the layers in their breadth, and show them arranged in lines parallel with the surface of the dentine. Each layer has in this view a denticulated margin, similar to the lamellæ in the *Rats*.

A transverse section of a lower incisor exposes the enamel lamellæ divided transversely to their length. Those which arise from the median side of the tooth are directed forwards and towards the median line, while those that start from the anterior and outer surface of the dentine, are directed in a curved line outwards in an opposite course. Each layer thickens slightly as it advances outwards, and exhibits slightly serrated margins.

The component fibres have their long axes placed obliquely (fig. 28). Transverse sections made with different degrees of obliquity, will give variety in the appearance of the enamel layers. Thus a longitudinal section of one set of fibres, and a transverse section of another may be obtained, as partly shown in fig. 28. But if the section be oblique to each axis of the tooth, the enamel may present a confused intersection of lines, from which little or nothing can be made out. This observation may be applied with equal truth to similar sections of other rodential teeth.

The dentinal tubes in the lower incisor are oval in section, and have the long diameter placed transversely to the length of the tooth, hence they appear larger in the transverse than in the longitudinal section (figs. 26 and 28). In the molar teeth, the dentinal tubes leave the pulp-cavity for the crown of the tooth with a diameter of about the 10,000th of an inch, and are very closely packed. They give off very few, if any branches, till near the periphery of the dentine, and here they are far from numerous, as compared with those seen in other molar teeth. The branches are short and bristle-like, and the parent tubes, or a large branch, is usually continued into the enamel. The dentinal tubes of the fangs commence with a similar diameter to those of the crown of the tooth, but they speedily dilate to the 7500th of an inch, and give off branches during the greater part of their course.

Previous to entering the enamel the dentinal tubes are reduced to about the

15,000th of an inch, which dimensions are retained after they have passed with that tissue. The tubes pass onwards with slight tortuosities in a line with the direction of the enamel fibres, until they reach the outer third, when they are lost or turn suddenly at a right angle, and after advancing a short distance downwards, disappear. These conditions are shown in fig. 29. The fibres of the enamel show no disposition towards a lamelliform arrangement, excepting near the terminal edge, where the lamellæ have, in a longitudinal section, serrated margins. The fibres leave the surface of the dentine on the sides of the tooth at an angle of about 50° , and in the outer third of their course come a little outwards. In the depression on the masticating surface, they proceed at a right angle from the surface of the dentine.

The molars of the Jerboa, though like those of marsupial animals in having the dentinal tubes continued into the enamel, differ from them in having serrated lamellæ in the enamel near its terminal edge, and hence may be distinguished both as not belonging to the marsupial order, and as belonging to the Muridæ.

I have been obliged to make upwards of twenty sections of the teeth of this interesting animal before I could fully satisfy myself on the various points of the dental structures; indeed in the early part of the investigation I despaired of making out the arrangement of the component fibres of the enamel.

The next animal on the list is *Pedetes Cafur*, but as the teeth resemble more closely the teeth of the Hystricidæ than any other group of animals, and are altogether dissimilar to those of the Muridæ, I shall postpone the description till I have gone through my specimens of Hystricine rodents.

The teeth which have come within my reach from members of the following genera, *Mus*, *Hapalotis*, *Gerbillus*, *Hydromys*, *Hesperomys*, *Arvicola* and *Lemmus*, so closely resemble each other in the general characters of the structure of the dental tissues, that it will be necessary to describe minutely those of a typical species only, and afterwards to note any specific differences that are found in teeth from other members of these genera. I will therefore take the teeth of the common Rat (*Mus decumanus*) as being typical of the family, and also on account of the ease with which the teeth may be obtained by any subsequent observer.

Mus decumanus.—From a longitudinal section of a lower incisor, we learn that the dentine presents no specific or generic peculiarities. The dentinal tubes from their commencement give off numerous minute pilose branches, and terminate near the surface of the dentine by forming a dense plexus of minute ramifications. Their course is straight, or nearly so, excepting the secondary undulation, which exists in a greater or less degree in almost every specimen of dentine that has come under my observation. The tubes are oval in their transverse section, having a short diameter of about the 15,000th of an inch, and a long diameter which is placed in the length of the tooth, and averages the 10,000th of an inch.

In the anterior part of the tooth the tubes gradually diminish in diameter from their commencement, while those in the posterior part retain their original size till

near their termination, when they form a plexus, but less dense than that in the anterior part of the tooth.

The enamel is seen to be composed of fibres arranged in serrated lamellæ, which leave the surface of the dentine with a short but gentle curve, and then proceed upwards and outwards in nearly a straight line till about to terminate in the outer division of the enamel, when they make a slight sigmoid curve with the terminal portion directed upwards, their general course being at an angle of 50° with the surface of the dentine (fig. 30).

At the outer fifth of the thickness of the enamel the layers are broken up, and their component fibres take a parallel course upwards and outwards, and with a slight curve, which is strongest near the outer extremity, when they reach the surface of the tooth, their general courses being at an angle of 30° with the surface of the dentine.

Each lamella commences at the surface of the dentine with a diameter of about the 7500th of an inch, which gradually increases till at the distal extremity it attains the 6000th of an inch. The margins of the lamellæ are strongly serrated, and the projections of one layer fit into corresponding depressions in the contiguous lamellæ. This peculiar form and arrangement, as exhibited in a longitudinal section, may be regarded as typical of the enamel of this family of Rodentia.

In an oblique transverse section cut nearly parallel with the worn surface of the tooth, it may be seen that each layer is composed of a single series of enamel fibres, and that the fibres of contiguous layers cross each other at such an angle as to produce a diamond pattern over the lamelliform portion of the enamel; and also that the fibres curve a little in their course outwards (fig. 31). The upper and lower surfaces of the component fibres of each lamella appear to be a little uneven, and these irregularities no doubt contribute to the development of the serrations observed in the longitudinal section of the tooth, but in the section now under consideration these appearances are seen but obscurely. When the crossing sets of fibres have arrived within the 750th of an inch of the surface, the decussation ceases and they proceed outwards in parallel lines directed obliquely towards the median line of the skull; and in the latter 3000th of an inch of their course they turn directly outwards in a line with the long axis of the section.

If a section be so made as to display one set of fibres in their length, and the adjoining ones divided transversely, the latter will exhibit an oval section, while the former are seen to be armed with minute processes which fit into the small interspaces that would otherwise be left between the non-touching surfaces of the oval fibres. These conditions are shown in fig. 32. To these lateral processes the serrated margins of the lamellæ, as seen in the longitudinal section, are due, as are the irregularities of surface seen in the transverse section.

The outer ends of the enamel fibres are best seen in the middle and lower part of the tooth. Near the cutting edge, in the outer portion of the enamel, the union between

the component fibres is so perfect that all appearance of structure is lost. This observation applies equally to other scalpriform teeth. The coloured surface presents the character of a stain, through which the fibres are continued. If the section be tolerably thick and a little oblique, the two cut edges will give the appearance of a coloured lamina. But the structure of the enamel may be demonstrated, though in a less complete manner, by taking a little of the soft partially developed tissue from the base of the tooth, and with a little water placing it between two slips of glass. The decussation of the fibres will be then shown, and some will present a beaded outline; small portions may also be found in which development is more forward, and some of the fibres armed with small lateral processes will appear in the field of the microscope. Some of these appearances are shown in fig. 33.

The upper have a somewhat thicker coat of enamel than the lower incisors; it averages about the 211th of an inch, of which the lamelliform portion occupies about the 333rd and the outer or fibrous portion the 666th of an inch.

In a longitudinal section the lamellæ leave the surface of the dentine at an angle of 55° , which is a little wider than that formed by the corresponding parts in the lower incisors. The layers describe a gentle curve upwards and outwards, and the margins are serrated through the greater part of their course, but less strongly than in the corresponding lower teeth; in addition to which the layers are frequently marked by transverse lines. Towards the outer part of their course, the serrations become faint and ultimately give place to a smooth outline. The fibres in the outer part of the enamel run at an angle of 25° with the surface of the dentine.

In the molar teeth the dentine presents no generic peculiarity, neither does the enamel about the cusps of the teeth, but at and near its terminal edge on the neck of the tooth, the lamelliform arrangement with the serrated edges holds good, both in the Rat and in other rooted molars of the genera *Mus*, *Hapalotes*, *Hydromys* and *Hesperomys*. The cementum about the neck of the tooth is arranged in rods, similar to those already described in the corresponding teeth of the Squirrels.

The teeth of *Mus rattus* present no structural peculiarities by which they can be distinguished from *M. decumanus*, neither do those of the following rodents, excepting in size:—*Mus Alexandrinus*, *sylvaticus*, *musculus*, *minutus* and *fusipes*. In examining the molar teeth of *Mus giganteus*, I find a peculiarity which may perhaps be specific. The fibrous enamel on one side of the cusps is separated from the dentine by a layer of perfectly transparent and apparently structureless enamel, which is thickest near the apices of the cusps, and gradually thins till it is lost at the bottom of the fissures. On the sides of the tooth the serrated laminae of the enamel are strongly marked, and extend through a larger portion of the tissue than is common in the corresponding teeth of any other rat which I have examined.

In the teeth of *Hapalotes albipes* and *longicaudatus* of New South Wales, I find a very close structural resemblance to those of the Rat, the principal difference being in the more blunted shape of the serrations of the enamel lamellæ, and the greater

frequency and strength of their transverse markings. In a longitudinal section of a lower incisor the layers leave the dentine at an angle of 40° , and have a thickness of about the $\frac{7500}{1}$ th of an inch. The whole thickness of the enamel is about the $\frac{13}{1500}$ ths of an inch, of which $\frac{11}{1500}$ ths is occupied by the lamelliform, and $\frac{2}{1500}$ ths by the outer or fibrous portion of the enamel. The latter lies at an angle of 15° with the surface of the dentine.

It will be seen, on referring to the description of the corresponding teeth and sections of *Mus decumanus*, that the angle at which the laminæ of enamel fibres leave the surface of the dentine, is sufficiently different from that in the *Hapalotes* to distinguish the teeth of these creatures from each other.

The molars of the *Hapalotes* resemble those of the Rat. I am indebted to the kindness of Mr. GOULD for an opportunity of examining the teeth of these animals.

Gerbillus Shawii (DEVERN.) stands next on my list. The dentine of the incisors of this small rodent is peculiar in having a few vascular canals extended from the pulp-cavity a short distance into its substance, which in a transverse section gives an uneven outline to the surface of the pulp-cavity. The dentinal tubes give off branches throughout the whole of their course, are interspersed with small cells, and are subject to irregular secondary undulations; in addition to which, the whole substance of the dentine has a cellular appearance as though the developmental cells had retained their outline during the process of calcification, instead of becoming confluent and homogeneous.

In a longitudinal section the laminæ leave the surface of the dentine at an angle of 55° , and curve upwards and outwards through about $\frac{6}{1500}$ ths of an inch: they then give place to the fibrous portion in which the fibres curve upwards and outwards, their general course being at an angle of 20° with the surface of the dentine.

The laminæ are bordered by blunt serrations, and are subject to transverse markings, in both particulars resembling the enamel of the corresponding teeth of the *Hapalotes* more closely than that of the Rat.

In a transverse section the enamel of the incisors could not be distinguished from that in the Rat.

In the molar teeth the dentinal tubes are continued into the enamel the $\frac{1500}{1}$ th of an inch. In no part of the latter tissue could I distinguish a lamelliform arrangement in the enamel.

The teeth of *Hydromys chrysogaster* of New South Wales resemble those of the Rat. The incisors of the Hamster, *Cricetus fumentarius* (PALL.), can scarcely be distinguished from those of *Mus decumanus*.

Hesperomys Darwinii (WATERHOUSE) possess teeth so like in minute structure to those of *Mus decumanus* that a special description is unnecessary.

Geomys umbrinus (RICH.), though not placed by Mr. WATERHOUSE in the family Muridæ, have incisors so Rat-like, that it would require the presence of sections of the teeth of this creature and of the Rat to distinguish the one from the other, and even then there would be some difficulty in finding characteristic differences

sufficiently well-marked to render the conclusion trustworthy if any doubts were thrown on the authenticity of either of the specimens.

Arvicola amphibius (LINN.).—It would be extremely difficult to point out the characters by which sections of the incisor teeth of this creature could be distinguished from the corresponding ones of several teeth I have already described, especially those of the common Rat (*M. decumanus*). The serrated enamel lamellæ leave the dentine at nearly the same angle; the serrations are perhaps finer and less strongly marked, and the lamellæ are more frequently crossed by equidistant transverse lines. The rootless molar teeth, however, are sufficiently different from those of the Rat. In a longitudinal section, it will be seen that on one side of each denticle the enamel is composed of an inner lamelliform portion, with the edges of the lamellæ serrated as in the incisors, and another portion in which the enamel fibres are parallel; while on the opposite and posterior surface of the denticles the lamellæ are absent, and the enamel fibres pass across the structure in a curved line to the surface. In a transverse section, it is seen that the two conditions pass insensibly into each other at the bottom of the longitudinal grooves, where the component denticle coalesces, and also immediately behind the longitudinal ridges which mark the sides of the teeth.

In the Field Vole, *Arvicola nivalis* (MARTIN), the teeth, both molars and incisors, structurally resemble those of the *A. amphibius*.

The incisors of the Bank Vole, *Arvicola glareolus* (SCHREB.), are rat-like; but in the molar teeth the serrated lamelliform arrangement of the enamel is very indistinct. In the lower incisors the serrations of the lamellæ are shallow, while the transverse markings are rather strong. The appearances presented in a longitudinal section are delineated in fig. 34.

The incisors of *Lemmus Norwegicus*, DESM. (Zoological Society), do not offer any structural differences from the preceding group worthy of description.

Fiber zibethicus (LINN.).—This animal is placed by Mr. WATERHOUSE in the family MURIDÆ, section *Arvicolina*. The dental tissues do not well accord with that position, but seem to indicate a nearer relation to the Beaver and Dormouse. In the molar teeth, however, the enamel in places resembles that in the corresponding organs of *Arvicola amphibius* and *A. nivalis*, but the serrated lamelliform arrangement is not as uniform or as well-marked as in those animals. Yet Mr. WATERHOUSE'S arrangement of Rodentia is, with but few exceptions, so strongly corroborated by the structure of the dental tissues, that in this case, where there is conflicting testimony in these tissues as to where they should be placed, I shall do well to describe them in the position he has assigned to the animal.

In the upper incisors, a few vascular canals radiate from the pulp-cavity into the dentine, but they are far less numerous, and run a shorter course than in the corresponding teeth of the Beaver. The dentinal tubes resemble those of the latter animal, excepting that they terminate at the enamel, without the presence of a peripheral layer of cells.

A longitudinal section exhibits the enamel lamellæ passing outwards in an irre-

gular sigmoidal curve, their general direction being at an angle of 80° with the surface of the dentine. Immediately on leaving the dentine the layers make a short curve upwards and outwards, during which the margins are serrated; the serrations then become indistinct or altogether cease, and the layers pursue a tolerably straight course till near their termination, when they turn upwards, after which the component fibres become parallel and advance to the surface at an angle of 33° with the dentine.

On looking carefully over a longitudinal section, parts will be found in which the transverse direction of the lamellæ appear to be reversed. Fibres, or layers of fibres, will be seen running for a short distance obliquely in the long axis of the tooth.

In a transverse section the fibres of the alternate layers are seen to cross each other obliquely, so as to produce a diamond pattern over the lamelliform portion of the enamel. In the earlier part of their course the fibres curve a little, but afterwards become straight. In the outer part of the enamel the fibres pass directly outwards without leaning to the one side or the other.

In the lower incisors the structure of the enamel not unfrequently presents a confused appearance, as though the lamellæ were subject to some irregularity in arrangement. In a longitudinal section the enamel layers are seen leaving the surface of the dentine at an angle of 50° , and in their course curve a little outwards. The margins are pretty strongly marked with small oblique serrations and oblique transverse lines. The lamellæ have a thickness of about the 5000th of an inch. The enamel has a thickness of about the $\frac{9}{1800}$ ths, the lamelliform portion of which is about the $\frac{7}{1500}$ ths of an inch. In a transverse section parallel with the course of the lamellæ, the decussation of the alternate layers of fibres may be seen; and in a section a little more oblique, the fibres in the terminal part of their course may be seen passing in straight lines obliquely outwards from the median side of the tooth. In the dentine of the lower incisors, the vascular canals are much less abundant than in that of the corresponding upper teeth.

The confluent denticles of the molar teeth are coated with enamel, which is very irregularly lamelliform, with serrations so indistinctly marked and inconstant, that the appearance scarcely merits the name. A longitudinal section will best exhibit this view. In a transverse section, parts may be found in which the decussation of adjoining layers of fibres is visible, but generally the fibres seem to follow a much less regular and constant course; and in places they are parallel, as in the outer part of the enamel of the incisors. However, when we find the decussation, it will be situated on the anterior surface of the denticles; so far the structure resembles that found in the corresponding teeth of the Water-Rat, and, as in that animal, the enamel on the posterior surface of the denticles is uniformly free from the lamelliform arrangement. Near the masticating surface of the molar teeth the enamel fibres are so intimately blended, that little or no structure can be discerned.

The cementum, in no part of the tooth very abundant, is occupied by very large irregular cells and vascular canals. The latter are very large, have nodulated mar-

gins, and run principally in the transverse axis of the tooth. The tissue of the cementum, as seen in a transverse section, is unusually clear and transparent.

I am indebted to Mr. WATERHOUSE for a list of those rodents which he considers the most typical species of the several divisions of his family Hystricidæ, and have been fortunate in obtaining the teeth of all he has enumerated, excepting *Echimys*.

In the dentine of these teeth, I find nothing that is characteristic of the group. But the enamel is very peculiar, and the peculiarity is constant in each species I have examined. So strongly is the family characteristic marked by the peculiar arrangement of the fibres of this tissue, that it is necessary to have seen the structure in one hystricine tooth only, to be enabled to recognize at first sight the tooth of any other species as a member of the same group. We no longer see in a longitudinal section of an incisor uniform laminæ separated in the lamelliform portion of the tissue by well-defined lines, but in their stead find thick and confluent layers of obliquely placed fibres, which in a transverse section are seen to pursue a serpentine course from the dentine towards the surface, near to which they become straight and parallel as in the corresponding part of the enamel of the teeth previously described. Hence in this as in the preceding group, I need describe minutely the structure of the incisors of one species only. The molar teeth offer greater variety in the arrangement of the component tissues, and may require farther notice.

Hystrix cristata (LINN.).—In the incisors, the enamel attains a thickness of about the 45th and the dentine the 4th of an inch. The latter tissue offers no striking peculiarities; near the enameled surface it is tenanted by obliquely placed elongated cells, similar to those found in the incisors of the Beaver and many other teeth: they are shown in fig. 35 D.

In a longitudinal section, the enamel presents a very beautiful and, as compared with the tissue as it occurs in the preceding families, a very novel appearance. Large confluent laminæ of from the 1000th to the 1500th of an inch in thickness, leave the dentine at an angle of 80° . Each layer is composed of enamel fibres directed obliquely, and the obliquity varies in the adjoining layers, but corresponds in the alternate ones, in the manner delineated in fig. 35 E. But the fibres are not oblique in one direction only; one extremity of each fibre may be traced to dip into or under those of the contiguous layers, while the other extremity is usually cut obliquely across, and exhibits a diameter of about the 5000th of an inch. When within the 250th of an inch of the surface the layers gradually disappear, and their component fibres take a parallel course, and at an angle of 30° proceed to the surface.

In an oblique transverse section parallel with the course of the enamel laminæ, the appearances are even more striking than in the longitudinal one. The enamel looks as though the fibres were thrown into waves, the furrows of which commence at the surface of the dentine, and proceeding obliquely outwards, crop out where the fibres become parallel, and form the external portion of this tissue; their direction is shown in fig. 36. A close inspection of a favourable section will enable the observer

to see that the enamel fibres pursue a serpentine course, and in the lamelliform portion describe three tolerably uniform curves (fig. 36 E.). Then again, by altering the focus of the microscope, without changing the position of the section, it may be seen that the fibres immediately above and below those already observed, pursue a similar serpentine course, but arranged so that the concavities and convexities point in opposite directions, like the two sides of the figure 8. The appearance thus produced is shown in fig. 39, which in this particular must be regarded as a diagram rather than an accurate portrait. This crossing and re-crossing in curved lines, together with the cropping out of the curves of the contiguous fibres, produces a most complex appearance; and if the section be not parallel with the length of the fibres, the structure appears, to one who has not given attention to the subject, so confused as to defy explanation. If the section be so made as to expose in their length the enamel fibres of the middle of the anterior part of the tooth, those near the sides will be cut obliquely and present a penniform arrangement. An oblique longitudinal section will exhibit the fibres of alternate layers divided almost transversely, while those of the intermediate ones are exposed, taking an oblique course: this point is shown in fig. 37. In addition to the peculiarities already enumerated, small rounded cells are scattered through the enamel of this and most other Hystricine teeth.

The dentine of the molar teeth of *Hystrix cristata* is peculiar in having its tubes unusually free from lateral branches during the greater part of their course. The secondary undulations are strongly marked; and on approaching the enamel, the terminal branches are comparatively few in number and large in size, and commonly pass the 750th of an inch into the enamel.

Near the termination of the dentine in the root of the tooth, the dentinal tubes radiate from a number of centres, and the tissue graduates into the cementum, which is very abundant in this situation, and forms a considerable portion of the root.

In a longitudinal section the enamel fibres are seen to proceed upwards and outwards in parallel lines till near the surface, when they assume a similar arrangement to that seen in the incisor teeth. When the enamel is thin, the lamelliform arrangement is scarcely seen; but where it exists in a tolerably thick layer, the confluent laminae commence near the dentine. It should be remarked that in the Hystricine molar teeth, the usual position of the fibrous and lamelliform divisions of the enamel is reversed. Hitherto we have found the fibrous enamel placed externally; but here and in the succeeding family, the lamelliform enamel occupies the external position in the molar teeth.

Hystrix prehensilis (LINN.).—The incisors in microscopic structure closely resemble those of the common Porcupine. In the molar teeth, the dentinal tubes are continued about the 1000th of an inch into the enamel.

Dasyprocta Aguti (LINN.).—A longitudinal section of an incisor shows that the dentine of the anterior part of the tooth is bordered by a layer of obliquely placed elongated cells, about the 750th of an inch broad. The enamel is composed of con-

fluent laminae of obliquely placed enamel fibres, which have a diameter of about the 5000th of an inch, while the layers have a thickness of from the 1362nd to the 2150th of an inch, and leave the dentine at an angle of 65° . In the outer division of this tissue the fibres lie at an angle of 35° with the surface of the dentine.

Prof. OWEN describes the structure of the teeth of the Agouti from a longitudinal section of an upper incisor, and says, "The fibres composing the inner and more opaque part of the enamel proceed obliquely, but almost transversely across that substance, with a gentle curve in the opposite direction to the last curve of the contiguous dentinal tubes, viz. with the convexity towards the crown: the fibres of the peripheral layer of the enamel make a slight bend towards the crown; these enamel fibres are as thick as two of the dentinal tubes with their interspaces; their ends are lost in the clear peripheral substance to which the distinct, apparently structureless brown layer of cement is attached, and to which the colour of the convex surface of the incisor is due*."

Had Prof. OWEN made transverse sections of this tooth, he would I think have been led to give a wholly different account of the enamel; he would have seen the waved appearance which closely corresponds with that I have described in the incisor teeth of the Porcupine, and is produced by a similar flexuous arrangement of the component fibres; he would also have seen that the brown colour is resident in, and is due to a stain in the terminal ends of the enamel fibres. The enamel of the molar teeth of this animal resembles that of the corresponding teeth of the Porcupine.

Dasyprocta Acouchy (ERXL.). The dental tissues of this creature closely resemble those of the preceding species.

Cælogenys Paca (SCHREB.).—The dentine of the incisor teeth does not differ very perceptibly from that of the corresponding teeth of the Agouti and Porcupine. It measures about the 5th of an inch, while the lamelliform portion of the enamel is about the 107th, and the fibrous 300th of an inch in thickness. In a longitudinal section the confluent layers of enamel fibres leave the dentine at an angle of 70° , and the fibres in the outer fibrous part of the tissue lie at an angle of 40° . The layers have a thickness of from the 1000th to the 1667th of an inch; and the fibres are about the 5000th of an inch in diameter. In an oblique transverse section the waves of the enamel fibres are more strongly marked than in the enamel of the Porcupine, as shown in fig. 38.

An oblique longitudinal section shows with great distinctness alternate layers of fibres divided more or less transversely, and intermediate ones pursuing an oblique course. Fig. 37 illustrates faithfully this strongly-marked and peculiar appearance.

Capromys Fournieri (DESM.).—The dentine terminates at the enamel without the presence of oblique elongated cells, but small rounded cells are present and intermingled with the terminal anastomosing branches of the dentinal tubes. The dentine of a lower incisor measures about the $\frac{3}{25}$ th, the lamelliform portion of the enamel the

* Odontography, page 404.

83rd, and the external about the 500th of an inch. In a longitudinal section the confluent laminae leave the dentine at an angle of 55° , while fibres of the outer part are placed at an angle of 20° with the surface of the dentine (fig. 40). The layers have a thickness of from the 1500th to the 3000th of an inch.

Myopotamus Coypus, MOLINA (Zoological Society).—The dentine of the incisors at its anterior termination is occupied by small rounded cells, with which the terminal branches of the dentinal tubes freely communicate, and in addition to which many areolar-shaped cavities exist similar to those found in imperfectly developed human and other dentine*.

The enamel presents the true Hystricine character, but the layers in a longitudinal section are more confluent than in the teeth previously described. They leave the dentine at an angle of 56° , and the fibres in the outer portion of the texture lie at an angle of 40° with the surface of the dentine.

In an oblique transverse section of an incisor parallel with the worn surface of the tooth, the fibres are seen to make four undulations, but they are less deep than those seen in the *Porcupine* and *Paca*. Near the terminal edge of the enamel on the sides of the tooth, in this as in other Hystricine incisors, the fibres make but one or two gentle curves. The confluent laminae, as seen in a longitudinal section, have an average thickness of about the 1000th of an inch, and the enamel fibres a diameter of the 5000th of an inch.

I find in the enamel of this tooth here and there irregularly rounded interspaces, vacant or occupied by a transparent structureless mass. This perhaps may be a peculiarity confined to the individual specimen. The dentine of the lower incisor has a thickness from back to front of the 3rd, the lamelliform portion of the enamel the 40th, and the external fibrous part the 500th of an inch. The cementum is continued from the sides of the tooth a short distance upon the enamel, but does not blend with the terminal ends of the enamel fibres. On the contrary, the two tissues are separated by a well-defined line.

Octodon Degus, MOLINA (Zoological Society).—In the lower incisors the dentinal tubes of the anterior half of the tooth terminate in fine branches, with which few if any cells are intermingled. The tubes at their commencement in the pulp-cavity are comparatively large, and attain a diameter of about the 5000th of an inch.

The enamel of this small tooth is truly Hystricine in character. The confluent layers leave the dentine at an angle of 45° , which in the outer fibrous part of the texture is reduced to 20° . The 1500th of an inch is the average breadth of the layers, the component fibres of which have a diameter of from the 7500th to the 5000th of an inch. The dentine has a thickness of about the $\frac{3}{55}$ th, the lamelliform portion of enamel the 16th, and the external part the 750th of an inch.

In the molar teeth the enamel fibres describe a faint sigmoid curve in their passage

* Lectures on Dental Physiology and Surgery.

outwards, where the tissue exists as a thin layer; but in those parts in which it is more abundant in quantity, the fibres in the external part of their course assume the confluent lamelliform arrangement.

Schizodon fuscus (WATERH.).—In the incisor teeth, a few vascular canals are continued from the pulp-cavity into the posterior half of the dentine. The dentinal tubes branch from their commencement and terminate in the anterior part of the tooth in fine tubules without the presence of peripheral cells. They have a diameter of about the 6000th of an inch.

The enamel has a general resemblance to that described in the last species. The confluent laminæ have a thickness of about the 2300th of an inch and leave the dentine at an angle of 50° , which in the fibres of the exterior is reduced to 15° . The dentine has a thickness of about the 15th, and the enamel the 166th of an inch, of which 13 parts are lamelliform and 5 parts fibrous and external.

In the molar teeth the enamel fibres advance one third of their course in parallel lines, and then fall into the confluent lamelliform arrangement, but with less precision than in the incisor teeth.

Spalacopus Pœppigii (WAGNER).—The dental tissues of the incisor teeth of this animal resemble pretty closely those of the preceding species. The posterior half is not however permeated by vascular canals. The enamel has a thickness of about the 150th of an inch, of which seven-tenths is lamelliform, and three-tenths external and fibrous. The inner part of the external division is tenanted by small rounded cells, which confuse the fibrous character of the part. The laminæ lie at an angle of 50° with the surface of the dentine, while the fibres of the outer part pass upwards at an angle of 25° , and finally turn outwards and advance to the surface at an angle of 90° .

Habrocoma Bennettii (WATERH.).—In the incisors of this creature, a few vascular canals are continued from the pulp-cavity for a short distance into the posterior half of the dentine. The dentinal tubes give off short branches from their commencement, undulate irregularly, and are not very uniform in size. They end without the presence of an anterior peripheral layer of cells. The confluent layers of enamel fibres leave the dentine at an angle of 50° , and have a thickness of about the 1666th of an inch. The fibres of the outer portion of this texture lie at an angle of 15° , the thickness of this part being about $\frac{2}{14}$ ths, while the lamelliform portion occupies $\frac{12}{14}$ ths of the whole thickness, which measures about the 108th of an inch in thickness: fig. 42 and 43 show the texture in a longitudinal and a transverse section. The molar teeth of this species of *Habrocoma* closely resemble those of *Schizodon fuscus*.

Chinchilla lanigera (MOLINA).—The dental tissues both of the molar and incisor teeth strongly resemble those of the four preceding species. In the incisor the dentine is without a peripheral layer of cells in the anterior half, and without vascular canals in the posterior half of the tooth. In a longitudinal section the confluent layers of enamel fibres have a thickness of about the 1500th of an inch, and leave the dentine

at an angle of 50° , which is diminished to 20° in the fibres of the outer portion of the tissue. In a transverse section, it is seen that the fibres in the outer part of the enamel are directed obliquely from the median line of the skull. The enamel fibres have a diameter of about the 6000th of an inch, and are intermingled in the lamelliform portion of the tissue with minute rounded or oval cells, which contribute to give the structure a confused appearance.

Cavia Aperea (ERXL).—A layer of obliquely placed cells occupies the periphery of the enamel-coated anterior of the incisors. The dentinal tubes have slightly irregular parietes, and the intervening tissue has a mottled cellular appearance. In the posterior half of the tooth, the tubes as they approach the periphery throw out numerous characteristic thick branches, which from their number and size render a section of this part very opaque.

The enamel is strongly Hystricine in character, and is dotted over with minute rounded and branchless cells*. In a longitudinal section of a lower incisor, the confluent laminæ leave the dentine at an angle of 45° , which is reduced to 20° in the fibres of the external part of the tissue, and the layers are about the 1500th of an inch thick: these characteristics are shown in fig. 44. The whole thickness of the enamel amounts to the 170th of an inch, of which two-thirds is occupied by the lamelliform portion of the tissue.

In the upper incisors the angle of 60° is that at which the lamellæ leave the surface of the dentine, while the terminal extremities of the fibres lie at an angle of 20° with the dentine. The enamel does not exceed the 212th of an inch in thickness, of which five-sevenths is lamelliform.

Cavia Kingii (BENNETT).—The dental tissues of this animal are very similar in structural character to those of the common Guinea Pig. The enamel is however less crowded with cells, and hence is much more transparent.

Hydrochærus Capybara (ERXL).—Many vascular canals are continued from the pulp-cavity into the posterior half of the dentine in the incisor teeth of this great rodent. A few branches pass from the dentinal tubes throughout the whole of their course, and become more numerous near the periphery of the tissue, which in the anterior part of the tooth is bordered by a dense layer of irregular-shaped cells, that occupy a line the 500th of an inch thick, as shown in fig. 46.

The enamel exhibits the true Hystricine character, both in the longitudinal and transverse sections, but less strongly marked than in any of the previously described teeth belonging to animals of this group. The laminæ are more confluent, and the component fibres occupy a less oblique and more parallel position than we have been accustomed to see them; in a longitudinal section the enamel near the dentinal surface is crowded with small cells, and the laminæ are at this part indistinctly marked. A little farther out they become more strongly developed, and have the

* The cells in the enamel of this and in all the species described in this paper, have no proper parietes, and should be regarded as interspaces rather than cells in the sense now attached to that term.

appearance of being in pairs, the fibres of which proceed obliquely outwards from a central line common to the two, as shown in fig. 46. In the outer division of the tissue the component fibres are so intimately united, that in places only can their course be traced. In a longitudinal section the lamellæ leave the dentine at an angle of 70° , which is reduced to 30° in the outer part of this substance. The layers have a thickness of about the 700th of an inch, and the component fibres a diameter of the 7500th of an inch. The whole thickness of the enamel amounts to the 79th of an inch, of which $\frac{1}{19}$ ths is lamelliform.

In a transverse section of an upper incisor, the enamel fibres are seen to make one bold sigmoid curve in the lamelliform portion of the tissue. In fig. 45, a layer of fibres is shown with as much of the one immediately beneath as could be seen without shifting the focus of the instrument.

The enamel of the molar teeth exhibits much the same structural appearance as that of the incisors, excepting that the cells which occupy the inner part of the tissue in the latter teeth, are absent in these.

Brathyergus maritimus, GML. (Zoological Society).—This animal has been placed by Mr. WATERHOUSE in a section immediately preceding Hystricidæ*. The teeth are however Hystricine in structural character, and might be described either in this place or at the beginning of the family.

The dentine of the anterior parts of the tooth is bordered by a narrow layer of cells. The dentinal tubes have small hair-like branches through the whole of their course. In a longitudinal section of an upper incisor confluent layers of enamel fibres leave the surface of the dentine at an angle of 50° , and after extending about the 210th of an inch, are insensibly lost in the parallel arrangement of the fibres in the unusually thick external division of the tissue, which in this tooth amounts to the 120th of an inch in thickness, as shown in fig. 47. The tissue is dotted near the surface with minute cells. A transverse section is not altogether unlike a corresponding one from the incisor of the *Capibara*.

Pedetes Cafer (PALL.).—This animal is placed by Mr. WATERHOUSE in the family *Muridæ*, section *Dipodina*. The dental tissues of the incisor teeth have the Hystricine character strongly marked, while those of the molars are intermediate between the Hystricidæ and Leporidæ. The true position of the tissues in this family can only be determined after the majority of the species have been examined, which in itself will be a work of some labour, apart from the difficulty of obtaining authentic specimens. In the absence of correct information of its position, I have as a matter of convenience placed my description at the end of the Hystricine group.

In the incisors the dentine has several minor points of peculiarity. The pulp-cavity in a transverse section of a lower incisor approaches a triangular figure with the angles extended and rounded at their extremities, two of which are directed to the lateral anterior angles of the tooth, and the third extends in the median line into the

* Johnston's Physical Atlas.

posterior half, in addition to which the walls of the cavity have two deep indentations on the median side and one on the outer side of the tooth. From each of the angles a line of small vascular canals is continued a short distance into the dentine, which tissue is marked by numerous concentric and broad, but ill-defined and interrupted contour lines, which follow the involutions of the surface of the pulp-cavity. They seem to be produced by a greater density of the tissue in these than at other parts. The dentine has a generally diffused cellular appearance. The dentinal tubes have an irregular outline, and have small lateral branches throughout the whole of their course. When divided transversely they show thick and strongly-marked parietes, and have an internal diameter of about the 6000th and an external one of the 3000th of an inch. On nearing the enamel, the tubes give off larger and more numerous branches, and ultimately terminate in small oval or rounded branching cells.

In the upper incisors the vascular canals are more abundant in the posterior than in the anterior part of the tooth. The pulp-cavity is occupied near its apex with secondary dentine, the tubes of which proceed from the surface towards the centre and give off many branches; when viewed by transmitted light they resemble tufts of moss. The enamel is strongly Hystricine in character. In a longitudinal section of a lower incisor the confluent laminae leave the dentine at an angle of 60° , which in the external division of the tissue is reduced to 25° . The enamel has a thickness of the 79th of an inch, of which $\frac{1}{9}$ is lamelliform. The component fibres of the lamellae have a diameter of about the 7500th of an inch.

The dentinal tubes in the molar teeth proceed from the pulp-cavity in nearly a straight course upwards and outwards at an angle of 20° . When within the 500th of an inch of the enamel, they turn a little more outwards and afterwards a little upwards, thus describing a small final curve, the convexity of which is directed towards the base of the tooth. But few branches pass off till the dentinal tubes make their final curve, when many leave both their convex and concave sides. Vascular canals are continued from the pulp-cavity into the dentine, as in the incisor teeth. The arrangement of the component fibres of the enamel in the molars is peculiar, and probably characteristic of the tooth of this creature. In a longitudinal section the fibres in the first two-fifths or half of their curve are straight and parallel, and lie at an angle of 40° with the surface of the dentine. Afterwards they suddenly fall into the confluent lamelliform arrangement, and with this disposition reach the surface of the tooth, as shown in fig. 48. In the folds which lie between the confluent denticles, the enamel is thinner than on the exterior of the tooth; the loss of thickness is principally at the expense of the outer lamelliform portion. In a transverse section the fibres of the lamelliform portion are seen to make an open letter *f* curve, which is reversed in direction in the contiguous layers, but parallel, or nearly so, in the alternate ones. The appearances seen in this section are delineated in fig. 49. Both in the transverse and longitudinal sections the lamelliform portion of the enamel is crowded with small branchless cells.

The uniform presence and more constant breadth of the inner fibrous portion of the enamel is rather unusual in Hystricine teeth, while it is constant and exists in even a greater degree in the molars of the Hare. In this particular therefore the molars of the *Helamys* show a slight relation to those of the Leporidæ.

LEPORIDÆ.—In this family of rodents my observations have been confined to members of the genus *Lepus*. The incisors exhibit a type of enamel which I have seen in the teeth of no other rodents. This tissue is no longer divided into an outer and inner portion, with the component fibres arranged in lamellæ in one and not in the other, and at different angles in the two parts; but, on the contrary, the fibres without a lamelliform arrangement proceed with but slight flexures from the surface of the dentine to the outer surface of the enamel. Neither is the enamel dotted over with cells, as is that of Hystricine teeth in the lamelliform portion of the texture.

Lepus timidus (LINN.).—In the Hare the dentine is permeated by vascular canals, both in the anterior and posterior half of the incisors; but they are more numerous in the latter than in the former part. These canals become in the extruded portion of the tooth lined by a layer of dense non-tubular tissue, presenting the appearances delineated in fig. 51. The anterior enameled part of the incisors is bordered by a peripheral plexus of branches interspersed with a few branching cells, and the posterior half by a plexus of branches without cells. In a longitudinal section, such as that shown in fig. 50, the dentinal tubes from their commencement in all parts of the tooth branch, but in a transverse section the branches seem rather less numerous; hence it would appear that they extend principally in the long axis of the tooth. Prof. OWEN has observed that “the tubes which pass to the opposite or posterior surface of the tooth are less numerous, less parallel, and less closely packed together; they send out more and larger branches, which decussate each other in an elegant arborescent manner*.” In addition to these peculiarities, the tubes are sensibly larger in the lateral and posterior than in the anterior part of the tooth. In a longitudinal section, such as that shown in fig. 50, the enamel fibres may be traced through the whole thickness of the tissue. Generally their course is straight, or nearly so, and at an angle of from 50° to 70° with the surface of the dentine, but in places the angle is varied, and the fibres are a little bent in the one or other direction. The tissue is rendered rather unusually transparent by the close union of the component fibres, and its comparative freedom from small cells.

A corresponding section from an upper incisor differs from the one already described principally in the diminished thickness of the enamel. The enamel fibres have a diameter of about the 6800th of an inch.

The molar teeth of the Hare have dentine, which is traversed by vascular canals, that extend from the pulp-cavity to near the peripheral surface of the tissue. Previous to the part coming into wear the canals are lined with a non-tubular tissue, and ultimately become almost or quite obliterated. The dentinal tubes are sensibly larger,

* Odontography, page 405.

and branch much more freely than in the incisors: I do not know a more beautiful microscopic object than a fine longitudinal section of the molar tooth of a common Hare. The enamel, where it exists as a thin layer lining the inflected parts of the confluent denticles, is composed of short fibres, which leave the dentine at a wide angle, and towards their terminal extremities turn a little downwards. But when this tissue invests the outer and more exposed parts of the tooth the amount is much greater; in these parts the enamel is divisible into two portions, the inner of which is composed of straight, uniform and parallel fibres, and the outer part of continuations of the same fibres, but bent about somewhat irregularly, and approaching in places to a confluent lamelliform arrangement. The appearances presented in a transverse section of a molar tooth are delineated in fig. 52; but even in this the arrangement of the enamel fibres in the outer portion of the tissue is regular as compared with what is seen in many parts of the tooth. In the outer part the fibres have the appearance of being smaller than those which lie next the dentine, as shown in the figure.

Lepus cuniculus (LINN.).—The dental tissues in the teeth of the Rabbit so closely resemble those of the Hare, that I doubt the possibility of telling the one from the other, excepting by the external form and size of the entire tooth. The vascular canals are perhaps less numerous in the Rabbit.

Of the following animals I have been able to obtain the molar teeth only.

Lepus Americanus, ERXL. (Zoological Society).—The vascular canals are very numerous and extend to within a short distance of the enamel, where they usually terminate in dilated extremities. In their passage they branch rectangularly and anastomose with neighbouring canals, a circumstance I have not before observed in the vessels of vascular dentine. Each canal becomes surrounded by a layer of transparent tissue, in which are a few lacunæ very similar to those seen in the cement; eventually the canals are lost by the encroaching inwards of the transparent tissue, and lines of branching cells alone remain to mark their former position.

The enamel could not be readily distinguished from that seen in the molars of *Lepus timidus*; a tendency to confluent lamelliform arrangement of the fibres is found in places, and as it appears in a longitudinal section is shown in fig. 53.

In the molar teeth of *Lepus aquaticus* (BACHM.) and *Lepus sylvaticus* (BACHM.), I find no characteristic differences in the dental tissue by which they could be distinguished from each other, or from the teeth of either of the preceding species of Hares.

Before leaving the subject of Hares' teeth, I should state that occasionally fine supplemental enamel fibres may be seen crossing the course of the ordinary ones at a right angle. They do not exceed the 15,000th of an inch in diameter, and are not constantly present; indeed I have only seen them near the basal half of the tooth, where the enamel is not perfectly hardened.

The facts which are recorded in the foregoing pages have been gathered from

careful and repeated observations made upon upwards of 350 sections, cut from the teeth of various members of the order Rodentia. When a doubt as to the nature of a tissue has arisen, I have made numerous sections from different parts, and in different directions of the same tooth. In some instances I have made as many as twenty-five from the teeth of one species; and have seldom contented myself with less than three sections.

The conclusions which these researches justify depend mainly on the accuracy with which the observations have been made and recorded.

Fortunately, preparations of dental tissues can be preserved for an unlimited period: hence my statements can at any time be tested by an examination of my own or corresponding sections.

Those who will go over the field of observation through which I have passed, will I do not doubt justify me in the following conclusions:—viz. That the teeth of some species of the order have specific structural characters by which they can be distinguished from any other known teeth. That in the teeth of all the Rodentia, excepting the family Leporidæ, a portion of the enamel has a lamelliform arrangement of its fibres. That the enamel lamellæ have a different and distinctive character in each of the larger groups, and that the variety of structure is constant throughout the members of the same group; we may take for examples, the Sciuridæ, the Muridæ, and Hystricidæ, in each of which the structure of the enamel is different, and in each is highly distinctive. And that the varieties in the structure of the dental tissues, with a few isolated exceptions, justify and accord with the arrangements of the members of the order into the several divisions proposed by Mr. WATERHOUSE, and deduced by him from the relations of the several parts of the skull.

The manner in which these various modifications in the structure of the enamel are brought about in its development, together with the adaptation of the varied forms of enamel-tissue to the wants of its possessors, will form the subjects of a future communication.

Feb. 16, 1850.

EXPLANATION OF THE FIGURES, in each of which D refers to the dentine,
and E to the enamel.

PLATE XLIII.

- Fig. 1. The middle portion of a transverse section of the lower incisor of *Tamias Lysteri*, showing the manner in which the dentinal tubes are disconnected from the pulp-cavity in that part of the tooth which is about to come into wear by the development of a laminated subgranular tissue. 150 linear.
- Fig. 2. A transverse section of a dentinal system, A, and peripheral portion of two contiguous ones, B and C, from the tooth of *Orycteropus*, showing the manner in which the connection of the dentinal tubes with the surface of the pulp-cavity is cut off by the development of a laminated mass of transparent and apparently structureless tissue.
- Fig. 3. A transverse section of a dentinal system, A, and a portion of a contiguous one, B, from the tooth of *Labyrinthodon Jaegeri*, showing the disconnection of the tubes with the pulp-cavity in A, and the process, C, by which this is connected with a contiguous system; also the peripheral line of cells which intervene and partially connect the terminal branches of the tubes of adjoining systems. (This drawing was made from a section, No. 4 of a series lent to me by Dr. MANTELL.) 75 linear.
- Fig. 4. A transverse section of a Haversian system from a Stag's antler which had been cast, showing the transparent tissue lining the canal, and thus cutting off the connection of the canaliculi with the surface of the canal.
- Fig. 5. A transverse section from the extruded portion of a molar tooth of *Lepus timidus*, showing that the medullary canals of vascular dentine become lined with a dense non-tubular tissue previous to the part coming into wear.
- Fig. 6. A portion of a longitudinal section from an upper incisor of *Sciurus niger*, showing, D, the dentine, E, the enamel lamellæ in their rectangular position, and F, the terminal or fibrous part of the enamel, in which the extent of the colour is marked by a vertical line. 225 linear.
- Fig. 7. A transverse section of the same tooth, showing, D, the dentine, and E, the enamel, in which the component fibres of two layers, the decussation and their continuance in the external part of the tissue, are seen. 225 linear.
- Fig. 8. An oblique longitudinal section from the base of the same tooth, in which E, the alternate layers of the enamel lamellæ, are cut transversely and longitudinally. In this part of the tooth the external part of the enamel is not fully developed.

- Fig. 9. A portion of a longitudinal section from the crown of a molar tooth of *Sciurus niger*, showing, **D**, the dentine, and **E**, the enamel, with the fibres interspersed with irregular cells.
- Fig. 10. A longitudinal section from the fang of the same tooth, showing, **D**, the dentine, and **C**, the cementum, in the outer portion of which the tissue is arranged in rods, and is free from lacunæ.
- Fig. 11. A portion of a longitudinal section from the crown of a molar tooth of *Sciurus erythropus*, showing, **D**, a part of the dentine with the tubes combined into **E**, a portion of the enamel.
- Fig. 12. A portion of a longitudinal section of an upper incisor of *Arctomys pruinosus*, showing, **D**, the dentine, **E**, the enamel, with the lamellæ leaving the surface of the dentine at a right angle, and **F**, the outer fibrous division of the enamel. 150 linear.
- Fig. 13. A transverse section from the same tooth, showing, **D**, the dentine, and **E**, the enamel.
- Fig. 14. A portion of a longitudinal section from the upper incisor of *Castor fiber*, showing, **D**, the dentine with a peripheral layer of cells, **E**, the lamelliform portion, and **F**, the outer fibrous portion of the enamel.
- Fig. 15. A transverse section from the same tooth, showing, **D**, the dentine, **E**, the enamel, with the decussation of the component fibres of two laminæ, and **F**, the outer part of the enamel.

PLATE XLIV.

- Fig. 16. A portion of a longitudinal section from an upper incisor of *Spalax typhlus*, showing a peripheral portion of dentine with the downward direction of the branches of the dentinal tubes, and **E**, the enamel; **A**, an oblique longitudinal section, showing the fibres of alternate laminæ divided transversely. 150 linear.
- Fig. 17. A transverse section from the same tooth; **D**, the dentine, **E**, the enamel. 150 linear.
- Fig. 18. A longitudinal section from an upper incisor of a Dormouse (*Myoxus avelanarius*); **D**, peripheral portion of dentine, **E**, the enamel, showing the curved enamel lamellæ and the fibres in the outer part of the tissue. 300 linear.
- Fig. 19. An oblique longitudinal section from the same tooth, showing at **E** alternate layers of enamel fibres divided transversely with the intermediate ones exposed in their length. 300 linear.
- Fig. 20. A transverse section of the same tooth. 300 linear.

- Fig. 21. A longitudinal section of a lower incisor of *Myoxus avellanarius*, showing at E the decussation of the parallel layers of enamel fibres, and the downward direction of the external ends.
- Fig. 22. A transverse section of the same tooth, showing the outward course of the enamel lamellæ, their serrated margins near the dentine, and their vertical position.
- Fig. 23. A vertical section from the upper incisor of a Jerboa (*Dipus Ægyptius*), showing, D, the dentine at its anterior peripheral surface, and E, the enamel with a few tubes continued into the outer part. 150 linear.
- Fig. 24. An oblique longitudinal section, showing enamel fibres divided transversely and longitudinally. 300 linear.
- Fig. 25. A transverse section of an upper incisor of the Jerboa, showing, D, the dentine, and E, the enamel, with the decussation of the fibres of contiguous layers in the lamelliform portion of the tissue, and their parallel course in the outer part of the enamel. 150 linear.
- Fig. 26. A longitudinal section of a lower incisor of the Jerboa from near the base of the tooth, showing, D, the dentine, and E, the enamel, with the lamellæ arranged in the length of the tooth. 150 linear.
- Fig. 27. Enamel fibres scraped from the partially calcified tissue near the base of the tooth. 600 linear.
- Fig. 28. A transverse section of a lower incisor of the Jerboa, showing the enamel lamellæ divided transversely with the fibres of alternate layers cut obliquely, and the intervening one longitudinally.
- Fig. 29. Plate XLV. A longitudinal section of a molar of the Jerboa, showing the periphery of the dentine and the dentinal tubes continued into the enamel, with the manner of termination of the tubes in the latter texture.
- Fig. 30. A longitudinal section of a lower incisor of a Rat (*Mus decumanus*), showing, D, the terminal portion of the dentine, and E, the enamel, with its serrated lamellæ and its outer fibrous portion. 300 linear.
- Fig. 31. An oblique transverse section from the same tooth, showing the crossing of the fibres of contiguous layers, and the pattern thus produced. 300 linear.
- Fig. 32. A section from the same tooth, in which the fibres of alternate layers are divided transversely, and the intermediate ones exposed in their length, and show minute denticulations.
- Fig. 33. Enamel fibres in various stages of development, obtained from the partially calcified tissue about the base of the incisor.
- Fig. 34. A longitudinal section from a lower incisor of the Bank Vole (*Arvicola glareolus*), showing at E the denticulated character of the enamel lamellæ and their transverse markings.

PLATE XLV.

- Fig. 35. A longitudinal section of the upper incisor of the Porcupine (*Hystrix cristata*), in which is shown, D, the terminal portion of the dentine with its obliquely placed elongated cells, and E, the enamel with its confluent layers of obliquely placed fibres and the parallel fibres of the outer portion of the tissue. 120 linear.
- Fig. 36. A transverse section from the same tooth, showing, D, the dentine, and E, the enamel fibres pursuing a serpentine course in the lamelliform part of the tissue, and a straight parallel course in the external division of the tissue. 120 linear.
- Fig. 37. An oblique longitudinal section from a lower incisor of the Spotted Cavy (*Cælogenys Paca*), showing, D, the dentine with its peripheral layer of cells, and E, the enamel with the confluent layers, and with the fibres of alternate ones divided more or less transversely.
- Fig. 38. An oblique transverse section from the same tooth, showing, D, the dentine, and E, the enamel with the fibres in their waved course in the lamelliform portion, and parallel course in the outer portion of the tissue.
- Fig. 39. An oblique transverse section from a lower incisor of *Capromys Fournieri*, showing, D, the dentine, and E, the enamel, which in this figure is rather a diagram illustrating the arrangement of the enamel fibres, than a faithful delineation of the appearance presented in the section.
- Fig. 40. A longitudinal section from the same tooth, showing, D, the dentine, and E, the enamel, with its confluent laminæ and the oblique constituent fibres.
- Fig. 41. An oblique transverse section from the same tooth, showing at E the appearance assumed by the enamel laminæ near the sides of the tooth when the fibres are exposed in their length in the middle part of the section.

PLATE XLVI.

- Fig. 42. An oblique transverse section from the upper incisor of *Habrocoma Bennettii*, showing, D, the dentine, and E, the enamel, with the direction of the enamel fibres.
- Fig. 43. A longitudinal section from the upper incisor of *Habrocoma Bennettii*, showing, D, the dentine, and E, the enamel with its confluent laminæ. 150 linear.
- Fig. 44. Plate XLV. A longitudinal section from a lower incisor of the Guinea Pig (*Cavia Aperea*), showing, D, the peripheral portion of the dentine with its terminal layer of oblique elongated cells, and E, the enamel and its confluent laminæ. 200 linear.

- Fig. 45. A transverse section from an upper incisor of the Capybara (*Hydrochærus Capybara*), showing, D, the dentine, and E, the enamel. 150 linear.
- Fig. 46. A longitudinal section from the same tooth, showing the peripheral layer of cells, D, and E, the enamel with the penniform character of the confluent lamellæ. 150 linear.
- Fig. 47. A longitudinal section from an upper incisor of *Brathyergus maritimus*, showing, D, the dentine, and E, the enamel with its peculiar Hystricine enamel laminæ, and the large amount of the external division of the tissue. 150 linear.
- Fig. 48. A longitudinal section of a molar of *Pedetes Cafer*, showing, D, the dentine, and E, the enamel, with the inner portion fibrous, and the outer lamelliform.
- Fig. 49. A transverse section from the same tooth ; D, the dentine, and E, the enamel.
- Fig. 50. A longitudinal section from a lower incisor of the Hare (*Lepus timidus*), showing, D, the dentine, and E, the enamel fibres, without a lamelliform arrangement, and without a division into an external and internal portion. 200 linear.
- Fig. 51. A vascular canal surrounded by a layer of non-tubular tissue, as seen in a longitudinal section of an incisor of the Hare. 300 linear.
- Fig. 52. A transverse section from a molar of the Hare (*Lepus timidus*), showing, D, the dentine with its large tubes, and E, the enamel with the fibres in the inner portion parallel, and in the outer curved and irregularly Hystricine. 200 linear.
- Fig. 53. A longitudinal section from a molar of *Lepus Americanus*, showing the irregular lamelliform character of the outer portion of the enamel. 200 linear.

XXIX. *Sequel to a paper on the Reduction of the Thermometrical Observations made at the Apartments of the Royal Society.* By JAMES GLAISHER, Esq., F.R.S., of the Royal Observatory, Greenwich.

Received December 14, 1849,—Read February 28, 1850.

IN a paper which the Royal Society did me the honour to publish in the last volume of its Transactions, I gave the results found from all the thermometrical observations which have been taken at the Apartments of this Society; and I stated that I had made some progress in the connection of this series of results with those deduced from the observations at the Royal Observatory, Greenwich. Since that time I have reduced the two series of observations to one and the same series, and I have now the honour to lay the results from their combination before the Society.

In my former paper I stated that no observations had been taken between the years 1781 and 1786. Had the particulars of these years been about their average values, their omission would not have materially affected the final results, but on examination I found that those years were distinguished by very severe weather, and that their omission would have a sensible effect; I have therefore supplied these particulars, as detailed below.

I also stated that it was doubtful whether the temperatures, as determined for Somerset House, were influenced by local causes. I have endeavoured to collect information upon this subject, and of which I shall speak presently.

I shall adopt the same plan in the arrangement of the final results, which I pursued in my former paper, and present them for monthly, quarterly and yearly periods. The numbering of the Tables is continued from the former paper. It may tend to clearness if I speak of each preliminary investigation separately.

Determination of the Mean Temperature of the Air at Lyndon in Rutlandshire, the longitude of which place is $0^{\circ} 3'$ East of Greenwich and the latitude is $52^{\circ} 32'$ North, for every month in the years from 1771 to 1799.

The results of meteorological observations taken by THOMAS BARKER, Esq., at Lyndon in Rutlandshire, and which seems to have been taken with care, were published in the volumes of the Philosophical Transactions for the years 1772 to 1799. From these papers I have determined the mean monthly temperatures of the air, and which are shown in the following Table:—

TABLE VIII.—Mean monthly temperature of the Air at Lyndon in Rutlandshire, from the year 1771 to the year 1798.

| Year. | January. | Feb. | March. | April. | May. | Junc. | July. | August. | Sept. | October. | Nov. | December. |
|-------|----------|------|--------|--------|------|-------|-------|---------|-------|----------|------|---------------|
| 1771. | 30·5 | 34·0 | 35·0 | 40·0 | 56·2 | 56·6 | 61·5 | 59·7 | 52·7 | 47·5 | 41·2 | 41·2 |
| 1772. | 32·8 | 34·8 | 38·8 | 43·5 | 50·3 | 62·0 | 62·0 | 61·0 | 55·7 | 52·7 | 43·7 | 39·3 |
| 1773. | 37·5 | 35·5 | 41·2 | 45·5 | 49·2 | 58·2 | 60·5 | 62·2 | 54·5 | 48·5 | 39·5 | 38·0 |
| 1774. | 31·2 | 37·8 | 41·0 | 46·5 | 51·5 | 60·2 | 61·0 | 61·2 | 54·2 | 48·2 | 39·0 | 35·8 |
| 1775. | 38·7 | 42·5 | 41·5 | 49·7 | 55·0 | 62·7 | 64·0 | 59·7 | 57·8 | 47·5 | 37·8 | 37·5 |
| 1776. | 27·5 | 38·2 | 43·2 | 47·8 | 52·0 | 59·2 | 63·8 | 60·0 | 55·2 | 49·8 | 41·2 | 38·8 |
| 1777. | 33·5 | 34·2 | 43·2 | 45·0 | 54·0 | 57·7 | 61·5 | 61·5 | 57·7 | 49·8 | 42·7 | 35·2 |
| 1778. | 34·5 | 35·8 | 40·0 | 46·0 | 55·5 | 62·2 | 66·0 | 62·5 | 52·2 | 44·8 | 43·2 | 42·0 |
| 1779. | 36·0 | 44·5 | 44·2 | 49·2 | 54·0 | 58·2 | 65·5 | 65·0 | 59·0 | 50·8 | 40·8 | 36·7 |
| 1780. | 29·5 | 35·0 | 45·5 | 43·0 | 55·8 | 58·8 | 63·5 | 64·0 | 58·5 | 48·5 | 38·0 | 36·7 |
| 1781. | 34·0 | 40·7 | 43·0 | 48·5 | 53·2 | 63·5 | 64·5 | 64·0 | 57·5 | 48·8 | 42·0 | 40·8 |
| 1782. | 39·5 | 35·0 | 39·0 | 42·0 | 49·8 | 60·5 | 61·2 | 58·0 | 56·2 | 45·5 | 35·0 | 36·0 |
| 1783. | 37·5 | 39·8 | 38·0 | 49·2 | 50·0 | 61·0 | 67·7 | 62·0 | 55·3 | 49·3 | 42·8 | 34·8 |
| 1784. | 29·8 | 32·5 | 36·5 | 43·3 | 58·5 | 58·8 | 61·5 | 57·5 | 58·0 | 44·2 | 41·0 | 30·8 |
| 1785. | 36·7 | 31·0 | 34·2 | 47·5 | 54·2 | 62·0 | 64·2 | 58·8 | 57·5 | 47·2 | 40·5 | 35·0 |
| 1786. | 36·5 | 36·8 | 34·5 | 46·0 | 54·0 | 62·2 | 61·0 | 60·2 | 52·0 | 45·0 | 37·0 | Ther. broken. |
| 1787. | 37·2 | 42·5 | 44·2 | 46·0 | 53·8 | 60·0 | 62·5 | 61·8 | 59·0 | 50·2 | 38·8 | 39·0 |
| 1788. | 38·5 | 39·0 | 39·0 | 50·8 | 59·3 | 61·5 | 65·5 | 62·0 | 57·5 | 50·2 | 42·0 | 34·2 |
| 1789. | 34·5 | 40·5 | 36·0 | 47·0 | 56·8 | 60·0 | 63·0 | 63·0 | 56·8 | 48·0 | 39·8 | 42·0 |
| 1790. | 39·0 | 42·8 | 44·8 | 43·8 | 55·2 | 61·5 | 63·0 | 62·5 | 55·2 | 50·2 | 42·2 | 40·8 |
| 1791. | | 39·8 | 43·2 | 50·5 | 52·0 | 59·8 | 61·5 | 63·0 | 58·0 | 47·8 | 42·2 | 33·0 |
| 1792. | 36·5 | 38·8 | 43·2 | 51·5 | 52·2 | 57·8 | 62·5 | 64·2 | 54·0 | 48·8 | 44·8 | 40·2 |
| 1793. | 36·5 | 40·5 | 40·2 | 43·0 | 53·2 | 60·0 | 68·2 | 62·5 | 55·0 | 53·8 | 43·2 | 41·0 |
| 1794. | 34·5 | 45·5 | 45·2 | 52·0 | 53·5 | 62·5 | 69·0 | 61·8 | 54·8 | 49·5 | 43·5 | 37·2 |
| 1795. | 26·8 | 32·8 | 39·8 | 46·8 | 54·5 | 58·0 | 60·2 | 64·5 | 61·8 | 54·0 | 41·0 | 44·5 |
| 1796. | 44·8 | 40·5 | 40·5 | 51·2 | 51·0 | 60·5 | 62·5 | 62·5 | 60·0 | 47·2 | 40·5 | 32·0 |
| 1797. | 38·0 | 38·2 | 40·0 | 45·8 | 55·0 | 57·8 | 66·8 | 63·0 | 55·0 | 48·0 | 41·2 | 40·2 |
| 1798. | 38·5 | 38·8 | 41·2 | 51·5 | 56·8 | 65·8 | 64·5 | 64·2 | 58·5 | 51·0 | 40·5 | 33·2 |

During twenty of these years simultaneous observations were taken at the Apartments of this Society. The following Table of comparison of results is formed by comparing the numbers in the preceding Table with those for the same months in Table I. of my paper in the Philosophical Transactions, Part II., 1849.

TABLE IX.—Comparison of the mean monthly temperature of the Air at the Apartments of the Royal Society, with the mean monthly temperature of the Air at Lyndon.

| Years. | January. | | | February. | | | March. | | | April. | | | May. | | | June. | | |
|--------|------------------------------|---------|---------------------------|------------------------------|---------|---------------------------|------------------------------|---------|---------------------------|------------------------------|---------|---------------------------|------------------------------|---------|---------------------------|------------------------------|---------|---------------------------|
| | Mean temperature of the air. | | | Mean temperature of the air. | | | Mean temperature of the air. | | | Mean temperature of the air. | | | Mean temperature of the air. | | | Mean temperature of the air. | | |
| | Somerset House. | Lyndon. | Higher at Somerset House. | Somerset House. | Lyndon. | Higher at Somerset House. | Somerset House. | Lyndon. | Higher at Somerset House. | Somerset House. | Lyndon. | Higher at Somerset House. | Somerset House. | Lyndon. | Higher at Somerset House. | Somerset House. | Lyndon. | Higher at Somerset House. |
| 1774. | 33.1 | 31.2 | +1.9 | 39.4 | 37.8 | +1.6 | 43.9 | 41.0 | +2.9 | 47.9 | 46.5 | +1.4 | 52.2 | 51.5 | +0.7 | 61.0 | 60.2 | +0.8 |
| 1775. | 42.0 | 38.7 | +3.3 | 43.3 | 42.5 | +0.8 | 42.8 | 41.5 | +1.3 | 50.8 | 49.7 | +1.1 | 55.2 | 55.0 | +0.2 | 63.5 | 62.7 | +0.8 |
| 1776. | 28.6 | 27.5 | +1.1 | 41.4 | 38.2 | +3.2 | 44.8 | 43.2 | +1.6 | 48.3 | 47.8 | +0.5 | 51.7 | 52.0 | -0.3 | 59.6 | 59.2 | +0.4 |
| 1777. | 35.5 | 33.5 | +2.0 | 37.2 | 34.2 | +3.0 | 45.7 | 43.0 | +2.5 | 45.1 | 45.0 | +0.1 | 53.4 | 54.0 | -0.6 | 57.2 | 57.7 | -0.5 |
| 1778. | 36.4 | 34.5 | +1.9 | 37.0 | 35.8 | +1.2 | 41.2 | 40.0 | +1.2 | 48.0 | 46.0 | +2.0 | 55.9 | 55.5 | +0.4 | 62.2 | 62.2 | 0.0 |
| 1779. | 36.4 | 36.0 | +0.4 | 46.7 | 44.5 | +2.2 | 48.1 | 44.2 | +3.9 | 51.8 | 49.2 | +2.6 | 55.8 | 54.0 | +1.8 | 58.9 | 58.2 | +0.7 |
| 1780. | 30.2 | 29.5 | +0.7 | 36.7 | 35.0 | +1.7 | 50.3 | 45.5 | +4.8 | 44.7 | 43.0 | +1.7 | 57.2 | 55.8 | +1.4 | 60.0 | 58.8 | +1.2 |
| 1781. | 37.8 | 34.0 | +3.8 | 41.7 | 40.7 | +1.0 | 43.7 | 43.0 | +0.7 | 47.2 | 48.5 | -1.3 | 54.2 | 53.2 | +1.0 | 63.4 | 63.5 | -0.1 |
| 1787. | 38.3 | 37.2 | +1.1 | 40.9 | 42.5 | -1.6 | 43.9 | 44.2 | -0.3 | 45.5 | 46.0 | -0.5 | 52.4 | 53.8 | -1.4 | 58.7 | 60.0 | -1.3 |
| 1788. | 39.0 | 38.5 | +0.5 | 40.1 | 39.0 | +1.1 | 39.7 | 39.0 | +0.7 | 50.6 | 50.8 | -0.2 | 57.4 | 59.3 | -1.9 | 59.5 | 61.5 | -2.0 |
| 1789. | 35.0 | 34.5 | +0.5 | 41.3 | 40.5 | +0.8 | 35.5 | 36.0 | -0.5 | 45.2 | 47.0 | -1.8 | 54.3 | 56.8 | -2.5 | 55.7 | 60.0 | -4.3 |
| 1790. | 40.2 | 39.0 | +1.2 | 42.6 | 42.8 | -0.2 | 44.3 | 44.8 | -0.5 | 42.0 | 43.8 | -1.8 | 53.7 | 55.2 | -1.5 | 57.7 | 61.5 | -3.8 |
| 1791. | 41.4 | No obs. | | 40.2 | 39.8 | +0.4 | 43.2 | 43.2 | 0.0 | 49.9 | 50.5 | -0.6 | 50.5 | 52.0 | -1.5 | 58.5 | 59.8 | -1.3 |
| 1792. | 36.5 | 36.5 | 0.0 | 38.8 | 38.8 | 0.0 | 43.2 | 43.2 | 0.0 | 50.0 | 51.5 | -1.5 | 50.7 | 52.2 | -1.5 | 55.3 | 57.8 | -2.5 |
| 1793. | 36.9 | 36.5 | +0.4 | 41.1 | 40.5 | +0.6 | 40.4 | 40.2 | +0.2 | 43.5 | 43.0 | +0.5 | 51.8 | 53.2 | -1.4 | 56.3 | 60.0 | -3.7 |
| 1794. | 34.9 | 34.5 | +0.4 | 46.1 | 45.5 | +0.6 | 45.4 | 45.2 | +0.2 | 50.7 | 52.0 | -1.3 | 51.7 | 53.5 | -1.8 | 58.5 | 62.5 | -4.0 |
| 1795. | 25.5 | 26.8 | -1.3 | 35.5 | 32.8 | +2.7 | 39.7 | 39.8 | -0.1 | 46.2 | 46.8 | -0.6 | 53.0 | 54.5 | -1.5 | 54.6 | 58.0 | -3.4 |
| 1796. | 46.9 | 44.8 | +2.1 | 41.0 | 40.5 | +0.5 | 40.1 | 40.5 | -0.4 | 49.4 | 51.2 | -1.8 | 51.2 | 51.0 | +0.2 | 57.0 | 60.5 | -3.5 |
| 1797. | 37.0 | 38.0 | -1.0 | 37.0 | 38.2 | -1.2 | 39.0 | 40.0 | -1.0 | 45.8 | 45.8 | 0.0 | 52.4 | 55.0 | -2.6 | 55.7 | 57.8 | -2.1 |
| 1798. | 39.4 | 38.5 | +0.9 | 39.3 | 38.8 | +0.5 | 41.8 | 41.2 | +0.6 | 50.3 | 51.5 | -1.2 | 54.7 | 56.8 | -2.1 | 62.1 | 65.8 | -3.7 |
| 1774. | 62.8 | 61.0 | +1.8 | 61.5 | 61.2 | +0.3 | 55.8 | 54.2 | +1.6 | 50.1 | 48.2 | +1.9 | 40.5 | 39.0 | +1.5 | 38.5 | 35.8 | +2.7 |
| 1775. | 64.0 | 64.0 | 0.0 | 62.1 | 59.7 | +2.4 | 59.5 | 57.8 | +1.7 | 49.5 | 47.5 | +2.0 | 41.5 | 37.8 | +3.7 | 40.7 | 37.5 | +3.2 |
| 1776. | 63.8 | 63.8 | 0.0 | 62.0 | 60.0 | +2.0 | 55.6 | 55.2 | +0.4 | 52.8 | 49.8 | +3.0 | 44.0 | 41.2 | +2.8 | 41.5 | 38.8 | +2.7 |
| 1777. | 61.5 | 61.5 | 0.0 | 63.7 | 61.5 | +2.2 | 59.2 | 57.7 | +1.5 | 52.6 | 49.8 | +2.8 | 45.0 | 42.7 | +2.3 | 37.2 | 35.2 | +2.0 |
| 1778. | 68.0 | 66.0 | +2.0 | 64.8 | 62.5 | +2.3 | 54.5 | 52.2 | +2.3 | 47.3 | 44.8 | +2.5 | 46.0 | 43.2 | +2.8 | 41.2 | 42.0 | -2.2 |
| 1779. | 65.9 | 65.5 | +0.4 | 65.2 | 65.0 | +0.2 | 61.8 | 59.0 | +2.8 | 53.2 | 50.8 | +2.4 | 43.2 | 40.8 | +2.4 | 41.6 | 41.6 | +4.9 |
| 1780. | 64.2 | 63.5 | +0.7 | 67.0 | 64.0 | +3.0 | 60.4 | 58.5 | +1.9 | 51.3 | 48.5 | +2.8 | 40.8 | 38.0 | +2.8 | 38.0 | 36.7 | +1.3 |
| 1781. | 66.3 | 64.5 | +1.8 | 64.3 | 64.0 | +0.3 | 55.5 | 59.0 | -3.5 | 49.9 | 50.2 | -0.3 | 40.9 | 38.8 | +2.1 | 41.0 | 39.0 | +2.0 |
| 1787. | 62.4 | 62.5 | -0.1 | 62.4 | 61.8 | +0.6 | 57.0 | 57.5 | -0.5 | 50.4 | 50.2 | +0.2 | 41.9 | 42.0 | -0.1 | 30.4 | 34.2 | -3.8 |
| 1788. | 61.6 | 65.5 | -3.9 | 61.2 | 62.0 | -0.8 | 57.7 | 56.8 | +0.9 | 48.1 | 48.0 | +0.1 | 40.0 | 39.8 | +0.2 | 43.0 | 42.0 | +1.0 |
| 1789. | 59.8 | 63.0 | -3.2 | 61.5 | 63.0 | -1.5 | 55.7 | 56.8 | -1.1 | 48.1 | 48.0 | +0.1 | 40.0 | 39.8 | +0.2 | 40.4 | 40.8 | -0.4 |
| 1790. | 60.1 | 63.0 | -2.9 | 61.2 | 62.5 | -1.3 | 55.0 | 55.2 | -0.2 | 50.8 | 50.2 | +0.6 | 43.3 | 42.2 | +1.1 | 36.2 | 33.0 | +3.2 |
| 1791. | 60.5 | 61.5 | -1.0 | 62.7 | 63.0 | -0.3 | 57.9 | 58.0 | -0.1 | 47.9 | 47.8 | +0.1 | 42.6 | 42.2 | +0.4 | 41.4 | 40.2 | +1.2 |
| 1792. | 59.6 | 62.5 | -2.9 | 63.5 | 64.2 | -0.7 | 56.5 | 54.0 | +2.5 | 50.0 | 48.8 | +1.2 | 44.5 | 44.8 | -0.3 | 41.4 | 40.2 | +1.2 |
| 1793. | 65.9 | 68.2 | -2.3 | 60.3 | 62.5 | -2.2 | 53.9 | 55.0 | -1.1 | 53.2 | 53.8 | -0.6 | 44.2 | 43.2 | +1.0 | 42.4 | 41.0 | +1.4 |
| 1794. | 66.3 | 69.0 | -2.7 | 60.7 | 61.8 | -1.1 | 54.8 | 54.8 | 0.0 | 49.6 | 49.5 | +0.1 | 44.6 | 43.5 | +1.1 | 38.2 | 37.2 | +1.0 |
| 1795. | 59.9 | 60.2 | -0.3 | 62.1 | 64.5 | -2.4 | 61.9 | 61.8 | +0.1 | 54.7 | 54.0 | +0.7 | 42.0 | 41.0 | +1.0 | 46.2 | 44.5 | +1.7 |
| 1796. | 59.6 | 62.5 | -2.9 | 61.2 | 62.5 | -1.3 | 60.2 | 60.0 | +0.2 | 47.8 | 47.2 | +0.6 | 41.6 | 40.5 | +1.1 | 31.8 | 32.0 | -0.2 |
| 1797. | 64.3 | 66.8 | -2.5 | 60.3 | 63.0 | -2.7 | 55.7 | 55.0 | +0.7 | 48.3 | 48.0 | +0.3 | 42.7 | 41.2 | +1.5 | 42.6 | 40.2 | +2.4 |
| 1798. | 62.2 | 64.5 | -2.3 | 62.8 | 64.2 | -1.4 | 57.6 | 58.5 | -0.9 | 51.1 | 51.0 | +0.1 | 41.3 | 40.5 | +0.8 | 35.1 | 33.2 | +1.9 |

By taking the means of the differences of the results, we find that the reading of the thermometer in air at the Apartments of the Royal Society in

| | |
|---|-----|
| January was higher than at Lyndon by | 1°0 |
| February was higher than at Lyndon by | 0°8 |
| March was higher than at Lyndon by | 0°8 |
| April was lower than at Lyndon by | 0°2 |
| May was lower than at Lyndon by | 0°6 |
| June was lower than at Lyndon by | 1°7 |
| July was lower than at Lyndon by | 1°0 |
| August was higher than at Lyndon by less than | 0°1 |
| September was higher than at Lyndon by | 0°4 |
| October was higher than at Lyndon by | 1°0 |
| November was higher than at Lyndon by | 1°0 |
| December was higher than at Lyndon by | 1°6 |

Determination of the Mean Temperature of each month at the Apartments of the Royal Society for those months when no observations were made there.

By applying the above numbers to those in Table VIII. when no observations were taken at the Apartments of the Royal Society, the following Table is formed:—

TABLE X.—Showing the approximate mean monthly temperature of the Air at the Apartments of the Royal Society.

| Year. | Approximate mean temperature of the air. | | | | | | | | | | | |
|-------|--|-------|--------|--------|-------|-------|-------|---------|-------|----------|------|------|
| | January. | Feb. | March. | April. | May. | June. | July. | August. | Sept. | October. | Nov. | Dec. |
| 1771. | 31°5 | 34°8 | 35°8 | 39°8 | 55°6 | 54°9 | 60°5 | 59°7 | 53°1 | 48°5 | 42°2 | 42°8 |
| 1772. | 33°8 | 35°6 | 39°6 | 43°3 | 49°7 | 60°3 | 61°0 | 61°0 | 56°1 | 53°7 | 44°7 | 40°9 |
| 1773. | 38°5 | 36°5 | 42°0 | 45°3 | 48°6 | 56°5 | 59°5 | 62°2 | 54°9 | 49°5 | 40°5 | 39°6 |
| 1781. | | | | | | | | | 57°9 | 49°8 | 43°0 | 42°4 |
| 1782. | 40°5 | 35°8 | 39°8 | 41°8 | 49°2 | 58°8 | 60°2 | 58°0 | 56°6 | 46°5 | 36°0 | 37°6 |
| 1783. | 38°5 | 40°6 | 38°8 | 49°0 | 49°4 | 59°3 | 66°7 | 62°0 | 55°7 | 50°3 | 43°8 | 36°4 |
| 1784. | 30°8 | 33°3 | 37°3 | 43°1 | 57°9 | 57°1 | 60°5 | 57°5 | 58°4 | 45°2 | 42°0 | 32°4 |
| 1785. | 37°7 | 31°8 | 35°0 | 47°3 | 53°6 | 60°3 | 63°2 | 58°8 | 57°9 | 48°2 | 41°5 | 36°6 |
| 1786. | 37°5 | 37°6 | 35°3 | 45°8 | 53°4 | 60°5 | 60°0 | 60°2 | 52°4 | 46°0 | 38°0 | |

And these numbers may be considered as being very nearly the true values; they are reduced to the same zero as those in Table I. of my former paper, and form a part of that series of values.

Determination of the Mean Temperature of the Air at Epping for every month from the year 1821 to 1840.

Let us now proceed to compare the results of observations taken simultaneously towards the end of the Royal Society's series, made as nearly as possible under the

same circumstances as those at Lyndon at the beginning of that series, with the view of determining whether an agreement exists in the differences at those different epochs, and also for the purpose of assisting to determine whether London be really warmer than the country, as affirmed. The observations which most fully satisfy these conditions are those made by Mr. THOMAS SQUIRE of Epping. This gentleman, on my request to furnish me with the monthly means of his observations for comparison with those of this Society, most promptly and obligingly sent me the monthly mean from twenty-eight years' observations taken on every day at 8^h in the morning.

The thermometer with which the observations were made was placed in the shade, at the height of 5 feet above the ground, facing the N.E., and an open country.

These numbers I have reduced to mean values by the application of corrections, for that purpose (see my paper in Philosophical Transactions, Part I. 1848) then I further reduced them to the elevation at Somerset House and for difference of latitude, and in this way the next Table was formed.

TABLE XI.—Mean monthly temperature of the Air at Epping reduced to the elevation and latitude of Somerset House, for the year 1821 to 1848.

| Year. | January. | Feb. | March. | April. | May. | June. | July. | August. | Sept. | October. | Nov. | Dec. | Year. |
|-------|----------|------|--------|--------|------|-------|-------|---------|-------|----------|------|------|-------|
| 1821. | 38.5 | 34.8 | 43.0 | 50.2 | 49.4 | 53.1 | 58.4 | 64.1 | 62.7 | 50.7 | 47.3 | 43.5 | 49.6 |
| 1822. | 39.0 | 43.0 | 46.9 | 48.9 | 57.6 | 65.3 | 64.1 | 62.7 | 58.1 | 52.6 | 46.6 | 33.9 | 51.6 |
| 1823. | 31.5 | 38.3 | 41.5 | 47.1 | 57.1 | 56.8 | 60.3 | 61.5 | 57.1 | 48.4 | 43.8 | 39.6 | 48.6 |
| 1824. | 38.0 | 38.8 | 41.6 | 46.2 | 52.1 | 56.8 | 62.9 | 61.9 | 59.9 | 51.0 | 46.7 | 42.2 | 49.8 |
| 1825. | 38.9 | 38.2 | 41.7 | 51.0 | 56.7 | 60.6 | 65.4 | 64.3 | 62.6 | 51.8 | 41.0 | 40.2 | 51.0 |
| 1826. | 31.8 | 42.3 | 43.4 | 50.6 | 53.1 | 63.9 | 66.3 | 66.1 | 59.8 | 53.7 | 40.2 | 42.7 | 51.2 |
| 1827. | 33.8 | 32.3 | 44.9 | 50.6 | 56.0 | 59.8 | 64.2 | 61.3 | 59.2 | 53.8 | 42.5 | 41.2 | 50.2 |
| 1828. | 40.7 | 41.8 | 44.7 | 49.8 | 57.0 | 61.9 | 62.8 | 61.5 | 60.1 | 50.7 | 44.8 | 45.2 | 51.8 |
| 1829. | 31.9 | 38.8 | 40.3 | 46.0 | 56.7 | 60.5 | 60.8 | 58.9 | 54.4 | 49.0 | 38.9 | 32.4 | 47.3 |
| 1830. | 31.4 | 34.4 | 46.4 | 50.7 | 56.8 | 56.2 | 63.9 | 59.1 | 55.2 | 52.1 | 43.1 | 35.3 | 48.7 |
| 1831. | 34.9 | 41.2 | 45.5 | 51.3 | 54.7 | 60.3 | 62.1 | 63.8 | 58.2 | 56.2 | 42.7 | 42.3 | 50.2 |
| 1832. | 36.8 | 37.0 | 41.8 | 48.9 | 53.4 | 59.8 | 61.1 | 61.8 | 58.3 | 52.2 | 53.6 | 43.1 | 50.3 |
| 1833. | 35.2 | 42.9 | 38.9 | 47.9 | 60.4 | 59.8 | 60.7 | 57.9 | 55.0 | 51.6 | 43.1 | 45.8 | 49.9 |
| 1834. | 45.6 | 40.1 | 45.1 | 47.6 | 57.7 | 61.5 | 64.0 | 63.2 | 60.5 | 51.9 | 44.4 | 41.3 | 51.9 |
| 1835. | 38.6 | 41.4 | 42.3 | 48.8 | 54.7 | 60.7 | 64.2 | 64.5 | 58.9 | 48.8 | 43.7 | 35.7 | 50.2 |
| 1836. | 37.9 | 37.0 | 44.5 | 46.1 | 52.6 | 61.0 | 62.6 | 60.3 | 55.6 | 49.7 | 42.1 | 40.4 | 49.2 |
| 1837. | 38.4 | 40.1 | 37.4 | 42.4 | 50.4 | 60.7 | 62.5 | 62.3 | 57.6 | 51.5 | 39.5 | 41.9 | 48.7 |
| 1838. | 28.6 | 32.9 | 42.5 | 44.8 | 53.7 | 60.2 | 62.4 | 62.1 | 57.5 | 51.1 | 40.4 | 38.7 | 47.9 |
| 1839. | 37.2 | 39.0 | 41.3 | 45.1 | 51.3 | 61.7 | 62.6 | 61.0 | 57.7 | 50.7 | 46.3 | 40.1 | 49.5 |
| 1840. | 39.2 | 38.0 | 39.4 | 50.1 | 56.4 | 62.1 | 61.0 | 64.2 | 54.2 | 46.4 | 42.6 | 32.6 | 48.9 |
| 1841. | 33.6 | 36.3 | 46.5 | 48.8 | 59.1 | 58.1 | 60.9 | 62.6 | 60.2 | 49.8 | 42.2 | 40.0 | 49.8 |
| 1842. | 33.1 | 40.1 | 44.8 | 47.3 | 55.1 | 64.7 | 62.4 | 67.3 | 59.4 | 44.9 | 42.4 | 44.1 | 50.4 |
| 1843. | 39.6 | 35.9 | 43.1 | 49.5 | 54.5 | 58.0 | 62.6 | 64.5 | 62.1 | 48.0 | 43.1 | 44.1 | 50.4 |
| 1844. | 38.5 | 33.9 | 42.3 | 51.8 | 54.4 | 62.0 | 63.6 | 59.4 | 59.2 | 47.9 | 43.5 | 33.9 | 49.3 |
| 1845. | 38.9 | 32.2 | 36.8 | 47.7 | 51.2 | 62.8 | 61.6 | 59.3 | 56.5 | 50.1 | 44.6 | 40.0 | 48.5 |
| 1846. | 42.7 | 42.2 | 43.9 | 48.4 | 56.1 | 67.3 | 65.4 | 64.5 | 60.6 | 50.5 | 44.4 | 31.2 | 51.5 |
| 1847. | 35.0 | 35.0 | 40.8 | 45.4 | 57.0 | 58.3 | 64.9 | 61.7 | 54.2 | 52.8 | 45.3 | 41.8 | 49.4 |
| 1848. | 35.0 | 42.6 | 43.0 | 48.9 | 59.4 | 60.1 | 62.5 | 59.3 | 56.6 | 51.7 | 40.5 | 41.9 | 50.2 |

During twenty-two of these years observations were taken at Somerset House, and the following Table exhibits the simultaneous results with their differences.

TABLE XII.—Comparison of the mean monthly temperature of the Air at Somerset House and at Epping.

| Year. | January. | | | February. | | | March. | | | April. | | | May. | | | June. | | |
|-------|--------------------------------|---------|---------------------------|--------------------------------|---------|---------------------------|--------------------------------|---------|---------------------------|--------------------------------|---------|---------------------------|--------------------------------|---------|---------------------------|--------------------------------|---------|---------------------------|
| | Mean temperature of the air at | | | Mean temperature of the air at | | | Mean temperature of the air at | | | Mean temperature of the air at | | | Mean temperature of the air at | | | Mean temperature of the air at | | |
| | Somerset House. | Epping. | Higher at Somerset House. | Somerset House. | Epping. | Higher at Somerset House. | Somerset House. | Epping. | Higher at Somerset House. | Somerset House. | Epping. | Higher at Somerset House. | Somerset House. | Epping. | Higher at Somerset House. | Somerset House. | Epping. | Higher at Somerset House. |
| 1821. | 39.1 | 38.5 | +0.6 | 37.4 | 34.8 | +2.6 | 43.9 | 43.0 | +0.9 | 51.5 | 50.2 | +1.3 | 50.1 | 49.4 | +0.7 | 55.0 | 53.1 | +1.9 |
| 1822. | 41.4 | 39.0 | +2.4 | 44.7 | 43.0 | +1.7 | 48.4 | 46.9 | +1.5 | 47.8 | 48.9 | -1.1 | 56.9 | 57.6 | -0.7 | 63.5 | 65.3 | -1.8 |
| 1823. | 33.4 | 31.5 | +1.9 | 39.5 | 38.3 | +1.2 | 40.9 | 41.5 | -0.6 | 43.9 | 47.1 | -3.2 | 55.7 | 57.1 | -1.4 | 56.3 | 56.8 | -0.5 |
| 1824. | 39.0 | 38.0 | +1.0 | 37.6 | 38.8 | -1.2 | 40.6 | 41.6 | -1.0 | 44.9 | 46.2 | -1.3 | 50.6 | 52.1 | -1.5 | 55.9 | 56.8 | -0.9 |
| 1825. | 40.0 | 38.9 | +1.1 | 39.5 | 38.2 | +1.3 | 39.6 | 40.7 | -1.1 | 49.8 | 51.0 | -1.2 | 54.7 | 56.7 | -2.0 | 59.8 | 60.6 | -0.8 |
| 1826. | 33.6 | 31.8 | +1.8 | 43.6 | 42.3 | +1.3 | 44.3 | 43.4 | +0.9 | 50.1 | 50.6 | -0.5 | 51.1 | 53.1 | -2.0 | 63.8 | 63.9 | -0.1 |
| 1827. | 35.0 | 33.8 | +1.2 | 33.0 | 32.3 | +0.7 | 44.2 | 44.9 | -0.7 | 47.9 | 50.6 | -2.7 | 53.8 | 56.0 | -2.2 | 58.5 | 59.8 | -1.3 |
| 1828. | 41.4 | 40.7 | +0.7 | 41.6 | 41.8 | -0.2 | 44.6 | 44.7 | -0.1 | 47.6 | 49.8 | -2.2 | 55.4 | 57.0 | -1.6 | 60.9 | 61.9 | -1.0 |
| 1829. | 33.3 | 31.9 | +1.4 | 39.8 | 38.8 | +1.0 | 40.1 | 40.3 | -0.2 | 44.8 | 46.0 | -1.2 | 55.6 | 56.7 | -1.1 | 59.9 | 60.5 | -0.6 |
| 1830. | 32.3 | 31.4 | +0.9 | 35.6 | 34.4 | +1.2 | 46.9 | 46.4 | +0.5 | 49.4 | 50.7 | -1.3 | 55.8 | 56.8 | -1.0 | 56.2 | 56.2 | 0.0 |
| 1831. | 36.0 | 34.9 | +1.1 | 42.6 | 41.2 | +1.4 | 45.0 | 45.5 | -0.5 | 49.2 | 51.3 | -2.1 | 53.9 | 54.7 | -0.8 | 60.3 | 60.3 | 0.0 |
| 1832. | 38.9 | 36.8 | +2.1 | 38.3 | 37.0 | +1.3 | 41.6 | 41.8 | -0.2 | 48.3 | 48.9 | -0.6 | 52.6 | 53.4 | -0.8 | 60.1 | 59.8 | +0.3 |
| 1833. | 36.1 | 35.2 | +0.9 | 43.8 | 42.9 | +0.9 | 38.7 | 38.9 | -0.2 | 46.3 | 47.9 | -1.6 | 60.5 | 60.4 | +0.1 | 60.7 | 59.8 | +0.9 |
| 1834. | 46.0 | 45.6 | +0.4 | 41.6 | 40.1 | +1.5 | 41.1 | 45.1 | -4.0 | 46.1 | 47.6 | -1.5 | 58.0 | 57.7 | +0.3 | 62.0 | 61.5 | +0.5 |
| 1835. | 39.6 | 38.6 | +1.0 | 42.6 | 41.4 | +1.2 | 42.1 | 42.3 | -0.2 | 47.5 | 48.8 | -1.3 | 54.0 | 54.7 | -0.7 | 60.9 | 60.7 | +0.2 |
| 1836. | 38.8 | 37.9 | +0.9 | 38.3 | 37.0 | +1.3 | 44.8 | 44.5 | +0.3 | 44.4 | 46.1 | -1.7 | 53.9 | 52.6 | +1.3 | 59.9 | 61.0 | -1.1 |
| 1837. | 38.8 | 38.4 | +0.4 | 41.7 | 40.1 | +1.6 | 36.9 | 37.4 | -0.5 | 40.2 | 42.4 | -2.2 | 48.9 | 50.4 | -1.5 | 59.0 | 60.7 | -1.7 |
| 1838. | 30.5 | 28.6 | +1.9 | 34.3 | 32.9 | +1.4 | 42.6 | 42.5 | +0.1 | 42.7 | 44.8 | -2.1 | 51.8 | 53.7 | -1.9 | 58.1 | 60.2 | -2.1 |
| 1839. | 38.8 | 37.2 | +1.6 | 40.5 | 39.0 | +1.5 | 40.1 | 41.3 | -1.2 | 42.0 | 45.1 | -3.1 | 51.0 | 51.3 | -0.3 | 59.6 | 61.7 | -2.1 |
| 1840. | 40.6 | 39.2 | +1.4 | 39.5 | 38.0 | +1.5 | 38.7 | 39.4 | -0.7 | 48.9 | 50.1 | -1.2 | 54.6 | 56.4 | -1.8 | 60.4 | 62.1 | -1.7 |
| 1841. | 36.1 | 33.6 | +2.5 | 36.6 | 36.3 | +0.3 | 47.9 | 46.5 | +1.4 | 47.4 | 48.8 | -1.4 | 57.9 | 59.1 | -1.2 | 57.2 | 58.1 | -0.9 |
| 1842. | 34.8 | 33.1 | +1.7 | 42.2 | 40.1 | +2.1 | 45.4 | 44.8 | +0.6 | 45.7 | 47.3 | -1.6 | 54.3 | 55.1 | -0.8 | 64.2 | 64.7 | -0.5 |
| 1843. | 41.3 | 39.6 | +1.7 | 37.5 | 35.9 | +1.6 | 43.6 | 43.1 | +0.5 | 48.6 | 49.5 | -0.9 | 52.8 | 54.5 | -1.7 | 56.4 | 58.0 | -1.6 |
| 1821. | 58.7 | 58.4 | +0.3 | 63.0 | 64.1 | -1.1 | 60.7 | 62.7 | -2.0 | 51.6 | 50.7 | +0.9 | 48.9 | 47.3 | +1.6 | 45.7 | 43.5 | +2.2 |
| 1822. | 63.5 | 64.1 | -0.6 | 62.6 | 62.7 | -0.1 | 57.1 | 58.1 | -1.0 | 53.3 | 52.6 | +0.7 | 49.5 | 46.6 | +2.9 | 37.8 | 33.9 | +3.9 |
| 1823. | 60.1 | 60.3 | -0.2 | 61.6 | 61.5 | +0.1 | 56.5 | 57.1 | -0.6 | 48.9 | 48.4 | +0.5 | 44.3 | 43.8 | +0.5 | 41.3 | 39.6 | +1.7 |
| 1824. | 63.5 | 62.9 | +0.6 | 61.3 | 61.9 | -0.6 | 58.8 | 59.9 | -1.1 | 51.1 | 51.0 | +0.1 | 47.5 | 46.7 | +0.8 | 43.2 | 42.2 | +1.0 |
| 1825. | 66.2 | 65.4 | +0.8 | 63.1 | 64.3 | -1.2 | 61.0 | 62.6 | -1.6 | 52.1 | 51.8 | +0.3 | 42.5 | 41.0 | +1.5 | 42.0 | 40.2 | +1.8 |
| 1826. | 66.6 | 66.3 | +0.3 | 64.7 | 66.1 | -1.4 | 57.4 | 59.8 | -2.4 | 53.7 | 53.7 | 0.0 | 41.2 | 40.2 | +1.0 | 43.2 | 42.7 | +0.5 |
| 1827. | 64.5 | 64.2 | +0.3 | 60.3 | 61.3 | -1.0 | 58.0 | 59.2 | -1.2 | 53.1 | 52.3 | +0.8 | 42.8 | 42.5 | +0.3 | 45.5 | 41.2 | +4.3 |
| 1828. | 62.9 | 62.8 | +0.1 | 60.3 | 61.5 | -1.2 | 58.6 | 60.1 | -1.5 | 51.2 | 50.7 | +0.5 | 45.6 | 44.8 | +0.8 | 45.9 | 45.2 | +0.7 |
| 1829. | 61.1 | 60.8 | +0.3 | 59.0 | 58.9 | +0.1 | 54.3 | 54.4 | -0.1 | 48.8 | 49.0 | -0.2 | 40.6 | 38.9 | +1.7 | 36.3 | 32.4 | +3.9 |
| 1830. | 64.0 | 63.9 | +0.1 | 59.5 | 59.1 | +0.4 | 54.6 | 55.2 | -0.6 | 52.2 | 52.1 | +0.1 | 45.7 | 43.1 | +2.6 | 36.3 | 35.3 | +1.0 |
| 1831. | 65.3 | 62.1 | +3.2 | 64.6 | 63.8 | +0.8 | 57.5 | 58.2 | -0.7 | 56.3 | 56.2 | +0.1 | 45.6 | 42.7 | +2.9 | 43.4 | 42.3 | +1.1 |
| 1832. | 62.2 | 61.1 | +1.1 | 62.3 | 61.8 | +0.5 | 57.7 | 58.3 | -0.6 | 52.5 | 52.2 | +0.3 | 45.0 | 43.6 | +1.4 | 43.8 | 43.1 | +0.7 |
| 1833. | 62.1 | 60.7 | +1.4 | 58.8 | 57.9 | +0.9 | 54.6 | 55.0 | -0.4 | 49.6 | 51.6 | -2.0 | 44.8 | 43.1 | +1.7 | 46.0 | 45.8 | +0.2 |
| 1834. | 65.1 | 64.0 | +1.1 | 63.6 | 63.2 | +0.4 | 59.4 | 60.5 | -1.1 | 51.8 | 51.9 | -0.1 | 45.4 | 44.4 | +1.0 | 42.4 | 41.3 | +1.1 |
| 1835. | 65.4 | 64.2 | +1.2 | 64.6 | 64.5 | +0.1 | 58.2 | 58.9 | -0.7 | 49.3 | 48.8 | +0.5 | 44.3 | 43.7 | +0.6 | 36.3 | 35.7 | +0.6 |
| 1836. | 63.9 | 62.6 | +1.3 | 60.2 | 60.3 | -0.1 | 54.5 | 55.6 | -1.1 | 48.7 | 49.7 | -1.0 | 42.8 | 42.1 | +0.7 | 41.0 | 40.4 | +0.6 |
| 1837. | 62.3 | 62.5 | -0.2 | 61.4 | 62.3 | -0.9 | 56.1 | 57.6 | -1.5 | 51.9 | 51.5 | +0.4 | 42.4 | 39.5 | +2.9 | 42.6 | 41.9 | +0.7 |
| 1838. | 61.5 | 62.4 | -0.9 | 60.9 | 62.1 | -1.2 | 55.5 | 57.5 | -2.0 | 51.3 | 51.1 | +0.2 | 42.1 | 40.4 | +1.7 | 40.0 | 38.7 | +1.3 |
| 1839. | 61.2 | 62.6 | -1.4 | 60.2 | 61.0 | -0.8 | 56.7 | 57.7 | -1.0 | 50.2 | 50.7 | -0.5 | 46.0 | 46.3 | -0.3 | 41.0 | 40.1 | +0.9 |
| 1840. | 59.8 | 61.0 | -1.2 | 63.4 | 64.2 | -0.8 | 55.2 | 54.2 | +1.0 | 48.1 | 46.4 | +1.7 | 44.7 | 42.6 | +2.1 | 34.7 | 32.6 | +2.1 |
| 1841. | 59.0 | 60.9 | -1.9 | 61.3 | 62.6 | -1.3 | 58.5 | 58.5 | 0.0 | 50.7 | 49.8 | +0.9 | 44.5 | 42.2 | +2.3 | 42.0 | 40.0 | +2.0 |
| 1842. | 61.5 | 62.4 | -0.9 | 67.6 | 67.3 | +0.3 | 57.5 | 59.4 | -1.9 | 47.2 | 44.9 | +2.3 | 44.2 | 42.4 | +1.8 | 45.3 | 44.1 | +1.2 |

By taking the mean of the numbers in each column of differences, we find that the temperature of the air at the Apartments of the Royal Society in

| | |
|---|-----|
| January was higher than at Epping reduced to the same level by . . . | 1·3 |
| February was higher than at Epping reduced to the same level by . . . | 1·2 |
| March was lower than at Epping reduced to the same level by less than . . . | 0·1 |
| April was lower than at Epping reduced to the same level by . . . | 1·5 |
| May was lower than at Epping reduced to the same level by . . . | 1·0 |
| June was lower than at Epping reduced to the same level by . . . | 0·6 |
| July was higher than at Epping reduced to the same level by . . . | 0·2 |
| August was lower than at Epping reduced to the same level by . . . | 0·3 |
| September was lower than at Epping reduced to the same level by . . . | 1·0 |
| October was higher than at Epping reduced to the same level by . . . | 0·2 |
| November was higher than at Epping reduced to the same level by . . . | 1·4 |
| December was higher than at Epping reduced to the same level by . . . | 1·5 |

And the mean temperature of the whole period was nearly of the same value at both places.

Having obtained these results, and finding that during the time the sun was situated north of the equator the temperature at the Apartments of the Royal Society was lower than at Epping, and that it was higher during the time the sun had south declination, I requested Mr. SQUIRE to furnish me with full particulars with respect to the position of his instrument to the sun and to surrounding objects: the following is the information he gave me:—

“The thermometer hangs near the north angle of a small projecting pier of a wall, nearly close to the brickwork, facing the N.E., and an open country. At the back of the wall is a grape-vine, and when in leaf, it so shades the wall that its temperature is not much affected by the sun’s rays; but, before the vine is in leaf, it may raise the temperature a trifle; yet from some casual observations scattered over my journal as tests, I do not find that the said thermometer is sensibly influenced by the heat of the sun at 8 A.M., the time of reading the instrument. On the 13th of May, 1847, I moved the thermometer a few feet from its former position on the wall, with the same aspect, but, at the back of this part of the wall, there is a sort of grotto or summer-house, which is covered by thatch and completely interrupts the sun’s rays from the wall; hence its present situation may perhaps be considered more eligible for a mean temperature than its former position, but I do not find any difference worth notice.”

The general fact, however, of a higher winter temperature, and of a lower summer temperature at the Apartments of the Royal Society, is satisfactorily proved by both sets of comparisons, and it is evident that the same cause has been in operation at both times, and to the same amount. There can be no doubt that this cause is the vicinity of the river Thames to the locality of the observations.

Determination of the Monthly Mean Temperature of the water of the Thames by night and by day, from the year 1846 to the year 1849.

The observations to determine the temperature of the Thames water are made by Lieut. SANDERS, R.N. The instruments consist of one maximum thermometer and of one minimum thermometer, suspended from the sides of the Dreadnought Hospital Ship, in a perforated trunk placed at about 2 feet below the surface of the water. The range of temperature during the day is usually about 2° , and the simple arithmetic mean of the readings of the maximum and minimum thermometers shows the mean temperature of the water.

TABLE XIII.—Mean monthly temperature of the water of the Thames.

| Month. | 1846. | | | 1847. | | | 1848. | | | 1849. | | |
|-------------|---|------|--------------------------------|---|------|--------------------------------|---|-------|--------------------------------|---|------|--------------------------------|
| | Mean of all the readings in each month. | | Mean temperature of the water. | Mean of all the readings in each month. | | Mean temperature of the water. | Mean of all the readings in each month. | | Mean temperature of the water. | Mean of all the readings in each month. | | Mean temperature of the water. |
| | Max. | Min. | | Max. | Min. | | Max. | Min. | | Max. | Min. | |
| January.... | 44.3 | 42.0 | 43.2 | 37.1 | 35.5 | 36.3 | 35.7 | 35.1 | 35.4 | 41.6 | 39.6 | 40.6 |
| February... | 45.3 | 42.5 | 43.9 | 38.9 | 37.2 | 38.1 | 41.8 | 40.3 | 41.1 | 44.2 | 42.6 | 43.4 |
| March..... | 48.2 | 46.3 | 47.3 | 42.1 | 41.4 | 41.8 | | | | 45.7 | 44.1 | 44.9 |
| April | 51.5 | 49.4 | 50.5 | 46.9 | 46.4 | 46.7 | 51.1 | 50.2 | 50.6 | 47.9 | 44.8 | 46.3 |
| May | 59.9 | 57.2 | 58.6 | 58.6 | 57.0 | 57.8 | 62.5 | 61.0 | 61.8 | 58.9 | 55.7 | 57.3 |
| June | 73.0 | 70.8 | 71.9 | 65.5 | 61.9 | 63.7 | 63.6 | 62.6 | 63.1 | 65.2 | 63.3 | 64.3 |
| July | 67.4 | 66.1 | 66.7 | 70.6 | 66.5 | 68.6 | 66.0 | 65.0 | 65.5 | 67.8 | 66.1 | 67.0 |
| August ... | 68.3 | 66.7 | 67.5 | 66.1 | 64.4 | 65.3 | 63.0 | 62.0 | 62.5 | 64.9 | 62.7 | 63.8 |
| September. | 64.7 | 63.5 | 64.1 | 57.0 | 56.5 | 56.8 | 59.5 | 58.8 | 59.1 | 61.4 | 58.7 | 60.0 |
| October ... | 54.2 | 52.8 | 53.5 | 53.3 | 53.0 | 53.2 | 53.7 | 50.8 | 52.2 | 52.8 | 49.5 | 51.2 |
| November. | 47.6 | 46.0 | 46.8 | 47.9 | 47.3 | 47.6 | | | | 47.1 | 44.1 | 45.6 |
| December. | 37.6 | 34.9 | 36.3 | 42.5 | 41.5 | 42.0 | 43.9 | 40.5 | 42.2 | 40.3 | 36.8 | 38.6 |

By comparing the means of these numbers for the four years, with the means of the readings of the maximum and minimum thermometers in air at the Royal Observatory, for the same months, we find that the mean lowest readings of the water were higher in the twelve months respectively by $3^{\circ}.9$; $4^{\circ}.6$; $7^{\circ}.7$; $12^{\circ}.3$; $11^{\circ}.5$; $16^{\circ}.7$; $12^{\circ}.4$; $10^{\circ}.4$; $10^{\circ}.7$; $6^{\circ}.8$; $6^{\circ}.3$ and $4^{\circ}.9$, than the mean of the lowest readings of the air; and it was lower than the mean maximum readings of the air by $3^{\circ}.2$; $4^{\circ}.6$; $5^{\circ}.3$; $9^{\circ}.2$; $6^{\circ}.0$; $7^{\circ}.5$; $8^{\circ}.1$; $6^{\circ}.7$; $7^{\circ}.4$; $6^{\circ}.0$; $4^{\circ}.7$ and $3^{\circ}.0$, in the respective months from January. These numbers are very large, and will fully account for the little higher temperature possessed by places in the vicinity of the river, and these differences of temperature are probably the fruitful source of the London fogs.

Mr. SANDERS, at my request, has taken daily observations of the temperature of the air at 32 feet above the water of the Thames at the hours of 6 A.M. and 6 P.M. during the years 1847 and 1848, and at the hours of 9 A.M. and 9 P.M. in the year 1849. The result of these observations, compared with simultaneous observations taken at the Royal Observatory, is as follows:—that the temperature of the air 32 feet above

the water, exceeds that at the observatory at 6 A.M. by 1°·6; 1°·0; 0°·8; 0°·3; 0°·6; 0°·7; 0°·9; 0°·8; 0°·2; 0°·0 and 0°·8, in the twelve months respectively; and at 6 P.M. by 1°·2; 0°·8; 1°·0; 0°·8; 0°·7; 0°·8; 0°·6; 0°·8; 1°·3; 1°·0; 1°·7 and 0°·9, in the twelve months respectively; that at 9 A.M. it was in excess in January by 1°·3; February by 1°·5; March by 0°·6; April by 0°·4; May by 2°·2; June by 0°·4; and in October by 0°·5; that it was of a lower temperature in July by 0°·7; August by 0°·5; and in September by 0°·1; that at 9 P.M. it was always of a higher temperature: the excesses were 0°·1; 0°·3; 0°·7; 0°·3; 1°·9; 2°·9; 1°·5; 3°·2; 1°·2 and 1°·3 respectively.

From these numbers, it seems that during the night hours, at all seasons of the year, the temperature of the air at the Dreadnought Hospital Ship is higher than at the Observatory, and that it is below only during the midday hours.

At times of extreme temperature the effect of the water upon the temperature of the air is very great. On February 12, 1847, the temperature of the air at my house, which is situated about one mile and a half from the river, was 6°·0; the lowest reading, 32 feet above the water of the Thames, was 16°·0; the temperature of the water was 33°; its heating effect upon the air in its immediate vicinity amounted to 10°; at the Observatory the reading was 10°·5; and the heat of the water of the Thames seems to have influenced the temperature of the air at the Observatory to the amount of 4°. Some time since, on comparing the temperatures of the air as recorded in the Philosophical Transactions in the year 1814, with corresponding temperatures as observed at Greenwich, I doubted the accuracy of the former in many instances, on account of their much higher values; these investigations have now led me to believe that the temperatures, as recorded in the Philosophical Transactions for that year, are correct.

TABLE XIV.—Comparison of the mean temperature of the Air at St. John's Wood, and at the Royal Observatory, Greenwich.

| Month. | 1841. | | | 1842. | | | 1843. | | |
|---------------|----------------------------------|---------------------|-------------------------------|----------------------------------|---------------------|-------------------------------|----------------------------------|---------------------|-------------------------------|
| | Mean temperature of the air. | | | Mean temperature of the air. | | | Mean temperature of the air. | | |
| | At Royal Observatory, Greenwich. | At St. John's Wood. | In excess at St. John's Wood. | At Royal Observatory, Greenwich. | At St. John's Wood. | In excess at St. John's Wood. | At Royal Observatory, Greenwich. | At St. John's Wood. | In excess at St. John's Wood. |
| January | 33·6 | 34·3 | +0·7 | 32·9 | 32·4 | -0·5 | 39·9 | 39·1 | -0·8 |
| February ... | 35·3 | 36·5 | +1·2 | 40·8 | 40·3 | -0·5 | 36·0 | 36·1 | +0·1 |
| March | 46·2 | 46·6 | +0·4 | 44·9 | 44·3 | -0·6 | 42·9 | 42·9 | 0·0 |
| April | 47·0 | 46·6 | -0·4 | 45·2 | 46·3 | +1·1 | 47·1 | 47·6 | +0·5 |
| May | 56·8 | 57·0 | +0·2 | 53·2 | 53·2 | 0·0 | 52·2 | 51·2 | -1·0 |
| June | 56·4 | 55·9 | -0·5 | 62·9 | 62·5 | -0·4 | 56·3 | 55·2 | -1·1 |
| July | 57·8 | 56·9 | -0·9 | 60·2 | 59·5 | -0·7 | 60·9 | 60·1 | -0·8 |
| August | 60·5 | 59·5 | -1·0 | 65·4 | 65·5 | +0·1 | 62·1 | 61·9 | -0·2 |
| September ... | 58·5 | 57·8 | -0·7 | 56·4 | 56·2 | -0·2 | 59·5 | 60·3 | +0·8 |
| October | 48·8 | 49·1 | +0·3 | 45·4 | 45·8 | +0·4 | 48·0 | 47·6 | -0·4 |
| November ... | 42·7 | 42·5 | -0·2 | 42·8 | 43·3 | +0·5 | 43·8 | 43·9 | +0·1 |
| December ... | 40·5 | 40·2 | -0·3 | 45·0 | 44·6 | -0·4 | 43·9 | 44·2 | +0·3 |

TABLE XIV. (Continued.)

| Month. | 1844. | | | 1845. | | | 1846. | | |
|---------------|---------------------------------|---------------------|-------------------------------|----------------------------------|---------------------|-------------------------------|----------------------------------|---------------------|-------------------------------|
| | Mean temperature of the air. | | | Mean temperature of the air. | | | Mean temperature of the air. | | |
| | At Royal Observatory Greenwich. | At St. John's Wood. | In excess at St. John's Wood. | At Royal Observatory, Greenwich. | At St. John's Wood. | In excess at St. John's Wood. | At Royal Observatory, Greenwich. | At St. John's Wood. | In excess at St. John's Wood. |
| January | 39 ^o ·1 | 36 ^o ·9 | -2 ^o ·2 | 38 ^o ·3 | 38 ^o ·7 | +0 ^o ·4 | 43 ^o ·7 | 43 ^o ·1 | -0 ^o ·6 |
| February ... | 35·2 | 35·7 | +0·5 | 32·7 | 32·9 | +0·2 | 43·9 | 43·7 | -0·2 |
| March..... | 41·5 | 41·6 | +0·1 | 35·2 | 35·3 | +0·1 | 43·3 | 44·0 | +0·7 |
| April | 51·7 | 52·2 | +0·5 | 46·3 | 47·5 | +1·2 | 47·1 | 46·8 | -0·3 |
| May | 52·9 | 52·5 | -0·4 | 49·4 | 49·2 | -0·2 | 54·6 | 55·6 | +1·0 |
| June | 60·7 | 59·9 | -0·8 | 60·7 | 60·6 | -0·1 | 65·3 | 65·2 | -0·1 |
| July | 61·4 | 61·0 | -0·4 | 59·8 | 59·4 | -0·4 | 64·5 | 63·6 | -0·9 |
| August | 57·7 | 57·4 | -0·3 | 57·3 | 57·6 | +0·3 | 63·2 | 62·5 | -0·7 |
| September ... | 56·9 | 57·4 | +0·5 | 53·6 | 53·8 | +0·2 | 60·1 | 60·1 | 0·0 |
| October | 49·5 | 49·2 | -0·3 | 50·2 | 50·1 | -0·1 | 50·5 | 49·9 | -0·6 |
| November ... | 44·0 | 43·3 | -0·7 | 45·8 | 45·3 | -0·5 | 46·0 | 44·9 | -1·1 |
| December ... | 33·0 | 33·8 | +0·8 | 41·7 | 40·5 | -1·2 | 32·9 | 32·7 | -0·2 |

The observations at St. John's Wood consisted of one observation of the maximum thermometer and of one observation of the minimum thermometer, daily, as well as three observations at different times every day of other thermometers. They were made by GEORGE LEACH, Esq., to whom I am indebted for these results. The mean values for the month were obtained by the application of corrections from my tables. By examining the column of differences, no certain difference exists between the temperatures of the air at Greenwich and at St. John's Wood.

TABLE XV.—Mean monthly temperature of the Air at Fleet Street, London, as determined from observations taken by Mr. W. SIMMS, optician.

| Year. | January. | Feb. | March. | April. | May. | June. | July. | August. | Sept. | Oct. | Nov. | Dec. |
|-------|----------|-------|--------|--------|-------|-------|-------|---------|-------|--------------------|--------------------|--------------------|
| 1838. | | | | | | | | | | 52 ^o ·6 | 42 ^o ·3 | 39 ^o ·9 |
| 1839. | 38·5 | 40·4 | 40·4 | 41·2 | 50·8 | 61·2 | 61·5 | 62·0 | 57·1 | 51·1 | 43·6 | 41·3 |
| 1840. | 41·4 | 38·9 | 39·8 | 52·3 | 55·5 | 58·9 | 59·4 | 65·1 | 54·8 | 48·9 | 45·8 | 36·6 |
| 1841. | 35·0 | 36·2 | | | | | | | | | | |
| 1842. | | | | | | | | | | | | 47·6 |
| 1843. | 42·6 | 37·8 | 43·6 | 46·2 | 49·4 | 53·4 | 58·4 | 62·1 | | 47·3 | 45·9 | 47·1 |
| 1844. | 43·6 | 35·8 | 43·5 | 49·3 | 50·0 | 58·2 | 60·8 | 56·8 | 57·5 | 50·4 | 44·8 | 36·7 |
| 1845. | 41·8 | 35·2 | 37·0 | 46·0 | 46·9 | 55·6 | 58·6 | 56·2 | 54·3 | 51·2 | 47·8 | 44·3 |
| 1846. | 46·1 | 45·4 | 47·8 | 45·9 | 53·9 | 62·3 | | | | | | |
| 1848. | 35·9 | 44·3 | 43·0 | 47·9 | 57·9 | 55·9 | 63·4 | 57·4 | 58·0 | 52·1 | 44·1 | 45·0 |

These observations were taken with good instruments, and believed to be taken with every care: Mr. SIMMS very kindly lent me the original observations, from which I have deduced the above values. By comparison with the simultaneous observations taken at Greenwich, it seems that the temperature at Fleet Street upon the whole year is 0^o·7 higher than at Greenwich.

TABLE XVI.—Comparison of the temperature of the Air at Somerset House, and at the Royal Observatory, Greenwich, and deduction of the numbers in every month, necessary to be applied to reduce the mean values at one place to those at the other.

| Year. | January. | | | February. | | | March. | | |
|-------|--|--------------------|---------------------------|--|--------------------|---------------------------|--|--------------------|---------------------------|
| | Mean reading of the thermometer in air | | | Mean reading of the thermometer in air | | | Mean reading of the thermometer in air | | |
| | At the Royal Observatory. | At Somerset House. | Higher at Somerset House. | At the Royal Observatory. | At Somerset House. | Higher at Somerset House. | At the Royal Observatory. | At Somerset House. | Higher at Somerset House. |
| 1834. | 44.1 | 46.0 | 1.9 | 40.5 | 41.6 | 1.1 | 43.8 | 45.1 | 1.3 |
| 1835. | 37.7 | 39.6 | 1.9 | 41.0 | 42.6 | 1.6 | 41.2 | 42.1 | 0.9 |
| 1836. | 38.5 | 38.8 | 0.3 | 37.1 | 38.3 | 1.2 | 43.7 | 44.8 | 1.1 |
| 1837. | 38.3 | 38.8 | 0.5 | 41.2 | 41.7 | 0.5 | 36.0 | 36.9 | 0.9 |
| 1838. | 28.3 | 30.5 | 2.2 | 32.1 | 34.3 | 2.2 | 41.6 | 42.6 | 1.0 |
| 1839. | 36.6 | 38.8 | 2.2 | 39.6 | 40.5 | 0.9 | 38.4 | 40.1 | 1.7 |
| 1840. | 39.6 | 40.6 | 1.0 | 37.0 | 39.5 | 2.5 | 37.2 | 38.7 | 1.5 |
| 1841. | 33.6 | 36.1 | 2.5 | 35.3 | 36.6 | 1.3 | 46.2 | 47.9 | 1.7 |
| 1842. | 32.9 | 34.8 | 1.9 | 40.8 | 42.2 | 1.4 | 44.9 | 45.4 | 0.5 |
| 1843. | 39.9 | 41.3 | 1.4 | 36.0 | 37.5 | 1.5 | 42.9 | 43.6 | 0.7 |
| | April. | | | May. | | | June. | | |
| 1834. | 44.7 | 46.1 | 1.4 | 56.2 | 58.0 | 1.8 | 59.6 | 62.0 | 2.4 |
| 1835. | 46.1 | 47.5 | 1.4 | 52.3 | 54.0 | 1.7 | 58.7 | 60.9 | 2.2 |
| 1836. | 42.7 | 44.4 | 1.7 | 52.2 | 53.9 | 1.7 | 60.0 | 59.9 | -0.1 |
| 1837. | 39.6 | 40.2 | 0.6 | 48.6 | 48.9 | 0.3 | 60.9 | 59.0 | -1.9 |
| 1838. | 41.4 | 42.7 | 1.3 | 51.7 | 51.8 | 0.1 | 56.6 | 58.1 | 1.5 |
| 1839. | 40.4 | 42.0 | 1.6 | 50.0 | 51.0 | 1.0 | 59.5 | 59.6 | 0.1 |
| 1840. | 48.6 | 48.9 | 0.3 | 53.2 | 54.6 | 1.4 | 57.9 | 60.4 | 2.5 |
| 1841. | 47.0 | 47.4 | 0.4 | 56.8 | 57.9 | 1.1 | 56.4 | 57.2 | 0.8 |
| 1842. | 45.2 | 45.7 | 0.5 | 53.2 | 54.3 | 1.1 | 62.9 | 64.2 | 1.3 |
| 1843. | 47.1 | 48.6 | 1.5 | 52.2 | 52.8 | 0.6 | 56.3 | 56.4 | 0.1 |
| | July. | | | August. | | | September. | | |
| 1833. | 59.7 | 62.1 | 2.4 | 56.9 | 58.8 | 1.9 | 53.0 | 54.6 | 1.6 |
| 1834. | 64.0 | 65.1 | 1.1 | 61.5 | 63.6 | 2.1 | 57.0 | 59.4 | 2.4 |
| 1835. | 63.9 | 65.4 | 1.5 | 63.0 | 64.6 | 1.6 | 57.6 | 58.2 | 0.6 |
| 1836. | 62.8 | 63.9 | 1.1 | 59.8 | 60.2 | 0.4 | 53.7 | 54.5 | 0.8 |
| 1837. | | | | 59.6 | 61.4 | 1.8 | 56.1 | 56.1 | 0.0 |
| 1838. | 61.0 | 61.5 | 0.5 | 60.0 | 60.9 | 0.9 | 55.7 | 55.5 | -0.2 |
| 1839. | 60.8 | 61.2 | 0.4 | 58.6 | 60.2 | 1.6 | 55.5 | 56.7 | 1.2 |
| 1840. | 59.3 | 59.0 | -0.3 | 63.0 | 63.4 | 0.4 | 52.5 | 55.2 | 2.7 |
| 1841. | 57.8 | 59.0 | 1.2 | 60.5 | 61.3 | 0.8 | 58.0 | 58.5 | 0.5 |
| 1842. | 60.2 | 61.5 | 1.3 | 65.4 | 66.6 | 1.2 | 56.4 | 57.5 | 1.1 |
| | October. | | | November. | | | December. | | |
| 1833. | 50.5 | 49.6 | -0.9 | 42.8 | 44.8 | 2.0 | 44.7 | 46.0 | 1.3 |
| 1834. | 51.1 | 51.8 | 0.7 | 43.9 | 45.4 | 1.5 | 40.6 | 42.4 | 1.8 |
| 1835. | 48.0 | 49.3 | 1.3 | 44.0 | 44.3 | 0.3 | 35.7 | 36.3 | 0.6 |
| 1836. | 47.9 | 48.7 | 0.8 | 41.9 | 42.8 | 0.9 | 39.6 | 41.0 | 1.4 |
| 1837. | 50.1 | 51.9 | 1.8 | 40.6 | 42.4 | 1.8 | 40.5 | 42.6 | 2.1 |
| 1838. | 49.7 | 51.3 | 1.6 | 40.9 | 42.1 | 1.2 | 38.4 | 40.0 | 1.6 |
| 1839. | 48.8 | 50.2 | 1.4 | 44.8 | 46.0 | 1.2 | 39.6 | 41.0 | 1.4 |
| 1840. | 45.7 | 48.1 | 2.4 | 44.0 | 44.7 | 0.7 | 32.3 | 34.7 | 2.4 |
| 1841. | 48.8 | 50.7 | 1.9 | 42.7 | 44.5 | 1.8 | 40.5 | 42.0 | 1.5 |
| 1842. | 45.4 | 47.2 | 1.8 | 42.8 | 44.2 | 1.4 | 45.0 | 45.3 | 0.3 |

By taking the means of the numbers in each column of differences, we find that the temperature of the air at the Apartments of the Royal Society was

| | |
|--|-----|
| Higher than at the Royal Observatory, Greenwich, in January by . . . | 1·6 |
| Higher than at the Royal Observatory, Greenwich, in February by . . . | 1·4 |
| Higher than at the Royal Observatory, Greenwich, in March by . . . | 1·1 |
| Higher than at the Royal Observatory, Greenwich, in April by . . . | 1·1 |
| Higher than at the Royal Observatory, Greenwich, in May by . . . | 1·1 |
| Higher than at the Royal Observatory, Greenwich, in June by . . . | 0·9 |
| Higher than at the Royal Observatory, Greenwich, in July by . . . | 1·0 |
| Higher than at the Royal Observatory, Greenwich, in August by . . . | 1·3 |
| Higher than at the Royal Observatory, Greenwich, in September by . . . | 1·1 |
| Higher than at the Royal Observatory, Greenwich, in October by . . . | 1·3 |
| Higher than at the Royal Observatory, Greenwich, in November by . . . | 1·3 |
| Higher than at the Royal Observatory, Greenwich, in December by . . . | 1·4 |

And upon the whole year the excess of temperature at Somerset House was $1^{\circ}\cdot 2$; and to reduce readings taken at Somerset House to those at Greenwich, it is necessary to subtract the preceding numbers from them; and it is necessary to increase the readings of the Royal Observatory by the above numbers to make them comparable with those taken at the Royal Society.

One part of these differences is owing to the difference of elevation, and which will amount to about $0^{\circ}\cdot 3$; the greater part of the remaining difference is most probably owing to the vicinity of the water of the Thames, whose temperature during the night hours, at all seasons of the year, is several degrees higher than that of the air (see remarks following Table XIII.).

The general result of the preceding investigations, with respect to the temperatures of London and the country is, that those parts of London situated near the river Thames, are somewhat warmer upon the whole year than the country, but that those parts of London which are situated at some distance from the river, do not enjoy higher temperatures than those due to their latitudes.

I proceed now to reduce the results at Somerset House to those of the Royal Observatory, Greenwich, by applying the numbers following the preceding Table to the numbers in Table I. of my former paper, and to those in Table X. till the year 1840. After this date the numbers are extracted from the several volumes of the Greenwich Meteorological Observations.

TABLE XVII.—Showing the mean temperature of each month at the Royal Observatory, Greenwich, as found from the numbers in Table I. of my former paper till the year 1840, and from the observations at Greenwich from the year 1841.

| Year. | January. | February. | March. | April. | May. | June. | July. | August. | September. | October. | November. | December. |
|-------|----------|-----------|--------|--------|------|-------|-------|---------|------------|----------|-----------|-----------|
| 1771. | 29·9 | 33·4 | 34·7 | 38·7 | 54·5 | 54·0 | 59·5 | 58·4 | 52·0 | 47·2 | 40·9 | 41·4 |
| 1772. | 32·2 | 34·2 | 38·5 | 42·2 | 48·6 | 59·4 | 60·0 | 59·7 | 55·0 | 52·4 | 43·4 | 39·5 |
| 1773. | 36·9 | 34·9 | 40·9 | 44·2 | 47·5 | 55·6 | 58·5 | 60·9 | 53·8 | 48·2 | 39·2 | 38·2 |
| 1774. | 31·5 | 38·0 | 42·8 | 46·8 | 51·1 | 60·1 | 61·8 | 62·4 | 54·7 | 48·8 | 39·2 | 37·1 |
| 1775. | 40·4 | 41·9 | 41·7 | 49·7 | 54·1 | 62·6 | 63·0 | 60·8 | 58·4 | 48·2 | 40·2 | 39·3 |
| 1776. | 27·0 | 40·0 | 43·7 | 47·2 | 50·6 | 58·7 | 62·8 | 60·7 | 54·5 | 51·5 | 42·7 | 40·1 |
| 1777. | 33·9 | 35·8 | 44·6 | 44·0 | 52·3 | 56·3 | 60·5 | 62·4 | 58·1 | 51·3 | 43·7 | 35·8 |
| 1778. | 34·8 | 35·6 | 40·1 | 46·9 | 54·8 | 61·3 | 67·0 | 63·5 | 53·4 | 46·0 | 44·7 | 42·8 |
| 1779. | 34·8 | 45·3 | 47·0 | 50·7 | 54·7 | 58·0 | 64·9 | 63·9 | 60·7 | 51·9 | 41·9 | 40·2 |
| 1780. | 28·6 | 35·3 | 49·2 | 43·6 | 56·1 | 59·1 | 63·2 | 65·7 | 59·3 | 50·0 | 39·5 | 36·6 |
| 1781. | 36·2 | 40·3 | 42·6 | 46·1 | 53·1 | 62·5 | 65·3 | 63·0 | 56·8 | 48·5 | 41·7 | 41·0 |
| 1782. | 38·9 | 34·4 | 38·7 | 40·7 | 48·1 | 57·9 | 59·2 | 56·7 | 55·5 | 45·2 | 34·7 | 36·2 |
| 1783. | 36·9 | 39·2 | 37·7 | 47·9 | 48·3 | 58·4 | 65·7 | 60·7 | 54·6 | 49·0 | 42·5 | 35·0 |
| 1784. | 29·2 | 31·9 | 36·2 | 42·0 | 56·8 | 56·2 | 59·5 | 56·2 | 57·3 | 43·9 | 40·7 | 31·0 |
| 1785. | 36·1 | 30·4 | 33·9 | 46·2 | 52·5 | 59·4 | 62·2 | 57·5 | 56·8 | 46·9 | 40·2 | 35·2 |
| 1786. | 35·9 | 36·2 | 34·2 | 44·7 | 52·3 | 59·6 | 59·0 | 58·9 | 51·3 | 44·7 | 36·7 | 35·9 |
| 1787. | 36·7 | 39·5 | 42·8 | 44·4 | 51·3 | 57·8 | 61·4 | 61·1 | 54·4 | 48·6 | 39·6 | 39·6 |
| 1788. | 37·4 | 38·7 | 38·6 | 49·5 | 56·3 | 58·6 | 60·6 | 59·9 | 55·9 | 49·1 | 40·6 | 29·0 |
| 1789. | 33·4 | 39·9 | 34·4 | 44·1 | 53·2 | 54·8 | 58·8 | 60·2 | 54·6 | 46·8 | 38·7 | 41·6 |
| 1790. | 38·6 | 41·2 | 43·2 | 40·9 | 52·6 | 56·8 | 59·1 | 59·9 | 53·9 | 49·5 | 42·0 | 39·0 |
| 1791. | 39·8 | 38·8 | 42·1 | 48·8 | 49·4 | 57·6 | 59·5 | 61·4 | 56·8 | 46·6 | 41·3 | 34·8 |
| 1792. | 34·9 | 37·4 | 42·1 | 48·9 | 49·6 | 54·4 | 58·6 | 62·2 | 55·4 | 48·7 | 43·2 | 40·0 |
| 1793. | 35·3 | 39·7 | 39·3 | 42·4 | 50·7 | 55·4 | 64·9 | 59·0 | 52·8 | 51·9 | 42·9 | 41·0 |
| 1794. | 33·3 | 44·7 | 44·3 | 49·6 | 50·6 | 57·6 | 65·3 | 59·4 | 53·7 | 48·3 | 43·3 | 36·8 |
| 1795. | 23·9 | 34·1 | 38·6 | 45·1 | 51·9 | 53·7 | 58·9 | 60·8 | 60·8 | 53·4 | 40·7 | 44·8 |
| 1796. | 45·3 | 39·6 | 39·0 | 48·3 | 50·1 | 56·1 | 58·6 | 59·9 | 59·1 | 46·5 | 40·3 | 30·4 |
| 1797. | 35·4 | 35·6 | 37·9 | 44·7 | 51·3 | 54·8 | 63·3 | 59·0 | 54·6 | 47·0 | 41·4 | 41·2 |
| 1798. | 37·8 | 37·9 | 40·7 | 49·2 | 53·6 | 61·2 | 61·2 | 61·5 | 56·5 | 49·8 | 40·0 | 33·7 |
| 1799. | 33·3 | 36·4 | 37·2 | 41·5 | 49·5 | 55·6 | 59·8 | 57·5 | 54·3 | 47·3 | 42·9 | 32·8 |
| 1800. | 36·9 | 34·1 | 37·5 | 48·4 | 54·0 | 55·1 | 63·2 | 63·7 | 57·9 | 47·9 | 42·2 | 38·2 |
| 1801. | 39·5 | 38·5 | 44·1 | 45·4 | 53·6 | 58·4 | 60·5 | 62·5 | 58·7 | 50·9 | 40·2 | 36·1 |
| 1802. | 32·9 | 38·9 | 41·2 | 48·5 | 50·2 | 57·6 | 56·5 | 64·8 | 57·0 | 49·5 | 40·5 | 37·8 |
| 1803. | 33·4 | 36·3 | 42·3 | 47·8 | 50·1 | 56·2 | 63·7 | 61·7 | 52·4 | 48·9 | 41·9 | 43·3 |
| 1804. | 43·2 | 36·9 | 41·1 | 43·7 | 56·6 | 61·3 | 60·2 | 59·9 | 59·4 | 51·4 | 44·1 | 35·6 |
| 1805. | 34·5 | 38·7 | 42·0 | 45·3 | 49·6 | 54·5 | 59·1 | 61·7 | 59·3 | 47·4 | 39·9 | 39·5 |
| 1806. | 40·6 | 41·5 | 40·7 | 43·0 | 55·0 | 59·8 | 61·2 | 61·4 | 57·0 | 51·2 | 47·4 | 46·8 |
| 1807. | 36·7 | 40·0 | 37·0 | 45·4 | 55·0 | 57·7 | 63·5 | 63·7 | 53·1 | 53·0 | 38·7 | 36·6 |
| 1808. | 37·0 | 36·3 | 37·1 | 42·5 | 57·1 | 58·0 | 65·7 | 62·5 | 55·3 | 46·1 | 43·9 | 36·0 |
| 1809. | 35·4 | 44·1 | 42·6 | 41·1 | 55·7 | 57·5 | 59·6 | 58·9 | 56·1 | 49·6 | 39·5 | 41·0 |
| 1810. | 34·4 | 38·6 | 42·2 | 46·4 | 49·7 | 58·5 | 60·9 | 60·5 | 59·4 | 51·8 | 42·8 | 38·6 |
| 1811. | 32·8 | 40·1 | 43·4 | 48·7 | 56·2 | 57·6 | 61·0 | 58·5 | 57·9 | 55·5 | 45·2 | 38·6 |
| 1812. | 35·9 | 41·6 | 38·4 | 41·5 | 51·2 | 54·0 | 57·4 | 57·0 | 55·9 | 48·8 | 40·6 | 35·1 |
| 1813. | 34·4 | 41·6 | 43·1 | 43·8 | 52·3 | 55·3 | 58·9 | 58·3 | 54·5 | 47·3 | 40·2 | 36·6 |
| 1814. | 26·9 | 34·0 | 35·1 | 48·1 | 48·6 | 53·4 | 61·1 | 58·6 | 54·9 | 47·3 | 40·7 | 41·1 |
| 1815. | 31·9 | 41·2 | 45·0 | 46·6 | 54·7 | 58·0 | 59·9 | 60·4 | 62·3 | 51·4 | 38·9 | 37·0 |
| 1816. | 36·7 | 36·6 | 39·2 | 43·4 | 48·8 | 53·1 | 54·5 | 57·9 | 58·9 | 50·8 | 39·3 | 37·8 |
| 1817. | 39·2 | 42·6 | 41·6 | 43·9 | 47·9 | 59·1 | 57·7 | 55·4 | 55·5 | 45·0 | 46·9 | 37·1 |
| 1818. | 39·3 | 35·8 | 40·9 | 45·6 | 52·5 | 62·9 | 66·2 | 63·6 | 60·7 | 53·7 | 49·2 | 38·8 |
| 1819. | 40·1 | 40·0 | 44·0 | 48·2 | 54·2 | 56·4 | 61·7 | 63·8 | 58·1 | 47·5 | 40·8 | 37·0 |
| 1820. | 31·7 | 36·9 | 41·3 | 49·3 | 52·0 | 56·1 | 59·5 | 58·5 | 54·4 | 47·0 | 41·4 | 39·9 |
| 1821. | 37·5 | 36·0 | 42·8 | 50·4 | 49·4 | 54·1 | 57·7 | 61·7 | 59·6 | 50·3 | 47·6 | 44·3 |
| 1822. | 39·8 | 43·3 | 47·3 | 46·7 | 55·8 | 62·6 | 62·5 | 61·3 | 56·0 | 52·0 | 48·2 | 36·4 |
| 1823. | 31·8 | 38·1 | 39·8 | 42·8 | 54·6 | 55·4 | 59·1 | 59·8 | 55·4 | 47·6 | 43·0 | 39·9 |
| 1824. | 37·4 | 36·2 | 39·5 | 43·8 | 49·5 | 55·0 | 62·5 | 60·0 | 57·7 | 49·8 | 46·2 | 41·8 |
| 1825. | 38·4 | 38·1 | 38·5 | 48·7 | 53·6 | 58·9 | 65·2 | 61·8 | 59·9 | 50·8 | 41·2 | 40·6 |
| 1826. | 32·0 | 42·2 | 43·2 | 49·0 | 50·0 | 62·9 | 65·6 | 63·4 | 56·3 | 52·4 | 39·9 | 41·8 |
| 1827. | 33·4 | 31·6 | 43·1 | 46·8 | 52·7 | 57·6 | 63·5 | 59·0 | 56·9 | 51·8 | 41·5 | 44·1 |
| 1828. | 39·8 | 40·2 | 43·5 | 46·5 | 54·3 | 60·0 | 61·9 | 59·0 | 57·5 | 49·9 | 44·3 | 44·5 |
| 1829. | 31·7 | 38·4 | 39·0 | 43·7 | 54·5 | 59·0 | 60·1 | 57·7 | 53·2 | 47·5 | 39·3 | 34·9 |
| 1830. | 30·7 | 34·2 | 45·8 | 48·3 | 54·7 | 55·3 | 63·0 | 58·2 | 53·5 | 50·9 | 44·4 | 34·9 |
| 1831. | 34·4 | 41·2 | 43·9 | 48·1 | 52·8 | 59·4 | 64·3 | 63·3 | 56·4 | 55·0 | 44·3 | 42·0 |
| 1832. | 37·3 | 36·9 | 40·5 | 47·2 | 51·5 | 59·2 | 61·2 | 61·0 | 56·6 | 51·2 | 43·7 | 42·4 |
| 1833. | 34·5 | 42·4 | 37·6 | 45·2 | 59·4 | 59·8 | 61·1 | 57·5 | 53·5 | 48·3 | 43·5 | 44·6 |
| 1834. | 44·4 | 40·2 | 44·0 | 45·0 | 56·9 | 61·1 | 64·1 | 62·3 | 58·3 | 50·5 | 44·1 | 41·0 |
| 1835. | 38·0 | 41·2 | 41·0 | 46·4 | 52·9 | 60·0 | 64·4 | 63·3 | 57·1 | 48·0 | 43·0 | 34·9 |
| 1836. | 37·2 | 36·9 | 43·7 | 43·3 | 52·8 | 59·0 | 62·9 | 58·9 | 53·4 | 47·4 | 41·5 | 39·6 |
| 1837. | 37·2 | 40·3 | 35·8 | 39·1 | 47·8 | 58·1 | 61·3 | 60·1 | 55·0 | 50·6 | 41·1 | 41·2 |
| 1838. | 28·9 | 32·9 | 41·5 | 41·6 | 50·7 | 57·2 | 60·5 | 59·6 | 54·4 | 50·0 | 40·8 | 38·6 |
| 1839. | 37·2 | 39·1 | 39·0 | 40·9 | 49·9 | 58·7 | 60·2 | 58·9 | 55·6 | 48·9 | 44·7 | 39·6 |
| 1840. | 39·0 | 38·1 | 37·6 | 47·8 | 53·5 | 59·5 | 58·0 | 62·1 | 54·1 | 46·8 | 43·4 | 33·3 |
| 1841. | 33·6 | 35·3 | 46·2 | 47·0 | 56·8 | 56·4 | 57·8 | 60·5 | 58·1 | 48·8 | 42·7 | 40·5 |
| 1842. | 32·9 | 40·8 | 44·9 | 45·2 | 53·2 | 62·9 | 60·2 | 65·4 | 56·4 | 45·4 | 42·8 | 45·0 |
| 1843. | 39·9 | 36·0 | 42·9 | 47·1 | 52·2 | 56·3 | 60·9 | 62·1 | 59·5 | 48·0 | 43·8 | 43·9 |
| 1844. | 39·1 | 35·2 | 41·5 | 51·7 | 52·9 | 60·7 | 61·4 | 57·7 | 56·9 | 49·5 | 44·0 | 33·0 |
| 1845. | 38·3 | 32·7 | 35·2 | 46·3 | 49·4 | 60·7 | 59·8 | 57·3 | 53·6 | 50·2 | 45·8 | 41·7 |
| 1846. | 43·7 | 43·9 | 43·3 | 47·1 | 54·6 | 65·3 | 64·5 | 63·2 | 60·1 | 50·5 | 46·0 | 32·9 |
| 1847. | 35·1 | 35·4 | 41·0 | 45·3 | 56·4 | 58·0 | 65·4 | 62·1 | 54·3 | 52·9 | 46·9 | 42·8 |
| 1848. | 34·6 | 43·4 | 43·8 | 47·6 | 59·7 | 58·5 | 61·5 | 58·5 | 55·8 | 51·6 | 43·8 | 44·0 |
| 1849. | 40·1 | 43·2 | 42·5 | 43·2 | 54·0 | 57·0 | 62·1 | 62·0 | 58·8 | 51·1 | 44·1 | 39·1 |

By taking the means of the numbers in each column, we find that

- The mean temperature of January from all the observations is . . . 35·7
- The mean temperature of February from all the observations is . . . 38·2
- The mean temperature of March from all the observations is . . . 40·9
- The mean temperature of April from all the observations is . . . 45·7
- The mean temperature of May from all the observations is . . . 52·6
- The mean temperature of June from all the observations is . . . 58·0
- The mean temperature of July from all the observations is . . . 61·3
- The mean temperature of August from all the observations is . . . 60·5
- The mean temperature of September from all the observations is . . . 56·3
- The mean temperature of October from all the observations is . . . 49·3
- The mean temperature of November from all the observations is . . . 42·4
- The mean temperature of December from all the observations is . . . 38·8

And the mean of all the monthly results is 48°·3.

TABLE XVIII.—Showing the Highest and Lowest monthly mean temperature in every year from 1771 to 1849, with the amount of difference of temperature.

| Year. | Monthly mean temperature. | | Difference between the hottest and coldest months. | Month of temperature. | | Year. | Monthly mean temperature. | | Difference between the hottest and coldest months. | Month of temperature. | |
|-------|---------------------------|---------|--|-----------------------|---------------|-------|---------------------------|---------|--|-----------------------|-----------|
| | Highest. | Lowest. | | Highest. | Lowest. | | Highest. | Lowest. | | Highest. | Lowest. |
| 1771. | 59·5 | 29·9 | 29·6 | July. | January. | 1811. | 61·0 | 32·8 | 28·2 | July. | January. |
| 1772. | 60·0 | 32·2 | 27·8 | July. | January. | 1812. | 57·4 | 35·1 | 22·3 | July. | December. |
| 1773. | 60·9 | 34·9 | 26·0 | August. | February. | 1813. | 58·9 | 34·4 | 24·5 | July. | January. |
| 1774. | 62·4 | 31·5 | 30·3 | August. | January. | 1814. | 61·1 | 26·9 | 34·2 | July. | January. |
| 1775. | 63·0 | 39·3 | 23·7 | July. | December. | 1815. | 62·3 | 31·9 | 30·4 | September. | January. |
| 1776. | 62·8 | 27·0 | 35·8 | July. | January. | 1816. | 58·9 | 36·6 | 22·3 | September. | February. |
| 1777. | 62·4 | 33·9 | 28·5 | August. | January. | 1817. | 59·1 | 37·1 | 22·0 | June. | December. |
| 1778. | 67·0 | 34·8 | 32·2 | July. | January. | 1818. | 66·2 | 35·8 | 30·4 | July. | February. |
| 1779. | 64·9 | 34·8 | 30·1 | July. | January. | 1819. | 63·8 | 37·0 | 26·8 | August. | December. |
| 1780. | 65·7 | 28·6 | 37·1 | August. | January. | 1820. | 59·5 | 31·7 | 27·8 | July. | January. |
| 1781. | 65·3 | 36·2 | 29·1 | July. | January. | 1821. | 61·7 | 36·0 | 25·7 | August. | February. |
| 1782. | 59·2 | 34·4 | 24·8 | July. | February. | 1822. | 62·6 | 36·4 | 26·2 | June. | December. |
| 1783. | 65·7 | 35·0 | 30·7 | July. | December. | 1823. | 59·8 | 31·8 | 28·0 | August. | January. |
| 1784. | 59·5 | 29·2 | 30·3 | July. | January. | 1824. | 62·5 | 36·2 | 26·3 | July. | February. |
| 1785. | 62·2 | 30·4 | 31·8 | July. | February. | 1825. | 65·2 | 38·1 | 27·1 | July. | February. |
| 1786. | 59·6 | 35·9 | 23·7 | June. | Jan. and Dec. | 1826. | 65·6 | 32·0 | 33·6 | July. | January. |
| 1787. | 61·4 | 36·7 | 24·7 | July. | January. | 1827. | 63·5 | 31·6 | 31·9 | July. | February. |
| 1788. | 60·6 | 29·0 | 31·6 | July. | December. | 1828. | 61·9 | 39·8 | 22·1 | July. | January. |
| 1789. | 60·2 | 33·4 | 26·8 | August. | January. | 1829. | 60·1 | 31·7 | 28·4 | July. | January. |
| 1790. | 59·9 | 38·6 | 21·3 | August. | January. | 1830. | 63·0 | 30·7 | 32·3 | July. | January. |
| 1791. | 61·4 | 34·8 | 26·6 | August. | December. | 1831. | 64·3 | 34·4 | 29·9 | July. | January. |
| 1792. | 62·2 | 34·9 | 27·3 | August. | January. | 1832. | 61·2 | 36·9 | 24·3 | July. | February. |
| 1793. | 64·9 | 35·3 | 29·6 | July. | January. | 1833. | 61·1 | 34·5 | 26·6 | July. | January. |
| 1794. | 65·3 | 33·3 | 32·0 | July. | January. | 1834. | 64·1 | 40·2 | 23·9 | July. | February. |
| 1795. | 60·8 | 23·9 | 36·9 | Aug. and Sept. | January. | 1835. | 64·4 | 34·9 | 29·5 | July. | December. |
| 1796. | 59·9 | 30·4 | 29·5 | August. | December. | 1836. | 62·9 | 36·9 | 26·0 | July. | February. |
| 1797. | 63·3 | 35·4 | 27·9 | July. | January. | 1837. | 61·3 | 35·8 | 25·5 | July. | March. |
| 1798. | 61·5 | 33·7 | 27·8 | August. | December. | 1838. | 60·5 | 28·9 | 31·6 | July. | January. |
| 1799. | 59·8 | 32·8 | 27·0 | July. | December. | 1839. | 60·2 | 37·2 | 23·0 | July. | January. |
| 1800. | 63·7 | 34·1 | 29·6 | August. | February. | 1840. | 62·1 | 33·3 | 28·8 | August. | December. |
| 1801. | 62·5 | 36·1 | 26·4 | August. | December. | 1841. | 60·5 | 33·6 | 26·9 | August. | January. |
| 1802. | 64·8 | 32·9 | 31·9 | August. | January. | 1842. | 65·4 | 32·9 | 32·5 | August. | January. |
| 1803. | 63·7 | 33·4 | 30·3 | July. | January. | 1843. | 62·1 | 36·0 | 26·1 | August. | February. |
| 1804. | 60·2 | 35·6 | 24·6 | July. | December. | 1844. | 61·4 | 33·0 | 28·4 | July. | December. |
| 1805. | 61·7 | 34·5 | 27·2 | August. | January. | 1845. | 60·7 | 32·7 | 28·0 | June. | February. |
| 1806. | 61·4 | 40·6 | 20·8 | August. | January. | 1846. | 65·3 | 32·9 | 32·4 | June. | December. |
| 1807. | 63·7 | 36·6 | 27·1 | August. | December. | 1847. | 65·4 | 35·1 | 30·3 | July. | January. |
| 1808. | 65·7 | 36·0 | 29·7 | July. | December. | 1848. | 61·5 | 34·6 | 26·9 | July. | January. |
| 1809. | 59·6 | 35·4 | 24·2 | July. | January. | 1849. | 62·9 | 39·1 | 23·8 | August. | December. |
| 1810. | 60·9 | 34·4 | 26·5 | July. | January. | | | | | | |

The mean of all the differences between the hottest and coldest months in every year is $28^{\circ}5$.

In the year 1790 the difference was $21^{\circ}3$ only, and in the year 1780 it was as large as $37^{\circ}1$, these numbers being respectively the smallest and largest within the period of seventy-nine years.

The coldest month in the year has occurred in January forty-three times, in February fifteen, in December twenty-one, and in March once; this unusual circumstance took place in the year 1837.

The hottest month in the year has taken place five times in June, forty-seven times in July, twenty-five times in August, and three times in September.

The following are the values of the extreme mean temperatures in every month:—

| | | |
|--------------|---|-----------------------------|
| In January | 1795 the mean temperature was $23^{\circ}9$, and in January | 1796 it was $45^{\circ}3$. |
| In February | 1785 the mean temperature was $30^{\circ}4$, and in February | 1794 it was $44^{\circ}7$. |
| In March | 1785 the mean temperature was $33^{\circ}9$, and in March | 1780 it was $49^{\circ}2$. |
| In April | 1771 the mean temperature was $38^{\circ}7$, and in April | 1844 it was $51^{\circ}7$. |
| In May | 1773 the mean temperature was $47^{\circ}5$, and in May | 1848 it was $59^{\circ}7$. |
| In June | 1816 the mean temperature was $53^{\circ}1$, and in June | 1846 it was $65^{\circ}3$. |
| In July | 1816 the mean temperature was $54^{\circ}5$, and in July | 1778 it was $67^{\circ}0$. |
| In August | 1817 the mean temperature was $55^{\circ}4$, and in August | 1780 it was $65^{\circ}7$. |
| In September | 1786 the mean temperature was $51^{\circ}3$, and in September | 1815 it was $62^{\circ}3$. |
| In October | 1784 the mean temperature was $43^{\circ}9$, and in October 1811 and 1831 it was $55^{\circ}0$. | |
| In November | 1782 the mean temperature was $34^{\circ}7$, and in November | 1822 it was $48^{\circ}2$. |
| In December | 1788 the mean temperature was $29^{\circ}0$, and in December | 1806 it was $46^{\circ}8$. |

It is clear from these numbers that observations for a few years only can never be of great importance, when we consider that the difference of the monthly means of the winter months may be as large as 20° , and of the summer months of 11° or 12° .

By taking the means of the numbers in the Table in different groups of years the next Table is formed.

TABLE XIX.—Showing the mean temperature of the Air at the Royal Observatory, Greenwich, in every month in successive groups of years.

| Period. | Jan. | Feb. | March. | April. | May. | June. | July. | August. | Sept. | Oct. | Nov. | Dec. |
|--------------------|---------------|---------------|---------------|---------------|---------------|---------------|---------------|---------------|---------------|---------------|---------------|---------------|
| From 1771 to 1779. | $33^{\circ}5$ | $37^{\circ}7$ | $41^{\circ}6$ | $45^{\circ}6$ | $52^{\circ}0$ | $58^{\circ}4$ | $62^{\circ}0$ | $61^{\circ}2$ | $55^{\circ}6$ | $49^{\circ}5$ | $41^{\circ}8$ | $39^{\circ}4$ |
| From 1780 to 1789. | $34^{\circ}9$ | $36^{\circ}6$ | $38^{\circ}8$ | $44^{\circ}9$ | $52^{\circ}8$ | $58^{\circ}4$ | $61^{\circ}5$ | $60^{\circ}0$ | $55^{\circ}7$ | $47^{\circ}3$ | $40^{\circ}5$ | $36^{\circ}1$ |
| From 1790 to 1799. | $35^{\circ}8$ | $38^{\circ}5$ | $40^{\circ}4$ | $45^{\circ}9$ | $50^{\circ}9$ | $56^{\circ}3$ | $60^{\circ}9$ | $60^{\circ}1$ | $55^{\circ}8$ | $48^{\circ}9$ | $41^{\circ}8$ | $37^{\circ}5$ |
| From 1800 to 1809. | $37^{\circ}0$ | $38^{\circ}5$ | $40^{\circ}6$ | $45^{\circ}1$ | $53^{\circ}7$ | $57^{\circ}6$ | $61^{\circ}3$ | $62^{\circ}1$ | $56^{\circ}6$ | $49^{\circ}6$ | $41^{\circ}8$ | $39^{\circ}1$ |
| From 1810 to 1819. | $35^{\circ}2$ | $39^{\circ}2$ | $41^{\circ}3$ | $45^{\circ}6$ | $51^{\circ}6$ | $56^{\circ}8$ | $59^{\circ}9$ | $59^{\circ}4$ | $57^{\circ}8$ | $49^{\circ}9$ | $42^{\circ}4$ | $37^{\circ}8$ |
| From 1820 to 1829. | $35^{\circ}4$ | $38^{\circ}1$ | $41^{\circ}8$ | $46^{\circ}8$ | $52^{\circ}6$ | $58^{\circ}2$ | $61^{\circ}8$ | $60^{\circ}2$ | $56^{\circ}7$ | $49^{\circ}9$ | $43^{\circ}3$ | $40^{\circ}8$ |
| From 1830 to 1839. | $36^{\circ}0$ | $38^{\circ}5$ | $41^{\circ}3$ | $44^{\circ}5$ | $52^{\circ}9$ | $58^{\circ}8$ | $62^{\circ}3$ | $60^{\circ}3$ | $55^{\circ}4$ | $50^{\circ}1$ | $43^{\circ}1$ | $39^{\circ}9$ |
| From 1840 to 1849. | $37^{\circ}6$ | $38^{\circ}4$ | $41^{\circ}9$ | $46^{\circ}9$ | $54^{\circ}3$ | $59^{\circ}6$ | $61^{\circ}2$ | $61^{\circ}2$ | $56^{\circ}8$ | $49^{\circ}5$ | $44^{\circ}0$ | $39^{\circ}7$ |

The next Table is formed by taking the difference between the mean temperature of each month, as found from all the years, and the mean temperature of the same month in every year.

TABLE XX.—Showing the excess of the monthly mean temperature at Greenwich, in every year, above the mean temperature of the month from all the years.

| Year. | January. | February. | March. | April. | May. | June. | July. | August. | September. | October. | November. | December. |
|-------|----------|-----------|--------|--------|------|-------|-------|---------|------------|----------|-----------|-----------|
| 1771. | - 5.8 | -4.8 | -6.2 | -7.0 | +1.9 | -4.0 | -1.8 | -2.1 | -4.3 | -2.1 | -1.5 | +2.6 |
| 1772. | - 3.5 | -4.0 | -2.4 | -3.5 | -4.0 | +1.4 | -1.3 | -0.8 | -1.3 | +3.1 | +1.0 | +0.7 |
| 1773. | + 1.2 | -3.3 | 0.0 | -1.5 | -5.1 | -2.4 | -2.8 | +0.4 | -2.5 | -1.1 | -3.2 | -0.6 |
| 1774. | - 4.2 | -0.2 | +1.9 | +1.1 | -1.5 | +2.1 | +0.5 | +1.9 | -1.6 | -0.5 | -3.2 | -1.7 |
| 1775. | + 4.7 | +3.7 | +0.8 | +4.0 | +1.5 | +4.6 | +1.7 | +0.3 | +2.1 | -1.1 | -2.2 | +0.5 |
| 1776. | - 8.7 | +1.8 | +2.8 | +1.5 | -2.0 | +0.7 | +1.5 | +0.2 | -1.8 | +2.2 | +0.3 | +1.3 |
| 1777. | - 1.8 | -2.4 | +3.7 | -1.7 | -0.3 | -1.7 | -0.8 | +1.9 | +1.8 | +2.0 | +1.3 | -3.0 |
| 1778. | - 0.9 | -2.6 | -0.8 | +1.2 | +2.2 | +3.3 | +5.7 | +3.0 | -2.9 | -3.3 | +2.3 | +4.0 |
| 1779. | - 0.9 | +7.1 | +6.1 | +5.0 | +2.1 | 0.0 | +3.6 | +3.4 | +4.4 | +2.6 | -0.5 | +1.4 |
| 1780. | - 7.1 | -2.9 | +8.3 | -2.1 | +3.5 | +1.1 | +1.9 | +5.2 | +3.0 | +0.7 | -2.9 | -2.2 |
| 1781. | + 0.5 | +2.1 | +1.7 | +0.4 | +0.5 | +4.5 | +4.0 | +2.5 | +0.5 | -0.8 | -0.7 | +2.2 |
| 1782. | + 3.2 | -3.8 | -2.2 | -5.0 | -4.5 | -0.1 | -2.1 | -3.8 | -0.8 | -4.1 | -7.7 | -2.6 |
| 1783. | + 1.2 | +1.0 | -3.2 | +2.2 | -4.3 | +0.4 | +4.4 | +0.2 | -1.7 | -0.3 | +0.1 | -3.8 |
| 1784. | - 6.5 | -6.3 | -4.7 | -3.7 | +4.2 | -1.8 | -1.8 | -4.3 | +1.0 | -5.4 | -1.7 | -7.8 |
| 1785. | + 0.4 | -7.8 | -7.0 | +0.5 | -0.1 | +1.4 | +0.9 | -3.0 | +0.5 | -2.4 | -2.2 | -3.6 |
| 1786. | + 0.2 | -2.0 | -6.7 | -1.0 | -0.3 | +1.6 | -2.3 | -1.6 | -5.0 | -4.6 | -5.7 | -2.9 |
| 1787. | + 1.0 | +1.3 | +1.9 | -1.3 | -1.3 | -0.2 | +0.1 | +0.6 | -1.9 | -0.7 | -2.8 | +0.8 |
| 1788. | + 1.7 | +0.5 | -2.3 | +3.8 | +3.7 | +0.6 | -0.7 | -0.6 | -0.4 | -0.2 | -1.8 | -9.8 |
| 1789. | - 2.3 | +1.7 | -6.5 | -1.6 | +0.6 | -3.2 | -2.5 | -0.3 | -1.7 | -2.5 | -3.7 | +2.8 |
| 1790. | + 2.9 | +3.0 | +2.3 | -4.8 | 0.0 | -1.2 | -2.2 | -0.6 | -2.4 | +0.2 | -0.4 | +0.2 |
| 1791. | + 4.1 | +0.6 | +1.2 | +3.1 | -3.2 | -0.4 | -1.8 | +0.9 | +0.5 | -2.7 | -1.1 | -4.0 |
| 1792. | - 0.8 | -0.8 | +1.2 | +3.2 | -3.0 | -3.6 | -2.7 | +1.7 | -0.9 | -0.6 | +0.8 | +1.2 |
| 1793. | - 0.4 | +1.5 | -1.6 | -3.3 | -1.9 | -2.6 | +3.6 | -1.5 | -3.5 | -2.6 | +0.5 | +2.2 |
| 1794. | - 2.4 | +6.5 | +3.4 | +3.9 | -2.0 | -0.4 | +4.0 | -1.1 | -2.6 | -1.0 | +0.9 | -2.0 |
| 1795. | -11.8 | -4.1 | -2.3 | -0.6 | -0.7 | -4.3 | -2.4 | +0.3 | +4.5 | +4.1 | -1.7 | +6.0 |
| 1796. | + 9.6 | +1.4 | -1.9 | +2.6 | -2.5 | -1.9 | -2.7 | -0.6 | +2.8 | -2.8 | -2.1 | -8.4 |
| 1797. | - 0.3 | -2.6 | -3.0 | -1.0 | -1.3 | -3.2 | +2.0 | -1.5 | -1.7 | -2.3 | -1.0 | +2.4 |
| 1798. | + 2.1 | -0.3 | -0.2 | +3.5 | +1.0 | +3.2 | -0.1 | +1.0 | +0.2 | +0.5 | -2.4 | -5.1 |
| 1799. | - 2.4 | -1.8 | -3.7 | -4.2 | -3.1 | -2.4 | -1.5 | -0.5 | -2.0 | -2.0 | +0.5 | -6.0 |
| 1800. | + 1.2 | -4.1 | -3.4 | +2.7 | +1.4 | -2.9 | +1.9 | +3.2 | +1.6 | -1.4 | -0.2 | -0.6 |
| 1801. | + 3.8 | +0.3 | +3.2 | -0.3 | +1.0 | +0.4 | -0.8 | +2.0 | +2.4 | +1.6 | -2.2 | -2.7 |
| 1802. | - 2.8 | +0.7 | +0.3 | +2.8 | -2.4 | -0.4 | -4.8 | +4.3 | +0.7 | +0.2 | -1.9 | -1.0 |
| 1803. | - 2.3 | -1.9 | +1.4 | +2.1 | -2.5 | -1.8 | +2.4 | +1.2 | -3.9 | -0.4 | -0.5 | +4.5 |
| 1804. | + 7.5 | -1.3 | +0.2 | -2.0 | +4.0 | +3.3 | -1.1 | -0.6 | +3.1 | +2.1 | +1.7 | -3.2 |
| 1805. | - 1.2 | +0.5 | +1.1 | -0.4 | -3.0 | -3.5 | -2.2 | +1.2 | +3.0 | -1.9 | -2.5 | +0.7 |
| 1806. | + 4.9 | +3.3 | -0.2 | -2.7 | +2.4 | +1.8 | -0.1 | +0.9 | +0.7 | +1.9 | +5.0 | +8.0 |
| 1807. | + 1.0 | +1.8 | -3.9 | -0.3 | +2.4 | -0.3 | +2.2 | +3.2 | -3.2 | +3.7 | -3.7 | -2.2 |
| 1808. | + 1.3 | -1.9 | -3.8 | -3.2 | +4.5 | 0.0 | +4.4 | +2.0 | -1.0 | -3.2 | +1.5 | -2.8 |
| 1809. | - 0.3 | +5.9 | +1.7 | -4.6 | +3.1 | -0.5 | -1.7 | -1.6 | -0.2 | +0.3 | -2.9 | +2.2 |
| 1810. | - 1.3 | +0.4 | +1.3 | +0.7 | -2.9 | +0.5 | -0.4 | 0.0 | +3.1 | +2.5 | +0.4 | -0.2 |
| 1811. | - 2.9 | +1.9 | +2.5 | +3.0 | +3.3 | -0.4 | -0.3 | -2.0 | +1.6 | +6.2 | +2.8 | -0.2 |
| 1812. | + 0.2 | +3.4 | -2.5 | -4.2 | -1.4 | -4.0 | -3.9 | -3.5 | -0.4 | -0.5 | -1.8 | -3.7 |
| 1813. | - 1.3 | +3.4 | +2.2 | -1.9 | -0.3 | -2.7 | -2.4 | -2.2 | -1.8 | -2.0 | -2.2 | -2.2 |
| 1814. | - 8.8 | -4.2 | -5.8 | +2.4 | -4.0 | -4.6 | -0.2 | -1.9 | -1.4 | -2.0 | -1.7 | +2.3 |
| 1815. | - 3.8 | +3.0 | +4.1 | +0.9 | +2.1 | 0.0 | -1.4 | -0.1 | +6.0 | +2.1 | -3.5 | -1.8 |
| 1816. | + 1.0 | -1.6 | -1.7 | -2.3 | -3.8 | -4.9 | -6.8 | -2.6 | +2.6 | +1.5 | -3.1 | -1.0 |
| 1817. | + 3.5 | +4.4 | +0.7 | -1.8 | -4.7 | +1.1 | -3.6 | -5.1 | -0.8 | -4.3 | +4.5 | -1.7 |
| 1818. | + 3.6 | -2.4 | 0.0 | -0.1 | -0.1 | +4.9 | +4.9 | +3.1 | +4.4 | +4.4 | +6.8 | 0.0 |
| 1819. | + 4.4 | +1.8 | +3.1 | +2.5 | +1.6 | -1.6 | +0.4 | +3.3 | +1.8 | -1.8 | -1.6 | -1.8 |
| 1820. | - 4.0 | -1.3 | +0.4 | +3.6 | -0.6 | -1.9 | -1.8 | -2.0 | -1.9 | -2.3 | -1.0 | +1.1 |
| 1821. | + 1.8 | -2.2 | +1.9 | +4.7 | -3.2 | -3.9 | -3.6 | +1.2 | +3.3 | +1.0 | +5.2 | +5.5 |
| 1822. | + 4.1 | +5.1 | +6.4 | +1.0 | +3.2 | +4.6 | +1.2 | +0.8 | -0.3 | +2.7 | +5.8 | -2.4 |
| 1823. | - 3.9 | -0.1 | -1.1 | -2.9 | +2.0 | -2.6 | -2.2 | -0.7 | -0.9 | -1.7 | +0.6 | +1.1 |
| 1824. | + 1.7 | -2.0 | -1.4 | -1.9 | -3.1 | -3.0 | +1.2 | -0.5 | +1.4 | +0.5 | +3.8 | +3.0 |
| 1825. | + 2.7 | -0.1 | -2.4 | +3.0 | +1.0 | +0.9 | +3.9 | +1.3 | +3.6 | +1.5 | -1.2 | +1.8 |
| 1826. | - 3.7 | +4.0 | +2.3 | +3.3 | -2.6 | +4.9 | +4.3 | +2.9 | 0.0 | +3.1 | -2.5 | +3.0 |
| 1827. | - 2.3 | -6.6 | +2.2 | +1.1 | +0.1 | -0.4 | +2.2 | -1.5 | +0.6 | +2.5 | -0.9 | +5.3 |
| 1828. | + 4.1 | +2.0 | +2.6 | +0.8 | +1.7 | +2.0 | +0.6 | -1.5 | +1.2 | +0.6 | +1.9 | +5.7 |
| 1829. | - 4.0 | +0.2 | -1.9 | -2.0 | +1.9 | +1.0 | -1.2 | -2.8 | -3.1 | -1.8 | -3.1 | -3.9 |
| 1830. | - 5.0 | -4.0 | +4.9 | +2.6 | +2.1 | -2.7 | +1.7 | -2.3 | -2.8 | +1.6 | +2.0 | -3.9 |
| 1831. | - 1.3 | +3.0 | +3.0 | +2.4 | +0.2 | +1.4 | +3.0 | +2.8 | +0.1 | +5.7 | +1.9 | +3.2 |
| 1832. | + 1.6 | -1.3 | -0.4 | +1.5 | -1.1 | +1.2 | -0.1 | +0.5 | +0.3 | +1.9 | +1.3 | +3.6 |
| 1833. | - 1.2 | +4.2 | -3.3 | -0.5 | +6.8 | +1.8 | -0.2 | -3.0 | -2.8 | -1.0 | +1.1 | +5.8 |
| 1834. | + 8.7 | +2.0 | +3.1 | -0.7 | +4.3 | +3.1 | +2.8 | +1.8 | +2.0 | +1.2 | +1.7 | +2.2 |
| 1835. | + 2.3 | +3.0 | +0.1 | +0.7 | +0.3 | +2.0 | +3.1 | +2.8 | +0.8 | -1.3 | +0.6 | -3.9 |
| 1836. | + 1.5 | -1.3 | +2.8 | -2.4 | +0.2 | +1.0 | +1.6 | -1.6 | -2.9 | -1.9 | -0.9 | +0.8 |
| 1837. | + 1.5 | +2.1 | -5.1 | -6.6 | -4.8 | +0.1 | 0.0 | -0.4 | -1.3 | +1.3 | -1.3 | +2.4 |
| 1838. | - 6.8 | -5.3 | +0.6 | -4.1 | -1.9 | -0.8 | -0.8 | -0.9 | -1.9 | +0.7 | -1.6 | -0.2 |
| 1839. | + 1.5 | +0.9 | -1.9 | -4.8 | -2.7 | +0.7 | -1.1 | -1.6 | -0.7 | -0.4 | +2.3 | +0.8 |
| 1840. | + 3.3 | -0.1 | -3.3 | +2.1 | +0.9 | +1.5 | -3.3 | +1.6 | -2.2 | -2.5 | +1.0 | -5.5 |
| 1841. | - 2.1 | -2.9 | +5.3 | +1.5 | +4.2 | -1.6 | -3.5 | 0.0 | +1.8 | -0.5 | +0.3 | +1.7 |
| 1842. | - 2.8 | +2.6 | +4.0 | -0.5 | +0.6 | +4.9 | -1.1 | +4.9 | +0.1 | -3.9 | +0.4 | +6.2 |
| 1843. | + 4.2 | -2.2 | +2.0 | +1.4 | -0.4 | -1.7 | -0.4 | +1.6 | +3.2 | -1.3 | +1.4 | +5.1 |
| 1844. | + 3.4 | -3.0 | +0.6 | +6.0 | +0.3 | +2.7 | +0.1 | -2.8 | +0.6 | +0.2 | +1.6 | -5.8 |
| 1845. | + 2.6 | -5.5 | -5.7 | +0.6 | -3.2 | +2.7 | -1.5 | -3.2 | -2.7 | +0.9 | +3.4 | +2.9 |
| 1846. | + 8.0 | +5.7 | +2.4 | +1.4 | +2.0 | +7.3 | +3.2 | +2.7 | +3.8 | +1.2 | +3.6 | -5.9 |
| 1847. | - 0.6 | -2.8 | +0.1 | -0.4 | +3.8 | 0.0 | +4.1 | +1.6 | -2.0 | +3.6 | +4.5 | +4.0 |
| 1848. | - 1.1 | +5.2 | +2.9 | -1.9 | +7.1 | +0.5 | +0.2 | -2.1 | -0.5 | +2.3 | +1.4 | +5.2 |
| 1849. | + 4.4 | +5.0 | +1.6 | -2.5 | +1.4 | -0.1 | +0.8 | +2.4 | +2.5 | +1.8 | +1.7 | +0.3 |

By taking the means of the numbers in each column without respect to sign, we find that the variability of temperature is greatest in the winter months; its mean value in January is $3^{\circ}1$; in both February and March is $2^{\circ}6$; in April is $2^{\circ}3$; in May and June is $2^{\circ}0$; in the months of August, September and October, whose temperatures are the steadiest, it is $1^{\circ}9$; in November it is $2^{\circ}0$, and in December it is $3^{\circ}1$, as in January.

The numbers in the preceding Table very clearly show that causes exist at different times, which raise or depress the temperature, and which continue through long periods.

As in the distribution of the positive and negative signs in the space of seventy-nine years, we perceive a gradual increasing preponderance of the positive signs over the negative signs, it seems that the temperature of the climate during this period has increased.

As the mean results from so long a series of observations may be considered as true, having the advantage of being free from errors of observation and from those arising from imperfect instruments, we may really consider the numbers in the above Table as abnormal values; yet as it seems most desirable to have those at the beginning of the series confirmed by the description of each year, made without instrumental means, for this purpose, as well as for the comparison of the character of the climate at the beginning and at the end of the series, I have collected the following brief particulars of every year till that of 1800; after this time the general characters of the years are well known.

1771.—There were frequent and very sharp frosts till April 20. On February 12 the reading of the thermometer was as low as 4° ; the month of May was warm; the summer was cool and dry; October was a wet and windy month, and the weather was mild to the end of the year. The severe weather of the beginning of the year caused a bad seed time, and the harvest was very late.

1772.—The beginning of the year was mild; from the middle of January frosts and great snows were frequent, and continued to the middle of March. The summer was very fine; the autumn was mild but wet, and there was no frost till December 22.

1773.—With the exception of the latter part of February, which was stormy and wet, there was much fine weather till the beginning of May; then many mornings were frosty, after which heavy rain fell frequently till June. The summer was fine; the autumn was wet. There were sharp frosts at the end of November and at the beginning of December.

1774.—The year began with severe frost, and for nearly two months the ground was frost-bound; occasionally there were great rains or snow; the weather was more moderate in April; the summer was cool with heavy rains. The autumnal months were wet, particularly in September. Some snow fell in November and beginning of December. This year was remarkably wet.

1775.—The weather was mild at the beginning of the year. The summer was dry

and hot; thunder-storms were frequent in autumn. The year was very fine, and grain was cheaper than it had been for many years past.

1776.—In January there fell a greater quantity of snow than had fallen for some years, and the frost was supposed to have been the most severe since 1740. The frost went away at the beginning of February, and the weather following was mild and wet; it became hot about the middle of April. May was cold and dry, with north winds; after this the weather was mostly fine till the end of December, when there was a sharp frost.

1777.—The year began with a sharp frost, and heavy falls of snow continued till towards the end of February; for a few days about the end of March the weather was unusually hot, the reading of the thermometer being nearly 70° ; after this the weather was windy and cold till June. The latter part of the summer and autumn was fine. The year ended with frost and snow.

1778.—There were frost and snow at the beginning of the year; the beginning of April was fine. The summer was fine and hot, supposed at the time to have been as fine a summer as that of 1762, if not as fine as the summer of 1750. Frosty mornings began in September, but were less frequent afterwards. On the last day of this year there was a violent storm, supposed by some to have been as violent as that of 1703.

1779.—After the beginning of January there was no frost; the spring months were remarkably warm. In February wall fruit flowered; the middle of April was quite hot, as was the summer and autumn; about the middle of November there was a little frost, and again on December 22: there was much sickness this year.

1780.—This year began with a frost almost as severe as that in 1772; there was not much snow, and the weather continued severe till near the end of February. The month of March was warm; it was hot from July to September, and mostly mild till Christmas, when a frost set in. The year was sickly.

1781.—There was a little frost at the beginning of the year; the spring was mild, the summer was hot, and the ground was much burned. Autumn was fine and pleasant, and there were only a few frosty mornings during the remainder of the year.

1782.—The beginning of the year was mild, but in February it was frosty, and the remainder of the winter was severe; the spring was cold; nearly 12 inches of rain fell in April and May; the weather was fine in June, but bad afterwards; the autumn was cold; it was severe in November, and during the first half of December.

1783.—The spring was pleasant, with frosty mornings very constant till near April. A remarkable haze was prevalent all over Europe during the summer. The autumn was fine, and the weather was mostly mild till the last week in December, when a great fall of snow took place.

1784.—There was steady frost with snow till February 21, and till the end of March the mornings were frosty; and at the end of March there were cold winds with snow. This weather continued till the middle of April; and till the first week in May frosty mornings were frequent, and the remainder of May was exceedingly hot. There

were a few hot days in July, but the weather was precarious throughout the autumn; and in December the frost was as severe as it was in January.

1785.—The severe frost of the preceding month broke early in January, but on the last day of that month a second very severe frost set in and continued till the middle of March. This winter was most severe. The summer and part of autumn were showery; a heavy fall of snow took place at Christmas, with severe frost.

1786.—The frosts at the beginning of the year were of short duration. From the beginning of March there was a severe frost of a fortnight's duration, and cold E. and N.E. winds were prevalent with frosty mornings till the beginning of May. June and July were moderately fine; August was cold and showery; and from this time to the end of the year there was a great deal of rain.

1787.—The year began with open weather. April was cold with N. winds, and vegetation was stopped; during April and May frosty mornings were frequent, and there was a sharp frost on the morning of the 7th of June; it was a cold summer; the autumn was mild, and there was a heavy fall of snow and a week's frost at the end of the year.

1788.—January and February were mild, the latter month being wet; there was a fortnight's frost in March; there were several periods of hot weather in April, May and June. The summer was in general dry; autumn was fine; there was a gentle frost at the beginning of December, then an exceedingly severe frost set in with heavy falls of snow, which continued to the end of the year. This year was remarkable for abundance of fruits, &c.

1789.—Very heavy storms of wind and snow took place till the middle of January; and large rivers were frozen over; there was a great loss of fish in ponds from the severity of the cold. After the frost broke the weather was mild, but windy and wet. During March there were nearly constant N. winds, and heavy falls of snow were frequent with sharp frost. The summer was mostly wet; August was fine, after which it was again wet, and continued so to the end of the year, with scarcely any frost.

1790.—The weather was mild and open till April, when the first snow fell in the year, and the weather, during the beginning of this month, was the most severe during the winter. The summer was cool, cloudy and windy; autumn was fine and pleasant; December was stormy with very changeable weather.

1791.—Till January 6th there was frost; after this the weather was mild till towards the end of April; there were many frosty mornings with cold N.E. winds in May. The former part of the summer was cold; frosty mornings were frequent till the middle of June, the latter part of summer and autumn. During November and December there were frequent storms and falls of snow and frost.

1792.—There were frequent sharp frosts till March, with stormy and wet weather; the beginning of March was mild, after this there was a frost of a week's duration. The summer was wet and cold; the autumn was wet, and December was cloudy, with very little frost. This year was very wet.

1793.—January and February and beginning of March were mild; a frost set in at the end of March; there was a great fall of snow in the first week in April. The former part of the summer was cold, with frequent frosty mornings till June; July was wet; the autumn was fine, mild and calm, and there was no frost till the end of the year.

1794.—The year began with slight frost, which continued till the end of January; February was very mild; the spring was warm till May, which was cold; July was hot; the autumn was wet but mild, as was the first part of December, but the weather during the latter half of the month was severe with heavy snow.

1795.—The frost began about the middle of December 1794, was excessively severe in January, and continued till the end of March. There were very large falls of snow, and the consequent floods were so great that nearly all the bridges in England were injured. Some snow fell in April. The summer was cold, with frequent frosty mornings till June; there were some hot days in July, but it was generally cold; after this the weather was fine till autumn. In December much injury was done to shipping by the strong S. and S.W. winds; there was no frost.

1796.—January was remarkably warm, with occasional thunder-storms; there was no frost till March, and then of no long duration. The summer was cool; the autumn was fine with a few frosty mornings at the end of November; in December a severe frost set in, and the reading of the thermometer in many places on the 24th was below zero of FAHRENHEIT'S scale.

1797.—During a few days in January the frost continued; after this, till the end of March, scarcely any rain fell, and the weather was fine with frequent frost. From April to September there were frequent heavy rains. The summer was cold; there was some warm weather in July; the autumn in general fine, and the weather continued open till the end of the year.

1798.—With the exception of a few slight frosts, which occasionally occurred till March, the weather was open and mild. The summer was fine, as was autumn and the beginning of December; after this a very severe frost set in, and the reading of the thermometer was as low as 5°.

1799.—The severe frost which set in about the middle of the preceding month continued to the middle of January, and again set in towards the end of the month with much snow, which continued during the first week in February; some snow fell in March, and the mornings were frosty till the end of the month. From April to the middle of November was wet; December was foggy; and after the 17th a severe frost set in with snow falling. The whole year was remarkably cloudy.

If we compare the character of the preceding years with the abnormal differences shown for the same years in Table XX., the agreement is most satisfactory, and leaves no doubt upon the correctness of the numbers at the beginning of this series. I do not think it necessary to describe the years from that of 1800, as most of them are well described by LUKE HOWARD in his 'Climate of London.'

TABLE XXI.—Showing the mean temperature in quarterly periods, for the year, and the same for successive groups of years, at the Royal Observatory, Greenwich, from the year 1771 to 1849.

| Year. | January, February, March. | Group of years. | April, May, June. | Group of years. | July, August, September. | Group of years. | October, November, December. | Group of years. | For the year. | Group of years. |
|-------|---------------------------------|--------------------|-------------------------|--------------------|--------------------------------|--------------------|------------------------------------|--------------------|------------------|--------------------|
| 1771. | 32.7 | 37.6 | 49.1 | 52.0 | 56.6 | 59.6 | 43.2 | 43.6 | 45.4 | 48.2 |
| 1772. | 35.0 | | 50.1 | | 58.2 | | 45.1 | | 47.1 | |
| 1773. | 37.6 | | 49.1 | | 57.7 | | 41.9 | | 46.6 | |
| 1774. | 37.4 | | 52.7 | | 58.9 | | 41.7 | | 47.7 | |
| 1775. | 41.3 | | 55.5 | | 60.7 | | 42.6 | | 50.0 | |
| 1776. | 36.9 | | 52.2 | | 59.3 | | 44.8 | | 48.3 | |
| 1777. | 38.1 | | 50.9 | | 60.3 | | 43.6 | | 48.2 | |
| 1778. | 36.8 | | 54.3 | | 61.3 | | 44.5 | | 49.2 | |
| 1779. | 42.4 | | 54.5 | | 63.2 | | 44.7 | | 51.2 | |
| 1780. | 37.7 | 36.8 | 52.9 | 52.0 | 62.7 | 59.0 | 42.0 | 41.0 | 48.8 | 47.2 |
| 1781. | 39.7 | | 53.9 | | 61.7 | | 43.7 | | 49.8 | |
| 1782. | 37.3 | | 48.9 | | 57.1 | | 38.7 | | 45.5 | |
| 1783. | 37.9 | | 51.5 | | 60.3 | | 42.2 | | 48.0 | |
| 1784. | 32.4 | | 51.7 | | 57.7 | | 38.5 | | 45.1 | |
| 1785. | 33.5 | | 52.7 | | 58.8 | | 40.8 | | 46.5 | |
| 1786. | 35.4 | | 52.2 | | 56.4 | | 39.1 | | 45.8 | |
| 1787. | 39.7 | | 51.2 | | 59.0 | | 42.6 | | 48.1 | |
| 1788. | 38.2 | | 54.8 | | 58.8 | | 39.6 | | 47.9 | |
| 1789. | 35.9 | | 50.7 | | 57.9 | | 42.4 | | 46.7 | |
| 1790. | 41.0 | 38.3 | 50.1 | 51.1 | 57.6 | 58.9 | 43.5 | 42.7 | 48.1 | 47.8 |
| 1791. | 40.2 | | 51.9 | | 59.2 | | 40.9 | | 48.1 | |
| 1792. | 38.1 | | 51.0 | | 58.7 | | 44.0 | | 48.0 | |
| 1793. | 38.1 | | 49.5 | | 58.9 | | 45.3 | | 47.9 | |
| 1794. | 40.8 | | 52.6 | | 59.5 | | 42.8 | | 48.9 | |
| 1795. | 32.2 | | 50.2 | | 60.2 | | 46.3 | | 47.2 | |
| 1796. | 41.3 | | 51.5 | | 59.2 | | 39.1 | | 47.8 | |
| 1797. | 36.3 | | 50.3 | | 59.0 | | 43.2 | | 47.2 | |
| 1798. | 38.8 | | 54.7 | | 59.7 | | 41.2 | | 48.6 | |
| 1799. | 35.6 | | 48.9 | | 57.2 | | 41.0 | | 45.7 | |
| 1800. | 36.2 | 38.7 | 52.5 | 52.1 | 61.6 | 60.0 | 42.8 | 43.5 | 48.3 | 48.5 |
| 1801. | 40.7 | | 52.5 | | 60.6 | | 42.4 | | 49.0 | |
| 1802. | 37.7 | | 52.1 | | 59.4 | | 42.6 | | 48.0 | |
| 1803. | 37.3 | | 51.4 | | 59.3 | | 44.7 | | 48.2 | |
| 1804. | 40.4 | | 53.9 | | 59.8 | | 43.7 | | 49.5 | |
| 1805. | 38.4 | | 49.9 | | 60.0 | | 42.3 | | 47.7 | |
| 1806. | 40.9 | | 52.6 | | 59.9 | | 48.5 | | 50.5 | |
| 1807. | 37.9 | | 52.6 | | 60.1 | | 42.8 | | 48.3 | |
| 1808. | 36.8 | | 52.5 | | 61.2 | | 42.0 | | 48.1 | |
| 1809. | 40.7 | | 51.4 | | 58.2 | | 43.4 | | 48.0 | |
| 1810. | 38.4 | 38.5 | 51.5 | 51.3 | 60.3 | 59.1 | 44.4 | 43.3 | 48.7 | 48.1 |
| 1811. | 38.8 | | 54.2 | | 59.1 | | 46.4 | | 49.6 | |
| 1812. | 38.6 | | 48.9 | | 56.8 | | 41.5 | | 46.5 | |
| 1813. | 39.7 | | 50.5 | | 57.2 | | 41.4 | | 47.2 | |
| 1814. | 32.0 | | 50.0 | | 58.2 | | 43.0 | | 45.8 | |
| 1815. | 39.4 | | 53.1 | | 60.9 | | 42.4 | | 49.0 | |
| 1816. | 37.5 | | 48.4 | | 57.1 | | 42.6 | | 46.4 | |
| 1817. | 41.1 | | 50.3 | | 56.2 | | 43.0 | | 47.7 | |
| 1818. | 38.7 | | 53.7 | | 63.5 | | 47.2 | | 50.8 | |
| 1819. | 41.4 | | 52.9 | | 61.2 | | 41.8 | | 49.3 | |

TABLE XXI. (Continued.)

| Year. | January, February, March. | Group of years. | April, May, June. | Group of years. | July, August, September. | Group of years. | October, November, December. | Group of years. | For the year. | Group of years. |
|-------|---------------------------------|--------------------|-------------------------|--------------------|--------------------------------|--------------------|------------------------------------|--------------------|------------------|--------------------|
| 1820. | 36.6 | } 38.4 | 52.5 | } 52.5 | 57.5 | } 59.6 | 42.8 | } 44.7 | 47.4 | } 48.8 |
| 1821. | 38.8 | | 51.3 | | 59.7 | | 47.4 | | 49.3 | |
| 1822. | 43.5 | | 55.0 | | 59.9 | | 45.5 | | 51.0 | |
| 1823. | 36.6 | | 50.9 | | 58.1 | | 43.5 | | 47.3 | |
| 1824. | 37.7 | | 49.4 | | 60.1 | | 45.9 | | 48.3 | |
| 1825. | 38.3 | | 53.7 | | 62.3 | | 44.2 | | 49.6 | |
| 1826. | 39.1 | | 54.0 | | 61.8 | | 44.7 | | 49.9 | |
| 1827. | 36.0 | | 52.4 | | 59.8 | | 45.8 | | 48.5 | |
| 1828. | 41.2 | | 53.6 | | 59.5 | | 46.2 | | 50.1 | |
| 1829. | 36.4 | | 52.4 | | 57.0 | | 40.6 | | 46.6 | |
| 1830. | 36.9 | } 38.6 | 52.8 | } 52.1 | 58.2 | } 59.3 | 43.4 | } 44.4 | 47.8 | } 48.6 |
| 1831. | 39.8 | | 53.4 | | 61.3 | | 47.1 | | 50.4 | |
| 1832. | 38.2 | | 52.6 | | 59.6 | | 45.8 | | 49.1 | |
| 1833. | 38.2 | | 54.8 | | 57.4 | | 45.5 | | 49.0 | |
| 1834. | 42.9 | | 54.3 | | 61.6 | | 45.2 | | 51.0 | |
| 1835. | 40.1 | | 53.1 | | 61.6 | | 42.0 | | 49.2 | |
| 1836. | 39.3 | | 51.7 | | 58.4 | | 42.8 | | 48.1 | |
| 1837. | 37.8 | | 48.3 | | 58.8 | | 44.3 | | 47.3 | |
| 1838. | 34.4 | | 49.8 | | 58.2 | | 43.1 | | 46.4 | |
| 1839. | 38.4 | | 49.8 | | 58.2 | | 44.4 | | 47.7 | |
| 1840. | 38.2 | } 39.3 | 53.6 | } 53.6 | 58.1 | } 59.7 | 41.2 | } 44.4 | 47.8 | } 49.2 |
| 1841. | 38.4 | | 53.5 | | 58.8 | | 44.0 | | 48.7 | |
| 1842. | 39.5 | | 53.8 | | 60.7 | | 44.4 | | 49.6 | |
| 1843. | 39.6 | | 51.9 | | 60.8 | | 45.2 | | 49.4 | |
| 1844. | 38.6 | | 55.1 | | 58.7 | | 42.2 | | 48.7 | |
| 1845. | 35.4 | | 52.1 | | 56.9 | | 45.9 | | 47.6 | |
| 1846. | 43.6 | | 55.7 | | 62.6 | | 43.1 | | 51.3 | |
| 1847. | 37.2 | | 53.2 | | 60.6 | | 47.5 | | 49.6 | |
| 1848. | 40.6 | | 55.3 | | 58.6 | | 46.5 | | 50.2 | |
| 1849. | 41.9 | | 51.7 | | 61.3 | | 44.8 | | 49.9 | |

The mean temperature from all the observations

For the quarter ending March . 31 was 38.3,

„ „ June . 30 was 52.1,

„ „ September 30 was 59.4,

„ „ December 31 was 43.4,

and for the year from all the observations was 48°·29.

By taking the difference between these numbers, and those contained in the preceding Table, the next Table is immediately formed.

TABLE XXII.—Showing the excess of the quarterly and yearly mean temperatures, in every year, and the same for groups of years, above the means from all the years.

| Year. | January, February, March. | Group of years. | April, May, June. | Group of years. | July, August, September. | Group of years. | October, November, December. | Group of years. | For the year. | Group of years. |
|-------|---------------------------|-----------------|-------------------|-----------------|--------------------------|-----------------|------------------------------|-----------------|---------------|-----------------|
| 1771. | -5.5 | -0.7 | -3.0 | -0.1 | -2.8 | +0.2 | -0.2 | -0.2 | -2.9 | -0.1 |
| 1772. | -3.3 | | -2.0 | | -1.2 | | +1.7 | | -1.2 | |
| 1773. | -0.6 | | -3.0 | | -1.7 | | -1.5 | | -1.7 | |
| 1774. | -0.9 | | +0.6 | | -0.5 | | -1.7 | | -0.6 | |
| 1775. | +3.1 | | +3.4 | | +1.3 | | -0.8 | | +1.7 | |
| 1776. | -1.4 | | +0.1 | | -0.1 | | +1.4 | | 0.0 | |
| 1777. | -0.1 | | -1.2 | | +0.9 | | +0.2 | | -0.1 | |
| 1778. | -1.5 | | +2.2 | | +1.9 | | +1.1 | | +0.9 | |
| 1779. | +4.2 | | +2.4 | | +3.8 | | +1.3 | | +2.9 | |
| 1780. | -0.6 | -1.5 | +0.8 | 0.0 | +3.3 | -0.4 | -1.4 | -2.4 | +0.5 | -1.1 |
| 1781. | +1.5 | | +1.8 | | +2.3 | | +0.3 | | +1.5 | |
| 1782. | -1.0 | | -3.2 | | -2.3 | | -4.7 | | -2.8 | |
| 1783. | -0.3 | | +0.4 | | +0.9 | | -1.2 | | -0.3 | |
| 1784. | -5.9 | | -0.4 | | -1.7 | | -4.9 | | -3.2 | |
| 1785. | -4.7 | | +0.8 | | -0.6 | | -2.6 | | -1.4 | |
| 1786. | -2.9 | | +0.1 | | -3.0 | | -4.3 | | -2.5 | |
| 1787. | +1.5 | | -0.9 | | -0.4 | | -0.8 | | -0.2 | |
| 1788. | 0.0 | | +2.7 | | -0.6 | | -3.8 | | -0.4 | |
| 1789. | -2.4 | | -1.4 | | -1.5 | | -1.0 | | -1.6 | |
| 1790. | +2.8 | 0.0 | -2.0 | -1.0 | -1.8 | -0.5 | +0.1 | -0.7 | -0.2 | -0.5 |
| 1791. | +1.9 | | -0.2 | | -0.2 | | -2.5 | | -0.2 | |
| 1792. | -0.1 | | -1.1 | | -0.7 | | +0.6 | | -0.3 | |
| 1793. | -0.2 | | -2.6 | | -0.5 | | +1.9 | | -0.4 | |
| 1794. | +2.6 | | +0.5 | | +0.1 | | -0.6 | | +0.6 | |
| 1795. | -6.0 | | -1.9 | | +0.8 | | +2.9 | | -1.1 | |
| 1796. | +3.1 | | -0.6 | | -0.2 | | -4.3 | | -0.5 | |
| 1797. | -2.0 | | -1.8 | | -0.4 | | -0.2 | | -1.1 | |
| 1798. | +0.5 | | +2.6 | | +0.3 | | -2.2 | | +0.3 | |
| 1799. | -2.6 | | -3.2 | | -2.2 | | -2.4 | | -2.6 | |
| 1800. | -2.0 | +0.4 | +0.4 | 0.0 | +2.2 | +0.6 | -0.6 | +0.1 | 0.0 | +0.3 |
| 1801. | +2.4 | | +0.4 | | +1.2 | | -1.0 | | +0.7 | |
| 1802. | -0.5 | | 0.0 | | 0.0 | | -0.8 | | -0.3 | |
| 1803. | -1.0 | | -0.7 | | -0.1 | | +1.3 | | -0.1 | |
| 1804. | +2.2 | | +1.8 | | +0.4 | | +0.3 | | +1.2 | |
| 1805. | +0.1 | | -2.2 | | +0.6 | | -1.1 | | -0.6 | |
| 1806. | +2.7 | | +0.5 | | +0.5 | | +5.1 | | +2.2 | |
| 1807. | -0.4 | | +0.5 | | +0.7 | | -0.6 | | 0.0 | |
| 1808. | -1.4 | | +0.4 | | +1.8 | | -1.4 | | -0.2 | |
| 1809. | +2.4 | | -0.7 | | -1.2 | | 0.0 | | -0.3 | |
| 1810. | +0.2 | +0.2 | -0.6 | -0.8 | +0.9 | -0.4 | +1.0 | -0.1 | +0.4 | -0.2 |
| 1811. | +0.5 | | +2.1 | | -0.3 | | +3.0 | | +1.3 | |
| 1812. | +0.4 | | -3.2 | | -2.6 | | -1.9 | | -1.8 | |
| 1813. | +1.4 | | -1.6 | | -2.2 | | -2.0 | | -1.1 | |
| 1814. | -6.2 | | -2.1 | | -1.2 | | -0.4 | | -2.5 | |
| 1815. | +1.1 | | +1.0 | | +1.5 | | -1.0 | | +0.7 | |
| 1816. | -0.7 | | -3.7 | | -2.3 | | -0.8 | | -1.9 | |
| 1817. | +2.8 | | -1.8 | | -3.2 | | -0.4 | | -0.6 | |
| 1818. | +0.5 | | +1.6 | | +4.1 | | +3.8 | | +2.5 | |
| 1819. | +3.1 | | +0.8 | | +1.8 | | -1.6 | | +1.0 | |

TABLE XXII. (Continued.)

| Year. | January, February, March. | Group of years. | April, May, June. | Group of years. | July, August, September. | Group of years. | October, November, December. | Group of years. | For the year. | Group of years. |
|-------|---------------------------------|--------------------|-------------------------|--------------------|--------------------------------|--------------------|------------------------------------|--------------------|------------------|--------------------|
| 1820. | -1.6 | } +0.2 | +0.4 | } +0.4 | -1.9 | } +0.2 | -0.6 | } +1.3 | -0.9 | } +0.5 |
| 1821. | +0.5 | | -0.8 | | +0.3 | | | | | |
| 1822. | +5.3 | | +2.9 | | +0.5 | | +4.0 | | +2.7 | |
| 1823. | -1.7 | | -1.2 | | -1.3 | | +2.1 | | -1.0 | |
| 1824. | -0.5 | | -2.7 | | +0.7 | | +0.1 | | 0.0 | |
| 1825. | 0.0 | | +1.6 | | +2.9 | | +2.5 | | +1.3 | |
| 1826. | +0.9 | | +1.9 | | +2.4 | | +0.8 | | +1.6 | |
| 1827. | -2.3 | | +0.3 | | +0.4 | | +1.3 | | +0.2 | |
| 1828. | +3.0 | | +1.5 | | +0.1 | | +2.4 | | +1.8 | |
| 1829. | -1.9 | | +0.3 | | -2.4 | | +2.8 | | -1.7 | |
| 1830. | -1.3 | } +0.4 | +0.7 | } 0.0 | -1.2 | } -0.1 | 0.0 | } +1.0 | -0.5 | } +0.3 |
| 1831. | +1.5 | | +1.3 | | +1.9 | | +3.7 | | +2.1 | |
| 1832. | 0.0 | | +0.5 | | +0.2 | | +2.4 | | +0.8 | |
| 1833. | -0.1 | | +2.7 | | -2.0 | | +2.1 | | +0.7 | |
| 1834. | +4.7 | | +2.2 | | +2.2 | | +1.8 | | +2.7 | |
| 1835. | +1.8 | | +1.0 | | +2.2 | | -1.4 | | +0.9 | |
| 1836. | +1.1 | | -0.4 | | -1.0 | | -0.6 | | -0.2 | |
| 1837. | -0.5 | | -3.8 | | -0.6 | | +0.9 | | -1.0 | |
| 1838. | -3.8 | | -2.3 | | -1.2 | | -0.3 | | -1.9 | |
| 1839. | +0.1 | | -2.3 | | -1.2 | | +1.0 | | -0.6 | |
| 1840. | 0.0 | } +1.0 | +1.5 | } +1.5 | -1.3 | } +0.3 | -2.2 | } +1.0 | -0.5 | } +1.0 |
| 1841. | +0.1 | | +1.4 | | -0.6 | | +0.6 | | +0.4 | |
| 1842. | +1.3 | | +1.7 | | +1.3 | | +1.0 | | +1.3 | |
| 1843. | +1.3 | | -0.2 | | +1.4 | | +1.8 | | +1.1 | |
| 1844. | +0.4 | | +3.0 | | -0.7 | | -1.2 | | +0.4 | |
| 1845. | -2.9 | | 0.0 | | -2.5 | | +2.5 | | -0.7 | |
| 1846. | +5.4 | | +3.6 | | +3.2 | | -0.3 | | +3.0 | |
| 1847. | -1.1 | | +1.1 | | +1.2 | | +4.1 | | +1.3 | |
| 1848. | +2.3 | | +3.2 | | -0.8 | | +3.1 | | +1.9 | |
| 1849. | +3.6 | | -0.4 | | +1.9 | | +1.4 | | +1.6 | |

The sign — denotes that the temperature of that period was below the average, and the sign + denotes that it was above the average.

These numbers do not at all confirm the idea that a hot summer is either preceded or followed by a cold winter, or *vice versa*; on the contrary, it would seem that any hot or cold period has been mostly accompanied by weather of the same character. The cold year of 1771 was followed by two cold years. The hot year of 1779 was preceded by one warm year and followed by two others. In 1780 the extreme cold of January was more than counterbalanced by the extreme heat of March. The cold year of 1782 was followed by a long series of cold years. The very cold year of 1799 was followed by a cold autumn and winter. The warm year of 1806 was preceded by a warm winter. The very cold year of 1814 (the last very cold year we have had) was preceded by a cold summer, autumn and winter. The hot year of 1818 was preceded by a moderate winter, and was followed by a warm one. The hot year of 1822 was preceded by a warm winter and was followed by a moderately cold one. The hot year of 1834 followed a very mild winter and was followed by another. The hot

year of 1846 was preceded by a warm winter and was followed by a moderate one. The warm year 1848 was both preceded and followed by warm periods.

The mean temperatures of the years 1771, 1782, 1784, 1786, 1799 and 1814, were all below 46°; the coldest was 1784, and its value was 45°·1.

The mean temperatures of the years 1779, 1818, 1822, 1834 and 1846, were all above 50°·5; the year of highest temperature was 1846, and its value was 51°·3.

Thus seventy-nine years, from 1771 to 1849 inclusive, gives a mean temperature of 48°·3, with a variation, between one year and another, from 45°·1 in 1784 to 51°·3 in 1846; the difference is 6°·2.

TABLE XXIII.—Showing the mean temperature of the Air in Spring, Summer, Autumn, Winter, and for the year from March, and the same for successive groups of years.

| Year. | Spring. | | Summer. | | Autumn. | | Winter. | | The year from March. | |
|-------|--------------------|-----------------|---------------------|-----------------|-------------------------------|-----------------|------------------------------|-----------------|----------------------|-----------------|
| | March, April, May. | Group of years. | June, July, August. | Group of years. | September, October, November. | Group of years. | December, January, February. | Group of years. | Whole year. | Group of years. |
| 1771. | 42·6 | 46·4 | 57·3 | 60·5 | 46·7 | 49·0 | 35·9 | 36·9 | 45·6 | 48·2 |
| 1772. | 43·1 | | 59·7 | | 50·3 | | 37·1 | | 47·5 | |
| 1773. | 44·2 | | 58·3 | | 47·1 | | 35·9 | | 46·4 | |
| 1774. | 46·9 | | 60·7 | | 47·6 | | 39·8 | | 48·7 | |
| 1775. | 48·5 | | 62·1 | | 48·9 | | 35·4 | | 48·8 | |
| 1776. | 47·2 | | 60·7 | | 49·6 | | 36·6 | | 48·5 | |
| 1777. | 47·0 | | 59·7 | | 51·0 | | 35·4 | | 48·3 | |
| 1778. | 47·3 | | 63·9 | | 48·0 | | 41·0 | | 50·0 | |
| 1779. | 50·8 | | 62·3 | | 51·5 | | 34·7 | | 49·8 | |
| 1780. | 49·6 | 45·5 | 62·7 | 60·0 | 49·6 | 47·5 | 37·7 | 36·3 | 49·9 | 47·3 |
| 1781. | 47·3 | | 63·6 | | 49·0 | | 38·1 | | 49·5 | |
| 1782. | 42·5 | | 57·9 | | 45·1 | | 37·4 | | 45·7 | |
| 1783. | 44·6 | | 61·6 | | 48·7 | | 32·0 | | 46·7 | |
| 1784. | 45·0 | | 57·3 | | 47·3 | | 32·5 | | 45·5 | |
| 1785. | 44·2 | | 59·8 | | 48·0 | | 35·8 | | 46·9 | |
| 1786. | 43·7 | | 59·2 | | 44·2 | | 37·4 | | 46·1 | |
| 1787. | 46·2 | | 60·1 | | 47·5 | | 38·6 | | 48·1 | |
| 1788. | 48·1 | | 59·7 | | 48·5 | | 34·1 | | 47·6 | |
| 1789. | 43·9 | | 57·9 | | 46·7 | | 40·5 | | 47·3 | |
| 1790. | 45·6 | 45·8 | 58·6 | 59·1 | 48·5 | 48·8 | 39·2 | 37·0 | 48·0 | 47·7 |
| 1791. | 46·8 | | 59·5 | | 48·2 | | 35·7 | | 47·6 | |
| 1792. | 46·9 | | 58·4 | | 49·1 | | 38·3 | | 48·2 | |
| 1793. | 44·1 | | 59·8 | | 49·2 | | 39·7 | | 48·2 | |
| 1794. | 48·2 | | 60·8 | | 48·4 | | 31·6 | | 47·2 | |
| 1795. | 45·2 | | 57·8 | | 51·6 | | 43·2 | | 49·5 | |
| 1796. | 45·8 | | 58·2 | | 48·6 | | 33·8 | | 46·6 | |
| 1797. | 44·6 | | 59·0 | | 47·7 | | 39·0 | | 47·6 | |
| 1798. | 47·8 | | 61·3 | | 48·8 | | 34·5 | | 48·1 | |
| 1799. | 42·7 | | 57·6 | | 48·2 | | 34·6 | | 45·8 | |
| 1800. | 46·6 | | 46·5 | | 60·7 | | 60·3 | | 49·3 | |
| 1801. | 47·7 | 60·5 | | 49·9 | 36·0 | 48·5 | | | | |
| 1802. | 46·6 | 59·6 | | 49·0 | 35·8 | 47·7 | | | | |
| 1803. | 46·7 | 60·5 | | 47·7 | 41·1 | 49·0 | | | | |
| 1804. | 47·1 | 60·5 | | 51·6 | 36·3 | 48·9 | | | | |
| 1805. | 45·6 | 58·4 | | 48·9 | 40·5 | 48·4 | | | | |
| 1806. | 46·2 | 60·8 | | 51·9 | 41·2 | 50·0 | | | | |
| 1807. | 45·8 | 61·6 | | 48·3 | 36·6 | 48·1 | | | | |
| 1808. | 45·6 | 62·1 | | 48·4 | 38·5 | 48·7 | | | | |
| 1809. | 46·5 | 58·7 | | 48·4 | 38·0 | 47·9 | | | | |

TABLE XXIII. (Continued.)

| Year. | Spring. | | Summer. | | Autumn. | | Winter. | | The year from March. | |
|-------|--------------------|-----------------|---------------------|-----------------|-------------------------------|-----------------|------------------------------|-----------------|----------------------|-----------------|
| | March, April, May. | Group of years. | June, July, August. | Group of years. | September, October, November. | Group of years. | December, January, February. | Group of years. | Whole year. | Group of years. |
| 1810. | 46.1 | 46.1 | 60.0 | 58.6 | 51.3 | 50.0 | 37.2 | 37.2 | 48.6 | 48.0 |
| 1811. | 49.4 | | 59.0 | | 52.9 | | 38.6 | | 50.0 | |
| 1812. | 43.7 | | 56.1 | | 48.4 | | 37.0 | | 48.0 | |
| 1813. | 46.4 | | 57.5 | | 47.3 | | 32.5 | | 48.0 | |
| 1814. | 43.9 | | 57.7 | | 47.6 | | 38.1 | | 48.0 | |
| 1815. | 48.8 | | 59.4 | | 50.9 | | 36.8 | | 49.0 | |
| 1816. | 43.8 | | 55.2 | | 49.7 | | 39.9 | | 47.1 | |
| 1817. | 44.5 | | 57.4 | | 49.1 | | 37.4 | | 47.1 | |
| 1818. | 46.3 | | 64.2 | | 54.5 | | 39.6 | | 51.2 | |
| 1819. | 48.8 | | 60.6 | | 48.8 | | 35.2 | | 48.4 | |
| 1820. | 47.5 | 47.1 | 58.0 | 60.0 | 47.6 | 50.0 | 37.8 | 38.0 | 47.7 | 48.8 |
| 1821. | 47.5 | | 57.8 | | 52.6 | | 42.5 | | 48.8 | |
| 1822. | 49.9 | | 62.1 | | 52.1 | | 35.4 | | 48.8 | |
| 1823. | 45.7 | | 58.0 | | 48.7 | | 37.8 | | 47.6 | |
| 1824. | 44.3 | | 59.2 | | 51.2 | | 39.4 | | 48.5 | |
| 1825. | 46.9 | | 62.0 | | 50.6 | | 38.3 | | 49.5 | |
| 1826. | 47.4 | | 63.9 | | 49.5 | | 35.6 | | 49.1 | |
| 1827. | 47.5 | | 60.0 | | 50.1 | | 41.4 | | 49.8 | |
| 1828. | 48.1 | | 60.3 | | 50.6 | | 38.2 | | 49.3 | |
| 1829. | 45.7 | | 58.9 | | 46.7 | | 33.3 | | 46.2 | |
| 1830. | 49.6 | 46.3 | 58.8 | 60.5 | 49.6 | 49.5 | 36.8 | 38.5 | 48.7 | 48.7 |
| 1831. | 48.3 | | 62.3 | | 51.9 | | 38.7 | | 48.7 | |
| 1832. | 46.4 | | 60.5 | | 50.5 | | 39.8 | | 49.3 | |
| 1833. | 47.4 | | 59.5 | | 48.4 | | 43.1 | | 49.6 | |
| 1834. | 48.6 | | 62.5 | | 51.0 | | 40.1 | | 50.5 | |
| 1835. | 46.8 | | 62.6 | | 49.4 | | 36.3 | | 48.8 | |
| 1836. | 46.6 | | 60.3 | | 47.4 | | 39.0 | | 48.3 | |
| 1837. | 40.9 | | 59.8 | | 48.9 | | 34.3 | | 46.0 | |
| 1838. | 44.6 | | 59.1 | | 48.4 | | 38.3 | | 47.6 | |
| 1839. | 43.3 | | 59.3 | | 49.7 | | 38.9 | | 47.8 | |
| 1840. | 46.3 | 47.7 | 59.9 | 60.7 | 48.1 | 50.1 | 34.1 | 38.5 | 47.1 | 49.3 |
| 1841. | 50.1 | | 58.2 | | 49.9 | | 38.1 | | 49.1 | |
| 1842. | 47.8 | | 62.8 | | 48.2 | | 40.3 | | 49.8 | |
| 1843. | 47.4 | | 59.8 | | 50.4 | | 39.4 | | 49.3 | |
| 1844. | 48.7 | | 59.9 | | 50.1 | | 34.7 | | 48.4 | |
| 1845. | 43.6 | | 59.3 | | 49.9 | | 43.1 | | 49.0 | |
| 1846. | 48.3 | | 64.3 | | 52.2 | | 34.5 | | 49.8 | |
| 1847. | 47.6 | | 61.8 | | 51.4 | | 40.3 | | 50.2 | |
| 1848. | 50.3 | | 59.5 | | 50.4 | | 42.4 | | 50.7 | |
| 1849. | 46.6 | | 61.0 | | 51.3 | | 39.2 | | 49.5 | |

The mean temperature from all the results for Spring is 46.4

The mean temperature from all the results for Summer is 60.0

The mean temperature from all the results for Autumn is 49.3

The mean temperature from all the results for Winter is 37.6

The mean temperature from all the results for the Year is 48.3

The mean temperature of spring, from all the observations, is 46.4.

The years distinguished by cold springs were 1771, 1772, 1782, 1786, 1789, 1799,

1812, 1814, 1816, 1837, 1839 and 1845, and the mean of their temperatures was $43^{\circ}1$.

The coldest spring, during the whole period, was in the year 1837, and its mean temperature was $40^{\circ}9$.

The years distinguished by hot springs were 1779, 1780, 1811, 1822, 1830, 1841 and 1848, and the mean of their temperatures was $50^{\circ}0$.

The hottest spring, during the whole period, was 1779, and its mean temperature was $50^{\circ}8$.

The mean temperature of summer, from all the observations, is $60^{\circ}0$. The years distinguished by cold summers were 1771, 1784, 1799, 1812, 1813, 1814, 1816, 1817, and the mean of their temperatures was $56^{\circ}9$.

The years distinguished by hot summers were 1778, 1779, 1780, 1781, 1818, 1826, 1831, 1834, 1835, 1842 and 1846, and the mean of their temperatures was $63^{\circ}2$. The coldest summer within the period was that in the year 1816, and its mean temperature was $55^{\circ}2$. The hottest summer within the period was that in the year 1846, and its mean temperature was $64^{\circ}3$.

The mean temperature of autumn, from all the observations, is $49^{\circ}3$. The years distinguished by cold autumns were 1771, 1782, 1786, 1789 and 1829, and the mean of their temperatures was $45^{\circ}9$.

The years distinguished by hot autumns were 1779, 1795, 1804, 1806, 1811, 1818, 1821, 1822, 1831 and 1846, and the mean of their temperatures was $52^{\circ}3$. The coldest autumn within the period was that in the year 1786, and its mean temperature was $44^{\circ}2$. The hottest autumn within the period was that in the year 1718, and its mean temperature was $54^{\circ}5$.

The mean temperature of winter, from all the observations, was $37^{\circ}6$. The years distinguished by cold winters were 1783, 1784, 1794, 1796, 1813 and 1829; the mean of their temperatures was $32^{\circ}6$.

The years distinguished by warm winters were 1778, 1795, 1803, 1806, 1821, 1827, 1833, 1845 and 1848, and the mean of their temperatures was $42^{\circ}1$.

The coldest winter within the period was that in the year 1794, and its mean temperature was $31^{\circ}6$.

The warmest winter within the period was that in the year 1795, and its mean value was $43^{\circ}2$. The winters of the years 1833 and 1845 were remarkably warm, being both of the value of $43^{\circ}1$.

By taking the difference between the mean temperature of each period from all the observations, and the mean temperature for the same period, in every year, the next Table is formed.

TABLE XXIV.—Showing the excess of the mean temperature, in every year, in Spring, Summer, Autumn, Winter, and the Year, above the mean temperature for each period from all the years, and the same for groups of years.

| Year. | Spring. | | Summer. | | Autumn. | | Winter. | | The year from March. | |
|-------|--------------------|-----------------|---------------------|-----------------|-------------------------------|-----------------|------------------------------|-----------------|----------------------|-----------------|
| | March, April, May. | Group of years. | June, July, August. | Group of years. | September, October, November. | Group of years. | December, January, February. | Group of years. | Whole year. | Group of years. |
| 1771. | -3.8 | 0.0 | -2.7 | +0.5 | -2.6 | -0.3 | -1.7 | -0.7 | -2.7 | -0.1 |
| 1772. | -3.3 | | -0.3 | | +1.0 | | -0.5 | | -0.8 | |
| 1773. | -2.2 | | -1.7 | | -2.1 | | -1.7 | | -1.9 | |
| 1774. | +0.5 | | +0.7 | | -1.7 | | +2.2 | | +0.4 | |
| 1775. | +2.1 | | +2.1 | | -0.3 | | -2.2 | | +0.5 | |
| 1776. | +0.8 | | +0.7 | | +0.3 | | -1.0 | | +0.2 | |
| 1777. | +0.6 | | -0.3 | | +1.8 | | -2.2 | | 0.0 | |
| 1778. | +0.9 | | +3.9 | | -1.3 | | +3.4 | | +1.7 | |
| 1779. | +4.4 | | +2.3 | | +2.3 | | -2.9 | | +1.5 | |
| 1780. | +3.2 | | -0.9 | | +2.7 | | 0.0 | | +0.3 | |
| 1781. | +0.9 | +3.6 | | -0.2 | +0.5 | +1.2 | | | | |
| 1782. | -3.9 | -2.1 | | -4.2 | -0.2 | -2.6 | | | | |
| 1783. | -1.8 | +1.6 | | -0.5 | -5.6 | -1.6 | | | | |
| 1784. | -1.4 | -2.7 | | -2.0 | -5.1 | -2.8 | | | | |
| 1785. | -2.2 | -0.2 | | -1.2 | -1.8 | -1.4 | | | | |
| 1786. | -2.7 | -0.8 | | -5.1 | -0.2 | -2.2 | | | | |
| 1787. | -0.2 | +0.1 | | -1.7 | +1.0 | -0.2 | | | | |
| 1788. | +1.7 | -0.3 | | -0.8 | -3.5 | -0.7 | | | | |
| 1789. | -2.5 | -2.1 | | -2.5 | +2.9 | -1.0 | | | | |
| 1790. | -0.8 | -0.6 | -1.4 | -0.9 | -0.8 | -0.4 | +1.6 | -0.6 | -0.3 | -0.6 |
| 1791. | +0.4 | | -0.5 | | -1.0 | | -1.9 | | -0.7 | |
| 1792. | +0.5 | | -1.6 | | -0.2 | | +0.7 | | -0.1 | |
| 1793. | -2.3 | | -0.2 | | 0.0 | | +2.1 | | -0.1 | |
| 1794. | +1.8 | | +0.8 | | -0.9 | | -6.0 | | -1.1 | |
| 1795. | -1.2 | | -2.2 | | +2.4 | | +5.6 | | +1.2 | |
| 1796. | -0.6 | | -1.8 | | -0.7 | | -3.8 | | -1.7 | |
| 1797. | -1.8 | | -1.0 | | -1.5 | | +1.4 | | -0.7 | |
| 1798. | +1.4 | | +1.3 | | -0.5 | | -3.1 | | -0.2 | |
| 1799. | -3.7 | | -2.4 | | -1.0 | | -3.0 | | -2.5 | |
| 1800. | +0.2 | +0.1 | +0.7 | +0.3 | +0.1 | -0.1 | +1.1 | +0.5 | +0.5 | +0.3 |
| 1801. | +1.3 | | +0.5 | | +0.6 | | -1.6 | | +0.2 | |
| 1802. | +0.2 | | -0.4 | | -0.3 | | -1.8 | | -0.6 | |
| 1803. | +0.3 | | +0.5 | | -1.6 | | +3.5 | | +0.7 | |
| 1804. | +0.7 | | +0.5 | | +2.4 | | -1.3 | | +0.6 | |
| 1805. | -0.8 | | -1.6 | | -0.3 | | +2.9 | | +0.1 | |
| 1806. | -0.2 | | +0.8 | | +2.6 | | +3.6 | | +1.7 | |
| 1807. | -0.6 | | +1.6 | | -0.9 | | -1.0 | | -0.2 | |
| 1808. | -0.8 | | +2.1 | | -0.9 | | +0.9 | | +0.4 | |
| 1809. | +0.1 | | -1.3 | | -0.8 | | +0.4 | | -0.4 | |
| 1810. | -0.3 | -0.3 | 0.0 | -1.4 | +2.1 | +0.8 | -0.4 | -0.4 | +0.3 | -0.3 |
| 1811. | +3.0 | | -1.0 | | +3.6 | | +1.0 | | +1.7 | |
| 1812. | -2.7 | | -3.9 | | -0.8 | | -0.6 | | -2.0 | |
| 1813. | 0.0 | | -2.5 | | -2.0 | | -5.1 | | -2.4 | |
| 1814. | -2.5 | | -2.3 | | -1.6 | | +0.5 | | -1.5 | |
| 1815. | +2.4 | | -0.6 | | +1.6 | | -0.8 | | +0.7 | |
| 1816. | -2.6 | | -4.8 | | +0.5 | | +2.3 | | -1.2 | |
| 1817. | -1.9 | | -2.6 | | -0.2 | | -0.2 | | -1.2 | |
| 1818. | -0.1 | | +4.2 | | +5.3 | | +2.0 | | +2.9 | |
| 1819. | +2.4 | | +0.6 | | -0.5 | | -2.4 | | +0.1 | |

TABLE XXIV. (Continued.)

| Year. | Spring. | | Summer. | | Autumn. | | Winter. | | The year from March. | |
|-------|--------------------|-----------------|---------------------|-----------------|-------------------------------|-----------------|------------------------------|-----------------|----------------------|-----------------|
| | March, April, May. | Group of years. | June, July, August. | Group of years. | September, October, November. | Group of years. | December, January, February. | Group of years. | Whole year. | Group of years. |
| 1820. | +1.1 | } +0.7 | -2.0 | } 0.0 | -1.6 | } -0.7 | +0.2 | } +0.4 | -0.6 | } +0.5 |
| 1821. | +1.1 | | -2.2 | | +3.3 | | +4.9 | | +1.8 | |
| 1822. | +3.5 | | +2.1 | | +2.9 | | -2.2 | | +1.6 | |
| 1823. | -0.7 | | -2.0 | | -0.6 | | +0.2 | | -0.7 | |
| 1824. | -2.1 | | -0.8 | | +2.0 | | +1.8 | | +0.2 | |
| 1825. | +0.5 | | +2.0 | | +1.3 | | +0.7 | | +1.2 | |
| 1826. | +1.0 | | +3.9 | | +0.3 | | -2.0 | | +0.8 | |
| 1827. | +1.1 | | 0.0 | | +0.8 | | +3.8 | | +1.5 | |
| 1828. | +1.7 | | +0.3 | | +1.4 | | +0.6 | | +1.0 | |
| 1829. | -0.7 | | -1.1 | | -2.6 | | -4.3 | | -2.1 | |
| 1830. | +3.2 | } +0.1 | -1.2 | } +0.5 | +0.4 | } -0.2 | -0.8 | } +0.9 | +0.4 | } +0.4 |
| 1831. | +1.9 | | +2.3 | | +2.6 | | +1.1 | | +2.0 | |
| 1832. | 0.0 | | +0.5 | | +1.3 | | +2.2 | | +1.0 | |
| 1833. | +1.0 | | -0.5 | | -0.9 | | +5.5 | | +1.3 | |
| 1834. | +2.2 | | +2.5 | | +1.8 | | +2.5 | | +2.2 | |
| 1835. | +0.4 | | +2.6 | | +0.1 | | -1.3 | | +0.5 | |
| 1836. | +0.2 | | +0.3 | | -1.8 | | +1.4 | | 0.0 | |
| 1837. | -5.5 | | -0.2 | | -0.4 | | -3.3 | | -2.3 | |
| 1838. | -1.8 | | -0.9 | | -0.8 | | +0.7 | | -0.7 | |
| 1839. | -3.1 | | -0.7 | | +0.4 | | +1.3 | | -0.5 | |
| 1840. | -0.1 | } +1.3 | -0.1 | } +0.7 | -1.1 | } +0.8 | -3.5 | } +0.9 | -1.2 | } +1.0 |
| 1841. | +3.7 | | -1.8 | | +0.6 | | +0.5 | | +0.8 | |
| 1842. | +1.4 | | +2.8 | | -1.0 | | +2.7 | | +1.5 | |
| 1843. | +1.0 | | -0.2 | | +1.1 | | +1.8 | | +1.0 | |
| 1844. | +2.3 | | -0.1 | | +0.9 | | -2.9 | | +0.1 | |
| 1845. | -2.8 | | -0.7 | | +0.6 | | +5.5 | | +0.7 | |
| 1846. | +1.9 | | +4.3 | | +3.0 | | -3.1 | | +1.5 | |
| 1847. | +1.2 | | +1.8 | | +2.1 | | +2.7 | | +1.9 | |
| 1848. | +3.9 | | -0.5 | | +1.2 | | +4.8 | | +2.4 | |
| 1849. | +0.2 | | +1.0 | | +2.0 | | +1.6 | | +1.2 | |

The sign - denotes that the temperature of that period was below the average, and the sign + denotes that it was above the average.

By taking the mean of the numbers for each period, without regard to gauge,

- The mean variability in Spring is . . . 1.6
- The mean variability in Summer is . . . 1.5
- The mean variability in Autumn is . . . 1.4
- The mean variability in Winter is . . . 2.2
- The mean variability in the Year is . . . 1.1

All the following Tables are based upon the readings of self-registering thermometers, and exhibit the extreme readings at the Apartments of the Royal Society, and at the Royal Observatory, Greenwich. The first process in their formation was the copying from the Philosophical Transactions every reading of these thermometers, arranging all the minimum readings one under the other, and all the maximum readings similarly under each other, and then taking their monthly mean readings, or otherwise as was necessary to the construction of the Tables.

TABLE XXV.—Showing the monthly mean reading of the minimum temperature, and during the whole time that the maximum and minimum self-registering thermometer, at the Royal Observatory, Greenwich.

| Year. | January. | | February. | | March. | | April. | | May. | | June. | |
|-------|-------------------|-------------------|-------------------|-------------------|-------------------|-------------------|-------------------|-------------------|-------------------|-------------------|-------------------|-------------------|
| | Mean of all the | | Mean of all the | | Mean of all the | | Mean of all the | | Mean of all the | | Mean of all the | |
| | Minimum readings. | Maximum readings. | Minimum readings. | Maximum readings. | Minimum readings. | Maximum readings. | Minimum readings. | Maximum readings. | Minimum readings. | Maximum readings. | Minimum readings. | Maximum readings. |
| 1794. | 32.0 | 38.5 | 43.6 | 49.5 | 40.6 | 51.4 | 45.8 | 58.9 | 46.5 | 60.1 | 52.3 | 67.7 |
| 1795. | 23.0 | 29.7 | 32.8 | 39.0 | 35.6 | 45.3 | 42.4 | 53.3 | 46.3 | 62.1 | 50.9 | 63.3 |
| 1796. | 43.8 | 50.8 | 37.9 | 45.9 | 35.3 | 46.6 | 43.1 | 57.9 | 45.5 | 59.7 | 51.2 | 66.7 |
| 1797. | 34.7 | 40.0 | 38.9 | 42.9 | 34.3 | 45.7 | 41.0 | 53.7 | 45.7 | 62.0 | 49.2 | 65.9 |
| 1798. | 36.1 | 43.2 | 35.2 | 44.8 | 37.5 | 48.1 | 44.1 | 59.5 | 49.0 | 63.7 | 55.2 | 72.8 |
| 1799. | 32.1 | 38.5 | 33.8 | 42.9 | 35.0 | 44.0 | 39.1 | 49.1 | 45.5 | 59.0 | 50.5 | 65.7 |
| 1800. | 35.7 | 41.7 | 33.1 | 40.7 | 34.7 | 44.1 | 45.6 | 56.0 | 50.9 | 64.3 | 51.1 | 64.7 |
| 1801. | 37.1 | 45.0 | 36.8 | 43.9 | 41.1 | 50.7 | 39.8 | 55.8 | 47.2 | 63.3 | 52.7 | 68.9 |
| 1802. | 31.2 | 37.4 | 37.0 | 44.7 | 36.7 | 49.6 | 43.3 | 58.6 | 54.0 | 61.8 | 51.6 | 67.6 |
| 1803. | 33.1 | 37.5 | 34.6 | 42.0 | 38.8 | 50.3 | 43.9 | 57.3 | 46.7 | 59.4 | 52.3 | 65.5 |
| 1804. | 41.8 | 47.8 | 35.8 | 43.1 | 38.4 | 47.8 | 45.3 | 51.7 | 52.4 | 66.8 | 55.1 | 71.8 |
| 1805. | 33.6 | 38.9 | 36.5 | 44.9 | 38.4 | 49.4 | 41.4 | 54.6 | 45.0 | 59.6 | 50.2 | 65.3 |
| 1806. | 38.8 | 46.0 | 39.3 | 47.5 | 39.0 | 46.5 | 40.3 | 50.8 | 49.9 | 65.1 | 54.2 | 70.9 |
| 1807. | 35.5 | 42.8 | 37.4 | 46.2 | 34.0 | 44.6 | 44.7 | 55.8 | 51.1 | 64.2 | 52.5 | 68.2 |
| 1808. | 35.2 | 42.5 | 34.1 | 42.5 | 35.2 | 43.3 | 39.1 | 51.4 | 52.2 | 67.8 | 53.8 | 68.3 |
| 1809. | 33.8 | 40.3 | 41.8 | 50.0 | 39.6 | 49.9 | 38.0 | 49.7 | 50.2 | 65.2 | 52.3 | 68.2 |
| 1810. | 33.6 | 39.0 | 37.2 | 43.7 | 39.2 | 49.1 | 42.2 | 54.9 | 45.2 | 59.7 | 52.7 | 70.0 |
| 1820. | 30.5 | 37.9 | 35.3 | 43.0 | 37.2 | 50.3 | 44.9 | 59.5 | 48.3 | 62.7 | 52.5 | 66.2 |
| 1821. | 35.6 | 43.7 | 33.5 | 43.4 | 39.6 | 50.6 | 45.4 | 58.7 | 44.9 | 60.5 | 50.2 | 63.6 |
| 1822. | 35.8 | 46.0 | 40.5 | 50.7 | 44.0 | 55.5 | 43.9 | 55.3 | 52.6 | 65.0 | 58.3 | 73.6 |
| 1823. | | | | | | | | | 49.7 | 64.2 | 49.9 | 66.4 |
| 1824. | 36.6 | 41.7 | 37.7 | 43.8 | 37.3 | 45.7 | 40.7 | 51.6 | 46.5 | 58.5 | 51.1 | 64.6 |
| 1825. | 37.3 | 43.3 | 36.7 | 44.2 | 36.4 | 45.2 | 44.1 | 58.6 | 48.5 | 63.1 | 51.9 | 69.7 |
| 1826. | 29.8 | 37.3 | 40.4 | 47.9 | | | 44.6 | 58.8 | 46.3 | 60.8 | 56.4 | 74.6 |
| 1827. | 31.2 | 39.2 | 29.3 | 37.5 | 40.1 | 49.7 | 43.3 | 55.3 | 49.1 | 61.6 | 52.8 | 67.5 |
| 1828. | 37.5 | 45.0 | 38.4 | 45.2 | 40.0 | 51.0 | 43.1 | 55.0 | 50.0 | 64.2 | 55.9 | 70.2 |
| 1829. | 30.1 | 36.3 | 36.4 | 43.7 | 35.9 | 45.7 | 40.6 | 52.4 | 48.4 | 64.9 | 54.1 | 69.6 |
| 1830. | 29.3 | 35.0 | 30.9 | 40.5 | 41.5 | 53.9 | 44.1 | 57.9 | 50.0 | 64.8 | 52.0 | 65.2 |
| 1831. | 32.5 | 38.9 | 38.5 | 47.2 | 40.9 | 50.8 | 45.1 | 57.2 | 47.1 | 63.0 | 54.7 | 69.0 |
| 1832. | 34.5 | 40.8 | 34.7 | 42.6 | 36.9 | 47.7 | 42.0 | 56.4 | 46.3 | 61.6 | 55.2 | 69.5 |
| 1833. | 32.8 | 39.0 | 39.6 | 48.1 | 34.6 | 44.3 | 41.7 | 54.7 | 52.9 | 70.4 | 54.5 | 70.6 |
| 1834. | 42.5 | 49.0 | 36.7 | 46.6 | 40.4 | 51.3 | 40.3 | 54.4 | 50.5 | 67.7 | 55.0 | 72.5 |
| 1835. | 35.3 | 43.1 | 37.1 | 47.7 | 37.1 | 48.3 | 42.4 | 55.8 | 48.0 | 62.5 | 54.6 | 70.7 |
| 1836. | 34.5 | 43.8 | 34.0 | 42.3 | 40.2 | 50.5 | 40.5 | 51.3 | 44.7 | 60.6 | 55.2 | 69.1 |
| 1837. | 35.3 | 42.7 | 38.0 | 46.5 | 33.9 | 42.6 | 37.3 | 47.0 | 44.4 | 57.6 | 53.8 | 68.5 |
| 1838. | 27.1 | 34.4 | 31.2 | 38.4 | 38.1 | 49.2 | 39.2 | 50.9 | 45.8 | 61.3 | 53.6 | 68.6 |
| 1839. | 34.7 | 43.3 | 37.1 | 47.7 | 37.4 | 44.2 | 39.7 | 46.0 | 45.0 | 60.5 | 54.9 | 70.2 |
| 1840. | 36.9 | 43.5 | 36.5 | 42.4 | 35.9 | 41.7 | 43.3 | 53.5 | 49.6 | | 55.5 | 71.2 |
| 1841. | 32.7 | 40.3 | 34.9 | 40.8 | 42.7 | 55.4 | 43.2 | 56.4 | 52.4 | 68.0 | 52.2 | 69.7 |
| 1842. | 32.0 | 38.1 | 38.4 | 46.4 | 41.6 | 51.5 | 41.1 | 53.8 | 48.8 | 64.9 | 58.3 | 76.6 |
| 1843. | 37.7 | 45.7 | 34.9 | 41.6 | 39.6 | 50.0 | 44.0 | 57.9 | 48.2 | 64.3 | 51.9 | 67.6 |

At the Royal Observatory, Greenwich.

| | | | | | | | | | | | | |
|-------|-------|-------|-------|-------|-------|-------|-------|-------|-------|-------|-------|-------|
| 1840. | | | | | | | | | | | | |
| 1841. | 28.4 | 39.5 | 31.6 | 40.7 | 38.7 | 56.2 | 39.9 | 56.4 | 48.4 | 69.7 | 48.2 | 67.0 |
| 1842. | 29.3 | 36.6 | 36.0 | 46.6 | 39.2 | 51.8 | 37.3 | 54.7 | 45.0 | 64.5 | 52.2 | 75.2 |
| 1843. | 35.4 | 44.7 | 31.9 | 40.2 | 37.5 | 50.5 | 40.7 | 57.9 | 45.5 | 63.3 | 49.0 | 67.0 |
| 1844. | 34.1 | 43.9 | 30.9 | 41.6 | 35.7 | 48.9 | 41.8 | 63.6 | 45.1 | 65.9 | 51.6 | 74.1 |
| 1845. | 34.3 | 43.3 | 27.9 | 38.4 | 30.8 | 42.4 | 39.3 | 57.5 | 42.7 | 59.6 | 52.2 | 72.5 |
| 1846. | 39.4 | 48.1 | 39.3 | 49.0 | 38.1 | 51.6 | 41.8 | 56.4 | 47.4 | 66.7 | 55.1 | 80.4 |
| 1847. | 31.5 | 40.1 | 30.5 | 41.5 | 34.3 | 50.1 | 36.8 | 55.4 | 47.5 | 68.0 | 49.7 | 69.4 |
| 1848. | 29.8 | 38.1 | 38.0 | 48.7 | 36.4 | 50.7 | 39.0 | 57.2 | 43.4 | 75.4 | 38.7 | 78.4 |
| 1849. | 35.7 | 45.2 | 36.5 | 49.4 | 36.3 | 50.1 | 36.5 | 52.5 | 46.7 | 63.8 | 48.5 | 69.1 |

the monthly mean reading of the maximum temperature of Air as observed daily, meters were in use at the Apartments of the Royal Society, and from 1840, No-

| Year. | July. | | August. | | September. | | October. | | November. | | December. | |
|-------|-------------------|-------------------|-------------------|-------------------|-------------------|-------------------|-------------------|-------------------|-------------------|-------------------|-------------------|-------------------|
| | Mean of all the | | Mean of all the | | Mean of all the | | Mean of all the | | Mean of all the | | Mean of all the | |
| | Minimum readings. | Maximum readings. | Minimum readings. | Maximum readings. | Minimum readings. | Maximum readings. | Minimum readings. | Maximum readings. | Minimum readings. | Maximum readings. | Minimum readings. | Maximum readings. |
| 1794. | 59.9 | 76.4 | 55.3 | 70.2 | 50.8 | 61.3 | 45.9 | 55.0 | 41.6 | 49.1 | 35.3 | 40.1 |
| 1795. | 53.0 | 66.1 | 56.6 | 71.7 | 55.6 | 70.4 | 51.0 | 60.3 | 38.2 | 46.9 | 43.2 | 48.9 |
| 1796. | 53.7 | 68.7 | 54.4 | 70.9 | 54.6 | 67.4 | 44.3 | 52.9 | 38.9 | 45.1 | 28.4 | 35.7 |
| 1797. | 56.5 | 75.8 | 53.8 | 70.0 | 50.4 | 63.5 | 44.3 | 53.3 | 38.8 | 48.0 | 38.7 | 46.3 |
| 1798. | 55.8 | 71.7 | 57.8 | 73.6 | 52.5 | 65.1 | 47.0 | 57.0 | 37.8 | 45.3 | 32.2 | 38.0 |
| 1799. | 55.6 | 69.1 | 53.4 | 67.7 | 49.9 | 63.0 | 45.0 | 54.7 | 41.1 | 48.0 | 32.3 | 36.3 |
| 1800. | 57.1 | 74.7 | 57.6 | 75.2 | 54.1 | 66.1 | 44.8 | 55.4 | 39.9 | 48.1 | 37.1 | 42.0 |
| 1801. | 55.1 | 70.9 | 57.4 | 73.4 | 55.3 | 67.0 | 47.7 | 57.7 | 38.5 | 45.8 | 34.3 | 41.5 |
| 1802. | 51.3 | 66.9 | 58.5 | 76.3 | 52.0 | 68.5 | 46.3 | 58.7 | 39.1 | 45.7 | 35.8 | 43.0 |
| 1803. | 58.4 | 70.7 | 56.5 | 72.6 | 46.9 | 63.8 | 46.3 | 56.2 | 39.7 | 47.7 | 40.2 | 45.4 |
| 1804. | 57.9 | 69.7 | 56.3 | 70.0 | 55.3 | 68.5 | 48.4 | 58.9 | 42.7 | 48.8 | 34.8 | 39.7 |
| 1805. | 55.1 | 69.1 | 58.0 | 72.0 | 54.9 | 68.6 | 45.0 | 53.9 | 37.6 | 45.6 | 37.5 | 44.3 |
| 1806. | 57.1 | 70.9 | 57.2 | 71.9 | 53.0 | 66.1 | 48.4 | 58.0 | 45.5 | 53.1 | 44.8 | 50.7 |
| 1807. | 59.0 | 74.3 | 60.0 | 73.7 | 48.7 | 61.4 | 50.2 | 60.2 | 36.9 | 45.0 | 34.7 | 41.4 |
| 1808. | 59.8 | 76.9 | 58.4 | 72.5 | 52.1 | 63.8 | 43.2 | 53.8 | 42.3 | 49.1 | 35.2 | 40.6 |
| 1809. | 55.6 | 69.4 | 59.5 | 69.4 | 53.0 | 64.6 | 47.2 | 56.3 | 37.5 | 45.1 | 38.8 | 45.3 |
| 1810. | 55.8 | 70.7 | 55.9 | 70.8 | 55.2 | 68.0 | 47.7 | 58.8 | | | | |
| 1820. | 56.3 | 68.8 | 55.7 | 69.8 | 49.7 | 64.1 | 44.2 | 55.5 | 39.8 | 48.1 | 38.5 | 45.3 |
| 1821. | 54.0 | 67.3 | 58.2 | 71.3 | 56.4 | 67.7 | 47.0 | 58.8 | 44.3 | 54.0 | 41.0 | 50.6 |
| 1822. | 59.3 | 70.6 | 58.7 | 69.9 | 53.2 | 64.1 | 50.3 | 58.6 | 47.1 | 54.1 | 34.5 | 41.3 |
| 1823. | 55.4 | 67.7 | 56.9 | 68.6 | 51.2 | 64.1 | 45.0 | 53.9 | 42.0 | 46.8 | 38.9 | 44.0 |
| 1824. | 57.4 | 72.1 | 56.9 | 69.1 | 54.9 | 65.1 | 47.5 | 56.3 | 43.2 | 51.4 | 39.6 | 46.3 |
| 1825. | 59.9 | 74.5 | 57.5 | 71.0 | 57.7 | 68.0 | 48.7 | 56.9 | 38.3 | 46.4 | 39.2 | 43.9 |
| 1826. | | | 61.2 | 73.6 | 54.3 | 65.3 | 50.3 | 59.4 | 38.3 | 45.5 | 40.8 | 45.7 |
| 1827. | 58.1 | 73.4 | 55.2 | 68.8 | 54.2 | 65.0 | 49.2 | 58.5 | 39.5 | 48.0 | 41.0 | 49.1 |
| 1828. | 58.3 | 71.5 | 55.9 | 68.6 | 54.2 | 66.4 | 46.2 | 57.0 | 41.8 | 49.9 | 42.6 | 49.2 |
| 1829. | 56.2 | 69.8 | 55.2 | 66.6 | 50.3 | 61.6 | 45.8 | 53.9 | 36.7 | 44.9 | 31.4 | 36.6 |
| 1830. | 58.1 | 73.0 | 53.9 | 68.5 | 50.1 | 62.0 | 47.0 | 58.4 | 41.9 | 49.7 | 32.2 | 39.4 |
| 1831. | 58.3 | 76.6 | 59.9 | 73.2 | 52.9 | 65.2 | 53.1 | 61.6 | 39.3 | 49.1 | 40.6 | 46.0 |
| 1832. | 56.1 | 71.2 | 56.8 | 71.3 | 51.8 | 66.2 | 48.4 | 57.9 | 41.9 | 49.0 | 39.0 | 47.0 |
| 1833. | 56.1 | 71.5 | 53.0 | 68.4 | 49.4 | 62.5 | 46.9 | 58.1 | 40.4 | 49.1 | 40.8 | 50.3 |
| 1834. | 59.3 | 74.7 | 57.9 | 72.8 | 54.1 | 67.3 | 46.2 | 58.2 | 41.4 | 49.4 | 38.1 | 45.6 |
| 1835. | 57.3 | 74.8 | 58.4 | 73.8 | 52.8 | 65.8 | 45.4 | 54.5 | 41.5 | 47.5 | 33.6 | 39.6 |
| 1836. | 57.1 | 71.9 | 54.5 | 68.9 | 50.3 | 61.2 | 45.3 | 53.5 | 38.7 | 47.6 | 38.0 | 44.4 |
| 1837. | 56.7 | 71.7 | 56.6 | 70.0 | 51.7 | 63.2 | 46.1 | 58.8 | 37.2 | 49.0 | 39.8 | 46.0 |
| 1838. | 56.0 | 70.8 | 56.4 | 69.0 | 51.5 | 62.6 | 47.0 | 57.4 | 38.9 | 46.8 | 37.5 | 43.5 |
| 1839. | 56.7 | 69.9 | 55.4 | 68.6 | 53.0 | 63.5 | 47.3 | 54.3 | 43.8 | 48.0 | 38.0 | 41.8 |
| 1840. | 54.9 | 69.8 | 57.9 | 72.7 | 50.0 | 63.3 | 43.2 | 54.8 | 40.8 | 50.7 | 31.5 | 38.8 |
| 1841. | 54.8 | 68.8 | 57.2 | 70.0 | 51.7 | 67.3 | 47.0 | 56.9 | 40.8 | 49.8 | 38.8 | 47.1 |
| 1842. | 55.5 | 73.5 | 60.8 | 76.0 | 53.5 | 65.6 | 42.9 | 53.4 | 41.5 | 49.0 | 41.9 | 50.5 |

At the Royal Observatory, Greenwich.

| | | | | | | | | | | | | |
|-------|-------|-------|-------|-------|-------|-------|-------|-------|------|------|------|------|
| 1840. | | | | | | | | | 35.7 | 46.7 | 27.1 | 36.1 |
| 1841. | 51.5 | 67.1 | 54.3 | 70.6 | 51.2 | 67.2 | 43.9 | 55.6 | 38.0 | 48.7 | 35.4 | 44.8 |
| 1842. | 52.1 | 71.2 | 56.3 | 78.1 | 49.8 | 64.3 | 39.3 | 53.4 | 39.0 | 48.1 | 40.2 | 49.4 |
| 1843. | 53.5 | 71.8 | 55.2 | 72.5 | 52.3 | 70.4 | 42.0 | 55.5 | 38.5 | 50.0 | 40.3 | 48.2 |
| 1844. | 54.1 | 72.8 | 50.3 | 67.9 | 50.2 | 67.5 | 44.4 | 56.7 | 39.6 | 48.1 | 30.4 | 36.8 |
| 1845. | 53.5 | 71.2 | 50.5 | 67.7 | 46.9 | 63.9 | 44.0 | 59.0 | 40.3 | 51.8 | 35.8 | 47.6 |
| 1846. | 56.5 | 77.9 | 56.6 | 74.4 | 51.4 | 71.9 | 44.5 | 58.7 | 40.0 | 50.3 | 27.9 | 37.2 |
| 1847. | 54.8 | 78.1 | 52.8 | 74.4 | 46.1 | 64.9 | 46.4 | 61.5 | 40.8 | 52.7 | 37.2 | 46.7 |
| 1848. | 51.2 | 73.7 | 50.4 | 68.9 | 45.9 | 66.8 | 43.8 | 59.2 | 36.1 | 50.5 | 37.3 | 48.9 |
| 1849. | 51.6 | 74.2 | 54.0 | 74.2 | 51.2 | 68.7 | 44.1 | 59.2 | 38.1 | 49.8 | 34.1 | 43.2 |

TABLE XXVI.—Showing the highest and lowest readings by the self-registering were in use at the Apartments of the Royal Society, and at the Royal Observatory,

| Year. | January. | | February. | | March. | | April. | | May. | | June. | |
|--------------------------------------|---|----------|---|----------|---|----------|---|----------|---|----------|---|----------|
| | Reading of the thermometers in the month. | | Reading of the thermometers in the month. | | Reading of the thermometers in the month. | | Reading of the thermometers in the month. | | Reading of the thermometers in the month. | | Reading of the thermometers in the month. | |
| | Lowest. | Highest. | Lowest. | Highest. | Lowest. | Highest. | Lowest. | Highest. | Lowest. | Highest. | Lowest. | Highest. |
| 1794. | 22° | 51° | 35° | 56° | 34° | 56° | 38° | 73° | 40° | 71° | 46° | 79° |
| 1795. | 7 | 46 | 24 | 51 | 24 | 54.5 | 36 | 61 | 36 | 81.5 | 41 | 77.5 |
| 1796. | 36 | 56 | 30 | 56 | 26.5 | 60 | 36 | 70 | 39 | 65 | 45 | 80 |
| 1797. | 25 | 49 | 24.5 | 50 | 27.5 | 54 | 34 | 65 | 34 | 79 | 40 | 73 |
| 1798. | 28 | 53 | 24 | 54 | 30 | 58 | 30 | 69 | 43 | 76 | 47 | 86 |
| 1799. | 20 | 50 | 18 | 56 | 28 | 56 | 27 | 59 | 36 | 70 | 43 | 77 |
| 1800. | 18 | 51 | 25 | 53 | 23 | 57 | 38 | 62 | 40 | 75 | 43 | 75 |
| 1801. | 24 | 54 | 25 | 57 | 31 | 59 | 30 | 67 | 39 | 71 | 43 | 80 |
| 1802. | 15 | 48 | 29 | 56 | 27 | 65 | 33 | 68 | 31 | 76 | 40 | 78 |
| 1803. | 19 | 48 | 19 | 53 | 25 | 66 | 36 | 72 | 38 | 69 | 49 | 74 |
| 1804. | 27 | 55 | 25 | 51 | 28 | 62 | 34 | 71 | 44 | 73 | 47 | 87 |
| 1805. | 25 | 48 | 23 | 54 | 29 | 62 | 35 | 64 | 37 | 72 | 41 | 75 |
| 1806. | 28 | 55 | 30 | 56 | 26 | 56 | 31 | 64 | 43 | 75 | 46 | 83 |
| 1807. | 23 | 51 | 25 | 57 | 25 | 55 | 31 | 77 | 44 | 84 | 48 | 77 |
| 1808. | 18 | 53 | 18 | 53 | 26 | 54 | 27 | 64 | 42 | 82 | 48 | 76 |
| 1809. | 20 | 55 | 34 | 57 | 33 | 62 | 29 | 57 | 36 | 78 | 45 | 78 |
| 1810. | 14 | 51 | 18 | 54 | 28 | 59 | 31 | 69 | 34 | 67 | 45 | 78 |
| 1820. | 20 | 53 | 26 | 52 | 28 | 66 | 36 | 67 | 39 | 70 | 45 | 85 |
| 1821. | 25 | 52 | 25 | 61 | 31 | 58 | 36 | 72 | 37 | 70 | 43 | 73 |
| 1822. | 31 | 51 | 34 | 54 | 35 | 66 | 35 | 64 | 45 | 75 | 50 | 84 |
| 1823. | 24 | | | | | | | | 40 | 75 | 43 | 74 |
| 1824. | 25 | 52.5 | 28 | 52 | 28 | 56 | 28 | 66.5 | 42 | 73 | 43 | 74 |
| 1825. | 30 | 54 | 26 | 51 | 28 | 53 | 34 | 66 | 40 | 71.5 | 42 | 81 |
| 1826. | 16 | 47 | 32 | 54 | | | | | 36.5 | 72.5 | 49.8 | 87.5 |
| 1827. | 16 | 48.8 | 19 | 52.5 | 31.2 | 57.6 | 32.8 | 73.5 | 37.8 | 69.8 | 46.3 | 74.5 |
| 1828. | 28 | 54.5 | 29 | 55.2 | 29.1 | 61.3 | 32.8 | 70.7 | 42.7 | 72.1 | 49.3 | 78.4 |
| 1829. | 19.5 | 45.7 | 23.2 | 50.8 | 26.8 | 58.6 | 30.7 | 59.3 | 44.3 | 70.6 | 41.1 | 77.8 |
| 1830. | 17.2 | 42.7 | 17.7 | 56.3 | 32.7 | 65.7 | 29.7 | 72.0 | 42.6 | 77.3 | 46.6 | 76.7 |
| 1831. | 24.3 | 48.5 | 26.7 | 59.5 | 31.7 | 59.4 | 35.3 | 65.2 | 33.8 | 72.6 | 48.6 | 75.7 |
| 1832. | 27.8 | 48.7 | 28.3 | 49.6 | 30.7 | 55.3 | 36.7 | 67.0 | 38.4 | 74.7 | 46.8 | 76.7 |
| 1833. | 27.3 | 46.6 | 32.4 | 55.2 | 27.8 | 54.2 | 34.0 | 62.4 | 43.4 | 81.4 | 46.6 | 80.8 |
| 1834. | 32.5 | 55.2 | 29.3 | 54.7 | 30.7 | 57.8 | 33.2 | 64.3 | 43.0 | 75.0 | 47.3 | 86.7 |
| 1835. | 25.0 | 49.7 | 27.9 | 53.2 | 32.7 | 54.2 | 30.0 | 66.2 | 41.7 | 72.8 | 44.6 | 83.6 |
| 1836. | 17.5 | 53.4 | 25.3 | 50.6 | 31.8 | 64.4 | 32.2 | 61.3 | 35.3 | 69.5 | 47.7 | 82.6 |
| 1837. | 24.0 | 50.7 | 30.0 | 54.0 | 26.7 | 49.0 | 28.0 | 59.2 | 35.5 | 68.6 | 43.2 | 75.8 |
| 1838. | 11.4 | 50.2 | 24.8 | 48.7 | 31.0 | 58.3 | 29.8 | 64.2 | 36.2 | 73.3 | 44.2 | 79.7 |
| 1839. | 23.7 | 51.8 | 26.8 | 51.3 | 26.0 | 53.2 | 30.5 | 58.7 | 33.7 | 72.2 | 45.6 | 85.0 |
| 1840. | 22.3 | 54.2 | 27.8 | 50.8 | 30.7 | 53.7 | 34.4 | 72.2 | 41.3 | | 48.3 | 83.0 |
| 1841. | 14.9 | 52.8 | 21.6 | 52.2 | 35.0 | 64.2 | 36.7 | 72.4 | 45.3 | 79.4 | 45.3 | 87.0 |
| 1842. | 27.3 | 44.6 | 32.0 | 53.0 | 33.6 | 58.5 | 34.2 | 69.3 | 41.8 | 78.3 | 52.7 | 83.6 |
| 1843. | 29.8 | 57.7 | 23.8 | 53.0 | 30.5 | 61.0 | 33.0 | 66.0 | 40.3 | 73.4 | 47.3 | 79.7 |
| At the Royal Observatory, Greenwich. | | | | | | | | | | | | |
| 1840. | | | | | | | | | | | | |
| 1841. | 4.0 | 53.0 | 12.4 | 54.6 | 29.5 | 66.9 | 31.8 | 76.5 | 41.2 | 82.8 | 40.3 | 78.5 |
| 1842. | 23.2 | 46.8 | 26.4 | 53.2 | 29.9 | 60.5 | 28.0 | 73.7 | 36.4 | 74.7 | 44.7 | 87.4 |
| 1843. | 24.0 | 57.0 | 20.3 | 51.9 | 26.5 | 63.7 | 27.2 | 70.8 | 37.3 | 69.5 | 42.9 | 77.3 |
| 1844. | 18.8 | 53.7 | 20.0 | 50.4 | 24.1 | 60.2 | 33.4 | 74.9 | 33.9 | 77.4 | 43.4 | 87.6 |
| 1845. | 24.4 | 51.3 | 7.7 | 48.5 | 13.1 | 59.4 | 29.5 | 70.3 | 34.4 | 68.2 | 43.8 | 86.0 |
| 1846. | 29.4 | 55.3 | 26.9 | 62.3 | 26.5 | 58.0 | 33.3 | 63.0 | 33.3 | 84.3 | 49.4 | 91.1 |
| 1847. | 23.0 | 52.7 | 10.2 | 55.0 | 16.9 | 64.2 | 27.0 | 63.8 | 36.0 | 86.2 | 41.0 | 80.4 |
| 1848. | 15.8 | 50.4 | 29.2 | 55.0 | 27.3 | 71.5 | 29.7 | 75.0 | 33.5 | 83.0 | 38.7 | 78.4 |
| 1849. | 20.0 | 56.4 | 26.8 | 58.0 | 27.7 | 60.7 | 28.6 | 64.3 | 36.8 | 75.0 | 38.6 | 80.7 |

By comparing the readings of the two places for the years 1841, 1842 and 1843, it grees below those at the Apartments of the Royal Society. In January 1841 the the difference is wholly attributable to the effect of the comparative heated water of places at some distance from and those near the river. The maximum temperatures 1841 at Somerset House I think must be erroneous.

maximum and minimum thermometers in each month during the whole time they Greenwich, from the year 1841 to 1849.

| Year. | July. | | August. | | September. | | October. | | November. | | December. | |
|-------|---|----------|---|----------|---|----------|---|----------|---|----------|---|----------|
| | Reading of the thermometers in the month. | | Reading of the thermometers in the month. | | Reading of the thermometers in the month. | | Reading of the thermometers in the month. | | Reading of the thermometers in the month. | | Reading of the thermometers in the month. | |
| | Lowest. | Highest. | Lowest. | Highest. | Lowest. | Highest. | Lowest. | Highest. | Lowest. | Highest. | Lowest. | Highest. |
| 1794. | 54 | 84 | 48 | 78 | 37 | 68 | 35 | 63 | 30.5 | 57 | 25.5 | 54 |
| 1795. | 46 | 76 | 51 | 79 | 45 | 78 | 42 | 68 | 28 | 56 | 34 | 56 |
| 1796. | 44.5 | 77.5 | 48 | 80 | 45 | 79 | 30 | 59 | 29 | 57 | 4 | 51 |
| 1797. | 48 | 85 | 48 | 76 | 42 | 71 | 35 | 63 | 27 | 57 | 29 | 56 |
| 1798. | 51 | 78 | 52 | 83 | 44 | 76 | 32 | 64 | 25 | 60 | 11 | 50 |
| 1799. | 48 | 77 | 47 | 73 | 42 | 72 | 35 | 63 | 32 | 58 | 17 | 50 |
| 1800. | 50 | 81 | 49 | 89 | 41 | 77 | 35 | 66 | 30 | 59 | 29 | 51 |
| 1801. | 47 | 79 | 51 | 79 | 46 | 73 | 34 | 66 | 26 | 60 | 23 | 52 |
| 1802. | 45 | 71 | 50 | 82 | 40 | 75 | 33 | 75 | 30 | 53 | 29 | 50 |
| 1803. | 51 | 86 | 47 | 81 | 38 | 75 | 38 | 67 | 31 | 57 | 21 | 55 |
| 1804. | 49 | 80 | 49 | 81 | 45 | 81.5 | 38 | 68 | 34 | 59 | 19 | 51 |
| 1805. | 50 | 79 | 51 | 79 | 43 | 79 | 35 | 63 | 31 | 55 | 25 | 54 |
| 1806. | 52 | 81 | 51 | 80 | 44 | 73 | 35 | 65 | 36 | 60 | 39 | 57 |
| 1807. | 48 | 85 | 52 | 80 | 38 | 72 | 39 | 68 | 28 | 56 | 23 | 51 |
| 1808. | 50 | 93.5 | 51 | 80 | 39 | 71 | 35 | 63 | 31 | 56 | 19 | 53 |
| 1809. | 50 | 78 | 49 | 79 | 40 | 72 | 35 | 65 | 29 | 54 | 32 | 54 |
| 1810. | 51 | 78 | 50 | 80 | 48 | 83 | 30 | 68 | | | | |
| 1820. | 50 | 80 | 46 | 77 | 38 | 73 | 39 | 65 | 31 | 56 | 25 | 57 |
| 1821. | 46 | 74 | 50 | 77 | 46 | 75 | 41 | 68 | 34 | 63 | 36 | 58 |
| 1822. | 53 | 76 | 50 | 80 | 45 | 70 | 41 | 66 | 38 | 61 | 23 | 54 |
| 1823. | 49 | 74 | 49 | 78 | 40 | 73 | 37 | 62 | 29 | 55 | 29 | 53 |
| 1824. | 51 | 81 | 50.5 | 77 | 37 | 81 | 31 | 65 | 29 | 60 | 31 | 54 |
| 1825. | 51 | 89 | 53 | 84 | 47 | 77 | 33 | 68 | 29 | 58 | 28 | 53.5 |
| 1826. | | | 55 | 81.2 | 43.8 | 72.3 | 37.6 | 67.8 | 26.8 | 52.3 | 32.2 | 53 |
| 1827. | 51.8 | 81.1 | 48.3 | 80.2 | 47.7 | 70.0 | 36.4 | 67.7 | 23.8 | 55.8 | 30.8 | 54.8 |
| 1828. | 46.8 | 78.7 | 49.8 | 72.7 | 44.9 | 72.8 | 36.5 | 63.3 | 25.7 | 58.4 | 33.8 | 55.3 |
| 1829. | 48.7 | 74.7 | 46.7 | 76.5 | 42.4 | 66.7 | 33.3 | 61.4 | 26.8 | 52.7 | 18.2 | 46.0 |
| 1830. | 48.8 | 85.8 | 46.0 | 77.7 | 43.8 | 69.8 | 35.2 | 66.5 | 33.0 | 58.5 | 15.8 | 47.2 |
| 1831. | 52.3 | 80.8 | 54.4 | 79.7 | 46.5 | 72.2 | 40.3 | 68.2 | 28.7 | 57.2 | 29.8 | 55.6 |
| 1832. | 49.6 | 81.2 | 47.0 | 81.8 | 41.6 | 72.9 | 39.4 | 68.2 | 36.3 | 59.3 | 32.3 | 55.8 |
| 1833. | 47.3 | 80.5 | 48.2 | 75.3 | 41.0 | 67.2 | 38.3 | 62.3 | 31.6 | 59.7 | 32.9 | 55.6 |
| 1834. | 51.4 | 86.7 | 46.2 | 85.3 | 46.8 | 74.0 | 34.4 | 70.2 | 33.2 | 61.5 | 29.2 | 54.5 |
| 1835. | 50.6 | 84.2 | 51.8 | 80.6 | 46.4 | 76.3 | 35.4 | 62.6 | 34.9 | 55.5 | 21.0 | 51.6 |
| 1836. | 46.2 | 85.2 | 48.4 | 73.4 | 40.7 | 69.6 | 30.0 | 61.2 | 31.3 | 56.7 | 27.4 | 55.7 |
| 1837. | 47.5 | 79.6 | 48.5 | 78.8 | 44.4 | 69.7 | 35.4 | 68.5 | 28.0 | 56.4 | 31.7 | 55.3 |
| 1838. | 49.6 | 79.0 | 46.5 | 76.0 | 42.8 | 69.5 | 32.8 | 63.5 | 30.0 | 57.7 | 29.8 | 55.0 |
| 1839. | 48.6 | 80.3 | 45.4 | 78.6 | 45.0 | 70.0 | 37.3 | 63.5 | 33.8 | 55.3 | 32.0 | 54.6 |
| 1840. | 49.4 | 77.2 | 52.4 | 80.0 | 41.7 | 75.7 | 35.3 | 60.7 | 30.3 | 60.6 | 21.2 | 55.5 |
| 1841. | 49.8 | 80.3 | 50.0 | 77.5 | 42.8 | 74.6 | 37.2 | 64.3 | 28.2 | 58.6 | 29.9 | 55.8 |
| 1842. | 50.4 | 82.7 | 50.0 | 87.0 | 44.4 | 76.0 | 34.0 | 60.7 | 35.6 | 55.5 | 34.7 | 57.5 |

At the Royal Observatory, Greenwich.

| | | | | | | | | | | | | |
|-------|-------|-------|-------|-------|-------|-------|-------|-------|------|------|------|------|
| 1840. | | | | | | | | | 23.8 | 61.2 | 16.4 | 55.2 |
| 1841. | 44.3 | 76.0 | 45.5 | 79.6 | 36.6 | 79.6 | 32.2 | 64.6 | 22.2 | 58.3 | 24.3 | 53.9 |
| 1842. | 45.5 | 78.8 | 47.5 | 90.5 | 41.1 | 75.8 | 28.3 | 60.9 | 31.1 | 55.9 | 30.8 | 58.2 |
| 1843. | 44.6 | 89.8 | 47.2 | 82.8 | 34.0 | 79.9 | 28.5 | 70.4 | 27.4 | 57.5 | 25.6 | 54.7 |
| 1844. | 47.1 | 87.4 | 42.8 | 75.4 | 34.8 | 78.0 | 30.8 | 67.4 | 27.4 | 58.1 | 21.1 | 49.3 |
| 1845. | 44.6 | 83.3 | 43.2 | 77.8 | 33.4 | 73.5 | 31.4 | 67.6 | 29.1 | 59.6 | 28.0 | 55.5 |
| 1846. | 49.1 | 93.3 | 47.5 | 92.0 | 39.2 | 86.4 | 35.0 | 67.7 | 23.4 | 61.5 | 18.8 | 49.9 |
| 1847. | 45.4 | 89.0 | 42.0 | 87.3 | 32.0 | 72.5 | 33.0 | 73.2 | 24.5 | 66.3 | 25.0 | 59.5 |
| 1848. | 42.2 | 85.3 | 42.5 | 75.5 | 32.8 | 78.8 | 32.4 | 74.0 | 25.2 | 57.8 | 21.8 | 62.8 |
| 1849. | 47.0 | 84.1 | 42.4 | 82.5 | 42.7 | 79.0 | 31.5 | 69.7 | 23.5 | 61.7 | 18.8 | 56.3 |

will be seen that the minimum temperatures at the Observatory are usually some de-reading at the Observatory was as low as 4°, whilst that at Somerset House was 14°·9; the Thames, and this difference is always shown at those low temperatures between at the Observatory are usually the higher, but not always so; the maximum in June

TABLE XXVII.—Showing the extreme readings of the thermometer in every year that self-registering thermometers were used at the Royal Society's Apartments, and from the year 1840 to 1849 at the Royal Observatory, Greenwich.

| Year. | At the Apartments of the Royal Society. | | | | |
|--------------------------------------|---|------------------------------------|---|------------------------------------|----------------------------------|
| | Highest reading of the thermometer. | Lowest reading of the thermometer. | Difference or range of reading in the year. | Month and day of | |
| | | | | Highest readings. | Lowest readings. |
| 1794. | 84·0 | 22·0 | 62·0 | On July 13. | On January 10. |
| 1795. | 81·5 | 7·0 | 74·5 | On May 23. | On January 25. |
| 1796. | 80·0 | 4·0 | 76·4 | On June 26 and August 22. | On December 25. |
| 1797. | 85·0 | 24·5 | 60·5 | On July 14. | On February 28. |
| 1798. | 86·0 | 11·0 | 75·0 | On June 28. | On December 29. |
| 1799. | 77·0 | 17·0 | 60·0 | On June 10, 30, July 6 and 8. | On December 31. |
| 1800. | 89·0 | 18·0 | 71·0 | On August 2. | On January 1. |
| 1801. | 80·0 | 23·0 | 57·0 | On June 29. | On December 20. |
| 1802. | 82·0 | 15·0 | 67·0 | On August 30. | On January 16. |
| 1803. | 86·0 | 19·0 | 67·0 | On July 2. | On January 26 and February 11. |
| 1804. | 87·0 | 19·0 | 68·0 | On June 25. | On December 24. |
| 1805. | 79·0 | 23·0 | 56·0 | On July 4, August 12 and Sept. 18. | On February 2. |
| 1806. | 83·0 | 26·0 | 57·0 | On June 10. | On March 13. |
| 1807. | 85·0 | 23·0 | 62·0 | On July 22. | On January 15 and December 8. |
| 1808. | 93·5 | 18·0 | 75·5 | On July 13. | On January 22 and February 15. |
| 1809. | 79·0 | 20·0 | 59·0 | On August 17. | On January 18 and 19. |
| 1810. | 83·0 | 14·0 | 69·0 | On September 2. | On January 17. |
| 1820. | 85·0 | 20·0 | 65·0 | On June 27. | On January 5. |
| 1821. | 77·0 | 25·0 | 52·0 | On August 5, 6, 22, 24 and 25. | On January 2, 3 and February 27. |
| 1822. | 84·0 | 23·0 | 61·0 | On June 10. | On December 30. |
| 1823. | 78·0 | 24·0 | 49·0 | On August 13. | On January 15. |
| 1824. | 81·0 | 25·0 | 56·0 | On July 13, 14 and September 1. | On January 14. |
| 1825. | 89·0 | 26·0 | 63·0 | On July 19. | On February 5. |
| 1826. | 87·5 | 16·0 | 71·5 | On June 27. | On January 16. |
| 1827. | 81·1 | 16·0 | 65·1 | On July 29. | On January 3. |
| 1828. | 78·7 | 25·7 | 53·0 | On July 3. | On November 12. |
| 1829. | 77·8 | 18·2 | 59·6 | On June 3. | On December 28. |
| 1830. | 85·8 | 15·8 | 70·0 | On July 30. | On December 25. |
| 1831. | 80·8 | 24·3 | 56·5 | On July 29. | On January 8. |
| 1832. | 81·8 | 27·8 | 54·0 | On August 10. | On January 5. |
| 1833. | 81·4 | 27·3 | 54·1 | On May 15. | On January 23. |
| 1834. | 86·7 | 29·2 | 57·5 | On June 21 and July 17. | On December 24. |
| 1835. | 84·2 | 21·0 | 63·2 | On July 28. | On December 25. |
| 1836. | 85·2 | 17·5 | 67·7 | On July 4. | On January 2. |
| 1837. | 79·6 | 24·0 | 55·6 | On July 28. | On January 2. |
| 1838. | 79·7 | 11·4 | 68·3 | On June 24. | On January 16. |
| 1839. | 85·0 | 23·7 | 61·3 | On June 20. | On January 30. |
| 1840. | 83·0 | 21·2 | 61·8 | On June 1. | On December 18. |
| 1841. | 87·0 | 14·9 | 72·1 | On June 20. | On January 9. |
| 1842. | 87·0 | 27·3 | 59·7 | On August 11. | On January 24. |
| At the Royal Observatory, Greenwich. | | | | | |
| 1841. | 82·8 | 4·0 | 78·8 | On May 27. | On January 9. |
| 1842. | 90·5 | 23·2 | 67·3 | On August 10. | On January 23. |
| 1843. | 89·8 | 20·3 | 69·5 | On July 6. | On February 15. |
| 1844. | 87·6 | 18·8 | 68·6 | On June 25. | On January 3. |
| 1845. | 86·0 | 7·7 | 78·3 | On June 13. | On February 11. |
| 1846. | 93·3 | 18·8 | 74·5 | On July 5. | On December 14 and 30. |
| 1847. | 89·0 | 10·2 | 78·8 | On July 12. | On February 11. |
| 1848. | 85·3 | 15·8 | 69·5 | On July 14. | On January 28. |
| 1849. | 84·1 | 18·8 | 65·3 | On July 8. | On December 29. |

From the particulars in this Table, it seems that the highest reading of the thermometer within the year has occurred three times in May, seventeen times in June, twenty-four times in July, ten times in August, and three times in September.

The lowest reading of the thermometer in the year has occurred twenty-eight times in January, nine times in February, once in March, once in November, and fourteen times in December.

TABLE XXVIII.—Showing the highest and lowest temperature during the period in each month.

| Month. | At the Apartments of the Royal Society. | | | | | At the Royal Observatory, Greenwich. | | | | |
|-------------|---|---|-------------------------|------------------|-------------------|--|---|-------------------------|------------------|-------------------|
| | The lowest reading of the thermometer. | The highest reading of the thermometer. | Difference of readings. | Mean of all the | | The lowest reading of the thermometer. | The highest reading of the thermometer. | Difference of readings. | Mean of all the | |
| | | | | Lowest readings. | Highest readings. | | | | Lowest readings. | Highest readings. |
| January ... | 7.0 | 57.7 | 50.7 | 22.6 | 51.0 | 4.0 | 57.0 | 53.0 | 20.2 | 52.9 |
| February... | 17.7 | 61.0 | 43.3 | 26.1 | 53.7 | 7.7 | 62.3 | 54.6 | 19.9 | 54.3 |
| March..... | 23.0 | 66.0 | 43.0 | 29.2 | 58.5 | 13.1 | 71.5 | 58.4 | 24.6 | 62.7 |
| April | 27.0 | 77.0 | 50.0 | 32.8 | 66.5 | 27.0 | 76.5 | 49.5 | 29.8 | 70.3 |
| May | 31.0 | 84.0 | 53.0 | 39.3 | 73.8 | 33.5 | 86.2 | 52.7 | 36.4 | 77.9 |
| June | 40.0 | 87.5 | 47.5 | 45.5 | 79.5 | 38.6 | 87.6 | 49.0 | 42.5 | 83.0 |
| July..... | 44.5 | 93.5 | 49.0 | 49.3 | 80.5 | 42.2 | 93.3 | 51.1 | 45.5 | 85.2 |
| August ... | 45.4 | 89.0 | 43.6 | 49.4 | 79.3 | 42.0 | 92.0 | 50.0 | 44.5 | 82.6 |
| September | 37.0 | 83.0 | 46.0 | 42.9 | 73.6 | 32.0 | 86.4 | 54.4 | 36.3 | 78.2 |
| October ... | 30.0 | 75.0 | 45.0 | 35.5 | 65.2 | 28.3 | 74.0 | 45.7 | 31.4 | 68.4 |
| November | 23.8 | 63.0 | 39.2 | 30.4 | 57.4 | 22.2 | 66.3 | 44.1 | 26.0 | 59.6 |
| December | 4.0 | 58.0 | 54.0 | 25.9 | 53.6 | 16.4 | 62.8 | 46.4 | 23.5 | 55.5 |

The lowest reading, as observed at the Apartments of the Royal Society, was 4°; it occurred in the night of December 24, 1796 (at this time the reading in the environs of London was -6°). The highest reading was 89°; the difference of these readings is 85°.

The lowest reading, as observed at the Royal Observatory within the years 1841 to 1849, was 4°, and the highest was 93°·3; the difference of these readings is 89°·3.

TABLE XXIX.—Showing the extreme range of the thermometer in every month during the time self-registering instruments were in use at the Apartments of the Royal Society, and at the Royal Observatory, Greenwich, from 1840.

| Year. | At the Apartments of the Royal Society. | | | | | | | | | | | |
|-------|---|-----------|--------|--------|-------|-------|-------|---------|------------|----------|-----------|-----------|
| | Extreme range of readings of the thermometer in each month. | | | | | | | | | | | |
| | January. | February. | March. | April. | May. | June. | July. | August. | September. | October. | November. | December. |
| 1794. | 29 | 21 | 22 | 35 | 31 | 33 | 30 | 30 | 31 | 28 | 26.5 | 28.5 |
| 1795. | 39 | 27 | 30.5 | 25 | 45.5 | 36.5 | 30 | 28 | 33 | 26 | 28 | 22 |
| 1796. | 20 | 26 | 33.5 | 34 | 26 | 35 | 33 | 32 | 34 | 29 | 28 | 47 |
| 1797. | 24 | 25.5 | 26.5 | 31 | 45 | 33 | 37 | 28 | 29 | 28 | 30 | 27 |
| 1798. | 25 | 30 | 28 | 39 | 33 | 39 | 27 | 31 | 32 | 32 | 35 | 39 |
| 1799. | 30 | 38 | 28 | 32 | 34 | 34 | 29 | 26 | 30 | 28 | 26 | 33 |
| 1800. | 33 | 28 | 34 | 24 | 35 | 32 | 31 | 40 | 36 | 31 | 29 | 22 |
| 1801. | 30 | 32 | 28 | 37 | 32 | 37 | 32 | 28 | 27 | 32 | 34 | 29 |
| 1802. | 33 | 27 | 38 | 35 | 45 | 38 | 26 | 32 | 35 | 42 | 23 | 21 |
| 1803. | 29 | 34 | 41 | 36 | 31 | 25 | 35 | 34 | 37 | 29 | 26 | 34 |
| 1804. | 28 | 26 | 34 | 37 | 29 | 40 | 31 | 32 | 36.5 | 30 | 25 | 32 |
| 1805. | 23 | 31 | 33 | 29 | 35 | 34 | 29 | 28 | 36 | 28 | 24 | 29 |
| 1806. | 27 | 26 | 30 | 33 | 32 | 37 | 29 | 29 | 29 | 30 | 24 | 18 |
| 1807. | 28 | 32 | 30 | 46 | 40 | 29 | 37 | 28 | 34 | 29 | 28 | 28 |
| 1808. | 35 | 35 | 28 | 37 | 40 | 28 | 43.5 | 29 | 32 | 28 | 25 | 34 |
| 1809. | 35 | 23 | 29 | 28 | 42 | 33 | 28 | 30 | 32 | 30 | 25 | 22 |
| 1810. | 37 | 36 | 31 | 38 | 33 | 33 | 27 | 30 | 35 | 38 | | |
| 1820. | 33 | 26 | 38 | 31 | 31 | 40 | 30 | 31 | 35 | 26 | 25 | 32 |
| 1821. | 27 | 36 | 27 | 36 | 33 | 30 | 28 | 27 | 29 | 27 | 29 | 22 |
| 1822. | 20 | 20 | 31 | 29 | 30 | 34 | 23 | 30 | 25 | 25 | 23 | 31 |
| 1823. | | | | | 35 | 31 | 25 | 29.0 | 33 | 25 | 26 | 24 |
| 1824. | 27.5 | 24 | 28 | 38.5 | 31 | 31 | 30 | 26.5 | 44 | 34 | 31 | 23 |
| 1825. | 24 | 25 | 25 | 32 | 31.5 | 39 | 38 | 31.0 | 30 | 35 | 29 | 25.5 |
| 1826. | 31 | 22 | | | 36 | 37.7 | | 26.2 | 28.5 | 30.2 | 25.5 | 20.8 |
| 1827. | 32.8 | 33.5 | 26.4 | 40.7 | 32 | 28.2 | 29.3 | 31.9 | 22.3 | 31.3 | 32.0 | 24.0 |
| 1828. | 26.5 | 26.2 | 32.2 | 37.9 | 29.4 | 29.1 | 31.9 | 22.9 | 27.9 | 26.8 | 32.7 | 21.5 |
| 1829. | 26.2 | 27.6 | 31.8 | 28.6 | 26.3 | 36.7 | 26.0 | 29.8 | 24.3 | 28.1 | 25.9 | 27.8 |
| 1830. | 25.5 | 38.6 | 33.0 | 42.3 | 34.7 | 30.1 | 37.0 | 31.7 | 26.0 | 31.3 | 25.5 | 31.4 |
| 1831. | 24.2 | 32.8 | 27.7 | 29.9 | 38.8 | 27.1 | 28.5 | 25.3 | 25.7 | 27.9 | 28.5 | 25.8 |
| 1832. | 20.9 | 21.3 | 24.6 | 30.3 | 36.3 | 29.9 | 31.6 | 34.8 | 31.3 | 28.8 | 23.0 | 23.5 |
| 1833. | 19.3 | 22.8 | 26.4 | 28.4 | 38.0 | 34.2 | 33.2 | 27.1 | 26.2 | 24.0 | 28.1 | 22.7 |
| 1834. | 22.7 | 25.4 | 27.1 | 31.1 | 32.0 | 39.4 | 35.3 | 39.1 | 27.2 | 35.8 | 28.3 | 25.3 |
| 1835. | 24.7 | 25.3 | 21.5 | 36.2 | 31.1 | 39.0 | 33.6 | 28.8 | 29.9 | 27.2 | 20.6 | 30.6 |
| 1836. | 35.9 | 25.3 | 32.6 | 29.1 | 34.2 | 34.9 | 39.0 | 25.0 | 28.9 | 31.2 | 25.4 | 28.3 |
| 1837. | 26.7 | 24.0 | 22.3 | 31.2 | 33.1 | 32.6 | 32.1 | 30.3 | 25.3 | 33.1 | 28.4 | 23.6 |
| 1838. | 38.8 | 23.9 | 27.3 | 34.4 | 37.1 | 35.5 | 29.4 | 29.5 | 26.7 | 30.7 | 27.7 | 25.2 |
| 1839. | 28.1 | 24.5 | 27.2 | 28.2 | 38.5 | 39.4 | 31.7 | 33.2 | 25.0 | 26.2 | 21.5 | 22.6 |
| 1840. | 31.9 | 23.0 | 23.0 | 37.8 | | 34.7 | 27.8 | 27.6 | 34.0 | 25.4 | 30.3 | 34.3 |
| 1841. | 37.9 | 30.6 | 29.2 | 35.7 | 34.1 | 41.7 | 30.5 | 27.5 | 31.8 | 27.1 | 30.4 | 25.9 |
| 1842. | 17.3 | 21.0 | 24.9 | 35.1 | 36.5 | 30.9 | 32.3 | 37.0 | 31.6 | 26.7 | 19.9 | 22.8 |
| 1843. | 27.9 | 29.2 | 30.5 | 33.0 | 33.1 | 32.4 | | | | | | |
| | At the Royal Observatory, Greenwich. | | | | | | | | | | | |
| 1840. | | | | | | | | | | | 37.4 | 38.8 |
| 1841. | 49.0 | 42.2 | 37.4 | 44.7 | 41.6 | 38.2 | 31.7 | 34.1 | 43.0 | 32.4 | 36.1 | 29.6 |
| 1842. | 23.6 | 26.8 | 30.6 | 45.7 | 38.3 | 42.7 | 33.3 | 43.0 | 34.7 | 32.6 | 24.8 | 27.4 |
| 1843. | 33.0 | 31.6 | 37.2 | 43.6 | 32.2 | 34.4 | 45.2 | 35.6 | 45.9 | 41.9 | 30.1 | 29.1 |
| 1844. | 34.9 | 30.4 | 36.1 | 41.5 | 43.5 | 44.2 | 40.3 | 32.6 | 43.2 | 36.6 | 30.7 | 28.2 |
| 1845. | 26.9 | 40.8 | 46.3 | 40.8 | 33.8 | 42.2 | 38.7 | 34.6 | 40.1 | 36.2 | 30.5 | 27.5 |
| 1846. | 25.9 | 35.4 | 31.5 | 29.7 | 46.0 | 41.7 | 44.2 | 44.5 | 47.2 | 32.7 | 38.1 | 31.1 |
| 1847. | 29.7 | 44.8 | 47.3 | 36.8 | 50.2 | 39.4 | 43.6 | 45.3 | 40.5 | 40.2 | 41.8 | 34.5 |
| 1848. | 34.6 | 25.8 | 44.2 | 45.3 | 49.5 | 39.7 | 43.1 | 33.0 | 46.0 | 41.6 | 32.6 | 41.0 |
| 1849. | 36.4 | 31.2 | 33.0 | 35.7 | 38.2 | 42.1 | 37.1 | 40.1 | 36.3 | 38.2 | 38.2 | 35.9 |

TABLE XXX.—Showing the mean daily range of temperature in each month.

| Year. | At the Apartments of the Royal Society. | | | | | | | | | | | |
|--------------------------------------|---|-----------|--------|--------|-------|-------|-------|---------|------------|----------|-----------|-----------|
| | The average daily range of temperature. | | | | | | | | | | | |
| | January. | February. | March. | April. | May. | June. | July. | August. | September. | October. | November. | December. |
| 1794. | 6.5 | 5.9 | 10.8 | 13.1 | 13.6 | 15.4 | 16.5 | 14.9 | 10.5 | 9.1 | 7.5 | 4.8 |
| 1795. | 6.7 | 6.2 | 9.7 | 10.9 | 15.8 | 12.4 | 13.1 | 15.1 | 14.8 | 9.3 | 8.7 | 5.7 |
| 1796. | 7.0 | 8.0 | 11.3 | 14.8 | 14.2 | 15.5 | 15.0 | 16.5 | 12.8 | 8.6 | 6.2 | 7.3 |
| 1797. | 5.3 | 4.0 | 11.4 | 12.7 | 16.3 | 16.7 | 19.3 | 16.2 | 13.1 | 9.0 | 9.2 | 7.6 |
| 1798. | 7.1 | 9.6 | 10.6 | 15.4 | 14.7 | 17.6 | 15.9 | 15.8 | 12.6 | 10.0 | 7.5 | 5.8 |
| 1799. | 6.4 | 9.1 | 9.0 | 10.0 | 13.5 | 15.2 | 13.5 | 14.3 | 13.1 | 9.7 | 6.9 | 4.0 |
| 1800. | 6.0 | 7.6 | 9.4 | 10.4 | 13.4 | 13.6 | 17.6 | 17.6 | 12.0 | 10.6 | 8.2 | 4.9 |
| 1801. | 7.9 | 7.1 | 9.6 | 16.0 | 16.1 | 16.2 | 15.8 | 16.0 | 11.7 | 10.0 | 7.3 | 7.2 |
| 1802. | 6.2 | 7.7 | 12.9 | 15.3 | 7.8 | 16.0 | 15.6 | 17.8 | 16.5 | 12.4 | 6.6 | 7.2 |
| 1803. | 4.4 | 7.4 | 11.5 | 13.4 | 12.7 | 13.2 | 12.3 | 16.1 | 16.9 | 9.9 | 8.0 | 5.2 |
| 1804. | 6.0 | 7.3 | 9.4 | 6.4 | 14.4 | 16.7 | 11.8 | 13.7 | 13.2 | 10.5 | 6.1 | 4.9 |
| 1805. | 5.3 | 8.4 | 11.0 | 13.2 | 14.6 | 15.1 | 14.0 | 14.0 | 13.7 | 8.9 | 8.0 | 6.8 |
| 1806. | 7.2 | 8.2 | 7.5 | 10.5 | 15.2 | 16.7 | 13.8 | 14.7 | 13.1 | 9.6 | 7.6 | 5.9 |
| 1807. | 7.3 | 8.8 | 10.6 | 11.1 | 13.1 | 15.7 | 15.3 | 13.7 | 12.7 | 10.0 | 8.1 | 6.7 |
| 1808. | 7.3 | 8.4 | 8.1 | 12.3 | 15.5 | 14.5 | 17.1 | 14.1 | 11.7 | 10.6 | 6.8 | 5.4 |
| 1809. | 6.5 | 8.2 | 10.3 | 11.7 | 15.0 | 15.9 | 13.8 | 9.9 | 11.6 | 9.1 | 7.6 | 6.5 |
| 1810. | 5.4 | 6.5 | 9.9 | 12.7 | 14.5 | 17.3 | 14.9 | 14.9 | 12.8 | 11.1 | | |
| 1820. | 7.4 | 7.7 | 13.1 | 14.6 | 14.4 | 13.7 | 12.5 | 14.1 | 14.4 | 11.3 | 8.3 | 6.8 |
| 1821. | 8.1 | 9.9 | 11.0 | 13.3 | 15.6 | 13.4 | 13.3 | 13.1 | 11.3 | 11.8 | 9.7 | 9.6 |
| 1822. | 10.2 | 10.2 | 11.5 | 11.4 | 12.4 | 15.3 | 11.3 | 11.2 | 10.9 | 8.3 | 7.0 | 6.8 |
| 1823. | | | | | 14.5 | 16.5 | 12.3 | 11.7 | 12.9 | 8.9 | 4.8 | 5.1 |
| 1824. | 5.1 | 6.1 | 8.4 | 10.9 | 12.0 | 13.5 | 14.7 | 12.2 | 10.2 | 8.8 | 8.2 | 6.7 |
| 1825. | 6.0 | 7.5 | 8.8 | 14.5 | 14.6 | 17.8 | 14.6 | 13.5 | 10.3 | 8.2 | 8.1 | 4.7 |
| 1826. | 7.5 | 7.5 | | 14.2 | 14.5 | 18.2 | | 12.4 | 11.0 | 9.1 | 7.2 | 4.9 |
| 1827. | 8.0 | 8.2 | 9.6 | 12.0 | 12.5 | 14.7 | 15.3 | 13.6 | 10.8 | 9.3 | 8.5 | 8.1 |
| 1828. | 7.5 | 6.8 | 11.0 | 11.9 | 14.2 | 14.3 | 13.2 | 12.7 | 12.2 | 10.8 | 8.1 | 6.6 |
| 1829. | 6.2 | 7.3 | 9.8 | 11.8 | 16.5 | 15.5 | 13.6 | 11.4 | 11.3 | 8.1 | 8.2 | 5.2 |
| 1830. | 5.7 | 9.6 | 12.4 | 13.8 | 14.8 | 13.2 | 14.9 | 14.6 | 11.9 | 11.4 | 7.8 | 7.2 |
| 1831. | 6.4 | 8.7 | 9.9 | 12.1 | 15.9 | 14.3 | 18.3 | 13.3 | 12.3 | 8.5 | 9.8 | 5.4 |
| 1832. | 6.3 | 7.9 | 10.8 | 14.4 | 15.3 | 14.3 | 15.1 | 14.5 | 14.4 | 9.5 | 7.1 | 8.0 |
| 1833. | 6.2 | 8.5 | 9.7 | 13.0 | 17.5 | 16.1 | 15.4 | 15.4 | 13.1 | 11.2 | 8.7 | 9.5 |
| 1834. | 6.5 | 9.9 | 10.9 | 14.1 | 17.2 | 17.5 | 15.4 | 14.9 | 13.2 | 12.0 | 8.0 | 7.5 |
| 1835. | 7.8 | 10.6 | 11.1 | 13.4 | 14.5 | 16.1 | 17.5 | 15.4 | 13.0 | 9.1 | 6.0 | 6.0 |
| 1836. | 9.3 | 8.3 | 10.3 | 10.8 | 15.9 | 13.7 | 14.8 | 14.4 | 10.9 | 8.2 | 8.9 | 6.4 |
| 1837. | 7.4 | 8.5 | 8.7 | 9.7 | 13.2 | 14.7 | 15.0 | 13.4 | 11.5 | 12.7 | 11.8 | 6.8 |
| 1838. | 7.3 | 7.2 | 11.1 | 11.7 | 15.5 | 15.0 | 14.8 | 12.6 | 11.1 | 10.4 | 7.9 | 6.0 |
| 1839. | 8.6 | 10.6 | 6.8 | 6.3 | 15.5 | 15.3 | 13.2 | 13.2 | 10.5 | 7.0 | 4.2 | 3.8 |
| 1840. | 6.6 | 5.9 | 5.8 | 10.2 | | 15.7 | 14.9 | 14.8 | 13.3 | 11.6 | 9.9 | 7.3 |
| 1841. | 7.6 | 5.9 | 12.7 | 13.2 | 15.6 | 17.5 | 14.0 | 12.8 | 15.6 | 9.9 | 9.0 | 8.3 |
| 1842. | 6.1 | 8.0 | 9.9 | 12.7 | 16.1 | 18.3 | 18.0 | 15.2 | 12.1 | 10.5 | 7.5 | 8.6 |
| 1843. | 8.0 | 6.7 | 10.4 | 13.9 | 16.1 | 15.7 | | | | | | |
| At the Royal Observatory, Greenwich. | | | | | | | | | | | | |
| 1840. | | | | | | | | | | | 11.0 | 9.0 |
| 1841. | 11.1 | 9.1 | 17.5 | 16.5 | 21.3 | 18.8 | 15.6 | 16.3 | 16.0 | 11.7 | 10.7 | 9.4 |
| 1842. | 6.4 | 10.4 | 10.9 | 16.1 | 16.7 | 22.2 | 17.7 | 20.3 | 12.8 | 13.2 | 7.9 | 8.2 |
| 1843. | 7.9 | 7.5 | 12.4 | 15.4 | 14.7 | 15.2 | 15.6 | 16.4 | 17.4 | 12.8 | 10.2 | 6.6 |
| 1844. | 8.7 | 10.5 | 12.1 | 21.0 | 18.6 | 19.9 | 16.2 | 15.4 | 15.3 | 12.4 | 7.4 | 5.4 |
| 1845. | 6.4 | 8.7 | 11.1 | 16.8 | 14.2 | 18.2 | 14.9 | 14.8 | 15.6 | 13.3 | 10.9 | 9.9 |
| 1846. | 7.7 | 8.3 | 12.7 | 13.1 | 16.6 | 22.5 | 17.5 | 15.5 | 18.0 | 10.4 | 8.0 | 10.3 |
| 1847. | 8.8 | 11.6 | 16.0 | 18.3 | 21.2 | 19.4 | 23.3 | 21.0 | 18.7 | 14.0 | 11.4 | 9.7 |
| 1848. | 8.3 | 10.7 | 14.3 | 16.7 | 30.5 | 17.7 | 22.5 | 18.5 | 20.9 | 16.5 | 15.7 | 12.7 |
| 1849. | 10.8 | 12.9 | 13.8 | 16.0 | 16.3 | 20.6 | 22.6 | 20.2 | 17.5 | 15.1 | 11.7 | 9.1 |

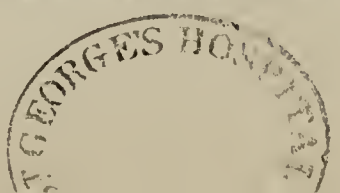


TABLE XXXI.—Showing the mean monthly minimum temperature by night, the mean monthly maximum temperature by day, the mean daily and monthly range of temperature, at the Apartments of the Royal Society, and at the Royal Observatory, Greenwich, together with the increase of temperature month by month; by night and by day.

| Month. | Mean of all the minimum readings, or of the lowest temperature by night at the | | Higher mean minimum reading at the Royal Society. | Mean of all the maximum readings, or of the highest temperature by day at the | | Lower mean maximum reading at the Royal Society. | The mean daily range of temperature at the | | Less daily range at the Royal Society. | The mean monthly range of temperature at the | | Less monthly range at the Royal Society. | Monthly increase in the mean | | | | | |
|----------------|--|--------------------|---|---|--------------------|--|--|--------------------|--|--|--------------------|--|------------------------------|-----------------------|---------------------------|------------------------------------|-----------------------|---------------------------|
| | Royal Society. | Royal Observatory. | | Royal Society. | Royal Observatory. | | Royal Society. | Royal Observatory. | | Royal Society. | Royal Observatory. | | Temperature of the air. | At the Royal Society. | At the Royal Observatory. | Of the lowest temperature by night | At the Royal Society. | At the Royal Observatory. |
| | ° | ° | ° | ° | ° | ° | ° | ° | ° | ° | ° | ° | ° | ° | ° | ° | ° | ° |
| December ... | | | | | | | | | | | | | | | | | | |
| January | 34.4 | 33.1 | 1.3 | 46.2 | 42.2 | -3.0 | 6.8 | 8.5 | 1.7 | 28.4 | 32.7 | 4.3 | 28.4 | 32.7 | 4.3 | 28.4 | 32.7 | |
| February | 36.4 | 33.6 | 2.8 | 44.3 | 44.0 | -0.3 | 7.9 | 9.9 | 2.0 | 27.6 | 34.3 | 6.7 | 27.6 | 34.3 | 6.7 | 27.6 | 34.3 | |
| March..... | 37.8 | 36.3 | 1.5 | 48.2 | 50.3 | 2.1 | 10.2 | 13.4 | 3.2 | 29.3 | 38.2 | 8.9 | 29.3 | 38.2 | 8.9 | 29.3 | 38.2 | |
| April | 42.5 | 39.2 | 3.3 | 54.7 | 56.8 | 2.1 | 12.3 | 16.7 | 4.4 | 33.7 | 40.5 | 6.8 | 33.7 | 40.5 | 6.8 | 33.7 | 40.5 | |
| May | 48.3 | 45.7 | 2.6 | 63.1 | 66.3 | 3.5 | 14.8 | 18.9 | 4.1 | 34.8 | 41.5 | 6.7 | 34.8 | 41.5 | 6.7 | 34.8 | 41.5 | |
| June | 53.1 | 49.5 | 3.6 | 68.6 | 72.6 | 4.0 | 15.5 | 19.4 | 3.9 | 34.0 | 40.5 | 6.5 | 34.0 | 40.5 | 6.5 | 34.0 | 40.5 | |
| July | 56.6 | 53.2 | 3.4 | 71.4 | 73.1 | 1.7 | 14.9 | 18.4 | 3.5 | 31.2 | 39.7 | 8.5 | 31.2 | 39.7 | 8.5 | 31.2 | 39.7 | |
| August | 56.9 | 53.4 | 3.5 | 70.8 | 72.1 | 1.3 | 14.1 | 17.6 | 3.5 | 29.9 | 38.1 | 8.2 | 29.9 | 38.1 | 8.2 | 29.9 | 38.1 | |
| September ... | 52.6 | 49.4 | 3.2 | 65.1 | 67.3 | 2.2 | 12.5 | 17.0 | 4.5 | 30.7 | 41.8 | 11.1 | 30.7 | 41.8 | 11.1 | 30.7 | 41.8 | |
| October | 46.8 | 43.6 | 3.2 | 56.7 | 57.6 | 0.9 | 9.9 | 13.3 | 3.4 | 29.5 | 36.9 | 7.4 | 29.5 | 36.9 | 7.4 | 29.5 | 36.9 | |
| November ... | 40.4 | 38.6 | 1.8 | 48.2 | 49.7 | 1.5 | 8.0 | 10.5 | 2.5 | 27.0 | 34.0 | 7.0 | 27.0 | 34.0 | 7.0 | 27.0 | 34.0 | |
| December ... | 37.5 | 34.6 | 2.9 | 43.9 | 44.0 | 0.1 | 6.4 | 9.0 | 2.6 | 27.1 | 32.3 | 5.2 | 27.1 | 32.3 | 5.2 | 27.1 | 32.3 | |

The successive differences shown here between the results at the Apartments of the Royal Society and at the Royal Observatory, are harmonious with the differences exhibited in Table XIII. and following remarks, between the temperatures of the water of the Thames and those of the air at Greenwich, but of less amount, and they indicate the great influence the presence of a tidal river has upon the meteorological elements of the district through which it passes.

The subjects of this paper are the determination of mean numerical values, and the establishment of the laws of periodic variation from the long series of observations which were taken under the direction of this Society, combined with that still being made at Greenwich. I have not attempted to deduce any rules for non-periodic variations.

It is most fortunate that through all reports this series of observations continued unbroken for so many years, and that it did not cease till that at Greenwich had been in operation for two or three years.

The number of observations treated of in this paper exceeds 200,000, spread nearly equally over seventy-nine years, and the results generally are important additions to science. I consider the determination of the mean temperature at Greenwich as a real addition; it is probably the best determination of this element of any spot on the globe, and it will help to an accurate knowledge of the mean temperature of its surface.

I may however here remark, that none of the mean results in this paper could have been calculated if observations at equal intervals had not been taken throughout the twenty-four hours and continued for a few years. The observations at Greenwich have supplied this want. It was upon them, taken for five years, I based my determinations of curve of hourly mean temperature, and by this means have made all the observations available.

As it is difficult to have instruments read more frequently than twice or thrice in a day, yet, to make these available, it is necessary that the laws of diurnal changes of temperature be known; and where such is not the case, an effort should be made in all countries to have a series of hourly or bi-hourly observations made for a few years, so as to be able to deduce useful results. Such series of frequent observations need not be made near each other, as it is found that the observations made over a considerable extent of country are subject to the same general laws.

XXX. *On the Dynamical Stability and on the Oscillations of Floating Bodies.*

*By the Rev. HENRY MOSELEY, M.A., F.R.S.,
Corresponding Member of the Institute of France.*

Received January 24,—Read June 13, 1850.

IF a body be made, by the action of certain disturbing forces, to pass from one position of equilibrium into another, and if in each of the intermediate positions these forces are in excess of the forces opposed to its motion, it is obvious that, by reason of this excess, the motion will be continually accelerated, and that the body will reach its second position with a certain finite velocity, whose effect (measured under the form of *vis viva*) will be to carry it beyond that position. This however passed, the case will be reversed, the resistances will be in excess of the moving forces, and the body's velocity being continually diminished and eventually destroyed, it will, after resting for an instant, again return towards the position of equilibrium through which it had passed. It will not however finally rest in this position until it has completed other oscillations about it. Now the amplitude of the first oscillation of the body beyond the position in which it is finally to rest, being its greatest amplitude of oscillation, involves practically an important condition of its stability; for it may be an amplitude sufficient to carry the body into its next adjacent position of equilibrium, which being, of necessity, a position of unstable equilibrium, the motion will be yet further continued and the body overturned. Different bodies requiring moreover different amounts of work to be done upon them to produce in all the same amplitude of oscillation, that is (relatively to that amplitude) the most stable which requires the greatest amount of work to be so done upon it. It is this condition of stability, dependent upon dynamical considerations, to which, in the following paper, the name of dynamical stability is given.

I cannot find that the question has before been considered in this point of view, but only in that which determines whether any given position be one of stable, unstable or mixed equilibrium; or which determines what pressure is necessary to retain the body at any given inclination from such a position.

1. To the discussion of the conditions of the dynamical stability of a body the principle of *vis viva* readily lends itself. That principle*, when translated into a language which the labours of M. PONCELET have made familiar to the uses of practical science, may be stated as follows:—

* See POISSON, *Mécanique*, chap. ix. Art. 565; PONCELET, *Mécanique Industrielle*, *passim*; *Mechanical Principles of Engineering* by the author of this paper, Art. 129.

“When, being acted upon by given forces, a body or system of bodies has been moved from a state of rest, the difference between the aggregate *work* of those forces whose tendencies are *in* the directions in which their points of application have been moved, and that of the forces whose tendencies are in the opposite direction, is equal to one-half the *vis viva* of the system.”

Thus, if Σu_1 be taken to represent the aggregate work of the forces by which a body has been displaced from a position in which it was at rest, and Σu_2 the aggregate work (during this displacement) of the other forces applied to it; and if the terms which compose Σu_1 and Σu_2 be understood to be taken positively or negatively, according as the tendencies of the corresponding forces are in the directions in which their points of application have been made to move or in the opposite directions; then representing the aggregate *vis viva* of the body by $\frac{1}{g} \Sigma wv^2$

$$\Sigma u_1 + \Sigma u_2 = \frac{1}{2g} \Sigma wv^2, \quad \dots \dots \dots (1.)$$

Now Σu_2 representing the aggregate work of those forces which acted upon the body in the position from which it has been moved, may be supposed to be known; Σu_1 may therefore be determined in terms of the *vis viva*, or conversely.

2. In the extreme position into which the body is made to oscillate and from which it begins to return, it, for an instant, *rests*. In this position, therefore, its *vis viva* disappears, and we have

$$\Sigma u_1 + \Sigma u_2 = 0. \quad \dots \dots \dots (2.)$$

This equation, in which Σu_1 and Σu_2 are functions of the impressed forces and of the inclination, determines the extreme position into which the body is made to roll by the action of given disturbing forces; or, conversely, it determines the forces by which it may be made to roll into a given extreme position.

3. The position in which it will finally *rest* is determined by the *maximum* value of $\Sigma u_1 + \Sigma u_2$ in equation 1; for, by a well-known property, the *vis viva* of a system* attains a maximum value when it passes through a position of stable, and a minimum, when it passes through a position of unstable equilibrium. The extreme position into which the body oscillates is therefore essentially different from that in which it will finally rest.

4. Different bodies, requiring different amounts of work to be done upon them to bring them to the same given inclination, *that* is (relatively to that inclination) the most stable, which requires the greatest amount of work to be so done upon it, or in respect to which Σu_1 is the greatest. If, instead of all being brought to the same given inclination, each is brought into a position of unstable equilibrium, the corresponding value of Σu_1 represents the amount of work which must be done upon it to *overthrow* it, and may be considered to measure its *absolute*, as the former value

* POISSON, Mécanique, Art. 571.

7. Let a body be conceived to float, acted upon by no other forces than its weight W , and the upward pressure of the water (equal to its weight); which forces may be conceived to be applied respectively to the centre of gravity of the body and to the centre of gravity of the displaced fluid; and let it be supposed to be subjected to the action of a third force whose direction is parallel to the surface of the fluid. Let ΔH_1 represent the vertical displacement of the centre of gravity of the body thereby produced*, and ΔH_2 that of the centre of gravity of its immersed part. Let moreover the volume of the immersed part be conceived to remain unaltered† whilst the body is in the act of displacement. If each centre of gravity be assumed to ascend, the work of the weight of the body will be represented by $-W.\Delta H_1$, and that of the upward pressure of the fluid by $+W.\Delta H_2$, the negative sign being taken in the former case, because the force acts in a direction opposite to that in which the point of application is moved, and the positive sign in the latter, because it acts in the same direction, so that the aggregate work Σu_2 (see equation 1.) of the forces which constituted the equilibrium of the body in the state from which it has been disturbed is represented by

$$-W.\Delta H_1 + W.\Delta H_2.$$

If the centre of gravity of the body or of the displaced fluid *descends* (a property which will be found to characterize a large class of vessels), ΔH_1 in the one case, and ΔH_2 in the other, must be taken with the negative sign, since the weight of the body will be applied in the same direction, and the pressure of the fluid in an opposite direction to that in which their respective points of application are moved. Moreover, the system put in motion includes, with the floating body, the particles of the fluid displaced by it as it changes its position, so that if the weight of any element of the floating body be represented by w_1 , and of the fluid by w_2 , and if their velocities be v_1 and v_2 , the whole *vis viva* is represented by

$$\frac{1}{g}\Sigma w_1 v_1^2 + \frac{1}{g}\Sigma w_2 v_2^2,$$

and we have by equation 1,

$$U(\theta) - W(\Delta H_1 - \Delta H_2) = \frac{1}{2g}\Sigma w_1 v_1^2 + \frac{1}{2g}\Sigma w_2 v_2^2. \quad \dots \quad (4.)$$

In the extreme position into which the body is made to roll and in which $\Sigma w_1 v_1^2 = 0$,

$$U(\theta) = W.(\Delta H_1 - \Delta H_2) + \frac{1}{2g}\Sigma w_2 v_2^2, \quad \dots \quad (5.)$$

* When a floating body is so made to incline from any one position into any other as that the volume of fluid displaced by it may in the one position be equal to that in the other, its centre of gravity is also vertically displaced; for if this be not the case, the perpendicular distance of the centre of gravity of the body from its plane of flotation must remain unchanged, and the form of that portion of its surface, which is subject to immersion, must be *determined geometrically* by this condition; but by the supposition the form of the body is undetermined. It is remarkable what currency has been given to the error, that whilst a vessel is rolling or pitching its centre of gravity remains at rest. I should not otherwise have thought this note necessary.

† It will be shown that this supposition is only approximately true.

or if the inertia of the displaced fluid be neglected,

$$U(\theta) = W.(\Delta H_1 - \Delta H_2). \quad (6.)$$

Whence it follows that the work necessary to incline a floating body through any given angle is equal to that necessary to raise it bodily through a height equal to the difference of the vertical displacements of its centre of gravity and of that of its immersed part, so that other things being the same, that ship is the most stable the product of whose weight by this difference is the greatest.

In the case in which the centre of gravity of the displaced fluid descends, the *sum* of the displacements is to be taken instead of the difference.

8. This conclusion is nevertheless in error in the following respects:—

1st. It supposes that throughout the motion the weight of the displaced fluid remains equal to that of the floating body, which equality cannot accurately have been preserved by reason of the inertia of the body and of the displaced fluid*.

From this cause there cannot but result small vertical oscillations of the body about those positions which, whilst it is in the act of inclining, correspond to this equality, which oscillations are independent of its principal oscillation.

2ndly. It involves the hypothesis of absolute rigidity in the floating body, so that the motion of every part and its *vis viva* may cease at *once* when the principal oscillation terminates. The frame of a ship and its masts are however elastic, and by reason of this elasticity there cannot but result oscillations, which are independent of, and may not synchronize with, the principal oscillation of the ship as she rolls, so that the *vis viva* of every part cannot be assumed to cease and determine at one and the same instant, as it has been supposed to do.

3rdly. No account has been taken of the work expended in communicating *motion* to the displaced fluid, measured by half its *vis viva* and represented by the term $\frac{1}{2g} \sum w_2 v_2^2$ in equation 5.

9. From a careful consideration of these causes of error, I was led to conclude that they would not affect that practical application of the formula which I had principally in view in investigating it, especially as in certain respects they tended to neutralize one another. The question appeared however of sufficient importance to be subjected to the test of experiment, and on my application, the Lords Commissioners of the Admiralty were pleased to direct that such experiments should be made in Her Majesty's Dockyard at Portsmouth, and Mr. FINCHAM, the eminent

* The motion of the centre of gravity of the body being the same as though all the disturbing forces were applied directly to it, it follows, that no elevation of this point is caused in the beginning of the motion, by the application of a horizontal disturbing force, or by a horizontal displacement of the weight of the body, which, if it be a ship, may be effected by moving its ballast. The motion of rotation thereby produced takes place therefore, in the first instance, about the centre of gravity, but it cannot so take place without destroying the equality of the weight of the displaced fluid to that of the body. From this inequality there results a vertical motion of the centre of gravity, and another axis of rotation.

Master Shipwright of that dockyard, and Mr. RAWSON were kind enough to undertake them.

The details of these experiments accompany my paper; they extend beyond the object originally contemplated by me; and whether regard be had to the practical importance of the question under discussion, the great care and labour bestowed upon them, or the many expedients by which these gentlemen have succeeded in giving to them a degree of accuracy hitherto, I believe, unknown in experiments of this kind, they claim to rank as authentic and valuable contributions to the science of naval construction.

10. That it might be determined experimentally whether the work which must be done upon a floating body to incline it through a given angle be that represented by equation 6, it was necessary to do upon such a body an amount of work which could be measured; and it was further necessary to ascertain what were the elevations of the centres of gravity of the body and of its immersed part thus produced, and then to see whether the amount of work done upon the body equaled the difference of these elevations multiplied by its weight.

To effect this, I proposed that a vessel should be constructed of a simple geometrical form, such that the place of the centre of gravity of its immersed part might readily be determined in every position into which it might be inclined, that of its plane of flotation being supposed to be known; and that a mast should be fixed to it, and a long yard to this mast, and that when the body floated in a vertical position a weight suspended from one extremity of the yard should suddenly be allowed to act upon it causing it to roll over; that the position into which it thus rolled should be ascertained, together with the corresponding elevations of its centre of gravity and the centre of gravity of its immersed part, and the vertical descent of the weight suspended from the extremity of its arm. The product of this vertical descent by the weight suspended from the arm ought then, by the formula, to be found nearly equal to the difference of the elevations of the two centres of gravity multiplied by the weight of the body; and this was the test to which I proposed that the formula should be subjected, having in view its adoption by practical men as a principle of naval construction.

To give to the deflecting weight that *instantaneous* action on the extremity of the arm which was necessary to the accuracy of the experiment, a string was in the first place to be affixed to it and attached to a point vertically above, in the ceiling. When the deflecting weight was first applied this string would sustain its pressure, but this might be thrown at once upon the extremity of the arm by cutting it. A transverse section of the vessel, with its mast and arm, was to be plotted on a large scale on a board, and the extreme position into which the vessel rolled being by some means observed, the water-line corresponding to this position was to be drawn. The position of the yard, in respect to the surface of the water in that position, would then be known, and the vertical descent of the deflecting weight could be measured, and also the vertical ascent of the centre of gravity of the immersed part or displacement.

To determine the position of the centre of gravity of the vessel, it was to be allowed to rest in an inclined position under the action of the deflecting weight; and the water-line corresponding to this position being drawn on the board, the corresponding position of the deflecting weight and of the centre of gravity of the immersion were thence to be determined. The determination of the position of the vertical passing through the centre of gravity of the body would thus become an elementary question of statics; and the intersection of this line, with that about which the section was symmetrical, would mark the position of the centre of gravity, This determination might be verified by a second similar experiment with a different deflecting weight.

These suggestions have received a great development at the hands of Mr. RAWSON, and he has adopted many new and ingenious expedients in carrying them out. Among these, that by which the position of the water-line was determined in the extreme position into which the vessel rolls, appears to me specially worthy of observation. A strip of wood was fastened at right angles to that extremity of the yard to which the deflecting weight was attached, of sufficient length to dip into the water when the vessel rolled, on this slip of wood, and also on the side of the vessel nearest to it, a strip of glazed paper was fixed. The highest points at which these strips of paper were wetted in the rolling of the vessel, were obviously points in the water-line in its extreme position, and being plotted upon the board, a line drawn through them determined that position with a degree of accuracy which left nothing to be desired.

11. Two forms of vessels were used (see Plate XLVII. figs. 1 and 2); one of them had a triangular and the other a semicircular section. The following Table contains the general results of the experiments, of which the particulars are detailed in the Appendix:—

| Form of the model experimented on. | No. of experiment. | Weight of model and loading. | Disturbing weight. | Dynamical stability, as determined by experiment. | Dynamical stability calculated from the formula $U(\theta) = W\Delta(H_1 - H_2)$. | Extreme inclination into which the vessel rolled, as determined by experiment. | Extreme inclination into which the vessel should roll, as determined by calculation from the formula $U(\theta) = W\Delta(H_1 - H_2)$.* | Inclination in which the vessel finally rested when subjected to the action of the disturbing weight. | Ratio of the volume of the displaced fluid in the extreme position into which the vessel rolled to that in the position in which it originally rested. |
|------------------------------------|--------------------|------------------------------|--------------------|---|--|--|--|---|--|
| Triangular model. | 1. | lbs. 33·8626 | lbs. ·5485 | ·5161 | ·5361 | 23° 30' | | 12° 30' | ·8961 |
| | 2. | 36·8590 | ·3450 | ·4887 | ·4951 | 15 30 | | 8 0 | ·98114 |
| | 3. | 37·3563 | ·5377 | 1·1724 | 1·4503 | 24 0 | | 13 0 | ·88512 |
| | 4. | 38·2911 | ·5739 | 1·2673 | 1·8460 | 25 0 | | 13 30 | ·9330 |
| Circular model. | 1. | 197·18 | 2·8225 | 7·3761 | 7·394 | 26 0 | 24 20 | 13 0 | |
| | 2. | 197·18 | 1·9570 | 3·2486 | 3·122 | 17 0 | 16 22 | 9 0 | |
| | 3. | 255·43 | 1·9570 | 1·7727 | 1·7667 | 10 0 | 10 0 | 4 30 | |

In the experiments with the smaller triangular model the differences between the

* The inclinations are calculated by the formula (9.).

results and those given by the formula are much greater than in the experiments with the heavier cylindrical vessel.

In explanation of this difference, it will be observed, *first*, that the conditions of the experiment with the cylindrical model more nearly approach to those which are assumed in the formula than those with the other; the disturbance of the water in the change of the position of the former being less, and therefore the work expended upon the inertia of the water, of which the formula takes no account, less in the one case than the other; and, *secondly*, that the weight of the model being greater, this inertia bears a less proportion to the amount of work required for inclining it than in the other case.

The effect of this inertia adding itself to the buoyancy of the fluid, cannot but be to lift the vessel out of the water and to cause the displacement to be less at the termination of each rolling oscillation than at its commencement*. This variation in volume of the displacement was apparent in all the experiments. Its amount was measured and is recorded in the last column of the Table; its tendency is to produce in the body vertical oscillations, which are so far independent of its rolling motion that they will not probably synchronize with it. The body displacing, when rolling, less fluid than it would at rest, the effect of the weight used in the experiments to incline it is thereby increased, and thus is explained the fact (apparent in the eighth and ninth columns of the Table) that the inclination by experiment is somewhat greater than the formula would make it.

12. *The dynamical stability of a vessel whose athwart sections (where they are subject to immersion and emersion) are circular, having their centres in a common axis.*

Let EDF, Plate XLVIII. fig. 3 or 4, be an athwart section of such a vessel, the parts of whose periphery ES and FR, subject to immersion and emersion, are parts of the same circular arc ETF, whose centre is C. Let G_1 represent the projection of the centre of gravity of the vessel on this section, and G_2 that of the centre of gravity of the space whose section is SDRT, supposing it filled with water. This space lies wholly within the vessel in fig. 3 and without it in fig. 4. Let

$$h_1 = CG_1, \quad h_2 = CG_2.$$

W_1 = weight of vessel.

W_2 = weight of water occupying, or which would occupy, the space whose section is STRD.

θ = the inclination from the vertical.

Since in the act of the inclination of the vessel the whole volume of the displaced fluid remains constant, and also that volume of which STRD is the section †, it follows that the volume of that portion of which the circular area PSRQ is the section

* This result connects itself with the well-known fact of the rise of a vessel out of the water when propelled rapidly, which is so great in the case of fast track-boats, as considerably to reduce the resistance upon them.

† It will be observed that the space STRD is supposed always to be under water.

remains also constant, and that the water-line PQ, which is the chord of that area, remains at the same distance from C, so that the point C neither ascends nor descends. Now the forces which constituted the equilibrium of the vessel in its vertical position were its weight and that of the fluid it displaced. Since the point C is not vertically displaced, the work of the former force, as the body inclines through the angle θ , is represented by $-W_1h_1$ vers θ . The work of the latter is equal to that of the upward pressure of the water which would occupy the space of which the circular area PTQ is the section *increased*, in the case represented in fig. 3, by that of the water which would occupy STRD; and *diminished* by it in the case represented in fig. 4.

But since the space, of which the circular area PTQ is the section, remains similar and equal to itself, its centre of gravity remains always at the same distance from the centre C, and therefore neither ascends nor descends. Whence it follows that the work of the water which would occupy this space is *zero*; so that the work of the *whole* displaced fluid is equal to that of the *part* of it which occupies the space STRD, taken in the case represented in fig. 3 with the positive, and in that represented in fig. 4 with the negative sign. It is represented therefore generally by the formula $\pm W_2h_2$ vers θ . On the whole, therefore, the work Σu_2 (see Art. 1.) of those forces, which in the vertical position of the body constituted its equilibrium, is represented by the formula

$$\Sigma u_2 = -W_1h_1 \text{ vers } \theta \pm W_2h_2 \text{ vers } \theta.$$

Representing therefore the dynamical stability Σu_1 by $U(\theta)$, we have by equation (2.)

$$U(\theta) = (W_1h_1 \mp W_2h_2) \text{ vers } \theta, \quad (7.)$$

in which expression the sign \mp is to be taken according as the circular area ATB lies wholly within the area ADB, as in fig. 3, or partly without it, as in fig. 4. Other things being the same, the latter is therefore a more stable form than the former.

13. The work of the upward pressure of the water upon the vessel represented in fig. 4 being a negative quantity, $-W_2h_2$ vers θ , it follows that the point of application of the pressure must be moved in a direction opposite to that in which the pressure acts; but the pressure acts upwards, therefore its point of application, *i. e.* the centre of gravity of the displaced fluid, *descends*. This property may be considered to distinguish *mechanically* the class of vessels whose type is fig. 3, from that class whose type is fig. 4; as the property of including wholly or only partly, within the area of any of their athwart sections, the corresponding circular area ETF, distinguishes them geometrically.

14. To obtain from the formula 7 an expression adapted to the experiments with the circular model, Plate XLVII. fig. 2, let

$$OM = b, MQ = c, \text{ Disturbing weight } = w.$$

Now it may readily be shown that the vertical descent of the point Q, when the vessel is made to incline through the angle θ , is represented by

$$b \text{ vers } \theta + c \sin \theta.$$

ζ = inclination to horizon of line about which the plane PQ is symmetrical.

x = distance of section CAD, measured along the line whose projection is O, from the point where that line intersects the midship section.

$$y = O\beta.$$

$$y_1 = PQ.$$

$$y_2 = RS.$$

$$z = hn + mg.$$

$$\lambda = KL.$$

I = moment of inertia of plane PQ about axis O.

A and B = moments of inertia of PQ about its principal axes.

μ = weight of a cubic unit of water.

Suppose the water actually *displaced* by the vessel to be, on the contrary, *contained* by it; and conceive that which occupies the space QOS to pass into the space POR, the whole becoming solid. Let ΔH_3 represent the corresponding elevation of the centre of gravity of the whole contained fluid. Then will $\Delta H_2 + \Delta H_3$ represent the total elevation of the centre of gravity of this fluid as it passes from the position it occupied when the vessel was vertical into the position PAQ. But this elevation is obviously the same as though the fluid had assumed the solid state in the vertical position of the body, and the latter had revolved with it, in that state, into its present position. It is therefore represented by $KH - NH^*$;

$$\therefore \Delta H_2 + \Delta H_3 = KH - NH \text{ and } \Delta H_3 = KH - NH - \Delta H_2.$$

Since, moreover, by the elevation of the fluid in QOS, whose weight is w , into the space OPR, and of its centre of gravity through $(gm + hn)$, the centre of gravity of mass of fluid of which it forms a part, and whose weight is W , is raised through the space ΔH_3 ; it follows, by a well-known property of the centre of gravity of a system†, that

$$W \cdot \Delta H_3 = w(gm + hn);$$

$$\therefore W(KH - NH - \Delta H_2) = w(gm + hn).$$

But

$$NH = KH \cos \theta - KL = H_2 \cos \theta - \lambda;$$

$$\therefore KH - NH = H_2 \text{ vers } \theta + \lambda,$$

and

$$mg + nh = z;$$

$$\therefore W(H_2 \text{ vers } \theta + \lambda - \Delta H_2) = wz;$$

$$\therefore W \cdot \Delta H_2 = W(H_2 \text{ vers } \theta + \lambda) - wz. \quad \dots \dots \dots (10.)$$

* The line joining the centres of gravity of the vessel and its immersed part, in its vertical position, is parallel to the plane CAD, for it is perpendicular to the plane PQ, to whose intersection with the plane RS the plane CAD is perpendicular; $\therefore GK = H_1$ and $HK = H_2$.

† PONCELET, Mécanique Industrielle, 2^{me} partie, Art. 50, or MOSELEY'S Mechanical Principles of Engineering, Art. 59.

Also $\Delta H_1 = KG - MG = H_1 - (H_1 \cos \theta - \lambda) = H_1 \text{ vers } \theta + \lambda;$
 $\therefore W(\Delta H_1 \mp \Delta H_2) = W(H_1 \mp H_2) \text{ vers } \theta + wz^* ;$
 $\therefore (\text{equation 6.}) U(\theta, \eta) = W(H_1 \mp H_2) \text{ vers } \theta + wz ; \quad (11.)$

the sign \mp being taken according as the vessel is of the class represented in fig. 3, in which the centre of gravity of the displaced fluid ascends, or of that represented in fig. 4, in which it descends.

If $\alpha\beta$ be a vertical prismatic element of the space QOS, whose base is $dx dy \cos \theta$, and height $y \sin \theta$, then will $w \cdot \overline{mg}$ be represented, in respect to that element, by $\mu y \sin \theta \cdot dx dy \cos \theta \cdot \frac{1}{2} y \sin \theta$, or by $\frac{1}{2} \mu \sin^2 \theta \cos \theta y^2 dx dy$; and wz will be represented, in respect to the whole space of which PrsQ is the section, by

$$\frac{1}{2} \mu \sin^2 \theta \cos \theta \iint y^2 dx dy,$$

or by $\frac{1}{2} \mu \sin^2 \theta \cos \theta \cdot I.$

If therefore we represent by ϕ the value of wz , in respect to the spaces of which the mixtilinear areas PRr and QSs are the sections, we have

$$wz = \frac{1}{2} \mu I \sin^2 \theta \cos \theta + \phi.$$

But the axis O, about which the moment of inertia of the plane PQ is I, is inclined to the principal axes of that plane at the angles η and $\frac{\pi}{2} - \eta$, about which principal axes the moments of inertia are A and B; and it has been shown by M. DUPIN † that when θ is small the line in which the planes PQ or RS intersect passes through the centre of gravity of each;

$$\therefore I = A \cos^2 \eta + B \sin^2 \eta;$$

therefore by equation (11.),

$$U(\theta, \eta) = W(H_1 \mp H_2) \text{ vers } \theta + \frac{1}{2} \mu (A \cos^2 \eta + B \sin^2 \eta) \sin^2 \theta \cos \theta + \phi. \quad (12.)$$

If θ be so small that the spaces PrR and QsS are evanescent in comparison with PO r and QOs, then, assuming $\phi = 0$ and $\cos \theta = 1$,

$$U(\theta, \eta) = W(H_1 \mp H_2) \text{ vers } \theta + \frac{1}{2} \mu (A \cos^2 \eta + B \sin^2 \eta) \sin^2 \theta, \quad (13.)$$

which may be put under the form

$$U(\theta, \eta) = \left\{ W(H_1 \mp H_2) + \mu (A \cos^2 \eta + B \sin^2 \eta) \right\} \text{vers } \theta.$$

Again, since

$$\sin \zeta = \sin \theta \sin \eta, \quad (14.)$$

* The sign \mp is here taken to include the case in which the centre of gravity of the displaced fluid descends. See Art. 7.

† Sur la Stabilité des Corps Flottants, p. 32.

and $(A \cos^2\eta + B \sin^2\eta) \sin^2\theta = \{A + (B - A) \sin^2\eta\} \sin^2\theta,$

$\therefore (A \cos^2\eta + B \sin^2\eta) \sin^2\theta = A \sin^2\theta + (B - A) \sin^2\zeta;$

\therefore by equation 13,

$$U(\theta, \zeta) = W(H_1 \mp H_2) \text{ vers } \theta + \frac{1}{2} \mu \{A \sin^2\theta + (B - A) \sin^2\zeta\}, \dots \dots \dots (15.)$$

by which formula the dynamical stability of the ship is represented, both as it regards a pitching and a rolling motion.

If in equation 13 $\eta = \frac{\pi}{2}$, the line in which the plane PQ (parallel to the deck of the ship) intersects its plane of flotation is at right angles to the length of the ship, and we have, since in this case $\theta = \zeta$ (see equation 14.),

$$U(\zeta) = W(H_1 \mp H_2) \text{ vers } \zeta + \frac{1}{2} \mu B \sin^2 \zeta, \dots \dots \dots (16.)$$

which expression represents the dynamical stability, in regard to a pitching motion alone, as the equation

$$*U(\theta) = W(H_1 \mp H_2) \text{ vers } \theta + \frac{1}{2} \mu A \sin^2\theta \dots \dots \dots (17.)$$

represents it in regard to a rolling motion alone.

16. If a *given* quantity of work represented by $U(\theta)$ be supposed to be done upon the vessel, the angle θ through which it is thus made to roll may be determined by solving equation 17 with respect to $\sin \frac{\theta}{2}$. We thus obtain

$$\sin^2 \frac{\theta}{2} = \frac{W(H_1 \mp H_2) + \mu A - \sqrt{\{W(H_1 \mp H_2) + \mu A\}^2 - 2\mu A \cdot U(\theta)}}{2\mu A} \dots \dots \dots (18.)$$

17. If PR and QS be conceived to be straight lines, so that POR and QOS are triangles, then $w.z$, taken in respect to an element included between the section CAD, and another parallel to it and distant by the small space dx , is represented by

$$\frac{1}{4} \mu y_1 y_2 \sin \theta dx (mg + nh);$$

or, since $mg + nh = \frac{1}{3} y_1 \sin \theta,$

by $\frac{1}{12} \mu \sin^2 \theta y_1^2 y_2 dx;$

$$\therefore wz = \frac{1}{12} \mu \sin^2 \theta \int y_1^2 y_2 dx,$$

and, equation 11

$$U(\theta, \zeta) = W(H_1 \mp H_2) \text{ vers } \theta + \frac{1}{12} \mu \sin^2 \theta \int y_1^2 y_2 dx, \dots \dots \dots (19.)$$

which formula may be considered an approximate measure of the stability of the vessel under all circumstances.

* This formula may be verified experimentally by a method similar to that applied to equation 6. See Art. 10.

If, as in the case of the experiments of Messrs. FINCHAM and RAWSON, the vessel be prismatic and the direction of the disturbance perpendicular to its axis,

$$y = \text{constant} = a, \text{ and } z = \frac{1}{3} a \sin \theta;$$

$$\therefore wz = \frac{1}{3} aw \sin \theta, \text{ and}$$

$$U(\theta) = W(H_1 \mp H_2) \text{ vers } \theta + \frac{1}{3} aw \sin \theta.$$

Mr. RAWSON has obligingly undertaken the verification of this formula by comparing it with his experiments on the cylindrical model. The following is the result:—

| No. of experiment. | W. | w. | H ₁ . | H ₂ . | θ. | U(θ) by formula. | U(θ) by experiment. |
|--------------------|--------|--------|------------------|------------------|----|------------------|---------------------|
| | lbs. | lbs. | | | | | |
| 3 | 255.43 | 17.294 | 3.903 | 4.800 | 9 | 1.760 | 1.766 |
| 4 | 255.43 | 46.84 | 4.02 | 4.82 | 26 | 13.478 | 13.5015 |
| 5 | 197.18 | 37.98 | 0.80 | 3.80 | 26 | 6.807 | 7.3761 |

18. *A rigid surface on which the vessel may be supposed to rest whilst in the act of pitching and rolling.*

If we imagine the position of the centre of gravity of a vessel afloat to be continually changed by altering the positions of some of its contained weights without altering the weight of the whole, so as to cause the vessel to incline into an infinite number of different positions displacing, in each, the same volume of water, then will the different planes of flotation, corresponding to these different positions, envelope a curved surface, called the surface of the planes of flotation (*surface des flotaisons*), whose properties have been discussed at length by M. DUPIN in his excellent memoir, *Sur la Stabilité des Corps Flottants*, which forms part of his *Applications de Géométrie**. So far as the properties of this surface concern the conditions of the vessel's *equilibrium*, they have been exhausted in that memoir, but the following property, which has reference rather to the conditions of its dynamical stability than its equilibrium, is not stated by M. DUPIN:—

If we conceive the surface of the planes of flotation to become a rigid surface, and also the surface of the fluid to become a rigid plane without friction, so that the former surface may rest upon the latter and roll and slide upon it, the other parts of the vessel being imagined to be so far immaterial as not to interfere with this motion, but not so as to take away their weight or to interfere with the application of the upward pressure of the fluid to them, then will the motion of the vessel, when resting by this curved surface upon this rigid but perfectly smooth horizontal plane, be the same as it was when, acted upon by the same forces, it rolled and pitched in the fluid.

In this general case of the motion of a body resting by a curved surface upon a horizontal plane, that motion may be, and generally will be, of a complicated cha-

* BACHELIER, Paris, 1822.

racter, including a sliding motion upon the plane, and simultaneous motions round two axes passing through the point of contact of the surface with the planes and corresponding with the rolling and pitching motion of a ship. It being however possible to determine these motions by the known laws of dynamics, when the form of the surface of the planes of flotation is known, the complete solution of the question is involved in the determination of the latter surface.

The following property*, proved by M. DUPIN in the memoir before referred to (p. 32), effects this determination:—

“The intersection of any two planes of flotation, infinitely near to each other, passes through the centre of gravity of the area intercepted upon either of these planes by the external surface of the vessel.”

If, therefore, any plane of flotation be taken, and the centre of gravity of the area here spoken of be determined with reference to that plane of flotation, then that point will be one in the curved surface in question, called the surface of the planes of flotation, and by this means any number of such points may be found and the surface determined.

19. *The axis about which a vessel rolls may be determined, the direction in which it is rolling being given.*

If, after the vessel has been inclined through any angle, it be left to itself, the only forces acting upon it (the inertia of the fluid being neglected) will be its weight and the upward pressure of the fluid it displaces; the motion of its centre of gravity will therefore, by a well-known principle of mechanics, be wholly in the same vertical line.

Let HK (fig. 6) represent this vertical line, PQ the surface of the fluid, and aMb the surface of the planes of flotation. As the centre of gravity G traverses the vertical HK, this surface will partly roll and partly slide by its point of contact M on the plane PQ.

If we suppose, therefore, PRQ to be a section of the vessel through the point M, and perpendicular to the axis about which it is rolling, and if we draw a vertical line MO through the point M, and through G a horizontal line GO parallel to the plane PRQ, then the position of the axis will be determined by a line perpendicular to these, whose projection on the plane PRQ is O.

For since the motion of the point G is in the vertical line HK, the axis about which the body is revolving passes through GO, which is perpendicular to HK; and since the point M of the vessel traverses the line PQ, the axis passes also through MO which is perpendicular to PQ; and GO is drawn parallel to, and MO in the plane PRQ, which, by supposition, is perpendicular to the axis, therefore the axis is perpendicular to GO and MO.

If HK be in the plane PRQ, which is the case whenever the motion is exclusively one of rolling or one of pitching, the point O is determined by the intersection of GO and MO.

20. *The time of the rolling through a small angle of a vessel whose athwart sections*

* This property appears to have been first given by EULER.

are (in respect to the parts subject to immersion and emersion) circular, and have their centres in the same longitudinal axis.

Let EDF (fig. 3 or fig. 4) represent the midship section of such a vessel, in which section let the centre of gravity G_1 be supposed to be situated, and let HK be the vertical line traversed by G_1 as the vessel rolls. Imagine it to have been inclined from its vertical position through a given angle θ_1 and the forces which so inclined it then to have ceased to act upon it, so as to have allowed it to roll freely back again towards its position of equilibrium until it had attained the inclination OCD to the vertical, which suppose to be represented by θ .

Referring to equation 1., let it be observed that in this case $\Sigma u_2=0$, so that the motion is determined by the condition

$$\Sigma u_1 = \frac{1}{2g} \Sigma wv^2. \quad \dots \dots \dots (20.)$$

But the forces which have displaced it from the position in which it was, for an instant, at rest are its weight and the upward pressure of the water; and the work of these, $U(\theta_1) - U(\theta)$, done between the inclinations θ and θ_1 when the vessel was in the act of receding from the vertical, was shown to be represented by $(W_1h_1 \mp W_2h_2)$ (vers $\theta - \text{vers } \theta_1$) by Art. 12 (adopting the same notation as in that article); therefore the work, between the same inclinations, when the motion is in the opposite direction, is represented by the same expression with the sign changed;

$$\therefore \Sigma u_1 = (W_1h_1 \mp W_2h_2)(\text{vers } \theta_1 - \text{vers } \theta),$$

and since the axis about which the vessel is revolving is perpendicular to the plane EDF, and passes through the point O (Art. 19.), if W_1k_2 represent its moment of inertia about an axis perpendicular to the plane EDF, and passing through its centre of gravity G_1 ,

$$\Sigma wv^2 = W_1(k^2 + \overline{OG_1^2}) \left(\frac{d\theta}{dt}\right)^2.$$

Substituting in equation 20 and writing for OG_1 its value $h_1 \sin \theta$, we have

$$(W_1h_1 \mp W_2h_2)(\text{vers } \theta_1 - \text{vers } \theta) = \frac{W_1}{2g} (k^2 + h_1^2 \sin^2 \theta) \left(\frac{d\theta}{dt}\right)^2;$$

$$\therefore t(\theta_1) = \frac{-1}{\sqrt{2gh_1 \left(1 \mp \frac{W_2h_2}{W_1h_1}\right)}} \int_{+\theta_1}^{-\theta_1} \sqrt{\frac{k^2 + h_1^2 \sin^2 \theta}{\text{vers } \theta_1 - \text{vers } \theta}} d\theta. \quad \dots \dots \dots (21.)$$

$$t(\theta_1) = \frac{1}{\sqrt{2gh_1 \left(1 \mp \frac{W_2h_2}{W_1h_1}\right)}} \int_{-\theta_1}^{+\theta_1} \sqrt{\frac{k^2 + 4h_1^2 \sin^2 \frac{1}{2} \theta \cos^2 \frac{1}{2} \theta}{2 \left(\sin^2 \frac{1}{2} \theta_1 - \sin^2 \frac{1}{2} \theta\right)}} d\theta$$

$$= \frac{1}{\sqrt{gh_1 \left(1 \mp \frac{W_2h_2}{W_1h_1}\right)}} \int_{-\theta_1}^{+\theta_1} \sqrt{\frac{k^2 \sec^2 \frac{1}{2} \theta + 4h_1^2 \sin^2 \frac{1}{2} \theta}{\sin^2 \frac{1}{2} \theta_1 - \sin^2 \frac{1}{2} \theta}} \cdot \cos \frac{1}{2} \theta d \frac{1}{2} \theta,$$

or assuming θ to be so small that the fourth and all higher powers of $\sin \frac{1}{2} \theta$ may be neglected, and observing that, this being the case,

$$\begin{aligned} \sqrt{k^2 \sec^2 \frac{1}{2} \theta + 4h_1^2 \sin^2 \frac{1}{2} \theta} &= \sqrt{k^2 \left(1 + \sin^2 \frac{1}{2} \theta\right) + 4h_1^2 \sin^2 \frac{1}{2} \theta} \\ &= k \sqrt{1 + \frac{4h_1^2 + k^2}{k^2} \sin^2 \frac{1}{2} \theta} = k \left\{ 1 + \frac{4h_1^2 + k^2}{2k^2} \sin^2 \frac{1}{2} \theta \right\} \end{aligned}$$

$$t(\theta_1) = \frac{k}{\sqrt{gh_1 \left(1 \mp \frac{W_2 h_2}{W_1 h_1}\right)}} \int_{-\theta_1}^{+\theta_1} \frac{1 + \frac{4h_1^2 + k^2}{2k^2} \sin^2 \frac{1}{2} \theta}{\sqrt{\sin^2 \frac{1}{2} \theta_1 - \sin^2 \frac{1}{2} \theta}} d \sin \frac{1}{2} \theta.$$

But

$$\int_{-\theta_1}^{+\theta_1} \frac{d \sin \frac{1}{2} \theta}{\sqrt{\sin^2 \frac{1}{2} \theta_1 - \sin^2 \frac{1}{2} \theta}} = \pi,$$

and

$$\int_{-\theta_1}^{+\theta_1} \frac{\sin^2 \frac{1}{2} \theta d \sin \frac{1}{2} \theta}{\sqrt{\sin^2 \frac{1}{2} \theta_1 - \sin^2 \frac{1}{2} \theta}} = \frac{1}{2} \pi \sin^2 \frac{1}{2} \theta_1,$$

$$\therefore t(\theta_1) = \frac{\pi k}{\sqrt{gh_1 \left(1 \mp \frac{W_2 h_2}{W_1 h_1}\right)}} \left\{ 1 + \frac{4h_1^2 + k^2}{4k^2} \sin^2 \frac{1}{2} \theta_1 \right\} \dots \dots \dots (22.)$$

The sign \mp being taken according as the centre of gravity of the displaced fluid ascends or descends.

21. *The time of a vessel's rolling or pitching through a small angle, its form and dimensions being any whatever.*

Let EDF (figs. 3 or 4) represent the midship section of such a vessel, supposed to be rolling about an axis whose projection is O; and let C represent the centre of the circle of curvature of the surface of its planes of flotation (Art. 18.) at the point M where that surface is touched by the plane PQ, being above the load water-line AB in fig. 3, and beneath it in fig. 4. Let the radius of curvature CM be represented by ρ ; then adopting the same notation as in the last article, and observing that the axis O about which the vessel is turning is perpendicular to EDF, we shall find its moment of inertia to be represented by

$$W_1 \{ k^2 + (H_1 \mp \rho)^2 \sin^2 \theta \} \left(\frac{d\theta}{dt} \right)^2,$$

where H_1 represents the depth of the centre of gravity in the vertical position of the vessel.

Also, by equation 17, reasoning as in Art. 20,

$$\Sigma u_1 = U(\theta_1) - U(\theta) = W_1 (H_1 \mp H_2) (\cos \theta - \cos \theta_1) + \frac{1}{2} \mu A (\cos^2 \theta - \cos^2 \theta_1),$$

∴ by equation 20,

$$W_1(H_1 \mp H_2)(\cos \theta - \cos \theta_1) + \frac{1}{2} \mu A (\cos^2 \theta - \cos^2 \theta_1) = \frac{W_1}{2g} \left\{ k^2 + (H_1 \mp \rho)^2 \sin^2 \theta \right\} \left(\frac{d\theta}{dt} \right)^2$$

$$\therefore t(\theta_1) = \frac{1}{\sqrt{2g}} \int_{-\theta_1}^{+\theta_1} \sqrt{\frac{k^2 + (H_1 \mp \rho)^2 \sin^2 \theta}{(H_1 \mp H_2)(\cos \theta - \cos \theta_1) + \frac{1}{2} \frac{\mu A}{W_1} (\cos^2 \theta - \cos^2 \theta_1)}} d\theta$$

$$t(\theta_1) = \frac{1}{\sqrt{2g}} \int_{-\theta_1}^{+\theta_1} \sqrt{\frac{k^2 + (H_1 \mp \rho)^2 \sin^2 \theta}{\left\{ H_1 \mp H_2 + \frac{1}{2} \frac{\mu A}{W_1} (\cos \theta + \cos \theta_1) \right\} \left\{ \cos \theta - \cos \theta_1 \right\}}} d\theta.$$

Assuming θ and θ_1 to be so small that $\cos \theta + \cos \theta_1 = 2$, and observing that

$$\cos \theta - \cos \theta_1 = \text{vers } \theta_1 - \text{vers } \theta,$$

$$t(\theta_1) = \frac{1}{\sqrt{2g \left\{ H_1 \mp H_2 + \frac{\mu A}{W_1} \right\}}} \int_{-\theta_1}^{+\theta_1} \sqrt{\frac{k^2 + (H_1 \mp \rho)^2 \sin^2 \theta}{\text{vers } \theta_1 - \text{vers } \theta}} d\theta.$$

Supposing, moreover, ρ to remain constant between the limits $-\theta_1$ and $+\theta_1$, and integrating as in Art. 20, equation 21,

$$t(\theta_1) = \frac{\pi k}{\sqrt{g \left(H_1 \mp H_2 + \frac{\mu A}{W_1} \right)}} \left\{ 1 + \frac{4(H_1 \mp \rho)^2 + k^2}{4k^2} \sin^2 \frac{1}{2} \theta_1 \right\} \dots \dots \dots (23.)$$

where ρ is to be taken with the sign \mp according as the surface of the planes of flotation is above or below the load-water line, and H_2 , according as the centre of gravity of the displaced fluid ascends or descends.

Since the value of $\sin^2 \frac{1}{2} \theta_1$ is exceedingly small, the oscillations are nearly tautochronous, and the period of each is nearly represented by the formula

$$t(\theta_1) = \frac{\pi k}{\sqrt{g \left(H_1 \mp H_2 + \frac{\mu A}{W_1} \right)}} \dots \dots \dots (24.)$$

The following method is given by M. DUPIN for determining the value of ρ^* :—

“If the periphery of the plane of flotation be imagined to be loaded at every point with a weight represented by the tangent of the inclination of the sides of the vessel at that point to the vertical, then will the moments of inertia of that curve, so loaded, about its two principal axes, when divided by the area of the plane of flotation, represent the radii of greatest and least curvature of the envelope of the planes of flotation.”

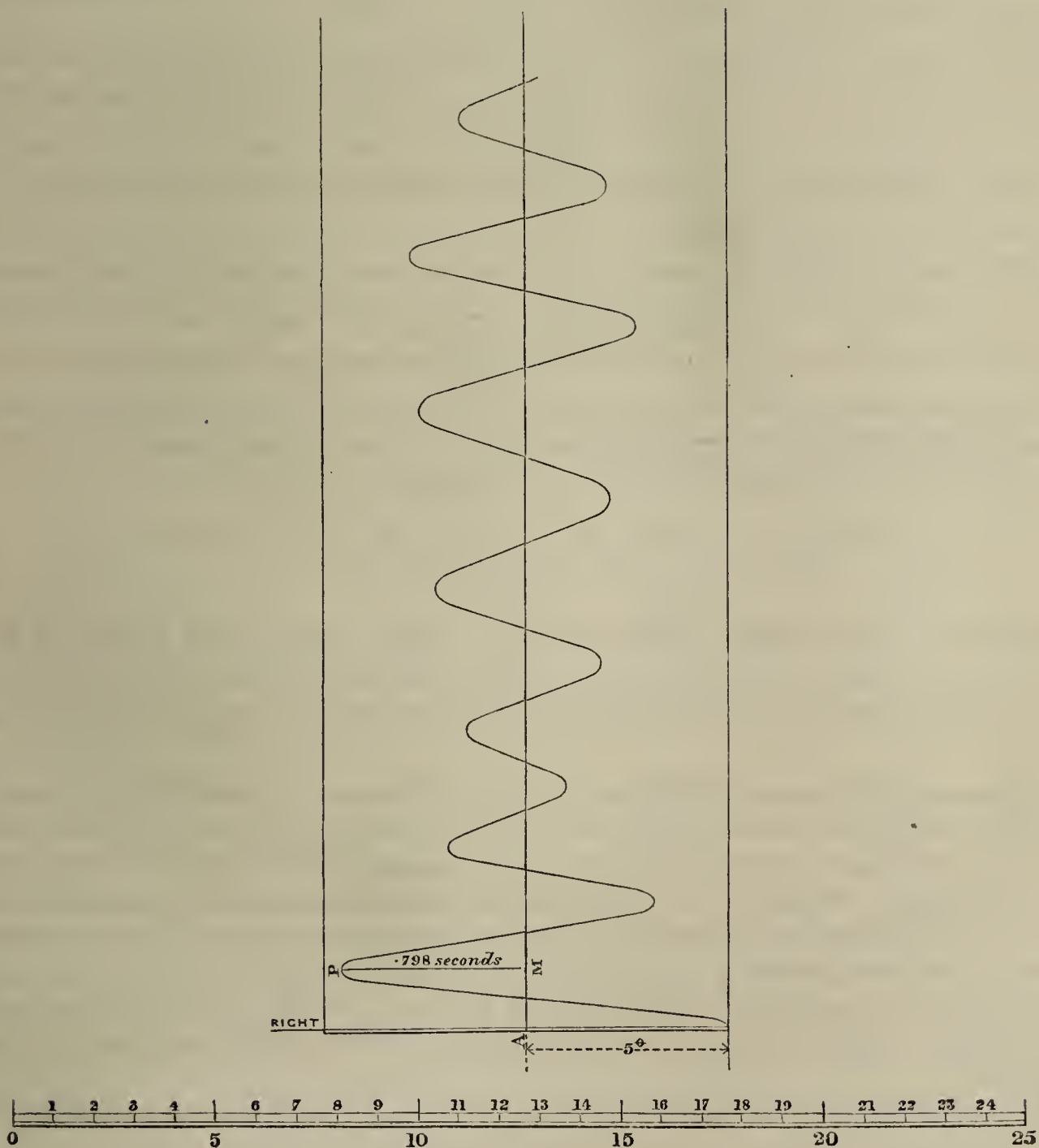
If ρ be taken to represent the radius of greatest curvature, the formula 25 will represent the time of the vessel's rolling; if the radius of least curvature (B being also substituted for A), it will represent the time of pitching.

* Applications de Géométrie, p. 47.

22. *Experiments made by Messrs. FINCHAM and RAWSON with the cylindrical model (Plate XLVII. fig. 2) to verify the formula 22, which represents the time of the rolling of a vessel of that form.*

The following ingenious expedient for determining the time of the oscillations of a floating body was suggested by Mr. FINCHAM and found fully to answer the purpose.

The motion of the vessel, when floating in the tank, was limited to a rolling motion by means of upright guides (A, B, Plate XLIX.), receiving between them the extremities of a longitudinal axis fixed in the vessel so as nearly to pass through the centre of gravity. A frame, PKL, resting on two parallel rails, was made to traverse uniformly by means of clockwork, M, in the direction of this axis produced, that is, in the direction of the length of the model, and at right angles to the direction in which it rolled. This frame carried a cylindrical piece of wood, PL, having its axis in the direction of the motion of the frame, and its surface so curved that an arm, HI, fixed to the model parallel to its length and projecting beyond its extremity, should, as it



rolled, sweep parallel to the surface of the cylinder. A pencil was fixed at the extremity of this arm and pressed lightly by a spring upon the surface of the cylinder, which was covered by a piece of paper. The frame which carried this cylinder advancing in the direction of its axis, and the vessel at the same time rolling so as to sweep the arm over its surface perpendicular to that direction, a zigzag line was, by the combination of the two motions, described, as represented in the diagram on the preceding page, of which each two consecutive loops mark the beginning and end of the same oscillation, and the distance AM between them, measured in the direction in which the frame moved, shows the space traversed by it in the time occupied by that oscillation. This space being known from the experiment, and the rate at which the frame travels uniformly being also known, the time occupied in the oscillation may be determined*.

At a certain point the amplitudes of the oscillations will be observed suddenly to increase. This is due to the return of the wave created by the vessel in the act of rolling and reflected by the sides of the tank †.

Before the times of oscillation could be calculated by the formula (22.) to compare them with those determined by experiment, it was necessary that the moment of inertia $W_1 k^2$ of the floating body should be ascertained. To ascertain it by calculation would have been a difficult task, involving in some respects an uncertain result; it was sought therefore by experiment.

With this view a knife-edge was fixed at each extremity of the cylinder, so as accurately to coincide with its axis prolonged. The vessel taken out of the water was then made to rest by means of these knife-edges on two hard steel plates, accurately adjusted to the same level, and in this position it was allowed to oscillate, the times of its oscillations being determined as before. It then became possible to determine the moment of inertia from the following well-known formula—

$$t = \pi \sqrt{\frac{k^2 + h^2}{gh}} \left\{ 1 + \left(\frac{1}{2}\right)^2 \sin^2 \frac{\theta}{2} + \left(\frac{1.3}{2.4}\right)^2 \sin^4 \frac{\theta}{2} + \dots \right\} \dots \dots \dots (25.)$$

Two series of experiments were made, the model vessel being loaded in the one series so as to weigh 197.18 lbs. gross, and in the other so as to weigh 255.43 lbs. Having obtained from the above formula a mean value of k in respect to each of

* The apparatus, and the method of experimenting with it, are more fully described in the Appendix. It will be observed that in the diagram the amplitudes of the successive oscillations are shown to have diminished, up to a certain point. This diminution was found in a great number of experiments to take place with remarkable uniformity. The uniform diminution of the amplitude of oscillation as the body comes to rest, is of course due to the absorption of the *vis viva* of the rolling body by the water which it puts in motion, to the friction of the water which adheres to it on the rest of the water, to the resistance of the air, and to the friction and abrasion of the parts of the rolling body itself in the act of rolling. Mr. RAWSON has made some experiments on this subject, the results of which he communicated to the British Association for the Advancement of Science.

† The precision with which the instant of the return of this wave and its progress are indicated, seems to show this method of experimenting to be well-suited to determining the velocities of waves.

these series of experiments, Mr. RAWSON verified these mean values by calculating from them the times of oscillation by the following equivalent formula:—

$$t = \sqrt{\frac{k^2 + h^2}{gh}} \cdot \text{Fc} \frac{\pi}{2},$$

which I had previously communicated to him, in which $\text{Fc} \frac{\pi}{2}$ represents that complete elliptic function of the first order whose modulus is c . The results of these experiments and calculations are given in the following Table:—

| Gross weight of model. | Amplitude of oscillation on either side of vertical. | Time of oscillation by experiment. | Value of $\sqrt{\frac{k^2 + h^2}{gh}}$ by formula $\frac{\sqrt{ag} \cdot t}{\pi(1+f\theta)}$ (see Appendix). | Mean value of k deduced from the preceding column. | Time of oscillation calculated from the formula $t = 2 \sqrt{\frac{k^2 + h^2}{gh}} \cdot \text{F}\left(c \frac{\pi}{2}\right)$ with the preceding value of k , verifying that value. |
|------------------------|--|------------------------------------|--|--|--|
| lbs. | ° ' " | " | in. | in. | " |
| 197·18 | 5 0 | ·8190 | 11·983 | | ·8348 |
| | 7 30 | ·8905 | 12·562 | 10·465 | ·8352 |
| | 10 0 | ·7930 | 11·554 | | ·8359 |
| 255·43 | 2 30 | ·7280 | 11·070 | | ·7280 |
| | 5 0 | ·6500 | 10·451 | 9·3294 | ·6500 |
| | 7 30 | ·7800 | 11·784 | | |
| | 10 0 | ·6760 | 11·706 | | |

Table of the times of the oscillation in water of a model vessel as determined,—1st, by the experiments of Messrs. FINCHAM and RAWSON; and 2ndly, by the formula (22.),

$$t = \frac{\pi k}{\sqrt{gh_1 \left(1 + \frac{W_2 h_2}{W_1 h_1}\right)}} \left\{ 1 + \frac{4h_1^2 + k^2}{4k^2} \sin^2 \frac{1}{2} \theta_1 \right\},$$

| Constants of formula. | Angle of oscillation θ_1 . | Time of oscillation in seconds by formula. | Time of oscillation in seconds by experiment. |
|--|-----------------------------------|--|---|
| Weight of model = 197·18 lbs. $W_2 = 0$ $k = 10·465$ in. $h_1 = 4·9$ in. $t = 75668 \left\{ 1 + 46924 \sin^2 \frac{1}{2} \theta_1 \right\}$ | 5 | ·75637 | ·798 |
| | 10 | ·75840 | ·798 |
| | 15 | ·76172 | ·840* |
| | 20 | ·76641 | ·784 |
| Weight of model = 255·43 lbs. $W_2 = 0$ $k = 9·3294$ in. $h_1 = 5·97$ in. $t = 61033 \left\{ 1 + 56021 \sin^2 \frac{1}{2} \theta_1 \right\}$ | 5 | ·61094 | ·658 |
| | 10 | ·61289 | ·665 |
| | 15 | ·61471 | ·616 |
| | 20 | ·64811 | ·602 |

23. *General considerations applicable to the stability of floating bodies.*

An exceedingly small pressure is sufficient to move a floating body from its position of stable equilibrium. As the inclination becomes greater the pressure must be increased until it attains, in a given position, its maximum value. Now if instead of this variable and continually increasing pressure we conceive a constant one to

* This experiment was faulty.

have been applied, less than the maximum one spoken of above, but considerably greater than that necessary to produce the initial motion, it is not difficult to see that this lesser pressure, by reason of its continued action on the body, may be sufficient to carry it *through* the position in which it would have required the *maximum* pressure to have *held* it; for in all the positions in which this pressure exceeded that necessary to move the body, the excess of its work over that of the resistance is accumulated under the form of *vis viva*, and in all those in which it fell short of that pressure, the work thus accumulated comes to its aid, and carries the body forward*.

24. To move a body from a given position into any other, it is not necessary that the work of the forces whence this change of position results should continue to be done upon it during the whole period of such change. They may be in the nature of pressures whose action ceases when they have communicated the *vis viva* necessary to continue the motion until the second position is attained, as in the case of the impact of one body on another, or of a gust of wind acting on a floating body, or of a blow of the sea.

In all these cases the excess of the work of the disturbing forces over that of the

* As an illustration of this principle, let us take the analogous case of a cylindrical body (fig. 7)—whose radius CD is represented by a —rolling on a horizontal plane, and to simplify the investigation let us suppose the force P, which causes it to roll, to be applied horizontally to the axis c . Let the weight of the cylinder be represented by W , and suppose it to be so loaded that the distance of its centre of gravity from its axis may be $CG(=c)$. Let the cylinder be made to roll through an angle (θ) from the position in which it would rest, and in which CG is vertical. The work done upon it by P, whilst it thus rolls, is represented by $Pa\theta$, and the work opposed to its rolling by the weight of the cylinder, is $Wc \text{ vers } \theta$,

$$Pa\theta - Wc \text{ vers } \theta$$

is therefore the excess of the work of the forces whose tendency is in the direction of the motion over the work of those whose tendency is in the opposite direction. This excess represents one-half the *vis viva*, and in the extreme position into which the cylinder rolls and from which it begins to roll back, this vanishes, so that in this position

$$Pa\theta - Wc \text{ vers } \theta = 0.$$

If this position be the inverted position of the body $\theta = \pi$, and

$$P = \frac{2Wc}{\pi a}.$$

Now let us suppose that P, instead of being a constant pressure, had been made so to vary that in every position into which the body rolled it was only just sufficient to make it roll *slowly* out of that position. The maximum pressure P' , applied under these circumstances, would have been that corresponding to the position in which CG is horizontal, and would have been represented by the formula

$$P' = \frac{Wc}{a},$$

whence it follows that

$$P = \frac{2}{\pi} P' = .6366 P';$$

so that the pressure, which, being continually applied the same in amount, would be sufficient to overturn the body, is less than two-thirds of that which must be exerted in its position of maximum effort, the lesser but constant pressure accumulating in its previous position, an excess of work which is sufficient to carry the body through and far beyond that position in which it would have required the greater pressure to have held it.

resistances accumulates, so as to be represented at any time by half the *vis viva* of the body, and it is the work accumulated under this form and in this amount, which, when the operation of the disturbing forces is withdrawn, carries the body forwards.

25. If, in the case of an oscillatory motion, the force which causes that motion be intermittent, and if the periods of this intermission so coincide with those of the body's oscillation that the force is withdrawn when any oscillation in its direction is completed, and renewed when the next oscillation in *that direction* begins, it is evident that the *vis viva* created by it in all such successive oscillations will be accumulated, and the amplitudes of the oscillations rendered, in succession, greater than one another, so that by the intermittent action of a small force which so synchronizes with the oscillations of the body on which it is made to act, a great inclination of its position from that of its equilibrium may eventually result*. This might for instance be produced, in respect to a floating body, by the action of gusts of wind or blows of the waves, repeated at stated intervals.

If the periods at which the intermittent work is done upon the body, instead of synchronizing with the commencement of each oscillation and thus favouring the motion, had so occurred as to oppose it at stated intervals (which may or may not synchronize with the body's own oscillations), it is evident that a complicated motion dependent on these several conditions will result, in which the oscillations will be repeated in cycles.

* As an illustration of this, let us suppose that in case of the cylinder (fig. 7), the motive force, instead of being applied horizontally to the axis, is a weight w applied to the point D on its surface when the cylinder was inclined at the angle θ to its position of stable equilibrium; and that when the point D had, by the rolling of the cylinder, been made to descend until it again touched the plane, the weight w was withdrawn, the cylinder completing its oscillation on the other side of the vertical by reason of the *vis viva* thus communicated to it.

On its return it will oscillate (the resistance being neglected) through the same angle, on the side of the vertical from which it started, as it completed on the opposite side. Let the weight w be then placed again on the point D, and taken off a second time when this point comes in contact with the plane; and so continually, a rocking motion of increasing amplitude being produced by the alternate placing and withdrawal of the weight until at last the position of CG is reversed and the cylinder is overturned.

Let $\theta_1, \theta_2, \theta_3 \dots \theta_n$ be the angles on either side of the vertical through which, in its successive oscillations, the cylinder is made to roll, then shall we obviously have the following relations:—

$$\begin{aligned} (Wc + wa) \text{ vers } \theta &= Wc \text{ vers } \theta_1, \\ (Wc + wa) \text{ vers } \theta_1 &= Wc \text{ vers } \theta_2, \\ &\text{\&c.} \quad = \quad \text{\&c.} \\ (Wc + wa) \text{ vers } \theta_{n-1} &= Wc \text{ vers } \theta_n. \end{aligned}$$

Multiplying these equations together,

$$(Wc + wa)^n \text{ vers } \theta = (Wc)^n \text{ vers } \theta_n.$$

But $\theta_n = \pi$, $\therefore \text{vers } \theta_n = 2$ and $\text{vers } \theta = 2 \sin^2 \frac{1}{2} \theta$,

$$\therefore (Wc + wa)^n \sin^2 \frac{1}{2} \theta = (Wc)^n,$$

and

$$w = \frac{Wc}{a} \left\{ \left(\text{cosec } \frac{1}{2} \theta \right)^{\frac{2}{n}} - 1 \right\}.$$

26. If, when the work of any disturbing force begins to be done upon a floating body, it be already acted upon by some other force, which has caused it to incline from the position in which it would otherwise rest through some given angle α , as in the case of a squall or a heavy sea striking a ship already inclined by the action of a steady wind upon her beam; representing by θ the additional inclination given to it by the action of the disturbing force, whose work, in giving it this inclination, is represented by $u(\theta)$, and representing the work done through this same angle θ by the forces originally impressed, and still acting, upon it by $U(\theta)$, we have

$$Wc\{\text{vers}(\alpha + \theta) - \text{vers} \alpha\} = U(\theta) + u(\theta).$$

Differentiating and transposing,

$$\delta\theta = \{\delta U(\theta) + \delta u(\theta)\} \frac{1}{Wc \sin(\alpha + \theta)}.$$

The small additional angle $\delta\theta$ through which the body is made to roll by the application to it of a given small additional amount of work,

$$\delta U(\theta) + \delta u(\theta),$$

varies therefore inversely as the sine of the inclination, and is greatest in the position nearest to the vertical position; or, in other words, the body sustains in an inclined position a less change of that position by the application of a given disturbing force than it does in a vertical position. It yields most readily to the action of any disturbing force in its vertical position, and the further it is made to deviate from this position (within certain limits and under certain conditions), the more resolutely does it oppose any further deviation. This explains the liability of a ship to rolling when sailing before the wind, and her stiffness in the water when close hauled.

Conclusions applicable to Ship-building.

27. To make an alteration in the angle through which a ship rolls, it is necessary to elevate or to depress her weights. In the former case she will roll through a greater, and in the latter through a less angle. It does not alter the amplitude of rolling to move the weights horizontally, but only the time of rolling, provided the trim of the ship remain unaltered; for this does not alter the position of the centre of gravity of the ship or of the displaced fluid, and it is upon these that the stability of the ship depends (Art. 7 and equation 18.).

28. When a ship's motion is only a rolling motion, or about an axis parallel to her length, the position of that axis is, at any instant, determined by the intersection of a horizontal line through her centre of gravity, and a vertical line through the centre of gravity of her plane of flotation at that instant (Art. 19).

29. A ship should be so constructed that the centre of gravity of that plane of flotation, whose boundary is the load water-line, may be vertically above the centre of gravity of the ship. If this be not the case, the pressure of the additional water displaced by any vertical oscillation of the ship, acting obviously at the centre of gravity

of that plane and not in the same vertical with the centre of gravity of the ship, will cause, in addition to that vertical oscillation, a pitching or a rolling motion.

30. All the planes of flotation of the ship, when it is made to roll through small angles from its vertical position, should have their centres of gravity in the midship section (supposed to be that which contains the centre of gravity of the ship), and the centre of gravity of the displaced fluid should also always remain in this plane; for if that be not the case, it is obvious, from Art. 28, that the axis about which the vessel rolls cannot be parallel to its length, so that every rolling must be accompanied also by a pitching motion.

31. The angle through which a ship rolls under the action of a gust of wind, is essentially different from that at which it would be held inclined by the steady action of the same force of the wind, so that when the inclination which a given pressure would give to the ship, if applied to the centre of effort of the wind on the sails, is calculated (as is customary) by the formula known as that of Atwood, it is erroneous to conclude that the vessel, if subjected suddenly to that force of the wind, would incline only through that angle.

The experiments of Messrs. FINCHAM and RAWSON, of which the results are stated in the Table, p. 615, show that it will roll through nearly double that angle, confirming, in this respect, the deductions of theory (Art. 2).

Neither can calculations, made by means of the theorem of Atwood, as to the respective pressures which would hold different ships inclined at the same given angle, be considered as determining with certainty their *relative* stabilities in respect to rolling; for the amplitude of each oscillation depends upon the stiffness of the vessel, not only in respect to that given inclination, but upon its stiffness at every other inclination which it must have passed through to reach that angle, and at every inclination which by reason of its acquired momentum it may pass through afterwards. The same observation is applicable to the effect of disturbances in the water-line and to blows of the waves.

32. All the causes which produce the rolling motion of a ship, whether they be gusts of wind, disturbances of the water-line, or blows of the waves, are measured in their effect upon it under the form of *work* (travail), so that according as a ship requires a greater or a less amount of work to be done upon her to cause her to roll through a given angle, there is a greater or less probability that, when at sea, she will roll through so great an angle as that. The angle through which the ship will be made to roll under the action of a given amount of *work*, is measured (Art. 7) by the product of her weight, by the difference or the sum of the vertical displacements of her centre of gravity, and the centre of gravity of her immersed part whilst she is in the act of rolling through that angle; the difference being taken or the sum according as these centres of gravity both ascend, or as the one ascends and the other descends; or in other words, it is *the work necessary to raise the vessel bodily through the difference or the sum of these vertical displacements.*

33. If therefore some existing vessel were fixed upon whose qualities in respect to rolling were well known, and if it were determined by calculation from this theorem what amount of work must be done upon that vessel to make it roll through some *given angle*; and this amount of work being so determined in respect to that existing ship, if, before all other ships of the same class were built, it were determined by a similar calculation, made from the drawings of those ships, whether a greater or a less amount of work would be necessary to make *them* roll through the same angle, then it would be known whether *these* ships would, under the like circumstances, roll more or less than *that* ship, and the forms proposed to be given them might be adopted or might be altered accordingly.

I conceive that by this means, if duly applied, great certainty might be given to the construction of ships in respect to rolling, and of course to pitching, for the same principles which apply to the one apply also to the other, with no other difference than in the direction in which the inclination is supposed to take place.

34. The force of the winds and waves, to the action of which a vessel is liable, may be supposed to vary as the surface she opposes to them, that is, to the area of her sails and the superficial dimensions of her hull. In vessels geometrically similar these vary as the squares of any of their similar linear dimensions, their lengths for instance. On the other hand, the weights of such vessels, supposed to be similarly loaded, varying as the cubes of their lengths; and the depths of their centres of gravity, and of the centres of gravity of their immersed parts, varying as their lengths; their dynamical stabilities, with reference to a given inclination, vary as the fourth powers of their lengths. Since, then, in reference to vessels thus geometrically similar, the disturbing forces, to the action of which they are subject, vary as the squares of their lengths and their stabilities as the fourth powers, it follows that their actual steadiness in the water will vary as the *squares* of their lengths, the greater vessel being more steady than the less in this proportion.

35. The expedients which I have pointed out for so designing a ship as to satisfy the conditions of easy rolling and pitching, suppose a knowledge of the exact position of the centre of gravity of the ship and of the centre of gravity of her displacement. The determination of these however is no new question; a knowledge of them has always been considered necessary to the skilful building of a ship, and the methods given for that purpose in books on ship-building are sufficiently accurate for the purpose, if the data are to be relied upon; and if not, nothing is required but the labour to determine these data.

36. That form of vessel in which the surfaces subject to immersion and emersion, when intersected by planes perpendicular to the vessel's length, *have circular* sections, having their centres in a common axis, is, *cæteris paribus*, eminently a *stable form*; because in a vessel of such a form (Art. 12.) the centre of gravity of the portion of the displaced fluid which is included within the solid of revolution (ATB figs. 3, 4) formed by all these circular sections, does not in the act of rolling *rise*.

If it be not practicable to give to the vessel, throughout its whole length, a form subject to these conditions, this is practicable with regard to the midship section, which is the governing section.

37. Of vessels having this general form, those are, *cæteris paribus*, the most stable in which the circular area, when completed, includes entirely the corresponding section of the ship (as shown in fig. 4), because, in respect to these ships, the centre of gravity of the displaced fluid *descends* as the ship rolls (Art. 13.); and when this is the case, the work necessary to incline the ship through any given angle (which measures its dynamical stability) is equal to that necessary to raise it bodily through a height equal to the *sum* of the vertical displacements which its centre of gravity, and the centre of gravity of the displaced fluid, suffer in that inclination, whilst in the opposite case, represented in fig. 3, it is equal to the work necessary to raise it through the *difference* of those heights*.

Of the class of vessels represented in fig. 4, the stability of those is the greatest, other things being the same, in respect to which the space STD between the circumference of the circular area and the hull of the vessel is the greatest.

38. It is not necessary to these results, taken in a general sense, that the sections of the vessels should be accurately circular as to their parts subject to immersion and emersion. If on the midship section of a ship a circle can be described, having its centre in the vertical axis of the section so as nearly to coincide with the parts of the periphery subject to immersion and emersion, then the ship may be distinguished as to whether it belongs to the class in which the centre of gravity of the immersion ascends or descends, by observing whether this circular area is wholly or only partly included within the section. The midship sections of Her Majesty's ships Vanguard, Bellerophon and Canopus present illustrations of this principle. They are represented in figs. 8, 9, 10. It will be observed, that if a circular area be struck on each section according to the conditions stated above, that area will in the Bellerophon and Canopus entirely include the corresponding sections of the hulls of the two ships, a wider space intervening between the two areas in the Canopus than the Bellerophon. Other things being the same, the former ought therefore to be the more stable ship. In the Vanguard the circular section does not wholly include that of the hull. This should therefore be the least stable ship of the three. These conclusions are, I believe, in accordance with the known qualities of the ships. If there be any ship whose midship section resembles that represented in fig. 3, the centre of gravity of its displacement will ascend in the act of rolling, and, *cæteris paribus*, it cannot but be an unstable ship.

* The hull may be so shaped as to cause the centre of gravity of the vessel to descend in the act of rolling. In this case ΔH_1 , equation 6, must be taken negatively. If the centre of gravity of the immersed part ascends, $U(\theta)$ will in this case be negative, and the position will be one of unstable equilibrium. If the centre of gravity of the immersion descends, ΔH_2 , in equation 6, must be taken positively; and if it exceeds ΔH_1 , the equilibrium will be stable.

In all these comparisons it has been supposed that the ships do not otherwise differ as it regards their stability, than in their approximation to the typical forms represented in figs. 3 and 4. It has been supposed therefore (see equation 17) that the depths of their centres of gravity and of the centres of gravity of the fluid they displace in a vertical position are the same, and that the moments of inertia of their planes of flotation are equal. This cannot be the case; and it is impossible to know to what extent this error in the hypothesis may in any particular case affect the measure of the dynamical stability, except by calculating it by formula 17. The problem is far too complicated to render the application of any general principle—except with this precaution—safe. It is not—in this respect as in others—more practicable to dispense with the resources of mathematical reasoning and of calculation, in building the ship, than, after she is built, in sailing her.

39. It is a deduction of theory (equation 24.), and is confirmed by experiment, that, within the ordinary limits of rolling, the *Time* of a vessel's rolling is independent of the angle through which it rolls, being dependent only upon the form of the vessel, its weight, the position of its centre of gravity, and its moment of inertia about an axis passing through that point (see equation 24); so that every different vessel, when loaded in a given manner, has *a time of rolling proper and peculiar to it*, and which may be said to *characterize* it. And the same is true of the time of pitching.

40. This time of the oscillations of the ship may have such a relation to the times of oscillation of the waves* as to cause the blows of the sea to be received by the ship at those instants when they will produce the greatest effect on the amplitude of her oscillations (Art. 25.), and thus a little sea may, under certain circumstances, produce very heavy rolling.

If there be not this relation between successive oscillations of the ship and of the waves, then there will be, during a certain number of oscillations, an antagonism of the two, until the times of the one class of oscillations have so gained upon those of the other as to bring about an interference. The vessel will then probably be comparatively at rest. Then will follow a series of oscillations of the waves and the ship, which will in various degrees concur to produce heavy rolling, until it reaches a maximum, when the same cycle of changes will be gone through again†.

41. The straining of the ship in the act of rolling, is dependent upon the time of its oscillations. This straining takes place in every part of it, but more particularly (by reason of their elasticity) in the masts. When the rolling begins, the higher parts of the masts, by reason of their inertia, remain behind the lower portions, and the masts bend; as the rolling proceeds they receive an independent motion

* If the ship be under sail, the rate at which she sails and the distances of the waves from one another, measured in the direction in which she sails, are also among the conditions on which her rolling depends.

† This cyclical antagonism and concurrence of the independent oscillations of the waves and the ship will interfere, to a certain extent, with the tautochronism of the ship's oscillations.

from their elasticity, influenced, besides this cause, by their weight and length, and this motion assumes the form of an independent oscillation, affecting more or less the oscillatory motion of the vessel itself.

If, at the instant when the ship would otherwise begin to roll back, the elasticity of its masts is in the act of carrying them forwards, there will be a violent strain of the ship, which would not take place in a ship so constructed or so loaded as to create that synchronism of the independent oscillations of the vessel and its masts, which is implied in the fact that she does not strain herself in rolling.

42. The properties of different ships with regard to the strain they suffer in rolling, and whether, in respect to the seas which are of most frequent occurrence, they roll easily or heavily, are probably well known, so that it would be possible to fix upon some ship of each class which might in this respect serve as a standard with which other ships of that class might be compared. The time of oscillation proper and peculiar to this ship might also be ascertained by experiment. It would then become possible to build and load all other ships of that class so as to oscillate in the same time as that ship, and thereby ensure, supposing them to be masted in the same way, very nearly the same qualities in regard to the strain they suffer in rolling.

The form of the ship so constructed need not however in any respect resemble that of the standard ship; all that is required is, that—in respect to the dimensions of its parts and the distribution of its weights when loaded—it should satisfy the conditions implied in assigning a given value to $t(\theta_1)$ in equation 24. In all other respects full latitude is allowed to the builder*.

43. I have shown (Art. 19.) that the axis about which the ship may at any instant be conceived to roll is perpendicular to two straight lines, one of which is drawn horizontally from the vessel's centre of gravity parallel to the direction in which it is rolling, and the other vertically through the centre of gravity of its plane of flotation at that instant.

Its *vis viva*, when rolling or pitching, is therefore greater as its weights are placed at a greater distance from this axis, and less as they are nearer to it.

Whence it follows as a general principle (equation 24.), that the ship is made to roll more slowly by moving its weights to a greater distance from this axis, as when the yards are run up; and more quickly by bringing them nearer to it, as when the guns are run back in a heavy sea to diminish the strain on the ship's timbers.

44. The form under which H_2 enters equation 24, shows that the greater the depth of the centre of gravity of the ship's displacement the more slowly (other things being the same) will she roll, provided that she be a ship of that class of which fig. 3 is the type, in which this quantity (*i. e.* the depth of the centre of gravity of the displacement) diminishes as the vessel rolls; but that if, on the contrary, she belongs to

* Taking a ship, whose form may indeed (within certain assignable limits) be any whatever, it is in his power, guided by that equation, so to load it as that it shall oscillate in the same time with any other ship whose form may be in all respects different.

the class of which fig. 4 is the type, the centre of gravity of whose displacement descends in the act of rolling, she will roll the faster as this centre of gravity is seated deeper in her hull.

45. It may be received as a general rule that (other things being the same) vessels of the class fig. 4 roll more quickly than those of the class fig. 3, but do not roll so far. So that unless some special provision be made for that end, stability in rolling may not, and will not probably be obtained except at the expense of quick rolling.

46. The form under which A enters equation 24, shows that breadth of beam is not *of itself* conducive to slow rolling, and that it can only tend to it indirectly, by carrying the ship's weights further from the axis about which it rolls, and thereby augmenting the quantity k , which represents in the formula the moment of inertia of the ship, and is the ruling element of the time. The form under which W_1 enters the equation shows heavy loading to be conducive to slow rolling.

47. It would be unsafe however to be guided in the construction of a ship by any one of these considerations taken separately from the rest, for there is scarcely any element of the discussion which can be changed without bringing about a change in an opposite direction in some other.

What will be the total result of any proposed change, and by what means the whole object sought by it is to be accomplished, can only be determined by that complete mathematical discussion of the question in all its elements, the principles of which it has been the object of this paper to develop, and which the formulæ contained in it afford a means of applying.

December 1, 1849.

APPENDIX.

Experiments on the Dynamical Stability and the Oscillations of Floating Bodies. By JOHN FINCHAM, *Esq.*, Master Shipwright in Her Majesty's Dockyard, Portsmouth, and ROBERT RAWSON, *Esq.*

Experiments necessary to verify the formula 6,

$$U(\theta) = W(\Delta H_1 - \Delta H_2),$$

which represents the work done in deflecting a floating body through an angle such that the height through which the centre of gravity of the floating body is raised shall be ΔH_1 ; and the height through which the centre of gravity of displacement is raised, shall be ΔH_2 .

For this purpose two models were made, such that their sections were uniform throughout the whole length of the model: the section of one was a triangle, and of the other a circle (see figs. 1, 2).

If the reader will refer to Art. 10 for a general description of the apparatus, the following explanation of the drawing fig. 1 will be sufficient to show how the experi-

ments have been conducted. It represents a section of the model; TK is the yard by means of which the deflecting weight hanging at Q, deflects the model from the upright position. AC is water-line in the upright position, and BD that in the extreme position into which it rolls; EF that in the position in which it finally rests.

In the first place, the model is adjusted by means of moveable weights, until the water-line AC is parallel to the upper side, LN, of the model; and then a string, SK, is fixed at S and K, so that when the deflecting weight is placed at Q no effect is produced by the deflecting weight on the model until the string SK is cut (RS is a fixed beam independent of the model).

When the string SK is cut there is an extreme deflection where the water-line becomes BD, and a permanent deflection where the water-line becomes EF.

These lines are determined in the following manner: PX is a thin graduated scale, fixed at P at right angles to the arm of the lever TK, and having a strip of prepared paper fixed upon its surface, which shows distinctly, by the depth to which it is wetted when the vessel rolls, a point in the extreme position of the water-line. Two other points in this position of the water-line are determined by means of scales similarly applied to L and N.

When any two of these three points are observed, a section of the model being drawn of the half-size on a drawing-board, we could set off upon it the distances Pp, Ll, Nn, and thus draw in the water-line BD. There is no occasion to use prepared paper to show the water-lines, excepting in the ultimate deflection.

The paper which we used, and which answered the purpose admirably, was nothing more than common writing-paper rubbed over with a little colouring, in order to take off from the surface of the paper any oily matter which might prevent the water's making a distinct mark upon it.

This means was adopted as the best means, after several other expedients had been tried with partial success.

The centre of gravity G was determined by observing the permanent water-line EF in a number of deflections by means of various deflecting weights. The position of this water-line, for any given deflecting weight, being set out on the drawing, we were enabled, knowing the weight of the vessel, to determine the position of the centre of gravity, by well-known principles of statics, with no other aid than that of the scale and compasses. Suffice it to say, that great care was taken to get this point.

The points H and h, which are the centres of gravity of the part immersed in the vertical position of the vessel and in the position into which it rolls, were determined from the known property of the centre of gravity of a triangle in fig. 1, and from the common formula for determining the centre of gravity of the segment of circle in fig. 2.

The drawings were made to half size from the following Table, which was filled up during the time the experiments were in operation: this circumstance enabled us obtain all the data required for our computations with extreme exactness.

Cylindrical Model.

| Model at rest, without the deflecting weight. | | | Model at rest, with the deflecting weight. | | | Model at ultimate deflection, with deflecting weight. | | | Weight of the model and deflecting weight. | | Distance from centre of model to P and Q. | | |
|---|-----------------|-----------------|--|-----------------|------------------|---|-----------------|-----|--|------------------|---|---------------------------|--------|
| L. | Lk. | Ns. | Po. | Lq. | Nr. | Pp. | Ll. | Nn. | Deflecting weight. | Weight of model. | P. | Q. | |
| | $8\frac{1}{16}$ | $8\frac{1}{16}$ | ... | 6 | $10\frac{1}{8}$ | $31\frac{5}{16}$ | $4\frac{3}{16}$ | ... | lbs. Av. 1.957 | lbs. Av. 197.18 | ft. in. $3\ 6\frac{1}{4}$ | ft. in. $5\ 4\frac{5}{8}$ | } (2.) |
| | 8 | $8\frac{1}{8}$ | ... | 6 | $10\frac{1}{8}$ | $31\frac{5}{16}$ | $4\frac{1}{4}$ | ... | | | $3\ 6\frac{1}{4}$ | $5\ 4\frac{5}{8}$ | |
| | 6 | $6\frac{1}{4}$ | ... | $6\frac{1}{2}$ | $9\frac{1}{2}$ | | ... | ... | | | $3\ 6\frac{1}{4}$ | $4\ 0\frac{5}{8}$ | } (3.) |
| | 6 | $6\frac{1}{16}$ | 31 | $4\frac{3}{4}$ | $7\frac{3}{16}$ | $34\frac{3}{16}$ | $3\frac{3}{4}$ | ... | 1.957 | 255.43 | $3\ 6\frac{1}{4}$ | $5\ 4\frac{5}{8}$ | |
| | 6 | $6\frac{1}{16}$ | $33\frac{1}{2}$ | $5\frac{1}{6}$ | 7 | | ... | ... | | | $3\ 6\frac{1}{4}$ | $4\ 0\frac{5}{8}$ | } (4.) |
| | $8\frac{1}{8}$ | $8\frac{1}{8}$ | 34 | $2\frac{1}{2}$ | $9\frac{7}{16}$ | $20\frac{7}{8}$ | $0\frac{5}{8}$ | ... | 5.0285 | 255.43 | $3\ 6\frac{1}{4}$ | $5\ 4\frac{5}{8}$ | |
| | $8\frac{1}{8}$ | $8\frac{1}{8}$ | $36\frac{1}{4}$ | $3\frac{7}{16}$ | $8\frac{9}{16}$ | 21 | ... | ... | | | $3\ 6\frac{1}{4}$ | $4\ 0\frac{5}{8}$ | } (5.) |
| | | | | 5 | $11\frac{3}{16}$ | $24\frac{5}{16}$ | $2\frac{3}{16}$ | ... | 2.8225 | 197.18 | $3\ 6\frac{1}{4}$ | $5\ 4\frac{5}{8}$ | |
| | | | | $5\frac{3}{4}$ | $10\frac{5}{16}$ | ... | ... | ... | | | $3\ 6\frac{1}{4}$ | $4\ 0\frac{5}{8}$ | |

The position of the water-line corresponding to the extreme position into which the model rolled being thus determined in every experiment, the corresponding displacement was also known. In fig. 1, this displacement having a triangular section eMf' , its centre of gravity h could readily be determined by construction. In fig. 2, the displacement having a circular section, its centre of gravity h could be determined by known rules. Drawing a perpendicular hc from h upon BD , this line measures the depth of the centre of gravity of the immersion in the extreme position into which the vessel rolls, and Ha measures it in the vertical position; therefore the difference of these lines measures its elevation in the act of rolling. In like manner the perpendicular Gb measures the depth of the centre of gravity of the *model* when the water-line was BD , and Ga was its depth in the vertical position, therefore the difference of these lines is its elevation in the act of rolling.

Thus the elevations of the centre of gravity of the model and of the centre of gravity of the displaced fluid, in the act of rolling, are found, and its weight being known, the work which must have been done upon it to cause it thus to roll may be determined according to equation 6.

But the work actually done upon it by the deflecting weight may, in like manner, be determined; for if a perpendicular Qo be drawn from Q on BD , the length of this line will be the height of Q when the water-line was BD , and Qm was its height in the vertical position, therefore the difference of these lines is the space through which the deflecting weight has descended vertically; and the product of this distance of the deflecting weight gives the work actually done by it upon the rolling body. This amount of work ought, by the theory, to be the same with that found as above from equation 6; and the comparison of results thus obtained, by theory and experiment, constitutes a verification of the formula, and is given in the Table, p. 615.

A single example will show the way in which the calculations were made.

In the triangular model, Experiment 1, the following dimensions were measured in inches :—

$$\begin{aligned} Ga &= 1.75, & Gb &= 1.05, & Ha &= 2.75 \\ hc &= 2.24, & Qm &= 15.2, & Qo &= 3.9 \end{aligned}$$

$$\therefore \text{elevation of centre of gravity of model, in feet} = \frac{1.75 - 1.05}{12} = \Delta H_1$$

$$\text{elevation of centre of gravity of displaced fluid, in feet} = \frac{2.75 - 2.24}{12} = \Delta H_2$$

$$\text{weight of model in lbs.} \dots \dots \dots = 33.8626 = W.$$

$$\therefore \text{by equation 6, } U(\theta) = \left\{ \frac{(1.75 - 1.05) - (2.75 - 2.24)}{12} \right\} \times 33.8626 = .5361.$$

$$\text{Also vertical descent of deflecting weight, in feet} = \frac{15.2 - 3.9}{12},$$

$$\text{deflecting weight } Q \text{ in lbs.} = .5485 ;$$

$$\therefore \text{by experiment } U(\theta) = \left\{ \frac{15.2 - 3.9}{12} \right\} \times .5485 = .5165.$$

The computations on both these models, made in accordance with formula 6, agree with the experiments.

All the experiments show what we conceive to be important, that the same moment of force which is necessary to maintain a vessel in a position θ at rest, will deflect the vessel through nearly twice θ when made to act upon a vessel which is not deflected. Atwood's statistical stability therefore appears to us to be of little use, so far as the rolling of the vessel is concerned.

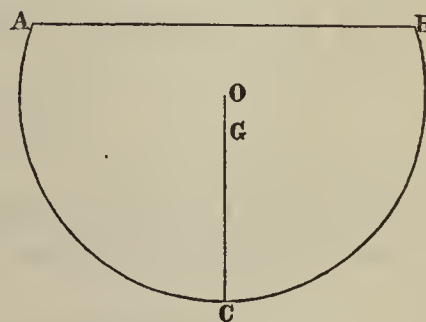
Experiments on the Time of Oscillation.

To find the moment of inertia of a cylindrical model, whose radius is 13.5 inches, weight 197.18 lbs. avoirdupois, round an axis passing through the axis of the cylinder.

ABC is a vertical section of the cylinder passing through its centre of gravity G.

It is required to find the moment of inertia of the cylindrical model, about an axis passing through O, the centre of the cylinder at right angles to the section ABC.

For this purpose the model was made to oscillate out of the water, upon knife-edges passing through O and parallel to the sides of the cylinder. Several experiments were carefully made, and the times of oscillations were observed through the amplitude of 5° , $7\frac{1}{2}^\circ$ and 10° . The apparatus by means of which the times were observed, enables us to measure the times of oscillation to an exactness of .013 of a second, or in round numbers to the one-hundredth part of a second of time.



If $T =$ time of oscillation of a simple pendulum,

$2\theta =$ angle of amplitude of oscillation,

$r =$ length of pendulum,

$g = 32.19084$ feet,

$\pi = 3.1415927$, &c. &c.,

we have

$$T = \pi \sqrt{\frac{r}{g}} \left\{ 1 + \left(\frac{1}{2}\right)^2 \left(\frac{\text{vers } \theta}{2}\right) + \left(\frac{1.3}{2.4}\right)^2 \left(\frac{\text{vers } \theta}{2}\right)^2 + \left(\frac{1.3.5}{2.4.6}\right)^2 \left(\frac{\text{vers } \theta}{2}\right)^3 + \&c.* \right\}.$$

Put $R =$ radius of oscillation of a compound pendulum.

Then the time of oscillation of the compound pendulum will be the same as in the case of the simple pendulum, if we put R instead of r in the above formula.

$$T = \pi \sqrt{\frac{R}{g}} \left\{ 1 + \left(\frac{1}{2}\right)^2 \left(\frac{\text{versin } \theta}{2}\right) + \left(\frac{1.3}{2.4}\right)^2 \left(\frac{\text{versin } \theta}{2}\right)^2 + \left(\frac{1.3.5}{2.4.6}\right)^2 \left(\frac{\text{versin } \theta}{2}\right)^3 + \&c. \right\} \dots (26.)$$

We may here observe that

$$R = \frac{k^2 + h^2}{h},$$

where $k =$ the radius of gyration about the centre of gravity, $h =$ the distance from the centre of suspension to the centre of gravity of the model.

Since

$$\frac{\text{versin } \theta}{2} = \frac{1 - \cos \theta}{2} = \sin^2 \frac{\theta}{2},$$

we shall have

$$T = \pi \sqrt{\frac{k^2 + h^2}{gh}} \left\{ 1 + \left(\frac{1}{2}\right)^2 \sin^2 \frac{\theta}{2} + \left(\frac{1.3}{2.4}\right)^2 \sin^4 \frac{\theta}{2} + \left(\frac{1.3.5}{2.4.6}\right)^2 \sin^6 \frac{\theta}{2} + \&c. \right\} \dots (27.)$$

If we put

$$f(\theta) = \left(\frac{1}{2}\right)^2 \sin^2 \frac{\theta}{2} \left\{ 1 + \left(\frac{3}{4}\right)^2 \sin^2 \frac{\theta}{2} + \left(\frac{3.5}{4.6}\right)^2 \sin^4 \frac{\theta}{2} + \&c. \&c. \right\}, \dots (28.)$$

equation (4.) will become

$$T = \pi \sqrt{\frac{k^2 + h^2}{gh}} \{ 1 + f(\theta) \}.$$

From which equation we obtain

$$\sqrt{k^2 + h^2} = \frac{\sqrt{gs}}{\pi \{ 1 + f(\theta) \}} \times T \dots (29.)$$

If T_1, T_2, T_3 be the time of the first, second and third oscillations during the time that θ and s remain constant, we shall have

$$\begin{aligned} n \sqrt{k^2 + h^2} &= \frac{\sqrt{gs}}{\pi \{ 1 + f(\theta) \}} \left\{ T_1 + T_2 + T_3 + \&c. \text{ to } n \text{ terms} \right\}, \\ \therefore \sqrt{k^2 + h^2} &= \frac{\sqrt{gs}}{n\pi \{ 1 + f(\theta) \}} \left\{ T_1 + T_2 + T_3 + \&c. \text{ to } n \text{ terms} \right\} \dots (30.) \end{aligned}$$

* See POISSON'S *Traité de Mécanique*, p. 348.

For very small angles of amplitude $f(\theta)$ is very small, and may be entirely neglected, showing that for small angles the oscillations are independent of the angles.

The value of $\sqrt{k^2+h^2}$ was in the first place calculated in respect to *one* of the quantities $T_1, T_2, \&c.$, then in respect to *two*, and so on, to *four*. The mean of these four values being then taken in respect to each experiment, a final mean was taken in regard to all the experiments. The data and the results are stated in the following Table as it regards the value of $\sqrt{k^2+h^2}$, and the rest in the first Table, p. 629. The times of oscillation, as calculated by formula (22.) and as determined by experiment, are stated in the second Table on that page.

| | Angle of oscillation θ . | $1+f\theta$. | Value of $\sqrt{k^2+h^2}$ calculated in inches from time of | | | | Mean value of $\sqrt{k^2+h^2}$ in each experiment. | Mean value of $\sqrt{k^2+h^2}$ in all the experiments. | |
|----------------------|---------------------------------|---------------|---|-------------------|---------------------|--------------------|--|--|--------|
| | | | One oscillation. | Two oscillations. | Three oscillations. | Four oscillations. | | | |
| W = 197.18 lbs. | 5 | 1.0004762 | 11.336 | 11.780 | 12.356 | 12.461 | 11.983 | } 12.033 | |
| | 7 30 | 1.0010723 | 12.318 | 12.200 | 12.828 | 12.903 | 12.562 | | |
| | h = 4.9 inches | 10 | 1.0019072 | 12.003 | 11.620 | 11.620 | 11.870 | | 11.550 |
| W = 255.43 lbs. | 2 30 | 1.0000235 | 11.128 | 10.731 | 11.194 | 11.227 | 11.07 | } 11.076 | |
| | 5 | 1.0004762 | 9.429 | 10.328 | 10.924 | 11.123 | 10.451 | | |
| | h = 5.97 inches | 7 30 | 1.0010723 | 11.910 | 11.315 | 11.976 | 11.935 | | 11.784 |
| | 10 | 1.0019072 | 10.332 | 10.818 | 11.446 | 11.414 | 11.000 | | |

XXXI. *Electro-Physiological Researches. On Induced Contraction.—Ninth Series.*

By Signor CARLO MATTEUCCI, Professor in the University of Pisa, &c. &c.

Communicated by W. R. GROVE, Esq., F.R.S.

Received May 13,—Read June 20, 1850.

IT is not without considerable regret that I am compelled to depart from my established rule of never publishing any facts relating to electro-physiology without having previously endeavoured to connect them with those already discovered, and without having succeeded in reproducing them in such a constant and unvarying manner as to remove the slightest doubt of their truth. The announcement, however, just made to the Académie des Sciences by M. DU BOIS RAYMOND of a work "*On the Law of Muscular Current, and on the Modification which that law undergoes by the effect of Contraction,*" obliges me, though unwillingly, to transmit to the Royal Society the continuation of my researches on induced contraction, confining myself, for the present, to some fundamental experiments, made a long time since, for the publication of which I should have wished to await a more favourable moment.

In the Third and Fifth Series of my Electro-physiological Researches*, I studied, with all possible care, and in its minute details, the fact of induced contraction, in order to deduce the law of this phenomenon, and from thence to be led to the discovery of its cause. In the Fifth Series, principally, I was led to conclude, that, according to all the analogies, and without being in opposition to the experiments, induced contraction might be considered to be the effect of an electric discharge which takes place during the act of muscular contraction.

In a memoir published in the *Annales de Physique et de Chimie*, Octobre 1847, after having given an exposition of the laws of the electrical discharge of fish, and demonstrated all the analogies existing between this function and muscular contraction, I declared still more explicitly, that experiment leads to the admission that in muscular contraction there is a phenomenon analogous to that of the discharge of the Leyden phial, and which was the cause of induced contraction. Nevertheless it has been my wish that this conclusion, which I have always studiously announced with extreme reserve, should be demonstrated by direct experiment, and this object I have vainly endeavoured to attain in making use of the galvanometer.

In the memoirs above cited, are to be found a description of all the efforts made to this purpose; by forming piles with muscular elements of the frog and making these elements contract, I endeavoured, but always without satisfactory result, to obtain

* *Philosophical Transactions*, Part II. 1845, 1847.

from the galvanometer signs of electrical phenomena produced by the act of contraction. The variations produced in the conductivity of the circuit, by the convulsive movements of the muscles of the frogs, which alter the points of contact between the elements of the pile, the agitation of the liquid into which the platina plates of the galvanometer are plunged, are constant and inevitable causes of the production of an electric current, which involves a constant uncertainty as to the effects which may depend on contraction. These same causes of error exist in the experiment made by M. DU BOIS REYMOND on voluntary contraction of a man's arm; I have tried a great number of experiments, following his method, increasing the number of elements which contract at the same time, without ever succeeding in obtaining an evident and constant development of electricity by muscular contraction. In the researches for the discovery of this development, I have not failed to employ, with all proper care, the galvanoscopic frog. Operating on a circle of thirty and forty individuals, who all contracted the same arm at the same time, and although the galvanoscopic frog, the nerve of which formed part of the circuit (being in contact with the two outermost fingers of this pile of men), was extremely sensitive, yet never did we obtain the slightest sign of a current from voluntary contraction. Yet the circuit, though composed of a great number of individuals, was always a sufficiently good conductor for the transmission of a current of some muscular elements, capable of producing contraction in the galvanoscopic frog.

Since, therefore, the galvanometer employed in my first experiments on induced contraction, and by means of which M. DU BOIS REYMOND thinks that he has discovered the development of electricity in voluntary muscular contraction, never has with me led to any other but uncertain and very doubtful results, since by the aid of the galvanoscopic frog, used as a substitute for the galvanometer, I have *never obtained the slightest signs* of an electric current in the voluntary contraction of the muscles of the arms, I was authorized in concluding that the development of electricity by muscular contraction still remained to be demonstrated by experiment, and that the phenomenon of induced contraction was still that which led most directly to this result.

I will now give some new experiments on induced contraction, of incontestable evidence and certainty, and which undoubtedly lend an increasing probability to the conclusion that induced contraction is due to an electric discharge, and that muscular contraction is accompanied by a development of electricity.

Exp. 1. I prepare a frog in the usual manner, and I lay on the muscles of its thighs, legs, and on the articulations of its claws, the nerves of highly sensitive galvanoscopic frogs: on provoking the contraction of the muscles of the first frog by irritating its lumbar nerves, the galvanoscopic frogs contract, and when these first contractions are very violent, induced contraction may be seen to take place on contact even with the extremities of the limb of the entire* frog. The signs of in-

* I apply the word entire to the frog fastened on the glass tubes: see figs. 1 and 3.

duced contraction are always obtained stronger and more durably on the muscles of the thigh and leg, than on the other parts of the frog.

Exp. 2. Induced contraction is very evident at the moment when the muscle itself, on which is laid the nerve of the galvanoscopic frog, is divided. This experiment is perfectly analogous to that which is made by cutting, in different directions, a very small piece of the organ of the torpedo, upon which a nerve of the galvanoscopic frog has been placed.

Exp. 3. Induced contraction is produced in the same manner, and with equal intensity, whatever may be the direction in which the nerve of the galvanoscopic frog is extended, in respect to the muscular fibres.

Exp. 4. If we interpose between the nerve of the galvanoscopic frog and the surface of the thigh of the entire frog several layers of wet paper, we cease to obtain induced contraction: if there is only a layer or two of very thin paper, induced contraction continues to be produced.

Exp. 5. We dispose a prepared frog, as in Plate L. fig. 1; *ac* and *bd* are two glass tubes covered with varnish, upon which the frog is fixed by means of Indian rubber rings, *e* and *f*; *g* and *h* are two bits of linen, or of thick paper moistened with salt water. If we touch separately the point *g* or the point *h* with the nerve of the galvanoscopic frog, there is no sign of induced contraction; but if the nerve of the galvanoscopic frog be disposed as in fig. 1, so that the nerve touches at the same time the points *g* and *h*, we have immediate contraction in the galvanoscopic frog, exciting contractions in the muscles of the entire frog. This takes place in whatever manner the contractions are provoked, whether by wounding or cutting the spinal marrow, or in passing an electric current from a small pair of zinc and platina along the lumbar nerves.

Exp. 6. If, while making the preceding experiment, a communication be established between the two legs of the frog, by placing a wetted cotton wick over the points *ts* or *p* and *q*, or over all the intervening points, the contractions of the galvanoscopic frog cease instantly, although the members of the entire frog are in contraction: we have only to remove the cotton wick and the phenomenon reappears. These alternatives are constant, and are always reproduced in the same manner.

Exp. 7. The results of the preceding experiments are obtained whether the legs of the entire frog are brought into contact or whether they are kept separate. We see from this the advantage of the arrangement adopted in these experiments in order to avoid placing the frog on a plane, which would soon become moistened and serve as a conductor.

Exp. 8. By means of a solution of the extract of nux vomica, I produce a state of nervous superexcitation in the frogs. While in this condition these animals are subject at intervals to violent contractions, which may also be excited by the slightest contact. I place a frog in this condition on the apparatus, fig. 1. The galvanoscopic frog rarely gives signs of contraction, while the entire frog contracts violently. *One*

of the lumbar nerves ought now to be cut; this being done, we are certain to obtain contractions in the galvanoscopic frog, at each contraction of the entire frog; these contractions cease if the two legs are brought into communication with the wetted cotton, as in the preceding experiment.

Exp. 9. I take a half frog, and instead of the other half, I employ a wick of cotton, v, r (fig. 2), one end of which touches the upper part of the leg or thigh, and the other the nerve of the galvanoscopic frog, $g p n$. The other extremity of this nerve rests on the lower part of the leg of the half frog, a thick stratum of wetted paper (o) being placed between the nerve and the leg. Every time that the half frog contracts the galvanoscopic frog contracts also; the latter ceases to contract if one removes the upper end (v) of the cotton wick from its contact with the upper part of the leg. It ought to be observed, that in this arrangement of the experiment we obtain the contraction of the galvanoscopic frog at the instant that we place the nerve in this sort of circuit.

This experiment has been tried with equal success operating on the limb of a living rabbit.

Exp. 10. Instead of one galvanoscopic frog I dispose two, as in fig. 3, and by irritating first one lumbar nerve and then the other, I produce contractions in each limb separately. During the first moments the two galvanoscopic frogs, c and d , contract, whichever may be the limb of the entire frog which contracts. Afterwards, when the galvanoscopic frogs begin to be less sensitive, we are sure to obtain contractions in the galvanoscopic frog, d , only when the limb a contracts, and the contraction in the galvanoscopic frog c , when it is the limb b which contracts. We obtain the same result by employing the arrangement adopted in fig. 2, representing the non-contracting limb by the wet cotton wick, disposed in the manner already described. Thus, if instead of having the nerve, $g p$, disposed as in fig. 2, we reverse the position of the nerve of the galvanoscopic frog in such a manner as to touch the cotton wick with its upper part, and the point, o , superposed on the limb with its lower part, either no contraction at all is obtained, or it soon ceases.

Exp. 11. I cut the thigh of a frog, above and below, so as to form a piece, $a b$ (fig. 4), similar to a portion of a cylinder the two circular bases of which are the interior surfaces of muscle. The nerve of the galvanoscopic frog, $g p$, is disposed on the surface of this cylinder so as to be exactly parallel with the two bases. If we irritate the point c there are signs of induced contraction.

It is impossible for me to confine myself to the simple description of these experiments without deducing from them some conclusions, the most evident of which appear to me to be the following:—

1. The cause of induced contraction, according to all analogies, is the same as that which produces contraction of the galvanoscopic frog in the *sixth* and *following* experiments.
2. The cause of these contractions is evidently an electrical phenomenon developed

in the act of contraction, and which consists in a different state of electricity in the different points of the contracted limb.

3. This electrical phenomenon, like the contraction which produces it, lasts only for an instant.

4. These electric states, developed by contraction, tend to produce electrical currents which circulate in opposite directions across a conducting arch interposed between the two limbs, which contract at the same time.

5. The tenth experiment proves the existence of these currents and their directions; here we should remember that the galvanoscopic frog is more sensitive to the passage of the current when that current traverses the nerve in the direction of its ramification. Thus the contraction of the galvanoscopic frog, *d* (fig. 3), during the contraction of the limb, *a*, proves the existence of the electrical current, which goes from *a* towards *d*. The contraction of the galvanoscopic frog, *c*, during the contraction of the limb, *b*, proves, in the same manner, the existence of an electrical current going from *b* towards *c*.

Whatever the theory of these phenomena may be, it is certain that they demonstrate the production of an electrical *disequilibrium* in the act of muscular contraction.

In the experiments which have been described, this electro-physiological phenomenon may consist in a species of discharge, propagated in muscles in the direction of the ramification of the nerves. Is the cause of this discharge a phenomenon analogous to that of electrical fish, or does it consist in a change in the natural conditions of the muscular current, produced by contraction? In the present state of science it is impossible for us to answer this question. According to all the analogies, and according to our present experimental knowledge, we lean to the former of these two explanations; but we wait the light of new experiments to proceed safely further in this difficult field of science.

Pisa, April 1, 1850.

XXXII. *Contributions to the Chemistry of the Urine.*—Paper IV.*On so-called Chylous Urine.*

By HENRY BENICE JONES, M.D., M.A. Cantab., F.R.S., Physician to St. George's Hospital.

Received January 21,—Read March 14, 1850.

URINE white from the suspension of a quantity of fatty matter in it, has been called chylous urine, and the albumen and fibrin which escape from the blood with the fat have been considered to belong to the chyle and not to the blood.

An opportunity of observing a case of this disease having occurred to me, I was led to make the following experiments. The conclusions therefrom are,—

1st. That the fat on which the white colour of the urine depends does indeed appear in the urine after the chyle is absorbed, but the albumen, fibrin, blood-globules and alkaline salts, may be found in the urine previous to any food being taken, and these substances can be made to appear in, or disappear from the urine according as the circulation is hurried by motion or quieted by rest.

2nd. That the disease consists in some slight alteration in the structure of the kidney, by which, when the circulation is most active, one or more of the constituents of the blood passing through the filter escape from the vessels into the urine.

The supposition that the disease consists in an accumulation of fat in the blood which is thrown out by the kidneys carrying with it albumen, fibrin, blood-globules and salts, is altogether disproved, both by actual analysis of the blood itself, and by the frequent occurrence of a large jelly-like coagulum in the urine, when no white fatty matter can be seen to be present.

For an account of the patient and for the treatment and its ultimate effect in stopping the escape of the white water, which he had passed more or less frequently for nine months previous to my seeing him, I must refer to the *Medico-Chirurgical Transactions* for 1850.

On the 19th of October he came to me, having taken food last at 11 A.M. The water passed at 2 P.M. solidified like blanc mange in ten minutes. It contained, when passed from the bladder, some clots ready-formed. It was very feebly acid to test-paper. Thrown on a filter, a very small quantity of reddish streaked fibrin remained on it. The filtered fluid, at 60° FAHR., had a specific gravity = 1015. It coagulated by heat and acid. In appearance it was quite milky, but became clear when agitated with a considerable excess of ether. Some perfectly healthy blood-globules were seen with the microscope, and the granules of fat were so small as scarcely to be resolvable by a high power.

of onions; passed just before tea; three quarters of a pint of cocoa with milk and bread.

10 P.M. Very white, milky, with some blood. Twelve ounces, alkaline.

Second day. Water passed at

7 A.M. Lost.

8^h 30^m A.M. Nearly clear; a little blood and very slight coagulum. An ounce and a half, acid; passed just before breakfast. Pint of boiled milk with sago, bread, and a little butter.

9^h 30^m A.M. Very slightly opalescent, with a delicate transparent coagulum filling the lower half of the bottle, containing some streaks of blood. The clear liquid coagulated strongly with heat and acid. An ounce and a half in quantity, alkaline.

11^h 30^m A.M. Milky, with a little blood, alkaline.

1^h 15^m P.M. Milky, with more blood; six ounces more alkaline; made just before dinner, which consisted of a mutton chop, broccoli and bread.

3 P.M. Milky; about eight ounces, alkaline.

5 P.M. Milky; eight ounces, feebly acid; passed just before tea; three quarters of a pint of milk and sago, bread, very little butter.

8 P.M. Milky; eight ounces, feebly acid.

10^h 30^m P.M. Milky; eight ounces, slightly more acid.

Third day. Water passed at

6 A.M. Opalescent yellow, did not clear with heat; gave the slightest trace of albumen with heat and acid; about eight ounces, slightly acid.

7^h 30^m A.M. Clear when passed; cloudy about twelve from urate of ammonia; about one ounce passed immediately after getting out of bed; gave a more distinct trace of albumen, contained a few blood-globules; slightly acid.

8^h 30^m A.M. The whole of the urine in the bottle consisted of coagulum of a yellow opalescent colour, not at all milky; a few drops of liquid only could be poured from it, and this was excessively albuminous; the quantity made was nearly two ounces, alkaline to test-paper, passed just *before* breakfast, which consisted of a pint of boiled milk and sago, bread, and a little butter.

9^h 30^m A.M. More opalescent; slightly milky, with a tinge of blood; the bottle was full of coagulum from which a drachm or two of liquid could be poured; about five ounces; alkaline highly.

12^h 30^m A.M. Milky; eight ounces, neutral.

1^h 15^m P.M. Milky; two ounces, neutral; passed just before dinner; steak, roast onion and bread.

4^h 45^m P.M. Milky; five ounces, neutral.

5^h 30^m P.M. Milky; five ounces, alkaline just before tea; three quarters of a pint of coffee, bread, with little butter.

9^h 30^m P.M. Milky; eight ounces, neutral.

10^h 30^m P.M. Milky; four ounces, feebly acid.

Fourth day. Water passed at

6 A.M. Clear, six ounces, strongly acid; the slightest trace of albumen with heat and acid.

7^h 15^m A.M. Clear; half an ounce, very strongly acid. Passed immediately on getting out of bed for the day; the slightest trace of albumen with heat and acid. This and a little of the urine passed at six, had specific gravity 1027, 513.5 grs. precipitate with alcohol = 0.40 gr. = 0.8 gr. per 1000 grs. of urine.

9^h 50^m A.M. Slightly opalescent, solid, yellow, coagulum; three ounces, alkaline. Passed just *before* breakfast. Pint of boiled milk with sago and bread, with but little butter or sugar. When filtered a bloody coagulum remained on the filter. The clear liquid left at rest deposited a layer of blood-globules. Specific gravity = 1015.6, gave a nearly solid coagulum with heat and acid. 507.8 grs. precipitated by alcohol = 7.20 grs. = 14.1 grs. per 1000 grs. of urine.

11 A.M. Chylous with clots and pink coagulum; six ounces, alkaline, filtered; bloody coagulum was left on the filter. Milky fluid on standing deposited a layer of blood-globules. Specific gravity = 1013.4, 506.7 grs. precipitated by alcohol = 7.35 grs. = 14.5 grs. per 1000 grs. of urine.

1^h 35^m P.M. Very milky; eight ounces, with little blood; neutral. Passed just before dinner; mutton chop with broccoli and bread.

3^h 40^m P.M. Very milky; eight ounces, very little blood; neutral.

5^h 40^m P.M. Very milky; one and a half ounce; blood doubtful; feebly acid; passed just before tea; three quarters of a pint of coffee, half a pint of milk with bread, but little butter or sugar.

7^h 40^m P.M. Very milky; four and a half ounces; little blood; neutral.

10 P.M. Very milky; five ounces; little blood; very feebly acid.

Fifth day. Water passed at

6 A.M. Slightly milky; yellowish; eight ounces; strongly acid. Specific gravity = 1017. No blood; contained a very minute trace of albumen; did not clear with heat.

8^h 15^m A.M. Slightly cloudy; no blood; no coagulum; one and a half ounce, acid. Specific gravity = 1020.7. Contained a considerable quantity of albumen, though he had nothing to eat and remained in bed.

9^h 30^m A.M. Almost quite clear; three quarters of an ounce, acid. Passed just before breakfast, which consisted of a pint of boiled milk, sago, bread, with a little butter. Apparently rather less albumen. Specific gravity = 1022.

11^h 20^m A.M. Yellowish milky. Three ounces made just before he got up for the day; very feebly acid. Contained a considerable quantity of albumen; more than the two preceding specimens. No spontaneous coagulation. Did not clear by heat. Specific gravity = 1019.4.

1 P.M. Milky; coagulated spontaneously; four ounces, neutral; passed just before dinner; mutton chop, onion with bread.

4^h 50^m P.M. Milky; neutral; six ounces just before tea; three quarters of a pint of milk boiled, bread with butter.

8 P.M. Milky; five ounces; neutral.

10 P.M. Milky; three ounces; feebly acid.

Sixth day. Water passed at

6^h 35^m A.M. Yellow milky; more than opalescent; six ounces, strongly acid.

Specific gravity 1026·6. Passed on getting up. 513·3 grs. precipitated by alcohol = 1·85 gr. = 3·6 grs. per 1000 grs. of urine.

8^h 10^m A.M. More milky, with large pinkish coagula; two ounces, alkaline. Specific gravity 1016·4. 508·2 grs. precipitated by alcohol = 8·40 grs. = 16·5 grs. per 1000 grs. of urine.

9 A.M. Pink coagulum filling an ounce bottle, alkaline; passed just before breakfast; a pint of boiled milk, sago, with a little butter.

11^h 30^m A.M. Very milky, with large coagula.

From these observations, and more particularly from the 3rd, 4th and 6th days, it is evident that the fibrin and albumen appear in the urine when no fat is perceptible, and previous to breakfast being taken, thus:—

The 3rd day, 8^h 30^m A.M., the urine passed before breakfast, after he had been up an hour, was highly albuminous, and a nearly solid coagulum filled the bottle.

The 4th day, 7^h 15^m A.M., on first getting up the urine contained the slightest trace of albumen. The specific gravity = 1027. The precipitate by alcohol = 0·8 gr. per 1000 grs. of urine.

The 4th day, 9^h 50^m A.M., just before breakfast the urine formed a solid coagulum, and contained a visible deposit of blood. Specific gravity = 1015·6. The precipitate by alcohol = 14·1 grs. per 1000 grs. of urine.

The 4th day, 11 A.M., the urine was chylous.

The 6th day, 6^h 35^m A.M., on first getting up, the specific gravity = 1026·6. The precipitate by alcohol = 3·6 grs. per 1000 grs. of urine.

The 6th day, 8^h 10^m A.M., before breakfast the urine coagulated spontaneously. Specific gravity = 1016·4. The precipitate by alcohol = 16·5 per 1000 grs. of urine.

Further experiments on the influence of rest and motion in lessening or increasing the albumen in the urine, previous to breakfast, were then made.

On the Influence of Rest and Motion in Lessening or Increasing the Albumen in the Urine previous to and after Food was taken.

Seventh day. Last food was taken at 5^h 15^m P.M. yesterday. He laid in bed this morning till 9^h 30^m A.M.

Urine passed at

10 P.M. Last night, milky; eight ounces.

6^h 40^m A.M. Yellow, slightly milky; six ounces, acid; contained a little albumen.

8^h 10^m A.M. Clear, healthy looking urine, made just before breakfast (boiled milk, a pint of sago, bread, with a little butter). The quantity, one and a half ounce.

- Specific gravity = 1021.3. Gave no coagulum with heat and acid. 510.65 grs. precipitated by alcohol. Precipitate = 0.30 gr. = 0.6 gr. per 1000 grs. of urine.
- 9^h 30^m A.M. Opalescent, no spontaneous coagulation. Two and a half ounces passed when he got up. Specific gravity = 1019.0. Gave a considerable precipitate with heat and acid. 509.5 grs. precipitated by alcohol. Precipitate = 1.40 gr. = 2.7 grs. per 1000 grs. of urine.
- 12^h 30^m A.M. Milky; spontaneously coagulating.
- Eighth, being the next day. Last food between 5 and 6 P.M. yesterday. Up this morning at 6 A.M. Urine passed at 10 P.M., last night, was chylous.
- 2 A.M. Yellow milky; three ounces, acid. Slightly coagulating with heat and acid.
- 6^h A.M. Quite clear; healthy-looking. Two ounces; acid. Contained no trace of albumen. Specific gravity = 1026.4. 513.2 grs. precipitated by alcohol. Precipitate = 0.85 gr. = 1.65 gr. per 1000 grs. of urine.
- 7^h 30^m A.M. Opalescent; one and a half ounce; feebly acid; gave a large precipitate with nitric acid and heat; contained multitudes of healthy blood-globules; no casts. On long standing gave a small bloody coagulum, which fell to the bottom of the bottle. Specific gravity = 1018.8. 509.4 grs. precipitated by alcohol. Precipitate = 0.65 gr. = 1.19 grs. per 1000 grs. of urine.
- 9 A.M. Opalescent; by 12 o'clock became a solid jelly; two ounces, alkaline. Passed just before breakfast, which consisted of a pint of milk and sago, with bread and little butter.
- 11^h 30^m A.M. Coagulated spontaneously to a strong, unclear, slightly milky jelly. About three ounces, alkaline, passed in my room. Says that he thinks he can tell when the urine will be most thick and bloody by the pain, pressure and dragging, with heat in the loins.
- Ninth, being the next day. Last food at 6 P.M. the day previous; staid in bed today until 9^h 30^m A.M.
- Urine passed at
- 3 A.M. Cloudy, opalescent; five ounces.
- 6^h 30^m A.M. Clear healthy water; an ounce and a half, highly acid. No precipitate with heat and acid.
- 8^h 40^m A.M. Clear, one ounce; contained the smallest trace of albumen. Specific gravity = 1024.2. He did not sleep from 6^h 30^m, but he remained in bed. This water was passed just before breakfast, which consisted of a pint of boiled milk and sago, bread, with a little butter. 512.1 grs. precipitated by alcohol. Precipitate = 0.85 gr. = 1.61 gr. per 1000 grs. of urine.
- 9^h 30^m A.M. Still clear, an ounce and a half in quantity, made on first getting up. Gave the most minute trace of albumen. Specific gravity = 1022.2. Very slightly acid. 511.1 grs. precipitated by alcohol. Precipitate = 0.60 gr. = 1.1 gr. per 1000 grs. of urine.
- 10^h 30^m A.M. Very milky, alkaline.

Tenth day. After animal food had formed the greatest part of his diet for ten days; he remained this day in bed until after breakfast.

Urine passed at

8^h 20^m A.M. Clear; no trace of albumen; acid. Specific gravity = 1023·4 grs. passed before breakfast. 511·7 grs. precipitated by alcohol. Precipitate = 0·40 gr. = 0·78 gr. per 1000 grs. of urine.

Eleventh day. The following morning; up early.

Urine passed at

8^h 10^m A.M. Cloudy; contained some blood-globules, but no trace of fibrinous casts; acid. Specific gravity = 1022·6; passed before breakfast. Gave a considerable precipitate with heat and acid. 511·3 grs. precipitated by alcohol. Precipitate = 9·40 grs. = 18·38 grs. per 1000 grs. of urine.

The following table shows these results clearly:—

Seventh day. Remained in bed late.

| | Specific gravity. | Precipitate by alcohol. |
|--|-------------------|-----------------------------------|
| 8 ^h 10 ^m A.M. In bed. Urine passed before breakfast, clear | = 1021·3 | = 0·6 gr. per 1000 grs. of urine. |
| 9 ^h 30 ^m A.M. In bed. Urine passed after breakfast, opalescent | = 1019·0 | = 2·7 |

Eighth day. Up early.

| | | |
|---|----------|--------|
| 6 A.M. On getting up. Urine passed before breakfast, clear | = 1026·4 | = 1·6 |
| 7 ^h 30 ^m A.M. Up. Urine passed before breakfast, opalescent | = 1018·8 | = 11·9 |

Ninth day. Remained in bed late.

| | | |
|--|----------|-------|
| 8 ^h 40 ^m A.M. In bed. Urine passed before breakfast, clear | = 1024·2 | = 1·6 |
| 9 ^h 30 ^m A.M. On getting up. Urine passed after breakfast, clear | = 1022·2 | = 1·1 |

Tenth day. Remained in bed.

| | | |
|--|----------|--------|
| 8 ^h 20 ^m A.M. Urine passed before breakfast, clear | = 1023·4 | = 0·78 |
|--|----------|--------|

Eleventh day. Up early.

| | | |
|---|----------|---------|
| 8 ^h 10 ^m A.M. Urine passed before breakfast, cloudy | = 1022·6 | = 18·38 |
|---|----------|---------|

| | | |
|--|----------|--------|
| Healthy urine free from albumen, precipitated by } alcohol in excess..... | = 1020·2 | = 2·15 |
| Second experiment..... | = 1021·2 | = 3·48 |

The precipitate chiefly consisted of sulphates and a little phosphate of lime, and no uric acid.

These experiments show most clearly the influence of rest and the effect of rising, (and even of waking) in causing the albumen to appear in the urine. The comparison of the 8th day with the 7th or 9th, and the great difference between the 11th and 10th days is quite conclusive. In other experiments I frequently determined before-hand whether the urine before breakfast should be albuminous or not, by directing the patient to get up and move about early or to keep very quiet in bed. And by keeping in bed all the day the urine throughout the whole day was very slightly albuminous.

It appeared to me to be very desirable to see whether the blood was milky. Mr. WILSON, of Tavistock Street, through whose kindness the patient came to me, bled him for me. The veins were filled with blood rather longer than usual before the opening was made; the blood came in a tolerable stream. The dinner, at 1^h 30^m P.M., consisted of a mutton chop with vegetables and bread. The blood was taken at 4^h 30^m P.M. into a thin wide mouth bottle. It was left to stand fourteen hours. There was no appearance of buff or cupping. The serum was opalescent, but not at all milky; and when agitated with ether it did not become clear, and the quantity of fat dissolved in the ether was very small.

Blood . . . = 1216·2 grs.

(1.) Serum poured off = 288·5 grs. Residue on evaporation = 26·9 grs.

Hence water . . . = 261·6 grs.

(2.) Clot washed with distilled water until colourless.

Fibrin dried, *in vacuo* . . . = 3·20 grs.

= 2·63 grs. per 1000 grs. of blood.

(3.) Blood-globules, *plus* residue of serum, } = 924·3 grs.
minus fibrin. }

Evaporated to dryness = 261·8 grs.

Hence water = 662·5 grs.

contain by (1.) 68·1 grs. of solids of serum.

Therefore blood-globules = 261·8 - 68·1 = 193·7 grs. = 159·3 grs. per 1000 grs. of blood.

Total solids of serum = 68·1 + 26·9 = 95·0 grs. = 78·1 grs. per 1000 grs. of blood.

(4.) Dried blood-globules, and serum, in the proportion of one-quarter serum to three-quarters globules, were treated with ether frequently: 99·7 grs. gave 0·25 gr., soluble in ether = 2·6 grs. of fat per 1000 grs. of dry residue.

Hence in 1000 parts of blood—

| | |
|-------------------------------|--------|
| Fibrin | 2·63 |
| Blood-globules | 159·3 |
| Solids of serum | 78·1 |
| Total solid residue | 240·03 |
| Water | 759·97 |
| Fat | 0·62 |

The urine made the same day on which he was bled was also examined.

That passed at

6^h 30^m A.M. Clear.

8 A.M. Slightly cloudy. Then got up and had breakfast on arrow-root.

10 A.M. A solid and pinkish-white coagulum formed in the urine spontaneously.

1^h 30^m P.M. Milky, with some blood and spontaneous coagula. Six ounces passed just before dinner, which consisted of a mutton chop, with vegetables and bread.

4 P.M. Milky; five ounces.

respects, excepting in the diminution of the solids in the serum, the analysis of the blood corresponds with that of a case of cerebral congestion given by ANDRAL.

| | Cerebral congestion. | So-called chylous urine. |
|---------------------------|----------------------|--------------------------|
| Fibrin | 2·7 | 2·63 |
| Globules | 152·3 | 159·3 |
| Solids of serum | 105·0 | 78·1 |
| Water | 740·0 | 759·97 |

The general results are—

1st. That the most important changes in the urine take place independently of the influence of digestion.

2ndly. That the urine in one respect only resembles chyle, and that is in containing, after digestion, a large quantity of fat in a very fine state of division; but the excess of fat in the urine is not caused by any excess of fat in the blood, for no excess of fat was found there.

3rdly. It appears that some change is produced in the kidney by which fibrin, albumen, globules and salts are allowed to pass out whenever the circulation through the kidney is increased: if, at the same time, fat is present in the blood, it escapes also into the urine.

That this change of structure is not visible to the naked eye on *post mortem* examination of the kidneys, Dr. PROUT long since demonstrated; and in a case of this disease, which was in St. George's Hospital, and was examined at Plymouth, no disease of the kidney was observed. From the total absence of fibrinous casts of the tubes from this urine, it is not improbable that by the microscope a difference may be detected in the structure of the mammary processes rather than in that of the cortical part of the kidney.

XXXIII. *Contributions to the Chemistry of the Urine.*—Paper III.PART IV. *On the Variations of the Sulphates and Phosphates in Disease.*

By HENRY BENCE JONES, M.D., M.A. Cantab., F.R.S., Physician to St. George's Hospital.

Received April 19,—Read June 13, 1850.

THE object of the following experiments was to determine whether the sulphates in the urine were increased or diminished in any class of diseases. The total amount of phosphates in the urine in the same diseases was at the same time made the subject of experiment, partly to see whether the deductions made in a paper published in the Philosophical Transactions for 1846 would be confirmed, and partly to determine whether the same disease produced the same or a different effect on the phosphates as on the sulphates; whether, in diseases in which the phosphates were increased the sulphates would be also increased in the same proportion; and whether, in those diseases in which the phosphates were diminished, the sulphates also would be found to be below the average amount.

Most of the following experiments were made on the urine first passed in the morning before food. When this could not be obtained, the afternoon or night urine was taken. Almost all the cases were in St. George's Hospital, and therefore under nearly the same circumstances as regards exercise. The diet usually varied with the state of the patient.

In two papers in the Philosophical Transactions for 1845 and 1849, I have shown that in the healthy state on full diet the total amount of sulphates and phosphates in the urine varies as regards sulphates—

| | Spec. grav. |
|---|-------------|
| After food from 11·85 grs. of sulphate of baryta per 1000 grs. of urine . | 1033·9 |
| Before food to 7·93 grs. of sulphate of baryta per 1000 grs. of urine . . | 1026·5 |

As regards the total phosphates—

| | |
|---|--------|
| After food from 7·22 grs. of phosphate of lime per 1000 grs. of urine . . | 1030·0 |
| Before food to 7·96 grs. of phosphate of lime per 1000 grs. of urine . . | 1027·9 |

In the following paper I shall give the amount of the sulphates and the total amount of the phosphates in the urine:—

1. In acute and chronic diseases in which the muscular structures are chiefly affected.

2. In some functional diseases of the brain, as delirium tremens and some other forms of delirium.

3. In acute inflammatory disease of the nervous structures.

4. In chronic diseases of the nervous structures.

5. In *acute* diseases in which neither the nervous nor the muscular structures are chiefly affected.

6. In *chronic* diseases in which neither the muscular nor nervous structures are chiefly affected.

TABLE I.—On the amount of Sulphates and the total amount of Earthy and Alkaline Phosphates in those diseases in which the muscular structures are chiefly affected.

| | Sulphate of baryta per 1000 grs. of urine. | Specific gravity. | Total phosphates per 1000 grs. of urine. |
|-------------------------------------|---|----------------------|---|
| Case 1. Acute chorea after salts. | | | |
| 5th day | 25.09 | 1032.3 | 0.68 |
| 5th day | 21.73 | 1035.2 | |
| 8th day | 7.28 | 1030.0 | 7.34 |
| 9th day | 2.56 | 1013.1 | 4.70 |
| Case 2. Acute chorea. Boy, æt. 8. | | | |
| 6th day | 11.25 | 1030.6 | 3.29 |
| 7th day | 10.66 | 1031.8 | 2.52 |
| 8th day | 11.15 | 1031.2 | 2.54 |
| 10th day | 7.39 | 1028.4 | 3.50 |
| 11th day | 3.92 | 1018.6 | 1.57 |
| 102nd day | 8.01 | 1030.6 | |
| Case 3. Acute chorea. Girl, æt. 22. | | | |
| 3rd day | 19.88 | 1036.0 | |
| 5th day | 15.86 | 1033.8 | |
| 6th day | 13.80 | 1028.4 | 6.51 |
| 7th day | 9.36 | 1026.8 | |
| 8th day | 6.08 | 1025.4 | |
| 13th day | 4.72 | 1016.4 | |
| Case 4. Chronic chorea | 1.86 | 1008.2 | |
| Case 5. Chronic chorea | 3.49 | 1014.7 | 1.61 |
| | 1.91 | 1014.3 | 1.12 |
| | 2.66 | 1013.0 | 4.05 |
| Case 6. Chronic tetanus | 1.58 | 1009.9 | 2.47 |
| | 2.95 | 1015.5 | 2.75 |

Hence in three cases of acute chorea the most remarkable increase was observed in the amount of sulphates in the urine. That this did not arise from the small quantity of urine passed is evident from the small amount of the total phosphates in the urine. Moreover the actual quantity passed, when it could be determined by measure, was found occasionally to be above thirty ounces in twenty-four hours. It is worthy of notice that the amount of urea was also very greatly increased in these cases; so much so, that on the addition of nitric acid to the urine without any evaporation, nitrate of urea immediately crystallized out.

A very small quantity of food was taken by these patients, whilst the muscular action was most severe; and the contrast between the amount of sulphates when they were recovering and taking full diet, and the amount when they took little food, but were in a state of violent muscular action, is very remarkable.

The general conclusion is, that in acute chorea the amount of sulphates in the urine is increased, whilst the phosphates are in some cases as remarkably diminished.

TABLE II.—On the amount of Sulphates and the total amount of Earthy and Alkaline Phosphates in some functional diseases of the brain, as delirium tremens and some other forms of delirium.

| | Sulphate of baryta per 1000 grs. of urine. | Specific gravity. | Total phosphates. |
|--|---|----------------------|-------------------|
| Case 1. Delirium tremens. 6th day | 5.74 | 1017.9 | |
| 6th night. Death. | | | |
| Case 2. Delirium tremens. 5th day | 13.34 | 1018.0 | |
| Case 3. Delirium tremens. 3rd day | 10.60 | 1023.94 | 5.29 |
| Case 4. Delirium tremens. 10th day | 17.31 | 1024.74 | 0.87 |
| Case 5. Delirium tremens. Chloroform. 8th day | 8.51 | 1026.8 | |
| Case 6. Delirium tremens. 5th day | 20.77 | 1037.8 | 2.14 |
| 5th night | 37.07 pink. | 1041.2 | 5.95 |
| 6th died. | | | |
| Case 7. Delirium tremens. Uncertain day | 2.96 | 1013.2 | 1.18 |
| Uncertain day | 7.83 | 1021.6 | 7.24 |
| Uncertain day | 8.61 | 1022.0 | 7.43 |
| Case 8. Delirium tremens. 13th day | 13.10 | 1037.4 | 9.83 |
| 14th day | 12.95 | 1034.6 | 8.89 |
| Case 9. Traumatic delirium tremens. 3rd day | | 1014.8 | 1.97 |
| 5th day | 8.45 | 1028.0 | 3.11 |
| 6th day | 8.77 | 1026.2 | 6.23 |
| Case 10. Poisoned by laudanum, with de- lirium and excitement. 2nd day | 7.83 | 1026.8 | 7.53 |
| 3rd day | 6.78 | 1023.0 | 1.11 |
| Re-admitted again poisoned. 1st day..... | 6.35 | 1029.2 | 8.88 |
| 2nd day | 6.38 | 1024.0 | 8.24 |
| 3rd day | 15.89 | 1028.0 | 4.22 |
| 4th day | 13.01 | 1026.0 | 4.81 |
| 6th day | 7.55 | 1025.0 | 4.42 |
| 7th day | 8.22 | 1026.3 | 5.88 |
| Case 11. Delirium, with phthisis. 4th day | 10.84 | 1027.34 | 1.44 |
| 4th night..... | 6.97 | 1024.2 | 0.72 |
| 7th day | 4.45 | 1018.3 | 1.51 |

In the 2nd, 3rd, 4th, 6th and 8th cases of delirium tremens the sulphates were found to be above the average. In the 6th case the sulphates are in the greatest quantity ever observed in health or disease. Sulphate of magnesia had also been taken by this patient, so that the amount of sulphates is partly owing to the medicine; but that this is not the sole or chief cause of the increase is proved by the fact that many of the patients with other diseases took the same quantity of sulphate of magnesia, but the sulphates in the urine were never increased to the same amount.

The phosphates, in seven out of the nine cases of delirium tremens, were below the average. The same fact was stated in my previous paper, but from the diminution

of the phosphates in acute chorea, it becomes doubtful how far this result is owing to the action of alcohol in the system.

Further experiments are required; meanwhile excessive abstinence from food must be admitted as a cause of the diminution of the phosphates in the urine, provided there is no inflammatory action of the nervous structures.

In a case of restless excitement leading to self-destruction, the sulphates in the urine were found to be increased, and the same thing was also observed with a diminution of the phosphates in a case of delirium and phthisis.

In the 6th and 10th cases urea was found to be in great excess when the sulphates were increased. In the other cases the excess of urea was not looked for.

TABLE III.—On the amount of Sulphates and the total amount of Earthy and Alkaline Phosphates in acute inflammatory diseases of the nervous structures.

| | Sulphate of baryta per 1000 grs. of urine. | Specific gravity. | Total phosphates. |
|--|---|----------------------|-------------------|
| Case 1. Inflammation of the brain. 20th day | 7.67 | 1031.8 | |
| Case 2. Inflammation of the brain. 12th day | 3.96 | 1018.7 | 5.14 |
| 13th day | 11.23 | 1027.26 | 11.13 |
| 14th day | 2.91 | 1013.1 | 6.06 |
| 16th day | 7.34 } 7.69 } | 1027.0 | { 10.75 11.04 |
| 16th night. Died. | | | |
| Case 3. Subacute hydrocephalus. 15th day | 8.83 | 1030.0 | 9.41 |
| 16th day | 10.69 | 1029.0 | 8.45 |
| 22nd day | 8.83 | 1029.8 | 10.19 |
| 26th day | 9.46 | 1031.4 | 9.01 |
| 28th day. Died. | | | |
| Case 4. Acute after chronic disease. Uncertain | 3.54 | 1024.9 | 0.91 |
| | 9.39 | 1026.0 | 9.31 |
| Died. | | | |
| Case 5. Head symptoms, with tubercles in cerebellum and lungs. 15th day | 9.88 | 1031.6 | 8.72 |
| 15th night | 10.07 | 1032.2 | 8.91 |
| 16th day | 6.69 | 1016.4 | 4.72 |
| 16th night | 8.25 | 1018.2 | 5.69 |
| 18th day. Died. | | | |
| Case 6. Inflammation of the lungs, with tu- berclés and violent head symptoms. 4th day | 8.55 | 1027.85 | 7.19 |
| 6th day | 7.81 | 1026.1 | 6.43 |
| 8th day | 11.63 | 1031.4 | 9.30 |
| 9th day | 10.13 | 1026.2 | 7.99 |
| 9th night. Died. | | | |
| Case 7. Injury, with head symptoms not violent. 2nd day | 7.34 | 1026.8 | 5.20 |
| 4th day | 9.66 | 1028.6 | 7.52 |
| 5th day | 13.74 | 1028.6 | 7.91 |
| 32nd day | 2.11 | 1011.66 | 1.52 |
| Case 8. Injury of the head, slight. 7th day | 6.59 | 1022.9 | 8.93 |

TABLE III. (continued.)

| | Sulphate of baryta per 1000 grs. of urine. | Specific gravity. | Total phosphates. |
|---------------------------|--|-------------------|-------------------|
| Case 9. Fractured spine. | | | |
| 5th day | 3.75 | 1014.2 | 3.15 |
| 6th day | 12.23 | 1030.2 | 10.68 |
| 7th day | 9.91 | 1028.8 | 10.10 |
| 7th night. Died. | | | |
| Case 10. Fractured spine. | | | |
| 4th day | 14.57 | 1029.2 | 9.26 |
| 5th day | 15.54 | 1029.2 | 8.16 |
| 6th day | 13.00 | 1030.2 | 7.96 |
| 7th day | 6.65 | 1021.6 | 4.30 |
| 8th day | 8.80 | 1022.0 | 6.67 |
| 9th day | 2.18 | 1007.3 | 1.58 |
| 10th day | 2.37 | 1010.8 | 2.57 |
| Died. | | | |
| Case 11. Fractured spine. | | | |
| 1st day | 5.59 | 1012.0 | 4.15 |
| 1st night. Died. | | | |
| Case 12. Fractured spine. | | | |
| 1st day..... | 5.90 | 1019.4 | 2.47 |
| 2nd day | 6.45 | 1025.3 | 4.31 |
| 2nd night..... | 3.37 | 1012.4 | 1.40 |
| 3rd day | 5.87 | 1023.0 | 1.09 |
| 3rd night..... | 10.32 | 1027.0 | 3.11 |
| 4th day | 6.65 | 1022.6 | 5.77 |
| 4th night..... | 7.61 | 1024.1 | 4.90 |
| 5th day | 13.03 | 1027.8 | 4.08 |
| 6th day. Died. | | | |



In the first eight cases of inflammatory action in the brain, there is an increase in the amount of sulphates as well as in the total amount of phosphates in the urine. In the second and third cases this increase is most apparent. In the previous paper the phosphates in the urine were shown to be decidedly increased in inflammation of the brain, and from these experiments it is evident that the sulphates are increased also.

From the amount of albumen in the nervous structures, it is certain that the amount of sulphur present therein is but little if at all less than the amount of phosphorus which it contains.

TABLE IV.—On the amount of Sulphates and the total amount of Phosphates, Earthy and Alkaline, in some slight and chronic diseases of the nervous or neighbouring structures.

| | Sulphate of baryta per 1000 grs. urine. | Specific gravity. | Total phosphates. |
|--|---|-------------------|-------------------|
| Case 1. Pain in the head. After salts. | | | |
| 40th day | 9.98 | 1026.2 | |
| Case 2. Hemiplegia. | | | |
| 7th day | 5.13 | 1021.6 | 5.22 |
| 21st day | 2.60 | 1017.0 | 1.51 |
| Case 3. Scalp wound. After salts. | | | |
| 6th day | 8.34 | 1023.7 | 4.63 |
| 8th day | 4.84 | 1018.7 | 3.77 |
| Case 4. Fracture of the skull. After salts | 11.97 | 1019.1 | 6.08 |
| Case 5. Recent paraplegia | 7.24 | 1021.6 | 4.50 |

In these diseases no increase of sulphates was observed, except after sulphate of magnesia had been taken as a medicine. The quantity taken was usually two drachms; yet the amount in the urine never reached to what it was when there was excessive action of the muscular or nervous structures.

TABLE V.—On the amount of Sulphates and the total amount of Earthy and Alkaline Phosphates in acute diseases, in which neither the nervous nor muscular structures are chiefly affected.

| | Sulphate of baryta per 1000 grs. of urine. | Specific gravity. | Total phosphates. |
|---|---|----------------------|-------------------|
| Case 1. Petechial fever. | | | |
| 5th day | 5.65 | 1014.6 | 2.62 |
| 6th day | 3.79 | 1012.9 | 2.01 |
| 9th day | 1.30 | 1010.0 | 0.73 |
| 13th day | 0.93 | 1011.5 | 2.61 |
| 18th day | 5.25 | 1016.2 | 0.73 |
| 19th day | 10.06 | 1027.4 | 4.80 |
| 20th day | 1.12 | 1010.94 | 2.10 |
| 22nd day | 2.58 | 1020.80 | 2.68 |
| 55th day. Recovered. | | | |
| Case 2. The same patient with ague and | | | |
| 28th day | 5.71 | 1021.6 | 5.13 |
| 33rd day | 4.86 | 1015.6 | 1.41 |
| afterwards with petechial fever. | | | |
| 5th day | 5.39 | 1027.0 | 4.32 |
| 8th day | 6.56 | 1026.2 | 4.32 |
| 16th day | 3.19 | 1014.2 | 3.09 |
| 21st day. Recovered. | | | |
| Case 3. Scarlet fever. | | | |
| 3rd day | 8.27 | 1032.2 | 6.33 |
| 10th day | 2.01 | 1012.0 | 2.90 |
| 19th day | 4.14 | 1022.1 | 5.42 |
| Case 4. Inflammation of the lungs. | | | |
| 7th day | 6.21 | 1019.7 | 6.41 |
| 8th day | 5.91 | 1021.5 | 6.98 |
| 9th day | 6.59 | 1021.5 | 4.24 |
| 10th day | 6.96 | 1025.4 | 6.96 |
| 11th day | 8.13 | 1025.5 | 4.23 |
| 13th day | 8.02 | 1027.1 | 2.86 |
| 16th day | 4.16 | 1018.0 | 3.77 |
| Case 5. Petechial fever. | | | |
| 16th day | 3.05 | 1013.7 | 4.08 |
| Case 6. Petechial fever. | | | |
| 10th day | 3.35 | 1013.2 | 2.90 |
| 11th day | 4.04 | 1013.7 | 3.94 |
| 14th day | 3.73 | 1016.8 | 7.08 |
| Case 7. Inflammation of the lungs and membranes of the brain. | | | |
| 7th day | 4.05 | 1012.5 | 2.86 |
| Case 8. Acute rheumatism. After sulphur. | | | |
| 9th day | 11.75 | 1031.10 | |
| Case 9. Acute rheumatism. | | | |
| 11th day | 6.96 | 1025.7 | 5.59 |
| Case 10. Acute rheumatism. After salts. | | | |
| 5th day | 11.89 | 1026.0 | 9.84 |
| 7th day. After salts | 10.78 | 1029.1 | 5.53 |
| 20th day | 6.94 | 1021.8 | 5.97 |
| Case 11. Acute rheumatism. | | | |
| 8th day | 7.17 | 1023.2 | 5.60 |
| 17th day | 5.68 | 1027.5 | 6.26 |

In these acute diseases, except after sulphate of magnesia, the amount of sulphates was not found above the average. The amount both of phosphates and sulphates appeared not to be influenced by these diseases.

TABLE VI.—On the amount of Sulphates and the total amount of Earthy and Alkaline Phosphates in Chronic Diseases, in which neither the nervous nor muscular structures are chiefly affected.

| | Sulphate of baryta per 1000 grs. of urine. | Specific gravity. | Total phosphates. |
|---|---|----------------------|-------------------|
| Case 1. Exostosis | 1.75 | 1016.6 | |
| Case 2. Exostosis | 7.09 | 1023.4 | 6.03 |
| Case 3. Exostosis | 9.08 | 1026.4 | 11.58 |
| Case 4. Diabetes..... | 7.45 | 1025.2 | 3.94 |
| Case 5. Diabetes..... | 4.21 | 1030.2 | 0.91 |
| Case 6. Diuresis. Albumen | 0.49 | 1003.6 | 1.09 |
| | 0.89 | 1005.36 | 1.49 |
| Case 7. Obstruction of the œsophagus. Albumen | 1.38 | 1012.2 | 4.70 |
| Case 8. Aneurism of aorta? | 6.03 | 1017.8 | 2.39 |
| Case 9. Obstruction of the bowels. Sulphate of magnesia. 8th day | 22.55 | 1024.3 | 3.51 |
| 9th. Died. | | | |
| Case 10. Excessive oxalate of lime | 7.89 | 1025.5 | 6.14 |
| Case 11. Indigestion. Alkaline from fixed alkali | 3.26 | 1024.7 | 3.65 |
| Case 12. Chronic rheumatism. After sulphur | 5.85 | 1011.82 | 4.86 |
| Case 13. Chronic rheumatism | 7.93 | 1023.44 | |
| Case 14. Chronic gout. Vichy water..... | 10.04 | 1025.8 | 5.26 |

In these chronic diseases nothing remarkable was observed as to the amount of sulphates or phosphates, excepting in case 3 of exostosis, in which the amount of sulphates and of phosphates was above the average.

In case 9, of total obstruction of the bowels, sulphate of magnesia was given frequently during the day in small doses: nothing passed through the intestine. The whole of the sulphate was absorbed, and hence the great increase in the sulphates in the urine.

In a patient, case 14, who was taking Vichy water, the sulphates were observed to be slightly above the average.

The conclusions I have drawn may be thus enumerated:—

Table I. In three cases of acute chorea the most remarkable increase was observed in the amount of sulphates in the urine. In the same cases the quantity of urea was very much increased. The quantity of urine made in twenty-four hours was not excessively diminished, and the total amount of earthy and alkaline phosphates was below the average amount.

The general conclusion was, that in acute chorea the amount of sulphates in the urine is increased, whilst sometimes the phosphates are as remarkably diminished.

Table II. In delirium tremens and in other delirium a remarkable increase in the amount of sulphates in the urine was frequently observed, and the total phosphates were in the same cases occasionally remarkably diminished; and the resemblance to

the state of chorea was still closer, inasmuch as occasionally a very great excess of urea was found in these cases also.

Table III. In acute inflammatory diseases of the nervous structures, during the most febrile symptoms, an increase was observed in the amount of sulphates in the urine, and the total amount of earthy and alkaline phosphates in these diseases appeared to be increased in the same proportion as the sulphates were increased.

Table IV. In some slight and chronic diseases of the nervous structures, no increase in the amount of sulphates in the urine was observed, excepting when sulphate of magnesia had been taken as a medicine.

Table V. In acute diseases, in which neither the nervous nor the muscular structures were chiefly affected, no increase in the sulphates or phosphates was observed, except after sulphate of magnesia.

Table VI. In chronic diseases, in which neither the nervous nor the muscular structures were chiefly affected, no decided increase in the sulphates or phosphates in the urine was observed, except after sulphate of magnesia. One case of exostosis may be regarded as a doubtful exception to this statement.

The general conclusions are—

1. That in acute chorea, in which the muscles are in excessive action, the sulphates and urea in the urine are greatly increased.

2. That in delirium tremens the same state of urine is frequently met with; that in these diseases the phosphates are not at all increased.

3. That in acute inflammation of the nervous structures, sulphates and phosphates are both increased in the urine.

4. That in chronic diseases of the brain, and that in other acute inflammations and diseases and in other chronic diseases, no increase in the total amount of sulphates is observed, excepting when sulphate of magnesia is taken as a medicine.

The result of this investigation is that—

Muscular action increases the sulphates in the urine without increasing the phosphates; whilst

Inflammation of the brain increases both the sulphates and phosphates in the urine.

XXXIV. *Second Appendix to a paper on the Variations of the Acidity of the Urine in the state of Health.*

By HENRY BENICE JONES, M.D., M.A., Cantab., F.R.S., Physician to St. George's Hospital.

Received June 6,—Read June 20, 1850.

On the Influence of Tartrate of Ammonia and of Carbonate of Ammonia on the Acidity of the Urine.

IN a previous paper and appendix on the acidity of the urine, published in the Philosophical Transactions for 1849, I have shown the effect of different diets, of sulphuric acid, of tartaric acid, of caustic potash and of tartrate of potash on the acidity of the urine; in this Appendix I purpose tracing the effect of tartrate of ammonia and of carbonate of ammonia.

III. (e.) The effect of tartrate of potash having been so remarkable, it was thought, that by observing the effect of tartrate of ammonia, some conclusion might most rapidly and decidedly be obtained, as to the comparative effect of fixed and volatile alkalies on the acidity of the urine.

Mr. MORSON prepared for me some beautifully crystalline tartrate of ammonia: one portion was dried by pressure on blotting paper; another portion was dried in a water bath. When dissolved in water no acid reaction was perceptible.

(36.) The first day for comparison no tartrate of ammonia was taken. Breakfast at 8^h 40^m A.M. Dinner at 6^h P.M. On mixed diet.

| | h m | Spec. gr. | Acidity per 1000 grs. of urine. | Appearance. |
|-----------------|-----------|-----------|---------------------------------|--------------------|
| Water passed at | 7 25 A.M. | | | was thrown away. |
| Water passed at | 8 40 | 1015·3 | + 4·93 measures. | Clear. |
| Water passed at | 9 45 | 1021·7 | — 2·93 | Clear. |
| Water passed at | 10 50 | 1018·5 | — 7·85 | Clear. |
| Water passed at | 1 0 P.M. | 1025·8 | +10·72 | Thick from urates. |
| Water passed at | 3 25 | 1024·2 | +19·52 | Thick from urates. |
| Water passed at | 6 0 | 1023·5 | +26·38 | Clear. |
| Water passed at | 8 15 | 1029·4 | +25·26 | Thick from urates. |
| Water passed at | 10 15 | 1031·7 | +15·50 | Thick from urates. |
| Water passed at | 7 10 A.M. | 1022·3 | +10·76 | Clear. |

(37.) For the following days tartrate of ammonia was taken. The first day two drachms of imperfectly dry tartrate of ammonia were taken, in two ounces of distilled water, at a few minutes after one o'clock P.M.

| | | | | |
|-----------------|-----------|--------|------------------|-------------------------------|
| Water passed at | 8 35 A.M. | 1025·1 | +13·65 measures. | Thick appearance from urates. |
| Water passed at | 10 5 | 1023·9 | +11·72 | Thick from urates. |
| Water passed at | 11 30 | 1027·2 | — 7·78 | Clear. |

| | h m | Spec. gr. | Acidity per 1000 grs. of urine. | Appearance. |
|-----------------|-----------|-----------|---------------------------------|--------------------|
| Water passed at | 1 5 P.M. | 1027.0 | + 5.84 measures. | Thick from urates. |
| Water passed at | 2 10 | 1025.2 | + 11.70 | Thick from urates. |
| Water passed at | 2 50 | 1025.6 | + 18.52 | Thick from urates. |
| Water passed at | 4 30 | 1025.9 | + 20.47 | Cloudy. |
| Water passed at | 6 30 | 1024.6 | + 18.54 | Clear. |
| Water passed at | 11 45 | 1031.0 | + 12.62 | Thick from urates. |
| Water passed at | 6 55 A.M. | 1021.1 | + 16.64 | Clear. |

(38.) The following day 180 grains of tartrate of ammonia, dried at 100, were taken soon after twelve o'clock; and at three o'clock 108 grains more were taken. In all then, 288 grains. Breakfast at 8^h 24^m A.M. Dinner at 6^h 30^m P.M. The salt caused severe griping pain of the bowels, which lasted until the night, but the bowels were not relaxed.

| | | | | |
|-----------------|-----------|--------|-------------------|--------------------|
| Water passed at | 8 24 A.M. | 1026.0 | + 17.54 measures. | Thick from urates. |
| Water passed at | 10 10 | 1027.0 | + 13.63 | Thick from urates. |
| Water passed at | 12 5 | 1027.4 | + 11.68 | Thick from urates. |
| Water passed at | 1 0 P.M. | 1024.8 | + 17.56 | Thick from urates. |
| Water passed at | 3 0 | 1027.4 | + 23.36 | Thick from urates. |
| Water passed at | 5 0 | 1025.5 | + 25.35 | Clear. |
| Water passed at | 6 20 | 1026.0 | + 27.29 | Clear. |
| Water passed at | 11 15 | 1029.2 | + 15.54 | Thick from urates. |
| Water passed at | 6 40 A.M. | 1022.9 | + 17.59 | Clear. |

(39.) The following day a single dose of tartrate of ammonia was taken. At twelve o'clock 177 grains of imperfectly dry tartrate of ammonia were taken. Breakfast at 8^h 10^m A.M. Dinner at 6^h 30^m P.M. as before.

| | | | | |
|-----------------|-----------|--------|-------------------|--------------------|
| Water passed at | 8 10 A.M. | 1027.0 | + 19.47 measures. | Thick from urates. |
| Water passed at | 9 45 | 1024.8 | + 17.56 | Thick from urates. |
| Water passed at | 12 0 | 1026.9 | + 14.60 | Thick from urates. |
| Water passed at | 1 30 P.M. | 1026.0 | + 16.57 | Thick from urates. |
| Water passed at | 3 20 | 1027.3 | + 25.30 | Thick from urates. |
| Water passed at | 4 50 | 1027.9 | + 27.24 | Thick from urates. |
| Water passed at | 6 30 | 1027.7 | + 28.21 | Thick from urates. |
| Water passed at | 11 40 | 1027.2 | - 8.75 | Clear. |
| Water passed at | 7 0 A.M. | 1017.5 | + 17.69 | Thick from urates. |

The medicine caused slight uneasiness of the bowels, which lasted until the evening.

(40.) The following day no tartrate of ammonia was taken. Breakfast at 8^h 30^m A.M. Dinner at 6^h 50^m P.M., as before.

| | | | | |
|-----------------|-----------|--------|-------------------|---------------------|
| Water passed at | 8 30 A.M. | 1024.8 | + 21.46 measures. | Thick from urates. |
| Water passed at | 10 10 | 1020.6 | + 11.75 | Thick from urates. |
| Water passed at | 11 20 | 1023.0 | 0 | Clear. |
| Water passed at | 1 0 P.M. | 1027.0 | + 5.84 | Thick from urates. |
| Water passed at | 2 30 | 1027.1 | + 14.60 | Thick from urates. |
| Water passed at | 5 5 | 1025.0 | + 26.34 | Cloudy from urates. |
| Water passed at | 6 50 | 1026.6 | + 29.22 | Clear. |
| Water passed at | 11 0 | 1032.1 | + 8.72 | Thick from urates. |

| | h m | Spec. gr. | Acidity per 1000 grs. of urine. | Appearance. |
|-----------------|-----------|-----------|---------------------------------|--------------------|
| Water passed at | 6 45 A.M. | 1016·7 | +15·73 measures. | Clear. |
| Water passed at | 8 30 | 1026·8 | +23·37 | Thick from urates. |
| Water passed at | 9 45 | 1027·2 | +15·56 | Thick from urates. |
| Water passed at | 10 40 | 1025·0 | + 5·85 | Thick from urates. |
| Water passed at | 12 0 | 1026·2 | - 3·89 | Clear. |
| Water passed at | 1 30 P.M. | 1026·5 | +11·69 | Thick from urates. |

It follows from these experiments, which are best seen in Plate LI., that the influence of tartrate of ammonia in lessening the acidity of the urine is not perceptible.

By comparing this Plate with Plate XXIII. 1849, the remarkable difference between the action of volatile alkali and fixed alkali is very apparent. When two drachms of tartrate of potash were taken, the effect was perceptible in thirty-five minutes. When three drachms of tartrate of ammonia were taken, no diminution of the acidity of the urine was observed.

In three days, one ounce, one drachm, two scruples and five grains of tartrate of ammonia were taken without any apparent effect in diminishing the acidity of the urine.

III. (*f.*) The effect of carbonate of ammonia on the acidity of the urine was then examined; and for this purpose Mr. MORSON gave me some of the so-called sesqui-carbonate of pharmacy. Each dose was reduced to powder immediately before it was taken, in distilled water.

(41.) The first day for comparison no carbonate of ammonia was taken. Breakfast at 8^h 20^m A.M. Dinner at 6^h 40^m P.M. As before.

| | h m | Spec. gr. | Acidity per 1000 grs. of urine. | Appearance. |
|-----------------|-----------|-----------|---------------------------------|--------------------|
| Water passed at | 8 20 A.M. | 1028·4 | lost. | Thick from urates. |
| Water passed at | 11 5 | 1025·2 | + 4·87 measures. | Cloudy. |
| Water passed at | 12 50 | 1024·4 | + 6·83 | Clear. |
| Water passed at | 3 5 P.M. | 1026·0 | +16·57 | Clear. |
| Water passed at | 5 15 | 1016·7 | +18·68 | Clear. |
| Water passed at | 6 40 | 1023·6 | +25·40 | Clear. |
| Water passed at | 11 5 | 1031·4 | 0 | Clear. |
| Water passed at | 6 55 A.M. | 1021·1 | +12·73 | Clear. |

(42.) The following day. Breakfast at 8^h 15^m A.M. Dinner at 6^h 50^m P.M., as before. Eighteen grains of carbonate of ammonia were taken at 12^h 50^m.

| | | | | |
|-----------------|-----------|--------|------------------|--------------------|
| Water passed at | 8 15 A.M. | 1021·7 | +15·66 measures. | Clear. |
| Water passed at | 9 50 | 1012·6 | + 7·90 | Clear. |
| Water passed at | 11 35 | 1020·3 | 0 | Clear. |
| Water passed at | 12 50 | 1022·5 | +11·63 | Clear. |
| Water passed at | 3 0 P.M. | 1022·1 | +17·61 | Clear. |
| Water passed at | 4 30 | 1021·1 | +20·56 | Clear. |
| Water passed at | 6 50 | 1023·7 | +24·42 | Clear. |
| Water passed at | 11 0 | 1031·1 | +19·39 | Thick from urates. |
| Water passed at | 6 50 A.M. | 1023·4 | +15·63 | Clear. |

(43.) The following day. Breakfast at 8^h 12^m A.M. Dinner at 6^h 35^m P.M. Twenty

grains of carbonate of ammonia were taken at 1^m P.M.; and the same quantity at 3^h 30^m P.M.

| | h m | Spec. gr. | Acidity per 1000 grs. of urine. | Appearance. |
|-----------------|-----------|-----------|---------------------------------|--------------------|
| Water passed at | 8 12 A.M. | 1024.6 | +22.49 measures. | Clear. |
| Water passed at | 9 45 | 1021.0 | +16.65 | Thick from urates. |
| Water passed at | 11 0 | 1025.0 | +11.70 | Thick from urates. |
| Water passed at | 1 0 P.M. | 1027.5 | +15.57 | Thick from urates. |
| Water passed at | 2 35 | 1029.6 | +21.36 | Thick from urates. |
| Water passed at | 4 25 | 1027.2 | +29.20 | Thick from urates. |
| Water passed at | 6 35 | 1026.2 | +29.23 | Clear. |
| Water passed at | 9 25 | 1033.4 | +27.09 | Thick from urates. |
| Water passed at | 11 25 | 1029.3 | + 2.91 | Clear. |
| Water passed at | 6 50 A.M. | 1026.4 | +29.23 | Clear. |

(44.) The following day. Breakfast at 8^h 10^m A.M. Dinner at 6^h 40^m P.M., as before. Twenty grains of carbonate of ammonia at 11^h 15^m A.M. The same quantity at 12^h 45^m noon. Repeated at 2^h 15^m P.M.; and again repeated at 4^h P.M. In all, eighty grains of carbonate of ammonia in the day.

| | | | | |
|-----------------|-----------|--------|------------------|--------------------|
| Water passed at | 8 10 A.M. | 1030.6 | +32.99 measures. | Thick from urates. |
| Water passed at | 9 45 | 1025.1 | +22.34 | Thick from urates. |
| Water passed at | 11 15 | 1027.4 | +13.62 | Thick from urates. |
| Water passed at | 12 45 | 1029.0 | +19.43 | Thick from urates. |
| Water passed at | 2 15 P.M. | 1028.4 | +24.31 | Thick from urates. |
| Water passed at | 4 0 | 1026.2 | +27.28 | Clear. |
| Water passed at | 6 40 | 1027.7 | +30.16 | Clear. |
| Water passed at | 10 45 | 1031.1 | +29.09 | Thick from urates. |
| Water passed at | 6 10 A.M. | 1022.6 | +25.42 | Clear. |

(45.) The following day. Breakfast at 8^h 15^m A.M. Dinner at 6^h 45^m P.M., as before. For comparison no carbonate of ammonia was taken.

| | | | | |
|-----------------|-----------|--------|------------------|--------------------|
| Water passed at | 8 15 A.M. | 1023.6 | +26.37 measures. | Clear. |
| Water passed at | 10 0 | 1023.5 | +23.44 | Thick from urates. |
| Water passed at | 12 45 | 1027.2 | +21.41 | Thick from urates. |
| Water passed at | 3 20 P.M. | 1029.0 | +34.02 | Thick from urates. |
| Water passed at | 5 35 | 1028.3 | +35.00 | Clear. |
| Water passed at | 6 45 | 1030.8 | +36.86 | Thick from urates. |
| Water passed at | 9 20 | 1032.9 | +37.75 | Thick from urates. |
| Water passed at | 11 45 | 1031.4 | + 7.75 | Cloudy. |
| Water passed at | 7 25 A.M. | 1029.8 | +22.33 | Thick from urates. |

(46.) Breakfast at 8^h 30^m A.M.

| | | | | |
|-----------------|----------|--------|--------|--------------------|
| Water passed at | 8 30 | 1028.6 | +27.22 | Thick from urates. |
| Water passed at | 9 35 | 1025.4 | +17.55 | Clear. |
| Water passed at | 11 0 | 1027.7 | + 8.75 | Clear. |
| Water passed at | 1 0 P.M. | 1030.3 | +17.47 | Thick from urates. |
| Water passed at | 3 0 | 1029.3 | +25.26 | Thick from urates. |
| Water passed at | 5 45 | 1029.0 | +27.21 | Thick from urates. |

The result of these experiments is very evident in Plate LII.

It follows therefrom, that carbonate of ammonia, taken in large doses, does not diminish the acidity of the urine. On the contrary, the third day (experiment 44.), when most carbonate of ammonia was taken, the acidity was higher than it had been any previous day. By experiment (45.) it appears that the acidity of the urine was still high on the following day. The effect of the eighty grains of carbonate of ammonia was very evident twenty-four hours after it was taken.

The comparison between Plate XXII. Philosophical Transactions, 1849, representing the acidity when tartaric acid was taken, and this Plate, which shows the effect of carbonate of ammonia, is worthy of observation. The urine was more acid when carbonate of ammonia was taken than when tartaric acid was taken. It is possible that there was some difference in the irritability of the stomach when the two series of observations were made. But the gradual increase of the acidity, as the quantity of carbonate of ammonia taken was increased, shows that the difference of the state of the stomach was not the cause of the state of the acidity of the urine. When no carbonate of ammonia was taken, the acidity of the urine, after food was taken, was diminished to a greater degree than it was when the volatile alkali was taken.

The comparison between Plate XXI. Philosophical Transactions, 1849, which represents the acidity of the urine when liquor potassæ was taken, and this Plate, which shows the acidity when carbonate of ammonia was taken, is also very interesting, as it establishes the important difference of the effect of volatile and fixed alkali on the acidity of the urine.

That 138 grains of carbonate of ammonia, taken in three consecutive days, should not diminish the acidity of the urine is very remarkable. It is still more worthy of attention that it actually increases the acidity. It appeared very desirable to test these facts by further experiments.

(47.) The experiment with large doses of carbonate of ammonia was therefore repeated. For comparison, the day previous to that on which the carbonate of ammonia was taken, the variations in the acidity of the urine were determined. Breakfast at 8^h 30^m A.M. Dinner at 7 P.M.

| | h m | Spec. gr. | Acidity per 1000 grs. of urine. | Appearance. |
|-----------------|-----------|--------------|---------------------------------|-------------------------|
| Water passed at | 7 20 A.M. | thrown away. | | |
| Water passed at | 8 30 | 1028·8 | +19·44 measures. | Thick from urates. |
| Water passed at | 9 40 | 1026·0 | +14·62 | Thick from urates. |
| Water passed at | 10 35 | 1025·2 | + 5·85 | Clear. |
| Water passed at | 11 55 | 1027·6 | -14·59 | Cloudy from phosphates. |
| Water passed at | 1 0 P.M. | 1027·9 | +12·64 | Cloudy from urates. |
| Water passed at | 2 55 | 1026·8 | +18·50 | Thick from urates. |
| Water passed at | 5 10 | 1025·4 | +24·38 | Thick from urates. |
| Water passed at | 7 0 | 1027·9 | +31·13 | Thick from urates. |
| Water passed at | 11 0 | 1031·8 | + 7·75 | Thick from urates. |
| Water passed at | 6 45 A.M. | 1024·7 | + 9·76 | Clear. |

(48.) The following day. Breakfast at 8^h 15^m A.M. Dinner at 7 P.M. Twenty

grains of carbonate of ammonia were taken at 11^h 40^m A.M. The same quantity at 1^h 15^m P.M. It was repeated at 2^h 25^m, and again repeated at 3^h 55^m. In all, eighty grains dissolved in about eight ounces of distilled water.

| | h m | Spec. gr. | Acidity per 1000 grs. of urinc. | Appearance. |
|-----------------|-----------|-----------|---------------------------------|--------------------|
| Water passed at | 8 15 A.M. | 1026·2 | + 17·54 measures. | Clear. |
| Water passed at | 9 30 | 1025·0 | + 12·68 | Thick from urates. |
| Water passed at | 10 25 | 1023·8 | + 6·83 | Clear. |
| Water passed at | 11 40 | 1027·0 | + 2·92 | Clear. |
| Water passed at | 1 15 P.M. | 1026·7 | + 11·69 | Clear. |
| Water passed at | 2 25 | 1027·3 | + 19·47 | Thick from urates. |
| Water passed at | 3 55 | 1023·9 | + 23·44 | Clear. |
| Water passed at | 5 30 | 1022·8 | + 25·42 | Clear. |
| Water passed at | 7 0 | 1025·2 | + 29·26 | Clear. |
| Water passed at | 10 55 | 1028·9 | + 3·94 | Clear. |
| Water passed at | 5 10 A.M. | 1024·6 | + 2·94 | Clear. |

Plate LIII. gives the means of comparing the acidity of the urine on these days. Here also it is evident that the acidity is not so much diminished after food when carbonate of ammonia is taken, but the increase in the acidity after the volatile alkali is taken is not so evident as in the previous Plate LII.: this probably arose from the very considerable increase in the quantity of water made on the day the carbonate of ammonia was last taken. The volatile alkali acted as a diuretic. This is seen by the lower specific gravity of the urine the second day. The actual quantity of water passed was one-third more than it was on the previous day.

Still this experiment shows that eighty grains of carbonate of ammonia do not lessen the acidity of the urine.

(49.) The following day no carbonate of ammonia was taken. Breakfast at 8^h 20^m A.M. Dinner at 7^h 15^m P.M. An increased quantity of urine was secreted during this day also.

| | h m | Spec. gr. | Acidity per 1000 grs. of urinc. | Appearance. |
|-----------------|-----------|-----------|---------------------------------|-------------|
| Water passed at | 8 20 A.M. | 1017·2 | + 13·76 | Clear. |
| Water passed at | 9 30 | 1014·5 | + 8·87 | Clear. |
| Water passed at | 10 15 | 1014·5 | + 7·88 | Clear. |
| Water passed at | 11 25 | 1021·3 | + 12·72 | Clear. |
| Water passed at | 1 10 P.M. | 1023·8 | + 17·58 | Clear. |
| Water passed at | 2 30 | 1023·5 | + 20·51 | Clear. |
| Water passed at | 3 50 | 1021·5 | + 19·58 | Clear. |
| Water passed at | 5 20 | 1022·2 | + 21·42 | Clear. |
| Water passed at | 7 15 | 1025·9 | + 23·39 | Clear. |
| Water passed at | 10 30 | 1028·3 | 0 | Clear. |
| Water passed at | 6 25 A.M. | 1026·4 | + 11·69 | Clear. |

(50.) The next day eighty grains of carbonate of ammonia were taken in divided doses: twenty grains at 11^h 45^m A.M.; the same quantity at 1^h 15^m P.M., at 2^h 30^m P.M., and at 3^h 45^m P.M. Breakfast was at 8^h 20^m A.M., and dinner at 7^h 30^m P.M.

The quantity of urine was much less than on the two previous days.

| | h m | Spec. gr. | Acidity per 1000 grs. of urine. | Appearance. |
|-----------------|-----------|-----------|---------------------------------|--------------------|
| Water passed at | 8 20 A.M. | 1026.5 | +18.50 measures. | Thick from urates. |
| Water passed at | 9 30 | 1025.6 | +14.62 | Thick from urates. |
| Water passed at | 10 35 | 1028.4 | + 7.78 | Thick from urates. |
| Water passed at | 11 45 | 1029.3 | 0 | Clear. |
| Water passed at | 1 15 P.M. | 1027.9 | +14.59 | Thick from urates. |
| Water passed at | 2 30 | 1027.4 | +21.41 | Clear. |
| Water passed at | 3 45 | 1026.7 | +26.29 | Clear. |
| Water passed at | 5 20 | 1026.9 | +28.24 | Clear. |
| Water passed at | 7 30 | 1028.7 | +32.08 | Clear. |
| Water passed at | 11 15 | 1029.7 | +17.48 | Clear. |
| Water passed at | 6 55 A.M. | 1028.4 | +19.44 | Thick from urates. |

Here again there is decided evidence of an increase in the acidity of the urine after a large dose of carbonate of ammonia. There was no diuretic action, but during the night a most profuse and unusual perspiration took place. The following morning no carbonate of ammonia was taken.

(51.) Breakfast was at 8^h 35^m A.M. Dinner at 6^h 15^m P.M. The same as on the previous days.

| | | | | |
|-----------------|-----------|--------|--------|--------------------|
| Water passed at | 8 35 A.M. | 1026.7 | +22.40 | Thick from urates. |
| Water passed at | 9 40 | 1026.2 | +13.64 | Thick from urates. |
| Water passed at | 11 0 | 1027.4 | + 8.76 | Thick from urates. |
| Water passed at | 1 0 P.M. | 1030.6 | +11.64 | Thick from urates. |
| Water passed at | 3 0 | 1028.9 | +21.38 | Thick from urates. |
| Water passed at | 6 15 | 1030.8 | +29.10 | Thick from urates. |
| Water passed at | 10 30 | 1033.3 | +13.55 | Thick from urates. |
| Water passed at | 2 0 A.M. | 1030.3 | + 8.73 | Thick from urates. |
| Water passed at | 7 20 | 1028.8 | +18.47 | Thick from urates. |
| Water passed at | 8 20 | 1029.8 | +20.39 | Thick from urates. |

Perhaps the acidity did not rise higher on account of the perspiration, which must have removed much acid from the system. The effect of the carbonate of ammonia may be traced in a smaller fall than usual in the acidity after breakfast and dinner.

These experiments, well seen in Plate LII., then tend to the confirmation of the results previously obtained:—first, that there is a very great difference between the effects of volatile and fixed alkalis on the acidity of the urine; secondly, that carbonate of ammonia, in large doses, does not diminish the acidity of the urine; thirdly, that carbonate of ammonia, in large doses, actually increases the acidity of the urine; and this was evident, not only in the acidity not falling so low as it did after food when no carbonate of ammonia was taken, but in an actual rise before food to a higher degree than was reached when no carbonate of ammonia was administered.

The conclusions from these experiments with tartrate and carbonate of ammonia may be shortly stated thus—

(e.) That tartrate of ammonia in large doses produces no effect on the alkalescence of the urine. It differs entirely in this respect from tartrate of potash.

(f.) That carbonate of ammonia in large doses increases the acidity of the urine.

I hope to determine the cause of this in a future paper on the variations of the nitrates in the urine.

XXXV. *An Experimental Inquiry into the Strength of Wrought-Iron Plates and their Riveted Joints as applied to Ship-building and Vessels exposed to severe strains.*

By WILLIAM FAIRBAIRN, *Esq.*

Communicated by the Rev. HENRY MOSELEY, F.R.S.

Received April 25,—Read June 13, 1850.

THE experiments herein recorded were instituted early in the spring of 1838, and before the close of the following winter most of them had been completed; owing however to a long series of professional engagements they have stood over (with the exception of some additions made in the following year) to the present time. The object of the inquiry was twofold—first, to ascertain by direct experiment the strength of wrought-iron plates and their riveted joints in their application as materials for ship-building; and secondly, to determine their relative value when used as a substitute for wood. On these two points it cannot be expected that our knowledge should be far advanced, as a very few years have elapsed since it was asserted that iron, from its high specific gravity, was not calculated for such a purpose, and that the greatest risk was likely to be incurred in attempting to construct vessels of what was then considered a doubtful material. Time has however proved the fallacy of these views, and I hope, in the following experiments, to show that the iron ship, when properly constructed, is not only more buoyant, but safer, and more durable than vessels built of the strongest English oak.

At the commencement of the experiments I felt desirous of conducting them upon a scale of such magnitude as would supply sound practical data, and at the same time establish a series of results calculated to ensure confidence as well as economy in the use of the material. My views were ably carried out by Mr. HODGKINSON, who conducted the experiments under my direction, and from whom I received valuable assistance.

In conducting the investigation I found it necessary to divide the subject into four distinct parts:—

1st. The strength of plates when torn asunder by a direct tensile strain in the direction of the fibre, and when torn asunder across it.

2ndly. On the strength of the joints of plates when united by rivets as compared with the plates themselves.

3rdly. On the resistance of plates to the force of compression, whether applied by a dead weight or by impact.

And lastly. On the strength and value of wrought-iron frames and ribs as applied to ships and other vessels*.

PART I.

At the commencement of iron ship-building, in which I took an active part, the absence of acknowledged facts relative to the strength and varied conditions under which the material was applied, was the principal reason which induced me to enter upon this inquiry. I have extended the investigation into the best methods of riveting, and the proportional strength of rivets, joints, &c., as compared with the plates and the uses for which they are intended. The latter is a practical and highly important inquiry, as great difference of opinion exists amongst engineers and others, as to the form, strength and proportions of rivets, and the joints of which they form an essential part. I therefore considered an experimental investigation much wanted, not only on account of its important practical bearing, but what was probably of equal value, in order to remove existing discrepancies and to establish a sounder principle of construction founded upon the unerring basis of experiment. From these considerations I bestowed increased attention upon the inquiry, and endeavoured to render it practically useful. Before detailing the experiments, it may be necessary to describe the apparatus by which the results were obtained.

The annexed drawings, Plate LIV., represent a side and end view of the apparatus used in the experiments. The large lever A was made of malleable iron and was fixed to the lower cross beam B (fig. 1) by a strong bolt O, which passed through it at B. At the top end of this bolt a preparation was made to receive the end of the lever, and by means of the screw-nut at *a*, the lever A was raised or lowered to suit the length of the plates to be experimented upon. Upon the top side of the beam, and under the gable wall of a building five stories high, were placed two cast-iron columns, D, D, which retained the beam B in its place and prevented it from rising when the lever was heavily loaded during the experiment. The frame E guided the end of the lever and the weight W, and close to the fulcrum were placed two wooden standards,

* Several important facts and improvements in the construction of iron ships have been ascertained since my experiments were made, but I apprehend none of them have tended in the least degree to diminish their value. Nor have they, to the best of my knowledge, been superseded by others of a more elaborate or more decisive character. It is true, that a series of interesting and important experiments have been made at the instance of the Admiralty on the effect of shot upon the sides of iron ships. At some of these experiments I had the honour to be present, and witnessed some curious and unexpected results.

The first series was conducted at the Arsenal, Woolwich, and subsequently others were made at Portsmouth. Both were important as respects the effect of shot upon wrought-iron plates, with enlarged and diminished charges of powder and at different velocities, but discouraging as regards the use of iron in the construction of ships of war. These experiments, however interesting in themselves, do not appear to be conclusive; and it is to be hoped that the apparent danger, indicated by the experiments, may yet be overcome, and the superiority as well as the greater security of the iron ship fully established.

F F, on which were fixed the cast-iron saddles receiving the cross bar G, from which the plates to be experimented upon were suspended. These plates were nearly all of the same form as shown at H, and were made narrower in the middle to ensure fracture in that part; the ends, as at *b, b*, had plates riveted to them on both sides, in order to strengthen them at those parts when attached to the bolts and shackle under strain.

The specimens thus prepared were suspended by the cross bolts *i, i*, and resting upon the standards were torn asunder by weights suspended from the large beam, as exhibited in the Plate.

In addition to the large weight W, a strong seale was attached to the extreme end of the lever at I, for the purpose of increasing the weights when required in the larger description of experiments, and by the application of a pair of blocks and the windlass K, the load was removed, and the changes produced upon the plates were by these means carefully determined.

The following data respecting the weight W, lever, shackle, &c., are taken from the actual weights from which the calculations are made:—

| | lbs. |
|---|------|
| W. The weight with its carriage | 2552 |
| A. The weight of the beam | 1070 |
| 2 A. The weight of the beam | 2140 |
| 3 A. The weight of the beam | 3210 |
| K. Shackle | 24 |
| 4 K. Shaekle | 96 |
| 6 K. Shackle | 144 |

Experiments to ascertain the Strength of Plates, &c.

In the following experiments all the plates were of uniform thickness, and of the form exhibited in fig. 2 in the column of remarks; the ends had plates riveted to them on both sides to render them inflexible; they had holes, O, O, bored through them perpendicular to the plate, in order to connect it by bolts, with the apparatus for tearing it asunder in the part A B, which was made narrower than the rest. The centres of the holes O, O were in a direct line through the middle between A and B*.

TABLE I. Strength of Plates.—Low Moor Yorkshire Iron.

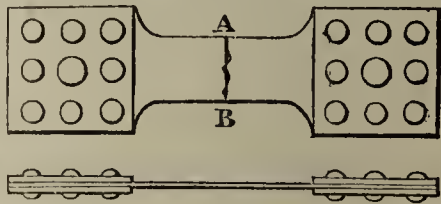
| No. of exp. | Description of plate and dimensions in the middle. | Weight laid on in lbs. | Reduced dimensions in middle of plate through weights laid on. | Breaking weight in lbs. | Mean breaking weight in lbs. | Remarks. |
|-------------|--|--------------------------------------|---|-------------------------|--|---|
| 1. | Drawn in the direction of the fibre. Area of section in middle $2\cdot00 \times \cdot22 = \cdot44$ in. | 24,043 | $1\cdot96 \times \cdot21$ | 25,531 | 25,400, or 25·77 tons per square inch. | <p>Fig. 2. Plan and section of the plates, the line AB being that of the fracture.</p>  <p>All the plates were laminated as if formed of three or more plates, the external ones being thinner than the internal ones†.</p> <p>In the last experiment there was a disunion between the lamina which admitted the point of a penknife.</p> |
| 2. | | 23,571 24,747 | Reduced. $1\cdot93 \times \cdot18$ | 24,747 | | |
| 3. | | 25,923 | $1\cdot94 \times \cdot18$ | 25,923 | | |
| 4. | Same iron drawn across the fibre. Area of section $2\cdot00 \times \cdot22 = \cdot44$ in. | 23,179 24,355 25,923 27,099 | Altered. $1\cdot99 \times \cdot215$ $2\cdot2 \times \cdot19$ | 27,099 | 27,099, or 27·49 tons per square inch. | This, it will be seen, did not break at the narrowest place. |

TABLE II. Strength of Plates.—Low Moor Yorkshire Iron.

| No. of exp. | Description of plate and dimensions in the middle. | Weight laid on in lbs. | Reduced dimensions in middle of plate through weights laid on. | Breaking weight in lbs. | Mean breaking weight in lbs. | Remarks. |
|-------------|--|------------------------|---|-------------------------|---|---|
| 5. | Same iron as in Table I., drawn across the fibre. Area of section $2\cdot00 \times \cdot22 = \cdot44$ in. | 24,355 | Stretching. $21\cdot5 \times \cdot20$ $2\cdot25 \times \cdot20$ | 26,315 | 25,662, or 26·037 tons per square inch. | <p>The form and size of specimen as before, fig. 2.</p> <p>In these experiments it was observed, as in No. 4. in the preceding Table, that the plate did not break at the narrowest part, a circumstance the more anomalous, as there did not appear to be anything in the apparatus to cause it.</p> |
| 6. | | 26,315 23,571 | | 23,571 | | |
| 7. | Same iron, thicker plates, drawn in direction of fibre. Area of section $2\cdot00 \times \cdot26 = \cdot52$ in. | 27,099 25,923 | Thickness $\cdot25$ $1\cdot96 \times \cdot24$ | 27,099 25,923 | 26,511, or 22·76 tons per square inch. | <p>Very uniform in texture.</p> <p>The fracture of this specimen showed a great want of regularity; about one-third of the area had the appearance of steel. All the other plates appeared to be uniform, but laminated, as mentioned before.</p> |

* For the appearance of the fractures see Plate LV.

† Nearly the whole of the plates manufactured in this country are laminated, owing to the manner in which the shingles are formed, by piling a number of flat bars one upon another, which are made larger or smaller according as the plate may be required heavier or lighter.

The results obtained from the Low Moor plates in the preceding Tables give fair indications of their strength. It will be observed, on comparing the mean of the breaking weights in this case with the experiments of BROWN and TELFORD, that there is a very slight difference between the strength of plates and bar iron.


Taking the results of Captain BROWN, we have in eight experiments on Swedish, Welsh and Russian iron, 25 tons as a mean of the breaking weight when reduced to an inch square.

In Mr. TELFORD's experiments on Swedish, Welsh, Staffordshire and faggoted iron, the mean breaking weight obtained from nine different bars was $29\frac{1}{4}$ tons to the square inch. The comparison will then be—

| | | |
|--|---|---------------------|
| Captain BROWN's experiments, 25 tons to the square inch | } | Mean 26·41 tons. |
| MINORD and DESAMES' experiments, 25 tons to the square inch | | |
| Mr. TELFORD's experiments, $29\frac{1}{4}$ tons to the square inch | | |
| Yorkshire plates' experiments, $24\frac{1}{2}$ tons to the square inch. | | |

Making the strength of plates to that of bars as 24·5 : 26·4, being a comparatively small difference in their respective powers to resist a tensile force.

TABLE III. Strength of Plates.—Derbyshire Iron.

| No. of exp. | Description of plate and dimensions in the middle. | Weight laid on in lbs. | Reduced dimensions in middle of plate through weights laid on. | Breaking weight in lbs. | Mean breaking weight in lbs. | Remarks. |
|-------------|--|----------------------------|--|-------------------------|--|---|
| 9. | Drawn in the direction of the fibre. Area of section $2\cdot00 \times \cdot 28$ in. | 21,219 28,667 | Stretched. $2\cdot00 \times \cdot 27$ | 28,667 | | Form of specimen the same as shown in Table I. fig. 2.  There was a stripe resembling steel across the fracture near one side. |
| 10. | $2\cdot00 \times \cdot 29$ in. | 21,219 22,789 26,707 | Sinking. Sinking. $2\cdot15 \times \cdot 27$ | 26,707 | 27,687, or 21·68 tons per square inch. | |
| 11. | Plates drawn across the fibre. Area of section $2\cdot00 \times \cdot 28 = \cdot 56$ in. | 22,395 23,179 | Stretching. Thickness ·27 | 23,179 | | In the broken surface there seemed to be a stratum of steel, the rest was laminated but imperfectly. Short streaks of steel in fractured surface. |
| 12. | $2\cdot00 \times \cdot 28 = \cdot 56$ in. | 24,747 | $2\cdot00 \times \cdot 28$ | 24,747 | 23,963, or 18·65 tons per square inch. | |

If we compare the results in the Derbyshire plates with those in the preceding Tables, we have in the mean of four experiments a ratio of 20·165 : 24·850, or 5 to 6 nearly.

Again, by comparing the same plates with the mean strength of bars reduced to an inch square, the difference will be as 20 to 26, being an excess of 6 tons in favour of the bars.

TABLE IV. Strength of Plates.—Shropshire Iron.

| No. of exp. | Description of plate and dimensions in the middle. | Weight laid on in lbs. | Reduced dimensions in middle of plate through weights laid on. | Breaking weight in lbs. | Mean breaking weight in lbs. | Remarks. |
|-------------|---|------------------------|--|-------------------------|---|--|
| 13. | Drawn in the direction of the fibre. Area of section $2.00 \times .265 = .53$ in. | | | 28,275 | 27,099, or 22.826 tons per square inch. | Form of specimen the same as shown in Table I. fig. 2. In the first experiment the fracture showed an iron very uniform, except a few bright spots like steel. Experiment 2. Appearance of fracture as before, but a crack up the middle showed that the plate was formed of two plates of equal thickness, not well united. |
| 14. | | | | 25,923 | | |
| 15. | Plates of the same iron drawn across the fibre. $2.00 \times .265 = .53$ in. | | | 26,315 | 26,119, or 22 tons per square inch. | Fracture as before, with a laminated diversion, as in last experiment. |
| 16. | | | | 25,923 | | |

The Shropshire iron gives better indications of strength than those obtained from the Derbyshire plates; the mean breaking weights in the last Table being 22.41 tons. From the Yorkshire plates we have a mean breaking weight of 24.85 tons, exhibiting a difference of $2\frac{1}{2}$ tons in favour of the Yorkshire iron, and 2 tons or about $\frac{1}{10}$ th greater than the Derbyshire.

TABLE V. Strength of Plates.—Staffordshire Iron.

| No. of exp. | Description of plate and dimensions in the middle. | Weight laid on in lbs. | Reduced dimensions in middle of plate through weights laid on. | Breaking weight in lbs. | Mean breaking weight in lbs. | Remarks. |
|-------------|--|------------------------|--|-------------------------|---|--|
| 17. | Drawn in the direction of the fibre. $2.00 \times .26 = .52$ in. | | | 23,571 | 22,787, or 19.563 tons per square inch. | Form of specimen the same as before, fig. 2. Fracture dark grey colour, very similar to that from the four preceding plates. It had however a few specks of bright matter in it, and was without any laminated appearance. |
| 18. | | | | 22,003 | | |
| 19. | Plates of the same iron drawn across the fibre. Area of section $2.00 \times .265 = .53$ in. | | | 24,335 | 24,943, or 21.01 tons per square inch. | Irregular in texture, air-bubbles in fractured surface, with bright crystallized matter like steel. This iron has much of the same irregularity as the Derbyshire iron. Surface of fracture showed the iron to be very irregular, one-half being bright matter like steel. |
| 20. | | 23,571 | The thickness .26 | 25,531 | | |

On comparing the strengths of the different irons, it appears that the Derbyshire and Staffordshire plates are nearly equal, the former indicating 20.165 tons as the mean of the breaking weight per square inch, and the latter, as in the preceding Table, 20.28 tons per square inch. The same comparison further applies to the above and those made on the Derbyshire plates in Table III.

Taking therefore the results as derived from these experiments, it will be observed, that in every instance little or no difference appears to exist in the resisting powers of plates, whether drawn in the direction of the fibre or across it. This fact is clearly established by the following comparison, which evidently shows, that in whatever direction the plates are torn asunder, their strength is nearly the same.

| | Mean breaking weight in the direction of the fibre, in tons per square inch. | Mean breaking weight across the fibre, in tons per square inch. |
|----------------------------|--|---|
| Yorkshire plates..... | 25.770 | 27.490 |
| Yorkshire plates..... | 22.760 | 26.037 |
| Derbyshire plates | 21.680 | 18.650 |
| Shropshire plates | 22.826 | 22.000 |
| Staffordshire plates | 19.563 | 21.010 |
| Mean..... | 22.519 | 23.037 |

Or as 22.5 : 23.0, equal to about $\frac{1}{45}$ in favour of those torn across the fibre*.

From the above it is satisfactory to know, so far as regards uniformity in the strength of plates, that the liability to rupture is as great when drawn in one direction as in the other; and it is not improbable that the same property would be exhibited, and the same resistance maintained, if the plates were drawn in any particular direction obliquely across their fibrous or laminated structure.

In order however to establish the relative powers of resistance in plates of rolled iron, I have endeavoured to tabulate the results, as derived from the preceding experiments, in such form as will indicate their respective values, and place them in comparison with each other, and also with those made on bars by TELFORD and BROWN. The comparisons are made from the Yorkshire plates, as producing the best results; and conceiving them to be a fair average of the strength of rolled iron, I have selected them as the standard of comparison.

Comparative results of rolled iron as derived from experiment, the Yorkshire plates being unity.

| Names of Iron. | No. of experiments. | Mean breaking weight in tons per square inch. | Mean breaking weight in tons per square inch. | Ratio of the strength of plates drawn in the direction of the fibre, and across it. Also of rolled and faggoted bars drawn in the direction of the fibre. |
|--|---------------------|---|---|---|
| Yorkshire plates..... | 8 | 25.514 | | |
| Derbyshire plates | 4 | | 20.160 | 1 : 0.7882 |
| Shropshire plates | 4 | | 22.413 | 1 : 0.8789 |
| Staffordshire plates | 4 | | 20.264 | 1 : 0.7946 |
| Mean..... | | 25.514 | 20.945 | 1 : 0.8209 |
| From Mr. TELFORD and Captain BROWN's experiments on bars | | | 26.41 | 1 : 1.0351 |

* In some experiments by NAVIER upon the strengths of plates of wrought iron, both in the direction of the fibre and perpendicular to it, he found them as 40.8 to 36.4. The new methods of piling the rough bars before rolling may however account for the difference, and in a great measure determines the strength of the plate. In this country the process of piling is by equal layers of flat bars at right angles to each other, which produces great uniformity of strength and texture in the manufacture. At other places there is sometimes a difference in the mode of piling, which varies the texture of the plate, and also the strength of the layers are greater in one direction than another.

Here it will be observed that the difference between the strength of the Low Moor plates in their resistance to a tensile strain, when compared with bar iron, is inconsiderable; but taking the mean of the other irons, viz. the Derbyshire, Shropshire and Staffordshire, there is a falling off in the strength of about 21 per cent., the ratio being in favour of bar iron as 1·035 : ·8209.

In treating of the strength of iron, it may be useful to compare the foregoing experiments on the tensile strength of plates with those of a similar description on timber. On this subject I feel the more desirous of establishing a comparison, as the two kinds of material are now applied to similar purposes, such as ship-building and other constructions, and the question becomes every day more important as to which of the two materials is the best. There is every reason to believe that the advocates of improvement would arrange themselves on the side of iron, and those for the "wooden walls" would be equally zealous on that of timber. This is however a question which time and experience alone can determine, and conceiving that our knowledge of the properties of iron, as a material for ship-building, is far from perfect, we may safely leave its final decision to the evidence of experimental research, and a more extended application of its practical results.

When we attempt a comparison of the value of one material, in its application to a specific purpose, with that of another material similarly applied, the comparison is only correct when the two materials are placed in juxtaposition, or when they are contrasted under the same circumstances as to the trials and tests to which they are respectively subjected. Now in this comparison I am fortunate in having before me the able experiments of MUSSCHENBROCK, BUFFON, and those of a more recent date on direct cohesion by Professor BARLOW of Woolwich. I have selected from the experiments of the latter those which appear to approach most nearly to the present inquiry; and impressed with the conviction of their having been carefully conducted and being from English timber, I attach the greatest value to them.

According to MUSSCHENBROCK'S, the strengths of direct cohesion per square inch of the following kinds of timber are as follows:—

| | | | |
|-------------------------|-------------|-----------------------|-----------|
| Locust-tree | lbs. 20,100 | Pomegranate | lbs. 9750 |
| Locust-tree | 18,500 | Lemon. | 9250 |
| Beech and oak | 17,300 | Tamarind. | 8750 |
| Orange | 15,500 | Fir | 8330 |
| Alder | 13,900 | Walnut | 8130 |
| Elm | 13,200 | Pitch pine | 7630 |
| Mulberry | 12,500 | Quince | 6750 |
| Willow | 12,500 | Cyprus | 6000 |
| Ash | 12,500 | Poplar | 5500 |
| Plum | 11,800 | Cedar | 4880 |
| Elder | 10,000 | | |

From BARLOW the strengths are,—

| | | | |
|---------------|--------|--------------------|--------|
| | lbs. | | lbs. |
| Box | 20,000 | Beech | 11,500 |
| Ash | 17,000 | Oak | 10,000 |
| Teak. | 15,000 | Pear | 9800 |
| Fir | 12,000 | Mahogany | 8000 |

Mr. BARLOW, in adverting to the experiments of MUSSCHENBROCK, observes, that some of them differ considerably from his own, a circumstance probably not difficult to account for, as the different degrees of dryness have a great effect upon the strength of timber*.

Dr. ROBISON, in speaking of the experiments of MUSSCHENBROCK, states, that we may presume they were carefully made and faithfully narrated, but they were made on such small specimens, that the unavoidable natural inequalities of growth or texture produced irregularities in the results which have too great a proportion to the whole quantities observed. It is for the same reason that I give preference to Mr. BARLOW's results, as he observes, "that the experiments from which they are drawn were made with every possible care the delicacy of the operation would admit." Assuming therefore that BARLOW is correct, and taking the mean strength of iron plates, as given in the preceding Tables, at 49,656 lbs. to the square inch, or calling it 50,000 lbs., and the resistance of the direct cohesion of different kinds of timber as given by Mr. BARLOW, the following ratio of strengths will be obtained:—

| | Timber lbs. | : | Iron. lbs. | Ratio, taking timber as unity. |
|-----------------|----------------|---|---------------|-----------------------------------|
| Ash | 17,000 | : | 50,000, | or as 1 : 2·94 |
| Teak. | 15,000 | : | 50,000, | or as 1 : 3·33 |
| Fir | 12,000 | : | 50,000, | or as 1 : 4·16 |
| Beech | 11,500 | : | 50,000, | or as 1 : 4·34 |
| Oak | 10,000 | : | 50,000, | or as 1 : 5·00 |

Hence it appears that the direct cohesion of iron plates is five times greater than oak; or in other words, their powers of resistance to a force applied to tear them asunder is as 5 to 1, making an iron plate $\frac{1}{2}$ inch thick equal to an oak plank of $2\frac{1}{2}$ inches thick. In the teak wood and fir specimens, which exhibit greater resisting powers, nearly the same rule will apply, and thinner planks, as regards the tensile strength, would answer the purpose. This is a circumstance which may be applicable to teak wood, but unfavourable to fir when viewed as a building material exposed to a great variety of strains, or when used for sheathing and similar purposes in the art of ship-building. The teak wood being timber of greater density and of

* It has been shown by Mr. HODGKINSON, that timber, when wet, will be crushed by a force less than one-half of what would take to crush it when dry. It therefore follows that much depends upon the samples selected and the way in which the timber has been seasoned.

higher specific gravity, is better calculated to resist shocks than a tough fibrous substance of a soft and spongy nature, such as fir.

On this subject it should however be noticed, that whatever material is used for covering the ribs of vessels, it should be strong and elastic, in order to resist not only the force of direct tension, but that of lateral and compressed action. In a ship at sea these forces are strikingly exemplified, and that under circumstances embarrassing as well to the practical builder as the man of science.

Remarks on the foregoing experiments.

Having determined the strength of iron plates when drawn in the direction of the fibre as well as across it, and having compared the results with experiments of a similar character on timber, it may be useful to offer a few general observations on the question now under consideration.

Dr. ROBINSON, in his article on the strength of materials*, when discussing the nature of a stretching force applied to materials, observes, "that in pulling a body asunder the force of cohesion is directly opposed with very little modification of its action; that all parts are equally stretched, and the strain in every transverse section is the same in every part of that section." From this it would appear, that a body of a homogeneous texture will have the cohesion of its parts equal, and since every part is equally stretched, it follows that the particles will be drawn to equal distances, and the forces thus exerted must be equal. Now if this were true, the application of an external force to a body might be increased to such an extent as not only to separate the parts furthest asunder, but ultimately to destroy the cohesion of all the particles *at once*, a circumstance under which instantaneous rupture would follow as a result. These views are however not borne out by facts, as the experiments of Mr. HODGKINSON on iron wire show that the same iron may be torn asunder many times in succession without impairing its strength†; and some recent experiments at the Royal Dockyard, Woolwich, clearly show, that an iron bar may be stretched until its transverse section is considerably reduced and ultimately broken without injury to its tensile strength. Nay, more, the same iron (so elongated), when again submitted to experiment, exhibited increased strength, and continued to increase, under certain limitations, beyond the bearing powers of the same bar in its original form‡. That all the parts of a body "subjected to a tensile strain are equally stretched" is therefore questionable. Bodies vary considerably in their powers of resistance, and exhibit peculiar properties of cohesion under the influence of forces calculated to tear them asunder. Fibrous substances, for instance, such as ropes and some kinds of timber having their fibres twisted, are enabled to resist tension under the influence of considerable elongation without impairing their ultimate strength.

* Encyclopædia Britannica.

† Manchester Memoirs, vol. v.

‡ I am indebted to Mr. THOMAS LOYD of the Admiralty for a series of interesting results on this subject. See Appendix.

Many of the fibres are stretched, but only to the extent of bringing the others to bear upon the load, which done, their united force constitutes the maximum of resistance to a tensile strain.

Other bodies of less ductility and more of a crystalline structure, such as cast iron, stone, glass, &c., seem to be subject to the same law. In these cases it seldom happens that the whole of the particles are brought into action at once, as much depends upon the conditions of the body, the unequal state of tension of its parts, and the strain which some of the particles must sustain before the others receive their due portion of the load. Should the non-resisting particles be within the limits of elongation of the other particles, the body will then have attained its maximum power of resistance; but in the event of rupture to any of the resisting particles, the cohesive force of the body is thereby reduced, and that to the extent of the injury sustained by the fractured parts.

“There are however,” as Dr. ROBINSON truly observes, “immense varieties in the structure and composition of bodies which lead to important facts, and prove that the absolute cohesion of all bodies, whatever be their texture, is proportional to the areas of their sections.” Undoubtedly this is the case in bodies having an uniform texture with straight fibres, and hence it follows that the absolute strength of a body, resisting a tensile strain, will be as the area of its section.

The peculiar nature of the material combining a crystalline as well as a fibrous structure has led to these observations. In some instances the specimens experimented upon exhibited an almost distinct fibrous texture, and in others a clearly developed crystalline structure*. At other times some of the specimens were of a mixed kind, with the crystalline and fibrous forms united; the fracture having a laminated appearance, with the crystalline parts closely bound on each side by layers of the fibrous structure. These varieties are probably produced in the manufacture, and may be easily effected either by the mode of “piling” the layers of bars which form the plate, or from the unequal temperature of the parts as they pass through the rolls. But whichever way they are produced, it is evident, from the experiments, that the fractures gave, in most cases, indications of an unequal and varied texture.

In the foregoing experiments, and also in those which follow, great attention was paid to the appearance of the fracture, in order to ascertain the structure of the plate, and to determine how far it could be depended upon in its application to the varied purposes for which it was intended.

These appearances are all shown in the drawings appended to the experiments, and to which I beg to refer.

* See the fractured parts of the different specimens, Plate LV.

PART II.

On the Strength of Iron Plates united by Rivets, and the best mode of Riveting.

The extensive and almost innumerable uses to which iron is applied, constitute one of the most important features in the improvements of civilized life. It contributes to the domestic comforts and commercial greatness of the country, and from its cheapness, strength and power of being moulded, rolled and forged into almost every shape, it is not only the strongest, but in many respects the most eligible material for the construction of vessels exposed to severe strain. Large vessels composed of iron plates, such as steam-boilers, cisterns, ships, &c., cannot however be formed upon the anvil or the rolling-mill. They are constructed of many pieces, and these pieces have to be joined together in such a manner as to ensure the requisite strength and effect all the requirements of sound construction. This operation is called riveting, and although practically understood, it has not, to my knowledge, on any previous occasion, received that attention which the importance of the subject demands.

Up to the present time* nothing of consequence has been done to improve or enhance the value of this process. We possess no facts or experiments calculated to establish principles sufficient to guide our operations in effecting constructions of this kind, on which the lives of the public as well as the property of individuals depend. In fact, such has been our ignorance of the relative strength of plates and their riveted joints, that until the commencement of the present inquiry the subject was considered of scarcely sufficient importance to merit attention. Even now, it is by many assumed that a well-riveted joint is stronger than the plate itself, and a number of persons, judging from appearances alone, concur in that opinion. Now this is a great mistake, and although the double thickness of the joint indicates increased strength, it is nevertheless much weaker than the solid plate, a circumstance of some importance, as we hope to show in the following experiments.

It would probably be superfluous to offer any lengthened description of the principle upon which wrought-iron plates are united together; riveting is so familiar to every person in this country, that it might appear a work of supererogation to attempt it; and, assuming that the usual method of riveting by hammers to be generally known, we shall proceed to describe another method by machinery which effects the same object in considerably less time and at less cost, and completes the union of the plates with much greater perfection than could possibly be done by the hand. In hand-riveting it will be observed, that the tightness of the joint and the soundness of the work depends upon the skill and also upon the will of the workman, or those who undertake to form the joint and close the rivets. In the machine-riveting neither the will nor the hand of man has anything to do with it, the machine closes the joint and forms the rivet with an unerring precision, and in no instance can imperfect work be accomplished so long as the rivets are heated to the extent compressible by the machine.

* 1838, when these observations were written.

This property of unvarying soundness in the work, constitutes the superiority of the machine over the hand-riveting. The machine produces much sounder work, as the time occupied in the hand process allows the rivet to cool, and thus by destroying its ductility, the rivet is imperfectly closed, and hence follow the defects of leaky rivets and imperfect joints. It is evident that an instrument, such as the riveting-machine, having sufficient force to compress the rivet at once, or within an almost infinitely short period of time, must obviate, if not entirely remedy, these evils, as the force of compression being nearly instantaneous, the heads on both sides cannot be formed until the body of the rivet is squeezed tight into the hole; and in every case (even where the holes are not exactly straight) the compressed rivets are never loose, but fill the holes with the same degree of tightness as if placed directly opposite to each other. If, for example, we take a circular boiler, such as represented at A*, Plate LVI. fig. 3, and having all the perforations made and the plates attached to each other by temporary bolts and suspended over the machine in the position as shown at A, and having brought the holes in a line with the die marked *i*, *k*, the machine then is set to work, and by means of the cam or excentric raising the pulley of the elbow-joint C, the die *k* is advanced against the fixed die *i* in the wrought-iron stem, and the rivet is compressed into the required form with an increasing force as the die advances which gives the "nip," or greatest pressure, at the required time, namely, at the closing of the rivet.

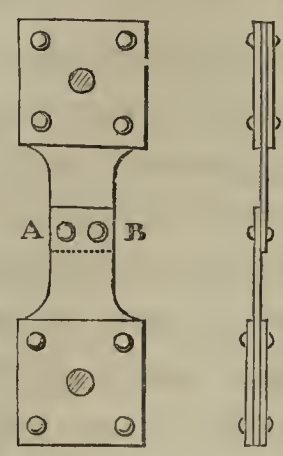
From this description it will appear that a very limited portion of time is occupied in the process, and as twelve rivets can be inserted and finished by the machine in a minute, it follows, from the rapidity of the operation and the absence of hammering, that the ductility of the rivets is retained, and their subsequent contraction upon the plate renders the joint perfectly tight and the rivets sound in every respect. Under all the circumstances the machine-riveting is preferable to that executed by the hammer; it saves much time and labour, and that in proportion of 12 to 1, when compared to a long series of impacts applied by the hammer.

Having described the process of uniting wrought-iron plates by rivets, it may be of some importance to know the value of joints thus formed as regards their strength when compared with the plates themselves. To attain this object, and satisfactorily to determine their powers of resistance to a tensile strain, a great variety of joints were made, and having prepared the different specimens with the utmost care and attention, they were submitted to the test of experiment as follows:—

* The plan represents the machine in the act of riveting the corners of a square cistern or a locomotive fire-box.



TABLE VI. Strength of riveted Plates.—Yorkshire Iron*.

| No. of exp. | Description of plates and mode of riveting. | Weight laid on in lbs. | Changes produced by weights. | Breaking weight in lbs. | Form of specimen and mode of fracture. | Remarks. |
|-------------|--|------------------------|---|-------------------------|---|---|
| 21. | Plates 22 inches thick, overlap joints, two rivets half-inch diameter, lap $1\frac{1}{2}$ inch, AB=3 inches, riveted by the patent machine. | | | 20,011 | <p>Fig. 4.</p>  | Torn across at the rivet-holes. |
| 22. | Same as last, area 44 in. | | | 18,667 | | Rivet-holes torn out. |
| 23. | | | | 21,703 | | Rivet-holes torn out. |
| | | | | | Mean 20,127 | |
| 24. | Plates as before, riveted by the hammer, the rivets half-inch diameter, being of the usual length, but rather shorter than those used for the machine. | 14,839 | | 16,115 | Specimen same as before, fig. 4. | Rivet-heads broke off and the plate torn across them in consequence. |
| 25. | | 15,343 | Plates bent. | 16,099 | | Rivet-heads cracked across and rivet-holes torn out. |
| | | | | | Mean 16,107 | |
| 26. | Plates same as before and riveted by the hammer, with half-inch rivets, the rivets being a little longer and 2 inches lap | 14,839 | Plates bent nearly into a direct line with straining force. | 17,833 | Specimen same as before, fig. 4. | Here the rivets were the same length as the machine rivets, experiments 1, 2, 3, and were worked with great care on both sides. |
| 27. | | 14,839 | | 20,131 | | Both rivet-heads broken and the plate torn across them. |
| | | | | | Mean 18,982 | Torn across at rivet-holes, and one rivet-head split. |
| 28. | Plates same as before, lap 2 inches, and the rivets the same as in the last experiment, but riveted by the machine | 14,839 | Plates bent into a direct line by the straining force. | 19,123 | Specimen same as before, fig. 4. | Both rivets cracked across, metal torn across the rivet-holes. |
| 29. | | 18,667 | Joint apparently sound. | 19,171 | | Torn across at the rivet-holes, both rivets slightly cracked near the head. |
| | | | | | Mean 19,147 | |

The plates used in the foregoing experiments are of Yorkshire iron, the same as those employed in Tables I. and II. The specimens were prepared in the same manner and of the same thickness, but 1 inch wider at the joint. This was done in order to retain sufficient metal round the rivet-holes, making the breadth of the plate the same after the rivet-holes were punched out as that of the plates torn asunder in the preceding experiments. In all these experiments only two half-inch rivets were used in the breadth of the plate. The lap was however increased, after the three first experiments, from $1\frac{1}{2}$ to 2 inches, to give greater strength in the longitudinal line of the plate and to prevent the metal tearing in that direction. This precaution was

* The nature and appearance of the fractures of all the irons and their riveted joints are shown in Plate LVII.

found necessary, as the metal gave indications of weakness in consequence of the lap being rather narrow. Another reason for enlarging the lap was a desire at the commencement to begin with the least possible quantity, and by direct experiment to ascertain the maximum distance which the plates should overlap each other in the joints, and to determine the strongest and best form of uniting them. To these points every attention was given, for the purpose of collecting the facts on which are founded the tabulated results on that part of the subject which treats of the comparative dimensions of rivets and extent of the lap in reference to the thickness of the plates. In this department of the inquiry will be found the depth of lap, diameter and length of rivets, and the distances of holes for nearly every description of joint; also the thickness of the plate, with a column of strengths as deduced from the experiments.

If we examine the nature of the fracture in the foregoing experiments, it will be found that the machine-riveting is superior to that done by the hammer; the mean of the three first experiments being to the mean of the fourth and fifth as 5:4. In the eighth and ninth the strengths are nearly the same.

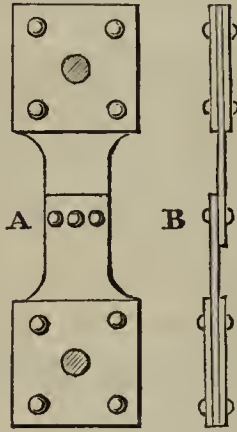
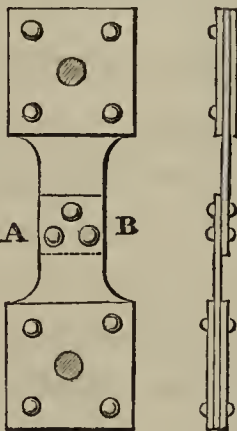
On comparing the strength of plates with their riveted joints, it will be necessary to examine the sectional areas taken in a line through the rivet-holes with the section of the plates themselves. It is perfectly obvious, that in perforating a line of holes along the edge of a plate, we must reduce its strength; and it is also clear, that the plate so perforated, will be to the plate itself nearly, as the areas of their respective sections, with a small deduction for the irregularities of the pressure of the rivets upon the plate; or in other words, the joint will be reduced in strength somewhat more than the ratio of its section, through that line, to the solid section of the plate. For example, suppose two plates, each 2 feet wide and three-eighths of an inch thick, to be riveted together with ten $\frac{3}{4}$ -inch rivets. It is evident that out of 2 feet, the length of the joint, the strength of the plates is reduced by perforation to the extent of $7\frac{1}{2}$ inches; and here the strength of the plates will be to that of the joint as 9:6.187, which is nearly the same as the respective areas of the solid plate, and that through the rivet-holes, namely, as 24:16.5. From these facts it is evident that the rivets cannot add to the strength of the plates, their object being to keep the two surfaces of the lap in contact, and being headed on both sides, the plates are brought into very close union by the contraction or cooling of the rivets after they are closed. It may be said that the pressure or adhesion of the two surfaces of the plates would add to the strength; but this is not found to be the case, to any great extent, as in almost every instance the experiments indicate the resistance to be in the ratio of their sectional areas, or nearly so.

If we take the ultimate strength of the Yorkshire plates in Tables I. and II., it will be found that the mean breaking weight of eight specimens, each with a sectional area of .46 inch, is 26,168, and the strength of the single joint*, of the same description of plates with an area of .44 inch, is 18,591; this reduced gives the ratio of the

* I use the term single joint to distinguish it from the double riveted joint, which will be treated of hereafter.

strength as 25,030 : 18,591, or as 1 : .742, the comparative strength of a single riveted plate of equal area through the line of the rivets. It will be observed that in this comparison the areas of the sections are nearly equal, and consequently there is a difference in strength between the solid part of the plate and that part where the perforations have been made of 32 per cent. The difference is considerable, but it probably arises from the narrowness of the specimen and the lateral strain induced by the position of the rivet, and the bending upwards of the end of the plates. From these facts I would infer that single riveting is weaker, and probably the loss of strength in this description of joint, including loss caused by the rivet-holes, is not less, under ordinary circumstances, than 40 per cent.


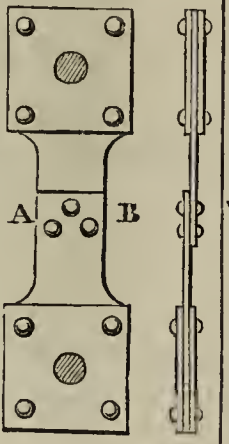
TABLE VII. Strength of riveted Plates.

| No. of exp. | Description of plates and mode of riveting. | Weight laid on in lbs. | Changes produced by weight. | Breaking weight in lbs. | Form of specimen and mode of fracture. | Remarks. |
|-------------|--|----------------------------|--|-------------------------|--|---|
| 30. | Plates 22 inches thick, with three rivets, each $\frac{3}{8}$ inch diameter, AB 3 inches, lap $1\frac{1}{2}$ inch, area through rivet-holes .4125 | 14,839 | Bent into a straight line. | 16,603 | <p>Fig. 5.</p>  | The plates were sound, but two of the rivets were cut directly across. Rivets too weak. |
| 31. | Plates the same as before, overlap joints differing from the last in having three rivets $\frac{1}{2}$ inch diameter, forming an isosceles triangle, AB 3 inches ... | 18,667 20,683 22,027 | Joint apparently sound. Single rivet slightly opened. The other two rivets quite tight. | 22,699 | <p>Fig. 6.</p>  | With the first weight the plates became bent, so as to be in a direct line with the straining force. |
| 32. | Same as before | 18,667 22,027 23,035 | Separation at end of plate, single rivet slightly opened. Slightly drawn at the rivets | 23,371 | | Tore across the two rivet-holes, in the direction AB. With 22,027 lbs. the single rivet seemed somewhat opened, but the other two seemed quite close. Plate torn across at the single rivet and one of the double ones. Rivets sound in this and the preceding experiment. |

In the first experiment the rivets (two in number) were evidently too weak, which caused them to shear directly across as if cut by a pair of scissors. In the next experiment the rivets were increased in number and size, which gave an excess of strength to the retaining power of the rivets and caused the plate to tear. If we take the mean of the experiments as respects the area of the rivets to that of the plates,

we find two half-inch rivets about the proportion, or the area of the rivets in the last experiments should have been .4 inches, which is nearly equal to the area of the plate through the rivet-holes*.

TABLE VIII. Strength of riveted Plates.

| No. of exp. | Description of plates and mode of riveting. | Weight laid on in lbs. | Changes produced by weight. | Breaking weight in lbs. | Form of specimen and mode of fracture. | Remarks. |
|-------------|---|------------------------|---|-------------------------------------|---|--|
| 33. | Plates same as before, .22 inch thick, but wider, AB being 3½ inches, with three rivets ½ inch diameter, all in a line; lap 1¾ in. | 18,667 | Ends of plate much separated by bending. | 19,675 | Fig. 7.  | Though the ends of the plates were much separated, the light of a candle could not be seen through the line of the rivets. Plate torn across the rivet-holes. |
| 34. | Thicker plates .26 in. thick, in other respects the same as in experiments 31, 32, Table VII.; lap 3 inches; rivets ½ inch diameter | 18,667 | Ends of plate separated, joints apparently good. | 23,707 } Mean 25,387 27,067 } | Fig. 8.  | Tore across the two rivet-holes. |
| 35. | Plates the same as the last..... | 22,699 21,019 | One plate much bent; joint apparently good. One end separated so far as to exhibit the single rivet. | | | Tore across the two rivet-holes, where the breadth was 3½ inches. |

Here the section of the rivets is to that of the plates, through the line of the rivets, in the ratio of .58 to .44; had they been equal, it is probable that fracture would have taken place as soon by the rivets shearing as through the plates.

During the whole of the experiments on single riveted joints, it was observed that the ends of the plates under strain curled upwards on each side, and produced a diagonal strain upon the plates, which materially reduced the strength of the joint, as shown at *a* fig. 7.

This position gave an oblique direction to the forces, and caused the plate to break in some degree transversely through the rivet-holes. In order to obviate this defect, and prevent as much as possible a transverse strain upon the plates through the

* Subsequent experiments made for ascertaining the strength of rivets (*vide* experiments on the strength of rivets for the Britannia and Conway Tubular Bridges) fully corroborate these views, namely, that riveted joints exposed to a tensile strain are directly, or nearly so, as their respective areas, or in other words, the collective areas of the rivets are equal to the sectional area of the plate taken through the line of the rivets.

points in contact, the lap was increased and a third rivet introduced to keep down the ends of the plates.

The sketches in the 31st experiment, Table VII., and those in the 34th and 35th experiment, Table VIII., represent the form of joint, and the methods adopted for securing the plates in the direct line of the strain.

On comparing the breaking weights, it will be seen that the increased lap, with a rivet to keep down and retain the ends of the plates, gives a considerable accession of strength, and exhibits several important facts in connection with the construction of vessels exposed to severe pressure. But this becomes more apparent in the forthcoming experiments on the double-riveted joints.

TABLE IX. Strength of riveted Plates.

| No. of exp. | Description of plates and mode of riveting. | Weight laid on in lbs. | Changes produced by weight. | Breaking weight in lbs. | Form of specimen and mode of fracture. | Remarks. |
|-------------|---|------------------------|--|-----------------------------------|--|--|
| 36. | Double-riveted plates $\frac{1}{2}$ inch thick; overlap joints riveted with five rivets of $\frac{3}{8}$ inch diameter each; lap 2 inches; AB=3 inches in breadth ... | 16,115 | Plates bent in a right line between the points of tension. | 24,043 } Mean 22,531 21,019 | | Torn right across at the three rivet-holes, all the rivets being sound after fracture. |
| 37. | Plates the same as before, except that AB= $2\frac{7}{8}$ inches in breadth | 21,715 | Little or no alteration. | | | |
| | | 18,667 | Plates bent into right line, as before. | | | Broke as before; rivets all sound. |

In these experiments, as in those in the preceding Table, the area of the rivets is in excess, and hence follows rupture through the plates.

TABLE X. Strength of riveted Plates, &c.

| No. of exp. | Description of plates and mode of riveting. | Weight laid on in lbs. | Changes produced by weight. | Breaking weight in lbs. | Form of specimen and mode of fracture. | Remarks. |
|-------------|---|------------------------|--------------------------------------|-----------------------------------|--|--|
| 38. | "Jump Joints." Plates the same as before, both riveted to an extra plate of the same thickness laid on one side of them; lap of extra plate over each end 2 inches; each plate riveted by five rivets $\frac{3}{8}$ inch diameter; AB= $3\frac{1}{8}$ inches. | 14,839 | Bent into straight line. | 23,371 } Mean 23,707 24,043 | | Tore across the rivet-holes. |
| | | 19,627 | All sound. | | | Rivets sound after fracture. |
| | | 21,691 | Rivets sound; plates much bent. | | | |
| 39. | Same as above..... | 18,667 | Bent nearly into a straight line. | 24,043 | | Tore across as before; one rivet-head crooked. |
| | | 22,699 | Rivets sound; joint apparently good. | | | |

The same observations will apply to these experiments as to the last; the area of the rivets is in excess of that of the plates.

The system of double riveting exhibits several remarkable properties as regards strength, and the plates appear to retain their position under strain much better than single-riveted joints. These circumstances have induced a comparison of the results of the preceding experiments with those contained in Tables VII., VIII., IX. and X. The experiments in Tables VII. and VIII. give indications of increased strength by a slight enlargement of the lap and the introduction of a single rivet to keep down the end of the plate. In those experiments it was found that the additional rivet gave an increase of 26 per cent. over those obtained from the single rivets; a circumstance which suggested a further extension of the experiments, accompanied with a minute investigation of the parts, in order to ascertain their relative strengths, and the strongest form of joint.

The mean breaking weights of equal sections of single-riveted joints, as given in Table VI. and taken from nine experiments, are respectively as follows:—

| | |
|--------|-------------------|
| lbs. | |
| 20,127 | } |
| 16,107 | |
| 18,982 | |
| 19,147 | |
| | Mean . . . 18,590 |

giving a mean of 18,590 lbs. for the strength of single-riveted joints. Now in the second and third experiments, Table VII., with the rivets inserted in the shape of an isosceles triangle (which in fact is double riveting), and of equal sections to the specimens in Table VI., the mean breaking weight is 23,035, which gives an excess of 4445, or a ratio of 10 : 8 in favour of the experiments recorded in Table VII.

In the experiments (Table X.), the area of the section, taken through the line of the rivet-holes, is .44 inch, or precisely equal to the section of the specimens experimented upon in Table VI., in which the mean breaking weight is 18,590 lbs. In these experiments the breaking weight is 23,707 lbs., which is rather more than that in Table IX., where the material had a smaller section, but having its dimensions exactly corresponding with the proportions given above. It therefore follows that in plates jointed with single rivets, the ratio of the strength of the single rivets is to that of the double-riveted joints as 8 to 10, the latter being one-fourth stronger.

It has been ascertained that it required a weight of 23,707 lbs. to tear asunder double-riveted plates, $3\frac{1}{8}$ inches wide and .22 inches thick, with a flush joint, having a plate on the back and held together by five $\frac{3}{8}$ -inch rivets on each side; the quantity of metal between the holes, in a direct line across the plate, being $.2 \times .22 = .44$ inch, which is the same transverse section as those operated upon in the first Table.

Now if we take the mean breaking weights of the riveted joints in Tables X. and VI. and compare them with the section of the plate itself as given in Table I., the areas being the same, we have for the tensile strength of plates—

| | Section of iron torn asunder. | lbs. |
|---|-------------------------------|--------|
| In Table I., solid plate | .44 | 25,400 |
| In Table X., double-riveted joints | .44 | 23,707 |
| In Table VI., single-riveted joints | .44 | 18,590 |

Assuming therefore the strength of the plates to be 1000, we have—

| | |
|--|------|
| For the strength of plates of equal sections | 1000 |
| For the double-riveted joints | 933 |
| For the single-riveted joints | 731 |

We may safely assume these ratios as the comparative values of jointed plates of equal sections when acted upon by a force calculated to tear them asunder.

The correct value of the plates, computed from a sectional area taken through the rivet-holes, will therefore be to their riveted joints as 100, 93 and 73, or in round numbers as 10, 9 and 7.

In addition to a loss of nearly one-tenth in the double-riveted joints, and three-tenths in the single ones, it will be observed that the strength of the plates is still further reduced by the quantity of iron punched out for the rivets.

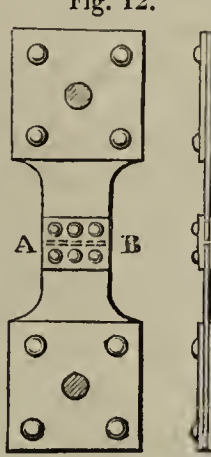
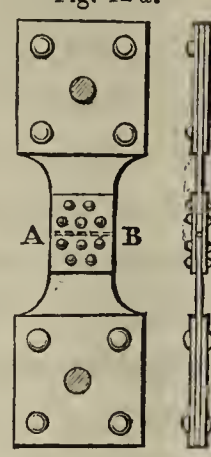
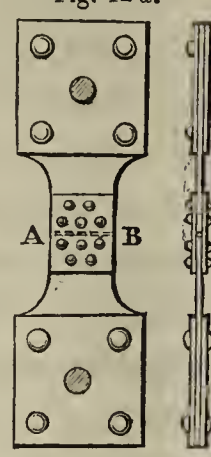
TABLE XI. Single riveted Plates.

| No. of exp. | Description of plates and mode of riveting. | Weight laid on in lbs. | Changes produced by weight. | Breaking weight in lbs. | Form of specimen and mode of fracture. | Remarks. |
|-------------|---|------------------------|--|-------------------------|--|--|
| 40. | Plates same as before, .22 inch thick, with overlap joint and double rivets; countersunk on one side; AB = 3 1/8 inches; five rivets, each 3/8 diameter. | 19,675 | Plates bent in a right line; doubtful whether the joint would hold water | 23,707 | <p>Fig. 11.</p> | <p>By the word countersunk is understood a conical recess on one side of the plate to receive the head of the rivet, in order that it might not project beyond the surface of the plate.</p> <p>Tore across the three rivet-holes.</p> |
| 41. | Plates the same strength, but different from the last in having only 3/8-inch rivets all in a line; AB = 3 1/8 ins. | 14,839 | Plates bent into a right line with the fixing..... | 16,351 | | <p>In an unsuccessful experiment made before this upon plates precisely the same, and riveted in the same manner, they were torn across the rivet-holes in attempting to lay on 18,667 lbs.</p> <p>Plates tore across the rivet-holes.</p> |
| 42. | Same as last, except in not having the rivet-holes countersunk; lap 1 1/8 inch; AB = 3 1/8 inches | 14,839 | Joint sound..... | 16,351 | | <p>All the rivets on one side were cut in two in the middle, and the plates left sound.</p> |

The results in the two last experiments, in the above Table, are identical as to strength. In the first, with the countersunk rivets, the plates were torn asunder, and in the latter the rivets appear the weakest, owing to the increased sectional area of the plates, which in the preceding experiment was reduced by countersinking the rivets.

In both experiments it will be observed that the strengths of the rivets are proportional to the strengths of the plates, their powers of resistance being equal, or nearly so. In forty-one experiments the sectional area of the rivets was to that of the plates as .340 to .347, that is, the sections were nearly equal; and in forty-two experiments as .34 to .44, which accounts for the nature of the fracture in both cases.

TABLE XII. Strength of riveted Plates.

| No. of exp. | Description of plates and mode of riveting. | Weight laid on in lbs. | Changes produced by weight. | Breaking weight in lbs. | Form of specimen and mode of fracture. | Remarks. |
|-------------|--|----------------------------------|-----------------------------|-------------------------------------|---|---|
| 43. | Plates the same as before, their edges brought into contact, and each plate riveted by three rivets $\frac{3}{8}$ of an inch diameter, to a plate on each side of the joint, each external plate being half the thickness of the internal, or a little thicker; AB = $3\frac{1}{8}$ ins. | 19,879 | Sound; no alteration. | 25,723 } Mean 23,539 21,355 } |  | Both side plates were torn across, and two of the rivets cut off. The sum of the thickness of the side plates was .24 inch, the middle plates being .22 inch thick. |
| 44. | Plate same as last ... | 24,715 | | | | The middle plates were left sound. Second experiment broken as before, the two outside plates torn off; all the rest sound. |
| 45. | Same as the last experiment, having thicker plates outside, each being .15 inch thick. | 23,371 | Joint good | 24,715 |  | Middle plate torn straight across the rivet-holes. All the rivets and both plates left sound. |
| 46. | Differing from the last only in having five rivets to each plate in double rows instead of three rivets $\frac{3}{8}$ diameter; AB = $3\frac{1}{4}$ inches ... | 23,371 | Joint sound | |  | Both outside plates torn across at the three rivets. |
| 47. | Same as the last | 25,387 } 23,371 } 24,715 } | Joint sound | 26,059 } 27,403 } | | Mean 26,731 |

When the comparative merits of plates and their riveted joints were under consideration, it appeared desirable to repeat several of the experiments, particularly those which seemed to throw light upon their relative powers of resistance. I considered these experiments to be of importance, as they increased our knowledge, as respects the strength of the material, and also its properties in combination.

In ship-building these objects are of some value, as any reduction in the powers or parts of a vessel by imperfect construction, or misapplied material, might lead to serious error and even great risk to the safety of the ship.

Since the first use of iron for these objects, it has been the practice to countersink the heads of the rivets in order to present a smooth surface for the passage of the vessel through the water. This practice is in general use at my works at Millwall, and I believe the same methods are pursued at the establishment of Messrs. JOHN LAIRD and Co., and others in different parts of the country. The introduction of this system of riveting caused a further extension of the experiments, in order to elucidate the various forms of joints given in the preceding Tables, and further to investigate the strength of the joint with a plate riveted on each side, which appears to be the strongest and best calculated to resist a tensile strain. This description of joint is seldom used in ship-building, but in order to render the experiments as perfect as

possible, it will be necessary to consider it in this paper with others of equal importance and probably of more general use.

The system of countersinking the rivets is only used when smooth surfaces are required; under other circumstances their introduction would not be desirable, as they do not add to the strength of the joint, but to a certain extent reduce it. This reduction is not observable in the experiments, but the simple fact of sinking the head of the rivet into the plate and cutting out a greater portion of metal, must of necessity lessen its strength, and render it weaker than the plain joint with raised heads. This must appear evident from the fact of the sectional area of the plate being diminished, and the consequent reduction of the heads of the rivets, which in this state are less able to sustain the effects of an oblique or transverse strain.

It is, however, satisfactory to observe that countersinking the heads of the rivets does not seriously injure the joint in its powers of resistance to a direct tensile force; but the rivets are liable to start when exposed to collisions or a strong impinging force, such as the sides of ships are frequently doomed to encounter.

On referring to experiments (Table XI.), the same results as to strength are obtained with the countersunk rivets as those with rounded heads; they are rather under the mean of the former experiments, but not more than is easily accounted for by the reduced section of the countersunk plates.

The joint with plates, riveted on each side, is seldom used, a circumstance which probably arises from its greater complexity of form and the danger which a treble thickness of plate would be subject to if used in boilers or vessels exposed to the action of intense heat. It is also inadmissible in ship-building, as the smooth surface requires to be maintained, and the greatest care observed in the formation of the outer sheathing to lessen the resistance of every part of the hull immersed in the water. In other respects the double-riveted plate is a strong joint, and in every case, where great strength is required, it may be used with perfect safety.

It will be unnecessary to go through a further comparison of the experiments, as sufficient data have already been furnished to enable us to calculate the force per square inch, and to resolve the whole into a general summary exhibiting the relative strengths—1st, of the plates; 2ndly, of the single- and double-riveted joints; and lastly, the ratio of the strengths as deduced from the whole series of experiments.

General summary of Results as obtained from the foregoing Experiments.

| | Cohesive strength of plates. Breaking weight in lbs. per square inch. | Strength of single-riveted joints of equal section to the plates, taken through the line of rivets. Breaking weight in lbs. per square inch. | Strength of double-riveted joints of equal section to the plates, taken through the line of rivets. Breaking weight in lbs. per square inch. |
|----------|---|--|--|
| | 57,724 | 45,743 | 52,352 |
| | 61,579 | 36,606 | 48,821 |
| | 58,322 | 43,141 | 58,286 |
| | 50,983 | 43,515 | 54,594 |
| | 51,130 | 40,249 | 53,879 |
| | 49,281 | 44,715 | 53,879 |
| | 43,805 | 37,161 | |
| | 47,062 | | |
| Mean ... | 52,486 | 41,590 | 53,635 |

The relative strengths will therefore be,—

| | |
|--------------------------------|------|
| For the plate | 1000 |
| Double-riveted joint | 1021 |
| Single-riveted joint | 791 |

From the above, it will be seen that the single-riveted joints have lost one-fifth of the actual strength of the plates, whilst the double-riveted have retained their resisting powers unimpaired. These are important and convincing proofs of the superior value of the double joint, and in all cases where strength is required this description of joint should never be omitted.

On referring to the experiments contained in the separate tables, there will be found a striking coincidence in the facts tending to establish the principle of double riveting as superior in every respect to the general practice now in use of the single rivets. It appears, when plates are riveted in this manner, that the strength of the joints is to the strength of the plates of equal sections of metal as the numbers,—

$$1000 : 1021 \text{ and } 791^*.$$

In a former analysis it was $1000 : 933 \text{ and } 731,$

which gives us a mean of $1000 : 977 \text{ and } 761$

which in practice we may safely assume as the correct value of each. Exclusive of this difference, we must however deduct 30 per cent. for the loss of metal actually punched out for the reception of the rivets, and the absolute strength of the plates will then be, to that of the riveted joints, as the numbers 100, 68 and 46. In some cases, where the rivets are wider apart, the loss sustained is however not so great;

* The cause of the increase of strength in the double-riveted plates may be attributed to the riveted specimens being made from the best iron, whereas the mean strength of the plates is taken from all the irons experimented upon, some of inferior quality, which will account for the high value of the double-riveted joint. In ordinary cases and in practice it will therefore be safer to take the mean of the whole, viz.—

| | |
|----------------------------------|-----|
| Strength of plates..... | 100 |
| Strength of double-riveting..... | 97 |
| And of single-riveting | 76 |

but in boilers and similar vessels, where the rivets require to be close to each other, the edges of the plates are weakened to that extent. In this estimate we must however take into consideration the circumstances under which the results were obtained, as only two or three rivets came within the reach of experiment: and again, looking at the increase of strength which might be gained by having a greater number of rivets in combination, and the adhesion of the two surfaces of the plates in contact, which in the compressed rivets by machine is considerable, we may fairly assume the following relative strengths as the value of plates with their riveted joints:—

| | |
|--|-----|
| Taking the strength of the plate at | 100 |
| The strength of the double-riveted joint would then be . . . | 70 |
| And the strength of the single-riveted joint | 56 |

These proportions may therefore in practice be safely taken as nearly the standard value of joints, such as used in vessels where they are required to be steam- or water-tight, and subjected to pressure varying from 10 to 100 lbs. upon the square inch.

Since the above was written, I have ascertained, on a recent visit to Bristol, that the large steam-ship* now building there is double-riveted, the plates being three-fourths of an inch thick over the bottom and bilge, and five-eighths thick up to the water-line. These plates are joined together with double rivets of 1 inch diameter, and inserted at distances of 3 inches apart. The proportions appear to be good; and conceiving the workmanship to be equally so, I should infer that this fine vessel would fairly establish the principle, that iron, in all the ramifications of ship-building, is an article of paramount importance to the war as well as to the mercantile navy.

In the pursuit of the foregoing inquiry, I was naturally led to the consideration of the best proportions and best forms of riveting plates together. I investigated this subject with great care, and from my own personal knowledge and that of others, I have collected a number of practical facts, such as long experience alone could furnish. From these data I have been enabled to complete the following Table, which for practical use I have found highly valuable in proportioning the distances and strength of rivets in joints requiring to be steam- or water-tight.

Table exhibiting the strongest forms and best proportions of riveted joints as deduced from the experiments and actual practice.

| Thickness of plates in inches. | Diameter of rivets in inches. | Length of rivets from the head in inches. | Distance of rivets from centre to centre in inches. | Quantity of lap in single joints in inches. | Quantity of lap in double-riveted joints in inches. |
|--------------------------------|-------------------------------|---|---|---|--|
| $\cdot 19 = \frac{3}{16}$ | $\cdot 38$ | $\cdot 88$ | $1\cdot 25$ | $1\cdot 25$ | For the double-riveted joint, add two-thirds of the depth of the single lap. |
| $\cdot 25 = \frac{4}{16}$ | $\cdot 50$ | $1\cdot 13$ | $1\cdot 50$ | $1\cdot 50$ | |
| $\cdot 31 = \frac{5}{16}$ | $\cdot 63$ | $1\cdot 38$ | $1\cdot 63$ | $1\cdot 88$ | |
| $\cdot 38 = \frac{6}{16}$ | $\cdot 75$ | $1\cdot 63$ | $1\cdot 75$ | $2\cdot 00$ | |
| $\cdot 50 = \frac{8}{16}$ | $\cdot 81$ | $2\cdot 25$ | $2\cdot 00$ | $2\cdot 25$ | |
| $\cdot 63 = \frac{10}{16}$ | $\cdot 94$ | $2\cdot 75$ | $2\cdot 50$ | $2\cdot 75$ | |
| $\cdot 75 = \frac{12}{16}$ | $1\cdot 13$ | $3\cdot 25$ | $3\cdot 00$ | $3\cdot 25$ | |
| | | | | | |

* The Great Britain steam-ship.

The figures 2, 1·5, 4·5, 6, 5, &c. in the preceding Table are multipliers for the diameter, length and distance of rivets, also for the quantity of lap allowed for the single and double joints. These multipliers may be considered as proportionals of the thicknesses of the plates to the diameter, length, distance of rivets, &c. For example, suppose we take three-eighth plates and required the proportionate parts of the strongest form of joint, it will be—

$$\cdot 375 \times 2 = \cdot 750 \text{ diameter of rivet, } \frac{3}{4} \text{ inch.}$$

$$\cdot 375 \times 4\frac{1}{2} = 1\cdot 688 \text{ length of rivet, } 1\frac{3}{4} \text{ inch.}$$

$$\cdot 375 \times 5 = 1\cdot 875 \text{ distance between rivets, } 1\frac{3}{4} \text{ inch.}$$

$$\cdot 375 \times 5\frac{1}{2} = 2\cdot 063 \text{ quantity of lap, 2 inches.}$$

$$\cdot 375 \times 5\frac{1}{2} = 3\cdot 438 \text{ quantity of lap for double joints, } 3\frac{1}{2} \text{ inches.}$$

·75, 1·68, 1·87, 2·06 and 3·43 are therefore the proportionate quantities necessary to form the strongest steam- or water-tight joints on plates three-eighths of an inch thick.

In the preceding pages I have endeavoured to investigate almost every circumstance having a practical bearing on the question of the strength of rolled plates, and the best methods of uniting them together. In conclusion, I would venture a few remarks on the value and judicious use of this material, in its adaptation to ship-building, and other purposes to which it may be successfully applied. It is not my intention to enter into the question as to whether wood or iron be the preferable material, as a number of circumstances, such as cost, durability, &c., must be considered in order to form a correct decision.

I would however observe, that in ship-building alone, it appears from the facts already recorded, that iron is very superior in its powers of resistance to strain; it is highly ductile in its character, and easily moulded into any required form without impairing its strength. It is also stronger in combination than timber, arising from the nature of the construction, and the materials composing the iron ship become a homogeneous mass when united together, forming as it were a solid, without joints, and presenting as a whole the most formidable powers of resistance*. These are some of the properties which appear to distinguish iron from other materials, and which give it an ascendancy of combined action, which cannot be obtained in the union of timber however ingeniously contrived. It moreover possesses the property of lightness along with strength; in fact, its buoyancy, strength and durability constitute the elements of its utility in the innumerable cases to which it may be applied. In ship-building it possesses other advantages over timber. Its hull is free from the

* Since the above was written we have had many examples of the enormous strength of iron ships, and amongst others we may instance an iron vessel which took the ground with nearly one-half of her length at the stern hanging over a shelf for a whole tide; another, the Vanguard iron steamer, which for several hours (under the action of a heavy surf) was beating upon sharp shelving rocks without going to pieces; and lastly, the Great Britain steam-ship, which was stranded in Dundrum Bay, and resisted the force of the winter storms for many months.

risk of fire; and in case of shipwreck, either on rocks or sand-banks, it will resist the heaviest sea, endure the severest concussion, and with proper attention to the construction, it may be the means of saving the lives of all on board. It moreover has the advantage of bulkheads, which, made perfectly water-tight, not only strengthen the vessel, but give greater security to it, and by a judicious arrangement in the divisions will float the ship under the adverse circumstance of a leak occurring in any one of the compartments. These are the qualities and powers of the iron ship; and I trust the present research into the strength and proportions of the material of which it is composed, will not only give increased confidence in its security, but will lead to an extension of its application in every branch of marine and mechanical architecture.

PART III.

Resistance of Wrought-iron Plates to Pressure by a Blunt Instrument at right angles to the surface of the Plate.

Irrespective of the experiments made to determine the strength of wrought-iron plates and the relative strength of the joints by which they are united, the investigation would be incomplete if we omitted another inquiry of equal importance, namely, the resistance offered by plates to a crushing force, such as exhibited in the injuries received by vessels when stranded on rocks or taking the ground in harbours where the surfaces are uneven.

Almost every person connected with nautical affairs is acquainted with the nature of the injuries received by timber-built vessels when placed in circumstances affecting their stability, or when resting on hard and unequal ground, such as frequently occurs in tidal harbours at low water. Such a position is attended with danger under every circumstance; and in order to determine the relative values of the two materials, wood and iron, it was considered desirable to institute a similar class of experiments on both, and thus to afford the means of comparison between them. English oak, as the strongest and best material used for the construction of first class vessels, was selected for this purpose, and the results obtained from both are given, under circumstances as nearly similar as the nature of the experiment would admit. They are as follows.

In each of the experiments the plate was fastened upon a frame of cast iron, 1 foot square inside and 1 foot 6 inches outside, its breadth being 3 inches and thickness half an inch. The sides of the plates, when hot, were twisted round the frame, to which they were firmly bolted. The contraction, by cooling, caused it to be very tight, and the force to burst it was applied in the centre. This was done in order that the force might in some degree resemble that from a stone or other body with a blunt end pressing against the side or bottom of a vessel: a bolt of iron, terminating in a hemisphere 3 inches in diameter, had thus its rounded end pressed perpendicularly to the plate in the middle. The results are given in the following Tables.

TABLE XIII. Experiments to determine the Resistance of Plates of Wrought Iron to a force tending to burst them.

| No. of exp. | Description of plates. | Weight laid on in lbs. | Permanent indentation of plate. | Remarks. |
|-------------|--|------------------------|---------------------------------|---|
| 1. | Plate of the best Staffordshire iron $\frac{1}{4}$ inch thick. | 8,617 | inch. ·3 | Plate not cracked. |
| | | 9,893 | ·35 | Plate not cracked. |
| | | 11,169 | ·5 | Crack on convex side 8 inches long. |
| | | 12,445 | ·6 | Crack on convex side 9 inches long; not opened on concave side. |
| | | 13,789 | ·7 | Hole through the plate about $1\frac{1}{2}$ inch long, and $\frac{1}{8}$ inch wide. |
| 2. | Plate of the same iron and the same thickness. | 9,893 | ·25 | Double crack on convex side 1 inch long. |
| | | 11,169 | ·34 | Double crack increased. |
| | | 12,445 | ·4 | |
| | | 13,789 | ·47 | |
| | | 16,477 | ·6 | Form of crack on convex side ($\frac{1}{8}$ inch wide). |
| | | 17,821 | ·65 | Not cracked through. |
| | | 19,769 | | Cracked through. |
| 3. | Plate of the same iron $\frac{1}{2}$ inch thick. | 18,523 | | No crack. |
| | | 21,075 | ·33 | Incipient crack on convex side. |
| | | 22,787 | ·45 | Crack above-mentioned 4 inches long, forming a cross. |
| | | 25,923 | ·60 | Crack above, 6 inches long. |
| | | 29,059 | ·75 | Crack above, $\frac{1}{8}$ inch wide. |
| | | 32,195 | ·80 | |
| | | 35,331 | ·97 | |
| | | 36,899 | 1·10 | No crack on concave side. |
| | | 37,519 | | Plate cracked through. |
| 4. | Plate same as the last. | 21,219 | | No crack. |
| | | 21,985 | ·35 | Slight crack on convex side. |
| | | 27,708 | ·47 | Form of crack on convex side. |
| | | 31,796 | ·7 | Form of crack increased. |
| | | 33,431 | ·75 | |
| | | 35,066 | ·83 | Form of crack 4 inches deep. |
| | | 36,701 | ·97 | Not cracked through. |
| | | 37,928 | | Cracked through. |

In Plate LVIII. figs. 13 and 14, will be found representations of the fractures of the plates experimented upon in this Table.

From the above we obtain the strength of plates to resist rupture from pressure from a blunt body, or a ball 3 inches diameter.

| | | |
|---|--------|----------|
| | lbs. | Mean. |
| In experiment 1, a plate one-fourth of an inch thick was burst by | 13,789 | } 16,779 |
| In experiment 2, a plate one-fourth of an inch thick was burst by | 19,769 | |
| In experiment 3, a plate half an inch thick was burst by . . . | 37,519 | } 37,723 |
| In experiment 4, a plate half an inch thick was burst by . . . | 37,928 | |

Here the strengths are as the depths, a half-inch plate requiring double the weight to produce fracture that had previously burst the quarter of an inch plate. In the succeeding experiments on oak timber, the powers of resistance follow the ratio of the squares of the depth, so that a wrought-iron plate of only one-quarter of an inch thick is able to resist a force equal to that required in the rupture of a 3-inch plank.

The experiments were made upon good English oak, of different thicknesses, and of the same width as the iron plates. The specimens were laid upon solid planks, 12 inches asunder, and by the same apparatus the rounded end of the 3-inch pin was forced through them as follows:—

Resistance of planks of timber to the entrance of a ball, 3 inches diameter, the planks being laid upon props 12 inches asunder; the object of the experiments being to burst them by pressing a pin, terminated by a hemispherical end, 3 inches diameter, through the centre of the plank, as was done with the plates of iron.

TABLE XIV.

| No. of exp. | Description of plank. | Weight laid on. | Remarks. |
|-------------|--|--------------------------|--|
| 1. | English oak, very dry and good, $11\frac{3}{4}$ inches broad, and $2\frac{1}{2}$ inches deep. | lbs. 16,115 17,235 | Indentation from hemisphere $\frac{1}{2}$ inch deep; wood otherwise uninjured. Hole through the middle, 3 inches diameter nearly broke out, all the rest remaining sound. |
| 2. | English oak, rather green, 8 inches broad, 3 inches deep. | 18,941 | It bore 18,941 lbs. about ten minutes, and then exploded with violence, dividing into three parts, the middle one on which the pin rested being about an inch thick at the top, and $\frac{1}{2}$ an inch at the bottom. With a ton less weight there was a crack under the plank in the centre, and an indentation by the pin $\frac{1}{2}$ inch deep on the upper side. Sap was driven out from the ends on the side nearest to the heart. |
| 3. | English oak plank, and dimensions same as in last experiment. | 12,445 16,925 | Sap driven out as in last experiment; plank without crack; indentation by the pressure about $\frac{1}{2}$ inch. The plank split with bearing the pressure about ten minutes. |
| 4. | English oak from same plank as in experiment 2 and 3; breadth 8 inches, depth $1\frac{1}{2}$ inch. | 4,532 | The plank broke by splitting. |
| 5. | English oak from same plank and same size as in the last experiment. | 4,280 | Broke by splitting diagonally. |

Taking the results of the four last experiments, which were on pieces from the same plank, we obtain—

| | | |
|--|--------|---------|
| Strength from planks 3 inches thick | 18,941 | } Mean. |
| Strength from planks 3 inches thick | 16,925 | |
| Strength from planks $1\frac{1}{2}$ inch thick | 4,532 | } 4,406 |
| Strength from planks $1\frac{1}{2}$ inch thick | 4,280 | |

Here the strength to resist crushing follows the ratio of the square of the depth, as is found to be the case in the transverse fracture of rectangular bodies of constant breadth and span.

If we compare the foregoing results with the experiments performed by Mr. HODGKINSON on timber, it will be found that the strength of dry English oak to resist a crushing force is 4.24 tons to the square inch, whereas wrought iron, according to RONDELET, requires a pressure of about 31 tons per square inch, and with this weight it is reduced about one-sixteenth of its length. The resistance of wrought iron to a crushing force is therefore about seven and a quarter times greater than that of oak: and according to the experiments in the preceding Table, it appears that the resistance of wrought-iron plates to a force calculated to burst them, follows a different law to that of oak, the resistance of the former being directly as the depth and of the latter as the square of the depth. Reasoning from these facts, it may be interesting to know that in the use of timber, such as the oak sheathing of ships, the strength to ex-

ternal pressure increases in the ratio of the squares of its thickness ; and, where great strength is required, it will be necessary, in the construction of vessels, to consider the nature of the service and the required thickness of the planks.

The same remarks will apply to vessels constructed of iron, computed from the formula deduced from the experiments. In a table of experimental results by Mr. HODGKINSON we have the mean force per square inch required for crushing timber of different kinds ; and assuming RONDELET's experiments, which give 70,000 lbs. as the resistance per square inch of wrought iron, to be correct, we then have as the ratio of their respective powers of resistance as follows :—

TABLE XV.

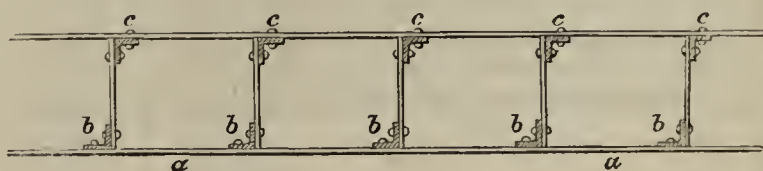
| Specific gravities. | Description of timber used. | Resistance per square inch. | Resistance of wrought iron per square inch. | Ratio, the wood representing unity. |
|---------------------|-----------------------------|-----------------------------|---|-------------------------------------|
| | | lbs. | lbs. | |
| 7·700 | Wrought iron | | 70,000 | |
| 0·560 | Yellow pine | 5375 | 70,000 | 1 : 13·02 |
| 0·540 | Cedar | 5674 | 70,000 | 1 : 12·33 |
| 0·580 | Red deal | 5748 | 70,000 | 1 : 12·16 |
| 0·640 | Birch | 6402 | 70,000 | 1 : 10·93 |
| 0·660 | Sycamore..... | 7082 | 70,000 | 1 : 9·88 |
| 0·753 | Spanish mahogany ... | 8198 | 70,000 | 1 : 8·53 |
| 0·780 | Ash | 8683 | 70,000 | 1 : 8·06 |
| 0·700 | Dry English oak | 9509 | 70,000 | 1 : 7·36 |
| 0·980 | Box | 9771 | 70,000 | 1 : 7·16 |

In addition to the relative resisting forces of the different kinds of timber above enumerated, will be found the specific gravities of each, which enables the reader to determine the comparative weights as well as strength of the different kinds of wood.

PART IV.

In the preceding researches I have endeavoured to determine the value of iron chiefly in reference to its application for the purposes of ship-building. It now only remains to determine the best form and condition of another part of the structure, namely, the frames and ribs of vessels, also composed of iron. Some of the forms experimented upon indicate weakness, but certain modifications which have since been introduced, have given increased support to the bilge and sides of the ship, and greater powers of resistance to the outer sheathing. The beam shown at fig. 19, Plate LVIII., is probably one of the strongest and most suitable for the support of the decks, but it is inadmissible as a frame for receiving the exterior sheathing plates. These frames are generally formed of a plate with angle-irons along the edges on both sides, of which the annexed sketch are sections. *a, a, &c.*

Fig. 15.



represents a portion of the outside plates ; *b, b* the angle-iron frames or ribs, which vary from 18 to 24 inches asunder, according to the position in the direction

of the length of the ship; *c, c*, angle-iron of the same strength is riveted along the edge of each rib for the purpose of stiffening the sides of the ship and giving increased resistance to those parts, also to receive interior plates, some of which, in large vessels, are riveted diagonally to the interior angle-irons *c, c*, &c., forming stringers and braces from the kelsons round the bilge to the upper decks.



Other kinds of frames might be used with double angle-iron, as shown at *d, d*, &c. in the annexed sketch, but they are more expensive, and from the increased complexity of construction, the extra strength obtained does not compensate for

the difference of cost. Altogether, the frames recorded in fig. 15 have come into general use as the most effective and easy of construction. Those experimented upon were of different kinds, as shown in Plate LVIII. fig. 17, 18, &c., and in sections given in the Tables, and from which the following results were obtained:—

Fig. 16.



TABLE XVI. Experiments to ascertain the strengths of uniform wrought-iron beams of different forms to support the sides and other parts of vessels, the beams having their ends placed upon props and being loaded in the middle.

| No. of exp. | Description and form of the beam. | Weight laid on middle. | Deflections with these weights. | Breaking weight of the beam of 7 feet between the supports. | Weight of the beam of 7 feet 6 inches long. | Oak beams. | | Remarks. |
|-------------|---|--|--|---|---|--|--|---|
| | | | | | | Side of square of oak beams of equal strength with the iron one. | Weight of such beams of 7 feet 6 inches long and specific gravity 900. | |
| 1. | Beam formed from two $2\frac{1}{2}$ angle-irons, riveted together with rivets 6 inches asunder, and a plate $\frac{1}{4}$ inch thick riveted to the back, with rivets 4 inches asunder. Distance between the supports 7 feet, and whole length 7 feet 6 inches, its weight being 109 lbs. Thickness. AB = 5 inches. CD = 2.6 inches. aa = .5 inch. bb = .56 inch. cc = .64 inch. ee = .25 inch. The part C was downwards during the experiment, the weight being laid upon the part D.  | lbs. | | lbs. | lbs. | inches. | lbs. | The weight 3355 lbs. was laid on at once, and the beam almost immediately sunk with it; a weight something less would have done it. |
| 2. | The beam last used, cut in two; distance between supports 2 feet 3 inches; vertical rib downwards, that it might be stretched as before; weight of 3 feet 9 inches = 54 lbs. | 4,039 5,383 6,055 6,727 7,399 7,735 } sunk | .18 .30 .43 .64 .88 | 2486 | 109 | 3.287 | 31.80 | With 7735 lbs. it sunk, by stretching and tearing at a rivet-hole. |
| 3. | The other half of the beam (exp. 1.) cut in two. Distance between the supports 2 feet 3 inches; weight of 3 feet 9 inches = 55 lbs.; vertical rib upwards thus,  that fracture might take place by the compression of that rib. | 4,039 5,383 6,055 6,727 7,399 8,071 8,743 9,415 10,087 10,423 10,759 } sunk | .17 .23 .26 .34 .47 .63 .85 1.10 1.95 2.90 | 3458 | 109 | 3.6692 | 39.44 | With 10,759 lbs. it sunk; the vertical rib becoming twisted. |

All the beams experimented upon in the foregoing Table are shown in view and in section, Plate LVIII. figs. 17 and 18. In the first experiment the beam was 7 feet between the supports, but having yielded to the first weight, 3355 lbs., laid on, it was subsequently cut in two, as shown in the drawings above referred to. In experiment 2, it will be observed that a frame of this form is weak, arising from the deficiency of material on the lower side of the rib formed by angle-iron, which, yielding to a tensile strain, becomes elongated in the act of bending, and would thus deflect through a considerable space before actual fracture took place. Reversing the other part of the beam with the broad flange downwards it carried more weight, but ultimately sunk under a load of 10,759 lbs., being in the ratio of 10 : 7 in favour of the beam with the rib upwards.

These experiments, when reduced to 7 feet between the supports, gave nearly the same proportion, viz. nearly as 34 : 24. They are however all weak, arising almost exclusively from want of material on the top edge of the ribs, and a due proportion in the construction of the beam.

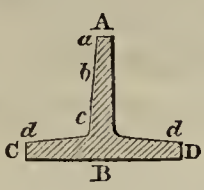
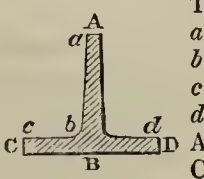
TABLE XVII. Experiments on Wrought-iron Beams (continued).

| No. of exp. | Description and form of the beam. | Weight laid on middlc. | Deflections with these weights. | Breaking weight of the beam of 7 feet between the supports. | Weight of the beam of 7 feet 6 inches long. | Oak beams. | | Remarks. |
|-------------|--|--|--|---|---|--|--|---|
| | | | | | | Side of square of oak beams of equal strength with the iron one. | Weight of such beams of 7 feet 6 inches long and specific gravity 900. | |
| 4. | Beam differing from that in exp. 1 only in being of greater strength, this beam being formed of two 3-inch angle-irons, riveted as before to a plate a ¼-inch thick. Distance between the supports 7 feet; weight of the beam 7 feet 6 inches long, 167½ lbs.; vertical rib downwards Υ . | lbs. 3,355 4,711 5,383 5,719 6,055 6,391 6,727 7,063 7,399 | ·40 ·62 ·82 ·98 1·12 1·30 1·87 1·92 2·29 3·25 | lbs. 7399 | lbs. 167·5 | inches. 4·7281 | lbs. 65·49 | After bearing the weight 7399 lbs. a short time the beam became cracked at a rivet-hole and sunk. From the experiments of BUFFON upon green oak, the side of a square beam of equal strength would be 4·558 inches, and its weight 708 lbs. |
| 5. | Half the beam used in exp. 4, now 3 feet 9 inches long, and weighing 82½ lbs. Distance between supports 3 feet 6 inches; vertical rib downwards. | 4,039 7,399 10,759 11,431 12,103 12,439 | 0·85 0·25 0·43 0·53 0·65 broke at a rivet-hole. | } 6219 | 1675 | 4·462 | | |
| 6. | The other half of the beam in exp. 4, weighing 85 lbs.; length 3 feet 6 inches. Distance between the supports 2 feet 3 inches; rib upwards \perp . | 8,304 12,392 16,480 18,115 | 0·12 0·24 0·75 sunk, the vertical rib being twisted. | } 5823 | 1675 | 4·3653 | 55·83 | |

The whole of the experiments herein recorded are of the same description as the last, with the exception of the beam being composed of thicker angle-iron, and consequently rendered much stiffer and stronger than those first experimented upon. This increased stiffness reversed the resisting powers of the beam, when taken at a 7-foot

span, in the ratio of 6 : 5 in favour of the first position with the rib downwards. For plans and sections of these beams see Plate LVIII. fig. 18.

TABLE XVIII. Experiments on Wrought-iron Beams (continued).

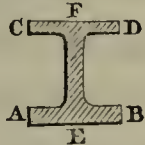
| No. of exp. | Description and form of the beam. | Weight laid on middle. | Deflections with these weights. | Breaking weight of the beam of 7 feet between the supports. | Weight of the beam of 7 feet 6 inches long. | Oak beams. | | Remarks. |
|-------------|---|--|---|---|---|--|--|--|
| | | | | | | Side of square of oak beams of equal strength with the iron one. | Weight of such beams of 7 feet 6 inches long and specific gravity 900. | |
| 7. | Solid wrought-iron beam, 4 feet 2 inches long, weighing 23 lbs., placed upon props 4 feet asunder; vertical rib upwards. Form and dimension of section.  Thickness at $a = .24$ $b = .29$ $c = .41$ $d = .36$ $AB = 2.50$ $CD = 2.85$ | lbs. 1394 1932 2470 2739 3008 | .135 .24 .59 .90 1.35 | lbs. 1790 | lbs. 41.4 | inches. 2.9461 | lbs. 25.43 | With 3008 lbs. the elasticity was entirely destroyed, and a like additional weight would have destroyed the form of the beam. |
| 8. | Same beam rendered straight, and turned with its rib downwards \top . | 1394 1932 2470 2739 3008 3142 | .17 .25 .66 1.22 2.20 sunk | 1870 | 41.4 | 2.9894 | 26.18 | |
| 9. | Solid beam, same form as before; length 5 feet $\frac{2}{3}$ inch; weight 25 $\frac{1}{2}$ lbs. Distance between supports 4 feet; rib upwards thus. See fig. to experiment 7.  Thickness at $a = .23$ $b = .30$ $c = .40$ $d = .33$ $AB = 2.05$ $CD = 2.95$ | 1394 1932 1526 2201 2335 in a few minutes | .30 .86 1.19 1.59 2.04 2.13 | 1334 | 37.6 | 2.671 | 20.90 | After bearing the weight, 2335 lbs., it had taken a permanent set, or flexure = 1.71 inch, and would have sunk more if it had not been unloaded. |
| 10. | Same beam rendered straight and turned upside down thus \top . Distance between supports 4 feet. | 1394 1932 2201 2335 in a minute 2469 | .27 .51 1.01 1.57 1.60 2.50 | 1411 | 37.6 | 2.7215 | 21.70 | After bearing 2469 lbs. it was unloaded, as a little additional weight would have destroyed its form. |

The experiments in this Table were made on solid \top iron, and indicate nearly the same proportions, as respects their strength, as the beams composed of a plate and double angle-iron riveted together. The whole of these beams appear to be defective in form, and are therefore not calculated to sustain a severe transverse strain. To attain the section of greatest strength, it is probable a different form would be required, as well as a different proportion of the parts, such as in the annexed figure with a double flange*.

* Since the experiments herein recorded were made, others have been instituted on some deck-beams by Mr. KENNEDY of Messrs. BURY, CURTIS and KENNEDY, Liverpool, the particulars of which are inserted in the Appendix.

TABLE XIX. Experiments on Wrought-iron Beams (continued).

| No. of exp. | Description and form of the beam. | Weight laid on middle. | Deflections with these weights. | Breaking weight of the beam of 7 feet between the supports. | Weight of the beam of 7 feet 6 inches long. | Oak beams. | | Remarks. |
|-------------|--|--|---|---|---|--|--|---|
| | | | | | | Side of square of oak beams of equal strength with the iron one. | Weight of such beams of 7 feet 6 inches long and specific gravity 900. | |
| 11. | Beam of wrought iron, formed of two bars (nearly equal), whose section is riveted together; length of the beam 4 feet 2 inches; its weight 44 lbs. 5 oz. Distance between the supports 4 feet. Dimensions of section. AB = 2.86 inches. Mean thickness of AB = .33 inch. EF = 3.70 inches. | lbs. 4,195 7,465 10,735 10,735 laid on again. 14,005 | 0.75 0.148 0.22 0.24 broke | lbs. 8336 | lbs. 79.76 | inches. 4.9199 | lbs. 70.91 | After bearing the weight 10,735 lbs., the beam had taken a set = .06. Pieces of wood were driven tightly in between the ribs AB, CD, at each side of the beam in the middle, to prevent the load laid on it there from deranging its form. The beam broke by the bottom rib being torn asunder, preceded by one of the bars cracking at a rivet-hole. |



The above is probably the strongest form of beam, if duly proportioned, by adapting the material to a balance of the two opposing forces of extension and compression.

TABLE XX. Experiments on Wrought-iron Beams (continued).

| No. of exp. | Description and form of the beam. | Weight laid on middle. | Deflections with these weights. | Breaking weight of the beam of 7 feet between the supports. | Weight of the beam of 7 feet 6 inches long. | Oak beams. | | Remarks. |
|-------------|---|---|---|---|---|--|--|--|
| | | | | | | Side of square of oak beams of equal strength with the iron one. | Weight of such beams of 7 feet 6 inches long and specific gravity 900. | |
| 12. | Beam of wrought iron composed of an uniform vertical rib (7 inches deep and 7 feet 6 inches long) with two 2-inch angle-irons riveted to both top and bottom of the rib; rivets 4 inches asunder; weight of beam 161½ lbs. Distance between the supports 7 feet. Dimensions of section. CD = 7 inches. AB = 4.5 inches. EF = 4.5 inches. Mean thickness of AB = .28 inch. EF = .30 inch. Plate GH = .25. | lbs. 4,216 8,304 16,480 18,667 22,027 in five minutes 24,379 | .10 .18 .25 .36 .52 } .54 sunk | lbs. 24,379 | lbs. 161½ | inches. 7.0358 | lbs. 145.03 | With the weight 24,379 lbs. the top ribs of the beam became twisted. |
| 13. | Same beam rendered straight and uniform; experiment 12 repeated. | 16,115 18,355 19,475 20,595 21,715 | .29 .36 .42 .51 sunk | 21,715 | 161½ | 6.7695 | 134.26 | The beam was heated by the smiths, and when reduced to its original form, it was allowed to cool gradually. With 21,715 lbs. it became bent, towards the wall, in a direction in which it was slightly drawn by the lever; ribs not twisted as before. It bore the weight a minute or two before giving way. |



This experiment shows the superior quality of wrought-iron beams in giving timely notice before fracture; it further exhibits weakness on the top sides of the beams, a circumstance requiring great attention in their construction, which in some recent experiments, instituted for attaining the section of greatest strength, have been strikingly developed*.

In the preceding experiments, we have endeavoured to compare the strengths, as well as the weights of the beams or frames which form the ribs of ships. As regards the strengths with equal weights, it is in favour of oak; but the circumstance of the fastenings by rivets in the sheathing being so much superior to those of timber, the iron ship-builder is enabled to dispense with one-half the number of frames, and consequently a great reduction of weight is effected and more strength obtained in the vessel as a whole, than could possibly be accomplished in the timber-built ship, however ingenious the construction or the arrangement and distribution of the material. The very act of caulking the joints of a wooden vessel has a tendency to loosen the fastenings, whereas, in the iron ship, there are no actual joints, for the whole being bound together *en masse*, the same, or nearly the same, strength is obtained as if the whole ship were composed of solid plates and ribs.

The best sectional form of beams for the decks of ships is probably that exhibited in Table XX., which, along with the box beam of the annexed form for supporting the shafts and paddle-boxes of steamers, is that generally used in the construction of vessels of this description. Other forms have been adopted, particularly those suggested by Mr. KENNEDY of Liverpool, alluded to in the Appendix.



Having carefully investigated the different properties of wrought iron in its varied forms of construction, and conceiving that the results obtained from the experiments may be useful in a variety of circumstances connected with the useful arts, I have endeavoured to collect them in the abstract, in order that the practical builder and engineer may the more readily ascertain the comparative value of the different forms of beams, the properties of the material, and their adaptation to any particular construction in which he may be engaged. Should further information be required, we must then refer to the experiments, in which will be found the facts more in detail, and which are probably better calculated to satisfy the inquiring mind and to effect that conviction essential to success.

I have not attempted any inquiry into the laws of oxidation, the adhesion of barnacles and marine vegetation, and the means necessary to prevent such evils. This is a subject which does not come within the province of the present inquiry, and more properly belongs to that of the chemist. I would however briefly notice, that in the whole of my experience I have had little to complain of from the effects of oxidation, as that destructive process, as regards iron, appears to be greatly mitigated, if not almost suspended, by constant use, and under the influence of vibratory action the operation appears to be rendered nugatory, if it does not entirely cease, and that

* See my work on the Construction of the Britannia and Conway Tubular Bridges.

under circumstances exceedingly difficult to explain. This is an investigation not unworthy the attention of some of our best chemists, to whom the causes may be known, but which are at present, as far as I know, unaccounted for. For example, I may mention that an iron ship, if kept constantly in use, or nearly so, will last for a number of years exposed to all the changes of weather and temperature without any sensible appearance of decay. The same may be said of iron rails, over which are passing daily such enormous weights, and at such velocities as almost to neutralize the action of the elements. All these are striking examples of the durability of wrought iron, which may be considered as an important element of its security, and a recommendation for its extended application. There is another circumstance in connection with this subject to which it may be necessary in this place to advert, and that is the effect which a long continuance in salt water has upon the hull of an iron ship. It is well known that a long immersion of cast iron in the sea will convert it into plumbago, and that a similar process with malleable iron, from its contact with the saline particles of the ocean, produces oxidation; and in case the immersions were long continued, the effects of this destructive process might endanger the safety of the ship. As yet we have not had sufficient evidence of its effects to enable us to come to any definite conclusion, but it is not improbable that an occasional visit to harbours of fresh water may mitigate, if it does not entirely neutralize, the injurious effects which the material is likely to sustain. With these observations, which I offer with diffidence, I now beg to direct attention to the abstracts as deduced from the experiments.

Abstract of Results as obtained from the experiments.

In Part I. of this inquiry we have endeavoured to show that 50,000 lbs. per square inch is the mean breaking weight of iron plates, whether torn asunder in the direction of the fibre or across it; and we have also shown that the tensile strength of different kinds of timber drawn in the direction of the fibre varies in a given ratio to that of iron: the timber in this comparison being represented by unity, we have the following ratio of strength:—

| | Timber : | Iron. |
|--------------------|----------|--------|
| Ash as | 1 | : 2·94 |
| Teak as | 1 | : 3·33 |
| Fir as | 1 | : 4·16 |
| Beech as | 1 | : 4·34 |
| Oak as | 1 | : 5·00 |

These, for practical purposes, may be taken as a fair measure of the strength of the different woods as compared with that of iron plates.

It has been shown that wrought-iron plates, when riveted together, lose a considerable portion of their strength, as may be seen by the experiments in Part IV., where the plates, by their union with each other, lose by the ordinary process of riveting 44 per cent., and by the best mode of riveting 30 per cent. This should not however

create serious alarm, as the loss of strength is almost entirely obviated by the new process of riveting used in the bottom of the Britannia and Conway Tubular Bridges*; and it should also be observed that in timber the same injuries are sustained by splicing or any other method of forming the joints as are here exhibited in the riveting of iron plates. The two processes, that of riveting (according to the method used in the experiments) and splicing, when intended to resist a tensile strain, must therefore be considered analogous, and the comparison under such circumstances will nearly follow the same law as regards a diminution of strength.

In this section of the inquiry the results obtained from the experiments indicate a loss in the joints as compared with the solid plate, as the numbers 100, 70 and 56, viz.—

| | |
|--|-----|
| For the solid plate | 100 |
| For the double-riveted joint | 70 |
| For the single-riveted joint | 56 |

which numbers may be considered as a fair average value of the strengths of the different parts of vessels constructed in this manner.

Part V. exhibits the strength of plates to resist vertical pressure from a blunt instrument, which was forced through them for the purpose of ascertaining their comparative powers of resistance with oak timber, placed under circumstances precisely similar and subjected to the same force. The results are interesting, as the iron plates appear to follow a different law in their resistance to pressure to that of oak, the strength being as the depth or thickness of the plates in the first case, and as the squares of the depth in the second. The resistances are therefore in the ratio of 1 : 12, the iron being 12 times stronger than oak.

In Part IV. we have some curious facts illustrative of the necessity and value of experimental research. In the earlier experiments of the inquiry it is evident, that angle and T iron beams or frames are not the best, as regards form, to resist a transverse strain. In every case they are weak, and although exceedingly useful, and in fact indispensable for many purposes of construction, they are nevertheless not calculated to resist strain in the form of beams or girders. These defects I have endeavoured to obviate by the introduction of beams with double flanges formed of a body plate and riveted angle-irons at the top and bottom. All these latter constructions may however be left with safety to the practical engineer †.

The strengths of nearly the whole of these beams have been mathematically investigated by Mr. TATE, to whose friendship and analytical research I am indebted for the annexed mathematical inquiry into the different forms of the wrought-iron beams which have been experimented upon. To the mathematician this part of the subject will be the more interesting, as the utmost care has been observed in the measurements

* See my process of chain-riveting as exhibited in the lower sides of the Britannia and Conway Tubular Bridges, where the injuries above enumerated are entirely obviated.

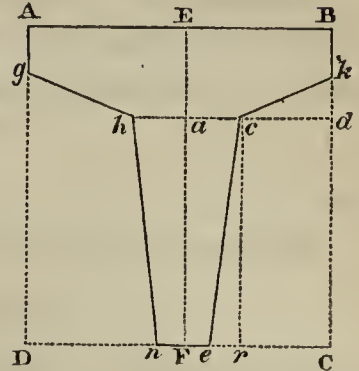
† For a more elaborate inquiry into the strengths of wrought-iron beams, see my work on the Britannia and Conway Bridges.

and exact proportions of the parts, in order to obtain the necessary formula for calculating the strength of beams and frames of this description.

FORMULÆ RELATIVE TO THE BEAMS IN THE FOREGOING EXPERIMENTS.

Beams with a Single Flanch.

Let ABF be a section of a beam having a single flanch ABkh, the material being symmetrically distributed with respect to the vertical line EF. Let hacd and DFC be parallel to AB; cr and kdC parallel to EF. Put EB=EA=e, CB=DA=e₁, ac=Fr=t, Bk=Ag=t₁, Ea=Bd=t₂, Fe=Fn=t₃, area section ABcenhg=A, and the distance of the centre of gravity of this section from the edge ne=X.



To find the Position of the Neutral Axis.

Assuming the material to be perfectly elastic, the neutral axis will be in the centre of gravity of the section. Hence we have, by calculating the moments with respect to the line DC,

$$A \times X = ee_1^2 - (e_1 - t_2)^2(e - t) - \frac{1}{3}(e_1 - t_2)^2(t - t_3) - (e - t)(t_2 - t_1)\left(e_1 - \frac{2}{3}t_2 - \frac{1}{3}t_1\right),$$

$$\therefore X = \frac{3ee_1^2 - (e_1 - t_2)^2(3e - 2t - t_3) - (e - t)(t_2 - t_1)(3e_1 - 2t_2 - t_1)}{3A}, \dots \dots \dots (1.)$$

which expresses the distance of the neutral axis from the edge ne, where

$$A = (t + t_3)(e_1 - t_2) + (t_1 + t_2)(e - t) + 2tt_2 \dots \dots \dots (2.)$$

To find the Moments of Rupture.

Let I = the moment of inertia of the section about the neutral axis.

I₁ = the moment of inertia of the section about DC.

W = the breaking weight of the beam.

l = the distance between the supports.

S = the force per square inch of the material opposed to extension or compression, as the case may be, at the thin edge of the beam.

Taking DC as the axis,—

I₁ = moment inertia ABCD - 2 moment inertia rCdc - 2 moment inertia erc - 2 moment inertia cdk.

Now, moment inertia ABCD = $\frac{2}{3} ee_1^3,$

2 moment inertia rCdc = $\frac{2}{3} (e - t)(e_1 - t_2)^3,$

2 moment inertia erc = $\frac{1}{6} (t - t_3)(e_1 - t_2)^3,$

2 moment inertia cdk = $\frac{1}{6} (e - t) \{ (e_1 - t_1)^3 - 3(e_1 - t_2)^3 + (e_1 - t_1)(e_1 - t_2)(2e_1 - t_1 - t_2) \}.$

Substituting these values and reducing, we find

$$I_1 = \frac{1}{6} [4ee_1^3 - (e_1 - t_2)^3(e - t_3) - (e - t)(e_1 - t_1)\{(e_1 - t_1)^2 + (e_1 - t_2)(2e_1 - t_1 - t_2)\}]. \quad (3.)$$

Also (MOSELEY'S Engineering, p. 82) we have

$$I = I_1 - AX^2. \quad (4.)$$

Moreover, by the formula of rupture,

$$\frac{Wl}{4} = \frac{SI}{X},$$

$$\therefore S = \frac{WlX}{4I}. \quad (5.)$$

Taking the data of Table XVI., we have

$$e = 2.5, \quad e_1 = 2.6, \quad t = .32, \quad t_1 = .35, \quad t_3 = .25, \quad t_2 = .42;$$

therefore, by equation (2.),

$$A = (.32 + .25)(2.6 - .42) + (.35 + .42)(2.5 - .32) + 2 \times .32 \times .42 = 3.19.$$

By equation (1.),

$$X = \{3 \times 2.5 \times 2.6^2 - (2.6 - .42)^2(7.5 - .64 - .25) - (2.5 - .32) \times (.42 - .35)(7.8 - .84 - .35)\} \div 3 \times 3.19 = 1.91,$$

which is the distance of the neutral axis from the edge *ne* of the beam.

By equation (3.),

$$I_1 = \frac{1}{6} [4 \times 2.5 \times 2.6^3 - (2.6 - .42)^3(2.5 - .25) - (2.5 - .32)(2.6 - .35) \times \{(2.6 - .35)^2 + (2.6 - .42)(5.2 - .35 - .42)\}] = 13.375.$$

By equation (4.),

$$I = 13.375 - 3.19 \times 1.91^2 = 1.738.$$

By equation (5.),

$$S = Wl \times \frac{1.91}{4 \times 1.738} \text{ lbs.} = Wl \times \frac{1.91}{15568} \text{ tons.}$$

In experiment 1, $W = 3409$, $l = 7 \times 12 = 84$,

$$\therefore S = \frac{3409 \times 84 \times 1.91}{15568} = 35 \text{ tons.}$$

Let X_1 = the distance of the neutral axis from the edges *AB*, and S_1 = the force per square inch opposed to extension or compression, as the case may be, at the edge *AB*, then

$$X_1 = 2.6 - 1.91 = .69,$$

and

$$S_1 = \frac{X_1}{X} \cdot S = \frac{.69 \times 35}{1.91} = 12.6 \text{ tons.}$$

In experiment 2, $W = 7735 + 18 = 7753$, and $l = 27$,

$$\therefore S = \frac{7753 \times 27 \times 1.91}{15568} = 25.6 \text{ tons,}$$

and

$$S_1 = \frac{.69 \times 25.6}{1.91} = 9.3 \text{ tons.}$$

In experiment 3, $W=10759+18=10777$, $l=27$,

$$\therefore S = \frac{10777 \times 27 \times 1.91}{15568} = 35 \text{ tons,}$$

and $S_1 = 12.6$ tons.

Taking the data of Table XVIII., experiments 7 and 8,

$$e=1.425, e_1=2.5, t=.2, t_1=.36, t_2=.4, t_3=.12.$$

Hence we find from equation (2.), $A=1.762$; from equation (1.), $X=1.86$, and $\therefore X_1=2.5-1.86=.64$; from equation (3.), $I_1=6.943$; and from equations (4.) and (5.), $S=Wl \times .00021$ tons.

In experiment 7, $W=3008+11=3019$, $l=48$,

$$\therefore S = 3019 \times 48 \times .00021 = 30.4 \text{ tons,}$$

and $S_1 = \frac{.64 \times 30.4}{1.86} = 10.4$ tons.

In experiment 8, $W=3142 \times 11=3153$, $l=48$,

$$\therefore S = 3153 \times 48 \times .00021 = 31.7 \text{ tons,}$$

and $S_1 = \frac{.64 \times 31.7}{1.86} = 10.9$ tons.

Observations.—The value of S determined from experiment 1, is the resistance of the material to extension, whereas the value of S determined from experiment 3, is the resistance to compression. Hence it appears, that in beams of this form and *thickness of plates* the resistance to extension is equal to that of compression. The same observation applies to the values of S determined from experiments 7 and 8; and the same law also holds true for experiments 9 and 10.

These calculations further show, that the material in these beams is not properly distributed, for while the thin side of the beam is about to undergo rupture, the broad side has not attained one-half of the tension or compression, as the case may be, which it is capable of sustaining.

It will also be observed, that the resistance of the material at the thin side, as indicated by these calculations, is greater than what it would be under ordinary circumstances, viz. about 25 tons per square inch. This apparent discrepancy may be explained as follows:—as a beam of wrought iron approaches the limit of tension it undergoes an accelerated rate of elongation, even while the cohesion of the material remains unimpaired*. Now this unusual extension of the particles in the lower laminæ (in a beam having a single flanch placed upwards) allows a succession of particles in the higher laminæ to come into full tensile strain, so that the particles at the lower edge of the beam apparently attain a tensile strain greater than they would have under ordinary circumstances. And it may be presumed, that a similar law obtains in reference to the compression of wrought-iron beams. Hence it follows, that all calculations which assume the tensile or compressive forces, in beams of this form, at the edges of the beam equal to what they are under ordinary circumstances, must lead to erroneous results.

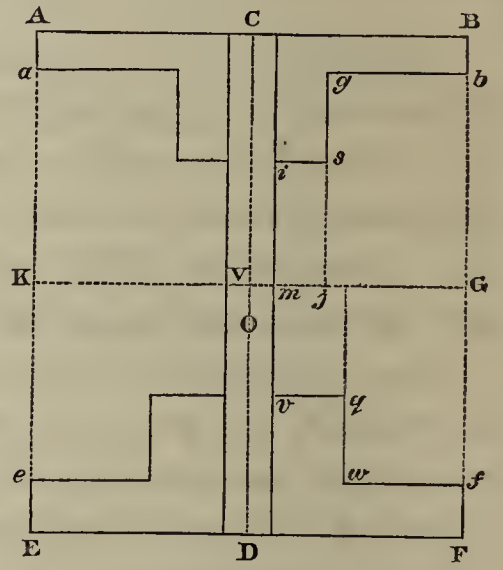
* See remarks on experiment 2, p. 720.

It may be further worthy of remark, that experiments 2 and 3, 8 and 7, show that when the flanches of the beams are placed upwards the deflections are considerably greater than what they are when the flanches are placed downwards; thus in experiments 2 and 3, we have

| Weight on the beams. lbs. | Deflections when the flanch is upwards. inch. | Deflections when the flanch is downwards. inch. |
|------------------------------|--|--|
| 6055 | ·43 | ·26 |
| 6727 | ·68 | ·34 |
| 7399 | ·88 | ·47 |
| and in experiments 8 and 7, | | |
| 2470 | ·66 | ·59 |
| 2739 | 1·22 | ·90 |
| 3008 | 2·20 | 1·35 |

Beams with a Double Flanch.

Let ABFE be a section of a beam having two flanches ABba and EFfe formed by angle-irons riveted to a vertical plate CD, the material being symmetrically distributed with respect to the vertical line CD. Let O be the neutral axis, and KVG a line passing through the centre V of the vertical line CD parallel to AB or EF. Put A = the area of the section of the material, A₁ = area ABFE or 2 area ABGK, A₂ = 2 area mj₂si, A₃ = 2 area jgbG, a₂ = 2 area mj₂qv, a₃ = 2 area jw₂fG, D₁ = GB = GF, D₂ = sj, D₃ = bG, d₂ = jq, d₃ = fG, X = OV, I₁ = moment of inertia about KG, I = moment of inertia about O, W = the breaking upon the centre of the beam, l = the distance of the supports, S, S₁ = the resistance of the material per square inch at the edges EF and AB respectively.



To find the Neutral Axis.

Taking KG as the axis of moments,

$$A \times X = \frac{1}{2}(A_2 D_2 + A_3 D_3 - a_2 d_2 - a_3 d_3),$$

$$\therefore X = \frac{A_2 D_2 + A_3 D_3 - a_2 d_2 - a_3 d_3}{2A} \dots \dots \dots (6.)$$

where $A = A_1 - A_2 - A_3 - a_2 - a_3 \dots \dots \dots (7.)$

To find the Moments of Rupture, &c.

Taking the moments of inertia with respect to the line KG,

$$I_1 = \text{moment inertia ABFE} - 2 \text{ moment inertia space } bgsiqf$$

$$= \frac{1}{3}(A_1 D_1^2 - A_2 D_2^2 - A_3 D_3^2 - a_2 d_2^2 - a_3 d_3^2) \dots \dots \dots (8.)$$

$$I = I_1 - AX^2 \dots \dots \dots (9.)$$

$$S = \frac{Wl(D_1 - X)}{4I} \dots \dots \dots (10.)$$

and

$$W = \frac{4SI}{l(D_1 - X)} \dots \dots \dots (11.)$$

If
then

$$a_2 = A_2, a_3 = A_3,$$

$$X = 0, I_1 = I,$$

and

$$I = \frac{1}{3} \{ A_1 D_1^2 - 2A_2 D_2^2 - 2A_3 D_3^2 \},$$

$$\therefore S = \frac{WlD_1}{4I}$$

$$= \frac{3WlD_1}{4 \{ A_1 D_1^2 - 2A_2 D_2^2 - 2A_3 D_3^2 \}} \dots \dots \dots (12.)$$

and

$$W = \frac{4S(A_1 D_1^2 - 2A_2 D_2^2 - 2A_3 D_3^2)}{3lD_1}, \dots \dots \dots (13.)$$

which expresses the breaking weight when S is given.

Let $D'_1, D'_2, \dots, A', A_1, \dots$ &c. be the corresponding dimensions of a beam in all respects similar, and let r be the ratio of the linear dimensions, then

$$D'_1 = rD_1, \text{ \&c.}, A' = r^2 A_1, \text{ \&c.}, A'_2 D'_2 = r^3 A_2 D_2, \text{ \&c.}, A'_1 D_1'^2 = r^4 A_1 D_1^2, \text{ \&c.}$$

By equation (6.),

$$\begin{aligned} X' &= \frac{A'_2 D'_2 + A'_3 D'_3 - a'_2 d'_2 - a'_3 d'_3}{2A'} \\ &= \frac{r^3 A_2 D_2 + r^3 A_3 D_3 - r^3 a_2 d_2 - r^3 a_3 d_3}{2r^2 A} \\ &= r \times \frac{A_2 D_2 - A_3 D_3 - a_2 d_2 - a_3 d_3}{2A} \\ &= r \times X. \end{aligned}$$

By equation (8.),

$$\begin{aligned} I'_1 &= \frac{1}{3} \{ A'_1 D_1'^2 - A'_2 D_2'^2 - A'_3 D_3'^2 - a'_2 d_2'^2 - a'_3 d_3'^2 \} \\ &= r^4 \times \frac{1}{3} \{ A_1 D_1^2 - A_2 D_2^2 - A_3 D_3^2 - a_2 d_2^2 - a_3 d_3^2 \} \\ &= r^4 \times I_1. \end{aligned}$$

By equation (11.),

$$\begin{aligned} W' &= \frac{4SI'}{l'(D'_1 - X')} \\ &= \frac{4S \times r^4 I}{rl(rD_1 - rX)} \\ &= r^2 \times \frac{4SI}{l(D_1 - X)} \\ &= r^2 \times W \dots \dots \dots (14.) \end{aligned}$$

That is, THE BREAKING WEIGHTS IN SIMILAR BEAMS ARE TO EACH OTHER AS THE SQUARES OF THEIR LIKE LINEAR DIMENSIONS.

The method of demonstration here used in establishing this important theorem may be applied to any other form of beam.

When the sections of the beams are similar, but the distance between the supports any quantity l_1 , then we have

$$W' = \frac{l'}{l_1} \cdot r^2 W. \quad \dots \quad (15.)$$

Suppose W in equation (11.) to be determined by experiment, then we are at liberty to assume

$$W = \frac{AdC}{l},$$

where d is the depth of the beam, and C a constant determined by the assumed relation.

$$\begin{aligned} \text{From equation (14.),} \quad W' &= r^2 W \\ &= r^2 \cdot \frac{AdC}{l} \\ &= \frac{r^2 A \cdot rd \cdot C}{rl} \\ &= \frac{A'd'C}{l'} \cdot \dots \dots \dots (16.) \end{aligned}$$

That is, THE BREAKING WEIGHTS IN BEAMS ARE FOUND BY MULTIPLYING TOGETHER THE AREA OF THE SECTION, THE DEPTH, AND A CONSTANT DETERMINED FROM EXPERIMENT ON BEAMS OF THE PARTICULAR FORM, AND DIVIDING THIS PRODUCT BY THE DISTANCE BETWEEN THE SUPPORTS.

The value of l' in this formula is not restricted to the condition of similarity.

In experiment 12,

$$D_1 = 3.5, D_2 = 1.375, D_3 = 3.22, d_2 = 1.375, d_3 = 3.2, W = 24380 + 80 = 24460, l = 84,$$

$$A_1 = 4.5 \times 7 = 31.5, A_2 = 1.375 \times .28 \times 2 = .7, A_3 = 3.22 \times 1.845 \times 2 = 11.8818,$$

$$a_2 = 1.375 \times .3 \times 2 = .75, a_3 = 3.2 \times 1.825 \times 2 = 11.68,$$

$$A = A_1 - A_2 - A_3 - a_2 - a_3 = 32.5 - 25.01 = 6.48,$$

$$\therefore \text{ by equation (6.), } X = .0611.$$

$$\text{By equation (8.), } I_1 = 46.782.$$

$$\text{By equation (9.), } I = 46.782 - 6.48 \times .0611^2 = 46.758.$$

By equation (10.),

$$S = \frac{24460 \times 84(3.5 - .0611)}{4 \times 46.758 \times 2240} = 17 \text{ tons nearly,}$$

and $S_1 = 17\frac{1}{2}$ tons nearly.


In experiment 13, $W = 21715 + 80 = 21800$ nearly,

and $S_1 = \frac{21800 \times 84(3.5 + .0611)}{4 \times 46.7854 \times 2240} = 15.5$ tons,

$$S = \frac{21800 \times 84(3.5 - .0611)}{4 \times 46.7854 \times 2240} = 15 \text{ tons.}$$

The values of S and S₁, as determined by these calculations, being less for the beam in experiment 13 than they are for the beam in experiment 12, it follows that the latter has a better distribution of the material than the former. And at the same time the difference of the value of these constants is so small as to lead us to infer that the form of the beam in experiment 12 approaches to that of maximum strength with a given quantity of material. The sectional areas of the top and bottom flanches are to each other as 28 : 30 or 14 : 15, which is very nearly a ratio of equality.


APPENDIX.

Experiments by THOMAS LOYD, Esq., Inspector of Machinery, to ascertain the effect of a tensile strain upon bars of wrought iron under varied conditions. Twenty pieces of 1 $\frac{3}{8}$ S C  bar iron, each 10 feet long, were cut out of the middle of twenty rods of iron. These 10-foot lengths were cut into two parts of 5 feet each, and marked with the same letter. A, B, C, &c. were first broken so as to get the average breaking strain. A₂, B₂, C₂ were subjected to the constant action of three-fourths of the breaking weight for five minutes. The load was then taken off, and they were afterwards broken. It will be seen that the breaking strain was about the same as before, thus proving that the previous strain had not weakened them.

Experiment 1.

| First. | | | | Second. | | | |
|-------------------|-------------------------|--------------------------|---------------------------------------|-------------------|-------------------------|--------------------------|---|
| Mark on the bars. | Dimensions of the bars. | Breaking weight in tons. | Ultimate elongation of bar in inches. | Mark on the bars. | Dimensions of the bars. | Breaking weight in tons. | Ultimate elongation of bars in inches with 25 tons. |
| A. | 1·37 | 33·75 | 9·12 | A 2. | | 33·75 | 1·56 |
| B. | 1·37 | 30·00 | 9·12 | B 2. | | 33·00 | 1·61 |
| C. | 1·37 | 33·25 | 9·75 | C 2. | | 33·25 | 1·56 |
| D. | 1·37 | 32·75 | 9·22 | D 2. | | 32·25 | 1·75 |
| E. | 1·37 | 32·50 | 9·22 | E 2. | | 32·50 | 1·75 |
| F. | 1·37 | 33·25 | 10·50 | F 2. | | 33·00 | 1·56 |
| G. | 1·37 | 32·75 | 8·50 | G 2. | | 33·00 | 1·61 |
| H. | 1·37 | 33·25 | 10·61 | H 2. | | 33·50 | 1·50 |
| I. | 1·37 | 33·50 | 8·37 | I 2. | | 32·75 | 1·67 |
| J. | 1·37 | 33·50 | 9·22 | J 2. | | 33·25 | 1·67 |
| K. | 1·37 | 32·25 | 8·00 | K 2. | | 32·50 | 1·86 |
| L. | 1·37 | 32·25 | 7·50 | L 2. | | 31·50 | 2·00 |
| M. | 1·37 | 30·25 | 9·12 | M 2. | | 32·75 | Broke mark 1·75 in s. c. |
| N. | 1·37 | 34·25 | 9·22 | N 2. | | 34·00 | 1·12 |
| O. | 1·37 | 31·75 | 7·61 | O 2. | | 32·50 | 1·75 |
| P. | 1·37 | 29·75 | 10·00 | P 2. | | 31·00 | 1·75 |
| Q. | 1·37 | 33·50 | 9·22 | Q 2. | | 33·75 | 1·50 |
| R. | 1·37 | 33·75 | 9·75 | R 2. | | 33·75 | 1·56 |
| S. | 1·37 | 33·00 | 9·12 | S 2. | | 33·25 | 1·12 |
| T. | 1·37 | 32·25 | 8·75 | T 2. | | 31·00 | 2·18 |
| Mean ... | | 32·87 | 9·09 | | | 32·81 | 1·64 |

In the first columns of the experiments it will be observed that the force required to break the bars was 32·37 tons, with a mean stretch of 9 inches upon twenty bars. In the second column the mean of the elongations, with a strain of 25 tons, was only 1·6 inch, whereas the ultimate breaking strain was 32·8 tons, evidently showing an increase instead of a diminution of strength from the previous strain of 25 tons, to which the bars had been respectively subjected.

Experiments made in the testing-machine of Woolwich Dockyard to ascertain the effect upon iron-bolt staves or iron bars to a tensile strain. The following results show the strains required for each of four successive breakages of the same pieces of iron as in the first experiment, $1\frac{3}{8}$ ths of an inch diameter S C .

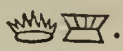
Experiment 2.

| Distinguishing mark. | First breakage. | | Second breakage. | | Third breakage. | | Fourth breakage. | | Reduced from 1·37 to |
|---------------------------|-----------------|-----------------------|------------------|-----------------------|-----------------|-----------------------|------------------|-----------------------|----------------------|
| | Tons. | Stretch in 54 inches. | Tons. | Stretch in 36 inches. | Tons. | Stretch in 24 inches. | Tons. | Stretch in 15 inches. | |
| A. | 33·75 | 9·125 | 35·5 | 2·00 | | | | | |
| C. | 33·75 | 9·250 | 35·25 | ·25 | 37·00 | 1·00 | 38·75 | | 1·25 |
| E. | 32·5 | 9·250 | 34·75 | 1·25 | | | | | |
| F. | 33·25 | 10·500 | 35·50 | 1·12 | 37·25 | ·62 | ·40 | | 1·18 |
| G. | 32·75 | 8·500 | 35·00 | 1·25 | 37·5 | | ·41 | | 1·25 |
| H. | 33·75 | 10·625 | 36·25 | 1·87 | | | | | |
| I. | 33·50 | 8·375 | 34·50 | ·62 | 36·5 | 1·50 | | | |
| J. | 33·50 | 9·250 | 36·00 | ·25 | 36·75 | 1·120 | 41·75 | | 1·25 |
| L. | 32·25 | Defective | 36·50 | 1·5 | 37·75 | | 41·00 | ·31 | 1·25 |
| M. | 30·25 | Defective | 36·50 | ·62 | 37·75 | ·06 | 38·50 | ·06 | 1·25 |
| Mean | 32·92 | | 35·57 | | 37·21 | | 40·16 | | 1·24 |
| Mean per square inch..... | 23·94 | | 25·86 | | 27·06 | | 29·20 | | ·90 |

The results of the above experiments are highly interesting, as they not only confirm those previously made, but they indicate a progressive increase of strength, notwithstanding the reduced sectional area of the bars. These interesting facts are of considerable value, as they show that a severe tensile strain is not injurious to the bearing powers of wrought iron even when repeated to the extent of four times. In practice it may not be prudent to test bars and chains to their utmost limit of resistance; it is however satisfactory to know that in cases of emergency those limits may be approached without incurring serious risk of injury to the ultimate strength of the material.

It is further important to observe, that the elongations are not in proportion to the forces of extension; thus in the bar F, experiment 2, the elongation of a bar 54 inches long with 33·25 tons, is 10·5 inches, giving an elongation per unit of weight and length = $\frac{10\cdot5}{33\cdot25 \times 54} = \cdot0058$; whereas an additional weight of 2·25 tons produces an

elongation of 1.25 inch in 36 inches length of bar, giving an elongation per unit of weight and length = $\frac{1.25}{2.25 \times 36} = .0154$; that is, the elongation in this latter case is about three times that in the former.

Experiments made to ascertain whether a shorter bar of iron is stronger than a longer one of the same kind and size, $1\frac{3}{8}$ ths of an inch diameter, SC .

Experiment 3.

| Length between the nippers 10 feet. | | | | | | |
|-------------------------------------|------------------------|---------------------|---------|-------------------------|--------------------|---------------------------------|
| Distin- guishing mark. | Stretch in 10 feet. | Breaking strain. | Mean. | Reduced at fracture. | To else- where. | Remarks. |
| | in. | tons. | tons. | in. | in. | |
| 1. | 26.00 | 33.00 | } 32.21 | 1 | 1.25 | } Mean of elongation 26 inches. |
| 2. | 26.75 | 31.75 | | | 1.18 | |
| 3. | 26.25 | 32.25 | | | 1.25 | |
| 4. | 23.00 | 32.00 | | | | |
| 5. | 27.50 | 32.25 | | B. | B. | |
| 6. | 26.75 | 32.00 | | 1.06 | | |

Experiment 4.

| Length between the nippers 42 inches. | | | | | | |
|---------------------------------------|--------------------------|---------------------|----------|-------------------------|--------------------|----------------------------------|
| Distin- guishing mark. | Stretch in 42 inches. | Breaking strain. | Mean. | Reduced at fracture. | To else- where. | Remarks. |
| | in. | tons. | tons. | in. | in. | |
| B. | 9.50 | 32.50 | } 32.125 | 1.06 | 1.25 | } Mean of elongation 9.8 inches. |
| B. | 9.37 | 33.00 | | B. | | |
| B. | 10.25 | 31.75 | | 1 | B. | |
| B. | 10.37 | 31.50 | | | B. | |
| B. | 8.62 | 32.00 | | 1.06 | F. | |
| B. | 8.87 | 32.00 | | F. | F. | |

Experiment 5.

| Length between the nippers 36 inches. | | | | | | |
|---------------------------------------|--------------------------|---------------------|---------|-------------------------|--------------------|----------------------------------|
| Distin- guishing mark. | Stretch in 36 inches. | Breaking strain. | Mean. | Reduced at fracture. | To else- where. | Remarks. |
| | in. | tons. | tons. | in. | in. | |
| A. | 8.50 | 32.25 | } 32.25 | 1.06 | 1.25 | } Mean of elongation 8.8 inches. |
| A. | 8.75 | 32.25 | | 1 | B. | |
| A. | 9.00 | 31.25 | | F. | B. | |
| A. | 9.12 | 31.50 | | | | |
| A. | 9.37 | 33.50 | | B. | B. | |
| A. | 8.87 | 33.25 | | B. | B. | |

Experiment 6.

| Length between the nippers 24 inches. | | | | | | |
|---------------------------------------|-----------------------|---------------------|---------|-------------------------|--------------------|----------------------------------|
| Distin- guishing mark. | Stretch in 2 feet. | Breaking strain. | Mean. | Reduced at fracture. | To else- where. | Remarks. |
| C 1. | in. 6·00 | tons. 31·75 | } 32·00 | in. 1 | in. 1·25 | } Mean of elongation 6·2 inches. |
| C 2. | 6·62 | 31·50 | | 1·06 B. | F. | |
| C 3. | 6·12 | 32·50 | | 1 | | |
| C 4. | 6·12 | 31·75 | | 1 | | |
| C. | 6·00 | 32·25 | | 1 | | |
| C. | 6·37 | 32·25 | | | B. | |

Experiment 7.

| Length between the nippers 10 inches. | | | | | | |
|---------------------------------------|--------------------------|---------------------|---------|-------------------------|--------------------|----------------------------------|
| Distin- guishing mark. | Stretch in 10 inches. | Breaking strain. | Mean. | Reduced at fracture. | To else- where. | Remarks. |
| A. | in. 4·00 | tons. 32·25 | } 32·29 | in. 1·06 | in. 1·25 | } Mean of elongation 4·2 inches. |
| A. | 3·87 | 32·50 | | B. | B. | |
| A. | 4·62 | 30·50 | | 1 | 1·18 | |
| A. | 4·75 | 31·50 | | | 1·25 | |
| A. | 4·00 | 33·25 | | | | |
| A. | 4·12 | 33·75 | | | | |

Abstract of the foregoing.

| Length between the nippers. | Breaking strain in tons. | Mean elongation in inches. |
|--------------------------------|-----------------------------|-------------------------------|
| in. 120 | 32·21 | 26 |
| 42 | 32·125 | 9·8 |
| 36 | 32·35 | 8·8 |
| 24 | 32·00 | 6·2 |
| 10 | 32·29 | 4·2 |

As these experiments were made upon the same description of iron, it may be fairly inferred that the length of a bar does not in any way affect its strength.

Reduction of the preceding Table.

| Length of bar. | Elongation. | Elongation per unit of length. |
|----------------|-------------|-----------------------------------|
| in. 120 | 26 | ·216 |
| 42 | 9·8 | ·233 |
| 36 | 8·8 | ·244 |
| 24 | 6·2 | ·258 |
| 10 | 4·2 | ·420 |

Here it appears that the rate of elongation of bars of wrought iron increases with the decrease of their length; thus while a bar of 120 inches has an elongation of .216 inch per unit of its length, a bar of 10 inches has an elongation of .42 inch per unit of its length, or nearly double what it is in the former case. The relation between the length of and its maximum elongation per unit, may be approximately expressed by the following formula, viz.—

$$l = .18 + \frac{2.5}{L},$$

where L represents the length of the bar, and l the elongation per unit of length of the bar.

These results are of some value, as they exhibit the ductility of wrought iron at a low temperature, and also the greatly increased strength which it exhibits with a reduced section under severe strain.

On some future occasion we may refer to this subject in order to show the bearing powers of wrought iron when compared with its elongated transverse section when reduced by forces sufficient to ensure fracture.

The following experiments were made to determine the transverse strength of beams, recommended by Mr. KENNEDY of Liverpool, for supporting the decks of iron ships.

Experiment 8.—October 10, 1845.

On a malleable iron beam, of the annexed sectional form, 11 feet 7 inches long, and 11 feet between the supports.

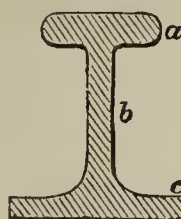
Dimensions at a = 1.000 in. × 2½ in.

Dimensions at b = .325 in. × 7 in.

Dimensions at c = .380 in. × 4 in.

Weight of beam = 227 lbs.

Weight of shackle = 885 lbs.



| Weight in lbs. | Deflection in inches. | Deflection load removed. | Remarks. |
|----------------------------|-----------------------|--------------------------|---|
| 885 | .04 | | |
| 2,581 | .12 | | |
| 4,317 | .20 | | |
| 6,050 | .26 | | |
| 7,743 | .35 | | |
| 9,493 | .46 | | |
| 11,253 | .60 | .09 | |
| 12,955 | | | With this weight the beam became distorted, and continuing the weight for some time, the deflection kept increasing until it bent laterally so as to be no longer able to sustain the load. |
| Ultimate deflection = .69. | | | |

Experiment 9.—October 10, 1845.

On a malleable iron beam, of the annexed sectional form (see fig. 66), 10 feet 8 inches long, and 10 feet between the supports.

Dimensions at $a=1\cdot000$ in. $\times 2\frac{3}{7}$ in.

Dimensions at $b= \cdot350$ in. $\times 8$ in.

Dimensions at $c= \cdot440$ in. $\times 4\cdot30$ in.

Weight of beam= 247 lbs.

Weight of shackle= 885 lbs.

| Weight in lbs. | Deflection in inches. | Deflection load removed. | Remarks. |
|----------------------------------|-----------------------|--------------------------|--|
| 885 | | | |
| 2,631 | ·04 | | |
| 4,358 | ·12 | | |
| 6,098 | ·15 | | |
| 7,827 | ·19 | | |
| 9,585 | ·21 | | |
| 11,278 | ·26 | | |
| 12,980 | ·30 | ·03 | |
| 14,693 | ·35 | ·03 | |
| 16,373 | ·45 | ·09 | |
| 18,115 | ·68 | ·26 | |
| 18,962 | | | With this weight the beam was distorted and the experiment discontinued. |
| Ultimate deflection= $\cdot71$. | | | |

In both these experiments the beams yielded to lateral deflection, showing certain defects of form arising from want of lateral strength and breadth in the top and bottom flanges.

Experiment 10.—October 10, 1845.

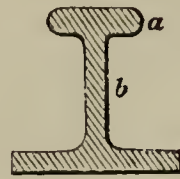
Malleable iron beam of the same form as the last, 10 feet 7 inches long and 10 feet between the supports.

Thickness, $a = 1.000 \text{ in.} \times 2.75 \text{ in.}$

Thickness, $b = .380 \text{ in.} \times 8 \text{ in.}$

Thickness, $c = .420 \text{ in.} \times 4.30 \text{ in.}$

Weight of beam = 276 lbs.



| Weight in lbs. | Deflection in inches. | Deflection load removed. | Remarks. |
|---------------------------|-----------------------|--------------------------|----------|
| 885 | .020 | | |
| 2,606 | .050 | | |
| 4,364 | .090 | | |
| 6,105 | .100 | | |
| 7,835 | .140 | | |
| 9,559 | .165 | .03 | |
| 11,257 | .195 | .03 | |
| 12,999 | .220 | .04 | |
| 14,728 | .250 | | |
| 16,407 | .250 | | |
| 18,108 | .290 | | |
| 19,839 | .370 | | |
| 21,553 | .475 | | |
| 22,387 | .590 | | |
| 23,046 | | | |
| Ultimate deflection = .6. | | | |

With 21,553 lbs. the deflection increased in four minutes .025; in the next four minutes .10; and in four minutes more it had sunk to .34.

Bent laterally upwards of 2.65 inches, when the experiment was discontinued.

In these experiments it will be necessary to remark, that they were made with the narrow flange uppermost; a position rather favourable to the strength than otherwise, on account of the increased area of the top flange, which is equal to 2.75 inches; and the bottom flange is only 1.8 inch, a circumstance (deduced from subsequent experiments) favourable to the resisting powers of a wrought-iron beam.

Manchester, April 10, 1850.

XXXVI. *On the Mutual Relations of the Vital and Physical Forces* *.

By WILLIAM B. CARPENTER, M.D., F.R.S., F.G.S.,

Examiner in Physiology and Comparative Anatomy in the University of London.

Received June 20,—Read June 20, 1850.

I. *Introductory Remarks.*

THE degree to which the phenomena of Life are dependent upon Physical agencies, has been a subject of inquiry and speculation among scientific investigators of almost every school. That many of the actions taking place in the living body are conformable to the laws of mechanics, has been hastily assumed as justifying the conclusion that *all* its actions are mechanical; and hence arose the *iatro-mathematical* doctrines, which obtained considerable currency among the physicians and physiologists of the seventeenth century †. In like manner, the fact that many of the

* The author thinks it due to himself to state, that the inquiry whose results are embodied in this paper has been occupying his attention for some years; in proof of which he may cite the following passage from a review of Prof. MATTEUCCI'S "Lectures on the Physical Phenomena of Living Beings," contributed by him to the "British and Foreign Medico-Chirurgical Review" for Jan. 1848 (p. 235):—"There can be no doubt that the present tendency of scientific investigation is to show a much more intimate relation than has been commonly supposed to exist between *vital* and *physical* agencies; and to prove that, whilst the former are of a nature altogether peculiar, they are yet dependent upon conditions supplied by the latter. And the more closely these phenomena are investigated, the more intimate and uniform does that dependence appear; so that we seem to have the general conclusion almost forced upon us, that the *vital* forces of various kinds bear the same relation to the several *physical* forces of the inorganic world, that they bear to each other; the great and essential modification or transformation being effected by their passage, so to speak, through the germ of the organic structure, somewhat after the same fashion that heat becomes electricity when passed through certain mixtures of metals." Of the paper communicated by Dr. FOWLER to the British Association at its last meeting (September 1849) under the title—"If Vitality be a Force having Correlations with the Forces, Chemical Affinities, Motion, Heat, Light, Electricity, Magnetism, Gravity, so ably shown by Professor GROVE to be modifications of one and the same Force?"—he has no more knowledge than that which he has obtained from the short abstract of it in the Report of that meeting, published since the greater part of his own paper had been written; and whilst it is evident from that abstract that Dr. FOWLER has been pursuing the same line of investigation with himself, and with somewhat of the same results, he has not thought this a sufficient reason for keeping back his own communication from the Royal Society. For he thinks it will appear, from the extract he has cited, that he may fairly claim priority in the enunciation of the *idea*; and he ventures to believe that the systematic working out of that idea, which he has attempted in this paper, will give it a claim to the consideration of physicists and physiologists, such as it scarcely derives from the treatment which it has received from Dr. FOWLER—so far, at least, as the author can judge from the abstract referred to. (See the *Supplementary Note*, p. 757.)

† "The body," says Dr. BOSTOCK (History of Medicine, p. 165), "was regarded simply as a machine composed of a certain system of tubes; and calculations were made of their diameter, of the friction of the fluids in

changes of composition which take place within living bodies are analogous to those occurring externally to them, was assumed by another party as the foundation of the hypothesis that *all* the phenomena of life are of the nature of Chemical actions ; and of that hypothesis the *iatro-chemical* doctrines which superseded the system of GALEN, and which held their ground under various modifications for several centuries, were the natural expressions *. The insufficiency of either of these hypotheses, or of both of them combined, to explain the phenomena of life, gave origin to a third, which was undoubtedly more correct in its fundamental conception than either of its predecessors had been ; the position assumed being, that the phenomena of each living body proceed from a *vital* agency, or *anima*, peculiar to each organized structure, and having nothing in common with chemical or mechanical principles †. The sect of the Vitalists, however, did not steer clear of the exclusiveness which had been the great fault of the chemists and physicists ; but, in looking at every action of the living body as the immediate result of vital agency, claimed for that agency much that is clearly attributable to the operation of chemical and physical forces.

Among modern Physiologists there is a distinct recognition of the fact, that many of the phenomena of living bodies may be placed in the same category with those of inanimate matter, and that such are not otherwise affected by vital agency than as this prepares or modifies the conditions under which they occur. But there is also a distinct recognition of the fact, that living bodies present a large class of phenomena which are altogether peculiar to them, and which can only be attributed to agencies of which the inorganic world is altogether independent ; and hence has arisen the notion of *vital agency* as the foundation of Physiological science, just as the notion of *affinity* is the foundation of Chemistry, and that of *mutual attraction* of General Physics. And putting aside all hypothetical considerations with regard to the abstract nature of that agency, Physiologists have been aiming to determine the laws

passing along them, of the size of the particles and the pores, the amount of retardation arising from friction and other mechanical causes, while the doctrines of derivation, revulsion, lentor, obstruction, and resolution, with others of an analogous kind, all founded upon mechanical principles, were the almost universal language of both physicians and physiologists towards the close of the seventeenth century."

* "The leading principle of the chemists," says Dr. Bostock (*op. cit.* p. 138), "was, that the living body is subject to the same chemical laws with inanimate matter, and that all the phenomena of vitality may be explained by the operation of these laws." The chemical physicians of the seventeenth century held "that the operations of the living body are all guided by chemical actions, of which one of the most important and the most universal is fermentation. The states of health and disease were supposed to be ultimately referable to certain fermentations, which took place in the blood or other fluids ; while these fluids themselves were the result of specific fermentations, by which they were elaborated from the elements of which the body is composed" (*op. cit.* p. 157).

† "We are told," says Dr. Bostock (*op. cit.* p. 175), "that the *anima* superintends and directs every part of the animal economy from its first formation ; that it prevents or repairs injuries, counteracts the effects of morbid causes, or tends to remove them when actually present, yet that we are unconscious of its existence ; and that, while it manifests every attribute of reason and design, it is devoid of these qualities, and is, in fact, a necessary and unintelligent agent."

of its operation ; following the same mode of inquiry for this purpose, as that which has been found successful in other departments of scientific investigation. In doing this, it has been necessary for them to *isolate*, as much as possible, those phenomena which may be regarded as Chemical or Physical, from those which must be distinguished as Vital ; in order that, by the collocation and comparison of the latter, their mutual relations may be discovered. Still, after making every possible allowance for the operation of chemical and physical agencies, in the *direct* production of the changes of composition, mechanical movements, &c. which connect living beings (so to speak) with the universe around them, it is impossible for the discriminating inquirer not to see, that the influence of these agencies is *indirectly* exerted, to a yet greater extent, in the production or modification of purely vital phenomena. Thus, to take a very simple case, it cannot be for a moment doubted that heat and light exert an influence upon the vegetable germ, which is essential to its growth and development into the perfect plant, and to the performance of all the actions of the latter, whether these have reference to the extension of its own fabric, to the formation of organic compounds from the materials supplied by the inorganic world, or to the production of the germs of new individuals which are in like manner to go through the same series of phases. Hence light and heat have been designated as “vital stimuli ;” the current idea being, that their agency upon the vegetable germ excites or awakens the forces which were dormant in it ; and that, by enabling it thus to assimilate the new materials supplied by the inorganic world, and to give to these the structure of organized bodies, they contribute to develop the latent powers of these materials, which in their turn exhibit vital properties as they are made to form part of organized structures. Such, at least, is the doctrine of those who have most clearly expressed themselves upon the relation of the “vital stimuli” to the “vital properties” of organized bodies ; and the author has not been able to find in physiological writings, any indication of a more intimate relationship between the physical forces and vital phenomena, than that just stated,—save on the part of those who have vaguely identified Heat or Electricity with the “vital principle,” with about the same amount of philosophical discrimination as that which was exercised by the iatro-chemists and iatro-mathematicians of the sixteenth and seventeenth centuries.

The views of physical philosophers have been directed of late almost exclusively to the *dynamical* aspect of the inorganic universe ; that is to say, its phenomena have been studied as the manifestations of certain *forces* ; and each department of science takes cognizance of one or more of these, its *general* laws being nothing else than expressions of the modes and conditions of their operation, so far as known to the scientific investigator. That among all these forces there are very intimate mutual relations, is a conviction which has been gradually increasing in strength in the minds of philosophical inquirers during the whole of the present century ; in consequence of the extraordinary development which the sciences of Chemistry, Electricity, Mag-

netism, Optics, and Thermotics, have undergone during that period, and of the accumulation of facts which more or less distinctly indicate the existence of such relations to those who know how to read them aright. Amongst those who have laboured most successfully in this line of inquiry, Prof. FARADAY stands pre-eminent; but the author is not aware that any other attempt has been made to *formularize* the entire series of these mutual relations, than that which has been put forth by Prof. GROVE in his short treatise ‘On the Correlation of Physical Forces;’ in which he seeks to establish “that the various imponderable agencies, or the affections of matter which constitute the main objects of experimental physics, viz. heat, light, electricity, magnetism, chemical affinity, and motion, are all correlative or have a reciprocal dependence:—that neither, taken abstractedly, can be said to be the essential or proximate cause of the others, but that either may, as a force, produce or be convertible into the other; thus heat may mediately or immediately produce electricity, electricity may produce heat, and so of the rest” (p. 8).

That the same view might be probably applied to the mutual relations of some of the Vital forces, did not escape Prof. GROVE’s sagacity, as will appear from the following passage near the conclusion of his essay:—“I believe that the same principles and mode of reasoning might be applied to the organic, as well as the inorganic world, and that muscular force, animal and vegetable heat, &c., might, and at some time will, be shown to have similar definite correlations; but I have purposely avoided this subject, as pertaining to a department of science to which I have not devoted my attention” (p. 49). The forces here alluded to by Prof. GROVE, however,—those of muscular *motion* and *heat*,—are really *physical* in their manifestations, though generated in living bodies; the purely *vital* operations of growth, development, and reproduction are not even named by him; and not the slightest hint is given by him of the existence of any such relation between the Vital and Physical forces, as it is the chief object of this paper to establish.

Believing, as the author himself does, that all *force* which does not emanate from the will of created sentient beings, directly and immediately proceeds from the Will of the Omnipotent and Omnipresent Creator (which is evidently the idea entertained by LOCKE*),—and looking therefore at what we are accustomed to call the physical forces, as so many *modi operandi* of one and the same agency, the creative and sustaining will of the Deity,—he does not feel the validity of the objections which have been raised by some to whose opinions on philosophical questions he attaches great weight, against the idea of the absolute metamorphosis or conversion of forces. In deference to those opinions, however, he would here say *in limine* that his present object is to show, that *the same relation* (in whatever way defined) exists among the several vital forces, whose operation may be traced in living bodies, as exists among the physical; and that the vital and physical forces are themselves connected by a similar relationship. And as a mode of expressing that relationship

* Human Understanding, Book II. Chap. xxi. *On Power*, § 4.

without any hypothetical assumption, he would state his idea of the "correlation" of two forces, A and B, to be this;—that A, operating upon a certain form of matter, ceases to manifest itself, but that B is developed in its stead; and that, *vice versá*, B, operating upon some other form of matter, ceases to manifest itself, but that A is reproduced in its stead. The idea of correlation also involves that of a *certain definite ratio* or equivalent between the two forces thus mutually interchangeable; so that the measure of force B, which is excited by a certain exertion of force A, shall, in its turn, give rise to the same measure of force A as that originally in operation. Thus, when an electric current is set in motion (to use the common phraseology) by galvanic action, the amount of chemical decomposition which it will effect bears a precise correspondence (*cæteris paribus*) with the amount of zinc which has undergone oxidation; chemical action thus exciting electricity, which in its turn reproduces the original equivalent of chemical action. In like manner, when water at 212° is converted into steam, the heat which it receives is no longer manifested *as* heat, but mechanical force is developed in its stead, and this in a certain definite ratio; as soon, however, as the steam, losing its elasticity by condensation, returns to the condition of water, the original equivalent of heat is again developed, its mechanical force being no longer manifested.

Whether we regard it as most consonant to our ideas of the nature of force, to consider the one force, in any such case, as itself becoming *latent*, whilst it excites an equivalent measure of a force of another kind which was previously *dormant*,—or whether we consider that the one force is actually *converted* into the other, and that there is really no such condition as dormant or latent force,—the fact of the mutual relationship, and the definite character of that relationship, remains the same; and it is upon this, rather than upon any hypothetical representation of it, that the author wishes chiefly to insist. Although, therefore, the terms "conversion" and "metamorphosis" will be occasionally employed in the present paper, as the most convenient modes of expressing the author's meaning, he is desirous that it should be understood that he does not desire to imply anything else than the existence of the relationship just defined.

One more preliminary remark is necessary, upon a point on which Prof. GROVE has not thought it requisite strongly to dwell; namely, the necessity for a certain *material substratum* as the medium of the change in question. Thus, to take a familiar case, the correlation of Electricity and Magnetism is indicated by the development of magnetic attractions and repulsions in iron, when a current of electricity is made to circulate around it. In like manner, the correlation between Heat and Electricity is shown in the disturbance of electric equilibrium, which ensues on the application of heat to bars of certain dissimilar metals (especially bismuth and antimony) in contact with each other. The iron, in the first case, is the necessary medium for the development of the magnetic force by electricity; as the bars of dissimilar metals are in the second, for the development of the electric force by heat. So, again, in the

(so-called) magnetization of light by Prof. FARADAY, it seems necessary that the magnetic force should act through some material substratum, in order to produce any effect upon the luminous ray; the intensity of the effect varying according to the medium employed.—This consideration will be found of great importance hereafter, when the mutual relations of the Physical and Vital forces are brought under discussion.

II. *Mutual Relations of the Vital Forces.*

Our clearest idea of the agencies essentially concerned in the production of vital phenomena, is derived from the study of the history of the development of any single organism; and it will be convenient to take that of the Plant in the first instance, as presenting us with these phenomena in their least complex assemblage.

The germ of a Cryptogamic plant, when set free from its parent, is a minute particle, apparently homogeneous in its character, but probably *a cell* in the earliest stage of development.—I. The first change which we witness, is its *growth* or enlargement; and this, when analysed, is found to involve several distinct operations. 1. The germ, under the influence of light, decomposes carbonic acid, and unites its carbon with the elements of water; at the same time decomposing ammonia, and uniting its azote with oxygen, hydrogen and carbon derived from the sources just named; thus forming *organic compounds*, such as no operation of ordinary chemistry has yet been able to imitate. 2. These organic compounds, at first in the condition of crude amy-laceous and albuminous substances, need to be rendered *plastic* or organizable, by the process of assimilation, before they are fit to be applied to the extension of the living structure. 3. The organization of this plastic material then takes place, by which its materials are withdrawn from the fluid, and incorporated with the solid texture; and in this process they become fully possessed of the properties of the fabric of which they form part. 4. At the same time, a further process of organic transformation may generate other compounds, which occupy the cavity of the cell, and which are not destined to undergo organization, but are *secreted* or set apart for some ulterior purpose. In these, as in the organic compounds first generated, it is probable that the elements are arranged according to the laws of chemical affinity, although no agency but that of a living organized body has yet been found capable of bringing about their combination in these modes.

Thus we have in operation, in the simple *growth* of a vegetable cell, a force closely allied to chemical affinity, but so far different that it can only be exerted through a living organism; a force of assimilation or vital transformation; and a force of organization and complete vitalization. In speaking of them as distinct forces, it is only meant to affirm that their manifestations are diverse; for it cannot but be observed that they are all mutually dependent, and that they form part of a continuous series of phenomena which have but one ostensible cause,—the action of light and heat upon a living cell,—and but one destiny, the growth of that cell.

II. The *multiplication* of the cell, by spontaneous division or fission, is a process intimately connected with its growth, and takes place under precisely the same influences. It is by this kind of multiplication, that the simpler forms of vegetation are chiefly extended; and that the "germinal mass" is produced in the higher, the component cells of which, resembling each other in all their ostensible characters, seem to be nothing else than repetitions of that in which they all originated.

III. But from this homogeneous germinal mass, a complex and heterogeneous fabric is gradually evolved, of which the several parts or organs present wide diversities in structure and endowments. In this process of evolution or *development* (which obviously differs essentially both from growth and multiplication) it is usual to regard two separate agencies as in operation; namely, *Morphological Transformation*, which is concerned in the evolution of the several organs of which the entire body is composed; and *Histological Transformation*, the operation of which is limited to the component tissues of which these several organs are made up. It appears to the author, however, that, strictly speaking, there is but one such force; the form as well as the composition of each organ being determined by the *development* of particular tissues, and by their *multiplication* in one direction rather than another; he would therefore consider that the transformation of the simple primordial cells into other forms of tissue is the only indication of a distinct force which is manifested in the development of the fabric. Its assumption of its complete and perfect structure, is the result of that perfect harmony and balancing of the several forces of *growth*, *multiplication*, and *transformation*, which indicates, in the most distinct and unmistakable manner, the controlling and sustaining action of an intelligent mind, acting in accordance with a determinate plan*.

In the life of the fully-developed organism, we have still to trace the persistence of the same phenomena; for this is entirely made up of the vital manifestations of its component parts; and these, in the plant, are either cells of various forms, or are tubes formed by the coalescence of cells, which minister simply to the conveyance of liquids. The vegetable physiologist has long been familiar with the fact, that all the operations of the most truly *vital* nature are performed in *cells*, which have not departed in any considerable degree from their primitive type. These operations do not essentially differ in the most elaborate vegetable structure, from those which are performed in the simplest plants, and in the earliest stage of development of the more complex; the chief difference being, that the products of the actions of individual cells

* The term "*germ-force*" has been employed by Mr. PAGET (Lectures on Repair and Reproduction) to designate the power which each germ possesses "to develop itself into the perfection of an appropriate specific form." The author has elsewhere shown (Brit. and For. Med.-Chir. Review, Oct. 1849, p. 413) that this term cannot be logically understood as anything else than "a comprehensive expression of all the individual forces which are separately concerned in the evolution, maintenance, and reparation of a living being." And so far from regarding the whole force which produces the evolution as being possessed by, or as residing in, the germ, it will be the author's object to prove that it is of *external* origin.

are employed for other purposes in the economy, instead of being appropriated by the cells alone. Thus the cells of the spongioles absorb the water, and those of the green surfaces obtain the carbon (from the carbonic acid of the atmosphere), which are required for the nutrition of the entire fabric; and it is especially in the cells of the leaves that those assimilating processes are performed, whereby the plastic fluid is prepared, at the expense of which the organization of new tissue may take place elsewhere, or from which the cells in remote portions of the fabric may draw the materials of their peculiar secretion. So, again, we find that the process of multiplication of cells is limited to certain parts in which the actions of growth are most actively going on; and that a large proportion of the solid fabric is composed of structures which have ceased to take any active share in the performance of the vital functions, and which retain their integrity simply because they are not exposed to influences that would occasion their decomposition.

Everywhere it is to be noticed, that if the condition of the tissues is such as to cause it to be changed by the play of the ordinary chemical affinities, it can only retain its normal character so long as it is performing vital actions; and when these cease, it either undergoes decay (which is the case with the softer tissues), or it becomes transformed into a substance which resists decay, as is seen in the conversion of "sap-wood" into "heart-wood" by the filling-up of the woody tubes with sclerogen, resinous secretions, &c., which have little tendency to decomposition. And it will be observed, too, that the combined influence of warmth, air, and moisture, which favours the rapid decay of dead tissue, is that which most promotes the growth of the living plant. Further, the more rapid and energetic are the processes of growth, the sooner (generally speaking) are they succeeded by decomposing changes; this is seen especially in the Fungi, whose growth is more speedy, and whose degeneration is more immediately consequent upon the completion of their term of life, than that of any other tribe of plants; and it is seen also in cases in which the leaves have been forced into extraordinary activity by an excess of heat and light, their death and exuviation being thus induced at a comparatively early period. Conversely, if the vital operations be retarded by the withdrawal of the external agencies on which they are dependent, we find that the life of the structure is proportionally prolonged, and the decomposing changes are retarded accordingly; this is seen in the well-known fact, that a bouquet of flowers may be made to preserve its appearance of freshness for some time longer when kept in a dark room than it would do if exposed to light. These facts, and many others which might be cited, indicate that every integral part of the living fabric possesses within itself a capacity of being so acted on by external agencies, that the very forces which would tend to decompose and destroy it if it were dead, only excite it to vital activity if it be alive; but that this capacity lasts no longer than the completion of its own term of growth, every individual cell being destined to pass through a certain series of changes, the completion of which leaves it at the mercy of the physical and chemical agencies to which it may

happen to be subjected; and the duration of its life being inversely proportional to the rapidity with which these operations are performed.

In addition to the phenomena included under the general term of growth or development, we have to study those which constitute the proper *generative* process. This appears to consist, as the author has elsewhere shown*, in the reunion of the contents of two of the cells which had been previously separated by the process of fission. In the simplest tribes of plants, it would seem as if *all* the cells thus springing from the same primordial source, were capable of performing the generative act by "conjugation;" but this capability, like other endowments, is limited in the higher plants to particular groups of cells, which are developed in organs distinct from those concerned in the acts of nutrition, and are obviously set apart from the first for the performance of the act of generation alone.

Various kinds of *motion*, again, are performed by the agency of the vegetable structure, although these are less remarkable than they are in animals. From the extended researches of Prof. SCHLEIDEN it appears probable that within *every* cell, at some stage of its formation, a circulation of fluid takes place †, which is sustained by agencies that cannot be regarded as mechanical, and that are intimately connected with the formative processes; varying in its rate with the general activity of those processes, and only ceasing with their cessation. Wherever a cytoblast exists, the currents radiate from it and return to it again; in other cases (as the Chara) they are observed to extend over the whole lining of the cell-wall; in both cases being connected with the part that shows the greatest vital activity. The *zoospores* of various inferior Algæ are covered with *cilia*, by the vibration of which these bodies are carried through the water, and deposited at a distance from their parent. These zoospores are minute cells, formed within certain cells of the parent fabric, and liberated by their rupture. So, again, the spiral filaments long since observed in the Characeæ, the Hepaticæ, and in Mosses, and more recently discovered in the Fucaceæ and in Ferns, have a peculiar independent movement, which seems obviously destined to diffuse them, and thus to bring them into contact with the germ-cells which they are to fertilize. Each of these spiral filaments is developed within a distinct cell. And lastly, in certain plants, both of high and low organization, sensible movements are occasionally to be witnessed, which are immediately due to changes of form in their component cells; these changes of form being sometimes spontaneous, that is, occurring as a part of the regular series of the vital operations of those cells, and not directly excited by any external influences, as we see in the rhythmical movements of the *Oscillatoria*; and being sometimes consequent upon mechanical or other irritations applied to the cells which exhibit them, as in the case of the closure of the fly-trap of the *Dionæa*, but not being at all the less dependent upon the vital endowments of those cells, which cease to exhibit them when their vital activity is diminished. The folding of the leaves of the *Mimosa pudica* appears to take place

* Brit. and For. Med.-Chir. Review, Oct. 1849, p. 346.

† Principles of Scientific Botany, p. 95.

spontaneously in some cases, and to be an excited phenomenon in others, thus combining the characters of both classes of movement, and showing their dependence on similar properties of the contractile cells.

Further, in many of the higher plants, and also in animals, we witness movements of fluid through a capillary network, which must be wholly or in part due to the vital relations of the fluid and the tissues through which it is carried; no physical agency being capable of entirely accounting for these movements, and some of them taking place under circumstances, which, as in the case of the rotation within the cells of the *Chara*, &c., seem to exclude the idea of such agency. Thus the *cyclosis* of SCHULTZ (a recent observation upon which, apparently free from all fallacy, has been recorded by Prof. BALFOUR, 'Manual of Botany,' p. 128), whether or not an universal phenomenon, seems unquestionably to present the spectacle of a rapid capillary circulation, not maintained by any *vis a tergo*, but depending upon forces connected with the vital endowments of the parts through which it takes place. The movement of nutritive fluid in the canals excavated in the tissues of many of the lower Animals, in like manner, seems to be but little dependent on mechanical propulsion, and to be chiefly maintained by some power originating in the living tissues. And even the capillary circulation of the highest animals, in which the regular flow is sustained by the propulsive power of the heart, exhibits certain residual phenomena,—such as local accelerations and stagnations,—which cannot be attributed to changes in the rate or power of the heart's contractions, and indicate the existence of influences arising out of the vital relations of the nutritious fluids to the tissues through which its movement takes place;—this movement being most active when the formative actions of the part are being most energetically performed, and exhibiting a retardation as soon as any influence depresses them*.

The forces concerned in the growth, development, and movements of Animals appear to be essentially the same with those whose existence has thus been traced in plants. The animal, however, deriving its nutriment from organic compounds previously elaborated, does not perform that preliminary operation, which is so remarkably intermediate between chemical and vital agency, viz. the production of ternary and quaternary compounds, of complex atomic constitution, by the union of their elements. But in animals we find an additional power, termed Nervous Agency, nothing analogous to which exists in plants; this power, related on the one hand to the conscious mind, to which it communicates impressions derived from the external world, is also related, in a very remarkable manner, to the vital endowments of the organism in general, as will be presently seen, and particularly to the contractile tissues; the most perfect form of which (the striated muscular fibre) is usually called into action through its instrumentality, in obedience to mental impulses.

* That such is the case, must be admitted, the author believes, by all Physiologists and Pathologists who study the phenomena of the capillary circulation, whether or not they be disposed to admit the validity of the hypothesis of "vital attractions and repulsions" which has been offered by Prof. ALISON as an explanation of this order of phenomena.

In order to meet the more varied requirements of the Animal organism, a much larger proportion of its tissues undergoes various transformations, so as to depart more or less widely from the original cellular type, than we find to be the case in the plant; still it is no less true in the animal than in the plant—as proved by the researches of SCHWANN, extended and confirmed as they have been in this particular by the researches of all subsequent histologists—that *all the tissues possessing distinctly vital endowments**, originate, directly or indirectly, in the transformation of cells. And further, it may be stated, that *all the most active vital operations*, in the Animal as in the Vegetable organism, are performed by tissues which retain their original cellular constitution with little or no change†.

The several modifications of vital force which have now been enumerated will be found, when closely examined, to have a very intimate mutual relationship, however dissimilar may be the phenomena they produce. In the first place they are all exerted, even in the most highly organized living being, through a common instrumentality, the simple cell. Secondly, the entire assemblage of cells making up the totality of any organism, have all a common parentage; being linearly descended from the single primordial cell in which the organism originated. Thirdly, they are manifested in connection with each other, in those single-celled organisms, which are the lowest members of the two kingdoms respectively, and in which there is no separation or specialization of function.—Hence we may express them collectively under the general term of *Cell-force*; and seem entitled to affirm that each is a particular *modus operandi* of the same force as that which is concerned in cell-formation‡.

* It may now be considered as a well-established fact, that the *simple fibrous tissues* may originate in a structureless blastema, and may be produced by its fibrillation, without passing through the intermediate condition of cells. But these tissues cannot be regarded as possessing any truly *vital* endowments; their properties being simply physical, and their uses in the economy merely mechanical.

† This general proposition was first advanced by the author in regard to the operations in which organic life consists (and which are common, therefore, to plants and animals), in his “Report on the Origin and Functions of Cells” in the Brit. and For. Med. Review for January 1843. The subsequent discovery of the cellular composition of the ultimate fibrilla of striated muscular fibre, by himself and Prof. SHARPEY contemporaneously, and the accumulation of various facts relative to the existence of cells or cell-nuclei at the peripheral extremities of the afferent nerves, as well as in the central organs, seem to justify the assertion that unmetamorphosed cells are the active agents in the production of Muscular and Nervous force; in the former case effecting contraction by their change of form, and in the latter developing nerve-force, which is transmitted along the fibres as its conductors.

‡ The author is particularly desirous that he should be understood as implying by the term “cell-force,” *not* that the force is produced or generated *by* the cell, but that the growth of the cell is the most general objective manifestation of that force, and that the cell affords the ordinary instrumental condition for its exertion, though there can be no doubt that the force may be exerted in many cases in which cell-development does not take place. The use which he would make of the term is just that which is commonly made of the term “Engine-power;” every one knowing that the steam-engine possesses no power itself, but that it is simply the instrument most commonly employed, because the most convenient and advantageous yet devised, for the application of the expansive force of steam, generated by the application of heat, to the production of mechanical motion.

This inference derives a remarkable confirmation from a series of facts, which indicate that when that *specialization* of function takes place, which has been mentioned as a characteristic of the higher organisms, the cells which become the instruments of some one particular kind of operation seem to lose their other endowments,—as if the expenditure of the vital force of each cell upon any one purpose, unfitted it for any other agency. Thus the *assimilating* cells (whether floating in the nutrient fluids, or included in the absorbent glandulæ), whose function it is to convert the raw material supplied by the food into organizable *plasma*, exercise little or no purely chemical transformation; they do not undergo change of form; they do not exert any mechanical or nervous power; and they do not reproduce their kind. So, again, the cells which are specially endowed with the power of *multiplication*, seem to possess no other special vital endowment; simply receiving the nutriment which has been prepared for them by other agencies, and applying it to the production of new cells, which, if themselves possessed of more special endowments, do not reproduce themselves. Of this we see an example in the first development of the embryonic structure, the cells of which rapidly multiply by the process of fission, up to the time at which histological transformations commence, and then this multiplication almost or entirely ceases; so that (as in the case of the insect, whose larva is an embryonic mass of very rapid production, composed almost entirely of cells destined to undergo histological change during the metamorphosis) the perfect structure *may* be even smaller than that from which it is developed. In the formation of new parts which make their appearance at a subsequent time, the same rule generally holds good, viz. that their foundation is laid in a mass of cells which rapidly multiply up to a certain point without histological transformation, and then undergo histological transformation with little further multiplication. But the most striking illustrations of this principle are perhaps to be derived from those cases, in which a continual production of cells possessed of some special endowment goes on during adult life. Thus it is necessary for every act of *secretion*, that a new formation of secreting cells should take place within the ultimate follicles of glands. These ultimate follicles are really to be regarded (as shown by Prof. GOODSIR*) in the light of parent-cells, which produce the true secreting cells in proportion as the materials of their growth are supplied by the blood. Now *these parent-cells themselves possess no secreting power, their vital force being entirely expended in the production of the true secreting cells.* On the other hand, *the true secreting cells possess no reproductive power, but die and are cast off when they have reached their maturity; as if their whole vital force were expended in the secreting process,* which is itself nothing else than a portion of the act of growth. This will be found, the author believes, to be the type of a large order of facts, of which some others will be presently noticed. Again, the cells which are endowed with the special *reproductive* power, exercised in the true act of generation, seem to possess no other endowment; they do not exercise chemical transformation, nor do they undergo

* Anatomical and Pathological Observations, No. V.

histological change, nor do they multiply after the ordinary fashion. But here, again, we find that these cells are produced within others, whose whole endowment seems that of multiplication; the *sperm-cells* being generated in vast numbers within follicles or parent-cells, which have themselves no power of producing spermatic filaments; and each *germ-cell*, also, being a secondary product of the parent-cell of the ovule,—the other cells to which it gives origin (those which fill the embryo-sac in the vegetable ovule, and which form the vitellus of the animal unimpregnated ovum) being of very inferior character and transient duration. That a relation of reciprocity exists between the forces concerned in the growth, development, and maintenance of the individual organism, and those which are employed in the generative act,—so that an excessive expenditure of either diminishes the amount of vital force which is applicable to the other,—is an idea so familiar to physiologists, that the author need not here dwell upon it, further than to point out how completely it coincides with, and illustrates, the view for which he is contending.

When we look, moreover, at the tissues which have been developed from the original cells by histological transformation, we find that in proportion as they lose the cellular character, they for the most part cease to perform any strictly vital operation; as if the act of transformation had expended their vital power. We seem to see this in the development of tubes from cells, alike in the plant and in the animal, the tubes thenceforth serving merely for the conveyance of liquids; and in the development of the simple fibrous tissues of animals, the endowments of these fibres being purely physical, and what vital force they may retain serving merely to enable them to resist chemical change. When we look at the cells concerned in the production of *mechanical movement*, we find the same principle holding good in a most remarkable manner, these cells being apparently incapable of performing any other function. Thus the cells which constitute the fibrillæ of striated muscular fibre exercise no power of chemical transformation, they undergo no histological change, and they appear to be entirely destitute of the power of multiplication; the expenditure of their vital force in the act of muscular contraction involves their death and disintegration; and their renewal appears to be accomplished by a production of new cells by the continued agency of the parent-cell (or sarcolemma), which, itself possessing no contractile power, seems to hold the same relation to the contractile cells of the fibrillæ, that the parent-cells or follicles of glands hold to the true secreting cells occupying their interior. Again, the ciliary action, when the special endowment of a particular set of cells—as those lining the excretory ducts of the glands, respiratory organs, &c. of higher animals—appears to be in like manner incompatible with any other action, but to be the sole manifestation of the vital force of these cells. For the *ciliated epithelium is never a secreting epithelium*; so that in tracing the one form into the other, there seems to be such a marked transition in function (the mode of production and the general conditions of development being essentially the same) as clearly indicates that the ciliary action and the secreting agency, although very

dissimilar in themselves, are both to be looked upon as modes of operation of the same vital force as that which is exerted in the production of the cell. And this view derives remarkable confirmation from the fact, that in the history of the "zoospores" of the Algæ we have two distinct periods, one of ciliary action, and the other of growth and multiplication; *so long as the ciliary action continues, which is provided for their dispersion, no further vital change seems to take place in them; but so soon as this ceases and they become stationary, they begin to exercise chemico-vital transformations, and to grow and multiply as cells.*

These views in regard to the mutual relationship of the different kinds of vital force, are strikingly confirmed by the phenomena of *Nervous Agency*. There can be no reasonable doubt that the production of nerve-force in the central organs is dependent upon the development of the peculiar cells constituting the ganglionic or vesicular substance; and, as already remarked, the progress of physiological inquiry seems to justify the belief (long since entertained and expressed by the author) that either cells or cell-nuclei are the agents in the origination of nerve-force at the peripheral extremities of the nerve-fibres*. The nerve-force thus generated is not merely expended in arousing mental activity on the one hand, or in exciting muscular contraction on the other, but has an intimate relationship (there can be no doubt) with all the other manifestations of vital force which the animal organism exhibits. So intimate is this relationship, so obvious is the controlling and regulating action of the nervous system over the operations of nutrition, secretion, &c., especially in the higher animals, that many physiologists have regarded these actions as necessarily *dependent* upon the exertion of nervous force. On the other hand, it has been urged with great plausibility by Prof. ALISON and others, that since the functions of organic life in Animals are performed under the same essential conditions as those of Plants, and since the acts of formation, secretion, &c. are effected by the very same agency in animals as in plants,—namely, by cell-growth,—there is no valid reason for regarding them as dependent upon nervous agency; although it must be freely admitted that they are greatly affected by that agency, being not merely accelerated and retarded through its influence, but also altered in kind. The view here advocated will, it is believed, afford a definite scientific expression for all the phenomena which bear upon this question. For, just as electricity developed by chemical change may operate (by its correlation with chemical affinity) in producing other chemical changes

* There can be little doubt that such is the function of the cells of the retina, which are shown, by the history of the development of the eye, actually to originate in the optic ganglion. The same appears to be the fact in regard to the cells in relation with the peripheric expansion of the auditory nerve, which originate in the auditory ganglion. (See Mr. H. GRAY's paper "On the Development of the Retina and Optic Nerve, and of the Membranous Labyrinth and Auditory Nerve," at p. 189 of the present volume of the Philosophical Transactions.) And it seems probable from the researches of KÖLLIKER (*Annales des Sciences Naturelles*, Ser. III. Zool. tom. vi. p. 102), that the plexuses which appear to constitute the ultimate distribution of the sensory nerves in the skin, are really composed of nerve-cells, which have sent out very slender prolongations to inosculate with each other.

elsewhere,—so may nerve-force, which has its origin in cell-formation, excite or modify the process of cell-formation in other parts, and thus influence all the vital manifestations of the several tissues, whatever may be their own individual characters. And this expression will also be found available for the well-known influence of mental conditions upon the properties of the various tissues and secretions, since this influence can only be exerted through the medium of nervous agency. Further, it not only appears that a simple withdrawal or disturbance of the nervous force supplied to particular organs occasions a retardation or perversion of their vital operations; but there also seems evidence that an influence of *an opposite kind* may be transmitted through the nervous system, which is positively and directly antagonistic to the vital powers of the several tissues and organs;—such, at least, appears to be the only mode of accounting for the extraordinary effect of a *shock*, mechanical or mental, in at once and completely destroying the contractility of the heart, and in immediately bringing to a stand the vital operations of other parts; and it harmonizes well with the fact that, in hemiplegia, the “palsy-stroke” transmitted from the brain along the spinal cord almost invariably affects the leg less injuriously than the arm, and for a shorter duration, recovery first taking place in the leg, even when it has been at first paralysed as completely as the arm. If the nervous force be regarded as a *polar* force (as suggested by Messrs. TODD and BOWMAN, ‘Physiological Anatomy,’ vol. i. p. 237 *et seq.*), analogous in its mode of transmission to electricity or galvanism, it is not difficult to understand that the *reversal* of the usual direction of its action may produce the effects in question, regard being had to the opposite effects shown by Prof. MATTEUCCI to be produced upon nervous excitability by the *direct* and the *inverse* electric currents*.

It is hoped that the foregoing considerations (in support of which many others might be adduced †) will have served to establish the general proposition, that so close a mutual relation exists between all the vital forces, that they may be legitimately regarded as *modes* of one and the same force. The most general and characteristic of the manifestations of this force, which serves to unite and connect all the rest, is that which is concerned in *cell-formation*; and to this act, many of the other agencies appear to be essentially related. Thus the tissue of a muscle is constructed solely with a view to its manifestation of contractile power; whilst the development of nervous matter has reference entirely to the peculiar operations in which it is to be concerned. We find only one kind of tissue serving for the generation and transmission of nervous power; this alone affording the *material substratum* through which the vital force can manifest itself as nervous agency. And so, in like manner, it can scarcely be doubted that the contractile tissues, the assimilating cells,

* Lectures on the Physical Phenomena of Living Beings, translated by Dr. PEREIRA, p. 262.

† The dynamical relations of the nerve-force to mental agency, on the one hand, and to the several vital forces on the other, constitute a field of inquiry of vast extent and profound interest. To this inquiry the author purposes to apply himself, should the views enunciated in this paper be accepted as true, or even probable, by those most competent to judge of their merits.

the secreting cells, &c., have their own respective peculiarities of structure or composition, whereby they are severally enabled to serve as the material substrata, through which the vital force is exerted in the production of the various phenomena of life.

III. *Relations of the Vital and Physical Forces.*

Having thus endeavoured to develop the fundamental relations which subsist between all strictly Vital phenomena, by showing that a "correlation" may be traced among the several forces to whose agency they are attributable, it is the author's purpose to inquire, whether any similar relation can be shown to exist between the *vital* and the *physical* forces.

In the conduct of this inquiry, it will be advantageous to take, as our starting-point, a case in which the existence of such a correlation appears particularly obvious; that, namely, of Nervous Force, the strong *analogy* of which to *Electricity* is admitted by all who do not believe in the *identity* of these two agents. The disproof of their identity will be found, the author believes, in the numerous experiments of Prof. MATTEUCCI and others, who have failed to procure any manifestations of a change in the electric state of nerves, through whose agency muscular contractions were being most vigorously excited; and in the well-known fact, that the conduction of nervous force is prevented by pressure on the nerve-trunk, or by other disorganizing changes, which do not impair its power of conducting electricity. All the facts which have been adduced in support of the *identity* of these two forces will be found readily explicable on the idea of their "correlation" or mutual convertibility;—electricity, when acting through nerve-fibres, developing nervous force; and nerve-force, when operating upon a certain special form of apparatus, developing electricity. This view the author purposes now to unfold in more detail; adducing in support of it facts which are so well known to physiologists and electricians, that there can be no occasion to do more than cite them.

1. If an electric current be made to traverse the trunk of a *motor* nerve for a short distance only, it will produce contraction of the muscles which are supplied from its branches. It was formerly supposed that the contraction was excited by the immediate action of the electricity upon the muscles; but it has been clearly proved that the electric current need not proceed to them, its passage along the trunk for a very short distance being sufficient to develop the nervous force in its branches.

2. In like manner, if the electric current be passed for a short distance only along a *sensory* nerve, it will excite in the sensorium the peculiar sensations ordinarily produced by impressions conveyed through that nerve; that is to say, the ordinary tactile sensations, if the current be transmitted along a nerve of common sensation; or those of sight, hearing, smell, or taste, if the current be transmitted along the optic, auditory, olfactive, or gustative nerves. And thus, as remarked by MÜLLER, we may, by proper management, be made conscious at one and the same time of pricking sensations, of flashes of light, of a phosphoric odour, and of a peculiar taste;

all excited by a peculiar cause, the transmission of an electric current along the sensory nerves, through which these modes of consciousness are respectively excited.

This production of muscular contraction on the one hand, and of various forms of sensation on the other, by the transmission of an electric current through a nerve-trunk, along a short distance only, appear to indicate that it is to the nervous force called into activity by the electric, and not to the electric force itself, that the phenomena are immediately due; and so strong an analogy presents itself between this development of nerve-force in a nerve, and the development of the magnetic force in a piece of iron, as the immediate and direct result of a certain application of the electric current, that, whatever may be the view taken of the relation of the magnetic force to the electric, the relation of the nervous force to the electric can scarcely but be placed in the same category. It is no objection to this view to say, that the nervous force can only be excited in the nerve of a living animal, or in that of an animal recently killed. In all instances of conversion of force, as already noticed, some form of matter is required as the medium of the metamorphosis; and a slight change in the condition of that matter may have a very considerable effect in modifying the process of conversion. Thus, it is by causing an electric current to circulate around a bar of iron, that we most readily develop the magnetic force; but the molecular condition of that iron, whether hard or soft, crystalline or fibrous, has an important influence upon the result. Now we know that the normal condition of the nerve-fibre can only be kept up by the continual performance of the changes which constitute nutrition; so that if these changes be interrupted, its molecular condition speedily undergoes alteration. Hence, the fact that the electric force can no longer call forth the manifestations of nervous force, when a short time has elapsed after the suspension of the nutritive processes by the stoppage of the circulation, is in no way inconsistent with the idea here advocated of the intimate relation between the two.

In order to complete the idea of "correlation," however, it must be shown that the nervous force may be the means of developing electricity; and it seems the only feasible method of accounting for the results of the experiments of DAVY, FARADAY, MATTEUCCI, and others, upon the Electric Fishes, to look upon the development of electricity as the result of the action of their nervous force upon the peculiar organic apparatus to which its production is attributed. For the electric power has been ascertained to be entirely dependent upon the connection of that apparatus with the nervous centres, by nerve-trunks of large size, whose branches are distributed with extraordinary minuteness through the ultimate subdivisions of the electric organs; if these nerves be wholly divided, the electric discharge can no longer be called forth in the usual mode; if they be partially divided, the electric power is proportionably weakened; if the "electric lobe" of the encephalon be destroyed, removed, or injured, the electric power is annihilated or weakened, in precise accordance with the degree of damage inflicted; whilst, on the other hand, if the "electric lobe" be

mechanically irritated, or if the nerves proceeding from it be excited to action, even after their separation from the central organ, electric manifestations are obtained, the intensity of which is proportional to the excitement of nervous power thus effected. Various other phenomena recorded by MATTEUCCI make it evident, that the amount of electric force generated by the electrical apparatus is in precise accordance with the amount of nervous force which is transmitted to it*.

Thus it appears that whilst electricity excites nervous force through the instrumentality of the nervous structure, nervous force excites electricity through the instrumentality of the electrical apparatus; and the case seems to be one which points directly to the existence of the *same kind of relation* between nervous force and electricity, as exists between electricity and magnetism, heat, chemical affinity, &c., whatever may be the form in which we think it best to express our notion of that relation. No one, the author believes, who has once adopted the idea of "correlation" as subsisting among the physical forces, can look at the peculiar connections to which he has adverted, as existing between the nervous and electrical forces, without perceiving how completely it is applicable to them. And he cannot but think that some such idea must have been present to the mind of Prof. MATTEUCCI, although he has not met with any distinct expression of it in his writings †.

But Electricity is not the only physical force possessing this peculiar relation to the nervous force.

Our sensations of heat and cold are entirely dependent upon the power which *Heat* possesses of exciting nerve-force in the sensory nerves. Further, if heat be applied to a motor nerve in its course, it will call forth muscular contractions; and if applied to a sensory nerve, it will occasion sensations, both common and special; precisely after the manner of electricity. Conversely, there are phenomena well known to physiologists, which have not yet been explained upon the purely chemical doctrine of calorification, and for which it does not seem possible that any such explanation can account. Several of these phenomena appear to point to the nervous force as a direct agent in the production of heat; the amount of caloric thus generated being

* The question whether a disturbance of electric equilibrium occurs during the contraction of a muscle, and whether this is to be looked upon as the direct result of the operation of the nervous force, or is consequent upon the molecular changes taking place in the muscle under the influence of that force, must be regarded as at present *sub judice*. If the former prove to be the case, we have another instance of the direct production of electricity by nervous force; if the latter, the same metamorphosis would seem to take place through the intermediate condition of muscular force.

† [Since this paper was written, the author has had the satisfaction of learning, from the perusal of Prof. MATTEUCCI's Eighth Series of "Electro-Physiological Researches," that he has formally adopted the doctrine of the correlation between the nervous and electrical forces, which the author had himself put forth, nearly two years before, in a review of Prof. MATTEUCCI's "Lectures." (See Brit. and For. Med.-Chir. Review, Jan. 1848, p. 232.) In addition to the proofs adduced above, Prof. MATTEUCCI has furnished a new series, arising out of the action of an electric current transmitted through a *muscle*, on the *nerves* which ramify through it. (See p. 296 of the present volume of the Philosophical Transactions.)—Nov. 20th, 1850.]

proportional to the expenditure of that force.—Thus a “correlation” is distinctly indicated between Nervous force and Heat.

Precisely the same may be said of *Chemical Affinity*; for the application of various reagents to the nerve-trunks may be made to call into action their peculiar endowments, whether these be motor or sensory; whilst, on the other hand, there is ample evidence that the chemical properties of secretions may be greatly changed under the direct influence of nervous force.

The power of *Light* to excite the nervous force is clearly indicated by the influence of this agent upon the optic nerve, whose peculiar force is excited by the impression of light upon its peripheral extremities; conversely, there are certain phenomena of animal luminosity, especially among the *Annelida*, which do not appear to be directly referable to chemical change, but which seem to be rather dependent upon a direct exertion of nervous power; vivid scintillations (resembling the luminous effects of an electric discharge through a glass tube spotted with tin-foil) being excited by any irritation applied to the nervous system of these animals*.

The relation of *Motion* to the nervous force is too striking to be passed by. The peculiar vital endowments of a nerve may be called into active exercise, as well by pinching or pricking it, as by electrical or chemical stimuli; thus by pressure on a nerve of common sensation, pain is excited; by pressure on a motor nerve, muscular contraction; by pressure upon the eyeball, sensations of light and colours may be produced in complete darkness; pressure applied to the meatus of the ear, so as to affect the auditory nerve, will give rise to a ringing sound; and by quickly but lightly striking the surface of the tongue, near its tip, with the finger, a distinct taste, sometimes acid, sometimes saline, is produced†. Conversely, the nervous force appears convertible into motion through the medium of the Muscular apparatus, just as it excites electricity through the instrumentality of the electric organs of Fishes. That the motor force thus generated is always proportional, *cæteris paribus*, to the

* This is the conclusion at which the author arrived some years since, from observations which he made at Tenby on a small Annelide (probably a species of *Syllis*), in which the luminous discharges are seen with extraordinary brilliancy, when the animal is subjected to irritation, as by slightly pinching or pricking it, or by the movement of the water around it. The same conclusion was contemporaneously arrived at by M. DE QUATREFAGES, from observations made on the Annelida of the coast of France. “En étudiant, à l'aide du microscope, de petites Annélides transparents, M. DE QUATREFAGES est arrivé à découvrir un rapport curieux entre certains phénomènes de phosphorescence animale, et l'influence de l'agent qui détermine la contraction musculaire, et qui, à plusieurs égards, semble tant d'analogie avec l'électricité. Il est probable que la lumière plus ou moins vive, que répandent un grand nombre d'animaux inférieurs, ne dépend pas toujours de la même cause; que tantôt c'est un phénomène qui accompagne la décomposition des matières organiques, et que d'autres fois c'est le résultat de la sécrétion d'un liquide particulier; mais il est probable que, dans un grand nombre de cas, la cause de la phosphorescence est entièrement physique, *et se lie, comme la contraction musculaire, à l'influence nerveuse.*”—Rapport sur une Série de Mémoires de M. A. DE QUATREFAGES, relatifs à l'organisation des Animaux sans Vertèbres des Côtes de la Manche, par M. MILNE-EDWARDS (Annales des Sciences Naturelles, Troisième Série, tom. i. p. 23).

† See Dr. BALY's Translation of MÜLLER's Physiology, p. 1062.

degree of nervous power exerted, will be (the author believes) disputed by no physiologist; it is most remarkably illustrated in the extraordinary force developed under the influence of emotional excitement, which often calls forth a much greater measure of muscular power than the will can command.

Of the relations between *Magnetism* and the nervous force, the author thinks it preferable to say nothing more at present, than that various indications appear to him to be afforded, by recent investigations, of the existence of a direct and influential connection*.

The relation thus pointed out between Nervous agency and the various Physical forces, is the more remarkable, when it is considered that the nervous power must be regarded as the *highest* of all the forms of vital force, both in its relations to mental action, and in its dominant power over organic processes of every kind. Considering how closely, as already pointed out, it is correlated to the forces concerned in muscular and ciliary movement †, in nutrition and secretion, in development and reproduction, it cannot be thought improbable that what is true of it should be true of them also; and that a relation of mutual convertibility should exist between these and one or more of the physical forces. Such relations the author believes to exist; and he now proceeds to adduce facts which appear to him adequate to support that belief.

The *muscular* force may be called forth, as is well known, by electricity directly applied to the muscle itself; by heat, cold, and chemical agents; and by mechanical irritation. These agencies, however, do not appear so directly concerned in the production of the motor power, as in occasioning that metamorphosis of living organized tissue into chemical compounds, whereon the development of the muscular force seems to be immediately dependent. It is now universally admitted that the disintegration of a certain amount of muscular tissue, and the new arrangement of its components in combination with oxygen supplied by the blood, is necessary for the development of its contractile force; and the considerations adduced by Prof. LIEBIG render it highly probable, that the muscular contraction may be regarded as proceeding from the expenditure or metamorphosis of the cell-force, which ceases to exist as a *vital* power, in giving rise to *mechanical* agency. The amount of muscular force developed appears to bear an exact correspondence with the amount of urea formed by the metamorphosis of the muscular tissue; and this metamorphosis involves the cessation of its existence as a living structure, and consequently the annihilation of the vital

* Whatever scientific value we might have otherwise been disposed to attach to the researches of Baron von REICHENBACH on "Magnetism, Crystallization, &c. in their relations to Vital Force," they seem to derive some additional claims on our attention from the discoveries of Prof. FARADAY in regard to the universal operation of the magnetic force, and its relations to light and to the polar force of crystals,—discoveries which, be it observed, had not been made when the phenomena observed by Baron von REICHENBACH were first made public.

† In man and the higher animals, the ciliary movement does not appear to be in any degree controllable by nervous agency; but there can scarcely be a doubt that in the *Rotifera* it is thus governed.

forces which that structure possessed. We are, then, to regard the nervous, electrical, and other stimuli, under whose influence the muscular force is called forth, less as the immediate sources of that force, than as furnishing the conditions under which the vital force acting through the muscle is converted into the mechanical force developed in its contraction.

We do not yet know enough of the conditions under which *ciliary movement* takes place, to enable us to affirm that the production of mechanical motion through its means is in like manner the result of an expenditure of vital force; but the considerations formerly adduced in regard to the relation of ciliary action to other vital manifestations, together with the remarkable similarity between the influence of strychnia, opium, electric discharges, &c. upon the ciliary movement and upon muscular contractility, leave little room for doubt that what is true of the muscular force is true also of ciliary motion, and that it, too, is to be regarded as directly depending upon a conversion of vital force into mechanical motion. The continuance of motion in the cilia appears to be intimately related to changes taking place in the cells on which they are borne; and its persistence after the detachment of these cells from the remainder of the body, like the persistence in the contractility of muscular fibre which has been completely isolated from all its connections, proves that we must look to forces existing in them, and not to influences derived from any other source, for the maintenance of this curious operation.

Passing from these particular manifestations of vital force, which so remarkably indicate its relations to physical agencies, to those which, being concerned in the development and growth of organized structures, seem to have less in common with them, we shall fix our attention on the fundamental fact, that these Organizing forces (as we may conveniently designate them) are so completely dependent upon the continual agency of *Heat* (and in some cases of *Light* also), that they may be considered as the manifestations of the action of heat upon organized fabrics.

The necessity for this agency may be seen at every period of the life of organized beings of all kinds. In the lower tribes of animals, and in the entire vegetable kingdom, we trace this dependence in *the precise relation between the vital activity of each individual, and the amount of heat which it receives from external sources*. Every species is adapted to flourish within a certain range of temperature; and that amount of heat which is most effective in sustaining the life of one species, may be injurious or even fatal to another. But within the range which is compatible with the manifestation of its vital powers, we find that the relation is most constant between the temperature and the organizing force exhibited by each species. It is scarcely necessary to accumulate facts in support of a position so generally admitted; but the author particularly wishes to direct attention to the definiteness and exactness of this relation, and may instance the following facts as examples.

1. According to BOUSSINGAULT, the same annual plant, in arriving at its full development, and going through all the processes of flowering and maturation of its

seed, *everywhere receives the same amount of solar light and heat*, whether it be grown at the equator or in the temperate zone ; its *rate of growth being in a precisely inverse ratio to the amount it receives in any given time*. Hence it appears that the organizing force of Plants bears a relation of equivalence to the Heat and Light which act upon them.

2. This has been separately demonstrated with regard to the special influence of Light, in producing the decomposition of carbonic acid and the formation of chlorophyll, &c. ; the amount of carbon fixed by plants being *cæteris paribus* in accordance with the amount of illumination they receive. The influence of Light, it may be remarked, seems to be exerted only in this peculiar process of vital chemistry ; whilst that of Heat is exercised in *all* the other operations in which growth consists ; and hence it is that Animals are comparatively little dependent upon light, their food being prepared for them by the agency of the vegetable kingdom.

3. The rate of "rotation" of the fluid within the cells of *Chara*, &c., and the rate of "cyclosis" in the latex-vessels of *Ficus elastica*, &c., appear to be in precise relation (within certain definite limits) with the temperature to which these organisms are subjected ; the movement of the fluids being accelerated by warmth, and retarded or checked by cold*.

4. In cold-blooded Animals, the same relation may be seen, between the activity of the organizing processes, and the amount of Heat to which they are subjected. The production of larvæ from the eggs of Insects, like the germination of the seeds of plants, may be accelerated or retarded at pleasure, simply by the regulation of the temperature ; and the time required for the last metamorphosis is precisely in the inverse ratio to the heat supplied ; so that, as in the maturation of the plant, each individual of the same species receives the same amount of heat, whether the intensity of its action be greater or less. Further, it has been remarked by Mr. PAGET†, that the processes of *development* seem to require a higher degree of Vital force than those of simple *growth* ; and it harmonizes admirably with the doctrine here contended for, that there appears to be a necessity for a higher temperature for developmental operations, than for those of simple increase. Thus in the economy of the Social Bees, as shown by Mr. NEWPORT, there is a special provision for generating heat during the last few hours of the metamorphosis, in which the tissues and organs of the imago are being completed ; and in the Viper and some other ovo-viviparous Reptiles, there seems to be an unusual calorifying power, for the purpose of promoting the development of the embryo. So, again, it has been found by Dr. EDWARDS and Mr. HIGGINBOTTOM that the metamorphosis of Batrachia requires a larger amount of light and heat than

* It would almost seem as if some anti-vital influence, resembling that of "shock" in animals, could be exerted by mechanical injury on plants. When a portion of the leaf of *Vallisneria* is detached for the exhibition of the movement of "rotation" in its cells, the movement generally ceases for some little time ; the application of warmth will usually re-excite it ; and it may then continue for several hours or even days.

† Lectures on Repair and Reproduction.

suffices for their growth in the larva state, being retarded or even prevented by the want of a due amount of these agencies (see p. 753); and it has been also shown by Mr. HIGGINBOTTOM that the *development* of new limbs in the Triton, to replace those which have been lost, cannot take place at a lower temperature than about 60°, although the processes of *growth* go on under a much less degree of heat*. The general propositions enunciated by Prof. MILNE-EDWARDS†, in regard to the geographical distribution of the Crustacea, indicate the existence of this relation in the most decided manner. They are, briefly, as follows:—I. The varieties of form and organization (which may be regarded as so many varied manifestations of the organizing force) increase as we pass from the Polar Seas towards the equator, the number of species thus augmenting greatly as we go southwards. II. The differences of form and organization are not only more numerous and more characteristic in the warm than in the cold regions of the globe; they are also more important. III. Not only are those Crustacea which are most elevated in the scale deficient in the polar regions, but their relative number decreases rapidly as we pass from the equator towards the pole. IV. The average size of the Crustacea of tropical regions is considerably greater than that of the tribes inhabiting temperate or frigid climes. V. It is where the temperature is most elevated, that the peculiarities of structure which characterize the several groups are most strongly manifested. And VI., there is a remarkable coincidence between the temperature of different regions, and the prevalence of certain forms of Crustacea.—It is interesting to observe, that the want of a high temperature is no obstacle to the growth and multiplication of individuals of a comparatively small size and low grade of organization; the Arctic and Antarctic seas being as numerously peopled with such, as the tropical ocean is with higher forms. But the preceding statements point to a direct and definite relation between Heat and the Organizing force, as manifested in this group of animals. A comparison of the facts relating to the geographical distribution of other classes of cold-blooded animals would probably justify the same conclusions. There can be no doubt of their general applicability to the Vegetable kingdom.

5. The influence of temperature upon the general vital activity of cold-blooded animals is no less remarkable. The facts determined by the experiments of Dr. W. F. EDWARDS‡ lead to this general conclusion;—that the *rate of life* of Batrachia and Fishes, of which the activity of their respiratory process is the exponent, varies directly (within certain limits) as the temperature of the surrounding medium; so that the *duration of life*, when these animals are deprived of air, either partially or completely, or are placed in any other circumstances unfavourable to its sustenance, varies inversely with the external temperature. Thus when frogs were confined in a limited quantity of water, and were not allowed to come to the surface to breathe, it

* Proceedings of the Royal Society, March 18, 1847.

† Histoire des Crustacés, tom. iii. p. 555 *et seq.*

‡ On the Influence of Physical Agents on Life, *passim*.

was found that they died in from 12 to 32 minutes, when its temperature was 90° ; in from 35 to 90 minutes, when its temperature was 72° ; in from 350 to 375 minutes, when its temperature was 50° ; and from 367 to 498 minutes, when it was cooled down to the freezing-point. The prolongation of life at the lower temperatures was not due to torpidity, for the animals performed the functions of voluntary motion and enjoyed the use of their senses; but it was occasioned by the diminished activity of *all* their functions, and their consequent less demand for air. On the other hand, the elevation of temperature increases the demand for air, and occasions speedier death when it is withheld, chiefly by producing a vast acceleration in the rate at which all the operations, both of animal and organic life, take place.

6. Although the warm-blooded animals are in great degree removed, by the independent calorifying power which they possess, from the influence of external temperature, yet it is very easily shown that their vital activity is no less under the direct and immediate influence of heat, than is that of cold-blooded animals. In fact, it would seem to be for the sake of keeping up their vital energy to a certain high and uniform rate, that they are endowed with the heat-generating power; and if this power be not exercised, and the body be cooled down, its vital activity is reduced, and at last extinguished. From the experiments of CHOSSAT* it appears that Birds and Mammals cannot (except in the case of the hibernating species) be cooled down more than 30° below their natural standard, without the entire suspension of their animal and organic functions. This depression of temperature consequent upon prolonged starvation, was found to take place as soon as all the fat and other disposable materials in the body had been burned off. But so soon as animals thus reduced to a moribund condition were subjected to external heat, which artificially raised the temperature of their bodies, their sensibility and muscular power were renewed; they flew about the room, and took food when it was presented to them; and their secretions were restored. If this artificial assistance was prolonged, until the digested aliment was prepared in sufficient amount to maintain the combustive process, they recovered; but if it was withdrawn too soon, they died.—The hibernating species of Mammalia differ from the rest essentially in this, that the lowering of the temperature of their bodies does not destroy their vitality, but merely suspends their activity, so that they are reduced for a time to a condition in all respects comparable to that of cold-blooded animals but little removed above absolute torpidity; and in this condition, all that has been said respecting the influence of external temperature upon the rate of life of cold-blooded animals, applies to them also.

The vast mass of facts, of which the foregoing are examples, appears to the author to justify the conclusion, that Heat is something more than a *stimulus* capable of arousing a dormant vital force; but, on the other hand, they by no means justify the assumption that heat and the “vital principle” are identical. That Heat, acting upon or through an Organized structure, then manifests itself as Vital force,—or that heat

* Expériences sur l’Inanition.

and vital force are “correlated,”—seems to be the expression of their mutual dependence, which is most in accordance with all our knowledge of the influence of heat upon organized beings; whilst conversely (as will be shown hereafter) it accords with the fact of the restoration to the inorganic world—under some form or other—of all the *force* thus withdrawn from it.

It may serve, however, to bring this idea into contrast with the notions usually entertained, and to illustrate its application more fully, if it be considered in its relation to the Development of any highly organized being from its primordial germ-cell. According to the doctrine current among some physiologists, the whole “organizing force,” “*nisus formativus*,” or “*bildungstrieb*,” which is to be exerted in the development of the complete structure, *lies dormant in this single cell*, the germ (it has been affirmed) being “potentially” the entire organism. And thus all the organizing force required to build up an oak or a palm, an elephant or a whale, is concentrated in a minute particle only discernible by microscopic aid.

As a refuge from this doctrine, which seems almost too absurd ever to have gained believers, other physiologists (among whom the author formerly ranked himself) have affirmed that *vital force must exist in a dormant condition in all matter capable of becoming organized*; that the germ-cell, in drawing to itself organizable materials, and in incorporating these into the living structure, does nothing else than evoke into activity their latent powers; and thus that, with every act of growth and cell-multiplication, new vital force is called into operation, whereby the process is continually maintained. This proposition, it may be safely asserted, does not involve any manifest absurdity. It attributes to oxygen, hydrogen, carbon, and nitrogen, properties which they were not previously supposed to possess; but no one could logically deny to these elements the possession of dormant vital powers, whilst they held that a dormant magnetic power might be attributed to iron. In the one case, as in the other (it may be affirmed), a certain combination of conditions is needed to call the property into exercise; and the living cell, combining the elementary substances into the pabulum of its growth, and then applying this to its own nutrition, calls their latent vital properties into activity,—just as (it has been argued) an electric current, made to circulate around a piece of iron, develops the latent magnetic force of that metal.

The views of Prof. GROVE, however, strike at the root of the notion of *latent force* of any description whatever; all force once generated being, in his estimation, perpetually *active* under one form or other; and its supposed “latency” being a hypothetical condition, the idea of which is quite unnecessary when the force which has ceased to manifest itself is recognized under some other form. Thus, in his view, when iron is rendered magnetic by an electric current, the development of the magnetic force is rather to be looked on as the result of the conversion of the electric, by the instrumentality of the iron, than as a case of the excitation of one force previously

dormant, by another which is expended in thus evoking it. Such an analogy should rather lead the physiologist to look for some extraneous source of the organizing force; and to suspect that when organizable materials are applied to the extension of a living structure, and are caused to manifest vital forces, *some agency external to the organism is the moving spring of the whole series of operations*. And thus, according to the view here advocated, the vital force which causes the primordial cell of the germ first to multiply itself, and then to develop itself into a complex and extensive organism, was not either originally locked up in that single cell, nor was it latent in the materials which are progressively assimilated by itself and its descendants; but is directly and immediately supplied by the Heat which is constantly operating upon it, and which is transformed into vital force by its passage through the organized fabric that manifests it. The facts already cited, which show how completely dependent the process of germ-development, both in plants and animals, is upon the constant agency of heat, and how precisely its rate may be regulated by the measure of that force supplied to it, appear to the author to be so much better accounted for upon this view than upon either of the others, that he ventures to think that they demonstrate it almost as fully as the nature of physiological evidence will admit.

Having thus contrasted the doctrine for which he is contending, with those which are current among physiologists, the author thinks it well to point out that he no more regards heat as the "vital principle," or as itself identical with the "vital force," than it is identical with electricity or with chemical affinity. Nor does he in the least recognize the possibility, that any action of heat upon the inorganic elements can of itself develop an organized structure of even the simplest kind. The pre-existence of a living organism, through which *alone* can heat be converted into vital force, is as necessary upon this theory, as it is upon any of those currently received amongst physiologists. And it is the *speciality* of the material substratum thus furnishing the medium or instrument of the metamorphosis, which in his opinion establishes, and must ever maintain, a well-marked boundary-line between the Physical and the Vital forces. Starting with the abstract notion of Force, as emanating at once from the Divine Will, we might say that this force, operating through inorganic matter, manifests itself in electricity, magnetism, light, heat, chemical affinity, and mechanical motion; but that, when directed through organized structures, it effects the operations of growth, development, chemico-vital transformation, and the like; and is further metamorphosed, through the instrumentality of the structures thus generated, into nervous agency and muscular power. If we *only* knew of heat as it acts upon the organized creation, the peculiarities of its operation upon inorganic matters would seem as strange to the physiologist, as the effects here attributed to it may appear to those who are only accustomed to contemplate the physical phenomena to which it gives rise.

The variety of organic forms called forth by the agency of heat, which may be regarded as the products of its operation upon living germs, does not present any

real obstacle to the reception of this doctrine; since in *any* hypothesis which assumes a common force as operative in the living kingdoms of nature, it is necessary to admit that this force is modified in its action by the properties of the germ, just as that the general force of chemical affinity manifests itself differently in the reactions of each elementary and composite substance. And just as the chemist seeks to determine the laws of chemical affinity by observation and experiment, so does the philosophic physiologist aim to discover the general plan on which the vital force is exerted, in the production of the wonderful series of organized structures which have successively presented themselves on this globe.

In speaking of Heat as the physical agent especially concerned in the development of living organisms, and in the maintenance of their activity, the author would by no means leave out of view the other physical forces, *all* of which, if correlated to each other, as well as to the vital forces, must be capable of exerting an important influence on these processes. He has merely selected Heat, as the one whose operation is most extensive and most easily demonstrated; and every fact which indicates that other physical agencies are also in operation, will (of course) only add weight to his argument. To the universally-admitted agency of *Light*, in directly exciting one (at least) of the most important processes of vegetable growth, reference has already been made. But there is evidence that light has an influence upon certain processes of *development*, which cannot be accounted for by its agency in the fixation of carbon from the atmosphere, and in the production of organic compounds. One of the most remarkable examples of this agency is furnished by the experiments of MIRBEL upon the *gemmæ* of *Marchantia polymorpha*. He found, after repeated trials, that during the development of these little discs, stomata are formed on the side exposed to the light, whilst root-fibres grow from the lower surface; and that it is a matter of indifference *which* side of the disc is at first turned upwards, since each has the power of developing stomata, or roots, according to the influence it receives*. The experiments of Dr. W. F. EDWARDS indicate that a decided influence is exerted by light upon the metamorphosis of the Batrachia; since, according to his statements, when tadpoles, *arrived at nearly their full growth*, were secluded from the influence of light, but were supplied with aërated water and food, *they continued to increase as tadpoles* (so as to attain an extraordinary size, doubling or even trebling their usual full weight) without undergoing any metamorphosis †. The influence of light upon the

* Nouvelles Annales du Muséum, tom. i.

† On the Influence of Physical Agents on Life, p. 53.—The results of the recent experiments of Mr. HIGGINBOTTOM appear to negative those obtained by Dr. EDWARDS, and to show that metamorphosis is only retarded by privation of light, when accompanied by reduction of temperature. But the remarkable fact above quoted from Dr. EDWARDS's statements, to which Mr. HIGGINBOTTOM has recorded nothing parallel, shows that there was some difference in the conditions of the two sets of experiments, which should prevent us from setting aside those statements, made (as they are) by a most trustworthy observer, until they shall have been more fully disproved.

minute Entomostracous Crustacea is well known. Their development is greatly retarded by the want of it; and the exuviation of their shells, which normally takes place at short intervals when they have attained their complete form and size (apparently for the purpose of freeing them from the minute plants with which their surface becomes clothed), is much less frequently performed*. With these facts before us, we can scarcely refrain from suspecting that the deprivation of light may be the cause of the atrophy of the visual organs in certain animals which pass their whole lives in complete seclusion from its influence. This condition, which has been long known to exist in the common Mole, and also in the *Proteus anguineus*, and which has also been discovered in the *Amblyopsis spelæus*, a fish inhabiting the waters of the Great Cave of Kentucky, has recently been detected in a considerable number of species of Insects discovered in the very caverns of the Tyrol whose waters afford a *habitat* to the *Proteus*†. It may be supposed that the non-development of eyes in all these animals is a part of their original constitution, and is to be looked upon as an example of the adaptation of their organisms to the peculiar conditions of their existence; and such a view cannot at present be positively disproved. But the actual dependence of the nutrition of the visual organs, or (at least) of the nervous apparatus which forms the essential part of them, upon the continued agency of light, appears from the well-known fact, that if, by the complete opacity of the cornea, light is entirely prevented from entering the eye, the retina and the optic nerve become atrophied, and in time altogether lose their characteristic structure; thus clearly indicating the direct influence of light in keeping up those nutritive actions, by which the integrity of that structure is normally maintained.

That *Electricity*, also, has an important influence on the operations concerned in the development and maintenance of organized structures, can scarcely be doubted by any one who duly considers the proofs of the disturbance of the electric equilibrium in those parts of vegetable as well as animal bodies which are in a state of greatest functional activity, afforded by the observations and experiments of Prof. MATTEUCCI and others. At present, however, it would be premature to make any positive statement as to its *modus operandi*; although it would certainly appear most probable that it is more directly related to the chemico-vital changes of composition which take place in the living body, than to the operations of cell-growth, multiplication, and development, properly so called.

If the views advocated in this communication be correct, it follows that not merely are the *materials*, withdrawn from the inorganic world by vital agencies, given back to it again by the disintegration of the living structures of which they have formed

* See Dr. BAIRD'S "Natural History of the Entomostracous Crustacea" (published by the Ray Society), p. 192.

† Specimen *Faunæ Subterraneæ*, Bidrag til den underjordiske Fauna, ved J. C. SCHJÖDTE: Kjöbenhavn, 1849.

a part, but all the *forces*, which are operative in producing the phenomena of life, are in the first place derived from the inorganic universe, and are finally restored to it again. The author thinks it not difficult to show that such is actually the case; the very same antagonism existing, in respect to the relation of the Vegetable and Animal kingdoms respectively, to the *forces* of the universe, as exists in regard to their *material components*. Plants, it will be recollected, form those organic compounds at the expense of which animal life (as well as their own) is sustained, by the decomposition of carbonic acid, water, and ammonia; and the *light*, by whose agency alone these compounds can be generated, may be considered as metamorphosed into the *chemico-vital affinity* by which their components are held together. The *heat* which plants receive, acting through their organized structures as *vital force*, serves to augment these structures to an almost unlimited extent, and thus to supply new instruments for the agency of light and for the production of organic compounds. The whole *nisus* of vegetable life may be considered as manifested in this production; and in effecting it, each organism is not only drawing *material*, but *force*, from the universe around it. Supposing that no animals existed to consume these organic compounds, they would be all restored to the inorganic condition by spontaneous decay, which would reproduce carbonic acid, water, and ammonia, from which they were generated. In this decay, however slow, the same amount of Heat would be given off, as in more rapid processes of combustion; and the faint luminosity which has been perceived in some vegetable substances in a state of *eremacausis*, makes it probable that the same is true of Light. And though the process of decay may be prevented or modified, so that the whole or a part of the materials of vegetable structures are disposed of in other ways, yet whenever they return to the condition from which they were at first withdrawn, they not only give back to the inorganic world the materials out of which they were formed, but the light and heat to which their production was due. Thus in making use of the stores of Coal which have been prepared for his wants by the luxuriant flora of past ages, man is not only restoring to the atmosphere the carbonic acid, the water, and the ammonia which it must have contained in the carboniferous period, but is artificially reproducing the Light and Heat which were then expended in the operations of vegetable growth. That the relative proportion of the light and heat thus restored, should be the same as that which they originally bore to each other, is by no means necessary; since each (according to Prof. GROVE's views) is convertible into the other*. In the few cases in which *motion* is affected by the vital force of plants, this may be considered as restoring to the inorganic universe a certain measure of the force which they have derived from it, in the form of light and heat.

But the organic compounds which the agency of Light and Heat upon the Vege-

* [In the second edition of his Essay on the "Correlation of the Physical Forces," just published, Prof. GROVE advances the opinion (p. 59) that when Light is "absorbed" (to use the ordinary phraseology), that is, when it ceases to manifest itself as light, it is usually converted into Heat.—Nov. 20, 1850.]

table structures has produced, are destined for a much higher purpose than that of being merely given back to the inorganic universe by *eremacausis* or combustion. In serving as the food of Animals, they not merely become the materials of their structures, but are rendered subservient to the production of the nervous and muscular forces. The animal, like the plant, receives *heat* from external sources ; and this is expended, in the form of vital force, not merely in the building-up of the organism from its germ, but also in its subsequent maintenance. For, as was first definitely stated by Prof. LIEBIG, the vital force, which is applied in Plants to the extension of the structure, is appropriated in Animals to the development of muscular and nervous power ; and this development, depending as it does upon a continual disintegration of the tissues which are its instruments, requires as continual a reconstruction of them. The organizing force required for this reconstruction or maintenance, appears, like that employed in the original operations of development, to be supplied by Heat ; and it is a confirmation of this view, that we should find a provision (in those classes of animals which are constructed for the greatest development of nervo-muscular power) for the maintenance of a constantly high temperature, by the combustion of a portion of the organic compounds supplied to them as food.—Of the amount of *light* which is appropriated by Animals, we have no means of forming an estimate ; but from the limited nature of its action on their economy, it probably bears an insignificant proportion to that which is applied to the purposes of vegetable nutrition. Thus, then, the forces on which the animal is essentially dependent, are the *affinities* which hold together the elements of its food, and which are embodiments (so to speak) of the light and heat by whose agency they were combined ; the *heat*, which it derives in part from the physical universe, and in part from the combustion of some of its alimentary materials ; and the small amount of *light* required by them, which is supplied from external sources alone. These forces may be considered as in a state of *continual restoration* during the whole life of animals, in the heat, light, and electricity, and still more in the motion, which they develop ; and, after their death, in the production of heat and light during the processes of decay. During animal life there is a continual restoration to the inorganic world of carbonic acid, water, and ammonia ; and the amount thus given up by the animal organism bears an exact proportion, on the one hand, to the amount of heat and motion which are generated by it, and on the other to the amount of organic compounds consumed as food. So that, on the whole there is strong reason to believe that *the entire amount of force of all kinds* (as of materials) *received by an animal during a given period, is given back by it during that period*, his condition at the end of the term being the same as at the beginning. And all that has been expended in the building up of the organism, is given back by its decay after death.

In bringing this communication to a close, the author would remark, that he has not sought in it to increase the knowledge of existing *facts*, so much as to develop new

relations between those already known. He has preferred, in fact, rather to build upon the foundation afforded by the generally admitted facts of Physiological science*, than to go in search of phenomena, his account of which might be questioned by those indisposed to admit his leading ideas. If those ideas be correct, they will be found, he believes, to afford a precision to Physiological doctrines which they have never before possessed; and to open out a vast number of new lines of inquiry, which promise an ample harvest of results, not only valuable in a scientific view, but likely to be fertile in applications to various departments of the therapeutic art. At any rate, it is very important that Physiological science should be considered under the same *dynamic* aspect, as that under which the Physical sciences are now viewed by the most enlightened philosophers; and he trusts that the present attempt may thus aid in its advancement, even if it should answer no higher purpose.

Supplementary Note.—[Since the foregoing paper was written, the author's attention has been drawn to the fact, that Mr. NEWPORT had been led, in the year 1845—“by the close relation shown by Dr. FARADAY to subsist between light and electricity, and by MATTEUCCI between electricity and nervous power, and by the known dependence of most of the functions of the body on the latter,”—“to consider light as the primary source of all vital and instinctive power, the degrees and variations of which, he suggested, may, perhaps, be referred to modifications of this influence on the special organization of each animal body.” (See “Athenæum” for Dec. 6, 1845.) These views were embodied in a paper “On the Natural History of *Meloë*,” presented to the Linnæan Society, and printed in the 20th volume of its Transactions. But as the passages in which they had been enunciated were omitted by the desire of the Council of that Society, no other public record of them exists than that just cited.—Nov. 20, 1850.]

* [To his mode of stating some of these facts, the author is aware that exceptions may be taken; but he trusts that it may be perceived that his argument is a *cumulative* one, and that his conclusions rest upon a large number of *independent* probabilities. Consequently, even if *some* of his data should be found questionable, it does not follow that the validity of his general doctrine is disproved.—Nov. 20, 1850.]

XXXVII. *On the Condition of certain Elements at the moment of Chemical Change.*By BENJAMIN COLLINS BRODIE, *Esq.*, *F.R.S.*

Received June 6,—Read June 20, 1850.

THE experimental inquiry which I now lay before the Society is so intimately connected with certain theoretical considerations, in which it took its rise, and which are necessary to its right comprehension, that I am unwilling to separate them. These considerations alone can explain why it appeared to me desirable to devote much time and labour to the determination of a simple analytical problem, which it has been open for the last thirty years to any chemist to undertake, but which, although doubtless connected with some of the most curious and obscure phenomena of chemical science, no one has thought it worth his while to enter upon. The reason of this may have been, that from other points of view this inquiry seemed of little importance, or, which is also probable, the question may have been, at various times, partially investigated, and the answer to it thought to be other than what it truly is, because approached from a wrong side. I shall therefore lay before the Society theory as well as experiment; for the theory is necessary to render the experiment intelligible, although this latter, in so far as it is true, has an independent value, and may be explained by others in some totally different manner.

The difference which chemists draw between the chemical elements and all other bodies, is far greater and indeed of altogether another kind to that which exists between any two compound substances. Other bodies are composed and decomposed; but applied to the elements, these words are altogether inappropriate; when the element is formed there is no chemical synthesis, and when it passes from the free to the combined state, there is no chemical decomposition. This difference the atomic theory expresses by assigning to the two classes of bodies a different molecular constitution. The element it considers as consisting of single and isolated atoms, and all other bodies as systems more or less complex of combined particles. This fundamental difference of conception is well given in the following passage from BERZELIUS* :—“ Les atomes d'un même corps élémentaire ne possèdent aucune force de combinaison mutuelle; ils n'adhèrent ensemble qu'en vertu de la force d'agrégation. Plus deux corps élémentaires se ressemblent quant à leurs propriétés chimiques, moins ils tendent à s'unir, et le nouveau corps qui résulte de leur combinaison, a tant d'analogies avec ses éléments constituants, qu'il diffère peu d'un mélange mécanique. Plus, au contraire, les corps élémentaires diffèrent de propriétés chimiques, plus la

* BERZELIUS, *Traité de Chimie*, Paris, 1845, vol. i. p. 25.

force de combinaison qu'ils exercent les uns sur les autres est grande et plus aussi les propriétés de leurs composés diffèrent de celles de leurs éléments. C'est là un problème dont je ne pourrais entreprendre la solution qu'en traitant de l'influence de l'électricité sur la matière."

This view, although the received doctrine, has not passed quite unquestioned. AMPÈRE invented a molecular theory, which led him to conclusions inconsistent with it. For reasons not of a chemical nature only, but which had reference principally to the propagation of light and sound and to other physical phenomena, he had arrived at the idea that in every chemical substance there were what may be called three forms of matter, the indivisible atom, the molecule or system of atoms, and the particle or system of molecules. He conceived, moreover, that every gas contained in the same space an equal number of these molecules. From this it was a necessary inference, that in that contraction which takes place when oxygen and hydrogen combine to form water, a division must take place of the elemental molecule. He considered that the oxygen divided, half a molecule of oxygen combining with each molecule of hydrogen*. On this view therefore the atoms, even of the elements, formed what was in a certain sense a compound group. The discovery of isomeric forms of hydrocarbon in different states of condensation, and of other similar facts, gave rise to new ideas as to the possible differences of bodies, and explanations similar to that by which the differences between certain isomeric organic bodies have been accounted for came to be applied to the case of the elemental bodies themselves. Thus the allotropy of sulphur has been explained by assuming it, in its various forms, to be the same substance in different states of condensation, in which case the difference between these forms might be expressed by giving to them the different chemical formulæ of S, S₂, S₃. Those physical relations however of density and specific heat, which might give a true scientific value to such speculations, and prove that these substances were really thus connected, have not yet been made out to exist; nor indeed has any fact been discovered which places such a notion beyond a conjecture. GRAHAM again, to explain the mode in which the metals conduct electricity in the voltaic circuit, assigns to these bodies what he terms a sali-molecular structure, and regards them as consisting of two atoms of a chlorous or acid combined with one atom of a zincous or basile element, "the three atoms of the molecule being of one metal and of the same nature†." The latest work in this direction is a paper of M. LAURENT, in which he has attempted, among other things, to account for the differences in the different classes of salts of the same metal in which, hitherto, different oxides of a different degree of saturation have been supposed to exist, by assuming them to contain different molecules or atomic groups of the metal; and he has shown how, on this idea, our classification of chemical substances may be much simplified; on this

* Annales de Chimie, vol. lviii. p. 434. See also GERHARDT, Comptes Rendus des Travaux de Chimie, 1847, p. 90, note.

† See GRAHAM'S Chemistry, Ed. 1842, pp. 226 and 541.

view it is necessary to suppose that the present elemental atoms are susceptible of a yet further division*.

These ideas, however philosophical and suggestive, are yet, it must be allowed, very hypothetical. The proof of the compound nature of a chemical substance is of a very simple kind. It lies in the fact, that it has been made by the composition of certain parts, or broken up into those parts, or at least in some phenomena which are supposed to be the evidence of this. Indeed the rational formula of a chemical substance is but a memorandum of its reactions, and a particular mode of expressing the law of the synthesis and analysis of the body, apart from which it has but little meaning. The true nature therefore and chemical formula of the elemental bodies, as of all other substances, is to be discovered by the study of the series of chemical changes in which they are formed, and by the phenomena which they present when they pass into the combined condition. There are even well-known facts of great importance in this point of view, some unexplained, and some, I conceive, misinterpreted.

The point which I shall seek to establish is this,—that at the moment of chemical change a chemical difference exists between the particles of which certain elemental bodies consist, perfectly the same in kind to that which exists between the particles of compound substances under similar circumstances, and on which the phenomena of combination and decomposition depend. That a peculiar chemical relation exists between two particles which combine, is generally admitted and expressed by the term affinity. The electro-chemical theory has defined more exactly in what this affinity consists, and states that the two particles are to one another in a positive and negative electric relation. But I do not know that it has ever been pointed out that this chemical relation—this affinity between the particles of a substance—is an essential condition of the decomposition as well as of the composition of the body. As I am about to infer a chemical difference between the particles of the element from the fact of their chemical separation, I must say a few words upon this point, and I shall simplify the whole question by stating briefly the mode in which I consider chemical change to be effected. I may do this sufficiently for my present purpose in the following propositions:—

1. That when two particles chemically combine, a certain chemical relation exists between them which is expressed by the terms positive and negative. The chemical difference of the particles I term the difference between their conditions in this respect.

2. That when chemical combination takes place between the particles of which any two or more substances consist, a chemical difference exists between the particles of each substance, so that the particles of the same substance are to one another in a positive and negative relation.

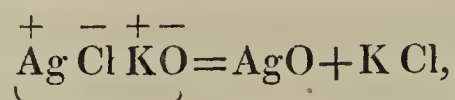
3. That the chemical relation between any two particles of these substances is

* Comptes Rendus des Travaux de Chimie, August 1849.

determined by the chemical relation of all the other particles with which they are for the time being associated. Substances, the particles of which are to one another in this peculiar chemical relation, I term chemically polar.

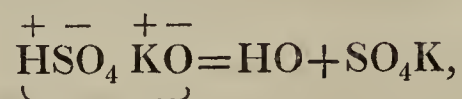
The electro-chemical theory was developed before even the true laws of the propagation of electricity had been discovered, and in the above propositions I have but transferred to chemical change some of the more exact ideas as to the nature of electric action which have since arisen; and we may transfer the ideas and mode of thought without making any hypothesis as to the mutual relation of the phenomena. This is not the place to enter fully on this question, and I shall confine myself to the application of these principles to explain certain phenomena of change in compound substances, to which I shall presently show the parallel in the case of the element. These phenomena are those which go under the name of the "phenomena of the nascent state."

Silver cannot be oxidized by the direct action of oxygen on the metal, but oxide of silver is readily formed by boiling the chloride of this metal with potash. The particles of oxygen and silver have therefore acquired by this association with the chlorine and potassium a chemical relation or affinity which at other times they have not. This is the fact. The rational conception of the fact is given in the expression



in which I have indicated the polar relation of the substances. The chemical relation therefore between the oxygen and silver is essentially dependent on the chemical relation between the oxygen and potassium, in the same way as a negative and positive electricity are related to each other. The same is true of the relation between any other two particles of the system. Hence chemical decomposition is an essential condition of chemical combination; so that when we see one of these events we may infer the other.

On the other hand, where this polar division of the substance cannot take place, there is no chemical action, or at any rate it takes place with greater difficulty; thus anhydrous sulphuric acid may (as has been shown by MILLON) be distilled off carbonate of potash without alteration, and generally the so-called anhydrous acids have none of the combining properties of the hydrates to which they correspond. The reason of this being, that when these bodies combine they do not decompose, and that it is by the very fact alone of the decomposition of the substance that the combining power is developed in the particles of which they consist, so that in the chemical change which is thus represented—

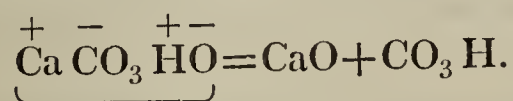


the two combinations which take place are not two combinations accidentally simul-

taneous, but correlative and mutually dependent phenomena which we cannot separate.

In the case of double decomposition, each of the four substances which enter into the change is combined, but it does not appear that this state of combination is necessary to the action. It can take place also, and in the same manner, when the combining substances are only in contact with each other, and not in combination, provided always that there is the right chemical difference between them, which however is essential. Thus, for example, when iodine and phosphorus decompose water (in the usual mode of the formation of hydriodic acid), the chemical relation between the iodine and phosphorus is an essential condition of the action. The same remark applies to the decomposition of water between nitric oxide and chlorine, which can be effected by neither body separately; so that the changes which take place in these experiments are not simply due to the fact that the chlorine or iodine stand in one relation to water, or to the elements of water, and the nitric oxide or phosphorus in another, and that thus the water breaks up, being acted upon by two opposite forces; but that there is also, and must be, a certain chemical difference between the chlorine and nitric oxide and between the iodine and phosphorus, which is as essential and important a condition to the propagation of the action as their relation to the water itself, and indeed without which they could not have this relation. I am not aware that this remark has before been made, nor do I think it likely that it should have been made, but upon the view which I have given, of which it is a consequence.

Facts corresponding to these cases of composition are to be observed, as might be expected, in the decomposition of bodies, for if decomposition be the condition of combination, so of course must combination be the condition of decomposition. FARADAY long since showed that dry carbonate of lime withstands the highest temperatures and is not to be decomposed by heat, but that when a little steam is thrown upon the heated carbonate, decomposition takes place with facility. Why is this? but that the water is the medium for the transference of the polar action which can now take place with the division of the masses: thus—

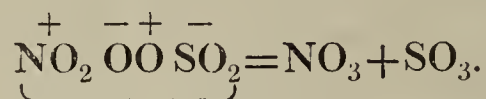


I might mention many other examples of the same class.

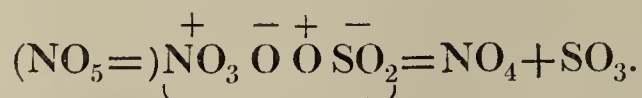
On the view which I have here given of the nature of chemical change, the very existence of the elemental bodies was a strange and unaccountable anomaly. I have regarded the molecular structure of bodies but as an expression of the law of their synthesis and analysis, and this law again as a result of the peculiar nature of chemical force. It was therefore truly difficult to conceive how an element in the sense of BERZELIUS was formed. The formation of this “uncombined particle” was a fact quite different to the formation of a compound substance, and yet it seemed as unreasonable to suppose that the laws of chemical action should vary in different

materials, as that the laws of motion should be different in different bodies. I therefore considered attentively what we really knew of the laws of chemical change in these bodies. Examples occurred to me, both of the chemical division and chemical synthesis of the elements, by which various phenomena hitherto obscure might be explained. The experiments of the first class prove that a division of the elemental bodies which is known to occur in certain cases of chemical change, is truly a chemical and not simply a mechanical division of these substances. This is shown by the fact that the particles of the element thus separated show the peculiar combining properties of "nascent bodies." It is not necessary to my argument that the precise view which I have given of the nature of this "nascent state" should be admitted; provided only it be allowed, that these properties depend upon the fact that the particle is issuing from a state of combination, which is generally allowed.

1. No theory of chemical change has given rise to more discussion among chemists, than the usual mode of the formation of sulphuric acid by the mutual action of sulphurous acid, nitric oxide, air and water. On this question there are some six recognized theories. The problem is simply this: Why, when the oxygen is made a part of this system of particles, does it possess oxidizing properties which otherwise it has not? On the view I have stated the cause is plain. When nitric oxide acts chemically upon oxygen, the gas is thrown into a polar condition; the result of which is to give to other particles of the mass a combining power, in a direction the reverse of that in which the oxygen combines with the nitric oxide; the change being in all respects analogous to the decomposition of water by the joint action of nitric oxide and chlorine*; thus—



The best of the other explanations of this fact is, in my opinion, that of PÉLIGOT†, who considers the formation of the sulphuric acid to be the result of the successive formation and decomposition of nitric acid. This, however, does but shift the difficulty to another point; for why does nitric acid oxidize sulphurous acid? In truth, in this case, a perfectly similar polarization takes place within the acid itself—

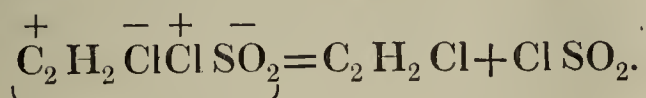


* In the following experiments I am compelled to call by the same name three very different things—the isolated element, the particles of the element at the moment of their chemical separation or synthesis, and the combined element; and I wish to observe, that when I state that there is a chemical difference between the particles of the element, I mean simply the particles of which the element consists. The chemical nature of these particles is a further question.

† Annales de Chimie, 3rd Series, vol. xii. p. 266. PÉLIGOT states that nitric oxide always forms hyponitric acid and no nitrous acid, in contact with atmospheric air; but it by no means follows, even if this be the substance formed with atmospheric air alone, that the same substance is formed in the presence of sulphurous acid; indeed, on the view I have given, a difference in the reaction would rather be anticipated.

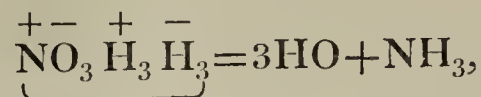
For the formation of the hyponitric acid from the nitric acid is just as much the formation of a new chemical substance as if it were made by the direct action of oxygen upon nitric oxide, and is attended with a similar division of the oxygen. But this stage of the formation of nitric acid is useless, and not necessary to the conception of the change; for there are other perfectly parallel cases which do not admit of such an explanation.

2. I will take the formation of chloro-sulphuric acid, in the remarkable experiment by which REGNAULT prepared this body*. Olefiant gas, as usually prepared from alcohol and sulphuric acid, contains a large quantity of sulphurous acid; when chlorine is brought in contact with this mixture of gases, two substances are formed, chloro-sulphuric acid, SO_2Cl , and the Dutchman's liquid, $\text{C}_4\text{H}_4\text{Cl}_2$. Upon sulphurous acid alone (in the circumstances under which the experiment is made) chlorine has no action whatever, nor, according to REGNAULT, upon olefiant gas, when both gases are dry, and only in diffused daylight. The formation, therefore, of this body is due to the polar division of the chlorine, just as the formation of sulphuric acid to the polar division of the oxygen; the olefiant gas being to the chlorine in the same relation as the nitric oxide to the oxygen in the other experiments, so that we may conceive the change to take place thus—



This example is not open to those objections which, from the formation of the oxides of nitrogen, might be raised to the other instance, for here the combinations mutually determine each other. With water, the chloro-sulphuric acid decomposes with the formation of sulphuric and hydrochloric acids; but through this experiment we can distinctly trace back the cause of the formation of the sulphuric acid, in this, as in the more usual mode of its formation, to the polarization of the element; and on considering attentively the mode of the formation of chemical substances, it may be seen that the formation of a large class of compounds, among which are the oxides of chlorine and iodine, is ever preceded by a similar fact.

3. It is well known that when a mixture of hydrogen and any oxide of nitrogen † is passed over heated spongy platinum, the oxide of nitrogen is decomposed and ammonia and water formed. Were the hydrogen a compound substance, it would be thought that the simultaneous formation of these substances was sufficiently explained, by saying that it was a case of double decomposition, and it is indeed the same phenomenon; thus—

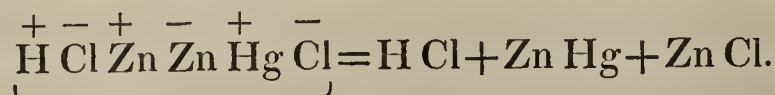


the hydrogen being “nascent” from itself.

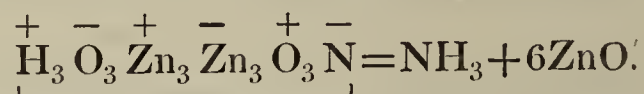
* Annales de Chimie, 2nd Series, lxi. p. 170, and lxxi. p. 445.

† See KUHLMANN, LIEBIG'S Annalen, vol. xxix. p. 286.

4. We know from the researches of H. ROSE, that in a neutral solution of the bichloride of mercury, the mercury is precipitated on zinc in the form of a black powder, but on the addition of an acid the metal becomes bright and the zinc is amalgamated*. The addition of bichloride of mercury also instantly stops the most violent evolution of hydrogen from the action of hydrochloric acid upon zinc, with the formation of the same amalgam. These curious experiments, which certainly caused much surprise in ROSE, become intelligible from the considerations which I have mentioned. The combination of zinc with mercury is a combination in a different direction to that of the zinc with chlorine, hence the latter determines and causes the first; thus—



5. A very beautiful illustration of the way in which one chemical combination determines another, is seen in another experiment with the same metal. Zinc, it is known, decomposes slowly, with evolution of hydrogen, a strong and boiling solution of caustic potash; but when into the solution a few crystals of nitre or nitrite of potash are thrown, the zinc is rapidly dissolved with the evolution of ammonia. The reason of this I consider to be, that the polar division of the zinc now takes place with the greatest facility, the zinc being oxidized in two directions; the zinc decomposes the water, by which a polarity is given to the hydrogen, which causes it to combine with the nitrogen of the nitric acid to form ammonia, by which combination the other particles of the nitric acid become in their turn polar and oxidize again the zinc; the action, as it were, proceeding from and returning back again to that element. The change, for example, may be represented thus:—



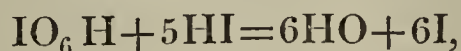
6. To the preceding experiments I will only add the phenomena of substitution, which, viewed in relation to them, assume a new form. The division of the chlorine which takes place in substitution is a very similar fact to that distribution of the element which takes place in the formation of chloro-sulphuric acid (which I have before cited), and admits of a similar explanation. The problem is, why, with even the smallest quantity of chlorine, does a portion of the chlorine ever combine with the organic body? Why is the hydrogen never simply removed? The solution is, that one of these two changes determines the other, precisely as the combination with olefiant gas determines the combination with sulphurous acid. Nor do I see what intelligible distinction is to be drawn between the action of chlorine on the organic body and that of hydrogen on nitric oxide, or between either of these two cases and that of water itself on chloro-sulphuric acid. The organic body behaves as though it were a simple compound of hydrogen on the one hand, and the remaining ele-

* LIEBIG'S Annalen, vol. lxiv. 283.

ments of the system on the other, and this, during the action and under the influence of the chlorine, it may truly be.

If it be true that in the preceding experiments this polar division of the element takes place, (a division, at any rate, in many points analogous to the decomposition of the compound body when no elemental substance is isolated, but the particles are transferred from one system to another,) it cannot but be, that in the *formation* of the element the correlative fact is to be observed, and that the element itself is made by the synthesis of polar particles. This is indicated by theory, and although the more usual mode of forming these elemental bodies is not such as to bring to light the true nature of this synthesis, there are other, although as yet rarer, instances of the formation of these bodies, which not only are not opposed to this view, but prove it.

1. When an acid is added to a perfectly pure solution of an alkaline iodide, such as may readily be procured by precipitating any iodate it contains by baryta water and filtering, the solution remains perfectly clear. Neither, when an acid is added to a pure solution of iodate of potash, is there any alteration, but on mixing these solutions an abundant precipitate of iodine is formed. It is said that the iodate and iodide of zinc, without acid, undergo a similar decomposition. It is very plain that these changes are simple cases of what is called double decomposition. The hydriodic and iodic acids decompose one another, and it is my opinion that in the change



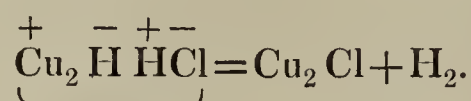
whatever be that combining relation which subsists between the oxygen and hydrogen, that same relation must also be between the particles of the iodine itself. What is commonly called the affinity of hydrogen for oxygen is not sufficient to account for this change, for hydrogen alone will not decompose the iodic acid, unless it be in the nascent condition. When hydrochloric acid is the decomposing body, chloride of iodine is formed, when hydriodic acid, the iodine itself. Are we not to admit that these two substances are formed according to the same law? To this synthesis of the iodine, the division of the element which takes place at the formation of the hydriodic and iodic acids, is the correlative fact, to explain which we must assume the same polar difference between its particles (see page 765).

2. In the course of his researches on the hypophosphites, WURZ discovered a very singular substance, the hydruret of copper*. This substance is formed by the action of hypophosphorous acid upon copper salts. It readily decomposes, so that it is not easy to determine its constitution, but his analyses very closely corresponded with the formula Cu_2H . That this is truly the formula of the substance, may be inferred with yet more certainty than from the analyses, from the following curious reaction.

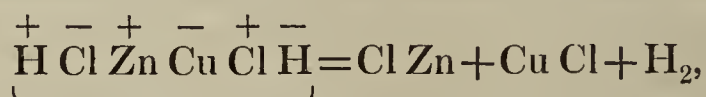
* BERZELIUS attempted to throw some doubt upon the existence of this body, but the correctness of the facts, as stated by WURZ, is guaranteed, not only by the well-known skill and ability of this chemist, but also by the fact that POGGENDORFF had succeeded in procuring a hydruret of copper by the electrolysis of the sulphate of this metal.

In contact with strong hydrochloric acid hydrogen is evolved, and the protochloride of copper, Cu_2Cl , formed. Both substances are decomposed, and WURZ satisfied himself, and gives the experiments, which show that the volume of the hydrogen evolved was the double of that due to the simple decomposition of the substance. I will add the remark which he makes on this experiment:—"On sait que l'acide chlorhydrique n'attaque le cuivre qu'avec une extrême difficulté, et la présence de l'hydrogène, loin de favoriser la réaction, devrait, d'après les lois de l'affinité, y ajouter un nouvel obstacle. La décomposition de l'hydrure de cuivre par l'acide chlorhydrique paraît donc s'effectuer en vertu d'une action de contact*."

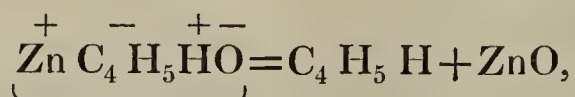
This fact, the conception of which offers these theoretical difficulties, becomes perfectly intelligible, and indeed might have been predicted from the principles I have laid down. The decomposition is perfectly similar to that of the suboxide of copper under analogous circumstances, arises from the same cause, and may be expressed thus—



This experiment enables us to see clearly the cause of a class of decompositions very analogous to it, and which have presented similar theoretical difficulties†. An alloy of platinum and silver will dissolve in nitric acid, which will not act upon the platinum alone; acids will, in like manner, dissolve the alloy of copper and zinc‡, which on the copper alone have no action. Now the hydruret of copper is itself, in its chemical relations, an alloy, and the action of the acid on the alloy of copper and zinc is a fact very analogous to the action of the hydrochloric acid upon this body, and the explanation of this fact involves similar phenomena; thus—



the polar composition of the hydrogen being essential to the comprehension of the experiment. A further confirmation of this view is found in the decomposition by water of the remarkable bodies discovered by FRANKLAND§, to which he has given the names of zinc-methyl and zinc-ethyl. The theoretical analogy of these bodies to the hydrogen compounds of the metal is perfect, and with water they give a precisely similar reaction to that of the hydruret of copper with hydrochloric acid. Zinc-ethyl, for example, breaks up thus—



in which decomposition the hydrogen and the hydrocarbon (which is the analogue of

* Annales de Chimie, 3rd Series, vol. xi. 251.

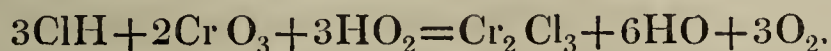
† These facts have been cited by LIEBIG with another view. LIEBIG'S Annalen, vol. xxx. p. 262.

‡ GMELIN'S Handbuch, vol. iii. p. 448.

§ Journal of the Chemical Society, January 1850.

hydrogen) are to one another in the same polar relation, and fulfill the same part in the change as the two equivalents of the hydrogen itself in the decomposition of the hydruret.

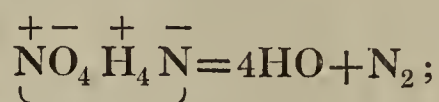
3. When a solution of bichromate of potash is poured into a strong and acid solution of the peroxide of barium in hydrochloric or nitric acid, a violent effervescence and escape of oxygen takes place; apart, these solutions are perfectly stable; bring them together, they are both decomposed; the chromic acid passes into chloride of chrome, the peroxide of hydrogen into water, and the oxygen formed is due to the simultaneous decomposition of both bodies, thus—



I certainly regard the oxygen itself, in this experiment, as the true reducing agent, and I believe that the chromic acid is decomposed by the oxygen of the peroxide of hydrogen, according to the same law of decomposition, and for the very same reason, as it would be by hydrogen itself if a piece of zinc were thrown into the acid solution, this reason being the polarity of the particle induced by chemical change. In this experiment is brought before us, in a very forcible manner, the very slight difference which truly separates the phenomena of oxidation and reduction, which are usually regarded as so distinct. In speaking of the formation of sulphuric acid, I have said that the oxidation of sulphurous acid by nitric acid is to be attributed to a polar condition of the oxygen liberated from the nitric acid, which polar condition is induced by the formation of hyponitric acid within the system of which it forms a part. Now the formation of water in the peroxide of hydrogen is a fact precisely similar to the formation of the hyponitric acid in the nitric acid, and it might reasonably be anticipated that this oxygen would have a similar oxidizing power. This is in truth the case; for when the temperature is low, the solutions dilute, and the experiment carefully managed, no gas is given off, but a deep blue solution is formed, containing perhaps, as stated by BARRESWIL*, who first examined this reaction, a higher oxide of chrome. This solution however rapidly decomposes, oxygen is evolved, the blue colour disappears, and the final result is the same as if the compound had never been formed. When manganate of potash, peroxide of manganese and various other substances are substituted for the chromate of potash in this experiment, a similar decomposition takes place, but without any signs of the intermediate stage of oxidation. Under other circumstances the oxidation and reduction may be separated. Thus, when peroxide of barium is thrown into an acid solution of the prussiate of potash, the prussiate is oxidized and the red prussiate is formed. When, on the other hand, the same experiment is made with the alkaline or neutral solution of the red prussiate, oxygen gas is given off in abundance from the peroxide of barium as well as from the red prussiate, and the latter passes into prussiate. On adding to this solution an acid solution of perchloride of iron, care being taken that

* Annales de Chimie, vol. xx. p. 364.

the whole of the peroxide of barium is decomposed, prussian blue is produced in abundance. In this experiment one atom of oxygen is first added, and this atom is then removed by the contact of another atom under suitable circumstances. I infer therefore from these experiments, not that the oxidation is a necessary antecedent to the disoxidation, but that the spontaneous decomposition of the oxidized body and the reduction of the chromic acid, where no oxidation takes place, and the oxidation of the body, are due to one and the same cause, namely, to the mutual attraction of the elemental particles. When, for example, arsenious acid is oxidized by the action of chlorine, I consider that the oxygen is oxidized as well as the arsenic. We are led to the same conclusions by various well-known experiments; in the case, for example, of the decomposition of the nitrate of ammonia on boiling, when this compound breaks up into water and nitrogen, thus—



while from no point of view is it very logical to draw a distinction between two facts so very similar as the formation of the water and the nitrogen, it is proved, by the experiments I have cited, that the mutual attraction of the particles of the nitrogen is a most important condition of the change.

The transition from these cases of spontaneous decomposition to other instances, in which no one of the substances usually called compound is formed, but the elements alone are liberated, is obvious; and I cannot but think that these phenomena, viewed as the last of a series of chemical changes, proceeding from the simplest case of double decomposition to the curious experiments I have just cited, each successive link of which is bound to the preceding by the closest analogies, reasonably admit of a very different interpretation to that which we should put upon them when regarded out of this connection. It is hard to draw a distinction between the decomposition of the chloride of nitrogen and of the nitrite of ammonia. From quite independent considerations, the conclusion is forced upon us, that the mutual attraction of the particles of chlorine and of nitrogen plays a most important part in other cases of chemical change. Why may we not admit that in this case the decomposition is determined solely by these relations? The heat which attends upon this and other similar decompositions is, on the electro-chemical theory, as confessed by its greatest supporters, an inexplicable enigma. Heat is the constant sign of combination, but here it asserts is only decomposition, so that theory and fact are plainly at issue. On the other hand, admitting that in this experiment the formation of the elements is a true chemical synthesis, the evolution of heat is accounted for; and as the elements, chlorine and nitrogen, are far more permanent forms of matter, and less readily altered by chemical action than the chloride of nitrogen, so it is reasonable to believe that the particles of which they are composed are in a far more intimate state of combination. The transition from these experiments to the most ordinary cases of the formation of

the element is obvious, it being plain that the reduction of oxide of silver* into oxygen gas and the metal, differs only from the spontaneous decomposition of the chloride of nitrogen in the temperature at which it takes place.

In the preceding statement, I have used the word polar to express that alternate difference of the condition of the particles by which I conceive chemical action to be propagated. It is no objection to the use of this word that it is undefined, and that I have not pointed out in what this difference consists. It may be a real difference, which we can use for purposes of thought and inquiry, and yet an unknown difference, to which we cannot at present assign a true value. A more serious objection lies in the way in which this word has been misused, and the false associations which, in some minds, are connected with it. It is, however, not difficult for those who must ultimately fix the meaning of this term, to draw the distinctions necessary to its right application; and as I myself have found the word very useful, and also found that through the associations which are rightly connected with it, it conveyed to some persons, whose opinion was well worth considering, an idea which could not otherwise have been so simply given, I have here used it. At the same time let me observe, that that to which I wish to direct the attention of chemists, is to a new analogy between certain chemical changes and to the correlation of phenomena which have not before been grouped together, and, provided that analogy and relation be recognized, the word by which it is expressed is of less importance†. I now proceed to an experimental inquiry which originated in the considerations I have here given.

The discoverer of the peroxide of hydrogen, THÉNARD, observed certain singular and remarkable properties of this compound, of a kind altogether new and calculated to fix the interest and attention of chemists. To prepare the peroxide of hydrogen, according to his directions, is a process so troublesome and tedious, that it may have deterred chemists from the further and full investigation of these phenomena. It is at any rate to THÉNARD alone that we owe whatever knowledge we possess of this singular body. Since his investigation, which dates from the year

* In certain cases we can trace the very mode in which this decomposition by heat takes place. Thus in the decomposition of chlorate of potash by heat, the true way in which this substance is decomposed is, as discovered by SERULLAS, the decomposition of one particle by the next. The chlorate is first oxidized to perchlorate, and this perchlorate, as shown by MILLON, again reduced to chlorate with evolution of oxygen. Thus the action proceeds by a continual oxidation and reduction of the substance, the phenomena being very similar to the oxidation of the chromic acid by the peroxide of hydrogen and the spontaneous decomposition of the compound formed. By mixing the chlorate of potash with oxide of copper, the formation of the perchlorate is entirely prevented, and the action converted into one of spontaneous decomposition.

† The idea of polarity has been applied to the explanation of chemical phenomena by other chemists as well as myself. I may refer especially to LÖWIG's Introduction to his Organic Chemistry (vol. i. p. 1. Edition 1845). GRAHAM also has given, in the last edition of his Treatise on Chemistry, a chapter on Chemical Polarity. It would be out of place to enter here on any criticism of their views or comparison of them with my own, but I give the reference for those who may be desirous to see the way in which others have treated this subject.

1818, no new fact of the slightest importance has been added to its history. The properties however of which I speak, can all be observed with the solution of the peroxide of barium, in hydrochloric or acetic acid; which can be readily prepared. The properties of this solution are different according as it is alkaline or acid. The alkaline solution is of an unstable nature; even at ordinary temperatures it continually loses oxygen, and on heating undergoes rapid decomposition. The acid solution is more permanent, may be long kept without sensible alteration, and may even be heated to the boiling-point with no evident evolution of gas. Either solution, however, is violently decomposed when certain substances (among which finely divided carbon or platinum are very effective) are thrown into it. In these cases the peroxide is decomposed, while the carbon and platinum remain, as far as we know, unaltered. There are however other bodies which cause this decomposition with perhaps greater energy, and themselves undergo a chemical change of the most surprising nature; these bodies are all those metallic oxides which can readily be reduced,—the oxides of gold, and silver and mercury, and the peroxides of lead, manganese, nickel and other similar substances. These bodies decompose the solution, as does platinum or carbon, while the substances themselves also, during the decomposition, lose oxygen, and are reduced either to a metal or to a lower degree of oxidation. The solution, whether acid or alkaline, is ever decomposed by these bodies; but the facility with which the substance itself is reduced, and in some cases whether this reduction takes place at all, depends upon the neutral or acid condition of the solution, and varies with the particular substance taken in a way on which it is not now necessary to dwell. The decomposition caused by platinum and carbon, however strange, is not quite without parallel. But the simultaneous reduction of the peroxide of hydrogen and the oxide of silver is a solitary fact, by the side of which chemists have been able to place scarcely an analogous much less a similar instance. Yet eminent chemists have offered an explanation of these phenomena, and if these are adequate, further inquiry is unnecessary. I shall not criticise the absolute or the relative value of these explanations; but they add so much to the interest of the question, so clearly show the difficulties under which chemical theory has laboured in dealing with these facts, and also, as I believe, how inadequate it has proved to meet them, that I shall briefly mention the most remarkable.

The following quotation gives the impression made by these facts upon THÉNARD, who first discovered them:—

“Quelle est la cause des phénomènes que nous venons d'exposer? Voilà maintenant ce qu'il s'agit de rechercher. Pour cela qu'il nous soit permis de rappeler ceux que présentent l'oxide d'argent et l'argent avec le nitrate oxigéné neutre du potasse. L'argent très divisé dégage rapidement l'oxigène de ce sel; il ne s'altère point, et le nitrate oxigéné devient nitrate neutre.

“L'oxide d'argent dégage plus rapidement encore que l'argent l'oxigène du nitrate oxigéné; lui-même est décomposé, il se réduit, l'argent se précipite tout entier, et l'on

ne retrouve dans la liqueur que du nitrate neutre de potasse ordinaire. Or, dans ces décompositions, *l'action chimique est évidemment nulle*; il faut donc les attribuer à une cause physique; mais elles ne dépendent ni de la chaleur, ni de la lumière; d'où il suit qu'elles sont probablement dues à l'électricité. Je chercherai à m'en assurer d'une manière positive; je chercherai aussi à savoir si la cause, quelle qu'elle soit, ne pourrait point être produite par le contact de deux liquides, et même de deux gaz. De là, découlera peut-être l'explication d'un grand nombre de phénomènes*."

An idea as to the possible cause of these phenomena was thrown out, some years back, by another distinguished French chemist, DUMAS, which, although but an incidental observation and unaccompanied with any experimental research, has a special interest as giving the scientific conception of these facts from the electrochemical point of view, from which this chemist then regarded them.

“La répulsion que les molécules de même signe exercent l'une sur l'autre, répulsion qui nous a servi à expliquer plus haut les effets qu'on observe dans la formation des composés multiples, va nous servir maintenant à expliquer aussi ceux que l'on observe entre deux corps qui contiennent un excès de molécules semblables. Ces corps tendent à se décomposer mutuellement par suite de cette action répulsive.

“En effet c'est ainsi qu'on peut se rendre compte de l'action des acides sur beaucoup de peroxides qui perdent sur leur influence une partie de leur oxygène, c'est ainsi qu'on peut concevoir l'action si bigarre et si remarquable de l'eau oxygénée sur certains oxides. Ce composé perd par le contact de l'oxide d'argent, par exemple, la moitié de son oxygène repasse à l'état d'eau, chasse l'oxygène de l'oxide et le ramène à l'état métallique. Quant on envisage ce simple fait avec les anciennes idées de l'affinité, il est inintelligible, tandis qu'avec les idées électriques il pouvait en quelque sorte être prévu †.”

Another view has been put forward by LIEBIG. These experiments with the peroxide of hydrogen he places by the side of the fermentation and decay of organic bodies, of which chemical changes he thus gives the cause ‡:—“The cause,” says he, “is the power which a body possesses in the act of decomposition or composition to elicit the same action in a body in contact with it, or to render it capable of undergoing the same change which itself experiences. Thus the decomposition of the ferment decomposes also the sugar, and the decomposition of the peroxide of hydrogen decomposes the metallic oxide.” The simultaneous decomposition of the two substances is the fact. That it is the very chemical change itself in the one instance which determines the chemical change in the other; this relation LIEBIG has pointed out. But why and how, consistently with what we otherwise know of the nature of chemical action, and the mode of its transference and propagation, this can be the

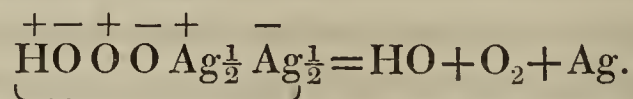
* Annales de Chimie, 2nd Series, vol. ix. p. 98?

† DUMAS, Chimie Appliquée aux Arts, vol. i. Introduction, p. 64.

‡ LIEBIG'S Annalen, vol. xxx. pp. 280, 262 and 279.

case, is a problem which remained to us, and which, in the case of one at least of these experiments, it was my hope to solve.

Hitherto, in the breaking up of the oxide of silver and the peroxide of hydrogen, no chemical fact has been recognised but the simultaneous decomposition of two chemical substances. This is that fact for which it has been so difficult to account. Were it, for example, a hydride of silver which was thus decomposed and water formed and not simply oxygen, the experiment would have attracted no attention. On the view I have given, the formation of the oxygen itself is as truly a chemical synthesis as the formation of water, and may be substituted for it in a chemical change. This supplies an explanation of these facts at once adequate and simple; the oxide of silver in this experiment being reduced by the oxygen of the peroxide of hydrogen, just as in other cases it might be by hydrogen; the formation of the silver from the particles of which it is composed being the corresponding fact in the decomposition of the oxide of silver to the formation of water in the peroxide, so that we may represent the change thus:—



No one can be more sensible than I am of the wide interval which exists between such a mode of representing a chemical change and an ascertained fact. The very form in which I have just expressed the decomposition involves an important assumption, an assumption indeed on which, in my opinion, the whole question rests. If it be true that these bodies are thus decomposed in definite and equivalent proportions, and that the simultaneous decomposition of the bodies proceeds according to this law, it is impossible to deny the chemical relation of these changes and the mutual chemical action of the substances; and, on the other hand, if the formation of this oxygen is to be regarded as a true chemical synthesis, this synthesis must follow the universal law of the formation of chemical substances, and the masses must combine in definite and equivalent proportions. It is only the apparent absence of this relation between the decomposing bodies which removes fermentation from ordinary chemical changes, and causes its chemical nature to be denied; and in that parallel which LIEBIG draws between these decompositions and fermentation, it is tacitly assumed that in this case also, as well as in the case of fermentation, no such relation exists. The following words of LIEBIG, from the paper I have already referred to, clearly show this point:—"A certain quantity of ferment is required to cause fermentation in a portion of sugar; its action however is *no action of mass*, but is entirely limited to its presence up to that moment when the last atom of sugar is decomposed. It is therefore no peculiar body, no substance or matter which effects decomposition, but these are the carriers of an activity* which extends itself over the sphere of the decomposing body."

* "Träger einer Thätigkeit." LIEBIG'S Annalen, vol. xxx. p. 279.

It was therefore the quantitative relation of the decomposing substances which seemed to me the essential point to be determined, and which experiment alone could decide; for it was quite possible (and indeed had been taken for granted) that the action varied according to some other law. It might have none of the characters of a chemical change; it might, for example, vary directly with the acting masses, or with the temperature alone, or be a function, so to say, of so many variables that the true law of action would be altogether hidden.

Preparation of the Peroxide of Barium.

The baryta used in the following experiments was prepared by the ignition of the pure nitrate in a crucible of fine white earthenware. This was protected externally by a common earthenware crucible, and the space between the two filled up with crucible dust. The nitrate was thrown gradually into the crucible, one portion being thoroughly decomposed before the addition of the next. Baryta, as commonly prepared, contains large quantities of peroxide, as may readily be ascertained by dissolving in hydrochloric acid and adding bichromate of potash to the solution; and a very long and strong ignition is necessary to drive off the last portion of oxygen. The purest baryta is not porous, but perfectly compact, very heavy, and of the crystalline grain of fine marble. The baryta thus prepared contains traces only of matter from the crucible, the adhering particles of which are to be carefully broken off, and hardly any impurities, but a little water, and a very little carbonic acid. If an ordinary Hessian crucible be used for its preparation, as was the case with the baryta used in some of the earlier of my experiments, the baryta will be very impure.

To prepare the peroxide, oxygen was passed over the baryta, broken into pieces of the size of a small pea and placed in a combustion-tube, which was heated in an ordinary charcoal trough. The oxygen was made from peroxide of manganese and carefully freed from carbonic acid, and dried before entering the tube. The gas was contained in a gas-holder so as to regulate the current, and was passed over the peroxide, after all absorption had ceased, until the tube was cool. The temperature necessary for the absorption is a low red heat, which is not to be exceeded, as a portion of oxygen is given off at a higher temperature. The operation may be distinctly followed through the tube, the baryta glowing when the stream of gas comes in contact with it. The absorption is both rapid and complete; and I have repeatedly made the experiment of attaching to the end of the tube, where the oxygen not absorbed would pass out, a small tube dipping into mercury, and have found that the experiment can readily be so regulated that a considerable stream of gas will enter at one end of the tube and not a bubble pass out at the other; and indeed the absorption was often so rapid that the gas was absorbed faster than it entered, and the mercury rose several inches in the tube; the whole oxygen therefore is absorbed.

The peroxide presents after the experiment a mass of uniform texture and appearance, and is very white, the baryta itself being of a darker colour. A little of the

powdered substance, moistened with water on the back of the hand, gives no sensible heat. The peroxide was carefully freed from any adhering glass, or pieces in which the absorption was incomplete, from which it may be distinguished by the colour, and was preserved in stoppered bottles over sulphuric acid; a precaution which was desirable, as the preparations had to be preserved for a long time without any alteration in the per-centage of oxygen.

The peroxide of barium thus obtained is a perfectly stable body. When dry, it is only a very intense heat which can drive off its oxygen. It is nearly insoluble in water, the filtered solution giving no gas with oxide of silver, which would be the case if any substance were dissolved; and when preserved from the action of the carbonic acid of the air, it may be long kept even in water without any sensible evolution of gas. When the powdered substance is even boiled with water, no gas is given off; and after long boiling, on examining the dried residue, I have found that the effect of boiling has actually been to increase the per-centage of oxygen, the baryta, of which a certain quantity is always present, being dissolved. These facts are contrary to the usual statements*, and probably this stability only belongs to a very pure substance, for a small quantity of the oxides of iron or of manganese would alter these reactions.

The peculiar experiments of the reduction of the metallic oxides, as stated by THÉNARD and other chemists, are referred to the peroxide of hydrogen; and it is on the peculiar instability of this body that the explanation of LIEBIG of these phenomena rests, the spontaneous decomposition of the peroxide being considered as antecedent to and necessary to set up the action in the other substances. I was however anxious to see whether the peroxides of metals themselves would not produce similar effects; and on placing the peroxide of potassium (the mass which is produced by the action of potassium on melted nitre) in contact with moist chloride of silver in water, I found that the chloride was reduced, just as it might be by zinc, and oxygen evolved; and the same takes place with the iodide, bromide, cyanide, nitrate and oxide of silver and with other metallic combinations. Water alone, as is well known, decomposes the peroxide of potassium; this body therefore was in a similar unstable state to that supposed in the peroxide of hydrogen; but on extending my experiments to the peroxide of barium itself, I found that all the reductions which could be made with the peroxide of hydrogen, took place with this body also with the greatest facility. Finely-divided platinum, silver or carbon, decompose it, but far less rapidly than those substances which are themselves also decomposed. I will not here discuss the general chemical reactions of this peroxide, but defer their consideration until I can treat with advantage, in a more exact manner, of the general theory of this action.

The facts I have just mentioned gave a direction to my experiments, and instead of the peroxide of hydrogen, the preparation and preservation of which involved many difficulties, and with which it was inconvenient to work, I determined to use, in the experiments I proposed, the peroxide of barium itself.

* See Barium superoxyd, Handwörterbuch der Chemie, vol. i. p. 667.

Before the study of these decompositions was possible, it was necessary to have some ready and accurate method of determining the amount of oxygen in the various preparations of the peroxide, which could never be obtained absolutely pure and corresponding to a theoretical formula, and of which I cannot indeed find that any satisfactory analysis has yet been made.

After various experiments I selected two methods, which combined the advantage of great facility of execution with perfect agreement in their results. One of these methods depends on the chemical change which takes place when the peroxide of barium is brought in contact with an acid solution of chromic acid, when, as I have before mentioned, both the peroxide and the chromic acid are decomposed with evolution of gas. Supposing this to be a definite and constant reaction, we have, it is evident, in the evolved gas, a measure of the oxygen in the peroxide, from which, if the reaction were known, the latter might be calculated. For this, however, it was necessary first to discover the nature of the decomposition. The other method depends on the decomposition of the acid solution of the peroxide by finely-divided platinum or carbon, in which case the oxygen evolved is plainly half the total oxygen in the peroxide itself. For the determination of the oxygen in the preparation of a small quantity of the peroxide, it was quite practicable to weigh the baryta before and after the absorption of the gas; and although this plan could not be applied to those larger quantities of the substance which it was desirable to prepare at once, yet, as there could be no doubt as to the general accuracy of the determination if the experiment were conducted with care, I availed myself of it for determining the reaction in question with chromic acid, and for a general control over the methods. The baryta was placed in a platinum tube about 8 inches long and half an inch wide, and the whole experiment conducted precisely in the manner already described in the preparation of the peroxide. The tube was first weighed empty, the ends being closed with dry corks, again with the baryta, and again after the experiment. The peroxide was then rapidly pounded and used for the other determinations. A glass tube cannot be used for this experiment, as the glass is always slightly acted upon, where in contact with the baryta, which, although of little consequence in an experiment on a large scale, as causing an impurity in the peroxide, yet gives rise to a discrepancy between the amount of oxygen calculated from the absorption and the percentage of oxygen deduced from the other experiments.

Two experiments, conducted in this manner, gave the following results:—

A. 12.581 grms. of baryta increased in weight 0.952 gm., corresponding to an increase in weight of 7.53 on 100 parts.

B. 15.180 grms. of baryta increased in weight 1.111 gm., corresponding to an increase in weight of 7.318 on 100 parts.

Hence the two preparations of peroxide of barium contained respectively—

Preparation A, 7.03 per cent.; preparation B, 6.81 per cent. of oxygen in addition to the oxygen of the baryta.

The experiment with the acid solution of chromic acid was made thus:—a weighed quantity of the peroxide was mixed with a very large excess of powdered bichromate of potash in a small flask, such as is often used for the determination of carbonic acid, provided, that is, with a drying tube (in this case filled with small pieces of caustic potash) and a small tube reaching to the bottom of the flask, through which a little air might be drawn after the conclusion of the experiment. Strong hydrochloric acid was contained in the usual small tube, and the whole experiment, in short, conducted precisely as a carbonic acid determination. It is essential to the accuracy of the experiment that care should be taken to have present a great excess of bichromate (at least three or four times the weight of the peroxide taken), an excess of acid, and also to have fresh potash in the drying tube, as there is a considerable rush of gas, and a little carbonic acid or water might otherwise pass through the tube. The peroxide, however, in a good preparation contains a mere trace of carbonate; and I have made the experiment of passing the gas from the potash tube through baryta water, and have found that no carbonic acid escaped the apparatus, with a far more violent evolution of gas than need take place in the experiment.

I. 2·1015 grms. of the preparation A. gave a loss of 0·243 grm., corresponding to a loss of 11·56 on 100 parts of the substance taken.

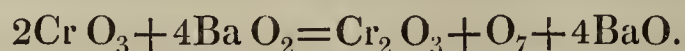
II. 2·1265 grms. of the preparation A. gave a loss of 0·252 grm., corresponding to a loss of 11·85 on 100 parts of the substance.

III. 2·2127 grms. of the preparation B. gave a loss of 0·268 grm. corresponding to a loss of 12·11 on 100 parts of the substance.

IV. 2·0975 grms. of the preparation B. gave a loss of 0·259 grm., corresponding to a loss of 12·34 on 100 parts of the substance.

V. 2·0395 grms. of the preparation B. gave a loss of 0·243 grm., corresponding to a loss of 11·91 on 100 parts of the substance.

From these experiments it results that in this reaction the chromic acid loses three and the peroxide four equivalents of oxygen, that is, that the total loss is to the loss from the peroxide as 7 : 4. For calculating on this hypothesis the amount of oxygen in the two preparations, we find for the preparation A. from experiments I. and II. respectively, 6·60 and 6·67 per cent. of oxygen, and for the preparation B. from experiments III., IV. and V., 6·91, 7·05 and 6·80 per cent. of oxygen, which are the numbers given in the other experiments. The reaction would therefore be represented thus—

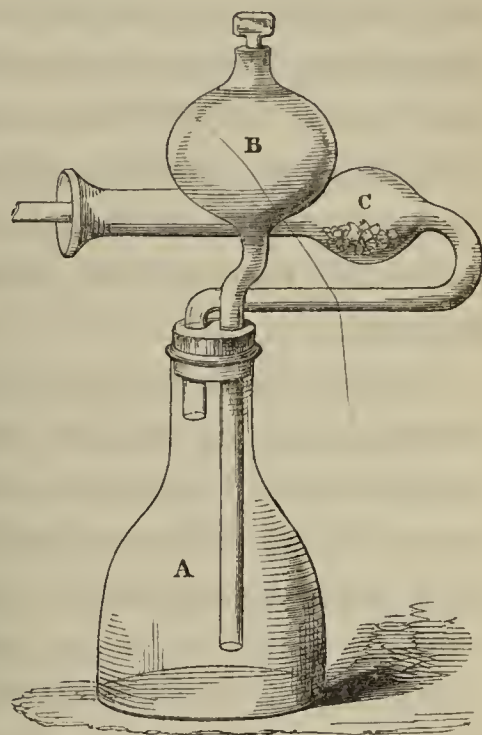


This method has the advantage of giving a considerable loss of oxygen with a small quantity only of the substance; and the perfect agreement with one another of numerous experiments made in this way, led me to place in it the greatest confidence. Facts, however, afterwards came to my knowledge, which proved that this action was not so absolutely uniform as had at first appeared; and although under the circumstances, and with the precautions (especially as to the relative quantities of the sub-

stances) which I have mentioned, the entire agreement of the experiments proves that the action is that which I have here given, yet this threw a certain doubt upon it, and it is only in some of my first experiments that I have used this plan of determining the oxygen uncontrolled by the following.

The determinations with platinum were made in a little apparatus of a very simple construction, which, as I shall elsewhere have occasion to mention it, I will call a bulb apparatus.

A is a small flask in which the weighed substance, together with a small portion of finely-divided platinum (prepared from platinum black by ignition) or of animal charcoal, which is equally effective, is placed. B is a glass bulb holding about two fluid ounces, which, before the experiment, is filled with dilute hydrochloric or acetic acid, and is closed by a well-ground stopper. C is a drying tube of potash. After weighing the apparatus, the stopper is loosened and the acid allowed to flow into the interior. The evolution of gas takes place immediately, but goes much slower than in the experiments with chromic acid. After eighteen or twenty hours the apparatus is again weighed, when the action may be considered terminated. It is, however, of course, to be weighed again until it ceases to lose weight. During the experiment a second potash tube, or a small tube dipping into a vessel of lime, is to be attached to the first, to prevent any increase of weight by absorption of moisture from the atmosphere. The following experiments were made in this manner:—



I. 2·389 grms. of the preparation A. gave a loss of 0·162 gm.

II. 2·437 grms. of the same gave a loss of 0·162 gm.

These experiments correspond to a loss per cent. of

| | |
|------|------|
| I. | II. |
| 6·78 | 6·64 |

III. 2·615 grms. of preparation B. gave a loss of 0·175 gm.

IV. 2·785 grms. of the same gave a loss of 0·184 gm.

These experiments correspond to a loss per cent. of

| | |
|------|------|
| III. | IV. |
| 6·63 | 6·60 |

These determinations entirely agree with each other; and the per-centage of oxygen in the substance is probably in fact (as is given by this experiment) a little less than that calculated from the amount of oxygen taken up, as in pulverizing it it is not possible to prevent the absorption of a little water by the baryta present, which must diminish the per-centage of oxygen. There is no violent rush of gas during the

experiment, nor is any variation of the action to be feared. I consider therefore this method to be as accurate as can be desired.

Experiments with Metallic Oxides.

The method of weighing the loss of oxygen, which succeeds very well for determining the amount of oxygen given off in the preceding experiments, cannot be employed with advantage for determining the amount given off by a metallic oxide in contact with the peroxide of barium. The evolution of gas is not rapid, continuing, at ordinary temperatures, sometimes for several days before all action ceases, during which time the apparatus is liable to alter in weight; and also more water is required to dissolve the baryta than can be introduced into the bulb of the apparatus, or conveniently and accurately be weighed. In these experiments, therefore, I determined indirectly the amount of oxygen given off by ascertaining the amount of metal reduced.

The form of the experiment was very simple. The weighed peroxide was intimately mixed in a flask with the metallic oxide, and a certain portion of water, about twelve ounces, poured upon the mixture. In the following experiments, those at the temperature of the air were placed in a cellar where the temperature was uniform, so that they might be comparable with one another, and the action was allowed to continue until all evolution of gas had ceased. In the experiments at 100° and at other temperatures, the water was first brought to the temperature required, then poured on the mixed substances and the mixture kept at the same temperature, either boiling or in a water-bath, during the action. In the experiments with oxide of silver, to determine the silver reduced, the residue, after the evolution of the gas had ceased, was treated with very dilute hydrochloric acid, with which it was allowed to remain in contact at least twelve hours. All oxide was thus converted into chloride. The fluid was now filtered from the residue and the hydrochloric acid washed out, the bulk of the solid substance being still kept in the flask in which the experiment was made. From this residue, consisting of chloride of silver and metallic silver, the silver was extracted by boiling with nitric acid, the substance on the filter being added to the rest and the filter also treated with acid. The solution was diluted and the silver dissolved, which was in fact the silver reduced, estimated as chloride. It is plain, that whether the oxide were reduced to metal or to a lower degree of oxidation, this silver must still be a correct measure of the oxygen lost. This method of determining the loss of oxygen I followed in all the experiments with silver compounds.

My first experiments were made before I had ascertained all the points necessary for the careful preparation of the peroxide, and the preparations used for these contained considerably less per-centage of oxygen than that which I afterwards readily procured, and contained also impurities from which the other preparations were free; in these experiments also the oxygen was determined only with bichromate of potash and hydrochloric acid. These circumstances in no way affect their general

result. But as the conclusions which they indicated were afterwards brought out and confirmed by experiments not open to these objections, it would be superfluous to give in their case also the numerical details of the determinations. As however they threw much light on the general nature of the inquiry, I cannot omit some account of them.

In the Tables which follow, I have arranged the chief results of these experiments.

The column A. contains the amount of oxygen = a in 100 parts of the peroxide of barium employed, as given by the determination with bichromate of potash. The column B. contains the relative loss of oxygen from the metallic oxide; the loss, that is, calculated on 100 parts of the peroxide of barium. This loss = ψ . The column C. contains the ratio of the quantity of oxygen in the peroxide of barium to the loss from the metallic oxide; the ratio, that is, of $a : \psi$ and the calculated value of ψ . In the column D. I have given the approximate ratio of the oxygen in the amount of peroxide of barium taken, to that in the oxide of silver or peroxide of lead taken in each experiment. The first Table contains the experiments made at 100° C. The first six experiments were made with oxide of silver, the rest with peroxide of lead. In the case of the peroxide of lead, the amount of oxygen lost by the peroxide was determined by extracting the residue after the experiment with very dilute nitric acid, which, leaving the peroxide, dissolves the oxide formed. The lead thus dissolved was estimated as sulphide.

Experiments at 100° C.

| | A. | B. | C. | D. |
|-----|------|------|---------------|-------------------------------|
| 1. | 4.03 | 1.65 | 5 : 2 1.61 | 3 : 2 |
| 2. | | 1.64 | | |
| 3. | 4.18 | 1.95 | 2 : 1 2.09 | 3 : 2 1 : 1 |
| 4. | | 2.08 | | |
| 5. | 5.85 | 3.08 | 2 : 1 2.92 | AgO not weighed. |
| 6. | | 2.99 | | |
| 7. | 4.32 | 1.85 | 5 : 2 1.72 | 5 : 4 1 : 1 |
| 8. | | 1.71 | | |
| 9. | 6.10 | 3.31 | 7 : 4 3.48 | PbO ₂ not weighed. |
| 10. | | 3.37 | | |

Classifying these ten experiments with reference to the ratios given in the third column, we find that they may be arranged thus:—

5 : 2, four experiments.

4 : 2, four experiments.

3½ : 2, two experiments.

In the next Table the experiments were made below 100°; where the temperature is not given they were at the temperature of the air. The two last experiments were made with the peroxide of lead, the rest with the oxide of silver.

Experiments below 100°.

| | A. | B. | C. | D. | | |
|-----|------|-------|-------|------|---|----------------|
| 1. | 4.18 | 2.35 | 7 : 4 | 2.38 | 3 : 1 | |
| 2. | | 2.53 | | | | T. 38° to 42°. |
| 3. | 4.18 | 2.51 | 5 : 3 | 2.50 | 5 : 2 | |
| 4. | | 2.81 | | | | T. 24° to 26°. |
| 5. | 4.32 | 2.93 | 3 : 2 | 2.88 | About 1 : 1 in the four experiments. | |
| 6. | | 3.00 | | | | T. 16°. |
| 7. | | *2.96 | 3 : 2 | | | T. 0° upwards. |
| 8. | | 2.77 | | | | |
| 9. | 4.47 | 3.25 | 4 : 3 | 3.35 | AgO not weighed. | |
| 10. | | 3.30 | | | | |
| 11. | 6.10 | 4.21 | 3 : 2 | 4.06 | PbO ₂ not weighed. | |
| 12. | | 3.93 | | | | |

The experiments in this Table, arranged in the order of ratios, as those at the higher temperature, give the following series:—

$3\frac{1}{2} : 2$, one experiment.

5 : 3, two experiments.

3 : 2, seven experiments.

4 : 3, two experiments.

These experiments placed beyond doubt, that, under similar circumstances of temperature and mass, the loss of oxygen from the metallic oxide stood in a certain fixed relation to the quantity of the peroxide of barium employed. They showed also (speaking generally) that this loss varied inversely with the temperature, but yet it appeared that within certain limits (II. experiments 5, 6, 7, 8) the temperature might be very considerably altered without affecting the action. This was also the case, to a certain extent at any rate, with the mass; for a perfect agreement was found between experiments where the quantity of oxide of silver taken was considerably varied or even accidental. At the same time it was to be observed, that in determining these ratios a great deal would depend on the limits allowed for the error of analysis; and it was a question of great importance, and yet by no means easy to decide, whether they were absolutely such as I have here assumed them to be; that is to say, whether the difference between two nearly identical experiments was to be attributed to the error of analysis or to a real, though small, difference in the action. I determined therefore to make a more extended series of experiments, in which I might ob-

* The water in these two experiments was cooled down in ice before it was poured on the substances; at this low temperature no gas was given off. The action was allowed gradually to proceed as the temperature rose in the air.

serve the effect of varying the mass, at a constant temperature, and with the same preparation of the peroxide.

The great accuracy of the silver determination and the comparative facility of determining by it the loss of oxygen from the compounds of this metal, caused me to confine to them my attention. Indeed it was plain from experiments I had made with the oxide of mercury, as well as with peroxide of lead, that the general nature of the changes in question was, with any one of these substances, the same.

The following experiments were made with the chloride and the oxide of silver at 100° , and at the temperature of the air: I had already found how very greatly at the lower temperature this circumstance might be varied without alteration of the action; and in this case the experiments are arranged without any special reference to the slight variations of the temperature of the air. The peroxide taken is the same for each series; the general form of the experiments was precisely as already described.

Oxygen determinations.

The determinations of the oxygen in the different preparations of the peroxide of barium employed, gave the following results:—

I. Peroxide P.

I.—(1.) 2.8970 grms. of a peroxide (P) gave with hydrochloric acid and bichromate of potash, a total loss of 0.425 gm. of oxygen, corresponding to a loss of 14.67 per cent. on the peroxide.

(2.) 2.9215 grms. of the same substance gave, in a similar experiment, a total loss of 0.427 gm. of oxygen, corresponding to a loss of 14.61 per cent.

The oxygen in 100 parts of the peroxide, calculated from the above experiments, is,—

| | |
|------|-------|
| I. | II. |
| 8.38 | 8.36. |

(3.) 2.823 grms. of the same peroxide in an experiment with platinum and acetic acid, gave a loss of 0.235 gm., corresponding to a loss of 8.32 per cent. oxygen.

The mean of these three experiments gives 8.35 as the per-centage of oxygen in the substance.

II. Peroxide Q.

II.—(1.) 2.9565 grms. of a peroxide (Q) gave with hydrochloric acid and bichromate of potash, a total loss of 0.457 gm. of oxygen, corresponding to a loss of 15.45 per cent.

(2.) 2.9555 grms. of the same gave in a similar experiment, a total loss of 0.450 gm. of oxygen, corresponding to a loss of 15.22 per cent.

(3.) 2.955 grms. of the same gave with nitric acid and bichromate of potash, a total loss of 0.453 gm. of oxygen, corresponding to a loss of 15.32 per cent.

The oxygen in 100 parts of the peroxide, calculated from the above experiments, is,—

| | | | |
|------|------|------|-------|
| I. | II. | III. | Mean. |
| 8.82 | 8.69 | 8.75 | 8.75 |

(1.) 2·6355 grms. of the peroxide gave with platinum and acetic acid, a total loss of 0·227 gm. of oxygen.

(2.) 2·9474 grms. of the same gave with platinum and acetic acid, a total loss of 0·257 gm. of oxygen.

(3.) 2·847 grms. of the same gave with platinum and hydrochloric acid, a total loss of 0·241 gm. of oxygen.

(4.) 2·9815 grms. of the same gave, in a similar experiment, a total loss of 0·254 gm. of oxygen.

These determinations correspond to a loss of oxygen per cent. of—

| | | | | |
|------|------|------|------|-------|
| I. | II. | III. | IV. | Mean. |
| 8·65 | 8·71 | 8·46 | 8·51 | 8·58 |

III. Peroxide O.

III.—(1.) 2·4875 grms. of a peroxide (O) gave with platinum and hydrochloric acid, a loss of 0·191 gm. of oxygen.

(2.) 2·515 grms. of the same, in a similar experiment, lost 0·191 gm. of oxygen.

(3.) 2·7296 grms. of the same, in a similar experiment, lost 0·204 gm. of oxygen.

These determinations correspond to a loss of oxygen per cent. of—

| | | | |
|------|------|------|-------|
| I. | II. | III. | Mean. |
| 7·67 | 7·59 | 7·47 | 7·57 |

Experiments with Chloride of Silver at 100° C.

The following experiments were made with the peroxide P and chloride of silver at 100° C. The chloride of silver was in the finely-divided state in which it is produced by precipitating nitrate of silver with chloride of sodium. The precipitate with hydrochloric acid cannot so readily be mixed with the peroxide. The chloride of silver was dried either at 100° or at a gentle heat over a lamp; it was, when dried, in the state of a fine powder.

The following Table contains the details of the experiments:—

TABLE I.—A.

| | Peroxide of barium P. | Chloride of silver taken. | Chloride of silver obtained. | Equivalent of oxygen. |
|-----|-----------------------|---------------------------|------------------------------|-----------------------|
| | grms. | grms. | grms. | grms. |
| 1. | 3·0115 | 0·527 | 0·280 | 0·0155 |
| 2. | 3·014 | 1·003 | 0·3945 | 0·0219 |
| 3. | 3·0865 | 1·404 | 0·5633 | 0·0312 |
| 4. | 3·0455 | 2·057 | 0·8085 | 0·0449 |
| 5. | 3·0036 | 4·011 | 1·019 | 0·0566 |
| 6. | 3·0206 | 5·963 | 1·0573 | 0·0587 |
| 7. | 3·0295 | 7·983 | 1·1815 | 0·0656 |
| 8. | 2·958 | 9·235 | 1·087 | 0·0605 |
| 9. | 2·967 | 11·139 | 1·170 | 0·0652 |
| 10. | 3·0465 | 11·064 | 1·3105 | 0·0728 |
| 11. | 3·0375 | 15·960 | 1·3515 | 0·0759 |
| 12. | 3·0695 | 19·920 | 1·3425 | 0·0745 |
| 13. | 3·0125 | 8·059 | 1·4795 | 0·0822 |

In the second Table, B, which follows, the oxygen equivalent to the reduced silver is compared with the oxygen in the peroxide; the peroxide being taken as 100, and the oxygen therefore as 8.34. In the third Table, the oxygen in the peroxide is taken as the unit. The third and fourth columns in both cases contain the assumed and calculated ratio of the oxygen lost by the peroxide to that equivalent to the reduced silver. I have assumed as this ratio the simplest ratio which agrees with the experiments, as a convenient and sufficiently accurate expression of the loss.

TABLE I.—B.

| | Oxygen in the peroxide of barium $P=a$. | Oxygen equivalent to the chloride of silver reduced $=\psi$. | Ratio, $a : \psi$. | Calculated ratio. |
|-----|--|---|---------------------|-------------------|
| 1. | | 0.51 | | |
| 2. | | 0.72 | | |
| 3. | | 1.01 | | |
| 4. | | 1.47 | | |
| 5. | | 1.88 | | |
| 6. | | 1.94 | 9 : 2 | 1.85 |
| 7. | 8.34 | 2.18 | | |
| 8. | | 2.04 | 4 : 1 | 2.08 |
| 9. | | 2.19 | | |
| 10. | | 2.42 | | |
| 11. | | 2.47 | 7 : 2 | 2.38 |
| 12. | | 2.42 | | |
| 13. | | 2.73 | 3 : 1 | 2.78 |

TABLE I.—C*.

| | Oxygen in the peroxide of barium $=a$. | Oxygen equivalent to the chloride of silver reduced $=\psi$. | Ratio, $a : \psi$. | Calculated ratio. |
|-----|---|---|---------------------|-------------------|
| 1. | | 6.11 | | |
| 2. | | 8.63 | | |
| 3. | | 12.11 | | |
| 4. | | 17.62 | | |
| 5. | | 22.54 | | |
| 6. | | 23.26 | 9 : 2 | 22.22 |
| 7. | 100 | 26.13 | | |
| 8. | | 24.46 | 4 : 1 | 25.0 |
| 9. | | 26.25 | | |
| 10. | | 29.01 | | |
| 11. | | 29.61 | 7 : 2 | 28.57 |
| 12. | | 29.01 | | |
| 13. | | 32.73 | 3 : 1 | 33.33 |

* In these Tables the experiments are arranged in all cases according to the nature of the actions, and not with reference to the quantities taken of the decomposed bodies. But for the sake of a ready general compa-

100 parts of this peroxide require 149.7 parts of chloride of silver to one equivalent of the oxygen it contains. Hence 3 grms. of the peroxide require 4.491 grms. of the chloride for the same proportion.

In the first four experiments, in which comparatively small quantities of chloride of silver, at most not half an equivalent, were taken, the loss increases nearly with the mass of the chloride, and bears therefore no constant ratio to the loss from the peroxide. In all these four experiments the chloride has been reduced nearly in the same proportion, but yet between the first and second experiment there is a difference which is not found between the other three, as may be seen from the following comparison of the chloride of silver taken with the chloride found.

| Exp. | Chloride of silver taken. | Chloride of silver found. |
|------|---------------------------|---------------------------|
| 1. | 100 | 53.1 |
| 2. | 100 | 39.3 |
| 3. | 100 | 40.1 |
| 4. | 100 | 39.3 |

It appears from this comparison that in the three last of these experiments exactly two-fifths of the chloride taken are reduced, and we may regard this limit of reduction as the circumstance which here determines the action. The gradual increase of loss, with the mass, does not continue, or the increase becomes very small, for one and three equivalents of chloride give very nearly the same amount of reduced silver, equivalent to exactly one-fourth of the oxygen in the peroxide. There is also a constant ratio of loss, which appears likewise to be connected with the increase of mass where the ratio is as 7 : 2, and there is one exception to the order of the series where the loss does not stand in the same general relation to the mass, which may be observed in the other experiments. In this, however, the same simplicity of ratio prevails, and it is evidently a term of the series; the ratio of the loss being as 3 : 1. It is worthy of observation, that the turning-point of the action where the loss ceases to increase with the mass, lies at any rate near to that point where the decomposing bodies are taken in equal equivalent proportions.

My experiments had led me to suspect that some circumstance connected with the particular preparation of the peroxide employed materially influenced the results. This circumstance might be the proportion of free baryta in the peroxide, which was not quite the same in different preparations, or it might be some peculiarity in the molecular condition of the peroxide itself due to some other cause; I repeated therefore the experiments made with one peroxide with another preparation, and arranged these experiments apart.

The following experiments were made also with chloride of silver at 100°, but with the peroxide Q containing 8.58 per cent. of oxygen. The Tables are of the same nature as before.

Comparison of these quantities, nearly the same quantity of the peroxide, 3 grms., was, with some few exceptions, always employed. The experiments, as will be seen, do not call for any more exact comparison than can thus at a glance be made.

TABLE II.—A.

| | Peroxide of barium Q. | Chloride of silver taken. | Chloride of silver obtained. | Equivalent of oxygen. |
|----|-----------------------|---------------------------|------------------------------|-----------------------|
| 1. | 3.0065 grms. | 4.0015 grms. | 0.5305 grms. | 0.0295 grms. |
| 2. | 2.971 | 5.003 | 0.709 | 0.03952 |
| 3. | 2.9995 | 8.0015 | 0.732 | 0.0408 |
| 4. | 3.0145 | 8.0745 | 0.9845 | 0.0548 |
| 5. | 2.962 | 10.129 | 0.968 | 0.05396 |
| 6. | 3.001 | 11.9955 | 1.003 | 0.05591 |
| 7. | 2.985 | 14.936 | 1.126 | 0.0627 |
| 8. | 2.9545 | 12.0175 | 1.2245 | 0.06826 |
| 9. | 2.9965 | 16.0105 | 1.3205 | 0.07361 |

TABLE II.—B.

| | Oxygen in the peroxide of barium Q = a. | Oxygen equivalent to the chloride of silver reduced = ψ . | Ratio, a : ψ . | Calculated ratio. |
|----|---|--|---------------------|-------------------|
| 1. | 8.58 | 0.96 | 9 : 1 | 0.95 |
| 2. | | 1.33 | 6 : 1 | 1.43 |
| 3. | | 1.36 | | |
| 4. | | 1.81 | 9 : 2 | 1.90 |
| 5. | | 1.82 | | |
| 6. | | 1.86 | | |
| 7. | | 2.10 | 4 : 1 | 2.14 |
| 8. | | 2.31 | 7 : 2 | 2.45 |
| 9. | | 2.45 | | |

TABLE II.—C.

| | Oxygen in the peroxide of barium Q = a. | Oxygen equivalent to the chloride of silver reduced = ψ . | Ratio, a : ψ . | Calculated ratio. |
|----|---|--|---------------------|-------------------|
| 1. | 100 | 11.18 | 9 : 1 | 11.11 |
| 2. | | 15.5 | 6 : 1 | 16.6 |
| 3. | | 15.8 | | |
| 4. | | 21.0 | 9 : 2 | 22.22 |
| 5. | | 21.2 | | |
| 6. | | 21.6 | | |
| 7. | | 24.4 | 4 : 1 | 25.00 |
| 8. | | 26.9 | 7 : 2 | 28.57 |
| 9. | | 28.5 | | |

3 grms. of this peroxide require 4 grms. of chloride of silver as equivalent to the oxygen it contains. Thus the experiments from 1 to 6 in this series, were made with a proportion of the chloride, on the whole greater than the experiments 5 to 9 on the first Table. Yet a great diminution is to be observed in the loss of oxygen; in experi-

ment 1 only 13·2 parts out of 100 of the chloride are reduced. And here the ratio 9 : 2 occupies the place of the ratio 4 : 1 or 8 : 2 on the other series. But the limiting ratio of 7 : 2 is in both series the same, and on the whole a certain increase of loss, although not a gradual increase, is to be observed with the increase of the chloride taken. These experiments confirm the fact, that under similar circumstances the different preparations of the peroxide have a different reducing power.

Experiments with Chloride of Silver at the temperature of the air.

The next experiments were made also with the chloride of silver, but at a lower temperature, the temperature of the air. I had already found how very much at this low temperature the temperature might be varied without alteration of the action, and in this case the experiments are arranged without any special reference to the variation of the temperature. The peroxide in the first series was the same as that taken in the last experiments, namely, the peroxide Q containing 8·58 per cent. of oxygen.

TABLE III.—A.

| | Peroxide of barium Q. | Chloride of silver taken. | Chloride of silver obtained. | Equivalent of oxygen. |
|----|-----------------------|---------------------------|------------------------------|-----------------------|
| 1. | 3·034 grms. | 4·0125 grms. | 1·366 grms. | 0·076 grms. |
| 2. | 2·9942 | 4·988 | 1·480 | 0·0825 |
| 3. | 3·0275 | 6·1315 | 1·545 | 0·08613 |
| 4. | 2·994 | 8·0905 | 1·9415 | 0·10823 |
| 5. | 2·9742 | 10·016 | 2·043 | 0·1138 |
| 6. | 2·9532 | 14·916 | 2·019 | 0·1125 |
| 7. | 3·014 | 9·9915 | 2·336 | 0·1302 |
| 8. | 2·9915 | 12·9075 | 2·3125 | 0·1289 |
| 9. | 2·0132 | 14·916 | 1·5485 | 0·0863 |

TABLE III.—B.

| | Oxygen in the peroxide of barium Q = a. | Oxygen equivalent to the chloride of silver reduced = ψ . | Ratio, a : ψ . | Calculated ratio. |
|----|---|--|---------------------|-------------------|
| 1. | 8·58 | 2·50 | 7 : 2 | 2·48 |
| 2. | | 2·75 | 3 : 1 | 2·86 |
| 3. | | 2·84 | | |
| 4. | | 3·61 | 7 : 3 | 3·67 |
| 5. | | 3·82 | 9 : 4 | 3·81 |
| 6. | | 3·80 | | |
| 7. | | 4·31 | 2 : 1 | 4·29 |
| 8. | | 4·30 | | |
| 9. | | 4·28 | | |

TABLE III.—C.

| | Oxygen in the peroxide of barium $Q = a$. | Oxygen equivalent to the chloride of silver reduced = ψ . | Ratio, $a : \psi$. | Calculated ratio. |
|----|--|--|---------------------|-------------------|
| 1. | 100 | 29.13 | 7 : 2 | 28.57 |
| 2. | | 32.05 | 3 : 1 | 33.33 |
| 3. | | 33.10 | | |
| 4. | | 42.07 | 7 : 3 | 42.85 |
| 5. | | 44.52 | 9 : 4 | 44.44 |
| 6. | | 44.28 | | |
| 7. | | 50.23 | 2 : 1 | 50.0 |
| 8. | | 50.11 | | |
| 9. | | 49.88 | | |

The point to be observed in these experiments is the great increase of reduction at the lower temperature. The comparative experiments in this and the last series, show that from corresponding quantities of the chloride, as nearly as possible twice the amount of silver is reduced; and these experiments, it is worthy of remark, take up the action exactly at the point where the other series terminates, so that the expression of the relative loss forms a continuation of the series of ratios commencing with 7 : 2 and terminating with 2 : 1.

The following are a few experiments made with the peroxide P, containing 8.34 per cent. of oxygen.

TABLE IV.—A.

| | Peroxide of barium Q. | Chloride of silver taken. | Chloride of silver obtained. | Equivalent of oxygen. |
|----|-----------------------|---------------------------|------------------------------|-----------------------|
| 1. | 3.020 grms. | 1.012 grms. | 0.5715 grms. | 0.03175 grms. |
| 2. | 3.032 | 2.009 | 0.765 | 0.0426 |
| 3. | 3.0256 | 3.895 | 1.484 | 0.08244 |
| 4. | 3.0005 | 8.879 | 1.733 | 0.0962 |
| 5. | 3.0046 | 6.11 | 1.9495 | 0.1083 |
| 6. | 3.05 | 11.983 | 2.065 | 0.1147 |

TABLE IV.—B.

| | Oxygen in the peroxide of barium $P = a$. | Oxygen equivalent to the chloride of silver reduced = ψ . | Ratio, $a : \psi$. | Calculated ratio. |
|----|--|--|---------------------|-------------------|
| 1. | 8.34 | 1.04 | 8 : 1 | 1.04 |
| 2. | | 1.40 | 6 : 1 | 1.39 |
| 3. | | 2.72 | 3 : 1 | 2.78 |
| 4. | | 3.26 | 5 : 2 | 3.33 |
| 5. | | 3.60 | 9 : 4 | 3.70 |
| 6. | | 3.72 | | |

TABLE IV.—C.

| | Oxygen in the peroxide of barium P = a . | Oxygen equivalent to the chloride of silver reduced = ψ . | Ratio, $a : \psi$. | Calculated ratio. |
|----|--|--|---------------------|-------------------|
| 1. | 100 | 12.47 | 8 : 1 | 12.5 |
| 2. | | 16.06 | 6 : 1 | 16.66 |
| 3. | | 32.61 | 3 : 1 | 33.33 |
| 4. | | 39.08 | 5 : 2 | 40.0 |
| 5. | | 43.16 | 9 : 4 | 44.44 |
| 6. | | 44.60 | | |

The experiments with this peroxide give about the same range of action as with the last. On the whole, however, the loss here, as at 100° with the same substance, is rather less, but the difference is not so apparent.

Experiments with the Oxide of Silver at 100° C.

The following are experiments with the oxide of silver at 100° C. The oxide was prepared either by precipitation with baryta water or with a pure potash. It contained no chloride but some carbonate, and was dried at 100° . The peroxide employed was the peroxide P, containing 8.34 per cent. of oxygen; 3.63 grms. of the oxide of silver are equivalent to 3 grms. of the peroxide.

TABLE V.—A.

| | Peroxide of barium P. | Oxide of silver. | Chloride of silver found. | Equivalent of oxygen. |
|-----|-----------------------|------------------|---------------------------|-----------------------|
| 1. | 3.0225 grms. | 0.855 grms. | 0.625 grms. | 0.0347 grms. |
| 2. | 3.0295 | 1.525 | 0.8353 | 0.0463 |
| 3. | 2.9807 | 1.205 | 0.9784 | 0.0543 |
| 4. | 3.006 | 1.832 | 1.165 | 0.0647 |
| 5. | 3.0107 | 2.235 | 1.369 | 0.0760 |
| 6. | 2.997 | 2.920 | 1.5565 | 0.0864 |
| 7. | 2.982 | 4.692 | 1.492 | 0.0831 |
| 8. | 3.007 | 4.890 | 1.510 | 0.0841 |
| 9. | 3.0185 | 6.182 | 1.483 | 0.08238 |
| 10. | 3.601 | 6.266 | 1.874 | 0.1041 |
| 11. | 2.986 | 6.4675 | 1.503 | 0.0837 |
| 12. | 3.067 | 9.339 | 1.6345 | 0.0908 |
| 13. | 3.019 | 11.051 | 1.7325 | 0.09625 |
| 14. | 3.0485 | 7.810 | 1.7785 | 0.0988 |
| 15. | 2.983 | 4.932 | 1.84 | 0.1025 |
| 16. | 3.616 | 15.675 | 2.395 | 0.133 |
| 17. | 2.9725 | 9.5345 | 2.001 | 0.1115 |
| 18. | 3.0075 | 12.2035 | 2.2365 | 0.1248 |

TABLE V.—B.

| | Oxygen in the peroxide of barium P = a . | Oxygen of the oxide of silver reduced = ψ . | Ratio, $a : \psi$. | Calculated ratio. |
|-----|--|--|---------------------|-------------------|
| 1. | | 1.14 | | |
| 2. | | 1.52 | 5 : 1 | 1.67 |
| 3. | | 1.82 | | |
| 4. | | 2.15 | 4 : 1 | 2.08 |
| 5. | | 2.52 | 7 : 2 | 2.38 |
| 6. | | 2.88 | | |
| 7. | | 2.78 | | |
| 8. | | 2.79 | | |
| 9. | 8.34 | 2.72 | 3 : 1 | 2.78 |
| 10. | | 2.88 | | |
| 11. | | 2.80 | | |
| 12. | | 2.96 | | |
| 13. | | 3.18 | | |
| 14. | | 3.24 | 5 : 2 | 3.33 |
| 15. | | 3.43 | | |
| 16. | | 3.67 | | |
| 17. | | 3.75 | 9 : 4 | 3.70 |
| 18. | | 4.14 | 2 : 1 | 4.17 |

TABLE V.—C.

| | Oxygen in the peroxide of barium P = a . | Oxygen of the oxide of silver reduced = ψ . | Ratio, $a : \psi$. | Calculated ratio. |
|-----|--|--|---------------------|-------------------|
| 1. | | 13.66 | | |
| 2. | | 18.22 | 5 : 1 | 20.0 |
| 3. | | 21.82 | | |
| 4. | | 25.77 | 4 : 1 | 25.0 |
| 5. | | 30.21 | 7 : 2 | 28.57 |
| 6. | | 34.53 | | |
| 7. | | 33.33 | | |
| 8. | | 33.45 | | |
| 9. | | 32.61 | 3 : 1 | 33.33 |
| 10. | 100 | 34.53 | | |
| 11. | | 33.57 | | |
| 12. | | 35.49 | | |
| 13. | | 38.12 | | |
| 14. | | 38.84 | 5 : 2 | 40.00 |
| 15. | | 41.12 | | |
| 16. | | 44.00 | | |
| 17. | | 44.84 | 9 : 4 | 44.44 |
| 18. | | 49.63 | 2 : 1 | 50.00 |

These experiments give the same results as those made with the chloride of silver at the lower temperature, and comprise as these a series of ratios beginning with 7 : 2 and ending with 2 : 1. The experiments with the smaller quantities of oxide show

also the same kind of progressive increase of loss, as already observed with the chloride; the increase however is not so constant. In experiments 4 and 5 exactly half the oxide is reduced; the ratio of the oxygen in the oxide of silver taken, to the oxygen from the oxide reduced, being in the two experiments as 100 : 51.2 and 100 : 49.31; the presence however of carbonate of silver in the oxide renders this fact less certain than the similar fact observed in the case of the chloride of silver (Table I.).

I repeated these experiments with another preparation of the peroxide, the peroxide O, containing 7.57 per cent. of oxygen; 3.12 grms. of oxide of silver are equivalent to 3 grms. of this peroxide.

TABLE VI.—A.

| | Peroxide of barium O. | Oxide of silver. | Chloride of silver obtained. | Equivalent of oxygen. |
|----|-----------------------|------------------|------------------------------|-----------------------|
| 1. | 3.0666 grms. | 2.737 grms. | 1.692 grms. | 0.094 grms. |
| 2. | 3.006 | 3.659 | 1.7146 | 0.0952 |
| 3. | 3.098 | 4.801 | 1.7335 | 0.0963 |
| 4. | 3.007 | 5.426 | 2.0735 | 0.1151 |
| 5. | 3.0806 | 11.592 | 2.5123 | 0.1395 |

TABLE VI.—B.

| | Oxygen in the peroxide of barium O = a. | Oxygen of the oxide of silver reduced = ψ . | Ratio, a : ψ . | Calculated ratio. |
|----|---|--|---------------------|-------------------|
| 1. | 7.57 | 3.09 | 5 : 2 | 3.02 |
| 2. | | 3.16 | | |
| 3. | | 3.10 | | |
| 4. | | 3.85 | 2 : 1 | 37.8 |
| 5. | | 4.52 | 5 : 3 | 4.74 |

TABLE VI.—C.

| | Oxygen in the peroxide of barium O = a. | Oxygen of the oxide of silver reduced = ψ . | Ratio, a : ψ . | Calculated ratio. |
|----|---|--|---------------------|-------------------|
| 1. | 100 | 40.81 | 5 : 2 | 40.00 |
| 2. | | 40.74 | | |
| 3. | | 40.95 | | |
| 4. | | 50.59 | 2 : 1 | 50.00 |
| 5. | | 59.70 | 7 : 3 | 60.00 |

The experiments 1, 2, 3 here correspond to the experiments 6, 7, 8, 9 in Table V.; they give however a considerably greater loss, the ratio being 5 : 2 instead of 3 : 1. This difference, it is probable, extends also to the higher terms in the series, for we

have here a ratio 5 : 3, which is a greater loss than any in the other series of experiments. It is worthy of remark, that the loss per cent. on the peroxide is nearly the same in the two, which might lead us to think that this loss stood in some fixed ratio to the baryta of the substance, with the whole of which the oxygen of the peroxide may be considered to be in combination. This however is doubtless but a coincidence, as the experiments with chloride of silver, made with different preparations of the peroxide, where similar differences exist, do not show this relation.

Experiments with the Oxide of Silver at the temperature of the air.

The following experiments were made with the peroxide P (containing 8.34 per cent. of oxygen) and oxide of silver at the temperature of the air.

TABLE VII.—A.

| | Peroxide of barium P. | Oxide of silver. | Chloride of silver found. | Equivalent of oxygen. |
|-----|-----------------------|------------------|---------------------------|-----------------------|
| 1. | 2.999 grms. | 0.824 grms. | 0.528 grms. | 0.2293 grms. |
| 2. | 3.004 | 1.604 | 0.9135 | 0.05075 |
| 3. | 3.017 | 3.123 | 1.3915 | 0.0773 |
| 4. | 3.022 | 3.994 | 1.6815 | 0.0934 |
| 5. | 3.039 | 6.313 | 1.990 | 0.1105 |
| 6. | 3.04 | 7.788 | 2.057 | 0.1142 |
| 7. | 3.029 | 9.400 | 2.041 | 0.1133 |
| 8. | 2.9417 | 2.964 | 2.2055 | 0.1225 |
| 9. | 3.059 | 15.720 | 2.3785 | 0.132 |
| 10. | 15.925 | 26.522 | 13.677 | 0.759 |
| 11. | 3.478 | 9.405 | 2.965 | 0.1647 |
| 12. | 3.021 | 7.6195 | 3.222 | 0.1796 |

TABLE VII.—B.

| | Oxygen in the peroxide of barium P = a. | Oxygen of the oxide of silver reduced = ψ . | Ratio, a : ψ . | Calculated ratio. |
|-----|---|--|---------------------|-------------------|
| 1. | | 0.97 | | |
| 2. | | 1.68 | | |
| 3. | | 2.56 | 7 : 2 | 2.38 |
| 4. | | 3.10 | 5 : 2 | 3.33 |
| 5. | | 3.63 | | |
| 6. | 8.34 | 3.75 | 9 : 4 | 3.70 |
| 7. | | 3.74 | | |
| 8. | | 4.16 | | |
| 9. | | 4.31 | 2 : 1 | 4.17 |
| 10. | | 4.76 | | |
| 11. | | 4.70 | 7 : 4 | 4.76 |
| 12. | | 5.94 | 7 : 5 | 5.95 |

TABLE VII.—C.

| | Oxygen in the peroxide of barium $P = a$. | Oxygen of the oxide of silver reduced = ψ . | Ratio, $a : \psi$. | Calculated ratio. | | |
|-----|--|--|---------------------|-------------------|-------|-------|
| 1. | 100 | 11.63 | | | | |
| 2. | | 20.14 | | | | |
| 3. | | 30.69 | | | 7 : 2 | 28.57 |
| 4. | | 37.17 | | | 5 : 2 | 40.0 |
| 5. | | 43.52 | | | 9 : 4 | 44.44 |
| 6. | | 44.96 | | | | |
| 7. | | 44.84 | | | 2 : 1 | 50.00 |
| 8. | | 49.88 | | | | |
| 9. | | 51.67 | | | 7 : 4 | 57.1 |
| 10. | | 57.07 | | | | |
| 11. | | 56.35 | | | 7 : 5 | 71.42 |
| 12. | | 71.22 | | | | |

When small quantities of the oxide of silver are taken, the loss is not very different from that at the higher temperature, as is also the case in the experiments with the chloride; but after a certain point the actions diverge, and the total general result gives an entirely different range of action in the two series. In all cases, after a certain point, the mass ceases to have a determinate influence on the action; and here this influence would seem soon to be entirely lost, for after the first two or three experiments, no relation whatever can be traced between the relative masses of the substances and the proportion of reduced silver. At the same time, even these experiments, which we may regard as accidental, arrange themselves in a certain order, and give on the whole higher numbers in the series of ratios than any yet obtained. This series may be extended yet further; thus two experiments with peroxide O, at the temperature of the air, gave—

TABLE VIII.—A.

| | Peroxide of barium O. | Oxide of silver. | Chloride found. | Equivalent of oxygen. |
|----|-----------------------|------------------|-----------------|-----------------------|
| 1. | 2.926 grms. | 5.186 grms. | 2.8557 grms. | 0.1586 gm. |
| 2. | 3.06 | 5.064 | 3.0402 | 0.1689 |

TABLE VIII.—B.

| | Oxygen in the peroxide of barium O = a . | Oxygen of the oxide of silver reduced = ψ . | Ratio, $a : \psi$. | Calculated ratio. |
|----|--|--|---------------------|-------------------|
| 1. | 7.57 | 5.42 | 7 : 5 | 5.40 |
| 2. | | 5.51 | | |

TABLE VIII.—C.

| | Oxygen in the peroxide of barium $O = a$. | Oxygen of the oxide of silver reduced = ψ . | Ratio, $a : \psi$. | Calculated ratio. |
|----|--|--|---------------------|-------------------|
| 1. | 100 | 71.59 | 7 : 5 | 71.42 |
| 2. | | 72.78 | | |

These experiments, although made with but small quantities of the oxide, give a loss as great as any made with the other preparation.

Two experiments with the peroxide Q, at the same temperature, gave a yet greater loss.

TABLE IX.—A.

| | Peroxide of barium Q. | Oxide of silver. | Chloride of silver found. | Equivalent of oxygen. |
|----|-----------------------|------------------|---------------------------|-----------------------|
| 1. | 2.985 grms. | 7.878 grms. | 3.843 grms. | 0.2142 gm. |
| 2. | 2.9544 | 7.9215 | 3.801 | 0.2119 |

TABLE IX.—B.

| | Oxygen in the peroxide of barium $Q = a$. | Oxygen of the oxide of silver reduced = ψ . | Ratio, $a : \psi$. | Calculated ratio. |
|----|--|--|---------------------|-------------------|
| 1. | 8.58 | 7.17 | 6 : 5 | 7.15 |
| 2. | | 7.17 | | |

TABLE IX.—C.

| | Oxygen in the peroxide of barium $Q = a$. | Oxygen of the oxide of silver reduced = ψ . | Ratio, $a : \psi$. | Calculated ratio. |
|----|--|--|---------------------|-------------------|
| 1. | 100 | 83.56 | 6 : 5 | 83.33 |
| 2. | | 83.56 | | |

This is the greatest amount of loss which I have yet obtained in these experiments with silver compounds, which has never quite equaled the oxygen in the peroxide.

The specific difference in the amount of reduction of the chloride and of the oxide of silver under otherwise similar circumstances with the same preparation of the peroxide, that is, at the same temperature, depends doubtless on the difference in the chemical nature of the substances. It was an interesting matter of inquiry whether this difference would be found with other silver compounds: I have not yet extended my experiments in this direction so far as the importance of the question demands, but the following results show both the identity and the difference which may exist in the reaction.

The following experiments were made at 100° C. with carbonate of silver and with

the peroxide Q, which was used also in the experiments with the chloride (Table II.). Two equivalents of the carbonate were taken to one of the peroxide.

TABLE X.—A.

| | Peroxide of barium Q. | Carbonate of silver. | Chloride of silver found. | Equivalent of oxygen. |
|----|-----------------------|----------------------|---------------------------|-----------------------|
| 1. | 3.025 grms. | 9.2055 grms. | 1.339 grm. | 0.0746 grm. |
| 2. | 3.03 | 9.2085 | 1.490 | 0.0830 |

TABLE X.—B.

| | Oxygen in the peroxide of barium Q = a . | Oxygen of the carbonate of silver reduced = ψ . | Ratio, $a : \psi$. | Calculated ratio. |
|----|--|--|---------------------|-------------------|
| 1. | 8.58 | 2.46 | 7 : 2 | 2.45 |
| 2. | | 2.73 | 3 : 1 | 2.86 |

TABLE X.—C.

| | Oxygen in the peroxide of barium Q = a . | Oxygen of the carbonate of silver reduced = ψ . | Ratio, $a : \psi$. | Calculated ratio. |
|----|--|--|---------------------|-------------------|
| 1. | 100 | 28.67 | 7 : 2 | 28.57 |
| 2. | | 31.81 | 3 : 1 | 33.3 |

Two other experiments were made with the same substance at a lower temperature, 17° C.

TABLE XI.—A.

| | Peroxide of barium Q. | Carbonate of silver. | Chloride of silver found. | Equivalent of oxygen. |
|----|-----------------------|----------------------|---------------------------|-----------------------|
| 1. | 2.926 grms. | 9.2075 grms. | 1.714 grm. | 0.95556 grm. |
| 2. | 3.012 | 9.1525 | 1.938 | 0.108 |

TABLE XI.—B.

| | Oxygen in the peroxide of barium Q = a . | Oxygen of the carbonate of silver reduced = ψ . | Ratio, $a : \psi$. | Calculated ratio. |
|----|--|--|---------------------|-------------------|
| 1. | 8.58 | 3.26 | 5 : 2 | 3.43 |
| 2. | | 3.58 | | |

TABLE XI.—C.

| | Oxygen in the peroxide of barium Q = a . | Oxygen of the carbonate of silver reduced = ψ . | Ratio, $a : \psi$. | Calculated ratio. |
|----|--|--|---------------------|-------------------|
| 1. | 100 | 37.99 | 5 : 2 | 40 |
| 2. | | 41.72 | | |

These two experiments were made in the small bulb-apparatus used for the oxygen determinations, and thus the total loss of oxygen was estimated as well as the reduced silver. The action proceeds more rapidly than in the experiments with the chloride and oxide, so as to render it probable that a more accurate result might in this manner be obtained with the carbonate than with those substances. In the first experiment the total loss was 12.19 per cent.; in the second, 11.91 per cent. The sum of the oxygen in the peroxide and that due to the silver reduced, as given by the determinations, is in the first experiment 11.84 per cent.; in the second, 12.16 per cent.; which so agree with the other numbers as to show that no oxygen is retained by the substances.

On turning to those experiments with the chloride of silver at 100° C. and at the lower temperature, with which these experiments are comparable (Tables I. and II.), it will be seen that the reduction is nearly the same with the two substances.

With sulphate of silver the result was very different. The two following experiments were made with pure crystallized sulphate of silver and the peroxide Q, at 100° C. In the first experiment one equivalent, in the second two equivalents of the sulphate were taken.

TABLE XII.—A.

| | Peroxide of barium Q. | Sulphate of silver. | Chloride of silver found. | Equivalent of oxygen. |
|----|-----------------------|---------------------|---------------------------|-----------------------|
| 1. | 2.969 grms. | 5.449 grms. | 0.118 gm. | 0.00657 gm. |
| 2. | 3.005 | 10.805 | 0.542 | 0.03021 |

TABLE XII.—B.

| | Oxygen in the peroxide of barium Q = a. | Oxygen of the sulphate of silver reduced = ψ . | Ratio, a : ψ . | Calculated ratio. |
|----|---|---|---------------------|-------------------|
| 1. | 8.58 | 0.221 | 40 : 1 | 0.21 |
| 2. | | 1.00 | 9 : 1 | 0.95 |

TABLE XII.—C.

| | Oxygen in the peroxide of barium Q = a. | Oxygen of the sulphate of silver reduced = ψ . | Ratio, a : ψ . | Calculated ratio. |
|----|---|---|---------------------|-------------------|
| 1. | | 2.57 | 40 : 1 | 2.5 |
| 2. | 100 | 11.66 | 9 : 1 | 11.1 |

The amount of reduction is here so small that the action of the sulphate of silver is very nearly the same as the so-called contact action of platinum. I have already pointed out that the action of very small quantities of the chloride and of the oxide of silver is also of the same nature. In the case of these different chemical substances, therefore, it approaches the same limit, although according to a different law.

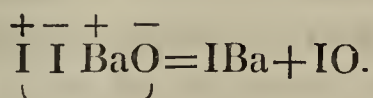
I have now brought this investigation to that point at which for the present I shall leave it. I would willingly have attempted to render these tables of experiments more complete, had it not appeared to me that there were certain defects in the method of experimenting which rendered this course unadvisable. One most important question is, whether the series of ratios by which I have expressed the relative loss of oxygen from the two substances is truly an intermittent or a continuous series, that is to say, whether there are or are not certain points where this ratio is constant although the proportions of the masses are varied. That there is with each chemical substance at least one such point, namely, a certain limit of reduction beyond which a great increase of the mass of the substance to be reduced does not alter the action, may, I think, be asserted with confidence, and without in any way implying that all the ratios which these experiments have brought to light are of this nature; yet it is difficult to account for the great coincidence of experiments made with very different proportions of the substances, without admitting a tendency of the action to fall into certain ratios rather than into others. Indeed the experiments appear to me to indicate both that for certain intervals the loss of oxygen truly does vary directly with the mass of the substance reduced, and that in certain other points the mass may be varied and the loss yet be constant. In these experiments, however, I could never secure that perfect agreement between two experiments made under exactly similar circumstances, by which alone I could hope to answer a question demanding such exactness. One principal reason of the anomalies which the experiments occasionally exhibit is doubtless, that by simply mixing the substances, even where the same quantities are taken in two experiments, the same conditions of mass are yet not realized: I therefore turned my attention to other methods of experimenting, by which it is my hope to answer this question in a more exact and satisfactory manner. My experiments are not yet complete, but I may mention, that by operating with solutions, I have obviated this difficulty. Lastly, let me thus sum up the general results of these experiments. First, the amount of oxygen lost by the substance reduced is, under circumstances otherwise similar, in a definite and constant ratio to the quantity of the peroxide of barium employed. Secondly, this loss is greater as the mass of the substance reduced is increased, and diminishes as the temperature at which the reduction takes place is raised. It varies also with the preparation of the peroxide. Thirdly, in each series of experiments there is a certain definite limit of reduction beyond which at any rate a very great increase of the mass of the substance reduced causes no increase of the loss of oxygen*. Lastly, in reference to that chemical question from which this inquiry proceeded, namely, how much oxygen is lost by the substance reduced in proportion to the loss of oxygen from the peroxide of barium, it is to be observed, that however much the circumstances are varied, there are yet two limiting

* It appears from other experiments which I have made, that with each chemical substance there is a specific limit of reduction of this kind; thus, for example, in the experiment with chromic acid (p. 779), the only reason of the constant reaction there obtained, is that by taking a very great excess of the bichromate of potash,

ratios between which the whole action is comprised, either of which may be almost indefinitely approached. These are the limit of least reduction, in which the ratio of the loss from the peroxide of barium to that from the metallic oxide is infinite, or as 1 : 0 ; and the limit of greatest reduction, which is the ratio of equality, in which the two substances would lose an equal amount of oxygen. This limit also, in no one experiment with any silver compound, have I ever exceeded or reached. The first limit is that in which the action would be a pure reduction by contact, such as takes place when platinum or carbon are the substances which cause the decomposition. The other would be a purely chemical action, such as may be seen in an experiment to which I will now proceed, and which, although perhaps not at first sight as striking as the reduction of the metallic oxides, is, philosophically considered, quite as remarkable, being indeed the same experiment, but detached from circumstances which give in the other case the apparent differences to the reaction.

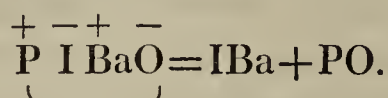
Action of Iodine on the Peroxide of Barium.

It occurred to me, that if it were for the reasons I have stated, that the iodide and chloride of silver decompose the peroxide of barium with the evolution of the oxygen it contains, iodine and chlorine should produce a similar effect. Indeed this was a very critical and important experiment; for we know the action of chlorine and iodine on baryta; and on the view which is usually taken of this decomposition and of other analogous changes, namely, that the iodine takes away the barium from the oxygen because of its superior affinity for the metal, and that the oxygen which is thus liberated combines with the iodine because it is in a nascent condition, and thus converts it into iodous or iodic acid; by acting on iodine with the peroxide of barium, we ought to have just twice as much iodic acid formed as in the other case; nor was there any apparent reason why the oxygen from the peroxide of barium should not oxidize as well as the oxygen from the baryta. The same iodine, the same barium, and the same oxygen are supposed to be present; and if the iodine acted at all on the peroxide, the oxygen would still be nascent. Considered however from that theoretical point of view which I have given in the early part of this paper, there was no reason to expect this result. I have there suggested (p. 767), that in the action of iodine upon baryta, the combination of iodine and oxygen takes place solely on account of the polar relation in which the particles are placed under the peculiar circumstances of the action. Each particle in the change being alternately positive and negative, thus:—

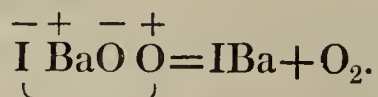


I at once determined the action to a limit which it could not exceed. When small quantities of the bichromate are employed the result is entirely different, and a very small quantity of the bichromate decomposes a very great excess of the peroxide. The reaction which I have given (p. 769) is to a certain extent hypothetical, it is the limit of greatest reduction.

When phosphorus and iodine are used instead of iodine in this experiment, no essential change has taken place in the causes which determine the combining condition of the particles, but a particle of phosphorus now stands in the same relation to the baryta as the particle of iodine in the other experiment, thus:—



Now if thus intercalating the particle of phosphorus transfers the action from the iodine to the phosphorus, so also intercalating a particle of oxygen might transfer the action from the iodine to the oxygen itself, which would now be the truly oxidized body, provided of course that the particle of oxygen thus intercalated were a body which stood to the other particles with which it was in contact, in the same chemical relation as the iodine and phosphorus in the other changes; nor do I see that this substitution of the oxygen for the iodine is more truly extraordinary than the substitution of the iodine for the phosphorus. Indeed, if we inquire into the causes of chemical change, the two would depend essentially upon one and the same fact, namely, a chemical difference between the particles of the element. In the one case we have the chemical division of the element, in the other the chemical synthesis to explain; and to give a philosophical account of either fact we must assume alike the existence of a chemical difference between its particles. Now, when we substitute peroxide of barium for baryta in the iodine experiment, this very intercalation of the oxygen has been effected, and the conditions of the change been fulfilled, the polar cycle being completed, thus:—



In fact, when water is poured upon a mixture of peroxide of barium and iodine, a violent evolution of gas occurs, and the same when chlorine is led into water containing the peroxide, or when the peroxide is thrown into a solution of hypochlorite of lime in acetic acid.

This experiment with iodine is so important, that I shall give at full length the determinations of the quantity of gas evolved in this reaction. The experiment was made in the small bulb-apparatus already described, p. 779.

The weighed peroxide and weighed iodine were mixed in the flask, the bulb being filled with distilled water; the apparatus was weighed, and the water then allowed to descend on the mixture. The loss on again weighing the apparatus is the oxygen evolved. The same precautions are to be taken in the experiment as in the oxygen determination.

The peroxide used in the following experiments was the peroxide Q, containing 8.58 per cent. of oxygen; 100 parts of this peroxide require 138 parts of iodine as one equivalent to the oxygen it contains. The first of the following Tables contains

the quantities of the substances taken and the loss; in the second the comparison is made between this loss and the oxygen of the peroxide.

TABLE XIII.—A.

| | Peroxide of barium Q. | Iodine. | Loss of oxygen. |
|-----|-----------------------|--------------|-----------------|
| 1. | 1.094 grms. | 30.242 grms. | 0.187 grm. |
| 2. | 0.973 | 16.082 | 0.164 |
| 3. | 0.843 | 11.633 | 0.140 |
| 4. | 1.409 | 15.5485 | 0.238 |
| 5. | 1.845 | 17.8225 | 0.315 |
| 6. | 2.0675 | 17.130 | 0.358 |
| 7. | 0.7995 | 5.5325 | 0.140 |
| 8. | 1.9364 | 10.6495 | 0.331 |
| 9. | 1.2405 | 5.277 | 0.212 |
| 10. | 1.275 | 3.517 | 0.215 |

TABLE XIII.—B.

| | Oxygen in the peroxide Q. | Loss of oxygen. | Oxygen in the peroxide. | Loss of oxygen. |
|-----|---------------------------|-----------------|-------------------------|-----------------|
| 1. | | 17.09 | | 199.1 |
| 2. | | 16.85 | | 196.3 |
| 3. | | 16.60 | | 193.4 |
| 4. | | 16.89 | | 196.8 |
| 5. | | 17.06 | | 198.8 |
| 6. | 8.58 | 17.31 | 100 | 201.7 |
| 7. | | 17.51 | | 204.0 |
| 8. | | 17.09 | | 199.1 |
| 9. | | 17.08 | | 199.0 |
| 10. | | 16.86 | | 196.5 |

The mean of these experiments gives the ratio of the oxygen in the peroxide compared with the loss, as 8.58 : 17.03, or as 100 : 198.4. They clearly prove that the reaction is as I have stated. The quantity of iodine taken varies from 2 to 20 equivalents. The number of these experiments may appear superfluous, but there were some circumstances connected with the reaction when a smaller quantity of iodine was employed, which caused me particularly to inquire whether any excess of iodine would alter its nature. It is plain that this cannot be done. I have also ascertained the fact, that with a perfectly pure peroxide an equivalent of iodine always decomposes exactly an equivalent of the peroxide, so that if an excess of the peroxide be taken it remains undecomposed. In this important point this reaction differs from the other experiments I have given, in which very small quantities of the substance decompose the *whole* of the peroxide present. With iodine this will not take place.

The decomposition of the chloride of silver by the peroxide of barium is a true link between these experiments with iodine and the reduction of the metallic oxides. In whatever rational form we may express these facts, the facts themselves are the same. We cannot *see* the mode in which the action is effected, nor for the present argument is it at all important whether we consider, as we reasonably may, that the

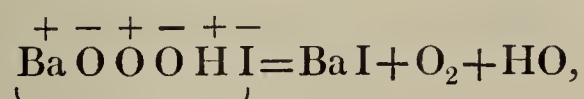
change takes place* by the decomposition of water, and that the oxygen which is formed is the result of the combination of the element of the water with the element of the peroxide, or whether we consider the iodine to be transferred directly to the barium, and the whole of the oxygen to come from the peroxide itself. Whatever theory accounts for this reaction, the same theory, I will venture to assert, will explain the decomposition of the metallic oxides. It remains only to show why it is that this decomposition with iodine comes before us as a chemical reaction of the simplest nature, and that in the other experiments the decomposition is apparently so variable. The reason I believe to be this, that in these latter experiments the peroxide is simultaneously decomposed in two ways, between which we must discriminate, by the action of contact and by the chemical action of the oxide or chloride. The decomposition by platinum is a pure contact action, in which the peroxide loses only one equivalent of oxygen. The decomposition with iodine is a pure chemical action, in which two equivalents of oxygen are given off. The action with metallic oxides is an action compounded of these two, and therefore it is that the loss, as I have already pointed out, ever lies between these two limits. There are two causes by either or by both of which this decomposition may be effected; the one, the metallic silver or other substance which is the result of the reduction; the other, the very oxide or chloride or peroxide itself which is reduced. Certain oxides which are not themselves reduced, can unquestionably act in this manner; and it is highly probable therefore that those which are reduced, and which belong to the same class of bodies, have the same property. On this view therefore the law of the formation of the oxygen is ever one and the same, and so far as relates to the chemical action of the peroxide of barium on the metallic oxide this is ever definite. The fact therefore which is expressed by the series of ratios is by no means any different forms of combination of the particles of the oxygen with each other, but simply the way in which the decomposition of the peroxide of barium is distributed between these different modes of action, and the relative velocity with which these two modes of decomposition take place. If, for example, the ratio of the loss of oxygen from the peroxide of barium to that from the metallic oxide, be as 4 : 1, three parts of the peroxide of barium will have been decomposed by the contact and one by the chemical action; if the ratio be as 2 : 1, the decomposition will have taken place in equal proportions between the two. All the phenomena are perfectly consistent with this view. As a fact, we know that the contact action proceeds far more rapidly at a high than at a low temperature; we need not therefore be surprised if the relative velocity of this to the chemical action

* I have made the experiment of heating the dry peroxide with oxide of silver until the latter was reduced, but the loss of oxygen was only that of the silver. It is however remarkable, that when it is heated in a similar manner with chloride of silver, the chloride is reduced and the two equivalents of oxygen of the peroxide evolved. This decomposition takes place also with baryta, but not with lime; and I cannot but suspect that it is connected with the peculiar property of baryta of taking up a second equivalent of oxygen which does not belong to lime. It is moreover extremely difficult to prepare a baryta quite free from peroxide and water, so as to make a truly comparative experiment.

increases with the temperature. By increasing the mass of the oxide or chloride, on the other hand, the velocity of the chemical action is relatively increased; in this case therefore we have a great reduction. Again, a substance in a fine state of division is decomposed more rapidly than one which is dense and compact; here, therefore, and in other similar differences, is the cause of the different results given by different preparations of the peroxide*.

By the words *contact* and *chemical*, I mean to express no theory, and am indeed drawing but a momentary distinction between facts, for I cannot believe that the one of these portions of oxygen is formed according to one law and the other in a different manner, that the one fact is a chemical synthesis and the other not. The only difference between them I believe to be, that in the case of the action I have called *chemical*, the peroxide of barium decomposes peroxide of lead, or oxide of silver, or the like; and in the *contact* action one particle of peroxide of barium decomposes another particle of the same substance, the platinum, silver oxide or other body causing that chemical relation between the particles which renders the decomposition possible. The important question as to the nature of that definite relation which these experiments indicate between the contact action and the chemical action, I reserve for future inquiry.

I have made various experiments to ascertain whether the same kind of reduction could be effected by means of other metallic peroxides, such, for example, as the peroxide of lead or manganese, as with the peroxide of barium and potassium, but without success. I believe this to admit of a very rational explanation, and that this reducing power is a result of the peculiar chemical nature of the alkaline metals and their compounds; in short, of what is usually termed their powerful chemical affinities and position on the electro-chemical scale, to which indeed we may distinctly trace it. This relation may be expressed in various ways, but which mean essentially one and the same thing. If, for example, in the last experiment we express the change which takes place thus—



it follows, from the view I have given of the mutual relation of these particles, and the interdependence of these chemical changes, that we cannot substitute for the barium a metal which stands in a different chemical relation to the particles between which it is placed without altering the relation of all the other particles of the system, so that if the chemical difference on which combination depends does not exist between the metal and the iodine, neither can it exist between the particles of the oxygen. In this way the fact, at first sight very anomalous, admits of a very simple explanation,

* I by no means wish to exclude from these a real chemical difference in their nature, which the behaviour of certain analogous bodies leads me to suspect.

that the peroxide of barium, the less reducible peroxide, is that which under these circumstances is thus readily decomposed.

Lastly, let me observe, that I have limited my assertions as to the nature of the elemental bodies, to the statement, that, under certain conditions, there exists a chemical difference between the particles of which they consist. On the chemical nature of these particles I have offered no opinion. The apparent and obvious inference from the experiments is doubtless that the elements form a peculiar group of chemical substances, consisting of similar particles or atoms in a state of combination, as other bodies consist of dissimilar. Of this view, in the early part of this paper, I have already spoken; it is the hypothesis of AMPÈRE. Many theoretical difficulties however meet us, when we come logically and consistently to carry out this idea to the explanation of chemical phenomena, especially to the phenomena of direct combination and to the simplest cases of chemical decomposition; and it by no means follows that, although the apparent, it is the rational and philosophical interpretation of the experiments. Besides this view and that of BERZELIUS, there is yet a third hypothesis which we may form as to the constitution of these elements, namely, that they consist of yet other and further elements. On this view, the real fact which lay hid under these phenomena, might be the synthesis of the oxygen from the ultimate and further elements of which the oxygen consisted. In the present state of our knowledge it is useless to dilate on this idea; but on the assumption that the elemental bodies are in this sense compound, we may, I believe, account for all these experiments without ever assuming a chemical difference between two similar particles; and it appears to me perfectly possible, that in such a constitution of the elemental bodies, these experiments, together with the phenomena of allotropy, may find their ultimate solution.

XXXVIII. *Supplementary Observations on the Diffusion of Liquids.*By THOMAS GRAHAM, *F.R.S., F.C.S.*

Received May 2,—Read June 20, 1850.

THE experiments of my former paper furnished strong grounds for believing that isomorphous salts possess a similar diffusibility. All the salts of potash and ammonia, which were compared, appeared to be equi-diffusive; so also were the salts of certain magnesian bases. A single preliminary observation on the nitrates of lead and baryta, however, opposed the general conclusion, and demanded further inquiry. It is scarcely necessary to say that any new means of recognizing the existence of the isomorphous relation between different substances, must prove highly valuable. Let us inquire therefore how far liquid diffusion is available for that purpose.

The salts were still diffused from weak solutions, that is from solutions containing from 1 to 8 per cent. of salt; but now a measure of the solution, equal to 100 grs. of water, was made to contain 1 grain of the salt, to form what is called the 1 per cent. solution; instead of 1 grain of salt being added to 100 grs. of water, as before, without reference to the condensation which generally occurs. The quantities 1, 2, 4 and 8 per cent. thus indicate the parts of salt present in a constant volume of liquid,—as 10, 20, 40 and 80 grs. of the salt in 1000 water grain-measures of the solution. The same phials for the solution and jars for the external water-atmosphere continued to be used, and the manipulations were similar. It is believed, however, that the temperature of the liquids was maintained more uniform in the new experiments than the old, partly by the better regulation of the temperature of the apartment, and partly by placing the jars close together upon a table with upright ledges, and covering the whole over with sheets of paper during the continuance of an experiment. The mass of fluid in 80 or 100 jars, which were employed at once and placed together, made the small oscillations of temperature, which might still occur, slow and less injurious.

The investigation is also extended to several new substances, such as hydrocyanic acid, acetic acid, sulphurous acid, alcohol, ammonia and salts of organic bases, without reference to isomorphous relations. It is very necessary to have data which are minute and accurate respecting the diffusion of a considerable variety of substances. This it is my present object to endeavour to supply, leaving speculative deductions in general respecting the nature and laws of liquid diffusion for a future occasion.

The density of all the solutions was observed at a constant temperature, namely, 60° FAHR.

1. *Hydrochloric Acid.*

The period of diffusion arbitrarily chosen for this acid was five days. The diffusate, or quantity of acid diffused, was determined by precipitating the liquid of the external reservoirs with nitrate of silver, and weighing the chloride of silver formed. In the 1 and 2 per cent. solutions, the liquids of two jars were generally mixed and precipitated together.

(1.) Hydrochloric acid, 0.99 per cent.; density 1.0043. Diffused at 53°5, in six cells, 7.52, 7.52, 7.42; mean 7.49 grs. for two cells. Calculated for 1 per cent., 7.56 grs. at 53°5 for two cells, or 7.41 grs. at 51°, when corrected for that temperature.

(2.) Hydrochloric acid, 1.92 per cent.; density 1.009. Diffused at 51°, in eight cells, 14.71, 14.05, 14.54, 14.47; mean 14.44 grs. for two cells. Calculated for 2 per cent., 15.04 grs. at 51° for two cells.

(3.) Hydrochloric acid, 1.993 per cent.; density 1.0094. Diffused at 62°8, in six cells, two experiments on one-sixth part of the mixed jars gave 8.203, 8.198; mean 8.20 grs. for one cell, or 16.40 grs. for two cells. Calculated for 2 per cent., 16.46 grs. at 62°8 for two cells.

(4.) Hydrochloric acid, 3.90 per cent.; density 1.0190. Diffused at 51°, in eight cells, 29.18, 30.70, 30.70, 29.26; mean 29.96 grs. for two cells. Calculated for 4 per cent., 30.72 grs. at 51° for two cells.

(5.) Hydrochloric acid, 7.90 per cent.; density 1.0380. Diffused at 51°, in four cells, 32.71, 33.64, 33.64, 33.74; mean 33.43 grs. for one cell. Calculated for 8 per cent., 33.84 grs. at 51° for one cell.

Comparing the diffusibilities of the 2 per cent. solutions (2 and 3) at 51° and 62°8, an increase is observed from 15.04 to 16.40 grs., or from 100 to 109.1, which gives an increase of 0.77 per cent. for 1°. This method of estimating the effect of temperature is not exact, as the times only in which an equal diffusion at the different temperatures takes place are truly comparable. We may deduce from it, however, the effect of the small difference of temperature of 2°5 of the 1 per cent. solution from the others, as has been done, without sensible error. The diffusates at the same temperature would then be as follows:—

Diffusion of Hydrochloric Acid in five days at 51° FAHR.; two cells.

| | Grs. | Ratio. |
|-------------------------------------|-------|--------|
| From 1 per cent. solution | 7.41 | 0.97 |
| From 2 per cent. solution | 15.04 | 2.00 |
| From 4 per cent. solution | 30.72 | 4.08 |
| From 8 per cent. solution | 67.68 | 9.00 |

The increasing diffusibility with the larger proportions of acid here observed is unusual, at least in the degree exhibited by the 8 per cent. solution. Other substances, as will be immediately observed of nitric acid, appear to lose proportionally in diffusibility as their solutions are concentrated.

Hydrochloric acid belongs to the most diffusive class of substances known; it appears to exceed hydrate of potash at $53^{\circ}5$, as 7.56 to 6.12, or as 100 to 80.9*.

The rapidity with which hydrochloric acid diffuses, and the facility with which that substance may be estimated, induced me to examine the progression with which its diffusion takes place with increasing times in a minute manner. The 2 per cent. solution was diffused for times increasing by six hours, from twelve hours or 0.5 day to 4.75 days, six cells being diffused for every period. Instead of determining the acid diffused separately in each jar or pair of jars, the contents of the six jars of each experiment were mixed together, and a definite proportion of the liquid precipitated by nitrate of silver, so as to obtain at once the mean result. Another observation for 5.75 days is added, although made at a sensibly higher temperature.

Diffusion of Hydrochloric Acid, 2 per cent. solution; one cell.

| Time. | Temperature. | Diffusate in grains. | Differences. |
|-------|----------------|----------------------|--------------|
| days. | | | |
| 0.5 | $53^{\circ}75$ | 0.909 | |
| 0.75 | $53^{\circ}75$ | 1.312 | .403 |
| 1 | $53^{\circ}75$ | 1.766 | .454 |
| 1.25 | $53^{\circ}75$ | 2.353 | .587 |
| 1.5 | $53^{\circ}75$ | 2.596 | .243 |
| 1.75 | $53^{\circ}58$ | 3.178 | .582 |
| 2 | $53^{\circ}58$ | 3.410 | .232 |
| 2.25 | $53^{\circ}42$ | 3.967 | .557 |
| 2.5 | $53^{\circ}58$ | 4.339 | .372 |
| 2.75 | $53^{\circ}50$ | 4.618 | .279 |
| 3 | $53^{\circ}50$ | 4.969 | .351 |
| 3.25 | $53^{\circ}50$ | 5.304 | .335 |
| 3.5 | $54^{\circ}85$ | 5.857 | .553 |
| 3.75 | $54^{\circ}85$ | 6.254 | .397 |
| 4 | $54^{\circ}85$ | 6.407 | .153 |
| 4.25 | $54^{\circ}85$ | 6.795 | .388 |
| 4.5 | $54^{\circ}71$ | 7.034 | .239 |
| 4.75 | $54^{\circ}71$ | 7.473 | .339 |
| 5.75 | $56^{\circ}46$ | 8.363 | |

The differences are evidently affected by accidental errors of observation. The diffusion at 3.5 days is also increased by a rise of temperature of more than 1° in that and the following experiments. The diffusion always increases with the time, but less rapidly, according to a gradually diminishing progression.

2. *Hydriodic Acid, Hydrobromic Acid and Bromine.*

Hydriodic Acid.—Time of diffusion five days, as for hydrochloric acid. The acid diffused was estimated from the iodide of silver which it gave when precipitated by nitrate of silver.

Hydriodic acid, 1.98 per cent.; density 1.0142. Diffused at $53^{\circ}5$, in eight cells, 14.90, 15.67, 15.25, 15.27; mean 15.27 grs. for two cells. Calculated for 2 per cent., 15.42 grs. at $53^{\circ}5$ for two cells, or 15.11 grs. at 51° .

* Philosophical Transactions, 1850, p. 39.

These experiments indicate a similarity of diffusion between the two isomorphous substances, hydrochloric and hydriodic acids.

Diffusion from 2 per cent. solutions at 51° FAHR.

| | | |
|-----------------------------|-------|--------|
| Hydrochloric acid | 15·04 | 100 |
| Hydriodic acid | 15·11 | 100·46 |

Hydrobromic Acid.—Time of diffusion five days. The diffusate was estimated from the bromide of silver.

(1.) Hydrobromic acid, 1·556 per cent.; density 1·0112. Diffused at 59°·7, in eight cells. The whole diffusates mixed together gave by analysis a mean of 12·90 grs. of hydrobromic acid in two cells; calculated for 2 per cent., 16·58 grs. in two cells, at 59°·7.

(2.) The experiment was repeated at 59°·8, with a solution containing 1·578 per cent. of hydrobromic acid, of density 1·0116, with five diffusion phials not employed above. The mean diffusate for a pair of cells was 13·05 grs. of hydrobromic acid; that is, 16·53 grs. for a 2 per cent. solution, which is as nearly as possible the result of the preceding series of experiments.

(3.) Another solution containing exactly 2 per cent. of hydrochloric acid was diffused for comparison in eight cells, in the same circumstances of time and temperature as (1.); its density was 1·0104.

Diffusate from 2 per cent. solutions at 59°·7 FAHR.

| | | |
|-----------------------------|-------|--------|
| Hydrochloric acid | 16·55 | 100 |
| Hydrobromic acid | 16·58 | 100·18 |

Hydrobromic acid appears therefore to coincide in diffusibility with hydrochloric acid at this temperature. It may be remarked that these three acids, hydrochloric, hydrobromic and hydriodic, do not exhibit the same correspondence in another physical property, namely, the densities of their aqueous solutions containing the same proportion of acid. The densities of 2 per cent. solutions of hydrochloric and hydriodic acids appear to be respectively 1·0104 and 1·0143, at 60° FAHR., and that of hydrobromic acid will obviously be an intermediate number. The same acids are also known to differ considerably in the boiling-points of solutions containing the same proportion of acid. A considerable diversity of physical properties appears here to be compatible with equal diffusibility in substances which are isomorphous.

Bromine.—Pure water readily dissolves more than 1 per cent. of this substance. The solution prepared, however, contained only 0·864 per cent. of bromine, as was ascertained by treating it with sulphurous acid and afterwards precipitating by nitrate of silver. Its density was 1·0070. It was evident, from the slow appearance of the brown colour in the exterior cell, that bromine diffuses less rapidly than hydrobromic acid.

The diffusion-time of bromine was made ten days, or double the time of hydrobromic acid. Two cells contained together a diffusate of 5.80 grs. of bromine; another two cells a diffusate of 5.88 grs.; mean 5.84 grs. at $60^{\circ}1$ FAHR.; or 6.76 grs. for a 1 per cent. solution. Doubling the last result we have 13.52 grs. for a 2 per cent. solution, which is still considerably under the diffusate of hydrobromic acid (16.58 grs.) in half the time.

3. *Hydrocyanic Acid.*

Time of diffusion five days. The acid diffused was estimated from the cyanide of silver which it gave with nitrate of silver.

Hydrocyanic acid, 1.766 per cent., made up to a density of 1.0142 with sulphate of potash. Diffused at $64^{\circ}2$, in six cells, 11.40, 11.86, 11.80; mean 11.68 grs. for two cells. Calculated for 2 per cent., 13.23 grs. at $64^{\circ}2$ in two cells, or about 13.10 grs. at $62^{\circ}8$, assuming this acid to be affected in the same way by temperature as hydrochloric acid.

Hydrocyanic acid here appears less diffusive than hydrochloric acid, at the same temperature $62^{\circ}8$, as 13.10 to 16.40, or as 79.6 to 100, and not to belong therefore to the same class of diffusive substances.

4. *Nitric Acid.*

Time of diffusion five days. The quantity of this acid diffused was always determined with great exactness by neutralization by means of a normal solution of carbonate of soda.

1. Nitrate of water (HO.NO_5), 1 per cent.; density 1.0052. Diffused at $50^{\circ}8$, in eight cells, 6.77, 6.77, 7.26, 6.97; mean 6.94 grs. of nitrate of water in two cells at $50^{\circ}8$, and 6.99 grs. by estimate at $51^{\circ}2$.

2. Nitrate of water, 1 per cent.; density 1.0052. Diffused at $53^{\circ}5$, in six cells, 7.32, 7.32, 7.20; mean 7.28 grs. in two cells.

3. Nitrate of water, 1.92 per cent.; density 1.0112. Diffused at $51^{\circ}2$, in eight cells, 14.34, 14.24, 14.10, 13.96; mean 14.16 grs. in two cells. Calculated for 2 per cent., 14.74 grs. at $51^{\circ}2$ in two cells.

4. Nitrate of water, 2 per cent.; density 1.0106. Diffused at $63^{\circ}2$, in eight cells, 16.97, 16.64, 16.81, 16.64; mean 16.76 grs. in two cells.

5. Nitrate of water, 3.88 per cent.; density 1.0209. Diffused at $51^{\circ}2$, in eight cells, 27.76, 28.34, 27.90, 27.62; mean 27.90 grs. in two cells. Calculated for 4 per cent., 28.76 grs. at $51^{\circ}2$ in two cells.

6. Nitrate of water, 7.96 per cent.; density 1.0432. Diffused at $51^{\circ}2$, in four cells, 29.17, 29.17, 29.17, 27.76; mean 28.82 grs. in one cell. Calculated for 8 per cent., 28.96 grs. at $51^{\circ}2$ in one cell.

For the difference of temperature between $51^{\circ}2$ and $63^{\circ}2$, the diffusion rises, in the 2 per cent. solution, from 14.74 to 16.76 grs., or from 100 to 113.7; which gives an increase of 1.142 per cent. for one degree of temperature.

The diffusion of the different proportions of this acid at one temperature is as follows:—

Diffusion of Nitrate of Water in five days at $51^{\circ}2$; two cells.

| | Grs. | Ratio. |
|-------------------------------------|-------|--------|
| From 1 per cent. solution | 6·99 | 0·95 |
| From 2 per cent. solution | 14·74 | 2 |
| From 4 per cent. solution | 28·76 | 3·90 |
| From 8 per cent. solution | 57·92 | 7·86 |

The 2 per cent. solution is taken as the standard of comparison for the ratios, instead of the 1 per cent. solution, from the greater accuracy with which the diffusion of the former can be observed.

The usual approach to equality of diffusion, between chlorides and nitrates, is observable in hydrochloric and nitric acids, at least in the 1 and 2 per cent. solutions.

Diffusion from 1 per cent. solution at $53^{\circ}5$.

| | | |
|-----------------------------|------|------|
| Hydrochloric acid | 7·56 | 100 |
| Nitrate of water | 7·28 | 96·3 |

Diffusion from 2 per cent. solution.

| | | |
|---|-------|------|
| Hydrochloric acid at 51° | 15·04 | 100 |
| Nitrate of water at $51^{\circ}2$ | 14·74 | 98·0 |

The 2 per cent. solutions of both acids were also diffused at higher temperatures.

Diffusion from 2 per cent solution.

| | | |
|--|-------|-------|
| Hydrochloric acid at $62^{\circ}8$ | 16·46 | 100 |
| Nitrate of water at $63^{\circ}2$ | 16·76 | 101·8 |

Here the diffusibility of the two acids is as nearly as possible equal.

Diffusion from 4 per cent. solution.

| | | |
|---|-------|------|
| Hydrochloric acid at 51° | 30·72 | 100 |
| Nitrate of water at $51^{\circ}2$ | 28·76 | 93·7 |

Diffusion from 8 per cent. solution.

| | | |
|---|-------|------|
| Hydrochloric acid at 51° | 67·68 | 100 |
| Nitrate of water at $51^{\circ}2$ | 57·92 | 85·3 |

The wide divergence between these two acids, in the 8 per cent. solution, is produced by the remarkably increased diffusion of hydrochloric acid in that high proportion.

5. *Sulphuric Acid.*

That time of diffusion arbitrarily chosen for this acid was ten days. The diffusate of this acid was determined in the same manner as that of nitric acid.

1. Sulphate of water (HO.SO_3), 0.993 per cent.; density 1.0065. Diffused at $51^\circ.7$, in eight cells, 8.87, 8.87, 8.87, 8.69; mean 8.82 grs. of sulphate of water for two cells. Calculated for 1 per cent., 8.91 grs. at $51^\circ.7$ for two cells, and 8.69 grs. at $49^\circ.7$.

2. Sulphate of water, 1.89 per cent.; density 1.0130. Diffused at $49^\circ.7$, in eight cells, 16.13, 16.16, 15.58, 16.03; mean 15.98 grs. for two cells. Calculated for 2 per cent., 16.91 grs. at $49^\circ.7$ for two cells.

3. Sulphate of water, 2 per cent.; density 1.0133. Diffused at $63^\circ.5$, in eight cells, 19.80, 20.05, 19.67, 19.41; mean 19.73 grs. for two cells.

4. Sulphate of water, 3.87 per cent.; density 1.0261. Diffused at $49^\circ.7$, in eight cells, 32.72, 32.72, 33.06, 32.58; mean 32.77 grs. for two cells. Calculated for 4 per cent., 33.89 grs. at $49^\circ.7$ for two cells.

5. Sulphate of water, 7.90 per cent.; density 1.0513. Diffused at $49^\circ.7$, in four cells, 34.08, 34.76, 33.74, 33.63; mean 34.05 grs. for one cell. Calculated for 8 per cent., 34.48 grs. at $49^\circ.7$ for one cell.

In the 2 per cent. solution the diffusion rises, with the difference of temperature between $49^\circ.7$ and $63^\circ.5$, from 16.91 to 19.73 grs., or from 100 to 116.68. This is an increase of 1.209 per cent. for one degree of temperature.

The diffusion of the different proportions of sulphuric acid is as follows:—

Diffusion of Sulphate of Water in ten days at $49^\circ.7$; two cells.

| | Grs. | Ratio. |
|-------------------------------------|-------|--------|
| From 1 per cent. solution | 8.69 | 1.03 |
| From 2 per cent. solution | 16.91 | 2 |
| From 4 per cent. solution | 33.89 | 4.01 |
| From 8 per cent. solution | 68.96 | 8.16 |

The diffusibility of different strengths of this acid appears to be pretty uniform, but with a slight tendency to increase in the higher proportions, like hydrochloric acid.

Sulphuric acid is greatly inferior in velocity of diffusion to hydrochloric acid, but still appears to possess considerably more than half the diffusibility of the latter.

6. *Chromic Acid.*

Time of diffusion ten days. The diffusates from four cells of the 2 per cent. solution were mixed together, and the quantity of chromic acid diffused for two cells reduced by means of hydrochloric acid and alcohol, and weighed as oxide of chromium.

1.762 per cent. of anhydrous chromic acid, density 1.01404, diffused at $67^\circ.3$, gave 19.78 grs. of chromic acid in two cells. Calculated for 2 per cent., 22.43 grs. of chromic acid, in two cells, at $67^\circ.3$. The diffusion of sulphuric acid at $63^\circ.5$, was 19.73 grs., which would give about 21 grs. of that acid at $67^\circ.3$.

7. *Acetic Acid.*

Time of diffusion ten days. This acid cannot be determined accurately by the acidimetical method, owing to the acetates of potash and soda being essentially alkaline to test-paper, like the carbonates of the same bases, although neutral in composition. The weight of carbonate of baryta dissolved by the acid was had recourse to.

1. Acetate of water ($\text{HO.C}_4\text{H}_3\text{O}_3$), 2 per cent.; density 1.0030. Diffused at 48°.8 , in eight cells, 12.62, 10.94, 11.10, 11.39 grs. of acetate of water; mean 11.51 grs. for two cells.

2. Acetate of water, 4 per cent.; density 1.0060. Diffused at 48°.8 , in eight cells, 22.12, 21.71, 21.59, 22.67; mean 22.02 grs. for two cells.

3. Acetate of water, 8 per cent.; density 1.0117. Diffused at 48°.8 , in four cells, 21.19, 20.13, 21.84, 20.44; mean 20.90 grs. for one cell. The diffusion of the different proportions of acetic acid is as follows:—

Diffusion of Acetate of Water in ten days at 48°.8 ; two cells.

| | Grs. | Ratio. |
|-------------------------------------|-------|--------|
| From 2 per cent. solution | 11.31 | 2 |
| From 4 per cent. solution | 22.02 | 3.83 |
| From 8 per cent. solution | 41.80 | 7.26 |

The diffusibility diminishes with the larger proportions of acid. This acid appears to be considerably less diffusive than sulphuric acid. I was led to over-estimate the diffusion of acetic acid in a preliminary observation of my former paper, by trusting to the acidimetical method of determination. Hydrochloric acid appears to diffuse about two and a half times more rapidly than acetate of water, at the same temperature.

8. *Sulphurous Acid.*

The time of diffusion chosen for this acid was ten days, for comparison with sulphuric acid. The usual number of eight cells of the 1 and 2 per cent. solutions were diffused, and four cells of the 4 and 8 per cent. solutions. The whole diffusates of each proportion were then mixed together, and the proportional quantity of liquid representing two cells in the 1 and 2 per cent. solutions, and 1 cell in the 4 and 8, was converted into sulphuric acid by a slight excess of bromine, and determined from the sulphate of baryta.

1. 0.982 per cent. of sulphurous acid, density 1.0056, diffused at 68°.1 , gave 7.94 grs. in two cells. Calculated for 1 per cent., 8.09 grs. of sulphurous acid in two cells at 68°.1 .

2. 1.965 per cent. of sulphurous acid, density 1.01055, diffused at 68°.1 , gave 16.66 grs. for two cells. Calculated for 2 per cent., 16.96 grs. of sulphurous acid in two cells at 68°.1 .

3. 3.93 per cent. of sulphurous acid, density 1.01991, diffused at 68°.1 , gave

16.21 grs. for one cell. Calculated for 4 per cent., 16.50 grs. of sulphurous acid in one cell at $68^{\circ}1$.

4. 7.86 per cent. of sulphurous acid, density 1.0384, diffused at $68^{\circ}1$, gave 32.60 grs. for one cell. Calculated for 8 per cent., 33.19 grs. of sulphurous acid in one cell at $68^{\circ}1$.

Diffusion of Sulphurous Acid in ten days at $68^{\circ}1$; two cells.

| | Grs. | Ratio. |
|---------------------------------|-------|--------|
| From 1 per cent. solution . . . | 8.09 | 0.954 |
| From 2 per cent. solution . . . | 16.96 | 2 |
| From 4 per cent. solution . . . | 33.00 | 3.891 |
| From 8 per cent. solution . . . | 66.38 | 7.827 |

This substance appears to be less diffusive than sulphuric acid at the same temperature; the diffusion of sulphurous acid at $68^{\circ}1$ considerably resembles that of sulphuric acid at $49^{\circ}7$ (p. 811).

9. *Ammonia.*

The time of diffusion chosen was 4.041 days, or that of hydrate of potash with chloride of sodium at seven days. The usual number of eight cells of the 1 and 2 per cent. solutions were diffused, and four cells of the 4 and 8 per cent. solutions. The whole diffusates of each proportion were then mixed together, and the quantity of ammonia diffused for two cells determined by an alkalimetric experiment, which was always repeated twice. It was necessary for diffusion to have the ammoniacal solution made denser than water, which was effected by the addition of common salt.

1. 1.005 per cent. of ammonia, density made up to 1.00352 with chloride of sodium, diffused at $63^{\circ}4$, gave 4.96 grs. for two cells; calculated for 1 per cent., 4.93 grs. of ammonia in two cells at $63^{\circ}4$.

2. 2.01 per cent. of ammonia, density made up to 1.00617 with chloride of sodium, diffused at $63^{\circ}4$, gave 9.64 grs. for two cells; calculated for 2 per cent., 9.59 grs. of ammonia in two cells at $63^{\circ}4$.

3. 4.02 per cent. of ammonia, density made up to 1.01141 with chloride of sodium, diffused at $63^{\circ}4$, gave 9.91 grs. for one cell; calculated for 4 per cent., 9.86 grs. of ammonia, in one cell, at $63^{\circ}4$.

4. 8.04 per cent. of ammonia, density made up to 1.0215 with chloride of sodium, diffused at $63^{\circ}4$, gave 20.71 grs. for one cell; calculated for 8 per cent., 20.61 grs. of ammonia in one cell at $63^{\circ}4$.

Diffusion of Ammonia in 4.04 days at $63^{\circ}4$; two cells.

| | Grs. | Ratio. |
|---------------------------------|-------|--------|
| From 1 per cent. solution . . . | 4.93 | 1.029 |
| From 2 per cent. solution . . . | 9.59 | 2 |
| From 4 per cent. solution . . . | 19.72 | 4.117 |
| From 8 per cent. solution . . . | 41.22 | 8.605 |

Ammonia appears to have a diffusibility approaching to that of hydrate of potash. It appears somewhat less diffusive than hydrocyanic acid at the same temperature, in the proportion of 12 to 13 nearly; or to possess about three-fourths of the diffusibility of hydrochloric acid.

10. *Alcohol.*

Time of diffusion ten days. The quantity of alcohol diffused was determined by careful distillation.

1. Alcohol, 2 per cent.; density made up to 1·0237 with chloride of sodium. Diffused at 40°·7, in eight cells, 17·80, 16·70; mean 17·25 grs. for four cells, or 8·62 grs. for two cells.

2. Alcohol, 4 per cent.; density made up to 1·0203 with chloride of sodium. Diffused at 48°·7, in eight cells, 34·30, 30·20; mean 32·25 grs. for four cells, or 16·12 grs. for two cells.

3. Alcohol, 8 per cent.; density made up to 1·0154 with chloride of sodium. Diffused at 48°·7, in four cells, 30·80, 40·2; mean 35·50 grs. for two cells, or 17·75 grs. for one cell.

The results accord less closely with each other than usual, owing, I believe, chiefly to the difficulties of manipulation when the density of the liquid placed in the phials to be diffused approaches so nearly to that of water. This is more particularly true of the 8 per cent. solution.

Diffusion of Alcohol in ten days at 48°·7; two cells.

| | |
|-------------------------------------|-------|
| From 2 per cent. solution | 8·62 |
| From 4 per cent. solution | 16·12 |
| From 8 per cent. solution | 35·50 |

It would be unsafe to draw any conclusion as to the proportionality of the diffusion of alcohol to the strength of the solution from these experiments.

Alcohol does not appear to belong to the same class of diffusive substances as acetic acid, which might be expected from their similarity of composition, but possesses a considerably lower diffusibility.

Diffusion from 2 per cent. solutions in ten days.

| | | |
|-------------------------------------|-------|------|
| Acetate of water at 48°·8 | 11·51 | 100 |
| Alcohol at 48°·7 | 8·62 | 74·9 |

The diffusion of alcohol approaches to one-half of that of sulphate of water at nearly the same temperature, p. 811.

Alcohol may be substituted for water to dissolve certain salts, and also as an atmosphere into which these salts may diffuse. From experiments which have been commenced on this subject, it appears that the diffusion of hydrate of potash, iodide of potassium, chloride of calcium and others is about four times slower into alcohol of density 0·840 than into water. The salts likewise often exhibit the same rela-

tions in their diffusibility in alcohol, as in water, with some singular exceptions, such as chloride of mercury.

11. *Nitrate of Baryta.*

Time of diffusion 11.43 days*. The salt diffused was precipitated by sulphuric acid, and calculated from the weight of the sulphate of baryta formed.

1. Nitrate of baryta, 1 per cent.; density 1.0083. Diffused at 51°5, in eight cells, 6.71, 6.71, 6.84, 6.68; mean 6.73 grs. for two cells.

2. Nitrate of baryta, 0.993 per cent.; density 1.00886. Diffused at 64°1, in eight cells, 7.64, 7.70, 7.74, 7.61; mean 7.67 grs. for two cells. Calculated for 1 per cent., 7.72 grs. for two cells.

3. Nitrate of baryta, 2 per cent; density 1.01686. Diffused at 64°1, in eight cells, 15.63, 14.81, 14.41, 15.32; mean 15.04 grs. for two cells.

4. Nitrate of baryta, 4 per cent.; density 1.03319. Diffused at 64°1, in four cells, 15.36, 14.78, 14.79, 14.30; mean 14.80 grs. for one cell.

5. Nitrate of baryta, 8 per cent; density 1.06556. Diffused at 64°1, in four cells, 26.46, 26.77, 28.63, 27.13; mean 27.25 grs. for one cell.

The diffusion from the 1 per cent. solution increases by a rise of temperature from 51°5 to 64°1, from 6.73 grs. to 7.72, or from 100 to 114.7, which is an increase of 1.17 per cent for 1°.

Diffusion of Nitrate of Baryta in 11.43 days at 64°1; two cells.

| | Grs. | Ratio. |
|---------------------------------|-------|--------|
| From 1 per cent. solution . . . | 7.72 | 1.026 |
| From 2 per cent. solution . . . | 15.04 | 2 |
| From 4 per cent. solution . . . | 29.60 | 3.936 |
| From 8 per cent. solution . . . | 54.50 | 7.247 |

12. *Nitrate of Strontia.*

Time of diffusion 11.43 days. Of anhydrous nitrate of strontia 0.82 per cent.; density 1.0063. Diffused at 51°5, in eight cells, 5.59, 5.62, 5.44, 5.69; mean 5.59 grs. for two cells; calculated for 1 per cent., 6.79 grs. at 51°5 for two cells.

The diffusion of nitrate of strontia almost coincides with that of the isomorphous nitrate of baryta at the same temperature.

Diffusion from 1 per cent. solutions at 51°5 in 11.43 days.

| | | |
|-------------------------------|------|--------|
| Nitrate of baryta | 6.73 | 100 |
| Nitrate of strontia | 6.79 | 100.89 |

* This time is to that of sulphate of magnesia (16.166 days) as the square root of 8 is to the square of 16; but does not appear to express the true relation between these salts.

13. *Nitrate of Lime.*

Time of diffusion 11·43 days. The diffusate was evaporated to dryness with an excess of sulphuric acid, and the nitrate of lime, which is always supposed anhydrous, was estimated from the sulphate of lime produced.

1. Nitrate of lime, 1·17 per cent; density 1·0088. Diffused at 51°·5, in eight cells, 7·39, 7·76, 7·69, 7·80; mean 7·66 grs. for two cells; calculated for 1 per cent., 6·54 grs. at 51°·5 for two cells.

2. Nitrate of lime, 0·985 per cent.; density 1·00802. Diffused at 64°·1, in eight cells, 7·47, 7·38, 7·63, 7·72; mean 7·55 grs. for two cells; calculated for 1 per cent., 7·66 grs. at 64°·1 for two cells.

3. Nitrate of lime, 1·97 per cent.; density 1·01508. Diffused at 64°·1, in eight cells, 15·04, 14·74, 14·55, 14·83; mean 14·79 grs. for two cells; calculated for 2 per cent., 15·01 grs. at 64°·1 for two cells.

4. Nitrate of lime, 3·94 per cent.; density 1·0296. Diffused at 64°·1, in four cells, 14·30, 15·29, 13·79, 13·93; mean 14·33 grs. for one cell; calculated for 4 per cent., 14·52 grs. at 64°·1 for one cell.

5. Nitrate of lime, 7·88 per cent.; density 1·0582. Diffused at 64°·1, in four cells, 27·95, 27·10, 26·80, 26·73; mean 27·14 grs. for one cell; calculated for 8 per cent., 27·55 grs. at 64°·1 for one cell.

By a rise of temperature from 51°·5 to 64°·1, the diffusion of the 1 per cent. solution increases from 6·54 to 7·66 grs., or from 100 to 117·1; which is an increase of 1·357 per cent. for 1°.

Diffusion of Nitrate of Lime in 11·43 days at 64°·1; two cells.

| | Grs. | Ratio. |
|---------------------------------|-------|--------|
| From 1 per cent. solution . . . | 7·66 | 1·021 |
| From 2 per cent. solution . . . | 15·01 | 2 |
| From 4 per cent. solution . . . | 29·04 | 3·872 |
| From 8 per cent. solution . . . | 55·10 | 7·334 |

The results throughout for this salt are almost identical with those of nitrate of baryta (p. 815), although these two salts differ greatly in solubility, and in one being a hydrated, and the other an anhydrous salt.

14. *Acetate of Lead.*

Diffused for 16·166 days; the time chosen before for sulphate of magnesia, with seven days for chloride of sodium. The solution contained 0·965 per cent. of anhydrous salt, with the density 1·0080. As this solution of acetate of lead was found to be precipitated by pure water, about 2 per cent. of strong acetic acid was introduced into the solution, and the same acid was added in a less proportion to the water jars. The salt of lead diffused was afterwards determined by means of sulphuric acid. Diffused in eight cells, at 53°·1, 7·45, 7·29, 7·46 and 8·07 grs.; mean 7·56; or 7·84 for 1 per cent. in two cells.

15. *Acetate of Baryta.*

Diffused for 16·166 days. The solution contained 0·977 per cent. of anhydrous salt, with the density 1·0073. The same addition of acetic acid was made to it as to the preceding acetate of lead, in order that the circumstances of diffusion might be similar for both salts. The salt diffused was estimated also in the form of sulphate.

Diffused at 53°·5, in eight cells, 7·30, 7·38, 7·40 and 7·21 grs. in two cells; mean 7·33; or 7·50 for 1 per cent. in two cells.

Diffusion of 1 per cent. solutions in 16·166 days; two cells.

| | | |
|--------------------------------------|------|--------|
| Acetate of baryta at 53°·5 | 7·50 | 100 |
| Acetate of lead at 53°·1 | 7·84 | 104·53 |

Here, of two isomorphous salts, that of greatest atomic weight sensibly exceeds the other in diffusibility.

16. *Chloride of Barium.*

Time of diffusion 11·43 days. The diffused salt was weighed as sulphate of baryta.

1. Chloride of barium, 0·99 per cent. Diffused at 50°·9, in eight cells, 7·91, 7·27, 7·42, 7·12; mean 7·43 grs. of chloride of barium for two cells; calculated for 1 per cent., 7·50 grs. at 50°·9 for two cells.

The diffusion of this salt being manifestly more rapid than that of the chloride of calcium, a shorter time was tried, which is to seven days, the time of chloride of sodium, as the square root of 3 to the square root of 4·5. Time of diffusion 8·57 days.

2. Chloride of barium, 1·01 per cent.; density 1·0095. Diffused at 63°, in eight cells, 6·46, 6·44, 6·41, 6·27; mean 6·39 grs. for two cells; calculated for 1 per cent., 6·32 grs. at 63° for two cells.

3. Chloride of barium, 2·02 per cent.; density 1·0183. Diffused at 63°, in eight cells, 11·98, 12·03, 12·75, 12·03; mean 12·20 grs. for two cells; calculated for 2 per cent., 12·07 grs. at 63° for two cells.

4. Chloride of barium, 4·04 per cent.; density 1·0359. Diffused at 63°, in four cells, 12·43, 12·30, 11·87, 11·86; mean 12·10 grs. for one cell; calculated for 4 per cent., 11·98 grs. at 63° for one cell.

5. Chloride of barium, 8·08 per cent.; density 1·0712. Diffused at 63°, in four cells, 23·17, 23·05, 22·98, 23·62; mean 23·20 grs. for one cell; calculated for 8 per cent., 22·96 grs. at 63° for one cell.

Diffusion of Chloride of Barium in 8·57 days at 63°; two cells.

| | Grs. | Ratio. |
|-------------------------------------|-------|--------|
| From 1 per cent. solution | 6·32 | 1·047 |
| From 2 per cent. solution | 12·07 | 2 |
| From 4 per cent. solution | 23·96 | 3·970 |
| From 8 per cent. solution | 45·92 | 7·608 |

17. *Chloride of Strontium.*

First time of diffusion 11.43 days. The diffused salt was weighed as sulphate of strontia.

1. Chloride of strontium, 0.803 per cent.; density 1.0076. Diffused at 51°, in eight cells, 6.36, 6.06, 5.93, 5.73; mean 6.02 grs. of chloride of strontium for two cells; calculated for 1 per cent., 7.52 grs. at 51° for two cells.

Second time of diffusion 8.57 days.

2. Chloride of strontium, 1 per cent.; density 1.00936. Diffused at 63°, in eight cells, 6.10, 6.17, 6.02, 6.09; mean 6.09 grs. for two cells.

3. Chloride of strontium, 2 per cent.; density 1.01806. Diffused at 63°, in eight cells, 11.62, 11.71, 11.53, 11.79; mean 11.66 grs. for two cells.

4. Chloride of strontium, 4.014 per cent.; density 1.03537. Diffused at 63°, in four cells, 12.09, 11.75, 11.64, 11.79; mean 11.82 grs. for one cell; calculated for 4 per cent., 11.78 grs. at 63° for one cell.

5. Chloride of strontium, 8.028 per cent.; density 1.06959. Diffused at 63°, in four cells, 22.29, 22.34, 22.03, 22.57; mean 22.31 grs. for one cell; calculated for 8 per cent., 22.23 grs. at 63° for two cells.

Diffusion of Chloride of Strontium in 8.57 days at 63°; two cells.

| | Grs. | Ratio. |
|---------------------------------|-------|--------|
| From 1 per cent. solution . . . | 6.09 | 1.045 |
| From 2 per cent. solution . . . | 11.66 | 2 |
| From 4 per cent. solution . . . | 23.56 | 4.041 |
| From 8 per cent. solution . . . | 44.46 | 7.626 |

The series of ratios in the preceding table will be found on comparison to correspond closely with the ratios of chloride of barium. It may be useful to compare further the amounts diffused from similar solutions of these two isomorphous compounds.

Diffusion in 8.57 days at 63°; two cells.

| | | |
|--|-------|-------|
| Chloride of barium, 1 per cent. . . | 6.32 | 100 |
| Chloride of strontium, 1 per cent. . . | 6.09 | 96.36 |
| Chloride of barium, 2 per cent. . . | 12.07 | 100 |
| Chloride of strontium, 2 per cent. . . | 11.66 | 96.90 |
| Chloride of barium, 4 per cent. . . | 23.96 | 100 |
| Chloride of strontium, 4 per cent. . . | 23.56 | 99.16 |
| Chloride of barium, 8 per cent. . . | 45.92 | 100 |
| Chloride of strontium, 8 per cent. . . | 44.46 | 96.83 |

The near coincidence of the 4 per cent. solutions probably arises from an accidental error of observation in the chloride of barium, for the latter departs here from the progression of its ratios. We appear then to have a small but constant difference of

about $3\frac{1}{2}$ per cent. in the diffusion of these two isomorphous salts, the chloride of barium, which possesses the highest atomic weight, having the advantage.

The diffusion of the 1 per cent. solution of the same salts for the longer period of 11.43 days, gives 7.50 for chloride of barium at $50^{\circ}9$, and $7^{\circ}52$ for chloride of strontium at 51° , or nearly the same temperature. For the first time we have in the barytic salts a divergence between chlorides and nitrates, for the nitrates of the same bases have a number about 6.8 only at the same temperature. I am led however to believe that this discrepancy becomes much less at low temperatures by experiments which are at present in progress.

18. *Chloride of Calcium.*

Time of diffusion 11.43 days. The salt diffused was weighed as sulphate of lime.

1. Chloride of calcium, 1.065 per cent. ; density 1.0091. Diffused at $50^{\circ}9$, in eight cells, 6.95, 7.09, 6.78, 6.94; mean 6.94 grs. of chloride of calcium for two cells; calculated for 1 per cent., 6.51 grs. at $50^{\circ}9$ for two cells.

2. Chloride of calcium, 1.03 per cent. ; density 1.0089. Diffused at $63^{\circ}8$, in eight cells, 8.08, 8.13, 8.28, 8.19; mean 8.17 grs. for two cells; calculated for 1 per cent., 7.92 grs. at $63^{\circ}8$ for two cells.

3. Chloride of calcium, 2.06 per cent. ; density 1.0171. Diffused at $63^{\circ}8$, in eight cells, 15.70, 15.33, 16.48, 15.82; mean 15.83 grs. for two cells; calculated for 2 per cent., 15.35 grs. at $63^{\circ}8$ for two cells.

4. Chloride of calcium, 4.12 per cent. ; density 1.0334. Diffused at $63^{\circ}8$, in four cells, 15.24, 16.20, 15.89, 16.20; mean 15.88 grs. for one cell; calculated for 4 per cent., 15.39 grs. at $63^{\circ}8$ for one cell.

5. Chloride of calcium, 8.23 per cent. ; density 1.0652. Diffused at $63^{\circ}8$, in four cells, 32.97, 31.17, 30.64, 31.90; mean 31.67 grs. for one cell; calculated for 8 per cent., 30.78 grs. at $62^{\circ}8$ for one cell.

The diffusion of the 1 per cent. solution of chloride of calcium is increased by a rise of temperature from $50^{\circ}9$ to $63^{\circ}8$, from 6.51 to 7.92, or from 100 to 121.6, which is an increase of 1.674 per cent. for 1° .

Diffusion of Chloride of Calcium in 11.43 days at $63^{\circ}8$; two cells.

| | Grs. | Ratio. |
|---------------------------------|-------|--------|
| From 1 per cent. solution . . . | 7.92 | 1.032 |
| From 2 per cent. solution . . . | 15.35 | 2 |
| From 4 per cent. solution . . . | 30.78 | 4.010 |
| From 8 per cent. solution . . . | 61.56 | 8.021 |

We may now observe how far the diffusion of the chloride of calcium is analogous to that of nitrate of lime. At the inferior temperatures, the results for the 1 per cent. solution of these two salts were as follows:—

| | | |
|--|------|--------|
| Chloride of calcium at $50^{\circ}9$. . . | 6.51 | 100 |
| Nitrate of lime at $51^{\circ}5$ | 6.54 | 100.46 |

While at the higher temperatures, namely, $63^{\circ}8$ for the chloride of calcium, and $64^{\circ}1$ for the nitrate of lime, the results for the different proportions of salt are—

| | | |
|--|-------|-------|
| Chloride of calcium, 1 per cent. | 7.92 | 100 |
| Nitrate of lime, 1 per cent. | 7.66 | 96.72 |
| Chloride of calcium, 2 per cent. | 15.35 | 100 |
| Nitrate of lime, 2 per cent. | 15.01 | 97.79 |
| Chloride of calcium, 4 per cent. | 30.78 | 100 |
| Nitrate of lime, 4 per cent. | 29.04 | 94.35 |
| Chloride of calcium, 8 per cent. | 61.56 | 100 |
| Nitrate of lime, 8 per cent. | 55.10 | 89.51 |

The correspondence between the 1 and 2 per cent. solutions of chloride and nitrate is sufficiently close, but in the 4 and 8 per cent. the salts diverge, as happens also with hydrochloric and nitric acids themselves. The nitrate in both cases falls off, while the chloride sustains throughout the high diffusibility of the lower proportions.

19. *Chloride of Manganese.*

Time of diffusion 11.43 days. The salt diffused was estimated by means of nitrate of silver.

The 1 per cent. solution, of density 1.0085, gave at $50^{\circ}8$, in eight cells, 6.67, 6.26, 6.79 and 6.81 grs.; mean 6.63 for two cells.

20. *Nitrate of Magnesia.*

Time of diffusion 11.43 days. The salt diffused was estimated as sulphate.

The 1 per cent. solution, of density 1.0073, gave at $50^{\circ}8$, in eight cells, 6.29, 6.39, 6.52 and 6.76 grs.; mean 6.49 for two cells.

21. *Nitrate of Copper.*

Time of diffusion 11.43 days. The salt diffused was estimated from the oxide of copper obtained by ignition.

The 1 per cent. solution, of density 1.0075, in eight cells, at $50^{\circ}8$, gave 6.52, 6.36, 6.18 and 6.70 grs.; mean 6.44 for two cells.

Comparing the preceding salts with chloride of calcium diffused at the same temperature, $50^{\circ}8$, we have the following results:—

| | | |
|---------------------------------|------|--------|
| Chloride of calcium | 6.51 | 100 |
| Chloride of manganese | 6.63 | 101.85 |
| Nitrate of magnesia | 6.49 | 99.69 |
| Nitrate of copper | 6.44 | 98.92 |

This group of salts, belonging to the same isomorphous family of bases, the magnesian, again correspond closely in diffusibility.

The following additional magnesian chlorides were diffused, all 1 per cent. solu-

tions, either in six or in eight cells. The salt diffused was estimated by means of nitrate of silver.

22. *Chloride of Zinc* at 51° , solution of density 1.0091, gave 6.55, 6.20, 6.21 and 6.28 grs.; mean 6.29 for two cells.

23. *Chloride of Magnesium* at $50^{\circ}6$, density 1.0077, gave 6.40, 5.84 and 6.29; mean 6.17 for two cells.

24. *Chloride of Copper* at $50^{\circ}6$, solution of density 1.0093, gave 6.08, 6.08 and 6.02 grs.; mean 6.06 for two cells.

The results referred to chloride of calcium, at nearly the same temperature, $50^{\circ}8$, are as follows:—

| | | |
|---------------------------------|------|-------|
| Chloride of calcium | 6.51 | 100 |
| Chloride of zinc | 6.29 | 96.61 |
| Chloride of magnesium | 6.17 | 94.77 |
| Chloride of copper | 6.06 | 93.08 |

These salts present a greater latitude in their diffusibility, if belonging to the same class, than is usual.

25. *Protochloride of Iron.*

A solution of this salt of 1.023 per cent. was diffused at $53^{\circ}5$, a somewhat higher temperature than the corresponding chlorides. It gave 6.45, 6.48, 6.48 and 6.28 grs. in two cells; mean 6.44, or 6.30 for 1 per cent. in two cells. This salt appears therefore to belong to the last group.

26. *Sesquichloride of Iron.*

A full series of observations was made upon the diffusion of the different proportions of this salt from 1 to 8 per cent., but in all of them decomposition was determined by the diffusion, with turbidity also in the solution phial except in the 8 per cent. solution.

The mean diffusion from the 1 per cent. solution in 11.43 days, at $63^{\circ}3$, was 4.13 grs. of sesquichloride of iron with 1.28 gr. of free hydrochloric acid, in two cells. This result indicates that one-half nearly of the sesquichloride of iron is decomposed in the diffusion.

The mean diffusion from the 8 per cent. solution, at $63^{\circ}3$, was 55.88 grs. of sesquichloride of iron, with 6.66 grs. of free hydrochloric acid, in two cells. It appears from this experiment that perchloride of iron approaches the chloride of calcium in diffusibility. That the proto- and persalts of the magnesian metals should have a similar rate of diffusion, is not unlikely from other analogies which they exhibit.

27. *Sulphate of Magnesia.*

The time chosen for the diffusion of this salt, namely, 16.166 days, is a multiple by 2 of the time of sulphate of potash, and by 4 of the time of hydrate of potash. The diffusate was evaporated to dryness and weighed.

1. 1.012 per cent. of anhydrous sulphate of magnesia, density 1.0108, diffused at 65°4, in eight cells, 7.34, 7.66, 7.43, 7.18; mean 7.40 grs. for two cells; calculated for 1 per cent., 7.31 grs. of sulphate of magnesia in two cells at 65°4.

2. 2.024 per cent. of sulphate of magnesia, density 1.02089, diffused at 65°4, in eight cells, 12.91, 13.13, 12.83, 12.93; mean 12.95 grs. for two cells; calculated for 2 per cent., 12.79 grs. of sulphate of magnesia in two cells at 65°4.

3. 4.048 per cent. of sulphate of magnesia, density 1.04033, diffused at 65°4, in four cells, 12.06, 12.56, 10.63, 12.24; mean 11.87 grs. for one cell; calculated for 4 per cent., 11.73 grs. of sulphate of magnesia in one cell at 65°4.

4. 8.096 per cent. of sulphate of magnesia, density 1.07830, diffused at 65°4, in four cells, 22.25, 20.56, 21.80, 22.06; mean 21.67 grs. for one cell; calculated for 8 per cent., 21.41 grs. of sulphate of magnesia in one cell at 65°4.

5. 8.07 per cent. of sulphate of magnesia, density 1.07830, diffused at 62°8, in four cells, 21.12, 21.20, 22.13, 21.77; mean 21.55 grs. for one cell; calculated for 8 per cent., 21.33 grs. of sulphate of magnesia in one cell at 62°8.

6. 16.14 per cent. of sulphate of magnesia, density 1.15054, diffused at 62°8, in four cells, 37.08, 38.39, 38.65, 37.50; mean 37.90 grs. for one cell; calculated for 16 per cent., 37.53 grs. of sulphate of magnesia in one cell at 62°8.

7. 24.22 per cent. of sulphate of magnesia, density 1.21882, diffused at 62°8, in four cells, 49.38, 50.40, 53.36, 53.00; mean 51.53 grs. for one cell; calculated for 24 per cent., 51.02 grs. of sulphate of magnesia in one cell at 62°8.

Diffusion of Sulphate of Magnesia in 16.16 days at 65°4; two cells.

| | Grs. | Ratio. |
|--------------------------------------|--------|--------|
| From 1 per cent. solution | 7.31 | 1.144 |
| From 2 per cent solution | 12.79 | 2 |
| From 4 per cent. solution | 23.46 | 3.671 |
| From 8 per cent. solution | 42.82 | 6.701 |
| From 8 per cent. solution at 62°8 . | 42.66 | 1 |
| From 16 per cent. solution at 62°8 . | 75.06 | 1.759 |
| From 24 per cent. solution at 62°8 . | 102.04 | 2.340 |

28. Sulphate of Zinc.

Time of diffusion 16.166 days. The diffused salt was evaporated to dryness and weighed.

1. 1.001 per cent. of anhydrous sulphate of zinc, density 1.01093, diffused at 65°4, in eight cells, 6.66, 6.76, 6.51, 6.80; mean 6.68 grs. for two cells; calculated for 1 per cent., 6.67 grs. of sulphate of zinc in two cells at 65°4.

2. 2.002 per cent. sulphate of zinc, density 1.02120, diffused at 65°4, in eight cells, 12.16, 12.19, 12.52, 12.05; mean 12.23 grs. for two cells; calculated for 2 per cent., 12.22 grs. of sulphate of zinc in two cells at 65°4.

3. 4.005 per cent. of sulphate of zinc, density 1.04146, diffused at $65^{\circ}4$, in four cells, 11.63, 11.70, 11.00, 11.95; mean 11.57 grs. for one cell; calculated for 4 per cent., 11.56 grs. of sulphate of zinc in one cell at $65^{\circ}4$.

4. 8.01 per cent. of sulphate of zinc, density 1.08063, diffused at $65^{\circ}4$, in four cells, 21.22, 20.52, 21.06, 21.84; mean 21.16 grs. for one cell; calculated for 8 per cent., 21.13 grs. of sulphate of zinc in one cell at $65^{\circ}4$.

5. 8.04 per cent. of sulphate of zinc, density 1.08084, diffused at $62^{\circ}8$, in four cells, 20.70, 18.57, 20.32, 20.36; mean 19.99 grs. for one cell; calculated for 8 per cent., 19.81 grs. of sulphate of zinc in one cell at $62^{\circ}8$.

6. 16.08 per cent. of sulphate of zinc, density 1.15734, diffused at $62^{\circ}8$, in four cells, 36.70, 37.15, 37.51, 38.21; mean 37.39 grs. for one cell; calculated for 16 per cent., 37.20 grs. of sulphate of zinc in one cell at $62^{\circ}8$.

7. 24.11 per cent. of sulphate of zinc, density 1.23156, diffused at $62^{\circ}8$, in three cells, 51.12, 50.14, 51.66; mean 50.97 grs. for one cell; calculated for 24 per cent., 50.71 grs. of sulphate of zinc in one cell at $62^{\circ}8$.

Diffusion of Sulphate of Zinc in 16.16 days at $65^{\circ}4$; two cells.

| | Grs. | Ratio. |
|--|--------|--------|
| From 1 per cent. solution | 6.67 | 1.091 |
| From 2 per cent. solution | 12.22 | 2 |
| From 4 per cent. solution | 23.12 | 3.784 |
| From 8 per cent. solution | 42.26 | 6.916 |
| From 8 per cent. solution at $62^{\circ}8$. | 39.62 | 1 |
| From 16 per cent. solution at $62^{\circ}8$. | 74.40 | 1.878 |
| From 24 per cent. solution at $62^{\circ}8$.. | 101.42 | 2.560 |

It will be remarked that the diffusion of these two isomorphous salts, sulphate of magnesia and sulphate of zinc, differs so much, in the 1 per cent. solution, as 7.31 to 6.67, that is, as 100 to 91.25; or 8.75 per cent. This I have no doubt, however, is an accidental error, the disturbances from changes of temperature and other causes of dispersion being in direct proportion to the duration of the experiment, and therefore much increased with these long times; while the 1 per cent. solution also appears to be generally the proportion most exposed to such errors. The sulphate of zinc appears to be the truest throughout, in its diffusion, of these two salts. The approach to equality becomes close in the 4 per cent. and larger proportions of salt, particularly with the unusually high proportions of 16 and 24 per cent., which were observed in these salts. The diffusion of both salts falls off remarkably in the higher proportions. The result of the comparison of these two magnesian sulphates is no doubt favourable to the similarity of diffusion of isomorphous salts.

29. *Sulphate of Alumina.*

The time of diffusion chosen was 16·166 days, or the same as that for sulphate of magnesia. The usual number of eight cells of the 1 and 2 per cent. solutions were diffused, and four cells of the 4 and 8 per cent. solutions. The whole diffusates of each proportion were then mixed together and the quantities of alumina and sulphuric acid, diffused for two cells, determined separately.

1. 1·045 per cent. of sulphate of alumina, density 1·01160, diffused at 65°·4, gave 1·80 gr. of alumina and 3·93 grs. of sulphuric acid, in all 5·73 grs. for two cells. Calculated for 1 per cent., 1·72 gr. alumina and 3·76 grs. sulphuric acid, in all 5·48 grs. of sulphate of alumina in two cells at 65°·4.

2. 2·091 per cent. of sulphate of alumina, density 1·02251, diffused at 65°·4, gave 3·32 grs. of alumina and 7·35 grs. of sulphuric acid, in all 10·67 grs. for two cells. Calculated for 2 per cent., 3·18 grs. of alumina and 7·03 grs. of sulphuric acid, in all 10·21 grs. of sulphate of alumina for two cells at 65°·4.

3. 4·182 per cent. of sulphate of alumina, density 1·0438, diffused at 65°·4, gave 3·17 grs. of alumina and 6·91 grs. of sulphuric acid, in all 10·08 grs. for one cell. Calculated for 4 per cent., 3·03 grs. of alumina and 6·61 grs. of sulphuric acid, in all 9·64 grs. of sulphate of alumina for one cell at 65°·4.

4. 8·364 per cent. of sulphate of alumina, density 1·08518, diffused at 65°·4, gave 5·37 grs. of alumina and 12·15 grs. of sulphuric acid, in all 17·52 grs. for one cell. Calculated for 8 per cent., 5·14 grs. of alumina and 11·62 grs. of sulphuric acid, in all 16·76 grs. of sulphate of alumina for one cell at 65°·4.

Diffusion of Sulphate of Alumina in 16·166 days at 65°·4; two cells.

| | Grs. | Ratio. |
|---------------------------------|-------|--------|
| From 1 per cent. solution . . . | 5·48 | 1·074 |
| From 2 per cent. solution . . . | 10·21 | 2 |
| From 4 per cent. solution . . . | 19·28 | 3·780 |
| From 8 per cent. solution . . . | 33·52 | 6·572 |

The diffusion of sulphate of alumina, it will be observed, is very sensibly less than that of sulphate of zinc at the same temperature.

30. *Nitrate of Silver.*

Time of diffusion seven days. The quantity of salt diffused was ascertained by precipitation with hydrochloric acid, and weighing the chloride of silver formed.

1. Nitrate of silver, 0·996 per cent.; density 1·0089. Diffusion at 51°·4, in eight cells, 5·39, 5·39, 5·74, 5·50; mean 5·50 grs. for two cells; calculated for 1 per cent., 5·52 grs. at 51°·4 for two cells.

2. Nitrate of silver, 1·98 per cent.; density 1·0161. Diffusion at 53°, in eight cells, 11·27, 11·16, 11·05, 11·06; mean 11·13 grs. for two cells; calculated for 2 per cent., 11·24 grs. at 53° for two cells.

3. Nitrate of silver, 1.967 per cent.; density 1.01696. Diffusion at $63^{\circ}41$, in eight cells, 13.85, 13.29, 13.70, 12.73; mean 13.39 grs. for two cells; calculated for 2 per cent., 13.61 grs. at $63^{\circ}4$ for two cells.

4. Nitrate of silver, 3.93 per cent.; density 1.032. Diffusion at $63^{\circ}4$, in four cells, 13.27, 12.70, 12.90, 12.90; mean 12.94 grs. for one cell; calculated for 4 per cent., 13.17 grs. at $63^{\circ}4$ for one cell.

5. Nitrate of silver, 7.88 per cent.; density 1.066. Diffusion at $63^{\circ}4$, in four cells, 26.45, 25.49, 24.57, 25.73; mean 25.56 grs. for one cell; calculated for 8 per cent., 25.94 grs. at $63^{\circ}4$ for one cell.

A rise of $10^{\circ}4$ of temperature, or from 53° to $63^{\circ}4$, increases the diffusibility of this salt from 11.24 to 13.61, or from 100 to 121.2; which is an increase of 2.04 per cent. for 1° .

Diffusion of Nitrate of Silver for seven days at $63^{\circ}4$; two cells.

| | Grs. | Ratio. |
|-----------------------------------|-------|--------|
| From 2 per cent. solution | 13.61 | 2 |
| From 4 per cent. solution | 26.34 | 3.87 |
| From 8 per cent. solution | 51.88 | 7.62 |

31. *Nitrate of Soda.*

Time of diffusion seven days. The quantity of salt diffused was ascertained by evaporation to dryness.

1. Nitrate of soda, 1.987 per cent.; density 1.0130. Diffusion at 53° , in eight cells, 11.37, 10.44, 10.76, 10.40; mean 10.74 grs. for two cells; calculated for 2 per cent., 10.81 grs. for two cells.

2. Nitrate of soda, 1.998 per cent. Diffusion at $63^{\circ}4$, in eight cells, 12.53, 12.38, 12.39, 12.06; mean 12.34 grs. for two cells; calculated for 2 per cent., 12.35 grs. for two cells.

3. Nitrate of soda, 3.98 per cent.; density 1.027. Diffusion at $63^{\circ}4$, in four cells, 12.21, 11.32, 12.10, 11.31; mean 11.73 grs. for one cell; calculated for 4 per cent., 11.78 grs. for one cell.

4. Nitrate of soda, 7.96 per cent.; density 1.053. Diffusion at $63^{\circ}4$, in four cells, 24.96, 22.53, 23.16, 24.38; mean 23.76 grs. for one cell; calculated for 8 per cent., 23.87 grs. for one cell.

A rise of temperature from 53° to $63^{\circ}4$ increases the diffusibility of nitrate of soda from 10.81 to 12.35, or from 100 to 114.3, which is an increase of 1.37 per cent. for 1° . The increase on the nitrate of silver for the same rise of temperature appeared to be considerably greater, namely, 2.04 per cent. for 1° .

Diffusion of Nitrate of Soda in seven days at $63^{\circ}4$; two cells.

| | Grs. | Ratio. |
|------------------------------------|-------|--------|
| From solution of 2 per cent. . . . | 12.35 | 2 |
| From solution of 4 per cent. . . . | 23.56 | 3.82 |
| From solution of 8 per cent. . . . | 47.74 | 7.73 |

The ratios of the last column of the preceding Table are sensibly the same as those already obtained for nitrate of silver. But the diffusibility of nitrate of soda appears to be increased less rapidly by temperature than nitrate of silver. Hence the diffusibility of these two salts appears more similar at low than high temperatures.

Diffusion from 2 per cent. solutions in seven days at 53° .

| | | |
|---------------------------|-------|-------|
| Nitrate of silver | 11.24 | 100 |
| Nitrate of soda | 10.81 | 96.17 |

Diffusion from 2 per cent. solutions in seven days at $63^{\circ}4$.

| | | |
|---------------------------|-------|-------|
| Nitrate of silver | 13.61 | 100 |
| Nitrate of soda | 12.35 | 90.74 |

32. Chloride of Sodium.

Time of diffusion seven days. The salt diffused was treated with nitrate of silver, and the chloride of silver weighed.

1. Chloride of sodium, 1 per cent. Diffused at $50^{\circ}5$, in eight cells, 5.96, 5.69, 5.54, 5.50; mean 5.70 grs. of chloride of sodium for two cells.

2. Chloride of sodium, 0.985 per cent. Diffused at $53^{\circ}4$, in eight cells, 5.86, 5.86, 5.77, 5.76; mean 5.81 grs. for two cells; calculated for 1 per cent., 5.89 grs. at $53^{\circ}4$ for two cells.

3. Chloride of sodium, 1 per cent.; density 1.00776. Diffused at $63^{\circ}4$, in eight cells, 6.30, 6.18, 6.52, 6.30; mean 6.32 grs. for two cells.

4. Chloride of sodium, 2 per cent.; density 1.01483. Diffused at $63^{\circ}4$, in eight cells, 12.37, 12.08, 12.45, 12.53; mean 12.37 grs. for two cells.

5. Chloride of sodium, 4 per cent.; density 1.02879. Diffused at $63^{\circ}4$, in four cells, 12.56, 12.65, 12.55, 12.17; mean 12.48 grs. for one cell.

6. Chloride of sodium, 8 per cent.; density 1.0562. Diffused at $63^{\circ}4$, in four cells, 25.11, 25.36, 22.82, 23.59; mean 24.22 grs. for one cell.

The rise of temperature from $50^{\circ}5$ to $63^{\circ}4$ increases the diffusion of the 1 per cent. solution of chloride of sodium from 5.70 to 6.32, or from 100 to 110.9, which is an increase of 0.843 per cent. for 1° .

Diffusion of Chloride of Sodium in seven days at $63^{\circ}4$; two cells.

| | Grs. | Ratio. |
|-----------------------------------|-------|--------|
| From 1 per cent. solution | 6.32 | 1.023 |
| From 2 per cent. solution | 12.37 | 2 |
| From 4 per cent. solution | 24.96 | 4.036 |
| From 8 per cent. solution | 48.44 | 7.832 |

These numbers resemble closely those obtained in the diffusion of chloride of barium during the longer period of 8·57 days.

The chloride of sodium and nitrate of soda will be seen to exhibit the usual approach to parallelism between the chloride and nitrate of the same metal, by the following comparison:—

Diffusion of Chloride of Sodium and Nitrate of Soda, both at 63°·4.

| | | |
|---------------------------------------|-------|-------|
| Chloride of sodium, 2 per cent. . . . | 12·37 | 100 |
| Nitrate of soda, 2 per cent. . . . | 12·35 | 99·83 |
| Chloride of sodium, 4 per cent. . . . | 24·96 | 100 |
| Nitrate of soda, 4 per cent. . . . | 23·58 | 94·48 |
| Chloride of sodium, 8 per cent. . . . | 48·44 | 100 |
| Nitrate of soda, 8 per cent. . . . | 47·74 | 98·55 |

As usual the chloride is slightly more rapid in its diffusion than the nitrate.

33. *Chloride of Potassium.*

Time of diffusion 5·71 days. The salt diffused was treated with nitrate of silver, and the chloride of silver weighed.

1. Chloride of potassium, 1 per cent.; density 1·00697. Diffused at 62°, in eight cells, 6·70, 6·75, 6·53, 6·77; mean 6·69 grs. of chloride of potassium for two cells.

2. Chloride of potassium, 2 per cent.; density 1·01333. Diffused at 62°, in eight cells, 13·36, 13·35, 13·60, 12·96; mean 13·32 grs. for two cells.

3. Chloride of potassium, 4 per cent.; density 1·0258. Diffused at 62°, in four cells, 12·51, 13·21, 13·46, 12·71; mean 12·97 grs. for one cell.

4. Chloride of potassium, 8 per cent.; density 1·0503. Diffused at 62°, in four cells, 26·88, 26·64, 26·15, 27·63; mean 26·82 grs. for one cell.

Diffusion of Chloride of Potassium in 5·71 days at 62°; two cells.

| | Grs. | Ratio. |
|-----------------------------------|-------|--------|
| From 1 per cent. solution | 6·69 | 1·005 |
| From 2 per cent. solution | 13·32 | 2 |
| From 4 per cent. solution | 25·94 | 3·895 |
| From 8 per cent. solution | 53·64 | 8·054 |

The ratios are in remarkably close accordance with the proportions of salt diffused.

The times 5·71 and seven days chosen for the chloride of potassium and sodium, it will be observed, are as the square roots of 2 and 3. A certain deviation from this ratio of the times of equal diffusion, appears on comparing the experimental results obtained at present for these salts.

Diffusion of Chloride of Potassium in 5·71 days at 62°, and of Chloride of Sodium in 7 days at 63°·4.

| | | |
|--|-------|-------|
| Chloride of potassium, 1 per cent. | 6·69 | 100 |
| Chloride of sodium, 1 per cent. | 6·32 | 94·47 |
| Chloride of potassium, 2 per cent. | 13·32 | 100 |
| Chloride of sodium, 2 per cent. | 12·37 | 92·86 |
| Chloride of potassium, 4 per cent. | 25·94 | 100 |
| Chloride of sodium, 4 per cent. | 24·96 | 96·23 |
| Chloride of potassium, 8 per cent. | 53·64 | 100 |
| Chloride of sodium, 8 per cent. | 48·44 | 90·30 |

The difference would be about 1 per cent. greater if the diffusion of both salts were reduced to the same temperature. The chloride of potassium deviates of course from the nitrate of soda in a similar manner. But chloride of potassium corresponds more closely with nitrate of silver than with chloride of sodium and nitrate of soda, at the temperature of the experiments.

Diffusion of Chloride of Potassium for 5·71 days at 62°, and of Nitrate of Silver for 7 days at 63°·4.

| | | |
|--|-------|--------|
| Chloride of potassium, 2 per cent. | 13·32 | 100 |
| Nitrate of silver, 2 per cent. | 13·61 | 102·18 |
| Chloride of potassium, 4 per cent. | 25·94 | 100 |
| Nitrate of silver, 4 per cent. | 26·34 | 101·54 |
| Chloride of potassium, 8 per cent. | 53·64 | 100 |
| Nitrate of silver, 8 per cent. | 51·88 | 96·71 |

The coincidence in rate would appear even closer in the 2 and 4 per cent. solutions, if the diffusion of the nitrate of silver was diminished about 1 per cent., on account of its higher temperature. It might thus be supposed that the nitrate of silver followed the sodium rate more accurately than the nitrate of soda and chloride of sodium themselves do.

A series of observations were made upon the diffusion of the 1 per cent. solution of chloride of potassium at a nearly constant temperature of 56°, but for different times, varying from five days to eight days, and eighteen hours, to discover the progression, which proved to be pretty similar to that of the 2 per cent. solution of hydrochloric acid. Six cells were diffused for each period, of which the mean result is given: the times advance by ten hours.

Diffusion of Chloride of Potassium, 1 per cent. solution; two cells.

| Time. | Temperature. | Diffusion in two cells. | Differences. |
|------------------|--------------------|-------------------------|--------------|
| 5 days. | 55 ^o 71 | 5.89 | |
| 5 days 10 hours. | 55.90 | 6.25 | 0.36 |
| 5 days 20 hours. | 55.79 | 6.55 | 0.30 |
| 6 days 6 hours. | 55.79 | 6.71 | 0.16 |
| 6 days 16 hours. | 55.90 | 6.95 | 0.24 |
| 7 days 2 hours. | 55.9 | 7.48 | 0.53 |
| 7 days 12 hours. | 55.9 | 7.58 | 0.10 |
| 7 days 22 hours. | 56.03 | 8.08 | 0.50 |
| 8 days 8 hours. | 56.28 | 8.34 | 0.26 |
| 8 days 18 hours. | 56.15 | 8.60 | 0.26 |

When the quantities of chloride of potassium are placed beside the same quantities of hydrochloric acid in the former Table, it is found that the times of diffusion of the salt and acid exhibit an approximately constant ratio. The squares of these times of equal diffusion are as 1 to 2.04 for the shortest period of the chloride of potassium, and as 1 to 2.10 for the longest period but one. The variation in the differences towards the middle of the Table is too great to be explained, except I fear by some error of observation, although no ordinary precaution was neglected in the execution of this laborious series of experiments.

34. *Iodides and Bromides of Potassium and Sodium.*

Iodide of Potassium.—Time of diffusion 5.716 days. The diffusate was estimated by means of nitrate of silver.

(1.) Iodide of potassium, 1.977 per cent.; density 1.0145. Diffused at 53^o.5, in eight cells, 11.415, 11.506, 10.942 and 11.062 grs.; mean 11.24 for two cells, and 11.36 for two per cent.

Comparing this salt with the isomorphous chloride of potassium, we have—

Diffusion of 2 per cent. solutions in 5.716 days.

| | | |
|---|-------|-------|
| Chloride of potassium at 55 ^o . . . | 11.48 | 100 |
| Iodide of potassium at 53 ^o .5 . . . | 11.36 | 99.65 |

The diffusion of the iodide would slightly exceed that of the chloride, instead of falling below it as in the Table, if the temperatures were made equal.

(2.) Again, iodide of potassium 1.971 per cent., observed density 1.01486. Diffused at 59^o.8, in eight cells, and the mean diffusate of the whole cells determined, it gave 12.33 grs. of iodide of potassium for two cells; or 12.51 grs. for a 2 per cent. solution.

Bromide of Potassium.—Time of diffusion and mode of estimating diffusate as above. The solution contained 1.975 per cent. of salt, and had a density of 1.014850. Diffused

at $59^{\circ}8$, in eight cells, it gave a mean diffusate of 12.30 grs. for two cells; or 12.46 grs. for 2 per cent.

For comparison, a solution of *chloride of potassium*, containing exactly 2 per cent. of salt and having the density 1.0133, was diffused in the same circumstances of time and temperature as the two preceding salts. The mean diffusate of eight cells was 12.24 grs. for two cells.

Hence the following result of the diffusion of three isomorphous salts:—

Diffusion of 2 per cent. solutions in 5.716 days, at $59^{\circ}8$.

| | Grs. | Ratio. |
|-------------------------------|--------------|--------|
| Chloride of potassium | 12.24 | 100 |
| Bromide of potassium | 12.46 | 101.80 |
| Iodide of potassium | 12.51 | 102.21 |
| Mean | <u>12.40</u> | |

Iodide of Sodium.—Time of diffusion 7 days, temperature $59^{\circ}8$. A solution of 2.011 per cent. and density 1.01618, diffused in eight cells, gave a mean diffusate of 12.24 grs. for two cells; that is, 12.18 grs. for 2 per cent. solution.

Bromide of Sodium.—Time of diffusion and temperature as above. A solution of 2.146 per cent., of density 1.01726, diffused in eight cells, gave a mean diffusate of 12.80 grs.; that is, 11.93 grs. for 2 per cent.

A comparative experiment was made with a solution of *chloride of sodium*, containing 1.917 per cent. of salt and of density 1.01376, in eight cells, at 60° . The diffusates for four pairs of cells were 11.65, 11.75, 11.63 and 11.47 grs.; mean 11.63 grs., which gives by proportion 12.14 grs. for a 2 per cent. solution. As the present salt differs only $0^{\circ}2$ FAHR. in diffusion-temperature from the two preceding salts, which is inadequate to produce an assignable difference of diffusion, the three salts may be supposed to be diffused at the same temperature, without sensible error.

Diffusion of 2 per cent. solutions for 7 days.

| | Grs. | Ratio. |
|--|--------------|--------|
| Chloride of sodium at 60° | 12.14 | 100 |
| Bromide of sodium at $59^{\circ}8$ | 11.93 | 98.27 |
| Iodide of sodium at $59^{\circ}8$ | 12.18 | 100.33 |
| Mean | <u>12.08</u> | |

In both these isomorphous groups of salts of potassium and sodium, there is certainly a near approach to equality of diffusion. The times for the salts of the two bases being in the empirical proportion of the square roots of 2 and 3, the mean diffusates also approach pretty closely; namely, 12.40 grs. for the salts of potassium and 12.08 grs. for the salts of sodium, which are as 100 to 97.42. Here the members of each group are certainly very similar to each other in density and probably other physical pro-

erties, which was not the case with the equidiffusive group containing the hydrogen acids of the same salt-radicals' (p. 807).

35. *Chloride of Ammonium.*

Time of diffusion 5.716 days. The salt diffused was estimated by means of nitrate of silver.

Solution 0.988 per cent.; density 1.0036. Diffused at 53° , in eight cells, 6.09, 6.07, 5.67, 5.87; mean 5.92 grs., and 5.99 for one per cent. in two cells. This is somewhat more than 5.68, one-half of the diffusate of the 2 per cent. solution of iodide of potassium, at nearly the same temperature. The diffusion, however, of the small proportions of salts of ammonium, such as the 1 per cent. solution, is apt to be given in excess, from their low density.

36. *Dichloride of Copper.*

Time of diffusion seven days, or that of chloride of sodium. The salt diffused was obtained by evaporation to dryness, in an air-bath, after treating the liquid with an excess of chlorine, in the form of chloride, from which the dichloride was calculated.

It was an object of interest to discover whether the dichloride of copper (Cu_2Cl), which should be isomorphous with the chloride of sodium, may separate from the protochloride of copper and other magnesian salts, and assume the high diffusibility of the salts of alkaline metals. But the salt in question is entirely insoluble in water. A solution, however, was obtained by dissolving an equivalent quantity of the red suboxide of copper recently precipitated, in hydrochloric acid, of density 1.033, so as to give one grain of dichloride in every hundred water-grain measures of the solution. This acid solution did not precipitate by dilution with water. The salt was diffused into pure water at a mean temperature of $53^{\circ}.2$.

1. Dichloride of copper diffused, 6.66, 6.57, 7.01 and 6.48 grs.; mean 6.68 grs. in two cells. Chloride of sodium at $53^{\circ}.4$, nearly the same temperature, gave 5.90 grs. in the same time. Reducing the result to the temperature of 51° by an approximative correction, we should have 6.48 grs. of dichloride of copper for that temperature, at which chloride of calcium gave 6.51 grs. in 11.43 days, and protochloride of copper (CuCl) 6.06 grs. at nearly the same temperature, also in 11.43 days.

So far as we can judge from an experiment at a single temperature, it would appear that the diffusion of dichloride of copper is more rapid than that of the chloride (CuCl), in a proportion which supposes the former compound to possess half the "solution-density" of the latter, the times of equal diffusion 7 and 11.43 days, being when squared as 1 to 2.

With the view of discovering whether the large proportion of hydrochloric acid, amounting to 7 per cent., present in the preceding solution of dichloride of copper, modified the diffusion of the salt, a portion of the same acid solution was treated with chlorine gas, to convert the copper salt into chloride, and diffused into water, after

the excess of chlorine was removed by agitation of the solution with air. The proportion of salt present was thus increased in weight from 1 to 1.36 per cent. The time of diffusion was 11.43 days, and the temperature 53° .

2. Chloride of copper diffused from a 1.36 per cent. solution of the salt in hydrochloric acid, 5.83, 5.66, and 5.30 grs. in two cells; mean 5.60 grs.

The corresponding diffusion from a 1 per cent. solution may be supposed to be less than 5.6 grs., in the proportion of 1.36 to 1, without any great error. The results thus become chloride of copper diffused, 3.98, 3.85 and 3.58 grs.; mean 3.80 grs. in two cells.

It hence appears that the diffusion of chloride of copper is much diminished by the presence of a great excess of hydrochloric acid in the same solution. Different causes suggest themselves for this result, such as the possibility of a combination existing of chloride of copper with chloride of hydrogen, in the acid solution; or the influence which must be admitted of the more soluble substance, in a mixture of two similar substances, in repressing the diffusion of the less soluble. The present result, however, is entirely opposed to the idea that the high diffusibility of the dichloride of copper, observed before, is due to the hydrochloric acid present.

3. The diffusion of chloride of sodium also appears to be repressed by contact with a large excess of hydrochloric acid. One per cent. of chloride of sodium raised the density of dilute hydrochloric acid from 1.035 to 1.0408. Diffused into pure water for seven days at $52^{\circ}.9$, in eight cells, the diffusates of chloride of sodium were 3.80, 3.87, 4.00 and 3.86 grs.; mean 3.88 for two cells. The diffusion of chloride of sodium is thus reduced in a corresponding measure with that of chloride of copper by association with seven times its weight of hydrochloric acid.

These results are interesting in a very different point of view. I have always watched for the appearance of some absorbent or imbibing power on the part of the acids, more analogous to an endosmotic attraction for water, as usually conceived. If such an attraction existed, it would complicate the phenomena of diffusion, for the volume of water absorbed by the acid would displace and project a portion of the latter into the reservoir, the phial not being extensible. The high diffusibility of hydrochloric and nitric acids would be thus explained. But by such a mechanical displacement the chloride of sodium would be thrown out in the preceding experiment, as well as the hydrochloric acid, which is not the case.

4. Even in hydrochloric acid of density 1.124 (25 per cent.), the diffusion of 1 per cent. of chloride of sodium for seven days, at $56^{\circ}.6$, was found to amount to 4.7 grs. only in two cells, and is less than from a solution in pure water.

5. In comparing the influence of nitric acid with that of hydrochloric acid upon the diffusion of chloride of sodium, it was found that in a 7 per cent. solution of nitric acid, the chloride of sodium (1 per cent.) was entirely decomposed in the diffusive process, at $56^{\circ}.6$, and gave hydrochloric acid in the full diffusive equivalent of that acid, together with nitrate of soda.

37. *Bicarbonate of Potash.*

Time of diffusion 8·083 days, or double that of hydrate of potash. The water of the jars was partially charged with carbonic acid gas, to prevent the decomposition of this and the other bicarbonates in the act of diffusion. The usual number of eight cells of the 1 and 2 per cent. solutions were diffused, and four cells of the 4 and 8 per cent. solutions. The whole diffusates of each proportion were then mixed together, and the quantity of bicarbonate of potash diffused for two cells, converted into the chloride of potassium, evaporated to dryness and weighed.

1. 1·059 per cent. of bicarbonate of potash ($\text{HO} \cdot \text{CO}_2 + \text{KO} \cdot \text{CO}_2$), density 1·00788, diffused at 68°.2 , gave 7·66 grs. for two cells. Calculated for 1 per cent., 7·23 grs. of bicarbonate of potash in two cells.

2. 2·12 per cent. of bicarbonate of potash, density 1·01489, diffused at 62°.2 , gave 14·88 grs. for two cells. Calculated for 2 per cent., 14·05 grs. of bicarbonate of potash in two cells.

3. 4·236 per cent. of bicarbonate of potash, density 1·0288, diffused at 68°.2 , gave 14·15 grs. for 1 cell. Calculated for 4 per cent., 13·36 grs. of bicarbonate of potash in one cell.

4. 8·472 per cent. of bicarbonate of potash, density 1·05600, diffused at 68°.2 , gave 27·55 grs. for one cell. Calculated for 8 per cent., 26·01 grs. of bicarbonate of potash in one cell.

Diffusion of Bicarbonate of Potash in 8·08 days at 68°.2 ; two cells.

| | Grs. | Ratio. |
|---------------------------------|-------|--------|
| From 1 per cent. solution . . . | 7·23 | 1·029 |
| From 2 per cent. solution . . . | 14·05 | 2 |
| From 4 per cent. solution . . . | 26·72 | 3·806 |
| From 8 per cent. solution . . . | 52·01 | 7·408 |

38. *Bicarbonate of Ammonia.*

Time of diffusion 8·083 days. The usual number of eight cells of the 1 and 2 per cent. solutions of this substance were diffused, and four cells of the 4 and 8 per cent. solutions. The whole diffusates of each proportion were then mixed together, and the quantity of bicarbonate of ammonia, diffused for two cells, determined by an alkalimetric experiment, which was always repeated twice.

1. 1·109 per cent. of bicarbonate of ammonia ($\text{HO} \cdot \text{CO}_2 + \text{NH}_4 \text{O} \cdot \text{CO}_2$), density 1·00553, diffused at 68°.2 , gave 7·66 grs. for two cells. Calculated for 1 per cent., 6·91 grs. of bicarbonate of ammonia in two cells.

2. 2·218 per cent. of bicarbonate of ammonia, density 1·01056, diffused at 68°.2 , gave 15·14 grs. for two cells. Calculated for 2 per cent., 13·65 grs. of bicarbonate of ammonia in two cells.

3. 4·436 per cent. of bicarbonate of ammonia, density 1·02000, diffused at 68°.2 ,

gave 14.98 grs. for one cell. Calculated for 4 per cent., 13.50 grs. of bicarbonate of ammonia in one cell.

4. 8.872 per cent. of bicarbonate of ammonia, density 1.03856, diffused at 68°2, gave 27.78 grs. for one cell. Calculated for 8 per cent., 25.05 grs. of bicarbonate of ammonia in one cell.

Diffusion of Bicarbonate of Ammonia in 8.08 days at 68°2; two cells.

| | Grs. | Ratio. |
|-------------------------------------|-------|--------|
| From 1 per cent. solution | 6.91 | 1.013 |
| From 2 per cent. solution | 13.65 | 2 |
| From 4 per cent. solution | 27.00 | 3.959 |
| From 8 per cent. solution | 50.10 | 7.346 |

The amount and progression of the diffusion of this salt correspond well, for all the proportions diffused, with the preceding isomorphous bicarbonate of potash.

39. Bicarbonate of Soda.

Time of diffusion 9.875 days. The usual number of eight cells of the 1 and 2 per cent. solutions were diffused, and four cells of the 4 and 8 per cent. solutions. The whole diffusates of each proportion were then mixed together, and the quantity of bicarbonate of soda, diffused for two cells, converted into chloride of sodium, evaporated to dryness and weighed.

1. 1.135 per cent. of bicarbonate of soda, $\text{HO} \cdot \text{CO}_2 + \text{NaO} \cdot \text{CO}_2$, density 1.00892, diffused at 68°1, gave 8.30 grs. for two cells. Calculated for 1 per cent., 7.31 grs. of bicarbonate of soda in two cells.

2. 2.27 per cent. of bicarbonate of soda, density 1.01703, diffused at 68°1, gave 15.68 grs. for two cells. Calculated for 2 per cent., 13.81 grs. of bicarbonate of soda in two cells.

3. 4.54 per cent. of bicarbonate of soda, density 1.03306, diffused at 68°1, gave 15.16 grs. for one cell. Calculated for 4 per cent., 13.35 grs. of bicarbonate of soda in one cell.

4. 9.08 per cent. of bicarbonate of soda, density 1.06386, diffused at 68°1, gave 29.73 grs. for one cell. Calculated for 8 per cent., 26.19 grs. of bicarbonate of soda in one cell.

Diffusion of Bicarbonate of Soda in 9.87 days at 68°1; two cells.

| | Grs. | Ratio. |
|-------------------------------------|-------|--------|
| From 1 per cent. solution | 7.31 | 1.059 |
| From 2 per cent. solution | 13.81 | 2 |
| From 4 per cent. solution | 26.70 | 3.869 |
| From 8 per cent. solution | 52.38 | 7.590 |

A remarkable approach to equality in the diffusion of the bicarbonates of potash

and soda, in the times chosen, is observed equally in all the proportions of salt from 1 to 8 per cent.

The results for the three bicarbonates may be stated as follows, the diffusate of the 2 per cent. solution of bicarbonate of potash being made equal to 200, as a standard of comparison.

Diffusion of Bicarbonates of Potash and Ammonia in 8.08 days, at 68°2, and of Bicarbonate of Soda in 9.875 days, at 68°1 :

| | Bicarbonate of potash. | Bicarbonate of ammonia. | Bicarbonate of soda. |
|---------------------------------|------------------------|-------------------------|----------------------|
| From 1 per cent. solution | 102.9 | 98.3 | 104.0 |
| From 2 per cent. solution | 200.0 | 194.3 | 196.4 |
| From 4 per cent. solution | 380.6 | 384.3 | 380.0 |
| From 8 per cent. solution | 740.8 | 712.6 | 748.3 |

Or, making the diffusate from each proportion of the bicarbonate of potash equal to 100 :—

| | Bicarbonate of potash. | Bicarbonate of ammonia. | Bicarbonate of soda. |
|---------------------------------|------------------------|-------------------------|----------------------|
| From 1 per cent. solution | 100 | 95.53 | 101.07 |
| From 2 per cent. solution | 100 | 97.15 | 98.20 |
| From 4 per cent. solution | 100 | 100.97 | 99.84 |
| From 8 per cent. solution | 100 | 96.19 | 101.03 |

The bicarbonate of ammonia is slightly lower in general than the bicarbonate of potash, possibly from a small loss of the former salt by evaporation in the different operations. The times chosen for these two bicarbonates is to that of the bicarbonate of soda, as the square root of 2 to the square root of 3, and the remarkable agreement observed in the diffusion of these salts gives support therefore to that relation. In alluding to this relation, however, it is proper to add that the carbonates of potash and soda deviate from it in a sensible degree, and the hydrates of potash and soda very considerably. If the relation therefore has a real foundation, it must be masked in the salts last named by differences existing between them in certain properties, the discovery and investigation of which is of the last importance for the theory of liquid diffusion.

40. *Hydrochlorate of Morphine.*

Time of diffusion 11.43 days. The crystallized salt was assumed to be of the composition $C_{34}H_{18}NO_6 \cdot HCl + 6HO$, with the equivalent 374.5. The quantity diffused was determined from the chlorine, which was precipitated as chloride of silver in an acid solution. Hydrochlorate of morphine, 1.88 per cent. of the salt supposed anhydrous, diffused at 64°1, in six cells, 11.03, 10.72, 11.01; mean 10.92 grs. of the anhydrous salt for two cells. Calculated for 2 per cent., 11.60 grs. at 64°1 for two cells.

41. *Hydrochlorate of Strychnine.*

Time of diffusion 11·43 days. The crystallized salt was assumed to be of the composition $C_{42}H_{22}N_2O_4 \cdot HCl + 3HO$, with the equivalent 397·5. Hydrochlorate of strychnine, 2 per cent., density 1·0065, diffused at $64^\circ 1$, in six cells, 11·54, 11·62, 11·31; mean 11·49 grs. for two cells. The quantities refer to anhydrous salt, and were estimated from the chlorine, as with hydrochlorate of morphine.

These two analogous salts appear to approach very closely in diffusibility.

Diffusion from 2 per cent. solutions at $64^\circ 1$; two cells.

| | | |
|-------------------------------------|-------|-------|
| Hydrochlorate of morphine | 11·60 | 100 |
| Hydrochlorate of strychnine | 11·49 | 99·05 |

For a similar period of 11·43 days, but at a lower temperature, $53^\circ 4$, the 1 per cent. solution of hydrochlorate of morphine gave a mean result of 5·49 grs. from two cells, and the hydrochlorate of strychnine 5·77 grs. from two cells. But the weights of chloride of silver from which these numbers are deduced were too small to admit of much precision.

The diffusion of these salts of organic bases in 11·43 days, is exceeded by the diffusion of chloride of ammonium or potassium in 5·71 days, or half the former time. The vegeto-alkalies appear thus to be divided from ammonia and potash.

The new observations of the present paper are favourable to the existence of a relation amounting to close similarity or equality in diffusibility between certain classes of substances.

The chlorides and nitrates of the same metal generally exhibit this correspondence, as in the chloride of calcium and nitrate of lime, the chloride of sodium and nitrate of soda, and also in hydrochloric and nitric acids.

Isomorphous salts exhibit the same relation, as has been observed in the chlorides, bromides and iodides of potassium, sodium and hydrogen, in various salts of baryta, strontia and lead, in numerous magnesian salts, in the salts of silver, soda, and probably those of suboxide of copper, and in several additional salts of potash and ammonia.

Corresponding salts of two of the vegeto-alkalies are also found to be equidiffusive.

Before discussing the relations between the different groups of equidiffusive substances which are thus formed, it will be necessary to examine their diffusion at widely different temperatures, a subject attended with considerable difficulty.

INDEX
TO THE
PHILOSOPHICAL TRANSACTIONS
FOR THE YEAR 1850.

A.

- Aden*, Hourly readings of the Barometer at, 318; range of temperature at, 333.
Albumen of Eggs, on the freezing of, 221.
Algebraic expression of the number of partitions of which a given number is susceptible, 399.
Alkaloids, artificial, on the nitrogenated principles of vegetables as the sources of, 47.
Ammonia, salts of, diffusion of, 25.
Amyl, Bromide of, its action upon aniline, 115; upon amyraniline, 116; upon ethylaniline, 117.
Aniline, action of phenyl-alcohol upon, 97; action of bromide of ethyl upon, 98; action of bromide and iodide of methyl upon, 113; action of bromide of amyl upon, 115.
Arctomys Empetra and pruinosa, on the dental structures in, 538-539.
Atmospheric temperature, on the effect of its changes on the temperature of the human body, 442.
Auditory nerve, development of, 195.

B.

- BAKERIAN LECTURE, the, 1.
Barometrical observations in India, 298-321.
Bases derived from aniline and ammonia, their relation with other groups of alkaloids, 124.
Belemnite and Belemnoteuthis, supplementary observations on the structure of, 393.
Bombay, range of Barometer at, 305. Temperature at, 324. Rain at, 353-367. Winds, 369.
BRODIE (BENJAMIN C., Esq.). On the Condition of certain Elements at the moment of Chemical Change, 759.
Bromaniline, action of bromide of ethyl upon, 109.
BROOKE (CHARLES, Esq., M.B.). On the Automatic Registration of Magnetometers and Meteorological Instruments, by Photography, No. III., 83.
BROUGHAM (Lord). Experiments and Observations upon the Properties of Light, 235.

C.

- Calcutta*, range of barometer at, 305. Temperature at, 324–332. Winds, 370.
- CARPENTER (WILLIAM B., M.D.). On the Mutual Relations of the Vital and Physical Forces, 727.
- Castor fiber*, on the dental structures in, 539.
- Chemical change*, on the condition of certain elements at the moment of, 759.
- Chloraniline*, action of bromide of ethyl upon, 108.
- Chloride of sodium*, diffusion of, 6.
- Cælogenys Paca*, on the dental tissues of, 554.
- Cohesion*, strength of, in different woods, 684.
- Contraction*, on induced, 645.
- Copper*, ammoniated salts of, diffusion of, 12.
- Crocodylia*, on the communications between the cavity of the tympanum and the palate in the, 526.

D.

- Dasyprocta Aguti*, on the dental structures of, 553.
- DAVY (Dr. JOHN). On the Temperature of Man within the Tropics, 437.
- Decomposition of salts by diffusion, 19.
- Development of the Tadpole of the Triton and the Frog*, on the influence of physical agents on the, 431.
- Diamagnetic bodies*, on the polar or other condition of, 171.
- Diethylaniline*, a new basic compound, 103; Hydrobromate of, 104; Platinum salt of, 105; action of bromide of ethyl on, 106; action of iodide of methyl upon, 114.
- Diffusion of Liquids*, on the, 1. Characters of liquid diffusion, 6. Diffusion of chloride of sodium, 6; of various salts, 8; of ammoniated salts of copper, 12. Separation of salts of different bases by diffusion, 16. Decomposition of salts by diffusion, 19. Diffusion of double salts, 21. Diffusion of one salt into the solution of another salt, 22. Diffusion of salts of potash and ammonia, 25. Diffusion of salts of soda, 40. Diffusion of sulphate of magnesia, 43.
- Diffusion of Liquids*. Supplementary observations on, 805. Hydrochloric acid, 806. Hydroiodic acid, Hydrobromic acid and bromine, 807. Hydrocyanic acid, 809. Nitric acid, 809. Sulphuric acid, 811. Chromic acid, *ibid.* Acetic acid, 812. Ammonia, 813. Alcohol, 814. Nitrate of baryta, 815. Nitrate of strontia, *ibid.* Nitrate of lime, 816. Acetate of lead, *ibid.* Acetate of baryta, 817. Chloride of barium, *ibid.* Chloride of strontium, 818. Chloride of calcium, 819. Chloride of manganese, 820. Nitrate of magnesia, *ibid.* Nitrate of copper, *ibid.* Protochloride of iron, 821. Sesquichloride of iron, *ibid.* Sulphate of magnesia, *ibid.* Sulphate of zinc, 822. Sulphate of alumina, 824. Nitrate of silver, *ibid.* Nitrate of soda, 825. Chloride of sodium, 826. Chloride of potassium, 827. Iodides and bromides of potassium and sodium, 829. Chloride of ammonium, 831. Dichloride of copper, *ibid.* Bicarbonate of potash, 833. Bicarbonate of soda, 834. Hydrochlorate of morphine, 835. Hydrochlorate of strychnine, 836.
- Dodabetta*, Barometrical Observations at, 300–304, 308–313. Temperature at, 335. Observations on the wet-bulb at, 338. Winds, 372.
- Dynamic stability of floating bodies, 609.

E.

Electricity, atmospheric, observations on, in India, 374.

Electro-Physiological Researches, 287. Conductibility of the Muscles in relation to that of the Nerve, 288. Difference of excitability produced in a nerve according to the direction of the electric current, 289. Excitability of the nerves in relation to the integrity of the nervous system, 290. Analogy between electricity and nervous force, 294.

—————. Induced contraction, 645.

Epping, on the mean monthly temperature at, 572.

Equations, linear, in finite differences, and linear differential equations, 261.

Ethyl, Bromide of, its action upon aniline, 98; upon ethylaniline, 103; upon diethylaniline, 106; upon chloraniline and upon ethylochloraniline, 108; upon bromaniline, 109; upon nitraniline, 110; upon amylaniline, 117.

Ethylaniline, a new basic compound, 100. Hydrobromate of, 101. Platinum-salt of, *ibid.* Action of bromide of ethyl upon, 103. Action of iodide of methyl upon, 114. Action of bromide of amyl upon, 117.

Ethylochloraniline, action of bromide of ethyl upon, 109.

Exercise, on the effect of, on the temperature of the body, 441.

Experiments and observations upon the properties of light, 235.

F.

FAIRBAIRN (WILLIAM, Esq.). An Experimental Inquiry into the Strength of Wrought-Iron Plates and their Riveted Joints as applied to Ship-building and Vessels exposed to severe strains, 677.

FARADAY (Prof. M.). Experimental Researches in Electricity. Twenty-third Series. § 29. On the polar or other condition of diamagnetic bodies, 171.

Fiber zibethicus, on the dental structures of, 550.

Floating bodies, on the dynamic stability and on the oscillations of, 609.

Fogs, observations on, in India, 374.

Forces, on the mutual relations of the vital and physical, 727.

Fucusamide, 473.

Fucusine, 474. Nitrate of, 475. Muriate of, 477. Double platinum-salt of, *ibid.* Oxalate of, *ibid.*

Fucusol, 471.

Furfuramide. Furfurol, 467.

Furfurine, double chloride of, and platinum, 470. Nitrate of, 476. Opaque crystals of, *ibid.*

G.

Gerbillus Shawii, on the dental structures of, 549.

GLAISHER (JAMES, Esq.). Sequel to a paper on the reduction of the Thermometrical Observations made at the Apartments of the Royal Society, 569.

GRAHAM (Prof. THOMAS). On the Diffusion of Liquids, 1.

—————. Supplementary Observations on the Diffusion of Liquids, 805.

GRAY (HENRY, Esq.). On the Development of the Retina and Optic Nerve, and of the Membranous Labyrinth and Auditory Nerve, 189.

Greenwich, on the thermometrical observations taken at the Royal Observatory, 569. Comparison of the temperature at, with that at Somerset House, 579.

H.

- HARGREAVE (C. J., Esq.). General Methods in Analysis for the resolution of Linear Equations in Finite Differences and Linear Differential Equations, 261.
- Heat, mechanical equivalent of, 61. Friction of water, 66. Friction of mercury, 70-75. Friction of cast iron, 77-80.
- HERSCHEL (Sir J. F. W.). On the Algebraic Expression of the number of Partitions of which a given number is susceptible, 399.
- HIGGINBOTTOM (JOHN, Esq.). On the Influence of Physical Agents on the development of the Tadpole of the Triton and the Frog, 431.
- HOFMANN (Dr. A. W.). Researches regarding the Molecular Constitution of the Volatile Organic Bases, 93.
- Hylæosaurus*, on a dorsal dermal spine of, 391.
- Hystrix cristata*, on the dental structures of, 552.

I.

- India, meteorological observations in, 297.

J.

- Jerboa Ægyptius*, on the dental structures in, 544.
- JONES (HENRY BENICE, M.D.). Contributions to the Chemistry of the Urine. Paper IV. On the so-called Chylous Urine, 651.
- JOULE (JAMES P., Esq.). On the Mechanical Equivalent of Heat, 61.

L.

- Ligamentum Rotundum Uteri*, on the structure and use of, 515.
- Light, experiments and observations upon the properties of, 235.
- Linear Equations in Finite Differences and Linear Differential Equations*. General methods in analysis for the resolution of, 261. Linear equations in finite differences, *ibid*. Solution of differential equations in series, 270.
- Liquid diffusion, characters of, 6.
- Liquids, on the diffusion of, 1. Supplementary observations, 805.
- Lyndon, on the mean monthly temperature at, 569.

M.

- Madras, range of barometer at, 305. Temperature at, 324-331. Winds, 368.
- Magnesia, sulphate of, diffusion of, 43.
- Magnetic Observatories (British). On the means adopted therein for determining the absolute values, secular change, and annual variation of the magnetic force, 201. Sources of irregularity in the indications of the Bifilar, 202, 203. Portable Unifilar Magnetometer, 204. Instruments employed at Toronto, 205. Monthly results, 208. Total Force, its mean value and secular change, 210. Annual variation, 211.
- Magnetometers, automatic registration of, 83.

Magnets, scale and temperature coefficients of, new method of determining, 85.

MANTELL (Dr. G. A.). On a Dorsal dermal Spine of the Hylæosaurus, recently discovered in the Strata of Tilgate Forest, 391.

—————. Supplementary Observations on the Structure of the Belemnite and Belemnoteuthis, 393.

—————. On the Pelorosaurus; an undescribed gigantic terrestrial reptile whose remains are associated with those of the Iguanodon and other Saurians in the Strata of Tilgate Forest, in Sussex, 379.

MARSHALL (JOHN, Esq.). On the development of the Great Anterior Veins in Man and Mammalia; including an account of certain remains of Fœtal Structure found in the Adult, a Comparative View of these Great Veins in the different Mammalia, and an Analysis of their occasional peculiarities in the Human Subject, 133.

MATTEUCCI (Signor CARLO). Electro-Physiological Researches. Eighth Series, 287.

—————. Ninth Series. On Induced Contraction, 645.

Mechanical equivalent of heat, 61.

Membranous labyrinth and auditory nerve, on the development of, 195.

Meteorological Instruments, automatic registration of, 83.

Meteorological Observations taken in India, discussion of, 297. Diurnal tides, 298. Table of daily oscillations of the barometer at Dodabetta, 300. Range of barometer at Dodabetta, 304–308. Dates of the maximum and minimum pressure at Madras, and range of barometer at Madras, Bombay, Calcutta, &c., 305. Horary oscillations, 308, 309, 314. Table of monthly means of daily atmospheric tides, 311. Table of movements of the atmosphere in twenty-four hours in each month at Dodabetta, 313. Table of means of the hourly readings of the barometer at Aden, 318. Pressure of the atmosphere, 321. Temperature, 323. Table of monthly mean temperatures at Madras, Bombay and Calcutta, &c., 324. Curves of temperature at high levels, 330. Range of temperature and hours of maxima and minima:—Madras, 331; Calcutta, 332; Aden, 333. Range of temperature at high levels, 333; at Sattara, 334; Mahabuleshwur, 335; Dodabetta, *ibid.* Aqueous vapour, 336. Observations by the wet-bulb at Dodabetta, 338; at Mahabuleshwur, 339. Rain, 352; at Bombay, 353; on the coast of Malabar and Coromandel, 357. Rain at different elevations, 363. Register of pluviometer at Bombay, 367. Winds at Madras, 368; at Bombay, 369; at Calcutta, 370; at Mahabuleshwur, 372; at Dodabetta, *ibid.* Fogs, 374. Electricity, 374.

Methyl, bromide and iodide of, their action upon aniline, 113; iodide of, its action upon ethylaniline, 114.

Methylaniline, 113. Methylethylaniline, 114.

Molecular constitution of the volatile organic bases, 93.

MOSELEY (The Rev. HENRY). On the Dynamic Stability and on the Oscillations of Floating Bodies, 609.

Moss, Lichens and Ferns, oils produced from, 478.

Muridæ, on the dental structures in, 542.

Mus decumanus, on the dental structure of, 546.

Muscular fibres of uterus, changes in, during gestation, 518.

Myopotamus Coypus, on the dental tissues of, 555.

Myoxus avellanarius, on the dental structure in, 543.

N.

- Nebulæ*, observations on, 499. Account of the great telescope of the Earl of Rosse, *ibid.*
- Nerves*, experiments on the section of, and observations of the alterations produced thereby in the structure of their primitive fibres, 423.
- Nitraniline*, action of bromide of ethyl upon, 110.
- Nitrogenated principles of vegetables*, on the, as the sources of artificial alkaloids, 47. *Phaseolus communis*, 48. *Linum usitatissimum*, 53. Wheat, 54. Peat, *ibid.* Distillation of wood, 55. Formation of organic bases from the nitrogenated principles of vegetables and animals by means of alkaline lye, 56; by sulphuric acid, 57; by putrefaction, 57-59. Guano, 57. Bases from *Lycopodium*, 59. Bases from *Pteris aquilina*.
- Notation*, on a system of, for the teeth in Mammalia, 481.

O.

- Observatories*, British Magnetic, 201.
- Octodon Degus*, on the dental tissues of, 555.
- Oils*, on the, produced by the action of sulphuric acid upon various classes of vegetables, 467. Furfuramide, *ibid.* Furfurol, *ibid.* Double chloride of furfurine and platinum, 470. Nitrate of furfurine, *ibid.* Fucusol, 471. Fucusamide, 473. Thiofucusol, *ibid.* Pyrofucusol, 474. Fucusine, *ibid.* Nitrate of fucusine, 475. Nitrate of furfurine, 476. Muriate of fucusine, 477. Double platinum salt of, *ibid.* Oxalate of, *ibid.* Oil from Moss, Lichens and Ferns, 478. Opaque crystals of nitrate of furfurine, 480.
- Optic nerve*, development of, 189.
- Oscillations of floating bodies, 609.
- OWEN (Professor R.). On the Development and Homologies of the Molar Teeth of the Wart-Hogs (*Phacochoerus*), with Illustrations of a System of Notation for the Teeth in the Class Mammalia, 481.
- . On the Communications between the Cavity of the Tympanum and the Palate in the Crocodilia, 521.

P.

- PAGET (Professor JAMES). Observations on the Freezing of the Albumen of Eggs, 221.
- Pelorosaurus Conybearii*, a gigantic fossil reptile, description of its remains, 379. Indications of, in the Oolitic strata, 384.
- Phacochoerus*, or Wart-Hogs, on the development and homologies of the molar teeth of, 481.
- Phenyl-alcohol*, its action upon aniline, 97.
- Photography as a means of automatic registration, 83.
- Physical and Vital Forces*, on the mutual relations of, 727.
- Plates, wrought-iron*, on the strength of, 677.
- Potash*, salts of, diffusion of, 25.
- Pyrofucusol*, 474.

R.

- Rain*, fall of, in India, 352-367.
- RAINEY (G. Esq.). On the Structure and Use of the Ligamentum Rotundum Uteri, with some observations upon the changes which take place in the Structure of the Uterus during Gestation, 515.

- Registration, automatic*, of magnetometers and meteorological instruments by photography, 83.
Reptile, fossil (Pelorosaurus), description of, 379.
Retina and optic nerve, on the development of, 189.
Rodentia, on the dental tissues of the Order, 529.
Rolling of ships, on the, 611.
 ROSSE (The Earl of). Observations on the Nebulæ, 499.
Royal Society, on the thermometrical observations taken at the Apartments of, 569. Comparison of the temperature at, with that of Greenwich, 579.

S.

- SABINE (Lieut.-Col. R.A.). On the means adopted in the British Colonial Magnetic Observatories for determining the Absolute Values, Secular Change, and Annual Variation of the Magnetic Force, 201.
Salts, double, diffusion of, 21.
Salts, various, diffusion of, 8.
Sciurus niger, on the dental structures in, 535.
Sea-sickness, on its effect on the temperature of the body, 445.
 Separation of salts by diffusion, 16.
Ship-building, conclusions applicable to, from experiments and considerations on the dynamical stability, and on the oscillations of floating bodies, 632.
Ships, on the rolling of, 611; on the dynamic stability of, 612.
Soda, salts of, diffusion of, 40.
Spalax typhlus, on the dental structures in, 541.
 STENHOUSE (Dr. JOHN). On the Nitrogenated Principles of Vegetables as the Sources of Artificial Alkaloids, 47.
 —————. On the Oils produced by the Action of Sulphuric Acid upon various Classes of Vegetables, 467.
Sulphuric acid, on the oils produced by the action of, upon various classes of vegetables, *ibid.*
 SYKES (Lieut.-Col. W.H.). Discussion of Meteorological Observations taken in India, at various heights, embracing those at Dodabetta, on the Neelgherry Mountains, at 8640 feet above the level of the Sea, 297.

T.

- Tadpole of the Triton and the Frog*, on the influence of physical agents on the development of, 431; of the Triton, *ibid.*; of the Frog, 432. On the influence of atmospheric air, *ibid.*; of food, 433; of temperature, 434; of light, 435.
Tamias Lysteri, on the dental structures in, 538.
Teeth, a system of notation for, in the Class Mammalia, 481.
Teeth, molar, in the Wart-Hogs (Phacochærus), on the development and homologies of, 481.
Temperature of India, observations on, 323-335.
Temperature of Man within the Tropics, on the, 437; variation of, during the twenty-four hours, *ibid.*; during different seasons of the year, 439; of the effect of active exercise and of rest after exercise, 440; of the effect of carriage exercise and of gentle walking exercise, 441; of the effect of change of temperature of the atmosphere, 442; of the effect of excited

and sustained attention, 443; of the effect of cool and heated rooms, 444; of the effect of sea-sickness, 445; of the effect of the temperature at sea, 446.

Thames, mean monthly temperature of the water of the, 576.

Thermometer apparatus, self-registering, 83.

Thermometrical observations (on the reduction of) *made at the Apartments of the Royal Society and at the Royal Observatory, Greenwich, &c.*, 569.

Thiofucusol, 473.

Tides, researches on, 227.

TOMES (JOHN, Esq.). On the Structure of the Dental Tissues in the Order Rodentia, 529.

Toronto, Magnetic Observatory at, 205.

Triethylamine, formation of, 121.

Tropics, on the temperature of man within the, 437.

Tympanum and palate of the Crocodilia, communications between them, 526.

U.

Urine, Contributions to the Chemistry of. On chylous urine, 551. On the influence of rest and motion in lessening or increasing the albumen in the urine previous to and after food was taken, 655.

Uterus, on the changes which take place in the structure of, during utero-gestation, 518.

V.

Vegetables, on the action of sulphuric acid upon, and the oils produced thereby, 467.

Veins, Great Anterior, in Man and Mammalia, on the development of, 133. Metamorphosis of the primitive lateral and symmetrical venous trunks, 137; development in the Sheep, 137; in Man, 141. Comparative view of those veins in Man and Mammalia, 148. Analysis of the varieties of these veins in Man, 153.

Vital and Physical Forces, on the mutual relations of, 727.

Volatile organic bases, on the molecular constitution of, 93.

W.

WALLER (Dr. AUG.). Experiments on the Section of the Glossopharyngeal and Hypoglossal Nerves of the Frog, and observations of the alterations produced thereby in the Structure of their Primitive Fibres, 423.

Wart-Hogs (Phacochærus), on the development and homologies of the molar teeth of, 481.

Wet-bulb thermometer, observations on, in India, 336 *et seq.*

WHEWELL (Rev. W., D.D.). Researches on the Tides.—Fourteenth Series, 227.

Winds, observations on, in India, 368–372.

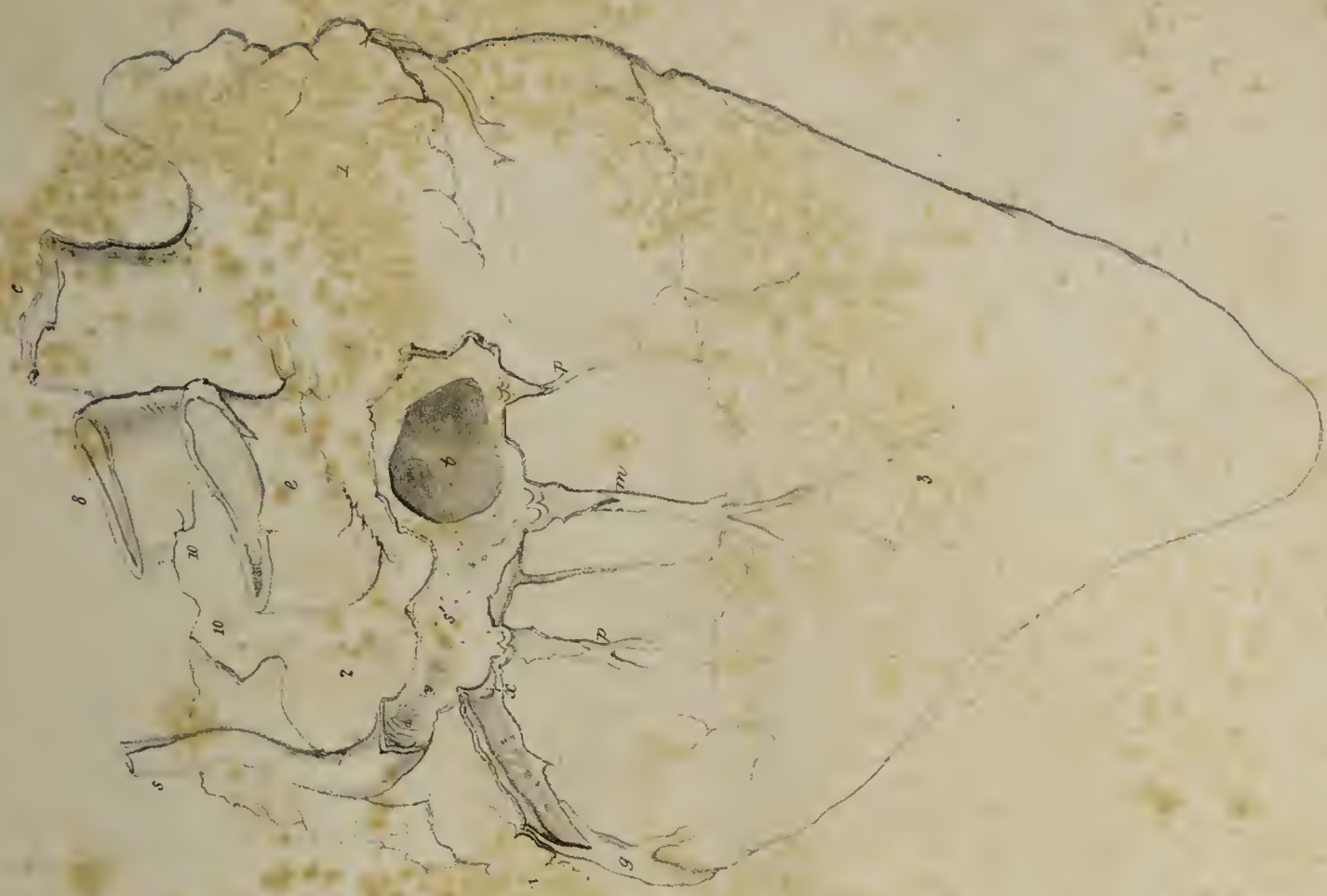
Woods, various, on the strength of direct cohesion in, 684.

Wrought-iron plates, on the strength of, 677.

LONDON:

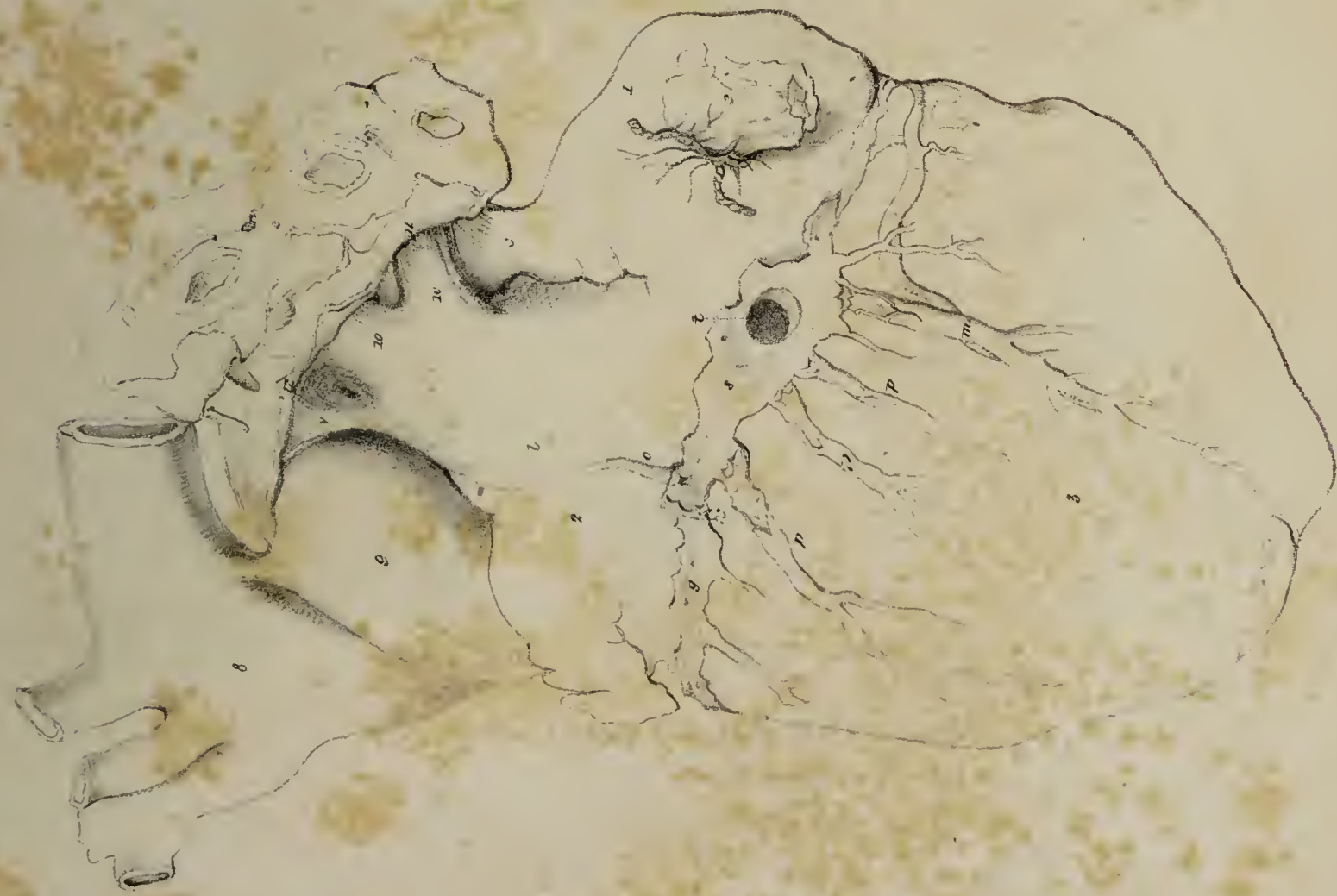
PRINTED BY RICHARD AND JOHN E. TAYLOR,
RED LION COURT, FLEET STREET.

Fig. 2.

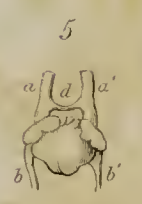
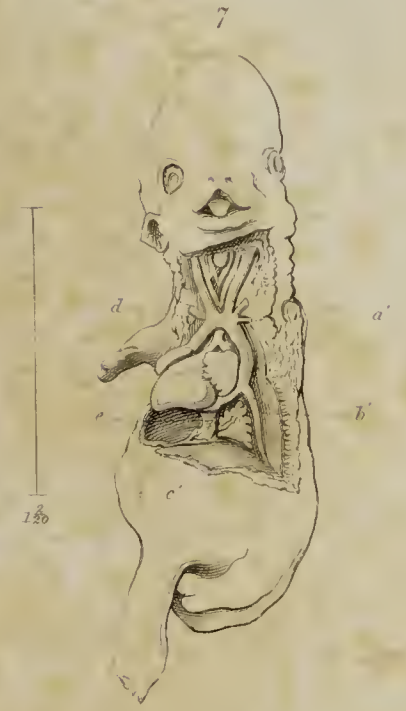
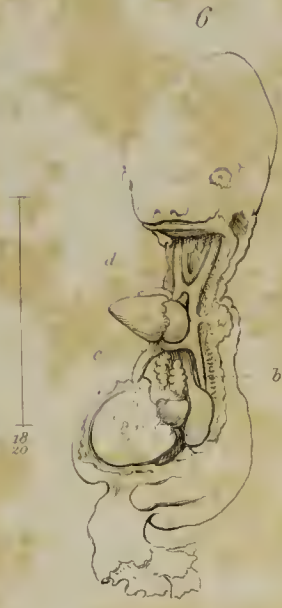
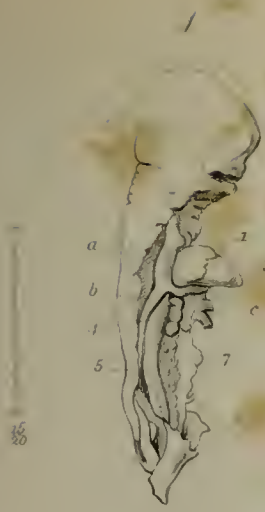


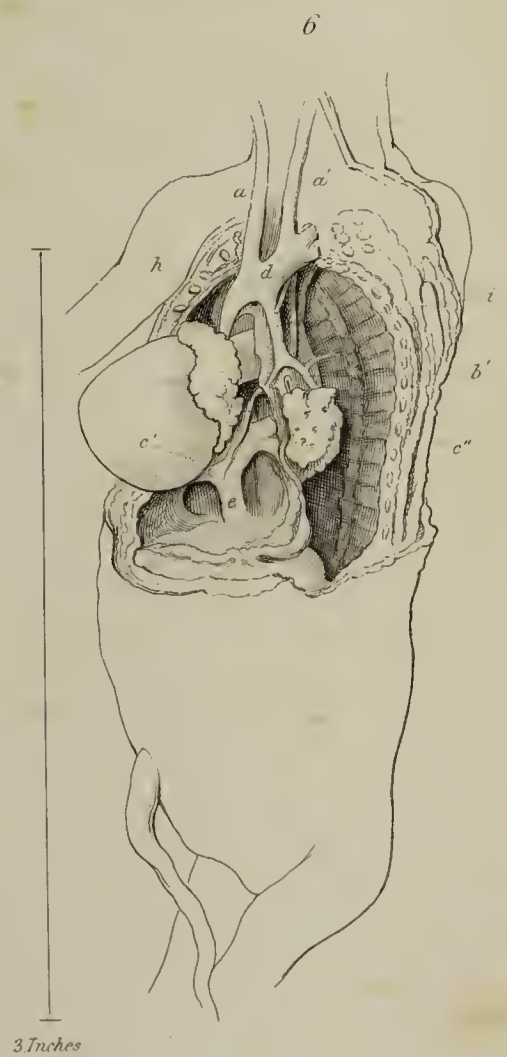
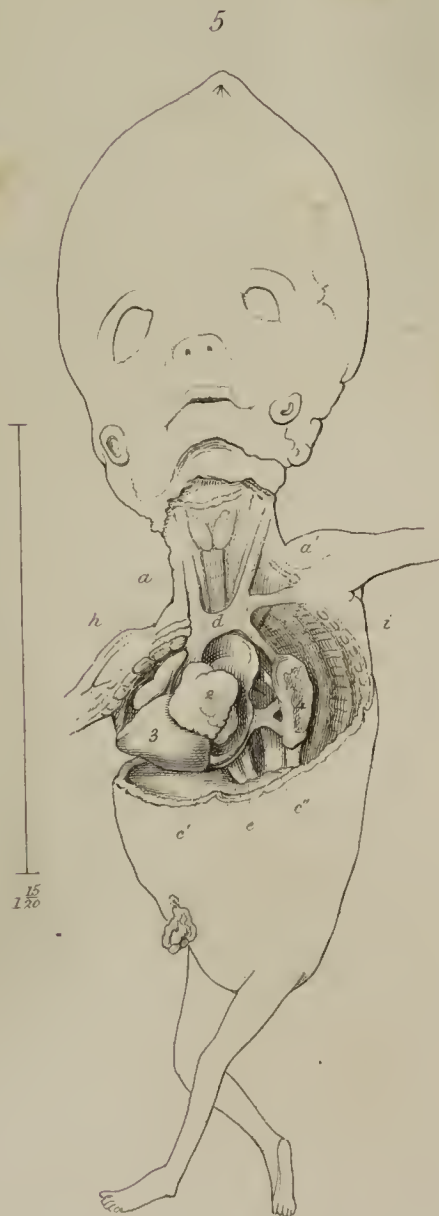
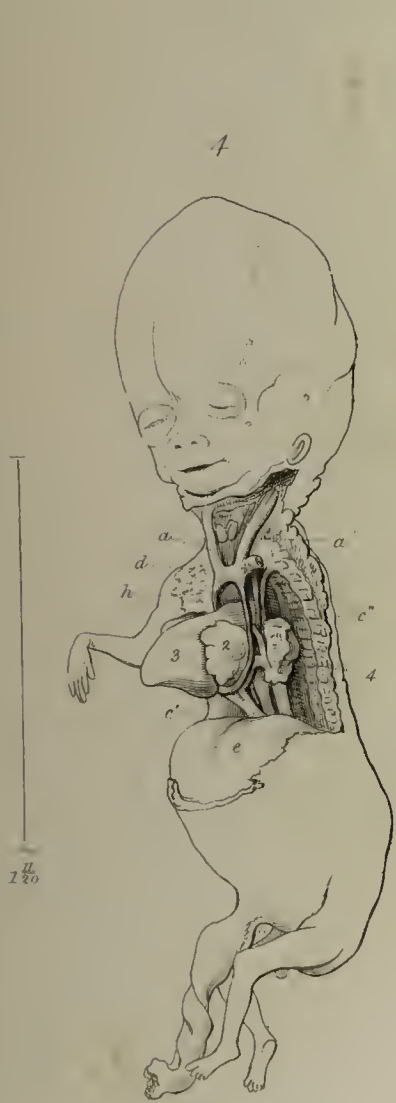
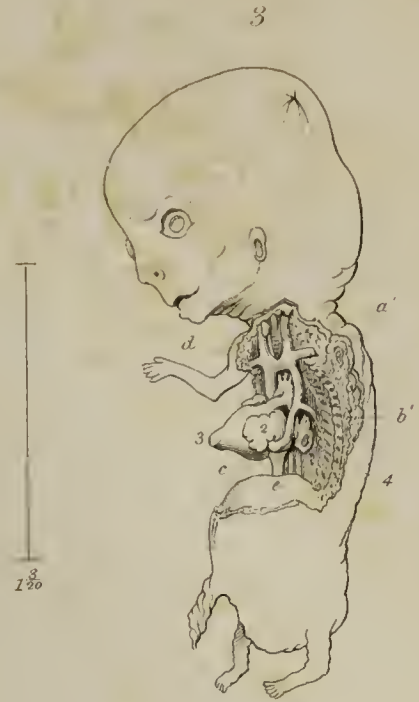
natural size.

Fig. 1.



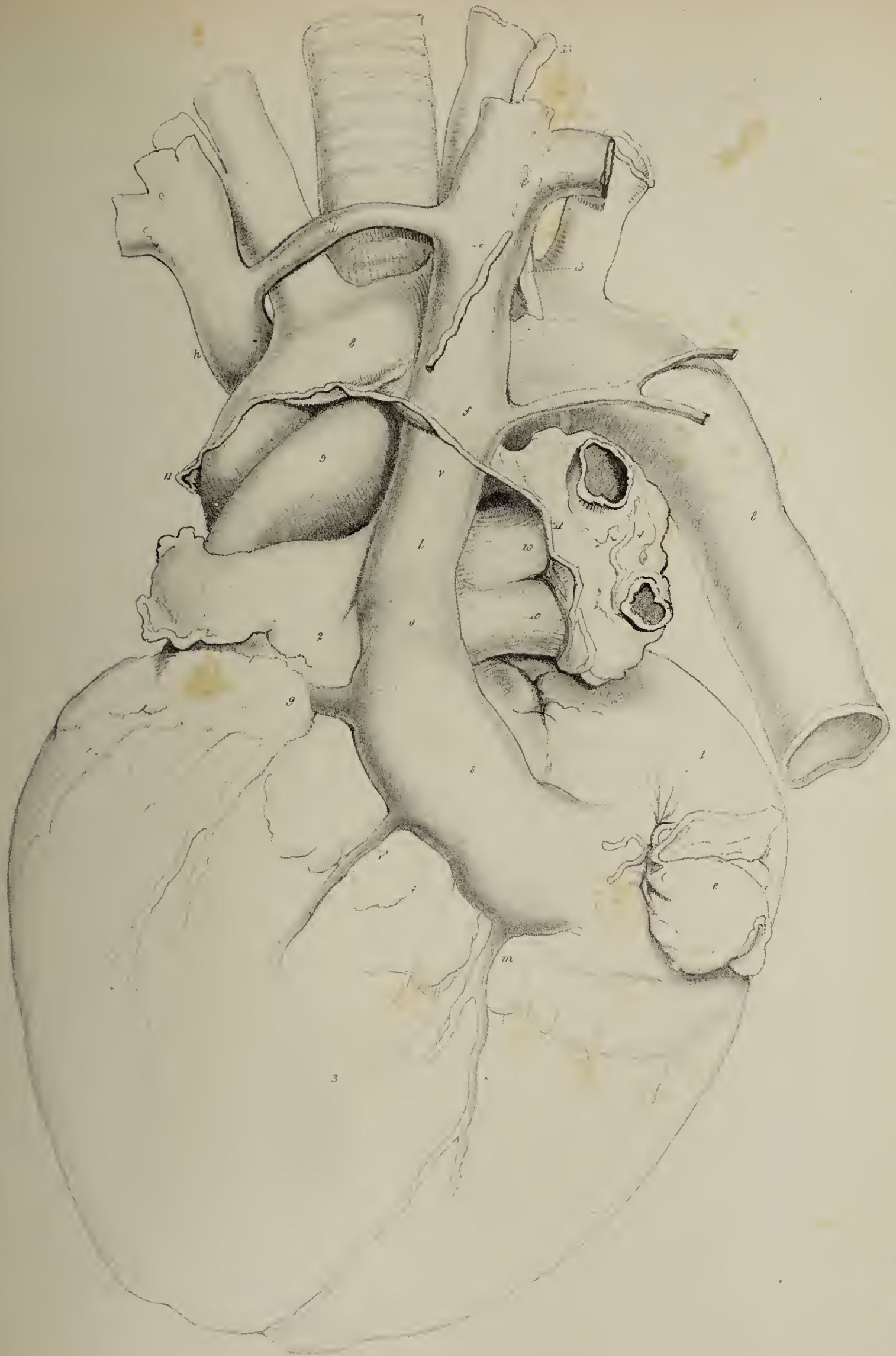
reduced $\frac{1}{5}$ in.











Scale One Inch to a Foot.

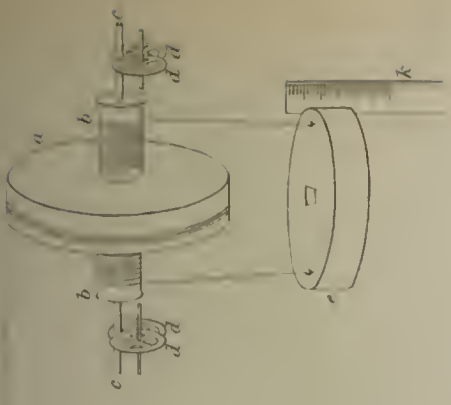


Fig. 1.

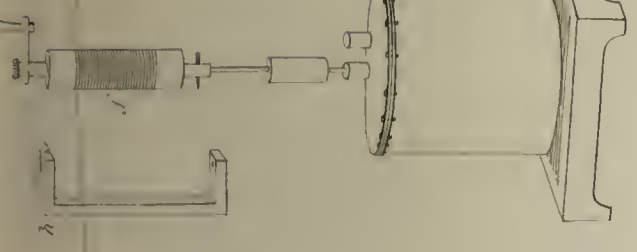


Fig. 3. a b

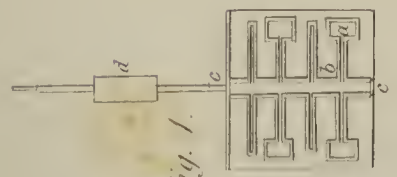


Fig. 4.

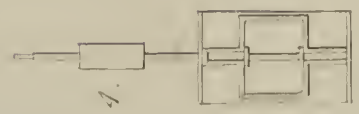


Fig. 5.



Fig. 6.



Fig. 7.

Fig. 8.

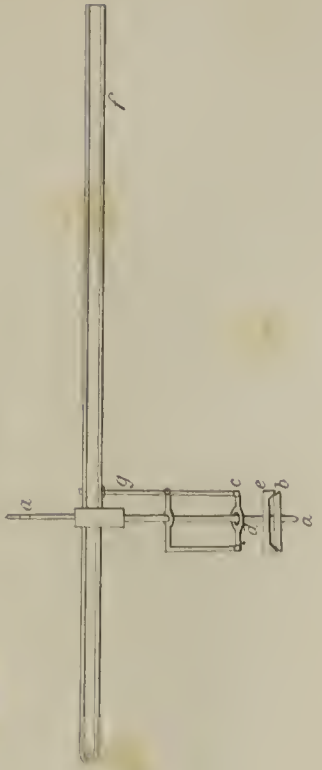


Fig. 9.

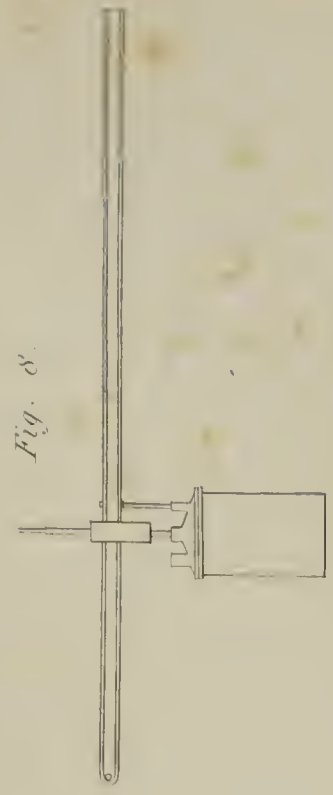


Fig. 10.

Fig. 1.



Fig. 2.



Fig. 3.



Fig. 4.

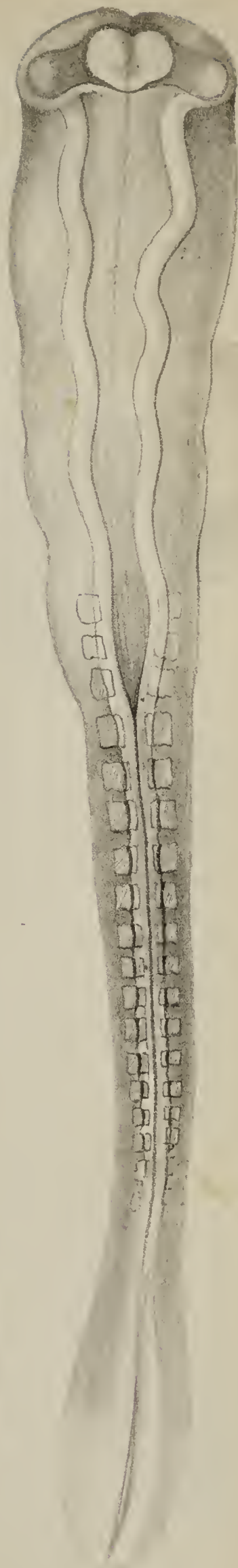


Fig. 5.

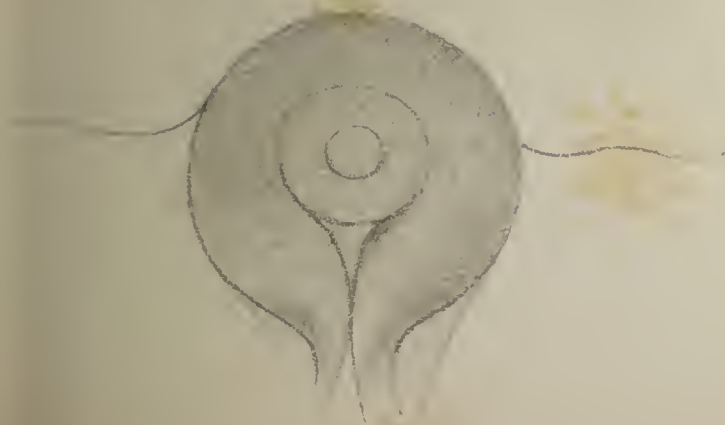


Fig. 8.

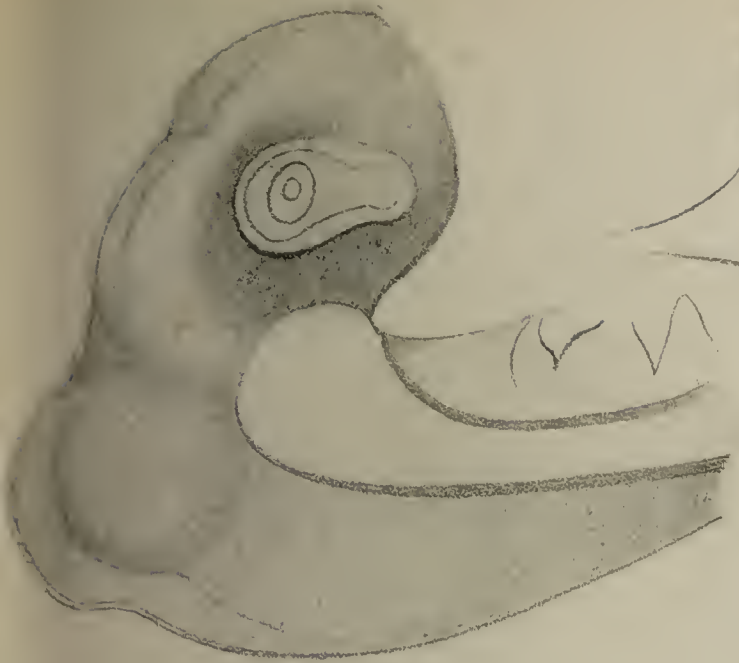


Fig. 9.

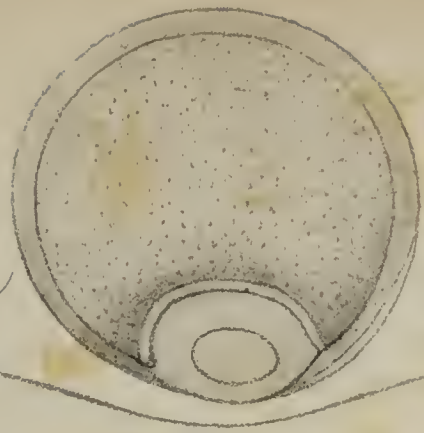


Fig. 10.

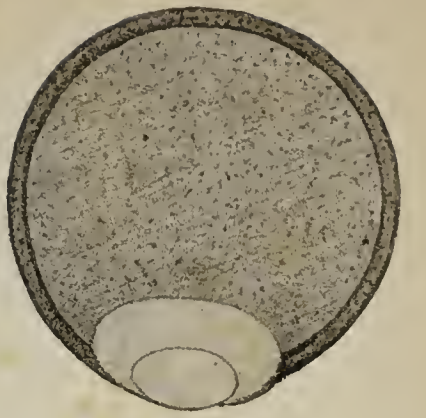


Fig. 11.



Fig. 12.

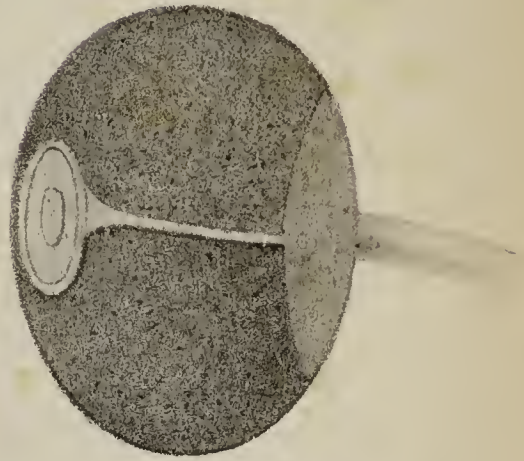


Fig. 13.

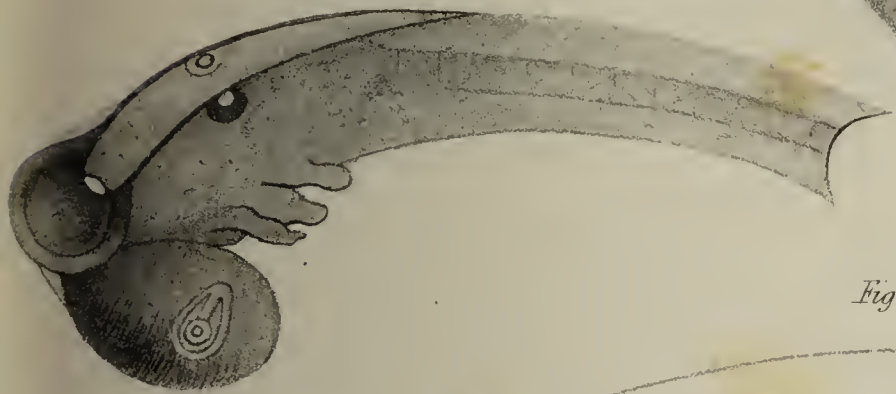


Fig. 15.

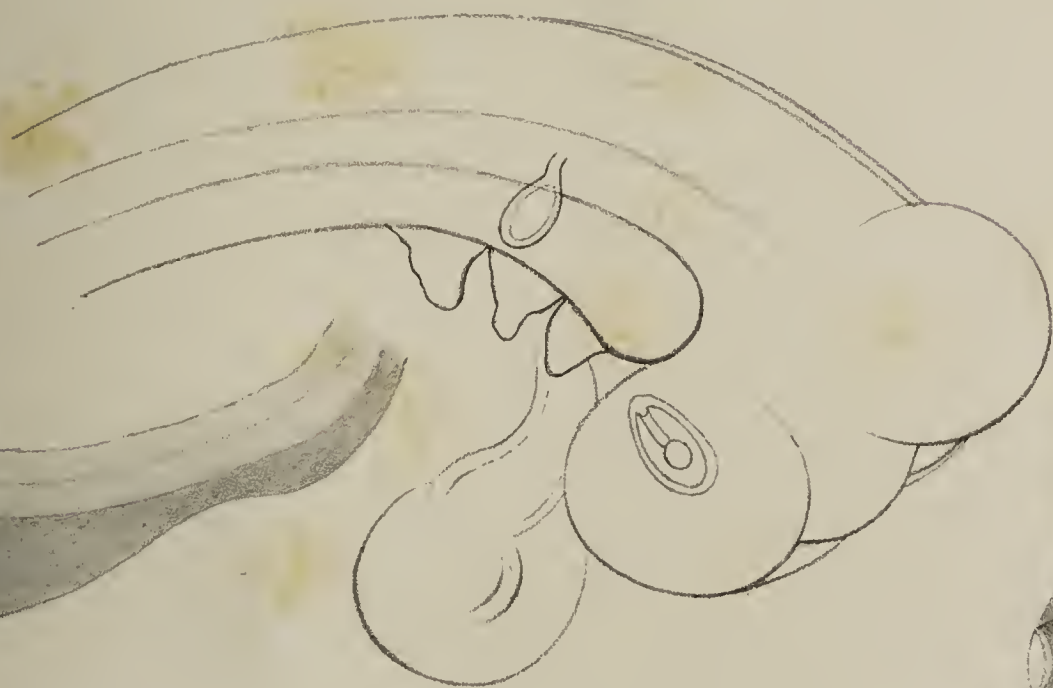


Fig. 17.



Fig. 14.

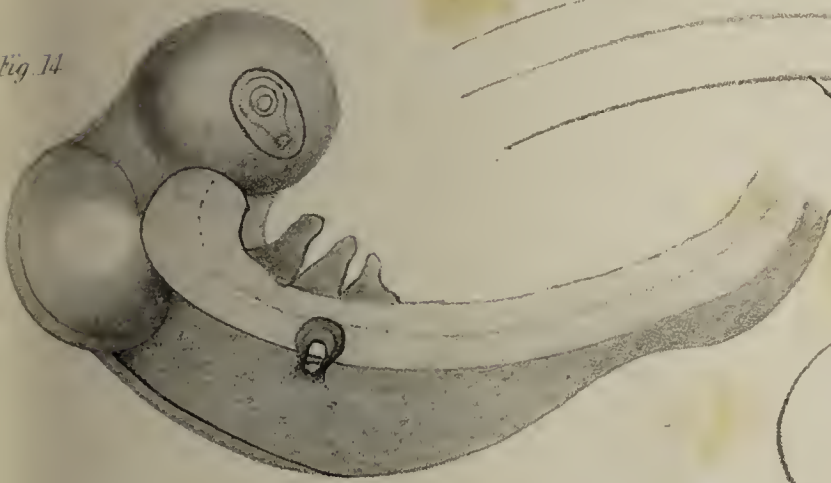


Fig. 16.



Fig. 18.

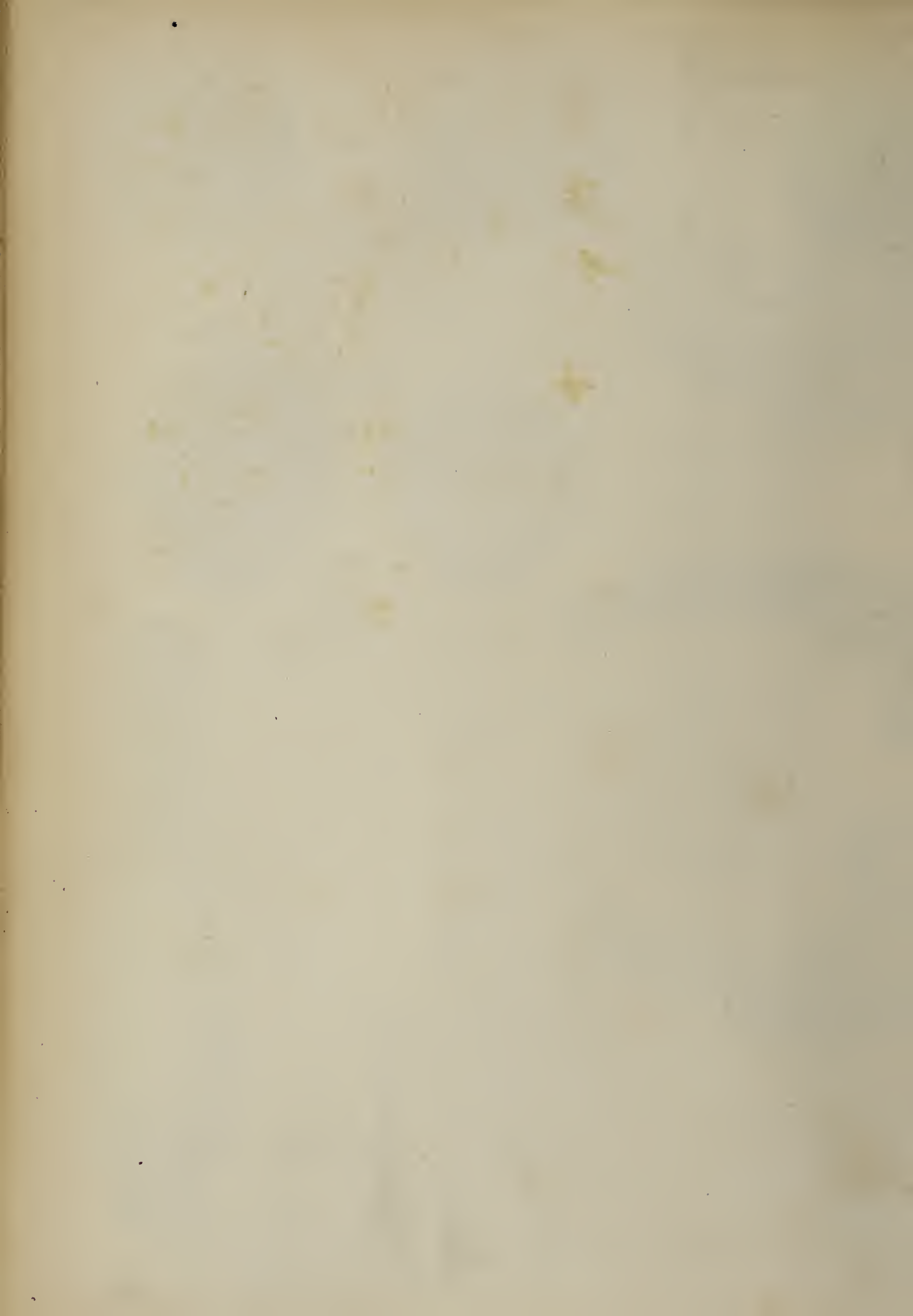


Fig. 1.

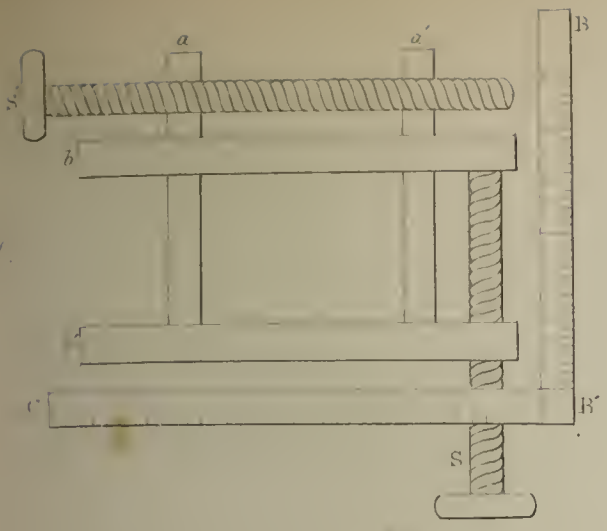


Fig. 2.

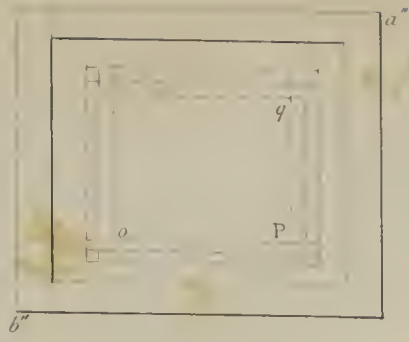


Fig. 3.

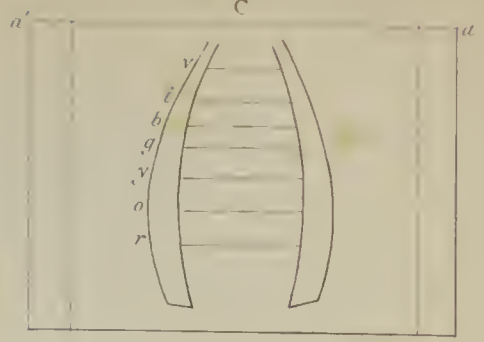


Fig. 4.

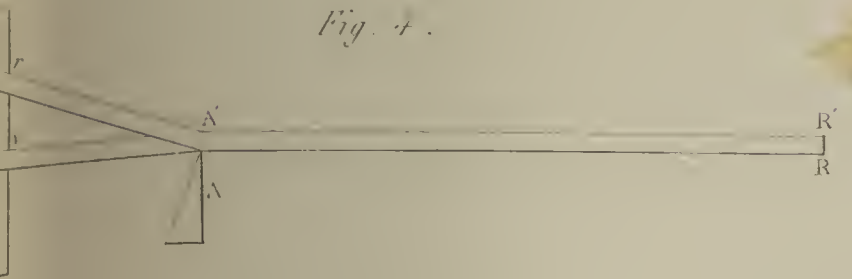


Fig. 6.

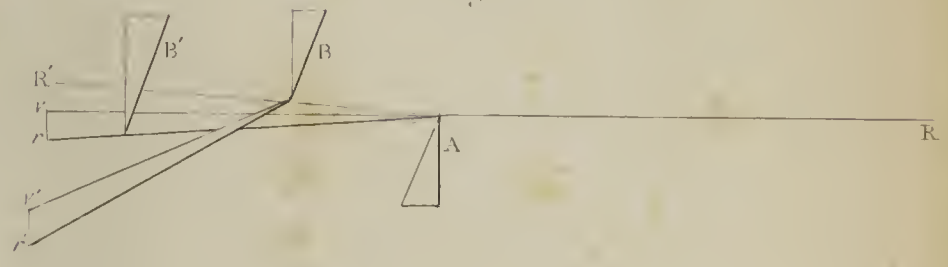


Fig. 5.

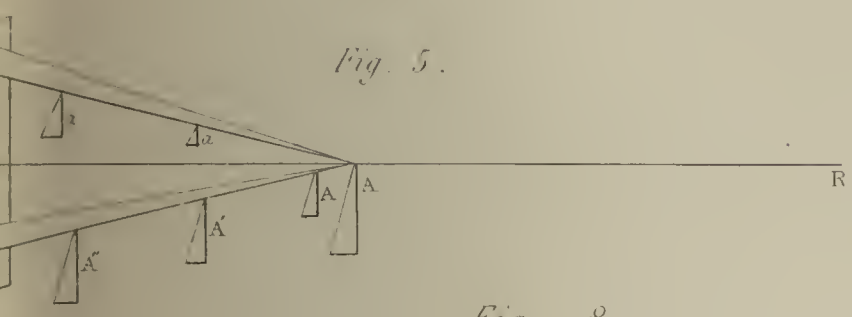


Fig. 7.

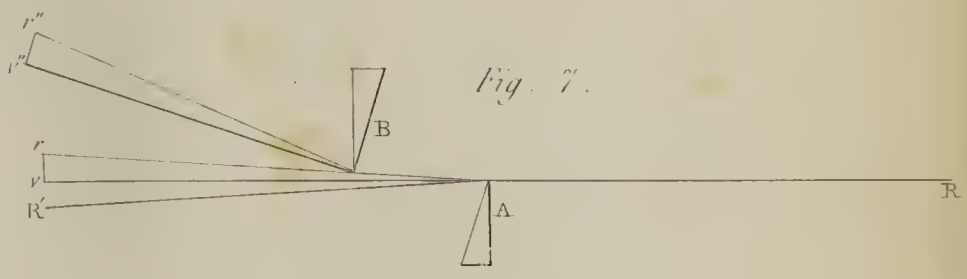


Fig. 8.

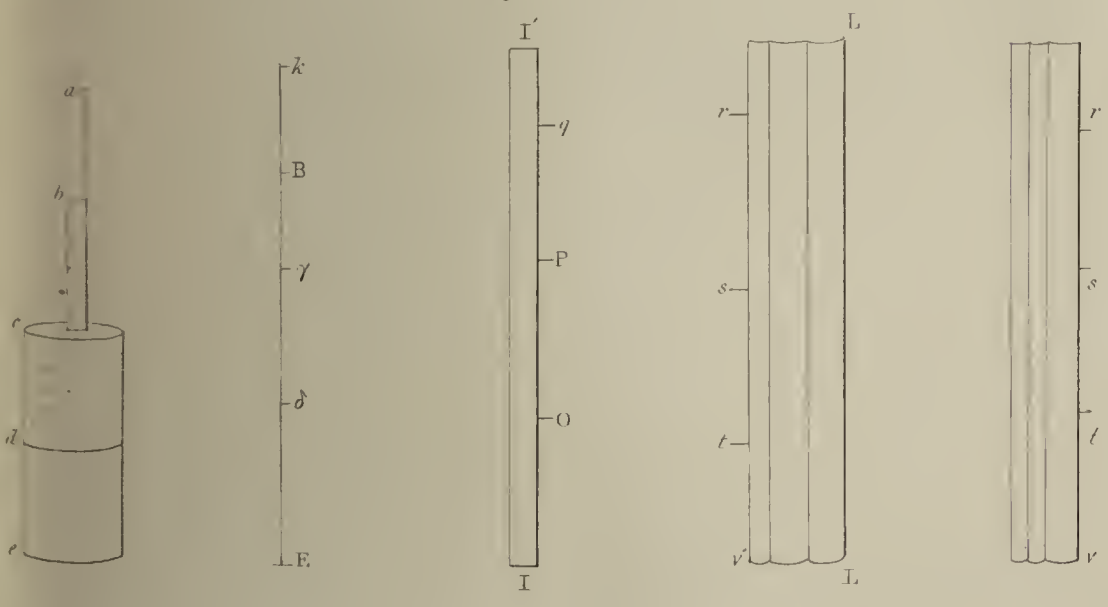


Fig. 9.

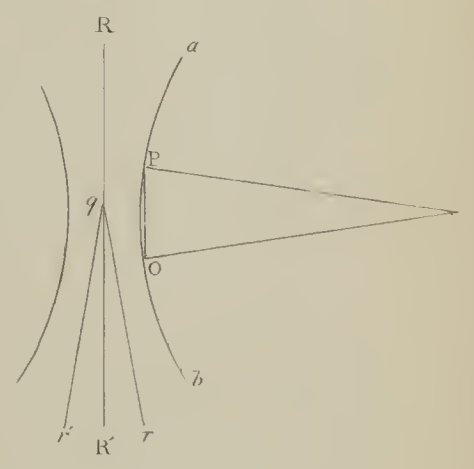


Fig. 10.

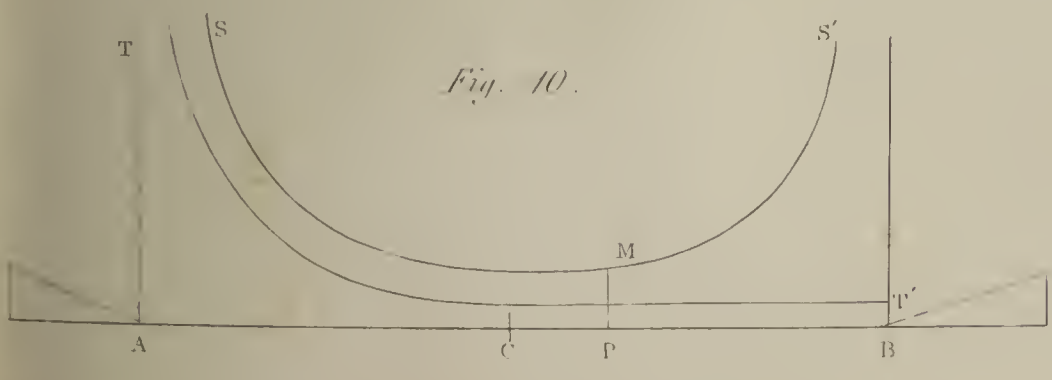
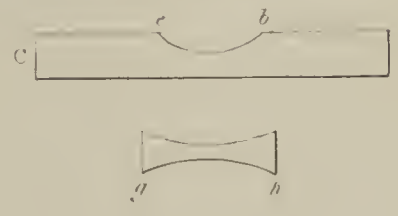


Fig. 12.



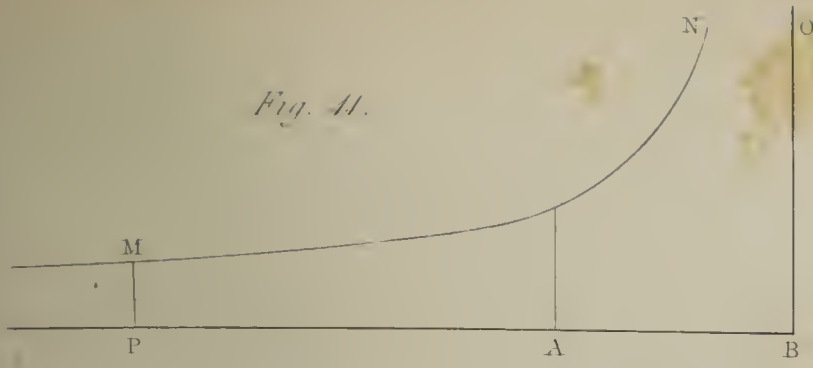


Fig. 11.

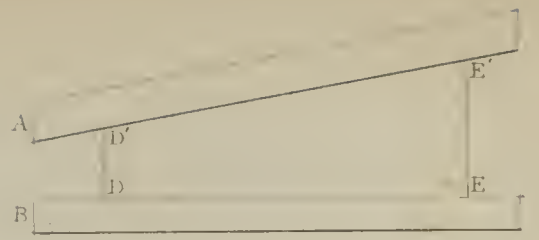


Fig. 13.

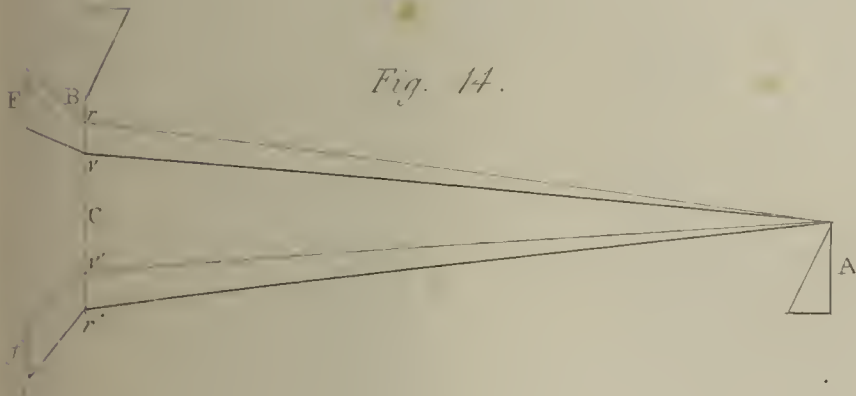


Fig. 14.

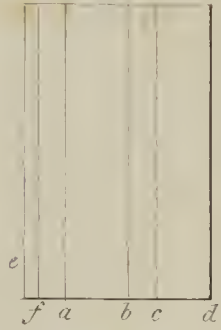


Fig. 16.

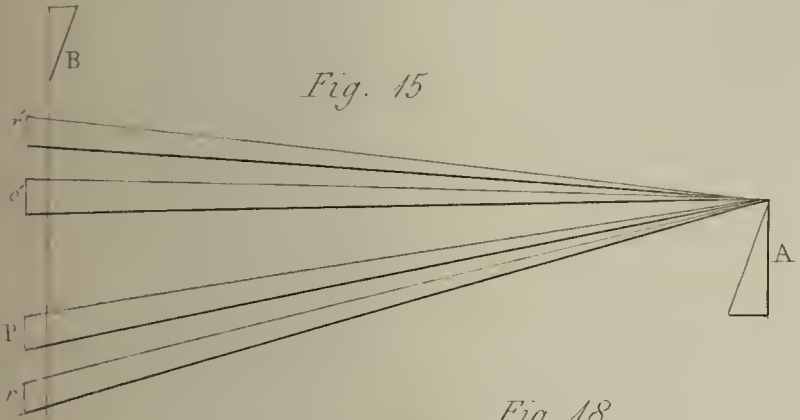


Fig. 15.

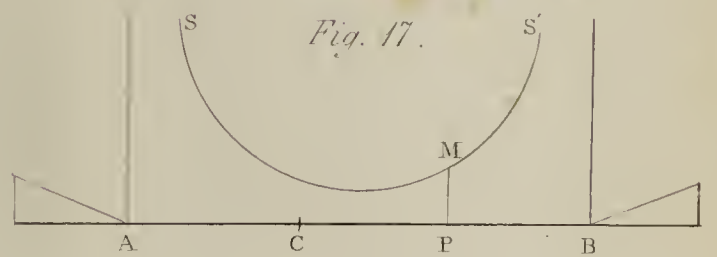


Fig. 17.

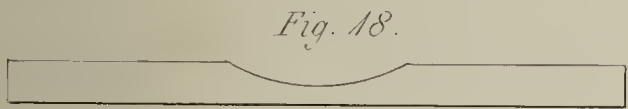


Fig. 18.

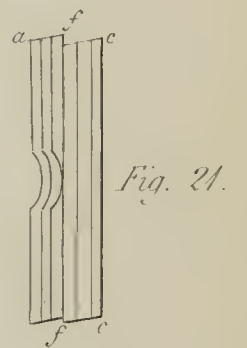
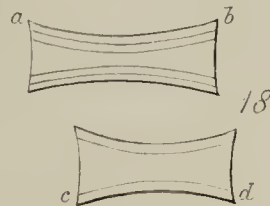


Fig. 21.

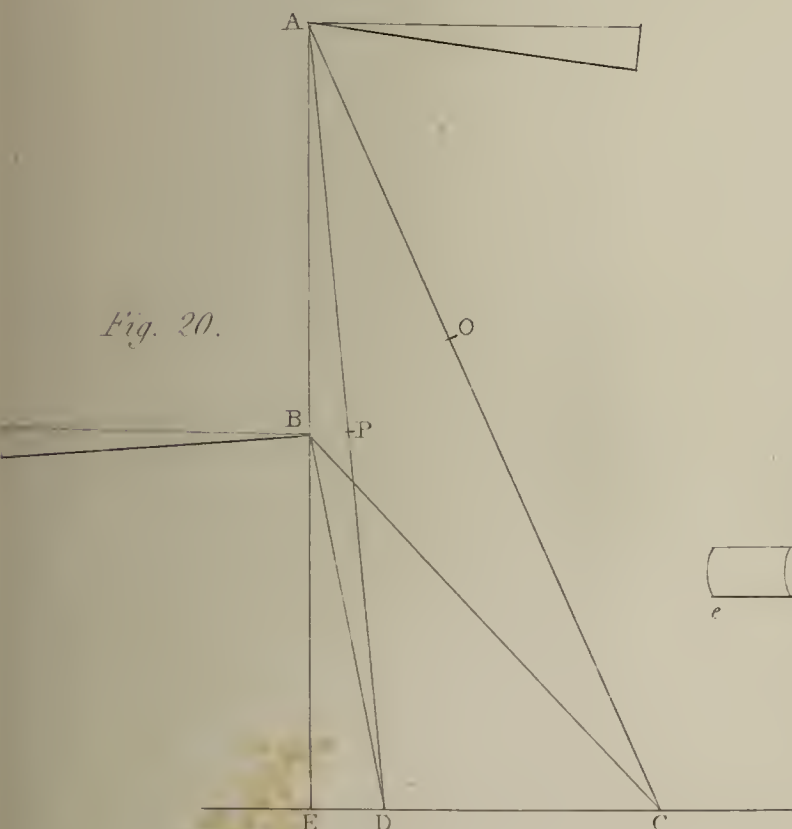


Fig. 20.



Fig. 19.

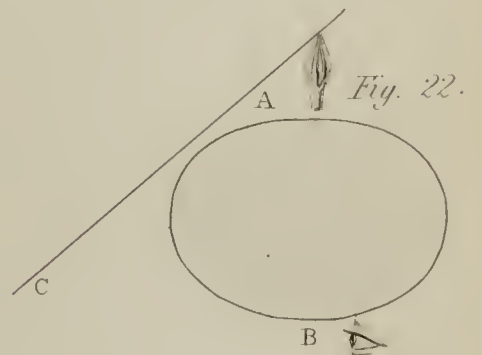


Fig. 22.



Fig. 19.

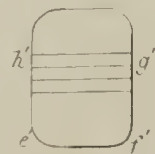
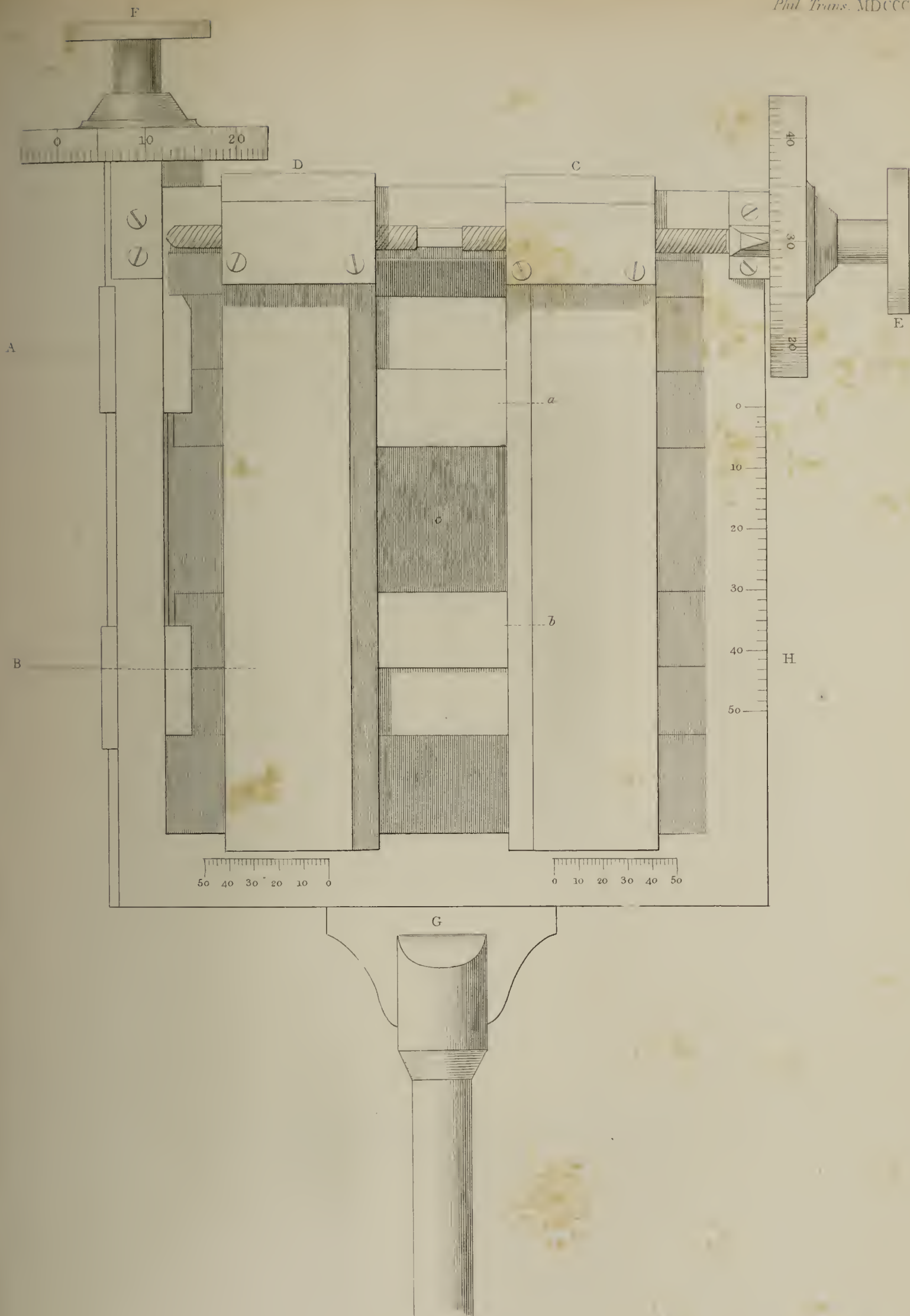
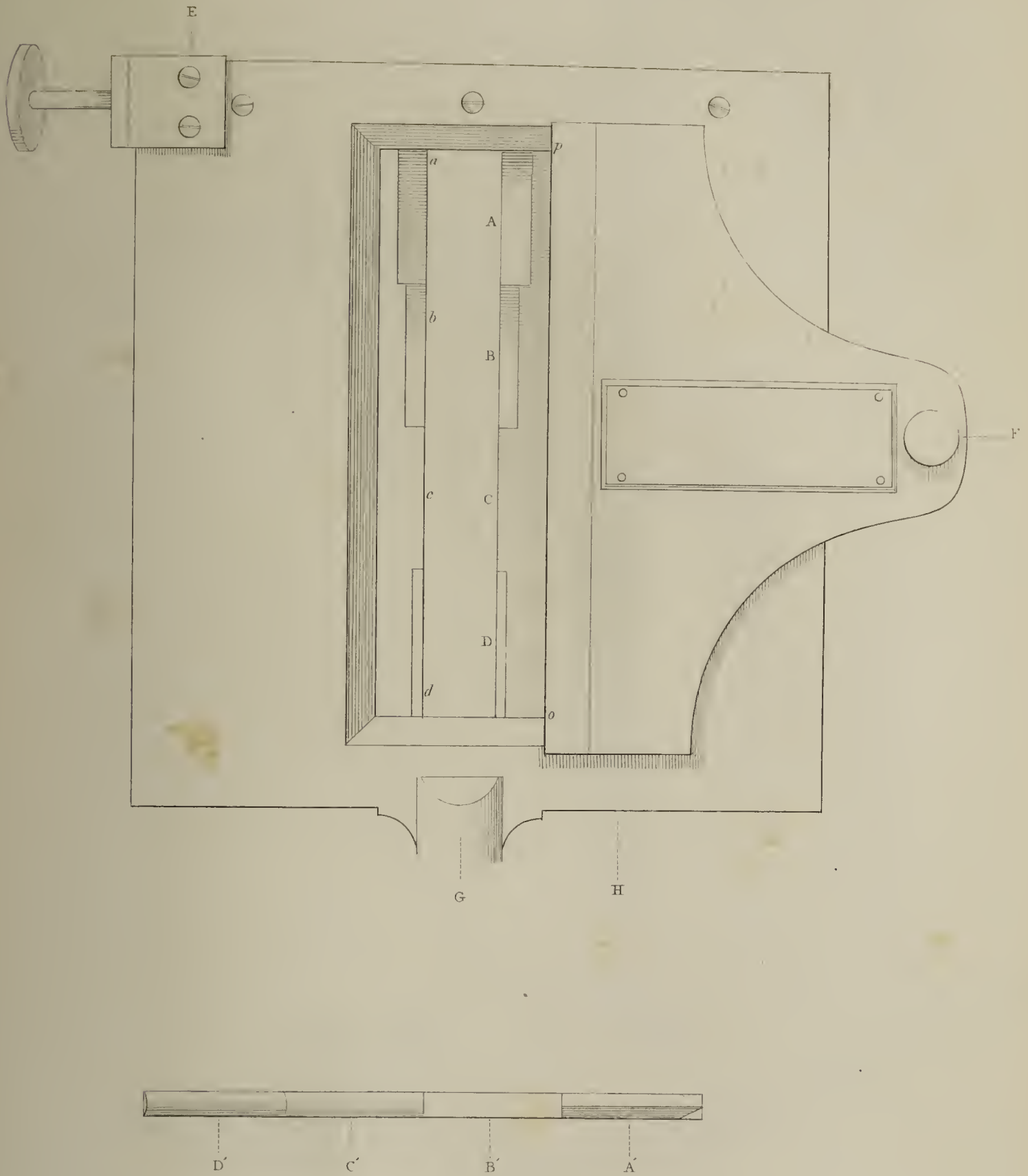
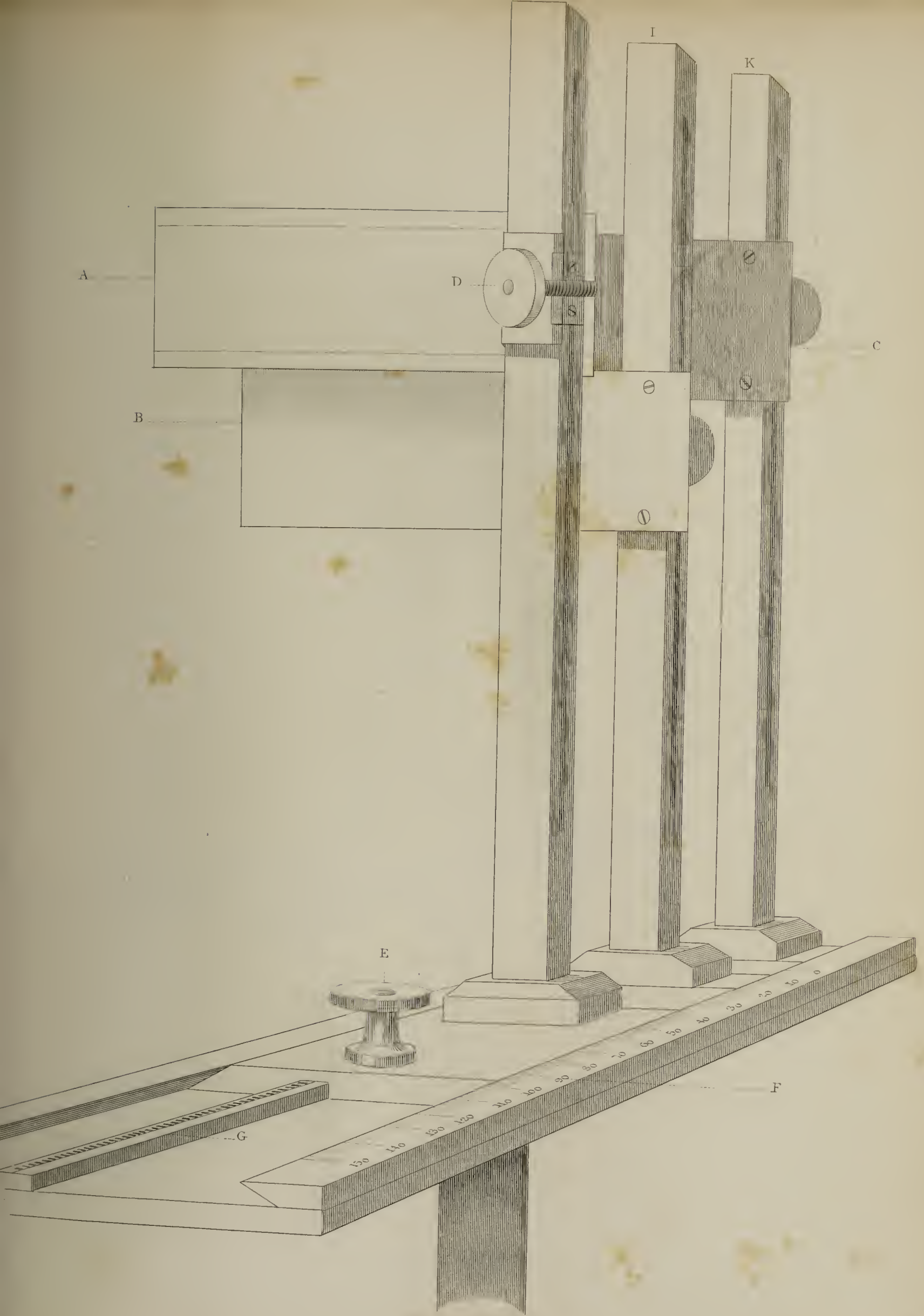


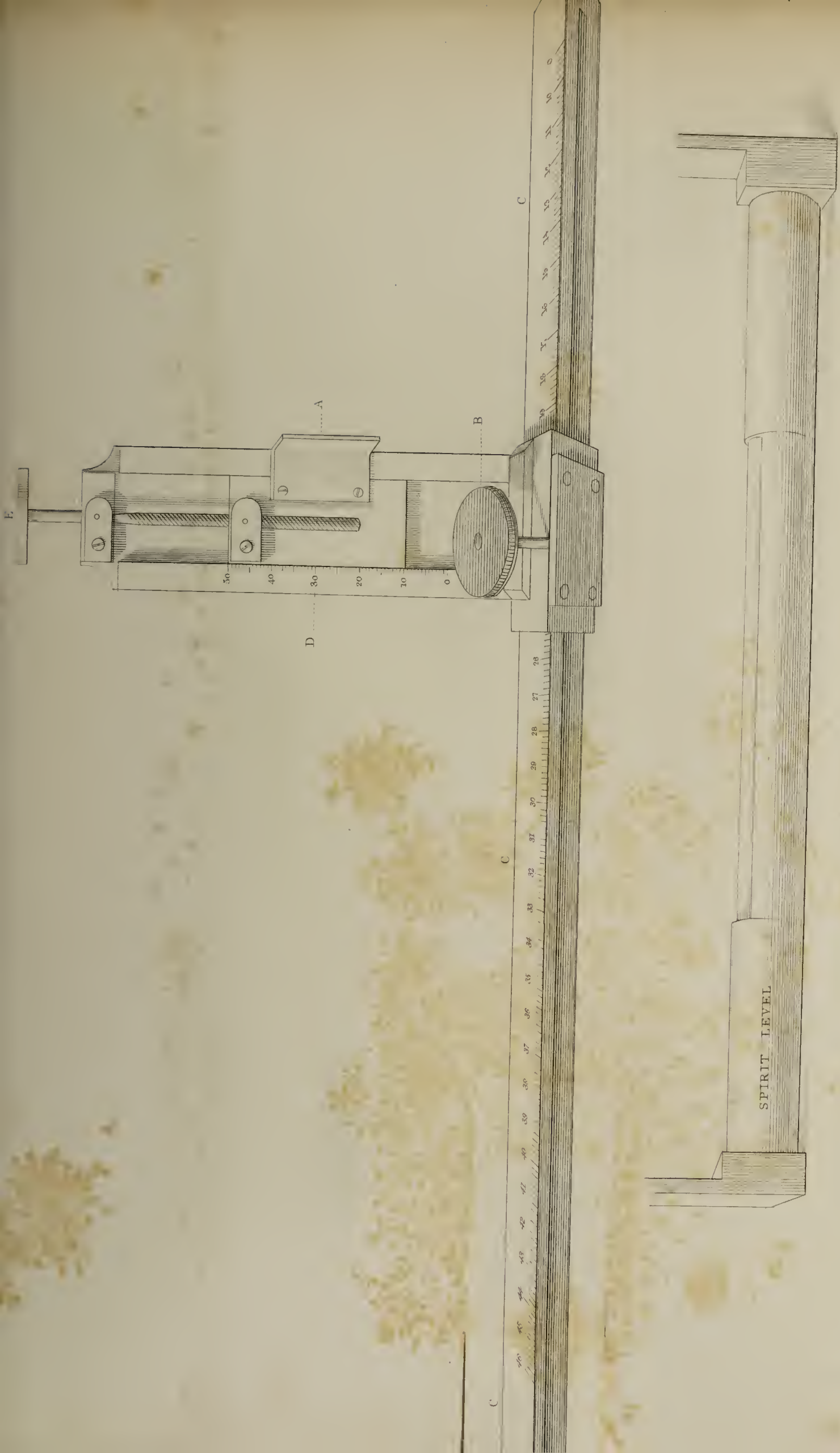
Fig. 19.









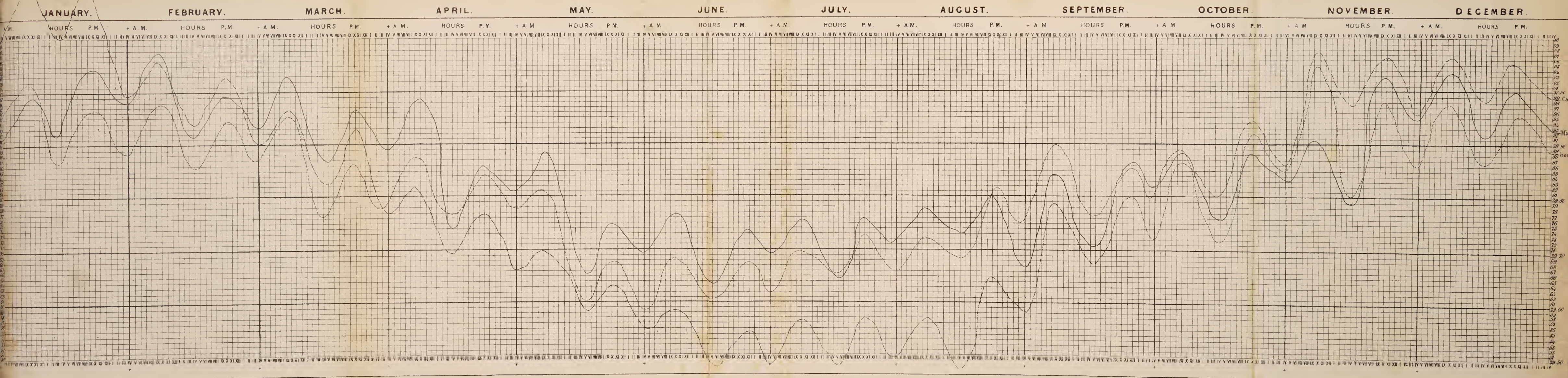


Faint, illegible text running vertically down the right side of the page.



Mean Oscillations of the Barometer corrected for Temperature at Calcutta, Bombay and Madras

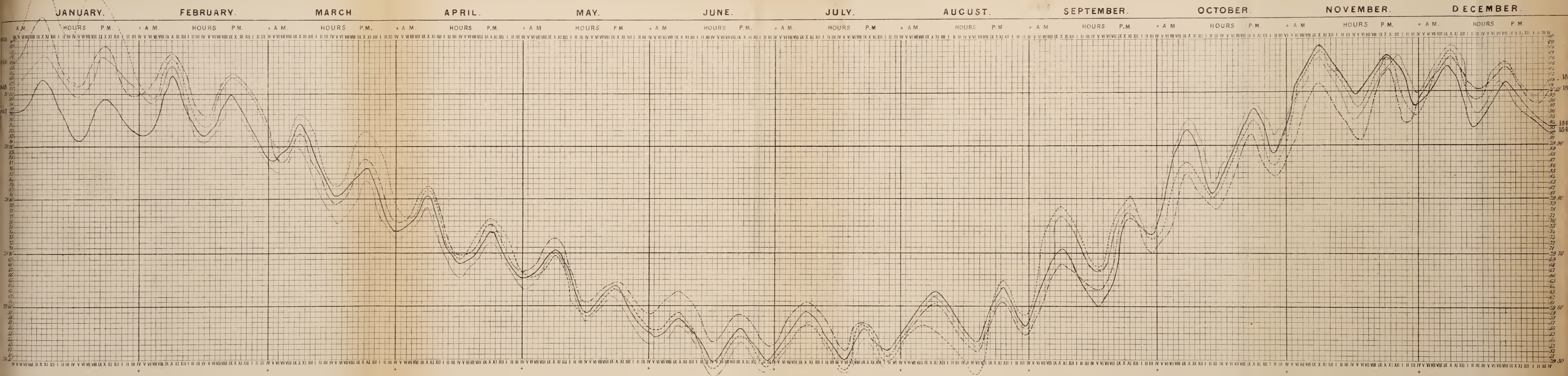
1845.



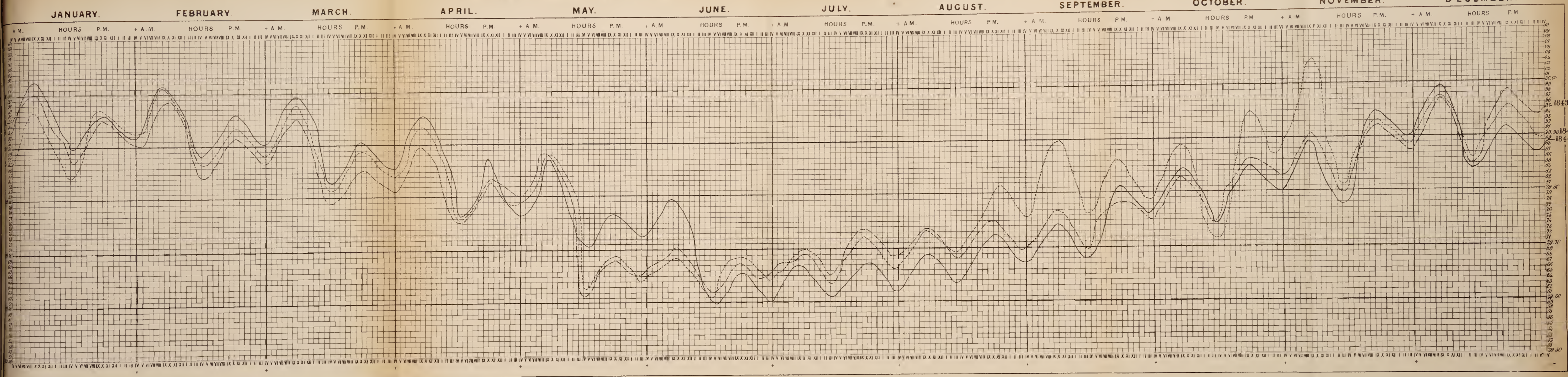
These Barometric Curves represent 1st the mean daily oscillations of the barometer for each month of the year. 2^{ndly} The mean monthly pressure for each month in the year. 3^{rdly} The Annual curve of pressure.

For example At Bombay in 1845, the mean maximum daily pressure in Jan^r was between 9 and 10 a.m. — The mean minimum daily pressure was between 3 and 4 p.m. The mean maximum night pressure was between 10 and 11 p.m. and the mean minimum night pressure was between 3 and 4 a.m. — The mean monthly range of the barometer was from 29.65 to 29.865. — Similarly in the monsoon months of June, July & August the heavy oscillations or atmospheric tides continue at the same hours as in January, but the mean range of the Barometer in June is from 29.683 to 29.607.

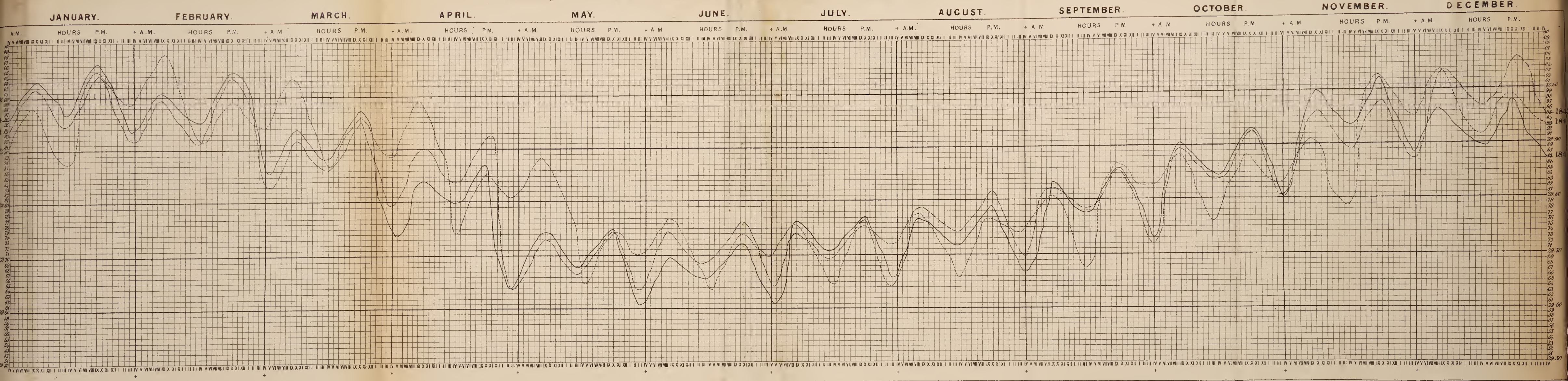
Mean hourly oscillation of the Barometer at CALCUTTA for the years 1845, 1846, 1847 and 1848.



Mean hourly oscillation of the Barometer at BOMBAY, for the years 1843, 1844 & 1845.



Mean hourly oscillation of the Barometer at MADRAS, for the years 1843, 1844, and 1845.

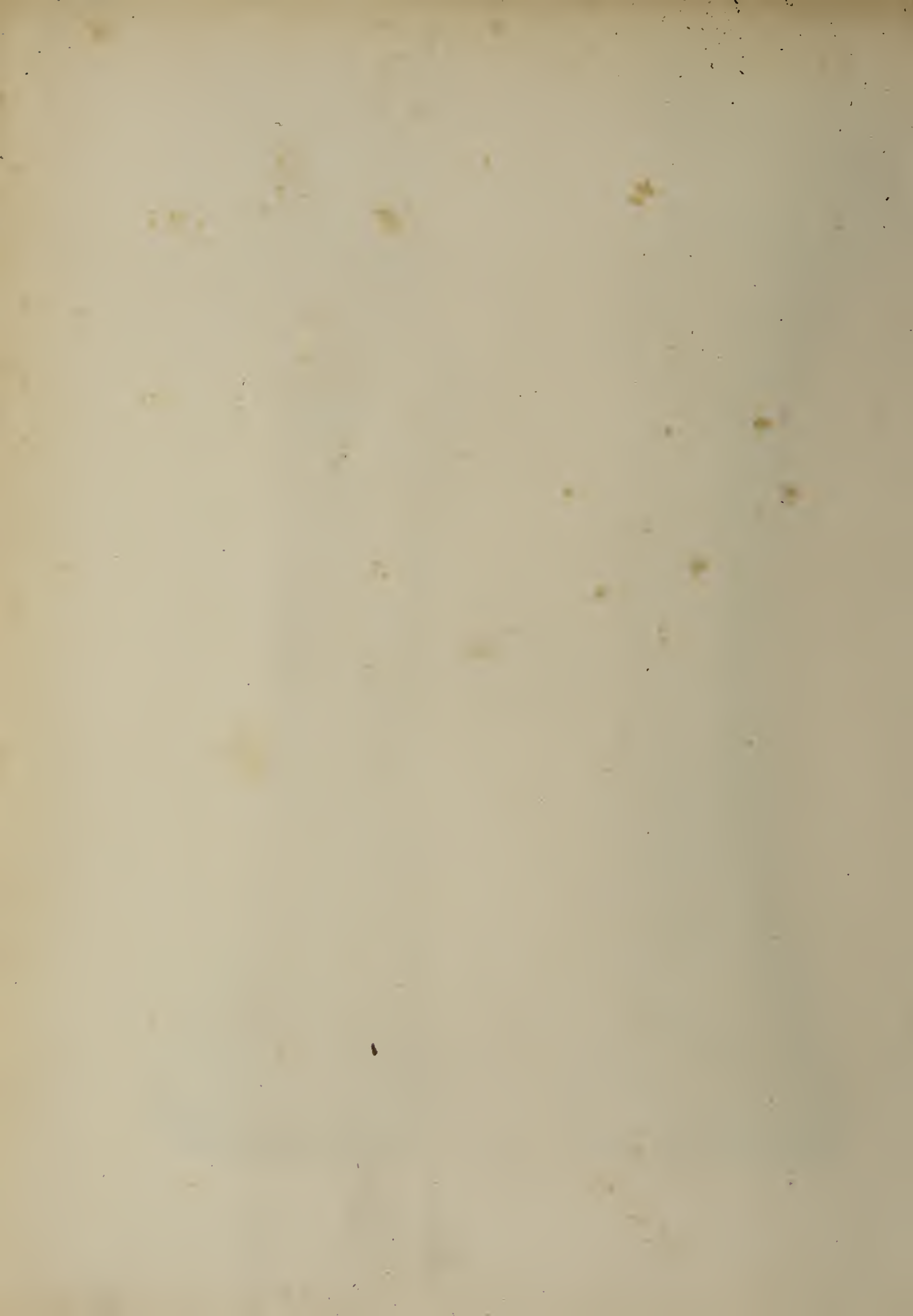


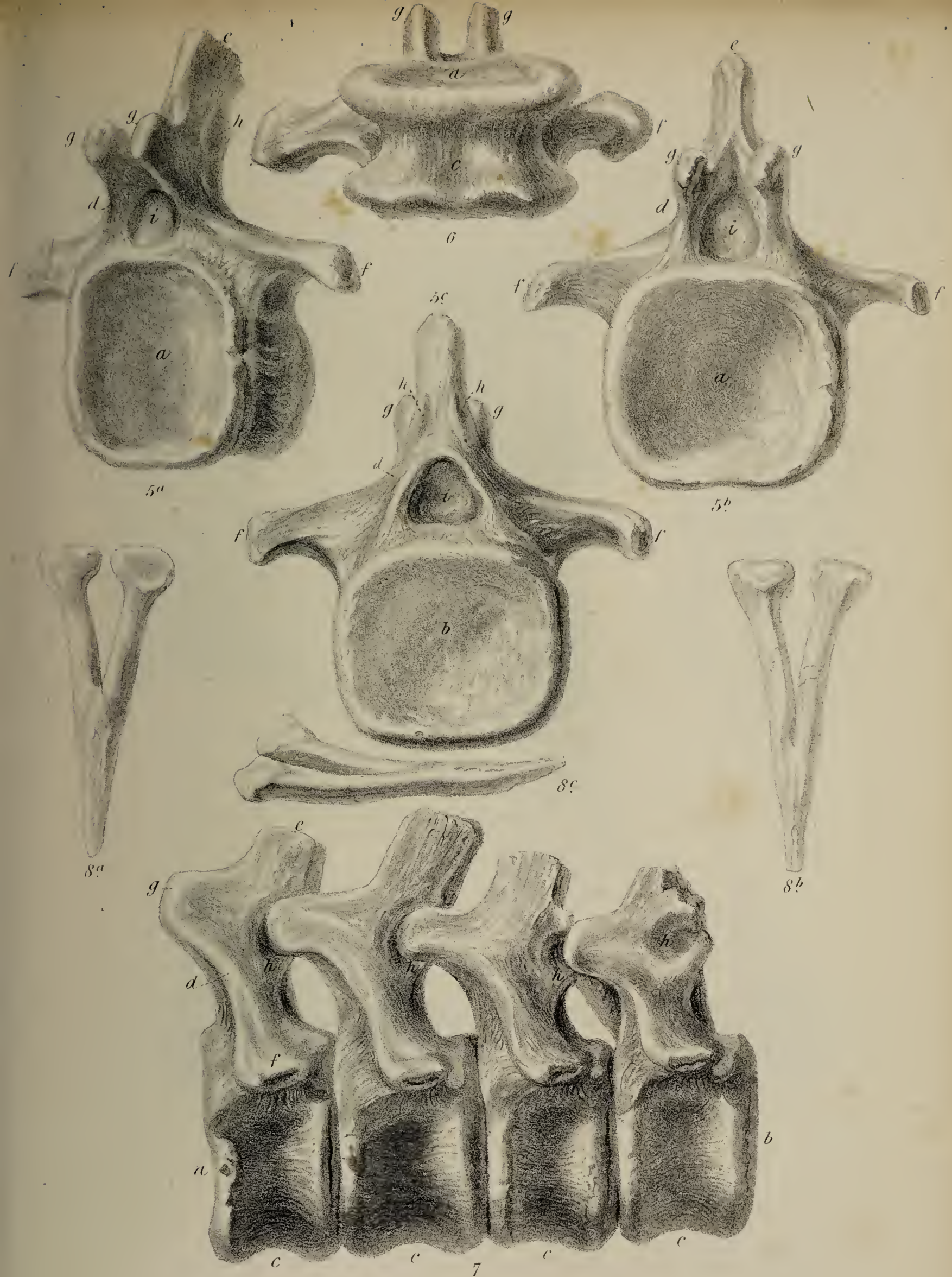


1^a
Anterior aspect.

1^b
Posterior aspect.

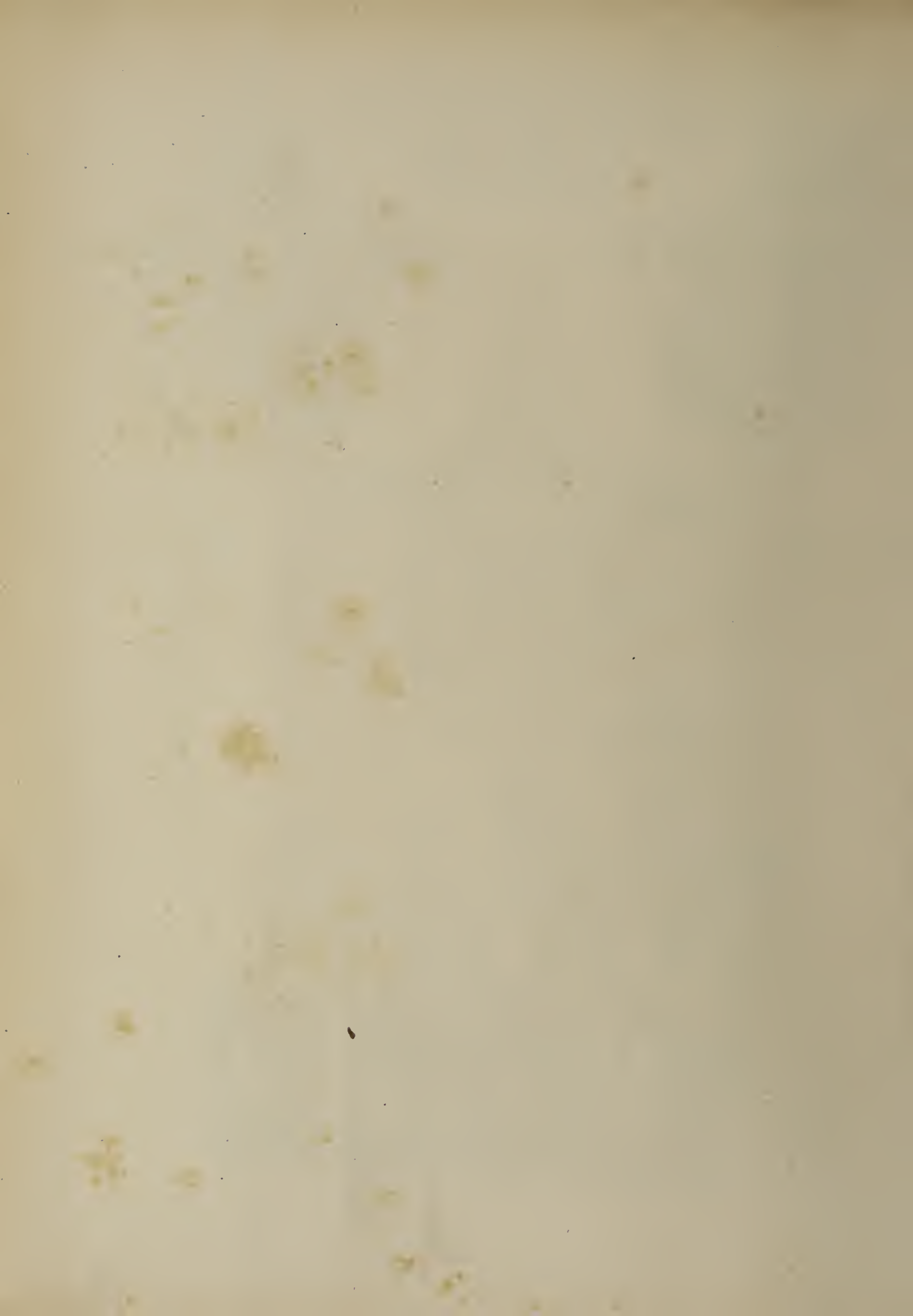
Right Humerus of *Pelorosaurus Conybearei*.

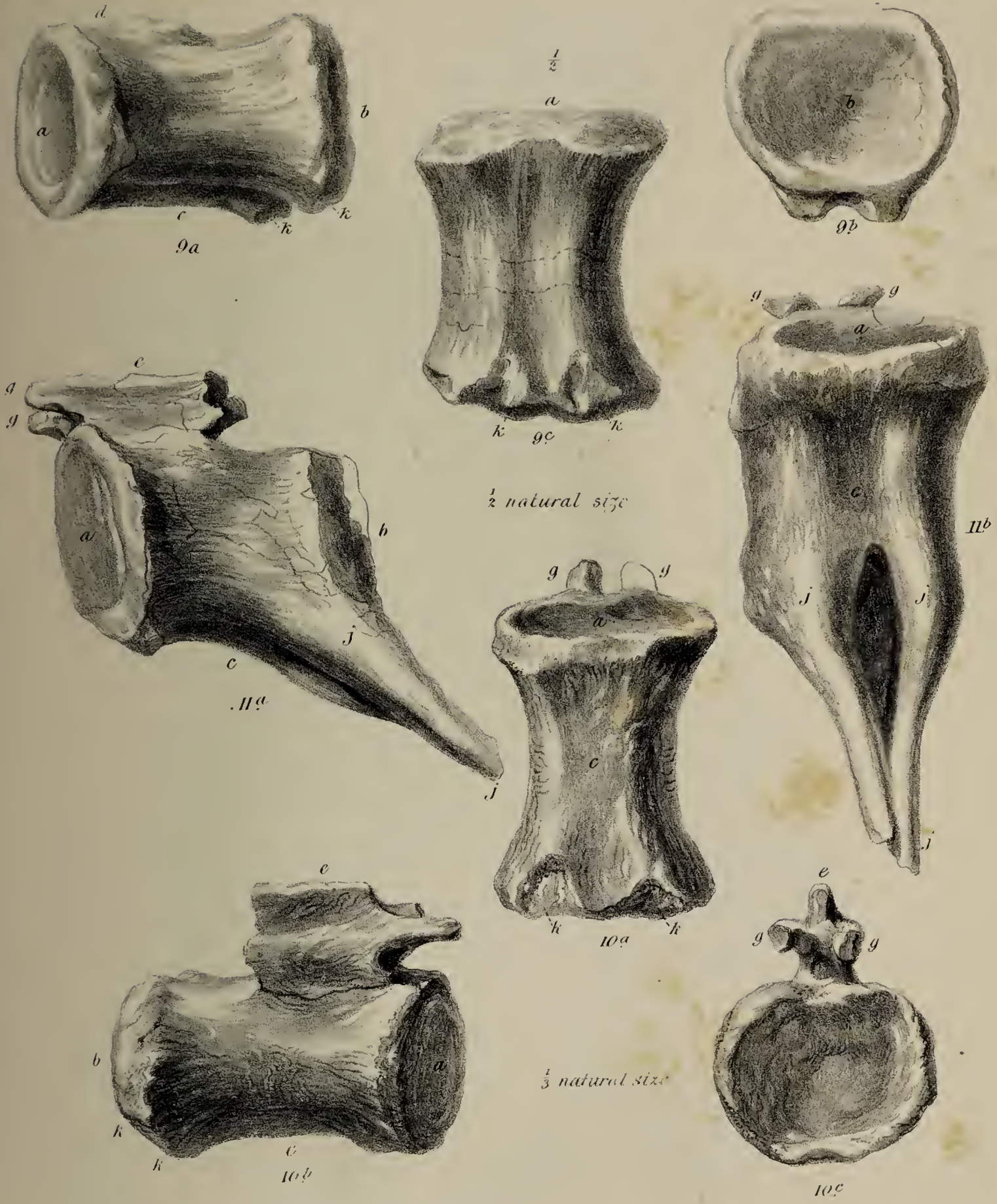




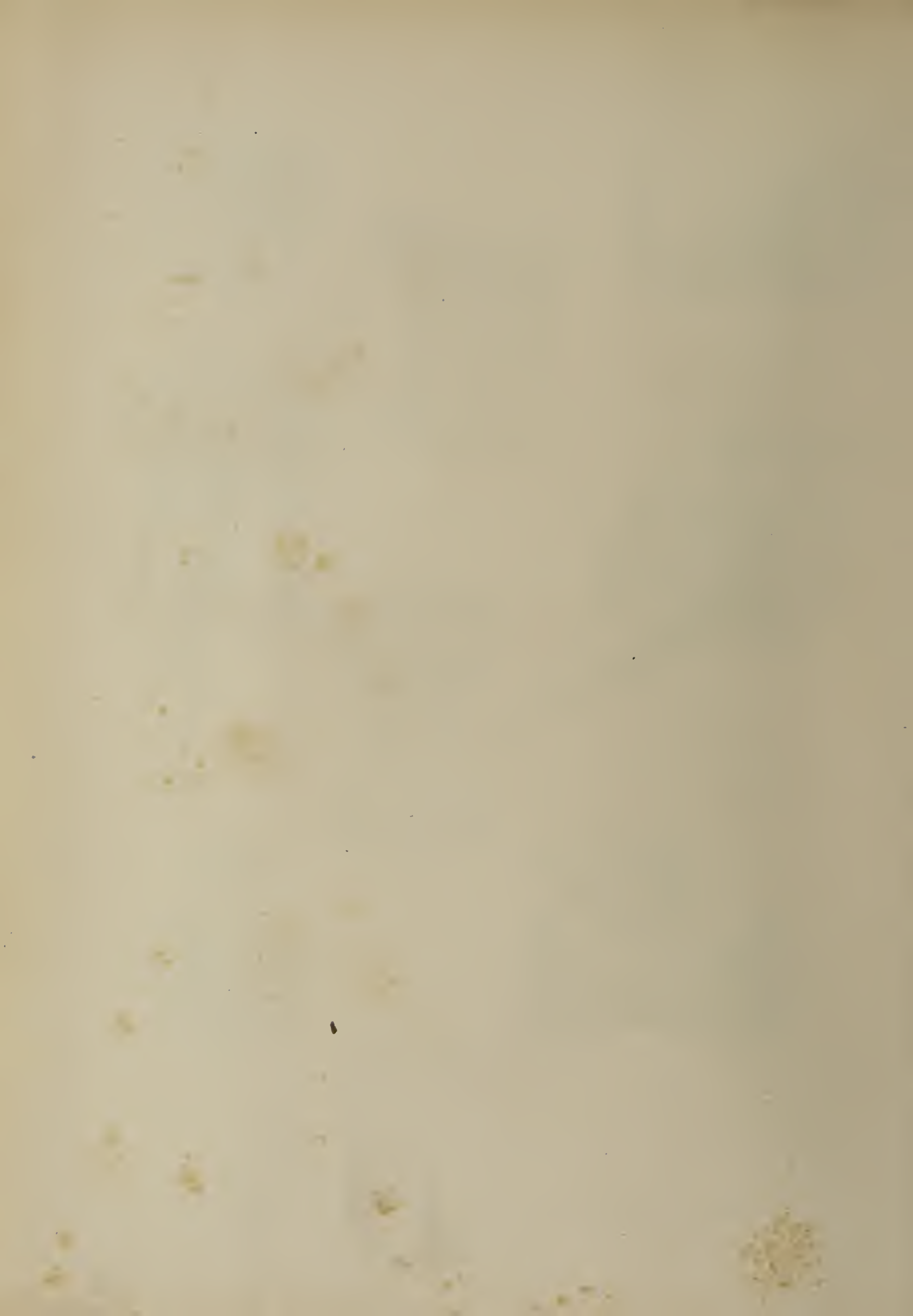
Caudal Vertebrae of Pelorosaurus Conyhcaeri.

From the Strata of Tilgate For.





Saurian caudal Vertebrae, from the strata of Tilgate Forest.



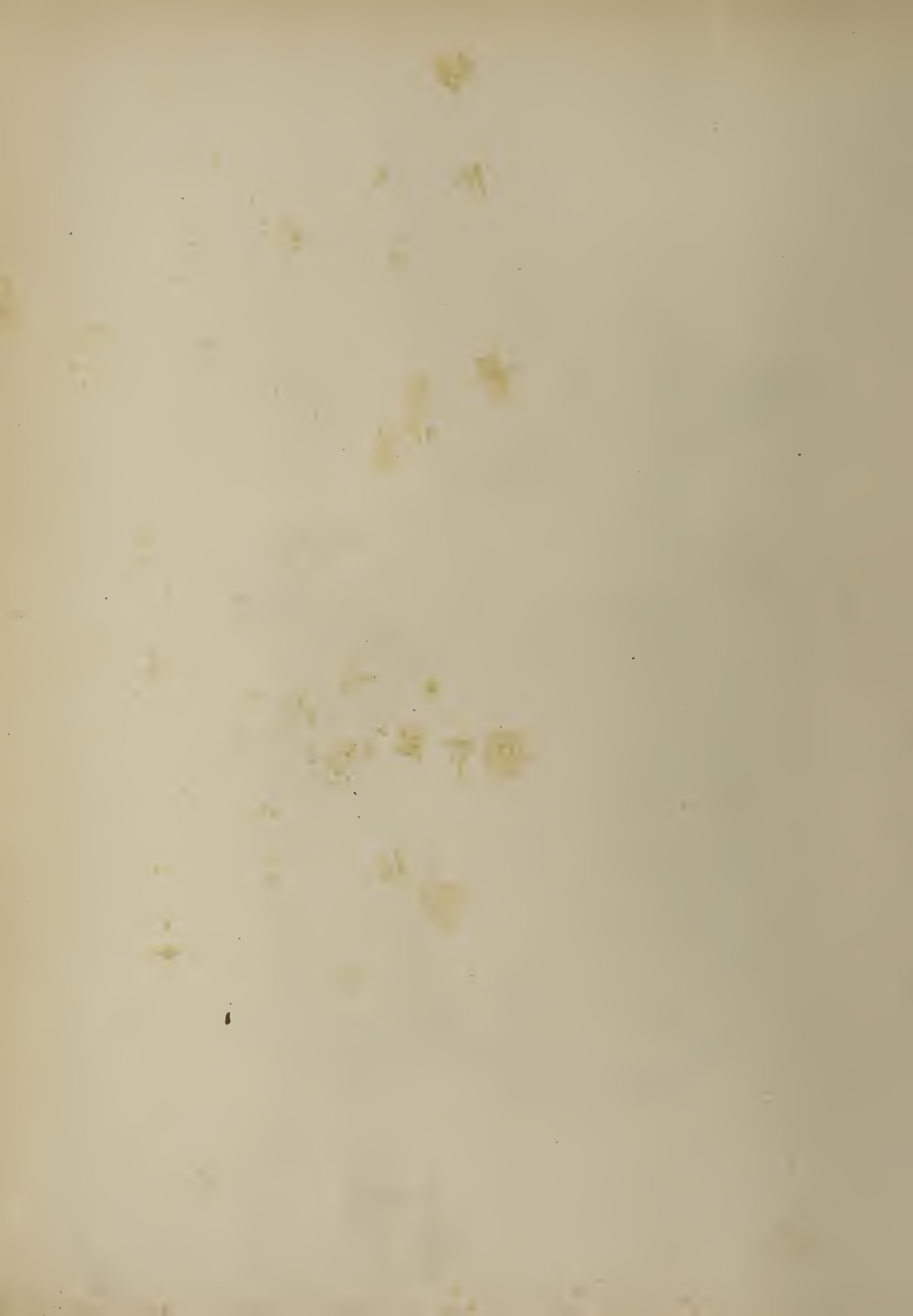


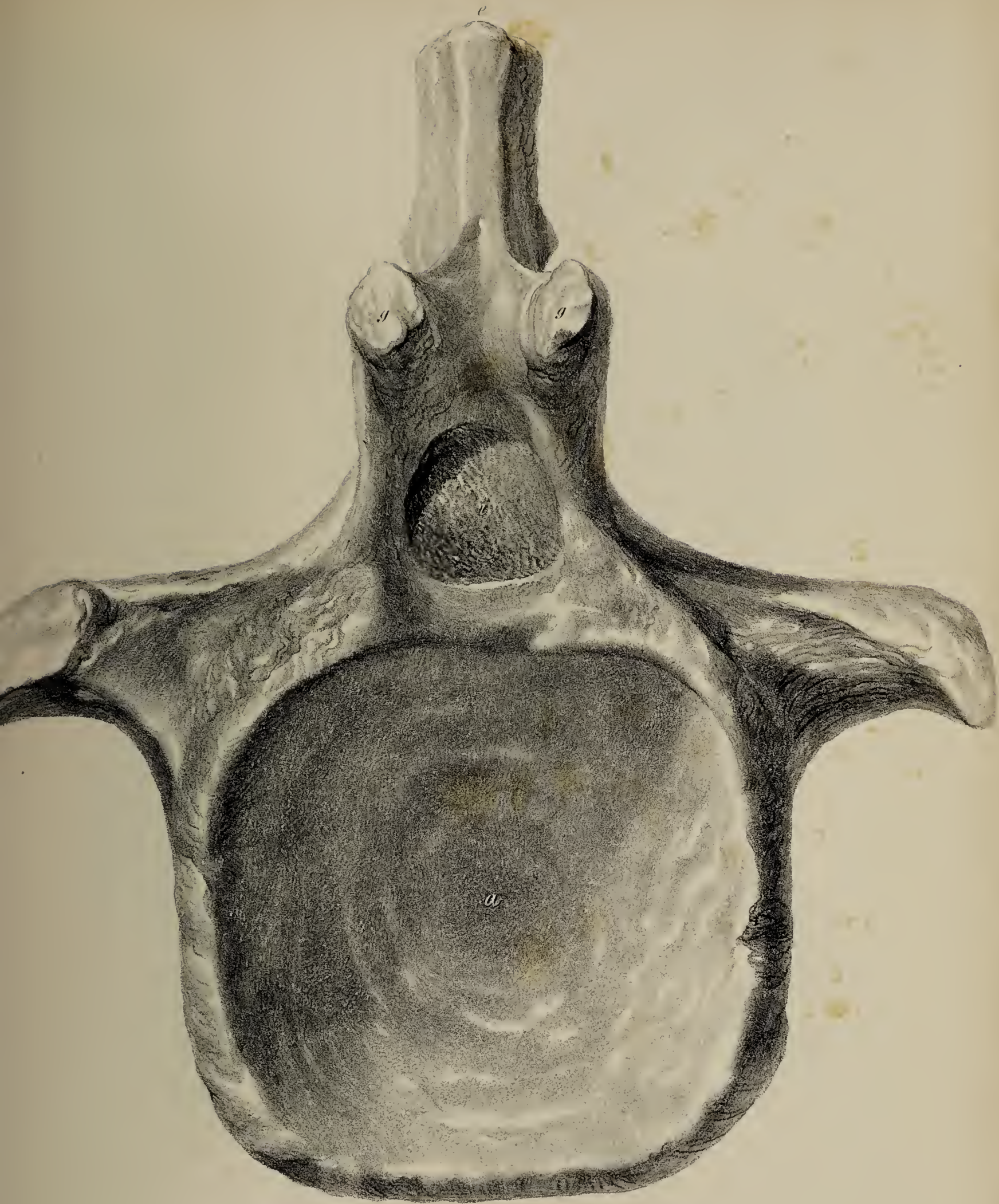
Caudal Vertebra of Pelorosaurus Conybearei.

($\frac{5}{8}$ Natural Size)

Printed by J. Buswe

G. Scharf delin



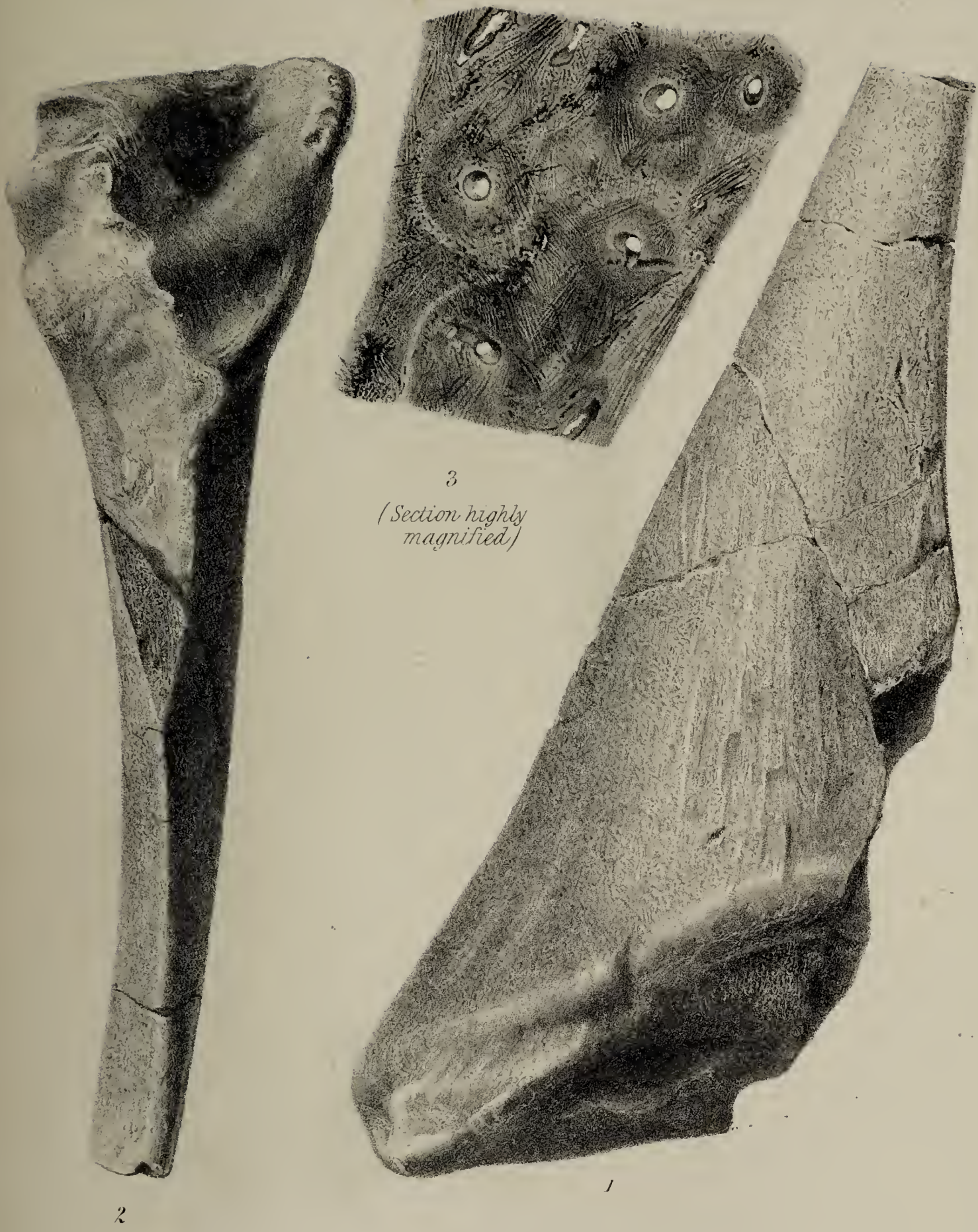


Anterior view of a caudal vertebra of Pelorosanrus Coneybearei.

($\frac{5}{8}$ Natural Size)

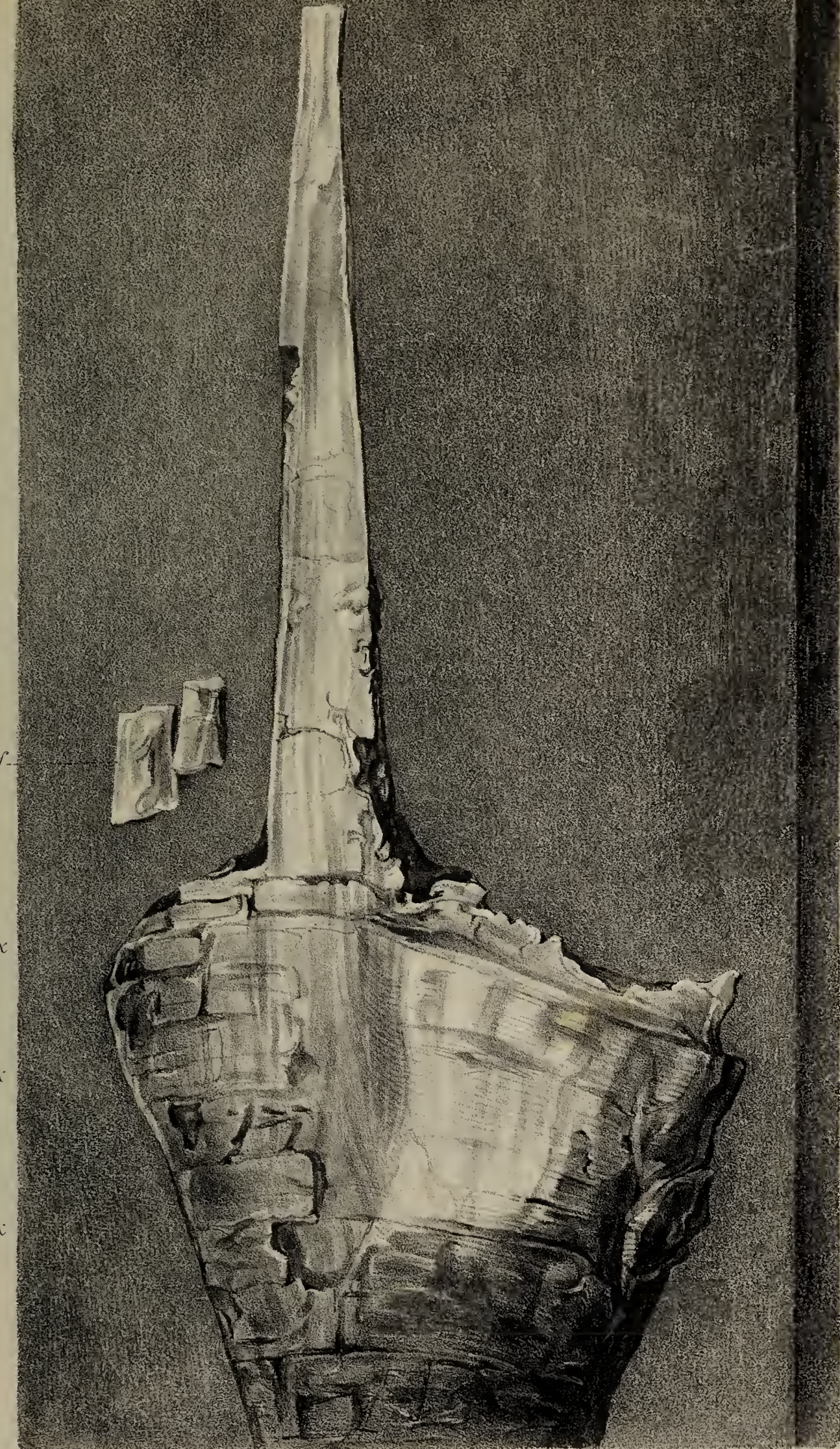
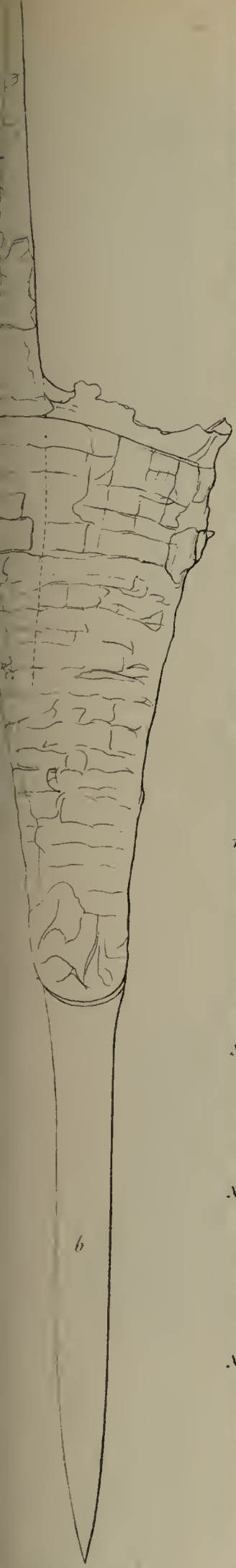


Median caudal Vertebra of Pterosaurius (?),
 from the strata of Tülgate Forest, by Cap.ⁿ Lambari Brichenden.
 (Natural Size.)



3
(Section highly magnified)

Dorsal dermal Spine of the Hylceosaurus
($\frac{1}{2}$ Nat. Size linear.)



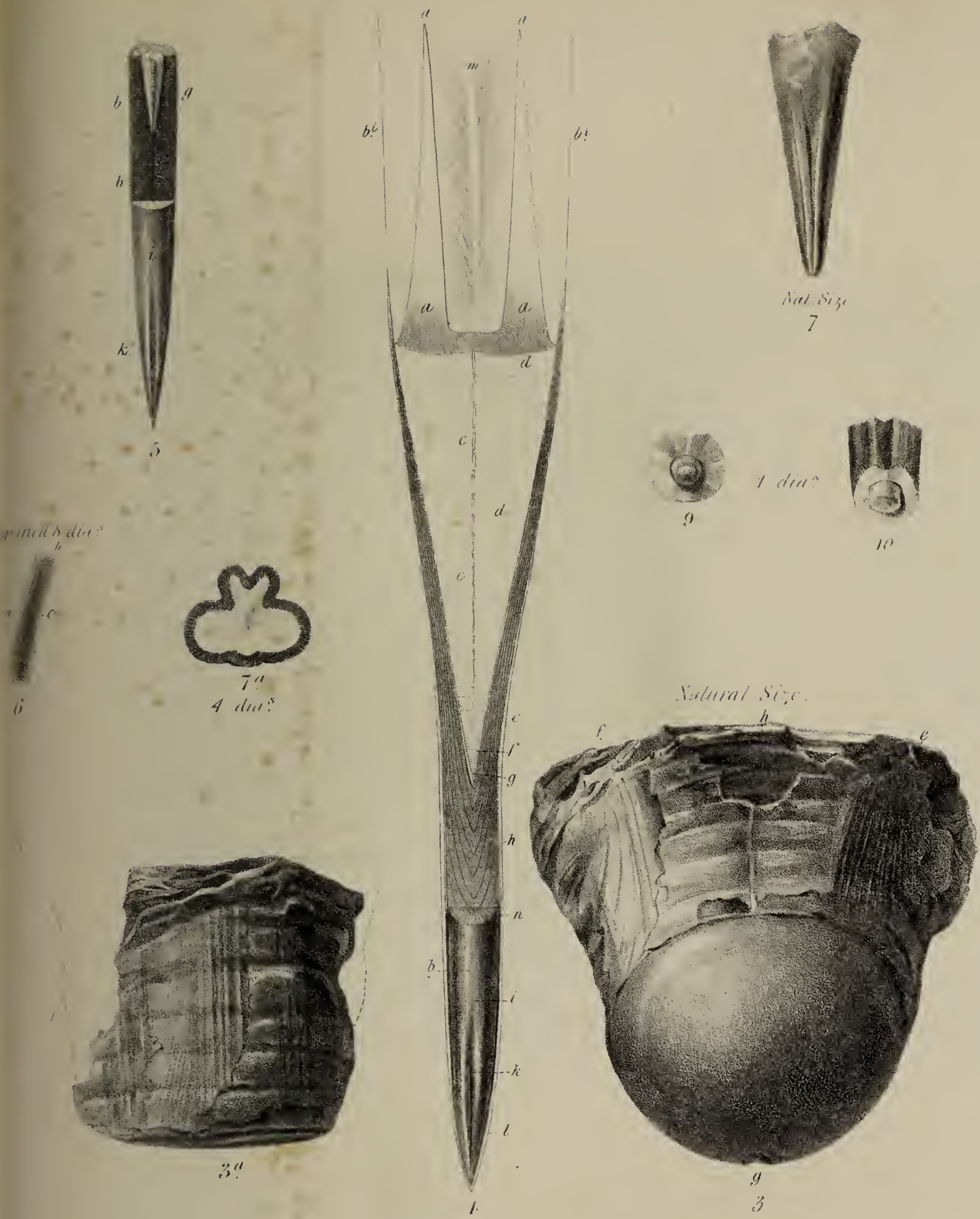
$\frac{1}{2}$ Natural Size.
1.

2

*Upper portion of the Phragmocone of a Belemnite.
(in the British Museum)
Natural size*

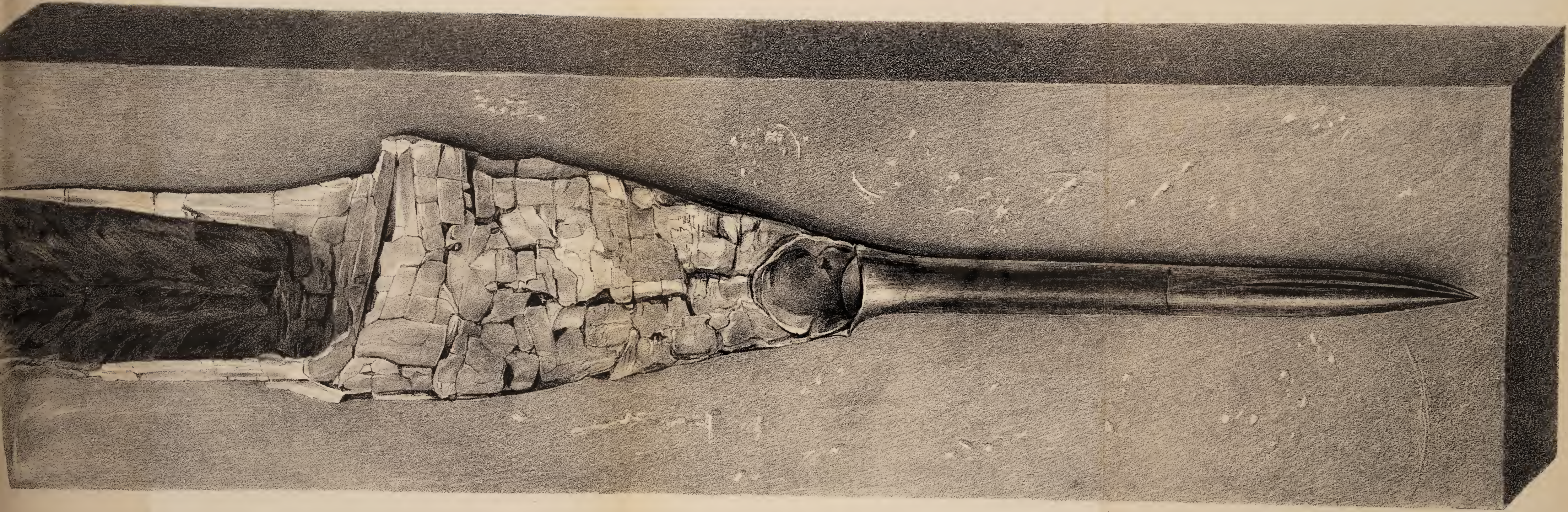
L. Duxbury del.

Moussy del.



Belemnites and Belemnoteuthis.



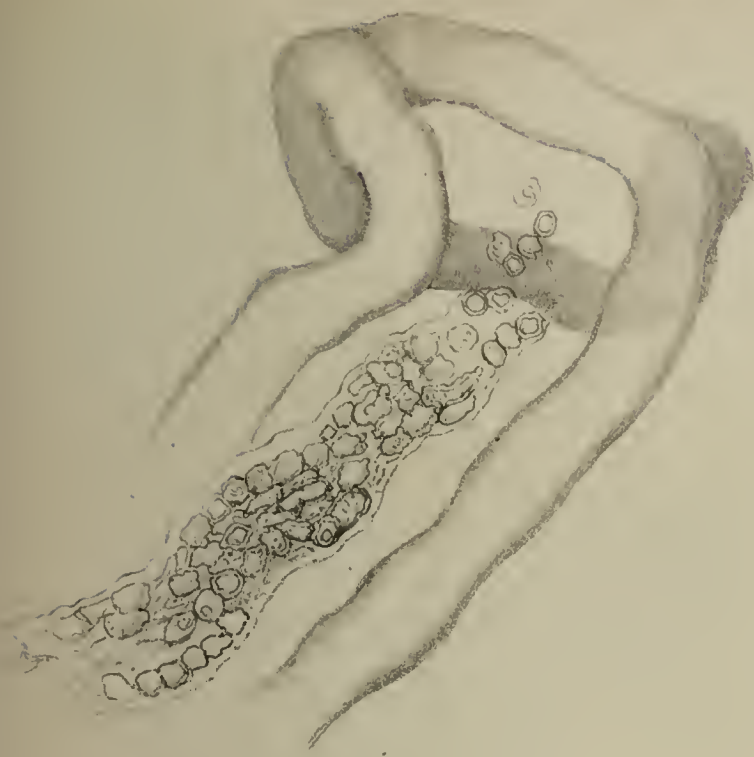


Belonites Puzosianus, showing the upper part of the phragmone with
the pair of elongated processes; from the Oxford Clay, Wiltshire.

(In the possession of P. Martell.)



Fig. 1.



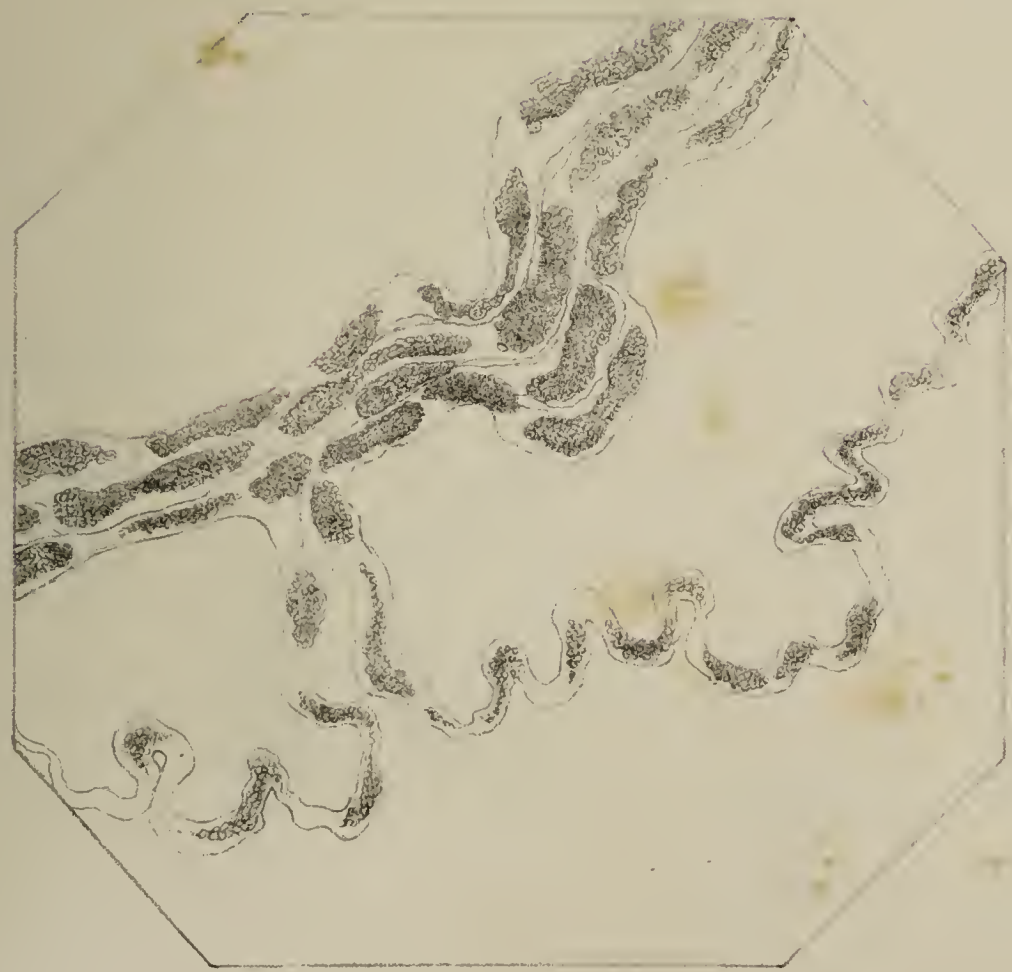
Magnified 400 diam^{rs}

Fig. 2.



Magnified 400 diam^{rs}

Fig. 3.



Magn^d 400 diam^{rs}

Mean Temp^{re}
60° Fahr.

Mean Temp^{re}
56° Fahr.

Mean Temp^{re}
53° Fahr.

Mean Temp^{re}
51° Fahr.

1848.

March 11th



20th



23rd



25th



27th



28th



31st



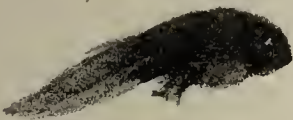
April 4th



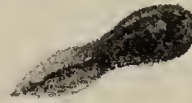
6th



10th



May 22nd



Aug^t 16th



28th



Oct^r 31st





Fig. 2.



Fig. 3.



Fig. 1.



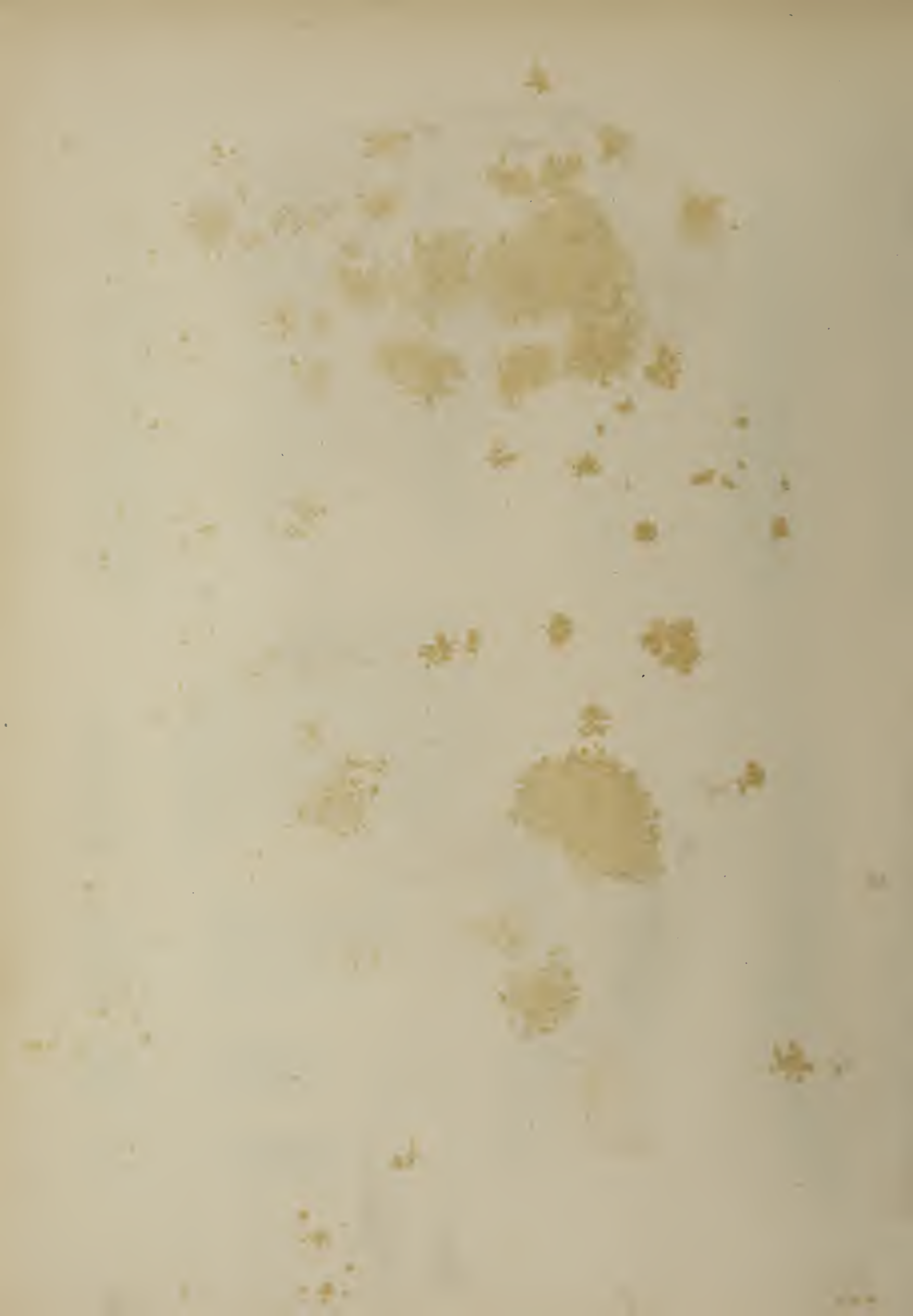
See Dunder's 'tel et lita'





Fig. 1, 7, 9, 10 & 12, *Phacochærus Aliani*, Fig. 8 & 11 *Ph. Pallasi*.

Les Drouai del et lith.



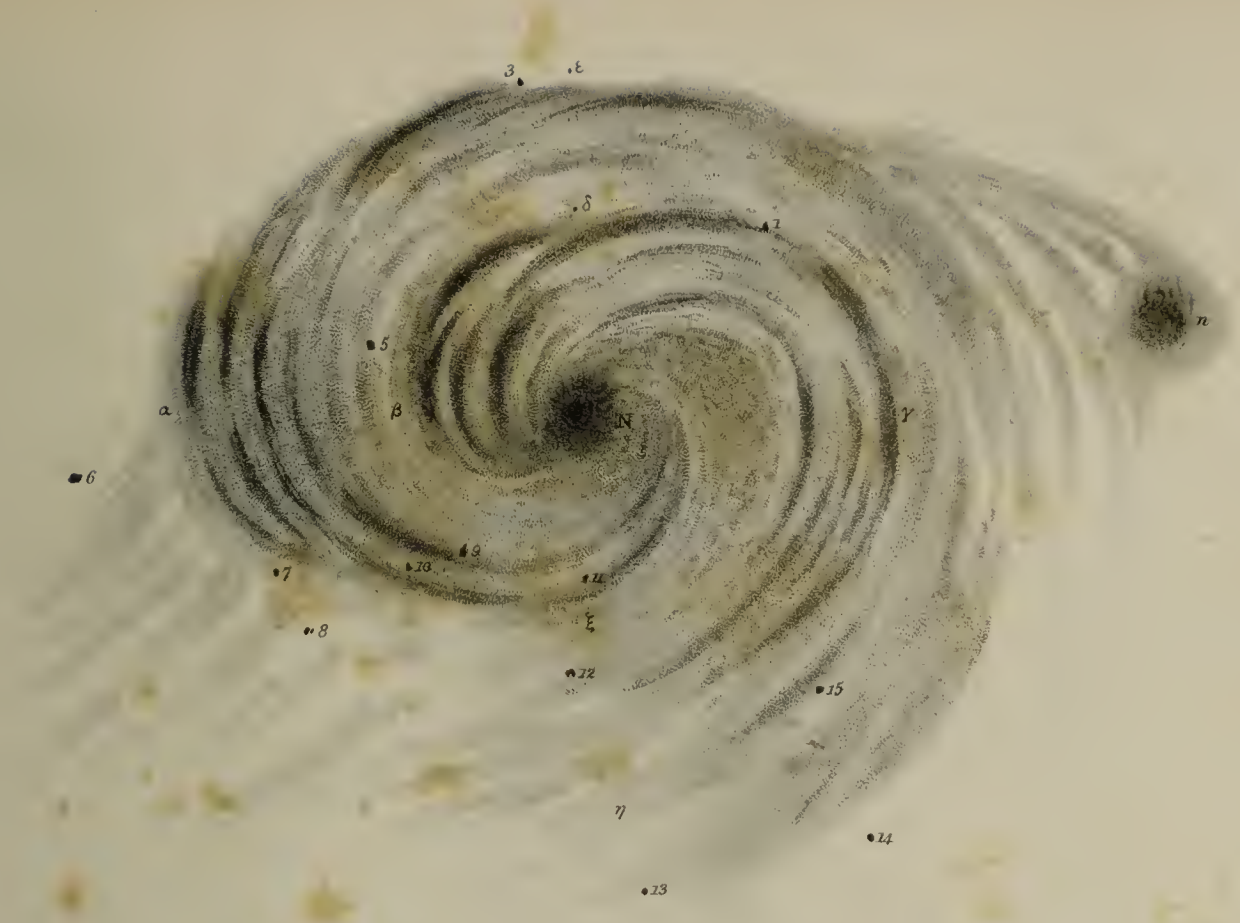


Fig. 2.

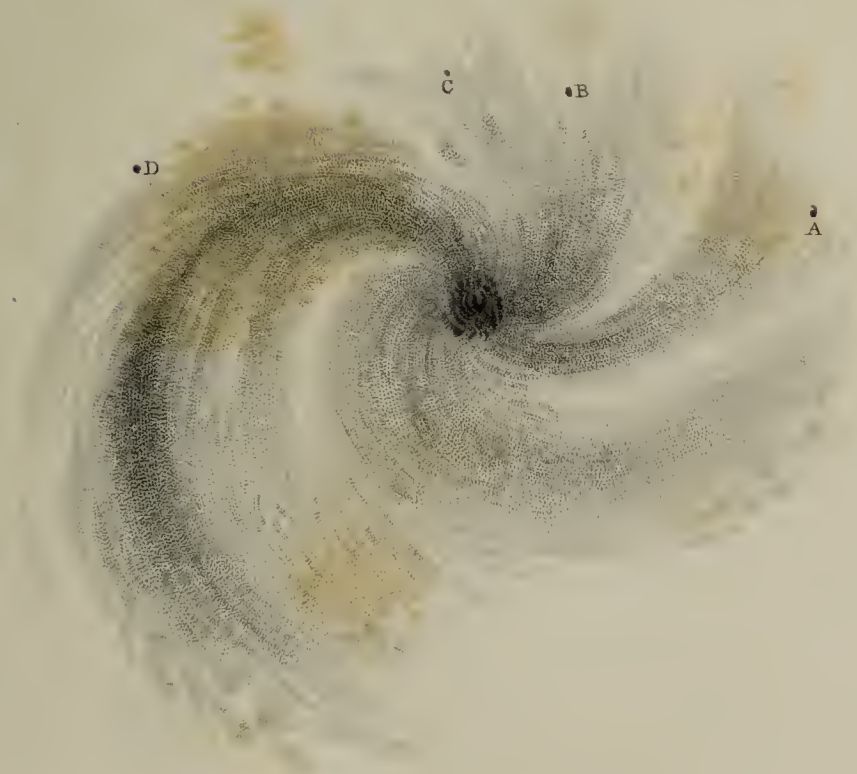


Fig. 3.

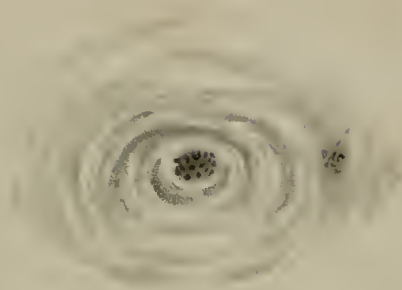


Fig. 4.

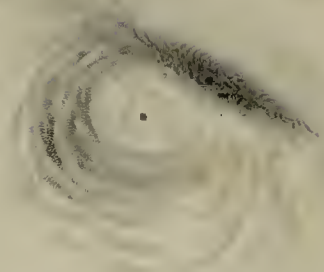


Fig. 5.

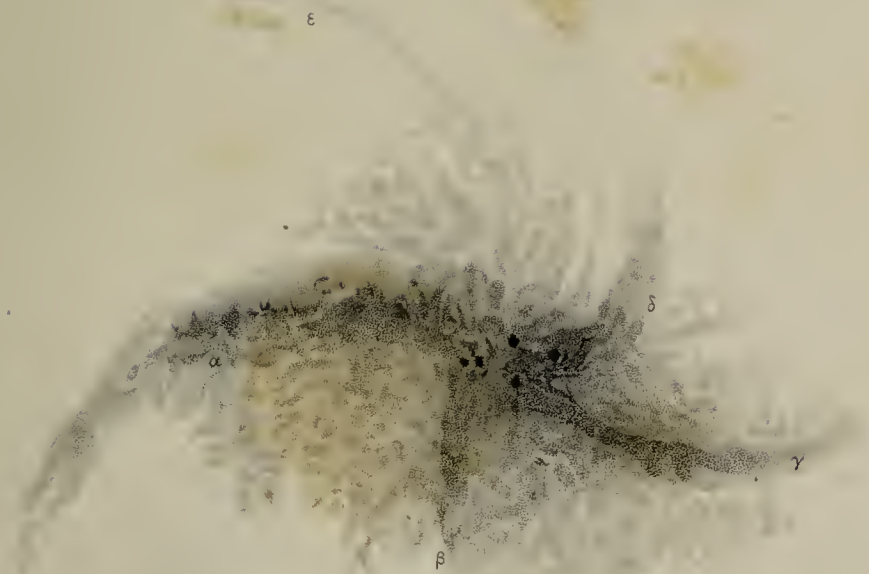


Fig. 6.



Fig. 9.



Fig. 7.

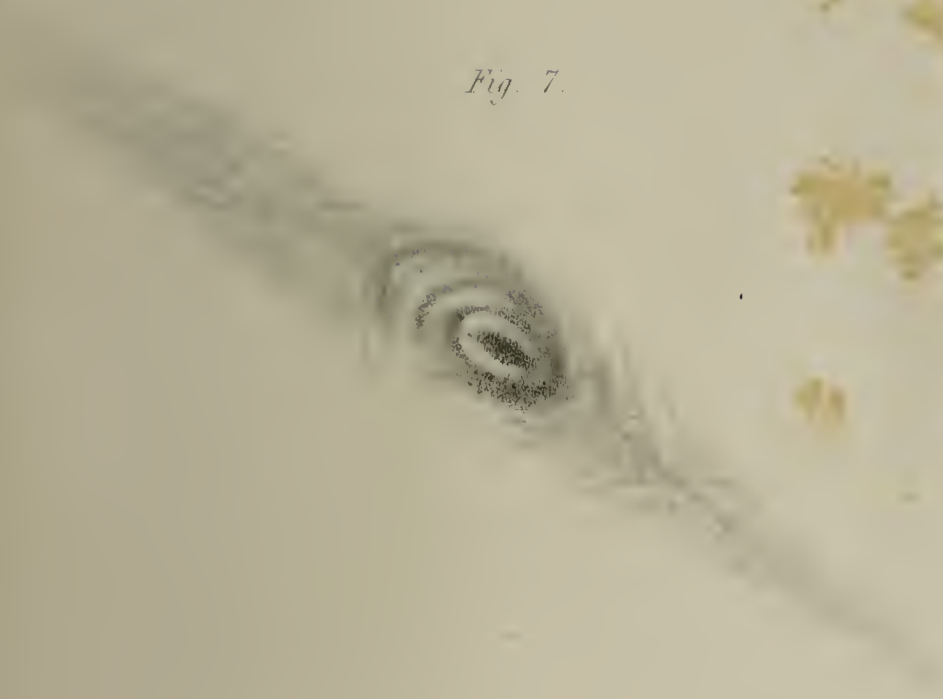


Fig. 10.



Fig. 8.



Fig. 11.

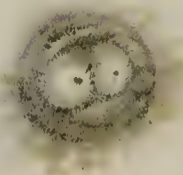




Fig. 12.



Fig. 15.



Fig. 13.

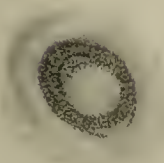


Fig. 16.

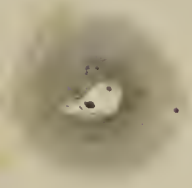


Fig. 14.



Fig. 17.

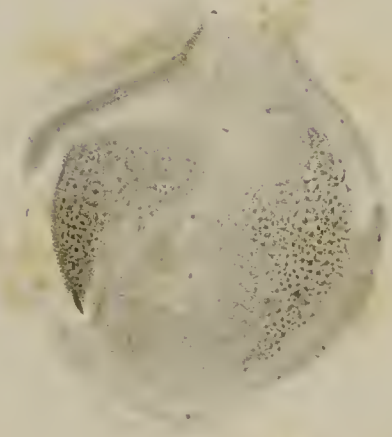




Fig. 1.

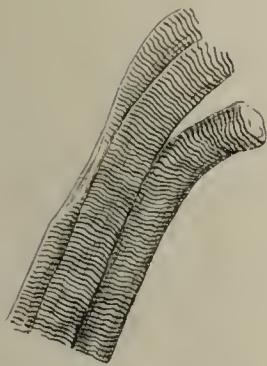


Fig. 2.

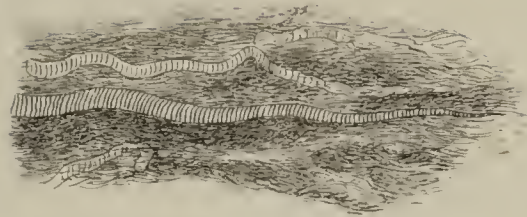


Fig. 3.

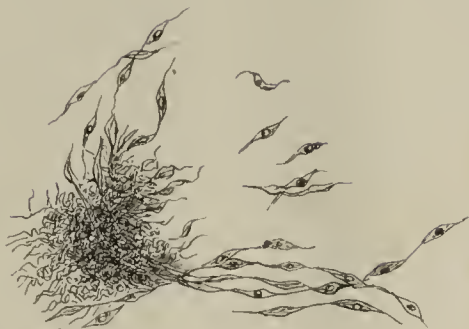
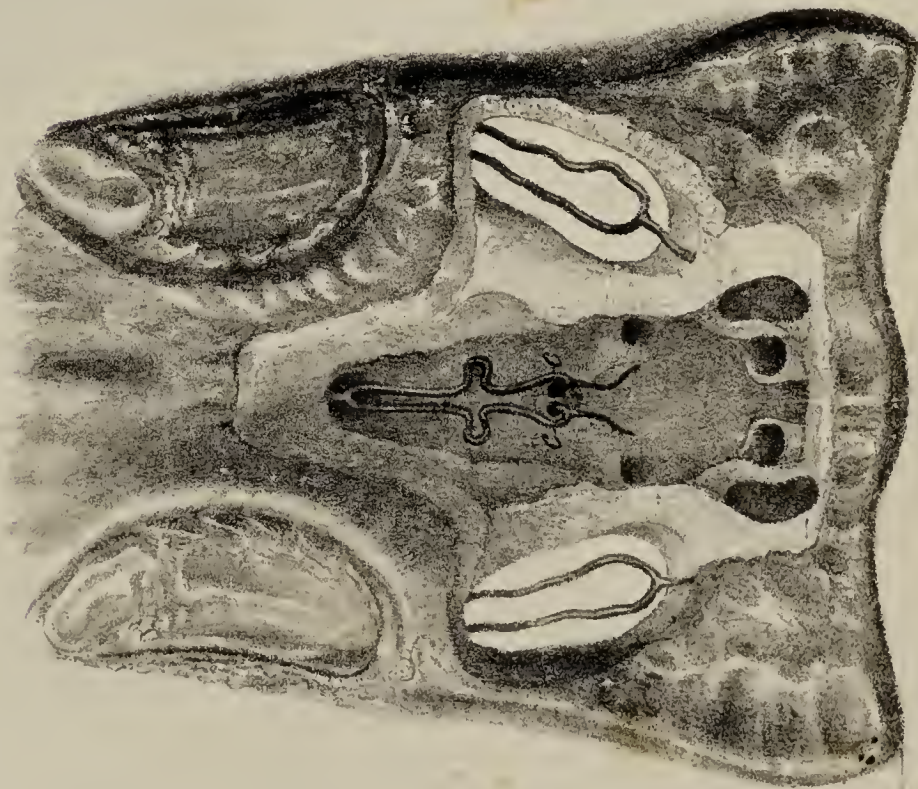


Fig. 4.





Crocodilus acutus.

Crocodilus biporcatus.

Fig. 5.

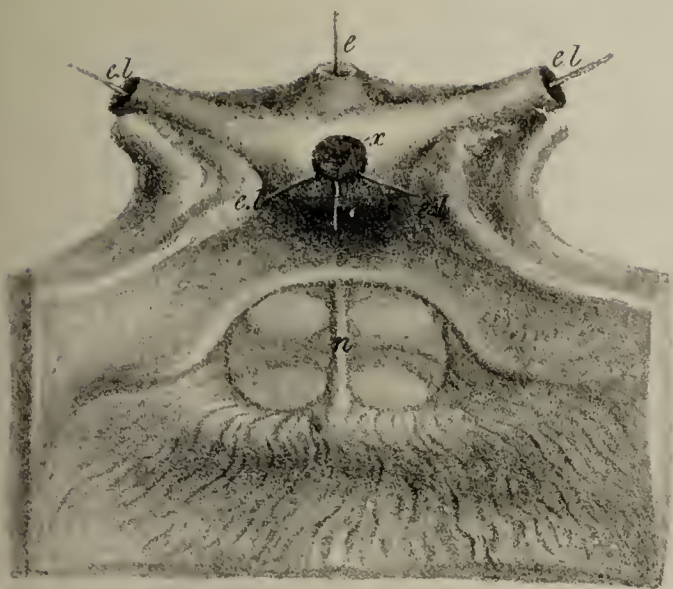


Fig 6.

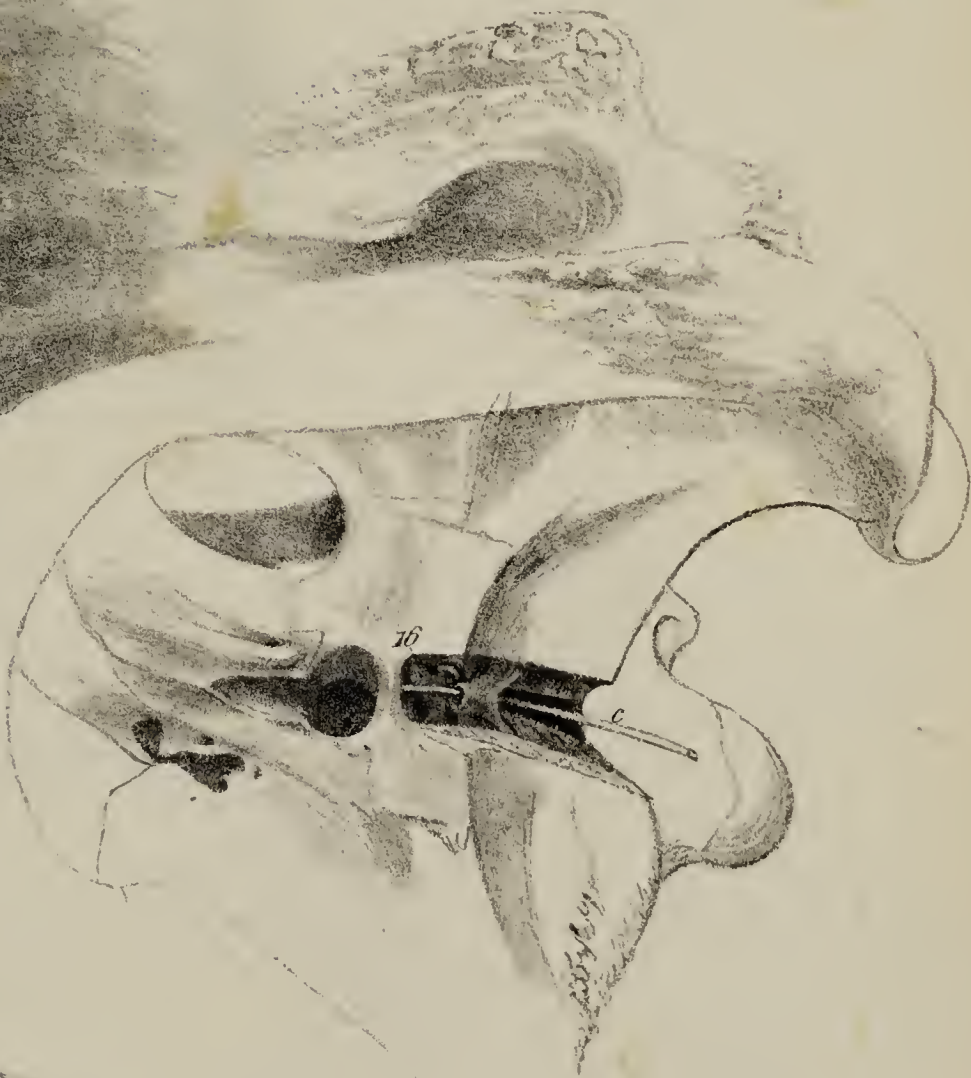


Alligator lucius

Fig 7.



Fig 4.



Crocodilus acutus.

Crocodilus biporcatus

Fig. 8.

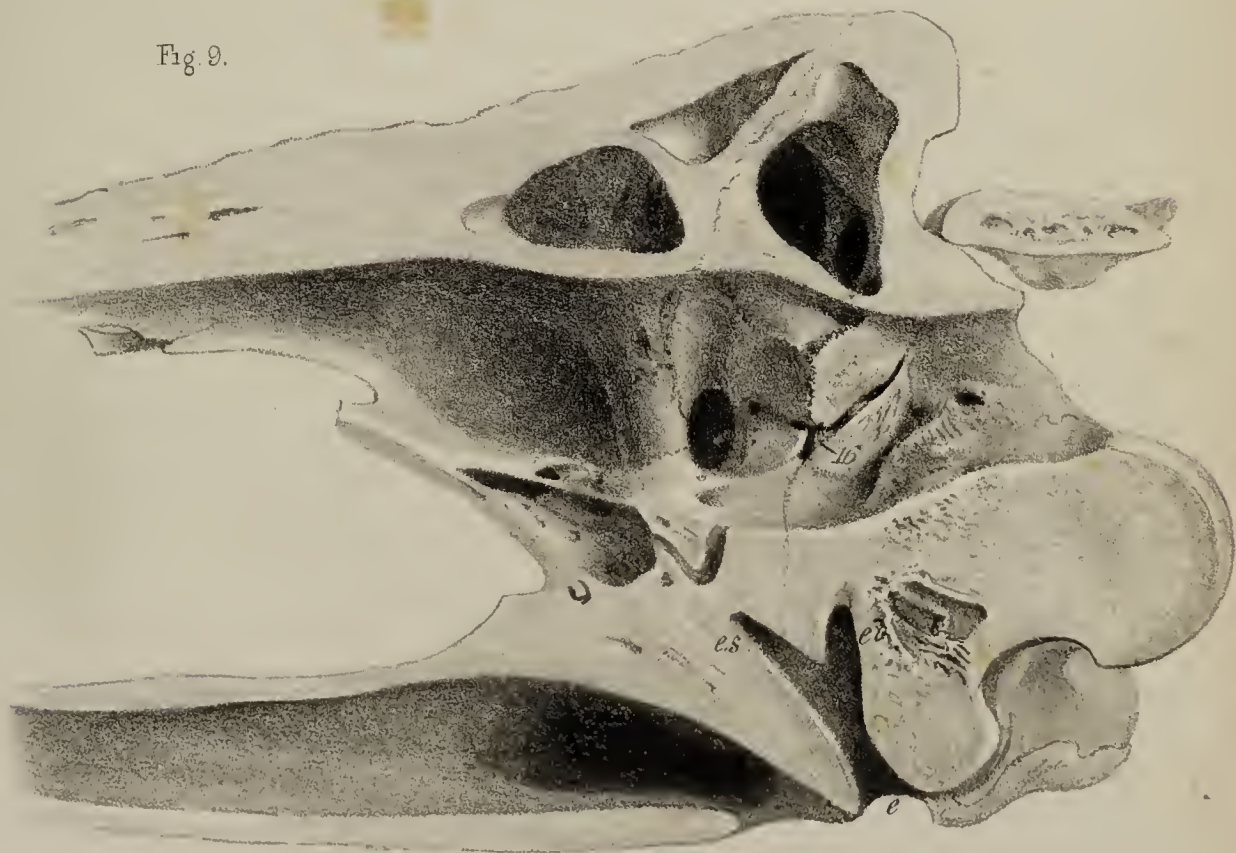


Crocodilus biporcatus.

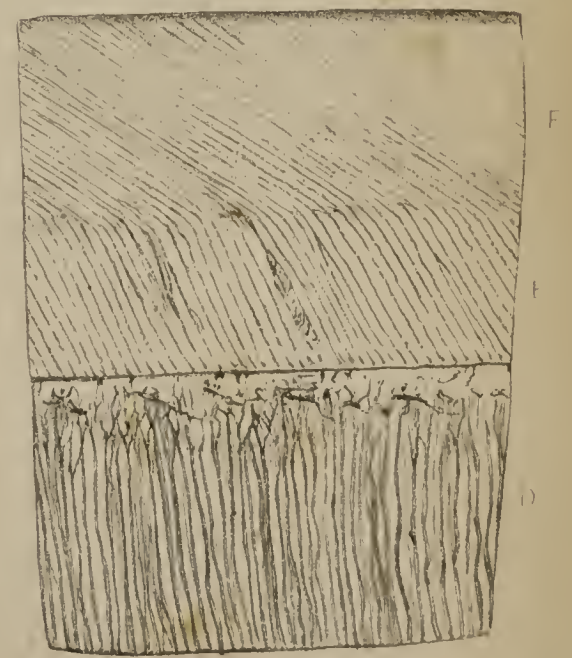
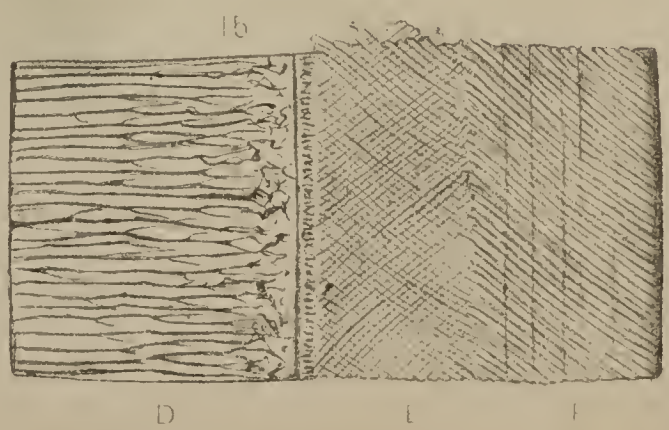
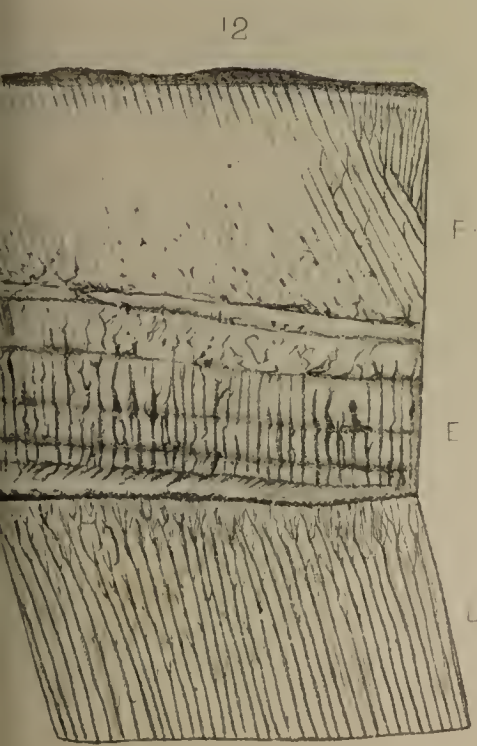
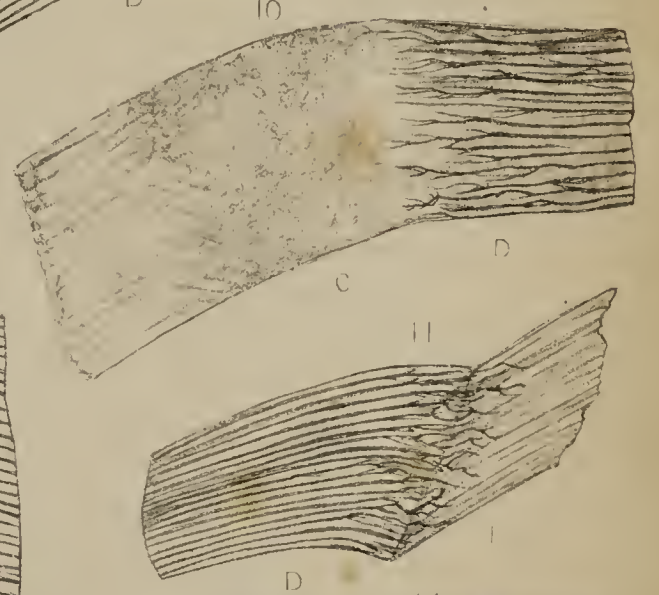
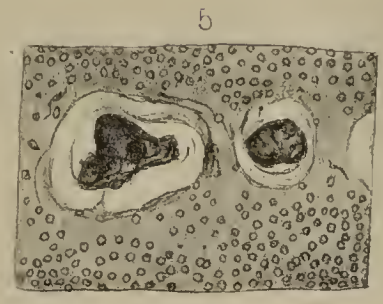
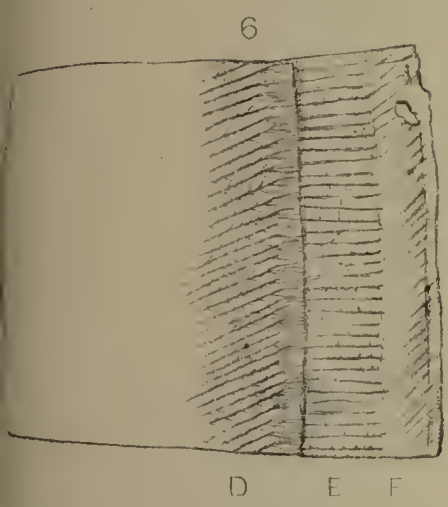
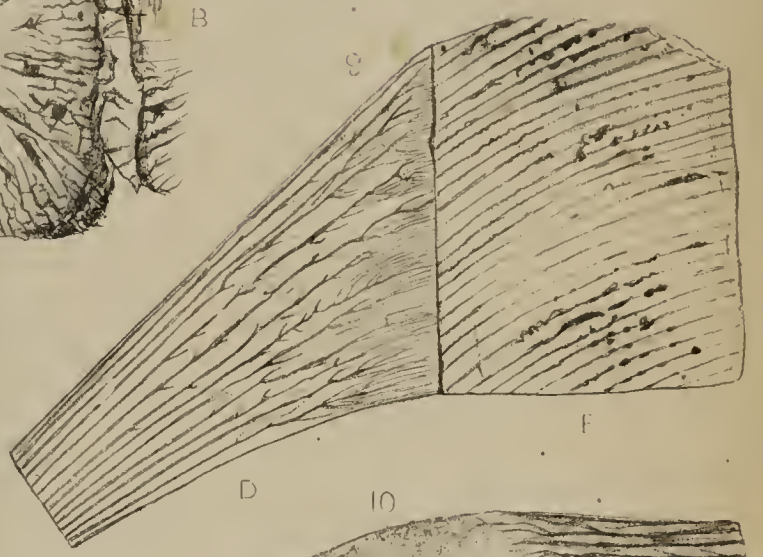
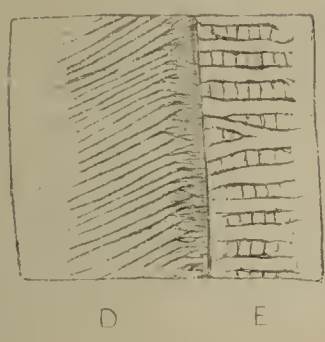
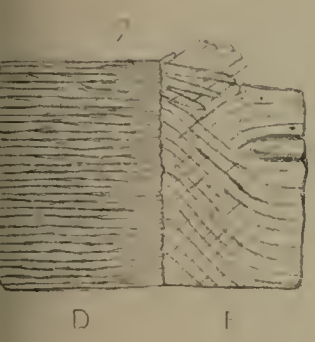
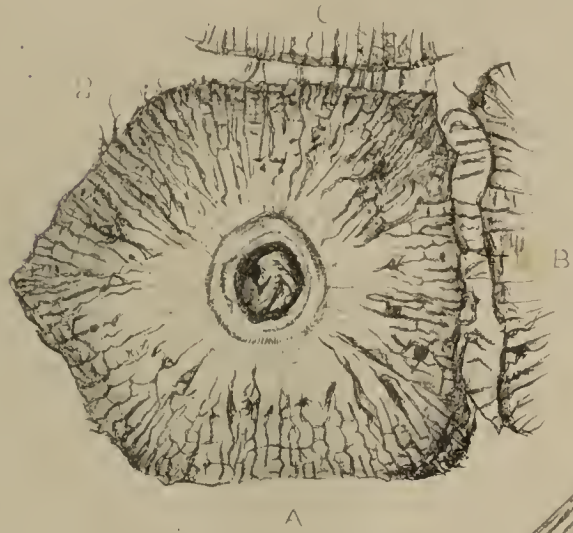
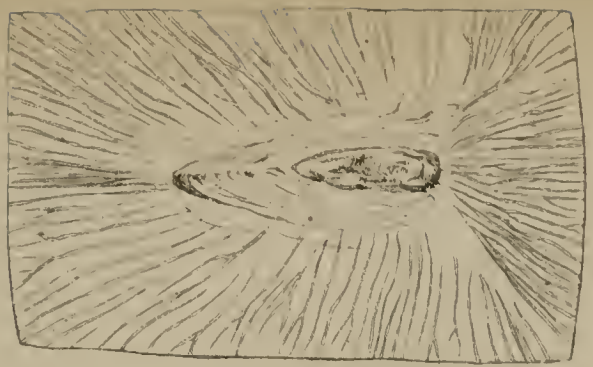
Fig 10.

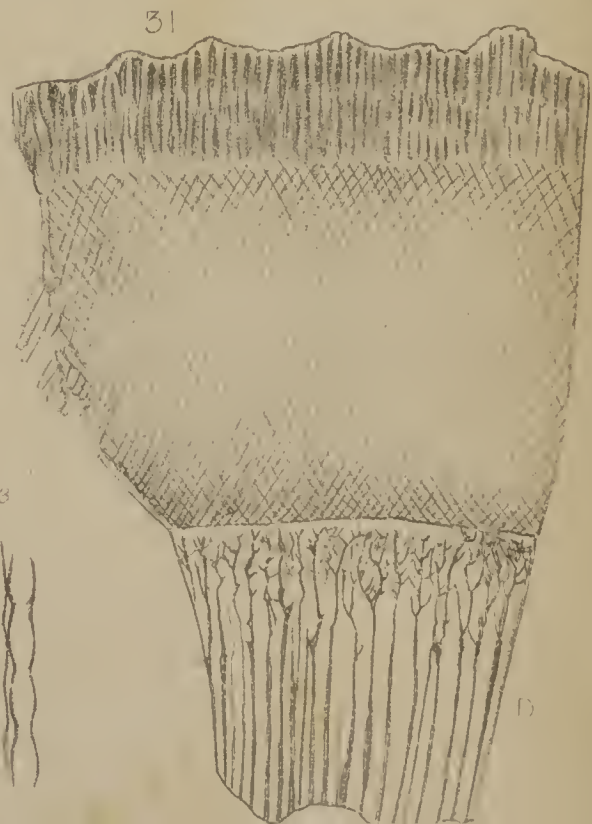
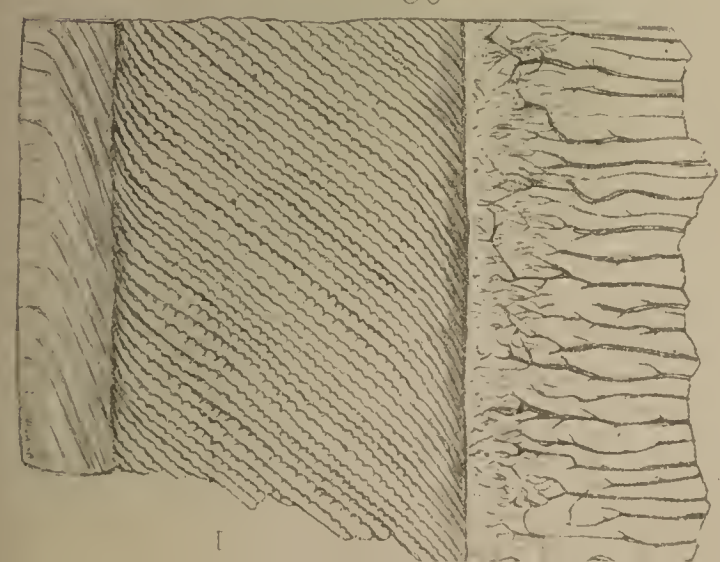
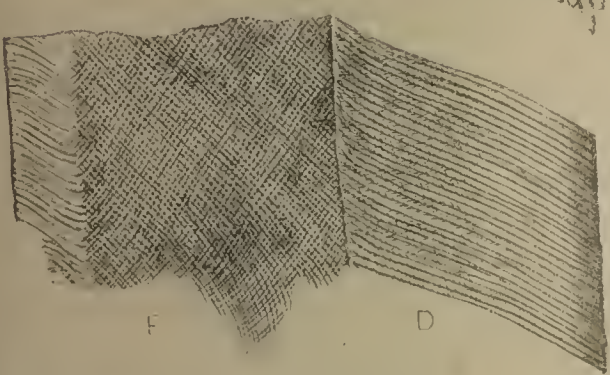
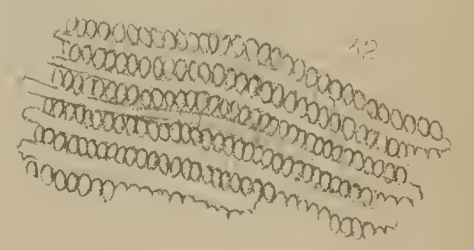
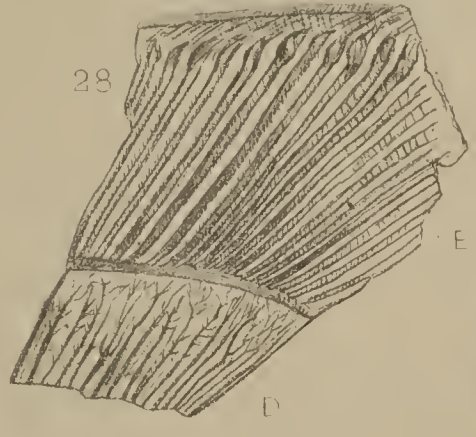
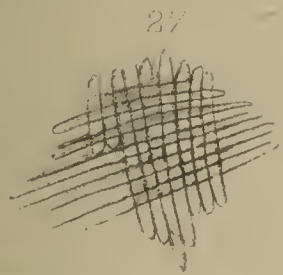
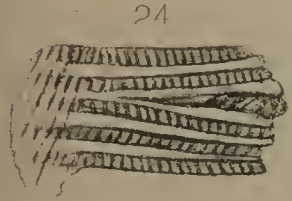
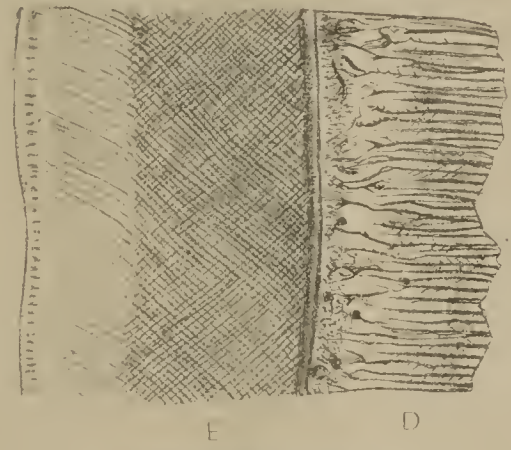
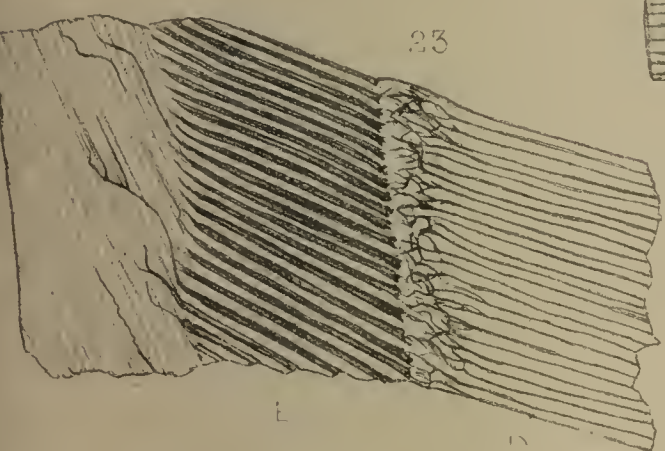
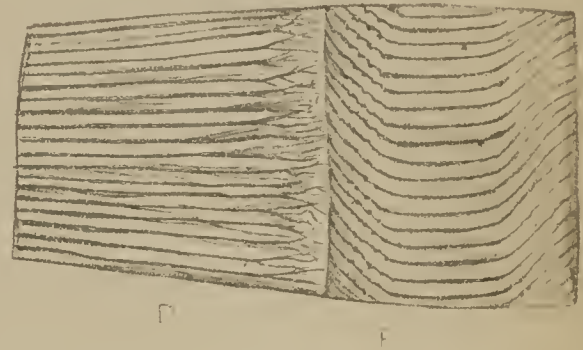
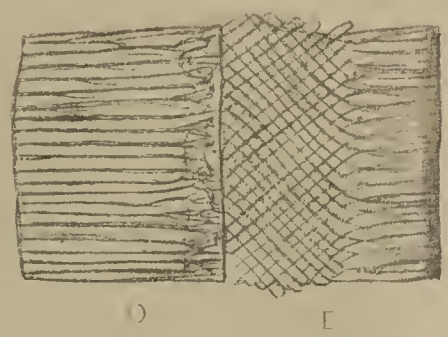
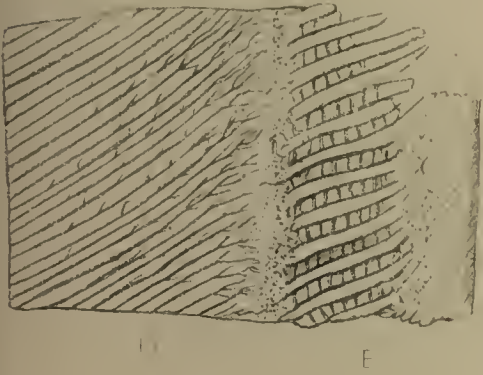
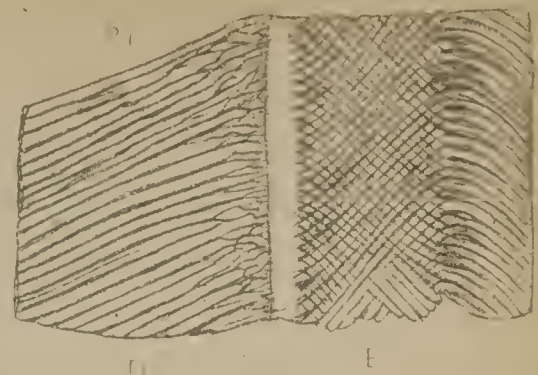
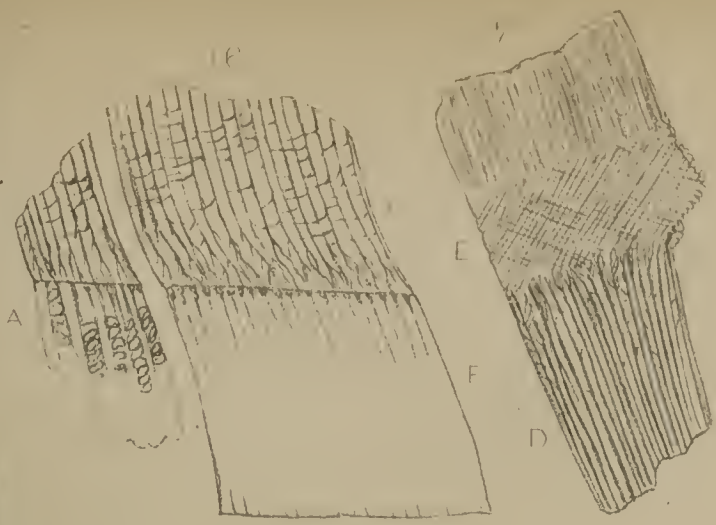
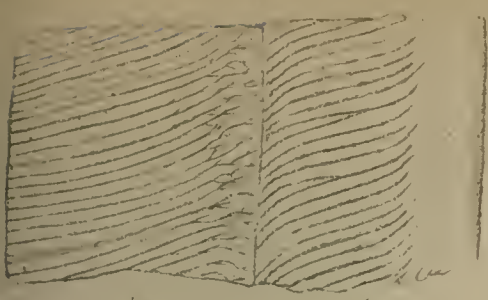


Fig. 9.

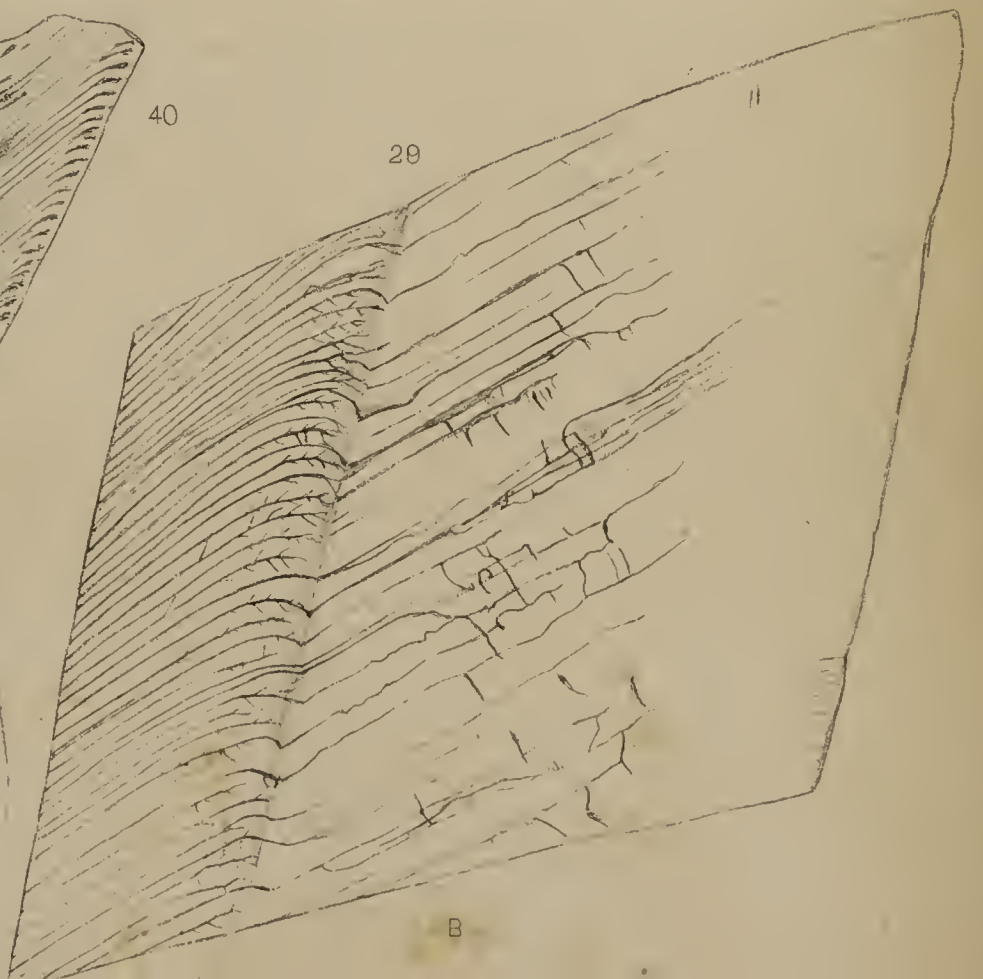
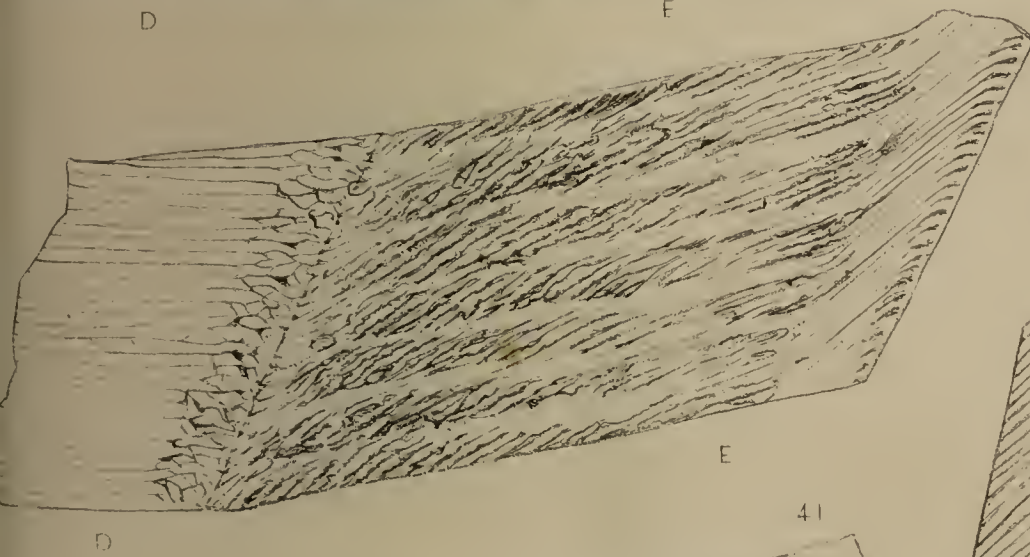
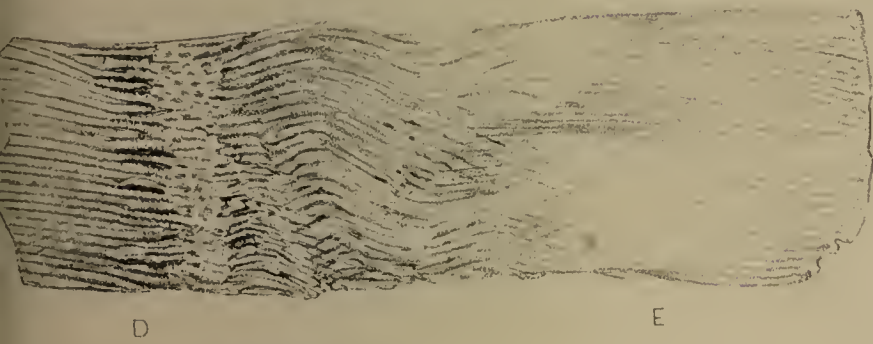
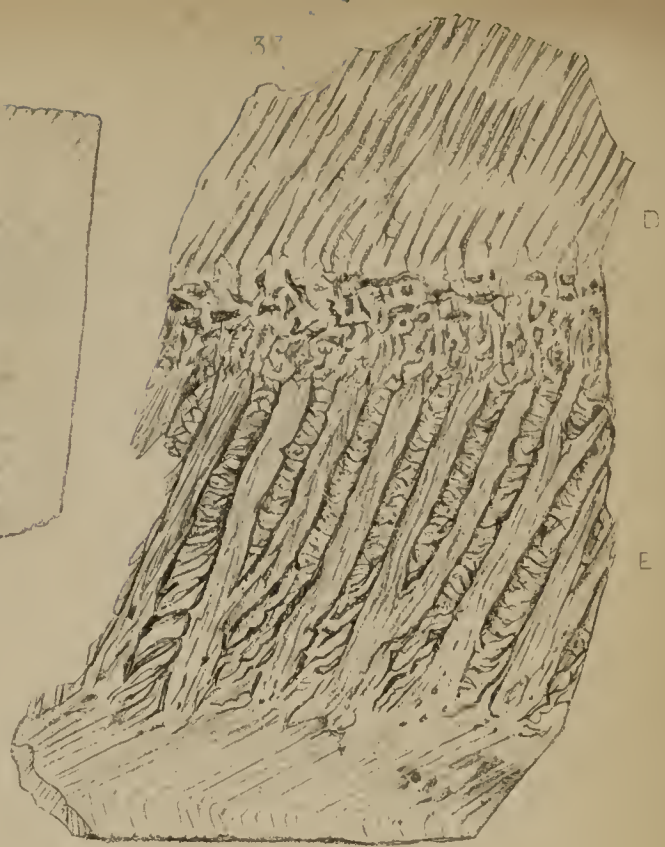
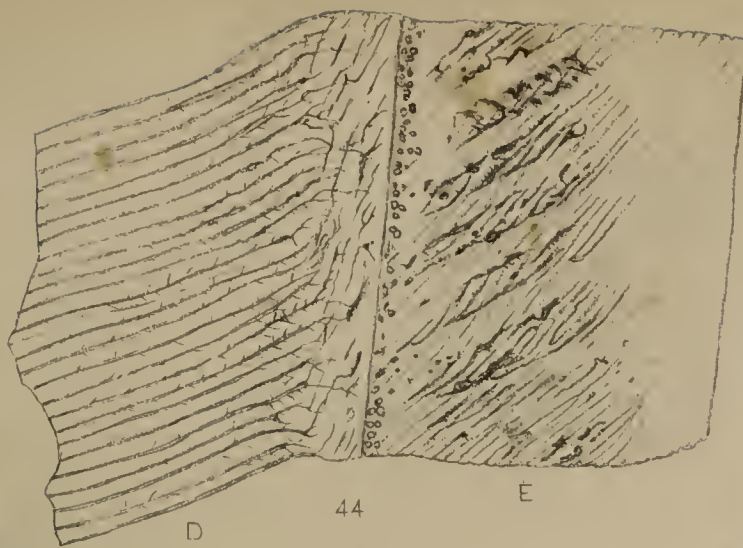
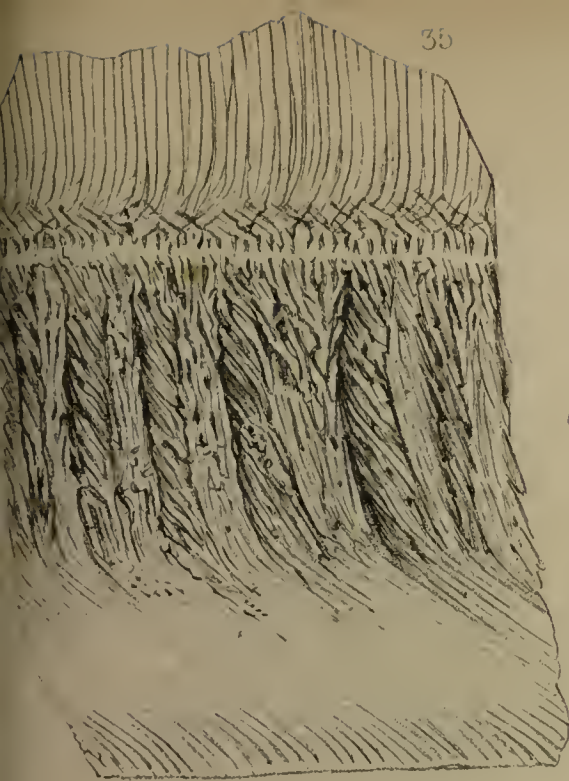


Gairalis gangeticus

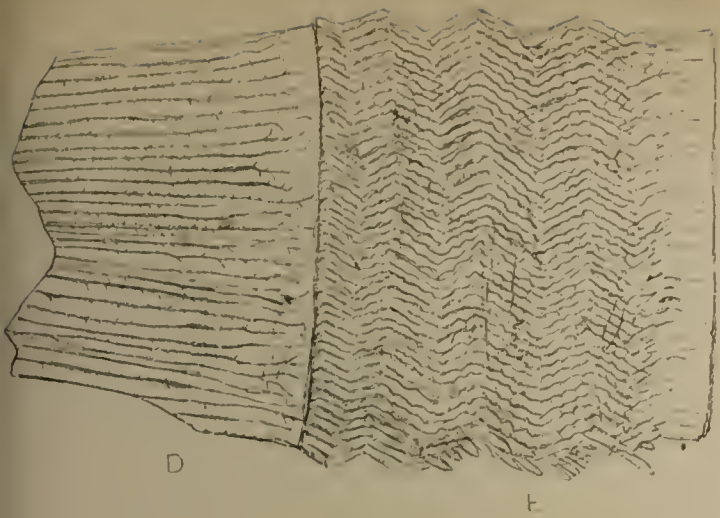




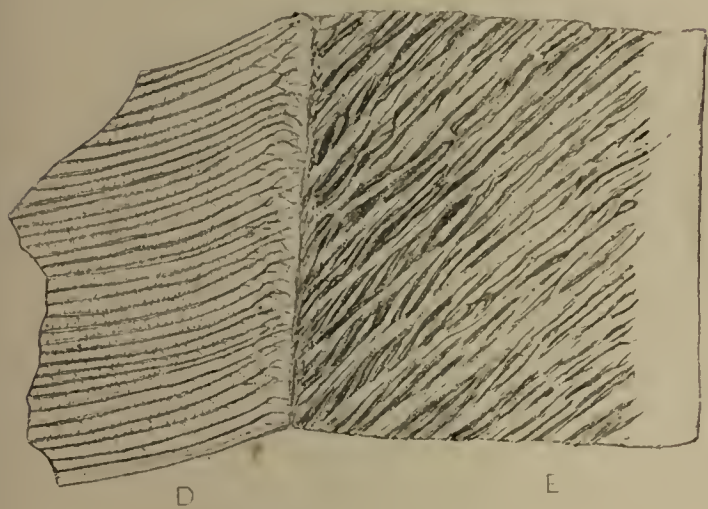
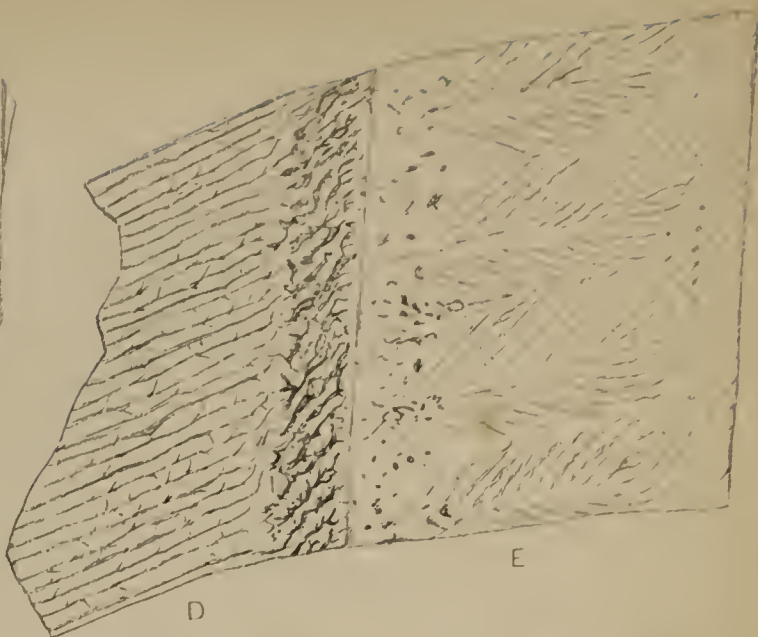






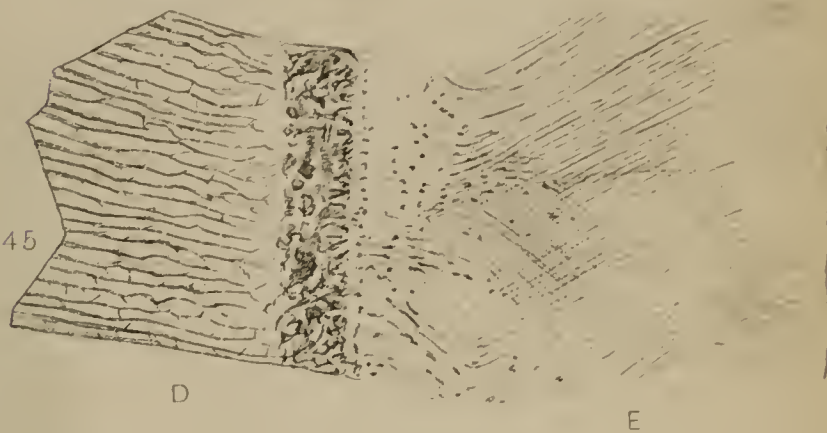


46

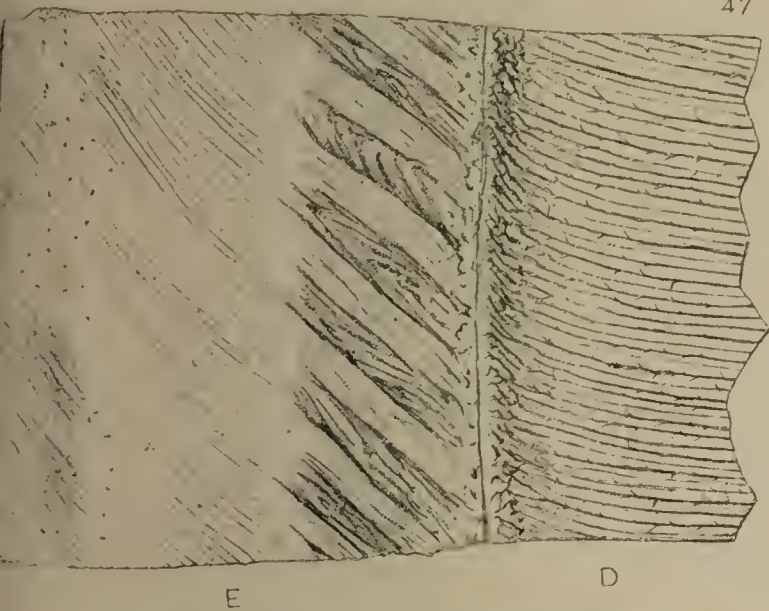


43

45



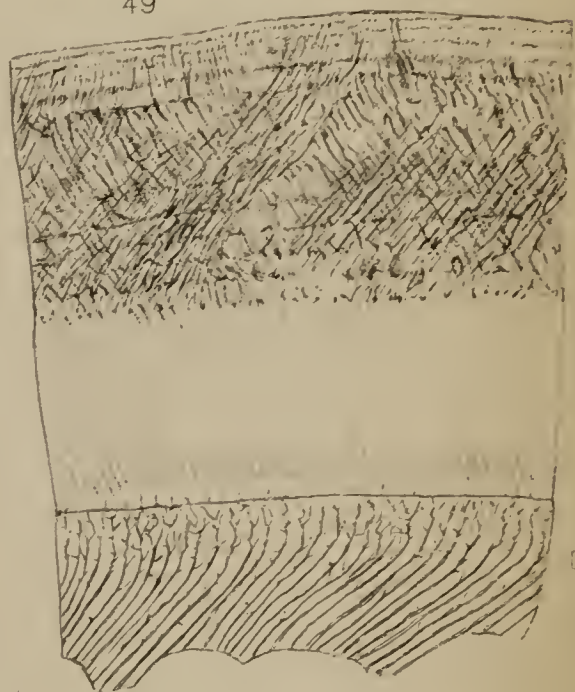
47



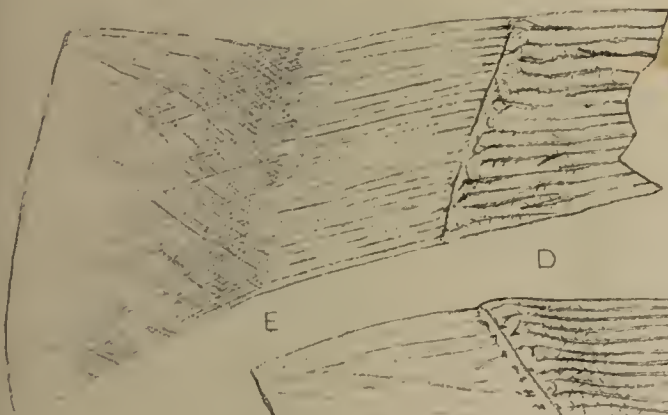
53



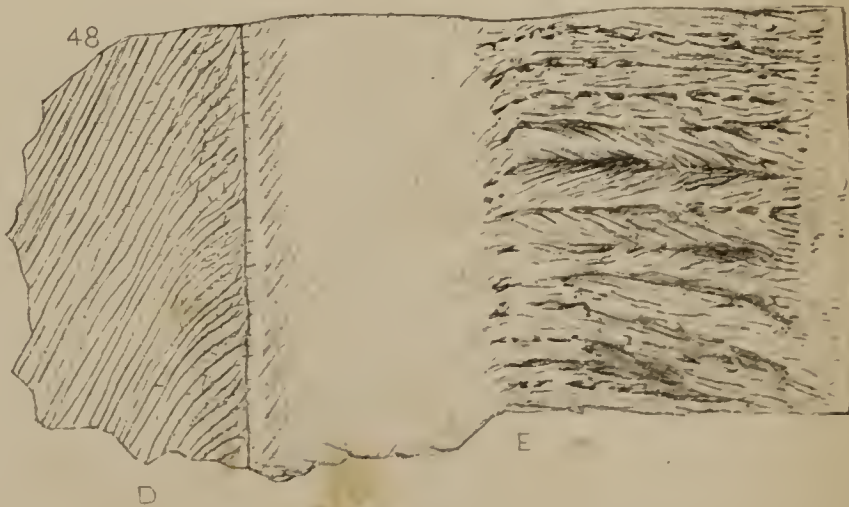
49



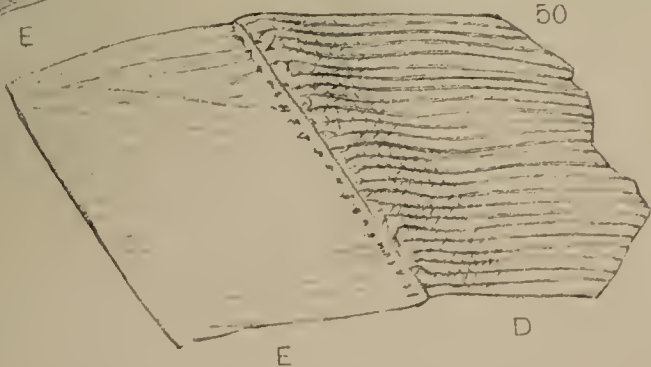
52

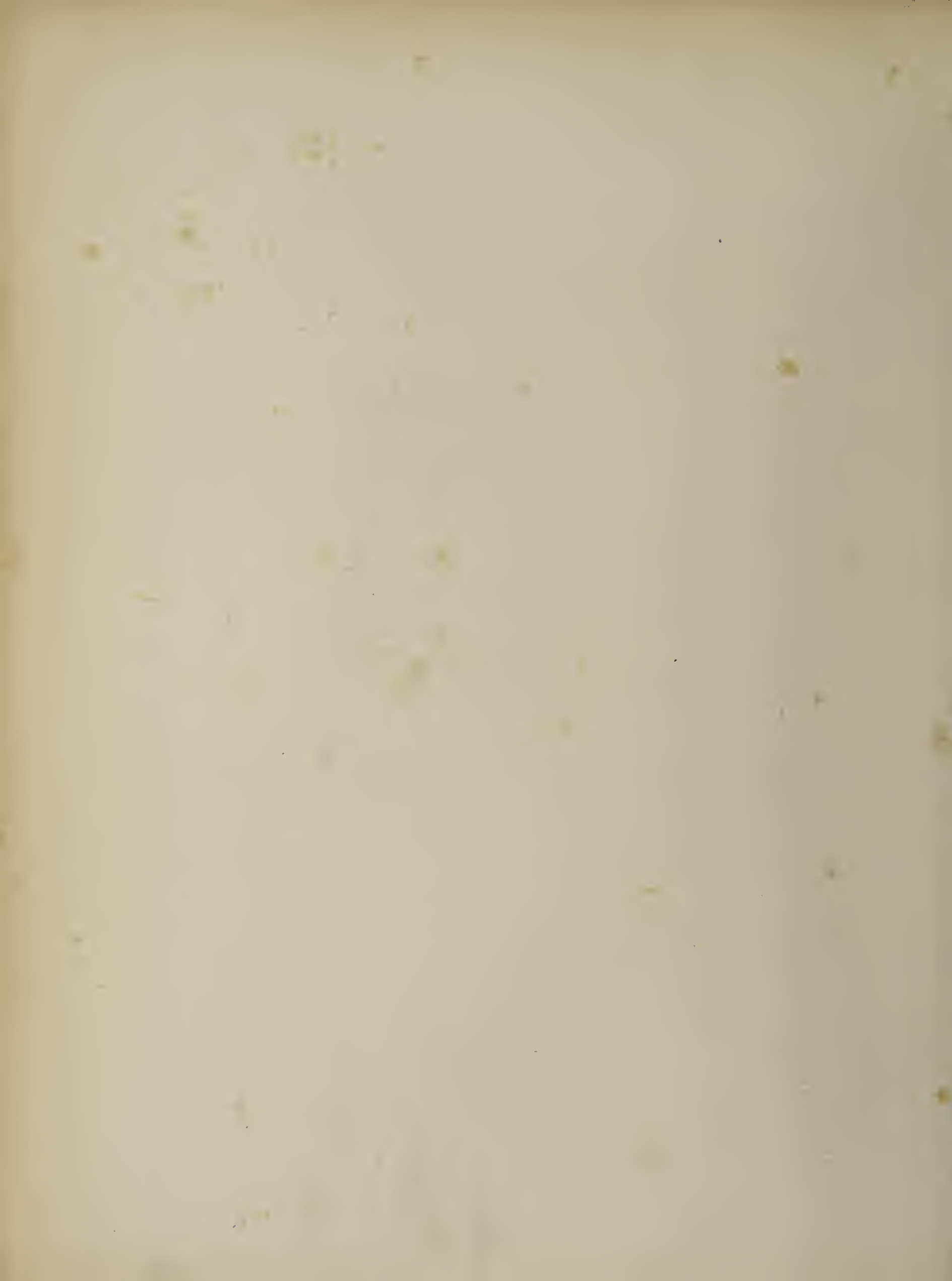


48



50





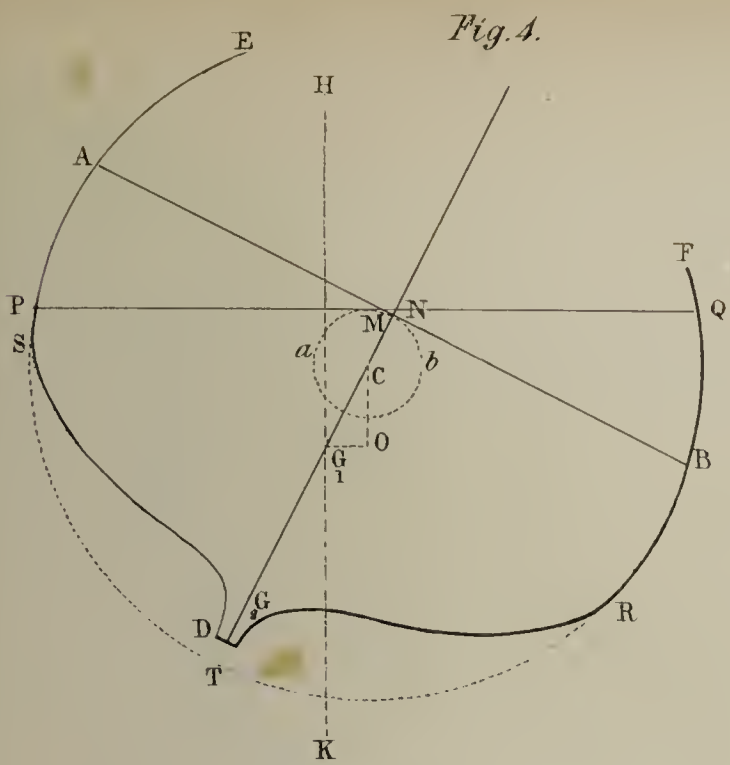


Fig. 4.

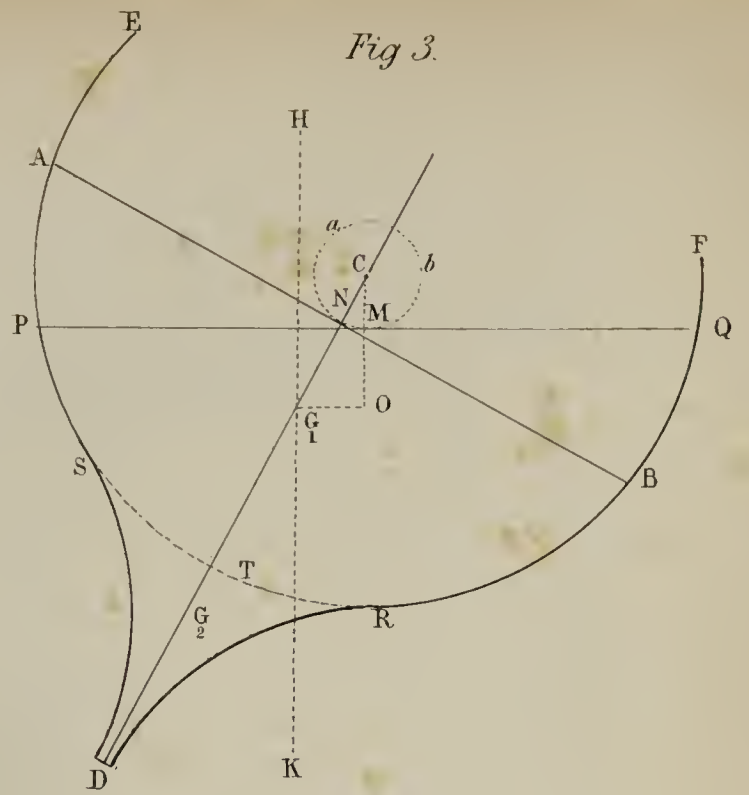


Fig. 3.

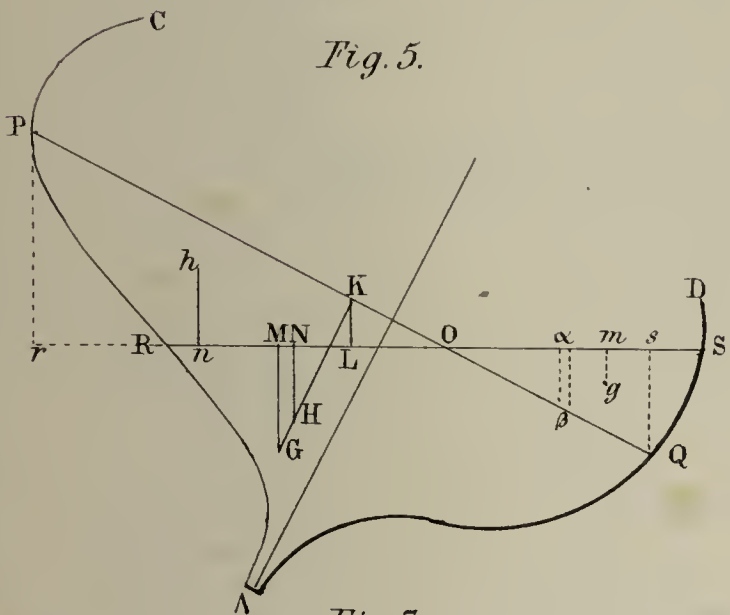


Fig. 5.

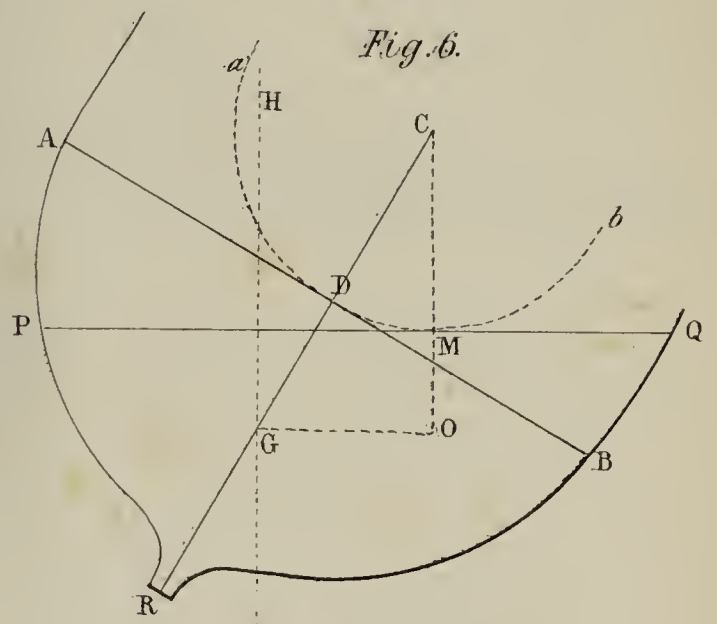


Fig. 6.



Fig. 7.

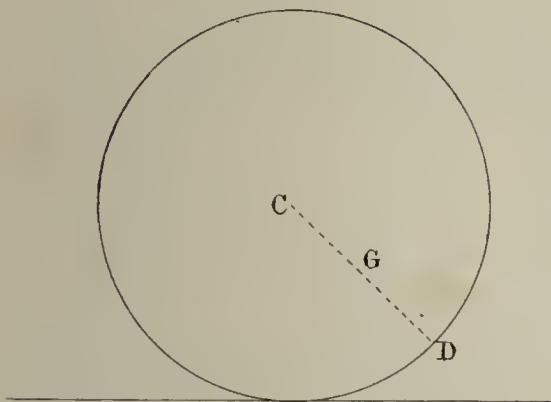


Fig. 8.

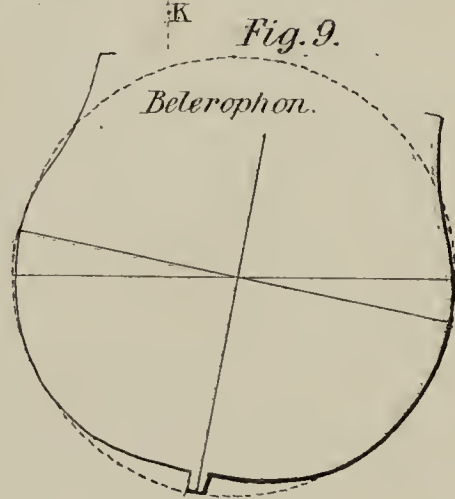


Fig. 9.

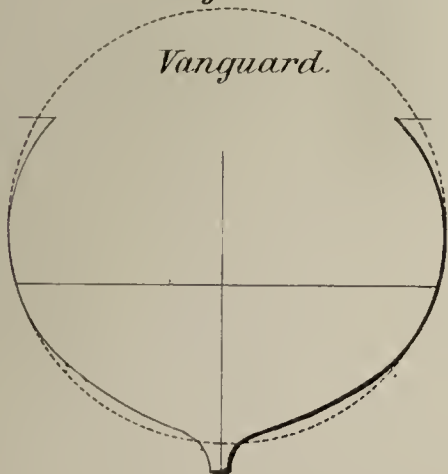
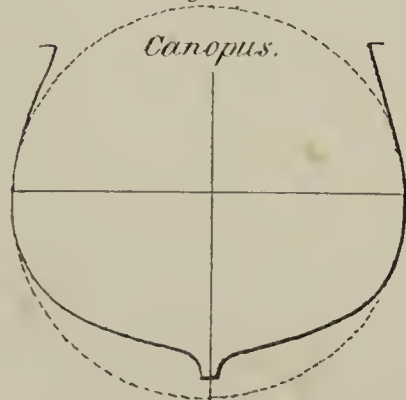


Fig. 10.



Canopus.

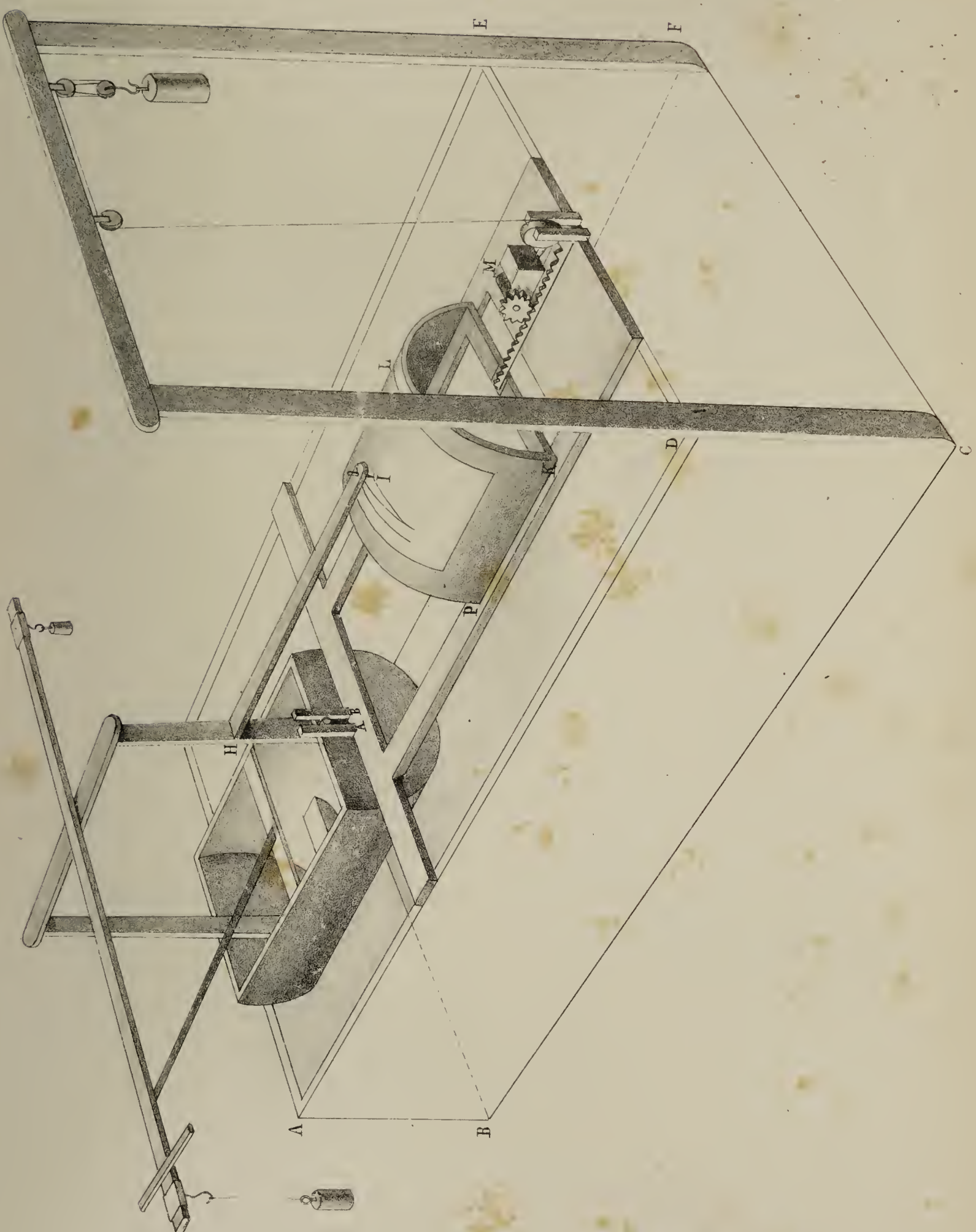




Fig. 1.

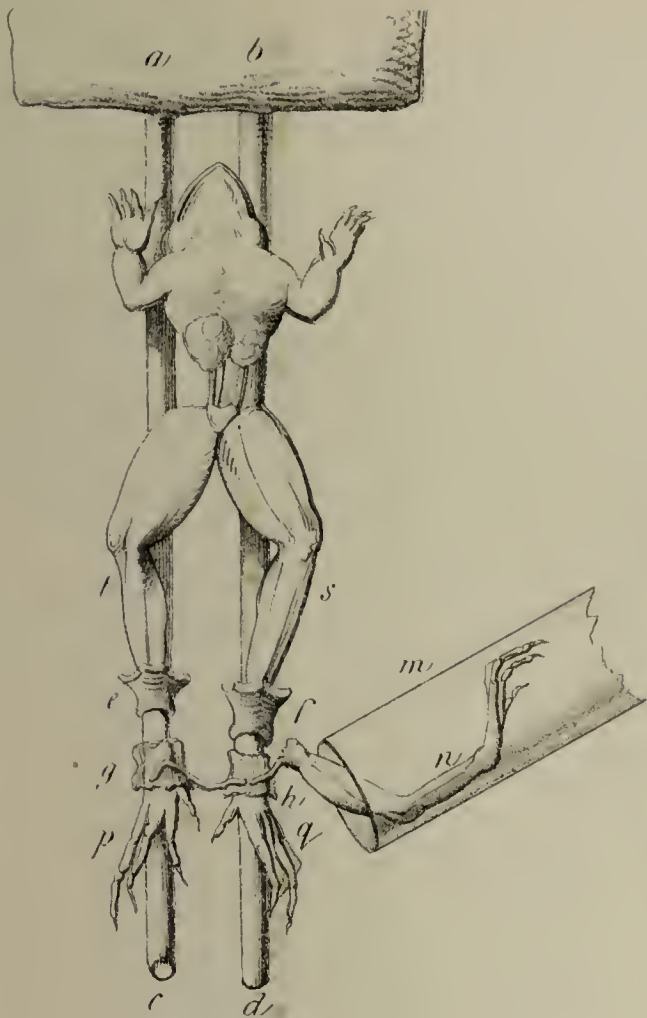


Fig. 3.

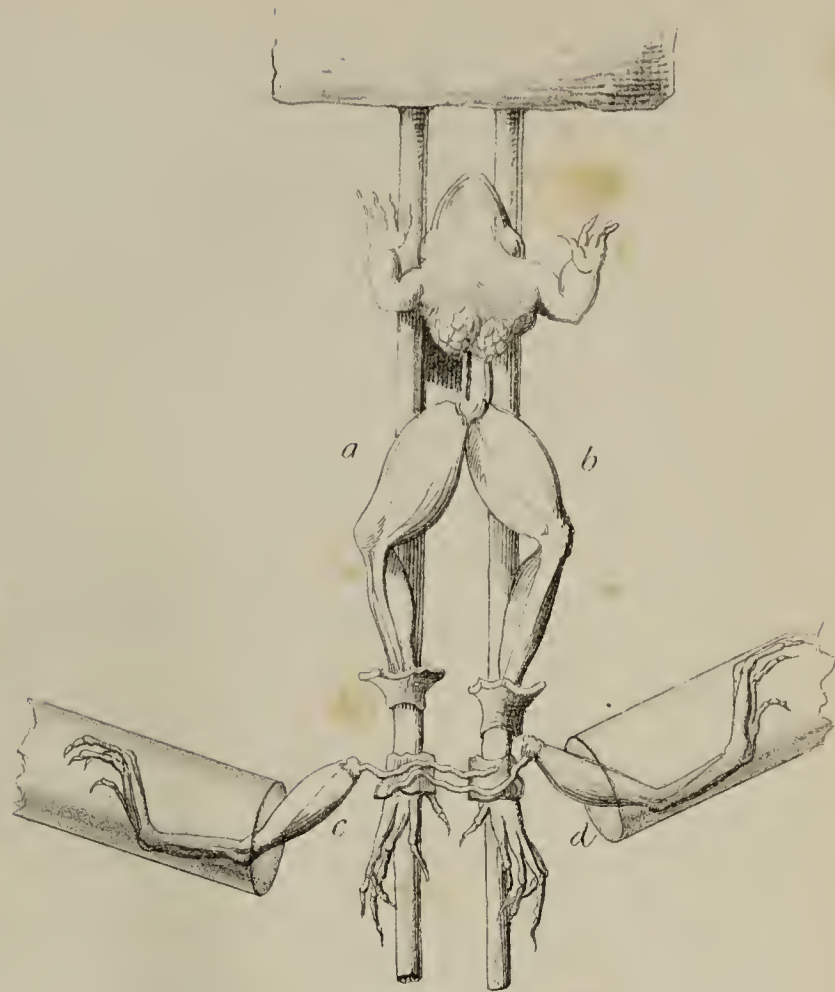


Fig. 2.

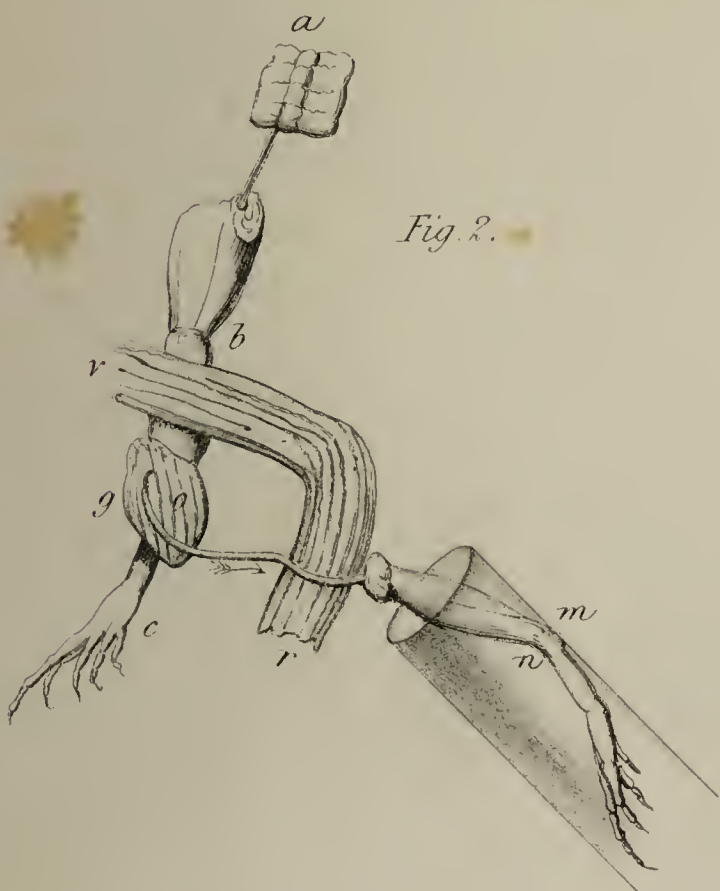
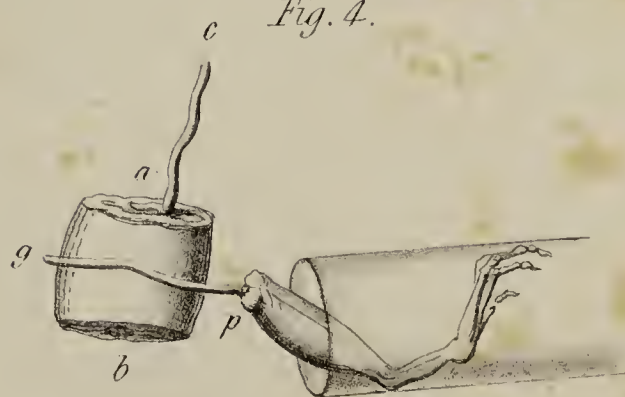
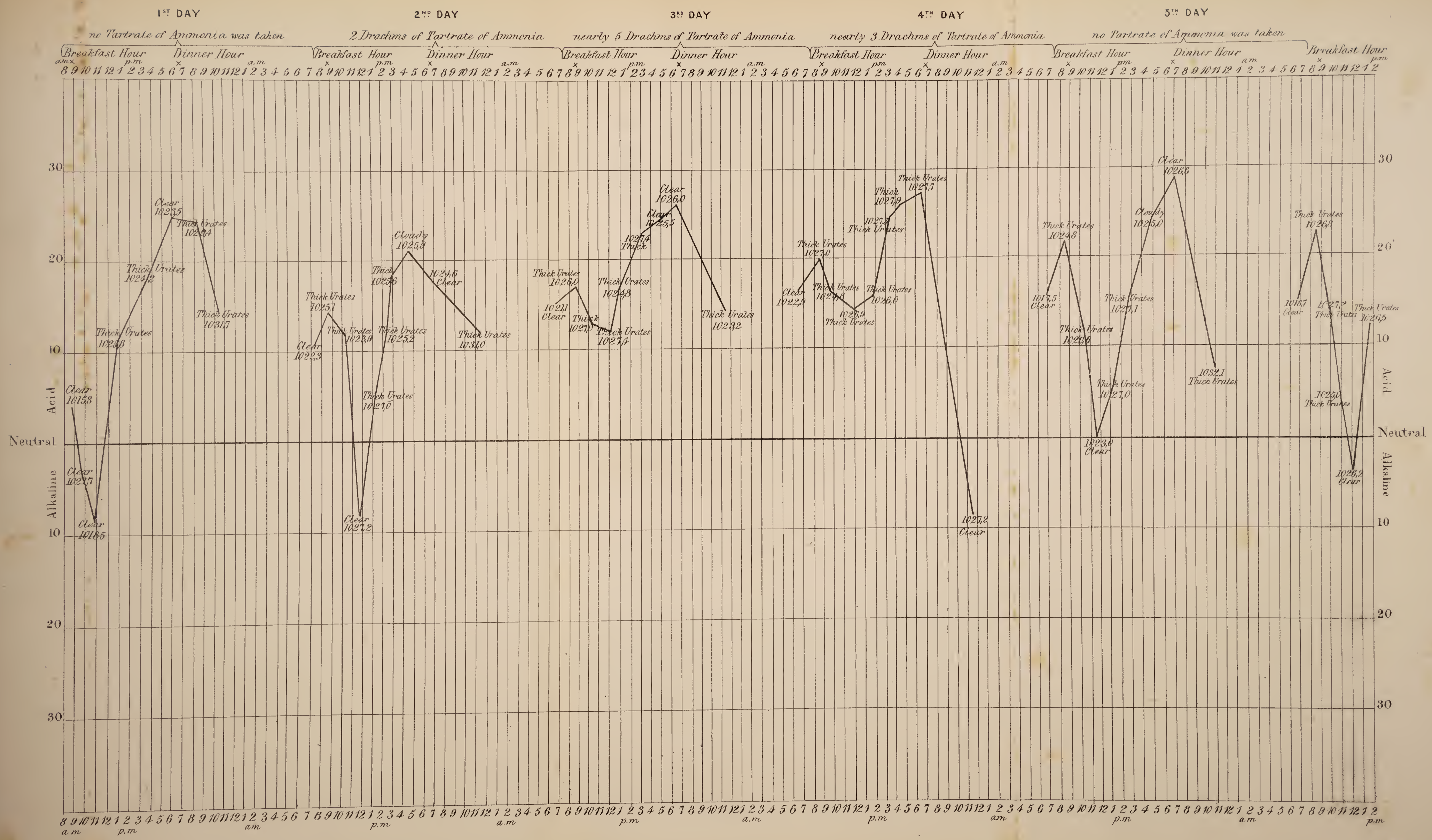


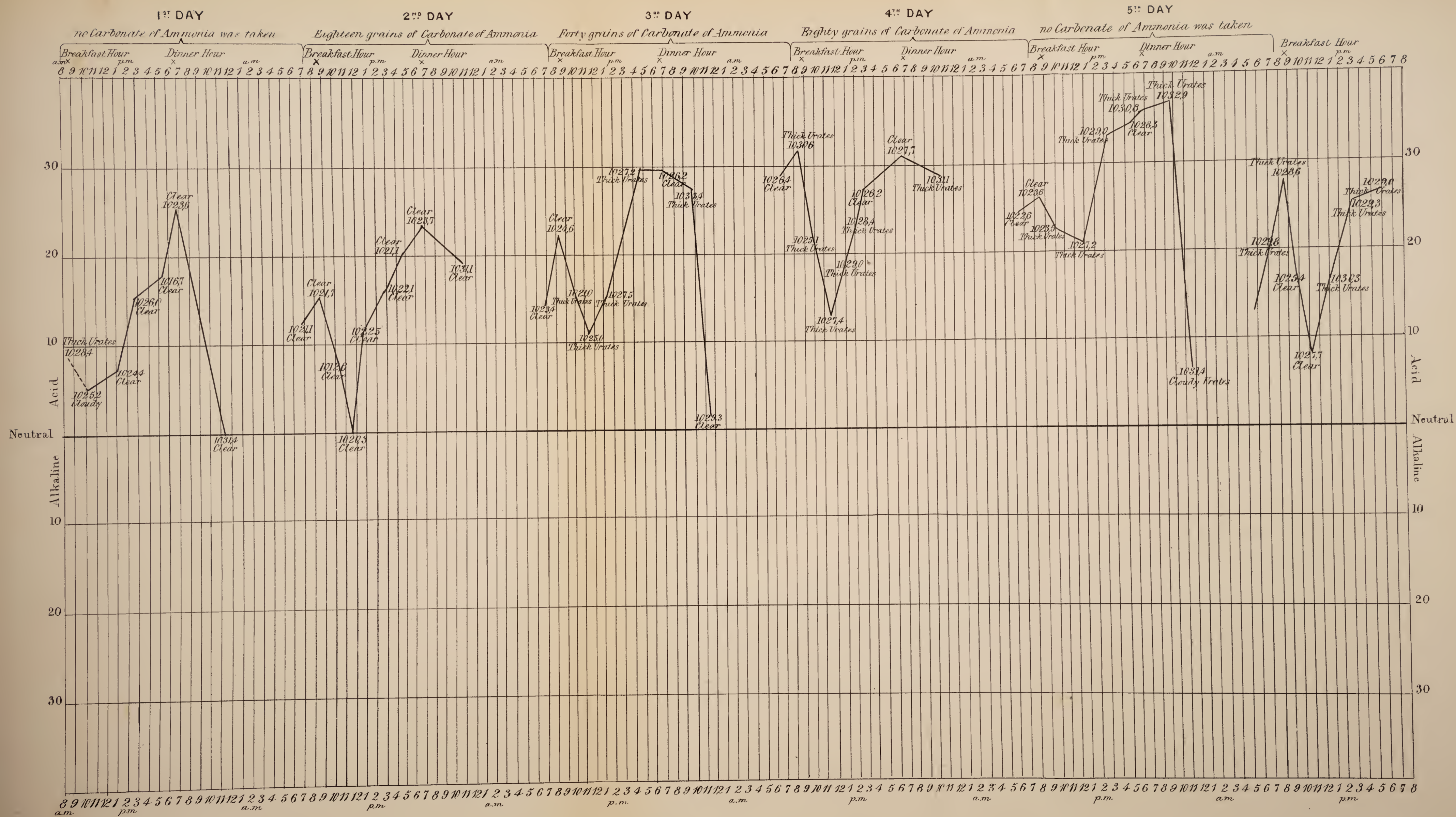
Fig. 4.



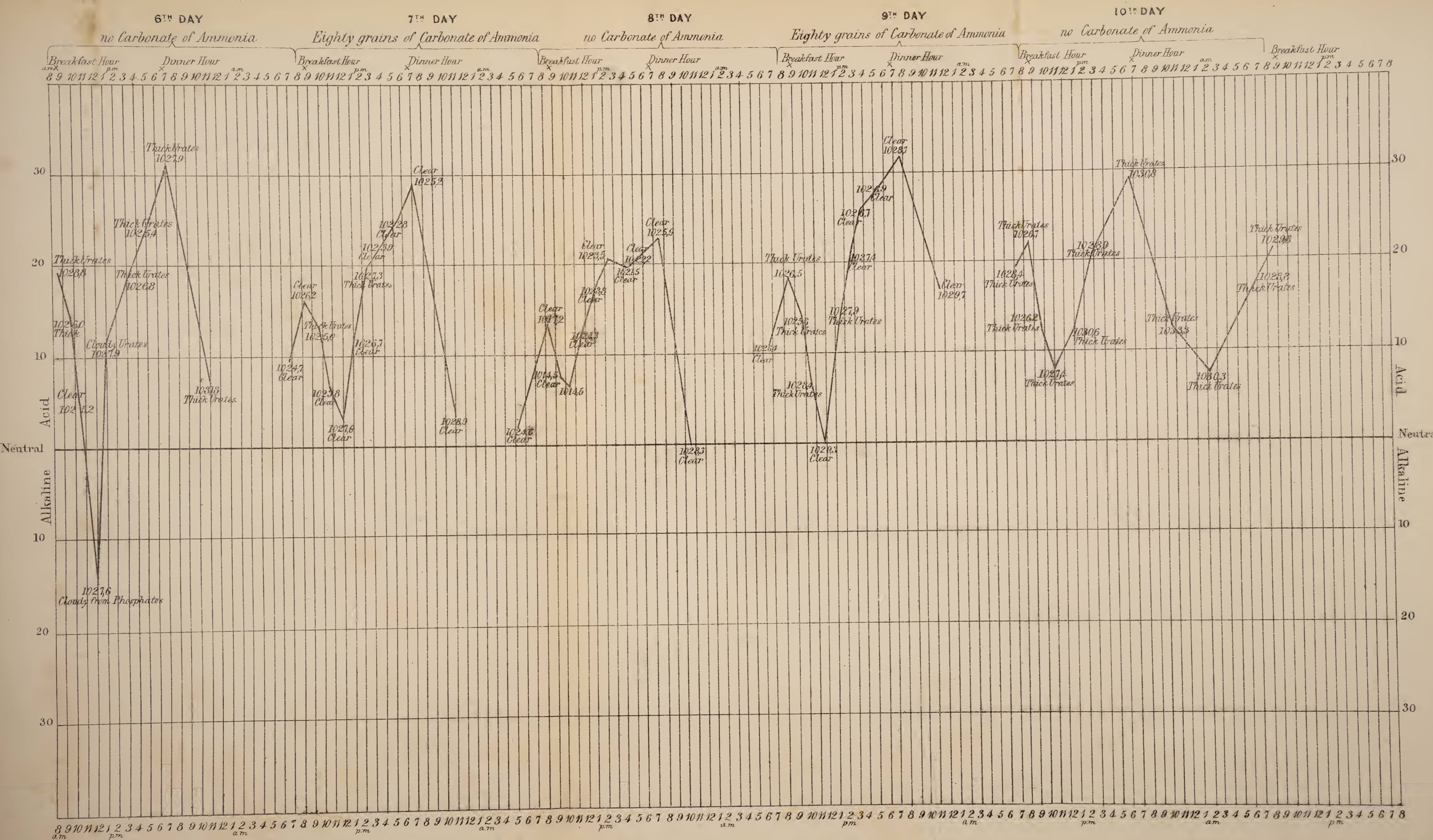
The Variations of the Acidity of the Urine when Tartrate of Ammonia was taken.



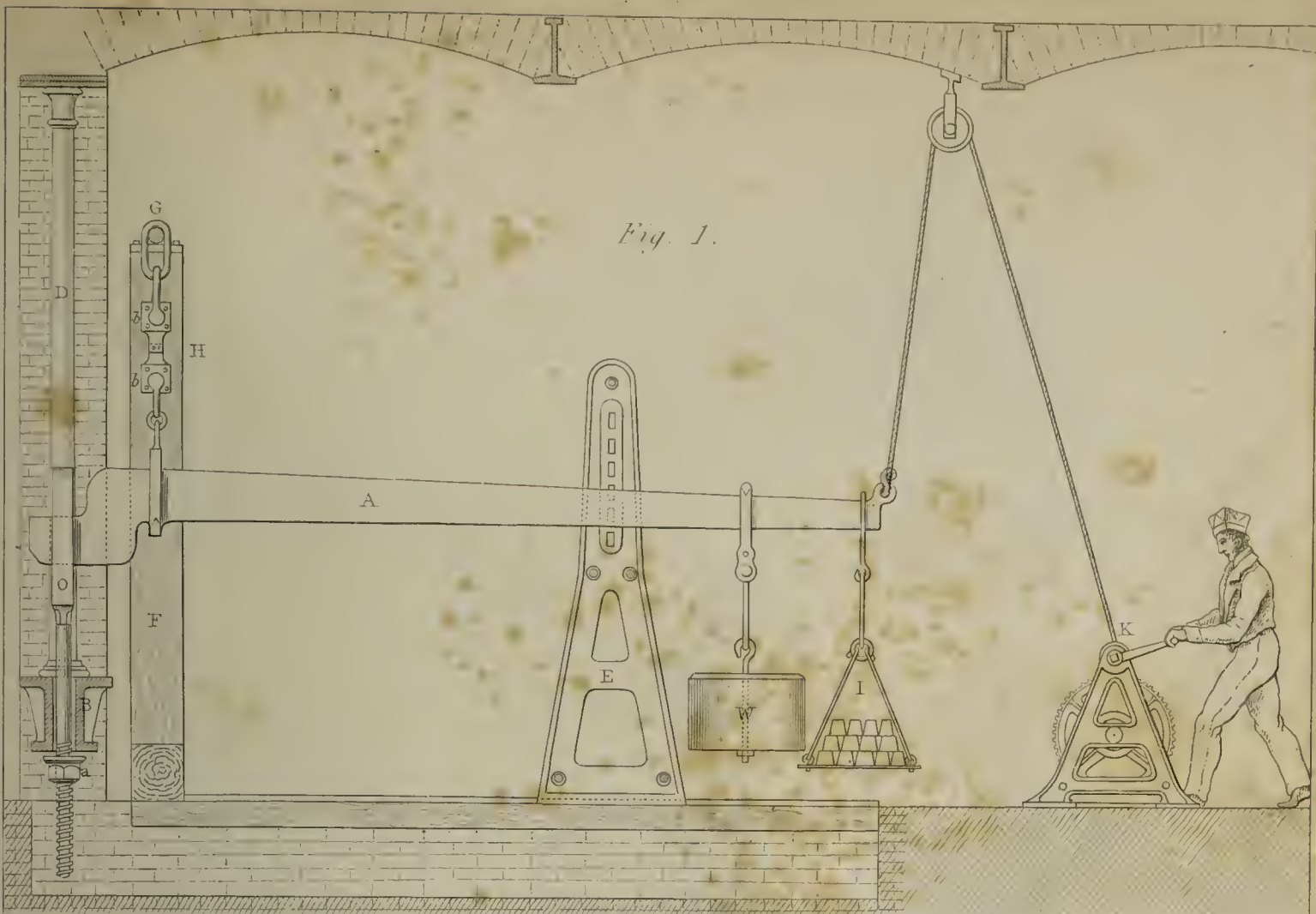
The Variations of the Acidity of the Urine when Carbonate of Ammonia was taken



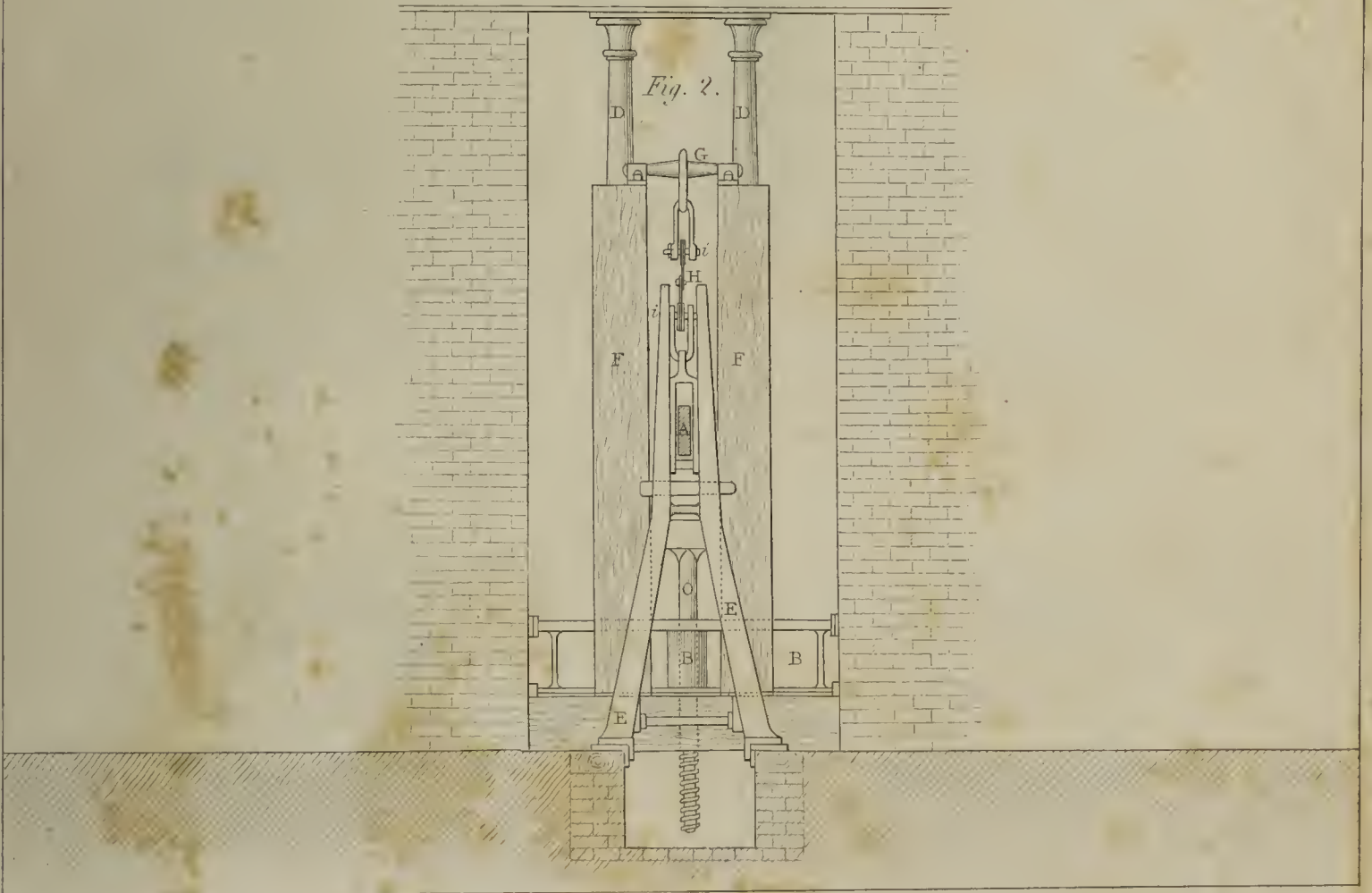
The Variations of the Acidity of the Urine when Carbonate of Ammonia was taken

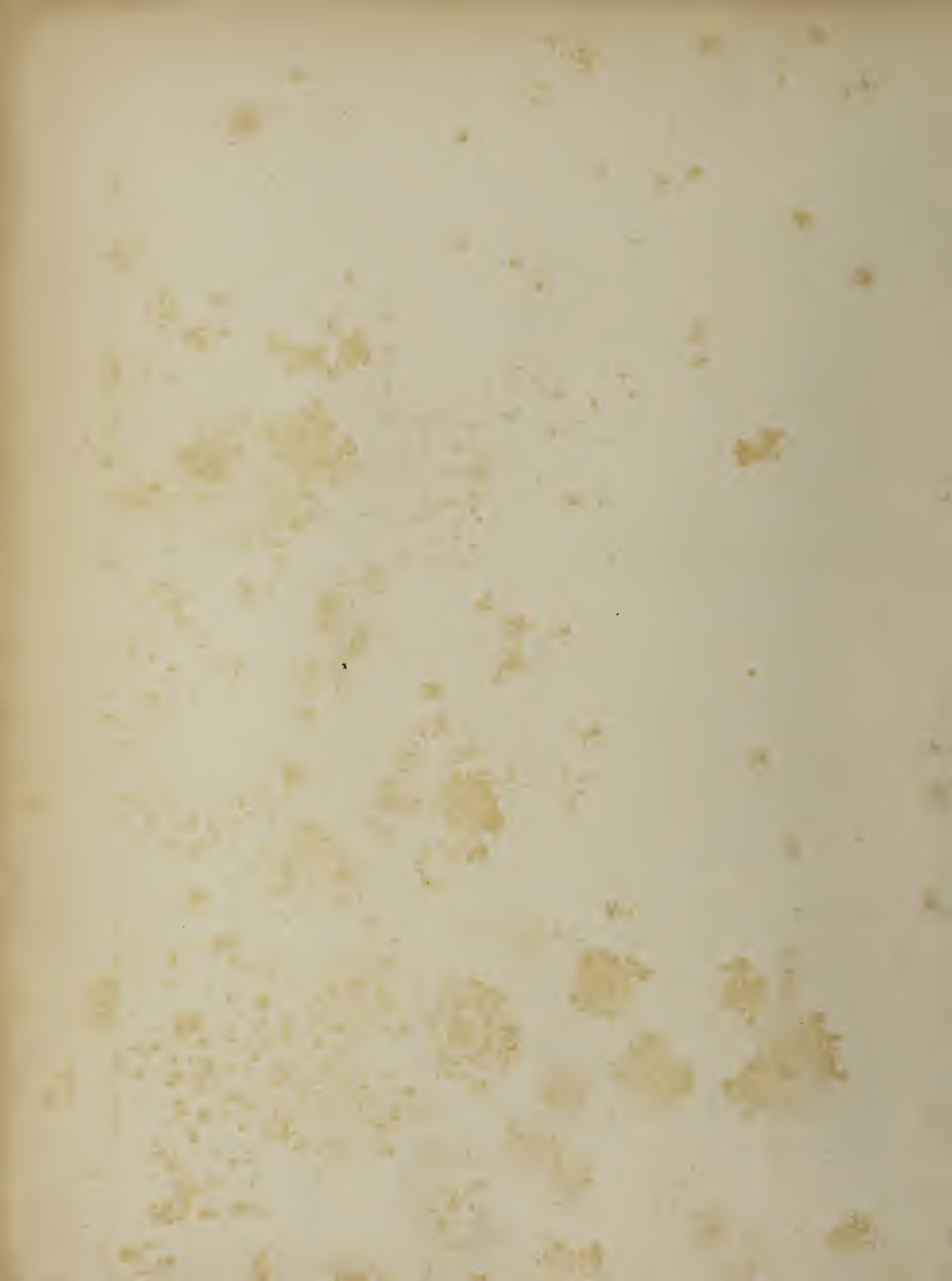


Side View.



End View.





YORKSHIRE PLATES.

TABLE I

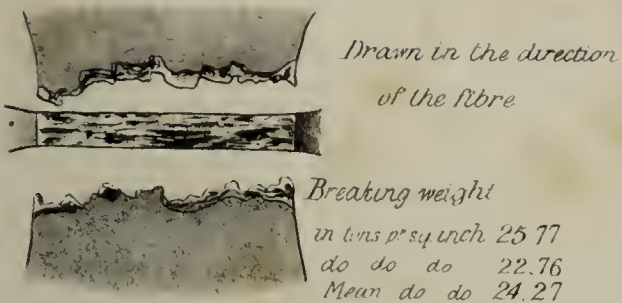
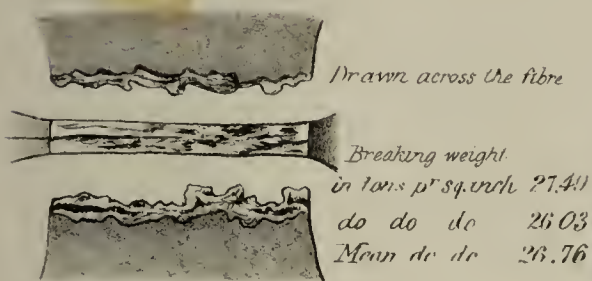
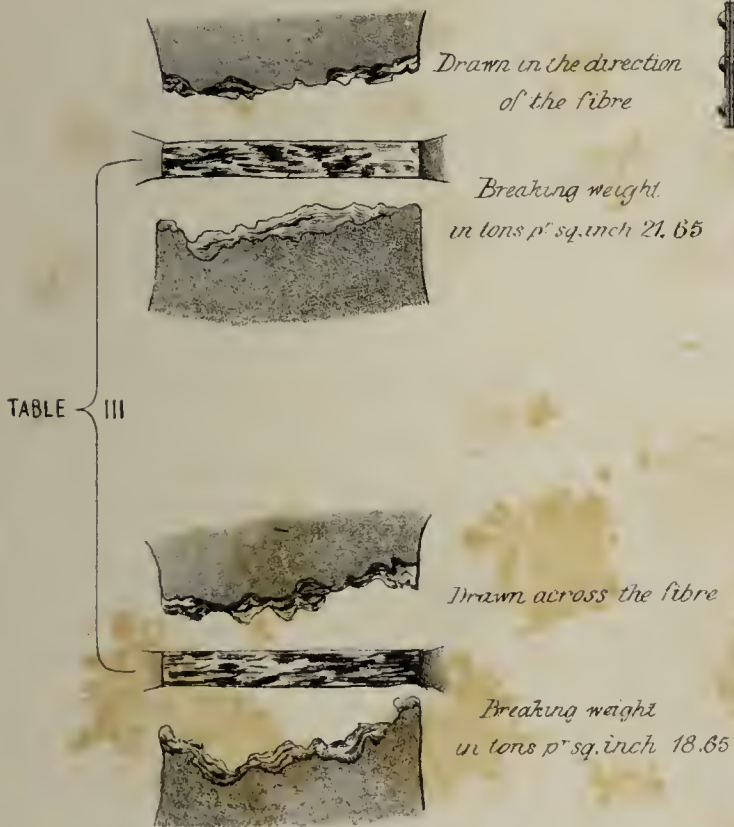


TABLE II



DERBYSHIRE PLATES



SHROPSHIRE PLATES.

TABLE IV

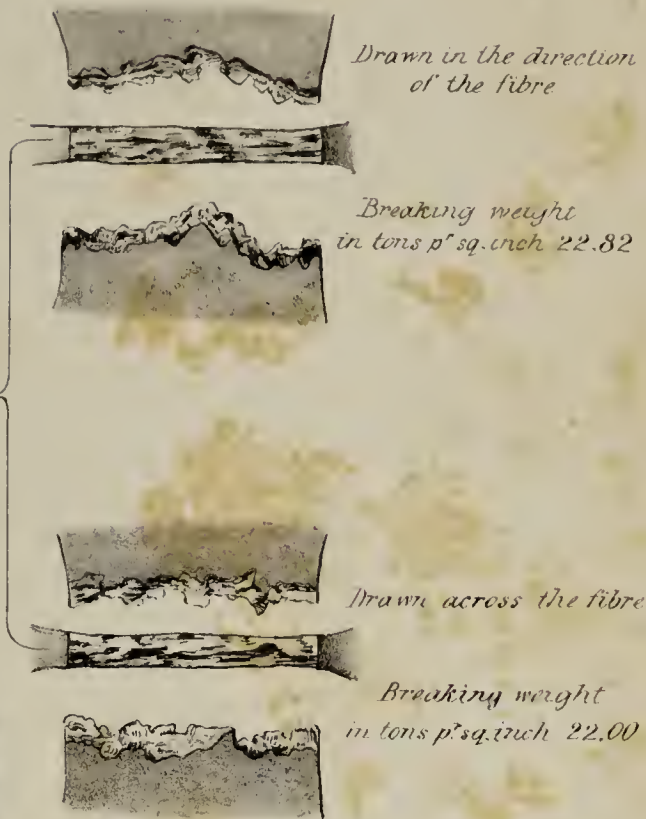
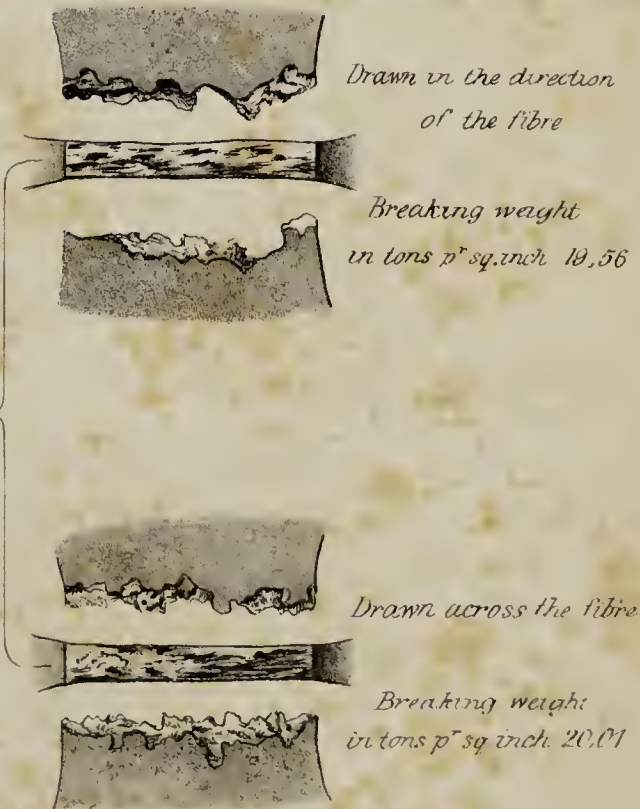


Fig. 2.



STAFFORDSHIRE PLATES

TABLE V



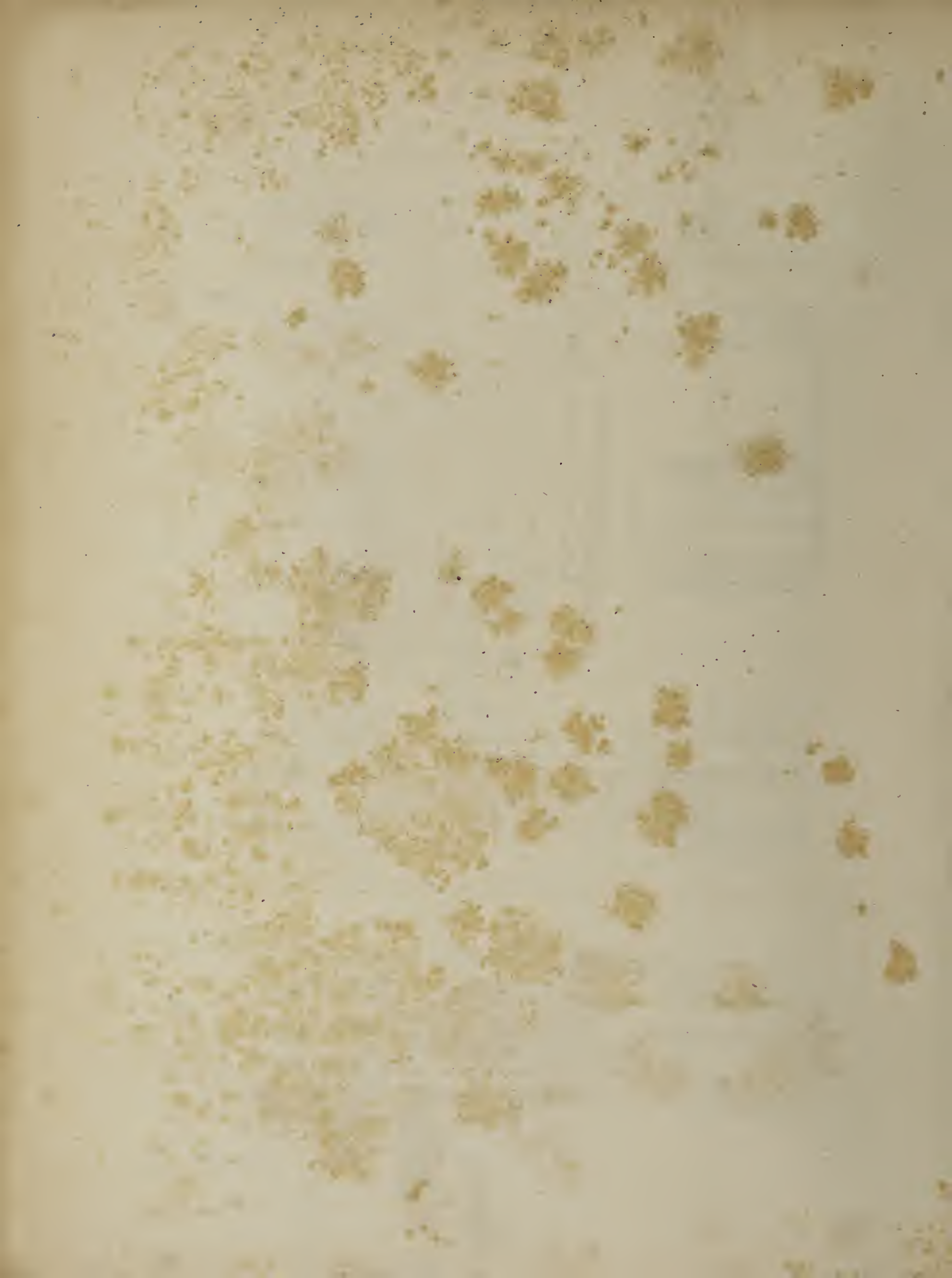
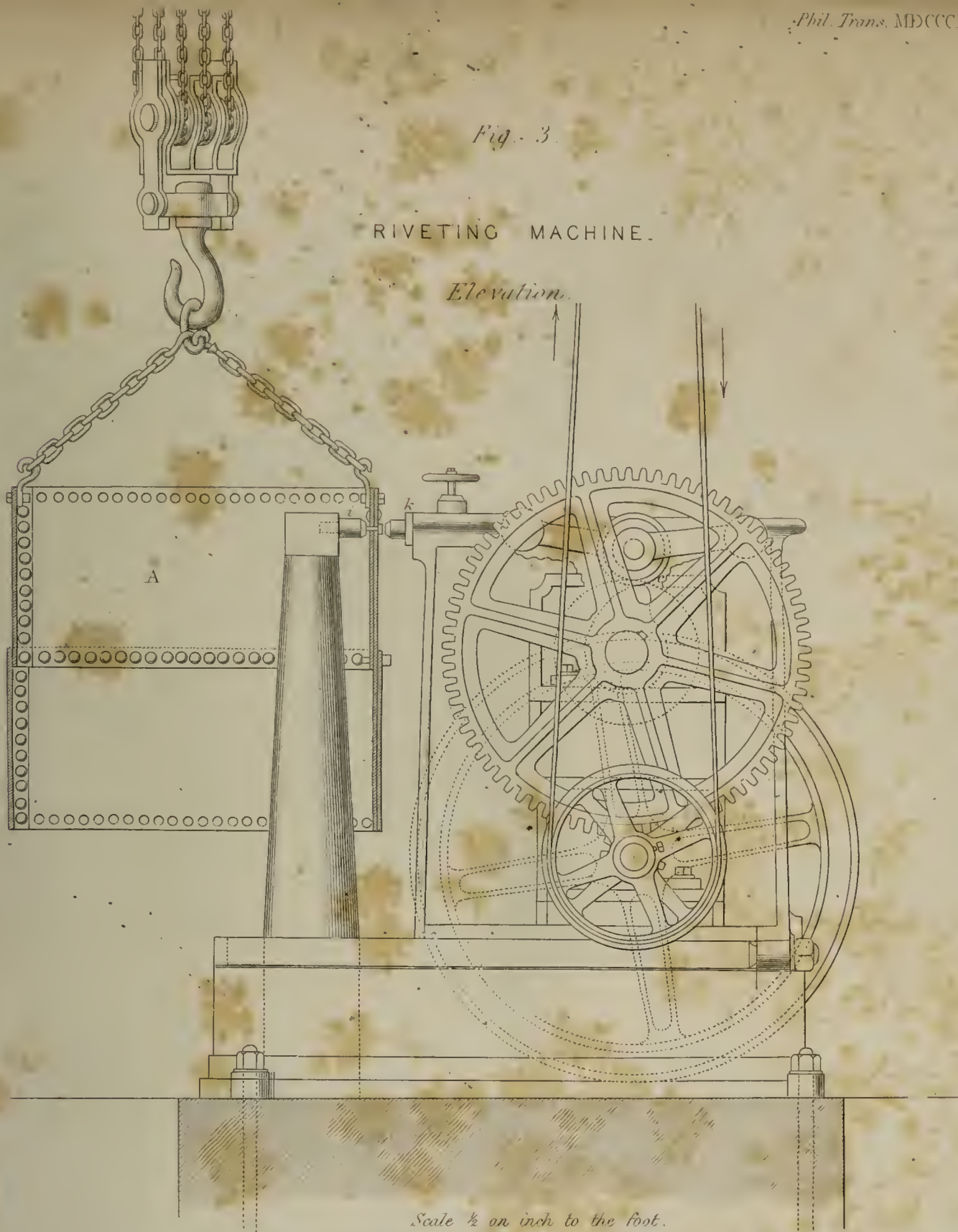


Fig. 3.

RIVETING MACHINE.

Elevation.



Plan.

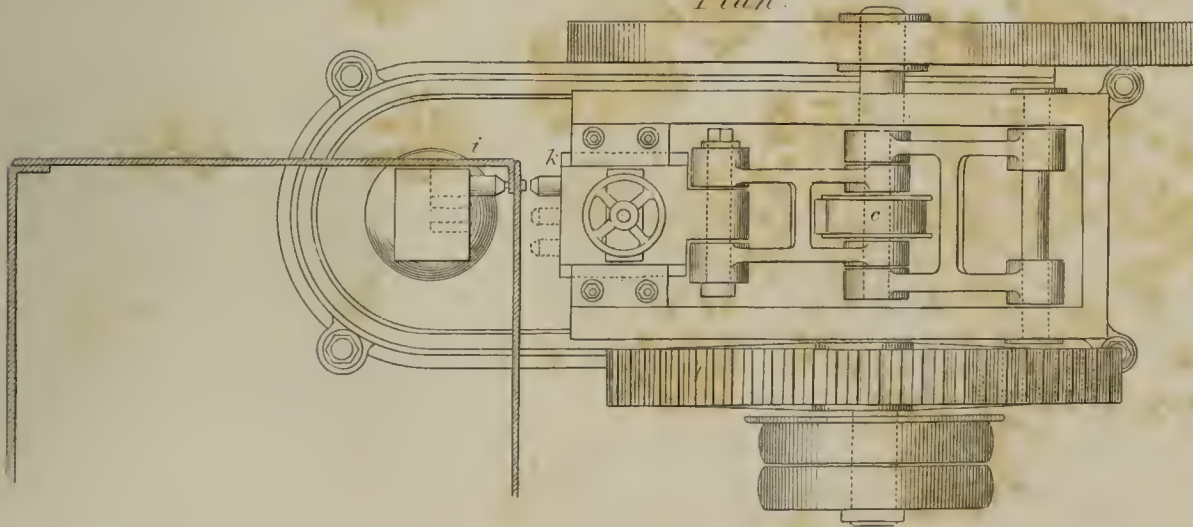


TABLE VI.

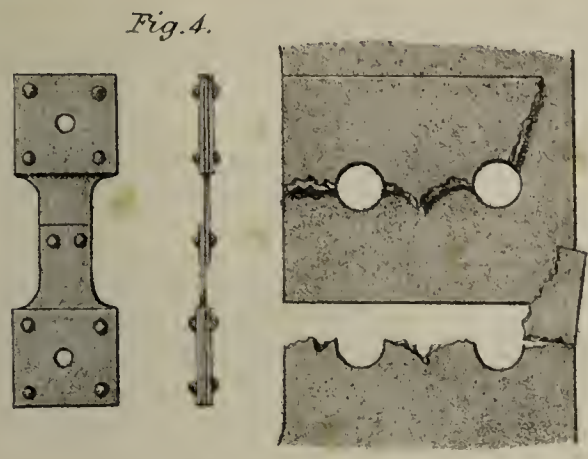


TABLE VII.

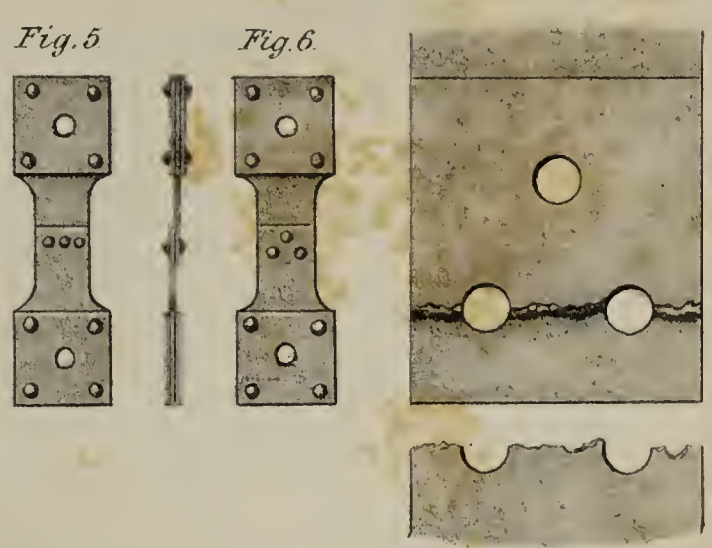


TABLE VIII.

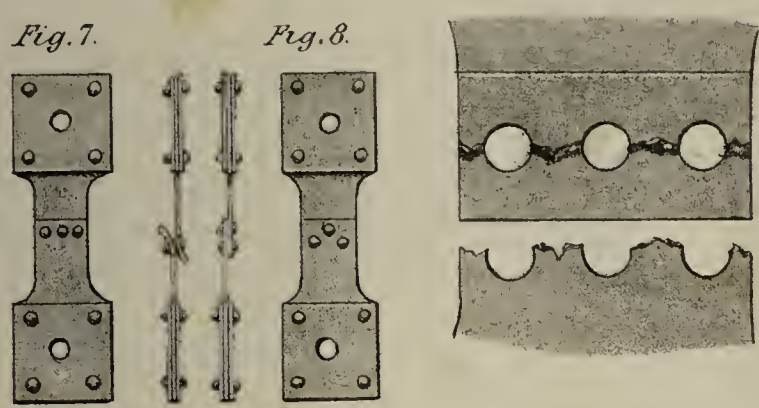


TABLE IX.

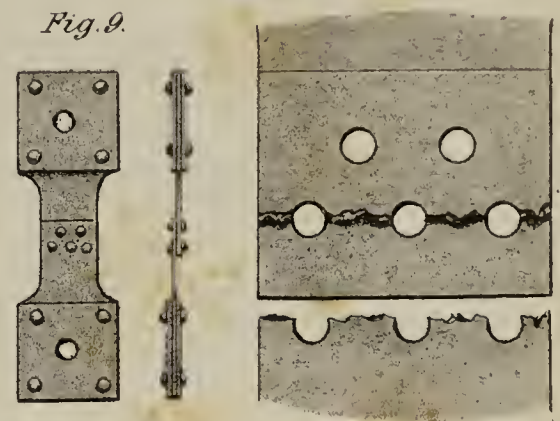


TABLE X.

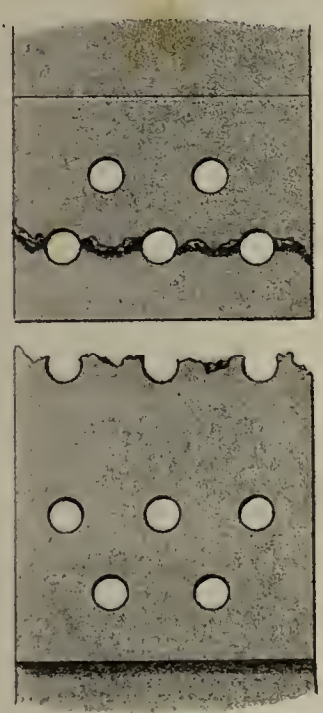


TABLE XI.

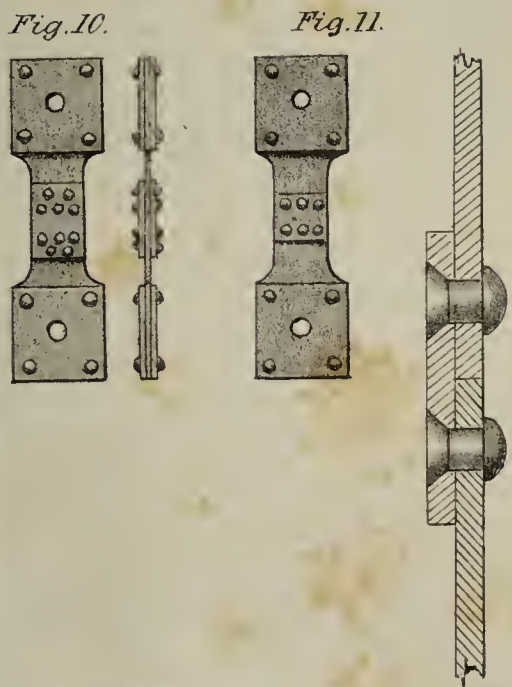


TABLE XII.

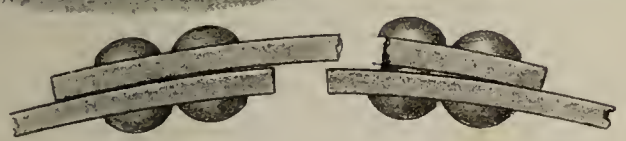
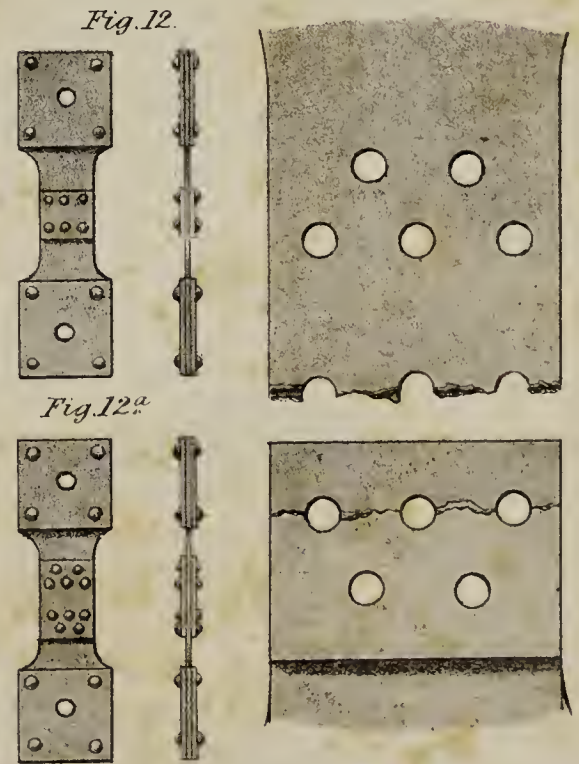


TABLE XVI

Fig. 17.

Beam before the Experiment rib downwards

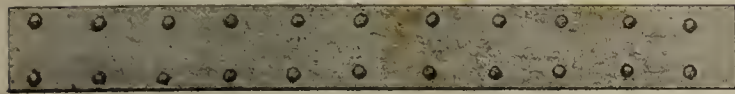
Weight of Beam 54 lbs



Beam after the Experiment



Beam, shewing the flange rib downwards



Section



Beam before the Experiment rib upwards

Weight of Beam 55 lbs



Beam after the Experiment



Plan of beam before the Experiment



Beam after the Experiment



TABLE XVI

Fig 18

Beam before the Experiment rib downwards

Weight of Beam 82½ lbs



Beam after the experiment



Beam with the flange downwards



Section



Beam before the Experiment rib upwards

Weight of Beam 85 lbs



Beam after the Experiment



Plan of beam before the Experiment



Beam after the Experiment



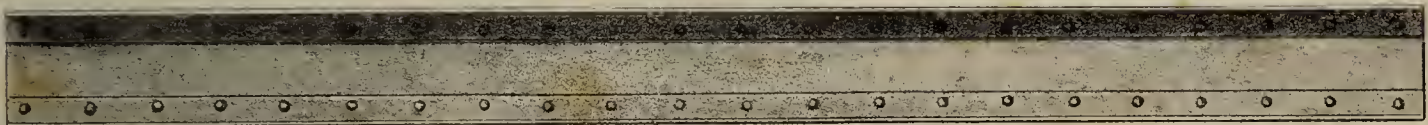
TABLE XX

Fig. 19.

Side view of Beam before the Experiment

Weight of Beam 161½ lbs

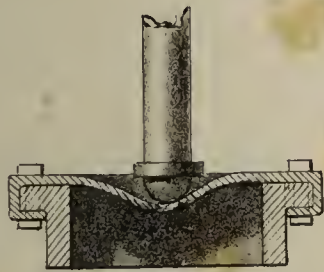
Section



Plan



TABLE XIII



Edge view of the fracture

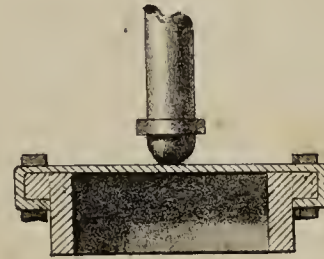


Plan



½ inch thick

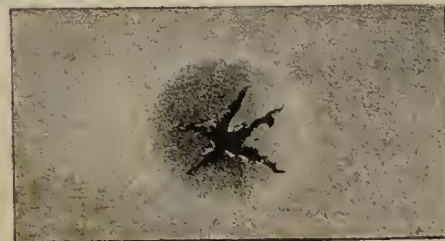
Fig 13.



Edge view of the fracture



Plan



½ inch thick

Fig 14.

