



Calhoun: The NPS Institutional Archive
DSpace Repository

Theses and Dissertations

1. Thesis and Dissertation Collection, all items

2007

Integrating the Non-Line of Sight Launching System (NLOS-LS) in the United States Navy

Emis, Jonathon; Huang, Bryan; Jones, Timothy; Li, Mei;
Tumbocon, Don

Monterey, California. Naval Postgraduate School

<http://hdl.handle.net/10945/6929>

Downloaded from NPS Archive: Calhoun



Calhoun is a project of the Dudley Knox Library at NPS, furthering the precepts and goals of open government and government transparency. All information contained herein has been approved for release by the NPS Public Affairs Officer.

Dudley Knox Library / Naval Postgraduate School
411 Dyer Road / 1 University Circle
Monterey, California USA 93943

<http://www.nps.edu/library>



**NAVAL
POSTGRADUATE
SCHOOL**

MONTEREY, CALIFORNIA

**Integrating the Non-Line
of Sight Launching System (NLOS-LS)
in the United States Navy**

by

**Jonathon Emis
Bryan Huang
Timothy Jones
Mei Li
Don Tumbocon**

March 2007

Approved for public release; distribution is unlimited.

THIS PAGE INTENTIONALLY LEFT BLANK

NAVAL POSTGRADUATE SCHOOL
MONTEREY, CALIFORNIA 93943-5001

Leonard A Ferrari
Acting President

Leonard A Ferrari
Associate Provost

This report was prepared for the Chairman of the Systems Engineering Department in partial fulfillment of the requirements for the degree of Master of Science in Systems Engineering.

Reproduction of all or part of this report is authorized.

This report was prepared by the Masters of Science in Systems Engineering (MSSE) Cohort Four from the Space and Naval Warfare Systems Center, San Diego:

Authors:

Authors:

Jonathon Emis

Bryan Huang

Timothy Jones

Mei Li

Don Tumbocon

Approved by:

John M. Green, Project Advisor

Edouard Kujawski, Second Reader

David H. Olwell, Ph. D.
Chairman, Department of Systems Engineering

Dan C. Boger, Ph. D.
Interim Associate Provost and
Dean of Research

| REPORT DOCUMENTATION PAGE | | | <i>Form Approved OMB No. 0704-0188</i> | |
|---|---|--|---|--|
| Public reporting burden for this collection of information is estimated to average 1 hour per response, including the time for reviewing instruction, searching existing data sources, gathering and maintaining the data needed, and completing and reviewing the collection of information. Send comments regarding this burden estimate or any other aspect of this collection of information, including suggestions for reducing this burden, to Washington headquarters Services, Directorate for Information Operations and Reports, 1215 Jefferson Davis Highway, Suite 1204, Arlington, VA 22202-4302, and to the Office of Management and Budget, Paperwork Reduction Project (0704-0188) Washington DC 20503. | | | | |
| 1. AGENCY USE ONLY (Leave blank) | | 2. REPORT DATE March 2007 | 3. REPORT TYPE AND DATES COVERED Technical Report | |
| 4. TITLE AND SUBTITLE: Title (Mix case letters) Integrating the Non-Line of Sight Launching System (NLOS-LS) in the United States Navy | | | 5. FUNDING NUMBERS | |
| 6. AUTHORS: Jonathon Emis, Bryan Huang, Timothy Jones, Mei Li, Don Tumbocon | | | | |
| 7. PERFORMING ORGANIZATION NAME(S) AND ADDRESS(ES) Naval Postgraduate School Monterey, CA 93943-5000 | | | 8. PERFORMING ORGANIZATION REPORT NUMBER | |
| 9. SPONSORING / MONITORING AGENCY NAME(S) AND ADDRESS(ES) N/A | | | 10. SPONSORING / MONITORING AGENCY REPORT NUMBER | |
| 11. SUPPLEMENTARY NOTES The views expressed in this report are those of the author(s) and do not reflect the official policy or position of the Department of Defense or the U.S. Government. | | | | |
| 12a. DISTRIBUTION / AVAILABILITY STATEMENT Approved for public release; distribution is unlimited. | | | 12b. DISTRIBUTION CODE | |
| 13. ABSTRACT (maximum 200 words) The global war on terror emphasizes the need for a weapon system that can improve the self-defense capability of the U.S Navy ship against small surface craft threats. This MSSE Capstone Project investigated the feasibility of integrating the Non-Line of Sight Launching System (NLOS-LS) onto U.S. Navy ships. In particular, the focus of the project was on the DDG-51 class ships. The NLOS-LS was originally designed to provide support to Army ground forces against over the horizon threats. The U.S. Navy recognizes the prospect of this weapon in an at-sea environment. The capability of the system has been proven through its developmental testing to date and illustrates the potential to the U.S. Navy for ship defense. System integration involves incorporating a stand-alone, land-based system onto a ship with an existing shipboard combat system. This report addresses the top-level integration issues, such as the physical installation and combat system integration, and provides recommendations related to some important concerns that include interface analysis, functional analysis, system behavior, and physical installation. This analysis concludes with a notional implementation for many issues and provides a risk analysis for those issues. It also identifies many integration areas requiring further research. | | | | |
| 14. SUBJECT TERMS Non-Line of Sight Launching System, NLOS-LS, Integration, DDG-51 | | | 15. NUMBER OF PAGES 108 | |
| | | | 16. PRICE CODE | |
| 17. SECURITY CLASSIFICATION OF REPORT Unclassified | 18. SECURITY CLASSIFICATION OF THIS PAGE Unclassified | 19. SECURITY CLASSIFICATION OF ABSTRACT Unclassified | 20. LIMITATION OF ABSTRACT UL | |

THIS PAGE INTENTIONALLY LEFT BLANK

INTEGRATING THE NON-LINE OF SIGHT LAUNCHING SYSTEM (NLOS-LS) IN THE UNITED STATES NAVY

ABSTRACT

The global war on terror emphasizes the need for a weapon system that can improve the self-defense capability of the U.S Navy ship against small surface craft threats. This MSSE Capstone Project investigated the feasibility of integrating the Non-Line of Sight Launching System (NLOS-LS) onto U.S. Navy ships. In particular, the focus of the project is on the DDG-51 class ships. The NLOS-LS was originally designed to provide support to Army ground forces against over the horizon threats. The U.S. Navy recognizes the prospect of this weapon in an at-sea environment. The capability of the system has been proven through its developmental testing to date and illustrates the potential to the U.S. Navy for ship defense. System integration involves incorporating a stand-alone, land-based system onto a ship with an existing shipboard combat system. This report addresses the top-level integration issues, such as the physical installation and combat system integration, and provides recommendations related to some important concerns that include interface analysis, functional analysis, system behavior, and physical installation. This analysis concludes with a notional implementation for many issues and provides a risk analysis for those issues. It also identifies many integration areas requiring further research.

THIS PAGE INTENTIONALLY LEFT BLANK

TABLE OF CONTENTS

| | | |
|-------------|--|-----------|
| I. | INTRODUCTION..... | 1 |
| A. | PROBLEM DESCRIPTION / PROJECT GOALS..... | 1 |
| | 1. Background | 1 |
| | 2. Scope of the Project | 3 |
| B. | DESCRIPTION OF NLOS-LS | 4 |
| | 1. Container Launch Unit (CLU) | 4 |
| | 2. Computer & Communication System (CCS) | 5 |
| | 3. Precision Attack Missile (PAM) | 5 |
| | 4. System Performance | 7 |
| C. | CONCEPT OF OPERATION (CONOPS)..... | 12 |
| | 1. U.S. Army NLOS-LS CONOPS..... | 12 |
| | 2. U.S. Navy NLOS-LS CONOPS..... | 13 |
| II. | APPROACH..... | 17 |
| A. | OVERVIEW | 17 |
| B. | LCS RELATED WORK | 19 |
| III. | ANALYSIS | 21 |
| A. | INTEGRATION ISSUES..... | 21 |
| B. | COMBAT SYSTEM INTEGRATION | 21 |
| | 1. NLOS-LS Interfaces | 22 |
| | 2. NLOS-LS Functional Analysis..... | 34 |
| | 3. NLOS-LS System Behavior..... | 41 |
| B. | DDG-51 PHYSICAL INSTALLATION ANALYSIS..... | 45 |
| | 1. Scope of Physical Installation | 45 |
| | 2. Equipment Analysis..... | 48 |
| | 3. CIC Console Configuration | 50 |
| | 4. CLU Location Footprint Analysis..... | 51 |
| | 5. Safety Issues..... | 59 |
| C. | EVALUATION OF ISSUES | 59 |
| | 1. Notional Implementation..... | 59 |
| | 2. Risk Mitigation..... | 60 |
| IV. | CONCLUSION | 65 |
| | APPENDIX A. CRADA DOCUMENT..... | 69 |
| | APPENDIX B. PAM BASELINE WARHEAD CALCULATION..... | 75 |
| | APPENDIX C. ARENA MODEL..... | 79 |
| | A. ARENA MODEL | 79 |
| | B. MODEL EXPLANATION..... | 79 |
| | C. BASIC ANIMATION AND EXPLANATION..... | 81 |
| | APPENDIX D. AN/SPY 1 RADAR HORIZON CALCULATION..... | 83 |

| | |
|--|-----------|
| APPENDIX E. RCS CALCULATION | 85 |
| APPENDIX F. LIST OF REFERENCES..... | 87 |
| APPENDIX G. ACRONYM LIST | 91 |
| INITIAL DISTRIBUTION LIST | 95 |

LIST OF FIGURES

| | |
|---|----|
| Figure 1: NLOS-LS Platform Independence. The flexibility of the launcher allows interoperability among various manned/unmanned platforms. The system can be launch on a M998 High Mobility Multipurpose Wheeled Vehicle (HMMWV) and deployable by a C130 aircraft. | 3 |
| Figure 2: Container Launch Unit (CLU). The CLU has 15 canister missiles. Each CLU is self-contained with a communication system and a launch control systems. | 5 |
| Figure 3: Precision Attack Missile (PAM). The PAM consists of a variable thrust motor, dual-mode precision uncooled infrared/semi-active laser seeker and a large multimode warhead effective against both moving and stationary targets. | 6 |
| Figure 4: U.S. Navy PAM Seeker Capability. The PAM consists of a variable thrust motor, dual-mode precision uncooled infrared/semi-active laser seeker and a large multimode warhead effective against both moving and stationary targets. UCIIR begins acquisition process at 4.4 nautical miles. | 7 |
| Figure 5: DARPA Tests. Multiple tests were conducted to illustrate the seeker capability to search and track land targets (T-90 tank) and sea targets (Riverine Assault Craft). | 8 |
| Figure 6: PAM Baseline Warhead. The front of the warhead attaches to the guidance section, the aft attaches to the seeker section. This warhead consist of PBXN-9 billet explosive, copper liner, aluminum retaining ring, syntac 350 wave shaper, 1020 steel body, ULTEM IM FI Barrier, ULTEM Boat tail, Aluminum ESAD fixture, Nylon PIC spacer, and CRES/ PBX-5 PIC. | 9 |
| Figure 7: U.S. Navy PAM Test Results⁷. A PAM baseline warhead was place inside the RAC to test the effectiveness and lethality of the PAM. | 10 |
| Figure 8: NLOS-LS Threat Methodology. The PAM Response illustrates the pattern that each PAM can utilize each assigned target. | 11 |
| Figure 9: Single Container Launch Unit (CLU) vs. 60 Targets¹⁴. The two graphs are the results from a Raytheon presentation LCS versus 60 targets. | 11 |
| Figure 10: OV-1 Diagram for U.S. Army. The Army concept of operation showed that the CLU is platform independent and the control unit can be located inside a truck or a HMMWV. | 13 |
| Figure 11: OV-1 Diagram for U.S. Navy. During the PAM in flight, the PAM sends health and status, and battle damage imagery back to the platform. The MH-60 provides target location back to the platform. | 14 |
| Figure 12: System Engineering Vee Model. This widely used model provided a general systems engineering approach and was adapted to fit this project. | 18 |
| Figure 13: NLOS-LS Installation and Integration Functional Flow Block Diagram (FFBD). This FFBD steps through the functions necessary to install and integrate the NLOS-LS onto a ship. | 19 |
| Figure 14: NLOS-LS Entity Model. This model gives a visualization of the interfaces with NLOS-LS and the ship framework. | 22 |

| | |
|--|-----------|
| Figure 15: Aegis Weapon Interfaces. The AWS element interface shows a notional concept of how NLOS-LS fits in the complement of weapon systems in the Aegis suite. | 23 |
| Figure 16: NLOS-LS Overview Diagram. This diagram was created to show the system element interfaces between NLOS-LS and the AWS. | 24 |
| Figure 17: MH-60R. MH-60R helicopters counter the anti-surface threat by serving as a forward-looking, off-board system. | 27 |
| Figure 18: Module Engagement Control FFBD. In order to schedule an engagement, the proper weapon system must be selected and designated to be in control. | 30 |
| Figure 19: Maximum range of the NLOS-LS Radio. The line-of-sight of the radio from an antenna mounted 100ft from the deck of a DDG-51 class destroyer to an antenna on a PAM in flight. The curvature of the earth limits the range of the radio. Due to the receiver sensitivity, transmitter power, and antenna efficiency the actual range of the radio is usually lower. | 31 |
| Figure 20: Network Communication Use Case Diagram. This is a notional use case diagram of how the communications paths flow. | 32 |
| Figure 21: Priority Doctrine. Since NLOS-LS is a Surface Warfare (SuW) weapon, it is recommended that the priority fall between AAW and STRIKE. | 34 |
| Figure 22: Required NLOS-LS Architecture Functions. The required functions illustrate in what manner NLOS-LS must interact with systems external to its boundaries. | 35 |
| Figure 23: AFCD NLOS-LS. NLOS-LS receives and processes data from the Radio, C&D, WSN, NAVSSI, and the consoles. | 36 |
| Figure 24: AFD 0 NLOS-LS NEP. The top-level architecture flow diagram for the NLOS-LS includes the major components of the weapon system. | 37 |
| Figure 25: AFD 1 CLU and CCS. The CLU acts as a communication node via a direct-wired Ethernet interface with engagement data from the NEP and updating the Radio and PAM. | 38 |
| Figure 26: AFD 2 PAM. The PAM must maintain constant communication with the Radio and CLU to ensure that the PAM can transition to flight and intercept its target. | 40 |
| Figure 27: AFD 3 Radio. The NLOS-LS communicates with the PAM via the NLOS-LS Radio to allow continuous tracking of the PAM after it has been launched from the ship. | 40 |
| Figure 28: NLOS-LS System Behavior FFBD. This diagram shows the general flow of events of a typical NLOS-LS engagement. | 42 |
| Figure 29: NLOS-LS Engagement Sequence Diagram. This is a functional sequence diagram of the AWS and the path that is taken to search, detect, designate, and engage a hostile target. | 43 |
| Figure 30: Organic and Off-Board Sensor FFBD. The NLOS-LS can search, detect, and track targets to support the NLOS-LS engagement. | 44 |
| Figure 31: NLOS Engagement Planner FFBD. The NEP can receive missions from on-board ship by the command and control system to plan an engagement. .. | 44 |

| | |
|---|-----------|
| Figure 32: Alteration Decision Tree. From the Fleet Modernization Manual, this flow chart determines which type of SHIPALT is required..... | 48 |
| Figure 33: Exhaust Gases. During a missile launch, the exhaust gases exit the top of the unit into the atmosphere, thus reducing the impact to the ship. | 50 |
| Figure 34: Combat Information Center (CIC). This is a diagram of a typical layout inside CIC. | 51 |
| Figure 35: Footprint Location. Four candidate locations for the NLOS-LS installation are located port and starboard of the forward and aft Vertical Launching System (VLS)..... | 52 |
| Figure 36: Footprint Location Advantages vs. Disadvantages. Advantages and disadvantages are provided for each location, considered in descending priority..... | 53 |
| Figure 37: Standard Missile vs. PAM. Engineering judgment shows that blast damage will be minimal when comparing the size dimensions between a PAM and SM-2. | 54 |
| Figure 38: Environmental Effects. These environmental requirements provide a foundation for the NLOS-LS system..... | 55 |
| Figure 39: Definitions of the Electromagnetic Disciplines Covered by E3. Provided from <i>E3 and SM Assessment Guide for Operational Testing</i> | 58 |
| Figure 40: DDG-51 Topside Configuration. The recommended location is the port and starboard locations of the aft VLS launcher for both the DDG-51 Flight II and IIA ships. | 60 |
| Figure 41: NLOS-LS Integration Risk Matrix. These issues and their respective risks must be addressed when installing NLOS-LS on a DDG-51. | 62 |
| Figure 42: BOFORS 3P Round Data. The BOFORS 3P rounds data represented by BOFORS Defense AB, A United Defense Company on June 2002..... | 76 |
| Figure 43: Detect-Track-Engage Sequence for NLOS-LS. The objective of the ARENA Model is to better understand the NLOS-LS operational sequence in naval combat environments and evaluate system performance..... | 80 |

EXECUTIVE SUMMARY

The Non-Line of Sight Launching System (NLOS-LS) was originally designed for Army use in a stand-alone, autonomous environment. It is designed to be highly maneuverable and easily transported by many means such as a High Mobility Multipurpose Wheeled Vehicle (HMMWV) or plane, and networked with a variety of dissimilar sensor systems such as Electro-Optics and Infrared (EO/IR) and lasers to provide over-the-horizon support against advancing threats. The U.S. Navy, recognizing the NLOS-LS capabilities and maritime potential, wants to take advantage of the Army's initial development and install and integrate the system onto ships. This report addresses the feasibility of integrating NLOS-LS onto the DDG-51 class destroyer. Many combat system integration issues involving control, physical equipment locations, and sensor and command connections produce concerns that must be resolved. The NLOS-LS is a highly modular system, which allows it to be included on ships in a cohesive manner. However, while placing a modular system onto a new platform is possible, it is not without its challenges.

System integration activities focused on the physical location, command and control interfaces, radio communication, and sensor targeting data integration. There were also safety aspects that were addressed which include safety to the ship and its equipment, danger to the crew and weapon system operators, firing zones and cutouts. Risks to these activities were considered and identified mandatory efforts required to complete the integration. Additional issues included providing targeting data to NLOS-LS, incorporating NLOS-LS into the threat evaluation, assigning control to weapons, and avoiding fratricide with existing systems. The NLOS-LS is designed to allow two-way communications between a radio system and the missile. This communication path includes an on-board antenna on the mast of the ship and a common data line. This data line feeds the Combat Information Center (CIC) with the targeting data as well as the location of the missile in-flight. The weapon assignment methodology must be updated to incorporate the NLOS-LS with its potential targets and reduces the probability of fratricide in the event of a Standard Missile-2 (SM-2) or Tomahawk missile launch.

I. INTRODUCTION

A. PROBLEM DESCRIPTION / PROJECT GOALS

With the end of the Cold War and the advent of a shift in strategy to the littoral, the United States Navy has need of a weapon system to improve the self defense capability of surface ships against multiple small surface craft attacks; an expected threat in the littorals. One weapon system that has the potential to be effective in combating such an enemy is the NLOS-LS system, which is being employed by the United States Army. This system is planned as a mission capability package for the Littoral Combat Ship (LCS) and may have application in improving the self-defensive capability of the DDG-51 class destroyer.

The goal of this project is to analyze the installation and integration issues associated with the NLOS-LS system on-board DDG-51 class destroyers. Specifically, it is an analysis of the high level issues that have an impact on such an integration. It does not contain material on the mechanics of such integration. This material is covered in a separate report.

1. Background

The NLOS-LS program is a Defense Advanced Research Project Agency (DARPA) NetFires system focused on a new non-line-of-sight missile system to be used by the United States Army's Future Combat System (FCS). On 19 March 2004, a combined Raytheon and Lockheed Martin team was awarded a six-year contract worth \$1.1 billion on the System Design and Development (SDD) phase of the NLOS-LS.¹ While the NLOS-LS is already being developed for the U.S. Army, it is also being considered for joint service applicability with the U.S. Navy for inclusion on LCS and

¹ Global Security Website, "Non-Line-of-Site Launch System (NLOS-LS)", November 2005, www.globalsecurity.org/military/systems/munitions/net-fires.htm. access date on 6 Oct 2006.

other ship classes.² The U.S. Navy recently awarded a \$54.8 million contract to develop a NLOS-LS for the Navy LCS. The U.S. Navy expects to build in excess of 50 such ships, with the first ship being the USS Freedom, which is scheduled to be commissioned in fiscal year 2007. The NLOS-LS is also slated for integration on the USS Independence in 2008.³ It is this integration effort that gave rise to the concept of integrating the NLOS-LS onto the Aegis destroyer platform, which in turn resulted in this research project. The Naval Postgraduate School (NPS) in Monterey, California entered into a Cooperative Research and Development Agreement (CRADA) with Raytheon to analyze the issues associated with NLOS-LS integration onto DDG-51 class destroyers.⁴ NPS was tasked to explore the issues involved with installing and integrating the NLOS-LS system onto U.S. Navy platforms.

The main concept behind the NLOS-LS system is a vertically launched set of missiles with a command and control system combined together in a stand-alone box. It is designed to be platform independent, with a self-contained tactical fire control for remote or manned operations. Unlike normal cannon and other rocket artillery systems that depend on their specific launch platform, the NLOS-LS round in its launch canister are a complete entity. Figure 1 illustrates the NLOS-LS platform independence. In addition, the NLOS-LS has joint service applicability with the U.S. Navy for potential inclusion on LCS and Unmanned Surface Vehicles (USV) using weapon mission module concepts.⁵

² Lockheed Martin Website, "NLOS-LS", 2006, available from the internet , http://www.missilesandfirecontrol.com/our_products/firesupport/NLOS-LS/product-NLOS-LS.html, access date on 6 Oct 2006.

³ Lockheed Martin Website, "Precision Attack Missile (PAM)", 2004, available from the internet, <http://www.defense-update.com/products/p/pam.htm>, access date on 10 Feb 2007.

⁴ Standard Navy Cooperative Research and Development Agreement Between Naval Postgraduate School and Raytheon Company. Agreement No. NCRADA-NPS-05-0084, 7 Jan 2006, Page 41, Section 1.1.

⁵ Lockheed Martin Website, "NLOS-LS", 2006, available from the internet, http://www.missilesandfirecontrol.com/our_products/firesupport/NLOS-LS/product-NLOS-LS.html, access date on 6 Oct 2006.



Figure 1: NLOS-LS Platform Independence⁶. The flexibility of the launcher allows interoperability among various manned/unmanned platforms. The system can be launch on a M998 High Mobility Multipurpose Wheeled Vehicle (HMMWV) and deployable by a C130 aircraft.

2. Scope of the Project

The Statement of Work (provided as Appendix A-1) actually resulted in two projects. The project described by this report was focused on the high level issues associated with integration on a DDG-51 class destroyer. The second project is being performed by Naval Surface Warfare Center Port Hueneme Division (NSWC PHD) and focused on the low level issues such as sources for power and how and where connection boxes will be located.

Due to the fact that the NLOS-LS/DDG-51 study is an informal look (i.e., not formally sponsored by the Navy) at the issues associated with this concept, most of the literature available was obtained from the Internet. Also, because this is a new concept there is little in the way of a literature review from which to extend the concept. There

⁶ Netfires LLC, “Precise and Persistent Naval Fires Non-Line of Sight Launcher System (NLOS-LS)” Presentation, provided by Raytheon for the project.

is, however a solid body of material that described the integration process as well as the key components. This material is introduced at the relevant points in the analysis.

B. DESCRIPTION OF NLOS-LS

The physical components of the NLOS-LS consist of a family of missiles with a highly deployable, platform-independent Container Launch Unit (CLU) with self-contained tactical fire control electronics and software for remote and unmanned operations. The U.S. Navy version of the NLOS-LS consists of the Precision Attack Missile (PAM) and the CLU. The system, as designed today, is a box with sixteen sections. Fifteen of those sections hold missiles, while the last section contains the command and control unit. The missiles fire from the canister like the U.S. Navy's Vertical Launch System (VLS). Exhaust gases follow the missile out of the top of the launcher, so there is little impact on the surrounding area. Below are the system component descriptions of NLOS-LS.

1. Container Launch Unit (CLU)

The CLU is the physical structure that houses the missile All-Up-Rounds (AUR) and the Computer & Communication System (CCS). This equipment piece would be the physical item to be installed topside on the ship structure. The CLU contains a removable base assembly and a removable forklift structure for ease of maneuvering. The base unit is the means by which the PAM AUR and CCS communicate. This unit, once installed, could be removed or replaced with minimal effort. Each CLU contains fifteen PAM AURs and one CCS. A fully loaded unit would weigh approximately 3250 pounds and has dimensions of four feet by four feet by six feet. Figure 2 shows the baseline concept of the CLU.

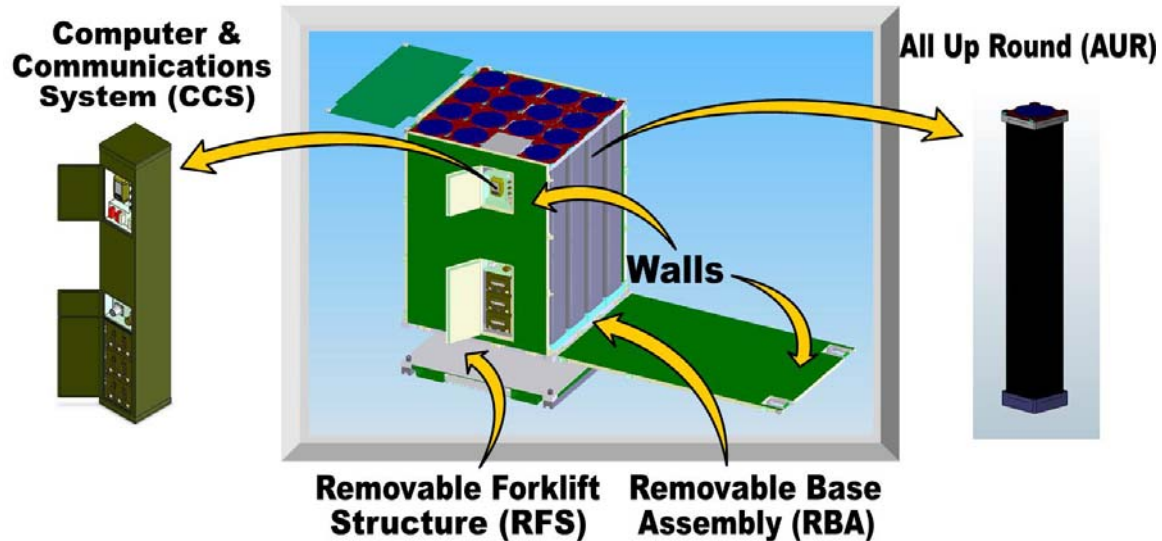

Figure 2: Container Launch Unit (CLU)⁷. The CLU has 15 canister missiles. Each CLU is self-contained with a communication system and a launch control systems.

2. Computer & Communication System (CCS)

The CCS is the heart of the NLOS-LS. This unit is the same size as one of the PAM AURs and fits into the CLU base as the AUR. This unit contains the means by which the PAM AUR is fired and updates the missile while in flight. It also provides the main interface to the NLOS-LS. The Army concept incorporates power into the CCS, which energizes the CCS functions as well as the firing signal to the missile. One CCS can interface with the fifteen PAM AURs in a single CLU.

3. Precision Attack Missile (PAM)

The PAM is a low-cost direct attack missile that is 7 inches in diameter, 60 inches long and weighs 117.5 pounds. It has a boost sustain rocket motor, dual-mode uncooled infrared/semi-active laser seeker, and a multi-mode warhead. Two-way data links on the PAM allow the missile to be re-tasked in-flight and to downlink images of targets. Figure 3 shows a pictorial description of the PAM.

⁷ Netfires LLC, "Precise and Persistent Naval Fires Non-Line of Sight Launcher System (NLOS-LS)" Presentation, provided by Raytheon for the project.

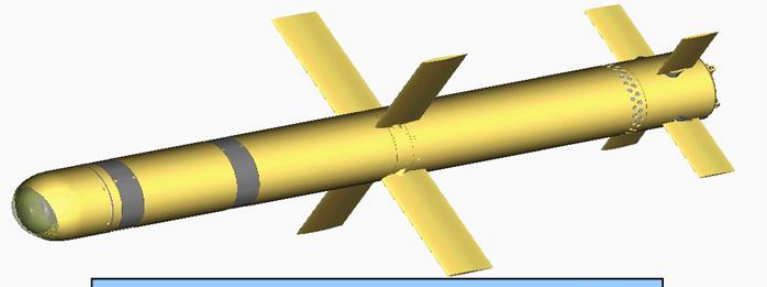

Precision Attack Missile (PAM)
60.3" Long; 7" diameter; 117.5 lbs
GPS/INS w/UCIIR and SAL

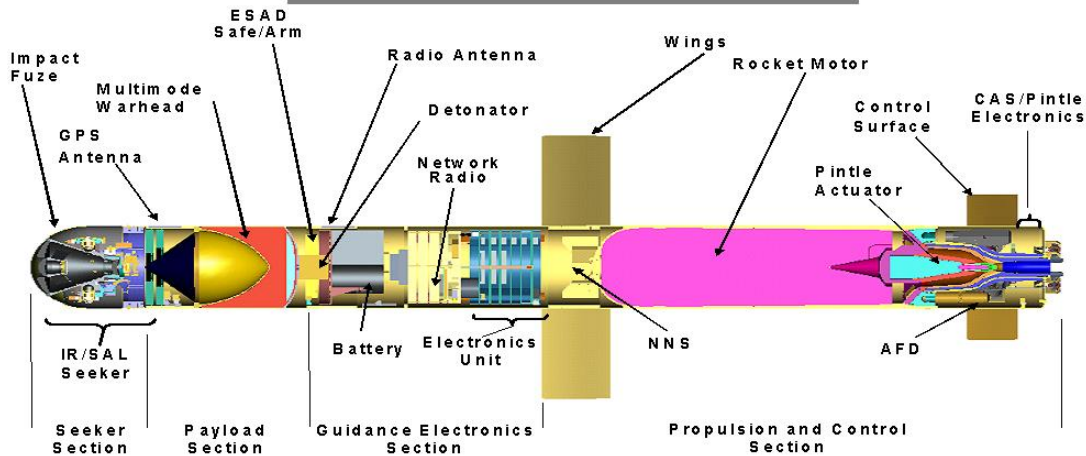

Figure 3: Precision Attack Missile (PAM)⁸. The PAM consists of a variable thrust motor, dual-mode precision uncooled infrared/semi-active laser seeker and a large multimode warhead effective against both moving and stationary targets.

The PAM consists of four major sections: seeker, payload, guidance electronics, and propulsion and control. The Seeker section holds the impact fuze and Infrared/Semi-active Laser (IR/SAL) seeker. Impact fuze ignites the multimode warhead on impact. Figure 4 shows the seeker of PAM in U.S. Navy concepts. The Payload section consists of the GPS Antenna and Multimode Warhead. The Guidance Electronics section house all electronic communication, guidance, and detonation. The last section of the PAM provides the propulsion and control.

The weapon system uses a "soft launch concept," meaning that the missile does not encounter the high g-forces and acceleration that artillery shells and most missiles

⁸ Netfires LLC, "NLOS-LS (PAM/CLU) Accelerating Capability To the U.S. Navy" Presentation, provided by Raytheon for the project.

experience when traveling at high speeds.⁹ The launch impact to the deck of the ship can be considered to be much less than other missile systems on-board.¹⁰ Initially, there is just enough force to get the missile out of the box and move it upward.

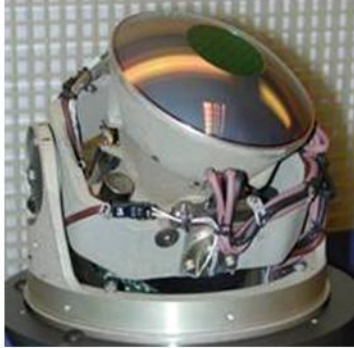

**SAL/UCIR
(320 x 240 Array)**



**Multi-Mode
Target Acquisition
Capability**

Figure 4: U.S. Navy PAM Seeker Capability¹¹. The PAM consists of a variable thrust motor, dual-mode precision uncooled infrared/semi-active laser seeker and a large multimode warhead effective against both moving and stationary targets. UCIIR begins acquisition process at 4.4 nautical miles.

4. System Performance

Currently, the NLOS-LS is in the System Development and Demonstration phase for the Army. Prior to this, the DARPA program completed a successful flight test program. The successful completion of the guided flight-tests show that PAM has the capability to be used against moving and stationary heavy armor and soft targets ranging from 0.5 to 40 kilometers. Moreover, during testing the PAM's ability to receive target location updates while in flight was validated. The PAM Semi-Active Laser (SAL)/Infrared (IR)/Moving Target Indicator (MTI) seeker demonstrated the capability to search and track land and sea targets during the terminal portion of the flight and make

⁹ Global Security Website, "Non-Line-of-Site Launch System (NLOS-LS)", November 2005, <http://www.globalsecurity.org/military/systems/munitions/net-fires.htm>, access date on 6 Oct 2006.

¹⁰ Netfires LLC, "Precise and Persistent Naval Fires Non-Line of Sight Launcher System (NLOS-LS)" Presentation, provided by Raytheon for the project.

¹¹ Netfires LLC, "NLOS-LS (PAM/CLU) Accelerating Capability To the U.S. Navy" Presentation, provided by Raytheon for the project.

final corrections for the PAM to hit the target during DARPA missile tests, as shown in Figure 5.

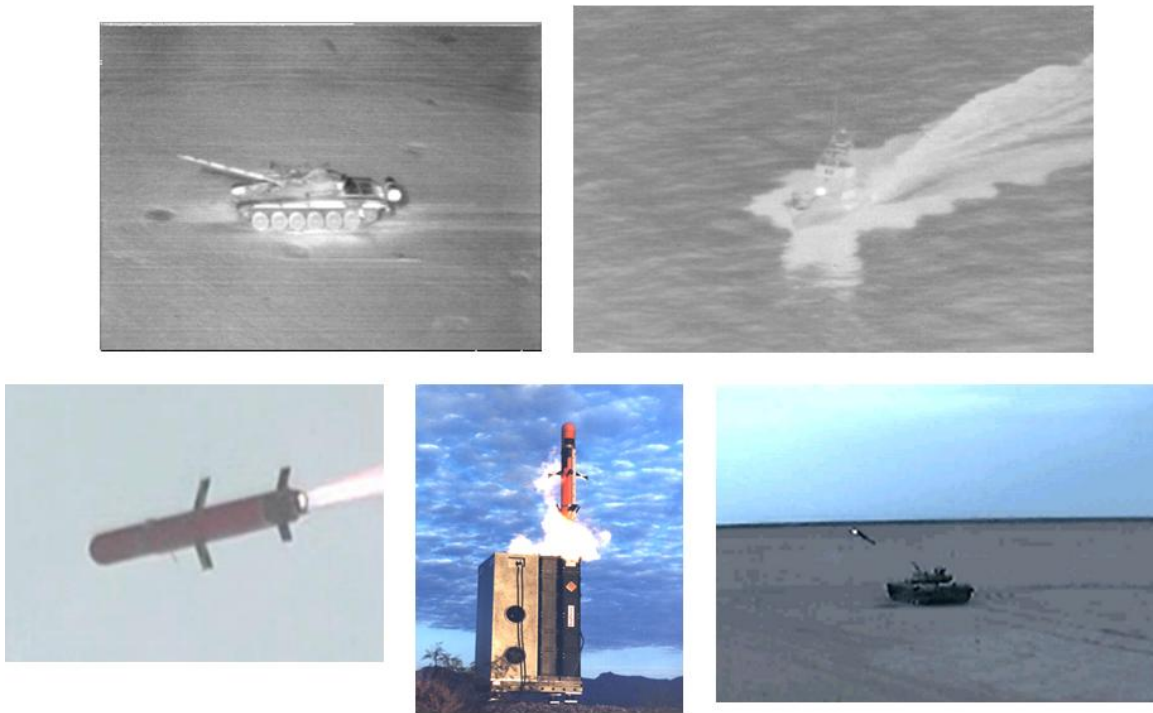

Figure 5: DARPA Tests¹². Multiple tests were conducted to illustrate the seeker capability to search and track land targets (T-90 tank) and sea targets (Riverine Assault Craft).

The PAM is armed with a large multimode warhead and is used primarily as an anti-armor weapon. The warhead consists of a stainless steel case filled with explosive. The warhead case incorporates the joints for mechanical connection to the Seeker Section and Guidance Section. When assembled, the warhead is 8 inches in length. The warhead houses the safety arming device and a fuze booster. It utilizes an initiation system compatible with the explosive output. The fuze booster starts the detonation of the warhead. When detonated, the warhead expands and breaks into controlled shape fragments. Figure 6 illustrates the description and effectiveness of the baseline warhead for the PAM.

¹² Netfires LLC, “NLOS-LS (PAM/CLU) Accelerating Capability To the U.S. Navy” Presentation, provided by Raytheon for the project.

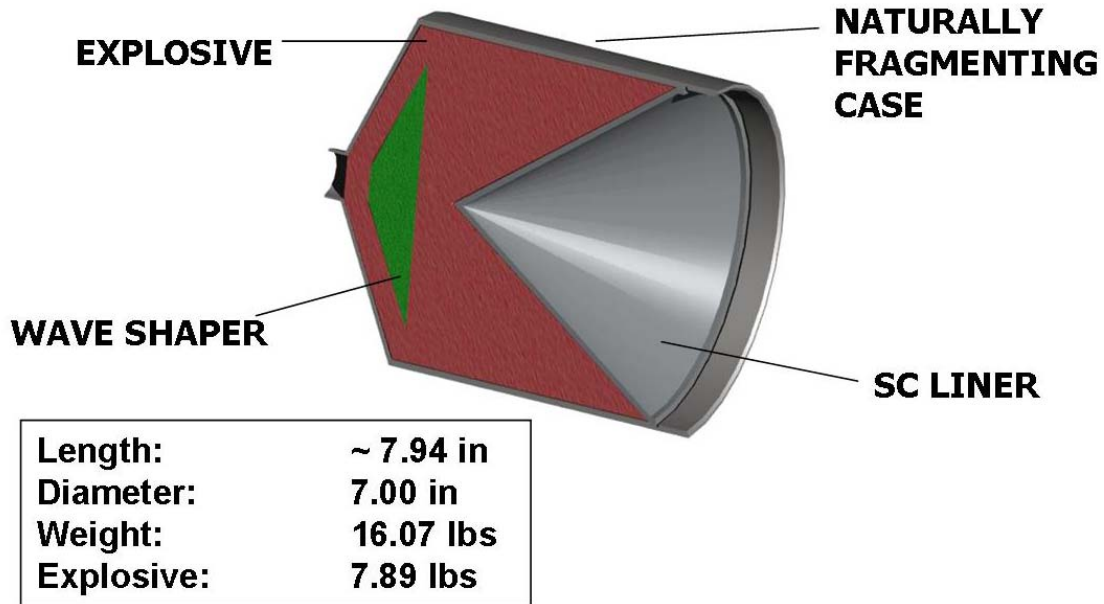

Figure 6: PAM Baseline Warhead¹³. The front of the warhead attaches to the guidance section, the aft attaches to the seeker section. This warhead consist of PBXN-9 billet explosive, copper liner, aluminum retaining ring, syntac 350 wave shaper, 1020 steel body, ULTEM IM FI Barrier, ULTEM Boat tail, Aluminum ESAD fixture, Nylon PIC spacer, and CRES/ PBX-5 PIC.

The U.S. Navy conducted a test with the PAM warhead against an unconventional small surface craft. The test was conducted with a Riverine Assault Craft (RAC) as a target. This aluminum hull craft is 9 foot wide, 35 foot long with a twin engine and a weapons station on-board. Figure 7 shows images of the target after the impact of the PAM baseline warhead. The hull damage on the left side was a 36” tear in the hull skin and the right side panel bowed out 8”. As evidenced by the pictures, the relatively small PAM missile generated considerable damage. However, this was a static test with the warhead mounted in the boat.

¹³ Netfires LLC, “NLOS-LS (PAM/CLU) Accelerating Capability To the U.S. Navy” Presentation, provided by Raytheon for the project.

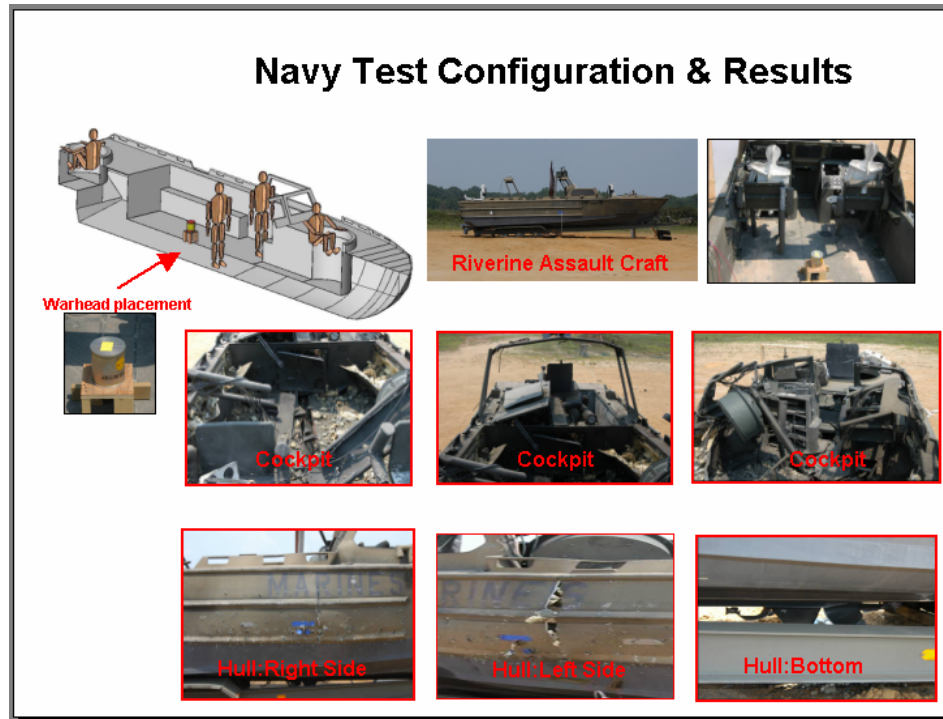

Figure 7: U.S. Navy PAM Test Results⁷. A PAM baseline warhead was placed inside the RAC to test the effectiveness and lethality of the PAM

The performance of PAM can be enhanced by use of a fragmentation warhead operating in an air burst mode. Each warhead would generate approximately 9,077 of high velocity fragments dispersed over a lethal area approximately of 1600m² giving it the capability to engage multiple targets. Appendix B shows the calculation for this PAM baseline warhead. The scenario of multiple small boats arriving in a chevron formation illustrates the overall engagement capabilities. The NLOS-LS system response against these simultaneous threats is shown in Figure 8. The NLOS-LS can assign each PAM to specific threats during target acquisition. The threat formation is nine targets in a chevron formation with each threat spaced 30 degrees apart from each other.

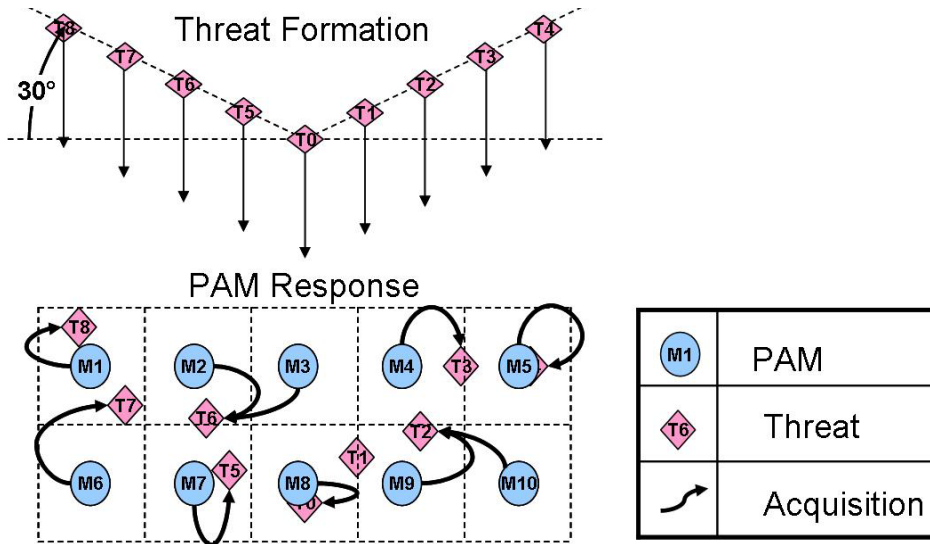
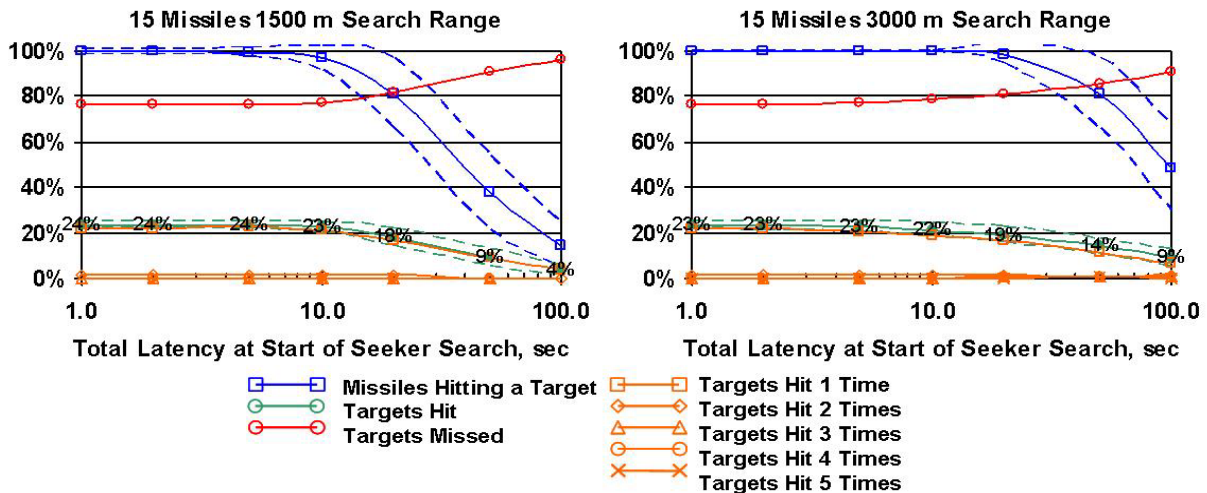

Figure 8: NLOS-LS Threat Methodology¹⁴. The PAM Response illustrates the pattern that each PAM can utilize each assigned target.

Figure 9 presents the results of 15 PAM missiles used against 60 targets arriving in multiple chevron formations or 1500 and 3000 meter search ranges. The probability of kill remains relatively high, despite the swarm attack against a single ship. The analytic results are that the integration of the NLOS-LS onto U.S. Navy ships will improve the surface ship’s defense capability.



(solid lines represent mean; dotted lines represent 1 sigma error)

Figure 9: Single Container Launch Unit (CLU) vs. 60 Targets¹⁴. The two graphs are the results from a Raytheon presentation LCS versus 60 targets.

¹⁴ Netfires LLC, “NLOS-LS (PAM/CLU) Accelerating Capability To the U.S. Navy” Presentation, provided by Raytheon for the project.

C. CONCEPT OF OPERATION (CONOPS)

The operational concept of the NLOS-LS system is to provide precision non-line of sight fire for ships against unconventional small surface forces. The NLOS-LS is designed to overcome large Target Location Errors (TLEs) which allows it to differentiate between the actual location of the target versus the expected location. The PAM has laser-designated and autonomous operation modes and transmits near-real-time information in the form of target imagery prior to impact. In addition, NLOS-LS has the capability to kill hard targets with armored plating and soft targets with light armor that can be both moving or stationary out to forty kilometers. A secondary goal is to provide the U.S. Navy with rapid response and lethality in packages requiring, fewer personnel, less logistical support, and lower life cycle costs. The idea of this joint procurement of NLOS-LS by the Army and Navy is to provide better interoperability, command and control, and mutual support between land and sea forces within littoral regions.¹⁵

Below are descriptions of both the Army and Navy CONOPS. The Army CONOPS is provided as a baseline. Because the U.S. Navy is leveraging off of the Army's system, the Navy CONOPS is similar but modified for a maritime application.

1. U.S. Army NLOS-LS CONOPS

The Army's Future Combat System (FCS) is integrating NLOS-LS into different launch configurations. The NLOS-LS unique configuration allows it to be mounted on a HMMWV, truck, or placed on the ground. NLOS-LS is designed to provide responsive, networked, extended-range targeting and precision attack of armored, lightly armored and other stationary and moving targets during day/night and near all weather conditions. The NLOS-LS provides support to ground forces, particularly in the conduct of extended-range and non-line-of-sight engagements. Figure 10 shows the Army's concept of operations for the NLOS-LS precision engagement capability.

¹⁵ Emerson, Laflamme, and Cunningham. *NLOS Systems for the modular and Future Forces*, Field Artillery, Nov-Dec 2004, page 7-11.

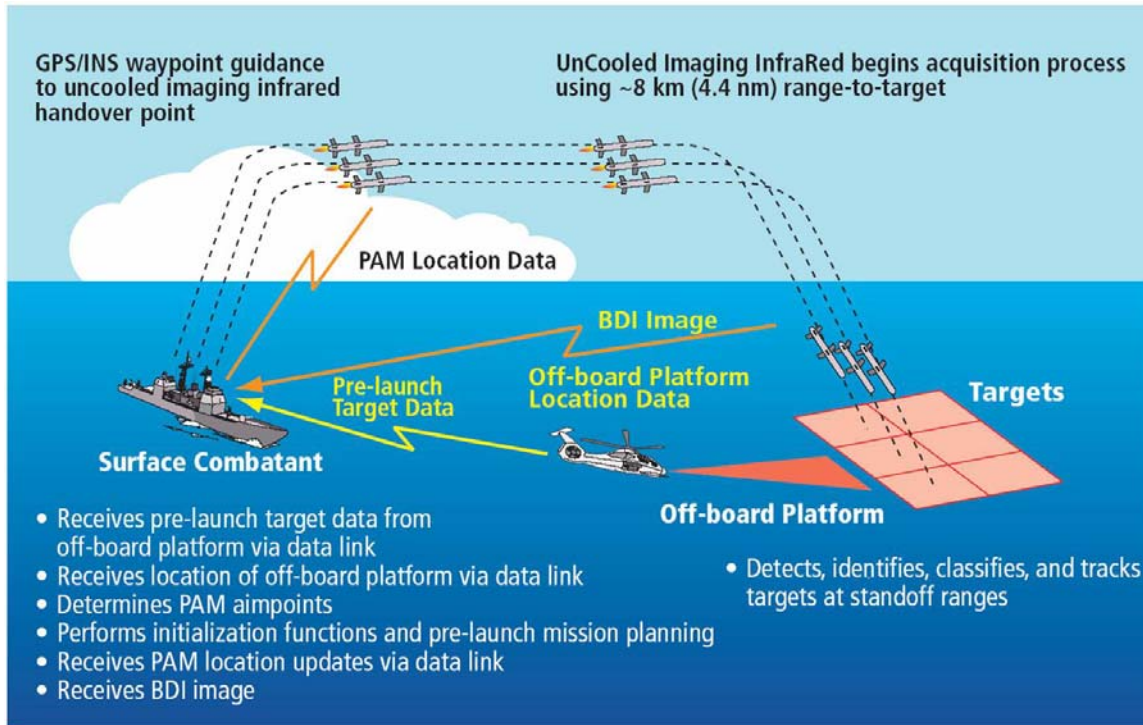

Figure 11: OV-1 Diagram for U.S. Navy¹⁷. During the PAM in flight, the PAM sends health and status, and battle damage imagery back to the platform. The MH-60 provides target location back to the platform.

The goal of NLOS-LS is to provide a commander with rapid fire support on surface targets, given the appropriate real-time sensor data and control. The PAM is a direct attack missile suitable for use against moving and stationary targets at ranges from zero to forty kilometers. The missile includes a networked data link that provides in-flight updates with sea, ground and airborne sensor nodes and has a multi-mode warhead designed to be used against both hard and soft targets¹⁸. Retargeted missions are typically planned and executed in tactical situations against emerging targets. A retargeted mission occurs as a result of revised tactical priorities or from updated tactical

¹⁷ Raytheon website, “Non-Line of Sight-Launch System (NLOS-LS) Product Data sheet”, 2006, available from the internet, http://www.raytheon.com/products/stellent/groups/public/documents/content/cms01_055756.pdf, access date on 24 Oct 2006.

¹⁸ Spacewar website, “NetFires Conducts Navy Ballistic Flight Test For NLOS-LS Missile”, Staff Writer, 29 March 2006, available from the internet, http://www.spacewar.com/reports/NetFires_Conducts_Navy_Ballistic_Flight_Test_For_NLOS_LS_Missile.html, access date on 6 Oct 2006.

information. This information is normally developed using target information provided by external sources. The “in-flight retargeting” capability redirects a PAM missile from an existing action point to a new aim point.¹⁹

¹⁹ *OD 63835 Attack Weapon Control System Concept of Operations*, Strategic System Program, April 1, 2003.

THIS PAGE INTENTIONALLY LEFT BLANK

II. APPROACH

A. OVERVIEW

This section lays the groundwork for integrating the NLOS-LS onto the DDG-51 class destroyer. The Vee-Model illustrated in Figure 12 was used as a general systems engineering approach and adapted to fit this project.²⁰ After understanding the customer's needs as the input to the process, an approach was developed to facilitate the integration into the combat system and physical installation. The steps in green shown in Figure 12 represent this integration and installation effort. In addition, the current integration effort for the LCS was studied and evaluated for applicability to the DDG-51 problem. The take away was the potential value of the Module Engagement Control (MEC) as an interface between the AEGIS weapon system and the NLOS-LS. All other development considerations were specific to the LCS only.

Next, the DDG-51 ship systems were researched. In order to install and integrate the NLOS-LS, one must know what already exists. These systems were then identified and researched. In general, NLOS-LS requires sensor inputs, communication links, data interfaces, and locations for the system components. With the ship support elements identified, a list of integration issues was developed.

This was followed by an analysis on how to install and integrate the NLOS-LS. The analysis is presented in Section III. Section IV provides the recommendations and outlines future work and analysis that need to be completed.

²⁰ Buede, Dennis M. *The Engineering Design of Systems- Models and Methods*, New York, NY: John Wiley & Sons, Inc. 2000, pg 8.

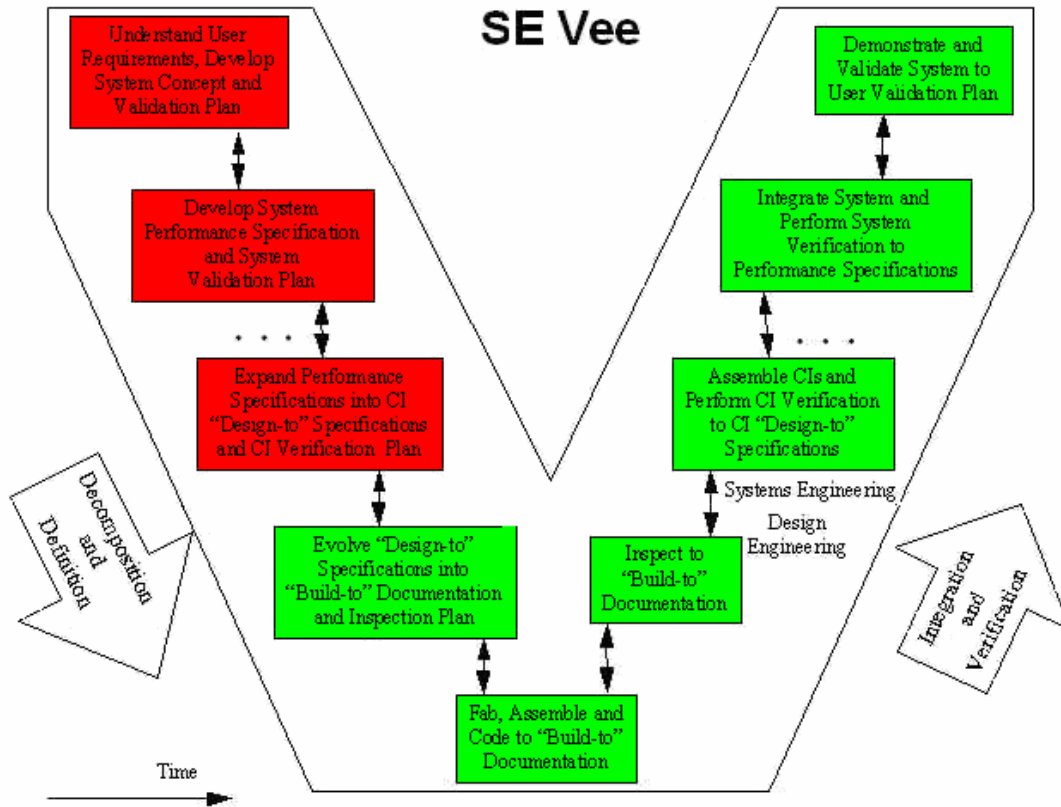

Figure 12: System Engineering Vee Model²¹. This widely used model provided a general systems engineering approach and was adapted to fit this project.

The Fleet Modernization Program (FMP) Manual²² is a guide by which to implement Proposed Military Improvements (PMI) on-board U.S. Navy ships. With this as a guide the Functional Flow Block Diagram (FFBD) in Figure 13 steps through the sequence necessary to install and integrate the NLOS-LS. This approach was chosen since it has been proven to be mature and has been used at Port Hueneme for past U.S. Navy systems. Most of the analysis conducted focused heavily on blocks 1.0 through 5.0. The remaining blocks cover the physical installation, which is beyond the scope of this study.

²¹ Forsberg K., & Mooz, H., The Relationship Of Systems Engineering To The Project Cycle, *Engineering Management Journal*, Vol. 4, No. 3 September 1992, pp. 36-43.

²² *Fleet Modernization Program Management and Operations Manual – Revision 2*, Commander, NAVSEA Systems Command, 10 June 2002.

NLOS-LS Installation Functional Flow Block Diagram

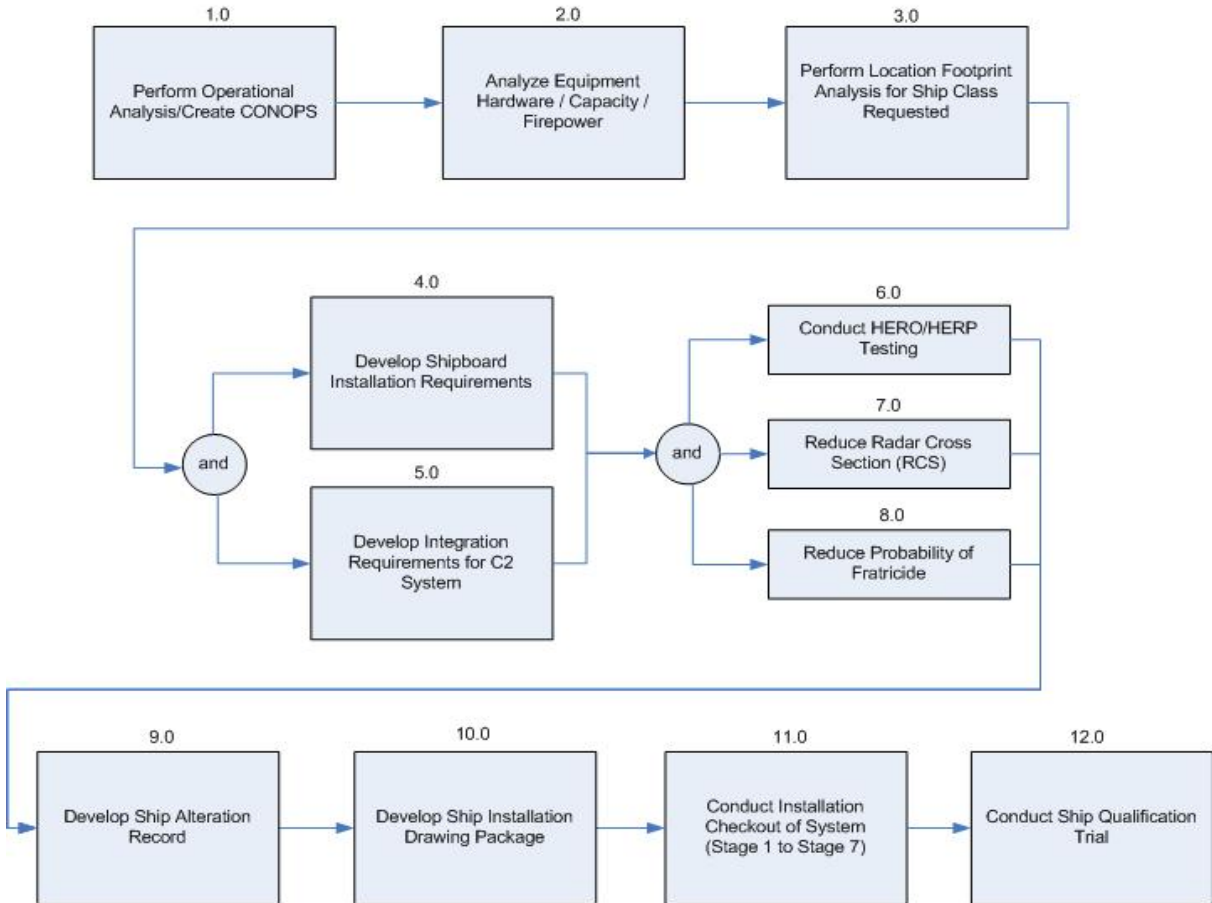

Figure 13: NLOS-LS Installation and Integration Functional Flow Block Diagram (FFBD). This FFBD steps through the functions necessary to install and integrate the NLOS-LS onto a ship.

B. LCS RELATED WORK

The U.S. Navy has shown its interest in extending the potential of NLOS-LS to other platforms as a result of the planned integration into LCS. LCS is a member of the family of future surface combatants and plays an integral role in the SEA SHIELD component of SEA POWER 21, which is the projection of defensive power from the sea.

The first fielding date for the NLOS-LS for the Navy is projected to be in July 2007 on-board the LCS Flight 0.²³

The integration of NLOS-LS into the LCS surface warfare (SuW) mission package testing occurred between August 2005 and February 2006. A series of warhead characterization tests were conducted from August to September of 2005 to assess the damage of the PAM surrogate warhead against test targets in littoral environments. At the end of September 2005, the tests were conducted to demonstrate and evaluate the Semi-Active Laser (SAL)/Uncooled Infrared (IR) Imager, Real-Time Address Translation Agent (ATA) and handoff to an IR Tracker, and Moving Target Indicator (MTI) mode of operation of the PAM seeker in a naval littoral environment. On 17 November 2005, a set of tests demonstrated the PAM rocket motor's ability to safely extinguish on command by rapidly decreasing the internal motor pressure to prevent propellant burn and keep the motor from reigniting. The final integration tests were conducted on 16 February 2006. These tests showed the safe vertical launch and fly-out dynamics of the PAM from the launcher in motion. Also demonstrated during these tests was the integration of the CLU simulator with the prototype naval command and control (C2) system.²⁴

The results of these tests successfully illustrated the NLOS-LS capability to provide beyond line of sight precision attacks against LCS threats in the littorals. These results can be used show how NLOS-LS would enhance the capabilities of the DDG-51 class ships. This study will concentrate on discussing the issues involved with physically integrating the NLOS-LS system onto the DDG 51 class. Unlike the LCS class ships which are still in the design and production phases, the DDG-51 class ships which are already designed, built, and commissioned will have a different set of integration issues that must be resolved. This means that it is much more difficult to add systems onto the DDG-51 class than it is for the LCS class.

²³ Raytheon Missile Systems, *NLOS-LS Integrated Logistics Strategy Report Rev. A* (Document No. 2259985), Tucson, AZ, September 2005, pg 2.

²⁴ Naval Surface Warfare Center (Dahlgren Division), "*NLOS-LS, 30mm Gun Weapons System, and SUW Mission Module, Test and Evaluation Status and Path Forward*", presentation, provided by Paul Lefeave, March 17, 2006.

III. ANALYSIS

A. INTEGRATION ISSUES

The integration issues from the CRADA in Appendix A and system integration analysis that need resolution before installation onto naval ship platforms are listed below:

| Combat System Integration | Physical Installation |
|--|---|
| <ul style="list-style-type: none"> • Interface analysis to existing ship systems • Interfaces analysis internal to NLOS-LS • NLOS-LS functional analysis • NLOS-LS system behavior | <ul style="list-style-type: none"> • Location/Footprint of NLOS-LS system components • Blockage Zones • Blast Effects • Environmental Effects • Stabilization • Electromagnetic Environmental Effects • Radar Cross Section • Fratricide • Safety • CIC Integration • NLOS-LS physical cabling connections to include power, ship navigation, alignment data, command and control, and communications (both internal and external) |

B. COMBAT SYSTEM INTEGRATION

The ship has an existing organization and framework and it is necessary to understand how different components work together. Figure 14 was developed to illustrate the interfaces involved with the NLOS-LS system. This entity model provided a generic picture of how the different DDG-51 systems and NLOS-LS components interact with each other and served as a background for the analysis. From here, the installation and integration interfaces were generated.

NLOS-LS Entity Model

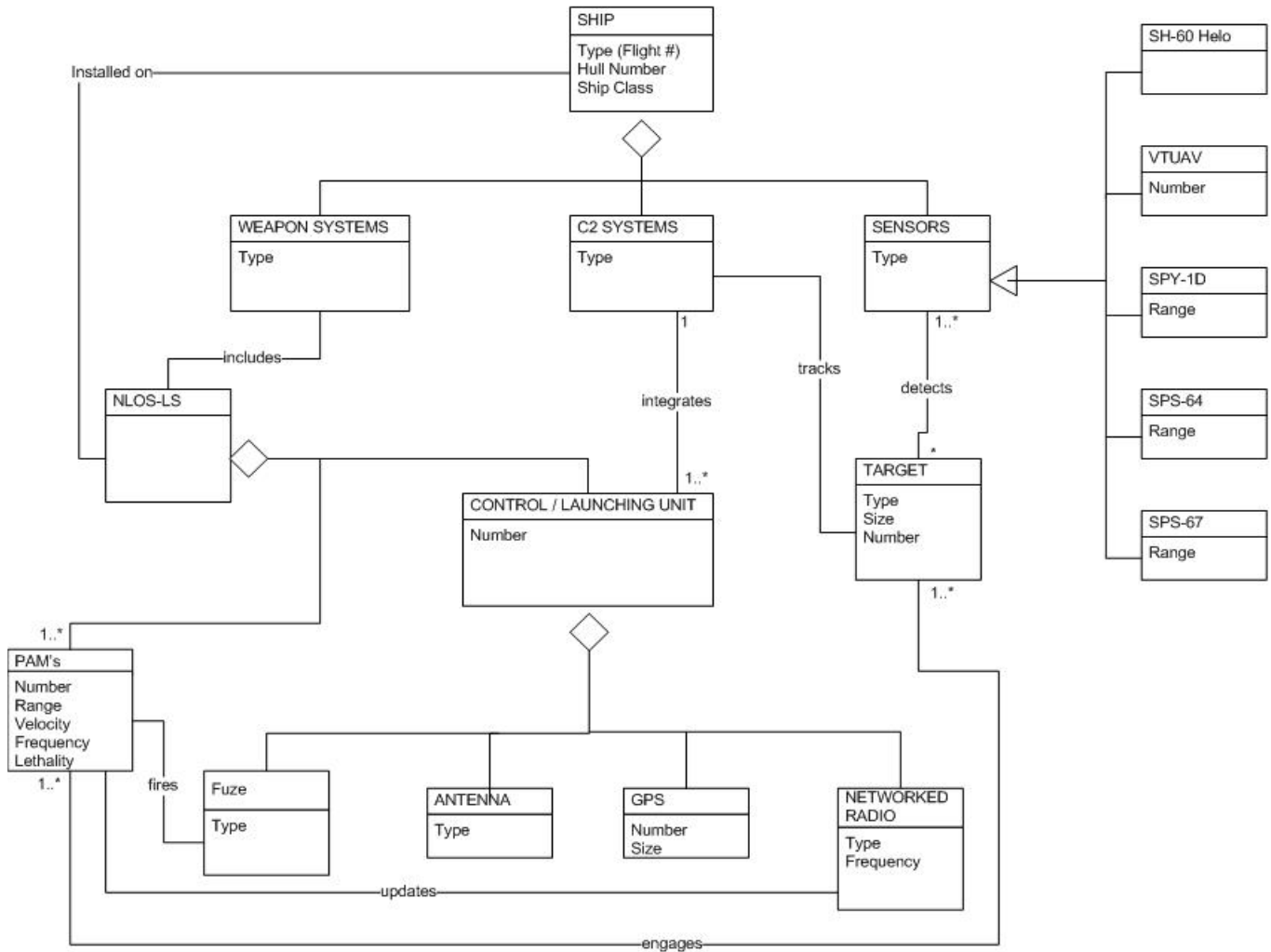

Figure 14: NLOS-LS Entity Model. This model gives a visualization of the interfaces with NLOS-LS and the ship framework.

1. NLOS-LS Interfaces

In order to integrate NLOS-LS, the following combat system elements need to be accounted for:

- AN/SPY-1D Radar
- AN/SPS-67 Radar
- Command and Decision System (C&D)
- Weapons Control System (WCS)
- Gun Fire Control System

- Vertical Launching System
- Tomahawk
- Harpoon
- Phalanx

The AWS element interface illustrated in Figure 15 shows a notional concept of how NLOS-LS fits in the complement of weapon systems in the Aegis suite.

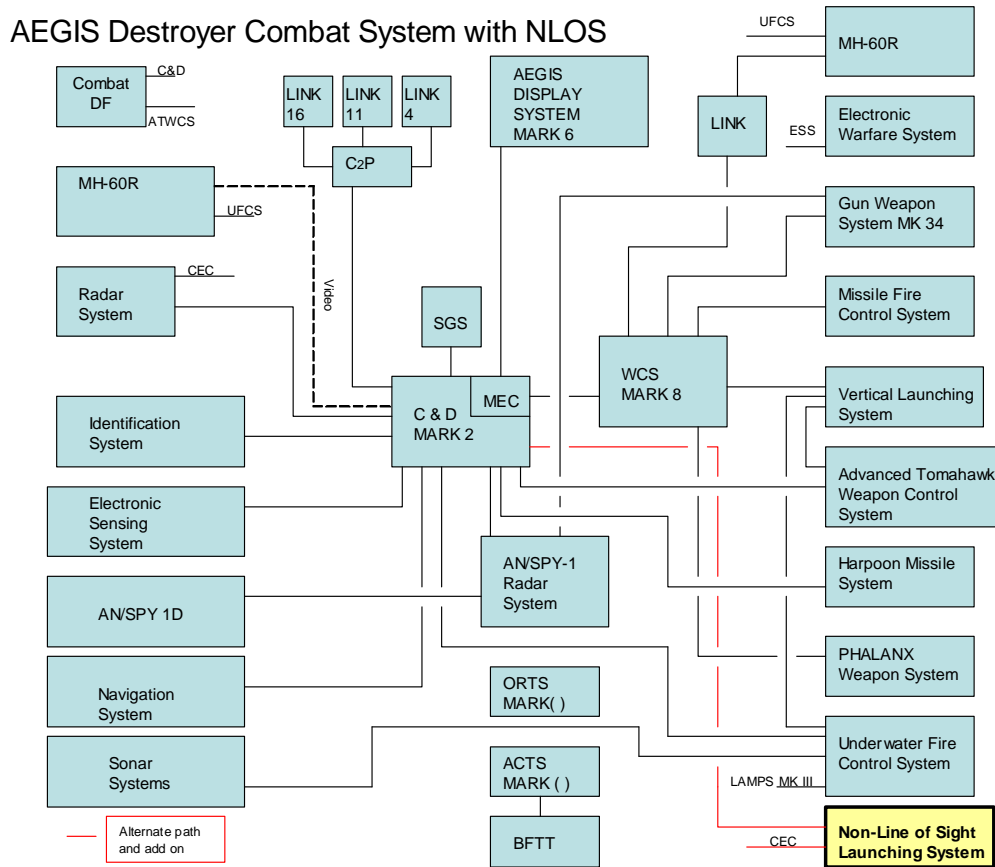

Figure 15: Aegis Weapon Interfaces. The AWS element interface shows a notional concept of how NLOS-LS fits in the complement of weapon systems in the Aegis suite.

There are three sources within the Aegis Weapon System (AWS) that can provide targeting data for NLOS-LS:

1. Cooperative Engagement Planner (CEP): Requires an extra stage to interface and perform data translation.
2. Weapon Control System (WCS): Entails extensive integration with the existing weapon system data sources on-board the DDG-51.

3. Command & Decision (C&D) Data line: Taps into available information, in an appropriate format, and has an appropriate bandwidth.

The Command and Decision (C&D) element is the core of the AWS as shown in Figure 16. It is this targeting data source that makes Aegis capable of simultaneous operations against the following multi-mission threats: anti-air, anti-surface, and anti-submarine warfare.

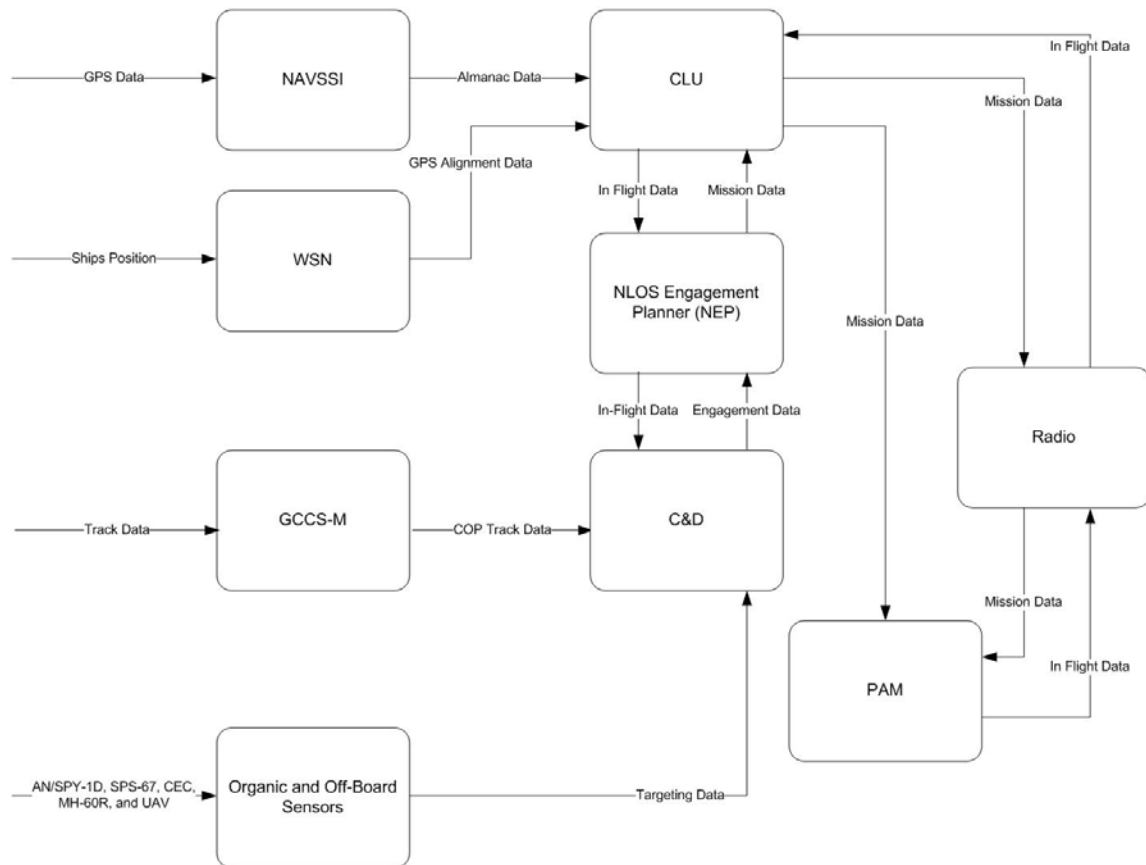

Figure 16: NLOS-LS Overview Diagram. This diagram was created to show the system element interfaces between NLOS-LS and the AWS.

Figure 16 drills down one level deeper and looks at the system-to-system level interfaces between NLOS-LS and AWS. The NLOS-LS interfaces are defined as follows:

- NLOS-LS to AWS – provides two-way data communication from the AWS to the console in CIC.

- NLOS-LS CIC console to CLU – provides a two-way interface to the CLU, to control and monitor missile launch and support maintenance and training operations.
- CLU to Radio – provides a two-way interface to receive and transmit communication information.
- Radio to PAM – provides updated targeting data to in-flight missile and missile position data while in flight.
- Organic and Non-Organic Sensors track data to AWS – provides new target location or updated target information to ship.
- Ship Systems to CLU – provides NLOS-LS with data for system operations.

The NLOS-LS, as integrated into the DDG-51 class destroyer, consists of the following subsystems: CLU, PAM, NAVSSI, WSN, Radio System, and NLOS-LS Engagement Planner. NLOS-LS receives and processes calls for fire and mission data from C&D and provides monitoring and control of the missile launch sequence for the PAM. The CLU provides two-way communication to the PAM via the NLOS Radio to provide real-time targeting data. In addition, the CLU provides the support for the operation by preparing the launch of the PAM. The CLU provides the interface to the fifteen PAMs. The PAM receives targeting information prior to launch. While in-flight, the PAM can be updated and respond to an updated target location. Furthermore, prior to impact, the PAM can transmit near-real-time target imagery data back to the ship.

The system interfaces to the NLOS-LS provide the necessary data in order for NLOS-LS to function. Below are descriptions of the different systems that NLOS-LS may interface with.

a. Organic and Off-Board Sensors

DDG-51 class destroyers are equipped with several organic and off-board sensors such as AN/SPY-1D Radar, AN/SPS-67 Radar, the Cooperative Engagement Capability (CEC), MH-60R LAMPS MK III Seahawk helicopter, and Unmanned Aerial Vehicles (UAV) such as Fire Scout. These sensors provide the DDG-51 class destroyer with the ability to search, detect, and track targets with various ranges. The capabilities of these sensors are as follows:

- **AN/SPY-1D Radar system** is used as a primary air and surface radar for the Aegis Combat System for the DDG-51 class ships. It is a multi-function phased-array radar capable of search, automatic detection, transition to track, tracking of air and surface targets, and missile engagement support. Its use as a sensor will be restricted to the radar horizon. By using a simple computation from the EW Handbook²⁵ (see Appendix D), and assuming a radar height of 60 feet and a target height of 5 feet, the SPY radar horizon is 22.7 kilometers. Because NLOS-LS has a maximum range of forty kilometers, the AN/SPY-1D has limited utility.
- **AN/SPS-67** is a short-range, two-dimensional, surface-search/navigation radar system that provides highly accurate surface and limited low-flyer detection and tracking capabilities. The AN/SPS-67 provides excellent performance in rain and sea clutter, and is useful in harbor navigation, since the AN/SPS-67 is capable of detecting buoys and small obstructions without difficulty. The transmitter/receiver is capable of operation in a long (1.0 sec), medium (0.25 msec), or short (0.10 msec) pulse mode to enhance radar performance for specific operational or tactical situations. The AN/SPS-67 is located at the top of the forward mast and has an operating range of 35 nm or 65km.²⁶
- **Cooperative Engagement Capability (CEC)** is a system that allows the sharing of sensor data among ships. CEC is capable of using a line-of-sight data distribution system to transmit sensor data from individual ships of a Battle Group to other ships in the group. With these capabilities, an individual ship can launch an anti-air missile at a threat aircraft or anti-

²⁵ Naval Air Warfare Center, Weapons Division, *Electronic Warfare and Radar Systems Engineering Handbook*, NAWCWPNS TP 8347: Naval Air Systems Command, 1 April 1997.

²⁶ Harpoonhq Website, "CG 16 Leahy (1987/NTU)", 1987, available from the internet, http://www.harpoonhq.com/encyclopedia/HTML_Files/Ships/249.htm, access date on 4 March 2007.

ship cruise missile within its engagement envelope, based on track data relayed to it by another ship. It is reasonable that this system may have utility as a sensor source for NLOS-LS. A detailed evaluation is warranted but is beyond the scope of this study.

- **MH-60R** helicopters counter the anti-surface threat by serving as a forward-looking, off-board system. The MH-60R, when configured for the anti-surface mission, has the capability to counter surface threats. To locate, shoot, and survive against such threats, the MH-60R will be equipped with a multi-mode radar, Forward Looking Infrared (FLIR) sensor, Electronic Support Measures (ESM) system, a retrievable, low frequency sonar with advanced signal processing, and an integrated self-defense system. With the enhanced command and control and situational awareness provided by its Link 4, 11, and 16 interfaces, the armed MH-60R can be a viable data source and provide initial and follow-up threat updates to execute far-ranging search and destroy missions. Facilitated by a 3.5 hours maximum time on station, the MH-60R will be capable of reaching ranges at which surface threats are projected to be located.²⁷



Figure 17: MH-60R. MH-60R helicopters counter the anti-surface threat by serving as a forward-looking, off-board system.

²⁷ Deagel Website, “MH-60R STRIKEHAWK-MULTI-MISSION NAVAL HELICOPTER, USA”, 2006, available from the internet, <http://www.deagel.com/pandora/index.aspx?p=pm00101010>, access date on 6 Oct 2006.

- **Unmanned Aerial Vehicles (UAVs)** are used for both attack and reconnaissance missions. It helps commanders at different echelons to know what is on or approaching the battlefield before their forces get there, and employ forces and weapon systems more efficiently as the result of precision targeting and Battle Damage Assessment information.²⁸ UAVs are potential off-board sensors but further technological development is required before they are a feasible data source.

NLOS-LS requires a sensor that can provide the ship with the capability to search, detect, and track numerous targets simultaneously over the horizon. UAVs can potentially provide the forward-looking target data for over the horizon threats.

b. Navigation Sensor System Interface (NAVSSI)

The NAVSSI system consolidates all navigation data from the Inertial Navigation System (INS) AN/WSN-7. NAVSSI also receives Global Positioning Signal (GPS) satellite data for ship position. This information is then distributed to combat systems throughout the ship. It currently aids weapon systems, such as Tomahawk, in the location and acquisition of target tracks to be designated. Due to the PAM already having its own GPS information, NAVSSI could provide a redundant source in the event that information is lost or inaccurate.

c. Global Command and Control System-Maritime (GCCS-M)

For planning purposes, the GCCS-M can provide C&D with a Common Operational Picture (COP) of the current situation. This COP allows the user to see all friendly, neutral, and hostile tracks. The C&D can utilize GCCS-M to receive, process, display, and manage data on the readiness of neutral, friendly, and hostile forces. It also can provide a tactical picture to plan and help execute NLOS-LS missions.

d. Inertial Navigation System (INS) AN/WSN-7

²⁸ FAS Website, "UAV Annual Report FY1996", 6 November 1996, available from the internet, <http://www.fas.org/irp/agency/daro/uav96/page35.html>, access date on 8 Nov 2006.

The INS AN/WSN-7 is a navigation system that continuously updates the ship's navigation data by referencing the meridian and zenith. Duplicate systems on ships generally provide the necessary redundancy to provide ship information such as roll, pitch, and heading. This system is another alternative for the CLU to receive information to pass to the PAM. The benefit of using GPS data is in the ability of operating worldwide with no time-delay in updates.

e. Cryptographic Key (CYZ-10)

The CYZ-10 is currently used to load cryptographic keys into different systems like Tomahawk and the KG-84 communication security device. The NLOS-LS Radio could use this cryptographic key to load two weeks of the most current GPS update information into the NLOS-LS unit. Two weeks of cryptographic data are needed in the event that the system is operational between two consecutive weeks as the cryptographic keys used to access GPS satellites changes weekly. The NLOS-LS can use the GPS data to provide missile position updates to the CCS. NLOS-LS can download the GPS cryptographic data to the missile prior to launch so that the missile's GPS receiver can acquire GPS data. During a missile power-up, the NLOS-LS can load the GPS data into the CCS for missile alignment. Further research needs to be done to determine the feasibility of using the CYZ-10. Another solution would be to use the cryptographic key planned for the LCS integration. No specific key has been identified as part of the LCS development, just that one would be used.

f. Module Engagement Control (MEC)

The MEC is currently planned for the LCS design and does not currently exist. It is envisioned that the MEC will have the capability to task NLOS-LS or other weapon systems to engage hostile targets. The concept calls for the MEC to contain targeting data from internal or external sensors, as well as to integrate tactical information, mission planning data, weapon scheduling and engagement data.

Figure 18 demonstrates the steps to schedule an engagement in order to select the proper weapon system and be designated in control. This is a process to ensure

that all other weapon systems on-board will not engage at the same time as the NLOS-LS. This prevents the possibility of a mid-air collision or destruction of the PAM during its initial launch stage. It also ensures that the NLOS-LS is in the “make ready” state to Aegis and the other weapon systems. The MEC concept could be integrated with the C&D of the AWS. This concept of integrating and using the MEC on Aegis ships is another area requiring further analysis.

*Lower Level Diagram 5.0

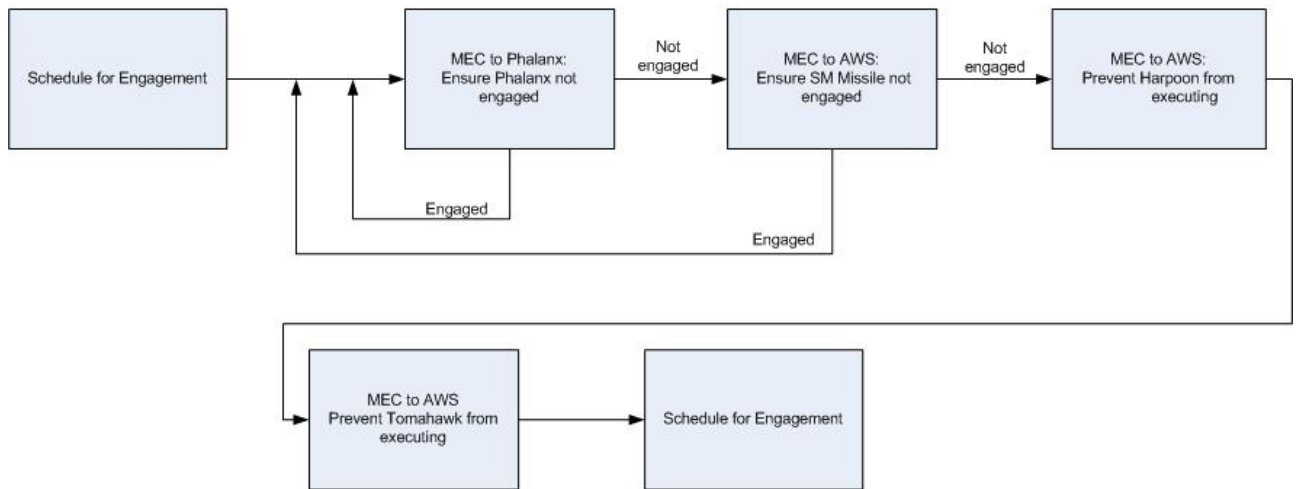

Figure 18: Module Engagement Control FFBD. In order to schedule an engagement, the proper weapon system must be selected and designated to be in control.

Pre-launch communications will be performed by a hard-wired Ethernet connection between the CLU and command and control. The original design for NLOS-LS incorporates the Joint Tactical Radio System (JTRS) Cluster 5 for in-flight missile communication. At the time of this report, the JTRS radios are not technically mature and need more time before fielding²⁹. The proposed interim solution is to utilize a NLOS Radio for post-launch communications, operating at a maximum link burst data rate of 2642 kbps.³⁰ The range of the NLOS Radio is dependent upon the height of the PAM. Figure 19 shows the results for the maximum range calculation of the NLOS-LS Radio, with an assumed antenna height of 100 feet.

$$D = 1.33(\sqrt{2 * Hr} + \sqrt{2 * Ht})$$

Ht = Height of Antenna (in feet)
Hr = Height of PAM in Flight (in feet)
D = Radio Line-of-Sight (in miles)

| Ht (feet) | Hr (feet) | Maximum range of the radio (miles) |
|----------------------|----------------------|---|
| 100 ft | 500 ft | 61 mi |
| 100 ft | 1000 ft | 78 mi |
| 100 ft | 1500 ft | 92 mi |
| 100 ft | 2000 ft | 103 mi |

Figure 19: Maximum range of the NLOS-LS Radio. The line-of-sight of the radio from an antenna mounted 100ft from the deck of a DDG-51 class destroyer to an antenna on a PAM in flight. The curvature of the earth limits the range of the radio. Due to the receiver sensitivity, transmitter power, and antenna efficiency the actual range of the radio is usually lower.³¹

The antenna associated with the NLOS Radio will provide 360 degrees of azimuth coverage and can handle multiple PAMs in flight. Figure 20 shows a notional use case diagram of how the communications paths flow.

²⁹ Government Accountability Office, *DEFENSE ACQUISITIONS, Restructured JTRS Program Reduces Risk, but Significant Challenges Remain*, GAO Report 05-669, June 2005.

³⁰ *Performance Specification For The Non-Line of Sight - Launch System (NLOS-LS) Precision Attack Missile (PAM) Radio*, Raytheon Company, 31 January 2006.

³¹ Pacific Crest Corporation Application Note, "UHF/VHF Range Calculations", 2007, available from the internet, www.paccrst.com/downloads/application_notes/AppNote_UHF_VHF_Calc.pdf, access date on 6 Mar 2007.

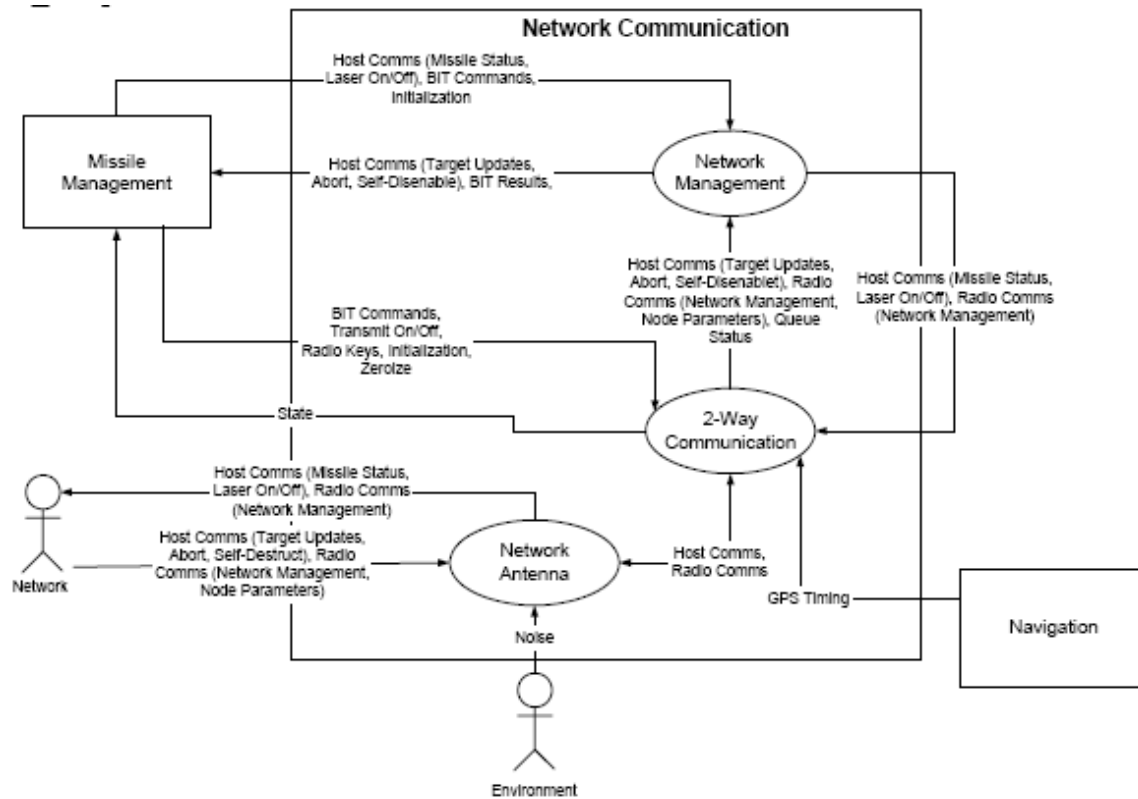

Figure 20: Network Communication Use Case Diagram. This is a notional use case diagram of how the communications paths flow.³²

g. Combat information Center (CIC)

The CIC is the tactical center of the DDG. This space is used to collect, manage, present, evaluate and disseminate the Command and Decision (C&D) information for the use by the Weapons Officer (WEPS), Executive Officer (XO), or Commanding Officer (CO).

- **Multi Function Console (MFC)**

The existing NLOS-LS controls could be migrated to a MFC to provide a tactical picture for the Strike Officer (STRIKE) and WEPS to see. The previously mentioned MEC functionality could also be integrated into a MFC. The console would have one interface to the C&D and internally with the NLOS Engagement Planner (NEP).

³² Performance Specification For The Non-Line of Sight - Launch System (NLOS-LS) Precision Attack Missile (PAM) Radio, Raytheon Company, 31 January 2006.

Further research would need to be conducted for the integration issues of this particular configuration.

- **Aegis Target Data Line**

The best option for target sensor data will be through the C&D data line in the CIC. This data line provides targeting data to NLOS-LS from the Aegis Weapon System. Dependent upon the operational mode of Tactical or Training, NLOS-LS utilizes information of a pending launch of the PAM. The C&D in CIC prioritizes and designates NLOS-LS with the other weapon systems. For security purposes, the CO can lockout an impending launch with his launch inhibit key.

- **WCS Scheduling / Doctrine**

The WCS schedules engagements upon receipt of direction from the C&D in a manner designed to eliminate fratricide. The priorities set by the WCS are for Anti-Air Warfare (AAW), STRIKE warfare, and Anti-Submarine Warfare (ASW). The highest priority is AAW which uses the Phalanx Close-In Weapon System (CIWS) and the Standard Missile. Next would be STRIKE, which uses Tomahawk. Finally, the last in priority would be ASW that utilizes the Mk-46 torpedo. This priority dictates what weapon system would be the first to execute and is based on the response required to engage the threat (e.g. AAW threats require fast response weapons). As an example, a strike engagement is planned and the Tomahawk element has control of the launcher and has missiles powered up while threats are present. If an AAW emerges, the missile fire control element would be activated and immediately lockout the launcher, bringing all of the Tomahawk missiles to a hold fire state until control is released back to Tomahawk. The same logic can be applied to NLOS-LS and priorities would need to be determined in the C&D. Since NLOS-LS is a Surface Warfare (SuW) weapon, it is recommended that the priority fall between AAW and STRIKE as seen in Figure 21. The reasoning is based on the required response to engage the threat. Surface engagement timelines are slightly slower (in minutes) than the AAW/engagement timeline (in seconds) of Standard Missile and other systems. In this case the WCS would need to schedule engagements to eliminate fratricide between Standard Missile, Tomahawk, PAM, and CIWS due to the

general proximity to the AFT VLS launcher. The location of the NLOS-LS launcher is discussed later in this report.

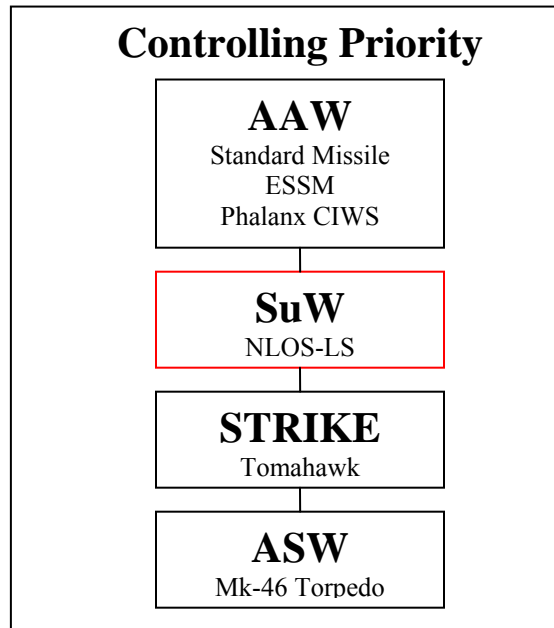

Figure 21: Priority Doctrine. Since NLOS-LS is a Surface Warfare (SuW) weapon, it is recommended that the priority fall between AAW and STRIKE.

2. NLOS-LS Functional Analysis

The combat system interface requirements of the NLOS-LS, as outlined in the previous section, can now be functionally integrated. Using the Hatley-Pirbhai PSARE (Process for System Architecture and Requirements Engineering) process, the following series of architecture diagrams illustrate the structure of how NLOS-LS will be integrated.³³ The required functions, shown in Figure 22, illustrate in what manner NLOS-LS must interact with systems external to its boundaries. These requirements will be addressed through the Architecture Flow Context Diagram (AFCD) and assorted Architecture Flow Diagrams (AFDs) which cover the main components of the launching system.

³³ Hatley, Derek, Peter Hruschka, and Imtiaz Pirbhai. *Process for System Architecture and Requirements Engineering*. New York, NY: Dorset House Publishing, 2000.

NLOS Behavior Enhanced Requirements Model

| | | |
|---|---|---|
| <div style="display: flex; justify-content: space-between;"> <div style="width: 25%;">User Interface</div> <div style="width: 50%;"> <ol style="list-style-type: none"> 1. Schedule Firings 2. Process target information 3. Monitor PAM engagement 4. Interface with NLOS display 5. Clear deck for firings </div> </div> | | |
| <div style="text-align: center;">Input Functions</div> <ol style="list-style-type: none"> 1. Receive sensor input (organic and onboard) 2. Provide firing signal via NLOS controller 3. Provide ship environmental data | <div style="text-align: center;">Core Functions</div> <ol style="list-style-type: none"> 1. Receive target position information 2. Receive ship environmental data 3. Fire PAM's 4. Update In-Flight PAM's 5. Translate sensor input | <div style="text-align: center;">Output Functions</div> <ol style="list-style-type: none"> 1. Update C2 system 2. Assess PAM engagement 3. Provide kill assessment |
| <div style="display: flex; justify-content: space-between;"> <div style="width: 25%;">Support Functions</div> <div style="width: 50%;"> <ol style="list-style-type: none"> 1. Maintain system 2. Provide physical interfaces (cabling) 3. Provide communication system </div> </div> | | |

Figure 22: Required NLOS-LS Architecture Functions. The required functions illustrate in what manner NLOS-LS must interact with systems external to its boundaries.

Figure 23 was developed to map the NLOS-LS component into the Hatley-Pirbhai paradigm. This places the data flows between components in context and allows the identification of interfaces.

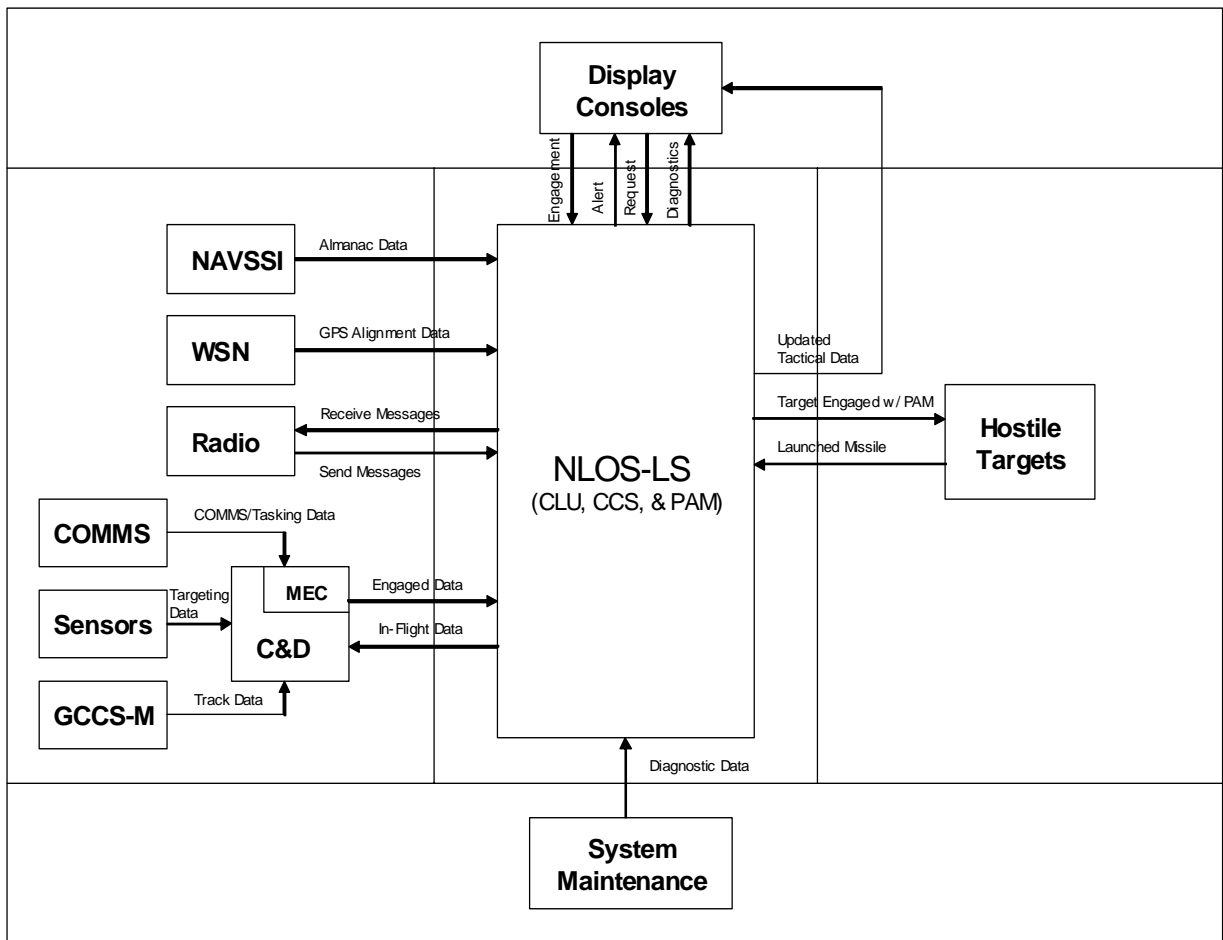

Figure 23: AFCD NLOS-LS. NLOS-LS receives and processes data from the Radio, C&D, WSN, NAVSSI, and the consoles.

As can be seen from Figure 23, NLOS-LS processes data from the Radio, C&D, WSN, NAVSSI, and the consoles. When NLOS-LS processes the data, it is passed to the CLU for storage and assignment by the Computer & Communication System, which sends the signal to the PAM. The system as envisioned has the capability to perform a built-in-test and provide information of any failures in the system and its interfaces. A Power-On Built-In Test (BIT) is automatically executed when power is applied to the system. Additionally, NLOS-LS has the capability to be operated and viewed from the MFC's in CIC. The primary outcome of the system is an engaged hostile target with a PAM missile.

a. AFD 0 NLOS Engagement Planner (NEP)

Figure 24 shows the top-level architecture flow diagram for the NLOS-LS. It includes the major components of the weapon system, which include the C&D data from CIC, the control panel used to operate the system, the CLU, PAM, and the Power-On BIT function. The C&D is connected to the NEP via the MEC in CIC to provide the engagement data. The operator interfaces with the system through the control panel in CIC. The NLOS Radio allows communication with the in-flight PAM and off-board sensors. The CLU serves as the interface to the PAM missiles and performs the firing sequence after receiving a valid target engagement. The Power-On BIT verifies proper operation of the system itself prior to entering any operational mode. The NEP is a mission-critical application for NLOS-LS.

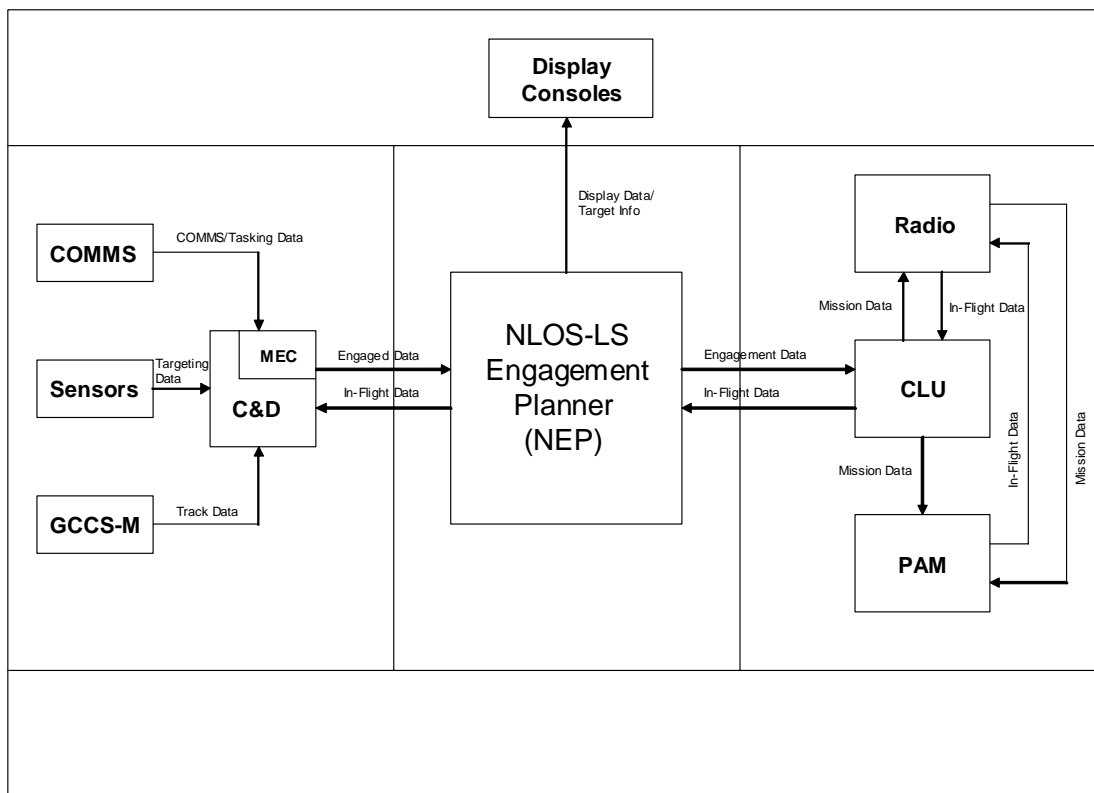

Figure 24: AFD 0 NLOS-LS NEP. The top-level architecture flow diagram for the NLOS-LS includes the major components of the weapon system.

The NEP ensures the external inputs such as tracks, almanac data, cryptographic data, and INS are usable. When the PAM is in-flight, the NEP processes data and sends

updates to the PAM via the NLOS Radio. The NEP has the capability to process incoming target locations and preplanned mission and verification codes sent from another platform or a forward observer. Thus, NLOS-LS will have the capability to select a missile from a certain cell and power up that particular PAM.

b. AFD 1 CLU

The CLU acts as a communication node via a direct-wired Ethernet interface with engagement data from the NEP and updating the Radio and PAM, as seen in Figure 25. The CLU performs the missile assignment and the initial launch of the missile. The CLU receives data from the NEP and acts as a direct interface to the PAM

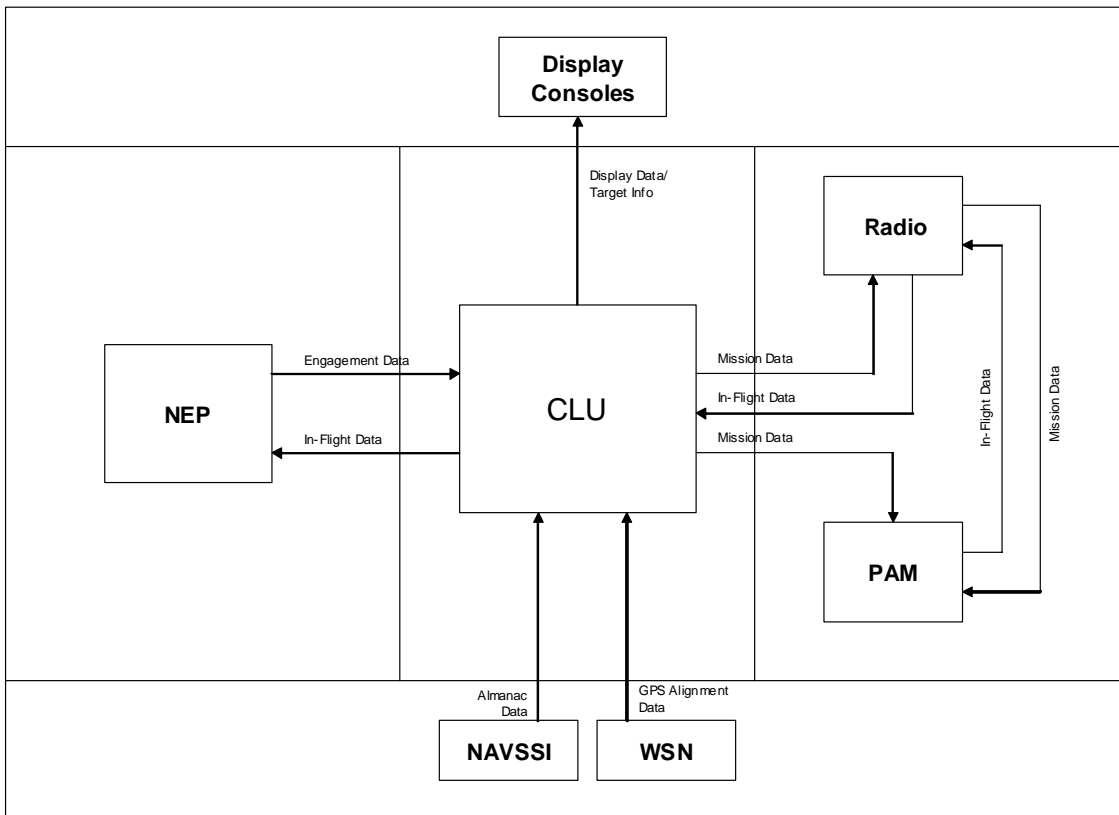

Figure 25: AFD 1 CLU and CCS. The CLU acts as a communication node via a direct-wired Ethernet interface with engagement data from the NEP and updating the Radio and PAM.

The CLU currently has the capability to receive health and status updates from the PAM via the NLOS Radio and send it to the NEP. Moreover, the C&D needs doctrine safety measures as mentioned previously to ensure a firing lockout during the firing of another

weapon system or from turning the Commanding Officer's (CO) Fire Inhibit Switch. During system power up, a built-in test is performed to ensure proper operation of the launcher. If selected, the WSN can provide the CLU with alignment data, which will align the system relative to the ship's position and the particular location of the launcher on the ship. Once the alignment is complete and the data is loaded into the PAM, the operator releases the PAM by sending a fire signal to the selected PAM.

c. AFD 2 PAM

Proper functionality of the PAM is a mission-critical process, therefore, the PAM must maintain constant communication with the Radio and CLU to ensure that the PAM can transition to flight and intercept its target as seen in Figure 26. When in-flight, the PAM sends health status updates back to the NEP. The operator monitors the PAM in-flight and is alerted of battle damage imagery or complications during flight. A new intercept point is sent to the in-flight PAM from the NEP if organic or off-board sensors detect new target coordinates to engage or updated locations of existing targets. This real-time update affords a capable missile with quick reaction times.

d. AFD 3 NLOS Communications

The NLOS-LS will establish communications with the PAM via the NLOS-LS Radio as seen in Figure 27. This allows continuous tracking of the PAM after it has been launched from the ship. The NLOS-LS platform will utilize a communication link between the radio and the C&D via the NEP for updated target information. This updated target data can originate from one of two locations: organic, on-board sensors or an off-board location. The PAM sends a health status update at interval times back to the NEP through the NLOS Radio to report its latest information. This allows the PAM to update its mission after its launch in case of higher priority threats or a change in the tactical threat environment.

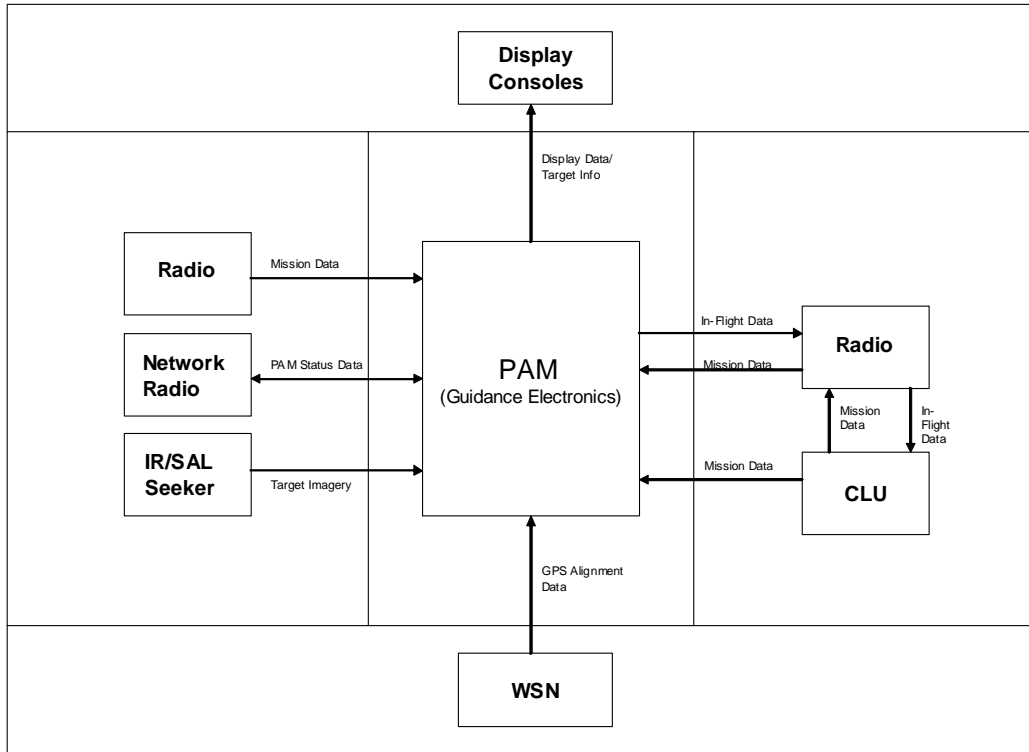

Figure 26: AFD 2 PAM. The PAM must maintain constant communication with the Radio and CLU to ensure that the PAM can transition to flight and intercept its target.

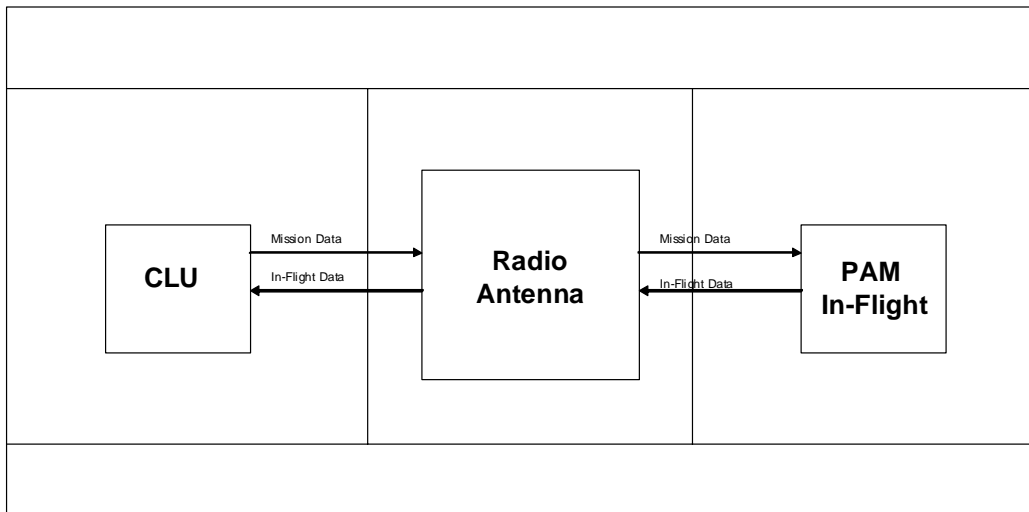

Figure 27: AFD 3 Radio. The NLOS-LS communicates with the PAM via the NLOS-LS Radio to allow continuous tracking of the PAM after it has been launched from the ship.

3. NLOS-LS System Behavior

a. Functional Flow Block Diagram (FFBD)

Given the coherent operational picture that can be created via organic sensors, off-board sensors, and networked intelligence feeds, a notional implementation of NLOS-LS allows the initiation and launch of offensive operations to destroy potential threats. Initially, the AN/SPY-1D and AN/SPS-67 radar systems perform the search, detection, transition to track, and tracking of surface targets for non-over-the-horizon threats. For an over the horizon scenario the MH-60, UAV, or other surface platform would provide the search, detection, transition to track, and tracking of surface targets. The sensor, both on and off board, provides the target data to the AWS. Next, AWS coordinates the NLOS-LS Engagement Planner with the Mission Area Plan. If a PAM is in flight, an off-board platform provides pre-launch target data via a data link back to the ship. This method presents the advantage of incurring no direct risk to the ship crew while engaging the enemy through an aggressive offensive maneuver. The functional flow block diagram in Figure 28 shows the general flow of events of an NLOS-LS engagement. An ARENA model expanding upon the operational flow is presented in Appendix C.

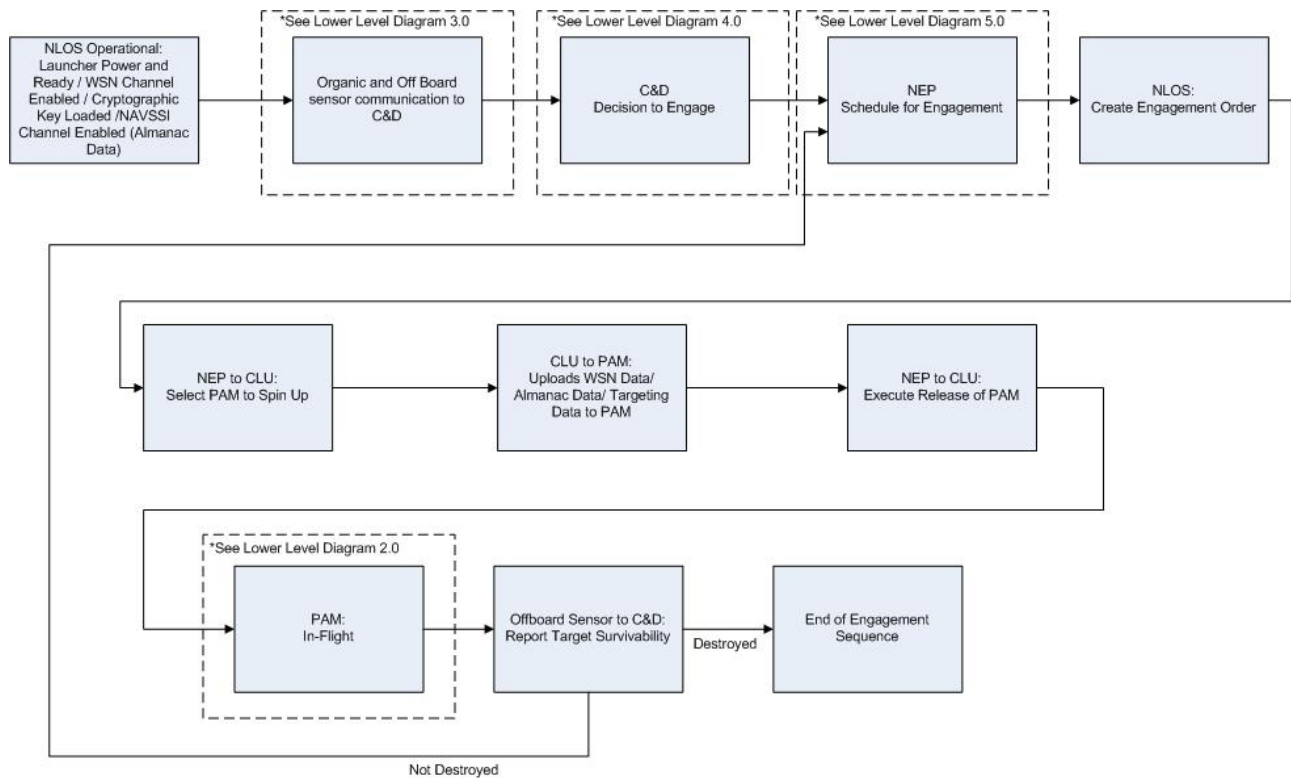

Figure 28: NLOS-LS System Behavior FFBD. This diagram shows the general flow of events of a typical NLOS-LS engagement.

b. NLOS-LS Engagement and Mission Planning

NLOS-LS plans tactical missions in CIC via a MFC. NLOS-LS relies on external ship systems to operate such as power, INS, NAVSSI, C&D and organic and off-board sensors from the ship or other external assets. Once a target is reported, it is added to the C&D track database and a decision is made to engage the target. The schedule for engagement will follow the decision to engage by designating the NLOS-LS as the priority system for engagement. With the permission to engage, the NLOS-LS can create an engagement order, select PAM missiles from the CLU, and execute the release of the PAMs. When the PAMs are in-flight, it will provide missile health, position status and target engagement imagery back to the ship.

Figure 29 shows the functional sequence diagram of the AWS and the path that is taken to search, detect, designate, and engage a hostile target with NLOS-LS integrated into the system.

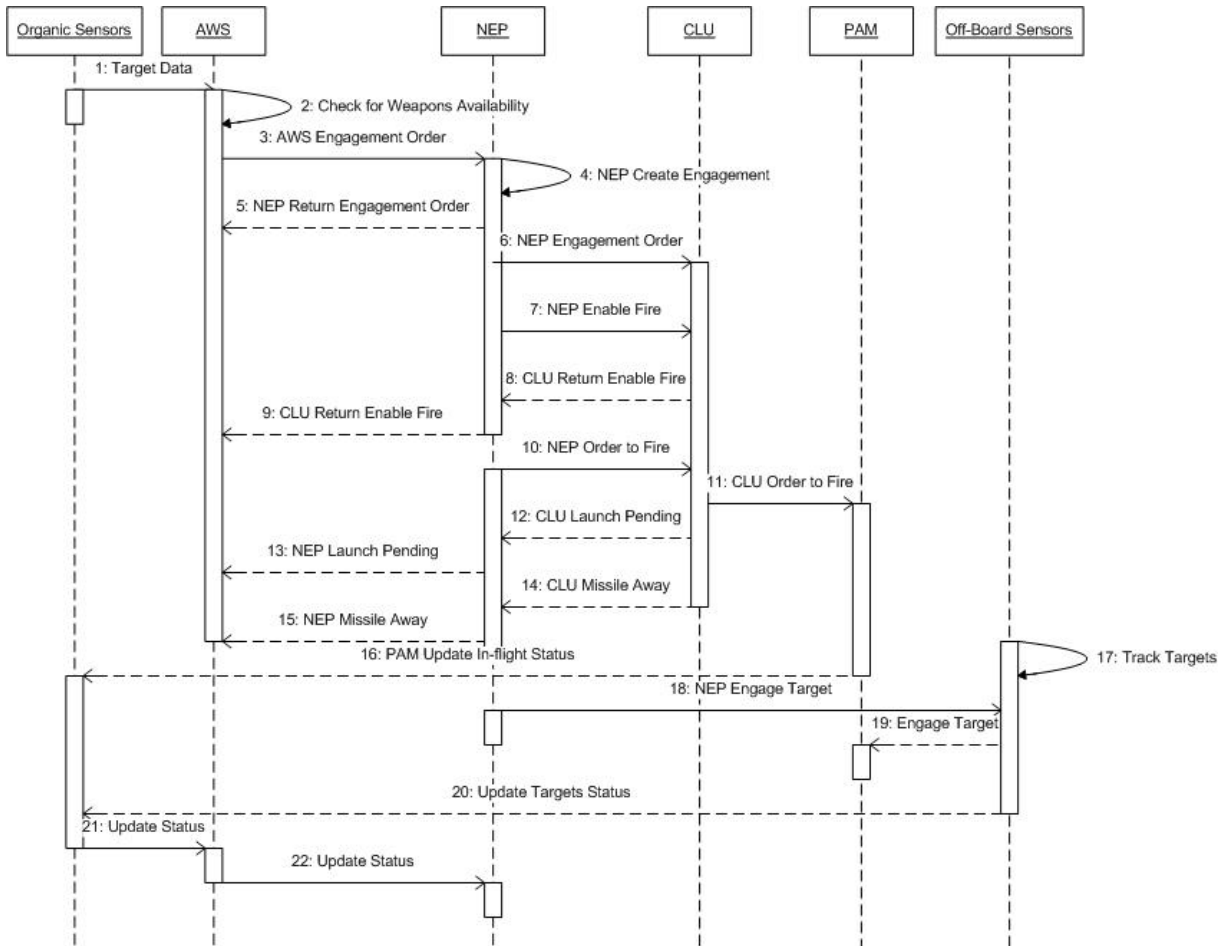

Figure 29: NLOS-LS Engagement Sequence Diagram. This is a functional sequence diagram of the AWS and the path that is taken to search, detect, designate, and engage a hostile target.

c. Organic and Off-Board Sensors

The organic and off-board sensors (Figure 30) provide the NLOS-LS with a search, detect, and track capability that will support NLOS-LS engagements, ranging from 0.5 km to beyond NLOS-LS’s maximum range of 40 kilometers. The NLOS-LS target database system converts all information received from organic and off-board

sensors into a NLOS-LS readable data format. With the use of communication data links, the system can share information between ships, MH-60R, and UAVs.

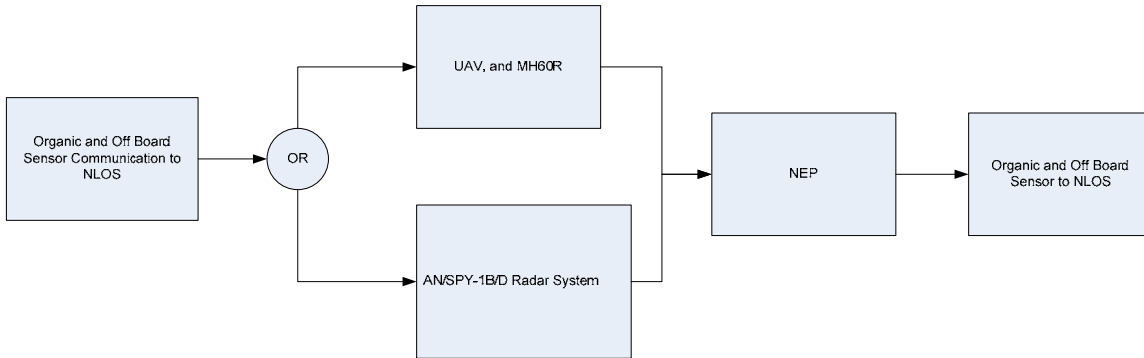

Figure 30: Organic and Off-Board Sensor FFBD. The NLOS-LS can search, detect, and track targets to support the NLOS-LS engagement.

d. NLOS Engagement Planner

The NEP can receive missions from on-board ship by the command and control system. The Decision to Engage flowchart in Figure 31 is a lower level of the System Behavior FFBD from Figure 28. This process requires the following: all personnel need to be clear on the top deck for safety reasons, coordination is performed with other platforms, and approval to engage comes from the CO.

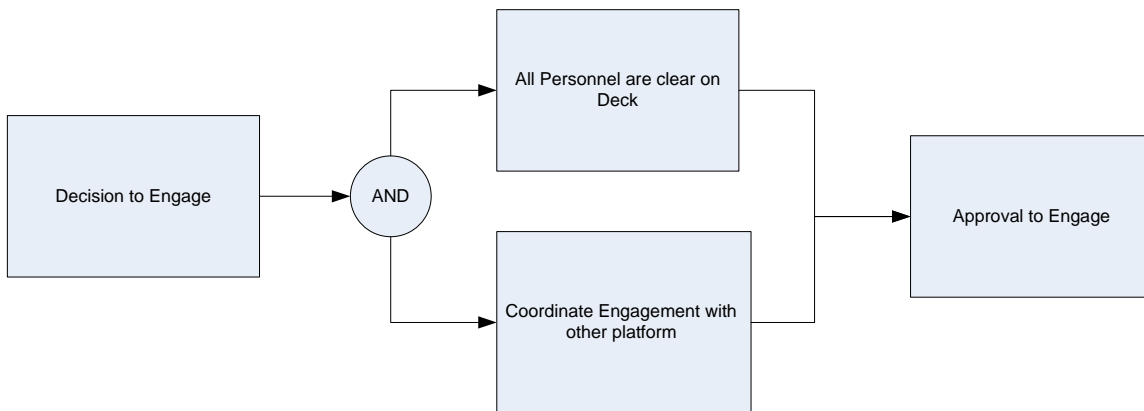

Figure 31: NLOS Engagement Planner FFBD. The NEP can receive missions from on-board ship by the command and control system to plan an engagement.

e. Deployment Operations

The NLOS-LS will normally be operating in the Tactical Mode and the CLU in the Standby Mode during underway operations when hostilities are expected. When NLOS-LS has engagements at a state of Make Ready, NLOS-LS will order the CLU to the Ready Alert mode. While in the Ready Alert Mode, NLOS-LS will order missile selection and the CLU will power up the selected PAMs. When there are no powered-up PAMs and no engagements have reached the Make Ready state, NLOS-LS will order the CLU to the Standby Mode. Normally PAMs will not be powered up except to launch, to conduct missile inventory (to update missile flight software), and to perform operational checks as directed by the Type Commander (TYCOM) approved operating procedures³⁴.

For Training scenarios, NLOS-LS will be placed in the Training Mode and the CLU will be ordered to the Simulation mode. NLOS-LS will be returned to the Tactical Mode upon completion of the training exercises and the CLU will be ordered back to the Standby mode.

f. Availability Operations

During in-port periods, the NLOS-LS equipment will be placed in a mode to support the required in-port maintenance, training and monitoring operational states. During availability, PAM missiles will not be routinely powered up, with the exception of performing missile inventory at which time the missile software may be updated. During in-port periods, the NLOS-LS can be capable of receiving and storing mission data. Mission and/or Strike Plans may be developed during this timeframe.

B. DDG-51 PHYSICAL INSTALLATION ANALYSIS

1. Scope of Physical Installation

The scope of this section is to discuss the different physical installation factors needed to determine what, where, and how the NLOS-LS is to be installed on-board U.S. Navy ships. In particular, this discussion focuses on the DDG-51 class destroyer. The

³⁴ OD 63835 *Attack Weapon Control System Concept of Operations*, Strategic System Program, 1 April 2003.

U.S. Navy and projects at NSWC Port Hueneme, CA use the Fleet Modernization Program (FMP) as the guiding process for new installation requirements. The FMP mission is to provide a disciplined process to deliver operational and technical modifications to the Fleet in the most operationally effective and cost efficient way. It defines a standard methodology to plan, budget, engineer, and install timely, effective, and affordable shipboard improvements while maintaining configuration management and supportability³⁵. It is the means used to provide better technology and innovation to:

- Keep the war-fighting edge
- Fix systemic and safety problems
- Improve Battle Force Interoperability (BFI)
- Improve platform reliability and maintainability
- Reduce the burden on the sailor

In the case of the NLOS-LS, the goal is to give the war-fighter an additional capability for the surface craft threat. Because the NLOS-LS is a new capability, a Ship Alteration (SHIPALT) package will need to be developed. A SHIPALT is an approved permanent change to the configuration of a ship that is documented in a Ship Alteration Record (SAR) and implemented through the FMP Process. SHIPALTs are classified by title/type and comprise any change in hull, machinery, equipment, or fittings, which involves changes in design, material, quantity, location, or relationship of the component parts of an assembly. The title assigned to a SHIPALT identifies the approving authority and responsibility for funding. SHIPALT titles are:

- a. Title “K” SHIPALT - A permanent alteration to provide a military characteristic, upgrade existing systems or provide additional capability not previously held by a ship, which affects configuration-controlled areas or systems of a ship or which otherwise requires the installation of Headquarters Centrally Provided Material (HCPM). These SHIPALTs are approved for development and authorized for accomplishment by the CNO (military improvements) or the

³⁵ *Fleet Modernization Program Management and Operations Manual – Revision 2*, Commander, NAVSEA Systems Command, June 10, 2002.

Figure 32: Alteration Decision Tree³⁶. From the Fleet Modernization Manual, this flow chart determines which type of SHIPALT is required.

NLOS-LS would be categorized as a Type K SHIPALT because it is a new permanent installation that is adding a capability not previously held. This is true for the DDG-51 ship class as seen in the NLOS-LS concept of operations. It is also determined that this will be a conjunctive SHIPALT—ORDALT because of the nature of the NLOS-LS system. Conjunctive SHIPALT – ORDALTs are described as imposing an impact on a ship’s system (such as an increase in ship’s power, increase in cooling requirements, change in weight and moment, and impact on water-tight integrity).

2. Equipment Analysis

This section will describe the key equipments of the system that need to be installed both topside and internal to the ship structure.

- a. **Precision Attack Missile All Up Round (PAM AUR)**—The PAM AUR is the container housing the weapon to be used on-board the DDG-51. The AUR is the means by which the PAM is stored, transported, and launched. Once fired, the container would need to be replaced by another AUR. The AUR resides in the frame of the CLU providing the fire control interface. Some issues the will need to be explored further related to the AUR are listed below:

- Storage
- Reloading
- Disposal of expended canisters
- Maintenance of loaded AURs

- b. **Computer & Communication System (CCS)**—The CCS is the heart of the NLOS-LS. This unit is the same size as one of the PAM AUR and fits into the CLU base as the AUR does. This unit contains the means by

³⁶ *Fleet Modernization Program Management and Operations Manual – Revision 2*, Commander, NAVSEA Systems Command, 10 June 2002.

which the PAM AUR is fired. It also provides the man interface to the NLOS-LS. The Army concept incorporates power into the CCS, which energizes the CCS functions as well as the firing signal to the missile. One CCS can interface with fifteen PAM AURs. The Army concept in theory could work but is not practical for the Navy. The functions performed by the different pieces of equipment in an Army CCS are performed already by ships systems. The ship can provide the needed power, navigation data, and GPS data to the CCS for operations as discussed previously. Some of the CCS functions will be distributed to different locations on-board the ship. The communication/radio system will be relocated inside the ship structure, while the antennas associated with the radios will be installed on the mast. Raytheon is investigating the dual use of existing antennas. The display portion of the CLU would be relocated to the CIC where the engagement can be scheduled, monitored, and controlled. The ship will translate the sensor data for input into an NLOS-LS engagement. This translated data would be filtered and enter the system in CIC.

- c. **CLU**—The CLU is basically the physical structure that houses the missile AUR and the CCS. It is designed so that the PAM, when launched vertically, allows the exhaust gases to exit the top of the unit into the atmosphere. This equipment piece would be the physical item to be installed to the ship structure. The CLU contains a removable base assembly and a removable forklift structure for ease of maneuvering. The base unit is the means by which the PAM AUR and CCS communicate. A fully loaded unit would weigh approximately 3250 pounds and have dimensions of four feet by four feet by six feet.

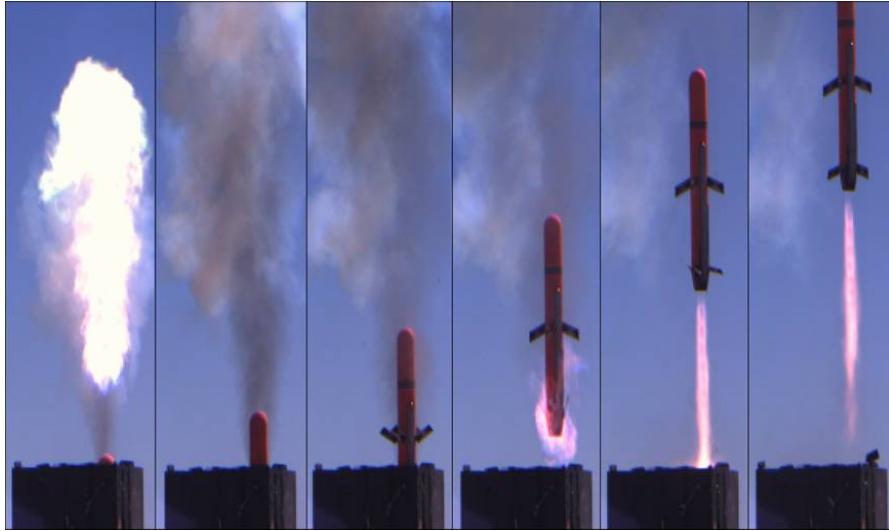

Figure 33: Exhaust Gases. During a missile launch, the exhaust gases exit the top of the unit into the atmosphere, thus reducing the impact to the ship.

3. CIC Console Configuration

Currently, DDGs have the Advanced Tactical Display Consoles (ATDC) that are used for both the Tomahawk Weapons Control System and Naval Fires Control System (NFCS) and are located in Figure 34 by the red circles. The ATDC is a type of MFC which consists of a dual CRT or LCD display with a keyboard and a mouse, which has the capability to switch between NFCS and Tomahawk by the use of the Ultra Matrix. The Ultra Matrix is a video, keyboard, and mouse switch, which has the capability to switch between different computer processors on one console. The ATDCs have the security capability of displaying information up to Top Secret. Thus, by adding a video, keyboard, and mouse connection from NLOS-LS to the Ultra Matrix, the cost of adding new equipment in CIC is minimized and no additional modifications to the CIC are needed. It is recommended that these MFC be used.

of the analysis due to proximity of personnel and blockage zones created by the superstructure and mast.

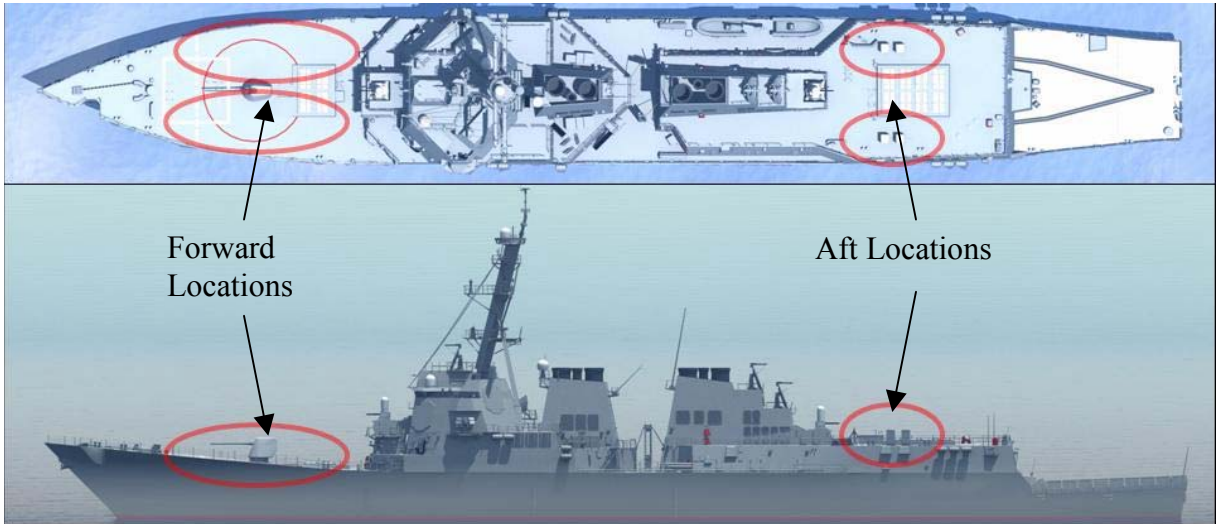

Figure 35: Footprint Location³⁷. Four candidate locations for the NLOS-LS installation are located port and starboard of the forward and aft Vertical Launching System (VLS).

For this analysis the focus will be on the forward and aft locations as options. Figure 36 below shows some advantages and disadvantages of each location. The areas considered are in descending priority, blockage zones being most important and cabling runs being the least. The purpose of creating the table was to recommend an optimal topside location for installing multiple CLU's.

| Location | Advantages | Disadvantages |
|-----------------------|--|--|
| Blockage Zones | | |
| Forward | 1. None | 1. Blockage of pilot house and forward mast 2. Roughly 180 degree firing cutouts needed |
| Aft | 1. No significant blockage areas 2. Roughly 90 degree firing cutouts needed | |

³⁷ Netfires LLC, "NLOS-LS (PAM/CLU) Accelerating Capability To the U.S. Navy" Presentation, provided by Raytheon for the project.

| Location | Advantages | Disadvantages |
|--------------------------------|---|--|
| Existing Infrastructure | | |
| Forward | 1. Closer to forward mast for communications integration | 1. Close proximity to 5" gun 2. Smaller footprint area for RCS material (if added) |
| Aft | 1. Minimal vertical ship structure in proximity. 2. Larger footprint area for additional RCS material (if added) | 1. Close proximity of Harpoon Launcher (Flight II) 2. CIWS firings over CLU 3. Closer proximity to helicopter operations 4. Torpedo Tubes (Flight II) |
| Blast Area | | |
| Forward | | 1. Smaller footprint area for blast exhaust and more vertical ship structure (Flight IIA) |
| Aft | 1. Bigger footprint area for and minimal vertical structures for blast exhaust (Flight IIA) | |
| Cabling Runs | | |
| Forward | 1. Closer to CIC for computer control integration. | |
| Aft | | 1. Larger distance from forward mast and CIC |

Figure 36: Footprint Location Advantages vs. Disadvantages. Advantages and disadvantages are provided for each location, considered in descending priority.

Installing the CLU on the VLS deck would need to take into account the VLS launched missiles' blast radius and maximize the distance relative to the VLS launcher. Additional analysis would need to be performed to analyze this missile blast pattern and the impact on the CLU. The following issues need to be examined to determine the optimal location for the CLU:

- a. Blast Damage
- b. Environmental Effects
- c. Stabilization and Alignment
- d. Electromagnetic Environmental Effects (E3) & Spectrum Management (SM)
- e. Radar Cross Section (RCS) Reduction Analysis
- f. Fratricide Analysis

The following subsections present a first order analysis of the issues mentioned in a through f above. A more detailed analysis is needed in all areas and is beyond the scope of the CRADA shown in Appendix A.

a. Blast Damage

PAM blast damage impact to the ship is minimal. Engineering judgment is used to compare the size dimensions between a PAM and a Standard Missile in Figure 37 (figure is roughly to scale). One concludes that the impact of a PAM launch is far less (more than an order of magnitude in weight) than that of a Standard Missile. Considering the current ship configuration can support Standard Missile or Tomahawk firings, and the fact that when a PAM is fired the exhaust exits the top of the CLU, blast damage to topside equipment would be minimal especially if installed on the aft VLS deck.

| | | |
|--|---|------------------------------------|
| <p>SM-2</p> <p><u>Size</u></p>  <p>15.5'</p> <p>13.5"</p> | <p><u>Weight</u></p> <p>1558 pounds</p> | <p><u>Speed</u></p> <p>Mach 3+</p> |
| <p>PAM</p>  <p>5'</p> <p>7"</p> | <p>117.5 pounds</p> | <p>Subsonic</p> |

Figure 37: Standard Missile³⁸ vs. PAM. Engineering judgment shows that blast damage will be minimal when comparing the size dimensions between a PAM and SM-2.

b. Environmental Effects

Whenever a system is placed on-board a U.S. Navy ship, the environmental effects on all the associated system components must be taken into account. One approach would be to examine the Navy specification for the electronic

³⁸ Raytheon Website, “Standard Missile-2: International Fleet Defense”, 2006, available from the Internet, http://www.raytheon.com/products/stellent/groups/public/documents/content/cms01_055768.pdf, access date on 25 Oct 2006.

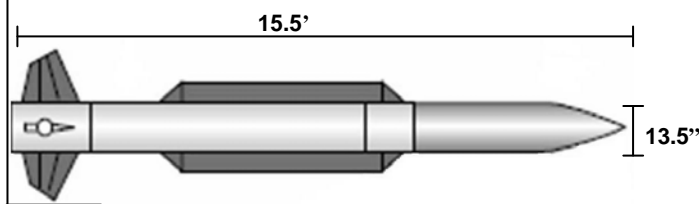
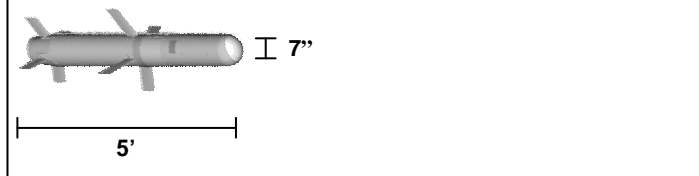
equipment as it relates to different environmental conditions. Some of the key areas that would need to be tested are shown in Figure 38.

After examining the Navy environmental effects specification, a determination can be made whether the NLOS-LS system meets or exceeds what the U.S. Navy would deem acceptable.

c. Stabilization and Alignment

The Army concept is for the NLOS-LS to be fired from a static location and have an internal self-aligning capability. In a shipboard environment, the NLOS-LS would be subjected to ship motion. The issue then arises of the conditions needed in order for the NLOS-LS to operate. NetFires, composed of Raytheon Missile Systems and Lockheed Martin Missiles and Fire Control, successfully conducted a Ballistic Test Vehicle (BTV) flight test for the NLOS-LS PAM at the Eglin Air Force Base, Florida test range on February 16, 2006.³⁹

| Environmental Condition | Shipboard Requirement (Test Method) |
|--------------------------|--|
| Temperature (High / Low) | -33°C to +71°C for 2 hours after stabilization (Method 501.4 / 502.4) |
| Solar Radiation | Cycle A1: 1120 W/m ² and 49°C for continuous 24 hour diurnal cycle (Method 505.4) |
| Salt Fog | 48 hour exposure to 5±1% salt solution concentration / 48 hour drying time, at 35±2°C (Method 509.4) |
| Vibration | Shipboard random vibration exposure of 0.0010 g ² /Hz from 1.0 to 100 Hz for 2 hours (Method 514.5) |
| Ballistic Shock | Ballistic Hull and Turret, Full spectrum, Ballistic Shock Qualification, with Peak Displacement < 42 mm (Method 522) |

Figure 38: Environmental Effects. These environmental requirements provide a foundation for the NLOS-LS system.⁴⁰

³⁹ Spacewar Website, “Netfires Conducts Navy Ballistic Flight Test For NLOS-LS Missile”, 29 March 2006, available from the internet, http://www.spacewar.com/reports/NetFires_Conducts_Navy_Ballistic_Flight_Test_For_NLOS_LS_Missile.html, access date on 28 February 2007.

⁴⁰ MIL-STD-810F Test Method Standard for Environmental Engineering Considerations and Laboratory Tests, Department of Defense, 1 January 2000.

The PAM missile BTV was vertically launched from the NLOS-LS CLU that was integrated onto a motion simulator. The ship motion simulator was able to replicate a range of sea conditions that the LCS is likely to encounter while under way. The PAM BTV flight test was conducted in upper-sea-state-three conditions to demonstrate the safe egress of the PAM missile from the CLU. Sea state three represents conditions where a vessel experiences three- to five-foot waves and winds exceeding 15 knots.

This testing demonstrated the ability of the NLOS-LS to fire missiles in a simulated at sea environment. These results can be applied to this case study of the DDG 51 concluding that stabilization and alignment are not an issue.

d. Electromagnetic Environmental Effects (E3) and Spectrum Management (SM)

An evaluation of NLOS-LS to analyze and assess the E3 impact to the system would need to be completed. This E3 analysis would include most, if not everything, as described in the following paragraphs. Further information is provided in detail below.

E3 is defined as the impact of the electromagnetic environment upon the operational capability of military forces, equipment, systems, and platforms. It encompasses all electromagnetic disciplines, including electromagnetic compatibility (EMC), electromagnetic interference (EMI), electromagnetic vulnerability (EMV), electromagnetic pulse (EMP), electronic protection (EP), hazards of electromagnetic radiation to personnel (HERP), ordnance (HERO), and volatile materials (HERF), and natural phenomenon effects of lightning and precipitation static (PStatic).

SM is defined as planning, coordinating, and managing the use of the electromagnetic spectrum through operational, engineering, and administrative procedures, with the objective of enabling electronic systems to perform their functions in the intended environment without causing or suffering unacceptable interference. The major components of SM are Spectrum Certification (SC) and frequency assignment. SC

is the process (called the JF-12 Process) by which spectrum dependent systems/equipment are certified to operate in a portion of the electromagnetic spectrum⁴¹.

e. Radar Cross Section (RCS) Analysis

Appendix E shows the detailed calculation of the RCS of the CLU and the DDG 51. The CLU was calculated assuming the worst possible case in which it acts as a flat plate. A radar frequency of 9 GHz was used in the calculations. The CLU RCS is 44.8 dB. The DDG 51 RCS was calculated using an empirical formula and is a function of the radar frequency and the displacement. The DDG 51 RCS is 51.5 dB. A power dB addition was next performed to show the resultant RCS gain accounting for 2 CLU’s being installed on the same side of the ship. The resultant total value is 53.1 or a gain of 1.6 dB. RCS mitigation techniques can now be used to reduce the additional RCS.

| Discipline | Definition |
|------------|--|
| EMC | The ability of systems, equipment, and devices that utilize the electromagnetic spectrum to operate in their intended operational environments without suffering unacceptable degradation or causing unintentional degradation because of electromagnetic radiation or response. It involves the application of sound electromagnetic spectrum management; system, equipment, and device design configurations that ensure interference-free operation; and clear concepts and doctrines that maximize operational effectiveness. (Joint Pub 1-02) |
| EMI | Any electromagnetic disturbance that interrupts, obstructs, or otherwise degrades or limits the effective performance of electronics/electrical equipment. It can be induced intentionally, as in some forms of electronic warfare, or unintentionally, as a result of spurious emissions and responses, intermodulation products, and the like. (Joint Pub 1-02) |
| EMV | The characteristics of a system that cause it to suffer a definite degradation (incapability to perform the designated mission) as a result of having been subjected to a certain level of electromagnetic environmental effects. (Joint Pub 1-02) |
| EMP | The electromagnetic radiation from a nuclear explosion caused by Compton-recoil electrons and photoelectrons from photons scattered in the materials of the nuclear device or in a surrounding medium. The resulting electric and magnetic fields may couple with electrical/electronic systems to produce damaging current and voltage surges (pulses). May also be caused by non-nuclear means. (Joint Pub 1-02) |
| EP | That division of electronic warfare involving actions taken to protect personnel, facilities, and equipment from any effects of friendly or enemy employment of electronic warfare that degrade, neutralize, or destroy friendly combat capability. (Joint Pub 1-02) |
| HERO | The danger of accidental actuation of electro-explosive devices or otherwise electrically activating ordnance because of radio frequency (RF) electromagnetic fields. This unintended actuation could have safety (premature firing) or reliability (dudding) consequences. (Joint Pub 1-02) |
| HERP | Potential for electromagnetic radiation to produce harmful biological effects in humans. (ANSI C63.14-1998) |
| HERF | Potential for electromagnetic radiation to cause spark ignition of volatile combustibles, such as aircraft fuel. (ANSI C63.14-1998) |

⁴¹ E3 and SM Assessment Guide for Operational Testing, Director Operational Test and Evaluation DOT&E, 13 June 2001.

| Discipline | Definition |
|------------|---|
| Lightning | <p>Direct Effects - Any physical damage to the system structure and electrical/electronic equipment due to the direct attachment of the lightning channel. These effects include tearing, bending, burning, vaporization, or blasting of hardware.</p> <p>Indirect Effects - Electrical transients induced by lightning in electrical circuits due to coupling of electromagnetic fields. (MIL-STD 464)</p> |
| P-Static | <p>Electromagnetic interference effects primarily on antenna-connected receivers caused by corona discharge at sharp edges or points of a structure, arcing across non-conductive surfaces, and arching between conductive joints or panels which are not electrically bonded. (ANSI STD C63.14-1998)</p> |

Figure 39: Definitions of the Electromagnetic Disciplines Covered by E3. Provided from *E3 and SM Assessment Guide for Operational Testing*.

The CLU's Radar Cross Section (RCS) can be reduced by treating them with a material that will absorb the radar energy at the frequency of interest. A specular or free space absorber will act through phase cancellation or impedance taper to effectively absorb the radar energy. Greater reductions in RCS can be achieved through shaping, i.e. making the target object of such a shape as to either scatter the incoming radar waves in a direction other than back towards the receiver or rounding the object to minimize the return. Often though, this cannot be done as it is needed to reduce the RCS of an existing object or an objects operation forbids much shaping. In these cases RCS can be reduced by the application of Radar Absorbent Material (RAM). Both of these issues can be addressed further to determine if they are viable solutions. The additional shaping material may not be acceptable if it were to increase the footprint of CLU installation. Also, while RAM may be a solution analysis would need to be conducted to determine if the RAM could withstand the blast of either a PAM or missiles housed in the VLS launcher.

f. Fratricide Analysis

With the addition of a new weapon system on DDG-51 class destroyer ships, fratricide becomes a bigger concern. NLOS-LS needs to be coordinated and scheduled with fratricide taken into account due to the relative slow speed of the PAM compared to other possible weapons. For example, NLOS-LS can be launched immediately after an SM-2 but there should be a delay in launching a SM-2 after a NLOS-LS launch to give the slower (on the order of five times slower) and smaller PAM

an opportunity to get clear of the ship and/or the SM-2 path. This potential issue between the weapon systems and PAM is beyond the scope of this paper and requires further analysis.

5. Safety Issues

When integrating NLOS-LS on the DDGs, safety is considered the highest priority. Currently, on all DDGs, Closed Circuit Televisions (CCTV) are used to ensure that the top deck is clear of personnel prior to a missile launch. Salvo warning alarms and lights are also required to be energized just before a launch to alert personnel on the weather deck of a pending launch. Finally, toxic vent dampers must also be cycled during a launch to ensure toxic gases released by a missile do not enter the ship and cause injury or death to personnel. These safety features would also be appropriate for PAM.

C. EVALUATION OF ISSUES

1. Notional Implementation

As a result of the physical installation analysis and applying the U.S. Navy's FMP process, NLOS-LS could be installed topside on the DDG-51 ship class. The size of the NLOS-LS is such that multiple units could and should be installed on-board to maximize effectiveness. The best location would be on the port and starboard sides of the aft MK41 VLS launcher. This location would minimize blockage and provide larger footprint area for which the NLOS-LS can operate. Procedures would need to be developed to determine how NLOS-LS will be utilized to eliminate fratricide. For example, a necessary delay will be determined by the intercept time of the PAM with its target and ensures that the missile is out of the near-vicinity of the ship before a SM launch. Radar cross section is important on this ship class and if by installing NLOS-LS topside increased the RCS dramatically, material could be shaped and installed around the launchers to minimize RCS. As with any system, the cabling requirements would need to be determined in order for the system to function.

The recommended location is the port and starboard locations of the aft VLS launcher as seen in Figure 40 (red circles) for both the DDG-51 Flight II and IIA ships. The following is a list of reasons for the following reasons:

- Maximizes the firing zones
- Minimal blockage
- Larger area for blast damage dispersion
- Less vertical infrastructure impact than forward option

The set of yellow circles provide an alternative location in the event that analysis shows that the SM-2 / Tomahawk blast radius is too large. It could also be used to site additional NLOS-LS modules if desired.

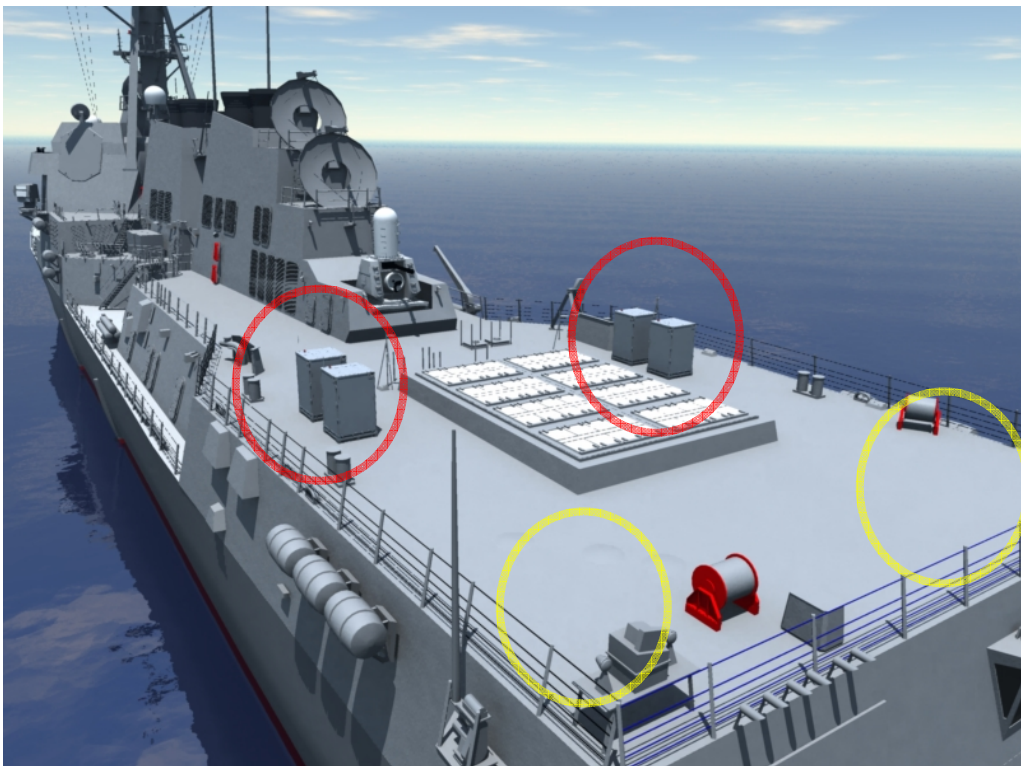

Figure 40: DDG-51 Topside Configuration⁴². The recommended location is the port and starboard locations of the aft VLS launcher for both the DDG-51 Flight II and IIA ships.

2. Risk Mitigation

⁴² Netfires LLC, “NLOS-LS (PAM/CLU) Accelerating Capability To the U.S. Navy” Presentation, provided by Raytheon for the project.

Figure 41 shows the issues that must be addressed when installing NLOS-LS on a DDG-51. Included in this table are a preliminary level of risk that is involved and a brief recommendation to resolve each issue. This figure presents a starting point for follow on studies that must be done to ensure a proper integration of the combat system. The level of risk is defined as follows:

- High – Significant Impact, Mission Critical
- Medium – Some Impact, Non Mission Critical
- Low – Minimal Impact, Non Mission Critical

| Integration Issues | Risk | Recommendations |
|--|---|--|
| Physical Location of CLU | Medium: <ul style="list-style-type: none"> • Blast Damage created by the PAM. • Physical obstructions of the flight path of the PAM | <ul style="list-style-type: none"> • Place the CLU near the rear VLS launcher. • The area near the VLS launcher has no obstructions to the flight path of a missile launch. |
| RCS Issues with CLU | Medium: <ul style="list-style-type: none"> • Increases the Radar Cross Section of the ship. | <ul style="list-style-type: none"> • Modify CLUs radar signature to reduce RCS |
| Integration with CIC | Low: <ul style="list-style-type: none"> • Available space in CIC. • Impact to other systems. | <ul style="list-style-type: none"> • Use the existing ATDC to minimize change to the CIC. |
| Integration with Radio | Medium: <ul style="list-style-type: none"> • Location of Antenna. | <ul style="list-style-type: none"> • Further investigation need to be done. |
| Integration with Sensors | High: <ul style="list-style-type: none"> • Data compatibility with existing sensors. • Need for a sensor that detects targets over the horizon. | <ul style="list-style-type: none"> • Use of the MH-60 and UAVs as a forward-looking sensor. |
| Safety Issues | Low: <ul style="list-style-type: none"> • Impact to the safety of the crew during a missile launch. | <ul style="list-style-type: none"> • Use current safety procedures during a missile launch. • Verify weather deck is clear by using the CCTV. • Ensure Toxic Vent Dampers are cycled. |
| Integration with Existing Ship Systems | Medium: <ul style="list-style-type: none"> • Incompatible data source | <ul style="list-style-type: none"> • Modify hardware and software for compatibility. |

| Integration Issues | Risk | Recommendations |
|-----------------------------|--|---|
| Environmental Effects | Medium: <ul style="list-style-type: none"> • Damage to equipment due to salt water, fog, temperature, solar radiation, shipboard shock and vibration. | <ul style="list-style-type: none"> • Examine the Army specification for NLOS environmental conditions. |
| Stabilization and Alignment | Low: <ul style="list-style-type: none"> • Unable to Launch due to Sea State and weather conditions. | <ul style="list-style-type: none"> • Initial tests demonstrate feasibility |
| Integration of C&D and WCS | Medium: <ul style="list-style-type: none"> • Hardware and Software change required | <ul style="list-style-type: none"> • Further investigation need to be done |

Figure 41: NLOS-LS Integration Risk Matrix. These issues and their respective risks must be addressed when installing NLOS-LS on a DDG-51.

The tasks involved with each integration issue have varying degrees of scope:

- Physical Location of CLU
 - Power/shipboard resources analysis (outside the scope of this study)
 - Blast damage analysis (completed by this study)
 - Fratricide analysis (outside the scope of this study)
- RCS Issues with CLU
 - RCS Impact on ship (completed by this study)
 - RCS Reduction (outside the scope of this study)
- Integration with CIC
 - Interface analysis of existing systems (completed by this study)
 - Implement communication interface with MFC's (outside the scope of this study)
- Integration with Radio
 - Conduct risk assessment of JTRS Radio (to be completed when JTRS is technologically ready)
- Integration with Sensors
 - Off-board sensor feasibility analysis (completed by this study)
- Safety Issues
 - Safety analysis (outside the scope of this study)
- Integration with Existing Ship Systems (such as WSN, NAVSSI, GCCS-M, and Cryptographic.)
 - Coordinate with ship systems (outside the scope of this study)
- Environmental Effects
 - Environmental Impact analysis (outside the scope of this study)

- Stabilization and Alignment
 - Launcher movement impact on missile launch (completed by Raytheon previously)
- Integration of C&D and WCS
 - Coordinate with C&D to implement interface (outside the scope of this study)

THIS PAGE INTENTIONALLY LEFT BLANK

IV. CONCLUSION

This system engineering integration project has focused on integrating the NLOS-LS onto the DDG-51 class destroyer. Prior to performing any analysis, this report addressed topics relevant to why NLOS-LS should be incorporated into the U.S. Navy. These topics included:

- NLOS-LS providing over the horizon fire support against multiple small craft threats
- The demonstrated capability of NLOS-LS in tests performed to date against small surface craft threats.
- The damage results by the PAM missile/warhead to a typical small craft.

The approach methodology of the project was the next logical step. A bottom-up approach was used because the project dealt with the integration of an existing weapon system, NLOS-LS, onto DDG-51 class ships. LCS related work was also researched as background to determine if any of the LCS concepts could be applied to the DDG-51. One concept, the MEC, appears to have application. The MEC could provide the interface between the AEGIS combat system and NLOS-LS. This concept was explored further in the combat system integration analysis.

The overall integration analysis was split into two parts: one part analyzed the physical installation issues while the other focused on the combat system integration issues.

The physical components of NLOS-LS consist of a CLU, CCS, and PAM. The Army concept of operations includes having all functional components of the NLOS-LS contained in a single unit, self-powered, and usable by a local or remote operator. Part of the integration analysis focused primarily on the physical components of the NLOS-LS system and how they would be installed on-board the DDG-51 class ships. The following points are the results of this analysis:

- The functionality of the CCS can be redistributed to the DDG's CIC. The CCS as built in the Army configuration contains the user interface, power, radio, antenna, GPS and interface to the missiles.

- NAVSSI is a possible source of navigation data
- WSN-7 can provide own ship's position information
- Ship power would be provided to NLOS-LS (this is included in the second study, currently in progress)
- The user interface would be relocated to CIC in a MFC
- The antenna would be relocated to the mast for a maximum range of 103 miles at a PAM height of 2000 feet
- The NLOS Radio would communicate with the CCS housed in the CLU
- Hardwire Ethernet cables would be required to provide two way communication between the NEP and the CLU and also between the CLU and the NLOS Radio

In addition to determining the physical interfaces, a location analysis was performed and a recommendation was made to install up to four CLU units on the port and starboard side of the aft VLS launchers. This analysis took into account the blockage zones, existing infrastructure, blast area, and cabling runs. Once the location was determined, further analysis was performed on the blast damage, environmental effects, stabilization and alignment, electromagnetic environmental effects, radar cross section, and fratricide. Time constraints limited the work done in these areas and a recommendation to conduct further work was provided and will be discussed shortly. Finally as part of the physical installation analysis, the FMP was briefly described as the governing process to follow when it was determined to integrate NLOS-LS with the DDG-51 class destroyer. The key point here is to recognize that NLOS-LS is a Type K SHIPALT because it is a permanent installation and is adding a capability not previously held.

The combat system integration first focused on the data interface paths. Although NLOS-LS could interface at a couple different points on the DDG, it was recommended to connect through the C&D data line. The C&D seemed a logical choice because it receives all of the sensor inputs as well as interfaces with the WCS. By incorporating the MEC functionality mentioned above, the C&D with MEC could provide the NLOS-LS with the communication path needed for engagements.

Once the data paths were determined, a series of Hatley-Pirbhai architecture diagrams were created showing the interactions of the different system components and how functions are traced to those components. AFD's were created for the NEP, CLU, PAM, and NLOS communications. In addition to the AFD's, a series of FFBD's were created, breaking down the NLOS-LS system behavior. The system behavior and associated drawings provide a high-level view of how NLOS-LS would plan and execute missions.

Areas that need to be addressed in future studies include: logistics, power interface requirements, optimal number and location of launchers on deck, maintenance, and lower level interfaces to the ship's existing combat systems.

1. For logistics, more in-depth analysis needs to be done to address issues such as individual canister storage (i.e. magazines), intra-ship movement, loading and reloading, spare parts, etc.
2. An analysis of ship support services including cable runs and lengths, minimum power requirements, and heating and ventilation concerns is required.
3. The optimal number of launchers and the location of the launchers will have to be addressed so that the NLOS-LS system has maximum capability without affecting other shipboard systems.
4. A list of maintenance requirements is needed for the NLOS-LS system to be integrated onto the DDG-51.
5. An in-depth study needs to be done on the lower-level interfaces to the ship's existing combat systems.
6. A detailed location and footprint analysis including missile blast impact and fratricide issues is necessary.
7. Environmental and electromagnetic effects need further research.
8. Alignment and stabilization issues need to be researched thoroughly.
9. Targeting data from the C&D data line with the inclusion of the MEC needs to be analyzed.
10. Scheduling and doctrine issues need to be further defined along with the issue of fratricide.

In closing, this project report focused on key integration issues. Using a system engineering approach to research the issues provides one with recommendations but more importantly awareness into other areas that must be further researched. While the scope of the project was limited to the issues addressed, the overall conclusion is that NLOS-LS can be integrated with DDG-51's AEGIS weapons system.

THIS PAGE INTENTIONALLY LEFT BLANK

APPENDIX A. CRADA DOCUMENT
FIRST AMENDMENT OF
COOPERATIVE RESEARCH AND DEVELOPMENT AGREEMENT
BETWEEN
NAVAL POSTGRADUATE SCHOOL
AND
RAYTHEON COMPANY

Per Article 11, NCRADA-NPS-05-0084, the Naval Postgraduate School (NPS) and Raytheon Company agree to amend the Cooperative Research and Development Agreement (CRADA), titled, "Maximizing The Utility of Shipboard System: Shipboard Missile Reloading and Integration Study" as follows:

1. Cover Page:

Naval Postgraduate School Principal Investigator

From: Jeffery Crowson, Code OR, 831.656.2618

To: Mike Green, Code SE, 831.656.1084

2. Article 3.1 is replaced in its entirety with:

3.1 **NPS** Personnel and Facilities

The Cooperative Work done by **NPS** will be performed under the program guidance of **Mike Green, PI, NPS** Code SE, who has the responsibility for the scientific and technical conduct of the Cooperative Work performed within the facilities of **NPS** or done on behalf of **NPS** by third parties in support of this Agreement.

RAYTHEON personnel who perform Cooperative Work at **NPS** facilities will be supervised by the **RAYTHEON** PI.

4. Article 5.1 is amended as follows:

Replace: Raytheon agrees to pay NPS \$100,000.

With: Raytheon agrees to pay NPS \$125,000.

5. Appendix A-1 is appended herein.

For Raytheon Company (Raytheon):

I, the undersigned, am duly authorized to bind Raytheon Company to the amendments of this Agreement and do so by affixing my signature hereto.

Entered into this ___ day of _____, 200_.

By: _____
SUSAN G. SLOJKOWSKI
Contracts Negotiator

For the Department of the Navy:

I, the undersigned, by 15 USC 3710a and Navy regulations, am duly authorized to bind the U.S. Navy to this Agreement and do so by affixing my signature hereto.

Entered into this ___ day of _____, 200_.

By: _____

APPENDIX A-1

STATEMENT OF WORK

BETWEEN

NAVAL POSTGRADUATE SCHOOL

AND

RAYTHEON COMPANY

NCRADA-NPS-05-0084

The Collaborators agree to perform the following tasks with options that can be executed in follow-on studies:

1.0 NPS will be responsible for the following tasks:

1.1 NLOS PAM Weapon System on DDG-51 Study:

NPS will be responsible for working with the Naval Surface Warfare Center Port Hueneme Division (NSWC PHD) on the tasks described in Figure 1 and will submit a final report to Raytheon.

The effort will be covered in two phases with the sub-tasks of each phase listed in Figure 1. Raytheon will provide up to \$25,000 for completion of the Phase I tasks listed in Figure 1 below. Raytheon will have an option to execute Phase II for up to \$25,000 in additional funds. The period of performance for Phase 1 is six months from execution. The period of performance will be determined for Phase 2 if the option is exercised.

1.2 NPS, along with NSWC will ensure that any RAYTHEON proprietary models or data for future weapons and sensor technologies are not released to outside contractors or foreign students.

1.3 During each phase of this project NPS working with NSWC will submit hard copies and electronic copies of the following reports:

1.3.1 A “Start-Up Status Report” at the beginning of the CRADA, summarizing thoughts and issues prior to beginning work. This should include a schedule showing baseline milestones and a projected spending plan.

1.3.2 “Status Reports” (interim reports, at 1 month intervals) describing NPS/NSWC PHD progress, findings, problems encountered, etc.

1.3.3 Phase I and Phase II Final Reports describing the completed project, and incorporating all findings and work completed, summarizing problems encountered and unresolved issues, as well as suggestions for the direction of future work.

1.3.4 NPS will coordinate a final debriefing at PHD in PowerPoint format.

2.0 **RAYTHEON** will be responsible for the following tasks:

2.1 Provide RAYTHEON weapon systems data of interest to NPS and NSWC PHD through the Technical Interchange Meeting Format required by NSWC PHD.

2.2 Provide direction to NPS/NSWC PHD on technical matters relevant to all tasks.

3.0 **NPS and RAYTHEON** will be responsible for the following joint tasks:

3.1 Raytheon will review all reports produced by NPS/NSWC PHD and provide feedback and critiques as necessary and relevant. NPS working with NSWC PHD will respond to this feedback and critiques and incorporate them into a revised document. Each party will have 30 days to respond to the other and this process will continue for a single iteration.

3.2 Both NPS working with NSWC PHD and Raytheon will hold a joint “Kick-Off” meeting to establish a conduit for the sharing of data and technical expertise as needed.

FIGURE 1 – WORK SCHEDULE

| System Analysis | Phase I Subtasks | Phase II Subtasks |
|----------------------------|------------------------------|---|
| C2 Integration | Target Designation CONOPS | Fire Inhibit |
| | IFF | Break Engage |
| | Local Control | Battleshort |
| | Displays | Fratricide |
| Safety | Firing Cutouts | Hangfire/Dud Procedures |
| | HERO levels | Aviation Interference |
| Installation | Location footprint | Ballistic Protection (if needed) |
| | Mech/Elec Interface | Corrosion Control |
| | RCS Reduction | Installation and Fielding |
| | Grounding | Installation and verification testing |
| | SHIPALT Prep | |
| | Conjunctive ORDALT Prep | |
| Test and Evaluation | | Operational Test Plan |
| | | Test Conduct |
| | | Use of Self-Defense Test Ship (SDTS) |
| | | Surface Targets |
| | | Range Time / Scheduling |
| | | Surface Targets |
| | | Range Time / Scheduling |
| Logistics | | Interactive Electronic Technical Manuals |
| | | Sparing Plan / On-Board Allowance / On-Board Repair Parts |

THIS PAGE INTENTIONALLY LEFT BLANK

APPENDIX B. PAM BASELINE WARHEAD CALCULATION

The calculations for PAM Baseline Warhead are based on the following formulas⁴³:

1. The initial velocity of fragments of warhead:

$$V_0 = \sqrt{2\Delta E} \sqrt{\frac{C/M}{1 + K(C/M)}},$$

Where:

$\sqrt{2\Delta E}$ = the Gurney Constant for the explosive material.

C = explosive weight

M = weight of the casing

K = configuration constant (flat plate=1/3, cylinder=1/2, sphere=3/5)

2. The fragment's velocity as a function of distance (S) traveled:

$$V_s = V_0 e^{-C_d \rho \frac{A}{2m} s},$$

Where:

ρ = the density of air, normally 1.2 kg/m³

V_0 = the fragment velocity

C_d = the coefficient of drag. (Depends on the shape of the fragment and to some extent, the velocity)

A = the cross-sectional area of the fragment (m²).

m = mass of individual fragment (kg)

3. The kinetic energy equation relates mass of the fragment to its velocity at range S:

$$KE = (1/2)mv_s^2,$$

Where:

KE = kinetic energy (J)

m = mass of individual fragment (kg)

V_s = velocity at range S (m/s)

4. The expected number of fragments hitting the target:

$$N_{hits} = A(N_0 / 4\pi R^2)$$

Where:

N_{hits} = the expected number of fragments hitting the target;

N_0 = the initial number of fragments from the warhead;

A = the frontal area of the target presented to the warhead; and

R = the range of the target to the warhead.

⁴³ Commander, Naval Ordnance Systems Command. *Weapons Systems Fundamentals*. NAVORD OP 3000, vol. 2, 1st Rev. Washington, D.C.: GPO, 1971.

5. When estimating the P_k from a fragmentation warhead, you must take into account the number of fragments that are expected to hit the target. Multiple hits must be handled appropriately. To wit, the correct manipulation of probabilities. For multiple hits the overall P_k is found from

$$P_k = 1 - (1 - P_{k|hit})^{N_{hits}}, \text{ if } N_{hits} > 1, \text{ or } P_k = N_{hits} P_{k|hit}, \text{ if } N_{hits} < 1$$

6. The Lethal Radius (LR) of the weapon:

$$P_k = 1 - 0.5 \left(\frac{LR}{CEP} \right)^2; LR = \sqrt{\frac{\ln(1 - P_k)}{\ln(0.5)}} (CEP),$$

Where:

CEP = the Circular Error Probable of the weapon;

NOTE: The calculations for PAM Baseline Warhead are based on assumptions of BOFORS 3P rounds data.

|  | 40 mm 3P IM | 57 mm 3P IM |
|---|-----------------|-----------------|
| Total weight (kg) | 2.5 | 6.2 |
| Weight of shell (kg) | 0.975 | 2.4 |
| Weight of explosive (PBX) | 0.120 kg | 0.460 kg |
| Total length (mm) | 534.4 | 675.3 |
| IM capability in acc. with SE Req./MIL-STD 2105B | Yes | Yes |
| Number of fragments | >3000 | >8000 |
| Muzzle Velocity (+21°C) | 1012 m/s | 1035 m/s |

Figure 42: BOFORS 3P Round Data. The BOFORS 3P rounds data represented by BOFORS Defense AB, A United Defense Company on June 2002⁴⁴.

The data for PAM Baseline warhead:

Length: ~ 7.94 in
 Diameter: 7.00in
 Total weight: 16.07lbs (~7.29 kg)
 Weight of explosive: 7.89lbs (~3.58 kg)

⁴⁴ BOFORS DEFENCE, *BOFORS 3P and System Concept*, Presentation by Mr. Michael Boren, June 2002.

Range: 40 km (~21.60 nautical miles)

Calculations:

1. Calculate the number of fragments of PAM baseline warhead (base on the radio of 3P rounds data).

$$(7.29/2.5)*3000 \approx 8748$$

$$(7.29/6.2)*8000 \approx 9406$$

$$\text{The average} \approx (8748 + 9406)/2 \approx 9077$$

$$\text{Mass of individual fragments: } 7.3/9077 = 0.0008 \text{ kg}$$

2. Calculate the velocity at range S (m/s). Assuming small surface crafts target has 20kJ fragment energy of heavy damage.

$$KE = (1/2)mV_s^2$$

$$20 = (1/2)(0.0008)V_s^2 \quad \rightarrow \quad V_s \approx 223.60$$

3. Calculate the initial velocity of the fragments of warhead.

$$V_0 = \sqrt{2\Delta E} \sqrt{\frac{C/M}{1 + K(C/M)}}$$

Gurney Constant for the explosive material is PBX-9404 ≈ 2637 m/s

$$C/M = (3.58/7.29) \approx 0.49$$

K=1/2 for cylinder

$$1 + (1/2)(0.49) \approx 1.245$$

$$V_0 = (2637)\text{Sqrt}\{(0.49)/(1.245)\} \approx 1654.34 \text{ m/s}$$

4. Calculate the distance traveled (assuming the coefficient of drag is 0.5, and the cross-sectional area of the fragment is 1m^2).

$$V_s = V_0 e^{-C_d \rho \frac{A}{2m} s}$$

$$S = \{\ln(V_s/V_0)\} / \{-\rho C_d (A/2m)\}$$

$$S \approx \{\ln(223.60/1654.34)\} / \{-(1.2)(0.5)(1/(2(0.0008)))\} \approx 1.8 \text{ m}$$

5. Calculate the expected number of fragments hitting and probability of kill of the target.

The frontal area of the target presented to the warhead is

$$2.7\text{m} \times 10.1\text{m} \approx 27.13 \text{ m}^2 \text{ RAC.}$$

$$N_{hits} = A(N_0 / 4\pi R^2)$$

$$N_{\text{hits}} = 3(27.13)/(4\pi(1.8)^2) = 2.$$

The probability heavy damage of small surface crafts is $6/24=0.25$ from Raytheon chevron formation simulation.

Therefore,

$$P_k = 1 - (0.25)^2 = 0.9375.$$

6. Calculate the Lethal Radius (LR) of the PAM.

CEP = the radius of the circle that can be drawn to include 1/2 of the warheads (base on the radio of 3P rounds data, PAM has approximately twice of CEP $2 \times 400\text{m}^2 = 800\text{m}^2$).

$$LR = \sqrt{\frac{\ln(1 - P_k)}{\ln(0.5)}} (CEP) = \sqrt{\frac{\ln(1 - 0.9375)}{\ln(0.5)}} (800\text{m}^2)$$

$$LR = 1600 \text{ m}^2$$

APPENDIX C. ARENA MODEL

A. ARENA MODEL

The objective of the ARENA Model is to better understand the NLOS-LS operational sequence in naval combat environments and evaluate system performance. It was developed with the intent to insert usable data to reflect the actual NLOS-LS environment. Due to the fact that this system data was not available during the time period of this study, the simulation provided only speculative results. Further work can be carried out with more accurate data to understand the performance of NLOS-LS better. The model will be used to analyze the number of missiles needed and the number of threats disposed to NLOS-LS or another weapon system.

B. MODEL EXPLANATION

There are four parts to model the scenario of a single inbound target, detected at the maximum range. The first part of the model shows the off-board sensor search, detect, and track of targets. The second part of the model shows the off-board sensor providing targets' data to naval ship's target database system. The ship will process the data and make the decision to engage either to the NLOS-LS or another weapon system on-board the ship. The third part of the model shows the schedule of engagements already made for NLOS-LS. The NEP will receive NAVSSI's almanac data, WSN's GPS alignment data, COP's track data, COMMS's communication/tasking data, and sensor's target data. When all the data is received, the NEP will select a PAM to spin up and upload mission data. The final part of the model shows a PAM that is in-flight. During a PAM in-flight mission, the target data will update continuously. If the target survives the first PAM engagement, the NEP will command another engagement.

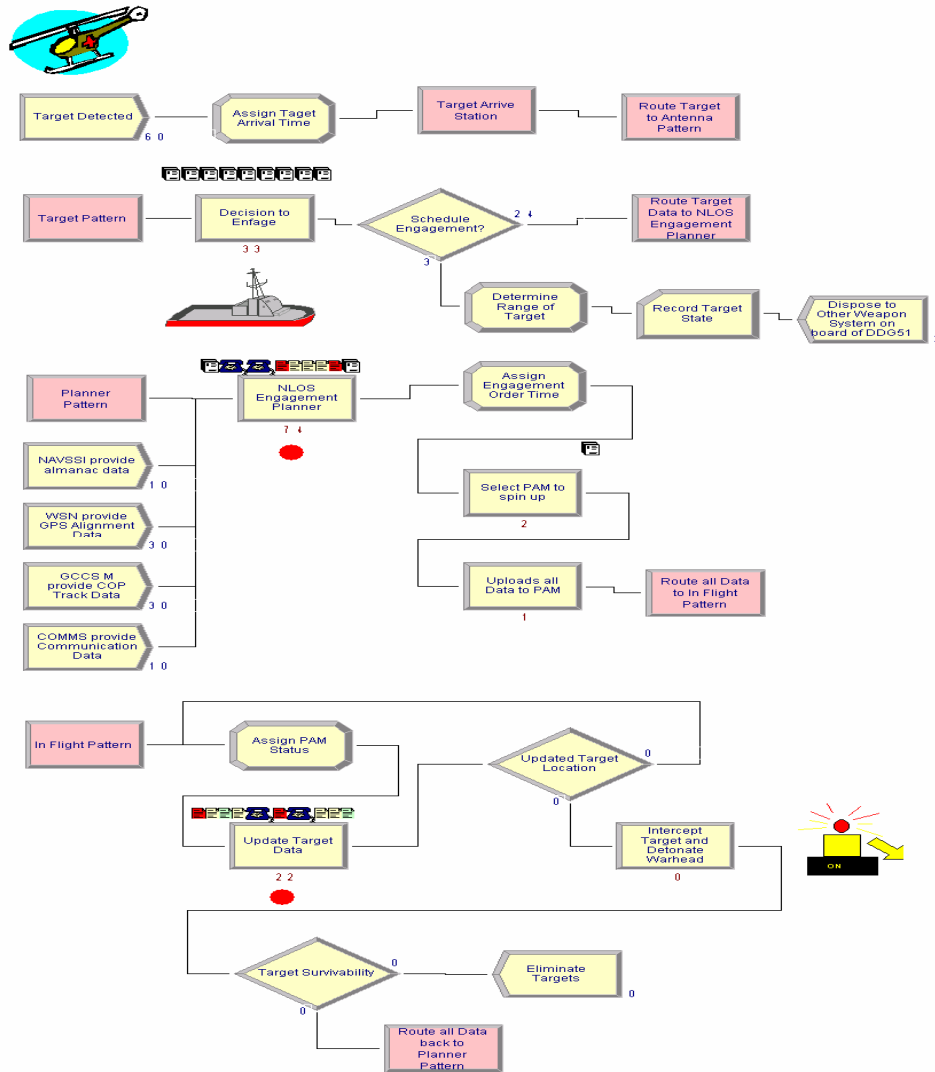

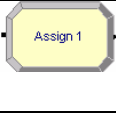



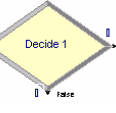
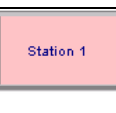
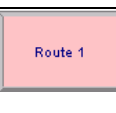







Figure 43: Detect-Track-Engage Sequence for NLOS-LS. The objective of the ARENA Model is to better understand the NLOS-LS operational sequence in naval combat environments and evaluate system performance.

C. BASIC ANIMATION AND EXPLANATION

| Symbols | Description |
|---|--|
|  | The CREATE block generates arriving entities to a process model. |
|  | The ASSIGN block is used for assigning new values to variables. |
|  | The PROCESS block is intended as the main processing method in the simulation. |
|  | The DISPOSE block immediately disposes of any arriving entities. |
|  | The RECORD block is used to collect statistics in the simulation model. |
|  | The DECIDE block allows for decision-making processes in the system. |
|  | The STATION block represents a point in the model to which entities are transferred. |
|  | The ROUTE block transfers the entity in Duration time units to the station specified by the operand Destination. |
|  | This picture represents the off-board sensor (MH-60R). |
|  | This picture represents the DDG-51. |
|  | This picture represents the target data, communication/tasking data, GPS alignment data, track data, and almanac data. |
|  | This picture represents a busy signal in the PROCESS block. |
|  | This picture represents the target intercept point and detonated warhead. |

THIS PAGE INTENTIONALLY LEFT BLANK

APPENDIX D. AN/SPY 1 RADAR HORIZON CALCULATION

The formula for the distance to the radar horizon is:⁴⁵

$$\text{Distance to the radar horizon } R = (2 \cdot ((4/3) \cdot R_{\text{earth}}) \cdot h)^{0.5}$$

The radius of the earth at the equator is 6378155 m.

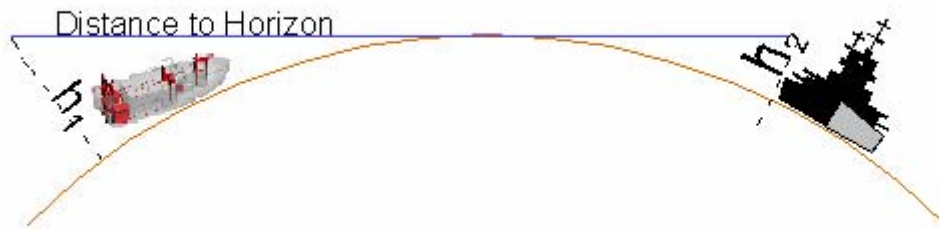

Assume 60 ft (18.28800m) antenna height
5 ft (1.52400m) height of the target.

The radar horizon for antenna height
 $(2 \cdot (4/3) \cdot 6378155 \cdot 18.28800)^{0.5} = 17636.61\text{m}$

The radar horizon for target height
 $(2 \cdot (4/3) \cdot 6378155 \cdot 1.52400)^{0.5} = 5091.25\text{m}$

The horizon limitation is

$$17636.61\text{m} + 5091.25\text{m} = 22727.85\text{m} = \mathbf{22.7 \text{ km}}$$

⁴⁵ Introduction to Airborne Radar Website, "Radio Waves and Alternating Current Signals", 1997, available from the internet, <http://radarproblems.com/chapters/ch04.dir/ch04pr.dir/c04p3.dir/c04p3.htm>, access date 25 Oct 06.

THIS PAGE INTENTIONALLY LEFT BLANK

APPENDIX E. RCS CALCULATION

The below calculations will show the CLU RCS and the DDG 51 at a frequency of 9 GHz. The DDG was calculated using a simple empirical expression that permits the cross section to be expressed in terms of the ship's displacement and the radar frequency.⁴⁶

Assumption: The worst-case scenario is when the CLU is seen as a flat plate.

$$RCS = \sigma = \frac{4\pi a^2}{\lambda^2}$$

$$a_{CLU} = h_{CLU} * w_{CLU}$$

$$\lambda_{9GHz} = \frac{c}{f} = \frac{3 * 10^8 \frac{m}{s}}{9GHz} = 0.03m$$

$$\lambda_{9GHz}^2 = 0.009m^2$$

$$h_{CLU} = 1.88m$$

$$w_{CLU} = 1.14m$$

$$a_{CLU} = (1.88m)(1.14m) = 2.14m^2$$

$$a_{CLU}^2 = 4.58m^4$$

$$RCS_{CLU} = \sigma_{CLU} = \frac{4\pi a_{CLU}^2}{\lambda_{9GHz}^2} = \frac{4\pi(4.58m^4)}{0.009m^2} = 2.99 \times 10^4 m^2$$

Converting this to dB :

$$10 \log(2.99 \times 10^4 m^2) = 44.8dB$$

⁴⁶ Nathanson Fred E., Reilly J. Patrick, Cohen Marvin N., *Radar Design Principles Signal Processing and the Environment 2nd Edition*, Mendham NJ: Scitech Publishing Inc., 1999, pages 182-183.

Assumption: The average of the cross section for the DDG-51 was taken about the port and starboard bow and quarter aspects of the ship. The simple empirical expression is as follows:

$$RCS_{DDG} = \sigma_{DDG} = 52 f_{MHz}^{\frac{1}{2}} (D_{ktons}^{\frac{3}{2}}) m^2$$

$$f = 9000 MHz$$

$$Displacement = D = 9.4 ktons$$

$$RCS_{DDG} = \sigma_{DDG} = 52(9000)^{\frac{1}{2}}_{MHz} ((9.4^{\frac{3}{2}})_{ktons}) m^2 = 1.42 \times 10^5 m^2$$

Converting this to dB :

$$10 \log(1.42 \times 10^5 m^2) = 51.5 dB$$

Now that the RCS for the CLU and DDG have been calculated and converted to dB, a power addition is performed to show the additional RCS the CLU has on the DDG.

Combining Power Levels By Decibel Addition

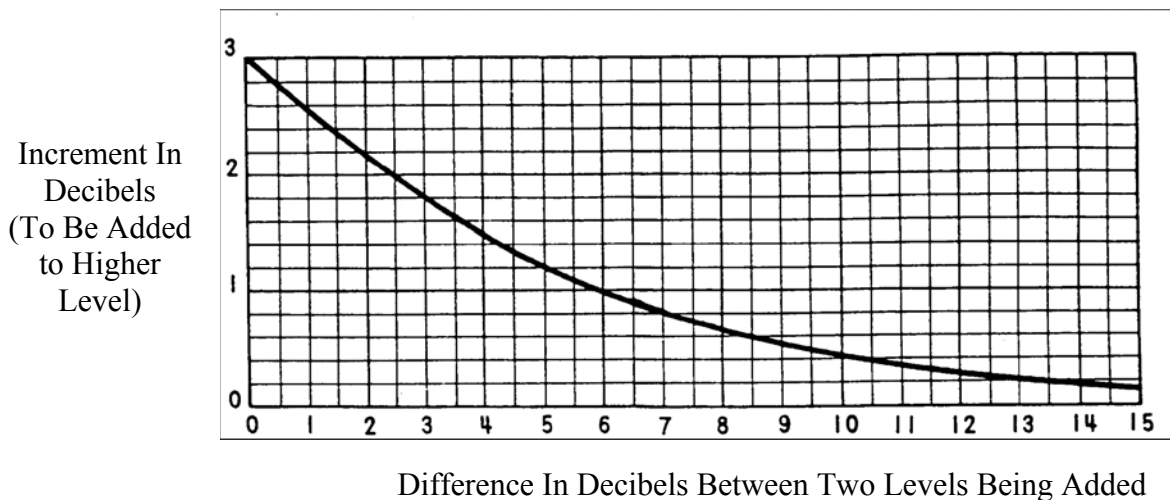

Difference in between the DDG and the CLU is $51.5 dB - 44.8 dB = 6.7 dB$. Using the graph above the Increment in dB to be added to the higher level or the DDG is roughly 0.85dB.

Therefore the new total RCS of the DDG with a single CLU added is 52.35dB. Performing this calculation for another CLU if two are installed on the same side of the DDG results is a total RCS of 53.1dB.

The comparison shows that the addition of two CLU's would only add 1.6dB. This accounts for the worst case scenario and can be minimized further by using RCS reduction techniques.

APPENDIX F. LIST OF REFERENCES

- Blanchard, Benjamin S., Wolter J. Fabricky, *Systems Engineering and Analysis 3rd Edition*, Upper Saddle River, NJ: Prentice Hall, 1998.
- BOFORS DEFENCE, *BOFORS 3P and System Concept*, Presentation by Mr. Michael Boren, June 2002.
- Buede, Dennis M. *The Engineering Design of Systems- Models and Methods*, New York, NY: John Wiley & Sons, Inc. 2000.
- Commander, Naval Ordnance Systems Command. *Weapons Systems Fundamentals*. NAVORD OP 3000, vol. 2, 1st Rev. Washington, D.C.: GPO, 1971.
- Deagel Website, “MH-60R STRIKEHAWK-MULTI-MISSION NAVAL HELICOPTER, USA”, 2006, available from the internet, <http://www.deagel.com/pandora/index.aspx?p=pm00101010>, access date on 6 Oct 2006.
- Emerson, Laflamme, and Cunningham. *NLOS Systems for the modular and Future Forces*, Field Artillery, Nov-Dec 2004, page 7-11.
- E3 and SM Assessment Guide for Operational Testing*, Director Operational Test and Evaluation DOT&E, 13 June 2001.
- FAS Website, “AN/SPY-1 Radar”, 2000, available from the internet, <http://www.fas.org/man/dod-101/sys/ship/weaps/an-spy-1.htm>, access date on 6 Oct 2006.
- FAS Website, “UAV Annual Report FY1996”, 6 November 1996, available from the internet, <http://www.fas.org/irp/agency/daro/uav96/page35.html>, access date on 8 Nov 2006.
- Federation of American Scientist Website, “DDG-51 Arleigh Burke-class”, 01 December 2005, <http://www.fas.org/man/dod-101/sys/ship/ddg-51.htm>, access date on 6 Oct 2006.
- Fleet Modernization Program Management and Operations Manual – Revision 2*, Commander, NAVSEA Systems Command, 10 June 2002.
- Forsberg K., & Mooz, H., The Relationship Of Systems Engineering To The Project Cycle, *Engineering Management Journal*, Vol. 4, No. 3 September 1992, pp. 36-43.

- Fowler, Northrup III, Dr. (Chief Scientist), Dr. Paul W. Phister, Jr., and Mr. Igor G. Plonisch, of the Air Force Research Laboratory's Information Directorate, and Dr. Robert L. Herklotz, of the Air Force Office of Scientific Research, "Command and Control", April 2004, available from the internet, <http://www.afrlhorizons.com/Briefs/Apr04/IF0319.html>, access date on 6 Oct 2006.
- Future Combat System (Brigade Combat Team) White Paper*, FCS Program Manager, 11 April 2006, available from the internet, www.army.mil/fcs/resources/FCS%20White%20Paper.pdf, access date on 6 Oct 2006.
- Government Accountability Office, *DEFENSE ACQUISITIONS, Restructured JTRS Program Reduces Risk, but Significant Challenges Remain*, GAO Report 05-669, June 2005.
- Global Security Website, "AN/SPY-1 Radar", April 2005, available from the internet, <http://www.globalsecurity.org/military/systems/ship/systems/an-spy-1.htm>, access date on 6 Oct 2006.
- Global Security Website, "Non-Line-of-Site Launch System (NLOS-LS)", November 2005, www.globalsecurity.org/military/systems/munitions/net-fires.htm, access date on 6 Oct 2006.
- Harpoonhq Website, "CG 16 Leahy (1987/NTU)", 1987, available from the internet, http://www.harpoonhq.com/encyclopedia/HTML_Files/Ships/249.htm, access date on 4 March 2007
- Hatley, Derek, Peter Hruschka, and Imtiaz Pirbhai. *Process for System Architecture and Requirements Engineering*. New York, NY: Dorset House Publishing, 2000.
- Introduction to Airborne Radar Website, "Radio Waves and Alternating Current Signals", 1997, available from the internet, <http://radarproblems.com/chapters/ch04.dir/ch04pr.dir/c04p3.dir/c04p3.htm>, access date 25 Oct 06.
- Lockheed Martin Website, "NLOS-LS", 2006, available from the internet, http://www.missilesandfirecontrol.com/our_products/firesupport/NLOS-LS/product-NLOS-LS.html, access date on 6 Oct 2006.
- Lockheed Martin Website, "Precision Attack Missile (PAM)", 2004, available from the internet, <http://www.defense-update.com/products/p/pam.htm>, access date on 10 Feb 2007.

MIL-STD-810F Test Method Standard for Environmental Engineering Considerations and Laboratory Tests, Department of Defense, 1 January 2000.

Nathanson Fred E., Reilly J. Patrick, Cohen Marvin N., *Radar Design Principles Signal Processing and the Environment 2nd Edition*, Mendham NJ: Scitech Publishing Inc., 1999.

Naval Air Warfare Center, Weapons Division, *Electronic Warfare and Radar Systems Engineering Handbook*, NAWCWPNS TP 8347: Naval Air Systems Command, 1 April 1997.

Naval Surface Warfare Center (Dahlgren Division), “*NLOS-LS, 30mm Gun Weapons System, and SUW Mission Module, Test and Evaluation Status and Path Forward*”, presentation, provided by Paul Lefeave, March 17, 2006.

Naval Transformation Roadmap 2003. Anti-Surface Warfare, available from the internet, <http://www.chinfo.navy.mil/navpalib/transformation/trans-pg31.html>, access date on 6 Oct 2006.

Navy Training System Plan Guided Missile Submarine Nuclear Powered (SSGN) Attack Weapon System, Strategic System Program, 25 November 2003.

Netfires LLC, “NLOS-LS (PAM/CLU) Accelerating Capability To the U.S. Navy” Presentation, provided by Raytheon for the project.

Netfires LLC, “Precise and Persistent Naval Fires Non-Line of Sight Launcher System (NLOS-LS)” Presentation, provided by Raytheon for the project.

OD 63835 Attack Weapon Control System Concept of Operations, Strategic System Program, 1 April 2003.

Ohio State University Website, “GLOBAL POSITION, VELOCITY, AND TIME DETERMINATION ACQUISITION MASTER PLAN”, 23 August 1997, available from the internet, <http://geodesy.eng.ohio-state.edu/course/g609/AMP823.html>, access date on 6 Oct 2006.

Pacific Crest Corporation Application Note, “UHF/VHF Range Calculations”, 2007, available from the internet, www.paccrst.com/downloads/application_notes/AppNote_UHF_VHF_Calc.pdf, access date on 6 Mar 2007.

Performance Specification For The Non-Line of Sight - Launch System (NLOS-LS) Precision Attack Missile (PAM) Radio, Raytheon Company, 31 January 2006.

Program Executive Officer Cruise Missile Project and Unmanned Aerial Vehicle Joint Project Office, *Integrated Test Plan for Tomahawk Weapons Control System AN/SWG-4(V) T3L4 & TL4*, 25 December 1998.

Raytheon Missile Systems, *NLOS-LS Integrated Logistics Strategy Report Rev. A* (Document No. 2259985), Tucson, AZ, September 2005, pg 2.

Raytheon website, “NetFire LLC Awarded”, Aug 2006, available from the internet, <http://www.preneswire.com/micro/RTNB12>, access date on 6 Oct 2006.

Raytheon website, “Non-Line of Sight-Launch System (NLOS-LS) Product Data sheet”, 2006, available from the internet, http://www.raytheon.com/products/stellent/groups/public/documents/content/cms_01_055756.pdf, access date on 6 Oct 2006.

Raytheon Website, “Standard Missile-2: International Fleet Defense”, 2006, available from the Internet, http://www.raytheon.com/products/stellent/groups/public/documents/content/cms_01_055768.pdf, access date on 25 Oct 2006.

Spacewar website, “NetFires Conducts Navy Ballistic Flight Test For NLOS-LS Missile”, Staff Writer, 29 March 2006, available from the internet, http://www.spacewar.com/reports/NetFires_Conducts_Navy_Ballistic_Flight_Test_For_NLOS_LS_Missile.html, access date on 6 Oct 2006.

Standard Navy Cooperative Research and Development Agreement Between Naval Postgraduate School and Raytheon Company. Agreement No. NCRADA-NPS-05-0084, 7 Jan 2006, Page 41, Section 1.1.

Tpub Website, “Aegis Combat System”, 2000, available from the internet, http://www.tpub.com/content/administration/12966/css/12966_356.htm, access date on 6 Oct 2006.

APPENDIX G. ACRONYM LIST

| | |
|---------|---|
| AAW | Anti-Air Warfare |
| ACS | Aegis Combat System |
| AFCD | Architecture Flow Context Diagram |
| AFD | Architecture Flow Diagram |
| ASW | Anti-Submarine Warfare |
| ATDC | Advanced Tactical Display Consoles |
| ATR | Automatic Target Recognition |
| AUR | All Up Round |
| AWS | Aegis Weapons System |
| BDI | Battle Damage Imagery |
| BDII | Battle Damage Indication Imagery |
| BFI | Battle Force Interoperability |
| BIT | Built-In Test |
| CCS | Computer and Communications System |
| CCTV | Closed Caption Television |
| CEP | Cooperative Engagement Planner |
| CFE | Call For Fire |
| CIC | Combat Information Center |
| CIWS | Close-In Weapon System |
| CLU | Container Launch Unit |
| CO | Commanding Officer |
| COA | Course of Action |
| COP | Common Operational Picture |
| CPM | Centrally Provided Material |
| CRADA | Cooperative Research and Development Agreement |
| CS | Combat System |
| C2 | Command and Control |
| C&D | Command and Decision |
| DARPA | Defense Advanced Research Projects Agency |
| DOTMLPF | Doctrine, Organization, Training, Materiel, Leadership and Education, Personnel and Facilities |
| EMC | Electromagnetic Compatibility |
| EMI | Electromagnetic Interference |
| EMP | Electromagnetic Pulse |
| EMV | Electromagnetic Vulnerability |
| EO/IR | Electro-Optics and Infrared |
| EP | Electronic Protection |
| ESM | Electronic Support Measures |
| E3 | Electromagnetic, Environmental Effects |
| FC | Fire Controlman |
| FCS | Future Combat Systems |
| FFBD | Functional Flow Block Diagram |

| | |
|----------|---|
| FLIR | Forward Looking Infrared |
| FLTCINC | Fleet Commander in Chief |
| FMP | Fleet Modernization Program |
| GCCS-M | Global Command and Control System-Maritime |
| GPS | Global Positioning System |
| HCPM | Headquarters Centrally Provided Material |
| HERF | Hazards of Electromagnetic Radiation to Volatile Materials |
| HERO | Hazards of Electromagnetic Radiation to Ordnance |
| HERP | Hazards of Electromagnetic Radiation to Personnel |
| HMMWV | High Mobility Multipurpose Wheeled Vehicle |
| ICD | Initial Capabilities Document |
| IMA | Intermediate Maintenance Activity |
| INS | Inertial Navigation System |
| IR | Infrared |
| JCF | Justification/Cost Form |
| JCIDS | Joint Capabilities Integration and Development System |
| JROC | Joint Requirements Oversight Council |
| JTRS | Joint Tactical Radio System |
| LCS | Littoral Combat Ships |
| MEC | Module Engagement Control |
| MFC | Multi-Function Console |
| MP | Mission Package |
| MTI | Moving Target Indicator |
| NAVSSI | Navigation Sensor System Interface |
| NEP | NLOS Engagement Planner |
| NFCS | Naval Fires Control System |
| NLOS-LS | Non-Line of Sight Launching System |
| NSWC PHD | Naval Surface Warfare Center Port Hueneme Division |
| PAM | Precision Attack Missile |
| PMI | Proposed Military Improvement |
| PSARE | Process for System Architecture and Requirements Engineering |
| RAM | Radar Absorbent Material |
| RCS | Radar Cross Section |
| RF | Radio Frequency |
| SAL | Semi-Active Laser |
| SAR | Ship Alteration Record |
| SC | Spectrum Certification |
| SDD | System Design and Development |
| SFF | Small Form-Factor |
| SHIPALT | Ship Alteration |
| SM | Spectrum Management |

| | |
|--------|---------------------------|
| SM-2 | Standard Missile-2 |
| STRIKE | Strike Officer |
| SuW | Surface Warfare |
| TLE | Target Location Error |
| TYCOM | Type Commander |
| UA | Unit of Action |
| UAV | Unmanned Aerial Vehicle |
| USV | Unmanned Surface Vehicle |
| VLS | Vertical Launching System |
| WCS | Weapon Control System |
| WEPS | Weapons Officer |
| XO | Executive Officer |

THIS PAGE INTENTIONALLY LEFT BLANK

INITIAL DISTRIBUTION LIST

1. John M. Green
MSSE Project Advisor
Naval Postgraduate School
San Diego, CA
2. Dr. David H. Olwell
Chairman, Department of Systems Engineering
Naval Postgraduate School
Monterey, CA
3. Edouard Kujawski
Department of Systems Engineering
Naval Postgraduate School
Monterey, CA
4. Jonathon Emis
MSSE Cohort #4, NSWC PHD
Port Hueneme, CA
5. Bryan Huang
MSSE Cohort #4, NSWC PHD
Port Hueneme, CA
6. Timothy Jones
MSSE Cohort #4, NSWC PHD
Port Hueneme, CA
7. Mei Li
MSSE Cohort #4, NSWC PHD
Port Hueneme, CA
8. Don Tumbocon
MSSE Cohort #4, NSWC PHD
Port Hueneme, CA