

23 May 1978 (Supersedes LO F432234 12, 14 March 1976)

**PUMP, CENTRIFUGAL, SELF-PRIMING, GASOLINE ENGINE DRIVEN,  
WHEEL MOUNTED, 6-INCH, 1500 GPM CAPACITY AT 60 FOOT  
HEAD (PEABODY BARNES MODEL US90CCG-1) W/ENGINE  
CONTINENTAL MODEL FS244-6100P**

Reference: C9100-IL

Intervals and related task-hour timer are based on normal hours of operation. The task-hour time specified is the time you need to do all the services prescribed for 1 particular interval. Change the interval if your lubricants re contaminated or if you are operating the equipment under adverse operating condition, including longer-than usual operating hours. You may extend the interval during periods of low activity, but you must take adequate preservation precautions.

\*The time specified is the time required to perform all services at the particular interval.

Clean fittings before lubricating. Relubricate all arm ex-pose to water after amphibious operation. Lubricate points indicated by dotted arrow shaft on both side of equipment

Clean part with SOLVENT, dry cleaning, or with OIL, fuel, diesel. Dry before lubricating. Drain crankcase when HOT. Fill end check level. The lowest level of maintenance authorized to lubricate a point is indicated by one of the following: (C) Operator/crew; or (O) Organizational Maintenance.

You can help improve this publication. If you find any mistake or if you know of a way to improve the procedures, people let us know. Your letter or DA Form 2028 (Recommended Changes to Publication and Blank Form) should be mailed directly to: Command, U.S. Army Troop Support & Aviation Materiel Readiness Command, ATTN: DRSTS-MTPS, 4300 Goodfellow Blvd. St. Louis, MO G3120. A reply will be furnished to you.

*TOTAL TASK-HR		*TOTAL TASK-HR	
INTERVAL	TASK-HR	INTERVAL	TASK-HR
10	0.1	150	0.5
50	0.3	2000	2.0

FOLD

FOLD

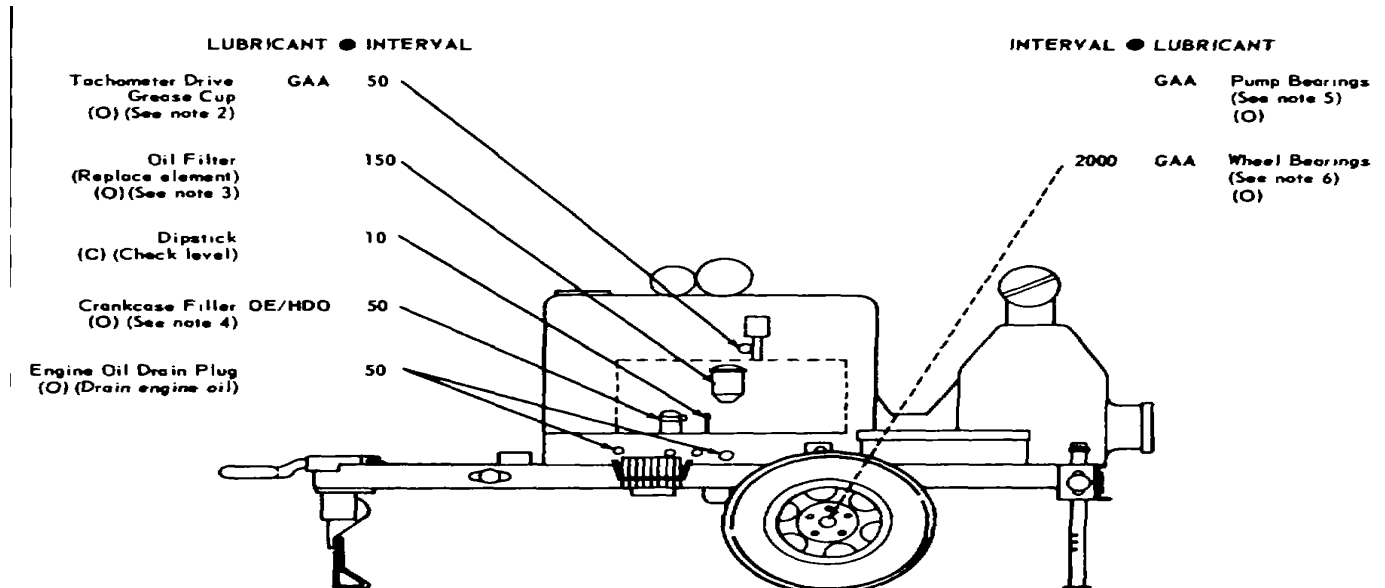

LUBRICANTS	REFILL CAPACITY (APP)	-KEY- EXPECTED TEMPERATURES			INTERVALS
		Above +32°F Above 0°C	+40°F to -10°F + 5°C to -230C	0°F to -65°F -18°C to -50°C	
OE/HDO LUBRICATING OIL. (MIL-L-2104C) Engine Crankcase (See note 3) Oil Can Points	4.5 qt (4.2L)	OE/HDO 30	OEA/APG-PD-1	OEA/APG-PD-1	Intervals given are in hours of normal operation.
OEA/APG-PD-1 Oil, Engine, Subzero GAA GREASE, Auto & (MIL-G-10024) Artillery		All Temperatures			

NOTES:

- FOR OPERATION OF EQUIPMENT IN PROTRACTED COLD TEMPERATURES BELOW -10°F (-23°C). Remove lubricants prescribed in the key for temperatures above -10F (-23°C). Clean parts with SOLVENT, dry-cleaning Relubricate with lubricants specified in the key for temperatures below -10°F (-23°C).
- TACHOMETER DRIVE GREASE CUP. Give cup one full turn every 50 hours. When cup is turned down fully, the grease is depleted; refill the cup.
- ENGINE OIL FILTER. Replace filter to coincide with every third oil change. Remove filter while crankcase is drained, clean filter housing with clean cloth, and install new filter element before replenishing engine oil. Crankcase requires extra quart of oil at intervals in which filter is changed.
- CRANKCASE FILLER. Check oil level every 10 hours. Add oil through filler if dipstick level is low. Remove both engine drain plugs to drain crankcase at oil change interval. Drain oil while engine is hot.
- PUMP BEARINGS. Pump bearings are lubricated by the manufacturer at assembly and require no subsequent lubrication except at scheduled overhaul

periods.

6. WHEEL BEARINGS. Remove wheels and hubs, clean and inspect bearings, and repack with grease at reassembly. Refer to TM 54320-234-12 for required wheel nut adjustment.

7. OIL CAN POINTS. Every 250 hours, using an oil can filled with OE/HDO, lubricate carburetor and governor linkages, trailer front leg, and hinged panels.

Copy of this Lubrication Order will remain with the equipment at all times; instructions contained herein are mandatory.

**BY ORDER OF THE SECRETARY OF THE ARMY:**

BERNARD W. ROGERS  
General, United States Army  
Chief of Staff

OFFICIAL:

J. C. PENNINGTON  
Brigadier General, United States Army  
The Adjutant General

FOLD

FOLD

**DISTRIBUTION: To be distributed in accordance with DA Form 12-25A, Operator Maintenance requirements for Petroleum Distribution.**

\*U.S. GOVERNMENT PRINTING OFFICE: 1962 0-38-737

RECOMMENDED CHANGES TO EQUIPMENT TECHNICAL PUBLICATIONS



THEN... JOT DOWN THE DOPE ABOUT IT ON THIS FORM, CAREFULLY TEAR IT OUT, FOLD IT AND DROP IT IN THE MAIL!

**SOMETHING WRONG WITH THIS PUBLICATION?**

FROM: (PRINT YOUR UNIT'S COMPLETE ADDRESS)

DATE SENT

PUBLICATION NUMBER

PUBLICATION DATE

PUBLICATION TITLE

BE EXACT... PIN-POINT WHERE IT IS

IN THIS SPACE TELL WHAT IS WRONG AND WHAT SHOULD BE DONE ABOUT IT:

PAGE NO.	PARA-GRAPH	FIGURE NO.	TABLE NO.
----------	------------	------------	-----------

TEAR ALONG PERFORATED LINE

PRINTED NAME, GRADE OR TITLE, AND TELEPHONE NUMBER

SIGN HERE:

# THE METRIC SYSTEM AND EQUIVALENTS

## LENGTH MEASURE

1 Centimeter = 10 Millimeters = 0.01 Meters = 0.3937 Inches  
 1 Meter = 100 Centimeters = 1000 Millimeters = 39.37 Inches  
 1 Kilometer = 1000 Meters = 0.621 Miles

## WEIGHTS

1 Gram = 0.001 Kilograms = 1000 Milligrams = 0.035 Ounces  
 1 Kilogram = 1000 Grams = 2.2 lb.  
 1 Metric Ton = 1000 Kilograms = 1 Megagram = 1.1 Short Tons

## LIQUID MEASURE

1 Milliliter = 0.001 Liters = 0.0338 Fluid Ounces  
 1 Liter = 1000 Milliliters = 33.82 Fluid Ounces

## SQUARE MEASURE

1 Sq. Centimeter = 100 Sq. Millimeters = 0.155 Sq. Inches  
 1 Sq. Meter = 10,000 Sq. Centimeters = 10.76 Sq. Feet  
 1 Sq. Kilometer = 1,000,000 Sq. Meters = 0.386 Sq. Miles

## CUBIC MEASURE

1 Cu. Centimeter = 1000 Cu. Millimeters = 0.06 Cu. Inches  
 1 Cu. Meter = 1,000,000 Cu. Centimeters = 35.31 Cu. Feet

## TEMPERATURE

$5/9(^{\circ}\text{F} - 32) = ^{\circ}\text{C}$   
 212° Fahrenheit is equivalent to 100° Celsius  
 90° Fahrenheit is equivalent to 32.2° Celsius  
 32° Fahrenheit is equivalent to 0° Celsius  
 $9/5^{\circ}\text{C} + 32 = ^{\circ}\text{F}$

## APPROXIMATE CONVERSION FACTORS

TO CHANGE	TO	MULTIPLY BY
Inches	Centimeters	2.540
Feet	Meters	0.305
Yards	Meters	0.914
Miles	Kilometers	1.609
Square Inches	Square Centimeters	6.451
Square Feet	Square Meters	0.093
Square Yards	Square Meters	0.836
Square Miles	Square Kilometers	2.590
Acres	Square Hectometers	0.405
Cubic Feet	Cubic Meters	0.028
Cubic Yards	Cubic Meters	0.765
Fluid Ounces	Milliliters	29.573
its	Liters	0.473
arts	Liters	0.946
allons	Liters	3.785
Ounces	Grams	28.349
Pounds	Kilograms	0.454
Short Tons	Metric Tons	0.907
Pound-Feet	Newton-Meters	1.356
Pounds per Square Inch	Kilopascals	6.895
Miles per Gallon	Kilometers per Liter	0.425
Miles per Hour	Kilometers per Hour	1.609

TO CHANGE	TO	MULTIPLY BY
Centimeters	Inches	0.394
Meters	Feet	3.280
Meters	Yards	1.094
Kilometers	Miles	0.621
Square Centimeters	Square Inches	0.155
Square Meters	Square Feet	10.764
Square Meters	Square Yards	1.196
Square Kilometers	Square Miles	0.386
Square Hectometers	Acres	2.471
Cubic Meters	Cubic Feet	35.315
Cubic Meters	Cubic Yards	1.308
Milliliters	Fluid Ounces	0.034
Liters	Pints	2.113
Liters	Quarts	1.057
ers	Gallons	0.264
ms	Ounces	0.035
ograms	Pounds	2.205
Metric Tons	Short Tons	1.102
Newton-Meters	Pounds-Feet	0.738
Kilopascals	Pounds per Square Inch	0.145
ometers per Liter	Miles per Gallon	2.354
ometers per Hour	Miles per Hour	0.621

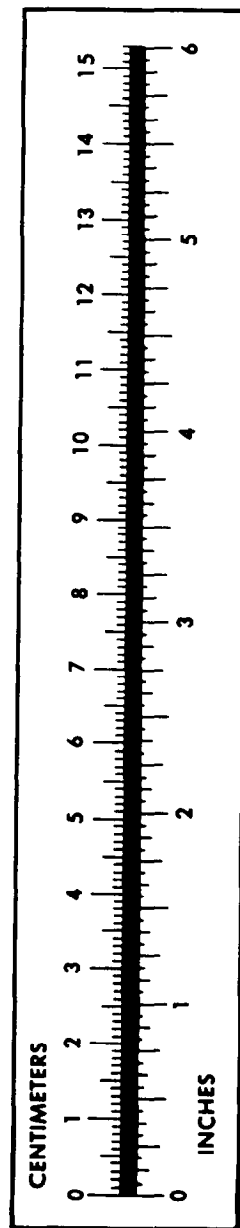



This fine document...

Was brought to you by me:



## [Liberated Manuals -- free army and government manuals](#)

Why do I do it? I am tired of sleazy CD-ROM sellers, who take publicly available information, slap “watermarks” and other junk on it, and sell it. Those masters of search engine manipulation make sure that their sites that sell free information, come up first in search engines. They did not create it... They did not even scan it... Why should they get your money? Why are not letting you give those free manuals to your friends?

I am setting this document FREE. This document was made by the US Government and is NOT protected by Copyright. Feel free to share, republish, sell and so on.

I am not asking you for donations, fees or handouts. If you can, please provide a link to [liberatedmanuals.com](http://liberatedmanuals.com), so that free manuals come up first in search engines:

<A HREF=<http://www.liberatedmanuals.com/>>Free Military and Government Manuals</A>

– Sincerely  
Igor Chudov  
<http://igor.chudov.com/>